

Released for Permit
 02/10/2021 10:43:13 AM
 Pikes Peak
 REGIONAL
 Building Department
 shelley
 CONSTRUCTION

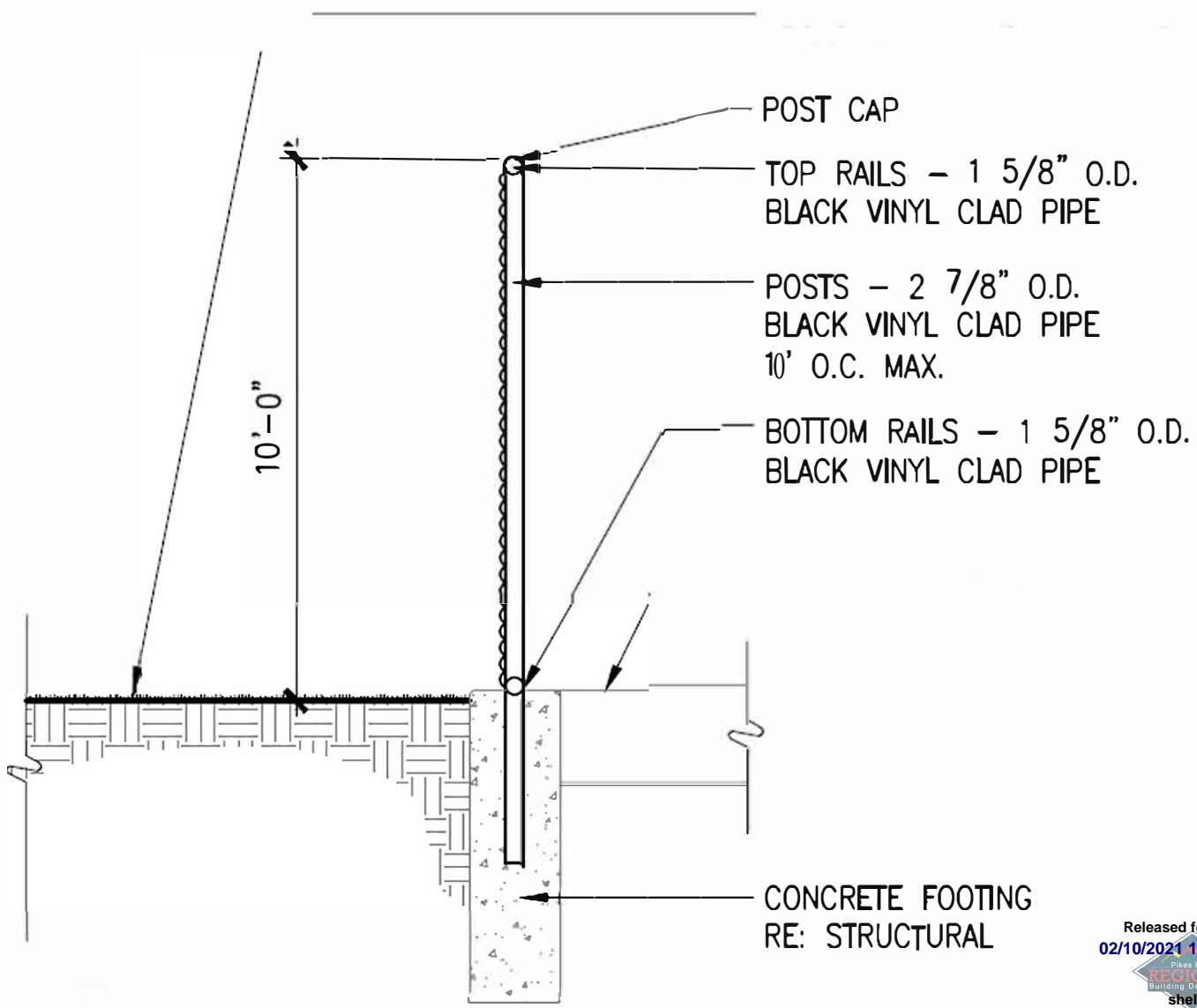

PERSON GATE

SCALE: 1/2" = 1'-0"



Released for Permit
 02/10/2021 10:43:13 AM
 REGIONAL Building Department
 shelley
 CONSTRUCTION

A

10' CHAINLINK FENCE

SCALE: 1/2"=1'-0"

- DESIGNED IN ACCORDANCE WITH 2015 IBC AND 2017 PPRBC
- PIPE: ASTM A53, GRADE B
- REINFORCING: ASTM A615, GRADE 60
- CONCRETE: $f_c = 3,000$ MIN

DESIGN WIND LOADS	
V_{3s}	= 130 mph
EXPOSURE	= C

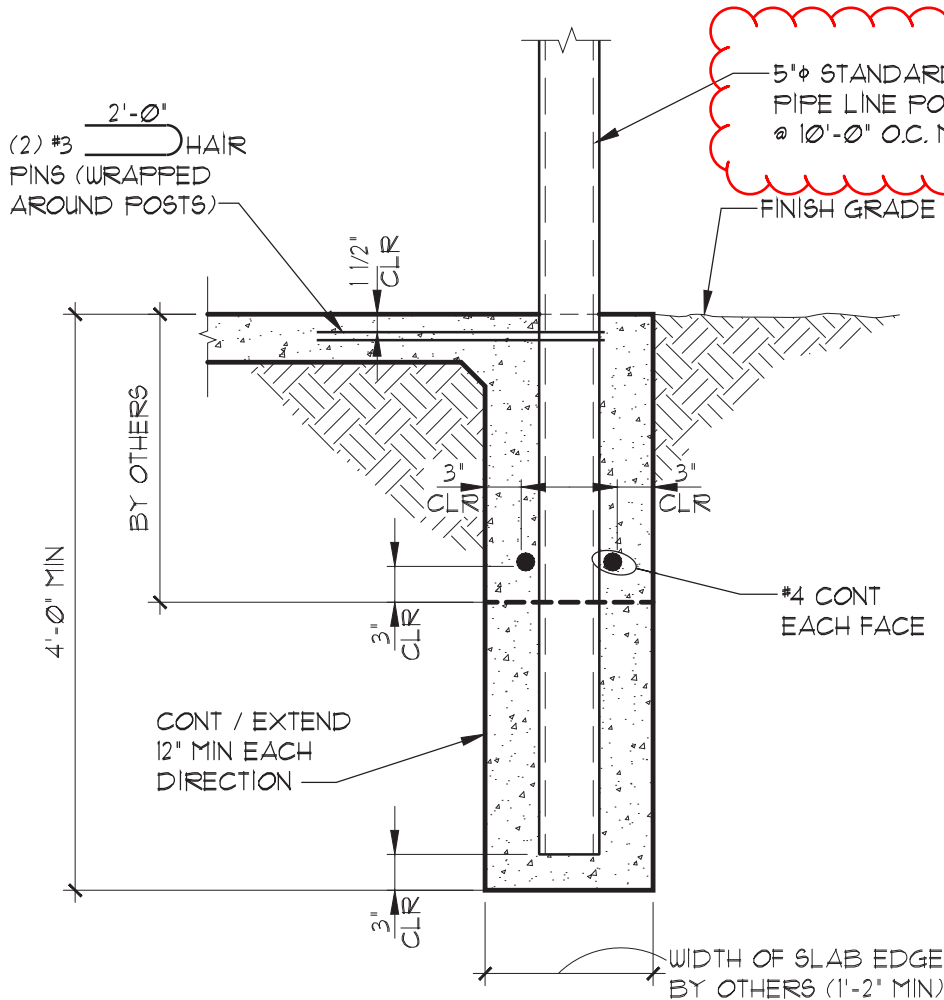

A DETAIL
SCALE: 3/4" = 1'-0"

Released for Permit
02/10/2021 10:43:10 AM
Pikes Peak REGIONAL Building Department
shelley
CONSTRUCTION



ROCKY MOUNTAIN GROUP

Architectural
Structural
Forensics



Geotechnical
Materials, Testing
Civil, Planning

SOUTHERN COLORADO
2910 AUSTIN BLUFFS PKWY, SUITE 100, COLORADO SPRINGS, CO 80918
(719) 548-0600 ~ WWW.RMGENGINEERS.COM
SOUTHERN COLORADO, DENVER METRO, NORTHERN COLORADO

**FENCE POST
FOUNDATION**

1905 SPRING VALLEY DRIVE
COLORADO SPRINGS, COLORADO

ALTITUDE ATHLETIC SURFACES

JOB No.	179427
SHEET No.	1 of 1
DATE:	2-03-2020
REVISION:	.
ENGINEER:	MDT
DRAWN:	CL