

EPC STORMWATER REVIEW COMMENTS
IN ORANGE BOXES WITH BLACK TEXT

Noted, thank you.



Preliminary Drainage Report

Overlook at Homestead Subdivision El Paso County, Colorado

Prepared for:

PT Overlook LLC

1864 Woodmoor Drive, Suite 100

Monument, CO 80132

Prepared by:

Kimley-Horn and Associates, Inc.

2 North Nevada Avenue, Suite 900

Colorado Springs, Colorado 80903

(719) 453-0180

Contact: Kevin Kofford, P.E.

Project #: 196239003

PCD Filing No.: **SP238**

Prepared: August 7, 2023

Added

Kimley»Horn

CERTIFICATION

DESIGN ENGINEER'S STATEMENT

The attached drainage plan and report were prepared under my direction and supervision and are correct to the best of my knowledge and belief. Said drainage report has been prepared according to the criteria established by the County for drainage reports and said report is in conformity with the master plan of the drainage basin. I accept responsibility for any liability caused by any negligent acts, errors or omissions on my part in preparation of this report.

SIGNATURE (Affix Seal): _____
Kevin Kofford, P.E. Date

OWNER/DEVELOPER'S STATEMENT

I, the developer, have read and will comply with all of the requirements specified in this Drainage Report and Plan.

PT Overlook LLC

Authorized Signature Date

Joseph W. DesJardin

Director of Entitlements

Address:
1864 Woodmoor Drive
Monument, CO 80132

EL PASO COUNTY

Filed in accordance with the requirements of the Drainage Criteria Manual, Volumes 1 and 2, El Paso County Engineering Criteria Manual and Land Development Code as amended.

Josh Palmer, P.E. Date
County Engineer/ ECM Administrator

Conditions:

TABLE OF CONTENTS

CERTIFICATION1
DESIGN ENGINEER'S STATEMENT1
OWNER/DEVELOPER'S STATEMENT1
EL PASO COUNTY1

TABLE OF CONTENTS2

INTRODUCTION3
PURPOSE AND SCOPE OF STUDY3
LOCATION3
DESCRIPTION OF PROPERTY3

FLOODPLAIN STATEMENT3

DRAINAGE BASINS4
MAJOR BASIN DESCRIPTIONS4
COMPLIANCE WITH PREVIOUS FINAL DRAINAGE REPORT4
EXISTING SUB-BASIN DESCRIPTIONS4
PROPOSED SUB-BASIN DESCRIPTIONS7

DRAINAGE DESIGN CRITERIA.....11
DEVELOPMENT CRITERIA REFERENCE11
HYDROLOGIC CRITERIA11
HYDRAULIC CRITERIA11
DETENTION.....11
CULVERT SIZING12
CHANNEL STABILIZATION12

THE FOUR STEP PROCESS12

DRAINAGE FEES13
FEES13

SUMMARY13

REFERENCES14

APPENDIX
APPENDIX A: VICINITY MAP
APPENDIX B: FEMA MAP & SOILS REPORT
APPENDIX C: HYDROLOGY
APPENDIX D: HYDRUALICS
APPENDIX E: EL PASO COUNTY DRAINAGE BASIN MAP
APPENDIX F: APEX RANCH DRAINAGE REPORT
APPENDIX G: DRAINAGE MAPS

INTRODUCTION

PURPOSE AND SCOPE OF STUDY

The purpose of this Preliminary Drainage Report (PDR) is to provide the hydrologic and preliminary hydraulic calculations and to document the drainage design methodology in support of the proposed Overlook at Homestead Subdivision (“the Project”) for PT Overlook LLC. The finalized hydraulic design and associated calculations will be provided with the Final Drainage Report. The Project is located within the jurisdictional limits of El Paso County (“the County”). Therefore, the hydrologic and hydraulic design is based on the County’s criteria which is described in further detail within the report.

LOCATION

The Project Site located east of Elbert Road within El Paso County, Colorado including parcels 4122000005, 4100000255, 4100000256. More specifically, the site is a Portion of Section 22 and a Portion of Section 27, Township 11 South, Range 64 West of the 6th PM, County of El Paso, State of Colorado. North of the project site is agricultural and rural residential land, to the east is Homestead Ranch Park owned and maintained by El Paso County, and to the south and west is Homestead Ranch subdivisions. A vicinity map has been provided in the **Appendix** of this report.

The Site is currently owned by PT Overlook LLC and will be developed by PT Overlook LLC.

DESCRIPTION OF PROPERTY

The Site is approximately 350.8 acres consisting of mostly vacant, undeveloped land with native vegetation and a rural single-family residential home situated within the north of the Project Site and is classified as Agricultural Grazing Land. Vegetation within the site is characterized primarily by prairie grasses along with some area of scrub brush and trees. The Site does not currently provide water quality or detention for the Project area.

The existing topography consists of slopes ranging from 1% to 33% with an existing butte covering much of the northern portion of the Site. Flows in the existing conditions run off site into one of four major drainage basins. Detailed descriptions of the existing major drainage basins can be found later in the report.

According to NRCS soil mapping data, USCS Type B soils are the primary soil type within the site. Type B soils having a moderate infiltration rate when thoroughly wet. These consist chiefly of moderately deep or deep, moderately well drained, or well drained soils that have moderately fine texture to moderately coarse texture. These soils have a moderate rate of water transmission. Soils mapping information has been provided in the **Appendix**.

The full development of this site will consist of 62, five (5) acre residential lots with roadway improvements, roadway grading, six full spectrum detention ponds, roadside ditches, culverts, and drainage swales. The property is planned to be developed as two separate filings.

FLOODPLAIN STATEMENT

The Site is located outside the 100-year floodplain and within Zone X (an area of minimal flood hazard) as noted on the FEMA FIRM Map No. 08041C0350G revised on December 7, 2018 (See

Appendix).

DRAINAGE BASINS

MAJOR BASIN DESCRIPTIONS

The Project Site is tributary to four major drainage basins in the El Paso County Drainage Basin Map. Bijou Creek, East Kiowa Creek, Upper Black Squirrel, and La Vega Ranch Drainage Basins. These drainage basins are located in the north central portion of El Paso County. The northeast portion of the site is tributary to Bijou Creek Drainage Basin, the northwest portion of the site is tributary to East Kiowa Creek Drainage Basin, the southwest portion of the site is tributary to Upper Black Squirrel Drainage Basin, and the southeast portion of the site is tributary to La Vega Ranch Drainage Basin. In an effort to simplify basin nomenclature, the following naming conventions have been used for both existing and proposed drainage sub-basins labeling. Proposed Basins have been designed in effort to keep runoff within the same existing basins, as to not transfer runoff between basins.

- A - Upper Black Squirrel Drainage Basin (CHBS2000)
- B - La Vega Ranch Drainage Basin (CHBR0400)
- C - East Kiowa Creek Drainage Basin (KIKI0400)
- D - Bijou Creek Drainage Basin (BIBI0200)

El Paso County Drainage Basin map has been provided in the **Appendix**. A summary of flows in existing and proposed conditions has been added to the **Appendix**.

COMPLIANCE WITH PREVIOUS FINAL DRAINAGE REPORT

A portion of the proposed Project Site falls within the existing approved "Final Drainage Report for Apex Ranch Estates" by Terra Nova Engineering, Inc. approval date September 3, 2008. The basins OS-1, OS-2, and OS-3 as outlined in the report are captured by the existing stormwater facilities. These sub-basins are part of proposed sub-basins C1, C2, and C3 in the proposed drainage study Area. Flows from sub basins C2 and C3 as described in detail later in this report, are to be captured and treated by a proposed private full spectrum extended detention basin. Flows from these basins will be at or below history values. In the proposed conditions sub-basin C3 (Which includes a portion of existing sub-basin OS-1) is to flow directly into the existing Apex Ranch subdivision. These flows are to be captured and treated by the existing stormwater facilities. The assumed impervious value of sub-basin OS-1 used in previous calculations is 10%, under the proposed conditions a conservative estimate of 11% was used. As the total area tributary to the existing stormwater infrastructure is less than that of the previously studied area and the studied impervious values are at extremely minor in nature, any changes in flows from sub-basin C3 will be insignificant. Excerpts from the previously approved FDR have been provided in the **Appendix**.

EXISTING SUB-BASIN DESCRIPTIONS

Historically the runoff from the Site drains into one of four major drainage basins as described above. Slopes vary from 2-33% throughout the site with various natural features. The Site has

been divided into 13 onsite basins A1-A2, B1-B5, C1-C5, D1, and 5 offsite basins OS-A1 to OS-A2, and OS-C1 to OS-C3. The offsite basins are located west of the Site and generally flow west towards to existing stormwater infrastructure. Descriptions of each individual sub-basin can be found below.

Sub-Basin A1

This on-site sub-basin consists of an area of 19.92 acres, located in the southwest corner of the Site. Drainage flows overland from the northeast to the southwest where it is captured by an existing culvert at DP 1 and outfalls west of Elbert Rd. The weighted imperviousness for this sub-basin is 8%. Runoff during the 5-year and 100-year events are 8.43 cfs and 38.41 cfs respectively. Refer to the **Appendix** for the Existing Conditions Drainage Map.

Sub-Basin A2

This on-site sub-basin consists of an area of 61.50 acres, located in the southwest corner of the Site. Drainage flows overland from the northeast to the southwest where it flows offsite at DP 2 into Reata subdivision south of the Site. The weighted imperviousness for this sub-basin is 1%. Runoff during the 5-year and 100-year events are 13.00 cfs and 87.58 cfs respectively. Refer to the **Appendix** for the Existing Conditions Drainage Map.

Sub-Basin B1

This on-site sub-basin consists of an area of 45.75 acres, located in the south-central portion of the Site. Drainage flows overland from the north to the south where it flows offsite at DP 3 into Reata subdivision south of the Site. The weighted imperviousness for this sub-basin is 0%. Runoff during the 5-year and 100-year events are 9.87 cfs and 72.48 cfs respectively. Refer to the **Appendix** for the Existing Conditions Drainage Map.

Sub-Basin B2

This on-site sub-basin consists of an area of 42.42 acres, located in the south-central portion of the Site. Drainage flows overland from the north to the south where it flows offsite at DP 4 into Reata subdivision south of the Site. The weighted imperviousness for this sub-basin is 0%. Runoff during the 5-year and 100-year events are 9.41 cfs and 69.09 cfs respectively. Refer to the **Appendix** for the Existing Conditions Drainage Map.

Sub-Basin B3

This on-site sub-basin consists of an area of 49.65 acres, located in the southeast portion of the Site. Drainage flows overland from the north to the south where it flows offsite at DP 5 into Reata subdivision south of the Site. The weighted imperviousness for this sub-basin is 0%. Runoff during the 5-year and 100-year events are 11.54 cfs and 84.76 cfs respectively. Refer to the **Appendix** for the Existing Conditions Drainage Map.

Sub-Basin B4

This on-site sub-basin consists of an area of 8.59 acres, located in the eastern portion of the Site. Drainage flows overland from west to east where it flows offsite at DP 6 into Homestead Ranch Park east of the Site. The weighted imperviousness for this sub-basin is 0%. Runoff during the 5-year and 100-year events are 2.54 cfs and 18.64 cfs respectively. Refer to the **Appendix** for the Existing Conditions Drainage Map.

Sub-Basin B5

This on-site sub-basin consists of an area of 8.95 acres, located in the eastern portion of the Site. Drainage flows overland from west to east where it flows offsite at DP 7 into Homestead Ranch Park east of the Site. The weighted imperviousness for this sub-basin is 0%. Runoff during the 5-

year and 100-year events are 2.67 cfs and 19.63 cfs respectively. Refer to the **Appendix** for the Existing Conditions Drainage Map.

Sub-Basin C1

This on-site sub-basin consists of an area of 53.41 acres, located in the central portion of the Site. Drainage flows overland from east to west where it flows offsite at DP 8 into offsite basin OS-C1 where flows travel overland into an existing roadside ditch and ultimately into an existing stormwater detention pond. The weighted imperviousness for this sub-basin is 0%. Runoff during the 5-year and 100-year events are 13.04 cfs and 95.74 cfs respectively. Refer to the **Appendix** for the Existing Conditions Drainage Map.

Sub-Basin C2

This on-site sub-basin consists of an area of 8.47 acres, located in the central portion of the Site. Drainage flows overland from northeast to southwest where it flows offsite at DP 9 into offsite basin OS-C2 where flows travel overland into an existing roadside ditch and ultimately into an existing stormwater detention pond. The weighted imperviousness for this sub-basin is 0%. Runoff during the 5-year and 100-year events are 2.28 cfs and 16.77 cfs respectively. Refer to the **Appendix** for the Existing Conditions Drainage Map.

Sub-Basin C3

This on-site sub-basin consists of an area of 5.55 acres, located in the central portion of the Site. Drainage flows overland from east to west where it flows offsite at DP 10 into offsite basin OS-C3 where flows travel overland into an existing roadside ditch and then north along Fletcherville Lane. The weighted imperviousness for this sub-basin is 0%. Runoff during the 5-year and 100-year events are 1.62 cfs and 11.89 cfs respectively. Refer to the **Appendix** for the Existing Conditions Drainage Map.

Sub-Basin C4

This on-site sub-basin consists of an area of 6.40 acres, located in the northern central portion of the Site. Drainage flows overland from south to north where it flows offsite at DP 11 into the agricultural grazing land to the north. The weighted imperviousness for this sub-basin is 0%. Runoff during the 5-year and 100-year events are 1.89 cfs and 13.87 cfs respectively. Refer to the **Appendix** for the Existing Conditions Drainage Map.

Sub-Basin C5

This on-site sub-basin consists of an area of 10.50 acres, located in the northern central portion of the Site. Drainage flows overland from south to north where it flows offsite at DP 12 into the agricultural grazing land to the north. The weighted imperviousness for this sub-basin is 0%. Runoff during the 5-year and 100-year events are 2.96 cfs and 21.72 cfs respectively. Refer to the **Appendix** for the Existing Conditions Drainage Map.

Sub-Basin D1

This on-site sub-basin consists of an area of 29.73 acres, located in the northeast portion of the Site. Drainage flows overland from southwest to northeast where it flows offsite at DP 13 Homestead Ranch Park east of the Site. The weighted imperviousness for this sub-basin is 0%. Runoff during the 5-year and 100-year events are 7.71 cfs and 56.62 cfs respectively. Refer to the **Appendix** for the Existing Conditions Drainage Map.

Sub-Basin OS-A1

The off-site sub-basin consists of an area of 4.06 acres, located in the western central portion of the drainage study area. Drainage flows overland from the northeast to southwest where it is captured by an existing drainage culvert at DP 14 and directed west of Elbert Road. The weighted

imperviousness for this sub-basin is 19%. Runoff during the 5-year and 100-year events are 3.76 cfs and 12.49 cfs respectively. Refer to the **Appendix** for the Existing Conditions Drainage Map.

Sub-Basin OS-A2

The off-site sub-basin consists of an area of 4.45 acres, located in the central portion of the drainage study area. Drainage flows overland from the north to south where it enters sub-basin A2 at DP 15 and follows the patterns described in sub-basin A2. The weighted imperviousness for this sub-basin is 19%. Runoff during the 5-year and 100-year events are 3.76 cfs and 12.49 cfs respectively. Refer to the **Appendix** for the Existing Conditions Drainage Map.

Sub-Basin OS-C1

The off-site sub-basin consists of an area of 27.49 acres, located in the central portion of the drainage study area. Drainage flows overland from east to west where it enters the existing roadside ditch at Apex Ranch Road at DP 16 and is ultimately conveyed through an existing culvert to the existing detention pond just west of Fletcherville Road. The weighted imperviousness for this sub-basin is 9%. Runoff during the 5-year and 100-year events are 12.21 cfs and 59.93 cfs respectively. Refer to the **Appendix** for the Existing Conditions Drainage Map.

Sub-Basin OS-C2

The off-site sub-basin consists of an area of 6.15 acres, located in the central portion of the drainage study area. Drainage flows overland from the east to west where it enters the existing roadside ditch at Apex Ranch Road at DP 17 and is ultimately conveyed through an existing culvert to the existing detention pond just west of Fletcherville Road. The weighted imperviousness for this sub-basin is 17%. Runoff during the 5-year and 100-year events are 4.26 cfs and 15.78 cfs respectively. Refer to the **Appendix** for the Existing Conditions Drainage Map.

Sub-Basin OS-C3

The off-site sub-basin consists of an area of 21.89 acres, located in the northwest portion of the drainage study area. Drainage flows overland from the west to east where it enters the existing roadside ditch at Fletcherville Road and flows north at DP 18. The weighted imperviousness for this sub-basin is 11%. Runoff during the 5-year and 100-year events are 11.63 cfs and 51.77 cfs respectively. Refer to the **Appendix** for the Existing Conditions Drainage Map.

PROPOSED SUB-BASIN DESCRIPTIONS

For the proposed condition, stormwater will generally maintain historic flow patterns. The proposed roadways will alter some of the existing flow paths. The roadway ditches will capture runoff from the roadways and direct flows via proposed culverts back to the existing flow paths, which will ultimately follow historic patterns or be captured by one of the six (6) proposed storm water ponds to 15 onsite basins A1-A2, B1-B6, C1-C6, D1, and E1 to OS-C3. The offsite basins are located west of the existing detention pond, and existing grass lined swales in can be found below. The off-site basins are fully captured by the existing basins are anticipated. Based on the existing approved "Site Plan for Overlook Estates" by Terra Nova Engineering, Inc. conditions flows will be released at less than approval historic rates and no additional flows will be added to the existing detention pond.

Information regarding existing pond added. Information referencing the detention section of this report as well as the appendix has been added. The existing pond did not account for offsite drainage

Sub-Basin A1

This on-site sub-basin consists of an area of 19.55 acres, located in the southwest corner of the Site. Drainage flows overland from the northeast to the southwest where it is captured by an

Also discuss the proposed 6 detention basins. Verify the existing detention pond is functioning as intended and if the existing pond provides WQ treatment as well.

existing culvert at DP 1 and outfalls west of Elbert Rd. There are no proposed improvements in sub-basin A1. The weighted imperviousness for this sub-basin is 15%. Runoff during the 5-year and 100-year events are 10.41 cfs and 41.24 cfs respectively. Refer to the **Appendix** for the Proposed Conditions Drainage Map.

Sub-Basin A2

This on-site sub-basin consists of an area of 19.11 acres, located in the southwest corner of the Site. Drainage flows overland from the northeast to the southwest where it flows into proposed roadside ditches, is conveyed through proposed stormwater culverts, and is ultimately captured by proposed private stormwater pond A2 at DP 2. The weighted imperviousness for this sub-basin is 12%. Runoff during the 5-year and 100-year events are 20.99 cfs and 92.96 cfs respectively. Refer to the **Appendix** for the Proposed Conditions Drainage Map.

Noted, thank you. Roadways are proposed to be public. All discrepancies revised in PDR.

Sub-Basin B1

This on-site sub-basin consists of an area of 40.74 acres, located in the north-central portion of the Site. Drainage flows overland from the north to the south where it flows offsite at DP 3. The weighted imperviousness for this sub-basin is 10%. Runoff during the 5-year and 100-year events are 16.77 cfs and 80.40 cfs respectively. Refer to the **Appendix** for the Proposed Conditions Drainage Map.

The letter of intent indicates that the roadways will be public. Did you mean private driveways? Please clarify throughout the narrative

Sub-Basin B2

This on-site sub-basin consists of an area of 16.00 acres, located in the south-central portion of the Site. Drainage flows overland from the north to the south where it flows offsite at DP 4. The weighted imperviousness for this sub-basin is 9%. Runoff during the 5-year and 100-year events are 11.64 cfs and 46.64 cfs respectively. Refer to the **Appendix** for the Proposed Conditions Drainage Map.

Noted, sub-basins, areas and associate exclusions are now outlined in a table in step 2 of the 4-step process.

Sub-Basin B3

This on-site sub-basin consists of an area of 19.11 acres, located in the southeastern portion of the Site. Drainage flows overland from the north-west to the southeast where it flows off site at DP 5. There are no proposed improvements within this sub-basin. The weighted imperviousness for this sub-basin is 7%. Runoff during the 5-year and 100-year events are 7.83 cfs and 42.71 cfs respectively. Refer to the **Appendix** for the Proposed Conditions Drainage Map.

As this basin has lots that will be developed please identify how WQ will be addressed. Identify any exclusions such as large lot SFD exclusion I.7.1.B.5. This comment applies to other basin that just include the lots to be developed an no other public improvements. please address accordingly.

Discussion regarding increase in flows added.

This on-site sub-basin consists of an area of 8.50 acres, located in the eastern portion of the Site. Drainage flows overland from west to east where it flows offsite at DP 6. The weighted imperviousness for this sub-basin is 7%. Runoff during the 5-year and 100-year events are 11.64 cfs and 20.58 cfs respectively. Refer to the **Appendix** for the proposed Conditions Drainage Map.

identify how increase in flows will be mitigated for this basin

Sub-Basin B5

This on-site sub-basin consists of an area of 8.95 acres, located in the eastern portion of the Site. Drainage flows overland from west to east where it flows offsite at DP 7. The weighted imperviousness for this sub-basin is 7%. Runoff during the 5-year and 100-year events are 11.64 cfs and 21.85 cfs respectively. Refer to the **Appendix** for the Proposed Conditions Drainage Map.

Noted, a more detailed discussion, including table has been added to Step-2 of the four-step process section of this report. This detailed discussion outlines specific basins, areas, and what, if any exclusions are being considered.

There are basins that are not being captured by the proposed ponds, such as Basin B2 (see highlights throughout the basins). Explain in the narrative how WQ is being addressed for these basins. Possible exclusions include I.7.1.B.7 (land disturbance to undeveloped land that will remain undeveloped) and/or I.7.1.C.1 (which allows for 20% not to exceed 1 acre of the applicable development site area to not be captured).

Sub-Basin B6

This on-site sub-basin consists of an area of 2.46 acres, located in the central portion of the Site. Improvements within this sub-basin include proposed roads, roadside ditches, and culverts. Drainage flows overland from the northeast to the southwest where it flows into proposed roadside ditches, is conveyed through a proposed stormwater culvert at DP 8, and into sub-basin B8. The weighted imperviousness for this sub-basin is 10%. Runoff during the 5-year and 100-year events are 22.55 cfs and 106.95 cfs respectively. Refer to the **Appendix** for the Proposed Conditions Drainage Map.

Noted, discussion added describing flows once they enter sub-basin B8.

please also state that this will flow to pond B8

Sub-Basin B7

This on-site sub-basin consists of an area of 2.46 acres, located in the southern portion of the Site. Drainage flows overland from the north to south where it flows off site at DP 9. There are no proposed improvements within this sub-basin. The weighted imperviousness for this sub-basin is 7%. Runoff during the 5-year and 100-year events are 1.13 cfs and 6.17 cfs respectively. Refer to the **Appendix** for the Proposed Conditions Drainage Map.

recommend indicating that this basin accepts flows from DP8 (basin B6)

Sub-Basin B8

This on-site sub-basin consists of an area of 9.52 acres, located in the southern portion of the Site. Drainage flows overland from the north to south where it is captured by proposed private full spectrum extended detention basin DP 10. Aside from the proposed extended detention basin there are no proposed improvements within this sub-basin. The weighted imperviousness for this sub-basin is 12%. Runoff during the 5-year and 100-year events are 4.22 cfs and 23.05 cfs respectively. Refer to the **Appendix** for the Proposed Conditions Drainage Map.

Discussion regarding flows from sub-basin B6 have been added.

Sub-Basin C1

This on-site sub-basin consists of an area of 25.91 acres, located in the central portion of the Site. Drainage flows overland from east to west where it flows offsite at DP 11 into offsite basin OS-C1 where flows travel overland into an existing roadside ditch and ultimately into an existing stormwater detention pond. Improvements within this sub-basin include proposed private roads. This sub-basin includes an approx. 22,316 sq ft improved area of roadway that will not be receiving water quality treatment. The weighted imperviousness for this sub-basin is 9%. Runoff during the 5-year and 100-year events are 11.18 cfs and 55.47 cfs respectively. Refer to the **Appendix** for the Proposed Conditions Drainage Map.

discuss any exclusions that preclude this area from water quality

Noted, a more detailed discussion, including table has been added to Step-2 of the four-step process section of this report. This detailed discussion outlines specific basins, areas, and what, if any exclusions are being considered.

This on-site sub-basin consists of an area of 17.03 acres, located in the central portion of the Site. Drainage flows overland from the northeast to southwest where it is captured by proposed roadside ditches, is conveyed to proposed private stormwater pond C2 at DP 12. Improvements within this sub-basin include proposed private roads, and a proposed private stormwater detention pond. The weighted imperviousness for this sub-basin is 12%. Runoff during the 5-year and 100-year events are 11.18 cfs and 34.64 cfs respectively. Refer to the **Appendix** for the Proposed Conditions Drainage Map.

Sub-Basin C3

This on-site sub-basin consists of an area of 3.96 acres, located in the central portion of the Site. Drainage flows overland from east to west where it flows offsite at DP 13 into offsite basin OS-C3 where flows travel overland into an existing roadside ditch and then north along Fletcherville Lane. Improvements within this sub-basin include proposed private roads. This sub-basin includes an approx. 6,530 sq ft improved area of roadway that will not be receiving water quality treatment. The weighted imperviousness for this sub-basin is 11%. Runoff during the 5-year and 100-year events are 2.36 cfs and 10.80 cfs respectively. Refer to the **Appendix** for the Proposed Conditions Drainage Map.

Sub-Basin C4

This on-site sub-basin consists of an area of 6.37 acres, located in the northern central portion of the Site. Drainage flows overland from south to north where it flows offsite at DP 14. The weighted imperviousness for this sub-basin is 7%. Runoff during the 5-year and 100-year events are 2.83 cfs and 15.42 cfs respectively. Refer to the **Appendix** for the Proposed Conditions Drainage Map.

Sub-Basin C5

This on-site sub-basin consists of an area of 10.50 acres, located in the northern central portion of the Site. Drainage flows overland from south to north where it flows offsite at DP 15. The weighted imperviousness for this sub-basin is 7%. Runoff during the 5-year and 100-year events are 4.44 cfs and 24.20 cfs respectively. Refer to the **Appendix** for the Proposed Conditions Drainage Map.

Sub-Basin C6

This on-site sub-basin consists of an area of 21.1 acres, located in the northern central portion of the Site. Improvements within this sub-basin include roadside ditches, a stormwater pond, and culverts. Drainage flows overland from south to north where it gets captured by roadside ditches and ultimately flows to proposed private stormwater pond C6 at DP 16. The weighted imperviousness for this sub-basin is 13%. Runoff during the 5-year and 100-year events are 12.27 cfs and 50.85 cfs respectively. Refer to the **Appendix** for the Proposed Conditions Drainage Map.

Sub-Basin D1

This on-site sub-basin consists of an area of 29.1 acres, located in the eastern portion of the Site. Improvements within this sub-basin include roadside ditches, a stormwater pond, and culverts. Drainage flows overland from southwest to northeast where it gets captured by roadside ditches and ultimately flows to proposed private stormwater pond D1 at DP 17. The weighted imperviousness for this sub-basin is 9%. Runoff during the 5-year and 100-year events are 13.56 cfs and 67.33 cfs respectively. Refer to the **Appendix** for the Proposed Conditions Drainage Map.

Sub-Basin OS-A1

The off-site sub-basin consists of an area of 4.06 acres, located in the western central portion of the drainage study area. Drainage flows overland from the northeast to southwest where it is captured by an existing drainage culvert at DP 18 and directed west of Elbert Road. The weighted imperviousness for this sub-basin is 25%. Runoff during the 5-year and 100-year events are 4.12 cfs and 12.86 cfs respectively. Refer to the **Appendix** for the Proposed Conditions Drainage Map.

Sub-Basin A2

This on-site sub-basin consists of an area of 4.45 acres, located in the central portion of the drainage study area. Drainage flows overland from the north to south where it enters sub-basin A2. The weighted imperviousness for this sub-basin is 7%. Runoff during the 5-year and 100-year events are 2.10 cfs and 11.46 cfs respectively. Refer to the **Appendix** for the Proposed Conditions Drainage Map.

Sub-Basin OS-C1

The off-site sub-basin consists of an area of 27.49 acres, located in the central portion of the drainage study area. Drainage flows overland from east to west where it enters the existing roadside ditch at Apex Ranch Road at DP 20 and is ultimately conveyed through an existing culvert to the existing detention pond just west of Fletcherville Road. The weighted imperviousness for this sub-basin is 9%. Runoff during the 5-year and 100-year events are 12.21 cfs and 59.93 cfs respectively. Refer to the **Appendix** for the Proposed Conditions Drainage Map.

identify how increase in flows will be mitigated for this basin

Noted, a more detailed discussion, including table has been added to Step-2 of the four-step process section of this report. This detailed discussion outlines specific basins, areas, and what, if any exclusions are being considered.

Unsure of specific comment associated with this highlight. Please clarify if change required.

Sub-Basin OS-C2

The off-site sub-basin consists of an area of 6.15 acres, located in the central portion of the drainage study area. Drainage flows overland from the east to west where it enters the existing roadside ditch at Apex Ranch Road at DP 21 and is ultimately conveyed through an existing culvert to the existing detention pond just west of Fletcherville Road. The weighted imperviousness for this sub-basin is 17%. Runoff during the 5-year and 100-year events are 4.26 cfs and 15.78 cfs respectively. Refer to the **Appendix** for the Proposed Conditions Drainage Map.

Sub-Basin OS-C3

The off-site sub-basin consists of an area of 21.89 acres, located in the northwest portion of the drainage study area. Drainage flows overland from the west to east where it enters the existing roadside ditch at Fletcherville Road and flows north at DP 22. The weighted imperviousness for this sub-basin is 11%. Runoff during the 5-year and 100-year events are 11.63 cfs and 51.77 cfs respectively. Refer to the **Appendix** for the Proposed Conditions Drainage Map.

DRAINAGE DESIGN CRITERIA

DEVELOPMENT CRITERIA REFERENCE

The proposed storm facilities are designed to be in compliance with the City of Colorado Springs and El Paso County “Drainage Criteria Manual (DCM)” dated October 2018 (“the MANUAL”), El Paso County “Engineering Criteria Manual” (“the Engineering Manual”), Chapter 6 and Section 3.2.1 of Chapter 13 of the City of Colorado Springs Drainage Criteria Manual dated May 2014 (“the Colorado Springs MANUAL”).

Site drainage is not significantly impacted by such constraints as utilities or existing development.

HYDROLOGIC CRITERIA

The 5-year and 100-year design storm events were used in determining rainfall and runoff for the proposed drainage system per chapter 6 of the CRITERIA. Table 6-2 of the CRITERIA is the source for rainfall data for the 5-year and 100-year design storm events. Design runoff was calculated using the Rational Method for developed conditions as established in the CRITERIA and MANUAL. Runoff coefficients for the proposed development were determined using Table 6-6 of the CRITERIA by calculating weighted impervious values for each specific site basin. The detention storage required for the proposed development is being determined using Full Spectrum Detention methods as specified in the CRITERIA.

Discussion regarding existing detention pond has been added.

HYDRAULIC CRITERIA

Applicable design methods were utilized to size the proposed ponds, and culverts, which includes the use of the UD-Detention spreadsheet, rational calculations spreadsheet, and FlowMaster, V8i software.

DETENTION

Is the existing detention pond proposed to be used for detention/flood control as well as the 6 proposed? Please clearly distinguish.

Six full spectrum detention ponds are proposed in order to maintain historic flows and water quality. Mile High Flood District’s UD-detention spreadsheet was utilized to design the preliminary sizing of each pond. Preliminary sizing table can be found below. UD-Detention Sizing calculations can be found in the Appendix.

Pond Calculation Comparison Table

Pond	Basin Area (Acres)	WQCV Volume* (Ac-ft)	100YR Volume (Ac-ft)	Total Volume Required (Ac-ft)	Total Volume Provided (Ac-ft)
A2	58.27	0.120	1.679	2.346	3.722
B1	40.74	0.048	1.120	1.503	2.132
B8	62.83	0.069	1.680	2.207	3.484
C2	17.03	0.042	0.491	0.686	1.033
C6	21.29	0.061	0.626	0.891	1.463
D1	29.38	0.025	0.786	1.032	1.724

*WQCV volume is sized only for proposed impervious roadways

CULVERT SIZING

Detailed sizing of the road culvert crossings will be included in a subsequent Final Drainage Report. It is anticipated that the report will include the design of the proposed culverts.

CHANNEL STABILIZATION

There is no anticipated channel stabilization.

THE FOUR STEP PROCESS

The Project was designed to follow the four-step process to minimize adverse impacts of urbanization, as outlined in the El Paso County Engineering Manual for BMP selection below:

Step 2. WQCV section of report has been revised to provide more clarity on existing detention as well as exclusions

Discussion regarding roadside ditches and sizing has been included in report text. Preliminary drainage report focuses on hydrology. We anticipate to full detail any hydraulic calculations in the final drainage report.

Discuss the condition of the channels /swales

FYI: at the final drainage report, these will need to be analyzed to ensure they are hydraulically adequate

Practices – The project is proposing a low-density design to minimize the impact to the current existing roadways will increase the Site’s impervious area, however, roadside ditches and channels will be constructed to slow down the runoff velocity and reduce runoff peaks. The six proposed detention ponds will be used to capture stormwater, provide water quality treatment, and maintain flows discharging off site at or below historic levels.

Is the existing detention pond proposed to be used for WQ as well as the 6 proposed? Please clearly distinguish.

Step 2. Provide a Water Quality Capture Volume – Permanent water quality measures and detention facilities will be necessary for the Project. Temporary water quality and erosion control measures will be provided during construction to prevent sediment laden water from discharging from the Site. The required water quality capture volume will be required to be treated for all roadway surfaces, excluding 1.0 acres which cannot practicably be treated. Per ECM Appendix I Section 1.7.C.A., 20% of the development site

or less than 1 acre can be excluded from providing water quality. As mentioned, 0.99 acres (43,197 sq ft of impervious area will not be able to be treated which is less than 20% of the overall site. Per ECM Appendix I Section 1.7.1.B, large lot development is exempt from water quality treatment requirement, lot imperviousness shall be limited to 10 percent or less. Refer to **Appendix F** for PBMP Tributary Areas map.

Updated

Step 3 Stabilize Drainageways– Stabilizing proposed roadside ditches, swales, and channels by designing them with slopes that control the flow rates. Placement of riprap upstream and downstream of culverts to help reduce erosion of the roadside ditches. Check dams will be used in areas with steeper grades to slow the runoff. We anticipate this will minimize erosion. Existing drainage ways will be graded to reduce the velocity of the water to minimize erosion.

Step 4. Implement Site Specific and Other Source Control BMPs – The erosion control construction BMPs of the Project were designed to reduce contamination. Source control BMPs include the use of vehicle tracking control, culvert protection, stockpile management, and stabilized staging areas.

DRAINAGE FEES

FEES

The pr
Draina
Draina
Fee Pr

Final design of outfall ad spillway will be included in Final Drainage Report submittal. As the the final pond design is required to release flows below historic rates there are no anticipated downstream impacts. Preliminary drainage report focuses on hydrology. We anticipate to full detail any hydraulic calculations in the final drainage report.

age Basin (CHBS2000), La Vega Ranch
ainage Basin (KIKI0400), and Bijou Creek
part of the El Paso County Drainage Basin
th this Project.

SUMM

This report has been prepared in accordance with El Paso County stormwater criteria. It outlines the Site design for the 5-year and 100-year storm events drainage system. The drainage design presented within this report conforms to the criteria presented in the MANUAL Additionally, the Site runoff and storm drain facilities will not adversely affect the downstream and surrounding developments.

please discuss the outfalls of the ponds (see ECM 3.2.4). Are improvements downstream anticipated to be needed? Additionally, discuss the pond spillway locations and the impacts to the downstream residences.

Provide a comparison between existing design points and their flow rates with proposed conditions/design points. It appears that there are a design points where flows are increasing and not meeting historic values. Identify how the increase in flows will be mitigated and/or whether the downstream is adequate and capable to accept the increase in flows.

REFERENCES

1. Final Drainage Report for Apex Ranch Estates by Terra Nova Engineering, Inc. dated September 3, 2008
2. El Paso County “Engineering Criteria Manual” Volumes 1 & 2, dated October 31, 2018
3. Natural Resources Conservation Service, Web Soil Survey, dated June 21, 2023.
4. Urban Drainage and Flood Control District Drainage Criteria Manuals (UDFCDCM), (Volumes 1, 2 and 3), prepared by Wright-McLaughlin Engineers, June 2001, with latest revisions.
5. Flood Insurance Rate Map, El Paso County, Colorado and Incorporated Areas, Map Number 08041C0350G, Effective Date December 7, 2018, prepared by the Federal Emergency Management Agency (FEMA).

APPENDIX

APPENDIX A: VICINITY MAP

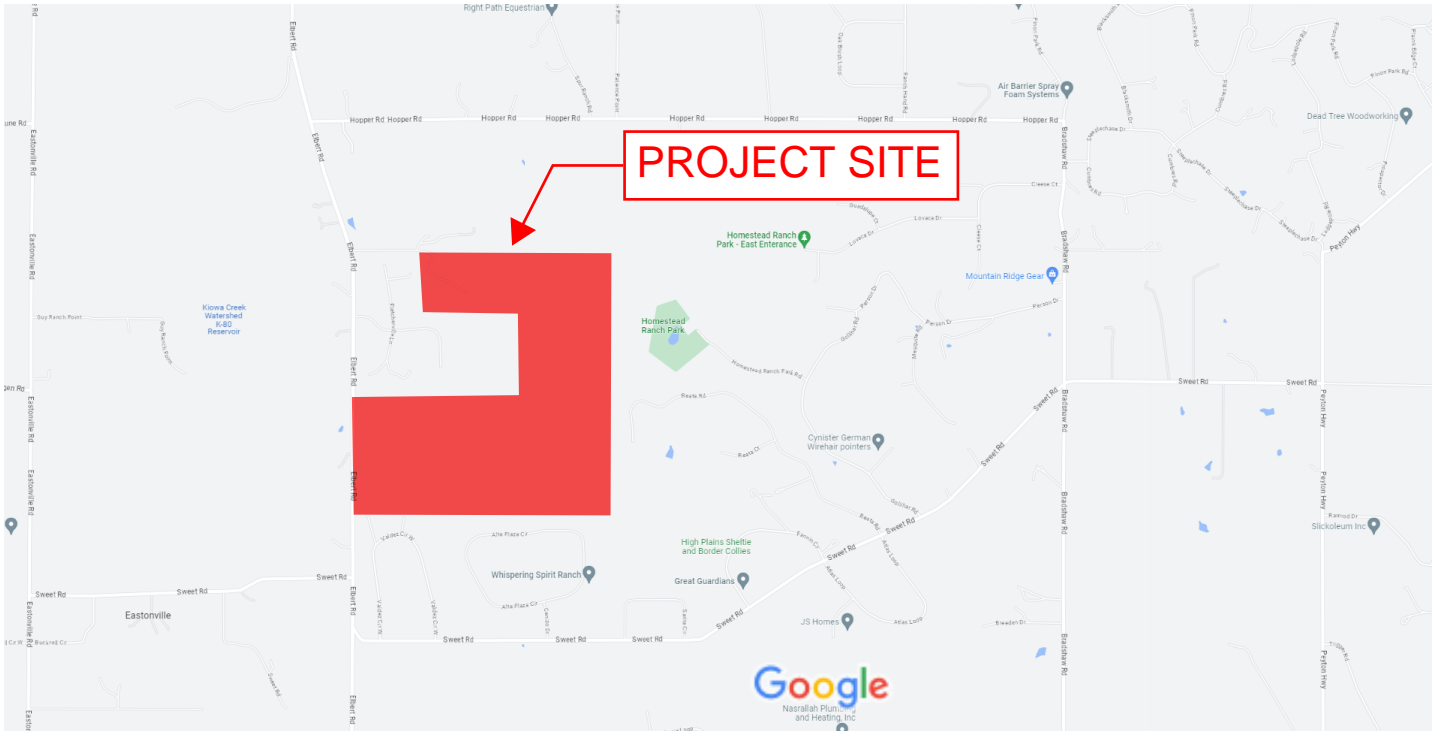

APPENDIX B: FEMA MAP & SOILS REPORT

NOTES TO USERS

This map is for use in administering the National Flood Insurance Program. It does not necessarily identify all areas subject to flooding, particularly from local drainage sources of small size. The community map repository should be consulted for possible updated or additional flood hazard information.

To obtain more detailed information in areas where **Base Flood Elevations (BFEs)** and/or **floodways** have been determined, users are encouraged to consult the Flood Profiles and Floodway Data and/or Summary of Stillwater Elevations tables contained within the Flood Insurance Study (FIS) report that accompanies this FIRM. Users should be aware that BFEs shown on the FIRM represent rounded whole-foot elevations. These BFEs are intended for flood insurance rating purposes only and should not be used as the sole source of flood elevation information. Accordingly, flood elevation data presented in the FIS report should be utilized in conjunction with the FIRM for purposes of construction and/or floodplain management.

Coastal Base Flood Elevations shown on this map apply only landward of 0.0' North American Vertical Datum of 1988 (NAVD88). Users of this FIRM should be aware that coastal flood elevations are also provided in the Summary of Stillwater Elevations table in the Flood Insurance Study report for this jurisdiction. Elevations shown in the Summary of Stillwater Elevations table should be used for construction and/or floodplain management purposes when they are higher than the elevations shown on this FIRM.

Boundaries of the **floodways** were computed at cross sections and interpolated between cross sections. The floodways were based on hydraulic considerations with regard to requirements of the National Flood Insurance Program. Floodway widths and other pertinent floodway data are provided in the Flood Insurance Study report for this jurisdiction.

Certain areas not in Special Flood Hazard Areas may be protected by **flood control structures**. Refer to section 2.4 "Flood Protection Measures" of the Flood Insurance Study report for information on flood control structures for this jurisdiction.

The **projection** used in the preparation of this map was Universal Transverse Mercator (UTM) zone 13. The **horizontal datum** was NAD83, GRS80 spheroid. Differences in datum, spheroid, projection or UTM zones zones used in the production of FIRMs for adjacent jurisdictions may result in slight positional differences in map features across jurisdiction boundaries. These differences do not affect the accuracy of this FIRM.

Flood elevations on this map are referenced to the **North American Vertical Datum of 1988 (NAVD88)**. These flood elevations must be compared to structure and ground elevations referenced to the same **vertical datum**. For information regarding conversion between the National Geodetic Vertical Datum of 1929 and the North American Vertical Datum of 1988, visit the National Geodetic Survey website at <http://www.ngs.noaa.gov/> or contact the National Geodetic Survey at the following address:

NGS Information Services
NOAA, NUNCS12
National Geodetic Survey
SSMC-3, #9202
1315 East-West Highway
Silver Spring, MD 20910-3282

To obtain current elevation, description, and/or location information for **bench marks** shown on this map, please contact the Information Services Branch of the National Geodetic Survey at (301) 713-3242 or visit its website at <http://www.ngs.noaa.gov/>.

Base Map information shown on this FIRM was provided in digital format by El Paso County, Colorado Springs Utilities, City of Fountain, Bureau of Land Management, National Oceanic and Atmospheric Administration, United States Geological Survey, and Anderson Consulting Engineers, Inc. These data are current as of 2006.

This map reflects more detailed and up-to-date **stream channel configurations and floodplain delineations** than those shown on the previous FIRM for this jurisdiction. The floodplains and floodways that were transferred from the previous FIRM may have been adjusted to conform to these new stream channel configurations. As a result, the Flood Profiles and Floodway Data tables in the Flood Insurance Study Report (which contains authoritative hydraulic data) may reflect stream channel distances that differ from what is shown on this map. The profile baselines depicted on this map represent the hydraulic modeling baselines that match the flood profiles and Floodway Data Tables if applicable, in the FIS report. As a result, the profile baselines may deviate significantly from the new base map channel representation and may appear outside of the floodplain.

Corporate limits shown on this map are based on the best data available at the time of publication. Because changes due to annexations or de-annexations may have occurred after this map was published, map users should contact appropriate community officials to verify current corporate limit locations.

Please refer to the separately printed **Map Index** for an overview map of the county showing the layout of map panels; community map repository addresses; and a Listing of Communities table containing National Flood Insurance Program dates for each community as well as a listing of the panels on which each community is located.

Contact **FEMA Map Service Center (MSC)** via the FEMA Map Information eXchange (FMIX) 1-877-336-2627 for information on available products associated with this FIRM. Available products may include previously issued Letters of Map Change, a Flood Insurance Study Report, and/or digital versions of this map. The MSC may also be reached by Fax at 1-800-358-9620 and its website at <http://www.msc.fema.gov/>.

If you have **questions about this map** or questions concerning the National Flood Insurance Program in general, please call 1-877-FEMA MAP (1-877-336-2627) or visit the FEMA website at <http://www.fema.gov/business/nfp>.

El Paso County Vertical Datum Offset Table	
Flooding Source	Vertical Datum Offset (ft)
REFER TO SECTION 3.3 OF THE EL PASO COUNTY FLOOD INSURANCE STUDY FOR STREAM BY STREAM VERTICAL DATUM CONVERSION INFORMATION	

Panel Location Map

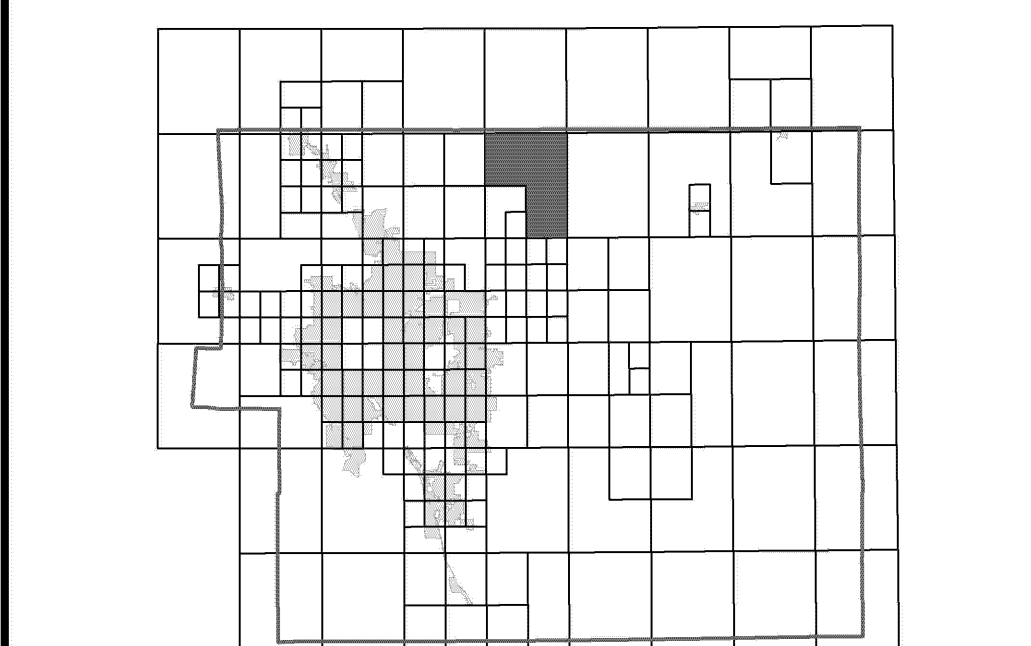

This Digital Flood Insurance Rate Map (DFIRM) was produced through a Cooperating Technical Partner (CTP) agreement between the State of Colorado Water Conservation Board (CWCB) and the Federal Emergency Management Agency (FEMA).



Additional Flood Hazard information and resources are available from local communities and the Colorado Water Conservation Board.

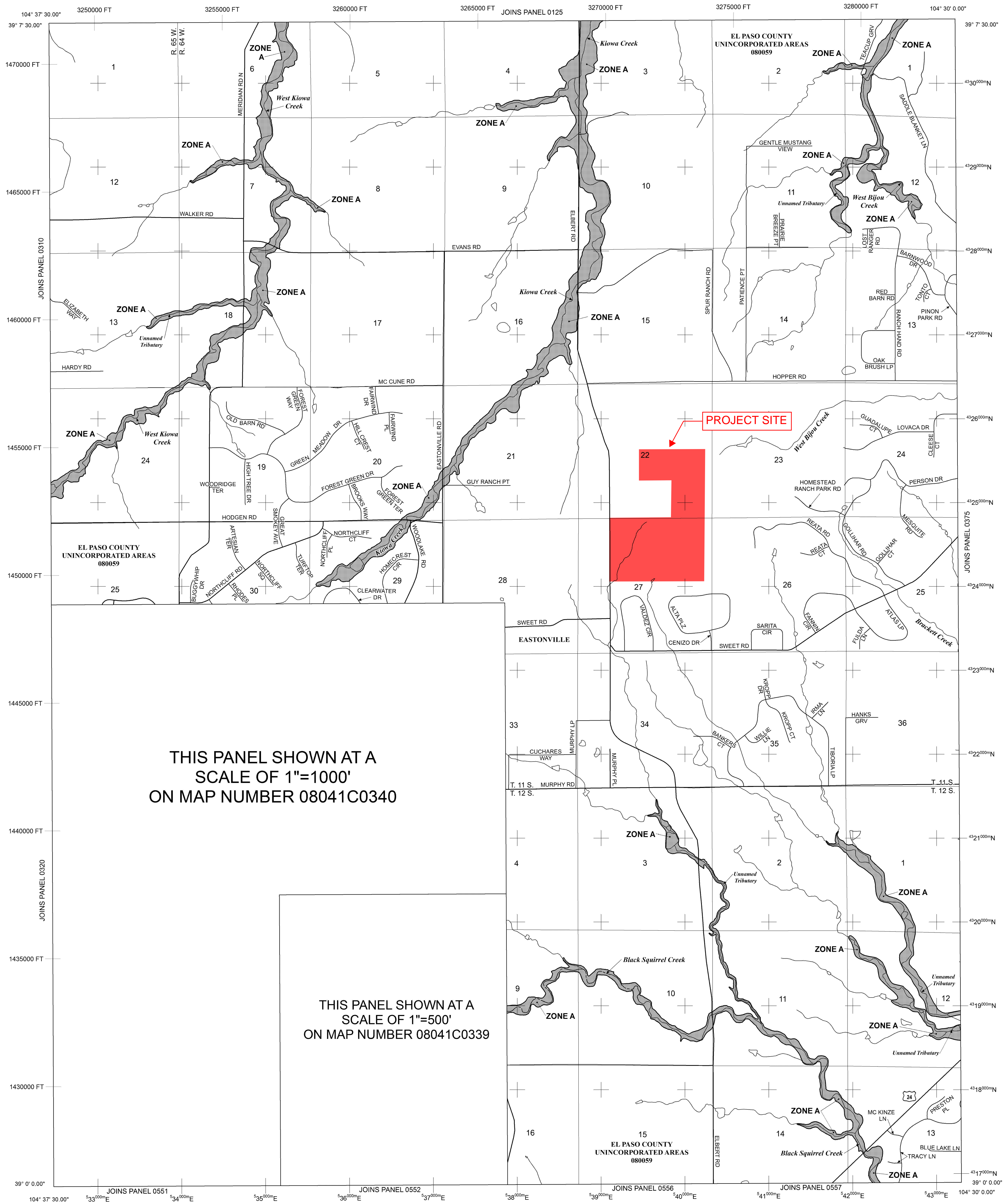

THIS PANEL SHOWN AT A
SCALE OF 1"=1000'
ON MAP NUMBER 08041C0340

THIS PANEL SHOWN AT A
SCALE OF 1"=500'
ON MAP NUMBER 08041C0339

LEGEND

SPECIAL FLOOD HAZARD AREAS (SFHAS) SUBJECT TO INUNDATION BY THE 1% ANNUAL CHANCE FLOOD

The 1% annual chance flood (100-year flood), also known as the base flood, is the flood that has a 1% chance of being equalled or exceeded in any given year. The Special Flood Hazard Area is the area subject to flooding by the 1% annual chance flood. Areas of Special Flood Hazard include Zones A, AE, AH, AO, AR, A99, V, and VE. The Base Flood Elevation is the water-surface elevation of the 1% annual chance flood.

ZONE A No Base Flood Elevations determined.
ZONE AE Base Flood Elevations determined.
ZONE AH Flood depths of 1 to 3 feet (usually areas of ponding); Base Flood Elevations determined.
ZONE AO Flood depths of 1 to 3 feet (usually sheet flow on sloping terrain); average depths determined. For areas of alluvial fan flooding, velocities also determined.
ZONE AR Special Flood Hazard Area Formerly protected from the 1% annual chance flood by a flood control system that was subsequently decertified. Zone AR indicates that the former flood control system is being restored to provide protection from the 1% annual chance or greater flood.
ZONE A99 Area to be protected from 1% annual chance flood by a Federal flood protection system under construction; no Base Flood Elevations determined.
ZONE V Coastal flood zone with velocity hazard (wave action); no Base Flood Elevations determined.
ZONE VE Coastal flood zone with velocity hazard (wave action); Base Flood Elevations determined.

FLOODWAY AREAS IN ZONE AE

The floodway is the channel of a stream plus any adjacent floodplain areas that must be kept free of encroachment so that the 1% annual chance flood can be carried without substantial increases in flood heights.

OTHER FLOOD AREAS

ZONE X Areas of 0.2% annual chance flood; areas of 1% annual chance flood with average depths of less than 1 foot, or with drainage areas less than 1 square mile; and areas protected by levees from 1% annual chance flood.

OTHER AREAS

ZONE X Areas determined to be outside the 0.2% annual chance floodplain.
ZONE D Areas in which flood hazards are undetermined, but possible.

COASTAL BARRIER RESOURCES SYSTEM (CBRS) AREAS

OTHERWISE PROTECTED AREAS (OPAs)

CBRS areas and OPAs are normally located within or adjacent to Special Flood Hazard Areas.

Floodplain boundary
 Floodway boundary
 Zone D Boundary
 CBRS and OPA boundary
 Boundary dividing Special Flood Hazard Areas of different Base Flood Elevations, flood depths or flood velocities.
 Base Flood Elevation line and value; elevation in feet* (EL 987)
 Base Flood Elevation value where uniform within zone; elevation in feet*

* Referenced to the North American Vertical Datum of 1988 (NAVD 88)

A Cross section line
23 Transsect line

57° 07' 30.00" Datum of 1983 (NAD 83)
 42° 55' 00" 1000-meter Universal Transverse Mercator grid ticks, zone 13
 6000000 FT 5000-foot grid ticks; Colorado State Plane coordinate system, central zone (FIPS ZONE 0502), Lambert Conformal Conic Projection
 DX5510 Bench mark (see explanation in Notes to Users section of this FIRM map)
 M1.5 River Mile

MAP REPOSITORIES
 Refer to Map Repositories list on Map Index

EFFECTIVE DATE OF COUNTYWIDE FLOOD INSURANCE RATE MAP
MARCH 17, 1997

EFFECTIVE DATE(S) OF REVISION(S) TO THIS PANEL
DECEMBER 7, 2018 to update corporate limits, to change Base Flood Elevations and Special Flood Hazard Areas, to update map format, to add roads and road names, and to incorporate previously issued Letters of Map Revision.

For community map revision history prior to countywide mapping, refer to the Community Map History Table located in the Flood Insurance Study report for this jurisdiction.
 To determine if flood insurance is available in this community, contact your insurance agent or call the National Flood Insurance Program at 1-800-638-6620.

MAP SCALE 1" = 2000'

1000 0 2000 4000 FEET
 600 0 600 1200 METERS

NFIP **PANEL 0350G**

FIRM
FLOOD INSURANCE RATE MAP
EL PASO COUNTY, COLORADO AND INCORPORATED AREAS

PANEL 350 OF 1300
 (SEE MAP INDEX FOR FIRM PANEL LAYOUT)

CONTAINS:	COMMUNITY	NUMBER	PANEL	SUFFIX
	EL PASO COUNTY	08059	0350	G

Notice to User: The Map Number shown below should be used when placing map orders. The Community Number shown above should be used on insurance applications for the subject community.

MAP NUMBER 08041C0350G

MAP REVISED DECEMBER 7, 2018
 Federal Emergency Management Agency

Hydrologic Soil Group—El Paso County Area, Colorado

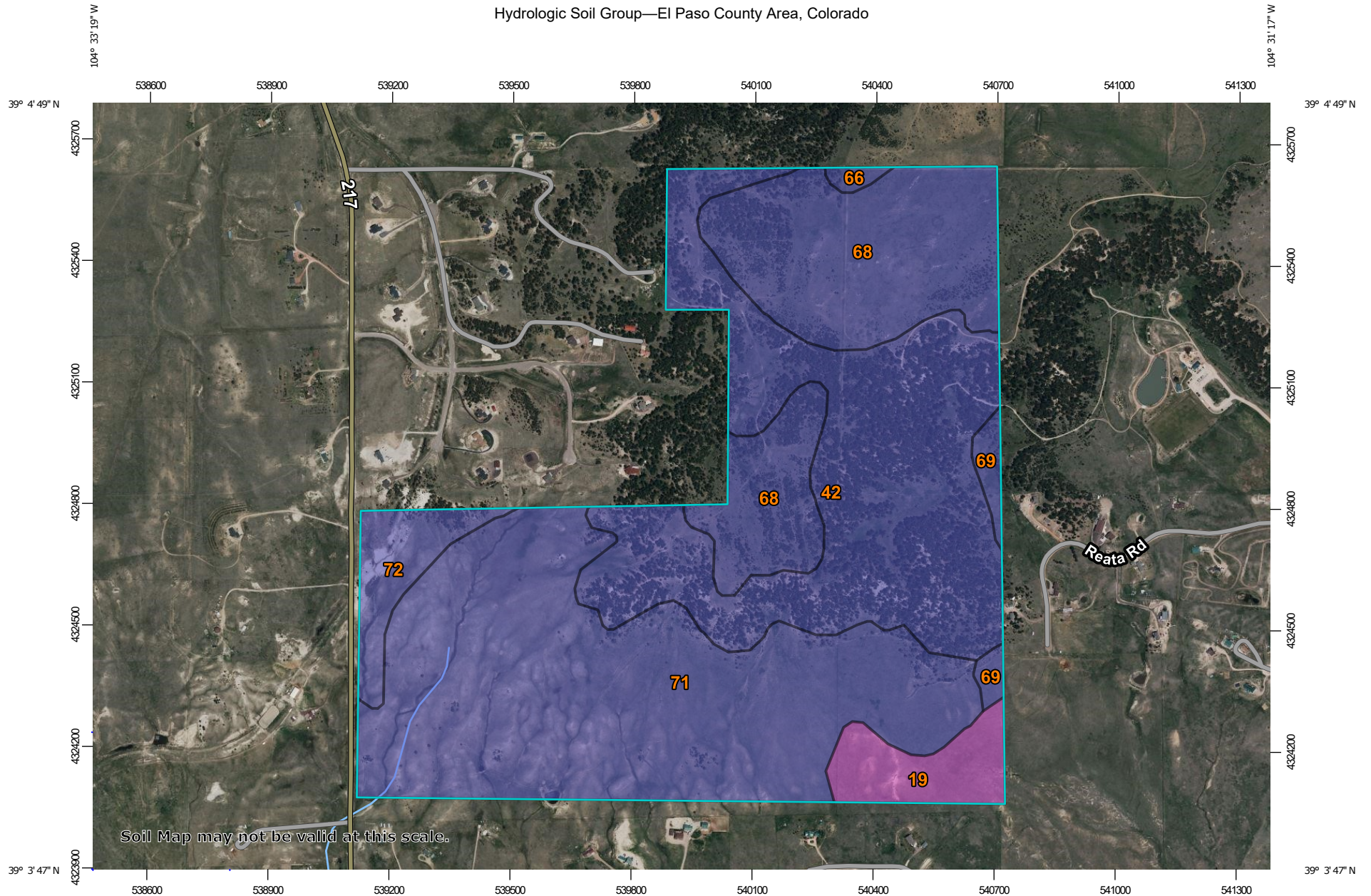

Soil Map may not be valid at this scale.

Map Scale: 1:13,300 if printed on A landscape (11" x 8.5") sheet.

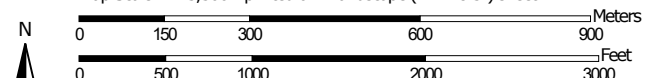

Map projection: Web Mercator Corner coordinates: WGS84 Edge tics: UTM Zone 13N WGS84

MAP LEGEND

Area of Interest (AOI)









 Area of Interest (AOI)

Soils

Soil Rating Polygons





-  A
-  A/D
-  B
-  B/D
-  C
-  C/D
-  D
-  Not rated or not available

Soil Rating Lines

-  A
-  A/D
-  B
-  B/D
-  C
-  C/D
-  D
-  Not rated or not available

Soil Rating Points





-  A
-  A/D
-  B
-  B/D

-  C
-  C/D
-  D
-  Not rated or not available

Water Features

 Streams and Canals

Transportation

-  Rails
-  Interstate Highways
-  US Routes
-  Major Roads
-  Local Roads

Background

 Aerial Photography

MAP INFORMATION

The soil surveys that comprise your AOI were mapped at 1:24,000.

Warning: Soil Map may not be valid at this scale.

Enlargement of maps beyond the scale of mapping can cause misunderstanding of the detail of mapping and accuracy of soil line placement. The maps do not show the small areas of contrasting soils that could have been shown at a more detailed scale.

Please rely on the bar scale on each map sheet for map measurements.

Source of Map: Natural Resources Conservation Service
 Web Soil Survey URL:
 Coordinate System: Web Mercator (EPSG:3857)

Maps from the Web Soil Survey are based on the Web Mercator projection, which preserves direction and shape but distorts distance and area. A projection that preserves area, such as the Albers equal-area conic projection, should be used if more accurate calculations of distance or area are required.

This product is generated from the USDA-NRCS certified data as of the version date(s) listed below.

Soil Survey Area: El Paso County Area, Colorado
 Survey Area Data: Version 20, Sep 2, 2022

Soil map units are labeled (as space allows) for map scales 1:50,000 or larger.

Date(s) aerial images were photographed: Jun 9, 2021—Jun 12, 2021

The orthophoto or other base map on which the soil lines were compiled and digitized probably differs from the background imagery displayed on these maps. As a result, some minor shifting of map unit boundaries may be evident.

Hydrologic Soil Group

Map unit symbol	Map unit name	Rating	Acres in AOI	Percent of AOI
19	Columbine gravelly sandy loam, 0 to 3 percent slopes	A	18.1	4.1%
42	Kettle-Rock outcrop complex	B	135.4	30.8%
66	Peyton sandy loam, 1 to 5 percent slopes	B	1.7	0.4%
68	Peyton-Pring complex, 3 to 8 percent slopes	B	91.1	20.7%
69	Peyton-Pring complex, 8 to 15 percent slopes	B	5.6	1.3%
71	Pring coarse sandy loam, 3 to 8 percent slopes	B	171.8	39.0%
72	Pring coarse sandy loam, 8 to 15 percent slopes	B	16.2	3.7%
Totals for Area of Interest			440.0	100.0%

Description

Hydrologic soil groups are based on estimates of runoff potential. Soils are assigned to one of four groups according to the rate of water infiltration when the soils are not protected by vegetation, are thoroughly wet, and receive precipitation from long-duration storms.

The soils in the United States are assigned to four groups (A, B, C, and D) and three dual classes (A/D, B/D, and C/D). The groups are defined as follows:

Group A. Soils having a high infiltration rate (low runoff potential) when thoroughly wet. These consist mainly of deep, well drained to excessively drained sands or gravelly sands. These soils have a high rate of water transmission.

Group B. Soils having a moderate infiltration rate when thoroughly wet. These consist chiefly of moderately deep or deep, moderately well drained or well drained soils that have moderately fine texture to moderately coarse texture. These soils have a moderate rate of water transmission.

Group C. Soils having a slow infiltration rate when thoroughly wet. These consist chiefly of soils having a layer that impedes the downward movement of water or soils of moderately fine texture or fine texture. These soils have a slow rate of water transmission.

Group D. Soils having a very slow infiltration rate (high runoff potential) when thoroughly wet. These consist chiefly of clays that have a high shrink-swell potential, soils that have a high water table, soils that have a claypan or clay layer at or near the surface, and soils that are shallow over nearly impervious material. These soils have a very slow rate of water transmission.

If a soil is assigned to a dual hydrologic group (A/D, B/D, or C/D), the first letter is for drained areas and the second is for undrained areas. Only the soils that in their natural condition are in group D are assigned to dual classes.

Rating Options

Aggregation Method: Dominant Condition

Component Percent Cutoff: None Specified

Tie-break Rule: Higher

APPENDIX C: HYDROLOGY



STANDARD FORM SF-1
RUNOFF COEFFICIENTS - IMPERVIOUS CALCULATION
 EXISTING CONDITIONS

PROJECT NAME: Overlook
 PROJECT NUMBER: 196239003
 CALCULATED BY: GKS
 CHECKED BY: KRK

DATE: 7/18/2023

SOIL: B		RESIDENTIAL (>5AC)	PASTURE/MEADOW (SOIL GROUP A/B)	PAVEMENT							
LAND USE:	AREA	AREA	AREA	AREA	AREA						
2-YEAR COEFF.	0.05	0.02	0.89								
5-YEAR COEFF.	0.12	0.08	0.90								
10-YEAR COEFF.	0.20	0.15	0.92								
100-YEAR COEFF.	0.39	0.35	0.96								
IMPERVIOUS %	7%	0%	100%								
DESIGN BASIN	DESIGN POINT	RESIDENTIAL (>5AC) AREA (AC)	PASTURE/MEADOW (SOIL GROUP A/B) AREA (AC)	PAVEMENT AREA (AC)	AREA (AC)	TOTAL AREA (AC)	C(2)	C(5)	C(10)	C(100)	Imp %
FDR Basins											
A1	1		18.28	1.64		19.92	0.09	0.15	0.21	0.40	8%
A2	2		60.84	0.66		61.50	0.03	0.09	0.16	0.36	1%
B1	3		45.75			45.75	0.02	0.08	0.15	0.35	0%
B2	4		42.42			42.42	0.02	0.08	0.15	0.35	0%
B3	5		49.65			49.65	0.02	0.08	0.15	0.35	0%
B4	6		8.59			8.59	0.02	0.08	0.15	0.35	0%
B5	7		8.95			8.95	0.02	0.08	0.15	0.35	0%
C1	8		53.41			53.41	0.02	0.08	0.15	0.35	0%
C2	9		8.47			8.47	0.02	0.08	0.15	0.35	0%
C3	10		5.55			5.55	0.02	0.08	0.15	0.35	0%
C4	11		6.40			6.40	0.02	0.08	0.15	0.35	0%
C5	12		10.50			10.50	0.02	0.08	0.15	0.35	0%
D1	13		29.73			29.73	0.02	0.08	0.15	0.35	0%
OS-A1	14		3.29	0.77		4.06	0.19	0.24	0.30	0.47	19%
OS-A2	15	4.45				4.45	0.05	0.12	0.20	0.39	7%
OS-C1	16	26.86	0.63			27.49	0.07	0.14	0.22	0.40	9%
OS-C2	17	5.48	0.67			6.15	0.14	0.20	0.28	0.45	17%
OS-C3	18	20.84	1.05			21.89	0.09	0.16	0.23	0.42	11%
TOTAL - OVERALL		57.63	351.83	5.42	0.00	414.88	0.04	0.10	0.17	0.36	2%
		14%	85%	1%	0%	100%					

Note: Land use coefficients sourced from City of Colorado Springs Drainage Criteria Manual, Volume 1, Table 6-6.

**STANDARD FORM SF-2
Time of Concentration**

PROJECT NAME: **Overlook**
 PROJECT NUMBER: **196239003**
 CALCULATED BY: **GKS**
 CHECKED BY: **KRK**

EXISTING CONDITIONS

DATE: 7/18/2023

SUB-BASIN DATA			INITIAL TIME (T _i)			TRAVEL TIME (T _t)					T _c CHECK (URBANIZED BASINS)				FINAL T _c	
DESIGN BASIN (1)	AREA Ac (2)	C5 (3)	LENGTH Ft (4)	SLOPE % (5)	T _i Min. (6)	LENGTH Ft (7)	SLOPE % (8)	C _v (9)	VEL fps (11)	T _t Min. (12)	COMP. t _c (13)	TOTAL LENGTH (14)	TOTAL SLOPE (15)	TOTAL IMP. (16)	T _c Min. (17)	Min.
FDR Basins																
A1	19.92	0.15	300	18.0%	11.5	2,066	5.7%	2.5	0.6	57.7	69.2	2366	7.3%	8%	23.1	23.1
A2	61.50	0.09	300	18.0%	12.3	3,677	5.7%	2.5	0.6	102.7	114.9	3977	6.6%	1%	32.1	32.1
B1	45.75	0.08	300	25.0%	11.1	2,577	6.5%	2.5	0.6	67.4	78.5	2877	8.4%		26.0	26.0
B2	42.42	0.08	300	6.9%	17.0	2,347	10.3%	2.5	0.8	48.8	65.8	2647	9.9%		24.7	24.7
B3	49.65	0.08	300	23.0%	11.4	1,968	9.9%	2.5	0.8	41.7	53.1	2268	11.6%		22.6	22.6
B4	8.59	0.08	300	2.0%	25.7	308	13.4%	2.5	0.9	5.6	31.3	608	7.8%		13.4	13.4
B5	8.95	0.08	300	2.5%	23.9	243	2.4%	2.5	0.4	10.5	34.3	543	2.5%		13.0	13.0
C1	53.41	0.08	300	1.6%	27.7	1,593	6.3%	2.5	0.6	42.3	70.0	1893	5.6%		20.5	20.5
C2	8.47	0.08	300	25.0%	11.1	887	4.9%	2.5	0.6	26.7	37.8	1187	10.0%		16.6	16.6
C3	5.55	0.08	300	6.9%	17.0	383	5.6%	2.5	0.6	10.8	27.8	683	6.2%		13.8	13.8
C4	6.40	0.08	300	5.9%	17.9	317	6.4%	2.5	0.6	8.4	26.3	617	6.2%		13.4	13.4
C5	10.50	0.08	300	2.5%	23.9	602	14.8%	2.5	1.0	10.4	34.3	902	10.7%		15.0	15.0
D1	29.73	0.08	300	1.5%	28.3	1,153	1.6%	2.5	0.3	60.8	89.1	1453	1.6%		18.1	18.1
OS-A1	4.06	0.24	300	5.0%	16.1	161	5.0%	2.5	0.6	4.8	20.9	461	5.0%		12.6	12.6
OS-A2	4.45	0.12	250	10.0%	13.2			2.5			13.2	250	10.0%	19%	11.4	11.4
OS-C1	27.49	0.14	300	25.0%	10.4	1,195	5.0%	2.5	0.6	35.6	46.1	1495	9.0%	9%	18.3	18.3
OS-C2	6.15	0.20	300	5.8%	15.9	865	5.8%	2.5	0.6	24.0	39.9	1165	5.8%	17%	16.5	16.5
OS-C3	21.89	0.16	300	6.9%	15.7	874	6.9%	2.5	0.7	22.2	37.9	1174	6.9%	11%	16.5	16.5

$$t_i = \frac{0.395(1.1 - C_5)\sqrt{L_i}}{S_0^{0.33}} \quad t_c = \frac{L}{180} + 10 \quad V = C_v S_w^{0.5}$$

Note: Conveyance coefficient from Table 6-7 of DCM



**STANDARD FORM SF-3
STORM DRAINAGE DESIGN - RATIONAL METHOD 2 YEAR EVENT**

PROJECT NAME: Overlook
PROJECT NUMBER: 196239003
CALCULATED BY: GKS
CHECKED BY: KRK

EXISTING CONDITIONS

DATE: 7/18/2023

STORM LINE	DESIGN POINT	DIRECT RUNOFF							TOTAL RUNOFF				STREET		PIPE		TRAVEL TIME			REMARKS	
		DESIGN BASIN	AREA (AC)	RUNOFF COEFF	t _c (min)	C*A(ac)	I (in/hr)	Q (cfs)	t _c (max)	S(C*A) (ac)	I (in/hr)	Q (cfs)	SLOPE (%)	STREET FLOW(cfs)	DESIGN FLOW(cfs)	SLOPE (%)	PIPE SIZE (in)	LENGTH (ft)	VELOCITY		t _t (min)
(1)	(2)	(3)	(4)	(5)	(6)	(7)	(8)	(9)	(10)	(11)	(12)	(13)	(14)	(15)	(16)	(17)	(18)	(19)	(20)	(21)	(22)
	1	A1	19.92	0.09	23.14	1.83	2.30	4.19													
	2	A2	61.50	0.03	32.09	1.80	1.91	3.44													
	3	B1	45.75	0.02	25.98	0.92	2.16	1.98													
	4	B2	42.42	0.02	24.71	0.85	2.22	1.88													
	5	B3	49.65	0.02	22.60	0.99	2.32	2.31													
	6	B4	8.59	0.02	13.38	0.17	2.95	0.51													
	7	B5	8.95	0.02	13.02	0.18	2.98	0.53													
	8	C1	53.41	0.02	20.52	1.07	2.44	2.61													
	9	C2	8.47	0.02	16.59	0.17	2.69	0.46													
	10	C3	5.55	0.02	13.79	0.11	2.91	0.32													
	11	C4	6.40	0.02	13.43	0.13	2.94	0.38													
	12	C5	10.50	0.02	15.01	0.21	2.81	0.59													
	13	D1	29.73	0.02	18.07	0.59	2.59	1.54													
	14	OS-A1	4.06	0.19	11.39	0.75	3.14	2.36													
	15	OS-A2	4.45	0.05	18.31	0.22	2.58	0.57													
	16	OS-C1	27.49	0.07	18.31	1.90	2.58	4.90													
	17	OS-C2	6.15	0.14	16.47	0.87	2.70	2.35													
	18	OS-C3	21.89	0.09	16.52	1.98	2.70	5.33													

Note: Rainfall intensity from Figure 6-5 IDF Equations

$$I_2 = -1.19 \ln(t_{c,min}) + 6.035$$



**STANDARD FORM SF-3
STORM DRAINAGE DESIGN - RATIONAL METHOD 5 YEAR EVENT**

PROJECT NAME: Overlook
PROJECT NUMBER: 196239003
CALCULATED BY: GKS
CHECKED BY: KRK

EXISTING CONDITIONS

DATE: 7/18/2023

STORM LINE	DESIGN POINT	DIRECT RUNOFF							TOTAL RUNOFF				STREET		PIPE		TRAVEL TIME			REMARKS	
		DESIGN BASIN	AREA (AC)	RUNOFF COEFF	t _c (min)	C*A(ac)	I (in/hr)	Q (cfs)	t _c (max)	S(C*A) (ac)	I (in/hr)	Q (cfs)	SLOPE (%)	STREET FLOW(cfs)	DESIGN FLOW(cfs)	SLOPE (%)	PIPE SIZE (in)	LENGTH (ft)	VELOCITY		t _t (min)
(1)	(2)	(3)	(4)	(5)	(6)	(7)	(8)	(9)	(10)	(11)	(12)	(13)	(14)	(15)	(16)	(17)	(18)	(19)	(20)	(21)	(22)
	1	A1	19.92	0.15	23.14	2.94	2.87	8.43													
	2	A2	61.50	0.09	32.09	5.46	2.38	13.00													
	3	B1	45.75	0.08	25.98	3.66	2.70	9.87													
	4	B2	42.42	0.08	24.71	3.39	2.77	9.41													
	5	B3	49.65	0.08	22.60	3.97	2.91	11.54													
	6	B4	8.59	0.08	13.38	0.69	3.69	2.54													
	7	B5	8.95	0.08	13.02	0.72	3.73	2.67													
	8	C1	53.41	0.08	20.52	4.27	3.05	13.04													
	9	C2	8.47	0.08	16.59	0.68	3.37	2.28													
	10	C3	5.55	0.08	13.79	0.44	3.65	1.62													
	11	C4	6.40	0.08	13.43	0.51	3.69	1.89													
	12	C5	10.50	0.08	15.01	0.84	3.52	2.96													
	13	D1	29.73	0.08	18.07	2.38	3.24	7.71													
	14	OS-A1	4.06	0.24	11.39	0.96	3.93	3.76													
	15	OS-A2	4.45	0.12	18.31	0.53	3.22	1.72													
	16	OS-C1	27.49	0.14	18.31	3.79	3.22	12.21													
	17	OS-C2	6.15	0.20	16.47	1.26	3.38	4.26													
	18	OS-C3	21.89	0.16	16.52	3.45	3.38	11.63													

Note: Rainfall intensity from Figure 6-5 IDF Equations

$$I_5 = -1.5 \ln(t_{c,min}) + 7.583$$



**STANDARD FORM SF-3
STORM DRAINAGE DESIGN - RATIONAL METHOD 100 YEAR EVENT**

PROJECT NAME: Overlook
PROJECT NUMBER: 196239003
CALCULATED BY: GKS
CHECKED BY: KRK

EXISTING CONDITIONS

DATE: 7/18/2023

STORM LINE	DESIGN POINT	DIRECT RUNOFF							TOTAL RUNOFF				STREET		PIPE		TRAVEL TIME			REMARKS	
		DESIGN BASIN	AREA (AC)	RUNOFF COEFF	t _c (min)	C*A(ac)	I (in/hr)	Q (cfs)	t _c (max)	S(C*A) (ac)	I (in/hr)	Q (cfs)	SLOPE (%)	STREET FLOW(cfs)	DESIGN FLOW(cfs)	SLOPE (%)	PIPE SIZE (in)	LENGTH (ft)	VELOCIT Y		t _t (min)
(1)	(2)	(3)	(4)	(5)	(6)	(7)	(8)	(9)	(10)	(11)	(12)	(13)	(14)	(15)	(16)	(17)	(18)	(19)	(20)	(21)	(22)
	1	A1	19.92	0.40	23.14	7.97	4.82	38.41													
	2	A2	61.50	0.36	32.09	21.93	3.99	87.58													
	3	B1	45.75	0.35	25.98	16.01	4.53	72.48													
	4	B2	42.42	0.35	24.71	14.85	4.65	69.09													
	5	B3	49.65	0.35	22.60	17.38	4.88	84.76													
	6	B4	8.59	0.35	13.38	3.01	6.20	18.64													
	7	B5	8.95	0.35	13.02	3.13	6.27	19.63													
	8	C1	53.41	0.35	20.52	18.69	5.12	95.74													
	9	C2	8.47	0.35	16.59	2.96	5.66	16.77													
	10	C3	5.55	0.35	13.79	1.94	6.12	11.89													
	11	C4	6.40	0.35	13.43	2.24	6.19	13.87													
	12	C5	10.50	0.35	15.01	3.68	5.91	21.72													
	13	D1	29.73	0.35	18.07	10.41	5.44	56.62													
	14	OS-A1	4.06	0.47	11.39	1.89	6.60	12.49													
	15	OS-A2	4.45	0.39	18.31	1.74	5.41	9.39													
	16	OS-C1	27.49	0.40	18.31	11.08	5.41	59.93													
	17	OS-C2	6.15	0.45	16.47	2.78	5.67	15.78													
	18	OS-C3	21.89	0.42	16.52	9.14	5.67	51.77													

Note: Rainfall intensity from Figure 6-5 IDF Equations

$$I_{100} = -2.52 \ln(t_{c,min}) + 12.735$$



PROJECT NAME: Overlook
 PROJECT NUMBER: 196239003
 CALCULATED BY: GKS
 CHECKED BY: KRK

7/18/2023

EXISTING CONDITIONS RATIONAL CALCULATIONS SUMMARY

DESIGN POINT	TRIBUTARY BASINS	TRIBUTARY AREA (AC)	CFS			% IMPERVIOUS
			Q2	Q5	Q100	
PDR Basins						
1	A1	19.92	4.19	8.43	38.41	8%
2	A2	61.50	3.44	13.00	87.58	1%
3	B1	45.75	1.98	9.87	72.48	0%
4	B2	42.42	1.88	9.41	69.09	0%
5	B3	49.65	2.31	11.54	84.76	0%
6	B4	8.59	0.51	2.54	18.64	0%
7	B5	8.95	0.53	2.67	19.63	0%
8	C1	53.41	2.61	13.04	95.74	0%
9	C2	8.47	0.46	2.28	16.77	0%
10	C3	5.55	0.32	1.62	11.89	0%
11	C4	6.40	0.38	1.89	13.87	0%
12	C5	10.50	0.59	2.96	21.72	0%
13	D1	29.73	1.54	7.71	56.62	0%
14	OS-A1	4.06	2.36	3.76	12.49	19%
15	OS-A2	4.45	0.57	1.72	9.39	7%
16	OS-C1	27.49	4.90	12.21	59.93	9%
17	OS-C2	6.15	2.35	4.26	15.78	17%
18	OS-C3	21.89	5.33	11.63	51.77	11%
ON-SITE BASIN TOTAL						
BASIN A TOTAL		81.42	7.63	21.43	125.99	3%
BASIN B TOTAL		155.36	7.21	36.03	264.60	0%
BASIN C TOTAL		84.33	4.35	21.78	159.98	0%
BASIN D TOTAL		29.73	1.54	7.71	56.62	0%
ON-SITE TOTAL		350.84	20.73	86.96	607.18	1%
OFF-SITE BASIN TOTAL						
OFF-SITE BASIN A		8.51	2.93	5.48	21.87	13%
OFF-SITE BASIN C		55.53	12.58	28.11	127.48	11%
OFF-SITE TOTAL		64.04	15.52	33.59	149.36	11%
SITE TOTAL		414.88	36.25	120.55	756.54	2%

STANDARD FORM SF-1
 RUNOFF COEFFICIENTS - IMPERVIOUS CALCULATION
 PROPOSED CONDITIONS

PROJECT NAME: Overlook
 PROJECT NUMBER: 196239003
 CALCULATED BY: GKS
 CHECKED BY: KRK

DATE: 8/7/2023

SOIL: B		RESIDENTIAL (>5AC) AREA	PASTURE/MEADOW (SOIL GROUP A/B) AREA	PAVEMENT AREA							
LAND USE:		AREA	AREA	AREA	AREA						
2-YEAR COEFF.		0.05	0.02	0.89							
5-YEAR COEFF.		0.12	0.08	0.90							
10-YEAR COEFF.		0.20	0.15	0.92							
100-YEAR COEFF.		0.39	0.35	0.96							
IMPERVIOUS %		7%	0%	100%							
DESIGN BASIN	DESIGN POINT	RESIDENTIAL (>5AC) AREA (AC)	PASTURE/MEADOW (SOIL GROUP A/B) AREA (AC)	PAVEMENT AREA (AC)	AREA (AC)	TOTAL AREA (AC)	C(2)	C(5)	C(10)	C(100)	Imp %
FDR Basins											
A1	1	17.91		1.64		19.55	0.12	0.19	0.26	0.44	15%
A2	2	55.40		2.87		58.27	0.09	0.16	0.24	0.42	12%
B1	3	39.58		1.16		40.74	0.07	0.14	0.22	0.41	10%
B2	4	15.66		0.34		16.00	0.07	0.14	0.22	0.40	9%
B3	5	19.11				19.11	0.05	0.12	0.20	0.39	7%
B4	6	8.50				8.50	0.05	0.12	0.20	0.39	7%
B5	7	8.95				8.95	0.05	0.12	0.20	0.39	7%
B6	8	51.65		1.66		53.31	0.08	0.14	0.22	0.41	10%
B7	9	2.46				2.46	0.05	0.12	0.20	0.39	7%
B8	10	9.52				9.52	0.05	0.12	0.20	0.39	7%
C1	11	25.38		0.53		25.91	0.07	0.14	0.21	0.40	9%
C2	12	16.03		1.00		17.03	0.10	0.17	0.24	0.42	12%
C3	13	3.80		0.16		3.96	0.08	0.15	0.23	0.41	11%
C4	14	6.37				6.37	0.05	0.12	0.20	0.39	7%
C5	15	10.50				10.50	0.05	0.12	0.20	0.39	7%
C6	16	19.82		1.47		21.29	0.11	0.17	0.25	0.43	13%
D1	17	28.79		0.59		29.38	0.07	0.14	0.21	0.40	9%
OS-A1	18	3.29		0.77		4.06	0.21	0.27	0.34	0.50	25%
OS-A2	19	4.45				4.45	0.05	0.12	0.20	0.39	7%
OS-C1	20	26.86		0.63		27.49	0.07	0.14	0.22	0.40	9%
OS-C2	21	5.48		0.67		6.15	0.14	0.20	0.28	0.45	17%
OS-C3	22	20.84		1.05		21.89	0.09	0.16	0.23	0.42	11%
TOTAL - OVERALL		400.35	0.00	14.54	0.00	414.89	0.08	0.15	0.23	0.41	10%
		96%	0%	4%	0%	100%					

Note: Land use coefficients sourced from City of Colorado Springs Drainage Criteria Manual, Volume 1, Table 6-6.

STANDARD FORM SF-2
Time of Concentration

PROJECT NAME: Overlook
PROJECT NUMBER: 196239003
CALCULATED BY: GKS
CHECKED BY: KRK

PROPOSED CONDITIONS

DATE: 8/7/2023

SUB-BASIN DATA			INITIAL TIME (T _i)			TRAVEL TIME (T _t)					T _c CHECK (URBANIZED BASINS)				FINAL T _c	
DESIGN BASIN (1)	AREA Ac (2)	C5 (3)	LENGTH Ft (4)	SLOPE % (5)	T _i Min. (6)	LENGTH Ft. (7)	SLOPE % (8)	C _v (9)	VEL fps (11)	T _t Min. (12)	COMP. t _c (13)	TOTAL LENGTH (14)	TOTAL SLOPE (15)	TOTAL IMP. (16)	T _c Min. (17)	Min.
FDR Basins																
A1	19.55	0.19	300	18.0%	11.1	2,066	5.0%	2.5	0.6	61.6	72.7	2366	6.6%	15%	23.1	23.1
A2	58.27	0.16	300	18.0%	11.4	4,100	4.0%	2.5	0.5	136.7	148.1	4400	5.0%	12%	34.4	34.4
B1	40.74	0.14	300	8.0%	15.2	2,000	4.5%	2.5	0.5	62.9	78.1	2300	5.0%	10%	22.8	22.8
B2	16.00	0.14	300	7.0%	16.0	500	6.0%	2.5	0.6	13.6	29.6	800	6.4%	9%	14.4	14.4
B3	19.11	0.12	300	21.0%	11.3	800	8.0%	2.5	0.7	18.9	30.1	1100	11.5%	7%	16.1	16.1
B4	8.50	0.12	300	2.0%	24.7	300	13.5%	2.5	0.9	5.4	30.1	600	7.8%	7%	13.3	13.3
B5	8.95	0.12	300	2.5%	22.9	250	2.5%	2.5	0.4	10.5	33.5	550	2.5%	7%	13.1	13.1
B6	53.31	0.14	300	22.0%	10.8	1,900	3.0%	2.5	0.4	73.1	84.0	2200	5.6%	10%	22.2	22.2
B7	2.46	0.12	300	6.0%	17.1	100	6.0%	2.2	0.5	3.1	20.2	400	6.0%	7%	12.2	12.2
B8	9.52	0.12	300	6.0%	17.1	300	10.0%	2.5	0.8	6.3	23.5	600	8.0%	7%	13.3	13.3
C1	25.91	0.14	300	10.0%	14.2	1,300	8.0%	2.5	0.7	30.6	44.9	1600	8.4%	9%	18.9	18.9
C2	17.03	0.17	140	28.0%	6.7	2,250	3.0%	2.5	0.4	86.6	93.3	2390	4.5%	12%	23.3	23.3
C3	3.96	0.15	200	12.5%	10.6	50	3.0%	2.5	0.4	1.9	12.5	250	10.6%	11%	11.4	11.4
C4	6.37	0.12	300	5.5%	17.6	300	6.0%	2.5	0.6	8.2	25.8	600	5.8%	7%	13.3	13.3
C5	10.50	0.12	300	9.5%	14.7	600	11.0%	2.5	0.8	12.1	26.8	900	10.5%	7%	15.0	15.0
C6	21.29	0.17	300	3.0%	20.4	1,000	3.0%	2.5	0.4	38.5	58.9	1300	3.0%	13%	17.2	17.2
D1	29.38	0.14	300	1.0%	30.6	825	2.0%	2.5	0.4	38.9	69.5	1125	1.7%	9%	16.3	16.3
OS-A1	4.06	0.27	300	5.0%	15.5	161	5.0%	2.5	0.6	4.8	20.3	461	5.0%	25%	12.6	12.6
OS-A2	4.45	0.12	250	10.0%	13.2			2.5			13.2	250	10.0%	7%	11.4	11.4
OS-C1	27.49	0.14	300	25.0%	10.4	1,195	5.0%	2.5	0.6	35.6	46.1	1495	9.0%	9%	18.3	18.3
OS-C2	6.15	0.20	300	5.8%	15.9	865	5.8%	2.5	0.6	24.0	39.9	1165	5.8%	17%	16.5	16.5
OS-C3	21.89	0.16	300	6.9%	15.7	874	6.9%	2.5	0.7	22.2	37.9	1174	6.9%	11%	16.5	16.5

$$t_i = \frac{0.395(1.1 - C_5)\sqrt{L_i}}{S_0^{0.33}} \quad t_c = \frac{L}{180} + 10 \quad V = C_p S_w^{0.5}$$

Note: Conveyance coefficient from Table 6-7 of DCM



**STANDARD FORM SF-3
STORM DRAINAGE DESIGN - RATIONAL METHOD 2 YEAR EVENT**

PROJECT NAME: Overlook
PROJECT NUMBER: 196239003
CALCULATED BY: GKS
CHECKED BY: KRK

PROPOSED CONDITIONS

DATE: 8/7/2023

STORM LINE	DESIGN POINT	DIRECT RUNOFF							TOTAL RUNOFF				STREET		PIPE			TRAVEL TIME			REMARKS
		DESIGN BASIN	AREA (AC)	RUNOFF COEFF	t _c (min)	C*A(ac)	I (in/hr)	Q (cfs)	t _c (max)	S(C*A) (ac)	I (in/hr)	Q (cfs)	SLOPE (%)	STREET FLOW(cfs)	DESIGN FLOW(cfs)	SLOPE (%)	PIPE SIZE (in)	LENGTH (ft)	VELOCITY	t _t (min)	
(1)	(2)	(3)	(4)	(5)	(6)	(7)	(8)	(9)	(10)	(11)	(12)	(13)	(14)	(15)	(16)	(17)	(18)	(19)	(20)	(21)	(22)
	1	A1	19.55	0.12	23.14	2.36	2.30	5.41													
	2	A2	58.27	0.09	34.44	5.32	1.82	9.71													
	3	B1	40.74	0.07	22.78	3.01	2.32	6.97													
	4	B2	16.00	0.07	14.44	1.09	2.86	3.10													
	5	B3	19.11	0.05	16.11	0.96	2.73	2.61													
	6	B4	8.50	0.05	13.33	0.43	2.95	1.25													
	7	B5	8.95	0.05	13.06	0.45	2.98	1.33													
	8	B6	53.31	0.08	22.22	4.06	2.34	9.52													
	9	B7	2.46	0.05	12.22	0.12	3.06	0.38													
	10	B8	9.52	0.05	13.33	0.48	2.95	1.41													
	11	C1	25.91	0.07	18.89	1.74	2.54	4.42													
	12	C2	17.03	0.10	23.28	1.69	2.29	3.87													
	13	C3	3.96	0.08	11.39	0.33	3.14	1.04													
	14	C4	6.37	0.05	13.33	0.32	2.95	0.94													
	15	C5	10.50	0.05	15.00	0.53	2.81	1.48													
	16	C6	21.29	0.11	17.22	2.30	2.65	6.09													
	17	D1	29.38	0.07	16.25	1.96	2.72	5.34													
	18	OS-A1	4.06	0.21	12.56	0.85	3.02	2.57													
	19	OS-A2	4.45	0.05	11.39	0.22	3.14	0.70													
	20	OS-C1	27.49	0.07	18.31	1.90	2.58	4.90													
	21	OS-C2	6.15	0.14	16.47	0.87	2.70	2.35													
	22	OS-C3	21.89	0.09	16.52	1.98	2.70	5.33													

Note: Rainfall intensity from Figure 6-5 IDF Equations

$$I_2 = -1.19 \ln(t_{c,min}) + 6.035$$



**STANDARD FORM SF-3
STORM DRAINAGE DESIGN - RATIONAL METHOD 5 YEAR EVENT**

PROJECT NAME: Overlook
PROJECT NUMBER: 196239003
CALCULATED BY: GKS
CHECKED BY: KRK

PROPOSED CONDITIONS

DATE: 8/7/2023

STORM LINE	DESIGN POINT	DIRECT RUNOFF							TOTAL RUNOFF				STREET		PIPE			TRAVEL TIME			REMARKS
		DESIGN BASIN	AREA (AC)	RUNOFF COEFF	t _c (min)	C*A(ac)	I (in/hr)	Q (cfs)	t _c (max)	S(C*A) (ac)	I (in/hr)	Q (cfs)	SLOPE (%)	STREET FLOW(cfs)	DESIGN FLOW(cfs)	SLOPE (%)	PIPE SIZE (in)	LENGTH (ft)	VELOCITY	t _t (min)	
(1)	(2)	(3)	(4)	(5)	(6)	(7)	(8)	(9)	(10)	(11)	(12)	(13)	(14)	(15)	(16)	(17)	(18)	(19)	(20)	(21)	(22)
	1	A1	19.55	0.19	23.14	3.63	2.87	10.41													
	2	A2	58.27	0.16	34.44	9.23	2.27	20.99													
	3	B1	40.74	0.14	22.78	5.79	2.89	16.77													
	4	B2	16.00	0.14	14.44	2.19	3.58	7.82													
	5	B3	19.11	0.12	16.11	2.29	3.41	7.83													
	6	B4	8.50	0.12	13.33	1.02	3.70	3.77													
	7	B5	8.95	0.12	13.06	1.07	3.73	4.01													
	8	B6	53.31	0.14	22.22	7.69	2.93	22.55													
	9	B7	2.46	0.12	12.22	0.30	3.83	1.13													
	10	B8	9.52	0.12	13.33	1.14	3.70	4.22													
	11	C1	25.91	0.14	18.89	3.52	3.18	11.18													
	12	C2	17.03	0.17	23.28	2.82	2.86	8.08													
	13	C3	3.96	0.15	11.39	0.60	3.93	2.36													
	14	C4	6.37	0.12	13.33	0.76	3.70	2.83													
	15	C5	10.50	0.12	15.00	1.26	3.52	4.44													
	16	C6	21.29	0.17	17.22	3.70	3.31	12.27													
	17	D1	29.38	0.14	16.25	3.99	3.40	13.56													
	18	OS-A1	4.06	0.27	12.56	1.09	3.79	4.12													
	19	OS-A2	4.45	0.12	11.39	0.53	3.93	2.10													
	20	OS-C1	27.49	0.14	18.31	3.79	3.22	12.21													
	21	OS-C2	6.15	0.20	16.47	1.26	3.38	4.26													
	22	OS-C3	21.89	0.16	16.52	3.45	3.38	11.63													

Note: Rainfall intensity from Figure 6-5 IDF Equations

$$I_5 = -1.5 \ln(t_{c,min}) + 7.583$$



**STANDARD FORM SF-3
STORM DRAINAGE DESIGN - RATIONAL METHOD 100 YEAR EVENT**

PROJECT NAME: Overlook
PROJECT NUMBER: 196239003
CALCULATED BY: GKS
CHECKED BY: KRK

PROPOSED CONDITIONS

DATE: 8/7/2023

STORM LINE	DESIGN POINT	DIRECT RUNOFF							TOTAL RUNOFF				STREET		PIPE			TRAVEL TIME			REMARKS
		DESIGN BASIN	AREA (AC)	RUNOFF COEFF	t _c (min)	C*A(ac)	I (in/hr)	Q (cfs)	t _c (max)	S(C*A) (ac)	I (in/hr)	Q (cfs)	SLOPE (%)	STREET FLOW(cfs)	DESIGN FLOW(cfs)	SLOPE (%)	PIPE SIZE (in)	LENGTH (ft)	VELOCITY	t _t (min)	
(1)	(2)	(3)	(4)	(5)	(6)	(7)	(8)	(9)	(10)	(11)	(12)	(13)	(14)	(15)	(16)	(17)	(18)	(19)	(20)	(21)	(22)
	1	A1	19.55	0.44	23.14	8.56	4.82	41.24													
	2	A2	58.27	0.42	34.44	24.36	3.82	92.96													
	3	B1	40.74	0.41	22.78	16.55	4.86	80.40													
	4	B2	16.00	0.40	14.44	6.43	6.01	38.64													
	5	B3	19.11	0.39	16.11	7.45	5.73	42.71													
	6	B4	8.50	0.39	13.33	3.32	6.21	20.58													
	7	B5	8.95	0.39	13.06	3.49	6.26	21.85													
	8	B6	53.31	0.41	22.22	21.74	4.92	106.95													
	9	B7	2.46	0.39	12.22	0.96	6.43	6.17													
	10	B8	9.52	0.39	13.33	3.71	6.21	23.05													
	11	C1	25.91	0.40	18.89	10.41	5.33	55.47													
	12	C2	17.03	0.42	23.28	7.21	4.80	34.64													
	13	C3	3.96	0.41	11.39	1.64	6.60	10.80													
	14	C4	6.37	0.39	13.33	2.48	6.21	15.42													
	15	C5	10.50	0.39	15.00	4.10	5.91	24.20													
	16	C6	21.29	0.43	17.22	9.14	5.56	50.85													
	17	D1	29.38	0.40	16.25	11.79	5.71	67.33													
	18	OS-A1	4.06	0.50	12.56	2.02	6.36	12.86													
	19	OS-A2	4.45	0.39	11.39	1.74	6.60	11.46													
	20	OS-C1	27.49	0.40	18.31	11.08	5.41	59.93													
	21	OS-C2	6.15	0.45	16.47	2.78	5.67	15.78													
	22	OS-C3	21.89	0.42	16.52	9.14	5.67	51.77													

Note: Rainfall intensity from Figure 6-5 IDF Equations

$$I_{100} = -2.52 \ln(t_{c,min}) + 12.735$$



PROJECT NAME: Overlook
 PROJECT NUMBER: 196239003
 CALCULATED BY: GKS
 CHECKED BY: KRK

8/7/2023

PROPOSED CONDITIONS RATIONAL CALCULATIONS SUMMARY

DESIGN POINT	TRIBUTARY BASINS	TRIBUTARY AREA (AC)	CFS			% IMPERVIOUS
			Q2	Q5	Q100	
PDR Basins						
1	A1	19.55	5.41	10.41	41.24	15%
2	A2	58.27	9.71	20.99	92.96	12%
3	B1	40.74	6.97	16.77	80.40	10%
4	B2	16.00	3.10	7.82	38.64	9%
5	B3	19.11	2.61	7.83	42.71	7%
6	B4	8.50	1.25	3.77	20.58	7%
7	B5	8.95	1.33	4.01	21.85	7%
8	B6	53.31	9.52	22.55	106.95	10%
9	B7	2.46	0.38	1.13	6.17	7%
10	B8	9.52	1.41	4.22	23.05	7%
11	C1	25.91	4.42	11.18	55.47	9%
12	C2	17.03	3.87	8.08	34.64	12%
13	C3	3.96	1.04	2.36	10.80	11%
14	C4	6.37	0.94	2.83	15.42	7%
15	C5	10.50	1.48	4.44	24.20	7%
16	C6	21.29	6.09	12.27	50.85	13%
17	D1	29.38	5.34	13.56	67.33	9%
18	OS-A1	4.06	2.57	4.12	12.86	25%
19	OS-A2	4.45	0.70	2.10	11.46	7%
20	OS-C1	27.49	4.90	12.21	59.93	9%
21	OS-C2	6.15	2.35	4.26	15.78	17%
22	OS-C3	21.89	5.33	11.63	51.77	11%
ON-SITE BASIN TOTAL						
BASIN A TOTAL		77.82	15.12	31.40	134.20	12%
BASIN B TOTAL		158.59	26.57	68.09	340.34	8%
BASIN C TOTAL		85.06	17.84	41.15	191.38	10%
BASIN D TOTAL		29.38	4.90	12.21	59.93	9%
ON-SITE TOTAL		350.85	49.75	122.80	599.06	10%
OFF-SITE BASIN TOTAL						
OFF-SITE BASIN A		8.51	3.27	6.22	24.32	15%
OFF-SITE BASIN C		55.53	12.58	28.11	127.48	11%
OFF-SITE TOTAL		64.04	15.85	34.33	151.80	12%
SITE TOTAL		414.89	65.60	157.13	750.86	10%

APPENDIX D: HYDRUALICS

Project: Overlook A2 WOCV
Basin ID:

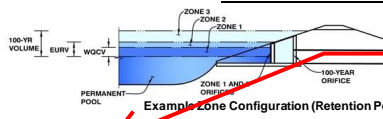

Example Zone Configuration (Retention Pond)

As the single family lots are considered exempt from water quality, these tables were used to determine the required WQCV for each pond. That was done by calculating WQCV based on the impervious roadway areas tributary to each pond.

why is an override used?
Typical comment

VOLUME USED IN POND SIZING

Selected BMP Type =	EDB
Watershed Area =	2.87 acres
Watershed Length =	1,000 ft
Watershed Length to Centroid =	500 ft
Watershed Slope =	0.030 ft/ft
Watershed Imperviousness =	100.00% percent
Percentage Hydrologic Soil Group A =	0.0% percent
Percentage Hydrologic Soil Group B =	100.0% percent
Percentage Hydrologic Soil Groups C/D =	0.0% percent
Target WQCV Drain Time =	40.0 hours
Location for 1-hr Rainfall Depths =	Denver - Capitol Building

After providing required inputs above including 1-hour rainfall data, click 'Run CUHP' to generate runoff hydrographs using the embedded Colorado Urban Hydrograph Procedure.

Water Quality Capture Volume (WQCV) =	0.120 acre-feet	Optional User Overrides	
Excess Urban Runoff Volume (EURV) =	0.324 acre-feet		
2-yr Runoff Volume (P1 = 1.19 in.) =	0.281 acre-feet	1.19	inches
5-yr Runoff Volume (P1 = 1.5 in.) =	0.360 acre-feet	1.50	inches
10-yr Runoff Volume (P1 = 1.75 in.) =	0.424 acre-feet	1.75	inches
25-yr Runoff Volume (P1 = 2 in.) =	0.487 acre-feet	2.00	inches
50-yr Runoff Volume (P1 = 2.25 in.) =	0.550 acre-feet	2.25	inches
100-yr Runoff Volume (P1 = 2.52 in.) =	0.619 acre-feet	2.52	inches
500-yr Runoff Volume (P1 = 3.14 in.) =	0.777 acre-feet		inches
Approximate 2-yr Detention Volume =	0.263 acre-feet		
Approximate 5-yr Detention Volume =	0.340 acre-feet		
Approximate 10-yr Detention Volume =	0.412 acre-feet		
Approximate 25-yr Detention Volume =	0.442 acre-feet		
Approximate 50-yr Detention Volume =	0.458 acre-feet		
Approximate 100-yr Detention Volume =	0.470 acre-feet		

Define Zones and Basin Geometry

Zone 1 Volume (WOCV) =	0.120 acre-feet
Zone 2 Volume (EURV - Zone 1) =	0.205 acre-feet
Zone 3 Volume (100-year - Zones 1 & 2) =	0.146 acre-feet
Total Detention Basin Volume =	0.470 acre-feet
Initial Surcharge Volume (ISV) =	16 ft ³
Initial Surcharge Depth (ISD) =	ft
Total Available Detention Depth (H _{total}) =	ft
Depth of Trickle Channel (H _{TC}) =	ft
Slope of Trickle Channel (S _{TC}) =	ft/ft
Slopes of Main Basin Sides (S _{main}) =	H:V
Basin Length-to-Width Ratio (R _{L/W}) =	
Initial Surcharge Area (A _{ISV}) =	ft ²
Surcharge Volume Length (L _{ISV}) =	ft
Surcharge Volume Width (W _{ISV}) =	ft
Depth of Basin Floor (H _{FLOOR}) =	ft
Length of Basin Floor (L _{FLOOR}) =	ft
Width of Basin Floor (W _{FLOOR}) =	ft
Area of Basin Floor (A _{FLOOR}) =	ft ²
Volume of Basin Floor (V _{FLOOR}) =	ft ³
Depth of Main Basin (H _{MAIN}) =	ft
Length of Main Basin (L _{MAIN}) =	ft
Width of Main Basin (W _{MAIN}) =	ft
Area of Main Basin (A _{MAIN}) =	ft ²
Volume of Main Basin (V _{MAIN}) =	ft ³
Calculated Total Basin Volume (V _{total}) =	acre-feet

Note that the full MHFD will be required during the Final Drainage Report and Final Design and a more detailed review will be conducted then

Noted, statement has been added to text body in detention section.

Volume (ac-ft)

Large empty table grid for stage storage data.

DETENTION BASIN STAGE-STORAGE TABLE BUILDER

MHFD-Detention, Version 4.06 (July 2022)

Project: Overlook A2 Prelim Pond Sizing

Basin ID:

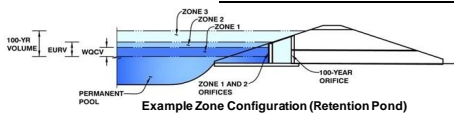

Watershed Information

Table with watershed parameters: Selected BMP Type (EDB), Watershed Area (58.27 acres), Watershed Length (3,500 ft), Watershed Length to Centroid (1,750 ft), Watershed Slope (0.100 ft/ft), Watershed Imperviousness (12.00%), etc.

After providing required inputs above including 1-hour rainfall depths, click 'Run CUHP' to generate runoff hydrographs using the embedded Colorado Urban Hydrograph Procedure.

Optional User Overrides

Table of optional user overrides for runoff volumes and detention volumes, including Water Quality Capture Volume (WOCV), Excess Urban Runoff Volume (EURV), and various return period runoff volumes.

Define Zones and Basin Geometry

Table of basin geometry parameters: Zone 1 Volume (WOCV), Zone 2 Volume (EURV - Zone 1), Zone 3 Volume (100-year - Zones 1 & 2), Total Detention Basin Volume, Initial Surcharge Volume (ISV), Initial Surcharge Depth (ISD), Total Available Detention Depth (Htotal), Depth of Trickle Channel (Htc), Slope of Trickle Channel (Stc), Slopes of Main Basin Sides (Smain), Basin Length-to-Width Ratio (RLW), Initial Surcharge Area (AISV), Surcharge Volume Length (LSV), Surcharge Volume Width (WSV), Depth of Basin Floor (HFLOOR), Length of Basin Floor (LFLOOR), Width of Basin Floor (WFLOOR), Area of Basin Floor (AFLOOR), Volume of Basin Floor (VFLOOR), Depth of Main Basin (HMAIN), Length of Main Basin (LMAIN), Width of Main Basin (WMAIN), Area of Main Basin (AMAIN), Volume of Main Basin (VMAIN), Calculated Total Basin Volume (Vtotal).

Main Stage-Storage Table with columns: Stage - Storage Description, Stage (ft), Optional Override Stage (ft), Length (ft), Width (ft), Area (ft^2), Optional Override Area (ft^2), Area (acre), Volume (ft^3), Volume (ac-ft). It contains stage-storage data for various depths from 1.00 ft to 5.00 ft.

DETENTION BASIN STAGE-STORAGE TABLE BUILDER

MHFD-Detention, Version 4.06 (July 2022)

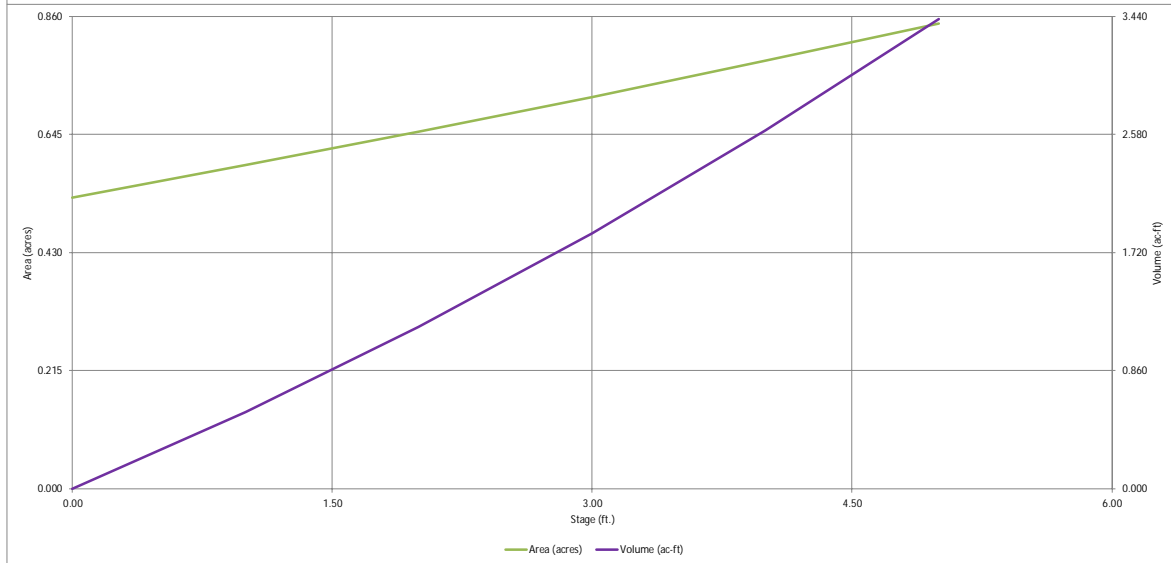
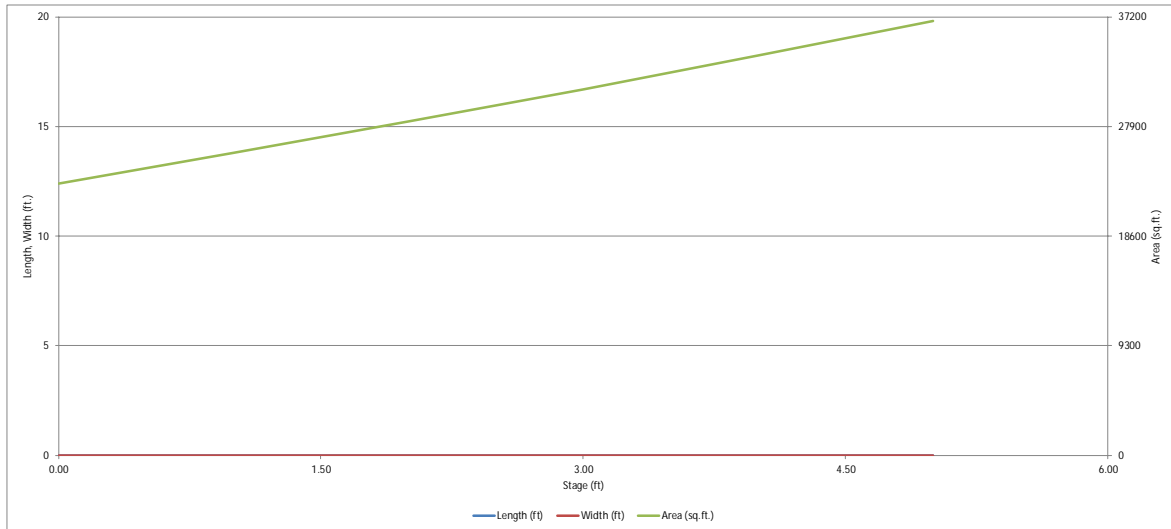

DETENTION BASIN STAGE-STORAGE TABLE BUILDER

MHFD-Detention, Version 4.06 (July 2022)

Project: Overlook B1 Prelim Pond Sizing

Basin ID:

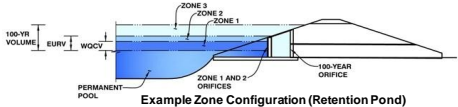

Example Zone Configuration (Retention Pond)

Watershed Information

Table with watershed parameters: Selected BMP Type, Watershed Area, Watershed Length, Watershed Length to Centroid, Watershed Slope, Watershed Imperviousness, Percentage Hydrologic Soil Group A, etc.

After providing required inputs above including 1-hour rainfall depths, click 'Run CUHP' to generate runoff hydrographs using the embedded Colorado Urban Hydrograph Procedure.

Optional User Overrides

Table for optional user overrides including Water Quality Capture Volume (WQCV), Excess Urban Runoff Volume (EURV), and various runoff volumes for different return periods.

Define Zones and Basin Geometry

Table for defining zones and basin geometry, including Zone 1 Volume, Zone 2 Volume, Zone 3 Volume, Total Detention Basin Volume, Initial Surcharge Volume, etc.

Main stage-storage table with columns: Stage - Storage Description, Stage (ft), Optional Override Stage (ft), Length (ft), Width (ft), Area (ft²), Optional Override Area (ft²), Area (acre), Volume (ft³), Volume (ac-ft). Rows show depth increments from 0.00 to 5.00 ft.

DETENTION BASIN STAGE-STORAGE TABLE BUILDER

MHFD-Detention, Version 4.06 (July 2022)

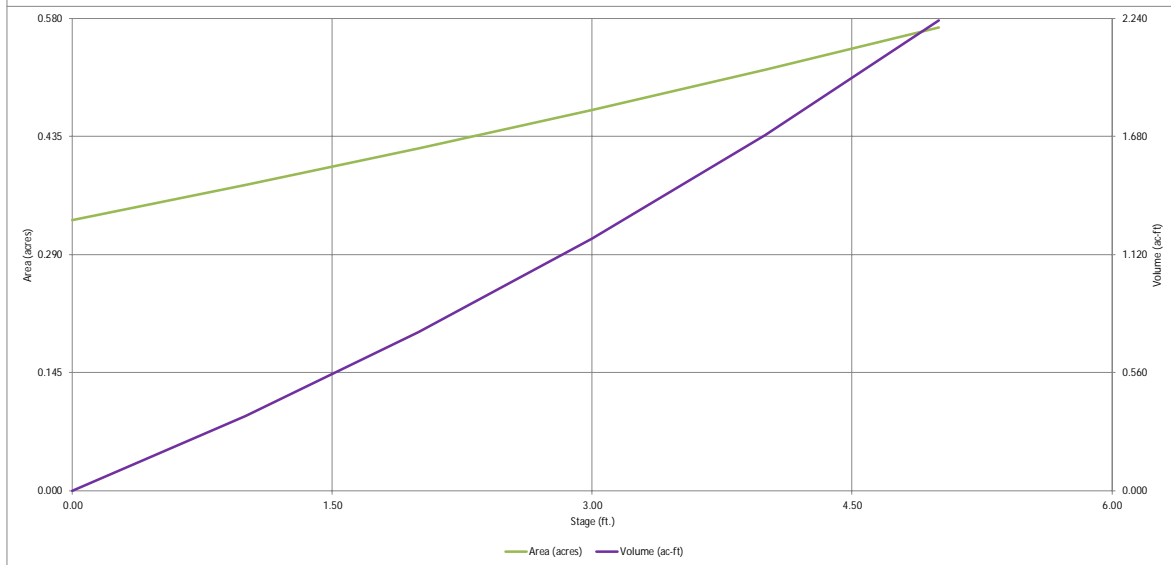
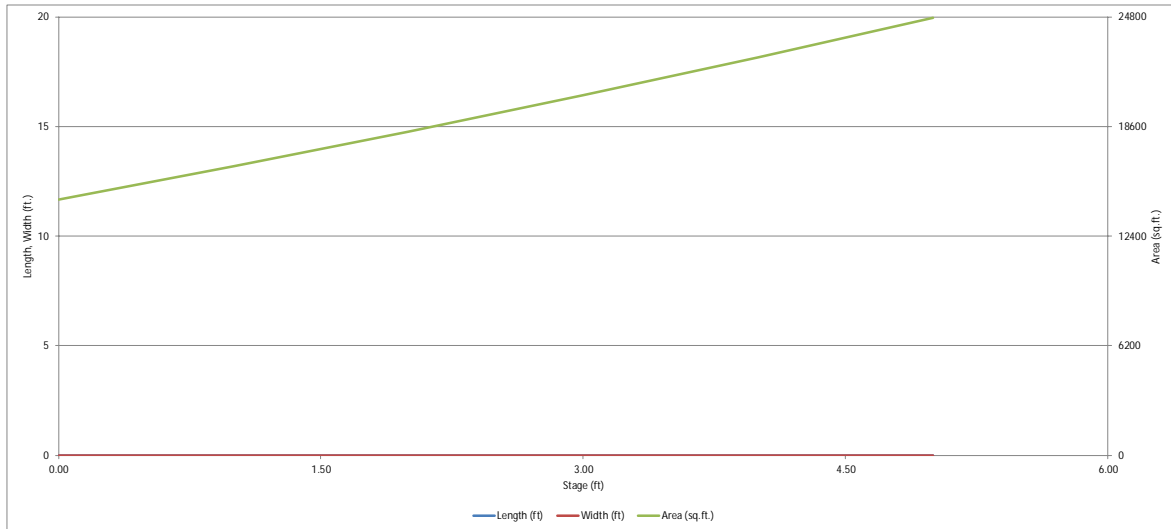

DETENTION BASIN STAGE-STORAGE TABLE BUILDER

MHFD-Detention, Version 4.06 (July 2022)

Project: Overlook B8 WOCV

Basin ID:

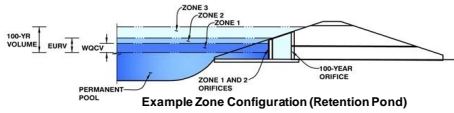

Example Zone Configuration (Retention Pond)

Watershed Information

- Selected BMP Type = EDB
Watershed Area = 1.66 acres
Watershed Length = 1,000 ft
Watershed Length to Centroid = 500 ft
Watershed Slope = 0.035 ft/ft
Watershed Imperviousness = 100.00% percent
Percentage Hydrologic Soil Group A = 0.0% percent
Percentage Hydrologic Soil Group B = 100.0% percent
Percentage Hydrologic Soil Groups C/D = 0.0% percent
Target WOCV Drain Time = 40.0 hours
Location for 1-hr Rainfall Depths = Denver - Capitol Building

Note: L / W Ratio > 8
L / W Ratio = 13.83

After providing required inputs above including 1-hour rainfall data, click 'Run CUHP' to generate runoff hydrographs using the embedded Colorado Urban Hydrograph Procedure.

- Water Quality Capture Volume (WOCV) = 0.069 acre-feet
Excess Urban Runoff Volume (EURV) = 0.188 acre-feet
2-yr Runoff Volume (P1 = 1.19 in.) = 1.19 inches
5-yr Runoff Volume (P1 = 1.5 in.) = 1.50 inches
10-yr Runoff Volume (P1 = 1.75 in.) = 1.75 inches
25-yr Runoff Volume (P1 = 2 in.) = 2.00 inches
50-yr Runoff Volume (P1 = 2.25 in.) = 2.25 inches
100-yr Runoff Volume (P1 = 2.52 in.) = 2.52 inches
500-yr Runoff Volume (P1 = 3.14 in.) = inches
Approximate 2-yr Detention Volume = acre-feet
Approximate 5-yr Detention Volume = acre-feet
Approximate 10-yr Detention Volume = acre-feet
Approximate 25-yr Detention Volume = acre-feet
Approximate 50-yr Detention Volume = acre-feet
Approximate 100-yr Detention Volume = acre-feet

Optional User Overrides

- acre-feet
acre-feet
1.19 inches
1.50 inches
1.75 inches
2.00 inches
2.25 inches
2.52 inches
inches
inches

Define Zones and Basin Geometry

- Select Zone 1 Storage Volume (Required) = acre-feet
Select Zone 2 Storage Volume (Optional) = acre-feet
Select Zone 3 Storage Volume (Optional) = acre-feet
Total Detention Basin Volume = acre-feet
Initial Surge Volume (ISV) = 9 ft^3
Initial Surge Depth (ISD) = ft
Total Available Detention Depth (Htotal) = ft
Depth of Trickle Channel (Htc) = ft
Slope of Trickle Channel (Stc) = ft/ft
Slopes of Main Basin Sides (Smain) = H:V
Basin Length-to-Width Ratio (RL/W) =
Initial Surge Area (AISV) = ft^2
Surcharge Volume Length (LSV) = ft
Surcharge Volume Width (WSV) = ft
Depth of Basin Floor (Hflood) = ft
Length of Basin Floor (Lflood) = ft
Width of Basin Floor (Wflood) = ft
Area of Basin Floor (Aflood) = ft^2
Volume of Basin Floor (Vflood) = ft^3
Depth of Main Basin (HMAIN) = ft
Length of Main Basin (LMAIN) = ft
Width of Main Basin (WMAIN) = ft
Area of Main Basin (AMAIN) = ft^2
Volume of Main Basin (VMMAIN) = ft^3
Calculated Total Basin Volume (Vtotal) = acre-feet

Table with columns: Stage - Storage Description, Stage (ft), Optional Override Stage (ft), Length (ft), Width (ft), Area (ft^2), Optional Override Area (ft^2), Area (acre), Volume (ft^3), Volume (ac-ft). The table contains one row labeled 'Top of Micropool' and many empty rows below.

VOLUME USED IN POND SIZING

DETENTION BASIN STAGE-STORAGE TABLE BUILDER

MHFD-Detention, Version 4.06 (July 2022)

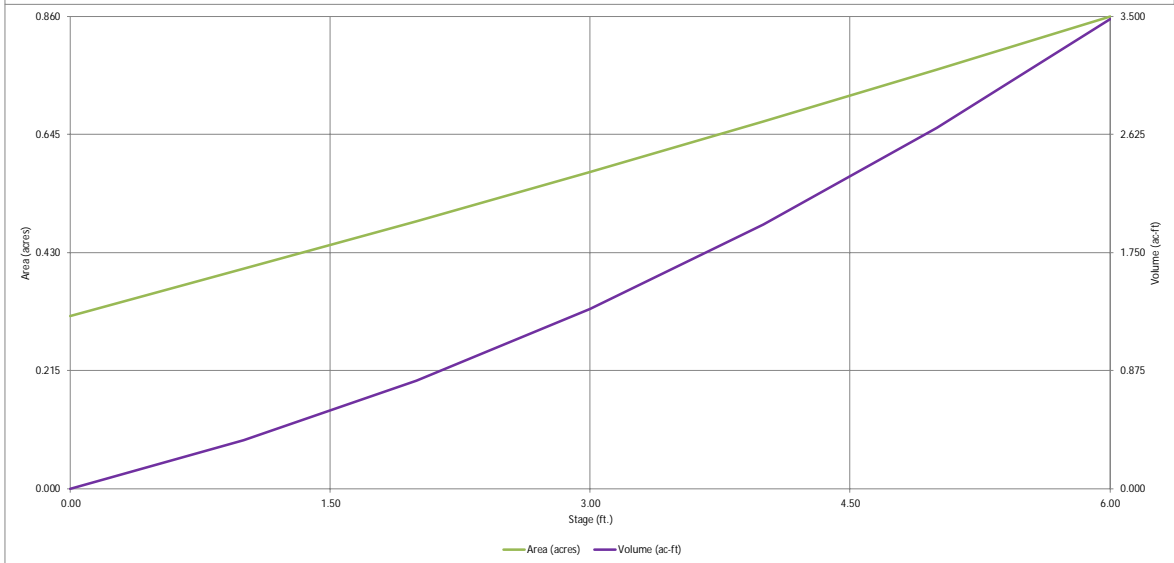
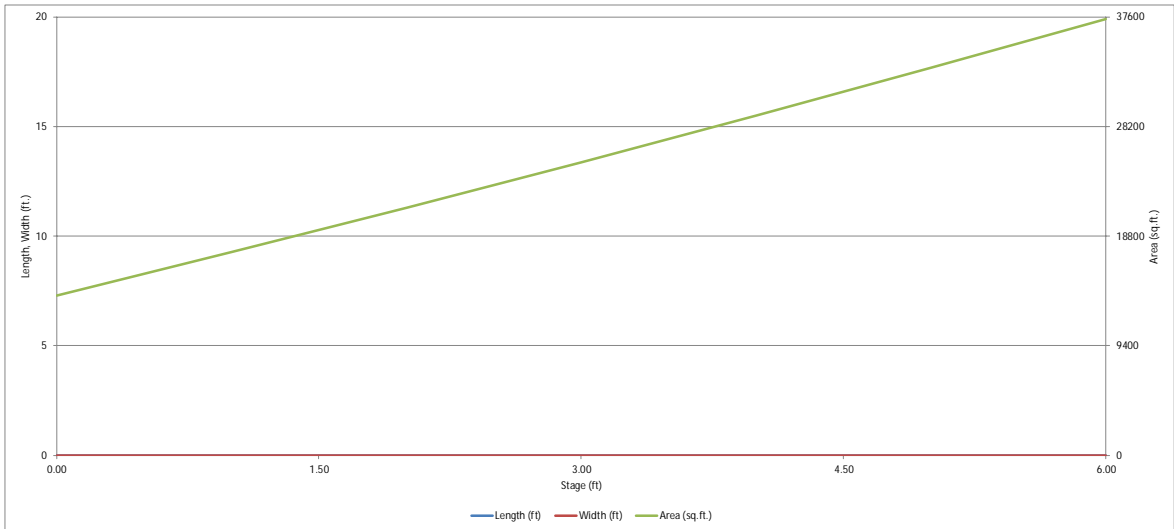

DETENTION BASIN STAGE-STORAGE TABLE BUILDER

MHFD-Detention, Version 4.06 (July 2022)

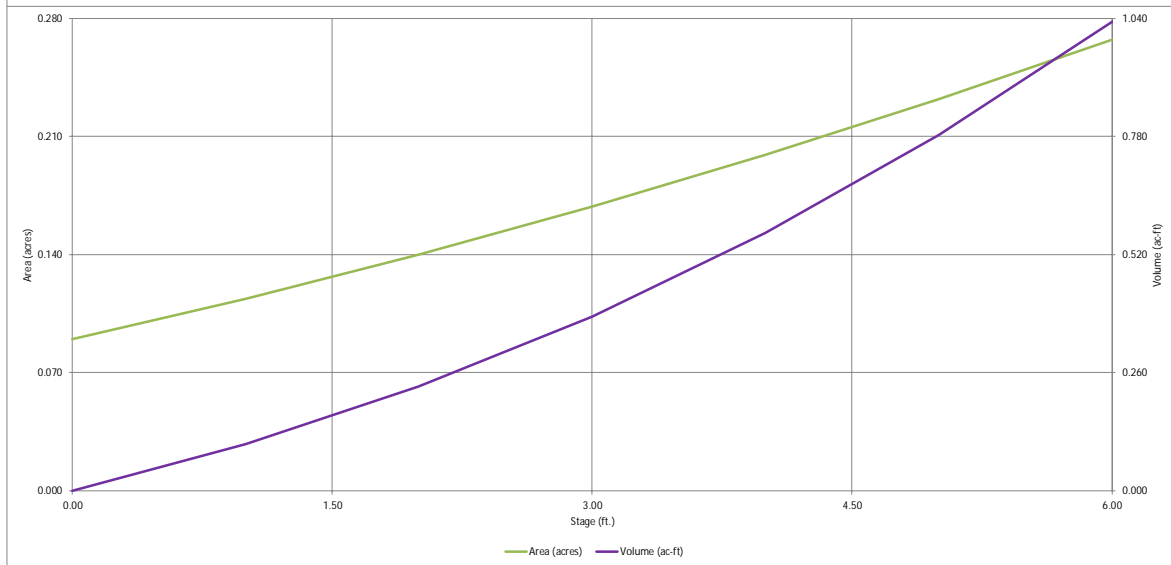
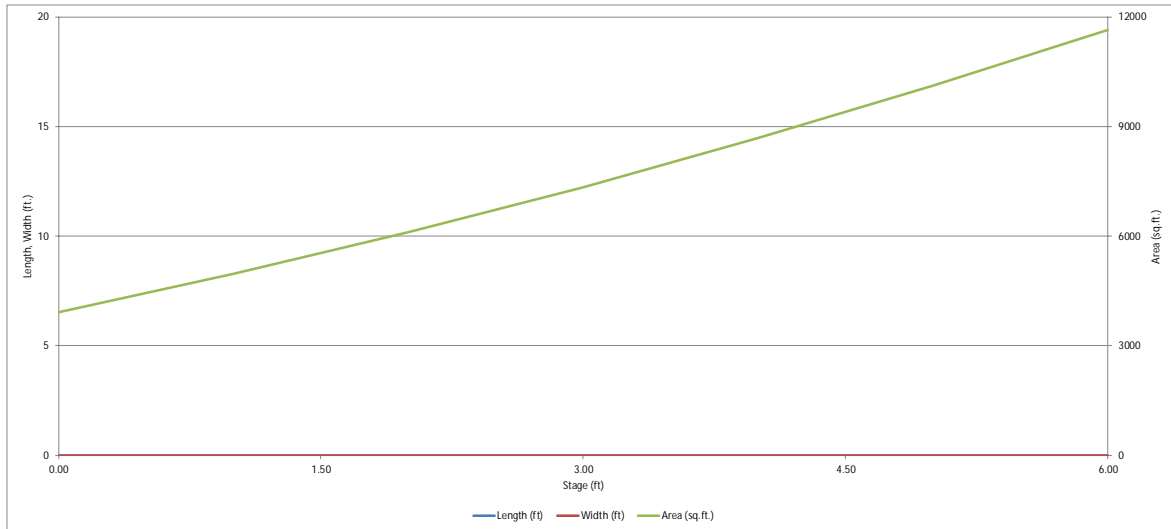

DETENTION BASIN STAGE-STORAGE TABLE BUILDER

MHFD-Detention, Version 4.06 (July 2022)

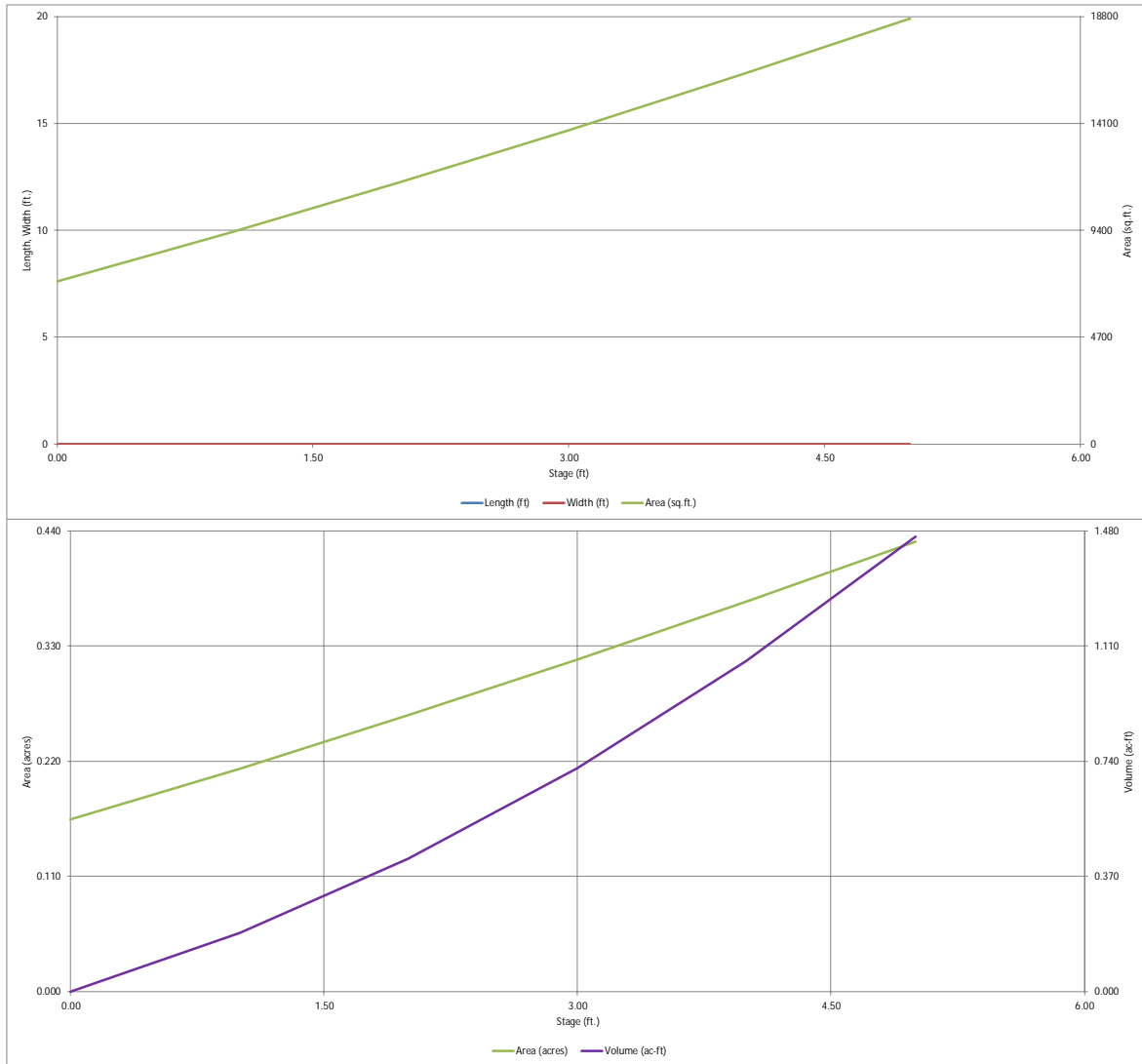

DETENTION BASIN STAGE-STORAGE TABLE BUILDER

MHFD-Detention, Version 4.06 (July 2022)

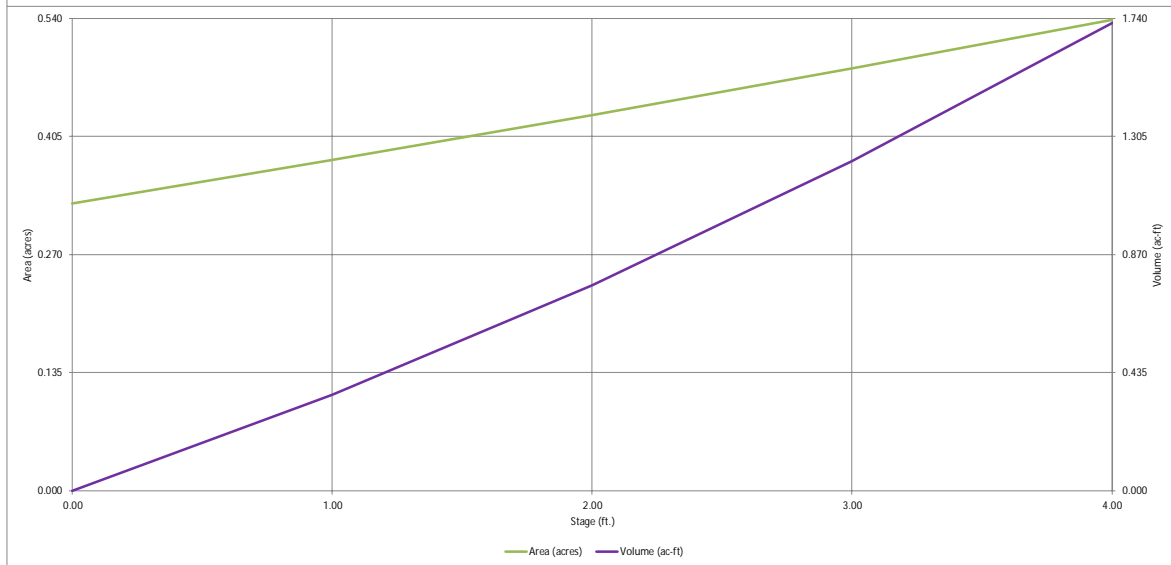
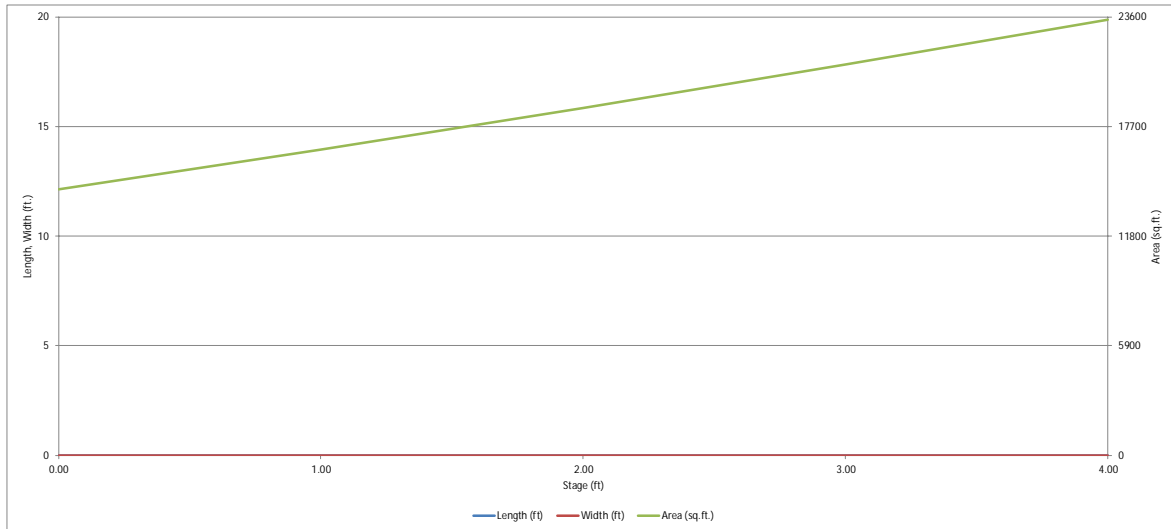

APPENDIX E: EL PASO COUNTY DRAINAGE BASIN MAP

Douglas County

Elbert County

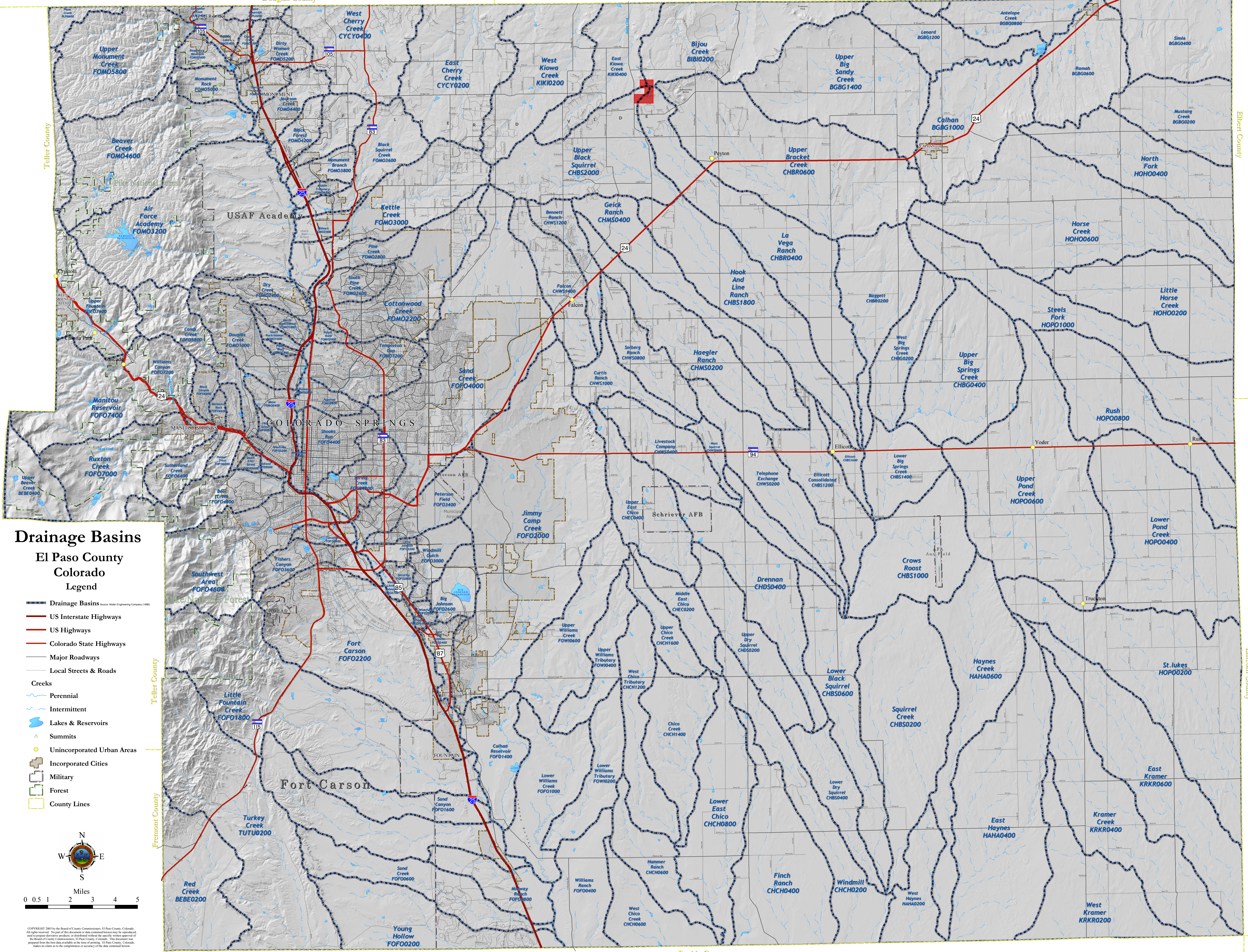

Drainage Basins

El Paso County Colorado Legend

- Drainage Basins (Source: Muler Engineering Company 1986)
- US Interstate Highways
- US Highways
- Colorado State Highways
- Major Roadways
- Local Streets & Roads
- Creeks**
- Perennial
- Intermittent
- Lakes & Reservoirs
- Summits
- Unincorporated Urban Areas
- Incorporated Cities
- Military
- Forest
- County Lines



Copyright 2007 by the Board of County Commissioners, El Paso County, Colorado. All rights reserved. No part of this document or data contained herein may be reproduced or transmitted in any form or by any means, electronic or mechanical, including photocopying, recording, or by any information storage and retrieval system, without the prior written permission of the Board of County Commissioners, El Paso County, Colorado. This document was prepared from the best data available at the time of printing. El Paso County, Colorado, makes no claim as to the completeness or accuracy of the data contained herein.

APPENDIX F: APEX RANCH DRAINAGE REPORT

Design Procedure Form: Extended Detention Basin (EDB) - Sedimentation Facility

Designer: QUENTIN ARMIJO
 Company: TERRA NOVA ENG.
 Date: April 2, 2008
 Project: APEX RANCH ESTATES
 Location: PEYTON, CO

<p>1. Basin Storage Volume</p> <p>A) Tributary Area's Imperviousness Ratio ($i = I_a / 100$)</p> <p>B) Contributing Watershed Area (Area)</p> <p>C) Water Quality Capture Volume (WQCV) $(WQCV = 1.0 * (0.91 * I^3 - 1.19 * I^2 + 0.78 * I))$</p> <p>D) Design Volume: $Vol = (WQCV / 12) * Area * 1.2$</p>	<p>$I_a =$ <u>10.00</u> %</p> <p>$i =$ <u>0.10</u></p> <p>Area = <u>76.80</u> acres</p> <p>WQCV = <u>0.07</u> watershed inches</p> <p>Vol = <u>0.515</u> acre-feet</p>
<p>2. Outlet Works</p> <p>A) Outlet Type (Check One)</p> <p>B) Depth at Outlet Above Lowest Perforation (H)</p> <p>C) Required Maximum Outlet Area per Row, (A_o)</p> <p>D) Perforation Dimensions (enter one only): i) Circular Perforation Diameter OR ii) 2" Height Rectangular Perforation Width</p> <p>E) Number of Columns (nc, See Table 6a-1 For Maximum)</p> <p>F) Actual Design Outlet Area per Row (A_o)</p> <p>G) Number of Rows (nr)</p> <p>H) Total Outlet Area (A_{ot})</p>	<p><input checked="" type="checkbox"/> Orifice Plate <input type="checkbox"/> Perforated Riser Pipe Other: _____</p> <p>H = <u>2.50</u> feet</p> <p>$A_o =$ <u>0.81</u> square inches</p> <p>D = <u>1.0000</u> inches, OR W = _____ inches</p> <p>$nc =$ <u>1</u> number</p> <p>$A_o =$ <u>0.79</u> square inches</p> <p>$nr =$ <u>8</u> number</p> <p>$A_{ot} =$ <u>5.89</u> square inches</p>
<p>3. Trash Rack</p> <p>A) Needed Open Area: $A_t = 0.5 * (\text{Figure 7 Value}) * A_{ot}$</p> <p>B) Type of Outlet Opening (Check One)</p> <p>C) For 2", or Smaller, Round Opening (Ref.: Figure 6a): i) Width of Trash Rack and Concrete Opening (W_{conc}) from Table 6a-1 ii) Height of Trash Rack Screen (H_{TR})</p>	<p>$A_t =$ <u>200</u> square inches</p> <p><input checked="" type="checkbox"/> < 2" Diameter Round <input type="checkbox"/> 2" High Rectangular Other: _____</p> <p>$W_{conc} =$ <u>9</u> inches</p> <p>$H_{TR} =$ <u>54</u> inches</p>

APEX RANCH ESTATES EL PASO COUNTY, COLORADO FINAL DRAINAGE MAP AUGUST 2008

412200006
COLLEEN KRASOVICH
3650 GARRISON ST
WHEAT RIDGE, CO.
ZONED A-35

DEVELOPED CONDITIONS

BASIN	ACRES	Q5 CFS	Q100 CFS
OS-1	72.1	45	102
OS-2	5.2	4	9
OS-3	21.9	13	29
OS-4	1.9	4	8
OS-5	0.7	1	3
A	28.2	29	64
B	0.6	2	3
C	6.9	6	12
D	4.7	4	9
E	10.0	8	18
G	4.7	5	10
H	13.0	10	22
I	4.2	4	8
J	4.4	5	11
K	23.2	22	50
M	18.2	15	33
N	4.2	5	10
O	4.0	4	9

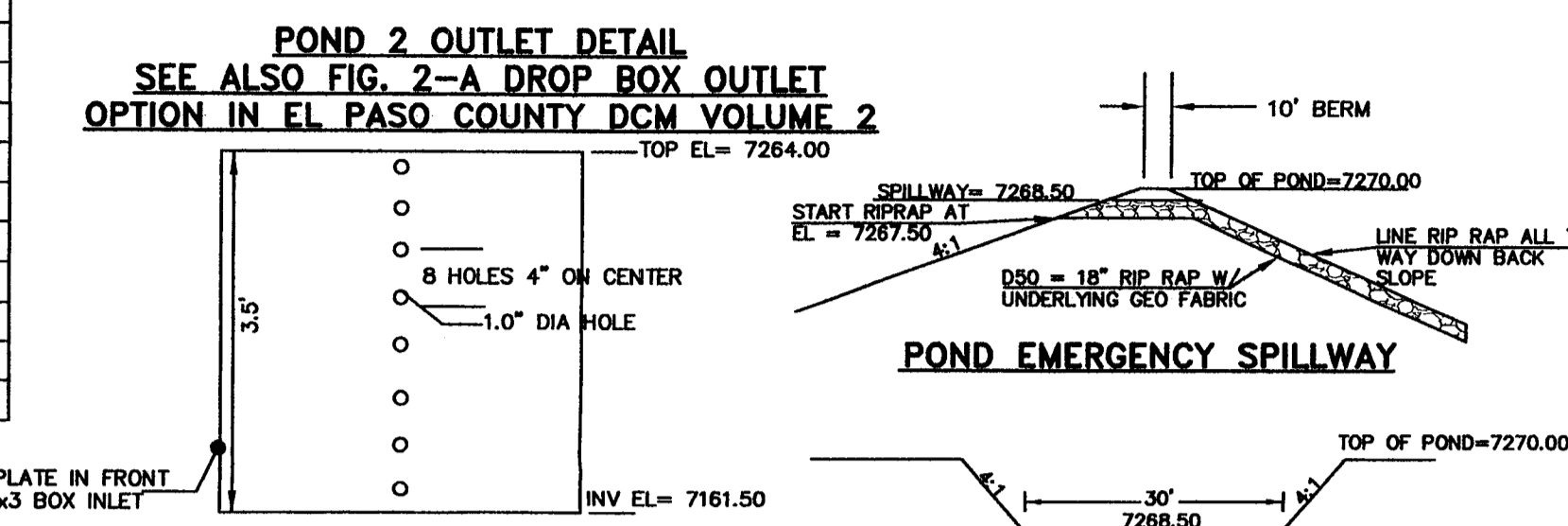
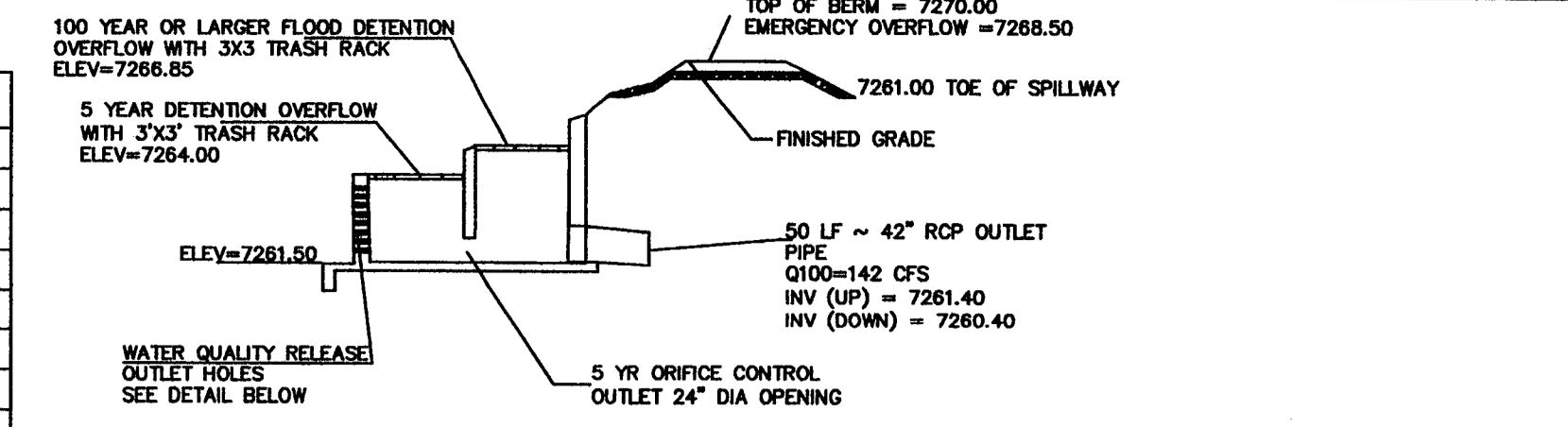

DESIGN POINT SUMMARY

DP	CONTRIBUTING BASINS	Q5 CFS	Q100 CFS
1	OS-1 & A	58	130
2	DP-1 & B	59	131
3	DP-2 & C	61	134
4	DP-3, D & E	68	148
5	DP-4, G & H	78	170
6	OS-2 & I	8	18
7	DP-5, DP-6, J & OS-4	87	188
8	OS-3 & K	29	64
9	DP-8, L, M, OS-5 & POND RELEASE	102	227
10	N & O	8	19

POND PERFORATED HOLE PATTERN

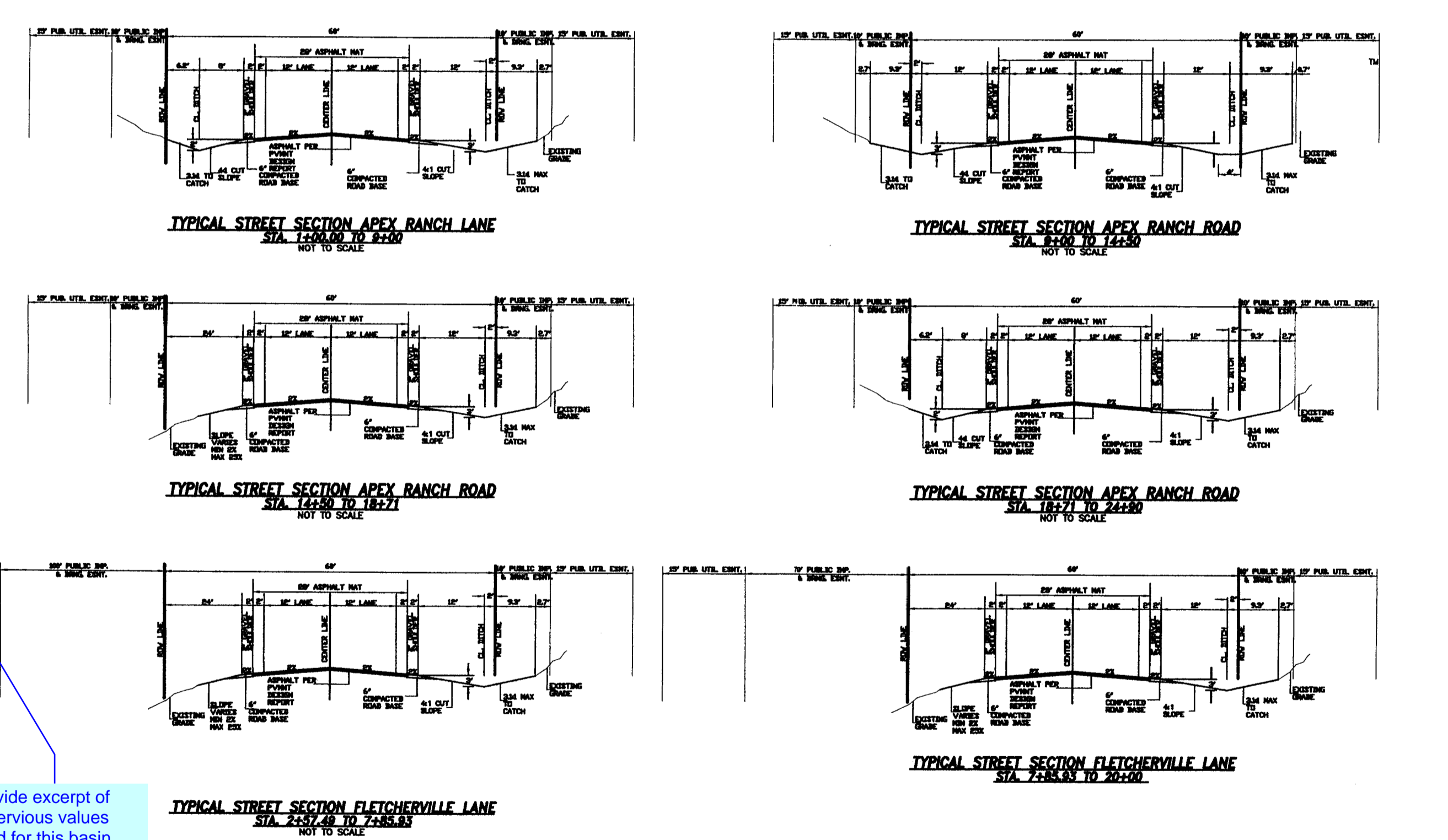
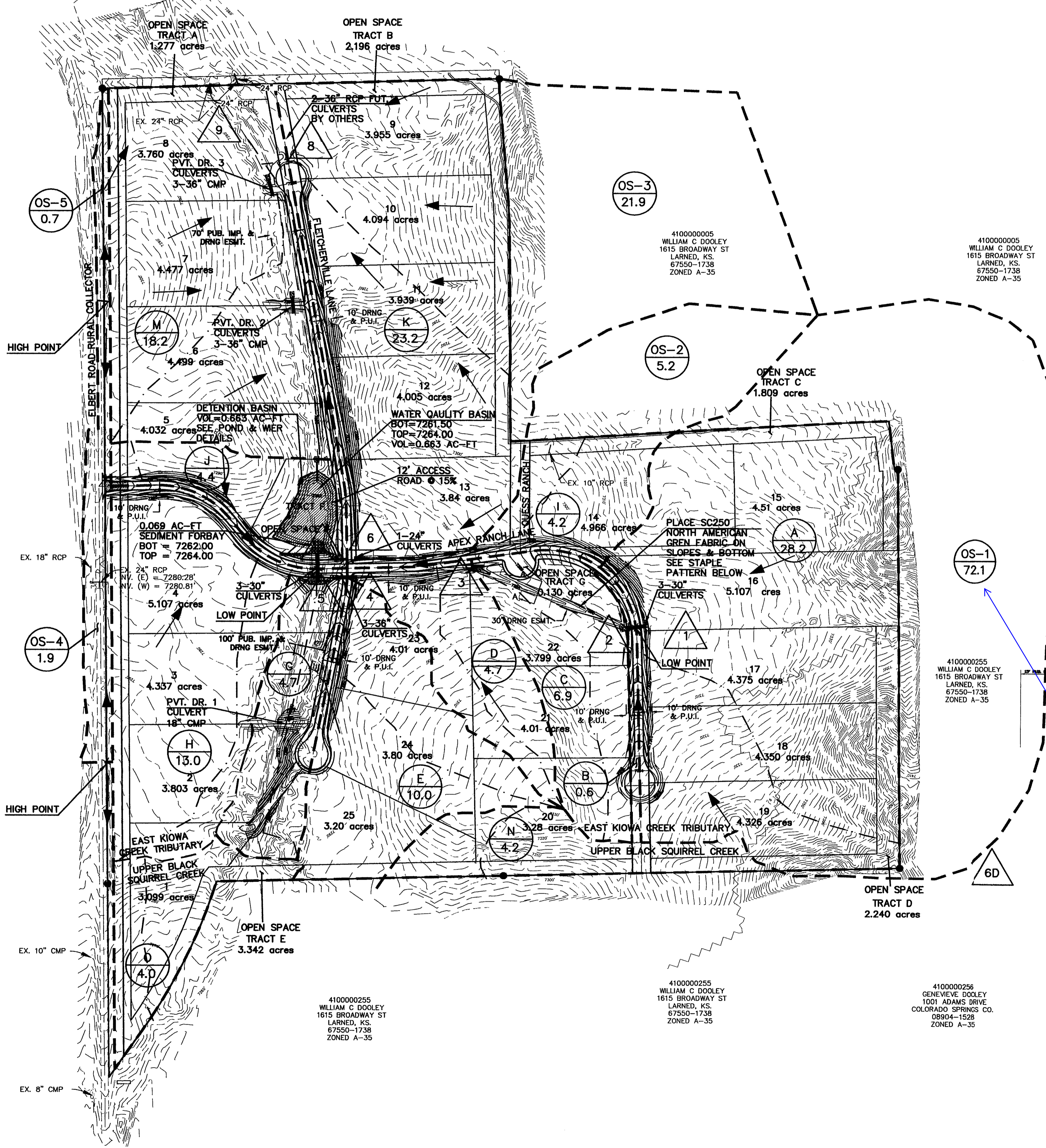
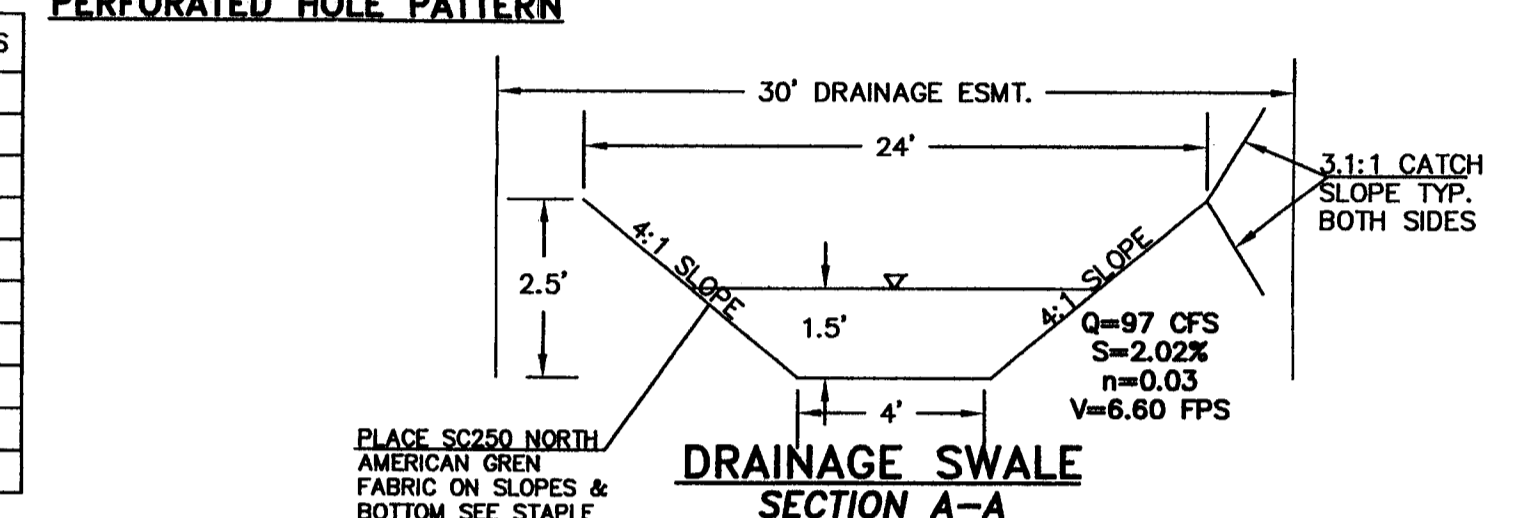

Provide excerpt of impervious values used for this basin

Impervious values are not provided in existing report. The only impervious values provided are those used in pond sizing.

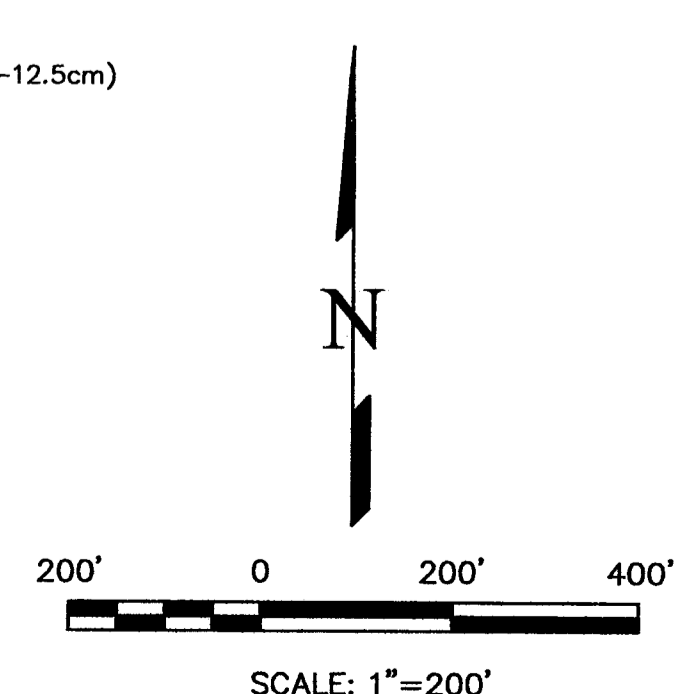
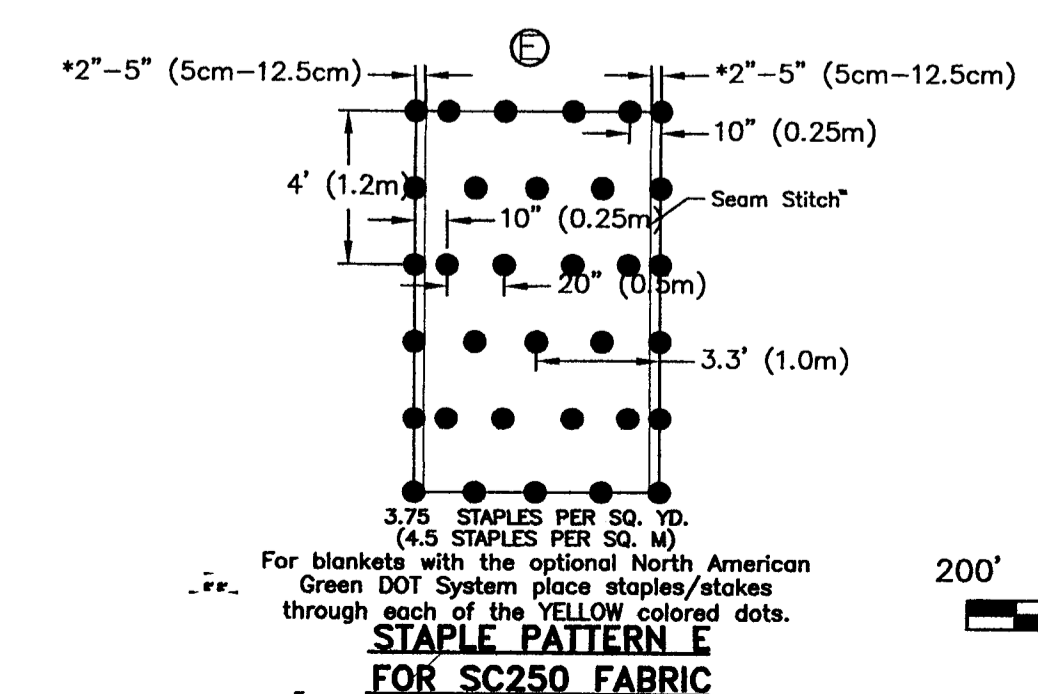

LEGEND

- EXISTING 10' CONTOUR
- EXISTING 2' CONTOUR
- PROPOSED 10' CONTOUR
- PROPOSED 2' CONTOUR
- PROPOSED CULVERT
- DIRECTION OF FLOW
- BASIN BOUNDARY
- TIME OF CONCENTRATION
- BASIN ID
- ACRES
- DESIGN POINT
- DETENTION AREA

DATE: 11/9/07
DESCRIPTION: REVISED PER COUNTY COMMENTS

REVISIONS:

UNTIL SUCH TIME AS THESE DRAWINGS ARE APPROVED BY THE APPROPRIATE TERRA NOVA ENGINEERING, INC. APPROVES THEIR USE ONLY FOR THE PURPOSES DESIGNATED BY WRITTEN AUTHORIZATION.

PREPARED FOR:
APEX RANCH ESTATES, LLC
ATTN: CRAIG MCCONNELL
P.O. BOX 267
PEYTON, COLORADO 80831

412200006
COLLEEN KRASOVICH
3650 GARRISON ST
WHEAT RIDGE, CO.
ZONED A-35

410000005
WILLIAM C DOOLEY
1615 BROADWAY ST
LARNED, KS.
67550-1738
ZONED A-35

410000005
WILLIAM C DOOLEY
1615 BROADWAY ST
LARNED, KS.
67550-1738
ZONED A-35

410000025
WILLIAM C DOOLEY
1615 BROADWAY ST
LARNED, KS.
67550-1738
ZONED A-35

410000025
GENEVEVE DOOLEY
1001 ADAMS DRIVE
COLORADO SPRINGS CO.
08904-1528
ZONED A-35

125 N. WAHSATCH AVE., SUITE 101
COLORADO SPRINGS, CO. 80903
OFFICE: 719-635-6422
FAX: 719-635-6426
www.tnainc.com

APEX RANCH ESTATES
FINAL DRAINAGE MAP
DEVELOPED CONDITIONS

DESIGNED BY QNA
DRAWN BY LAE
CHECKED BY LDR

H-SCALE 1"=200'
V-SCALE

JOB NO. 0565.00
DATE ISSUED 8/26/08
SHEET NO. 1 OF 1

APPENDIX G: DRAINAGE MAPS

THIS DOCUMENT, TOGETHER WITH THE CONCEPTS AND DESIGNS PRESENTED HEREIN, IS AN INSTRUMENT OF SERVICE. IT IS INTENDED ONLY FOR THE SPECIFIC PURPOSE AND CLIENT FOR WHICH IT WAS PREPARED. REUSE OF AND IMPROPER RELIANCE ON THIS DOCUMENT WITHOUT WRITTEN AUTHORIZATION AND ADAPTATION BY KIMLEY-HORN AND ASSOCIATES, INC. SHALL BE WITHOUT LIABILITY TO KIMLEY-HORN AND ASSOCIATES, INC.

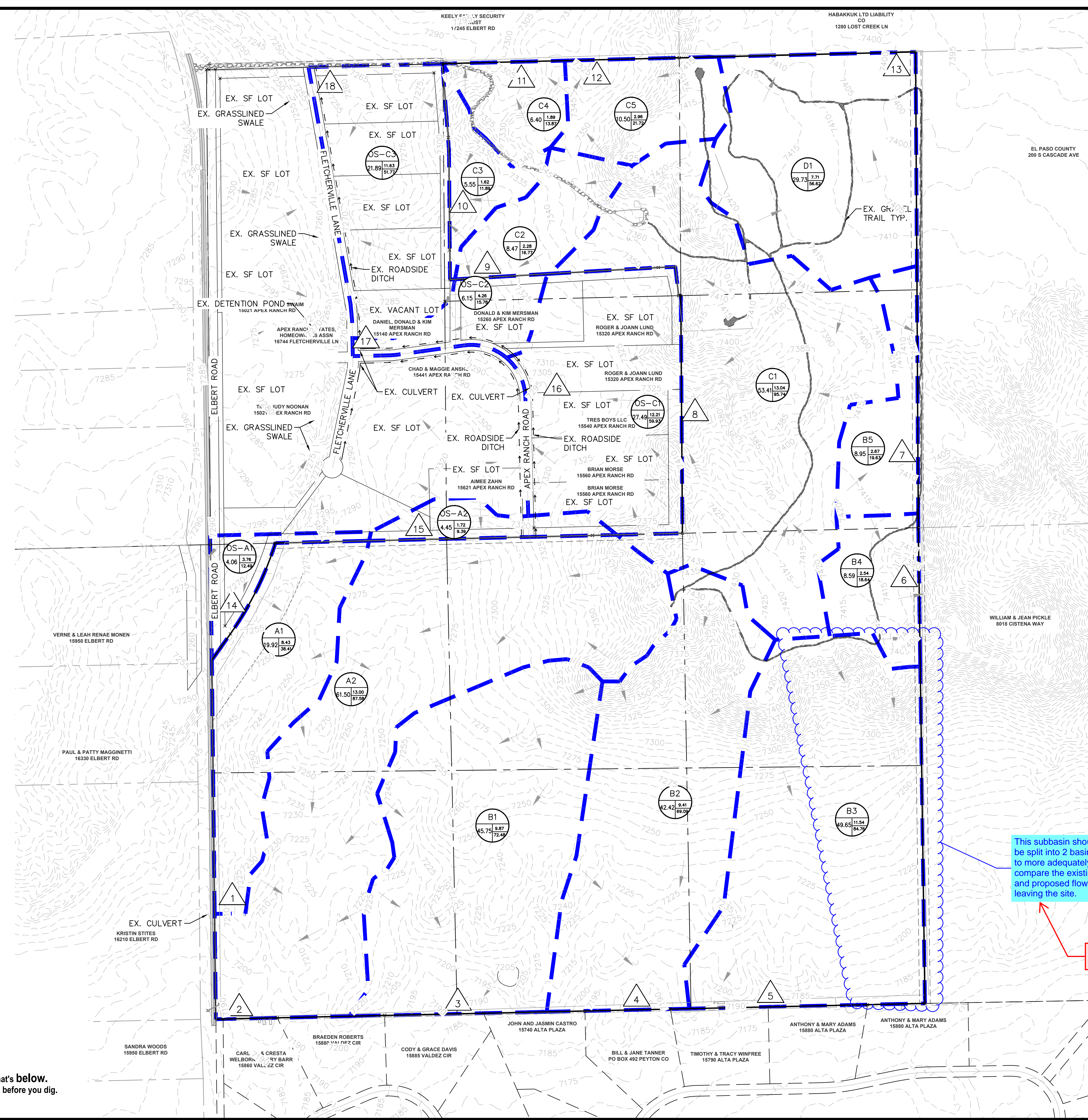

LEGEND

- A = BASIN DESIGNATION
- B = AREA (ACRES)
- C = BASIN IMPERVIOUSNESS
- D = 100YR DESIGN STORM RUNOFF (CFS)
- # = DESIGN POINT
- EXISTING FLOW DIRECTION
- PROPERTY LINE
- DRAINAGE BASIN BOUNDARY
- EXISTING MAJOR CONTOUR
- EXISTING MINOR CONTOUR

- A - Upper Black Squirrel Drainage Basin (CHBS2000)
- B - La Vega Ranch Drainage Basin (CHBR0400)
- C - East Kiowa Creek Drainage Basin (KIKI0400)
- D - Bijou Creek Drainage Basin (BIBI0200)

DESIGN POINT	TRIBUTARY BASINS	TRIBUTARY AREA (AC)	CFS			% IMPERVIOUS
			Q2	Q5	Q100	
PDR Basins						
1	A1	19.92	4.19	8.43	38.41	8%
2	A2	61.50	3.44	13.00	87.58	1%
3	B1	45.75	1.98	9.87	72.48	0%
4	B2	42.42	1.88	9.41	69.09	0%
5	B3	49.65	2.31	11.54	84.76	0%
6	B4	8.59	0.51	2.54	18.64	0%
7	B5	8.95	0.53	2.67	19.63	0%
8	C1	53.41	2.61	13.04	95.74	0%
9	C2	8.47	0.46	2.28	16.77	0%
10	C3	5.55	0.32	1.62	11.89	0%
11	C4	6.40	0.38	1.89	13.87	0%
12	C5	10.50	0.59	2.96	21.72	0%
13	D1	29.73	1.54	7.71	56.62	0%
14	OS-A1	4.06	2.36	3.76	12.49	19%
15	OS-A2	4.45	0.57	1.72	9.39	7%
16	OS-C1	27.49	4.90	12.21	59.93	9%
17	OS-C2	6.15	2.35	4.26	15.78	17%
18	OS-C3	21.89	5.33	11.63	51.77	11%
ON-SITE BASIN TOTAL		81.42	7.63	21.43	125.99	3%
BASIN A TOTAL		81.42	7.63	21.43	125.99	3%
BASIN B TOTAL		155.36	7.21	36.03	264.60	0%
BASIN C TOTAL		84.33	4.35	21.78	159.98	0%
BASIN D TOTAL		29.73	1.54	7.71	56.62	0%
ON-SITE TOTAL		350.84	20.73	86.96	607.18	1%
OFF-SITE BASIN TOTAL		8.51	2.93	5.48	21.87	13%
OFF-SITE BASIN A		8.51	2.93	5.48	21.87	13%
OFF-SITE BASIN C		55.53	12.58	28.11	127.48	11%
OFF-SITE TOTAL		64.04	15.52	33.59	149.36	11%
SITE TOTAL		414.88	36.25	120.55	756.54	2%

This subbasin should be split into 2 basins to more adequately compare the existing and proposed flows leaving the site.

Noted, sub-basin split to provide better clarity for comparison.

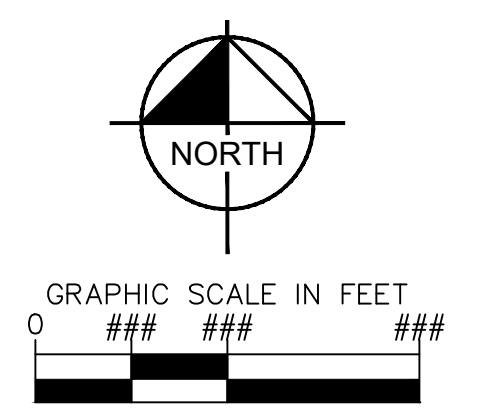

BY: DATE: APPR

NO. REVISION

C 2018 KIMLEY-HORN AND ASSOCIATES, INC.
4582 South Ulster Street, Suite 1500
Denver, Colorado 80237 (303) 228-2300

DESIGNED BY: XXX
DRAWN BY: XXX
CHECKED BY: XXX
DATE: XX/XX/XX

OVERLOOK FILING NO. 1
EL PASO COUNTY, COLORADO
PRELIMINARY DESIGN PLANS
EXISTING DRAINAGE MAP

PRELIMINARY
FOR REVIEW ONLY
NOT FOR
CONSTRUCTION

PROJECT NO.
196239003

SHEET
EX-1



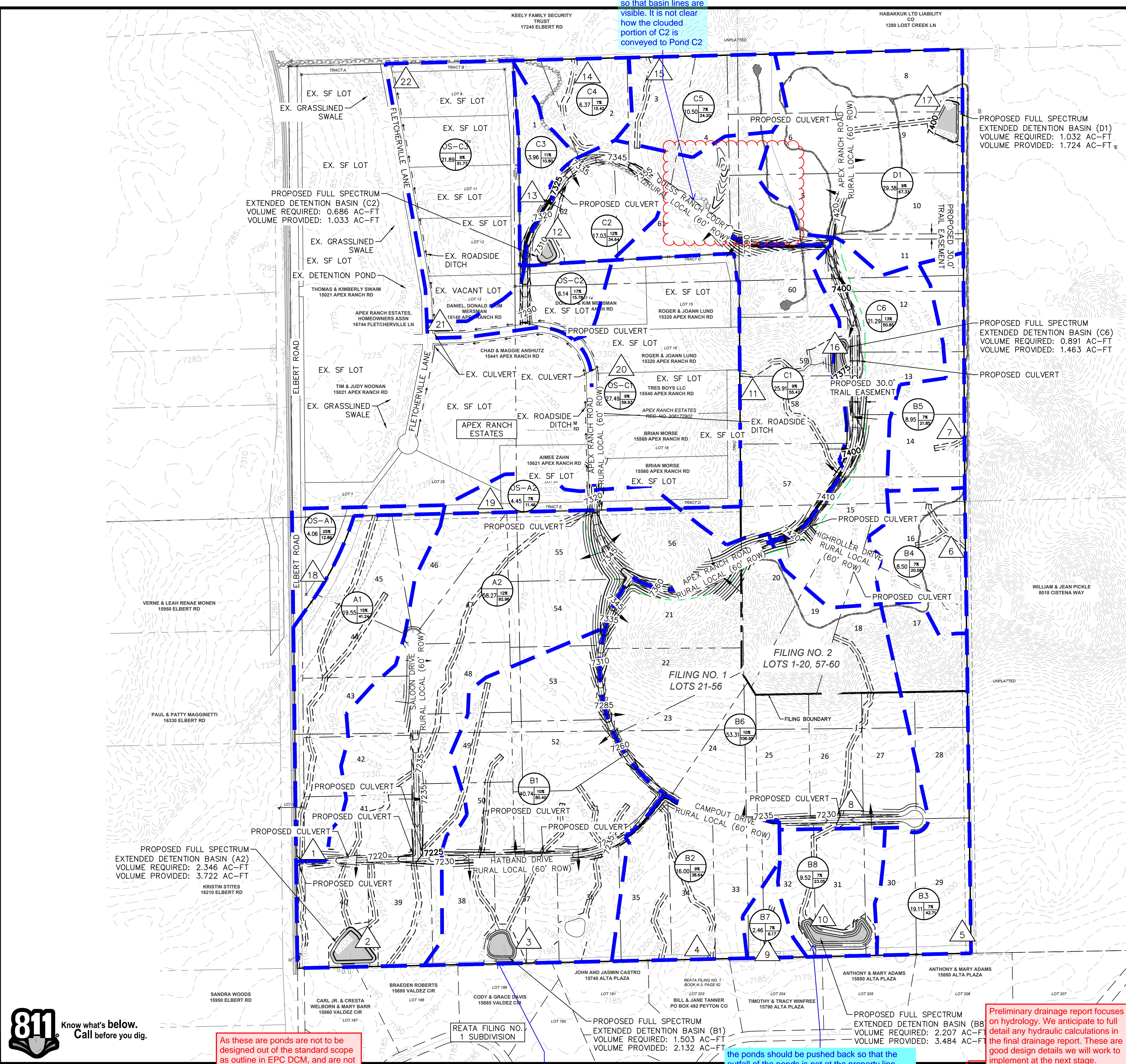



THIS DOCUMENT, TOGETHER WITH THE CONCEPTS AND DESIGNS PRESENTED HEREIN, AS AN INSTRUMENT OF SERVICE, IS INTENDED ONLY FOR THE SPECIFIC PURPOSE AND CLIENT FOR WHICH IT WAS PREPARED. REUSE OF AND IMPROPER RELIANCE ON THIS DOCUMENT WITHOUT WRITTEN AUTHORIZATION AND ADAPTATION BY KIMLEY-HORN AND ASSOCIATES, INC. SHALL BE WITHOUT LIABILITY TO KIMLEY-HORN AND ASSOCIATES, INC.

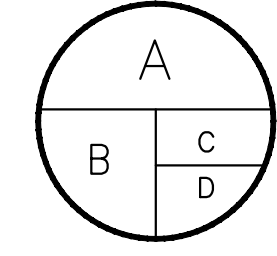
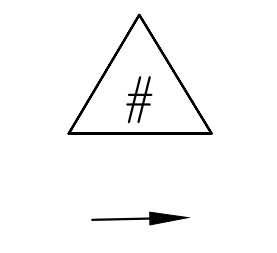
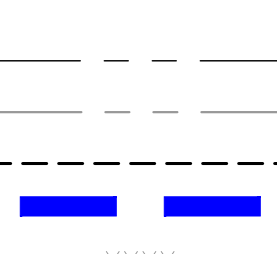
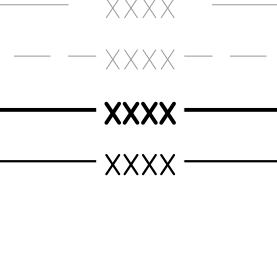
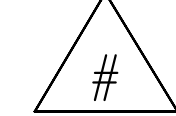
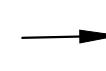
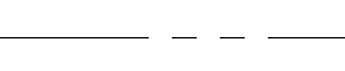

Text position adjusted

please relocate text so that basin lines are visible. It is not clear how the clouded portion of C2 is conveyed to Pond C2

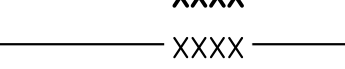
LEGEND

-  A = BASIN DESIGNATION
-  B = AREA (ACRES)
-  C = BASIN IMPERVIOUSNESS
-  D = 100YR DESIGN STORM RUNOFF (CFS)
-  # = DESIGN POINT
-  PROPOSED FLOW DIRECTION
-  PROPOSED PROPERTY LINE
-  EXISTING PROPERTY LINE
-  PROPOSED EASEMENT LINE
-  DRAINAGE BASIN BOUNDARY
-  EXISTING MAJOR CONTOUR
-  EXISTING MINOR CONTOUR
-  PROPOSED MAJOR CONTOUR
-  PROPOSED MINOR CONTOUR

EASEMENT NOTE

- ALL PROPOSED EASEMENTS ARE 30' DRAINAGE EASEMENTS UNLESS OTHERWISE NOTED

- A - Upper Branch Squirrel Drainage Basin (CHBS2000)
- B - La Vega Ranch Drainage Basin (CHBR0400)
- C - East Kiowa Creek Drainage Basin (KIKI0400)
- D - Bijou Creek Drainage Basin (BIBI0200)

PROPOSED CONDITIONS RATIONAL CALCULATIONS SUMMARY

DESIGN POINT	TRIBUTARY BASINS	TRIBUTARY AREA (AC)	CFS			% IMPERVIOUS
			Q2	Q5	Q100	
PDR Basins						
1	A1	19.55	5.41	10.41	41.24	15%
2	A2	58.27	9.71	20.99	92.96	12%
3	B1	40.74	6.97	16.77	80.40	10%
4	B2	16.00	3.10	7.82	38.64	9%
5	B3	19.11	2.61	7.83	42.71	7%
6	B4	8.50	1.25	3.77	20.58	7%
7	B5	8.95	1.33	4.01	21.85	7%
8	B6	53.31	9.52	22.55	106.95	10%
9	B7	2.46	0.38	1.13	6.17	7%
10	B8	9.52	1.41	4.22	23.05	7%
11	C1	25.91	4.42	11.18	55.47	9%
12	C2	17.03	3.87	8.08	34.64	12%
13	C3	3.96	1.04	2.36	10.80	11%
14	C4	6.37	0.94	2.83	15.42	7%
15	C5	10.50	1.48	4.44	24.20	7%
16	C6	21.29	6.09	12.27	50.85	13%
17	D1	29.38	5.34	13.56	67.33	9%
18	OS-A1	4.06	2.57	4.12	12.86	25%
19	OS-A2	4.45	0.70	2.10	11.46	7%
20	OS-C1	27.49	4.90	12.21	59.93	9%
21	OS-C2	6.15	2.35	4.26	15.78	17%
22	OS-C3	21.89	5.33	11.63	51.77	11%
ON-SITE BASIN TOTAL						
BASIN A TOTAL		77.82	15.12	31.40	134.20	12%
BASIN B TOTAL		158.59	26.57	68.09	340.34	8%
BASIN C TOTAL		85.06	17.84	41.15	191.38	10%
BASIN D TOTAL		29.38	4.90	12.21	59.93	9%
ON-SITE TOTAL		350.85	49.75	122.80	599.06	10%
OFF-SITE BASIN TOTAL						
OFF-SITE BASIN A		8.51	3.27	6.22	24.32	15%
OFF-SITE BASIN C		55.53	12.58	28.11	127.48	11%
OFF-SITE TOTAL		64.04	15.85	34.33	151.80	12%
SITE TOTAL		414.89	65.60	157.13	750.86	10%

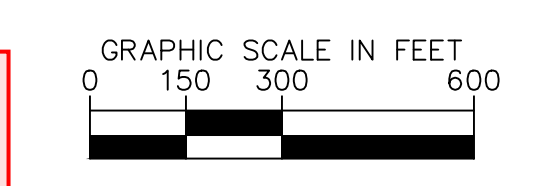
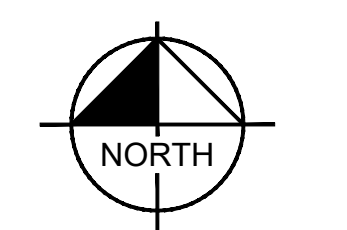

As these are ponds are not to be designed out of the standard scope as outline in EPC DCM, and are not planned on being state jurisdictional dams, thus we anticipate that state breach analysis should not be required. Preliminary drainage report focuses on hydrology. We anticipate to full detail any hydraulic calculations in the final drainage report.

Please contact the state regarding the location of these ponds. A breach analysis may be required due to the proximity of the down stream residences.

The ponds should be pushed back so that the outfall of the ponds is not at the property line point discharging. The flow leaving the site shall meet the quantity and manner. Downstream easements may be necessary. Refer to project SF231 Hillside at Lorson Ranch where a similar situation is addressed by pushing the ponds further back and level spreaders are used to match historic outfalls.

Preliminary drainage report focuses on hydrology. We anticipate to full detail any hydraulic calculations in the final drainage report. These are good design details we will work to implement at the next stage. Specific pond location and outfall location are to be designed in detail in final drainage report. Ponds release rates are to be designed less than historic conditions.

NO.
REVISION
BY
DATE



C 2018 KIMLEY-HORN AND ASSOCIATES, INC.
4882 South Ulster Street, Suite 1500
Denver, Colorado 80237 (303) 228-2300

DESIGNED BY: XXX
DRAWN BY: XXX
CHECKED BY: XXX
DATE: XX/XX/XX

OVERLOOK FILING NO. 1
EL PASO COUNTY, COLORADO

PRELIMINARY DESIGN PLANS
PROPOSED DRAINAGE MAP

PRELIMINARY
FOR REVIEW ONLY
NOT FOR CONSTRUCTION

Kimley-Horn and Associates, Inc.

PROJECT NO. 196239003

SHEET

EX-2

THIS DOCUMENT, TOGETHER WITH THE CONCEPTS AND DESIGNS PRESENTED HEREIN, AS AN INSTRUMENT OF SERVICE, IS INTENDED ONLY FOR THE SPECIFIC PURPOSE AND CLIENT FOR WHICH IT WAS PREPARED. REUSE OF AND IMPROPER RELEASE ON THIS DOCUMENT WITHOUT WRITTEN AUTHORIZATION AND ADAPTATION BY KIMLEY-HORN AND ASSOCIATES, INC. SHALL BE WITHOUT LIABILITY TO KIMLEY-HORN AND ASSOCIATES, INC.

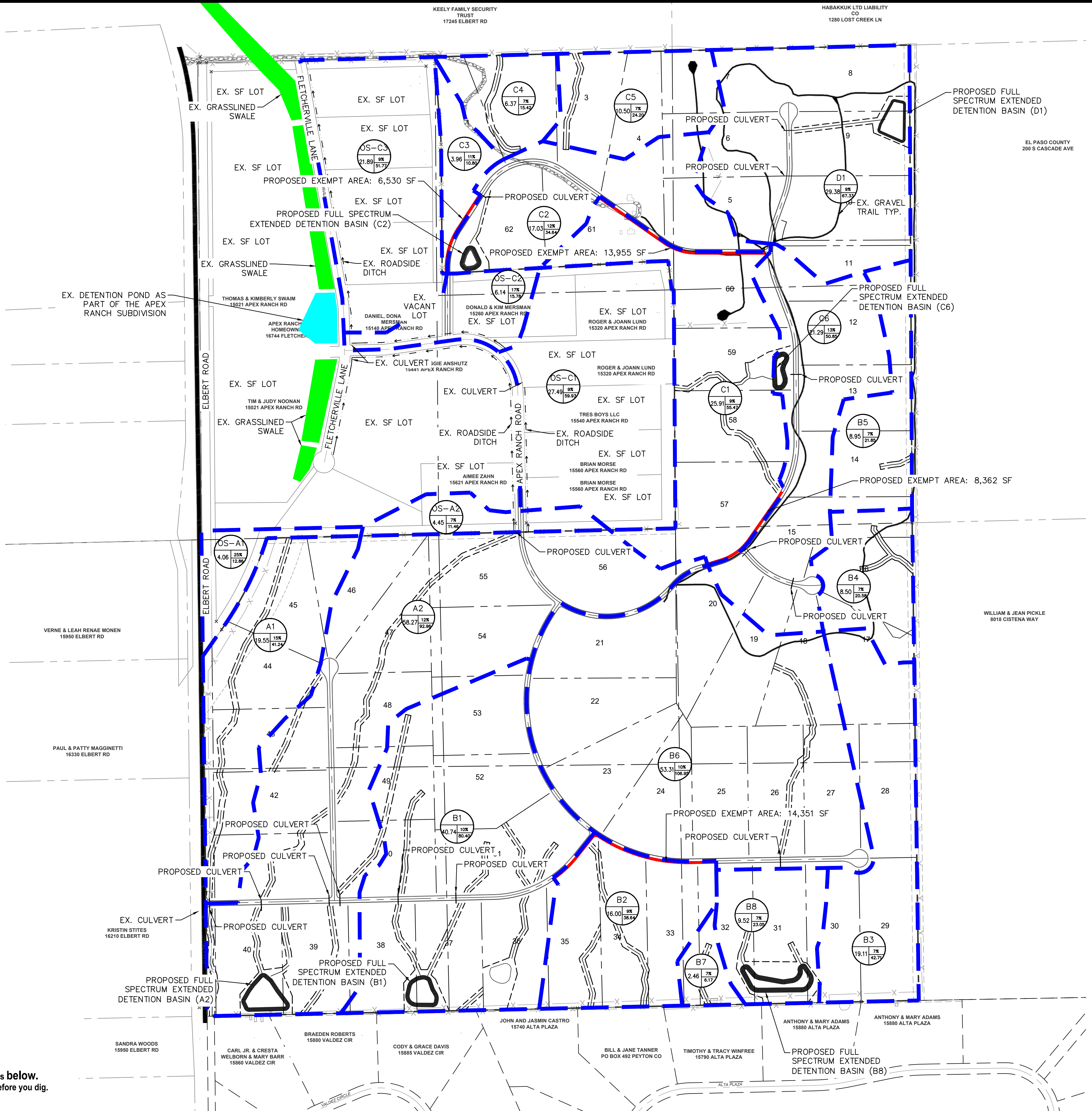

LEGEND

- | | |
|--|-------------------------------------|
| | A = BASIN DESIGNATION |
| | B = AREA (ACRES) |
| | C = BASIN IMPERVIOUSNESS |
| | D = 100YR DESIGN STORM RUNOFF (CFS) |
| | PROPOSED PROPERTY LINE |
| | EXISTING PROPERTY LINE |
| | PROPOSED EASEMENT LINE |
| | DRAINAGE BASIN BOUNDARY |
| | EXISTING STORMWATER POND |
| | EXISTING GRASSLINED DRAINAGE SWALE |
| | PROPOSED EXEMPT AREA |

EASEMENT NOTE

1. ALL PROPOSED EASEMENTS ARE 30' DRAINAGE EASEMENTS UNLESS OTHERWISE NOTED

EXEMPT AREAS

BASIN B2	= ±14,351 SF
BASIN C1	= ±22,316 SF
BASIN C3	= ±6,530 SF
TOTAL	= ±43,197 SF (0.99 ACRES)

Please add the exclusion number for this (ECM App I.7.1.C.1)

Exclusion number added to table.

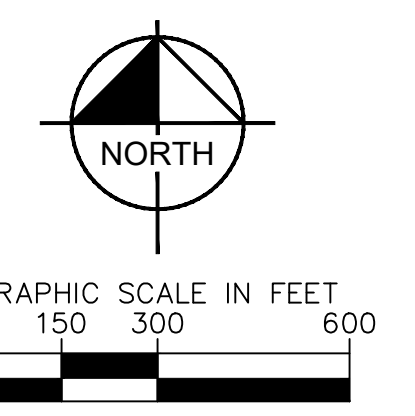

NO.	REVISION	BY	DATE	APPR

Kimley»Horn
 C 2018 KIMLEY-HORN AND ASSOCIATES, INC.
 4582 South Ulster Street, Suite 1500
 Denver, Colorado 80237 (303) 228-2300

DESIGNED BY: XXX
 DRAWN BY: XXX
 CHECKED BY: XXX
 DATE: XX/XX/XX

OVERLOOK FILING NO. 1
 EL PASO COUNTY, COLORADO
 PRELIMINARY DESIGN PLANS
EXCLUSION EXHIBIT DRAINAGE MAP

PRELIMINARY
 FOR REVIEW ONLY
 NOT FOR
 CONSTRUCTION

 Kimley-Horn and Associates, Inc.

PROJECT NO.
196239003
 SHEET
EX-3