

**PRIVATE STORMWATER FACILITY
MAINTENANCE AGREEMENT AND EASEMENT**

This PRIVATE STORMWATER FACILITY MAINTENANCE AGREEMENT AND EASEMENT (Agreement) is made by and between EL PASO COUNTY by and through THE BOARD OF COUNTY COMMISSIONERS OF EL PASO COUNTY, COLORADO (County) and GORILLA CAPITAL CO SADDLEHORN RANCH, LLC (Developer) and SADDLEHORN RANCH METROPOLITAN DISTRICT NO. 1 (Metro District), a quasi-municipal corporation and political subdivision of the State of Colorado. The above may occasionally be referred to herein singularly as “Party” and collectively as “Parties.”

Recitals

A. WHEREAS, the Metro District provides various municipal services to certain real property in El Paso County, Colorado referred to as SADDLEHORN RANCH; and

B. WHEREAS, Developer is the owner of certain real estate (the Subject Property) in El Paso County, Colorado, which Property is legally described in Exhibit A attached hereto and incorporated herein by this reference; and

C. WHEREAS, Developer desires to plat and develop on the Subject Property a Subdivision to be known as SADDLEHORN RANCH FILING NO. 1 (the Development); and

D. WHEREAS, the development of the Subject Property will materially increase the volume and decrease the quality of stormwater runoff from the Property; therefore, it is in the best interest of the public health, safety and welfare for the County to condition approval of this Development on Developer’s promise to construct adequate stormwater control facilities including permanent stormwater quality structural Best Management Practices (“BMPs”) for the Development; and

E. WHEREAS, the El Paso County Land Development Code, as periodically amended, requires the construction and maintenance of detention ponds and other drainage facilities adequate to maintain historic stormwater flow patterns, protect natural and man-made drainage conveyances, and prevent property damage in connection with land development and subdivisions, and further requires that developers enter into maintenance agreements and easements with the County for such drainage facilities; and

F. WHEREAS, the El Paso County Drainage Criteria Manual, Volume 2, as amended by Appendix I of the El Paso County Engineering Criteria Manual (ECM), as each may be periodically amended, promulgated pursuant to the County’s Colorado Discharge Permit System General Permit (MS4 Permit), which MS4 Permit requires that the County take measures to protect the quality of stormwater from sediment and other contaminants, requires subdividers, developers, landowners, and owners of facilities located in the County’s rights-of-way or easements to provide adequate permanent stormwater quality facilities and BMPs with new development or significant redevelopment and to enter into maintenance agreements and easements with the County for such facilities and BMPs; and

G. WHEREAS, Section 2.9 of the El Paso County Drainage Criteria Manual, Volume I provides for a developer's promise to maintain a development's drainage facilities in the event the County does not assume such responsibility; and

H. WHEREAS, Developer desires to construct for the Development drainage conveyance facilities, detention basins, stormwater control measures, and/or permanent stormwater quality BMPs (collectively, "Stormwater Facilities") as the means for providing adequate drainage and stormwater runoff control and to meet the requirements of the County's MS4 Permit, and to operate, clean, maintain and repair such Stormwater Facilities; and

I. WHEREAS, Developer desires to construct the Stormwater Facilities on property as set forth on Exhibit B attached hereto and incorporated herein by this reference (the Stormwater Facilities Area); and

J. WHEREAS, Developer shall be charged with the duty of constructing the Stormwater Facilities and the Metro District shall be charged with the duties of operating, maintaining and repairing the Stormwater Facilities and any appurtenant improvements on the property described in Exhibit B; and

K. WHEREAS, the County, in order to protect the public health, safety and welfare, desires the means to access, construct, maintain, and repair the Stormwater Facilities and to recover its costs incurred in connection therewith in the event the Developer or District fails to meet their obligations to do the same; and

L. WHEREAS, the County conditions approval of this Development on the Developer's promise to construct the Stormwater Facilities, and further conditions approval on the Metro District's promise to clean, maintain and repair the Stormwater Facilities, and on the Metro District's promise to reimburse the County in the event the burden falls upon the County to construct, clean, maintain or repair the Stormwater Facilities serving this Development; and

M. WHEREAS, the County, in order to secure performance of the promises contained herein, conditions approval of this Development upon Developer's grant herein of a perpetual Easement over the Stormwater Facilities Area as described in Exhibit B for the purpose of allowing the Metro District access to construct, upgrade, clean, maintain and/or repair the Stormwater Facilities, and allowing the County to periodically access and inspect the Stormwater Facilities and, when necessary, to construct, clean, maintain or repair the Stormwater Facilities; and

N. WHEREAS, Pursuant to Colorado Constitution, Article XIV, Section 18(2) and Section 29-1-203, Colorado Revised Statutes, governmental entities may cooperate and contract with each other to provide any function, services, or facilities lawfully authorized to each.

Agreement

NOW, THEREFORE, in consideration of the mutual Promises contained herein, the sufficiency of which are hereby acknowledged, the Parties agree as follows:

1. Incorporation of Recitals: The Parties incorporate the Recitals above into this Agreement.

2. Covenants Running with the Land: Developer agrees that this entire Agreement and the performance thereof shall become a covenant running with the land, which land is legally described in Exhibit A attached hereto, and that this entire Agreement and the performance thereof shall be binding upon itself and its successors and assigns.

3. Construction: Developer shall construct the following Stormwater Facilities on the Stormwater Facilities Area described in Exhibit B: Stormwater Detention Basin I on portions of Lots 12 and 13, Stormwater Detention Basin H on a portion of Lot 20, Stormwater Detention Basin G on portions of Lots 37 and 38, and portions of Drainageway T-6 on portions of Tracts B and C. Developer shall not commence construction of the Stormwater Facilities until the El Paso County Planning and Community Development Department (PCD) has approved in writing the plans and specifications for the Stormwater Facilities and this Agreement has been signed by all Parties and returned to the PCD. Developer shall complete construction of the Stormwater Facilities in substantial compliance with the County-approved plans and specifications for the Stormwater Facilities and shall provide certification from a Colorado registered Professional Engineer that the Stormwater Facilities were constructed in compliance with and provide the volume and capacity required by such plans and specifications in accordance with ECM requirements. Failure to meet these requirements shall be a material breach of this Agreement and shall entitle the County to pursue any remedies available to it at law or in equity to enforce the same. Construction of the Stormwater Facilities shall be substantially completed within one (1) year (defined as 365 days), which one-year period will commence to run on the date the Erosion and Stormwater Quality Control Permit (ESQCP) and associated Construction Permit are issued. Rough grading of the permanent stormwater BMP facilities must be completed and inspected by the PCD prior to commencing road construction, and water quality capture volume (WQCV) outlet control structures must be substantially complete prior to paving roads or parking areas.

In the event construction of the Stormwater Facilities is not substantially completed within the one (1) year period, or if the Development is in violation of its ESQCP terms and conditions and Developer has not made an effort to remedy the violation in a reasonable amount of time as determined by the County, then the County may exercise its discretion to complete the Stormwater Facilities and shall have the right to seek reimbursement from the Developer and its respective successors and assigns for its actual costs and expenses incurred in the process of completing construction.

4. Maintenance of Stormwater Facilities: The Developer and the Metro District agree for themselves and their respective successors and assigns that they will regularly and routinely inspect, clean and maintain the Stormwater Facilities in compliance with the County-

reviewed Operation and Maintenance Manual, attached hereto and incorporated herein by this reference as Exhibit C, and otherwise keep the same in good repair, all at their own cost and expense. No trees or shrubs that will impair the structural integrity of the Stormwater Facilities shall be planted or allowed to grow within or adjacent to the Stormwater Facilities.

The Developer and the Metro District agree and covenant, for themselves and their respective successors and assigns, that they will maintain and properly manage the grasses and other vegetation in the Stormwater Facility Areas in compliance with the “Routine Maintenance Activities” specified in Exhibit D and other requirements or conditions of approval.

5. Creation of Easements: Developer hereby grants the County and the Metro District a non-exclusive perpetual easement upon and across the property described in Exhibit B. The purpose of the easement is to allow the County and the Metro District to access, inspect, clean, repair and maintain the Stormwater Facilities; however, the creation of the easement does not expressly or implicitly impose on the County a duty to so inspect, clean, repair or maintain the Stormwater Facilities or any appurtenant improvements.

6. County’s Rights and Obligations: Any time the County determines, in the sole exercise of its discretion, that the Stormwater Facilities have not been properly cleaned, maintained, or otherwise kept in good repair, the County shall give reasonable notice of such to the responsible Party and its successors and assigns. The notice shall provide a reasonable time to correct the problems. Should the responsible Parties fail to correct the specified problems, the County may enter upon the properties described in Exhibit B to perform the needed work and shall have the right to seek reimbursement from the responsible Parties for its actual costs and expenses in performing the work. Notice shall be effective to the above by the County’s deposit of the same into the regular United States mail, postage pre-paid. Notwithstanding the foregoing, this Agreement does not expressly or implicitly impose on the County a duty to inspect, construct, clean, repair or maintain the Stormwater Facilities.

7. Actual Costs and Expenses: The Developer and the Metro District agree and covenant, for themselves and their successors and assigns, that they will reimburse the County for its actual costs and expenses incurred in the process of completing construction of, cleaning, maintaining, or repairing the Stormwater Facilities or vegetated areas pursuant to the provisions of this Agreement.

The term “actual costs and expenses” as used in this Agreement shall be liberally construed in favor of the County, and shall include, but shall not be limited to, labor costs, tools and equipment costs, supply costs, engineering and design costs, and costs to contract with specialized professionals or consultants, including but not limited to wetlands scientists, regardless of whether the County uses its own personnel, tools, equipment and supplies, etc. to perform the work. In the event the County initiates any litigation or engages the services of legal counsel in order to enforce the provisions arising herein, the County shall be entitled to its damages and costs, including reasonable attorney’s fees, regardless of whether the County contracts with outside legal counsel or utilizes in-house legal counsel for the same.

8. Contingencies of Land Use/Land Disturbance Approval: Developer's and the Metro District's execution of this Agreement is a condition of subdivision, land use, or land disturbance approval. Additional conditions of this Agreement include, but are not limited to, the following:

- a. Conveyance of Tracts B and C from Developer to the Metro District (which will include a reservation of easement in favor of the County for purposes of accessing, inspecting, cleaning, maintaining, and repairing the Stormwater Facilities), and recording of the Deed for the same; and
- b. [Reserved]

The County shall have the right, in the sole exercise of its discretion, to approve or disapprove any documentation submitted to it under the conditions of this Paragraph, including but not limited to, any separate agreement or amendment, if applicable, identifying any specific maintenance responsibilities not addressed herein. The County's rejection of any documentation submitted hereunder shall mean that the appropriate condition of this Agreement has not been fulfilled.

9. Agreement Monitored by El Paso County Planning and Community Development Department and/or El Paso County Department of Public Works: Any and all actions and decisions to be made hereunder by the County shall be made by the Executive Director of the El Paso County Planning and Community Development Department and/or the Executive Director of the El Paso County Department of Public Works. Accordingly, any and all documents, submissions, plan approvals, inspections, etc. shall be submitted to and shall be made by the Executive Director of the Planning and Community Development Department and/or the Executive Director of the El Paso County Department of Public Works.

10. Indemnification and Hold Harmless: Developer and the Metro District agree, for themselves, their successors and assigns, that they will indemnify, defend, and hold the County harmless from any and all loss, costs, damage, injury, liability, claim, lien, demand, action and causes of action whatsoever, whether at law or in equity, arising from or related to their intentional or negligent acts, errors or omissions or that of their agents, officers, servants, employees, invitees and licensees in the construction, operation, inspection, cleaning (including analyzing and disposing of any solid or hazardous wastes as defined by State and/or Federal environmental laws and regulations), maintenance, and repair of the Stormwater Facilities and such obligation arising under this Paragraph shall be joint and several. Nothing in this Paragraph shall be deemed to waive or otherwise limit the defense available to the County pursuant to the Colorado Governmental Immunity Act, Sections 24-10-101, *et seq.* C.R.S., or as otherwise provided by law.

11. Severability: In the event any Court of competent jurisdiction declares any part of this Agreement to be unenforceable, such declaration shall not affect the enforceability of the remaining parts of this Agreement.

12. Third Parties: This Agreement does not and shall not be deemed to confer upon or grant to any third party any right to claim damages or to bring any lawsuit, action or other

proceeding against the County, the Developer, the Metro District, or their respective successors and assigns, because of any breach hereof or because of any terms, covenants, agreements or conditions contained herein.

13. Solid Waste or Hazardous Materials: Should any refuse from the Stormwater Facilities be suspected or identified as solid waste or petroleum products, hazardous substances or hazardous materials (collectively referred to herein as “hazardous materials”), the Developer and the Metro District shall take all necessary and proper steps to characterize the solid waste or hazardous materials and properly dispose of it in accordance with applicable State and/or Federal environmental laws and regulations, including, but not limited to, the following: Solid Wastes Disposal Sites and Facilities Acts, §§ 30-20-100.5 – 30-20-119, C.R.S., Colorado Regulations Pertaining to Solid Waste Disposal Sites and Facilities, 6 C.C.R. 1007-2, *et seq.*, Solid Waste Disposal Act, 42 U.S.C. §§ 6901-6992k, and Federal Solid Waste Regulations 40 CFR Ch. I. The County shall not be responsible or liable for identifying, characterizing, cleaning up, or disposing of such solid waste or hazardous materials. Notwithstanding the previous sentence, should any refuse cleaned up and disposed of by the County be determined to be solid waste or hazardous materials, the Developer and the Metro District, but not the County, shall be responsible and liable as the owner, generator, and/or transporter of said solid waste or hazardous materials.

14. Applicable Law and Venue: The laws, rules, and regulations of the State of Colorado and El Paso County shall be applicable in the enforcement, interpretation, and execution of this Agreement, except that Federal law may be applicable regarding solid waste or hazardous materials. Venue shall be in the El Paso County District Court.

15. Limitation on Developer’s Obligation and Liability: The obligation and liability of the Developer hereunder shall only continue until such time as the Final Plat as described in the third paragraph (Paragraph C) of the Recitals set forth above is recorded (if applicable) and the Developer completes the construction of the Stormwater Facilities and transfers all applicable maintenance and operation responsibilities to the Metro District. By execution of this agreement, the Metro District agrees to accept all responsibilities and to perform all duties assigned to it, including those of the Developer, as specified herein, upon transfer of maintenance responsibilities for the Stormwater Facilities from Developer to the Metro District.

[Remainder of page intentionally left blank]

IN WITNESS WHEREOF, the Parties affix their signatures below.

Executed this 10 day of April, 2021, by:

GORILLA CAPITAL CO SADDLEHORN RANCH, LLC

By: [Signature]
JOHN HELMICK,

The foregoing instrument was acknowledged before me this 10 day of April, 2021, by John Helmick as President of GORILLA CAPITAL CO SADDLEHORN RANCH, LLC

Witness my hand and official seal.

My commission expires: 1/20/24

[Signature]
Notary Public Jessica Purdy

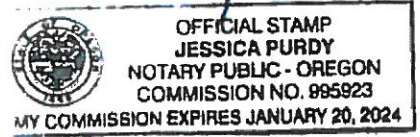

Executed this 6th day of May, 2021, by:

SADDLEHORN RANCH METROPOLITAN DISTRICT

By: [Signature]
Bill Guman, President

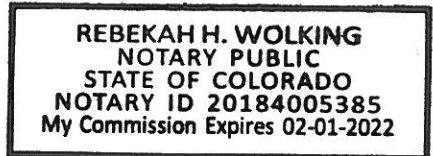

Attest:
By: [Signature]
Michael Bramlett, Treasurer

The foregoing instrument was acknowledged before me this 6th day of May, 2021, by Bill Guman as President of SADDLEHORN RANCH METROPOLITAN DISTRICT

Witness my hand and official seal.

My commission expires: 2-1-2022

[Signature]
Notary Public

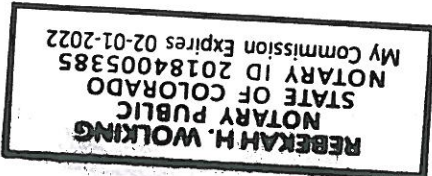

Executed this _____ day of _____, 20____, by:

BOARD OF COUNTY COMMISSIONERS
OF EL PASO COUNTY, COLORADO

By: _____

Craig Dossey, Executive Director
Planning and Community Development Department
Authorized Signatory pursuant to LDC

The foregoing instrument was acknowledged before me this _____ day of _____, 20____, by _____, Executive Director, Planning and Community Development Department.

Witness my hand and official seal.

My commission expires: _____

Notary Public

Approved as to Content and Form:

Assistant County Attorney

EXHIBIT A
Subject Property
SADDLEHORN RANCH Filing No. 1

A PARCEL OF LAND LOCATED IN THE SOUTH HALF OF SECTION 3 AND THE NORTH HALF OF THE NORTH HALF OF SECTION 10, TOWNSHIP 13 SOUTH, RANGE 64 WEST OF THE 6TH P.M., COUNTY OF EL PASO, STATE OF COLORADO, BEING MORE PARTICULARLY DESCRIBED AS FOLLOWS:

BEGINNING AT THE SOUTHWEST CORNER OF SECTION 3, TOWNSHIP 13 SOUTH, RANGE 64 WEST OF THE 6TH PRINCIPAL MERIDIAN;

THENCE ON THE WEST LINE OF OF SAID SECTION 3, N00°32'28"W A DISTANCE OF 1987.87 FEET;

THENCE DEPARTING SAID WEST LINE, THE FOLLOWING TWENTY-TWO (22) COURSES:

1. N89°27'32"E A DISTANCE OF 72.00 FEET;
2. S68°03'22"E A DISTANCE OF 227.58 FEET;
3. S53°08'37"E A DISTANCE OF 71.78 FEET;
4. S32°24'01"E A DISTANCE OF 240.57 FEET;
5. S24°10'40"E A DISTANCE OF 207.55 FEET;
6. S33°50'17"E A DISTANCE OF 610.26 FEET;
7. N63°48'26"E A DISTANCE OF 1002.65 FEET;
8. N42°34'07"E A DISTANCE OF 60.00 FEET, TO THE POINT OF A NON-TANGENT CURVE;
9. ON THE ARC OF A CURVE TO THE RIGHT WHOSE CENTER BEARS S42°34'07"W, HAVING A RADIUS OF 1680.00 FEET, A CENTRAL ANGLE OF 05°10'02" AND AN ARC LENGTH OF 151.51 FEET, TO A POINT OF NON-TANGENT;
10. N42°31'10"E A DISTANCE OF 422.77 FEET;
11. S56°30'41"E A DISTANCE OF 35.01 FEET;
12. S44°25'17"E A DISTANCE OF 280.03 FEET;
13. S26°10'49"E A DISTANCE OF 266.32 FEET;
14. S21°16'04"E A DISTANCE OF 343.92 FEET;
15. S16°11'46"E A DISTANCE OF 261.98 FEET;
16. S16°11'46"E A DISTANCE OF 257.34 FEET;
17. THENCE S05°58'59"E A DISTANCE OF 349.19 FEET;
18. THENCE S00°00'00"E A DISTANCE OF 964.76 FEET;
19. THENCE N89°34'03"E A DISTANCE OF 197.98 FEET;
20. N89°34'03"E A DISTANCE OF 197.98 FEET, TO A POINT OF CURVE;
21. ON THE ARC OF A CURVE TO THE LEFT, HAVING A RADIUS OF 170.00 FEET, A CENTRAL ANGLE OF 19°02'46" AND AN ARC LENGTH OF 56.51 FEET, TO A POINT OF NON-TANGENT;
22. S49°37'00"W A DISTANCE OF 565.01 FEET, TO A POINT ON THE SOUTH LINE OF THE NORTH HALF OF THE NORTHEAST QUARTER OF SECTION 10, TOWNSHIP 13 SOUTH, RANGE 64 WEST OF THE 6TH PRINCIPAL MERIDIAN;

THENCE ON SAID SOUTH LINE, S89°34'01"W A DISTANCE OF 900.39 FEET, TO THE SOUTHWEST CORNER OF THE NORTH HALF OF THE NORTHEAST QUARTER OF SAID SECTION 10;

THENCE ON THE SOUTH LINE OF THE NORTH HALF OF THE NORTHWEST QUARTER OF SAID SECTION 10, S89°34'07"W A DISTANCE OF 2642.73 FEET, TO A POINT ON THE WEST LINE OF THE NORTH HALF OF THE NORTHWEST QUARTER OF SAID SECTION 10;

THENCE ON SAID WEST LINE, N00°05'54"E A DISTANCE OF 1319.14 FEET, TO THE POINT OF BEGINNING;

CONTAINING A CALCULATED AREA OF 7,753,314 SQUARE FEET OR 177.9916 ACRES.

EXHIBIT B

Stormwater Facilities Areas

Tract B, Tract C, and the portions of Lots 12, 13, 20, 37, and 38 shown as drainage easements as indicated on the Saddlehorn Ranch Filing No. 1 Final Plat

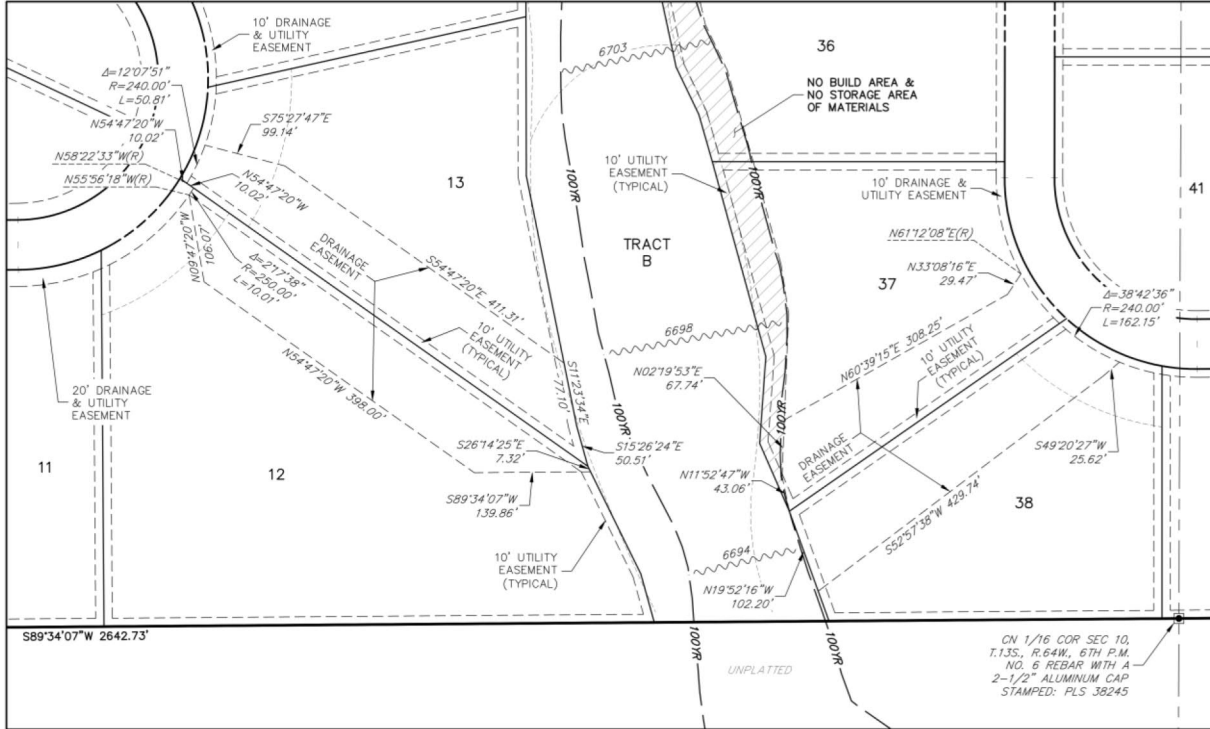

DETAIL B

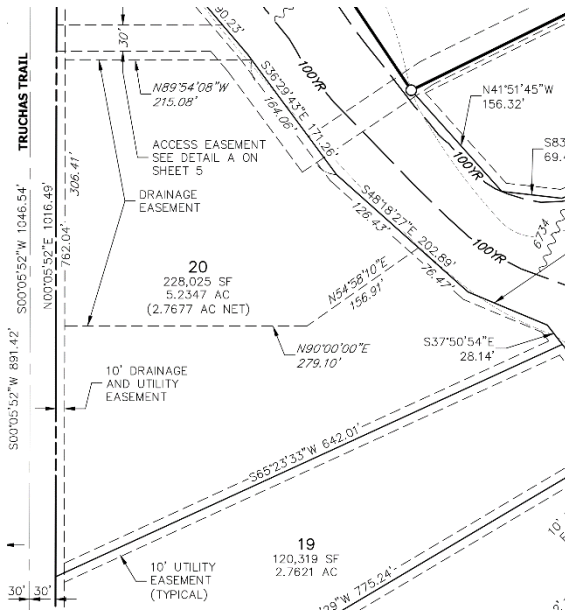

SADDLEHORN RANCH - FILING 1

PERMANENT BMP APPLICABILITY MAP

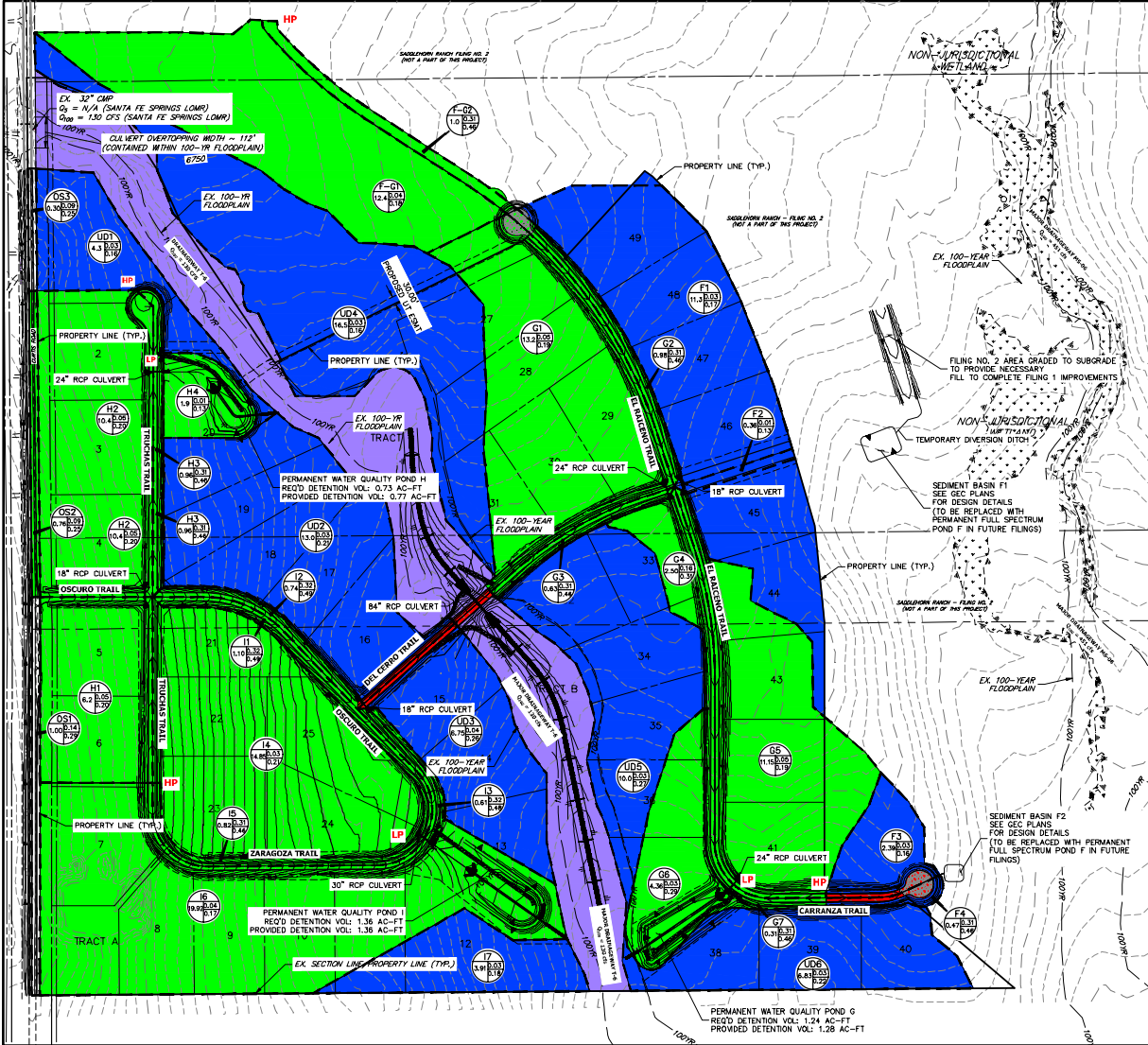

LEGEND

- BASIN DESIGNATION**
 I.D.: BASIN IDENTIFIER
 A: BASIN AREA
 B: C₁₀₀
 C: C₁₀₀
- BASIN DELINEATION**
- EXISTING INDEX CONTOURS**
- EXISTING INTERMEDIATE CONTOURS**
- PROPOSED INDEX CONTOURS**
- PROPOSED INTERMEDIATE CONTOURS**
- EXISTING FLOW DIRECTION**
- PROPOSED FLOW DIRECTION**
- PROPOSED HIGH POINT**
- PROPOSED LOW POINT**
- AREA DETAINED IN PBMP**
- AREA NOT DETAINED IN PBMP PER SECTION 17.1.B.5 (RURAL 2.5+ ACRE LOTS W/ IMPERVIOUSNESS < 10%)**
- AREA NOT DETAINED IN PBMP PER SECTION 17.1.C.1 (20% UP TO 1 AC. OF DEVELOPMENT SITE CAN BE EXCLUDED - DUE TO TOPOGRAPHY)**
- AREA NOT DETAINED IN PBMP PER SECTION 17.1.B.7 (LAND DISTURBANCE TO UNDEVELOPED LAND THAT WILL REMAIN UNDEVELOPED)**

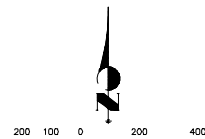

SADDLEHORN RANCH FILING 1
 MS4 PERMIT EXCLUSION AREAS
 2514202
 01/09/20
 SHEET 1 OF 1



Central 333-740-9333 • Colorado Springs, 719-539-2593
 Fort Collins 970-491-8888 • www.jrengineering.com

EXHIBIT C
Permanent BMP Inspections, Operations and Maintenance (O&M)
(78 pages)



Stormwater Management Facility Operation and Maintenance (O&M) Plan Template

for:

Saddlehorn Ranch

Located at:

***Southeast Corner of the intersection of
Judge Orr Road and Curtis Road***

Prepared for:

***Brady Williams
ROI Property Group, LLC
2495 Rigdon Street
Nap, CA
94558
(707) 365-6891***

Prepared by:

Mike Bramlett; 5475 Tech Center Drive, Colorado Springs, CO 80919

08/26/20

**Stormwater Management Facility
Inspection and Maintenance (I&M) Plan**

Table of Contents

- I. Compliance with Stormwater Facility Maintenance Requirements**
- II. Inspection & Maintenance- Annual Reporting**
- III. Preventative Measures to Reduce Maintenance Costs**
- IV. Access and Easements**
- V. Safety**
- VI. Field Inspection Equipment**
- VII. Inspecting Stormwater Management Facilities**
 - A. Inspection Procedures
 - B. Inspection Report
 - C. Verification of Inspection and Form Submittal
- VIII. Maintaining Stormwater Management Facilities**
 - A. Maintenance Categories
 - B. Maintenance Personnel
 - C. Maintenance Forms

Appendices

- Appendix A** - Maintenance Agreement(s)
- Appendix B** - Description of Stormwater Management Facilities
- Appendix C** - Standard Operation Procedures (SOP) for Extended Detention Basins; Grass Buffers and Grass Swales
- Appendix D** - Inspection Form(s)
- Appendix E** - Maintenance Form(s)
- Appendix F**- Stormwater Facilities Map; Facility plan and detail sheets

Stormwater Management Facility Inspection and Maintenance (I&M) Plan

I. Compliance with Stormwater Facility Maintenance Requirements

All property owners are responsible for ensuring stormwater facilities installed on their property are properly maintained and function as designed. Saddlehorn Ranch Metro District may elect to assign many of the management and maintenance functions described in this plan to a third party. Saddlehorn Ranch Metro District is aware of their responsibilities regarding stormwater facility maintenance. Maintenance agreement(s) associated with this property are provided in Appendix A.

II. Inspection & Maintenance – Annual Reporting

Requirements for the inspection and maintenance of stormwater facilities, as well as reporting requirements are included in this Stormwater Management Facility Inspection and Maintenance (I&M) Plan.

Verification that the Stormwater facilities have been properly inspected and maintained; submittal of the required Inspection and Maintenance Forms and Inspector qualifications shall be provided to the Owners Representative, and to El Paso County upon request.

Copies of the Inspection and Maintenance forms for each of the stormwater facilities are located in Appendix D and E. A standard annual reporting form is provided in Appendix F. Each form shall be reviewed and submitted by the property owner or property manager to:

El Paso County
Department of Public Works - Stormwater
3275 Akers Drive
Colorado Springs, CO 80922

III. Preventative Measures to Reduce Maintenance Costs

The most effective way to maintain your water quality facility is to prevent the pollutants from entering the facility in the first place. Common pollutants include sediment, trash & debris, chemicals, dog wastes, runoff from stored materials, illicit discharges into the storm drainage system and many others. Saddlehorn Ranch Metro District's maintenance program includes measures to address these potential contaminants. Depending on the storm water quality facilities installed on the site the maintenance program includes:

- Educate property owners/residents to be aware of how their actions affect water quality, and how they can help reduce maintenance costs.
- Keep properties, streets and gutters, and parking lots free of trash, debris, and lawn clippings.
- Ensure the proper disposal of hazardous wastes and chemicals.
- Plan lawn care to minimize the use of chemicals and pesticides.

- Sweep paved surfaces regularly and dispose the sweepings properly.
- Be aware of automobiles leaking fluids. Use absorbents such as cat litter to soak up drippings – dispose of properly.
- Re-vegetate disturbed and bare areas to maintain vegetative stabilization.
- Clean out the upstream components of the storm drainage system, including inlets, storm sewers and outfalls.
- Do not store materials outdoors (including landscaping materials) unless properly protected from runoff.

IV. Access and Easements

Saddlehorn Ranch Metro District shall prepare a drawing showing all stormwater management facilities located on the site including designated access locations as well as a required easements. Refer to the Stormwater Facilities Map located in Appendix G for access and easement locations.

V. Safety

Keep safety considerations at the forefront of inspection procedures at all times. Likely hazards should be anticipated and avoided. Saddlehorn Ranch Metro District personnel should never enter a confined space (outlet structure, manhole, etc) without proper training or equipment. A confined space should never be entered without at least one additional person present and without using appropriate personal protection equipment.

If a toxic or flammable substance is discovered, leave the immediate area and call 911.

Vertical drops and fall hazards may be encountered in areas located within and around the facility. Saddlehorn Ranch Metro District shall avoid walking on top of retaining walls or other structures that have a significant vertical drop. If a vertical drop is identified that is greater than 48" in height, make the appropriate note/comment on the maintenance inspection form.

If any hazard is found within the facility area that poses an immediate threat to public safety, call 911.

VI. Field Inspection Equipment

Saddlehorn Ranch Metro District's inspectors shall have the appropriate equipment to take to the field. This is to ensure the safety of the inspector and allow the inspections to be performed as efficiently as possible. Below is a list of the equipment that may be necessary to perform the inspections of all Stormwater Management Facilities:

- Protective clothing and boots.
- Safety equipment (vest, hard hat, confined space entry equipment).
- Communication equipment.

- Inspection and Maintenance Plan for the site including stormwater management facility location maps.
- Clipboard.
- Stormwater Facility Maintenance Inspection Forms (See Appendix D).
- Manhole Lid Remover
- Shovel.

Some of the items identified above need not be carried by the inspector (manhole lid remover, shovel, and confined space entry equipment). However, this equipment should be available in the vehicle driven to the site.

VII. Inspecting Stormwater Management Facilities

The quality of stormwater entering the waters of the state relies heavily on the proper operation and maintenance of permanent best management practices. Stormwater management facilities shall be periodically inspected to ensure they function as designed. The inspection will determine the appropriate maintenance required for the facility.

A. Inspection Procedures

All stormwater management facilities shall be inspected by a qualified individual at a minimum of once per year. See the *City of Colorado Springs/El Paso County Drainage Criteria Manual* for general guidelines for an inspector. Inspections will follow the inspection guidance found in the SOP for the specific type of facility. (Appendix C of this plan).

B. Inspection Report

Saddlehorn Ranch Metro District's personnel or inspector conducting the inspection activities shall complete the appropriate inspection report for the specific facility. Inspection reports are located in Appendix D.

The following information explains how to fill out the Inspection Forms:

General Information

This section identifies the facility location, person conducting the inspection, the date and time the facility was inspected, and approximate days since the last rainfall. Property classification is identified as single-family residential, multi-family residential, commercial, or other.

The reason for the inspection is also identified on the form depending on the nature of the inspection. All facilities shall be inspected on an annual basis at a minimum. In addition, all facilities shall be inspected after a significant precipitation event to ensure the facility is draining appropriately and to identify any damage that occurred as a result of the increased runoff.

Inspection Scoring

For each inspection item, a score must be given to identify the urgency of required maintenance. The scoring is as follows:

- 0 = No deficiencies identified.
- 1 = Monitor – Although maintenance may not be required at this time, a potential problem exists that will most likely need to be addressed in the future. This can include items like minor erosion, concrete cracks/spalling, or minor sediment accumulation. This item should be revisited at the next inspection.
- 2 = Routine Maintenance Required – Some inspection items can be addressed through the routine maintenance program (See SOP in appendix C). This can include items like vegetation management or debris/trash removal.
- 3 = Immediate Repair Necessary – This item needs immediate attention because failure is imminent or has already occurred. This could include items such as structural failure of a feature (outlet works, forebay, etc), significant erosion, or significant sediment accumulation. This score should be given to an item that can significantly affect the function of the facility.
- N/A This is checked by an item that may not exist in a facility. Not all facilities have all of the features identified on the form (forebay, micro-pool, etc.).

Inspection Summary/Additional Comments

Additional explanations to inspection items, and observations about the facility not covered by the form, are recorded in this section.

Overall Facility Rating

An overall rating must be given for each facility inspected. The overall facility rating should correspond with the highest score (0, 1, 2, 3) given to any feature on the inspection form.

C. Verification of Inspection and Form Submittal

The Stormwater Management Facility Inspection Form provides a record of inspection of the facility. Inspection Forms for each facility type are provided in Appendix D. Verification of the inspection of the stormwater facilities, the facility inspection form(s), and Inspector Qualifications shall be provided to the Owners Representative, and to El Paso County if requested. The verification and the inspection form(s) shall be reviewed and submitted by Saddlehorn Ranch Metro District or his property manager.

Refer to Section II of this Plan regarding the annual reporting of inspections.

VIII. Maintaining Stormwater Management Facilities

Stormwater management facilities shall be properly maintained to ensure they operate correctly and provide the water quality treatment for which they were designed. Routine maintenance performed on a frequently scheduled basis, can help avoid more costly rehabilitative maintenance that results when facilities are not adequately maintained.

A. Maintenance Categories

Stormwater management facility maintenance programs are separated into three broad categories of work. These categories are based largely on the Urban Drainage and Flood Control District's Maintenance Program for regional drainage facilities. The categories are separated based upon the magnitude and type of the maintenance activities performed. A description of each category follows:

Routine Work

The majority of this work consists of scheduled mowings and trash and debris pickups for stormwater management facilities during the growing season. This includes items such as the removal of debris/material that may be clogging the outlet structure well screens and trash racks. It also includes activities such as weed control, mosquito treatment, and algae treatment. These activities normally will be performed numerous times during the year. These items can be completed without any prior correspondence with El Paso County; however, completed inspection and maintenance forms shall be submitted to El Paso County for each inspection and maintenance activity with the annual report.

Restoration Work

This work consists of a variety of isolated or small-scale maintenance and work needed to address operational problems. Most of this work can be completed by a small crew, with minor tools, and small equipment. The Saddlehorn Ranch Metro District shall correspond with El Paso County and submit completed maintenance forms to the owner's representative & El Paso County, if requested, for each maintenance activity.

Rehabilitation Work

This work consists of large-scale maintenance and major improvements needed to address failures within the stormwater management facilities. This work requires consultation with El Paso County and may require an engineering design with construction plans to be prepared for review and approval. This work may also require more specialized maintenance

equipment, surveying, construction permits or assistance through private contractors and consultants. If these items are needed the Saddlehorn Ranch Metro District shall correspond with El Paso County and submit completed maintenance forms to El Paso County for each maintenance activity.

B. Maintenance Personnel

Saddlehorn Ranch Metro District's maintenance personnel shall be qualified to properly maintain stormwater management facilities. Inadequately trained personnel can cause additional problems resulting in additional maintenance costs.

C. Maintenance Forms

The Stormwater Management Facility Maintenance Form provides a record of maintenance activities. Maintenance Forms for each facility type are provided in Appendix E. Maintenance Forms shall be completed by the Saddlehorn Ranch Metro District's contractor completing the required maintenance items. The form shall then be reviewed by the Saddlehorn Ranch Metro District or an authorized agent of the property owner and submitted to El Paso County, when requested.

Refer to Section II of this Plan regarding the annual reporting of inspections and maintenance activities performed.

A P P E N D I X A

Stormwater Maintenance Agreement Template

A P P E N D I X B

General Location and Description of Stormwater Management Facilities Example

Appendix B

General Location and Description of Stormwater Management Facilities

A. General Site Description

The site is comprised of rural 2.5 acre minimum lots. The site is located at the southeast corner of Judge Orr Road and Curtis Road. The 172 acre site consists of 55 2.5 acre rural lots.

B. General Stormwater Management Description

All stormwater is conveyed via roadside swales and conventional reinforced concrete pipe (RCP) to one of three detention basins that provide detention and water quality treatment. Developed runoff is released at or below historic rates.

C. Stormwater Facilities Site Plan

Inspection or maintenance personnel may utilize the Stormwater Facilities Map located in Appendix G for locating the stormwater facilities within this development.

D. On-Site Stormwater Management Facilities

Volume Reduction Facilities

Residential Site utilizes Level I MDCIA – All impervious surfaces are routed through grass lined swales.

Storage Facilities (Detention)

Detention for the site is provided in three full spectrum water quality and detention ponds. See the Facilities Map located in Appendix G for location of ponds.

Water Quality Facilities

Water quality is provided in the three full spectrum ponds.

Source Control Best Management Practices

Residential Site does not include any nonstructural BMPs.

A P P E N D I X C

Standard Operating Procedures

For:

Extended Detention Basins (EDBs)

Grass Buffers and Grass Swales (GB-GS)

A P P E N D I X C – 1

Extended Detention Basins

Standard Operation Procedures for Inspection and Maintenance

Extended Detention Basins (EDBs)

September 2010

TABLE OF CONTENTS

EDB-1	Background	3
EDB-2	INSPECTING EXTENDED DETENTION BASINS (EDBs).....	3
EDB-2.1	Access and Easements	3
EDB-2.2	Stormwater Management Facilities Locations	3
EDB-2.3	Extended Detention Basin (EDB) Features.....	3
EDB-2.3.1	Inflow Points.....	4
EDB-2.3.2	Forebay.....	5
EDB-2.3.3	Trickle Channel (Low-Flow)	6
EDB-2.3.4	Bottom Stage	7
EDB-2.3.5	Micropool	8
EDB-2.3.6	Outlet Works	9
EDB-2.3.7	Emergency Spillway.....	10
EDB-2.3.8	Upper Stage (Dry Storage)	10
EDB-2.3.9	Miscellaneous	12
EDB-2.4	Inspection Forms	13
EDB-3	MAINTAINING EXTENDED DETENTION BASINS (EDBS)	13
EDB-3.1	Maintenance Personnel	13
EDB-3.2	Equipment.....	13
EDB-3.3	Safety.....	14
EDB-3.4	Maintenance Forms	14
EDB-3.5	Maintenance Categories and Activities	14
EDB-3.6	Routine Maintenance Activities.....	15
EDB-3.6.1	Mowing.....	15
EDB-3.6.2	Trash/Debris Removal	16
EDB-3.6.3	Outlet Works Cleaning	16
EDB-3.6.4	Weed Control	16
EDB-3.6.5	Mosquito/Algae Treatment.....	16
EDB-3.7	Minor Maintenance Activities	16
EDB-3.7.1	Sediment Removal.....	17
EDB-3.7.2	Erosion Repair	17
EDB-3.7.3	Vegetation Removal/Tree Thinning.....	18
EDB-3.7.4	Clearing Drains/Jet-Vac	18
EDB-3.8	Major Maintenance Activities	18
EDB-3.8.1	Major Sediment Removal.....	19
EDB-3.8.2	Major Erosion Repair	19
EDB-3.8.3	Structural Repair	20

EDB-1 BACKGROUND

Extended Detention Basins (EDBs) are one of the most common types of Stormwater Management Facilities utilized within the Front Range of Colorado. An EDB is a sedimentation basin designed to “extend” the runoff detention time, but to drain completely dry sometime after stormwater runoff ends. The EDB’s drain time for the water quality portion of the facility is typically 40 hours. The basins are considered to be “dry” because the majority of the basin is designed not to have a significant permanent pool of water remaining between runoff events.

EDBs are an adaptation of a detention basin used for flood control, with the primary difference is the addition of forebays, micro-pools and a slow release outlet design. Forebays are shallow concrete “pans” located at the inflow point to the basin and are provided to facilitate sediment removal within a contained area prior to releasing into the pond. These forebays collect and briefly hold stormwater runoff resulting in a process called sedimentation, dropping sediment out of the stormwater. The stormwater is then routed from the forebay into the concrete trickle channel and upper basin, the large grassy portion of the basin. The EDB uses a much smaller outlet that extends the emptying time of the more frequently occurring runoff events to facilitate pollutant removal. An EDB should have a small micro-pool just upstream of the outlet. This micro-pool is designed to hold a small amount of water to keep sediment and floatables from blocking the outlet orifices.

EDB-2 INSPECTING EXTENDED DETENTION BASINS (EDBs)

EDB-2.1 Access and Easements

Inspection or maintenance personnel may utilize the stormwater facility map located in Appendix G containing the location(s) of the access points and maintenance easements of the EDB(s) within this development.

EDB-2.2 Stormwater Management Facilities Locations

Inspection or maintenance personnel may utilize the stormwater facility map located in Appendix G containing the location(s) of the EDB(s) within this development.

EDB-2.3 Extended Detention Basin (EDB) Features

EDBs have a number of features that are designed to serve a particular function. Many times the proper function of one feature depends on another. For example, if a forebay is not properly maintained, it could negatively affect the performance of a feature downstream (trickle channel, micro-pool, etc.). Therefore, it is critical that each feature of the EDB is properly inspected and maintained to ensure the overall facility functions as it was intended. Below is a list and description of the most common features within an EDB and the corresponding maintenance inspection items that can be anticipated:

Table EDB-1
Typical Inspection & Maintenance Requirements Matrix

EDB Features	Sediment Removal	Mowing/ Weed control	Trash & Debris Removal	Erosion	Overgrown Vegetation Removal	Standing Water (mosquito/ algae control)	Structure Repair
Inflow Points (outfalls)	X		X				X
Forebay	X		X				X
Low-flow channel	X		X	X	X		X
Bottom Stage	X	X	X	X	X	X	
Micro-pool	X		X		X	X	X
Outlet Works	X		X				X
Emergency Spillway			X	X	X		X
Upper Stage			X	X			
Embankment		X		X	X		

EDB-2.3.1 Inflow Points

Inflow Points or Outfalls into EDBs are the point source of the stormwater discharge into the facility. An inflow point is commonly a storm sewer pipe with a flared end section that discharges into the EDB. In some instances, an inflow point could be a drainage channel or ditch that flows into the facility.

An energy dissipater (riprap or hard armor protection) is typically immediately downstream of the discharge point into the EDB to protect from erosion. In some cases, the storm sewer outfall can have a toe-wall or cut-off wall immediately below the structure to prevent undercutting of the outfall from erosion.

The typical maintenance items found with inflow points are as follows:

a. Riprap Displaced – Many times, because the repeated impact/force of water, the riprap can shift and settle. If any portion of the riprap apron appears to have settled, soil is present between the riprap, or the riprap has shifted, maintenance may be required to ensure future erosion is prevented. Depending on the nature of the maintenance the use of heavy equipment and proper bedding material may be required to repair the riprap. See Section EDB-3.5 – EDB-3.8.

b. Erosion Present/Outfall Undercut – In some situations, the energy dissipater may not have been sized, constructed, or maintained appropriately and erosion has occurred. Any erosion within the vicinity of the inflow point will require maintenance to prevent damage to the structure(s) and sediment transport within the facility. If there is any

question to whether the original design is inadequate, a qualified engineer should review the situation to avoid chronic maintenance repairs if it is a design issue.

c. Sediment Accumulation – Because of the turbulence in the water created by the energy dissipater, sediment often deposits immediately downstream of the inflow point. To prevent a loss in hydraulic performance of the upstream infrastructure, sediment that accumulates in this area must be removed in a timely manner.

d. Structural Damage – Structural damage can occur at anytime during the life of the facility. Typically, for an inflow, the structural damage occurs to the pipe flared end section (concrete or steel). Structural damage can lead to additional operating problems with the facility, including loss of hydraulic performance.

e. Woody Growth/Weeds Present – Undesirable vegetation can grow in and around the inflow area to an EDB that can significantly affect the performance of the drainage facilities discharging into the facility. This type of vegetation includes trees (typically cottonwoods) and dense areas of shrubs (willows). If woody vegetation is not routinely mowed/removed, the growth can cause debris/sediment to accumulate, resulting in blockage of the discharge. Also, tree roots can cause damage to the structural components of the inflow. Routine maintenance is essential for trees (removing a small tree/sapling is much cheaper and “quieter” than a mature tree). In addition, noxious weeds growing in the facility can result in the loss of desirable native vegetation and impact adjacent open spaces/land.

EDB-2.3.2 Forebay

A forebay is a solid surface (pad), typically constructed of concrete, immediately downstream of the inflow point. The forebay is designed to capture larger particles and trash to prevent them from entering the main portion of the EDB. The solid surface is designed to facilitate mechanical sediment removal (skid steer). The forebay typically includes a small diameter discharge pipe or v-notch weir on the downstream end and designed to drain the forebay in a specified period of time to promote sedimentation. The forebays vary in size and depth depending on the design and site constraints.

The typical maintenance items found with forebays are as follows:

a. Sediment/Debris Accumulation – Because this feature of the EDB is designed to provide the initial sedimentation, debris and sediment frequently accumulate in this area. If the sediment and debris is not removed from the forebay on a regular basis, it can significantly affect the

function of other features within the EDB. Routine sediment removal from the forebay can **significantly** reduce the need for dredging of the main portion of the EDB using specialized equipment (long reach excavators). Routine removal of sediment from the forebay can **substantially** decrease the long-term sediment removal costs of an EDB.

b. Concrete Cracking/Failing – The forebay is primarily constructed of concrete, which cracks, spalls, and settles. Damage to the forebay can result in decreased performance and impact maintenance efforts.

c. Drain Pipe/Weir Clogged – Many times the drainpipe or weir can be clogged with debris, and prevent the forebay from draining properly. If standing water is present in the forebay (and there is not a base flow), the forebay is most likely not draining properly. This can result in a decrease in performance and create potential nuisances with stagnant water (mosquitoes).

d. Weir/Drain Pipe Damaged – Routine maintenance activities, vandalism, or age may cause the weir or drain pipe in the forebay to become damaged. Weirs are typically constructed of concrete, which cracks and spalls. The drainpipe is typically smaller in diameter and constructed with plastic, which can fracture.

EDB-2.3.3 Trickle Channel (Low-Flow)

The trickle channel conveys stormwater from the forebay to the micro-pool of the EDB. The trickle channel is typically made of concrete. However, grass lined (riprap sides protected) is also common and can provide for an additional means of water quality within the EDB. The trickle channel is typically 6-9 inches in depth and can vary in width.

The typical maintenance items found with trickle channels are as follows:

a. Sediment/Debris Accumulation – Trickle channels are typically designed with a relatively flat slope that can promote sedimentation and the collection of debris. Also, if a trickle channel is grass lined it can accumulate sediment and debris at a much quicker rate. Routine removal of accumulated sediment and debris is essential in preventing flows from circumventing the trickle channel and affecting the dry storage portion of the pond.

b. Concrete/Riprap Damage – Concrete can crack, spall, and settle and must be repaired to ensure proper function of the trickle channel. Riprap can also shift over time and must be replaced/repared as necessary.

c. Woody Growth/Weeds Present – Because of the constant moisture in the area surrounding the trickle channel, woody growth (cottonwoods/willows) can become a problem. Trees and dense shrub type vegetation can affect the capacity of the trickle channel and can allow flows to circumvent the feature.

d. Erosion Outside of Channel – In larger precipitation events, the trickle channel capacity will likely be exceeded. This can result in erosion immediately adjacent to the trickle channel and must be repaired to prevent further damage to the structural components of the EDB.

EDB-2.3.4 Bottom Stage

The bottom stage is at least 1.0 to 2.0 feet deeper than the upper stage and is located in front of the outlet works structure. The bottom stage is designed to store the smaller runoff events, assists in keeping the majority of the basin bottom dry resulting in easier maintenance operations, and enhances the facilities pollutant removal capabilities. This area of the EDB may develop wetland vegetation.

The typical maintenance items found with the bottom stage are as follows:

a. Sediment/Debris Accumulation – The bottom stage can frequently accumulate sediment and debris. This material must be removed to maintain pond volume and proper function of the outlet structure.

b. Woody Growth/Weeds Present - Because of the constant moisture in the soil surrounding the micro-pool, woody growth (cottonwoods/willows) can create operational problems for the EDB. If woody vegetation is not routinely mowed/removed, the growth can cause debris/sediment to accumulate outside of the micro-pool (see EDB 2.3.5), which can cause problems with other EDB features. Also, tree roots can cause damage to the structural components of the outlet works. Routine management is essential for trees (removing a small tree/sapling is much cheaper and “quieter” than a mature tree).

c. Bank Erosion – The bottom stage is usually a couple feet deeper than the other areas of the ponds. Erosion can be caused by water dropping into the bottom stage if adequate protection/armor is not present. Erosion in this area must be mitigated to prevent sediment transport and other EDB feature damage.

d. Mosquitoes/Algae Treatment – Nuisance created by stagnant water can result from improper maintenance/treatment of the bottom stage. Mosquito larvae can be laid by adult mosquitoes within the permanent pool. Also, aquatic vegetation that grows in shallow pools of water can decompose causing foul odors. Chemical/mechanical treatment of the

bottom stage may be necessary to reduce these impacts to adjacent homeowners.

e. Petroleum/Chemical Sheen – Many indicators of illicit discharges into the storm sewer systems will be present in the bottom stage area of the EDB. These indicators can include sheens, odors, discolored soil, and dead vegetation. If it is suspected that an illicit discharge has occurred, contact the supervisor immediately. Proper removal/mitigation of contaminated soils and water in the EDB is necessary to minimize any environmental impacts downstream.

EDB-2.3.5 Micro-pool

The micro-pool is a concrete or grouted boulder walled structure directly in front of the outlet works. At a minimum, the micro-pool is 2.5 feet deep and is designed to hold water. The micro-pool is critical in the proper function of the EDB; it allows suspended sediment to be deposited at the bottom of the micro-pool and prevents these sediments from being deposited in front of the outlet works causing clogging of the outlet structure, which results in marshy areas within the top and bottom stages.

The typical maintenance items found with micro-pools are as follows:

a. Sediment/Debris Accumulation – The micro-pool can frequently accumulate sediment and debris. This material must be removed to maintain the micro pool volume, depth, and proper function of the outlet structure.

b. Woody Growth/Weeds Present - Because of the constant moisture in the soil surrounding the micro-pool, woody growth (cottonwoods/willows) can create operational problems for the EDB. If woody vegetation is not routinely mowed/removed, the growth can cause debris/sediment to accumulate outside of the micro-pool, which can cause problems with other EDB features. Also, tree roots can cause damage to the structural components of the outlet works. Routine management is essential for trees (removing a small tree/sapling is much cheaper and “quieter” than a mature tree).

c. Mosquitoes/Algae Treatment – Nuisance created by stagnant water can result from improper maintenance/treatment of the micro-pool. Mosquito larvae can be laid by adult mosquitoes within the permanent pool. If mosquitoes are breeding within the micro-pool this may also be an indication there is significant sediment build-up that is reducing the depth of the micro-pool. Also, aquatic vegetation that grows in shallow pools of water can decompose causing foul odors. Chemical/mechanical treatment of the micro-pool may be necessary to reduce these impacts to adjacent homeowners.

d. Petroleum/Chemical Sheen – Many indicators of illicit discharges into the storm sewer systems will be present in the micro-pool area of the EDB. These indicators can include sheens, odors, discolored soil, and dead vegetation. If it is suspected that an illicit discharge has occurred, contact the supervisor immediately. Proper removal/mitigation of contaminated soils and water in the EDB is necessary to minimize any environmental impacts downstream.

EDB-2.3.6 Outlet Works

The outlet works is the feature that drains the EDB in specified quantities and periods of time. The outlet works is typically constructed of reinforced concrete into the embankment of the EDB. The concrete structure typically has steel orifice plates anchored/embedded into it to control stormwater release rates. The larger openings (flood control) on the outlet structure typically have trash racks over them to prevent clogging. The water quality orifice plate (smaller diameter holes) will typically have a well screen covering it to prevent smaller materials from clogging it. The outlet structure is the single most important feature in the EDB operation. Proper inspection and maintenance of the outlet works is essential in ensuring the long-term operation of the EDB.

The typical maintenance items found with the outlet works are as follows:

a. Trash Rack/Well Screen Clogged – Floatable material entering the EDB will most likely make its way to the outlet structure. This material is trapped against the trash racks and well screens on the outlet structure (which is why they are there). This material must be removed on a routine basis to ensure the outlet structure drains in the specified design period.

b. Structural Damage - The outlet structure is primarily constructed of concrete, which can crack, spall, and settle. The steel trash racks and well screens are also susceptible to damage.

c. Orifice Plate Missing/Not Secure – Many times residents, property owners, or maintenance personnel will remove or loosen orifice plates if they believe the pond is not draining properly. Any modification to the orifice plate(s) will significantly affect the designed discharge rates for water quality and/or flood control. Modification of the orifice plates is not allowed without approval from El Paso County Public Works Department, Engineering Control Division.

d. Manhole Access – Access to the outlet structure is necessary to properly inspect and maintain the facility. If access is difficult or not available to inspect the structure, chances are it will be difficult to maintain as well.

e. Woody Growth/Weeds Present - Because of the constant moisture in the soil surrounding the outlet works, woody growth (cottonwoods/willows) can create operational problems for the EDB. If woody vegetation is not routinely mowed/removed, the growth can cause debris/sediment to accumulate around the outlet works, which can cause problems with other EDB features. Also, tree roots can cause damage to the structural components of the outlet works. Routine management is essential for trees (removing a small tree/sapling is much cheaper and “quieter” than a mature tree).

EDB-2.3.7 Emergency Spillway

An emergency spillway is typical of all EDBs and designed to serve as the overflow in the event the volume of the pond is exceeded. The emergency spillway is typically armored with riprap (or other hard armor) and is sometimes buried with soil. The emergency spillway is typically a weir (notch) in the pond embankment. Proper function of the emergency spillway is essential to ensure flooding does not affect adjacent properties.

The typical maintenance items found with emergency spillways are as follows:

a. Riprap Displaced – As mentioned before, the emergency spillway is typically armored with riprap to provide erosion protection. Over the life of an EDB, the riprap may shift or dislodge due to flow. Depending on the nature of the maintenance the use of heavy equipment and proper bedding material may be required to repair the riprap. See Section EDB-3.5 – EDB-3.8.

b. Erosion Present – Although the spillway is typically armored, stormwater flowing through the spillway can cause erosion damage. Erosion must be repaired to ensure the integrity of the basin embankment, and proper function of the spillway.

c. Woody Growth/Weeds Present – Management of woody vegetation is essential in the proper long-term function of the spillway. Larger trees or dense shrubs can capture larger debris entering the EDB and reduce the capacity of the spillway.

d. Obstruction Debris – The spillway must be cleared of any obstruction (man-made or natural) to ensure the proper design capacity.

EDB-2.3.8 Upper Stage (Dry Storage)

The upper stage of the EDB provides the majority of the water quality flood detention volume. This area of the EDB is higher than the bottom stage and

typically stays dry, except during storm events. The upper stage is the largest feature/area of the basin. Sometimes, the upper stage can be utilized for park space and other uses in larger EDBs. With proper maintenance of the bottom stage, micro-pool, and forebay(s), the upper stage should not experience much sedimentation; however, bottom elevations should be monitored to ensure adequate volume.

The typical maintenance items found with upper stages are as follows:

a. Vegetation Sparse – The upper basin is the most visible part of the EDB, and therefore aesthetics is important. Adequate and properly maintained vegetation can greatly increase the overall appearance and acceptance of the EDB by the public. In addition, vegetation can reduce the potential for erosion and subsequent sediment transport to the other areas of the pond.

b. Woody Growth/Undesirable Vegetation – Although some trees and woody vegetation may be acceptable in the upper basin, some thinning of cottonwoods and willows may be necessary. Remember, the basin will have to be dredged to ensure volume, and large trees and shrubs will be difficult to protect during that operation.

c. Standing Water/Boggy Areas – Standing water or boggy areas in the upper stage is typically a sign that some other feature in the pond is not functioning properly. Routine maintenance (mowing, trash removal, etc) can be extremely difficult for the upper stage if the ground is saturated. If this inspection item is checked, make sure you have identified the root cause of the problem.

d. Sediment Accumulation – Although other features within the EDB are designed to capture sediment, the upper storage area will collect sediment over time. Excessive amounts of sedimentation will result in a loss of storage volume. It may be more difficult to determine if this area has accumulated sediment without conducting a field survey.

Below is a list of indicators:

1. Ground adjacent to the trickle channel appears to be several inches higher than the concrete/riprap trickle channel.
2. Standing water or boggy areas in upper stage
3. Uneven grades or mounds
4. Bottom Stage, Micro-pool, or Forebay has excessive amounts of sediment

e. Erosion (banks and bottom) – The bottom grades of the dry storage area are typically flat enough that erosion should not occur. However, inadequate vegetative cover may result in erosion of the upper stage. Erosion that occurs in the upper stage can result in increased

dredging/maintenance of the bottom stage/micro-pool.

f. Trash/Debris – Trash and debris can accumulate in the upper area after large events, or from illegal dumping. Over time, this material can accumulate and clog the EDB outlet works.

g. Maintenance Access – Most EDBs typically have a gravel/concrete maintenance access path to either the upper stage or forebay. This access path should be inspected to ensure the surface is still drivable. Some of the smaller EDBs may not have maintenance access paths; however, the inspector should verify that access is available from adjacent properties.

EDB-2.3.9 Miscellaneous

There are a variety of inspection/maintenance issues that may not be attributed to a single feature within the EDB. This category on the inspection form is for maintenance items that are commonly found in the EDB, but may not be attributed to an individual feature.

a. Encroachment in Easement Area – Private lots/property can sometimes be located very close to the EDBs, even though they are required to be located in tracts with drainage easements. Property owners may not place landscaping, trash, fencing, or other items within the easement area that may adversely affect maintenance or the operation of the facility.

b. Graffiti/Vandalism – Damage to the EDB infrastructure can be caused by vandals. If criminal mischief is evident, the inspector should forward this information to the El Paso County Police Department.

c. Public Hazards – Public hazards include items such as vertical drops of greater than 4-feet, containers of unknown/suspicious substances, exposed metal/jagged concrete on structures. **If any hazard is found within the facility area that poses an immediate threat to public safety, call 911 immediately!**

d. Burrowing Animals/Pests – Prairie dogs and other burrowing rodents may cause damage to the EDB features and negatively affect the vegetation within the EDB.

e. Other – Any miscellaneous inspection/maintenance items not contained on the form should be entered here.

EDB-2.4 Inspection Forms

EDB Inspection forms are located in Appendix D. Inspection forms shall be completed by the person(s) conducting the inspection activities. Each form shall be reviewed and submitted by the property owner or property manager to El Paso County per the requirements of the Inspection and Maintenance Plan. These inspection forms shall be kept indefinitely and made available to El Paso County upon request.

EDB-3 MAINTAINING EXTENDED DETENTION BASINS (EDBS)

EDB-3.1 Maintenance Personnel

Maintenance personnel must be qualified to properly maintain EDBs. Inadequately trained personnel can cause additional problems resulting in additional maintenance costs.

EDB-3.2 Equipment

It is imperative the appropriate equipment and tools are taken to the field with the operations crew. The types of equipment/tools will vary depending on the task at hand. Below is a basic list of tools, equipment, and material(s) that may be necessary to perform maintenance on an EDB:

- 1.) Loppers/Tree Trimming Tools
- 2.) Mowing Tractors
- 3.) Trimmers (extra string)
- 4.) Shovels
- 5.) Rakes
- 6.) All Surface Vehicle (ASVs)
- 7.) Skid Steer
- 8.) Back Hoe
- 9.) Track Hoe/Long Reach Excavator
- 10.) Dump Truck
- 11.) Jet-Vac Machine
- 12.) Engineers Level (laser)
- 13.) Riprap (Minimum - Type M, or as shown on the approved civil plans)
- 14.) Filter Fabric
- 15.) Erosion Control Blanket(s)

- 16.) Seed Mix (See seed mix in the *Rules and Regulations Regarding Stormwater (Quality) Discharge for Construction Activities*, Std Det. SM, Seeding & Mulching)
- 17.) Illicit Discharge Cleanup Kits
- 18.) Trash Bags
- 19.) Tools (wrenches, screw drivers, hammers, etc)
- 20.) Chain Saw
- 21.) Confined Space Entry Equipment
- 22.) Approved Stormwater Facility Inspection and Maintenance Plan

Some of the items identified above may not be needed for every maintenance operation. However, this equipment should be available to the maintenance operations crews should the need arise.

EDB-3.3 Safety

Vertical drops may be encountered in areas located within and around the facility. Avoid walking on top of retaining walls or other structures having a significant vertical drop. If a vertical drop within the EDB is identified as greater than 48" in height, make the appropriate note/comment on the maintenance inspection form.

EDB-3.4 Maintenance Forms

The EDB Maintenance Form provides a record of each maintenance operation performed by maintenance contractors. The EDB Maintenance Form shall be filled out in the field after the completion of the maintenance operation. Each form shall be reviewed and submitted by the property owner or property manager to El Paso County per the requirements of the Inspection and Maintenance Plan. The EDB Maintenance form is located in Appendix E.

EDB-3.5 Maintenance Categories and Activities

A typical EDB Maintenance Program will consist of three broad categories of work. Within each category of work, a variety of maintenance activities can be performed on an EDB. A maintenance activity can be specific to each feature within the EDB, or general to the overall facility. This section of the SOP explains each of the categories and briefly describes the typical maintenance activities for an EDB.

A variety of maintenance activities are typical of EDBs. The maintenance activities range in magnitude from routine trash pickup to the reconstruction of drainage infrastructure. Below is a description of each maintenance activity, the objectives, and frequency of actions:

EDB-3.6 Routine Maintenance Activities

The majority of this work consists of regularly scheduled mowing and trash and debris pickups for stormwater management facilities during the growing season. This includes items such as the removal of debris/material that may be clogging the outlet structure well screens and trash racks. It also includes activities such as weed control, mosquito treatment, and algae treatment. These activities normally will be performed numerous times during the year. These items can be completed without any prior correspondence with El Paso County; however, completed inspection and maintenance forms shall be submitted to El Paso County for each inspection and maintenance activity in accordance with the Inspection and Maintenance Plan.

The Maintenance Activities are summarized below, and further described in the following sections.

**TABLE – EDB-2
Summary of Routine Maintenance Activities**

Maintenance Activity	Minimum Frequency	Look for:	Maintenance Action
Mowing	Twice annually	Excessive grass height/aesthetics	Mow grass to a height of 4" to 6"
Trash/Debris Removal	Twice annually	Trash & debris in EDB	Remove and dispose of trash and debris
Outlet Works Cleaning	As needed - after significant rain events – twice annually min.	Clogged outlet structure; ponding water	Remove and dispose of debris/trash/sediment to allow outlet to function properly
Weed control	Minimum twice annually	Noxious weeds; Unwanted vegetation	Treat w/ herbicide or hand pull; Consult the local weed specialist
Mosquito Treatment	As needed	Standing water/mosquito habitat	Treat w/ EPA approved chemicals
Algae Treatment	As needed	Standing water/ Algal growth/green color	Treat w/ EPA approved chemicals

EDB-3.6.1 Mowing

Occasional mowing is necessary to limit unwanted vegetation and to improve the overall appearance of the EDB. Native vegetation should be mowed to a height of 4-to-6 inches tall. Grass clippings should be collected and disposed of properly.

Frequency – Routine - Minimum of twice annually or depending on aesthetics.

EDB-3.6.2 Trash/Debris Removal

Trash and debris must be removed from the entire EDB area to minimize outlet clogging and to improve aesthetics. This activity must be performed prior to mowing operations.

Frequency – Routine – Prior to mowing operations and minimum of twice annually and should be done after significant storm events.

EDB-3.6.3 Outlet Works Cleaning

Debris and other materials can clog the outlet work's well screen, orifice plate(s) and trash rack. This activity must be performed anytime other maintenance activities are conducted to ensure proper operation.

Frequency - Routine – After significant rainfall event or concurrently with other maintenance activities.

EDB-3.6.4 Weed Control

Noxious weeds and other unwanted vegetation must be treated as needed throughout the EDB. This activity can be performed either through mechanical means (mowing/pulling) or with herbicide. Consultation with the local Weed Inspector is highly recommended prior to the use of an herbicide. All herbicide applications should be applied in accordance with the manufacturer's recommendations.

Frequency – Routine – As needed based on inspections.

EDB-3.6.5 Mosquito/Algae Treatment

Treatment of permanent pools is necessary to control mosquitoes and undesirable aquatic vegetation that can create nuisances. Only EPA approved chemicals/materials can be used in areas that are warranted.

Frequency – As needed.

EDB- 3.7 Minor Maintenance Activities

This work consists of a variety of isolated or small-scale maintenance or operational problems. Most of this work can be completed by a small crew, tools, and small equipment. These items require prior correspondence with El Paso County Water Staff and require completed inspection and maintenance forms to be submitted to the El Paso County Water Staff for each inspection and maintenance activity.

**Table – EDB-3
Summary of Minor Maintenance Activities**

Maintenance Activity	Minimum Frequency	Look for:	Maintenance Action
<u>Sediment Removal*</u>	As needed; typically every 1 –2 years	Sediment build-up; decrease in pond volume	Remove and dispose of sediment
Erosion Repair	As needed, based upon inspection	Rills/gullies forming on side slopes, trickle channel, other areas	Repair eroded areas Revegetate; address source of erosion
Vegetation Removal/Tree Thinning	As needed, based upon inspection	Large trees/wood vegetation in lower chamber of pond	Remove vegetation; restore grade and surface
Drain Cleaning/Jet Vac	As needed, based upon inspection	Sediment build-up /non draining system	Clean drains; Jet Vac if needed

*Usually from the forebay, trickle channel, and/or micro-pool

EDB-3.7.1 Sediment Removal

Sediment removal is necessary to maintain the original design volume of the EDB and to ensure proper function of the infrastructure. Regular sediment removal (minor) from the forebay, inflow(s), and trickle channel can significantly reduce the frequency of major sediment removal activities (dredging) in the upper and lower stages. The minor sediment removal activities can typically be addressed with shovels and smaller equipment.

Stormwater sediments removed from EDBs do not meet the criteria of “hazardous waste”. However, these sediments are contaminated with a wide array of organic and inorganic pollutants and handling must be done with care. Sediments from permanent pools must be carefully removed to minimize turbidity, further sedimentation, or other adverse water quality impacts. Sediments should be transported by motor vehicle only after they are dewatered. All sediments must be taken to a landfill for proper disposal. Prompt and thorough cleanup is important should a spill occur during transportation.

Frequency – Nonroutine – As necessary based upon inspections. Sediment removal in the forebay, trickle channel, and micro-pool may be necessary as frequently as every 1-2 years.

EDB-3.7.2 Erosion Repair

The repair of eroded areas is necessary to ensure the proper function of the EDB, minimize sediment transport, and to reduce potential impacts to other features. Erosion can vary in magnitude from minor repairs to trickle channels, energy dissipaters, and rilling to major gullies in the embankments

and spillways. The repair of eroded areas may require the use of excavators, earthmoving equipment, riprap, concrete, erosion control blankets, and turf reinforcement mats. Major erosion repair to the pond embankments, spillways, and adjacent to structures will require consultation with El Paso County Stormwater and Engineering Staff.

Frequency – Nonroutine – As necessary based upon inspections.

EDB-3.7.3 Vegetation Removal/Tree Thinning

Dense stands of woody vegetation (willows, shrubs, etc) or trees can create maintenance problems for the infrastructure within an EDB. Tree roots can damage structures and invade pipes/channels thereby blocking flows. Also, trees growing in the upper and lower stages of the EDB will most likely have to be removed when sediment/dredging operations occur. A small tree is easier to remove than a large tree, therefore, regular removal/thinning is imperative. All trees and woody vegetation that is growing in the bottom of the EDB or near structures (inflows, trickle channels, outlet works, emergency spillways, etc) should be removed. Any trees or woody vegetation in the EDB should be limited to the upper portions of the pond banks.

Frequency – Nonroutine – As necessary based upon inspections.

EDB-3.7.4 Clearing Drains/Jet-Vac

An EDB contains many structures, openings, and pipes that can be frequently clogged with debris. These blockages can result in a decrease of hydraulic capacity and create standing water in areas outside of the micro-pool. Many times the blockage to this infrastructure can be difficult to access and/or clean. Specialized equipment (jet-vac machines) may be necessary to clear debris from these difficult areas.

Frequency – Nonroutine – As necessary based upon inspections.

EDB-3.8 Major Maintenance Activities

This work consists of larger maintenance/operational problems and failures within the stormwater management facilities. All of this work requires consultation with El Paso County to ensure the proper maintenance is performed. This work requires El Paso County Stormwater Staff review the original design before approval of the proposed maintenance. **A ESQCP permit shall be required for all major maintenance activities.** This work may also require more specialized maintenance equipment, design/details, submittal of plans to El Paso County for review and approval, surveying, or assistance through private contractors and consultants.

**Table – EDB-4
Summary of Major Maintenance Activities**

Maintenance Activity	Minimum Frequency	Look for:	Maintenance Action
Major Sediment Removal	As needed – based upon scheduled inspections	Large quantities of sediment; reduced pond capacity	Remove and dispose of sediment. Repair vegetation as needed
Major Erosion Repair	As needed – based upon scheduled inspections	Severe erosion including gullies, excessive soil displacement, areas of settlement, holes	Repair erosion – find cause of problem and address to avoid future erosion
Structural Repair	As needed – based upon scheduled inspections	Deterioration and/or damage to structural components – broken concrete, damaged pipes, outlet works	Structural repair to restore the structure to its original design

EDB-3.8.1 Major Sediment Removal

Major sediment removal consists of removal of large quantities of sediment or removal of sediment from vegetated areas. Care shall be given when removing large quantities of sediment and sediment deposited in vegetated areas. Large quantities of sediment need to be carefully removed, transported and disposed of. Vegetated areas need special care to ensure design volumes and grades are preserved.

Major sediment removal activities will require larger and more specialized equipment. The major sediment activities will also require surveying with an engineer’s level, and consultation with El Paso County Stormwater and Engineering Staff to ensure design volumes/grades are achieved. Pond volume recertification will be required in accordance with El Paso County’s drainage criteria manual.

Frequency – Nonroutine – Repair as needed based upon inspections.

EDB-3.8.2 Major Erosion Repair

Major erosion repair consists of filling and revegetating areas of severe erosion. Determining the cause of the erosion as well as correcting the condition that caused the erosion should also be part of the erosion repair. Care should be given to ensure design grades and volumes are preserved. Any condition/repair affecting design grades or pond volumes requires consultation with El Paso County Stormwater and Engineering Staff.

Frequency – Nonroutine – Repair as needed based upon inspections.
EDB-3.8.3 Structural Repair

An EDB includes a variety of structures that can deteriorate or be damaged during the course of use and routine maintenance. These structures are constructed of steel and concrete that can degrade or be damaged and may need to be repaired or re-constructed from time to time. These structures include items like outlet works, trickle channels, forebays, inflows and other features. In-house operations staff can perform some of the minor structural repairs. Major repairs to structures may require input from a structural engineer and specialized contractors. Consultation with El Paso County and Engineering Staff shall take place prior to all structural repairs.

Frequency – Nonroutine – Repair as needed based upon inspections.

A P P E N D I X C - 2

Grass Buffers and Grass Swales Including Channels

Standard Operation Procedures
for
Inspection and Maintenance

Grass Buffers and Grass Swales
(GB-GS)

September 2010

Table of Contents

GB-GS-1 BACKGROUND 3

GB-GS-2 INSPECTING GRASS BUFFERS AND SWALES (GB-GS) 3

GB-GS-2.1 Access and Easements 3

GB-GS-2.2 Stormwater Management Facilities Locations 3

GB-GS-2.3 Grass Buffer - Grass Swale (GB-GS) Features 3

GB-GS-2.3.1 Grass Swale Bottom and Side Slopes; Grass Buffer Strips..... 4

GB-GS-2.3.2 Inflow Points 5

GB-GS-2.3.3 Underdrain System..... 5

GB-GS-2.3.4 Grade Control Level Spreader..... 6

GB-GS-2.3.5 Irrigation 6

GB-GS-2.3.6 Miscellaneous..... 7

GB-GS-2.4 Inspection Forms 7

GB-GS-3 MAINTAINING GRASS BUFFERS & GRASS SWALES (GB-GS)..... 7

GB-GS-3.1 Maintenance Personnel..... 7

GB-GS-3.2 Equipment 8

GB-GS-3.3 Maintenance Forms..... 8

GB-GS-3.4 Maintenance Categories and Activities..... 8

GB-GS-3.5 Routine Maintenance Activities 9

GB-GS-3.5.1 Trash/Debris Removal..... 9

GB-GS-3.5.2 Mowing..... 10

GB-GS-3.5.3 Irrigation 10

GB-GS-3.5.4 Weed Control 10

GB-GS-3.5.5 Mosquito Treatment 11

GB-GS-3.5.6 Level Spreader (Grass Buffer only) 11

GB-GS-3.5.7 Rodent Damage 11

GB-GS-3.6 Minor Maintenance Activities..... 11

GB-GS-3.6.1 Sediment Removal..... 12

GB-GS-3.6.2 Erosion Repair..... 12

GB-GS-3.6.3 Vegetation Removal 13

GB-GS-3.6.4 Revegetation 13

GB-GS-3.6.5 Level Spreader 13

GB-GS-3.6.6 Fertilization/Soil Amendment..... 13

GB-GS-3.6.7 Vehicle Tracks..... 14

GB-GS-3.7 Major Maintenance Activities..... 14

GB-GS-3.7.1 Major Sediment/Pollutant Removal 15

GB-GS-3.7.2 Major Erosion Repair..... 16

GB-GS-3.7.3 Structural Repair 16

GB-GS-3.7.4 GB-GS Rebuild..... 16

GB-GS-1 BACKGROUND

Grass Buffers and Grass Swales are common types of Stormwater Management Facilities utilized within the Front Range of Colorado. Grass Buffers and Grass Swales promote filtration, infiltration, and settling to reduce runoff volume.

Grass Buffers are uniformly graded and densely vegetated areas of turf grass. They are designed to accommodate sheet flow rather than concentrated or channelized flow. They are typically located adjacent to impervious areas such as parking lots or along roads. Grass Buffers are designed to evenly distribute runoff across the width of the buffer to achieve uniform sheet-flow conditions. A flow spreader may be incorporated for this purpose. In some cases, grass buffers may have underdrain systems.

Grass Swales are densely vegetated drainage ways with low-pitched side slopes that collect and convey runoff. Design of their longitudinal slope and cross section forces the flow to be slow and shallow, thereby facilitating sedimentation while limiting erosion. Berms or check dams may be installed perpendicular to the flow to decrease the slope and slow down the flow. Grass swales are used in open space and landscaped areas to collect and convey overland flows, and can be used as an alternative to curb and gutter (when approved by the County Engineer) to collect and convey street flows. Some grass swales are designed with underdrain systems.

Channels

GB-GS-2 INSPECTING GRASS BUFFERS AND SWALES (GB-GS)

GB-GS-2.1 Access and Easements

Inspection and maintenance personnel may utilize the stormwater facility map located in Appendix G containing the locations of the access points and maintenance easements of the GB-GSs within this development.

GB-GS-2.2 Stormwater Management Facilities Locations

Inspection and maintenance personnel may utilize the stormwater facility map located in Appendix G containing the locations of the GB-GSs within this development.

GB-GS-2.3 Grass Buffer - Grass Swale (GB-GS) Features

GB-GSs are unique stormwater quality facilities, in that they are typically viewed as landscaping or ground cover, and are often overlooked as water quality treatment facilities. GB-GSs have a number of features designed to serve a particular function. It is important for maintenance personnel to understand the function of each of these features. Below is a list of the common features of a Grass Swale or Grass Buffer and the corresponding maintenance inspection items anticipated:

**Table GB-GS-1
Typical Inspection & Maintenance Requirements Matrix**

	Sediment Removal	Mowing Weed control	Trash & Debris Removal	Erosion	Removal/ Replacement	Structural Repair
Swale Bottom	X	X	X	X		
Side Slope		X	X	X		
Buffer Strip	X	X	X	X		
Inflows	X	X	X	X	X	X
Underdrain System*					X	
Grade Control/Level Spreader				X		X
Irrigation System					X	

*If the design and inspection allows, flushing of the system may be all that is needed.

GB-GS-2.3.1 Grass Swale Bottom and Side Slopes; Grass Buffer Strips

Grass Swales and Grass Buffers require general maintenance of the turf grass and repair of any rill or gully development. The bottom and side slopes of grass swales and the area of grass buffer strips should be maintained with dense vegetative cover, and should not be eroded or bare. Inspection over the first few years will help to determine if any problems are developing.

The typical maintenance items required at the side slopes and bottoms of grass swales and within grass buffer areas are as follows:

- a. *Sediment Accumulation* – The purpose of the grass swale or buffer is to slow down flow and allow sedimentation to occur. To prevent a loss in performance of the swale or buffer, sediment that accumulates must be removed on a timely basis.

- b. *Vegetation Sparse* – Grass Swales and Buffers rely on a healthy, dense cover of grass to decrease the flow velocities and promote sedimentation and infiltration. Grasses that are diseased, dying or otherwise damaged should be replaced. All bare areas should be reseeded or patched. Causes which contribute to the damaged grass cover, including lack of adequate irrigation, traces of pedestrian or vehicular traffic, uncontrolled weeds, excessive sedimentation accumulation, etc., should be identified and remedied.

- c. *Erosion Present* – Lack of adequate vegetative cover or excessive flow velocities may result in rill or gully development, and erosion of the swale or buffer strip. Erosion will require maintenance to prevent further damage to the area and to prevent sediment transport.

d. *Standing Water/Boggy Areas* – Grass swales and buffers are generally intended to drain and be dry in between rain events. If areas of standing water are present, the swale or buffer may need to be evaluated for proper grade to ensure drainage or the addition of underdrains. In some cases, where underdrains are used, the underdrains should be inspected to ensure that they are not clogged.

GB-GS-2.3.2 Inflow Points

Inflow points are the points of stormwater discharge into the swale or buffer. Inflow points are typically pipe outfalls, other grass swales or buffers, or curb cuts from upstream impervious areas, such as parking lots. Some form of energy dissipation is typically provided immediately downstream of the inflow point into the grass swale or buffer. Energy dissipation devices may include riprap aprons, or flow spreader devices.

The typical maintenance items required at inflow points are as follows:

- a. *Riprap Displaced/Rundown Damaged* – Often, because of the repeated impact/force of water, the riprap can shift and settle. If any portion of the riprap rundown or apron appears to have settled, if soil is present between the riprap, or if the riprap has shifted, maintenance may be required to ensure future erosion is prevented.
- b. *Erosion Present/Outfall Undercut* – In some situations, an energy dissipater may have not been provided, or may not have been sized, constructed, or maintained appropriately and erosion has occurred. Any erosion within the vicinity of the inflow point will require maintenance to prevent damage to the structure(s) and sediment transport within the facility.
- c. *Sediment Accumulation* – Because of the turbulence in the water created by the energy dissipater, sediment often deposits immediately downstream of the inflow point. To prevent a loss in performance, sediment that accumulates in this area must be removed on a timely basis.

GB-GS-2.3.3 Underdrain System

Some grass swales and buffers that have a flatter slope or soils which do not allow adequate percolation or are in areas with a continuous base flow may have been installed with an underdrain system. Underdrains typically consist of a layer of geotextile fabric, gravel storage area and perforated PVC pipe. The geotextile fabric is utilized to prevent the filter material from entering the underdrain system. The gravel storage area allows for storage of treated stormwater runoff prior to the discharge of the runoff through the perforated PVC pipe.

The typical maintenance activities required for the underdrain system are as follows:

With proper maintenance of the grassed areas, there should be a minimum amount of maintenance required on the underdrain system. Generally the only maintenance performed on the underdrain system is jet-vac cleaning in the event it becomes clogged.

GB-GS-2.3.4 Grade Control Level Spreader

Grass swales installed in areas with steep longitudinal slopes often necessitate the use of grade control checks or drop structures. Grade control structures are typically either concrete walls or rip rap structures that serve to provide a reinforced drop at specific locations in the channel, reducing the longitudinal slope between the control structures.

Level Spreaders are installed on the upstream of grass buffers to evenly distribute flows along the design length. Level spreaders may consist of slotted curbing, modular block porous pavement, level walls or other spreader devices.

The typical maintenance activities required for grade control structures and level spreaders are as follows:

a. Erosion present – Grade control structures and level spreaders are provided to reduce the potential for erosion of the grassed swale or buffer areas. Erosion within the vicinity of the control structure or level spreader indicates the structure is not functioning as intended and requires maintenance to prevent future erosion and damage. Or, review the original design if erosion becomes chronic.

b. Structural damage – Structural damage can occur at anytime along the life of the facility. Typically, structural damage occurs with the deterioration of concrete, including cracking, spalling or settling and the erosion and deterioration of the riprap structures. Level spreaders may settle unevenly creating low areas, which concentrate the flows. Partial or full replacement may be required depending on the extent of the damage.

GB-GS-2.3.5 Irrigation

Grass Buffers and Grass Swales depend on healthy, dense turf grass to function, and therefore require an irrigation system, to provide a consistent water supply. Typically, the condition of the grass cover will provide evidence of the effectiveness and maintenance needs of the irrigation system.

The typical maintenance activities required for irrigation systems are as follows:
Irrigation systems will generally require routine periodic maintenance and

adjustment to ensure proper amounts of water are being applied given the weather conditions, and that they are providing coverage to all areas of the grass to eliminate bare spots.

GB-GS-2.3.6 Miscellaneous

There are a variety of inspection/maintenance issues that may not be attributed to a single feature within the GB-GS. This category on the inspection form is for maintenance items commonly found in the GB-GS, but may not be attributed to an individual feature.

a. Encroachment in Easement Area – The El Paso County requires GB-GS be located in tracts or drainage easements. Property owners may not place landscaping, trash, fencing, or other items within the easement area that may adversely affect maintenance or the operation of the facility.

b. Public Hazards – Public hazards include items such as containers of unknown/suspicious substances, and exposed metal/jagged concrete on structures. **If any unknown/suspicious hazard is found within the facility area that poses an immediate threat to public safety, call 911 immediately.**

c. Burrowing Animals/Pests– Prairie dogs and other burrowing rodents may cause damage to the GB-GS features and negatively affect the vegetation within the GB-GS.

d. Other – Any miscellaneous inspection/maintenance items not contained on the form should be entered here.

GB-GS-2.4 Inspection Forms

GB-GS Inspection forms are located in Appendix D. Inspection forms shall be completed by the person(s) conducting the inspection activities. Each form shall be reviewed and submitted by the property owner or property manager to the El Paso County per the requirements of the Inspection and Maintenance Plan. These inspection forms shall be kept indefinitely and made available to the El Paso County upon request

GB-GS-3 MAINTAINING GRASS BUFFERS & GRASS SWALES (GB-GS)

GB-GS-3.1 Maintenance Personnel

Maintenance personnel must be experienced to properly maintain GB-GSs. Inadequately trained personnel can cause additional problems resulting in additional maintenance costs.

GB-GS-3.2 Equipment

It is imperative the appropriate equipment and tools are taken to the field with the operations crew. The types of equipment/tools will vary depending on the task at hand. Below is a basic list of tools, equipment, and material(s) that may be necessary to perform maintenance on a GB-GS:

- 1.) Mowing Tractors
- 2.) Trimmers (extra string)
- 3.) Shovels
- 4.) Rakes
- 5.) All Surface Vehicle (ASVs)
- 6.) Engineers Level (laser)
- 7.) Erosion Control Blanket(s)
- 8.) Mulch
- 9.) Sod or Seed (See seed mix in the *Rules and Regulations Regarding Stormwater (Quality) Discharge for Construction Activities*, Std Det. SM, Seeding & Mulching)
- 10.) Illicit Discharge Cleanup Kits
- 11.) Trash Bags
- 12.) Jet-Vac Equipment
- 13.) Stormwater Facility Inspection and Maintenance Plan

Some of the items identified above may not be needed for every maintenance operation. However, this equipment should be available to the maintenance operations crews should the need arise.

GB-GS-3.3 Maintenance Forms

The GB-GS Maintenance Form provides a record of each maintenance operation performed by maintenance contractors. The GB-GS Maintenance Form shall be filled out in the field after the completion of the maintenance operation. Each form shall be reviewed and submitted by the property owner or property manager to the El Paso County per the requirements of the Inspection and Maintenance Plan. The GB-GS Maintenance form is located in Appendix E.

GB-GS-3.4 Maintenance Categories and Activities

A typical GB-GS Maintenance Program will consist of three broad categories of work: Routine, Minor and Major. Within each category of work, a variety of maintenance activities can be performed on a GB-GS. A maintenance activity can be specific to each feature within the GB-GS, or general to the overall facility. This section of the SOP explains each of the categories and briefly describes the typical maintenance activities for a GB-GS.

A variety of maintenance activities are typical of GB-GSs. The maintenance activities range in magnitude from routine trash pickup to the reconstruction of the GB-GS or underdrain system. Below is a description of each maintenance activity, the objectives, and frequency of actions.

GB-GS-3.5 Routine Maintenance Activities

The majority of this work consists of scheduled mowing, trash and debris pickups and landscape care for the GB-GS during the growing season. It also includes activities such as weed control. These activities normally will be performed numerous times during the year. These items do not require any prior approval by the El Paso County, however, completed inspection and maintenance forms shall be submitted to the El Paso County for each inspection and maintenance activity in accordance with the Inspection and Maintenance plan.

The Routine Maintenance Activities are summarized below, and further described in the following sections.

**Table GB-GS-2
Summary of Routine Maintenance Activities**

Maintenance Activity	Minimum Frequency	Indication Action is Needed:	Maintenance Action
Trash/Debris Removal	Twice annual and before mowing	Trash & debris in GB-GS	Remove and properly dispose of trash and debris
Mowing	Routine – as necessary to maintain 2” – 4” grass height	Excessive grass height/aesthetics	2”-4” grass height for turf grass; 4” to 6” for native grass
Irrigation (Not Automatic)	As needed to maintain healthy grass	Areas of insufficient or excess watering	Water as needed to maintain healthy grass; (follow watering regulations)
Weed Control	Minimum twice annually	Noxious weeds; Unwanted vegetation	Treat w/herbicide or hand pull; consult a local Weed Inspector
Mosquito Treatment	As needed, based upon inspections	Standing water/ mosquito habitat	Perform maintenance to eliminate standing water*; Treat w/ EPA approved chemicals
Level Spreader (Grass Buffer only)	As needed, based upon inspections	Evidence of uneven flow/localized erosion	Look for cause; repair, fill or revegetate areas of erosion
Rodent Damage	As needed, based upon inspections	Holes, small piles of dirt, raised burrows	Evaluate damage; contact Parks Dept. or Division of Wildlife for guidance

*See Section GB-GS-2.3.1d for further discussion

GB-GS-3.5.1 Trash/Debris Removal

Trash and debris must be removed from the GB-GS area to allow for proper functioning and to improve aesthetics. This activity must be performed prior to mowing operations.

Frequency – Routine – Prior to mowing operations and a minimum of twice annually.

GB-GS-3.5.2 Mowing

Routine mowing of the turf grass embankments is necessary to maintain an appropriate grass height and to improve the overall appearance of the GB-GS. Turf grass should be mowed to a height of 2 to 4- inches (4 – 6- inches for native grass) and shall be bagged to prevent potential contamination of the filter media, especially if there is an underdrain system.

Frequency – Routine – as necessary to maintain grass height.

GB-GS-3.5.3 Irrigation

Irrigation systems should be maintained in proper working order to provide an adequate water supply to support the grass cover. When automatic irrigation systems are not available, alternate methods for providing a water supply during times of drought must be provided.

Automatic irrigation systems should be maintained routinely throughout the growing season to ensure that they are providing the appropriate amounts of water, and are providing complete coverage of the area. Sprinkler heads should be adjusted as necessary, and checked for broken or missing parts.

Frequency - Routine as needed throughout the growing season, plus the following:

 SPRING: Start up the system and test for even coverage and correct timer settings.

 SUMMER: Test for even coverage and correct timer settings.

 FALL: Drain and winterize the system.

GB-GS-3.5.4 Weed Control

Noxious weeds and other unwanted vegetation must be treated as needed throughout the GB-GS. This activity can be performed either through mechanical means (mowing/pulling) or with herbicide. Consultation with a local Weed Inspector is highly recommended prior to the use of herbicide. Herbicides should be utilized sparingly and as a last resort. All herbicide applications should be in accordance with the manufacturer's recommendations.

Frequency – Routine – As needed based upon inspections.

GB-GS-3.5.5 Mosquito Treatment

GB-GS facilities are intended to drain, and should not have areas of standing water which creates mosquito habitat. Causes of the standing water or boggy conditions should be investigated and remediated as necessary to eliminate the standing water. Only EPA approved chemicals should be applied in accordance with the recommendations of the manufacturer. See Section GB-GS-2.3.1d.

Frequency – As needed based upon inspections.

GB-GS-3.5.6 Level Spreader (Grass Buffer only)

Evidence of uneven flow and localized erosion downstream of the level spreader indicates the flow is not evenly distributed along the length of the spreader. Areas of erosion should be repaired, filled and revegetated. Causes for the erosion should be investigated and repaired.

Frequency – As needed based upon inspections.

GB-GS-3.5.7 Rodent Damage

Small holes, piles of dirt, and raised burrows are evidence of rodent damage. Damaged areas should be repaired and revegetated. Consultation with an animal control specialist or the Division of Wildlife may be required for persistent problems.

Frequency – As needed based on inspections.

GB-GS-3.6 Minor Maintenance Activities

This work consists of a variety of isolated or small-scale maintenance/operational problems. Most of this work can be completed by a small crew, hand tools, and small equipment. These items do not require approval by the El Paso County. Completed inspection and maintenance forms shall be submitted to the El Paso County for each inspection and maintenance activity. These minor maintenance activities are to be used for the grass swales, grass buffers, channels, and riprap berms onsite as applicable and deemed necessary by inspection. Maintenance activities for drainage facilities include mowing, trash/debris removal, outlet works cleaning, & weed control. For additional detail on these activities, see table GB-GS-2 above.

**Table GB-GS-3
Summary of Minor Maintenance Activities**

Maintenance Activity	Minimum Frequency	Indication Action is Needed:	Maintenance Action
Sediment Removal	As needed.	Sediment build-up.	Remove and properly dispose of sediment
Erosion Repair	As needed, based upon inspection	Rills and gullies forming on slopes and other areas	Repair eroded areas & revegetate; address cause
Vegetation Removal	As needed, based upon inspection	Trees, willows, shrubs impeding flow	Remove vegetation; restore correct grade and surface
Revegetation	As needed, based upon inspection	Areas without grass	Replace grass by sodding or seeding
Level Spreader (Grass Buffer Only)	As needed, based upon inspection.	Evidence of uneven flow; erosion; or rills/gullies	Repair sections of level spreader and address cause
Fertilization or Soil Amendment	As needed, minimize fertilization	Grass with pale color; areas with poor grass growth not due to irrigation problems	Consult with turf specialist; Test soil
Vehicle Tracks (Along Roadways)	As needed, based upon inspection	Depressions from vehicle tracks; vegetation damage	Repair and fill depressions; sod or seed damaged areas

GB-GS-3.6.1 Sediment Removal

Sediment removal is necessary to ensure proper function of the grass swale or buffer. Care should be taken when removing sediment to prevent damage to the turf grass and surrounding areas. Excessive amounts of sediment are an indication of upstream erosion or lack of adequate BMPs during construction activities. Causes for contributions of excess sediment should be investigated and addressed.

Frequency – As needed based upon inspections.

GB-GS-3.6.2 Erosion Repair

The repair of eroded areas is necessary to ensure the proper functioning of the GB-GS or channel, to minimize sediment transport, and to reduce potential impacts to other features. Erosion can vary in magnitude from minor repairs to vegetation and embankments, to rills and gullies in the embankments and inflow points. The repair of eroded areas may require the use of excavators, riprap, new poured-in-place concrete, and sod. Extreme care should be taken when utilizing motorized or heavy equipment to ensure damage to the underdrain system, if present, does not occur. Major erosion in a GS-GB is generally the result of excessive velocities caused by steep slopes. It may be necessary to

make design improvements to the swale or buffer when erosion becomes a major maintenance item.

Frequency – As necessary, based upon inspections.

GB-GS-3.6.3 Vegetation Removal

Weeds, Shrubs, Willows and other unwanted vegetation that develops in the grass swale or buffer area may impede the flow and cause standing water or back flow problems. It is necessary to remove unwanted vegetation as soon as it appears. Remove the unwanted vegetation, and restore the correct grade. Revegetate with seed or sod. Supplement irrigation as needed until new vegetation is sufficiently established.

Frequency – As necessary, based upon inspections.

GB-GS -3.6.4 Revegetation

Bare areas should be repaired as soon as possible. Repair bare areas with appropriate grass seed or sod. Supplement irrigation as needed until new vegetation is sufficiently established. Causes of the problem, such as inadequate water supply or diseased grasses, should be investigated and resolved.

Frequency – As necessary, based upon inspections.

GB-GS-3.6.5 Level Spreader

Level Spreaders that are no longer level, or have developed damaged areas of cracking or spalling, allow flows to concentrate in these depressed areas instead of being distributed over the length of the structure. Also, build up of grasses along the edge of the spreader may create an uneven flow distribution. Rills, gullies and other erosion that develop downstream of level spreaders should be repaired and reseeded or sodded. Causes of the erosion should be investigated and addressed.

Frequency – As necessary, based upon inspections.

GB-GS-3.6.6 Fertilization/Soil Amendment

Grass Buffers and Swales rely on healthy, dense turf in order to function properly. Grasses that appear to be diseased, dying or unhealthy may require amendments. Fertilizers should be applied in the minimum amounts recommended by the manufacturer. Check for insect infestation also.

Frequency – As necessary, based upon inspections.

GB-GS-3.6.7 Vehicle Tracks

GB-GSs adjacent to roadway sections or drive aisles in parking lots may be damaged by vehicle tracks. Rutted areas should be filled in and revegetated as soon as possible. Frequent problems associated with vehicle traffic (such as around corners) may require a barrier or sign to avoid vehicular traffic within the grassed areas.

Frequency – As necessary, based upon inspections.

GB-GB-3.7 Major Maintenance Activities

This work consists of larger maintenance/operational problems and failures within the stormwater management facilities. All of this work requires consultation with the El Paso County Water Staff to ensure the proper maintenance is performed. This work requires the El Paso County Stormwater and Engineering Staff review the original design and construction drawings to assess the situation before approval of the proposed maintenance. This work may also require more specialized maintenance equipment, design/details, submittal of plans to the El Paso County for review and approval, surveying, or assistance through private contractors and consultants.

**Table GB-GS-4
Summary of Major Maintenance Activities**

Maintenance Activity	Minimum Frequency	Look for:	Maintenance Action
Major Sediment/Pollutant Removal	As needed – based upon scheduled inspections	Large quantities of sediment	Remove and dispose of sediment. Repair vegetation as needed
Major Erosion Repair	As needed – based upon scheduled inspections	Severe erosion including gullies, excessive soil displacement, areas of settlement, holes	Repair erosion – find cause of problem and address to avoid future erosion
Structural Repair	As needed – based upon scheduled inspections	Deterioration and/or damage to structural components – level spreader, grade control structures, irrigation components, and ponding water.	Structural repair to restore the structure to its original design
GB-GS/Channel Rebuild	As needed – due to complete failure of BMP	Removal of filter media and underdrain system	Contact El Paso County Water Staff

GB-GS-3.7.1 Major Sediment/Pollutant Removal

Major sediment removal consists of removal of large quantities of pollutants/sediment /landscaping material. Stormwater sediments removed from GB-GS or channels do not meet the regulatory definition of “hazardous waste”. However, these sediments can be contaminated with a wide array of organic and inorganic pollutants and handling must be done with care to insure proper removal and disposal. Sediments should be transported by motor vehicle only after they are dewatered. All sediments must be taken to a licensed landfill for proper disposal. Should a spill occur during transportation, prompt and thorough cleanup and disposal is imperative. Vegetated areas need special care to ensure design volumes and grades are preserved or may need to be replaced due to the removal activities.

Frequency – Non-routine – Repair as needed, based upon inspections.

GB-GS-3.7.2 Major Erosion Repair

Major erosion repair consists of filling and revegetating areas of severe erosion. Determining the cause of the erosion as well as correcting the condition that caused the erosion should also be part of the erosion repair. Care should be given to ensure design grades and volumes are preserved.

Frequency – Non-routine – Repair as needed, based upon inspections.

GB-GS-3.7.3 Structural Repair

A GB-GS generally includes level spreader and grade control structure that can deteriorate or be damaged during the service life of the facility. These structures are constructed of steel and concrete that can degrade or be damaged and may need to be repaired or re-constructed from time to time. Major repairs to structures may require input from a structural engineer and specialized contractors. Consultation with the El Paso County Water and Engineering Staff shall take place prior to all structural repairs.

Frequency – Non-routine – Repair as needed, based upon inspections.

GB-GS-3.7.4 GB-GS Rebuild

In very rare cases, a GB-GS or channel may need to be rebuilt. Generally, the need for a complete rebuild is a result of improper construction, improper maintenance resulting in structural damage to the underdrain system, if present, or extensive contamination of the GB-GS. Consultation with the El Paso County Water and Engineering Staff shall take place prior to any rebuild project.

Frequency – Non-routine – As needed based upon inspections.

A P P E N D I X D

Inspection Forms



GRASS BUFFER-GRASS SWALE INSPECTION FORM

Date: _____

Subdivision/Business Name: _____ Inspector: _____

Subdivision/Business Address: _____

Weather: _____

Date of Last Rainfall: _____ Amount: _____ Inches

Property Classification: Residential Multi Family Commercial Other: _____
(Circle One)

Reason for Inspection: Routine Complaint After Significant Rainfall Event
(Circle One)

INSPECTION SCORING - For each facility inspection item, insert one of the following scores:
0 = No deficiencies identified 2 = Routine maintenance required
1 = Monitor (potential for future problem) 3 = Immediate repair necessary
N/A = Not applicable

FEATURES

1.) Grass Swale Bottom & Side Slopes

- ___ Sediment/Debris Accumulation
- ___ Vegetation Cover
- ___ Erosion Present
- ___ Standing Water/Boggy Areas

2.) Grass Buffer

- ___ Sediment/Debris Accumulation
- ___ Vegetation Cover
- ___ Erosion Present
- ___ Standing Water/Boggy Areas

3.) Inflow Points

- ___ Rip Rap Displaced/Run-down or Pipe Damage
- ___ Erosion Present/Outfall Undercut
- ___ Sediment Accumulation

4.) Underdrain System

- ___ Standing water/Not draining
- ___ Evidence of clogged system

5.) Grade Control

- ___ Erosion Present
- ___ Structural Damage

6.) Level Spreader

- ___ Erosion Present
- ___ Structural Damage
- ___ Unlevel/Uneven Distribution of flow

7.) Irrigation

- ___ General Grass Condition
- ___ Bare Spots
- ___ Broken sprinkler heads

8.) Miscellaneous

- ___ Encroachment in Easement Area
- ___ Public Hazards
- ___ Burrowing Animals/Pests
- ___ Other

Inspection Summary / Additional Comments: _____

OVERALL FACILITY RATING (Circle One)

0 = No Deficiencies Identified 2 = Routine Maintenance Required
1 = Monitor (potential for future problem exists) 3 = Immediate Repair Necessary

This inspection form shall be kept indefinitely and made available to the City of Aurora upon request.

A P P E N D I X E

Maintenance Forms



EXTENDED DETENTION BASIN (EDB) MAINTENANCE FORM

Subdivision/Business Name: _____ Completion Date: _____

Subdivision/Business Address: _____ Contact Name: _____

Maintenance Category: (Circle All That Apply)	Routine	Restoration	Rehabilitation
---	---------	-------------	----------------

MAINTENANCE ACTIVITIES PERFORMED

ROUTINE WORK

- MOWING
- TRASH/DEBRIS REMOVAL
- OUTLET WORKS CLEANING (TRASH RACK/WELL SCREEN)
- WEED CONTROL (HERBICIDE APPLICATION)
- MOSQUITO TREATMENT
- ALGAE TREATMENT

RESTORATION WORK

- SEDIMENT REMOVAL
 - FOREBAY
 - TRICKLE CHANNEL
 - INFLOW
- EROSION REPAIR
 - INFLOW POINT
 - TRICKLE CHANNEL
- VEGETATION REMOVAL/TREE THINNING
 - INFLOW(S)
 - TRICKLE CHANNEL
 - UPPER STAGE
 - BOTTOM STAGE
- REVEGETATION
- JET-VAC/CLEARING DRAINS
 - FOREBAY
 - OUTLET WORKS
 - INFLOWS

REHABILITATION WORK

- SEDIMENT REMOVAL (DREDGING)
 - BOTTOM STAGE
 - UPPER STAGE
- EROSION REPAIR
 - OUTLET WORKS
 - UPPER STAGE
 - BOTTOM STAGE
 - SPILLWAY
- STRUCTURAL REPAIR
 - INFLOW
 - OUTLET WORKS
 - FOREBAY
 - TRICKLE CHANNEL

OTHER _____

ESTIMATED TOTAL MANHOURS: _____

EQUIPMENT/MATERIAL USED: _____

COMMENTS/ADDITIONAL INFO: _____

This Maintenance Activity Form shall be kept indefinitely and made available to the City of Aurora upon request.



**GRASS BUFFERS AND GRASS SWALES
(GB-GS)
MAINTENANCE FORM**

Subdivision/Business Name: _____ Completion Date: _____

Subdivision/Business Address: _____ Contact Name: _____

Maintenance Category: Routine Restoration Rehabilitation
(Circle all that apply)

MAINTENANCE ACTIVITIES PERFORMED

ROUTINE WORK

- MOWING
- TRASH/DEBRIS REMOVAL
- OUTLET WORKS CLEANING (TRASH RACK/WELL SCREEN)
- WEED CONTROL (HERBICIDE APPLICATION)

RESTORATION WORK

- SEDIMENT REMOVAL
 - INFLOW POINT
 - SWALE BOTTOM
 - SIDE SLOPE
 - BUFFER STRIP
- EROSION REPAIR
 - INFLOW POINT
 - SWALE BOTTOM
 - SIDE SLOPE
 - BUFFER STRIP
 - GRADE CONTROL/LEVEL SPREADER
- REVEGETATION
 - SWALE BOTTOM
 - SIDE SLOPE
 - BUFFER STRIP

REHABILITATION WORK

- SEDIMENT REMOVAL (DREDGING)
 - SWALE BOTTOM
 - INFLOW POINT
- EROSION REPAIR
 - INFLOW POINT
 - SWALE BOTTOM
 - SIDE SLOPE
 - BUFFER STRIP
- STRUCTURAL REPAIR
 - INFLOW
 - UNDERDRAIN
 - LEVEL SPREADER

OTHER _____

ESTIMATED TOTAL MANHOURS: _____

EQUIPMENT/MATERIAL USED: _____

COMMENTS/ADDITIONAL INFO: _____

This Maintenance Activity Form shall be kept indefinitely and made available to the City of Aurora upon request.

A P P E N D I X F

Inspection and Maintenance Site Plan(s)

Check Lists

Facilities Map Checklist

EDB Checklist

GB-GS Checklist

**INSPECTION AND MAINTENANCE SITE PLANS
STORMWATER FACILITIES MAP
CHECKLIST FOR REQUIRED ITEMS**

Stormwater facilities map shall include:

- Labels for all streets (includes line work for edge of street and street name)
- Line work for right-of-way lines, lot lines, and tracts
- Line work and labels for all major drainage ways
- Label roadways, developments, etc adjacent to project site
- Labels for all BMPs being constructed on project site including a summary table when multiple BMPs are present
- Legend for identifying features/line types on drawing (optional)

INSPECTION AND MAINTENANCE SITE PLANS EXTENDED DETENTION BASIN (EDB) CHECKLIST FOR REQUIRED ITEMS

PLAN AND PROFILE SHEET

Plan view shall include:

- Location and labels for all major features of EDB (inflow structure(s), forebay, micro-pool, trickle channel, access road, outlet work(s), spillway, maintenance access ramps, embankment, etc.)
- Contours
- Other utilities in vicinity of EDB
- Cross-reference to EDB Operation and Maintenance Details sheet
- Line work for right-of-way lines, lot lines, easements, and tracts
- Hatch indicating permanent water elevation in micro-pool.

Profile view shall include:

- Location and labels for all major features of EDB (inflow structure(s), forebay, micro-pool, trickle channel, access road, outlet work(s), spillway, maintenance access ramps, embankment, etc.)
- Invert elevations at major features of EDB (inflow structure(s), forebay, micro-pool, outlet work(s))
- Permanent pool elevation of micro-pool
- Water quality water surface elevation
- Water surface elevation of all applicable storm events
- Label for upper and bottom stages for EDB

DETAIL SHEET

Detail sheet shall include:

- Volume provided by the EDB forebay and micro-pool, including the WQCV
- WQCV drain time
- Seed mix
- Total mow area including approximate mow boundaries on each side of EDB
- Duplicate the following tables from the “Standard Operation Procedure for Extended Detention Basin Inspection and Maintenance” document:
 - Inspection and Maintenance Requirements at Specific EDB Features

- Summary of Routine Maintenance Activities for an EDB
 - Summary of Minor Maintenance Activities for an EDB
 - Summary of Major Maintenance Activities for an EDB
- Water quality outlet works detail
- Water quality plate detail
- Maintenance access road detail
- Trickle channel typical section
- Forebay edge detail (or cross section) which includes maximum allowed sediment depth in forebay
- Forebay release structure detail
- Spillway detail(s), including cutoff wall

**INSPECTION AND MAINTENANCE SITE PLANS
GRASS SWALES/GRASS BUFFERS (GS/GB)
CHECKLIST FOR REQUIRED ITEMS**

PLAN SHEET

Plan view shall include:

- Location of grass swale(s) and/or buffer(s)
- Contours
- Line work for right-of-way lines, lot lines, easements, and tracts
- Labels for streets adjacent to grass swale(s)/buffer(s)
- Line work for all storm sewer structures
- Cross-reference to Grass Swale/Buffer Operation and Maintenance Details sheet

DETAIL SHEET

Detail sheet shall include:

- Duplicate the following tables from the “Standard Operation Procedure for Grass Swales/Grass Buffers Inspection and Maintenance” document:
 - Typical Inspection and Maintenance Requirements Matrix
 - Summary of Routine Maintenance Activities
 - Summary of Minor Maintenance Activities
 - Summary of Major Maintenance Activities
- Typical grass swale and/or buffer section including typical horizontal and vertical dimensions, side slopes, subgrade material, and underdrain (if applicable).
- Underdrain details (if applicable) including trench dimensions, perforated PVC dimensions, and trench fill material.

SADDLEHORN RANCH -
FILING 1
FACILITIES MAP

NO.	REVISION
1-150	
DATE	03/07/20
DESIGNED BY	NJU
CHECKED BY	NJU

BY	DATE

J.R. ENGINEERING
A Western Company
Central 303-740-3333 • Colorado Springs 719-593-2593
FPO Color 970-671-9880 • www.jrengineering.com

PREPARED FOR
ROI PROPERTY GROUP, LLC
2496 RICHMOND STREET
NAPA, CALIFORNIA
(707) 343-6391
BRADY WILLIAMS
DESIGNATED BY WRITTEN
AUTHORIZATION.

UNTIL SUCH TIME AS
THESE DRAWINGS ARE
APPROVED BY THE
APPROPRIATE REVIEWING
AGENCIES IN ENGINEERING
OR ARCHITECTURE.
ONLY FOR THE PURPOSES
INDICATED BY WRITTEN
AUTHORIZATION.

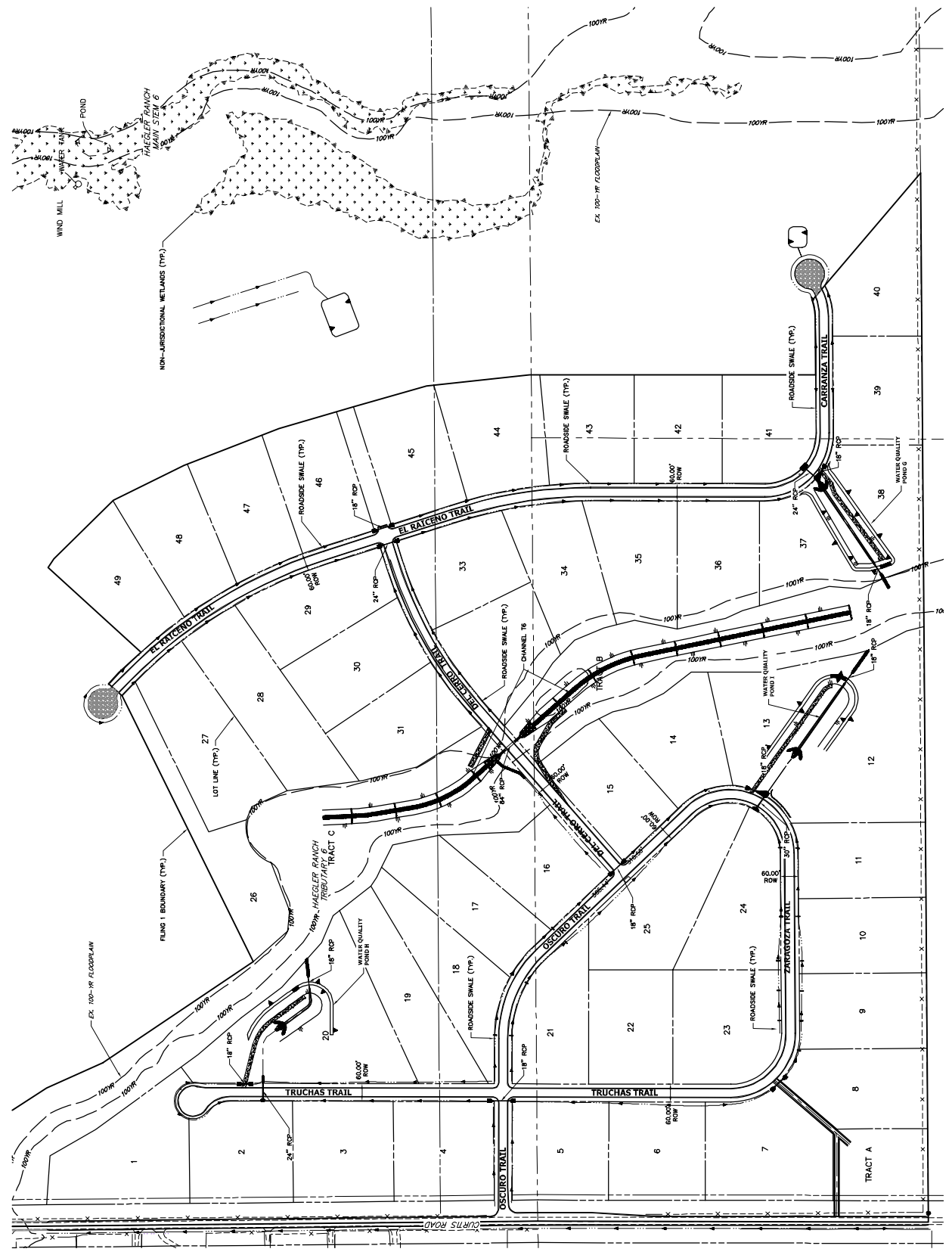

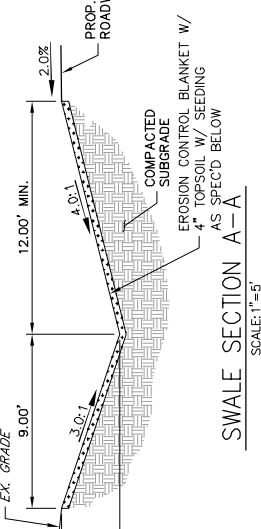
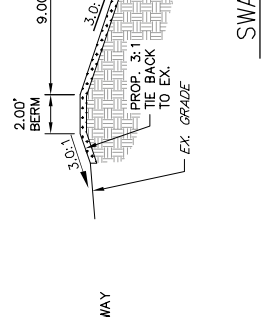
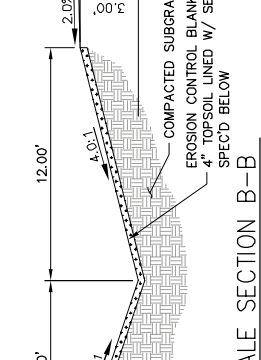
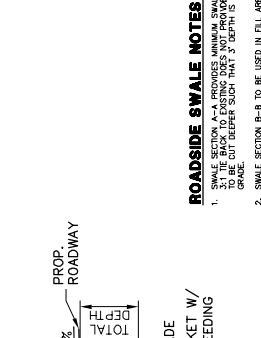

ROADSIDE SWALE NOTES

- SWALE SECTION A-A PROVIDES MINIMUM SWALE DIMENSIONS. IN AREAS WHERE TOE OF SWALE IS ON EXISTING ROADWAY, SWALE SHALL BE CUT INTO EXISTING ROADWAY 2' DEPTH TO MAINTAIN ROADWAY TO EXISTING GRADE.
- SWALE SECTION B-B TO BE USED IN ALL AREAS OF ROADWAY WHERE CUTTING IS REQUIRED DUE TO DOWN SLOPE GRADE REQUIREMENTS. 2.0' BERM MUST BE PROVIDED TO MINIMIZE FUTURE EROSION.

SWALE SECTION B-B
 SCALE: 1"=5'

SWALE SEED MIX:
 EROSION CONTROL BLANKET WITH PAMNEE BUTTES SEED INC. - "LOW GROW NATIVE MIX"
 -IDAHO FESCUE
 -SANDBERG BLUEGRASS
 -ROCKY MOUNTAIN FESCUE
 -BIG BLUEGRASS

SWALE SECTION A-A
 SCALE: 1"=5'

SWALE SEED MIX:
 EROSION CONTROL BLANKET WITH PAMNEE BUTTES SEED INC. - "LOW GROW NATIVE MIX"
 -IDAHO FESCUE
 -SANDBERG BLUEGRASS
 -ROCKY MOUNTAIN FESCUE
 -BIG BLUEGRASS

SWALE SECTION D-D
 SCALE: 1"=5'

SWALE SEED MIX:
 EROSION CONTROL BLANKET WITH PAMNEE BUTTES SEED INC. - "LOW GROW NATIVE MIX"
 -IDAHO FESCUE
 -SANDBERG BLUEGRASS
 -ROCKY MOUNTAIN FESCUE
 -BIG BLUEGRASS

TABLE GB-GS-2
 SUMMARY OF MAJOR MAINTENANCE ACTIVITIES

Maintenance Activity	Minimum Frequency	Indication Action is Needed:	Maintenance Action
Trash/Debris Removal	Twice annual and before mowing	Trash & debris in GB/GS	Remove and properly dispose of trash and debris
Mowing	Routine - as necessary to maintain 2" - 4" grass height	Excessive grass heights/aesthetics	2"-4" grass height for turf grass; 4" to 6" for native grass
Irrigation (Automatic)	Three times annually	Areas of insufficient or excess watering; broken or missing parts	SPRING: start up system; test for even coverage and correct timer settings SUMMER: test for even coverage and correct timer settings FALL: drain and winterized system (follow watering regulations)
Irrigation (Not Automatic)	As needed to maintain healthy grass	Areas of insufficient or excess watering	Water as needed to maintain healthy grass; (follow watering regulations)
Weed Control	Minimum twice annually	Noxious weeds; Unwanted vegetation	Treat w/herbicide or hand pull; consult a local Weed Inspector
Mosquito Treatment	As needed, based upon inspections	Standing water/mosquito habitat	Perform maintenance to eliminate standing water; Treat w/ EPA approved chemicals
Level Spreader (Grass Buffer only)	As needed, based upon inspections	Evidence of uneven flow/localized erosion	Look for cause; repair, fill or revegetate areas of erosion
Rodent Damage	As needed, based upon inspections	Holes, small piles of dirt, raised burrows	Evaluate damage; contact Parks Dept. or Division of Wildlife for guidance

TABLE GB-GS-3
 SUMMARY OF MAJOR MAINTENANCE ACTIVITIES

Maintenance Activity	Minimum Frequency	Indication Action is Needed:	Maintenance Action
Sediment Removal	As needed	Sediment build-up	Remove and properly dispose of sediment
Erosion Repair	As needed, based upon inspection	Rills and gullies forming on slopes and other areas	Repair eroded areas & revegetate; address cause
Vegetation Removal	As needed, based upon inspection	Trees, willows, shrubs impeding flow	Remove vegetation; restore correct grade and surface
Revegetation	As needed, based upon inspection	Areas without grass	Replace grass by sodding or seeding
Irrigation (Automatic)	As needed, based upon inspection	Evidence of broken or missing parts	Replace parts and test system
Level Spreader (Grass Buffer Only)	As needed, based upon inspection	Evidence of uneven flow, erosion, or rills/gullies	Repair sections of level spreader and address cause
Fertilization or Soil Amendment	As needed, minimize fertilization	Grass with pale color; areas with poor grass growth not due to irrigation problems	Consult with turf specialist; Test soil
Vehicle Tracks (Along Roadways)	As needed, based upon inspection	Depressions from vehicle tracks; vegetation damage	Repair and fill depressions; sod or seed damaged areas

TABLE GB-GS-4
 SUMMARY OF MAJOR MAINTENANCE ACTIVITIES

Maintenance Activity	Minimum Frequency	Look for:	Maintenance Action
Major Sediment/Pollutant Removal	As needed - based upon scheduled inspections	Large quantities of sediment	Remove and dispose of sediment. Repair vegetation as needed
Major Erosion Repair	As needed - based upon scheduled inspections	Severe erosion including gullies, excessive soil displacement, areas of settlement, holes	Repair erosion - find cause of problem and address to avoid future erosion
Structural Repair	As needed - based upon scheduled inspections	Deterioration and/or damage to structural components - level control structures, irrigation components, and ponding water.	Structural repair to restore the structure to its original design
GB-GS/Channel Rebuild	As needed - due to complete failure of BMP	Removal of filter media and underdrain system	Contact El Paso County Water Staff

*See Section GB-GS 2.3.1.d for further discussion.

POND G	
(33.57 TRIBUTARY ACRES,	
18.6% COMP. IMPERVIOUSNESS)	
DESIGN STORM	STAGE
WQCV (AC-FT)	0.307
EURV (AC-FT)	0.239
100-YEAR (AC-FT)	0.698
6691.84	
6692.34	
6692.46	

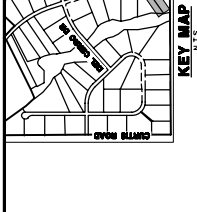
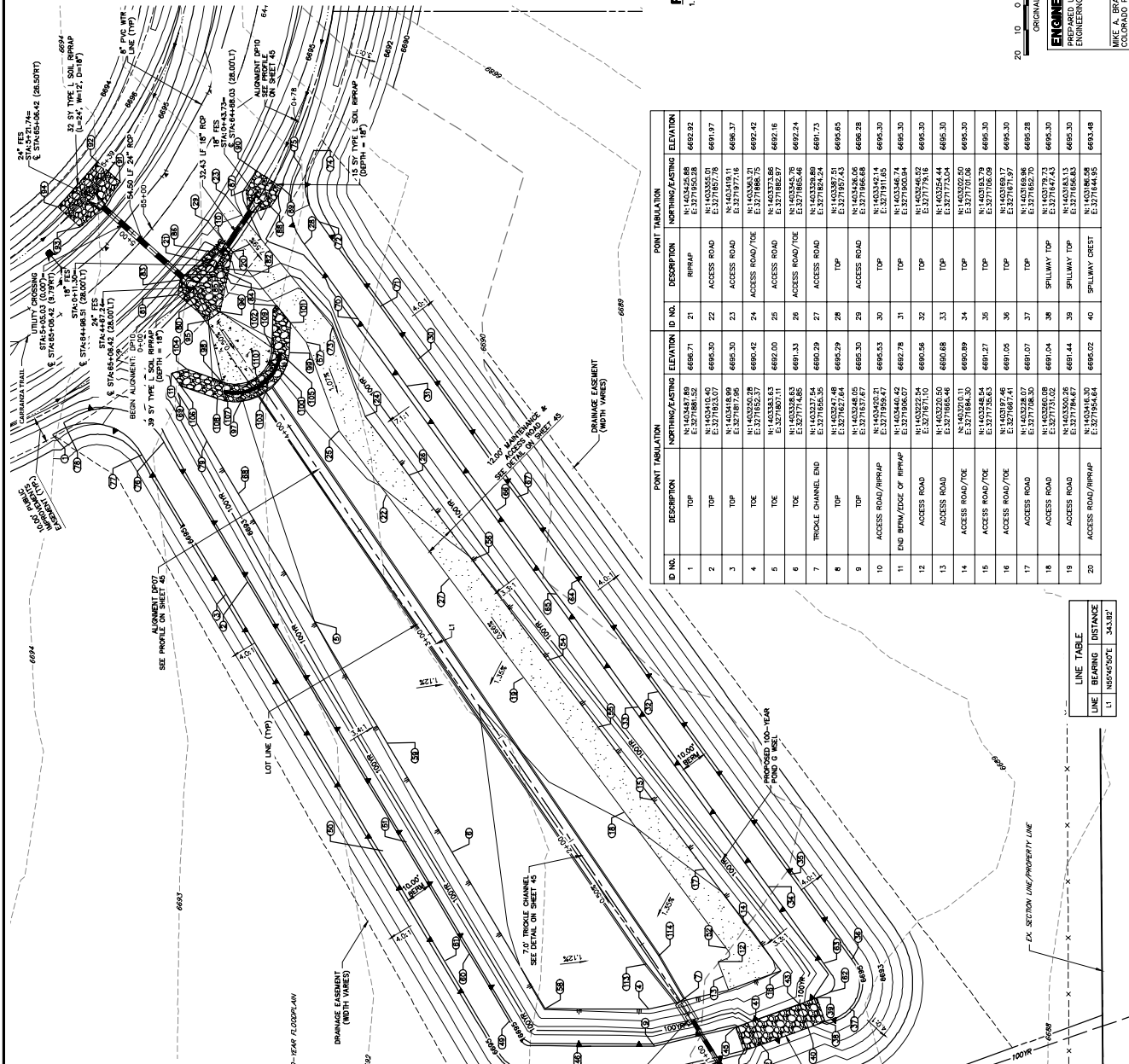

ID NO.	DESCRIPTION	NORTHING/EASTING	ELEVATION
41	SPILLWAY CREST	N: 1403252.78 E: 3271824.07	6693.46
42	SPILLWAY CREST	N: 1403252.58 E: 3271824.15	6693.46
43	SPILLWAY CREST	N: 1403189.97 E: 3271824.22	6693.46
44	SPILLWAY TOP	N: 1403212.37 E: 3271824.28	6693.30
45	SPILLWAY TOP	N: 1403212.69 E: 3271824.35	6693.30
46	TOP	N: 1403227.25 E: 3271827.87	6693.30
47	TOP	N: 1403205.74 E: 3271829.75	6693.28
48	TOP	N: 1403205.74 E: 3271829.75	6693.28
49	TOP	N: 1403246.79 E: 3271818.97	6693.40
50	TOP	N: 1403271.82 E: 3271818.25	6693.64
51	TOP	N: 1403271.82 E: 3271818.25	6693.64
52	ACCESS ROAD	N: 1403200.34 E: 3271791.45	6691.69
53	ACCESS ROAD/TOE	N: 1403271.39 E: 3271801.44	6691.99
54	ACCESS ROAD/TOE	N: 1403200.34 E: 3271801.44	6691.99
55	ACCESS ROAD	N: 1403206.91 E: 3271822.58	6693.08
56	ACCESS ROAD	N: 1403206.91 E: 3271822.58	6693.08
57	ACCESS ROAD	N: 1403206.91 E: 3271822.58	6693.08
58	TOE	N: 1403206.91 E: 3271822.58	6693.08
59	TOE	N: 1403206.91 E: 3271822.58	6693.08
60	TOP	N: 1403206.91 E: 3271822.58	6693.08
61	TOP	N: 1403206.91 E: 3271822.58	6693.08

ID NO.	DESCRIPTION	NORTHING/EASTING	ELEVATION
21	RRPAP	N: 1403487.89 E: 3271824.07	6692.92
22	ACCESS ROAD	N: 1403487.89 E: 3271824.07	6691.97
23	ACCESS ROAD	N: 1403419.11 E: 3271824.07	6696.37
24	ACCESS ROAD/TOE	N: 1403419.11 E: 3271824.07	6692.42
25	ACCESS ROAD	N: 1403373.86 E: 3271822.58	6692.16
26	ACCESS ROAD/TOE	N: 1403373.86 E: 3271822.58	6692.24
27	ACCESS ROAD	N: 1403329.89 E: 3271824.28	6691.73
28	ACCESS ROAD	N: 1403329.89 E: 3271824.28	6695.85
29	ACCESS ROAD	N: 1403246.05 E: 3271822.58	6696.28
30	ACCESS ROAD	N: 1403246.05 E: 3271822.58	6696.30
31	TOP	N: 1403246.05 E: 3271822.58	6695.30
32	TOP	N: 1403246.05 E: 3271822.58	6695.30
33	TOP	N: 1403254.44 E: 3271773.04	6695.30
34	TOP	N: 1403254.44 E: 3271773.04	6695.30
35	TOP	N: 1403254.44 E: 3271773.04	6695.30
36	TOP	N: 1403199.17 E: 3271824.07	6695.30
37	TOP	N: 1403199.17 E: 3271824.07	6695.28
38	SPILLWAY TOP	N: 1403199.17 E: 3271824.07	6695.30
39	SPILLWAY TOP	N: 1403199.17 E: 3271824.07	6695.30
40	SPILLWAY CREST	N: 1403199.17 E: 3271824.07	6693.46

POND GRADING NOTES

1. POND GRADING POINT TABLES ARE CONTINUED ON NEXT SHEET.

ID NO.	DESCRIPTION	NORTHING/EASTING	ELEVATION
1	TOP	N: 1403487.89 E: 3271824.07	6692.92
2	TOP	N: 1403487.89 E: 3271824.07	6691.97
3	TOP	N: 1403419.11 E: 3271824.07	6696.37
4	TOE	N: 1403419.11 E: 3271824.07	6692.42
5	TOE	N: 1403373.86 E: 3271822.58	6692.16
6	TOE	N: 1403373.86 E: 3271822.58	6692.24
7	TRICKLE CHANNEL END	N: 1403329.89 E: 3271824.28	6691.73
8	TOP	N: 1403329.89 E: 3271824.28	6695.85
9	TOP	N: 1403246.05 E: 3271822.58	6696.28
10	ACCESS ROAD/RRPAP	N: 1403246.05 E: 3271822.58	6696.30
11	END RRPAP/DOE OF RRPAP	N: 1403246.05 E: 3271822.58	6695.30
12	ACCESS ROAD	N: 1403254.44 E: 3271773.04	6695.30
13	ACCESS ROAD/TOE	N: 1403254.44 E: 3271773.04	6695.30
14	ACCESS ROAD/TOE	N: 1403254.44 E: 3271773.04	6695.30
15	ACCESS ROAD/TOE	N: 1403254.44 E: 3271773.04	6695.30
16	ACCESS ROAD/TOE	N: 1403199.17 E: 3271824.07	6695.30
17	ACCESS ROAD	N: 1403199.17 E: 3271824.07	6695.28
18	ACCESS ROAD	N: 1403199.17 E: 3271824.07	6695.30
19	ACCESS ROAD	N: 1403199.17 E: 3271824.07	6695.30
20	ACCESS ROAD/RRPAP	N: 1403199.17 E: 3271824.07	6693.46

LINE	BEARING	DISTANCE
L1	N45°46'50"E	343.92'

ENGINEER'S STATEMENT
 PREPARED UNDER MY DIRECT SUPERVISION AND ON BEHALF OF J.R. ENGINEERING

811
 Know what's below.
 Call before you dig.

ORIGINAL SCALE: 1" = 20'
 20 10 0 20 40

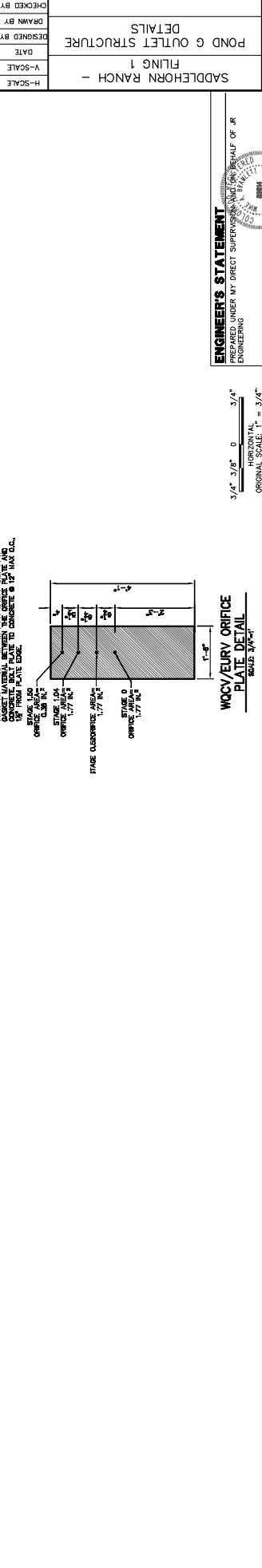
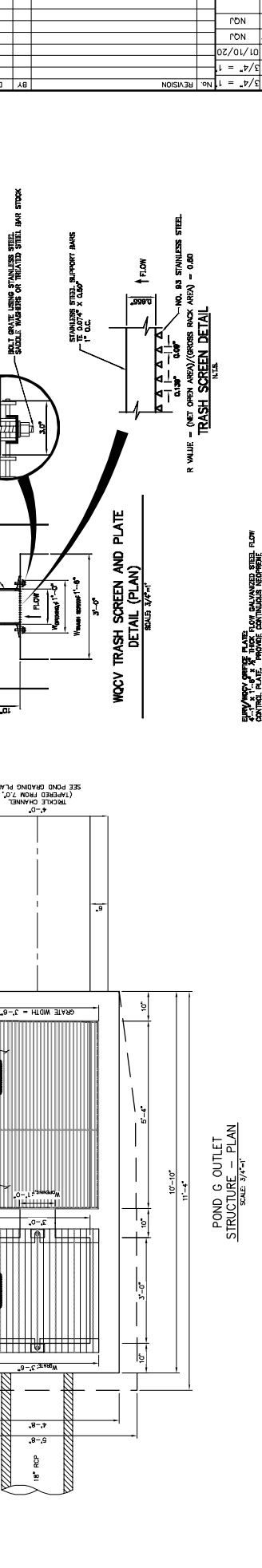
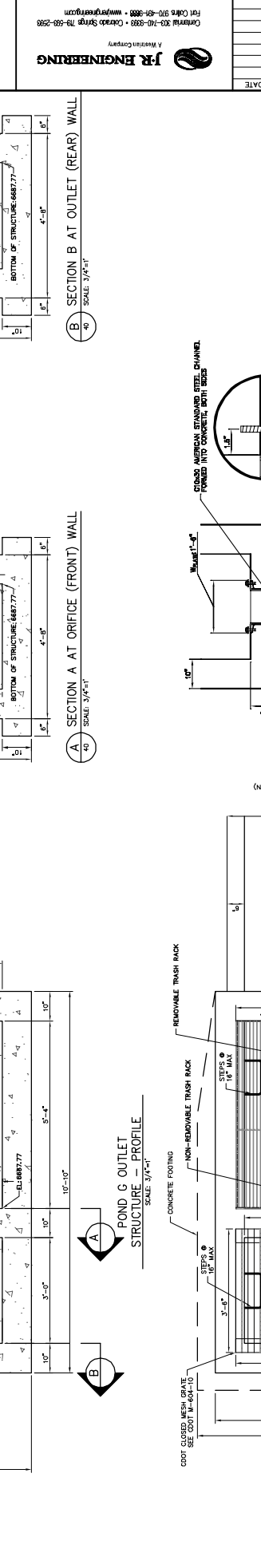
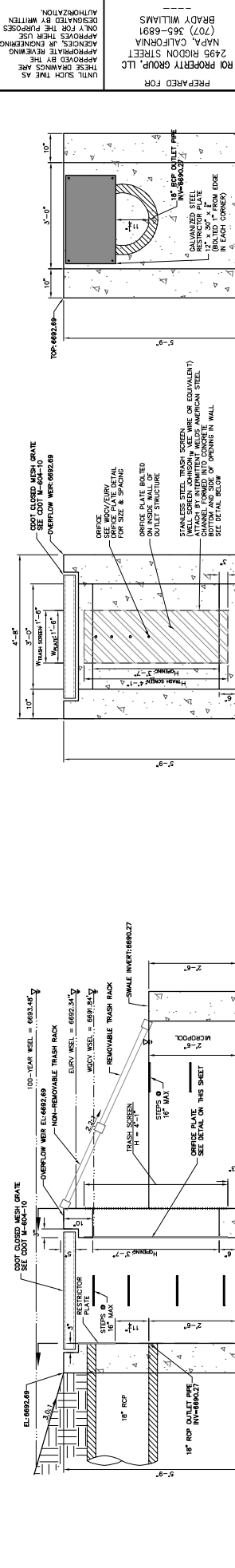

ENGINEER'S STATEMENT
 PREPARED UNDER MY DIRECT SUPERVISION AND ON BEHALF OF J.R. ENGINEERING
 ENGINEERING
 MIKE A. BRAMLETT, P.E.
 COLORADO P.E. 22314
 FOR AND ON BEHALF OF J.R. ENGINEERING

SADDLEHORN RANCH -
POND H GRADING PLAN
FILING 1

SHEET 1 OF 3
JOB NO. 2514202

Know what's below,
Call before you dig

ORIGINAL SCALE: 1" = 20'
20 10 0 20 40

ENGINEER'S STATEMENT
PREPARED UNDER MY DIRECT SUPERVISION AND ON BEHALF OF JR ENGINEERING
MAKE A. BRAMLETT, P.E.
COLORADO P.E. 32314
FOR AND ON BEHALF OF JR ENGINEERING, INC.

JR ENGINEERING
A Multi-Service Company
Colorado 303-742-9393 • Colorado Springs 719-593-2993
Fort Collins 970-221-9988 • www.jr-engineering.com

PREPARED FOR
ROI PROPERTY GROUP, LLC
2496 RIDGON STREET
NAPA, CALIFORNIA 94933
APPROVED BY THE ARCHITECT
UNTIL SUCH TIME AS THESE DRAWINGS ARE APPROVED BY THE ARCHITECT
DESIGNATED BY WRITER
BRADY WILLIAMS
AUTHORIZATION.

NO.	REVISION	BY	DATE
1	20"		
2			
3			
4			
5			
6			
7			
8			
9			
10			
11			
12			
13			
14			
15			
16			
17			
18			
19			
20			
21			
22			
23			
24			
25			
26			
27			
28			
29			
30			
31			
32			
33			
34			
35			
36			
37			
38			
39			
40			
41			
42			
43			
44			
45			
46			
47			
48			



LINE	BEARING	DISTANCE	CURVE	DELTA	RAIADIUS	LENGTH	CHORD	CHORD BEARING
L1	S89°54'27"E	115.62'	C1	154°09'27"	50.00'	47.40'		
L2	S35°52'27"E	166.10'	C2	159°49'39"	25.00'	26.10'		
L3	N84°34'54"E	23.93'						

ID NO.	DESCRIPTION	NORTHING/EASTING	ELEVATION
49	50' LOW FLOW CHANNEL	N: 1450278.70 E: 3270066.30	6736.86
50	TIE INTO D&A	N: 1450253.30 E: 3270033.30	6742.00
51	OUTLET STRUCTURE	N: 1450142.42 E: 3270189.95	6740.00
52	SPILLWAY CREST	N: 1450183.55 E: 3270189.95	6740.00
53	SPILLWAY CREST	N: 1450183.55 E: 3270189.95	6740.00
54	SPILLWAY CREST	N: 1450183.55 E: 3270189.95	6740.00
55	SPILLWAY CREST	N: 1450183.55 E: 3270189.95	6740.00
56	LOW FLOW CHANNEL	N: 1450296.60 E: 3270189.95	6741.24
57	R/R/APP	N: 1450319.75 E: 3270189.95	6732.81
58	R/R/APP	N: 1450319.75 E: 3270189.95	6732.81
59	R/R/APP	N: 1450319.75 E: 3270189.95	6732.81
60	R/R/APP	N: 1450319.75 E: 3270189.95	6732.81
61	R/R/APP	N: 1450319.75 E: 3270189.95	6732.81
62	R/R/APP	N: 1450319.75 E: 3270189.95	6732.81
63	R/R/APP	N: 1450319.75 E: 3270189.95	6732.81
64	R/R/APP	N: 1450319.75 E: 3270189.95	6732.81
65	R/R/APP	N: 1450319.75 E: 3270189.95	6732.81
66	R/R/APP	N: 1450319.75 E: 3270189.95	6732.81
67	R/R/APP	N: 1450319.75 E: 3270189.95	6732.81
68	R/R/APP	N: 1450319.75 E: 3270189.95	6732.81

GRADING POINT NOTES
1. GRADING POINTS CONTINUED ON NEXT PAGE.

DESIGN STORM	STORAGE	STAGE
WQCW (AC-FT)	0.181	6738.17
EURV (AC-FT)	0.126	6738.71
100-YEAR (AC-FT)	0.424	6739.91

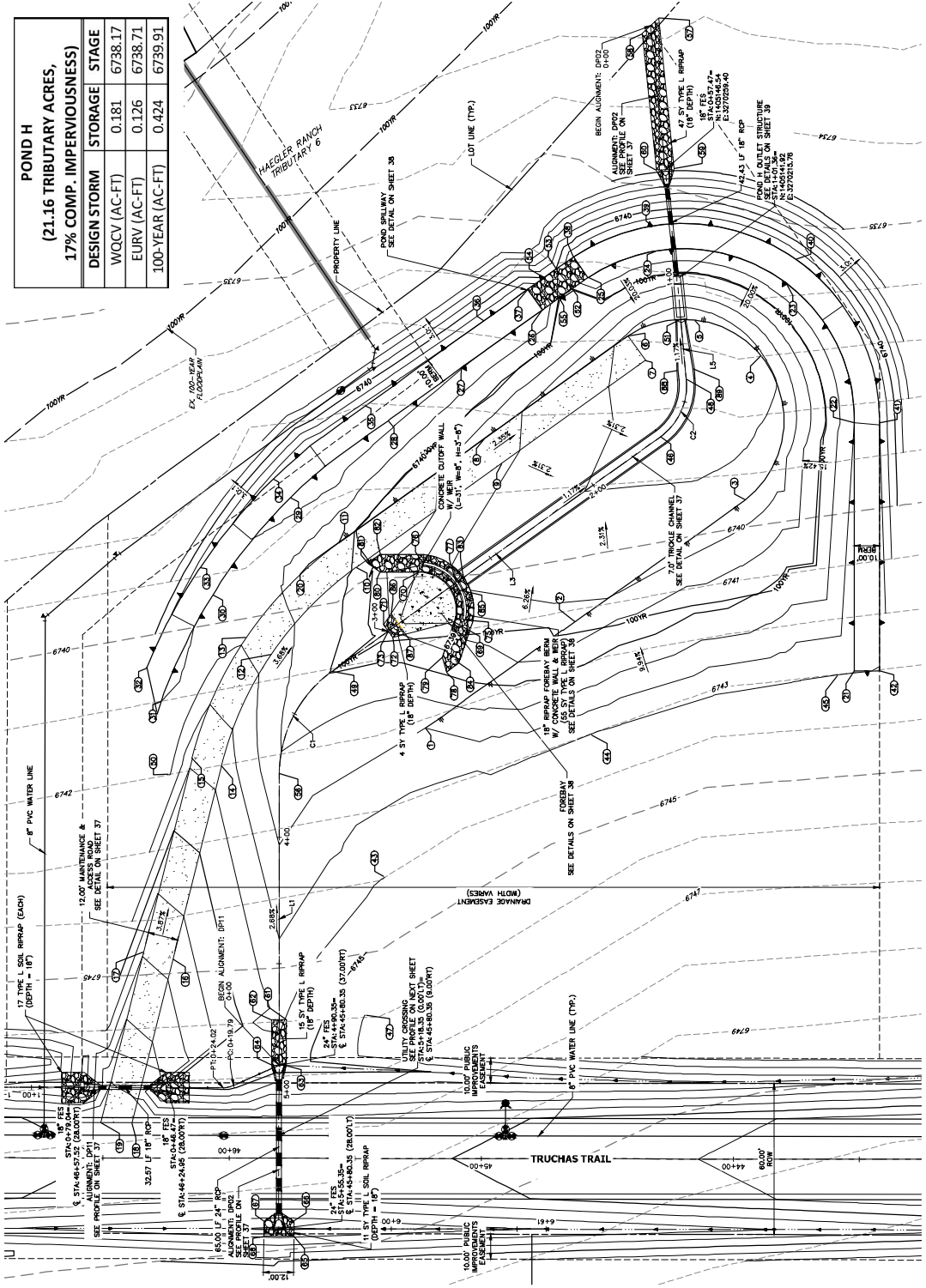

ID NO.	DESCRIPTION	NORTHING/EASTING	ELEVATION
1	TOE	N: 1450243.57 E: 3270037.69	6742.00
2	TOE	N: 1450243.57 E: 3270037.69	6742.00
3	TOE	N: 1450148.7 E: 3270189.95	6739.84
4	TOE	N: 1450148.7 E: 3270189.95	6739.84
5	TOE	N: 1450148.7 E: 3270189.95	6739.84
6	ACCESS ROAD	N: 1450334.27 E: 3270037.69	6743.61
7	ACCESS ROAD	N: 1450334.27 E: 3270037.69	6743.61
8	ACCESS ROAD	N: 1450334.27 E: 3270037.69	6743.61
9	ACCESS ROAD	N: 1450214.35 E: 3270189.95	6738.21
10	ACCESS ROAD	N: 1450214.35 E: 3270189.95	6738.21
11	ACCESS ROAD	N: 1450214.35 E: 3270189.95	6738.21
12	ACCESS ROAD	N: 1450214.35 E: 3270189.95	6738.21
13	ACCESS ROAD	N: 1450214.35 E: 3270189.95	6738.21
14	ACCESS ROAD	N: 1450214.35 E: 3270189.95	6738.21
15	ACCESS ROAD	N: 1450214.35 E: 3270189.95	6738.21
16	ACCESS ROAD	N: 1450214.35 E: 3270189.95	6738.21
17	ACCESS ROAD	N: 1450334.27 E: 3270037.69	6743.61
18	ACCESS ROAD/EOA	N: 1450334.27 E: 3270037.69	6743.61
19	ACCESS ROAD/EOA	N: 1450334.27 E: 3270037.69	6743.61
20	TOE	N: 1450214.35 E: 3270189.95	6740.57
21	TOE	N: 1450214.35 E: 3270189.95	6740.57
22	TOE	N: 1450214.35 E: 3270189.95	6740.57
23	TOE	N: 1450214.35 E: 3270189.95	6740.57
24	TOE	N: 1450214.35 E: 3270189.95	6740.57
25	SPILLWAY TOP	N: 1450176.94 E: 3270207.73	6742.00
26	SPILLWAY TOP	N: 1450176.94 E: 3270207.73	6742.00
27	TOP	N: 1450214.35 E: 3270189.95	6742.00
28	TOP	N: 1450214.35 E: 3270189.95	6742.00
29	TOP	N: 1450214.35 E: 3270189.95	6742.00
30	TOP	N: 1450214.35 E: 3270189.95	6742.00
31	TOP/TIE INTO EXH	N: 1450334.27 E: 3270037.69	6742.00
32	TOP/TIE INTO EXH	N: 1450334.27 E: 3270037.69	6742.00
33	TOP	N: 1450334.27 E: 3270037.69	6741.49
34	TOP	N: 1450334.27 E: 3270037.69	6741.49
35	TOP	N: 1450334.27 E: 3270037.69	6741.49
36	TOP	N: 1450334.27 E: 3270037.69	6741.49
37	SPILLWAY TOP	N: 1450214.35 E: 3270189.95	6742.00
38	SPILLWAY TOP	N: 1450214.35 E: 3270189.95	6742.00
39	TOP	N: 1450214.35 E: 3270189.95	6741.00
40	TOP	N: 1450214.35 E: 3270189.95	6741.00
41	TOP	N: 1450214.35 E: 3270189.95	6741.00
42	TOP	N: 1450214.35 E: 3270189.95	6741.00
43	TIE INTO D&A	N: 1450214.35 E: 3270189.95	6742.00
44	TIE INTO D&A	N: 1450214.35 E: 3270189.95	6742.00
45	TIE INTO D&A	N: 1450214.35 E: 3270189.95	6742.00
46	LOW FLOW CHANNEL	N: 1450214.35 E: 3270189.95	6742.00
47	TIE INTO D&A	N: 1450214.35 E: 3270189.95	6742.00
48	LOW FLOW CHANNEL	N: 1450214.35 E: 3270189.95	6742.00

**DP02 PROFILE
STA 0+00.00 TO 6+00.00**

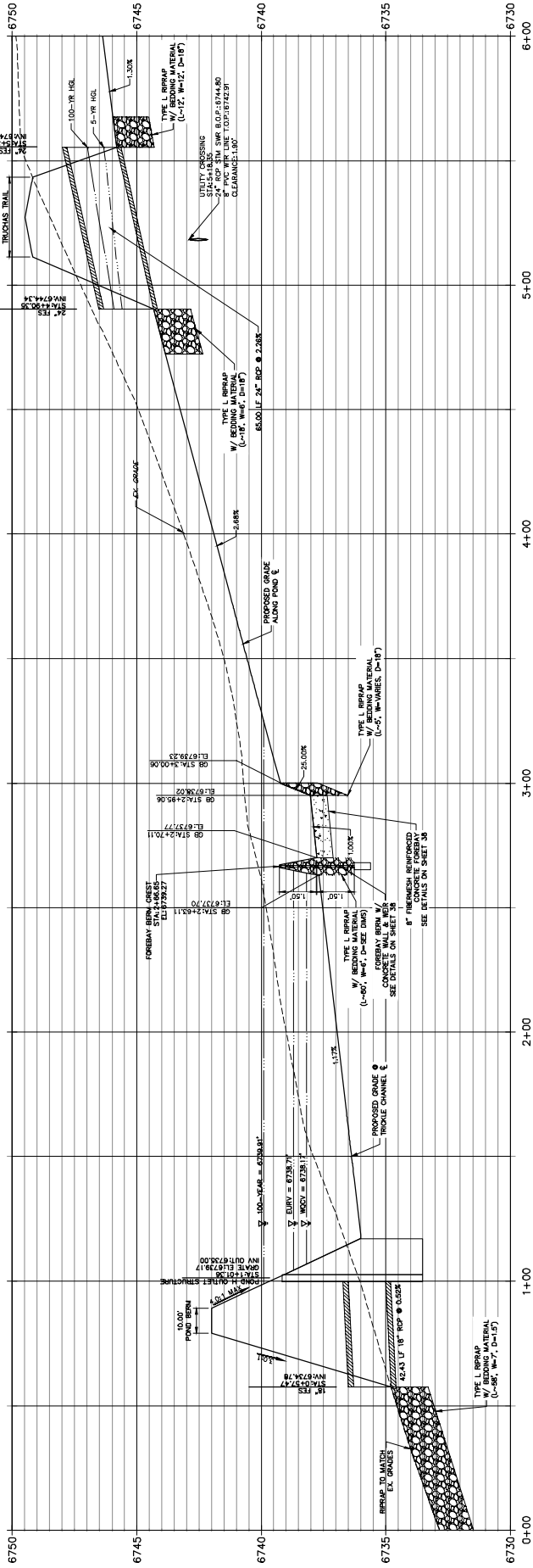

**DP11 PROFILE
STA 0+00.00 TO 1+11.64**

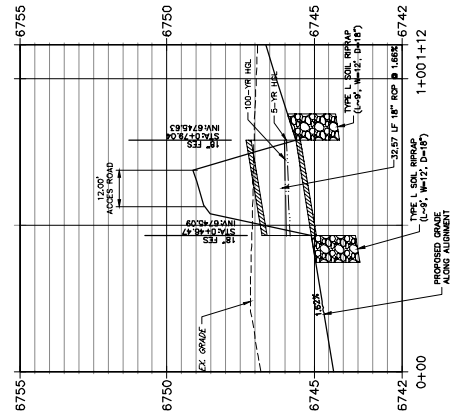

ID NO.	DESCRIPTION	POINT TABULATION	NORTHING/EASTING	ELEVATION
69	EDGE OF CONCRETE	N1465235.18 E-3370080.14		6737.86
70	EDGE OF CONCRETE	N1465244.35 E-3370089.72		6737.85
71	EDGE OF RIPRAP	E-3370078.71		6739.22
72	EDGE OF RIPRAP	N1465254.65 E-3370074.83		6739.22
73	TRICKLE CHANNEL INV.	N1465207.27 E-3370076.27		6739.22
74	END CONCRETE WALL/TOP OF BERM	N1465226.33 E-3370088.89		6739.27
75	END CONCRETE WALL/TOP OF BERM	E-3370043.19 E-3370043.19		6739.27
76	TOP OF BERM	N1465228.33 E-3370096.64		6739.27
77	TOP OF BERM	N1465233.17 E-3370096.64		6739.89
78	TOE OF BERM	N1465234.94 E-3370096.94		6739.29
79	TOE OF BERM	N1465259.63 E-3370103.38		6739.26
80	TOE OF BERM	N1465261.60 E-3370103.38		6739.74
81	TOE OF BERM	N1465269.57 E-3370106.64		6739.31
82	TOE OF BERM	E-3370097.68 E-3370097.68		6737.70
83	TRICKLE CHANNEL INV	N1465228.27 E-3370083.75		6739.35
84	TOE OF BERM	E-3370053.67 E-3370053.67		6737.77
85	TOE OF BERM	N1465256.24 E-3370083.13		6738.83
86	RIPRAP/CONCRETE	E-3370053.67 E-3370053.67		6738.83
87	RIPRAP/CONCRETE	N1465147.57 E-3370178.66		6738.31
88	BEIN TRICKLE CHANNEL TAPER TO 4.0' TRICKLE CHANNEL			6736.26
89	BEIN TRICKLE CHANNEL TAPER TO 4.0' TRICKLE CHANNEL			6736.26

811
Know what's below.
Call before you dig.

HORIZONTAL SCALE: 1" = 20'
ORIGINAL SCALE: 1" = 2'

ENGINEER'S STATEMENT
I, the undersigned, being a duly Licensed Professional Engineer in the State of Colorado, do hereby certify that I am the author of the design and drawings hereon, and that I am a duly Licensed Professional Engineer in the State of Colorado, P.E. No. 1465235.18.
FOR AND ON BEHALF OF J.R. ENGINEERING, L.L.C.
MIKE A. BRAMLETT, P.E.
COLORADO P.E. #33314
ENGINEERING

PREPARED FOR
ROI PROPERTY GROUP, LLC
2496 RICHMOND STREET
NAPA, CALIFORNIA
94957-4699
APPROVED BY THE
APPROPRIATE REVIEWING
AGENCIES IN ENGINEERING
AND ARCHITECTURE
UNTIL SUCH TIME AS
THESE DRAWINGS ARE
REVISIONED OR
REPLACED BY WRITTEN
AUTHORIZATION.

J.R. ENGINEERING
A Member Company
Fort Collins 973-67-9888 • www.jrengineering.com
Colorado 303-740-3035 • Colorado Springs 719-593-2939

NO.	REVISION	BY	DATE
1	"2"		
2	"2"		
3	"2"		
4	"2"		
5	"2"		
6	"2"		
7	"2"		
8	"2"		
9	"2"		
10	"2"		
11	"2"		
12	"2"		
13	"2"		
14	"2"		
15	"2"		
16	"2"		
17	"2"		
18	"2"		
19	"2"		
20	"2"		

SADDLEHORN RANCH -
FILING 1
POND H GRADING PLAN

DESIGNED BY
NOU

DRAWN BY
NOU

CHECKED BY
NOU

DATE
01/10/20

H-SCALE
1"=20'

SHEET 2 OF 3
JOB NO. 2514202

UNTIL SUCH TIME AS APPROVED BY THE APPROPRIATE REVIEWING AGENCIES IN EXERCISE OF THEIR USE AUTHORITY FOR THE CROSS SECTION OF THESE DRAWINGS ARE PREPARED FOR
 ROI PROPERTY GROUP, LLC
 2496 RICHMON STREET
 NAPV, CALIFORNIA
 (707) 563-6391
 BRADY WILLIAMS
 DESIGNATED BY WRITER AUTHORIZATION.

J-R ENGINEERING
 A Member of Centric
 Centric 303-761-9989 • Centric Springs 70-693-2938
 Fort Collins 970-671-9989 • www.jrengineering.com

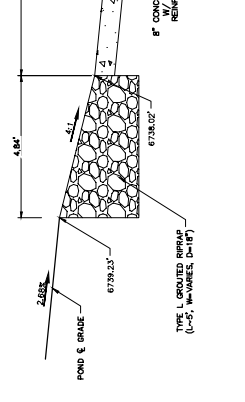
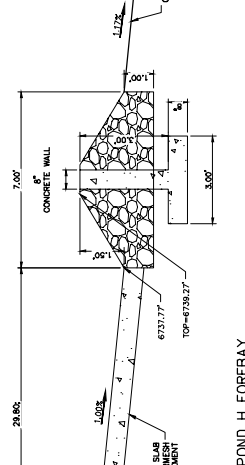
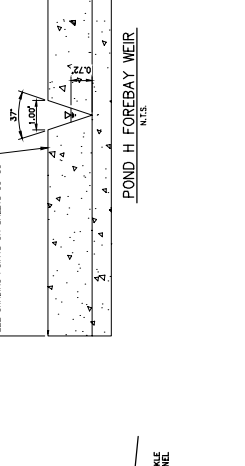
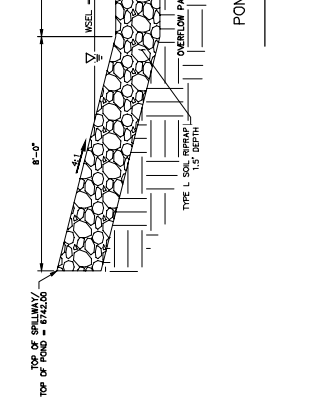
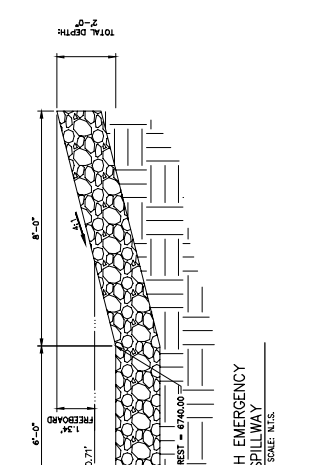
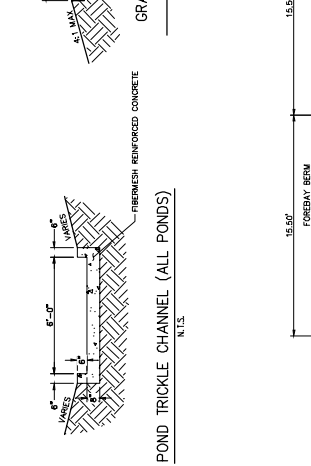

TABLE EDB-2

SUMMARY OF ROUTINE MAINTENANCE ACTIVITIES

Maintenance Activity	Minimum Frequency	Look for:	Maintenance Action
Mowing	Twice annually	Excessive grass height/aesthetics	Mow grass to a height of 4" to 6"
Trash/Debris Removal	Twice annually	Trash & debris in EDB	Remove and dispose of trash and debris
Outlet Works Cleaning	As needed - after significant rain events - twice annually min.	Clogged outlet structure; ponding water	Remove and dispose of debris/trash/sediment to allow outlet to function properly
Weed control	Minimum twice annually	Noxious weeds; Unwanted vegetation	Treat w/ herbicide or hand pull; Consult the local weed specialist
Mosquito Treatment	As needed	Standing water/mosquito habitat	Treat w/ EPA approved chemicals
Algae Treatment	As needed	Standing water/Algal growth/green color	Treat w/ EPA approved chemicals

TABLE EDB-3

SUMMARY OF MINOR MAINTENANCE ACTIVITIES

Maintenance Activity	Minimum Frequency	Look for:	Maintenance Action
Sediment Removal*	As needed; typically every 1-2 years	Sediment build-up; decrease in pond volume	Remove and dispose of sediment
Erosion Repair	As needed, based upon inspection	Rills/gullies forming on side slopes, trickle channel, other areas	Repair eroded areas Revegetate; address source of erosion
Vegetation Removal/Tree Thinning	As needed, based upon inspection	Large trees/wood chamber of pond	Remove vegetation; restore grade and surface
Drain Cleaning/Jet Vac	As needed, based upon inspection	Sediment build-up /non draining system	Clean drains; Jet Vac if needed

TABLE EDB-4

SUMMARY OF MAJOR MAINTENANCE ACTIVITIES

Maintenance Activity	Minimum Frequency	Look for:	Maintenance Action
Major Sediment Removal	As needed - based upon scheduled inspections	Large quantities of sediment, reduced pond capacity	Remove and dispose of sediment. Repair vegetation as needed
Major Erosion Repair	As needed - based upon scheduled inspections	Severe erosion including gullies, excessive soil displacement, areas of settlement, holes	Repair erosion - find cause of problem and address to avoid future erosion
Structural Repair	As needed - based upon scheduled inspections	Deterioration and/or damage to structural components - broken concrete, damaged pipes, outlet works	Structural repair to restore the structure to its original design

*Usually from the forebay, trickle channel, and/or micropool

ENGINEER'S STATEMENT
 PREPARED UNDER MY DIRECT SUPERVISION AND ON BEHALF OF J-R ENGINEERING, INC.
 I, MIKE A. BRAMLETT, P.E.,
 COLORADO P.E. #32314,
 FOR AND ON BEHALF OF J-R ENGINEERING, INC.

PREPARED FOR
 ROI PROPERTY GROUP, LLC
 2498 RIDDON STREET
 NAPA, CALIFORNIA
 (707) 246-8333
 APPROVED BY THE
 ARCHITECTURE REVIEWING
 BOARD FOR THE PROPOSED
 PROJECT. THESE DRAWINGS ARE
 UNLESS SHOWN AS
 OTHERWISE INDICATED BY THE
 ARCHITECTURE REVIEWING
 BOARD FOR THE PROPOSED
 PROJECT. THESE DRAWINGS ARE
 UNLESS SHOWN AS
 OTHERWISE INDICATED BY THE
 ARCHITECTURE REVIEWING
 BOARD FOR THE PROPOSED
 PROJECT.

J.R. ENGINEERING
 A Western Company
 4000 Central Expressway, Suite 200
 Concord, CA 94520
 (925) 309-8888 • www.jrengineering.com

NO.	REVISION	BY	DATE
1	ISSUE FOR PERMIT		
2	REVISED PER COMMENTS		
3	REVISED PER COMMENTS		
4	REVISED PER COMMENTS		
5	REVISED PER COMMENTS		
6	REVISED PER COMMENTS		
7	REVISED PER COMMENTS		
8	REVISED PER COMMENTS		
9	REVISED PER COMMENTS		
10	REVISED PER COMMENTS		

SADDLEHORN RANCH -
 FILING 1
 POND H OUTLET STRUCTURE

SHEET 39 OF 50
 JOB NO. 2514202

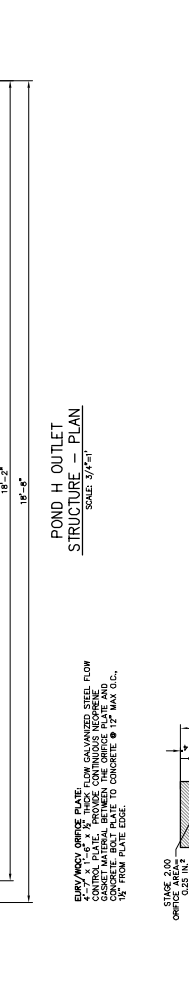
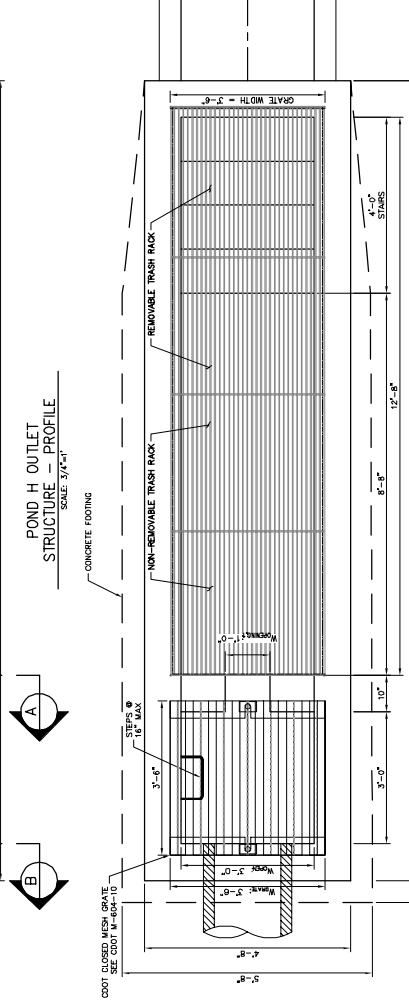
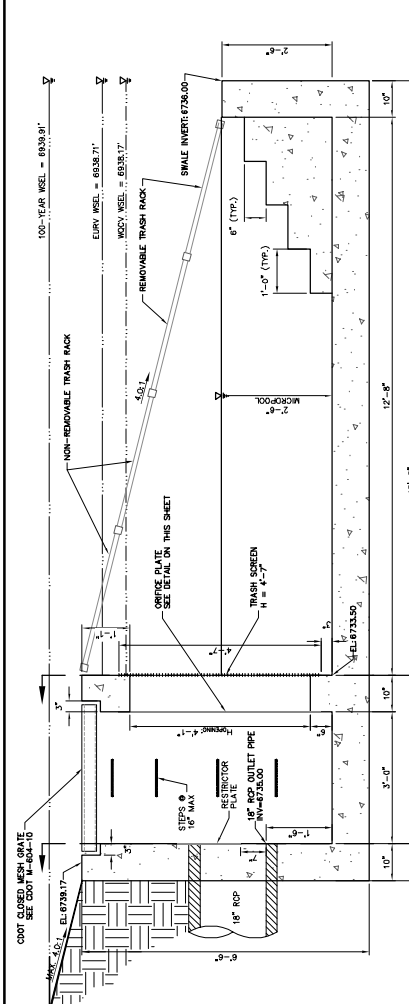
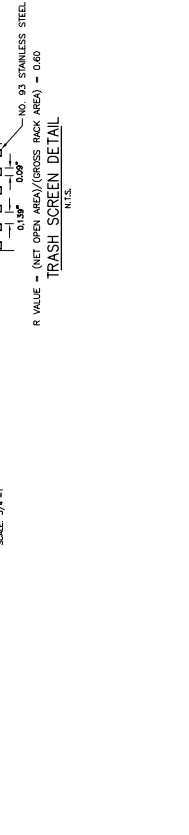
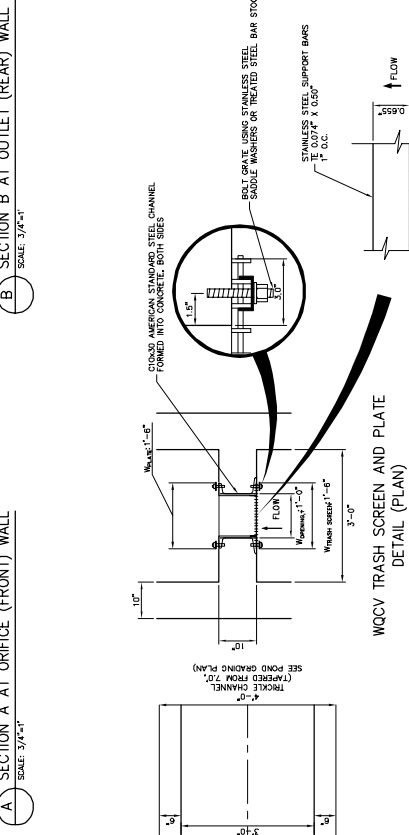
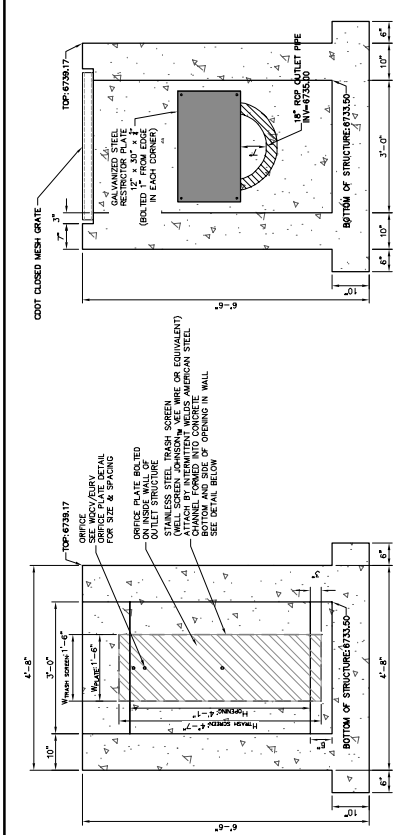

3/4" = 3/8" 0 3/4"
 ORIGINAL SCALE: 1" = 3/4"
 ORIGINAL SCALE: 1" = 3/4"
 ORIGINAL SCALE: 1" = 3/4"

ENGINEER'S STATEMENT
 PREPARED UNDER MY DIRECT SUPERVISION AND ON BEHALF OF J.R.
 ENGINEERING
 MIKE A. BRAMLETT, P.E.
 COLORADO P.E. 72314
 FOR AND ON BEHALF OF J.R. ENGINEERING

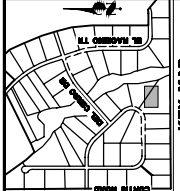

PREPARED FOR
 RPI PROPERTY GROUP, LLC
 2493 RICHMOND STREET
 NAPV, CALIFORNIA
 APPROVED BY THE
 APPROPRIATE AGENCIES
 APPROVED BY THE
 THESE DRAWINGS ARE
 UNTIL SUCH TIME AS
 AUTHORIZATION.
 BRADY WILLIAMS
 (707) 462-8399

J-R ENGINEERING
 A Member Company
 Fort Collins 973-998-0000 • Colorado Springs 761-593-2998

ID NO.	DESCRIPTION	NORTHING/EXISTING ELEVATION	ELEVATION
67	TOP	N:1403254.04 E:3270934.83	6713.37
68	TOP	N:1403254.04 E:3270934.83	6715.71
69	TOP	N:1403254.04 E:3270934.83	6713.45
70	TOP	N:1403254.04 E:3270934.83	6713.45
71	TOP	N:1403254.04 E:3270934.83	6713.45
72	TOP	N:1403254.04 E:3270934.83	6713.45
73	OUTLET STRUCTURE	N:1403254.04 E:3270934.83	6713.45
74	RRPAP	N:1403254.04 E:3270934.83	6713.45
75	RRPAP	N:1403254.04 E:3270934.83	6713.45
76	RRPAP	N:1403254.04 E:3270934.83	6713.45
77	RRPAP	N:1403254.04 E:3270934.83	6713.45
78	RRPAP	N:1403254.04 E:3270934.83	6713.45
79	RRPAP	N:1403254.04 E:3270934.83	6713.45
80	RRPAP	N:1403254.04 E:3270934.83	6713.45
81	RRPAP	N:1403254.04 E:3270934.83	6713.45
82	RRPAP	N:1403254.04 E:3270934.83	6713.45
83	RRPAP	N:1403254.04 E:3270934.83	6713.45
84	RRPAP	N:1403254.04 E:3270934.83	6713.45
85	TYPE M RRPAP	N:1403254.04 E:3270934.83	6697.37
86	TYPE M RRPAP	N:1403254.04 E:3270934.83	6697.37

ID NO.	DESCRIPTION	NORTHING/EXISTING ELEVATION	ELEVATION
45	SPILLWAY CREST	N:1403274.15 E:3271288.81	6705.50
46	SPILLWAY CREST	N:1403274.15 E:3271288.81	6705.50
47	SPILLWAY CREST	N:1403274.15 E:3271288.81	6705.50
48	SPILLWAY TOP	N:1403274.15 E:3271288.81	6707.05
49	SPILLWAY TOP	N:1403274.15 E:3271288.81	6707.05
50	TOP	N:1403274.15 E:3271288.81	6707.05
51	TOP	N:1403274.15 E:3271288.81	6707.05
52	TOP	N:1403274.15 E:3271288.81	6707.05
53	TOP	N:1403274.15 E:3271288.81	6707.05
54	TOP	N:1403274.15 E:3271288.81	6707.05
55	TOP	N:1403274.15 E:3271288.81	6707.05
56	TOP	N:1403274.15 E:3271288.81	6707.05
57	TOP	N:1403274.15 E:3271288.81	6707.05
58	TOP	N:1403274.15 E:3271288.81	6707.05
59	TOP	N:1403274.15 E:3271288.81	6707.05
60	TOP	N:1403274.15 E:3271288.81	6707.05
61	TOP	N:1403274.15 E:3271288.81	6707.05
62	TOP	N:1403274.15 E:3271288.81	6707.05
63	TOP	N:1403274.15 E:3271288.81	6707.05
64	TOP	N:1403274.15 E:3271288.81	6707.05
65	TOP	N:1403274.15 E:3271288.81	6707.05

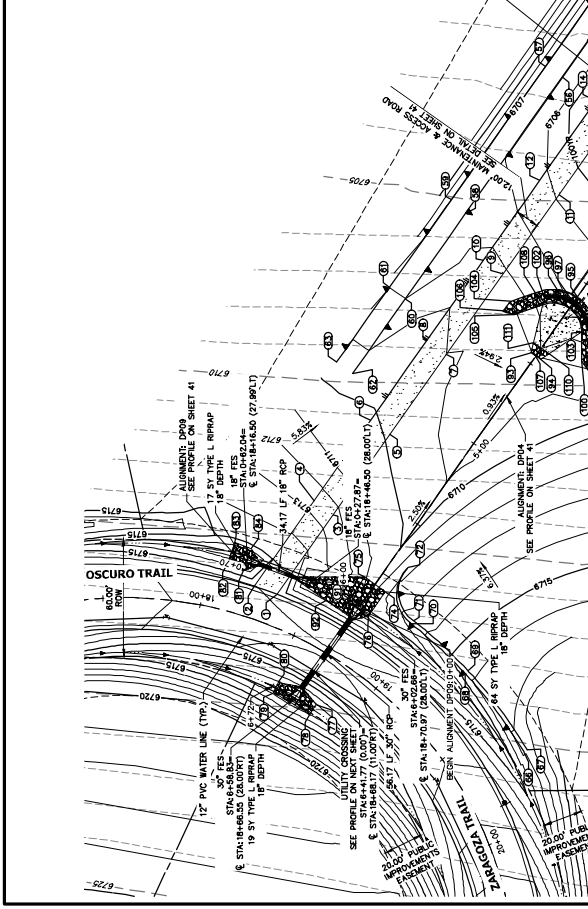

LINE TABLE

LINE BEARINGS	DISTANCE
U1	154°48'20" E 451.28'

POINT TABULATION

ID NO.	DESCRIPTION	NORTHING/EXISTING ELEVATION	ELEVATION
22	DE	N:1403261.67 E:3271033.27	6705.85
23	DE	N:1403261.67 E:3271033.27	6705.85
24	DE	N:1403261.67 E:3271033.27	6705.85
25	DE	N:1403261.67 E:3271033.27	6705.85
26	DE	N:1403261.67 E:3271033.27	6705.85
27	DE	N:1403261.67 E:3271033.27	6705.85
31	TOP	N:1403261.67 E:3271033.27	6708.31
32	TOP	N:1403261.67 E:3271033.27	6707.05
33	TOP	N:1403261.67 E:3271033.27	6707.05
34	TOP	N:1403261.67 E:3271033.27	6707.05
35	TOP	N:1403261.67 E:3271033.27	6707.05
36	TOP	N:1403261.67 E:3271033.27	6707.05
37	TOP	N:1403261.67 E:3271033.27	6707.05
38	TOP	N:1403261.67 E:3271033.27	6707.05
39	TOP	N:1403261.67 E:3271033.27	6707.05
40	TOP	N:1403261.67 E:3271033.27	6707.05
41	TOP	N:1403261.67 E:3271033.27	6707.05
42	SPILLWAY TOP	N:1403261.67 E:3271033.27	6707.05
43	SPILLWAY TOP	N:1403261.67 E:3271033.27	6707.05
44	SPILLWAY CREST	N:1403261.67 E:3271033.27	6705.50

POINT TABULATION

ID NO.	DESCRIPTION	NORTHING/EXISTING ELEVATION	ELEVATION
1	BEGIN ACCESS ROAD	N:1403261.67 E:3270934.83	6715.80
2	BEGIN ACCESS ROAD	N:1403261.67 E:3270934.83	6716.03
3	ACCESS ROAD	N:1403261.67 E:3270934.83	6712.35
4	ACCESS ROAD	N:1403261.67 E:3270934.83	6712.97
5	ACCESS ROAD	N:1403261.67 E:3270934.83	6719.80
6	ACCESS ROAD	N:1403261.67 E:3270934.83	6719.14
7	ACCESS ROAD	N:1403261.67 E:3270934.83	6719.01
8	ACCESS ROAD	N:1403261.67 E:3270934.83	6719.25
9	ACCESS ROAD	N:1403261.67 E:3270934.83	6718.14
10	ACCESS ROAD	N:1403261.67 E:3270934.83	6718.36
11	ACCESS ROAD	N:1403261.67 E:3270934.83	6718.30
12	ACCESS ROAD	N:1403261.67 E:3270934.83	6716.17
13	ACCESS ROAD	N:1403261.67 E:3270934.83	6714.64
14	ACCESS ROAD	N:1403261.67 E:3270934.83	6714.86
15	ACCESS ROAD	N:1403261.67 E:3270934.83	6713.35
16	ACCESS ROAD	N:1403261.67 E:3270934.83	6712.07
17	ACCESS ROAD	N:1403261.67 E:3270934.83	6712.31
18	ACCESS ROAD	N:1403261.67 E:3270934.83	6712.31
19	ACCESS ROAD	N:1403261.67 E:3270934.83	6712.77
20	ACCESS ROAD	N:1403261.67 E:3270934.83	6712.01

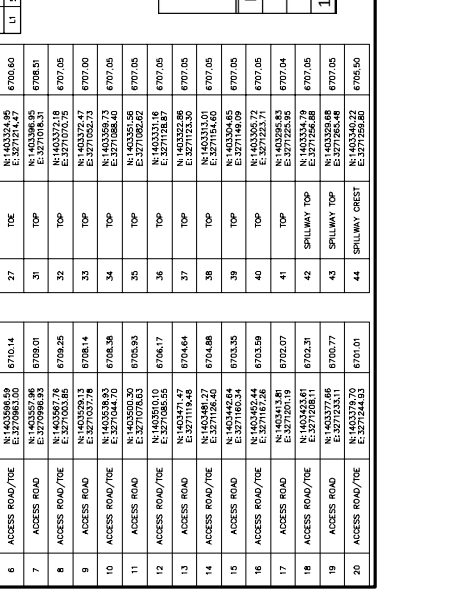
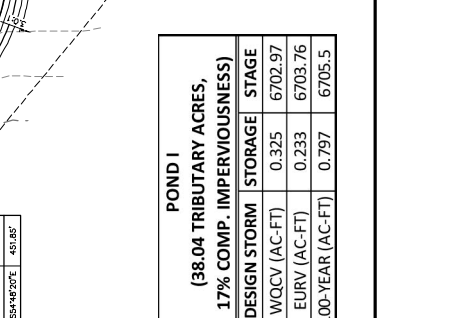

DP09 PROFILE
STA 0+00.00 TO 0+70.00

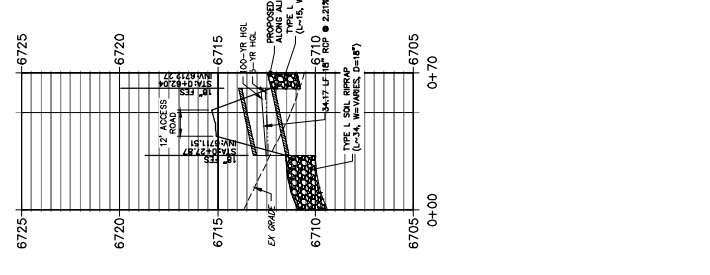

DP04 PROFILE
STA 0+00.00 TO 6+71.61

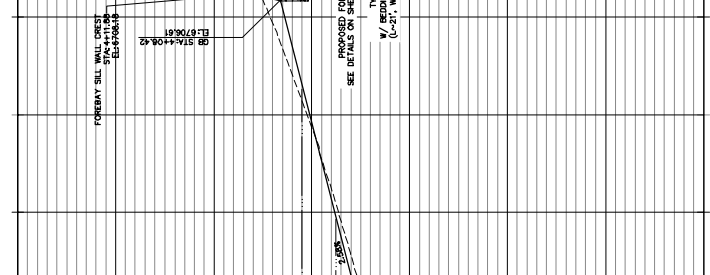

POINT TABULATION

ID NO.	DESCRIPTION	NORTHING/EASTING	ELEVATION
110	BEGIN FOREBAY CONCRETE/END RIPRAP	N:1403502.85 E:3270992.19	6707.78
111	BEGIN FOREBAY CONCRETE/END RIPRAP	N:1403513.28 E:3270502.85	6707.78
113	BEGIN TRICKLE CHANNEL/TAPER TO 40" TRICKLE CHANNEL	N:1403512.83 E:3271218.43	6700.51
114	BEGIN TRICKLE CHANNEL/TAPER TO 40" TRICKLE CHANNEL	N:1403551.50 E:3271218.37	6700.51

POINT TABULATION

ID NO.	DESCRIPTION	NORTHING/EASTING	ELEVATION
89	RIPRAP/MATCH EX	N:1403248.89 E:3271062.90	6694.68
90	RIPRAP/MATCH EX	N:1403292.78 E:3271062.90	6694.77
91	RIPRAP	N:1403265.14 E:3270983.30	6712.42
92	RIPRAP	N:1403189.25 E:3270983.30	6712.95
93	END TRICKLE CHANNEL/BEGIN FOREBAY CONCRETE	N:1403514.58 E:3270991.71	6708.07
94	END TRICKLE CHANNEL/BEGIN FOREBAY CONCRETE	N:1403509.68 E:3270991.25	6708.07
95	BEGIN TRICKLE CHANNEL/INV.	N:1403514.58 E:3271026.05	6706.61
96	EDGE OF CONCRETE/BOTTOM OF BERM	N:1403494.90 E:3271026.30	6706.68
97	CREST/END OF WEIR WALL	N:1403514.58 E:3271026.16	6708.18
98	CREST/END OF WEIR WALL	N:1403485.23 E:3271010.24	6708.18
99	BOTTOM OF BERM/EDGE OF RIPRAP	N:1403509.68 E:3270983.30	6708.06
100	BOTTOM OF BERM/EDGE OF RIPRAP	N:1403488.43 E:3270983.30	6707.66
101	BOTTOM OF BERM/EDGE OF RIPRAP	N:1403488.13 E:3270983.30	6707.85
102	CREST/END OF WEIR WALL	N:1403507.70 E:3271026.97	6708.18
103	EDGE OF CONCRETE/BOTTOM OF BERM	N:1403488.02 E:3271026.81	6706.68
104	BOTTOM OF BERM/EDGE OF RIPRAP	N:1403502.82 E:3271026.81	6708.12
105	BOTTOM OF BERM/EDGE OF RIPRAP	N:1403502.82 E:3271016.88	6708.71
106	BOTTOM OF BERM/EDGE OF RIPRAP	N:1403521.1 E:3270983.30	6708.07
108	EDGE OF CONCRETE/BOTTOM OF BERM	N:1403521.1 E:3271022.05	6706.68



ENGINEER'S STATEMENT
 PREPARED UNDER MY DIRECT SUPERVISION AND ON BEHALF OF J.R. ENGINEERING, INC.
 ENGINEERING
 MAKE A. BRAMLETT, P.E.
 COLORADO P.E. #3314
 FOR AND ON BEHALF OF J.R. ENGINEERING, INC.

FOR THE PURPOSES OF THIS PLAN, THE EXISTING CONDITIONS ARE AS SHOWN ON THESE DRAWINGS AND AS APPROVED BY THE APPROPRIATE AGENCIES. APPROVED FOR THE USE OF THE ENGINEER BY THE WRITER. AUTHORIZATION.

UNLESS OTHERWISE NOTED, ALL DIMENSIONS ARE IN FEET AND INCHES. DIMENSIONS SHALL BE TO FACE UNLESS OTHERWISE NOTED.

ALL DIMENSIONS ARE TO FACE UNLESS OTHERWISE NOTED.

ALL DIMENSIONS ARE TO FACE UNLESS OTHERWISE NOTED.

ALL DIMENSIONS ARE TO FACE UNLESS OTHERWISE NOTED.

ALL DIMENSIONS ARE TO FACE UNLESS OTHERWISE NOTED.

ALL DIMENSIONS ARE TO FACE UNLESS OTHERWISE NOTED.

UNTIL SUCH TIME AS THESE DRAWINGS ARE APPROVED BY THE APPROPRIATE REVIEWING AGENCIES IN ENDEAVORING TO OBTAIN THE NECESSARY PERMITS FOR THE PROPOSED PROJECT. THIS DOCUMENT IS NOT TO BE USED FOR ANY OTHER PURPOSES WITHOUT THE WRITTEN AUTHORIZATION OF J-R ENGINEERING.

PREPARED FOR
 ROI PROPERTY GROUP, LLC
 2496 RICCORN STREET
 NAPA, CALIFORNIA
 (707) 253-6391
 BRADY WILLIAMS
 PROJECT MANAGER

J-R ENGINEERING
 A Member of Conterra
 10000 S. RAYBURN AVENUE
 SUITE 100
 DENVER, CO 80231
 (303) 751-9988 • www.jrengr.com

NO. REVISION
 BY DATE
 H-SCALE NTS
 V-SCALE N/A
 DATE 01/10/20
 DESIGNED BY NQU
 DRAWN BY NQU
 CHECKED BY NQU

SADDLEHORN RANCH -
 FILING 1
 POND 1 DETAILS

SHEET 3 OF 3
 JOB NO. 2514202

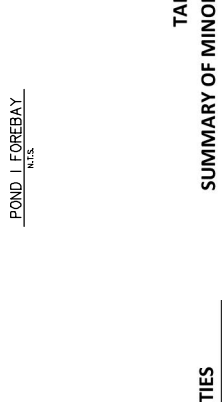
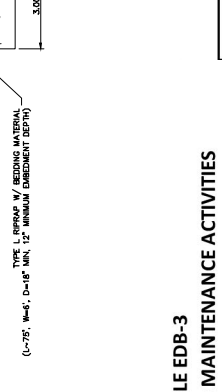
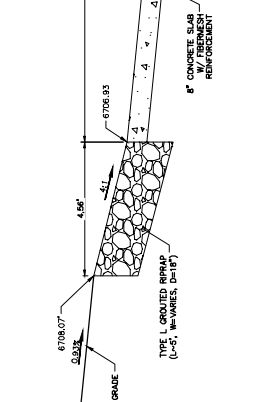
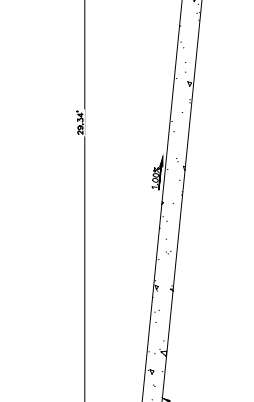
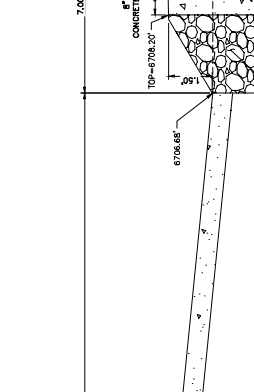
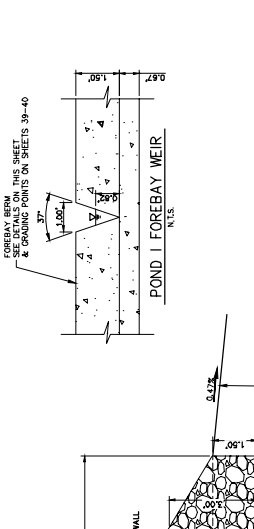
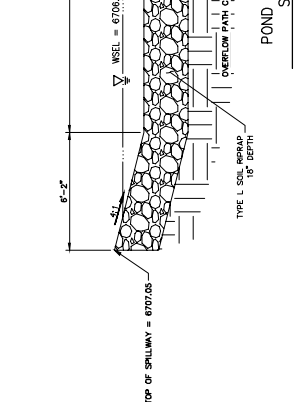
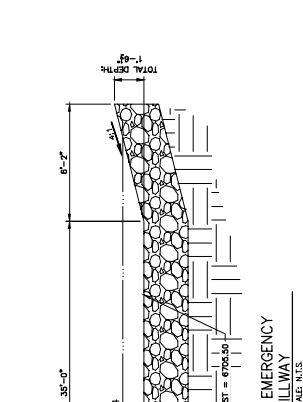
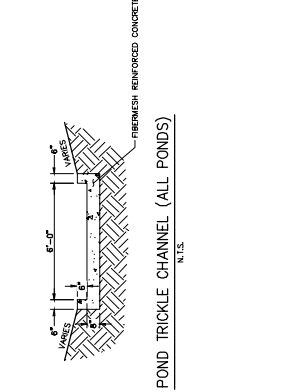
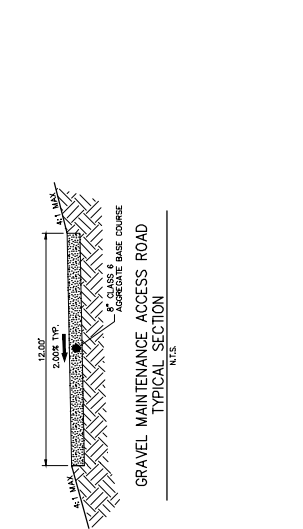

TABLE EDB-2
 SUMMARY OF ROUTINE MAINTENANCE ACTIVITIES

Maintenance Activity	Minimum Frequency	Look for:	Maintenance Action
Mowing	Twice annually	Excessive grass height/aesthetics	Mow grass to a height of 4" to 6"
Trash/Debris Removal	Twice annually	Trash & debris in EDB	Remove and dispose of trash and debris
Outlet Works Cleaning	As needed - after significant rain events - twice annually min.	Clogged outlet structure, ponding water	Remove and dispose of debris/trash/sediment to allow outlet to function properly
Weed control	Minimum twice annually	Noxious weeds; Unwanted vegetation	Treat w/ herbicide or hand pull; Consult the local weed specialist
Mosquito Treatment	As needed	Standing water/mosquito habitat	Treat w/ EPA approved chemicals
Algae Treatment	As needed	Standing water/Algal growth/green color	Treat w/ EPA approved chemicals

TABLE EDB-3
 SUMMARY OF MINOR MAINTENANCE ACTIVITIES

Maintenance Activity	Minimum Frequency	Look for:	Maintenance Action
Sediment Removal*	As needed; typically every 1-2 years	Sediment build-up; decrease in pond volume	Remove and dispose of sediment
Erosion Repair	As needed, based upon inspection	Rills/gullies forming on side slopes, trickle channel, other areas	Repair eroded areas Revegetate; address source of erosion
Vegetation Removal/Tree Thinning	As needed, based upon inspection	Large trees/wood vegetation in lower chamber of pond	Remove vegetation; restore grade and surface
Drain Cleaning/Jet Vac	As needed, based upon inspection	Sediment build-up /non draining system	Clean drains; Jet Vac if needed

TABLE EDB-4
 SUMMARY OF MAJOR MAINTENANCE ACTIVITIES

Maintenance Activity	Minimum Frequency	Look for:	Maintenance Action
Major Sediment Removal	As needed - based upon scheduled inspections	Large quantities of sediment; reduced pond capacity	Remove and dispose of sediment. Repair vegetation as needed
Major Erosion Repair	As needed - based upon scheduled inspections	Severe erosion including gullies, excessive soil displacement; areas of settlement, holes	Repair erosion - find cause of problem and address to avoid future erosion
Structural Repair	As needed - based upon scheduled inspections	Deterioration and/or damage to structural components - broken concrete, damaged pipes, outlet works	Structural repair to restore the structure to its original design

*Usually from the forebay, trickle channel, and/or micropool

ENGINEER'S STATEMENT
 PREPARED UNDER MY DIRECT SUPERVISION AND ON BEHALF OF J-R ENGINEERING

MIKE A. BRAMLETT, P.E.
 COLORADO P.E. #3314
 FOR AND ON BEHALF OF J-R ENGINEERING, INC.

PROFESSIONAL SEAL

EXHIBIT D
Open Drainage Channel Inspections, Operations and Maintenance (O&M)

Routine maintenance of the open drainage channel system consists of litter and debris pickup, vegetation management, erosion control, and sediment removal when necessary. Removal of excessive shrubs and trees is required to ensure that the channel will flow in conformance with the original design. Mowing and vegetation management shall be performed with care to ensure that soils remain stable and not to cause erosion. Noxious weed management shall be performed as necessary and as required under project approval conditions. All dead trees and trees growing in the flowline of a structure such as a bridge or culvert shall be removed.

Removal of sediment shall be performed with the use of equipment such as a skid steer, backhoe, and front-end loader. The removed materials shall be hauled to an acceptable landfill site unless otherwise legally permitted to be utilized elsewhere. Materials are not to be stored onsite. Equipment shall utilize the designated access roads and shall not be used in a manner to cause damage to adjacent vegetated and stable areas to the extent possible. If drainage channels contain wetlands many activities, including maintenance, may be subject to regulation and permitting.

Erosion control and restoration work such as side slope reconstruction, revegetation, riprap installation, and other stabilization methods will require the use of heavy equipment.

Maintaining altered watercourses is a minimum requirement of the National Flood Insurance Program (NFIP). In fact, failure to maintain such watercourses may result in a revision to the community's Flood Insurance Rate Map (FIRM). If a stream is altered after the community's FIRM is published, the NFIP requires the community to ensure that the channel's carrying capacity is not adversely altered. This is required in 44 CFR 60.3(b)(7) of the Federal Emergency Management Agency's (FEMA's) NFIP regulations.
--

Table 1 – General Channel Maintenance Guidelines

Activity	Maintenance Action	Frequency of Action
Mowing, vegetation management, and lawn care	Occasional mowing to limit unwanted vegetation. Maintain irrigated turf grass as 2 to 4 inches tall and non-irrigated native grasses at 4 to 6 inches tall.	Routine – depending on aesthetic requirements.
Debris and litter removal	Remove debris and litter from the entire channel to improve flow characteristics and aesthetics. Dispose of as appropriate.	Routine – including annual, pre-storm season (April and May) and following significant rainfall events.
Erosion and sediment control	Repair and revegetate eroded areas in the channel.	Non-routine –as necessary based on inspection.
Structural	Repair inflow structures, low flow channel linings, and energy dissipation structures as needed.	Non-routine – repair as needed based on regular inspections.
Inspections	Inspect channel to ensure continued function as initially intended. Check for erosion, slumping, excessive sedimentation, overgrowth, embankment and inflow integrity, and damage to any structural elements. Report any illicit discharge immediately.	Routine – annual inspection of hydraulic and structural facilities. Also check for obvious problems during routine maintenance visits.
Nuisance control	Address odor, insects, and other issues associated with stagnant or standing water.	Non-routine –as necessary per inspection or complaint.
Sediment removal	Remove accumulated sediment from the channel bottom.	Non-routine –as necessary per inspection.

Routine Maintenance Activities

The majority of this work consists of scheduled mowing, litter and debris pickups for the drainage channel during the growing season. It also includes activities such as weed control. These activities normally will be performed numerous times during the year. These items typically do not require any prior correspondence with EPC, however, completed inspection and maintenance forms shall be retained and submitted to EPC for each inspection and maintenance upon request. The Routine Maintenance Activities are summarized below, and further described in the following sections.

Table 2 – Summary of Routine Maintenance Activities

Activity	Maintenance Action	Look for:	Minimum Frequency
Mowing	2"-4" irrigated grass height; 4-6" natural grass height	Excessive grass height/aesthetics	Routine – twice annually
Litter / Debris Removal	Remove and dispose of litter and debris	Litter / debris in drainage channel	Routine – twice annually
Woody growth control / weed removal	Treat w/herbicide or hand pull	Noxious weeds, undesirable vegetation	Routine – minimum twice annually

Properly dispose of litter and debris materials at an approved landfill or recycling facility. It should be noted that major debris removal may require other regulatory permits prior to completing the work.

Noxious weeds and other unwanted vegetation must be treated as needed throughout the drainage channel. This activity can be performed either through mechanical means (mowing/pulling) or with herbicide. Consultation with the County Environmental Division is recommended prior to the use of herbicide. Herbicides should be utilized sparingly and as a last resort. All herbicide applications should be in accordance with the manufacturer’s recommendations.

Minor Maintenance Activities

This work consists of a variety of isolated or small-scale maintenance/operational problems. Most of this work can be completed by a small crew, hand tools, and small equipment. These items may require prior approval from EPC depending on the scope of work. Completed inspection and maintenance forms shall be retained for each inspection and maintenance period. In the event that the drainage channel needs to be dewatered, care should be given to ensure sediment, filter material and other pollutants are not discharged. The appropriate permits shall be obtained prior to any dewatering activity.

Table 3 – Summary of Minor Maintenance Activities

Activity	Maintenance Action	Look for:	Minimum Frequency
Sediment/Pollutant Removal	Remove and dispose of accumulated sediment from the channel bottom.	Minor sediment and pollution build-up in channel bottom; potential decrease in channel flow rate	Non-routine – as needed based on inspection.
Erosion Repair	Repair eroded areas and revegetate; address cause.	Rills/gullies on sides of channel	Non-routine – as needed, based on inspection.

Major Maintenance Activities

This work consists of larger maintenance/operational problems and failures within the stormwater drainage facilities. This work will likely require approval from EPC Engineering to ensure the proper maintenance is performed. This work requires that Engineering Staff review the original design and construction drawings to assess the situation and necessary maintenance activities. This work may also require more specialized maintenance equipment, design plans/details, surveying, and assistance through private contractors and consultants. In the event that the drainage channel needs to be dewatered, care should be given to ensure sediment, filter material and other pollutants are not discharged. The appropriate permits shall be obtained prior to any dewatering activity.

Table 4 – Summary of Major Maintenance Activities

Activity	Maintenance Action	Look for:	Minimum Frequency
Major Sediment / Pollutant Removal	Remove and dispose of sediment. Repair vegetation as necessary	Large quantities of sediment in the channel and reduced conveyance rate/capacity	Non-routine –as necessary based on inspection.
Major Erosion Repair	Repair erosion – find cause of problem and address to avoid future erosion	Severe erosion including gullies, excessive soil displacement, unusual areas of settlement, holes	Non-routine –as necessary based on inspection.
Structural Repair	Structural repair to restore portions of the channel to its original design	Deterioration and/or damage to structural components – broken concrete, damaged pipe, drop/check structures or dissipators	Non-routine –as necessary based on inspection.
Drainage Channel Rebuild	Contact EPC Engineering	Overall channel failure	Non-routine –as needed due to complete failure of drainage channel

Inspection Procedures

Periodic inspections of drainage channels and associated stormwater control measures in developed areas are needed in every community to prevent the accumulation of debris deposited by storms, dumping, or natural processes. Inspections must be conducted at least once each year and after each storm that could adversely impact the drainage system. Inspections are also needed in response to citizen complaints.

Conduct annual visual inspections during the dry season to determine if there are problem inlets where sediment/trash or other pollutants accumulate. Inspection and maintenance records should be used to determine problem areas that may need to be checked more often. Appropriate action must be taken after an inspection identifies the need for maintenance or cleaning.

The attached form includes the typical information necessary for and during an inspection. Similar forms or electronic record keeping may be utilized if all relevant information is recorded. The entity responsible for channel maintenance is required to submit the periodic inspection reports upon request by County Staff. Inspections involving decisions about structural issues shall be signed by a licensed professional engineer.

Inspections of inflow structures including detention spillways and water quality outlet pipes discharging to the channel shall be coordinated with channel inspections.

Illicit discharges such as dumping of home goods or garbage, appliances, yard wastes, paint spills, abandoned oil containers and other pollutants shall be immediately reported to EPC Staff and other agencies as appropriate. Reference El Paso County Ordinance No. 07-01, as amended. EPC recommends that the responsible entity encourage public

reporting of improper waste disposal by posting “No Dumping” signs, neighborhood notices, and/or social media when available, with contact information to report violations.

Wetlands

If drainage channels contain wetlands many activities, including maintenance, may be subject to regulation and permitting. The responsible maintenance entity shall maintain wetlands vegetation as appropriate and in consultation with the proper authorities including the U.S. Army Corps of Engineers when applicable. The responsible maintenance entity shall ensure proper training / licensing of contractors and staff to minimize the potential for damages to the wetlands.

All applicable safety and environmental considerations with regards to the application of any pesticides or herbicides shall be verified. It is also strongly encouraged that the responsible entity employ or consult a wetlands specialist or certified arborist with the ability to identify invasive/exotic species. Due to the sensitive nature of using chemicals near water bodies, a written Quality Assurance/Quality Control (QA/QC) plan shall be implemented.

Employees shall be trained in accordance with any local, state, and federal regulations and laws prior to any application of chemicals. A copy of the QA/QC plan must be submitted to the County Environmental Division prior to any chemical applications. In addition to the QA/QC plan, copies of the Safety Data Sheets (SDS) for all the chemicals being used shall be provided upon request.

The Clean Water Act (CWA) establishes the basic structure for regulating discharges of pollutants into the waters of the United States and regulating quality standards for surface waters. The basis of the CWA was enacted in 1948 and was called the Federal Water Pollution Control Act, but the Act was significantly reorganized and expanded in 1972. "Clean Water Act" became the Act's common name with amendments in 1972.

Section 404 - establishes a program to regulate the discharge of dredged and fill material into waters of the United States, including wetlands. CWA Section 404(b)(1) Guidelines – U.S. Environmental Protection Agency (EPA) (Although they are called “guidelines,” these criteria are established in regulations (40 CFR Part 230) and are legally binding.)

<https://www.epa.gov/cwa-404/clean-water-laws-regulations-and-executive-orders-related-section-404>

Open Drainage Channel Inspection Report Form

Date: _____ Inspector: _____

Type of inspection: Post-Storm _____ Complaint _____ Routine _____

Location: (Identify stream or basin name, downstream and upstream streets or reference points, and location of problem. Provide sketch as needed.)

Type of problem: Litter ___ Minor ___ Obstruction ___ Structural ___ Illicit Discharge** ___

Recommended maintenance: _____

Is equipment needed? _____ If so, list equipment needed: _____

Date: _____ Offsite Right of entry needed? _____

Work order description: _____

State permit(s) needed? _____ Work order number: _____

Date: _____ Crew chief: _____

Maintenance performed: _____

Inspected by: _____

Use other side for additional recommendations for this site.

****Report illicit discharges to the County and appropriate agencies.**