

WASTEWATER DISPOSAL REPORT

for

***SADDLEHORN RANCH
FILING No. 2***



June 2022

Prepared By:



SADDLEHORN RANCH
FILING No. 2

WASTEWATER DISPOSAL REPORT

June 2022

Prepared for:

ROI Property Group, LLC
2495 Rigdon Street
Napa, CO 94558

Prepared by:

JDS-Hydro, a Division of RESPEC
5540 Tech Center Drive, Suite 100
Colorado Springs, CO 80919

Table of Contents

1.0	INTRODUCTION AND EXECUTIVE SUMMARY.....	2
2.0	PROJECTED LAND USES.....	2
2.1	<i>Projected Land Uses</i>	2
2.2	<i>Water Demands for the Subject Property</i>	2
3.0	WASTEWATER REPORT.....	3
3.1	<i>Unit Use Wastewater Loads:</i>	3
3.2	<i>On-Site Wastewater Treatment Systems:</i>	3
4.0	CONCLUSION.....	3

APPENDICES

Appendix A – Land Use Exhibit

Appendix B – On-site Wastewater Treatment System Evaluation

1.0 INTRODUCTION AND EXECUTIVE SUMMARY

The purpose of this report is to address the specific wastewater loads of the proposed Saddlehorn Ranch Filing No. 2 in Falcon, CO. This project is currently seeking Final Plat approval through El Paso County, and this report is a requirement of approval.

EXECUTIVE SUMMARY: The Saddlehorn development is proposed as and approved for On-Site Wastewater Treatment Systems (OWTS). No central sewer conveyance or treatment is proposed. Please refer to the On-Site Wastewater Treatment System Evaluation in Appendix B.

2.0 PROJECTED LAND USES

2.1 Projected Land Uses

Lands within the subject area have been planned as 42 lots of residential development. Please refer to the Land Use Exhibit in **Appendix A**.

2.2 Water Demands for the Subject Property

A summary of expected water demands for this land use are provided in Table 2-1 below:

Summary of Expected Water Demands

Table 2-1

Land Use	Water		
	Number of Units	Indoor & Irrigation Usage (AF/YR) ^{1, 2}	Indoor & Irrigation Usage (GPD)
Residential	42	28.14	25,122
<i>Note 1 - @ 0.67 AF/YR/SFE</i>			
<i>Note 2 - AF = Acre-Feet</i>			
<i>Note 3 - SFE = Single Family Equivalent</i>			

3.0 WASTEWATER REPORT

3.1 Unit Use Wastewater Loads:

Unit wastewater load characteristics have been developed for this area, and a value of 172 gallons per SFE per day has been established.

3.2 On-Site Wastewater Treatment Systems:

The proposed single-family homes (minimum lot size of 2.5 acres) will be served by individual on-site wastewater treatment systems. The site was evaluated for on-site wastewater treatment systems by Entech Engineering, Inc. in early 2019. Four (4) test borings and forty (40) tactile test pits were performed on the site to verify soil conditions and suitability for OWTS.

Laboratory testing was also performed to classify and determine the soils engineering characteristics. Soils in the area are described as having moderate to very rapid percolation rates, with most of the soils being described with rapid permeabilities.

The Natural Resource Conservation Service (NRCS) has rated the soil suitability with respect to septic tank absorption fields, and the soils have been described as very limited due to seepage, bottom layer, and filtering capacity.

Based on the evaluation mentioned above, the site is suitable for individual on-site wastewater treatment systems. Contamination of surface and subsurface water resources should not occur provided the OWTS sites are evaluated and installed according to El Paso County and State Guidelines and properly maintained. Areas where shallow bedrock or groundwater is encountered may require designed systems. Additional investigation of individual lots would be required to identify areas that are suitable for the use of conventional systems.

The Soil, Geology, and Geologic Hazard, and Wastewater Study by Entech Engineering, Inc. dated April 29th, 2019, is included in **Appendix B**.

4.0 CONCLUSION

The Saddlehorn development is proposed as and approved for On-Site Wastewater Treatment Systems (OWTS). No central sewer conveyance or treatment is proposed. Please refer to the On-Site Wastewater Treatment System Evaluation in *Appendix B*.

Appendix A

SADDLEHORN RANCH FILING NO. 2

A PARCEL OF LAND LOCATED IN SECTION 3 AND THE NORTH HALF OF THE NORTH EAST QUARTER OF SECTION 10, TOWNSHIP 13 SOUTH, RANGE 64 WEST OF THE 6TH PRINCIPAL MERIDIAN COUNTY OF EL PASO, STATE OF COLORADO

KNOW ALL MEN BY THESE PRESENTS

THAT GORILLA CAPITAL CO SADDLEHORN RANCH, LLC, BEING THE OWNER OF THE FOLLOWING TRACT OF LAND:

A PARCEL OF LAND LOCATED IN SECTION 3 AND THE NORTH HALF OF THE NORTH HALF OF SECTION 10, TOWNSHIP 13 SOUTH, RANGE 64 WEST OF THE 6TH P.M., COUNTY OF EL PASO, STATE OF COLORADO, BEING MORE PARTICULARLY DESCRIBED AS FOLLOWS:

COMMENCING AT THE SOUTHWEST CORNER OF SECTION 3, TOWNSHIP 13 SOUTH, RANGE 64 WEST OF THE 6TH PRINCIPAL MERIDIAN;

THENCE ON THE WEST LINE OF SAID SECTION 3, N00°32'28"W A DISTANCE OF 1987.87 FEET, TO THE NORTHWESTERLY CORNER OF SADDLEHORN RANCH FILING NO. 1 RECORDED UNDER RECEPTION NO. 221714749 IN THE RECORDS OF THE EL PASO COUNTY CLERK AND RECORDER AND THE POINT OF BEGINNING;

THENCE CONTINUING ON SAID WEST LINE, N00°32'28"W A DISTANCE OF 799.26 FEET;

THENCE DEPARTING SAID WEST LINE THE FOLLOWING THIRTY-TWO (32) COURSES:

1. S89°59'23"E A DISTANCE OF 442.27 FEET;
2. N00°00'37"E A DISTANCE OF 35.00 FEET;
3. S89°59'23"E A DISTANCE OF 60.00 FEET;
4. S00°00'37"W A DISTANCE OF 35.00 FEET;
5. S89°59'23"E A DISTANCE OF 303.52 FEET, TO A POINT OF CURVE;
6. ON THE ARC OF A CURVE TO THE RIGHT, HAVING A RADIUS OF 780.00 FEET, A CENTRAL ANGLE OF 18°44'59" AND AN ARC LENGTH OF 255.25 FEET, TO A POINT OF TANGENT;
7. S71°14'24"E A DISTANCE OF 260.86 FEET, TO A POINT OF CURVE;
8. ON THE ARC OF A CURVE TO THE RIGHT, HAVING A RADIUS OF 2780.00 FEET, A CENTRAL ANGLE OF 13°06'52" AND AN ARC LENGTH OF 636.31 FEET, TO A POINT OF TANGENT;
9. S58°07'32"E A DISTANCE OF 223.80 FEET;
10. N29°44'39"E A DISTANCE OF 35.38 FEET;
11. S60°15'21"E A DISTANCE OF 60.00 FEET;
12. N29°44'39"E A DISTANCE OF 495.87 FEET, TO A POINT OF CURVE;
13. ON THE ARC OF A CURVE TO THE LEFT, HAVING A RADIUS OF 3780.00 FEET, A CENTRAL ANGLE OF 03°09'58" AND AN ARC LENGTH OF 208.89 FEET, TO A POINT OF NON-TANGENT;
14. S63°25'19"E A DISTANCE OF 253.86 FEET;
15. N78°29'56"E A DISTANCE OF 122.41 FEET;
16. S65°55'05"E A DISTANCE OF 154.37 FEET;
17. S80°55'05"E A DISTANCE OF 329.85 FEET;
18. S83°17'36"E A DISTANCE OF 453.41 FEET;
19. S58°21'31"E A DISTANCE OF 99.14 FEET;
20. S12°59'32"E A DISTANCE OF 287.70 FEET;
21. S84°04'11"W A DISTANCE OF 116.39 FEET;
22. S00°27'54"W A DISTANCE OF 933.68 FEET;
23. S36°54'54"E A DISTANCE OF 330.03 FEET;
24. S13°21'17"E A DISTANCE OF 83.07 FEET;
25. S00°07'31"W A DISTANCE OF 82.66 FEET;
26. S07°55'12"W A DISTANCE OF 107.85 FEET;
27. S34°24'44"W A DISTANCE OF 178.42 FEET;
28. S26°04'25"W A DISTANCE OF 85.34 FEET;
29. S07°51'44"E A DISTANCE OF 510.21 FEET;
30. S33°40'12"E A DISTANCE OF 357.56 FEET;
31. S09°52'53"W A DISTANCE OF 673.53 FEET;
32. S00°38'45"W A DISTANCE OF 417.04 FEET, TO A POINT ON THE SOUTH LINE OF THE NORTH HALF OF THE NORTHEAST QUARTER OF SAID SECTION 10;

THENCE ON SAID SOUTH LINE, S89°34'01"W A DISTANCE OF 416.11 FEET, TO THE SOUTHEASTERLY CORNER OF SADDLEHORN RANCH FILING NO. 1;

THENCE ON THE EASTERLY AND NORTHEASTLY LINES OF SADDLEHORN RANCH FILING NO. 1 THE FOLLOWING TWENTY-ONE (21) COURSES:

1. N49°37'00"W A DISTANCE OF 565.00 FEET, TO A POINT OF NON-TANGENT CURVE;
2. ON THE ARC OF A CURVE TO THE RIGHT WHOSE CENTER BEARS N19°28'44"W, HAVING A RADIUS OF 170.00 FEET, A CENTRAL ANGLE OF 19°02'46" AND AN ARC LENGTH OF 56.51 FEET, TO A POINT OF TANGENT;
3. S89°34'03"W A DISTANCE OF 197.98 FEET;
4. N00°00'00"E A DISTANCE OF 964.76 FEET;
5. N05°58'59"W A DISTANCE OF 349.19 FEET;
6. N16°11'46"W A DISTANCE OF 257.34 FEET;
7. N16°11'46"W A DISTANCE OF 261.98 FEET;
8. N21°16'04"W A DISTANCE OF 343.92 FEET;
9. N26°10'49"W A DISTANCE OF 266.32 FEET;
10. N44°25'17"W A DISTANCE OF 280.03 FEET;
11. N56°30'41"W A DISTANCE OF 35.01 FEET;
12. S42°31'10"W A DISTANCE OF 422.77 FEET, TO A POINT OF NON-TANGENT CURVE;
13. ON THE ARC OF A CURVE TO THE LEFT WHOSE CENTER BEARS S47°44'09"W, HAVING A RADIUS OF 1680.00 FEET, A CENTRAL ANGLE OF 05°10'02" AND AN ARC LENGTH OF 151.51 FEET, TO A POINT OF NON-TANGENT;

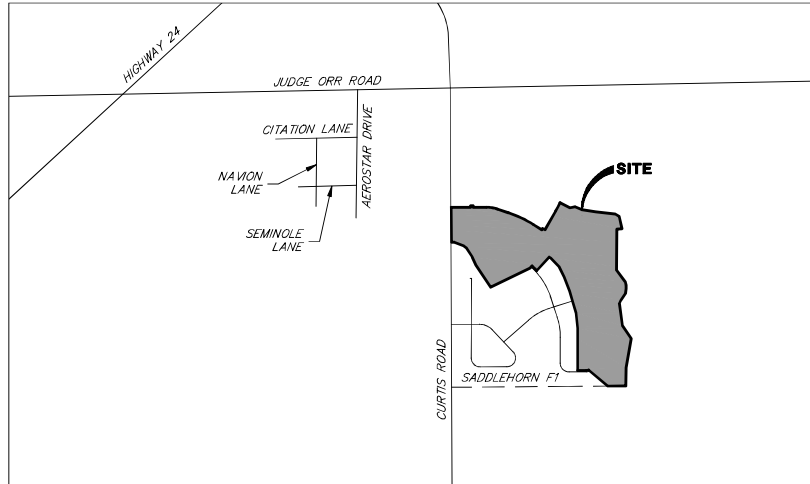

14. S42°34'07"W A DISTANCE OF 60.00 FEET;
15. S63°48'26"W A DISTANCE OF 1002.65 FEET;
16. N33°50'17"W A DISTANCE OF 610.26 FEET;
17. N24°10'40"W A DISTANCE OF 207.55 FEET;
18. N32°24'01"W A DISTANCE OF 240.57 FEET;
19. N53°08'37"W A DISTANCE OF 71.78 FEET;
20. N68°03'22"W A DISTANCE OF 227.58 FEET;
21. S89°27'32"W A DISTANCE OF 72.00 FEET, TO THE POINT OF BEGINNING.

CONTAINING A CALCULATED AREA OF 7,703,680 SQUARE FEET OR 176.8522 ACRES.

DEDICATION

THE ABOVE OWNER HAS CAUSED SAID TRACT OF LAND TO BE PLATTED INTO 42 LOTS, STREETS, 2 TRACTS, AND EASEMENTS AS SHOWN ON THIS PLAT. THE UNDERSIGNED DOES HEREBY DEDICATE, GRANT AND CONVEY TO EL PASO COUNTY THOSE STREETS AND PUBLIC EASEMENTS AS SHOWN ON THE PLAT; AND FURTHER RESTRICTS THE USE OF ALL PUBLIC EASEMENTS TO EL PASO COUNTY AND/OR ITS ASSIGNS, PROVIDED HOWEVER, THAT THE SOLE RIGHT AND AUTHORITY TO VACATE, RELEASE OR QUIT-CLAIM ALL OR ANY SUCH PUBLIC EASEMENTS SHALL REMAIN EXCLUSIVELY VESTED IN EL PASO COUNTY. ALL PUBLIC STREETS ARE HEREBY DEDICATED TO EL PASO COUNTY FOR PUBLIC USE. THIS TRACT OF LAND AS HEREIN PLATTED SHALL BE KNOWN AS "SADDLEHORN RANCH FILING NO. 2" IN EL PASO COUNTY, COLORADO.

CLERK AND RECORDER

STATE OF COLORADO)
)
COUNTY OF EL PASO)

I HEREBY CERTIFY THAT THIS INSTRUMENT WAS FILED FOR RECORD IN MY OFFICE

AT _____ O'CLOCK _____M., THIS _____ DAY OF _____, 20____, A.D.

AND IS DULY RECORDED AT RECEPTION NO. _____ OF THE RECORDS OF EL PASO COUNTY, COLORADO.

CHUCK BROERMAN, RECORDER

BY: _____
DEPUTY

OWNERS CERTIFICATE

THE UNDERSIGNED, BEING ALL THE OWNERS, MORTGAGEES, BENEFICIARIES OF DEEDS OF TRUST AND HOLDERS OF OTHER INTERESTS IN THE LAND DESCRIBED HEREIN, HAVE LAID OUT, SUBDIVIDED, AND PLATTED SAID LANDS INTO LOTS, TRACTS, STREETS, AND EASEMENTS AS SHOWN HEREON UNDER THE NAME AND SUBDIVISION OF SADDLEHORN RANCH FILING NO. 2. ALL PUBLIC IMPROVEMENTS SO PLATTED ARE HEREBY DEDICATED TO PUBLIC USE AND SAID OWNER DOES HEREBY COVENANT AND AGREE THAT THE PUBLIC IMPROVEMENTS WILL BE CONSTRUCTED TO EL PASO COUNTY STANDARDS AND THAT PROPER DRAINAGE AND EROSION CONTROL FOR SAME WILL BE PROVIDED AT SAID OWNER'S EXPENSE, ALL TO THE SATISFACTION OF THE BOARD OF COUNTY COMMISSIONERS OF EL PASO COUNTY, COLORADO, UPON ACCEPTANCE BY RESOLUTION, ALL PUBLIC IMPROVEMENTS SO DEDICATED WILL BECOME MATTERS OF MAINTENANCE BY EL PASO COUNTY, COLORADO. THE UTILITY EASEMENTS SHOWN HEREON ARE HEREBY DEDICATED FOR PUBLIC UTILITIES AND COMMUNICATION SYSTEMS AND OTHER PURPOSES AS SHOWN HEREON. THE ENTITIES RESPONSIBLE FOR PROVIDING THE SERVICES FOR WHICH THE EASEMENTS ARE ESTABLISHED ARE HEREBY GRANTED THE PERPETUAL RIGHT OF INGRESS AND EGRESS FROM AND TO ADJACENT PROPERTIES FOR INSTALLATION, MAINTENANCE, AND REPLACEMENT OF UTILITY LINES AND RELATED FACILITIES.

GORILLA CAPITAL CO SADDLEHORN RANCH, LLC

BY: _____

STATE OF COLORADO)
COUNTY OF _____)SS.

ACKNOWLEDGED BEFORE ME THIS _____ DAY OF _____, 20____ BY _____

MY COMMISSION EXPIRES _____

WITNESS MY HAND AND OFFICIAL SEAL _____
NOTARY PUBLIC

ACCEPTANCE CERTIFICATE FOR TRACTS

THE DEDICATION OF TRACTS A, B AND C ARE HEREBY ACCEPTED FOR OWNERSHIP AND MAINTENANCE BY THE SADDLEHORN RANCH METROPOLITAN DISTRICT.

SADDLEHORN RANCH METROPOLITAN DISTRICT

BY: _____

STATE OF COLORADO)
COUNTY OF _____)SS.

ACKNOWLEDGED BEFORE ME THIS _____ DAY OF _____, 20____ BY _____ AS _____

MY COMMISSION EXPIRES: _____

WITNESS MY HAND AND OFFICIAL SEAL _____
NOTARY PUBLIC

SURVEYORS CERTIFICATE

I DEREK LEE VAGIAS, A DULY REGISTERED PROFESSIONAL LAND SURVEYOR IN THE STATE OF COLORADO, DO HEREBY CERTIFY THAT THIS PLAT TRULY AND CORRECTLY REPRESENTS THE RESULTS OF A SURVEY MADE ON DATE OF SURVEY, BY ME OR UNDER MY DIRECT SUPERVISION AND THAT ALL MONUMENTS EXIST AS SHOWN HEREON; THAT MATHEMATICAL CLOSURE ERRORS ARE LESS THAN 1:10,000 ; AND THAT SAID PLAT HAS BEEN PREPARED IN FULL COMPLIANCE WITH ALL APPLICABLE LAWS OF THE STATE OF COLORADO DEALING WITH MONUMENTS, SUBDIVISION, OR SURVEYING OF LAND AND ALL APPLICABLE PROVISIONS OF THE EL PASO COUNTY LAND DEVELOPMENT CODE.

I ATTEST THE ABOVE ON THIS _____ DAY OF _____, 20____.

DEREK LEE VAGIAS, _____ DATE _____
COLORADO REGISTERED PLS #38578
FOR AND ON BEHALF OF JR ENGINEERING, LLC

PLANNING AND COMMUNITY DEVELOPMENT DIRECTOR CERTIFICATE

THIS PLAT FOR SADDLEHORN RANCH FILING NO. 2 WAS APPROVED FOR FILING BY THE EL PASO COUNTY, COLORADO PLANNING AND COMMUNITY DEVELOPMENT DEPARTMENT DIRECTOR ON THE _____ DAY OF _____, 20____, SUBJECT TO ANY NOTES OR CONDITIONS SPECIFIED HEREON.

PLANNING AND COMMUNITY DEVELOPMENT DIRECTOR _____

CONTACTS:

OWNER	GORILLA CAPITAL, LLC 1342 HIGH STREET EUGENE, OR 97401 P~541-393-9043
DEVELOPER	ROI PROPERTY GROUP, LLC 2495 RIGDON STREET NAPA, CALIFORNIA 94558 P~707-633-9700
ENGINEER	JR ENGINEERING, LLC ATTN: BRYAN LAW 5475 TECH CENTER DRIVE, SUITE 235 COLORADO SPRINGS, CO 80919 P~(303) 267-6254
SURVEYOR	JR ENGINEERING, LLC ATTN: DEREK VAGIAS 7200 S ALTON WAY, C400, CENTENNIAL, CO 80112 P~(303) 740-9393

FEES:

RECORDING: _____
PARK: _____
SCHOOL: _____
DRAINAGE: _____
BRIDGE: _____

PCD FILE: SF-21-033

JOB NO. 25142.04
JUNE 10, 2022
SHEET 1 OF 5



Centennial 303-740-9393 • Colorado Springs 719-593-2593
Fort Collins 970-491-9888 • www.jrengineering.com

SADDLEHORN RANCH FILING NO. 2

A PARCEL OF LAND LOCATED IN SECTION 3 AND THE NORTH HALF OF THE NORTHEAST QUARTER OF SECTION 10,
TOWNSHIP 13 SOUTH, RANGE 64 WEST OF THE 6TH PRINCIPAL MERIDIAN
COUNTY OF EL PASO, STATE OF COLORADO

GENERAL NOTES:

- PER C.R.S. 38-51-106, "ALL LINEAL UNITS DEPICTED ON THIS LAND SURVEY PLAT ARE U.S. SURVEY FEET". ONE METER EQUALS 39.37/12 U.S. SURVEY FEET, EXACTLY ACCORDING TO THE NATIONAL INSTITUTE OF STANDARDS AND TECHNOLOGY
- BASIS OF BEARING: THE WEST LINE OF SECTION 3, T3S, R64W, 6TH P.M., MONUMENTED BY A 3-1/4" ALUMINUM CAP STAMPED "PLS 17496" IN A RANGE BOX AT THE NORTHWEST CORNER OF SECTION 3 AND A NO. 6 REBAR IN A RANGE BOX AT THE SOUTHWEST CORNER OF SECTION 3, BEARING N00°32'28"W AS REFERENCED TO COLORADO STATE PLANE CENTRAL ZONE.
- ALL REFERENCES TO BOOKS, PAGES, MAPS, AND RECEPTION NUMBERS ARE PUBLIC DOCUMENTS ON FILE WITH THE CLERK AND RECORDER OF EL PASO COUNTY, STATE OF COLORADO.
- THIS SITE IS WITHIN A SPECIAL FLOOD HAZARD AREA "ZONE AE" (SPECIAL FLOOD HAZARD AREAS SUBJECT TO INUNDATION BY THE 1% ANNUAL CHANCE FLOOD), AS DETERMINED BY GRAPHIC INTERPRETATION. FLOODPLAIN INFORMATION WAS OBTAINED FROM F.E.M.A. FLOODPLAIN, AS SHOWN ON THE FLOOD INSURANCE RATE MAPS FOR EL PASO COUNTY, COLORADO, MAP NUMBERS 08041C0558G AND 08041C0566G BOTH WITH REVISED DATES OF DECEMBER 7, 2018.
- THIS LAND SURVEY DOES NOT CONSTITUTE A TITLE SEARCH BY JR ENGINEERING, LLC. FOR ALL INFORMATION REGARDING EASEMENTS, RIGHT-OF-WAY OR TITLE OF RECORD, JR ENGINEERING, LLC RELIED UPON TITLE COMMITMENT NO. 83142ECS, AMENDMENT NO. 2, PREPARED BY STEWART TITLE GUARANTY COMPANY COMPANY, DATED JULY 10, 2021, 7:30 A.M.
- BY APPROVAL OF THIS PLAT EL PASO COUNTY VACATES THE POTENTIAL ROW ALONG THE SOUTH LINE OF SECTION 3 AND THE NORTH LINE OF SECTION 10 AS MAY HAVE BEEN ACQUIRED BY BOCC RESOLUTION RECORDED AT BOOK A, PAGE 78 IN THE RECORDS OF THE EL PASO COUNTY CLERK AND RECORDER.
- TRACTS A AND B ARE FOR OPEN SPACE AND DRAINAGE PURPOSES. TRACTS A AND B SHALL BE OWNED AND MAINTAINED BY THE SADDLEHORN RANCH METROPOLITAN DISTRICT.
- THE ADDRESSES EXHIBITED ON THIS PLAT ARE FOR INFORMATIONAL PURPOSES ONLY. THEY ARE NOT THE LEGAL DESCRIPTION AND ARE SUBJECT TO CHANGE.
- ALL PROPERTY OWNERS ARE RESPONSIBLE FOR MAINTAINING PROPER STORM WATER DRAINAGE IN AND THROUGH THEIR PROPERTY. PUBLIC DRAINAGE EASEMENTS SHALL BE MAINTAINED BY THE INDIVIDUAL LOT OWNERS UNLESS OTHERWISE INDICATED. STRUCTURES, FENCES, MATERIALS OR LANDSCAPING THAT COULD IMPEDE THE FLOW OR RUNOFF SHALL NOT BE PLACED IN THE DRAINAGE EASEMENTS.
- WATER SERVICE SHALL BE SUPPLIED BY SADDLEHORN RANCH METROPOLITAN DISTRICT.
- SEWAGE TREATMENT IS THE RESPONSIBILITY OF EACH INDIVIDUAL PROPERTY OWNER. THE EL PASO COUNTY HEALTH DEPARTMENT MUST APPROVE EACH SYSTEM AND IN SOME CASES THE DEPARTMENT MAY REQUIRE AN ENGINEER DESIGNED SYSTEM PRIOR TO PERMIT APPROVAL.
- IMPERVIOUS LOT COVERAGE IS RESTRICTED TO NO MORE THAN 10,900 SQUARE FEET PER LOT TO CONFORM WITH THE EL PASO COUNTY'S M4 STORM WATER DISCHARGE PERMIT.
- UNLESS SHOWN OTHERWISE, ALL SIDE, FRONT AND REAR LOT LINES ARE HEREBY PLATTED WITH A 10 FOOT WIDE PUBLIC UTILITY AND DRAINAGE EASEMENT. ALL EXTERIOR SUBDIVISION BOUNDARIES ARE HEREBY PLATTED WITH A 20 FOOT WIDE PUBLIC UTILITY AND DRAINAGE EASEMENT. THE SOLE RESPONSIBILITY FOR MAINTENANCE OF THESE EASEMENTS IS HEREBY VESTED WITH THE INDIVIDUAL PROPERTY OWNERS.
- THE FOLLOWING REPORTS HAVE BEEN SUBMITTED IN ASSOCIATION WITH THE PRELIMINARY PLAN OR FINAL PLAT FOR THIS SUBDIVISION AND ARE ON FILE AT THE COUNTY PLANNING AND COMMUNITY DEVELOPMENT DEPARTMENT: TRANSPORTATION IMPACT STUDY; DRAINAGE REPORT; WATER RESOURCES REPORT; WASTEWATER DISPOSAL REPORT; GEOLOGY AND SOILS REPORT; FIRE PROTECTION REPORT; WILDFIRE HAZARDS REPORT; NATURAL FEATURES REPORT.
- DEVELOPER SHALL COMPLY WITH FEDERAL AND STATE LAWS, REGULATION, ORDINANCES, REVIEW AND PERMIT REQUIREMENTS, AND ANY OTHER AGENCY REQUIREMENT, IF ANY, OF APPLICABLE AGENCIES INCLUDING, BUT NOT LIMITED TO, THE COLORADO DEPARTMENT OF PARKS AND WILDLIFE, COLORADO DEPARTMENT OF TRANSPORTATION, U.S. ARMY CORPS OF ENGINEERS, AND THE U.S. FISH & WILDLIFE SERVICE REGARDING THE ENDANGERED SPECIES ACT, PARTICULARLY AS IT RELATES TO THE LISTED SPECIES (E.G., PREBLES MEADOW JUMPING MOUSE).
- NO LOT OR INTEREST THEREIN, SHALL BE SOLD, CONVEYED, OR TRANSFERRED WHETHER BY DEED OR BY CONTRACT, NOR SHALL BUILDING PERMITS BE ISSUED, UNTIL AND UNLESS EITHER THE REQUIRED PUBLIC AND COMMON DEVELOPMENT IMPROVEMENTS HAVE BEEN CONSTRUCTED AND PRELIMINARILY ACCEPTED IN ACCORDANCE WITH THE SUBDIVISION IMPROVEMENTS AGREEMENT BETWEEN THE APPLICANT/OWNER AND EL PASO COUNTY AS RECORDED UNDER RECEPTION NO. [REDACTED] IN THE OFFICE OF THE CLERK AND RECORDER OF EL PASO COUNTY, COLORADO OR, IN THE ALTERNATIVE, OTHER COLLATERAL IS PROVIDED TO MAKE PROVISION FOR THE COMPLETION OF SAID IMPROVEMENTS IN ACCORDANCE WITH THE EL PASO LAND DEVELOPMENT CODE AND ENGINEERING CRITERIA MANUAL. ANY SUCH ALTERNATIVE COLLATERAL MUST BE APPROVED BY THE BOARD OF COUNTY COMMISSIONERS OR, IF PERMITTED BY THE SUBDIVISION IMPROVEMENTS AGREEMENT, BY THE DEVELOPMENT SERVICES DEPARTMENT DIRECTOR AND MEET THE POLICY AND PROCEDURE REQUIREMENTS OF EL PASO COUNTY PRIOR TO THE RELEASE BY THE COUNTY OF ANY LOTS FOR SALE, CONVEYANCE OR TRANSFER. THIS PLAT RESTRICTION MAY BE REMOVED OR RESCINDED BY THE BOARD OF COUNTY COMMISSIONERS OR, IF PERMITTED BY THE SUBDIVISION IMPROVEMENTS AGREEMENT, BY THE PLANNING AND COMMUNITY DEVELOPMENT DEPARTMENT DIRECTOR UPON EITHER APPROVAL OF AN ALTERNATIVE FORM OF COLLATERAL OR COMPLETION AND PRELIMINARY ACCEPTANCE BY THE EL PASO BOARD OF COUNTY COMMISSIONERS OF ALL IMPROVEMENT REQUIRED TO BE CONSTRUCTED AND COMPLETED IN ACCORDANCE WITH SAID SUBDIVISION IMPROVEMENTS AGREEMENT. THE PARTIAL RELEASE OF LOTS FOR SALE, CONVEYANCE OR TRANSFER MAY ONLY BE GRANTED IN ACCORDANCE WITH ANY PLANNED PARTIAL RELEASE OF LOTS AUTHORIZED BY THE SUBDIVISION IMPROVEMENTS AGREEMENT.
- A DRIVEWAY PERMIT IS REQUIRED TO BE APPLIED FOR AND APPROVED BY EL PASO COUNTY PLANNING AND COMMUNITY DEVELOPMENT DEPARTMENT PRIOR TO THE ESTABLISHMENT OF ANY DRIVEWAY. INDIVIDUAL LOT PURCHASERS ARE RESPONSIBLE FOR CONSTRUCTING DRIVEWAYS, INCLUDING DRAINAGE CULVERTS FROM ESTACADO PLACE, DEL CERRO TRAIL, EL RAICENO TRAIL, AND BENITO WELLS TRAIL PER LAND DEVELOPMENT CODE SECTION 6.3.3.C.2 AND 6.3.3.C.3. DUE TO THEIR LENGTH, SOME OF THE DRIVEWAYS WILL NEED TO BE SPECIFICALLY APPROVED BY THE FALCON FIRE PROTECTION DISTRICT.
- THERE SHALL BE NO DIRECT LOT ACCESS TO CURTIS ROAD.
- THE FOLLOWING LOTS (24, 25, 26, 33, 34, 35, 36, 37, 41 & TRACT B) HAVE BEEN FOUND TO BE IMPACTED BY GEOLOGIC HAZARDS. MITIGATION MEASURES AND A MAP OF THE HAZARD CAN BE FOUND IN THE GEOLOGIC HAZARD REPORT PREPARED BY ENTECH ENGINEERING DATED FEBRUARY 9, 2022 IN THE SADDLEHORN RANCH PRELIMINARY PLAN FILE # SF-2133 AVAILABLE AT THE EL PASO COUNTY PLANNING AND COMMUNITY DEVELOPMENT DEPARTMENT. IF ANY STRUCTURES ARE PROPOSED IN ANY HAZARD AREA, A SUBSURFACE SOILS INVESTIGATION AND AN ENGINEERED SITE PLAN WILL BE REQUIRED FOR COUNTY REVIEW.
 - ARTIFICIAL FILL: SOUTHWEST CORNER OF SITE
 - HYDROCOMPACTION: SOUTHEAST CORNER OF THE SITE
 - LOOSE OR COLLAPSIBLE SOILS: SOUTHERN PORTION OF SITE
 - FLOODPLAIN AND DRAINAGE AREAS: CENTRAL AND NORTHWESTERN PORTION OF SITE
- THIS SUBDIVISION IS SURROUNDED BY AGRICULTURAL LAND. PROPERTY OWNERS MAY BE IMPACTED BY SOUNDS, SMELLS AND/OR ACTIVITIES ASSOCIATED WITH ACTIVE AGRICULTURAL PRACTICES. PURSUANT TO ARTICLE 3.5, TITLE 35, C.R.S., IT IS THE DECLARED POLICY OF THE STATE OF COLORADO TO CONSERVE, PROTECT, AND ENCOURAGE THE DEVELOPMENT AND IMPROVEMENT OF ITS AGRICULTURAL LAND FOR THE PRODUCTION OF FOOD AND OTHER AGRICULTURAL PRODUCTS. COLORADO IS A "RIGHT-TO-FARM" STATE PURSUANT TO C.R.S. 35-3.5-101, ET SEQ. LANDOWNERS, RESIDENTS AND VISITORS MUST BE PREPARED TO ACCEPT THE ACTIVITIES, SIGHTS, SOUNDS, AND SMELLS OF AGRICULTURAL OPERATIONS AS A NORMAL AND NECESSARY IMPACT OF LIVING IN A COUNTY WITH A STRONG RURAL CHARACTER AND A HEALTHY AGRICULTURAL SECTOR. STATE LAW PROVIDES THAT RANCHING, FARMING, OR OTHER AGRICULTURAL ACTIVITIES AND OPERATIONS SHALL NOT BE CONSIDERED TO BE NUISANCES SO LONG AS OPERATED IN CONFORMANCE WITH THE LAW AND IN A NON-NEGLIGENT MANNER. THEREFORE, ALL MUST BE PREPARED TO ENCOUNTER NOISES, ODORS, LIGHTS, MUD, DUST, SMOKE, CHEMICALS, MACHINERY ON PUBLIC ROADS, LIVESTOCK ON PUBLIC ROADS, STORAGE AND DISPOSAL OF MANURE, AND THE APPLICATION BY SPRAYING OR OTHERWISE OF CHEMICAL FERTILIZERS, SOIL AMENDMENTS, HERBICIDES, AND PESTICIDES, AND ONE OR MORE OF WHICH MAY NATURALLY OCCUR AS A PART OF LEGAL AND NON-NEGLIGENT AGRICULTURAL OPERATIONS.

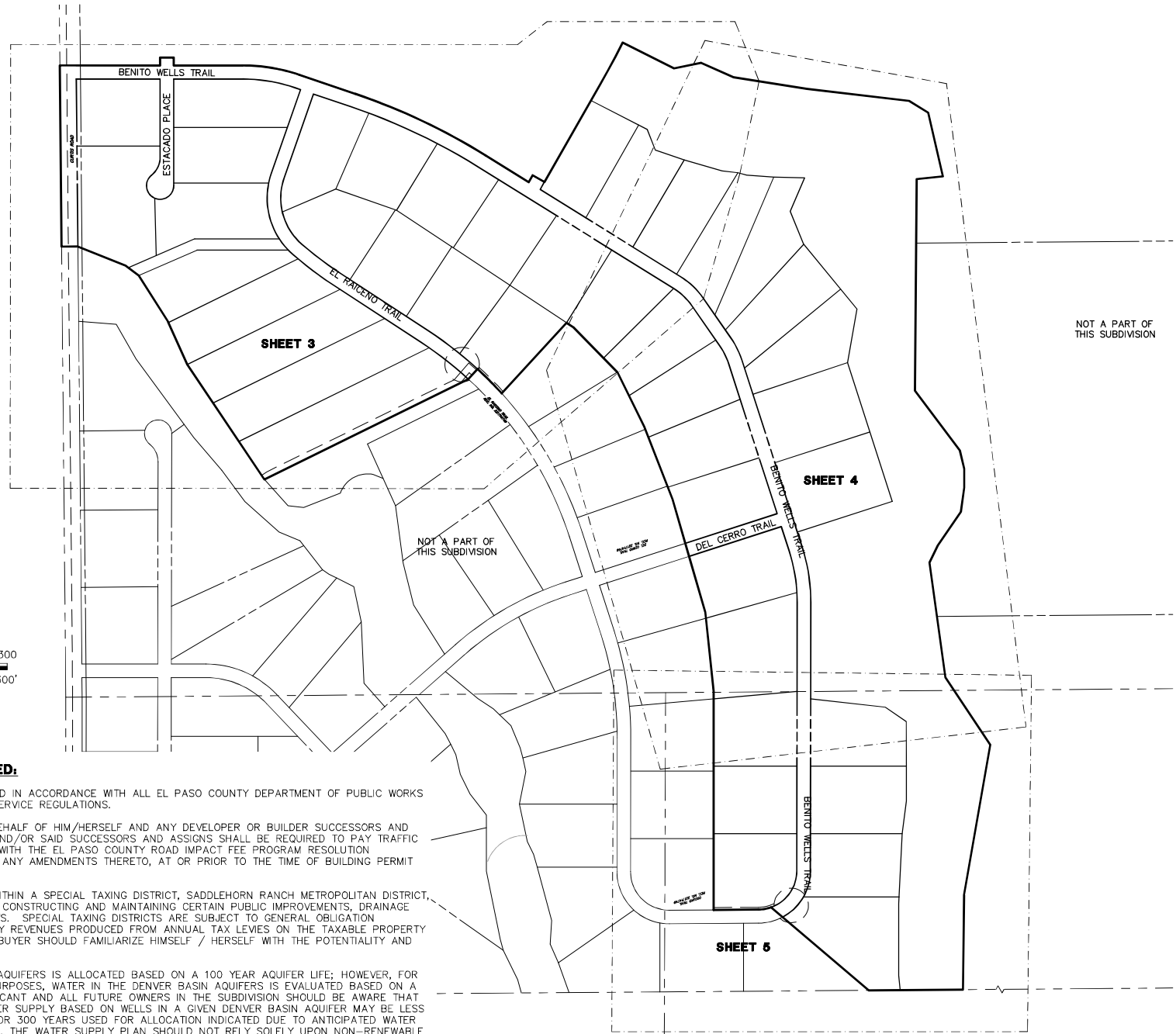
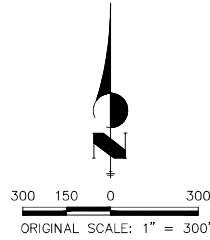

GENERAL NOTES CONTINUED:

- MAILBOXES SHALL BE INSTALLED IN ACCORDANCE WITH ALL EL PASO COUNTY DEPARTMENT OF PUBLIC WORKS AND UNITED STATES POSTAL SERVICE REGULATIONS.
- THE SUBDIVIDER AGREES ON BEHALF OF HIM/HERSELF AND ANY DEVELOPER OR BUILDER SUCCESSORS AND ASSIGNEES THAT SUBDIVIDER AND/OR SAID SUCCESSORS AND ASSIGNS SHALL BE REQUIRED TO PAY TRAFFIC IMPACT FEES IN ACCORDANCE WITH THE EL PASO COUNTY ROAD IMPACT FEE PROGRAM RESOLUTION (RESOLUTION NO. 19-471), OR ANY AMENDMENTS THERETO, AT OR PRIOR TO THE TIME OF BUILDING PERMIT SUBMITTALS.
- THIS PROPERTY IS INCLUDED WITHIN A SPECIAL TAXING DISTRICT, SADDLEHORN RANCH METROPOLITAN DISTRICT, CREATED OF THE PURPOSE OF CONSTRUCTING AND MAINTAINING CERTAIN PUBLIC IMPROVEMENTS, DRAINAGE AND RECREATION IMPROVEMENTS. SPECIAL TAXING DISTRICTS ARE SUBJECT TO GENERAL OBLIGATION INDEBTEDNESS THAT IS PAID BY REVENUES PRODUCED FROM ANNUAL TAX LEVIES ON THE TAXABLE PROPERTY WITHIN SUCH DISTRICTS. THE BUYER SHOULD FAMILIARIZE HIMSELF / HERSELF WITH THE POTENTIALITY AND RAMIFICATIONS THEREOF.
- WATER IN THE DENVER BASIN AQUIFERS IS ALLOCATED BASED ON A 100 YEAR AQUIFER LIFE; HOWEVER, FOR EL PASO COUNTY PLANNING PURPOSES, WATER IN THE DENVER BASIN AQUIFERS IS EVALUATED BASED ON A 300 YEAR AQUIFER LIFE. APPLICANT AND ALL FUTURE OWNERS IN THE SUBDIVISION SHOULD BE AWARE THAT THE ECONOMIC LIFE OF A WATER SUPPLY BASED ON WELLS IN A GIVEN DENVER BASIN AQUIFER MAY BE LESS THAN EITHER THE 100 YEARS OR 300 YEARS USED FOR ALLOCATION INDICATED DUE TO ANTICIPATED WATER LEVEL DECLINES. FURTHERMORE, THE WATER SUPPLY PLAN SHOULD NOT RELY SOLELY UPON NON-RENEWABLE AQUIFERS. ALTERNATIVE RENEWABLE WATER RESOURCES SHOULD BE ACQUIRED AND INCORPORATED IN A PERMANENT WATER SUPPLY PLAN THAT PROVIDES FUTURE GENERATIONS WITH A WATER SUPPLY.
- THIS PROPERTY IS PRESENTLY LOCATED IN THE VICINITY OF AN AIRPORT, WITHIN WHAT IS KNOWN AS AN AIRPORT INFLUENCE AREA. FOR THIS REASON, THE PROPERTY MAY BE SUBJECT TO SOME OF THE ANNOYANCES OR INCONVENIENCES ASSOCIATED WITH PROXIMITY TO AIRPORT OPERATIONS (E.G. NOISE, VIBRATION, OR ODORS). INDIVIDUAL SENSITIVITIES TO THOSE ANNOYANCES CAN VARY FROM PERSON TO PERSON. YOU MAY WISH TO CONSIDER WHAT AIRPORT ANNOYANCES, IF ANY, ARE ASSOCIATED WITH THE PROPERTY BEFORE YOU COMPLETE YOUR PURCHASE AND DETERMINE WHETHER THEY ARE ACCEPTABLE TO YOU.

OWNERSHIP & MAINTENANCE TABLE

TRACT	AREA (SF)	AREA (AC)	USE	OWNER	MAINTENANCE
A	1,971,799	45.2663	OPEN SPACE, DRAINAGE	SADDLEHORN RANCH METROPOLITAN DISTRICT	SADDLEHORN RANCH METROPOLITAN DISTRICT
B	34,307	0.7876	OPEN SPACE, DRAINAGE	SADDLEHORN RANCH METROPOLITAN DISTRICT	SADDLEHORN RANCH METROPOLITAN DISTRICT
TOTAL TRACT AREA	2,006,106	46.0539			
TOTAL ROW AREA	577,173	13.2501			
TOTAL LOT AREA(42 LOTS)	5,120,401	117.5482			(NET AREA)
TOTAL SITE AREA	7,703,680	176.8522			(GROSS AREA)
GROSS DENSITY	0.237 DU/AC				DU=DWELLING UNIT
NET DENSITY	0.357 DU/AC				

JOB NO. 25142.04
JUNE 10, 2022
SHEET 2 OF 5



Centennial 303-740-9393 • Colorado Springs 719-593-2593
Fort Collins 970-491-9888 • www.jrengineering.com

SADDLEHORN RANCH FILING NO. 2

A PARCEL OF LAND LOCATED IN SECTION 3 AND THE NORTH HALF OF THE NORTHEAST QUARTER OF SECTION 10,
TOWNSHIP 13 SOUTH, RANGE 64 WEST OF THE 6TH PRINCIPAL MERIDIAN
COUNTY OF EL PASO, STATE OF COLORADO

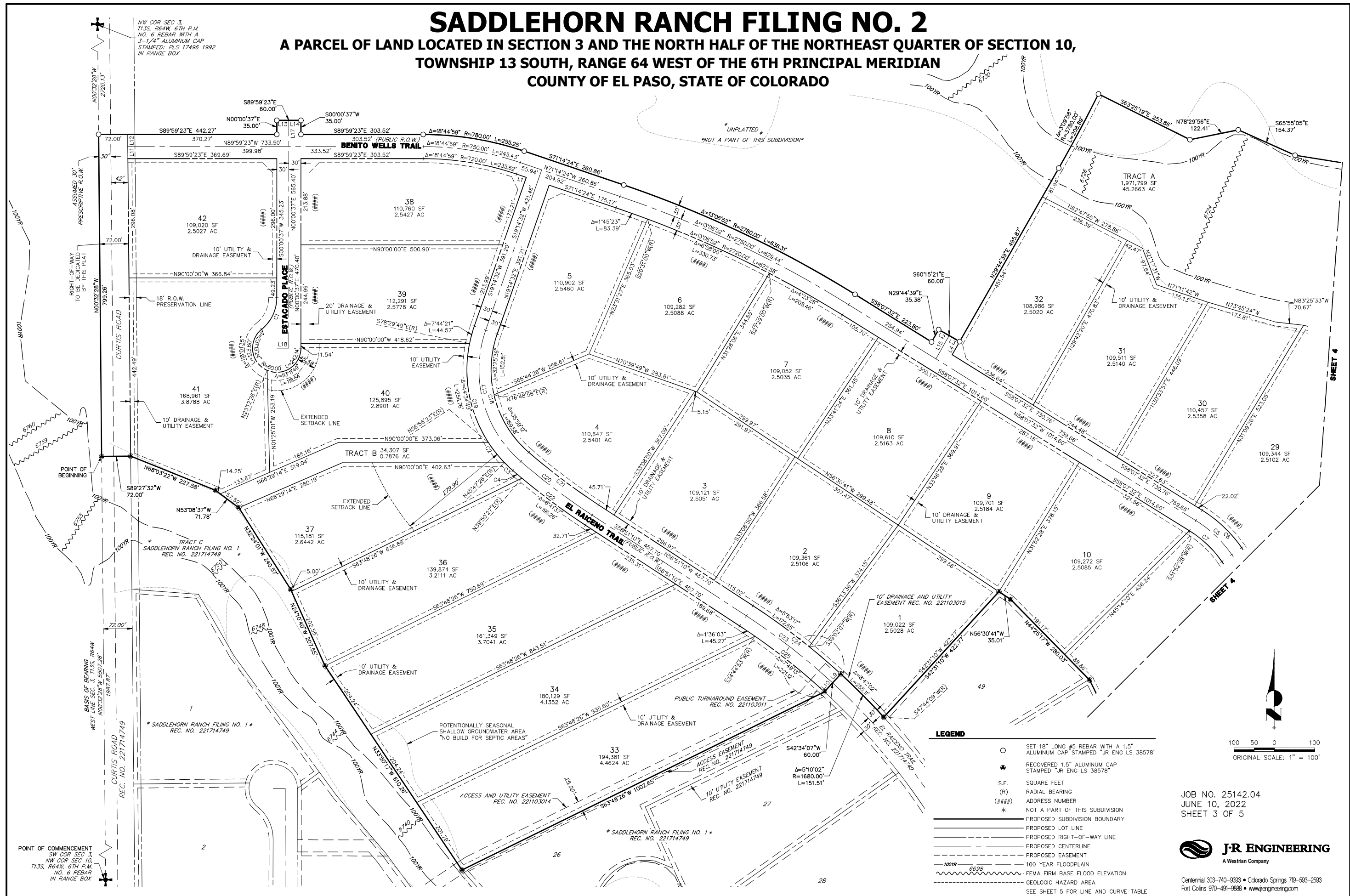

LEGEND

- SET 18" LONG #5 REBAR WITH A 1.5" ALUMINUM CAP STAMPED "JR ENG LS 38578"
- RECOVERED 1.5" ALUMINUM CAP STAMPED "JR ENG LS 38578"
- S.F. SQUARE FEET
- (R) RADIAL BEARING
- ### ADDRESS NUMBER
- * NOT A PART OF THIS SUBDIVISION
- PROPOSED SUBDIVISION BOUNDARY
- PROPOSED LOT LINE
- PROPOSED RIGHT-OF-WAY LINE
- PROPOSED CENTERLINE
- PROPOSED EASEMENT
- 100 YEAR FLOODPLAIN
- FEMA FIRM BASE FLOOD ELEVATION
- GEOLOGIC HAZARD AREA
- SEE SHEET 5 FOR LINE AND CURVE TABLE

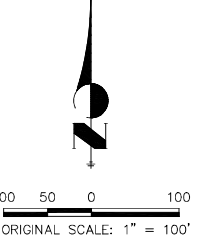

JOB NO. 25142.04
JUNE 10, 2022
SHEET 3 OF 5



Centennial 303-740-9393 • Colorado Springs 719-593-2593
Fort Collins 970-491-9888 • www.jrengineering.com

SADDLEHORN RANCH FILING NO. 2

A PARCEL OF LAND LOCATED IN SECTION 3 AND THE NORTH HALF OF THE NORTHEAST QUARTER OF SECTION 10,
TOWNSHIP 13 SOUTH, RANGE 64 WEST OF THE 6TH PRINCIPAL MERIDIAN
COUNTY OF EL PASO, STATE OF COLORADO

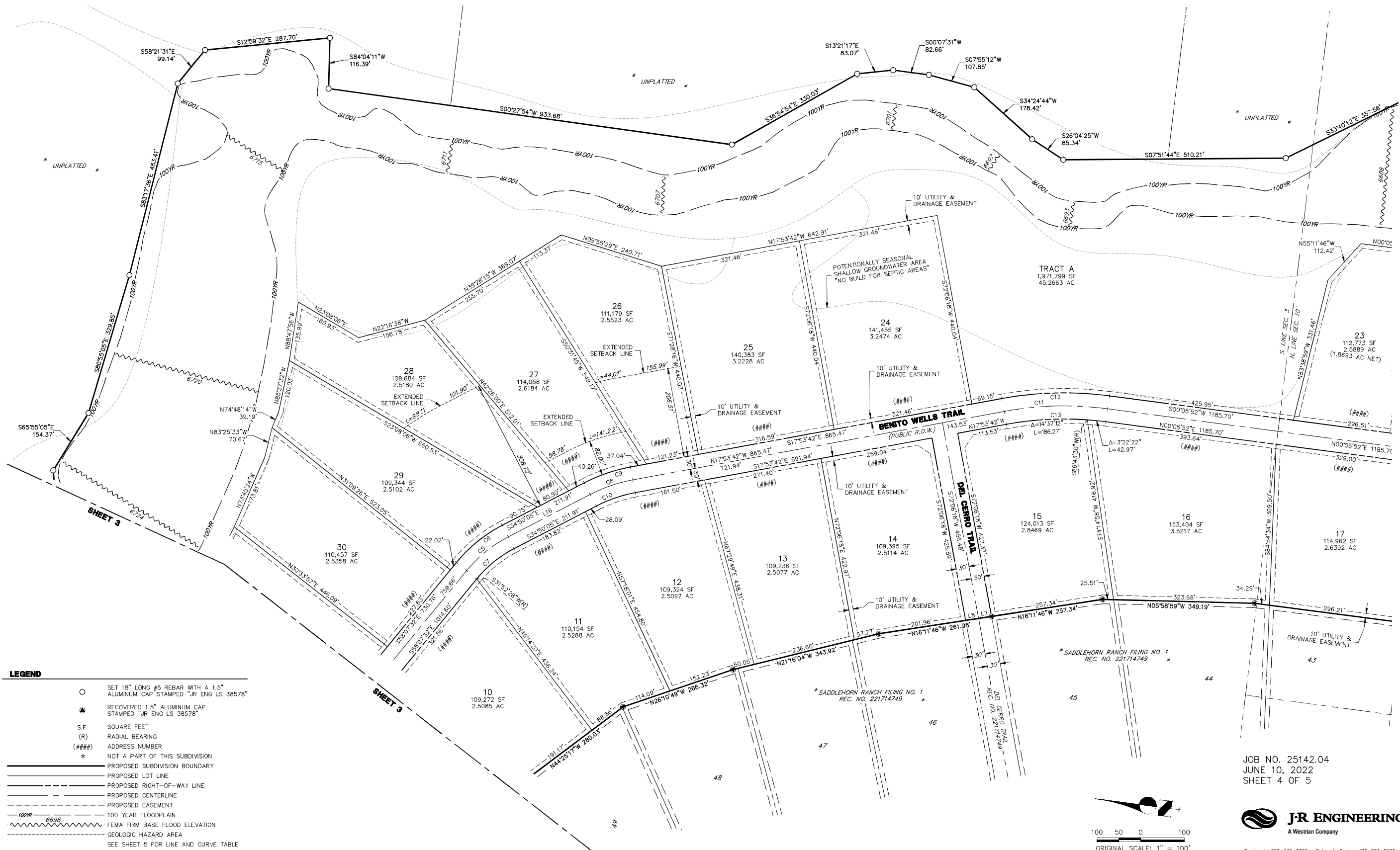

- LEGEND**
- SET 18" LONG #5 REBAR WITH A 1.5" ALUMINUM CAP STAMPED "JR ENG LS 38578"
 - RECOVERED 1.5" ALUMINUM CAP STAMPED "JR ENG LS 38578"
 - S.F. SQUARE FEET
 - (R) RADIAL BEARING
 - (###) ADDRESS NUMBER
 - * NOT A PART OF THIS SUBDIVISION
 - PROPOSED SUBDIVISION BOUNDARY
 - PROPOSED LOT LINE
 - PROPOSED RIGHT-OF-WAY LINE
 - PROPOSED CENTERLINE
 - PROPOSED EASEMENT
 - 100 YR FLOODPLAIN
 - FEMA FIRM BASE FLOOD ELEVATION
 - GEOLOGIC HAZARD AREA
 - SEE SHEET 5 FOR LINE AND CURVE TABLE

JOB NO. 25142.04
JUNE 10, 2022
SHEET 4 OF 5

J-R ENGINEERING
A Westrian Company

Centennial 303-740-9393 • Colorado Springs 719-593-2533
Fort Collins 970-491-9888 • www.jrengineering.com

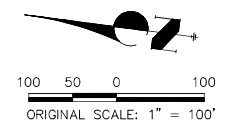

SADDLEHORN RANCH FILING NO. 2

A PARCEL OF LAND LOCATED IN SECTION 3 AND THE NORTH HALF OF THE NORTHEAST QUARTER OF SECTION 10,
TOWNSHIP 13 SOUTH, RANGE 64 WEST OF THE 6TH PRINCIPAL MERIDIAN
COUNTY OF EL PASO, STATE OF COLORADO

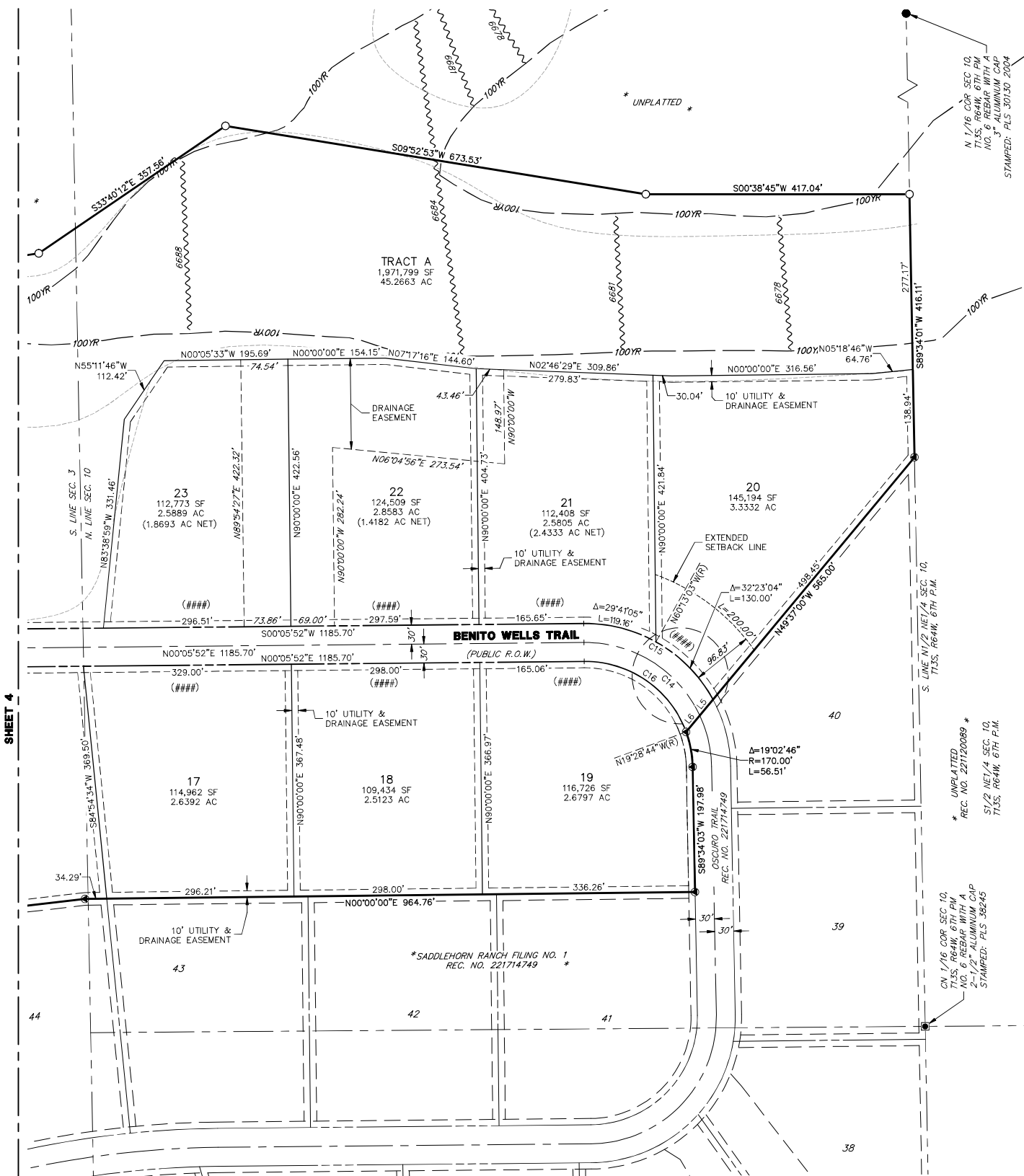

LINE	BEARING	DISTANCE
L1	S71°14'24"E	25.69'
L2	S60°15'21"E	30.00'
L3	S60°15'21"E	30.00'
L4	N29°44'39"E	37.61'
L5	N49°37'00"W	32.70'
L6	N49°37'00"W	33.85'
L7	N16°11'46"W	30.01'
L8	N16°11'46"W	30.01'
L9	S42°34'07"W	30.00'
L10	S42°34'07"W	30.00'
L11	N00°32'28"W	30.00'
L12	N00°32'28"W	30.00'
L13	S89°59'23"E	30.00'
L14	S89°59'23"E	30.00'
L15	N29°44'39"E	66.52'
L16	N34°50'05"W	211.91'
L17	S00°00'37"W	65.00'
L18	S89°59'23"E	30.00'

CURVE	DELTA	RADIUS	LENGTH
C1	51°13'24"	100.55'	89.89'
C2	11°07'56"	330.00'	64.12'
C3	4°57'43"	330.00'	28.58'
C4	0°59'17"	1680.00'	28.97'
C5	23°17'28"	305.00'	123.98'
C6	23°17'28"	335.00'	136.18'
C7	23°17'28"	275.00'	111.79'
C8	16°56'23"	350.00'	103.48'
C9	16°56'23"	380.00'	112.35'
C10	16°56'23"	320.00'	94.61'
C11	17°59'34"	760.00'	238.67'
C12	17°59'34"	790.00'	248.09'
C13	17°59'34"	730.00'	229.25'
C14	65°32'54"	200.00'	228.81'
C15	62°04'09"	230.00'	249.16'
C16	70°25'24"	170.00'	208.95'
C17	68°24'48"	300.00'	358.21'
C18	68°24'48"	270.00'	322.39'
C19	68°24'48"	330.00'	394.03'
C20	7°40'54"	1650.00'	221.21'

CURVE	DELTA	RADIUS	LENGTH
C21	7°40'54"	1620.00'	217.19'
C22	7°40'54"	1680.00'	225.23'
C23	9°25'17"	1650.00'	271.31'
C24	9°25'17"	1680.00'	276.25'
C25	9°25'17"	1620.00'	266.38'

- LEGEND**
- SET 18" LONG #5 REBAR WITH A 1.5" ALUMINUM CAP STAMPED "JR ENG LS 38578"
 - RECOVERED 1.5" ALUMINUM CAP STAMPED "JR ENG LS 38578"
 - S.F. SQUARE FEET
 - (R) RADIAL BEARING
 - (###) ADDRESS NUMBER
 - * NOT A PART OF THIS SUBDIVISION
 - PROPOSED SUBDIVISION BOUNDARY
 - PROPOSED LOT LINE
 - PROPOSED RIGHT-OF-WAY LINE
 - PROPOSED CENTERLINE
 - PROPOSED EASEMENT
 - 100YR 100 YEAR FLOODPLAIN
 - FEMA FIRM BASE FLOOD ELEVATION
 - GEOLOGIC HAZARD AREA

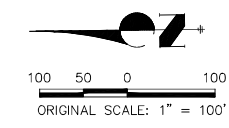

JOB NO. 25142.04
JUNE 10, 2022
SHEET 5 OF 5



Centennial 303-740-9393 • Colorado Springs 719-593-2593
Fort Collins 970-491-9888 • www.jrengineering.com

Appendix B



ENTECH
ENGINEERING, INC.

505 ELKTON DRIVE
COLORADO SPRINGS, CO 80907
PHONE (719) 531-5599
FAX (719) 531-5238

**SOIL, GEOLOGY, GEOLOGIC HAZARD,
AND WASTEWATER STUDY,
SADDLEHORN RANCH SUBDIVISION
EL PASO COUNTY, COLORADO**

Prepared for

William Guman and Associates, LTD
731 North Weber Street, Suite 100
Colorado Springs, Colorado 80903

Attn: William Guman

April 29, 2019

Respectfully Submitted,

ENTECH ENGINEERING, INC.

Logan L. Langford, P.G.
Geologist

Kristen A. Andrew-Hoeser, P.G.
Senior Geologist

LLL/nc

Encl.

Entech Job No. 181823
AAprojects/2018/181823 countysoil/geo/ww

Reviewed by:

Joseph C. Goode, Jr. P.E.
President

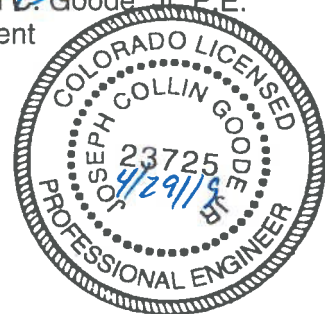

TABLE OF CONTENTS

1.0 SUMMARY..... 1
2.0 GENERAL SITE CONDITIONS AND PROJECT DESCRIPTION2
3.0 SCOPE OF THE REPORT2
4.0 FIELD INVESTIGATION3
5.0 SOIL, GEOLOGY AND ENGINEERING GEOLOGY.....3
 5.1 General Geology.....3
 5.2 Soil Conservation Survey.....4
 5.3 Site Stratigraphy.....5
 5.4 Soil Conditions6
 5.5 Groundwater8
6.0 ENGINEERING GEOLOGY – IDENTIFICATION AND MITIGATION OF GEOLOGIC HAZARDS.....8
 6.1 Relevance of Geologic Conditions to Land Use Planning 12
7.0 ON-SITE DISPOSAL OF WASTEWATER..... 13
8.0 ECONOMIC MINERAL RESOURCES..... 15
9.0 EROSION CONTROL 16
10.0 CLOSURE..... 17
BIBLIOGRAPHY..... 18

TABLES

- Table 1: Summary of Laboratory Test Results from Test Borings
- Table 2: Summary of Laboratory Test Results from Test Pits
- Table 3: Summary of Tactile Test Pits Results

FIGURES

- Figure 1: Vicinity Map
- Figure 2: USGS Map
- Figure 3: Site Plan/Testing Location Map
- Figure 4: Soil Survey Map
- Figure 5: Falcon Quadrangle Geology Map
- Figure 6: Geology Map/Engineering Geology
- Figure 7: Floodplain Map
- Figure 8: Typical Perimeter Drain Details
- Figure 9: Underslab Drainage Layer (Capillary Break)
- Figure 10: Interceptor Drain Detail
- Figure 11: Septic Suitability Map

- APPENDIX A: Site Photographs
- APPENDIX B: Test Boring Logs and Test Pit Logs
- APPENDIX C: Laboratory Test Results
- APPENDIX D: Soil Survey Descriptions
- APPENDIX E: NRCS Septic Tank Absorption Field Soil Rating

1.0 SUMMARY

Project Location

The project site lies in Section 3 and a portion of the N¼ of Section 10, Township 13 South, Range 64 West of the 6th Principal Meridian in El Paso County, Colorado. The site is located approximately 3 miles east of Falcon, Colorado, southeast of the intersection of Curtis Road and Judge Orr Road.

Project Description

Total acreage involved in the project is approximately 824 acres. The proposed site development consists of two hundred and twenty-five (225) single-family rural residential lots. The development will utilize municipal water and individual on-site wastewater treatment systems.

Scope of Report

This report presents the results of our geologic evaluation, treatment of engineering geologic hazard study and wastewater study for individual on-site wastewater treatment systems.

Land Use and Engineering Geology

This site was found to be suitable for the proposed development. Areas were encountered where the geologic conditions will impose some constraints on development and land use. These include areas of artificial fill, potentially expansive soils, hydrocompaction, loose/collapsible soils, floodplain, potentially seasonal shallow groundwater, seasonal shallow groundwater and areas of ponded water. Based on the proposed development plan, it appears that these areas will have some impact on the development. These conditions will be discussed in greater detail in the report.

In general, it is our opinion that the development can be achieved if the observed geologic conditions on site are either avoided or properly mitigated. All recommendations are subject to the limitations discussed in the report.

2.0 GENERAL SITE CONDITIONS AND PROJECT DESCRIPTION

The site is located in Section 3 and a portion of the N¼ of Section 10, Township 13 South, Range 64 West of the 6th Principal Meridian in El Paso County, Colorado. The site is located approximately 3 miles east of Falcon, Colorado, southeast of Curtis Road and Judge Orr Road. The location of the site is as shown on the Vicinity Map, Figure 1.

The topography of the site varies from very gradually to moderately sloping generally to the southeast and southwest. Three drainages bisect the site. Steeper slopes are located along portions of some of the drainages on the site. The drainages on site flow in a northeasterly direction through the central portion of the site. Water was observed in portions of the central drainage near the windmill and in the northwestern portion of the site at the time of this investigation. The site boundaries are indicated on the USGS Map, Figure 2. Previous land uses have included grazing and pasture land. The site contains primarily field grasses and weeds. Site photographs, taken December 6 and 7, 2018, and January 23, 2019, are included in Appendix A.

Total acreage involved in the proposed development is approximately 824 acres with two-hundred and twenty-five (225) single-family rural residential lots. The proposed residential lots range from approximately 2.5 to 4.2 acres. The majority of the lots are approximately 2.5 acres in size. The area will be serviced by municipal water and on-site wastewater treatment systems. The proposed Site Plan/Testing Location Map is presented in Figure 3.

3.0 SCOPE OF THE REPORT

The scope of the report will include the following:

- A general geologic analysis utilizing published geologic data. Detailed site-specific mapping will be conducted to obtain general information in respect to major geographic and geologic features, geologic descriptions and their effects on the development of the property.
- The site will be evaluated for individual on-site wastewater treatment systems in accordance with El Paso Land Development Code.

4.0 FIELD INVESTIGATION

Our field investigation consisted of the preparation of a geologic map of any bedrock features and significant surficial deposits. The Natural Resource Conservation Service (NRCS) (previously the Soil Conservation Service (SCS)) survey data was also reviewed to evaluate the site. The position of mappable units within the subject property are shown on the Geologic Map. Our mapping procedures involved both field reconnaissance and measurements and air photo reconnaissance and interpretation. The same mapping procedures have also been utilized to produce the Geology/Engineering Geology Map which identified pertinent geologic conditions affecting development. The field mapping was performed by personnel of Entech Engineering, Inc. on December 6 and 7, 2018, and January 23, 2019.

Four (4) test borings, and forty (40) tactile test pits were performed on the site to verify general soil conditions and the suitability of the site for the use of on-site wastewater treatment systems. The locations of the test borings, and test pits are indicated on the Site Plan/Testing Location Map, Figure 3. The Test Boring and Test Pit Logs are presented in Appendix B. Results of this testing will be discussed later in this report.

Laboratory testing was also performed on some of the soils to classify and determine the soils engineering characteristics. Laboratory tests included grain-size analysis, ASTM D-422, and Atterberg Limits, ASTM D-4318 for classification purposes. Volume change testing was performed on selected samples using the FHA Swell Test and Swell/Consolidation Test, ASTM D-4546, in order to evaluate the expansion/consolidation potential of the soils. Soluble sulfate testing was performed on selected samples to determine the corrosive characteristics of the soils on concrete placed below ground. Results of the laboratory testing are included in Appendix C. The Laboratory Test Results are summarized in Tables 1 and 2.

5.0 SOIL, GEOLOGY AND ENGINEERING GEOLOGY

5.1 General Geology

Physiographically, the site lies in the western portion of the Great Plains Physiographic Province. Approximately 18 miles to the west is a major structural feature known as the Rampart Range

Fault. This fault marks the boundary between the Great Plains Physiographic Province and the Southern Rocky Mountain Province. The site exists within the southeastern edge of a large structural feature known as the Denver Basin. Bedrock in the area tends to be very gently dipping in a northwesterly direction (Reference 1). The rocks in the area of the site are sedimentary in nature and typically Tertiary to Upper Cretaceous in age. The bedrock underlying the site consists of the Dawson Arkose Formation. Overlying this formation are unconsolidated deposits of man-made fill deposits, residual soils, eolian soils, and alluvial soils of the Quaternary Age. The residual soils are produced by the in-situ action of weathering of the bedrock on site. The alluvial soils were deposited by water in the major drainages on the site and as stream terrace deposits. The eolian soils were deposited by prevailing winds from the west and northwest. Man-made fill piles are located near the two water wells in the southwest corner of the site. The site's stratigraphy will be discussed in more detail in Section 5.3.

5.2 Soil Conservation Survey

The Natural Resource Conservation Service (Reference 2), previously the Soil Conservation Service (Reference 3) has mapped four soil types on the site (Figure 4). In general, they vary from loam, loamy sands, and sandy loam. The soils are described as follows:

<u>Type</u>	<u>Description</u>
8	Blakeland Loamy Sand, 1-9% slopes
19	Columbine Gravelly Sandy Loam, 0 to 3% slopes
29	Fluvaquentic Haplaquolls, nearly level
83	Stapleton Sandy Loam, 3 to 8% slopes

Complete descriptions of each soil type are presented in Appendix D. The soils have generally been described to typically have moderate to very rapid permeabilities. The majority of the soils have rapid permeabilities. Limitations described for the soils include the hazard of flooding on Soil Type Nos. 19 and 29. Soil Type No. 29 is mapped in the floodplain zone that is designated as open space. Roads may need to be designed to minimize frost-heave potential. Possible hazards with soil erosion are present on the site. The erosion potential can be controlled with vegetation. The majority of the soils have been described to have slight to moderate erosion hazards.

5.3 Site Stratigraphy

The Falcon Quadrangle Geology Map showing the site is presented in Figure 5 (Reference 4). The Geology Map prepared for the site is presented in Figure 6. Eight mappable units were identified on this site which are described as follows:

- Qaf Recent Artificial Fill of Holocene Age:** These are man-made fill deposits associated with fill piles in the southwest corner of the site.
- Qpl Playa Deposits of Holocene Age:** These are moderately consolidated clay, silt and sand formed by blowouts in the eolian sands that form seasonal ponds during wet seasons.
- Qal Recent Alluvium – Post Piney Creek (Alluvium One) of Late Holocene Age:** These materials consist of water deposited sands located along some of the minor drainages across the site. The materials consist of silty to clayey sand and sandy clays.
- Qp Piney Creek Alluvium (Alluvium Two) of Early Holocene Age:** These materials consist of low stream-terrace deposits above the current stream channels. The materials typically consist of silty to well graded sand.
- Qb Broadway Alluvium (Alluvium Three) of Late Pleistocene Age:** These materials consist of middle steam terrace deposits. The materials typically consist of silty to clayey gravelly sands.
- Qes Eolian Sand of Quaternary Age:** These deposits are fine to medium grained soil deposited on the site by the action of prevailing winds from the west and northwest. They typically occur as large dune deposits or narrow ridges. These soils are typically tan to brown in color and tend to have very uniform or well-sorted gradation. These materials tend to have a relatively high permeability and low density.
- Qsw Sheetwash Deposits of Holocene to Late Pleistocene Age:** These materials consist of silty to clayey sands with some gravel. The material was deposited by the action of sheetwash.

Qes/Tkd Sand Deposits of Quaternary Age overlying Dawson Formation of Tertiary to Cretaceous Age: The Dawson Formation typically consists of arkosic sandstone with interbedded fine-grained sandstone, siltstone and claystone. Overlying this formation is a variable layer of eolian sand and residual soil, undifferentiated. The eolian sands were deposited by the action of the prevailing winds. The residual soils were derived from the in-situ weathering of the bedrock materials on-site. These soils consisted of silty to clayey sands, sandy clays and sandy silts.

The soils listed above were mapped from site-specific mapping, the *Geologic Map of the Falcon Quadrangle* distributed by the Colorado Geological Survey in 2012 (Reference 4), and the *Geologic Map of the Pueblo 1^o x 2^o Quadrangle*, distributed by the US Geological Survey in 1978 (Reference 5). The Test Pits and Test Borings were also used in evaluating the site and are included in Appendix B. The Geology Map prepared for the site is presented in Figure 6.

5.4 Soil Conditions

The soils encountered in the Test Borings and Test Pits can be grouped into four general soil and rock types. The soils were classified using the Unified Soil Classification System (USCS). The test pit soils were also classified using the USDA Textural Soil Classification.

Soil Type 1 is a well-graded sand, slightly silty to silty sand and clayey to very clayey sand (SW, SM-SW, SM, SC). This material was encountered in the test borings and in all of the test pits. The sand was encountered at the existing surface and extending to depths of 2 to 15 feet bgs and to the termination of Test Boring No. 1 (20 feet). These soils were encountered at loose to dense states and at dry to moist conditions. Samples tested had 2 to 44 percent of the soil size particles passing the No. 200 Sieve. Atterberg Limits Testing resulted in liquid limits of 25 to no value and plastic indexes of 11 to non-plastic. FHA Swell Testing on samples of the sand resulted in expansion pressures of 430 to 820 psf, indicating a low expansion potential. Sulfate testing resulted in less than 0.01 percent soluble sulfate by weight, indicating the sand exhibits negligible potential for below grade concrete degradation due to sulfate attack.

Soil Type 2 is a sandy clay (CL). This material was encountered in five of Test Pits with clay lenses in others. The clays were encountered at depths of 6 to 7 feet bgs and extended to the

termination of the test pits (7.5 to 8 feet). Very sandy clay lenses were encountered at shallower depths in Test Pit No. 4. The clays were encountered at firm consistencies and moist conditions. The samples tested had 56 to 93 percent of the soil size particles passing the No. 200 sieve. Atterberg Limits Testing resulted in liquid limits of 49 to 26 and plastic indexes of 31 to 12. FHA well Testing resulted in expansion pressures of 880 to 4420 psf, indicating low to very high expansion potential.

Soil Type 3 is a silty to clayey sandstone and very clayey sandstone (SM, SC). This material was encountered Test Boring Nos. 2 and 3, and in seven of the test pits. The sandstone was encountered at depths ranging from 2 to 16 feet bgs and extended to 5 feet or the termination of the boring and pits (5 to 20 feet). The sandstone was encountered at dense to very dense states and moist conditions. Samples tested had 13 to 45 percent of the soil sized particles passing the No. 200 sieve. Atterberg Limits Testing resulted in liquid limit of 29 to no value and plastic indexes of 13 to non-plastic. Highly expansive clayey sandstone and claystone are commonly interbedded in the sandstone in the area. Sulfate testing resulted in less than 0.01 percent soluble sulfate by weight, indicating the sandstone exhibits negligible potential for below grade concrete degradation due to sulfate attack.

Soil Type 4 is a sandy claystone and very sandy siltstone (CL, ML). This material was encountered Test Boring Nos. 2 and 4, and in five of the test pits at depths ranging from 2.5 to 15 feet bgs and extended to the termination of the boring or pit (4.5 to 20 feet). The claystone and siltstone were encountered at hard consistencies and moist conditions. Samples tested had 53 to 92 percent of the soil size particles passing the No. 200 sieve. Atterberg Limits Testing resulted in liquid limits of 47 to no value and plastic indexes of 23 to non-plastic. FHA Swell Testing resulted in expansion pressures of 450 to 3160 psf, indicating low to very high expansion potential. Swell/Consolidation Testing on a sample of the siltstone resulted in no volume change (0.0 percent), indicating a low expansion potential.

The Test Boring Logs and Test Pit Logs are presented in Appendix B. Laboratory Test Results are presented in Appendix C. The Laboratory Test Results are summarized in Tables 1 and 2.

5.5 Groundwater

Groundwater was encountered in all of the test borings and in seven of the test pits at depths ranging from 6 to 13 feet with signs of seasonal water at 2.5 feet in Test Pit No. 4. Areas of seasonal and potentially seasonal shallow groundwater have been mapped in low-lying areas and in the drainages on-site. These areas are discussed in the following section. Fluctuation in groundwater conditions may occur due to variations in rainfall and other factors not readily apparent at this time. Isolated sand layers within the variable soil profile, sometimes only a few feet in thickness and width, can carry water in the subsurface. Additionally, perched water conditions can occur on this site where water can flow through permeable sands overlying less permeable bedrock. Builders and planners should be cognizant of the potential for the occurrence of such subsurface water features during construction on-site and deal with each individual problem as necessary at the time of construction.

6.0 ENGINEERING GEOLOGY – IDENTIFICATION AND MITIGATION OF GEOLOGIC HAZARDS

As mentioned previously, detailed mapping has been performed on this site to produce an Geology/Engineering Geology Map (Figure 6). This map shows the location of various geologic conditions of which the developers should be cognizant during the planning, design and construction stages of the project. These hazards and the recommended mitigation techniques are as follows:

Artificial Fill

These are man-made fill deposits associated with fill piles located in the southwest corner of the site. The fill piles are located near the two existing water wells.

Mitigation: The fill piles can easily be removed or regraded. Should any uncontrolled fill be encountered beneath foundations, removal and recompaction at 95% of its maximum Modified Proctor Dry Density, ASTM D-1557 will be required.

Hydrocompaction

Areas in which hydrocompaction have been identified are acceptable as building sites. In areas identified for this hazard classification, however, we anticipate a potential for settlement upon saturation of these surficial soils. The low density, uniform grain sized, windblown sand deposits are particularly susceptible to this type of phenomenon.

Mitigation: The potential for settlement is directly related to saturation of the soils below the foundation areas. Therefore, good surface and subsurface drainage is extremely critical in these areas in order to minimize the potential for saturation of these soils. The ground surface around all permanent structures should be positively sloped away from the structure to all points, and water must not be allowed to stand or pond anywhere on the site. We recommend that the ground surface within 10 feet of the structures be sloped away with a minimum gradient of five percent. If this is not possible on the upslope side of the structures, then a well-defined swale should be created to intercept the surface water and carry it quickly and safely around and away from the structures. Roof drains should be made to discharge well away from the structures and into areas of positive drainage. Where several structures are involved, the overall drainage design should be such that water directed away from one structure is not directed against an adjacent building. Planting and watering in the immediate vicinity of the structures, as well as general lawn irrigation, should be minimized.

Loose or Collapsible Soils

Loose soils were encountered in several of the test pits and one of the test borings. These soils are typically encountered in areas mapped as eolian sand deposits. Other areas of loose soils could be encountered across the site. Any loose or collapsible soils encountered beneath foundations or floor slabs will require mitigation.

Mitigation: Any loose or collapsible soils encountered beneath foundations or floor slabs should be overexcavated, moisture-conditioned and recompacted. The soils should be recompacted to 95 percent of the soils maximum Modified Proctor Dry Density ASTM D-1557 at ± 2 percent of optimum moisture content. The reconditioned soils on this site should be observed and tested to verify adequate compaction. Areas requiring recompaction should be determined after additional investigation of each building site and during the excavation observations.

Expansive Soils

Expansive soils were encountered in two test borings drilled and several test pits excavated on-site. Expansive claystone is commonly encountered within the Dawson Formation. These occurrences are typically sporadic; therefore, none have been indicated on the maps. These expansive soils, if encountered beneath foundations, can cause differential movement in the structure foundation. These occurrences should be identified and mitigated on an individual basis.

Mitigation: Should expansive soils be encountered beneath the foundation, mitigation will be necessary. Mitigation of expansive soils will require special foundation design. Overexcavation and replacement with non-expansive soils at a minimum of 95% of its maximum Modified Proctor Dry Density, ASTM D-1557 is a suitable mitigation, which is common in the area. Overexcavation depths of 3 to 5 feet should be anticipated where expansive soils are encountered. Another alternative in areas of highly expansive soils is the use of drilled pier foundation systems. Typical minimum pier depths are on the order of 25 feet or more and require penetration into the bedrock material a minimum of 4 to 6 feet, depending upon building loads. Floor slabs on expansive soils should be expected to experience movement. Overexcavation and replacement has been successful in minimizing slab movements. The use of structural floors should be considered for basement construction on highly expansive clays. Final recommendations should be determined after additional investigation of each building site.

Floodplain and Drainage Areas

Portions of the site associated with the West Kiowa Creek drainage are mapped within a floodplain zone according to the FEMA Map Nos. 08041C0558G and 08041C0566G, dated December 7, 2018 (Figure 7, Reference 6). Areas of ponded water were observed in the central portion of the site near the windmill, and in the northwestern portion of the site adjacent to Curtis Road. The floodplain areas have been designated as open space and/or can be avoided by construction. Additionally, areas of seasonal and potentially seasonal shallow groundwater were observed across the site. In these areas, we would anticipate the potential for periodically high subsurface moisture conditions and frost heave potential. These are low-lying areas along the drainage in the southeastern portion of the site and in the low-lying areas and minor drainages across the site. These areas can likely be avoided or properly mitigated by development. Perched water conditions could be encountered across the entire site where water can flow within permeable

sand layers overlying impermeable bedrock. These areas should be identified on an individual basis at the time of construction. Where perched water conditions are encountered, the mitigation recommendations for seasonal and potentially seasonal shallow groundwater should be followed. The floodplain should be avoided by construction unless site-specific floodplain determination and drainage studies are performed. These areas are discussed below.

sw, psw – Seasonal and Potentially Seasonal shallow groundwater areas: In these areas, we would anticipate the potential for periodically high subsurface moisture conditions, frost heave potential, and highly organic soils. Areas where perched water conditions are encountered should also follow these recommendations. Construction proposed in or adjacent to these areas, should follow these precautions:

Mitigation: In these locations, foundations are subject to severe frost heave and should penetrate to a sufficient depths so as to prevent the formation of ice lenses beneath foundations. At this location and elevation, a foundation depth for frost protection of 30-inches is recommended. In areas where high subsurface moisture conditions are anticipated periodically, a subsurface perimeter drain will be necessary to help prevent the seepage of water into areas below grade. A typical perimeter drain detail is presented in Figure 8. Any grading in these areas should be done in a manner that directs surface flow around construction to avoid areas of ponded water. Areas of organic material will require removal prior to any fill placement. Unstable soil conditions should be expected in areas of shallow groundwater. Where foundations approach the groundwater level, stabilization of the excavations utilizing shot rock may be necessary. Underslab drains or capillary breaks, and interceptor drains may be necessary to prevent intrusion of water into areas below grade. Typical drain details are presented in Figures 9 and 10.

w – Areas of ponded water: These are areas where water could potentially pool in low-lying areas of the drainages. According to the site plan, Figure 6 these areas are within designated as open space. Any areas of ponded water to be filled or regraded should have all soft organic soils removed prior to fill placement. All uncontrolled fill associated with the dams should be recompacted at a minimum of 95% of its maximum Modified Dry Density ASTM D-1557.

fp – Floodplain: Areas of the site have been mapped as floodplains according to the FEMA Map Nos. 08041C0558G and 08041C0566G (Figure 7, Reference 6). The physiographic floodplains

on site have been mapped on the Engineering Geology Map (Figure 6). The floodplain areas have been designated as open space and area to be avoided by development. Any area within the FEMA floodplain area will require approval of the Drainage Report. Finished floor levels must be a minimum of one foot above the floodplain level. Structures should not block drainages. Specific floodplain locations and drainage studies are beyond the scope of this report.

6.1 Relevance of Geologic Conditions to Land Use Planning

We understand that the development will be rural residential lots. It is our opinion that the existing geologic and engineering geologic conditions will impose some minor constraints on the proposed development and construction. The most significant problems affecting development will be those associated with the shallow groundwater areas on-site that can be avoided or properly mitigated during construction on each lot. Other hazards on site can be satisfactorily mitigated through proper engineering design and construction practices or avoidance.

The upper materials are typically at medium dense to dense states. Areas of loose soils were encountered that may require recompaction. The medium dense to dense granular soils encountered in the upper soil profiles of the test borings and test pits should provide good support for foundations. Loose soils, if encountered beneath foundations or slabs, will require removal and recompaction. Expansive soils, although sporadic, were encountered. Expansive clayey sandstone and claystone are common in the Dawson Formation, and may require mitigation. Foundations anticipated for the site are standard spread footings possibly in conjunction with overexcavation in areas of expansive soils or loose soils. Areas of artificial fill, if encountered beneath foundations will require penetration or recompaction. Areas containing arkosic sandstone will have high allowable bearing conditions. Expansive layers may also be encountered in the soil and bedrock on this site. Expansive soils, if encountered, will require special foundation design and/or overexcavation. These soils will not prohibit development.

Areas of seasonal and potentially seasonal shallow groundwater, ponded water, and floodplains exist on this site. The floodplains and areas of ponded water are to be avoided by development and preserved as open space in drainage easements. Finished floor levels must be a minimum of one foot above the floodplain level. Exact floodplain locations are beyond the scope of this

report. According to the site plan (Figure 6), some of the minor drainages can be avoided or filled which will mitigate the hazard.

Areas of perched groundwater may be encountered on this site. Permeable sands exist on the site that may carry water in the subsurface perched on less permeable bedrock. Groundwater was encountered at depths ranging from 12 to 14 feet in the test borings and at 6 to 7.5 feet in seven of the test pits with signs of seasonal water at 2.5 feet in Test Pit No. 40. Fluctuation in groundwater conditions may occur due to variations in rainfall, soil conditions and development of surrounding areas. Builders should be cognizant of the potential for the occurrence of subsurface water features during construction and deal with each individual problem as necessary at the time of construction. Subsurface drains may be necessary in some areas to prevent the intrusion of water below grade. Dewatering systems may be necessary in some areas where seepage and perched water occurs. Drain details are included in Figures 8 through 10. Unstable conditions should be expected where excavations approach the groundwater level. Stabilization using geofabric or shot rock may be necessary.

Areas of hydrocompaction have been identified on this site where there is the potential for settlement movements upon saturation of the surficial soils. Good surface and subsurface drainage is critical in these areas and the ground surface should be positively sloped away from structures at all points. Roof drains should be made to discharge well away from structures and planting and watering in the immediate vicinity of structures should be minimized.

In summary, development of the site can be achieved if the items discussed above are mitigated. These items can be mitigated through proper design and construction or by avoidance. Investigation on each lot is recommended prior to construction.

7.0 ON-SITE WASTEWATER TREATMENT

The site was evaluated for individual and commercial on-site wastewater treatment systems in accordance with El Paso Land Development Code. Forty (40) tactile test pits were performed on the property. The test pits were located in potential locations of future systems. The approximate locations of the test pits are indicated on Figure 3, on the Geology/Engineering Geology Map,

Figure 6, and on the Septic Suitability Map, Figure 11. A table showing the results of the Tactile Test Pits is presented in Table 3. Test Pit Logs are included in Appendix B.

The Natural Resource Conservation Service (Reference 2), previously the Soil Conservation Service (Reference 3) has mapped the site with four soil descriptions. The Soil Survey Map (Reference 2) is presented in Figure 4, and the Soil Survey Descriptions are presented in Appendix D. The soils are described as having moderate to very rapid percolation rates. The majority of the soils have been described with rapid permeabilities. The Natural Resource Conservation Service (NRCS) has rated the soil suitability with respect to septic tank absorption fields. The soils in the area have been described as very limited due to seepage, bottom layer, and filtering capacity. These areas are typically associated with shallow groundwater, shallow bedrock, and unsuitable soils which require designed systems. Flooding and depth to saturation zone are limitations on Soil Type 29. The majority of the areas mapped with Soil Type 29 lie within the drainage areas and will be avoided by development. The map and descriptions for the NRCS Septic Tank Absorption Field Soil Rating are included in Appendix E.

Soils encountered in the tactile test pits consisted of loamy sand, sandy clay loam and sandy clay. Bedrock was encountered in the test pits at 2 to 6 feet bgs, which were excavated to 5 to 8 feet. Groundwater or signs of seasonally occurring groundwater were encountered at depths ranging from 3.5 to 7.5 in Test Pit Nos. 13, 28, 33, 36, 38 and 40. The limiting layers encountered in the test pits are the sandy loam (Soil Type 2), sandy clay loam (Soil Type 3A) and sandy claystone and sandstone (Soil Type 4A) which corresponds to LTAR values ranging from 0.80 to 0.15 gallons per day per square foot. Designed systems will be required where bedrock or groundwater are encountered at 6 feet bgs or shallower. Approximately half of the areas tested would require designed systems due to restrictive clay soils, shallow bedrock or shallow groundwater. Additional investigation of individual lots may identify areas where suitable for conventional systems could be used.

In summary, it is our opinion the site is suitable for individual on-site wastewater treatment systems (OWTS) and that contamination of surface and subsurface water resources should not occur provided the OWTS sites are evaluated and installed according to El Paso County and State Guidelines and properly maintained. Based on the testing performed as part of this investigation designed systems will likely be required for the majority of the lots. A Septic

Suitability Map is presented in Figure 11. Areas where OWTS sites are not recommended are also indicated on Figure 11. Individual soil testing is required on each lot prior to construction. Absorption fields must be located a minimum of 100 feet from any well, including those on adjacent properties. Absorption fields must also be located a minimum of 50 feet from any drainages, floodplains or ponded areas and 25 feet from dry gulches.

8.0 ECONOMIC MINERAL RESOURCES

Some of the sandy materials on-site could be considered a low-grade sand resource. According to the *El Paso County Aggregate Resource Evaluation Map* (Reference 7), the area is mapped with upland deposits. According to the *Atlas of Sand, Gravel and Quarry Aggregate Resources, Colorado Front Range Counties* distributed by the Colorado Geological Survey (Reference 8), areas of the site are mapped with alluvial fan: sand deposits, upland deposits: sand and probable aggregate resource, and valley fill: probable aggregate resource. According to the *Evaluation of Mineral and Mineral Fuel Potential* (Reference 9), the area of the site has been mapped as “Good” for industrial minerals. However, considering the abundance of similar materials through the region and the close proximity to developed land, they would be considered to have little significance as an economic resource.

According to *the Evaluation of Mineral and Mineral Fuel Potential of El Paso County State Mineral Lands* (Reference 9), the site is mapped within the Denver Basin Coal Region. However, the area of the site has been mapped as “Poor” for coal resources. No active or inactive mines have been mapped in the area of the site. No metallic mineral resources have been mapped on the site (Reference 9).

The site has been mapped as “Fair” for oil and gas resources (Reference 9). No oil or gas fields have been discovered in the area of the site. The sedimentary rocks in the area may lack the geologic structure for trapping oil or gas; therefore, it may not be considered a significant resource. Hydraulic fracturing is a new method that is being used to extract oil and gas from rocks. It utilizes pressurized fluid to extract oil and gas from rocks that would not normally be productive. The area of the site has not been explored to determine if the rocks underlying the site would be commercially viable utilizing hydraulic fracturing. The practice of hydraulic fracturing has come under review due to concerns about environmental impacts, health and safety.

9.0 EROSION CONTROL

The soil types observed on the site are mildly to highly susceptible to wind erosion, and moderately to highly susceptible to water erosion. A minor wind erosion and dust problem may be created for a short time during and immediately after construction. Should the problem be considered severe enough during this time, watering of the cut areas or the use of chemical palliative may be required to control dust. However, once construction has been completed and vegetation re-established, the potential for wind erosion should be considerably reduced.

With regard to water erosion, loosely compacted soils will be the most susceptible to water erosion, residually weathered soils and weathered bedrock materials become increasingly less susceptible to water erosion. For the typical soils observed on site, allowable velocities or unvegetated and unlined earth channels would be on the order of 3 to 4 feet/second, depending upon the sediment load carried by the water. Permissible velocities may be increased through the use of vegetation to something on the order of 4 to 7 feet/second, depending upon the type of vegetation established. Should the anticipated velocities exceed these values, some form of channel lining material may be required to reduce erosion potential. These might consist of some of the synthetic channel lining materials on the market or conventional riprap. In cases where ditch-lining materials are still insufficient to control erosion, small check dams or sediment traps may be required. The check dams will serve to reduce flow velocities, as well as provide small traps for containing sediment. The determination of the amount, location and placement of ditch linings, check dams and of the special erosion control features should be performed by or in conjunction with the drainage engineer who is more familiar with the flow quantities and velocities.

Cut and fill slope areas will be subjected primarily to sheetwash and rill erosion. Unchecked rill erosion can eventually lead to concentrated flows of water and gully erosion. The best means to combat this type of erosion is, where possible, the adequate re-vegetation of cut and fill slopes. Cut and fill slopes having gradients more than three (3) horizontal to one (1) vertical become increasingly more difficult to revegetate successfully. Therefore, recommendations pertaining to the vegetation of the cut and fill slopes may require input from a qualified landscape architect and/or the Soil Conservation Service.

10.0 CLOSURE

It is our opinion that the existing geologic engineering and geologic conditions will impose some minor constraints on development and construction of the site. The majority of these conditions can be avoided by construction. Others can be mitigated through proper engineering design and construction practices. The proposed development and use is consistent with anticipated geologic and engineering geologic conditions.

It should be pointed out that because of the nature of data obtained by random sampling of such variable and non-homogeneous materials as soil and rock, it is important that we be informed of any differences observed between surface and subsurface conditions encountered in construction and those assumed in the body of this report. Individual investigations for building sites and septic systems will be required prior to construction. Construction and design personnel should be made familiar with the contents of this report. Reporting such discrepancies to Entech Engineering, Inc. soon after they are discovered would be greatly appreciated and could possibly help avoid construction and development problems.

This report has been prepared for William Guman and Associates, Ltd for application to the proposed project in accordance with generally accepted geologic soil and engineering practices. No other warranty expressed or implied is made.

We trust that this report has provided you with all the information that you required. Should you require additional information, please do not hesitate to contact Entech Engineering, Inc.

BIBLIOGRAPHY

1. Scott, G.R., Taylor, R.B, Epis, R.C., and Wobus, 1978. *Geologic Structure Map of the Pueblo 1° x 2° Quadrangle, South-Central Colorado*. Sheet 2. U.S. Geologic Survey. Map I-1022.
2. Natural Resource Conservation Service, September 23, 2016. *Web Soil Survey*. United States Department Agriculture, <http://websoilsurvey.sc.egov.usda.gov/App/HomePage.htm>.
3. United States Department of Agriculture Soil Conservation Service. June 1981. *Soil Survey of El Paso County Area, Colorado*.
4. Morgan, Matthew L. and White, Jonathan L. 2012. *Geologic Map of the Falcon Quadrangle, El Paso and Elbert Counties, Colorado*. Colorado Geological Survey. Open-File Report 12-03.
5. Scott, G.R., Taylor, R.B, Epis, R.C., and Wobus. 1978. *Geologic Map of the Pueblo 1° x 2° Quadrangle, South-Central Colorado*. U.S. Geologic Survey. Map 1-1022.
6. Federal Emergency Management Agency. December 7, 2018. *Flood Insurance Rate Maps for the City of Colorado Springs, Colorado*. Map Numbers 08041C0558G and 08041C0566G.
7. El Paso County Planning Development. December 1995. *El Paso County Aggregate Resource Evaluation Maps*.
8. Schwochow, S.D.; Shroba, R.R. and Wicklein, P.C. 1974. *Atlas of Sand, Gravel, and Quarry Aggregate Resources, Colorado Front Range Counties*. Colorado Geological Survey. Special Publication 5-B.
9. Keller, John W.; TerBest, Harry and Garrison, Rachel E. 2003. *Evaluation of Mineral and Mineral Fuel Potential of El Paso County State Mineral Lands Administered by the Colorado State Land Board*. Colorado Geological Survey. Open-File Report 03-07.

TABLES

TABLE 1
SUMMARY OF LABORATORY TEST RESULTS FROM TEST BORINGS

CLIENT WILLIAM GUMAN
 PROJECT CURTIS AND JUDGE ORR
 JOB NO. 181823

SOIL TYPE	TEST BORING NO.	DEPTH (FT)	WATER (%)	DRY DENSITY (PCF)	PASSING NO. 200 SIEVE (%)	LIQUID LIMIT (%)	PLASTIC INDEX (%)	SULFATE (WT %)	FHA SWELL (PSF)	SWELL/CONSOL (%)	UNIFIED CLASSIFICATION	SOIL DESCRIPTION
1	1	2-3			12.0	NV	NP	<0.01			SM	SAND, SILTY
1	2	5			13.8						SM	SAND, SILTY
1	4	2-3			3.2						SW	SAND
3	3	10			12.9	NV	NP	<0.01			SM	SANDSTONE, SILTY
4	4	20	21.4	104.2	52.5	NV	NP	<0.01		0.0	ML	SILTSTONE, VERY SANDY

TABLE 2

SUMMARY OF LABORATORY TEST RESULTS FROM TEST PITS

CLIENT GUMAN AND ASSOCIATES
 PROJECT CURTIS RD AND JUGRE ORR RD
 JOB NO. 181823

SOIL TYPE	TEST PIT NO.	DEPTH (FT)	WATER (%)	DRY DENSITY (PCF)	PASSING NO. 200 SIEVE (%)	LIQUID LIMIT (%)	PLASTIC INDEX (%)	SULFATE (WT %)	FHA SWELL (PSF)	SWELL/CONSOL (%)	UNIFIED CLASSIFICATION	SOIL DESCRIPTION
1	2	2-3			7.6						SM-SW	SAND, SLIGHTLY SILTY
1	3	5-6			9.8						SM-SW	SAND, SLIGHTLY SILTY
1	6	4-6			5.5						SM-SW	SAND, SLIGHTLY SILTY
1	9	2-3			26.5	24	9				SC	SAND, CLAYEY
1	11	5-6			10.4						SM-SW	SAND, SLIGHTLY SILTY
1	12	2-3			6.6						SM-SW	SAND, SLIGHTLY SILTY
1	13	5-6			30.3	25	11				SC	SAND, CLAYEY
1	15	2-3			27.5			820			SC	SAND, CLAYEY
1	18	5-6			1.6						SW	SAND
1	21	5-6			23.4						SC	SAND, CLAYEY
1	37	6-7			30.1	19	3		430		SM	SAND, SILTY
1	31	2-3			16.6						SM	SAND, SILTY
1	32	4-5			44.3						SC	SAND, VERY CLAYEY
1	33	2-3			4.3						SW	SAND
1	35	5-6			2.2						SW	SAND
1	36	2-3			8.2						SM-SW	SAND, SLIGHTLY SILTY
1	38	2-3			3.1						SW	SAND
1	39	5-6			12.4						SM	SAND, SILTY
2	1	7-8			70.3	49	31		1360		CL	CLAY, SANDY
2	4	2-3			56.4	26	12				CL	CLAY, VERY SANDY
2	5	7-8			69.6	32	19		880		CL	CLAY, SANDY
2	16	7-8			92.9				4420		CL	CLAY, SANDY
3	8	4-5			44.8	29	13				SC	SANDSTONE, VERY CLAYEY
3	10	5-6			16.6						SM	SANDSTONE, SILTY
3	17	5-6			12.6						SM	SANDSTONE, SILTY
3	34	5-6			16.9						SM	SANDSTONE, SILTY
3	40	5-6			13.9						SM	SANDSTONE, SILTY
4	7	6-7			91.8				2300		CL	CLAYSTONE, SANDY
4	14	4-5			76.1	47	23		3160		CL	CLAYSTONE, SANDY
4	23	5-6			57.0				450		CL	CLAYSTONE, VERY SANDY

TABLE 3: SUMMARY OF TACTILE TEST PIT RESULTS

Test Pit No.	USDA Soil Type	LTAR Value	Depth to Bedrock (ft)	Depth to Groundwater (ft)
TP-1	4A*	0.15	N/A	N/A
TP-2	1	0.8	N/A	N/A
TP-3	4A*	0.15	N/A	N/A
TP-4	3A*	0.3	N/A	N/A
TP-5	4A*	0.15	N/A	N/A
TP-6	2A	0.5	N/A	N/A
TP-7	4A*	0.15	2.5	N/A
TP-8	4A*	0.15	2.5	N/A
TP-9	3A*	0.3	N/A	N/A
TP-10	3A*	0.3	4	N/A
TP-11	1	0.8	N/A	N/A
TP-12	1	0.8	N/A	N/A
TP-13	4A*	0.15	N/A	6
TP-14	4A*	0.15	2.5	N/A
TP-15	4A*	0.15	2.5	N/A
TP-16	2A	0.5	N/A	N/A
TP-17	4A*	0.15	4	N/A
TP-18	2A	0.5	N/A	N/A
TP-19	2A	0.5	N/A	N/A
TP-20	2A	0.5	N/A	N/A
TP-21	2	0.6	N/A	N/A
TP-22	2A	0.5	N/A	N/A
TP-23	4A*	0.3	N/A	N/A
TP-24	2A	0.5	N/A	N/A
TP-25	1	0.8	N/A	N/A
TP-26	3A*	0.3	N/A	N/A
TP-27	2A	0.5	N/A	N/A
TP-28	2A	0.5	N/A	6.5
TP-29	2A	0.5	N/A	N/A
TP-30	4A*	0.15	N/A	6.5
TP-31	2A	0.5	N/A	N/A
TP-32	4A*	0.15	6	N/A
TP-33	2A	0.5	N/A	7.5
TP-34	3A*	0.3	4.5	N/A
TP-35	2A	0.5	N/A	N/A
TP-36	3A*	0.3	N/A	6
TP-37	3A*	0.3	N/A	N/A
TP-38	2A	0.5	N/A	6.5
TP-39	2A	0.5	N/A	N/A
TP-40	4A*	0.15	2.5	3.5

*- CONDITIONS THAT REQUIRE AND ENGINEERED OWTS

FIGURES



ENTECH
ENGINEERING, INC.

505 ELKTON DRIVE
COLORADO SPRINGS, CO. 80907 719 531-5599

VICINITY MAP
CURTIS ROAD SUBDIVISION
CURTIS ROAD AND JUDGE ORR ROAD
EL PASO COUNTY, CO.
FOR: WILLIAM GUMAN AND ASSOCIATES, LTD

DRAWN:
LLL

DATE:
2/11/19

CHECKED:

DATE:

JOB NO.:
181823

FIG NO.:
1

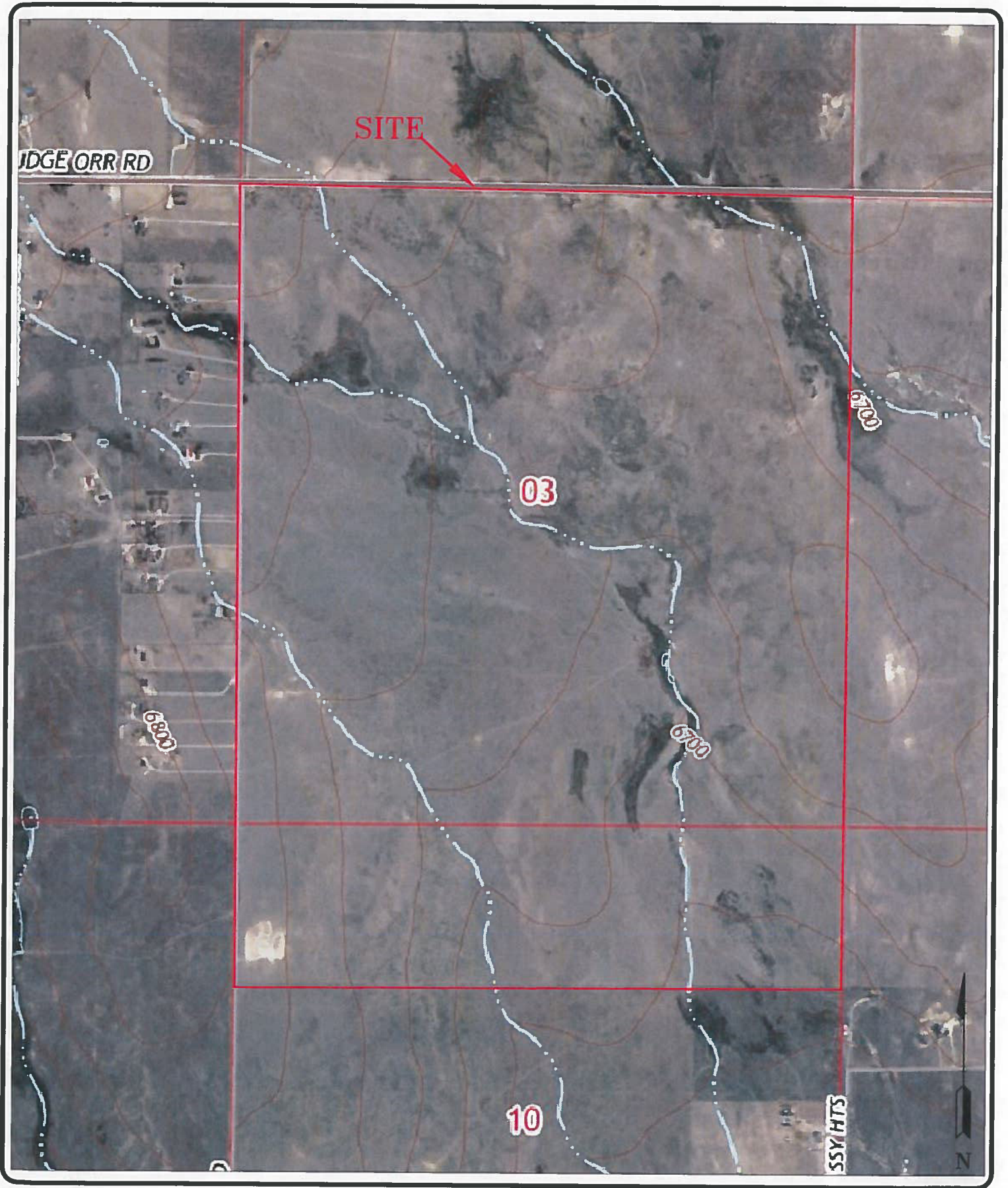

ENTECH
ENGINEERING, INC.

505 ELKTON DRIVE
COLORADO SPRINGS, CO. 80907 (719) 531-5599

USGS MAP
CURTIS ROAD SUBDIVISION
CURTIS ROAD AND JUDGE ORR ROAD
EL PASO COUNTY, CO.
FOR: WILLIAM GUMAN AND ASSOCIATES, LTD

DRAWN:
LLL

DATE:
2/11/19

CHECKED:

DATE:

JOB NO.:
181823

FIG NO.:
2

LEGEND

⊕ TB- APPROXIMATE TEST BORING LOCATION AND NUMBER

⊕ P- APPROXIMATE PHOTOGRAPH LOCATION AND NUMBER

⊕ TP- APPROXIMATE TEST PIT LOCATION AND NUMBER

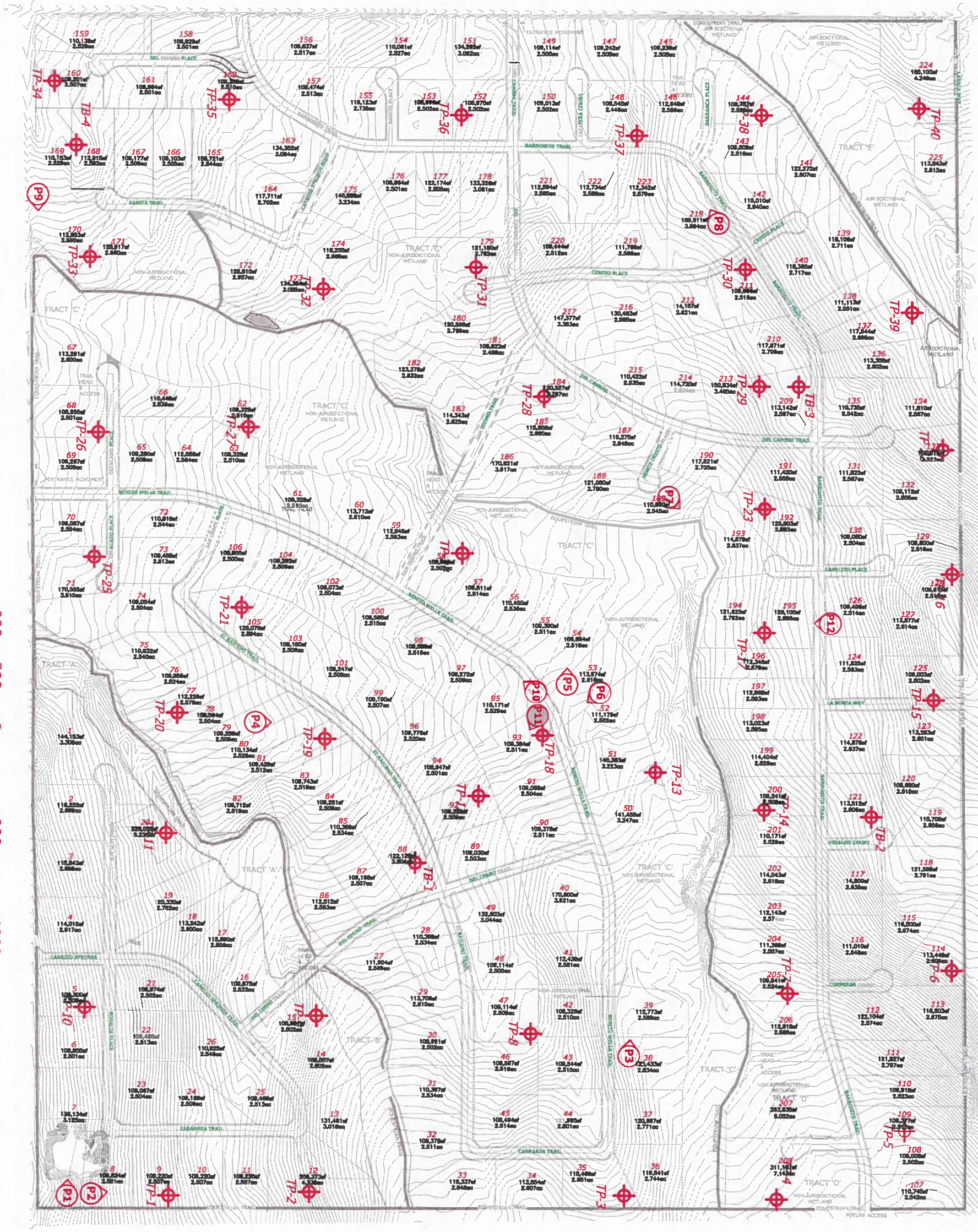

DATE	4/25/19
SCALE	AS SHOWN
DRAWN BY	101023
CHECKED BY	101023
REVISED	3

SITE PLAN/TEST BORING LOCATION MAP
SADDLEHORN RANCH SUBDIVISION
CURTIS ROAD AND JUDGE ORR ROAD
EL PASO COUNTY, CO.
FOR: WILLIAM GUMAN AND ASSOCIATES, LTD

ENTECH
ENGINEERING, INC.

505 ELKTON DRIVE
 COLORADO SPRINGS, CO. 80907 (719) 531-5599

REVISION	BY

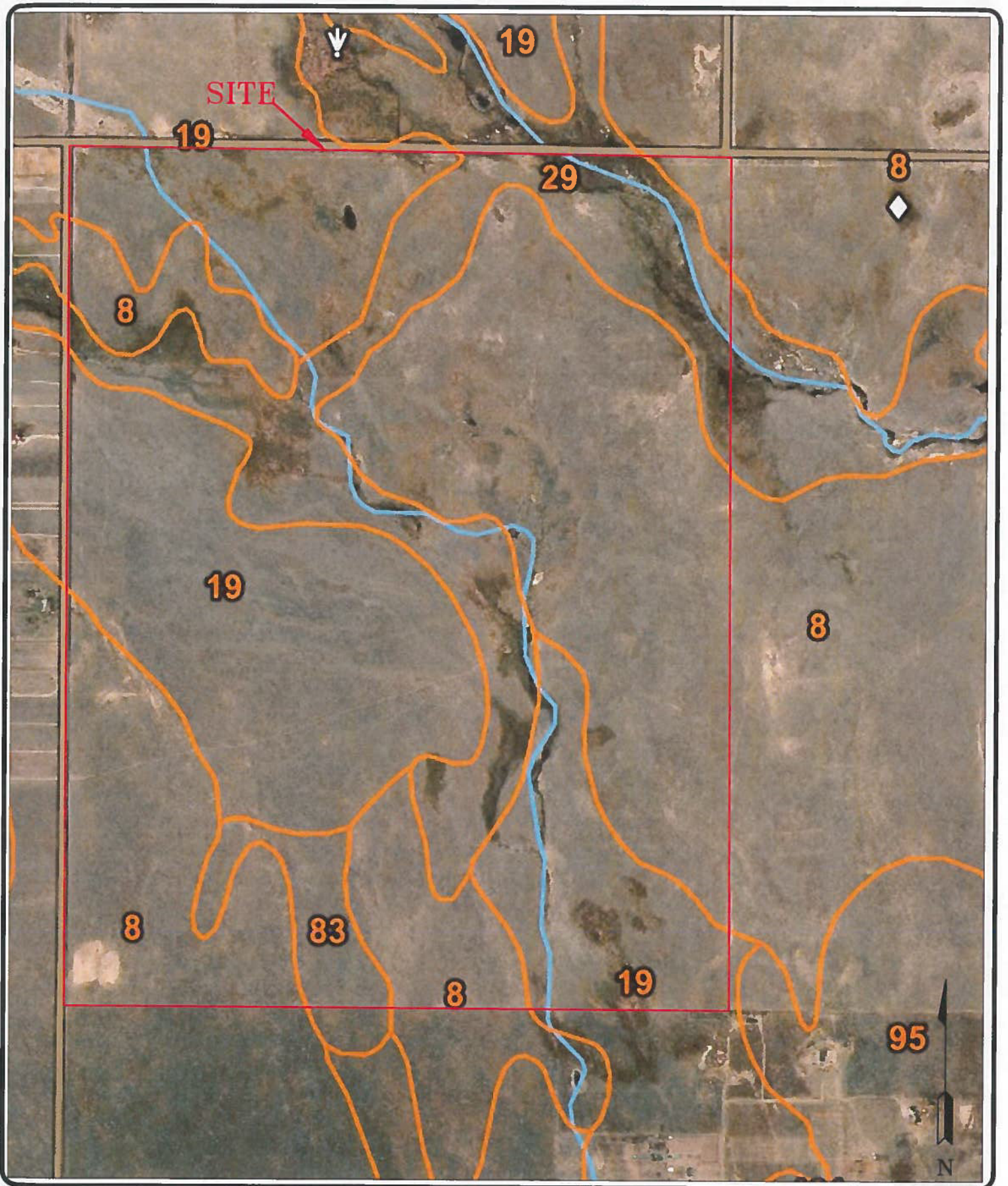

ENTECH
ENGINEERING, INC.

505 ELKTON DRIVE
COLORADO SPRINGS, CO. 80907 (719) 531-5599

SOIL SURVEY MAP
CURTIS ROAD SUBDIVISION
CURTIS ROAD AND JUDGE ORR ROAD
EL PASO COUNTY, CO.
FOR: WILLIAM GUMAN AND ASSOCIATES, LTD

DRAWN:
LLL

DATE:
2/11/19

CHECKED:

DATE:

JOB NO.:
181823

FIG NO.:
4

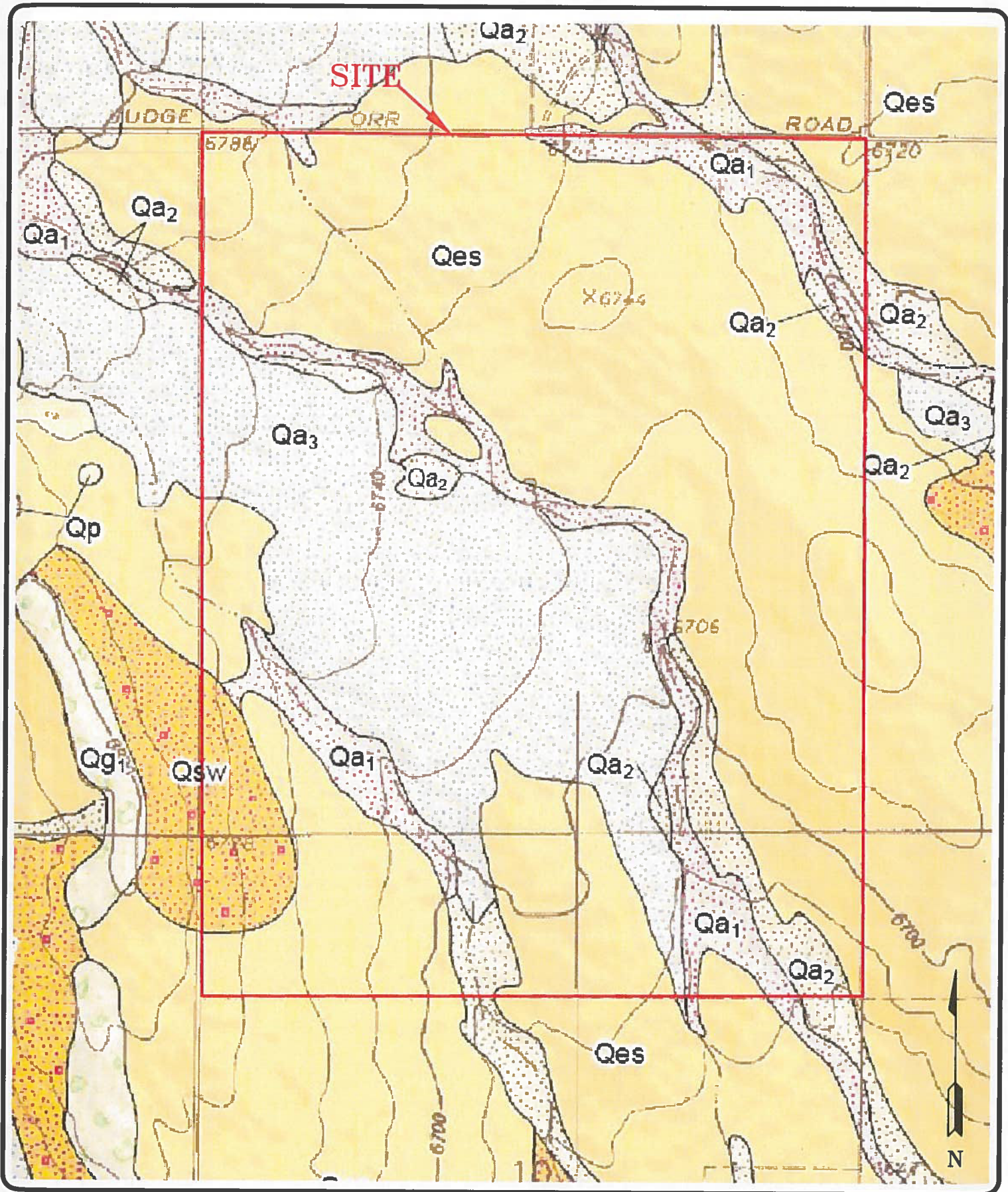

ENTECH
ENGINEERING, INC.
 505 ELKTON DRIVE
 COLORADO SPRINGS, CO. 80907 (719) 531-5599

FALCON QUADRANGLE GEOLOGIC MAP
CURTIS ROAD SUBDIVISION
CURTIS ROAD AND JUDGE ORR ROAD
EL PASO COUNTY, CO.
FOR: WILLIAM GUMAN AND ASSOCIATES, LTD

JOB NO.:
181823

FIG NO.:
5

DRAWN:
LLL

DATE:
2/11/19

CHECKED:

DATE:

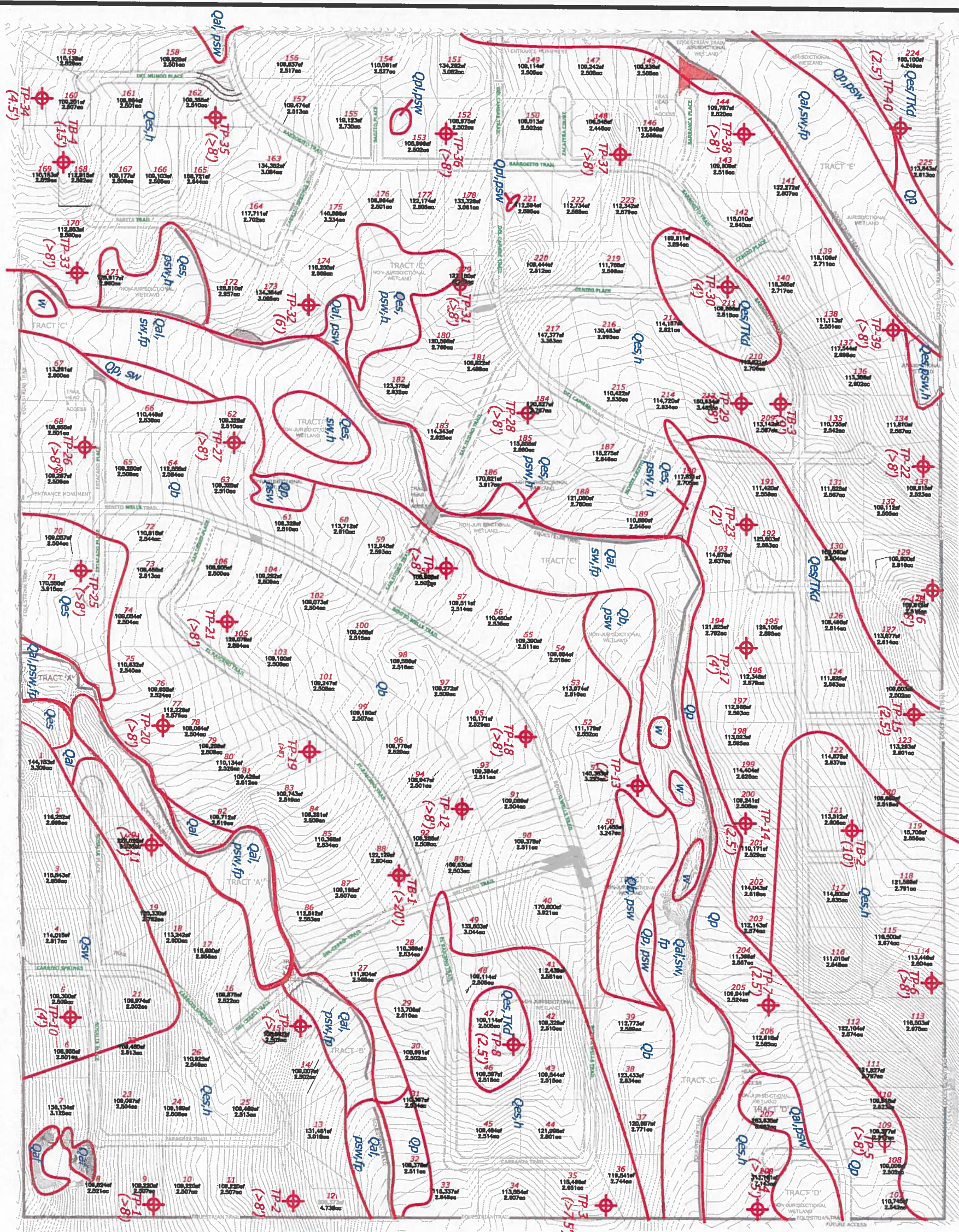

LEGEND:

- Qaf - Artificial Fill of Holocene Age: man made fill deposits
- Qal - Post Piney Creek (Alluvium One)-Recent Alluvium of Late Holocene Age: recent stream deposits
- Qpl - Playa Deposits of Holocene Age: blowouts in eolian sand that form seasonal ponds
- Qp - Piney Creek Alluvium (Alluvium Two) of Early Holocene Age: low stream terrace deposits above current stream channels
- (Qa) - Broadway Alluvium (Alluvium Three) of Late Pleistocene Age: stream terrace deposited sands
- Qb - Eolian Sand of Holocene to Late Pleistocene Age: wind blown sand deposits
- Qsw - Sheetwash of Holocene to Late Pleistocene Age: silty to clayey sand sheetwash deposits
- Qes/Tkd - Sand Deposits of Quaternary Age Overlying Dawson Arkose Formation of Tertiary to Cretaceous Age: windblown sands and residual soil deposits overlying arkosic sandstone with interbedded siltstone and claystone
- h - hydrocompaction
- fp - floodplain
- psw - potentially seasonal shallow groundwater area
- sw - seasonal shallow groundwater area flowing / ponded water
- w - Approximate Test Boring Location
- TP - Approximate Test Pit Location (Depth to bedrock in feet)

GEOLOGY/ENGINEERING GEOLOGY MAP
SADDEHORNS RANCH SUBDIVISION
 CURTIS ROAD AND JUDGE ORR ROAD
 EL PASO COUNTY, CO.
 FOR: WILLIAM GUMAN AND ASSOCIATES, LTD

ENTECH
ENGINEERING, INC.
 505 ELKTON DRIVE
 COLORADO SPRINGS, CO. 80907 (719) 531-5599

NO.	DATE	BY	REVISION
1	4/29/19	SCUT	
2		AS SHOWN	
3		191.B93	
4			
5			
6			

DATE: 4/29/19
 BY: SCUT
 AS SHOWN
 191.B93
 6

LEGEND

SPECIAL FLOOD HAZARD AREAS SUBJECT TO INUNDATION BY THE 1% ANNUAL CHANCE FLOOD

The 1% annual chance flood (100-year flood), also known as the base flood, is the flood that has a 1% chance of being equaled or exceeded in any given year. The Special Flood Hazard Area is the area subject to flooding by the 1% annual chance flood. Areas of Special Flood Hazard include Zone A, AE, AH, AO, AR, AP, V, and VE. The Base Flood Elevation is the water-surface elevation of the 1% annual chance flood.

ZONE A No Base Flood Elevations determined.

ZONE AE Base Flood Elevations determined.

ZONE AH Flood depths of 1 to 3 feet (usually areas of ponding); Base Flood Elevations determined.

ZONE AO Flood depths of 1 to 3 feet (usually sheet flow on sloping terrain); average depths determined. For areas of alluvial fan flooding, velocities also determined.

ZONE AR Special Flood Hazard Area formerly protected from the 1% annual chance flood by a flood control system that was subsequently abandoned. Zone AR indicates that the former flood control system is being restored to provide protection from the 1% annual chance or greater flood.

ZONE AP Area to be protected from 1% annual chance flood by a Federal flood protection system under construction; no Base Flood Elevations determined.

ZONE V Coastal flood zone with velocity hazard (wave action); no Base Flood Elevations determined.

ZONE VE Coastal flood zone with velocity hazard (wave action); Base Flood Elevations determined.

FLOODWAY AREAS IN ZONE AE

The floodway is the channel of a stream plus any adjacent floodplain areas that must be kept free of encroachment so that the 1% annual chance flood can be carried without substantial increases in flood heights.

OTHER FLOOD AREAS

Areas of 0.2% annual chance flood: areas of 1% annual chance flood with average depths of less than 1 foot or with discharge areas less than 1 square mile; and areas protected by levees from 1% annual chance flood.

OTHER AREAS

Areas determined to be outside the 0.2% annual chance floodplain.

ZONE D Areas in which flood hazards are undetermined, but possible.

COASTAL BARRIER RESOURCES SYSTEM (CBRS) AREAS

CBRS areas and OPAs are normally located within or adjacent to Special Flood Hazard Areas.

OTHERWISE PROTECTED AREAS (OPAs)

1% annual chance floodplain boundary

0.2% annual chance floodplain boundary

Floodway boundary

Zone D boundary

CBRS and OPA boundary

Boundary dividing Special Flood Hazard Area Zone and boundary dividing Special Flood Hazard Areas of different Base Flood Elevations, flood depths or flood velocities

River Flood Elevation line and value; elevation in feet

Base Flood Elevation value where uniform within areas (L.L. 5107)

Referenced to the National Geodetic Vertical Datum of 1929

Traverse line

Traverse line

Geographic coordinates referenced to the North American Datum of 1983 (NAD 83), Western Hemisphere

1000-meter Universal Transverse Mercator grid tick values, zone 4

5000-foot tick values, Hawaii State Plane coordinate system, zone 3 (SPSZONE 5103), Transverse Mercator projection

Bench mark (see explanation in Notes to Users section of this FRM, panel)

Canadian Mile marker

MAP REPOSITORY

Refer to listing of Map Repositories on Map Index

EFFECTIVE DATE OF COUNTWIDE FLOOD INSURANCE RATE MAP

November 20, 2000

EFFECTIVE DATE(S) OF REVISION(S) TO THIS PANEL

September 30, 2004 - to change Special Flood Hazard Areas, to update map format, to reflect revised shoreline and to incorporate previously issued letters of Map Revision.

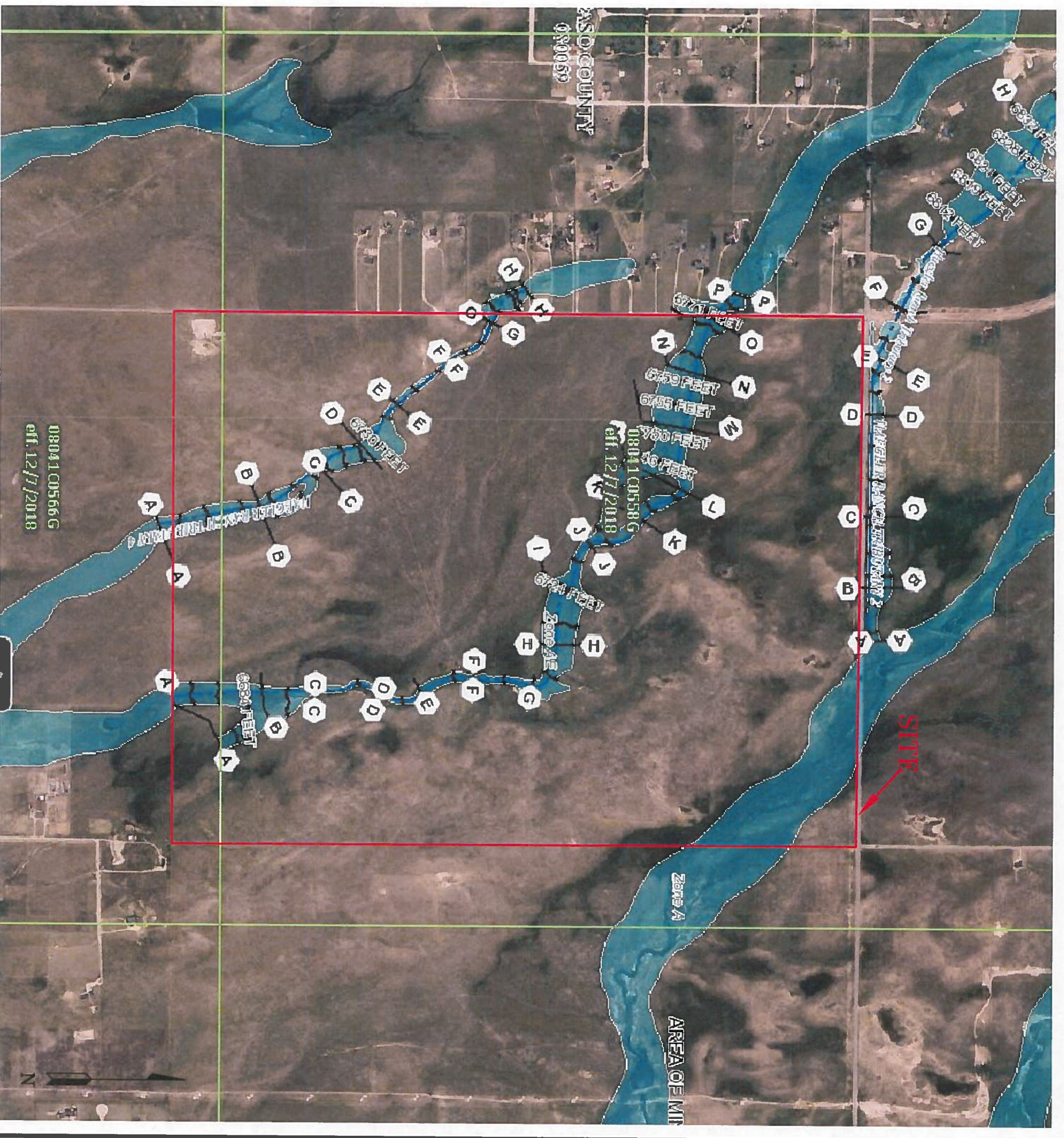

08041 C0566 G
eff. 12/7/2018

DATE	BY
CHECKED	2/21/19
DATE	AS SEIGNED
2/21/19	10/0/19
DATE	BY
10/0/19	10/0/19

FLOODPLAIN MAP
CURTIS ROAD SUBDIVISION
CURTIS ROAD AND JUDGE ORR ROAD
EL PASO COUNTY, CO.
FOR: WILLIAM GUMAN AND ASSOCIATES, LTD



ENTECH
ENGINEERING, INC.
505 ELKTON DRIVE
COLORADO SPRINGS, CO. 80907 (719) 531-5599

REVISION	BY

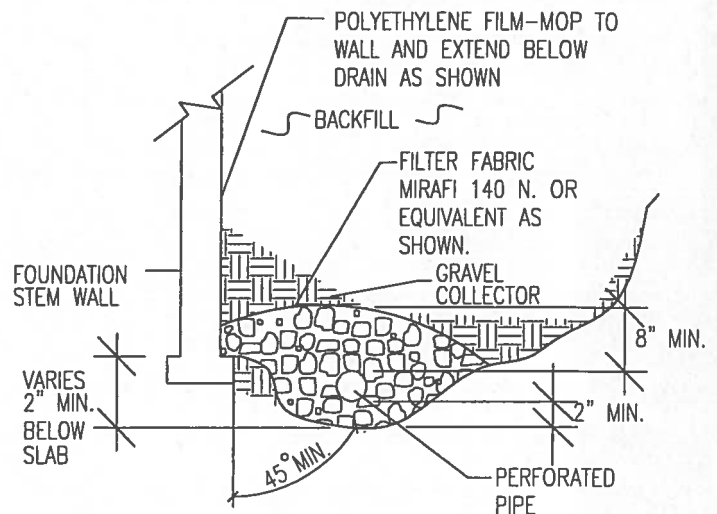
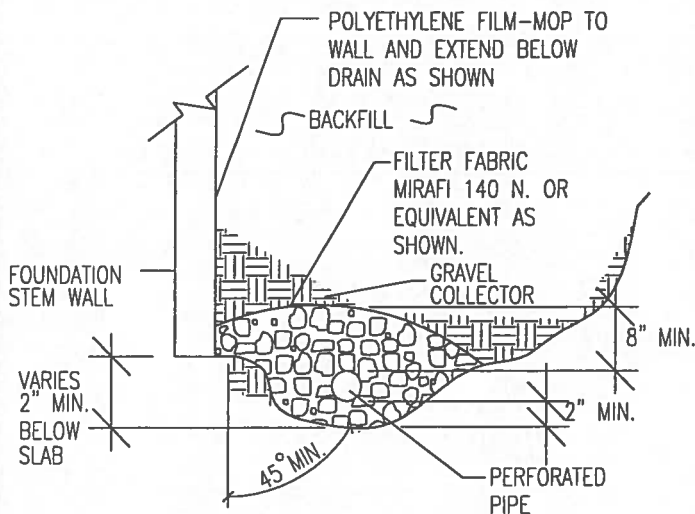

NOTES:

-GRAVEL SIZE IS RELATED TO DIAMETER OF PIPE PERFORATIONS-85% GRAVEL GREATER THAN 2x PERFORATION DIAMETER.

-PIPE DIAMETER DEPENDS UPON EXPECTED SEEPAGE. 4-INCH DIAMETER IS MOST OFTEN USED.

-ALL PIPE SHALL BE PERFORATED PLASTIC. THE DISCHARGE PORTION OF THE PIPE SHOULD BE NON-PERFORATED PIPE.

-FLEXIBLE PIPE MAY BE USED UP TO 8 FEET IN DEPTH, IF SUCH PIPE IS DESIGNED TO WITHSTAND THE PRESSURES. RIGID PLASTIC PIPE WOULD OTHERWISE BE REQUIRED.

-MINIMUM GRADE FOR DRAIN PIPE TO BE 1% OR 3 INCHES OF FALL IN 25 FEET.

-DRAIN TO BE PROVIDED WITH A FREE GRAVITY OUTFALL, IF POSSIBLE. A SUMP AND PUMP MAY BE USED IF GRAVITY OUTFALL IS NOT AVAILABLE.



ENTECH
ENGINEERING, INC.
505 ELKTON DRIVE
COLORADO SPRINGS, CO. 80907 (719) 531-5599

PERIMETER DRAIN DETAIL

DRAWN:

DATE:

4/20/19

DESIGNED:

DS

CHECKED:

[Signature]

JOB NO.:

101823

FIG NO.:

8

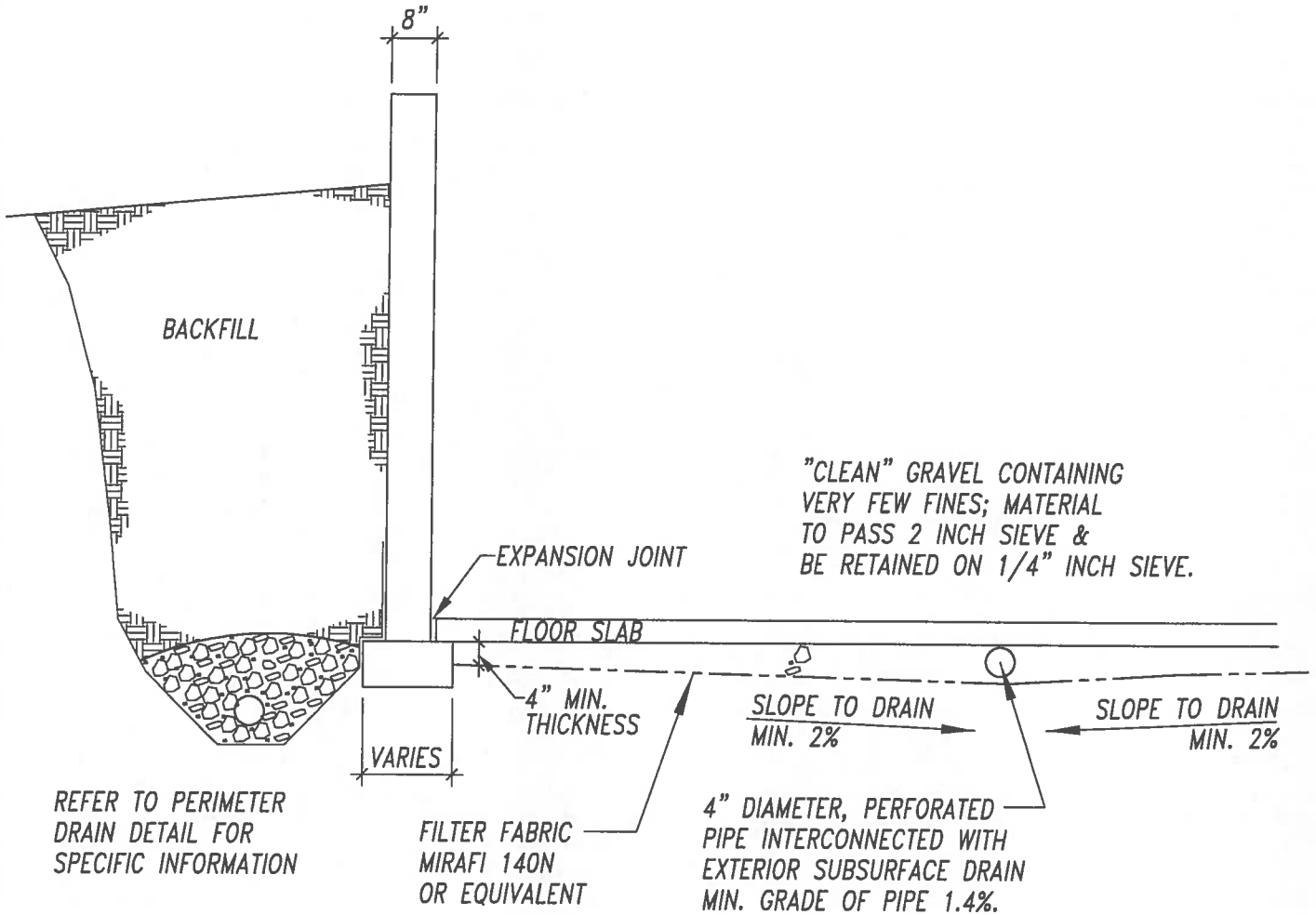

ENTECH
ENGINEERING, INC.

565 ELKTON DRIVE
COLORADO SPRINGS, CO. 80907 (719) 531-5599

TYP. UNDERSLAB DRAINAGE
LAYER (CAPILLARY BREAK)

DRAWN:

DATE:

7/22/19

DESIGNED:

DS

CHECKED:

h

JOB NO.:

181823

FIG NO.:

9

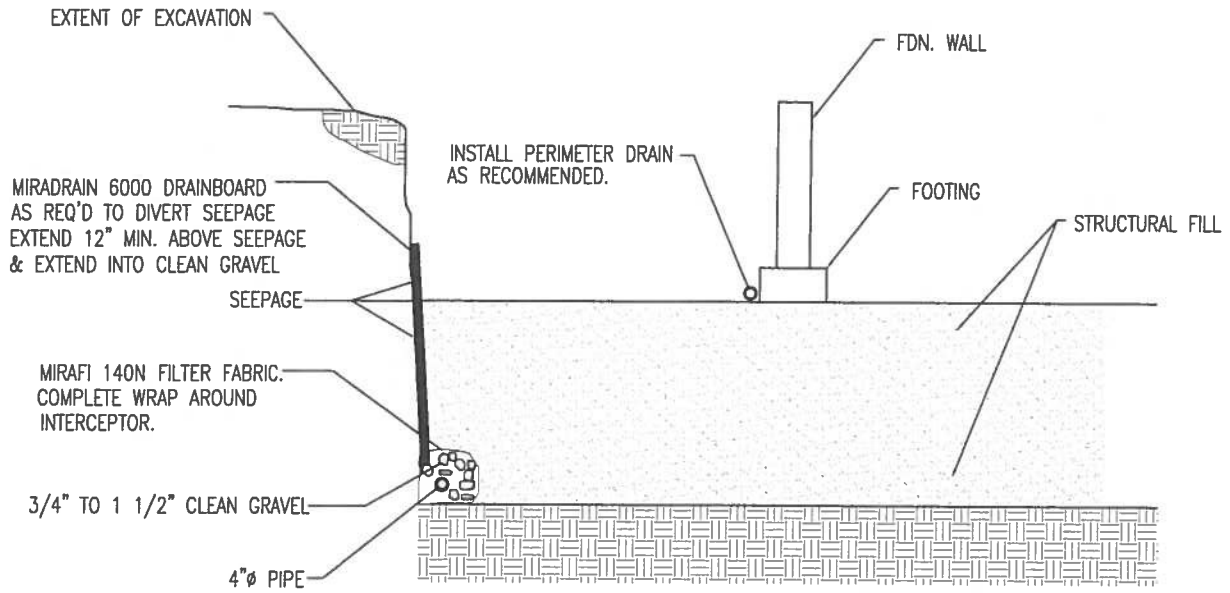

NOTE:
EXTEND INTERCEPTOR DRAIN TO DAYLIGHT

INTERCEPTOR DRAIN DETAIL
N.T.S.



ENTECH
ENGINEERING, INC.
505 ELKTON DRIVE
COLORADO SPRINGS, CO. 80907 (719) 531-5599

INTERCEPTOR DRAIN DETAIL

DRAWN BY:

DATE DRAWN:

4/22/19

CHECKED:

h

JOB NO.:

181023

FIG. NO.:

10

- APPROXIMATE LOCATION OF PERCOLATION TEST
- AREAS WHERE DESIGNED SYSTEMS ARE RECOMMENDED DUE TO UNSUITABLE SOILS, SHALLOW BEDROCK OR SHALLOW GROUNDWATER
- AREAS WHERE SEPTIC SYSTEMS ARE NOT RECOMMENDED
- AREAS WHERE CONVENTIONAL SYSTEMS CAN BE USED UNLESS SHALLOW BEDROCK, SHALLOW GROUNDWATER OR UNSUITABLE SOILS ARE ENCOUNTERED REQUIRING DESIGNED SYSTEMS
- POSSIBLE HOUSE LOCATION
- TWO POSSIBLE OWTS (ON SITE WASTEWATER TREATMENT SITES)
- APPROXIMATE TEST BORING LOCATIONS
- APPROXIMATE TEST PIT LOCATIONS

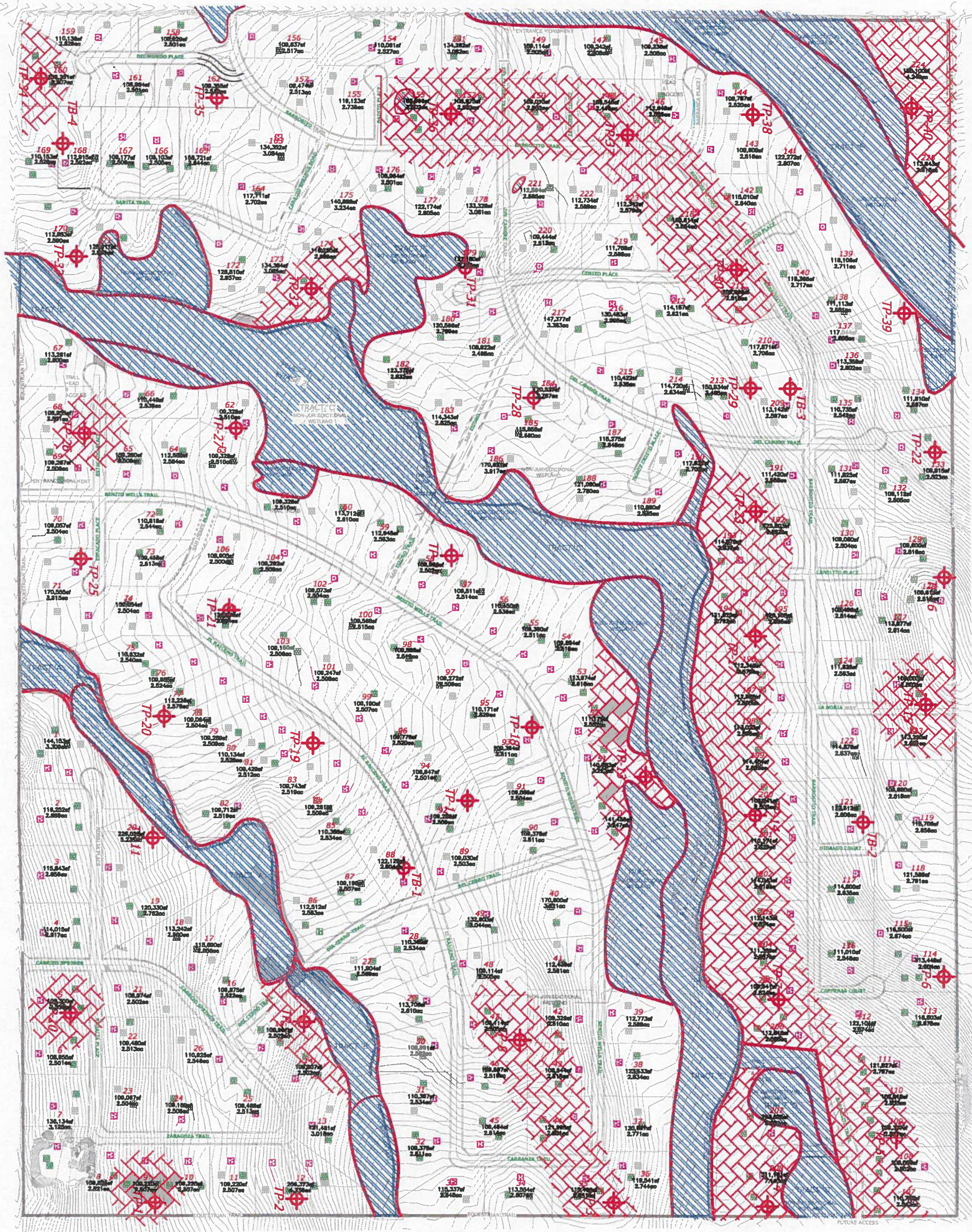

SEPTIC SUITABILITY MAP
 SADDLEHORN RANCH SUBDIVISION
 CURTIS ROAD AND JUDGE ORR ROAD
 EL PASO COUNTY, CO.
 FOR: WILLIAM GUMAN AND ASSOCIATES, LTD

ENTECH
 ENGINEERING, INC.
 505 ELKTON DRIVE
 COLORADO SPRINGS, CO. 80907 (719) 531-5599

DATE	4/29/19
SCALE	AS SHOWN
JOB NO.	181023
ISSUE NO.	11

REVISION BY	
-------------	--

APPENDIX A: Site Photographs

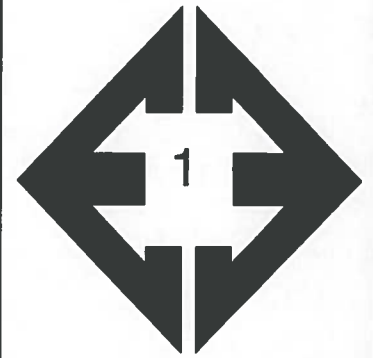

Looking north from the southwest corner of the site.

December 6, 2018



Looking east from the southwest corner of the site.

December 6, 2018

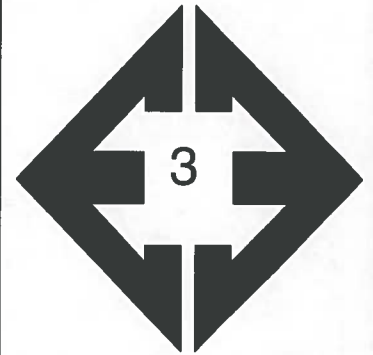

**Looking north along
drainage in the
southeastern portion
of the site.**

December 6, 2018



**Looking east from the
west central portion of
the site.**

December 6, 2018



**Looking north along
drainage in the east
central of the site.**

December 6, 2018



**Looking southwest
towards pond and
windmill in the east
central portion of the
site.**

December 6, 2018



**Looking southeast
from the northeastern
portion of the site.**

December 7, 2018



**Looking northwest
from the northeastern
portion of the site.**

December 7, 2018

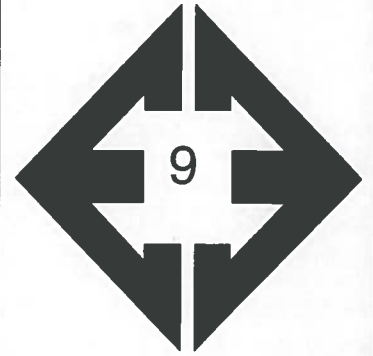

**Looking south from
the northwestern
portion of the site.**

December 7, 2018

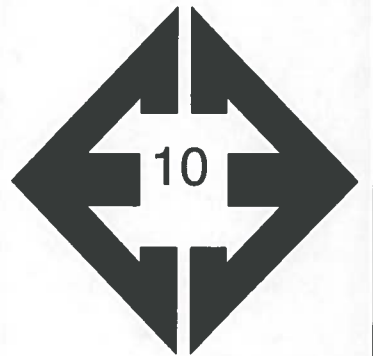

**Looking northwest
from the east central
portion of the site.**

December 7, 2018

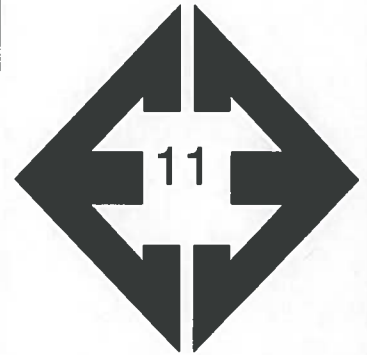

**Looking north from the
east central portion of
the site.**

December 7, 2018



**Looking west from the
eastern portion of the
site.**

January 23, 2019

APPENDIX B: Test Pit Logs

TEST BORING NO. 1
 DATE DRILLED 4/2/2019
 Job # 181823

TEST BORING NO. 2
 DATE DRILLED 4/2/2019
 CLIENT WILLIAM GUMAN
 LOCATION CURTIS AND JUDGE ORR

REMARKS

WATER @ 12', 4/3/19

6" TOPSOIL, SAND, SILTY, FINE
 TO COARSE GRAINED, TAN,
 DENSE TO MEDIUM DENSE,
 MOIST TO WET

Depth (ft)	Symbol	Samples	Blows per foot	Watercontent %	Soil Type
0-6	*		37	2.9	1
5			13	5.8	1
10			15	19.7	1
15			38	10.4	1
20			41	7.6	1



REMARKS

WATER @ 13', 4/3/19

6" TOPSOIL, SAND, SILTY, FINE
 TO COARSE GRAINED, TAN,
 DENSE, MOIST TO WET

SILTSTONE, SANDY, BROWN,
 HARD, WET

SANDSTONE, SILTY, FINE TO
 COARSE GRAINED, BROWN,
 VERY DENSE, WET

Depth (ft)	Symbol	Samples	Blows per foot	Watercontent %	Soil Type
0-6	*		33	6.0	1
5			45	6.6	1
10			44	37.5	1
15			50	22.2	4
20			50	10.2	3
20-25			5"		



ENTECH
ENGINEERING, INC.

505 ELKTON DRIVE
 COLORADO SPRINGS, COLORADO 80907

TEST BORING LOG

DRAWN:

DATE:

CHECKED:
 LLL

DATE:

4/12/19

JOB NO.:
 181823

FIG NO.:

B-1

TEST BORING NO. 3
 DATE DRILLED 4/2/2019
 Job # 181823

TEST BORING NO. 4
 DATE DRILLED 4/2/2019
 CLIENT WILLIAM GUMAN
 LOCATION CURTIS AND JUDGE ORR

REMARKS

REMARKS

WATER @ 12', 4/3/19

WATER @ 14', 4/3/19

6" TOPSOIL, SAND, SILTY, FINE TO COARSE GRAINED, TAN, DENSE TO MEDIUM DENSE, MOIST TO WET

6" TOPSOIL, SAND, CLEAN TO SILTY, FINE TO COARSE GRAINED, TAN, LOOSE TO DENSE, MOIST

SANDSTONE, SILTY, FINE TO COARSE GRAINED, GRAY BROWN, VERY DENSE, WET

SILTSTONE, VERY SANDY, DARK GRAY, HARD, WET

Depth (ft)	Symbol	Samples	Blows per foot	Watercontent %	Soil Type	Depth (ft)	Symbol	Samples	Blows per foot	Watercontent %	Soil Type
0-5	*		44	7.3	1	0-5	*		7	2.6	1
5-10	*		41	8.6	1	5-10	*		10	2.3	1
10-15	*		50 9"	11.8	3	10-15	*		30	4.0	1
15-20	*		50 8"	11.7	3	15-20	*		32	9.6	1
20-25	*		50 6"	14.8	3	20-25	*		50 4"	21.3	4



ENTECH
ENGINEERING, INC.

505 ELKTON DRIVE
 COLORADO SPRINGS, COLORADO 80907

TEST BORING LOG

DRAWN:

DATE:

CHECKED:

DATE:

LLL

4/12/19

JOB NO.:
 181823

FIG NO.:

B-2

TEST PIT NO. 1
 DATE EXCAVATED 12/14/2018
 Job # 181823

TEST PIT NO. 2
 DATE EXCAVATED 12/14/2018
 CLIENT GUMAN AND ASSOCIATES, LTD
 LOCATION CURTIS ROAD AND JUDGE ORR ROAD

REMARKS	Depth (ft)	Symbol	Samples	Soil Structure Shape	Soil Structure Grade	USDA Soil Type	REMARKS	Depth (ft)	Symbol	Samples	Soil Structure Shape	Soil Structure Grade	USDA Soil Type
topsoil, loamy sand, brown	1	⌘					topsoil, loamy sand, brown	1	⌘				
loamy sand, fine to medium grained, tan	2	⋯		sg		1	loamy sand, fine to medium grained, tan	2	⋯		sg		1
	3	⋯						3	⋯				
	4	⋯						4	⋯				
	5	⋯						5	⋯				
	6	⋯						6	⋯				
sandy clay, orangish brown	7	▨		gr	w	4A		7	⋯				
	8	▨						8	⋯				
	9							9					
	10							10					

Soil Structure Shape
 granular - gr
 platy - pl
 blocky - bl
 prismatic - pr
 single grain - sg
 massive - ma

Soil Structure Grade
 weak - w
 moderate - m
 strong - s
 loose - l



**ENTECH
 ENGINEERING, INC.**

505 ELKTON DRIVE
 COLORADO SPRINGS, COLORADO 80907

TEST PIT LOG

DRAWN:

DATE:

CHECKED:
 LLL

DATE:
 2/16/19

JOB NO.:
 181823

FIG NO.:
 B-3

TEST PIT NO. 3
 DATE EXCAVATED 12/14/2018
 Job # 181823

TEST PIT NO. 4
 DATE EXCAVATED 12/14/2018
 CLIENT GUMAN AND ASSOCIATES, LTD
 LOCATION CURTIS ROAD AND JUDGE ORR ROAD

REMARKS	Depth (ft)	Symbol	Samples	Soil Structure Shape	Soil Structure Grade	USDA Soil Type	REMARKS	Depth (ft)	Symbol	Samples	Soil Structure Shape	Soil Structure Grade	USDA Soil Type
topsoil sandy loam, brown	1						topsoil sandy clay loam, brown	1					
sandy loam, fine to medium grained, tan	2			gr	w	2A	sandy clay loam, brown	2			gr	w	3A
	3						clay lenses	3			sg		1
	4						loamy sand, fine to coarse grained, tan	4					
	5							5					
sandy clay, gray brown	6			gr	m	4A		6					
	7							7					
	8							8					
	9							9					
	10							10					

Soil Structure Shape
 granular - gr
 platy - pl
 blocky - bl
 prismatic - pr
 single grain - sg
 massive - ma

Soil Structure Grade
 weak - w
 moderate - m
 strong - s
 loose - l



ENTECH
ENGINEERING, INC.

505 ELKTON DRIVE
 COLORADO SPRINGS, COLORADO 80907

TEST PIT LOG

DRAWN:

DATE:

CHECKED:

DATE: 7/22/17

JOB NO.:

181823

FIG NO.:

B-4

TEST PIT NO. 5
 DATE EXCAVATED 12/14/2018
 Job # 181823

TEST PIT NO. 6
 DATE EXCAVATED 12/14/2018
 CLIENT GUMAN AND ASSOCIATES, LTD
 LOCATION CURTIS ROAD AND JUDGE ORR ROAD

REMARKS	Depth (ft)	Symbol	Samples	Soil Structure Shape	Soil Structure Grade	USDA Soil Type	REMARKS	Depth (ft)	Symbol	Samples	Soil Structure Shape	Soil Structure Grade	USDA Soil Type
topsoil sandy loam, brown	1	[Symbol]					topsoil sandy loam, brown	1	[Symbol]				
sandy loam, fine to medium grained, light brown	2	[Symbol]		gr	w	2A	sandy loam, fine to coarse grained, tan	2	[Symbol]		gr	w	2A
	3	[Symbol]						3	[Symbol]				
	4	[Symbol]						4	[Symbol]				
	5	[Symbol]						5	[Symbol]				
	6	[Symbol]					loamy sandy, fine to medium grained, tan	6	[Symbol]		sg		1
sandy clay, light brown	7	[Symbol]		gr	w	4A		7	[Symbol]				
	8	[Symbol]						8	[Symbol]				
	9	[Symbol]						9	[Symbol]				
	10	[Symbol]						10	[Symbol]				

Soil Structure Shape
 granular - gr
 platy - pl
 blocky - bl
 prismatic - pr
 single grain - sg
 massive - ma

Soil Structure Grade
 weak - w
 moderate - m
 strong - s
 loose - l



**ENTECH
 ENGINEERING, INC.**

505 ELKTON DRIVE
 COLORADO SPRINGS, COLORADO 80907

TEST PIT LOG

DRAWN:

DATE:

CHECKED:
 LLL

DATE:
 2/16/19

JOB NO.:
 181823

FIG NO.:
 B-5

TEST PIT NO. 7
 DATE EXCAVATED 12/14/2018
 Job # 181823

TEST PIT NO. 8
 DATE EXCAVATED 12/14/2018
 CLIENT GUMAN AND ASSOCIATES, LTD
 LOCATION CURTIS ROAD AND JUDGE ORR ROAD

REMARKS	Depth (ft)	Symbol	Samples	Soil Structure Shape	Soil Structure Grade	USDA Soil Type	REMARKS	Depth (ft)	Symbol	Samples	Soil Structure Shape	Soil Structure Grade	USDA Soil Type
topsoil sandy loam, brown	1						topsoil sandy loam, brown	1					
sandy loam, fine to medium grained, tan	2			gr	w	2A	sandy loam, fine to medium grained, tan	2			gr	w	2A
weathered to formational sandy claystone, gray brown	3			ma		4A	weathered clayey sandstone, gray brown	3			ma		4A
	4							4					
	5							5					
	6							6					
	7							7					
	8							8					
	9							9					
	10							10					

Soil Structure Shape
 granular - gr
 platy - pl
 blocky - bl
 prismatic - pr
 single grain - sg
 massive - ma

Soil Structure Grade
 weak - w
 moderate - m
 strong - s
 loose - l



**ENTECH
 ENGINEERING, INC.**

505 ELKTON DRIVE
 COLORADO SPRINGS, COLORADO 80907

TEST PIT LOG

DRAWN:

DATE:

CHECKED:
ELL

DATE:
2/16/19

JOB NO.:
 181823

FIG NO.:

B-6

TEST PIT NO. 9
 DATE EXCAVATED 12/15/2018
 Job # 181823

TEST PIT NO. 10
 DATE EXCAVATED 12/15/2018
 CLIENT GUMAN AND ASSOCIATES, LTD
 LOCATION CURTIS ROAD AND JUDGE ORR ROAD

REMARKS	Depth (ft)	Symbol	Samples	Soil Structure Shape	Soil Structure Grade	USDA Soil Type	REMARKS	Depth (ft)	Symbol	Samples	Soil Structure Shape	Soil Structure Grade	USDA Soil Type
topsoil sandy loam, brown	1	[Symbol]					topsoil sandy loam, brown	1	[Symbol]				
sandy clay loam, fine to coarse grained, light brown	2	[Symbol]		gr	w	3A	gravelly sandy loam, fine to coarse grained, tan	2	[Symbol]		gr	w	2A
	3	[Symbol]						3	[Symbol]				
sandy loam, fine to coarse grained, tan	4	[Symbol]		gr	w	2A	weathered silty sandstone, fine to coarse grained, tan	4	[Symbol]		ma		3A
	5	[Symbol]						5	[Symbol]				
	6	[Symbol]						6	[Symbol]				
	7	[Symbol]						7	[Symbol]				
	8	[Symbol]						8	[Symbol]				
	9	[Symbol]						9	[Symbol]				
	10	[Symbol]						10	[Symbol]				

Soil Structure Shape
 granular - gr
 platy - pl
 blocky - bl
 prismatic - pr
 single grain - sg
 massive - ma

Soil Structure Grade
 weak - w
 moderate - m
 strong - s
 loose - l



ENTECH
ENGINEERING, INC.

505 ELKTON DRIVE
 COLORADO SPRINGS, COLORADO 80907

TEST PIT LOG

DRAWN:

DATE:

CHECKED:
 LLL

DATE:
 2/16/19

JOB NO.:

181823

FIG NO.:

B-7

TEST PIT NO. 11
 DATE EXCAVATED 12/15/2018
 Job # 181823

TEST PIT NO. 12
 DATE EXCAVATED 12/15/2018
 CLIENT GUMAN AND ASSOCIATES, LTD
 LOCATION CURTIS ROAD AND JUDGE ORR ROAD

REMARKS	Depth (ft)	Symbol	Samples	Soil Structure Shape	Soil Structure Grade	USDA Soil Type	REMARKS	Depth (ft)	Symbol	Samples	Soil Structure Shape	Soil Structure Grade	USDA Soil Type
topsoil sandy loam, brown	1						topsoil sandy loam, brown	1					
gravelly loamy sand, fine to coarse grained, tan	2			sg		1	loamy sand, fine to coarse grained	2			sg		1
	3							3					
	4							4					
	5							5					
	6							6					
	7							7					
	8							8					
	9							9					
	10							10					

Soil Structure Shape
 granular - gr
 platy - pl
 blocky - bl
 prismatic - pr
 single grain - sg
 massive - ma

Soil Structure Grade
 weak - w
 moderate - m
 strong - s
 loose - l



ENTECH
ENGINEERING, INC.

505 ELKTON DRIVE
 COLORADO SPRINGS, COLORADO 80907

TEST PIT LOG

DRAWN:

DATE:

CHECKED:
 LLL

DATE:
 2/16/19

JOB NO.:

181823

FIG NO.:

B-8

TEST PIT NO. 13
 DATE EXCAVATED 12/15/2018
 Job # 181823

TEST PIT NO. 14
 DATE EXCAVATED 12/15/2018
 CLIENT GUMAN AND ASSOCIATES, LTD
 LOCATION CURTIS ROAD AND JUDGE ORR ROAD

REMARKS	Depth (ft)	Symbol	Samples	Soil Structure Shape	Soil Structure Grade	USDA Soil Type	REMARKS	Depth (ft)	Symbol	Samples	Soil Structure Shape	Soil Structure Grade	USDA Soil Type
topsoil sandy clay loam, brown	1			gr	m	3	topsoil sandy loam, brown	1			gr	w	2A
sandy clay loam, fine to coarse grained, light brown	2						sandy loam, fine to coarse grained, tan	2					
	3						weathered to formational sandy claystone, gray brown	3			ma		4A
	4							4					
	5							5					
	6							6					
*-groundwater at 6'	7							7					
	8							8					
	9							9					
	10							10					

Soil Structure Shape
 granular - gr
 platy - pl
 blocky - bl
 prismatic - pr
 single grain - sg
 massive - ma

Soil Structure Grade
 weak - w
 moderate - m
 strong - s
 loose - l



**ENTECH
 ENGINEERING, INC.**

505 ELKTON DRIVE
 COLORADO SPRINGS, COLORADO 80907

TEST PIT LOG

DRAWN:

DATE:

CHECKED:
 LLL

DATE:
 2/16/19

JOB NO.:

181823

FIG NO.:

B-9

TEST PIT NO. 15
 DATE EXCAVATED 12/15/2018
 Job # 181823

TEST PIT NO. 16
 DATE EXCAVATED 12/15/2018
 CLIENT GUMAN AND ASSOCIATES, LTD
 LOCATION CURTIS ROAD AND JUDGE ORR ROAD

REMARKS	Depth (ft)	Symbol	Samples	Soil Structure Shape	Soil Structure Grade	USDA Soil Type	REMARKS	Depth (ft)	Symbol	Samples	Soil Structure Shape	Soil Structure Grade	USDA Soil Type
topsoil sandy clay loam, brown	1	[Symbol]		gr	w	3A	topsoil sandy loam, brown	1	[Symbol]		gr	w	2A
sandy clay loam, fine to coarse grained	2	[Symbol]					sandy loam, fine to medium grained, tan	2	[Symbol]				
formational sandy claystone, gray brown	3	[Symbol]		ma		4A		3	[Symbol]				
	4	[Symbol]						4	[Symbol]				
	5	[Symbol]						5	[Symbol]				
	6	[Symbol]						6	[Symbol]				
	7	[Symbol]					sandy clay, light brown	7	[Symbol]		gr	w	4A
	8	[Symbol]						8	[Symbol]				
	9	[Symbol]						9	[Symbol]				
	10	[Symbol]						10	[Symbol]				

Soil Structure Shape
 granular - gr
 platy - pl
 blocky - bl
 prismatic - pr
 single grain - sg
 massive - ma

Soil Structure Grade
 weak - w
 moderate - m
 strong - s
 loose - l



ENTECH
ENGINEERING, INC.

505 ELKTON DRIVE
 COLORADO SPRINGS, COLORADO 80907

TEST PIT LOG

DRAWN:

DATE:

CHECKED:
 LLL

DATE:
 2/16/19

JOB NO.:

181823

FIG NO.:

B-10

TEST PIT NO. 17
 DATE EXCAVATED 12/15/2018
 Job # 181823

TEST PIT NO. 18
 DATE EXCAVATED 12/15/2018
 CLIENT GUMAN AND ASSOCIATES, LTD
 LOCATION CURTIS ROAD AND JUDGE ORR ROAD

REMARKS	Depth (ft)	Symbol	Samples	Soil Structure Shape	Soil Structure Grade	USDA Soil Type	REMARKS	Depth (ft)	Symbol	Samples	Soil Structure Shape	Soil Structure Grade	USDA Soil Type
topsoil sandy loam, brown	1	[Symbol]		gr	w	2A	topsoil sandy loam, brown	1	[Symbol]		gr	w	2A
sandy loam, fine to medium grained, tan	2	[Symbol]					sandy loam, fine to medium grained, tan	2	[Symbol]				
	3	[Symbol]						3	[Symbol]		sg		1
	4	[Symbol]		ma		4A	gravelly loamy sand, fine to coarse grained, tan	4	[Symbol]				
weathered to formational clayey sandstone, fine to medium grained, grayish tan	5	[Symbol]						5	[Symbol]				
	6	[Symbol]						6	[Symbol]				
	7	[Symbol]						7	[Symbol]				
	8	[Symbol]						8	[Symbol]				
	9	[Symbol]						9	[Symbol]				
	10	[Symbol]						10	[Symbol]				

Soil Structure Shape
 granular - gr
 platy - pl
 blocky - bl
 prismatic - pr
 single grain - sg
 massive - ma

Soil Structure Grade
 weak - w
 moderate - m
 strong - s
 loose - l



ENTECH
ENGINEERING, INC.

505 ELKTON DRIVE
 COLORADO SPRINGS, COLORADO 80907

TEST PIT LOG

DRAWN:

DATE:

CHECKED:
 LLL

DATE:
 2/16/19

JOB NO.:
 181823

FIG NO.:
 B-11

TEST PIT NO. 19
 DATE EXCAVATED 1/23/2019
 Job # 181823

TEST PIT NO. 20
 DATE EXCAVATED 1/23/2019
 CLIENT GUMAN AND ASSOCIATES, LTD
 LOCATION CURTIS ROAD AND JUDGE ORR ROAD

REMARKS	Depth (ft)	Symbol	Samples	Soil Structure Shape	Soil Structure Grade	USDA Soil Type	REMARKS	Depth (ft)	Symbol	Samples	Soil Structure Shape	Soil Structure Grade	USDA Soil Type
topsoil loamy sand, brown	1						topsoil loamy sand, brown	1					
loamy sand, fine to coarse grained, tan	2			sg		1	loamy sand, fine to coarse grained, tan	2			gr	w	2A
sandy loam, fine to coarse grained, tan	3			gr	w	2A	sandy loam, fine to coarse grained, tan	3			sg		1
	4							4					
	5							5					
	6							6					
	7							7					
	8							8					
	9							9					
	10							10					

Soil Structure Shape
 granular - gr
 platy - pl
 blocky - bl
 prismatic - pr
 single grain - sg
 massive - ma

Soil Structure Grade
 weak - w
 moderate - m
 strong - s
 loose - l



ENTECH
ENGINEERING, INC.

505 ELKTON DRIVE
 COLORADO SPRINGS, COLORADO 80907

TEST PIT LOG

DRAWN:

DATE:

CHECKED:
 LLL

DATE:
 2/16/19

JOB NO.:

181823

FIG NO.:

B-12

TEST PIT NO. 21
 DATE EXCAVATED 1/23/2019
 Job # 181823

TEST PIT NO. 22
 DATE EXCAVATED 1/4/2019
 CLIENT GUMAN AND ASSOCIATES, LTD
 LOCATION CURTIS ROAD AND JUDGE ORR ROAD

REMARKS	Depth (ft)	Symbol	Samples	Soil Structure Shape	Soil Structure Grade	USDA Soil Type	REMARKS	Depth (ft)	Symbol	Samples	Soil Structure Shape	Soil Structure Grade	USDA Soil Type
topsoil sandy loam, brown	1						topsoil sandy loam, brown	1					
sandy loam, fine to medium grained, tan	2			gr	m	2	loamy sand, fine to coarse grained, tan	2			sg		1
loamy sand to sand, fine to coarse grained, tan	3			sg		1		3					
	4							4					
	5							5					
	6						sandy loam, fine to coarse grained, tan	6			gr	w	2A
	7							7					
	8							8					
	9							9					
	10							10					

Soil Structure Shape
 granular - gr
 platy - pl
 blocky - bl
 prismatic - pr
 single grain - sg
 massive - ma

Soil Structure Grade
 weak - w
 moderate - m
 strong - s
 loose - l



**ENTECH
 ENGINEERING, INC.**

505 ELKTON DRIVE
 COLORADO SPRINGS, COLORADO 80907

TEST PIT LOG

DRAWN:

DATE:

CHECKED:
 LLL

DATE:
 2/16/19

JOB NO.:

181823

FIG NO.:

B-13

TEST PIT NO. 23
 DATE EXCAVATED 1/4/2019
 Job # 181823

TEST PIT NO. 24
 DATE EXCAVATED 1/23/2019
 CLIENT GUMAN AND ASSOCIATES, LTD
 LOCATION CURTIS ROAD AND JUDGE ORR ROAD

REMARKS	Depth (ft)	Symbol	Samples	Soil Structure Shape	Soil Structure Grade	USDA Soil Type	REMARKS	Depth (ft)	Symbol	Samples	Soil Structure Shape	Soil Structure Grade	USDA Soil Type
topsoil sandy clay loam, brown	1	[Symbol]		gr	w	3A	topsoil sandy loam, brown	1	[Symbol]		gr	w	2A
sandy clay loam, light brown	2	[Symbol]		ma		3A	sandy loam, fine to coarse grained, tan	2	[Symbol]		gr	w	2A
weathered silty sandstone, fine to coarse grained, grayish tan	3	[Symbol]		ma		3A	loamy sand to sand, fine to coarse grained, tan	3	[Symbol]		sg		1
weathered sandy claystone, gray brown	4	[Symbol]		ma		4A		4	[Symbol]				
	5	[Symbol]						5	[Symbol]				
	6	[Symbol]						6	[Symbol]				
	7	[Symbol]						7	[Symbol]				
	8	[Symbol]						8	[Symbol]				
	9	[Symbol]						9	[Symbol]				
	10	[Symbol]						10	[Symbol]				

Soil Structure Shape
 granular - gr
 platy - pl
 blocky - bl
 prismatic - pr
 single grain - sg
 massive - ma

Soil Structure Grade
 weak - w
 moderate - m
 strong - s
 loose - l



**ENTECH
 ENGINEERING, INC.**

505 ELKTON DRIVE
 COLORADO SPRINGS, COLORADO 80907

TEST PIT LOG

DRAWN:

DATE:

CHECKED:
 LLL

DATE:
 2/16/19

JOB NO.:
 181823
 FIG NO.:
 B-14

TEST PIT NO. 25
 DATE EXCAVATED 1/23/2019
 Job # 181823

TEST PIT NO. 26
 DATE EXCAVATED 1/23/2019
 CLIENT GUMAN AND ASSOCIATES, LTD
 LOCATION CURTIS ROAD AND JUDGE ORR ROAD

REMARKS	Depth (ft)	Symbol	Samples	Soil Structure Shape	Soil Structure Grade	USDA Soil Type	REMARKS	Depth (ft)	Symbol	Samples	Soil Structure Shape	Soil Structure Grade	USDA Soil Type
topsoil loamy sand, brown	1	⌘		sg		1	topsoil loamy sand, brown	1	⌘		sg		1
loamy sand to sand, fine to medium grained, light brown	2	⌘					loamy sand, fine to coarse grained, light brown	2	⌘				
	3	⌘					sandy clay loam, fine to coarse grained, light brown	3	⌘		gr	w	3A
	4	⌘					sand, fine to coarse grained	4	⌘		sg		1
	5	⌘						5	⌘				
	6	⌘						6	⌘				
	7	⌘						7	⌘				
	8	⌘						8	⌘				
	9	⌘						9	⌘				
	10	⌘						10	⌘				

Soil Structure Shape
 granular - gr
 platy - pl
 blocky - bl
 prismatic - pr
 single grain - sg
 massive - ma

Soil Structure Grade
 weak - w
 moderate - m
 strong - s
 loose - l



**ENTECH
 ENGINEERING, INC.**

505 ELKTON DRIVE
 COLORADO SPRINGS, COLORADO 80907

TEST PIT LOG

DRAWN:

DATE:

CHECKED:
 LLL

DATE:
 2/16/19

JOB NO.:

181823

FIG NO.:

B-15

TEST PIT NO. 27
 DATE EXCAVATED 1/23/2019
 Job # 181823

TEST PIT NO. 28
 DATE EXCAVATED 1/23/2019
 CLIENT GUMAN AND ASSOCIATES, LTD
 LOCATION CURTIS ROAD AND JUDGE ORR ROAD

REMARKS	Depth (ft)	Symbol	Samples	Soil Structure Shape	Soil Structure Grade	USDA Soil Type	REMARKS	Depth (ft)	Symbol	Samples	Soil Structure Shape	Soil Structure Grade	USDA Soil Type
topsoil sandy loam, brown	1	[Symbol]		gr	w	2A	topsoil sandy loam, brown	1	[Symbol]		gr	w	2A
sandy loam, fine to coarse grained, light brown	2	[Symbol]					sandy loam, fine to coarse grained, light brown	2	[Symbol]				
loamy sand to sand, fine to coarse grained, tan	3	[Symbol]		sg		1	sand, fine to coarse grained, tan	3	[Symbol]		sg		1
	4	[Symbol]						4	[Symbol]				
	5	[Symbol]					*-groundwater at 6.5'	5	[Symbol]				
	6	[Symbol]						6	[Symbol]				
	7	[Symbol]						7	[Symbol]				
	8	[Symbol]						8	[Symbol]				
	9	[Symbol]						9	[Symbol]				
	10	[Symbol]						10	[Symbol]				

Soil Structure Shape
 granular - gr
 platy - pl
 blocky - bl
 prismatic - pr
 single grain - sg
 massive - ma

Soil Structure Grade
 weak - w
 moderate - m
 strong - s
 loose - l



ENTECH
ENGINEERING, INC.

505 ELKTON DRIVE
 COLORADO SPRINGS, COLORADO 80907

TEST PIT LOG

DRAWN:

DATE:

CHECKED:
 LLL

DATE:
 2/16/19

JOB NO.:
 181823

FIG NO.:
 B-16

TEST PIT NO. 29
 DATE EXCAVATED 1/23/2019
 Job # 181823

TEST PIT NO. 30
 DATE EXCAVATED 1/23/2019
 CLIENT GUMAN AND ASSOCIATES, LTD
 LOCATION CURTIS ROAD AND JUDGE ORR ROAD

REMARKS	Depth (ft)	Symbol	Samples	Soil Structure Shape	Soil Structure Grade	USDA Soil Type	REMARKS	Depth (ft)	Symbol	Samples	Soil Structure Shape	Soil Structure Grade	USDA Soil Type
topsoil sandy loam, brown	1	[Symbol]					topsoil sandy loam, brown	1	[Symbol]				
sandy loam, fine to coarse grained, light brown	2	[Symbol]		gr	w	2A	sandy loam, fine to coarse grained, light brown	2	[Symbol]		gr	w	2A
loamy sand, fine to coarse grained, tan	3	[Symbol]		sg		1	loamy sand, fine to coarse grained, tan	3	[Symbol]		sg		1
	4	[Symbol]					weathered clayey sandstone fine to coarse grained, grayish tan	4	[Symbol]		ma		4A
	5	[Symbol]						5	[Symbol]				
	6	[Symbol]						6	[Symbol]				
	7	[Symbol]					*-signs of seasonally occurring groundwater at 6.5'	7	[Symbol]				
	8	[Symbol]						8	[Symbol]				
	9	[Symbol]						9	[Symbol]				
	10	[Symbol]						10	[Symbol]				

Soil Structure Shape
 granular - gr
 platy - pl
 blocky - bl
 prismatic - pr
 single grain - sg
 massive - ma

Soil Structure Grade
 weak - w
 moderate - m
 strong - s
 loose - l



**ENTECH
 ENGINEERING, INC.**

505 ELKTON DRIVE
 COLORADO SPRINGS, COLORADO 80907

TEST PIT LOG

DRAWN:

DATE:

CHECKED:
 LLL

DATE:
 2/16/19

JOB NO.:
 181823

FIG NO.:
 B-17

TEST PIT NO. 31
 DATE EXCAVATED 1/4/2019
 Job # 181823

TEST PIT NO. 32
 DATE EXCAVATED 1/4/2019
 CLIENT GUMAN AND ASSOCIATES, LTD
 LOCATION CURTIS ROAD AND JUDGE ORR ROAD

REMARKS	Depth (ft)	Symbol	Samples	Soil Structure Shape	Soil Structure Grade	USDA Soil Type	REMARKS	Depth (ft)	Symbol	Samples	Soil Structure Shape	Soil Structure Grade	USDA Soil Type
topsoil sandy loam, brown	1	[Symbol]					topsoil sandy loam, brown	1	[Symbol]				
sandy loam, fine to coarse grained, light brown	2	[Symbol]		gr	w	2A	sandy loam, fine to coarse grained, light brown	2	[Symbol]		gr	w	2A
loamy sand, fine to medium grained, tan	3	[Symbol]		sg		1	sandy clay loam, gray brown	3	[Symbol]		gr	w	3A
	4	[Symbol]						4	[Symbol]				
	5	[Symbol]						5	[Symbol]				
	6	[Symbol]					weathered sandy claystone, gray brown	6	[Symbol]		ma		4A
	7	[Symbol]						7	[Symbol]				
	8	[Symbol]						8	[Symbol]				
	9	[Symbol]						9	[Symbol]				
	10	[Symbol]						10	[Symbol]				

Soil Structure Shape
 granular - gr
 platy - pl
 blocky - bl
 prismatic - pr
 single grain - sg
 massive - ma

Soil Structure Grade
 weak - w
 moderate - m
 strong - s
 loose - l



**ENTECH
 ENGINEERING, INC.**

505 ELKTON DRIVE
 COLORADO SPRINGS, COLORADO 80907

TEST PIT LOG

DRAWN:

DATE:

CHECKED:
 LLL

DATE:
 2/16/19

JOB NO.:
 181823
 FIG NO.:
 B-18

TEST PIT NO. 33
 DATE EXCAVATED 1/4/2019
 Job # 181823

TEST PIT NO. 34
 DATE EXCAVATED 1/4/2019
 CLIENT GUMAN AND ASSOCIATES, LTD
 LOCATION CURTIS ROAD AND JUDGE ORR ROAD

REMARKS						REMARKS					
Depth (ft)	Symbol	Samples	Soil Structure Shape	Soil Structure Grade	USDA Soil Type	Depth (ft)	Symbol	Samples	Soil Structure Shape	Soil Structure Grade	USDA Soil Type
1	[Symbol]		gr	w	2A	1	[Symbol]		gr	w	2A
2	[Symbol]					2	[Symbol]				
3	[Symbol]		sg		1	3	[Symbol]				
4	[Symbol]					4	[Symbol]				
5	[Symbol]					5	[Symbol]		ma		3A
6	[Symbol]					6	[Symbol]				
7	[Symbol]					7	[Symbol]				
8	[Symbol]					8	[Symbol]				
9	[Symbol]					9	[Symbol]				
10	[Symbol]					10	[Symbol]				

Soil Structure Shape
 granular - gr
 platy - pl
 blocky - bl
 prismatic - pr
 single grain - sg
 massive - ma

Soil Structure Grade
 weak - w
 moderate - m
 strong - s
 loose - l



**ENTECH
 ENGINEERING, INC.**

505 ELKTON DRIVE
 COLORADO SPRINGS, COLORADO 80907

TEST PIT LOG

DRAWN:

DATE:

CHECKED:
 LLL

DATE:
 2/16/19

JOB NO.:

181823

FIG NO.:

B-19

TEST PIT NO. 35
 DATE EXCAVATED 1/4/2019
 Job # 181823

TEST PIT NO. 36
 DATE EXCAVATED 1/4/2019
 CLIENT GUMAN AND ASSOCIATES, LTD
 LOCATION CURTIS ROAD AND JUDGE ORR ROAD

REMARKS

REMARKS

REMARKS	Depth (ft)	Symbol	Samples	Soil Structure Shape	Soil Structure Grade	USDA Soil Type	REMARKS	Depth (ft)	Symbol	Samples	Soil Structure Shape	Soil Structure Grade	USDA Soil Type
topsoil sandy loam, brown	1	[Symbol]		gr	w	2A	topsoil sandy loam, brown	1	[Symbol]		gr	w	2A
sandy loam, fine to coarse grained, tan	2	[Symbol]					sandy loam, fine to coarse grained, tan	2	[Symbol]				
	3	[Symbol]						3	[Symbol]				
gravelly loamy sand, fine to coarse grained, tan	4	[Symbol]		sg		1		4	[Symbol]				
	5	[Symbol]						5	[Symbol]				
	6	[Symbol]					sandy clay loam, gray	6	[Symbol]		gr	w	3A
	7	[Symbol]					*-signs of seasonal occurring groundwater at 6'	7	[Symbol]				
	8	[Symbol]						8	[Symbol]				
	9	[Symbol]						9	[Symbol]				
	10	[Symbol]						10	[Symbol]				

Soil Structure Shape
 granular - gr
 platy - pl
 blocky - bl
 prismatic - pr
 single grain - sg
 massive - ma

Soil Structure Grade
 weak - w
 moderate - m
 strong - s
 loose - l



**ENTECH
 ENGINEERING, INC.**

505 ELKTON DRIVE
 COLORADO SPRINGS, COLORADO 80907

TEST PIT LOG

DRAWN:

DATE:

CHECKED:
 LLL

DATE:
 2/16/19

JOB NO.:

181823

FIG NO.:

B-20

TEST PIT NO. 37
 DATE EXCAVATED 1/4/2019
 Job # 181823

TEST PIT NO. 38
 DATE EXCAVATED 1/4/2019
 CLIENT GUMAN AND ASSOCIATES, LTD
 LOCATION CURTIS ROAD AND JUDGE ORR ROAD

REMARKS	Depth (ft)	Symbol	Samples	Soil Structure Shape	Soil Structure Grade	USDA Soil Type	REMARKS	Depth (ft)	Symbol	Samples	Soil Structure Shape	Soil Structure Grade	USDA Soil Type
topsoil sandy loam, brown	1						topsoil sandy loam, brown	1					
loamy sand, fine to coarse grained, tan	2			sg		1	sandy loam, fine to coarse grained, tan	2			gr	w	2A
	3						loamy sand, fine to coarse grained, tan	3			sg		1
	4							4					
	5							5					
sandy clay loam, gray	6			gr	w	3A	sandy loam, fine to coarse grained, orangish tan	6			gr	w	2A
	7							7					
	8						*signs of seasonal occuring groundwater at 6.5'	8					
	9							9					
	10							10					

Soil Structure Shape
 granular - gr
 platy - pl
 blocky - bl
 prismatic - pr
 single grain - sg
 massive - ma

Soil Structure Grade
 weak - w
 moderate - m
 strong - s
 loose - l



**ENTECH
 ENGINEERING, INC.**

505 ELKTON DRIVE
 COLORADO SPRINGS, COLORADO 80907

TEST PIT LOG

DRAWN:

DATE:

CHECKED:
 LLL

DATE:
 2/16/19

JOB NO.:

181823

FIG NO.:

B-21

TEST PIT NO. 39
 DATE EXCAVATED 1/4/2019
 Job # 181823

TEST PIT NO. 40
 DATE EXCAVATED 1/4/2019
 CLIENT GUMAN AND ASSOCIATES, LTD
 LOCATION CURTIS ROAD AND JUDGE ORR ROAD

REMARKS						REMARKS					
Depth (ft)	Symbol	Samples	Soil Structure Shape	Soil Structure Grade	USDA Soil Type	Depth (ft)	Symbol	Samples	Soil Structure Shape	Soil Structure Grade	USDA Soil Type
1	[Symbol]					1	[Symbol]				
2	[Symbol]		sg		1	2	[Symbol]		gr	w	2A
3	[Symbol]					3	[Symbol]		ma		4A
4	[Symbol]					4	[Symbol]				
5	[Symbol]		gr	w	2A	5	[Symbol]				
6	[Symbol]					6	[Symbol]				
7	[Symbol]					7	[Symbol]				
8	[Symbol]					8	[Symbol]				
9	[Symbol]					9	[Symbol]				
10	[Symbol]					10	[Symbol]				

topsoil sandy loam, brown

loamy sand, fine to coarse grained, tan

sandy loam, fine to coarse grained, tan

topsoil sandy loam, brown

sandy loam, fine to coarse grained, tan

weathered to formational clayey sandstone, tan to orangish tan

*-signs of seasonal occuring groundwater at 3.5'

Soil Structure Shape

- granular - gr
- platy - pl
- blocky - bl
- prismatic - pr
- single grain - sg
- massive - ma

Soil Structure Grade

- weak - w
- moderate - m
- strong - s
- loose - l



ENTECH ENGINEERING, INC.

505 ELKTON DRIVE
 COLORADO SPRINGS, COLORADO 80907

TEST PIT LOG

DRAWN:

DATE:

CHECKED:

DATE:

LLL

2/16/19

JOB NO.:

181823

FIG NO.:

B-22

APPENDIX C: Laboratory Test Results

UNIFIED CLASSIFICATION	SM	CLIENT	WILLIAM GUMAN
SOIL TYPE #	1	PROJECT	CURTIS AND JUDGE ORR
TEST BORING #	1	JOB NO.	181823
DEPTH (FT)	2-3	TEST BY	BL

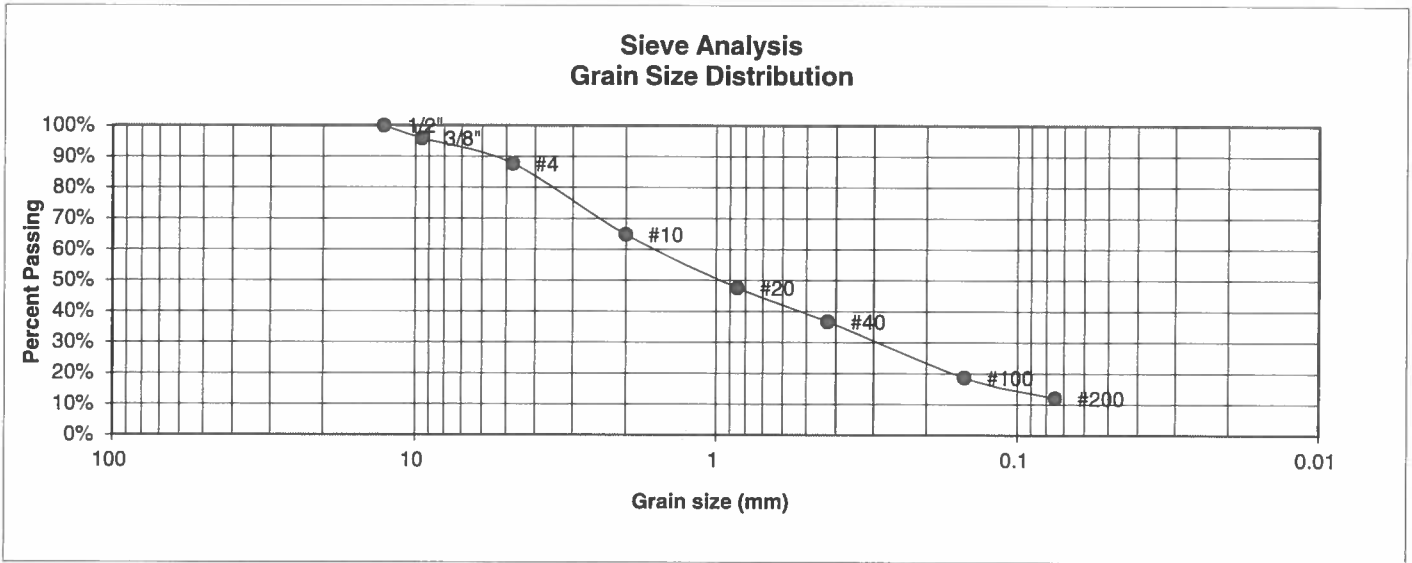

U.S. Sieve #	Percent Finer
3"	
1 1/2"	
3/4"	
1/2"	100.0%
3/8"	95.8%
4	87.7%
10	64.8%
20	47.7%
40	36.7%
100	18.7%
200	12.0%

Atterberg Limits

Plastic Limit	NP
Liquid Limit	NV
Plastic Index	NP

Swell

Moisture at start	
Moisture at finish	
Moisture increase	
Initial dry density (pcf)	
Swell (psf)	



**ENTECH
ENGINEERING, INC.**

505 ELKTON DRIVE
COLORADO SPRINGS, COLORADO 80907

**LABORATORY TEST
RESULTS**

DRAWN:	DATE:	CHECKED: LLL	DATE: 4/15/19
--------	-------	-----------------	------------------

JOB NO.:
181823

FIG NO.:

C-1

<u>UNIFIED CLASSIFICATION</u>	SM	<u>CLIENT</u>	WILLIAM GUMAN
<u>SOIL TYPE #</u>	1	<u>PROJECT</u>	CURTIS AND JUDGE ORR
<u>TEST BORING #</u>	2	<u>JOB NO.</u>	181823
<u>DEPTH (FT)</u>	5	<u>TEST BY</u>	BL

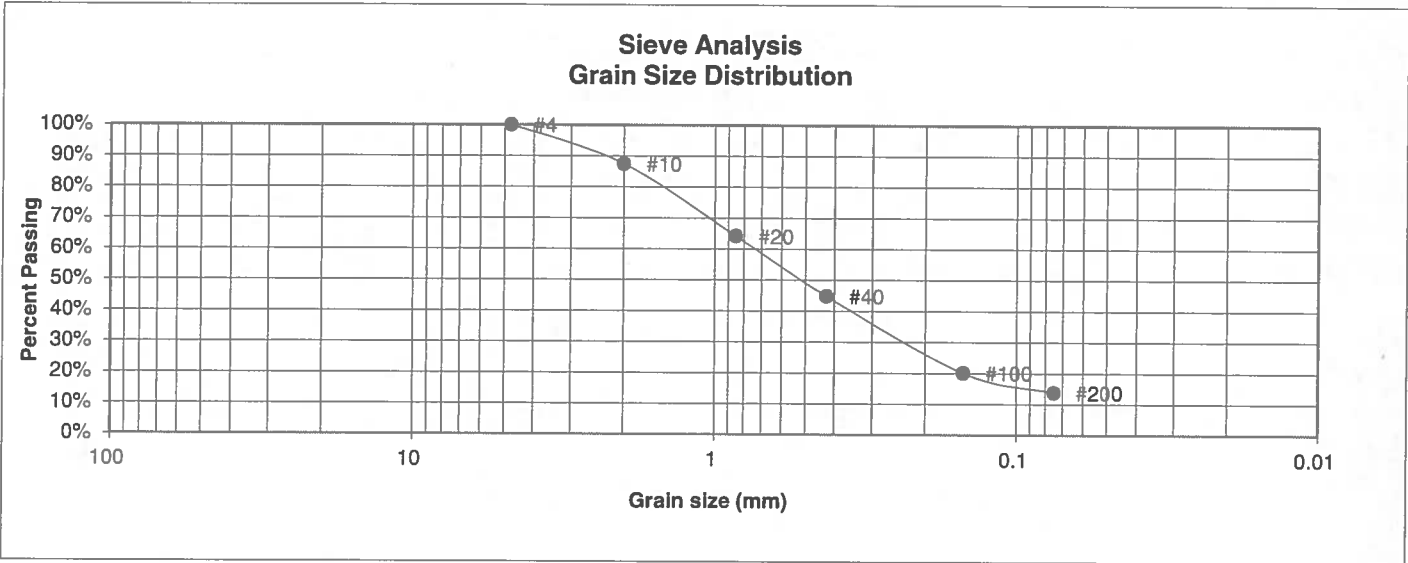

U.S. Sieve #	Percent Finer
3"	
1 1/2"	
3/4"	
1/2"	
3/8"	
4	100.0%
10	87.5%
20	64.2%
40	44.8%
100	20.1%
200	13.8%

Atterberg Limits
 Plastic Limit
 Liquid Limit
 Plastic Index

Swell
 Moisture at start
 Moisture at finish
 Moisture increase
 Initial dry density (pcf)
 Swell (psf)



**ENTECH
ENGINEERING, INC.**

505 ELKTON DRIVE
COLORADO SPRINGS, COLORADO 80907

**LABORATORY TEST
RESULTS**

DRAWN:	DATE:	CHECKED:	DATE:
		LLL	4/15/19

JOB NO.:
181823

FIG NO.:

C-2

<u>UNIFIED CLASSIFICATION</u>	SW	<u>CLIENT</u>	WILLIAM GUMAN
<u>SOIL TYPE #</u>	1	<u>PROJECT</u>	CURTIS AND JUDGE ORR
<u>TEST BORING #</u>	4	<u>JOB NO.</u>	181823
<u>DEPTH (FT)</u>	2-3	<u>TEST BY</u>	BL

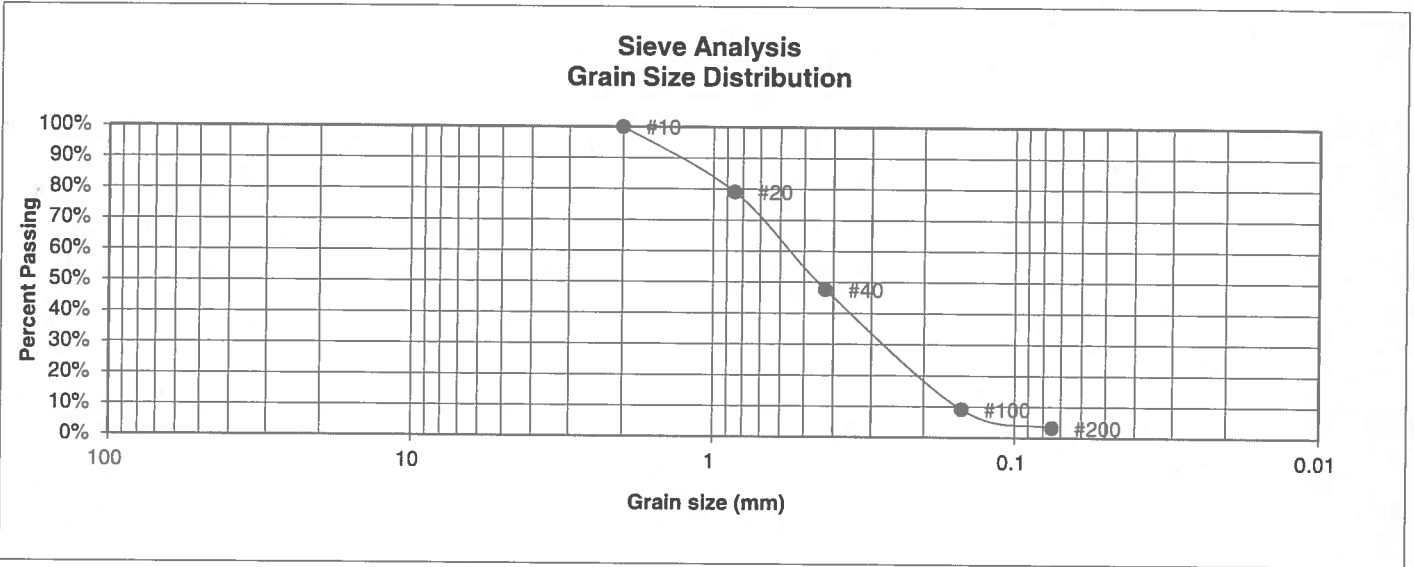

<u>U.S. Sieve #</u>	<u>Percent Finer</u>
3"	
1 1/2"	
3/4"	
1/2"	
3/8"	
4	
10	100.0%
20	79.1%
40	47.7%
100	9.1%
200	3.2%

Atterberg Limits
 Plastic Limit
 Liquid Limit
 Plastic Index

Swell
 Moisture at start
 Moisture at finish
 Moisture increase
 Initial dry density (pcf)
 Swell (psf)



**ENTECH
ENGINEERING, INC.**

505 ELKTON DRIVE
COLORADO SPRINGS, COLORADO 80907

**LABORATORY TEST
RESULTS**

<u>DRAWN:</u>	<u>DATE:</u>	<u>CHECKED:</u> LLL	<u>DATE:</u> 4/15/19
---------------	--------------	------------------------	-------------------------

JOB NO.:
181823

FIG NO.:
C-3

UNIFIED CLASSIFICATION	SM	CLIENT	WILLIAM GUMAN
SOIL TYPE #	3	PROJECT	CURTIS AND JUDGE ORR
TEST BORING #	3	JOB NO.	181823
DEPTH (FT)	10	TEST BY	BL

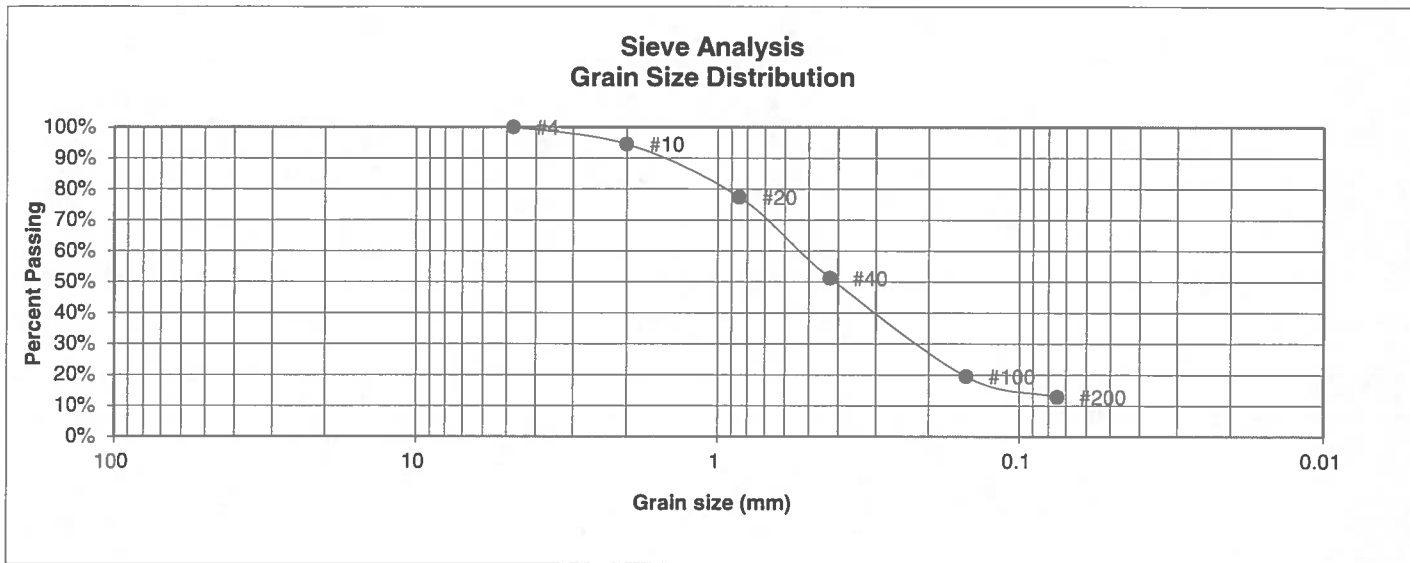

U.S. Sieve #	Percent Finer
3"	
1 1/2"	
3/4"	
1/2"	
3/8"	
4	100.0%
10	94.5%
20	77.4%
40	51.2%
100	19.5%
200	12.9%

Atterberg Limits

Plastic Limit	NP
Liquid Limit	NV
Plastic Index	NP

Swell

Moisture at start	
Moisture at finish	
Moisture increase	
Initial dry density (pcf)	
Swell (psf)	



**ENTECH
ENGINEERING, INC.**

505 ELKTON DRIVE
COLORADO SPRINGS, COLORADO 80907

**LABORATORY TEST
RESULTS**

DRAWN:	DATE:	CHECKED:	DATE:
		LL	4/15/19

JOB NO.:
181823

FIG NO.:

204

<u>UNIFIED CLASSIFICATION</u>	ML	<u>CLIENT</u>	WILLIAM GUMAN
<u>SOIL TYPE #</u>	3	<u>PROJECT</u>	CURTIS AND JUDGE ORR
<u>TEST BORING #</u>	4	<u>JOB NO.</u>	181823
<u>DEPTH (FT)</u>	20	<u>TEST BY</u>	BL

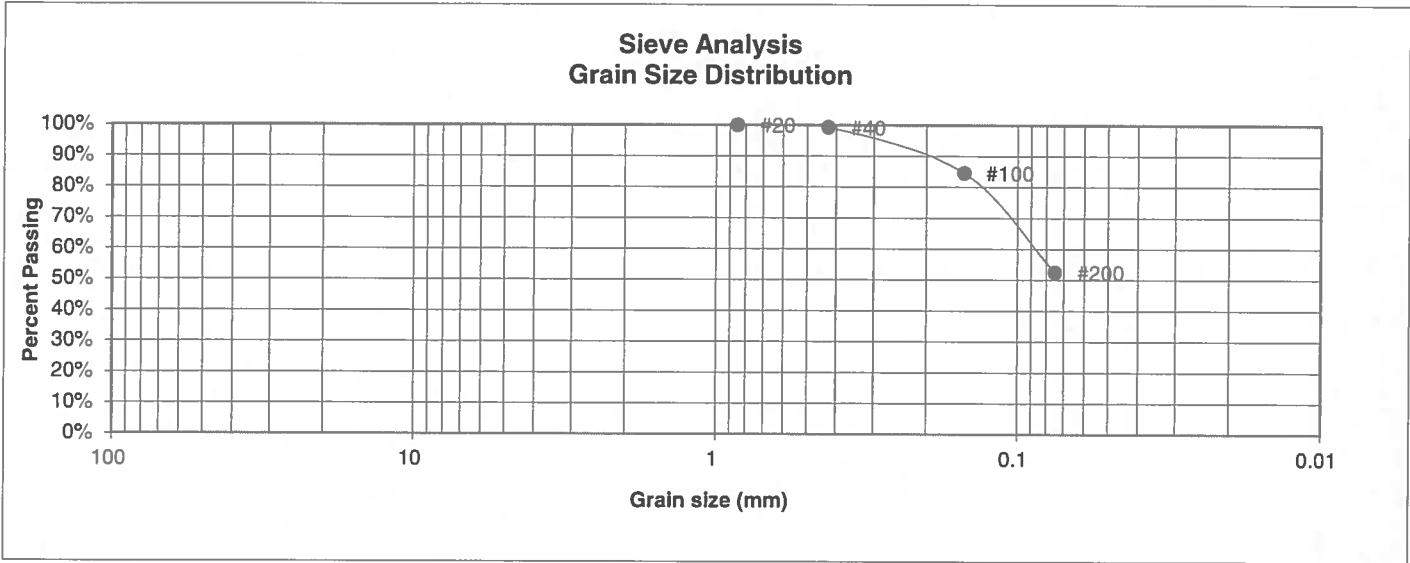

U.S. Sieve #	Percent Finer
3"	
1 1/2"	
3/4"	
1/2"	
3/8"	
4	
10	
20	100.0%
40	99.2%
100	84.5%
200	52.5%

<u>Atterberg Limits</u>	
Plastic Limit	NP
Liquid Limit	NV
Plastic Index	NP

<u>Swell</u>	
Moisture at start	
Moisture at finish	
Moisture increase	
Initial dry density (pcf)	
Swell (psf)	



**ENTECH
ENGINEERING, INC.**

505 ELKTON DRIVE
COLORADO SPRINGS, COLORADO 80907

**LABORATORY TEST
RESULTS**

DRAWN:	DATE:	CHECKED:	DATE:
		LLL	4/15/19

JOB NO.:
181823

FIG NO.:
6-5

UNIFIED CLASSIFICATION	SM-SW	CLIENT	GUMAN AND ASSOCIATES
SOIL TYPE #	1	PROJECT	CURTIS RD AND JUGRE ORR RD
TEST PIT #	2	JOB NO.	181823
DEPTH (FT)	2-3	TEST BY	BL

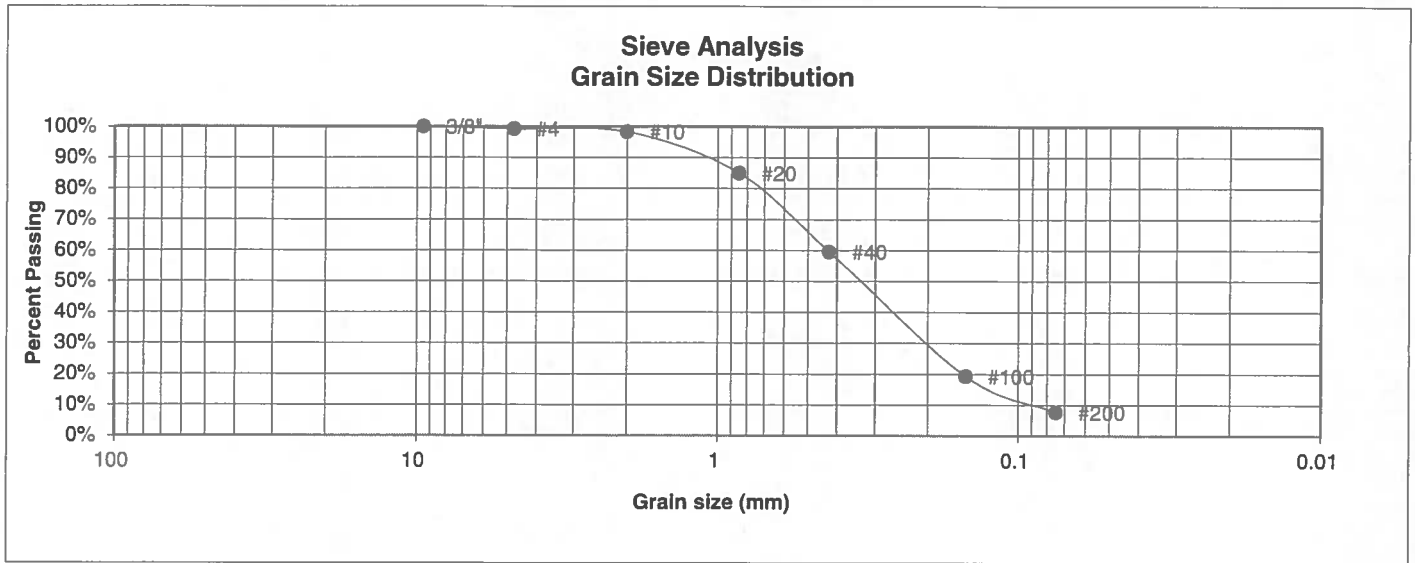

U.S. Sieve #	Percent Finer
3"	
1 1/2"	
3/4"	
1/2"	
3/8"	100.0%
4	99.3%
10	98.3%
20	85.0%
40	59.6%
100	19.3%
200	7.6%

Atterberg Limits
 Plastic Limit
 Liquid Limit
 Plastic Index

Swell
 Moisture at start
 Moisture at finish
 Moisture increase
 Initial dry density (pcf)
 Swell (psf)



**ENTECH
ENGINEERING, INC.**

505 ELKTON DRIVE
COLORADO SPRINGS, COLORADO 80907

**LABORATORY TEST
RESULTS**

DRAWN:	DATE:	CHECKED:	DATE:
		LLL	4/15/19

JOB NO.:
181823

FIG NO.:
L-6

<u>UNIFIED CLASSIFICATION</u>	SM-SW	<u>CLIENT</u>	GUMAN AND ASSOCIATES
<u>SOIL TYPE #</u>	1	<u>PROJECT</u>	CURTIS RD AND JUGRE ORR RD
<u>TEST PIT #</u>	3	<u>JOB NO.</u>	181823
<u>DEPTH (FT)</u>	5-6	<u>TEST BY</u>	BL

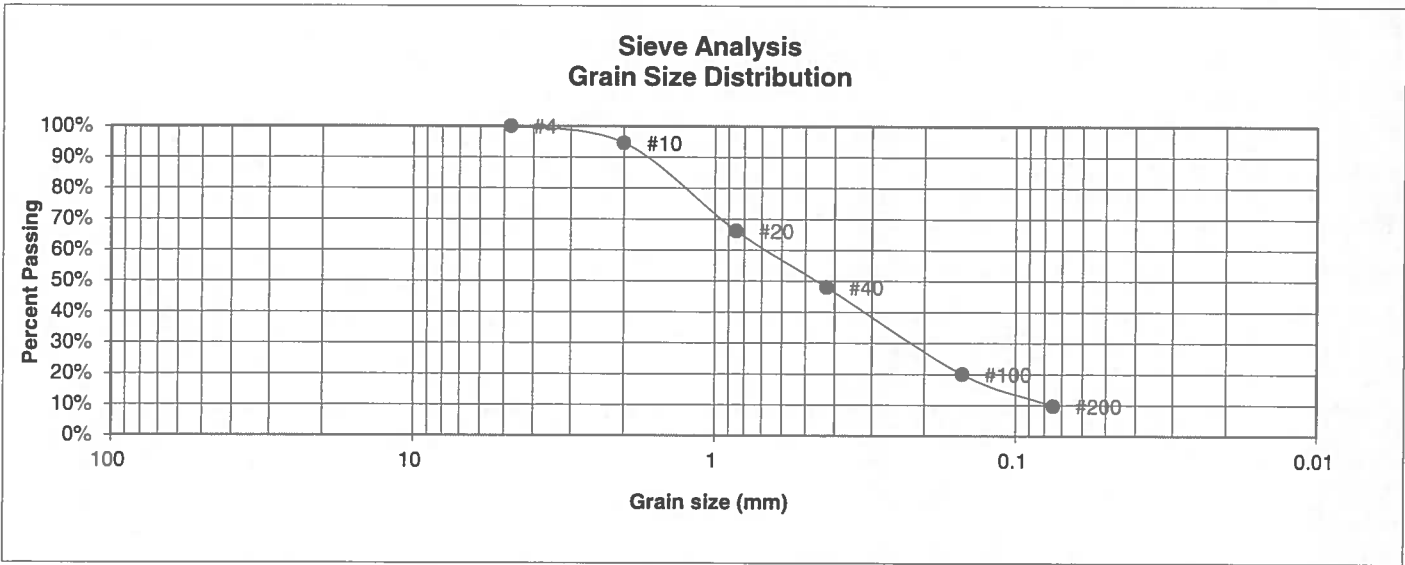

<u>U.S. Sieve #</u>	<u>Percent Finer</u>
3"	
1 1/2"	
3/4"	
1/2"	
3/8"	
4	100.0%
10	94.6%
20	66.2%
40	48.0%
100	20.0%
200	9.8%

Atterberg Limits
 Plastic Limit
 Liquid Limit
 Plastic Index

Swell
 Moisture at start
 Moisture at finish
 Moisture increase
 Initial dry density (pcf)
 Swell (psf)



**ENTECH
ENGINEERING, INC.**

505 ELKTON DRIVE
COLORADO SPRINGS, COLORADO 80907

**LABORATORY TEST
RESULTS**

<u>DRAWN:</u>	<u>DATE:</u>	<u>CHECKED:</u>	<u>DATE:</u>
		LLC	4/15/19

JOB NO.:
181823

FIG NO.:

C-7

UNIFIED CLASSIFICATION	SM-SW	CLIENT	GUMAN AND ASSOCIATES
SOIL TYPE #	1	PROJECT	CURTIS RD AND JUGRE ORR RD
TEST PIT #	6	JOB NO.	181823
DEPTH (FT)	4-6	TEST BY	BL

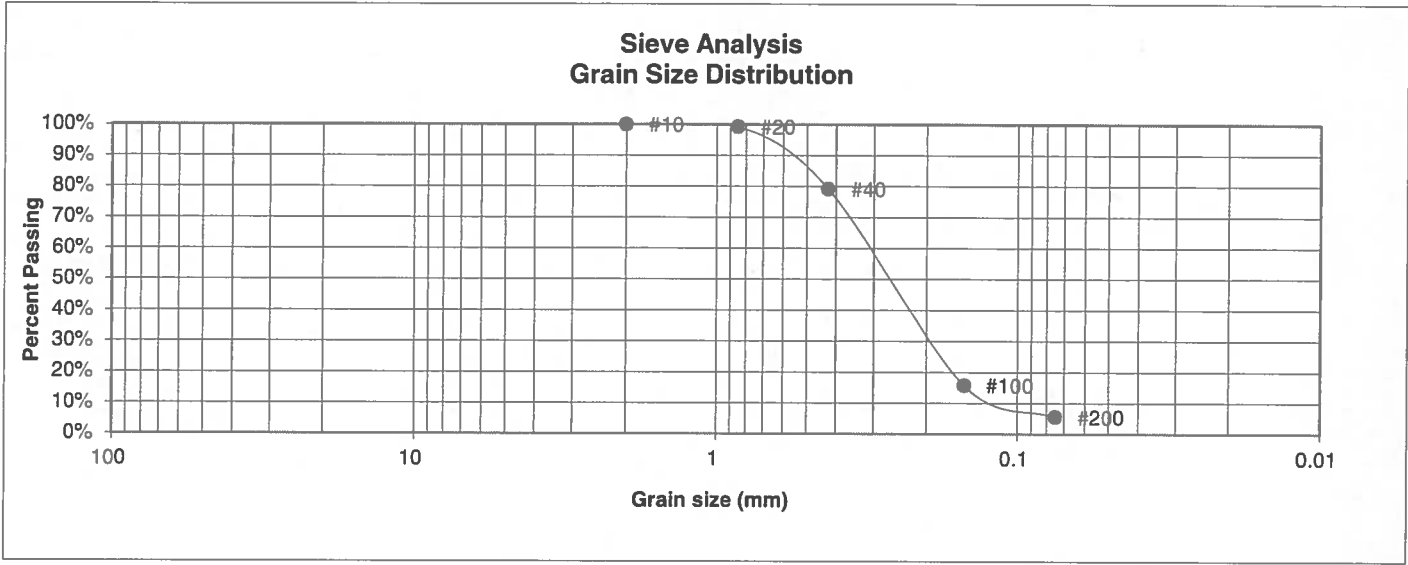

U.S. Sieve #	Percent Finer
3"	
1 1/2"	
3/4"	
1/2"	
3/8"	
4	
10	100.0%
20	99.3%
40	79.1%
100	15.7%
200	5.5%

Atterberg Limits
 Plastic Limit
 Liquid Limit
 Plastic Index

Swell
 Moisture at start
 Moisture at finish
 Moisture increase
 Initial dry density (pcf)
 Swell (psf)



**ENTECH
ENGINEERING, INC.**

505 ELKTON DRIVE
COLORADO SPRINGS, COLORADO 80907

**LABORATORY TEST
RESULTS**

DRAWN:	DATE:	CHECKED: LLL	DATE: 4/15/19
--------	-------	-----------------	------------------

JOB NO.:
181823

FIG NO.:
C-8

UNIFIED CLASSIFICATION	SC	CLIENT	GUMAN AND ASSOCIATES
SOIL TYPE #	1	PROJECT	CURTIS RD AND JUGRE ORR RD
TEST PIT #	9	JOB NO.	181823
DEPTH (FT)	2-3	TEST BY	BL

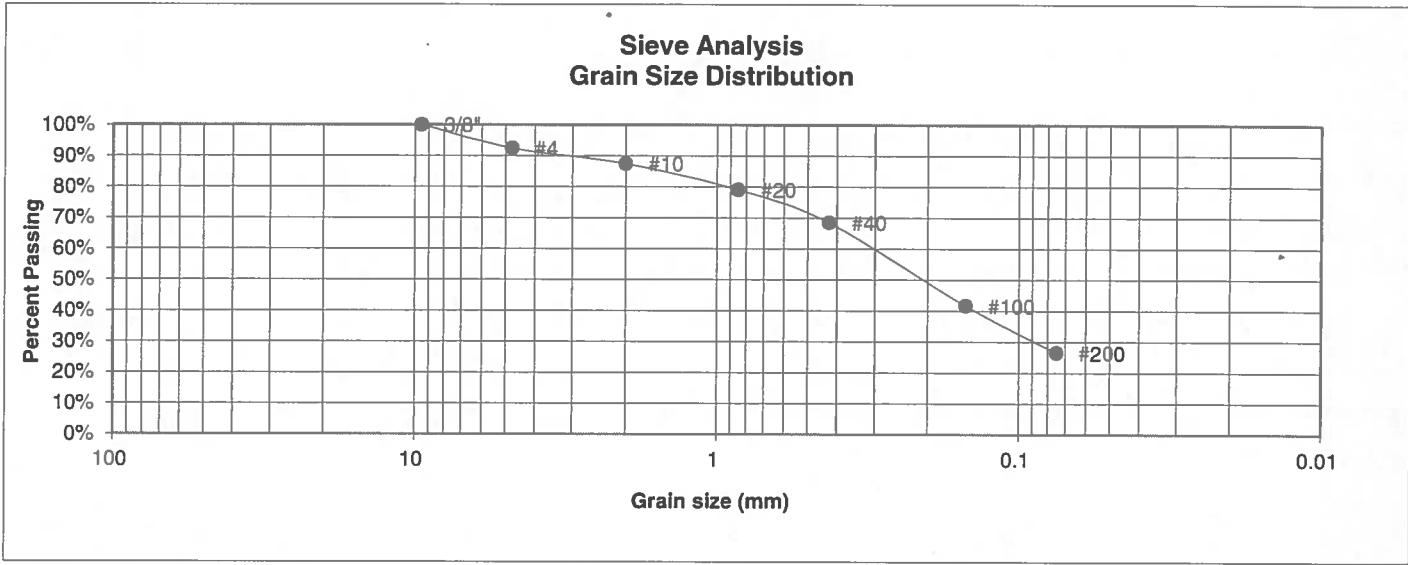

U.S. Sieve #	Percent Finer
3"	
1 1/2"	
3/4"	
1/2"	
3/8"	100.0%
4	92.4%
10	87.4%
20	79.0%
40	68.4%
100	41.7%
200	26.5%

Atterberg Limits	
Plastic Limit	15
Liquid Limit	24
Plastic Index	9

- Swell
- Moisture at start
 - Moisture at finish
 - Moisture increase
 - Initial dry density (pcf)
 - Swell (psf)



**ENTECH
ENGINEERING, INC.**
505 ELKTON DRIVE
COLORADO SPRINGS, COLORADO 80907

**LABORATORY TEST
RESULTS**

DRAWN:	DATE:	CHECKED: LLL	DATE: 4/15/19
--------	-------	-----------------	------------------

JOB NO.:
181823

FIG NO.:
C-9

UNIFIED CLASSIFICATION	SM-SW	CLIENT	GUMAN AND ASSOCIATES
SOIL TYPE #	1	PROJECT	CURTIS RD AND JUGRE ORR RD
TEST PIT #	12	JOB NO.	181823
DEPTH (FT)	2-3	TEST BY	BL

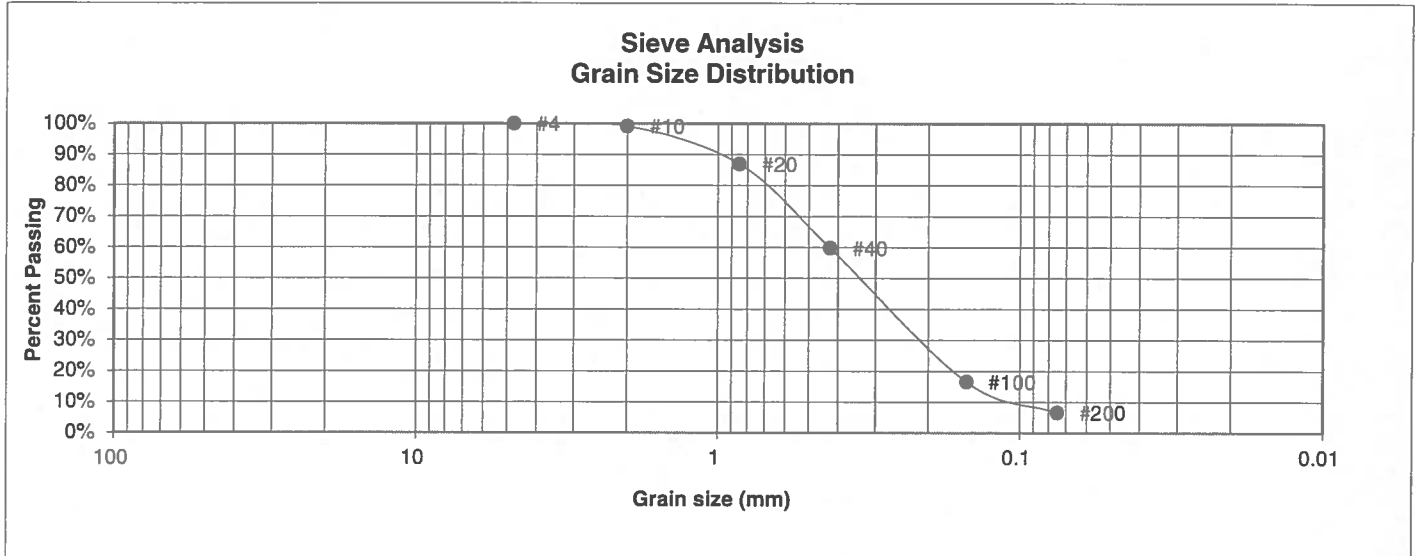

U.S. Sieve #	Percent Finer
3"	
1 1/2"	
3/4"	
1/2"	
3/8"	
4	100.0%
10	99.2%
20	86.9%
40	59.8%
100	16.5%
200	6.6%

Atterberg Limits
 Plastic Limit
 Liquid Limit
 Plastic Index

Swell
 Moisture at start
 Moisture at finish
 Moisture increase
 Initial dry density (pcf)
 Swell (psf)



ENTECH ENGINEERING, INC.
 505 ELKTON DRIVE
 COLORADO SPRINGS, COLORADO 80907

LABORATORY TEST RESULTS

DRAWN:	DATE:	CHECKED: <i>LLL</i>	DATE: <i>4/15/19</i>
--------	-------	---------------------	----------------------

JOB NO.:
181823

FIG NO.:
C-10

<u>UNIFIED CLASSIFICATION</u>	SC	<u>CLIENT</u>	GUMAN AND ASSOCIATES
<u>SOIL TYPE #</u>	1	<u>PROJECT</u>	CURTIS RD AND JUGRE ORR RD
<u>TEST PIT #</u>	13	<u>JOB NO.</u>	181823
<u>DEPTH (FT)</u>	5-6	<u>TEST BY</u>	BL

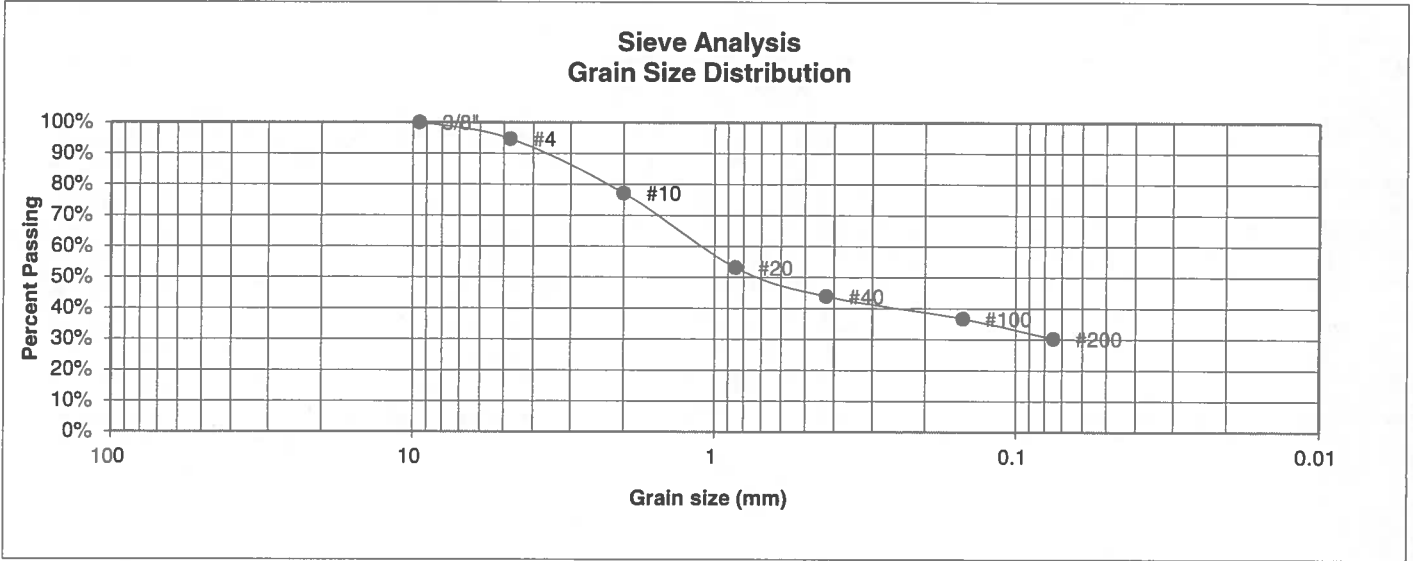

<u>U.S. Sieve #</u>	<u>Percent Finer</u>
3"	
1 1/2"	
3/4"	
1/2"	
3/8"	100.0%
4	94.7%
10	77.2%
20	53.2%
40	43.9%
100	36.7%
200	30.3%

<u>Atterberg Limits</u>	
Plastic Limit	14
Liquid Limit	25
Plastic Index	11

<u>Swell</u>	
Moisture at start	
Moisture at finish	
Moisture increase	
Initial dry density (pcf)	
Swell (psf)	



**ENTECH
ENGINEERING, INC.**

505 ELKTON DRIVE
COLORADO SPRINGS, COLORADO 80907

**LABORATORY TEST
RESULTS**

<u>DRAWN:</u>	<u>DATE:</u>	<u>CHECKED:</u> LLL	<u>DATE:</u> 4/15/19
---------------	--------------	------------------------	-------------------------

JOB NO.:
181823

FIG NO.:
C-11

UNIFIED CLASSIFICATION	SC	CLIENT	GUMAN AND ASSOCIATES
SOIL TYPE #	1	PROJECT	CURTIS RD AND JUGRE ORR RD
TEST PIT #	15	JOB NO.	181823
DEPTH (FT)	2-3	TEST BY	BL

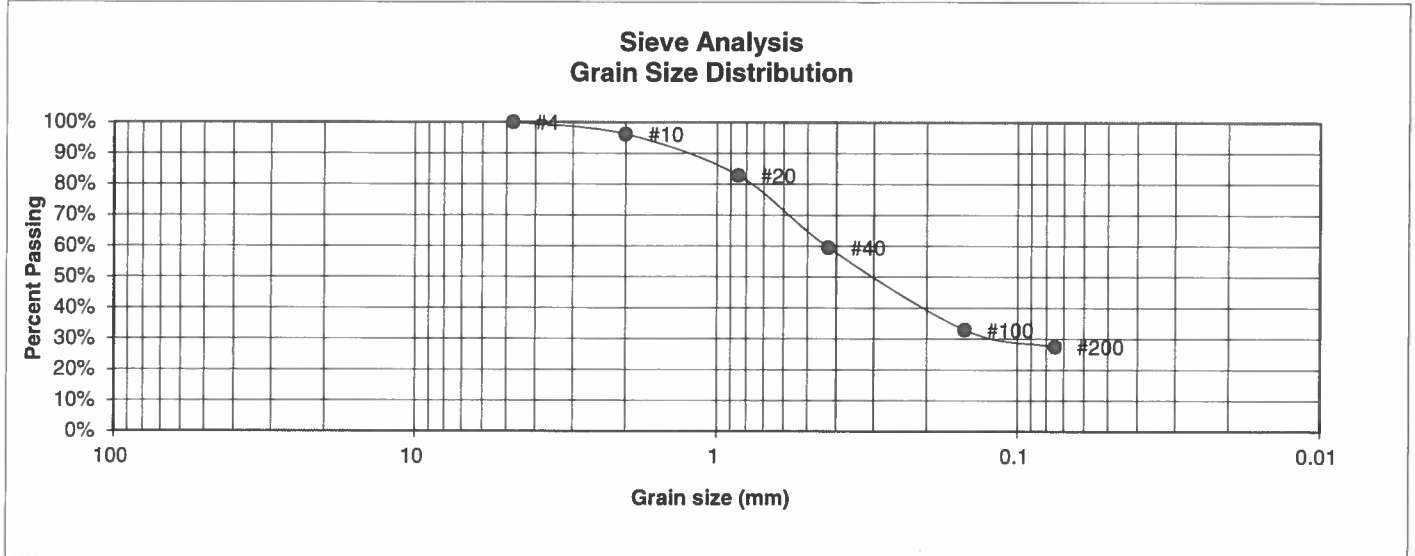

U.S. Sieve #	Percent Finer
3"	
1 1/2"	
3/4"	
1/2"	
3/8"	
4	100.0%
10	96.2%
20	82.8%
40	59.6%
100	32.9%
200	27.5%

Atterberg Limits
 Plastic Limit
 Liquid Limit
 Plastic Index

<u>Swell</u>	
Moisture at start	9.2%
Moisture at finish	15.5%
Moisture increase	6.3%
Initial dry density (pcf)	112
Swell (psf)	820



**ENTECH
ENGINEERING, INC.**

505 ELKTON DRIVE
COLORADO SPRINGS, COLORADO 80907

**LABORATORY TEST
RESULTS**

DRAWN:	DATE:	CHECKED: <i>LL</i>	DATE: 4/15/19
--------	-------	-----------------------	------------------

JOB NO.:
181823

FIG NO.:
C-12

<u>UNIFIED CLASSIFICATION</u>	SW	<u>CLIENT</u>	GUMAN AND ASSOCIATES
<u>SOIL TYPE #</u>	1	<u>PROJECT</u>	CURTIS RD AND JUGRE ORR RD
<u>TEST PIT #</u>	18	<u>JOB NO.</u>	181823
<u>DEPTH (FT)</u>	5-6	<u>TEST BY</u>	BL

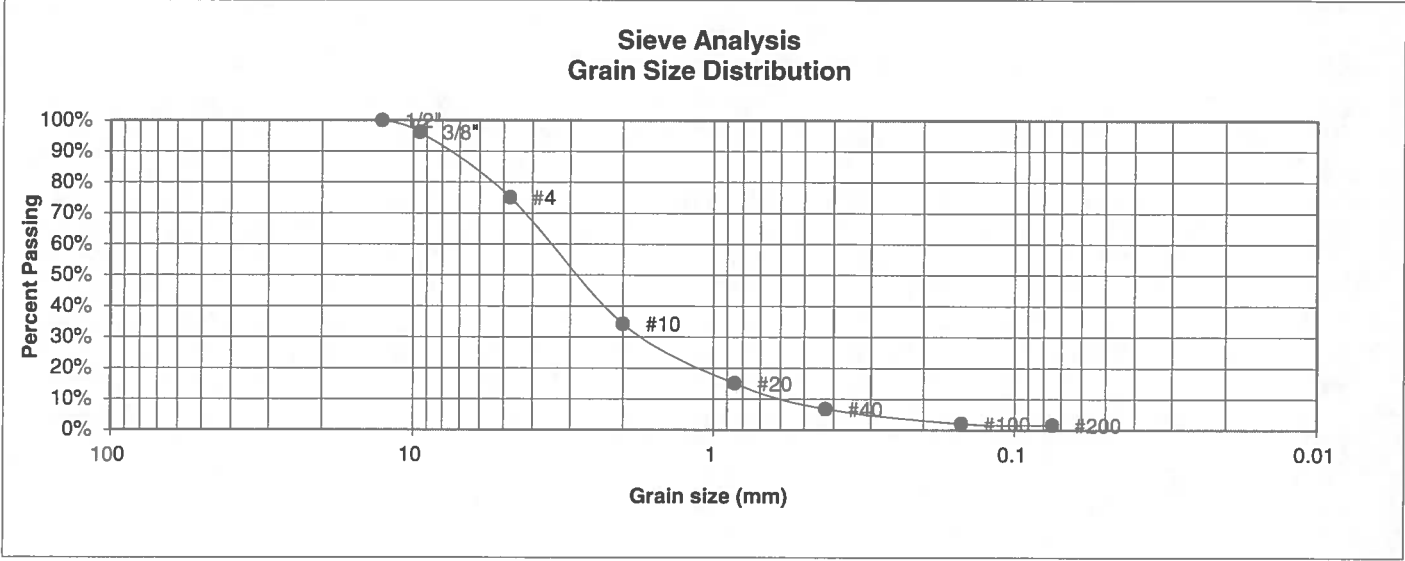

<u>U.S. Sieve #</u>	<u>Percent Finer</u>
3"	
1 1/2"	
3/4"	
1/2"	100.0%
3/8"	96.2%
4	75.1%
10	34.2%
20	15.1%
40	6.8%
100	2.1%
200	1.6%

- Atterberg Limits
 Plastic Limit
 Liquid Limit
 Plastic Index
- Swell
 Moisture at start
 Moisture at finish
 Moisture increase
 Initial dry density (pcf)
 Swell (psf)



ENTECH ENGINEERING, INC.
 505 ELKTON DRIVE
 COLORADO SPRINGS, COLORADO 80907

LABORATORY TEST RESULTS

DRAWN:	DATE:	CHECKED: <i>LL</i>	DATE: <i>4/15/19</i>
--------	-------	--------------------	----------------------

JOB NO.:
181823

FIG NO.:
C-13

UNIFIED CLASSIFICATION	SC	CLIENT	GUMAN AND ASSOCIATES
SOIL TYPE #	1	PROJECT	CURTIS RD AND JUGRE ORR RD
TEST PIT #	21	JOB NO.	181823
DEPTH (FT)	5-6	TEST BY	BL

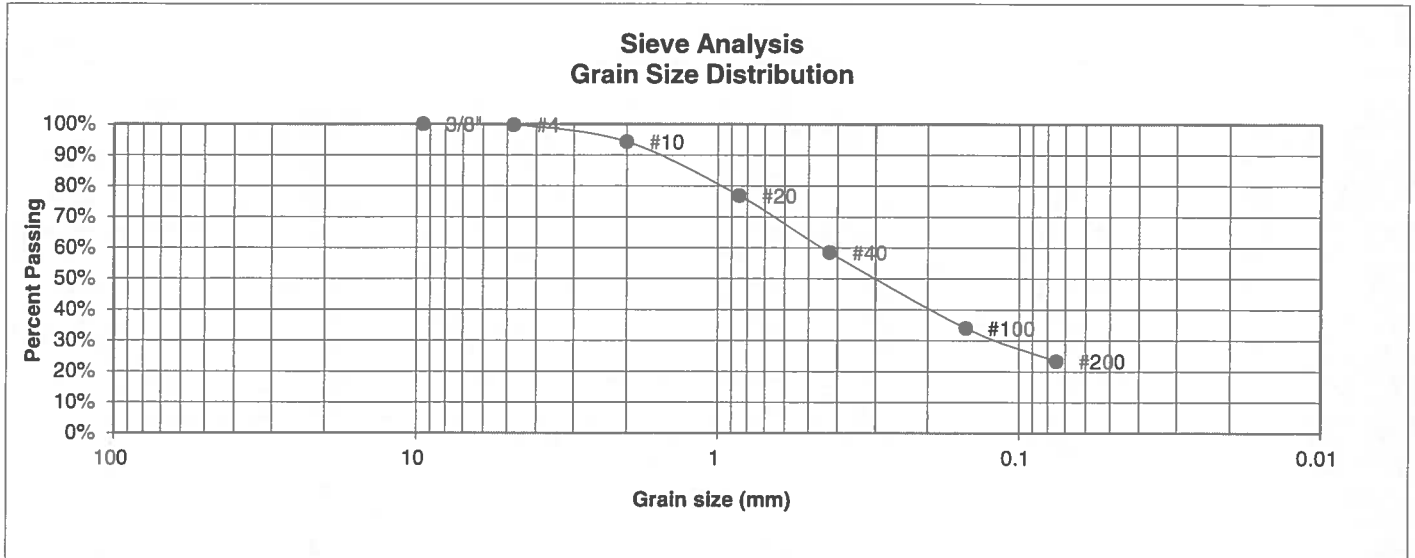

U.S. Sieve #	Percent Finer
3"	
1 1/2"	
3/4"	
1/2"	
3/8"	100.0%
4	99.8%
10	94.3%
20	76.9%
40	58.5%
100	34.1%
200	23.4%

Atterberg Limits
 Plastic Limit
 Liquid Limit
 Plastic Index

Swell
 Moisture at start
 Moisture at finish
 Moisture increase
 Initial dry density (pcf)
 Swell (psf)



**ENTECH
ENGINEERING, INC.**

505 ELKTON DRIVE
COLORADO SPRINGS, COLORADO 80907

**LABORATORY TEST
RESULTS**

DRAWN:

DATE:

CHECKED:
LLL

DATE:
4/15/19

JOB NO.:
181823

FIG NO.:

C-14

UNIFIED CLASSIFICATION	SM	CLIENT	GUMAN AND ASSOCIATES
SOIL TYPE #	1	PROJECT	CURTIS RD AND JUGRE ORR RD
TEST PIT #	37	JOB NO.	181823
DEPTH (FT)	6-7	TEST BY	BL

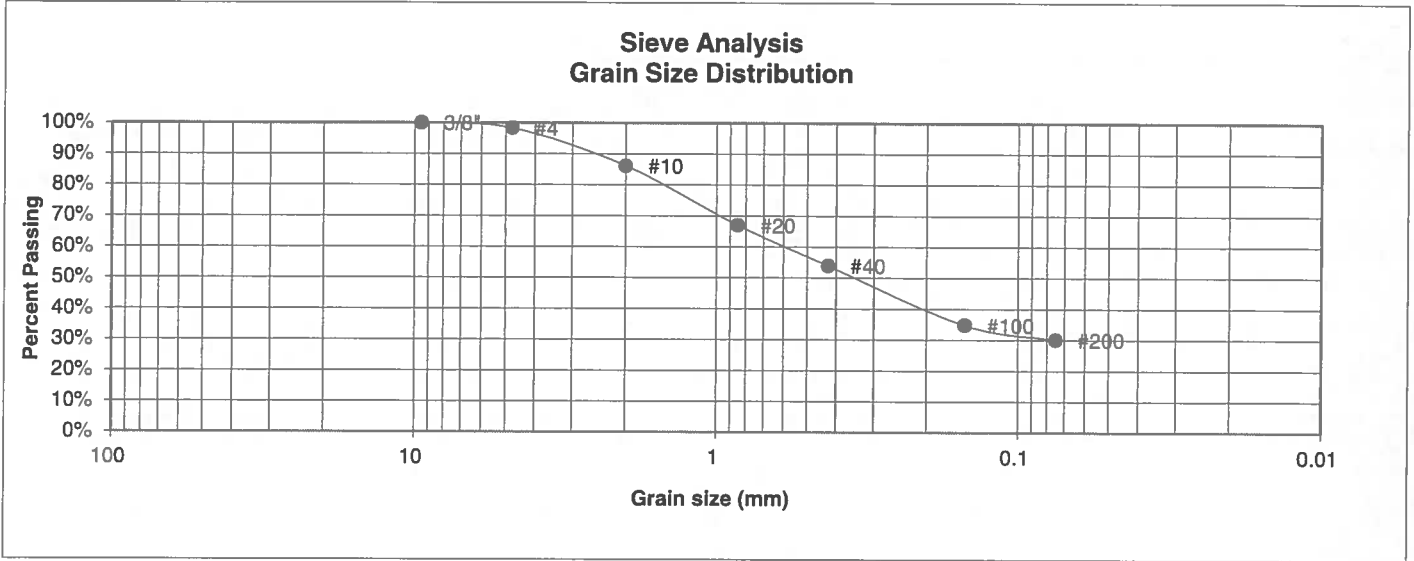

U.S. Sieve #	Percent Finer
3"	
1 1/2"	
3/4"	
1/2"	
3/8"	100.0%
4	98.3%
10	86.2%
20	67.0%
40	53.9%
100	34.8%
200	30.1%

Atterberg Limits	
Plastic Limit	16
Liquid Limit	19
Plastic Index	3

Swell	
Moisture at start	6.5%
Moisture at finish	20.5%
Moisture increase	14.0%
Initial dry density (pcf)	100
Swell (psf)	430



**ENTECH
ENGINEERING, INC.**

505 ELKTON DRIVE
COLORADO SPRINGS, COLORADO 80907

**LABORATORY TEST
RESULTS**

DRAWN:	DATE:	CHECKED: LLL	DATE: 4/15/19
--------	-------	-----------------	------------------

JOB NO.:
181823

FIG NO.:
C-15

<u>UNIFIED CLASSIFICATION</u>	SM	<u>CLIENT</u>	GUMAN AND ASSOCIATES
<u>SOIL TYPE #</u>	1	<u>PROJECT</u>	CURTIS RD AND JUGRE ORR RD
<u>TEST PIT #</u>	31	<u>JOB NO.</u>	181823
<u>DEPTH (FT)</u>	2-3	<u>TEST BY</u>	BL

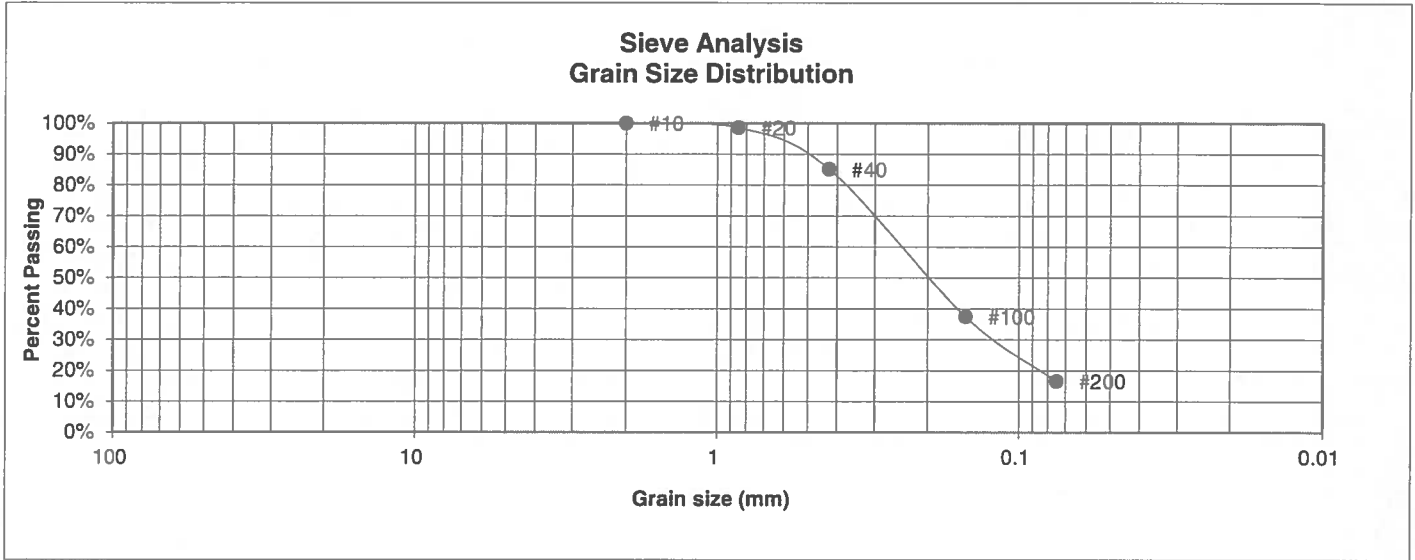

<u>U.S. Sieve #</u>	<u>Percent Finer</u>
3"	
1 1/2"	
3/4"	
1/2"	
3/8"	
4	
10	100.0%
20	98.6%
40	85.1%
100	37.4%
200	16.6%

Atterberg Limits
 Plastic Limit
 Liquid Limit
 Plastic Index

Swell
 Moisture at start
 Moisture at finish
 Moisture increase
 Initial dry density (pcf)
 Swell (psf)



**ENTECH
ENGINEERING, INC.**

505 ELKTON DRIVE
COLORADO SPRINGS, COLORADO 80907

**LABORATORY TEST
RESULTS**

<u>DRAWN:</u>	<u>DATE:</u>	<u>CHECKED:</u> LL	<u>DATE:</u> 4/15/19
---------------	--------------	-----------------------	-------------------------

JOB NO.:
181823

FIG NO.:
C-16

<u>UNIFIED CLASSIFICATION</u>	SC	<u>CLIENT</u>	GUMAN AND ASSOCIATES
<u>SOIL TYPE #</u>	1	<u>PROJECT</u>	CURTIS RD AND JUGRE ORR RD
<u>TEST PIT #</u>	32	<u>JOB NO.</u>	181823
<u>DEPTH (FT)</u>	4-5	<u>TEST BY</u>	BL

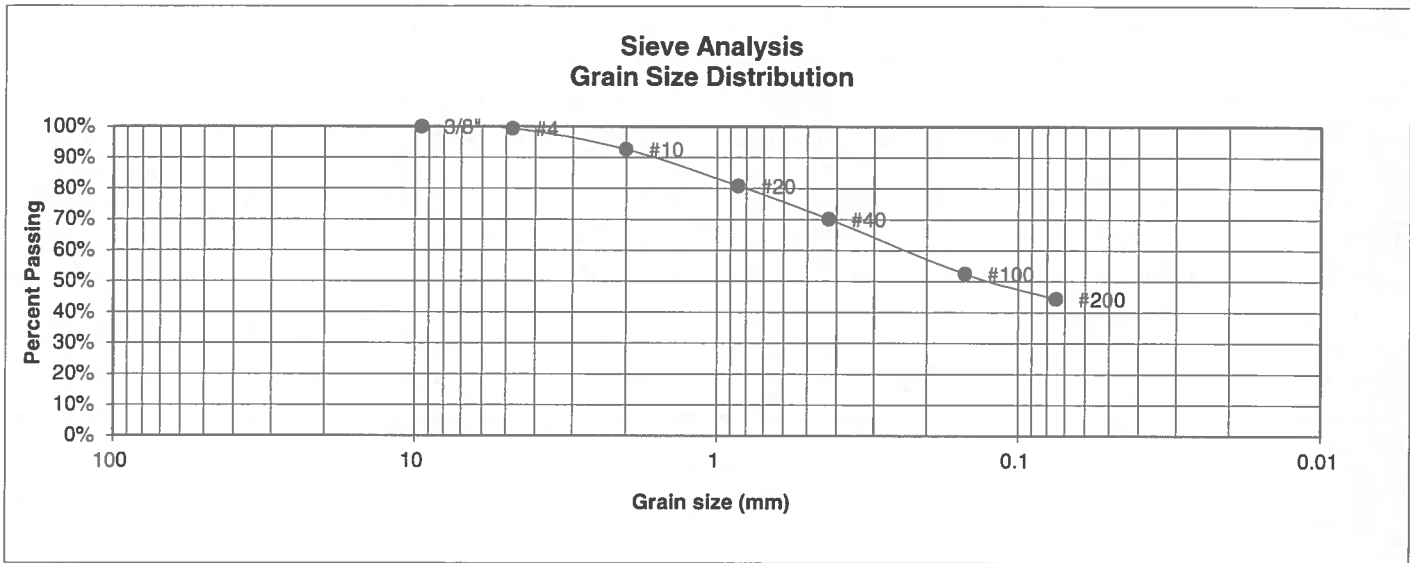

<u>U.S. Sieve #</u>	<u>Percent Finer</u>
3"	
1 1/2"	
3/4"	
1/2"	
3/8"	100.0%
4	99.4%
10	92.6%
20	80.8%
40	70.2%
100	52.5%
200	44.3%

Atterberg Limits
 Plastic Limit
 Liquid Limit
 Plastic Index

Swell
 Moisture at start
 Moisture at finish
 Moisture increase
 Initial dry density (pcf)
 Swell (psf)



**ENTECH
ENGINEERING, INC.**

505 ELKTON DRIVE
COLORADO SPRINGS, COLORADO 80907

**LABORATORY TEST
RESULTS**

DRAWN:

DATE:

CHECKED:
LLL

DATE:
4/15/19

JOB NO.:
181823

FIG NO.:

C-17

<u>UNIFIED CLASSIFICATION</u>	SW	<u>CLIENT</u>	GUMAN AND ASSOCIATES
<u>SOIL TYPE #</u>	1	<u>PROJECT</u>	CURTIS RD AND JUGRE ORR RD
<u>TEST PIT #</u>	33	<u>JOB NO.</u>	181823
<u>DEPTH (FT)</u>	2-3	<u>TEST BY</u>	BL

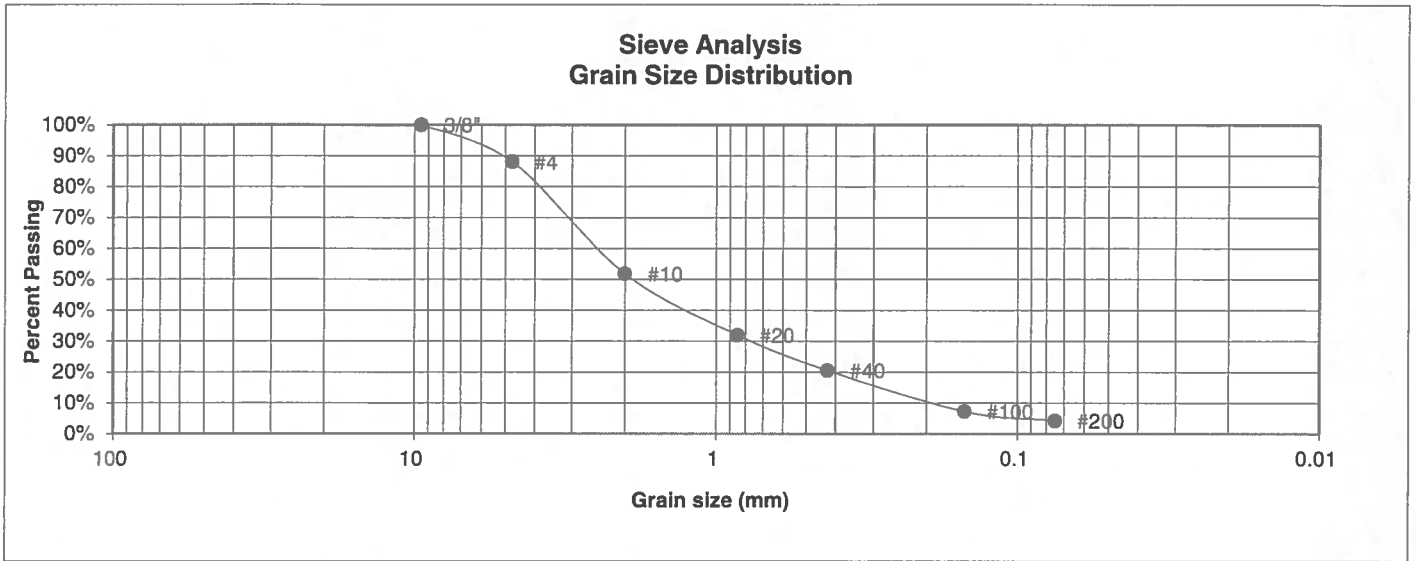

U.S. Sieve #	Percent Finer
3"	
1 1/2"	
3/4"	
1/2"	
3/8"	100.0%
4	88.0%
10	51.8%
20	32.0%
40	20.5%
100	7.2%
200	4.3%

Atterberg Limits
 Plastic Limit
 Liquid Limit
 Plastic Index

Swell
 Moisture at start
 Moisture at finish
 Moisture increase
 Initial dry density (pcf)
 Swell (psf)



**ENTECH
ENGINEERING, INC.**

505 ELKTON DRIVE
COLORADO SPRINGS, COLORADO 80907

**LABORATORY TEST
RESULTS**

DRAWN:	DATE:	CHECKED: LLL	DATE: 4/15/19
--------	-------	-----------------	------------------

JOB NO.:
181823

FIG NO.:
C-18

UNIFIED CLASSIFICATION	SW	CLIENT	GUMAN AND ASSOCIATES
SOIL TYPE #	1	PROJECT	CURTIS RD AND JUGRE ORR RD
TEST PIT #	35	JOB NO.	181823
DEPTH (FT)	5-6	TEST BY	BL

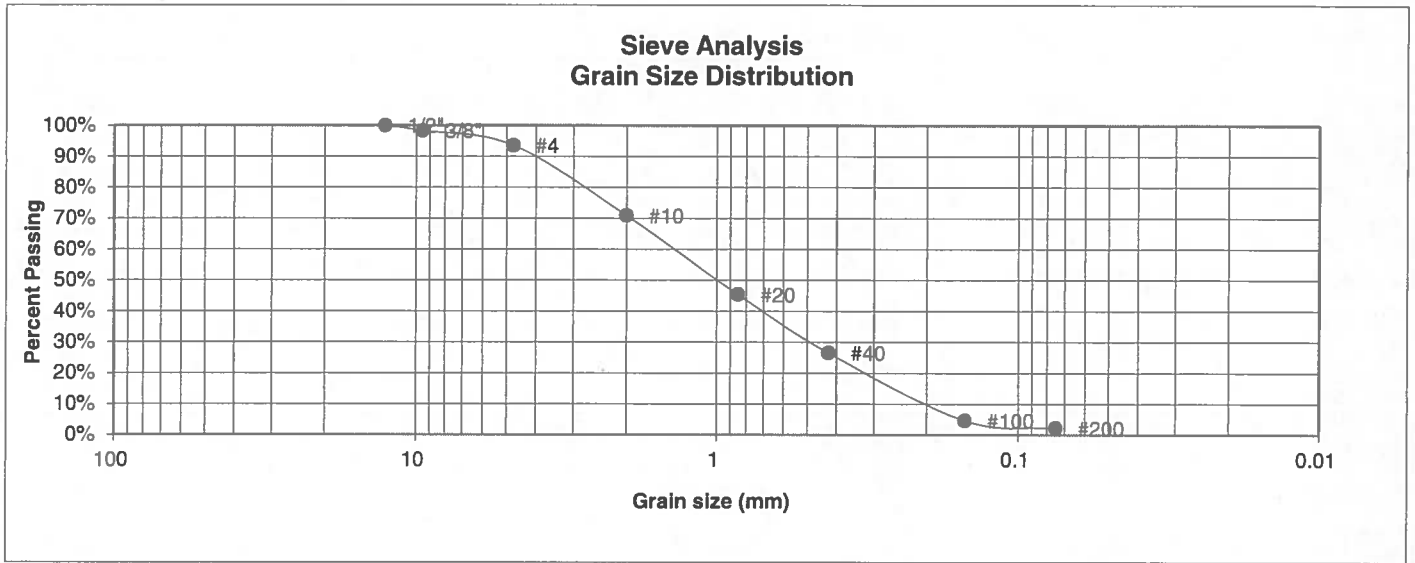

U.S. Sieve #	Percent Finer
3"	
1 1/2"	
3/4"	
1/2"	100.0%
3/8"	98.3%
4	93.6%
10	70.9%
20	45.4%
40	26.5%
100	4.7%
200	2.2%

Atterberg Limits
 Plastic Limit
 Liquid Limit
 Plastic Index

Swell
 Moisture at start
 Moisture at finish
 Moisture increase
 Initial dry density (pcf)
 Swell (psf)



**ENTECH
ENGINEERING, INC.**

505 ELKTON DRIVE
COLORADO SPRINGS, COLORADO 80907

**LABORATORY TEST
RESULTS**

DRAWN:	DATE:	CHECKED: LLL	DATE: 9/15/19
--------	-------	-----------------	------------------

JOB NO.:
181823

FIG NO.:

C-19

<u>UNIFIED CLASSIFICATION</u>	SM-SW	<u>CLIENT</u>	GUMAN AND ASSOCIATES
<u>SOIL TYPE #</u>	1	<u>PROJECT</u>	CURTIS RD AND JUGRE ORR RD
<u>TEST PIT #</u>	36	<u>JOB NO.</u>	181823
<u>DEPTH (FT)</u>	2-3	<u>TEST BY</u>	BL

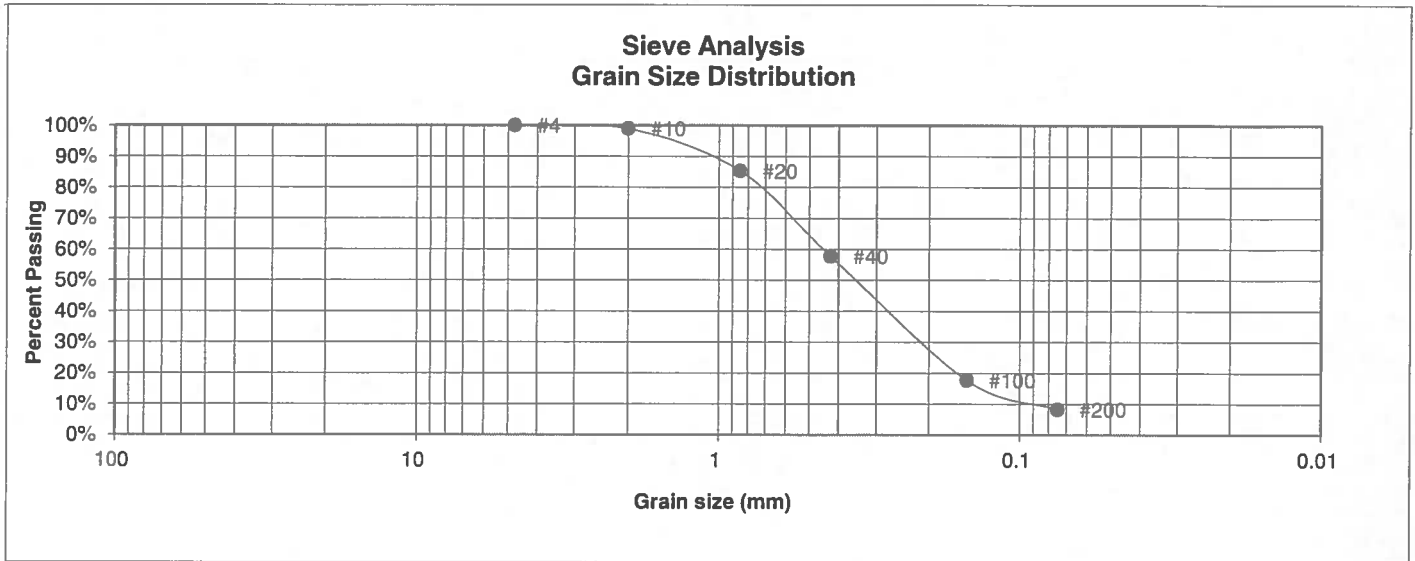

<u>U.S. Sieve #</u>	<u>Percent Finer</u>
3"	
1 1/2"	
3/4"	
1/2"	
3/8"	
4	100.0%
10	98.9%
20	85.3%
40	57.8%
100	17.7%
200	8.2%

Atterberg
Limits
Plastic Limit
Liquid Limit
Plastic Index

Swell
Moisture at start
Moisture at finish
Moisture increase
Initial dry density (pcf)
Swell (psf)



**ENTECH
ENGINEERING, INC.**

505 ELKTON DRIVE
COLORADO SPRINGS, COLORADO 80907

**LABORATORY TEST
RESULTS**

<u>DRAWN:</u>	<u>DATE:</u>	<u>CHECKED:</u> LLL	<u>DATE:</u> 4/15/19
---------------	--------------	------------------------	-------------------------

JOB NO.:
181823

FIG NO.:
C-20

UNIFIED CLASSIFICATION	SM-SW	CLIENT	GUMAN AND ASSOCIATES
SOIL TYPE #	1	PROJECT	CURTIS RD AND JUGRE ORR RD
TEST PIT #	36	JOB NO.	181823
DEPTH (FT)	2-3	TEST BY	BL

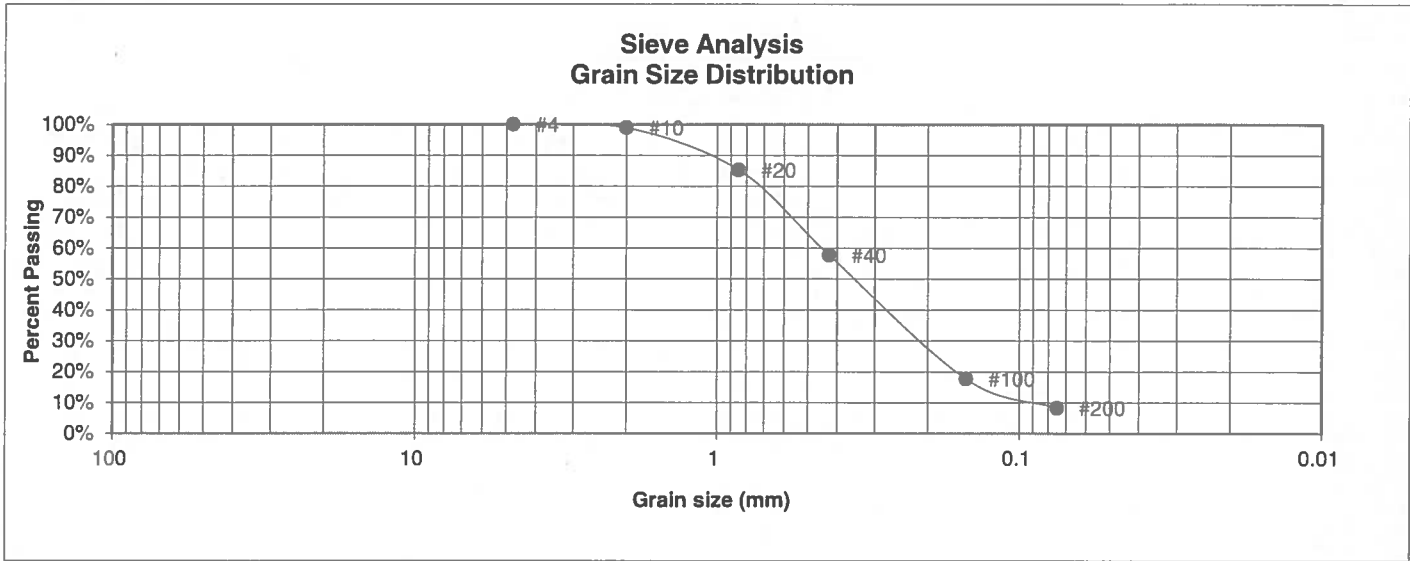

U.S. Sieve #	Percent Finer
3"	
1 1/2"	
3/4"	
1/2"	
3/8"	
4	100.0%
10	98.9%
20	85.3%
40	57.8%
100	17.7%
200	8.2%

Atterberg Limits
 Plastic Limit
 Liquid Limit
 Plastic Index

Swell
 Moisture at start
 Moisture at finish
 Moisture increase
 Initial dry density (pcf)
 Swell (psf)



**ENTECH
ENGINEERING, INC.**

505 ELKTON DRIVE
COLORADO SPRINGS, COLORADO 80907

**LABORATORY TEST
RESULTS**

DRAWN:	DATE:	CHECKED: LLL	DATE: 4/15/19
--------	-------	-----------------	------------------

JOB NO.:
181823

FIG NO.:
C-21

UNIFIED CLASSIFICATION	SM	CLIENT	GUMAN AND ASSOCIATES
SOIL TYPE #	1	PROJECT	CURTIS RD AND JUGRE ORR RD
TEST PIT #	39	JOB NO.	181823
DEPTH (FT)	5-6	TEST BY	BL

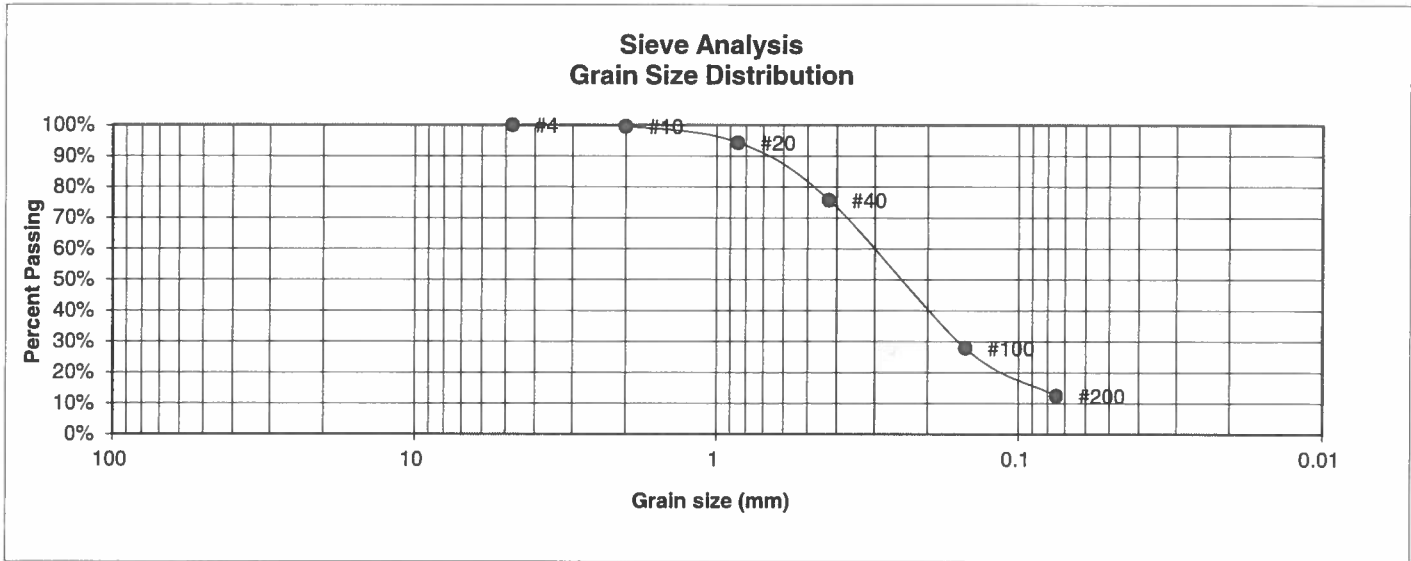

U.S. Sieve #	Percent Finer
3"	
1 1/2"	
3/4"	
1/2"	
3/8"	
4	100.0%
10	99.6%
20	94.3%
40	75.8%
100	27.9%
200	12.4%

Atterberg Limits
 Plastic Limit
 Liquid Limit
 Plastic Index

Swell
 Moisture at start
 Moisture at finish
 Moisture increase
 Initial dry density (pcf)
 Swell (psf)



**ENTECH
ENGINEERING, INC.**

505 ELKTON DRIVE
COLORADO SPRINGS, COLORADO 80907

**LABORATORY TEST
RESULTS**

DRAWN:	DATE:	CHECKED: LLL	DATE: 4/15/19
--------	-------	-----------------	------------------

JOB NO.:
181823

FIG NO.:
C-22

UNIFIED CLASSIFICATION	CL	CLIENT	GUMAN AND ASSOCIATES
SOIL TYPE #	2	PROJECT	CURTIS RD AND JUGRE ORR RD
TEST PIT #	1	JOB NO.	181823
DEPTH (FT)	7-8	TEST BY	BL

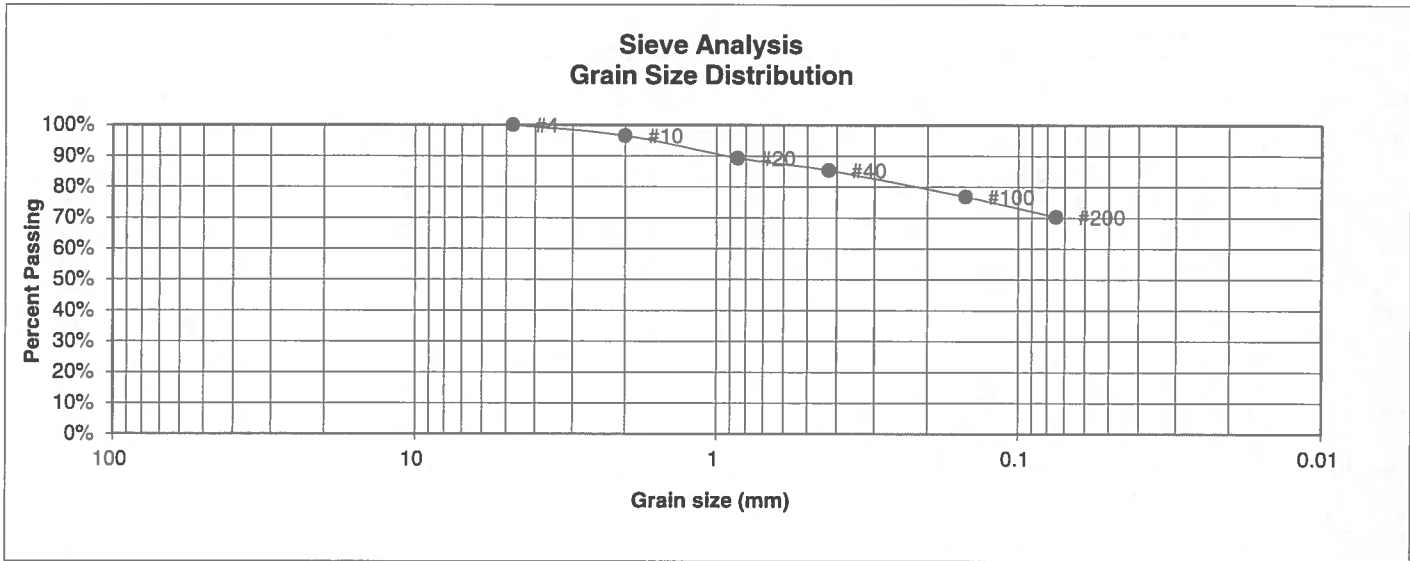

U.S. Sieve #	Percent Finer
3"	
1 1/2"	
3/4"	
1/2"	
3/8"	
4	100.0%
10	96.6%
20	89.3%
40	85.4%
100	76.9%
200	70.3%

Atterberg Limits	
Plastic Limit	18
Liquid Limit	49
Plastic Index	31

Swell	
Moisture at start	11.4%
Moisture at finish	19.8%
Moisture increase	8.4%
Initial dry density (pcf)	99
Swell (psf)	1360



**ENTECH
ENGINEERING, INC.**

505 ELKTON DRIVE
COLORADO SPRINGS, COLORADO 80907

**LABORATORY TEST
RESULTS**

DRAWN:	DATE:	CHECKED:	DATE:
		LLL	4/15/19

JOB NO.:
181823

FIG NO.:

C-23

UNIFIED CLASSIFICATION	CL	CLIENT	GUMAN AND ASSOCIATES
SOIL TYPE #	2	PROJECT	CURTIS RD AND JUGRE ORR RD
TEST PIT #	4	JOB NO.	181823
DEPTH (FT)	2-3	TEST BY	BL

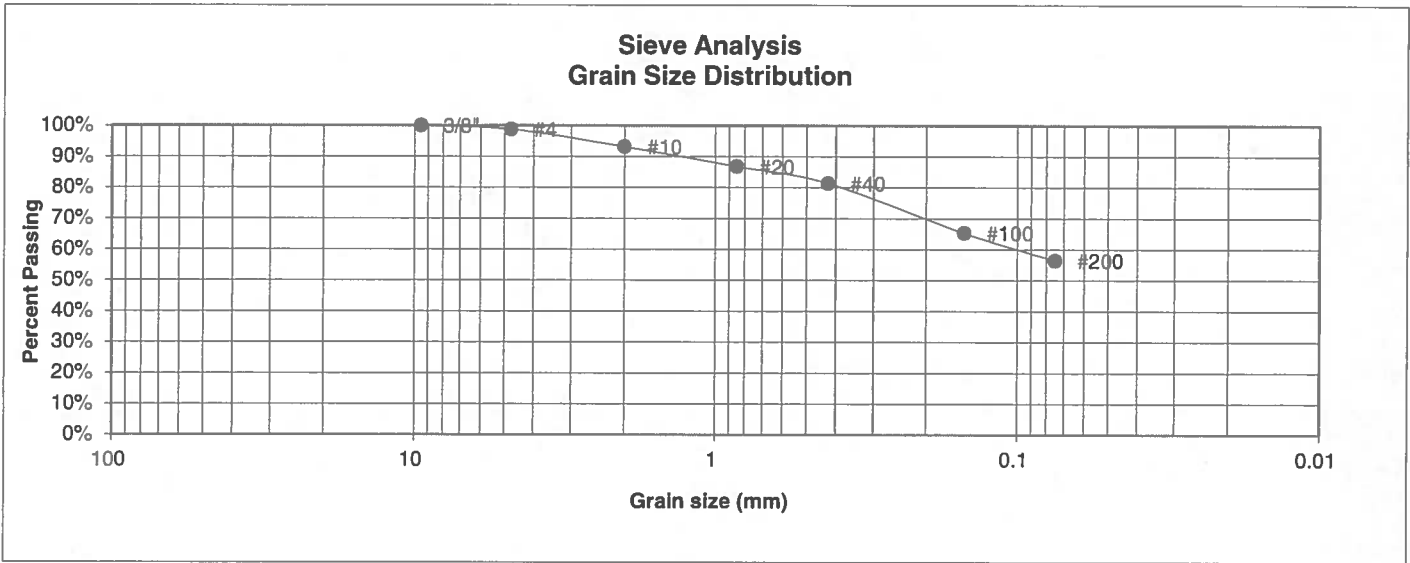

U.S. Sieve #	Percent Finer
3"	
1 1/2"	
3/4"	
1/2"	
3/8"	100.0%
4	98.8%
10	93.1%
20	86.8%
40	81.4%
100	65.3%
200	56.4%

Atterberg Limits	
Plastic Limit	14
Liquid Limit	26
Plastic Index	12

Swell	
Moisture at start	
Moisture at finish	
Moisture increase	
Initial dry density (pcf)	
Swell (psf)	



**ENTECH
ENGINEERING, INC.**

505 ELKTON DRIVE
COLORADO SPRINGS, COLORADO 80907

**LABORATORY TEST
RESULTS**

DRAWN:	DATE:	CHECKED: LLL	DATE: 4/15/19
--------	-------	-----------------	------------------

JOB NO.:
181823

FIG NO.:
C-24

<u>UNIFIED CLASSIFICATION</u>	CL	<u>CLIENT</u>	GUMAN AND ASSOCIATES
<u>SOIL TYPE #</u>	2	<u>PROJECT</u>	CURTIS RD AND JUGRE ORR RD
<u>TEST PIT #</u>	5	<u>JOB NO.</u>	181823
<u>DEPTH (FT)</u>	7-8	<u>TEST BY</u>	BL

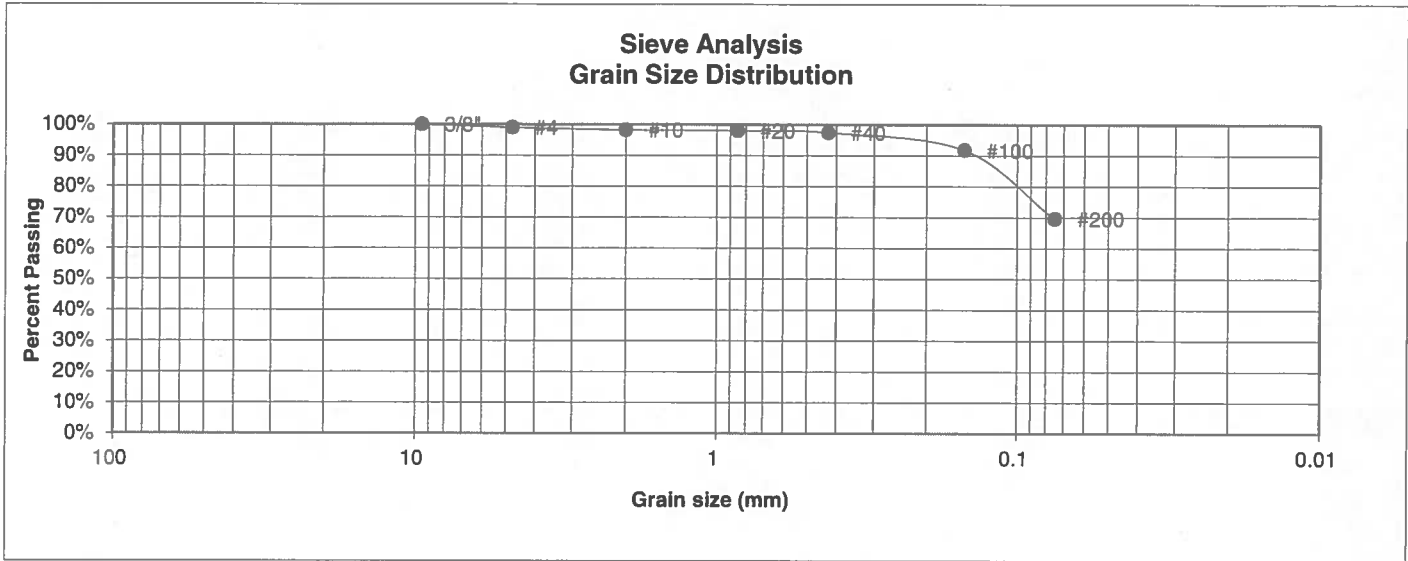

<u>U.S. Sieve #</u>	<u>Percent Finer</u>
3"	
1 1/2"	
3/4"	
1/2"	
3/8"	100.0%
4	99.1%
10	98.3%
20	98.1%
40	97.4%
100	91.8%
200	69.6%

<u>Atterberg Limits</u>	
Plastic Limit	13
Liquid Limit	32
Plastic Index	19

<u>Swell</u>	
Moisture at start	12.5%
Moisture at finish	20.6%
Moisture increase	8.1%
Initial dry density (pcf)	104
Swell (psf)	880



**ENTECH
ENGINEERING, INC.**

505 ELKTON DRIVE
COLORADO SPRINGS, COLORADO 80907

**LABORATORY TEST
RESULTS**

DRAWN:	DATE:	CHECKED:	DATE:
		LLL	4/15/19

JOB NO.:
181823

FIG NO.:
C-25

<u>UNIFIED CLASSIFICATION</u>	CL	<u>CLIENT</u>	GUMAN AND ASSOCIATES
<u>SOIL TYPE #</u>	2	<u>PROJECT</u>	CURTIS RD AND JUGRE ORR RD
<u>TEST PIT #</u>	16	<u>JOB NO.</u>	181823
<u>DEPTH (FT)</u>	7-8	<u>TEST BY</u>	BL

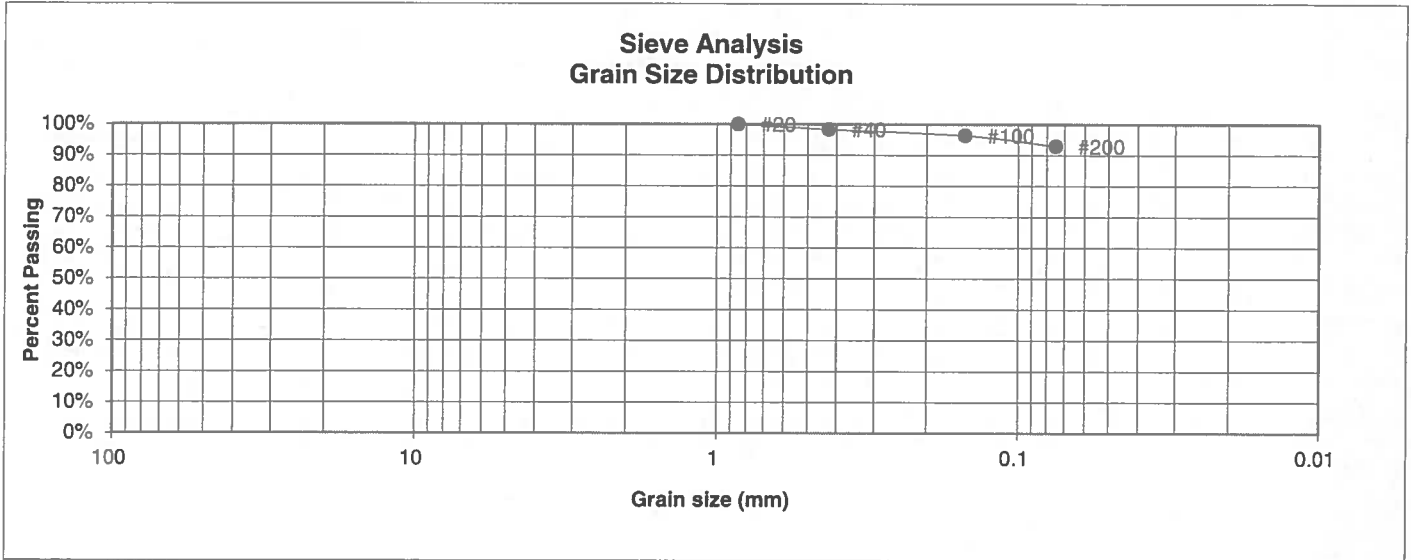

<u>U.S. Sieve #</u>	<u>Percent Finer</u>
3"	
1 1/2"	
3/4"	
1/2"	
3/8"	
4	
10	
20	100.0%
40	98.3%
100	96.4%
200	92.9%

Atterberg Limits
 Plastic Limit
 Liquid Limit
 Plastic Index

<u>Swell</u>	
Moisture at start	17.8%
Moisture at finish	33.1%
Moisture increase	15.3%
Initial dry density (pcf)	92
Swell (psf)	4420



**ENTECH
ENGINEERING, INC.**

505 ELKTON DRIVE
COLORADO SPRINGS, COLORADO 80907

**LABORATORY TEST
RESULTS**

<u>DRAWN:</u>	<u>DATE:</u>	<u>CHECKED:</u> LLL	<u>DATE:</u> 4/15/19
---------------	--------------	------------------------	-------------------------

JOB NO.:
181823

FIG NO.:

C-26

UNIFIED CLASSIFICATION	SC	CLIENT	GUMAN AND ASSOCIATES
SOIL TYPE #	3	PROJECT	CURTIS RD AND JUGRE ORR RD
TEST PIT #	8	JOB NO.	181823
DEPTH (FT)	4-5	TEST BY	BL

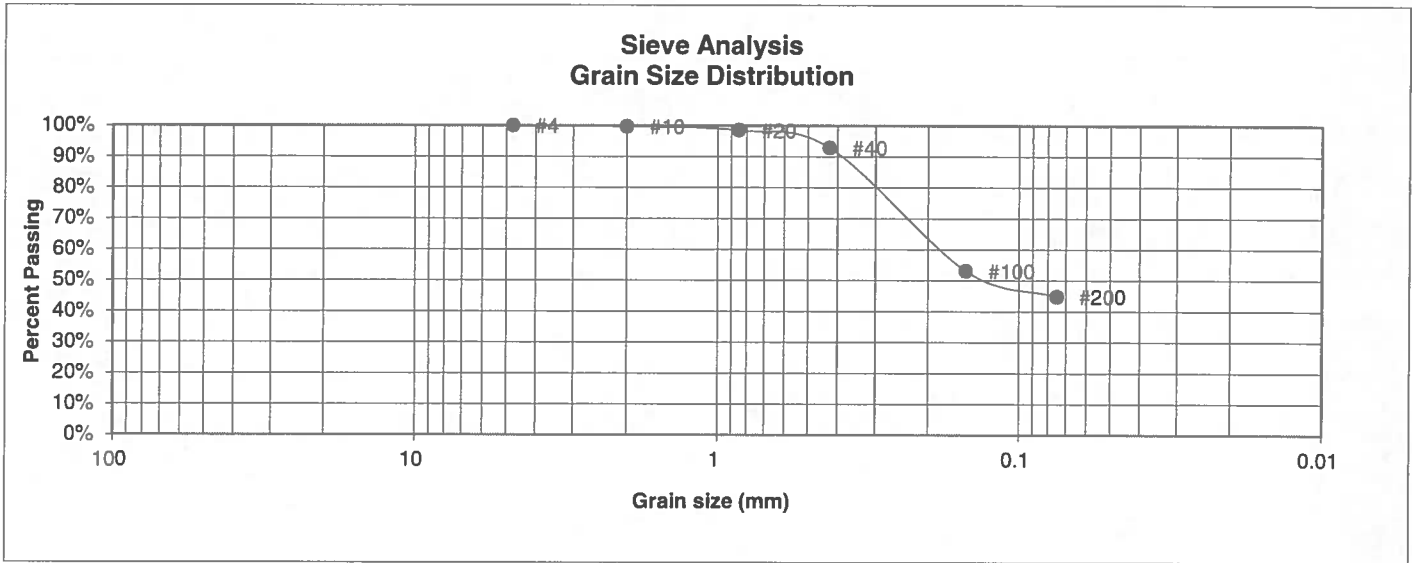

U.S. Sieve #	Percent Finer
3"	
1 1/2"	
3/4"	
1/2"	
3/8"	
4	100.0%
10	99.7%
20	98.5%
40	92.9%
100	53.2%
200	44.8%

Atterberg Limits	
Plastic Limit	16
Liquid Limit	29
Plastic Index	13

Swell	
Moisture at start	
Moisture at finish	
Moisture increase	
Initial dry density (pcf)	
Swell (psf)	



**ENTECH
ENGINEERING, INC.**

505 ELKTON DRIVE
COLORADO SPRINGS, COLORADO 80907

**LABORATORY TEST
RESULTS**

DRAWN:	DATE:	CHECKED:	DATE:
		LLL	4/15/19

JOB NO.:
181823

FIG NO.:

C-27

UNIFIED CLASSIFICATION	SM	CLIENT	GUMAN AND ASSOCIATES
SOIL TYPE #	3	PROJECT	CURTIS RD AND JUGRE ORR RD
TEST PIT #	10	JOB NO.	181823
DEPTH (FT)	5-6	TEST BY	BL

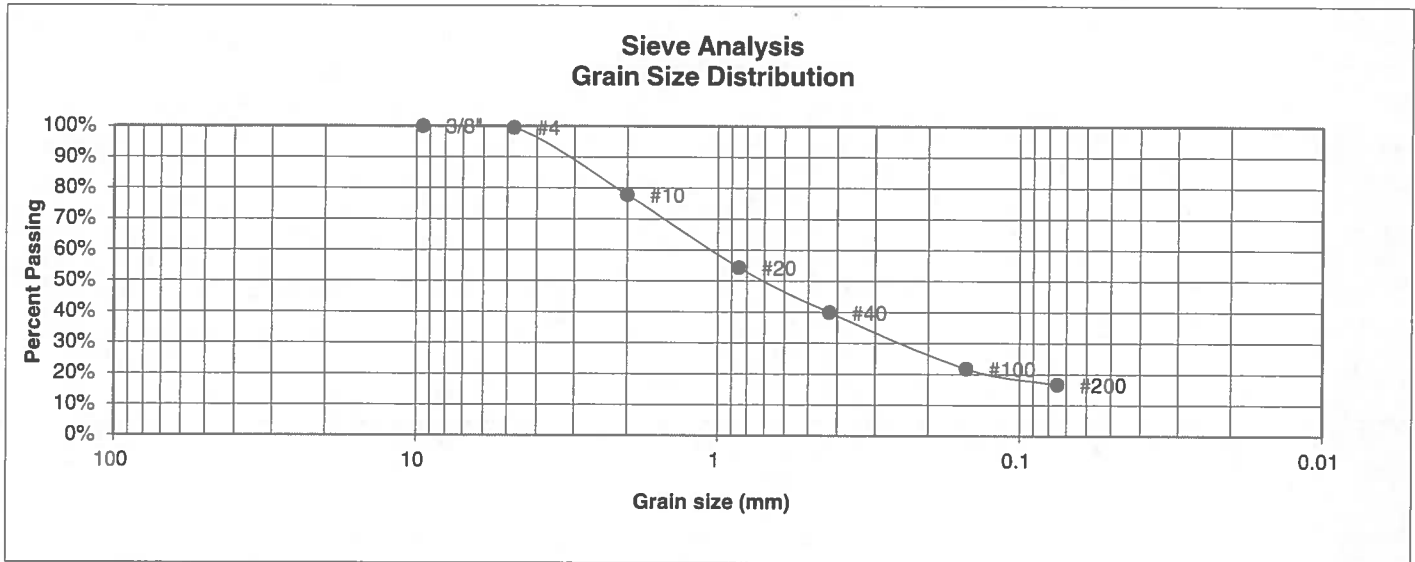

U.S. Sieve #	Percent Finer
3"	
1 1/2"	
3/4"	
1/2"	
3/8"	100.0%
4	99.5%
10	77.8%
20	54.4%
40	39.9%
100	21.8%
200	16.6%

Atterberg
Limits
Plastic Limit
Liquid Limit
Plastic Index

Swell
Moisture at start
Moisture at finish
Moisture increase
Initial dry density (pcf)
Swell (psf)



**ENTECH
ENGINEERING, INC.**

505 ELKTON DRIVE
COLORADO SPRINGS, COLORADO 80907

**LABORATORY TEST
RESULTS**

DRAWN:

DATE:

CHECKED:
LLL

DATE:
4/15/17

JOB NO.:
181823

FIG NO.:

C-28

<u>UNIFIED CLASSIFICATION</u>	SM	<u>CLIENT</u>	GUMAN AND ASSOCIATES
<u>SOIL TYPE #</u>	3	<u>PROJECT</u>	CURTIS RD AND JUGRE ORR RD
<u>TEST PIT #</u>	17	<u>JOB NO.</u>	181823
<u>DEPTH (FT)</u>	5-6	<u>TEST BY</u>	BL

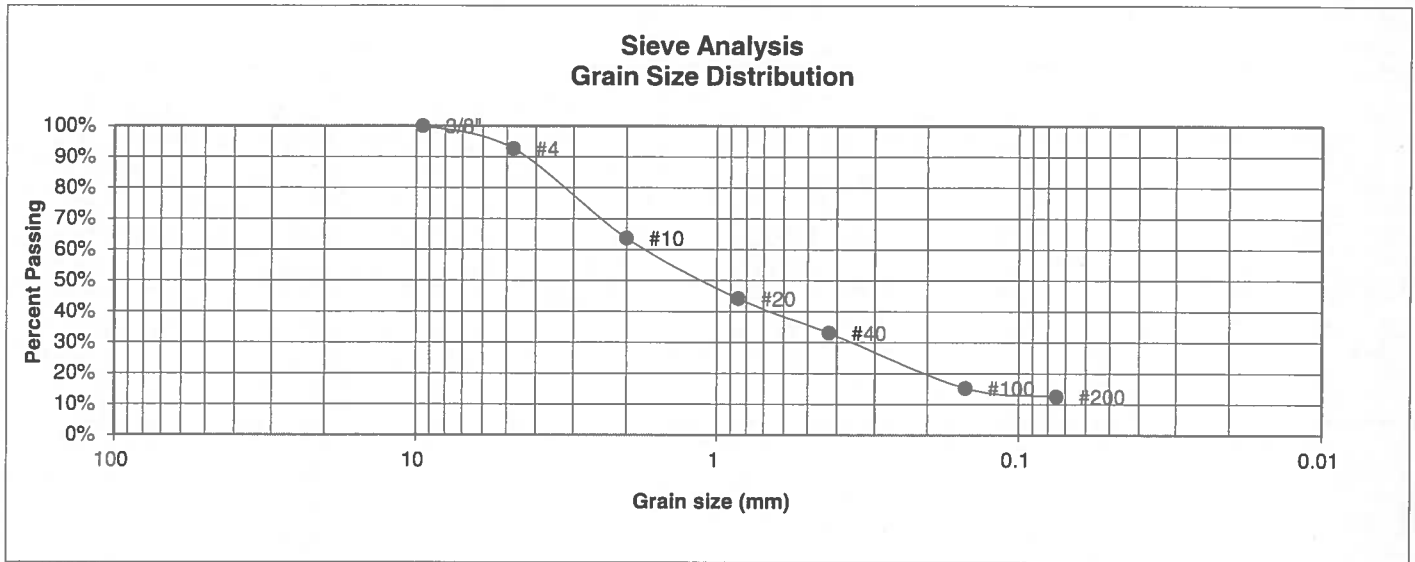

<u>U.S. Sieve #</u>	<u>Percent Finer</u>
3"	
1 1/2"	
3/4"	
1/2"	
3/8"	100.0%
4	92.7%
10	63.7%
20	44.2%
40	33.1%
100	15.3%
200	12.6%

Atterberg Limits
 Plastic Limit
 Liquid Limit
 Plastic Index

Swell
 Moisture at start
 Moisture at finish
 Moisture increase
 Initial dry density (pcf)
 Swell (psf)



**ENTECH
ENGINEERING, INC.**

505 ELKTON DRIVE
COLORADO SPRINGS, COLORADO 80907

**LABORATORY TEST
RESULTS**

<u>DRAWN:</u>	<u>DATE:</u>	<u>CHECKED:</u> LLL	<u>DATE:</u> 4/15/19
---------------	--------------	------------------------	-------------------------

JOB NO.:
181823

FIG NO.:
C-29

<u>UNIFIED CLASSIFICATION</u>	SM	<u>CLIENT</u>	GUMAN AND ASSOCIATES
<u>SOIL TYPE #</u>	3	<u>PROJECT</u>	CURTIS RD AND JUGRE ORR RD
<u>TEST PIT #</u>	34	<u>JOB NO.</u>	181823
<u>DEPTH (FT)</u>	5-6	<u>TEST BY</u>	BL

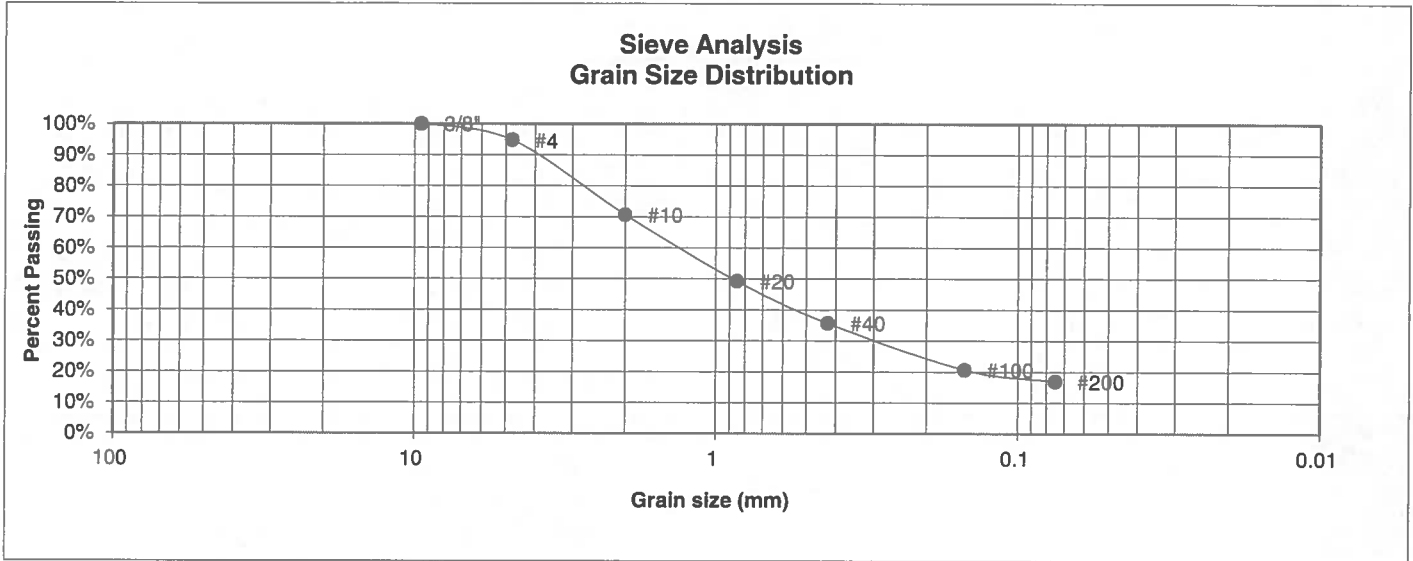

<u>U.S. Sieve #</u>	<u>Percent Finer</u>
3"	
1 1/2"	
3/4"	
1/2"	
3/8"	100.0%
4	94.8%
10	70.7%
20	49.2%
40	35.7%
100	20.7%
200	16.9%

Atterberg Limits
 Plastic Limit
 Liquid Limit
 Plastic Index

Swell
 Moisture at start
 Moisture at finish
 Moisture increase
 Initial dry density (pcf)
 Swell (psf)



**ENTECH
ENGINEERING, INC.**

505 ELKTON DRIVE
COLORADO SPRINGS, COLORADO 80907

**LABORATORY TEST
RESULTS**

<u>DRAWN:</u>	<u>DATE:</u>	<u>CHECKED:</u> LLL	<u>DATE:</u> 4/15/14
---------------	--------------	------------------------	-------------------------

JOB NO.:
181823

FIG NO.:
C-30

<u>UNIFIED CLASSIFICATION</u>	SM	<u>CLIENT</u>	GUMAN AND ASSOCIATES
<u>SOIL TYPE #</u>	3	<u>PROJECT</u>	CURTIS RD AND JUGRE ORR RD
<u>TEST PIT #</u>	40	<u>JOB NO.</u>	181823
<u>DEPTH (FT)</u>	5-6	<u>TEST BY</u>	BL

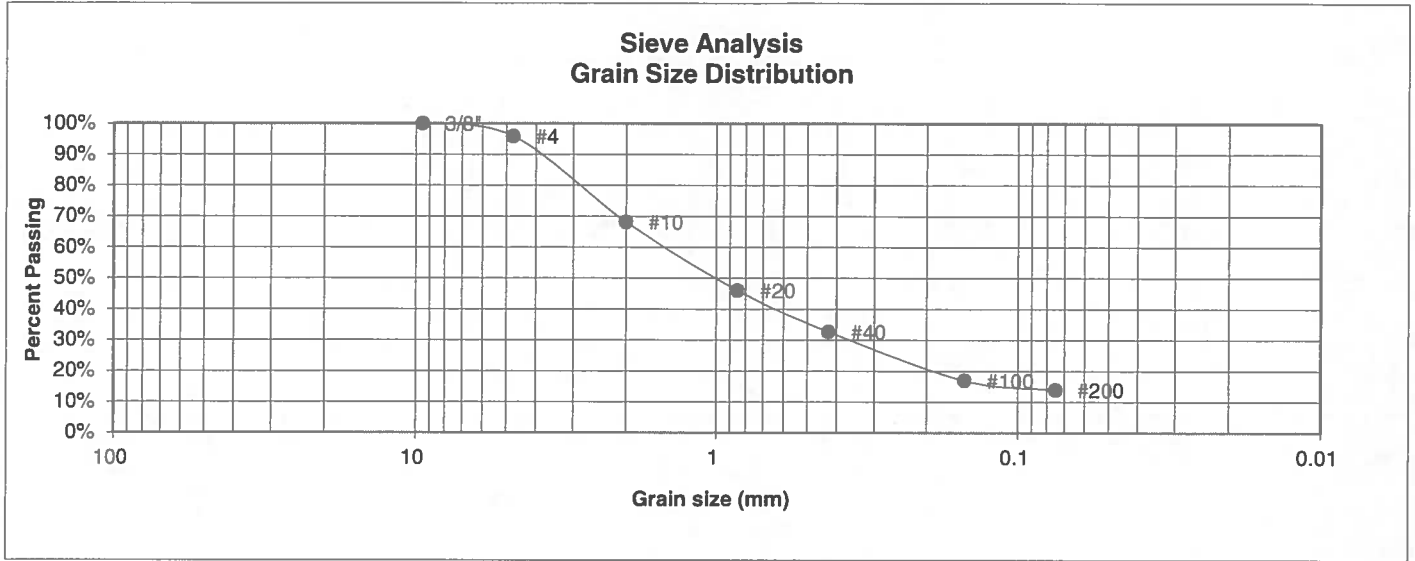

<u>U.S. Sieve #</u>	<u>Percent Finer</u>
3"	
1 1/2"	
3/4"	
1/2"	
3/8"	100.0%
4	95.9%
10	68.2%
20	46.1%
40	32.7%
100	17.0%
200	13.9%

Atterberg Limits
 Plastic Limit
 Liquid Limit
 Plastic Index

Swell
 Moisture at start
 Moisture at finish
 Moisture increase
 Initial dry density (pcf)
 Swell (psf)



**ENTECH
ENGINEERING, INC.**
 505 ELKTON DRIVE
 COLORADO SPRINGS, COLORADO 80907

**LABORATORY TEST
RESULTS**

DRAWN:	DATE:	CHECKED: LLL	DATE: 4/15/19
--------	-------	-----------------	------------------

JOB NO.:
181823

FIG NO.:
C-31

<u>UNIFIED CLASSIFICATION</u>	CL	<u>CLIENT</u>	GUMAN AND ASSOCIATES
<u>SOIL TYPE #</u>	4	<u>PROJECT</u>	CURTIS RD AND JUGRE ORR RD
<u>TEST PIT #</u>	7	<u>JOB NO.</u>	181823
<u>DEPTH (FT)</u>	6-7	<u>TEST BY</u>	BL

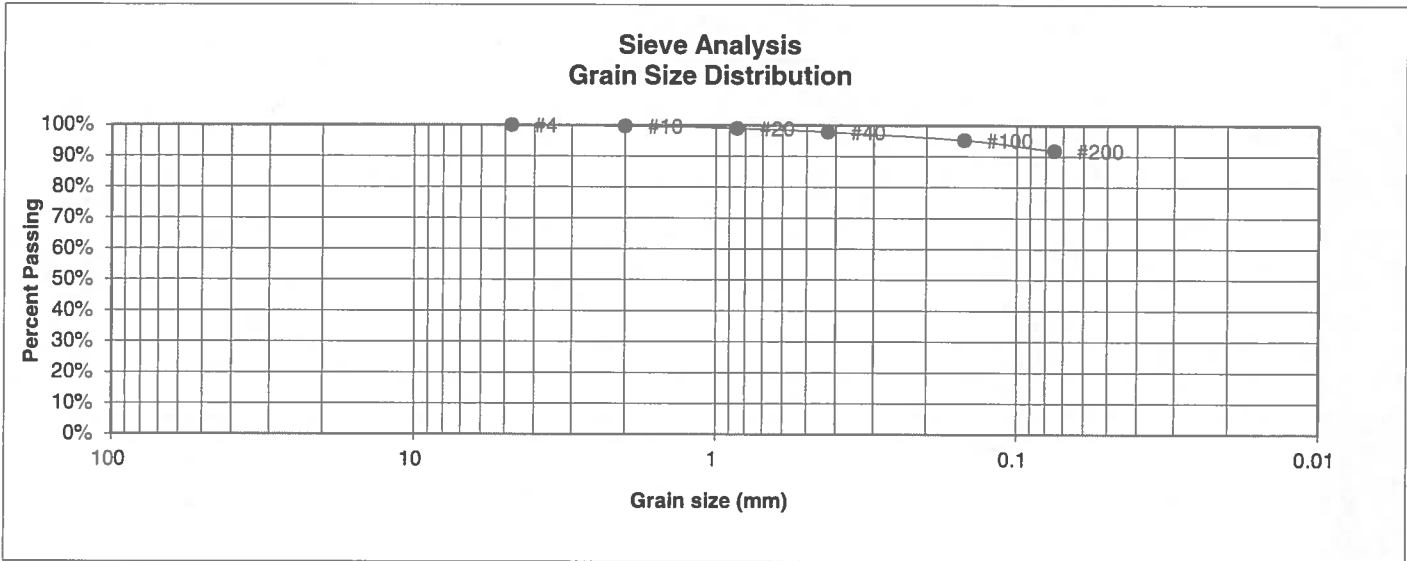

<u>U.S. Sieve #</u>	<u>Percent Finer</u>
3"	
1 1/2"	
3/4"	
1/2"	
3/8"	
4	100.0%
10	99.7%
20	99.0%
40	97.8%
100	95.2%
200	91.8%

Atterberg Limits
 Plastic Limit
 Liquid Limit
 Plastic Index

<u>Swell</u>	
Moisture at start	17.8%
Moisture at finish	27.8%
Moisture increase	10.0%
Initial dry density (pcf)	94
Swell (psf)	2300



**ENTECH
ENGINEERING, INC.**

505 ELKTON DRIVE
COLORADO SPRINGS, COLORADO 80907

**LABORATORY TEST
RESULTS**

<u>DRAWN:</u>	<u>DATE:</u>	<u>CHECKED:</u>	<u>DATE:</u>
		LLL	4/15/19

JOB NO.:
181823

FIG NO.:

C-32

<u>UNIFIED CLASSIFICATION</u>	CL	<u>CLIENT</u>	GUMAN AND ASSOCIATES
<u>SOIL TYPE #</u>	4	<u>PROJECT</u>	CURTIS RD AND JUGRE ORR RD
<u>TEST PIT #</u>	14	<u>JOB NO.</u>	181823
<u>DEPTH (FT)</u>	4-5	<u>TEST BY</u>	BL

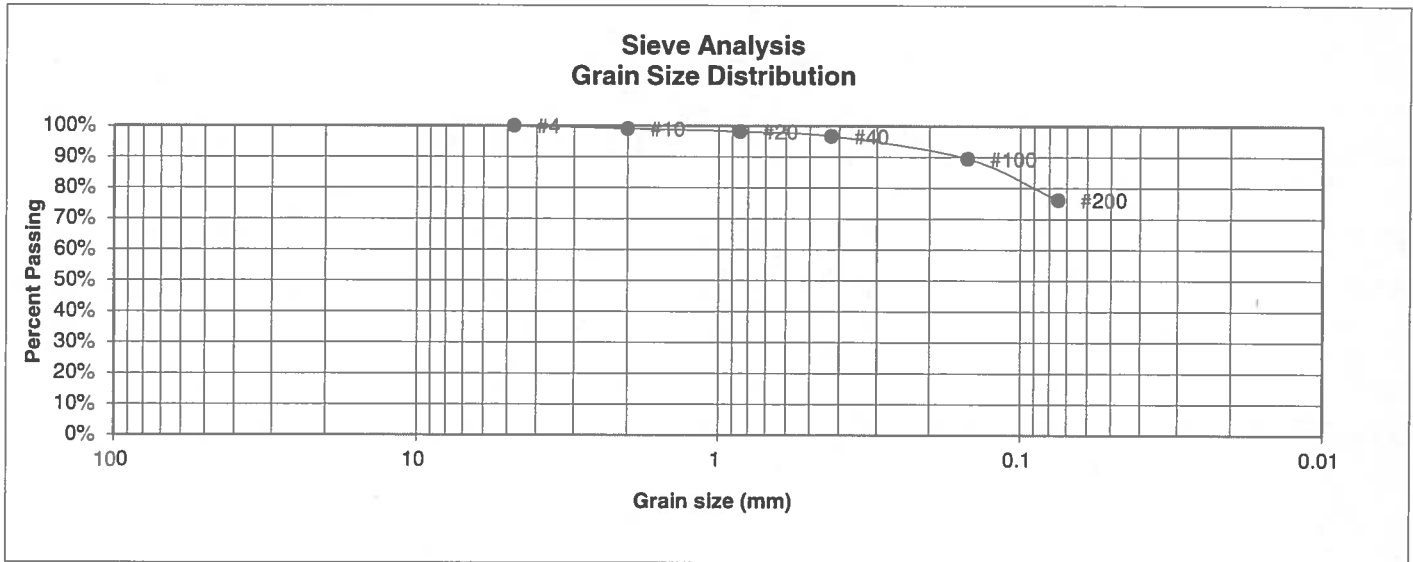

<u>U.S. Sieve #</u>	<u>Percent Finer</u>
3"	
1 1/2"	
3/4"	
1/2"	
3/8"	
4	100.0%
10	99.1%
20	98.2%
40	96.7%
100	89.5%
200	76.1%

<u>Atterberg Limits</u>	
Plastic Limit	24
Liquid Limit	47
Plastic Index	23

<u>Swell</u>	
Moisture at start	15.5%
Moisture at finish	29.0%
Moisture increase	13.5%
Initial dry density (pcf)	95
Swell (psf)	3160



**ENTECH
ENGINEERING, INC.**

505 ELKTON DRIVE
COLORADO SPRINGS, COLORADO 80907

**LABORATORY TEST
RESULTS**

DRAWN:	DATE:	CHECKED: LLL	DATE: 4/15/19
--------	-------	-----------------	------------------

JOB NO.:
181823

FIG NO.:
C-33

UNIFIED CLASSIFICATION	CL	CLIENT	GUMAN AND ASSOCIATES
SOIL TYPE #	4	PROJECT	CURTIS RD AND JUGRE ORR RD
TEST PIT #	23	JOB NO.	181823
DEPTH (FT)	5-6	TEST BY	BL

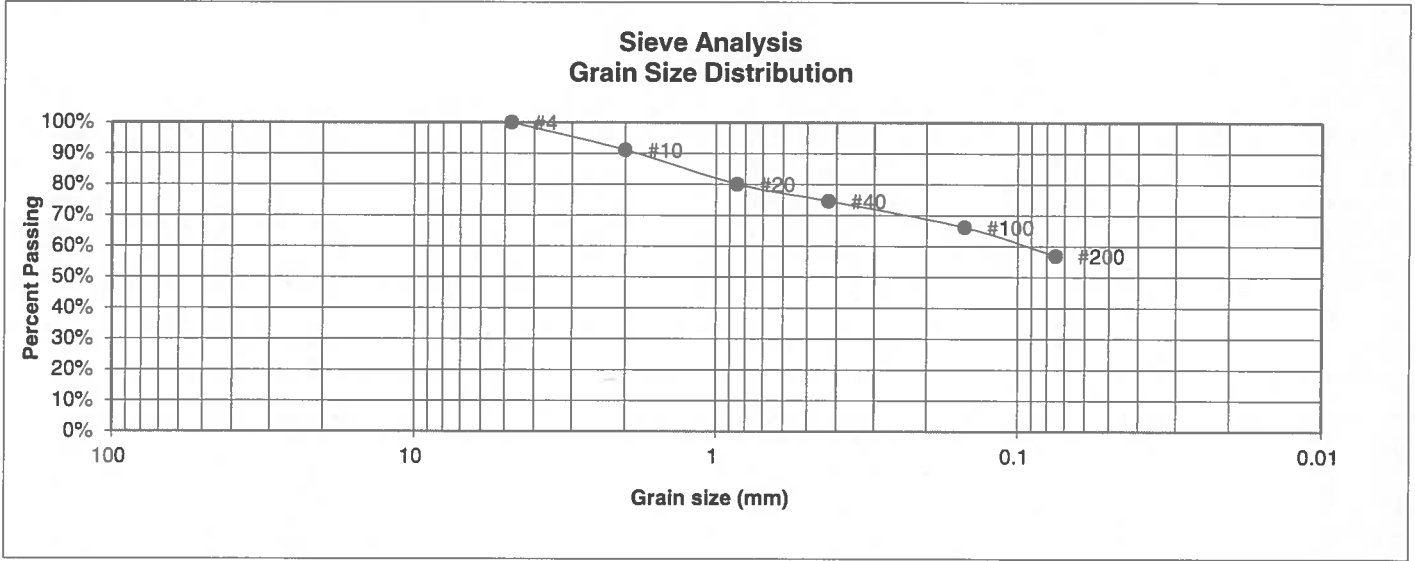

U.S. Sieve #	Percent Finer
3"	
1 1/2"	
3/4"	
1/2"	
3/8"	
4	100.0%
10	91.1%
20	80.1%
40	74.6%
100	66.2%
200	57.0%

Atterberg Limits
 Plastic Limit
 Liquid Limit
 Plastic Index

Swell	
Moisture at start	10.0%
Moisture at finish	16.1%
Moisture increase	6.2%
Initial dry density (pcf)	109
Swell (psf)	450



**ENTECH
ENGINEERING, INC.**

505 ELKTON DRIVE
COLORADO SPRINGS, COLORADO 80907

**LABORATORY TEST
RESULTS**

DRAWN:	DATE:	CHECKED: LL	DATE: 4/15/19
--------	-------	----------------	------------------

JOB NO.:
181823

FIG NO.:
C-39

CONSOLIDATION TEST RESULTS

TEST BORING #	4	DEPTH(ft)	20
DESCRIPTION	ML	SOIL TYPE	3
NATURAL UNIT DRY WEIGHT (PCF)			104
NATURAL MOISTURE CONTENT			21.4%
SWELL/CONSOLIDATION (%)			0.0%

JOB NO. 181823
 CLIENT WILLIAM GUMAN
 PROJECT CURTIS AND JUDGE ORR

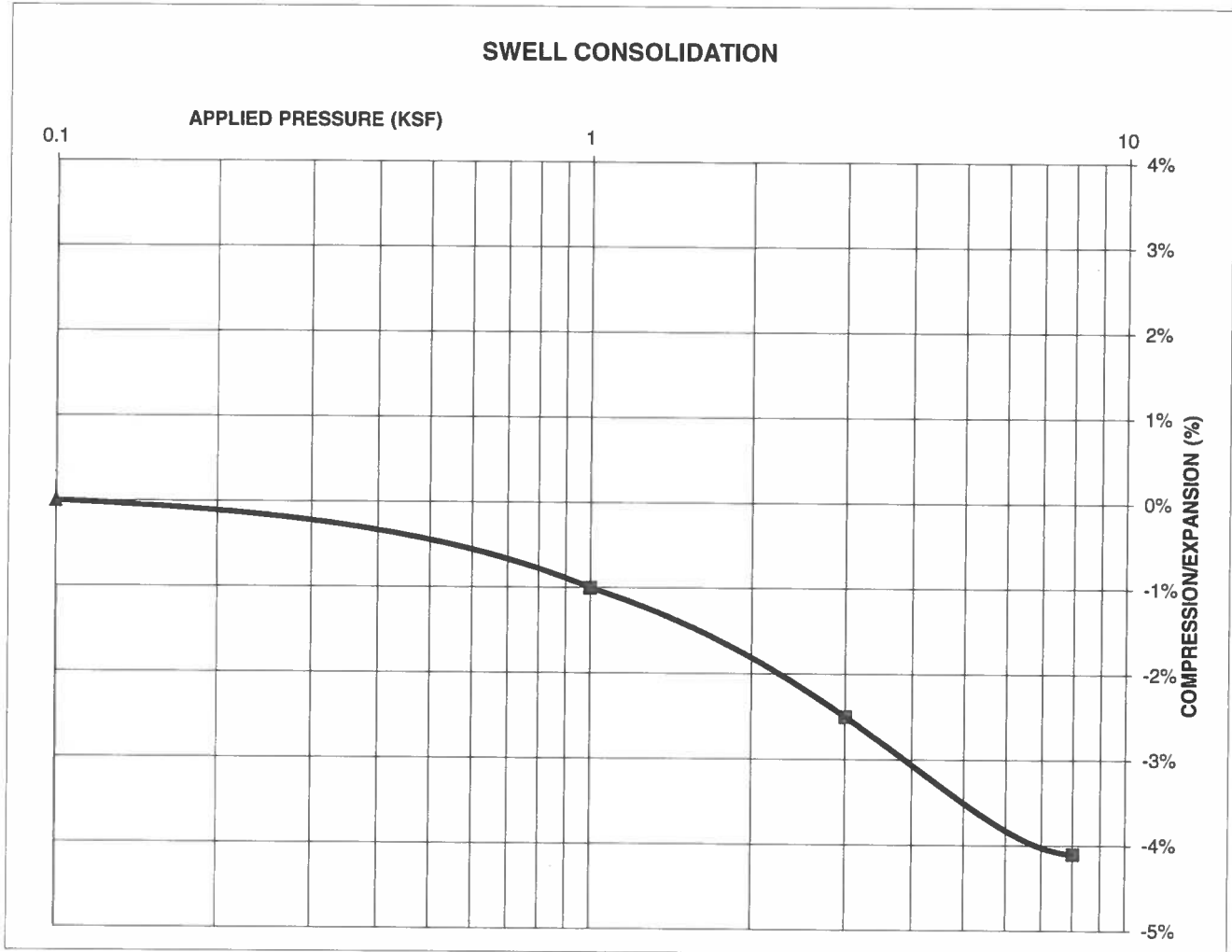

ENTECH
ENGINEERING, INC.

505 ELKTON DRIVE
 COLORADO SPRINGS, COLORADO 80907

**SWELL CONSOLIDATION
 TEST RESULTS**

DRAWN:

DATE:

CHECKED:

DATE:

ELL

4/15/19

JOB NO.:
 181823

FIG NO.:
C-35

CLIENT	WILLIAM GUMAN	JOB NO.	181823
PROJECT	CURTIS AND JUDGE ORR	DATE	4/11/2019
LOCATION	CURTIS AND JUDGE ORR	TEST BY	BL

BORING NUMBER	DEPTH, (ft)	SOIL TYPE NUMBER	UNIFIED CLASSIFICATION	WATER SOLUBLE SULFATE, (wt%)
TB-1	2-3	1	SM	<0.01
TB-3	10	2	SM	<0.01
TB-4	20	3	ML	<0.01

QC BLANK PASS



ENTECH
ENGINEERING, INC.
 505 ELKTON DRIVE
 COLORADO SPRINGS, COLORADO 80907

**LABORATORY TEST
 SULFATE RESULTS**

DRAWN: _____ DATE: _____ CHECKED: ELL DATE: 4/15/19

JOB NO.:
 181823
 FIG NO.:
 C-36

APPENDIX D: Soil Survey Descriptions

8—Blakeland loamy sand, 1 to 9 percent slopes. This deep, somewhat excessively drained soil formed in alluvial and eolian material derived from arkosic sedimentary rock on uplands. The average annual precipitation is about 15 inches, the average annual air temperature is about 47 degrees F, and the average frost-free period is about 135 days.

Typically, the surface layer is dark grayish brown loamy sand about 11 inches thick. The substratum, to a depth of 27 inches, is brown loamy sand; it grades to pale brown sand that extends to a depth of 60 inches.

Included with this soil in mapping are small areas of Bresser sandy loam, 0 to 3 percent slopes; Bresser sandy loam, 3 to 5 percent slopes; Truckton sandy loam, 0 to 3 percent slopes; Truckton sandy loam, 3 to 9 percent slopes; and Stapleton sandy loam, 3 to 8 percent slopes. In some areas, mainly north of Colorado Springs in the Cottonwood Creek area, arkosic beds of sandstone and shale are at a depth of 0 to 40 inches.

Permeability of this Blakeland soil is rapid. Effective rooting depth is 60 inches or more. Available water capacity is low to moderate. Organic matter content of the surface layer is medium. Surface runoff is slow, the hazard of erosion is moderate, and the hazard of soil blowing is severe.

Most areas of this soil are used for range, homesites, and wildlife habitat.

Native vegetation is dominantly western wheatgrass, side-oats grama, and needleandthread. This soil is best suited to deep-rooted grasses.

Proper range management is necessary to prevent excessive removal of plant cover from the soil. Interseeding improves the existing vegetation. Deferment of grazing in spring increases plant vigor and soil stability. Proper location of livestock watering facilities helps to control grazing.

Windbreaks and environmental plantings are fairly well suited to this soil. Blowing sand and low available water capacity are the main limitations for the establishment of trees and shrubs. The soil is so loose that trees need to be planted in shallow furrows and plant cover needs to be maintained between the rows. Supplemental irrigation may be needed to insure survival. Trees that are best suited and have good survival are Rocky Mountain juniper, eastern redcedar, ponderosa pine, and Siberian elm. Shrubs that are best suited are skunkbush sumac, lilac, and Siberian peashrub.

This soil is suited to wildlife habitat. It is best suited to habitat for openland and rangeland wildlife. Rangeland wildlife, such as pronghorn antelope, can be encouraged by developing livestock watering facilities, properly managing livestock grazing, and reseeding range where needed.

This soil has good potential for urban development. Soil blowing is a hazard if protective vegetation is removed. Special erosion control practices must be provided to minimize soil losses. Capability subclass VIe.



ENTECH
ENGINEERING, INC.

SCS SOIL DESCRIPTION

Drawn	Date	Checked	Date
		LLL	2/18/19

Job No.
181823
Fig. No.
0-1

19—Columbine gravelly sandy loam, 0 to 3 percent slopes. This deep, well drained to excessively drained soil formed in coarse textured material on alluvial terraces and fans and on flood plains. Elevation ranges from 6,500 to 7,300 feet. The average annual precipitation is about 15 inches, the average annual air temperature is about 47 degrees F, and the average frost-free period is about 135 days.

Typically, the surface layer is grayish brown gravelly sandy loam about 14 inches thick. The underlying material is light yellowish brown very gravelly loamy sand.

Included with this soil in mapping are small areas of Stapleton sandy loam, 3 to 8 percent slopes; Blendon sandy loam, 0 to 3 percent slopes; Louviers silty clay loam, 3 to 18 percent slopes; and Fluvaquentic Haplaquolls, nearly level. In places the parent arkose beds of sandstone or shale are at a depth of 0 to 40 inches.

Permeability of this Columbine soil is very rapid. Effective rooting depth is 60 inches or more. Available water capacity is low to moderate. Surface runoff is slow, and the hazard of erosion is slight to moderate.

This soil is used mainly for grazing livestock and for wildlife habitat. It is also used for homesites.

Native vegetation is mainly western wheatgrass, side-oats grama, needleandthread, and little bluestem. The main shrub is true mountainmahogany.

Proper location of livestock watering facilities helps to control grazing.

Windbreaks and environmental plantings are fairly well suited to this soil. Blowing sand and low available water capacity are the principal limitations to the establishment of trees and shrubs. The soil is so loose that trees need to be planted in the rows. Supplemental irrigation may be needed to insure survival. Trees that are best suited and have good survival are Rocky Mountain juniper, eastern redcedar, ponderosa pine, and Siberian elm. Shrubs that are best suited are skunkbush sumac, lilac, and Siberian peashrub.

Rangeland wildlife, such as pronghorn antelope, cottontail, coyote, and scaled quail, is best adapted to life on this droughty soil. Forage production is typically loam, and proper livestock grazing management is necessary if wildlife and livestock share the range. Livestock watering developments are also important and are used by various wildlife species.

The main limitation of this soil for urban development is a hazard of flooding in some areas. Care must be taken when locating septic tank absorption fields because of possible pollution as a result of the very rapid permeability of this soil. Capability subclass VIe.



ENTECH
ENGINEERING, INC.

SCS SOIL DESCRIPTION

Drawn	Date	Checked	Date
		LLH	2/18/77

Job No.

18/823

Fig. No.

D-2

29—Fluvaquentic Haplaquolls, nearly level. These deep, poorly drained soils are in marshes, in swales, and on creek bottoms. The average annual precipitation is about 14 inches, and the average annual air temperature is about 47 degrees F.

Included with these soils in mapping are small areas of Ustic Torrfluvents, loamy; Blakeland loamy sand, 1 to 9 percent slopes; Columbine gravelly sandy loam, 0 to 3 percent slopes; and Ellicott loamy coarse sand, 0 to 5 percent slopes.

These soils are stratified. Typically, the surface layer is light gray to very dark gray loamy fine sand to gravelly loam 2 to 6 inches thick. The underlying material, 48 to 58 inches thick, is very pale brown to gray, stratified heavy sandy clay loam to sand and gravel. The lower part of some of the soils, at depths ranging from 18 to 48 inches, ranges from light blueish gray to greenish gray. The water table is usually at a depth of less than 48 inches, and it is on the surface during part of the year.

Permeability of these soils is moderate. Effective rooting depth is limited by the water table. Available water capacity is moderate. Surface runoff is slow, and the hazard of erosion is slight. At times overflow deposits a damaging amount of silt and sand in the lower lying areas.

These soils are in meadow. They are used for native hay or for grazing.

These soils are well suited to the production of native vegetation suitable for grazing. The vegetation is mainly switchgrass, indiagrass, sedges, rushes, prairie cordgrass, western wheatgrass, and bluegrass. Cattails and bulrushes commonly grow in the swampy areas.

Management of distribution of livestock and stocking rates is necessary on these soils to avoid abuse of the range. In large areas, fences should be used to control grazing.

Wetland wildlife can be attracted to these soils and the wetland habitat enhanced by several means. Shallow water developments can be created by digging or by blasting potholes to create open-water areas. Fencing to control livestock use is beneficial, and it allows wetland plants such as cattails, reed canarygrass, and rushes to grow. Control of unplanned burning and prevention of drainage that would remove water from the wetlands are also good practices. These shallow marsh areas are often especially important for winter cover if natural vegetation is allowed to grow.

These soils are severely limited for use as homesites. The main limitations are a high water table and a hazard of periodic flooding. Community sewerage systems are needed because the high water table prevents septic tank absorption fields from functioning properly. Roads must also be designed to prevent frost-heave damage. Capability subclass Vw.



ENTECH
ENGINEERING, INC.

SCS SOIL DESCRIPTION

Drawn	Date	Checked	Date
		LLL	2/18/19

Job No.

181823

Fig. No.

D-3

83—Stapleton sandy loam, 3 to 8 percent slopes. This deep, noncalcareous, well drained soil formed in sandy alluvium derived from arkosic bedrock on uplands. Elevation ranges from 6,500 to 7,300 feet. The average annual precipitation is about 15 inches, the average annual air temperature is about 47 degrees F, and the average frost-free period is about 135 days.

Typically, the surface layer is grayish brown sandy loam about 11 inches thick. The subsoil is grayish brown gravelly sandy loam about 6 inches thick. The substratum extends to a depth of 60 inches or more. It is pale brown gravelly sandy loam in the upper part and grades to gravelly loamy sand in the lower part.

Included with this soil in mapping are small areas of Louviers silty clay loam, 3 to 18 percent slopes; Blakeland loamy sand, 1 to 9 percent slopes; Columbine gravelly sandy loam, 0 to 3 percent slopes; and Fluvaquentic Haplaquolls, nearly level. Also included are areas where arkose beds of sandstone and shale are at a depth of 0 to 40 inches. Included areas make up about 20 percent of the mapped acreage.

Permeability of this Stapleton soil is rapid. Effective rooting depth is 60 inches or more. Available water capacity is moderate. Surface runoff is slow, and the hazards of erosion and soil blowing are moderate.

This soil is used as rangeland, for wildlife habitat, and as homesites.

Native vegetation is mainly western wheatgrass, side-outs grama, needleandthread, and little bluestem. The predominant shrub on this soil is true mountainmahogany. Yucca occurs in some areas.

Deferred grazing late in summer and in fall improves the condition of the range. Properly locating livestock watering facilities helps to control grazing.

Windbreaks and environmental plantings are generally suited to this soil. Soil blowing is the principal limitation for the establishment of trees and shrubs. This limitation can be overcome by cultivating only in the tree rows and leaving a strip of vegetation between the rows. Supplemental irrigation may be needed when planting and during dry periods. Trees that are best suited and have good survival are Rocky Mountain juniper, eastern redcedar, ponderosa pine, Siberian elm, Russian-olive, and hackberry. Shrubs that are best suited are skunkbush sumac, lilac, and Siberian peashrub.

This soil is suited to habitat for openland and rangeland wildlife. Rangeland wildlife, such as pronghorn antelope, can be encouraged by developing livestock watering facilities, properly managing livestock grazing, and reseeding range where needed.

The main limitation of this soil for urban use is frost-action potential. Special design of roads and streets is necessary to minimize frost heave damage. Special practices must be provided to minimize water erosion and soil blowing on construction sites where vegetation has been removed. Access roads must have adequate cut-slope grade and be provided with drains to control surface runoff. Capability subclass IVE.



ENTECH
ENGINEERING, INC.

SCS SOIL DESCRIPTION

Drawn	Date	Checked	Date
		LLL	2/18/19

Job No.

181823

Fig. No.

D-4

APPENDIX E: NRCS Septic Tank Absorption Field Soil Rating

Septic Tank Absorption Fields—El Paso County Area, Colorado
(Saddlehorn Ranch)

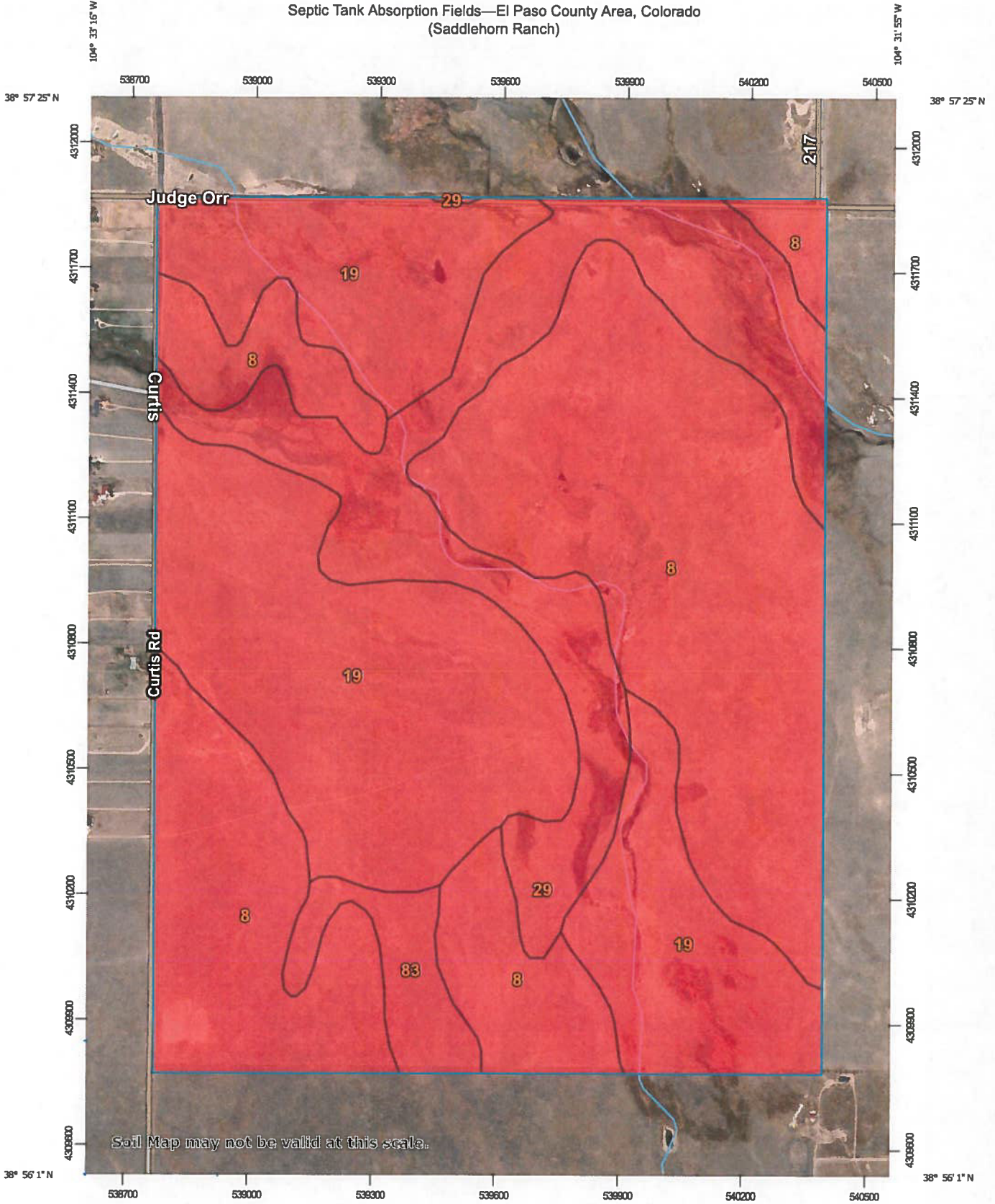



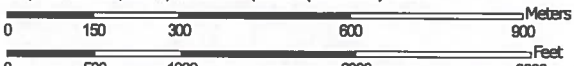

















Map Scale: 1:12,600 if printed on A portrait (8.5" x 11") sheet.



Map projection: Web Mercator Corner coordinates: WGS84 Edge tics: UTM Zone 13N WGS84



MAP LEGEND

- Area of Interest (AOI)**
 Area of Interest (AOI)
- Background**
 Aerial Photography
- Soils**
- Soil Rating Polygons**
-  Very limited
 -  Somewhat limited
 -  Not limited
 -  Not rated or not available
- Soil Rating Lines**
-  Very limited
 -  Somewhat limited
 -  Not limited
 -  Not rated or not available
- Soil Rating Points**
-  Very limited
 -  Somewhat limited
 -  Not limited
 -  Not rated or not available
- Water Features**
-  Streams and Canals
- Transportation**
-  Rails
 -  Interstate Highways
 -  US Routes
 -  Major Roads
 -  Local Roads

MAP INFORMATION

The soil surveys that comprise your AOI were mapped at 1:24,000.

Warning: Soil Map may not be valid at this scale.

Enlargement of maps beyond the scale of mapping can cause misunderstanding of the detail of mapping and accuracy of soil line placement. The maps do not show the small areas of contrasting soils that could have been shown at a more detailed scale.

Please rely on the bar scale on each map sheet for map measurements.

Source of Map: Natural Resources Conservation Service
 Web Soil Survey URL:
 Coordinate System: Web Mercator (EPSG:3857)

Maps from the Web Soil Survey are based on the Web Mercator projection, which preserves direction and shape but distorts distance and area. A projection that preserves area, such as the Albers equal-area conic projection, should be used if more accurate calculations of distance or area are required.

This product is generated from the USDA-NRCS certified data as of the version date(s) listed below.

Soil Survey Area: El Paso County Area, Colorado
 Survey Area Data: Version 16, Sep 10, 2018

Soil map units are labeled (as space allows) for map scales 1:50,000 or larger.

Date(s) aerial images were photographed: Jun 7, 2016—Aug 17, 2017

The orthophoto or other base map on which the soil lines were compiled and digitized probably differs from the background imagery displayed on these maps. As a result, some minor shifting of map unit boundaries may be evident.

Septic Tank Absorption Fields

Map unit symbol	Map unit name	Rating	Component name (percent)	Rating reasons (numeric values)	Acres in AOI	Percent of AOI
8	Blakeland loamy sand, 1 to 9 percent slopes	Very limited	Blakeland (85%)	Seepage, bottom layer (1.00)	371.3	44.0%
				Filtering capacity (1.00)		
19	Columbine gravelly sandy loam, 0 to 3 percent slopes	Very limited	Columbine (85%)	Filtering capacity (1.00)	303.8	36.0%
				Seepage, bottom layer (1.00)		
29	Fluvaquentic Haplaquolls, nearly level	Very limited	Fluvaquentic Haplaquolls (85%)	Flooding (1.00)	144.6	17.1%
				Depth to saturated zone (1.00)		
				Seepage, bottom layer (1.00)		
83	Stapleton sandy loam, 3 to 8 percent slopes	Very limited	Stapleton (80%)	Filtering capacity (1.00)	24.6	2.9%
Totals for Area of Interest					844.3	100.0%

Rating	Acres in AOI	Percent of AOI
Very limited	844.3	100.0%
Totals for Area of Interest	844.3	100.0%

Description

Septic tank absorption fields are areas in which effluent from a septic tank is distributed into the soil through subsurface tiles or perforated pipe. Only that part of the soil between depths of 24 and 60 inches is evaluated. The ratings are based on the soil properties that affect absorption of the effluent, construction and maintenance of the system, and public health. Saturated hydraulic conductivity (Ksat), depth to a water table, ponding, depth to bedrock or a cemented pan, and flooding affect absorption of the effluent. Stones and boulders, ice, and bedrock or a cemented pan interfere with installation. Subsidence interferes with installation and maintenance. Excessive slope may cause lateral seepage and surfacing of the effluent in downslope areas.

Some soils are underlain by loose sand and gravel or fractured bedrock at a depth of less than 4 feet below the distribution lines. In these soils the absorption field may not adequately filter the effluent, particularly when the system is new. As a result, the ground water may become contaminated.

The ratings are both verbal and numerical. Rating class terms indicate the extent to which the soils are limited by all of the soil features that affect the specified use. "Not limited" indicates that the soil has features that are very favorable for the specified use. Good performance and very low maintenance can be expected. "Somewhat limited" indicates that the soil has features that are moderately favorable for the specified use. The limitations can be overcome or minimized by special planning, design, or installation. Fair performance and moderate maintenance can be expected. "Very limited" indicates that the soil has one or more features that are unfavorable for the specified use. The limitations generally cannot be overcome without major soil reclamation, special design, or expensive installation procedures. Poor performance and high maintenance can be expected.

Numerical ratings indicate the severity of individual limitations. The ratings are shown as decimal fractions ranging from 0.01 to 1.00. They indicate gradations between the point at which a soil feature has the greatest negative impact on the use (1.00) and the point at which the soil feature is not a limitation (0.00).

The map unit components listed for each map unit in the accompanying Summary by Map Unit table in Web Soil Survey or the Aggregation Report in Soil Data Viewer are determined by the aggregation method chosen. An aggregated rating class is shown for each map unit. The components listed for each map unit are only those that have the same rating class as listed for the map unit. The percent composition of each component in a particular map unit is presented to help the user better understand the percentage of each map unit that has the rating presented.

Other components with different ratings may be present in each map unit. The ratings for all components, regardless of the map unit aggregated rating, can be viewed by generating the equivalent report from the Soil Reports tab in Web Soil Survey or from the Soil Data Mart site. Onsite investigation may be needed to validate these interpretations and to confirm the identity of the soil on a given site.

Rating Options

Aggregation Method: Dominant Condition

Component Percent Cutoff: None Specified

Tie-break Rule: Higher

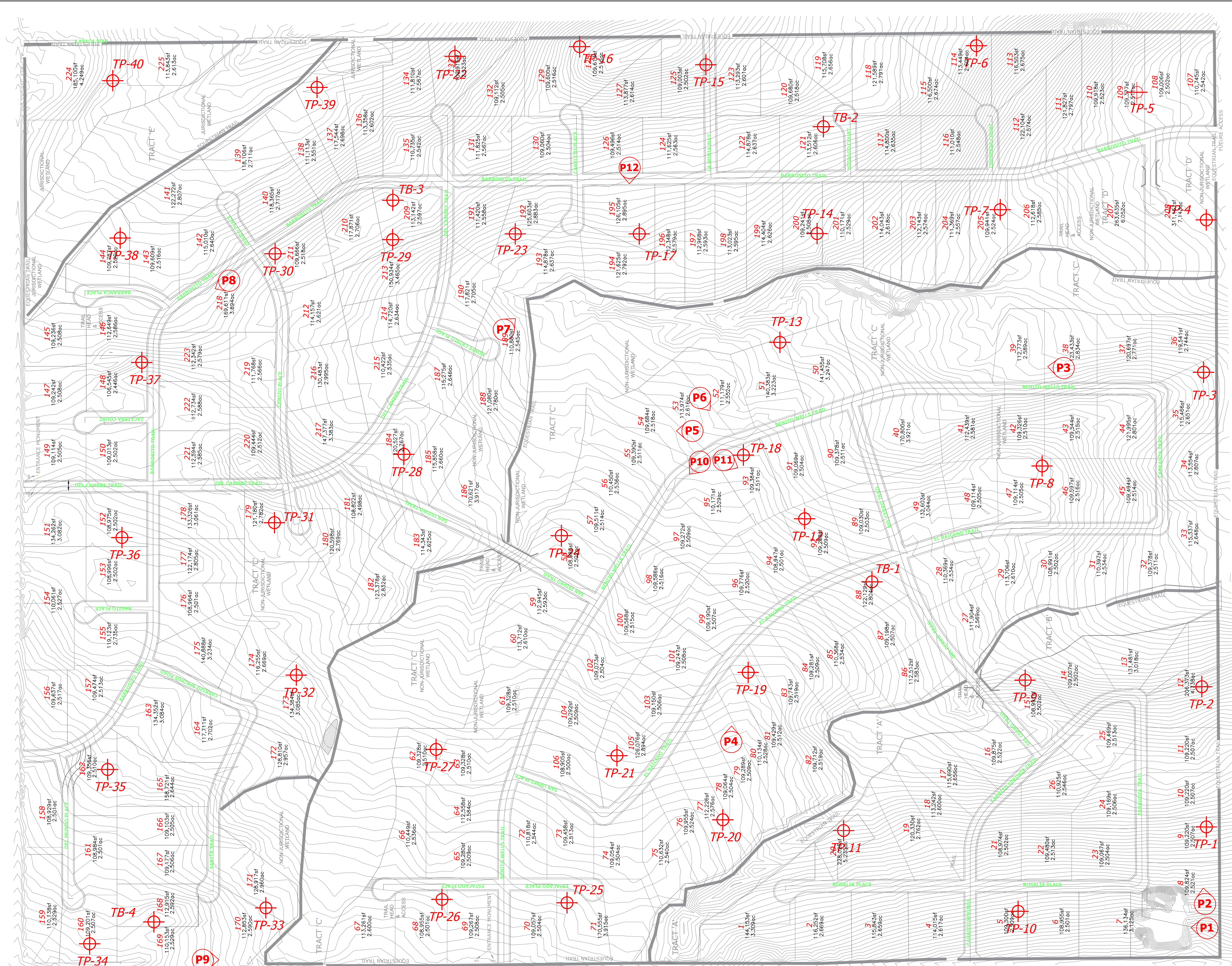

LEGEND: (P1-P12) - APPROXIMATE PHOTOGRAPH LOCATION AND NUMBER
TB - APPROXIMATE TEST BORING LOCATION AND NUMBER TP - APPROXIMATE TEST PIT LOCATION AND NUMBER

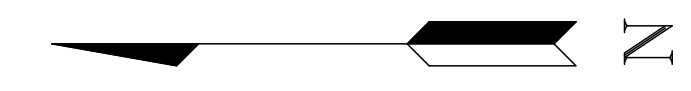
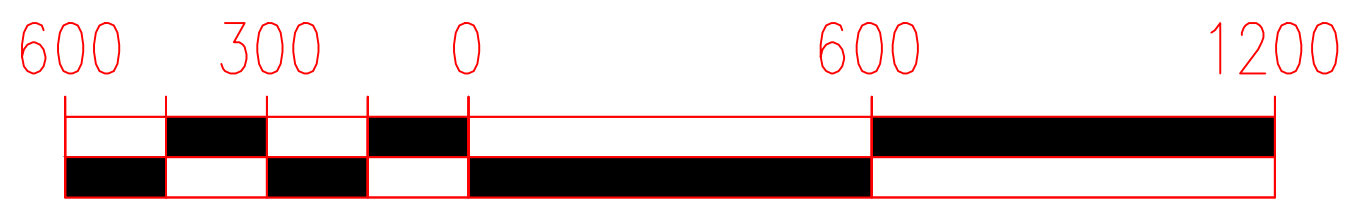

REVISION	BY

ENTTECH
ENGINEERING, INC.

COLORADO SPRINGS, CO. 80907
5055 ELKTON DRIVE (719) 531-5599

SITE PLAN/TEST BORING LOCATION MAP
 SADDLEHORN RANCH SUBDIVISION
 CURTIS ROAD AND JUDGE ORR ROAD
 EL PASO COUNTY, CO.
 FOR: WILLIAM GUMAN AND ASSOCIATES, LTD

DRAWN	LLL/JAG
CHECKED	
DATE	4/29/19
SCALE	AS SHOWN
JOB NO.	181823
FIGURE NO.	3

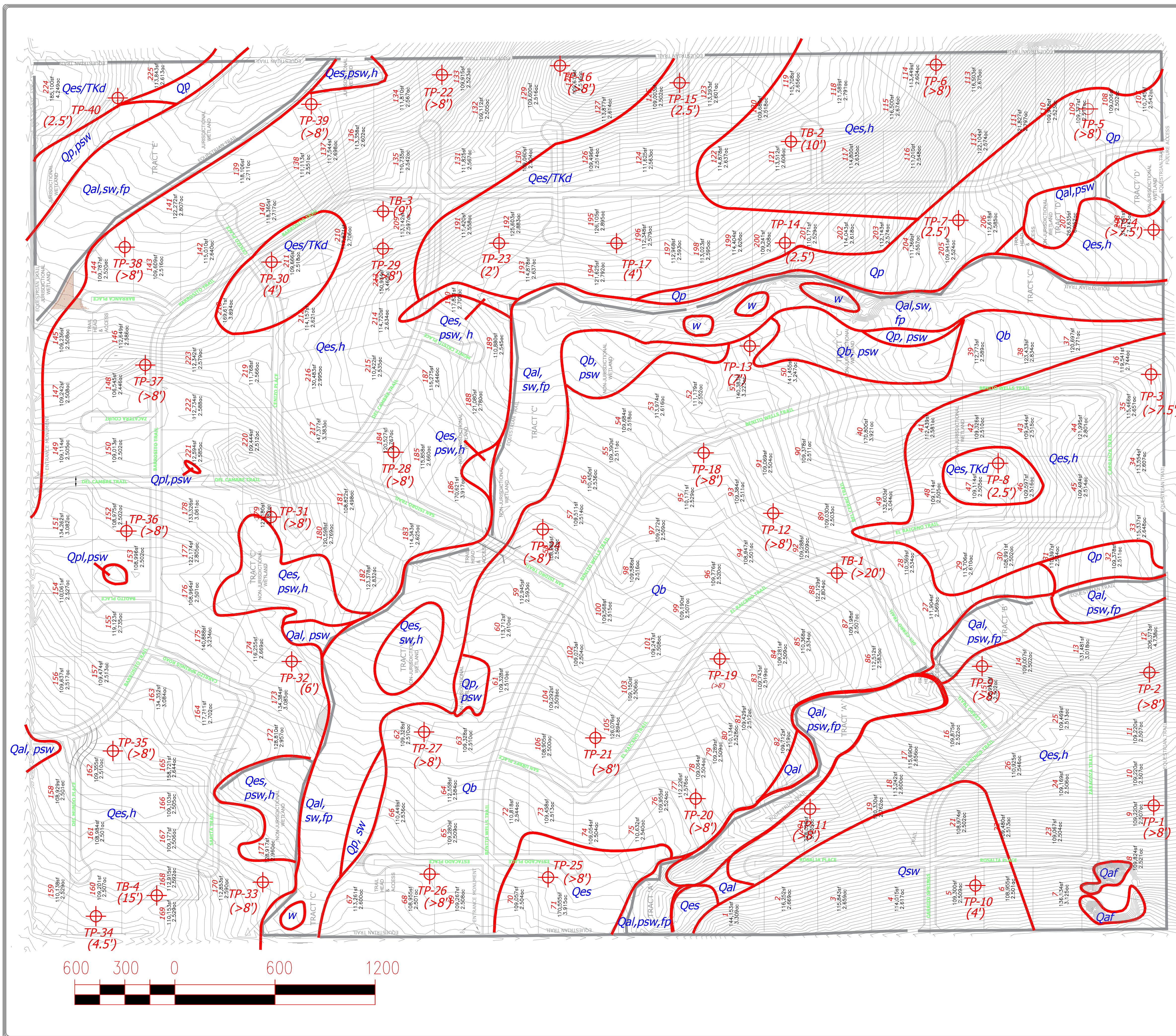

LEGEND:

- Qaf - Artificial Fill of Holocene Age: man made fill deposits
- Qal - Post Piney Creek (Alluvium One)-Recent Alluvium of Late Holocene Age: recent stream deposits
- Qpl - Playa Deposits of Holocene Age: blowouts in eolian sand that form seasonal ponds
- Qp - Piney Creek Alluvium (Alluvium Two) of Early Holocene Age: low stream terrace deposits above current stream channels
- Qb - Broadway Alluvium (Alluvium Three) of Late Pleistocene Age: stream terrace deposited sands
- Qes - Eolian Sand of Holocene to Late Pleistocene Age: wind blown sand deposits
- Qsw - Sheetwash of Holocene to Late Pleistocene Age: silty to clayey sand sheetwash deposits
- Qes/TKd - Sand Deposits of Quaternary Age Overlying Dawson Arkose Formation of Tertiary to Cretaceous Age: windblown sands and residual soil deposits overlying arkosic sandstone with interbedded siltstone and claystone
- h - hydrocompaction
- fp - floodplain
- psw - potentially seasonal shallow groundwater area
- sw - seasonal shallow groundwater area
- w - flowing / ponded water
- ⊕ TB - Approximate Test Boring Location
- ⊕ TP - Approximate Test Pit Location
- (6') - (Depth to bedrock in feet)

REVISION	BY

ENTTECH
ENGINEERING, INC.

505 ELKTON DRIVE (719) 531-5599
COLORADO SPRINGS, CO. 80907

GEOLOGY/ENGINEERING GEOLOGY MAP
SADDLEHORN RANCH SUBDIVISION
CURTIS ROAD AND JUDGE ORR ROAD
EL PASO COUNTY, CO.
FOR: WILLIAM GUMAN AND ASSOCIATES, LTD

DRAWN
LLL/JAG
CHECKED

DATE
4/29/19

SCALE
AS SHOWN

JOB NO.
181823

FIGURE No.
6

- APPROXIMATE LOCATION OF PERCOLATION TEST
- AREAS WHERE DESIGNED SYSTEMS ARE RECOMMENDED DUE TO UNSUITABLE SOILS, SHALLOW BEDROCK OR SHALLOW GROUNDWATER
- AREAS WHERE SEPTIC SYSTEMS ARE NOT RECOMMENDED
- AREAS WHERE CONVENTIONAL SYSTEMS CAN BE USE UNLESS SHALLOW BEDROCK, SHALLOW GROUNDWATER OR UNSUITABLE SOILS ARE ENCOUNTERED REQUIRING DESIGNED SYSTEMS
- POSSIBLE HOUSE LOCATION
- TWO POSSIBLE OWTS (ON-SITE WASTEWATER TREATMENT SITES)
- APPROXIMATE TEST BORING LOCATIONS
- APPROXIMATE TEST PIT LOCATIONS

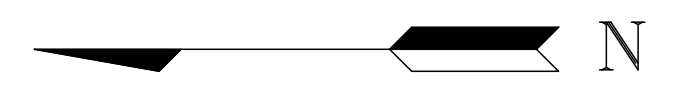
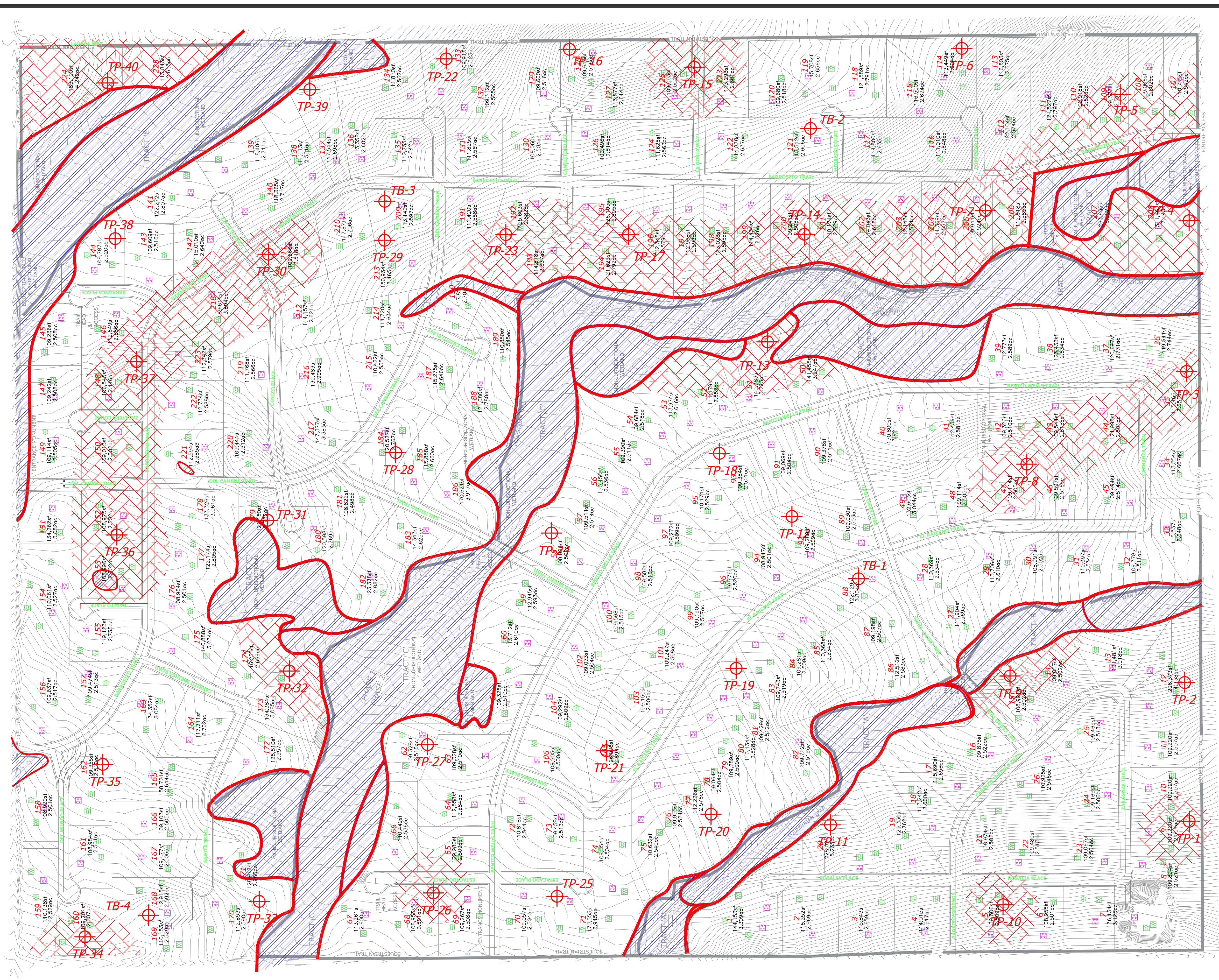

REVISION	BY

ENTTECH
ENGINEERING, INC.

505 ELKTON DRIVE (719) 531-5599
COLORADO SPRINGS, CO. 80907

SEPTIC SUITABILITY MAP
SADDLEHORN RANCH SUBDIVISION
CURTIS ROAD AND JUDGE ORR ROAD
EL PASO COUNTY, CO.
FOR: WILLIAM GUMAN AND ASSOCIATES, LTD

DRAWN	LLL/JAG
CHECKED	
DATE	4/29/19
SCALE	AS SHOWN
JOB NO.	181823
FIGURE No.	11