



**MVE, INC.**  
ENGINEERS SURVEYORS

1903 kelaray street, suite 200  
colorado springs, co 80909  
719.635.5736

Final  
Drainage  
Report

**Table Rock  
Homesteads**

**Project No. 61223**

**January 8, 2025**

PCD File No.

# Final Drainage Report

for

**Table Rock Homesteads**

**Project No. 61223**

**January 8, 2025**

prepared for

**Ted Jarosz**

8550 Kenosha Drive  
Colorado Springs, CO 80908

prepared by

**MVE, Inc.**

1903 Lelaray Street, Suite 200  
Colorado Springs, CO 80909  
719.635.5736

Copyright © MVE, Inc., 2025

61223 Drainage Report.odt

# Statements and Acknowledgments

## **Engineer's Statement**

The attached drainage plan and report were prepared under my direction and supervision and are correct to the best of my knowledge and belief. Said drainage report has been prepared according to the criteria established by the County for drainage reports and said report is in conformity with the applicable master plan of the drainage basin. I accept responsibility for any liability caused by any negligent acts, errors or omissions on my part in preparing this report.

David R. Gorman, P.E.  
Colorado No. 31672  
For and on Behalf of MVE, Inc.

## **Developer's Statement**

I, the owner/developer have read and will comply with all of the requirements specified in this drainage report and plan.

\_\_\_\_\_  
Ted Jarosz, Owner

\_\_\_\_\_  
Date

## **EI Paso County**

Filed in accordance with the requirements of the Drainage Criteria Manual, Volumes 1 and 2, EI Paso County Engineering Criteria Manual and Land Development Code as amended.

\_\_\_\_\_  
Joshua Palmer, P.E.  
County Engineer/ECM Administrator

\_\_\_\_\_  
Date

Conditions:

# Contents

Statements and Acknowledgments.....	iii
Contents.....	v
Final Drainage Report.....	1
<b>1 General Location and Description.....</b>	<b>1</b>
1.1 Location.....	1
1.2 Description of Property.....	1
1.3 Soil Description.....	1
<b>2 Drainage Basins and Sub-Basins.....</b>	<b>2</b>
2.1 Major Basin Descriptions.....	2
2.2 Sub-Basin Description.....	2
<b>3 Drainage Design Criteria.....</b>	<b>2</b>
3.1 Development Criteria Reference.....	2
3.2 Hydrologic Criteria.....	2
<b>4 Drainage Facility Design.....</b>	<b>3</b>
4.1 General Concept.....	3
4.2 Sub-Basin Specific Details.....	3
4.2.1 Offsite Conditions.....	3
4.2.2 Existing Onsite Conditions.....	3
4.2.3 Proposed Onsite Conditions .....	5
4.3 Reseeding and Allowable Ditch Flow Velocities.....	7
4.4 Permanent Water Quality Facilities.....	8
4.5 Channel Analysis and Proposed Protection.....	8
4.6 Water Quality Enhancement Best Management Practices.....	9
<b>5 Opinion of Probable Cost for Drainage Facilities.....</b>	<b>10</b>

<b>6 Drainage Fees</b> .....	10
<b>7 Conclusion</b> .....	10
References.....	10
Appendices.....	13
<b>1 General Maps and Supporting Data</b> .....	13
<b>2 Hydrologic Calculations</b> .....	24
<b>3 Hydraulic Calculations</b> .....	71
<b>4 Drainage Maps</b> .....	72

# Final Drainage Report

The purpose of this Final Drainage Report is to identify drainage patterns and quantities within and affecting the proposed Table Rock Homesteads, a 106.364± acre parcel in El Paso County, Colorado. The report presents the stormwater management issues specific to this site and discusses the aspects of the drainage design that addresses those issues. The report will identify specific solutions to drainage concerns on-site and off-site resulting from the proposed project. The report and included maps present results of hydrologic and drainage facilities analyses. The report will discuss the recommended drainage improvements to the site and identify drainage requirements relative to the proposed project. This report has been prepared and submitted in accordance with the requirements of the El Paso County development approval process. An **Appendix** is included with this report with pertinent calculations and graphs used in the drainage analyses and design.

## 1 General Location and Description

### 1.1 Location

The Table Rock Homesteads site is located within the Southeast ¼ of the Northeast ¼ of Section 6, Township 12 South, Range 65 West, of the 6<sup>th</sup> Principal Meridian in El Paso County, Colorado. The site is situated approximately 0.60 miles to the west of Black Forest Road and approximately 0.25 miles to the east of E. Thunder Road. E. Palmer Divide Road is about ½ mile to the north of the site. The site is made up of two unplatted properties having El Paso County Tax Assessor's Schedule Numbers: 5100000012, 5100000026 and the address is to be determined. A Vicinity Map is included in the **Appendix**. This report is submitted in connection with the application for a Final Plat.

### 1.2 Description of Property

The Table Rock Homesteads site encompasses 106.364± acres of land currently zoned RR-5 (Rural Residential 5 acres). The parcels are currently undeveloped. Access for this undeveloped area is an existing road named Gambler Place. The owners intend to subdivide the parcel into ten lots. The lots are sized per the following grouping: (5) +5 acre lots, (3) +10 acre lots and (2) +20 acre lots. Public roads will be constructed to access the proposed lots.

This parcel is undeveloped. The storm runoff from the site and the offsite basins generally drain from the north to the southeast and south. There are two distinct gullies located within the site boundary that convey drainage to the southeast.

### 1.3 Soil Description

According to the National Resource Conservation Service, there are two soil types identified at the Table Rock Homesteads site. Brusset Loam, 3 to 5 percent slopes (map unit 15), makes up the majority of the site and is contained in Hydrologic Soil Group B. This soil is deep and is well drained, permeability is moderate, surface runoff is medium to rapid, and the hazard of erosion is moderate.

The secondary soil group is: Peyton-Pring complex, 8 to 15 percent slopes (map unit 69). This soil is contained in Hydrologic Soil Group B. This soil is shallow to deep and well drained, permeability is moderate, surface runoff is medium to rapid, and the hazard of erosion is moderate to high. A portion of

the Soil Map and data tables from the National Cooperative Soil Survey and relevant Official Soil Series Descriptions (OSD) are included in the **Appendix**.<sup>1 2</sup>

Areas of Seasonally Shallow Groundwater and Potentially Seasonal Shallow Groundwater were identified in the Soils and Geology Study prepared by Entech Engineering, Inc. under Job No. 241483 and dated December 23, 2024. Said report details the locations of these areas, which includes the two gullies or drainages previously discussed in this report, and outlines appropriate mitigation measures. Mitigation measures for Potentially Seasonally Shallow Groundwater Areas include constructing foundations with sufficient depth for frost protection, installing subsurface perimeter drains, and grading to direct surface flows around structures. Mitigation measures for Seasonally Shallow Groundwater Areas include avoidance of placing structures in obvious drainage areas and observance of the same mitigation measures that apply to the Potentially Seasonal Groundwater Areas. Due to the large size of the lots, these areas can be avoided.

Expansive soils, potentially high radon levels and potentially unstable slopes were also identified in the Entech report. The majority of these conditions can be avoided by construction. Others can be mitigated through proper engineering design and construction practices. The proposed development and use are consistent with anticipated geologic and engineering geologic conditions.

## 2 Drainage Basins and Sub-Basins

### 2.1 Major Basin Descriptions

The Table Rock Homesteads site is located in the northeast portion of East Cherry Creek Drainage Basin (CYCY0200).

The current Flood Insurance Study of the region includes a Flood Insurance Rate Map (FIRM), effective on December 7, 2018.<sup>3</sup> The proposed subdivision is included in Community Panel Numbers 08041C0305G of the Flood Insurance Rate Maps for El Paso County and Incorporated Areas. No portion of the site lies within FEMA designated Special Flood Hazard Areas (SFHA's). An excerpt of the current FEMA Flood Insurance Rate Maps with the site delineated is included in the **Appendix**.

### 2.2 Sub-Basin Description

The existing drainage patterns of the Table Rock Homesteads site are described by four off-site drainage sub-basins and seven on-site drainage sub-basins. The offsite flows enter the site along the north and west sides of the property. Generally all flows route to the southeast and south portions of the site. There are two distinct gullies located within the site boundary that convey drainage to the southeast. Each existing drainage basin will be described in detail in Sub-Basin Specific Details. The drainage sub-basins are shown on the included **Existing Drainage Map**.

## 3 Drainage Design Criteria

### 3.1 Development Criteria Reference

This *Final Drainage Report for Table Rock Homesteads* has been prepared according to the report guidelines presented in the *El Paso County Drainage Criteria Manual* (DCM)<sup>4</sup>. The hydrologic analysis is based on a collection of data from the DCM, the NCSS Web Soil Survey<sup>5</sup>, Topographic mapping by El Paso County and property boundary information by Polaris Surveying, Inc.

### 3.2 Hydrologic Criteria

For this Final Drainage Report, the Rational Method as described in the *El Paso County Drainage Criteria Manual* has been used for all Storm Runoff calculations, as the development and all sub-basins are less

---

1 WSS  
 2 OSD  
 3 FIRM  
 4 DCM Section 4.3 and Section 4.4  
 5 WSS

than 130 acres in area and the hydrologic routing is relatively simple. “Colorado Springs Rainfall Intensity Duration Frequency” curves, Figure 6-5 in the DCM, was used to obtain the design rainfall values; a copy is included in the **Appendix**. The “Overland (Initial) Flow Equation” (Eq. 6-8) in the DCM, and Manning’s equation with estimated depths were used in time of concentration calculations. “Runoff Coefficients for Rational Method”, Table 6-6 in the DCM, was utilized as a guide in estimating runoff coefficient and Percent Impervious values; a copy is included in the **Appendix**. Peak runoff discharges were calculated for each drainage sub-basin for both the 5-year storm event and the 100-year storm event with the Rational Method formula, (Eq. 6-5) in the DCM.<sup>6</sup>

## 4 Drainage Facility Design

### 4.1 General Concept

The intent of the drainage concept presented in this Final Drainage Report is to provide adequate, safe and appropriate storm drainage, in accordance with El Paso County Drainage Criteria, within the proposed development and to the offsite discharge locations. The existing drainage conditions and the proposed drainage concept is described in more detail below. Input data and results for all calculations are included in the **Appendix**. Drainage maps of existing and proposed conditions are also included in the **Appendix**.

### 4.2 Sub-Basin Specific Details

#### 4.2.1 Offsite Conditions

Offsite sub-basin **OS-B1a** containing  $10.93 \pm$  acres is located north of the site. This sub-basin contains property zoned as RR-5 and a “5-acre” runoff coefficient was applied in the drainage calculations. The majority of this sub-basin features moderate slopes of 9% to 18%. This sub-basin generates peak flow discharges of  $Q_5 = 3.6$  cfs and  $Q_{100} = 22.8$  cfs (existing flows). This runoff enters onsite sub-basin B3 along the north property line and eventually combines with additional flows at Design Point B1 (DP-B1).

Offsite sub-basin **OS-B1b** containing  $5.68 \pm$  acres is located northwest of the site. This sub-basin contains property zoned as RR-5 and a “5-acre” runoff coefficient was applied in the drainage calculations. This sub-basin features moderate slopes of 9% to 18%. This sub-basin generates peak flow discharges of  $Q_5 = 2.0$  cfs and  $Q_{100} = 12.8$  cfs (existing flows). This runoff enters on-site sub-basin B3 along the northwest property line and combines with additional flows at Design Point B1 (DP-B1).

Offsite sub-basin **OS-B2** containing  $16.03 \pm$  acres is located west of the site. This sub-basin contains a portions of single-family residences along with several small detached buildings. The majority of this sub-basin features mild slopes of 6% to 10%. This sub-basin generates peak flow discharges of  $Q_5 = 4.6$  cfs and  $Q_{100} = 29.4$  cfs (existing flows). This runoff enters on-site sub-basin B4-5 along the west property line and combines with additional flows at Design Point B2-3 (DP-B2-3).

Offsite sub-basin **OS-D1-2** containing  $8.51 \pm$  acres is located west of the site. This sub-basin contains a single-family residence along with several small detached buildings. The majority of this sub-basin features mild slopes of 3% to 6%. This sub-basin generates peak flow discharges of  $Q_5 = 2.5$  cfs and  $Q_{100} = 15.8$  cfs (existing flows). This runoff enters on-site sub-basin D3-4 along the west property line and combines with additional flows at Design Point D2 (DP-D2), at which point, stormwater exists from the property at the south boundary in a wide drainage way.

#### 4.2.2 Existing Onsite Conditions

The existing onsite drainage patterns of the site are described by seven sub-basins. The site’s general slopes range between 4% and 15% and there are two distinct gullies located within the site’s boundary that have steep slopes ranging from 50% to 90%. The gullies are located at the north-central to the east side of the site and another gully is located in the south-west portion of the site. A small portion of the site, where sub-basins A1, C1 and E1 are identified, sheet flow off of the site. The majority of the site’s

---

<sup>6</sup> DCM



drainage exits the site in the gullies. The flows exiting the site from the gullies are summarized by design point B4 (DP-B4) and design point D2 (DP-D2).

Existing onsite sub-basin **A1** containing 3.18 ± acres is located within the north-east corner of the site. This sub-basin is undeveloped pasture/meadow. This sub-basin features mild to moderate slopes of 5% to 15%. This sub-basin generates peak flow discharges of  $Q_5 = 0.8$  cfs and  $Q_{100} = 6.2$  cfs (existing flows). This runoff flows offsite in a wide drainage way to the north-east, to Design Point A1 (DP-A1).

Existing onsite sub-basin **B3** containing 18.60 ± acres is located within the north-west portion of the site. This sub-basin is undeveloped pasture/meadow. This sub-basin features mild slopes of 5% to 15%. This sub-basin accepts flows from OS-B1a and OS-B1b, which uniformly flows in a wide drainage way and enters the most northerly gully at design point B1 (DP-B1). This sub-basin generates peak flow discharges of  $Q_5 = 3.9$  cfs and  $Q_{100} = 28.8$  cfs (existing flows).

Existing onsite sub-basin **B4-5** containing 21.70 ± acres is located within the westerly and middle portion of the site. This sub-basin is undeveloped pasture/meadow. This sub-basin features mild slopes of 4% to 13%. This sub-basin combines with flows from OS-B2 and flows in a wide drainage way to the beginning of the most northern gully and is summarized at design point B2-3 (DP-B2-3). This sub-basin generates peak flow discharges of  $Q_5 = 4.7$  cfs and  $Q_{100} = 34.4$  cfs (existing flows).

Existing onsite sub-basin **B6** containing 32.39 ± acres located within the east portion within the site. This sub-basin is undeveloped pasture/meadow and contains a gully. This sub-basin features steep slopes of 50% to 90% at the gully, moderate to steep slopes of 7% to 20% in the northern and central portion of the site and mild slopes of 5% in the south portion of the site. This sub-basin generates peak flow discharges of  $Q_5 = 6.3$  cfs and  $Q_{100} = 46.1$  cfs (existing flows). This runoff combines with flows from Design Point B2-3 (DP-B2-3) and Design Point B1 (DP-B1) and exits the site in the most northern gully at existing design point B4 (DP-B4).

Existing onsite sub-basin **C1** containing 8.33 ± acres located within the southeast portion of the site. This sub-basin is undeveloped pasture/meadow. This sub-basin features mild slopes of 4% to 6%. This sub-basin generates peak flow discharges of  $Q_5 = 1.5$  cfs and  $Q_{100} = 11.1$  cfs (existing flows). This runoff uniformly sheet flows offsite to design point C1 (DP-C1).

Existing onsite sub-basin **D3-4** containing 20.63 ± acres is located within the south-central portion of the site. This sub-basin is undeveloped pasture/meadow and contains the most southerly gully. This sub-basin features steep slopes of 50% to 90% at the gully, moderate to steep slopes of 7% to 20% in the western portion of the site and mild slopes of 5% in the eastern portion of the site. This sub-basin generates peak flow discharges of  $Q_5 = 5.2$  cfs and  $Q_{100} = 38.0$  cfs (existing flows). This runoff combines with flows from OSD1-2 at existing design Point D2 (DP-D2).

Existing onsite sub-basin **E1** containing 1.52 ± acres located within the southwest portion of the site. This sub-basin is undeveloped pasture/meadow. This sub-basin features mild to moderate slopes of 5% to 15%. This sub-basin generates peak flow discharges of  $Q_5 = 0.5$  cfs and  $Q_{100} = 3.4$  cfs (existing flows). The runoff sheet flows offsite at design point E1 (DP-E1).

**Existing Design Point A1 (DP-A1)** consists of only the flows generated in existing sub-basin A1. This design point is located at the northeast corner of the site. The design point collects peak flow discharges of  $Q_5 = 0.8$  cfs and  $Q_{100} = 6.2$  cfs (existing flows). This runoff flows offsite in a wide drainage way to the northeast.

**Existing Design Point B1 (DP-B1)** consists of OS-B1-a, O-SB1-b, and existing sub-basin B3 with a collective area of 35.21 ± acres. This design point is located at the southeast portion of B3 with the primary surface type of pasture/meadow. The design point collects peak flow discharges of  $Q_5 = 8.3$  cfs and  $Q_{100} = 56.8$  cfs (existing flows). These flows enter the existing natural gully and continues on into sub-basin B6.

**Existing Design Point B2-3 (DP-B2-3)** consists of OS-B2, and existing sub-basin B4-5 with a collective area of 37.73 ± acres. This design point is located at the northeast portion of B4-5 with the primary surface type of pasture/meadow. The design point collects peak flow discharges of  $Q_5 = 8.3$  cfs and  $Q_{100} = 56.8$  cfs (existing flows). These flows enter the existing natural gully and continues on into sub-basin B6.

**Existing Design Point B4 (DP-B4)** consists of DP-B2-3, DP-B1 and existing sub-basin B6 with a collective area of 105.33 ± acres. This design point is located at the east portion of existing sub-basin B6 with the primary surface type of pasture/meadow. The design point collects peak flow discharges of  $Q_5 = 20.7$  cfs and  $Q_{100} = 145.1$  cfs (existing flows). This runoff drains offsite in the most northerly gully.

**Existing Design Point E1 (DP-E1)** consists of only the flows generated in existing sub-basin E1. This design point is located at the southwest corner of the site. The design point collects peak flow discharges of  $Q_5 = 0.5$  cfs and  $Q_{100} = 3.4$  cfs (existing flows). This runoff uniformly sheet flows offsite to the southwest.

**Existing Design Point D2 (DP-D2)** consists of OS-D1-2 and existing sub-basin D3-4 with a collective area of 29.14 ± acres. This design point is located at the south of D3-4 with the primary surface type of pasture/meadow. The design point collects peak flow discharges of  $Q_5 = 6.7$  cfs and  $Q_{100} = 46.8$  cfs (existing flows). These flows exit the site on the south property line in a wide drainage way.

**Existing Design Point C1 (DP-C1)** consists of only the flows generated in existing sub-basin C1. This design point is located at the southeast corner of the site. The design point collects peak flow discharges of  $Q_5 = 1.5$  cfs and  $Q_{100} = 11.1$  cfs (existing flows). This runoff uniformly sheet flows offsite to the southeast.

#### 4.2.3 Proposed Onsite Conditions

The proposed onsite drainage patterns of the site are described by nine sub-basins.

For the interior onsite sub-basin delineation lines, the drainage paths and sub-basin shapes will change slightly due to the proposed public gravel roadway. A small portion of the site, where sub-basins A1, C1 and E1 are identified, sheet flow off of the site. The majority of the site's drainage exits the site in the gullies. The proposed development calculations all include a Land Use Characteristic of "5-acre" which pertains to the runoff coefficient applied to these proposed sub-basins in the drainage calculations. The drainage sub-basins are shown on the included **Proposed Drainage Map**.

Proposed onsite sub-basin **A1** containing 3.18 ± acres represents the same characteristics as existing sub-basin A1, except for the prescribed land use runoff coefficient applied in the drainage calculations from pasture/meadow to "5 acre." Proposed onsite sub-basin A1 is located within the north-east corner of the site. This sub-basin features mild to moderate slopes of 5% to 15%. This sub-basin generates a peak flow discharge of  $Q_5 = 1.1$  cfs and  $Q_{100} = 6.8$  cfs (proposed flows). This runoff flows offsite in a wide drainage way to the north-east, to Design Point A1 (DP-A1).

Proposed onsite sub-basin **B3** containing 18.60 ± acres represents the majority of the characteristics of existing onsite sub-basin B3, except for the prescribed land use runoff coefficient applied in the drainage calculations from pasture/meadow to "5 acre" and proposed sub-basin B-3 contains a portion of the proposed public gravel road. These aforementioned characteristics make the flow calculations a bit higher, but still negligible. This sub-basin generates a peak flow discharge of  $Q_5 = 4.9$  cfs and  $Q_{100} = 31.5$  cfs (proposed flows). Similar to existing onsite sub-basin B3, this proposed sub-basin accepts flows from OS-B1-a and OS-B1-b, which uniformly flows in a wide drainage way and enters the most northerly gully at design point B1 (DP-B1).

Proposed onsite sub-basin **B4** containing 18.09 ± acres is located within the westerly and middle portion of the site. The easterly boundary of this drainage sub-basin is along the centerline of the proposed public gravel road. This sub-basin combines with flows from OS-B2 and flows in a wide drainage way to the beginning of the most northern gully and is summarized at design point B2 (DPB2), at which, two (2) 18 inch culverts conveys flows under the proposed public gravel road and into proposed sub-basin B5. This sub-basin generates peak flow discharges of  $Q_5 = 5.2$  cfs and  $Q_{100} = 33.0$  cfs (proposed flows).

Proposed onsite sub-basin **B5** containing 4.09 ± acres is located within the westerly and middle portion of the site and to the east of the proposed public gravel road. This sub-basin receives the flows from the two (2) 18 inch culverts that convey flows under the public road from proposed sub-basin B-4. The westerly boundary of this drainage sub-basin is along the centerline of the proposed public gravel road. This sub-basin combines with flows from proposed sub-basin B4 and DP-B2. Flows from this sub-basin route into

the most northern gully and is summarized at design point B3 (DP-B3). This sub-basin generates peak flow discharges of  $Q_5 = 1.3$  cfs and  $Q_{100} = 8.2$  cfs (proposed flows).

Proposed onsite sub-basin **B6** containing  $28.74 \pm$  acres represents the majority of the characteristics of existing onsite sub-basin B6, however it is a bit smaller. The proposed onsite sub-basin is located within the east portion within the site. This sub-basin features steep slopes of 50% to 90% at the gully, moderate to steep slopes of 7% to 20% in the northern and central portion of the site and mild slopes of 5% in the south portion of the site. This sub-basin generates a peak flow discharge of  $Q_5 = 7.9$  cfs and  $Q_{100} = 50.1$  cfs (proposed flows). This runoff combines with flows from Design Point B1 (DP-B1) and Design Point B3 (DP-B3) and exits the site in the most northern gully at existing design point B4 (DP-B4).

Proposed onsite sub-basin **D3** containing  $1.80 \pm$  acres is located within the west-central portion of the site. The southern boundary of this drainage sub-basin is along the centerline of the proposed public gravel road. This sub-basin combines with flows from OS-D1 and sheet flows to design point D1 (DP-D1), at which, two (2) 18 inch culverts conveys flows under the proposed public gravel road and into proposed sub-basin D4. This sub-basin generates peak flow discharges of  $Q_5 = 0.6$  cfs and  $Q_{100} = 4.0$  cfs (proposed flows).

Proposed onsite sub-basin **D4** containing  $18.83 \pm$  acres is located within the south-central portion of the site. This sub-basin receives the flows from the two (2) 18 inch culverts that convey flows under the public road from proposed sub-basin D-3. The northern boundary of this drainage sub-basin is along the centerline of the proposed public gravel road. This sub-basin combines with flows from proposed sub-basin D3 and DP-D1. Flows from this sub-basin route into the most southern gully and then offsite at design point D2 (DP-D2). This sub-basin generates peak flow discharges of  $Q_5 = 6.0$  cfs and  $Q_{100} = 38.6$  cfs (proposed flows).

Proposed onsite sub-basin **C1** containing  $11.51 \pm$  acres is located within the southeast portion of the site. This sub-basin represents the majority of the characteristics of existing onsite sub-basin C3, except for the prescribed land use runoff coefficient applied in the drainage calculations from pasture/meadow to "5 acre" and proposed sub-basin C1 contains a portion of the proposed public gravel road. These aforementioned characteristics make the flow calculations a bit higher, but still negligible. This sub-basin generates a peak flow discharge of  $Q_5 = 2.6$  cfs and  $Q_{100} = 16.9$  cfs (proposed flows). This sub basin sheet flows offsite to the southeast at design point C1 (DP-C1).

Proposed onsite sub-basin **E1** containing  $1.52 \pm$  acres located within the southwest portion of the site. This sub-basin represents the same characteristics as existing sub-basin E1, except for the prescribed land use runoff coefficient applied in the drainage calculations from pasture/meadow to "5 acre." This sub-basin generates a peak flow discharge of  $Q_5 = 2.6$  cfs and  $Q_{100} = 16.9$  cfs (proposed flows). This runoff flows offsite in a wide drainage way to the southwest, to Design Point E1 (DP-E1).

**Proposed Design Point A1 (DP-A1)** consists of only the flows generated in proposed sub-basin A1. This design point is located at the northeast corner of the site and represents flows that travel offsite. The design point has an existing peak discharge of  $Q_5 = 0.8$  cfs and  $Q_{100} = 6.2$  cfs and a proposed peak discharge of  $Q_5 = 1.1$  cfs and  $Q_{100} = 6.8$  cfs. This results in a negligible increase of  $Q_5 = 0.3$  cfs and  $Q_{100} = 0.6$  cfs. This runoff flows offsite in a wide drainage way to the northeast.

**Proposed Design Point B1 (DP-B1)** consists of OS-B1-a, O-SB1-b, and proposed sub-basin B3 with a collective area of  $35.21 \pm$  acres. This design point is located at the southeast portion of B3. The design point has a proposed peak discharge of  $Q_5 = 9.3$  cfs and  $Q_{100} = 59.6$  cfs. These flows enter the existing natural gully and continues on into sub-basin B6.

**Proposed Design Point B2 (DP-B2)** consists of OS-B2, and sub-basin B4 with a collective area of  $34.11 \pm$  acres. This design point is located at the west side of the public gravel road at the entrance to two (2) 18" culverts. The design point collects peak flow discharges of  $Q_5 = 9.0$  cfs and  $Q_{100} = 57.2$  cfs (proposed flows). These flows continue through the culverts and into sub basin B5.

**Proposed Design Point B3 (DP-B3)** consists of DP-B2, and sub-basin B5 with a collective area of  $38.20 \pm$  acres. This design point is located at the northeast portion of sub basin B5. The design point a proposed peak discharge of  $Q_5 = 10.4$  cfs and  $Q_{100} = 66.1$  cfs. These flows continue into sub basin B6.

**Proposed Design Point B4 (DP-B4)** consists of DP-B3, DP-B1 and sub-basin B6 with a collective area of 102.15 ± acres. This design point is located at the east portion of sub-basin B6 and represents flows that travel offsite. The design point has an existing peak discharge of  $Q_5 = 20.7$  cfs and  $Q_{100} = 145.1$  cfs and a proposed peak discharge of  $Q_5 = 25.6$  cfs and  $Q_{100} = 163.1$  cfs. This results in an increase of  $Q_5 = 4.9$  cfs and  $Q_{100} = 18.0$  cfs. DP-B4 represents the largest offsite drainage summary and includes a cumulative drainage area of 102.15 acres. The design point collects peak flow discharges of  $Q_5 = 25.6$  cfs and  $Q_{100} = 163.1$  cfs (proposed flows). This runoff drains offsite in the most northerly gully.

**Proposed Design Point D1 (DP-D1)** consists of OS-D1, and sub-basin D3 with a collective area of 8.35 ± acres. This design point is located at the west side of the public gravel road at the entrance to two (2) 18" culverts. The design point collects peak flow discharges of  $Q_5 = 2.4$  cfs and  $Q_{100} = 15.1$  cfs (proposed flows). These flows continue through the culverts and into sub basin D4.

**Proposed Design Point D2 (DP-D2)** consists of OS-D2, DP-D1 and proposed sub-basin D4 with a collective area of 29.14 ± acres. This design point is located at the south of D4. The design point has a proposed peak discharge of  $Q_5 = 7.7$  cfs and  $Q_{100} = 49.3$  cfs. These flows exit the site on the south property line in a wide drainage way.

**Proposed Design Point C1 (DP-C1)** consists of only the flows generated in proposed sub-basin C1. This design point is located at the southwest corner of the site and represents flows that travel offsite. The design point has an existing peak discharge of  $Q_5 = 1.5$  cfs and  $Q_{100} = 11.1$  cfs and a proposed peak discharge of  $Q_5 = 2.6$  cfs and  $Q_{100} = 16.9$  cfs. This results in a negligible increase of  $Q_5 = 1.1$  cfs and  $Q_{100} = 5.8$  cfs. This runoff uniformly sheet flows offsite to the southwest.

**Proposed Design Point E1 (DP-E1)** consists of only the flows generated in proposed sub-basin E1. This design point is located at the southwest corner of the site and represents flows that travel offsite. The design point has an existing peak discharge of  $Q_5 = 0.5$  cfs and  $Q_{100} = 3.4$  cfs and a proposed peak discharge of  $Q_5 = 0.6$  cfs and  $Q_{100} = 3.7$  cfs. This results in a negligible increase of  $Q_5 = 0.1$  cfs and  $Q_{100} = 0.3$  cfs. This runoff uniformly sheet flows offsite.

Overall, to help reinforce the relationships of the existing and proposed drainage flow quantities, the main contribution for the increased flows in the calculations develops from the application of land use characteristics. In the existing conditions, the land use of pasture/meadow was applied and in developed conditions, the land use of "5-acre" was applied. This application reflects a 7% increase of impervious surfaces over the entire site. The majority of the site will actually be pasture/meadow with only 2.6 acres of the 106+ acre being the public gravel road and a small acreage will represent the future homes, out buildings and driveways.

### 4.3 Reseeding and Allowable Ditch Flow Velocities

All disturbed areas that are not access easement surfaces or otherwise protected by riprap shall be reseeded using the El Paso Low Grow Grass Seed Mix suggested by the El Paso County Conservation District. A copy of this recommendation is included in the **Appendix** of this report and on the Grading and Erosion Control Plan for this project. The seed mix contains a mixture of about 24% Western Wheatgrass, about 20% Blue Grama, Native, about 18% Buffalograss, about 13% Sideoats Grama, about 6% Green Needlegrass, and about 1.5% Sand Dropseed. These specific species of native seed are selected for erosion control properties, suitability to the local climate, growth potential and hardiness. Each of the seed species provides good soil holding capabilities ground coverage. The characteristics of the predominate seed species are shown on the Plant Guides also included in the **Appendix**. The El Paso County Drainage Criteria Manual Table 10-4 is intended to provide guidance on allowable flow velocities for various types of open channel grass linings. However, Table 10-4 does not address the predominate species contained in the suggested Seed Mix and is not useful for determining allowable flow velocities with these types of linings. Therefore, a supplemental data table from the "Stability Thresholds for Stream Materials" prepared by U.S. Army Engineer Research and Development Center is included in the appendix which contains better descriptions along with testing and research references that indicate the native grass types in the reseed mix are able to withstand flow velocities ranging from 4 ft/sec to 6 ft/sec or more. Flow velocities on all reseeded areas remain below 5 ft/sec and the native grasses are adequate to withstand to flows. Maximum ditch velocity calculation is included in the **Appendix**.

#### 4.4 Permanent Water Quality Facilities

A 4' Wide Grass Buffer, is represented in the Runoff Reduction calculations as a 100 foot long road section with 4' wide grass buffer. The grass buffer will be installed inside the property line with the allowance of one 20' wide driveway.

Sand filter basins shall be incorporated into the site at three locations as shown on the Water Quality Control Plan (WQCP). The sand filter basins have been designed to capture the flows at the outlet of the culverts and divert flow via a pipe to the sand filter basin. The sand filter basin has been sized to treat the required storm water quality volume and treatment facilities are outside of the public road right-of-way.

The sand filter basins will provide the necessary water quality treatment for the new public gravel road area. The sand filter basins vary in size and details are provided on the WQCP.

Grass Buffer and sand filter calculations and plans pertaining to water quality treatment facilities are included in the **Appendix**.

#### 4.5 Channel Analysis and Proposed Protection

The two existing gullies were analyzed for erosion potential by hydraulic modeling. The most northerly gully was analyzed in 5 sections: North Finger ( $Q_{100}=59.6$  cfs), South Finger ( $Q_{100}=16.7$  cfs), Main Channel U ( $Q_{100}=57.2$  cfs), Main Channel M ( $Q_{100}=117.2$  cfs) and Main Channel L ( $Q_{100}=163.1$  cfs). The gully at the south-west portion of the site was analyzed in two sections: Main Channel RS 1250 ( $Q_{100}=4.2$  cfs) and Main Channel RS 800 ( $Q_{100}=30.0$  cfs).

The HEC-RAS analysis was performed to evaluate the areas within the gully channels that may require stabilization. More specifically, from the modeled data, areas with velocities that surpassed 4.0-6.0 fps and Froude numbers that were greater than 0.9, may indicate areas that required stabilization. The criteria for the velocity range was selected from the El Paso Conservation District (included in the **Appendix**) as well as recommendations made in the Erosion Control Section of the Entech Soil and Geology Study. The Criteria established for the froude number is based on Section 6.5.2 from the EPC Drainage Criteria Manual.

In some sections of the gullies, the froude number was above 0.9, however, in the same section the velocities were still low. In these cases, stabilization was not prescribed because the velocities were within the range of what the native soils/plantings tolerated and therefore not considered highly erosive areas. In a few areas of the existing gullies, velocities and froude numbers correlated more, with both being higher values, indicating that these areas required stabilization. The proposed stabilization is detailed later in this section.

For the existing conditions HECRAS analysis, the calculated developed flow rates were used to identify sections of the gullies that may require stabilization once the site is developed. This analysis was used to design the stabilized sections of the gullies. The HECRAS was reran after sections of the gullies were regraded and riprap protection was added, with the revised HECRAS sections and Manning's n roughness coefficients. Applied composite roughness coefficients were selected from Table 10-1 from the EPC Drainage Criteria Manual and included in the **Appendix**.

For the areas discussed in the section below, refer to the HECRAS Maps.

Improvements are planned for in the most northern gully in almost the entire section of the North Finger, the beginning section of the Upper Main Channel, the middle section of the main channel where the North Finger section combines with this channel, a large portion of the South Finger and the lower section of the Main Channel where the South Finger combines with this channel. The proposed modifications to the northern gully will consist of riprap channel entrance protection, incorporation of a stilling basins in the Upper Main and South Finger and regrading of the channel as follows: the channel bottoms in the proposed riprap sections shall be dug out to place the riprap so as to only change the channel geometry slightly. Areas identified as needing channel riprap lining shall be excavated to the required depth and be replaced by soil riprap to the original channel grade.

Improvements are planned for in the south-western gully at the beginning section of the Main Channel. The proposed modifications to the south-western gully will consist of riprap protection and regrading as described in the above paragraph.

Existing heavy brush and natural vegetation between the proposed stabilized areas will remain. Riprap for the channel entrance protection and channel lining is sized according to MHFD Vol 1, ch 8.1.2 using RipRap Sizing procedure for channel longitudinal slopes greater than 2%, S. R. Abt 1988. Calculations are included in the **Appendix**. Channel Protection details are shown on **the Grading and Erosion Control plans**.

#### 4.6 Water Quality Enhancement Best Management Practices

The El Paso County Engineering Criteria Manual (Appendix I, Section I.7.2) requires the consideration of a "Four Step Process for receiving water protection that focuses on reducing runoff volumes, treating the water quality capture volume (WQCV), stabilizing drainage ways, and implementing long term source controls". The Four Step Process is incorporated in this project and the elements are discussed below.

**1) Step 1: Employ Runoff Reduction Practices:** Runoff Reduction Practices are employed in this project. Impervious surfaces have been reduced as much as practically possible. There is only minimal hard surfaces proposed which is gravel. Minimized Directly Connected Impervious Areas (MDCIA) is employed on the project because runoff passes through a public roadside ditch and an open space meadow area before leaving the site.

Water Quality provisions are required for all developments greater than 1.0 acre in area. The home sites in this development will be constructed to minimize directly connected impervious areas. Much of the impervious area in the proposed subdivision will drain through downstream pervious open areas, reducing directly connected impervious area and improving water quality.

The lots are exempted from the use of WQCV BMPs by ECM I.7.1.B.5 by virtue of the large lot rural residential nature of the site having percent imperviousness of less than 10%. The runoff generated from the impervious areas of the gravel road (not exempt) will be treated for water quality by the RPA's and sand filter basins.

These public roadsides are edged with Receiving Pervious Area (RPA) for the public roadway impervious surfaces as detailed in the **BMP Area ID** map attached in the **Appendix**. These RPA's are located outside of the ROW in adjacent lots.

Areas being used as RPA constitute vegetated areas down-gradient of impervious areas as specified in Water Quality Control Volume reduction procedure detailed in Chapter 4, Fact Sheet T-00 "Quantifying Runoff Reduction" of the Urban Storm Drainage Criteria Manual, Volume 3. Permanent seeding will follow the proposed construction, and temporary irrigation will establish a grass cover. The volume reduction calculation was made with the aid of the "UD-BMP\_v3.07" spreadsheet developed by Mile High Flood District and is attached in the **Appendix** showing a WQCV reduction more than 60%.

**2) Step 2: Stabilize Drainageways:** The two existing gullies were analyzed and the areas that were identified as having the potential of erosion shall be protected with riprap. The analysis and protection measures are described in detail in Section 4.5: Channel Analysis and Proposed Protection. Culverts shall be installed to route storm water flows under the public gravel road at low points.

**3) Step 3: Provide Water Quality Capture Volume (WQCV):** The site is exempted from the use of WQCV BMPs by ECM I.7.1.B.5 by virtue of the large lot rural residential nature of the site having actual percent imperviousness of less than 10%. The runoff generated from the impervious areas of the proposed roadway will be treated for water quality by utilizing the runoff reduction standard. Stormwater runoff from the proposed access easements will pass through a strip of RPA edging the impervious areas and will infiltrate into the ground, evaporate, or evapotranspire a quantity of water equal to at least 60% of what the calculated WQCV would be if all impervious area for the applicable development site discharged without infiltration. A uniform strip of at least 4 feet in width along the access easements and around the cul-de-sacs adjacent to the proposed impervious areas is sufficient to accomplish the necessary 60%

reduction minimum and provide for a consistent and manageable shape to the RPA. Runoff Reduction calculations are included in the **Appendix** that demonstrate the effectiveness of the uniform strip of RPA. The proposed RPAs are considered permanent BMPs and a signed PCM Maintenance Agreement and O&M Manual will be prepared and executed.

**4) Step 4: Consider Need for Industrial and Commercial BMPs:** The rural residential lot is not anticipated to contain storage of potentially harmful substances or use of potentially harmful substances. No site specific or other source control BMPs are required. There is no anticipated industrial or commercial use of the proposed roadways. No site specific or other source control BMPs are required.

## 5 Opinion of Probable Cost for Drainage Facilities

The following cost opinion is for the construction of the required private storm water appurtenances which are non reimbursable. There are no public storm water facilities required.

### Opinion of Costs – On-Site Public Permanent CM Facilities – Non Reimbursable

• 104 LF 18" RCP @ \$88.00/LF	= \$ 9,152
• 139 LF 24" RCP @ \$105.00/LF	= \$ 14,595
• 4 EA 18" FES @ \$528/EA	= \$ 2,112
• 4 EA 24" FES @ \$630/EA	= \$ 2,520
Public Sub – Total =	\$28,379

### Opinion of Costs – On-Site Private Permanent CM Facilities – Non Reimbursable

• (3) Water Quality diversion basins @ \$635/EA	= \$ 1,905
• (3) sand filter basins @ \$12,012/EA	= \$ 36,036
• (11) CY riprap outlet protection @ \$156.00/CY	= \$ 1,716
• (1300) CY channel protection riprap @ \$156/CY	= \$ 202,800
Private Sub – Total =	\$242,457

GRAND TOTAL (Public + Private) = \$270,836

## 6 Drainage Fees

The site is located within the East Cherry Creek Drainage Basin, El Paso Basin Number CYCY0200, which has no DBPS. There are no fees associated with this basin.

## 7 Conclusion

This Final Drainage Report presents existing and proposed drainage conditions for the proposed Table Rock Homesteads project. The development will have negligible and inconsequential effects on the existing site drainage and drainage conditions downstream. With such a negligible increase in stormwater flows from the site detention will not be necessary for the proposed development and will not be provided. The proposed project will not, with respect to stormwater runoff, negatively impact the adjacent properties and downstream properties.

## References

*NRCS Web Soil Survey.* United States Department of Agriculture, Natural Resources Conservation Service ("<http://websoilsurvey.nrcs.usda.gov/app/WebSoilSurvey.aspx>", accessed October 2016).

*NRCS Official Soil Series Descriptions.* United States Department of Agriculture, Natural Resources Conservation Service ("<http://soils.usda.gov/technical/classification/osd/index.html>", accessed October 2016).

*Flood Insurance Rate Map.* Federal Emergency Management Agency, National Flood Insurance Program (Washington D.C.: FEMA, December 7, 2018).

*City of Colorado Springs Drainage Criteria Manual Volume 1.* City of Colorado Springs Engineering Division with Matrix Design Group and Wright Water Engineers (Colorado Springs, Colorado: , May 2014).



# Appendices

## **1 General Maps and Supporting Data**

- Vicinity Map
- Portion of Flood Insurance Rate Map
- Soil Type map and Tables
- Official Soil Series Descriptions
- Hydrologic Soil Group Map and Tables
- Seed Mix Information

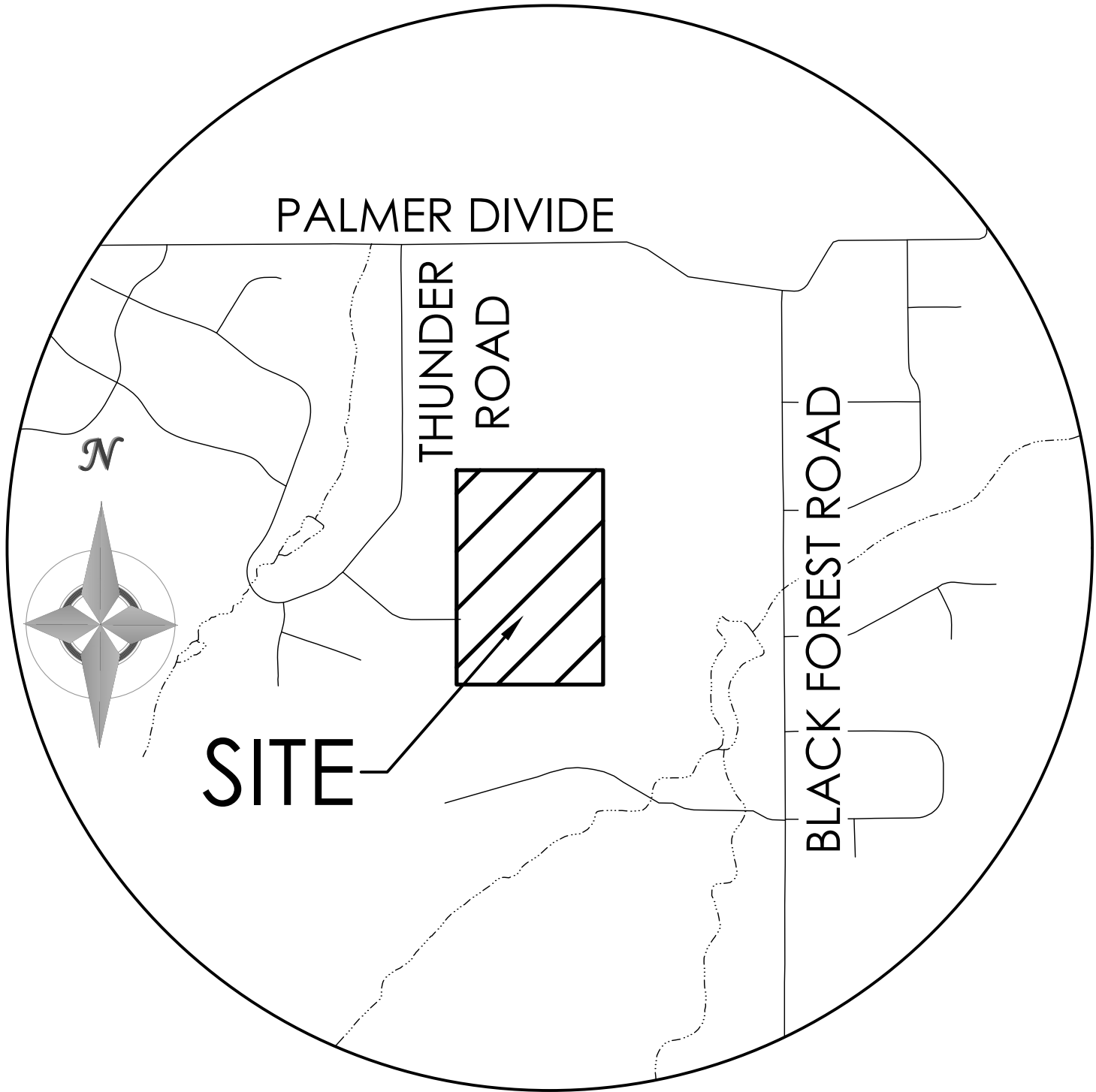

# VICINITY MAP

NOT TO SCALE

# National Flood Hazard Layer FIRMette



104°42'39"W 39°7'20"N

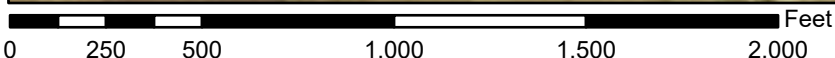

1:6,000

104°42'2"W 39°6'53"N

Basemap Imagery Source: USGS National Map 2023

## Legend

SEE FIS REPORT FOR DETAILED LEGEND AND INDEX MAP FOR FIRM PANEL LAYOUT

SPECIAL FLOOD HAZARD AREAS		Without Base Flood Elevation (BFE) <i>Zone A, V, A99</i>
		With BFE or Depth <i>Zone AE, AO, AH, VE, AR</i>
		Regulatory Floodway
OTHER AREAS OF FLOOD HAZARD		0.2% Annual Chance Flood Hazard, Areas of 1% annual chance flood with average depth less than one foot or with drainage areas of less than one square mile <i>Zone X</i>
		Future Conditions 1% Annual Chance Flood Hazard <i>Zone X</i>
		Area with Reduced Flood Risk due to Levee. See Notes. <i>Zone X</i>
		Area with Flood Risk due to Levee <i>Zone D</i>
OTHER AREAS		NO SCREEN Area of Minimal Flood Hazard <i>Zone X</i>
		Effective LOMRs
GENERAL STRUCTURES		Area of Undetermined Flood Hazard <i>Zone D</i>
		Channel, Culvert, or Storm Sewer
		Levee, Dike, or Floodwall
OTHER FEATURES		20.2 Cross Sections with 1% Annual Chance
		17.5 Water Surface Elevation
		8 Coastal Transect
		Base Flood Elevation Line (BFE)
		Limit of Study
MAP PANELS		Jurisdiction Boundary
		Coastal Transect Baseline
		Profile Baseline
		Hydrographic Feature
		Digital Data Available
		No Digital Data Available
		Unmapped
		The pin displayed on the map is an approximate point selected by the user and does not represent an authoritative property location.



This map complies with FEMA's standards for the use of digital flood maps if it is not void as described below. The basemap shown complies with FEMA's basemap accuracy standards

The flood hazard information is derived directly from the authoritative NFHL web services provided by FEMA. This map was exported on **10/17/2024 at 12:32 PM** and does not reflect changes or amendments subsequent to this date and time. The NFHL and effective information may change or become superseded by new data over time.

This map image is void if the one or more of the following map elements do not appear: basemap imagery, flood zone labels, legend, scale bar, map creation date, community identifiers, FIRM panel number, and FIRM effective date. Map images for unmapped and unmodernized areas cannot be used for regulatory purposes.



United States  
Department of  
Agriculture

**NRCS**

Natural  
Resources  
Conservation  
Service

A product of the National  
Cooperative Soil Survey,  
a joint effort of the United  
States Department of  
Agriculture and other  
Federal agencies, State  
agencies including the  
Agricultural Experiment  
Stations, and local  
participants

# Custom Soil Resource Report for El Paso County Area, Colorado

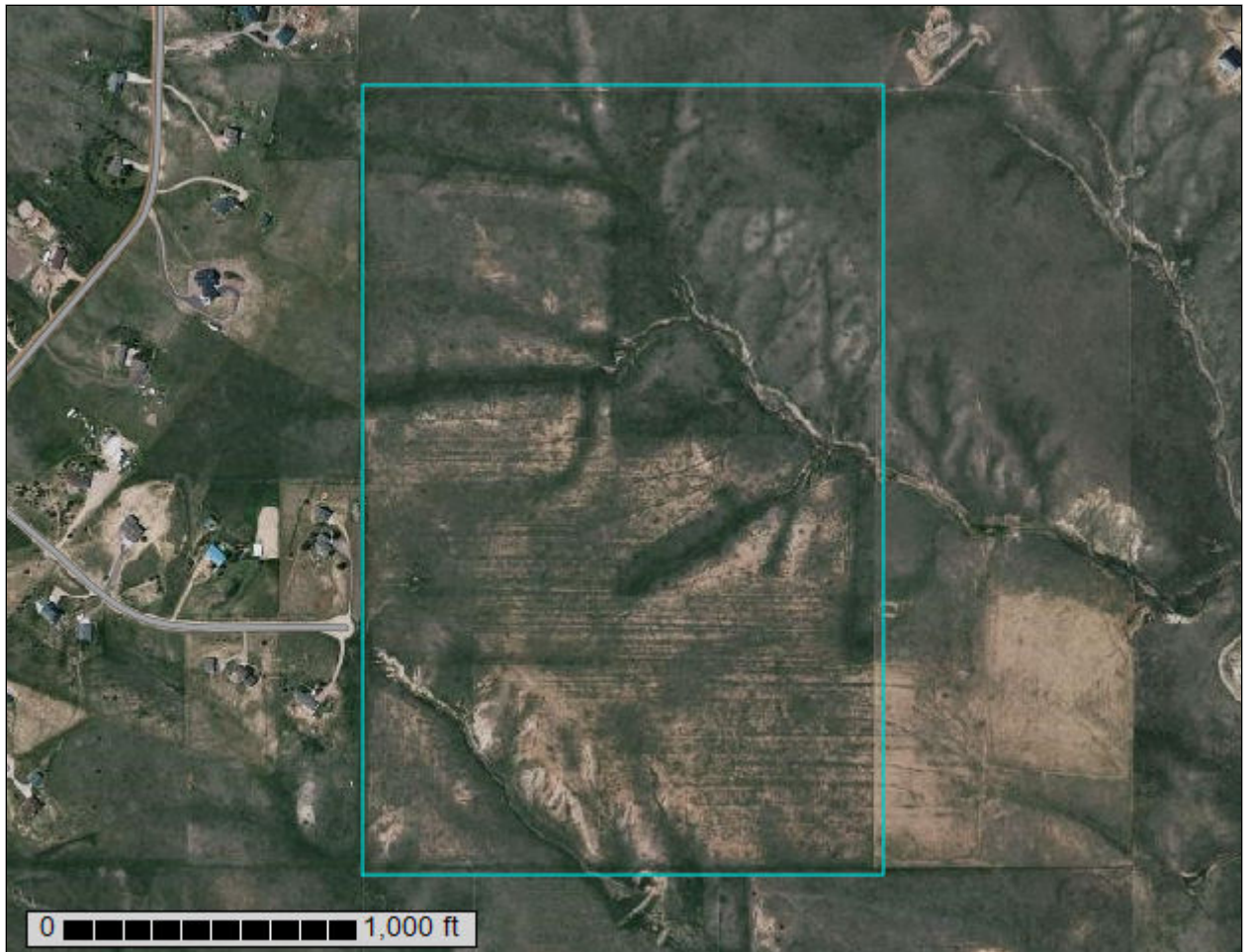

# Preface

---

Soil surveys contain information that affects land use planning in survey areas. They highlight soil limitations that affect various land uses and provide information about the properties of the soils in the survey areas. Soil surveys are designed for many different users, including farmers, ranchers, foresters, agronomists, urban planners, community officials, engineers, developers, builders, and home buyers. Also, conservationists, teachers, students, and specialists in recreation, waste disposal, and pollution control can use the surveys to help them understand, protect, or enhance the environment.

Various land use regulations of Federal, State, and local governments may impose special restrictions on land use or land treatment. Soil surveys identify soil properties that are used in making various land use or land treatment decisions. The information is intended to help the land users identify and reduce the effects of soil limitations on various land uses. The landowner or user is responsible for identifying and complying with existing laws and regulations.

Although soil survey information can be used for general farm, local, and wider area planning, onsite investigation is needed to supplement this information in some cases. Examples include soil quality assessments (<http://www.nrcs.usda.gov/wps/portal/nrcs/main/soils/health/>) and certain conservation and engineering applications. For more detailed information, contact your local USDA Service Center (<https://offices.sc.egov.usda.gov/locator/app?agency=nrcs>) or your NRCS State Soil Scientist ([http://www.nrcs.usda.gov/wps/portal/nrcs/detail/soils/contactus/?cid=nrcs142p2\\_053951](http://www.nrcs.usda.gov/wps/portal/nrcs/detail/soils/contactus/?cid=nrcs142p2_053951)).

Great differences in soil properties can occur within short distances. Some soils are seasonally wet or subject to flooding. Some are too unstable to be used as a foundation for buildings or roads. Clayey or wet soils are poorly suited to use as septic tank absorption fields. A high water table makes a soil poorly suited to basements or underground installations.

The National Cooperative Soil Survey is a joint effort of the United States Department of Agriculture and other Federal agencies, State agencies including the Agricultural Experiment Stations, and local agencies. The Natural Resources Conservation Service (NRCS) has leadership for the Federal part of the National Cooperative Soil Survey.

Information about soils is updated periodically. Updated information is available through the NRCS Web Soil Survey, the site for official soil survey information.

The U.S. Department of Agriculture (USDA) prohibits discrimination in all its programs and activities on the basis of race, color, national origin, age, disability, and where applicable, sex, marital status, familial status, parental status, religion, sexual orientation, genetic information, political beliefs, reprisal, or because all or a part of an individual's income is derived from any public assistance program. (Not all prohibited bases apply to all programs.) Persons with disabilities who require

alternative means for communication of program information (Braille, large print, audiotape, etc.) should contact USDA's TARGET Center at (202) 720-2600 (voice and TDD). To file a complaint of discrimination, write to USDA, Director, Office of Civil Rights, 1400 Independence Avenue, S.W., Washington, D.C. 20250-9410 or call (800) 795-3272 (voice) or (202) 720-6382 (TDD). USDA is an equal opportunity provider and employer.

# Contents

---

<b>Preface</b> .....	2
<b>Soil Map</b> .....	5
Soil Map.....	6
Legend.....	7
Map Unit Legend.....	8
Map Unit Descriptions.....	8
El Paso County Area, Colorado.....	10
15—Brussett loam, 3 to 5 percent slopes.....	10
69—Peyton-Pring complex, 8 to 15 percent slopes.....	11

# Soil Map

---

The soil map section includes the soil map for the defined area of interest, a list of soil map units on the map and extent of each map unit, and cartographic symbols displayed on the map. Also presented are various metadata about data used to produce the map, and a description of each soil map unit.



# Custom Soil Resource Report Soil Map

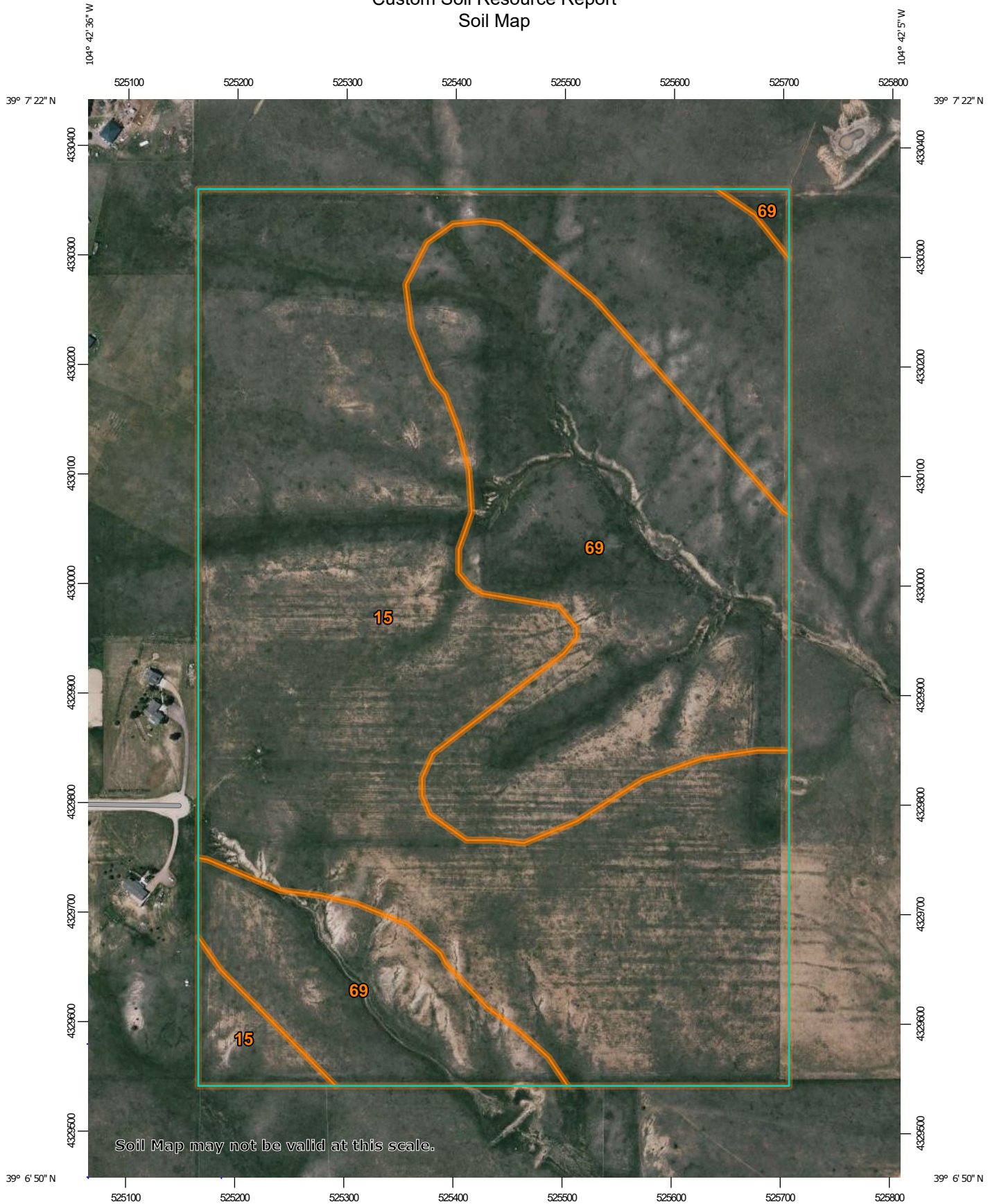

Soil Map may not be valid at this scale.

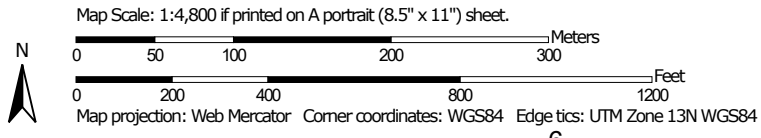

### MAP LEGEND

**Area of Interest (AOI)**

 Area of Interest (AOI)

**Soils**

 Soil Map Unit Polygons

 Soil Map Unit Lines

 Soil Map Unit Points

**Special Point Features**

-  Blowout
-  Borrow Pit
-  Clay Spot
-  Closed Depression
-  Gravel Pit
-  Gravelly Spot
-  Landfill
-  Lava Flow
-  Marsh or swamp
-  Mine or Quarry
-  Miscellaneous Water
-  Perennial Water
-  Rock Outcrop
-  Saline Spot
-  Sandy Spot
-  Severely Eroded Spot
-  Sinkhole
-  Slide or Slip
-  Sodic Spot

-  Spoil Area
-  Stony Spot
-  Very Stony Spot
-  Wet Spot
-  Other
-  Special Line Features

**Water Features**

 Streams and Canals

**Transportation**

-  Rails
-  Interstate Highways
-  US Routes
-  Major Roads
-  Local Roads

**Background**

 Aerial Photography

### MAP INFORMATION

The soil surveys that comprise your AOI were mapped at 1:24,000.

Warning: Soil Map may not be valid at this scale.

Enlargement of maps beyond the scale of mapping can cause misunderstanding of the detail of mapping and accuracy of soil line placement. The maps do not show the small areas of contrasting soils that could have been shown at a more detailed scale.

Please rely on the bar scale on each map sheet for map measurements.

Source of Map: Natural Resources Conservation Service  
 Web Soil Survey URL:  
 Coordinate System: Web Mercator (EPSG:3857)

Maps from the Web Soil Survey are based on the Web Mercator projection, which preserves direction and shape but distorts distance and area. A projection that preserves area, such as the Albers equal-area conic projection, should be used if more accurate calculations of distance or area are required.

This product is generated from the USDA-NRCS certified data as of the version date(s) listed below.

Soil Survey Area: El Paso County Area, Colorado  
 Survey Area Data: Version 22, Sep 3, 2024

Soil map units are labeled (as space allows) for map scales 1:50,000 or larger.

Date(s) aerial images were photographed: Jun 9, 2021—Jun 12, 2021

The orthophoto or other base map on which the soil lines were compiled and digitized probably differs from the background imagery displayed on these maps. As a result, some minor shifting of map unit boundaries may be evident.

## Map Unit Legend

Map Unit Symbol	Map Unit Name	Acres in AOI	Percent of AOI
15	Brussett loam, 3 to 5 percent slopes	69.7	63.4%
69	Peyton-Pring complex, 8 to 15 percent slopes	40.3	36.6%
<b>Totals for Area of Interest</b>		<b>110.0</b>	<b>100.0%</b>

## Map Unit Descriptions

The map units delineated on the detailed soil maps in a soil survey represent the soils or miscellaneous areas in the survey area. The map unit descriptions, along with the maps, can be used to determine the composition and properties of a unit.

A map unit delineation on a soil map represents an area dominated by one or more major kinds of soil or miscellaneous areas. A map unit is identified and named according to the taxonomic classification of the dominant soils. Within a taxonomic class there are precisely defined limits for the properties of the soils. On the landscape, however, the soils are natural phenomena, and they have the characteristic variability of all natural phenomena. Thus, the range of some observed properties may extend beyond the limits defined for a taxonomic class. Areas of soils of a single taxonomic class rarely, if ever, can be mapped without including areas of other taxonomic classes. Consequently, every map unit is made up of the soils or miscellaneous areas for which it is named and some minor components that belong to taxonomic classes other than those of the major soils.

Most minor soils have properties similar to those of the dominant soil or soils in the map unit, and thus they do not affect use and management. These are called noncontrasting, or similar, components. They may or may not be mentioned in a particular map unit description. Other minor components, however, have properties and behavioral characteristics divergent enough to affect use or to require different management. These are called contrasting, or dissimilar, components. They generally are in small areas and could not be mapped separately because of the scale used. Some small areas of strongly contrasting soils or miscellaneous areas are identified by a special symbol on the maps. If included in the database for a given area, the contrasting minor components are identified in the map unit descriptions along with some characteristics of each. A few areas of minor components may not have been observed, and consequently they are not mentioned in the descriptions, especially where the pattern was so complex that it was impractical to make enough observations to identify all the soils and miscellaneous areas on the landscape.

The presence of minor components in a map unit in no way diminishes the usefulness or accuracy of the data. The objective of mapping is not to delineate pure taxonomic classes but rather to separate the landscape into landforms or landform segments that have similar use and management requirements. The delineation of such segments on the map provides sufficient information for the development of resource plans. If intensive use of small areas is planned, however,

## Custom Soil Resource Report

onsite investigation is needed to define and locate the soils and miscellaneous areas.

An identifying symbol precedes the map unit name in the map unit descriptions. Each description includes general facts about the unit and gives important soil properties and qualities.

Soils that have profiles that are almost alike make up a *soil series*. Except for differences in texture of the surface layer, all the soils of a series have major horizons that are similar in composition, thickness, and arrangement.

Soils of one series can differ in texture of the surface layer, slope, stoniness, salinity, degree of erosion, and other characteristics that affect their use. On the basis of such differences, a soil series is divided into *soil phases*. Most of the areas shown on the detailed soil maps are phases of soil series. The name of a soil phase commonly indicates a feature that affects use or management. For example, Alpha silt loam, 0 to 2 percent slopes, is a phase of the Alpha series.

Some map units are made up of two or more major soils or miscellaneous areas. These map units are complexes, associations, or undifferentiated groups.

A *complex* consists of two or more soils or miscellaneous areas in such an intricate pattern or in such small areas that they cannot be shown separately on the maps. The pattern and proportion of the soils or miscellaneous areas are somewhat similar in all areas. Alpha-Beta complex, 0 to 6 percent slopes, is an example.

An *association* is made up of two or more geographically associated soils or miscellaneous areas that are shown as one unit on the maps. Because of present or anticipated uses of the map units in the survey area, it was not considered practical or necessary to map the soils or miscellaneous areas separately. The pattern and relative proportion of the soils or miscellaneous areas are somewhat similar. Alpha-Beta association, 0 to 2 percent slopes, is an example.

An *undifferentiated group* is made up of two or more soils or miscellaneous areas that could be mapped individually but are mapped as one unit because similar interpretations can be made for use and management. The pattern and proportion of the soils or miscellaneous areas in a mapped area are not uniform. An area can be made up of only one of the major soils or miscellaneous areas, or it can be made up of all of them. Alpha and Beta soils, 0 to 2 percent slopes, is an example.

Some surveys include *miscellaneous areas*. Such areas have little or no soil material and support little or no vegetation. Rock outcrop is an example.

## El Paso County Area, Colorado

### 15—Brussett loam, 3 to 5 percent slopes

#### Map Unit Setting

*National map unit symbol:* 367k  
*Elevation:* 7,200 to 7,500 feet  
*Frost-free period:* 115 to 125 days  
*Farmland classification:* Prime farmland if irrigated

#### Map Unit Composition

*Brussett and similar soils:* 85 percent  
*Estimates are based on observations, descriptions, and transects of the mapunit.*

#### Description of Brussett

##### Setting

*Landform:* Hills  
*Landform position (three-dimensional):* Side slope  
*Down-slope shape:* Linear  
*Across-slope shape:* Linear  
*Parent material:* Eolian deposits

##### Typical profile

*A - 0 to 8 inches:* loam  
*BA - 8 to 12 inches:* loam  
*Bt - 12 to 26 inches:* clay loam  
*Bk - 26 to 60 inches:* silt loam

##### Properties and qualities

*Slope:* 3 to 5 percent  
*Depth to restrictive feature:* More than 80 inches  
*Drainage class:* Well drained  
*Runoff class:* Low  
*Capacity of the most limiting layer to transmit water (Ksat):* Moderately high (0.20 to 0.60 in/hr)  
*Depth to water table:* More than 80 inches  
*Frequency of flooding:* None  
*Frequency of ponding:* None  
*Calcium carbonate, maximum content:* 5 percent  
*Maximum salinity:* Nonsaline to very slightly saline (0.0 to 2.0 mmhos/cm)  
*Available water supply, 0 to 60 inches:* High (about 9.1 inches)

##### Interpretive groups

*Land capability classification (irrigated):* None specified  
*Land capability classification (nonirrigated):* 4e  
*Hydrologic Soil Group:* B  
*Ecological site:* R048AY222CO - Loamy Park  
*Hydric soil rating:* No

#### Minor Components

##### Other soils

*Percent of map unit:*  
*Hydric soil rating:* No

## 69—Peyton-Pring complex, 8 to 15 percent slopes

### Map Unit Setting

*National map unit symbol:* 369g  
*Elevation:* 6,800 to 7,600 feet  
*Farmland classification:* Not prime farmland

### Map Unit Composition

*Peyton and similar soils:* 40 percent  
*Pring and similar soils:* 30 percent  
*Minor components:* 5 percent  
*Estimates are based on observations, descriptions, and transects of the mapunit.*

### Description of Peyton

#### Setting

*Landform:* Hills  
*Landform position (three-dimensional):* Side slope  
*Down-slope shape:* Linear  
*Across-slope shape:* Linear  
*Parent material:* Arkosic alluvium derived from sedimentary rock and/or arkosic residuum weathered from sedimentary rock

#### Typical profile

*A - 0 to 12 inches:* sandy loam  
*Bt - 12 to 25 inches:* sandy clay loam  
*BC - 25 to 35 inches:* sandy clay loam  
*C - 35 to 60 inches:* sandy loam

#### Properties and qualities

*Slope:* 8 to 9 percent  
*Depth to restrictive feature:* More than 80 inches  
*Drainage class:* Well drained  
*Runoff class:* Medium  
*Capacity of the most limiting layer to transmit water (Ksat):* Moderately high (0.20 to 0.60 in/hr)  
*Depth to water table:* More than 80 inches  
*Frequency of flooding:* None  
*Frequency of ponding:* None  
*Available water supply, 0 to 60 inches:* Moderate (about 7.3 inches)

#### Interpretive groups

*Land capability classification (irrigated):* None specified  
*Land capability classification (nonirrigated):* 4e  
*Hydrologic Soil Group:* B  
*Ecological site:* R049XY216CO - Sandy Divide  
*Hydric soil rating:* No

**Description of Pring**

**Setting**

*Landform:* Hills  
*Landform position (three-dimensional):* Side slope  
*Down-slope shape:* Linear  
*Across-slope shape:* Linear  
*Parent material:* Arkosic alluvium derived from sedimentary rock

**Typical profile**

*A - 0 to 14 inches:* coarse sandy loam  
*C - 14 to 60 inches:* gravelly sandy loam

**Properties and qualities**

*Slope:* 8 to 15 percent  
*Depth to restrictive feature:* More than 80 inches  
*Drainage class:* Well drained  
*Runoff class:* Low  
*Capacity of the most limiting layer to transmit water (Ksat):* High (2.00 to 6.00 in/hr)  
*Depth to water table:* More than 80 inches  
*Frequency of flooding:* None  
*Frequency of ponding:* None  
*Available water supply, 0 to 60 inches:* Low (about 6.0 inches)

**Interpretive groups**

*Land capability classification (irrigated):* None specified  
*Land capability classification (nonirrigated):* 6e  
*Hydrologic Soil Group:* B  
*Ecological site:* R048AY222CO - Loamy Park  
*Hydric soil rating:* No

**Minor Components**

**Pleasant**

*Percent of map unit:* 5 percent  
*Landform:* Depressions  
*Hydric soil rating:* Yes

**Other soils**

*Percent of map unit:*  
*Hydric soil rating:* No

mental irrigation may be needed when planting and during dry periods. Trees that are best suited and have good survival are Rocky Mountain juniper, eastern redcedar, ponderosa pine, Siberian elm, Russian-olive, and hackberry. Shrubs that are best suited are skunkbush sumac, lilac, and Siberian peashrub.

This soil is suited to wildlife habitat. It is best suited to habitat for openland and rangeland wildlife. In cropland areas, habitat favorable for ring-necked pheasant, mourning dove, and many nongame species can be developed by establishing areas for nesting and escape cover. For pheasant, undisturbed nesting cover is vital and should be provided for in plans for habitat development. This is especially true in areas of intensive farming. Rangeland wildlife, such as pronghorn antelope, can be encouraged by developing livestock watering facilities, properly managing livestock grazing, and reseeding range where needed.

This soil has good potential for homesites. Practices are needed to control surface runoff and keep soil losses to a minimum. Limiting the disturbance of the soil and the removal of existing plant cover during construction helps to control erosion. Capability subclass IVe.

**14—Brussett loam, 1 to 3 percent slopes.** This deep, well drained soil formed in eolian silt and sand on uplands. Elevation ranges from 7,200 to 7,500 feet. The average annual precipitation is about 18 inches, and the average annual air temperature is about 43 degrees F.

Typically, the surface layer is dark grayish brown loam about 8 inches thick. The subsoil is grayish brown and brown clay loam about 26 inches thick. The substratum is pale brown silt loam. Mycelia and soft masses of lime are common in the substratum.

Included with this soil in mapping are small areas of Peyton sandy loam, 1 to 5 percent slopes.

Permeability of this Brussett soil is moderate. Effective rooting depth is 60 inches or more. Available water capacity is high. Surface runoff is slow, and the hazard of erosion is moderate.

Nearly all the acreage of this soil is used for nonirrigated winter wheat, spring oats, and improved pasture that is grazed by cattle and sheep. The chief pasture grasses are smooth brome, intermediate wheatgrass, and pubescent wheatgrass. Winter wheat is grown under a wheat-fallow system. Stubble mulching is the most important conservation practice. Application of fertilizer generally is not needed in the wheat-fallow system. Other crops respond to application of nitrogen. The growing season is too short for warm-season field crops. Management of the plant cover is needed to control erosion.

Rangeland vegetation consists of mountain muhly, little bluestem, needleandthread, Parry oatgrass, and junegrass.

Deferment of grazing in spring helps to maintain the vigor and reproduction of the cool-season bunchgrasses. Fencing and properly distributing livestock watering facilities may be needed to control grazing. Locating salt blocks in areas not generally grazed increases the amount of forage that is used on this soil.

Windbreaks and environmental plantings are generally well suited to this soil. Summer fallow a year prior to planting and continued cultivation for weed control are needed to insure the establishment and survival of plantings. Trees that are best suited and have good survival potential are Rocky Mountain juniper, eastern redcedar, ponderosa pine, Siberian elm, Russian-olive, and hackberry. Shrubs that are best suited are skunkbush sumac, lilac, Siberian peashrub, and American plum.

This soil is suited to wildlife habitat. It is best suited to habitat for openland and rangeland wildlife. In cropland areas, habitat favorable for ring-necked pheasant, mourning dove, and many nongame species can be developed by establishing areas for nesting and escape cover. For pheasant, undisturbed nesting cover is vital and should be provided for in plans for habitat development. This is especially true in areas of intensive farming. Rangeland wildlife, such as pronghorn antelope, can be encouraged by developing livestock watering facilities, properly managing livestock grazing, and reseeding range where needed.

The main limitations for urban development are moderate shrink-swell potential and frost action potential. Dwellings and roads can be designed to overcome these limitations. Permeability adversely affects the performance of septic tank absorption fields. Capability subclass IIIc.

**15—Brussett loam, 3 to 5 percent slopes.** This deep, well drained soil formed in eolian silt and sand on uplands. Elevation ranges from 7,200 to 7,500 feet. The average annual precipitation is about 18 inches, and the average annual air temperature is about 43 degrees F.

Typically, the surface layer is dark grayish brown loam about 8 inches thick. The subsoil is grayish brown and brown clay loam about 26 inches thick. The substratum is pale brown silt loam. Mycelia and soft masses of lime are common in the substratum.

Included with this soil in mapping are small areas of Peyton sandy loam, 1 to 5 percent slopes, and Peyton-Pring complex, 3 to 8 percent slopes.

Permeability of this Brussett soil is moderate. Effective rooting depth is 60 inches or more. Available water capacity is high. Surface runoff is medium to rapid. The hazard of erosion is moderate, especially when snow melts in spring while the ground is frozen. Some gullies are present.

Nearly all the acreage of this soil is used for nonirrigated winter wheat, spring oats, and improved pasture that is grazed by cattle and sheep. The chief pasture grasses are smooth brome, intermediate wheatgrass, and pubescent wheatgrass. Winter wheat is grown under a wheat-fallow system. Stubble mulching is the most important conservation practice. Application of fertilizer generally is not needed in the wheat-fallow system. Other crops respond to application of nitrogen. The growing season is too short for warm-season field crops. Management of plant cover is needed to control erosion.

Rangeland vegetation consists of mountain muhly, little bluestem, needleandthread, Parry oatgrass, and junegrass.



Deferment of grazing in spring helps to maintain the vigor and production of the cool-season bunchgrasses. Fencing and properly distributing livestock watering facilities may be needed to control grazing. Locating salt blocks in areas not generally grazed increases the amount of forage that is used on this soil.

Windbreaks and environmental plantings are generally well suited to this soil. Summer fallow a year prior to planting and continued cultivation for weed control are needed to insure the establishment and survival of plantings. Trees that are best suited and have good survival potential are Rocky Mountain juniper, eastern redcedar, ponderosa pine, Siberian elm, Russian-olive, and hackberry. Shrubs that are best suited are skunkbush sumac, lilac, Siberian peashrub, and American plum.

This soil is suited to wildlife habitat. It is best suited to habitat for openland and rangeland wildlife. In cropland areas, habitat favorable for ring-necked pheasant, mourning dove, and many nongame species can be developed by establishing areas for nesting and escape cover. For pheasant, undisturbed nesting cover is vital and should be provided for in plans for habitat development. This is especially true in areas of intensive farming. Rangeland wildlife, such as pronghorn antelope, can be encouraged by developing livestock watering facilities, properly managing livestock grazing, and reseeding range where needed.

The main limitations for urban development are moderate shrink-swell potential and frost action potential. Dwellings and roads can be designed to overcome these limitations. Capability subclass IVe.

**16—Chaseville gravelly sandy loam, 1 to 8 percent slopes.** This deep, somewhat excessively drained soil formed in arkosic alluvial sediment on alluvial fans, terraces, and side slopes. Elevation ranges from 6,100 to 7,000 feet. Average annual precipitation is about 17 inches, average annual air temperature is about 47 degrees F, and the average frost-free season is about 135 days.

Typically, the surface layer is dark grayish brown gravelly sandy loam about 6 inches thick. The next layer is dark grayish brown very gravelly sandy loam about 13 inches thick. The substratum is reddish gray extremely gravelly loamy coarse sand and brown very gravelly loamy sand. The lower part of the substratum, below a depth of 40 inches, is about 10 percent cobbles.

Included with this soil in mapping are small areas of Jarre gravelly sandy loam, 1 to 8 percent slopes; Bresser sandy loam; Truckton sandy loam; and Ascalon sandy loam.

Permeability of this Chaseville soil is rapid. Effective rooting depth is 60 inches or more. Available water capacity is low. Surface runoff is slow, and the hazard of erosion is moderate.

This soil is used mainly as native rangeland. It is also used as homesites and for wildlife habitat.

Rangeland vegetation is mainly western wheatgrass, side-oats grama, needleandthread, and little bluestem. The main shrub on this site is true mountainmahogany.

Proper location of livestock watering facilities helps to control grazing.

Windbreaks and environmental plantings are suited to this soil. Low available water capacity is the main limitation to the establishment of tree and shrub plantings. Summer fallow a year in advance and continued cultivation for weed control are needed to insure the establishment and survival of plantings. Supplemental irrigation may be needed to insure survival. Trees that are best suited and have good survival are Rocky Mountain juniper, eastern redcedar, ponderosa pine, and Siberian elm. Shrubs that are best suited are skunkbush sumac and lilac.

This soil is suited to wildlife habitat. It is best suited to habitat for openland and rangeland wildlife. Rangeland wildlife, such as pronghorn antelope, can be encouraged by developing livestock watering facilities, properly managing livestock grazing, and reseeding range where needed.

This soil has good potential for homesites. Because of its high gravel content, problems with excavations may arise because cut banks cave in. A surface dressing of topsoil is needed where the very gravelly subsoil is exposed or where vegetation has been removed during site preparation. Caution should be exercised when locating septic tank absorption fields because of possible pollution of water supplies as a result of the rapid permeability of this soil. Capability subclass VIe.

**17—Chaseville gravelly sandy loam, 8 to 40 percent slopes.** This deep, somewhat excessively drained soil formed in arkosic alluvial sediment on alluvial fans, terraces, and side slopes. Elevation ranges from 6,100 to 7,000 feet. The average annual precipitation is about 17 inches, the average annual air temperature is about 47 degrees F, and the average frost-free season is about 135 days.

Typically, the surface layer is dark grayish brown gravelly sandy loam about 6 inches thick. The subsurface layer is dark grayish brown very gravelly sandy loam about 13 inches thick. The substratum is reddish gray extremely gravelly loamy coarse sand and brown very gravelly loamy sand. The part of the substratum below a depth of 40 inches is about 10 percent cobbles.

Included with this soil in mapping are small areas of Jarre gravelly sandy loam, 1 to 8 percent slopes; Nederland cobbly sandy loam, 9 to 25 percent slopes; and Bresser sandy loam, 5 to 9 percent slopes.

Permeability of this Chaseville soil is rapid. Effective rooting depth is 60 inches or more. Available water capacity is low. Surface runoff is slow to medium, and the hazard of erosion is moderate to high.

This soil is used mainly as rangeland. It is also used for recreation, wildlife habitat, and homesites.

Native vegetation is mainly western wheatgrass, side-oats grama, needleandthread, and little bluestem. The prominent shrub on this site is true mountainmahogany. Yucca is present in some places.

Proper location of livestock watering facilities helps to control grazing.

survival are Rocky Mountain juniper, eastern redcedar, ponderosa pine, Siberian elm, Russian-olive, and hackberry. Shrubs that are best suited are skunkbush sumac, lilac, and Siberian peashrub.

These soils are suited to habitat for openland and rangeland wildlife. Rangeland wildlife, such as pronghorn antelope, can be encouraged by developing livestock watering facilities, properly managing livestock grazing, and reseeding range where needed.

These soils have a good potential for homesites. The main limitations, especially on the Peyton soil, are low bearing strength and frost-action potential. Buildings and roads can be designed to overcome these limitations. Access roads should have adequate cut-slope grade and be provided with drains to control surface runoff and keep soil losses to a minimum. Capability subclass VIe.

**69—Peyton-Pring complex, 8 to 15 percent slopes.**

These gently to moderately sloping soils are on valley side slopes and on uplands. Elevation ranges from 6,800 to 7,600 feet. The average annual precipitation is about 17 inches, the average annual air temperature is about 43 degrees F, and the average frost-free period is about 120 days.

The Peyton soil makes up about 40 percent of the complex, the Pring soil about 30 percent, and other soils about 30 percent.

Included with these soils in mapping are areas of Holderness loam, 8 to 15 percent slopes; Tomah-Crowfoot loamy sands, 8 to 15 percent slopes; Kettle gravelly loamy sand, 8 to 40 percent slopes; and a few areas of Rock outcrop.

The Peyton soil is commonly on the less sloping part of the landscape. It is deep, noncalcareous, and well drained. It formed in alluvium and residuum derived from weathered, arkosic, sedimentary rock. Typically, the surface layer is grayish brown sandy loam about 12 inches thick. The subsoil, about 23 inches thick, is pale brown sandy clay loam in the upper 13 inches and pale brown sandy loam in the lower 10 inches. The substratum is pale brown sandy loam to a depth of 60 inches or more.

Permeability of the Peyton soil is moderate. Effective rooting depth is 60 inches or more. Available water capacity is high. Surface runoff is medium to rapid, and the hazard of erosion is moderate to high. Some gullies have developed along drainageways and livestock trails.

The Pring soil is deep, noncalcareous, and well drained. It formed in sandy sediment derived from weathered, arkosic, sedimentary rock. Typically, the surface layer is dark grayish brown coarse sandy loam about 4 inches thick. The substratum is dark grayish brown coarse sandy loam about 10 inches thick over pale brown gravelly sandy loam that extends to a depth of 60 inches or more.

Permeability of the Pring soil is rapid. Effective rooting depth is 60 inches or more. Available water capacity is moderate. Surface runoff is medium to rapid, and the hazard of erosion is moderate to high. Some gullies have developed along drainageways and livestock trails.

The soils in this complex are used as rangeland, for wildlife habitat, and for homesites.

These soils are well suited to the production of native vegetation suitable for grazing. The dominant native species are mountain muhly, bluestem grasses, needle-andthread, and blue grama. These soils are subject to invasion of Kentucky bluegrass and Gambel oak. Common forbs are hairy goldenrod, geranium, milkvetch, low larkspur, fringed sage, and buckwheat.

Properly locating livestock watering facilities helps to control grazing. Timely deferment of grazing is needed to protect the plant cover.

Windbreaks and environmental plantings generally are suited to these soils. Soil blowing is the main limitation to the establishment of trees and shrubs. This limitation can be overcome by cultivating only in the tree rows and leaving a strip of vegetation between the rows. Supplemental irrigation may be needed when planting and during dry periods. Trees that are best suited and have good survival are Rocky Mountain juniper, eastern redcedar, ponderosa pine, Siberian elm, Russian-olive, and hackberry. Shrubs that are best suited are skunkbush sumac, lilac, and Siberian peashrub.

These soils are well suited to wildlife habitat. They are best suited to habitat for openland and rangeland wildlife. Rangeland wildlife, such as pronghorn antelope, can be encouraged by developing livestock watering facilities, properly managing livestock grazing, and reseeding range where needed.

These soils have good potential for use as homesites. The main limitations are steepness of slope, limited ability to support a load, and frost-action potential. Buildings and roads can be designed to overcome these limitations. These soils also require special site or building designs because of the slope. Access roads should have adequate cut-slope grade, and drains should be provided to control surface runoff and keep soil losses to a minimum. Capability subclass VIe.

**70—Pits, gravel.** Gravel pits are in nearly level to rolling areas. They are open excavations several feet deep and commonly 5 acres or less in size.

Gravel pits are very low in natural fertility and are highly susceptible to soil blowing. A cover of weeds or straw helps to control erosion.

Windbreaks and environmental plantings generally are not suited to these areas. Onsite investigation is needed to determine if plantings are feasible. Capability subclass VIIIs.

**71—Pring coarse sandy loam, 3 to 8 percent slopes.**

This deep, noncalcareous, well drained soil formed in sandy sediment derived from arkosic sedimentary rock on valley side slopes and on uplands. Elevation ranges from 6,800 to 7,600 feet. The average annual precipitation is about 17 inches, the average annual air temperature is about 43 degrees F, and the average frost-free period is about 120 days.

Typically, the surface layer is dark grayish brown coarse sandy loam about 4 inches thick. The substratum is dark grayish brown coarse sandy loam about 10 inches thick over pale brown gravelly sandy loam that extends to a depth of 60 inches or more.



## EL PASO COUNTY CONSERVATION DISTRICT

5610 Industrial Pl #100  
Colorado Springs, CO 80916

719-600-4706

[districtmanager@epccd.org](mailto:districtmanager@epccd.org)

<https://epccd.org>

### BOARD OF SUPERVISORS

Ken Barker, President  
Katie Miller  
Roger Rasner  
Erica Carter  
Billy Richard  
Cassie Olgren

### DISTRICT MANAGER

Mariah Hudson

The El Paso County Conservation District serves landowners, land users, and partners to champion the responsible management and conservation of our finite natural resources.

To Whom It May Concern,

The El Paso County Conservation District (EPCCD) Board of Supervisors recommendations are as follows:

**Ground Disturbance:** If the ground is disturbed, it should be mulched or revegetated within **45 days of disturbance**. It is generally important that some type of native grass should be planted for the protection of natural resources, erosion control, native vegetation preservation, sedimentation prevention, habitat protection, stormwater management, and soil health. Please make sure the “native” grasses and plants already in place are in fact native to the area. The EPCCD store inventory generally includes both our Shotgun Native Grass Seed Mix as well as the El Paso Low Grow Grass Seed Mix; these are our recommendations should grass seed need to be implemented.

- Our **Shotgun Native Grass Seed Mix** is formulated specifically for the Pikes Peak Front Range by our NRCS District Conservationist and Rangeland Management partners. It is drought-tolerant and includes: about 20% each of Big Bluestem Native and Wheatgrass, Western Native, and about 10% each of Grama, Sideoats Native, Green Needlegrass Native, Little Bluestem Native, Prairie Sandreed Native, Switchgrass Native, and Yellow Indiangrass Native.
- The **El Paso Low Grow Grass Seed Mix** is a great drought-tolerant and low-grow grass seed mix designed for the Pikes Peak Front Range; it includes: about 24% Western Wheatgrass, about 20% Blue Grama, Native, about 18% Buffalograss, about 13% Sideoats Grama, about 6% Green Needlegrass, and about 1.5% Sand Dropseed.

More information about these grass seed mixes, as well as clover, cover crop, and wildflower seeds, and many waterwise/Coloradoscape plants, is available on our website at <https://epccd.org/>

**Integrated Noxious Weed Management:** Early intervention and integrated control measures are generally important, especially in areas where the ground is disturbed or undergoing development for: preservation of native vegetation, protection of land and soil, fire risk reduction, maintenance of water quality, cost savings, and long-term health and sustainability. An integrated noxious weed control plan typically includes a combination of prevention, mechanical, biological, and/or chemical control, and ongoing assessment and monitoring. It is a proactive approach to address the threat posed by invasive weeds and protect the ecological and economic health of the region. If there is no integrated noxious weed control plan in place, we recommend a weed program be reviewed and approved by the NRCS, Colorado Department of Agriculture, Colorado State University Extension - El Paso County, El Paso County Environmental Services Department, or a qualified weed management professional *prior* to the land use authority approval.

If you have any questions regarding these remarks please call us at 719-600-4706 or email [districtmanager@epccd.org](mailto:districtmanager@epccd.org)

Thank you,

*Kenneth Barker*

Kenneth Barker, Board President  
El Paso County Conservation District

**Table 2. Permissible Shear and Velocity for Selected Lining Materials<sup>1</sup>**

Boundary Category	Boundary Type	Permissible Shear Stress (lb/sq ft)	Permissible Velocity (ft/sec)	Citation(s)
<u>Soils</u>	Fine colloidal sand	0.02 - 0.03	1.5	A
	Sandy loam (noncolloidal)	0.03 - 0.04	1.75	A
	Alluvial silt (noncolloidal)	0.045 - 0.05	2	A
	Silty loam (noncolloidal)	0.045 - 0.05	1.75 – 2.25	A
	Firm loam	0.075	2.5	A
	Fine gravels	0.075	2.5	A
	Stiff clay	0.26	3 – 4.5	A, F
	Alluvial silt (colloidal)	0.26	3.75	A
	Graded loam to cobbles	0.38	3.75	A
	Graded silts to cobbles	0.43	4	A
	Shales and hardpan	0.67	6	A
<u>Gravel/Cobble</u>	1-in.	0.33	2.5 – 5	A
	2-in.	0.67	3 – 6	A
	6-in.	2.0	4 – 7.5	A
	12-in.	4.0	5.5 – 12	A
<u>Vegetation</u>	Class A turf	3.7	6 – 8	E, N
	Class B turf	2.1	4 - 7	E, N
	Class C turf	1.0	3.5	E, N
	Long native grasses	1.2 – 1.7	4 – 6	G, H, L, N
	Short native and bunch grass	0.7 - 0.95	3 – 4	G, H, L, N
<u>Temporary Degradable RECPS</u>	Reed plantings	0.1-0.6	N/A	E, N
	Hardwood tree plantings	0.41-2.5	N/A	E, N
	Jute net	0.45	1 – 2.5	E, H, M
	Straw with net	1.5 – 1.65	1 – 3	E, H, M
	Coconut fiber with net	2.25	3 – 4	E, M
<u>Non-Degradable RECPS</u>	Fiberglass roving	2.00	2.5 – 7	E, H, M
	Unvegetated	3.00	5 – 7	E, G, M
	Partially established	4.0-6.0	7.5 – 15	E, G, M
	Fully vegetated	8.00	8 – 21	F, L, M
<u>Riprap</u>	6 – in. d <sub>50</sub>	2.5	5 – 10	H
	9 – in. d <sub>50</sub>	3.8	7 – 11	H
	12 – in. d <sub>50</sub>	5.1	10 – 13	H
	18 – in. d <sub>50</sub>	7.6	12 – 16	H
	24 – in. d <sub>50</sub>	10.1	14 – 18	E
	<u>Soil Bioengineering</u>	Wattles	0.2 – 1.0	3
Reed fascine		0.6-1.25	5	E
Coir roll		3 - 5	8	E, M, N
Vegetated coir mat		4 - 8	9.5	E, M, N
Live brush mattress (initial)		0.4 – 4.1	4	B, E, I
Live brush mattress (grown)		3.90-8.2	12	B, C, E, I, N
Brush layering (initial/grown)		0.4 – 6.25	12	E, I, N
Live fascine		1.25-3.10	6 – 8	C, E, I, J
Live willow stakes		2.10-3.10	3 – 10	E, N, O
<u>Hard Surfacing</u>		Gabions	10	14 – 19
	Concrete	12.5	>18	H

<sup>1</sup> Ranges of values generally reflect multiple sources of data or different testing conditions.

A. Chang, H.H. (1988).	F. Julien, P.Y. (1995).	K. Sprague, C.J. (1999).
B. Florineth. (1982)	G. Kouwen, N.; Li, R. M.; and Simons, D.B., (1980).	L. Temple, D.M. (1980).
C. Gerstgraser, C. (1998).	H. Norman, J. N. (1975).	M. TXDOT (1999)
D. Goff, K. (1999).	I. Schiechl, H. M. and R. Stern. (1996).	N. Data from Author (2001)
E. Gray, D.H., and Sotir, R.B. (1996).	J. Schoklisch, A. (1937).	O. USACE (1997).

Fischenich, C. (2001). "Stability Thresholds for Stream Restoration Materials," EMRRP Technical Notes Collection (ERDC TN-EMRRP-SR-29), U.S. Army Engineer Research and Development Center, Vicksburg, MS.  
[www.wes.army.mil/el/emrrp](http://www.wes.army.mil/el/emrrp)

## REFERENCES

Chang, H.H. (1988). *Fluvial Processes in River Engineering*, John Wiley and Sons, New York and other cities, citing Fortier, S., and Scobey, F.C. (1926). "Permissible canal velocities," *Transactions of the ASCE*, 89:940-984.

Fischenich and Allen (2000). "Stream management," Water Operations Technical Support Program Special Report ERDC/EL SR-W-00-1, Vicksburg, MS.

Florineth, F., (1982). Begrünungen von Erosionszonen im Bereich über der Waldgrenze. *Zeitschrift für Vegetationstechnik* 5, S. 20-24 (In German).

Gerstgraser, C. (1998). "Bioengineering methods of bank stabilization," *GARTEN & LANDSCHAFT*, Vol. 9, September 1998, 35-37.

Goff, K. (1999). "Designer linings," *Erosion Control*, Vol. 6, No. 5.

Gray, D.H., and Sotir, R.B. (1996). *Biotechnical and soil bioengineering: a practical guide for erosion control*. John Wiley and Sons, New York.

Julien, P.Y. (1995). *Erosion and sedimentation*. Cambridge University Press, New York.

Kouwen, N.; Li, R.-M.; and Simons, D.B. (1980). "A stability criteria for vegetated Waterways." *Proceedings, International Symposium on Urban Storm Runoff*. University of Kentucky, Lexington, KY, 28-31 July 1980, 203-210.

Norman, J. N. (1975). "Design of stable channels with flexible linings," Hydraulic Engineering Circular 15, U.S. Dept. of Transportation, Federal Highway Adm., Washington, DC.

Schiechl, H. M., and Stern, R. (1996). *Water Bioengineering Techniques for Watercourse Bank and Shoreline Protection*. Blackwell Science, Inc. 224 pp.

Schoklitsch, A. (1937). *Hydraulic structures; a text and handbook*. Translated by Samuel Shulits. The American Society of Mechanical Engineers, New York.

Shields, A. (1936). "Anwendung der ähnlichkeits-mechanik und der turbulenz-forschung auf die geschiebebewegung," *Mitt. Preuss. Versuchsanst. Wasser. Schiffsbau*, 26, 1-26 (in German).

Sprague, C.J. (1999). "Green engineering: Design principles and applications using rolled erosion control products," *CE News Online*, downloaded from <http://www.cenews.com/edecp0399.html>.

Temple, D.M. (1980). "Tractive force design of vegetated channels," *Transactions of the ASAE*, 23:884-890.

TXDOT (1999). "Field Performance Testing of Selected Erosion Control Products," TXDOT / TTI Hydraulics and Erosion Control Laboratory, Bryan, TX.

USACE TR EL 97-8

## WESTERN WHEATGRASS

*Pascopyrum smithii* (Rydb.) A.  
Love  
Plant Symbol = PASM

Contributed by: USDA NRCS Plant Materials  
Program



Robert H. Mohlenbrock  
USDA NRCS 1989.  
Midwestern Wetland Flora  
@ USDA NRCS PLANTS

**Alternate Names**  
*Agropyron smithii* Rydb.

**Uses**  
*Erosion control:* Western wheatgrass is an excellent erosion control plant because of its spreading rhizomes. It is widely used in seed mixtures for range seeding, revegetation of saline and alkaline areas, and in critical areas for erosion control in the central and northern Great Plains region. This grass protected watershed dams in Kansas from damage when they were overtopped during a 14-inch rainfall event.

*Reclamation:* Western wheatgrass is frequently used in the northern Great Plains for surface mine revegetation. Because of its strong rhizomes and

adaptation to a variety of soils, it performs well as part of a reclamation mixture.

*Livestock:* Forage quality is high for pasture or range seedings.

### Status

Please consult the PLANTS Web site and your State Department of Natural Resources for this plant's current status (e.g. threatened or endangered species, state noxious status, and wetland indicator values).

### Description

*Pascopyrum smithii* (Rydb.) A. Love, western wheatgrass, is perhaps one of the best known and most commonly used native grasses. It is a long-lived, cool season species that has coarse blue-green leaves with prominent veins. Because of this bluish appearance it has sometimes been called bluestem wheatgrass or bluejoint. It is a sod former with very strong, spreading rhizomes. Stems arise singly or in clusters of a few and reach heights of 1 to 3 feet. The sheaths are hairy and the purplish auricles typically clasp the stem. The seed spike is erect and about 2 to 6 inches long.

### Adaptation and Distribution

Western wheatgrass is adapted to fine and very fine soils and is replaced by thickspike wheatgrass on coarser soils. Although it is able to grow on a wide variety of soils it prefers the heavier but well drained soils. It requires moderate to high soil moisture content and is most common in the 10 to 14 inch annual precipitation zones. Above 20 inches per year it behaves as an increaser on rangelands, below 20 inches it is a decreaser. Its elevational range is 1,000 to 9,000 feet.

Western wheatgrass tolerates saline and saline-sodic soils, poor drainage and moderately severe drought. It will tolerate spring flooding, high water tables, and considerable silt deposition. It is very cold hardy and can grow in partial shade. It is grazing resistant and can survive fires if in the dormant stage; recovery from fire, however, is slow.

Western wheatgrass grows in association with many species, the more common being blue grama, buffalograss, needlegrasses, bluebunch wheatgrass, rough fescue, Idaho fescue, and prairie junegrass. It begins growth about 2 to 3 weeks before blue grama

and does not mature until much later in the growing season.

Western wheatgrass performs poorly in the East and is not recommended for any use in the region.

Western wheatgrass is distributed throughout the west and midwest portions of the United States. For a current distribution map, please consult the Plant Profile page for this species on the PLANTS Website.

### **Establishment**

Seed of western wheatgrass should be planted 1/2 to 1 inch deep in fine to medium soil. Seeding rates should be 5 to 15 pounds PLS per acre drilled or 20 to 25 PLS per row foot. If seed is broadcast or used on harsh sites, the rate should be doubled. This species should be seeded in early spring, late fall or in the period of late summer, early fall. It can be sodded.

Seedling vigor is fair and stands may be slow to establish. It has stronger rooting abilities than does thickspike wheatgrass but spreads more slowly and may take several years to become firmly established. Once established, it is very hardy and enduring. It is moderately compatible with other species and is moderately aggressive.

### **Management**

Western wheatgrass greens up in March or early April and matures in August. If moisture is adequate, it will make fair summer or fall regrowth. If nitrogen is applied it will compete with warm season grasses.

Western wheatgrass is moderately palatable to elk and cattle all year although this quality diminishes in late summer. It is palatable to deer only in spring. It is preferred by cattle more than by sheep. It can be grazed if 50 to 60 percent of the annual growth is allowed to remain (3 or 4 inch stubble). Rest rotation of western wheatgrass is advised. In areas where it is dense, it makes an excellent hay as well as pasture.

Irrigation will improve western wheatgrass stands and aid establishment. Weed control and fertilization will also help. Pitting, chiseling, disking, and interseeding can be used to stimulate stands of western wheatgrass.

### **Pests and Potential Problems**

The primary pests to western wheatgrass are grasshoppers, ergot, and stem and leaf rusts.

### **Cultivars, Improved, and Selected Materials (and area of origin)**

'Ariba' western wheatgrass was released for dry land hay production, grazing, and conservation seedings in the western part of the Central Plains and in the southwestern United States. 'Flintlock' is a broad-based cultivar. It is recommended for conservation seeding, dry land hay production, and grazing in the Central Plains. 'Barton' is a strongly rhizomatous, leafy ecotype, intermediate in growth between northern and southern types. 'Barton' is relatively disease free and high in forage and seed production. 'Rosana' is a northern type western wheatgrass. Plants are blue-green, leafy, with moderately fine stems. Rhizomes produce a tight sod. 'Rosana' is recommended for reseeding depleted range lands and the reclamation of disturbed lands in the Northern Great Plains. 'Rodan' northern type western wheatgrass is moderately rhizomatous and forms a dense blue-green sward. Leaves are thinner and less heavily veined than other western wheatgrasses. Western wheatgrass seed is available at most farm seed stores.

### **Prepared By & Species Coordinator: USDA NRCS Plant Materials Program**

Edited: 05Feb2002 JLK; 060802 jsp

For more information about this and other plants, please contact your local NRCS field office or Conservation District, and visit the PLANTS Web site <<http://plants.usda.gov>> or the Plant Materials Program Web site <<http://Plant-Materials.nrcs.usda.gov>>

*The U.S. Department of Agriculture (USDA) prohibits discrimination in all its programs and activities on the basis of race, color, national origin, sex, religion, age, disability, political beliefs, sexual orientation, and marital or family status. (Not all prohibited bases apply to all programs.) Persons with disabilities who require alternative means for communication of program information (Braille, large print, audiotape, etc.) should contact USDA's TARGET Center at 202-720-2600 (voice and TDD).*

*To file a complaint of discrimination write USDA, Director, Office of Civil Rights, Room 326-W, Whitten Building, 14th and Independence Avenue, SW, Washington, DC 20250-9410 or call 202-720-5964 (voice or TDD). USDA is an equal opportunity provider and employer.*

*Read about [Civil Rights at the Natural Resources Conservation Service](#).*

## BLUE GRAMA

*Bouteloua gracilis* (Willd. ex  
Kunth.) Lag. ex Griffiths  
Plant Symbol = BOGR2

Contributed by: USDA NRCS Plant Materials  
Program



© W. L. Wagner  
Smithsonian Institution  
@USDA NRCS PLANTS

### Uses

**Livestock:** In southern states, blue grama grows as a bunchgrass; in northern states or areas of heavy grazing pressure, it is a sod former.

**Erosion control:** Blue grama is suitable for mixtures of grasses used in erosion control, low maintenance turf plantings, and surface mine revegetation.

### Status

Please consult the PLANTS Web site and your State Department of Natural Resources for this plant's current status (e.g. threatened or endangered species, state noxious status, and wetland indicator values).

### Description

*Bouteloua gracilis*, blue grama, is a major warm season grass found throughout the Great Plains. The plant is fairly short, reaching 10 to 20 inches with narrow basal leaves of 3 to 6 inches. Blue grama grows in definite bunches and reproduces by tillering and by seed. Mature seed heads are curved, resembling a human eyebrow. Blue grama can be found growing in association with buffalograss, western wheatgrass, needlegrasses and in some areas the bluegrasses.

### Adaptation and Distribution

Blue grama demonstrates good drought, fair salinity, and moderate alkalinity tolerances. In its dormant state, it will also tolerate burning. Blue grama will not tolerate dense shade, flooding, a high water table, or acid soils.

Blue grama is distributed throughout the western United States. For a current distribution map, please consult the Plant Profile page for this species on the PLANTS Website.

### Establishment

As with all native grasses, proper ground preparation is one of the most important considerations. The seedbed should be firm but not solid; cultivation to kill the roots of cool-season grasses is essential. Planting may be done by either drilling or broadcasting, with the seed being sown no more than 1/4 to 1/2 inches deep at a rate of 1 to 3 pounds PLS/acre. Seeding in late spring is recommended in the Great Plains; earlier seeding is recommended in areas further south. In the Southwest, seeding should be done during the period from June 15 to July 15. Mulching and irrigation is recommended on harsh sites. Soil tests should be made to test the soils for deficiencies. Blue grama will tolerate low-nutrient soils better than acidic conditions. Planting should be done by a native grass seed drill. In western areas plant blue grama in a sorghum cover crop, stubble, or in with the crop itself.

### Management

Once the grass is established, it is very palatable to livestock all year long. Since growing points are at or near the ground surface, the grass withstands fairly close grazing. For best yields, defer grazing during the growing season every 2 to 3 years. Blue grama cures well on stem, making it a good grass for grazing during the dormant season. Renovation of sodbound stands is also recommended. Weeds can be controlled by use of herbicides, mowing or controlled grazing.

### Pests and Potential Problems

There are no known serious pests of blue grama grass.



**Cultivars, Improved, and Selected Materials (and area of origin)**

Improved materials include the cultivars 'Lovington' (NM), 'Hachita' (NM), and 'Alma' (NM) and the selected class release Bad River Ecotype (SD). Seeds are available at most commercial seed sources.

**Prepared By & Species Coordinator:**  
*USDA NRCS Plant Materials Program*

Edited: 01Feb2002 JLK; 31may06jsp

For more information about this and other plants, please contact your local NRCS field office or Conservation District, and visit the PLANTS Web site <<http://plants.usda.gov>> or the Plant Materials Program Web site <<http://Plant-Materials.nrcs.usda.gov>>

*The U.S. Department of Agriculture (USDA) prohibits discrimination in all its programs and activities on the basis of race, color, national origin, sex, religion, age, disability, political beliefs, sexual orientation, and marital or family status. (Not all prohibited bases apply to all programs.) Persons with disabilities who require alternative means for communication of program information (Braille, large print, audiotape, etc.) should contact USDA's TARGET Center at 202-720-2600 (voice and TDD).*

*To file a complaint of discrimination write USDA, Director, Office of Civil Rights, Room 326-W, Whitten Building, 14th and Independence Avenue, SW, Washington, DC 20250-9410 or call 202-720-5964 (voice or TDD). USDA is an equal opportunity provider and employer.*

*Read about Civil Rights at the Natural Resources Conservation Service.*

## **BUFFALOGRASS** *Buchloe dactyloides* (Nutt.) **Engelm.** Plant Symbol = BUDA

Contributed by: USDA NRCS Plant Materials Program



Hitchcock 1950  
Manual of the Grasses of the U.S.

### **Alternate Names**

*Bouteloua dactyloides* (Nutt.) J.T. Columbus

### **Uses**

**Erosion control:** Buffalograss can be used on areas that do not receive a lot of rain but are affected by wind erosion, such as roadside cuts.

**Recreation and beautification:** This grass can be used in parks and on school grounds, golf course roughs, and open lawns.

**Livestock:** This is an important pasture grass for native and introduced animals.

### **Status**

Please consult the PLANTS Web site and your State Department of Natural Resources for this plant's current status (e.g. threatened or endangered species, state noxious status, and wetland indicator values).

### **Description**

*Buchloe dactyloides* (Nutt.) Engelm., buffalograss, is a perennial, native, low-growing, warm-season grass. Leaf blades are 10 to 12 inches long, but they fall over and give the turf a short appearance. Staminate plants have 2 to 3 flag-like, one-sided spikes on a seedstalk 4 to 6 inches long. Spikelets, usually 10, are 1/8 inch long in two rows on one side of the rachis. Pistillate spikelets are in a short spike or head and included in the inflated sheaths of the upper leaves. Both male and female plants have stolons from several inches to several feet in length, internodes 2 to 3 inches long, and nodes with tufts of short leaves.

### **Adaptation and Distribution**

This grass occurs naturally and grows best on clay loam to clay soils. It requires little mowing to achieve a uniform appearance. It has a low fertility requirement and it often will maintain good density without supplemental fertilization. Buffalograss is well suited for sites with 10 to 25 inches of annual precipitation. It is not adapted to shaded sites.

Buffalograss is distributed throughout the Midwest. For a current distribution map, please consult the Plant Profile page for this species on the PLANTS Website.

### **Establishment**

Buffalograss is propagated by seed and vegetatively. Establishment can be accomplished by seeding, solid sodding, or sprigging rooted and unrooted plugs. If seeds are used, drill at 1/2 inch deep and provide firm contact between the seed and moist soil. The seed may also be broadcast. When broadcasting seed, harrow or rake the area in two directions immediately after seeding to work the seeds into the soil. Broadcast seed must be covered with soil for the seeding to be successful. With any method, the soil must be firmed against the seed. Seedlings begin to appear 14 to 21 days after planting when moisture is available for germination. The amount of seed needed to ensure a stand at the end of the first year will depend on the method of seeding, the quality of seedbed preparation, the availability of water for

establishment, and certain climatic uncertainties. All planting should be delayed until the danger of frost has past. The time of planting depends upon the latitude of the location, and may extend to August 1 in lower latitudes.

Buffalograss can be established from pieces of sod or sod plugs. Sod should be planted on a well prepared seedbed in 18-inch rows. Sod should be spaced from 6 inches to 2 feet apart; plugs should be planted on 12 to 24 inch centers depending on how quickly a complete cover is desired. When planting, dig a hole deep enough to set a plant in with the grass blades above the ground. Pack soil around the sod making sure not to cover with soil because the plant will die. Once planted, the sod should be watered for about 3 weeks to ensure root establishment.

Sprigs should be planted into soil that has been tilled to a depth of 4 to 6 inches. Sprigging rate should be approximately 240 bushels of sprigs per acre, planted to a depth of 1 inch or less. A planted site should be rolled to ensure good sprig-soil contact and irrigated within 3 hours after planting. Newly planted areas will also require irrigation for several weeks to maintain a moist environment for root establishment.

Proper seedbed preparation for planting a home lawn is essential. Buffalograss will grow on heavy and compacted soils, but it is easier to start and maintain on good loam soils. Heavy soils may be improved by applying good quality organic matter such as peat moss, aged manure, or compost. Applying a phosphorus fertilizer stimulates seedling root growth, even on soils testing high in phosphorus. Work the soil to a depth of 4 to 6 inches. This may require plowing, discing, or tilling. The seedbed should be uniform, friable, and well-packed. Use tillage methods to control any weeds that may develop before seeding.

### **Management**

Buffalograss is only recommended for low maintenance and low use turfgrass areas. Mowing height and frequency depend on grass use, amount of irrigation, and time of year. Care must be taken when mowing not to cut shorter than 2 to 3 inches to avoid other grasses from out-competing the buffalograss. Buffalograss responds well to light applications of nitrogen. Over-fertilization will promote undesirable grasses within the planted area. Buffalograss is excellent for people who want a large, attractive lawn during the summer with a minimum of work involved. Other advantages of buffalograss for lawns is that it withstands heavy usage and has good drought tolerance. However, potential lawn

growers should note that buffalograss is a warm-season grass, it turns brown with fall's first freezing weather, and will not green-up until warm weather returns; it will be brown and unattractive when the neighbor's Kentucky Bluegrass is brilliant green. During extended dry periods in the summer months, buffalograss will go brown and become dormant if no supplemental water is provided. Because of aggressive runners, buffalograss can require edging along walks, driveway, and flower beds.

### **Pests and Potential Problems**

Buffalograss has no serious pests.

### **Cultivars, Improved, and Selected Materials (and area of origin)**

'Bison', 'Plains', 'Texoka', and 'Topgun' (cultivars); Bismarck Ecotype (selected class release). Seeds are available at most Midwestern commercial seed sources. Sod, sod plugs, and sprigs can be obtained from sod farms.

### **Prepared By & Species Coordinator:**

*USDA NRCS Plant Materials Program*

Edited: 01Feb2002 JLK; 31may06jsp

For more information about this and other plants, please contact your local NRCS field office or Conservation District, and visit the PLANTS Web site <<http://plants.usda.gov>> or the Plant Materials Program Web site <<http://Plant-Materials.nrcs.usda.gov>>

*The U.S. Department of Agriculture (USDA) prohibits discrimination in all its programs and activities on the basis of race, color, national origin, sex, religion, age, disability, political beliefs, sexual orientation, and marital or family status. (Not all prohibited bases apply to all programs.) Persons with disabilities who require alternative means for communication of program information (Braille, large print, audiotape, etc.) should contact USDA's TARGET Center at 202-720-2600 (voice and TDD).*

*To file a complaint of discrimination write USDA, Director, Office of Civil Rights, Room 326-W, Whitten Building, 14th and Independence Avenue, SW, Washington, DC 20250-9410 or call 202-720-5964 (voice or TDD). USDA is an equal opportunity provider and employer.*

*Read about [Civil Rights at the Natural Resources Conservation Service](#).*

## SIDEOATS GRAMA

### *Bouteloua curtipendula*

(Michx.) Torr.

Plant Symbol = BOCU

Contributed by: USDA NRCS Plant Materials Program



© W. L. Wagner  
Smithsonian Institution  
@USDA NRCS PLANTS

#### Uses

**Erosion Control:** This grass is adapted to most soil conditions. Successful seedings are obtained in rocky, stony, or shallow soils. It is a fair to good erosion control plant when mixed with the other plants naturally associated with it.

**Grazing:** This is one of the most important range grasses. Although not as palatable as some of the smaller gramas, e.g. blue grama, it is more palatable than many of the other grass species. It produces a much greater volume of forage than blue grama, and this tends to make up for its slightly lower palatability. It remains green later in the fall and usually begins growth in the spring before other gramas. It cures well, and maintains a fairly high feeding value throughout the year.

**Wildlife:** Furnishes some forage for deer and antelope when green. Elk use this plant throughout the year.

#### Status

Please consult the PLANTS Web site and your State Department of Natural Resources for this plant's current status (e.g. threatened or endangered species, state noxious status, and wetland indicator values). It is considered threatened in several states.

#### Description

*Bouteloua curtipendula*, sideoats grama, is a medium-size perennial bunchgrass, 15 to 30 inches tall or occasionally taller. This is the largest and most coarse of the grama grasses. It has a bluish-green color, sometimes with a purplish cast (especially in the spring), and cures to a reddish-brown or straw color. Leaves are coarser than other species of gramas, straight, comparatively stiff, and mostly basal. Ten to thirty small, non-comb-like spikes are borne mostly along one side of each central seed stalk. These spikes drop when mature, leaving a long zigzag stalk.

#### Adaptation and Distribution

Sideoats grama is found on rocky open slopes, woodlands, and forest openings up to an elevation of about 7,000 feet.

Sideoats grama is distributed throughout most of the United States. For a current distribution map, please consult the Plant Profile page for this species on the PLANTS Website.

#### Establishment

Seeding of improved strains of this grass is accomplished by drilling in firm, weed-free seedbeds at the rate of 2-1/2 to 5 pounds (or more) pure live seed per acre. Protect from grazing from date of seeding through the second growing season. Seedings should be delayed until good soil moisture is present.

#### Management

Sideoats grama is not as resistant to grazing as blue grama because of its taller growth habit, but sideoats grama stays green longer and can be grazed for a longer period. Reduced forage production, carrying capacity, and loss in cattle weight is a direct result of overgrazing. Sideoats grama is a normal component of a large number of range sites. The grass lengthens

the grazing season and increases forage production, in addition to providing variety in the feed. Sideoats grama will return to most ranges under good management. Practices that will bring the grass back include proper grazing use, planned grazing systems, and brush control.

### **Pests and Potential Problems**

There are no serious pests of sideoats grama.

### **Cultivars, Improved, and Selected Materials (and area of origin)**

Released cultivars include 'Butte' (NE), 'El Reno' (OK), 'Haskell' (TX), 'Niner' (NM), 'Premier' (Mexico), 'Trailway' (NE), and 'Vaughn' (NM); informal releases include Killdeer (ND) and Pierre (SD); and source identified releases include Northern Iowa Germplasm, Central Iowa Germplasm, Southern Iowa Germplasm (all from IA). Seeds are available at most western commercial seed sources.

### **Prepared By & Species Coordinator:**

*USDA NRCS Plant Materials Program*

Edited: 01Feb2002 JLK: 31may06jsp

For more information about this and other plants, please contact your local NRCS field office or Conservation District, and visit the PLANTS Web site <<http://plants.usda.gov>> or the Plant Materials Program Web site <<http://Plant-Materials.nrcs.usda.gov>>

*The U.S. Department of Agriculture (USDA) prohibits discrimination in all its programs and activities on the basis of race, color, national origin, sex, religion, age, disability, political beliefs, sexual orientation, and marital or family status. (Not all prohibited bases apply to all programs.) Persons with disabilities who require alternative means for communication of program information (Braille, large print, audiotape, etc.) should contact USDA's [TARGET Center](#) at 202-720-2600 (voice and TDD).*

*To file a complaint of discrimination write USDA, Director, Office of Civil Rights, Room 326-W, Whitten Building, 14th and Independence Avenue, SW, Washington, DC 20250-9410 or call 202-720-5964 (voice or TDD). USDA is an equal opportunity provider and employer.*

*Read about [Civil Rights at the Natural Resources Conservation Service](#).*

## **2 Hydrologic Calculations**

Runoff Coefficients and Percent Imperviousness Table 6-6

Colorado Springs Rainfall Intensity Duration Frequency Table 6-5

NOAA Rainfall Tables

Hydrologic Calculations Summary Form SF-1 for Existing Conditions

Hydrologic Calculations Summary 5-yr Form SF-2 for Existing Conditions

Hydrologic Calculations Summary 100-yr Form SF-2 for Existing Conditions

Hydrologic Basin & Design Point Calculations for Existing Conditions

Hydrologic Calculations Summary Form SF-1 for Developed Conditions

Hydrologic Calculations Summary 5-yr Form SF-2 for Developed Conditions

Hydrologic Calculations Summary 100-yr Form SF-2 for Developed Conditions

Hydrologic Basin & Design Point Calculations for Developed Conditions

**Table 6-6. Runoff Coefficients for Rational Method**  
(Source: UDFCD 2001)

Land Use or Surface Characteristics	Percent Impervious	Runoff Coefficients											
		2-year		5-year		10-year		25-year		50-year		100-year	
		HSG A&B	HSG C&D	HSG A&B	HSG C&D	HSG A&B	HSG C&D	HSG A&B	HSG C&D	HSG A&B	HSG C&D	HSG A&B	HSG C&D
<b>Business</b>													
Commercial Areas	95	0.79	0.80	0.81	0.82	0.83	0.84	0.85	0.87	0.87	0.88	0.88	0.89
Neighborhood Areas	70	0.45	0.49	0.49	0.53	0.53	0.57	0.58	0.62	0.60	0.65	0.62	0.68
<b>Residential</b>													
1/8 Acre or less	65	0.41	0.45	0.45	0.49	0.49	0.54	0.54	0.59	0.57	0.62	0.59	0.65
1/4 Acre	40	0.23	0.28	0.30	0.35	0.36	0.42	0.42	0.50	0.46	0.54	0.50	0.58
1/3 Acre	30	0.18	0.22	0.25	0.30	0.32	0.38	0.39	0.47	0.43	0.52	0.47	0.57
1/2 Acre	25	0.15	0.20	0.22	0.28	0.30	0.36	0.37	0.46	0.41	0.51	0.46	0.56
1 Acre	20	0.12	0.17	0.20	0.26	0.27	0.34	0.35	0.44	0.40	0.50	0.44	0.55
<b>Industrial</b>													
Light Areas	80	0.57	0.60	0.59	0.63	0.63	0.66	0.66	0.70	0.68	0.72	0.70	0.74
Heavy Areas	90	0.71	0.73	0.73	0.75	0.75	0.77	0.78	0.80	0.80	0.82	0.81	0.83
<b>Parks and Cemeteries</b>													
Parks and Cemeteries	7	0.05	0.09	0.12	0.19	0.20	0.29	0.30	0.40	0.34	0.46	0.39	0.52
Playgrounds	13	0.07	0.13	0.16	0.23	0.24	0.31	0.32	0.42	0.37	0.48	0.41	0.54
Railroad Yard Areas	40	0.23	0.28	0.30	0.35	0.36	0.42	0.42	0.50	0.46	0.54	0.50	0.58
<b>Undeveloped Areas</b>													
Historic Flow Analysis-- Greenbelts, Agriculture	2	0.03	0.05	0.09	0.16	0.17	0.26	0.26	0.38	0.31	0.45	0.36	0.51
Pasture/Meadow	0	0.02	0.04	0.08	0.15	0.15	0.25	0.25	0.37	0.30	0.44	0.35	0.50
Forest	0	0.02	0.04	0.08	0.15	0.15	0.25	0.25	0.37	0.30	0.44	0.35	0.50
Exposed Rock	100	0.89	0.89	0.90	0.90	0.92	0.92	0.94	0.94	0.95	0.95	0.96	0.96
Offsite Flow Analysis (when landuse is undefined)	45	0.26	0.31	0.32	0.37	0.38	0.44	0.44	0.51	0.48	0.55	0.51	0.59
<b>Streets</b>													
Paved	100	0.89	0.89	0.90	0.90	0.92	0.92	0.94	0.94	0.95	0.95	0.96	0.96
Gravel	80	0.57	0.60	0.59	0.63	0.63	0.66	0.66	0.70	0.68	0.72	0.70	0.74
<b>Drive and Walks</b>													
Drive and Walks	100	0.89	0.89	0.90	0.90	0.92	0.92	0.94	0.94	0.95	0.95	0.96	0.96
<b>Roofs</b>													
Roofs	90	0.71	0.73	0.73	0.75	0.75	0.77	0.78	0.80	0.80	0.82	0.81	0.83
<b>Lawns</b>													
Lawns	0	0.02	0.04	0.08	0.15	0.15	0.25	0.25	0.37	0.30	0.44	0.35	0.50

Figure 6-5. Colorado Springs Rainfall Intensity Duration Frequency

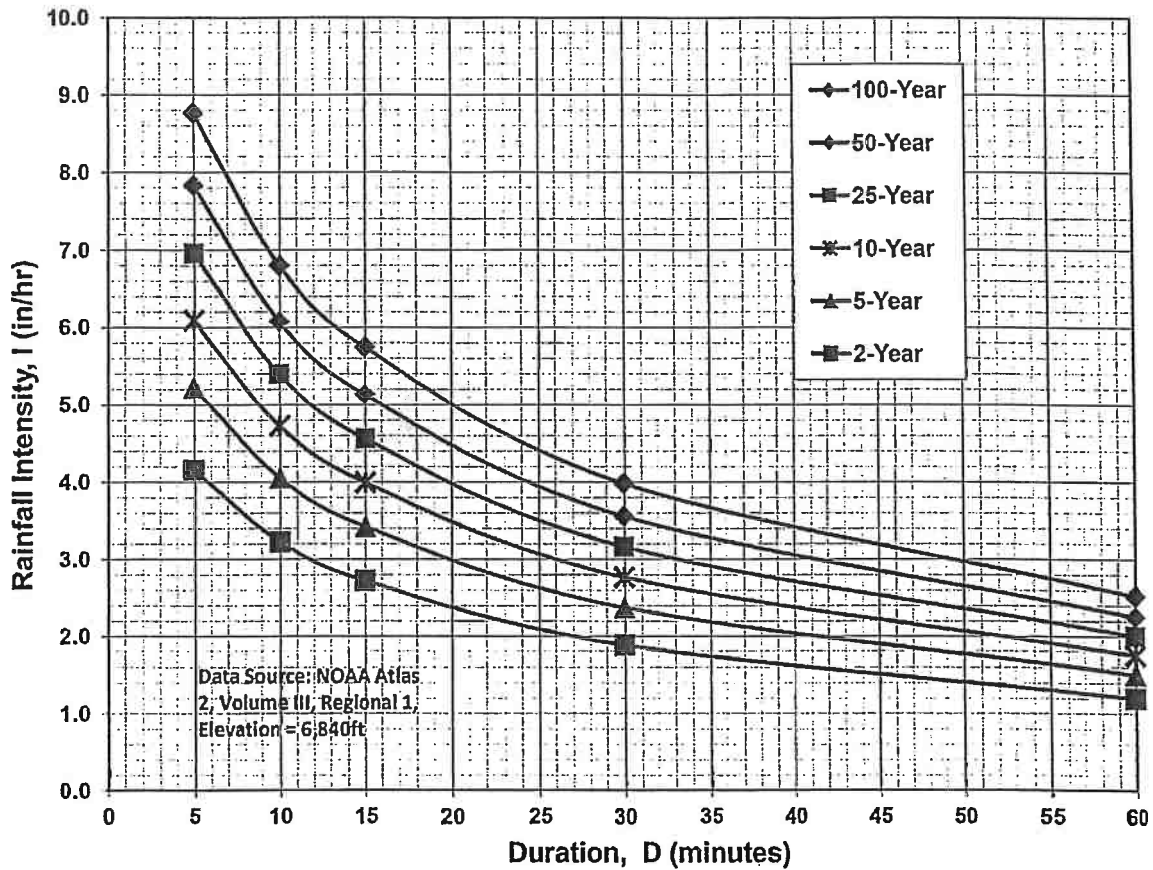

#### IDF Equations

$$I_{100} = -2.52 \ln(D) + 12.735$$

$$I_{50} = -2.25 \ln(D) + 11.375$$

$$I_{25} = -2.00 \ln(D) + 10.111$$

$$I_{10} = -1.75 \ln(D) + 8.847$$

$$I_5 = -1.50 \ln(D) + 7.583$$

$$I_2 = -1.19 \ln(D) + 6.035$$

Note: Values calculated by equations may not precisely duplicate values read from figure.





**POINT PRECIPITATION FREQUENCY ESTIMATES**

Sanja Perica, Deborah Martin, Sandra Pavlovic, Ishani Roy, Michael St. Laurent, Carl Trypaluk, Dale Unruh, Michael Yekta, Geoffery Bonnin

NOAA, National Weather Service, Silver Spring, Maryland

[PF tabular](#) | [PF graphical](#) | [Maps & aerials](#)

**PF tabular**

<b>PDS-based point precipitation frequency estimates with 90% confidence intervals (in inches)<sup>1</sup></b>										
Duration	Average recurrence interval (years)									
	1	2	5	10	25	50	100	200	500	1000
5-min	0.237 (0.194-0.293)	0.286 (0.234-0.353)	0.372 (0.302-0.460)	0.448 (0.362-0.556)	0.560 (0.439-0.724)	0.652 (0.498-0.851)	0.749 (0.552-1.00)	0.852 (0.601-1.16)	0.998 (0.675-1.40)	1.11 (0.731-1.57)
10-min	0.347 (0.284-0.429)	0.419 (0.342-0.518)	0.545 (0.443-0.674)	0.656 (0.530-0.815)	0.819 (0.644-1.06)	0.954 (0.729-1.25)	1.10 (0.808-1.46)	1.25 (0.881-1.71)	1.46 (0.989-2.04)	1.63 (1.07-2.30)
15-min	0.424 (0.346-0.523)	0.511 (0.417-0.631)	0.664 (0.540-0.822)	0.800 (0.646-0.993)	0.999 (0.785-1.29)	1.16 (0.890-1.52)	1.34 (0.986-1.78)	1.52 (1.07-2.08)	1.78 (1.21-2.49)	1.99 (1.31-2.81)
30-min	0.608 (0.497-0.750)	0.732 (0.597-0.904)	0.949 (0.771-1.17)	1.14 (0.922-1.42)	1.42 (1.12-1.84)	1.66 (1.27-2.17)	1.91 (1.40-2.54)	2.17 (1.53-2.97)	2.54 (1.72-3.56)	2.83 (1.86-4.00)
60-min	0.768 (0.627-0.947)	0.919 (0.750-1.14)	1.19 (0.967-1.47)	1.44 (1.16-1.78)	1.81 (1.42-2.35)	2.12 (1.62-2.78)	2.46 (1.81-3.29)	2.82 (1.99-3.87)	3.34 (2.26-4.68)	3.75 (2.47-5.30)
2-hr	0.928 (0.762-1.14)	1.11 (0.907-1.36)	1.43 (1.17-1.76)	1.73 (1.41-2.14)	2.19 (1.74-2.84)	2.58 (1.99-3.37)	3.01 (2.24-4.01)	3.47 (2.47-4.74)	4.13 (2.82-5.77)	4.67 (3.09-6.56)
3-hr	1.01 (0.831-1.23)	1.20 (0.983-1.46)	1.54 (1.26-1.89)	1.87 (1.52-2.30)	2.38 (1.90-3.09)	2.83 (2.19-3.69)	3.31 (2.48-4.41)	3.85 (2.75-5.24)	4.62 (3.17-6.44)	5.25 (3.49-7.34)
6-hr	1.17 (0.969-1.42)	1.37 (1.13-1.66)	1.76 (1.45-2.13)	2.13 (1.74-2.60)	2.72 (2.20-3.52)	3.25 (2.54-4.22)	3.82 (2.88-5.07)	4.47 (3.22-6.06)	5.40 (3.74-7.49)	6.18 (4.13-8.58)
12-hr	1.38 (1.15-1.66)	1.60 (1.33-1.93)	2.03 (1.68-2.45)	2.45 (2.02-2.97)	3.11 (2.52-3.99)	3.70 (2.90-4.76)	4.34 (3.29-5.71)	5.05 (3.67-6.80)	6.10 (4.25-8.39)	6.96 (4.69-9.60)
24-hr	1.62 (1.36-1.93)	1.89 (1.58-2.26)	2.40 (2.00-2.87)	2.87 (2.38-3.45)	3.60 (2.92-4.55)	4.23 (3.33-5.39)	4.91 (3.74-6.39)	5.66 (4.13-7.54)	6.74 (4.72-9.19)	7.62 (5.17-10.4)
2-day	1.89 (1.59-2.24)	2.24 (1.88-2.65)	2.85 (2.39-3.39)	3.40 (2.83-4.06)	4.21 (3.42-5.25)	4.88 (3.86-6.14)	5.60 (4.27-7.20)	6.36 (4.66-8.38)	7.43 (5.23-10.0)	8.29 (5.66-11.3)
3-day	2.06 (1.74-2.43)	2.45 (2.07-2.90)	3.13 (2.63-3.71)	3.73 (3.12-4.44)	4.60 (3.74-5.69)	5.32 (4.21-6.64)	6.06 (4.64-7.74)	6.85 (5.03-8.97)	7.95 (5.62-10.7)	8.82 (6.06-12.0)
4-day	2.21 (1.87-2.60)	2.62 (2.22-3.09)	3.34 (2.81-3.94)	3.97 (3.32-4.70)	4.88 (3.97-6.01)	5.62 (4.46-6.99)	6.39 (4.90-8.14)	7.21 (5.31-9.41)	8.34 (5.91-11.2)	9.24 (6.36-12.5)
7-day	2.61 (2.22-3.06)	3.05 (2.59-3.57)	3.80 (3.22-4.46)	4.47 (3.76-5.26)	5.43 (4.44-6.65)	6.22 (4.96-7.70)	7.04 (5.43-8.92)	7.92 (5.86-10.3)	9.13 (6.50-12.2)	10.1 (6.99-13.6)
10-day	2.97 (2.53-3.46)	3.43 (2.92-4.00)	4.22 (3.58-4.93)	4.91 (4.14-5.77)	5.92 (4.86-7.22)	6.75 (5.40-8.31)	7.61 (5.89-9.59)	8.52 (6.33-11.0)	9.79 (7.00-13.0)	10.8 (7.50-14.5)
20-day	3.94 (3.38-4.56)	4.52 (3.87-5.23)	5.48 (4.68-6.37)	6.31 (5.36-7.36)	7.49 (6.17-9.02)	8.43 (6.78-10.3)	9.40 (7.31-11.7)	10.4 (7.77-13.3)	11.8 (8.46-15.5)	12.8 (8.99-17.1)
30-day	4.73 (4.07-5.45)	5.43 (4.66-6.25)	6.56 (5.62-7.59)	7.52 (6.40-8.72)	8.84 (7.28-10.6)	9.87 (7.95-11.9)	10.9 (8.50-13.5)	12.0 (8.96-15.2)	13.4 (9.64-17.5)	14.4 (10.2-19.2)
45-day	5.73 (4.94-6.57)	6.57 (5.66-7.54)	7.93 (6.81-9.12)	9.04 (7.72-10.4)	10.5 (8.68-12.5)	11.7 (9.41-14.0)	12.8 (9.97-15.7)	13.9 (10.4-17.5)	15.3 (11.1-19.8)	16.3 (11.5-21.6)
60-day	6.57 (5.68-7.51)	7.54 (6.51-8.63)	9.09 (7.82-10.4)	10.3 (8.83-11.9)	12.0 (9.85-14.1)	13.2 (10.6-15.7)	14.3 (11.2-17.5)	15.4 (11.6-19.4)	16.8 (12.2-21.7)	17.8 (12.6-23.5)

<sup>1</sup> Precipitation frequency (PF) estimates in this table are based on frequency analysis of partial duration series (PDS). Numbers in parenthesis are PF estimates at lower and upper bounds of the 90% confidence interval. The probability that precipitation frequency estimates (for a given duration and average recurrence interval) will be greater than the upper bound (or less than the lower bound) is 5%. Estimates at upper bounds are not checked against probable maximum precipitation (PMP) estimates and may be higher than currently valid PMP values. Please refer to NOAA Atlas 14 document for more information.

[Back to Top](#)

**PF graphical**

PDS-based depth-duration-frequency (DDF) curves  
 Latitude: 39.1170°, Longitude: -104.7090°

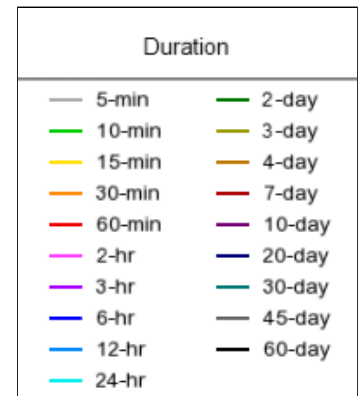
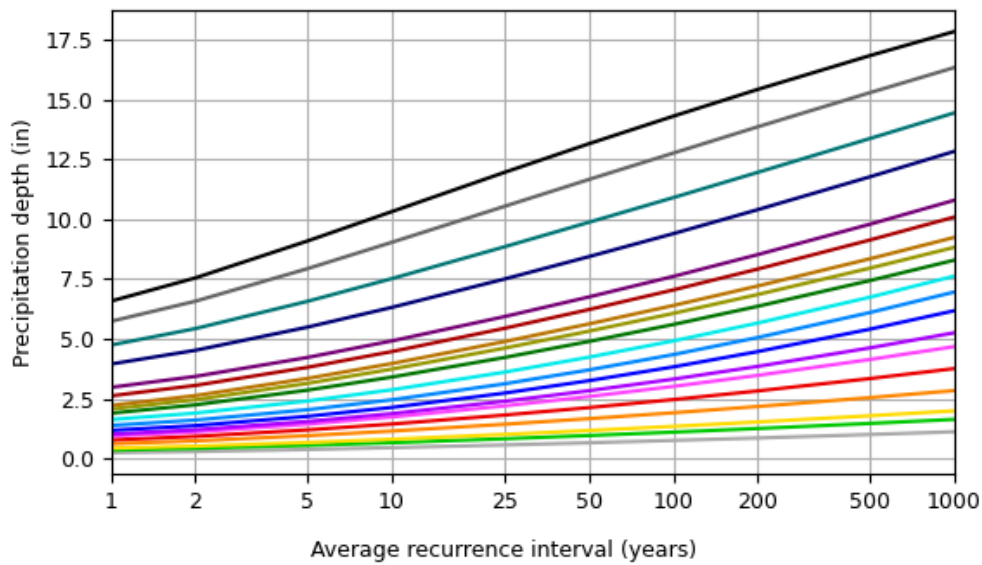
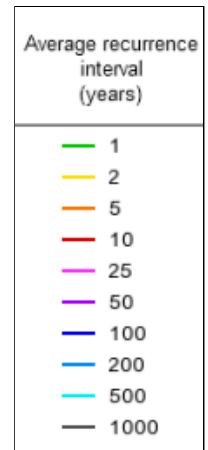
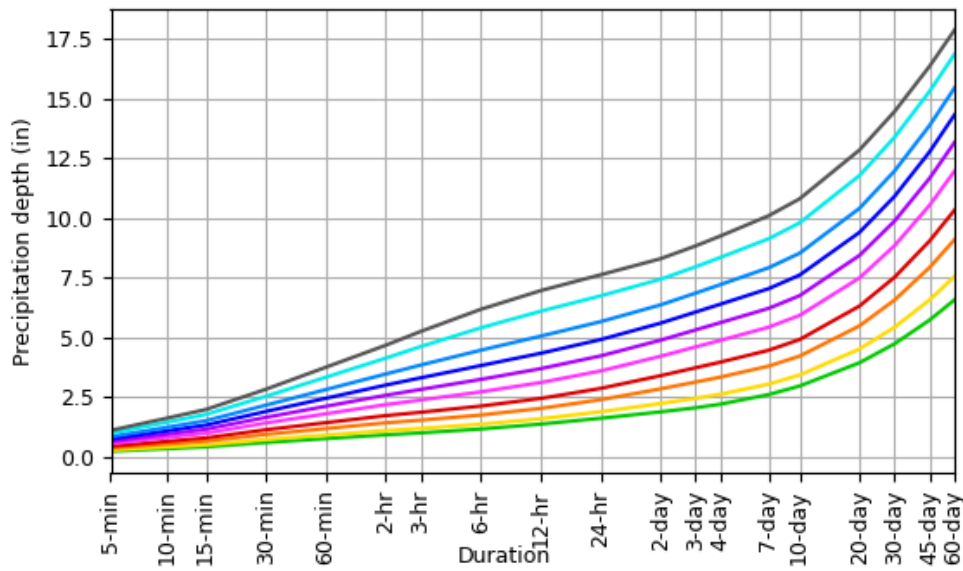

[Back to Top](#)

**Maps & aerials**

**Small scale terrain**

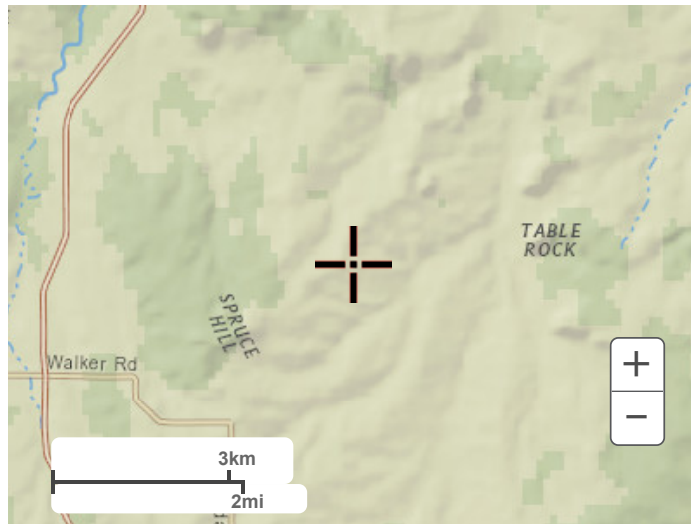

Large scale terrain



Large scale map

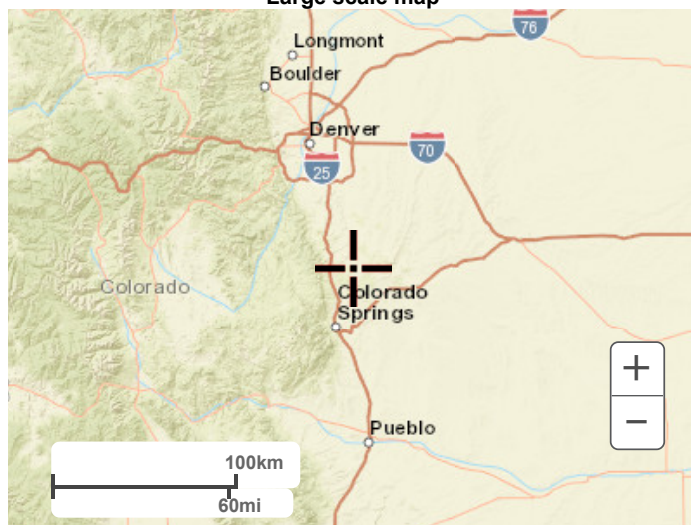

Large scale aerial

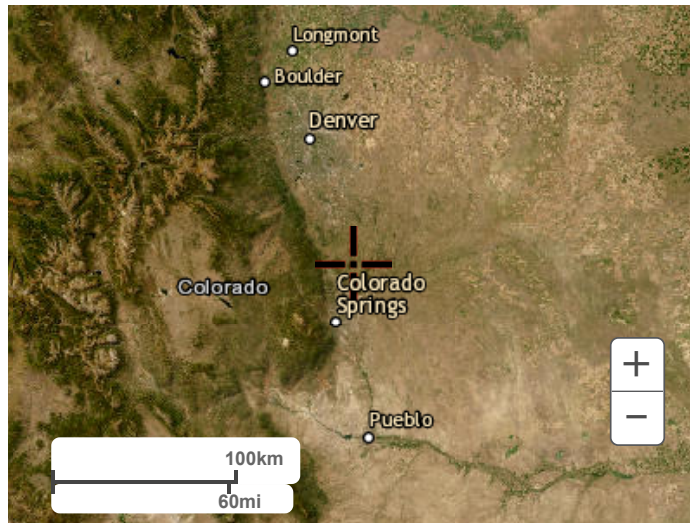

[Back to Top](#)

---

[US Department of Commerce](#)  
[National Oceanic and Atmospheric Administration](#)  
[National Weather Service](#)  
[National Water Center](#)  
1325 East West Highway  
Silver Spring, MD 20910  
Questions?: [HDSC.Questions@noaa.gov](mailto:HDSC.Questions@noaa.gov)

[Disclaimer](#)

Job No.: **61223**  
 Project: **Table Rock Homesteads - EXISTING**

Date: **1/23/2025 14:20**  
 Calcs By: **TJW**  
 Checked By: \_\_\_\_\_

**Time of Concentration** (Modified from Standard Form SF-1)

Sub-Basin	Sub-Basin Data				Overland			Shallow Channel				Channelized				t <sub>c</sub> Check		t <sub>c</sub> (min)
	Area (Acres)	C <sub>5</sub>	C <sub>100</sub> /CN	% Imp.	L <sub>0</sub> (ft)	S <sub>0</sub> (%)	t <sub>i</sub> (min)	L <sub>0t</sub> (ft)	S <sub>0t</sub> (ft/ft)	v <sub>0sc</sub> (ft/s)	t <sub>t</sub> (min)	L <sub>0c</sub> (ft)	S <sub>0c</sub> (ft/ft)	v <sub>0c</sub> (ft/s)	t <sub>c</sub> (min)	L (min)	t <sub>c,alt</sub> (min)	
A1	3.18	0.08	0.35	0%	280	7%	16.1	132	0.076	1.9	1.1	0	0.000	0.0	0.0	412	N/A	17.2
OS-B1a	10.93	0.10	0.38	7%	300	10%	14.6	400	0.090	2.1	3.2	0	0.000	0.0	0.0	700	N/A	17.8
OS-B1b	5.68	0.10	0.38	7%	165	6%	12.8	244	0.070	1.8	2.2	0	0.000	0.0	0.0	409	N/A	15.0
OS-B2	16.03	0.10	0.38	7%	300	7%	16.7	710	0.070	1.9	6.4	0	0.000	0.0	0.0	1010	N/A	23.1
B3	18.60	0.08	0.35	0%	300	9%	15.6	1022	0.049	1.5	11.0	143	0.070	6.2	0.4	1465	N/A	27.0
B4-5	21.70	0.08	0.35	0%	300	5%	18.4	553	0.040	1.4	6.6	346	0.058	5.7	1.0	1199	N/A	26.0
B6	32.39	0.08	0.35	0%	300	3%	21.4	784	0.077	1.9	6.7	446	0.009	2.5	3.0	1530	N/A	31.2
C1	8.33	0.08	0.35	0%	300	2%	24.1	530	0.015	0.9	10.3	0	0.000	0.0	0.0	830	N/A	34.4
OS-D1-2	8.51	0.10	0.38	7%	190	5%	14.4	360	0.056	1.6	3.6	370	0.027	1.4	4.5	920	N/A	22.5
D3-4	20.63	0.08	0.35	0%	144	6%	12.5	496	0.067	1.8	4.6	714	0.045	5.3	2.3	1354	N/A	19.4
E1	1.52	0.08	0.35	0%	172	10%	11.3	181	0.088	2.1	1.4	0	0.000	0.0	0.0	353	N/A	12.8

Job No.: **61223**  
 Project: **Table Rock Homesteads - EXISTING**  
 Design Storm: **5-Year Storm (20% Probability)**  
 Jurisdiction: **DCM**

Date: **1/23/2025 14:20**  
 Calcs By: **TJW**  
 Checked By: \_\_\_\_\_

**Sub-Basin and Combined Flows** (Modified from Standard Form SF-2)

DP	Sub-Basin	Area (Acres)	C5	Direct Runoff				Combined Runoff				Streetflow			Pipe Flow					Travel Time			
				t <sub>c</sub> (min)	CA (Acres)	I5 (in/hr)	Q5 (cfs)	t <sub>c</sub> (min)	CA (Acres)	I5 (in/hr)	Q5 (cfs)	Slope (%)	Length (ft)	Q (cfs)	Q (cfs)	Slope (%)	Mnngs n	Length (ft)	D <sub>pipe</sub> (in)	Length (ft)	V <sub>disc</sub> (ft/s)	t <sub>t</sub> (min)	
DP-A1	A1	3.18	0.08	17.2	0.25	3.31	0.84																
	OS-B1a	10.93	0.10	17.8	1.09	3.26	3.57																
	OS-B1b	5.68	0.10	15.0	0.57	3.52	2.00																
DP-B1	B3	18.60	0.08	27.0	1.49	2.64	3.93																
	B3	35.21	0.09					27.0	3.15	2.64	8.3												
	OS-B2	16.03	0.10	23.1	1.60	2.87	4.61																
DP-B2-3	B4-5	21.70	0.08	26.0	1.74	2.70	4.68																
	B4-5	37.73	0.09					30.1	3.34	2.47	8.3												
DP-B4	B6	32.39	0.08	31.2	2.59	2.42	6.28																
	B6	105.33	0.09					34.2	9.08	2.29	20.7												
DP-C1	C1	8.33	0.08	34.4	0.67	2.28	1.52																
	C1	8.33	0.08	34.4	0.67	2.28	1.52																
DP-D2	OS-D1-2	8.51	0.10	22.5	0.85	2.91	2.48																
	D3-4	20.63	0.08	19.4	1.65	3.14	5.18																
	D3-4	29.14	0.09					26.5	2.50	2.67	6.7												
DP-E1	E1	1.52	0.08	12.8	0.12	3.76	0.46																

DCM:  $I = C1 * \ln(t_c) + C2$   
 C1: 1.5  
 C2: 7.583

Job No.: **61223**  
 Project: **Table Rock Homesteads - EXISTING**  
 Design Storm: **100-Year Storm (1% Probability)**  
 Jurisdiction: **DCM**

Date: **1/23/2025 14:20**  
 Calcs By: **TJW**  
 Checked By: \_\_\_\_\_

**Sub-Basin and Combined Flows** (Modified from Standard Form SF-2)

DP	Sub-Basin	Area (Acres)	C100	Direct Runoff				Combined Runoff				Streetflow			Pipe Flow					Travel Time		
				t <sub>c</sub> (min)	CA (Acres)	I100 (in/hr)	Q100 (cfs)	t <sub>c</sub> (min)	CA (Acres)	I100 (in/hr)	Q100 (cfs)	Slope (%)	Length (ft)	Q (cfs)	Q (cfs)	Slope (%)	Mnngs n	Length (ft)	D <sub>Pipe</sub> (in)	Length (ft)	V <sub>0.5c</sub> (ft/s)	t <sub>t</sub> (min)
DP-A1	A1	3.18	0.35	17.2	1.11	5.56	6.19															
	OS-B1a	10.93	0.38	17.8	4.15	5.48	22.76															
	OS-B1b	5.68	0.38	15.0	2.16	5.91	12.75															
	B3	18.60	0.35	27.0	6.51	4.43	28.82															
DP-B1		35.21	0.36					27.0	12.82	4.43	56.8											
	OS-B2	16.03	0.38	23.1	6.09	4.82	29.37															
	B4-5	21.70	0.35	26.0	7.60	4.53	34.38															
DP-B2-3		37.73	0.36					30.1	13.68	4.15	56.8											
	B6	32.39	0.35	31.2	11.34	4.07	46.09															
DP-B4		105.33	0.36					34.2	37.84	3.83	145.1											
DP-C1	C1	8.33	0.35	34.4	2.92	3.82	11.14															
	OS-D1-2	8.51	0.38	22.5	3.23	4.89	15.82															
	D3-4	20.63	0.35	19.4	7.22	5.26	38.01															
DP-D2		29.14	0.36					26.5	10.45	4.47	46.8											
DP-E1	E1	1.52	0.35	12.8	0.53	6.31	3.37															

DCM:  $I = C1 * \ln(tc) + C2$   
 C1: 2.52  
 C1: 12.735

## Sub-Basin A1 Runoff Calculations (DP-A1)

Job No.: 61223  
 Project: Table Rock Homesteads - EXISTING  
 Jurisdiction: DCM  
 Runoff Coefficient: Surface Type

Date: 1/23/2025 14:20  
 Calcs by: TJW  
 Checked by: \_\_\_\_\_  
 Soil Type: B  
 Urbanization: Non-Urban

### Basin Land Use Characteristics

Surface	Area		Runoff Coefficient						% Imperv.
	(SF)	(Acres)	C2	C5	C10	C25	C50	C100	
Pasture/Meadow	138,647	3.18	0.02	0.08	0.15	0.25	0.3	0.35	0%
<b>Combined</b>	<b>138,647</b>	<b>3.18</b>	<b>0.02</b>	<b>0.08</b>	<b>0.15</b>	<b>0.25</b>	<b>0.30</b>	<b>0.35</b>	<b>0.0%</b>

### Basin Travel Time

	Shallow Channel	Ground Cover	Short Pasture/Lawns				
$L_{max,Overland}$	300	ft	$C_v$	7			
$L$ (ft)	$\Delta Z_0$ (ft)	$S_0$ (ft/ft)	$v$ (ft/s)	$t$ (min)	$t_{Alt}$ (min)		
Total	412	30	-	-	-		
Initial Time	280	20	0.071	-	16.1	N/A DCM Eq. 6-8	
Shallow Channel	132	10	0.076	1.9	1.1	- DCM Eq. 6-9	
Channelized			0.000	0.0	0.0	- V-Ditch	
				$t_c$	<b>17.2 min.</b>		

### Rainfall Intensity & Runoff

	2-Yr	5-Yr	10-Yr	25-Yr	50-Yr	100-Yr
Intensity (in/hr)	2.65	3.31	3.86	4.42	4.97	5.56
Runoff (cfs)	0.2	<b>0.8</b>	1.8	3.5	4.7	<b>6.2</b>
Release Rates (cfs/ac)	-	-	-	-	-	-
Allowed Release (cfs)	0.2	<b>0.8</b>	1.8	3.5	4.7	<b>6.2</b>

DCM:  $I = C1 * \ln(tc) + C2$

C1: 1.19    1.5    1.75    2    2.25    2.52  
 C2: 6.035    7.583    8.847    10.111    11.375    12.735

### Notes



## Sub-Basin OS-B1a Runoff Calculations

Job No.: 61223

Date: 1/23/2025 14:20

Project: Table Rock Homesteads - EXISTING

Calcs by: TJW

Jurisdiction: DCM  
Runoff Coefficient: Surface Type

Checked by: \_\_\_\_\_

Soil Type: B  
Urbanization: Non-Urban

### Basin Land Use Characteristics

Surface	Area		Runoff Coefficient						% Imperv.
	(SF)	(Acres)	C2	C5	C10	C25	C50	C100	
5 Acre	476,096	10.93	0.06	0.1	0.2	0.29	0.34	0.38	7%
<b>Combined</b>	<b>476,096</b>	<b>10.93</b>	<b>0.06</b>	<b>0.10</b>	<b>0.20</b>	<b>0.29</b>	<b>0.34</b>	<b>0.38</b>	<b>7.0%</b>

### Basin Travel Time

	Shallow Channel	Ground Cover	Short Pasture/Lawns				
$L_{max,Overland}$	300	ft	$C_v$	7			
$L$ (ft)	$\Delta Z_0$ (ft)	$S_0$ (ft/ft)	$v$ (ft/s)	$t$ (min)	$t_{Alt}$ (min)		
Total	700	66	-	-	-		
Initial Time	300	30	0.100	-	14.6	N/A DCM Eq. 6-8	
Shallow Channel	400	36	0.090	2.1	3.2	- DCM Eq. 6-9	
Channelized			0.000	0.0	0.0	- V-Ditch	
				$t_c$	17.8 min.		

### Rainfall Intensity & Runoff

	2-Yr	5-Yr	10-Yr	25-Yr	50-Yr	100-Yr
Intensity (in/hr)	2.61	3.26	3.81	4.35	4.90	5.48
Runoff (cfs)	1.7	3.6	8.3	13.8	18.2	22.8
Release Rates (cfs/ac)	-	-	-	-	-	-
Allowed Release (cfs)	1.7	3.6	8.3	13.8	18.2	22.8

DCM:  $I = C1 * \ln(tc) + C2$

C1: 1.19    1.5    1.75    2    2.25    2.52

C2: 6.035    7.583    8.847    10.111    11.375    12.735

### Notes

## Sub-Basin OS-B1b Runoff Calculations

Job No.: 61223

Date: 1/23/2025 14:20

Project: Table Rock Homesteads - EXISTING

Calcs by: TJW

Jurisdiction: DCM  
Runoff Coefficient: Surface Type

Checked by: \_\_\_\_\_

Soil Type: B  
Urbanization: Non-Urban

### Basin Land Use Characteristics

Surface	Area		Runoff Coefficient						% Imperv.
	(SF)	(Acres)	C2	C5	C10	C25	C50	C100	
5 Acre	247,241	5.68	0.06	0.1	0.2	0.29	0.34	0.38	7%
<b>Combined</b>	<b>247,241</b>	<b>5.68</b>	<b>0.06</b>	<b>0.10</b>	<b>0.20</b>	<b>0.29</b>	<b>0.34</b>	<b>0.38</b>	<b>7.0%</b>

### Basin Travel Time

	Shallow Channel Ground Cover		Short Pasture/Lawns			
	$L_{max,Overland}$	300 ft	$S_0$ (ft/ft)	$v$ (ft/s)	$t$ (min)	$t_{Alt}$ (min)
Total	409	27	-	-	-	-
Initial Time	165	10	0.061	-	12.8	N/A DCM Eq. 6-8
Shallow Channel	244	17	0.070	1.8	2.2	- DCM Eq. 6-9
Channelized			0.000	0.0	0.0	- V-Ditch
				$t_c$	<b>15.0 min.</b>	

### Rainfall Intensity & Runoff

	2-Yr	5-Yr	10-Yr	25-Yr	50-Yr	100-Yr
Intensity (in/hr)	2.81	3.52	4.11	4.70	5.28	5.91
Runoff (cfs)	1.0	<b>2.0</b>	4.7	7.7	10.2	<b>12.7</b>
Release Rates (cfs/ac)	-	-	-	-	-	-
Allowed Release (cfs)	1.0	<b>2.0</b>	4.7	7.7	10.2	<b>12.7</b>

DCM:  $I = C1 * \ln(tc) + C2$

C1: 1.19    1.5    1.75    2    2.25    2.52

C2: 6.035    7.583    8.847    10.111    11.375    12.735

### Notes

## Sub-Basin B3 Runoff Calculations

Job No.: 61223  
 Project: Table Rock Homesteads - EXISTING  
 Jurisdiction: DCM  
 Runoff Coefficient: Surface Type

Date: 1/23/2025 14:20  
 Calcs by: TJW  
 Checked by: \_\_\_\_\_  
 Soil Type: B  
 Urbanization: Non-Urban

### Basin Land Use Characteristics

Surface	Area		Runoff Coefficient						% Imperv.
	(SF)	(Acres)	C2	C5	C10	C25	C50	C100	
Pasture/Meadow	810,374	18.60	0.02	0.08	0.15	0.25	0.3	0.35	0%
<b>Combined</b>	<b>810,374</b>	<b>18.60</b>	<b>0.02</b>	<b>0.08</b>	<b>0.15</b>	<b>0.25</b>	<b>0.30</b>	<b>0.35</b>	<b>0.0%</b>

### Basin Travel Time

	Shallow Channel	Ground Cover	Short Pasture/Lawns				
$L_{max,Overland}$	300	ft	$C_v$	7			
$L$ (ft)	$\Delta Z_0$ (ft)	$S_0$ (ft/ft)	$v$ (ft/s)	$t$ (min)	$t_{Alt}$ (min)		
Total	1,465	86	-	-	-		
Initial Time	300	26	0.087	-	15.6	N/A DCM Eq. 6-8	
Shallow Channel	1,022	50	0.049	1.5	11.0	- DCM Eq. 6-9	
Channelized	143	10	0.070	6.2	0.4	- V-Ditch	
				$t_c$	<b>27.0 min.</b>		

### Rainfall Intensity & Runoff

	2-Yr	5-Yr	10-Yr	25-Yr	50-Yr	100-Yr
Intensity (in/hr)	2.11	2.64	3.08	3.52	3.96	4.43
Runoff (cfs)	0.8	<b>3.9</b>	8.6	16.4	22.1	<b>28.8</b>
Release Rates (cfs/ac)	-	-	-	-	-	-
Allowed Release (cfs)	0.8	<b>3.9</b>	8.6	16.4	22.1	<b>28.8</b>

DCM:  $I = C1 * \ln(tc) + C2$

C1      1.19      1.5      1.75      2      2.25      2.52  
 C2      6.035      7.583      8.847      10.111      11.375      12.735

### Notes

## Combined Sub-Basin Runoff Calculations (DP-B1)

Includes Basins OS-B1a OS-B1b B3

Job No.:	<b>61223</b>	Date:	<b>1/23/2025 14:20</b>
Project:	<b>Table Rock Homesteads - EXISTING</b>	Calcs by:	<b>TJW</b>
Jurisdiction	<b>DCM</b>	Checked by:	
Runoff Coefficient	<b>Surface Type</b>	Soil Type	<b>B</b>
		Urbanization	<b>Non-Urban</b>

### Basin Land Use Characteristics

Surface	Area		Runoff Coefficient						% Imperv.
	(SF)	(Acres)	C2	C5	C10	C25	C50	C100	
5 Acre	723,337	16.61	0.06	0.1	0.2	0.29	0.34	0.38	7%
Pasture/Meadow	810,374	18.60	0.02	0.08	0.15	0.25	0.3	0.35	0%
<b>Combined</b>	<b>1,533,711</b>	<b>35.21</b>	<b>0.04</b>	<b>0.09</b>	<b>0.17</b>	<b>0.27</b>	<b>0.32</b>	<b>0.36</b>	<b>3.3%</b>

### Basin Travel Time

	Sub-basin or Channel Type	Material Type	L (ft)	Elev. ΔZ <sub>0</sub> (ft)	Q <sub>i</sub> (cfs)	Base or Dia (ft)	Sides z:1 (ft/ft)	v (ft/s)	t (min)
Furthest Reach	B3	-	1,465	86	-	-	-	-	27.0
Channelized-1									
Channelized-2									
Channelized-3									
Total			1,465	86					
								<b>t<sub>c</sub> (min)</b>	<b>27.0</b>

### Contributing Offsite Flows (Added to Runoff and Allowed Release, below.)

Contributing Basins/Areas: [Redacted]

Q<sub>Minor</sub> (cfs) - 5-year Storm [Redacted]

Q<sub>Major</sub> (cfs) - 100-year Storm [Redacted]

### Rainfall Intensity & Runoff

	2-Yr	5-Yr	10-Yr	25-Yr	50-Yr	100-Yr
<b>Intensity (in/hr)</b>	2.11	2.64	3.08	3.52	3.96	4.43
<b>Site Runoff (cfs)</b>	2.89	<b>8.31</b>	18.81	33.30	44.43	<b>56.76</b>
<b>OffSite Runoff (cfs)</b>	-	<b>0.00</b>	-	-	-	<b>0.00</b>
<b>Release Rates (cfs/ac)</b>	-	-	-	-	-	-
<b>Allowed Release (cfs)</b>	-	<b>8.3</b>	-	-	-	<b>56.8</b>

DCM:  $I = C1 * \ln(tc) + C2$

C1	1.19	1.5	1.75	2	2.25	2.52
C2	6.035	7.583	8.847	10.111	11.375	12.735

### Notes

Runoff from Offsite basins have been assumed constant, despite additional times of concentration.

## Sub-Basin OS-B2 Runoff Calculations

Job No.: 61223  
 Project: Table Rock Homesteads - EXISTING  
 Jurisdiction: DCM  
 Runoff Coefficient: Surface Type

Date: 1/23/2025 14:20  
 Calcs by: TJW  
 Checked by: \_\_\_\_\_  
 Soil Type: B  
 Urbanization: Non-Urban

### Basin Land Use Characteristics

Surface	Area		Runoff Coefficient						% Imperv.
	(SF)	(Acres)	C2	C5	C10	C25	C50	C100	
5 Acre	698,050	16.03	0.06	0.1	0.2	0.29	0.34	0.38	7%
<b>Combined</b>	<b>698,050</b>	<b>16.03</b>	<b>0.06</b>	<b>0.10</b>	<b>0.20</b>	<b>0.29</b>	<b>0.34</b>	<b>0.38</b>	<b>7.0%</b>

### Basin Travel Time

	Shallow Channel	Ground Cover	Short Pasture/Lawns			
	$L_{max,Overland}$	300 ft	$S_0$ (ft/ft)	$v$ (ft/s)	$t$ (min)	$t_{Alt}$ (min)
Total	1,010	70	-	-	-	-
Initial Time	300	20	0.067	-	16.7	N/A DCM Eq. 6-8
Shallow Channel	710	50	0.070	1.9	6.4	- DCM Eq. 6-9
Channelized			0.000	0.0	0.0	- V-Ditch
				$t_c$	<b>23.1 min.</b>	

### Rainfall Intensity & Runoff

	2-Yr	5-Yr	10-Yr	25-Yr	50-Yr	100-Yr
Intensity (in/hr)	2.30	2.87	3.35	3.83	4.31	4.82
Runoff (cfs)	2.2	4.6	10.7	17.8	23.5	29.4
Release Rates (cfs/ac)	-	-	-	-	-	-
Allowed Release (cfs)	2.2	4.6	10.7	17.8	23.5	29.4

DCM:  $I = C1 * \ln(tc) + C2$

C1	1.19	1.5	1.75	2	2.25	2.52
C2	6.035	7.583	8.847	10.111	11.375	12.735

### Notes

## Sub-Basin B4-5 Runoff Calculations

Job No.: 61223

Date: 1/23/2025 14:20

Project: Table Rock Homesteads - EXISTING

Calcs by: TJW

Jurisdiction: DCM  
 Runoff Coefficient: Surface Type

Checked by: \_\_\_\_\_

Soil Type: B  
 Urbanization: Non-Urban

### Basin Land Use Characteristics

Surface	Area		Runoff Coefficient						% Imperv.
	(SF)	(Acres)	C2	C5	C10	C25	C50	C100	
Pasture/Meadow	945,313	21.70	0.02	0.08	0.15	0.25	0.3	0.35	0%
<b>Combined</b>	<b>945,313</b>	<b>21.70</b>	<b>0.02</b>	<b>0.08</b>	<b>0.15</b>	<b>0.25</b>	<b>0.30</b>	<b>0.35</b>	<b>0.0%</b>

### Basin Travel Time

	Shallow Channel	Ground Cover	Short Pasture/Lawns				
$L_{max,Overland}$	300	ft	$C_v$	7			
$L$ (ft)	$\Delta Z_0$ (ft)	$S_0$ (ft/ft)	$v$ (ft/s)	$t$ (min)	$t_{Alt}$ (min)		
Total	1,199	58	-	-	-		
Initial Time	300	16	0.053	-	18.4	N/A DCM Eq. 6-8	
Shallow Channel	553	22	0.040	1.4	6.6	- DCM Eq. 6-9	
Channelized	346	20	0.058	5.7	1.0	- V-Ditch	
				$t_c$	<b>26.0 min.</b>		

### Rainfall Intensity & Runoff

	2-Yr	5-Yr	10-Yr	25-Yr	50-Yr	100-Yr
Intensity (in/hr)	2.16	2.70	3.15	3.60	4.05	4.53
Runoff (cfs)	0.9	4.7	10.2	19.5	26.3	34.4
Release Rates (cfs/ac)	-	-	-	-	-	-
Allowed Release (cfs)	0.9	4.7	10.2	19.5	26.3	34.4

DCM:  $I = C1 * \ln(tc) + C2$

C1: 1.19    1.5    1.75    2    2.25    2.52

C2: 6.035    7.583    8.847    10.111    11.375    12.735

### Notes

## Combined Sub-Basin Runoff Calculations (DP-B2-3)

Includes Basins OS-B2 B4-5

Job No.:	<b>61223</b>	Date:	<b>1/23/2025 14:20</b>
Project:	<b>Table Rock Homesteads - EXISTING</b>	Calcs by:	<b>TJW</b>
Jurisdiction	<b>DCM</b>	Checked by:	
Runoff Coefficient	<b>Surface Type</b>	Soil Type	<b>B</b>
		Urbanization	<b>Non-Urban</b>

### Basin Land Use Characteristics

Surface	Area		Runoff Coefficient						% Imperv.
	(SF)	(Acres)	C2	C5	C10	C25	C50	C100	
5 Acre	698,050	16.03	0.06	0.1	0.2	0.29	0.34	0.38	7%
Pasture/Meadow	945,313	21.70	0.02	0.08	0.15	0.25	0.3	0.35	0%
<b>Combined</b>	<b>1,643,363</b>	<b>37.73</b>	<b>0.04</b>	<b>0.09</b>	<b>0.17</b>	<b>0.27</b>	<b>0.32</b>	<b>0.36</b>	<b>3.0%</b>

### Basin Travel Time

	Sub-basin or Channel Type	Material Type	L (ft)	Elev. ΔZ <sub>0</sub> (ft)	Q <sub>i</sub> (cfs)	Base or Dia (ft)	Sides z:1 (ft/ft)	v (ft/s)	t (min)
Furthest Reach	OS-B2	-	1,010	70	-	-	-	-	23.1
Channelized-1	Trap Ditch	2	1,200	66	29	20	8	2.8	7.1
Channelized-2									
Channelized-3									
Total			2,210	136					

2 = Natural, Winding, minimal vegetation/shallow grass

**t<sub>c</sub> (min) 30.1**

### Contributing Offsite Flows (Added to Runoff and Allowed Release, below.)

Contributing Basins/Areas

Q<sub>Minor</sub> (cfs) - 5-year Storm

Q<sub>Major</sub> (cfs) - 100-year Storm

### Rainfall Intensity & Runoff

	2-Yr	5-Yr	10-Yr	25-Yr	50-Yr	100-Yr
<b>Intensity (in/hr)</b>	1.98	2.47	2.89	3.30	3.71	4.15
<b>Site Runoff (cfs)</b>	2.77	<b>8.26</b>	18.65	33.23	44.38	<b>56.81</b>
<b>OffSite Runoff (cfs)</b>	-	<b>0.00</b>	-	-	-	<b>0.00</b>
<b>Release Rates (cfs/ac)</b>	-	-	-	-	-	-
<b>Allowed Release (cfs)</b>	-	<b>8.3</b>	-	-	-	<b>56.8</b>

DCM:  $I = C1 * \ln(tc) + C2$

C1	1.19	1.5	1.75	2	2.25	2.52
C2	6.035	7.583	8.847	10.111	11.375	12.735

### Notes

Runoff from Offsite basins have been assumed constant, despite additional times of concentration.

## Sub-Basin B6 Runoff Calculations

Job No.: 61223  
 Project: Table Rock Homesteads - EXISTING  
 Jurisdiction: DCM  
 Runoff Coefficient: Surface Type

Date: 1/23/2025 14:20  
 Calcs by: TJW  
 Checked by: \_\_\_\_\_  
 Soil Type: B  
 Urbanization: Non-Urban

### Basin Land Use Characteristics

Surface	Area		Runoff Coefficient						% Imperv.
	(SF)	(Acres)	C2	C5	C10	C25	C50	C100	
Pasture/Meadow	1,411,027	32.39	0.02	0.08	0.15	0.25	0.3	0.35	0%
<b>Combined</b>	<b>1,411,027</b>	<b>32.39</b>	<b>0.02</b>	<b>0.08</b>	<b>0.15</b>	<b>0.25</b>	<b>0.30</b>	<b>0.35</b>	<b>0.0%</b>

### Basin Travel Time

	Shallow Channel	Ground Cover	Short Pasture/Lawns				
$L_{max,Overland}$	300	ft	$C_v$	7			
$L$ (ft)	$\Delta Z_0$ (ft)	$S_0$ (ft/ft)	$v$ (ft/s)	$t$ (min)	$t_{Alt}$ (min)		
Total	1,530	74	-	-	-		
Initial Time	300	10	0.033	-	21.4	N/A DCM Eq. 6-8	
Shallow Channel	784	60	0.077	1.9	6.7	- DCM Eq. 6-9	
Channelized	446	4	0.009	2.5	3.0	- Trap Ditch	
				$t_c$	<b>31.2 min.</b>		

### Rainfall Intensity & Runoff

	2-Yr	5-Yr	10-Yr	25-Yr	50-Yr	100-Yr
Intensity (in/hr)	1.94	2.42	2.83	3.23	3.63	4.07
Runoff (cfs)	1.3	<b>6.3</b>	13.7	26.2	35.3	<b>46.1</b>
Release Rates (cfs/ac)	-	-	-	-	-	-
Allowed Release (cfs)	1.3	<b>6.3</b>	13.7	26.2	35.3	<b>46.1</b>

DCM:  $I = C1 * \ln(tc) + C2$

C1	1.19	1.5	1.75	2	2.25	2.52
C2	6.035	7.583	8.847	10.111	11.375	12.735

### Notes



## Combined Sub-Basin Runoff Calculations (DP-B4)

Includes Basins DP-B2-3 DP-B1 B6

Job No.:	<b>61223</b>	Date:	<b>1/23/2025 14:20</b>
Project:	<b>Table Rock Homesteads - EXISTING</b>	Calcs by:	<b>TJW</b>
Jurisdiction	<b>DCM</b>	Checked by:	
Runoff Coefficient	<b>Surface Type</b>	Soil Type	<b>B</b>
		Urbanization	<b>Non-Urban</b>

### Basin Land Use Characteristics

Surface	Area		Runoff Coefficient						% Imperv.
	(SF)	(Acres)	C2	C5	C10	C25	C50	C100	
5 Acre	1,421,387	32.63	0.06	0.1	0.2	0.29	0.34	0.38	7%
Pasture/Meadow	3,166,714	72.70	0.02	0.08	0.15	0.25	0.3	0.35	0%
<b>Combined</b>	<b>4,588,101</b>	<b>105.33</b>	<b>0.03</b>	<b>0.09</b>	<b>0.17</b>	<b>0.26</b>	<b>0.31</b>	<b>0.36</b>	<b>2.2%</b>

### Basin Travel Time

	Sub-basin or Channel Type	Material Type	L (ft)	Elev. ΔZ <sub>0</sub> (ft)	Q <sub>i</sub> (cfs)	Base or Dia (ft)	Sides z:1 (ft/ft)	v (ft/s)	t (min)
Furthest Reach	DP-B2-3	-	2,210	136	-	-	-	-	30.1
Channelized-1	Trap Ditch	2	851	21	57	10	4	3.5	4.0
Channelized-2									
Channelized-3									
Total			3,061	157					

2 = Natural, Winding, minimal vegetation/shallow grass

**t<sub>c</sub> (min) 34.2**

### Contributing Offsite Flows (Added to Runoff and Allowed Release, below.)

Contributing Basins/Areas

Q<sub>Minor</sub> (cfs) - 5-year Storm

Q<sub>Major</sub> (cfs) - 100-year Storm

### Rainfall Intensity & Runoff

	2-Yr	5-Yr	10-Yr	25-Yr	50-Yr	100-Yr
<b>Intensity (in/hr)</b>	1.83	2.29	2.67	3.05	3.43	3.83
<b>Site Runoff (cfs)</b>	6.25	<b>20.75</b>	46.47	84.22	112.80	<b>145.12</b>
<b>OffSite Runoff (cfs)</b>	-	<b>0.00</b>	-	-	-	<b>0.00</b>
<b>Release Rates (cfs/ac)</b>	-	-	-	-	-	-
<b>Allowed Release (cfs)</b>	-	<b>20.7</b>	-	-	-	<b>145.1</b>

DCM:  $I = C1 * \ln(tc) + C2$

C1	1.19	1.5	1.75	2	2.25	2.52
C2	6.035	7.583	8.847	10.111	11.375	12.735

### Notes

Runoff from Offsite basins have been assumed constant, despite additional times of concentration.

## Sub-Basin C1 Runoff Calculations (DP-C1)

Job No.: 61223  
 Project: Table Rock Homesteads - EXISTING  
 Jurisdiction: DCM  
 Runoff Coefficient: Surface Type

Date: 1/23/2025 14:20  
 Calcs by: TJW  
 Checked by: \_\_\_\_\_  
 Soil Type: B  
 Urbanization: Non-Urban

### Basin Land Use Characteristics

Surface	Area		Runoff Coefficient						% Imperv.
	(SF)	(Acres)	C2	C5	C10	C25	C50	C100	
Pasture/Meadow	362,869	8.33	0.02	0.08	0.15	0.25	0.3	0.35	0%
<b>Combined</b>	<b>362,869</b>	<b>8.33</b>	<b>0.02</b>	<b>0.08</b>	<b>0.15</b>	<b>0.25</b>	<b>0.30</b>	<b>0.35</b>	<b>0.0%</b>

### Basin Travel Time

	Shallow Channel	Ground Cover	Short Pasture/Lawns				
$L_{max,Overland}$	300	ft	$C_v$	7			
$L$ (ft)	830	$\Delta Z_0$ (ft)	$S_0$ (ft/ft)	$v$ (ft/s)	$t$ (min)	$t_{Alt}$ (min)	
Total	830	15	-	-	-	-	
Initial Time	300	7	0.023	-	24.1	N/A DCM Eq. 6-8	
Shallow Channel	530	8	0.015	0.9	10.3	- DCM Eq. 6-9	
Channelized			0.000	0.0	0.0	- V-Ditch	
				$t_c$	<b>34.4 min.</b>		

### Rainfall Intensity & Runoff

	2-Yr	5-Yr	10-Yr	25-Yr	50-Yr	100-Yr
<b>Intensity (in/hr)</b>	1.83	2.28	2.66	3.04	3.42	3.82
<b>Runoff (cfs)</b>	0.3	1.5	3.3	6.3	8.5	11.1
<b>Release Rates (cfs/ac)</b>	-	-	-	-	-	-
<b>Allowed Release (cfs)</b>	0.3	1.5	3.3	6.3	8.5	11.1

DCM:  $I = C1 * \ln(tc) + C2$

C1: 1.19    1.5    1.75    2    2.25    2.52  
 C2: 6.035    7.583    8.847    10.111    11.375    12.735

### Notes

## Sub-Basin OS-D1-2 Runoff Calculations

Job No.: 61223

Date: 1/23/2025 14:20

Project: Table Rock Homesteads - EXISTING

Calcs by: TJW

Jurisdiction: DCM  
Runoff Coefficient: Surface Type

Checked by: \_\_\_\_\_

Soil Type: B  
Urbanization: Non-Urban

### Basin Land Use Characteristics

Surface	Area		Runoff Coefficient						% Imperv.
	(SF)	(Acres)	C2	C5	C10	C25	C50	C100	
5 Acre	370,798	8.51	0.06	0.1	0.2	0.29	0.34	0.38	7%
<b>Combined</b>	<b>370,798</b>	<b>8.51</b>	<b>0.06</b>	<b>0.10</b>	<b>0.20</b>	<b>0.29</b>	<b>0.34</b>	<b>0.38</b>	<b>7.0%</b>

### Basin Travel Time

	Shallow Channel	Ground Cover	Short Pasture/Lawns			
	$L_{max,Overland}$	300 ft	$S_0$ (ft/ft)	$v$ (ft/s)	$t$ (min)	$t_{Alt}$ (min)
Total	920	40	-	-	-	-
Initial Time	190	10	0.053	-	14.4	N/A DCM Eq. 6-8
Shallow Channel	360	20	0.056	1.6	3.6	- DCM Eq. 6-9
Channelized	370	10	0.027	1.4	4.5	- V-Ditch
			<b><math>t_c</math> 22.5 min.</b>			

### Rainfall Intensity & Runoff

	2-Yr	5-Yr	10-Yr	25-Yr	50-Yr	100-Yr
<b>Intensity (in/hr)</b>	2.33	2.91	3.40	3.89	4.37	4.89
<b>Runoff (cfs)</b>	1.2	<b>2.5</b>	5.8	9.6	12.7	<b>15.8</b>
<b>Release Rates (cfs/ac)</b>	-	-	-	-	-	-
<b>Allowed Release (cfs)</b>	1.2	<b>2.5</b>	5.8	9.6	12.7	<b>15.8</b>

DCM:  $I = C1 * \ln(tc) + C2$

C1 1.19 1.5 1.75 2 2.25 2.52

C2 6.035 7.583 8.847 10.111 11.375 12.735

### Notes

## Sub-Basin D3-4 Runoff Calculations

Job No.: 61223

Date: 1/23/2025 14:20

Project: Table Rock Homesteads - EXISTING

Calcs by: TJW

Jurisdiction: DCM  
Runoff Coefficient: Surface Type

Checked by: \_\_\_\_\_

Soil Type: B  
Urbanization: Non-Urban

### Basin Land Use Characteristics

Surface	Area		Runoff Coefficient						% Imperv.
	(SF)	(Acres)	C2	C5	C10	C25	C50	C100	
Pasture/Meadow	898,573	20.63	0.02	0.08	0.15	0.25	0.3	0.35	0%
<b>Combined</b>	<b>898,573</b>	<b>20.63</b>	<b>0.02</b>	<b>0.08</b>	<b>0.15</b>	<b>0.25</b>	<b>0.30</b>	<b>0.35</b>	<b>0.0%</b>

### Basin Travel Time

	Shallow Channel	Ground Cover	Short Pasture/Lawns				
$L_{max,Overland}$	300	ft	$C_v$	7			
$L$ (ft)	$\Delta Z_0$ (ft)	$S_0$ (ft/ft)	$v$ (ft/s)	$t$ (min)	$t_{Alt}$ (min)		
Total	1,354	73	-	-	-		
Initial Time	144	8	0.056	-	12.5	N/A DCM Eq. 6-8	
Shallow Channel	496	33	0.067	1.8	4.6	- DCM Eq. 6-9	
Channelized	714	32	0.045	5.3	2.3	- V-Ditch	
				$t_c$	<b>19.4 min.</b>		

### Rainfall Intensity & Runoff

	2-Yr	5-Yr	10-Yr	25-Yr	50-Yr	100-Yr
Intensity (in/hr)	2.51	3.14	3.66	4.18	4.71	5.26
Runoff (cfs)	1.0	5.2	11.3	21.6	29.1	38.0
Release Rates (cfs/ac)	-	-	-	-	-	-
Allowed Release (cfs)	1.0	5.2	11.3	21.6	29.1	38.0

DCM:  $I = C1 * \ln(tc) + C2$

C1: 1.19    1.5    1.75    2    2.25    2.52

C2: 6.035    7.583    8.847    10.111    11.375    12.735

### Notes

## Combined Sub-Basin Runoff Calculations (DP-D2)

Includes Basins OS-D1-2 D3-4

Job No.:	<b>61223</b>	Date:	<b>1/23/2025 14:20</b>
Project:	<b>Table Rock Homesteads - EXISTING</b>	Calcs by:	<b>TJW</b>
Jurisdiction	<b>DCM</b>	Checked by:	
Runoff Coefficient	<b>Surface Type</b>	Soil Type	<b>B</b>
		Urbanization	<b>Non-Urban</b>

### Basin Land Use Characteristics

Surface	Area		Runoff Coefficient						% Imperv.
	(SF)	(Acres)	C2	C5	C10	C25	C50	C100	
5 Acre	370,798	8.51	0.06	0.1	0.2	0.29	0.34	0.38	7%
Pasture/Meadow	898,573	20.63	0.02	0.08	0.15	0.25	0.3	0.35	0%
<b>Combined</b>	<b>1,269,371</b>	<b>29.14</b>	<b>0.03</b>	<b>0.09</b>	<b>0.16</b>	<b>0.26</b>	<b>0.31</b>	<b>0.36</b>	<b>2.0%</b>

### Basin Travel Time

	Sub-basin or Channel Type	Material Type	L (ft)	Elev. ΔZ <sub>0</sub> (ft)	Q <sub>i</sub> (cfs)	Base or Dia (ft)	Sides z:1 (ft/ft)	v (ft/s)	t (min)
Furthest Reach	OS-D1-2	-	920	40	-	-	-	-	22.5
Channelized-1	V-Ditch	2	1,050	50	16	0	4	4.3	4.0
Channelized-2									
Channelized-3									
Total			1,970	90					

2 = Natural, Winding, minimal vegetation/shallow grass

**t<sub>c</sub> (min) 26.5**

### Contributing Offsite Flows (Added to Runoff and Allowed Release, below.)

Contributing Basins/Areas: \_\_\_\_\_

Q<sub>Minor</sub> (cfs) - 5-year Storm: \_\_\_\_\_

Q<sub>Major</sub> (cfs) - 100-year Storm: \_\_\_\_\_

### Rainfall Intensity & Runoff

	2-Yr	5-Yr	10-Yr	25-Yr	50-Yr	100-Yr
<b>Intensity (in/hr)</b>	2.13	2.67	3.11	3.56	4.00	4.47
<b>Site Runoff (cfs)</b>	1.97	<b>6.67</b>	14.92	27.11	36.33	<b>46.78</b>
<b>OffSite Runoff (cfs)</b>	-	<b>0.00</b>	-	-	-	<b>0.00</b>
<b>Release Rates (cfs/ac)</b>	-	-	-	-	-	-
<b>Allowed Release (cfs)</b>	-	<b>6.7</b>	-	-	-	<b>46.8</b>

DCM:  $I = C1 * \ln(tc) + C2$

C1	1.19	1.5	1.75	2	2.25	2.52
C2	6.035	7.583	8.847	10.111	11.375	12.735

### Notes

Runoff from Offsite basins have been assumed constant, despite additional times of concentration.

## Sub-Basin E1 Runoff Calculations (DP-E1)

Job No.: 61223

Date: 1/23/2025 14:20

Project: Table Rock Homesteads - EXISTING

Calcs by: TJW

Jurisdiction: DCM  
Runoff Coefficient: Surface Type

Checked by: \_\_\_\_\_

Soil Type: B  
Urbanization: Non-Urban

### Basin Land Use Characteristics

Surface	Area		Runoff Coefficient						% Imperv.
	(SF)	(Acres)	C2	C5	C10	C25	C50	C100	
Pasture/Meadow	66,414	1.52	0.02	0.08	0.15	0.25	0.3	0.35	0%
<b>Combined</b>	<b>66,414</b>	<b>1.52</b>	<b>0.02</b>	<b>0.08</b>	<b>0.15</b>	<b>0.25</b>	<b>0.30</b>	<b>0.35</b>	<b>0.0%</b>

### Basin Travel Time

	Shallow Channel Ground Cover		Short Pasture/Lawns				
	$L_{max,Overland}$ (ft)	$\Delta Z_0$ (ft)	$S_0$ (ft/ft)	$v$ (ft/s)	$t$ (min)	$t_{Alt}$ (min)	$C_v$
Total	353	33	-	-	-	-	7
Initial Time	172	17	0.099	-	11.3	-	N/A DCM Eq. 6-8
Shallow Channel	181	16	0.088	2.1	1.4	-	- DCM Eq. 6-9
Channelized			0.000	0.0	0.0	-	- V-Ditch
<b><math>t_c</math></b>					<b>12.8 min.</b>		

### Rainfall Intensity & Runoff

	2-Yr	5-Yr	10-Yr	25-Yr	50-Yr	100-Yr
<b>Intensity (in/hr)</b>	3.00	3.76	4.39	5.01	5.64	6.31
<b>Runoff (cfs)</b>	0.1	<b>0.5</b>	1.0	1.9	2.6	<b>3.4</b>
<b>Release Rates (cfs/ac)</b>	-	-	-	-	-	-
<b>Allowed Release (cfs)</b>	0.1	<b>0.5</b>	1.0	1.9	2.6	<b>3.4</b>

DCM:  $I = C1 * \ln(tc) + C2$

C1: 1.19    1.5    1.75    2    2.25    2.52

C2: 6.035    7.583    8.847    10.111    11.375    12.735

### Notes

Job No.: **61223**  
 Project: **Table Rock Homesteads - DEVELOPED**

Date: **1/23/2025 14:24**  
 Calcs By: **TJW**  
 Checked By: \_\_\_\_\_

**Time of Concentration** (Modified from Standard Form SF-1)

Sub-Basin	Sub-Basin Data				Overland			Shallow Channel				Channelized				t <sub>c</sub> Check		t <sub>c</sub> (min)
	Area (Acres)	C <sub>5</sub>	C <sub>100</sub> /CN	% Imp.	L <sub>0</sub> (ft)	S <sub>0</sub> (%)	t <sub>i</sub> (min)	L <sub>0t</sub> (ft)	S <sub>0t</sub> (ft/ft)	v <sub>0sc</sub> (ft/s)	t <sub>t</sub> (min)	L <sub>0c</sub> (ft)	S <sub>0c</sub> (ft/ft)	v <sub>0c</sub> (ft/s)	t <sub>c</sub> (min)	L (min)	t <sub>c,alt</sub> (min)	
A1	3.18	0.10	0.38	7%	280	7%	15.8	132	0.076	1.9	1.1	0	0.000	0.0	0.0	412	N/A	16.9
OS-B1a	10.93	0.10	0.38	7%	300	10%	14.6	400	0.090	2.1	3.2	0	0.000	0.0	0.0	700	N/A	17.8
OS-B1b	5.68	0.10	0.38	7%	165	6%	12.8	244	0.070	1.8	2.2	0	0.000	0.0	0.0	409	N/A	15.0
OS-B2	16.03	0.10	0.38	7%	300	7%	16.7	710	0.070	1.9	6.4	0	0.000	0.0	0.0	1010	N/A	23.1
B3	18.60	0.10	0.38	7%	300	9%	15.3	1022	0.049	1.5	11.0	143	0.070	6.2	0.4	1465	N/A	26.7
B4	18.09	0.10	0.38	7%	300	5%	18.0	412	0.053	1.6	4.2	346	0.058	5.5	1.1	1058	N/A	23.3
B5	4.09	0.10	0.38	7%	300	7%	16.7	160	0.125	2.5	1.1	346	0.058	4.0	1.5	806	N/A	19.3
B6	28.74	0.10	0.38	7%	300	5%	18.0	534	0.086	2.1	4.3	446	0.009	2.5	3.0	1280	N/A	25.4
C1	11.51	0.10	0.38	7%	300	2%	23.6	530	0.015	0.9	10.3	0	0.000	0.0	0.0	830	N/A	33.9
OS-D1	6.55	0.10	0.38	7%	190	5%	14.4	360	0.056	1.6	3.6	370	0.027	1.4	4.5	920	N/A	22.5
OS-D2	1.96	0.10	0.38	7%	135	4%	13.6	270	0.037	1.3	3.3	0	0.000	0.0	0.0	405	N/A	17.0
D3	1.80	0.10	0.38	7%	144	6%	12.3	195	0.031	1.2	2.6	75	0.027	3.6	0.3	414	N/A	15.3
D4	18.83	0.10	0.38	7%	182	4%	14.9	140	0.114	2.4	1.0	728	0.036	4.9	2.5	1050	N/A	18.4
E1	1.52	0.10	0.38	7%	172	10%	11.1	181	0.088	2.1	1.4	0	0.000	0.0	0.0	353	N/A	12.6

Job No.: **61223**  
 Project: **Table Rock Homesteads - DEVELOPED**  
 Design Storm: **5-Year Storm (20% Probability)**  
 Jurisdiction: **DCM**

Date: **1/23/2025 14:24**  
 Calcs By: **TJW**  
 Checked By: \_\_\_\_\_

**Sub-Basin and Combined Flows** (Modified from Standard Form SF-2)

DP	Sub-Basin	Area (Acres)	C5	Direct Runoff				Combined Runoff				Streetflow			Pipe Flow					Travel Time						
				t <sub>c</sub> (min)	CA (Acres)	I5 (in/hr)	Q5 (cfs)	t <sub>c</sub> (min)	CA (Acres)	I5 (in/hr)	Q5 (cfs)	Slope (%)	Length (ft)	Q (cfs)	Q (cfs)	Slope (%)	Mnngs n	Length (ft)	D <sub>Pipe</sub> (in)	Length (ft)	V <sub>0.5c</sub> (ft/s)	t <sub>t</sub> (min)				
DP-A1	A1	3.18	0.10	16.9	0.32	3.34	1.06																			
	OS-B1a	10.93	0.10	17.8	1.09	3.26	3.57																			
	OS-B1b	5.68	0.10	15.0	0.57	3.52	2.00																			
	B3	18.60	0.10	26.7	1.86	2.65	4.94																			
DP-B1		35.21	0.10					26.7	3.52	2.65	9.3															
	OS-B2	16.03	0.10	23.1	1.60	2.87	4.61																			
	B4	18.09	0.10	23.3	1.81	2.86	5.17																			
DP-B2		34.11	0.10					27.1	3.41	2.63	9.0															
	B5	4.09	0.10	19.3	0.41	3.15	1.29																			
DP-B3		38.20	0.10					25.7	3.82	2.71	10.4															
	B6	28.74	0.10	25.4	2.87	2.73	7.86																			
DP-B4		102.15	0.10					29.6	10.21	2.50	25.6															
DP-C1	C1	11.51	0.10	33.9	1.15	2.30	2.64																			
	OS-D1	6.55	0.10	22.5	0.66	2.91	1.91																			
	D3	1.80	0.10	15.3	0.18	3.49	0.63																			
DP-D1		8.35	0.10					23.7	0.84	2.84	2.4															
	OS-D2	1.96	0.10	17.0	0.20	3.34	0.65																			
	D4	18.83	0.10	18.4	1.88	3.21	6.05																			
DP-D2		29.14	0.10					26.8	2.91	2.65	7.7															
DP-E1	E1	1.52	0.10	12.6	0.15	3.79	0.58																			

DCM:  $I = C1 * \ln(tc) + C2$   
 C1: 1.5  
 C1: 7.583



Job No.: **61223**  
 Project: **Table Rock Homesteads - DEVELOPED**  
 Design Storm: **100-Year Storm (1% Probability)**  
 Jurisdiction: **DCM**

Date: **1/23/2025 14:24**  
 Calcs By: **TJW**  
 Checked By:

**Sub-Basin and Combined Flows** (Modified from Standard Form SF-2)

DP	Sub-Basin	Area (Acres)	C100	Direct Runoff				Combined Runoff				Streetflow			Pipe Flow					Travel Time		
				t <sub>c</sub>	CA	I100	Q100	t <sub>c</sub>	CA	I100	Q100	Slope	Length	Q	Q	Slope	Mnngs	Length	D <sub>Pipe</sub>	Length	V <sub>0.5c</sub>	t <sub>t</sub>
				(min)	(Acres)	(in/hr)	(cfs)	(min)	(Acres)	(in/hr)	(cfs)	(%)	(ft)	(cfs)	(cfs)	(%)	n	(ft)	(in)	(ft)	(ft/s)	(min)
DP-A1	A1	3.18	0.38	16.9	1.21	5.61	6.78															
	OS-B1a	10.93	0.38	17.8	4.15	5.48	22.76															
	OS-B1b	5.68	0.38	15.0	2.16	5.91	12.75															
	B3	18.60	0.38	26.7	7.07	4.46	31.50															
DP-B1		35.21	0.38					26.7	13.38	4.46	59.6											
	OS-B2	16.03	0.38	23.1	6.09	4.82	29.37															
	B4	18.09	0.38	23.3	6.87	4.80	33.00															
DP-B2		34.11	0.38					27.1	12.96	4.42	57.2											
	B5	4.09	0.38	19.3	1.55	5.28	8.20															
DP-B3		38.20	0.38					25.7	14.51	4.55	66.1											
	B6	28.74	0.38	25.4	10.92	4.59	50.11															
DP-B4		102.15	0.38					29.6	38.82	4.20	163.1											
DP-C1	C1	11.51	0.38	33.9	4.37	3.85	16.86															
	OS-D1	6.55	0.38	22.5	2.49	4.89	12.17															
	D3	1.80	0.38	15.3	0.68	5.86	4.01															
DP-D1		8.35	0.38					23.7	3.17	4.76	15.1											
	OS-D2	1.96	0.38	17.0	0.75	5.60	4.18															
	D4	18.83	0.38	18.4	7.15	5.39	38.58															
DP-D2		29.14	0.38					26.8	11.07	4.45	49.3											
DP-E1	E1	1.52	0.38	12.6	0.58	6.36	3.68															

DCM:  $I = C1 * \ln(tc) + C2$   
 C1: 2.52  
 C1: 12.735

## Sub-Basin A1 Runoff Calculations (DP-A1)

Job No.: 61223  
 Project: Table Rock Homesteads - DEVELOPED  
 Jurisdiction: DCM  
 Runoff Coefficient: Surface Type

Date: 1/23/2025 14:24  
 Calcs by: TJW  
 Checked by: \_\_\_\_\_  
 Soil Type: B  
 Urbanization: Non-Urban

### Basin Land Use Characteristics

Surface	Area		Runoff Coefficient						% Imperv.
	(SF)	(Acres)	C2	C5	C10	C25	C50	C100	
5 Acre	138,647	3.18	0.06	0.1	0.2	0.29	0.34	0.38	7%
<b>Combined</b>	<b>138,647</b>	<b>3.18</b>	<b>0.06</b>	<b>0.10</b>	<b>0.20</b>	<b>0.29</b>	<b>0.34</b>	<b>0.38</b>	<b>7.0%</b>

### Basin Travel Time

	Shallow Channel	Ground Cover	Short Pasture/Lawns			
	$L_{max,Overland}$	300 ft	$S_0$ (ft/ft)	$v$ (ft/s)	$t$ (min)	$t_{Alt}$ (min)
Total	412	30	-	-	-	-
Initial Time	280	20	0.071	-	15.8	N/A DCM Eq. 6-8
Shallow Channel	132	10	0.076	1.9	1.1	- DCM Eq. 6-9
Channelized			0.000	0.0	0.0	- V-Ditch
				$t_c$	<b>16.9 min.</b>	

### Rainfall Intensity & Runoff

	2-Yr	5-Yr	10-Yr	25-Yr	50-Yr	100-Yr
<b>Intensity (in/hr)</b>	2.67	3.34	3.90	4.45	5.01	5.61
<b>Runoff (cfs)</b>	0.5	1.1	2.5	4.1	5.4	6.8
<b>Release Rates (cfs/ac)</b>	-	-	-	-	-	-
<b>Allowed Release (cfs)</b>	0.5	1.1	2.5	4.1	5.4	6.8

DCM:  $I = C1 * \ln(tc) + C2$

C1	1.19	1.5	1.75	2	2.25	2.52
C2	6.035	7.583	8.847	10.111	11.375	12.735

### Notes

## Sub-Basin OS-B1a Runoff Calculations

Job No.: 61223 Date: 1/23/2025 14:24  
 Project: Table Rock Homesteads - DEVELOPED Calcs by: TJW  
 Checked by: \_\_\_\_\_  
 Jurisdiction: DCM Soil Type: B  
 Runoff Coefficient: Surface Type Urbanization: Non-Urban

### Basin Land Use Characteristics

Surface	Area		Runoff Coefficient						% Imperv.
	(SF)	(Acres)	C2	C5	C10	C25	C50	C100	
5 Acre	476,096	10.93	0.06	0.1	0.2	0.29	0.34	0.38	7%
<b>Combined</b>	<b>476,096</b>	<b>10.93</b>	<b>0.06</b>	<b>0.10</b>	<b>0.20</b>	<b>0.29</b>	<b>0.34</b>	<b>0.38</b>	<b>7.0%</b>

### Basin Travel Time

	Shallow Channel	Ground Cover	Short Pasture/Lawns			
$L_{max,Overland}$	300	ft			$C_v$	7
$L$ (ft)	$\Delta Z_0$ (ft)	$S_0$ (ft/ft)	$v$ (ft/s)	$t$ (min)	$t_{Alt}$ (min)	
Total	700	66	-	-	-	
Initial Time	300	30	0.100	-	14.6	N/A DCM Eq. 6-8
Shallow Channel	400	36	0.090	2.1	3.2	- DCM Eq. 6-9
Channelized			0.000	0.0	0.0	- V-Ditch
				$t_c$	<b>17.8 min.</b>	

### Rainfall Intensity & Runoff

	2-Yr	5-Yr	10-Yr	25-Yr	50-Yr	100-Yr
<b>Intensity (in/hr)</b>	2.61	3.26	3.81	4.35	4.90	5.48
<b>Runoff (cfs)</b>	1.7	<b>3.6</b>	8.3	13.8	18.2	<b>22.8</b>
<b>Release Rates (cfs/ac)</b>	-	-	-	-	-	-
<b>Allowed Release (cfs)</b>	1.7	<b>3.6</b>	8.3	13.8	18.2	<b>22.8</b>

DCM:  $I = C1 * \ln(tc) + C2$

C1: 1.19, 1.5, 1.75, 2, 2.25, 2.52  
 C2: 6.035, 7.583, 8.847, 10.111, 11.375, 12.735

### Notes

## Sub-Basin OS-B1b Runoff Calculations

Job No.: 61223  
 Project: Table Rock Homesteads - DEVELOPED  
 Jurisdiction: DCM  
 Runoff Coefficient: Surface Type

Date: 1/23/2025 14:24  
 Calcs by: TJW  
 Checked by: \_\_\_\_\_  
 Soil Type: B  
 Urbanization: Non-Urban

### Basin Land Use Characteristics

Surface	Area		Runoff Coefficient						% Imperv.
	(SF)	(Acres)	C2	C5	C10	C25	C50	C100	
5 Acre	247,241	5.68	0.06	0.1	0.2	0.29	0.34	0.38	7%
<b>Combined</b>	<b>247,241</b>	<b>5.68</b>	<b>0.06</b>	<b>0.10</b>	<b>0.20</b>	<b>0.29</b>	<b>0.34</b>	<b>0.38</b>	<b>7.0%</b>

### Basin Travel Time

	Shallow Channel	Ground Cover	Short Pasture/Lawns			
	$L_{max,Overland}$	300 ft	$S_0$ (ft/ft)	$v$ (ft/s)	$t$ (min)	$t_{Alt}$ (min)
Total	409	27	-	-	-	-
Initial Time	165	10	0.061	-	12.8	N/A DCM Eq. 6-8
Shallow Channel	244	17	0.070	1.8	2.2	- DCM Eq. 6-9
Channelized			0.000	0.0	0.0	- V-Ditch
				$t_c$	<b>15.0 min.</b>	

### Rainfall Intensity & Runoff

	2-Yr	5-Yr	10-Yr	25-Yr	50-Yr	100-Yr
<b>Intensity (in/hr)</b>	2.81	3.52	4.11	4.70	5.28	5.91
<b>Runoff (cfs)</b>	1.0	<b>2.0</b>	4.7	7.7	10.2	<b>12.7</b>
<b>Release Rates (cfs/ac)</b>	-	-	-	-	-	-
<b>Allowed Release (cfs)</b>	1.0	<b>2.0</b>	4.7	7.7	10.2	<b>12.7</b>

DCM:  $I = C1 * \ln(tc) + C2$

C1: 1.19    1.5    1.75    2    2.25    2.52  
 C2: 6.035    7.583    8.847    10.111    11.375    12.735

### Notes

## Sub-Basin B3 Runoff Calculations

Job No.: 61223 Date: 1/23/2025 14:24  
 Project: Table Rock Homesteads - DEVELOPED Calcs by: TJW  
 Checked by: \_\_\_\_\_  
 Jurisdiction: DCM Soil Type: B  
 Runoff Coefficient: Surface Type Urbanization: Non-Urban

### Basin Land Use Characteristics

Surface	Area		Runoff Coefficient						% Imperv.
	(SF)	(Acres)	C2	C5	C10	C25	C50	C100	
5 Acre	810,374	18.60	0.06	0.1	0.2	0.29	0.34	0.38	7%
<b>Combined</b>	<b>810,374</b>	<b>18.60</b>	<b>0.06</b>	<b>0.10</b>	<b>0.20</b>	<b>0.29</b>	<b>0.34</b>	<b>0.38</b>	<b>7.0%</b>

### Basin Travel Time

	Shallow Channel	Ground Cover	Short Pasture/Lawns			
	$L_{max,Overland}$	300 ft	$S_0$ (ft/ft)	$v$ (ft/s)	$t$ (min)	$t_{Alt}$ (min)
Total	1,465	86	-	-	-	-
Initial Time	300	26	0.087	-	15.3	N/A DCM Eq. 6-8
Shallow Channel	1,022	50	0.049	1.5	11.0	- DCM Eq. 6-9
Channelized	143	10	0.070	6.2	0.4	- V-Ditch
				$t_c$	<b>26.7 min.</b>	

### Rainfall Intensity & Runoff

	2-Yr	5-Yr	10-Yr	25-Yr	50-Yr	100-Yr
<b>Intensity (in/hr)</b>	2.13	2.65	3.10	3.54	3.98	4.46
<b>Runoff (cfs)</b>	2.4	<b>4.9</b>	11.5	19.1	25.2	<b>31.5</b>
<b>Release Rates (cfs/ac)</b>	-	-	-	-	-	-
<b>Allowed Release (cfs)</b>	2.4	<b>4.9</b>	11.5	19.1	25.2	<b>31.5</b>

DCM:  $I = C1 * \ln(tc) + C2$

C1: 1.19, 1.5, 1.75, 2, 2.25, 2.52  
 C2: 6.035, 7.583, 8.847, 10.111, 11.375, 12.735

### Notes

## Combined Sub-Basin Runoff Calculations (DP-B1)

Includes Basins OS-B1a OS-B1b B3

Job No.:	<b>61223</b>	Date:	<b>1/23/2025 14:24</b>
Project:	<b>Table Rock Homesteads - DEVELOPED</b>	Calcs by:	<b>TJW</b>
Jurisdiction	<b>DCM</b>	Checked by:	
Runoff Coefficient	<b>Surface Type</b>	Soil Type	<b>B</b>
		Urbanization	<b>Non-Urban</b>

### Basin Land Use Characteristics

Surface	Area		Runoff Coefficient						% Imperv.
	(SF)	(Acres)	C2	C5	C10	C25	C50	C100	
5 Acre	1,533,711	35.21	0.06	0.1	0.2	0.29	0.34	0.38	7%
<b>Combined</b>	<b>1,533,711</b>	<b>35.21</b>	<b>0.06</b>	<b>0.10</b>	<b>0.20</b>	<b>0.29</b>	<b>0.34</b>	<b>0.38</b>	<b>7.0%</b>

### Basin Travel Time

	Sub-basin or Channel Type	Material Type	L (ft)	Elev. ΔZ <sub>0</sub> (ft)	Q <sub>i</sub> (cfs)	Base or Dia (ft)	Sides z:1 (ft/ft)	v (ft/s)	t (min)
Furthest Reach	B3	-	1,465	86	-	-	-	-	26.7
Channelized-1									
Channelized-2									
Channelized-3									
Total			1,465	86					
								<b>t<sub>c</sub> (min)</b>	<b>26.7</b>

### Contributing Offsite Flows (Added to Runoff and Allowed Release, below.)

Contributing Basins/Areas: [Redacted]

Q<sub>Minor</sub> (cfs) - 5-year Storm: [Redacted]

Q<sub>Major</sub> (cfs) - 100-year Storm: [Redacted]

### Rainfall Intensity & Runoff

	2-Yr	5-Yr	10-Yr	25-Yr	50-Yr	100-Yr
<b>Intensity (in/hr)</b>	2.13	2.65	3.10	3.54	3.98	4.46
<b>Site Runoff (cfs)</b>	4.49	<b>9.35</b>	21.81	36.15	47.68	<b>59.61</b>
<b>OffSite Runoff (cfs)</b>	-	<b>0.00</b>	-	-	-	<b>0.00</b>
<b>Release Rates (cfs/ac)</b>	-	-	-	-	-	-
<b>Allowed Release (cfs)</b>	-	<b>9.3</b>	-	-	-	<b>59.6</b>

DCM:  $I = C1 * \ln(tc) + C2$

C1	1.19	1.5	1.75	2	2.25	2.52
C2	6.035	7.583	8.847	10.111	11.375	12.735

### Notes

Runoff from Offsite basins have been assumed constant, despite additional times of concentration.

## Sub-Basin OS-B2 Runoff Calculations

Job No.: 61223 Date: 1/23/2025 14:24  
 Project: Table Rock Homesteads - DEVELOPED Calcs by: TJW  
 Checked by: \_\_\_\_\_  
 Jurisdiction: DCM Soil Type: B  
 Runoff Coefficient: Surface Type Urbanization: Non-Urban

### Basin Land Use Characteristics

Surface	Area		Runoff Coefficient						% Imperv.
	(SF)	(Acres)	C2	C5	C10	C25	C50	C100	
5 Acre	698,050	16.03	0.06	0.1	0.2	0.29	0.34	0.38	7%
<b>Combined</b>	<b>698,050</b>	<b>16.03</b>	<b>0.06</b>	<b>0.10</b>	<b>0.20</b>	<b>0.29</b>	<b>0.34</b>	<b>0.38</b>	<b>7.0%</b>

### Basin Travel Time

	Shallow Channel	Ground Cover	Short Pasture/Lawns			
	$L_{max,Overland}$	300 ft	$S_0$ (ft/ft)	$v$ (ft/s)	$t$ (min)	$t_{Alt}$ (min)
Total	1,010	70	-	-	-	-
Initial Time	300	20	0.067	-	16.7	N/A DCM Eq. 6-8
Shallow Channel	710	50	0.070	1.9	6.4	- DCM Eq. 6-9
Channelized			0.000	0.0	0.0	- V-Ditch
				$t_c$	<b>23.1 min.</b>	

### Rainfall Intensity & Runoff

	2-Yr	5-Yr	10-Yr	25-Yr	50-Yr	100-Yr
Intensity (in/hr)	2.30	2.87	3.35	3.83	4.31	4.82
Runoff (cfs)	2.2	<b>4.6</b>	10.7	17.8	23.5	<b>29.4</b>
Release Rates (cfs/ac)	-	-	-	-	-	-
Allowed Release (cfs)	2.2	<b>4.6</b>	10.7	17.8	23.5	<b>29.4</b>

DCM:  $I = C1 * \ln(tc) + C2$

C1: 1.19, 1.5, 1.75, 2, 2.25, 2.52  
 C2: 6.035, 7.583, 8.847, 10.111, 11.375, 12.735

### Notes

## Sub-Basin B4 Runoff Calculations

Job No.: 61223 Date: 1/23/2025 14:24  
 Project: Table Rock Homesteads - DEVELOPED Calcs by: TJW  
 Checked by: \_\_\_\_\_  
 Jurisdiction: DCM Soil Type: B  
 Runoff Coefficient: Surface Type Urbanization: Non-Urban

### Basin Land Use Characteristics

Surface	Area		Runoff Coefficient						% Imperv.
	(SF)	(Acres)	C2	C5	C10	C25	C50	C100	
5 Acre	787,852	18.09	0.06	0.1	0.2	0.29	0.34	0.38	7%
<b>Combined</b>	<b>787,852</b>	<b>18.09</b>	<b>0.06</b>	<b>0.10</b>	<b>0.20</b>	<b>0.29</b>	<b>0.34</b>	<b>0.38</b>	<b>7.0%</b>

### Basin Travel Time

	Shallow Channel	Ground Cover	Short Pasture/Lawns			
$L_{max,Overland}$	300	ft			$C_v$	7
$L$ (ft)		$\Delta Z_0$ (ft)	$S_0$ (ft/ft)	$v$ (ft/s)	$t$ (min)	$t_{Alt}$ (min)
Total	1,058	58	-	-	-	-
Initial Time	300	16	0.053	-	18.0	N/A DCM Eq. 6-8
Shallow Channel	412	22	0.053	1.6	4.2	- DCM Eq. 6-9
Channelized	346	20	0.058	5.5	1.1	- V-Ditch
				$t_c$	<b>23.3 min.</b>	

### Rainfall Intensity & Runoff

	2-Yr	5-Yr	10-Yr	25-Yr	50-Yr	100-Yr
Intensity (in/hr)	2.29	2.86	3.34	3.81	4.29	4.80
Runoff (cfs)	2.5	5.2	12.1	20.0	26.4	33.0
Release Rates (cfs/ac)	-	-	-	-	-	-
Allowed Release (cfs)	2.5	5.2	12.1	20.0	26.4	33.0

DCM:  $I = C1 * \ln(tc) + C2$

C1: 1.19    1.5    1.75    2    2.25    2.52  
 C2: 6.035    7.583    8.847    10.111    11.375    12.735

### Notes



## Combined Sub-Basin Runoff Calculations (DP-B2)

Includes Basins OS-B2 B4

Job No.:	<b>61223</b>	Date:	<b>1/23/2025 14:24</b>
Project:	<b>Table Rock Homesteads - DEVELOPED</b>	Calcs by:	<b>TJW</b>
Jurisdiction	<b>DCM</b>	Checked by:	
Runoff Coefficient	<b>Surface Type</b>	Soil Type	<b>B</b>
		Urbanization	<b>Non-Urban</b>

### Basin Land Use Characteristics

Surface	Area		Runoff Coefficient						% Imperv.
	(SF)	(Acres)	C2	C5	C10	C25	C50	C100	
5 Acre	1,485,902	34.11	0.06	0.1	0.2	0.29	0.34	0.38	7%
<b>Combined</b>	<b>1,485,902</b>	<b>34.11</b>	<b>0.06</b>	<b>0.10</b>	<b>0.20</b>	<b>0.29</b>	<b>0.34</b>	<b>0.38</b>	<b>7.0%</b>

### Basin Travel Time

	Sub-basin or Channel Type	Material Type	L (ft)	Elev. ΔZ <sub>0</sub> (ft)	Q <sub>i</sub> (cfs)	Base or Dia (ft)	Sides z:1 (ft/ft)	v (ft/s)	t (min)
Furthest Reach	OS-B2	-	1,010	70	-	-	-	-	23.1
Channelized-1	Trap Ditch	2	652	30	29	20	8	2.7	4.1
Channelized-2									
Channelized-3									
Total			1,662	100					

2 = Natural, Winding, minimal vegetation/shallow grass

**t<sub>c</sub> (min) 27.1**

### Contributing Offsite Flows (Added to Runoff and Allowed Release, below.)

Contributing Basins/Areas

Q<sub>Minor</sub> (cfs) - 5-year Storm

Q<sub>Major</sub> (cfs) - 100-year Storm

### Rainfall Intensity & Runoff

	2-Yr	5-Yr	10-Yr	25-Yr	50-Yr	100-Yr
<b>Intensity (in/hr)</b>	2.11	2.63	3.07	3.51	3.95	4.42
<b>Site Runoff (cfs)</b>	4.31	<b>8.97</b>	20.94	34.71	45.78	<b>57.24</b>
<b>OffSite Runoff (cfs)</b>	-	<b>0.00</b>	-	-	-	<b>0.00</b>
<b>Release Rates (cfs/ac)</b>	-	-	-	-	-	-
<b>Allowed Release (cfs)</b>	-	<b>9.0</b>	-	-	-	<b>57.2</b>

DCM:  $I = C1 * \ln(tc) + C2$

C1	1.19	1.5	1.75	2	2.25	2.52
C2	6.035	7.583	8.847	10.111	11.375	12.735

### Notes

Runoff from Offsite basins have been assumed constant, despite additional times of concentration.

## Sub-Basin B5 Runoff Calculations

Job No.: 61223  
 Project: Table Rock Homesteads - DEVELOPED  
 Jurisdiction: DCM  
 Runoff Coefficient: Surface Type

Date: 1/23/2025 14:24  
 Calcs by: TJW  
 Checked by: \_\_\_\_\_  
 Soil Type: B  
 Urbanization: Non-Urban

### Basin Land Use Characteristics

Surface	Area		Runoff Coefficient						% Imperv.
	(SF)	(Acres)	C2	C5	C10	C25	C50	C100	
5 Acre	177,961	4.09	0.06	0.1	0.2	0.29	0.34	0.38	7%
<b>Combined</b>	<b>177,961</b>	<b>4.09</b>	<b>0.06</b>	<b>0.10</b>	<b>0.20</b>	<b>0.29</b>	<b>0.34</b>	<b>0.38</b>	<b>7.0%</b>

### Basin Travel Time

	Shallow Channel	Ground Cover	Short Pasture/Lawns			
	$L_{max,Overland}$	300 ft	$S_0$ (ft/ft)	$v$ (ft/s)	$t$ (min)	$t_{Alt}$ (min)
Total	806	60	-	-	-	-
Initial Time	300	20	0.067	-	16.7	N/A DCM Eq. 6-8
Shallow Channel	160	20	0.125	2.5	1.1	- DCM Eq. 6-9
Channelized	346	20	0.058	4.0	1.5	- V-Ditch
			<b><math>t_c</math> 19.3 min.</b>			

### Rainfall Intensity & Runoff

	2-Yr	5-Yr	10-Yr	25-Yr	50-Yr	100-Yr
<b>Intensity (in/hr)</b>	2.52	3.15	3.67	4.20	4.72	5.28
<b>Runoff (cfs)</b>	0.6	1.3	3.0	5.0	6.6	8.2
<b>Release Rates (cfs/ac)</b>	-	-	-	-	-	-
<b>Allowed Release (cfs)</b>	0.6	1.3	3.0	5.0	6.6	8.2

DCM:  $I = C1 * \ln(tc) + C2$

C1	1.19	1.5	1.75	2	2.25	2.52
C2	6.035	7.583	8.847	10.111	11.375	12.735

### Notes

## Combined Sub-Basin Runoff Calculations (DP-B3)

Includes Basins DP-B2 B5

Job No.:	<b>61223</b>	Date:	<b>1/23/2025 14:24</b>
Project:	<b>Table Rock Homesteads - DEVELOPED</b>	Calcs by:	<b>TJW</b>
Jurisdiction	<b>DCM</b>	Checked by:	
Runoff Coefficient	<b>Surface Type</b>	Soil Type	<b>B</b>
		Urbanization	<b>Non-Urban</b>

### Basin Land Use Characteristics

Surface	Area		Runoff Coefficient						% Imperv.
	(SF)	(Acres)	C2	C5	C10	C25	C50	C100	
5 Acre	1,663,863	38.20	0.06	0.1	0.2	0.29	0.34	0.38	7%
<b>Combined</b>	<b>1,663,863</b>	<b>38.20</b>	<b>0.06</b>	<b>0.10</b>	<b>0.20</b>	<b>0.29</b>	<b>0.34</b>	<b>0.38</b>	<b>7.0%</b>

### Basin Travel Time

	Sub-basin or Channel Type	Material Type	L (ft)	Elev. ΔZ <sub>0</sub> (ft)	Q <sub>i</sub> (cfs)	Base or Dia (ft)	Sides z:1 (ft/ft)	v (ft/s)	t (min)
Furthest Reach	OS-B2	-	1,010	70	-	-	-	-	23.1
Channelized-1	Trap Ditch	2	484	34	29	20	8	3.1	2.6
Channelized-2									
Channelized-3									
Total			1,494	104					

2 = Natural, Winding, minimal vegetation/shallow grass

**t<sub>c</sub> (min) 25.7**

### Contributing Offsite Flows (Added to Runoff and Allowed Release, below.)

Contributing Basins/Areas

Q<sub>Minor</sub> (cfs) - 5-year Storm

Q<sub>Major</sub> (cfs) - 100-year Storm

### Rainfall Intensity & Runoff

	2-Yr	5-Yr	10-Yr	25-Yr	50-Yr	100-Yr
<b>Intensity (in/hr)</b>	2.17	2.71	3.16	3.62	4.07	4.55
<b>Site Runoff (cfs)</b>	4.97	<b>10.36</b>	24.17	40.06	52.83	<b>66.06</b>
<b>OffSite Runoff (cfs)</b>	-	<b>0.00</b>	-	-	-	<b>0.00</b>
<b>Release Rates (cfs/ac)</b>	-	-	-	-	-	-
<b>Allowed Release (cfs)</b>	-	<b>10.4</b>	-	-	-	<b>66.1</b>

DCM:  $I = C1 * \ln(tc) + C2$

C1	1.19	1.5	1.75	2	2.25	2.52
C2	6.035	7.583	8.847	10.111	11.375	12.735

### Notes

Runoff from Offsite basins have been assumed constant, despite additional times of concentration.

## Sub-Basin B6 Runoff Calculations

Job No.: 61223 Date: 1/23/2025 14:24  
 Project: Table Rock Homesteads - DEVELOPED Calcs by: TJW  
 Checked by: \_\_\_\_\_  
 Jurisdiction: DCM Soil Type: B  
 Runoff Coefficient: Surface Type Urbanization: Non-Urban

### Basin Land Use Characteristics

Surface	Area		Runoff Coefficient						% Imperv.
	(SF)	(Acres)	C2	C5	C10	C25	C50	C100	
5 Acre	1,251,994	28.74	0.06	0.1	0.2	0.29	0.34	0.38	7%
<b>Combined</b>	<b>1,251,994</b>	<b>28.74</b>	<b>0.06</b>	<b>0.10</b>	<b>0.20</b>	<b>0.29</b>	<b>0.34</b>	<b>0.38</b>	<b>7.0%</b>

### Basin Travel Time

	Shallow Channel	Ground Cover	Short Pasture/Lawns			
$L_{max,Overland}$	300	ft			$C_v$	7
$L$ (ft)		$\Delta Z_0$ (ft)	$S_0$ (ft/ft)	$v$ (ft/s)	$t$ (min)	$t_{Alt}$ (min)
Total	1,280	66	-	-	-	-
Initial Time	300	16	0.053	-	18.0	N/A DCM Eq. 6-8
Shallow Channel	534	46	0.086	2.1	4.3	- DCM Eq. 6-9
Channelized	446	4	0.009	2.5	3.0	- Trap Ditch
				$t_c$	<b>25.4 min.</b>	

### Rainfall Intensity & Runoff

	2-Yr	5-Yr	10-Yr	25-Yr	50-Yr	100-Yr
Intensity (in/hr)	2.19	2.73	3.19	3.65	4.10	4.59
Runoff (cfs)	3.8	7.9	18.3	30.4	40.1	50.1
Release Rates (cfs/ac)	-	-	-	-	-	-
Allowed Release (cfs)	3.8	7.9	18.3	30.4	40.1	50.1

DCM:  $I = C1 * \ln(tc) + C2$

C1: 1.19, 1.5, 1.75, 2, 2.25, 2.52  
 C2: 6.035, 7.583, 8.847, 10.111, 11.375, 12.735

### Notes

## Combined Sub-Basin Runoff Calculations (DP-B4)

Includes Basins DP-B1 DP-B3

Job No.:	<b>61223</b>	Date:	<b>1/23/2025 14:24</b>
Project:	<b>Table Rock Homesteads - DEVELOPED</b>	Calcs by:	<b>TJW</b>
Jurisdiction	<b>DCM</b>	Checked by:	
Runoff Coefficient	<b>Surface Type</b>	Soil Type	<b>B</b>
		Urbanization	<b>Non-Urban</b>

### Basin Land Use Characteristics

Surface	Area		Runoff Coefficient						% Imperv.
	(SF)	(Acres)	C2	C5	C10	C25	C50	C100	
5 Acre	3,197,574	73.41	0.06	0.1	0.2	0.29	0.34	0.38	7%
<b>Combined</b>	<b>3,197,574</b>	<b>73.41</b>	<b>0.06</b>	<b>0.10</b>	<b>0.20</b>	<b>0.29</b>	<b>0.34</b>	<b>0.38</b>	<b>7.0%</b>

### Basin Travel Time

	Sub-basin or Channel Type	Material Type	L (ft)	Elev. ΔZ <sub>0</sub> (ft)	Q <sub>i</sub> (cfs)	Base or Dia (ft)	Sides z:1 (ft/ft)	v (ft/s)	t (min)
Furthest Reach	DP-B3	-	1,494	104	-	-	-	-	25.7
Channelized-1	Trap Ditch	2	851	21	66	10	4	3.7	3.8
Channelized-2									
Channelized-3									
Total			2,345	125					

2 = Natural, Winding, minimal vegetation/shallow grass

**t<sub>c</sub> (min) 29.6**

### Contributing Offsite Flows (Added to Runoff and Allowed Release, below.)

Contributing Basins/Areas

Q<sub>Minor</sub> (cfs) - 5-year Storm

Q<sub>Major</sub> (cfs) - 100-year Storm

### Rainfall Intensity & Runoff

	2-Yr	5-Yr	10-Yr	25-Yr	50-Yr	100-Yr
<b>Intensity (in/hr)</b>	2.00	2.50	2.92	3.34	3.76	4.20
<b>Site Runoff (cfs)</b>	8.83	<b>18.37</b>	42.87	71.05	93.72	<b>117.17</b>
<b>OffSite Runoff (cfs)</b>	-	<b>0.00</b>	-	-	-	<b>0.00</b>
<b>Release Rates (cfs/ac)</b>	-	-	-	-	-	-
<b>Allowed Release (cfs)</b>	-	<b>18.4</b>	-	-	-	<b>117.2</b>

DCM:  $I = C1 * \ln(tc) + C2$

C1	1.19	1.5	1.75	2	2.25	2.52
C2	6.035	7.583	8.847	10.111	11.375	12.735

### Notes

Runoff from Offsite basins have been assumed constant, despite additional times of concentration.

## Combined Sub-Basin Runoff Calculations (DP-B4)

Includes Basins DP-B1 DP-B3 B6

Job No.:	<b>61223</b>	Date:	<b>1/23/2025 14:24</b>
Project:	<b>Table Rock Homesteads - DEVELOPED</b>	Calcs by:	<b>TJW</b>
Jurisdiction	<b>DCM</b>	Checked by:	
Runoff Coefficient	<b>Surface Type</b>	Soil Type	<b>B</b>
		Urbanization	<b>Non-Urban</b>

### Basin Land Use Characteristics

Surface	Area		Runoff Coefficient						% Imperv.
	(SF)	(Acres)	C2	C5	C10	C25	C50	C100	
5 Acre	4,449,568	102.15	0.06	0.1	0.2	0.29	0.34	0.38	7%
<b>Combined</b>	<b>4,449,568</b>	<b>102.15</b>	<b>0.06</b>	<b>0.10</b>	<b>0.20</b>	<b>0.29</b>	<b>0.34</b>	<b>0.38</b>	<b>7.0%</b>

### Basin Travel Time

	Sub-basin or Channel Type	Material Type	L (ft)	Elev. ΔZ <sub>0</sub> (ft)	Q <sub>i</sub> (cfs)	Base or Dia (ft)	Sides z:1 (ft/ft)	v (ft/s)	t (min)
Furthest Reach	DP-B3	-	1,494	104	-	-	-	-	25.7
Channelized-1	Trap Ditch	2	851	21	66	10	4	3.7	3.8
Channelized-2									
Channelized-3									
Total			2,345	125					

2 = Natural, Winding, minimal vegetation/shallow grass

**t<sub>c</sub> (min) 29.6**

### Contributing Offsite Flows (Added to Runoff and Allowed Release, below.)

Contributing Basins/Areas: [Redacted]

Q<sub>Minor</sub> (cfs) - 5-year Storm: [Redacted]

Q<sub>Major</sub> (cfs) - 100-year Storm: [Redacted]

### Rainfall Intensity & Runoff

	2-Yr	5-Yr	10-Yr	25-Yr	50-Yr	100-Yr
<b>Intensity (in/hr)</b>	2.00	2.50	2.92	3.34	3.76	4.20
<b>Site Runoff (cfs)</b>	12.29	<b>25.57</b>	59.66	98.87	130.41	<b>163.05</b>
<b>OffSite Runoff (cfs)</b>	-	<b>0.00</b>	-	-	-	<b>0.00</b>
<b>Release Rates (cfs/ac)</b>	-	-	-	-	-	-
<b>Allowed Release (cfs)</b>	-	<b>25.6</b>	-	-	-	<b>163.1</b>

DCM:  $I = C1 * \ln(tc) + C2$

C1	1.19	1.5	1.75	2	2.25	2.52
C2	6.035	7.583	8.847	10.111	11.375	12.735

### Notes

Runoff from Offsite basins have been assumed constant, despite additional times of concentration.

## Sub-Basin C1 Runoff Calculations (DP-C1)

Job No.: 61223  
 Project: Table Rock Homesteads - DEVELOPED  
 Jurisdiction: DCM  
 Runoff Coefficient: Surface Type

Date: 1/23/2025 14:24  
 Calcs by: TJW  
 Checked by: \_\_\_\_\_  
 Soil Type: B  
 Urbanization: Non-Urban

### Basin Land Use Characteristics

Surface	Area		Runoff Coefficient						% Imperv.
	(SF)	(Acres)	C2	C5	C10	C25	C50	C100	
5 Acre	501,401	11.51	0.06	0.1	0.2	0.29	0.34	0.38	7%
<b>Combined</b>	<b>501,401</b>	<b>11.51</b>	<b>0.06</b>	<b>0.10</b>	<b>0.20</b>	<b>0.29</b>	<b>0.34</b>	<b>0.38</b>	<b>7.0%</b>

### Basin Travel Time

	Shallow Channel	Ground Cover	Short Pasture/Lawns			
	$L_{max,Overland}$	300 ft	$S_0$ (ft/ft)	$v$ (ft/s)	$t$ (min)	$t_{Alt}$ (min)
Total	830	15	-	-	-	-
Initial Time	300	7	0.023	-	23.6	N/A DCM Eq. 6-8
Shallow Channel	530	8	0.015	0.9	10.3	- DCM Eq. 6-9
Channelized			0.000	0.0	0.0	- V-Ditch
				$t_c$	<b>33.9 min.</b>	

### Rainfall Intensity & Runoff

	2-Yr	5-Yr	10-Yr	25-Yr	50-Yr	100-Yr
<b>Intensity (in/hr)</b>	1.84	2.30	2.68	3.06	3.45	3.85
<b>Runoff (cfs)</b>	1.3	<b>2.6</b>	6.2	10.2	13.5	<b>16.9</b>
<b>Release Rates (cfs/ac)</b>	-	-	-	-	-	-
<b>Allowed Release (cfs)</b>	1.3	<b>2.6</b>	6.2	10.2	13.5	<b>16.9</b>

DCM:  $I = C1 * \ln(tc) + C2$

C1	1.19	1.5	1.75	2	2.25	2.52
C2	6.035	7.583	8.847	10.111	11.375	12.735

### Notes

## Sub-Basin OS-D1 Runoff Calculations

Job No.: 61223

Date: 1/23/2025 14:24

Project: Table Rock Homesteads - DEVELOPED

Calcs by: TJW

Jurisdiction: DCM  
Runoff Coefficient: Surface Type

Checked by: \_\_\_\_\_

Soil Type: B  
Urbanization: Non-Urban

### Basin Land Use Characteristics

Surface	Area		Runoff Coefficient						% Imperv.
	(SF)	(Acres)	C2	C5	C10	C25	C50	C100	
5 Acre	285,352	6.55	0.06	0.1	0.2	0.29	0.34	0.38	7%
<b>Combined</b>	<b>285,352</b>	<b>6.55</b>	<b>0.06</b>	<b>0.10</b>	<b>0.20</b>	<b>0.29</b>	<b>0.34</b>	<b>0.38</b>	<b>7.0%</b>

### Basin Travel Time

	Shallow Channel	Ground Cover	Short Pasture/Lawns			
	$L_{max,Overland}$	300 ft	$S_0$ (ft/ft)	$v$ (ft/s)	$t$ (min)	$t_{Alt}$ (min)
Total	920	40	-	-	-	-
Initial Time	190	10	0.053	-	14.4	N/A DCM Eq. 6-8
Shallow Channel	360	20	0.056	1.6	3.6	- DCM Eq. 6-9
Channelized	370	10	0.027	1.4	4.5	- V-Ditch
			$t_c$ <b>22.5 min.</b>			

### Rainfall Intensity & Runoff

	2-Yr	5-Yr	10-Yr	25-Yr	50-Yr	100-Yr
<b>Intensity (in/hr)</b>	2.33	2.91	3.40	3.89	4.37	4.89
<b>Runoff (cfs)</b>	0.9	1.9	4.5	7.4	9.7	12.2
<b>Release Rates (cfs/ac)</b>	-	-	-	-	-	-
<b>Allowed Release (cfs)</b>	0.9	1.9	4.5	7.4	9.7	12.2

DCM:  $I = C1 * \ln(tc) + C2$

C1: 1.19    1.5    1.75    2    2.25    2.52

C2: 6.035    7.583    8.847    10.111    11.375    12.735

### Notes



## Sub-Basin D3 Runoff Calculations

Job No.: 61223

Date: 1/23/2025 14:24

Project: Table Rock Homesteads - DEVELOPED

Calcs by: TJW

Jurisdiction: DCM  
 Runoff Coefficient: Surface Type

Checked by: \_\_\_\_\_

Soil Type: B  
 Urbanization: Non-Urban

### Basin Land Use Characteristics

Surface	Area		Runoff Coefficient						% Imperv.
	(SF)	(Acres)	C2	C5	C10	C25	C50	C100	
5 Acre	78,485	1.80	0.06	0.1	0.2	0.29	0.34	0.38	7%
<b>Combined</b>	<b>78,485</b>	<b>1.80</b>	<b>0.06</b>	<b>0.10</b>	<b>0.20</b>	<b>0.29</b>	<b>0.34</b>	<b>0.38</b>	<b>7.0%</b>

### Basin Travel Time

	Shallow Channel	Ground Cover	Short Pasture/Lawns			
	$L_{max,Overland}$	300 ft	$S_0$ (ft/ft)	$v$ (ft/s)	$t$ (min)	$t_{Alt}$ (min)
Total	414	16	-	-	-	-
Initial Time	144	8	0.056	-	12.3	N/A DCM Eq. 6-8
Shallow Channel	195	6	0.031	1.2	2.6	- DCM Eq. 6-9
Channelized	75	2	0.027	3.6	0.3	- V-Ditch
			<b><math>t_c</math> 15.3 min.</b>			

### Rainfall Intensity & Runoff

	2-Yr	5-Yr	10-Yr	25-Yr	50-Yr	100-Yr
<b>Intensity (in/hr)</b>	2.79	3.49	4.07	4.66	5.24	5.86
<b>Runoff (cfs)</b>	0.3	<b>0.6</b>	1.5	2.4	3.2	<b>4.0</b>
<b>Release Rates (cfs/ac)</b>	-	-	-	-	-	-
<b>Allowed Release (cfs)</b>	0.3	<b>0.6</b>	1.5	2.4	3.2	<b>4.0</b>

DCM:  $I = C1 * \ln(tc) + C2$

C1: 1.19    1.5    1.75    2    2.25    2.52

C2: 6.035    7.583    8.847    10.111    11.375    12.735

### Notes

## Combined Sub-Basin Runoff Calculations (DP-D1)

Includes Basins OS-D1 D3

Job No.:	<b>61223</b>	Date:	<b>1/23/2025 14:24</b>
Project:	<b>Table Rock Homesteads - DEVELOPED</b>	Calcs by:	<b>TJW</b>
Jurisdiction	<b>DCM</b>	Checked by:	
Runoff Coefficient	<b>Surface Type</b>	Soil Type	<b>B</b>
		Urbanization	<b>Non-Urban</b>

### Basin Land Use Characteristics

Surface	Area		Runoff Coefficient						% Imperv.
	(SF)	(Acres)	C2	C5	C10	C25	C50	C100	
5 Acre	363,837	8.35	0.06	0.1	0.2	0.29	0.34	0.38	7%
<b>Combined</b>	<b>363,837</b>	<b>8.35</b>	<b>0.06</b>	<b>0.10</b>	<b>0.20</b>	<b>0.29</b>	<b>0.34</b>	<b>0.38</b>	<b>7.0%</b>

### Basin Travel Time

	Sub-basin or Channel Type	Material Type	L (ft)	Elev. ΔZ <sub>0</sub> (ft)	Q <sub>i</sub> (cfs)	Base or Dia (ft)	Sides z:1 (ft/ft)	v (ft/s)	t (min)
Furthest Reach	OS-D1	-	920	40	-	-	-	-	22.5
Channelized-1	V-Ditch	1	345	9	12	0	4	4.8	1.2
Channelized-2									
Channelized-3									
Total			1,265	49					

1 = Man-made, Smooth, Straight

**t<sub>c</sub> (min) 23.7**

### Contributing Offsite Flows (Added to Runoff and Allowed Release, below.)

Contributing Basins/Areas

Q<sub>Minor</sub> (cfs) - 5-year Storm

Q<sub>Major</sub> (cfs) - 100-year Storm

### Rainfall Intensity & Runoff

	2-Yr	5-Yr	10-Yr	25-Yr	50-Yr	100-Yr
<b>Intensity (in/hr)</b>	2.27	2.84	3.31	3.78	4.25	4.76
<b>Site Runoff (cfs)</b>	1.14	<b>2.37</b>	5.53	9.16	12.08	<b>15.10</b>
<b>OffSite Runoff (cfs)</b>	-	<b>0.00</b>	-	-	-	<b>0.00</b>
<b>Release Rates (cfs/ac)</b>	-	-	-	-	-	-
<b>Allowed Release (cfs)</b>	-	<b>2.4</b>	-	-	-	<b>15.1</b>

DCM:  $I = C1 * \ln(tc) + C2$

C1	1.19	1.5	1.75	2	2.25	2.52
C2	6.035	7.583	8.847	10.111	11.375	12.735

### Notes

Runoff from Offsite basins have been assumed constant, despite additional times of concentration.

## Sub-Basin OS-D2 Runoff Calculations

Job No.: 61223  
 Project: Table Rock Homesteads - DEVELOPED  
 Jurisdiction: DCM  
 Runoff Coefficient: Surface Type

Date: 1/23/2025 14:24  
 Calcs by: TJW  
 Checked by: \_\_\_\_\_  
 Soil Type: B  
 Urbanization: Non-Urban

### Basin Land Use Characteristics

Surface	Area		Runoff Coefficient						% Imperv.
	(SF)	(Acres)	C2	C5	C10	C25	C50	C100	
5 Acre	85,447	1.96	0.06	0.1	0.2	0.29	0.34	0.38	7%
<b>Combined</b>	<b>85,447</b>	<b>1.96</b>	<b>0.06</b>	<b>0.10</b>	<b>0.20</b>	<b>0.29</b>	<b>0.34</b>	<b>0.38</b>	<b>7.0%</b>

### Basin Travel Time

	Shallow Channel	Ground Cover	Short Pasture/Lawns			
	$L_{max,Overland}$	300 ft	$S_0$ (ft/ft)	$v$ (ft/s)	$t$ (min)	$t_{Alt}$ (min)
Total	405	15	-	-	-	-
Initial Time	135	5	0.037	-	13.6	N/A DCM Eq. 6-8
Shallow Channel	270	10	0.037	1.3	3.3	- DCM Eq. 6-9
Channelized			0.000	0.0	0.0	- V-Ditch
				$t_c$	<b>17.0 min.</b>	

### Rainfall Intensity & Runoff

	2-Yr	5-Yr	10-Yr	25-Yr	50-Yr	100-Yr
<b>Intensity (in/hr)</b>	2.67	3.34	3.89	4.45	5.01	5.60
<b>Runoff (cfs)</b>	0.3	<b>0.7</b>	1.5	2.5	3.3	<b>4.2</b>
<b>Release Rates (cfs/ac)</b>	-	-	-	-	-	-
<b>Allowed Release (cfs)</b>	0.3	<b>0.7</b>	1.5	2.5	3.3	<b>4.2</b>

DCM:  $I = C1 * \ln(tc) + C2$

C1	1.19	1.5	1.75	2	2.25	2.52
C2	6.035	7.583	8.847	10.111	11.375	12.735

### Notes

## Sub-Basin D4 Runoff Calculations

Job No.: 61223 Date: 1/23/2025 14:24  
 Project: Table Rock Homesteads - DEVELOPED Calcs by: TJW  
 Checked by: \_\_\_\_\_  
 Jurisdiction: DCM Soil Type: B  
 Runoff Coefficient: Surface Type Urbanization: Non-Urban

### Basin Land Use Characteristics

Surface	Area		Runoff Coefficient						% Imperv.
	(SF)	(Acres)	C2	C5	C10	C25	C50	C100	
5 Acre	820,088	18.83	0.06	0.1	0.2	0.29	0.34	0.38	7%
<b>Combined</b>	<b>820,088</b>	<b>18.83</b>	<b>0.06</b>	<b>0.10</b>	<b>0.20</b>	<b>0.29</b>	<b>0.34</b>	<b>0.38</b>	<b>7.0%</b>

### Basin Travel Time

	Shallow Channel	Ground Cover	Short Pasture/Lawns			
$L_{max,Overland}$	300	ft	$C_v$	7		
$L$ (ft)	$\Delta Z_0$ (ft)	$S_0$ (ft/ft)	$v$ (ft/s)	$t$ (min)	$t_{Alt}$ (min)	
Total	1,050	50	-	-	-	
Initial Time	182	8	0.044	-	14.9	N/A DCM Eq. 6-8
Shallow Channel	140	16	0.114	2.4	1.0	- DCM Eq. 6-9
Channelized	728	26	0.036	4.9	2.5	- V-Ditch
			$t_c$		<b>18.4 min.</b>	

### Rainfall Intensity & Runoff

	2-Yr	5-Yr	10-Yr	25-Yr	50-Yr	100-Yr
Intensity (in/hr)	2.57	3.21	3.75	4.28	4.82	5.39
Runoff (cfs)	2.9	6.0	14.1	23.4	30.9	38.6
Release Rates (cfs/ac)	-	-	-	-	-	-
Allowed Release (cfs)	2.9	6.0	14.1	23.4	30.9	38.6

DCM:  $I = C1 * \ln(tc) + C2$

C1: 1.19, 1.5, 1.75, 2, 2.25, 2.52  
 C2: 6.035, 7.583, 8.847, 10.111, 11.375, 12.735

### Notes

## Combined Sub-Basin Runoff Calculations (DP-D2)

Includes Basins DP-D1 OS-D2 D4

Job No.:	<b>61223</b>	Date:	<b>1/23/2025 14:24</b>
Project:	<b>Table Rock Homesteads - DEVELOPED</b>	Calcs by:	<b>TJW</b>
Jurisdiction	<b>DCM</b>	Checked by:	
Runoff Coefficient	<b>Surface Type</b>	Soil Type	<b>B</b>
		Urbanization	<b>Non-Urban</b>

### Basin Land Use Characteristics

Surface	Area		Runoff Coefficient						% Imperv.
	(SF)	(Acres)	C2	C5	C10	C25	C50	C100	
5 Acre	1,269,372	29.14	0.06	0.1	0.2	0.29	0.34	0.38	7%
<b>Combined</b>	<b>1,269,372</b>	<b>29.14</b>	<b>0.06</b>	<b>0.10</b>	<b>0.20</b>	<b>0.29</b>	<b>0.34</b>	<b>0.38</b>	<b>7.0%</b>

### Basin Travel Time

	Sub-basin or Channel Type	Material Type	L (ft)	Elev. $\Delta Z_0$ (ft)	$Q_i$ (cfs)	Base or Dia (ft)	Sides z:1 (ft/ft)	v (ft/s)	t (min)
Furthest Reach	OS-D1	-	920	40	-	-	-	-	22.5
Channelized-1	V-Ditch	2	1,050	50	12	0	4	4.1	4.3
Channelized-2									
Channelized-3									
Total			1,970	90					

2 = Natural, Winding, minimal vegetation/shallow grass

$t_c$  (min) **26.8**

### Contributing Offsite Flows (Added to Runoff and Allowed Release, below.)

Contributing Basins/Areas

$Q_{Minor}$  (cfs) - 5-year Storm

$Q_{Major}$  (cfs) - 100-year Storm

### Rainfall Intensity & Runoff

	2-Yr	5-Yr	10-Yr	25-Yr	50-Yr	100-Yr
<b>Intensity (in/hr)</b>	2.12	2.65	3.09	3.53	3.98	4.45
<b>Site Runoff (cfs)</b>	3.71	<b>7.72</b>	18.02	29.87	39.40	<b>49.26</b>
<b>OffSite Runoff (cfs)</b>	-	<b>0.00</b>	-	-	-	<b>0.00</b>
<b>Release Rates (cfs/ac)</b>	-	-	-	-	-	-
<b>Allowed Release (cfs)</b>	-	<b>7.7</b>	-	-	-	<b>49.3</b>

DCM:  $I = C1 * \ln(tc) + C2$

C1	1.19	1.5	1.75	2	2.25	2.52
C2	6.035	7.583	8.847	10.111	11.375	12.735

### Notes

Runoff from Offsite basins have been assumed constant, despite additional times of concentration.

## Sub-Basin E1 Runoff Calculations (DP-E1)

Job No.: 61223  
 Project: Table Rock Homesteads - DEVELOPED  
 Jurisdiction: DCM  
 Runoff Coefficient: Surface Type

Date: 1/23/2025 14:24  
 Calcs by: TJW  
 Checked by: \_\_\_\_\_  
 Soil Type: B  
 Urbanization: Non-Urban

### Basin Land Use Characteristics

Surface	Area		Runoff Coefficient						% Imperv.
	(SF)	(Acres)	C2	C5	C10	C25	C50	C100	
5 Acre	66,414	1.52	0.06	0.1	0.2	0.29	0.34	0.38	7%
<b>Combined</b>	<b>66,414</b>	<b>1.52</b>	<b>0.06</b>	<b>0.10</b>	<b>0.20</b>	<b>0.29</b>	<b>0.34</b>	<b>0.38</b>	<b>7.0%</b>

### Basin Travel Time

	Shallow Channel	Ground Cover	Short Pasture/Lawns			
	$L_{max,Overland}$	300 ft	$S_0$ (ft/ft)	$v$ (ft/s)	$t$ (min)	$t_{Alt}$ (min)
Total	353	33	-	-	-	-
Initial Time	172	17	0.099	-	11.1	N/A DCM Eq. 6-8
Shallow Channel	181	16	0.088	2.1	1.4	- DCM Eq. 6-9
Channelized			0.000	0.0	0.0	- V-Ditch
				$t_c$	<b>12.6 min.</b>	

### Rainfall Intensity & Runoff

	2-Yr	5-Yr	10-Yr	25-Yr	50-Yr	100-Yr
Intensity (in/hr)	3.02	3.79	4.42	5.05	5.68	6.36
Runoff (cfs)	0.3	<b>0.6</b>	1.3	2.2	2.9	<b>3.7</b>
Release Rates (cfs/ac)	-	-	-	-	-	-
Allowed Release (cfs)	0.3	<b>0.6</b>	1.3	2.2	2.9	<b>3.7</b>

DCM:  $I = C1 * \ln(tc) + C2$

C1	1.19	1.5	1.75	2	2.25	2.52
C2	6.035	7.583	8.847	10.111	11.375	12.735

### Notes

### **3 Hydraulic Calculations**

Grass Buffer design calculations (UD-BMP)

FS-SFB Calculations (UD-BMP)

Water Quality (MHFD-Detention)

Proposed Roadway B4 (Worst Case) Roadside Ditch Calculations

Proposed 5-yr & 100-yr Culvert Calculations For (2) 18" Concrete Culvert @ D1

Proposed 5-yr & 100-yr Culvert Calculations For (2) 24" Concrete Culvert @ B2

Riprap Sizing calculations for Outlet protection

Ditch Channel calculations

Riprap Sizing calculations for Channel (Gully) Protection

Existing HECRAS Reach & Section Map

HECRAS Modeling and Calculations-Existing Conditions

Proposed HECRAS Reach & Section Map

HECRAS Modeling and Calculations-Proposed Conditions

**Design Procedure Form: Runoff Reduction**

UD-BMP (Version 3.07, March 2018)

Sheet 1 of 1

**Designer:** TJW  
**Company:** MVE, Inc.  
**Date:** December 18, 2024  
**Project:** Table Rock Homesteads  
**Location:** 4' Wide Grass Buffer (100 foot long road section with 4' wide grass buffer inside property line allowing for one 20' wide driveway)

**SITE INFORMATION (User Input in Blue Cells)**

WQCV Rainfall Depth = 0.60 inches  
 Depth of Average Runoff Producing Storm,  $d_6$  = 0.43 inches (for Watersheds Outside of the Denver Region, Figure 3-1 in USDCM Vol. 3)

Area Type	UIA:RPA																			
Area ID	Typical GB																			
Downstream Design Point ID	Grass Strip																			
Downstream BMP Type	None																			
DCIA (ft <sup>2</sup> )	--																			
UIA (ft <sup>2</sup> )	1,600																			
RPA (ft <sup>2</sup> )	320																			
SPA (ft <sup>2</sup> )	--																			
HSG A (%)	100%																			
HSG B (%)	0%																			
HSG C/D (%)	0%																			
Average Slope of RPA (ft/ft)	0.330																			
UIA:RPA Interface Width (ft)	100.00																			

**CALCULATED RUNOFF RESULTS**

Area ID	Typical GB																			
UIA:RPA Area (ft <sup>2</sup> )	1,920																			
L / W Ratio	0.19																			
UIA / Area	0.8333																			
Runoff (in)	0.08																			
Runoff (ft <sup>3</sup> )	13																			
Runoff Reduction (ft <sup>3</sup> )	53																			

**CALCULATED WQCV RESULTS**

Area ID	Typical GB																			
WQCV (ft <sup>3</sup> )	67																			
WQCV Reduction (ft <sup>3</sup> )	53																			
WQCV Reduction (%)	80%																			
Untreated WQCV (ft <sup>3</sup> )	13																			

**CALCULATED DESIGN POINT RESULTS (sums results from all columns with the same Downstream Design Point ID)**

Downstream Design Point ID	Grass Strip																			
DCIA (ft <sup>2</sup> )	0																			
UIA (ft <sup>2</sup> )	1,600																			
RPA (ft <sup>2</sup> )	320																			
SPA (ft <sup>2</sup> )	0																			
Total Area (ft <sup>2</sup> )	1,920																			
Total Impervious Area (ft <sup>2</sup> )	1,600																			
WQCV (ft <sup>3</sup> )	67																			
WQCV Reduction (ft <sup>3</sup> )	53																			
WQCV Reduction (%)	80%																			
Untreated WQCV (ft <sup>3</sup> )	13																			

**CALCULATED SITE RESULTS (sums results from all columns in worksheet)**

Total Area (ft <sup>2</sup> )	1,920
Total Impervious Area (ft <sup>2</sup> )	1,600
WQCV (ft <sup>3</sup> )	67
WQCV Reduction (ft <sup>3</sup> )	53
WQCV Reduction (%)	80%
Untreated WQCV (ft <sup>3</sup> )	13



## Design Procedure Form: Sand Filter (SF)

UD-BMP (Version 3.07, March 2018)

Sheet 1 of 2

**Designer:** TJW  
**Company:** MVE Engineering  
**Date:** December 18, 2024  
**Project:** Table Rock Homestead-POND B2  
**Location:** 0 Gambler Place, El Paso County, CO.

### 1. Basin Storage Volume

- A) Effective Imperviousness of Tributary Area,  $I_a$   
(100% if all paved and roofed areas upstream of sand filter)
- B) Tributary Area's Imperviousness Ratio ( $i = I_a/100$ )
- C) Water Quality Capture Volume (WQCV) Based on 12-hour Drain Time  
 $WQCV = 0.8 * (0.91 * i^3 - 1.19 * i^2 + 0.78 * i)$
- D) Contributing Watershed Area (including sand filter area)
- E) Water Quality Capture Volume (WQCV) Design Volume  
 $V_{WQCV} = WQCV / 12 * Area$
- F) For Watersheds Outside of the Denver Region, Depth of Average Runoff Producing Storm
- G) For Watersheds Outside of the Denver Region, Water Quality Capture Volume (WQCV) Design Volume
- H) User Input of Water Quality Capture Volume (WQCV) Design Volume  
(Only if a different WQCV Design Volume is desired)

$I_a =$   %

$i =$

WQCV =  watershed inches

Area =  sq ft

$V_{WQCV} =$

$d_6 =$   in

$V_{WQCV \text{ OTHER}} =$   cu ft

$V_{WQCV \text{ USER}} =$   cu ft

### 2. Basin Geometry

- A) WQCV Depth
- B) Sand Filter Side Slopes (Horizontal distance per unit vertical, 4:1 or flatter preferred). Use "0" if sand filter has vertical walls.
- C) Minimum Filter Area (Flat Surface Area)
- D) Actual Filter Area
- E) Volume Provided

$D_{WQCV} =$   ft

$Z =$   ft / ft

$A_{Min} =$   sq ft

$A_{Actual} =$   sq ft

$V_T =$   cu ft

### 3. Filter Material

Choose One

18" CDOT Class B or C Filter Material

Other (Explain):

---



---

### 4. Underdrain System

- A) Are underdrains provided?
- B) Underdrain system orifice diameter for 12 hour drain time
  - i) Distance From Lowest Elevation of the Storage Volume to the Center of the Orifice
  - ii) Volume to Drain in 12 Hours
  - iii) Orifice Diameter, 3/8" Minimum

Choose One

YES

NO

$y =$   ft

$Vol_{12} =$   cu ft

$D_o =$   in

Design Procedure Form: Sand Filter (SF)

Sheet 2 of 2

Designer: TJW  
Company: MVE Engineering  
Date: December 18, 2024  
Project: Table Rock Homestead-POND B2  
Location: 0 Gambler Place, El Paso County, CO.

5. Impermeable Geomembrane Liner and Geotextile Separator Fabric

A) Is an impermeable liner provided due to proximity of structures or groundwater contamination?

Choose One

YES  NO

6. Inlet / Outlet Works

A) Describe the type of energy dissipation at inlet points and means of conveying flows in excess of the WQCV through the outlet

Riprap pad for energy dissipation and excess flow conveyance will be controlled by a spillway.

Notes: \_\_\_\_\_  
\_\_\_\_\_  
\_\_\_\_\_

## Design Procedure Form: Sand Filter (SF)

UD-BMP (Version 3.07, March 2018)

Sheet 1 of 2

**Designer:** TJW  
**Company:** MVE Engineering  
**Date:** December 18, 2024  
**Project:** Table Rock Homestead-POND D1  
**Location:** 0 Gambler Place, El Paso County, CO.

### 1. Basin Storage Volume

- A) Effective Imperviousness of Tributary Area,  $I_a$   
(100% if all paved and roofed areas upstream of sand filter)
- B) Tributary Area's Imperviousness Ratio ( $i = I_a/100$ )
- C) Water Quality Capture Volume (WQCV) Based on 12-hour Drain Time  
 $WQCV = 0.8 * (0.91 * i^3 - 1.19 * i^2 + 0.78 * i)$
- D) Contributing Watershed Area (including sand filter area)
- E) Water Quality Capture Volume (WQCV) Design Volume  
 $V_{WQCV} = WQCV / 12 * Area$
- F) For Watersheds Outside of the Denver Region, Depth of Average Runoff Producing Storm
- G) For Watersheds Outside of the Denver Region, Water Quality Capture Volume (WQCV) Design Volume
- H) User Input of Water Quality Capture Volume (WQCV) Design Volume  
(Only if a different WQCV Design Volume is desired)

$I_a =$   %

$i =$

WQCV =  watershed inches

Area =  sq ft

$V_{WQCV} =$

$d_6 =$   in

$V_{WQCV \text{ OTHER}} =$   cu ft

$V_{WQCV \text{ USER}} =$   cu ft

### 2. Basin Geometry

- A) WQCV Depth
- B) Sand Filter Side Slopes (Horizontal distance per unit vertical, 4:1 or flatter preferred). Use "0" if sand filter has vertical walls.
- C) Minimum Filter Area (Flat Surface Area)
- D) Actual Filter Area
- E) Volume Provided

$D_{WQCV} =$   ft

$Z =$   ft / ft

$A_{Min} =$   sq ft

$A_{Actual} =$   sq ft

$V_T =$   cu ft

### 3. Filter Material

- Choose One
- 18" CDOT Class B or C Filter Material
  - Other (Explain):

### 4. Underdrain System

- A) Are underdrains provided?
- B) Underdrain system orifice diameter for 12 hour drain time
  - i) Distance From Lowest Elevation of the Storage Volume to the Center of the Orifice
  - ii) Volume to Drain in 12 Hours
  - iii) Orifice Diameter, 3/8" Minimum

- Choose One
- YES
  - NO

$y =$   ft

$Vol_{12} =$   cu ft

$D_o =$   in

LESS THAN MINIMUM. USE 3/8" DIAMETER

Design Procedure Form: Sand Filter (SF)

Sheet 2 of 2

Designer: TJW  
Company: MVE Engineering  
Date: December 18, 2024  
Project: Table Rock Homestead-POND D1  
Location: 0 Gambler Place, El Paso County, CO.

5. Impermeable Geomembrane Liner and Geotextile Separator Fabric

A) Is an impermeable liner provided due to proximity of structures or groundwater contamination?

Choose One

YES     NO

6. Inlet / Outlet Works

A) Describe the type of energy dissipation at inlet points and means of conveying flows in excess of the WQCV through the outlet

Riprap pad for energy dissipation and excess flow conveyance will be controlled by a spillway.

Notes: \_\_\_\_\_  
\_\_\_\_\_  
\_\_\_\_\_

## Design Procedure Form: Sand Filter (SF)

UD-BMP (Version 3.07, March 2018)

Sheet 1 of 2

**Designer:** TJW  
**Company:** MVE Engineering  
**Date:** December 18, 2024  
**Project:** Table Rock Homestead-POND C1  
**Location:** 0 Gambler Place, El Paso County, CO.

<p>1. Basin Storage Volume</p> <p>A) Effective Imperviousness of Tributary Area, <math>I_a</math> (100% if all paved and roofed areas upstream of sand filter)</p> <p>B) Tributary Area's Imperviousness Ratio (<math>i = I_a/100</math>)</p> <p>C) Water Quality Capture Volume (WQCV) Based on 12-hour Drain Time <math>WQCV = 0.8 * (0.91 * i^3 - 1.19 * i^2 + 0.78 * i)</math></p> <p>D) Contributing Watershed Area (including sand filter area)</p> <p>E) Water Quality Capture Volume (WQCV) Design Volume <math>V_{WQCV} = WQCV / 12 * Area</math></p> <p>F) For Watersheds Outside of the Denver Region, Depth of Average Runoff Producing Storm</p> <p>G) For Watersheds Outside of the Denver Region, Water Quality Capture Volume (WQCV) Design Volume</p> <p>H) User Input of Water Quality Capture Volume (WQCV) Design Volume (Only if a different WQCV Design Volume is desired)</p>	<p><math>I_a = </math> <input style="width: 50px;" type="text" value="80.0"/> %</p> <p><math>i = </math> <input style="width: 50px;" type="text" value="0.800"/></p> <p>WQCV = <input style="width: 50px;" type="text" value="0.26"/> watershed inches</p> <p>Area = <input style="width: 50px;" type="text" value="14,788"/> sq ft</p> <p><math>V_{WQCV} = </math> <input style="width: 50px;" type="text" value=""/></p> <p><math>d_6 = </math> <input style="width: 50px;" type="text" value="0.42"/> in</p> <p><math>V_{WQCV \text{ OTHER}} = </math> <input style="width: 50px;" type="text" value="316"/> cu ft</p> <p><math>V_{WQCV \text{ USER}} = </math> <input style="width: 50px;" type="text" value=""/> cu ft</p>
<p>2. Basin Geometry</p> <p>A) WQCV Depth</p> <p>B) Sand Filter Side Slopes (Horizontal distance per unit vertical, 4:1 or flatter preferred). Use "0" if sand filter has vertical walls.</p> <p>C) Minimum Filter Area (Flat Surface Area)</p> <p>D) Actual Filter Area</p> <p>E) Volume Provided</p>	<p><math>D_{WQCV} = </math> <input style="width: 50px;" type="text" value="1.0"/> ft</p> <p><math>Z = </math> <input style="width: 50px;" type="text" value="4.00"/> ft / ft</p> <p><math>A_{Min} = </math> <input style="width: 50px;" type="text" value="148"/> sq ft</p> <p><math>A_{Actual} = </math> <input style="width: 50px;" type="text" value="204"/> sq ft</p> <p><math>V_T = </math> <input style="width: 50px;" type="text" value="376"/> cu ft</p>
<p>3. Filter Material</p>	<p>Choose One</p> <p><input checked="" type="radio"/> 18" CDOT Class B or C Filter Material</p> <p><input type="radio"/> Other (Explain):</p> <hr style="border: 0; border-top: 1px solid black; margin-top: 10px;"/> <hr style="border: 0; border-top: 1px solid black; margin-top: 5px;"/>
<p>4. Underdrain System</p> <p>A) Are underdrains provided?</p> <p>B) Underdrain system orifice diameter for 12 hour drain time</p> <p style="margin-left: 20px;">i) Distance From Lowest Elevation of the Storage Volume to the Center of the Orifice</p> <p style="margin-left: 20px;">ii) Volume to Drain in 12 Hours</p> <p style="margin-left: 20px;">iii) Orifice Diameter, 3/8" Minimum</p>	<p>Choose One</p> <p><input checked="" type="radio"/> YES</p> <p><input type="radio"/> NO</p> <p><math>y = </math> <input style="width: 50px;" type="text" value="2.0"/> ft</p> <p><math>Vol_{12} = </math> <input style="width: 50px;" type="text" value="316"/> cu ft</p> <p><math>D_o = </math> <input style="width: 50px;" type="text" value="7/16"/> in</p>

Design Procedure Form: Sand Filter (SF)

Sheet 2 of 2

Designer: TJW  
Company: MVE Engineering  
Date: December 18, 2024  
Project: Table Rock Homestead-POND C1  
Location: 0 Gambler Place, El Paso County, CO.

5. Impermeable Geomembrane Liner and Geotextile Separator Fabric

A) Is an impermeable liner provided due to proximity of structures or groundwater contamination?

Choose One

YES  NO

6. Inlet / Outlet Works

A) Describe the type of energy dissipation at inlet points and means of conveying flows in excess of the WQCV through the outlet

Riprap pad for energy dissipation and excess flow conveyance will be controlled by a spillway.

Notes: \_\_\_\_\_  
\_\_\_\_\_  
\_\_\_\_\_

# DETENTION BASIN STAGE-STORAGE TABLE BUILDER

MHFD-Detention, Version 4.06 (July 2022)

**Project:** Table Rock Homestead

**Basin ID:** Pond B2

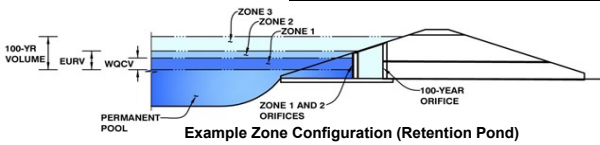

**Watershed Information**

Selected BMP Type =	<b>SF</b>
Watershed Area =	0.43 acres
Watershed Length =	660 ft
Watershed Length to Centroid =	330 ft
Watershed Slope =	0.020 ft/ft
Watershed Imperviousness =	80.00% percent
Percentage Hydrologic Soil Group A =	100.0% percent
Percentage Hydrologic Soil Group B =	0.0% percent
Percentage Hydrologic Soil Groups C/D =	0.0% percent
Target WQCV Drain Time =	12.0 hours
Location for 1-hr Rainfall Depths =	User Input

**Note: L / W Ratio > 8  
L / W Ratio = 23.3**

After providing required inputs above including 1-hour rainfall depths, click 'Run CUHP' to generate runoff hydrographs using the embedded Colorado Urban Hydrograph Procedure.

Water Quality Capture Volume (WQCV) =	0.009	acre-feet
Excess Urban Runoff Volume (EURV) =	0.045	acre-feet
2-yr Runoff Volume (P1 = 0.92 in.) =	0.024	acre-feet
5-yr Runoff Volume (P1 = 1.19 in.) =	0.032	acre-feet
10-yr Runoff Volume (P1 = 1.44 in.) =	0.040	acre-feet
25-yr Runoff Volume (P1 = 1.81 in.) =	0.052	acre-feet
50-yr Runoff Volume (P1 = 2.12 in.) =	0.063	acre-feet
100-yr Runoff Volume (P1 = 2.46 in.) =	0.075	acre-feet
500-yr Runoff Volume (P1 = 3.34 in.) =	0.107	acre-feet
Approximate 2-yr Detention Volume =	0.023	acre-feet
Approximate 5-yr Detention Volume =	0.031	acre-feet
Approximate 10-yr Detention Volume =	0.038	acre-feet
Approximate 25-yr Detention Volume =	0.049	acre-feet
Approximate 50-yr Detention Volume =	0.056	acre-feet
Approximate 100-yr Detention Volume =	0.063	acre-feet

**Optional User Overrides**

		acre-feet
		acre-feet
	0.92	inches
	1.19	inches
	1.44	inches
	1.81	inches
	2.12	inches
	2.46	inches
	3.34	inches

**Define Zones and Basin Geometry**

Zone 1 Volume (WQCV) =	0.009	acre-feet
Select Zone 2 Storage Volume (Optional) =		acre-feet
Select Zone 3 Storage Volume (Optional) =		acre-feet
Total Detention Basin Volume =	0.009	acre-feet
Initial Surcharge Volume (ISV) =	N/A	ft <sup>3</sup>
Initial Surcharge Depth (ISD) =	N/A	ft
Total Available Detention Depth (H <sub>total</sub> ) =	1.00	ft
Depth of Trickle Channel (H <sub>TC</sub> ) =	N/A	ft
Slope of Trickle Channel (S <sub>TC</sub> ) =	N/A	ft/ft
Slopes of Main Basin Sides (S <sub>main</sub> ) =	4	H:V
Basin Length-to-Width Ratio (R <sub>L/W</sub> ) =	1	

**Total detention volume is less than 100-year volume.**

Depth Increment = 0.10 ft									
Stage - Storage Description	Stage (ft)	Optional Override Stage (ft)	Length (ft)	Width (ft)	Area (ft <sup>2</sup> )	Optional Override Area (ft <sup>2</sup> )	Area (acre)	Volume (ft <sup>3</sup> )	Volume (ac-ft)
<b>Media Surface</b>	0.00		16.1	16.1	259		0.006		
	0.10		16.9	16.9	285		0.007	27	0.001
	0.20		17.7	17.7	313		0.007	57	0.001
	0.30		18.5	18.5	342		0.008	90	0.002
	0.40		19.3	19.3	372		0.009	126	0.003
	0.50		20.1	20.1	404		0.009	164	0.004
	0.60		20.9	20.9	437		0.010	206	0.005
	0.70		21.7	21.7	471		0.011	252	0.006
	0.80		22.5	22.5	506		0.012	301	0.007
	0.90		23.3	23.3	543		0.012	353	0.008
<b>Zone 1 (WQCV)</b>	1.00		24.1	24.1	581		0.013	409	0.009
	1.10		24.9	24.9	620		0.014	469	0.011
	1.20		25.7	25.7	660		0.015	533	0.012
	1.30		26.5	26.5	702		0.016	601	0.014
	1.40		27.3	27.3	745		0.017	674	0.015
	1.50		28.1	28.1	789		0.018	750	0.017
	1.60		28.9	28.9	835		0.019	832	0.019
	1.70		29.7	29.7	882		0.020	917	0.021
	1.80		30.5	30.5	930		0.021	1,008	0.023
	1.90		31.3	31.3	979		0.022	1,103	0.025
2.00		32.1	32.1	1,030		0.024	1,204	0.028	
2.10		32.9	32.9	1,082		0.025	1,310	0.030	
2.20		33.7	33.7	1,135		0.026	1,420	0.033	
2.30		34.5	34.5	1,190		0.027	1,537	0.035	
2.40		35.3	35.3	1,246		0.029	1,658	0.038	
2.50		36.1	36.1	1,303		0.030	1,786	0.041	
2.60		36.9	36.9	1,361		0.031	1,919	0.044	
2.70		37.7	37.7	1,421		0.033	2,058	0.047	
2.80		38.5	38.5	1,482		0.034	2,203	0.051	
2.90		39.3	39.3	1,544		0.035	2,355	0.054	
3.00		40.1	40.1	1,608		0.037	2,512	0.058	
3.10		40.9	40.9	1,672		0.038	2,676	0.061	
3.20		41.7	41.7	1,739		0.040	2,847	0.065	
3.30		42.5	42.5	1,806		0.041	3,024	0.069	
3.40		43.3	43.3	1,875		0.043	3,208	0.074	
3.50		44.1	44.1	1,944		0.045	3,399	0.078	
3.60		44.9	44.9	2,016		0.046	3,597	0.083	
3.70		45.7	45.7	2,088		0.048	3,802	0.087	
3.80		46.5	46.5	2,162		0.050	4,015	0.092	
3.90		47.3	47.3	2,237		0.051	4,234	0.097	
4.00		48.1	48.1	2,313		0.053	4,462	0.102	
4.10		48.9	48.9	2,391		0.055	4,697	0.108	
4.20		49.7	49.7	2,470		0.057	4,940	0.113	

# DETENTION BASIN OUTLET STRUCTURE DESIGN

MHFD-*Detention*, Version 4.06 (July 2022)

**Project:** Table Rock Homestead

**Basin ID:** Pond B2

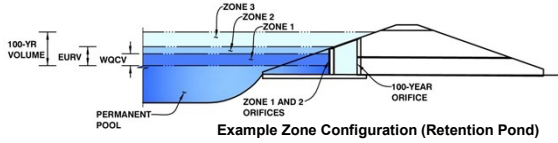

**Example Zone Configuration (Retention Pond)**

	Estimated Stage (ft)	Estimated Volume (ac-ft)	Outlet Type
Zone 1 (WQCV)	1.00	0.009	Filtration Media
Zone 2			
Zone 3			
<b>Total (all zones)</b>		<b>0.009</b>	

**User Input:** Orifice at Underdrain Outlet (typically used to drain WQCV in a Filtration BMP)

Underdrain Orifice Invert Depth =  ft (distance below the filtration media surface)  
 Underdrain Orifice Diameter =  inches

**Calculated Parameters for Underdrain**  
 Underdrain Orifice Area =  ft<sup>2</sup>  
 Underdrain Orifice Centroid =  feet

**User Input:** Orifice Plate with one or more orifices or Elliptical Slot Weir (typically used to drain WOCV and/or EURV in a sedimentation BMP)

Centroid of Lowest Orifice =  ft (relative to basin bottom at Stage = 0 ft)  
 Depth at top of Zone using Orifice Plate =  ft (relative to basin bottom at Stage = 0 ft)  
 Orifice Plate: Orifice Vertical Spacing =  inches  
 Orifice Plate: Orifice Area per Row =  sq. inches

**Calculated Parameters for Plate**  
 WQ Orifice Area per Row =  ft<sup>2</sup>  
 Elliptical Half-Width =  feet  
 Elliptical Slot Centroid =  feet  
 Elliptical Slot Area =  ft<sup>2</sup>

**User Input:** Stage and Total Area of Each Orifice Row (numbered from lowest to highest)

	Row 1 (optional)	Row 2 (optional)	Row 3 (optional)	Row 4 (optional)	Row 5 (optional)	Row 6 (optional)	Row 7 (optional)	Row 8 (optional)
Stage of Orifice Centroid (ft)	<input type="text"/>	<input type="text"/>	<input type="text"/>	<input type="text"/>	<input type="text"/>	<input type="text"/>	<input type="text"/>	<input type="text"/>
Orifice Area (sq. inches)	<input type="text"/>	<input type="text"/>	<input type="text"/>	<input type="text"/>	<input type="text"/>	<input type="text"/>	<input type="text"/>	<input type="text"/>
	Row 9 (optional)	Row 10 (optional)	Row 11 (optional)	Row 12 (optional)	Row 13 (optional)	Row 14 (optional)	Row 15 (optional)	Row 16 (optional)
Stage of Orifice Centroid (ft)	<input type="text"/>	<input type="text"/>	<input type="text"/>	<input type="text"/>	<input type="text"/>	<input type="text"/>	<input type="text"/>	<input type="text"/>
Orifice Area (sq. inches)	<input type="text"/>	<input type="text"/>	<input type="text"/>	<input type="text"/>	<input type="text"/>	<input type="text"/>	<input type="text"/>	<input type="text"/>

**User Input:** Vertical Orifice (Circular or Rectangular)

Invert of Vertical Orifice =   ft (relative to basin bottom at Stage = 0 ft)  
 Depth at top of Zone using Vertical Orifice =  ft (relative to basin bottom at Stage = 0 ft)  
 Vertical Orifice Diameter =  inches

**Calculated Parameters for Vertical Orifice**  
 Vertical Orifice Area =  ft<sup>2</sup>  
 Vertical Orifice Centroid =  feet

**User Input:** Overflow Weir (Dropbox with Flat or Sloped Grate and Outlet Pipe OR Rectangular/Trapezoidal Weir and No Outlet Pipe)

Overflow Weir Front Edge Height, H<sub>o</sub> =   ft (relative to basin bottom at Stage = 0 ft)  
 Overflow Weir Front Edge Length =  feet  
 Overflow Weir Grate Slope =  H:V  
 Horiz. Length of Weir Sides =  feet  
 Overflow Grate Type =   
 Debris Clogging % =  %

**Calculated Parameters for Overflow Weir**  
 Height of Grate Upper Edge, H<sub>g</sub> =  feet  
 Overflow Weir Slope Length =  feet  
 Grate Open Area / 100-yr Orifice Area =   
 Overflow Grate Open Area w/o Debris =  ft<sup>2</sup>  
 Overflow Grate Open Area w/ Debris =  ft<sup>2</sup>

**User Input:** Outlet Pipe w/ Flow Restriction Plate (Circular Orifice, Restrictor Plate, or Rectangular Orifice)

Depth to Invert of Outlet Pipe =   ft (distance below basin bottom at Stage = 0 ft)  
 Circular Orifice Diameter =  inches

**Calculated Parameters for Outlet Pipe w/ Flow Restriction Plate**  
 Outlet Orifice Area =  ft<sup>2</sup>  
 Outlet Orifice Centroid =  feet  
 Half-Central Angle of Restrictor Plate on Pipe =  radians

**User Input:** Emergency Spillway (Rectangular or Trapezoidal)

Spillway Invert Stage =  ft (relative to basin bottom at Stage = 0 ft)  
 Spillway Crest Length =  feet  
 Spillway End Slopes =  H:V  
 Freeboard above Max Water Surface =  feet

**Calculated Parameters for Spillway**  
 Spillway Design Flow Depth =  feet  
 Stage at Top of Freeboard =  feet  
 Basin Area at Top of Freeboard =  acres  
 Basin Volume at Top of Freeboard =  acre-ft

**Routed Hydrograph Results**

*The user can override the default CUHP hydrographs and runoff volumes by entering new values in the Inflow Hydrographs table (Columns W through AF).*

	WQCV	EURV	2 Year	5 Year	10 Year	25 Year	50 Year	100 Year	500 Year
Design Storm Return Period =	N/A	N/A	0.92	1.19	1.44	1.81	2.12	2.46	3.34
One-Hour Rainfall Depth (in) =	0.009	0.045	0.024	0.032	0.040	0.052	0.063	0.075	0.107
CUHP Runoff Volume (acre-ft) =	N/A	N/A	0.024	0.032	0.040	0.052	0.063	0.075	0.107
Inflow Hydrograph Volume (acre-ft) =	N/A	N/A	0.0	0.0	0.0	0.0	0.0	0.1	0.2
CUHP Predevelopment Peak Q (cfs) =	N/A	N/A	0.0	0.0	0.0	0.0	0.0	0.1	0.2
OPTIONAL Override Predevelopment Peak Q (cfs) =	N/A	N/A	N/A	N/A	N/A	N/A	N/A	N/A	N/A
Predevelopment Unit Peak Flow, q (cfs/acre) =	N/A	N/A	0.00	0.00	0.00	0.02	0.10	0.21	0.49
Peak Inflow Q (cfs) =	N/A	N/A	0.2	0.3	0.3	0.5	0.6	0.7	1.0
Peak Outflow Q (cfs) =	0.0	7.9	0.2	0.2	0.3	0.5	0.6	0.7	1.1
Ratio Peak Outflow to Predevelopment Q =	N/A	N/A	N/A	252.5	178.5	58.0	15.3	8.2	5.4
Structure Controlling Flow =	Filtration Media	Spillway	Spillway	Spillway	Spillway	Spillway	Spillway	Spillway	Spillway
Max Velocity through Gate 1 (fps) =	N/A	N/A	N/A	N/A	N/A	N/A	N/A	N/A	N/A
Max Velocity through Gate 2 (fps) =	N/A	N/A	N/A	N/A	N/A	N/A	N/A	N/A	N/A
Time to Drain 97% of Inflow Volume (hours) =	12	0	15	15	15	14	14	13	12
Time to Drain 99% of Inflow Volume (hours) =	12	0	16	16	16	16	16	16	15
Maximum Ponding Depth (ft) =	0.98	2.64	1.04	1.06	1.07	1.09	1.12	1.12	1.17
Area at Maximum Ponding Depth (acres) =	0.01	0.03	0.01	0.01	0.01	0.01	0.01	0.01	0.01
Maximum Volume Stored (acre-ft) =	0.009	0.045	0.010	0.010	0.010	0.011	0.011	0.011	0.012



# DETENTION BASIN OUTLET STRUCTURE DESIGN

*MHFD-Detention, Version 4.06 (July 2022)*

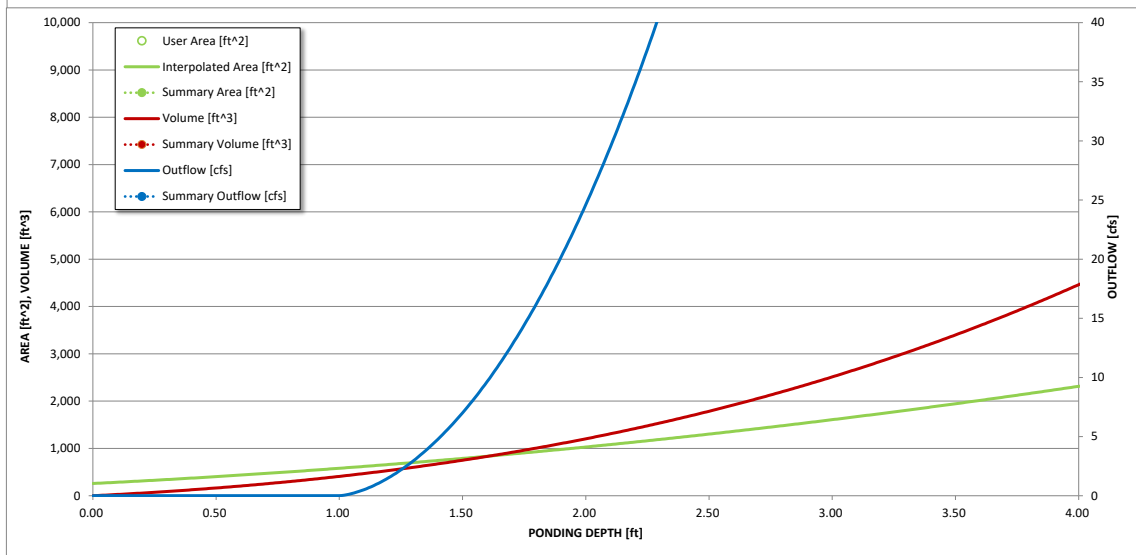
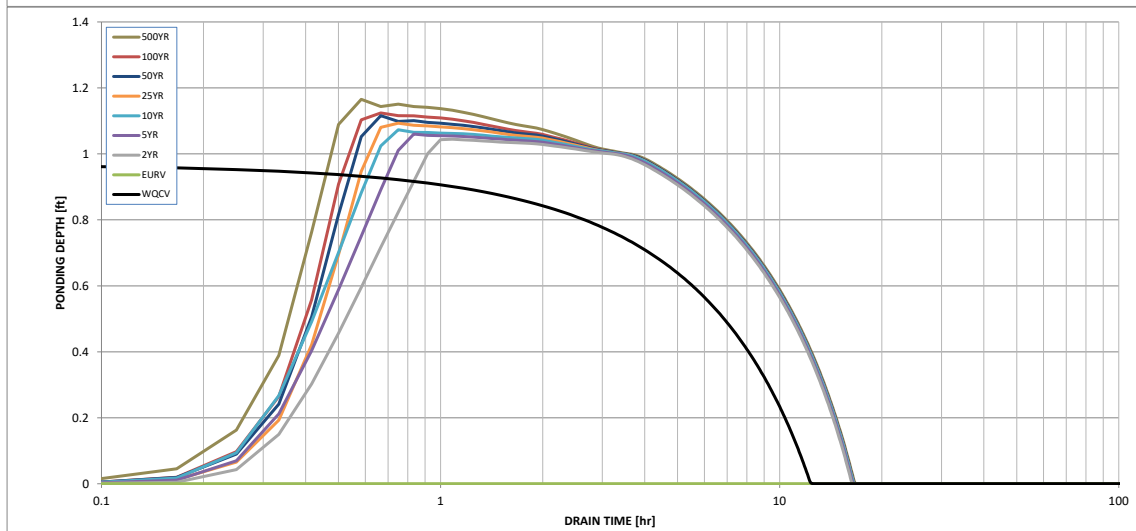
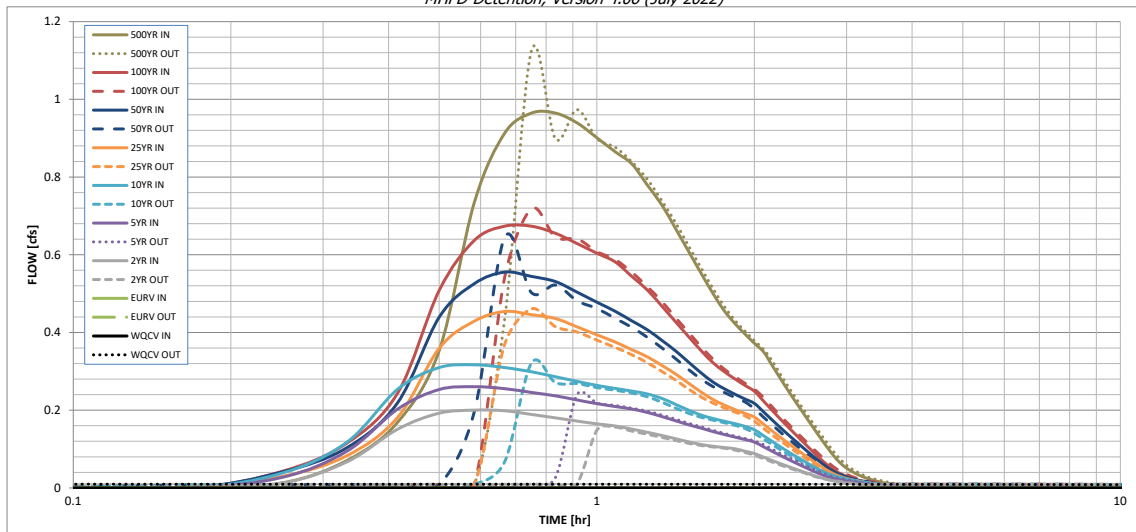

S-A-V-D Chart Axis Override	X-axis	Left Y-Axis	Right Y-Axis
minimum bound			
maximum bound			

# DETENTION BASIN OUTLET STRUCTURE DESIGN

Outflow Hydrograph Workbook Filename: \_\_\_\_\_

## Inflow Hydrographs

The user can override the calculated inflow hydrographs from this workbook with inflow hydrographs developed in a separate program.

Time Interval	SOURCE	CUHP	CUHP	CUHP	CUHP	CUHP	CUHP	CUHP	CUHP	CUHP
	TIME	WQCV [cfs]	EURV [cfs]	2 Year [cfs]	5 Year [cfs]	10 Year [cfs]	25 Year [cfs]	50 Year [cfs]	100 Year [cfs]	500 Year [cfs]
5.00 min	0:00:00	0.00	0.00	0.00	0.00	0.00	0.00	0.00	0.00	0.00
	0:05:00	0.00	0.00	0.00	0.00	0.00	0.00	0.00	0.00	0.00
	0:10:00	0.00	0.00	0.00	0.00	0.00	0.00	0.00	0.00	0.01
	0:15:00	0.00	0.00	0.01	0.03	0.04	0.03	0.04	0.04	0.07
	0:20:00	0.00	0.00	0.07	0.09	0.12	0.08	0.10	0.12	0.17
	0:25:00	0.00	0.00	0.15	0.20	0.25	0.18	0.22	0.24	0.35
	0:30:00	0.00	0.00	0.19	0.25	0.31	0.36	0.44	0.51	0.73
	0:35:00	0.00	0.00	0.20	0.26	0.32	0.43	0.53	0.64	0.91
	0:40:00	0.00	0.00	0.20	0.26	0.31	0.45	0.56	0.67	0.96
	0:45:00	0.00	0.00	0.19	0.25	0.30	0.45	0.54	0.67	0.96
	0:50:00	0.00	0.00	0.18	0.24	0.29	0.44	0.53	0.66	0.94
	0:55:00	0.00	0.00	0.17	0.23	0.27	0.41	0.50	0.63	0.90
	1:00:00	0.00	0.00	0.16	0.22	0.26	0.39	0.48	0.60	0.87
	1:05:00	0.00	0.00	0.16	0.21	0.26	0.38	0.45	0.58	0.83
	1:10:00	0.00	0.00	0.15	0.20	0.25	0.36	0.43	0.54	0.78
	1:15:00	0.00	0.00	0.14	0.19	0.24	0.34	0.41	0.51	0.73
	1:20:00	0.00	0.00	0.13	0.18	0.23	0.31	0.38	0.47	0.67
	1:25:00	0.00	0.00	0.13	0.17	0.21	0.29	0.35	0.43	0.61
	1:30:00	0.00	0.00	0.12	0.16	0.20	0.27	0.32	0.39	0.55
	1:35:00	0.00	0.00	0.11	0.15	0.19	0.25	0.30	0.35	0.50
	1:40:00	0.00	0.00	0.11	0.14	0.18	0.23	0.27	0.32	0.46
	1:45:00	0.00	0.00	0.10	0.14	0.17	0.21	0.26	0.30	0.42
	1:50:00	0.00	0.00	0.10	0.13	0.17	0.20	0.24	0.28	0.40
	1:55:00	0.00	0.00	0.09	0.12	0.16	0.19	0.23	0.26	0.37
	2:00:00	0.00	0.00	0.09	0.12	0.15	0.18	0.22	0.25	0.35
	2:05:00	0.00	0.00	0.08	0.11	0.13	0.16	0.20	0.22	0.31
	2:10:00	0.00	0.00	0.07	0.09	0.12	0.15	0.17	0.20	0.28
	2:15:00	0.00	0.00	0.06	0.08	0.10	0.13	0.15	0.17	0.25
	2:20:00	0.00	0.00	0.05	0.07	0.09	0.11	0.13	0.15	0.21
	2:25:00	0.00	0.00	0.05	0.06	0.08	0.10	0.12	0.13	0.19
	2:30:00	0.00	0.00	0.04	0.05	0.07	0.08	0.10	0.11	0.16
	2:35:00	0.00	0.00	0.03	0.04	0.06	0.07	0.08	0.09	0.13
	2:40:00	0.00	0.00	0.03	0.04	0.05	0.06	0.07	0.08	0.11
	2:45:00	0.00	0.00	0.02	0.03	0.04	0.05	0.05	0.06	0.08
	2:50:00	0.00	0.00	0.02	0.02	0.03	0.04	0.04	0.05	0.06
	2:55:00	0.00	0.00	0.02	0.02	0.03	0.03	0.03	0.04	0.05
	3:00:00	0.00	0.00	0.01	0.02	0.02	0.02	0.03	0.03	0.04
	3:05:00	0.00	0.00	0.01	0.01	0.02	0.02	0.02	0.02	0.03
	3:10:00	0.00	0.00	0.01	0.01	0.02	0.02	0.02	0.02	0.03
	3:15:00	0.00	0.00	0.01	0.01	0.01	0.01	0.02	0.02	0.02
	3:20:00	0.00	0.00	0.01	0.01	0.01	0.01	0.01	0.01	0.02
	3:25:00	0.00	0.00	0.01	0.01	0.01	0.01	0.01	0.01	0.01
	3:30:00	0.00	0.00	0.00	0.01	0.01	0.01	0.01	0.01	0.01
	3:35:00	0.00	0.00	0.00	0.00	0.01	0.01	0.01	0.01	0.01
	3:40:00	0.00	0.00	0.00	0.00	0.00	0.00	0.01	0.01	0.01
	3:45:00	0.00	0.00	0.00	0.00	0.00	0.00	0.00	0.00	0.01
	3:50:00	0.00	0.00	0.00	0.00	0.00	0.00	0.00	0.00	0.00
	3:55:00	0.00	0.00	0.00	0.00	0.00	0.00	0.00	0.00	0.00
	4:00:00	0.00	0.00	0.00	0.00	0.00	0.00	0.00	0.00	0.00
	4:05:00	0.00	0.00	0.00	0.00	0.00	0.00	0.00	0.00	0.00
	4:10:00	0.00	0.00	0.00	0.00	0.00	0.00	0.00	0.00	0.00
	4:15:00	0.00	0.00	0.00	0.00	0.00	0.00	0.00	0.00	0.00
	4:20:00	0.00	0.00	0.00	0.00	0.00	0.00	0.00	0.00	0.00
	4:25:00	0.00	0.00	0.00	0.00	0.00	0.00	0.00	0.00	0.00
	4:30:00	0.00	0.00	0.00	0.00	0.00	0.00	0.00	0.00	0.00
	4:35:00	0.00	0.00	0.00	0.00	0.00	0.00	0.00	0.00	0.00
	4:40:00	0.00	0.00	0.00	0.00	0.00	0.00	0.00	0.00	0.00
	4:45:00	0.00	0.00	0.00	0.00	0.00	0.00	0.00	0.00	0.00
	4:50:00	0.00	0.00	0.00	0.00	0.00	0.00	0.00	0.00	0.00
	4:55:00	0.00	0.00	0.00	0.00	0.00	0.00	0.00	0.00	0.00
5:00:00	0.00	0.00	0.00	0.00	0.00	0.00	0.00	0.00	0.00	
5:05:00	0.00	0.00	0.00	0.00	0.00	0.00	0.00	0.00	0.00	
5:10:00	0.00	0.00	0.00	0.00	0.00	0.00	0.00	0.00	0.00	
5:15:00	0.00	0.00	0.00	0.00	0.00	0.00	0.00	0.00	0.00	
5:20:00	0.00	0.00	0.00	0.00	0.00	0.00	0.00	0.00	0.00	
5:25:00	0.00	0.00	0.00	0.00	0.00	0.00	0.00	0.00	0.00	
5:30:00	0.00	0.00	0.00	0.00	0.00	0.00	0.00	0.00	0.00	
5:35:00	0.00	0.00	0.00	0.00	0.00	0.00	0.00	0.00	0.00	
5:40:00	0.00	0.00	0.00	0.00	0.00	0.00	0.00	0.00	0.00	
5:45:00	0.00	0.00	0.00	0.00	0.00	0.00	0.00	0.00	0.00	
5:50:00	0.00	0.00	0.00	0.00	0.00	0.00	0.00	0.00	0.00	
5:55:00	0.00	0.00	0.00	0.00	0.00	0.00	0.00	0.00	0.00	
6:00:00	0.00	0.00	0.00	0.00	0.00	0.00	0.00	0.00	0.00	



# DETENTION BASIN STAGE-STORAGE TABLE BUILDER

MHFD-Detention, Version 4.06 (July 2022)

**Project: Table Rock Homestead**

**Basin ID: Pond C1**

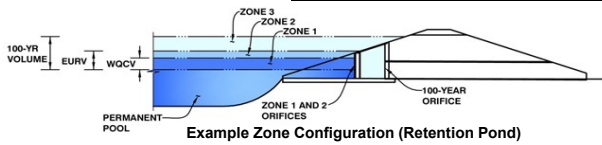

**Watershed Information**

Selected BMP Type =	<b>SF</b>
Watershed Area =	0.34 acres
Watershed Length =	880 ft
Watershed Length to Centroid =	440 ft
Watershed Slope =	0.020 ft/ft
Watershed Imperviousness =	80.00% percent
Percentage Hydrologic Soil Group A =	100.0% percent
Percentage Hydrologic Soil Group B =	0.0% percent
Percentage Hydrologic Soil Groups C/D =	0.0% percent
Target WQCV Drain Time =	12.0 hours
Location for 1-hr Rainfall Depths =	User Input

**Note: L / W Ratio > 8  
L / W Ratio = 52.38**

After providing required inputs above including 1-hour rainfall depths, click 'Run CUHP' to generate runoff hydrographs using the embedded Colorado Urban Hydrograph Procedure.

Water Quality Capture Volume (WQCV) =	0.007	acre-feet
Excess Urban Runoff Volume (EURV) =	0.036	acre-feet
2-yr Runoff Volume (P1 = 0.92 in.) =	0.019	acre-feet
5-yr Runoff Volume (P1 = 1.19 in.) =	0.026	acre-feet
10-yr Runoff Volume (P1 = 1.44 in.) =	0.032	acre-feet
25-yr Runoff Volume (P1 = 1.81 in.) =	0.041	acre-feet
50-yr Runoff Volume (P1 = 2.12 in.) =	0.050	acre-feet
100-yr Runoff Volume (P1 = 2.46 in.) =	0.060	acre-feet
500-yr Runoff Volume (P1 = 3.34 in.) =	0.086	acre-feet
Approximate 2-yr Detention Volume =	0.018	acre-feet
Approximate 5-yr Detention Volume =	0.024	acre-feet
Approximate 10-yr Detention Volume =	0.030	acre-feet
Approximate 25-yr Detention Volume =	0.039	acre-feet
Approximate 50-yr Detention Volume =	0.044	acre-feet
Approximate 100-yr Detention Volume =	0.050	acre-feet

**Optional User Overrides**

		acre-feet
		acre-feet
	0.92	inches
	1.19	inches
	1.44	inches
	1.81	inches
	2.12	inches
	2.46	inches
	3.34	inches

**Define Zones and Basin Geometry**

Zone 1 Volume (WQCV) =	0.007	acre-feet
Select Zone 2 Storage Volume (Optional) =		acre-feet
Select Zone 3 Storage Volume (Optional) =		acre-feet
Total Detention Basin Volume =	0.007	acre-feet
Initial Surcharge Volume (ISV) =	N/A	ft <sup>3</sup>
Initial Surcharge Depth (ISD) =	N/A	ft
Total Available Detention Depth (H <sub>total</sub> ) =	1.00	ft
Depth of Trickle Channel (H <sub>TC</sub> ) =	N/A	ft
Slope of Trickle Channel (S <sub>TC</sub> ) =	N/A	ft/ft
Slopes of Main Basin Sides (S <sub>main</sub> ) =	4	H:V
Basin Length-to-Width Ratio (R <sub>L/W</sub> ) =	1	

**Total detention volume is less than 100-year volume.**

Depth Increment = 0.10 ft									
Stage - Storage Description	Stage (ft)	Optional Override Stage (ft)	Length (ft)	Width (ft)	Area (ft <sup>2</sup> )	Optional Override Area (ft <sup>2</sup> )	Area (acre)	Volume (ft <sup>3</sup> )	Volume (ac-ft)
<b>Media Surface</b>	0.00		13.8	13.8	192		0.004		
	0.10		14.6	14.6	214		0.005	20	0.000
	0.20		15.4	15.4	238		0.005	43	0.001
	0.30		16.2	16.2	264		0.006	68	0.002
	0.40		17.0	17.0	290		0.007	96	0.002
	0.50		17.8	17.8	318		0.007	126	0.003
	0.60		18.6	18.6	347		0.008	159	0.004
	0.70		19.4	19.4	378		0.009	196	0.004
	0.80		20.2	20.2	410		0.009	235	0.005
	0.90		21.0	21.0	443		0.010	278	0.006
<b>Zone 1 (WQCV)</b>	1.00		21.8	21.8	477		0.011	324	0.007
	1.10		22.6	22.6	513		0.012	373	0.009
	1.20		23.4	23.4	549		0.013	426	0.010
	1.30		24.2	24.2	588		0.013	483	0.011
	1.40		25.0	25.0	627		0.014	544	0.012
	1.50		25.8	25.8	668		0.015	608	0.014
	1.60		26.6	26.6	710		0.016	677	0.016
	1.70		27.4	27.4	753		0.017	750	0.017
	1.80		28.2	28.2	797		0.018	828	0.019
	1.90		29.0	29.0	843		0.019	910	0.021
	2.00		29.8	29.8	890		0.020	997	0.023
	2.10		30.6	30.6	939		0.022	1,088	0.025
	2.20		31.4	31.4	988		0.023	1,184	0.027
	2.30		32.2	32.2	1,039		0.024	1,286	0.030
	2.40		33.0	33.0	1,092		0.025	1,392	0.032
2.50		33.8	33.8	1,145		0.026	1,504	0.035	
2.60		34.6	34.6	1,200		0.028	1,621	0.037	
2.70		35.4	35.4	1,256		0.029	1,744	0.040	
2.80		36.2	36.2	1,313		0.030	1,873	0.043	
2.90		37.0	37.0	1,372		0.031	2,007	0.046	
3.00		37.8	37.8	1,432		0.033	2,147	0.049	
3.10		38.6	38.6	1,493		0.034	2,293	0.053	
3.20		39.4	39.4	1,556		0.036	2,446	0.056	
3.30		40.2	40.2	1,619		0.037	2,604	0.060	
3.40		41.0	41.0	1,684		0.039	2,770	0.064	
3.50		41.8	41.8	1,751		0.040	2,941	0.068	
3.60		42.6	42.6	1,818		0.042	3,120	0.072	
3.70		43.4	43.4	1,887		0.043	3,305	0.076	
3.80		44.2	44.2	1,957		0.045	3,497	0.080	
3.90		45.0	45.0	2,029		0.047	3,697	0.085	
4.00		45.8	45.8	2,101		0.048	3,903	0.090	
4.10		46.6	46.6	2,175		0.050	4,117	0.095	
4.20		47.4	47.4	2,251		0.052	4,338	0.100	

# DETENTION BASIN OUTLET STRUCTURE DESIGN

MHFD-*Detention*, Version 4.06 (July 2022)

**Project:** Table Rock Homestead

**Basin ID:** Pond C1

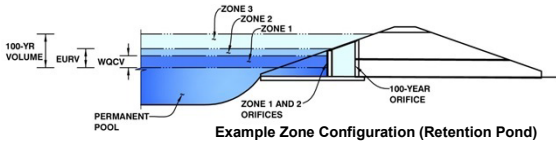

**Example Zone Configuration (Retention Pond)**

	Estimated Stage (ft)	Estimated Volume (ac-ft)	Outlet Type
Zone 1 (WQCV)	1.00	0.007	Filtration Media
Zone 2			
Zone 3			
<b>Total (all zones)</b>		<b>0.007</b>	

**User Input:** Orifice at Underdrain Outlet (typically used to drain WQCV in a Filtration BMP)

Underdrain Orifice Invert Depth =  ft (distance below the filtration media surface)  
 Underdrain Orifice Diameter =  inches

**Calculated Parameters for Underdrain**  
 Underdrain Orifice Area =  ft<sup>2</sup>  
 Underdrain Orifice Centroid =  feet

**User Input:** Orifice Plate with one or more orifices or Elliptical Slot Weir (typically used to drain WOCV and/or EURV in a sedimentation BMP)

Centroid of Lowest Orifice =  ft (relative to basin bottom at Stage = 0 ft)  
 Depth at top of Zone using Orifice Plate =  ft (relative to basin bottom at Stage = 0 ft)  
 Orifice Plate: Orifice Vertical Spacing =  inches  
 Orifice Plate: Orifice Area per Row =  sq. inches

**Calculated Parameters for Plate**  
 WQ Orifice Area per Row =  ft<sup>2</sup>  
 Elliptical Half-Width =  feet  
 Elliptical Slot Centroid =  feet  
 Elliptical Slot Area =  ft<sup>2</sup>

**User Input:** Stage and Total Area of Each Orifice Row (numbered from lowest to highest)

	Row 1 (optional)	Row 2 (optional)	Row 3 (optional)	Row 4 (optional)	Row 5 (optional)	Row 6 (optional)	Row 7 (optional)	Row 8 (optional)
Stage of Orifice Centroid (ft)	<input type="text"/>	<input type="text"/>	<input type="text"/>	<input type="text"/>	<input type="text"/>	<input type="text"/>	<input type="text"/>	<input type="text"/>
Orifice Area (sq. inches)	<input type="text"/>	<input type="text"/>	<input type="text"/>	<input type="text"/>	<input type="text"/>	<input type="text"/>	<input type="text"/>	<input type="text"/>
	Row 9 (optional)	Row 10 (optional)	Row 11 (optional)	Row 12 (optional)	Row 13 (optional)	Row 14 (optional)	Row 15 (optional)	Row 16 (optional)
Stage of Orifice Centroid (ft)	<input type="text"/>	<input type="text"/>	<input type="text"/>	<input type="text"/>	<input type="text"/>	<input type="text"/>	<input type="text"/>	<input type="text"/>
Orifice Area (sq. inches)	<input type="text"/>	<input type="text"/>	<input type="text"/>	<input type="text"/>	<input type="text"/>	<input type="text"/>	<input type="text"/>	<input type="text"/>

**User Input:** Vertical Orifice (Circular or Rectangular)

Invert of Vertical Orifice =   ft (relative to basin bottom at Stage = 0 ft)  
 Depth at top of Zone using Vertical Orifice =  ft (relative to basin bottom at Stage = 0 ft)  
 Vertical Orifice Diameter =  inches

**Calculated Parameters for Vertical Orifice**  
 Vertical Orifice Area =  ft<sup>2</sup>  
 Vertical Orifice Centroid =  feet

**User Input:** Overflow Weir (Dropbox with Flat or Sloped Grate and Outlet Pipe OR Rectangular/Trapezoidal Weir and No Outlet Pipe)

Overflow Weir Front Edge Height, Ho =   ft (relative to basin bottom at Stage = 0 ft)  
 Overflow Weir Front Edge Length =  feet  
 Overflow Weir Grate Slope =  H:V  
 Horiz. Length of Weir Sides =  feet  
 Overflow Grate Type =   
 Debris Clogging % =  %

**Calculated Parameters for Overflow Weir**  
 Height of Grate Upper Edge, H<sub>g</sub> =  feet  
 Overflow Weir Slope Length =  feet  
 Grate Open Area / 100-yr Orifice Area =   
 Overflow Grate Open Area w/o Debris =  ft<sup>2</sup>  
 Overflow Grate Open Area w/ Debris =  ft<sup>2</sup>

**User Input:** Outlet Pipe w/ Flow Restriction Plate (Circular Orifice, Restrictor Plate, or Rectangular Orifice)

Depth to Invert of Outlet Pipe =   ft (distance below basin bottom at Stage = 0 ft)  
 Circular Orifice Diameter =  inches

**Calculated Parameters for Outlet Pipe w/ Flow Restriction Plate**  
 Outlet Orifice Area =  ft<sup>2</sup>  
 Outlet Orifice Centroid =  feet  
 Half-Central Angle of Restrictor Plate on Pipe =  radians

**User Input:** Emergency Spillway (Rectangular or Trapezoidal)

Spillway Invert Stage =  ft (relative to basin bottom at Stage = 0 ft)  
 Spillway Crest Length =  feet  
 Spillway End Slopes =  H:V  
 Freeboard above Max Water Surface =  feet

**Calculated Parameters for Spillway**  
 Spillway Design Flow Depth =  feet  
 Stage at Top of Freeboard =  feet  
 Basin Area at Top of Freeboard =  acres  
 Basin Volume at Top of Freeboard =  acre-ft

**Routed Hydrograph Results**

*The user can override the default CUHP hydrographs and runoff volumes by entering new values in the Inflow Hydrographs table (Columns W through AF).*

	WQCV	EURV	2 Year	5 Year	10 Year	25 Year	50 Year	100 Year	500 Year
Design Storm Return Period =	N/A	N/A	0.92	1.19	1.44	1.81	2.12	2.46	3.34
One-Hour Rainfall Depth (in) =	0.007	0.036	0.019	0.026	0.032	0.041	0.050	0.060	0.086
CUHP Runoff Volume (acre-ft) =	N/A	N/A	0.019	0.026	0.032	0.041	0.050	0.060	0.086
Inflow Hydrograph Volume (acre-ft) =	N/A	N/A	0.0	0.0	0.0	0.0	0.0	0.0	0.1
CUHP Predevelopment Peak Q (cfs) =	N/A	N/A	0.0	0.0	0.0	0.0	0.0	0.0	0.1
OPTIONAL Override Predevelopment Peak Q (cfs) =	N/A	N/A	N/A	N/A	N/A	N/A	N/A	N/A	N/A
Predevelopment Unit Peak Flow, q (cfs/acre) =	N/A	N/A	0.00	0.00	0.00	0.01	0.07	0.14	0.35
Peak Inflow Q (cfs) =	N/A	N/A	0.1	0.2	0.2	0.3	0.3	0.4	0.6
Peak Outflow Q (cfs) =	0.0	6.3	0.1	0.1	0.2	0.3	0.4	0.4	0.6
Ratio Peak Outflow to Predevelopment Q =	N/A	N/A	N/A	278.2	195.1	67.6	16.5	8.7	5.1
Structure Controlling Flow =	Filtration Media	Spillway	Spillway	Spillway	Spillway	Spillway	Spillway	Spillway	Spillway
Max Velocity through Gate 1 (fps) =	N/A	N/A	N/A	N/A	N/A	N/A	N/A	N/A	N/A
Max Velocity through Gate 2 (fps) =	N/A	N/A	N/A	N/A	N/A	N/A	N/A	N/A	N/A
Time to Drain 97% of Inflow Volume (hours) =	12	0	16	16	16	15	15	14	13
Time to Drain 99% of Inflow Volume (hours) =	12	0	17	17	17	17	16	16	16
Maximum Ponding Depth (ft) =	0.97	2.56	1.04	1.05	1.06	1.08	1.09	1.10	1.13
Area at Maximum Ponding Depth (acres) =	0.01	0.03	0.01	0.01	0.01	0.01	0.01	0.01	0.01
Maximum Volume Stored (acre-ft) =	0.007	0.036	0.008	0.008	0.008	0.008	0.008	0.009	0.009

# DETENTION BASIN OUTLET STRUCTURE DESIGN

*MHFD-Detention, Version 4.06 (July 2022)*

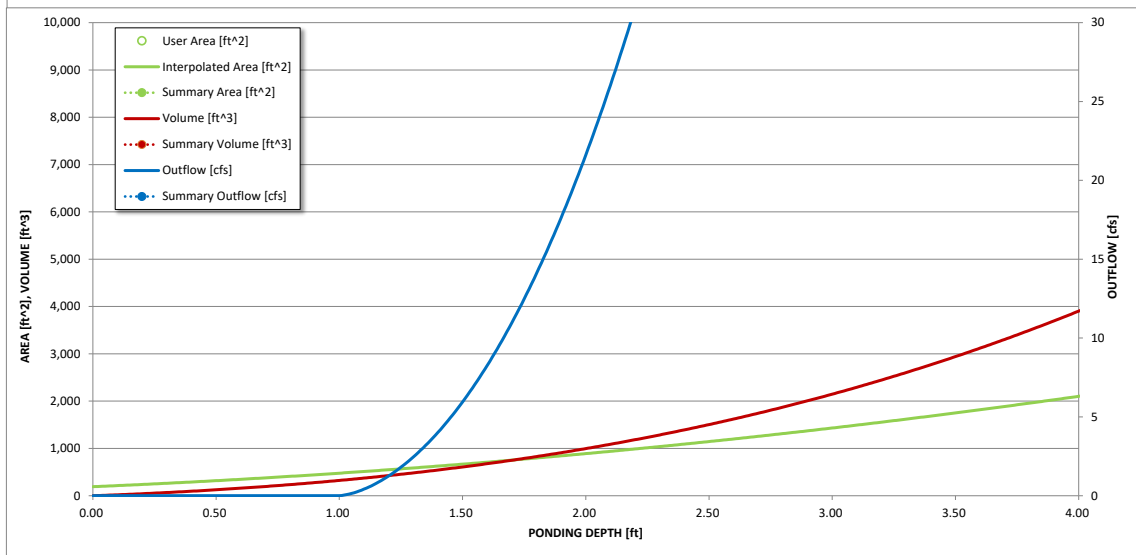
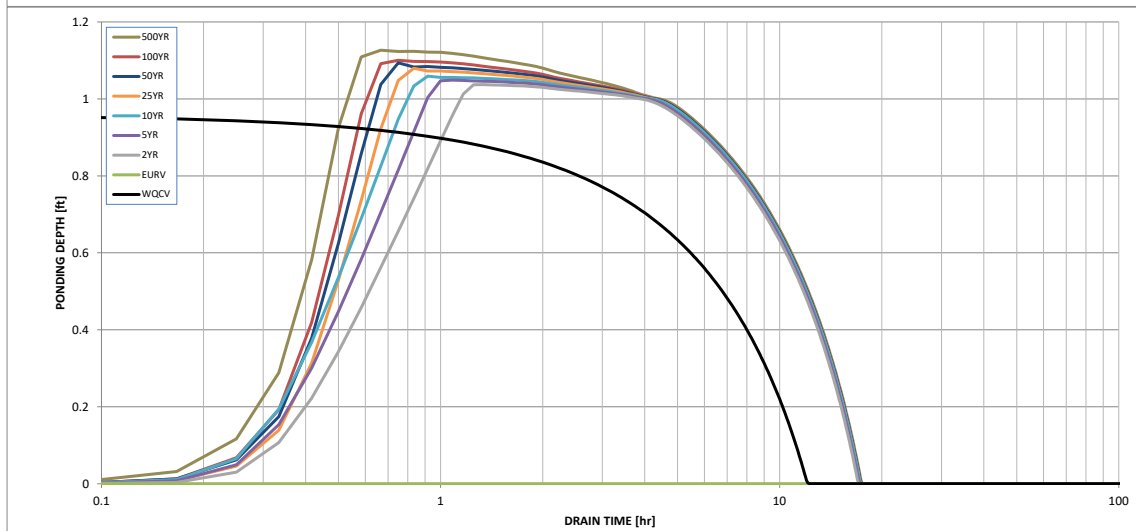
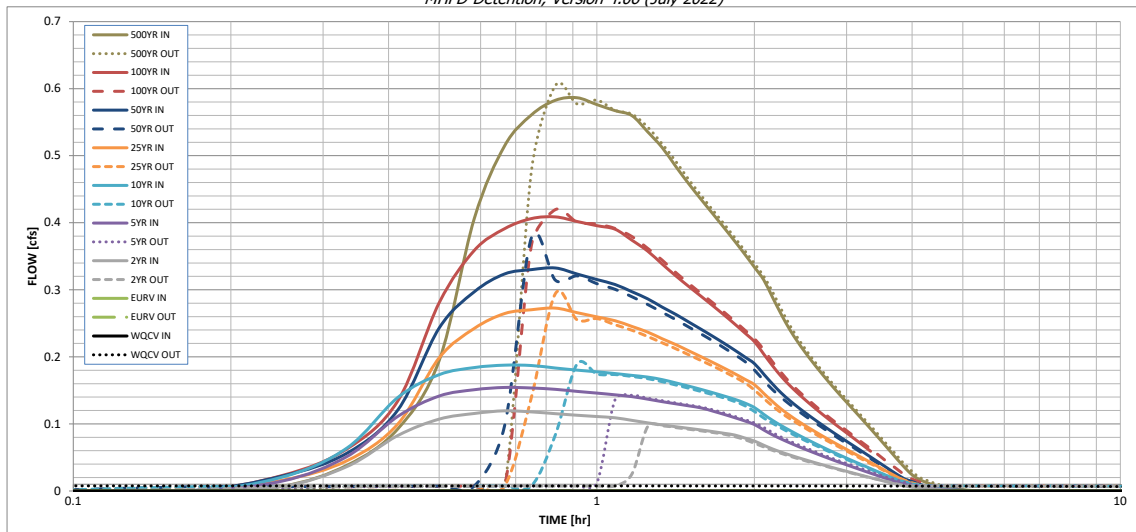

S-A-V-D Chart Axis Override	X-axis	Left Y-Axis	Right Y-Axis
minimum bound			
maximum bound			

# DETENTION BASIN OUTLET STRUCTURE DESIGN

*Outflow Hydrograph Workbook Filename:* \_\_\_\_\_

**Inflow Hydrographs**

The user can override the calculated inflow hydrographs from this workbook with inflow hydrographs developed in a separate program.

Time Interval	SOURCE	CUHP	CUHP	CUHP	CUHP	CUHP	CUHP	CUHP	CUHP	CUHP
	TIME	WQCV [cfs]	EURV [cfs]	2 Year [cfs]	5 Year [cfs]	10 Year [cfs]	25 Year [cfs]	50 Year [cfs]	100 Year [cfs]	500 Year [cfs]
5.00 min	0:00:00	0.00	0.00	0.00	0.00	0.00	0.00	0.00	0.00	0.00
	0:05:00	0.00	0.00	0.00	0.00	0.00	0.00	0.00	0.00	0.00
	0:10:00	0.00	0.00	0.00	0.00	0.00	0.00	0.00	0.00	0.01
	0:15:00	0.00	0.00	0.01	0.01	0.02	0.02	0.02	0.02	0.04
	0:20:00	0.00	0.00	0.04	0.05	0.06	0.05	0.06	0.06	0.09
	0:25:00	0.00	0.00	0.08	0.11	0.14	0.10	0.12	0.13	0.19
	0:30:00	0.00	0.00	0.11	0.14	0.17	0.20	0.24	0.28	0.41
	0:35:00	0.00	0.00	0.12	0.15	0.18	0.24	0.30	0.36	0.51
	0:40:00	0.00	0.00	0.12	0.15	0.19	0.26	0.32	0.39	0.56
	0:45:00	0.00	0.00	0.12	0.15	0.19	0.27	0.33	0.41	0.58
	0:50:00	0.00	0.00	0.12	0.15	0.18	0.27	0.33	0.41	0.59
	0:55:00	0.00	0.00	0.11	0.15	0.18	0.27	0.32	0.40	0.58
	1:00:00	0.00	0.00	0.11	0.15	0.18	0.26	0.32	0.40	0.57
	1:05:00	0.00	0.00	0.11	0.14	0.18	0.25	0.31	0.39	0.56
	1:10:00	0.00	0.00	0.11	0.14	0.17	0.25	0.30	0.37	0.54
	1:15:00	0.00	0.00	0.10	0.14	0.17	0.24	0.29	0.36	0.51
	1:20:00	0.00	0.00	0.10	0.13	0.17	0.23	0.27	0.34	0.48
	1:25:00	0.00	0.00	0.10	0.13	0.16	0.22	0.26	0.32	0.46
	1:30:00	0.00	0.00	0.09	0.13	0.16	0.21	0.25	0.30	0.43
	1:35:00	0.00	0.00	0.09	0.12	0.15	0.20	0.24	0.29	0.41
	1:40:00	0.00	0.00	0.09	0.12	0.15	0.19	0.23	0.28	0.39
	1:45:00	0.00	0.00	0.09	0.11	0.14	0.18	0.22	0.26	0.37
	1:50:00	0.00	0.00	0.08	0.11	0.14	0.17	0.21	0.25	0.35
	1:55:00	0.00	0.00	0.08	0.10	0.13	0.17	0.20	0.24	0.33
	2:00:00	0.00	0.00	0.07	0.10	0.12	0.16	0.19	0.22	0.31
	2:05:00	0.00	0.00	0.07	0.09	0.11	0.15	0.17	0.20	0.29
	2:10:00	0.00	0.00	0.06	0.08	0.11	0.13	0.16	0.19	0.26
	2:15:00	0.00	0.00	0.06	0.08	0.10	0.12	0.15	0.17	0.24
	2:20:00	0.00	0.00	0.05	0.07	0.09	0.11	0.14	0.16	0.22
	2:25:00	0.00	0.00	0.05	0.07	0.08	0.10	0.13	0.15	0.21
	2:30:00	0.00	0.00	0.05	0.06	0.08	0.10	0.12	0.14	0.19
	2:35:00	0.00	0.00	0.04	0.06	0.07	0.09	0.11	0.13	0.18
	2:40:00	0.00	0.00	0.04	0.05	0.07	0.08	0.10	0.12	0.17
	2:45:00	0.00	0.00	0.04	0.05	0.06	0.08	0.09	0.11	0.15
	2:50:00	0.00	0.00	0.03	0.05	0.06	0.07	0.09	0.10	0.14
	2:55:00	0.00	0.00	0.03	0.04	0.05	0.07	0.08	0.09	0.13
	3:00:00	0.00	0.00	0.03	0.04	0.05	0.06	0.07	0.09	0.12
	3:05:00	0.00	0.00	0.03	0.04	0.04	0.06	0.07	0.08	0.11
	3:10:00	0.00	0.00	0.02	0.03	0.04	0.05	0.06	0.07	0.10
	3:15:00	0.00	0.00	0.02	0.03	0.04	0.05	0.06	0.07	0.09
	3:20:00	0.00	0.00	0.02	0.03	0.03	0.04	0.05	0.06	0.08
	3:25:00	0.00	0.00	0.02	0.02	0.03	0.04	0.05	0.05	0.07
	3:30:00	0.00	0.00	0.02	0.02	0.03	0.03	0.04	0.05	0.06
	3:35:00	0.00	0.00	0.01	0.02	0.02	0.03	0.03	0.04	0.06
	3:40:00	0.00	0.00	0.01	0.02	0.02	0.02	0.03	0.03	0.05
	3:45:00	0.00	0.00	0.01	0.01	0.02	0.02	0.02	0.03	0.04
	3:50:00	0.00	0.00	0.01	0.01	0.01	0.02	0.02	0.02	0.03
	3:55:00	0.00	0.00	0.01	0.01	0.01	0.01	0.02	0.02	0.02
	4:00:00	0.00	0.00	0.01	0.01	0.01	0.01	0.01	0.01	0.02
	4:05:00	0.00	0.00	0.00	0.01	0.01	0.01	0.01	0.01	0.02
	4:10:00	0.00	0.00	0.00	0.01	0.01	0.01	0.01	0.01	0.01
	4:15:00	0.00	0.00	0.00	0.00	0.01	0.01	0.01	0.01	0.01
	4:20:00	0.00	0.00	0.00	0.00	0.01	0.01	0.01	0.01	0.01
	4:25:00	0.00	0.00	0.00	0.00	0.00	0.00	0.01	0.01	0.01
	4:30:00	0.00	0.00	0.00	0.00	0.00	0.00	0.00	0.00	0.01
	4:35:00	0.00	0.00	0.00	0.00	0.00	0.00	0.00	0.00	0.00
	4:40:00	0.00	0.00	0.00	0.00	0.00	0.00	0.00	0.00	0.00
	4:45:00	0.00	0.00	0.00	0.00	0.00	0.00	0.00	0.00	0.00
	4:50:00	0.00	0.00	0.00	0.00	0.00	0.00	0.00	0.00	0.00
	4:55:00	0.00	0.00	0.00	0.00	0.00	0.00	0.00	0.00	0.00
	5:00:00	0.00	0.00	0.00	0.00	0.00	0.00	0.00	0.00	0.00
	5:05:00	0.00	0.00	0.00	0.00	0.00	0.00	0.00	0.00	0.00
	5:10:00	0.00	0.00	0.00	0.00	0.00	0.00	0.00	0.00	0.00
	5:15:00	0.00	0.00	0.00	0.00	0.00	0.00	0.00	0.00	0.00
	5:20:00	0.00	0.00	0.00	0.00	0.00	0.00	0.00	0.00	0.00
	5:25:00	0.00	0.00	0.00	0.00	0.00	0.00	0.00	0.00	0.00
	5:30:00	0.00	0.00	0.00	0.00	0.00	0.00	0.00	0.00	0.00
	5:35:00	0.00	0.00	0.00	0.00	0.00	0.00	0.00	0.00	0.00
	5:40:00	0.00	0.00	0.00	0.00	0.00	0.00	0.00	0.00	0.00
	5:45:00	0.00	0.00	0.00	0.00	0.00	0.00	0.00	0.00	0.00
	5:50:00	0.00	0.00	0.00	0.00	0.00	0.00	0.00	0.00	0.00
	5:55:00	0.00	0.00	0.00	0.00	0.00	0.00	0.00	0.00	0.00
	6:00:00	0.00	0.00	0.00	0.00	0.00	0.00	0.00	0.00	0.00





# DETENTION BASIN STAGE-STORAGE TABLE BUILDER

MHFD-Detention, Version 4.06 (July 2022)

**Project: Table Rock Homestead**

**Basin ID: Pond D1**

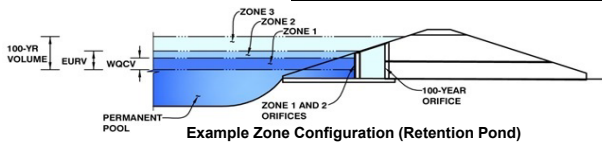

**Watershed Information**

Selected BMP Type =	<b>SF</b>
Watershed Area =	0.20 acres
Watershed Length =	390 ft
Watershed Length to Centroid =	195 ft
Watershed Slope =	0.020 ft/ft
Watershed Imperviousness =	80.00% percent
Percentage Hydrologic Soil Group A =	100.0% percent
Percentage Hydrologic Soil Group B =	0.0% percent
Percentage Hydrologic Soil Groups C/D =	0.0% percent
Target WQCV Drain Time =	12.0 hours
Location for 1-hr Rainfall Depths =	User Input

**Note: L / W Ratio > 8  
L / W Ratio = 17.28**

After providing required inputs above including 1-hour rainfall depths, click 'Run CUHP' to generate runoff hydrographs using the embedded Colorado Urban Hydrograph Procedure.

Water Quality Capture Volume (WQCV) =	0.004	acre-feet
Excess Urban Runoff Volume (EURV) =	0.021	acre-feet
2-yr Runoff Volume (P1 = 0.92 in.) =	0.011	acre-feet
5-yr Runoff Volume (P1 = 1.19 in.) =	0.015	acre-feet
10-yr Runoff Volume (P1 = 1.44 in.) =	0.019	acre-feet
25-yr Runoff Volume (P1 = 1.81 in.) =	0.024	acre-feet
50-yr Runoff Volume (P1 = 2.12 in.) =	0.029	acre-feet
100-yr Runoff Volume (P1 = 2.46 in.) =	0.035	acre-feet
500-yr Runoff Volume (P1 = 3.34 in.) =	0.050	acre-feet
Approximate 2-yr Detention Volume =	0.011	acre-feet
Approximate 5-yr Detention Volume =	0.014	acre-feet
Approximate 10-yr Detention Volume =	0.018	acre-feet
Approximate 25-yr Detention Volume =	0.023	acre-feet
Approximate 50-yr Detention Volume =	0.026	acre-feet
Approximate 100-yr Detention Volume =	0.030	acre-feet

**Optional User Overrides**

		acre-feet
		acre-feet
	0.92	inches
	1.19	inches
	1.44	inches
	1.81	inches
	2.12	inches
	2.46	inches
	3.34	inches

**Define Zones and Basin Geometry**

Zone 1 Volume (WQCV) =	0.004	acre-feet
Select Zone 2 Storage Volume (Optional) =		acre-feet
Select Zone 3 Storage Volume (Optional) =		acre-feet
Total Detention Basin Volume =	0.004	acre-feet
Initial Surcharge Volume (ISV) =	N/A	ft <sup>3</sup>
Initial Surcharge Depth (ISD) =	N/A	ft
Total Available Detention Depth (H <sub>total</sub> ) =	1.00	ft
Depth of Trickle Channel (H <sub>TC</sub> ) =	N/A	ft
Slope of Trickle Channel (S <sub>TC</sub> ) =	N/A	ft/ft
Slopes of Main Basin Sides (S <sub>main</sub> ) =	4	H:V
Basin Length-to-Width Ratio (R <sub>L/W</sub> ) =	1	

**Total detention volume is less than 100-year volume.**

Depth Increment = 0.10 ft									
Stage - Storage Description	Stage (ft)	Optional Override Stage (ft)	Length (ft)	Width (ft)	Area (ft <sup>2</sup> )	Optional Override Area (ft <sup>2</sup> )	Area (acre)	Volume (ft <sup>3</sup> )	Volume (ac-ft)
<b>Media Surface</b>	0.00		9.7	9.7	94		0.002		
	0.10		10.5	10.5	110		0.003	10	0.000
	0.20		11.3	11.3	127		0.003	22	0.001
	0.30		12.1	12.1	146		0.003	36	0.001
	0.40		12.9	12.9	166		0.004	51	0.001
	0.50		13.7	13.7	187		0.004	69	0.002
	0.60		14.5	14.5	210		0.005	89	0.002
	0.70		15.3	15.3	234		0.005	111	0.003
	0.80		16.1	16.1	259		0.006	136	0.003
	0.90		16.9	16.9	285		0.007	163	0.004
<b>Zone 1 (WQCV)</b>	1.00		17.7	17.7	313		0.007	193	0.004
	1.10		18.5	18.5	342		0.008	225	0.005
	1.20		19.3	19.3	372		0.009	261	0.006
	1.30		20.1	20.1	403		0.009	300	0.007
	1.40		20.9	20.9	436		0.010	342	0.008
	1.50		21.7	21.7	470		0.011	387	0.009
	1.60		22.5	22.5	506		0.012	436	0.010
	1.70		23.3	23.3	542		0.012	488	0.011
	1.80		24.1	24.1	580		0.013	544	0.012
	1.90		24.9	24.9	619		0.014	604	0.014
	2.00		25.7	25.7	660		0.015	668	0.015
	2.10		26.5	26.5	701		0.016	736	0.017
	2.20		27.3	27.3	745		0.017	809	0.019
	2.30		28.1	28.1	789		0.018	885	0.020
	2.40		28.9	28.9	834		0.019	966	0.022
2.50		29.7	29.7	881		0.020	1,052	0.024	
2.60		30.5	30.5	929		0.021	1,143	0.026	
2.70		31.3	31.3	979		0.022	1,238	0.028	
2.80		32.1	32.1	1,029		0.024	1,338	0.031	
2.90		32.9	32.9	1,081		0.025	1,444	0.033	
3.00		33.7	33.7	1,135		0.026	1,555	0.036	
3.10		34.5	34.5	1,189		0.027	1,671	0.038	
3.20		35.3	35.3	1,245		0.029	1,793	0.041	
3.30		36.1	36.1	1,302		0.030	1,920	0.044	
3.40		36.9	36.9	1,361		0.031	2,053	0.047	
3.50		37.7	37.7	1,420		0.033	2,192	0.050	
3.60		38.5	38.5	1,481		0.034	2,337	0.054	
3.70		39.3	39.3	1,543		0.035	2,489	0.057	
3.80		40.1	40.1	1,607		0.037	2,646	0.061	
3.90		40.9	40.9	1,672		0.038	2,810	0.065	
4.00		41.7	41.7	1,738		0.040	2,980	0.068	
4.10		42.5	42.5	1,805		0.041	3,158	0.072	
4.20		43.3	43.3	1,874		0.043	3,341	0.077	

# DETENTION BASIN OUTLET STRUCTURE DESIGN

MHFD-*Detention*, Version 4.06 (July 2022)

**Project:** Table Rock Homestead

**Basin ID:** Pond D1

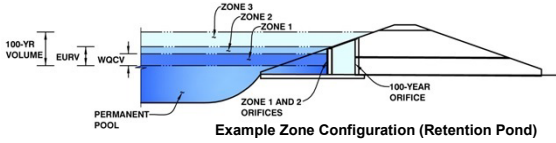

	Estimated Stage (ft)	Estimated Volume (ac-ft)	Outlet Type
Zone 1 (WQCV)	1.00	0.004	
Zone 2			
Zone 3			
<b>Total (all zones)</b>		<b>0.004</b>	

**User Input:** Orifice at Underdrain Outlet (typically used to drain WQCV in a Filtration BMP)

Underdrain Orifice Invert Depth =  ft (distance below the filtration media surface)  
 Underdrain Orifice Diameter =  inches

**Calculated Parameters for Underdrain**  
 Underdrain Orifice Area =  ft<sup>2</sup>  
 Underdrain Orifice Centroid =  feet

**User Input:** Orifice Plate with one or more orifices or Elliptical Slot Weir (typically used to drain WQCV and/or EURV in a sedimentation BMP)

Centroid of Lowest Orifice =  ft (relative to basin bottom at Stage = 0 ft)  
 Depth at top of Zone using Orifice Plate =  ft (relative to basin bottom at Stage = 0 ft)  
 Orifice Plate: Orifice Vertical Spacing =  inches  
 Orifice Plate: Orifice Area per Row =  sq. inches

**Calculated Parameters for Plate**  
 WQ Orifice Area per Row =  ft<sup>2</sup>  
 Elliptical Half-Width =  feet  
 Elliptical Slot Centroid =  feet  
 Elliptical Slot Area =  ft<sup>2</sup>

**User Input:** Stage and Total Area of Each Orifice Row (numbered from lowest to highest)

	Row 1 (optional)	Row 2 (optional)	Row 3 (optional)	Row 4 (optional)	Row 5 (optional)	Row 6 (optional)	Row 7 (optional)	Row 8 (optional)
Stage of Orifice Centroid (ft)	<input type="text"/>	<input type="text"/>	<input type="text"/>	<input type="text"/>	<input type="text"/>	<input type="text"/>	<input type="text"/>	<input type="text"/>
Orifice Area (sq. inches)	<input type="text"/>	<input type="text"/>	<input type="text"/>	<input type="text"/>	<input type="text"/>	<input type="text"/>	<input type="text"/>	<input type="text"/>
	Row 9 (optional)	Row 10 (optional)	Row 11 (optional)	Row 12 (optional)	Row 13 (optional)	Row 14 (optional)	Row 15 (optional)	Row 16 (optional)
Stage of Orifice Centroid (ft)	<input type="text"/>	<input type="text"/>	<input type="text"/>	<input type="text"/>	<input type="text"/>	<input type="text"/>	<input type="text"/>	<input type="text"/>
Orifice Area (sq. inches)	<input type="text"/>	<input type="text"/>	<input type="text"/>	<input type="text"/>	<input type="text"/>	<input type="text"/>	<input type="text"/>	<input type="text"/>

**User Input:** Vertical Orifice (Circular or Rectangular)

Invert of Vertical Orifice =   ft (relative to basin bottom at Stage = 0 ft)  
 Depth at top of Zone using Vertical Orifice =  ft (relative to basin bottom at Stage = 0 ft)  
 Vertical Orifice Diameter =  inches

**Calculated Parameters for Vertical Orifice**  
 Vertical Orifice Area =  ft<sup>2</sup>  
 Vertical Orifice Centroid =  feet

**User Input:** Overflow Weir (Dropbox with Flat or Sloped Grate and Outlet Pipe OR Rectangular/Trapezoidal Weir and No Outlet Pipe)

Overflow Weir Front Edge Height, H<sub>o</sub> =   ft (relative to basin bottom at Stage = 0 ft)  
 Overflow Weir Front Edge Length =  feet  
 Overflow Weir Grate Slope =  H:V  
 Horiz. Length of Weir Sides =  feet  
 Overflow Grate Type =   
 Debris Clogging % =  %

**Calculated Parameters for Overflow Weir**  
 Height of Grate Upper Edge, H<sub>u</sub> =  feet  
 Overflow Weir Slope Length =  feet  
 Grate Open Area / 100-yr Orifice Area =   
 Overflow Grate Open Area w/o Debris =  ft<sup>2</sup>  
 Overflow Grate Open Area w/ Debris =  ft<sup>2</sup>

**User Input:** Outlet Pipe w/ Flow Restriction Plate (Circular Orifice, Restrictor Plate, or Rectangular Orifice)

Depth to Invert of Outlet Pipe =   ft (distance below basin bottom at Stage = 0 ft)  
 Circular Orifice Diameter =  inches

**Calculated Parameters for Outlet Pipe w/ Flow Restriction Plate**  
 Outlet Orifice Area =  ft<sup>2</sup>  
 Outlet Orifice Centroid =  feet  
 Half-Central Angle of Restrictor Plate on Pipe =  radians

**User Input:** Emergency Spillway (Rectangular or Trapezoidal)

Spillway Invert Stage =  ft (relative to basin bottom at Stage = 0 ft)  
 Spillway Crest Length =  feet  
 Spillway End Slopes =  H:V  
 Freeboard above Max Water Surface =  feet

**Calculated Parameters for Spillway**  
 Spillway Design Flow Depth =  feet  
 Stage at Top of Freeboard =  feet  
 Basin Area at Top of Freeboard =  acres  
 Basin Volume at Top of Freeboard =  acre-ft

## Routed Hydrograph Results

*The user can override the default CUHP hydrographs and runoff volumes by entering new values in the Inflow Hydrographs table (Columns W through AF).*

	WQCV	EURV	2 Year	5 Year	10 Year	25 Year	50 Year	100 Year	500 Year
Design Storm Return Period	N/A	N/A	0.92	1.19	1.44	1.81	2.12	2.46	3.34
One-Hour Rainfall Depth (in)	N/A	N/A	0.021	0.011	0.015	0.019	0.024	0.029	0.050
CUHP Runoff Volume (acre-ft)	0.004	0.021	0.011	0.015	0.019	0.024	0.029	0.035	0.050
Inflow Hydrograph Volume (acre-ft)	N/A	N/A	0.011	0.015	0.019	0.024	0.029	0.035	0.050
CUHP Predevelopment Peak Q (cfs)	N/A	N/A	0.0	0.0	0.0	0.0	0.0	0.0	0.1
OPTIONAL Override Predevelopment Peak Q (cfs)	N/A	N/A	N/A	N/A	N/A	N/A	N/A	N/A	N/A
Predevelopment Unit Peak Flow, q (cfs/acre)	N/A	N/A	0.00	0.00	0.00	0.01	0.10	0.22	0.54
Peak Inflow Q (cfs)	N/A	N/A	0.1	0.1	0.2	0.2	0.3	0.4	0.5
Peak Outflow Q (cfs)	0.0	3.7	0.1	0.1	0.2	0.3	0.3	0.4	0.5
Ratio Peak Outflow to Predevelopment Q	N/A	N/A	N/A	#DIV/0!	#DIV/0!	135.6	14.8	9.7	5.0
Structure Controlling Flow	Filtration Media	Spillway	Spillway	Spillway	Spillway	Spillway	Spillway	Spillway	Spillway
Max Velocity through Gate 1 (fps)	N/A	N/A	N/A	N/A	N/A	N/A	N/A	N/A	N/A
Max Velocity through Gate 2 (fps)	N/A	N/A	N/A	N/A	N/A	N/A	N/A	N/A	N/A
Time to Drain 97% of Inflow Volume (hours)	13	0	16	16	16	15	15	14	13
Time to Drain 99% of Inflow Volume (hours)	13	0	17	17	17	17	17	16	16
Maximum Ponding Depth (ft)	0.94	2.34	1.04	1.05	1.06	1.09	1.10	1.12	1.14
Area at Maximum Ponding Depth (acres)	0.01	0.02	0.01	0.01	0.01	0.01	0.01	0.01	0.01
Maximum Volume Stored (acre-ft)	0.004	0.021	0.005	0.005	0.005	0.005	0.005	0.005	0.005

# DETENTION BASIN OUTLET STRUCTURE DESIGN

*MHFD-Detention, Version 4.06 (July 2022)*

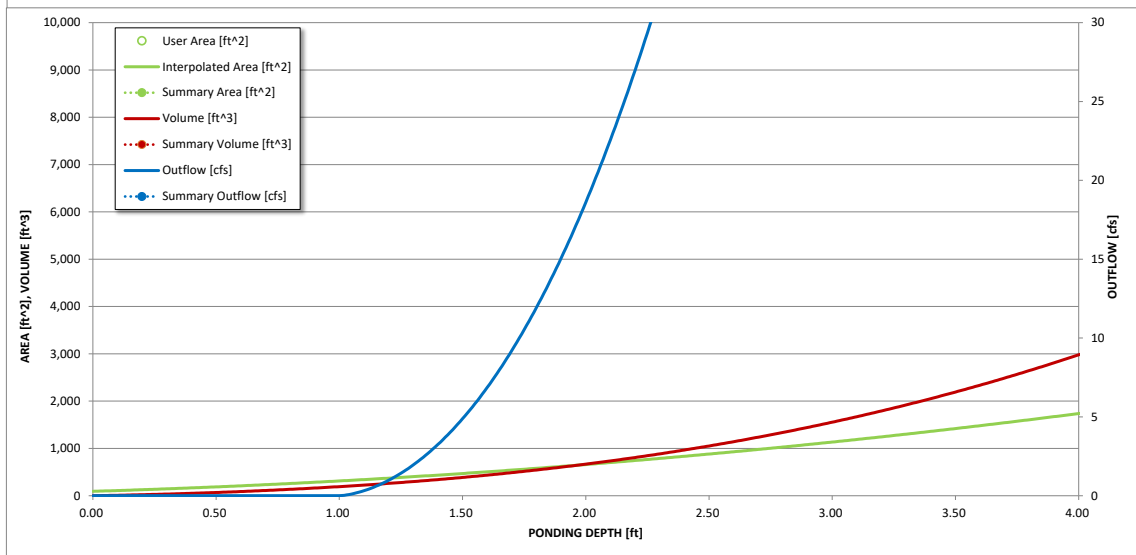
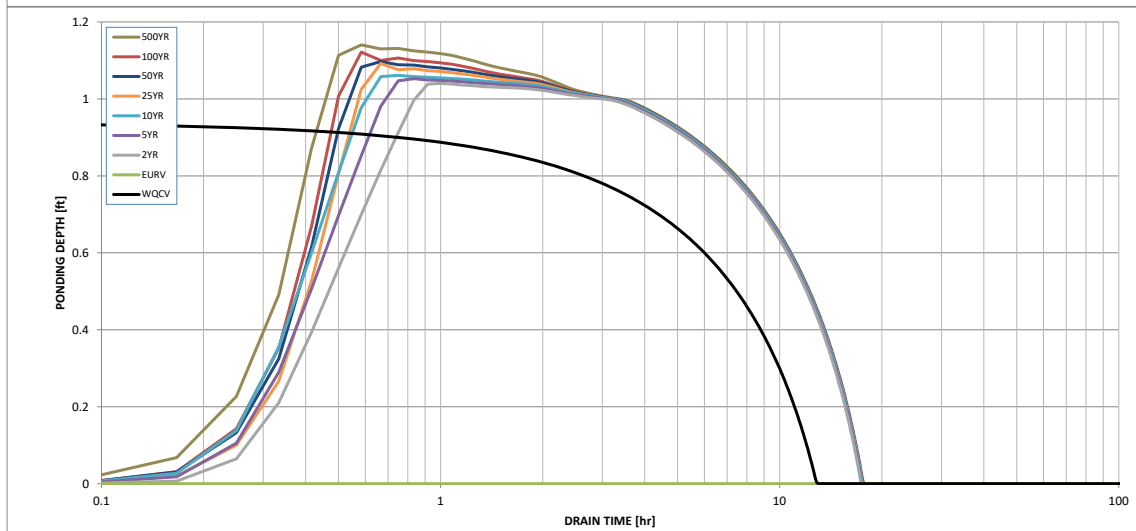
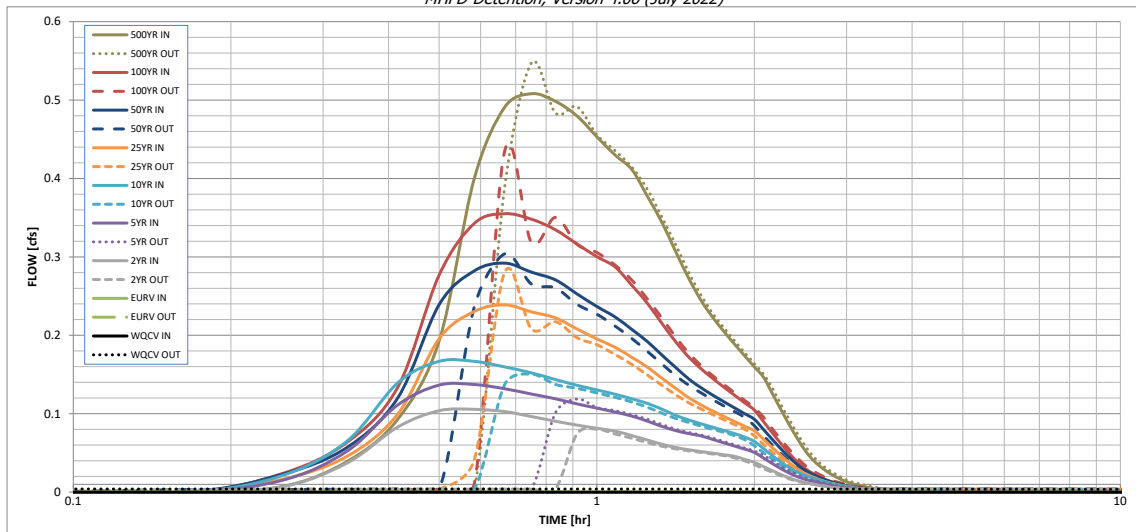

S-A-V-D Chart Axis Override	X-axis	Left Y-Axis	Right Y-Axis
minimum bound			
maximum bound			

# DETENTION BASIN OUTLET STRUCTURE DESIGN

Outflow Hydrograph Workbook Filename: \_\_\_\_\_

### Inflow Hydrographs

The user can override the calculated inflow hydrographs from this workbook with inflow hydrographs developed in a separate program.

Time Interval	SOURCE	CUHP	CUHP	CUHP	CUHP	CUHP	CUHP	CUHP	CUHP	CUHP
	TIME	WQCV [cfs]	EURV [cfs]	2 Year [cfs]	5 Year [cfs]	10 Year [cfs]	25 Year [cfs]	50 Year [cfs]	100 Year [cfs]	500 Year [cfs]
5.00 min	0:00:00	0.00	0.00	0.00	0.00	0.00	0.00	0.00	0.00	0.00
	0:05:00	0.00	0.00	0.00	0.00	0.00	0.00	0.00	0.00	0.00
	0:10:00	0.00	0.00	0.00	0.00	0.00	0.00	0.00	0.00	0.01
	0:15:00	0.00	0.00	0.01	0.01	0.02	0.02	0.02	0.02	0.04
	0:20:00	0.00	0.00	0.04	0.05	0.07	0.05	0.06	0.06	0.09
	0:25:00	0.00	0.00	0.08	0.11	0.14	0.10	0.12	0.13	0.19
	0:30:00	0.00	0.00	0.10	0.14	0.17	0.20	0.24	0.28	0.40
	0:35:00	0.00	0.00	0.11	0.14	0.17	0.23	0.28	0.34	0.49
	0:40:00	0.00	0.00	0.10	0.13	0.16	0.24	0.29	0.36	0.51
	0:45:00	0.00	0.00	0.10	0.13	0.15	0.23	0.28	0.35	0.50
	0:50:00	0.00	0.00	0.09	0.12	0.14	0.22	0.27	0.33	0.48
	0:55:00	0.00	0.00	0.09	0.11	0.14	0.21	0.25	0.32	0.45
	1:00:00	0.00	0.00	0.08	0.11	0.13	0.20	0.24	0.30	0.43
	1:05:00	0.00	0.00	0.08	0.10	0.12	0.18	0.22	0.29	0.41
	1:10:00	0.00	0.00	0.07	0.10	0.12	0.17	0.21	0.26	0.38
	1:15:00	0.00	0.00	0.07	0.09	0.11	0.16	0.19	0.24	0.34
	1:20:00	0.00	0.00	0.06	0.08	0.11	0.15	0.17	0.21	0.31
	1:25:00	0.00	0.00	0.06	0.08	0.10	0.13	0.16	0.19	0.27
	1:30:00	0.00	0.00	0.05	0.07	0.09	0.12	0.14	0.17	0.24
	1:35:00	0.00	0.00	0.05	0.07	0.09	0.11	0.13	0.16	0.22
	1:40:00	0.00	0.00	0.05	0.07	0.08	0.10	0.12	0.14	0.20
	1:45:00	0.00	0.00	0.05	0.06	0.08	0.10	0.12	0.13	0.19
	1:50:00	0.00	0.00	0.05	0.06	0.07	0.09	0.11	0.12	0.17
	1:55:00	0.00	0.00	0.04	0.05	0.07	0.08	0.10	0.11	0.16
	2:00:00	0.00	0.00	0.04	0.05	0.06	0.08	0.09	0.10	0.15
	2:05:00	0.00	0.00	0.03	0.04	0.06	0.07	0.08	0.09	0.12
	2:10:00	0.00	0.00	0.03	0.04	0.05	0.06	0.07	0.08	0.10
	2:15:00	0.00	0.00	0.02	0.03	0.04	0.05	0.05	0.06	0.09
	2:20:00	0.00	0.00	0.02	0.02	0.03	0.04	0.04	0.05	0.07
	2:25:00	0.00	0.00	0.01	0.02	0.03	0.03	0.03	0.04	0.05
	2:30:00	0.00	0.00	0.01	0.02	0.02	0.02	0.03	0.03	0.04
	2:35:00	0.00	0.00	0.01	0.01	0.02	0.02	0.02	0.02	0.03
	2:40:00	0.00	0.00	0.01	0.01	0.02	0.02	0.02	0.02	0.03
	2:45:00	0.00	0.00	0.01	0.01	0.01	0.01	0.02	0.02	0.02
	2:50:00	0.00	0.00	0.01	0.01	0.01	0.01	0.01	0.01	0.02
	2:55:00	0.00	0.00	0.00	0.01	0.01	0.01	0.01	0.01	0.01
	3:00:00	0.00	0.00	0.00	0.01	0.01	0.01	0.01	0.01	0.01
	3:05:00	0.00	0.00	0.00	0.00	0.01	0.01	0.01	0.01	0.01
	3:10:00	0.00	0.00	0.00	0.00	0.00	0.00	0.01	0.01	0.01
	3:15:00	0.00	0.00	0.00	0.00	0.00	0.00	0.00	0.00	0.01
	3:20:00	0.00	0.00	0.00	0.00	0.00	0.00	0.00	0.00	0.00
	3:25:00	0.00	0.00	0.00	0.00	0.00	0.00	0.00	0.00	0.00
	3:30:00	0.00	0.00	0.00	0.00	0.00	0.00	0.00	0.00	0.00
	3:35:00	0.00	0.00	0.00	0.00	0.00	0.00	0.00	0.00	0.00
	3:40:00	0.00	0.00	0.00	0.00	0.00	0.00	0.00	0.00	0.00
	3:45:00	0.00	0.00	0.00	0.00	0.00	0.00	0.00	0.00	0.00
	3:50:00	0.00	0.00	0.00	0.00	0.00	0.00	0.00	0.00	0.00
	3:55:00	0.00	0.00	0.00	0.00	0.00	0.00	0.00	0.00	0.00
	4:00:00	0.00	0.00	0.00	0.00	0.00	0.00	0.00	0.00	0.00
	4:05:00	0.00	0.00	0.00	0.00	0.00	0.00	0.00	0.00	0.00
	4:10:00	0.00	0.00	0.00	0.00	0.00	0.00	0.00	0.00	0.00
	4:15:00	0.00	0.00	0.00	0.00	0.00	0.00	0.00	0.00	0.00
	4:20:00	0.00	0.00	0.00	0.00	0.00	0.00	0.00	0.00	0.00
	4:25:00	0.00	0.00	0.00	0.00	0.00	0.00	0.00	0.00	0.00
	4:30:00	0.00	0.00	0.00	0.00	0.00	0.00	0.00	0.00	0.00
	4:35:00	0.00	0.00	0.00	0.00	0.00	0.00	0.00	0.00	0.00
	4:40:00	0.00	0.00	0.00	0.00	0.00	0.00	0.00	0.00	0.00
	4:45:00	0.00	0.00	0.00	0.00	0.00	0.00	0.00	0.00	0.00
	4:50:00	0.00	0.00	0.00	0.00	0.00	0.00	0.00	0.00	0.00
	4:55:00	0.00	0.00	0.00	0.00	0.00	0.00	0.00	0.00	0.00
5:00:00	0.00	0.00	0.00	0.00	0.00	0.00	0.00	0.00	0.00	
5:05:00	0.00	0.00	0.00	0.00	0.00	0.00	0.00	0.00	0.00	
5:10:00	0.00	0.00	0.00	0.00	0.00	0.00	0.00	0.00	0.00	
5:15:00	0.00	0.00	0.00	0.00	0.00	0.00	0.00	0.00	0.00	
5:20:00	0.00	0.00	0.00	0.00	0.00	0.00	0.00	0.00	0.00	
5:25:00	0.00	0.00	0.00	0.00	0.00	0.00	0.00	0.00	0.00	
5:30:00	0.00	0.00	0.00	0.00	0.00	0.00	0.00	0.00	0.00	
5:35:00	0.00	0.00	0.00	0.00	0.00	0.00	0.00	0.00	0.00	
5:40:00	0.00	0.00	0.00	0.00	0.00	0.00	0.00	0.00	0.00	
5:45:00	0.00	0.00	0.00	0.00	0.00	0.00	0.00	0.00	0.00	
5:50:00	0.00	0.00	0.00	0.00	0.00	0.00	0.00	0.00	0.00	
5:55:00	0.00	0.00	0.00	0.00	0.00	0.00	0.00	0.00	0.00	
6:00:00	0.00	0.00	0.00	0.00	0.00	0.00	0.00	0.00	0.00	

# DETENTION BASIN OUTLET STRUCTURE DESIGN

*MHFD-Detention, Version 4.06 (July 2022)*

Summary Stage-Area-Volume-Discharge Relationships

The user can create a summary S-A-V-D by entering the desired stage increments and the remainder of the table will populate automatically.  
 The user should graphically compare the summary S-A-V-D table to the full S-A-V-D table in the chart to confirm it captures all key transition points.

Stage - Storage Description	Stage [ft]	Area [ft <sup>2</sup> ]	Area [acres]	Volume [ft <sup>3</sup> ]	Volume [ac-ft]	Total Outflow [cfs]

For best results, include the stages of all grade slope changes (e.g. ISV and Floor) from the S-A-V table on Sheet 'Basin'.  
  
Also include the inverts of all outlets (e.g. vertical orifice, overflow grate, and spillway, where applicable).

# Channel Report

## Basin B4 Roadside Worst Case (25% of DP-B2 Sub-Basin Flows = 14.3 100 yr)

### Triangular

Side Slopes (z:1) = 3.00, 6.00  
Total Depth (ft) = 2.00

Invert Elev (ft) = 100.00  
Slope (%) = 5.50  
N-Value = 0.026

### Calculations

Compute by: Known Q  
Known Q (cfs) = 14.30

### Highlighted

Depth (ft) = 0.70  
Q (cfs) = 14.30  
Area (sqft) = 2.20  
Velocity (ft/s) = 6.49  
Wetted Perim (ft) = 6.47  
Crit Depth, Yc (ft) = 0.92  
Top Width (ft) = 6.30  
EGL (ft) = 1.35

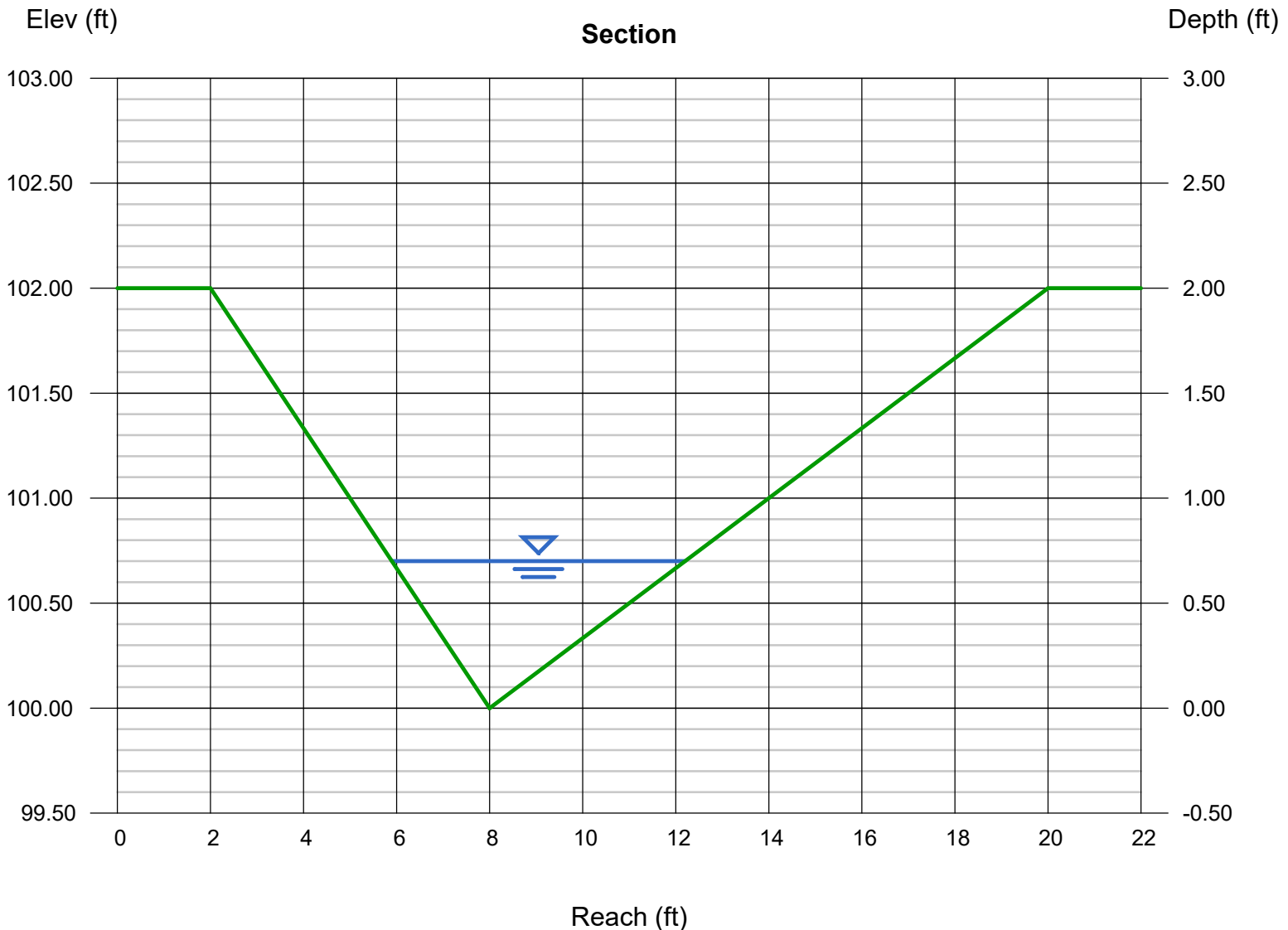

# Culvert Report

## 61223 - Gambler Place Culvert D1 (5yr - 2.4 cfs)

Invert Elev Dn (ft)	=	7410.80
Pipe Length (ft)	=	63.70
Slope (%)	=	0.50
Invert Elev Up (ft)	=	7411.12
Rise (in)	=	18.0
Shape	=	Circular
Span (in)	=	18.0
No. Barrels	=	2
n-Value	=	0.013
Culvert Type	=	Circular Concrete
Culvert Entrance	=	Groove end projecting (C)
Coeff. K,M,c,Y,k	=	0.0045, 2, 0.0317, 0.69, 0.2

### Embankment

Top Elevation (ft)	=	7413.50
Top Width (ft)	=	32.00
Crest Width (ft)	=	100.00

### Calculations

Qmin (cfs)	=	2.40
Qmax (cfs)	=	2.40
Tailwater Elev (ft)	=	(dc+D)/2

### Highlighted

Qtotal (cfs)	=	2.40
Qpipe (cfs)	=	2.40
Qovertop (cfs)	=	0.00
Veloc Dn (ft/s)	=	1.01
Veloc Up (ft/s)	=	1.80
HGL Dn (ft)	=	7411.75
HGL Up (ft)	=	7411.72
Hw Elev (ft)	=	7411.78
Hw/D (ft)	=	0.44
Flow Regime	=	Outlet Control

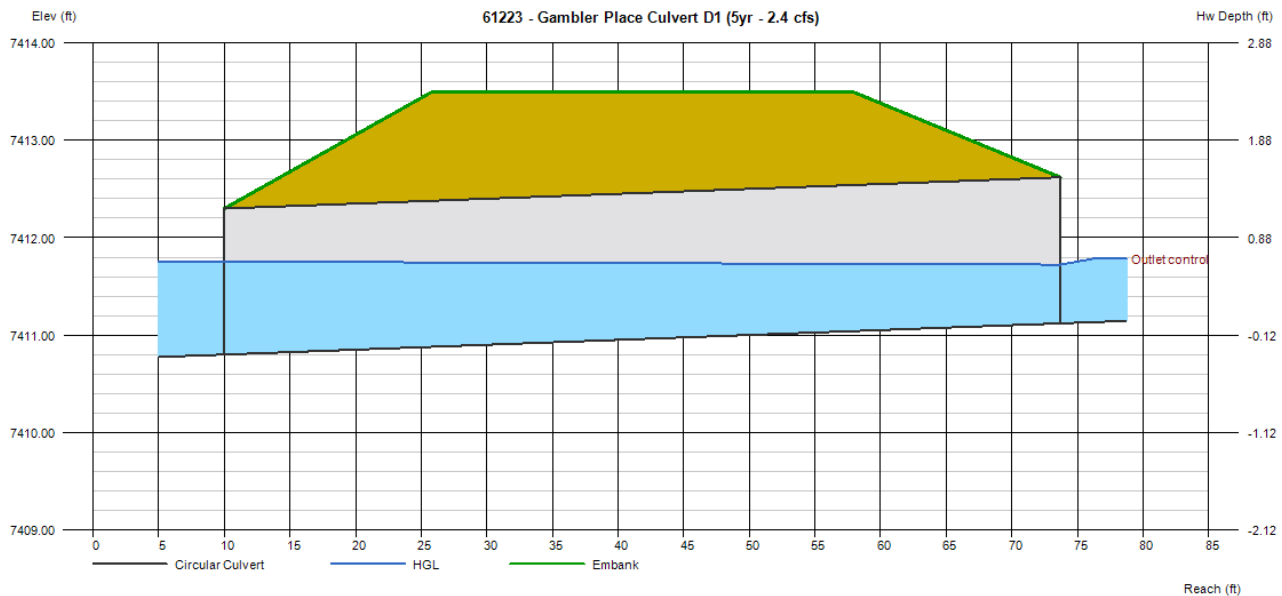

# Culvert Report

## 61223 - Gambler Place Culvert D1 (100yr - 15.1 cfs)

Invert Elev Dn (ft)	= 7410.80
Pipe Length (ft)	= 63.70
Slope (%)	= 0.50
Invert Elev Up (ft)	= 7411.12
Rise (in)	= 18.0
Shape	= Circular
Span (in)	= 18.0
No. Barrels	= 2
n-Value	= 0.013
Culvert Type	= Circular Concrete
Culvert Entrance	= Groove end projecting (C)
Coeff. K,M,c,Y,k	= 0.0045, 2, 0.0317, 0.69, 0.2

<b>Embankment</b>	
Top Elevation (ft)	= 7413.50
Top Width (ft)	= 32.00
Crest Width (ft)	= 100.00

<b>Calculations</b>	
Qmin (cfs)	= 15.10
Qmax (cfs)	= 15.10
Tailwater Elev (ft)	= (dc+D)/2

<b>Highlighted</b>	
Qtotal (cfs)	= 15.10
Qpipe (cfs)	= 15.10
Qovertop (cfs)	= 0.00
Veloc Dn (ft/s)	= 4.69
Veloc Up (ft/s)	= 5.64
HGL Dn (ft)	= 7412.08
HGL Up (ft)	= 7412.18
Hw Elev (ft)	= 7412.76
Hw/D (ft)	= 1.09
Flow Regime	= Inlet Control

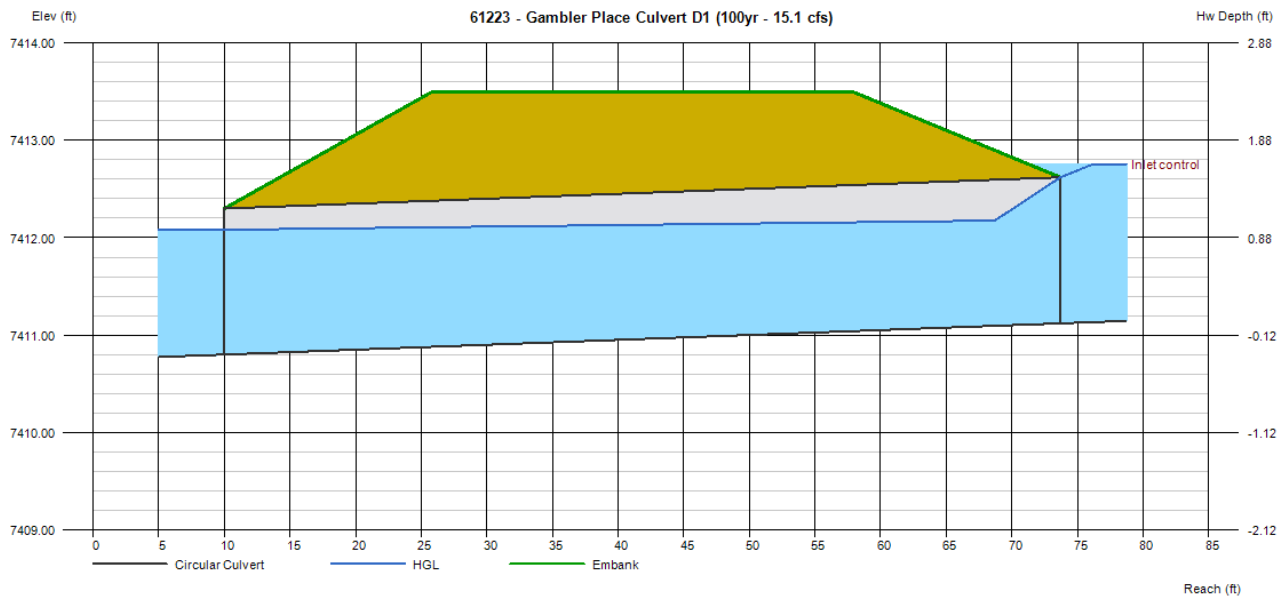



# Culvert Report

## 61223 - Gambler Place Culvert B2 (5yr - 9.0 cfs)

Invert Elev Dn (ft)	= 7372.65
Pipe Length (ft)	= 81.70
Slope (%)	= 3.26
Invert Elev Up (ft)	= 7375.31
Rise (in)	= 24.0
Shape	= Circular
Span (in)	= 24.0
No. Barrels	= 2
n-Value	= 0.013
Culvert Type	= Circular Concrete
Culvert Entrance	= Groove end projecting (C)
Coeff. K,M,c,Y,k	= 0.0045, 2, 0.0317, 0.69, 0.2

<b>Embankment</b>	
Top Elevation (ft)	= 7380.53
Top Width (ft)	= 32.00
Crest Width (ft)	= 100.00

<b>Calculations</b>	
Qmin (cfs)	= 9.00
Qmax (cfs)	= 9.00
Tailwater Elev (ft)	= (dc+D)/2

<b>Highlighted</b>	
Qtotal (cfs)	= 9.00
Qpipe (cfs)	= 9.00
Qovertop (cfs)	= 0.00
Veloc Dn (ft/s)	= 1.96
Veloc Up (ft/s)	= 4.22
HGL Dn (ft)	= 7374.02
HGL Up (ft)	= 7376.06
Hw Elev (ft)	= 7376.31
Hw/D (ft)	= 0.50
Flow Regime	= Inlet Control

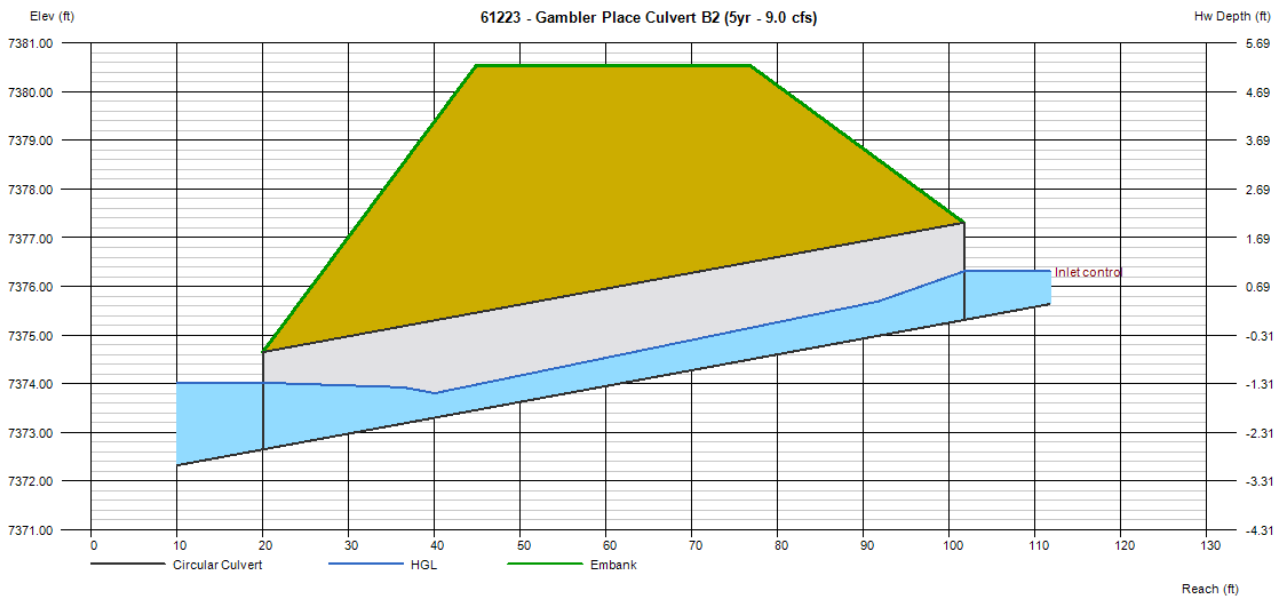

# Culvert Report

## 61223 - Gambler Place Culvert B2 (100yr - 57.2 cfs)

Invert Elev Dn (ft)	= 7372.65
Pipe Length (ft)	= 81.70
Slope (%)	= 3.26
Invert Elev Up (ft)	= 7375.31
Rise (in)	= 24.0
Shape	= Circular
Span (in)	= 24.0
No. Barrels	= 2
n-Value	= 0.013
Culvert Type	= Circular Concrete
Culvert Entrance	= Groove end projecting (C)
Coeff. K,M,c,Y,k	= 0.0045, 2, 0.0317, 0.69, 0.2

<b>Embankment</b>	
Top Elevation (ft)	= 7380.53
Top Width (ft)	= 32.00
Crest Width (ft)	= 100.00

<b>Calculations</b>	
Qmin (cfs)	= 57.20
Qmax (cfs)	= 57.20
Tailwater Elev (ft)	= (dc+D)/2

<b>Highlighted</b>	
Qtotal (cfs)	= 57.20
Qpipe (cfs)	= 57.20
Qovertop (cfs)	= 0.00
Veloc Dn (ft/s)	= 9.23
Veloc Up (ft/s)	= 9.46
HGL Dn (ft)	= 7374.57
HGL Up (ft)	= 7377.15
Hw Elev (ft)	= 7379.29
Hw/D (ft)	= 1.99
Flow Regime	= Inlet Control

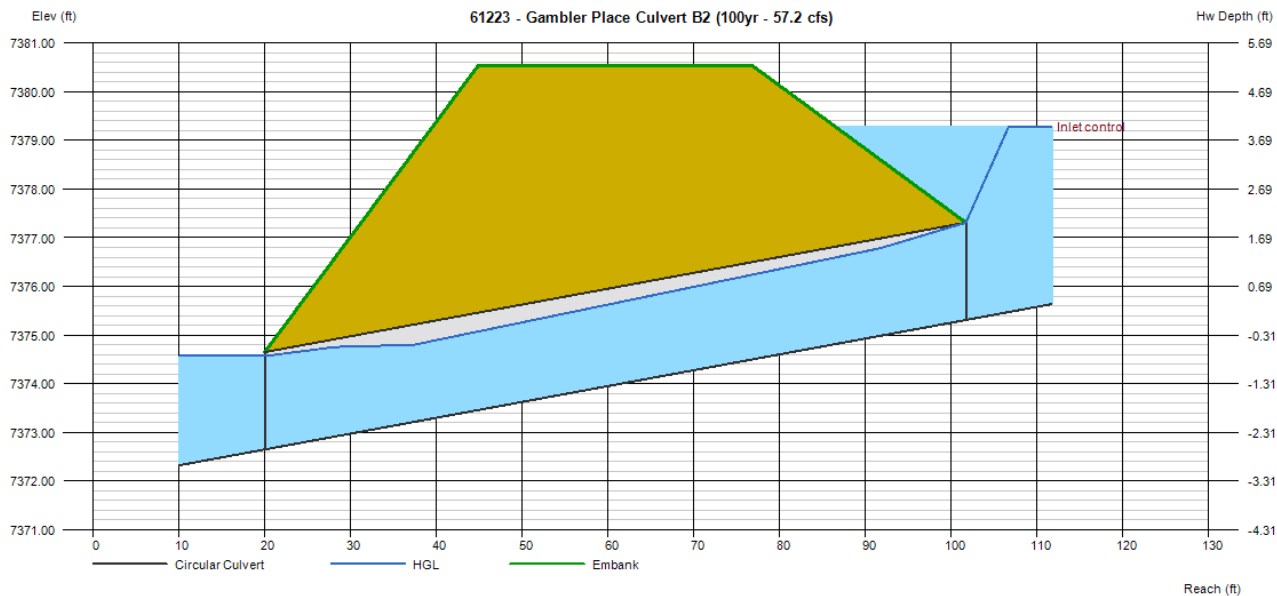

## Determination of Culvert Headwater and Outlet Protection

Project: **61223 - Table Rock Homesteads**

Basin ID: **Culvert D1**

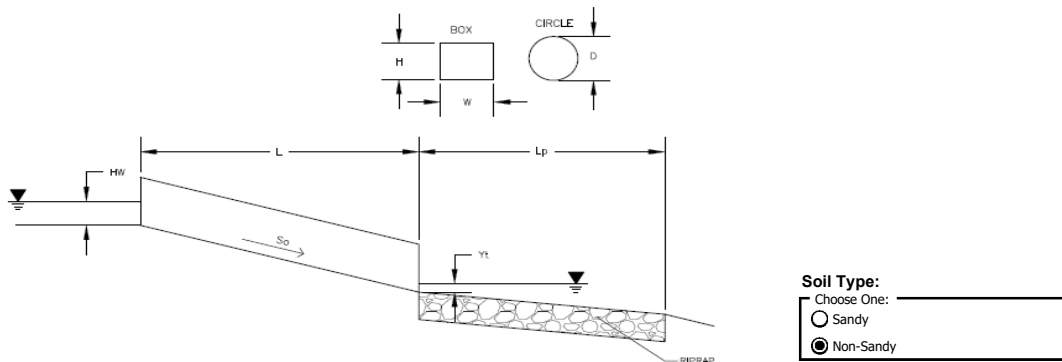

**Soil Type:**  
 Choose One:  Sandy  
 Non-Sandy

### Design Information (Input):

Design Discharge	Q =	<input type="text" value="15.1"/>	cfs
<b>Circular Culvert:</b>			
Barrel Diameter in Inches	D =	<input type="text" value="18"/>	inches
Inlet Edge Type (Choose from pull-down list)		<input type="text" value="1.5 : 1 Beveled Edge"/>	
<b>Box Culvert:</b>			
Barrel Height (Rise) in Feet	Height (Rise) =	<input type="text"/>	ft
Barrel Width (Span) in Feet	Width (Span) =	<input type="text"/>	ft
Inlet Edge Type (Choose from pull-down list)		<input type="text"/>	
Number of Barrels	No =	<input type="text" value="2"/>	
Inlet Elevation	Elev IN =	<input type="text" value="7411.12"/>	ft
Outlet Elevation <b>OR</b> Slope	Elev OUT =	<input type="text" value="7410.8"/>	ft
Culvert Length	L =	<input type="text" value="63.7"/>	ft
Manning's Roughness	n =	<input type="text" value="0.013"/>	
Bend Loss Coefficient	$k_b$ =	<input type="text" value="0"/>	
Exit Loss Coefficient	$k_x$ =	<input type="text" value="1"/>	
Tailwater Surface Elevation	Elev $Y_t$ =	<input type="text"/>	ft
Max Allowable Channel Velocity	V =	<input type="text" value="7"/>	ft/s

### Required Protection (Output):

Tailwater Surface Height	$Y_t$ =	<input type="text" value="0.60"/>	ft
Flow Area at Max Channel Velocity	$A_t$ =	<input type="text" value="1.08"/>	ft <sup>2</sup>
Culvert Cross Sectional Area Available	A =	<input type="text" value="1.77"/>	ft <sup>2</sup>
Entrance Loss Coefficient	$k_e$ =	<input type="text" value="0.20"/>	
Friction Loss Coefficient	$k_f$ =	<input type="text" value="1.15"/>	
Sum of All Losses Coefficients	$k_s$ =	<input type="text" value="2.35"/>	
Culvert Normal Depth	$Y_n$ =	<input type="text" value="1.24"/>	ft
Culvert Critical Depth	$Y_c$ =	<input type="text" value="1.06"/>	ft
Tailwater Depth for Design	d =	<input type="text" value="1.28"/>	ft
Adjusted Diameter <b>OR</b> Adjusted Rise	$D_a$ =	<input type="text" value="-"/>	ft
Expansion Factor	$1/(2*\tan(\theta))$ =	<input type="text" value="4.77"/>	
Flow/Diameter <sup>2.5</sup> <b>OR</b> Flow/(Span * Rise <sup>1.5</sup> )	Q/D <sup>2.5</sup> =	<input type="text" value="2.74"/>	ft <sup>0.5</sup> /s
Froude Number	Fr =	<input type="text" value="0.72"/>	
Tailwater/Adjusted Diameter <b>OR</b> Tailwater/Adjusted Rise	$Y_t/D$ =	<input type="text" value="0.40"/>	
Inlet Control Headwater	$HW_i$ =	<input type="text" value="1.61"/>	ft
Outlet Control Headwater	$HW_o$ =	<input type="text" value="1.63"/>	ft
<b>Design Headwater Elevation</b>	<b>HW</b> =	<input type="text" value="7,412.75"/>	ft
<b>Headwater/Diameter <b>OR</b> Headwater/Rise Ratio</b>	<b>HW/D</b> =	<input type="text" value="1.09"/>	
Minimum Theoretical Riprap Size	$d_{50}$ =	<input type="text" value="3"/>	in
Nominal Riprap Size	$d_{50}$ =	<input type="text" value="6"/>	in
<b>UDFCD Riprap Type</b>	<b>Type</b> =	<input type="text" value="VL"/>	
<b>Length of Protection</b>	$L_p$ =	<input type="text" value="5"/>	ft
<b>Width of Protection</b>	T =	<input type="text" value="3"/>	ft

## Determination of Culvert Headwater and Outlet Protection

Project: **61223 - Table Rock Homesteads**

Basin ID: **Culvert B2**

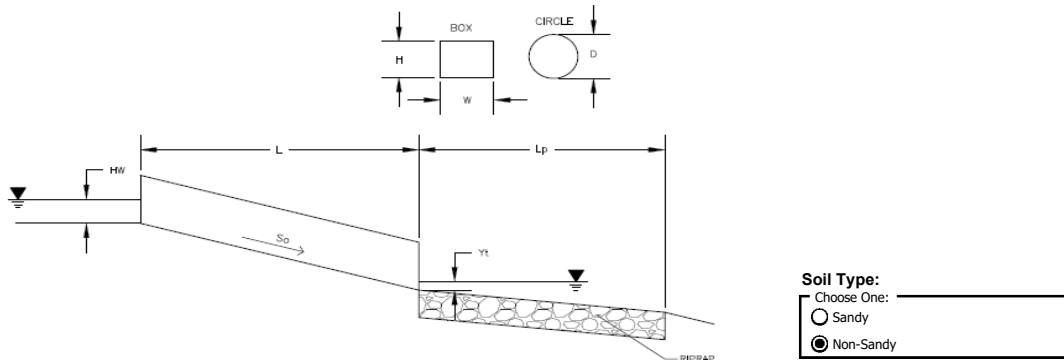

**Soil Type:**  
 Choose One:  Sandy  Non-Sandy

**Supercritical Flow! Using  $D_a$  to calculate protection type.**

Design Information (Input):	
Design Discharge	Q = <input style="width: 100px;" type="text" value="57.2"/> cfs
<b>Circular Culvert:</b>	
Barrel Diameter in Inches	D = <input style="width: 100px;" type="text" value="24"/> inches
Inlet Edge Type (Choose from pull-down list)	<input type="text" value="1.5 : 1 Beveled Edge"/> <b>OR</b>
<b>Box Culvert:</b>	
Barrel Height (Rise) in Feet	Height (Rise) = <input style="width: 100px;" type="text"/>
Barrel Width (Span) in Feet	Width (Span) = <input style="width: 100px;" type="text"/>
Inlet Edge Type (Choose from pull-down list)	<input type="text"/>
Number of Barrels	No = <input style="width: 100px;" type="text" value="2"/>
Inlet Elevation	Elev IN = <input style="width: 100px;" type="text" value="7375.31"/> ft
Outlet Elevation <b>OR</b> Slope	Elev OUT = <input style="width: 100px;" type="text" value="7372.65"/> ft
Culvert Length	L = <input style="width: 100px;" type="text" value="81.7"/> ft
Manning's Roughness	n = <input style="width: 100px;" type="text" value="0.012"/>
Bend Loss Coefficient	$k_b$ = <input style="width: 100px;" type="text" value="0"/>
Exit Loss Coefficient	$k_x$ = <input style="width: 100px;" type="text" value="1"/>
Tailwater Surface Elevation	Elev $Y_t$ = <input style="width: 100px;" type="text"/>
Max Allowable Channel Velocity	V = <input style="width: 100px;" type="text" value="7"/> ft/s
Required Protection (Output):	
Tailwater Surface Height	$Y_t$ = <input style="width: 100px;" type="text" value="0.80"/> ft
Flow Area at Max Channel Velocity	$A_t$ = <input style="width: 100px;" type="text" value="4.09"/> ft <sup>2</sup>
Culvert Cross Sectional Area Available	A = <input style="width: 100px;" type="text" value="3.14"/> ft <sup>2</sup>
Entrance Loss Coefficient	$k_e$ = <input style="width: 100px;" type="text" value="0.20"/>
Friction Loss Coefficient	$k_f$ = <input style="width: 100px;" type="text" value="0.86"/>
Sum of All Losses Coefficients	$k_s$ = <input style="width: 100px;" type="text" value="2.06"/> ft
Culvert Normal Depth	$Y_n$ = <input style="width: 100px;" type="text" value="1.17"/> ft
Culvert Critical Depth	$Y_c$ = <input style="width: 100px;" type="text" value="1.84"/> ft
Tailwater Depth for Design	d = <input style="width: 100px;" type="text" value="1.92"/> ft
Adjusted Diameter <b>OR</b> Adjusted Rise	$D_a$ = <input style="width: 100px;" type="text" value="1.58"/> ft
Expansion Factor	$1/(2*\tan(\theta))$ = <input style="width: 100px;" type="text" value="3.44"/>
Flow/Diameter <sup>2.5</sup> <b>OR</b> Flow/(Span * Rise <sup>1.5</sup> )	$Q/D^{2.5}$ = <input style="width: 100px;" type="text" value="5.06"/> ft <sup>0.5</sup> /s
Froude Number	Fr = <input style="width: 100px;" type="text" value="2.69"/> <b>Supercritical!</b>
Tailwater/Adjusted Diameter <b>OR</b> Tailwater/Adjusted Rise	$Y_t/D$ = <input style="width: 100px;" type="text" value="0.50"/>
Inlet Control Headwater	$H_{w1}$ = <input style="width: 100px;" type="text" value="3.71"/> ft
Outlet Control Headwater	$H_{w0}$ = <input style="width: 100px;" type="text" value="1.91"/> ft
<b>Design Headwater Elevation</b>	<b>HW</b> = <input style="width: 100px;" type="text" value="7,379.02"/> ft
<b>Headwater/Diameter <b>OR</b> Headwater/Rise Ratio</b>	<b>HW/D</b> = <input style="width: 100px;" type="text" value="1.86"/> <b>HW/D &gt; 1.5!</b>
Minimum Theoretical Riprap Size	$d_{50}$ = <input style="width: 100px;" type="text" value="9"/> in
Nominal Riprap Size	$d_{50}$ = <input style="width: 100px;" type="text" value="9"/> in
<b>UDFCD Riprap Type</b>	<b>Type</b> = <input style="width: 100px;" type="text" value="L"/>
<b>Length of Protection</b>	$L_p$ = <input style="width: 100px;" type="text" value="11"/> ft
<b>Width of Protection</b>	T = <input style="width: 100px;" type="text" value="6"/> ft

# Channel Report

## Channel D2-5 yr=7.7 cfs

### Trapezoidal

Bottom Width (ft) = 68.00  
Side Slopes (z:1) = 12.00, 6.00  
Total Depth (ft) = 6.00  
Invert Elev (ft) = 7365.00  
Slope (%) = 0.03  
N-Value = 0.040

### Highlighted

Depth (ft) = 0.35  
Q (cfs) = 7.700  
Area (sqft) = 24.90  
Velocity (ft/s) = 0.31  
Wetted Perim (ft) = 74.34  
Crit Depth, Yc (ft) = 0.08  
Top Width (ft) = 74.30  
EGL (ft) = 0.35

### Calculations

Compute by: Known Q  
Known Q (cfs) = 7.70

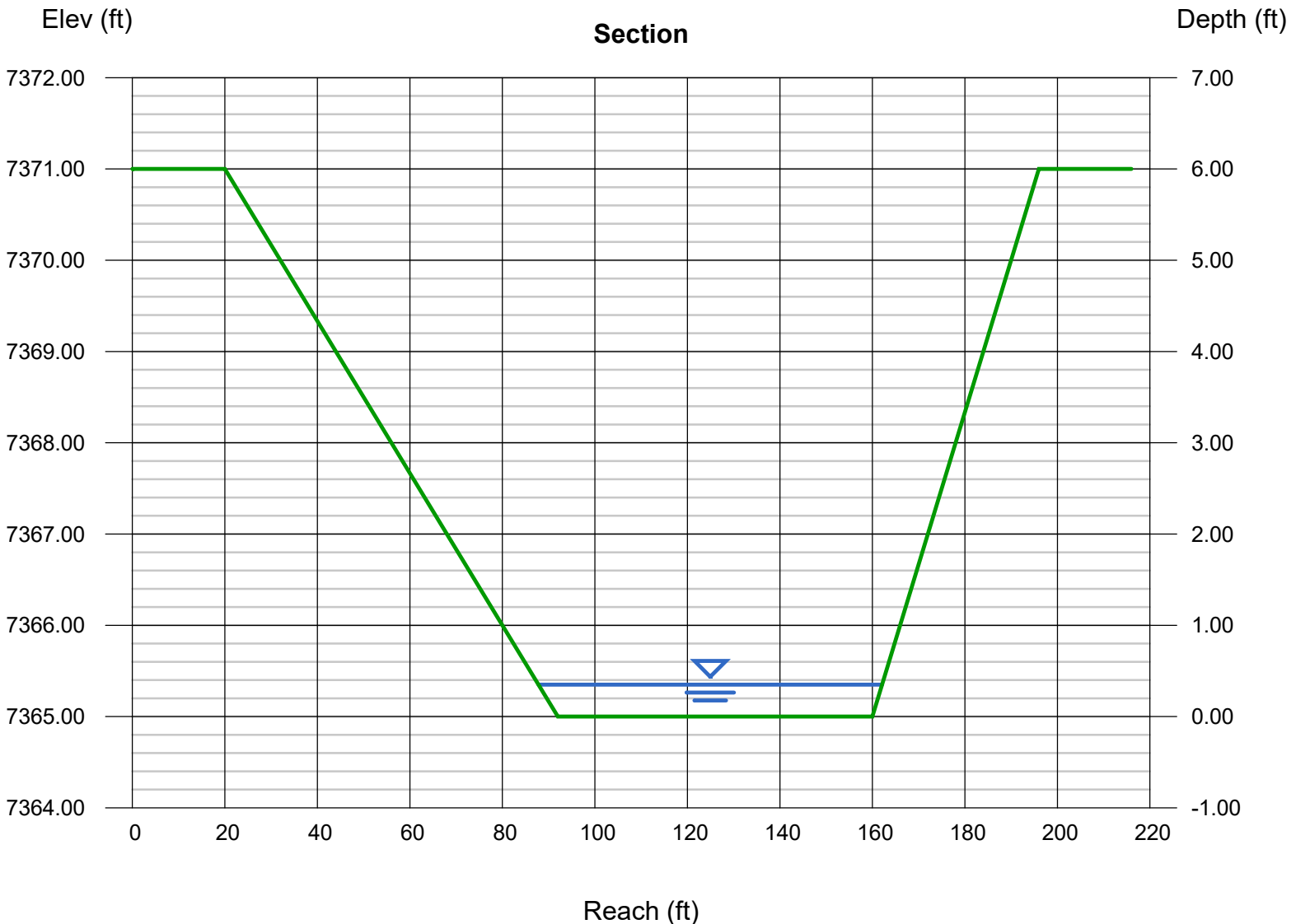

# Channel Report

## Channel D2-100 yr=49.3 cfs

### Trapezoidal

Bottom Width (ft)	= 68.00
Side Slopes (z:1)	= 12.00, 6.00
Total Depth (ft)	= 6.00
Invert Elev (ft)	= 7365.00
Slope (%)	= 0.03
N-Value	= 0.040

### Highlighted

Depth (ft)	= 1.05
Q (cfs)	= 49.30
Area (sqft)	= 81.32
Velocity (ft/s)	= 0.61
Wetted Perim (ft)	= 87.03
Crit Depth, Yc (ft)	= 0.26
Top Width (ft)	= 86.90
EGL (ft)	= 1.06

### Calculations

Compute by:	Known Q
Known Q (cfs)	= 49.30

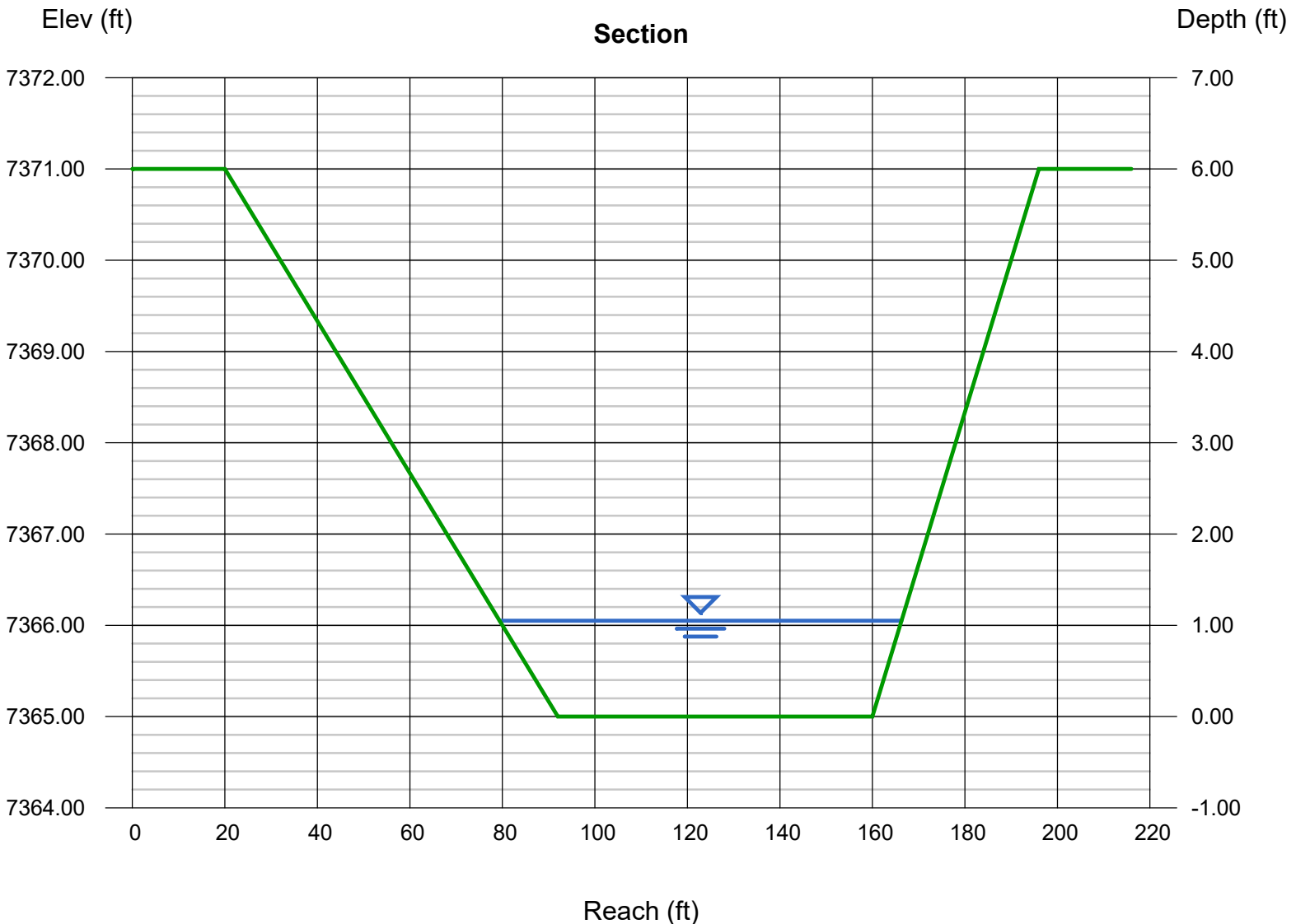

# Channel Report

## Channel B4-5 yr=25.6 cfs

### Trapezoidal

Bottom Width (ft)	= 30.00
Side Slopes (z:1)	= 19.00, 19.00
Total Depth (ft)	= 6.00
Invert Elev (ft)	= 7321.00
Slope (%)	= 0.04
N-Value	= 0.040

### Highlighted

Depth (ft)	= 0.94
Q (cfs)	= 25.60
Area (sqft)	= 44.99
Velocity (ft/s)	= 0.57
Wetted Perim (ft)	= 65.77
Crit Depth, Yc (ft)	= 0.27
Top Width (ft)	= 65.72
EGL (ft)	= 0.95

### Calculations

Compute by:	Known Q
Known Q (cfs)	= 25.60

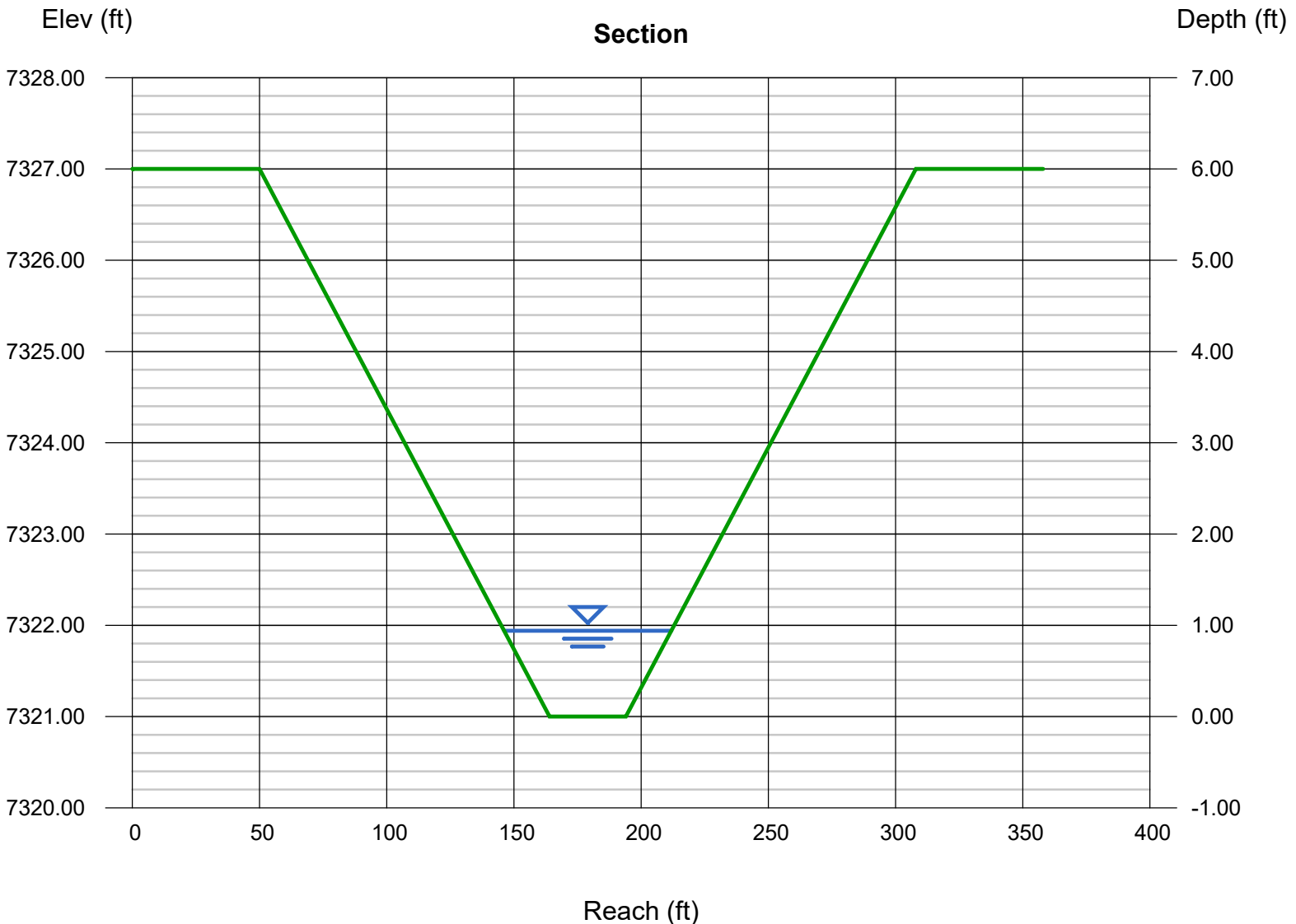

# Channel Report

## Channel B4-100 yr=163.10 cfs

### Trapezoidal

Bottom Width (ft) = 30.00  
Side Slopes (z:1) = 19.00, 19.00  
Total Depth (ft) = 6.00  
Invert Elev (ft) = 7321.00  
Slope (%) = 0.04  
N-Value = 0.040

### Highlighted

Depth (ft) = 2.32  
Q (cfs) = 163.10  
Area (sqft) = 171.87  
Velocity (ft/s) = 0.95  
Wetted Perim (ft) = 118.28  
Crit Depth, Yc (ft) = 0.82  
Top Width (ft) = 118.16  
EGL (ft) = 2.33

### Calculations

Compute by: Known Q  
Known Q (cfs) = 163.10

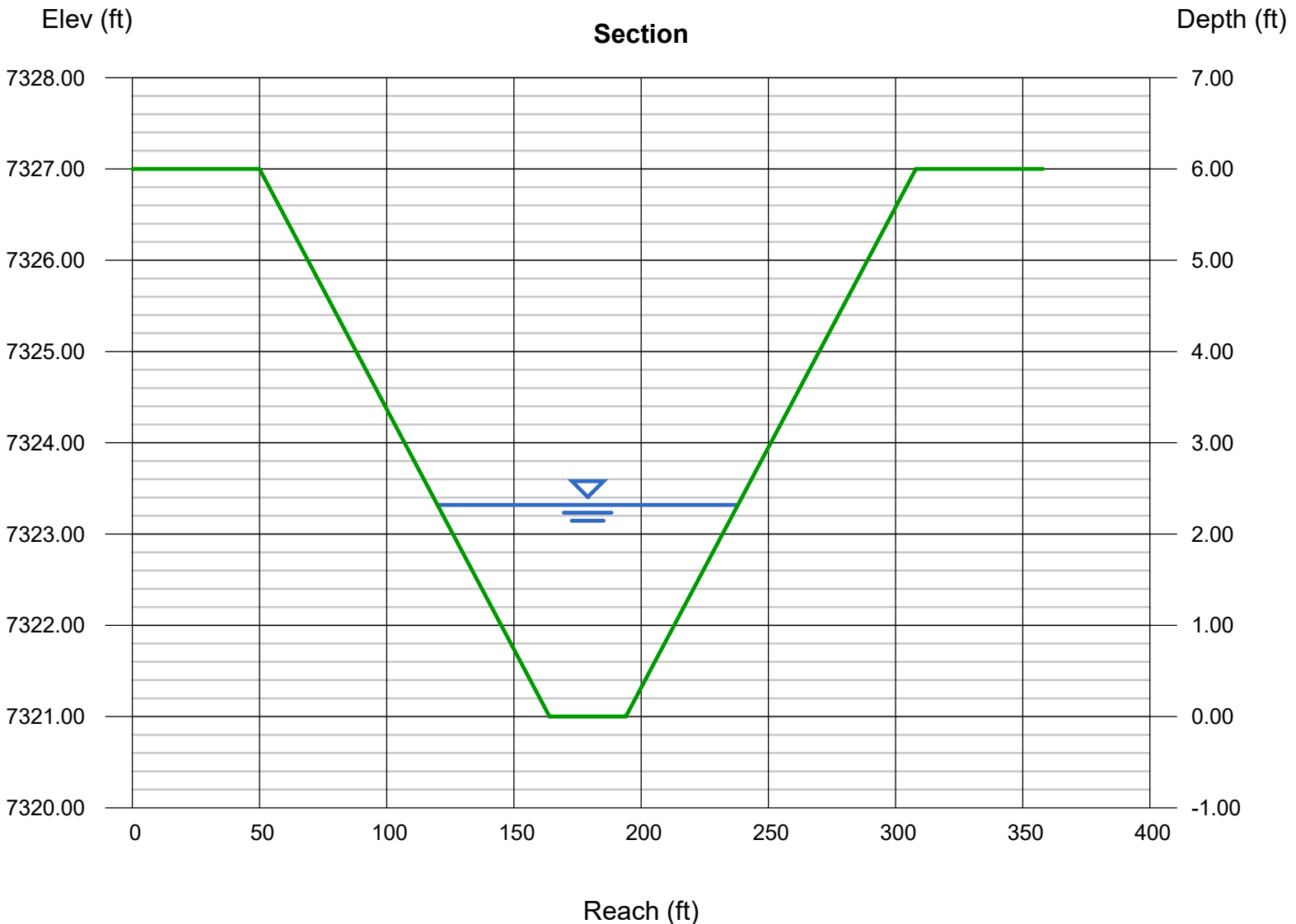



# NORTH GULLY - WEST ENTRANCE

## STEEP SLOPE RIP RAP SIZING

WHERE  $D_{50} = 5.23 S^{0.43} (Q^*_{DESIGN})^{0.56}$

$D_{50}$  IS IN INCHES

$S$  = LONGITUDINAL SLOPE

0.33

$Q$  = UNIT DISCHARGE

$57.2 \text{ cfs} / 20' = 2.86$

$C_f$  = CONCENTRATION FACTOR = 3

$Q_{DESIGN} = Q \times C_f$

$2.86 \times 3 = 8.58$

$Q^*_{DESIGN} = Q_{DESIGN} \times 1.35$

$8.58 \times 1.35 = 11.58$

$D_{50} = 5.23 \cdot 0.33^{0.43} \cdot (11.58)^{0.56}$

$= 5.23 \cdot 0.62 \cdot 3.94$

$D_{50} = 12.78$  - USE 12" (TYPE M)

SOIL RIPRAP

M.V.E., Inc.  
1903 Lelaray Street., Suite 200  
Colorado Springs, CO 80909  
(719) 635-5736

JOB 61223  
SHEET NO. 1 OF 1  
CALCULATED BY TJW DATE 1/14/2025  
CHECKED BY \_\_\_\_\_ DATE \_\_\_\_\_

SCALE \_\_\_\_\_

# NORTH GULLY - NORTH ENTRANCE

## STEEP SLOPE RIP RAP SIZING

WHERE  $D_{50} = 5.23 S^{0.43} (Q^*_{DESIGN})^{0.56}$

$D_{50}$  IS IN INCHES

$S$  = LONGITUDINAL SLOPE

0.25

$Q$  = UNIT DISCHARGE

$59.6 \text{ cfs/ft} = 4.26$

$C_F$  = CONCENTRATION FACTOR = 3

$$Q_{DESIGN} = Q \times C_F$$

$$4.26 \times 3 = 12.78$$

$$Q^*_{DESIGN} = Q_{DESIGN} \times 1.35$$

$$12.78 \times 1.35 = 17.25$$

$$D_{50} = 5.23 \times 0.25^{0.43} \times 17.25^{0.56}$$

$$= 5.23 \times 0.55 \times 4.93$$

$$D_{50} = 14.09" - \text{USE } 12" \text{ (TYPE M)}$$

SOIL RIPRAP

M.V.E., Inc.  
1903 Lelaray Street., Suite 200  
Colorado Springs, CO 80909  
(719) 635-5736

JOB G1223

SHEET NO. 1

OF 1

CALCULATED BY TJW

DATE 1/10/2025

CHECKED BY \_\_\_\_\_

DATE \_\_\_\_\_

SCALE \_\_\_\_\_

NORTH GULLY - SOUTH ENTRANCE

STEEP SLOPE RIP RAP SIZING

WHERE  $D_{50} = 5.23 S^{0.43} (Q^*_{DESIGN})^{0.56}$

$D_{50}$  IS IN INCHES

$S$  = LONGITUDINAL SLOPE

0.33

$Q$  = UNIT DISCHARGE

$16.7 \text{ cfs} / 5' = 3.34$

$C_p$  = CONCENTRATION FACTOR = 3

$Q_{DESIGN} = Q \times C_p$

$3.34 \times 3 = 10.02$

$Q^*_{DESIGN} = Q_{DESIGN} \times 1.35$

$10.02 \times 1.35 = 13.53$

$D_{50} = 5.23 \cdot 0.33^{0.43} \cdot 13.53^{0.56}$

$= 5.23 \cdot 0.62 \cdot 4.30$

$D_{50} = 13.94$  - USE 12" (TYPE M)

SOIL RIPRAP

SCALE \_\_\_\_\_

# SOUTH GULLY - NORTHWEST ENTRANCE

## STEEP SLOPE RIP RAP SIZING

WHERE  $D_{50} = 5.23 S^{0.43} (Q^*_{DESIGN})^{0.56}$

$D_{50}$  IS IN INCHES

$S$  = LONGITUDINAL SLOPE

0.33

$Q$  = UNIT DISCHARGE

$4.2 \text{ cfs} / 10' = 0.42$

$C_c$  = CONCENTRATION FACTOR = 3

$Q_{DESIGN} = Q \times C_c$

$0.42 \times 3 = 1.26$

$Q^*_{DESIGN} = Q_{DESIGN} \times 1.35$

$1.26 \times 1.35 = 1.70$

$D_{50} = 5.23 \cdot 0.33^{0.43} \cdot 1.70^{0.56}$

$= 5.23 \cdot 0.62 \cdot 1.35$

$D_{50} = 4.38$  - USE 6" (TYPE VL)

OR TYPE L

SOIL RIPRAP

SOUTH GULLY - NORTHEAST DRAIN ESMT  
STEEP SLOPE RIP RAP SIZING

WHERE  $D_{50} = 5.23 S^{0.43} (Q^*_{DESIGN})^{0.56}$

$D_{50}$  IS IN INCHES

$S$  = LONGITUDINAL SLOPE

0.33

$Q$  = UNIT DISCHARGE

$15.1 \text{ cfs} / 10' = 1.51$

$C_F$  = CONCENTRATION FACTOR = 3

$Q_{DESIGN} = Q \times C_F$

$1.51 \cdot 3 = 4.53$

$Q^*_{DESIGN} = Q_{DESIGN} \times 1.35$

$4.53 \cdot 1.35 = 6.12$

$D_{50} = 5.23 \cdot 0.33^{0.43} \cdot 6.12^{0.56}$

$= 5.23 \cdot 0.62 \cdot 2.76$

$D_{50} = 8.95$  - USE 9" (TYPE L)

SOIL RIPRAP

## TABLE ROCK HOMESTEADS

TYPICAL GULLY

TABLE 10-1

COMPOSITE ROUGHNESS COEFFICIENTS FOR UNLINED OPEN CHANNELS  
(Reference: Chow, Ven Te, 1959; Open-Channel Hydraulics)

$$n = (n_0 + n_1 + n_2 + n_3 + n_4)m \quad (10-2)$$

	<u>Channel Conditions</u>	<u>Value</u>	
Material Type $n_0$	Earth	0.020	
	Fine Gravel	0.024	-
	Coarse Gravel	0.028	
Degree of Irregularity $n_1$	Smooth	0.000	
	Minor	0.005	-
	Moderate	0.010	
	Severe	0.020	
Variation of Channel Cross Section $n_2$	Gradual	0.000	
	Alternating Occasionally	0.005	-
	Alternating Frequently	0.010	- 0.015
Relative Effect of Obstructions $n_3$	Negligible	0.000	0.005
	Minor	0.010	- 0.015
	Appreciable	0.020	- 0.030
	Severe	0.040	- 0.060
Vegetation $n_4$	Low	0.005	- 0.010
	Medium	0.010	- 0.025 - 0.010
	High	0.025	- 0.050
	Very High	0.050	- 0.100
Degree of Meandering $m$	Minor	1.000	- 1.200 - 1.1
	Appreciable	1.200	- 1.500
	Severe	1.500	

$$n = (0.024 + 0.005 + 0.005 + 0.005 + 0.010) 1.1$$

$$n = (0.049) 1.1$$

$$n = \underline{0.054} \text{ MAIN CHANNEL}$$

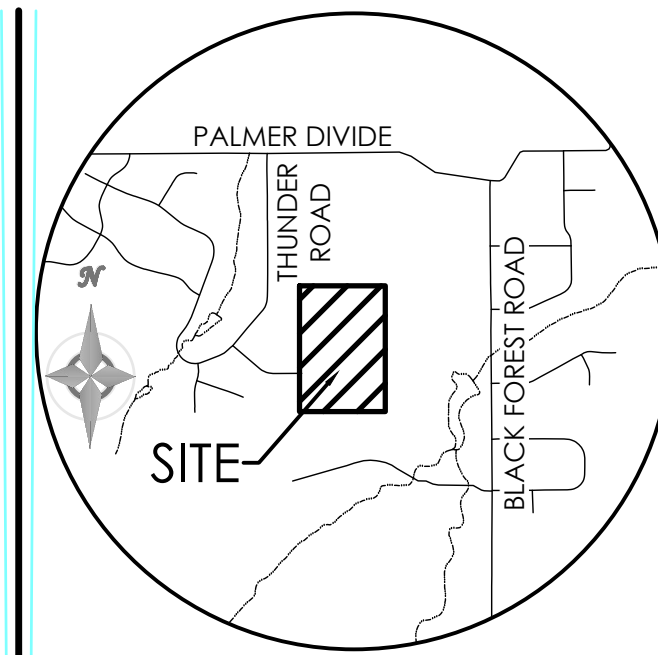
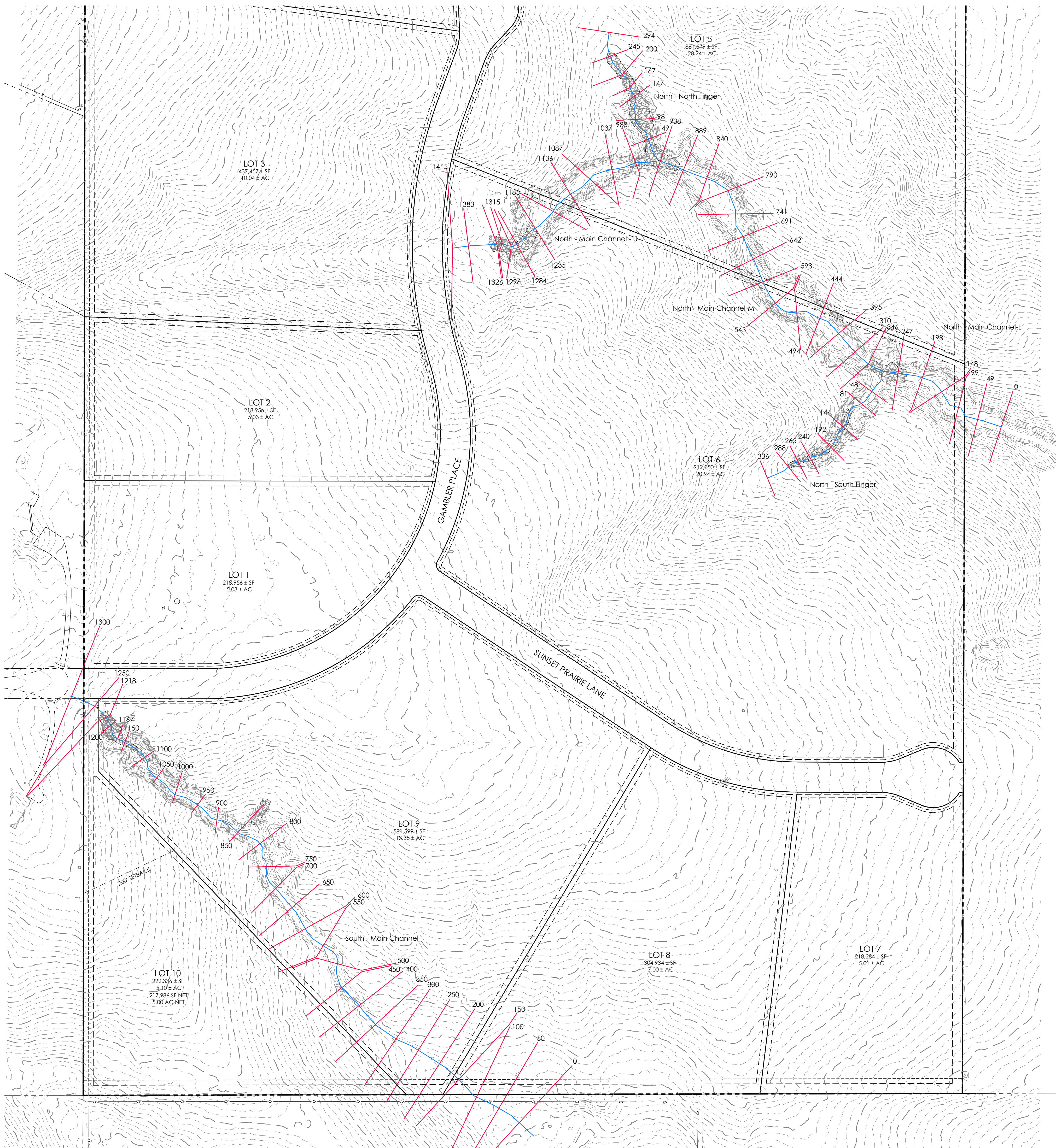

VICINITY MAP  
NOT TO SCALE

BENCHMARK  
THE BENCHMARK FOR THESE PLANS IS THE  
SOUTHWEST PROPERTY CORNER, A REBAR &  
CAP, ALESSI, PLS 30130.  
ELEVATION = 7385.63' (NAVD88).

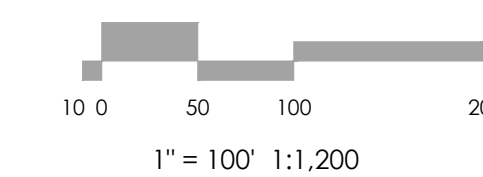
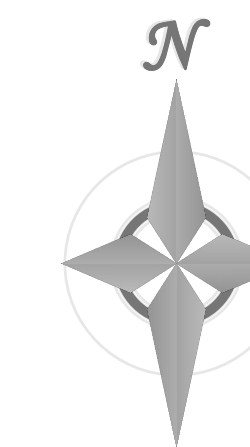

REVISIONS

DESIGNED BY \_\_\_\_\_  
DRAWN BY \_\_\_\_\_  
CHECKED BY \_\_\_\_\_  
AS-BUILT BY \_\_\_\_\_  
CHECKED BY \_\_\_\_\_

TABLE ROCK  
HOMESTEADS

HECRAS REACH &  
SECTION MAP

EXISTING

MVE PROJECT 61223

MVE DRAWING HECRAS-EX

JANUARY 24, 2025  
SHEET 1 OF 1

HEC-RAS Plan: Default Scenario Profile: 5 yr

Reach	River Sta	Profile	Q Total (cfs)	Min Ch El (ft)	Invert Slope	W.S. Elev (ft)	Crit W.S. (ft)	E.G. Elev (ft)	E.G. Slope (ft/ft)	Max Chl Dpth (ft)	Hydr Depth C (ft)	Flow Area (sq ft)	Top Width (ft)	Vel Chnl (ft/s)	Froude # Chl	Shear Chan (lb/sq ft)
North Finger	294	5 yr	26.70	7360.96	0.0484	7361.44	7361.44	7361.56	0.070692	0.48	0.24	9.41	38.89	2.84	1.02	1.07
North Finger	245	5 yr	26.70	7358.61	0.0269	7359.46	7359.40	7359.55	0.018066	0.85	0.60	12.44	42.32	2.63	0.60	0.68
North Finger	200	5 yr	26.70	7357.41	0.2036	7358.18	7358.18	7358.32	0.045972	0.77	0.38	9.28	33.04	3.07	0.88	1.08
North Finger	167	5 yr	26.70	7350.70	0.0848	7351.30	7351.79	7353.96	0.997117	0.60	0.34	2.04	6.08	13.09	3.98	20.46
North Finger	147	5 yr	26.70	7349.03	0.0769	7349.94	7349.95	7350.22	0.059512	0.91	0.51	6.28	12.24	4.25	1.05	1.87
North Finger	98	5 yr	26.70	7345.29	0.0455	7346.23	7346.03	7346.33	0.020303	0.94	0.52	10.59	20.28	2.52	0.62	0.65
North Finger	49	5 yr	26.70	7343.08	0.0000	7344.42	7344.42	7344.78	0.054450	1.34	0.67	5.61	8.34	4.76	1.02	2.17
Main Channel - U	1415	5 yr	9.00	7372.29	0.0358	7372.62	7372.62	7372.71	0.077707	0.33	0.18	3.63	19.69	2.48	1.02	0.89
Main Channel - U	1383	5 yr	9.00	7371.15	0.0359	7371.62	7371.50	7371.66	0.016929	0.47	0.28	5.90	21.19	1.52	0.51	0.29
Main Channel - U	1326	5 yr	9.00	7369.10	0.8662	7369.70	7369.70	7369.81	0.085131	0.60	0.19	3.40	17.77	2.65	1.07	1.01
Main Channel - U	1315	5 yr	9.00	7360.17	0.1454	7360.50	7361.04	7367.49	5.806384	0.33	0.19	0.42	2.21	21.21	8.53	65.57
Main Channel - U	1296	5 yr	9.00	7357.35	0.1111	7357.66	7357.71	7357.87	0.109464	0.31	0.26	2.44	9.25	3.69	1.27	1.76
Main Channel - U	1284	5 yr	9.00	7356.02	0.0703	7356.52	7356.54	7356.66	0.091178	0.50	0.22	3.01	13.85	2.99	1.13	1.23
Main Channel - U	1235	5 yr	9.00	7352.55	0.0541	7352.88	7352.83	7352.93	0.029593	0.33	0.22	5.18	23.20	1.74	0.65	0.41
Main Channel - U	1185	5 yr	9.00	7349.88	0.0403	7350.51	7350.51	7350.62	0.083419	0.63	0.19	3.44	17.98	2.62	1.06	0.99
Main Channel - U	1136	5 yr	9.00	7347.89	0.0283	7348.55	7348.40	7348.61	0.018748	0.66	0.39	4.50	11.52	2.00	0.56	0.45
Main Channel - U	1087	5 yr	9.00	7346.49	0.0413	7346.87	7346.87	7346.97	0.073851	0.38	0.20	3.49	17.20	2.58	1.01	0.93
Main Channel - U	1037	5 yr	9.00	7344.45	0.0243	7345.25	7345.02	7345.29	0.011822	0.80	0.39	5.69	14.61	1.58	0.45	0.28
Main Channel - U	988	5 yr	9.00	7343.25	0.0476	7344.02	7343.95	7344.16	0.039336	0.77	0.43	2.96	6.90	3.04	0.82	1.02
Main Channel-M	938	5 yr	18.40	7340.90	0.0277	7341.13	7341.48	7344.47	3.940852	0.23	0.14	1.26	9.00	14.66	6.92	34.21
Main Channel-M	889	5 yr	18.40	7339.53	0.0004	7340.69	7340.20	7340.73	0.005226	1.16	0.75	11.38	15.23	1.62	0.33	0.24
Main Channel-M	840	5 yr	18.40	7339.51	0.0310	7340.23		7340.29	0.018394	0.72	0.43	8.73	20.46	2.11	0.57	0.49
Main Channel-M	790	5 yr	18.40	7337.98	0.0328	7338.56	7338.56	7338.76	0.061291	0.58	0.39	5.13	13.29	3.59	1.02	1.46
Main Channel-M	741	5 yr	18.40	7336.36	0.0289	7337.18	7337.00	7337.23	0.014528	0.82	0.41	10.05	24.38	1.83	0.50	0.37
Main Channel-M	691	5 yr	18.40	7334.93	0.0682	7335.71	7335.71	7335.94	0.057189	0.78	0.45	4.78	10.52	3.85	1.01	1.60
Main Channel-M	642	5 yr	18.40	7331.56	0.0136	7332.74	7332.55	7332.89	0.023320	1.18	0.65	5.99	9.24	3.07	0.67	0.91
Main Channel-M	593	5 yr	18.40	7330.89	0.0209	7332.07		7332.14	0.010153	1.18	0.65	8.95	13.70	2.06	0.45	0.40
Main Channel-M	543	5 yr	18.40	7329.86	0.0075	7331.33		7331.43	0.021678	1.47	0.52	7.18	13.74	2.56	0.62	0.68
Main Channel-M	494	5 yr	18.40	7329.49	0.0117	7330.53	7330.34	7330.59	0.013699	1.04	0.43	10.16	23.82	1.81	0.49	0.36
Main Channel-M	444	5 yr	18.40	7328.91	0.0395	7329.44	7329.37	7329.54	0.036175	0.52	0.35	7.07	20.06	2.60	0.77	0.79
Main Channel-M	395	5 yr	18.40	7326.96	0.0271	7327.76		7327.88	0.031010	0.80	0.44	6.60	14.96	2.79	0.74	0.85
Main Channel-M	346	5 yr	18.40	7325.62	0.0117	7326.74		7326.85	0.014974	1.12	0.72	6.99	9.71	2.63	0.55	0.65
Main Channel-M	310	5 yr	18.40	7325.20	0.0098	7326.17	7325.67	7326.21	0.004205	0.97	0.79	12.27	15.55	1.50	0.30	0.20
South Finger	336	5 yr	2.60	7356.94	0.0839	7357.10	7357.10	7357.14	0.079709	0.16	0.08	1.81	22.87	1.43	0.90	0.39
South Finger	288	5 yr	2.60	7352.93	0.3933	7353.20	7353.20	7353.25	0.088920	0.27	0.10	1.43	13.59	1.82	0.99	0.58
South Finger	265	5 yr	2.60	7343.83	0.0377	7344.11	7344.43	7346.92	3.246218	0.27	0.16	0.19	1.24	13.45	6.00	28.63
South Finger	240	5 yr	2.60	7342.90	0.1082	7343.21	7343.21	7343.30	0.074080	0.31	0.18	1.08	5.88	2.41	0.99	0.84
South Finger	192	5 yr	2.60	7337.73	0.0948	7337.92	7337.96	7338.06	0.178616	0.19	0.13	0.89	7.00	2.93	1.45	1.41
South Finger	144	5 yr	2.60	7333.20	0.0789	7333.70	7333.70	7333.84	0.071620	0.50	0.27	0.87	3.17	2.99	1.01	1.16
South Finger	81	5 yr	2.60	7328.22	0.0298	7328.68	7328.57	7328.71	0.018226	0.46	0.24	1.84	7.75	1.41	0.51	0.27
South Finger	48	5 yr	2.60	7327.25	0.0000	7327.53	7327.53	7327.62	0.080571	0.28	0.16	1.12	6.88	2.32	1.01	0.81
Main Channel-L	247	5 yr	25.60	7324.66	0.0205	7325.12	7325.46	7327.41	1.673051	0.46	0.20	2.11	10.54	12.13	4.78	20.78
Main Channel-L	198	5 yr	25.60	7323.65	0.0300	7324.31	7324.31	7324.53	0.057820	0.66	0.44	6.78	15.52	3.78	1.01	1.56
Main Channel-L	148	5 yr	25.60	7322.17	0.0227	7322.84	7322.70	7322.92	0.018080	0.67	0.45	11.84	26.27	2.16	0.57	0.50
Main Channel-L	99	5 yr	25.60	7321.05	0.0354	7321.71		7321.80	0.028644	0.66	0.38	10.47	27.35	2.44	0.70	0.68
Main Channel-L	49	5 yr	25.60	7319.30	0.0456	7319.80	7319.78	7319.95	0.051849	0.50	0.33	8.50	25.43	3.01	0.92	1.08
Main Channel-L	0	5 yr	25.60	7317.05		7317.76	7317.68	7317.91	0.033394	0.71	0.48	8.39	17.61	3.05	0.78	0.99



HEC-RAS Plan: Default Scenario River: South Reach: Main Channel Profile: 5 yr

Reach	River Sta	Profile	Q Total (cfs)	Min Ch El (ft)	Invert Slope	W.S. Elev (ft)	Crit W.S. (ft)	E.G. Elev (ft)	E.G. Slope (ft/ft)	Max Chl Dpth (ft)	Hydr Depth C (ft)	Flow Area (sq ft)	Top Width (ft)	Vel Chnl (ft/s)	Froude # Chl	Shear Chan (lb/sq ft)
Main Channel	1300	5 yr	0.70	7421.22	0.0742	7421.30	7421.30	7421.32	0.133292	0.08	0.04	0.55	12.28	1.27	1.06	0.37
Main Channel	1250	5 yr	0.70	7417.51	0.0560	7417.64	7417.62	7417.66	0.035805	0.13	0.07	0.77	10.63	0.91	0.59	0.16
Main Channel	1218	5 yr	0.70	7415.73	0.5834	7415.91	7415.91	7415.95	0.090315	0.18	0.09	0.44	5.01	1.60	0.96	0.48
Main Channel	1200	5 yr	0.70	7405.10	0.1232	7405.20	7405.36	7406.70	4.834030	0.10	0.07	0.07	1.06	9.81	6.67	19.69
Main Channel	1167	5 yr	0.70	7400.98	0.1480	7401.24	7401.24	7401.30	0.067546	0.26	0.14	0.36	2.52	1.93	0.90	0.59
Main Channel	1150	5 yr	0.70	7398.53	0.0610	7398.71	7398.78	7398.94	0.466640	0.18	0.09	0.18	1.95	3.81	2.19	2.66
Main Channel	1100	5 yr	0.70	7395.48	0.0366	7395.75	7395.73	7395.80	0.063303	0.27	0.14	0.39	2.83	1.81	0.87	0.53
Main Channel	1050	5 yr	0.70	7393.65	0.0340	7394.04	7393.96	7394.07	0.021506	0.39	0.21	0.52	2.52	1.35	0.52	0.26
Main Channel	1000	5 yr	0.70	7391.95	0.0436	7392.07	7392.07	7392.12	0.090469	0.12	0.09	0.43	5.02	1.61	0.97	0.49
Main Channel	950	5 yr	0.70	7389.77	0.0806	7389.98	7389.97	7390.02	0.070420	0.21	0.11	0.41	3.60	1.71	0.89	0.50
Main Channel	900	5 yr	0.70	7385.74	0.0532	7385.91	7385.91	7385.95	0.095495	0.16	0.09	0.41	4.53	1.71	1.00	0.54
Main Channel	850	5 yr	0.70	7383.08	0.0252	7383.52	7383.42	7383.54	0.020618	0.44	0.20	0.54	2.64	1.30	0.51	0.24
Main Channel	800	5 yr	5.00	7381.82	0.0370	7382.36		7382.40	0.023223	0.54	0.28	2.82	10.10	1.77	0.59	0.40
Main Channel	750	5 yr	5.00	7379.97	0.0270	7380.54	7380.53	7380.68	0.056171	0.57	0.31	1.71	5.56	2.92	0.93	1.05
Main Channel	700	5 yr	5.00	7378.62	0.0246	7379.28	7379.16	7379.31	0.015667	0.66	0.30	3.27	10.91	1.53	0.49	0.29
Main Channel	650	5 yr	5.00	7377.39	0.0234	7377.88	7377.85	7377.98	0.054489	0.49	0.24	2.01	8.24	2.49	0.89	0.82
Main Channel	600	5 yr	5.00	7376.22	0.0262	7376.68	7376.55	7376.71	0.014314	0.46	0.22	4.19	19.12	1.19	0.45	0.19
Main Channel	550	5 yr	5.00	7374.91	0.0672	7375.23	7375.23	7375.32	0.073843	0.32	0.18	2.08	11.39	2.40	0.99	0.84
Main Channel	500	5 yr	5.00	7371.55	0.0328	7372.14	7372.11	7372.27	0.051398	0.59	0.32	1.75	5.50	2.86	0.89	1.00
Main Channel	450	5 yr	5.00	7369.91	0.0124	7370.73		7370.79	0.018630	0.82	0.40	2.53	6.36	1.97	0.55	0.44
Main Channel	400	5 yr	5.00	7369.29	0.0070	7370.05		7370.09	0.010806	0.76	0.42	3.17	7.57	1.58	0.43	0.28
Main Channel	350	5 yr	5.00	7368.94	0.0224	7369.35	7369.24	7369.38	0.019077	0.41	0.23	3.49	15.09	1.43	0.52	0.28
Main Channel	300	5 yr	5.00	7367.82	0.0214	7368.32		7368.36	0.021901	0.50	0.24	3.18	13.22	1.57	0.56	0.33
Main Channel	250	5 yr	5.00	7366.75	0.0266	7367.06		7367.10	0.029435	0.31	0.22	2.94	13.54	1.70	0.64	0.40
Main Channel	200	5 yr	5.00	7365.42	0.0238	7365.73	7365.68	7365.74	0.024770	0.31	0.12	4.66	37.72	1.07	0.54	0.19
Main Channel	150	5 yr	5.00	7364.23	0.0284	7364.66	7364.59	7364.68	0.018326	0.43	0.14	4.88	33.75	1.03	0.48	0.17
Main Channel	100	5 yr	5.00	7362.81	0.0306	7363.03	7363.03	7363.08	0.068687	0.22	0.11	2.95	25.80	1.70	0.89	0.49
Main Channel	50	5 yr	5.00	7361.28	0.0172	7361.60	7361.51	7361.62	0.016025	0.32	0.18	4.53	25.39	1.10	0.46	0.18
Main Channel	0	5 yr	5.00	7360.42		7360.62	7360.57	7360.63	0.024996	0.19	0.11	4.86	42.35	1.03	0.53	0.18

HEC-RAS Plan: Default Scenario Profile: 100 yr

Reach	River Sta	Profile	Q Total	Min Ch El	Invert Slope	W.S. Elev	Crit W.S.	E.G. Elev	E.G. Slope	Max Chl Dpth	Hydr Depth C	Flow Area	Top Width	Vel Chnl	Froude # Chl	Shear Chan
			(cfs)	(ft)		(ft)	(ft)	(ft)	(ft/ft)	(ft)	(ft)	(sq ft)	(ft)	(ft/s)		(lb/sq ft)
North Finger	294	100 yr	59.60	7360.96	0.0484	7361.62	7361.62	7361.80	0.063519	0.66	0.35	17.19	48.54	3.47	1.03	1.40
North Finger	245	100 yr	59.60	7358.61	0.0269	7359.49	7359.59	7359.85	0.070478	0.88	0.63	13.70	43.55	5.36	1.19	2.76
North Finger	200	100 yr	59.60	7357.41	0.2036	7358.40	7358.40	7358.56	0.032525	0.99	0.58	20.09	56.86	3.43	0.80	1.17
North Finger	167	100 yr	59.60	7350.70	0.0848	7351.56	7352.28	7355.22	0.826696	0.86	0.49	3.89	7.89	15.33	3.85	24.76
North Finger	147	100 yr	59.60	7349.03	0.0769	7350.22	7350.34	7350.78	0.075797	1.19	0.72	9.97	13.91	5.98	1.24	3.32
North Finger	98	100 yr	59.60	7345.29	0.0455	7346.65	7346.37	7346.77	0.017321	1.36	0.70	21.00	29.86	2.84	0.60	0.75
North Finger	49	100 yr	59.60	7343.08	0.0000	7344.94	7344.94	7345.44	0.047368	1.86	0.98	10.52	10.76	5.66	1.01	2.72
Main Channel - U	1415	100 yr	57.20	7372.29	0.0358	7373.08	7373.03	7373.25	0.040219	0.79	0.47	17.18	36.57	3.33	0.86	1.18
Main Channel - U	1383	100 yr	57.20	7371.15	0.0359	7372.06	7371.95	7372.23	0.028458	0.91	0.63	17.92	36.18	3.29	0.73	1.04
Main Channel - U	1326	100 yr	57.20	7369.10	0.8662	7370.16	7370.16	7370.37	0.040792	1.06	0.58	16.15	40.05	3.85	0.89	1.47
Main Channel - U	1315	100 yr	57.20	7360.17	0.1454	7361.13	7362.20	7368.43	1.482109	0.96	0.57	2.64	4.61	21.67	5.05	48.13
Main Channel - U	1296	100 yr	57.20	7357.35	0.1111	7358.11	7358.43	7359.15	0.171531	0.76	0.63	7.01	11.16	8.16	1.82	6.49
Main Channel - U	1284	100 yr	57.20	7356.02	0.0703	7356.89	7356.99	7357.28	0.116086	0.87	0.39	11.50	29.58	4.97	1.41	2.80
Main Channel - U	1235	100 yr	57.20	7352.55	0.0541	7353.29	7353.23	7353.51	0.039039	0.74	0.59	15.10	25.73	3.79	0.87	1.42
Main Channel - U	1185	100 yr	57.20	7349.88	0.0403	7350.98	7350.97	7351.26	0.053657	1.10	0.55	13.51	24.66	4.23	1.01	1.81
Main Channel - U	1136	100 yr	57.20	7347.89	0.0283	7349.22	7349.07	7349.44	0.028483	1.33	0.76	15.40	20.15	3.71	0.75	1.25
Main Channel - U	1087	100 yr	57.20	7346.49	0.0413	7347.34	7347.34	7347.63	0.053468	0.85	0.55	13.39	24.19	4.27	1.01	1.84
Main Channel - U	1037	100 yr	57.20	7344.45	0.0243	7346.11	7345.64	7346.23	0.010208	1.66	1.05	20.24	19.20	2.83	0.49	0.65
Main Channel - U	988	100 yr	57.20	7343.25	0.0476	7344.80	7344.80	7345.25	0.048411	1.55	0.87	10.63	12.33	5.38	1.02	2.53
Main Channel-M	938	100 yr	117.20	7340.90	0.0277	7341.67	7342.39	7345.14	0.671180	0.77	0.54	7.85	14.42	14.93	3.57	22.57
Main Channel-M	889	100 yr	117.20	7339.53	0.0004	7341.71	7341.19	7341.95	0.013092	2.18	1.44	29.82	20.68	3.93	0.58	1.14
Main Channel-M	840	100 yr	117.20	7339.51	0.0310	7341.02		7341.18	0.017556	1.51	0.86	35.82	41.87	3.27	0.62	0.93
Main Channel-M	790	100 yr	117.20	7337.98	0.0328	7339.40	7339.40	7339.80	0.048656	1.42	0.77	23.10	29.91	5.07	1.02	2.32
Main Channel-M	741	100 yr	117.20	7336.36	0.0289	7338.12	7337.66	7338.25	0.011749	1.76	1.00	39.62	39.78	2.96	0.52	0.72
Main Channel-M	691	100 yr	117.20	7334.93	0.0682	7336.69	7336.69	7337.19	0.046012	1.76	0.95	20.74	21.79	5.65	1.02	2.69
Main Channel-M	642	100 yr	117.20	7331.56	0.0136	7334.09	7333.78	7334.42	0.022215	2.53	1.23	25.46	20.69	4.60	0.73	1.65
Main Channel-M	593	100 yr	117.20	7330.89	0.0209	7333.15		7333.45	0.017108	2.26	1.40	26.73	19.14	4.38	0.65	1.44
Main Channel-M	543	100 yr	117.20	7329.86	0.0075	7332.23		7332.43	0.023918	2.37	0.79	32.68	41.30	3.59	0.71	1.16
Main Channel-M	494	100 yr	117.20	7329.49	0.0117	7331.44		7331.58	0.012321	1.94	1.02	38.21	37.40	3.07	0.54	0.77
Main Channel-M	444	100 yr	117.20	7328.91	0.0395	7330.08	7330.08	7330.50	0.046134	1.17	0.82	22.68	27.53	5.17	1.00	2.35
Main Channel-M	395	100 yr	117.20	7326.96	0.0271	7329.00	7328.51	7329.16	0.011099	2.04	1.21	35.96	29.73	3.26	0.52	0.83
Main Channel-M	346	100 yr	117.20	7325.62	0.0117	7327.93	7327.67	7328.35	0.025289	2.31	1.35	22.61	16.70	5.18	0.79	2.04
Main Channel-M	310	100 yr	117.20	7325.20	0.0098	7327.49		7327.65	0.006941	2.29	1.66	37.40	22.52	3.13	0.43	0.69
South Finger	336	100 yr	16.70	7356.94	0.0839	7357.28	7357.28	7357.38	0.071844	0.34	0.20	6.60	32.78	2.53	0.99	0.90
South Finger	288	100 yr	16.70	7352.93	0.3933	7353.41	7353.43	7353.55	0.089296	0.48	0.22	5.55	25.02	3.01	1.13	1.23
South Finger	265	100 yr	16.70	7343.83	0.0377	7344.55	7345.17	7348.09	1.235348	0.72	0.39	1.11	2.83	15.08	4.25	26.71
South Finger	240	100 yr	16.70	7342.90	0.1082	7343.60	7343.60	7343.81	0.059221	0.70	0.42	4.52	10.89	3.69	1.01	1.51
South Finger	192	100 yr	16.70	7337.73	0.0948	7338.16	7338.33	7338.72	0.239629	0.42	0.30	2.76	9.06	6.05	1.93	4.51
South Finger	144	100 yr	16.70	7333.20	0.0789	7334.30	7334.30	7334.61	0.054495	1.10	0.62	3.75	6.56	4.48	1.00	1.98
South Finger	81	100 yr	16.70	7328.22	0.0298	7329.13	7328.96	7329.22	0.019590	0.91	0.52	6.78	13.08	2.46	0.60	0.63
South Finger	48	100 yr	16.70	7327.25	0.0000	7327.93	7327.93	7328.18	0.058710	0.67	0.49	4.13	8.51	4.05	1.02	1.73
Main Channel-L	247	100 yr	163.10	7324.66	0.0205	7325.82	7326.38	7327.99	0.340236	1.16	0.64	13.80	21.63	11.82	2.61	13.43
Main Channel-L	198	100 yr	163.10	7323.65	0.0300	7325.32	7325.32	7325.92	0.039618	1.67	1.24	26.37	23.00	6.23	0.99	3.00
Main Channel-L	148	100 yr	163.10	7322.17	0.0227	7323.81	7323.46	7324.07	0.016603	1.64	1.26	39.87	31.57	4.09	0.64	1.28
Main Channel-L	99	100 yr	163.10	7321.05	0.0354	7322.39	7322.36	7322.84	0.040336	1.34	0.97	30.46	31.47	5.35	0.96	2.40
Main Channel-L	49	100 yr	163.10	7319.30	0.0456	7320.61	7320.53	7320.96	0.035054	1.31	0.88	34.44	38.92	4.74	0.89	1.93
Main Channel-L	0	100 yr	163.10	7317.05		7318.73	7318.65	7319.25	0.033411	1.68	1.25	28.27	22.92	5.77	0.91	2.57

HEC-RAS Plan: Default Scenario River: South Reach: Main Channel Profile: 100 yr

Reach	River Sta	Profile	Q Total (cfs)	Min Ch El (ft)	Invert Slope	W.S. Elev (ft)	Crit W.S. (ft)	E.G. Elev (ft)	E.G. Slope (ft/ft)	Max Chl Dpth (ft)	Hydr Depth C (ft)	Flow Area (sq ft)	Top Width (ft)	Vel Chnl (ft/s)	Froude # Chl	Shear Chan (lb/sq ft)
Main Channel	1300	100 yr	4.20	7421.22	0.0742	7421.38	7421.38	7421.42	0.119687	0.16	0.07	2.66	39.51	1.58	1.07	0.50
Main Channel	1250	100 yr	4.20	7417.51	0.0560	7417.80	7417.74	7417.82	0.031469	0.29	0.13	3.35	25.70	1.25	0.61	0.26
Main Channel	1218	100 yr	4.20	7415.73	0.5834	7416.08	7416.08	7416.12	0.108512	0.35	0.08	2.59	34.00	1.62	1.03	0.51
Main Channel	1200	100 yr	4.20	7405.10	0.1232	7405.34	7405.67	7408.98	4.670802	0.24	0.14	0.27	2.03	15.31	7.34	38.08
Main Channel	1167	100 yr	4.20	7400.98	0.1480	7401.52	7401.52	7401.68	0.071418	0.54	0.30	1.30	4.32	3.22	1.03	1.29
Main Channel	1150	100 yr	4.20	7398.53	0.0610	7398.92	7399.08	7399.43	0.333063	0.39	0.22	0.73	3.27	5.72	2.13	4.49
Main Channel	1100	100 yr	4.20	7395.48	0.0366	7396.13	7396.00	7396.19	0.020806	0.65	0.33	2.24	6.79	1.87	0.57	0.42
Main Channel	1050	100 yr	4.20	7393.65	0.0340	7394.28	7394.27	7394.45	0.067519	0.63	0.33	1.29	3.88	3.27	1.00	1.30
Main Channel	1000	100 yr	4.20	7391.95	0.0436	7392.34		7392.39	0.027100	0.39	0.25	2.33	9.18	1.81	0.63	0.43
Main Channel	950	100 yr	4.20	7389.77	0.0806	7390.20	7390.20	7390.31	0.070288	0.43	0.23	1.54	6.61	2.74	1.00	1.01
Main Channel	900	100 yr	4.20	7385.74	0.0532	7386.07	7386.10	7386.21	0.096832	0.33	0.20	1.42	6.98	2.95	1.15	1.22
Main Channel	850	100 yr	4.20	7383.08	0.0252	7384.03	7383.74	7384.07	0.009450	0.95	0.46	2.74	5.93	1.53	0.40	0.26
Main Channel	800	100 yr	30.00	7381.82	0.0370	7382.90		7383.06	0.022556	1.08	0.70	9.35	13.88	3.22	0.68	0.97
Main Channel	750	100 yr	30.00	7379.97	0.0270	7381.14	7381.14	7381.47	0.047678	1.17	0.69	6.58	10.75	4.62	0.98	2.01
Main Channel	700	100 yr	30.00	7378.62	0.0246	7379.83	7379.60	7379.97	0.017077	1.21	0.79	10.00	13.54	3.02	0.60	0.82
Main Channel	650	100 yr	30.00	7377.39	0.0234	7378.35	7378.34	7378.57	0.052744	0.96	0.46	7.96	17.15	3.77	0.98	1.52
Main Channel	600	100 yr	30.00	7376.22	0.0262	7377.09		7377.18	0.016160	0.87	0.59	12.31	20.89	2.44	0.56	0.59
Main Channel	550	100 yr	30.00	7374.91	0.0672	7375.62	7375.61	7375.81	0.055567	0.71	0.40	8.59	21.70	3.49	0.98	1.37
Main Channel	500	100 yr	30.00	7371.55	0.0328	7372.74	7372.74	7373.07	0.053334	1.19	0.64	6.51	10.22	4.61	1.02	2.06
Main Channel	450	100 yr	30.00	7369.91	0.0124	7371.54	7371.21	7371.66	0.015514	1.63	0.78	10.58	13.49	2.84	0.56	0.73
Main Channel	400	100 yr	30.00	7369.29	0.0070	7370.68		7370.83	0.018138	1.39	0.76	9.89	13.03	3.03	0.61	0.84
Main Channel	350	100 yr	30.00	7368.94	0.0224	7369.79		7369.89	0.018888	0.85	0.55	11.84	21.50	2.53	0.60	0.65
Main Channel	300	100 yr	30.00	7367.82	0.0214	7368.81		7368.93	0.019767	0.99	0.60	10.95	18.20	2.74	0.62	0.74
Main Channel	250	100 yr	30.00	7366.75	0.0266	7367.48	7367.42	7367.58	0.038764	0.73	0.32	11.84	36.89	2.53	0.79	0.77
Main Channel	200	100 yr	30.00	7365.42	0.0238	7365.96		7366.02	0.025435	0.54	0.30	15.15	49.84	1.98	0.63	0.48
Main Channel	150	100 yr	30.00	7364.23	0.0284	7364.93	7364.81	7364.97	0.017339	0.70	0.30	18.49	61.66	1.62	0.52	0.32
Main Channel	100	100 yr	30.00	7362.81	0.0306	7363.26	7363.26	7363.42	0.067954	0.45	0.30	9.35	31.20	3.21	1.03	1.27
Main Channel	50	100 yr	30.00	7361.28	0.0172	7361.96	7361.80	7362.00	0.010962	0.68	0.36	20.73	58.18	1.45	0.43	0.24
Main Channel	0	100 yr	30.00	7360.42		7360.76	7360.76	7360.86	0.072638	0.34	0.19	12.05	61.87	2.49	1.00	0.88

HEC-RAS Model Plan: Default Scenario 1/14/2025

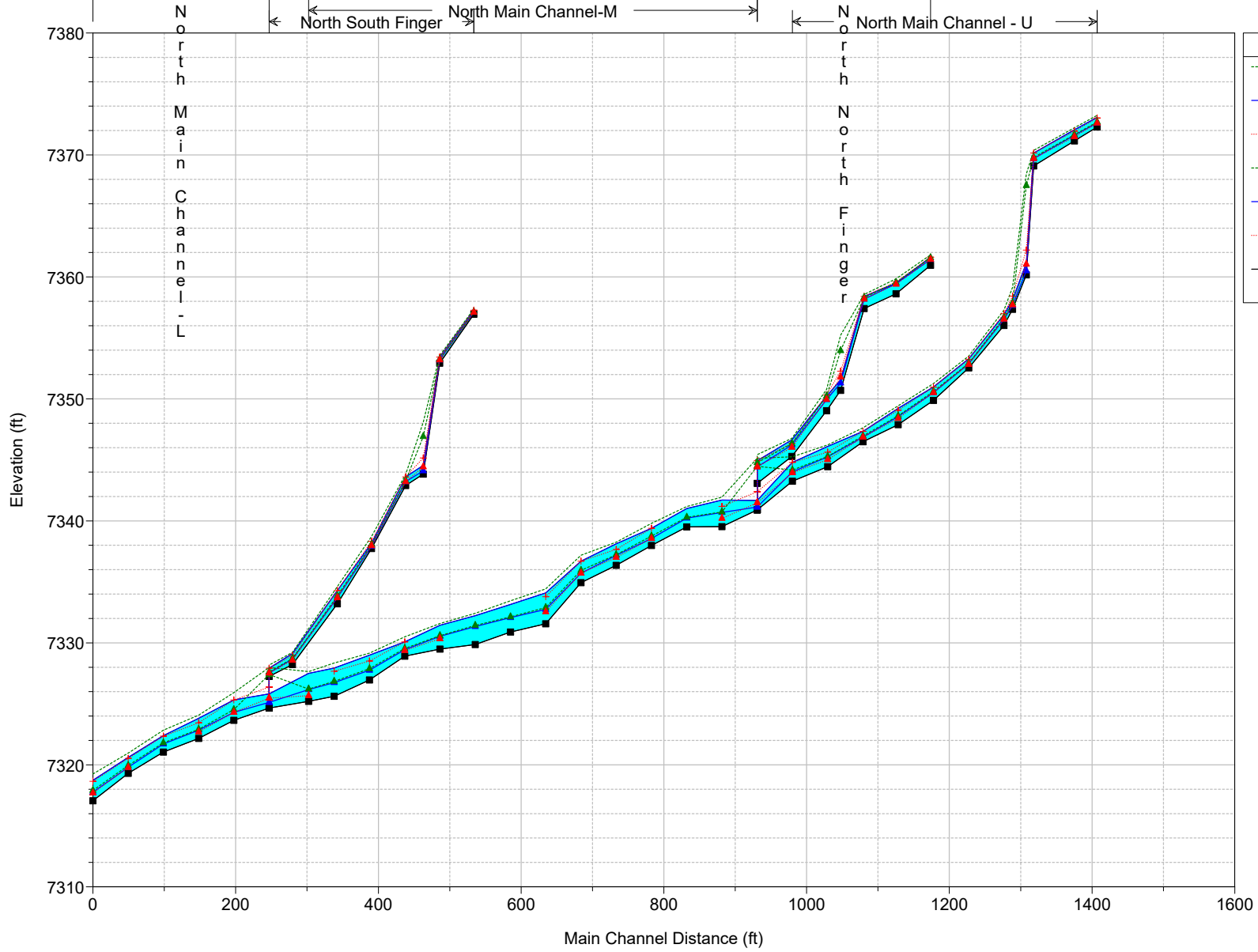

Legend	
EG 100 yr	(dotted green line)
WS 100 yr	(solid blue line)
Crit 100 yr	(dotted red line)
EG 5 yr	(dotted green line)
WS 5 yr	(solid blue line)
Crit 5 yr	(dotted red line)
Ground	(solid black line with square markers)

South Main Channel

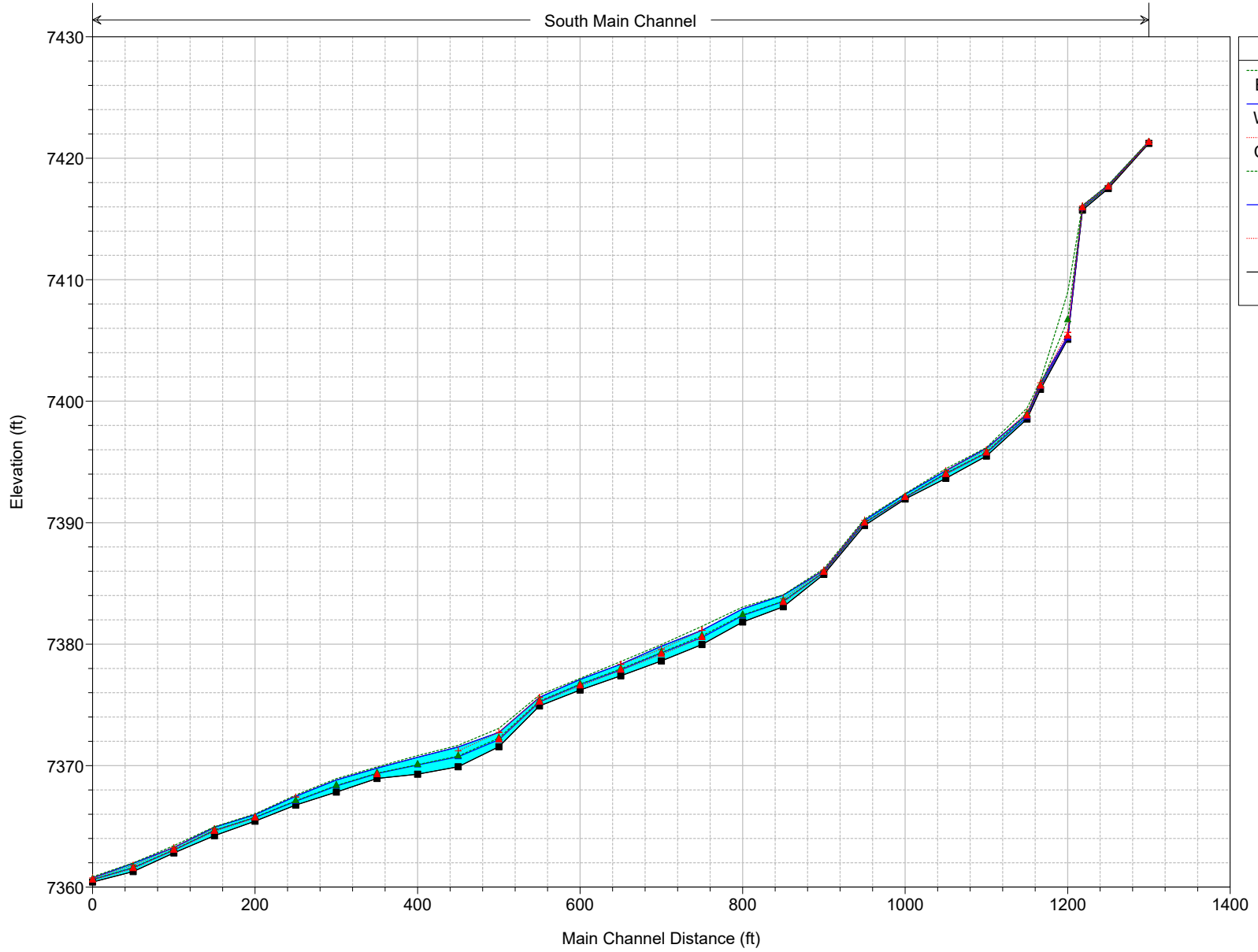

Legend	
EG 100 yr	—
WS 100 yr	—
Crit 100 yr	—
EG 5 yr	—
WS 5 yr	—
Crit 5 yr	—
Ground	—

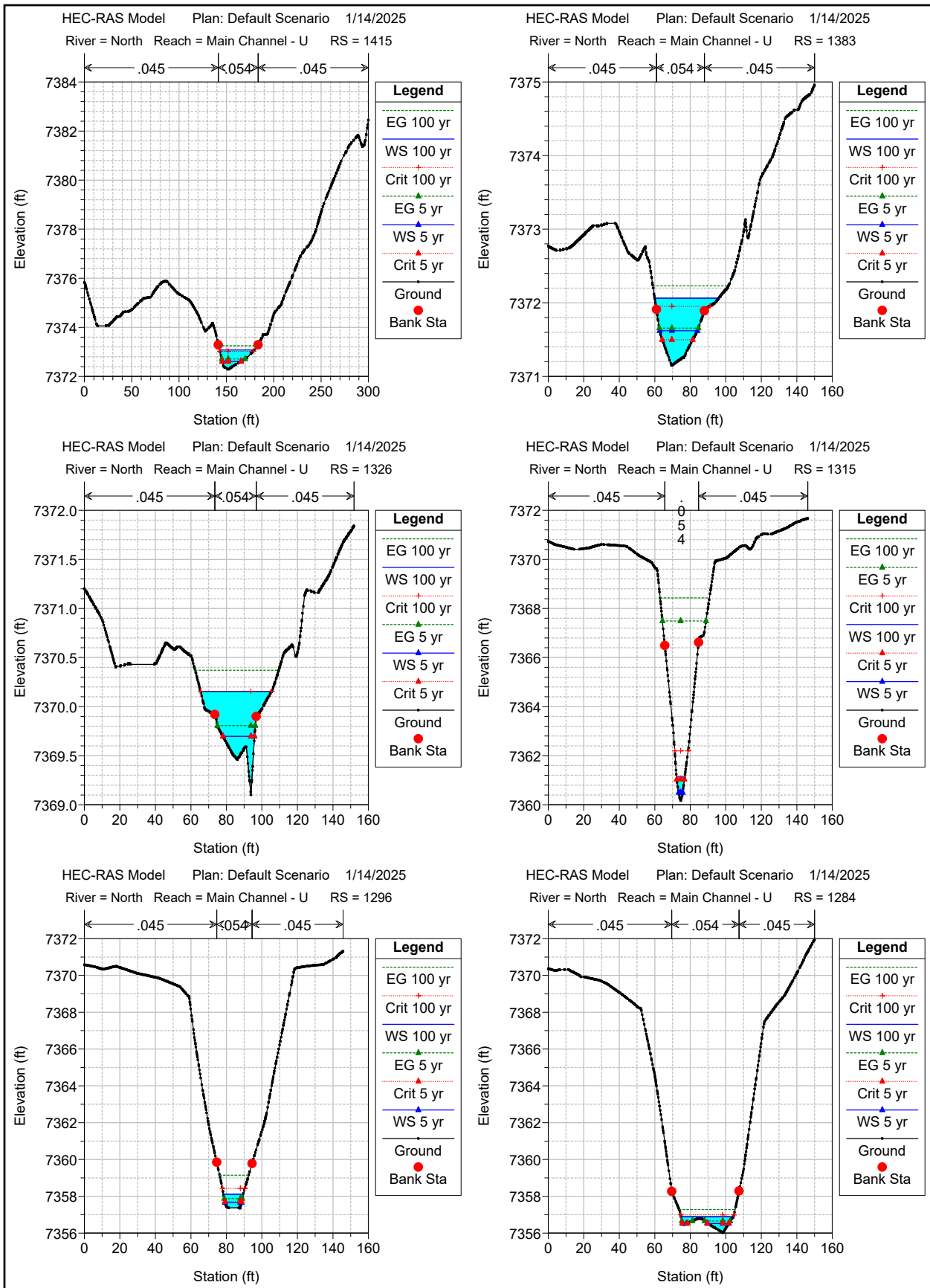

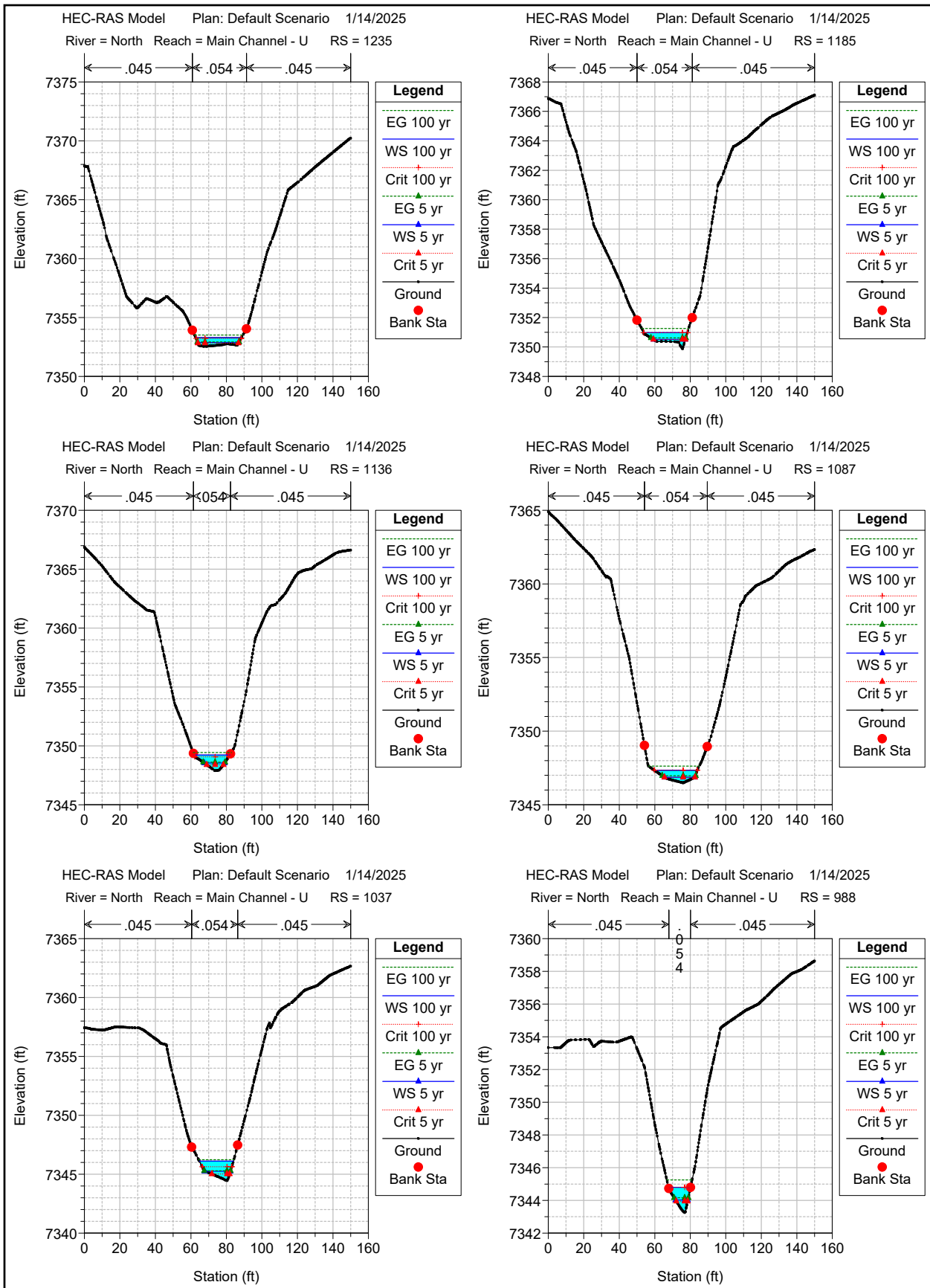

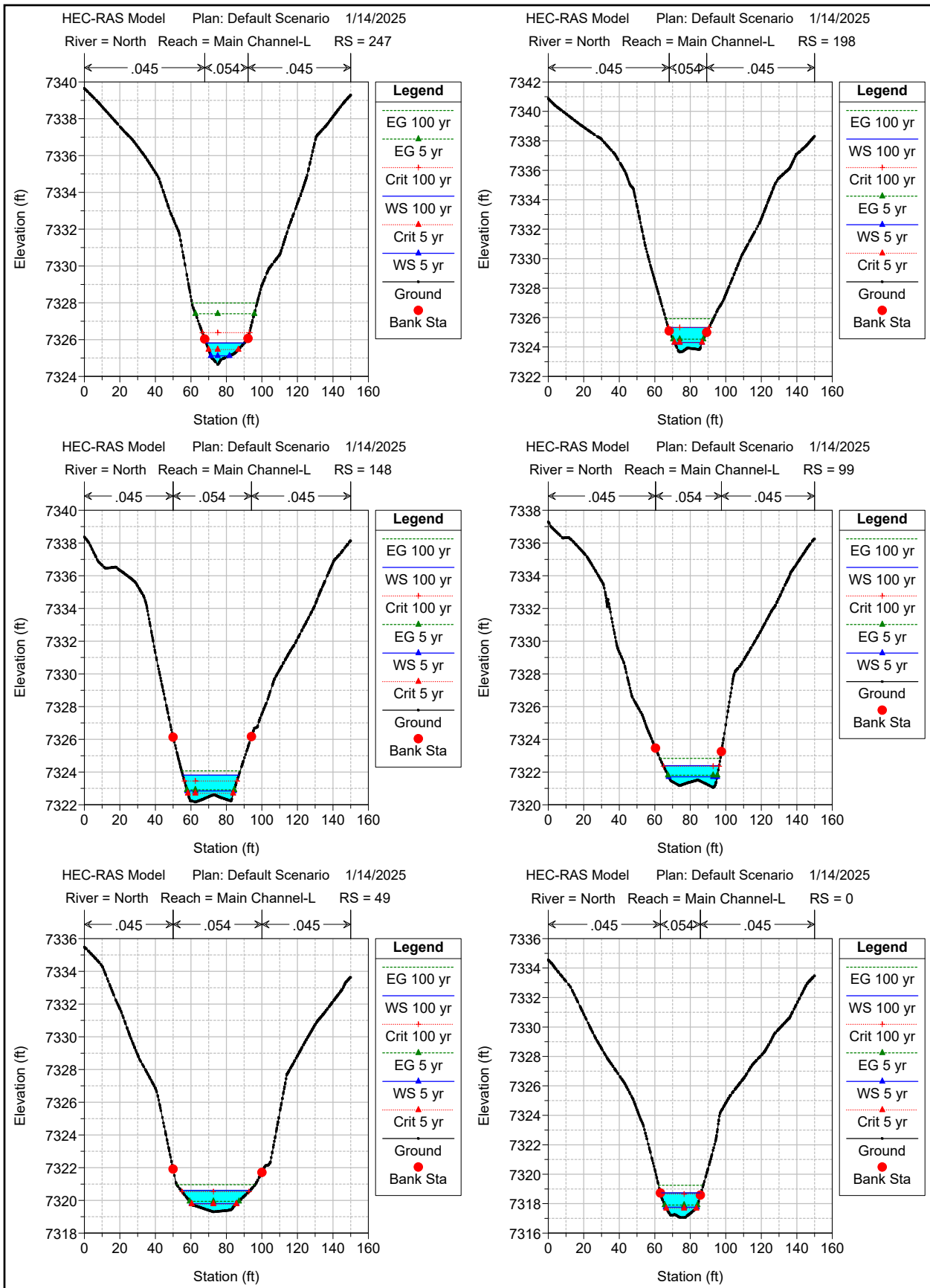



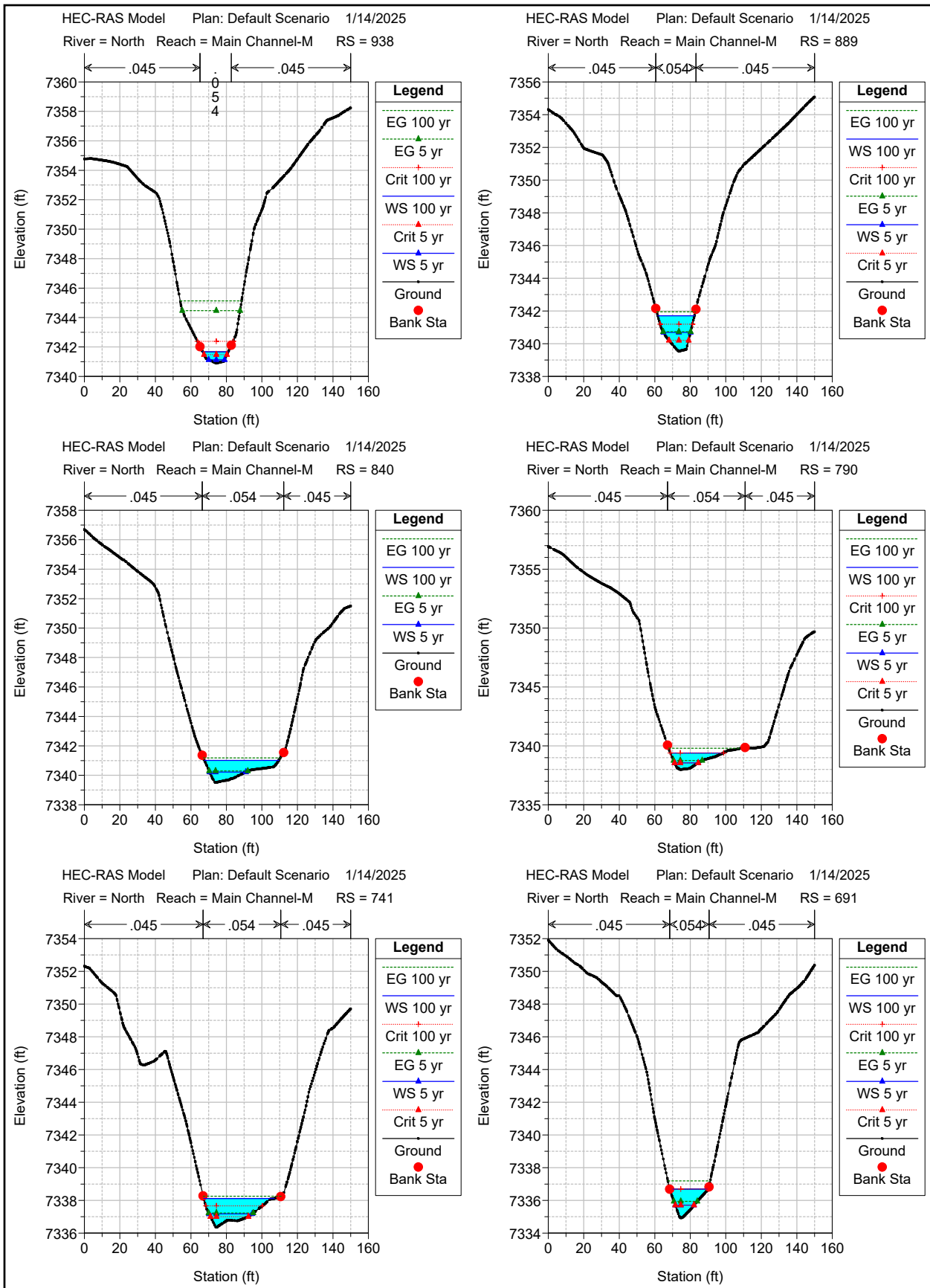

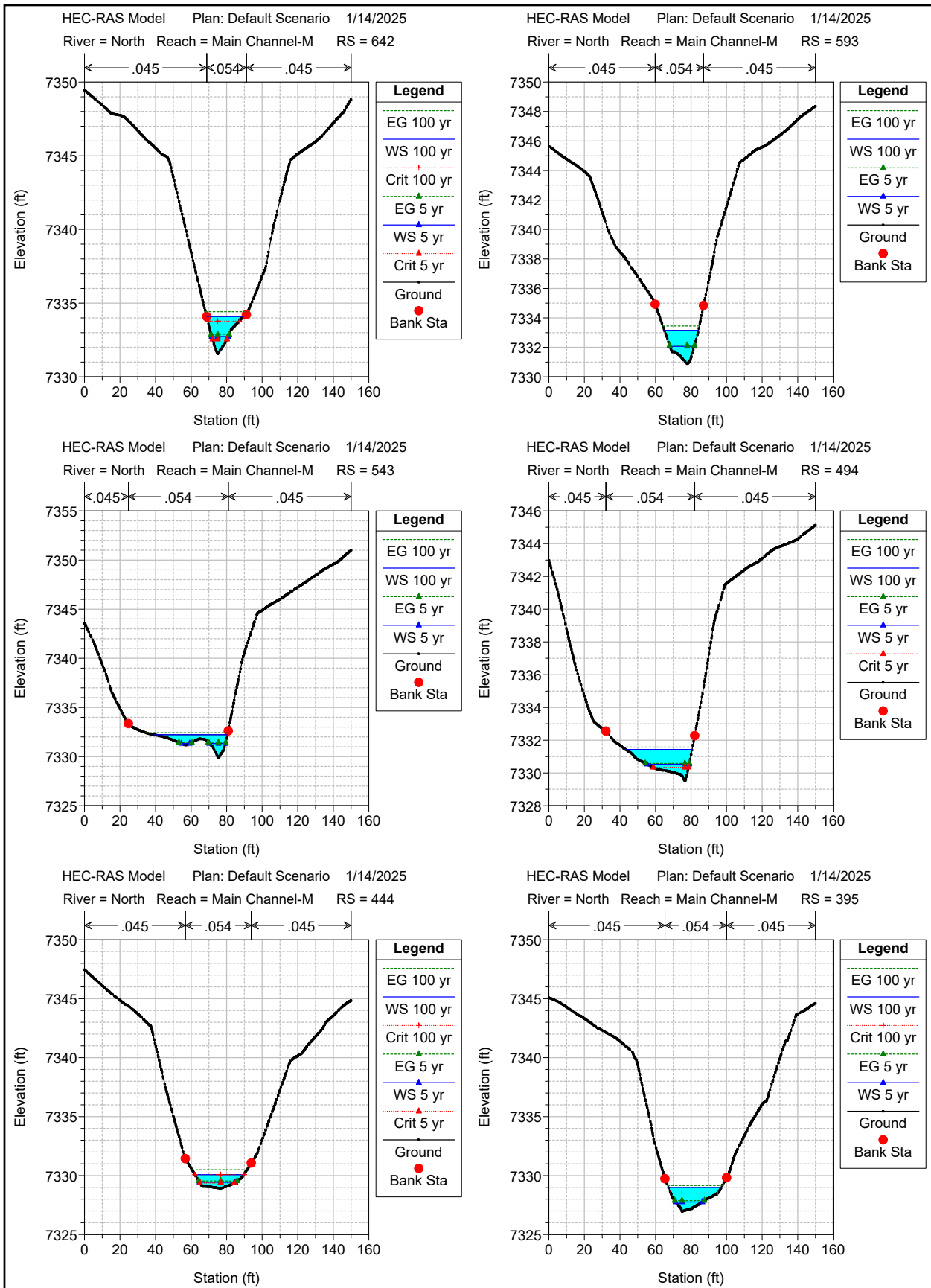

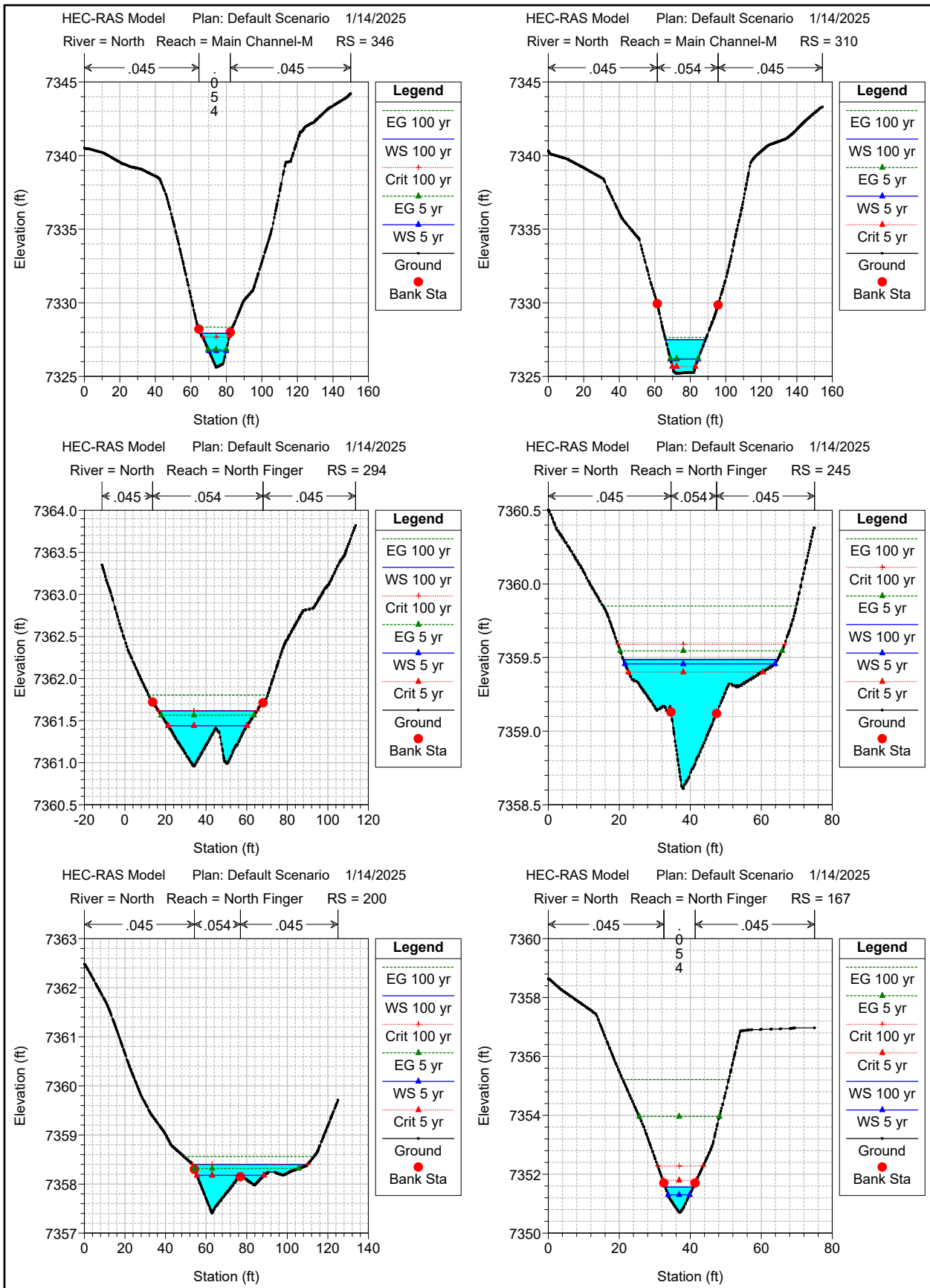

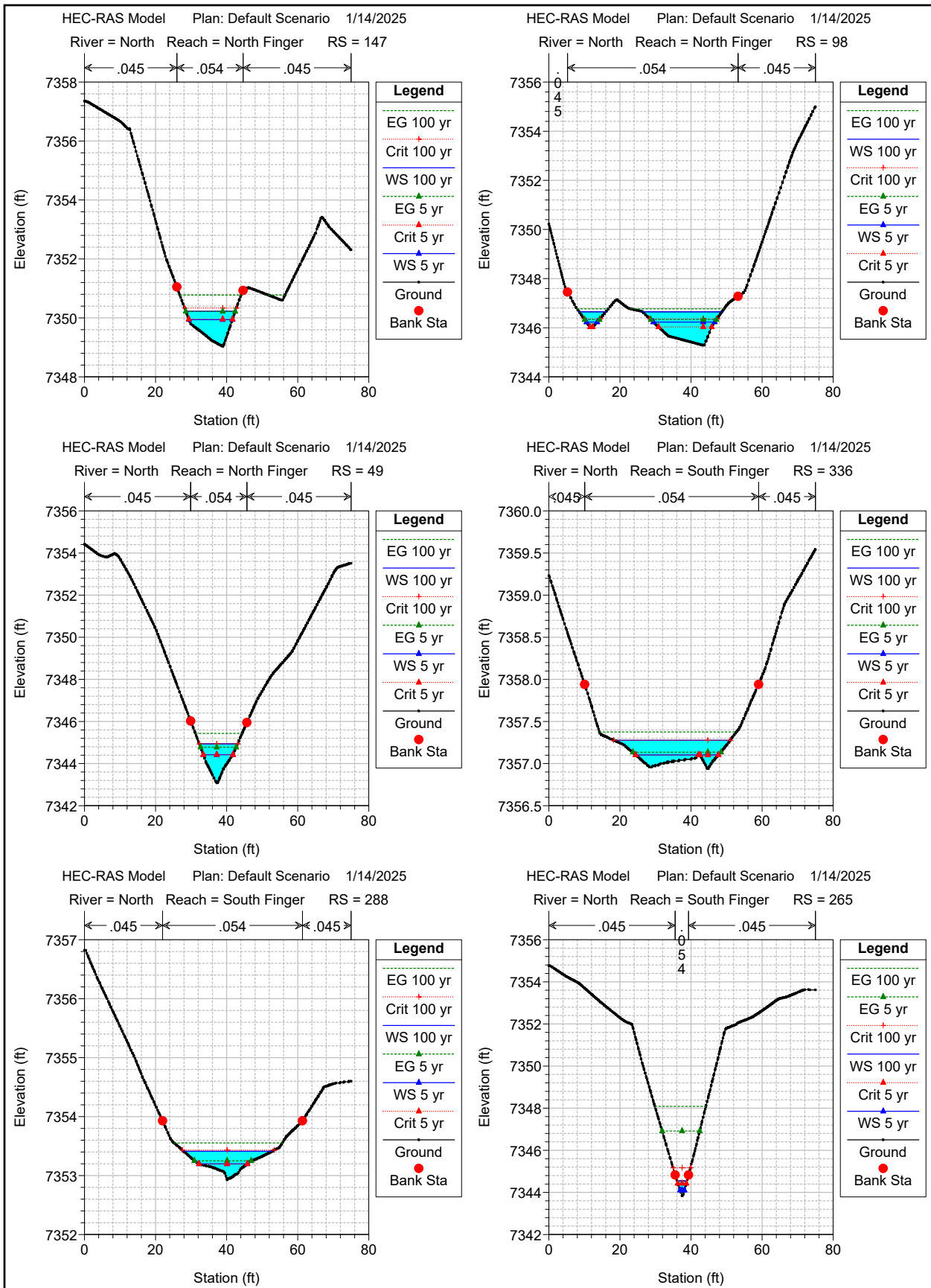

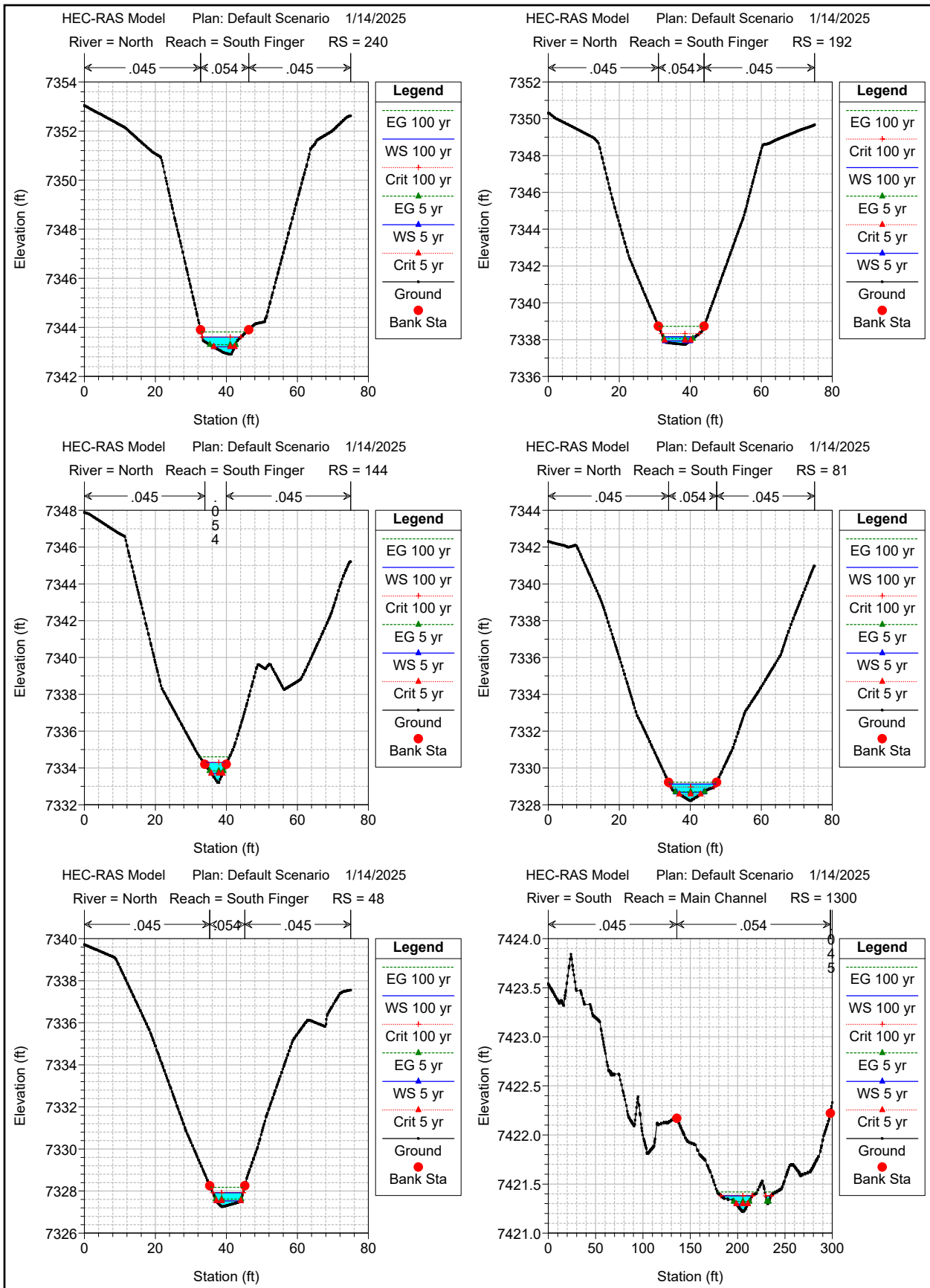

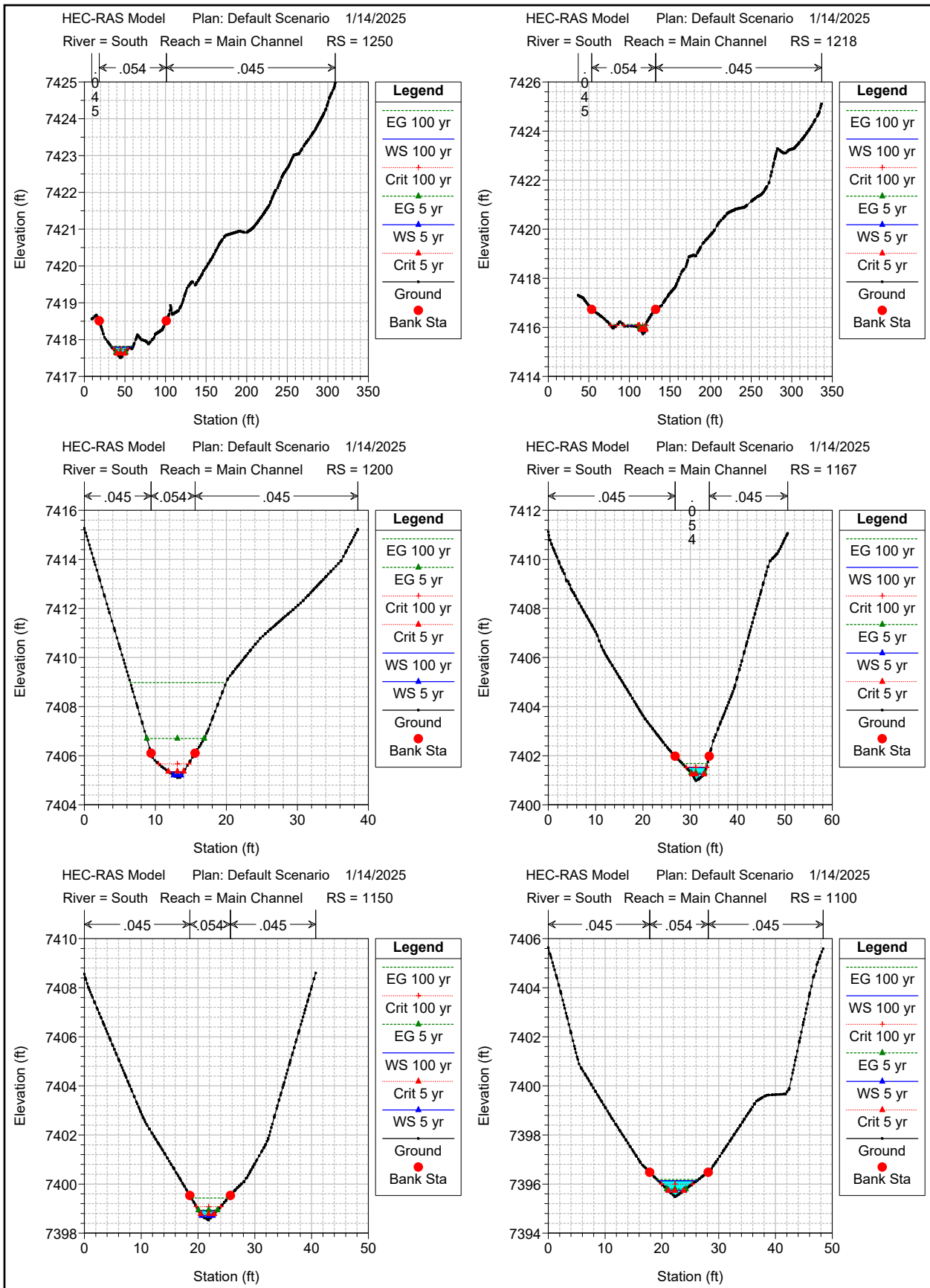

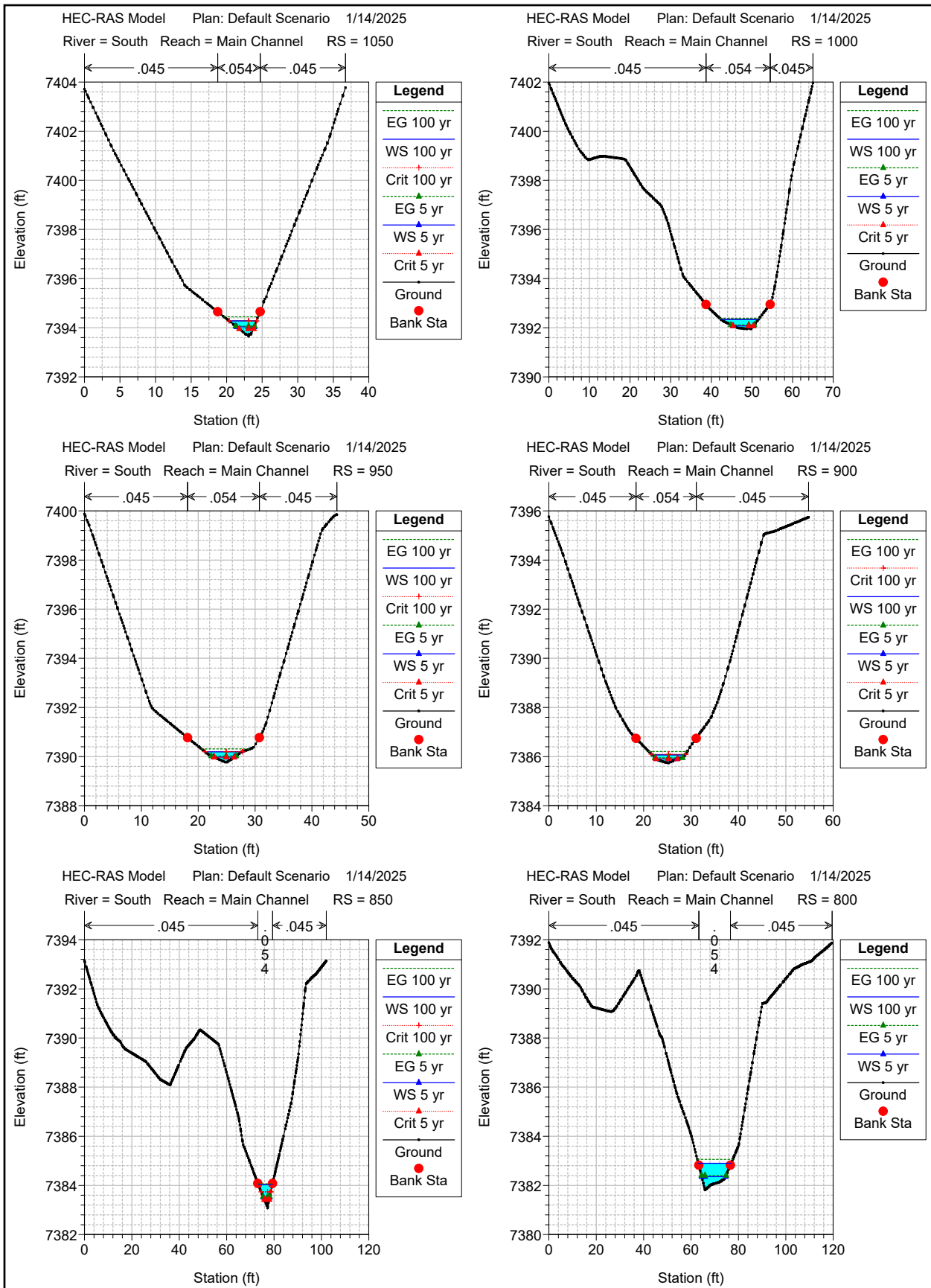

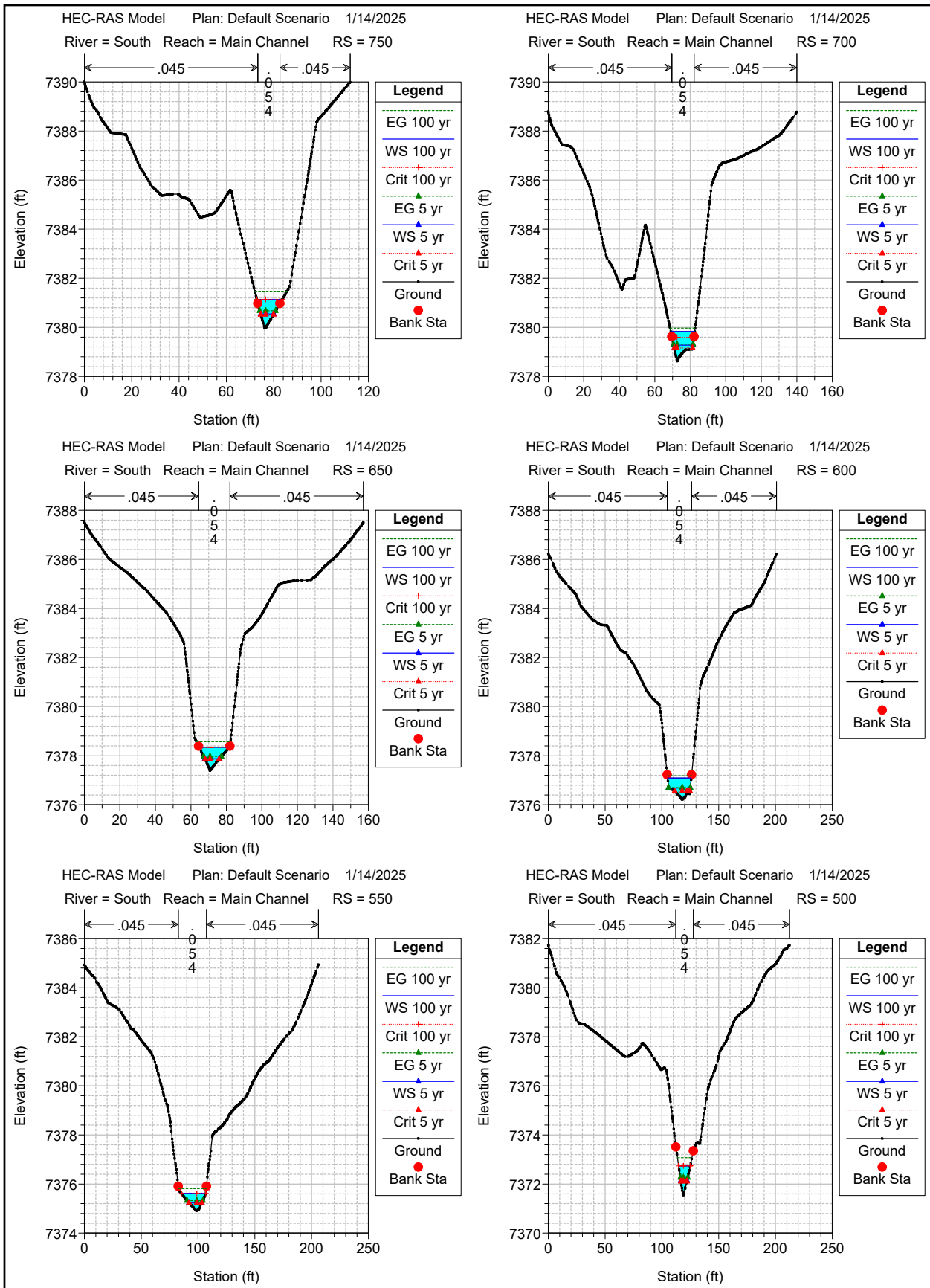



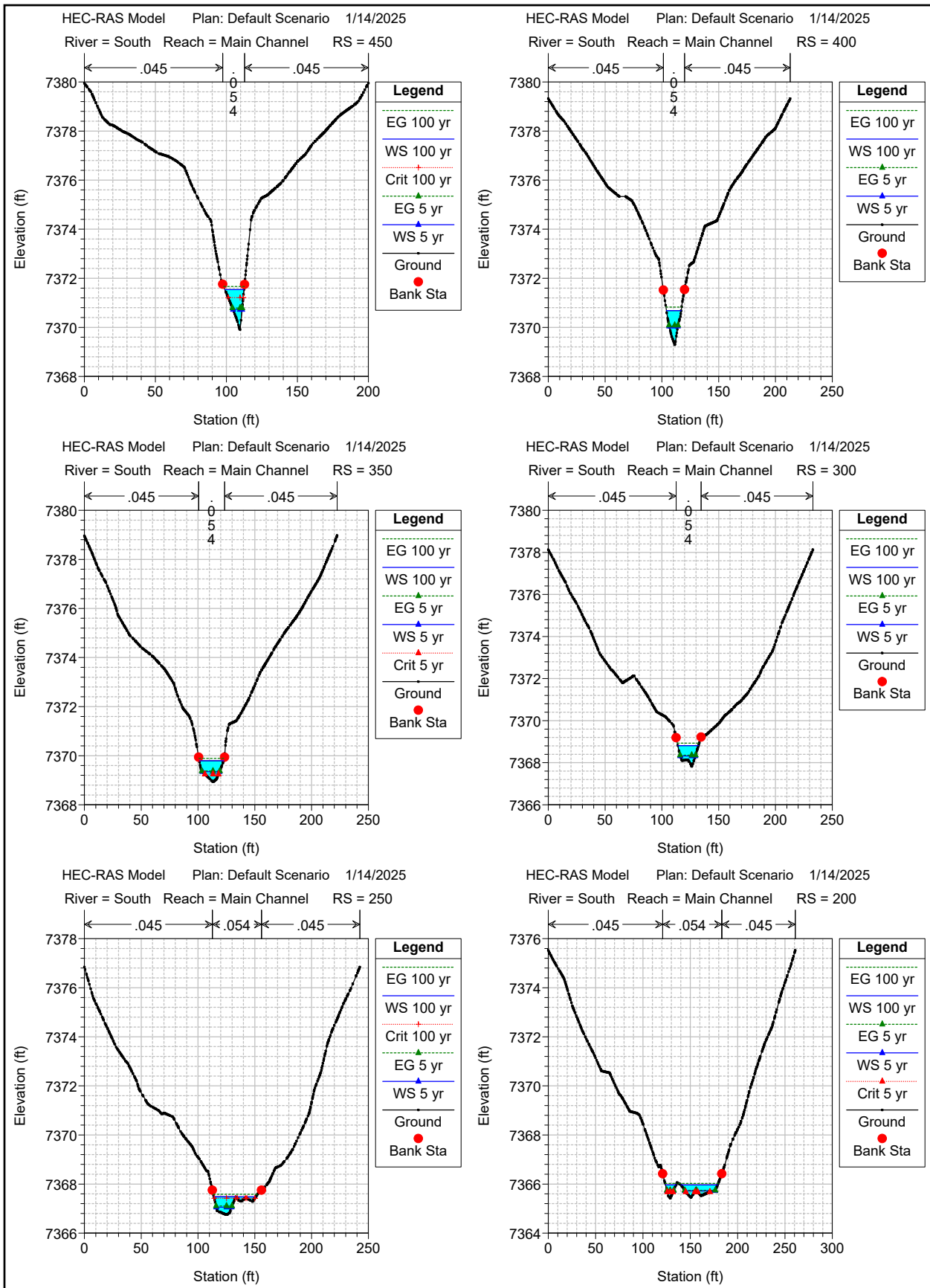

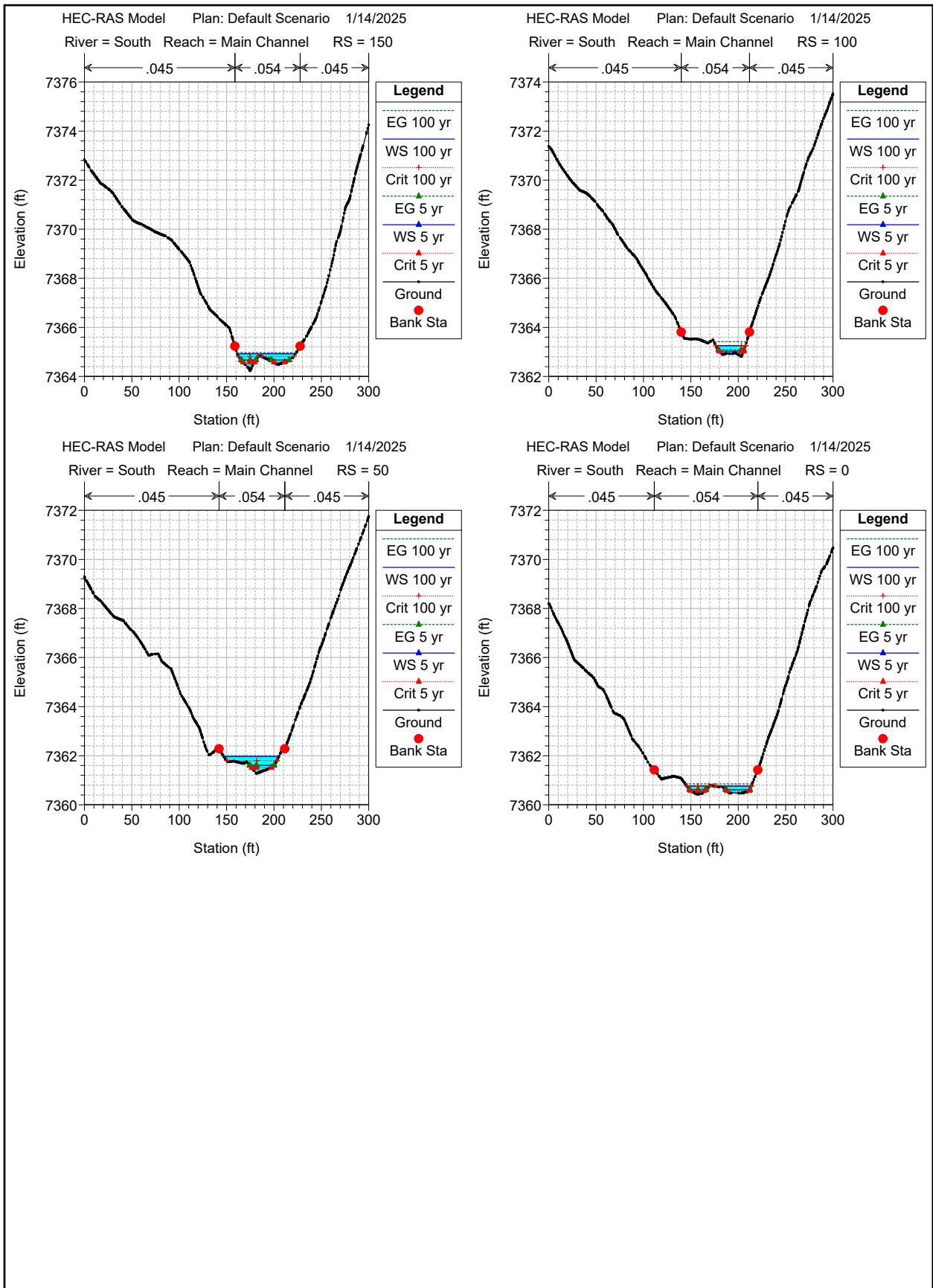

HEC-RAS HEC-RAS 5.0.7 March 2019  
U.S. Army Corps of Engineers  
Hydrologic Engineering Center  
609 Second Street  
Davis, California

```
X  X XXXXXX  XXXX  XXXX  XX  XXXX
X  X X      X  X  X  X  X  X
X  X X      X  X  X  X  X  X
XXXXXXXX XXXX  X  XXX XXXX XXXXXX XXXX
X  X X      X  X  X  X  X  X
X  X X      X  X  X  X  X  X
X  X XXXXXX  XXXX  X  X  X  X XXXXX
```

PROJECT DATA

Project Title: HEC-RAS Model  
Project File : 61223-Existing.prj  
Run Date and Time: 1/14/2025 10:27:46 AM

Project in English units

Project Description:

CRS Info=<SpatialReference> <CoordinateSystem Code="2232"  
Unit="US\_survey\_Foot" AcadCode="C083-CF" /></SpatialReference>

PLAN DATA

Plan Title: Default Scenario  
Plan File : C:\Users\tomw\Desktop\GEOHECRAS Projects\61223-Existing.p01

Geometry Title: Default Geometry  
Geometry File : C:\Users\tomw\Desktop\GEOHECRAS Projects\61223-Existing.g01

Flow Title : Default Steady Flow  
Flow File : C:\Users\tomw\Desktop\GEOHECRAS Projects\61223-Existing.f01

Plan Description:

Default Scenario

Plan Summary Information:

Number of:	Cross Sections =	76	Multiple Openings =	0
	Culverts =	0	Inline Structures =	0
	Bridges =	0	Lateral Structures =	0

Computational Information

Water surface calculation tolerance =	0.01
Critical depth calculation tolerance =	0.01
Maximum number of iterations =	20
Maximum difference tolerance =	0.33
Flow tolerance factor =	0.001

Computation Options

Critical depth computed only where necessary  
 Conveyance Calculation Method: At breaks in n values only  
 Friction Slope Method: Average Conveyance  
 Computational Flow Regime: Mixed Flow

FLOW DATA

Flow Title: Default Steady Flow  
 Flow File : C:\Users\tomw\Desktop\GEOHECRAS Projects\61223-Existing.f01

Flow Data (cfs)

River	Reach	RS	100 yr	5 yr
South	Main Channel	1300	4.2	.7
South	Main Channel	800	30	5
North	Main Channel - U1415		57.2	9
North	Main Channel-L	247	163.1	25.6
North	Main Channel-M	938	117.2	18.4
North	North Finger	294	59.6	26.7
North	South Finger	336	16.7	2.6

Boundary Conditions

River	Reach	Profile	Upstream	Downstream
North	Main Channel - U	100 yr	Normal S = 0.02	
North	Main Channel - U	5 yr	Normal S = 0.02	
North	Main Channel-L	100 yr		Normal S = 0.033408
North	Main Channel-L	5 yr		Normal S = 0.033408
North	North Finger	100 yr	Normal S = 0.035	
North	North Finger	5 yr	Normal S = 0.035	
North	South Finger	100 yr	Normal S = 0.038	
North	South Finger	5 yr	Normal S = 0.038	
South	Main Channel	100 yr	Normal S = 0.01	Normal S = 0.025
South	Main Channel	5 yr	Normal S = 0.01	Normal S = 0.025

SUMMARY OF MANNING'S N VALUES

River:North

Reach	River Sta.	n1	n2	n3
Main Channel - U	1415	.045	.054	.045
Main Channel - U	1383	.045	.054	.045
Main Channel - U	1326	.045	.054	.045
Main Channel - U	1315	.045	.054	.045
Main Channel - U	1296	.045	.054	.045
Main Channel - U	1284	.045	.054	.045
Main Channel - U	1235	.045	.054	.045
Main Channel - U	1185	.045	.054	.045
Main Channel - U	1136	.045	.054	.045
Main Channel - U	1087	.045	.054	.045
Main Channel - U	1037	.045	.054	.045
Main Channel - U	988	.045	.054	.045

Main Channel-L	247	.045	.054	.045
Main Channel-L	198	.045	.054	.045
Main Channel-L	148	.045	.054	.045
Main Channel-L	99	.045	.054	.045
Main Channel-L	49	.045	.054	.045
Main Channel-L	0	.045	.054	.045
Main Channel-M	938	.045	.054	.045
Main Channel-M	889	.045	.054	.045
Main Channel-M	840	.045	.054	.045
Main Channel-M	790	.045	.054	.045
Main Channel-M	741	.045	.054	.045
Main Channel-M	691	.045	.054	.045
Main Channel-M	642	.045	.054	.045
Main Channel-M	593	.045	.054	.045
Main Channel-M	543	.045	.054	.045
Main Channel-M	494	.045	.054	.045
Main Channel-M	444	.045	.054	.045
Main Channel-M	395	.045	.054	.045
Main Channel-M	346	.045	.054	.045
Main Channel-M	310	.045	.054	.045
North Finger	294	.045	.054	.045
North Finger	245	.045	.054	.045
North Finger	200	.045	.054	.045
North Finger	167	.045	.054	.045
North Finger	147	.045	.054	.045
North Finger	98	.045	.054	.045
North Finger	49	.045	.054	.045
South Finger	336	.045	.054	.045
South Finger	288	.045	.054	.045
South Finger	265	.045	.054	.045
South Finger	240	.045	.054	.045
South Finger	192	.045	.054	.045
South Finger	144	.045	.054	.045
South Finger	81	.045	.054	.045
South Finger	48	.045	.054	.045

River:South

Reach	River Sta.	n1	n2	n3
Main Channel	1300	.045	.054	.045
Main Channel	1250	.045	.054	.045
Main Channel	1218	.045	.054	.045
Main Channel	1200	.045	.054	.045
Main Channel	1167	.045	.054	.045
Main Channel	1150	.045	.054	.045
Main Channel	1100	.045	.054	.045
Main Channel	1050	.045	.054	.045
Main Channel	1000	.045	.054	.045
Main Channel	950	.045	.054	.045
Main Channel	900	.045	.054	.045
Main Channel	850	.045	.054	.045
Main Channel	800	.045	.054	.045
Main Channel	750	.045	.054	.045
Main Channel	700	.045	.054	.045
Main Channel	650	.045	.054	.045
Main Channel	600	.045	.054	.045
Main Channel	550	.045	.054	.045
Main Channel	500	.045	.054	.045
Main Channel	450	.045	.054	.045

Main Channel	400	.045	.054	.045
Main Channel	350	.045	.054	.045
Main Channel	300	.045	.054	.045
Main Channel	250	.045	.054	.045
Main Channel	200	.045	.054	.045
Main Channel	150	.045	.054	.045
Main Channel	100	.045	.054	.045
Main Channel	50	.045	.054	.045
Main Channel	0	.045	.054	.045

SUMMARY OF REACH LENGTHS

River: North

Reach	River Sta.	Left	Channel	Right
Main Channel - U	1415	31.89	31.89	31.89
Main Channel - U	1383	57.11	57.11	57.11
Main Channel - U	1326	10.31	10.31	10.31
Main Channel - U	1315	19.39	19.39	19.39
Main Channel - U	1296	11.97	11.97	11.97
Main Channel - U	1284	49.39	49.39	49.39
Main Channel - U	1235	49.39	49.39	49.39
Main Channel - U	1185	49.39	49.39	49.39
Main Channel - U	1136	49.39	49.39	49.39
Main Channel - U	1087	49.39	49.39	49.39
Main Channel - U	1037	49.39	49.39	49.39
Main Channel - U	988	49.39	49.39	49.39
Main Channel-L	247	49.39	49.39	49.39
Main Channel-L	198	49.39	49.39	49.39
Main Channel-L	148	49.39	49.39	49.39
Main Channel-L	99	49.39	49.39	49.39
Main Channel-L	49	49.39	49.39	49.39
Main Channel-L	0	0	0	0
Main Channel-M	938	49.39	49.39	49.39
Main Channel-M	889	49.39	49.39	49.39
Main Channel-M	840	49.39	49.39	49.39
Main Channel-M	790	49.39	49.39	49.39
Main Channel-M	741	49.39	49.39	49.39
Main Channel-M	691	49.39	49.39	49.39
Main Channel-M	642	49.39	49.39	49.39
Main Channel-M	593	49.39	49.39	49.39
Main Channel-M	543	49.39	49.39	49.39
Main Channel-M	494	49.39	49.39	49.39
Main Channel-M	444	49.39	49.39	49.39
Main Channel-M	395	49.39	49.39	49.39
Main Channel-M	346	35.93	35.93	35.93
Main Channel-M	310	0	0	0
North Finger	294	48.52	48.52	48.52
North Finger	245	44.56	44.56	44.56
North Finger	200	32.95	32.95	32.95
North Finger	167	19.7	19.7	19.7
North Finger	147	48.6	48.6	48.6
North Finger	98	48.6	48.6	48.6
North Finger	49	48.6	48.6	48.6
South Finger	336	47.8	47.8	47.8
South Finger	288	23.14	23.14	23.14
South Finger	265	24.66	24.66	24.66

South Finger	240	47.8	47.8	47.8
South Finger	192	47.8	47.8	47.8
South Finger	144	63.09	63.09	63.09
South Finger	81	32.51	32.51	32.51
South Finger	48	47.8	47.8	47.8

River: South

Reach	River Sta.	Left	Channel	Right
Main Channel	1300	50	50	50
Main Channel	1250	31.78	31.78	31.78
Main Channel	1218	18.22	18.22	18.22
Main Channel	1200	33.44	33.44	33.44
Main Channel	1167	16.56	16.56	16.56
Main Channel	1150	50	50	50
Main Channel	1100	50	50	50
Main Channel	1050	50	50	50
Main Channel	1000	50	50	50
Main Channel	950	50	50	50
Main Channel	900	50	50	50
Main Channel	850	50	50	50
Main Channel	800	50	50	50
Main Channel	750	50	50	50
Main Channel	700	50	50	50
Main Channel	650	50	50	50
Main Channel	600	50	50	50
Main Channel	550	50	50	50
Main Channel	500	50	50	50
Main Channel	450	50	50	50
Main Channel	400	50	50	50
Main Channel	350	50	50	50
Main Channel	300	50	50	50
Main Channel	250	50	50	50
Main Channel	200	50	50	50
Main Channel	150	50	50	50
Main Channel	100	50	50	50
Main Channel	50	50	50	50
Main Channel	0	0	0	0

SUMMARY OF CONTRACTION AND EXPANSION COEFFICIENTS

River: North

Reach	River Sta.	Contr.	Expan.
Main Channel - U	1415	.1	.3
Main Channel - U	1383	.1	.3
Main Channel - U	1326	.1	.3
Main Channel - U	1315	.1	.3
Main Channel - U	1296	.1	.3
Main Channel - U	1284	.1	.3
Main Channel - U	1235	.1	.3
Main Channel - U	1185	.1	.3
Main Channel - U	1136	.1	.3
Main Channel - U	1087	.1	.3
Main Channel - U	1037	.1	.3

Main Channel - U	988	.1	.3
Main Channel-L	247	.1	.3
Main Channel-L	198	.1	.3
Main Channel-L	148	.1	.3
Main Channel-L	99	.1	.3
Main Channel-L	49	.1	.3
Main Channel-L	0	.1	.3
Main Channel-M	938	.1	.3
Main Channel-M	889	.1	.3
Main Channel-M	840	.1	.3
Main Channel-M	790	.1	.3
Main Channel-M	741	.1	.3
Main Channel-M	691	.1	.3
Main Channel-M	642	.1	.3
Main Channel-M	593	.1	.3
Main Channel-M	543	.1	.3
Main Channel-M	494	.1	.3
Main Channel-M	444	.1	.3
Main Channel-M	395	.1	.3
Main Channel-M	346	.1	.3
Main Channel-M	310	.1	.3
North Finger	294	.1	.3
North Finger	245	.1	.3
North Finger	200	.1	.3
North Finger	167	.1	.3
North Finger	147	.1	.3
North Finger	98	.1	.3
North Finger	49	.1	.3
South Finger	336	.1	.3
South Finger	288	.1	.3
South Finger	265	.1	.3
South Finger	240	.1	.3
South Finger	192	.1	.3
South Finger	144	.1	.3
South Finger	81	.1	.3
South Finger	48	.1	.3

River: South

Reach	River Sta.	Contr.	Expan.
Main Channel	1300	.1	.3
Main Channel	1250	.1	.3
Main Channel	1218	.1	.3
Main Channel	1200	.1	.3
Main Channel	1167	.1	.3
Main Channel	1150	.1	.3
Main Channel	1100	.1	.3
Main Channel	1050	.1	.3
Main Channel	1000	.1	.3
Main Channel	950	.1	.3
Main Channel	900	.1	.3
Main Channel	850	.1	.3
Main Channel	800	.1	.3
Main Channel	750	.1	.3
Main Channel	700	.1	.3
Main Channel	650	.1	.3
Main Channel	600	.1	.3
Main Channel	550	.1	.3
Main Channel	500	.1	.3



Main Channel	450	.1	.3
Main Channel	400	.1	.3
Main Channel	350	.1	.3
Main Channel	300	.1	.3
Main Channel	250	.1	.3
Main Channel	200	.1	.3
Main Channel	150	.1	.3
Main Channel	100	.1	.3
Main Channel	50	.1	.3
Main Channel	0	.1	.3

Profile Output Table - Standard Table 2

River	Reach	River Sta	Profile	E.G. Elev (ft)	W.S. Elev (ft)	Vel Head (ft)	Frctn Loss (ft)	C & E Loss (ft)	Q Left (cfs)	Q Channel (cfs)	Q Right (cfs)	Top Width (ft)
South	Main Channel	1300	100 yr	7421.42	7421.38	0.04	2.75	0.00		4.20		39.51
South	Main Channel	1300	5 yr	7421.32	7421.30	0.03	3.11	0.00		0.70		12.28
South	Main Channel	1250	100 yr	7417.82	7417.80	0.02	1.69	0.00		4.20		25.70
South	Main Channel	1250	5 yr	7417.66	7417.64	0.01	1.71	0.00		0.70		10.63
South	Main Channel	1218	100 yr	7416.12	7416.08	0.04	6.12	0.42		4.20		34.00
South	Main Channel	1218	5 yr	7415.95	7415.91	0.04	5.83	0.45		0.70		5.01
South	Main Channel	1200	100 yr	7408.98	7405.34	3.64	2.28	0.00		4.20		2.03
South	Main Channel	1200	5 yr	7406.70	7405.20	1.49	2.57	0.01		0.70		1.06
South	Main Channel	1167	100 yr	7401.68	7401.52	0.16	2.21	0.03		4.20		4.32
South	Main Channel	1167	5 yr	7401.30	7401.24	0.06	2.35	0.02		0.70		2.52
South	Main Channel	1150	100 yr	7399.43	7398.92	0.51	1.72	0.03		4.20		3.27
South	Main Channel	1150	5 yr	7398.94	7398.71	0.23				0.70		1.95
South	Main Channel	1100	100 yr	7396.19	7396.13	0.05	1.72	0.01		4.20		6.79
South	Main Channel	1100	5 yr	7395.80	7395.75	0.05	1.72	0.01		0.70		2.83
South	Main Channel	1050	100 yr	7394.45	7394.28	0.17	2.03	0.03		4.20		3.88
South	Main Channel	1050	5 yr	7394.07	7394.04	0.03	1.94	0.00		0.70		2.52
South	Main Channel	1000	100 yr	7392.39	7392.34	0.05	2.06	0.01		4.20		9.18
South	Main Channel	1000	5 yr	7392.12	7392.07	0.04				0.70		5.02
South	Main Channel	950	100 yr	7390.31	7390.20	0.12	4.10	0.00		4.20		6.61
South	Main Channel	950	5 yr	7390.02	7389.98	0.05	4.08	0.00		0.70		3.60
South	Main Channel	900	100 yr	7386.21	7386.07	0.14	1.01	0.02		4.20		6.98
South	Main Channel	900	5 yr	7385.95	7385.91	0.05	1.92	0.01		0.70		4.53
South	Main Channel	850	100 yr	7384.07	7384.03	0.04	0.99	0.01		4.20		5.93
South	Main Channel	850	5 yr	7383.54	7383.52	0.03	1.14	0.00		0.70		2.64
South	Main Channel	800	100 yr	7383.06	7382.90	0.16	1.58	0.02	0.00	29.99	0.01	13.88
South	Main Channel	800	5 yr	7382.40	7382.36	0.05	1.72	0.01		5.00		10.10
South	Main Channel	750	100 yr	7381.47	7381.14	0.33	1.34	0.06	0.05	29.84	0.11	10.75
South	Main Channel	750	5 yr	7380.68	7380.54	0.13	1.34	0.03		5.00		5.56
South	Main Channel	700	100 yr	7379.97	7379.83	0.14	1.39	0.01	0.06	29.91	0.03	13.54
South	Main Channel	700	5 yr	7379.31	7379.28	0.04	1.33	0.01		5.00		10.91

South	Main Channel	650	100 yr	7378.57	7378.35	0.22	1.34	0.04		30.00		17.15
South	Main Channel	650	5 yr	7377.98	7377.88	0.10	1.25	0.02		5.00		8.24
South	Main Channel	600	100 yr	7377.18	7377.09	0.09	1.36	0.01		30.00		20.89
South	Main Channel	600	5 yr	7376.71	7376.68	0.02	1.38	0.01		5.00		19.12
South	Main Channel	550	100 yr	7375.81	7375.62	0.19	2.72	0.01		30.00		21.70
South	Main Channel	550	5 yr	7375.32	7375.23	0.09	3.06	0.00		5.00		11.39
South	Main Channel	500	100 yr	7373.07	7372.74	0.33	1.31	0.06		30.00		10.22
South	Main Channel	500	5 yr	7372.27	7372.14	0.13	1.45	0.02		5.00		5.50
South	Main Channel	450	100 yr	7371.66	7371.54	0.12	0.84	0.00		30.00		13.49
South	Main Channel	450	5 yr	7370.79	7370.73	0.06	0.70	0.01		5.00		6.36
South	Main Channel	400	100 yr	7370.83	7370.68	0.14	0.93	0.01		30.00		13.03
South	Main Channel	400	5 yr	7370.09	7370.05	0.04	0.70	0.00		5.00		7.57
South	Main Channel	350	100 yr	7369.89	7369.79	0.10	0.97	0.00		30.00		21.50
South	Main Channel	350	5 yr	7369.38	7369.35	0.03	1.02	0.00		5.00		15.09
South	Main Channel	300	100 yr	7368.93	7368.81	0.12	1.35	0.01		30.00		18.20
South	Main Channel	300	5 yr	7368.36	7368.32	0.04	1.26	0.00		5.00		13.22
South	Main Channel	250	100 yr	7367.58	7367.48	0.10	1.55	0.01		30.00		36.89
South	Main Channel	250	5 yr	7367.10	7367.06	0.04	1.35	0.01		5.00		13.54
South	Main Channel	200	100 yr	7366.02	7365.96	0.06	1.04	0.01		30.00		49.84
South	Main Channel	200	5 yr	7365.74	7365.73	0.02	1.06	0.00		5.00		37.72
South	Main Channel	150	100 yr	7364.97	7364.93	0.04	1.53	0.01		30.00		61.66
South	Main Channel	150	5 yr	7364.68	7364.66	0.02	1.59	0.00		5.00		33.75
South	Main Channel	100	100 yr	7363.42	7363.26	0.16	1.12	0.04		30.00		31.20
South	Main Channel	100	5 yr	7363.08	7363.03	0.04	1.46	0.01		5.00		25.80
South	Main Channel	50	100 yr	7362.00	7361.96	0.03	1.14	0.01		30.00		58.18
South	Main Channel	50	5 yr	7361.62	7361.60	0.02	0.99	0.00		5.00		25.39
South	Main Channel	0	100 yr	7360.86	7360.76	0.10				30.00		61.87
South	Main Channel	0	5 yr	7360.63	7360.62	0.02				5.00		42.35
North	North Finger	294	100 yr	7361.80	7361.62	0.19	2.13	0.00		59.60		48.54
North	North Finger	294	5 yr	7361.56	7361.44	0.13	1.55	0.01		26.70		38.89
North	North Finger	245	100 yr	7359.85	7359.49	0.36	1.23	0.00	10.07	43.42	6.11	43.55
North	North Finger	245	5 yr	7359.55	7359.46	0.09	1.22	0.00	4.17	20.31	2.22	42.32
North	North Finger	200	100 yr	7358.56	7358.40	0.16	2.99	0.35	0.04	45.03	14.54	56.86
North	North Finger	200	5 yr	7358.32	7358.18	0.14	4.11	0.25		24.85	1.85	33.04
North	North Finger	167	100 yr	7355.22	7351.56	3.65	3.52	0.93		59.60		7.89
North	North Finger	167	5 yr	7353.96	7351.30	2.66	3.03	0.71		26.70		6.08
North	North Finger	147	100 yr	7350.78	7350.22	0.56	1.32	0.09		59.60		13.91
North	North Finger	147	5 yr	7350.22	7349.94	0.28	1.52	0.05		26.70		12.24
North	North Finger	98	100 yr	7346.77	7346.65	0.13	1.31	0.04		59.60		29.86
North	North Finger	98	5 yr	7346.33	7346.23	0.10	1.52	0.03		26.70		20.28

North	North Finger	49	100 yr	7345.44	7344.94	0.50	0.00	0.02		59.60		10.76
North	North Finger	49	5 yr	7344.78	7344.42	0.35	0.00	0.05		26.70		8.34
North	Main Channel - U	1415	100 yr	7373.25	7373.08	0.17	1.03	0.00		57.20		36.57
North	Main Channel - U	1415	5 yr	7372.71	7372.62	0.10	1.00	0.02		9.00		19.69
North	Main Channel - U	1383	100 yr	7372.23	7372.06	0.17	1.85	0.00	0.08	56.33	0.79	36.18
North	Main Channel - U	1383	5 yr	7371.66	7371.62	0.04	1.85	0.01		9.00		21.19
North	Main Channel - U	1326	100 yr	7370.37	7370.16	0.22	1.24	0.71	2.92	52.23	2.05	40.05
North	Main Channel - U	1326	5 yr	7369.81	7369.70	0.11	2.73	0.59		9.00		17.77
North	Main Channel - U	1315	100 yr	7368.43	7361.13	7.30	7.41	1.88		57.20		4.61
North	Main Channel - U	1315	5 yr	7367.49	7360.50	6.99	7.61	2.03		9.00		2.21
North	Main Channel - U	1296	100 yr	7359.15	7358.11	1.03	1.67	0.20		57.20		11.16
North	Main Channel - U	1296	5 yr	7357.87	7357.66	0.21	1.19	0.02		9.00		9.25
North	Main Channel - U	1284	100 yr	7357.28	7356.89	0.38	2.31	0.01		57.20		29.58
North	Main Channel - U	1284	5 yr	7356.66	7356.52	0.14	2.16	0.02		9.00		13.85
North	Main Channel - U	1235	100 yr	7353.51	7353.29	0.22	2.25	0.01		57.20		25.73
North	Main Channel - U	1235	5 yr	7352.93	7352.88	0.05	2.30	0.01		9.00		23.20
North	Main Channel - U	1185	100 yr	7351.26	7350.98	0.28	1.80	0.02		57.20		24.66
North	Main Channel - U	1185	5 yr	7350.62	7350.51	0.11	1.70	0.01		9.00		17.98
North	Main Channel - U	1136	100 yr	7349.44	7349.22	0.21	1.80	0.01		57.20		20.15
North	Main Channel - U	1136	5 yr	7348.61	7348.55	0.06	1.64	0.00		9.00		11.52
North	Main Channel - U	1087	100 yr	7347.63	7347.34	0.28	0.98	0.05		57.20		24.19
North	Main Channel - U	1087	5 yr	7346.97	7346.87	0.10	1.19	0.02		9.00		17.20
North	Main Channel - U	1037	100 yr	7346.23	7346.11	0.12	0.95	0.03		57.20		19.20
North	Main Channel - U	1037	5 yr	7345.29	7345.25	0.04	1.13	0.02		9.00		14.61
North	Main Channel - U	988	100 yr	7345.25	7344.80	0.45	0.00	0.30	0.00	57.20		12.33
North	Main Channel - U	988	5 yr	7344.16	7344.02	0.14	0.00	0.30		9.00		6.90
North	Main Channel-M	938	100 yr	7345.14	7341.67	3.46	0.93	0.06		117.20		14.42
North	Main Channel-M	938	5 yr	7344.47	7341.13	3.34	0.61	0.05		18.40		9.00
North	Main Channel-M	889	100 yr	7341.95	7341.71	0.24	0.74	0.02		117.20		20.68
North	Main Channel-M	889	5 yr	7340.73	7340.69	0.04	0.44	0.00		18.40		15.23
North	Main Channel-M	840	100 yr	7341.18	7341.02	0.17	1.35	0.02		117.20		41.87
North	Main Channel-M	840	5 yr	7340.29	7340.23	0.07	1.52	0.01		18.40		20.46
North	Main Channel-M	790	100 yr	7339.80	7339.40	0.40	1.04	0.08		117.20		29.91
North	Main Channel-M	790	5 yr	7338.76	7338.56	0.20	1.30	0.04		18.40		13.29
North	Main Channel-M	741	100 yr	7338.25	7338.12	0.14	1.02	0.04		117.20		39.78
North	Main Channel-M	741	5 yr	7337.23	7337.18	0.05	1.27	0.02		18.40		24.38
North	Main Channel-M	691	100 yr	7337.19	7336.69	0.50	1.53	0.05	0.00	117.20		21.79
North	Main Channel-M	691	5 yr	7335.94	7335.71	0.23	1.72	0.03		18.40		10.52
North	Main Channel-M	642	100 yr	7334.42	7334.09	0.33	0.96	0.01	0.00	117.20		20.69
North	Main Channel-M	642	5 yr	7332.89	7332.74	0.15	0.73	0.02		18.40		9.24
North	Main Channel-M	593	100 yr	7333.45	7333.15	0.30	0.99	0.03		117.20		19.14

North	Main Channel-M	593	5 yr	7332.14	7332.07	0.07	0.71	0.00		18.40		13.70
North	Main Channel-M	543	100 yr	7332.43	7332.23	0.20	0.82	0.02		117.20		41.30
North	Main Channel-M	543	5 yr	7331.43	7331.33	0.10	0.84	0.02		18.40		13.74
North	Main Channel-M	494	100 yr	7331.58	7331.44	0.15	1.06	0.03		117.20		37.40
North	Main Channel-M	494	5 yr	7330.59	7330.53	0.05	1.04	0.01		18.40		23.82
North	Main Channel-M	444	100 yr	7330.50	7330.08	0.42	0.99	0.07		117.20		27.53
North	Main Channel-M	444	5 yr	7329.54	7329.44	0.11	1.65	0.00		18.40		20.06
North	Main Channel-M	395	100 yr	7329.16	7329.00	0.17	0.79	0.03		117.20		29.73
North	Main Channel-M	395	5 yr	7327.88	7327.76	0.12	1.03	0.00		18.40		14.96
North	Main Channel-M	346	100 yr	7328.35	7327.93	0.42	1.17	0.01		117.20		16.70
North	Main Channel-M	346	5 yr	7326.85	7326.74	0.11	0.96	0.01		18.40		9.71
North	Main Channel-M	310	100 yr	7327.65	7327.49	0.15	0.00	0.19		117.20		22.52
North	Main Channel-M	310	5 yr	7326.21	7326.17	0.03	0.00	0.22		18.40		15.55
North	South Finger	336	100 yr	7357.38	7357.28	0.10	3.82	0.00		16.70		32.78
North	South Finger	336	5 yr	7357.14	7357.10	0.03				2.60		22.87
North	South Finger	288	100 yr	7353.55	7353.41	0.14	5.13	0.34		16.70		25.02
North	South Finger	288	5 yr	7353.25	7353.20	0.05	6.06	0.28		2.60		13.59
North	South Finger	265	100 yr	7348.09	7344.55	3.54	1.28	0.05		16.70		2.83
North	South Finger	265	5 yr	7346.92	7344.11	2.81	1.32	0.01		2.60		1.24
North	South Finger	240	100 yr	7343.81	7343.60	0.21	5.05	0.04		16.70		10.89
North	South Finger	240	5 yr	7343.30	7343.21	0.09	5.24	0.00		2.60		5.88
North	South Finger	192	100 yr	7338.72	7338.16	0.57	2.74	0.01		16.70		9.06
North	South Finger	192	5 yr	7338.06	7337.92	0.13	3.58	0.01		2.60		7.00
North	South Finger	144	100 yr	7334.61	7334.30	0.31	1.93	0.07	0.02	16.67	0.01	6.56
North	South Finger	144	5 yr	7333.84	7333.70	0.14	2.03	0.03		2.60		3.17
North	South Finger	81	100 yr	7329.22	7329.13	0.09	1.02	0.02		16.70		13.08
North	South Finger	81	5 yr	7328.71	7328.68	0.03	1.09	0.01		2.60		7.75
North	South Finger	48	100 yr	7328.18	7327.93	0.25	0.00	0.00		16.70		8.51
North	South Finger	48	5 yr	7327.62	7327.53	0.08	0.00	0.00		2.60		6.88
North	Main Channel-L	247	100 yr	7327.99	7325.82	2.17	4.35	0.47		163.10		21.63
North	Main Channel-L	247	5 yr	7327.41	7325.12	2.29	1.24	0.01		25.60		10.54
North	Main Channel-L	198	100 yr	7325.92	7325.32	0.60	1.21	0.10	0.10	162.58	0.42	23.00
North	Main Channel-L	198	5 yr	7324.53	7324.31	0.22	1.47	0.04		25.60		15.52
North	Main Channel-L	148	100 yr	7324.07	7323.81	0.26	1.22	0.02		163.10		31.57
North	Main Channel-L	148	5 yr	7322.92	7322.84	0.07	1.11	0.00		25.60		26.27
North	Main Channel-L	99	100 yr	7322.84	7322.39	0.45	1.85	0.03		163.10		31.47
North	Main Channel-L	99	5 yr	7321.80	7321.71	0.09	1.86	0.00		25.60		27.35
North	Main Channel-L	49	100 yr	7320.96	7320.61	0.35	1.69	0.02		163.10		38.92
North	Main Channel-L	49	5 yr	7319.95	7319.80	0.14	2.03	0.00		25.60		25.43
North	Main Channel-L	0	100 yr	7319.25	7318.73	0.52			0.00	163.07	0.03	22.92
North	Main Channel-L	0	5 yr	7317.91	7317.76	0.14				25.60		17.61

ERRORS WARNINGS AND NOTES

Errors Warnings and Notes for Plan : Default Scenario

River: North Reach: North Finger RS: 294 Profile: 100 yr

Warning:The energy equation could not be balanced within the specified number of iterations. The program used critical depth for the water surface and continued on with the calculations.

Warning:The conveyance ratio (upstream conveyance divided by downstream conveyance) is less than 0.7 or greater than 1.4. This may indicate the need for additional cross sections.

Warning:The energy loss was greater than 1.0 ft (0.3 m). between the current and previous cross section. This may indicate the need for additional cross sections.

Warning:During the standard step iterations, when the assumed water surface was set equal to critical depth, the calculated water surface came back below critical depth. This indicates that there is not a valid subcritical answer. The program defaulted to critical depth.

River: North Reach: North Finger RS: 294 Profile: 5 yr

Warning:The energy equation could not be balanced within the specified number of iterations. The program used critical depth for the water surface and continued on with the calculations.

Warning:The conveyance ratio (upstream conveyance divided by downstream conveyance) is less than 0.7 or greater than 1.4. This may indicate the need for additional cross sections.

Warning:The energy loss was greater than 1.0 ft (0.3 m). between the current and previous cross section. This may indicate the need for additional cross sections.

Warning:During the standard step iterations, when the assumed water surface was set equal to critical depth, the calculated water surface came back below critical depth. This indicates that there is not a valid subcritical answer. The program defaulted to critical depth.

River: North Reach: North Finger RS: 245 Profile: 100 yr

Warning:The energy equation could not be balanced within the specified number of iterations. The program selected the water surface that had the least amount of error between computed and assumed values.

Warning:The energy loss was greater than 1.0 ft (0.3 m). between the current and previous cross section. This may indicate the need for additional cross sections.

River: North Reach: North Finger RS: 245 Profile: 5 yr

Warning:The conveyance ratio (upstream conveyance divided by downstream conveyance) is less than 0.7 or greater than 1.4. This may indicate the need for additional cross sections.

Warning:The energy loss was greater than 1.0 ft (0.3 m). between the current and previous cross section. This may indicate the need for additional cross sections.

Note: Hydraulic jump has occurred between this cross section and the previous upstream section.

River: North Reach: North Finger RS: 200 Profile: 100 yr

Warning:The energy equation could not be balanced within the specified number of iterations. The program used critical depth for the water surface and continued on with the calculations.

Warning:The energy loss was greater than 1.0 ft (0.3 m). between the current and previous cross section. This may indicate the need for additional cross sections.

Warning:During the standard step iterations, when the assumed water surface was set equal to critical depth, the calculated water surface came back below critical depth. This indicates that there is not a valid subcritical answer. The program defaulted to critical depth.

River: North Reach: North Finger RS: 200 Profile: 5 yr

Warning:The energy equation could not be balanced within the specified number of iterations. The program used critical depth for the water surface and continued on with the calculations.

Warning:The energy loss was greater than 1.0 ft (0.3 m). between the current and previous cross section. This may indicate the need for additional cross sections.

Warning:During the standard step iterations, when the assumed water surface was set equal to critical depth, the calculated water surface came back below critical depth. This indicates that there is not a valid subcritical answer. The program defaulted to critical depth.

River: North Reach: North Finger RS: 167 Profile: 100 yr

Warning:The velocity head has changed by more than 0.5 ft (0.15 m). This may indicate the need for additional cross sections.

Warning:The conveyance ratio (upstream conveyance divided by downstream conveyance) is less than 0.7 or greater than 1.4. This may indicate the need for additional cross sections.

Warning:The energy loss was greater than 1.0 ft (0.3 m). between the current and previous cross section. This may indicate the need for additional cross sections.

River: North Reach: North Finger RS: 167 Profile: 5 yr

Warning:The velocity head has changed by more than 0.5 ft (0.15 m). This may indicate the need for additional cross sections.  
Warning:The conveyance ratio (upstream conveyance divided by downstream conveyance) is less than 0.7 or greater than 1.4.  
This may indicate the need for additional cross sections.  
Warning:The energy loss was greater than 1.0 ft (0.3 m). between the current and previous cross section. This may indicate the need for additional cross sections.  
Note: Program found supercritical flow starting at this cross section.

River: North Reach: North Finger RS: 147 Profile: 100 yr  
Warning:The velocity head has changed by more than 0.5 ft (0.15 m). This may indicate the need for additional cross sections.  
Warning:The conveyance ratio (upstream conveyance divided by downstream conveyance) is less than 0.7 or greater than 1.4.  
This may indicate the need for additional cross sections.  
Warning:The energy loss was greater than 1.0 ft (0.3 m). between the current and previous cross section. This may indicate the need for additional cross sections.

River: North Reach: North Finger RS: 147 Profile: 5 yr  
Warning:The velocity head has changed by more than 0.5 ft (0.15 m). This may indicate the need for additional cross sections.  
Warning:The conveyance ratio (upstream conveyance divided by downstream conveyance) is less than 0.7 or greater than 1.4.  
This may indicate the need for additional cross sections.  
Warning:The energy loss was greater than 1.0 ft (0.3 m). between the current and previous cross section. This may indicate the need for additional cross sections.

River: North Reach: North Finger RS: 98 Profile: 100 yr  
Warning:Divided flow computed for this cross-section.  
Warning:The conveyance ratio (upstream conveyance divided by downstream conveyance) is less than 0.7 or greater than 1.4.  
This may indicate the need for additional cross sections.  
Warning:The energy loss was greater than 1.0 ft (0.3 m). between the current and previous cross section. This may indicate the need for additional cross sections.  
Note: Hydraulic jump has occurred between this cross section and the previous upstream section.

River: North Reach: North Finger RS: 98 Profile: 5 yr  
Warning:Divided flow computed for this cross-section.  
Warning:The conveyance ratio (upstream conveyance divided by downstream conveyance) is less than 0.7 or greater than 1.4.  
This may indicate the need for additional cross sections.  
Warning:The energy loss was greater than 1.0 ft (0.3 m). between the current and previous cross section. This may indicate the need for additional cross sections.  
Note: Hydraulic jump has occurred between this cross section and the previous upstream section.

River: North Reach: North Finger RS: 49 Profile: 100 yr  
Warning:The energy equation could not be balanced within the specified number of iterations. The program used critical depth for the water surface and continued on with the calculations.  
Warning:The energy loss was greater than 1.0 ft (0.3 m). between the current and previous cross section. This may indicate the need for additional cross sections.  
Warning:During the standard step iterations, when the assumed water surface was set equal to critical depth, the calculated water surface came back below critical depth. This indicates that there is not a valid subcritical answer. The program defaulted to critical depth.

River: North Reach: North Finger RS: 49 Profile: 5 yr  
Warning:The energy equation could not be balanced within the specified number of iterations. The program used critical depth for the water surface and continued on with the calculations.  
Warning:The energy loss was greater than 1.0 ft (0.3 m). between the current and previous cross section. This may indicate the need for additional cross sections.  
Warning:During the standard step iterations, when the assumed water surface was set equal to critical depth, the calculated water surface came back below critical depth. This indicates that there is not a valid subcritical answer. The program defaulted to critical depth.

River: North Reach: Main Channel - U RS: 1415 Profile: 100 yr  
Warning:The energy loss was greater than 1.0 ft (0.3 m). between the current and previous cross section. This may indicate the need for additional cross sections.

River: North Reach: Main Channel - U RS: 1415 Profile: 5 yr  
Warning:The energy equation could not be balanced within the specified number of iterations. The program used critical depth for the water surface and continued on with the calculations.  
Warning:The conveyance ratio (upstream conveyance divided by downstream conveyance) is less than 0.7 or greater than 1.4.  
This may indicate the need for additional cross sections.  
Warning:The energy loss was greater than 1.0 ft (0.3 m). between the current and previous cross section. This may indicate the need for additional cross sections.  
Warning:During the standard step iterations, when the assumed water surface was set equal to critical depth, the calculated water surface came back below critical depth. This indicates that there is not a valid subcritical answer. The program defaulted to critical depth.

River: North Reach: Main Channel - U RS: 1383 Profile: 100 yr  
Warning: The energy loss was greater than 1.0 ft (0.3 m). between the current and previous cross section. This may indicate the need for additional cross sections.

River: North Reach: Main Channel - U RS: 1383 Profile: 5 yr  
Warning: The conveyance ratio (upstream conveyance divided by downstream conveyance) is less than 0.7 or greater than 1.4. This may indicate the need for additional cross sections.  
Warning: The energy loss was greater than 1.0 ft (0.3 m). between the current and previous cross section. This may indicate the need for additional cross sections.  
Note: Hydraulic jump has occurred between this cross section and the previous upstream section.

River: North Reach: Main Channel - U RS: 1326 Profile: 100 yr  
Warning: The energy equation could not be balanced within the specified number of iterations. The program used critical depth for the water surface and continued on with the calculations.  
Warning: The energy loss was greater than 1.0 ft (0.3 m). between the current and previous cross section. This may indicate the need for additional cross sections.  
Warning: During the standard step iterations, when the assumed water surface was set equal to critical depth, the calculated water surface came back below critical depth. This indicates that there is not a valid subcritical answer. The program defaulted to critical depth.

River: North Reach: Main Channel - U RS: 1326 Profile: 5 yr  
Warning: The energy equation could not be balanced within the specified number of iterations. The program used critical depth for the water surface and continued on with the calculations.  
Warning: The energy loss was greater than 1.0 ft (0.3 m). between the current and previous cross section. This may indicate the need for additional cross sections.  
Warning: During the standard step iterations, when the assumed water surface was set equal to critical depth, the calculated water surface came back below critical depth. This indicates that there is not a valid subcritical answer. The program defaulted to critical depth.

River: North Reach: Main Channel - U RS: 1315 Profile: 100 yr  
Warning: The velocity head has changed by more than 0.5 ft (0.15 m). This may indicate the need for additional cross sections.  
Warning: The conveyance ratio (upstream conveyance divided by downstream conveyance) is less than 0.7 or greater than 1.4. This may indicate the need for additional cross sections.  
Warning: The energy loss was greater than 1.0 ft (0.3 m). between the current and previous cross section. This may indicate the need for additional cross sections.  
Note: Program found supercritical flow starting at this cross section.

River: North Reach: Main Channel - U RS: 1315 Profile: 5 yr  
Warning: The energy equation could not be balanced within the specified number of iterations. The program selected the water surface that had the least amount of error between computed and assumed values.  
Warning: The velocity head has changed by more than 0.5 ft (0.15 m). This may indicate the need for additional cross sections.  
Warning: The conveyance ratio (upstream conveyance divided by downstream conveyance) is less than 0.7 or greater than 1.4. This may indicate the need for additional cross sections.  
Warning: The energy loss was greater than 1.0 ft (0.3 m). between the current and previous cross section. This may indicate the need for additional cross sections.  
Note: Program found supercritical flow starting at this cross section.

River: North Reach: Main Channel - U RS: 1296 Profile: 100 yr  
Warning: The velocity head has changed by more than 0.5 ft (0.15 m). This may indicate the need for additional cross sections.  
Warning: The conveyance ratio (upstream conveyance divided by downstream conveyance) is less than 0.7 or greater than 1.4. This may indicate the need for additional cross sections.  
Warning: The energy loss was greater than 1.0 ft (0.3 m). between the current and previous cross section. This may indicate the need for additional cross sections.

River: North Reach: Main Channel - U RS: 1296 Profile: 5 yr  
Warning: The energy equation could not be balanced within the specified number of iterations. The program selected the water surface that had the least amount of error between computed and assumed values.  
Warning: The velocity head has changed by more than 0.5 ft (0.15 m). This may indicate the need for additional cross sections.  
Warning: The conveyance ratio (upstream conveyance divided by downstream conveyance) is less than 0.7 or greater than 1.4. This may indicate the need for additional cross sections.  
Warning: The energy loss was greater than 1.0 ft (0.3 m). between the current and previous cross section. This may indicate the need for additional cross sections.

River: North Reach: Main Channel - U RS: 1284 Profile: 100 yr  
Warning: The velocity head has changed by more than 0.5 ft (0.15 m). This may indicate the need for additional cross sections.  
Warning: The energy loss was greater than 1.0 ft (0.3 m). between the current and previous cross section. This may indicate the need for additional cross sections.

River: North Reach: Main Channel - U RS: 1284 Profile: 5 yr  
Warning: Divided flow computed for this cross-section.

Warning:The energy loss was greater than 1.0 ft (0.3 m). between the current and previous cross section. This may indicate the need for additional cross sections.

River: North Reach: Main Channel - U RS: 1235 Profile: 100 yr

Warning:The energy loss was greater than 1.0 ft (0.3 m). between the current and previous cross section. This may indicate the need for additional cross sections.

Note: Hydraulic jump has occurred between this cross section and the previous upstream section.

River: North Reach: Main Channel - U RS: 1235 Profile: 5 yr

Warning:The conveyance ratio (upstream conveyance divided by downstream conveyance) is less than 0.7 or greater than 1.4. This may indicate the need for additional cross sections.

Warning:The energy loss was greater than 1.0 ft (0.3 m). between the current and previous cross section. This may indicate the need for additional cross sections.

Note: Hydraulic jump has occurred between this cross section and the previous upstream section.

River: North Reach: Main Channel - U RS: 1185 Profile: 100 yr

Warning:The energy loss was greater than 1.0 ft (0.3 m). between the current and previous cross section. This may indicate the need for additional cross sections.

River: North Reach: Main Channel - U RS: 1185 Profile: 5 yr

Warning:The energy equation could not be balanced within the specified number of iterations. The program used critical depth for the water surface and continued on with the calculations.

Warning:The conveyance ratio (upstream conveyance divided by downstream conveyance) is less than 0.7 or greater than 1.4. This may indicate the need for additional cross sections.

Warning:The energy loss was greater than 1.0 ft (0.3 m). between the current and previous cross section. This may indicate the need for additional cross sections.

Warning:During the standard step iterations, when the assumed water surface was set equal to critical depth, the calculated water surface came back below critical depth. This indicates that there is not a valid subcritical answer. The program defaulted to critical depth.

River: North Reach: Main Channel - U RS: 1136 Profile: 100 yr

Warning:The conveyance ratio (upstream conveyance divided by downstream conveyance) is less than 0.7 or greater than 1.4. This may indicate the need for additional cross sections.

Warning:The energy loss was greater than 1.0 ft (0.3 m). between the current and previous cross section. This may indicate the need for additional cross sections.

River: North Reach: Main Channel - U RS: 1136 Profile: 5 yr

Warning:The conveyance ratio (upstream conveyance divided by downstream conveyance) is less than 0.7 or greater than 1.4. This may indicate the need for additional cross sections.

Warning:The energy loss was greater than 1.0 ft (0.3 m). between the current and previous cross section. This may indicate the need for additional cross sections.

River: North Reach: Main Channel - U RS: 1087 Profile: 100 yr

Warning:The energy equation could not be balanced within the specified number of iterations. The program used critical depth for the water surface and continued on with the calculations.

Warning:The conveyance ratio (upstream conveyance divided by downstream conveyance) is less than 0.7 or greater than 1.4. This may indicate the need for additional cross sections.

Warning:The energy loss was greater than 1.0 ft (0.3 m). between the current and previous cross section. This may indicate the need for additional cross sections.

Warning:During the standard step iterations, when the assumed water surface was set equal to critical depth, the calculated water surface came back below critical depth. This indicates that there is not a valid subcritical answer. The program defaulted to critical depth.

River: North Reach: Main Channel - U RS: 1087 Profile: 5 yr

Warning:The energy equation could not be balanced within the specified number of iterations. The program used critical depth for the water surface and continued on with the calculations.

Warning:The conveyance ratio (upstream conveyance divided by downstream conveyance) is less than 0.7 or greater than 1.4. This may indicate the need for additional cross sections.

Warning:The energy loss was greater than 1.0 ft (0.3 m). between the current and previous cross section. This may indicate the need for additional cross sections.

Warning:During the standard step iterations, when the assumed water surface was set equal to critical depth, the calculated water surface came back below critical depth. This indicates that there is not a valid subcritical answer. The program defaulted to critical depth.

River: North Reach: Main Channel - U RS: 1037 Profile: 100 yr

Warning:The conveyance ratio (upstream conveyance divided by downstream conveyance) is less than 0.7 or greater than 1.4. This may indicate the need for additional cross sections.

River: North Reach: Main Channel - U RS: 1037 Profile: 5 yr

Warning:The conveyance ratio (upstream conveyance divided by downstream conveyance) is less than 0.7 or greater than 1.4. This may indicate the need for additional cross sections.



Warning:The energy loss was greater than 1.0 ft (0.3 m). between the current and previous cross section. This may indicate the need for additional cross sections.

River: North Reach: Main Channel - U RS: 988 Profile: 100 yr

Warning:The energy equation could not be balanced within the specified number of iterations. The program used critical depth for the water surface and continued on with the calculations.

Warning:The energy loss was greater than 1.0 ft (0.3 m). between the current and previous cross section. This may indicate the need for additional cross sections.

Warning:During the standard step iterations, when the assumed water surface was set equal to critical depth, the calculated water surface came back below critical depth. This indicates that there is not a valid subcritical answer. The program defaulted to critical depth.

River: North Reach: Main Channel - U RS: 988 Profile: 5 yr

Warning:The energy loss was greater than 1.0 ft (0.3 m). between the current and previous cross section. This may indicate the need for additional cross sections.

River: North Reach: Main Channel-M RS: 938 Profile: 100 yr

Warning:The velocity head has changed by more than 0.5 ft (0.15 m). This may indicate the need for additional cross sections.

Warning:During supercritical flow calculations a junction was encountered. During standard step calculations the program used the stream with the greatest momentum to balance the energy equation.

River: North Reach: Main Channel-M RS: 938 Profile: 5 yr

Warning:The velocity head has changed by more than 0.5 ft (0.15 m). This may indicate the need for additional cross sections.

Warning:During supercritical flow calculations a junction was encountered. During standard step calculations the program used the stream with the greatest momentum to balance the energy equation.

River: North Reach: Main Channel-M RS: 889 Profile: 100 yr

Note: Hydraulic jump has occurred between this cross section and the previous upstream section.

River: North Reach: Main Channel-M RS: 889 Profile: 5 yr

Warning:The conveyance ratio (upstream conveyance divided by downstream conveyance) is less than 0.7 or greater than 1.4. This may indicate the need for additional cross sections.

Note: Hydraulic jump has occurred between this cross section and the previous upstream section.

River: North Reach: Main Channel-M RS: 840 Profile: 100 yr

Warning:The conveyance ratio (upstream conveyance divided by downstream conveyance) is less than 0.7 or greater than 1.4. This may indicate the need for additional cross sections.

Warning:The energy loss was greater than 1.0 ft (0.3 m). between the current and previous cross section. This may indicate the need for additional cross sections.

River: North Reach: Main Channel-M RS: 840 Profile: 5 yr

Warning:The conveyance ratio (upstream conveyance divided by downstream conveyance) is less than 0.7 or greater than 1.4. This may indicate the need for additional cross sections.

Warning:The energy loss was greater than 1.0 ft (0.3 m). between the current and previous cross section. This may indicate the need for additional cross sections.

River: North Reach: Main Channel-M RS: 790 Profile: 100 yr

Warning:The energy equation could not be balanced within the specified number of iterations. The program used critical depth for the water surface and continued on with the calculations.

Warning:The conveyance ratio (upstream conveyance divided by downstream conveyance) is less than 0.7 or greater than 1.4. This may indicate the need for additional cross sections.

Warning:The energy loss was greater than 1.0 ft (0.3 m). between the current and previous cross section. This may indicate the need for additional cross sections.

Warning:During the standard step iterations, when the assumed water surface was set equal to critical depth, the calculated water surface came back below critical depth. This indicates that there is not a valid subcritical answer. The program defaulted to critical depth.

River: North Reach: Main Channel-M RS: 790 Profile: 5 yr

Warning:The energy equation could not be balanced within the specified number of iterations. The program used critical depth for the water surface and continued on with the calculations.

Warning:The conveyance ratio (upstream conveyance divided by downstream conveyance) is less than 0.7 or greater than 1.4. This may indicate the need for additional cross sections.

Warning:The energy loss was greater than 1.0 ft (0.3 m). between the current and previous cross section. This may indicate the need for additional cross sections.

Warning:During the standard step iterations, when the assumed water surface was set equal to critical depth, the calculated water surface came back below critical depth. This indicates that there is not a valid subcritical answer. The program defaulted to critical depth.

River: North Reach: Main Channel-M RS: 741 Profile: 100 yr

Warning:The conveyance ratio (upstream conveyance divided by downstream conveyance) is less than 0.7 or greater than 1.4. This may indicate the need for additional cross sections.

Warning:The energy loss was greater than 1.0 ft (0.3 m). between the current and previous cross section. This may indicate

the need for additional cross sections.

River: North Reach: Main Channel-M RS: 741 Profile: 5 yr

Warning:The conveyance ratio (upstream conveyance divided by downstream conveyance) is less than 0.7 or greater than 1.4.  
This may indicate the need for additional cross sections.

Warning:The energy loss was greater than 1.0 ft (0.3 m). between the current and previous cross section. This may indicate the need for additional cross sections.

River: North Reach: Main Channel-M RS: 691 Profile: 100 yr

Warning:The energy equation could not be balanced within the specified number of iterations. The program used critical depth for the water surface and continued on with the calculations.

Warning:The conveyance ratio (upstream conveyance divided by downstream conveyance) is less than 0.7 or greater than 1.4.  
This may indicate the need for additional cross sections.

Warning:The energy loss was greater than 1.0 ft (0.3 m). between the current and previous cross section. This may indicate the need for additional cross sections.

Warning:During the standard step iterations, when the assumed water surface was set equal to critical depth, the calculated water surface came back below critical depth. This indicates that there is not a valid subcritical answer. The program defaulted to critical depth.

River: North Reach: Main Channel-M RS: 691 Profile: 5 yr

Warning:The energy equation could not be balanced within the specified number of iterations. The program used critical depth for the water surface and continued on with the calculations.

Warning:The conveyance ratio (upstream conveyance divided by downstream conveyance) is less than 0.7 or greater than 1.4.  
This may indicate the need for additional cross sections.

Warning:The energy loss was greater than 1.0 ft (0.3 m). between the current and previous cross section. This may indicate the need for additional cross sections.

Warning:During the standard step iterations, when the assumed water surface was set equal to critical depth, the calculated water surface came back below critical depth. This indicates that there is not a valid subcritical answer. The program defaulted to critical depth.

River: North Reach: Main Channel-M RS: 642 Profile: 5 yr

Warning:The conveyance ratio (upstream conveyance divided by downstream conveyance) is less than 0.7 or greater than 1.4.  
This may indicate the need for additional cross sections.

River: North Reach: Main Channel-M RS: 593 Profile: 100 yr

Warning:The energy loss was greater than 1.0 ft (0.3 m). between the current and previous cross section. This may indicate the need for additional cross sections.

River: North Reach: Main Channel-M RS: 593 Profile: 5 yr

Warning:The conveyance ratio (upstream conveyance divided by downstream conveyance) is less than 0.7 or greater than 1.4.  
This may indicate the need for additional cross sections.

River: North Reach: Main Channel-M RS: 543 Profile: 5 yr

Warning:Divided flow computed for this cross-section.

River: North Reach: Main Channel-M RS: 494 Profile: 100 yr

Warning:The conveyance ratio (upstream conveyance divided by downstream conveyance) is less than 0.7 or greater than 1.4.  
This may indicate the need for additional cross sections.

Warning:The energy loss was greater than 1.0 ft (0.3 m). between the current and previous cross section. This may indicate the need for additional cross sections.

River: North Reach: Main Channel-M RS: 494 Profile: 5 yr

Warning:The conveyance ratio (upstream conveyance divided by downstream conveyance) is less than 0.7 or greater than 1.4.  
This may indicate the need for additional cross sections.

Warning:The energy loss was greater than 1.0 ft (0.3 m). between the current and previous cross section. This may indicate the need for additional cross sections.

River: North Reach: Main Channel-M RS: 444 Profile: 100 yr

Warning:The energy equation could not be balanced within the specified number of iterations. The program used critical depth for the water surface and continued on with the calculations.

Warning:The conveyance ratio (upstream conveyance divided by downstream conveyance) is less than 0.7 or greater than 1.4.  
This may indicate the need for additional cross sections.

Warning:The energy loss was greater than 1.0 ft (0.3 m). between the current and previous cross section. This may indicate the need for additional cross sections.

Warning:During the standard step iterations, when the assumed water surface was set equal to critical depth, the calculated water surface came back below critical depth. This indicates that there is not a valid subcritical answer. The program defaulted to critical depth.

River: North Reach: Main Channel-M RS: 444 Profile: 5 yr

Warning:The energy loss was greater than 1.0 ft (0.3 m). between the current and previous cross section. This may indicate the need for additional cross sections.

River: North Reach: Main Channel-M RS: 395 Profile: 100 yr

Warning:The conveyance ratio (upstream conveyance divided by downstream conveyance) is less than 0.7 or greater than 1.4.  
This may indicate the need for additional cross sections.

River: North Reach: Main Channel-M RS: 395 Profile: 5 yr  
Warning:The conveyance ratio (upstream conveyance divided by downstream conveyance) is less than 0.7 or greater than 1.4.  
This may indicate the need for additional cross sections.

Warning:The energy loss was greater than 1.0 ft (0.3 m). between the current and previous cross section. This may indicate  
the need for additional cross sections.

River: North Reach: Main Channel-M RS: 346 Profile: 100 yr  
Warning:The energy loss was greater than 1.0 ft (0.3 m). between the current and previous cross section. This may indicate  
the need for additional cross sections.

River: North Reach: Main Channel-M RS: 346 Profile: 5 yr  
Warning:The conveyance ratio (upstream conveyance divided by downstream conveyance) is less than 0.7 or greater than 1.4.  
This may indicate the need for additional cross sections.

River: North Reach: South Finger RS: 336 Profile: 100 yr  
Warning:The energy equation could not be balanced within the specified number of iterations. The program used critical depth  
for the water surface and continued on with the calculations.

Warning:The energy loss was greater than 1.0 ft (0.3 m). between the current and previous cross section. This may indicate  
the need for additional cross sections.

Warning:During the standard step iterations, when the assumed water surface was set equal to critical depth, the calculated  
water surface came back below critical depth. This indicates that there is not a valid subcritical answer. The  
program defaulted to critical depth.

River: North Reach: South Finger RS: 336 Profile: 5 yr  
Warning:The energy equation could not be balanced within the specified number of iterations. The program used critical depth  
for the water surface and continued on with the calculations.

Warning:Divided flow computed for this cross-section.

Warning:The energy loss was greater than 1.0 ft (0.3 m). between the current and previous cross section. This may indicate  
the need for additional cross sections.

River: North Reach: South Finger RS: 288 Profile: 100 yr  
Warning:The energy loss was greater than 1.0 ft (0.3 m). between the current and previous cross section. This may indicate  
the need for additional cross sections.

River: North Reach: South Finger RS: 288 Profile: 5 yr  
Warning:The energy equation could not be balanced within the specified number of iterations. The program used critical depth  
for the water surface and continued on with the calculations.

Warning:The conveyance ratio (upstream conveyance divided by downstream conveyance) is less than 0.7 or greater than 1.4.  
This may indicate the need for additional cross sections.

Warning:The energy loss was greater than 1.0 ft (0.3 m). between the current and previous cross section. This may indicate  
the need for additional cross sections.

Warning:During the standard step iterations, when the assumed water surface was set equal to critical depth, the calculated  
water surface came back below critical depth. This indicates that there is not a valid subcritical answer. The  
program defaulted to critical depth.

River: North Reach: South Finger RS: 265 Profile: 100 yr  
Warning:The velocity head has changed by more than 0.5 ft (0.15 m). This may indicate the need for additional cross sections.

Warning:The conveyance ratio (upstream conveyance divided by downstream conveyance) is less than 0.7 or greater than 1.4.  
This may indicate the need for additional cross sections.

Warning:The energy loss was greater than 1.0 ft (0.3 m). between the current and previous cross section. This may indicate  
the need for additional cross sections.

River: North Reach: South Finger RS: 265 Profile: 5 yr  
Warning:The velocity head has changed by more than 0.5 ft (0.15 m). This may indicate the need for additional cross sections.

Warning:The conveyance ratio (upstream conveyance divided by downstream conveyance) is less than 0.7 or greater than 1.4.  
This may indicate the need for additional cross sections.

Warning:The energy loss was greater than 1.0 ft (0.3 m). between the current and previous cross section. This may indicate  
the need for additional cross sections.

River: North Reach: South Finger RS: 240 Profile: 100 yr  
Warning:The energy equation could not be balanced within the specified number of iterations. The program used critical depth  
for the water surface and continued on with the calculations.

Warning:The energy loss was greater than 1.0 ft (0.3 m). between the current and previous cross section. This may indicate  
the need for additional cross sections.

Warning:During the standard step iterations, when the assumed water surface was set equal to critical depth, the calculated  
water surface came back below critical depth. This indicates that there is not a valid subcritical answer. The  
program defaulted to critical depth.

River: North Reach: South Finger RS: 240 Profile: 5 yr

Warning:The energy equation could not be balanced within the specified number of iterations. The program used critical depth for the water surface and continued on with the calculations.

Warning:The energy loss was greater than 1.0 ft (0.3 m). between the current and previous cross section. This may indicate the need for additional cross sections.

Warning:During the standard step iterations, when the assumed water surface was set equal to critical depth, the calculated water surface came back below critical depth. This indicates that there is not a valid subcritical answer. The program defaulted to critical depth.

River: North Reach: South Finger RS: 192 Profile: 100 yr

Warning:The conveyance ratio (upstream conveyance divided by downstream conveyance) is less than 0.7 or greater than 1.4. This may indicate the need for additional cross sections.

Warning:The energy loss was greater than 1.0 ft (0.3 m). between the current and previous cross section. This may indicate the need for additional cross sections.

River: North Reach: South Finger RS: 192 Profile: 5 yr

Warning:The conveyance ratio (upstream conveyance divided by downstream conveyance) is less than 0.7 or greater than 1.4. This may indicate the need for additional cross sections.

Warning:The energy loss was greater than 1.0 ft (0.3 m). between the current and previous cross section. This may indicate the need for additional cross sections.

River: North Reach: South Finger RS: 144 Profile: 100 yr

Warning:The energy equation could not be balanced within the specified number of iterations. The program used critical depth for the water surface and continued on with the calculations.

Warning:The conveyance ratio (upstream conveyance divided by downstream conveyance) is less than 0.7 or greater than 1.4. This may indicate the need for additional cross sections.

Warning:The energy loss was greater than 1.0 ft (0.3 m). between the current and previous cross section. This may indicate the need for additional cross sections.

Warning:During the standard step iterations, when the assumed water surface was set equal to critical depth, the calculated water surface came back below critical depth. This indicates that there is not a valid subcritical answer. The program defaulted to critical depth.

River: North Reach: South Finger RS: 144 Profile: 5 yr

Warning:The energy equation could not be balanced within the specified number of iterations. The program used critical depth for the water surface and continued on with the calculations.

Warning:The conveyance ratio (upstream conveyance divided by downstream conveyance) is less than 0.7 or greater than 1.4. This may indicate the need for additional cross sections.

Warning:The energy loss was greater than 1.0 ft (0.3 m). between the current and previous cross section. This may indicate the need for additional cross sections.

Warning:During the standard step iterations, when the assumed water surface was set equal to critical depth, the calculated water surface came back below critical depth. This indicates that there is not a valid subcritical answer. The program defaulted to critical depth.

River: North Reach: South Finger RS: 81 Profile: 100 yr

Warning:The conveyance ratio (upstream conveyance divided by downstream conveyance) is less than 0.7 or greater than 1.4. This may indicate the need for additional cross sections.

Warning:The energy loss was greater than 1.0 ft (0.3 m). between the current and previous cross section. This may indicate the need for additional cross sections.

Note: Hydraulic jump has occurred between this cross section and the previous upstream section.

River: North Reach: South Finger RS: 81 Profile: 5 yr

Warning:The conveyance ratio (upstream conveyance divided by downstream conveyance) is less than 0.7 or greater than 1.4. This may indicate the need for additional cross sections.

Warning:The energy loss was greater than 1.0 ft (0.3 m). between the current and previous cross section. This may indicate the need for additional cross sections.

Note: Hydraulic jump has occurred between this cross section and the previous upstream section.

River: North Reach: South Finger RS: 48 Profile: 100 yr

Warning:The energy equation could not be balanced within the specified number of iterations. The program used critical depth for the water surface and continued on with the calculations.

Warning:The energy loss was greater than 1.0 ft (0.3 m). between the current and previous cross section. This may indicate the need for additional cross sections.

Warning:During the standard step iterations, when the assumed water surface was set equal to critical depth, the calculated water surface came back below critical depth. This indicates that there is not a valid subcritical answer. The program defaulted to critical depth.

River: North Reach: South Finger RS: 48 Profile: 5 yr

Warning:The energy equation could not be balanced within the specified number of iterations. The program used critical depth for the water surface and continued on with the calculations.

Warning:The energy loss was greater than 1.0 ft (0.3 m). between the current and previous cross section. This may indicate

the need for additional cross sections.

Warning:During the standard step iterations, when the assumed water surface was set equal to critical depth, the calculated water surface came back below critical depth. This indicates that there is not a valid subcritical answer. The program defaulted to critical depth.

River: North Reach: Main Channel-L RS: 247 Profile: 100 yr

Warning:The velocity head has changed by more than 0.5 ft (0.15 m). This may indicate the need for additional cross sections.

Warning:During supercritical flow calculations a junction was encountered. During standard step calculations the program used the stream with the greatest momentum to balance the energy equation.

River: North Reach: Main Channel-L RS: 247 Profile: 5 yr

Warning:The velocity head has changed by more than 0.5 ft (0.15 m). This may indicate the need for additional cross sections.

Warning:During supercritical flow calculations a junction was encountered. During standard step calculations the program used the stream with the greatest momentum to balance the energy equation.

River: North Reach: Main Channel-L RS: 198 Profile: 100 yr

Warning:The energy equation could not be balanced within the specified number of iterations. The program used critical depth for the water surface and continued on with the calculations.

Warning:The velocity head has changed by more than 0.5 ft (0.15 m). This may indicate the need for additional cross sections.

Warning:The conveyance ratio (upstream conveyance divided by downstream conveyance) is less than 0.7 or greater than 1.4. This may indicate the need for additional cross sections.

Warning:The energy loss was greater than 1.0 ft (0.3 m). between the current and previous cross section. This may indicate the need for additional cross sections.

River: North Reach: Main Channel-L RS: 198 Profile: 5 yr

Warning:The energy equation could not be balanced within the specified number of iterations. The program used critical depth for the water surface and continued on with the calculations.

Warning:The conveyance ratio (upstream conveyance divided by downstream conveyance) is less than 0.7 or greater than 1.4. This may indicate the need for additional cross sections.

Warning:The energy loss was greater than 1.0 ft (0.3 m). between the current and previous cross section. This may indicate the need for additional cross sections.

Warning:During the standard step iterations, when the assumed water surface was set equal to critical depth, the calculated water surface came back below critical depth. This indicates that there is not a valid subcritical answer. The program defaulted to critical depth.

River: North Reach: Main Channel-L RS: 148 Profile: 100 yr

Warning:The conveyance ratio (upstream conveyance divided by downstream conveyance) is less than 0.7 or greater than 1.4. This may indicate the need for additional cross sections.

Warning:The energy loss was greater than 1.0 ft (0.3 m). between the current and previous cross section. This may indicate the need for additional cross sections.

Warning:The energy loss was greater than 1.0 ft (0.3 m). between the current and previous cross section. This may indicate the need for additional cross sections.

Note: Hydraulic jump has occurred between this cross section and the previous upstream section.

River: North Reach: Main Channel-L RS: 148 Profile: 5 yr

Warning:The energy loss was greater than 1.0 ft (0.3 m). between the current and previous cross section. This may indicate the need for additional cross sections.

Note: Hydraulic jump has occurred between this cross section and the previous upstream section.

River: North Reach: Main Channel-L RS: 99 Profile: 100 yr

Warning:The energy loss was greater than 1.0 ft (0.3 m). between the current and previous cross section. This may indicate the need for additional cross sections.

River: North Reach: Main Channel-L RS: 99 Profile: 5 yr

Warning:The energy loss was greater than 1.0 ft (0.3 m). between the current and previous cross section. This may indicate the need for additional cross sections.

River: North Reach: Main Channel-L RS: 49 Profile: 100 yr

Warning:The energy loss was greater than 1.0 ft (0.3 m). between the current and previous cross section. This may indicate the need for additional cross sections.

River: North Reach: Main Channel-L RS: 49 Profile: 5 yr

Warning:The energy loss was greater than 1.0 ft (0.3 m). between the current and previous cross section. This may indicate the need for additional cross sections.

River: South Reach: Main Channel RS: 1300 Profile: 100 yr

Warning:The energy equation could not be balanced within the specified number of iterations. The program used critical depth for the water surface and continued on with the calculations.

Warning:Divided flow computed for this cross-section.

Warning:The conveyance ratio (upstream conveyance divided by downstream conveyance) is less than 0.7 or greater than 1.4. This may indicate the need for additional cross sections.

Warning:The energy loss was greater than 1.0 ft (0.3 m). between the current and previous cross section. This may indicate the need for additional cross sections.

Warning:During the standard step iterations, when the assumed water surface was set equal to critical depth, the calculated

water surface came back below critical depth. This indicates that there is not a valid subcritical answer. The program defaulted to critical depth.

River: South Reach: Main Channel RS: 1300 Profile: 5 yr

Warning: The energy equation could not be balanced within the specified number of iterations. The program used critical depth for the water surface and continued on with the calculations.

Warning: The conveyance ratio (upstream conveyance divided by downstream conveyance) is less than 0.7 or greater than 1.4. This may indicate the need for additional cross sections.

Warning: The energy loss was greater than 1.0 ft (0.3 m). between the current and previous cross section. This may indicate the need for additional cross sections.

Warning: During the standard step iterations, when the assumed water surface was set equal to critical depth, the calculated water surface came back below critical depth. This indicates that there is not a valid subcritical answer. The program defaulted to critical depth.

River: South Reach: Main Channel RS: 1250 Profile: 100 yr

Warning: The conveyance ratio (upstream conveyance divided by downstream conveyance) is less than 0.7 or greater than 1.4. This may indicate the need for additional cross sections.

Warning: The energy loss was greater than 1.0 ft (0.3 m). between the current and previous cross section. This may indicate the need for additional cross sections.

Note: Hydraulic jump has occurred between this cross section and the previous upstream section.

River: South Reach: Main Channel RS: 1250 Profile: 5 yr

Warning: The conveyance ratio (upstream conveyance divided by downstream conveyance) is less than 0.7 or greater than 1.4. This may indicate the need for additional cross sections.

Warning: The energy loss was greater than 1.0 ft (0.3 m). between the current and previous cross section. This may indicate the need for additional cross sections.

Note: Hydraulic jump has occurred between this cross section and the previous upstream section.

River: South Reach: Main Channel RS: 1218 Profile: 100 yr

Warning: The energy equation could not be balanced within the specified number of iterations. The program used critical depth for the water surface and continued on with the calculations.

Warning: Divided flow computed for this cross-section.

Warning: The energy loss was greater than 1.0 ft (0.3 m). between the current and previous cross section. This may indicate the need for additional cross sections.

Warning: During the standard step iterations, when the assumed water surface was set equal to critical depth, the calculated water surface came back below critical depth. This indicates that there is not a valid subcritical answer. The program defaulted to critical depth.

River: South Reach: Main Channel RS: 1218 Profile: 5 yr

Warning: The energy equation could not be balanced within the specified number of iterations. The program used critical depth for the water surface and continued on with the calculations.

Warning: Divided flow computed for this cross-section.

Warning: The energy loss was greater than 1.0 ft (0.3 m). between the current and previous cross section. This may indicate the need for additional cross sections.

Warning: During the standard step iterations, when the assumed water surface was set equal to critical depth, the calculated water surface came back below critical depth. This indicates that there is not a valid subcritical answer. The program defaulted to critical depth.

River: South Reach: Main Channel RS: 1200 Profile: 100 yr

Warning: The energy equation could not be balanced within the specified number of iterations. The program selected the water surface that had the least amount of error between computed and assumed values.

Warning: The velocity head has changed by more than 0.5 ft (0.15 m). This may indicate the need for additional cross sections.

Warning: The conveyance ratio (upstream conveyance divided by downstream conveyance) is less than 0.7 or greater than 1.4. This may indicate the need for additional cross sections.

Warning: The energy loss was greater than 1.0 ft (0.3 m). between the current and previous cross section. This may indicate the need for additional cross sections.

Note: Program found supercritical flow starting at this cross section.

River: South Reach: Main Channel RS: 1200 Profile: 5 yr

Warning: The energy equation could not be balanced within the specified number of iterations. The program selected the water surface that had the least amount of error between computed and assumed values.

Warning: The velocity head has changed by more than 0.5 ft (0.15 m). This may indicate the need for additional cross sections.

Warning: The conveyance ratio (upstream conveyance divided by downstream conveyance) is less than 0.7 or greater than 1.4. This may indicate the need for additional cross sections.

Warning: The energy loss was greater than 1.0 ft (0.3 m). between the current and previous cross section. This may indicate the need for additional cross sections.

Note: Program found supercritical flow starting at this cross section.

River: South Reach: Main Channel RS: 1167 Profile: 100 yr

Warning:The energy equation could not be balanced within the specified number of iterations. The program used critical depth for the water surface and continued on with the calculations.

Warning:The energy loss was greater than 1.0 ft (0.3 m). between the current and previous cross section. This may indicate the need for additional cross sections.

Warning:During the standard step iterations, when the assumed water surface was set equal to critical depth, the calculated water surface came back below critical depth. This indicates that there is not a valid subcritical answer. The program defaulted to critical depth.

River: South Reach: Main Channel RS: 1167 Profile: 5 yr

Warning:The energy equation could not be balanced within the specified number of iterations. The program used critical depth for the water surface and continued on with the calculations.

Warning:The energy loss was greater than 1.0 ft (0.3 m). between the current and previous cross section. This may indicate the need for additional cross sections.

Warning:During the standard step iterations, when the assumed water surface was set equal to critical depth, the calculated water surface came back below critical depth. This indicates that there is not a valid subcritical answer. The program defaulted to critical depth.

River: South Reach: Main Channel RS: 1150 Profile: 100 yr

Warning:The conveyance ratio (upstream conveyance divided by downstream conveyance) is less than 0.7 or greater than 1.4. This may indicate the need for additional cross sections.

Warning:The energy loss was greater than 1.0 ft (0.3 m). between the current and previous cross section. This may indicate the need for additional cross sections.

River: South Reach: Main Channel RS: 1150 Profile: 5 yr

Warning:The conveyance ratio (upstream conveyance divided by downstream conveyance) is less than 0.7 or greater than 1.4. This may indicate the need for additional cross sections.

Warning:The energy loss was greater than 1.0 ft (0.3 m). between the current and previous cross section. This may indicate the need for additional cross sections.

River: South Reach: Main Channel RS: 1100 Profile: 100 yr

Warning:The conveyance ratio (upstream conveyance divided by downstream conveyance) is less than 0.7 or greater than 1.4. This may indicate the need for additional cross sections.

Warning:The energy loss was greater than 1.0 ft (0.3 m). between the current and previous cross section. This may indicate the need for additional cross sections.

Note: Hydraulic jump has occurred between this cross section and the previous upstream section.

River: South Reach: Main Channel RS: 1100 Profile: 5 yr

Warning:The conveyance ratio (upstream conveyance divided by downstream conveyance) is less than 0.7 or greater than 1.4. This may indicate the need for additional cross sections.

Warning:The energy loss was greater than 1.0 ft (0.3 m). between the current and previous cross section. This may indicate the need for additional cross sections.

Note: Hydraulic jump has occurred between this cross section and the previous upstream section.

River: South Reach: Main Channel RS: 1050 Profile: 100 yr

Warning:The conveyance ratio (upstream conveyance divided by downstream conveyance) is less than 0.7 or greater than 1.4. This may indicate the need for additional cross sections.

Warning:The energy loss was greater than 1.0 ft (0.3 m). between the current and previous cross section. This may indicate the need for additional cross sections.

River: South Reach: Main Channel RS: 1050 Profile: 5 yr

Warning:The conveyance ratio (upstream conveyance divided by downstream conveyance) is less than 0.7 or greater than 1.4. This may indicate the need for additional cross sections.

Warning:The energy loss was greater than 1.0 ft (0.3 m). between the current and previous cross section. This may indicate the need for additional cross sections.

River: South Reach: Main Channel RS: 1000 Profile: 100 yr

Warning:The conveyance ratio (upstream conveyance divided by downstream conveyance) is less than 0.7 or greater than 1.4. This may indicate the need for additional cross sections.

Warning:The energy loss was greater than 1.0 ft (0.3 m). between the current and previous cross section. This may indicate the need for additional cross sections.

River: South Reach: Main Channel RS: 1000 Profile: 5 yr

Warning:The energy equation could not be balanced within the specified number of iterations. The program used critical depth for the water surface and continued on with the calculations.

Warning:The energy loss was greater than 1.0 ft (0.3 m). between the current and previous cross section. This may indicate the need for additional cross sections.

River: South Reach: Main Channel RS: 950 Profile: 100 yr

Warning:The energy equation could not be balanced within the specified number of iterations. The program used critical depth for the water surface and continued on with the calculations.

Warning:The energy loss was greater than 1.0 ft (0.3 m). between the current and previous cross section. This may indicate

the need for additional cross sections.

Warning:During the standard step iterations, when the assumed water surface was set equal to critical depth, the calculated water surface came back below critical depth. This indicates that there is not a valid subcritical answer. The program defaulted to critical depth.

River: South Reach: Main Channel RS: 950 Profile: 5 yr

Warning:The energy loss was greater than 1.0 ft (0.3 m). between the current and previous cross section. This may indicate the need for additional cross sections.

River: South Reach: Main Channel RS: 900 Profile: 100 yr

Warning:The energy loss was greater than 1.0 ft (0.3 m). between the current and previous cross section. This may indicate the need for additional cross sections.

Note: Program found supercritical flow starting at this cross section.

River: South Reach: Main Channel RS: 900 Profile: 5 yr

Warning:The energy equation could not be balanced within the specified number of iterations. The program used critical depth for the water surface and continued on with the calculations.

Warning:The conveyance ratio (upstream conveyance divided by downstream conveyance) is less than 0.7 or greater than 1.4. This may indicate the need for additional cross sections.

Warning:The energy loss was greater than 1.0 ft (0.3 m). between the current and previous cross section. This may indicate the need for additional cross sections.

Warning:During the standard step iterations, when the assumed water surface was set equal to critical depth, the calculated water surface came back below critical depth. This indicates that there is not a valid subcritical answer. The program defaulted to critical depth.

River: South Reach: Main Channel RS: 850 Profile: 100 yr

Warning:The conveyance ratio (upstream conveyance divided by downstream conveyance) is less than 0.7 or greater than 1.4. This may indicate the need for additional cross sections.

Warning:The energy loss was greater than 1.0 ft (0.3 m). between the current and previous cross section. This may indicate the need for additional cross sections.

Note: Hydraulic jump has occurred between this cross section and the previous upstream section.

River: South Reach: Main Channel RS: 850 Profile: 5 yr

Warning:The conveyance ratio (upstream conveyance divided by downstream conveyance) is less than 0.7 or greater than 1.4. This may indicate the need for additional cross sections.

Warning:The energy loss was greater than 1.0 ft (0.3 m). between the current and previous cross section. This may indicate the need for additional cross sections.

River: South Reach: Main Channel RS: 800 Profile: 100 yr

Warning:The conveyance ratio (upstream conveyance divided by downstream conveyance) is less than 0.7 or greater than 1.4. This may indicate the need for additional cross sections.

Warning:The energy loss was greater than 1.0 ft (0.3 m). between the current and previous cross section. This may indicate the need for additional cross sections.

River: South Reach: Main Channel RS: 800 Profile: 5 yr

Warning:The conveyance ratio (upstream conveyance divided by downstream conveyance) is less than 0.7 or greater than 1.4. This may indicate the need for additional cross sections.

Warning:The energy loss was greater than 1.0 ft (0.3 m). between the current and previous cross section. This may indicate the need for additional cross sections.

River: South Reach: Main Channel RS: 750 Profile: 100 yr

Warning:The energy equation could not be balanced within the specified number of iterations. The program used critical depth for the water surface and continued on with the calculations.

Warning:The conveyance ratio (upstream conveyance divided by downstream conveyance) is less than 0.7 or greater than 1.4. This may indicate the need for additional cross sections.

Warning:The energy loss was greater than 1.0 ft (0.3 m). between the current and previous cross section. This may indicate the need for additional cross sections.

Warning:During the standard step iterations, when the assumed water surface was set equal to critical depth, the calculated water surface came back below critical depth. This indicates that there is not a valid subcritical answer. The program defaulted to critical depth.

River: South Reach: Main Channel RS: 750 Profile: 5 yr

Warning:The conveyance ratio (upstream conveyance divided by downstream conveyance) is less than 0.7 or greater than 1.4. This may indicate the need for additional cross sections.

Warning:The energy loss was greater than 1.0 ft (0.3 m). between the current and previous cross section. This may indicate the need for additional cross sections.

River: South Reach: Main Channel RS: 700 Profile: 100 yr

Warning:The conveyance ratio (upstream conveyance divided by downstream conveyance) is less than 0.7 or greater than 1.4. This may indicate the need for additional cross sections.

Warning:The energy loss was greater than 1.0 ft (0.3 m). between the current and previous cross section. This may indicate



the need for additional cross sections.

River: South Reach: Main Channel RS: 700 Profile: 5 yr

Warning:The conveyance ratio (upstream conveyance divided by downstream conveyance) is less than 0.7 or greater than 1.4. This may indicate the need for additional cross sections.

Warning:The energy loss was greater than 1.0 ft (0.3 m). between the current and previous cross section. This may indicate the need for additional cross sections.

River: South Reach: Main Channel RS: 650 Profile: 100 yr

Warning:The conveyance ratio (upstream conveyance divided by downstream conveyance) is less than 0.7 or greater than 1.4. This may indicate the need for additional cross sections.

Warning:The energy loss was greater than 1.0 ft (0.3 m). between the current and previous cross section. This may indicate the need for additional cross sections.

River: South Reach: Main Channel RS: 650 Profile: 5 yr

Warning:The conveyance ratio (upstream conveyance divided by downstream conveyance) is less than 0.7 or greater than 1.4. This may indicate the need for additional cross sections.

Warning:The energy loss was greater than 1.0 ft (0.3 m). between the current and previous cross section. This may indicate the need for additional cross sections.

River: South Reach: Main Channel RS: 600 Profile: 100 yr

Warning:The conveyance ratio (upstream conveyance divided by downstream conveyance) is less than 0.7 or greater than 1.4. This may indicate the need for additional cross sections.

Warning:The energy loss was greater than 1.0 ft (0.3 m). between the current and previous cross section. This may indicate the need for additional cross sections.

River: South Reach: Main Channel RS: 600 Profile: 5 yr

Warning:The conveyance ratio (upstream conveyance divided by downstream conveyance) is less than 0.7 or greater than 1.4. This may indicate the need for additional cross sections.

Warning:The energy loss was greater than 1.0 ft (0.3 m). between the current and previous cross section. This may indicate the need for additional cross sections.

River: South Reach: Main Channel RS: 550 Profile: 100 yr

Warning:The energy loss was greater than 1.0 ft (0.3 m). between the current and previous cross section. This may indicate the need for additional cross sections.

River: South Reach: Main Channel RS: 550 Profile: 5 yr

Warning:The energy loss was greater than 1.0 ft (0.3 m). between the current and previous cross section. This may indicate the need for additional cross sections.

River: South Reach: Main Channel RS: 500 Profile: 100 yr

Warning:The energy equation could not be balanced within the specified number of iterations. The program used critical depth for the water surface and continued on with the calculations.

Warning:The conveyance ratio (upstream conveyance divided by downstream conveyance) is less than 0.7 or greater than 1.4. This may indicate the need for additional cross sections.

Warning:The energy loss was greater than 1.0 ft (0.3 m). between the current and previous cross section. This may indicate the need for additional cross sections.

Warning:During the standard step iterations, when the assumed water surface was set equal to critical depth, the calculated water surface came back below critical depth. This indicates that there is not a valid subcritical answer. The program defaulted to critical depth.

River: South Reach: Main Channel RS: 500 Profile: 5 yr

Warning:The conveyance ratio (upstream conveyance divided by downstream conveyance) is less than 0.7 or greater than 1.4. This may indicate the need for additional cross sections.

Warning:The energy loss was greater than 1.0 ft (0.3 m). between the current and previous cross section. This may indicate the need for additional cross sections.

River: South Reach: Main Channel RS: 350 Profile: 5 yr

Warning:The energy loss was greater than 1.0 ft (0.3 m). between the current and previous cross section. This may indicate the need for additional cross sections.

River: South Reach: Main Channel RS: 300 Profile: 100 yr

Warning:The conveyance ratio (upstream conveyance divided by downstream conveyance) is less than 0.7 or greater than 1.4. This may indicate the need for additional cross sections.

Warning:The energy loss was greater than 1.0 ft (0.3 m). between the current and previous cross section. This may indicate the need for additional cross sections.

River: South Reach: Main Channel RS: 300 Profile: 5 yr

Warning:The energy loss was greater than 1.0 ft (0.3 m). between the current and previous cross section. This may indicate the need for additional cross sections.

River: South Reach: Main Channel RS: 250 Profile: 100 yr

Warning:Divided flow computed for this cross-section.

Warning:The energy loss was greater than 1.0 ft (0.3 m). between the current and previous cross section. This may indicate

the need for additional cross sections.

River: South Reach: Main Channel RS: 250 Profile: 5 yr  
Warning:The energy loss was greater than 1.0 ft (0.3 m). between the current and previous cross section. This may indicate the need for additional cross sections.

River: South Reach: Main Channel RS: 200 Profile: 100 yr  
Warning:Divided flow computed for this cross-section.  
Warning:The energy loss was greater than 1.0 ft (0.3 m). between the current and previous cross section. This may indicate the need for additional cross sections.

River: South Reach: Main Channel RS: 200 Profile: 5 yr  
Warning:Divided flow computed for this cross-section.  
Warning:The energy loss was greater than 1.0 ft (0.3 m). between the current and previous cross section. This may indicate the need for additional cross sections.

River: South Reach: Main Channel RS: 150 Profile: 100 yr  
Warning:The conveyance ratio (upstream conveyance divided by downstream conveyance) is less than 0.7 or greater than 1.4. This may indicate the need for additional cross sections.  
Warning:The energy loss was greater than 1.0 ft (0.3 m). between the current and previous cross section. This may indicate the need for additional cross sections.

River: South Reach: Main Channel RS: 150 Profile: 5 yr  
Warning:Divided flow computed for this cross-section.  
Warning:The conveyance ratio (upstream conveyance divided by downstream conveyance) is less than 0.7 or greater than 1.4. This may indicate the need for additional cross sections.  
Warning:The energy loss was greater than 1.0 ft (0.3 m). between the current and previous cross section. This may indicate the need for additional cross sections.

River: South Reach: Main Channel RS: 100 Profile: 100 yr  
Warning:The energy equation could not be balanced within the specified number of iterations. The program used critical depth for the water surface and continued on with the calculations.  
Warning:The conveyance ratio (upstream conveyance divided by downstream conveyance) is less than 0.7 or greater than 1.4. This may indicate the need for additional cross sections.  
Warning:The energy loss was greater than 1.0 ft (0.3 m). between the current and previous cross section. This may indicate the need for additional cross sections.  
Warning:During the standard step iterations, when the assumed water surface was set equal to critical depth, the calculated water surface came back below critical depth. This indicates that there is not a valid subcritical answer. The program defaulted to critical depth.

River: South Reach: Main Channel RS: 100 Profile: 5 yr  
Warning:The conveyance ratio (upstream conveyance divided by downstream conveyance) is less than 0.7 or greater than 1.4. This may indicate the need for additional cross sections.  
Warning:The energy loss was greater than 1.0 ft (0.3 m). between the current and previous cross section. This may indicate the need for additional cross sections.

River: South Reach: Main Channel RS: 50 Profile: 100 yr  
Warning:The conveyance ratio (upstream conveyance divided by downstream conveyance) is less than 0.7 or greater than 1.4. This may indicate the need for additional cross sections.  
Warning:The energy loss was greater than 1.0 ft (0.3 m). between the current and previous cross section. This may indicate the need for additional cross sections.

River: South Reach: Main Channel RS: 0 Profile: 100 yr  
Warning:Slope-Area method could not converge on a starting water surface elevation within the specified number of trials. The program used critical depth as the starting water surface.  
Warning:Divided flow computed for this cross-section.

River: South Reach: Main Channel RS: 0 Profile: 5 yr  
Warning:Divided flow computed for this cross-section.

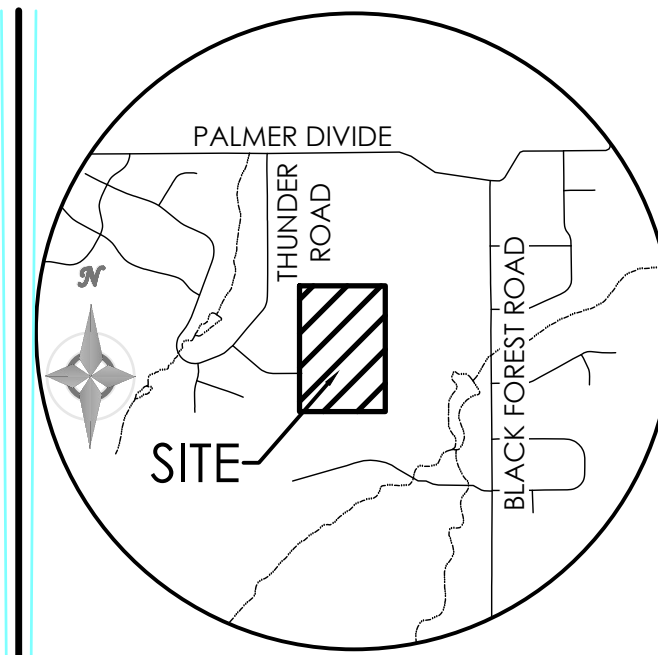
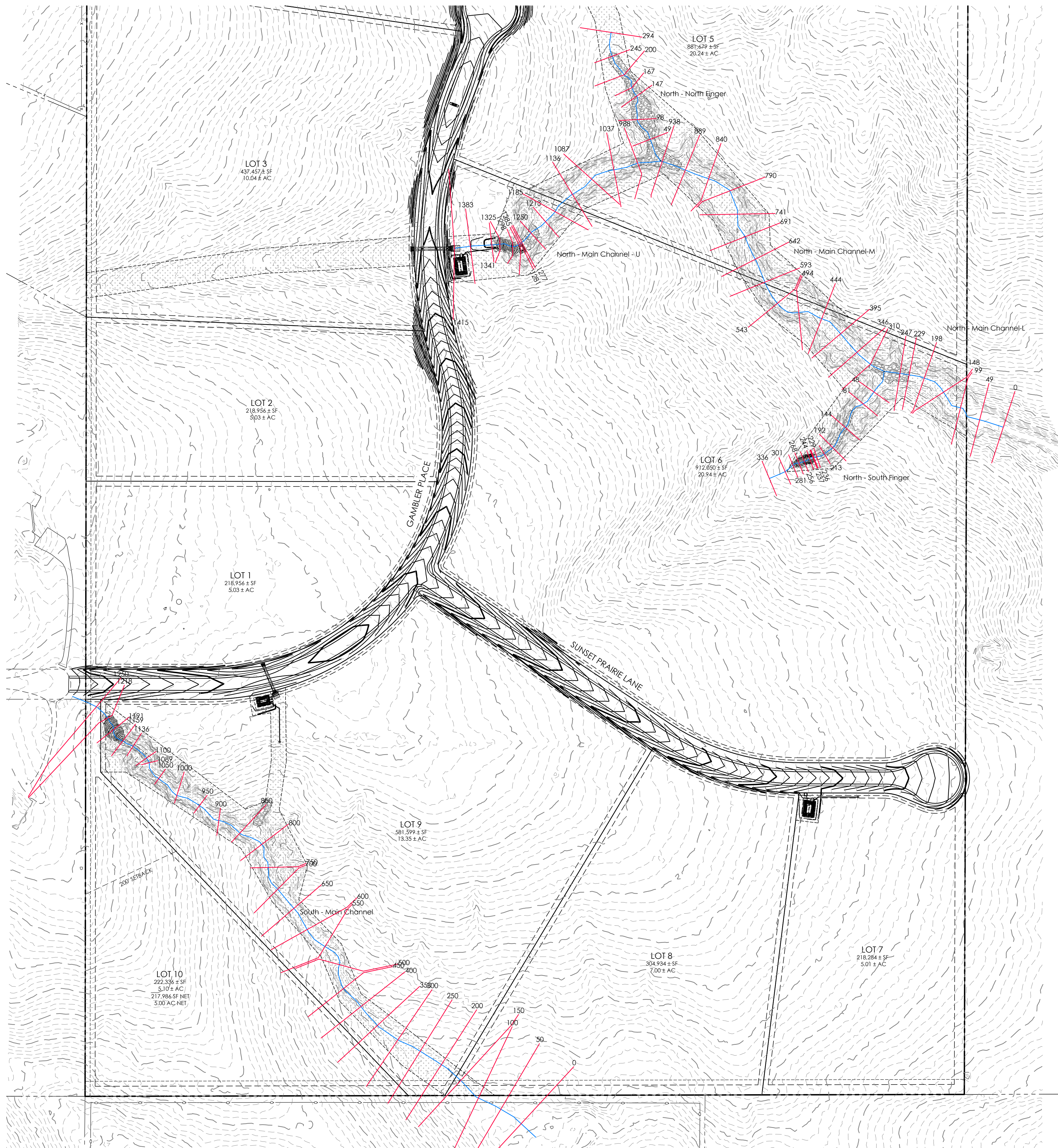

VICINITY MAP  
NOT TO SCALE

BENCHMARK  
THE BENCHMARK FOR THESE PLANS IS THE  
SOUTHWEST PROPERTY CORNER, A REBAR &  
CAP, ALESSI, PLS 30130.  
ELEVATION = 7385.63' (NAVD88).

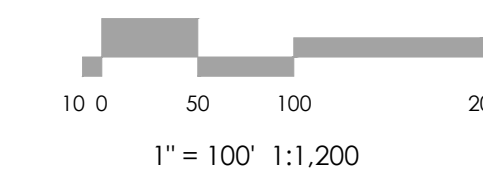
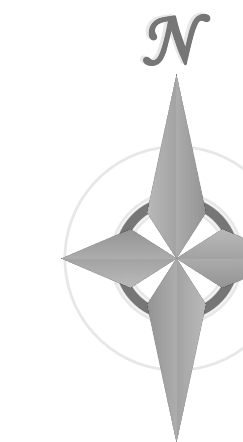

REVISIONS

DESIGNED BY \_\_\_\_\_  
DRAWN BY \_\_\_\_\_  
CHECKED BY \_\_\_\_\_  
AS-BUILT BY \_\_\_\_\_  
CHECKED BY \_\_\_\_\_

TABLE ROCK  
HOMESTEADS

HECRAS REACH &  
SECTION MAP

PROPOSED

MVE PROJECT 61223

MVE DRAWING HECRAS-PP

JANUARY 24, 2025

SHEET 1 OF 1

HEC-RAS Plan: Default Scenario Profile: 5 yr

Reach	River Sta	Profile	Q Total (cfs)	Min Ch El (ft)	Invert Slope	W.S. Elev (ft)	Crit W.S. (ft)	E.G. Elev (ft)	E.G. Slope (ft/ft)	Max Chl Dpth (ft)	Hydr Depth C (ft)	Flow Area (sq ft)	Top Width (ft)	Vel Chnl (ft/s)	Froude # Chl	Shear Chan (lb/sq ft)
North Finger	294	5 yr	26.70	7360.97	0.0480	7361.44	7361.44	7361.57	0.040180	0.47	0.24	9.31	38.89	2.87	1.03	0.60
North Finger	245	5 yr	26.70	7358.64	0.0267	7359.31	7359.40	7359.59	0.041350	0.67	0.44	6.92	24.42	4.37	1.16	1.14
North Finger	200	5 yr	26.70	7357.45	0.2030	7358.20	7358.20	7358.34	0.026736	0.75	0.37	9.33	35.09	3.13	0.91	0.62
North Finger	167	5 yr	26.70	7350.76	0.0853	7351.30	7351.85	7355.36	0.986469	0.54	0.30	1.65	5.58	16.17	5.24	17.87
North Finger	147	5 yr	26.70	7349.08	0.0767	7349.83	7349.98	7350.36	0.083516	0.74	0.41	4.56	11.19	5.85	1.62	2.10
North Finger	98	5 yr	26.70	7345.35	0.0473	7345.92	7346.06	7346.36	0.079860	0.57	0.36	5.01	13.74	5.33	1.56	1.80
North Finger	49	5 yr	26.70	7343.05	0.0000	7344.43	7344.43	7344.78	0.029575	1.38	0.68	5.61	8.27	4.76	1.02	1.19
Main Channel - U	1415	5 yr	9.00	7372.49	0.0420	7372.84	7372.80	7372.89	0.041975	0.35	0.19	4.86	25.78	1.85	0.75	0.49
Main Channel - U	1383	5 yr	9.00	7371.15	0.0402	7371.51		7371.57	0.040494	0.36	0.22	4.45	20.11	2.02	0.76	0.56
Main Channel - U	1341	5 yr	9.00	7369.42	0.1198	7369.76	7369.76	7369.89	0.037477	0.34	0.25	3.20	13.06	2.81	1.00	0.57
Main Channel - U	1325	5 yr	9.00	7367.50	0.3051	7367.71	7367.87	7368.37	0.457507	0.21	0.13	1.37	10.30	6.55	3.16	3.80
Main Channel - U	1298	5 yr	9.00	7359.39	0.3254	7359.65	7359.75	7359.94	0.150658	0.26	0.17	2.08	12.57	4.34	1.88	1.55
Main Channel - U	1285	5 yr	9.00	7355.00	0.0000	7356.16	7355.30	7356.16	0.000307	1.16	0.91	14.99	16.53	0.60	0.11	0.02
Main Channel - U	1281	5 yr	9.00	7355.00	-0.1886	7356.16		7356.16	0.000395	1.16	0.73	15.28	21.01	0.59	0.12	0.02
Main Channel - U	1277	5 yr	9.00	7355.66	0.0934	7356.07	7356.07	7356.15	0.042086	0.41	0.17	3.89	23.03	2.31	0.99	0.44
Main Channel - U	1250	5 yr	9.00	7353.21	0.0515	7353.44	7353.54	7353.81	0.287799	0.23	0.12	1.84	15.17	4.88	2.47	2.18
Main Channel - U	1213	5 yr	9.00	7351.30	0.0504	7351.82	7351.74	7351.87	0.030109	0.52	0.24	4.92	20.60	1.83	0.66	0.45
Main Channel - U	1185	5 yr	9.00	7349.90	0.0407	7350.51	7350.51	7350.61	0.073736	0.61	0.20	3.57	18.00	2.52	1.00	0.90
Main Channel - U	1136	5 yr	9.00	7347.89	0.0283	7348.55	7348.40	7348.62	0.018978	0.66	0.39	4.48	11.50	2.01	0.57	0.46
Main Channel - U	1087	5 yr	9.00	7346.49	0.0407	7346.87	7346.87	7346.97	0.072078	0.38	0.21	3.50	17.07	2.57	1.00	0.92
Main Channel - U	1037	5 yr	9.00	7344.48	0.0247	7345.21	7345.03	7345.26	0.015516	0.73	0.37	5.12	13.75	1.76	0.51	0.36
Main Channel - U	988	5 yr	9.00	7343.26	0.0476	7343.95	7343.95	7344.15	0.034871	0.69	0.39	2.48	6.36	3.62	1.02	0.82
Main Channel-M	938	5 yr	18.40	7340.91	0.0277	7341.14	7341.48	7344.48	2.168990	0.23	0.14	1.26	9.05	14.64	6.93	18.75
Main Channel-M	889	5 yr	18.40	7339.54	0.0004	7340.70	7340.21	7340.74	0.005207	1.16	0.75	11.38	15.18	1.62	0.33	0.24
Main Channel-M	840	5 yr	18.40	7339.52	0.0310	7340.23		7340.30	0.018947	0.71	0.42	8.63	20.34	2.13	0.58	0.50
Main Channel-M	790	5 yr	18.40	7337.99	0.0326	7338.59	7338.59	7338.78	0.057007	0.59	0.39	5.26	13.47	3.50	0.99	1.38
Main Channel-M	741	5 yr	18.40	7336.38	0.0287	7337.18	7337.01	7337.23	0.015138	0.80	0.41	9.93	24.41	1.85	0.51	0.38
Main Channel-M	691	5 yr	18.40	7334.96	0.0684	7335.70	7335.70	7335.92	0.056211	0.74	0.45	4.86	10.84	3.79	1.00	1.55
Main Channel-M	642	5 yr	18.40	7331.58	0.0144	7332.74	7332.55	7332.88	0.023163	1.16	0.65	5.99	9.22	3.07	0.67	0.91
Main Channel-M	593	5 yr	18.40	7330.87	0.0186	7332.08		7332.15	0.009873	1.21	0.66	9.04	13.75	2.03	0.44	0.40
Main Channel-M	543	5 yr	18.40	7329.95	0.0089	7331.32		7331.43	0.022619	1.37	0.54	6.85	12.62	2.68	0.64	0.74
Main Channel-M	494	5 yr	18.40	7329.51	0.0119	7330.55	7330.34	7330.60	0.012533	1.04	0.44	10.46	23.99	1.76	0.47	0.34
Main Channel-M	444	5 yr	18.40	7328.92	0.0395	7329.41	7329.38	7329.54	0.045504	0.49	0.33	6.53	19.59	2.82	0.86	0.94
Main Channel-M	395	5 yr	18.40	7326.97	0.0273	7327.80		7327.90	0.024962	0.83	0.46	7.11	15.37	2.59	0.67	0.71
Main Channel-M	346	5 yr	18.40	7325.62	0.0114	7326.66		7326.79	0.020488	1.04	0.67	6.25	9.32	2.95	0.63	0.83
Main Channel-M	310	5 yr	18.40	7325.21	0.0100	7326.06	7325.68	7326.10	0.003762	0.85	0.69	10.46	15.14	1.76	0.37	0.16
South Finger	336	5 yr	2.60	7356.94	0.0838	7357.10	7357.09	7357.13	0.070782	0.16	0.08	1.90	23.55	1.37	0.85	0.36
South Finger	301	5 yr	2.60	7354.06	0.0891	7354.34	7354.34	7354.38	0.090634	0.28	0.09	1.54	16.82	1.68	0.98	0.52
South Finger	281	5 yr	2.60	7352.27	0.2997	7352.51	7352.53	7352.62	0.084724	0.23	0.13	0.97	7.64	2.69	1.33	0.66
South Finger	268	5 yr	2.60	7348.26	0.3073	7348.34	7348.46	7349.36	2.180953	0.08	0.06	0.32	5.59	8.13	6.00	7.77
South Finger	256	5 yr	2.60	7344.84	0.3084	7345.00	7345.04	7345.16	0.109350	0.16	0.13	0.81	6.01	3.21	1.54	0.91
South Finger	244	5 yr	2.60	7341.12	0.0168	7342.34	7341.36	7342.34	0.000079	1.22	1.01	8.22	8.72	0.32	0.06	0.00
South Finger	237	5 yr	2.60	7341.00	-0.6052	7342.34		7342.34	0.000052	1.34	1.11	9.60	9.56	0.27	0.05	0.00
South Finger	236	5 yr	2.60	7341.92	-0.0081	7342.32		7342.34	0.003233	0.40	0.31	2.74	8.94	0.95	0.30	0.06
South Finger	229	5 yr	2.60	7341.97	0.1292	7342.20	7342.20	7342.28	0.039006	0.23	0.17	1.15	6.71	2.26	0.96	0.42
South Finger	213	5 yr	2.60	7339.87	0.1009	7340.07	7340.20	7340.66	0.524612	0.20	0.11	0.42	3.80	6.18	3.27	3.60
South Finger	192	5 yr	2.60	7337.73	0.0943	7337.96	7337.96	7338.04	0.049918	0.23	0.15	1.10	7.27	2.35	1.07	0.47
South Finger	144	5 yr	2.60	7333.22	0.0786	7333.59	7333.71	7333.99	0.170865	0.36	0.20	0.51	2.52	5.11	2.00	2.05
South Finger	81	5 yr	2.60	7328.26	0.0308	7328.68	7328.58	7328.71	0.020082	0.42	0.23	1.78	7.75	1.46	0.54	0.29
South Finger	48	5 yr	2.60	7327.26	0.0000	7327.55	7327.55	7327.62	0.064924	0.29	0.17	1.20	6.90	2.17	0.92	0.70
Main Channel-L	247	5 yr	25.60	7324.66	0.0043	7325.13	7325.46	7327.41	0.891459	0.46	0.20	2.11	10.32	12.13	4.73	11.32
Main Channel-L	229	5 yr	25.60	7324.58	0.0294	7325.42	7325.25	7325.51	0.018911	0.84	0.51	10.58	20.55	2.42	0.59	0.60
Main Channel-L	198	5 yr	25.60	7323.67	0.0298	7324.32	7324.32	7324.54	0.058541	0.65	0.43	6.75	15.53	3.79	1.01	1.57
Main Channel-L	148	5 yr	25.60	7322.20	0.0231	7322.85	7322.70	7322.93	0.018216	0.65	0.45	11.86	26.55	2.16	0.57	0.50
Main Channel-L	99	5 yr	25.60	7321.06	0.0352	7321.72		7321.82	0.028524	0.66	0.39	10.46	27.10	2.45	0.70	0.68
Main Channel-L	49	5 yr	25.60	7319.32	0.0452	7319.82	7319.80	7319.96	0.051791	0.50	0.33	8.55	25.79	3.00	0.92	1.07
Main Channel-L	0	5 yr	25.60	7317.09		7317.79	7317.71	7317.93	0.033431	0.70	0.47	8.40	17.72	3.05	0.78	0.98

HEC-RAS Plan: Default Scenario River: South Reach: Main Channel Profile: 5 yr

Reach	River Sta	Profile	Q Total (cfs)	Min Ch El (ft)	Invert Slope	W.S. Elev (ft)	Crit W.S. (ft)	E.G. Elev (ft)	E.G. Slope (ft/ft)	Max Chl Dpth (ft)	Hydr Depth C (ft)	Flow Area (sq ft)	Top Width (ft)	Vel Chnl (ft/s)	Froude # Chl	Shear Chan (lb/sq ft)
Main Channel	1250	5 yr	0.70	7417.92	0.0698	7418.02	7418.02	7418.04	0.120513	0.10	0.04	0.63	16.11	1.10	0.98	0.30
Main Channel	1218	5 yr	0.70	7415.70	0.2635	7415.79	7415.79	7415.83	0.130321	0.09	0.07	0.43	6.65	1.61	1.11	0.53
Main Channel	1191	5 yr	0.70	7408.62	0.2870	7408.71	7408.71	7408.75	0.144080	0.09	0.06	0.43	7.11	1.62	1.15	0.55
Main Channel	1159	5 yr	0.70	7399.36	0.0651	7399.51	7399.57	7399.70	0.397390	0.15	0.09	0.20	2.24	3.46	2.03	2.21
Main Channel	1136	5 yr	0.70	7397.85	0.0647	7398.10	7398.10	7398.19	0.087526	0.25	0.17	0.30	1.79	2.36	1.03	0.86
Main Channel	1100	5 yr	0.70	7395.53	0.0246	7395.83	7395.75	7395.85	0.020213	0.30	0.17	0.60	3.57	1.17	0.51	0.21
Main Channel	1089	5 yr	0.70	7395.26	0.0410	7395.54		7395.58	0.032752	0.28	0.18	0.46	2.62	1.53	0.64	0.35
Main Channel	1050	5 yr	0.70	7393.66	0.0338	7393.98	7393.94	7394.03	0.049470	0.32	0.17	0.39	2.29	1.81	0.78	0.50
Main Channel	1000	5 yr	0.70	7391.97	0.0434	7392.14	7392.10	7392.16	0.028896	0.17	0.11	0.65	5.77	1.08	0.57	0.20
Main Channel	950	5 yr	0.70	7389.80	0.0802	7390.02	7390.01	7390.07	0.066644	0.22	0.11	0.42	3.71	1.66	0.87	0.47
Main Channel	900	5 yr	0.70	7385.79	0.0528	7385.95	7385.95	7386.00	0.101124	0.16	0.09	0.39	4.23	1.79	1.04	0.58
Main Channel	850	5 yr	0.70	7383.15	0.0254	7383.51	7383.41	7383.53	0.016309	0.36	0.20	0.59	2.95	1.18	0.46	0.20
Main Channel	800	5 yr	5.00	7381.88	0.0352	7382.40		7382.45	0.022895	0.52	0.28	2.82	10.07	1.77	0.59	0.40
Main Channel	750	5 yr	5.00	7380.12	0.0288	7380.62	7380.60	7380.74	0.055947	0.50	0.30	1.76	5.96	2.84	0.92	1.00
Main Channel	700	5 yr	5.00	7378.68	0.0254	7379.29	7379.17	7379.33	0.016546	0.61	0.29	3.22	10.97	1.55	0.50	0.30
Main Channel	650	5 yr	5.00	7377.41	0.0234	7377.91	7377.88	7378.00	0.049436	0.50	0.25	2.09	8.50	2.39	0.85	0.75
Main Channel	600	5 yr	5.00	7376.24	0.0262	7376.69	7376.56	7376.71	0.015293	0.45	0.22	4.04	18.37	1.24	0.46	0.21
Main Channel	550	5 yr	5.00	7374.93	0.0662	7375.27	7375.25	7375.35	0.061678	0.34	0.19	2.21	11.64	2.26	0.91	0.73
Main Channel	500	5 yr	5.00	7371.62	0.0344	7372.24	7372.23	7372.39	0.056604	0.62	0.32	1.66	5.19	3.01	0.94	1.10
Main Channel	450	5 yr	5.00	7369.90	0.0116	7370.76		7370.82	0.019302	0.86	0.40	2.51	6.34	2.00	0.56	0.45
Main Channel	400	5 yr	5.00	7369.32	0.0074	7370.06		7370.10	0.010984	0.74	0.40	3.24	8.14	1.54	0.43	0.27
Main Channel	350	5 yr	5.00	7368.95	0.0220	7369.38	7369.27	7369.41	0.017300	0.43	0.24	3.62	15.34	1.38	0.50	0.25
Main Channel	300	5 yr	5.00	7367.85	0.0222	7368.33		7368.37	0.024777	0.48	0.23	3.05	13.02	1.64	0.60	0.36
Main Channel	250	5 yr	5.00	7366.74	0.0258	7367.05		7367.09	0.026452	0.31	0.23	3.02	13.41	1.65	0.61	0.37
Main Channel	200	5 yr	5.00	7365.45	0.0232	7365.73	7365.68	7365.75	0.027047	0.28	0.12	4.49	36.67	1.11	0.56	0.21
Main Channel	150	5 yr	5.00	7364.29	0.0286	7364.70	7364.62	7364.71	0.016605	0.41	0.15	5.09	34.93	0.98	0.45	0.15
Main Channel	100	5 yr	5.00	7362.86	0.0314	7363.05	7363.05	7363.10	0.086312	0.19	0.11	2.75	25.70	1.82	0.98	0.58
Main Channel	50	5 yr	5.00	7361.29	0.0174	7361.64	7361.52	7361.66	0.008655	0.35	0.21	5.62	27.39	0.89	0.35	0.11
Main Channel	0	5 yr	5.00	7360.42		7360.60	7360.60	7360.64	0.097140	0.18	0.08	3.11	38.27	1.61	0.99	0.49

HEC-RAS Plan: Default Scenario Profile: 100 yr

Reach	River Sta	Profile	Q Total (cfs)	Min Ch El (ft)	Invert Slope	W.S. Elev (ft)	Crit W.S. (ft)	E.G. Elev (ft)	E.G. Slope (ft/ft)	Max Chl Dpth (ft)	Hydr Depth C (ft)	Flow Area (sq ft)	Top Width (ft)	Vel Chnl (ft/s)	Froude # Chl	Shear Chan (lb/sq ft)
North Finger	294	100 yr	59.60	7360.97	0.0480	7361.63	7361.63	7361.81	0.035025	0.65	0.35	17.20	48.78	3.47	1.03	0.77
North Finger	245	100 yr	59.60	7358.64	0.0267	7359.51	7359.62	7359.91	0.042486	0.86	0.64	13.98	43.84	5.66	1.25	1.69
North Finger	200	100 yr	59.60	7357.45	0.2030	7358.42	7358.43	7358.59	0.020109	0.97	0.57	20.30	56.84	3.63	0.84	0.72
North Finger	167	100 yr	59.60	7350.76	0.0853	7351.57	7352.33	7356.23	0.631762	0.81	0.46	3.44	7.47	17.32	4.50	17.72
North Finger	147	100 yr	59.60	7349.08	0.0767	7350.06	7350.37	7351.08	0.100843	0.98	0.58	7.37	12.75	8.09	1.88	3.57
North Finger	98	100 yr	59.60	7345.35	0.0473	7346.21	7346.39	7346.80	0.072970	0.86	0.49	9.61	19.57	6.20	1.56	2.21
North Finger	49	100 yr	59.60	7343.05	0.0000	7344.94	7344.94	7345.44	0.026423	1.89	0.97	10.47	10.77	5.69	1.02	1.51
Main Channel - U	1415	100 yr	57.20	7372.49	0.0420	7373.27	7373.18	7373.38	0.031431	0.78	0.41	21.33	52.22	2.68	0.74	0.80
Main Channel - U	1383	100 yr	57.20	7371.15	0.0402	7371.96	7371.91	7372.17	0.046154	0.81	0.50	15.45	31.09	3.70	0.93	1.43
Main Channel - U	1341	100 yr	57.20	7369.42	0.1198	7370.31	7370.31	7370.61	0.029028	0.89	0.58	12.97	22.17	4.41	1.02	1.05
Main Channel - U	1325	100 yr	57.20	7367.50	0.3051	7368.05	7368.41	7369.46	0.259705	0.55	0.36	6.00	16.76	9.53	2.81	5.79
Main Channel - U	1298	100 yr	57.20	7359.39	0.3254	7359.88	7360.24	7361.46	0.349833	0.49	0.31	5.67	18.21	10.08	3.18	6.79
Main Channel - U	1285	100 yr	57.20	7355.00	0.0000	7356.67	7355.93	7356.76	0.003102	1.67	1.26	24.17	19.19	2.37	0.37	0.24
Main Channel - U	1281	100 yr	57.20	7355.00	-0.1886	7356.68		7356.74	0.003197	1.67	0.95	28.49	29.95	2.01	0.36	0.19
Main Channel - U	1277	100 yr	57.20	7355.66	0.0934	7356.45	7356.45	7356.69	0.031515	0.79	0.48	14.31	30.03	4.00	1.02	0.93
Main Channel - U	1250	100 yr	57.20	7353.21	0.0515	7353.72	7354.03	7354.87	0.214084	0.51	0.36	6.66	18.70	8.59	2.54	4.72
Main Channel - U	1213	100 yr	57.20	7351.30	0.0504	7352.25	7352.18	7352.46	0.036634	0.95	0.59	15.54	26.37	3.68	0.85	1.34
Main Channel - U	1185	100 yr	57.20	7349.90	0.0407	7350.98	7350.97	7351.25	0.051568	1.08	0.56	13.62	24.43	4.20	0.99	1.77
Main Channel - U	1136	100 yr	57.20	7347.89	0.0283	7349.22	7349.07	7349.44	0.027284	1.33	0.76	15.23	20.06	3.75	0.76	1.28
Main Channel - U	1087	100 yr	57.20	7346.49	0.0407	7347.35	7347.35	7347.63	0.052082	0.86	0.55	13.53	24.39	4.23	1.00	1.80
Main Channel - U	1037	100 yr	57.20	7344.48	0.0247	7346.02	7345.65	7346.17	0.013289	1.54	0.99	18.47	18.63	3.10	0.55	0.80
Main Channel - U	988	100 yr	57.20	7343.26	0.0476	7344.81	7344.81	7345.25	0.025700	1.55	0.89	10.70	12.36	5.36	1.00	1.37
Main Channel-M	938	100 yr	117.20	7340.91	0.0277	7341.68	7342.39	7345.15	0.371808	0.77	0.54	7.85	14.52	14.93	3.58	12.42
Main Channel-M	889	100 yr	117.20	7339.54	0.0004	7341.72	7341.20	7341.96	0.013081	2.18	1.44	29.84	20.71	3.93	0.58	1.14
Main Channel-M	840	100 yr	117.20	7339.52	0.0310	7341.03		7341.19	0.017546	1.51	0.86	35.70	41.50	3.28	0.62	0.94
Main Channel-M	790	100 yr	117.20	7337.99	0.0326	7339.41	7339.41	7339.81	0.048946	1.42	0.77	23.05	29.92	5.09	1.02	2.33
Main Channel-M	741	100 yr	117.20	7336.38	0.0287	7338.09	7337.67	7338.23	0.012167	1.71	1.03	38.19	37.26	3.07	0.53	0.77
Main Channel-M	691	100 yr	117.20	7334.96	0.0684	7336.67	7336.67	7337.17	0.044326	1.71	0.98	20.78	21.33	5.64	1.01	2.66
Main Channel-M	642	100 yr	117.20	7331.58	0.0144	7334.09	7333.78	7334.43	0.022525	2.51	1.24	25.13	20.32	4.66	0.74	1.69
Main Channel-M	593	100 yr	117.20	7330.87	0.0186	7333.17		7333.46	0.016751	2.29	1.40	26.95	19.22	4.35	0.65	1.41
Main Channel-M	543	100 yr	117.20	7329.95	0.0089	7332.23		7332.44	0.024861	2.28	0.78	32.24	41.14	3.64	0.72	1.19
Main Channel-M	494	100 yr	117.20	7329.51	0.0119	7331.45	7331.02	7331.59	0.012180	1.94	1.02	38.41	37.60	3.05	0.53	0.77
Main Channel-M	444	100 yr	117.20	7328.92	0.0395	7330.08	7330.08	7330.51	0.046782	1.16	0.82	22.51	27.32	5.21	1.01	2.39
Main Channel-M	395	100 yr	117.20	7326.97	0.0273	7329.06	7328.52	7329.21	0.009824	2.09	1.25	37.37	29.86	3.14	0.49	0.76
Main Channel-M	346	100 yr	117.20	7325.62	0.0114	7327.68	7327.67	7328.29	0.041634	2.06	1.24	18.65	15.02	6.28	0.99	3.08
Main Channel-M	310	100 yr	117.20	7325.21	0.0100	7327.26	7326.61	7327.46	0.005737	2.05	1.51	32.35	21.36	3.62	0.52	0.52
South Finger	336	100 yr	16.70	7356.94	0.0838	7357.27	7357.27	7357.37	0.073613	0.33	0.20	6.51	32.29	2.57	1.01	0.93
South Finger	301	100 yr	16.70	7354.06	0.0891	7354.54	7354.55	7354.67	0.083927	0.48	0.23	5.66	25.07	2.95	1.10	1.18
South Finger	281	100 yr	16.70	7352.27	0.2997	7352.77	7352.84	7353.01	0.080316	0.50	0.23	4.29	18.91	3.89	1.44	1.13
South Finger	268	100 yr	16.70	7348.26	0.3073	7348.52	7348.83	7350.38	0.778837	0.26	0.19	1.52	7.84	10.96	4.38	9.40
South Finger	256	100 yr	16.70	7344.84	0.3084	7345.21	7345.44	7346.05	0.207931	0.37	0.29	2.27	7.72	7.36	2.40	3.72
South Finger	244	100 yr	16.70	7341.12	0.0168	7342.87	7341.80	7342.90	0.000762	1.75	1.55	13.33	10.36	1.31	0.19	0.07
South Finger	237	100 yr	16.70	7341.00	-0.6052	7342.87		7342.89	0.000550	1.87	1.64	15.15	11.23	1.16	0.16	0.05
South Finger	236	100 yr	16.70	7341.92	-0.0081	7342.81		7342.89	0.005334	0.89	0.73	7.75	11.16	2.17	0.45	0.24
South Finger	229	100 yr	16.70	7341.97	0.1292	7342.59	7342.59	7342.81	0.031190	0.62	0.43	4.50	10.46	3.71	1.00	0.83
South Finger	213	100 yr	16.70	7339.87	0.1009	7340.33	7340.62	7341.52	0.334735	0.46	0.26	1.91	7.33	8.72	3.01	5.40
South Finger	192	100 yr	16.70	7337.73	0.0943	7338.24	7338.34	7338.59	0.065680	0.51	0.36	3.50	9.79	4.76	1.40	1.45
South Finger	144	100 yr	16.70	7333.22	0.0786	7334.09	7334.31	7334.79	0.096152	0.87	0.47	2.48	5.37	6.73	1.73	2.68
South Finger	81	100 yr	16.70	7328.26	0.0308	7329.13	7328.97	7329.23	0.020078	0.87	0.52	6.70	12.98	2.49	0.61	0.64
South Finger	48	100 yr	16.70	7327.26	0.0000	7327.93	7327.93	7328.18	0.057140	0.67	0.49	4.16	8.52	4.01	1.01	1.70
Main Channel-L	247	100 yr	163.10	7324.66	0.0043	7325.82	7326.38	7328.00	0.187290	1.16	0.64	13.77	21.61	11.84	2.61	7.39
Main Channel-L	229	100 yr	163.10	7324.58	0.0294	7326.47	7326.15	7326.80	0.019534	1.89	1.33	35.44	26.56	4.60	0.70	1.60
Main Channel-L	198	100 yr	163.10	7323.67	0.0298	7325.34	7325.34	7325.94	0.039599	1.67	1.24	26.38	23.00	6.23	0.99	3.00
Main Channel-L	148	100 yr	163.10	7322.20	0.0231	7323.83	7323.46	7324.08	0.016154	1.63	1.27	40.27	31.72	4.05	0.63	1.26
Main Channel-L	99	100 yr	163.10	7321.06	0.0352	7322.40	7322.37	7322.85	0.041388	1.34	0.96	30.18	31.32	5.40	0.97	2.45
Main Channel-L	49	100 yr	163.10	7319.32	0.0452	7320.62	7320.54	7320.96	0.034420	1.30	0.89	34.72	39.17	4.70	0.88	1.90
Main Channel-L	0	100 yr	163.10	7317.09		7318.75	7318.66	7319.27	0.033462	1.66	1.25	28.25	23.02	5.78	0.91	2.57

HEC-RAS Plan: Default Scenario River: South Reach: Main Channel Profile: 100 yr

Reach	River Sta	Profile	Q Total (cfs)	Min Ch El (ft)	Invert Slope	W.S. Elev (ft)	Crit W.S. (ft)	E.G. Elev (ft)	E.G. Slope (ft/ft)	Max Chl Dpth (ft)	Hydr Depth C (ft)	Flow Area (sq ft)	Top Width (ft)	Vel Chnl (ft/s)	Froude # Chl	Shear Chan (lb/sq ft)
Main Channel	1250	100 yr	4.20	7417.92	0.0698	7418.12	7418.10	7418.16	0.058691	0.20	0.11	2.75	25.15	1.53	0.81	0.40
Main Channel	1218	100 yr	4.20	7415.70	0.2635	7415.94	7415.94	7416.02	0.077370	0.24	0.16	1.89	12.14	2.22	0.99	0.75
Main Channel	1191	100 yr	4.20	7408.62	0.2870	7408.72	7408.86	7409.74	3.040502	0.10	0.07	0.52	7.47	8.10	5.42	13.17
Main Channel	1159	100 yr	4.20	7399.36	0.0651	7399.79	7399.84	7400.00	0.118589	0.43	0.25	1.14	4.62	3.68	1.31	1.79
Main Channel	1136	100 yr	4.20	7397.85	0.0647	7398.46	7398.46	7398.65	0.066970	0.61	0.37	1.21	3.27	3.48	1.01	1.43
Main Channel	1100	100 yr	4.20	7395.53	0.0246	7396.18	7396.02	7396.23	0.015628	0.65	0.35	2.50	7.18	1.68	0.50	0.33
Main Channel	1089	100 yr	4.20	7395.26	0.0410	7395.91		7396.00	0.027602	0.65	0.40	1.75	4.35	2.40	0.67	0.66
Main Channel	1050	100 yr	4.20	7393.66	0.0338	7394.26	7394.26	7394.42	0.063033	0.60	0.34	1.31	4.11	3.24	0.99	1.26
Main Channel	1000	100 yr	4.20	7391.97	0.0434	7392.36		7392.42	0.027183	0.39	0.26	2.29	8.88	1.83	0.64	0.44
Main Channel	950	100 yr	4.20	7389.80	0.0802	7390.24	7390.24	7390.35	0.070318	0.44	0.22	1.58	7.11	2.66	1.00	0.97
Main Channel	900	100 yr	4.20	7385.79	0.0528	7386.12	7386.15	7386.26	0.096547	0.33	0.20	1.44	7.18	2.91	1.15	1.20
Main Channel	850	100 yr	4.20	7383.15	0.0254	7384.02	7383.71	7384.06	0.007279	0.87	0.51	2.91	6.19	1.47	0.36	0.22
Main Channel	800	100 yr	30.00	7381.88	0.0352	7382.94		7383.10	0.022361	1.06	0.70	9.38	13.89	3.21	0.68	0.96
Main Channel	750	100 yr	30.00	7380.12	0.0288	7381.19	7381.19	7381.52	0.047423	1.07	0.69	6.62	10.93	4.61	0.98	2.00
Main Channel	700	100 yr	30.00	7378.68	0.0254	7379.84	7379.62	7379.98	0.017363	1.16	0.78	9.96	13.58	3.04	0.61	0.83
Main Channel	650	100 yr	30.00	7377.41	0.0234	7378.36	7378.35	7378.59	0.051819	0.95	0.47	7.94	16.84	3.78	0.97	1.51
Main Channel	600	100 yr	30.00	7376.24	0.0262	7377.10		7377.19	0.016633	0.86	0.59	12.15	20.68	2.47	0.57	0.60
Main Channel	550	100 yr	30.00	7374.93	0.0662	7375.65	7375.64	7375.84	0.051823	0.72	0.40	8.77	21.66	3.42	0.95	1.31
Main Channel	500	100 yr	30.00	7371.62	0.0344	7372.88	7372.88	7373.21	0.052271	1.26	0.65	6.50	10.00	4.62	1.01	2.05
Main Channel	450	100 yr	30.00	7369.90	0.0116	7371.54	7371.24	7371.68	0.017136	1.64	0.77	10.21	13.27	2.94	0.59	0.79
Main Channel	400	100 yr	30.00	7369.32	0.0074	7370.69		7370.82	0.017011	1.37	0.76	10.18	13.37	2.95	0.60	0.79
Main Channel	350	100 yr	30.00	7368.95	0.0220	7369.82		7369.92	0.019093	0.87	0.55	11.76	21.27	2.55	0.61	0.66
Main Channel	300	100 yr	30.00	7367.85	0.0222	7368.84		7368.96	0.019196	0.99	0.61	11.04	18.17	2.72	0.61	0.72
Main Channel	250	100 yr	30.00	7366.74	0.0258	7367.47	7367.41	7367.58	0.043444	0.73	0.31	11.33	35.98	2.65	0.83	0.85
Main Channel	200	100 yr	30.00	7365.45	0.0232	7365.99		7366.05	0.022416	0.54	0.31	15.81	50.47	1.90	0.60	0.44
Main Channel	150	100 yr	30.00	7364.29	0.0286	7364.95	7364.83	7364.99	0.019605	0.66	0.29	17.76	61.15	1.69	0.55	0.36
Main Channel	100	100 yr	30.00	7362.86	0.0314	7363.30	7363.29	7363.44	0.055190	0.44	0.32	10.01	31.63	3.00	0.94	1.09
Main Channel	50	100 yr	30.00	7361.29	0.0174	7361.92	7361.80	7361.96	0.017945	0.63	0.31	17.68	56.60	1.70	0.54	0.35
Main Channel	0	100 yr	30.00	7360.42		7360.86	7360.79	7360.91	0.024962	0.44	0.25	17.44	69.98	1.72	0.61	0.39

HEC-RAS Model Plan: Default Scenario 1/14/2025

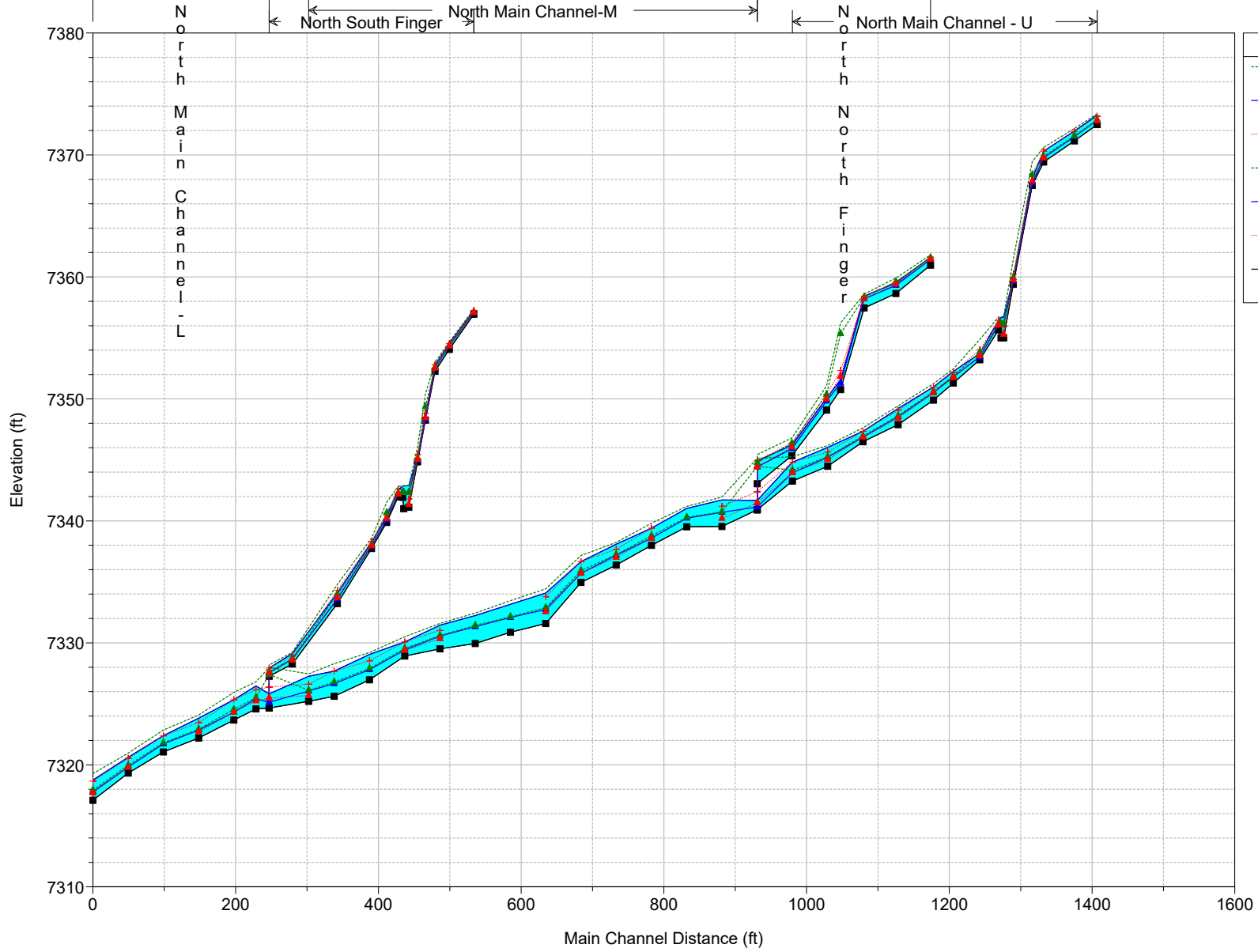

Legend	
EG 100 yr	(dotted green line with triangles)
WS 100 yr	(solid blue line with triangles)
Crit 100 yr	(dotted red line with triangles)
EG 5 yr	(dotted green line with triangles)
WS 5 yr	(solid blue line with triangles)
Crit 5 yr	(dotted red line with triangles)
Ground	(solid black line with squares)



South Main Channel

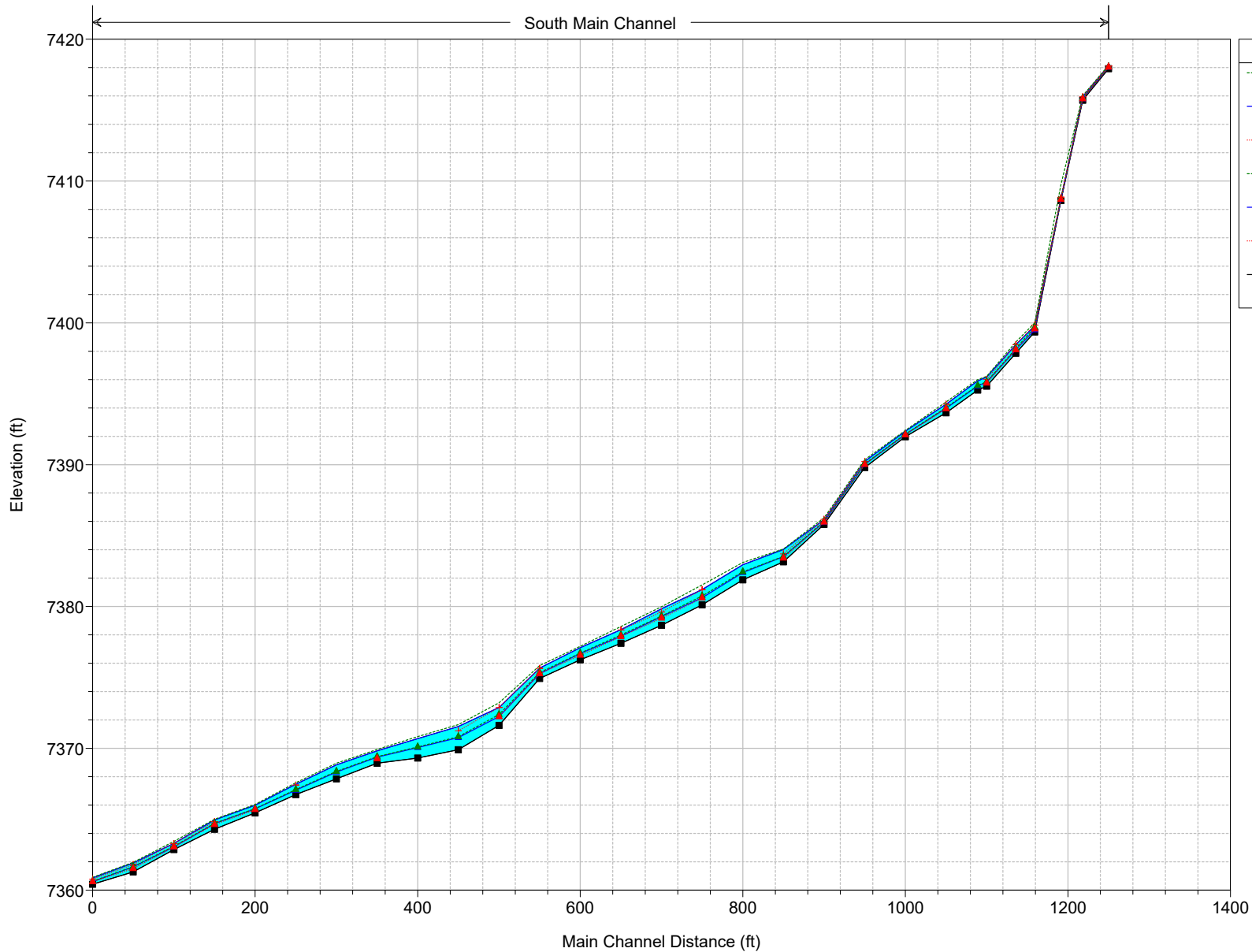

Legend	
EG 100 yr	--- (dashed green line)
WS 100 yr	— (solid cyan line)
Crit 100 yr	- - - (dashed red line)
EG 5 yr	--- (dashed green line)
WS 5 yr	— (solid blue line)
Crit 5 yr	- - - (dashed red line)
Ground	— (solid black line)

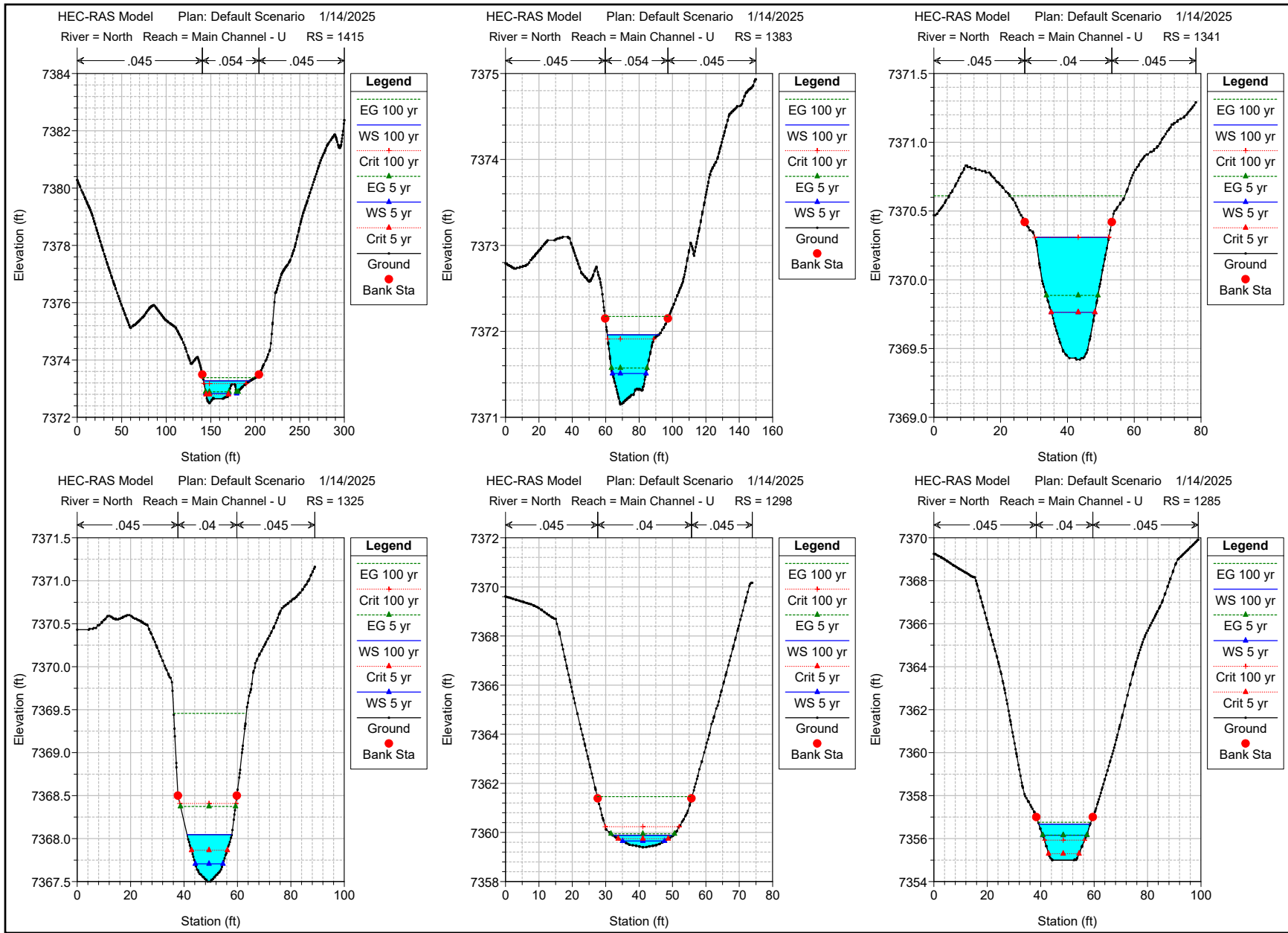

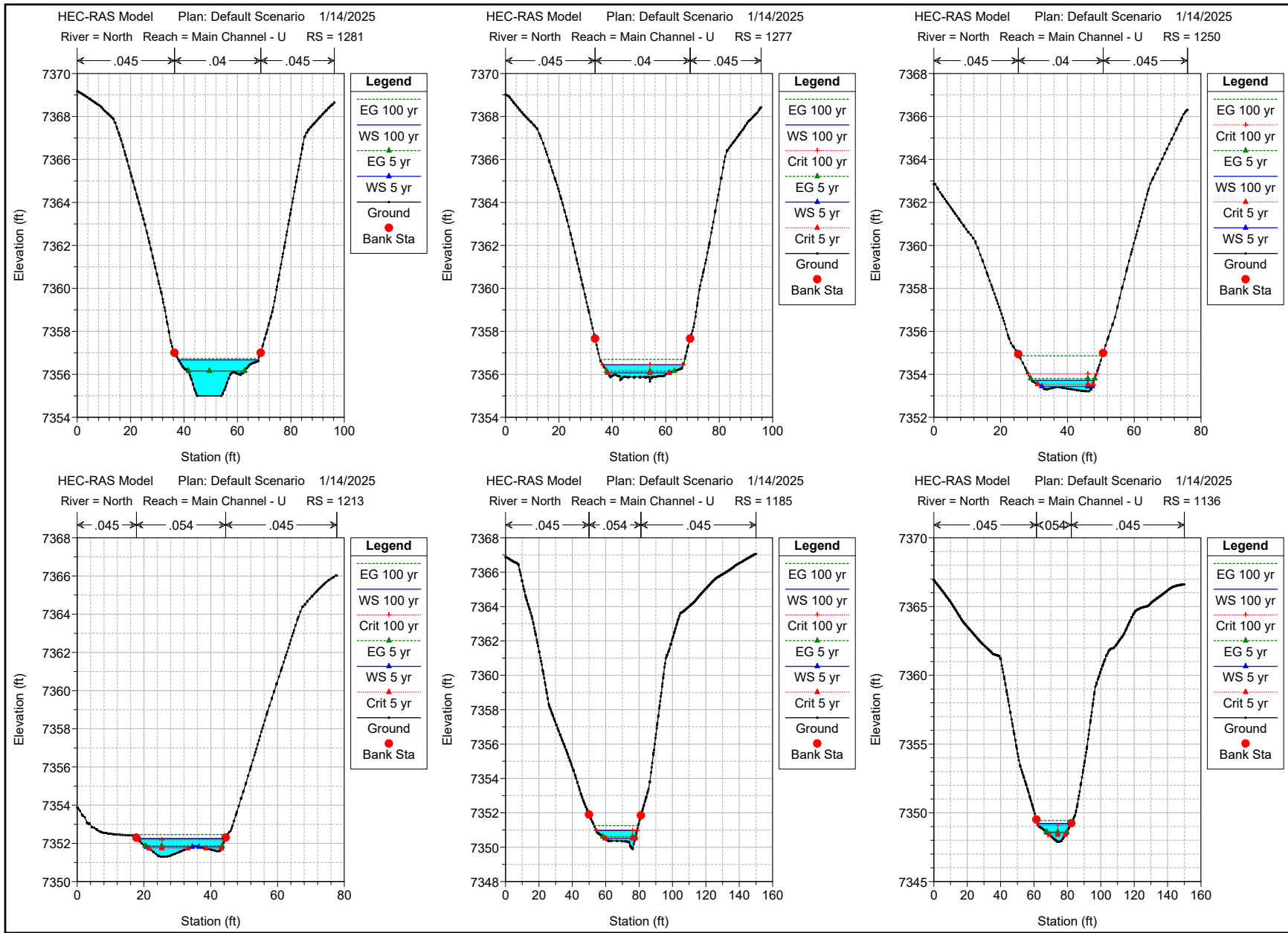

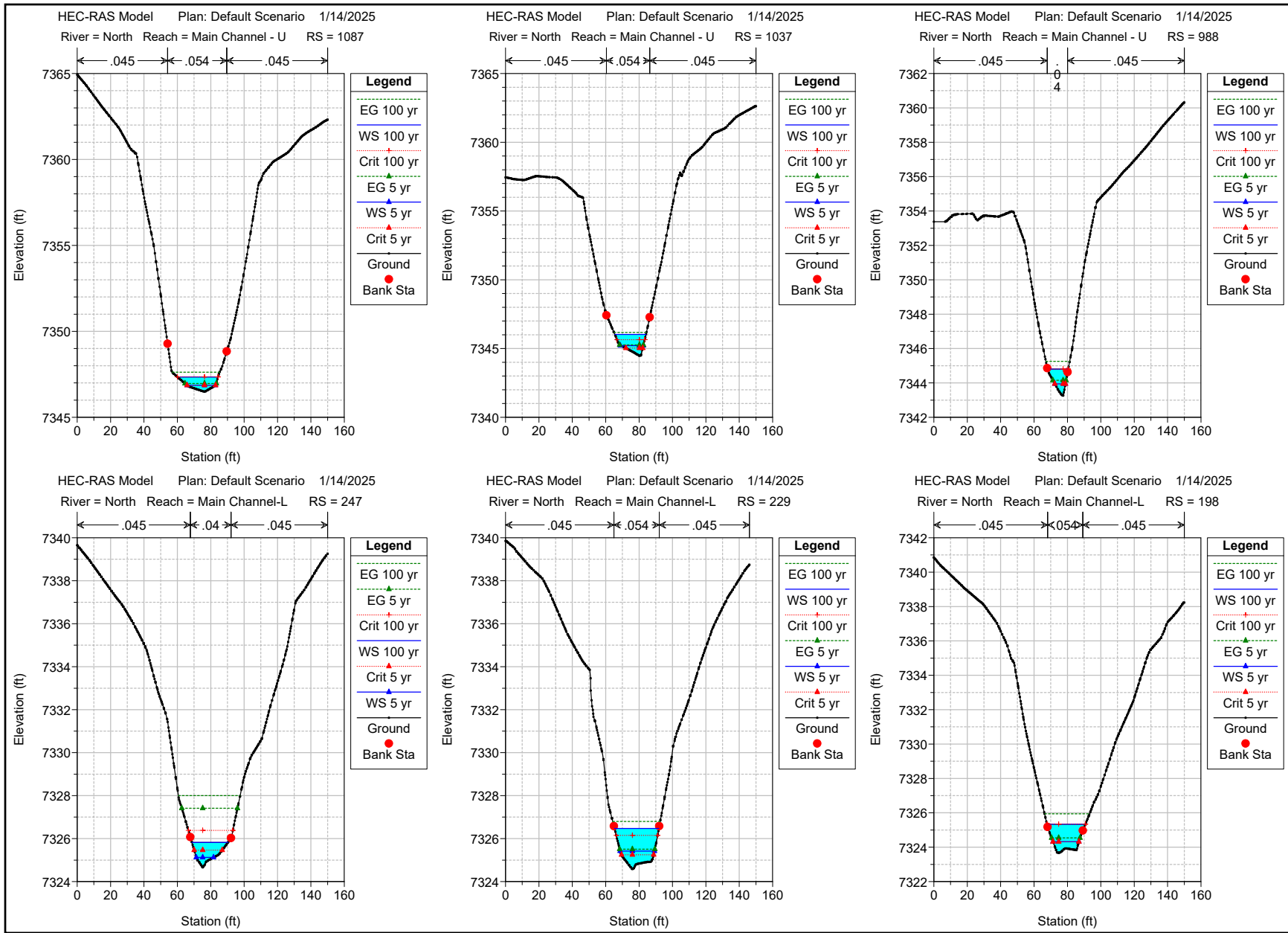

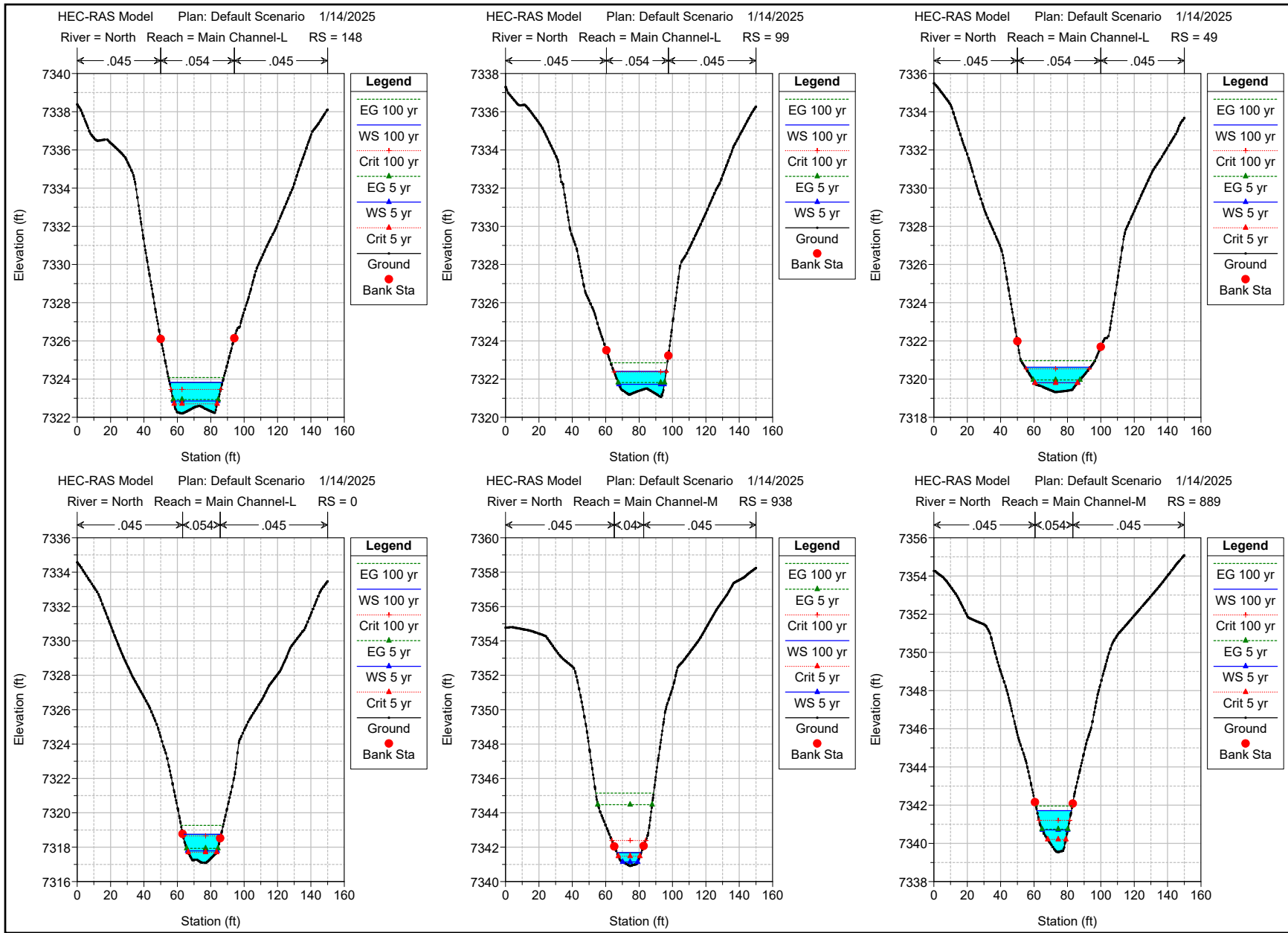

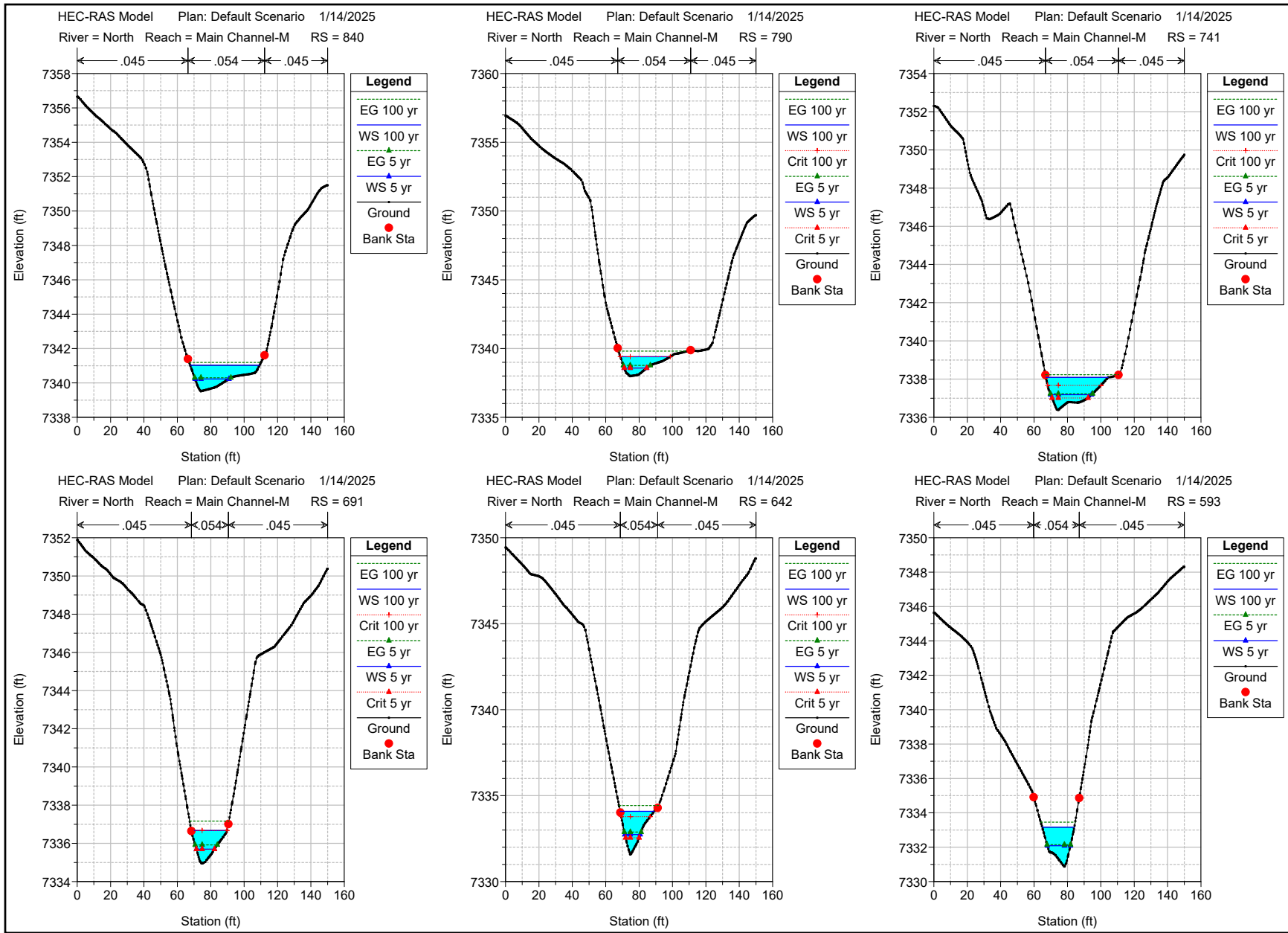

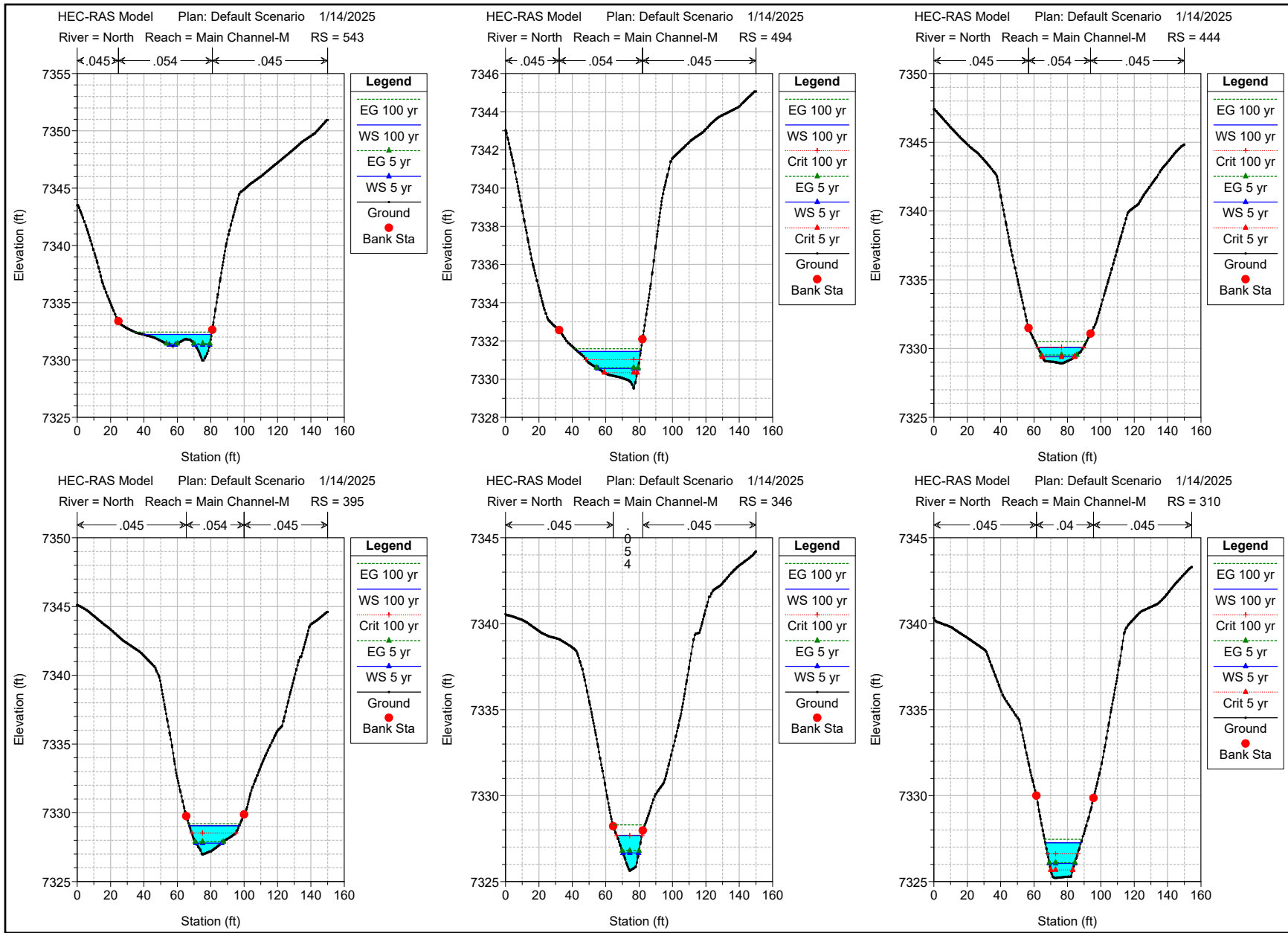

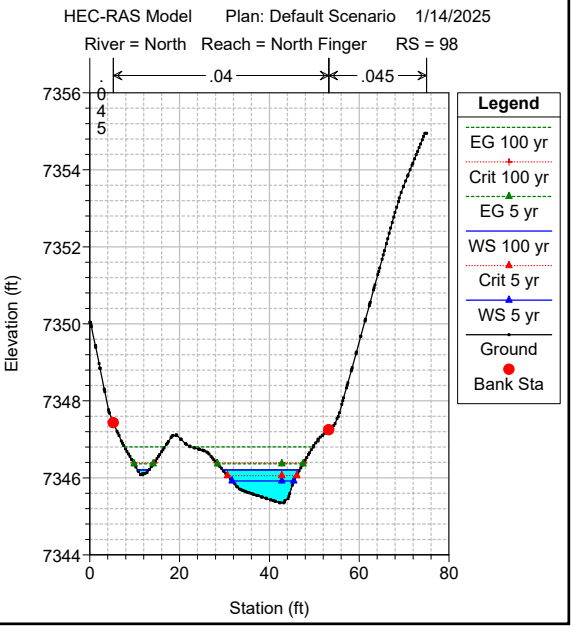
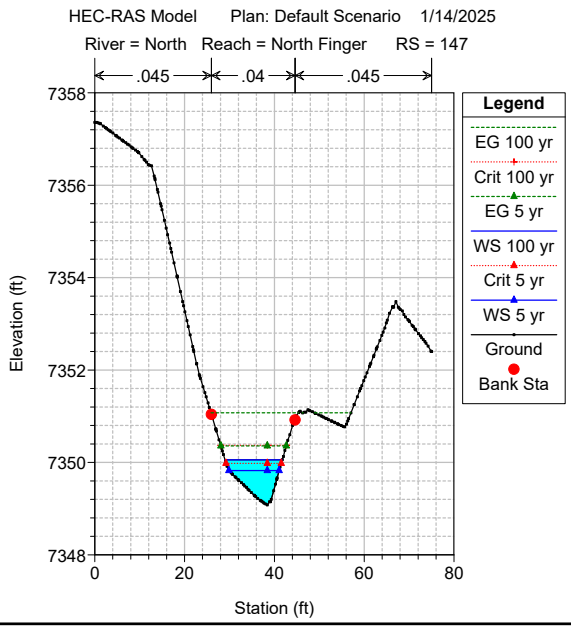
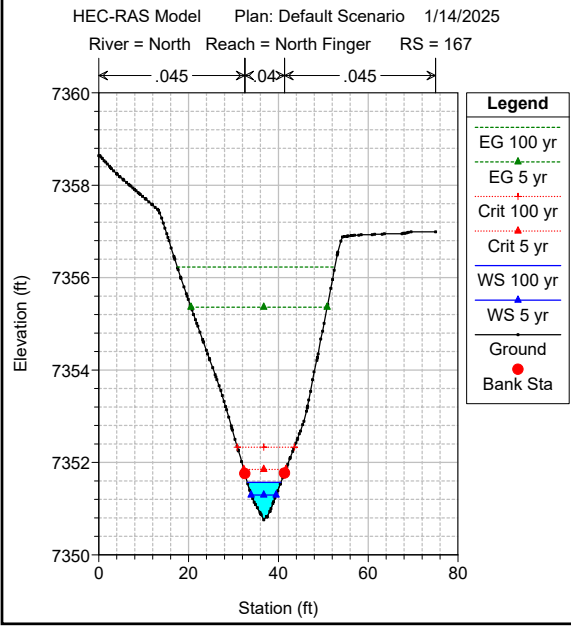
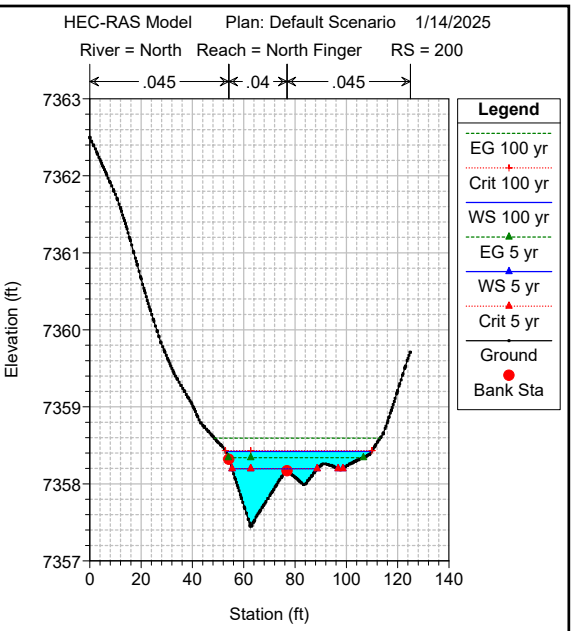
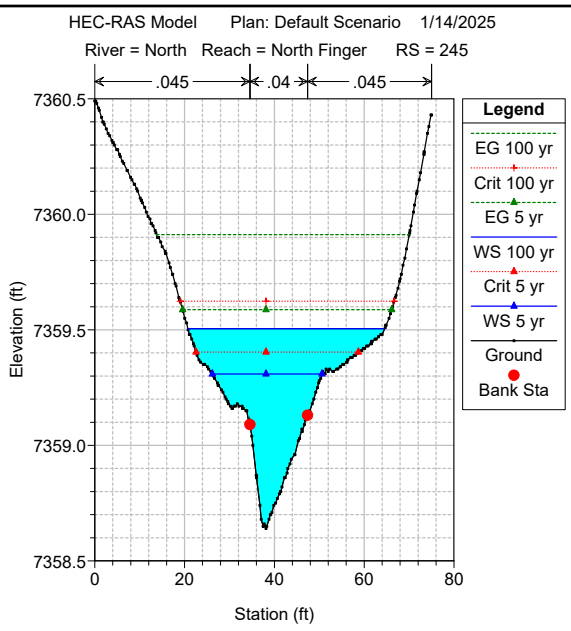
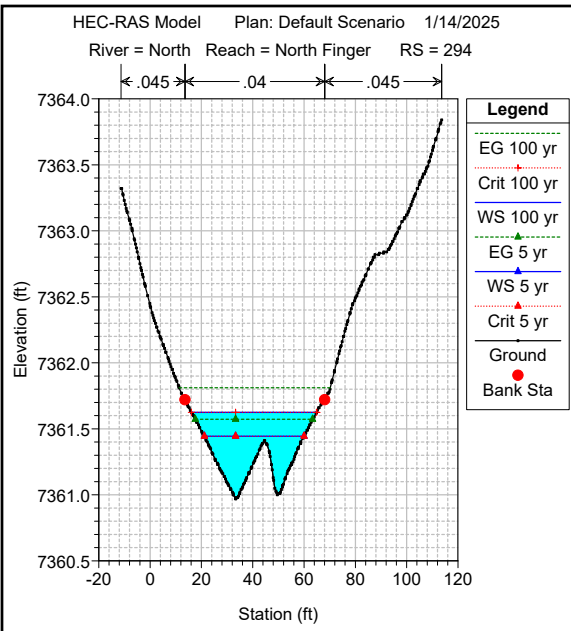



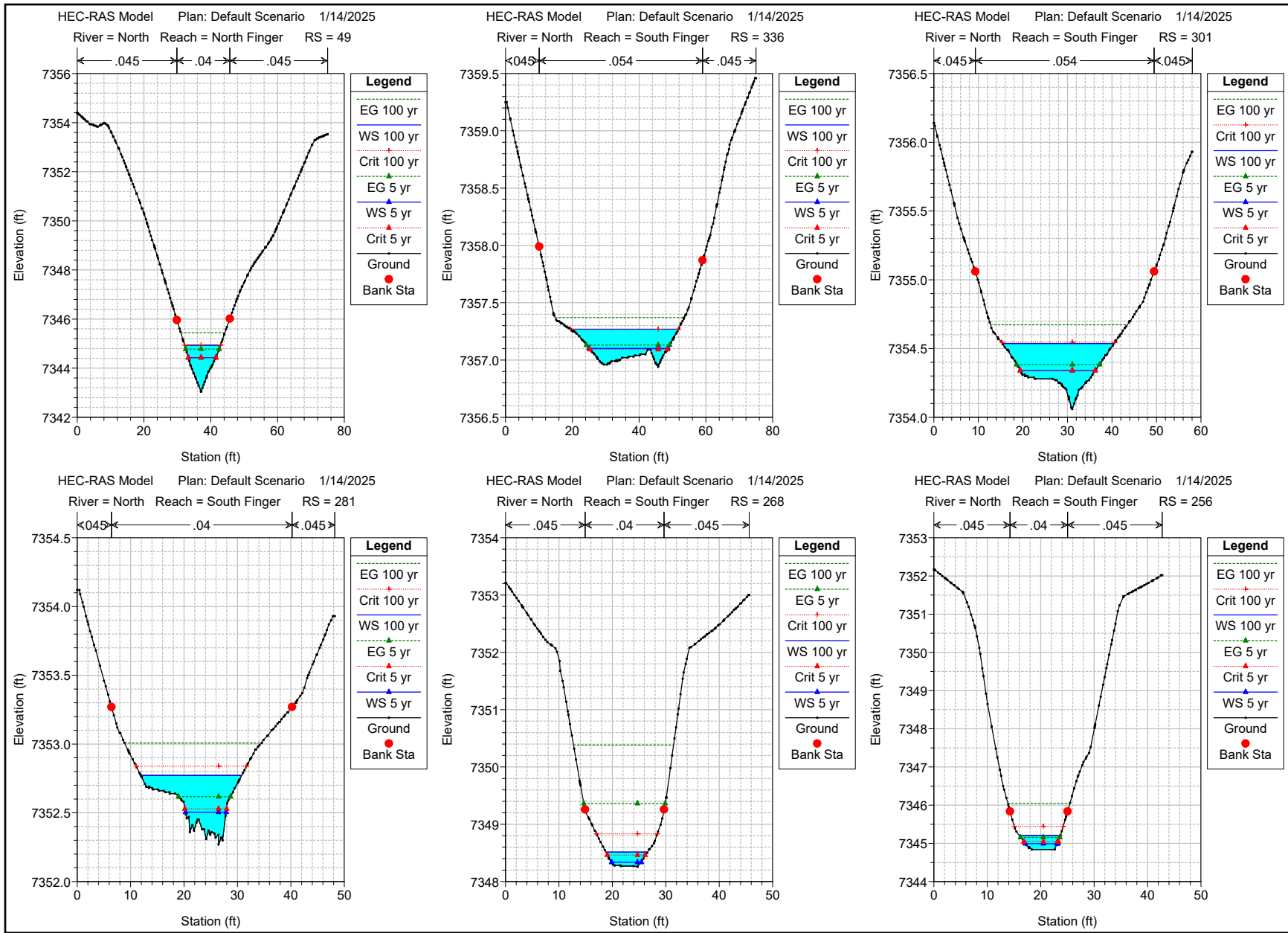

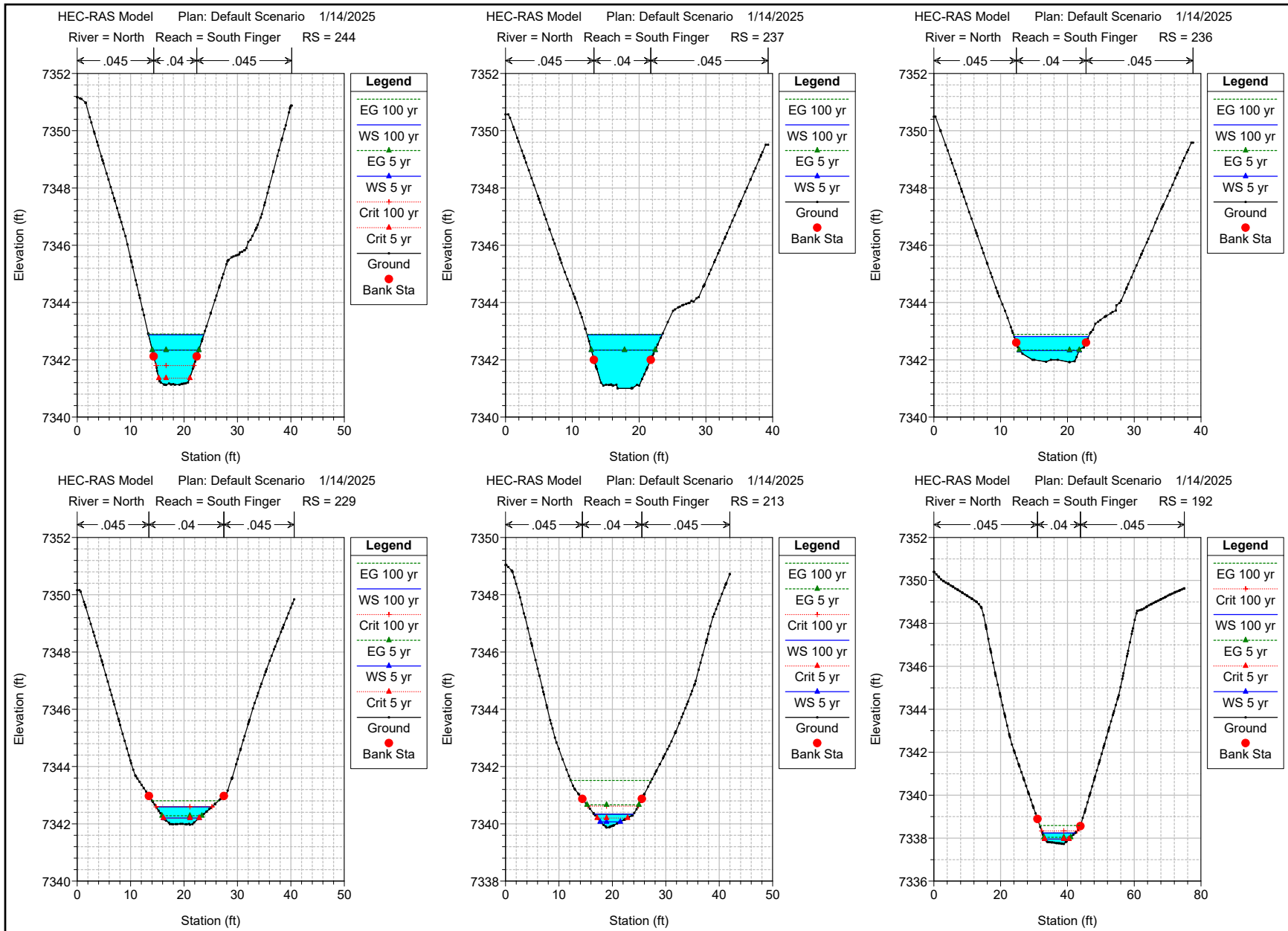

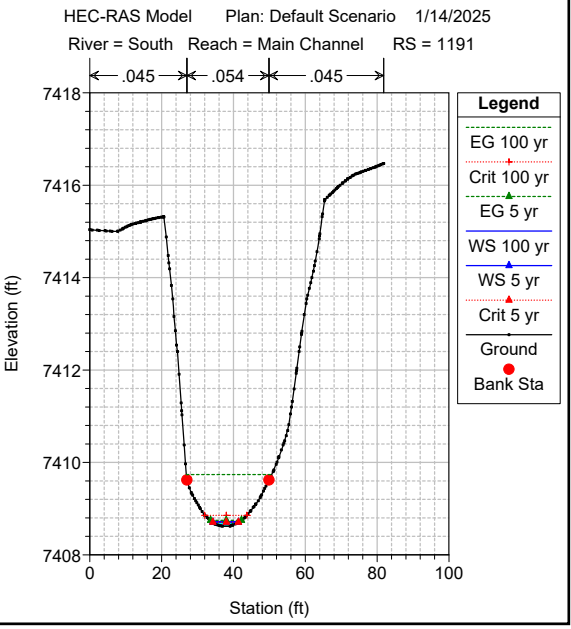
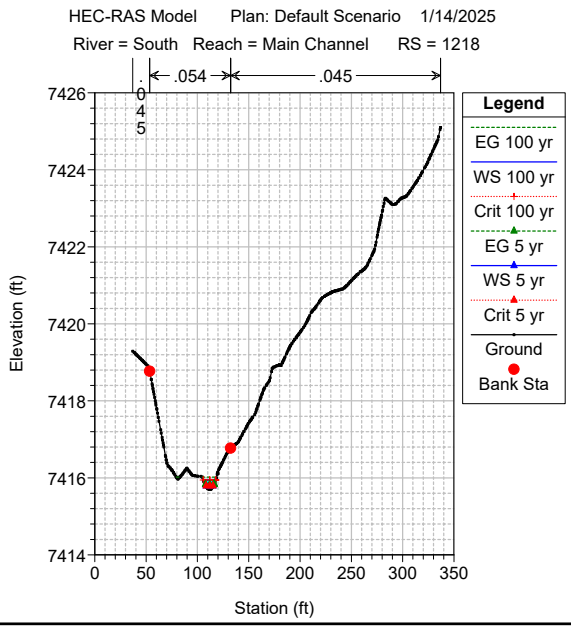
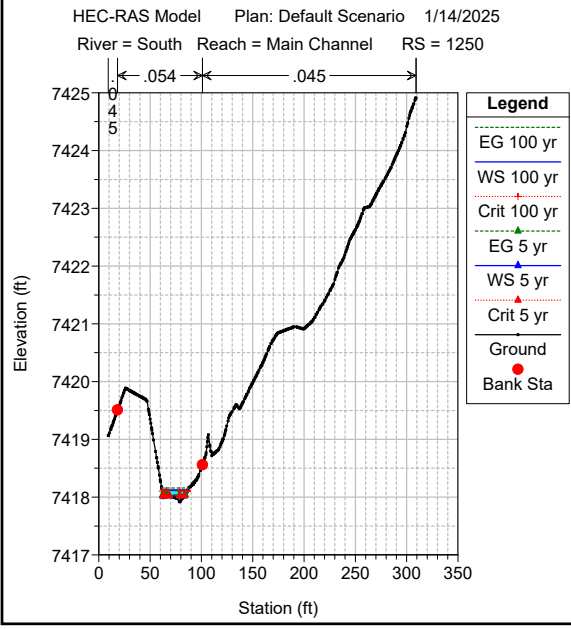
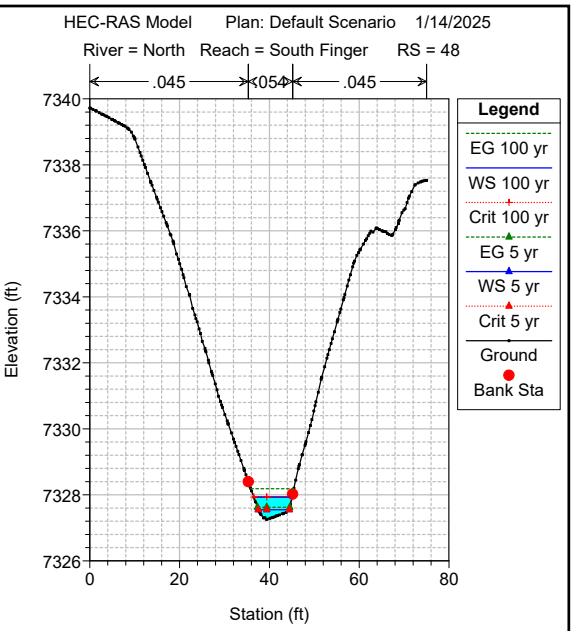
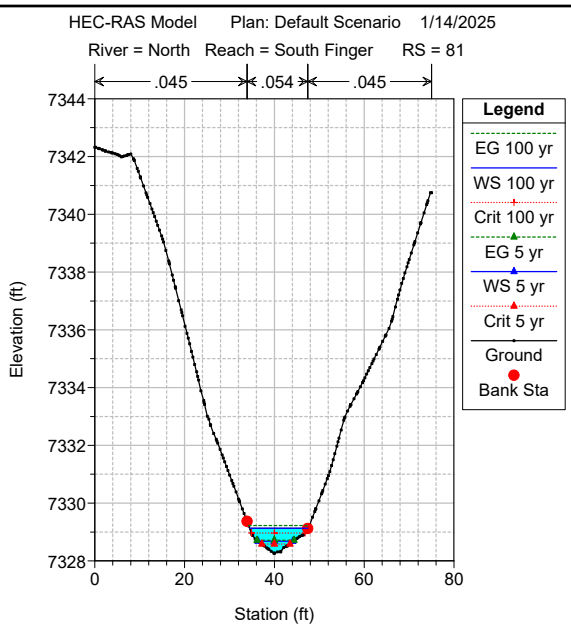
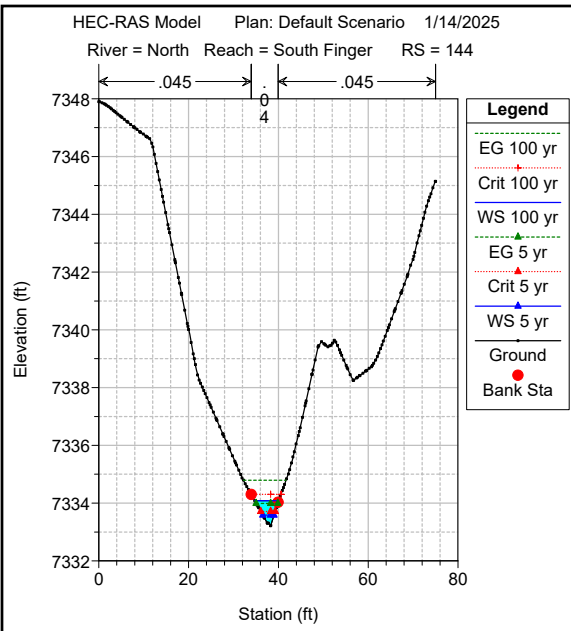

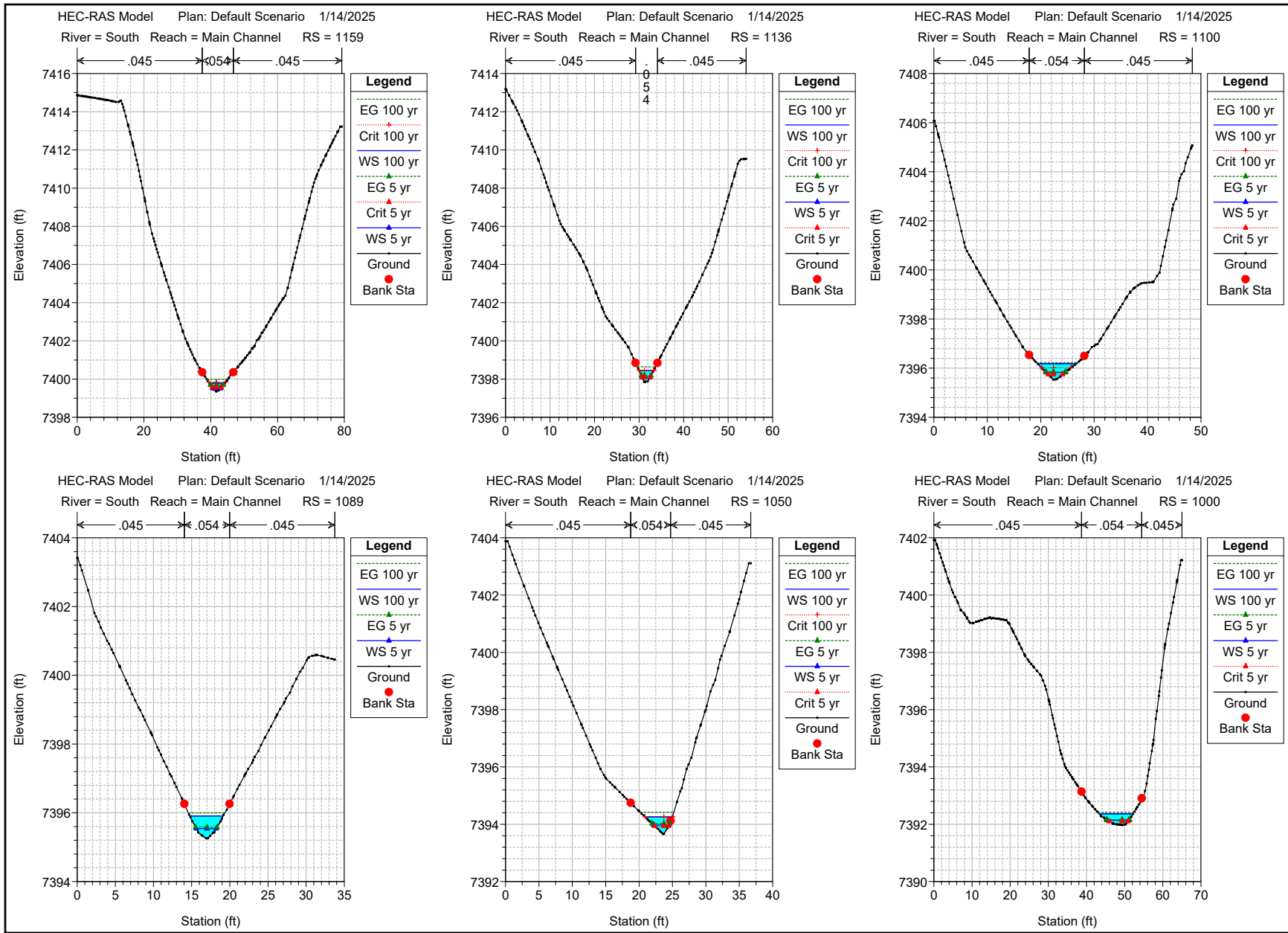

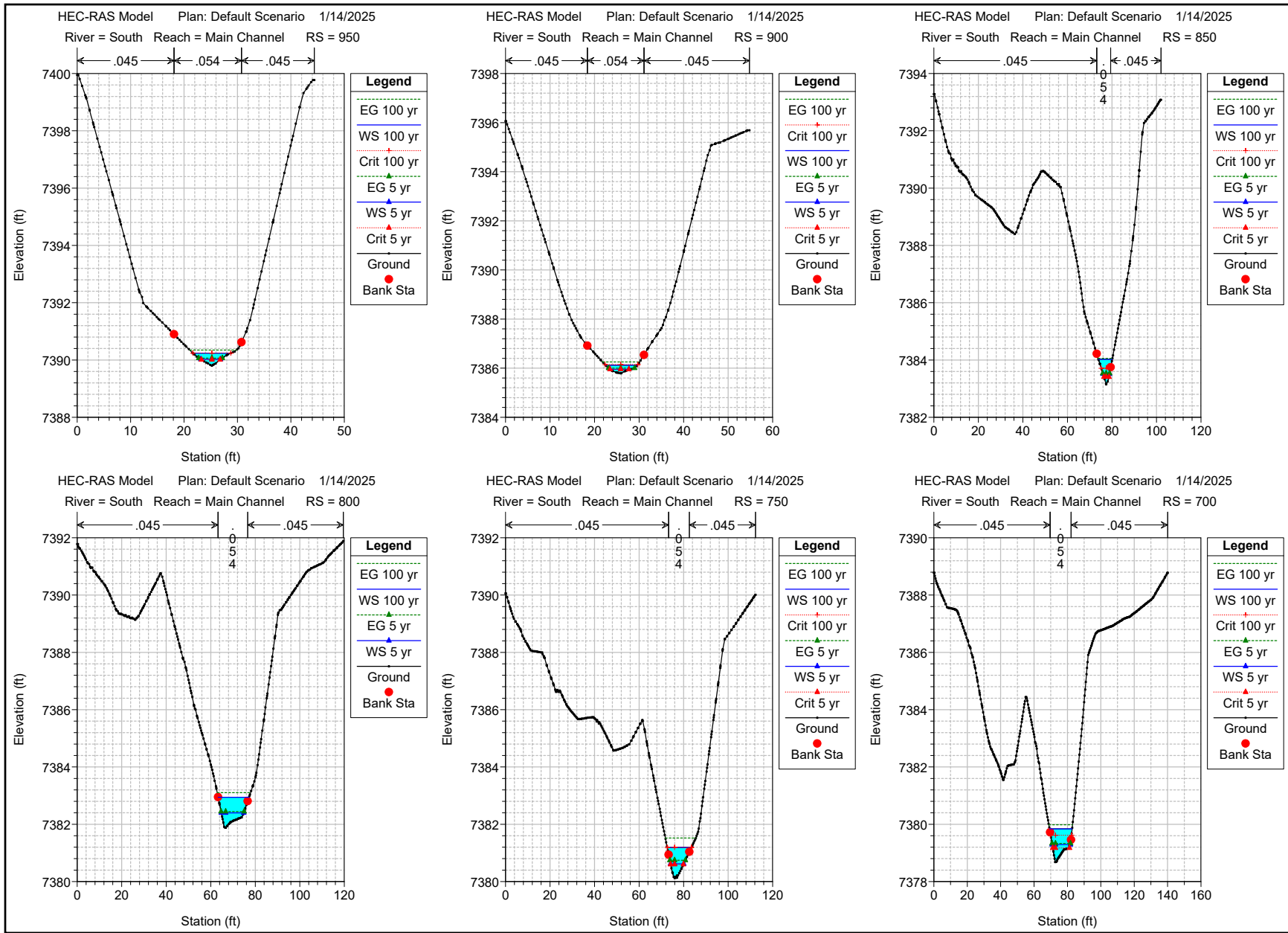

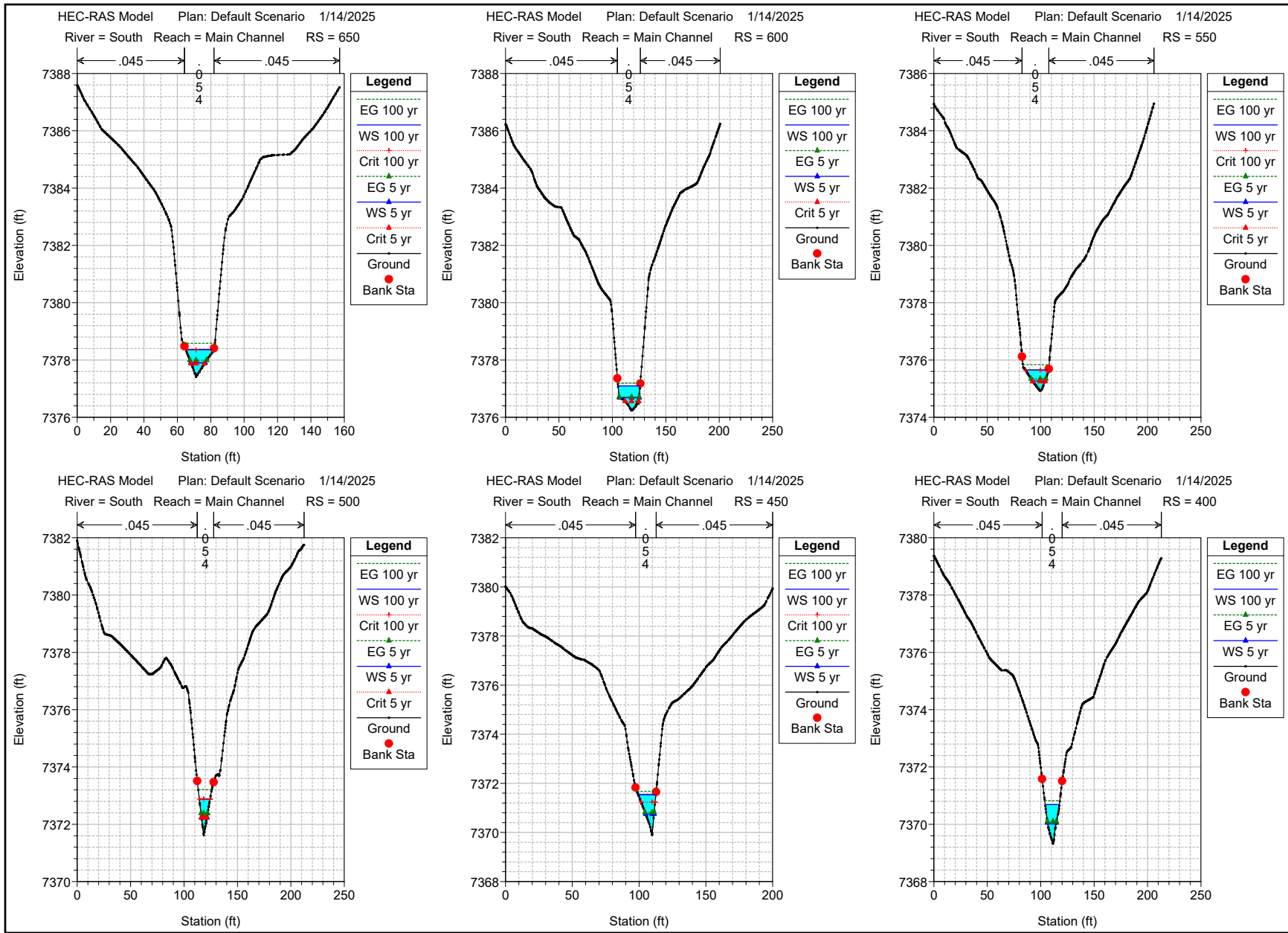

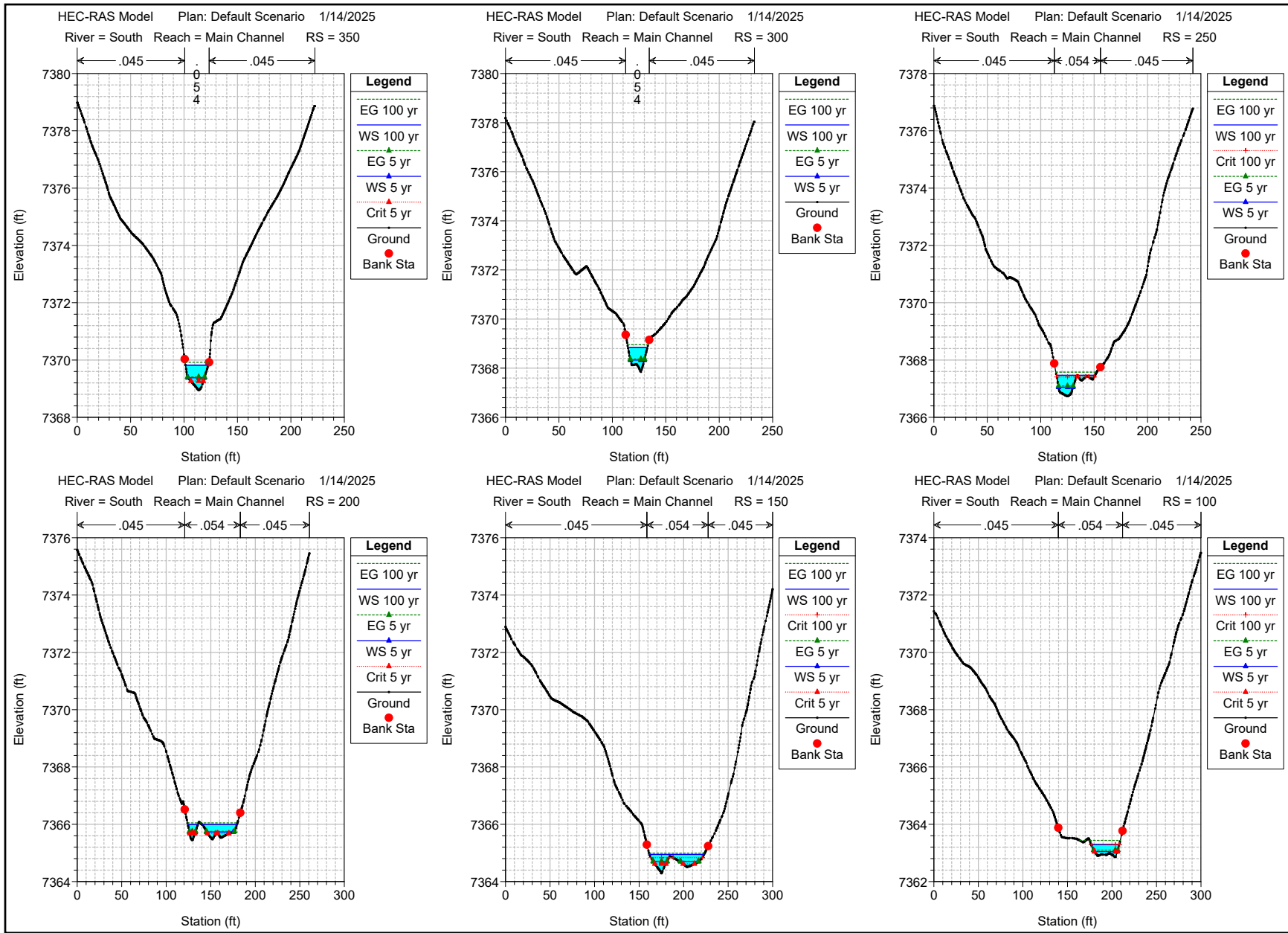

HEC-RAS Model Plan: Default Scenario 1/14/2025  
River = South Reach = Main Channel RS = 50

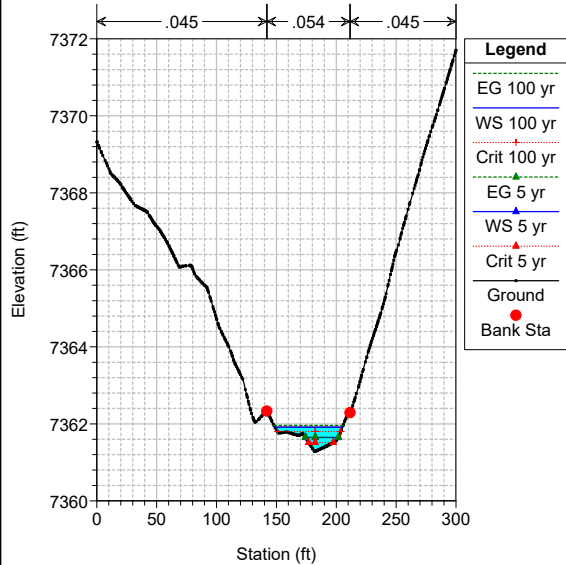

HEC-RAS Model Plan: Default Scenario 1/14/2025  
River = South Reach = Main Channel RS = 0

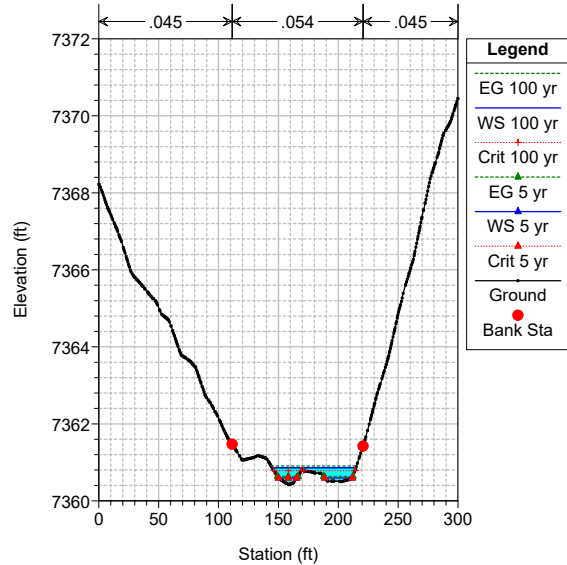



HEC-RAS HEC-RAS 5.0.7 March 2019  
U.S. Army Corps of Engineers  
Hydrologic Engineering Center  
609 Second Street  
Davis, California

```
X  X  XXXXXX  XXXX  XXXX  XX  XXXX
X  X  X      X  X  X  X  X  X
X  X  X      X  X  X  X  X  X
XXXXXXXX XXXX  X  XXX XXXX XXXXXX XXXX
X  X  X      X  X  X  X  X  X
X  X  X      X  X  X  X  X  X
X  X  XXXXXX  XXXX  X  X  X  X  XXXXX
```

PROJECT DATA

Project Title: HEC-RAS Model  
Project File : 61223-Proposed.prj  
Run Date and Time: 1/14/2025 2:26:56 PM

Project in English units

Project Description:

CRS Info=<SpatialReference> <CoordinateSystem Code="2232"  
Unit="US\_survey\_Foot" AcadCode="C083-CF" /></SpatialReference>

PLAN DATA

Plan Title: Default Scenario  
Plan File : C:\Users\tomw\Desktop\GEOHECRAS Projects\61223-Proposed.p01

Geometry Title: Default Geometry  
Geometry File : C:\Users\tomw\Desktop\GEOHECRAS Projects\61223-Proposed.g01

Flow Title : Default Steady Flow  
Flow File : C:\Users\tomw\Desktop\GEOHECRAS Projects\61223-Proposed.f01

Plan Description:

Default Scenario

Plan Summary Information:

Number of:	Cross Sections =	86	Multiple Openings =	0
	Culverts =	0	Inline Structures =	0
	Bridges =	0	Lateral Structures =	0

Computational Information

Water surface calculation tolerance =	0.01
Critical depth calculation tolerance =	0.01
Maximum number of iterations =	20
Maximum difference tolerance =	0.33
Flow tolerance factor =	0.001

Computation Options

Critical depth computed only where necessary  
 Conveyance Calculation Method: At breaks in n values only  
 Friction Slope Method: Average Conveyance  
 Computational Flow Regime: Mixed Flow

FLOW DATA

Flow Title: Default Steady Flow  
 Flow File : C:\Users\tomw\Desktop\GEOHECRAS Projects\61223-Proposed.f01

Flow Data (cfs)

River	Reach	RS	100 yr	5 yr
South	Main Channel	1250	4.2	.7
South	Main Channel	800	30	5
North	Main Channel - U1415		57.2	9
North	Main Channel-L	247	163.1	25.6
North	Main Channel-M	938	117.2	18.4
North	North Finger	294	59.6	26.7
North	South Finger	336	16.7	2.6

Boundary Conditions

River	Reach	Profile	Upstream	Downstream
North	Main Channel - U	100 yr	Normal S = 0.02	
North	Main Channel - U	5 yr	Normal S = 0.02	
North	Main Channel-L	100 yr		Normal S = 0.033408
North	Main Channel-L	5 yr		Normal S = 0.033408
North	North Finger	100 yr	Normal S = 0.035	
North	North Finger	5 yr	Normal S = 0.035	
North	South Finger	100 yr	Normal S = 0.038	
North	South Finger	5 yr	Normal S = 0.038	
South	Main Channel	100 yr	Normal S = 0.01	Normal S = 0.025
South	Main Channel	5 yr	Normal S = 0.01	Normal S = 0.025

SUMMARY OF MANNING'S N VALUES

River:North

Reach	River Sta.	n1	n2	n3
Main Channel - U	1415	.045	.054	.045
Main Channel - U	1383	.045	.054	.045
Main Channel - U	1341	.045	.04	.045
Main Channel - U	1325	.045	.04	.045
Main Channel - U	1298	.045	.04	.045
Main Channel - U	1285	.045	.04	.045
Main Channel - U	1281	.045	.04	.045
Main Channel - U	1277	.045	.04	.045
Main Channel - U	1250	.045	.04	.045
Main Channel - U	1213	.045	.054	.045
Main Channel - U	1185	.045	.054	.045
Main Channel - U	1136	.045	.054	.045

Main Channel - U	1087	.045	.054	.045
Main Channel - U	1037	.045	.054	.045
Main Channel - U	988	.045	.04	.045
Main Channel-L	247	.045	.04	.045
Main Channel-L	229	.045	.054	.045
Main Channel-L	198	.045	.054	.045
Main Channel-L	148	.045	.054	.045
Main Channel-L	99	.045	.054	.045
Main Channel-L	49	.045	.054	.045
Main Channel-L	0	.045	.054	.045
Main Channel-M	938	.045	.04	.045
Main Channel-M	889	.045	.054	.045
Main Channel-M	840	.045	.054	.045
Main Channel-M	790	.045	.054	.045
Main Channel-M	741	.045	.054	.045
Main Channel-M	691	.045	.054	.045
Main Channel-M	642	.045	.054	.045
Main Channel-M	593	.045	.054	.045
Main Channel-M	543	.045	.054	.045
Main Channel-M	494	.045	.054	.045
Main Channel-M	444	.045	.054	.045
Main Channel-M	395	.045	.054	.045
Main Channel-M	346	.045	.054	.045
Main Channel-M	310	.045	.04	.045
North Finger	294	.045	.04	.045
North Finger	245	.045	.04	.045
North Finger	200	.045	.04	.045
North Finger	167	.045	.04	.045
North Finger	147	.045	.04	.045
North Finger	98	.045	.04	.045
North Finger	49	.045	.04	.045
South Finger	336	.045	.054	.045
South Finger	301	.045	.054	.045
South Finger	281	.045	.04	.045
South Finger	268	.045	.04	.045
South Finger	256	.045	.04	.045
South Finger	244	.045	.04	.045
South Finger	237	.045	.04	.045
South Finger	236	.045	.04	.045
South Finger	229	.045	.04	.045
South Finger	213	.045	.04	.045
South Finger	192	.045	.04	.045
South Finger	144	.045	.04	.045
South Finger	81	.045	.054	.045
South Finger	48	.045	.054	.045

River:South

Reach	River Sta.	n1	n2	n3
Main Channel	1250	.045	.054	.045
Main Channel	1218	.045	.054	.045
Main Channel	1191	.045	.054	.045
Main Channel	1159	.045	.054	.045
Main Channel	1136	.045	.054	.045
Main Channel	1100	.045	.054	.045
Main Channel	1089	.045	.054	.045
Main Channel	1050	.045	.054	.045
Main Channel	1000	.045	.054	.045
Main Channel	950	.045	.054	.045

Main Channel	900	.045	.054	.045
Main Channel	850	.045	.054	.045
Main Channel	800	.045	.054	.045
Main Channel	750	.045	.054	.045
Main Channel	700	.045	.054	.045
Main Channel	650	.045	.054	.045
Main Channel	600	.045	.054	.045
Main Channel	550	.045	.054	.045
Main Channel	500	.045	.054	.045
Main Channel	450	.045	.054	.045
Main Channel	400	.045	.054	.045
Main Channel	350	.045	.054	.045
Main Channel	300	.045	.054	.045
Main Channel	250	.045	.054	.045
Main Channel	200	.045	.054	.045
Main Channel	150	.045	.054	.045
Main Channel	100	.045	.054	.045
Main Channel	50	.045	.054	.045
Main Channel	0	.045	.054	.045

SUMMARY OF REACH LENGTHS

River: North

Reach	River Sta.	Left	Channel	Right
Main Channel - U	1415	31.89	31.89	31.89
Main Channel - U	1383	43.03	43.03	43.03
Main Channel - U	1341	16.02	16.02	16.02
Main Channel - U	1325	26.58	26.58	26.58
Main Channel - U	1298	13.49	13.49	13.49
Main Channel - U	1285	3.81	3.81	3.81
Main Channel - U	1281	3.5	3.5	3.5
Main Channel - U	1277	26.24	26.24	26.24
Main Channel - U	1250	37.1	37.1	37.1
Main Channel - U	1213	27.78	27.78	27.78
Main Channel - U	1185	49.39	49.39	49.39
Main Channel - U	1136	49.39	49.39	49.39
Main Channel - U	1087	49.39	49.39	49.39
Main Channel - U	1037	49.39	49.39	49.39
Main Channel - U	988	49.39	49.39	49.39
Main Channel-L	247	18.43	18.43	18.43
Main Channel-L	229	30.96	30.96	30.96
Main Channel-L	198	49.39	49.39	49.39
Main Channel-L	148	49.38	49.38	49.38
Main Channel-L	99	49.39	49.39	49.39
Main Channel-L	49	49.39	49.39	49.39
Main Channel-L	0	0	0	0
Main Channel-M	938	49.38	49.38	49.38
Main Channel-M	889	49.39	49.39	49.39
Main Channel-M	840	49.39	49.39	49.39
Main Channel-M	790	49.39	49.39	49.39
Main Channel-M	741	49.39	49.39	49.39
Main Channel-M	691	49.39	49.39	49.39
Main Channel-M	642	49.38	49.38	49.38
Main Channel-M	593	49.39	49.39	49.39
Main Channel-M	543	49.39	49.39	49.39
Main Channel-M	494	49.39	49.39	49.39

Main Channel-M	444	49.39	49.39	49.39
Main Channel-M	395	49.39	49.39	49.39
Main Channel-M	346	35.93	35.93	35.93
Main Channel-M	310	0	0	0
North Finger	294	48.52	48.52	48.52
North Finger	245	44.56	44.56	44.56
North Finger	200	32.95	32.95	32.95
North Finger	167	19.7	19.7	19.7
North Finger	147	48.61	48.61	48.61
North Finger	98	48.6	48.6	48.6
North Finger	49	48.6	48.6	48.6
South Finger	336	34.38	34.38	34.38
South Finger	301	20.08	20.08	20.08
South Finger	281	13.38	13.38	13.38
South Finger	268	11.13	11.13	11.13
South Finger	256	12.06	12.06	12.06
South Finger	244	7.16	7.16	7.16
South Finger	237	1.52	1.52	1.52
South Finger	236	6.21	6.21	6.21
South Finger	229	16.26	16.26	16.26
South Finger	213	21.22	21.22	21.22
South Finger	192	47.81	47.81	47.81
South Finger	144	63.09	63.09	63.09
South Finger	81	32.51	32.51	32.51
South Finger	48	47.8	47.8	47.8

River: South

Reach	River Sta.	Left	Channel	Right
Main Channel	1250	31.78	31.78	31.78
Main Channel	1218	26.87	26.87	26.87
Main Channel	1191	32.27	32.27	32.27
Main Channel	1159	23.2	23.2	23.2
Main Channel	1136	35.88	35.88	35.88
Main Channel	1100	10.99	10.99	10.99
Main Channel	1089	39.01	39.01	39.01
Main Channel	1050	50	50	50
Main Channel	1000	50	50	50
Main Channel	950	50	50	50
Main Channel	900	50	50	50
Main Channel	850	50	50	50
Main Channel	800	50	50	50
Main Channel	750	50	50	50
Main Channel	700	50	50	50
Main Channel	650	50	50	50
Main Channel	600	50	50	50
Main Channel	550	50	50	50
Main Channel	500	50	50	50
Main Channel	450	50	50	50
Main Channel	400	50	50	50
Main Channel	350	50	50	50
Main Channel	300	50	50	50
Main Channel	250	50	50	50
Main Channel	200	50	50	50
Main Channel	150	50	50	50
Main Channel	100	50	50	50
Main Channel	50	50	50	50
Main Channel	0	0	0	0

## SUMMARY OF CONTRACTION AND EXPANSION COEFFICIENTS

River: North

Reach	River Sta.	Contr.	Expan.
Main Channel - U	1415	.1	.3
Main Channel - U	1383	.1	.3
Main Channel - U	1341	.1	.3
Main Channel - U	1325	.1	.3
Main Channel - U	1298	.1	.3
Main Channel - U	1285	.1	.3
Main Channel - U	1281	.1	.3
Main Channel - U	1277	.1	.3
Main Channel - U	1250	.1	.3
Main Channel - U	1213	.1	.3
Main Channel - U	1185	.1	.3
Main Channel - U	1136	.1	.3
Main Channel - U	1087	.1	.3
Main Channel - U	1037	.1	.3
Main Channel - U	988	.1	.3
Main Channel-L	247	.1	.3
Main Channel-L	229	.1	.3
Main Channel-L	198	.1	.3
Main Channel-L	148	.1	.3
Main Channel-L	99	.1	.3
Main Channel-L	49	.1	.3
Main Channel-L	0	.1	.3
Main Channel-M	938	.1	.3
Main Channel-M	889	.1	.3
Main Channel-M	840	.1	.3
Main Channel-M	790	.1	.3
Main Channel-M	741	.1	.3
Main Channel-M	691	.1	.3
Main Channel-M	642	.1	.3
Main Channel-M	593	.1	.3
Main Channel-M	543	.1	.3
Main Channel-M	494	.1	.3
Main Channel-M	444	.1	.3
Main Channel-M	395	.1	.3
Main Channel-M	346	.1	.3
Main Channel-M	310	.1	.3
North Finger	294	.1	.3
North Finger	245	.1	.3
North Finger	200	.1	.3
North Finger	167	.1	.3
North Finger	147	.1	.3
North Finger	98	.1	.3
North Finger	49	.1	.3
South Finger	336	.1	.3
South Finger	301	.1	.3
South Finger	281	.1	.3
South Finger	268	.1	.3
South Finger	256	.1	.3
South Finger	244	.1	.3
South Finger	237	.1	.3
South Finger	236	.1	.3
South Finger	229	.1	.3

South Finger	213	.1	.3
South Finger	192	.1	.3
South Finger	144	.1	.3
South Finger	81	.1	.3
South Finger	48	.1	.3

River: South

Reach	River Sta.	Contr.	Expan.
Main Channel	1250	.1	.3
Main Channel	1218	.1	.3
Main Channel	1191	.1	.3
Main Channel	1159	.1	.3
Main Channel	1136	.1	.3
Main Channel	1100	.1	.3
Main Channel	1089	.1	.3
Main Channel	1050	.1	.3
Main Channel	1000	.1	.3
Main Channel	950	.1	.3
Main Channel	900	.1	.3
Main Channel	850	.1	.3
Main Channel	800	.1	.3
Main Channel	750	.1	.3
Main Channel	700	.1	.3
Main Channel	650	.1	.3
Main Channel	600	.1	.3
Main Channel	550	.1	.3
Main Channel	500	.1	.3
Main Channel	450	.1	.3
Main Channel	400	.1	.3
Main Channel	350	.1	.3
Main Channel	300	.1	.3
Main Channel	250	.1	.3
Main Channel	200	.1	.3
Main Channel	150	.1	.3
Main Channel	100	.1	.3
Main Channel	50	.1	.3
Main Channel	0	.1	.3

ERRORS WARNINGS AND NOTES

Errors Warnings and Notes for Plan : Default Scenario

River: North Reach: North Finger RS: 294 Profile: 5 yr

Warning:The energy equation could not be balanced within the specified number of iterations. The program used critical depth for the water surface and continued on with the calculations.

Warning:The conveyance ratio (upstream conveyance divided by downstream conveyance) is less than 0.7 or greater than 1.4. This may indicate the need for additional cross sections.

Warning:The energy loss was greater than 1.0 ft (0.3 m). between the current and previous cross section. This may indicate the need for additional cross sections.

Warning:During the standard step iterations, when the assumed water surface was set equal to critical depth, the calculated water surface came back below critical depth. This indicates that there is not a valid subcritical answer. The program defaulted to critical depth.

River: North Reach: North Finger RS: 245 Profile: 100 yr

Warning:The energy loss was greater than 1.0 ft (0.3 m). between the current and previous cross section. This may indicate the need for additional cross sections.

River: North Reach: North Finger RS: 245 Profile: 5 yr

Warning:The energy loss was greater than 1.0 ft (0.3 m). between the current and previous cross section. This may indicate the need for additional cross sections.

River: North Reach: North Finger RS: 200 Profile: 100 yr

Warning:The conveyance ratio (upstream conveyance divided by downstream conveyance) is less than 0.7 or greater than 1.4. This may indicate the need for additional cross sections.

Warning:The energy loss was greater than 1.0 ft (0.3 m). between the current and previous cross section. This may indicate the need for additional cross sections.

River: North Reach: North Finger RS: 200 Profile: 5 yr

Warning:The energy equation could not be balanced within the specified number of iterations. The program used critical depth for the water surface and continued on with the calculations.

Warning:Divided flow computed for this cross-section.

Warning:The energy loss was greater than 1.0 ft (0.3 m). between the current and previous cross section. This may indicate the need for additional cross sections.

Warning:During the standard step iterations, when the assumed water surface was set equal to critical depth, the calculated water surface came back below critical depth. This indicates that there is not a valid subcritical answer. The program defaulted to critical depth.

River: North Reach: North Finger RS: 167 Profile: 100 yr

Warning:The velocity head has changed by more than 0.5 ft (0.15 m). This may indicate the need for additional cross sections.

Warning:The conveyance ratio (upstream conveyance divided by downstream conveyance) is less than 0.7 or greater than 1.4. This may indicate the need for additional cross sections.

Warning:The energy loss was greater than 1.0 ft (0.3 m). between the current and previous cross section. This may indicate the need for additional cross sections.

River: North Reach: North Finger RS: 167 Profile: 5 yr

Warning:The velocity head has changed by more than 0.5 ft (0.15 m). This may indicate the need for additional cross sections.

Warning:The conveyance ratio (upstream conveyance divided by downstream conveyance) is less than 0.7 or greater than 1.4. This may indicate the need for additional cross sections.

Warning:The energy loss was greater than 1.0 ft (0.3 m). between the current and previous cross section. This may indicate the need for additional cross sections.

River: North Reach: North Finger RS: 147 Profile: 100 yr

Warning:The velocity head has changed by more than 0.5 ft (0.15 m). This may indicate the need for additional cross sections.

Warning:The conveyance ratio (upstream conveyance divided by downstream conveyance) is less than 0.7 or greater than 1.4. This may indicate the need for additional cross sections.

Warning:The energy loss was greater than 1.0 ft (0.3 m). between the current and previous cross section. This may indicate the need for additional cross sections.

River: North Reach: North Finger RS: 147 Profile: 5 yr

Warning:The velocity head has changed by more than 0.5 ft (0.15 m). This may indicate the need for additional cross sections.

Warning:The conveyance ratio (upstream conveyance divided by downstream conveyance) is less than 0.7 or greater than 1.4. This may indicate the need for additional cross sections.

Warning:The energy loss was greater than 1.0 ft (0.3 m). between the current and previous cross section. This may indicate the need for additional cross sections.

River: North Reach: North Finger RS: 98 Profile: 100 yr

Warning:Divided flow computed for this cross-section.

Warning:The energy loss was greater than 1.0 ft (0.3 m). between the current and previous cross section. This may indicate the need for additional cross sections.

River: North Reach: North Finger RS: 98 Profile: 5 yr

Warning:The energy loss was greater than 1.0 ft (0.3 m). between the current and previous cross section. This may indicate the need for additional cross sections.

River: North Reach: North Finger RS: 49 Profile: 100 yr

Warning:The energy equation could not be balanced within the specified number of iterations. The program used critical depth for the water surface and continued on with the calculations.

Warning:The conveyance ratio (upstream conveyance divided by downstream conveyance) is less than 0.7 or greater than 1.4. This may indicate the need for additional cross sections.

Warning:The energy loss was greater than 1.0 ft (0.3 m). between the current and previous cross section. This may indicate the need for additional cross sections.

River: North Reach: North Finger RS: 49 Profile: 5 yr

Warning:The energy equation could not be balanced within the specified number of iterations. The program used critical depth for the water surface and continued on with the calculations.

Warning:The energy loss was greater than 1.0 ft (0.3 m). between the current and previous cross section. This may indicate the need for additional cross sections.

Warning:During the standard step iterations, when the assumed water surface was set equal to critical depth, the calculated water surface came back below critical depth. This indicates that there is not a valid subcritical answer. The



program defaulted to critical depth.

River: North Reach: Main Channel - U RS: 1415 Profile: 100 yr  
Warning: The energy loss was greater than 1.0 ft (0.3 m). between the current and previous cross section. This may indicate the need for additional cross sections.

River: North Reach: Main Channel - U RS: 1415 Profile: 5 yr  
Warning: Divided flow computed for this cross-section.  
Warning: The energy loss was greater than 1.0 ft (0.3 m). between the current and previous cross section. This may indicate the need for additional cross sections.

River: North Reach: Main Channel - U RS: 1383 Profile: 100 yr  
Warning: The energy loss was greater than 1.0 ft (0.3 m). between the current and previous cross section. This may indicate the need for additional cross sections.

River: North Reach: Main Channel - U RS: 1383 Profile: 5 yr  
Warning: The energy loss was greater than 1.0 ft (0.3 m). between the current and previous cross section. This may indicate the need for additional cross sections.

River: North Reach: Main Channel - U RS: 1341 Profile: 100 yr  
Warning: The energy equation could not be balanced within the specified number of iterations. The program used critical depth for the water surface and continued on with the calculations.  
Warning: The energy loss was greater than 1.0 ft (0.3 m). between the current and previous cross section. This may indicate the need for additional cross sections.  
Warning: During the standard step iterations, when the assumed water surface was set equal to critical depth, the calculated water surface came back below critical depth. This indicates that there is not a valid subcritical answer. The program defaulted to critical depth.

River: North Reach: Main Channel - U RS: 1341 Profile: 5 yr  
Warning: The energy equation could not be balanced within the specified number of iterations. The program used critical depth for the water surface and continued on with the calculations.  
Warning: The energy loss was greater than 1.0 ft (0.3 m). between the current and previous cross section. This may indicate the need for additional cross sections.  
Warning: During the standard step iterations, when the assumed water surface was set equal to critical depth, the calculated water surface came back below critical depth. This indicates that there is not a valid subcritical answer. The program defaulted to critical depth.

River: North Reach: Main Channel - U RS: 1325 Profile: 100 yr  
Warning: The velocity head has changed by more than 0.5 ft (0.15 m). This may indicate the need for additional cross sections.  
Warning: The conveyance ratio (upstream conveyance divided by downstream conveyance) is less than 0.7 or greater than 1.4. This may indicate the need for additional cross sections.  
Warning: The energy loss was greater than 1.0 ft (0.3 m). between the current and previous cross section. This may indicate the need for additional cross sections.  
Note: Program found supercritical flow starting at this cross section.

River: North Reach: Main Channel - U RS: 1325 Profile: 5 yr  
Warning: The velocity head has changed by more than 0.5 ft (0.15 m). This may indicate the need for additional cross sections.  
Warning: The conveyance ratio (upstream conveyance divided by downstream conveyance) is less than 0.7 or greater than 1.4. This may indicate the need for additional cross sections.  
Warning: The energy loss was greater than 1.0 ft (0.3 m). between the current and previous cross section. This may indicate the need for additional cross sections.  
Note: Program found supercritical flow starting at this cross section.

River: North Reach: Main Channel - U RS: 1298 Profile: 100 yr  
Warning: The energy loss was greater than 1.0 ft (0.3 m). between the current and previous cross section. This may indicate the need for additional cross sections.

River: North Reach: Main Channel - U RS: 1298 Profile: 5 yr  
Warning: The energy equation could not be balanced within the specified number of iterations. The program selected the water surface that had the least amount of error between computed and assumed values.  
Warning: The conveyance ratio (upstream conveyance divided by downstream conveyance) is less than 0.7 or greater than 1.4. This may indicate the need for additional cross sections.  
Warning: The energy loss was greater than 1.0 ft (0.3 m). between the current and previous cross section. This may indicate the need for additional cross sections.

River: North Reach: Main Channel - U RS: 1285 Profile: 100 yr  
Note: Hydraulic jump has occurred between this cross section and the previous upstream section.

River: North Reach: Main Channel - U RS: 1285 Profile: 5 yr  
Note: Hydraulic jump has occurred between this cross section and the previous upstream section.

River: North Reach: Main Channel - U RS: 1281 Profile: 100 yr  
Warning: The conveyance ratio (upstream conveyance divided by downstream conveyance) is less than 0.7 or greater than 1.4. This may indicate the need for additional cross sections.

River: North Reach: Main Channel - U RS: 1281 Profile: 5 yr  
Warning: The conveyance ratio (upstream conveyance divided by downstream conveyance) is less than 0.7 or greater than 1.4. This may indicate the need for additional cross sections.

River: North Reach: Main Channel - U RS: 1277 Profile: 100 yr  
Warning: The energy equation could not be balanced within the specified number of iterations. The program used critical depth for the water surface and continued on with the calculations.  
Warning: The energy loss was greater than 1.0 ft (0.3 m). between the current and previous cross section. This may indicate the need for additional cross sections.  
Warning: During the standard step iterations, when the assumed water surface was set equal to critical depth, the calculated water surface came back below critical depth. This indicates that there is not a valid subcritical answer. The program defaulted to critical depth.

River: North Reach: Main Channel - U RS: 1277 Profile: 5 yr  
Warning: The energy equation could not be balanced within the specified number of iterations. The program used critical depth for the water surface and continued on with the calculations.  
Warning: The energy loss was greater than 1.0 ft (0.3 m). between the current and previous cross section. This may indicate the need for additional cross sections.  
Warning: During the standard step iterations, when the assumed water surface was set equal to critical depth, the calculated water surface came back below critical depth. This indicates that there is not a valid subcritical answer. The program defaulted to critical depth.

River: North Reach: Main Channel - U RS: 1250 Profile: 100 yr  
Warning: The velocity head has changed by more than 0.5 ft (0.15 m). This may indicate the need for additional cross sections.  
Warning: The conveyance ratio (upstream conveyance divided by downstream conveyance) is less than 0.7 or greater than 1.4. This may indicate the need for additional cross sections.  
Warning: The energy loss was greater than 1.0 ft (0.3 m). between the current and previous cross section. This may indicate the need for additional cross sections.  
Note: Program found supercritical flow starting at this cross section.

River: North Reach: Main Channel - U RS: 1250 Profile: 5 yr  
Warning: The conveyance ratio (upstream conveyance divided by downstream conveyance) is less than 0.7 or greater than 1.4. This may indicate the need for additional cross sections.  
Warning: The energy loss was greater than 1.0 ft (0.3 m). between the current and previous cross section. This may indicate the need for additional cross sections.  
Note: Program found supercritical flow starting at this cross section.

River: North Reach: Main Channel - U RS: 1213 Profile: 100 yr  
Warning: The energy loss was greater than 1.0 ft (0.3 m). between the current and previous cross section. This may indicate the need for additional cross sections.  
Note: Hydraulic jump has occurred between this cross section and the previous upstream section.

River: North Reach: Main Channel - U RS: 1213 Profile: 5 yr  
Warning: Divided flow computed for this cross-section.  
Warning: The conveyance ratio (upstream conveyance divided by downstream conveyance) is less than 0.7 or greater than 1.4. This may indicate the need for additional cross sections.  
Warning: The energy loss was greater than 1.0 ft (0.3 m). between the current and previous cross section. This may indicate the need for additional cross sections.  
Note: Hydraulic jump has occurred between this cross section and the previous upstream section.

River: North Reach: Main Channel - U RS: 1185 Profile: 100 yr  
Warning: The energy loss was greater than 1.0 ft (0.3 m). between the current and previous cross section. This may indicate the need for additional cross sections.

River: North Reach: Main Channel - U RS: 1185 Profile: 5 yr  
Warning: The energy equation could not be balanced within the specified number of iterations. The program used critical depth for the water surface and continued on with the calculations.  
Warning: The conveyance ratio (upstream conveyance divided by downstream conveyance) is less than 0.7 or greater than 1.4. This may indicate the need for additional cross sections.  
Warning: The energy loss was greater than 1.0 ft (0.3 m). between the current and previous cross section. This may indicate the need for additional cross sections.  
Warning: During the standard step iterations, when the assumed water surface was set equal to critical depth, the calculated water surface came back below critical depth. This indicates that there is not a valid subcritical answer. The program defaulted to critical depth.

River: North Reach: Main Channel - U RS: 1136 Profile: 100 yr  
Warning: The energy loss was greater than 1.0 ft (0.3 m). between the current and previous cross section. This may indicate the need for additional cross sections.

River: North Reach: Main Channel - U RS: 1136 Profile: 5 yr  
Warning: The conveyance ratio (upstream conveyance divided by downstream conveyance) is less than 0.7 or greater than 1.4.

This may indicate the need for additional cross sections.

Warning: The energy loss was greater than 1.0 ft (0.3 m). between the current and previous cross section. This may indicate the need for additional cross sections.

River: North Reach: Main Channel - U RS: 1087 Profile: 100 yr

Warning: The energy equation could not be balanced within the specified number of iterations. The program used critical depth for the water surface and continued on with the calculations.

Warning: The conveyance ratio (upstream conveyance divided by downstream conveyance) is less than 0.7 or greater than 1.4. This may indicate the need for additional cross sections.

Warning: The energy loss was greater than 1.0 ft (0.3 m). between the current and previous cross section. This may indicate the need for additional cross sections.

Warning: During the standard step iterations, when the assumed water surface was set equal to critical depth, the calculated water surface came back below critical depth. This indicates that there is not a valid subcritical answer. The program defaulted to critical depth.

River: North Reach: Main Channel - U RS: 1087 Profile: 5 yr

Warning: The energy equation could not be balanced within the specified number of iterations. The program used critical depth for the water surface and continued on with the calculations.

Warning: The conveyance ratio (upstream conveyance divided by downstream conveyance) is less than 0.7 or greater than 1.4. This may indicate the need for additional cross sections.

Warning: The energy loss was greater than 1.0 ft (0.3 m). between the current and previous cross section. This may indicate the need for additional cross sections.

Warning: During the standard step iterations, when the assumed water surface was set equal to critical depth, the calculated water surface came back below critical depth. This indicates that there is not a valid subcritical answer. The program defaulted to critical depth.

River: North Reach: Main Channel - U RS: 1037 Profile: 5 yr

Warning: The conveyance ratio (upstream conveyance divided by downstream conveyance) is less than 0.7 or greater than 1.4. This may indicate the need for additional cross sections.

Warning: The energy loss was greater than 1.0 ft (0.3 m). between the current and previous cross section. This may indicate the need for additional cross sections.

River: North Reach: Main Channel - U RS: 988 Profile: 100 yr

Warning: The energy equation could not be balanced within the specified number of iterations. The program used critical depth for the water surface and continued on with the calculations.

Warning: The energy loss was greater than 1.0 ft (0.3 m). between the current and previous cross section. This may indicate the need for additional cross sections.

Warning: During the standard step iterations, when the assumed water surface was set equal to critical depth, the calculated water surface came back below critical depth. This indicates that there is not a valid subcritical answer. The program defaulted to critical depth.

River: North Reach: Main Channel - U RS: 988 Profile: 5 yr

Warning: The energy equation could not be balanced within the specified number of iterations. The program used critical depth for the water surface and continued on with the calculations.

Warning: The energy loss was greater than 1.0 ft (0.3 m). between the current and previous cross section. This may indicate the need for additional cross sections.

Warning: During the standard step iterations, when the assumed water surface was set equal to critical depth, the calculated water surface came back below critical depth. This indicates that there is not a valid subcritical answer. The program defaulted to critical depth.

River: North Reach: Main Channel-M RS: 938 Profile: 100 yr

Warning: The velocity head has changed by more than 0.5 ft (0.15 m). This may indicate the need for additional cross sections.

Warning: During supercritical flow calculations a junction was encountered. During standard step calculations the program used the stream with the greatest momentum to balance the energy equation.

River: North Reach: Main Channel-M RS: 938 Profile: 5 yr

Warning: The velocity head has changed by more than 0.5 ft (0.15 m). This may indicate the need for additional cross sections.

Warning: During supercritical flow calculations a junction was encountered. During standard step calculations the program used the stream with the greatest momentum to balance the energy equation.

River: North Reach: Main Channel-M RS: 889 Profile: 100 yr

Note: Hydraulic jump has occurred between this cross section and the previous upstream section.

River: North Reach: Main Channel-M RS: 889 Profile: 5 yr

Warning: The conveyance ratio (upstream conveyance divided by downstream conveyance) is less than 0.7 or greater than 1.4. This may indicate the need for additional cross sections.

Note: Hydraulic jump has occurred between this cross section and the previous upstream section.

River: North Reach: Main Channel-M RS: 840 Profile: 100 yr

Warning: The conveyance ratio (upstream conveyance divided by downstream conveyance) is less than 0.7 or greater than 1.4. This may indicate the need for additional cross sections.

Warning:The energy loss was greater than 1.0 ft (0.3 m). between the current and previous cross section. This may indicate the need for additional cross sections.

River: North Reach: Main Channel-M RS: 840 Profile: 5 yr

Warning:The conveyance ratio (upstream conveyance divided by downstream conveyance) is less than 0.7 or greater than 1.4. This may indicate the need for additional cross sections.

Warning:The energy loss was greater than 1.0 ft (0.3 m). between the current and previous cross section. This may indicate the need for additional cross sections.

River: North Reach: Main Channel-M RS: 790 Profile: 100 yr

Warning:The energy equation could not be balanced within the specified number of iterations. The program used critical depth for the water surface and continued on with the calculations.

Warning:The conveyance ratio (upstream conveyance divided by downstream conveyance) is less than 0.7 or greater than 1.4. This may indicate the need for additional cross sections.

Warning:The energy loss was greater than 1.0 ft (0.3 m). between the current and previous cross section. This may indicate the need for additional cross sections.

Warning:During the standard step iterations, when the assumed water surface was set equal to critical depth, the calculated water surface came back below critical depth. This indicates that there is not a valid subcritical answer. The program defaulted to critical depth.

River: North Reach: Main Channel-M RS: 790 Profile: 5 yr

Warning:The energy equation could not be balanced within the specified number of iterations. The program used critical depth for the water surface and continued on with the calculations.

Warning:The conveyance ratio (upstream conveyance divided by downstream conveyance) is less than 0.7 or greater than 1.4. This may indicate the need for additional cross sections.

Warning:The energy loss was greater than 1.0 ft (0.3 m). between the current and previous cross section. This may indicate the need for additional cross sections.

Warning:During the standard step iterations, when the assumed water surface was set equal to critical depth, the calculated water surface came back below critical depth. This indicates that there is not a valid subcritical answer. The program defaulted to critical depth.

River: North Reach: Main Channel-M RS: 741 Profile: 100 yr

Warning:The conveyance ratio (upstream conveyance divided by downstream conveyance) is less than 0.7 or greater than 1.4. This may indicate the need for additional cross sections.

Warning:The energy loss was greater than 1.0 ft (0.3 m). between the current and previous cross section. This may indicate the need for additional cross sections.

River: North Reach: Main Channel-M RS: 741 Profile: 5 yr

Warning:The conveyance ratio (upstream conveyance divided by downstream conveyance) is less than 0.7 or greater than 1.4. This may indicate the need for additional cross sections.

Warning:The energy loss was greater than 1.0 ft (0.3 m). between the current and previous cross section. This may indicate the need for additional cross sections.

River: North Reach: Main Channel-M RS: 691 Profile: 100 yr

Warning:The energy equation could not be balanced within the specified number of iterations. The program used critical depth for the water surface and continued on with the calculations.

Warning:The energy loss was greater than 1.0 ft (0.3 m). between the current and previous cross section. This may indicate the need for additional cross sections.

Warning:During the standard step iterations, when the assumed water surface was set equal to critical depth, the calculated water surface came back below critical depth. This indicates that there is not a valid subcritical answer. The program defaulted to critical depth.

River: North Reach: Main Channel-M RS: 691 Profile: 5 yr

Warning:The energy equation could not be balanced within the specified number of iterations. The program used critical depth for the water surface and continued on with the calculations.

Warning:The conveyance ratio (upstream conveyance divided by downstream conveyance) is less than 0.7 or greater than 1.4. This may indicate the need for additional cross sections.

Warning:The energy loss was greater than 1.0 ft (0.3 m). between the current and previous cross section. This may indicate the need for additional cross sections.

Warning:During the standard step iterations, when the assumed water surface was set equal to critical depth, the calculated water surface came back below critical depth. This indicates that there is not a valid subcritical answer. The program defaulted to critical depth.

River: North Reach: Main Channel-M RS: 642 Profile: 5 yr

Warning:The conveyance ratio (upstream conveyance divided by downstream conveyance) is less than 0.7 or greater than 1.4. This may indicate the need for additional cross sections.

River: North Reach: Main Channel-M RS: 593 Profile: 100 yr

Warning:The energy loss was greater than 1.0 ft (0.3 m). between the current and previous cross section. This may indicate the need for additional cross sections.

River: North Reach: Main Channel-M RS: 593 Profile: 5 yr  
Warning:The conveyance ratio (upstream conveyance divided by downstream conveyance) is less than 0.7 or greater than 1.4.  
This may indicate the need for additional cross sections.

River: North Reach: Main Channel-M RS: 543 Profile: 100 yr  
Warning:The conveyance ratio (upstream conveyance divided by downstream conveyance) is less than 0.7 or greater than 1.4.  
This may indicate the need for additional cross sections.

River: North Reach: Main Channel-M RS: 543 Profile: 5 yr  
Warning:Divided flow computed for this cross-section.

River: North Reach: Main Channel-M RS: 494 Profile: 100 yr  
Warning:The conveyance ratio (upstream conveyance divided by downstream conveyance) is less than 0.7 or greater than 1.4.  
This may indicate the need for additional cross sections.  
Warning:The energy loss was greater than 1.0 ft (0.3 m). between the current and previous cross section. This may indicate  
the need for additional cross sections.

River: North Reach: Main Channel-M RS: 494 Profile: 5 yr  
Warning:The conveyance ratio (upstream conveyance divided by downstream conveyance) is less than 0.7 or greater than 1.4.  
This may indicate the need for additional cross sections.  
Warning:The energy loss was greater than 1.0 ft (0.3 m). between the current and previous cross section. This may indicate  
the need for additional cross sections.

River: North Reach: Main Channel-M RS: 444 Profile: 100 yr  
Warning:The energy equation could not be balanced within the specified number of iterations. The program used critical depth  
for the water surface and continued on with the calculations.  
Warning:The conveyance ratio (upstream conveyance divided by downstream conveyance) is less than 0.7 or greater than 1.4.  
This may indicate the need for additional cross sections.  
Warning:The energy loss was greater than 1.0 ft (0.3 m). between the current and previous cross section. This may indicate  
the need for additional cross sections.  
Warning:During the standard step iterations, when the assumed water surface was set equal to critical depth, the calculated  
water surface came back below critical depth. This indicates that there is not a valid subcritical answer. The  
program defaulted to critical depth.

River: North Reach: Main Channel-M RS: 444 Profile: 5 yr  
Warning:The energy loss was greater than 1.0 ft (0.3 m). between the current and previous cross section. This may indicate  
the need for additional cross sections.

River: North Reach: Main Channel-M RS: 395 Profile: 100 yr  
Warning:The conveyance ratio (upstream conveyance divided by downstream conveyance) is less than 0.7 or greater than 1.4.  
This may indicate the need for additional cross sections.

River: North Reach: Main Channel-M RS: 395 Profile: 5 yr  
Warning:The energy loss was greater than 1.0 ft (0.3 m). between the current and previous cross section. This may indicate  
the need for additional cross sections.

River: North Reach: Main Channel-M RS: 346 Profile: 100 yr  
Warning:The energy loss was greater than 1.0 ft (0.3 m). between the current and previous cross section. This may indicate  
the need for additional cross sections.

River: North Reach: South Finger RS: 336 Profile: 100 yr  
Warning:The energy equation could not be balanced within the specified number of iterations. The program used critical depth  
for the water surface and continued on with the calculations.  
Warning:The energy loss was greater than 1.0 ft (0.3 m). between the current and previous cross section. This may indicate  
the need for additional cross sections.  
Warning:During the standard step iterations, when the assumed water surface was set equal to critical depth, the calculated  
water surface came back below critical depth. This indicates that there is not a valid subcritical answer. The  
program defaulted to critical depth.

River: North Reach: South Finger RS: 336 Profile: 5 yr  
Warning:The energy loss was greater than 1.0 ft (0.3 m). between the current and previous cross section. This may indicate  
the need for additional cross sections.

River: North Reach: South Finger RS: 301 Profile: 100 yr  
Warning:The energy loss was greater than 1.0 ft (0.3 m). between the current and previous cross section. This may indicate  
the need for additional cross sections.

River: North Reach: South Finger RS: 301 Profile: 5 yr  
Warning:The energy equation could not be balanced within the specified number of iterations. The program used critical depth  
for the water surface and continued on with the calculations.  
Warning:The energy loss was greater than 1.0 ft (0.3 m). between the current and previous cross section. This may indicate  
the need for additional cross sections.  
Warning:During the standard step iterations, when the assumed water surface was set equal to critical depth, the calculated  
water surface came back below critical depth. This indicates that there is not a valid subcritical answer. The

program defaulted to critical depth.

River: North Reach: South Finger RS: 281 Profile: 100 yr  
Warning: The energy loss was greater than 1.0 ft (0.3 m). between the current and previous cross section. This may indicate the need for additional cross sections.

River: North Reach: South Finger RS: 281 Profile: 5 yr  
Warning: The energy loss was greater than 1.0 ft (0.3 m). between the current and previous cross section. This may indicate the need for additional cross sections.  
Note: Program found supercritical flow starting at this cross section.

River: North Reach: South Finger RS: 268 Profile: 100 yr  
Warning: The velocity head has changed by more than 0.5 ft (0.15 m). This may indicate the need for additional cross sections.  
Warning: The conveyance ratio (upstream conveyance divided by downstream conveyance) is less than 0.7 or greater than 1.4. This may indicate the need for additional cross sections.  
Warning: The energy loss was greater than 1.0 ft (0.3 m). between the current and previous cross section. This may indicate the need for additional cross sections.

River: North Reach: South Finger RS: 268 Profile: 5 yr  
Warning: The velocity head has changed by more than 0.5 ft (0.15 m). This may indicate the need for additional cross sections.  
Warning: The conveyance ratio (upstream conveyance divided by downstream conveyance) is less than 0.7 or greater than 1.4. This may indicate the need for additional cross sections.  
Warning: The energy loss was greater than 1.0 ft (0.3 m). between the current and previous cross section. This may indicate the need for additional cross sections.

River: North Reach: South Finger RS: 256 Profile: 100 yr  
Warning: The velocity head has changed by more than 0.5 ft (0.15 m). This may indicate the need for additional cross sections.  
Warning: The conveyance ratio (upstream conveyance divided by downstream conveyance) is less than 0.7 or greater than 1.4. This may indicate the need for additional cross sections.  
Warning: The energy loss was greater than 1.0 ft (0.3 m). between the current and previous cross section. This may indicate the need for additional cross sections.

River: North Reach: South Finger RS: 256 Profile: 5 yr  
Warning: The energy equation could not be balanced within the specified number of iterations. The program selected the water surface that had the least amount of error between computed and assumed values.  
Warning: Divided flow computed for this cross-section.  
Warning: The velocity head has changed by more than 0.5 ft (0.15 m). This may indicate the need for additional cross sections.  
Warning: The conveyance ratio (upstream conveyance divided by downstream conveyance) is less than 0.7 or greater than 1.4. This may indicate the need for additional cross sections.  
Warning: The energy loss was greater than 1.0 ft (0.3 m). between the current and previous cross section. This may indicate the need for additional cross sections.

River: North Reach: South Finger RS: 244 Profile: 100 yr  
Note: Hydraulic jump has occurred between this cross section and the previous upstream section.

River: North Reach: South Finger RS: 244 Profile: 5 yr  
Note: Hydraulic jump has occurred between this cross section and the previous upstream section.

River: North Reach: South Finger RS: 237 Profile: 100 yr  
Warning: The conveyance ratio (upstream conveyance divided by downstream conveyance) is less than 0.7 or greater than 1.4. This may indicate the need for additional cross sections.

River: North Reach: South Finger RS: 237 Profile: 5 yr  
Warning: The conveyance ratio (upstream conveyance divided by downstream conveyance) is less than 0.7 or greater than 1.4. This may indicate the need for additional cross sections.

River: North Reach: South Finger RS: 236 Profile: 100 yr  
Warning: The conveyance ratio (upstream conveyance divided by downstream conveyance) is less than 0.7 or greater than 1.4. This may indicate the need for additional cross sections.

River: North Reach: South Finger RS: 236 Profile: 5 yr  
Warning: The conveyance ratio (upstream conveyance divided by downstream conveyance) is less than 0.7 or greater than 1.4. This may indicate the need for additional cross sections.

River: North Reach: South Finger RS: 229 Profile: 100 yr  
Warning: The energy equation could not be balanced within the specified number of iterations. The program used critical depth for the water surface and continued on with the calculations.  
Warning: The energy loss was greater than 1.0 ft (0.3 m). between the current and previous cross section. This may indicate the need for additional cross sections.  
Warning: During the standard step iterations, when the assumed water surface was set equal to critical depth, the calculated water surface came back below critical depth. This indicates that there is not a valid subcritical answer. The program defaulted to critical depth.

River: North Reach: South Finger RS: 229 Profile: 5 yr  
Warning: The energy equation could not be balanced within the specified number of iterations. The program used critical depth

for the water surface and continued on with the calculations.

Warning: The energy loss was greater than 1.0 ft (0.3 m). between the current and previous cross section. This may indicate the need for additional cross sections.

Warning: During the standard step iterations, when the assumed water surface was set equal to critical depth, the calculated water surface came back below critical depth. This indicates that there is not a valid subcritical answer. The program defaulted to critical depth.

River: North Reach: South Finger RS: 213 Profile: 100 yr

Warning: The velocity head has changed by more than 0.5 ft (0.15 m). This may indicate the need for additional cross sections.

Warning: The conveyance ratio (upstream conveyance divided by downstream conveyance) is less than 0.7 or greater than 1.4. This may indicate the need for additional cross sections.

Warning: The energy loss was greater than 1.0 ft (0.3 m). between the current and previous cross section. This may indicate the need for additional cross sections.

Note: Program found supercritical flow starting at this cross section.

River: North Reach: South Finger RS: 213 Profile: 5 yr

Warning: The velocity head has changed by more than 0.5 ft (0.15 m). This may indicate the need for additional cross sections.

Warning: The conveyance ratio (upstream conveyance divided by downstream conveyance) is less than 0.7 or greater than 1.4. This may indicate the need for additional cross sections.

Warning: The energy loss was greater than 1.0 ft (0.3 m). between the current and previous cross section. This may indicate the need for additional cross sections.

Note: Program found supercritical flow starting at this cross section.

River: North Reach: South Finger RS: 192 Profile: 100 yr

Warning: The velocity head has changed by more than 0.5 ft (0.15 m). This may indicate the need for additional cross sections.

Warning: The conveyance ratio (upstream conveyance divided by downstream conveyance) is less than 0.7 or greater than 1.4. This may indicate the need for additional cross sections.

Warning: The energy loss was greater than 1.0 ft (0.3 m). between the current and previous cross section. This may indicate the need for additional cross sections.

River: North Reach: South Finger RS: 192 Profile: 5 yr

Warning: The velocity head has changed by more than 0.5 ft (0.15 m). This may indicate the need for additional cross sections.

Warning: The conveyance ratio (upstream conveyance divided by downstream conveyance) is less than 0.7 or greater than 1.4. This may indicate the need for additional cross sections.

Warning: The energy loss was greater than 1.0 ft (0.3 m). between the current and previous cross section. This may indicate the need for additional cross sections.

River: North Reach: South Finger RS: 144 Profile: 100 yr

Warning: The energy loss was greater than 1.0 ft (0.3 m). between the current and previous cross section. This may indicate the need for additional cross sections.

River: North Reach: South Finger RS: 144 Profile: 5 yr

Warning: The conveyance ratio (upstream conveyance divided by downstream conveyance) is less than 0.7 or greater than 1.4. This may indicate the need for additional cross sections.

Warning: The energy loss was greater than 1.0 ft (0.3 m). between the current and previous cross section. This may indicate the need for additional cross sections.

River: North Reach: South Finger RS: 81 Profile: 100 yr

Warning: The conveyance ratio (upstream conveyance divided by downstream conveyance) is less than 0.7 or greater than 1.4. This may indicate the need for additional cross sections.

Warning: The energy loss was greater than 1.0 ft (0.3 m). between the current and previous cross section. This may indicate the need for additional cross sections.

Note: Hydraulic jump has occurred between this cross section and the previous upstream section.

River: North Reach: South Finger RS: 81 Profile: 5 yr

Warning: The conveyance ratio (upstream conveyance divided by downstream conveyance) is less than 0.7 or greater than 1.4. This may indicate the need for additional cross sections.

Warning: The energy loss was greater than 1.0 ft (0.3 m). between the current and previous cross section. This may indicate the need for additional cross sections.

Note: Hydraulic jump has occurred between this cross section and the previous upstream section.

River: North Reach: South Finger RS: 48 Profile: 100 yr

Warning: The energy equation could not be balanced within the specified number of iterations. The program used critical depth for the water surface and continued on with the calculations.

Warning: The energy loss was greater than 1.0 ft (0.3 m). between the current and previous cross section. This may indicate the need for additional cross sections.

Warning: During the standard step iterations, when the assumed water surface was set equal to critical depth, the calculated water surface came back below critical depth. This indicates that there is not a valid subcritical answer. The program defaulted to critical depth.

River: North Reach: South Finger RS: 48 Profile: 5 yr

Warning:The energy equation could not be balanced within the specified number of iterations. The program used critical depth for the water surface and continued on with the calculations.

Warning:The energy loss was greater than 1.0 ft (0.3 m). between the current and previous cross section. This may indicate the need for additional cross sections.

Warning:During the standard step iterations, when the assumed water surface was set equal to critical depth, the calculated water surface came back below critical depth. This indicates that there is not a valid subcritical answer. The program defaulted to critical depth.

River: North Reach: Main Channel-L RS: 247 Profile: 100 yr

Warning:The velocity head has changed by more than 0.5 ft (0.15 m). This may indicate the need for additional cross sections.

Warning:During supercritical flow calculations a junction was encountered. During standard step calculations the program used the stream with the greatest momentum to balance the energy equation.

River: North Reach: Main Channel-L RS: 247 Profile: 5 yr

Warning:The velocity head has changed by more than 0.5 ft (0.15 m). This may indicate the need for additional cross sections.

Warning:During supercritical flow calculations a junction was encountered. During standard step calculations the program used the stream with the greatest momentum to balance the energy equation.

River: North Reach: Main Channel-L RS: 229 Profile: 100 yr

Warning:The conveyance ratio (upstream conveyance divided by downstream conveyance) is less than 0.7 or greater than 1.4. This may indicate the need for additional cross sections.

Note: Hydraulic jump has occurred between this cross section and the previous upstream section.

River: North Reach: Main Channel-L RS: 229 Profile: 5 yr

Warning:The conveyance ratio (upstream conveyance divided by downstream conveyance) is less than 0.7 or greater than 1.4. This may indicate the need for additional cross sections.

Note: Hydraulic jump has occurred between this cross section and the previous upstream section.

River: North Reach: Main Channel-L RS: 198 Profile: 100 yr

Warning:The energy equation could not be balanced within the specified number of iterations. The program used critical depth for the water surface and continued on with the calculations.

Warning:The conveyance ratio (upstream conveyance divided by downstream conveyance) is less than 0.7 or greater than 1.4. This may indicate the need for additional cross sections.

Warning:The energy loss was greater than 1.0 ft (0.3 m). between the current and previous cross section. This may indicate the need for additional cross sections.

Warning:During the standard step iterations, when the assumed water surface was set equal to critical depth, the calculated water surface came back below critical depth. This indicates that there is not a valid subcritical answer. The program defaulted to critical depth.

River: North Reach: Main Channel-L RS: 198 Profile: 5 yr

Warning:The energy equation could not be balanced within the specified number of iterations. The program used critical depth for the water surface and continued on with the calculations.

Warning:The conveyance ratio (upstream conveyance divided by downstream conveyance) is less than 0.7 or greater than 1.4. This may indicate the need for additional cross sections.

Warning:The energy loss was greater than 1.0 ft (0.3 m). between the current and previous cross section. This may indicate the need for additional cross sections.

Warning:During the standard step iterations, when the assumed water surface was set equal to critical depth, the calculated water surface came back below critical depth. This indicates that there is not a valid subcritical answer. The program defaulted to critical depth.

River: North Reach: Main Channel-L RS: 148 Profile: 100 yr

Warning:The conveyance ratio (upstream conveyance divided by downstream conveyance) is less than 0.7 or greater than 1.4. This may indicate the need for additional cross sections.

Warning:The energy loss was greater than 1.0 ft (0.3 m). between the current and previous cross section. This may indicate the need for additional cross sections.

River: North Reach: Main Channel-L RS: 148 Profile: 5 yr

Warning:The energy loss was greater than 1.0 ft (0.3 m). between the current and previous cross section. This may indicate the need for additional cross sections.

River: North Reach: Main Channel-L RS: 99 Profile: 100 yr

Warning:The energy loss was greater than 1.0 ft (0.3 m). between the current and previous cross section. This may indicate the need for additional cross sections.

River: North Reach: Main Channel-L RS: 99 Profile: 5 yr

Warning:The energy loss was greater than 1.0 ft (0.3 m). between the current and previous cross section. This may indicate the need for additional cross sections.

River: North Reach: Main Channel-L RS: 49 Profile: 100 yr

Warning:The energy loss was greater than 1.0 ft (0.3 m). between the current and previous cross section. This may indicate the need for additional cross sections.

River: North Reach: Main Channel-L RS: 49 Profile: 5 yr



Warning:The energy loss was greater than 1.0 ft (0.3 m). between the current and previous cross section. This may indicate the need for additional cross sections.

River: South Reach: Main Channel RS: 1250 Profile: 100 yr

Warning:The energy loss was greater than 1.0 ft (0.3 m). between the current and previous cross section. This may indicate the need for additional cross sections.

River: South Reach: Main Channel RS: 1250 Profile: 5 yr

Warning:The energy equation could not be balanced within the specified number of iterations. The program used critical depth for the water surface and continued on with the calculations.

Warning:Divided flow computed for this cross-section.

Warning:The energy loss was greater than 1.0 ft (0.3 m). between the current and previous cross section. This may indicate the need for additional cross sections.

River: South Reach: Main Channel RS: 1218 Profile: 100 yr

Warning:The energy equation could not be balanced within the specified number of iterations. The program used critical depth for the water surface and continued on with the calculations.

Warning:The energy loss was greater than 1.0 ft (0.3 m). between the current and previous cross section. This may indicate the need for additional cross sections.

Warning:During the standard step iterations, when the assumed water surface was set equal to critical depth, the calculated water surface came back below critical depth. This indicates that there is not a valid subcritical answer. The program defaulted to critical depth.

River: South Reach: Main Channel RS: 1218 Profile: 5 yr

Warning:The energy equation could not be balanced within the specified number of iterations. The program used critical depth for the water surface and continued on with the calculations.

Warning:The energy loss was greater than 1.0 ft (0.3 m). between the current and previous cross section. This may indicate the need for additional cross sections.

Warning:During the standard step iterations, when the assumed water surface was set equal to critical depth, the calculated water surface came back below critical depth. This indicates that there is not a valid subcritical answer. The program defaulted to critical depth.

River: South Reach: Main Channel RS: 1191 Profile: 100 yr

Warning:The velocity head has changed by more than 0.5 ft (0.15 m). This may indicate the need for additional cross sections.

Warning:The conveyance ratio (upstream conveyance divided by downstream conveyance) is less than 0.7 or greater than 1.4. This may indicate the need for additional cross sections.

Warning:The energy loss was greater than 1.0 ft (0.3 m). between the current and previous cross section. This may indicate the need for additional cross sections.

Note: Program found supercritical flow starting at this cross section.

River: South Reach: Main Channel RS: 1191 Profile: 5 yr

Warning:The energy equation could not be balanced within the specified number of iterations. The program used critical depth for the water surface and continued on with the calculations.

Warning:The conveyance ratio (upstream conveyance divided by downstream conveyance) is less than 0.7 or greater than 1.4. This may indicate the need for additional cross sections.

Warning:The energy loss was greater than 1.0 ft (0.3 m). between the current and previous cross section. This may indicate the need for additional cross sections.

Warning:During the standard step iterations, when the assumed water surface was set equal to critical depth, the calculated water surface came back below critical depth. This indicates that there is not a valid subcritical answer. The program defaulted to critical depth.

River: South Reach: Main Channel RS: 1159 Profile: 100 yr

Warning:The energy equation could not be balanced within the specified number of iterations. The program selected the water surface that had the least amount of error between computed and assumed values.

Warning:The velocity head has changed by more than 0.5 ft (0.15 m). This may indicate the need for additional cross sections.

Warning:The conveyance ratio (upstream conveyance divided by downstream conveyance) is less than 0.7 or greater than 1.4. This may indicate the need for additional cross sections.

Warning:The energy loss was greater than 1.0 ft (0.3 m). between the current and previous cross section. This may indicate the need for additional cross sections.

River: South Reach: Main Channel RS: 1159 Profile: 5 yr

Warning:The energy equation could not be balanced within the specified number of iterations. The program selected the water surface that had the least amount of error between computed and assumed values.

Warning:The conveyance ratio (upstream conveyance divided by downstream conveyance) is less than 0.7 or greater than 1.4. This may indicate the need for additional cross sections.

Warning:The energy loss was greater than 1.0 ft (0.3 m). between the current and previous cross section. This may indicate the need for additional cross sections.

River: South Reach: Main Channel RS: 1136 Profile: 100 yr

Warning:The energy equation could not be balanced within the specified number of iterations. The program used critical depth

for the water surface and continued on with the calculations.

Warning:The conveyance ratio (upstream conveyance divided by downstream conveyance) is less than 0.7 or greater than 1.4. This may indicate the need for additional cross sections.

Warning:The energy loss was greater than 1.0 ft (0.3 m). between the current and previous cross section. This may indicate the need for additional cross sections.

Warning:During the standard step iterations, when the assumed water surface was set equal to critical depth, the calculated water surface came back below critical depth. This indicates that there is not a valid subcritical answer. The program defaulted to critical depth.

River: South Reach: Main Channel RS: 1136 Profile: 5 yr

Warning:The energy equation could not be balanced within the specified number of iterations. The program used critical depth for the water surface and continued on with the calculations.

Warning:The conveyance ratio (upstream conveyance divided by downstream conveyance) is less than 0.7 or greater than 1.4. This may indicate the need for additional cross sections.

Warning:The energy loss was greater than 1.0 ft (0.3 m). between the current and previous cross section. This may indicate the need for additional cross sections.

Warning:During the standard step iterations, when the assumed water surface was set equal to critical depth, the calculated water surface came back below critical depth. This indicates that there is not a valid subcritical answer. The program defaulted to critical depth.

River: South Reach: Main Channel RS: 1100 Profile: 100 yr

Note: Hydraulic jump has occurred between this cross section and the previous upstream section.

River: South Reach: Main Channel RS: 1100 Profile: 5 yr

Note: Hydraulic jump has occurred between this cross section and the previous upstream section.

River: South Reach: Main Channel RS: 1089 Profile: 100 yr

Warning:The conveyance ratio (upstream conveyance divided by downstream conveyance) is less than 0.7 or greater than 1.4. This may indicate the need for additional cross sections.

Warning:The energy loss was greater than 1.0 ft (0.3 m). between the current and previous cross section. This may indicate the need for additional cross sections.

River: South Reach: Main Channel RS: 1089 Profile: 5 yr

Warning:The energy loss was greater than 1.0 ft (0.3 m). between the current and previous cross section. This may indicate the need for additional cross sections.

River: South Reach: Main Channel RS: 1050 Profile: 100 yr

Warning:The conveyance ratio (upstream conveyance divided by downstream conveyance) is less than 0.7 or greater than 1.4. This may indicate the need for additional cross sections.

Warning:The energy loss was greater than 1.0 ft (0.3 m). between the current and previous cross section. This may indicate the need for additional cross sections.

River: South Reach: Main Channel RS: 1050 Profile: 5 yr

Warning:The energy loss was greater than 1.0 ft (0.3 m). between the current and previous cross section. This may indicate the need for additional cross sections.

River: South Reach: Main Channel RS: 1000 Profile: 100 yr

Warning:The conveyance ratio (upstream conveyance divided by downstream conveyance) is less than 0.7 or greater than 1.4. This may indicate the need for additional cross sections.

Warning:The energy loss was greater than 1.0 ft (0.3 m). between the current and previous cross section. This may indicate the need for additional cross sections.

River: South Reach: Main Channel RS: 1000 Profile: 5 yr

Warning:The conveyance ratio (upstream conveyance divided by downstream conveyance) is less than 0.7 or greater than 1.4. This may indicate the need for additional cross sections.

Warning:The energy loss was greater than 1.0 ft (0.3 m). between the current and previous cross section. This may indicate the need for additional cross sections.

River: South Reach: Main Channel RS: 950 Profile: 100 yr

Warning:The energy equation could not be balanced within the specified number of iterations. The program used critical depth for the water surface and continued on with the calculations.

Warning:The energy loss was greater than 1.0 ft (0.3 m). between the current and previous cross section. This may indicate the need for additional cross sections.

Warning:During the standard step iterations, when the assumed water surface was set equal to critical depth, the calculated water surface came back below critical depth. This indicates that there is not a valid subcritical answer. The program defaulted to critical depth.

River: South Reach: Main Channel RS: 950 Profile: 5 yr

Warning:The energy loss was greater than 1.0 ft (0.3 m). between the current and previous cross section. This may indicate the need for additional cross sections.

River: South Reach: Main Channel RS: 900 Profile: 100 yr

Warning:The energy loss was greater than 1.0 ft (0.3 m). between the current and previous cross section. This may indicate

the need for additional cross sections.

Note: Program found supercritical flow starting at this cross section.

River: South Reach: Main Channel RS: 900 Profile: 5 yr

Warning: The energy equation could not be balanced within the specified number of iterations. The program used critical depth for the water surface and continued on with the calculations.

Warning: The conveyance ratio (upstream conveyance divided by downstream conveyance) is less than 0.7 or greater than 1.4. This may indicate the need for additional cross sections.

Warning: The energy loss was greater than 1.0 ft (0.3 m). between the current and previous cross section. This may indicate the need for additional cross sections.

Warning: During the standard step iterations, when the assumed water surface was set equal to critical depth, the calculated water surface came back below critical depth. This indicates that there is not a valid subcritical answer. The program defaulted to critical depth.

River: South Reach: Main Channel RS: 850 Profile: 100 yr

Warning: The conveyance ratio (upstream conveyance divided by downstream conveyance) is less than 0.7 or greater than 1.4. This may indicate the need for additional cross sections.

Note: Hydraulic jump has occurred between this cross section and the previous upstream section.

River: South Reach: Main Channel RS: 850 Profile: 5 yr

Warning: The conveyance ratio (upstream conveyance divided by downstream conveyance) is less than 0.7 or greater than 1.4. This may indicate the need for additional cross sections.

Warning: The energy loss was greater than 1.0 ft (0.3 m). between the current and previous cross section. This may indicate the need for additional cross sections.

River: South Reach: Main Channel RS: 800 Profile: 100 yr

Warning: The conveyance ratio (upstream conveyance divided by downstream conveyance) is less than 0.7 or greater than 1.4. This may indicate the need for additional cross sections.

Warning: The energy loss was greater than 1.0 ft (0.3 m). between the current and previous cross section. This may indicate the need for additional cross sections.

River: South Reach: Main Channel RS: 800 Profile: 5 yr

Warning: The conveyance ratio (upstream conveyance divided by downstream conveyance) is less than 0.7 or greater than 1.4. This may indicate the need for additional cross sections.

Warning: The energy loss was greater than 1.0 ft (0.3 m). between the current and previous cross section. This may indicate the need for additional cross sections.

River: South Reach: Main Channel RS: 750 Profile: 100 yr

Warning: The energy equation could not be balanced within the specified number of iterations. The program used critical depth for the water surface and continued on with the calculations.

Warning: The conveyance ratio (upstream conveyance divided by downstream conveyance) is less than 0.7 or greater than 1.4. This may indicate the need for additional cross sections.

Warning: The energy loss was greater than 1.0 ft (0.3 m). between the current and previous cross section. This may indicate the need for additional cross sections.

Warning: During the standard step iterations, when the assumed water surface was set equal to critical depth, the calculated water surface came back below critical depth. This indicates that there is not a valid subcritical answer. The program defaulted to critical depth.

River: South Reach: Main Channel RS: 750 Profile: 5 yr

Warning: The conveyance ratio (upstream conveyance divided by downstream conveyance) is less than 0.7 or greater than 1.4. This may indicate the need for additional cross sections.

Warning: The energy loss was greater than 1.0 ft (0.3 m). between the current and previous cross section. This may indicate the need for additional cross sections.

River: South Reach: Main Channel RS: 700 Profile: 100 yr

Warning: The conveyance ratio (upstream conveyance divided by downstream conveyance) is less than 0.7 or greater than 1.4. This may indicate the need for additional cross sections.

Warning: The energy loss was greater than 1.0 ft (0.3 m). between the current and previous cross section. This may indicate the need for additional cross sections.

River: South Reach: Main Channel RS: 700 Profile: 5 yr

Warning: The conveyance ratio (upstream conveyance divided by downstream conveyance) is less than 0.7 or greater than 1.4. This may indicate the need for additional cross sections.

Warning: The energy loss was greater than 1.0 ft (0.3 m). between the current and previous cross section. This may indicate the need for additional cross sections.

River: South Reach: Main Channel RS: 650 Profile: 100 yr

Warning: The conveyance ratio (upstream conveyance divided by downstream conveyance) is less than 0.7 or greater than 1.4. This may indicate the need for additional cross sections.

Warning: The energy loss was greater than 1.0 ft (0.3 m). between the current and previous cross section. This may indicate the need for additional cross sections.

River: South Reach: Main Channel RS: 650 Profile: 5 yr  
Warning:The conveyance ratio (upstream conveyance divided by downstream conveyance) is less than 0.7 or greater than 1.4.  
This may indicate the need for additional cross sections.  
Warning:The energy loss was greater than 1.0 ft (0.3 m). between the current and previous cross section. This may indicate  
the need for additional cross sections.

River: South Reach: Main Channel RS: 600 Profile: 100 yr  
Warning:The conveyance ratio (upstream conveyance divided by downstream conveyance) is less than 0.7 or greater than 1.4.  
This may indicate the need for additional cross sections.  
Warning:The energy loss was greater than 1.0 ft (0.3 m). between the current and previous cross section. This may indicate  
the need for additional cross sections.

River: South Reach: Main Channel RS: 600 Profile: 5 yr  
Warning:The conveyance ratio (upstream conveyance divided by downstream conveyance) is less than 0.7 or greater than 1.4.  
This may indicate the need for additional cross sections.  
Warning:The energy loss was greater than 1.0 ft (0.3 m). between the current and previous cross section. This may indicate  
the need for additional cross sections.

River: South Reach: Main Channel RS: 550 Profile: 100 yr  
Warning:The energy loss was greater than 1.0 ft (0.3 m). between the current and previous cross section. This may indicate  
the need for additional cross sections.

River: South Reach: Main Channel RS: 550 Profile: 5 yr  
Warning:The energy loss was greater than 1.0 ft (0.3 m). between the current and previous cross section. This may indicate  
the need for additional cross sections.

River: South Reach: Main Channel RS: 500 Profile: 100 yr  
Warning:The energy equation could not be balanced within the specified number of iterations. The program used critical depth  
for the water surface and continued on with the calculations.  
Warning:The conveyance ratio (upstream conveyance divided by downstream conveyance) is less than 0.7 or greater than 1.4.  
This may indicate the need for additional cross sections.  
Warning:The energy loss was greater than 1.0 ft (0.3 m). between the current and previous cross section. This may indicate  
the need for additional cross sections.  
Warning:During the standard step iterations, when the assumed water surface was set equal to critical depth, the calculated  
water surface came back below critical depth. This indicates that there is not a valid subcritical answer. The  
program defaulted to critical depth.

River: South Reach: Main Channel RS: 500 Profile: 5 yr  
Warning:The conveyance ratio (upstream conveyance divided by downstream conveyance) is less than 0.7 or greater than 1.4.  
This may indicate the need for additional cross sections.  
Warning:The energy loss was greater than 1.0 ft (0.3 m). between the current and previous cross section. This may indicate  
the need for additional cross sections.

River: South Reach: Main Channel RS: 350 Profile: 5 yr  
Warning:The energy loss was greater than 1.0 ft (0.3 m). between the current and previous cross section. This may indicate  
the need for additional cross sections.

River: South Reach: Main Channel RS: 300 Profile: 100 yr  
Warning:The conveyance ratio (upstream conveyance divided by downstream conveyance) is less than 0.7 or greater than 1.4.  
This may indicate the need for additional cross sections.  
Warning:The energy loss was greater than 1.0 ft (0.3 m). between the current and previous cross section. This may indicate  
the need for additional cross sections.

River: South Reach: Main Channel RS: 300 Profile: 5 yr  
Warning:The energy loss was greater than 1.0 ft (0.3 m). between the current and previous cross section. This may indicate  
the need for additional cross sections.

River: South Reach: Main Channel RS: 250 Profile: 100 yr  
Warning:Divided flow computed for this cross-section.  
Warning:The energy loss was greater than 1.0 ft (0.3 m). between the current and previous cross section. This may indicate  
the need for additional cross sections.

River: South Reach: Main Channel RS: 250 Profile: 5 yr  
Warning:The energy loss was greater than 1.0 ft (0.3 m). between the current and previous cross section. This may indicate  
the need for additional cross sections.

River: South Reach: Main Channel RS: 200 Profile: 100 yr  
Warning:Divided flow computed for this cross-section.  
Warning:The energy loss was greater than 1.0 ft (0.3 m). between the current and previous cross section. This may indicate  
the need for additional cross sections.

River: South Reach: Main Channel RS: 200 Profile: 5 yr  
Warning:Divided flow computed for this cross-section.  
Warning:The energy loss was greater than 1.0 ft (0.3 m). between the current and previous cross section. This may indicate

the need for additional cross sections.

River: South Reach: Main Channel RS: 150 Profile: 100 yr

Warning: The conveyance ratio (upstream conveyance divided by downstream conveyance) is less than 0.7 or greater than 1.4. This may indicate the need for additional cross sections.

Warning: The energy loss was greater than 1.0 ft (0.3 m). between the current and previous cross section. This may indicate the need for additional cross sections.

River: South Reach: Main Channel RS: 150 Profile: 5 yr

Warning: Divided flow computed for this cross-section.

Warning: The conveyance ratio (upstream conveyance divided by downstream conveyance) is less than 0.7 or greater than 1.4. This may indicate the need for additional cross sections.

Warning: The energy loss was greater than 1.0 ft (0.3 m). between the current and previous cross section. This may indicate the need for additional cross sections.

River: South Reach: Main Channel RS: 100 Profile: 100 yr

Warning: The conveyance ratio (upstream conveyance divided by downstream conveyance) is less than 0.7 or greater than 1.4. This may indicate the need for additional cross sections.

Warning: The energy loss was greater than 1.0 ft (0.3 m). between the current and previous cross section. This may indicate the need for additional cross sections.

River: South Reach: Main Channel RS: 100 Profile: 5 yr

Warning: The energy equation could not be balanced within the specified number of iterations. The program used critical depth for the water surface and continued on with the calculations.

Warning: The conveyance ratio (upstream conveyance divided by downstream conveyance) is less than 0.7 or greater than 1.4. This may indicate the need for additional cross sections.

Warning: The energy loss was greater than 1.0 ft (0.3 m). between the current and previous cross section. This may indicate the need for additional cross sections.

Warning: During the standard step iterations, when the assumed water surface was set equal to critical depth, the calculated water surface came back below critical depth. This indicates that there is not a valid subcritical answer. The program defaulted to critical depth.

River: South Reach: Main Channel RS: 50 Profile: 100 yr

Warning: The energy loss was greater than 1.0 ft (0.3 m). between the current and previous cross section. This may indicate the need for additional cross sections.

River: South Reach: Main Channel RS: 50 Profile: 5 yr

Warning: The conveyance ratio (upstream conveyance divided by downstream conveyance) is less than 0.7 or greater than 1.4. This may indicate the need for additional cross sections.

Warning: The energy loss was greater than 1.0 ft (0.3 m). between the current and previous cross section. This may indicate the need for additional cross sections.

River: South Reach: Main Channel RS: 0 Profile: 5 yr

Warning: Slope-Area method could not converge on a starting water surface elevation within the specified number of trials. The program used critical depth as the starting water surface.

Warning: Divided flow computed for this cross-section.

## **4 Drainage Maps**

Existing Conditions Drainage Map  
Proposed Conditions Drainage Map  
Water Quality Control Plan

(Map Pocket)  
(Map Pocket)

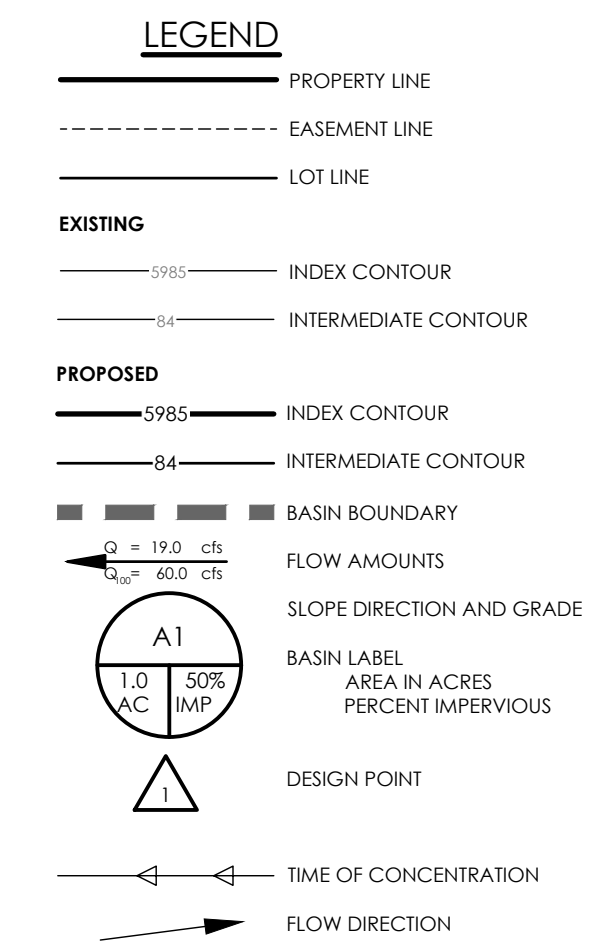
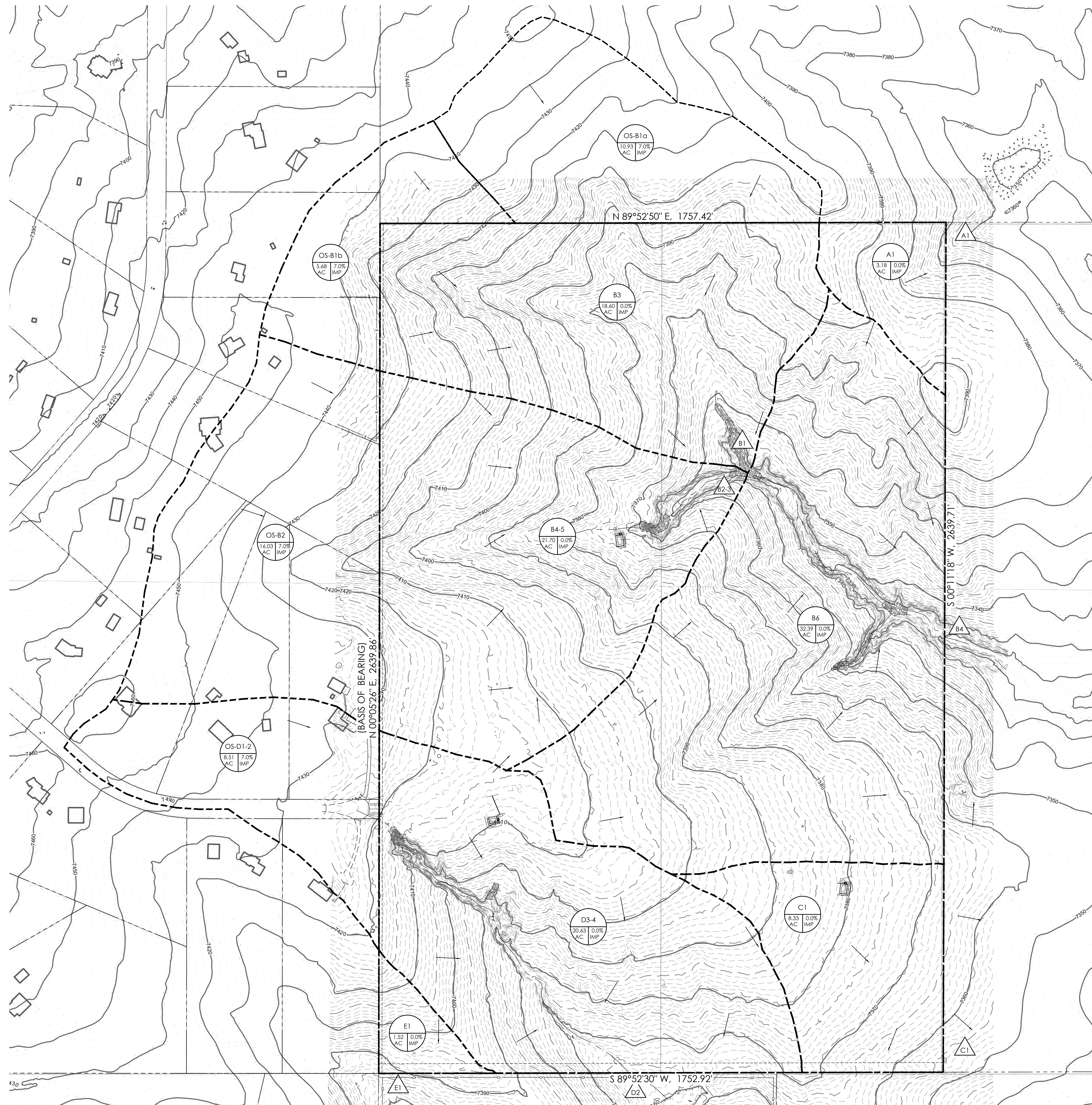

**FLOODPLAIN STATEMENT**

ACCORDING TO FEMA FLOOD INSURANCE RATE MAP COMMUNITY PANEL NO.08041C0305 G, DATED DECEMBER 7, 2018, THE PROPERTY IS LOCATED WITHIN FEMA DESIGNATED FLOOD HAZARD ZONE X.

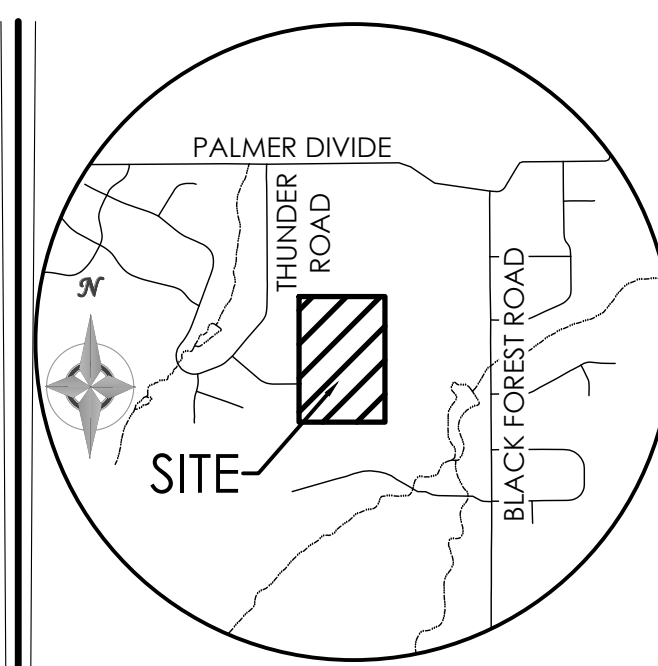

**VICINITY MAP**  
NOT TO SCALE

BENCHMARK  
 THE BENCHMARK FOR THESE PLANS IS THE SOUTHWEST PROPERTY CORNER, A REBAR & CAP, ALESSI, PLS 30130.  
 ELEVATION = 7385.63' (NAVD88).

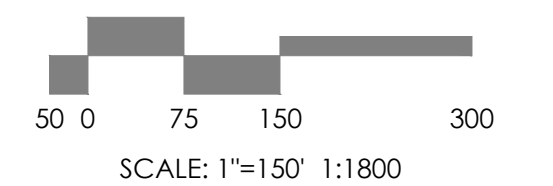
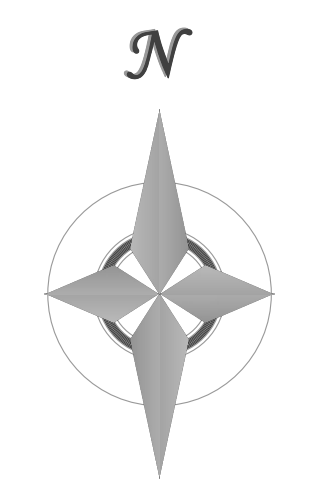

**EXISTING DRAINAGE SUMMARY TABLE**

DESIGN POINTS	INCLUDED BASINS	AREA (AC)	Tc (MIN.)	RUNOFF		METHOD
				Q5 (CFS)	Q100 (CFS)	
DP-A1	A1	3.18	17.2	0.8	6.2	RATIONAL
	OS-B1a	10.93	17.8	3.6	22.8	RATIONAL
	OS-B1b	5.68	15.0	2.0	12.8	RATIONAL
	B3	18.65	27.0	3.9	28.8	RATIONAL
DP-B1	OS-B1a, OS-B1b, B3	35.21	27.0	8.3	56.8	RATIONAL
	OS-B2	16.03	23.1	4.6	29.4	RATIONAL
	B4-5	21.70	26.0	4.7	34.4	RATIONAL
DP-B2-3	OS-B2, B4-5	37.73	30.1	8.3	56.8	RATIONAL
	B6	32.39	31.2	6.3	46.1	RATIONAL
DP-B4	DP-B1, 2, 3 & B6	105.33	34.2	20.7	145.1	RATIONAL
	C1	11.51	34.4	2.1	11.1	RATIONAL
	OS-D1-2	8.51	22.5	2.5	15.8	RATIONAL
	D3-4	20.63	19.4	5.2	38.0	RATIONAL
DP-D2	OS-D1-2, D3-4	29.14	26.5	6.7	46.8	RATIONAL
DP-E1	E1	1.52	12.8	0.5	3.4	RATIONAL

REVISIONS

DESIGNED BY \_\_\_\_\_  
 DRAWN BY \_\_\_\_\_  
 CHECKED BY \_\_\_\_\_  
 AS-BUILTS BY \_\_\_\_\_  
 CHECKED BY \_\_\_\_\_

TABLE ROCK  
 HOMESTEADS  
 DRAINAGE REPORT  
 EXISTING DRAINAGE MAP

MVE PROJECT 61223  
 MVE DRAWING EXDRAIN MAP

DECEMBER 20, 2024  
 SHEET 1 OF 1



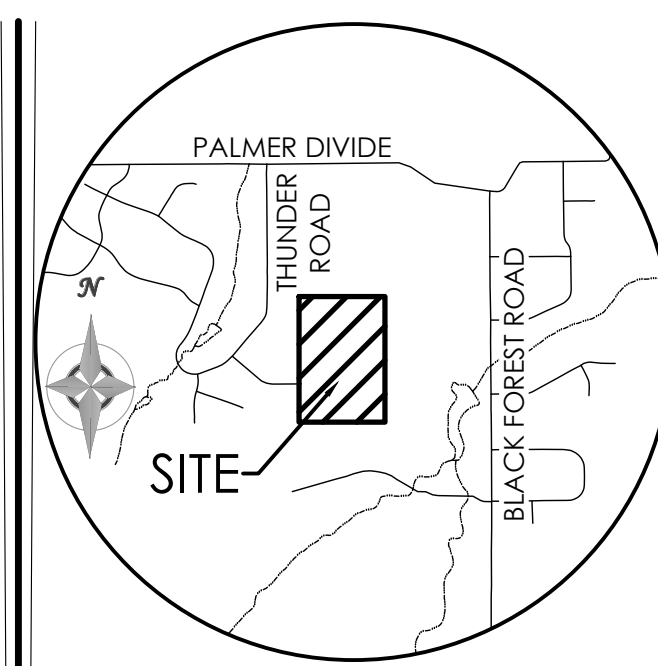
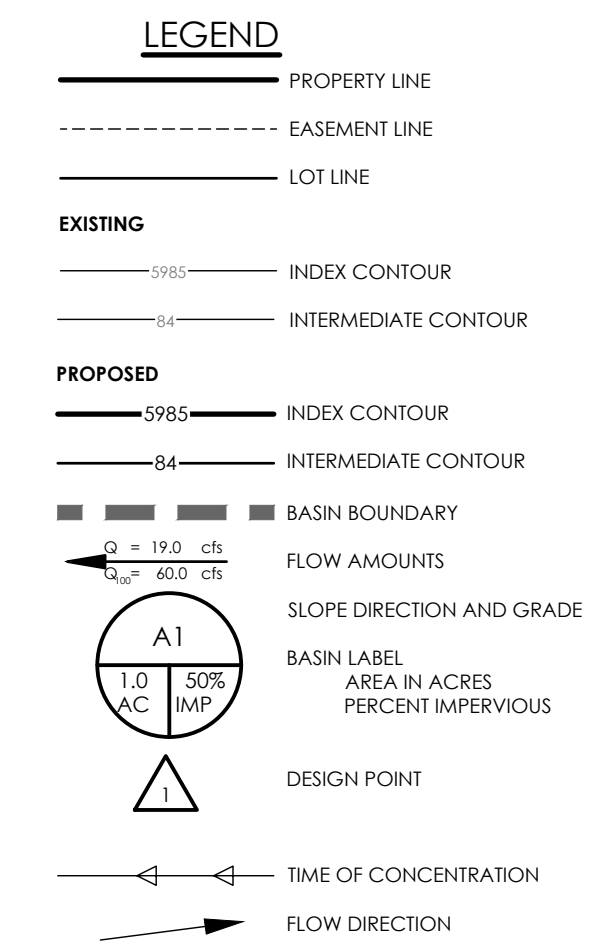
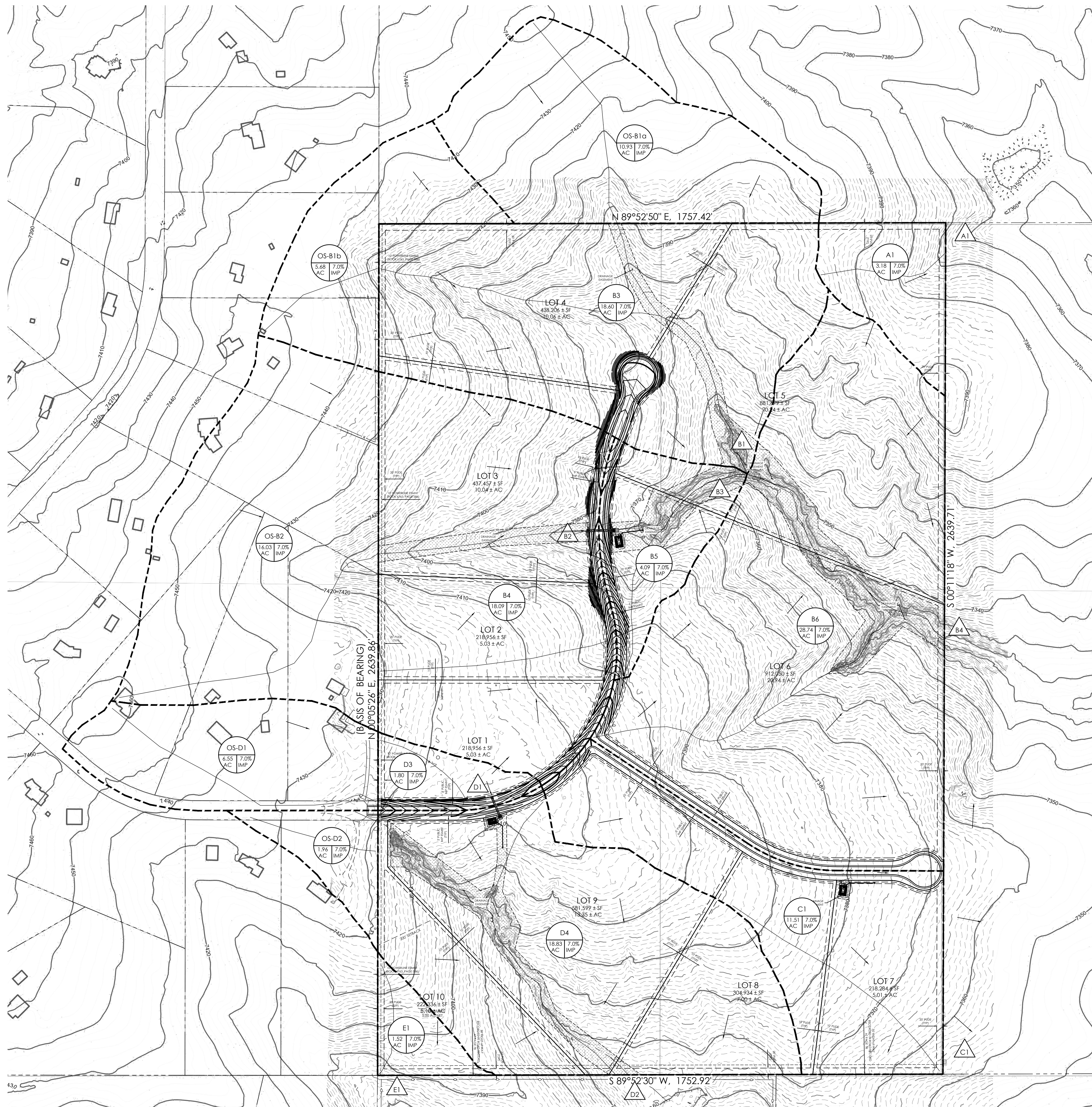

**VICINITY MAP**  
 NOT TO SCALE

BENCHMARK  
 THE BENCHMARK FOR THESE PLANS IS THE  
 SOUTHWEST PROPERTY CORNER, A REBAR &  
 CAP, ALESSI, PLS 30130.  
 ELEVATION = 7385.63' (NAVD88).

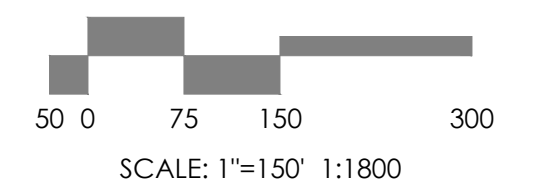
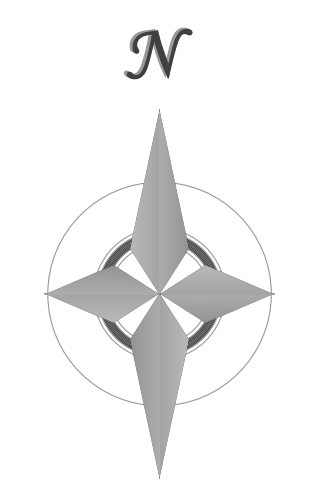

**FLOODPLAIN STATEMENT**

ACCORDING TO FEMA FLOOD INSURANCE RATE MAP COMMUNITY PANEL NO.08041C0305 G,  
 DATED DECEMBER 7, 2018, THE PROPERTY IS LOCATED WITHIN FEMA DESIGNATED FLOOD HAZARD ZONE X.

**DRAINAGE EASEMENTS:**

PUBLIC DRAINAGE EASEMENTS AS SPECIFICALLY NOTED ON THE PLAT SHALL BE MAINTAINED  
 BY THE INDIVIDUAL LOT OWNERS UNLESS OTHERWISE INDICATED. STRUCTURES, FENCES,  
 MATERIALS OR LANDSCAPING THAT COULD IMPEDE THE FLOW OF RUNOFF SHALL NOT BE  
 PLACED IN DRAINAGE EASEMENTS. COMPONENTS OF ONSITE WASTEWATER TREATMENT  
 SYSTEMS SHALL NOT BE PLACED IN DRAINAGE EASEMENTS.

**PROPOSED DRAINAGE SUMMARY TABLE**

DESIGN POINTS (CFS)	INCLUDED BASINS (CFS)	AREA (AC)	Tc (MIN.)	RUNOFF		METHOD
				Q5	Q100	
DP-A1	A1	3.18	16.9	1.1	6.8	RATIONAL
	OS-B1a	10.93	17.8	3.6	22.8	RATIONAL
	OS-B1b	5.68	15.0	2.0	12.8	RATIONAL
	B3	18.60	26.7	4.9	31.5	RATIONAL
DP-B1	OS-B1a, OS-B1b, B3	35.21	35.21	26.7	59.6	RATIONAL
	OS-B2	34.11	23.1	4.6	29.4	RATIONAL
	B4	18.09	23.3	5.2	33.0	RATIONAL
DP-B2	OS-B2, B4	34.11	27.1	9.0	57.2	RATIONAL
	B5	4.09	19.3	1.3	8.2	RATIONAL
DP-B3	DP-B2, B5	38.20	25.7	10.4	66.1	RATIONAL
	B6	28.74	25.4	7.9	50.1	RATIONAL
DP-B4	DP-B1, DP-B3, B6	102.15	29.6	25.6	163.1	RATIONAL
DP-C1	C1	11.51	33.9	2.6	16.9	RATIONAL
	OS-D1	6.55	22.5	1.9	12.2	RATIONAL
	D3	1.80	15.3	0.6	4.0	RATIONAL
DP-D1	OS-D1, D3	8.35	23.7	2.4	15.1	RATIONAL
	OS-D2	1.96	17.0	0.7	4.2	RATIONAL
	D4	18.83	18.4	6.1	38.6	RATIONAL
DP-D2	DP-D1, OS-D2, D4	29.14	26.8	7.7	49.3	RATIONAL
DP-E1	E1	1.52	12.6	0.6	3.7	RATIONAL



REVISIONS

DESIGNED BY \_\_\_\_\_  
 DRAWN BY \_\_\_\_\_  
 CHECKED BY \_\_\_\_\_  
 AS-BUILTS BY \_\_\_\_\_  
 CHECKED BY \_\_\_\_\_

TABLE ROCK  
 HOMESTEADS  
 DRAINAGE REPORT  
 PROP. DRAINAGE MAP

MVE PROJECT 61223  
 MVE DRAWING PPRAIN MAP  
 DECEMBER 20, 2024  
 SHEET 1 OF 1





**LEGEND**

- PROPERTY LINE
- EASEMENT LINE
- LOT LINE
- EXISTING INDEX CONTOUR
- EXISTING INTERMEDIATE CONTOUR
- PROPOSED INDEX CONTOUR
- PROPOSED INTERMEDIATE CONTOUR
- BASIN BOUNDARY
- FLOW AMOUNTS
- SLOPE DIRECTION AND GRADE
- BASIN LABEL
- AREA IN ACRES
- PERCENT IMPERVIOUS
- DESIGN POINT
- FLOW DIRECTION

**SURFACE TYPES**

UNCONNECTED IMPERVIOUS AREA (UIA) TO RECEIVING PERVIOUS AREA (RPA, GRASS BUFFER)	[Blue Box]
UNCONNECTED IMPERVIOUS AREA (UIA) TO RECEIVING PERVIOUS AREA (RPA, SAND FILTER)	[Magenta Box]
RECEIVING PERVIOUS AREA (RPA)	[Green Box]

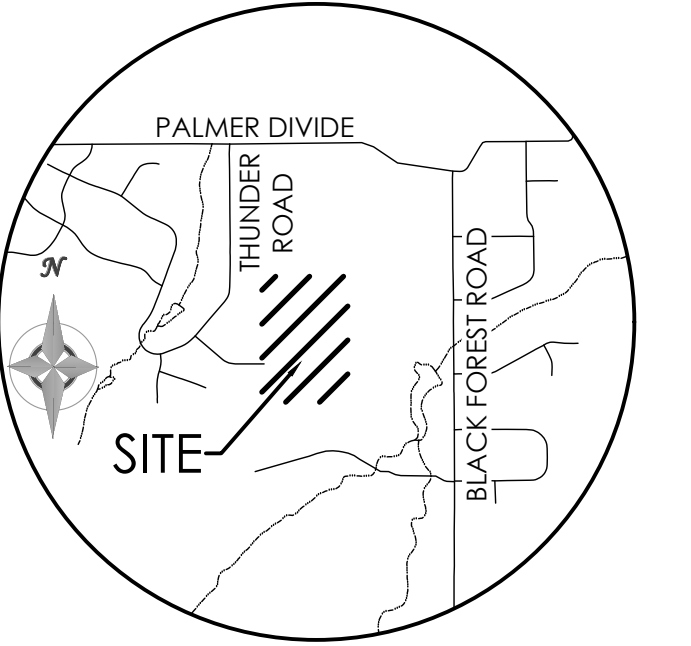

**VICINITY MAP**  
NOT TO SCALE

BENCHMARK  
THE BENCHMARK FOR THESE PLANS IS THE SOUTHWEST PROPERTY CORNER, A REBAR & CAP, ALESSI, PLS 30130.  
ELEVATION = 7385.63' (NAVD88).

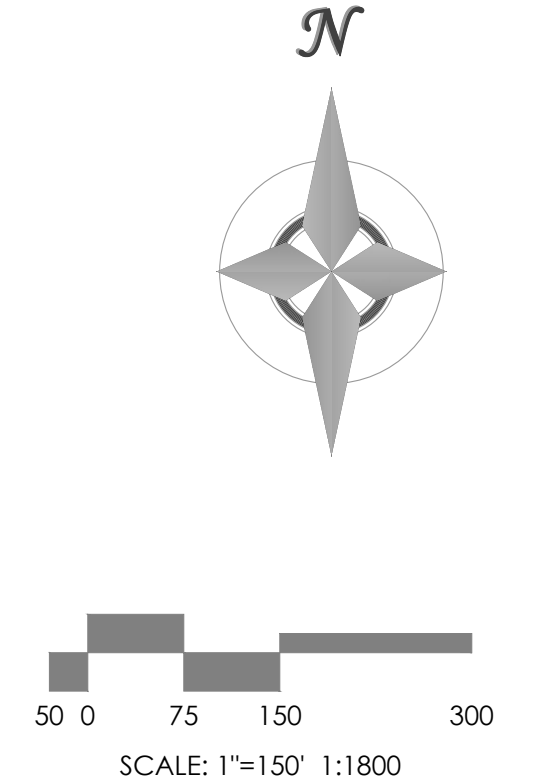

REVISIONS

DESIGNED BY \_\_\_\_\_  
DRAWN BY \_\_\_\_\_  
CHECKED BY \_\_\_\_\_  
AS-BUILTS BY \_\_\_\_\_  
CHECKED BY \_\_\_\_\_

TABLE ROCK  
HOMESTEADS

WATER QUALITY  
CONTROL PLAN

MVE PROJECT 61223  
MVE DRAWING PPWQCP MAP

DECEMBER 20, 2024  
SHEET 1 OF 1