



**MVE, INC.**  
ENGINEERS SURVEYORS

1903 kelaray street, suite 200  
colorado springs, co 80909  
719.635.5736

# Storm Water Management Plan

## Monument Small Engine

Project No. 61092

Revised: October 24, 2019

PCD File No.

PPR1946

Copyright © MVE, Inc., 2018

# Storm Water Management Plan

for

**Monument Small Engine**  
Repair and Storage

**Project No. 61092**

**Revised: October 24, 2019**

Remove the "revised"  
This is a 1st review  
of a new project.

prepared for

**DAVID HELLBUSCH**  
137 N. Monument Lake Rd  
Monument, CO 80132  
719.448.3230

prepared by

**MVE, Inc.**  
1903 Lelaray Street, Suite 200  
Colorado Springs, CO 80909  
719.635.5736

Copyright © MVE, Inc., 2018

61092-SWMP-Revised.odt

# Contents

|   |    |
|---|----|
| <b>1 Site Description</b> .....   | 1  |
| 1.1 Site Overview.....  | 1  |
| 1.2 Construction Activities.....  | 2  |
| 1.3 Activities Sequence.....  | 2  |
| 1.4 Area & Volume Estimates.....  | 2  |
| 1.5 Existing Soil.....  | 2  |
| 1.6 Existing Vegetation.....  | 3  |
| 1.7 Potential Stormwater Pollution Sources.....                               | 3  |
| 1.8 Potential Non-Stormwater Runoff.....                                      | 3  |
| 1.9 Receiving Waters.....   | 3  |
| <b>2 Site Map</b> .....   | 4  |
| <b>3 Best Management Practices for Stormwater Pollution Prevention</b> .....  | 4  |
| 3.1 Structural Erosion and Sediment Controls.....                             | 4  |
| 3.2 Nonstructural Erosion and Sediment Controls.....                          | 5  |
| 3.3 Materials Handling and Spill Prevention.....                              | 6  |
| <b>4 Final Stabilization and Long-Term Storm Water Management</b> .....       | 7  |
| <b>5 Other Stormwater Pollution Controls</b> .....                            | 7  |
| <b>6 Construction Scheduling / Phasing</b> .....                              | 8  |
| <b>7 Inspection and Maintenance</b> .....                                     | 8  |
| <b>8 SWMP Revision Procedure</b> .....  | 9  |
| <b>9 Batch Plants, Wetlands, and Control Measures by other Entities</b> ..... | 9  |
| References.....   | 11 |

Appendix..... A1



# Storm Water Management Plan

This Storm Water Management Plan (SWMP) is required for certification under the Colorado Discharge Permit System – General Permit for Stormwater Discharges Associated with Construction (Stormwater Construction Permit), and has been produced according to the guidelines provided in the *State of Colorado Stormwater Management Plan Guidance for Stormwater Discharges Associated with Construction Activity General Permit Application and Stormwater Management Plan Preparation Guidance*. The goal of this SWMP is to “...identify possible pollutant sources that may contribute pollutants to stormwater, and identify Best Management Practices (BMPs) that, when implemented, will reduce or eliminate any possible water quality impacts.”<sup>1</sup> A current copy of this SWMP must be maintained on the project site for the duration of the construction and stabilization period.

The Permit Holder or their agent will designate a SWMP Administrator for this project. The SWMP Administrator may be the Construction Project Manager, Owner, Construction Site Superintendent or other party so designated by the Permit Holder or their agent. The SWMP Administrator is responsible for implementing, maintaining, and revising the SWMP. The SWMP Administrator is the contact for all SWMP related issues. The SWMP Administrator will have specific site knowledge and authority to adequately manage and direct day-to-day stormwater quality management activities at the site.<sup>2</sup>

## 1 Site Description

### 1.1 Site Overview

The Monument Small Engine Repair and Storage site is in El Paso County, Colorado and is located within the southwest one-quarter of the northeast one-quarter of Section 15, Township 11 South, Range 67 west of the 6th principal meridian in El Paso County, Colorado. The 3.89± acre site is situated north of the intersection of Mitchell Avenue and Monument Lake Road. The site is generally west of the Denver & Rio Grand Railroad, north of Monument Lake Road at Mitchell Avenue. The site contains an existing business using the address of 137 N. Monument Lake Road. The El Paso County Assessor's Schedule Number for the site is 711510008. The proposed site has never been platted. A **Vicinity Map** is included in the **Appendix**.

The south edge of the site is adjacent to an unplatted parcel containing a single-family residence and zoned PRD (Planned Residential Development). This parcel is located in the Town of Monument and separates the site from Monument Lake Road (60' R.O.W.) which is located along the south edge of the parcel. Mount Herman RV Storage Subdivision, located along the east side of the site, is located within the Town of Monument, is zoned PID (Planned Industrial Development) and contains an RV storage business. Unplatted and undeveloped property, located within El Paso County and

---

<sup>1</sup> [CDPHE], App. A, Section A  
<sup>2</sup> [CDPHE], App. A, Section C.4 (a)

zoned RR-5 (Residential Rural), lies north of the site. Unplatted property zoned RR-5 and containing a single family residence is located adjacent to the east side of the site.

Crystal Creek, a tributary to Monument Creek, flows northeast to southwest through the adjacent property to north. The site is located in El Paso County's Crystal Creek Drainage Basin.

## 1.2 Construction Activities

The proposed construction involves one new building, one new parking area and two new water quality ponds.

## 1.3 Activities Sequence

Activities will commence with Site Preparation and the installation of Initial Best Management Practices (BMPs) – including a Vehicle Tracking Control at the east edge of the site, which will be used as construction access. Silt Fence will be placed along the downhill (generally westerly) sides of the construction activities. A temporary sediment basin will be constructed at the north of the site where the final water quality pond will be constructed. General site grading will then begin with removal of topsoil only from those areas that will be regraded. Because of the small size of the disturbed site, topsoil from the entire construction area may be removed at this time, however, smaller areas will be removed if the construction sequencing so requires. Topsoil, if it is to be stockpiled on the site, requires sediment control log to be installed on the downstream side of the storage area. General site grading, creation of building pad, parking areas and ditch/swales will then commence. Following the placement of the recycled asphalt parking areas, topsoil, seeding and mulch will be the removal of Vehicle Tracking Control. Following the construction of these items, final “touch up” grading and redistribution of topsoil will be done for all remaining disturbed unpaved areas on the site. Then, seeding and mulching will be applied to all remaining disturbed areas. Following completion of these construction activities, concrete washout area will be removed and mulching and seeding will be applied to the resulting disturbed areas. The site will then be ready for initial close out. The perimeter Silt Fence will remain until site stabilization. At the time of final stabilization, all remaining construction BMP's will be removed, and seeding and mulching will be placed over the resulting disturbed area.

Project closeout will be established at final stabilization, as defined in the UDFCD<sup>3</sup>. Construction Scheduling / Phasing is as defined in Section 6, below.

## 1.4 Area & Volume Estimates

The Monument Small Engine Repair and Storage site encompasses approximately 3.89 acres. Within that total area, approximately 1.57 acres are expected to undergo clearing, excavation, grading or other disturbance due to the construction activities of the Monument Small Engine Repair and Storage .

Earthwork activities will comprise of 1330 cubic yards (CY), and 1330 CY of fill, for a balanced site, assuming compacted soils will have about 15% higher density than natural embankment densities.

## 1.5 Existing Soil

According to the National Resource Conservation Service, the soil in the area of the Monument Small Engine Repair and Storage site is made up of Tomah-Crowfoot loamy sand (map unit 92). Tomah-Crowfoot loamy sand is typically The soil is deep and well drained. Permeability is moderately rapid, surface runoff is slow, and the hazard of erosion is slight to moderate. Tomah-Crowfoot loamy sand is classified as being part of Hydrologic Soil Group B. A portion of the Soil Map and data tables from the National Cooperative Soil Survey and relevant Official Soil Series Descriptions (OSD) are included in the **Appendix**.<sup>4 5</sup>

---

3 [UDFCD], Ch. 7, 3.1

4 [WSS]

5 [OSD]

The impervious area on the site is being increased by the development of the site. The building and recycled asphalt parking surface will increase the impervious area from approximately 18.7% to approximately 48.4%. The drainage patterns on and off site will not be significantly altered as a result of the proposed construction activities.

### 1.6 Existing Vegetation

Ground cover in the non gravels areas is typically native grasses and weeds with sparse trees and shrubs scattered. The condition of the ground cover on the site varies from poor to good, depending on location within the site having 70% ground cover as determined by visual observation. Former drive areas are relatively bare, but other areas are in good condition.

### 1.7 Potential Stormwater Pollution Sources

The primary potential stormwater pollution source from the Monument Small Engine Repair and Storage is sediment resulting from erosion. There is potential for sediment carrying stormwater to originate from nearly anywhere within the site, and such runoff might deposit sediment onto any of the downstream properties or into the downstream receiving waters. Erosion control and sediment reduction measures will be implemented to mitigate potential pollution from sediment. Such measures are described in the below section **Best Management Practices for Stormwater Pollution Prevention**.

No significant storage of chemicals will occur on site. Small amounts of vehicle and equipment fuel and maintenance chemicals (oil, antifreeze, hydraulic fluid, etc.) may be stored on site, but all such materials will be stored in appropriately contained and managed facilities. Storage of materials is described in the below section **Best Management Practices for Stormwater Pollution Prevention**.

Chemicals released from vehicles and equipment may also be a source of stormwater pollution. Appropriate procedures will be taken to limit the potential of stormwater pollution from spills and leaks. No significant maintenance of vehicles and equipment and no vehicle and equipment washing may be performed on site. "Rinsing of construction vehicles carrying concrete may only be performed in designated concrete rinse facilities." Proper handling of vehicles and equipment is described in the below section **Best Management Practices for Stormwater Pollution Prevention**.

### 1.8 Potential Non-Stormwater Runoff

In addition to being a potential stormwater pollution source, water from the rinsing of construction vehicles carrying concrete may be a potential source of non-stormwater runoff. This non-stormwater runoff is not permitted under the Stormwater Construction Permit. The installation of concrete rinse facilities will mitigate the potential of such rinse water becoming a non-stormwater runoff source.

Temporary irrigation for the establishment and/or maintenance of ground cover may also be a source of non-stormwater runoff from the site. This non-stormwater runoff is permitted under the Stormwater Construction Permit; however, appropriate irrigation practices will be used to limit the potential of runoff, and any runoff that does occur will be treated with the same control measures applied to stormwater runoff. Proper management of the irrigation schedules and duration will minimize excess irrigation runoff. The construction BMP's described below which are to remain in place until ground cover is established, as well as the permanent BMP's described below will mitigate the potential of such irrigation water becoming a non-stormwater runoff source.

### 1.9 Receiving Waters

Crystal Creek, a tributary to Monument Creek, flows northeast to southwest through the adjacent property to north. The site is located in El Paso County's Crystal Creek Drainage Basin. No streams cross the site.

## 2 Site Map

A **Site Map** is included with this SWMP for the Monument Small Engine project. The **Site Map** consists of the Monument Small Engine Erosion Control Plan as submitted and approved by El Paso County. The **Site Map** includes construction site boundaries, areas of ground surface disturbance, areas of cut and fill, areas used for storage of building materials, equipment, soil, and waste, the locations of structural and non-structural Best Management Practices, the locations of the existing water courses (if any exist), the soil type areas, existing and proposed contours, proposed structures and improvements, an explanation of the existing vegetation on the site, locations of existing water courses, locations of existing 100-year floodplains (if any exist), locations of existing and proposed utilities and a vicinity map. There are no asphalt or concrete batch plants planned and therefore are not shown on the **Site Map**.

## 3 Best Management Practices for Stormwater Pollution Prevention

“Best Management Practices (BMPs) encompass a wide range of erosion and sediment control practices, both structural and non-structural in nature, that are intended to reduce or eliminate any possible water quality impacts from stormwater leaving a construction site.”<sup>6</sup> “Structural BMPs” traditionally refers to any physical process, but in this SWMP “structural BMPs” refers only to practices involving the installation of a specific, definable object or structure. “Nonstructural BMPs” traditionally refers to definitions of operational and managerial techniques, but in this SWMP “nonstructural BMPs” also includes any physical process not involving the installation of a specific, definable object or structure. “Erosion control BMPs” prevent or reduce erosion, while “sediment control BMPs” remove or reduce sediment from runoff. Because sediment resulting from erosion is typically the primary pollutant of stormwater runoff from a construction site, erosion control practices are considered the primary and preferred method of stormwater pollution prevention in this SWMP, while sediment control practices will be implemented as secondary measures or when erosion control practices are not possible or are not fully effective. Prevention of stormwater pollutants other than sediment are addressed under an additional set of materials handling and spill prevention BMPs.<sup>7</sup>

### 3.1 Structural Erosion and Sediment Controls

Before any construction activities commence on the Monument Small Engine Repair and Storage site, vehicle tracking controls will be installed at all site access points. Vehicle tracking control helps reduce the deposition of sediment, dirt, mud, and debris by vehicles exiting the site onto the streets adjacent to the site. The locations of site entrance vehicle tracking controls are identified on the **Site Map**, and details for the installation and maintenance of the controls are included in the **Appendix**.<sup>8</sup>

Before any grading or other significant disturbance occurs on site, silt fence will be installed along any edge of an area to be disturbed where runoff would otherwise go untreated. Silt fence will be also installed along those portions of the site perimeter where potentially sediment laden runoff may flow into adjacent properties. Silt fence will also be installed along the downstream edges of the topsoil stockpile. During Construction, silt fencing, sediment control log, vehicle tracking control and concrete washout area will be in place to minimize erosion from the site. Silt Fencing will be placed along the northern and western sides of the disturbed areas. This will inhibit suspended sediment from leaving the site during construction. Silt fencing is to remain in place until the parking area is stabilized with the recycled asphalt and until vegetation is reestablished in the other disturbed areas which are to be reseeded. Silt fences help reduce pollution of stormwater by “filtering” out some of the sediment carried by runoff flowing through the fences and by facilitating deposition of sediment by slowing the runoff. Silt fences can also help reduce erosion by slowing and distributing runoff. The locations of silt fences are identified on the **Site Map**, and details for the installation and maintenance of silt fences are included in the **Appendix**. In addition to the silt fences indicated on

6 [CDPHE], App. A, Section B

7 [CDPHE], App. A, Section C.1 (4)

8 [UDFCD], SM-4

the **Site Map**, silt fences will be installed wherever the contractor deems them to be necessary or helpful. Silt fence installed at the contractor's discretion might not be shown on the **Site Map**.<sup>9</sup>

After the installation of the silt fence but before any other construction activities commence on the project, **Sediment Control Logs** (SCLs) will be installed at the designated locations identified on the **Site Map**. SCLs help reduce pollution of stormwater by “filtering” out much of the sediment carried by runoff flowing through the barriers and by facilitating deposition of sediment by slowing the runoff. SCLs also help reduce erosion by slowing and distributing runoff. SCLs should not be installed across significant concentrated flow paths. SCLs or silt fence will be required along the downstream side of stabilized staging areas. The details for the installation and maintenance of straw bale barriers which are included in the **Appendix** can also be generally applied to the installation and maintenance of SCLs. SCLs installed at the SWMP Administrator's discretion shall be added to the **Site Map** by the SWMP Administrator.

**Surface roughening** will be done on the sides of the proposed Sand Filter Basin. Surface roughening will also be applied to all steeply sloped areas (4:1 or greater) disturbed by construction and not otherwise stabilized. Surface roughening will be done immediately if possible or within 14 days of completion of final grading. Additionally, surface roughening will be applied to all areas disturbed by construction that are not at final grade but will remain dormant (undisturbed) for longer than 14 days. Ideally, surface roughening will be applied to all disturbed areas preceding any pause of disturbance activities in that area. “Surface roughening provides temporary stabilization of disturbed areas from wind and water erosion”<sup>10</sup> by reducing runoff velocity and increasing infiltration, and also provides some sediment trapping. Specifications for the installation and maintenance of surface roughening are included in an **Appendix**.

Prior to the pouring of any concrete on the site, a **Concrete Washout Area** (CWAs) will be installed on the site. CWAs captures and contains concrete wash water to prevent harmful pollutants in the concrete mixture from entering the general environment either directly or through mixing with stormwater. The location of the CWA is identified on the **Site Map**. Details for the installation and maintenance of CWAs are included in the **Appendix**. The location of the CWA indicated on the **Site Map**, may also be determined by the SWMP Administrator if an alternate location is deemed appropriate. A CWA installed at the SWMP Administrator's discretion will be added to the **Site Map** by the SWMP Administrator.<sup>11</sup>

### 3.2 Nonstructural Erosion and Sediment Controls

In order to minimize the total amount of soil exposed at any given time to “reduce the period of accelerated soil erosion”<sup>12</sup> the construction activities of the Monument Small Engine Repair and Storage project will be phased as described in the above section **Activities Sequence**. In addition to the phases described in the above section **Activities Sequence**, many of the details and specifications included in the index provide specific scheduling information.

An undisturbed “buffer” will be preserved around as much of the site as possible to help control erosive run-on and sediment laden runoff. The locations of undisturbed buffer areas are identified on the **Site Map**.

Before construction activities commence in any area of the site, the full layer of topsoil will be stripped only from the portions of that area that are to be disturbed and will be stockpiled in [“a”] location[“s”] identified on the **Site Map**. Rather than stripping topsoil from the entire site at once, as has been the traditional practice in some cases, topsoil will be stripped from particular areas of the site only as construction work progresses to that area as described in the above section **Activities Sequence**. Soils stockpiled for more than 60 days will be seeded and mulched within 14 days of completion of stockpiling activities.<sup>13</sup>

---

9 [UDFCD], SC-1

10 [UDFCD], C-20.

11 [UDFCD], MM-1

12 [UDFCD], Ch 7, 2.3

13 [UDFCD], MM-2

Before construction activities commence in any area of the site, the construction vehicle traffic areas to and around that area – including all construction roads, parking areas, loading and unloading zones, storage areas, and staging areas – will be stabilized through proper grading, compaction, and surfacing. Stabilization of traffic areas reduces erosion and vehicle tracking thus helping to eliminate potential pollution of stormwater by sediment. To prevent vehicle tracking of soil into the surrounding roadways, construction related traffic will be limited to entering the site at the designated construction entrance(s). The construction entrance will have a Vehicle Tracking Control as described above. Should significant soil still be deposited on the surrounding roadways, street sweeping will be utilized to remove the soil from the roadways immediately following deposition. The locations of areas to receive traffic area stabilization are identified on the **Site Map**, and specifications for the installation and maintenance of surface stabilization are included in the **Appendix**.<sup>14</sup>

Soil roughening will be applied to all disturbed areas (not otherwise stabilized) immediately if possible or within 14 days of completion of final grading. Additionally, soil roughening will be applied to all disturbed areas that are not at final grade but will remain dormant (undisturbed) for longer than 14 days. “Surface roughening provides temporary stabilization of disturbed areas from wind and water erosion”<sup>15</sup> by reducing runoff velocity and increasing infiltration, and also provides some sediment trapping. The locations of some areas to receive soil roughening are identified on the **Site Map** (some areas requiring soil roughening may not be indicated), and specifications for the installation and maintenance of surface stabilization are included in the **Appendix**.<sup>16</sup>

Mulch will be applied, in addition to soil roughening and seeding, to all disturbed areas (not otherwise stabilized) immediately if possible or within 14 days of completion of final grading. Additionally, mulch will be applied to all disturbed areas that are not at final grade but will remain dormant (undisturbed) for longer than 30 days. Mulch helps prevent erosion “by protecting bare soil from rainfall impact, increasing infiltration, and reducing runoff.”<sup>17</sup> The locations of some areas to receive mulch are identified on the **Site Map** (some areas requiring mulch may not be indicated), and specifications for revegetation are included in the **Appendix**.

When seasonally appropriate, seed will be applied to all disturbed areas (not otherwise stabilized) immediately if possible or within 14 days of completion of final grading. Additionally, seed will be applied to all disturbed areas that are not at final grade but will remain dormant (undisturbed) for longer than 1 year. When the season is inappropriate for seed application, surface roughening and mulch will be applied within 14 days and seed will be applied as soon as seasonally appropriate. The locations of some areas to receive seed are identified on the **Site Map** (some areas requiring seed may not be indicated), and specifications for revegetation are included in the **Appendix**.

### 3.3 Materials Handling and Spill Prevention

A vigorous program of “good housekeeping” will be implemented on the Monument Small Engine Repair and Storage site in an effort to prevent stormwater pollution by materials used and stored on-site.

No significant storage of chemicals and other potentially pollutive materials will be allowed on site. Only those chemicals and materials necessary for the described construction activities may be stored on site, and then only in the smallest amounts reasonable and for the shortest time possible. The location of a storage area for toxic, hazardous, and potentially pollutive materials is identified on the **Site Map** and a specification for on site materials handling is provided in the **Appendix**.

Portable toilets will be located away from direct traffic routs and will be situated out of the potential path of any potential stormwater runoff. Any grading necessary to achieve such a situation will be completed before the portable toilets are delivered to the site. The locations of portable toilets are identified on the **Site Map**. Portable toilets will be securely anchored to prevent tipping.

Fueling and minor preventative maintenance of vehicles and equipment may occur only on areas specifically stabilized for construction vehicle traffic. Appropriate procedures will be taken to limit the

---

14 [UDFCD], SM-6

15 [UDFCD], EC-1

16 [UDFCD], EC-2

17 [UDFCD], EC-4

potential of stormwater pollution from spills and leaks. The locations of areas specifically stabilized for construction vehicle traffic are identified on the **Site Map** and a specification for vehicle and equipment handling is provided in the **Appendix**. No significant maintenance of vehicles and equipment and no vehicle and equipment washing will be performed on site.

Rinsing of construction vehicles and equipment mixing or carrying concrete will only be performed in designated concrete rinse facilities. Concrete rinse facilities will only be used for the minimum necessary rinsing and will not be used for cleaning or emptying of construction vehicles and equipment. Cleaning and emptying of excess concrete will occur off site. The locations of concrete rinse facilities are identified on the **Site Map** and details for the installation and maintenance of concrete rinse facilities are included in the **Appendix**.

Any spills of potential pollutants on the site related to the construction activities will be addressed according to the requirements of Colorado Department of Public Health and Environment, Hazardous Materials and Waste Management Division.

Appropriate spill prevention and response measures will be implemented on the site. The details and specifications referenced above in this section provide general and specific guidelines for spill prevention and response measures relating to the various potential non-sediment pollution sources.

No groundwater and/or stormwater dewatering activities are proposed or expected for the proposed construction activities.

No significant waste generation is expected as a result of the proposed construction activities. Any minor waste that is produced will be disposed of properly.

#### **4 Final Stabilization and Long-Term Storm Water Management**

According to the Stormwater Construction Permit "Final stabilization is reached when all soil disturbing activities at the site have been completed, and uniform vegetative cover has been established with a density of at least 70 percent of pre-disturbance levels or equivalent permanent, physical erosion reduction methods have been employed."<sup>18</sup> Such a viable vegetative cover will be established within one year of completion of construction activities on all disturbed areas not otherwise stabilized. Unless otherwise indicated on a landscape plan, revegetation will be achieved through seedbed preparation, including but not necessarily limited to soil roughening, seeding, mulching, and irrigating when specified. Soil roughening, mulching, and seeding are all described in the above section **Best Management Practices for Stormwater Pollution Prevention**, and specifications for surface stabilization and revegetation are included in the **Appendix**.

In order to prevent or control erosion and pollution of stormwater by sediment after completion of construction activities, many of the structural BMPs described in the above section **Best Management Practices for Stormwater Pollution Prevention**, will remain in place until final stabilization. BMPs that must remain in place until final stabilization shall be removed following final stabilization and the resulting disturbed areas shall be seeded and mulched. The specifications or details corresponding to each BMP provide general guidelines for the removal of the BMP.

The Sand Filter basin planned for the site will provide permanent Water Quality Control for the site and also provide flood control. The Sand Filter basin will be functional prior to project close-out.

#### **5 Other Stormwater Pollution Controls**

All stormwater pollution control measures to be implemented on the Monument Small Engine one building and RV storage site are included in the above sections **Best Management Practices for Stormwater Pollution Prevention** and **Final Stabilization and Long-Term Storm Water Management**.

---

18 [CDPHE], App. A, Section C.5

## 6 Construction Scheduling / Phasing

The expected timing of the project is to install initial erosion control BMP's and start grading Fall, 2019. Grading and site operations are expected to continue through Fall, 2019 with final stabilization by Spring, 2020. Activities are expected to proceed as written above. Final Stabilization is described in a following section. This project will be performed from start to finish in one phase.

## 7 Inspection and Maintenance

The primary purpose of a regular inspection is to “determine if there is evidence of, or the potential for, pollutants entering the drainage system.”<sup>19</sup> “The Stormwater Construction Permit requires that a thorough inspection of the stormwater management system be performed and documented at least every 14 days, and after any precipitation or snowmelt event...that results in stormwater running across the ground.”<sup>20</sup> This is only a minimum requirement and more frequent inspection and regular maintenance of the stormwater management system is typically necessary to effectively reduce pollutants in stormwater discharges from a construction site. A thorough inspection of the Monument Small Engine Repair and Storage site will therefore be performed and documented weekly and after any precipitation or snowmelt event that results in stormwater running across the ground.

The regular inspections of the site will include observation of the construction site perimeter and all stormwater discharge points including storm drain system inlets and culverts. BMPs applied in the site perimeter or around stormwater discharge points include inlet protection, site entrance vehicle tracking controls, silt fences, straw bale barriers, and straw bale check structures. Specific inspection and maintenance requirements for each of these BMPs are included in the **Appendix**.

The regular inspections of the site will also include observation of all disturbed areas and all stabilized and revegetated areas. Inspection of these areas will involve particular attention on possible erosion problems. Specifications for surface stabilization and revegetation are included in the **Appendix** and provide specific inspection and maintenance requirements.

The regular inspections of the site will also include observation of material storage areas including waste collection areas and topsoil stockpiles. Inspection of these areas will involve particular attention on possible leaks and spills and, in the case of the topsoil stockpile, on possible ineffectively managed runoff. Specifications for on site materials handling and details for silt fence, used around topsoil stockpiles, are included in the **Appendix** and provide specific inspection and maintenance requirements.

Concrete rinse facilities will be included in the regular inspections of the site, but will require additional attention when in use. Details of a concrete rinse facility, with specific inspection and maintenance requirements, are included in the **Appendix**.

All structural BMPs on the site will be thoroughly examined during each inspection to “determine if they still meet the design and operational criteria in the SWMP and that they continue to adequately control pollutants at the site.”<sup>21</sup> Details of each BMP, with specific inspection and maintenance requirements, are included in the **Appendix**.

Following each inspection, repairs will be performed on BMPs that are found to no longer function as needed and designed, and preventative maintenance will be exercised on BMPs as needed to ensure continued operation. BMPs that have failed or have the potential to fail without maintenance or modifications will be addressed immediately to prevent the discharge of pollutants. As described above, the details of each BMP, included in the **Appendix**, provided specific maintenance instructions and requirements. When a BMP is found to be ineffective in preventing discharge of pollutants, even though the BMP is in good repair and is functioning as designed, that BMP will be modified or an alternative or additional BMP will be installed promptly.<sup>22</sup>

---

19 [CDPHE], App. A, Section C.6 (b)

20 [CDPHE], App. A, Section C.6 (a)

21 [CDPHE], App. A, Section C.6 (b)

22 [CDPHE], App. A, Section C.6 (c)



An **Inspection Log** will be maintained on site and will include a record of all stormwater management system inspections along with all BMP maintenance and repair activities<sup>23</sup>. All the inspection, maintenance, and repair requirements for each BMP, as described in this SWMP and as outlined in the details or specifications in the **Appendix**, will be performed as specified and will be recorded in the **Inspection Log**. The **Inspection Log** will also include a description of any incidence of non-compliance, such as uncontrolled releases of pollutants including mud, muddy water or measurable quantities of sediment found off the site along with a description of measures to be taken to cleanup pollutants that have left the site and a description of measures to be taken to prevent future pollutive discharges. Records of any spills, leaks, or overflows of non-sediment potential pollutants, whether or not such a spill, leak, or overflow results in pollution of stormwater, will be included.

Following an inspection that does not reveal any incidents of non-compliance, or following the completion of measures taken to correct any non-compliance issues, a **Certification** indicating the site is in compliance will be signed and dated.

In addition to regularly maintaining an **Inspection Log** and **Certification**, this SWMP will be updated regularly to reflect the actual stormwater management system as implemented on the site.

## 8 SWMP Revision Procedure

When BMPs or other site conditions change, the SWMP must be modified to accurately reflect the actual field conditions. Examples include, but are not limited to, removal of BMPs, identification of new potential pollutant sources, addition of BMPs, modification of BMP installation and implementation criteria or maintenance procedures, and changes in items included in the site map and/or descriptions. SWMP revisions must be made prior to changes in site conditions, except for Responsive SWMP Changes, as follows:

The SWMP Administrator is responsible for implementing, maintaining, and revising the SWMP. The SWMP administrator will update the Site Map by adding, deleting or modifying specific BMPs shown on the Site Map by hand marking on the full size hard copy Site Map.

- SWMP revisions must be made immediately after changes are made in the field to address BMP installation and/or implementation issues; or
- SWMP revisions must be made as soon as practicable, but in no case more than 72 hours, after change(s) in BMP installation and/or implementation occur at the site that require development of materials to modify the SWMP (e.g., design of retention pond capacity)

The SWMP should be viewed as a living document that is continuously being reviewed and modified as part of the overall process of assessing and managing stormwater quality issues at the site by the SWMP Administrator.

## 9 Batch Plants, Wetlands, and Control Measures by other Entities

There are no dedicated batch plants to be located on this project.

There are no springs, streams, wetlands and other surface waters, including areas that require maintenance of pre-existing vegetation that are located within 50 feet of a receiving waters for this project.

---

<sup>23</sup> [CDPHE], App. A, Section C.6 (d)

This project does not rely on control measure to be operated by another entity.

## References

CDPHE: Colorado Department of Public Health & Environment, Water Quality Control Division, *State of Colorado Stormwater Management Plan Guidance for Stormwater Discharges Associated with Construction Activity* (State of Colorado:Denver , April, 2011).

OSD: United States Department of Agriculture, Natural Resources Conservation Service, *NRCS Official Soil Series Descriptions* (: , March, 2018).

UDFCD: Urban Drainage and Flood Control District, *Urban Storm Drainage Criteria Manual Volume 3 - Best Management Practices* (Urban Drainage and Flood Control District:2480 W. 26th Ave. Ste 156B, Denver, CO 80211 , September 1992, Updated November 2010).

WSS: United States Department of Agriculture, Natural Resources Conservation Service, *NRCS Web Soil Survey* (: , March, 2018).

# Appendix

## Site Map (Grading, Erosion, and Stormwater Quality Plan)

### Vicinity Map

### Sample Field Inspection Sequence and Field Inspection Report

### BMP Installation and Maintenance Details\*

| <u>UDFCD Vol 3 Manual Section and Description</u> | <u>Vol. 3 Section Abbreviation</u> | <u>Map Key Abbreviation</u>  |
|---|------------------------------------|------------------------------|
| EC-1 – Surface Roughening                         | SR                                 | SR                           |
| EC-5 – Compost Blanket and Filter Berm            | CB                                 | CB                           |
| EC-6 – Rolled Erosion Control Products            | RECP                               | ECB (or TRM)                 |
| EC-7 – Temporary Slope Drain                      | TSD                                | TSD                          |
| EC-8 – Temporary Outlet Protection                | TOP                                | OP                           |
| EC-9 – Rough Cut Street Control                   | RCS                                | RCS                          |
| EC-10 – Earth Dikes and Drainage Swales           | ED/DS                              | ED/DS                        |
| EC-11 – Terracing                                 | TER                                | TER                          |
| EC-12 – Check Dams                                | CD                                 | CD, RCD                      |
| MM-1 – Concrete Washout Area                      | CWA                                | CWA                          |
| MM-2 – Stockpile Management with Protection       | SP                                 | SP, SSA/R (or SPR)           |
| SC-1 – Silt Fence                                 | SF                                 | SF                           |
| SC-2 – Sediment Control Log                       | SCL                                | SCL                          |
| SC-3 – Straw Bale Barrier                         | SBB                                | SBB                          |
| SC-5 – Rock Sock                                  | RS                                 | RS                           |
| SC-6 – Inlet Protection                           | IP                                 | IP, CIP                      |
| SC-7 – Sediment Basin                             | SB                                 | SB                           |
| SC-8 – Sediment Trap                              | ST                                 | ST                           |
| SM-3 – Construction Fence                         | CF                                 | CF                           |
| SM-4 – Vehicle Tracking Control                   | VTC                                | VTC, VTC/WW, VTC/CM, VTC/TRM |
| SM-6 – Stabilized Staging Area                    | SSA                                | SSA                          |
| SM-8 – Temporary Diversion Methods                | TDM                                | DC (or DD)                   |
| SM-9 – Dewatering Operations                      | DW                                 | DW                           |
| SM-10 – Temporary Stream Crossing                 | TSC                                | TSC (or TSCC, TSCF)          |

*Note: Additional BMP's, other than those shown to be utilized on the Site Map, are included in the BMP Details section to facilitate use of alternate or additional BMP's at the discretion of the SWMP Administrator. Any alternate or additional BMP's employed will be added to the Site Map by the SWMP Administrator. Additionally, the SWMP Administrator shall reference Volume 3 of the Current UDFCD Criteria Manual for additional Specification and Commentary on the above referenced BMPs as well as Specification of the following BMPs which are described but not detailed in the criteria.*

| <u>UDFCD Vol 3 Manual Section and Description</u> | <u>Vol. 3 Section Abbreviation</u> | <u>Map Key Abbreviation</u> |
|---|------------------------------------|-----------------------------|
| EC-2 – Temporary and Permanent Seeding            | TS, PS                             | TS, PS                      |
| EC-3 – Soil Binders                               | SB                                 |                             |
| EC-4 – Mulching                                   | MU                                 | MU                          |
| EC-13 – Streambank Stabilization                  | SS                                 |                             |
| EC-14 – Wind Erosion/Dust Control                 | DC                                 |                             |
| MM-3 – Good Housekeeping Practices                | GH                                 |                             |
| SC-4 – Brush Barrier                              | BB                                 | BB                          |
| SC-9 – Vegetated Buffers                          | VB                                 |                             |
| SC-10 – Chemical Treatment                        | CT                                 |                             |
| SM-1 – Construction Phasing/Sequencing            | CP                                 |                             |
| SM-2 – Protection of Existing Vegetation          | PV                                 |                             |
| SM-5 – Stabilized Construction Roadway            | SCR                                | SCR                         |
| SM-7 – Street Sweeping and Vacuuming              | SS                                 |                             |
| SM-11 – Temporary Batch Plant                     | TBP                                |                             |
| SM-12 – Paving and Grinding Operations            | PGO                                |                             |

# VICINITY MAP (no scale)

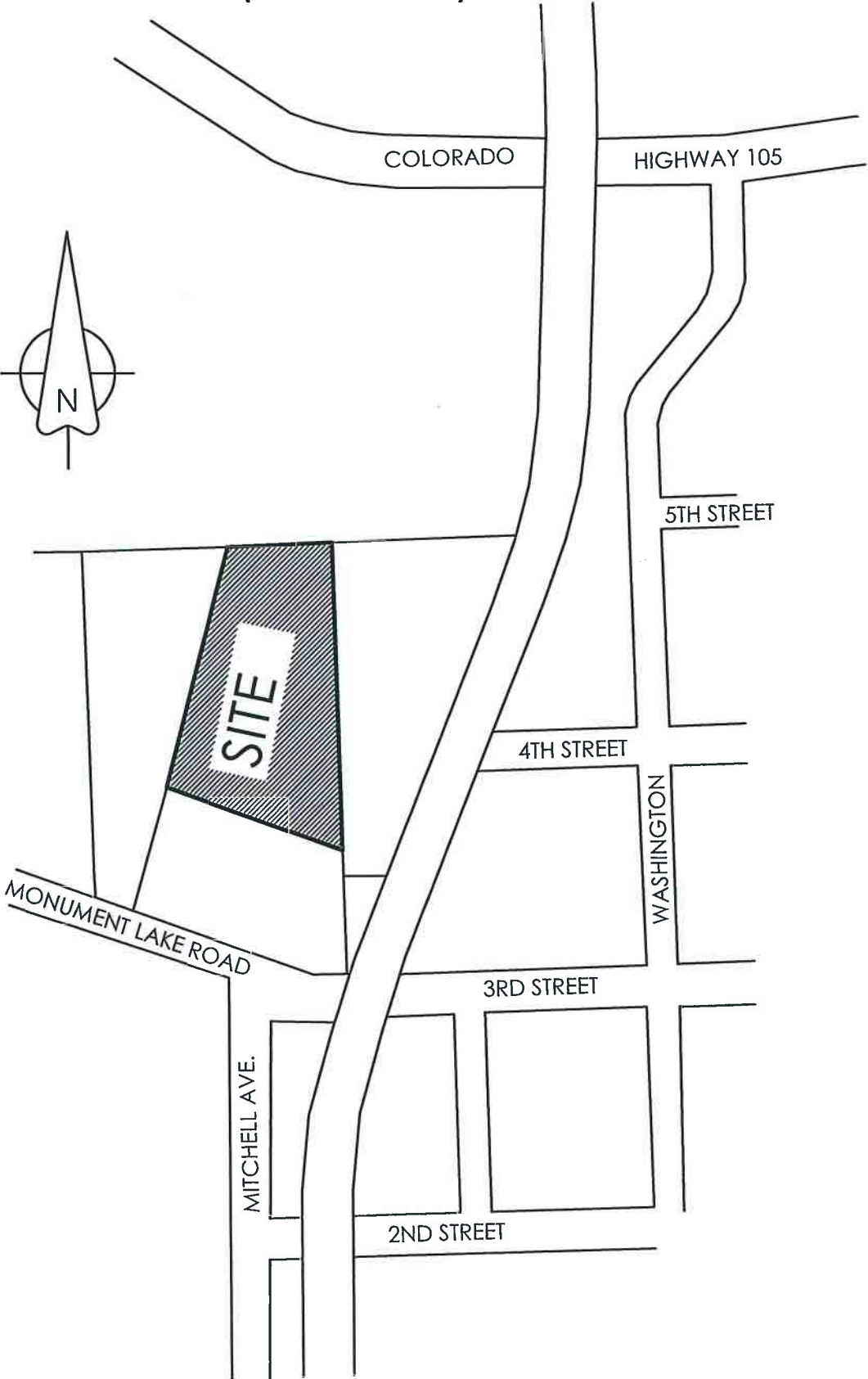

## Field Inspection Sequence

1. Pre-inspection Research:
  - a. Evaluate Project Phasing
  - b. Review Management Plan
  - c. Review inspection and maintenance files
  - d. Contact City Inspector for pre-construction inspection
2. Weekly or Post-Precipitation Field Inspection
  - a. Construction Exits and Entrances
    - i. Identified on Plan
    - ii. Installed correctly
    - iii. Properly maintained
    - iv. Proper Utilization
    - v. Tire wash area
    - vi. Sediment leaving site and entering adjacent properties or roadways
3. Are BMPs effective and are modifications necessary
4. Walk the perimeter of the site
5. Observe terrain and perimeter controls
  - a. Note type of sediment controls
    - i. Installed correctly
    - ii. Properly maintained
    - iii. According to Plan
  - b. Sediment leaving site and entering adjacent properties or roadways
  - c. BMPs effective and are modifications necessary
6. Inspect active construction areas
  - a. Documented in Management Plan
  - b. Mulch or other temporary stabilization should be applied to all exposed areas within seven (7) or fourteen (14) days of disturbance in accordance with the SWMP
  - c. Note type of controls
    - i. Installed correctly
    - ii. Properly maintained
7. Inspect non-active disturbed areas
  - a. Areas left idle for more than thirty (30) days should be stabilized
  - b. Note type of controls
    - i. Installed correctly
    - ii. Properly maintained
    - iii. Documented in Management Plan
    - iv. Are BMPs effective and are modifications necessary
8. Inspect discharge points, Structural Controls and adjacent off-site areas for impact
  - a. If sediment is leaving site and impacting adjacent properties or roadways
  - b. Document downstream impacts
  - c. Remediate potential downstream damages
  - d. Identify and implement more effective BMPs
9. Final Stabilization Inspections
  - a. Perimeter controls intact
  - b. Installed correctly
  - c. Properly maintained
  - d. Documented in Management Plan
  - e. Mulch cover
    - i. Estimate application density
  - f. Properly secured or crimped

## COLORADO DEPARTMENT OF TRANSPORTATION STORMWATER FIELD INSPECTION REPORT - ACTIVE CONSTRUCTION

|   |                                    |  |                                  |
|---|------------------------------------|--|----------------------------------|
| (1) Project Name:                         | (2) Project Contractor:            | (3) Erosion Control Supervisor/SWMP Administrator: |                                  |
| (4) CDOT Project Engineer/Representative: | (5) Inspector(s) (Name and Title): | (6) CDOT Project Number:                           |                                  |
| (7) Project Code (Sub Account #):         | (8) CDPS-SCP Certification#:       | (9) CDOT Region:                                   | (10) Date of Project Inspection: |
| (11) Weather at Time of Inspection:       |                                    |  |                                  |

**(12) REASON FOR INSPECTION / EXCLUSION**

Routine Inspection: (minimum every 14 Calendar Days)

Runoff Event: (Post-storm event inspections must be conducted within 24 hours after the end of any precipitation or snowmelt event that causes surface erosion. If no construction activities will occur following a storm event, post-storm event inspections shall be conducted prior to re-commencing construction activities, but no later than 72 hours following the storm event. The occurrence of any such delayed inspection must be documented in the inspection record.) Routine inspections still must be conducted every 14 calendar days.  
 Storm Start Date: \_\_\_\_\_ Approximate End Time of Storm (hrs): \_\_\_\_\_

Third Party Request:

Winter Conditions Inspections Exclusion: Inspections are not required at sites where construction activities are temporarily halted, snow cover exists over the entire site for an extended period, and melting conditions posing a risk of surface erosion do not exist. This exception is applicable only during the period where melting conditions do not exist, and applies to the routine 14-day inspections, as well as the post-storm-event inspections. If visual inspection of the site verifies that all of these conditions are satisfied, document the conditions in section 18 (General Notes) and proceed to section 19 (Inspection Certification). Documentation must include: dates when snow cover occurred, date when construction activities ceased, and date when melting conditions began.

Other:

**(13) SWMP MANAGEMENT**

**(14) CURRENT CONSTRUCTION ACTIVITIES:**

|   | Yes                      | No                       | NA                       |   |
|---|--------------------------|--------------------------|--------------------------|---|
| (a) Is the SWMP notebook located on site?   | <input type="checkbox"/> | <input type="checkbox"/> | <input type="checkbox"/> | Estimate of disturbed area at the time of the inspection: _____ Acres |
| (b) Are changes to the SWMP documents noted and approved?                               | <input type="checkbox"/> | <input type="checkbox"/> | <input type="checkbox"/> |   |
| (c) Are the inspection reports retained in the SWMP notebook?                           | <input type="checkbox"/> | <input type="checkbox"/> | <input type="checkbox"/> |   |
| (d) Are corrective actions from the last inspection completed?                          | <input type="checkbox"/> | <input type="checkbox"/> | <input type="checkbox"/> |   |
| (e) Is a Spill Prevention Control and Countermeasure Plan retained at the project site? | <input type="checkbox"/> | <input type="checkbox"/> | <input type="checkbox"/> |   |
| (f) Is a list of potential pollutants retained at the site?                             | <input type="checkbox"/> | <input type="checkbox"/> | <input type="checkbox"/> |   |

**(15) BMPs ON SITE AT TIME OF INSPECTION**

\*See Inspection Report Instructions for more detail.

|   | In SWMP                  | Used                     | Not Needed at this time  |  | In SWMP                  | Used                     | Not Needed at this time  |
|---|--------------------------|--------------------------|--------------------------|--|--------------------------|--------------------------|--------------------------|
| <b>(a) EROSION CONTROL BMPs ON SITE</b> |                          |                          |                          | <b>(b) SEDIMENT CONTROL BMPs ON SITE</b>   |                          |                          |                          |
| Seeding                                 | <input type="checkbox"/> | <input type="checkbox"/> | <input type="checkbox"/> | Stabilized Const. Entrance   | <input type="checkbox"/> | <input type="checkbox"/> | <input type="checkbox"/> |
| Mulching/Mulch Tackifier                | <input type="checkbox"/> | <input type="checkbox"/> | <input type="checkbox"/> | Sediment Trap  | <input type="checkbox"/> | <input type="checkbox"/> | <input type="checkbox"/> |
| Soil Binder                             | <input type="checkbox"/> | <input type="checkbox"/> | <input type="checkbox"/> | Inlet Protection*  | <input type="checkbox"/> | <input type="checkbox"/> | <input type="checkbox"/> |
| Soil Retention Blankets                 | <input type="checkbox"/> | <input type="checkbox"/> | <input type="checkbox"/> | Sediment Basin   | <input type="checkbox"/> | <input type="checkbox"/> | <input type="checkbox"/> |
| Embankment Protector*                   | <input type="checkbox"/> | <input type="checkbox"/> | <input type="checkbox"/> | Perimeter Control*   | <input type="checkbox"/> | <input type="checkbox"/> | <input type="checkbox"/> |
| Grading Techniques*                     | <input type="checkbox"/> | <input type="checkbox"/> | <input type="checkbox"/> | Other:   | <input type="checkbox"/> | <input type="checkbox"/> | <input type="checkbox"/> |
| Berm/Diversion                          | <input type="checkbox"/> | <input type="checkbox"/> | <input type="checkbox"/> | <b>(d) MATERIALS HANDLING, SPILL PREVENTION, WASTE MANAGEMENT AND GENERAL POLLUTION PREVENTION</b> |                          |                          |                          |
| Check Dams*                             | <input type="checkbox"/> | <input type="checkbox"/> | <input type="checkbox"/> | Stockpile Management*  | <input type="checkbox"/> | <input type="checkbox"/> | <input type="checkbox"/> |
| Outlet Protection*                      | <input type="checkbox"/> | <input type="checkbox"/> | <input type="checkbox"/> | Materials Management*  | <input type="checkbox"/> | <input type="checkbox"/> | <input type="checkbox"/> |
| Other:                                  | <input type="checkbox"/> | <input type="checkbox"/> | <input type="checkbox"/> | Concrete Waste Management*   | <input type="checkbox"/> | <input type="checkbox"/> | <input type="checkbox"/> |
| <b>(c) BMPs FOR SPECIAL CONDITIONS</b>  |                          |                          |                          | Saw Water Management*  | <input type="checkbox"/> | <input type="checkbox"/> | <input type="checkbox"/> |
| Dewatering Structure                    | <input type="checkbox"/> | <input type="checkbox"/> | <input type="checkbox"/> | Solid Waste/Trash Management   | <input type="checkbox"/> | <input type="checkbox"/> | <input type="checkbox"/> |
| Temp. Stream Crossing                   | <input type="checkbox"/> | <input type="checkbox"/> | <input type="checkbox"/> | Street Sweeping  | <input type="checkbox"/> | <input type="checkbox"/> | <input type="checkbox"/> |
| Clear Water Diversion                   | <input type="checkbox"/> | <input type="checkbox"/> | <input type="checkbox"/> | Sanitary Facility*   | <input type="checkbox"/> | <input type="checkbox"/> | <input type="checkbox"/> |
| Sensitive Area Fencing                  | <input type="checkbox"/> | <input type="checkbox"/> | <input type="checkbox"/> | Vehicle and Equip. Management  | <input type="checkbox"/> | <input type="checkbox"/> | <input type="checkbox"/> |
| Other:                                  | <input type="checkbox"/> | <input type="checkbox"/> | <input type="checkbox"/> | Other:   | <input type="checkbox"/> | <input type="checkbox"/> | <input type="checkbox"/> |









## Stormwater Management Field Inspection Report Instructions

State waters are defined to be any and all surface and subsurface waters which are contained in or flow through the state, including, streams, rivers, lakes, drainage ditches, storm drains, ground water, and wetlands, but not including waters in sewage systems, waters in treatment works or disposal systems, waters in potable water distribution systems, and all water withdrawn for use until use and treatment have been completed. (Per subsection 107.25 and 25-8-103 (19) CRS)

**(3) Erosion Control Supervisor/SWMP Administrator:** Indicate the name of the individual responsible for implementing, maintaining and revising the SWMP.

**(4) CDOT Project Engineer/Representative:** Indicate the name of the CDOT representative performing the inspection with the ECS/SWMP Administrator. This person should be the Project Engineer or an authorized representative.

**(9) CDPS-SCP Certification #:** Indicate the Colorado Discharge Permit System (CDPS) Stormwater Construction Permit (SCP) (for Stormwater Discharges Associated with Construction Activities) certification number, issued by CDPHE, for the project which the report is being completed. Certification number can be found on the first page of the SCP.

**(12) Reason(s) for Inspection / Exclusion:** Indicate the purpose for the inspection or exclusion. These inspections are required to comply with the CDOT Specifications and the CDPS-SCP.

Routine Inspections. These inspections are required at least every 14 calendar days during active construction. Suspended projects require the 14 calendar day inspection unless snow cover exists over the entire site for an extended period of time, and melting conditions do not exist (see, Winter Conditions Inspections Exclusions).

Runoff Event Inspection for Active Sites. See page 1 for definition.

Third Party Request. Indicate the name of the third party requesting the inspection and, if known, the reason the request was made.

Winter Conditions Inspections Exclusions. See page 1 for definition. An inspection does not need to be completed, but use this form to document the conditions that meet the Exclusion.

Other. Specify any other reason(s) that resulted in the inspection.

**(13) SWMP Management:** Review the SWMP records and documents and use a ✓ to answer the question. To comply with CDOT Standard Specifications and the CDPS-SCP, all of the items identified must be adhered to. If No is checked, document the reason and indicate the necessary corrective action in section 16 (Construction Site Assessment & Corrective Actions). If NA is checked, indicate why in the space provided or indicate in section 18 (General Notes).

**(a) Is the SWMP notebook located on site?** A copy of the SWMP notebook must be retained on site, unless another location, specified by the permit, is approved by the Division.

**(b) Are changes to the SWMP documents noted and approved?** Indicate all changes that have been made to any portion of the SWMP notebook documents during construction. Changes shall be dated and signed at the time of occurrence. Amendments may include items listed in subsection 208.03(c).

**(c) Are the inspection reports retained in the SWMP notebook?** The ECS/Engineer shall keep a record of inspections. Inspection reports must identify any incidents of non-compliance with the terms and conditions of the CDOT specifications or the CDPS-SCP. Inspection records must be retained for three years from expiration or inactivation of permit coverage.

**(d) Are corrective actions from the last inspection completed?** Have corrective actions from the last inspection been addressed? Is a description of the corrective action(s), the date(s) of the corrective action(s), and the measure(s) taken to prevent future violations (including changes to the SWMP, as necessary) documented?

**(e) Is a Spill Prevention Control and Countermeasure (SPCC) Plan retained in the SWMP notebook?** Subsection 208.06(c) requires that a SPCC plan be developed and implemented to establish operating procedures and that the necessary employee training be provided to minimize accidental releases of pollutants that can contaminate stormwater runoff. Records of spills, leaks or overflows that result in the discharge of pollutants must be documented and maintained. Information that should be recorded for all occurrences include the time and date, weather conditions, reasons for spill, etc. Some spills may need to be reported to the Water Quality Control Division immediately.

**(f) Is a list of potential pollutants retained at the site?** Subsection 107.25(b)6 requires the Erosion Control Supervisor to identify and describe all potential pollutant sources, including materials and activities, and evaluate them for the potential to contribute pollutants to stormwater discharge.

**(14) Current Construction Activities:** Provide a short description of the current construction activities/phase at the project site; include summary of grading activities, installation of utilities, paving, excavation, landscaping, etc.

- Estimate the acres of disturbed area at the time of the inspection. Include clearing, grading, excavation activities, areas receiving overburden (e.g. stockpiles), demolition areas and areas with heavy equipment/vehicle traffic, installation of new or improved haul roads and access roads, staging areas, borrow areas and storage that will disturb existing vegetative cover.

**(15) BMPs On Site at Time of Inspection:** Indicate the BMPs that are installed on-site at the time of inspection. All BMP details (e.g., Standard Plan M-208-1) shall be included with the SWMP documents.



## Stormwater Management Field Inspection Report Instructions (continued)

BMPs In SWMP/Used/Not Needed at this Time. This section can be used as follows:

- If the BMP is required by the SWMP and implemented, indicate by placing a ✓ in both the "In SWMP" and "Used" columns.
- If the BMP is required by the SWMP, but not implemented, indicate by placing a ✓ in the "In SWMP" and "Not Needed at this Time" columns.

### (a) Erosion Control BMPs On Site

- Embankment Protector (e.g., temporary slope drains, open-chute drains, etc.)
- Grading Techniques (e.g., vertical tracking, scarifying, or disking the surface on the contour, etc.)
- Check Dams (e.g., rock check, erosion logs, erosion bales, silt berms, etc.)
- Outlet Protection (e.g., riprap, erosion log around top of headwall, etc.)

### (b) Sediment Control BMPs On Site

- Inlet Protection (e.g., erosion logs, erosion bales, sand bags, gravel bags, etc.)
- Perimeter Control (e.g., silt fence, erosion logs, berms, etc.)

### (d) Materials Handling, Spill Prevention, Waste Management and General Pollution Prevention

- Stockpile Management. Stockpiles shall be located away from sensitive areas. All erodible stockpiles (including topsoil) shall be contained by silt fence, berms or other sediment control devices throughout construction (also see subsection 208.07).
- Materials Management. Material that could contribute pollutants to stormwater shall have secondary containment or other equivalent protection (also see subsection 208.06(a)).
- Concrete Waste Management. All concrete residue shall be contained in a signed structure as designed per subsection 208.02(j) and subsection 208.05(n). It shall be located a minimum of 50 feet from state waters.
- Saw Water Containment (e.g., pick-up broom or vacuum). Street washing is *not* allowed.
- Sanitary Facility. Temporary sanitary facilities shall be located 50 feet away from drainage ways, inlets, receiving waters, and located away from areas of high traffic, and areas susceptible to flooding or damage by construction equipment.

**(16) Construction Site Assessment & Corrective Actions:** Inspect the construction site and indicate where BMP feature(s) identified in section 15 (BMPs On Site at Time of Inspection), require corrective action. Erosion and sediment control practices identified in the SWMP shall be evaluated to ensure that they are operating correctly.

- Location. Site location (e.g., project station number, mile marker, intersection quadrant, etc.).
- BMP. Indicate the type of BMP at this location that requires corrective action (e.g., silt fence, erosion logs, soil retention blankets, etc.).
- Condition. Identify the condition of the BMP, using more than one letter (identified in section 16) if necessary.
- Description of Corrective Action and Preventative Measure Taken. Provide the proposed corrective action needed to bring the area or BMP into compliance. Once corrective actions are completed, state the measures taken to prevent future violations and ensure that the BMPs are operating correctly, including the required changes made to the SWMP.
- Date Completed & Initials. Date and initial when the corrective action was completed and the preventative measure statement finished.

**(17) Construction Site Assessment:** Was there any off site discharge of sediment at this site since the last inspection?

**(a) Is there evidence of discharge of sediment or other pollutants from the site? Off site pollutant discharges are a violation of the permit.** The construction site perimeter, all disturbed areas, material and/or waste storage areas that are exposed to precipitation, discharge locations, and locations where vehicles access the site shall be inspected for evidence of, or the potential for, pollutants leaving the construction site boundaries, entering the stormwater drainage system, or discharging to state water.

**(b) Has sediment or other pollutants discharging from the site reached state waters? Off site pollutant discharges are a violation of the permit.** If off site discharge has occurred, explain the discharge and the corrective actions in section 16 (Construction Site Assessment & Corrective Actions) or section 18 (General Notes).

**(18) General Notes:** Indicate any additional notes that add detail to the inspection; this may include positive practices noted on the project.

**(19) Inspection Certification:** In accordance with Part I, F.1.c of the CDPS-SCP, all reports for submittal shall be signed and certified for accuracy.

**(20) Compliance Certification:** In accordance with Part I, D.6.b.2.viii of the CDPS-SCP, compliance shall be certified through signature.

## Description

Surface roughening is an erosion control practice that involves tracking, scarifying, imprinting, or tilling a disturbed area to provide temporary stabilization of disturbed areas. Surface roughening creates variations in the soil surface that help to minimize wind and water erosion. Depending on the technique used, surface roughening may also help establish conditions favorable to establishment of vegetation.



Photograph SR-1. Surface roughening via imprinting for temporary stabilization.

## Appropriate Uses

Surface roughening can be used to provide temporary stabilization of disturbed areas, such as when revegetation cannot be immediately established due to seasonal planting limitations. Surface roughening is not a stand-alone BMP, and should be used in conjunction with other erosion and sediment controls.

Surface roughening is often implemented in conjunction with grading and is typically performed using heavy construction equipment to track the surface. Be aware that tracking with heavy equipment will also compact soils, which is not desirable in areas that will be revegetated. Scarifying, tilling, or ripping are better surface roughening techniques in locations where revegetation is planned. Roughening is not effective in very sandy soils and cannot be effectively performed in rocky soil.

## Design and Installation

Typical design details for surfacing roughening on steep and mild slopes are provided in Details SR-1 and SR-2, respectively.

Surface roughening should be performed either after final grading or to temporarily stabilize an area during active construction that may be inactive for a short time period. Surface roughening should create depressions 2 to 6 inches deep and approximately 6 inches apart. The surface of exposed soil can be roughened by a number of techniques and equipment. Horizontal grooves (running parallel to the contours of the land) can be made using tracks from equipment treads, stair-step grading, ripping, or tilling.

Fill slopes can be constructed with a roughened surface. Cut slopes that have been smooth graded can be roughened as a subsequent operation. Roughening should follow along the contours of the slope. The tracks left by truck mounted equipment working perpendicular to the contour can leave acceptable horizontal depressions; however, the equipment will also compact the soil.

| Surface Roughening       |     |
|--------------------------|-----|
| Functions                |     |
| Erosion Control          | Yes |
| Sediment Control         | No  |
| Site/Material Management | No  |

**Maintenance and Removal**

Care should be taken not to drive vehicles or equipment over areas that have been surface roughened. Tire tracks will smooth the roughened surface and may cause runoff to collect into rills and gullies.

Because surface roughening is only a temporary control, additional treatments may be necessary to maintain the soil surface in a roughened condition.

Areas should be inspected for signs of erosion. Surface roughening is a temporary measure, and will not provide long-term erosion control.

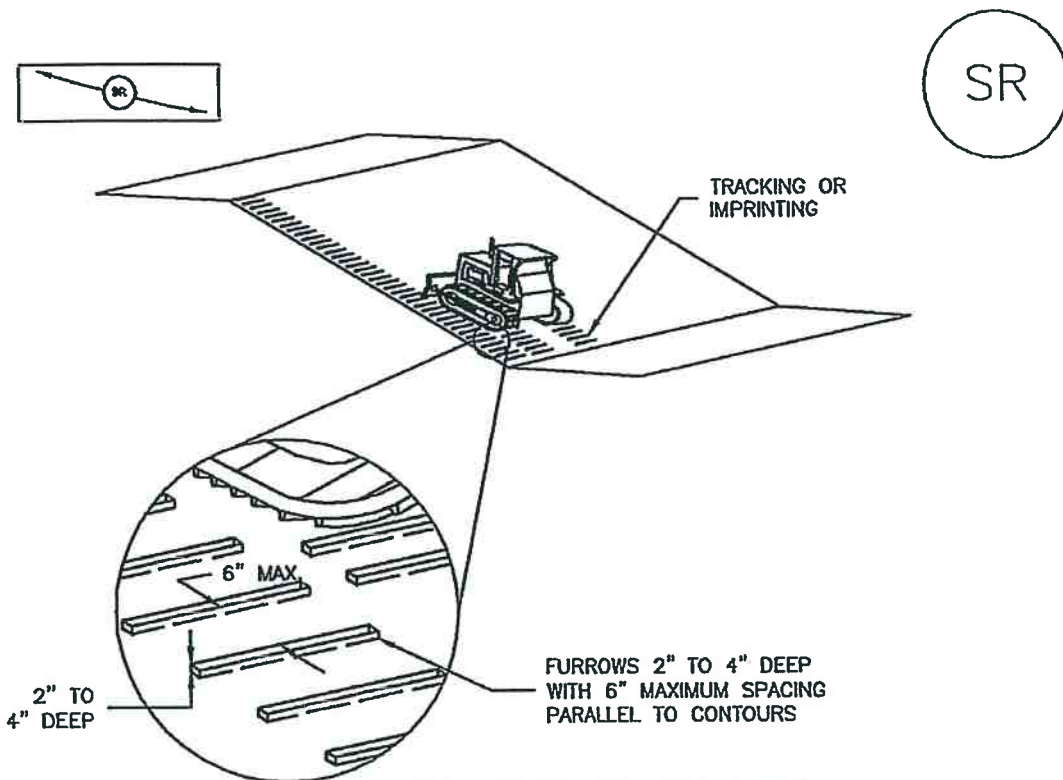

**SR-1. SURFACE ROUGHENING**  
FOR STEEP SLOPES (3:1 OR STEEPER)

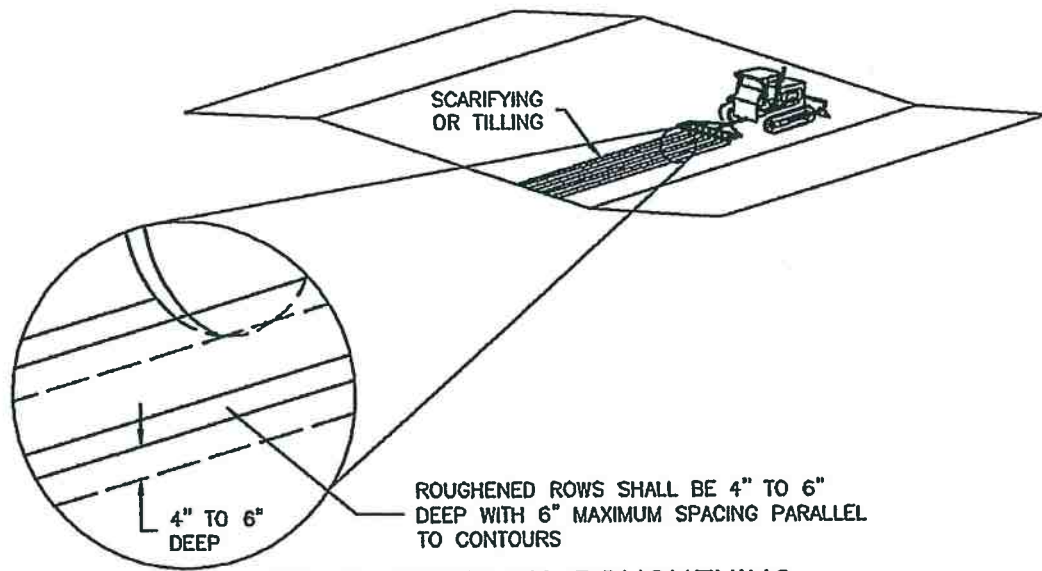

**SR-2. SURFACE ROUGHENING**  
FOR LOW SLOPES (LESS THAN 3:1)



SURFACE ROUGHENING INSTALLATION NOTES

1. SEE PLAN VIEW FOR:  
-LOCATION(S) OF SURFACE ROUGHENING.
2. SURFACE ROUGHENING SHALL BE PROVIDED PROMPTLY AFTER COMPLETION OF FINISHED GRADING (FOR AREAS NOT RECEIVING TOPSOIL) OR PRIOR TO TOPSOIL PLACEMENT OR ANY FORECASTED RAIN EVENT.
3. AREAS WHERE BUILDING FOUNDATIONS, PAVEMENT, OR SOD WILL BE PLACED WITHOUT DELAY IN THE CONSTRUCTION SEQUENCE, SURFACE ROUGHENING IS NOT REQUIRED.
4. DISTURBED SURFACES SHALL BE ROUGHENED USING RIPPING OR TILLING EQUIPMENT ON THE CONTOUR OR TRACKING UP AND DOWN A SLOPE USING EQUIPMENT TREADS.
5. A FARMING DISK SHALL NOT BE USED FOR SURFACE ROUGHENING.

SURFACE ROUGHENING MAINTENANCE NOTES

1. INSPECT BMPs EACH WORKDAY, AND MAINTAIN THEM IN EFFECTIVE OPERATING CONDITION. MAINTENANCE OF BMPs SHOULD BE PROACTIVE, NOT REACTIVE. INSPECT BMPs AS SOON AS POSSIBLE (AND ALWAYS WITHIN 24 HOURS) FOLLOWING A STORM THAT CAUSES SURFACE EROSION, AND PERFORM NECESSARY MAINTENANCE.
2. FREQUENT OBSERVATIONS AND MAINTENANCE ARE NECESSARY TO MAINTAIN BMPs IN EFFECTIVE OPERATING CONDITION. INSPECTIONS AND CORRECTIVE MEASURES SHOULD BE DOCUMENTED THOROUGHLY.
3. WHERE BMPs HAVE FAILED, REPAIR OR REPLACE UPON DISCOVERY OF THE FAILURE.
4. VEHICLES AND EQUIPMENT SHALL NOT BE DRIVEN OVER AREAS THAT HAVE BEEN SURFACE ROUGHENED.
5. IN NON-TURF GRASS FINISHED AREAS, SEEDING AND MULCHING SHALL TAKE PLACE DIRECTLY OVER SURFACE ROUGHENED AREAS WITHOUT FIRST SMOOTHING OUT THE SURFACE.
6. IN AREAS NOT SEEDED AND MULCHED AFTER SURFACE ROUGHENING, SURFACES SHALL BE RE-ROUGHENED AS NECESSARY TO MAINTAIN GROOVE DEPTH AND SMOOTH OVER RILL EROSION.

~(DETAILS ADAPTED FROM TOWN OF PARKER, COLORADO, NOT AVAILABLE IN AUTOCAD)

- ~NOTE: MANY JURISDICTIONS HAVE BMP DETAILS THAT VARY FROM UDFCD STANDARD DETAILS.  
~CONSULT WITH LOCAL JURISDICTIONS AS TO WHICH DETAIL SHOULD BE USED WHEN  
~DIFFERENCES ARE NOTED.

## Description

Temporary seeding can be used to stabilize disturbed areas that will be inactive for an extended period. Permanent seeding should be used to stabilize areas at final grade that will not be otherwise stabilized. Effective seeding includes preparation of a seedbed, selection of an appropriate seed mixture, proper planting techniques, and protection of the seeded area with mulch, geotextiles, or other appropriate measures.

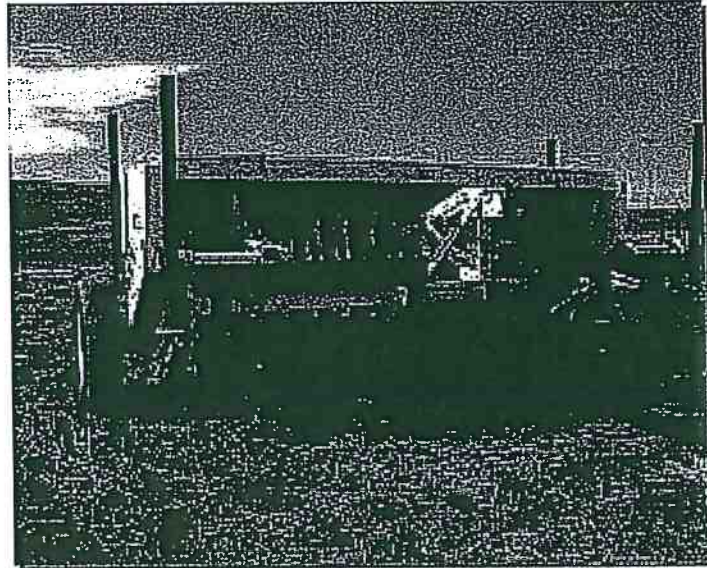

Photograph TS/PS -1. Equipment used to drill seed. Photo courtesy of Douglas County.

## Appropriate Uses

When the soil surface is disturbed and will remain inactive for an extended period (typically 30 days or longer), proactive stabilization measures should be implemented. If the inactive period is short-lived (on the order of two weeks), techniques such as surface roughening may be appropriate. For longer periods of inactivity, temporary seeding and mulching can provide effective erosion control. Permanent seeding should be used on finished areas that have not been otherwise stabilized.

Typically, local governments have their own seed mixes and timelines for seeding. Check jurisdictional requirements for seeding and temporary stabilization.

## Design and Installation

Effective seeding requires proper seedbed preparation, selection of an appropriate seed mixture, use of appropriate seeding equipment to ensure proper coverage and density, and protection with mulch or fabric until plants are established.

The USDCM Volume 2 *Revegetation* Chapter contains detailed seed mix, soil preparations, and seeding and mulching recommendations that may be referenced to supplement this Fact Sheet.

Drill seeding is the preferred seeding method. Hydroseeding is not recommended except in areas where steep slopes prevent use of drill seeding equipment, and even in these instances it is preferable to hand seed and mulch. Some jurisdictions do not allow hydroseeding or hydromulching.

## Seedbed Preparation

Prior to seeding, ensure that areas to be revegetated have soil conditions capable of supporting vegetation. Overlot grading can result in loss of topsoil, resulting in poor quality subsoils at the ground surface that have low nutrient value, little organic matter content, few soil microorganisms, rooting restrictions, and conditions less conducive to infiltration of precipitation. As a result, it is typically necessary to provide stockpiled topsoil, compost, or other

| Temporary and Permanent Seeding |     |
|---------------------------------|-----|
| Functions                       |     |
| Erosion Control                 | Yes |
| Sediment Control                | No  |
| Site/Material Management        | No  |



## EC-2 Temporary and Permanent Seeding (TS/PS)

---

soil amendments and rototill them into the soil to a depth of 6 inches or more.

Topsoil should be salvaged during grading operations for use and spread on areas to be revegetated later. Topsoil should be viewed as an important resource to be utilized for vegetation establishment, due to its water-holding capacity, structure, texture, organic matter content, biological activity, and nutrient content. The rooting depth of most native grasses in the semi-arid Denver metropolitan area is 6 to 18 inches. At a minimum, the upper 6 inches of topsoil should be stripped, stockpiled, and ultimately respread across areas that will be revegetated.

Where topsoil is not available, subsoils should be amended to provide an appropriate plant-growth medium. Organic matter, such as well digested compost, can be added to improve soil characteristics conducive to plant growth. Other treatments can be used to adjust soil pH conditions when needed. Soil testing, which is typically inexpensive, should be completed to determine and optimize the types and amounts of amendments that are required.

If the disturbed ground surface is compacted, rip or rototill the surface prior to placing topsoil. If adding compost to the existing soil surface, rototilling is necessary. Surface roughening will assist in placement of a stable topsoil layer on steeper slopes, and allow infiltration and root penetration to greater depth.

Prior to seeding, the soil surface should be rough and the seedbed should be firm, but neither too loose nor compacted. The upper layer of soil should be in a condition suitable for seeding at the proper depth and conducive to plant growth. Seed-to-soil contact is the key to good germination.

### Seed Mix for Temporary Vegetation

To provide temporary vegetative cover on disturbed areas which will not be paved, built upon, or fully landscaped or worked for an extended period (typically 30 days or more), plant an annual grass appropriate for the time of planting and mulch the planted areas. Annual grasses suitable for the Denver metropolitan area are listed in Table TS/PS-1. These are to be considered only as general recommendations when specific design guidance for a particular site is not available. Local governments typically specify seed mixes appropriate for their jurisdiction.

### Seed Mix for Permanent Revegetation

To provide vegetative cover on disturbed areas that have reached final grade, a perennial grass mix should be established. Permanent seeding should be performed promptly (typically within 14 days) after reaching final grade. Each site will have different characteristics and a landscape professional or the local jurisdiction should be contacted to determine the most suitable seed mix for a specific site. In lieu of a specific recommendation, one of the perennial grass mixes appropriate for site conditions and growth season listed in Table TS/PS-2 can be used. The pure live seed (PLS) rates of application recommended in these tables are considered to be absolute minimum rates for seed applied using proper drill-seeding equipment.

If desired for wildlife habitat or landscape diversity, shrubs such as rubber rabbitbrush (*Chrysothamnus nauseosus*), fourwing saltbush (*Atriplex canescens*) and skunkbrush sumac (*Rhus trilobata*) could be added to the upland seedmixes at 0.25, 0.5 and 1 pound PLS/acre, respectively. In riparian zones, planting root stock of such species as American plum (*Prunus americana*), woods rose (*Rosa woodsii*), plains cottonwood (*Populus sargentii*), and willow (*Populus spp.*) may be considered. On non-topsoiled upland sites, a legume such as Ladak alfalfa at 1 pound PLS/acre can be included as a source of nitrogen for perennial grasses.

Seeding dates for the highest success probability of perennial species along the Front Range are generally in the spring from April through early May and in the fall after the first of September until the ground freezes. If the area is irrigated, seeding may occur in summer months, as well. See Table TS/PS-3 for appropriate seeding dates.

**Table TS/PS-1. Minimum Drill Seeding Rates for Various Temporary Annual Grasses**

| Species <sup>a</sup><br>(Common name) | Growth Season <sup>b</sup> | Pounds of Pure Live Seed (PLS)/acre <sup>c</sup> | Planting Depth (inches) |
|---------------------------------------|----------------------------|--|-------------------------|
| 1. Oats                               | Cool                       | 35 - 50  | 1 - 2                   |
| 2. Spring wheat                       | Cool                       | 25 - 35  | 1 - 2                   |
| 3. Spring barley                      | Cool                       | 25 - 35  | 1 - 2                   |
| 4. Annual ryegrass                    | Cool                       | 10 - 15  | ½                       |
| 5. Millet                             | Warm                       | 3 - 15   | ½ - ¾                   |
| 6. Sudangrass                         | Warm                       | 5-10   | ½ - ¾                   |
| 7. Sorghum                            | Warm                       | 5-10   | ½ - ¾                   |
| 8. Winter wheat                       | Cool                       | 20-35  | 1 - 2                   |
| 9. Winter barley                      | Cool                       | 20-35  | 1 - 2                   |
| 10. Winter rye                        | Cool                       | 20-35  | 1 - 2                   |
| 11. Triticale                         | Cool                       | 25-40  | 1 - 2                   |

<sup>a</sup> Successful seeding of annual grass resulting in adequate plant growth will usually produce enough dead-plant residue to provide protection from wind and water erosion for an additional year. This assumes that the cover is not disturbed or mowed closer than 8 inches.

Hydraulic seeding may be substituted for drilling only where slopes are steeper than 3:1 or where access limitations exist. When hydraulic seeding is used, hydraulic mulching should be applied as a separate operation, when practical, to prevent the seeds from being encapsulated in the mulch.

<sup>b</sup> See Table TS/PS-3 for seeding dates. Irrigation, if consistently applied, may extend the use of cool season species during the summer months.

<sup>c</sup> Seeding rates should be doubled if seed is broadcast, or increased by 50 percent if done using a Brillion Drill or by hydraulic seeding.

# EC-2 Temporary and Permanent Seeding (TS/PS)

Table TS/PS-2. Minimum Drill Seeding Rates for Perennial Grasses

| Common <sup>a</sup><br>Name                 | Botanical<br>Name                    | Growth<br>Season <sup>b</sup> | Growth<br>Form | Seeds/<br>Pound | Pounds of<br>PLS/acre |
|---|--------------------------------------|-------------------------------|----------------|-----------------|-----------------------|
| <b>Alakali Soil Seed Mix</b>                |                                      |                               |                |                 |                       |
| Alkali sacaton                              | <i>Sporobolus airoides</i>           | Cool                          | Bunch          | 1,750,000       | 0.25                  |
| Basin wildrye                               | <i>Elymus cinereus</i>               | Cool                          | Bunch          | 165,000         | 2.5                   |
| Sodar streambank wheatgrass                 | <i>Agropyron riparium 'Sodar'</i>    | Cool                          | Sod            | 170,000         | 2.5                   |
| Jose tall wheatgrass                        | <i>Agropyron elongatum 'Jose'</i>    | Cool                          | Bunch          | 79,000          | 7.0                   |
| Arriba western wheatgrass                   | <i>Agropyron smithii 'Arriba'</i>    | Cool                          | Sod            | 110,000         | 5.5                   |
| <b>Total</b>                                |                                      |                               |                |                 | <b>17.75</b>          |
| <b>Fertile Loamy Soil Seed Mix</b>          |                                      |                               |                |                 |                       |
| Ephriam crested wheatgrass                  | <i>Agropyron cristatum 'Ephriam'</i> | Cool                          | Sod            | 175,000         | 2.0                   |
| Dural hard fescue                           | <i>Festuca ovina 'duriuscula'</i>    | Cool                          | Bunch          | 565,000         | 1.0                   |
| Lincoln smooth brome                        | <i>Bromus inermis leys 'Lincoln'</i> | Cool                          | Sod            | 130,000         | 3.0                   |
| Sodar streambank wheatgrass                 | <i>Agropyron riparium 'Sodar'</i>    | Cool                          | Sod            | 170,000         | 2.5                   |
| Arriba western wheatgrass                   | <i>Agropyron smithii 'Arriba'</i>    | Cool                          | Sod            | 110,000         | 7.0                   |
| <b>Total</b>                                |                                      |                               |                |                 | <b>15.5</b>           |
| <b>High Water Table Soil Seed Mix</b>       |                                      |                               |                |                 |                       |
| Meadow foxtail                              | <i>Alopecurus pratensis</i>          | Cool                          | Sod            | 900,000         | 0.5                   |
| Redtop                                      | <i>Agrostis alba</i>                 | Warm                          | Open sod       | 5,000,000       | 0.25                  |
| Reed canarygrass                            | <i>Phalaris arundinacea</i>          | Cool                          | Sod            | 68,000          | 0.5                   |
| Lincoln smooth brome                        | <i>Bromus inermis leys 'Lincoln'</i> | Cool                          | Sod            | 130,000         | 3.0                   |
| Pathfinder switchgrass                      | <i>Panicum virgatum 'Pathfinder'</i> | Warm                          | Sod            | 389,000         | 1.0                   |
| Alkar tall wheatgrass                       | <i>Agropyron elongatum 'Alkar'</i>   | Cool                          | Bunch          | 79,000          | 5.5                   |
| <b>Total</b>                                |                                      |                               |                |                 | <b>10.75</b>          |
| <b>Transition Turf Seed Mix<sup>c</sup></b> |                                      |                               |                |                 |                       |
| Ruebens Canadian bluegrass                  | <i>Poa compressa 'Ruebens'</i>       | Cool                          | Sod            | 2,500,000       | 0.5                   |
| Dural hard fescue                           | <i>Festuca ovina 'duriuscula'</i>    | Cool                          | Bunch          | 565,000         | 1.0                   |
| Citation perennial ryegrass                 | <i>Lolium perenne 'Citation'</i>     | Cool                          | Sod            | 247,000         | 3.0                   |
| Lincoln smooth brome                        | <i>Bromus inermis leys 'Lincoln'</i> | Cool                          | Sod            | 130,000         | 3.0                   |
| <b>Total</b>                                |                                      |                               |                |                 | <b>7.5</b>            |

Table TS/PS-2. Minimum Drill Seeding Rates for Perennial Grasses (cont.)

| Common Name  | Botanical Name                          | Growth Season <sup>b</sup> | Growth Form            | Seeds/Pound | Pounds of PLS/acre |
|--|---|----------------------------|------------------------|-------------|--------------------|
| <b>Sandy Soil Seed Mix</b>   |   |                            |                        |             |                    |
| Blue grama   | <i>Bouteloua gracilis</i>               | Warm                       | Sod-forming bunchgrass | 825,000     | 0.5                |
| Camper little bluestem   | <i>Schizachyrium scoparium</i> 'Camper' | Warm                       | Bunch                  | 240,000     | 1.0                |
| Prairie sandreed   | <i>Calamovilfa longifolia</i>           | Warm                       | Open sod               | 274,000     | 1.0                |
| Sand dropseed  | <i>Sporobolus cryptandrus</i>           | Cool                       | Bunch                  | 5,298,000   | 0.25               |
| Vaughn sideoats grama  | <i>Bouteloua curtipendula</i> 'Vaughn'  | Warm                       | Sod                    | 191,000     | 2.0                |
| Arriba western wheatgrass  | <i>Agropyron smithii</i> 'Arriba'       | Cool                       | Sod                    | 110,000     | 5.5                |
| <b>Total</b>   |   |                            |                        |             | <b>10.25</b>       |
| <b>Heavy Clay, Rocky Foothill Seed Mix</b>   |   |                            |                        |             |                    |
| Ephriam crested wheatgrass <sup>d</sup>  | <i>Agropyron cristatum</i> 'Ephriam'    | Cool                       | Sod                    | 175,000     | 1.5                |
| Oahe Intermediate wheatgrass   | <i>Agropyron intermedium</i> 'Oahe'     | Cool                       | Sod                    | 115,000     | 5.5                |
| Vaughn sideoats grama <sup>e</sup>   | <i>Bouteloua curtipendula</i> 'Vaughn'  | Warm                       | Sod                    | 191,000     | 2.0                |
| Lincoln smooth brome   | <i>Bromus inermis</i> leys 'Lincoln'    | Cool                       | Sod                    | 130,000     | 3.0                |
| Arriba western wheatgrass  | <i>Agropyron smithii</i> 'Arriba'       | Cool                       | Sod                    | 110,000     | 5.5                |
| <b>Total</b>   |   |                            |                        |             | <b>17.5</b>        |
| <p><sup>a</sup> All of the above seeding mixes and rates are based on drill seeding followed by crimped straw mulch. These rates should be doubled if seed is broadcast and should be increased by 50 percent if the seeding is done using a Brillion Drill or is applied through hydraulic seeding. Hydraulic seeding may be substituted for drilling only where slopes are steeper than 3:1. If hydraulic seeding is used, hydraulic mulching should be done as a separate operation.</p> <p><sup>b</sup> See Table TS/PS-3 for seeding dates.</p> <p><sup>c</sup> If site is to be irrigated, the transition turf seed rates should be doubled.</p> <p><sup>d</sup> Crested wheatgrass should not be used on slopes steeper than 6H to 1V.</p> <p><sup>e</sup> Can substitute 0.5 lbs PLS of blue grama for the 2.0 lbs PLS of Vaughn sideoats grama.</p> |   |                            |                        |             |                    |

## EC-2 Temporary and Permanent Seeding (TS/PS)

Table TS/PS-3. Seeding Dates for Annual and Perennial Grasses

| Seeding Dates            | Annual Grasses<br>(Numbers in table reference<br>species in Table TS/PS-1) |           | Perennial Grasses |      |
|--------------------------|--|-----------|-------------------|------|
|                          | Warm   | Cool      | Warm              | Cool |
| January 1–March 15       |  |           | ✓                 | ✓    |
| March 16–April 30        | 4  | 1,2,3     | ✓                 | ✓    |
| May 1–May 15             | 4  |           | ✓                 |      |
| May 16–June 30           | 4,5,6,7  |           |                   |      |
| July 1–July 15           | 5,6,7  |           |                   |      |
| July 16–August 31        |  |           |                   |      |
| September 1–September 30 |  | 8,9,10,11 |                   |      |
| October 1–December 31    |  |           | ✓                 | ✓    |

### Mulch

Cover seeded areas with mulch or an appropriate rolled erosion control product to promote establishment of vegetation. Anchor mulch by crimping, netting or use of a non-toxic tackifier. See the Mulching BMP Fact Sheet for additional guidance.

### Maintenance and Removal

Monitor and observe seeded areas to identify areas of poor growth or areas that fail to germinate. Reseed and mulch these areas, as needed.

An area that has been permanently seeded should have a good stand of vegetation within one growing season if irrigated and within three growing seasons without irrigation in Colorado. Reseed portions of the site that fail to germinate or remain bare after the first growing season.

Seeded areas may require irrigation, particularly during extended dry periods. Targeted weed control may also be necessary.

Protect seeded areas from construction equipment and vehicle access.



## Description

Mulching consists of evenly applying straw, hay, shredded wood mulch, rock, bark or compost to disturbed soils and securing the mulch by crimping, tackifiers, netting or other measures. Mulching helps reduce erosion by protecting bare soil from rainfall impact, increasing infiltration, and reducing runoff. Although often applied in conjunction with temporary or permanent seeding, it can also be used for temporary stabilization of areas that cannot be reseeded due to seasonal constraints.

Mulch can be applied either using standard mechanical dry application methods or using hydromulching equipment that hydraulically applies a slurry of water, wood fiber mulch, and often a tackifier.

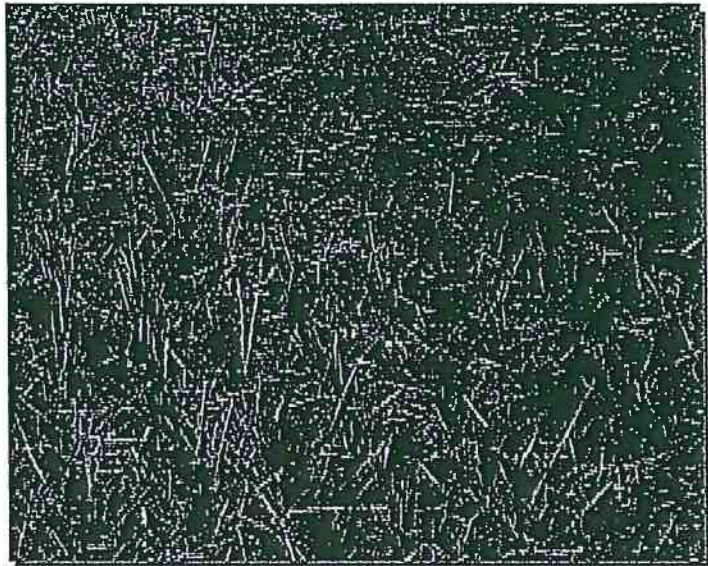

Photograph MU-1. An area that was recently seeded, mulched, and crimped.

## Appropriate Uses

Use mulch in conjunction with seeding to help protect the seedbed and stabilize the soil. Mulch can also be used as a temporary cover on low to mild slopes to help temporarily stabilize disturbed areas where growing season constraints prevent effective reseeded. Disturbed areas should be properly mulched and tacked, or seeded, mulched and tacked promptly after final grade is reached (typically within no longer than 14 days) on portions of the site not otherwise permanently stabilized.

Standard dry mulching is encouraged in most jurisdictions; however, hydromulching may not be allowed in certain jurisdictions or may not be allowed near waterways.

Do not apply mulch during windy conditions.

## Design and Installation

Prior to mulching, surface-roughen areas by rolling with a crimping or punching type roller or by track walking. Track walking should only be used where other methods are impractical because track walking with heavy equipment typically compacts the soil.

A variety of mulches can be used effectively at construction sites. Consider the following:

| Mulch                    |          |
|--------------------------|----------|
| <b>Functions</b>         |          |
| Erosion Control          | Yes      |
| Sediment Control         | Moderate |
| Site/Material Management | No       |

- Clean, weed-free and seed-free cereal grain straw should be applied evenly at a rate of 2 tons per acre and must be tacked or fastened by a method suitable for the condition of the site. Straw mulch must be anchored (and not merely placed) on the surface. This can be accomplished mechanically by crimping or with the aid of tackifiers or nets. Anchoring with a crimping implement is preferred, and is the recommended method for areas flatter than 3:1. Mechanical crimpers must be capable of tucking the long mulch fibers into the soil to a depth of 3 inches without cutting them. An agricultural disk, while not an ideal substitute, may work if the disk blades are dull or blunted and set vertically; however, the frame may have to be weighted to afford proper soil penetration.
- Grass hay may be used in place of straw; however, because hay is comprised of the entire plant including seed, mulching with hay may seed the site with non-native grass species which might in turn out-compete the native seed. Alternatively, native species of grass hay may be purchased, but can be difficult to find and are more expensive than straw. Purchasing and utilizing a certified weed-free straw is an easier and less costly mulching method. When using grass hay, follow the same guidelines as for straw (provided above).
- On small areas sheltered from the wind and heavy runoff, spraying a tackifier on the mulch is satisfactory for holding it in place. For steep slopes and special situations where greater control is needed, erosion control blankets anchored with stakes should be used instead of mulch.
- Hydraulic mulching consists of wood cellulose fibers mixed with water and a tackifying agent and should be applied at a rate of no less than 1,500 pounds per acre (1,425 lbs of fibers mixed with at least 75 lbs of tackifier) with a hydraulic mulcher. For steeper slopes, up to 2000 pounds per acre may be required for effective hydroseeding. Hydromulch typically requires up to 24 hours to dry; therefore, it should not be applied immediately prior to inclement weather. Application to roads, waterways and existing vegetation should be avoided.
- Erosion control mats, blankets, or nets are recommended to help stabilize steep slopes (generally 3:1 and steeper) and waterways. Depending on the product, these may be used alone or in conjunction with grass or straw mulch. Normally, use of these products will be restricted to relatively small areas. Biodegradable mats made of straw and jute, straw-coconut, coconut fiber, or excelsior can be used instead of mulch. (See the ECM/TRM BMP for more information.)
- Some tackifiers or binders may be used to anchor mulch. Check with the local jurisdiction for allowed tackifiers. Manufacturer's recommendations should be followed at all times. (See the Soil Binder BMP for more information on general types of tackifiers.)
- Rock can also be used as mulch. It provides protection of exposed soils to wind and water erosion and allows infiltration of precipitation. An aggregate base course can be spread on disturbed areas for temporary or permanent stabilization. The rock mulch layer should be thick enough to provide full coverage of exposed soil on the area it is applied.

## Maintenance and Removal

After mulching, the bare ground surface should not be more than 10 percent exposed. Reapply mulch, as needed, to cover bare areas.



## Description

Rolled Erosion Control Products (RECPs) include a variety of temporary or permanently installed manufactured products designed to control erosion and enhance vegetation establishment and survivability, particularly on slopes and in channels. For applications where natural vegetation alone will provide sufficient permanent erosion protection, temporary products such as netting, open weave textiles and a variety of erosion control blankets (ECBs) made of biodegradable natural materials (e.g., straw, coconut fiber) can be used. For applications where natural vegetation alone will not be sustainable under expected flow conditions, permanent rolled erosion control products such as turf reinforcement mats (TRMs) can be used. In particular, turf reinforcement mats are designed for discharges that exert velocities and shear stresses that exceed the typical limits of mature natural vegetation.

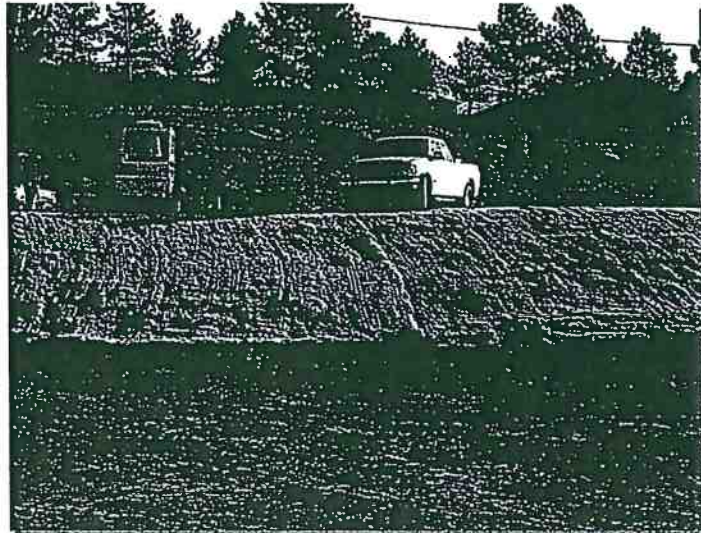

Photograph RECP-1. Erosion control blanket protecting the slope from erosion and providing favorable conditions for revegetation.

## Appropriate Uses

RECPs can be used to control erosion in conjunction with revegetation efforts, providing seedbed protection from wind and water erosion. These products are often used on disturbed areas on steep slopes, in areas with highly erosive soils, or as part of drainageway stabilization. In order to select the appropriate RECP for site conditions, it is important to have a general understanding of the general types of these products, their expected longevity, and general characteristics.

The Erosion Control Technology Council (ECTC 2005) characterizes rolled erosion control products according to these categories:

- **Mulch control netting:** A planar woven natural fiber or extruded geosynthetic mesh used as a temporary degradable rolled erosion control product to anchor loose fiber mulches.
- **Open weave textile:** A temporary degradable rolled erosion control product composed of processed natural or polymer yarns woven into a matrix, used to provide erosion control and facilitate vegetation establishment.
- **Erosion control blanket (ECB):** A temporary degradable rolled erosion control product composed of processed natural or polymer fibers which are mechanically, structurally or chemically bound together to form a continuous matrix to provide erosion control and facilitate vegetation establishment. ECBs can be further differentiated into rapidly degrading single-net and double-net types or slowly degrading types.

| Rolled Erosion Control Products |     |
|---------------------------------|-----|
| Functions                       |     |
| Erosion Control                 | Yes |
| Sediment Control                | No  |
| Site/Material Management        | No  |



- **Turf Reinforcement Mat (TRM):** A rolled erosion control product composed of non-degradable synthetic fibers, filaments, nets, wire mesh, and/or other elements, processed into a permanent, three-dimensional matrix of sufficient thickness. TRMs, which may be supplemented with degradable components, are designed to impart immediate erosion protection, enhance vegetation establishment and provide long-term functionality by permanently reinforcing vegetation during and after maturation. Note: TRMs are typically used in hydraulic applications, such as high flow ditches and channels, steep slopes, stream banks, and shorelines, where erosive forces may exceed the limits of natural, unreinforced vegetation or in areas where limited vegetation establishment is anticipated.

Tables RECP-1 and RECP-2 provide guidelines for selecting rolled erosion control products appropriate to site conditions and desired longevity. Table RECP-1 is for conditions where natural vegetation alone will provide permanent erosion control, whereas Table RECP-2 is for conditions where vegetation alone will not be adequately stable to provide long-term erosion protection due to flow or other conditions.

**Table RECP-1. ECTC Standard Specification for Temporary Rolled Erosion Control Products**  
(Adapted from Erosion Control Technology Council 2005)

| Product Description   | Slope Applications* |                         | Channel Applications*             | Minimum Tensile Strength <sup>1</sup> | Expected Longevity |
|---|---------------------|-------------------------|-----------------------------------|---------------------------------------|--------------------|
|   | Maximum Gradient    | C Factor <sup>2,5</sup> |                                   |                                       |                    |
| Mulch Control Nets  | 5:1 (H:V)           | ≤0.10 @ 5:1             | 0.25 lbs/ft <sup>2</sup> (12 Pa)  | 5 lbs/ft (0.073 kN/m)                 | Up to 12 months    |
| Netless Rolled Erosion Control Blankets                           | 4:1 (H:V)           | ≤0.10 @ 4:1             | 0.5 lbs/ft <sup>2</sup> (24 Pa)   | 5 lbs/ft (0.073 kN/m)                 |                    |
| Single-net Erosion Control Blankets & Open Weave Textiles         | 3:1 (H:V)           | ≤0.15 @ 3:1             | 1.5 lbs/ft <sup>2</sup> (72 Pa)   | 50 lbs/ft (0.73 kN/m)                 |                    |
| Double-net Erosion Control Blankets                               | 2:1 (H:V)           | ≤0.20 @ 2:1             | 1.75 lbs/ft <sup>2</sup> (84 Pa)  | 75 lbs/ft (1.09 kN/m)                 |                    |
| Mulch Control Nets  | 5:1 (H:V)           | ≤0.10 @ 5:1             | 0.25 lbs/ft <sup>2</sup> (12 Pa)  | 25 lbs/ft (0.36 kN/m)                 | 24 months          |
| Erosion Control Blankets & Open Weave Textiles (slowly degrading) | 1.5:1 (H:V)         | ≤0.25 @ 1.5:1           | 2.00 lbs/ft <sup>2</sup> (96 Pa)  | 100 lbs/ft (1.45 kN/m)                | 24 months          |
| Erosion Control Blankets & Open Weave Textiles                    | 1:1 (H:V)           | ≤0.25 @ 1:1             | 2.25 lbs/ft <sup>2</sup> (108 Pa) | 125 lbs/ft (1.82 kN/m)                | 36 months          |

\* C Factor and shear stress for mulch control nettings must be obtained with netting used in conjunction with pre-applied mulch material. (See Section 5.3 of Chapter 7 Construction BMPs for more information on the C Factor.)

<sup>1</sup> Minimum Average Roll Values, Machine direction using ECTC Mod. ASTM D 5035.

<sup>2</sup> C Factor calculated as ratio of soil loss from RECP protected slope (tested at specified or greater gradient, H:V) to ratio of soil loss from unprotected (control) plot in large-scale testing.

<sup>3</sup> Required minimum shear stress RECP (unvegetated) can sustain without physical damage or excess erosion (> 12.7 mm (0.5 in) soil loss) during a 30-minute flow event in large-scale testing.

<sup>4</sup> The permissible shear stress levels established for each performance category are based on historical experience with products characterized by Manning's roughness coefficients in the range of 0.01 - 0.05.

<sup>5</sup> Acceptable large-scale test methods may include ASTM D 6459, or other independent testing deemed acceptable by the engineer.

<sup>6</sup> Per the engineer's discretion. Recommended acceptable large-scale testing protocol may include ASTM D 6460, or other independent testing deemed acceptable by the engineer.

**Table RECP-2. ECTC Standard Specification for Permanent<sup>1</sup> Rolled Erosion Control Products**  
(Adapted from: Erosion Control Technology Council 2005)

| Product Type   | Slope Applications | Channel Applications                |   |
|--|--------------------|-------------------------------------|---|
| TRMs with a minimum thickness of 0.25 inches (6.35 mm) per ASTM D 6525 and UV stability of 80% per ASTM D 4355 (500 hours exposure). | Maximum Gradient   | Maximum Shear Stress <sup>4,5</sup> | Minimum Tensile Strength <sup>2,3</sup> |
|  | 0.5:1 (H:V)        | 6.0 lbs/ft <sup>2</sup> (288 Pa)    | 125 lbs/ft (1.82 kN/m)                  |
|  | 0.5:1 (H:V)        | 8.0 lbs/ft <sup>2</sup> (384 Pa)    | 150 lbs/ft (2.19 kN/m)                  |
|  | 0.5:1 (H:V)        | 10.0 lbs/ft <sup>2</sup> (480 Pa)   | 175 lbs/ft (2.55 kN/m)                  |

<sup>1</sup> For TRMs containing degradable components, all property values must be obtained on the non-degradable portion of the matting alone.

<sup>2</sup> Minimum Average Roll Values, machine direction only for tensile strength determination using ASTM D 6818 (Supersedes Mod. ASTM D 5035 for RECPs)

<sup>3</sup> Field conditions with high loading and/or high survivability requirements may warrant the use of a TRM with a tensile strength of 44 kN/m (3,000 lb/ft) or greater.

<sup>4</sup> Required minimum shear stress TRM (fully vegetated) can sustain without physical damage or excess erosion (> 12.7 mm (0.5 in.) soil loss) during a 30-minute flow event in large scale testing.

<sup>5</sup> Acceptable large-scale testing protocols may include ASTM D 6460, or other independent testing deemed acceptable by the engineer.

### Design and Installation

RECPs should be installed according to manufacturer’s specifications and guidelines. Regardless of the type of product used, it is important to ensure no gaps or voids exist under the material and that all corners of the material are secured using stakes and trenching. Continuous contact between the product and the soil is necessary to avoid failure. Never use metal stakes to secure temporary erosion control products. Often wooden stakes are used to anchor RECPs; however, wood stakes may present installation and maintenance challenges and generally take a long time to biodegrade. Some local jurisdictions have had favorable experiences using biodegradable stakes.

This BMP Fact Sheet provides design details for several commonly used ECB applications, including:

ECB-1 Pipe Outlet to Drainageway

ECB-2 Small Ditch or Drainageway

ECB-3 Outside of Drainageway

Staking patterns are also provided in the design details according to these factors:

- ECB type
- Slope or channel type

For other types of RECPs including TRMs, these design details are intended to serve as general guidelines for design and installation; however, engineers should adhere to manufacturer's installation recommendations.

## Maintenance and Removal

Inspection of erosion control blankets and other RECPs includes:

- Check for general signs of erosion, including voids beneath the mat. If voids are apparent, fill the void with suitable soil and replace the erosion control blanket, following the appropriate staking pattern.
- Check for damaged or loose stakes and secure loose portions of the blanket.

Erosion control blankets and other RECPs that are biodegradable typically do not need to be removed after construction. If they must be removed, then an alternate soil stabilization method should be installed promptly following removal.

Turf reinforcement mats, although generally resistant to biodegradation, are typically left in place as a dense vegetated cover grows in through the mat matrix. The turf reinforcement mat provides long-term stability and helps the established vegetation resist erosive forces.

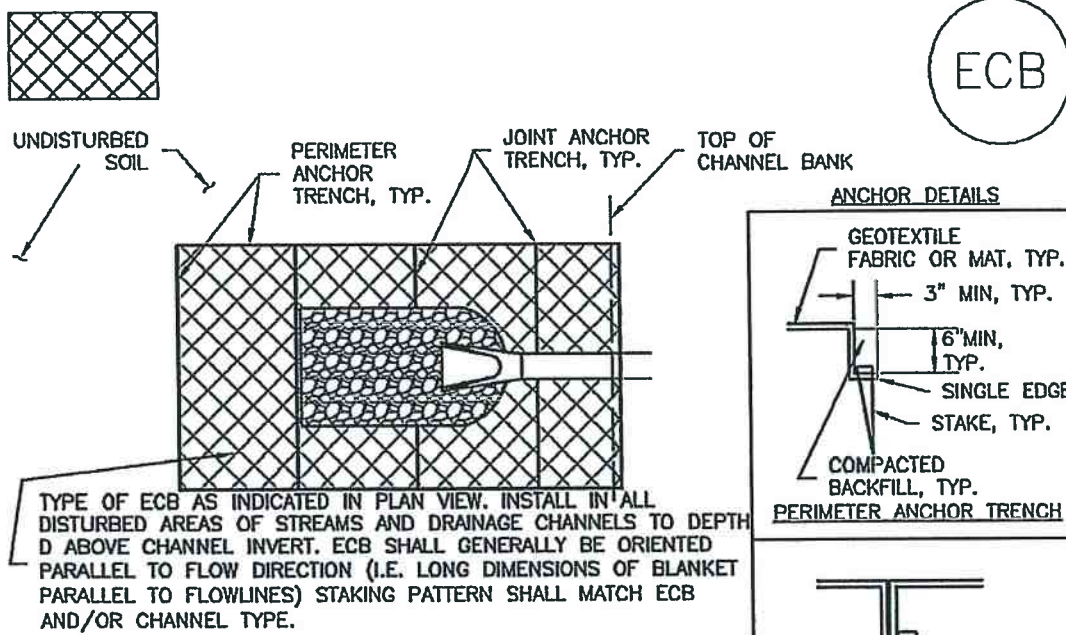

**ECB-1. PIPE OUTLET TO DRAINAGEWAY**

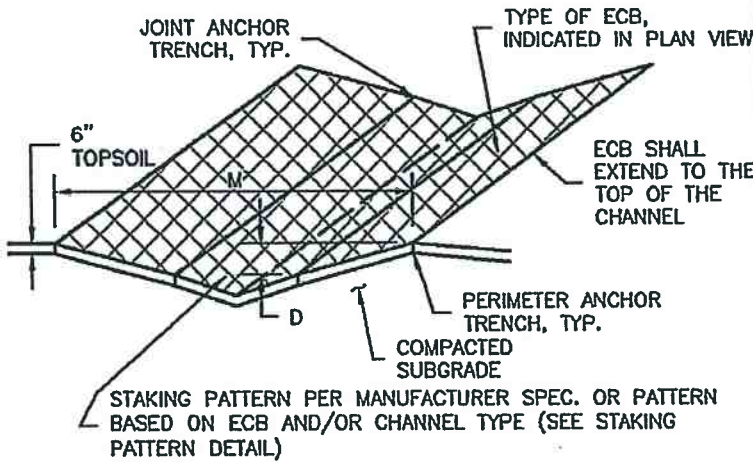

**ECB-2. SMALL DITCH OR DRAINAGEWAY**

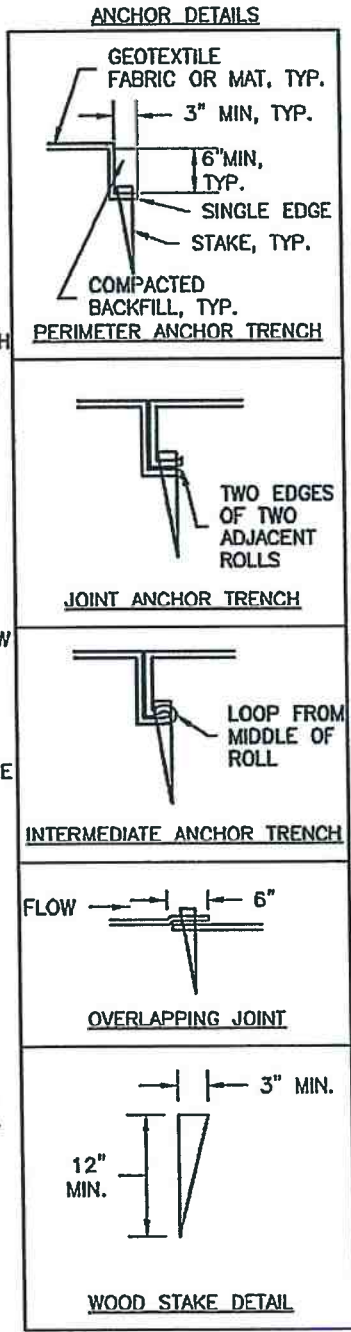



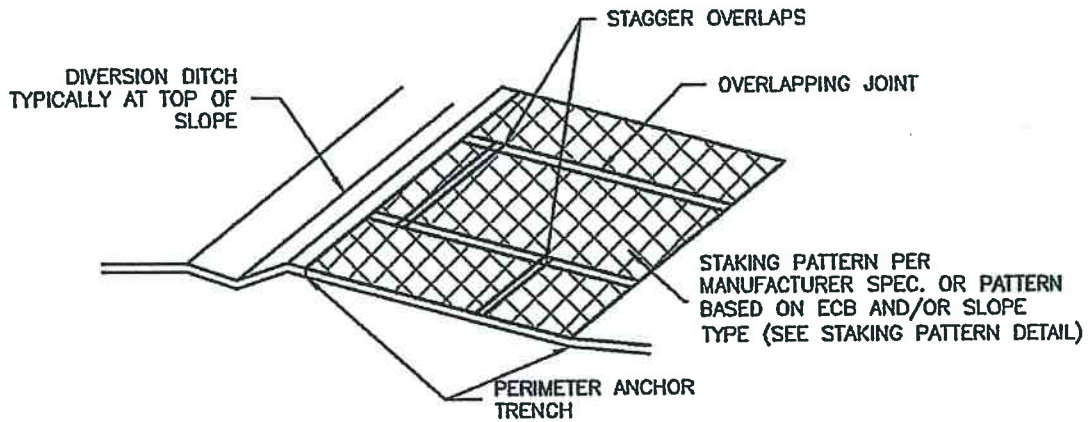

## ECB-3. OUTSIDE OF DRAINAGEWAY

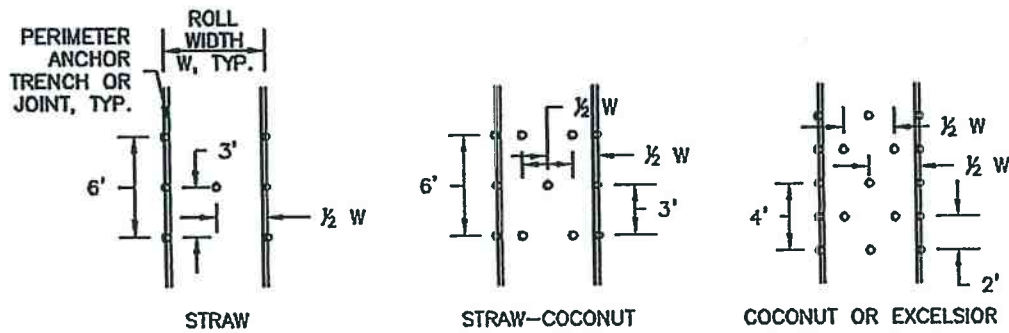

## STAKING PATTERNS BY ECB TYPE

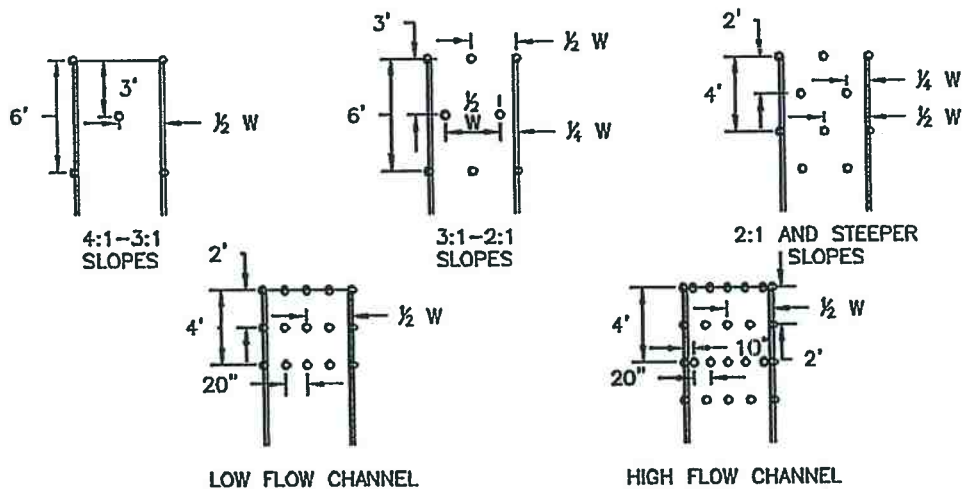

## STAKING PATTERNS BY SLOPE OR CHANNEL TYPE

EROSION CONTROL BLANKET INSTALLATION NOTES

1. SEE PLAN VIEW FOR:
  - LOCATION OF ECB.
  - TYPE OF ECB (STRAW, STRAW-COCONUT, COCONUT, OR EXCELSIOR).
  - AREA, A, IN SQUARE YARDS OF EACH TYPE OF ECB.
2. 100% NATURAL AND BIODEGRADABLE MATERIALS ARE PREFERRED FOR RECPs, ALTHOUGH SOME JURISDICTIONS MAY ALLOW OTHER MATERIALS IN SOME APPLICATIONS.
3. IN AREAS WHERE ECBs ARE SHOWN ON THE PLANS, THE PERMITTEE SHALL PLACE TOPSOIL AND PERFORM FINAL GRADING, SURFACE PREPARATION, AND SEEDING AND MULCHING. SUBGRADE SHALL BE SMOOTH AND MOIST PRIOR TO ECB INSTALLATION AND THE ECB SHALL BE IN FULL CONTACT WITH SUBGRADE. NO GAPS OR VOIDS SHALL EXIST UNDER THE BLANKET.
4. PERIMETER ANCHOR TRENCH SHALL BE USED ALONG THE OUTSIDE PERIMETER OF ALL BLANKET AREAS.
5. JOINT ANCHOR TRENCH SHALL BE USED TO JOIN ROLLS OF ECBs TOGETHER (LONGITUDINALLY AND TRANSVERSELY) FOR ALL ECBs EXCEPT STRAW WHICH MAY USE AN OVERLAPPING JOINT.
6. INTERMEDIATE ANCHOR TRENCH SHALL BE USED AT SPACING OF ONE-HALF ROLL LENGTH FOR COCONUT AND EXCELSIOR ECBs.
7. OVERLAPPING JOINT DETAIL SHALL BE USED TO JOIN ROLLS OF ECBs TOGETHER FOR ECBs ON SLOPES.
8. MATERIAL SPECIFICATIONS OF ECBs SHALL CONFORM TO TABLE ECB-1.
9. ANY AREAS OF SEEDING AND MULCHING DISTURBED IN THE PROCESS OF INSTALLING ECBs SHALL BE RESEDED AND MULCHED.
10. DETAILS ON DESIGN PLANS FOR MAJOR DRAINAGEWAY STABILIZATION WILL GOVERN IF DIFFERENT FROM THOSE SHOWN HERE.

| TABLE ECB-1. ECB MATERIAL SPECIFICATIONS |                 |               |                   |                       |
|--|-----------------|---------------|-------------------|-----------------------|
| TYPE                                     | COCONUT CONTENT | STRAW CONTENT | EXCELSIOR CONTENT | RECOMMENDED NETTING** |
| STRAW*                                   | -               | 100%          | -                 | DOUBLE/NATURAL        |
| STRAW-COCONUT                            | 30% MIN         | 70% MAX       | -                 | DOUBLE/NATURAL        |
| COCONUT                                  | 100%            | -             | -                 | DOUBLE/NATURAL        |
| EXCELSIOR                                | -               | -             | 100%              | DOUBLE/NATURAL        |

\*STRAW ECBs MAY ONLY BE USED OUTSIDE OF STREAMS AND DRAINAGE CHANNEL.  
 \*\*ALTERNATE NETTING MAY BE ACCEPTABLE IN SOME JURISDICTIONS

## EROSION CONTROL BLANKET MAINTENANCE NOTES

1. INSPECT BMPs EACH WORKDAY, AND MAINTAIN THEM IN EFFECTIVE OPERATING CONDITION. MAINTENANCE OF BMPs SHOULD BE PROACTIVE, NOT REACTIVE. INSPECT BMPs AS SOON AS POSSIBLE (AND ALWAYS WITHIN 24 HOURS) FOLLOWING A STORM THAT CAUSES SURFACE EROSION, AND PERFORM NECESSARY MAINTENANCE.
2. FREQUENT OBSERVATIONS AND MAINTENANCE ARE NECESSARY TO MAINTAIN BMPs IN EFFECTIVE OPERATING CONDITION. INSPECTIONS AND CORRECTIVE MEASURES SHOULD BE DOCUMENTED THOROUGHLY.
3. WHERE BMPs HAVE FAILED, REPAIR OR REPLACEMENT SHOULD BE INITIATED UPON DISCOVERY OF THE FAILURE.
4. ECBs SHALL BE LEFT IN PLACE TO EVENTUALLY BIODEGRADE, UNLESS REQUESTED TO BE REMOVED BY THE LOCAL JURISDICTION.
5. ANY ECB PULLED OUT, TORN, OR OTHERWISE DAMAGED SHALL BE REPAIRED OR REINSTALLED. ANY SUBGRADE AREAS BELOW THE GEOTEXTILE THAT HAVE ERODED TO CREATED A VOID UNDER THE BLANKET, OR THAT REMAIN DEVOID OF GRASS SHALL BE REPAIRED, RESEDED AND MULCHED AND THE ECB REINSTALLED.

NOTE: MANY JURISDICTIONS HAVE BMP DETAILS THAT VARY FROM UDFCD STANDARD DETAILS. CONSULT WITH LOCAL JURISDICTIONS AS TO WHICH DETAIL SHOULD BE USED WHEN DIFFERENCES ARE NOTED.

(DETAILS ADAPTED FROM DOUGLAS COUNTY, COLORADO AND TOWN OF PARKER COLORADO, NOT AVAILABLE IN AUTOCAD)



## Description

A temporary slope drain is a pipe or culvert used to convey water down a slope where there is a high potential for erosion. A drainage channel or swale at the top of the slope typically directs upgradient runoff to the pipe entrance for conveyance down the slope. The pipe outlet must be equipped with outlet protection.

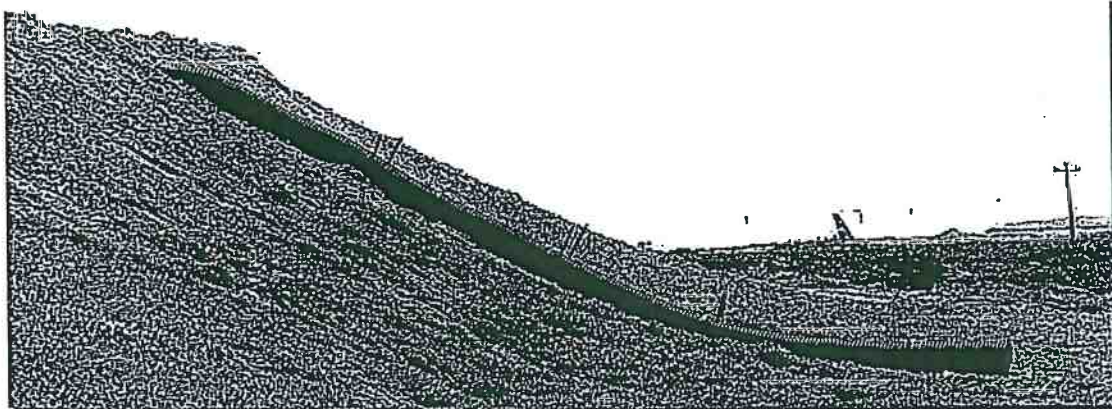

Photograph TSD-1. A temporary slope drain installed to convey runoff down a slope during construction. Photo courtesy of the City of Aurora.

## Appropriate Uses

Use on long, steep slopes when there is a high potential of flow concentration or rill development.

## Design and Installation

Effective use of temporary slope drains involves design of an effective collection system to direct flows to the pipe, proper sizing and anchoring of the pipe, and outlet protection. Upgradient of the temporary slope drain, a temporary drainage ditch or swale should be constructed to collect surface runoff from the drainage area and convey it to the drain entrance. The temporary slope drain must be sized to safely convey the desired flow volume. At a minimum, it should be sized to convey the 2-year, 24-hour storm.

Temporary slope drains may be constructed of flexible or rigid pipe, riprap, or heavy (30 mil) plastic lining. When piping is used, it must be properly anchored by burying it with adequate cover or by using an anchor system to secure it to the ground.

The discharge from the slope drain must be directed to a stabilized outlet, temporary or permanent channel, and/or sedimentation basin.

See Detail TSD-1 for additional sizing and design information.

| Temporary Slope Drains   |     |
|--------------------------|-----|
| Functions                |     |
| Erosion Control          | Yes |
| Sediment Control         | No  |
| Site/Material Management | No  |

**Maintenance and Removal**

Inspect the entrance for sediment accumulation and remove, as needed. Clogging as a result of sediment deposition at the entrance can lead to ponding upstream causing flooding or overtopping of the slope drain. Inspect the downstream outlet for signs of erosion and stabilize, as needed. It may also be necessary to remove accumulated sediment at the outfall. Inspect pipe anchors to ensure that they are secure. If the pipe is secured by ground cover, ensure erosion has not compromised the depth of cover.

Slope drains should be removed when no longer needed or just prior to installation of permanent slope stabilization measures that cannot be installed with the slope drain in place. When slope drains are removed, the disturbed areas should be covered with topsoil, seeded, mulched or otherwise stabilized as required by the local jurisdiction.

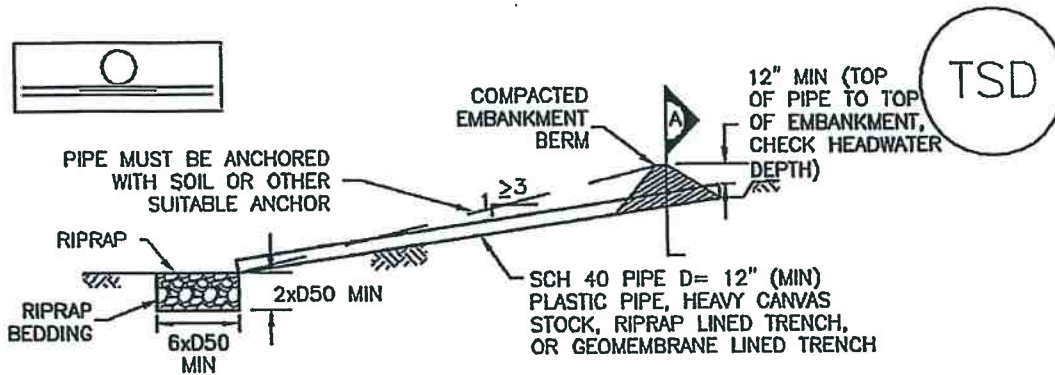

TEMPORARY SLOPE DRAIN PROFILE

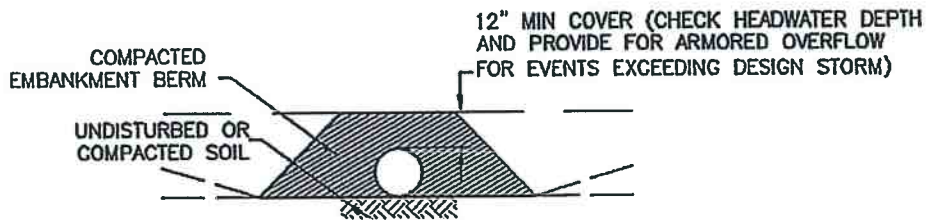

SECTION A

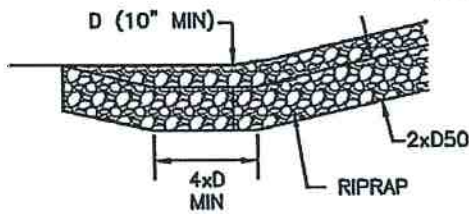

TERMINATION OF RIPRAP LINED SLOPE DRAIN

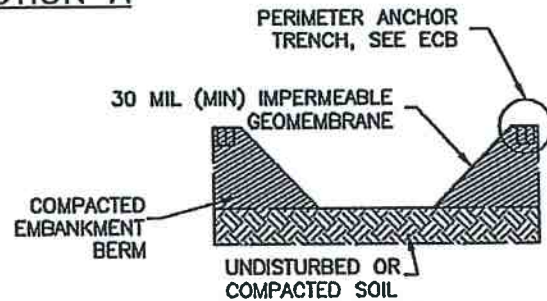

GEOMEMBRANE LINED SLOPE DRAIN

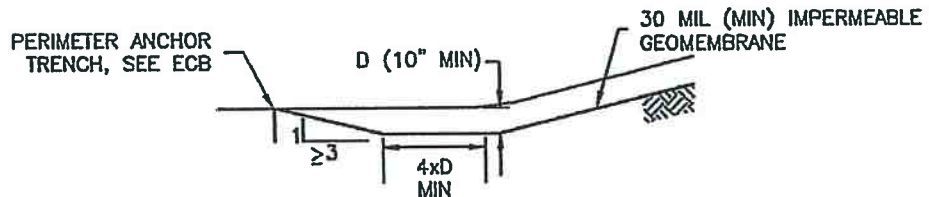

TERMINATION OF GEOMEMBRANE LINED SLOPE DRAIN

TSD-1. TEMPORARY SLOPE DRAIN PROFILE

**SLOPE DRAIN INSTALLATION NOTES**

1. SEE PLAN VIEW FOR:
  - LOCATION AND LENGTH OF SLOPE DRAIN
  - PIPE DIAMETER, D, AND RIPRAP SIZE, D50.
2. SLOPE DRAIN SHALL BE DESIGNED TO CONVEY PEAK RUNOFF FOR 2-YEAR 24-HOUR STORM AT A MINIMUM. FOR LONGER DURATION PROJECTS, LARGER MAY BE APPROPRIATE.
3. SLOPE DRAIN DIMENSIONS SHALL BE CONSIDERED MINIMUM DIMENSIONS; CONTRACTOR MAY ELECT TO INSTALL LARGER FACILITIES.
4. SLOPE DRAINS INDICATED SHALL BE INSTALLED PRIOR TO UPGRADIENT LAND-DISTURBING ACTIVITIES.
5. CHECK HEADWATER DEPTHS FOR TEMPORARY AND PERMANENT SLOPE DRAINS. DETAILS SHOW MINIMUM COVER; INCREASE AS NECESSARY FOR DESIGN HEADWATER DEPTH.
6. RIPRAP PAD SHALL BE PLACED AT SLOPE DRAIN OUTFALL.
7. ANCHOR PIPE BY COVERING WITH SOIL OR AN ALTERNATE SUITABLE ANCHOR MATERIAL.

**SLOPE DRAIN MAINTENANCE NOTES**

1. INSPECT BMPs EACH WORKDAY, AND MAINTAIN THEM IN EFFECTIVE OPERATING CONDITION. MAINTENANCE OF BMPs SHOULD BE PROACTIVE, NOT REACTIVE. INSPECT BMPs AS SOON AS POSSIBLE (AND ALWAYS WITHIN 24 HOURS) FOLLOWING A STORM THAT CAUSES SURFACE EROSION, AND PERFORM NECESSARY MAINTENANCE.
2. FREQUENT OBSERVATIONS AND MAINTENANCE ARE NECESSARY TO MAINTAIN BMPs IN EFFECTIVE OPERATING CONDITION. INSPECTIONS AND CORRECTIVE MEASURES SHOULD BE DOCUMENTED THOROUGHLY.
3. WHERE BMPs HAVE FAILED, REPAIR OR REPLACEMENT SHOULD BE INITIATED UPON DISCOVERY OF THE FAILURE.
4. INSPECT INLET AND OUTLET POINTS AFTER STORMS FOR CLOGGING OR EVIDENCE OF OVERTOPPING. BREACHES IN PIPE OR OTHER CONVEYANCE SHALL BE REPAIRED AS SOON AS PRACTICABLE IF OBSERVED.
5. INSPECT RIPRAP PAD AT OUTLET FOR SIGNS OF EROSION. IF SIGNS OF EROSION EXIST, ADDITIONAL ARMORING SHALL BE INSTALLED.
6. TEMPORARY SLOPE DRAINS ARE TO REMAIN IN PLACE UNTIL NO LONGER NEEDED, BUT SHALL BE REMOVED PRIOR TO THE END OF CONSTRUCTION. WHEN SLOPE DRAINS ARE REMOVED, THE DISTURBED AREA SHALL BE COVERED WITH TOP SOIL, SEEDED, MULCHED OR OTHERWISE STABILIZED IN A MANNER APPROVED BY THE LOCAL JURISDICTION.

(DETAIL ADAPTED FROM DOUGLAS COUNTY, COLORADO AND THE CITY OF COLORADO SPRINGS, COLORADO, NOT AVAILABLE IN AUTOCAD)

**NOTE:** MANY JURISDICTIONS HAVE BMP DETAILS THAT VARY FROM UDFCD STANDARD DETAILS. CONSULT WITH LOCAL JURISDICTIONS AS TO WHICH DETAIL SHOULD BE USED WHEN DIFFERENCES ARE NOTED.



## Description

Outlet protection helps to reduce erosion immediately downstream of a pipe, culvert, slope drain, rundown or other conveyance with concentrated, high-velocity flows. Typical outlet protection consists of riprap or rock aprons at the conveyance outlet.



Photograph TOP-1. Riprap outlet protection.

## Appropriate Uses

Outlet protection should be used when a conveyance discharges onto a disturbed area where there is potential for accelerated erosion due to concentrated flow. Outlet protection should be provided where the velocity at the culvert outlet exceeds the maximum permissible velocity of the material in the receiving channel.

Note: This Fact Sheet and detail are for temporary outlet protection, outlets that are intended to be used for less than 2 years. For permanent, long-term outlet protection, see the *Major Drainage* chapter of Volume 1.

## Design and Installation

Design outlet protection to handle runoff from the largest drainage area that may be contributing runoff during construction (the drainage area may change as a result of grading). Key in rock, around the entire perimeter of the apron, to a minimum depth of 6 inches for stability. Extend riprap to the height of the culvert or the normal flow depth of the downstream channel, whichever is less. Additional erosion control measures such as vegetative lining, turf reinforcement mat and/or other channel lining methods may be required downstream of the outlet protection if the channel is susceptible to erosion. See Design Detail OP-1 for additional information.

## Maintenance and Removal

Inspect apron for damage and displaced rocks. If rocks are missing or significantly displaced, repair or replace as necessary. If rocks are continuously missing or displaced, consider increasing the size of the riprap or deeper keying of the perimeter.

Remove sediment accumulated at the outlet before the outlet protection becomes buried and ineffective. When sediment accumulation is noted, check that upgradient BMPs, including inlet protection, are in effective operating condition.

Outlet protection may be removed once the pipe is no longer draining an upstream area, or once the downstream area has been sufficiently stabilized. If the drainage pipe is permanent, outlet protection can be left in place; however, permanent outlet protection should be designed and constructed in accordance with the requirements of the *Major Drainage* chapter of Volume 2.

| Outlet Protection        |          |
|--------------------------|----------|
| Functions                |          |
| Erosion Control          | Yes      |
| Sediment Control         | Moderate |
| Site/Material Management | No       |

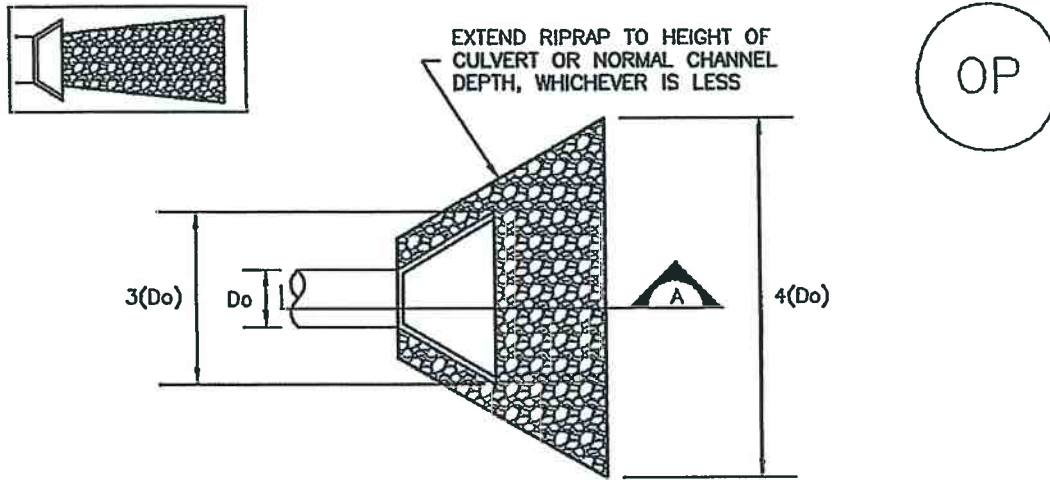

TEMPORARY OUTLET PROTECTION PLAN

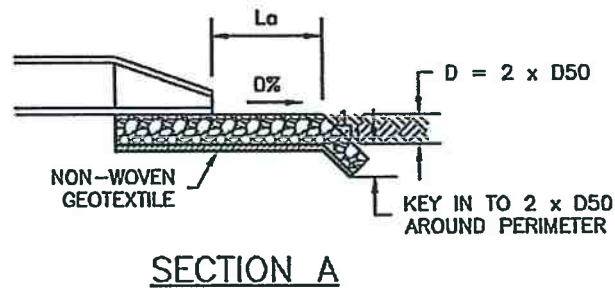

TABLE OP-1. TEMPORARY OUTLET PROTECTION SIZING TABLE

| PIPE DIAMETER, $D_o$ (INCHES) | DISCHARGE, Q (CFS) | APRON LENGTH, $L_o$ (FT) | RIPRAP D50 DIAMETER MIN (INCHES) |
|-------------------------------|--------------------|--------------------------|----------------------------------|
| 8                             | 2.5                | 5                        | 4                                |
|                               | 5                  | 10                       | 6                                |
| 12                            | 5                  | 10                       | 4                                |
|                               | 10                 | 13                       | 6                                |
| 18                            | 10                 | 10                       | 6                                |
|                               | 20                 | 16                       | 9                                |
|                               | 30                 | 23                       | 12                               |
| 24                            | 40                 | 26                       | 16                               |
|                               | 30                 | 16                       | 9                                |
|                               | 40                 | 26                       | 9                                |
|                               | 50                 | 26                       | 12                               |
|                               | 60                 | 30                       | 16                               |

OP-1. TEMPORARY OUTLET PROTECTION



## TEMPORARY OUTLET PROTECTION INSTALLATION NOTES

1. SEE PLAN VIEW FOR
  - LOCATION OF OUTLET PROTECTION.
  - DIMENSIONS OF OUTLET PROTECTION.
2. DETAIL IS INTENDED FOR PIPES WITH SLOPE  $\leq$  10%. ADDITIONAL EVALUATION OF RIPRAP SIZING AND OUTLET PROTECTION DIMENSIONS REQUIRED FOR STEEPER SLOPES.
3. TEMPORARY OUTLET PROTECTION INFORMATION IS FOR OUTLETS INTENDED TO BE UTILIZED LESS THAN 2 YEARS.

## TEMPORARY OUTLET PROTECTION INSPECTION AND MAINTENANCE NOTES

1. INSPECT BMPs EACH WORKDAY, AND MAINTAIN THEM IN EFFECTIVE OPERATING CONDITION. MAINTENANCE OF BMPs SHOULD BE PROACTIVE, NOT REACTIVE. INSPECT BMPs AS SOON AS POSSIBLE (AND ALWAYS WITHIN 24 HOURS) FOLLOWING A STORM THAT CAUSES SURFACE EROSION, AND PERFORM NECESSARY MAINTENANCE.
2. FREQUENT OBSERVATIONS AND MAINTENANCE ARE NECESSARY TO MAINTAIN BMPs IN EFFECTIVE OPERATING CONDITION. INSPECTIONS AND CORRECTIVE MEASURES SHOULD BE DOCUMENTED THOROUGHLY.
3. WHERE BMPs HAVE FAILED, REPAIR OR REPLACEMENT SHOULD BE INITIATED UPON DISCOVERY OF THE FAILURE.

NOTE: MANY JURISDICTIONS HAVE BMP DETAILS THAT VARY FROM UDFCD STANDARD DETAILS. CONSULT WITH LOCAL JURISDICTIONS AS TO WHICH DETAIL SHOULD BE USED WHEN DIFFERENCES ARE NOTED.

(DETAILS ADAPTED FROM AURORA, COLORADO AND PREVIOUS VERSION OF VOLUME 3, NOT AVAILABLE IN AUTOCAD)

## Description

Earth dikes and drainage swales are temporary storm conveyance channels constructed either to divert runoff around slopes or to convey runoff to additional sediment control BMPs prior to discharge of runoff from a site. Drainage swales may be lined or unlined, but if an unlined swale is used, it must be well compacted and capable of resisting erosive velocities.

## Appropriate Uses

Earth dikes and drainage swales are typically used to control the flow path of runoff at a construction site by diverting runoff around areas prone to erosion, such as steep slopes. Earth dikes and drainage swales may also be constructed as temporary conveyance features. This will direct runoff to additional sediment control treatment BMPs, such as sediment traps or basins.

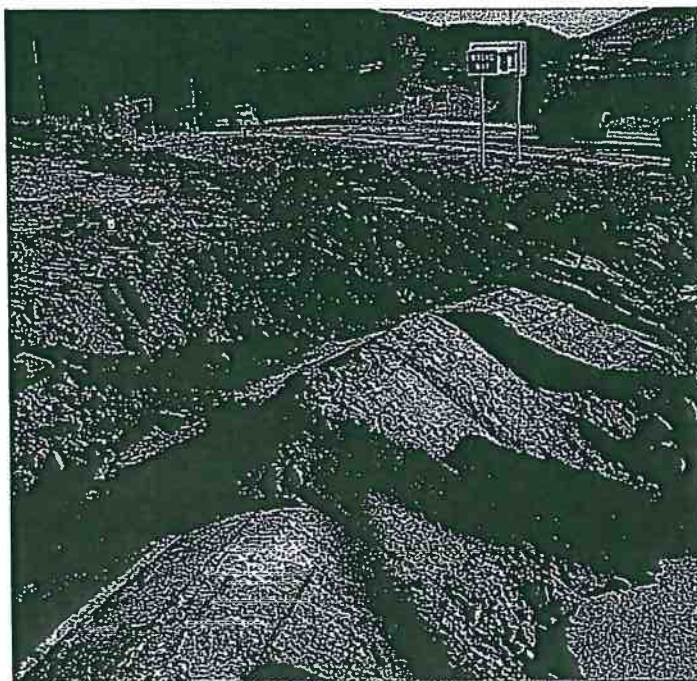

Photograph ED/DS-1. Example of an earth dike used to divert flows at a construction site. Photo courtesy of CDOT.

## Design and Installation

When earth dikes are used to divert water for slope protection, the earth dike typically consists of a horizontal ridge of soil placed perpendicular to the slope and angled slightly to provide drainage along the contour. The dike is used in conjunction with a swale or a small channel upslope of the berm to convey the diverted water. Temporary diversion dikes can be constructed by excavation of a V-shaped trench or ditch and placement of the fill on the downslope side of the cut. There are two types of placement for temporary slope diversion dikes:

- A dike located at the top of a slope to divert upland runoff away from the disturbed area and convey it in a temporary or permanent channel.
- A diversion dike located at the base or mid-slope of a disturbed area to intercept runoff and reduce the effective slope length.

Depending on the project, either an earth dike or drainage swale may be more appropriate. If there is a need for cut on the project, then an excavated drainage swale may be better suited. When the project is primarily fill, then a conveyance constructed using a berm may be the better option.

**All dikes or swales receiving runoff from a disturbed area should direct stormwater to a sediment control BMP such as a sediment trap or basin.**

| Earth Dikes and Drainage Swales |          |
|---------------------------------|----------|
| <b>Functions</b>                |          |
| Erosion Control                 | Yes      |
| Sediment Control                | Moderate |
| Site/Material Management        | No       |

**Unlined dikes or swales should only be used for intercepting sheet flow runoff and are not intended for diversion of concentrated flows.**

Details with notes are provided for several design variations, including:

ED-1. Unlined Earth Dike formed by Berm

DS-1. Unlined Excavated Swale

DS-2. Unlined Swale Formed by Cut and Fill

DS-3. ECB-lined Swale

DS-4. Synthetic-lined Swale

DS-5. Riprap-lined Swale

The details also include guidance on permissible velocities for cohesive channels if unlined approaches will be used.

### **Maintenance and Removal**

Inspect earth dikes for stability, compaction, and signs of erosion and repair. Inspect side slopes for erosion and damage to erosion control fabric. Stabilize slopes and repair fabric as necessary. If there is reoccurring extensive damage, consider installing rock check dams or lining the channel with riprap.

If drainage swales are not permanent, remove dikes and fill channels when the upstream area is stabilized. Stabilize the fill or disturbed area immediately following removal by revegetation or other permanent stabilization method approved by the local jurisdiction.

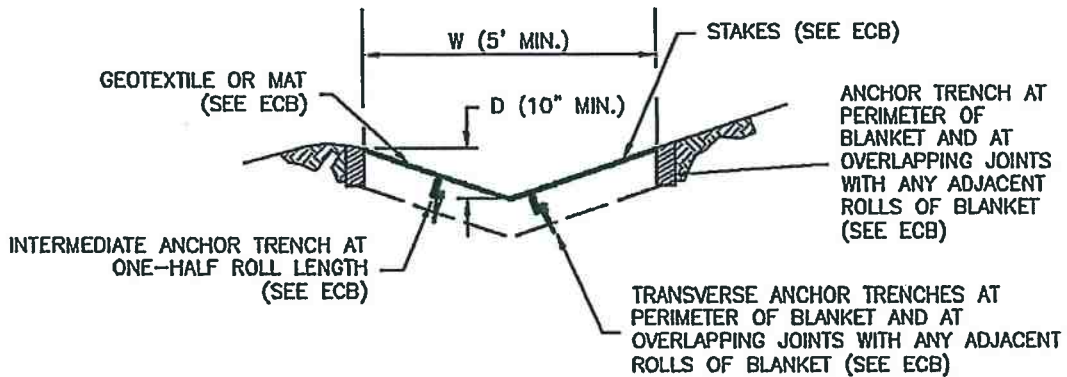
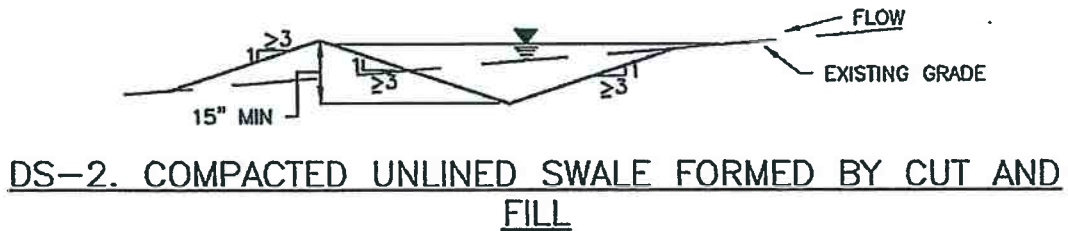
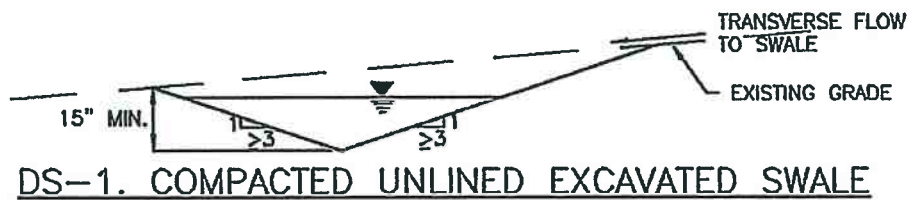
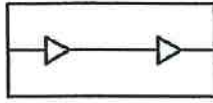

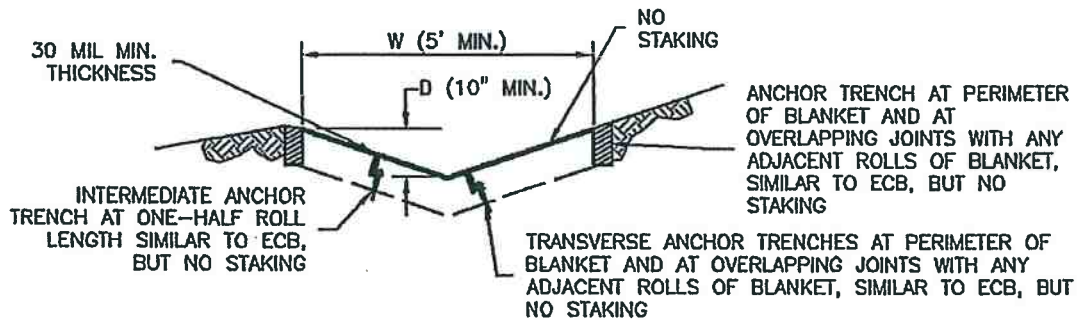

DS-4. SYNTHETIC LINED SWALE

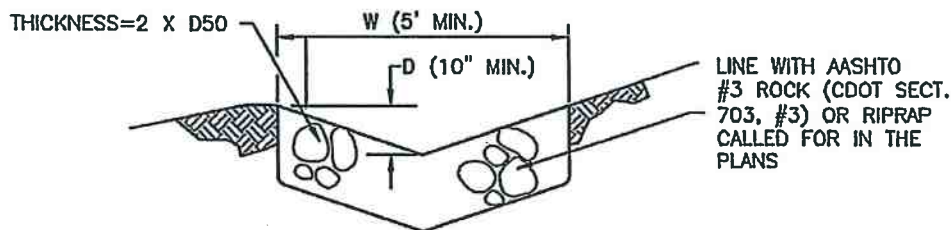

DS-5. RIPRAP LINED SWALE

EARTH DIKE AND DRAINAGE SWALE INSTALLATION NOTES

1. SEE SITE PLAN FOR:
  - LOCATION OF DIVERSION SWALE
  - TYPE OF SWALE (UNLINED, COMPACTED AND/OR LINED).
  - LENGTH OF EACH SWALE.
  - DEPTH, D, AND WIDTH, W DIMENSIONS.
  - FOR ECB/TRM LINED DITCH, SEE ECB DETAIL.
  - FOR RIPRAP LINED DITCH, SIZE OF RIPRAP, D50.
2. SEE DRAINAGE PLANS FOR DETAILS OF PERMANENT CONVEYANCE FACILITIES AND/OR DIVERSION SWALES EXCEEDING 2-YEAR FLOW RATE OR 10 CFS.
3. EARTH DIKES AND SWALES INDICATED ON SWMP PLAN SHALL BE INSTALLED PRIOR TO LAND-DISTURBING ACTIVITIES IN PROXIMITY.
4. EMBANKMENT IS TO BE COMPACTED TO 90% OF MAXIMUM DENSITY AND WITHIN 2% OF OPTIMUM MOISTURE CONTENT ACCORDING TO ASTM D698.
5. SWALES ARE TO DRAIN TO A SEDIMENT CONTROL BMP.
6. FOR LINED DITCHES, INSTALLATION OF ECB/TRM SHALL CONFORM TO THE REQUIREMENTS OF THE ECB DETAIL.
7. WHEN CONSTRUCTION TRAFFIC MUST CROSS A DIVERSION SWALE, INSTALL A TEMPORARY CULVERT WITH A MINIMUM DIAMETER OF 12 INCHES.



## EARTH DIKE AND DRAINAGE SWALE MAINTENANCE NOTES

1. INSPECT BMPs EACH WORKDAY, AND MAINTAIN THEM IN EFFECTIVE OPERATING CONDITION. MAINTENANCE OF BMPs SHOULD BE PROACTIVE, NOT REACTIVE. INSPECT BMPs AS SOON AS POSSIBLE (AND ALWAYS WITHIN 24 HOURS) FOLLOWING A STORM THAT CAUSES SURFACE EROSION, AND PERFORM NECESSARY MAINTENANCE.

2. FREQUENT OBSERVATIONS AND MAINTENANCE ARE NECESSARY TO MAINTAIN BMPs IN EFFECTIVE OPERATING CONDITION. INSPECTIONS AND CORRECTIVE MEASURES SHOULD BE DOCUMENTED THOROUGHLY.

3. WHERE BMPs HAVE FAILED, REPAIR OR REPLACEMENT SHOULD BE INITIATED UPON DISCOVERY OF THE FAILURE.

4. SWALES SHALL REMAIN IN PLACE UNTIL THE END OF CONSTRUCTION; IF APPROVED BY LOCAL JURISDICTION, SWALES MAY BE LEFT IN PLACE.

5. WHEN A SWALE IS REMOVED, THE DISTURBED AREA SHALL BE COVERED WITH TOPSOIL, SEEDED AND MULCHED OR OTHERWISE STABILIZED IN A MANNER APPROVED BY LOCAL JURISDICTION.

—(DETAIL ADAPTED FROM DOUGLAS COUNTY, COLORADO AND THE CITY OF COLORADO SPRINGS, COLORADO, NOT AVAILABLE IN AUTOCAD)

—NOTE: MANY JURISDICTIONS HAVE BMP DETAILS THAT VARY FROM UDFCD STANDARD DETAILS.

—CONSULT WITH LOCAL JURISDICTIONS AS TO WHICH DETAIL SHOULD BE USED WHEN DIFFERENCES ARE NOTED.

**Description**

Check dams are temporary grade control structures placed in drainage channels to limit the erosivity of stormwater by reducing flow velocity. Check dams are typically constructed from rock, gravel bags, sand bags, or sometimes, proprietary devices. Reinforced check dams are typically constructed from rock and wire gabion. Although the primary function of check dams is to reduce the velocity of concentrated flows, a secondary benefit is sediment trapping upstream of the structure.



Photograph CD-1. Rock check dams in a roadside ditch. Photo courtesy of WWE.

**Appropriate Uses**

Use as a grade control for temporary drainage ditches or swales until final soil stabilization measures are established upstream and downstream. Check dams can be used on mild or moderately steep slopes. Check dams may be used under the following conditions:

- As temporary grade control facilities along waterways until final stabilization is established.
- Along permanent swales that need protection prior to installation of a non-erodible lining.
- Along temporary channels, ditches or swales that need protection where construction of a non-erodible lining is not practicable.
- Reinforced check dams should be used in areas subject to high flow velocities.

**Design and Installation**

Place check dams at regularly spaced intervals along the drainage swale or ditch. Check dams heights should allow for pools to develop upstream of each check dam, extending to the downstream toe of the check dam immediately upstream.

When rock is used for the check dam, place rock mechanically or by hand. Do not dump rocks into the drainage channel. Where multiple check dams are used, the top of the lower dam should be at the same elevation as the toe of the upper dam.

When reinforced check dams are used, install erosion control fabric under and around the check dam to prevent erosion on the upstream and downstream sides. Each section of the dam should be keyed in to reduce the potential for washout or undermining. A rock apron upstream and downstream of the dam may be necessary to further control erosion.

| Check Dams               |          |
|--------------------------|----------|
| <b>Functions</b>         |          |
| Erosion Control          | Yes      |
| Sediment Control         | Moderate |
| Site/Material Management | No       |

Design details with notes are provided for the following types of check dams:

- Rock Check Dams (CD-1)
- Reinforced Check Dams (CD-2)

Sediment control logs may also be used as check dams; however, silt fence is not appropriate for use as a check dam. Many jurisdictions also prohibit or discourage use of straw bales for this purpose.

## Maintenance and Removal

Replace missing rocks causing voids in the check dam. If gravel bags or sandbags are used, replace or repair torn or displaced bags.

Remove accumulated sediment, as needed to maintain BMP effectiveness, typically before the sediment depth upstream of the check dam is within  $\frac{1}{2}$  of the crest height. Remove accumulated sediment prior to mulching, seeding, or chemical soil stabilization. Removed sediment can be incorporated into the earthwork with approval from the Project Engineer, or disposed of at an alternate location in accordance with the standard specifications.

Check dams constructed in permanent swales should be removed when perennial grasses have become established, or immediately prior to installation of a non-erodible lining. All of the rock and accumulated sediment should be removed, and the area seeded and mulched, or otherwise stabilized.

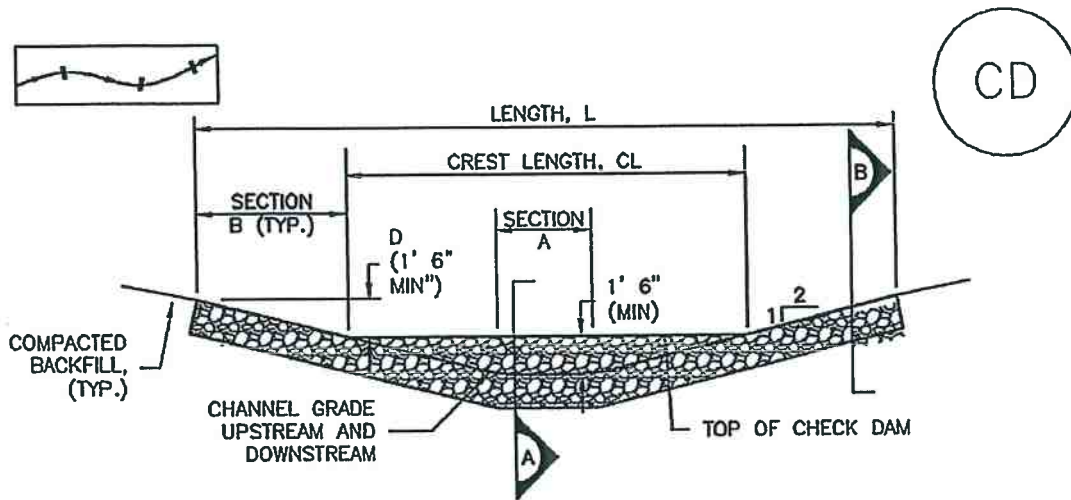

**CHECK DAM ELEVATION VIEW**

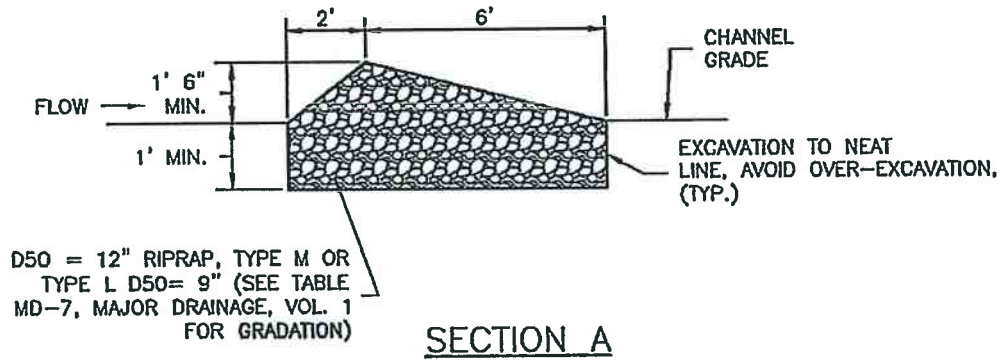

**SECTION A**

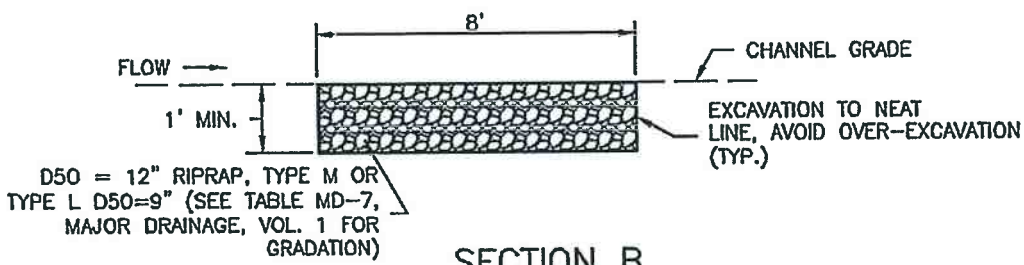

**SECTION B**

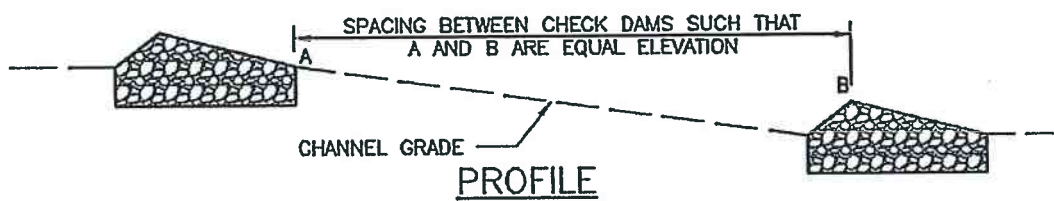

**CD-1. CHECK DAM**

CHECK DAM INSTALLATION NOTES

1. SEE PLAN VIEW FOR:
  - LOCATION OF CHECK DAMS.
  - CHECK DAM TYPE (CHECK DAM OR REINFORCED CHECK DAM).
  - LENGTH (L), CREST LENGTH (CL), AND DEPTH (D).
2. CHECK DAMS INDICATED ON INITIAL SWMP SHALL BE INSTALLED AFTER CONSTRUCTION FENCE, BUT PRIOR TO ANY UPSTREAM LAND DISTURBING ACTIVITIES.
3. RIPRAP UTILIZED FOR CHECK DAMS SHOULD BE OF APPROPRIATE SIZE FOR THE APPLICATION. TYPICAL TYPES OF RIPRAP USED FOR CHECK DAMS ARE TYPE M (D50 12") OR TYPE L (D50 9").
4. RIPRAP PAD SHALL BE TRENCHED INTO THE GROUND A MINIMUM OF 1'.
5. THE ENDS OF THE CHECK DAM SHALL BE A MINIMUM OF 1' 6" HIGHER THAN THE CENTER OF THE CHECK DAM.

CHECK DAM MAINTENANCE NOTES

1. INSPECT BMPs EACH WORKDAY, AND MAINTAIN THEM IN EFFECTIVE OPERATING CONDITION. MAINTENANCE OF BMPs SHOULD BE PROACTIVE, NOT REACTIVE. INSPECT BMPs AS SOON AS POSSIBLE (AND ALWAYS WITHIN 24 HOURS) FOLLOWING A STORM THAT CAUSES SURFACE EROSION, AND PERFORM NECESSARY MAINTENANCE.
2. FREQUENT OBSERVATIONS AND MAINTENANCE ARE NECESSARY TO MAINTAIN BMPs IN EFFECTIVE OPERATING CONDITION. INSPECTIONS AND CORRECTIVE MEASURES SHOULD BE DOCUMENTED THOROUGHLY.
3. WHERE BMPs HAVE FAILED, REPAIR OR REPLACEMENT SHOULD BE INITIATED UPON DISCOVERY OF THE FAILURE.
4. SEDIMENT ACCUMULATED UPSTREAM OF THE CHECK DAMS SHALL BE REMOVED WHEN THE SEDIMENT DEPTH IS WITHIN  $\frac{1}{2}$  OF THE HEIGHT OF THE CREST.
5. CHECK DAMS ARE TO REMAIN IN PLACE UNTIL THE UPSTREAM DISTURBED AREA IS STABILIZED AND APPROVED BY THE LOCAL JURISDICTION.
6. WHEN CHECK DAMS ARE REMOVED, EXCAVATIONS SHALL BE FILLED WITH SUITABLE COMPACTED BACKFILL. DISTURBED AREA SHALL BE SEEDED AND MULCHED AND COVERED WITH GEOTEXTILE OR OTHERWISE STABILIZED IN A MANNER APPROVED BY THE LOCAL JURISDICTION.

— (DETAILS ADAPTED FROM DOUGLAS COUNTY, COLORADO, NOT AVAILABLE IN AUTOCAD)

- NOTE: MANY JURISDICTIONS HAVE BMP DETAILS THAT VARY FROM UDFCD STANDARD DETAILS.  
— CONSULT WITH LOCAL JURISDICTIONS AS TO WHICH DETAIL SHOULD BE USED WHEN  
— DIFFERENCES ARE NOTED.



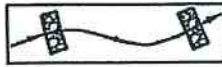

ALTERNATIVE TO STEPS ON BANKS ABOVE CREST:  
DEFORM GABIONS AS NECESSARY TO ALIGN TOP OF GABIONS  
WITH GROUND SURFACE: AVOID GAPS BETWEEN GABIONS

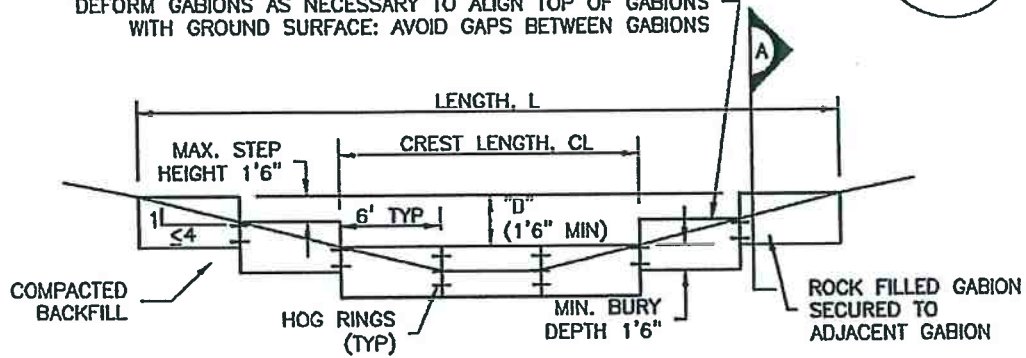

REINFORCED CHECK DAM ELEVATION VIEW

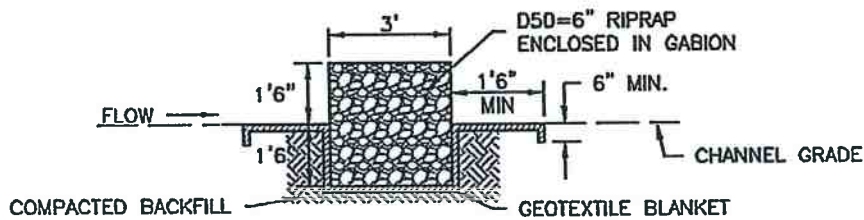

SECTION A

REINFORCED CHECK DAM INSTALLATION NOTES

1. SEE PLAN VIEW FOR:
  - LOCATIONS OF CHECK DAMS.
  - CHECK DAM TYPE (CHECK DAM OR REINFORCED CHECK DAM).
  - LENGTH (L), CREST LENGTH (CL), AND DEPTH (D).
2. CHECK DAMS INDICATED ON THE SWMP SHALL BE INSTALLED PRIOR TO AN UPSTREAM LAND-DISTURBING ACTIVITIES.
3. REINFORCED CHECK DAMS, GABIONS SHALL HAVE GALVANIZED TWISTED WIRE NETTING WITH A MAXIMUM OPENING DIMENSION OF 4½" AND A MINIMUM WIRE THICKNESS OF 0.10". WIRE "HOG RINGS" AT 4" SPACING OR OTHER APPROVED MEANS SHALL BE USED AT ALL GABION SEAMS AND TO SECURE THE GABION TO THE ADJACENT SECTION.
4. THE CHECK DAM SHALL BE TRENCHED INTO THE GROUND A MINIMUM OF 1' 6".
5. GEOTEXTILE BLANKET SHALL BE PLACED IN THE REINFORCED CHECK DAM TRENCH EXTENDING A MINIMUM OF 1' 6" ON BOTH THE UPSTREAM AND DOWNSTREAM SIDES OF THE REINFORCED CHECK DAM.

CD-2. REINFORCED CHECK DAM

REINFORCED CHECK DAM MAINTENANCE NOTES

1. INSPECT BMPs EACH WORKDAY, AND MAINTAIN THEM IN EFFECTIVE OPERATING CONDITION. MAINTENANCE OF BMPs SHOULD BE PROACTIVE, NOT REACTIVE. INSPECT BMPs AS SOON AS POSSIBLE (AND ALWAYS WITHIN 24 HOURS) FOLLOWING A STORM THAT CAUSES SURFACE EROSION, AND PERFORM NECESSARY MAINTENANCE.
2. FREQUENT OBSERVATIONS AND MAINTENANCE ARE NECESSARY TO MAINTAIN BMPs IN EFFECTIVE OPERATING CONDITION. INSPECTIONS AND CORRECTIVE MEASURES SHOULD BE DOCUMENTED THOROUGHLY.
3. WHERE BMPs HAVE FAILED, REPAIR OR REPLACEMENT SHOULD BE INITIATED UPON DISCOVERY OF THE FAILURE.
4. SEDIMENT ACCUMULATED UPSTREAM OF REINFORCED CHECK DAMS SHALL BE REMOVED AS NEEDED TO MAINTAIN THE EFFECTIVENESS OF BMP, TYPICALLY WHEN THE UPSTREAM SEDIMENT DEPTH IS WITHIN ½ THE HEIGHT OF THE CREST.
5. REPAIR OR REPLACE REINFORCED CHECK DAMS WHEN THERE ARE SIGNS OF DAMAGE SUCH AS HOLES IN THE GABION OR UNDERCUTTING.
6. REINFORCED CHECK DAMS ARE TO REMAIN IN PLACE UNTIL THE UPSTREAM DISTURBED AREA IS STABILIZED AND APPROVED BY THE LOCAL JURISDICTION.
7. WHEN REINFORCED CHECK DAMS ARE REMOVED, ALL DISTURBED AREAS SHALL BE COVERED WITH TOPSOIL, SEEDED AND MULCHED, AND COVERED WITH A GEOTEXTILE BLANKET, OR OTHERWISE STABILIZED AS APPROVED BY LOCAL JURISDICTION.

(DETAIL ADAPTED FROM DOUGLAS COUNTY, COLORADO AND CITY OF AURORA, COLORADO, NOT AVAILABLE IN AUTOCAD)

**NOTE:** MANY JURISDICTIONS HAVE BMP DETAILS THAT VARY FROM UDFCD STANDARD DETAILS. CONSULT WITH LOCAL JURISDICTIONS AS TO WHICH DETAIL SHOULD BE USED WHEN DIFFERENCES ARE NOTED.

## Description

Concrete waste management involves designating and properly managing a specific area of the construction site as a concrete washout area. A concrete washout area can be created using one of several approaches designed to receive wash water from washing of tools and concrete mixer chutes, liquid concrete waste from dump trucks, mobile batch mixers, or pump trucks. Three basic approaches are available: excavation of a pit in the ground, use of an above ground storage area, or use of prefabricated haul-away concrete washout containers. Surface discharges of concrete washout water from construction sites are prohibited.

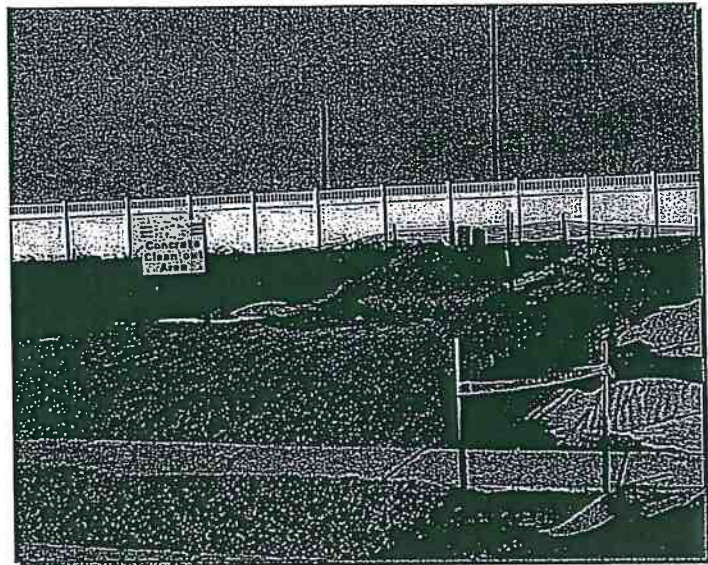

Photograph CWA-1. Example of concrete washout area. Note gravel tracking pad for access and sign.

## Appropriate Uses

Concrete washout areas must be designated on all sites that will generate concrete wash water or liquid concrete waste from onsite concrete mixing or concrete delivery.

Because pH is a pollutant of concern for washout activities, when unlined pits are used for concrete washout, the soil must have adequate buffering capacity to result in protection of state groundwater standards; otherwise, a liner/containment must be used. The following management practices are recommended to prevent an impact from unlined pits to groundwater:

- The use of the washout site should be temporary (less than 1 year), and
- The washout site should be not be located in an area where shallow groundwater may be present, such as near natural drainages, springs, or wetlands.

## Design and Installation

Concrete washout activities must be conducted in a manner that does not contribute pollutants to surface waters or stormwater runoff. Concrete washout areas may be lined or unlined excavated pits in the ground, commercially manufactured prefabricated washout containers, or aboveground holding areas constructed of berms, sandbags or straw bales with a plastic liner.

Although unlined washout areas may be used, lined pits may be required to protect groundwater under certain conditions.

**Do not locate an unlined washout area within 400 feet of any natural drainage pathway or waterbody or within 1,000 feet of any wells or drinking water sources.** Even for lined concrete washouts, it is advisable to locate the facility away from waterbodies and drainage paths. If site constraints make these

| Concrete Washout Area    |     |
|--------------------------|-----|
| Functions                |     |
| Erosion Control          | No  |
| Sediment Control         | No  |
| Site/Material Management | Yes |



setbacks infeasible or if highly permeable soils exist in the area, then the pit must be installed with an impermeable liner (16 mil minimum thickness) or surface storage alternatives using prefabricated concrete washout devices or a lined aboveground storage area should be used.

Design details with notes are provided in Detail CWA-1 for pits and CWA-2 for aboveground storage areas. Pre-fabricated concrete washout container information can be obtained from vendors.

## Maintenance and Removal

A key consideration for concrete washout areas is to ensure that adequate signage is in place identifying the location of the washout area. Part of inspecting and maintaining washout areas is ensuring that adequate signage is provided and in good repair and that the washout area is being used, as opposed to washout in non-designated areas of the site.

Remove concrete waste in the washout area, as needed to maintain BMP function (typically when filled to about two-thirds of its capacity). Collect concrete waste and deliver offsite to a designated disposal location.

Upon termination of use of the washout site, accumulated solid waste, including concrete waste and any contaminated soils, must be removed from the site to prevent on-site disposal of solid waste. If the wash water is allowed to evaporate and the concrete hardens, it may be recycled.

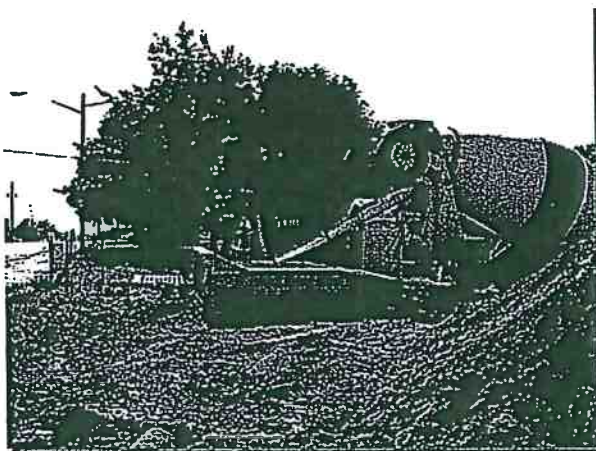

Photograph CWA-2. Prefabricated concrete washout. Photo courtesy of CDOT.

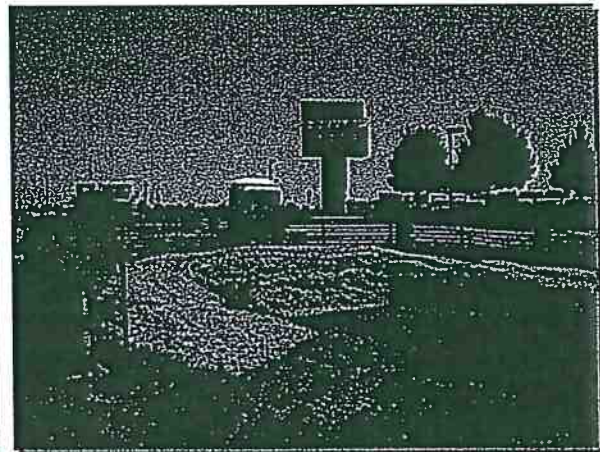

Photograph CWA-3. Earthen concrete washout. Photo courtesy of CDOT.

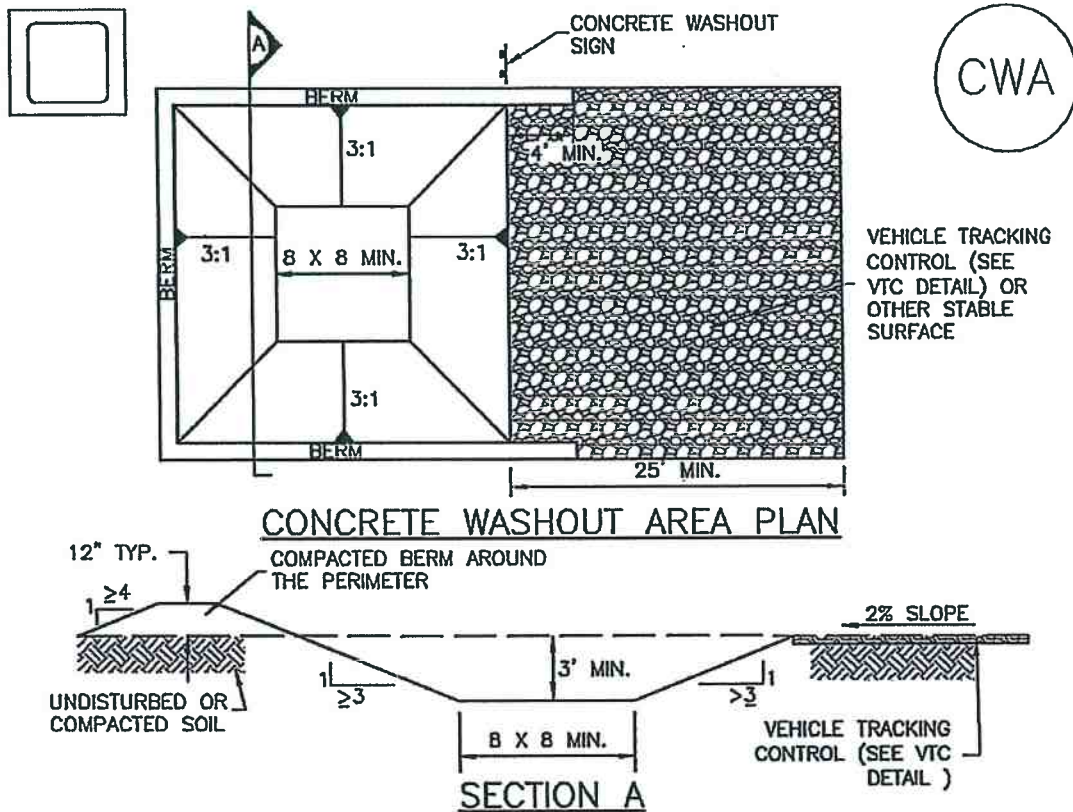

## CWA-1. CONCRETE WASHOUT AREA

### CWA INSTALLATION NOTES

1. SEE PLAN VIEW FOR:  
-CWA INSTALLATION LOCATION.
2. DO NOT LOCATE AN UNLINED CWA WITHIN 400' OF ANY NATURAL DRAINAGE PATHWAY OR WATERBODY. DO NOT LOCATE WITHIN 1,000' OF ANY WELLS OR DRINKING WATER SOURCES. IF SITE CONSTRAINTS MAKE THIS INFEASIBLE, OR IF HIGHLY PERMEABLE SOILS EXIST ON SITE, THE CWA MUST BE INSTALLED WITH AN IMPERMEABLE LINER (16 MIL. MIN. THICKNESS) OR SURFACE STORAGE ALTERNATIVES USING PREFABRICATED CONCRETE WASHOUT DEVICES OR A LINED ABOVE GROUND STORAGE ARE SHOULD BE USED.
3. THE CWA SHALL BE INSTALLED PRIOR TO CONCRETE PLACEMENT ON SITE.
4. CWA SHALL INCLUDE A FLAT SUBSURFACE PIT THAT IS AT LEAST 8' BY 8' SLOPES LEADING OUT OF THE SUBSURFACE PIT SHALL BE 3:1 OR FLATTER. THE PIT SHALL BE AT LEAST 3' DEEP.
5. BERM SURROUNDING SIDES AND BACK OF THE CWA SHALL HAVE MINIMUM HEIGHT OF 1'.
6. VEHICLE TRACKING PAD SHALL BE SLOPED 2% TOWARDS THE CWA.
7. SIGNS SHALL BE PLACED AT THE CONSTRUCTION ENTRANCE, AT THE CWA, AND ELSEWHERE AS NECESSARY TO CLEARLY INDICATE THE LOCATION OF THE CWA TO OPERATORS OF CONCRETE TRUCKS AND PUMP RIGS.
8. USE EXCAVATED MATERIAL FOR PERIMETER BERM CONSTRUCTION.



CWA MAINTENANCE NOTES

1. INSPECT BMPs EACH WORKDAY, AND MAINTAIN THEM IN EFFECTIVE OPERATING CONDITION. MAINTENANCE OF BMPs SHOULD BE PROACTIVE, NOT REACTIVE. INSPECT BMPs AS SOON AS POSSIBLE (AND ALWAYS WITHIN 24 HOURS) FOLLOWING A STORM THAT CAUSES SURFACE EROSION, AND PERFORM NECESSARY MAINTENANCE.

2. FREQUENT OBSERVATIONS AND MAINTENANCE ARE NECESSARY TO MAINTAIN BMPs IN EFFECTIVE OPERATING CONDITION. INSPECTIONS AND CORRECTIVE MEASURES SHOULD BE DOCUMENTED THOROUGHLY.

3. WHERE BMPs HAVE FAILED, REPAIR OR REPLACEMENT SHOULD BE INITIATED UPON DISCOVERY OF THE FAILURE.

4. THE CWA SHALL BE REPAIRED, CLEANED, OR ENLARGED AS NECESSARY TO MAINTAIN CAPACITY FOR CONCRETE WASTE. CONCRETE MATERIALS, ACCUMULATED IN PIT, SHALL BE REMOVED ONCE THE MATERIALS HAVE REACHED A DEPTH OF 2'.

5. CONCRETE WASHOUT WATER, WASTED PIECES OF CONCRETE AND ALL OTHER DEBRIS IN THE SUBSURFACE PIT SHALL BE TRANSPORTED FROM THE JOB SITE IN A WATER-TIGHT CONTAINER AND DISPOSED OF PROPERLY.

6. THE CWA SHALL REMAIN IN PLACE UNTIL ALL CONCRETE FOR THE PROJECT IS PLACED.

7. WHEN THE CWA IS REMOVED, COVER THE DISTURBED AREA WITH TOP SOIL, SEED AND MULCH OR OTHERWISE STABILIZED IN A MANNER APPROVED BY THE LOCAL JURISDICTION.

~ (DETAIL ADAPTED FROM DOUGLAS COUNTY, COLORADO AND THE CITY OF PARKER, COLORADO, NOT AVAILABLE IN AUTOCAD).

~ NOTE: MANY JURISDICTIONS HAVE BMP DETAILS THAT VARY FROM UDFCD STANDARD DETAILS.  
~ CONSULT WITH LOCAL JURISDICTIONS AS TO WHICH DETAIL SHOULD BE USED WHEN  
~ DIFFERENCES ARE NOTED.

## Description

Implement construction site good housekeeping practices to prevent pollution associated with solid, liquid and hazardous construction-related materials and wastes. Stormwater Management Plans (SWMPs) should clearly specify BMPs including these good housekeeping practices:

- Provide for waste management.
- Establish proper building material staging areas.
- Designate paint and concrete washout areas.
- Establish proper equipment/vehicle fueling and maintenance practices.
- Control equipment/vehicle washing and allowable non-stormwater discharges.
- Develop a spill prevention and response plan.

**Acknowledgement:** This Fact Sheet is based directly on EPA guidance provided in *Developing Your Stormwater Pollution Prevent Plan* (EPA 2007).

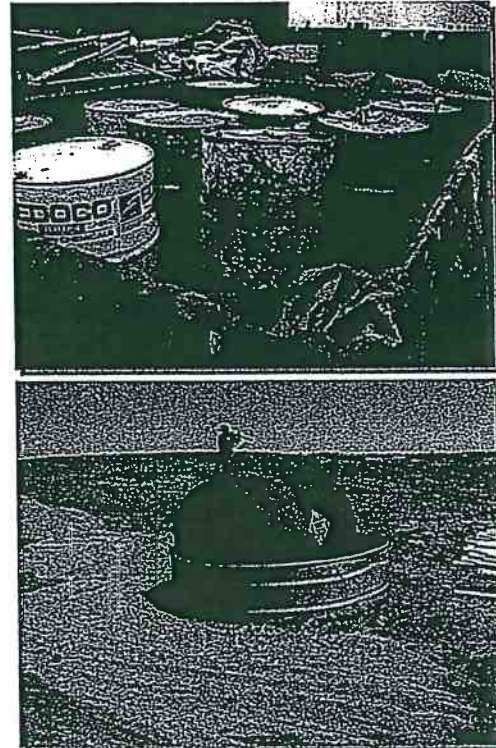

Photographs GH-1 and GH-2. Proper materials storage and secondary containment for fuel tanks are important good housekeeping practices. Photos courtesy of CDOT and City of Aurora.

## Appropriate Uses

Good housekeeping practices are necessary at all construction sites.

## Design and Installation

The following principles and actions should be addressed in SWMPs:

- **Provide for Waste Management.** Implement management procedures and practices to prevent or reduce the exposure and transport of pollutants in stormwater from solid, liquid and sanitary wastes that will be generated at the site. Practices such as trash disposal, recycling, proper material handling, and cleanup measures can reduce the potential for stormwater runoff to pick up construction site wastes and discharge them to surface waters. Implement a comprehensive set of waste-management practices for hazardous or toxic materials, such as paints, solvents, petroleum products, pesticides, wood preservatives, acids, roofing tar, and other materials. Practices should include storage, handling, inventory, and cleanup procedures, in case of spills. Specific practices that should be considered include:

### Solid or Construction Waste

- Designate trash and bulk waste-collection areas on-site.

| Good Housekeeping        |     |
|--------------------------|-----|
| Functions                |     |
| Erosion Control          | No  |
| Sediment Control         | No  |
| Site/Material Management | Yes |

- Recycle materials whenever possible (e.g., paper, wood, concrete, oil).
- Segregate and provide proper disposal options for hazardous material wastes.
- Clean up litter and debris from the construction site daily.
- Locate waste-collection areas away from streets, gutters, watercourses, and storm drains. Waste-collection areas (dumpsters, and such) are often best located near construction site entrances to minimize traffic on disturbed soils. Consider secondary containment around waste collection areas to minimize the likelihood of contaminated discharges.
- Empty waste containers before they are full and overflowing.

### Sanitary and Septic Waste

- Provide convenient, well-maintained, and properly located toilet facilities on-site.
- Locate toilet facilities away from storm drain inlets and waterways to prevent accidental spills and contamination of stormwater.
- Maintain clean restroom facilities and empty portable toilets regularly.
- Where possible, provide secondary containment pans under portable toilets.
- Provide tie-downs or stake-downs for portable toilets.
- Educate employees, subcontractors, and suppliers on locations of facilities.
- Treat or dispose of sanitary and septic waste in accordance with state or local regulations. Do not discharge or bury wastewater at the construction site.
- Inspect facilities for leaks. If found, repair or replace immediately.
- Special care is necessary during maintenance (pump out) to ensure that waste and/or biocide are not spilled on the ground.

### Hazardous Materials and Wastes

- Develop and implement employee and subcontractor education, as needed, on hazardous and toxic waste handling, storage, disposal, and cleanup.
- Designate hazardous waste-collection areas on-site.
- Place all hazardous and toxic material wastes in secondary containment.



Photograph GH-3. Locate portable toilet facilities on level surfaces away from waterways and storm drains. Photo courtesy of WWE.



- Hazardous waste containers should be inspected to ensure that all containers are labeled properly and that no leaks are present.
- **Establish Proper Building Material Handling and Staging Areas.** The SWMP should include comprehensive handling and management procedures for building materials, especially those that are hazardous or toxic. Paints, solvents, pesticides, fuels and oils, other hazardous materials or building materials that have the potential to contaminate stormwater should be stored indoors or under cover whenever possible or in areas with secondary containment. Secondary containment measures prevent a spill from spreading across the site and may include dikes, berms, curbing, or other containment methods. Secondary containment techniques should also ensure the protection of groundwater. Designate staging areas for activities such as fueling vehicles, mixing paints, plaster, mortar, and other potential pollutants. Designated staging areas enable easier monitoring of the use of materials and clean up of spills. Training employees and subcontractors is essential to the success of this pollution prevention principle. Consider the following specific materials handling and staging practices:
  - Train employees and subcontractors in proper handling and storage practices.
  - Clearly designate site areas for staging and storage with signs and on construction drawings. Staging areas should be located in areas central to the construction site. Segment the staging area into sub-areas designated for vehicles, equipment, or stockpiles. Construction entrances and exits should be clearly marked so that delivery vehicles enter/exit through stabilized areas with vehicle tracking controls (See Vehicle Tracking Control Fact Sheet).
  - Provide storage in accordance with Spill Protection, Control and Countermeasures (SPCC) requirements and plans and provide cover and impermeable perimeter control, as necessary, for hazardous materials and contaminated soils that must be stored on site.
  - Ensure that storage containers are regularly inspected for leaks, corrosion, support or foundation failure, or other signs of deterioration and tested for soundness.
  - Reuse and recycle construction materials when possible.
- **Designate Concrete Washout Areas.** Concrete contractors should be encouraged to use the washout facilities at their own plants or dispatch facilities when feasible; however, concrete washout commonly occurs on construction sites. If it is necessary to provide for concrete washout areas on-site, designate specific washout areas and design facilities to handle anticipated washout water. Washout areas should also be provided for paint and stucco operations. Because washout areas can be a source of pollutants from leaks or spills, care must be taken with regard to their placement and proper use. See the Concrete Washout Area Fact Sheet for detailed guidance.

Both self-constructed and prefabricated washout containers can fill up quickly when concrete, paint, and stucco work are occurring on large portions of the site. Be sure to check for evidence that contractors are using the washout areas and not dumping materials onto the ground or into drainage facilities. If the washout areas are not being used regularly, consider posting additional signage, relocating the facilities to more convenient locations, or providing training to workers and contractors.

When concrete, paint, or stucco is part of the construction process, consider these practices which will help prevent contamination of stormwater. Include the locations of these areas and the maintenance and inspection procedures in the SWMP.

- Do not washout concrete trucks or equipment into storm drains, streets, gutters, uncontained areas, or streams. Only use designated washout areas.
- Establish washout areas and advertise their locations with signs. Ensure that signage remains in good repair.
- Provide adequate containment for the amount of wash water that will be used.
- Inspect washout structures daily to detect leaks or tears and to identify when materials need to be removed.
- Dispose of materials properly. The preferred method is to allow the water to evaporate and to recycle the hardened concrete. Full service companies may provide dewatering services and should dispose of wastewater properly. Concrete wash water can be highly polluted. It should not be discharged to any surface water, storm sewer system, or allowed to infiltrate into the ground in the vicinity of waterbodies. Washwater should not be discharged to a sanitary sewer system without first receiving written permission from the system operator.
- **Establish Proper Equipment/Vehicle Fueling and Maintenance Practices.** Create a clearly designated on-site fueling and maintenance area that is clean and dry. The on-site fueling area should have a spill kit, and staff should know how to use it. If possible, conduct vehicle fueling and maintenance activities in a covered area. Consider the following practices to help prevent the discharge of pollutants to stormwater from equipment/vehicle fueling and maintenance. Include the locations of designated fueling and maintenance areas and inspection and maintenance procedures in the SWMP.
  - Train employees and subcontractors in proper fueling procedures (stay with vehicles during fueling, proper use of pumps, emergency shutoff valves, etc.).
  - Inspect on-site vehicles and equipment regularly for leaks, equipment damage, and other service problems.
  - Clearly designate vehicle/equipment service areas away from drainage facilities and watercourses to prevent stormwater run-on and runoff.
  - Use drip pans, drip cloths, or absorbent pads when replacing spent fluids.
  - Collect all spent fluids, store in appropriate labeled containers in the proper storage areas, and recycle fluids whenever possible.
- **Control Equipment/Vehicle Washing and Allowable Non-Stormwater Discharges.** Implement practices to prevent contamination of surface and groundwater from equipment and vehicle wash water. Representative practices include:
  - Educate employees and subcontractors on proper washing procedures.
  - Use off-site washing facilities, when available.
  - Clearly mark the washing areas and inform workers that all washing must occur in this area.
  - Contain wash water and treat it using BMPs. Infiltrate washwater when possible, but maintain separation from drainage paths and waterbodies.



- Use high-pressure water spray at vehicle washing facilities without detergents. Water alone can remove most dirt adequately.
- Do not conduct other activities, such as vehicle repairs, in the wash area.
- Include the location of the washing facilities and the inspection and maintenance procedures in the SWMP.
- **Develop a Spill Prevention and Response Plan.** Spill prevention and response procedures must be identified in the SWMP. Representative procedures include identifying ways to reduce the chance of spills, stop the source of spills, contain and clean up spills, dispose of materials contaminated by spills, and train personnel responsible for spill prevention and response. The plan should also specify material handling procedures and storage requirements and ensure that clear and concise spill cleanup procedures are provided and posted for areas in which spills may potentially occur. When developing a spill prevention plan, include the following:
  - Note the locations of chemical storage areas, storm drains, tributary drainage areas, surface waterbodies on or near the site, and measures to stop spills from leaving the site.
  - Provide proper handling and safety procedures for each type of waste. Keep Material Safety Data Sheets (MSDSs) for chemical used on site with the SWMP.
  - Establish an education program for employees and subcontractors on the potential hazards to humans and the environment from spills and leaks.
  - Specify how to notify appropriate authorities, such as police and fire departments, hospitals, or municipal sewage treatment facilities to request assistance. Emergency procedures and contact numbers should be provided in the SWMP and posted at storage locations.
  - Describe the procedures, equipment and materials for immediate cleanup of spills and proper disposal.
  - Identify personnel responsible for implementing the plan in the event of a spill. Update the spill prevention plan and clean up materials as changes occur to the types of chemicals stored and used at the facility.

**Spill Prevention, Control, and Countermeasure (SPCC) Plan**

Construction sites may be subject to 40 CFR Part 112 regulations that require the preparation and implementation of a SPCC Plan to prevent oil spills from aboveground and underground storage tanks. The facility is subject to this rule if it is a non-transportation-related facility that:

- Has a total storage capacity greater than 1,320 gallons or a completely buried storage capacity greater than 42,000 gallons.
- Could reasonably be expected to discharge oil in quantities that may be harmful to navigable waters of the United States and adjoining shorelines.

Furthermore, if the facility is subject to 40 CFR Part 112, the SWMP should reference the SPCC Plan. To find out more about SPCC Plans, see EPA's website on SPCC at [www.epa.gov/oilspill/spcc.htm](http://www.epa.gov/oilspill/spcc.htm).

**Reporting Oil Spills**

In the event of an oil spill, contact the National Response Center toll free at 1-800-424-8802 for assistance, or for more details, visit their website: [www.nrc.uscg.mil](http://www.nrc.uscg.mil).

## Maintenance and Removal

Effective implementation of good housekeeping practices is dependent on clear designation of personnel responsible for supervising and implementing good housekeeping programs, such as site cleanup and disposal of trash and debris, hazardous material management and disposal, vehicle and equipment maintenance, and other practices. Emergency response "drills" may aid in emergency preparedness.

Checklists may be helpful in good housekeeping efforts.

Staging and storage areas require permanent stabilization when the areas are no longer being used for construction-related activities.

Construction-related materials, debris and waste must be removed from the construction site once construction is complete.

## Design Details

See the following Fact Sheets for related Design Details:

MM-1 Concrete Washout Area

MM-2 Stockpile Management

SM-4 Vehicle Tracking Control

Design details are not necessary for other good housekeeping practices; however, be sure to designate where specific practices will occur on the appropriate construction drawings.



## Description

A silt fence is a woven geotextile fabric attached to wooden posts and trenched into the ground. It is designed as a sediment barrier to intercept sheet flow runoff from disturbed areas.

## Appropriate Uses

A silt fence can be used where runoff is conveyed from a disturbed area as sheet flow. Silt fence is not designed to receive concentrated flow or to be used as a filter fabric. Typical uses include:

- Down slope of a disturbed area to accept sheet flow.
- Along the perimeter of a receiving water such as a stream, pond or wetland.
- At the perimeter of a construction site.



Photograph SF-1. Silt fence creates a sediment barrier, forcing sheet flow runoff to evaporate or infiltrate.

## Design and Installation

Silt fence should be installed along the contour of slopes so that it intercepts sheet flow. The maximum recommended tributary drainage area per 100 lineal feet of silt fence, installed along the contour, is approximately 0.25 acres with a disturbed slope length of up to 150 feet and a tributary slope gradient no steeper than 3:1. Longer and steeper slopes require additional measures. This recommendation only applies to silt fence installed along the contour. Silt fence installed for other uses, such as perimeter control, should be installed in a way that will not produce concentrated flows. For example, a "J-hook" installation may be appropriate to force runoff to pond and evaporate or infiltrate in multiple areas rather than concentrate and cause erosive conditions parallel to the silt fence.

See Detail SF-1 for proper silt fence installation, which involves proper trenching, staking, securing the fabric to the stakes, and backfilling the silt fence. Properly installed silt fence should not be easily pulled out by hand and there should be no gaps between the ground and the fabric.

Silt fence must meet the minimum allowable strength requirements, depth of installation requirement, and other specifications in the design details. Improper installation of silt fence is a common reason for silt fence failure; however, when properly installed and used for the appropriate purposes, it can be highly effective.

| Silt Fence               |     |
|--------------------------|-----|
| Functions                |     |
| Erosion Control          | No  |
| Sediment Control         | Yes |
| Site/Material Management | No  |

## Maintenance and Removal

Inspection of silt fence includes observing the material for tears or holes and checking for slumping fence and undercut areas bypassing flows. Repair of silt fence typically involves replacing the damaged section with a new section. Sediment accumulated behind silt fence should be removed, as needed to maintain BMP effectiveness, typically before it reaches a depth of 6 inches.

Silt fence may be removed when the upstream area has reached final stabilization.

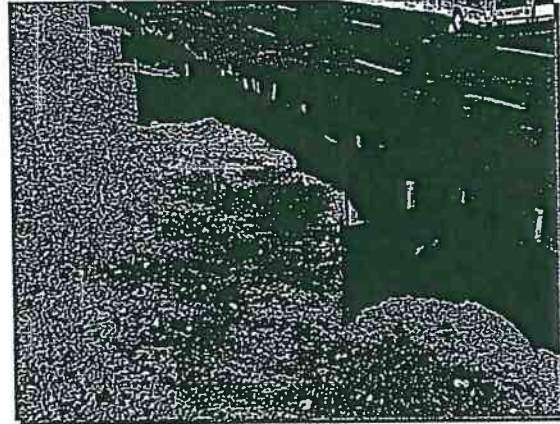

**Photograph SF-2.** When silt fence is not installed along the contour, a "J-hook" installation may be appropriate to ensure that the BMP does not create concentrated flow parallel to the silt fence. Photo courtesy of Tom Gore.

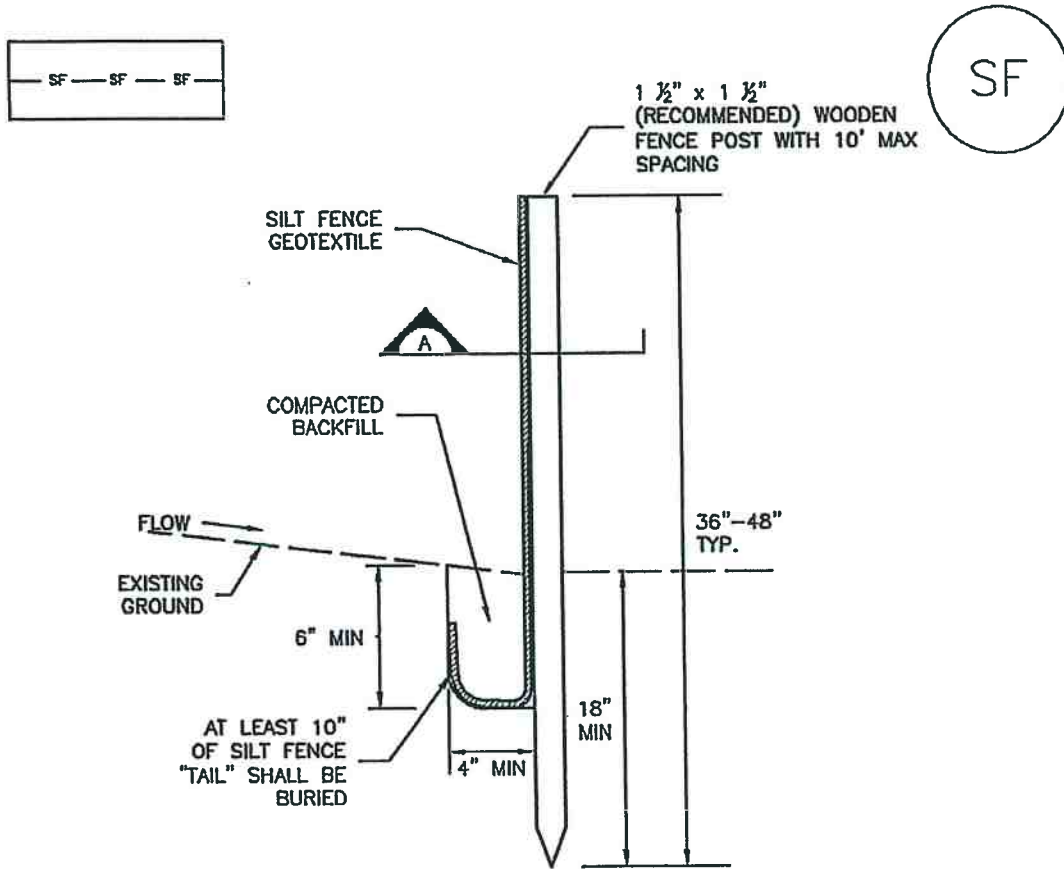

SILT FENCE

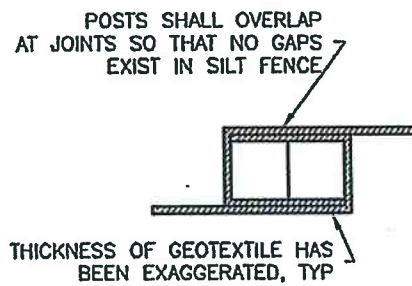
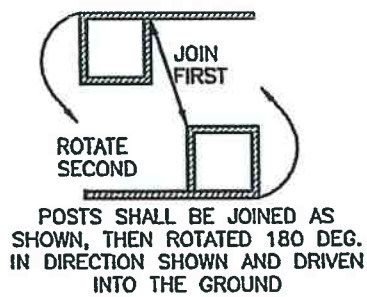

SECTION A

SF-1. SILT FENCE



SILT FENCE INSTALLATION NOTES

1. SILT FENCE MUST BE PLACED AWAY FROM THE TOE OF THE SLOPE TO ALLOW FOR WATER PONDING. SILT FENCE AT THE TOE OF A SLOPE SHOULD BE INSTALLED IN A FLAT LOCATION AT LEAST SEVERAL FEET (2-5 FT) FROM THE TOE OF THE SLOPE TO ALLOW ROOM FOR PONDING AND DEPOSITION.
2. A UNIFORM 6" X 4" ANCHOR TRENCH SHALL BE EXCAVATED USING TRENCHER OR SILT FENCE INSTALLATION DEVICE. NO ROAD GRADERS, BACKHOES, OR SIMILAR EQUIPMENT SHALL BE USED.
3. COMPACT ANCHOR TRENCH BY HAND WITH A "JUMPING JACK" OR BY WHEEL ROLLING. COMPACTION SHALL BE SUCH THAT SILT FENCE RESISTS BEING PULLED OUT OF ANCHOR TRENCH BY HAND.
4. SILT FENCE SHALL BE PULLED TIGHT AS IT IS ANCHORED TO THE STAKES. THERE SHOULD BE NO NOTICEABLE SAG BETWEEN STAKES AFTER IT HAS BEEN ANCHORED TO THE STAKES.
5. SILT FENCE FABRIC SHALL BE ANCHORED TO THE STAKES USING 1" HEAVY DUTY STAPLES OR NAILS WITH 1" HEADS. STAPLES AND NAILS SHOULD BE PLACED 3" ALONG THE FABRIC DOWN THE STAKE.
6. AT THE END OF A RUN OF SILT FENCE ALONG A CONTOUR, THE SILT FENCE SHOULD BE TURNED PERPENDICULAR TO THE CONTOUR TO CREATE A "J-HOOK." THE "J-HOOK" EXTENDING PERPENDICULAR TO THE CONTOUR SHOULD BE OF SUFFICIENT LENGTH TO KEEP RUNOFF FROM FLOWING AROUND THE END OF THE SILT FENCE (TYPICALLY 10' - 20').
7. SILT FENCE SHALL BE INSTALLED PRIOR TO ANY LAND DISTURBING ACTIVITIES.

SILT FENCE MAINTENANCE NOTES

1. INSPECT BMPs EACH WORKDAY, AND MAINTAIN THEM IN EFFECTIVE OPERATING CONDITION. MAINTENANCE OF BMPs SHOULD BE PROACTIVE, NOT REACTIVE. INSPECT BMPs AS SOON AS POSSIBLE (AND ALWAYS WITHIN 24 HOURS) FOLLOWING A STORM THAT CAUSES SURFACE EROSION, AND PERFORM NECESSARY MAINTENANCE.
2. FREQUENT OBSERVATIONS AND MAINTENANCE ARE NECESSARY TO MAINTAIN BMPs IN EFFECTIVE OPERATING CONDITION. INSPECTIONS AND CORRECTIVE MEASURES SHOULD BE DOCUMENTED THOROUGHLY.
3. WHERE BMPs HAVE FAILED, REPAIR OR REPLACEMENT SHOULD BE INITIATED UPON DISCOVERY OF THE FAILURE.
4. SEDIMENT ACCUMULATED UPSTREAM OF THE SILT FENCE SHALL BE REMOVED AS NEEDED TO MAINTAIN THE FUNCTIONALITY OF THE BMP, TYPICALLY WHEN DEPTH OF ACCUMULATED SEDIMENTS IS APPROXIMATELY 6".
5. REPAIR OR REPLACE SILT FENCE WHEN THERE ARE SIGNS OF WEAR, SUCH AS SAGGING, TEARING, OR COLLAPSE.
6. SILT FENCE IS TO REMAIN IN PLACE UNTIL THE UPSTREAM DISTURBED AREA IS STABILIZED AND APPROVED BY THE LOCAL JURISDICTION, OR IS REPLACED BY AN EQUIVALENT PERIMETER SEDIMENT CONTROL BMP.
7. WHEN SILT FENCE IS REMOVED, ALL DISTURBED AREAS SHALL BE COVERED WITH TOPSOIL, SEEDED AND MULCHED OR OTHERWISE STABILIZED AS APPROVED BY LOCAL JURISDICTION.

~ (DETAIL ADAPTED FROM TOWN OF PARKER, COLORADO AND CITY OF AURORA, NOT AVAILABLE IN AUTOCAD)

- ~NOTE: MANY JURISDICTIONS HAVE BMP DETAILS THAT VARY FROM UDFCD STANDARD DETAILS.  
 ~CONSULT WITH LOCAL JURISDICTIONS AS TO WHICH DETAIL SHOULD BE USED WHEN  
 ~DIFFERENCES ARE NOTED.

## Description

A sediment control log is a linear roll made of natural materials such as straw, coconut fiber, or other fibrous material trenched into the ground and held with a wooden stake. Sediment control logs are also often referred to as "straw wattles." They are used as a sediment barrier to intercept sheet flow runoff from disturbed areas.

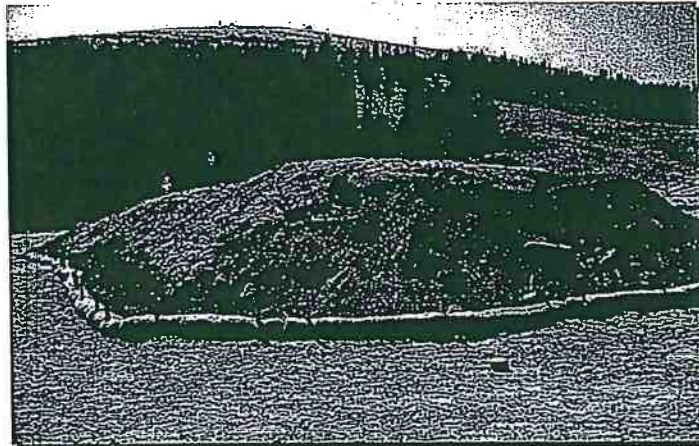

## Appropriate Uses

Sediment control logs can be used in the following applications to trap sediment:

- As perimeter control for stockpiles and the site.
- As part of inlet protection designs.
- As check dams in small drainage ditches. (Sediment control logs are not intended for use in channels with high flow velocities.)
- On disturbed slopes to shorten flow lengths (as an erosion control).
- As part of multi-layered perimeter control along a receiving water such as a stream, pond or wetland.

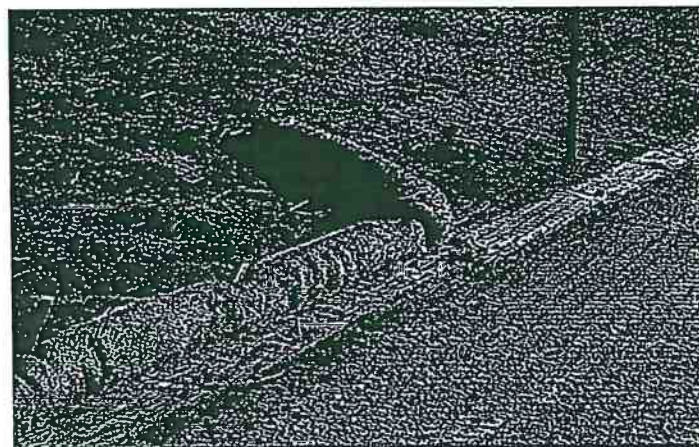

Photographs SCL-1 and SCL-2. Sediment control logs used as 1) a perimeter control around a soil stockpile; and, 2) as a "J-hook" perimeter control at the corner of a construction site.

Sediment control logs work well in combination with other layers of erosion and sediment controls.

## Design and Installation

Sediment control logs should be installed along the contour to avoid concentrating flows. The maximum allowable tributary drainage area per 100 lineal feet of sediment control log, installed along the contour, is approximately 0.25 acres with a disturbed slope length of up to 150 feet and a tributary slope gradient no steeper than 3:1. Longer and steeper slopes require additional measures. This recommendation only applies to sediment control logs installed along the contour. When installed for other uses, such as perimeter control, it should be installed in a way that will not produce concentrated flows. For example, a "J-hook" installation may be appropriate to force runoff to pond and evaporate or infiltrate in multiple areas rather than concentrate and cause erosive conditions parallel to the BMP.

| Sediment Control Log     |          |
|--------------------------|----------|
| Functions                |          |
| Erosion Control          | Moderate |
| Sediment Control         | Yes      |
| Site/Material Management | No       |

Although sediment control logs initially allow runoff to flow through the BMP, they can quickly become a barrier and should be installed if they are impermeable.

Design details and notes for sediment control logs are provided in Detail SCL-1. Sediment logs must be properly trenched and staked into the ground to prevent undercutting, bypassing and displacement. When installed on slopes, sediment control logs should be installed along the contours (i.e., perpendicular to flow).

Improper installation can lead to poor performance. Be sure that sediment control logs are properly trenched, anchored and tightly jointed.

### **Maintenance and Removal**

Be aware that sediment control logs will eventually degrade. Remove accumulated sediment before the depth is one-half the height of the sediment log and repair damage to the sediment log, typically by replacing the damaged section.

Once the upstream area is stabilized, remove and properly dispose of the logs. Areas disturbed beneath the logs may need to be seeded and mulched. Sediment control logs that are biodegradable may occasionally be left in place (e.g., when logs are used in conjunction with erosion control blankets as permanent slope breaks). However, removal of sediment control logs after final stabilization is typically recommended when used in perimeter control, inlet protection and check dam applications.



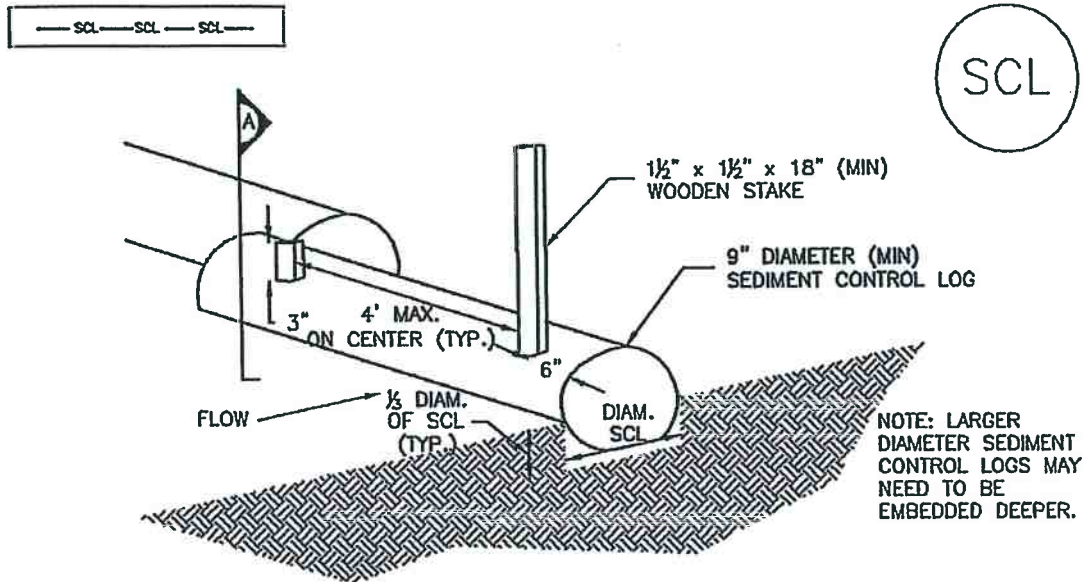

## SEDIMENT CONTROL LOG

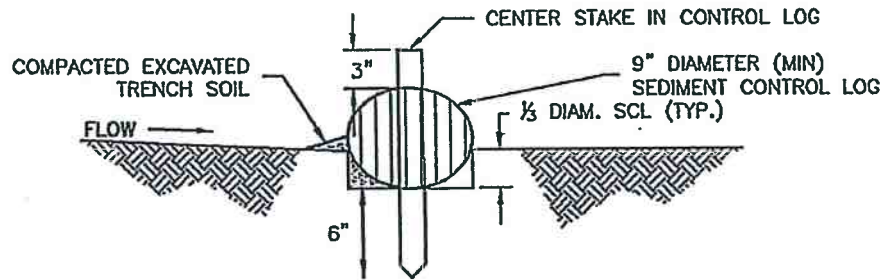

## SECTION A

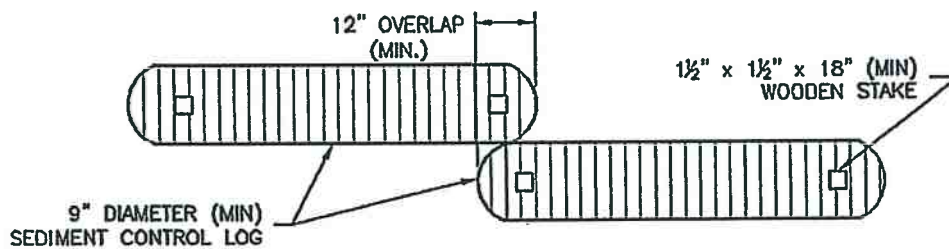

## SEDIMENT CONTROL LOG JOINTS

## SCL-1. SEDIMENT CONTROL LOG

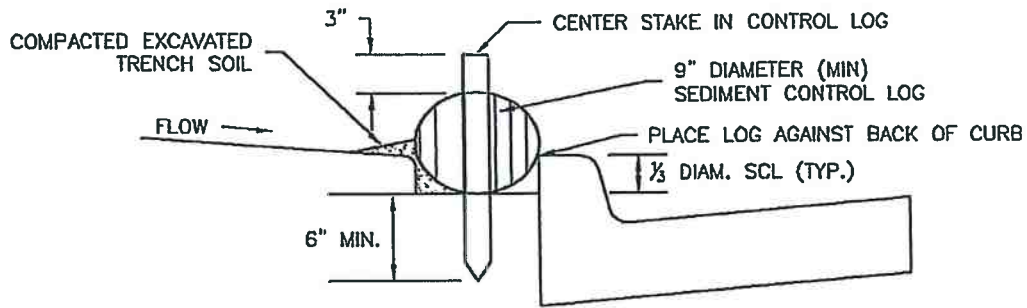

SCL-2. SEDIMENT CONTROL LOG AT BACK OF CURB

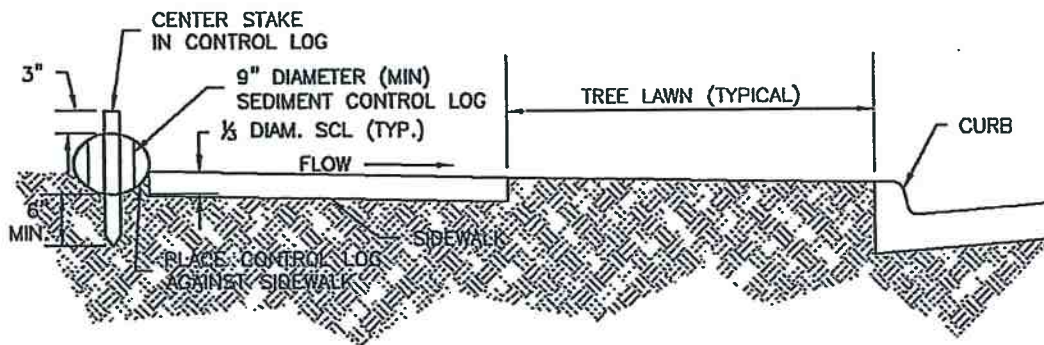

SCL-3. SEDIMENT CONTROL LOG AT SIDEWALK WITH TREE LAWN

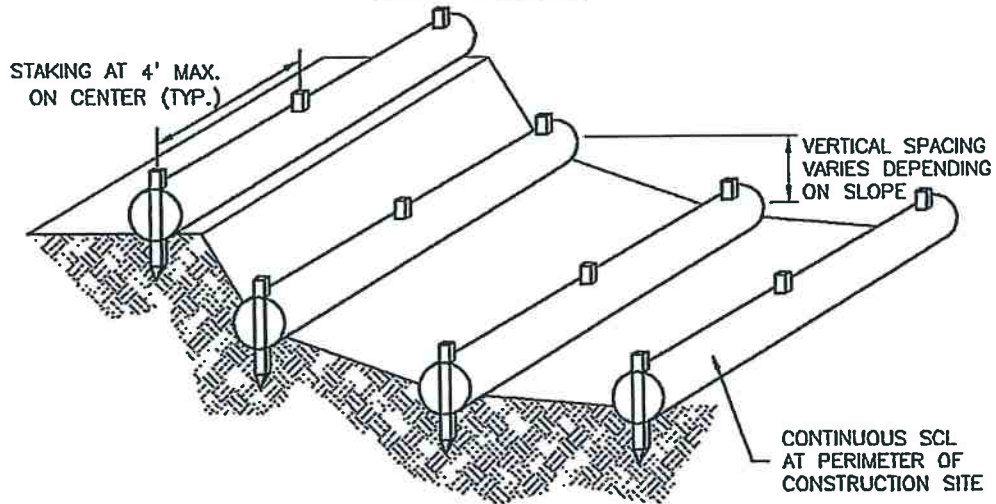

SCL-4. SEDIMENT CONTROL LOGS TO CONTROL SLOPE LENGTH



## SEDIMENT CONTROL LOG INSTALLATION NOTES

1. SEE PLAN VIEW FOR LOCATION AND LENGTH OF SEDIMENT CONTROL LOGS.
2. SEDIMENT CONTROL LOGS THAT ACT AS A PERIMETER CONTROL SHALL BE INSTALLED PRIOR TO ANY UPGRADIENT LAND-DISTURBING ACTIVITIES.
3. SEDIMENT CONTROL LOGS SHALL CONSIST OF STRAW, COMPOST, EXCELSIOR OR COCONUT FIBER, AND SHALL BE FREE OF ANY NOXIOUS WEED SEEDS OR DEFECTS INCLUDING RIPS, HOLES AND OBVIOUS WEAR.
4. SEDIMENT CONTROL LOGS MAY BE USED AS SMALL CHECK DAMS IN DITCHES AND SWALES. HOWEVER, THEY SHOULD NOT BE USED IN PERENNIAL STREAMS OR HIGH VELOCITY DRAINAGE WAYS.
5. IT IS RECOMMENDED THAT SEDIMENT CONTROL LOGS BE TRENCHED INTO THE GROUND TO A DEPTH OF APPROXIMATELY  $\frac{1}{3}$  OF THE DIAMETER OF THE LOG. IF TRENCHING TO THIS DEPTH IS NOT FEASIBLE AND/OR DESIRABLE (SHORT TERM INSTALLATION WITH DESIRE NOT TO DAMAGE LANDSCAPE) A LESSER TRENCHING DEPTH MAY BE ACCEPTABLE WITH MORE ROBUST STAKING
6. THE UPHILL SIDE OF THE SEDIMENT CONTROL LOG SHALL BE BACKFILLED WITH SOIL THAT IS FREE OF ROCKS AND DEBRIS. THE SOIL SHALL BE TIGHTLY COMPACTED INTO THE SHAPE OF A RIGHT TRIANGLE USING A SHOVEL OR WEIGHTED LAWN ROLLER.
7. FOLLOW MANUFACTURERS' GUIDANCE FOR STAKING. IF MANUFACTURERS' INSTRUCTIONS DO NOT SPECIFY SPACING, STAKES SHALL BE PLACED ON 4' CENTERS AND EMBEDDED A MINIMUM OF 6" INTO THE GROUND. 3" OF THE STAKE SHALL PROTRUDE FROM THE TOP OF THE LOG. STAKES THAT ARE BROKEN PRIOR TO INSTALLATION SHALL BE REPLACED.

## SEDIMENT CONTROL LOG MAINTENANCE NOTES

1. INSPECT BMPs EACH WORKDAY, AND MAINTAIN THEM IN EFFECTIVE OPERATING CONDITION. MAINTENANCE OF BMPs SHOULD BE PROACTIVE, NOT REACTIVE. INSPECT BMPs AS SOON AS POSSIBLE (AND ALWAYS WITHIN 24 HOURS) FOLLOWING A STORM THAT CAUSES SURFACE EROSION, AND PERFORM NECESSARY MAINTENANCE.
  2. FREQUENT OBSERVATIONS AND MAINTENANCE ARE NECESSARY TO MAINTAIN BMPs IN EFFECTIVE OPERATING CONDITION. INSPECTIONS AND CORRECTIVE MEASURES SHOULD BE DOCUMENTED THOROUGHLY.
  3. WHERE BMPs HAVE FAILED, REPAIR OR REPLACEMENT SHOULD BE INITIATED UPON DISCOVERY OF THE FAILURE.
  4. SEDIMENT ACCUMULATED UPSTREAM OF SEDIMENT CONTROL LOG SHALL BE REMOVED AS NEEDED TO MAINTAIN FUNCTIONALITY OF THE BMP, TYPICALLY WHEN DEPTH OF ACCUMULATED SEDIMENTS IS APPROXIMATELY  $\frac{1}{2}$  OF THE HEIGHT OF THE SEDIMENT CONTROL LOG.
  5. SEDIMENT CONTROL LOG SHALL BE REMOVED AT THE END OF CONSTRUCTION. IF DISTURBED AREAS EXIST AFTER REMOVAL, THEY SHALL BE COVERED WITH TOP SOIL, SEEDED AND MULCHED OR OTHERWISE STABILIZED IN A MANNER APPROVED BY THE LOCAL JURISDICTION.
- (DETAILS ADAPTED FROM TOWN OF PARKER, COLORADO, JEFFERSON COUNTY, COLORADO, DOUGLAS COUNTY, COLORADO, AND CITY OF AURORA, COLORADO, NOT AVAILABLE IN AUTOCAD)
- **NOTE:** MANY JURISDICTIONS HAVE BMP DETAILS THAT VARY FROM UDFCD STANDARD DETAILS.
- CONSULT WITH LOCAL JURISDICTIONS AS TO WHICH DETAIL SHOULD BE USED WHEN DIFFERENCES ARE NOTED.

## Description

A straw bale barrier is a linear wall of straw bales designed to intercept sheet flow and trap sediment before runoff exits a disturbed area.



Photograph SBB-1. Straw bale barrier used for perimeter control. Photo courtesy of Tom Gore.

## Appropriate Uses

Appropriate uses of properly installed straw bale barriers may include:

- As a perimeter control for a site or soil stockpile.
- As a sediment control at the toe of an erodible slope.
- Along the edge of a stream or drainage pathway to reduce sediment laden runoff from entering the waterway.
- As part of an inlet protection design in sump conditions (See Inlet Protection BMP).

Do not use straw bale barriers in areas of concentrated flow or in areas where ponding is not desirable. Straw bales tend to degrade quickly, so they should generally not be used in areas where longer term disturbance is expected.

Due to a history of inappropriate placement, poor installation, and short effective lifespan, the use of straw bales is discouraged or prohibited by some communities.

## Design and Installation

The maximum recommended tributary drainage area per 100 lineal feet of straw bale barrier is 0.25 acres with a disturbed slope length of up to 150 feet and a tributary slope gradient no steeper than 3:1; longer and steeper slopes require additional measures. Design details with notes are provided in Detail SBB-1. To be effective, bales must be installed in accordance with the design details with proper trenching, staking, and binding. Jute and cotton string must not be used to bind the straw bale. The bales should be certified weed-free prior to use.

## Maintenance and Removal

Check bales for rotting and replace as necessary. Straw bales degrade, and rotting bales require replacement on a regular basis (as often as every three months) depending on environmental conditions. Check for undercutting, bypassed flows, and displacement. Repair by properly re-installing the straw bale barrier and repairing washouts around the bales. Remove sediment accumulated behind the bale when it reaches one-quarter of the bale height. Remove and properly dispose of the straw bale once the upstream area has been stabilized. Areas of disturbance beneath the bale should be seeded and mulched when the bale is removed.

| Straw Bale Barrier       |          |
|--------------------------|----------|
| <b>Functions</b>         |          |
| Erosion Control          | No       |
| Sediment Control         | Moderate |
| Site/Material Management | No       |

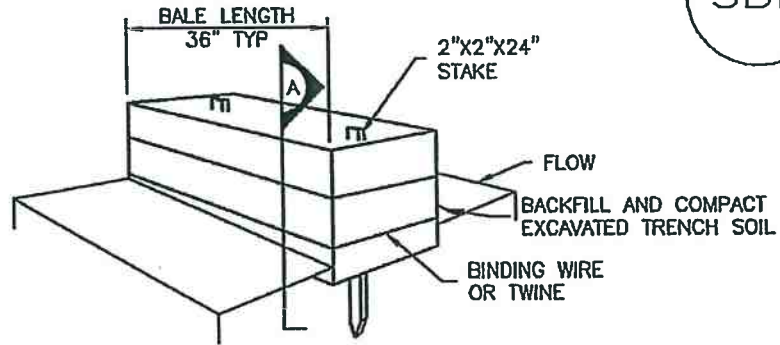
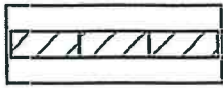

STRAW BALE

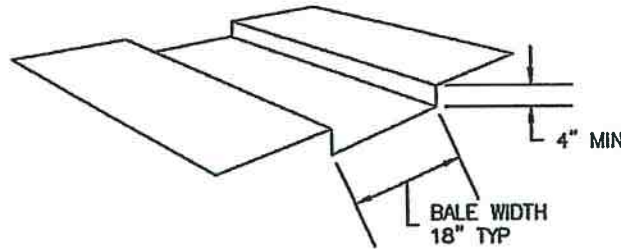

TRENCH FOR STRAW BALE

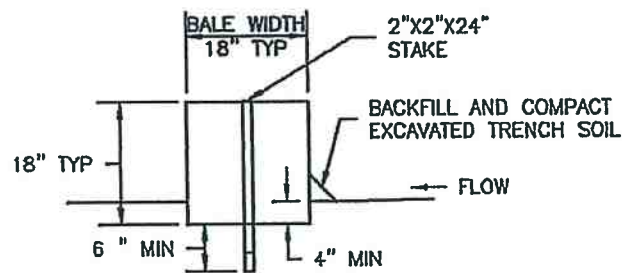

SECTION A

SBB-1. STRAW BALE

## STRAW BALE INSTALLATION NOTES

1. SEE PLAN VIEW FOR:  
-LOCATION(S) OF STRAW BALES.
2. STRAW BALES SHALL CONSIST OF CERTIFIED WEED FREE STRAW OR HAY. LOCAL JURISDICTIONS MAY REQUIRE PROOF THAT BALES ARE WEED FREE.
3. STRAW BALES SHALL CONSIST OF APPROXIMATELY 5 CUBIC FEET OF STRAW OR HAY AND WEIGH NOT LESS THAN 35 POUNDS.
4. WHEN STRAW BALES ARE USED IN SERIES AS A BARRIER, THE END OF EACH BALE SHALL BE TIGHTLY ABUTTING ONE ANOTHER.
5. STRAW BALE DIMENSIONS SHALL BE APPROXIMATELY 36"X18"X18".
6. A UNIFORM ANCHOR TRENCH SHALL BE EXCAVATED TO A DEPTH OF 4". STRAW BALES SHALL BE PLACED SO THAT BINDING TWINE IS ENCOMPASSING THE VERTICAL SIDES OF THE BALE(S). ALL EXCAVATED SOIL SHALL BE PLACED ON THE UPHILL SIDE OF THE STRAW BALE(S) AND COMPACTED.
7. TWO (2) WOODEN STAKES SHALL BE USED TO HOLD EACH BALE IN PLACE. WOODEN STAKES SHALL BE 2"X2"X24". WOODEN STAKES SHALL BE DRIVEN 6" INTO THE GROUND.

## STRAW BALE MAINTENANCE NOTES

1. INSPECT BMPs EACH WORKDAY, AND MAINTAIN THEM IN EFFECTIVE OPERATING CONDITION. MAINTENANCE OF BMPs SHOULD BE PROACTIVE, NOT REACTIVE. INSPECT BMPs AS SOON AS POSSIBLE (AND ALWAYS WITHIN 24 HOURS) FOLLOWING A STORM THAT CAUSES SURFACE EROSION, AND PERFORM NECESSARY MAINTENANCE.
2. FREQUENT OBSERVATIONS AND MAINTENANCE ARE NECESSARY TO MAINTAIN BMPs IN EFFECTIVE OPERATING CONDITION. INSPECTIONS AND CORRECTIVE MEASURES SHOULD BE DOCUMENTED THOROUGHLY.
3. WHERE BMPs HAVE FAILED, REPAIR OR REPLACEMENT SHOULD BE INITIATED UPON DISCOVERY OF THE FAILURE.
4. STRAW BALES SHALL BE REPLACED IF THEY BECOME HEAVILY SOILED, ROTTEN, OR DAMAGED BEYOND REPAIR.
5. SEDIMENT ACCUMULATED UPSTREAM OF STRAW BALE BARRIER SHALL BE REMOVED AS NEEDED TO MAINTAIN FUNCTIONALITY OF THE BMP, TYPICALLY WHEN DEPTH OF ACCUMULATED SEDIMENTS IS APPROXIMATELY  $\frac{1}{4}$  OF THE HEIGHT OF THE STRAW BALE BARRIER.
6. STRAW BALES ARE TO REMAIN IN PLACE UNTIL THE UPSTREAM DISTURBED AREA IS STABILIZED AND APPROVED BY THE LOCAL JURISDICTION.
7. WHEN STRAW BALES ARE REMOVED, ALL DISTURBED AREAS SHALL BE COVERED WITH TOPSOIL, SEEDED AND MULCHED OR OTHERWISE STABILIZED AS APPROVED BY LOCAL JURISDICTION.

(DETAILS ADAPTED FROM TOWN OF PARKER, COLORADO, NOT AVAILABLE IN AUTOCAD)

**NOTE:** MANY JURISDICTIONS HAVE BMP DETAILS THAT VARY FROM UDFCD STANDARD DETAILS. CONSULT WITH LOCAL JURISDICTIONS AS TO WHICH DETAIL SHOULD BE USED WHEN DIFFERENCES ARE NOTED.



## Description

A rock sock is constructed of gravel that has been wrapped by wire mesh or a geotextile to form an elongated cylindrical filter. Rock socks are typically used either as a perimeter control or as part of inlet protection. When placed at angles in the curb line, rock socks are typically referred to as curb socks. Rock socks are intended to trap sediment from stormwater runoff that flows onto roadways as a result of construction activities.

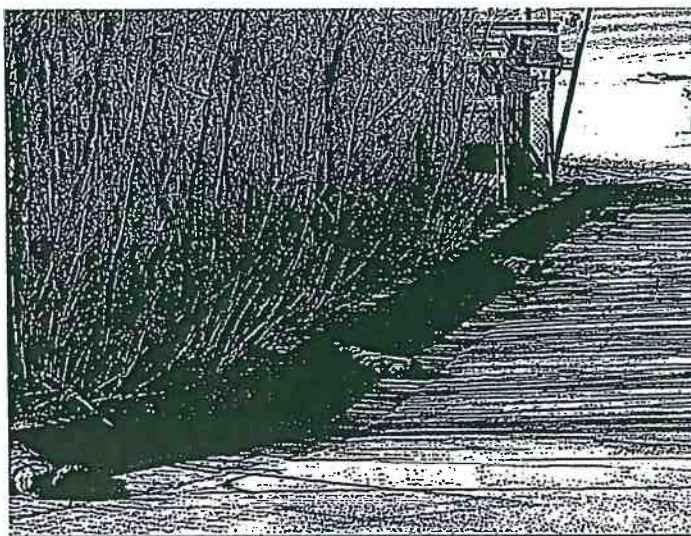

**Photograph RS-1.** Rock socks placed at regular intervals in a curb line can help reduce sediment loading to storm sewer inlets. Rock socks can also be used as perimeter controls.

## Appropriate Uses

Rock socks can be used at the perimeter of a disturbed area to control localized sediment loading. A benefit of rock socks as opposed to other perimeter controls is that they do not have to be trenched or staked into the ground; therefore, they are often used on roadway construction projects where paved surfaces are present.

Use rock socks in inlet protection applications when the construction of a roadway is substantially complete and the roadway has been directly connected to a receiving storm system.

## Design and Installation

When rock socks are used as perimeter controls, the maximum recommended tributary drainage area per 100 lineal feet of rock socks is approximately 0.25 acres with disturbed slope length of up to 150 feet and a tributary slope gradient no steeper than 3:1. A rock sock design detail and notes are provided in Detail RS-1. Also see the Inlet Protection Fact Sheet for design and installation guidance when rock socks are used for inlet protection and in the curb line.

When placed in the gutter adjacent to a curb, rock socks should protrude no more than two feet from the curb in order for traffic to pass safely. If located in a high traffic area, place construction markers to alert drivers and street maintenance workers of their presence.

## Maintenance and Removal

Rock socks are susceptible to displacement and breaking due to vehicle traffic. Inspect rock socks for damage and repair or replace as necessary. Remove sediment by sweeping or vacuuming as needed to maintain the functionality of the BMP, typically when sediment has accumulated behind the rock sock to one-half of the sock's height.

Once upstream stabilization is complete, rock socks and accumulated sediment should be removed and properly disposed.

| Rock Sock                |     |
|--------------------------|-----|
| Functions                |     |
| Erosion Control          | No  |
| Sediment Control         | Yes |
| Site/Material Management | No  |



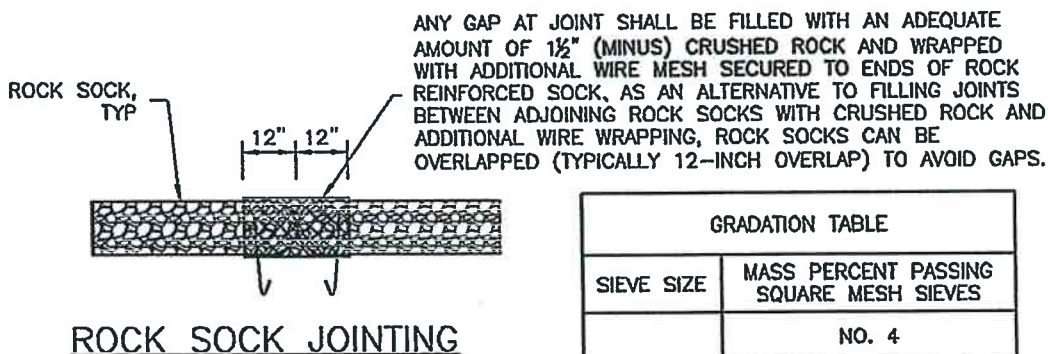
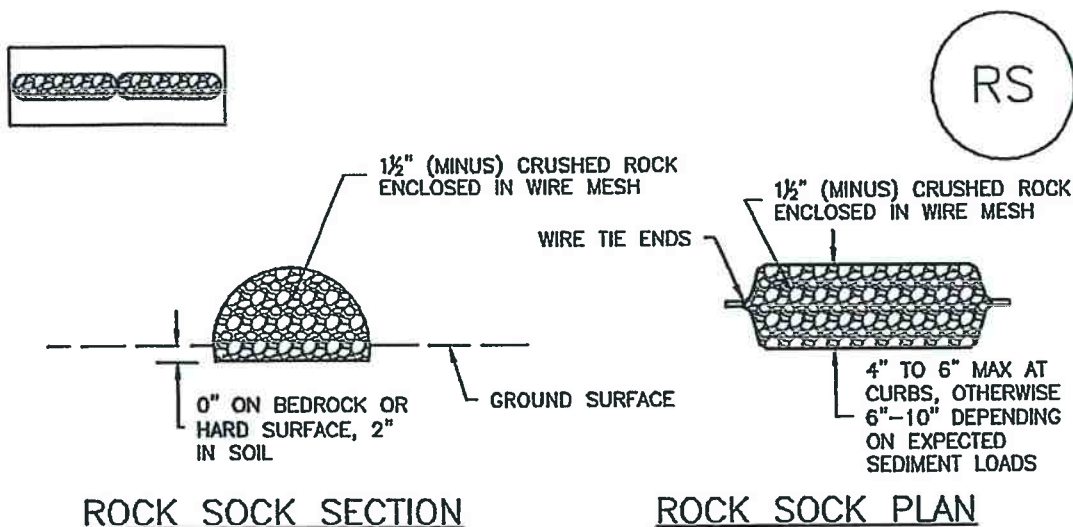

ROCK SOCK JOINTING

| GRADATION TABLE   |   |
|---|---|
| SIEVE SIZE  | MASS PERCENT PASSING SQUARE MESH SIEVES |
|   | NO. 4                                   |
| 2"  | 100                                     |
| 1½"   | 90 - 100                                |
| 1"  | 20 - 55                                 |
| ¾"  | 0 - 15                                  |
| ⅜"  | 0 - 5                                   |
| MATCHES SPECIFICATIONS FOR NO. 4 COARSE AGGREGATE FOR CONCRETE PER AASHTO M43. ALL ROCK SHALL BE FRACTURED FACE, ALL SIDES. |   |

ROCK SOCK INSTALLATION NOTES

1. SEE PLAN VIEW FOR:  
-LOCATION(S) OF ROCK SOCKS.
2. CRUSHED ROCK SHALL BE 1½" (MINUS) IN SIZE WITH A FRACTURED FACE (ALL SIDES) AND SHALL COMPLY WITH GRADATION SHOWN ON THIS SHEET (1½" MINUS).
3. WIRE MESH SHALL BE FABRICATED OF 10 GAGE POULTRY MESH, OR EQUIVALENT, WITH A MAXIMUM OPENING OF ½", RECOMMENDED MINIMUM ROLL WIDTH OF 48"
4. WIRE MESH SHALL BE SECURED USING "HOG RINGS" OR WIRE TIES AT 6" CENTERS ALONG ALL JOINTS AND AT 2" CENTERS ON ENDS OF SOCKS.
5. SOME MUNICIPALITIES MAY ALLOW THE USE OF FILTER FABRIC AS AN ALTERNATIVE TO WIRE MESH FOR THE ROCK ENCLOSURE.

RS-1. ROCK SOCK PERIMETER CONTROL

## ROCK SOCK MAINTENANCE NOTES

1. INSPECT BMPs EACH WORKDAY, AND MAINTAIN THEM IN EFFECTIVE OPERATING CONDITION. MAINTENANCE OF BMPs SHOULD BE PROACTIVE, NOT REACTIVE. INSPECT BMPs AS SOON AS POSSIBLE (AND ALWAYS WITHIN 24 HOURS) FOLLOWING A STORM THAT CAUSES SURFACE EROSION, AND PERFORM NECESSARY MAINTENANCE.
2. FREQUENT OBSERVATIONS AND MAINTENANCE ARE NECESSARY TO MAINTAIN BMPs IN EFFECTIVE OPERATING CONDITION. INSPECTIONS AND CORRECTIVE MEASURES SHOULD BE DOCUMENTED THOROUGHLY.
3. WHERE BMPs HAVE FAILED, REPAIR OR REPLACEMENT SHOULD BE INITIATED UPON DISCOVERY OF THE FAILURE.
4. ROCK SOCKS SHALL BE REPLACED IF THEY BECOME HEAVILY SOILED, OR DAMAGED BEYOND REPAIR.
5. SEDIMENT ACCUMULATED UPSTREAM OF ROCK SOCKS SHALL BE REMOVED AS NEEDED TO MAINTAIN FUNCTIONALITY OF THE BMP, TYPICALLY WHEN DEPTH OF ACCUMULATED SEDIMENTS IS APPROXIMATELY  $\frac{1}{2}$  OF THE HEIGHT OF THE ROCK SOCK.
6. ROCK SOCKS ARE TO REMAIN IN PLACE UNTIL THE UPSTREAM DISTURBED AREA IS STABILIZED AND APPROVED BY THE LOCAL JURISDICTION.
7. WHEN ROCK SOCKS ARE REMOVED, ALL DISTURBED AREAS SHALL BE COVERED WITH TOPSOIL, SEEDED AND MULCHED OR OTHERWISE STABILIZED AS APPROVED BY LOCAL JURISDICTION.

(DETAIL ADAPTED FROM TOWN OF PARKER, COLORADO AND CITY OF AURORA, COLORADO, NOT AVAILABLE IN AUTOCAD)

**NOTE:** MANY JURISDICTIONS HAVE BMP DETAILS THAT VARY FROM UDFCD STANDARD DETAILS. CONSULT WITH LOCAL JURISDICTIONS AS TO WHICH DETAIL SHOULD BE USED WHEN DIFFERENCES ARE NOTED.

**NOTE:** THE DETAILS INCLUDED WITH THIS FACT SHEET SHOW COMMONLY USED, CONVENTIONAL METHODS OF ROCK SOCK INSTALLATION IN THE DENVER METROPOLITAN AREA. THERE ARE MANY OTHER SIMILAR PROPRIETARY PRODUCTS ON THE MARKET. UDFCD NEITHER NDORSES NOR DISCOURAGES USE OF PROPRIETARY PROTECTION PRODUCTS; HOWEVER, IN THE EVENT PROPRIETARY METHODS ARE USED, THE APPROPRIATE DETAIL FROM THE MANUFACTURER MUST BE INCLUDED IN THE SWMP AND THE BMP MUST BE INSTALLED AND MAINTAINED AS SHOWN IN THE MANUFACTURER'S DETAILS.

## Description

Inlet protection consists of permeable barriers installed around an inlet to filter runoff and remove sediment prior to entering a storm drain inlet. Inlet protection can be constructed from rock socks, sediment control logs, silt fence, block and rock socks, or other materials approved by the local jurisdiction. Area inlets can also be protected by over-excavating around the inlet to form a sediment trap.

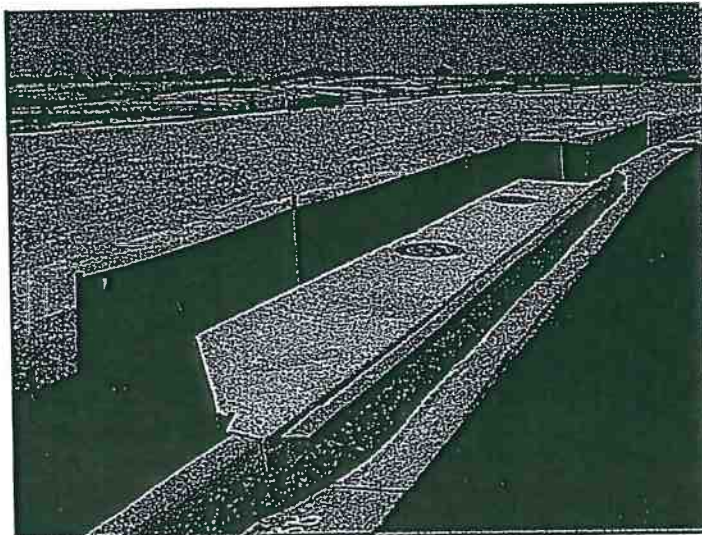

Photograph IP-1. Inlet protection for a curb opening inlet.

## Appropriate Uses

Install protection at storm sewer inlets that are operable during construction. Consider the potential for tracked-out sediment or temporary stockpile areas to contribute sediment to inlets when determining which inlets must be protected. This may include inlets in the general proximity of the construction area, not limited to downgradient inlets. Inlet protection is not a stand-alone BMP and should be used in conjunction with other upgradient BMPs.

## Design and Installation

To function effectively, inlet protection measures must be installed to ensure that flows do not bypass the inlet protection and enter the storm drain without treatment. However, designs must also enable the inlet to function without completely blocking flows into the inlet in a manner that causes localized flooding. When selecting the type of inlet protection, consider factors such as type of inlet (e.g., curb or area, sump or on-grade conditions), traffic, anticipated flows, ability to secure the BMP properly, safety and other site-specific conditions. For example, block and rock socks will be better suited to a curb and gutter along a roadway, as opposed to silt fence or sediment control logs, which cannot be properly secured in a curb and gutter setting, but are effective area inlet protection measures.

Several inlet protection designs are provided in the Design Details. Additionally, a variety of proprietary products are available for inlet protection that may be approved for use by local governments. If proprietary products are used, design details and installation procedures from the manufacturer must be followed. Regardless of the type of inlet protection selected, inlet protection is most effective when combined with other BMPs such as curb socks and check dams. Inlet protection is often the last barrier before runoff enters the storm sewer or receiving water.

Design details with notes are provided for these forms of inlet protection:

- IP-1. Block and Rock Sock Inlet Protection for Sump or On-grade Inlets
- IP-2. Curb (Rock) Socks Upstream of Inlet Protection, On-grade Inlets

| Inlet Protection<br>(various forms) |     |
|-------------------------------------|-----|
| Functions                           |     |
| Erosion Control                     | No  |
| Sediment Control                    | Yes |
| Site/Material Management            | No  |



IP-3. Rock Sock Inlet Protection for Sump/Area Inlet

IP-4. Silt Fence Inlet Protection for Sump/Area Inlet

IP-5. Over-excavation Inlet Protection

IP-6. Straw Bale Inlet Protection for Sump/Area Inlet

CIP-1. Culvert Inlet Protection

Proprietary inlet protection devices should be installed in accordance with manufacturer specifications.

More information is provided below on selecting inlet protection for sump and on-grade locations.

### **Inlets Located in a Sump**

When applying inlet protection in sump conditions, it is important that the inlet continue to function during larger runoff events. For curb inlets, the maximum height of the protective barrier should be lower than the top of the curb opening to allow overflow into the inlet during larger storms without excessive localized flooding. If the inlet protection height is greater than the curb elevation, particularly if the filter becomes clogged with sediment, runoff will not enter the inlet and may bypass it, possibly causing localized flooding, public safety issues, and downstream erosion and damage from bypassed flows.

Area inlets located in a sump setting can be protected through the use of silt fence, concrete block and rock socks (on paved surfaces), sediment control logs/straw wattles embedded in the adjacent soil and stacked around the area inlet (on pervious surfaces), over-excavation around the inlet, and proprietary products providing equivalent functions.

### **Inlets Located on a Slope**

For curb and gutter inlets on paved sloping streets, block and rock sock inlet protection is recommended in conjunction with curb socks in the gutter leading to the inlet. For inlets located along unpaved roads, also see the Check Dam Fact Sheet.

## **Maintenance and Removal**

Inspect inlet protection frequently. Inspection and maintenance guidance includes:

- Inspect for tears that can result in sediment directly entering the inlet, as well as result in the contents of the BMP (e.g., gravel) washing into the inlet.
- Check for improper installation resulting in untreated flows bypassing the BMP and directly entering the inlet or bypassing to an unprotected downstream inlet. For example, silt fence that has not been properly trenched around the inlet can result in flows under the silt fence and directly into the inlet.
- Look for displaced BMPs that are no longer protecting the inlet. Displacement may occur following larger storm events that wash away or reposition the inlet protection. Traffic or equipment may also crush or displace the BMP.
- Monitor sediment accumulation upgradient of the inlet protection.



- Remove sediment accumulation from the area upstream of the inlet protection, as needed to maintain BMP effectiveness, typically when it reaches no more than half the storage capacity of the inlet protection. For silt fence, remove sediment when it accumulates to a depth of no more than 6 inches. Remove sediment accumulation from the area upstream of the inlet protection as needed to maintain the functionality of the BMP.
- Proprietary inlet protection devices should be inspected and maintained in accordance with manufacturer specifications. If proprietary inlet insert devices are used, sediment should be removed in a timely manner to prevent devices from breaking and spilling sediment into the storm drain.

Inlet protection must be removed and properly disposed of when the drainage area for the inlet has reached final stabilization.

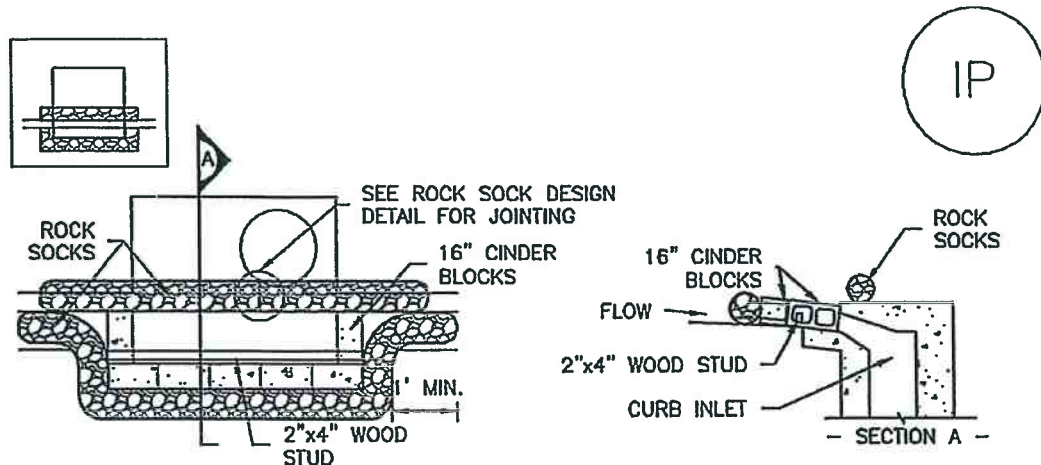

**IP-1. BLOCK AND ROCK SOCK SUMP OR ON GRADE INLET PROTECTION**

**BLOCK AND CURB SOCK INLET PROTECTION INSTALLATION NOTES**

1. SEE ROCK SOCK DESIGN DETAIL FOR INSTALLATION REQUIREMENTS.
2. CONCRETE "CINDER" BLOCKS SHALL BE LAID ON THEIR SIDES AROUND THE INLET IN A SINGLE ROW, ABUTTING ONE ANOTHER WITH THE OPEN END FACING AWAY FROM THE CURB.
3. GRAVEL BAGS SHALL BE PLACED AROUND CONCRETE BLOCKS, CLOSELY ABUTTING ONE ANOTHER AND JOINTED TOGETHER IN ACCORDANCE WITH ROCK SOCK DESIGN DETAIL.

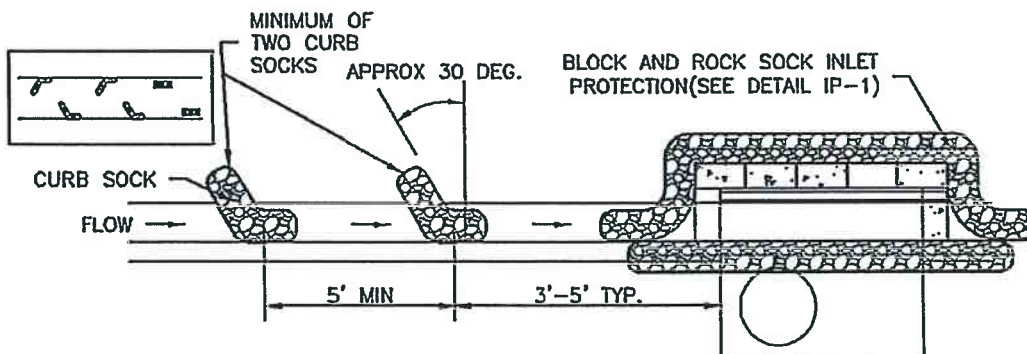

**IP-2. CURB ROCK SOCKS UPSTREAM OF INLET PROTECTION**

**CURB ROCK SOCK INLET PROTECTION INSTALLATION NOTES**

1. SEE ROCK SOCK DESIGN DETAIL INSTALLATION REQUIREMENTS.
2. PLACEMENT OF THE SOCK SHALL BE APPROXIMATELY 30 DEGREES FROM PERPENDICULAR IN THE OPPOSITE DIRECTION OF FLOW.
3. SOCKS ARE TO BE FLUSH WITH THE CURB AND SPACED A MINIMUM OF 5 FEET APART.
4. AT LEAST TWO CURB SOCKS IN SERIES ARE REQUIRED UPSTREAM OF ON-GRADE INLETS.

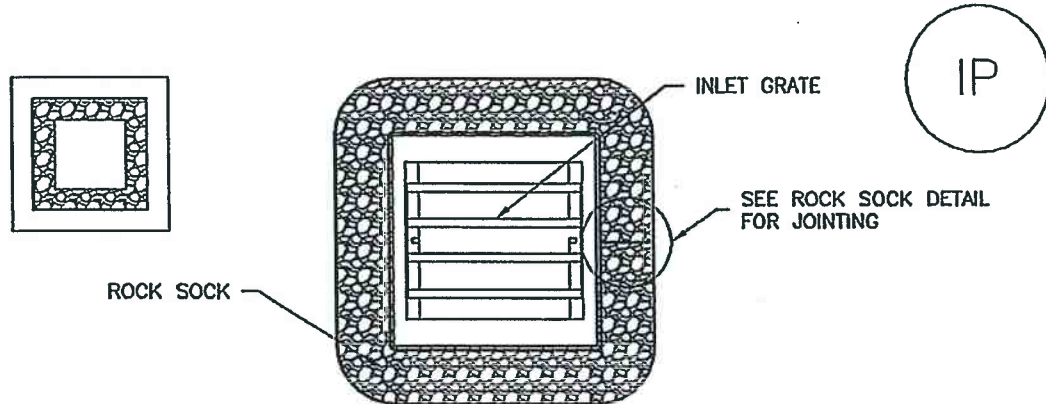

## IP-3. ROCK SOCK SUMP/AREA INLET PROTECTION

### ROCK SOCK SUMP/AREA INLET PROTECTION INSTALLATION NOTES

1. SEE ROCK SOCK DESIGN DETAIL FOR INSTALLATION REQUIREMENTS.
2. STRAW WATTLES/SEDIMENT CONTROL LOGS MAY BE USED IN PLACE OF ROCK SOCKS FOR INLETS IN PERVIOUS AREAS. INSTALL PER SEDIMENT CONTROL LOG DETAIL.

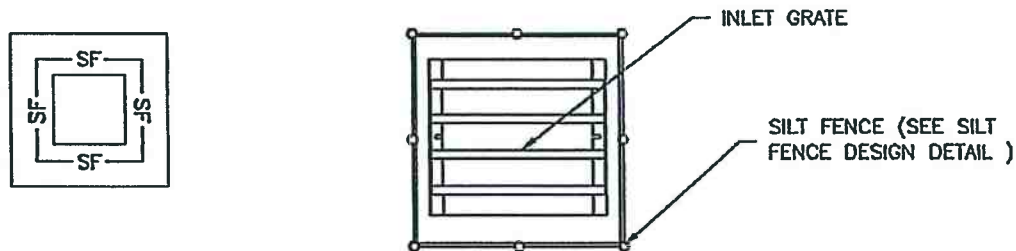

## IP-4. SILT FENCE FOR SUMP INLET PROTECTION

### SILT FENCE INLET PROTECTION INSTALLATION NOTES

1. SEE SILT FENCE DESIGN DETAIL FOR INSTALLATION REQUIREMENTS.
2. POSTS SHALL BE PLACED AT EACH CORNER OF THE INLET AND AROUND THE EDGES AT A MAXIMUM SPACING OF 3 FEET.
3. STRAW WATTLES/SEDIMENT CONTROL LOGS MAY BE USED IN PLACE OF SILT FENCE FOR INLETS IN PERVIOUS AREAS. INSTALL PER SEDIMENT CONTROL LOG DETAIL.

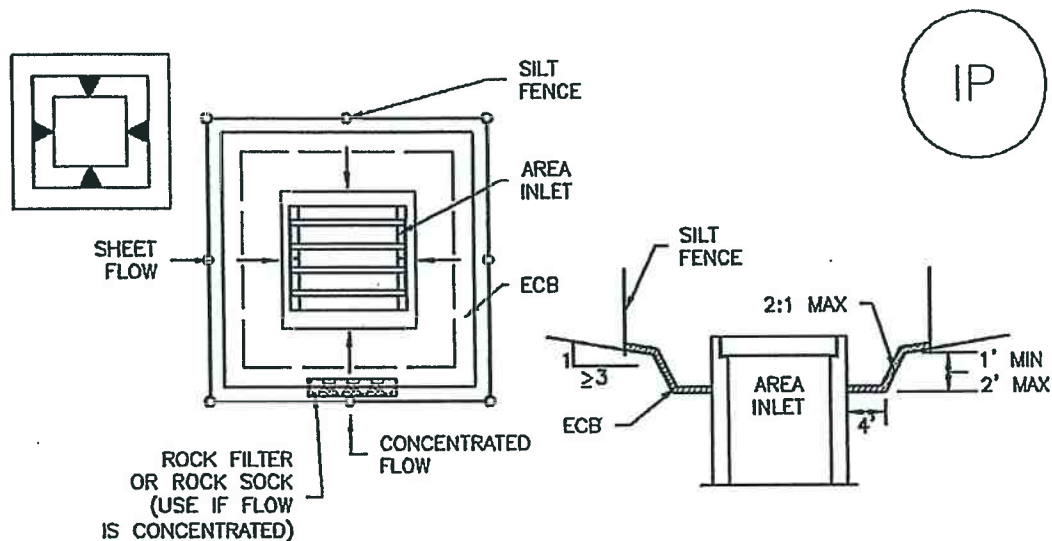

**IP-5. OVEREXCAVATION INLET PROTECTION**

**OVEREXCAVATION INLET PROTECTION INSTALLATION NOTES**

1. THIS FORM OF INLET PROTECTION IS PRIMARILY APPLICABLE FOR SITES THAT HAVE NOT YET REACHED FINAL GRADE AND SHOULD BE USED ONLY FOR INLETS WITH A RELATIVELY SMALL CONTRIBUTING DRAINAGE AREA.
2. WHEN USING FOR CONCENTRATED FLOWS, SHAPE BASIN IN 2:1 RATIO WITH LENGTH ORIENTED TOWARDS DIRECTION OF FLOW.
3. SEDIMENT MUST BE PERIODICALLY REMOVED FROM THE OVEREXCAVATED AREA.

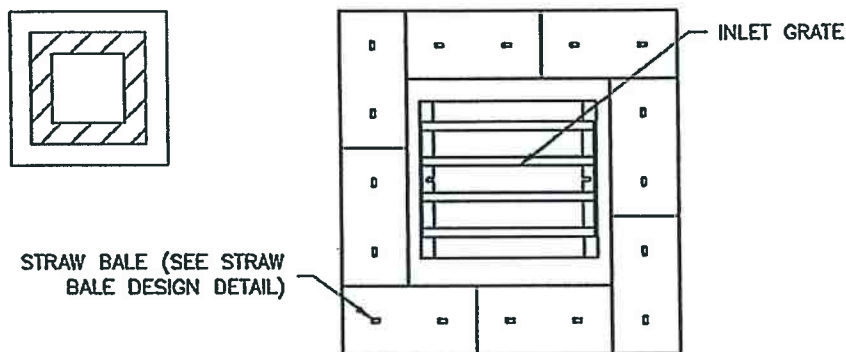

**IP-6. STRAW BALE FOR SUMP INLET PROTECTION**

**STRAW BALE BARRIER INLET PROTECTION INSTALLATION NOTES**

1. SEE STRAW BALE DESIGN DETAIL FOR INSTALLATION REQUIREMENTS.
2. BALES SHALL BE PLACED IN A SINGLE ROW AROUND THE INLET WITH ENDS OF BALES TIGHTLY ABUTTING ONE ANOTHER.



## GENERAL INLET PROTECTION INSTALLATION NOTES

1. SEE PLAN VIEW FOR:
  - LOCATION OF INLET PROTECTION.
  - TYPE OF INLET PROTECTION (IP.1, IP.2, IP.3, IP.4, IP.5, IP.6)
2. INLET PROTECTION SHALL BE INSTALLED PROMPTLY AFTER INLET CONSTRUCTION OR PAVING IS COMPLETE (TYPICALLY WITHIN 48 HOURS). IF A RAINFALL/RUNOFF EVENT IS FORECAST, INSTALL INLET PROTECTION PRIOR TO ONSET OF EVENT.
3. MANY JURISDICTIONS HAVE BMP DETAILS THAT VARY FROM UDFCD STANDARD DETAILS. CONSULT WITH LOCAL JURISDICTIONS AS TO WHICH DETAIL SHOULD BE USED WHEN DIFFERENCES ARE NOTED.

## INLET PROTECTION MAINTENANCE NOTES

1. INSPECT BMPs EACH WORKDAY, AND MAINTAIN THEM IN EFFECTIVE OPERATING CONDITION. MAINTENANCE OF BMPs SHOULD BE PROACTIVE, NOT REACTIVE. INSPECT BMPs AS SOON AS POSSIBLE (AND ALWAYS WITHIN 24 HOURS) FOLLOWING A STORM THAT CAUSES SURFACE EROSION, AND PERFORM NECESSARY MAINTENANCE.
2. FREQUENT OBSERVATIONS AND MAINTENANCE ARE NECESSARY TO MAINTAIN BMPs IN EFFECTIVE OPERATING CONDITION. INSPECTIONS AND CORRECTIVE MEASURES SHOULD BE DOCUMENTED THOROUGHLY.
3. WHERE BMPs HAVE FAILED, REPAIR OR REPLACEMENT SHOULD BE INITIATED UPON DISCOVERY OF THE FAILURE.
4. SEDIMENT ACCUMULATED UPSTREAM OF INLET PROTECTION SHALL BE REMOVED AS NECESSARY TO MAINTAIN BMP EFFECTIVENESS, TYPICALLY WHEN STORAGE VOLUME REACHES 50% OF CAPACITY, A DEPTH OF 6" WHEN SILT FENCE IS USED, OR ¼ OF THE HEIGHT FOR STRAW BALES.
5. INLET PROTECTION IS TO REMAIN IN PLACE UNTIL THE UPSTREAM DISTURBED AREA IS PERMANENTLY STABILIZED, UNLESS THE LOCAL JURISDICTION APPROVES EARLIER REMOVAL OF INLET PROTECTION IN STREETS.
6. WHEN INLET PROTECTION AT AREA INLETS IS REMOVED, THE DISTURBED AREA SHALL BE COVERED WITH TOP SOIL, SEEDED AND MULCHED, OR OTHERWISE STABILIZED IN A MANNER APPROVED BY THE LOCAL JURISDICTION.

1 ) (DETAIL ADAPTED FROM TOWN OF PARKER, COLORADO AND CITY OF AURORA, COLORADO, NOT AVAILABLE IN AUTOCAD)

1 ) **NOTE:** MANY JURISDICTIONS HAVE BMP DETAILS THAT VARY FROM UDFCD STANDARD DETAILS.  
1 ) CONSULT WITH LOCAL JURISDICTIONS AS TO WHICH DETAIL SHOULD BE USED WHEN  
1 ) DIFFERENCES ARE NOTED.

1 ) **NOTE:** THE DETAILS INCLUDED WITH THIS FACT SHEET SHOW COMMONLY USED, CONVENTIONAL  
1 ) METHODS OF INLET PROTECTION IN THE DENVER METROPOLITAN AREA. THERE ARE MANY  
1 ) PROPRIETARY INLET PROTECTION METHODS ON THE MARKET. UDFCD NEITHER ENDORSES NOR  
1 ) DISCOURAGES USE OF PROPRIETARY INLET PROTECTION; HOWEVER, IN THE EVENT  
1 ) PROPRIETARY METHODS ARE USED, THE APPROPRIATE DETAIL FROM THE MANUFACTURER MUST  
1 ) BE INCLUDED IN THE SWMP AND THE BMP MUST BE INSTALLED AND MAINTAINED AS SHOWN  
1 ) IN THE MANUFACTURER'S DETAILS.

1 ) **NOTE:** SOME MUNICIPALITIES DISCOURAGE OR PROHIBIT THE USE OF STRAW BALES FOR INLET  
1 ) PROTECTION. CHECK WITH LOCAL JURISDICTION TO DETERMINE IF STRAW BALE INLET  
1 ) PROTECTION IS ACCEPTABLE.

## Description

A sediment basin is a temporary pond built on a construction site to capture eroded or disturbed soil transported in storm runoff prior to discharge from the site. Sediment basins are designed to capture site runoff and slowly release it to allow time for settling of sediment prior to discharge. Sediment basins are often constructed in locations that will later be modified to serve as post-construction stormwater basins.



Photograph SB-1. Sediment basin at the toe of a slope. Photo courtesy of WWE.

## Appropriate Uses

Most large construction sites (typically greater than 2 acres) will require one or more sediment basins for effective management of construction site runoff. On linear construction projects, sediment basins may be impractical; instead, sediment traps or other combinations of BMPs may be more appropriate.

Sediment basins should not be used as stand-alone sediment controls. Erosion and other sediment controls should also be implemented upstream.

When feasible, the sediment basin should be installed in the same location where a permanent post-construction detention pond will be located.

## Design and Installation

The design procedure for a sediment basin includes these steps:

- **Basin Storage Volume:** Provide a storage volume of at least 3,600 cubic feet per acre of drainage area. To the extent practical, undisturbed and/or off-site areas should be diverted around sediment basins to prevent “clean” runoff from mixing with runoff from disturbed areas. For undisturbed areas (both on-site and off-site) that cannot be diverted around the sediment basin, provide a minimum of 500 ft<sup>3</sup>/acre of storage for undeveloped (but stable) off-site areas in addition to the 3,600 ft<sup>3</sup>/acre for disturbed areas. For stable, developed areas that cannot be diverted around the sediment basin, storage volume requirements are summarized in Table SB-1.
- **Basin Geometry:** Design basin with a minimum length-to-width ratio of 2:1 (L:W). If this cannot be achieved because of site space constraints, baffling may be required to extend the effective distance between the inflow point(s) and the outlet to minimize short-circuiting.
- **Dam Embankment:** It is recommended that embankment slopes be 4:1 (H:V) or flatter and no steeper than 3:1 (H:V) in any location.

| Sediment Basins          |     |
|--------------------------|-----|
| Functions                |     |
| Erosion Control          | No  |
| Sediment Control         | Yes |
| Site/Material Management | No  |

- **Inflow Structure:** For concentrated flow entering the basin, provide energy dissipation at the point of inflow.

**Table SB-1. Additional Volume Requirements for Undisturbed and Developed Tributary Areas Draining through Sediment Basins**

| Imperviousness (%) | Additional Storage Volume (ft <sup>3</sup> ) Per Acre of Tributary Area |
|--------------------|---|
| Undeveloped        | 500   |
| 10                 | 800   |
| 20                 | 1230  |
| 30                 | 1600  |
| 40                 | 2030  |
| 50                 | 2470  |
| 60                 | 2980  |
| 70                 | 3560  |
| 80                 | 4360  |
| 90                 | 5300  |
| 100                | 6460  |

- **Outlet Works:** The outlet pipe shall extend through the embankment at a minimum slope of 0.5 percent. Outlet works can be designed using one of the following approaches:
  - **Perforated Riser/Plate:** Follow the design criteria for Full Spectrum Detention outlets in the EDB BMP Fact Sheet provided in Chapter 4 of this manual for sizing of outlet perforations with an emptying time of approximately 72 hours. In lieu of the well-screen trash rack, pack uniformly sized 1½ - to 2-inch gravel in front of the plate. This gravel will need to be cleaned out frequently during the construction period as sediment accumulates within it. The gravel pack will need to be removed and disposed of following construction to reclaim the basin for use as a permanent detention facility. If the basin will be used as a permanent extended detention basin for the site, a well-screen trash rack will need to be installed once contributing drainage areas have been stabilized and the gravel pack and accumulated sediment have been removed.
  - **Floating Skimmer:** If a floating skimmer is used, install it using manufacturer’s recommendations. Illustration SB-1 provides an illustration of a Faircloth Skimmer Floating Outlet™, one of the more commonly used floating skimmer outlets. A skimmer should be designed to release the design volume in no less than 48 hours. The use of a floating skimmer outlet can increase the sediment capture efficiency of a basin significantly. A floating outlet continually decants cleanest water off the surface of the pond and releases cleaner water than would discharge from a perforated riser pipe or plate.



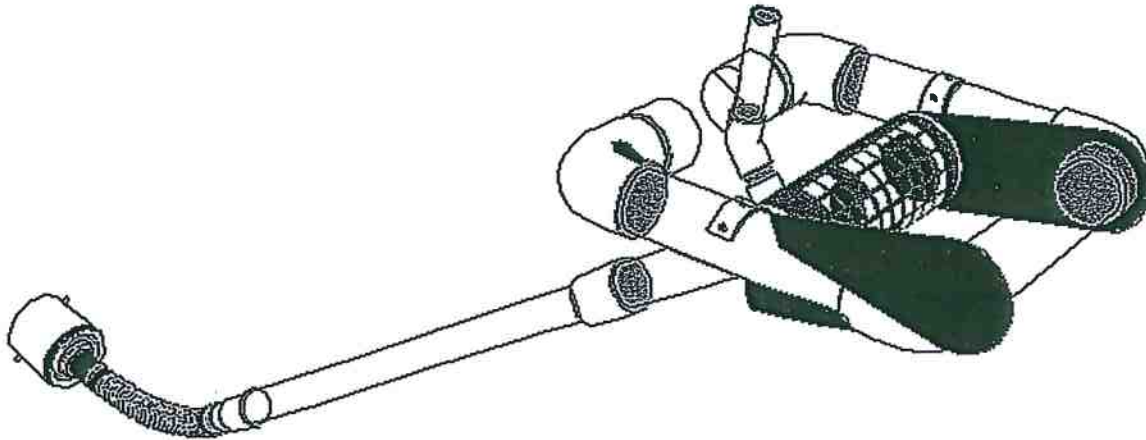

Illustration SB-1. Outlet structure for a temporary sediment basin - Faircloth Skimmer Floating Outlet. Illustration courtesy of J. W. Faircloth & Sons, Inc., FairclothSkimmer.com.

- **Outlet Protection:** Outlet protection should be provided where the velocity of flow will exceed the maximum permissible velocity of the material of the waterway into which discharge occurs. This may require the use of a riprap apron at the outlet location and/or other measures to keep the waterway from eroding.
- **Emergency Spillway:** Provide a stabilized emergency overflow spillway for rainstorms that exceed the capacity of the sediment basin volume and its outlet. Protect basin embankments from erosion and overtopping. If the sediment basin will be converted to a permanent detention basin, design and construct the emergency spillway(s) as required for the permanent facility. If the sediment basin will not become a permanent detention basin, it may be possible to substitute a heavy polyvinyl membrane or properly bedded rock cover to line the spillway and downstream embankment, depending on the height, slope, and width of the embankments.

## Maintenance and Removal

Maintenance activities include the following:

- Dredge sediment from the basin, as needed to maintain BMP effectiveness, typically when the design storage volume is no more than one-third filled with sediment.
- Inspect the sediment basin embankments for stability and seepage.
- Inspect the inlet and outlet of the basin, repair damage, and remove debris. Remove, clean and replace the gravel around the outlet on a regular basis to remove the accumulated sediment within it and keep the outlet functioning.
- Be aware that removal of a sediment basin may require dewatering and associated permit requirements.
- Do not remove a sediment basin until the upstream area has been stabilized with vegetation.



Final disposition of the sediment basin depends on whether the basin will be converted to a permanent post-construction stormwater basin or whether the basin area will be returned to grade. For basins being converted to permanent detention basins, remove accumulated sediment and reconfigure the basin and outlet to meet the requirements of the final design for the detention facility. If the sediment basin is not to be used as a permanent detention facility, fill the excavated area with soil and stabilize with vegetation.

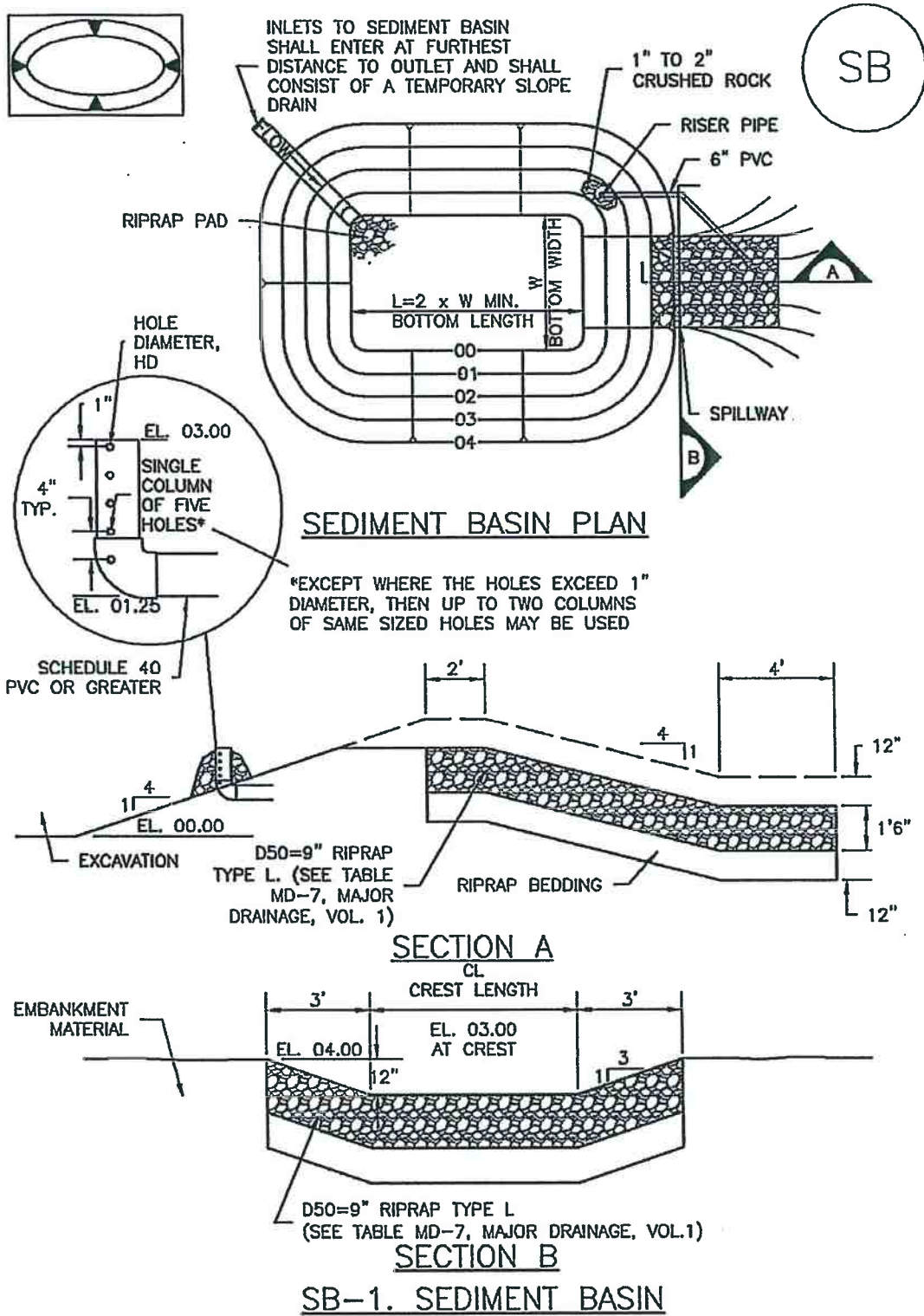

| TABLE SB-1. SIZING INFORMATION FOR STANDARD SEDIMENT BASIN |                              |                                  |                          |
|--|------------------------------|----------------------------------|--------------------------|
| Upstream Drainage Area (rounded to nearest acre), (ac)     | Basin Bottom Width (W), (ft) | Spillway Crest Length (CL), (ft) | Hole Diameter (HD), (in) |
| 1  | 12 ½                         | 2                                | 9/32                     |
| 2  | 21                           | 3                                | 13/16                    |
| 3  | 28                           | 5                                | ½                        |
| 4  | 33 ½                         | 6                                | 9/16                     |
| 5  | 38 ½                         | 8                                | 2 ½/32                   |
| 6  | 43                           | 9                                | 2 1/32                   |
| 7  | 47 ¼                         | 11                               | 25/32                    |
| 8  | 51                           | 12                               | 27/32                    |
| 9  | 55                           | 13                               | 7/8                      |
| 10   | 58 ¼                         | 15                               | 15/16                    |
| 11   | 61                           | 16                               | 3 1/32                   |
| 12   | 64                           | 18                               | 1                        |
| 13   | 67 ½                         | 19                               | 1 1/16                   |
| 14   | 70 ½                         | 21                               | 1 1/8                    |
| 15   | 73 ¼                         | 22                               | 1 3/16                   |

#### SEDIMENT BASIN INSTALLATION NOTES

- SEE PLAN VIEW FOR:
  - LOCATION OF SEDIMENT BASIN.
  - TYPE OF BASIN (STANDARD BASIN OR NONSTANDARD BASIN).
  - FOR STANDARD BASIN, BOTTOM WIDTH W, CREST LENGTH CL, AND HOLE DIAMETER, HD.
  - FOR NONSTANDARD BASIN, SEE CONSTRUCTION DRAWINGS FOR DESIGN OF BASIN INCLUDING RISER HEIGHT H, NUMBER OF COLUMNS N, HOLE DIAMETER HD AND PIPE DIAMETER D.
- FOR STANDARD BASIN, BOTTOM DIMENSION MAY BE MODIFIED AS LONG AS BOTTOM AREA IS NOT REDUCED.
- SEDIMENT BASINS SHALL BE INSTALLED PRIOR TO ANY OTHER LAND-DISTURBING ACTIVITY THAT RELIES ON ON BASINS AS AS A STORMWATER CONTROL.
- EMBANKMENT MATERIAL SHALL CONSIST OF SOIL FREE OF DEBRIS, ORGANIC MATERIAL, AND ROCKS OR CONCRETE GREATER THAN 3 INCHES AND SHALL HAVE A MINIMUM OF 15 PERCENT BY WEIGHT PASSING THE NO. 200 SIEVE.
- EMBANKMENT MATERIAL SHALL BE COMPACTED TO AT LEAST 95 PERCENT OF MAXIMUM DENSITY IN ACCORDANCE WITH ASTM D698.
- PIPE SCH 40 OR GREATER SHALL BE USED.
- THE DETAILS SHOWN ON THESE SHEETS PERTAIN TO STANDARD SEDIMENT BASIN(S) FOR DRAINAGE AREAS LESS THAN 15 ACRES. SEE CONSTRUCTION DRAWINGS FOR EMBANKMENT, STORAGE VOLUME, SPILLWAY, OUTLET, AND OUTLET PROTECTION DETAILS FOR ANY SEDIMENT BASIN(S) THAT HAVE BEEN INDIVIDUALLY DESIGNED FOR DRAINAGE AREAS LARGER THAN 15 ACRES.

## SEDIMENT BASIN MAINTENANCE NOTES

1. INSPECT BMPs EACH WORKDAY, AND MAINTAIN THEM IN EFFECTIVE OPERATING CONDITION. MAINTENANCE OF BMPs SHOULD BE PROACTIVE, NOT REACTIVE. INSPECT BMPs AS SOON AS POSSIBLE (AND ALWAYS WITHIN 24 HOURS) FOLLOWING A STORM THAT CAUSES SURFACE EROSION, AND PERFORM NECESSARY MAINTENANCE.
2. FREQUENT OBSERVATIONS AND MAINTENANCE ARE NECESSARY TO MAINTAIN BMPs IN EFFECTIVE OPERATING CONDITION. INSPECTIONS AND CORRECTIVE MEASURES SHOULD BE DOCUMENTED THOROUGHLY.
3. WHERE BMPs HAVE FAILED, REPAIR OR REPLACEMENT SHOULD BE INITIATED UPON DISCOVERY OF THE FAILURE.
4. SEDIMENT ACCUMULATED IN BASIN SHALL BE REMOVED AS NEEDED TO MAINTAIN BMP EFFECTIVENESS, TYPICALLY WHEN SEDIMENT DEPTH REACHES ONE FOOT (I.E., TWO FEET BELOW THE SPILLWAY CREST).
5. SEDIMENT BASINS ARE TO REMAIN IN PLACE UNTIL THE UPSTREAM DISTURBED AREA IS STABILIZED AND GRASS COVER IS ACCEPTED BY THE LOCAL JURISDICTION.
6. WHEN SEDIMENT BASINS ARE REMOVED, ALL DISTURBED AREAS SHALL BE COVERED WITH TOPSOIL, SEEDED AND MULCHED OR OTHERWISE STABILIZED AS APPROVED BY LOCAL JURISDICTION.

—(DETAILS ADAPTED FROM DOUGLAS COUNTY, COLORADO)

- NOTE: MANY JURISDICTIONS HAVE BMP DETAILS THAT VARY FROM UDFCD STANDARD DETAILS.
- CONSULT WITH LOCAL JURISDICTIONS AS TO WHICH DETAIL SHOULD BE USED WHEN DIFFERENCES ARE NOTED.



## Description

Vehicle tracking controls provide stabilized construction site access where vehicles exit the site onto paved public roads. An effective vehicle tracking control helps remove sediment (mud or dirt) from vehicles, reducing tracking onto the paved surface.

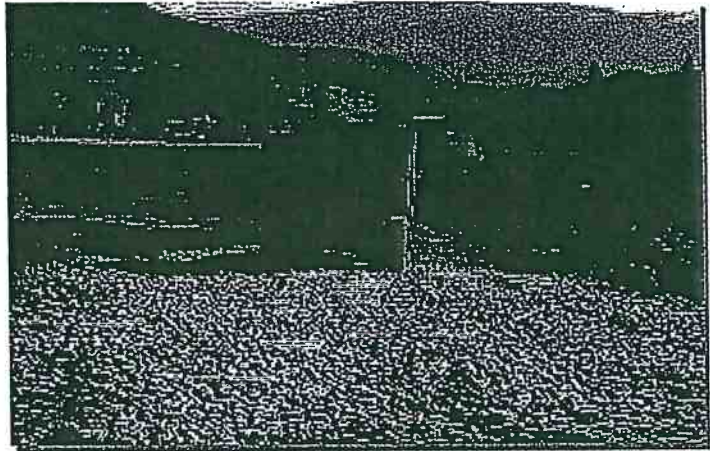

Photograph VTC-1. A vehicle tracking control pad constructed with properly sized rock reduces off-site sediment tracking.

## Appropriate Uses

Implement a stabilized construction entrance or vehicle tracking control where frequent heavy vehicle traffic exits the construction site onto a paved roadway. An effective vehicle tracking control is particularly important during the following conditions:

- Wet weather periods when mud is easily tracked off site.
- During dry weather periods where dust is a concern.
- When poorly drained, clayey soils are present on site.

Although wheel washes are not required in designs of vehicle tracking controls, they may be needed at particularly muddy sites.

## Design and Installation

Construct the vehicle tracking control on a level surface. Where feasible, grade the tracking control towards the construction site to reduce off-site runoff. Place signage, as needed, to direct construction vehicles to the designated exit through the vehicle tracking control. There are several different types of stabilized construction entrances including:

**VTC-1. Aggregate Vehicle Tracking Control.** This is a coarse-aggregate surfaced pad underlain by a geotextile. This is the most common vehicle tracking control, and when properly maintained can be effective at removing sediment from vehicle tires.

**VTC-2. Vehicle Tracking Control with Construction Mat or Turf Reinforcement Mat.** This type of control may be appropriate for site access at very small construction sites with low traffic volume over vegetated areas. Although this application does not typically remove sediment from vehicles, it helps protect existing vegetation and provides a stabilized entrance.

| Vehicle Tracking Control |          |
|--------------------------|----------|
| <b>Functions</b>         |          |
| Erosion Control          | Moderate |
| Sediment Control         | Yes      |
| Site/Material Management | Yes      |

**VTC-3. Stabilized Construction Entrance/Exit with Wheel Wash.** This is an aggregate pad, similar to VTC-1, but includes equipment for tire washing. The wheel wash equipment may be as simple as hand-held power washing equipment to more advanced proprietary systems. When a wheel wash is provided, it is important to direct wash water to a sediment trap prior to discharge from the site.

Vehicle tracking controls are sometimes installed in combination with a sediment trap to treat runoff.

## Maintenance and Removal

Inspect the area for degradation and replace aggregate or material used for a stabilized entrance/exit as needed. If the area becomes clogged and ponds water, remove and dispose of excess sediment or replace material with a fresh layer of aggregate as necessary.

With aggregate vehicle tracking controls, ensure rock and debris from this area do not enter the public right-of-way.

Remove sediment that is tracked onto the public right of way daily or more frequently as needed. Excess sediment in the roadway indicates that the stabilized construction entrance needs maintenance.

Ensure that drainage ditches at the entrance/exit area remain clear.

A stabilized entrance should be removed only when there is no longer the potential for vehicle tracking to occur. This is typically after the site has been stabilized.

When wheel wash equipment is used, be sure that the wash water is discharged to a sediment trap prior to discharge. Also inspect channels conveying the water from the wash area to the sediment trap and stabilize areas that may be eroding.

When a construction entrance/exit is removed, excess sediment from the aggregate should be removed and disposed of appropriately. The entrance should be promptly stabilized with a permanent surface following removal, typically by paving.

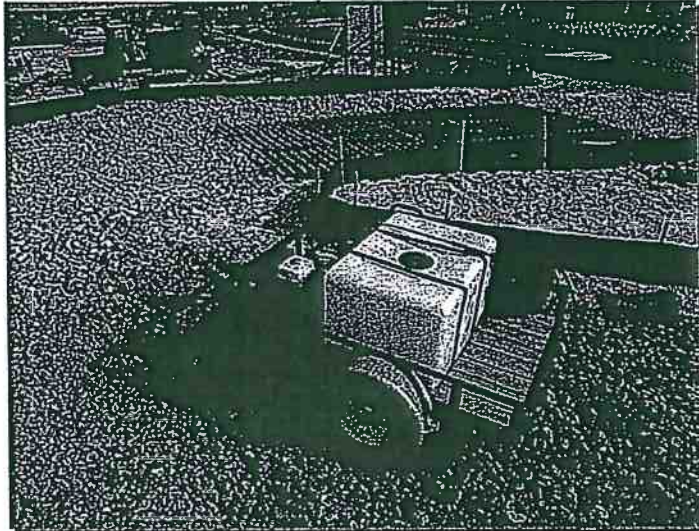

Photograph VTC-2. A vehicle tracking control pad with wheel wash facility. Photo courtesy of Tom Gore.

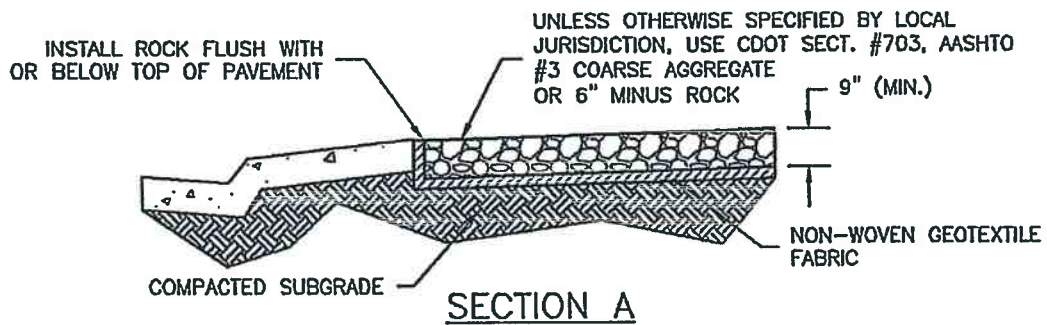
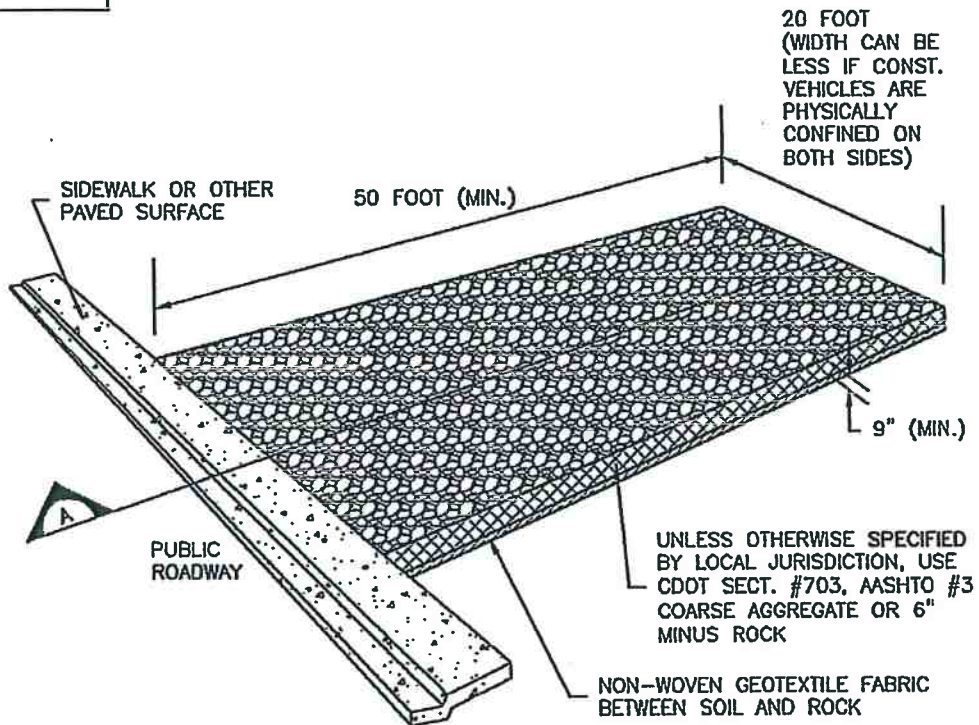
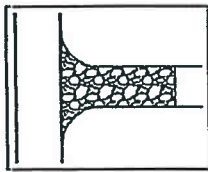

## VTC-1. AGGREGATE VEHICLE TRACKING CONTROL



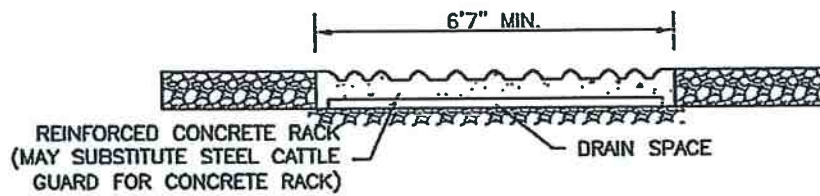
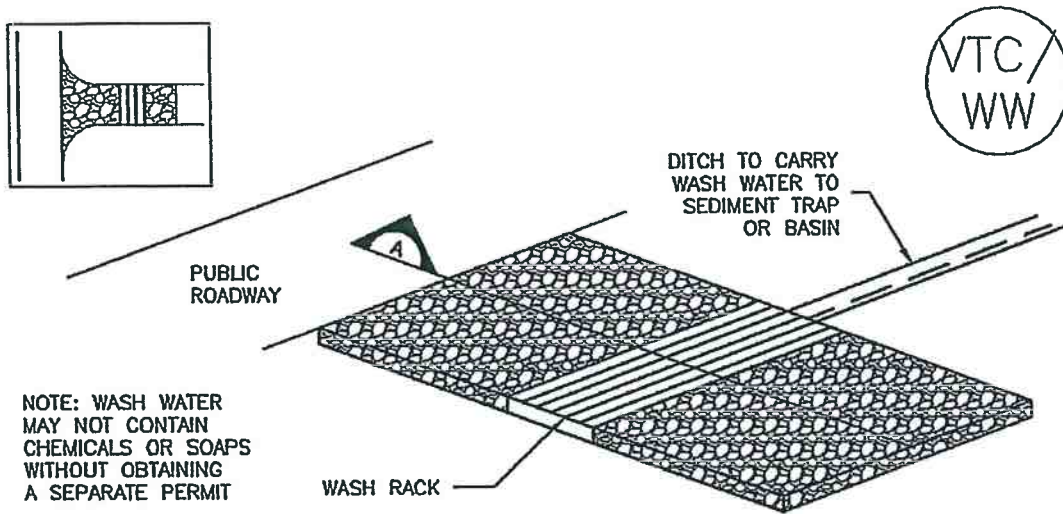

SECTION A

VTC-2. AGGREGATE VEHICLE TRACKING CONTROL WITH WASH RACK



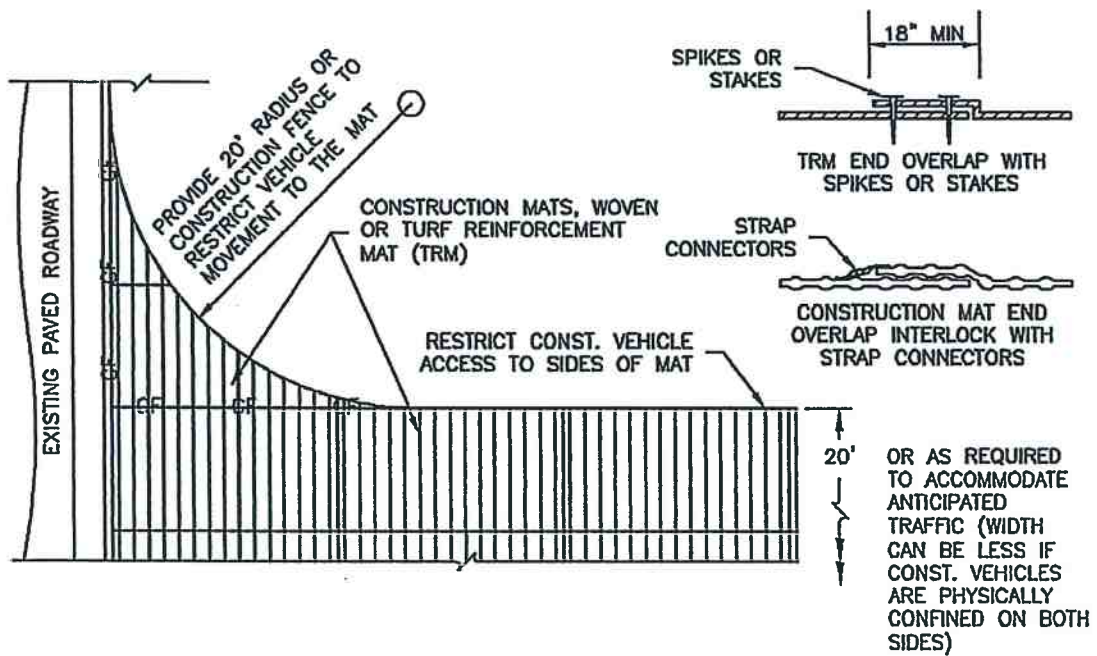
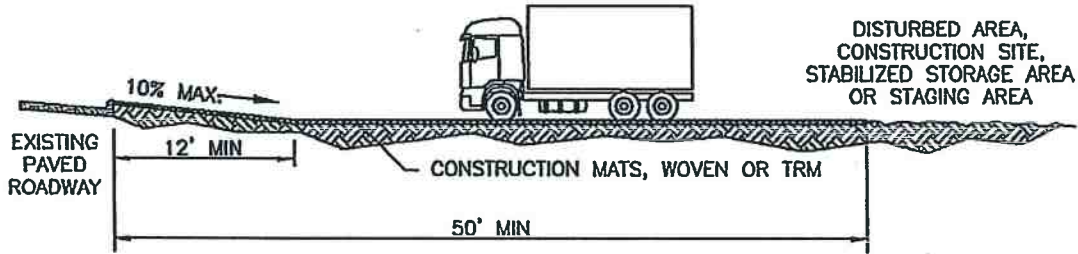
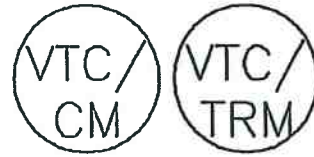
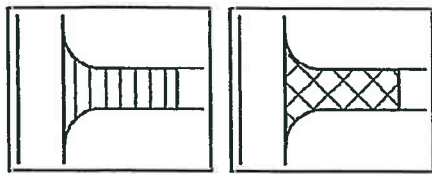

### VTC-3. VEHICLE TRACKING CONTROL W/ CONSTRUCTION MAT OR TURF REINFORCEMENT MAT (TRM)

STABILIZED CONSTRUCTION ENTRANCE/EXIT INSTALLATION NOTES

1. SEE PLAN VIEW FOR
  - LOCATION OF CONSTRUCTION ENTRANCE(S)/EXIT(S).
  - TYPE OF CONSTRUCTION ENTRANCE(S)/EXITS(S) (WITH/WITHOUT WHEEL WASH, CONSTRUCTION MAT OR TRM).
2. CONSTRUCTION MAT OR TRM STABILIZED CONSTRUCTION ENTRANCES ARE ONLY TO BE USED ON SHORT DURATION PROJECTS (TYPICALLY RANGING FROM A WEEK TO A MONTH) WHERE THERE WILL BE LIMITED VEHICULAR ACCESS.
3. A STABILIZED CONSTRUCTION ENTRANCE/EXIT SHALL BE LOCATED AT ALL ACCESS POINTS WHERE VEHICLES ACCESS THE CONSTRUCTION SITE FROM PAVED RIGHT-OF-WAYS.
4. STABILIZED CONSTRUCTION ENTRANCE/EXIT SHALL BE INSTALLED PRIOR TO ANY LAND DISTURBING ACTIVITIES.
5. A NON-WOVEN GEOTEXTILE FABRIC SHALL BE PLACED UNDER THE STABILIZED CONSTRUCTION ENTRANCE/EXIT PRIOR TO THE PLACEMENT OF ROCK.
6. UNLESS OTHERWISE SPECIFIED BY LOCAL JURISDICTION, ROCK SHALL CONSIST OF DOT SECT. #703, AASHTO #3 COARSE AGGREGATE OR 6" (MINUS) ROCK.

STABILIZED CONSTRUCTION ENTRANCE/EXIT MAINTENANCE NOTES

1. INSPECT BMPs EACH WORKDAY, AND MAINTAIN THEM IN EFFECTIVE OPERATING CONDITION. MAINTENANCE OF BMPs SHOULD BE PROACTIVE, NOT REACTIVE. INSPECT BMPs AS SOON AS POSSIBLE (AND ALWAYS WITHIN 24 HOURS) FOLLOWING A STORM THAT CAUSES SURFACE EROSION, AND PERFORM NECESSARY MAINTENANCE.
  2. FREQUENT OBSERVATIONS AND MAINTENANCE ARE NECESSARY TO MAINTAIN BMPs IN EFFECTIVE OPERATING CONDITION. INSPECTIONS AND CORRECTIVE MEASURES SHOULD BE DOCUMENTED THOROUGHLY.
  3. WHERE BMPs HAVE FAILED, REPAIR OR REPLACEMENT SHOULD BE INITIATED UPON DISCOVERY OF THE FAILURE.
  4. ROCK SHALL BE REAPPLIED OR REGRADED AS NECESSARY TO THE STABILIZED ENTRANCE/EXIT TO MAINTAIN A CONSISTENT DEPTH.
  5. SEDIMENT TRACKED ONTO PAVED ROADS IS TO BE REMOVED THROUGHOUT THE DAY AND AT THE END OF THE DAY BY SHOVELING OR SWEEPING. SEDIMENT MAY NOT BE WASHED DOWN STORM SEWER DRAINS.
- **NOTE:** MANY JURISDICTIONS HAVE BMP DETAILS THAT VARY FROM UDFCD STANDARD DETAILS.  
 — CONSULT WITH LOCAL JURISDICTIONS AS TO WHICH DETAIL SHOULD BE USED WHEN DIFFERENCES ARE NOTED.
- (DETAILS ADAPTED FROM CITY OF BROOMFIELD, COLORADO, NOT AVAILABLE IN AUTOCAD)

## Description

A stabilized staging area is a clearly designated area where construction equipment and vehicles, stockpiles, waste bins, and other construction-related materials are stored. The contractor office trailer may also be located in this area. Depending on the size of the construction site, more than one staging area may be necessary.

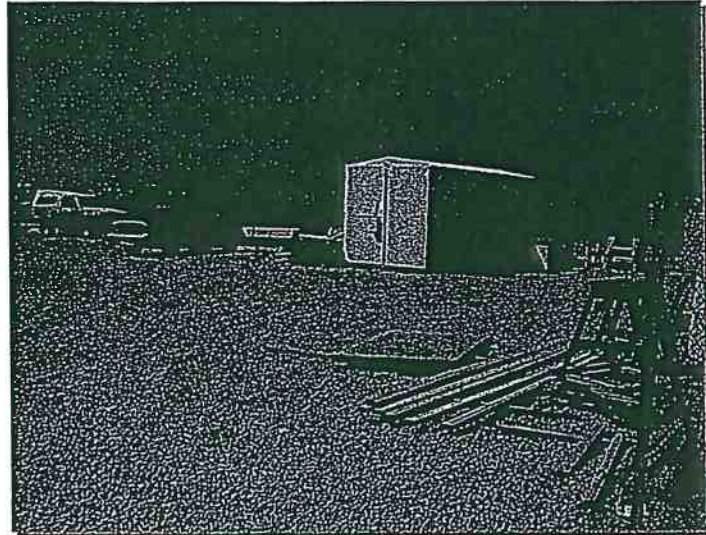

Photograph SSA-1. Example of a staging area with a gravel surface to prevent mud tracking and reduce runoff. Photo courtesy of Douglas County.

## Appropriate Uses

Most construction sites will require a staging area, which should be clearly designated in SWMP drawings. The layout of the staging area may vary depending on the type of construction activity. Staging areas located in roadways due to space constraints require special measures to avoid materials being washed into storm inlets.

## Design and Installation

Stabilized staging areas should be completed prior to other construction activities beginning on the site. Major components of a stabilized staging area include:

- Appropriate space to contain storage and provide for loading/unloading operations, as well as parking if necessary.
- A stabilized surface, either paved or covered, with 3-inch diameter aggregate or larger.
- Perimeter controls such as silt fence, sediment control logs, or other measures.
- Construction fencing to prevent unauthorized access to construction materials.
- Provisions for Good Housekeeping practices related to materials storage and disposal, as described in the Good Housekeeping BMP Fact Sheet.
- A stabilized construction entrance/exit, as described in the Vehicle Tracking Control BMP Fact Sheet, to accommodate traffic associated with material delivery and waste disposal vehicles.

Over-sizing the stabilized staging area may result in disturbance of existing vegetation in excess of that required for the project. This increases costs, as well as requirements for long-term stabilization following the construction period. When designing the stabilized staging area, minimize the area of disturbance to the extent practical.

| Stabilized Staging Area |          |
|-------------------------|----------|
| Functions               |          |
| Erosion Control         | Yes      |
| Sediment Control        | Moderate |
| Site/Material           | Yes      |



**Minimizing Long-Term Stabilization Requirements**

- Utilize off-site parking and restrict vehicle access to the site.
- Use construction mats in lieu of rock when staging is provided in an area that will not be disturbed otherwise.
- Consider use of a bermed contained area for materials and equipment that do not require a stabilized surface.
- Consider phasing of staging areas to avoid disturbance in an area that will not be otherwise disturbed.

See Detail SSA-1 for a typical stabilized staging area and SSA-2 for a stabilized staging area when materials staging in roadways is required.

**Maintenance and Removal**

Maintenance of stabilized staging areas includes maintaining a stable surface cover of gravel, repairing perimeter controls, and following good housekeeping practices.

When construction is complete, debris, unused stockpiles and materials should be recycled or properly disposed. In some cases, this will require disposal of contaminated soil from equipment leaks in an appropriate landfill. Staging areas should then be permanently stabilized with vegetation or other surface cover planned for the development.



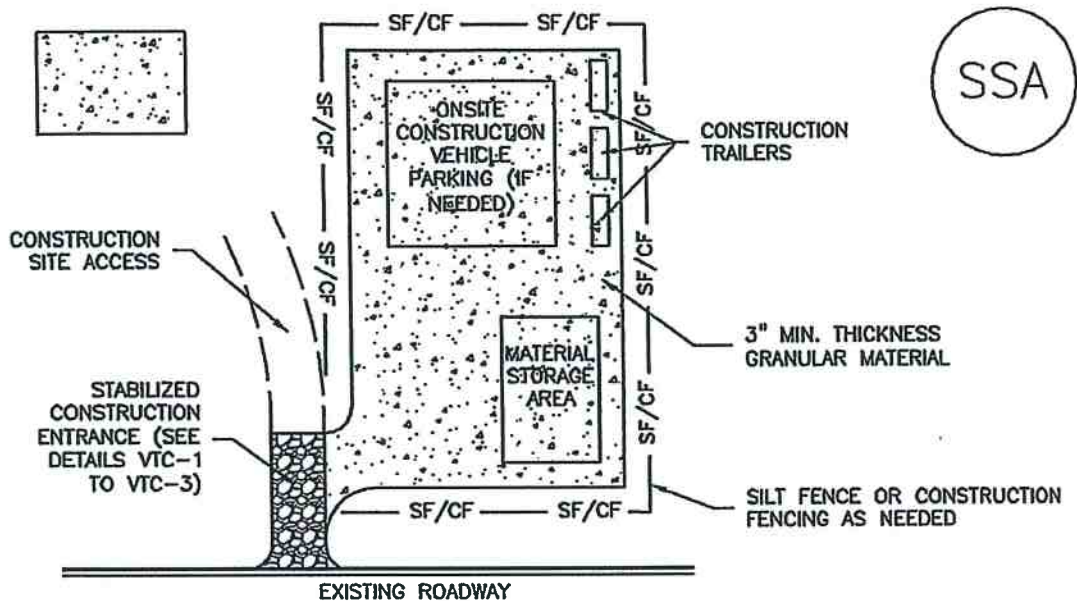

## SSA-1. STABILIZED STAGING AREA

### STABILIZED STAGING AREA INSTALLATION NOTES

- SEE PLAN VIEW FOR
  - LOCATION OF STAGING AREA(S).
  - CONTRACTOR MAY ADJUST LOCATION AND SIZE OF STAGING AREA WITH APPROVAL FROM THE LOCAL JURISDICTION.
- STABILIZED STAGING AREA SHOULD BE APPROPRIATE FOR THE NEEDS OF THE SITE. OVERSIZING RESULTS IN A LARGER AREA TO STABILIZE FOLLOWING CONSTRUCTION.
- STAGING AREA SHALL BE STABILIZED PRIOR TO OTHER OPERATIONS ON THE SITE.
- THE STABILIZED STAGING AREA SHALL CONSIST OF A MINIMUM 3" THICK GRANULAR MATERIAL.
- UNLESS OTHERWISE SPECIFIED BY LOCAL JURISDICTION, ROCK SHALL CONSIST OF DOT SECT. #703, AASHTO #3 COARSE AGGREGATE OR 6" (MINUS) ROCK.
- ADDITIONAL PERIMETER BMPs MAY BE REQUIRED INCLUDING BUT NOT LIMITED TO SILT FENCE AND CONSTRUCTION FENCING.

### STABILIZED STAGING AREA MAINTENANCE NOTES

- INSPECT BMPs EACH WORKDAY, AND MAINTAIN THEM IN EFFECTIVE OPERATING CONDITION. MAINTENANCE OF BMPs SHOULD BE PROACTIVE, NOT REACTIVE. INSPECT BMPs AS SOON AS POSSIBLE (AND ALWAYS WITHIN 24 HOURS) FOLLOWING A STORM THAT CAUSES SURFACE EROSION, AND PERFORM NECESSARY MAINTENANCE.
- FREQUENT OBSERVATIONS AND MAINTENANCE ARE NECESSARY TO MAINTAIN BMPs IN EFFECTIVE OPERATING CONDITION. INSPECTIONS AND CORRECTIVE MEASURES SHOULD BE DOCUMENTED THOROUGHLY.
- WHERE BMPs HAVE FAILED, REPAIR OR REPLACEMENT SHOULD BE INITIATED UPON DISCOVERY OF THE FAILURE.
- ROCK SHALL BE REAPPLIED OR REGRADED AS NECESSARY IF RUTTING OCCURS OR UNDERLYING SUBGRADE BECOMES EXPOSED.

STABILIZED STAGING AREA MAINTENANCE NOTES

5. STABILIZED STAGING AREA SHALL BE ENLARGED IF NECESSARY TO CONTAIN PARKING, STORAGE, AND UNLOADING/LOADING OPERATIONS.

6. THE STABILIZED STAGING AREA SHALL BE REMOVED AT THE END OF CONSTRUCTION. THE GRANULAR MATERIAL SHALL BE REMOVED OR, IF APPROVED BY THE LOCAL JURISDICTION, USED ON SITE, AND THE AREA COVERED WITH TOPSOIL, SEEDED AND MULCHED OR OTHERWISE STABILIZED IN A MANNER APPROVED BY LOCAL JURISDICTION.

NOTE: MANY MUNICIPALITIES PROHIBIT THE USE OF RECYCLED CONCRETE AS GRANULAR MATERIAL FOR STABILIZED STAGING AREAS DUE TO DIFFICULTIES WITH RE-ESTABLISHMENT OF VEGETATION IN AREAS WHERE RECYCLED CONCRETE WAS PLACED.

NOTE: MANY JURISDICTIONS HAVE BMP DETAILS THAT VARY FROM UDFCD STANDARD DETAILS. CONSULT WITH LOCAL JURISDICTIONS AS TO WHICH DETAIL SHOULD BE USED WHEN DIFFERENCES ARE NOTED.

— (DETAILS ADAPTED FROM DOUGLAS COUNTY, COLORADO, NOT AVAILABLE IN AUTOCAD)

## Description

Protection of existing vegetation on a construction site can be accomplished through installation of a construction fence around the area requiring protection. In cases where upgradient areas are disturbed, it may also be necessary to install perimeter controls to minimize sediment loading to sensitive areas such as wetlands. Existing vegetation may be designated for protection to maintain a stable surface cover as part of construction phasing, or vegetation may be protected in areas designated to remain in natural condition under post-development conditions (e.g., wetlands, mature trees, riparian areas, open space).

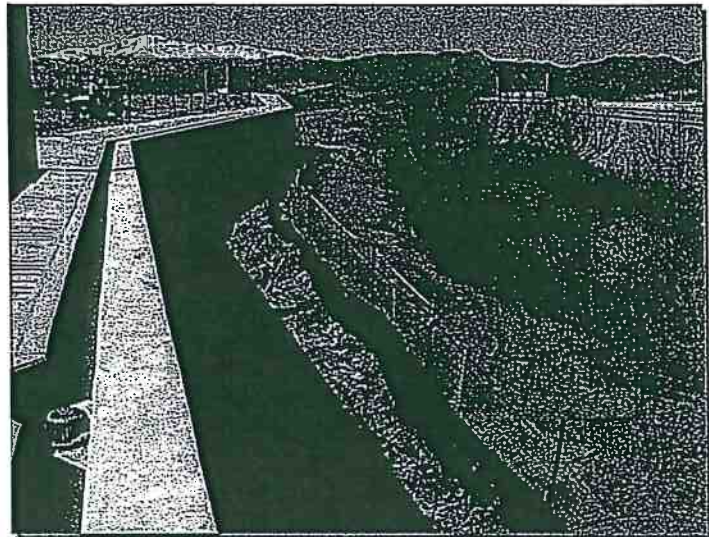

Photograph PV-1. Protection of existing vegetation and a sensitive area. Photo courtesy of CDOT.

## Appropriate Uses

Existing vegetation should be preserved for the maximum practical duration on a construction site through the use of effective construction phasing. Preserving vegetation helps to minimize erosion and can reduce revegetation costs following construction.

Protection of wetland areas is required under the Clean Water Act, unless a permit has been obtained from the U.S. Army Corps of Engineers (USACE) allowing impacts in limited areas.

If trees are to be protected as part of post-development landscaping, care must be taken to avoid several types of damage, some of which may not be apparent at the time of injury. Potential sources of injury include soil compaction during grading or due to construction traffic, direct equipment-related injury such as bark removal, branch breakage, surface grading and trenching, and soil cut and fill. In order to minimize injuries that may lead to immediate or later death of the tree, tree protection zones should be developed during site design, implemented at the beginning of a construction project, as well as continued during active construction.

## Design and Installation

### General

Once an area has been designated as a preservation area, there should be no construction activity allowed within a set distance of the area. Clearly mark the area with construction fencing. Do not allow stockpiles, equipment, trailers or parking within the protected area. Guidelines to protect various types of existing vegetation follow.

| Protection of Existing Vegetation |          |
|-----------------------------------|----------|
| Functions                         |          |
| Erosion Control                   | Yes      |
| Sediment Control                  | Moderate |
| Site/Material Management          | Yes      |

### Surface Cover During Phased Construction

Install construction fencing or other perimeter controls around areas to be protected from clearing and grading as part of construction phasing.

Maintaining surface cover on steep slopes for the maximum practical duration during construction is recommended.

### Open Space Preservation

Where natural open space areas will be preserved as part of a development, it is important to install construction fencing around these areas to protect them from compaction. This is particularly important when areas with soils with high infiltration rates are preserved as part of LID designs. Preserved open space areas should not be used for staging and equipment storage.

### Wetlands and Riparian Areas

Install a construction fence around the perimeter of the wetland or riparian (streamside vegetation) area to prevent access by equipment. In areas downgradient of disturbed areas, install a perimeter control such as silt fence, sediment control logs, or similar measure to minimize sediment loading to the wetland.

### Tree Protection<sup>1</sup>

- Before beginning construction operations, establish a tree protection zone around trees to be preserved by installing construction fences. Allow enough space from the trunk to protect the root zone from soil compaction and mechanical damage, and the branches from mechanical damage (see Table PV-1). If low branches will be kept, place the fence outside of the drip line. Where this is not possible, place fencing as far away from the trunk as possible. In order to maintain a healthy tree, be aware that about 60 percent of the tree's root zone extends beyond the drip line.

**Table PV-1**  
**Guidelines for Determining the Tree Protection Zone**  
 (Source: Matheny and Clark, 1998; as cited in GreenCO and WWE 2008)

| Species Tolerance to Damage | Distance from Trunk (ft) per inch of DBH |        |             |
|-----------------------------|--|--------|-------------|
|                             | Young                                    | Mature | Over mature |
| Good                        | 0.5'                                     | 0.75'  | 1.0'        |
| Moderate                    | 0.75'                                    | 1.0'   | 1.25'       |
| Poor                        | 1.0'                                     | 1.25'  | 1.5'        |

Notes: DBH = diameter at breast height (4.5 ft above grade); Young = <20% of life expectancy; Mature = 20%-80% of life expectancy; Over mature =>80% of life expectancy

- Most tree roots grow within the top 12 to 18 inches of soil. Grade changes within the tree protection zone should be avoided where possible because seemingly minor grade changes can either smother

<sup>1</sup> Tree Protection guidelines adapted from GreenCO and WWE (2008). *Green Industry Best Management Practices (BMPs) for the Conservation and Protection of Water Resources in Colorado: Moving Toward Sustainability, Third Release*. See [www.greenco.org](http://www.greenco.org) for more detailed guidance on tree preservation.



roots (in fill situations) or damage roots (in cut situations). Consider small walls where needed to avoid grade changes in the tree protection zone.

- Place and maintain a layer of mulch 4 to 6-inch thick from the tree trunk to the fencing, keeping a 6-inch space between the mulch and the trunk. Mulch helps to preserve moisture and decrease soil compaction if construction traffic is unavoidable. When planting operations are completed, the mulch may be reused throughout planting areas.
- Limit access, if needed at all, and appoint one route as the main entrance and exit to the tree protection zone. Within the tree protection zone, do not allow any equipment to be stored, chemicals to be dumped, or construction activities to take place except fine grading, irrigation system installation, and planting operations. These activities should be conducted in consultation with a landscaping professional, following Green Industry BMPs.
- Be aware that soil compaction can cause extreme damage to tree health that may appear gradually over a period of years. Soil compaction is easier to prevent than repair.

## Maintenance and Removal

Repair or replace damaged or displaced fencing or other protective barriers around the vegetated area.

If damage occurs to a tree, consult an arborist for guidance on how to care for the tree. If a tree in a designated preservation area is damaged beyond repair, remove and replace with a 2-inch diameter tree of the same or similar species.

Construction equipment must not enter a wetland area, except as permitted by the U.S. Army Corps of Engineers (USACE). Inadvertent placement of fill in a wetland is a 404 permit violation and will require notification of the USACE.

If damage to vegetation occurs in a protected area, reseed the area with the same or similar species, following the recommendations in the USDCM *Revegetation* chapter.

## Description

Street sweeping and vacuuming remove sediment that has been tracked onto roadways to reduce sediment transport into storm drain systems or a surface waterway.

## Appropriate Uses

Use this practice at construction sites where vehicles may track sediment offsite onto paved roadways.

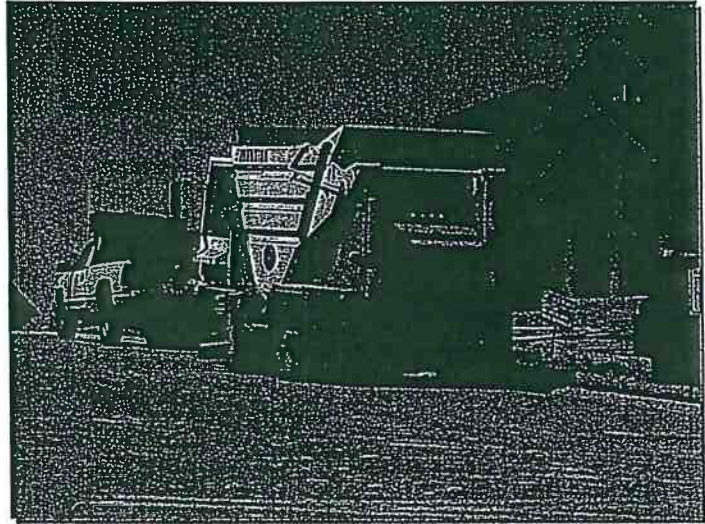

Photograph SS-1. A street sweeper removes sediment and potential pollutants along the curb line at a construction site. Photo courtesy of Tom Gore.

## Design and Installation

Street sweeping or vacuuming should be conducted when there is noticeable sediment accumulation on roadways adjacent to the construction site. Typically, this will be concentrated at the entrance/exit to the construction site. Well-maintained stabilized construction entrances, vehicle tracking controls and tire wash facilities can help reduce the necessary frequency of street sweeping and vacuuming.

On smaller construction sites, street sweeping can be conducted manually using a shovel and broom. Never wash accumulated sediment on roadways into storm drains.

## Maintenance and Removal

- Inspect paved roads around the perimeter of the construction site on a daily basis and more frequently, as needed. Remove accumulated sediment, as needed.
- Following street sweeping, check inlet protection that may have been displaced during street sweeping.
- Inspect area to be swept for materials that may be hazardous prior to beginning sweeping operations.

| <b>Street Sweeping/ Vacuuming</b> |     |
|-----------------------------------|-----|
| <b>Functions</b>                  |     |
| Erosion Control                   | No  |
| Sediment Control                  | Yes |
| Site/Material Management          | Yes |

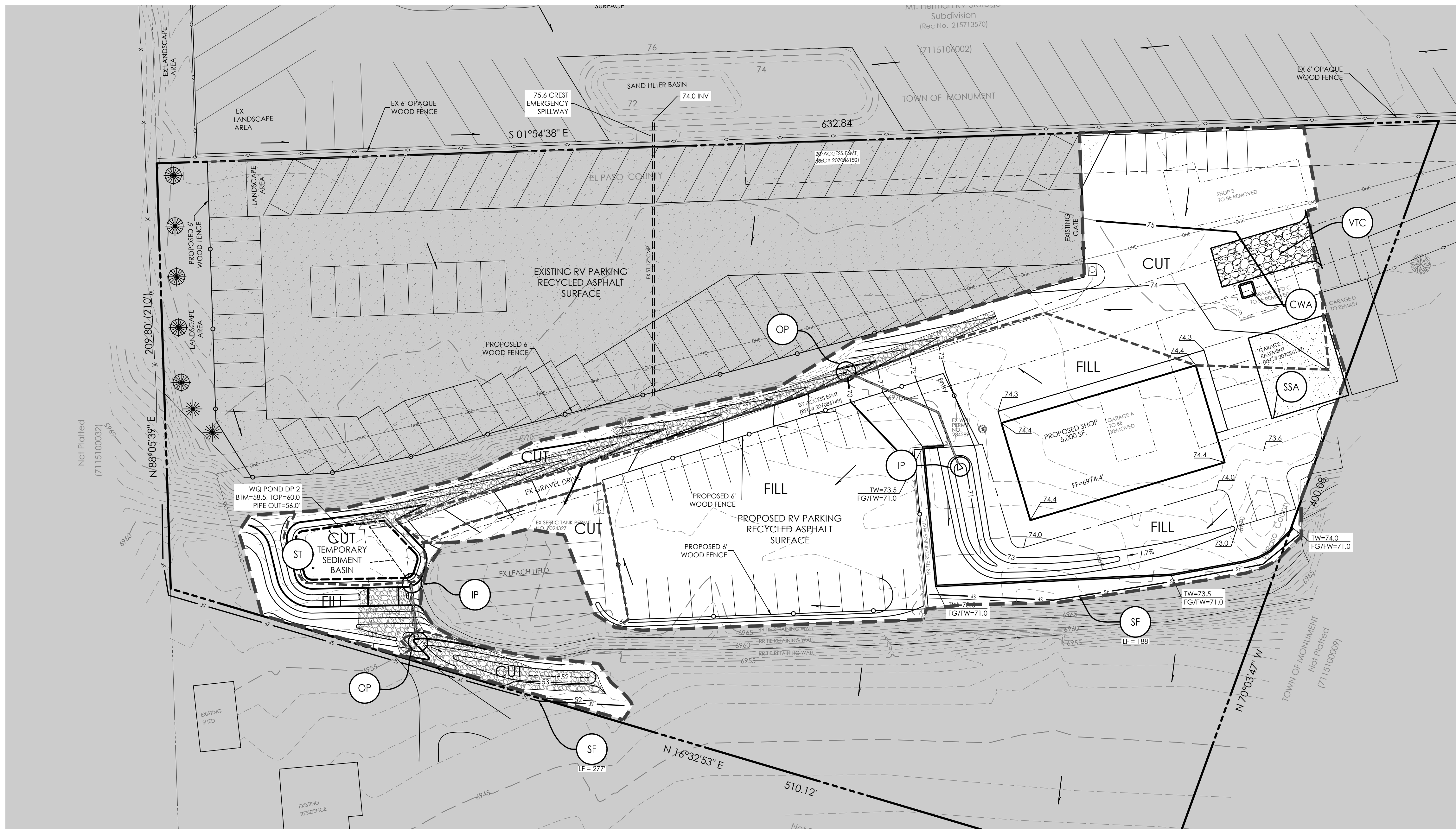

**BMP LEGEND**

| MAP SYMBOL | KEY | DESCRIPTION                                  |
|------------|-----|--|
|            | SF  | SILT FENCE                                   |
|            | SCL | SEDIMENT CONTROL LOGS                        |
|            | SBB | STRAW BALE BARRIER                           |
|            | VTC | VEHICLE TRACKING CONTROL                     |
|            | OP  | PERMANENT OUTLET PROTECTION (SEE CONST DWGS) |
|            | IP  | INLET PROTECTION                             |
|            | CWA | CONCRETE WASHOUT                             |
|            | ST  | SEDIMENT TRAP                                |
|            | MU  | MULCHING                                     |
|            | PS  | PERMANENT SEEDING                            |
|            | SR  | SURFACE ROUGHENING                           |
|            |     | LIMITS OF CONSTRUCTION SITE BOUNDARIES       |
|            |     | LIMITS OF CUT/FILL                           |

BENCHMARK

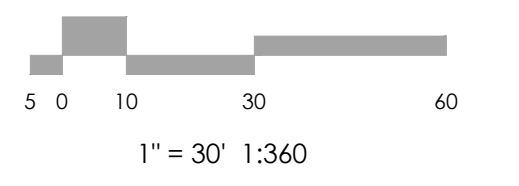
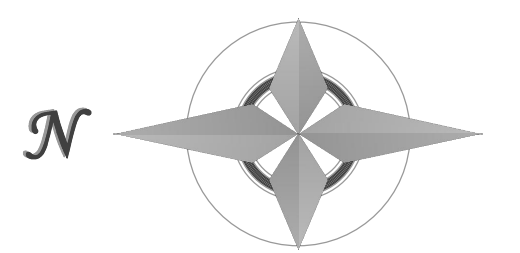

REVISIONS

|  |          |
|--|----------|
| 1. PCD FILE NO. PPR-18-013 GEC PLANS APPROVED. | 08/23/18 |
| 2. SITE CHANGES                                | 09/27/19 |
| 3. EPC RESUBMITTAL                             | 10/11/19 |
| 4. EPC REVISED SUBMITTAL                       | 10/24/19 |

DESIGNED BY \_\_\_\_\_  
 DRAWN BY \_\_\_\_\_  
 CHECKED BY \_\_\_\_\_  
 AS-BUILTS BY \_\_\_\_\_  
 CHECKED BY \_\_\_\_\_

Monument Small Engine Storage

**C1.4**  
 EROSION CONTROL PLAN

MVE PROJECT 61092  
 MVE DRAWING -GEC-EC

OCTOBER 24, 2019  
 SHEET 4 OF 5