

**Stormwater Best Management Practices
Operations and Maintenance Manual (O&M Manual)**

for:

Viewpoint Estates

Located at:

21209 & 21307 Chesley Drive

Date:

January 3, 2024

Prepared for:

***Global Water Systems, LLC
3270 Pony Tracks Drive, Colorado Springs, CO 80922
Phone no. (719) 332-9558***

Prepared by:

***M.V.E., Inc.
1903 Lelaray Street, Suite 200
Colorado Springs, CO 80909
(719) 635-5736***

Reference:

**This plan is adapted from various maintenance manuals developed in the
Colorado Front Range**

**Stormwater Best Management Practices
Operations and Maintenance Manual (O&M Manual)**

Table of Contents

- I. Compliance with Stormwater Best Management Practices Maintenance Requirements**
- II. Inspection & Maintenance**
- III. Preventative Measures to Reduce Maintenance Costs**
- IV. Access and Easements**
- V. Safety**
- VI. Field Inspection Equipment**
- VII. Inspecting Stormwater Best Management Practices**
 - A. Inspection Procedures
 - B. Inspection Report
 - C. Verification of Inspection and Form Submittal
- VIII. Maintaining Stormwater Best Management Practices**
 - A. Maintenance Categories
 - B. Maintenance Personnel
 - C. Maintenance Forms

Appendices

- Appendix A** - Description of Stormwater Best Management Practices
- Appendix B** - Standard Operation Procedures (SOP)
- Appendix C** - Inspection Form(s)
- Appendix D** - Maintenance Form(s)
- Appendix E** – Stormwater Facilities Map

Stormwater Best Management Practices Operations and Maintenance Manual (O&M Manual)

I. Compliance with Stormwater Best Management Practices Maintenance Requirements

All property owners are responsible for ensuring that stormwater best management practices (BMPs) or facilities installed on their property are properly maintained and that they function as designed. The property owner at the time of subdivision platting or development plan approval has executed a legally binding "Private Detention Basin/ Stormwater Quality Best Management Practice Maintenance Agreement and Easement" document which runs with the land/ BMP Maintenance Agreement. Property owners should be aware of their responsibilities regarding stormwater facility maintenance and need to be familiar with the contents of this Operations and Maintenance Manual (O&M Manual).

II. Inspection & Maintenance

The aforementioned BMP Maintenance Agreement requires the land owner or other responsible parties to conduct regular and routine inspections, cleanings, and maintenance.

Requirements for the inspection and maintenance of stormwater facilities are included in this Stormwater Best Management Practices O&M Manual.

Copies of the Inspection and Maintenance forms for each of the stormwater BMPs are located in Appendix C and D. These are provided for the convenience of the property owner or property manager and may be useful in demonstrating regular inspection and maintenance of the facility.

III. Preventative Measures to Reduce Maintenance Costs

The most effective way to maintain your water quality facility is to prevent the pollutants from entering the facility. Common pollutants include sediment, trash & debris, chemicals, pet wastes, runoff from stored materials, illicit discharges into the storm drainage system and many others. A thoughtful maintenance program will include measures to address these potential contaminants and will save money and time in the long run. Key points to consider in your maintenance program include:

- Educate property owners/residents to be aware of how their actions affect water quality and how they can help reduce maintenance costs.
- Keep properties, streets and gutters, and parking lots free of trash, debris, and lawn clippings.
- Ensure the proper use, storage, and disposal of hazardous wastes and chemicals. Promptly clean up and spilled materials and dispose of properly.
- Plan lawn care to minimize and properly use chemicals and pesticides.
- Sweep paved surfaces and put the sweepings back on the lawn.
- Be aware of automobiles leaking fluids. Use absorbents such as cat litter to soak up drippings – dispose of properly.
- Encourage pet owners to clean up pet wastes.
- Re-vegetate disturbed and bare areas to maintain vegetative stabilization.
- Clean any private storm drainage system components, including inlets, storm sewers, and outfalls.
- Do not store materials outdoors (including landscaping materials) unless properly protected from runoff.

IV. Access and Right to Enter

All stormwater management facilities located on the site should have both a designated access location and El Paso County has the right to enter for the purpose of inspecting and for maintaining BMPs where the owner has failed to do so, in accordance with the BMP Maintenance Agreement.

V. Safety

Keep safety considerations at the forefront of inspection procedures at all times. Likely hazards should be anticipated and avoided. Never enter a confined space (outlet structure, manhole, etc) without proper training, number of personal, and equipment.

Potentially dangerous (e.g., fuel, chemicals, hazardous materials) substances found in the areas must be referred emergency services at 911 (non-emergency number is 444-7000). If a toxic or flammable substance is discovered, leave the immediate area and contact the local emergency services at 911.

Vertical drops may be encountered in areas located within and around the facility. Avoid walking on top of retaining walls or other structures that have a significant vertical drop. If a vertical drop is greater than 48" in height, make the appropriate note/comment on the maintenance inspection form.

If any hazard is found within the facility area that poses an immediate threat to public safety, contact emergency services at 911 immediately.

VI. Field Inspection Equipment

It is imperative that the appropriate equipment is taken to the field with the inspector(s). This is to ensure the safety of the inspector and allow the inspections to be performed as efficiently as possible. Below is a list of the equipment that may be necessary to perform the inspections of all Stormwater BMPs:

- Protective clothing and boots.
- Safety equipment (vest, hard hat, confined space entry equipment [if certified to perform confined space entry]).
- Communication equipment.
- O&M Manual for the site.
- Clipboard.
- Stormwater BMP Inspection Forms (See Appendix C).
- Manhole Lid Remover
- Shovel.

Some of the items identified above need not be carried by the inspector (manhole lid remover, shovel, and confined space entry equipment), but should be available in the vehicle driven to the site. Specialized equipment may require specific training related to that equipment and should only be used by trained individuals.

VII. Inspecting Stormwater BMPs

The quality of stormwater entering the waters of the state relies heavily on the proper operation and maintenance of permanent BMPs. Stormwater BMPs must be periodically inspected to ensure that they function as designed. The inspection will determine the appropriate maintenance that is required for the facility.

A. Inspection Procedures

It is recommended that all Stormwater BMPs be inspected a minimum of once per year. Inspections should follow the inspection guidance found in the Standard Operation Procedures (SOP) for the specific type of facility. (Appendix B of this manual).

B. Inspection Report

It is recommended that the person(s) conducting the inspection activities complete the appropriate inspection report for the specific facility. Inspection reports are located in Appendix C. It is recommended that a copy of each inspection form be kept by the owner a minimum of 5 years.

The following information explains how to fill out the Inspection Forms:

General Information

This section identifies the facility location, person conducting the inspection, the date and time the facility was inspected, and approximate days since the last rainfall. Property classification is identified as single-family residential, multi-family residential, commercial, or other.

The reason for the inspection is also identified on the form depending on the nature of the inspection. It is recommended that all facilities must be inspected on an annual basis at a minimum. In addition, all facilities should be inspected after a significant precipitation event to ensure the facility is draining appropriately and to identify any damage that occurred as a result of the increased runoff.

Inspection Scoring

For each inspection item, a score must be given to identify the urgency of required maintenance. The scoring is as follows:

- 0 = No deficiencies identified.
 - 1 = Monitor – Although maintenance may not be required at this time, a potential problem exists that will most likely need to be addressed in the future. This can include items like minor erosion, concrete cracks/spalling, or minor sediment accumulation. This item should be revisited at the next inspection.
 - 2 = Routine Maintenance Required – Some inspection items can be addressed through the routine maintenance program. This can include items like vegetation management or debris/trash removal.
 - 3 = Immediate Repair Necessary – This item needs immediate attention because failure is imminent or has already occurred. This could include items such as structural failure of a feature (outlet works, forebay, etc), significant erosion, or significant sediment accumulation. This score should be given to an item that can significantly affect the function of the facility.
- N/A This is checked by an item that may not exist in a facility. Not all facilities have all of the features identified on the form (forebay, micro-pool, etc.).

Inspection Summary/Additional Comments

Additional explanations to inspection items, and observations about the facility not covered by the form, are recorded in this section.

Overall Facility Rating

An overall rating must be given for each facility inspected. The overall facility rating should correspond with the highest score (0, 1, 2, 3) given to any feature on the inspection form.

VIII. Maintaining Stormwater BMPs

Stormwater BMPs must be properly maintained to ensure that they operate correctly and provide the water quality treatment for which they were designed. Routine maintenance performed on a frequently scheduled basis, can help avoid more costly rehabilitative maintenance that results when facilities are not adequately maintained.

A. Maintenance Categories

Stormwater BMP maintenance programs are separated into three broad categories of work. The categories are separated based upon the magnitude and type of the maintenance activities performed. A description of each category follows:

Routine Work

The majority of this work consists of scheduled mowings and trash and debris pickups for stormwater management facilities during the growing season. This includes items such as the removal of debris/material that may be clogging the outlet structure well screens and trash racks. It also includes activities such as weed control, mosquito treatment, and algae treatment. These activities normally will be performed numerous times during the year. These items can be completed without any prior correspondence El Paso County; however, it is recommended that inspection and maintenance forms be completed with the information.

Restoration Work

This work consists of a variety of isolated or small-scale maintenance and work needed to address operational problems. Most of this work can be completed by a small crew, with minor tools, and small equipment. These items do not require prior correspondence with El Paso County. However, it is recommended that maintenance forms be completed and entered into the owner's maintenance records.

Rehabilitation Work

This work consists of large-scale maintenance and major improvements needed to address failures within the stormwater BMP. Consultation with El Paso County is recommended, which may result in a need for engineering design with construction plans to be prepared for review and approval by the County. This work may also require more specialized

maintenance equipment, surveying, construction permits or assistance through private contractors and consultants.

B. Maintenance Personnel

Maintenance personnel should be qualified to properly maintain stormwater BMPs, especially for restoration or rehabilitation work. Inadequately trained personnel can cause additional problems resulting in additional maintenance costs.

C. Maintenance Forms

The Stormwater BMP Maintenance Form provides a record of maintenance activities. Maintenance Forms for each facility type are provided in Appendix D. It is recommended that maintenance Forms shall be completed by the property owner, management company, or contractor completing the required maintenance items.

Appendix A

General Location and Description of Stormwater Best Management Practices

A. General Site Description

Viewpoint Estates and Viewpoint Estates Filing No. 2 is located in a portion of the West Half of the West Half of the East Half of Section 10, Township 14 South, Range 63 West of the 6th P.M., El Paso County, Colorado. The site is located on the north side of Highway #94, lying east and west of Antelope Drive.

B. General Stormwater Management Description

All stormwater is conveyed via roadside ditches and culverts to two existing detention basins located in Lots 71 & 72 of Viewpoint Estates, being replatted as Viewpoint Estates Filing No. 2. Flows from the detention basins are conveyed in outlet pipes to existing culverts south under Highway #94.

C. Stormwater Facilities Map

Inspection or maintenance personnel may utilize the map in Appendix E for locating the stormwater facilities within this development.

D. On-Site Stormwater Management Facilities

Volume Reduction Facilities

Viewpoint Estates site utilizes no Level I Minimize Directly Connected Impervious Areas (MDCIA).

Storage Facilities (Detention)

Detention for Viewpoint Estates is provided in the existing detention basins located in Lots 71 & 72 of Viewpoint Estates, being replatted as Viewpoint Estates Filing No. 2. Existing facilities consist of Riser Pipes w/ Trash Racks and Initial Storm Outlets. No changes to these facilities is occurring with the development of Viewpoint Estates Filing No. 2.

Water Quality Facilities

Viewpoint Estates does not include any structures for providing water quality volume for the site.

Source Control Best Management Practices

Viewpoint Estates does not include any nonstructural BMPs.

Appendix B

Standard Operation Procedures for Inspection and Maintenance

Extended Detention Basins (EDBs)

Note: Existing Detention Basins not constructed per current standards, not all elements of an EDB exist for these facilities. General references to EDBs apply to the existing facilities. Sections that no longer apply to Detention Basins are lined out.

TABLE OF CONTENTS

EDB-1	BACKGROUND	2
EDB-2	INSPECTING EXTENDED DETENTION BASINS (EDBS)	2
EDB-2.1	ACCESS AND EASEMENTS	2
EDB-2.2	STORMWATER BEST MANAGEMENT PRACTICE (BMP) LOCATIONS	2
EDB-2.3	EXTENDED DETENTION BASIN (EDB) FEATURES	2
EDB-2.3.1	Inflow Points	3
EDB-2.3.2	Forebay	4
EDB-2.3.3	Trickle Channel (Low-Flow)	5
EDB-2.3.4	Bottom Stage.....	6
EDB-2.3.5	Micropool	7
EDB-2.3.6	Outlet Works	8
EDB-2.3.7	Emergency Spillway	9
EDB-2.3.8	Upper Stage (Dry Storage)	9
EDB-2.3.9	Miscellaneous	11
EDB-2.4	INSPECTION FORMS	11
EDB-3	MAINTAINING EXTENDED DETENTION BASINS (EDBS)	12
EDB-3.1	MAINTENANCE PERSONNEL	12
EDB-3.2	EQUIPMENT	12
EDB-3.3	SAFETY	13
EDB-3.4	MAINTENANCE FORMS	13
EDB-3.5	MAINTENANCE CATEGORIES AND ACTIVITIES	13
EDB-3.6	ROUTINE MAINTENANCE ACTIVITIES	13
EDB-3.6.1	Mowing	14
EDB-3.6.2	Trash/Debris Removal	15
EDB-3.6.3	Outlet Works Cleaning	15
EDB-3.6.4	Weed Control	15
EDB-3.6.5	Mosquito/Algae Treatment.....	15
EDB-3.7	RESTORATION MAINTENANCE ACTIVITIES	16
EDB-3.7.1	Sediment Removal.....	17
EDB-3.7.2	Erosion Repair	17
EDB-3.7.3	Vegetation Removal/Tree Thinning.....	17
EDB-3.7.4	Clearing Drains/Jet-Vac	18
EDB-3.8	REHABILITATION MAINTENANCE ACTIVITIES	18
EDB-3.8.1	Major Sediment Removal	19
EDB-3.8.2	Major Erosion Repair	19
EDB-3.8.3	Structural Repair	19

EDB-1 BACKGROUND

Extended Detention Basins (EDBs) are one of the most common types of Stormwater BMPs utilized within the Front Range of Colorado. An EDB is a sedimentation basin designed to “extend” the runoff detention time, but to drain completely dry sometime after stormwater runoff ends. The EDB’s drain time for the water quality portion of the facility is typically 40 hours. The basins are considered to be “dry” because the majority of the basin is designed not to have a significant permanent pool of water remaining between runoff events.

EDBs are an adaptation of a detention basin used for flood control, with the primary difference is the addition of forebays, micropools and a slow release outlet design. Forebays are shallow concrete “pans” located at the inflow point to the basin and are provided to facilitate sediment removal within a contained area prior to releasing into the pond. These forebays collect and briefly hold stormwater runoff resulting in a process called sedimentation, dropping sediment out of the stormwater. The stormwater is then routed from the forebay into the concrete trickle channel and upper basin, the large grassy portion of the basin. The EDB uses a much smaller outlet that extends the emptying time of the more frequently occurring runoff events to facilitate pollutant removal. An EDB should have a small micropool just upstream of the outlet. This micropool is designed to hold a small amount of water to keep sediment and floatables from blocking the outlet orifices.

EDB-2 INSPECTING EXTENDED DETENTION BASINS (EDBs)

EDB-2.1 Access and Easements

Inspection or maintenance personnel may utilize the figures located in Appendix E containing the location(s) of the access points and potential maintenance easements of the EDB(s) within this development.

EDB-2.2 Stormwater Best Management Practice (BMP) Locations

Inspection or maintenance personnel may utilize the figures located in Appendix E containing the location(s) of the EDB(s) within this development.

EDB-2.3 Extended Detention Basin (EDB) Features

EDBs have a number of features that are designed to serve a particular function. Many times the proper function of one feature depends on another. For example, if a forebay is not properly maintained, it could negatively affect the performance of a feature downstream (trickle channel, micropool, etc.). Therefore, it is critical that each feature of the EDB is properly inspected and maintained to ensure that the overall facility functions as it was intended.

Below is a list and description of the most common features within an EDB and the corresponding maintenance inspection items that can be anticipated:

**Table EDB-1
Typical Inspection & Maintenance Requirements Matrix**

EDB Features	Sediment Removal	Mowing/ Weed control	Trash & Debris Removal	Erosion	Overgrown Vegetation Removal	Standing Water (mosquito/ algae control)	Structure Repair
Inflow Points (outfalls)	X		X				X
Forebay	X		X				X
Low flow channel	X		X	X	X		X
Bottom Stage	X	X	X	X	X	X	
Micropool	X		X		X	X	X
Outlet Works	X		X				X
Emergency Spillway			X	X	X		X
Upper Stage			X	X			
Embankment		X		X	X		

EDB-2.3.1 Inflow Points

Inflow Points or Outfalls into EDBs are the point source of the stormwater discharge into the facility. An inflow point is commonly a storm sewer pipe with a flared end section that discharges into the EDB. In some instances, an inflow point could be a drainage channel or ditch that flows into the facility.

An energy dissipater (riprap or hard armor protection) is typically immediately downstream of the discharge point into the EDB to protect from erosion. In some cases, the storm sewer outfall can have a toe wall or cut-off wall immediately below the structure to prevent undercutting of the outfall from erosion.

The typical maintenance items that are found with inflow points are as follows:

a. Riprap Displaced— Many times, because the repeated impact/force of water, the riprap can shift and settle. If any portion of the riprap apron appears to have settled, soil is present between the riprap, or the riprap has shifted, maintenance may be required to ensure future erosion is prevented.

b. Erosion Present/Outfall Undercut— In some situations, the energy dissipater may not have been sized, constructed, or maintained appropriately and erosion has occurred. Any erosion within the vicinity of the inflow point will require maintenance to prevent damage to the structure(s) and sediment transport within the facility.

c. Sediment Accumulation— Because of the turbulence in the water created by the energy dissipater, sediment often deposits immediately downstream of the inflow point. To prevent a loss in hydraulic performance of the upstream infrastructure, sediment that accumulates in this area must be removed in a timely manner.

d. Structural Damage— Structural damage can occur at anytime during the life of the facility. Typically, for an inflow, the structural damage occurs to the pipe flared end section (concrete or steel). Structural damage can lead to additional operating problems with the facility, including loss of hydraulic performance.

e. Woody Growth/Weeds Present— Undesirable vegetation can grow in and around the inflow area to an EDB that can significantly affect the performance of the drainage facilities discharging into the facility. This type of vegetation includes trees (typically cottonwoods) and dense areas of shrubs (willows). If woody vegetation is not routinely mowed/removed, the growth can cause debris/sediment to accumulate, resulting in blockage of the discharge. Also, tree roots can cause damage to the structural components of the inflow. Routine maintenance is essential for trees (removing a small tree/sapling is much cheaper and “quieter” than a mature tree). In addition, noxious weeds growing in the facility can result in the loss of desirable native vegetation and impact adjacent open spaces/land.

EDB 2.3.2 Forebay

A forebay is a solid surface (pad), typically constructed of concrete, immediately downstream of the inflow point. The forebay is designed to capture larger particles and trash to prevent them from entering the main portion of the EDB. The solid surface is designed to facilitate mechanical sediment removal (skid steer). The forebay typically includes a small diameter discharge pipe or v-notch weir on the downstream end and designed to drain the forebay in a specified period of time to promote sedimentation. The forebays vary in size and depth depending on the design and site constraints.

The typical maintenance items that are found with forebays are as follows:

a. Sediment/Debris Accumulation— Because this feature of the EDB is designed to provide the initial sedimentation, debris and sediment frequently accumulate in this area. If the sediment and debris is not removed from the forebay on a regular basis, it can significantly affect the function of other features within the EDB. Routine sediment removal from the forebay can **significantly** reduce the need for dredging of the main portion of the EDB using specialized equipment (long reach excavators). Routine removal of sediment from the forebay can **substantially** decrease the long-term sediment removal costs of an EDB.

b. Concrete Cracking/Failing— The forebay is primarily constructed of concrete, which cracks, spalls, and settles. Damage to the forebay can result in decreased performance and impact maintenance efforts.

c. Drain Pipe/Weir Clogged— Many times the drainpipe or weir can be clogged with debris, and prevent the forebay from draining properly. If standing water is present in the forebay (and there is not a base flow), the forebay is most likely not draining properly. This can result in a decrease in performance and create potential nuisances with stagnant water (mosquitoes).

d. Weir/Drain Pipe Damaged— Routine maintenance activities, vandalism, or age may cause the weir or drain pipe in the forebay to become damaged. Weirs are typically constructed of concrete, which cracks and spalls. The drainpipe is typically smaller in diameter and constructed with plastic, which can fracture.

EDB-2.3.3 Trickle Channel (Low Flow)

The trickle channel conveys stormwater from the forebay to the micro-pool of the EDB. The trickle channel is typically made of concrete. However, grass lined (riprap sides protected) is also common and can provide for an additional means of water quality within the EDB. The trickle channel is typically 6-9 inches in depth and can vary in width.

The typical maintenance items that are found with trickle channels are as follows:

a. Sediment/Debris Accumulation— Trickle channels are typically designed with a relatively flat slope that can promote sedimentation and the collection of debris. Also, if a trickle channel is grass lined it can accumulate sediment and debris at a much quicker rate. Routine removal of accumulated sediment and debris is essential in preventing flows from circumventing the trickle channel and affecting the dry storage portion of the pond.

~~*b. Concrete/Riprap Damage* – Concrete can crack, spall, and settle and must be repaired to ensure proper function of the trickle channel. Riprap can also shift over time and must be replaced/repared as necessary.~~

~~*c. Woody Growth/Weeds Present* – Because of the constant moisture in the area surrounding the trickle channel, woody growth (cottonwoods/willows) can become a problem. Trees and dense shrub type vegetation can affect the capacity of the trickle channel and can allow flows to circumvent the feature.~~

~~*d. Erosion Outside of Channel* – In larger precipitation events, the trickle channel capacity will likely be exceeded. This can result in erosion immediately adjacent to the trickle channel and must be repaired to prevent further damage to the structural components of the EDB.~~

EDB-2.3.4 Bottom Stage

The bottom stage is at least 1.0 to 2.0 feet deeper than the upper stage and is located in front of the outlet works structure. The bottom stage is designed to store the smaller runoff events, assists in keeping the majority of the basin bottom dry resulting in easier maintenance operations, and enhances the facilities pollutant removal capabilities. This area of the EDB may develop wetland vegetation.

The typical maintenance items that are found with the bottom stage are as follows:

a. Sediment/Debris Accumulation – The micro-pool can frequently accumulate sediment and debris. This material must be removed to maintain pond volume and proper function of the outlet structure.

b. Woody Growth/Weeds Present - Because of the constant moisture in the soil surrounding the micro-pool, woody growth (cottonwoods/willows) can create operational problems for the EDB. If woody vegetation is not routinely mowed/removed, the growth can cause debris/sediment to accumulate outside of the micro-pool, which can cause problems with other EDB features. Also, tree roots can cause damage to the structural components of the outlet works. Routine management is essential for trees (removing a small tree/sapling is much cheaper and “quieter” than a mature tree).

c. Bank Erosion – The micro-pool is usually a couple feet deeper than the other areas of the ponds. Erosion can be caused by water dropping into the micro-pool if adequate protection/armor is not present. Erosion in this area must be mitigated to prevent sediment transport and other EDB feature damage.

d. Mosquitoes/Algae Treatment – Nuisance created by stagnant water can result from improper maintenance/treatment of the micro-pool. Mosquito larvae can be laid by adult mosquitoes within the permanent pool. Also, aquatic vegetation that grows in shallow pools of water can decompose causing foul odors. Chemical/mechanical treatment of the micro-pool may be necessary to reduce these impacts to adjacent homeowners.

e. Petroleum/Chemical Sheen – Many indicators of illicit discharges into the storm sewer systems will be present in the micro-pool area of the EDB. These indicators can include sheens, odors, discolored soil, and dead vegetation. If it is suspected that an illicit discharge has occurred, contact the supervisor immediately. Proper removal/mitigation of contaminated soils and water in the EDB is necessary to minimize any environmental impacts downstream.

EDB-2.3.5 Micro-pool

~~The micro-pool is a concrete or grouted boulder walled structure directly in front of the outlet works. At a minimum, the micropool is 2.5 feet deep and is designed to hold water. The micro-pool is critical in the proper function of the EDB; it allows suspended sediment to be deposited at the bottom of the micro-pool and prevents these sediments from being deposited in front of the outlet works causing clogging of the outlet structure, which results in marshy areas within the top and bottom stages.~~

~~The typical maintenance items that are found with micro-pools are as follows:~~

~~*a. Sediment/Debris Accumulation* – The micro-pool can frequently accumulate sediment and debris. This material must be removed to maintain pond volume and proper function of the outlet structure.~~

~~*b. Woody Growth/Weeds Present* – Because of the constant moisture in the soil surrounding the micro-pool, woody growth (cottonwoods/willows) can create operational problems for the EDB. If woody vegetation is not routinely mowed/removed, the growth can cause debris/sediment to accumulate outside of the micro-pool, which can cause problems with other EDB features. Also, tree roots can cause damage to the structural components of the outlet works. Routine management is essential for trees (removing a small tree/sapling is much cheaper and “quieter” than a mature tree).~~

~~*c. Mosquitoes/Algae Treatment* – Nuisance created by stagnant water can result from improper maintenance/treatment of the micro-pool. Mosquito larvae can be laid by adult mosquitoes within the permanent pool. Also,~~

~~aquatic vegetation that grows in shallow pools of water can decompose causing foul odors. Chemical/mechanical treatment of the micro-pool may be necessary to reduce these impacts to adjacent homeowners.~~

~~*d. Petroleum/Chemical Sheen*— Many indicators of illicit discharges into the storm sewer systems will be present in the micro-pool area of the EDB. These indicators can include sheens, odors, discolored soil, and dead vegetation. If it is suspected that an illicit discharge has occurred, contact the supervisor immediately. Proper removal/mitigation of contaminated soils and water in the EDB is necessary to minimize any environmental impacts downstream.~~

EDB-2.3.6 Outlet Works

The outlet works is the feature that drains the EDB in specified quantities and periods of time. The outlet works for these Detention Basins is an outflow pipe that releases the initial storm. A riser pipe above the outlet pipe typically has trash racks over them to prevent clogging. The outlet structure is the single most important feature in the EDB operation. Proper inspection and maintenance of the outlet works is essential in ensuring the long-term operation of the EDB.

The typical maintenance items that are found with the outlet works are as follows:

a. Trash Rack – Floatable material that enters the EDB beyond the initial storm will most likely make its way to the riser pipe. This material is trapped against the trash racks on top of the riser pipe (which is why they are there). This material must be removed on a routine basis to ensure the outlet structure drains in the specified design period.

b. Structural Damage - The outlet structure pipe and riser is primarily constructed of corrugated metal pipe, which can crack, break, and settle. The steel trash rack is also susceptible to damage.

~~*c. Orifice Plate Missing/Not Secure*— Many times residents, property owners, or maintenance personnel will remove or loosen orifice plates if they believe the pond is not draining properly. Any modification to the orifice plate(s) will significantly affect the designed discharge rates for water quality and/or flood control. Modification of the orifice plates is not allowed without approval from the County.~~

~~*d. Outlet Box Access*— Access to the inside of the outlet box is gained by removing the top grate.~~

e. Woody Growth/Weeds Present - Because of the constant moisture in the soil surrounding the outlet works, woody growth (cottonwoods/willows) can create operational problems for the EDB. If woody vegetation is not routinely mowed/removed, the growth can cause debris/sediment to accumulate around the outlet works, which can cause problems with other EDB features. Also, tree roots can cause damage to the structural components of the outlet works. Routine management is essential for trees (removing a small tree/sapling is much cheaper and “quieter” than a mature tree).

EDB-2.3.7 Emergency Spillway

An emergency spillway is typical of all EDBs and designed to serve as the overflow in the event the volume of the pond is exceeded. The emergency spillway is typically armored with riprap (or other hard armor) and is sometimes buried with soil. The emergency spillway is typically a weir (notch) in the pond embankment. Proper function of the emergency spillway is essential to ensure flooding does not affect adjacent properties.

The typical maintenance items that are found with emergency spillways are as follows:

a. Riprap Displaced – As mentioned before, the emergency spillway is typically armored with riprap to provide erosion protection. Over the life of an EDB, the riprap may shift or dislodge due to flow.

b. Erosion Present – Although the spillway is typically armored, stormwater flowing through the spillway can cause erosion damage. Erosion must be repaired to ensure the integrity of the basin embankment, and proper function of the spillway.

c. Woody Growth/Weeds Present – Management of woody vegetation is essential in the proper long-term function of the spillway. Larger trees or dense shrubs can capture larger debris entering the EDB and reduce the capacity of the spillway.

d. Obstruction Debris – The spillway must be cleared of any obstruction (man made or natural) to ensure the proper design capacity.

EDB-2.3.8 Upper Stage (Dry Storage)

The upper stage of the EDB provides the majority of the water quality flood detention volume. This area of the EDB is higher than the micro-pool

and typically stays dry, except during storm events. The upper stage is the largest feature/area of the basin. Sometimes, the upper stage can be utilized for park space and other uses in larger EDBs. With proper maintenance of the micro-pool and forebay(s), the upper stage should not experience much sedimentation; however, bottom elevations should be monitored to ensure adequate volume.

The typical maintenance items that are found with upper stages are as follows:

a. Vegetation Sparse – The upper basin is the most visible part of the EDB, and therefore aesthetics is important. Adequate and properly maintained vegetation can greatly increase the overall appearance and acceptance of the EDB by the public. In addition, vegetation can reduce the potential for erosion and subsequent sediment transport to the other areas of the pond.

b. Woody Growth/Undesirable Vegetation – Although some trees and woody vegetation may be acceptable in the upper basin, some thinning of cottonwoods and willows may be necessary. Remember, the basin will have to be dredged to ensure volume, and large trees and shrubs will be difficult to protect during that operation.

c. Standing Water/Boggy Areas – Standing water or boggy areas in the upper stage is typically a sign that some other feature in the pond is not functioning properly. Routine maintenance (mowing, trash removal, etc) can be extremely difficult for the upper stage if the ground is saturated. If this inspection item is checked, make sure you have identified the root cause of the problem.

d. Sediment Accumulation – Although other features within the EDB are designed to capture sediment, the upper storage area will collect sediment over time. Excessive amounts of sedimentation will result in a loss of storage volume. It may be more difficult to determine if this area has accumulated sediment without conducting a field survey.

Below is a list of indicators:

1. Ground adjacent to the trickle channel appears to be several inches higher than concrete/riprap
2. Standing water or boggy areas in upper stage
3. Uneven grades or mounds
4. Micro-pool or Forebay has excessive amounts of sediment

e. Erosion (banks and bottom) – The bottom grades of the dry storage are typically flat enough that erosion should not occur. However, inadequate vegetative cover may result in erosion of the upper stage. Erosion that

occurs in the upper stage can result in increased dredging/maintenance of the micro-pool.

f. Trash/Debris – Trash and debris can accumulate in the upper area after large events, or from illegal dumping. Over time, this material can accumulate and clog the EDB outlet works.

~~*g. Maintenance Access* – Most EDBs typically have a gravel/concrete maintenance access path to either the upper stage or forebay. This access path should be inspected to ensure the surface is still drivable. Some of the smaller EDBs may not have maintenance access paths; however, the inspector should verify that access is available from adjacent properties.~~

EDB-2.3.9 Miscellaneous

There are a variety of inspection/maintenance issues that may not be attributed to a single feature within the EDB. This category on the inspection form is for maintenance items that are commonly found in the EDB, but may not be attributed to an individual feature.

a. Access – Access needs to be maintained.

b. Graffiti/Vandalism – Damage to the EDB infrastructure can be caused by vandals. If criminal mischief is evident, the inspector should forward this information to the local enforcement agency.

c. Public Hazards – Public hazards include items such as vertical drops of greater than 4-feet, containers of unknown/suspicious substances, exposed metal/jagged concrete on structures. **If any hazard is found within the facility area that poses an immediate threat to public safety, contact the local emergency services at 911 immediately!**

d. Burrowing Animals/Pests – Prairie dogs and other burrowing rodents may cause damage to the EDB features and negatively affect the vegetation within the EDB.

e. Other – Any miscellaneous inspection/maintenance items not contained on the form should be entered here.

EDB-2.4 Inspection Forms

EDB Inspection forms are located in Appendix C. Inspection forms shall be completed by the person(s) conducting the inspection activities. Each form shall be reviewed and submitted by the property owner or property manager to El Paso County per the requirements of the Inspection and Maintenance Plan. It is

recommended that these inspection forms be kept a minimum of 5 years. A continuing record of inspection and maintenance forms will demonstrate proper maintenance over time in compliance with the BMP Maintenance Agreement.

EDB-3 MAINTAINING EXTENDED DETENTION BASINS (EDBS)

EDB-3.1 Maintenance Personnel

Maintenance personnel must be qualified to properly maintain EDBs. Inadequately trained personnel can cause additional problems resulting in additional maintenance costs.

EDB-3.2 Equipment

It is imperative that the appropriate equipment and tools are taken to the field with the operations crew. The types of equipment/tools will vary depending on the task at hand. Below is a list of tools, equipment, and material(s) that may be necessary to perform maintenance on an EDB:

- 1.) Loppers/Tree Trimming Tools
- 2.) Mowing Tractors
- 3.) Trimmers (extra string)
- 4.) Shovels
- 5.) Rakes
- 6.) All Surface Vehicle (ASVs)
- 7.) Skid Steer
- 8.) Back Hoe
- 9.) Track Hoe/Long Reach Excavator
- 10.) Dump Truck
- 11.) Jet-Vac Machine
- 12.) Engineers Level (laser)
- 13.) Riprap (Minimum - Type M)
- 14.) Filter Fabric
- 15.) Erosion Control Blanket(s)
- 16.) Seed Mix (Native Mix)
- 17.) Illicit Discharge Cleanup Kits
- 18.) Trash Bags
- 19.) Tools (wrenches, screw drivers, hammers, etc)

- 20.) Chain Saw
- 21.) Confined Space Entry Equipment
- 22.) Approved Inspection and Maintenance Plan

Some of the items identified above may not be needed for every maintenance operation. However, this equipment should be available to the maintenance operations crews should the need arise.

EDB-3.3 Safety

Vertical drops may be encountered in areas located within and around the facility. Avoid walking on top of retaining walls or other structures that have a significant vertical drop. If a vertical drop is identified within the EDB that is greater than 48" in height, make the appropriate note/comment on the maintenance inspection form.

EDB-3.4 Maintenance Forms

The EDB Maintenance Form provides a record of each maintenance operation performed by maintenance contractors. It is recommended that the EDB Maintenance Form be filled out in the field after the completion of the maintenance operation. It is recommended that each form be retained by the property owner or property manager for a minimum of five years. The EDB Maintenance form is located in Appendix D.

EDB-3.5 Maintenance Categories and Activities

A typical EDB Maintenance Program will consist of three broad categories of work: Routine, Restoration (minor), and Rehabilitation (major). Within each category of work, a variety of maintenance activities can be performed on an EDB. A maintenance activity can be specific to each feature within the EDB, or general to the overall facility. This section of the SOP explains each of the categories and briefly describes the typical maintenance activities for an EDB.

A variety of maintenance activities are typical of EDBs. The maintenance activities range in magnitude from routine trash pickup to the reconstruction of drainage infrastructure. Below is a description of each maintenance activity, the objectives, and frequency of actions:

EDB-3.6 Routine Maintenance Activities

The majority of this work consists of regularly scheduled mowing and trash and debris pickups for stormwater management facilities during the growing season. This includes items such as the removal of debris/material that may be clogging the outlet structure well screens and trash racks. It also includes activities such as includes weed control, mosquito treatment, and algae treatment. These activities

normally will be performed numerous times during the year. These items can be completed without any prior correspondence with El Paso County; however, it is recommended that completed inspection and maintenance forms shall be retained by the owner for a minimum of five years.

The Maintenance Activities are summarized below, and further described in the following sections.

**TABLE – EDB-2
Summary of Routine Maintenance Activities**

Maintenance Activity	Minimum Frequency	Look for:	Maintenance Action
Mowing	Twice annually	Excessive grass height/aesthetics	Mow grass to a height of 4” to 6”
Trash/Debris Removal	Twice annually	Trash & debris in EDB	Remove and dispose of trash and debris
Outlet Works Cleaning	As needed - after significant rain events – twice annually min.	Clogged outlet structure; ponding water	Remove and dispose of debris/trash/sediment to allow outlet to function properly
Weed control	Minimum twice annually	Noxious weeds; Unwanted vegetation	Treat w/ herbicide or hand pull; Consult the local weed specialist
Mosquito Treatment	As needed	Standing water/mosquito habitat	Treat w/ EPA approved chemicals
Algae Treatment	As needed	Standing water/ Algal growth/green color	Treat w/ EPA approved chemicals

EDB-3.6.1 Mowing

Occasional mowing is necessary to limit unwanted vegetation and to improve the overall appearance of the EDB. Native vegetation should be mowed to a height of 4-to-6 inches tall. Grass clippings should be collected and disposed of properly.

Frequency – Routine - Minimum of twice annually or depending on aesthetics.

EDB-3.6.2 Trash/Debris Removal

Trash and debris must be removed from the entire EDB area to minimize outlet clogging and to improve aesthetics. This activity must be performed prior to mowing operations.

Frequency – Routine – Prior to mowing operations and minimum of twice annually.

EDB-3.6.3 Outlet Works Cleaning

~~Debris and other materials can clog the outlet work's well screen, orifice plate(s) and trash rack. This activity must be performed anytime other maintenance activities are conducted to ensure proper operation.~~

The riser pipe is still an outlet and needs to have a section discussing maintenance. The reference to well screen and orifice plate just need to be edited. The section should be specific to this sites riser pipe outlet structure and all components associated with that.

~~*Frequency* – Routine – After significant rainfall event or concurrently with other maintenance activities.~~

EDB-3.6.4 Weed Control

Noxious weeds and other unwanted vegetation must be treated as needed throughout the EDB. This activity can be performed either through mechanical means (mowing/pulling) or with herbicide. Consultation with the local Weed Inspector is highly recommended prior to the use of herbicide.

Frequency – Routine – As needed based on inspections.

EDB-3.6.5 Mosquito/Algae Treatment

Treatment of permanent pools is necessary to control mosquitoes and undesirable aquatic vegetation that can create nuisances. Only EPA approved chemicals/materials can be used in areas that are warranted.

Frequency – As needed.

EDB- 3.7 Restoration Maintenance Activities

This work consists of a variety of isolated or small-scale maintenance or operational problems. Most of this work can be completed by a small crew, tools, and small equipment. These items do not require prior correspondence with El Paso County. However, it is recommended that completed inspection and maintenance forms be retained for each inspection and maintenance activity for a minimum of five years by the owner.

**Table – EDB-3
Summary of Restoration Maintenance Activities**

Maintenance Activity	Minimum Frequency	Look for:	Maintenance Action
Sediment Removal	As needed; typically every 1 –2 years	Sediment build-up; decrease in pond volume	Remove and dispose of sediment
Erosion Repair	As needed, based upon inspection	Rills/gullies forming on side slopes, trickle channel, other areas	Repair eroded areas Revegetate; address source of erosion
Vegetation Removal/Tree Thinning	As needed, based upon inspection	Large trees/wood vegetation in lower chamber of pond	Remove vegetation; restore grade and surface
Drain Cleaning/Jet Vac	As needed, based upon inspection	Sediment build-up /non draining system	Clean drains; Jet Vac if needed

EDB-3.7.1 Sediment Removal

Sediment removal is necessary to maintain the original design volume of the EDB and to ensure proper function of the infrastructure. Regular sediment removal (minor) from the ~~forebay, inflow(s), and trickle channel~~ can significantly reduce the frequency of major sediment removal activities (dredging) in the upper and lower stages. The minor sediment removal activities can typically be addressed with shovels and smaller equipment. Major sediment removal activities will require larger and more specialized equipment. Major sediment removal activities involve surveying with an engineer's level, and verification to ensure design volumes/grades are achieved.

Stormwater sediments removed from EDBs do not meet the criteria of "hazardous waste". However, these sediments are contaminated with a wide array of organic and inorganic pollutants and handling must be done with care. Sediments from permanent pools must be carefully removed to minimize turbidity, further sedimentation, or other adverse water quality impacts. Sediments should be transported by motor vehicle only after they are dewatered. All sediments must be taken to a landfill for proper disposal. Prompt and thorough cleanup is important should a spill occur during transportation.

Frequency – Nonroutine – As necessary based upon inspections.
~~Sediment removal in the forebay and trickle channel may be necessary as frequently as every 1-2 years.~~

EDB-3.7.2 Erosion Repair

The repair of eroded areas is necessary to ensure the proper function of the EDB, minimize sediment transport, and to reduce potential impacts to other features. Erosion can vary in magnitude from minor repairs to ~~trickle channels, energy dissipaters,~~ and rilling to major gullies in the embankments and spillways. The repair of eroded areas may require the use of excavators, earthmoving equipment, riprap, concrete, erosion control blankets, and turf reinforcement mats. Major erosion repairs to the pond embankments, spillways, and adjacent to structures involve consultation with the County's Engineering staff.

Frequency – Nonroutine – As necessary based upon inspections.

EDB-3.7.3 Vegetation Removal/Tree Thinning

Dense stands of woody vegetation (willows, shrubs, etc) or trees can create maintenance problems for the infrastructure within an EDB. Tree roots can damage structures and invade pipes/channels thereby blocking

flows. Also, trees growing in the upper and lower stages of the EDB will most likely have to be removed when sediment/dredging operations occur. A small tree is easier to remove than a large tree, therefore, regular removal/thinning is imperative. All trees and woody vegetation that is growing in the bottom of the EDB or near structures (~~inflows, trickle channels~~, outlet works, emergency spillways, etc) should be removed. Any trees or woody vegetation in the EDB should be limited to the upper portions of the pond banks.

Frequency – Nonroutine – As necessary based upon inspections.

EDB-3.7.4 Clearing Drains/Jet-Vac

An EDB contains many structures, openings, and pipes that can be frequently clogged with debris. These blockages can result in a decrease of hydraulic capacity and create standing water in areas outside of the micro-pool. Many times the blockage to this infrastructure can be difficult to access and/or clean. Specialized equipment (jet-vac machines) may be necessary to clear debris from these difficult areas.

Frequency – Nonroutine – As necessary based upon inspections.

EDB-3.8 Rehabilitation Maintenance Activities

This work consists of larger maintenance/operational problems and failures within the stormwater management facilities. Consultation with County's Engineering staff is recommended to ensure the proper maintenance is performed, which may result in the need for engineering staff review of the original design and construction drawings to assess the situation and assign the necessary maintenance. This work may also require more specialized maintenance equipment, design/details, surveying, or assistance through private contractors and consultants. Any proper permits required for this activity must be obtained.

Table – EDB-4
Summary of Rehabilitation Maintenance Activities

Maintenance Activity	Minimum Frequency	Look for:	Maintenance Action
Major Sediment Removal	As needed – based upon scheduled inspections	Large quantities of sediment; reduced pond capacity	Remove and dispose of sediment. Repair vegetation as needed
Major Erosion Repair	As needed – based upon scheduled inspections	Severe erosion including gullies, excessive soil displacement, areas of settlement, holes	Repair erosion – find cause of problem and address to avoid future erosion
Structural Repair	As needed – based upon scheduled inspections	Deterioration and/or damage to structural components – broken concrete, damaged pipes, outlet works	Structural repair to restore the structure to its original design

EDB-3.8.1 Major Sediment Removal

Major sediment removal consists of removal of large quantities of sediment or removal of sediment from vegetated areas. Care shall be given when removing large quantities of sediment and sediment deposited in vegetated areas. Large quantities of sediment need to be carefully removed, transported and disposed of. Vegetated areas need special care to ensure design volumes and grades are preserved.

Frequency – Nonroutine – Repair as needed based upon inspections.

EDB-3.8.2 Major Erosion Repair

Major erosion repair consist of filling and revegetating areas of severe erosion. Determining the cause of the erosion as well as correcting the condition that caused the erosion should also be part of the erosion repair. Care should be given to ensure design grades and volumes are preserved.

Frequency – Nonroutine – Repair as needed based upon inspections.

EDB-3.8.3 Structural Repair

An EDB includes a variety of structures that can deteriorate or be damaged during the course of routine maintenance. These structures are

constructed of steel and concrete that can degrade or be damaged and may need to be repaired or re-constructed from time to time. These structures include items like outlet works, trickle channels, forebays, inflows and other features. In-house operations staff can perform some of the minor structural repairs. Major repairs to structures may require input from a structural engineer and specialized contractors. Consultation with the County's Engineering staff should take place prior to all structural repairs.

Frequency – Nonroutine – Repair as needed based upon inspections.

Reference:

This Manual is adapted from City of Colorado Springs Best Management Practices IM Plan, SEMSWA (2007) and from the Town of Parker, Colorado (2004), STORMWATER PERMANENT BEST MANAGEMENT PRACTICES (PBMP) LONG-TERM OPERATION AND MAINTENANCE MANUAL

APPENDIX C

INSPECTION FORM

EXTENDED DETENTION BASIN (EDB) INSPECTION FORM

Date: _____

Subdivision/Business Name: _____ Inspector: _____

Subdivision/Business Address: _____

Weather: _____

Date of Last Rainfall: _____ Amount: _____ Inches

Property Classification: Residential Multi Family Commercial Other: _____
(Circle One)

Reason for Inspection: Routine Complaint After Significant Rainfall Event
(Circle One)

INSPECTION SCORING - For each facility inspection item, insert one of the following scores:
0 = No deficiencies identified 2 = Routine maintenance required
1 = Monitor (potential for future problem) 3 = Immediate repair necessary
N/A = Not applicable

FEATURES

1.) Inflow Points

- ___ Riprap Displaced
- ___ Erosion Present/Outfall Undercut
- ___ Sediment Accumulation
- ___ Structural Damage (pipe, end-section, etc.)

2.) Forebay

- ___ Sediment/Debris Accumulation
- ___ Concrete Cracking/Failing
- ___ Drain Pipe/Wier Clogged (not draining)
- ___ Wier/Drain Pipe Damage ___ Woody Growth/Weeds Present

3.) Trickle Channel (Low-flow)

- ___ Sediment/Debris Accumulation
- ___ Concrete/Riprap Damage
- ___ Woody Growth/Weeds Present
- ___ Erosion Outside Channel

4.) Bottom Stage (Micro-Pool)

- ___ Sediment/Debris Accumulation
- ___ Woody Growth/Weeds Present
- ___ Bank Erosion
- ___ Mosquitoes/Algae Treatment
- ___ Petroleum/Chemical Sheen

5.) Outlet Works

- ___ Trash Rack/Well Screen Clogged
- ___ Structural Damage (concrete, steel, subgrade)
- ___ Orifice Plate(s) Missing/Not Secure
- ___ Manhole Access (cover, steps, etc.)
- ___ Woody Growth/Weeds Present

6.) Emergency Spillway

- ___ Riprap Displaced
- ___ Erosion Present
- ___ Woody Growth/Weeds Present
- ___ Obstruction/Debris

7.) Upper Stage (Dry Storage)

- ___ Vegetation Sparse
- ___ Woody Growth/Undesirable Vegetation
- ___ Standing Water/Boggy Areas
- ___ Sediment Accumulation
- ___ Erosion (banks and bottom)
- ___ Trash/Debris
- ___ Maintenance Access

8.) Miscellaneous

- ___ Encroachment in Easement Area
- ___ Graffiti/Vandalism
- ___ Public Hazards
- ___ Burrowing Animals/Pests
- ___ Other

Inspection Summary / Additional Comments: _____

OVERALL FACILITY RATING (Circle One)

0 = No Deficiencies Identified 2 = Routine Maintenance Required

1 = Monitor (potential for future problem exists) 3 = Immediate Repair Necessary

It is recommended that this inspection form be retained for a minimum of 5 years by owner.

APPENDIX D

MAINTENANCE FORM

EXTENDED DETENTION BASIN (EDB) MAINTENANCE FORM

Subdivision/Business Name: _____ Completion Date: _____

Subdivision/Business Address: _____ Contact Name: _____

Maintenance Category: Routine Restoration Rehabilitation
(Circle All That Apply)

MAINTENANCE ACTIVITIES PERFORMED

ROUTINE WORK

- MOWING
- TRASH/DEBRIS REMOVAL
- OUTLET WORKS CLEANING (TRASH RACK/WELL SCREEN)
- WEED CONTROL (HERBICIDE APPLICATION)
- MOSQUITO TREATMENT
- ALGAE TREATMENT

RESTORATION WORK

REHABILITATION WORK

- | | |
|--|--|
| <ul style="list-style-type: none"> <input type="checkbox"/> SEDIMENT REMOVAL <ul style="list-style-type: none"> <input type="checkbox"/> FOREBAY <input type="checkbox"/> TRICKLE CHANNEL <input type="checkbox"/> INFLOW <input type="checkbox"/> EROSION REPAIR <ul style="list-style-type: none"> <input type="checkbox"/> INFLOW POINT <input type="checkbox"/> TRICKLE CHANNEL <input type="checkbox"/> VEGETATION REMOVAL/TREE THINNING <ul style="list-style-type: none"> <input type="checkbox"/> INFLOW(S) <input type="checkbox"/> TRICKLE CHANNEL <input type="checkbox"/> UPPER STAGE <input type="checkbox"/> BOTTOM STAGE <input type="checkbox"/> REVEGETATION <input type="checkbox"/> JET-VAC/CLEARING DRAINS <ul style="list-style-type: none"> <input type="checkbox"/> FOREBAY <input type="checkbox"/> OUTLET WORKS <input type="checkbox"/> INFLOWS | <ul style="list-style-type: none"> <input type="checkbox"/> SEDIMENT REMOVAL (DREDGING) <ul style="list-style-type: none"> <input type="checkbox"/> BOTTOM STAGE <input type="checkbox"/> UPPER STAGE <input type="checkbox"/> EROSION REPAIR <ul style="list-style-type: none"> <input type="checkbox"/> OUTLET WORKS <input type="checkbox"/> UPPER STAGE <input type="checkbox"/> BOTTOM STAGE <input type="checkbox"/> SPILLWAY <input type="checkbox"/> STRUCTURAL REPAIR <ul style="list-style-type: none"> <input type="checkbox"/> INFLOW <input type="checkbox"/> OUTLET WORKS <input type="checkbox"/> FOREBAY <input type="checkbox"/> TRICKLE CHANNEL <p>OTHER _____</p> <p>_____</p> <p>_____</p> |
|--|--|

ESTIMATED TOTAL MANHOURS: _____

COSTS INCURRED (include description of costs):

EQUIPMENT/MATERIAL USED (include hours of equipment usage and quantity of material used):

COMMENTS/ADDITIONAL INFO:

It is recommended that this Maintenance Activity Form be retained for a minimum of 5 years by owner.

APPENDIX E

STORMWATER FACILITIES MAP

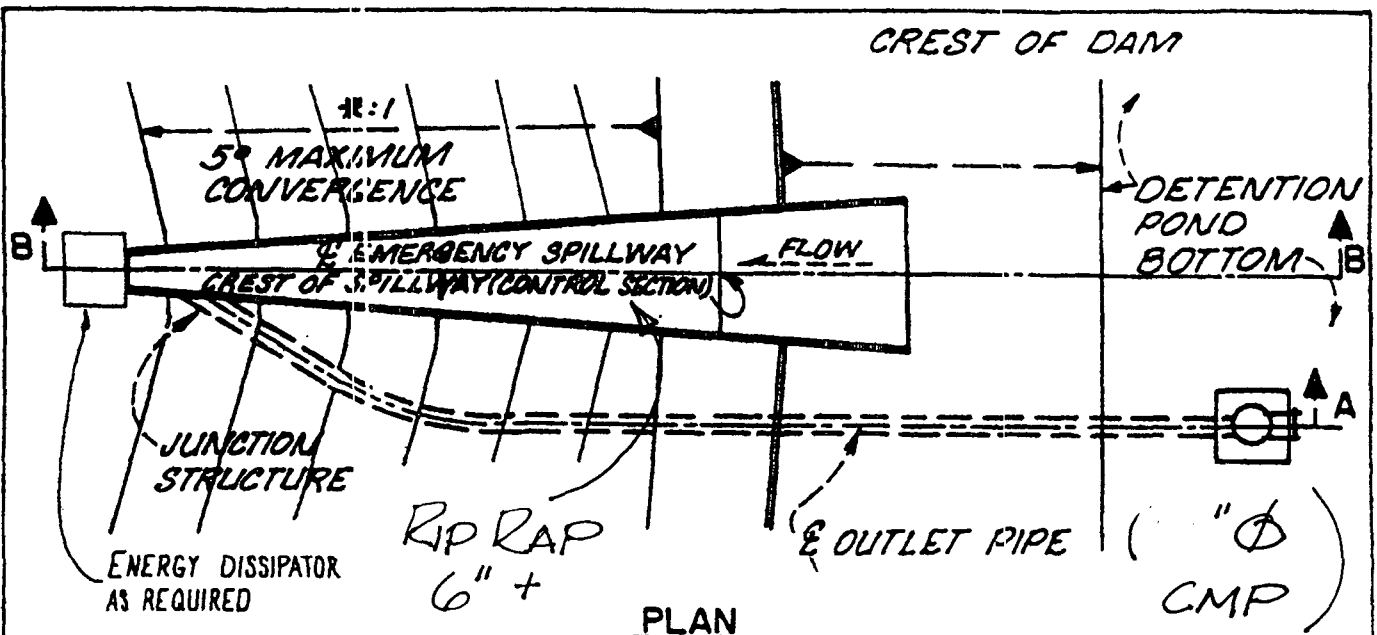

TYPICAL SPILLWAY AND OUTLET WORKS

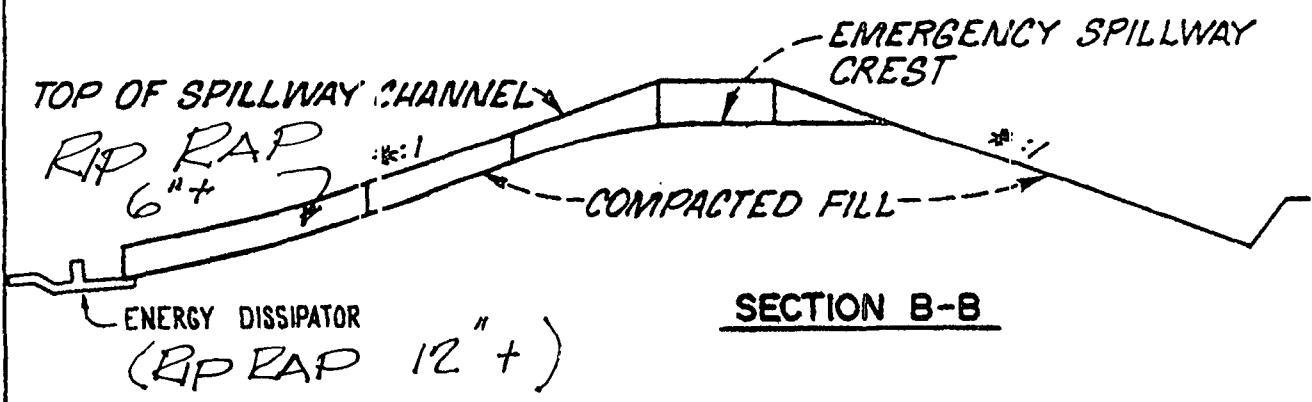
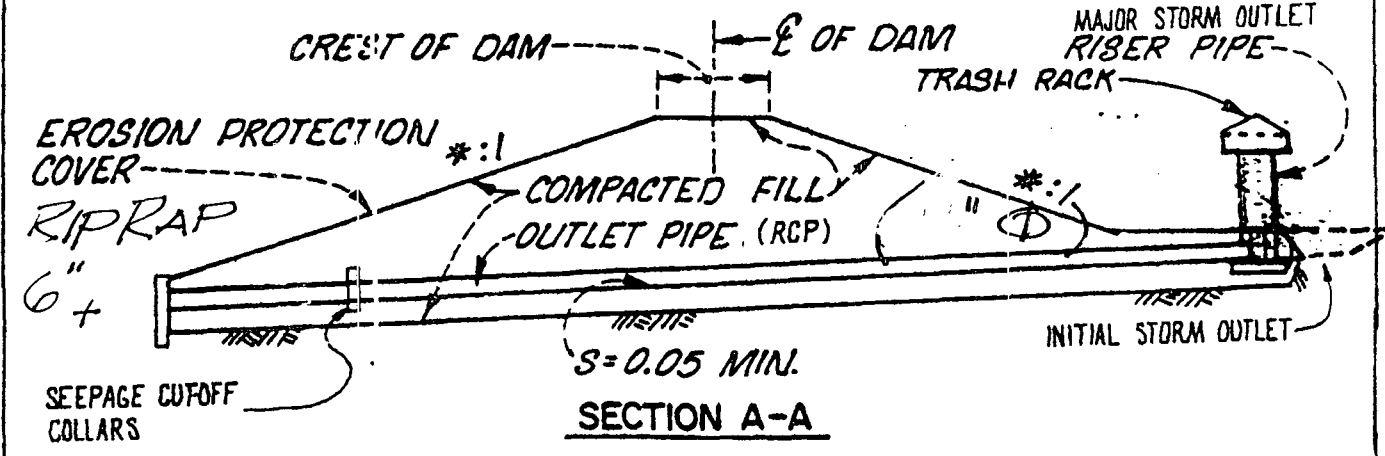

*** TO BE VERIFIED BY GEOTECHNICAL INVESTIGATION / DESIGN (4:1 REQUIRED BY CITY/COUNTY)**

9/30/90



HDR Infrastructure, Inc.
A Centerra Company

The City of Colorado Springs / El Paso County
Drainage Criteria Manual

EARTH EMBANKMENT
Typical Detention Pond Configuration

DETAIL SERVES
POND A1 & A2

Date	OCT. 1987
Figure	11-1

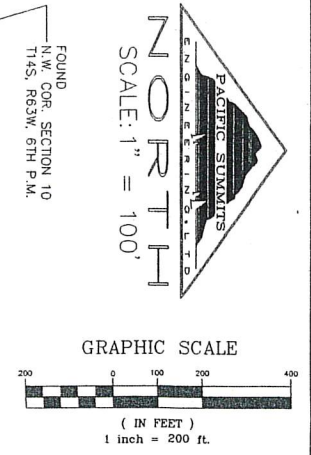

N.E. COR. SECTION 10
T14S, R63W, 6TH P.M.
CAP L.S. 6786
N. 1/4 COR. SEC. 10
SET NO. 5 REBAR
L.S. 7338



S.W. COR. SECTION 10
T14S, R63W, 6TH P.M.
CAP L.S. 9014

HIGHWAY #94 - 100' R.O.W.

DB DETENTION BASIN

WAT. M.H.

1/4 COR. SEC. 10
SET PK NAIL W/WASHER
L.S. 7338