



Final Drainage Report

Tract DD, Hannah Ridge at Feathergrass Filing No. 1 El Paso County, Colorado

Prepared for:

Watermark Residential
111 Monument Circle, Suite 1500
Indianapolis, IN 46204
Contact: Monica Unger

Prepared by:

Kimley-Horn and Associates, Inc.
2 North Nevada Avenue, Suite 300
Colorado Springs, Colorado 80903
(719) 453-0180
Contact: Eric Gunderson, P.E.

Project #: 096302009

Prepared: January 29, 2021

Resubmitted: June 10, 2021

PCD File Number: PPR-21-017

Kimley»»Horn



CERTIFICATION

DESIGN ENGINEER'S STATEMENT

The attached drainage plan and report were prepared under my direction and supervision and are correct to the best of my knowledge and belief. Said drainage report has been prepared according to the criteria established by the County for drainage reports and said report is in conformity with the master plan of the drainage basin. I accept responsibility for any liability caused by any negligent acts, errors or omissions on my part in preparation of this report.

SIGNATURE (Affix Seal): _____
Colorado P.E. No. 49487



OWNER/DEVELOPER'S STATEMENT

I, the developer, have read and will comply with all of the requirements specified in this Drainage Report and Plan.

Thompson Thrift Development, Inc.
Name of Developer

[Signature] 5/24/21
Authorized Signature Date

Jessica Tuttle
Printed Name

VP of Development
Title

111 Monument Circle, Suite 1500
Address: Indianapolis, IN 46204

EL PASO COUNTY

Filed in accordance with the requirements of the Drainage Criteria Manual, Volumes 1 and 2, El Paso County Engineering Criteria Manual and Land Development Code as amended.

Jennifer Irvine, P.E.
County Engineer/ ECM Administrator

Conditions:

APPROVED
Engineering Department

06/28/2021 2:39:16 PM

dsdnijkamp

**EPC Planning & Community
Development Department**

TABLE OF CONTENTS

CERTIFICATION2
 DESIGN ENGINEER’S STATEMENT2
 OWNER/DEVELOPER’S STATEMENT2
 EL PASO COUNTY.....2

TABLE OF CONTENTS3

INTRODUCTION4
 PURPOSE AND SCOPE OF STUDY4
 LOCATION4
 DESCRIPTION OF PROPERTY4

DRAINAGE BASINS4
 MAJOR BASIN DESCRIPTIONS4
 EXISTING SUB-BASIN DESCRIPTIONS5
 Sub-Basin EX-A.....5
 PROPOSED RATIONAL SUB-BASIN DESCRIPTIONS.....5

DRAINAGE DESIGN CRITERIA.....8
 DEVELOPMENT CRITERIA REFERENCE.....8
 HYDROLOGIC CRITERIA8
 HYDRAULIC CRITERIA.....8

THE FOUR STEP PROCESS9

DRAINAGE FACILITY DESIGN10
 GENERAL CONCEPT10
 SPECIFIC DETAILS10

SUMMARY10

REFERENCES11

APPENDIX12
 APPENDIX A: FIGURES13
 APPENDIX B: HYDROLOGY14
 APPENDIX C: HYDRAULICS.....15
 APPENDIX D: DRAINAGE MAPS.....16

INTRODUCTION

PURPOSE AND SCOPE OF STUDY

The purpose of this Final Drainage Report (FDR) is to provide the hydrologic and hydraulic calculations and to document and finalize the drainage design methodology in support of the proposed Tract DD of Hannah Ridge at Feathergrass (“the Project”) Filing No. 1 (“the Site”) for Watermark Residential. The Project is located within the jurisdictional limits of El Paso County (“the County”). Thus, the guidelines for the hydrologic and hydraulic design components were based on the criteria for the County and City of Colorado Springs, described below.

LOCATION

The 15.39-acre parcel (TSN: 53324-04-001) is located at the northwest corner of the Marksheffel Road and Constitution Avenue intersections. The site is also adjacent to Akers Drive at its terminus with Constitution Avenue on the westernmost site boundary. A vicinity map has been provided in the **Appendix A** of this report.

DESCRIPTION OF PROPERTY

The Project is located on approximately 15.39 acres of land consisting of vacant land with native vegetation and is classified as “Undeveloped” per Table 6-6 of the City of Colorado Springs Drainage Criteria Manual. Filing No 1 consists of 9 multi-family buildings, 12 garage buildings, a front office building, and a clubhouse amenity space with a pool deck. The Site does not currently provide water quality or detention for the Project area. The existing land use is undeveloped vacant land.

The existing topography consists of slopes ranging from 1% to 40% and generally slopes from North to South.

NRCS soil data is available for this Site and it has been noted that soils onsite are generally USCS Type A/B. The NRCS soil data can be found in **Appendix B**. There are no major drainage ways or irrigation facilities within the Site.

Improvements will consist of mowing, clearing and grubbing, weed control, paved access road construction, roadway grading, one detention ponds, culverts, drainage swales, and native seeding.

An updated Topographic field survey was completed for the Project by Barren Land, LLC. dated September 23, 2020 and is the basis for design for the drainage improvements.

DRAINAGE BASINS

MAJOR BASIN DESCRIPTIONS

The Site improvements are located in Zone X, as determined by the Flood Insurance Rate Map (FIRM) number 08041C0756G effective date, December 7, 2018 (see **Appendix A**).

The Project is located within El Paso County’s Sand Creek Drainage Basin.

EXISTING SUB-BASIN DESCRIPTIONS

Site runoff flows from north to south via sheet flow over vacant land to Constitution Ave. Below is a description of the existing onsite sub-basin.

Sub-Basin EX-A

Sub-Basin EX-A consists of the entirety of the 15.39-acre multi-family development. Drainage flows overland from North to South and conveys along the southern boundary to the West at Design Point 1. Runoff during the 5-year and 100-year events are 4.41 cfs and 29.59 cfs, respectively. Cumulative flows from this basin, including the flows from Sub-Basin OS-1, are 5.69 and 37.64 cfs, respectively. Runoff from this basin is currently directed to design point 1 where it will drain into the crossspan along the north side of Constitution Avenue across Akers Drive, where it conveys into an existing drainage inlet and storm drain system that runs underneath Constitution Avenue to the South. This sub-basin has an area of 15.39 acres. The impervious value for this basin is 2%. Refer to **Appendix D** for the Existing Conditions Drainage Map.

Sub-Basin OS-1

Sub-Basin OS-1 consists of an offsite basin to the North of the Property. Drainage flows overland from North to South and conveys to the northern line of Sub-basin EX-A at Design Point 2. Direct runoff during the 5-year and 100-year events are 1.28 cfs and 8.04 cfs, respectively. Runoff from this basin is currently directed to design point 2 where it will drain into the Sub-basin EX-A, which is on-site. This sub-basin has an area of 4.55 acres. The impervious value for this basin is 2%. Refer to **Appendix D** for the Existing Conditions Drainage Map.

Additionally, the adjacent property to the northwest of the site has a detention pond within the tributary area for this sub-basin. The release flows from this pond drain directly into the sub-basin at a rate of 0.1 cfs for the 5-year and 0.8 cfs for the 100-year events. These flows have been included in the cfs quantities as listed above, and account for all anticipated flows from offsite. Refer to **Appendix D** for the Offsite Detention Pond release rates as referenced.

PROPOSED RATIONAL SUB-BASIN DESCRIPTIONS

Sub-Basin B1 consists of a portion of the multi-family development in a portion of the west half of the site. Runoff from this basin will be directed to design point B1 where it will drain into the full spectrum detention South Pond, which will outfall through the proposed outlet structure to the west into an existing 24-inch storm drain pipe. This sub-basin has an area of 2.98 acres. The impervious value for this basin is 100%. The basin will generate runoff of 13.83 cfs and 24.74 cfs in the minor and major storm event.

Sub-Basin B2 consists of a portion of landscaping, club house, and building unit in the west side of the site. Runoff from this basin will be directed to Swale B2 which will outfall to Culvert 1 at design point B2 and ultimate outfall into the South Pond. Culvert 2 has been adequately sized to convey flows from this Sub-basin. This sub-basin has an area of 1.01 acres. The impervious value for Sub-Basin DA2 is 16%. The basin will generate runoff of 0.80 cfs and 3.10 cfs in the minor and major storm event.

Sub-Basin B3 consists of a portion of a roof of a proposed building unit. Runoff from this basin will be directed into the proposed storm drain system where it will be directed to the South

Pond. This sub-basin has an area of 0.16 acres. The impervious value for Sub-Basin DA3 is 90%. The basin will generate runoff of 0.61 cfs and 1.13 cfs in the minor and major storm event.

Sub-Basin B4 consists of landscaping, sidewalk and a parking lot. Runoff from this basin will be directed into design point B4 and where it will be directed to the west through a curb cut and outfall to a Swale B5. This sub-basin has an area of 0.23 acres. The impervious value for Sub-Basin DA4 is 100%. The basin will generate runoff of 1.08 cfs and 1.93 cfs in the minor and major storm event.

Sub-Basin B5 consists of landscaping at the west side of the site. Runoff from this basin will be directed into design point B5 and where it will be directed the South Pond. This sub-basin has an area of 0.17 acres. The impervious value is 2%. The basin will generate runoff of 0.05 cfs and 0.39 cfs in the minor and major storm event.

Sub-Basin B6 consists of a portion of a roof of a proposed building unit. Runoff from this basin will be directed into the proposed storm drain system where it will be directed to the South Pond. This sub-basin has an area of 0.13 acres. The impervious value for Sub-Basin DA6 is 90%. The basin will generate runoff of 0.49 cfs and 0.91 cfs in the minor and major storm event.

Sub-Basin B7 consists of the South Pond and portions of the roofs of the proposed building units. This sub-basin has an area of 1.66 acres. The impervious value for this basin is 17%. The basin will generate runoff of 1.58 cfs and 5.91 cfs in the minor and major storm event.

Sub-Basin B8 consists of a portion of a roof of a proposed building unit. Runoff from this basin will be directed into the proposed storm drain system where it will be directed to the South Pond. This sub-basin has an area of 0.16 acres. The impervious value for this basin is 90%. The basin will generate runoff of 0.62 cfs and 1.15 cfs in the minor and major storm event.

Sub-Basin B9 consists of a portion of the multi-family development in a portion of the east half of the site. Runoff from this basin will be directed into design point B9 where it will be directed to the South Pond. This sub-basin has an area of 4.10 acres. The impervious value for this basin is 100%. The basin will generate runoff of 16.87 cfs and 30.19 cfs in the minor and major storm event.

Sub-Basin B10 consists of landscaping and roofs of the multiple building units. Runoff from this basin will be directed into design point B10 where it will be capture by an inlet and directed to the South Pond via storm drain system. This sub-basin has an area of 0.94 acres. The impervious value for this basin is 41%. The basin will generate runoff of 1.59 cfs and 4.01 cfs in the minor and major storm event.

Sub-Basin B11 consists of a portion of a roof of a proposed building unit. Runoff from this basin will be directed into the proposed storm drain system where it will be directed to the South Pond. This sub-basin has an area of 0.16 acres. The impervious value for this basin is 90%. The basin will generate runoff of 0.61 cfs and 1.14 cfs in the minor and major storm event.

Sub-Basin B12 consists of a portion of a roof of a proposed building unit. Runoff from this basin will be directed into the proposed storm drain system where it will be directed to the South Pond. This sub-basin has an area of 0.15 acres. The impervious value for this basin is 90%. The basin will generate runoff of 0.56 cfs and 1.05 cfs in the minor and major storm event.

Sub-Basin B13 consists of a portion of a roof of a proposed building unit. Runoff from this basin will be directed into the proposed storm drain system where it will be directed to the South

Pond. This sub-basin has an area of 0.11 acres. The impervious value for this basin is 90%. The basin will generate runoff of 0.41 cfs and 0.76 cfs in the minor and major storm event.

Sub-Basin B14 consists of a portion of a roof of a proposed building unit. Runoff from this basin will be directed into the proposed storm drain system where it will be directed to the South Pond. This sub-basin has an area of 0.11 acres. The impervious value for this basin is 90%. The basin will generate runoff of 0.43 cfs and 0.80 cfs in the minor and major storm event.

Sub-Basin B15 consists of landscaping and roofs of the multiple building units. Runoff from this basin will be directed into design point B15 where it will be capture by an inlet and directed to the South Pond via storm drain system. This sub-basin has an area of 0.86 acres. The impervious value for this basin is 42%. The basin will generate runoff of 1.57 cfs and 3.93 cfs in the minor and major storm event.

Sub-Basin B16 consists of a portion of a roof of a proposed building unit. Runoff from this basin will be directed into the proposed storm drain system where it will be directed to the South Pond. This sub-basin has an area of 0.14 acres. The impervious value for this basin is 90%. The basin will generate runoff of 0.52 cfs and 0.97 cfs in the minor and major storm event.

Sub-Basin B17 consists of a portion of a roof of a proposed building unit. Runoff from this basin will be directed into the proposed storm drain system where it will be directed to the South Pond. This sub-basin has an area of 0.14 acres. The impervious value for this basin is 90%. The basin will generate runoff of 0.51 cfs and 0.95 cfs in the minor and major storm event.

Sub-Basin B18 consists of landscaping. Runoff from this basin will be directed into design point B18 and where it outfalls into the full spectrum detention South Pond. The drainage swale withing Sub-Basin B18 has been adequately sized to convey anticipated offsite flows from the northern property. This sub-basin has an area of 1.09 acres. The impervious value for this basin is 2%. The basin will generate runoff of 0.27 cfs and 1.96 cfs in the minor and major storm event.

Sub-Basin OS-1 consists of landscaping offsite to the North of the Property. Runoff from this basin will be directed into design point OS-1 and enters the swale in Basin B18 where it outfalls into the full spectrum detention South Pond. This sub-basin has an area of 4.62 acres. The impervious value for this basin is 2%. The basin will generate runoff of 2.11 cfs and 10.39 cfs in the minor and major storm event.

Additionally, the adjacent property to the northwest of the site has a detention pond within the tributary area for this sub-basin. The release flows from this pond drain directly into the sub-basin at a rate of 0.1 cfs for the 5-year and 0.8 cfs for the 100-year events. These flows have been included in the cfs quantities as listed above, and account for all anticipated flows from offsite. Refer to **Appendix D** for the Offsite Detention Pond release rates as referenced.

Sub-Basin OS-2 consists of landscaping offsite to the North of the Property. Runoff from this basin will be directed into design point OS-2 and travels through Basin B1 where it outfalls into the full spectrum detention South Pond. This sub-basin has an area of 0.18 acres. The impervious value for this basin is 2%. The basin will generate runoff of 0.08 cfs and 0.55 cfs in the minor and major storm event.

DRAINAGE DESIGN CRITERIA

DEVELOPMENT CRITERIA REFERENCE

The proposed storm facilities are designed to be in compliance with the City of Colorado Springs and El Paso County “Drainage Criteria Manual (DCM)” dated October 2018 (“the MANUAL”), El Paso County “Engineering Criteria Manual” (“the Engineering Manual”), Chapter 6 and Section 3.2.1 of Chapter 13 of the City of Colorado Springs Drainage Criteria Manual dated May 2014 (“the Colorado Springs MANUAL”).

There are no known master plans or studies for the site.

HYDROLOGIC CRITERIA

The 5-year and 100-year design storm events were used in determining rainfall and runoff for the existing and proposed drainage analysis per the MANUAL. The rainfall depths for site were determined from equation 6-1, equation 6-2 utilizing Figures 6-6, 6-11, 6-12, and 6 -17 from the DCM. Refer to **Table 1** below for the rainfall depths utilized for the site and **Appendix B** for the hydrologic calculations for the site.

Table 1: Rainfall Depths

	Duration (HRS)
Storm Event	1 HR
5 Year	1.52
100 Year	2.55

Calculations for the runoff coefficients and percent impervious are included in the **Appendix B**. Rational method was used to determine the peak flows for the project. These flows were used to determine the size of the proposed curb cuts, inlets, culvert, storm drain system and on-site swales.

The proposed impervious values in Table 6-6 of the DCM were utilized in this report for the final design. Refer to **Appendix B** of this report for Table 6-6.

The Site is providing one full spectrum detention pond. The Site is maintaining the historic drainage patterns as much as possible.

There are no additional provisions selected or deviations from the criteria in both the MANUAL and Colorado Springs MANUAL.

HYDRAULIC CRITERIA

Applicable design methods were utilized to size the proposed pond, culvert and drainage swales, which includes the use of the UD-Detention spreadsheet, UD-Inlet spreadsheet, rational calculations spreadsheet, StormCAD, HY-8 and FlowMaster, V8i software.

Proposed drainage features on-site have been analyzed and sized for the following design storm events:

- Major Storm: 100-year Storm Event

One full spectrum detention pond is proposed in order to maintain historic flows and water quality. The detention pond known as the South Pond. The South Pond is in the southwest corner of the Site with a proposed volume of 1.5 ac-ft and designed for the 100-year storm event. With a discharge rate of 21.9 cfs, water from the South Pond is discharged into an existing 24-inch storm drain located at the southwest corner of the site and ultimately out falling to Sand Creek (Sand Creek's East Fork). Pond calculations are provided in the **Appendix C**.

Curb cuts, inlets, grass lined swales, and storm drain pipes are designed to carry flows from to the South Pond. The curb cuts, inlets, swales, and storm drain pipes calculations are provided in the **Appendix C** and the design points are provided in the Proposed Drainage Map located in **Appendix D**. The pond is designed to release the 100-year flow rates below the pre-development flow rate.

Emergency overflows will be routed over the southwest corner of the pond. It will follow existing drainage conditions and enter the existing crossspan that conveys across Akers Drive on the North side of Constitution Avenue. This flow enters an existing 5' Type-R Inlet that flows into an existing box culvert that crosses underneath Constitution Avenue to the South.

THE FOUR STEP PROCESS

The Project was designed in accordance with the four-step process to minimize adverse impacts of urbanization, as outlined in the County's "Four-Step Process" for selecting structural BMPs (ECM Section I.7.2 BMP Selection).

Step 1. Employ Runoff Reduction Practices- The project is proposing a residential development that will be designed to minimize the impact to the current existing terrain. The Site's proposed paved roadways will increase the Site's impervious area; however, drainage swales will be constructed to slow down the runoff velocity and reduce runoff peaks. A full spectrum detention pond will be used to capture stormwater and maintain flows discharging off site at or below historic levels.

Step 2. Stabilize Drainageways– Stabilizing proposed drainage swales by designing them with slopes that control the flow rates. Placement of riprap upstream and downstream of culverts to help reduce erosion of the drainage swales. Rock chutes will be constructed to reduce the velocities of runoff entering the ponds at the channel locations. We anticipate this will minimize erosion.

Step 3. Provide Water Quality Capture Volume (WQCV) –Permanent water quality measures and detention facilities will be provided with the Project. More specifically, this project proposes the construction of an Extended Detention Basin to provide for the required water quality capture volume.

Step 4. Consider Need for Industrial and Commercial BMPs – The proposed project is proposing a residential development; therefore, covering of storage/handling areas and spill containment and control will not need to be provided.

DRAINAGE FACILITY DESIGN

GENERAL CONCEPT

The proposed drainage patterns will match the historic patterns. To maintain historic flows, a full spectrum detention pond is being proposed and will capture and control the flows from the proposed development to convey flows with a series of swales, parking lot sheet flow, and a storm drain system.

Provided in the **Appendix B** are hydrologic calculations utilizing the Rational method for the existing and proposed conditions. Provided in **Appendix C** are the hydraulic calculations for the proposed conditions HY-8 culvert calculations, Flowmaster details and cross sections for proposed drainage features. As previously mentioned, the and existing drainage map and proposed drainage map can be found in **Appendix D**.

SPECIFIC DETAILS

The existing conditions of the Site have flows conveying from the north to the south corner and spill into Constitution Ave. Runoff conditions for the Site were developed utilizing the Rational Method described in the Hydrologic Criteria section of this report.

Sub-basins B1 through B18 consist of a future multi-family buildings and detention pond. All basins have flows being captured and conveyed onsite. Flows are conveyed from the north side of the Site to the southwest corner of the Site. On site flows enter South Pond which then discharges into an existing 24-inch storm drain pipe at the northeast corner of Constitution Ave and Akers Drive.

The hydrologic calculations, hydraulic calculations, and Drainage Maps are included in the **Appendix B, Appendix C, and Appendix D** of this report for reference.

The Site will disturb more than 1 acre and will require a Colorado Discharge Permit System (CDPS) General Permit for Stormwater Discharge Associated with Construction Activities from the Colorado Department of Public Health and Environment (CDPHE).

The required fees for the Sand Creek Drainage Basin based upon the 2021 fee schedule, are listed below. Fees will be paid prior to plat recordation.

- Drainage Fee/Impervious Acre =	\$20,387	x	9.83 acres =	\$200,404.21
- Bridge Fee/Impervious Acre =	\$8,339	x	9.83 acres =	\$81,972.37
			Total =	\$282,376.58

SUMMARY

The proposed drainage design is to maintain the historic drainage patterns, the overall imperviousness and release rates for the Site. Runoff from the Site will flow through an existing storm drain system to an existing El Paso County drainage basin: The Sand Creek Basin. The basin ultimately discharges to Sand Creek. The drainage design presented within this report conforms to the criteria presented in both the MANUAL and the Colorado Springs MANUAL.

Additionally, the Site runoff and storm drain facilities will not adversely affect the downstream and surrounding developments, including Sand Creek.

REFERENCES

1. City of Colorado Springs “Drainage Criteria Manual (DCM) Volume 1”, dated May, 2014
2. El Paso County “Drainage Criteria Manual”, dated October 31, 2018
3. El Paso County “Engineering Criteria Manual” Revision 6, dated December 13, 2016
4. Chapter 6 and Section 3.2.1. of Chapter 13-City of Colorado Springs Drainage Criteria Manual, May 2014.
5. Urban Drainage and Flood Control District Drainage Criteria Manual (UDFCDCM), Vol. 1, prepared by Wright-McLaughlin Engineers, June 2001, with latest revisions.
6. Flood Insurance Rate Map, El Paso County, Colorado and Incorporated Areas, Map Number 08041C0756G, Effective Date December 7, 2018, prepared by the Federal Emergency Management Agency (FEMA).

APPENDIX

APPENDIX A: FIGURES

Vicinity Map



National Flood Hazard Layer FIRMette



104°41'25"W 38°52'21"N



Legend

SEE FIS REPORT FOR DETAILED LEGEND AND INDEX MAP FOR FIRM PANEL LAYOUT

SPECIAL FLOOD HAZARD AREAS	
	Without Base Flood Elevation (BFE) Zone A, V, A99
	With BFE or Depth Zone AE, AO, AH, VE, AR
	Regulatory Floodway

OTHER AREAS OF FLOOD HAZARD	
	0.2% Annual Chance Flood Hazard, Areas of 1% annual chance flood with average depth less than one foot or with drainage areas of less than one square mile Zone X
	Future Conditions 1% Annual Chance Flood Hazard Zone X
	Area with Reduced Flood Risk due to Levee. See Notes. Zone X
	Area with Flood Risk due to Levee Zone D

OTHER AREAS	
	NO SCREEN Area of Minimal Flood Hazard Zone X
	Effective LOMRs
	Area of Undetermined Flood Hazard Zone D

GENERAL STRUCTURES	
	Channel, Culvert, or Storm Sewer
	Levee, Dike, or Floodwall

OTHER FEATURES	
	20.2 Cross Sections with 1% Annual Chance Water Surface Elevation 17.5
	Coastal Transect
	Base Flood Elevation Line (BFE)
	Limit of Study
	Jurisdiction Boundary
	Coastal Transect Baseline
	Profile Baseline
	Hydrographic Feature

MAP PANELS	
	Digital Data Available
	No Digital Data Available
	Unmapped

The pin displayed on the map is an approximate point selected by the user and does not represent an authoritative property location.

This map complies with FEMA's standards for the use of digital flood maps if it is not void as described below. The basemap shown complies with FEMA's basemap accuracy standards

The flood hazard information is derived directly from the authoritative NFHL web services provided by FEMA. This map was exported on 1/5/2021 at 5:09 PM and does not reflect changes or amendments subsequent to this date and time. The NFHL and effective information may change or become superseded by new data over time.

This map image is void if the one or more of the following map elements do not appear: basemap imagery, flood zone labels, legend, scale bar, map creation date, community identifiers, FIRM panel number, and FIRM effective date. Map images for unmapped and unmodernized areas cannot be used for regulatory purposes.

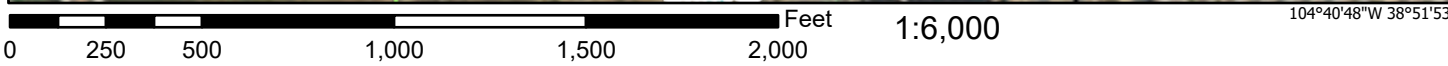

USGS The National Map: Orthoimagery. Data refreshed October, 2020.

APPENDIX B: HYDROLOGY



United States
Department of
Agriculture

NRCS

Natural
Resources
Conservation
Service

A product of the National
Cooperative Soil Survey,
a joint effort of the United
States Department of
Agriculture and other
Federal agencies, State
agencies including the
Agricultural Experiment
Stations, and local
participants

Custom Soil Resource Report for El Paso County Area, Colorado



Contents

Preface	2
How Soil Surveys Are Made	5
Soil Map	8
Soil Map.....	9
Legend.....	10
Map Unit Legend.....	11
Map Unit Descriptions.....	11
El Paso County Area, Colorado.....	13
8—Blakeland loamy sand, 1 to 9 percent slopes.....	13
10—Blendon sandy loam, 0 to 3 percent slopes.....	14
References	16

Soil Map

The soil map section includes the soil map for the defined area of interest, a list of soil map units on the map and extent of each map unit, and cartographic symbols displayed on the map. Also presented are various metadata about data used to produce the map, and a description of each soil map unit.

Custom Soil Resource Report Soil Map



Map Scale: 1:2,270 if printed on A landscape (11" x 8.5") sheet.

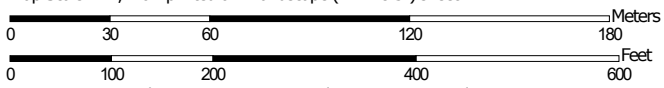

Map projection: Web Mercator Corner coordinates: WGS84 Edge tics: UTM Zone 13N WGS84

MAP LEGEND

Area of Interest (AOI)

 Area of Interest (AOI)



















Soils







 Soil Map Unit Polygons

 Soil Map Unit Lines

 Soil Map Unit Points

Special Point Features





-  Blowout
-  Borrow Pit
-  Clay Spot
-  Closed Depression
-  Gravel Pit
-  Gravelly Spot
-  Landfill
-  Lava Flow
-  Marsh or swamp
-  Mine or Quarry
-  Miscellaneous Water
-  Perennial Water
-  Rock Outcrop
-  Saline Spot
-  Sandy Spot
-  Severely Eroded Spot
-  Sinkhole
-  Slide or Slip
-  Sodic Spot

-  Spoil Area
-  Stony Spot
-  Very Stony Spot
-  Wet Spot
-  Other
-  Special Line Features

Water Features

 Streams and Canals

Transportation

-  Rails
-  Interstate Highways
-  US Routes
-  Major Roads
-  Local Roads

Background

 Aerial Photography

MAP INFORMATION

The soil surveys that comprise your AOI were mapped at 1:24,000.

Warning: Soil Map may not be valid at this scale.

Enlargement of maps beyond the scale of mapping can cause misunderstanding of the detail of mapping and accuracy of soil line placement. The maps do not show the small areas of contrasting soils that could have been shown at a more detailed scale.

Please rely on the bar scale on each map sheet for map measurements.

Source of Map: Natural Resources Conservation Service
 Web Soil Survey URL:
 Coordinate System: Web Mercator (EPSG:3857)

Maps from the Web Soil Survey are based on the Web Mercator projection, which preserves direction and shape but distorts distance and area. A projection that preserves area, such as the Albers equal-area conic projection, should be used if more accurate calculations of distance or area are required.

This product is generated from the USDA-NRCS certified data as of the version date(s) listed below.

Soil Survey Area: El Paso County Area, Colorado
 Survey Area Data: Version 18, Jun 5, 2020

Soil map units are labeled (as space allows) for map scales 1:50,000 or larger.

Date(s) aerial images were photographed: Aug 19, 2018—Sep 23, 2018

The orthophoto or other base map on which the soil lines were compiled and digitized probably differs from the background imagery displayed on these maps. As a result, some minor shifting of map unit boundaries may be evident.

Map Unit Legend

Map Unit Symbol	Map Unit Name	Acres in AOI	Percent of AOI
8	Blakeland loamy sand, 1 to 9 percent slopes	17.5	78.8%
10	Blendon sandy loam, 0 to 3 percent slopes	4.7	21.2%
Totals for Area of Interest		22.3	100.0%

Map Unit Descriptions

The map units delineated on the detailed soil maps in a soil survey represent the soils or miscellaneous areas in the survey area. The map unit descriptions, along with the maps, can be used to determine the composition and properties of a unit.

A map unit delineation on a soil map represents an area dominated by one or more major kinds of soil or miscellaneous areas. A map unit is identified and named according to the taxonomic classification of the dominant soils. Within a taxonomic class there are precisely defined limits for the properties of the soils. On the landscape, however, the soils are natural phenomena, and they have the characteristic variability of all natural phenomena. Thus, the range of some observed properties may extend beyond the limits defined for a taxonomic class. Areas of soils of a single taxonomic class rarely, if ever, can be mapped without including areas of other taxonomic classes. Consequently, every map unit is made up of the soils or miscellaneous areas for which it is named and some minor components that belong to taxonomic classes other than those of the major soils.

Most minor soils have properties similar to those of the dominant soil or soils in the map unit, and thus they do not affect use and management. These are called noncontrasting, or similar, components. They may or may not be mentioned in a particular map unit description. Other minor components, however, have properties and behavioral characteristics divergent enough to affect use or to require different management. These are called contrasting, or dissimilar, components. They generally are in small areas and could not be mapped separately because of the scale used. Some small areas of strongly contrasting soils or miscellaneous areas are identified by a special symbol on the maps. If included in the database for a given area, the contrasting minor components are identified in the map unit descriptions along with some characteristics of each. A few areas of minor components may not have been observed, and consequently they are not mentioned in the descriptions, especially where the pattern was so complex that it was impractical to make enough observations to identify all the soils and miscellaneous areas on the landscape.

The presence of minor components in a map unit in no way diminishes the usefulness or accuracy of the data. The objective of mapping is not to delineate pure taxonomic classes but rather to separate the landscape into landforms or landform segments that have similar use and management requirements. The delineation of such segments on the map provides sufficient information for the development of resource plans. If intensive use of small areas is planned, however,

Custom Soil Resource Report

onsite investigation is needed to define and locate the soils and miscellaneous areas.

An identifying symbol precedes the map unit name in the map unit descriptions. Each description includes general facts about the unit and gives important soil properties and qualities.

Soils that have profiles that are almost alike make up a *soil series*. Except for differences in texture of the surface layer, all the soils of a series have major horizons that are similar in composition, thickness, and arrangement.

Soils of one series can differ in texture of the surface layer, slope, stoniness, salinity, degree of erosion, and other characteristics that affect their use. On the basis of such differences, a soil series is divided into *soil phases*. Most of the areas shown on the detailed soil maps are phases of soil series. The name of a soil phase commonly indicates a feature that affects use or management. For example, Alpha silt loam, 0 to 2 percent slopes, is a phase of the Alpha series.

Some map units are made up of two or more major soils or miscellaneous areas. These map units are complexes, associations, or undifferentiated groups.

A *complex* consists of two or more soils or miscellaneous areas in such an intricate pattern or in such small areas that they cannot be shown separately on the maps. The pattern and proportion of the soils or miscellaneous areas are somewhat similar in all areas. Alpha-Beta complex, 0 to 6 percent slopes, is an example.

An *association* is made up of two or more geographically associated soils or miscellaneous areas that are shown as one unit on the maps. Because of present or anticipated uses of the map units in the survey area, it was not considered practical or necessary to map the soils or miscellaneous areas separately. The pattern and relative proportion of the soils or miscellaneous areas are somewhat similar. Alpha-Beta association, 0 to 2 percent slopes, is an example.

An *undifferentiated group* is made up of two or more soils or miscellaneous areas that could be mapped individually but are mapped as one unit because similar interpretations can be made for use and management. The pattern and proportion of the soils or miscellaneous areas in a mapped area are not uniform. An area can be made up of only one of the major soils or miscellaneous areas, or it can be made up of all of them. Alpha and Beta soils, 0 to 2 percent slopes, is an example.

Some surveys include *miscellaneous areas*. Such areas have little or no soil material and support little or no vegetation. Rock outcrop is an example.

El Paso County Area, Colorado

8—Blakeland loamy sand, 1 to 9 percent slopes

Map Unit Setting

National map unit symbol: 369v
Elevation: 4,600 to 5,800 feet
Mean annual precipitation: 14 to 16 inches
Mean annual air temperature: 46 to 48 degrees F
Frost-free period: 125 to 145 days
Farmland classification: Not prime farmland

Map Unit Composition

Blakeland and similar soils: 98 percent
Minor components: 2 percent
Estimates are based on observations, descriptions, and transects of the mapunit.

Description of Blakeland

Setting

Landform: Hills, flats
Landform position (three-dimensional): Side slope, talf
Down-slope shape: Linear
Across-slope shape: Linear
Parent material: Alluvium derived from sedimentary rock and/or eolian deposits derived from sedimentary rock

Typical profile

A - 0 to 11 inches: loamy sand
AC - 11 to 27 inches: loamy sand
C - 27 to 60 inches: sand

Properties and qualities

Slope: 1 to 9 percent
Depth to restrictive feature: More than 80 inches
Drainage class: Somewhat excessively drained
Runoff class: Low
Capacity of the most limiting layer to transmit water (Ksat): High to very high (5.95 to 19.98 in/hr)
Depth to water table: More than 80 inches
Frequency of flooding: None
Frequency of ponding: None
Calcium carbonate, maximum content: 5 percent
Available water capacity: Low (about 4.5 inches)

Interpretive groups

Land capability classification (irrigated): 3e
Land capability classification (nonirrigated): 6e
Hydrologic Soil Group: A
Ecological site: R049XB210CO - Sandy Foothill
Hydric soil rating: No

Minor Components

Pleasant

Percent of map unit: 1 percent

Custom Soil Resource Report

Landform: Depressions
Hydric soil rating: Yes

Other soils

Percent of map unit: 1 percent
Hydric soil rating: No

10—Blendon sandy loam, 0 to 3 percent slopes

Map Unit Setting

National map unit symbol: 3671
Elevation: 6,000 to 6,800 feet
Mean annual precipitation: 14 to 16 inches
Mean annual air temperature: 46 to 48 degrees F
Frost-free period: 125 to 145 days
Farmland classification: Not prime farmland

Map Unit Composition

Blendon and similar soils: 98 percent
Minor components: 2 percent
Estimates are based on observations, descriptions, and transects of the mapunit.

Description of Blendon

Setting

Landform: Terraces, alluvial fans
Down-slope shape: Linear
Across-slope shape: Linear
Parent material: Sandy alluvium derived from arkose

Typical profile

A - 0 to 10 inches: sandy loam
Bw - 10 to 36 inches: sandy loam
C - 36 to 60 inches: gravelly sandy loam

Properties and qualities

Slope: 0 to 3 percent
Depth to restrictive feature: More than 80 inches
Drainage class: Well drained
Runoff class: Low
Capacity of the most limiting layer to transmit water (Ksat): Moderately high to high
(0.60 to 2.00 in/hr)
Depth to water table: More than 80 inches
Frequency of flooding: None
Frequency of ponding: None
Calcium carbonate, maximum content: 2 percent
Available water capacity: Moderate (about 6.2 inches)

Interpretive groups

Land capability classification (irrigated): None specified
Land capability classification (nonirrigated): 3e

Custom Soil Resource Report

Hydrologic Soil Group: B

Ecological site: R049XB210CO - Sandy Foothill

Hydric soil rating: No

Minor Components

Pleasant

Percent of map unit: 1 percent

Landform: Depressions

Hydric soil rating: Yes

Other soils

Percent of map unit: 1 percent

Hydric soil rating: No

References

- American Association of State Highway and Transportation Officials (AASHTO). 2004. Standard specifications for transportation materials and methods of sampling and testing. 24th edition.
- American Society for Testing and Materials (ASTM). 2005. Standard classification of soils for engineering purposes. ASTM Standard D2487-00.
- Cowardin, L.M., V. Carter, F.C. Golet, and E.T. LaRoe. 1979. Classification of wetlands and deep-water habitats of the United States. U.S. Fish and Wildlife Service FWS/OBS-79/31.
- Federal Register. July 13, 1994. Changes in hydric soils of the United States.
- Federal Register. September 18, 2002. Hydric soils of the United States.
- Hurt, G.W., and L.M. Vasilas, editors. Version 6.0, 2006. Field indicators of hydric soils in the United States.
- National Research Council. 1995. Wetlands: Characteristics and boundaries.
- Soil Survey Division Staff. 1993. Soil survey manual. Soil Conservation Service. U.S. Department of Agriculture Handbook 18. http://www.nrcs.usda.gov/wps/portal/nrcs/detail/national/soils/?cid=nrcs142p2_054262
- Soil Survey Staff. 1999. Soil taxonomy: A basic system of soil classification for making and interpreting soil surveys. 2nd edition. Natural Resources Conservation Service, U.S. Department of Agriculture Handbook 436. http://www.nrcs.usda.gov/wps/portal/nrcs/detail/national/soils/?cid=nrcs142p2_053577
- Soil Survey Staff. 2010. Keys to soil taxonomy. 11th edition. U.S. Department of Agriculture, Natural Resources Conservation Service. http://www.nrcs.usda.gov/wps/portal/nrcs/detail/national/soils/?cid=nrcs142p2_053580
- Tiner, R.W., Jr. 1985. Wetlands of Delaware. U.S. Fish and Wildlife Service and Delaware Department of Natural Resources and Environmental Control, Wetlands Section.
- United States Army Corps of Engineers, Environmental Laboratory. 1987. Corps of Engineers wetlands delineation manual. Waterways Experiment Station Technical Report Y-87-1.
- United States Department of Agriculture, Natural Resources Conservation Service. National forestry manual. http://www.nrcs.usda.gov/wps/portal/nrcs/detail/soils/home/?cid=nrcs142p2_053374
- United States Department of Agriculture, Natural Resources Conservation Service. National range and pasture handbook. <http://www.nrcs.usda.gov/wps/portal/nrcs/detail/national/landuse/rangepasture/?cid=stelprdb1043084>

Custom Soil Resource Report

United States Department of Agriculture, Natural Resources Conservation Service. National soil survey handbook, title 430-VI. http://www.nrcs.usda.gov/wps/portal/nrcs/detail/soils/scientists/?cid=nrcs142p2_054242

United States Department of Agriculture, Natural Resources Conservation Service. 2006. Land resource regions and major land resource areas of the United States, the Caribbean, and the Pacific Basin. U.S. Department of Agriculture Handbook 296. http://www.nrcs.usda.gov/wps/portal/nrcs/detail/national/soils/?cid=nrcs142p2_053624

United States Department of Agriculture, Soil Conservation Service. 1961. Land capability classification. U.S. Department of Agriculture Handbook 210. http://www.nrcs.usda.gov/Internet/FSE_DOCUMENTS/nrcs142p2_052290.pdf

The methods described in this Manual require only that the 1-hour, 6-hour and 24-hours depths be used as input. The storm return periods required for the application of methods in this Manual are the 2-, 5-, 10-, 25-, 50- and 100-year events. The 6-hour and 24-hour depths for these return periods can be read directly from Figures 6-6 through 6-17 at the end of this chapter. The 1-hour depth for return periods can be calculated for all design return periods following this procedure:

Step 1: Calculate 2-year, 1-hour rainfall based on 2-year, 6-hour and 24-hour values.

$$Y_2 = 0.218 + 0.709 \cdot (X_1 \cdot X_1 / X_2) \quad (\text{Eq. 6-1})$$

Where:

Y_2 = 2-year, 1-hour rainfall (in)

X_1 = 2-year, 6-hour rainfall (in) from Figure 6-6

X_2 = 2-year, 24-hour rainfall (in) from Figure 6-12

Step 2: Calculate 100-year, 1-hour rainfall based on 2-year 6-hour and 24-hour values

$$Y_{100} = 1.897 + 0.439 \cdot (X_3 \cdot X_3 / X_4) - 0.008 Z \quad (\text{Eq. 6-2})$$

Where

Y_{100} = 100-year, 1-hour rainfall (in)

X_3 = 100-year, 6-hour rainfall (in) from Figure 6-11

X_4 = 100-year, 24-hour rainfall (in) from Figure 6-17

Z = Elevation in hundreds of feet above sea level

Step 3: Plot the 2-year and 100-year, 1-hour values on the diagram provided in Figure 6-18 and connect the points with a straight line. The 1-hour point rainfall values for other recurrence intervals can be read directly from the straight line drawn on Figure 6-18.

Example: Determine the 10-year, 1-hour rainfall depth for downtown Colorado Springs.

Step 1: Calculate 2-year, 1-hour rainfall (Y_2) based on 2-year, 6-hour and 24-hour values. From Figure 6-6, the 2-year, 6-hour rainfall depth for downtown Colorado Springs is approximately 1.7 inches (X_1), and from Figure 6-12, the 2-year 24-hour depth is approximately 2.1 inches (X_2). The 2-year, 1-hour rainfall is calculated as follows:

$$Y_2 = 0.218 + 0.709 \cdot (1.7 \cdot 1.7 / 2.1) = 1.19 \text{ in} \quad (\text{Eq. 6-3})$$

Step 2: Calculate 100-year, 1-hour rainfall (Y_{100}) based on 100-year, 6-hour and 24-hour values. From Figure 6-11, the 100-year, 6-hour rainfall depth for downtown Colorado Springs is approximately 3.5 inches (X_3), and from Figure 6-17, the 100-year 24-hour depth is approximately 4.5 inches (X_4). Assume an elevation of 6,840 feet for Colorado Springs. The 100-year, 1-hour rainfall is calculated as follows:

$$Y_{100} = 1.897 + 0.439 \cdot (3.5 \cdot 3.5 / 4.6) - 0.008 \cdot (6,840 / 100) = 2.52 \text{ in} \quad (\text{Eq. 6-4})$$

Step 3: Plot 2-year and 100-year, 1-hour rainfall depths on Figure 6-18 and read 10-year value from straight line. This example is illustrated on Figure 6-18, with a 1-hour, 10-year rainfall depth of approximately 1.75 inches. Figure 6-18a provides the example, and Figure 6-18b provides a blank chart.

Figure 6-6. 2-Year, 6-Hour Precipitation Tenths of an Inch (NOAA Atlas 2)

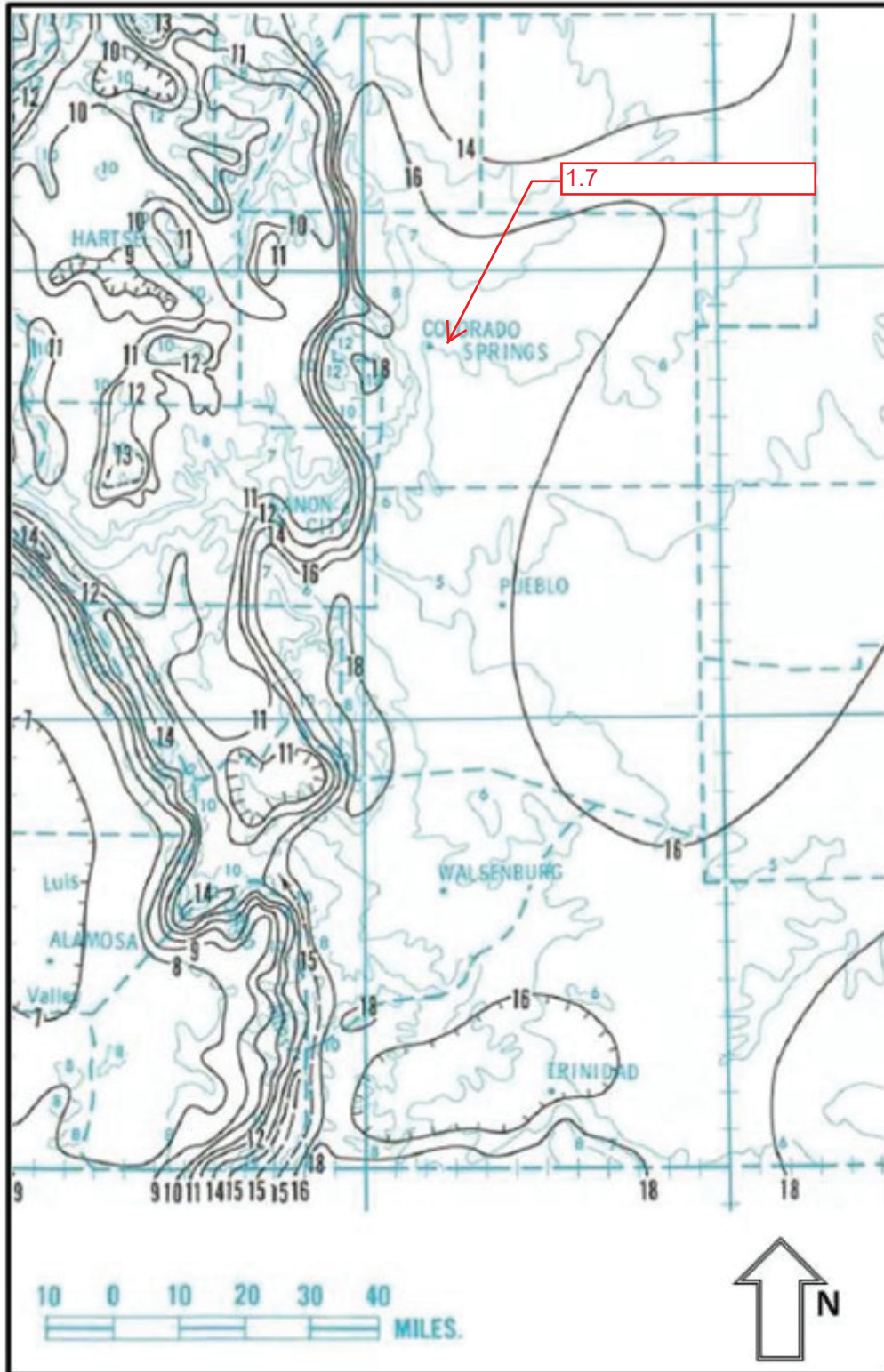

Figure 6-12. 2-Year, 24-Hour Precipitation Tenths of an Inch (NOAA Atlas 2)

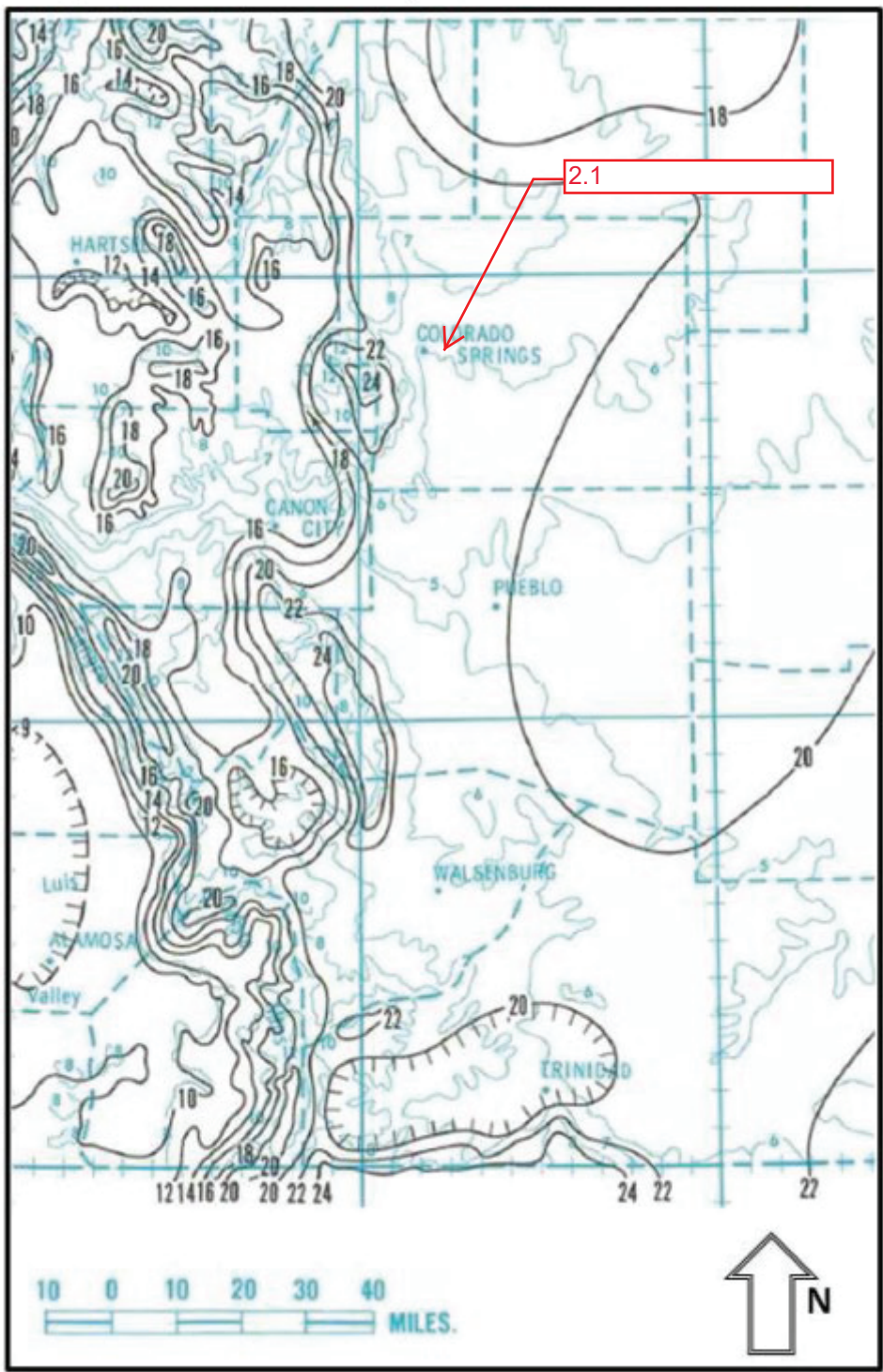

Figure 6-11. 100-Year, 6-Hour Precipitation Tenths of an Inch (NOAA Atlas 2)

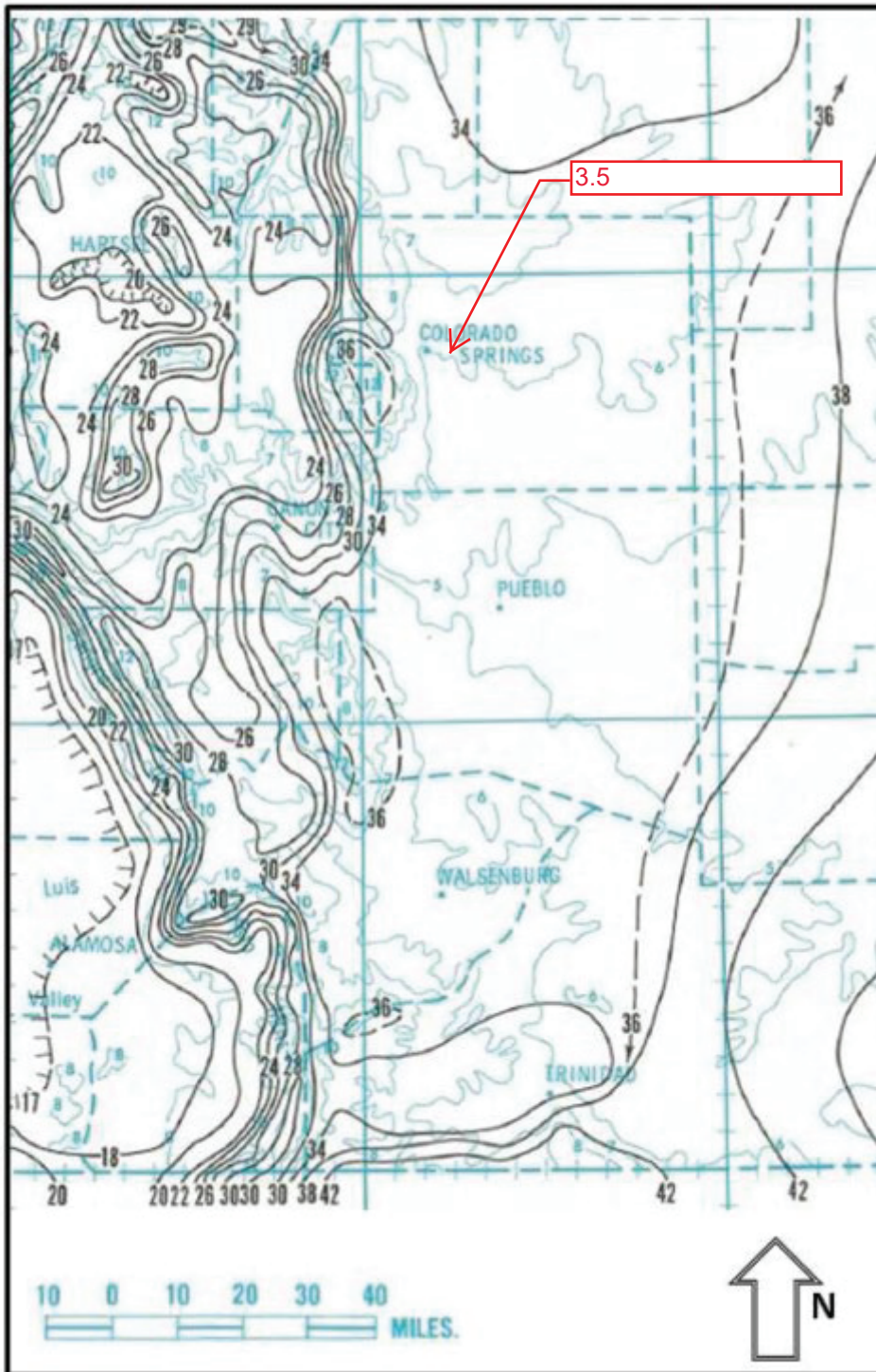
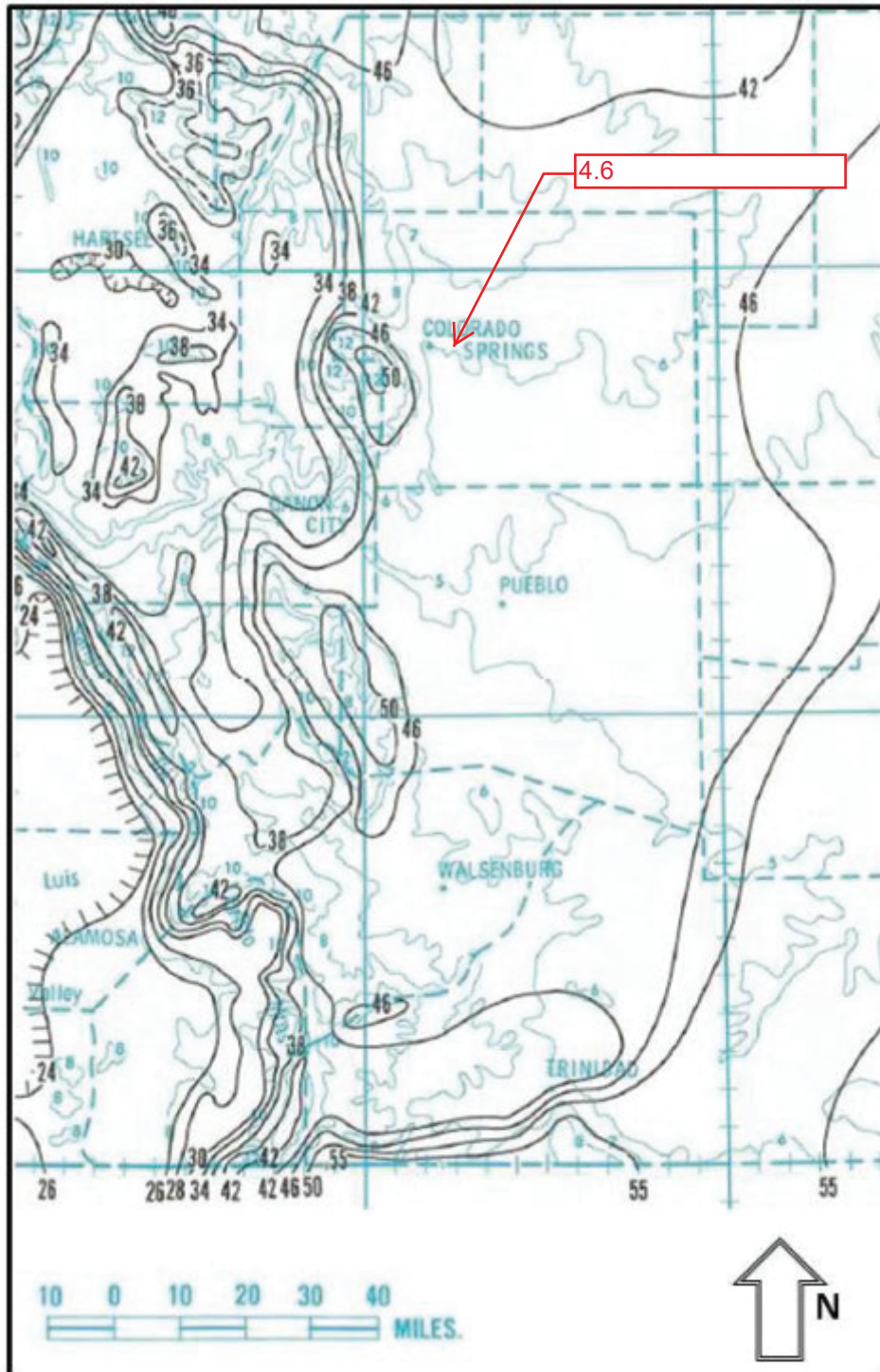
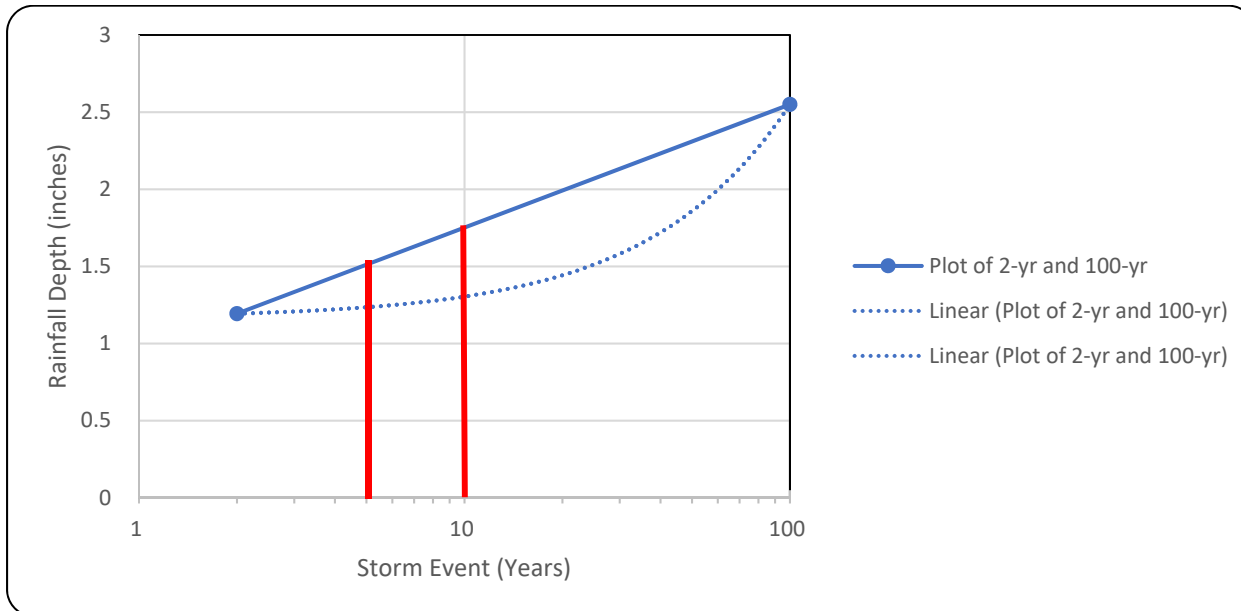

Figure 6-17. 100-Year, 24-Hour Precipitation Tenths of an Inch (NOAA Atlas 2)



Rainfall Depths			
			Notes
2 yr, 6 hr rainfall (in)	$X_1 =$	1.7	From Figure 6-6
2 yr, 24 hr rainfall (in)	$X_2 =$	2.1	From Figure 6-12
100 yr, 6 hr rainfall (in)	$X_3 =$	3.5	From Figure 6-11
100 yr, 24 hr rainfall (in)	$X_4 =$	4.6	From Figure 6-17
Elevation (hundreds of feet)]	$Z =$	64.5	
2 yr, 1 hr rainfall (in)	$Y_2 =$	1.193719	Equation 6-1
100 yr, 1 hr rainfall (in)	$Y_{100} =$	2.550076	Equation 6-2
Graph			
X-axis		Y-axis	
2	Y_2	1.193719	Calculated from Eq 6-1
100	Y_{100}	2.550076	Calculated from Eq 6-2
	Y_5	1.52	Determined From Graph below
	Y_{10}	2.75	Determined From Graph below



Drainage Report
Colorado Springs, CO

Calculated by:BAH

$$I = \frac{28.5 P_1}{(10 + T_D)^{0.786}}$$

Where:

I = rainfall intensity (inches per hour)

one-hour rainfall depth (inches) from Table 6-2 One-

P₁ = hour Point Rainfall Depth

City of Colorado Springs Drainage Design

T_c = storm duration (minutes)

	<u>2-yr</u>	<u>5-yr</u>	<u>10-yr</u>	<u>100-yr</u>
P ₁ =	1.19	1.52	1.75	2.55

Time Intensity Frequency Tabulation

TIME	2 YR	5 YR	10 YR	100 YR
5	4.05	5.16	5.94	8.65
10	3.23	4.11	4.73	6.90
15	2.71	3.45	3.97	5.79
30	1.87	2.38	2.75	4.00
60	1.21	1.54	1.77	2.58
120	0.74	0.94	1.09	1.58

Table 6-6. Runoff Coefficients for Rational Method

(Source: UDFCD 2001)

Land Use or Surface Characteristics	Percent Impervious	Runoff Coefficients											
		2-year		5-year		10-year		25-year		50-year		100-year	
		HSG A&B	HSG C&D	HSG A&B	HSG C&D	HSG A&B	HSG C&D	HSG A&B	HSG C&D	HSG A&B	HSG C&D	HSG A&B	HSG C&D
Business													
Commercial Areas	95	0.79	0.80	0.81	0.82	0.83	0.84	0.85	0.87	0.87	0.88	0.88	0.89
Neighborhood Areas	70	0.45	0.49	0.49	0.53	0.53	0.57	0.58	0.62	0.60	0.65	0.62	0.68
Residential													
1/8 Acre or less	65	0.41	0.45	0.45	0.49	0.49	0.54	0.54	0.59	0.57	0.62	0.59	0.65
1/4 Acre	40	0.23	0.28	0.30	0.35	0.36	0.42	0.42	0.50	0.46	0.54	0.50	0.58
1/3 Acre	30	0.18	0.22	0.25	0.30	0.32	0.38	0.39	0.47	0.43	0.52	0.47	0.57
1/2 Acre	25	0.15	0.20	0.22	0.28	0.30	0.36	0.37	0.46	0.41	0.51	0.46	0.56
1 Acre	20	0.12	0.17	0.20	0.26	0.27	0.34	0.35	0.44	0.40	0.50	0.44	0.55
Industrial													
Light Areas	80	0.57	0.60	0.59	0.63	0.63	0.66	0.66	0.70	0.68	0.72	0.70	0.74
Heavy Areas	90	0.71	0.73	0.73	0.75	0.75	0.77	0.78	0.80	0.80	0.82	0.81	0.83
Parks and Cemeteries	7	0.05	0.09	0.12	0.19	0.20	0.29	0.30	0.40	0.34	0.46	0.39	0.52
Playgrounds	13	0.07	0.13	0.16	0.23	0.24	0.31	0.32	0.42	0.37	0.48	0.41	0.54
Railroad Yard Areas	40	0.23	0.28	0.30	0.35	0.36	0.42	0.42	0.50	0.46	0.54	0.50	0.58
Undeveloped Areas													
Historic Flow Analysis-- Greenbelts, Agriculture	2	0.03	0.05	0.09	0.16	0.17	0.26	0.26	0.38	0.31	0.45	0.36	0.51
Pasture/Meadow	0	0.02	0.04	0.08	0.15	0.15	0.25	0.25	0.37	0.30	0.44	0.35	0.50
Forest	0	0.02	0.04	0.08	0.15	0.15	0.25	0.25	0.37	0.30	0.44	0.35	0.50
Exposed Rock	100	0.89	0.89	0.90	0.90	0.92	0.92	0.94	0.94	0.95	0.95	0.96	0.96
Offsite Flow Analysis (when landuse is undefined)	45	0.26	0.31	0.32	0.37	0.38	0.44	0.44	0.51	0.48	0.55	0.51	0.59
Streets													
Paved	100	0.89	0.89	0.90	0.90	0.92	0.92	0.94	0.94	0.95	0.95	0.96	0.96
Gravel	80	0.57	0.60	0.59	0.63	0.63	0.66	0.66	0.70	0.68	0.72	0.70	0.74
Drive and Walks	100	0.89	0.89	0.90	0.90	0.92	0.92	0.94	0.94	0.95	0.95	0.96	0.96
Roots	90	0.71	0.73	0.73	0.75	0.75	0.77	0.78	0.80	0.80	0.82	0.81	0.83
Lawns	0	0.02	0.04	0.08	0.15	0.15	0.25	0.25	0.37	0.30	0.44	0.35	0.50

3.2 Time of Concentration

One of the basic assumptions underlying the Rational Method is that runoff is a function of the average rainfall rate during the time required for water to flow from the hydraulically most remote part of the drainage area under consideration to the design point. However, in practice, the time of concentration can be an empirical value that results in reasonable and acceptable peak flow calculations.

For urban areas, the time of concentration (t_c) consists of an initial time or overland flow time (t_i) plus the travel time (t_t) in the storm sewer, paved gutter, roadside drainage ditch, or drainage channel. For non-urban areas, the time of concentration consists of an overland flow time (t_i) plus the time of travel in a concentrated form, such as a swale or drainageway. The travel portion (t_t) of the time of concentration can be estimated from the hydraulic properties of the storm sewer, gutter, swale, ditch, or drainageway. Initial time, on the other hand, will vary with surface slope, depression storage, surface cover, antecedent rainfall, and infiltration capacity of the soil, as well as distance of surface flow. The time of concentration is represented by Equation 6-7 for both urban and non-urban areas.

Weighted Imperviousness Calculations

SUB-BASIN	AREA (SF)	AREA (Acres)	ROOF AREA	ROOF IMPERVIOUSNESS	ROOF				LANDSCAPE AREA	LANDSCAPE IMPERVIOUSNESS	LANDSCAPE				PAVEMENT AREA	PAVEMENT IMPERVIOUSNESS	PAVEMENT				WEIGHTED IMPERVIOUSNESS	WEIGHTED COEFFICIENTS			
					C2	C5	C10	C100			C2	C5	C10	C100			C2	C5	C10	C100		C2	C5	C10	C100
B1	129791	2.98	0	90%	0.71	0.73	0.75	0.81	0	2%	0.02	0.08	0.15	0.35	2.979591	100%	0.89	0.90	0.92	0.96	100%	0.89	0.90	0.92	0.96
B2	44027	1.01	0.16	90%	0.71	0.73	0.75	0.81	0.850721	2%	0.02	0.08	0.15	0.35	0	100%	0.89	0.90	0.92	0.96	16%	0.13	0.18	0.24	0.42
B3	7044.7314	0.16	0.161725	90%	0.71	0.73	0.75	0.81	0	2%	0.02	0.08	0.15	0.35	0	100%	0.89	0.90	0.92	0.96	90%	0.71	0.73	0.75	0.81
B4	10113.61	0.23	0	90%	0.71	0.73	0.75	0.81	0	2%	0.02	0.08	0.15	0.35	0.232177	100%	0.89	0.90	0.92	0.96	100%	0.89	0.90	0.92	0.96
B5	7234	0.17	0	90%	0.71	0.73	0.75	0.81	0.16607	2%	0.02	0.08	0.15	0.35	0	100%	0.89	0.90	0.92	0.96	2%	0.02	0.08	0.15	0.35
B6	5654.3088	0.13	0.129805	90%	0.71	0.73	0.75	0.81	0	2%	0.02	0.08	0.15	0.35	0	100%	0.89	0.90	0.92	0.96	90%	0.71	0.73	0.75	0.81
B7	72490.486	1.66	0.29	90%	0.71	0.73	0.75	0.81	1.374153	2%	0.02	0.08	0.15	0.35	0	100%	0.89	0.90	0.92	0.96	17%	0.14	0.19	0.25	0.43
B8	7168.5788	0.16	0.164568	90%	0.71	0.73	0.75	0.81	0	2%	0.02	0.08	0.15	0.35	0	100%	0.89	0.90	0.92	0.96	90%	0.71	0.73	0.75	0.81
B9	178639.71	4.10	0	90%	0.71	0.73	0.75	0.81	0	2%	0.02	0.08	0.15	0.35	4.101004	100%	0.89	0.90	0.92	0.96	100%	0.89	0.90	0.92	0.96
B10	41057.563	0.94	0.42	90%	0.71	0.73	0.75	0.81	0.522552	2%	0.02	0.08	0.15	0.35	0	100%	0.89	0.90	0.92	0.96	41%	0.33	0.37	0.42	0.55
B11	7068.5201	0.16	0.162271	90%	0.71	0.73	0.75	0.81	0	2%	0.02	0.08	0.15	0.35	0	100%	0.89	0.90	0.92	0.96	90%	0.71	0.73	0.75	0.81
B12	6531.5353	0.15	0.149943	90%	0.71	0.73	0.75	0.81	0	2%	0.02	0.08	0.15	0.35	0	100%	0.89	0.90	0.92	0.96	90%	0.71	0.73	0.75	0.81
B13	4736.8861	0.11	0.108744	90%	0.71	0.73	0.75	0.81	0	2%	0.02	0.08	0.15	0.35	0	100%	0.89	0.90	0.92	0.96	90%	0.71	0.73	0.75	0.81
B14	4984.6058	0.11	0.114431	90%	0.71	0.73	0.75	0.81	0	2%	0.02	0.08	0.15	0.35	0	100%	0.89	0.90	0.92	0.96	90%	0.71	0.73	0.75	0.81
B15	37253.102	0.86	0.39	90%	0.71	0.73	0.75	0.81	0.465214	2%	0.02	0.08	0.15	0.35	0	100%	0.89	0.90	0.92	0.96	42%	0.33	0.38	0.42	0.56
B16	6028.3106	0.14	0.138391	90%	0.71	0.73	0.75	0.81	0	2%	0.02	0.08	0.15	0.35	0	100%	0.89	0.90	0.92	0.96	90%	0.71	0.73	0.75	0.81
B17	5882.7155	0.14	0.135049	90%	0.71	0.73	0.75	0.81	0	2%	0.02	0.08	0.15	0.35	0	100%	0.89	0.90	0.92	0.96	90%	0.71	0.73	0.75	0.81
B18	47410.979	1.09	0	90%	0.71	0.73	0.75	0.81	1.088406	2%	0.02	0.08	0.15	0.35	0	100%	0.89	0.90	0.92	0.96	2%	0.02	0.08	0.15	0.35
OS-1	201069	4.62	0	90%	0.71	0.73	0.75	0.81	4.615909	2%	0.02	0.08	0.15	0.35	0	100%	0.89	0.90	0.92	0.96	2%	0.02	0.08	0.15	0.35
OS-2	7927	0.18	0	90%	0.71	0.73	0.75	0.81	0.181979	2%	0.02	0.08	0.15	0.35	0	100%	0.89	0.90	0.92	0.96	2%	0.02	0.08	0.15	0.35
TOTAL		19.10	2.52	90%	0.71	0.73	0.75	0.81	4.47	2%	0.02	0.08	0.15	0.35	7.31	100%	0.89	0.90	0.92	0.96	51%	0.44	0.46	0.49	0.56

Tract DD, Hannah Ridge at Feathergrass Filing No. 1
Drainage Report
El Paso County, CO

SUMMARY - PROPOSED RUNOFF TABLE						
DESIGN POINT	BASIN DESIGNATION	BASIN AREA (ACRES)	DIRECT 5-YR RUNOFF (CFS)	DIRECT 100-YR RUNOFF (CFS)	CUMULATIVE 5-YR RUNOFF (CFS)	CUMULATIVE 100-YR RUNOFF (CFS)
B1	B1	2.98	13.83	24.74	13.90	25.29
B2	B2	1.01	0.80	3.10	0.80	3.10
B3	B3	0.16	0.61	1.13	0.61	1.13
B4	B4	0.23	1.08	1.93	1.08	1.93
B5	B5	0.17	0.05	0.39	1.93	5.41
B6	B6	0.13	0.49	0.91	0.49	0.91
B7	B7	1.66	1.58	5.91	5.89	23.68
B8	B8	0.16	0.62	1.15	0.62	1.15
B9	B9	4.10	16.87	30.19	16.87	30.19
B10	B10	0.94	1.59	4.01	1.59	4.01
B11	B11	0.16	0.61	1.14	0.61	1.14
B12	B12	0.15	0.56	1.05	0.56	1.05
B13	B13	0.11	0.41	0.76	0.41	0.76
B14	B14	0.11	0.43	0.80	0.43	0.80
B15	B15	0.86	1.57	3.93	1.57	3.93
B16	B16	0.14	0.52	0.97	0.52	0.97
B17	B17	0.14	0.51	0.95	0.51	0.95
B18	B18	1.09	0.27	1.96	2.37	12.35
OS-1	OS-1	4.62	2.11	10.39	2.11	10.39
OS-2	OS-2	0.18	0.08	0.55	0.08	0.55

**Tract DD, Hannah Ridge at Feathergrass Filing No. 1
Drainage Report
El Paso County, CO**

Tract DD, Hannah Ridge at Feathergrass Filing No. 1 - Drainage Report																
Proposed Runoff Calculations																
Time of Concentration																
Watercourse Coefficient																
					Forest & Meadow 2.50			Short Grass Pasture & Lawns 7.00			Grassed Waterway 15.00					
					Fallow or Cultivation 5.00			Nearly Bare Ground 10.00			Paved Area & Shallow Gutter 20.00					
DESIGN POINT	SUB-BASIN DATA				INITIAL / OVERLAND TIME			TRAVEL TIME T(t)					T(c) CHECK (URBANIZED BASINS)			FINAL T(c) min.
	DRAIN BASIN	AREA sq. ft.	AREA ac.	C(5)	Length ft.	Slope %	T(i) min	Length ft.	Slope %	Coeff.	Velocity fps	T(t) min.	COMP. T(c)	TOTAL LENGTH	L/180+10	
B1	B1	129,791	2.98	0.90	49	6.5%	1.4	772	3.5%	20.00	3.7	3.4	5.0	821	14.6	5.0
B2	B2	44,027	1.01	0.18	68	8.5%	6.8	218	7.0%	7.00	1.9	2.0	8.8	286	11.6	8.8
B3	B3	7,045	0.16	0.73	32	0.5%	4.8	0		20.00	0.0	0.0	5.0	32	10.2	5.0
B4	B4	10,114	0.23	0.90	15	4.5%	0.9	229	1.5%	20.00	2.4	1.6	5.0	244	11.4	5.0
B5	B5	7,234	0.17	0.08	36	3.0%	7.8	152	1.0%	7.00	0.7	3.6	11.4	188	11.0	11.0
B6	B6	5,654	0.13	0.73	29	0.5%	4.6	0		20.00	0.0	0.0	5.0	29	10.2	5.0
B7	B7	72,490	1.66	0.19	85	17.5%	5.9	0		20.00	0.0	0.0	5.9	85	10.5	5.9
B8	B8	7,169	0.16	0.73	33	0.5%	4.9	0		20.00	0.0	0.0	5.0	33	10.2	5.0
B9	B9	178,640	4.10	0.90	97	1.5%	3.2	813	2.5%	20.00	3.2	4.3	7.5	910	15.1	7.5
B10	B10	41,058	0.94	0.37	34	2.0%	6.2	240	2.5%	20.00	3.2	1.3	7.5	274	11.5	7.5
B11	B11	7,069	0.16	0.73	31	0.5%	4.8	0		20.00	0.0	0.0	5.0	31	10.2	5.0
B12	B12	6,532	0.15	0.73	30	0.5%	4.7	0		20.00	0.0	0.0	5.0	30	10.2	5.0
B13	B13	4,737	0.11	0.73	32	0.5%	4.8	0		20.00	0.0	0.0	5.0	32	10.2	5.0
B14	B14	4,985	0.11	0.73	33	0.5%	4.9	0		20.00	0.0	0.0	5.0	33	10.2	5.0
B15	B15	37,253	0.86	0.38	64	9.0%	5.1	190	2.8%	20.00	3.3	0.9	6.0	254	11.4	6.0
B16	B16	6,028	0.14	0.73	32	0.5%	4.8	0		20.00	0.0	0.0	5.0	32	10.2	5.0
B17	B17	5,883	0.14	0.73	32	0.5%	4.8	0		20.00	0.0	0.0	5.0	32	10.2	5.0
B18	B18	47,411	1.09	0.08	112	8.5%	9.7	1530	1.0%	7.00	0.7	36.4	46.1	1642	19.1	19.1
OS-1	OS-1	201,069	4.62	0.08	100	3.5%	12.3	650	3.5%	7.00	1.3	8.3	20.6	750	14.2	14.2
OS-2	OS-2	7,927	0.18	0.08	25	41.0%	2.7	0	1.0%	7.00	0.7	0.0	5.0	25	10.1	5.0

Tract DD, Hannah Ridge at Feathergrass Filing No. 1
Drainage Report
El Paso County, CO

Tract DD, Hannah Ridge at Feathergrass Filing No. 1 - Drainage Report Proposed Runoff Calculations <i>Design Storm 5 Year</i> (Rational Method Procedure)												
BASIN INFORMATION				DIRECT RUNOFF				CUMULATIVE RUNOFF				NOTES
DESIGN POINT	DRAIN BASIN	AREA ac.	RUNOFF COEFF	T(c) min	C x A	I in/hr	Q cfs	T(c) min	C x A	I in/hr	Q cfs	
B1	B1	2.98	0.90	5.0	2.68	5.16	13.83				13.90	Includes OS-2
B2	B2	1.01	0.18	8.8	0.18	4.32	0.80					
B3	B3	0.16	0.73	5.0	0.12	5.16	0.61					
B4	B4	0.23	0.90	5.0	0.21	5.16	1.08					
B5	B5	0.17	0.08	11.0	0.01	3.96	0.05				1.93	Includes B2, B4
B6	B6	0.13	0.73	5.0	0.09	5.16	0.49					
B7	B7	1.66	0.19	5.9	0.32	4.92	1.58				5.89	Includes B5, B18
B8	B8	0.16	0.73	5.0	0.12	5.16	0.62					
B9	B9	4.10	0.90	7.5	3.69	4.57	16.87					
B10	B10	0.94	0.37	7.5	0.35	4.57	1.59					
B11	B11	0.16	0.73	5.0	0.12	5.16	0.61					
B12	B12	0.15	0.73	5.0	0.11	5.16	0.56					
B13	B13	0.11	0.73	5.0	0.08	5.16	0.41					
B14	B14	0.11	0.73	5.0	0.08	5.16	0.43					
B15	B15	0.86	0.38	6.0	0.32	4.89	1.57					
B16	B16	0.14	0.73	5.0	0.10	5.16	0.52					
B17	B17	0.14	0.73	5.0	0.10	5.16	0.51					
B18	B18	1.09	0.08	19.1	0.09	3.06	0.27				2.37	Includes OS-1
OS-1	OS-1	4.62	0.08	14.2	0.37	3.54	2.11					Pond outfall included.
OS-2	OS-2	0.18	0.08	5.0	0.01	5.16	0.08					

Tract DD, Hannah Ridge at Feathergrass Filing No. 1
Drainage Report
El Paso County, CO

Tract DD, Hannah Ridge at Feathergrass Filing No. 1 - Drainage Report												
Proposed Runoff Calculations												
<i>(Rational Method Procedure)</i>												
BASIN INFORMATION				DIRECT RUNOFF				CUMULATIVE RUNOFF				NOTES
DESIGN POINT	DRAIN BASIN	AREA ac.	RUNOFF COEFF	T(c) min	C x A	I in/hr	Q cfs	T(c) min	C x A	I in/hr	Q cfs	
B1	B1	2.98	0.96	5.0	2.86	8.65	24.74				25.29	Includes OS-2
B2	B2	1.01	0.42	8.8	0.43	7.25	3.10					
B3	B3	0.16	0.81	5.0	0.13	8.65	1.13					
B4	B4	0.23	0.96	5.0	0.22	8.65	1.93					
B5	B5	0.17	0.35	11.0	0.06	6.64	0.39				5.41	Includes B2, B4
B6	B6	0.13	0.81	5.0	0.11	8.65	0.91					
B7	B7	1.66	0.43	5.9	0.72	8.26	5.91				23.68	Includes B5, B18
B8	B8	0.16	0.81	5.0	0.13	8.65	1.15					
B9	B9	4.10	0.96	7.5	3.94	7.67	30.19					
B10	B10	0.94	0.55	7.5	0.52	7.67	4.01					
B11	B11	0.16	0.81	5.0	0.13	8.65	1.14					
B12	B12	0.15	0.81	5.0	0.12	8.65	1.05					
B13	B13	0.11	0.81	5.0	0.09	8.65	0.76					
B14	B14	0.11	0.81	5.0	0.09	8.65	0.80					
B15	B15	0.86	0.56	6.0	0.48	8.20	3.93					
B16	B16	0.14	0.81	5.0	0.11	8.65	0.97					
B17	B17	0.14	0.81	5.0	0.11	8.65	0.95					
B18	B18	1.09	0.35	19.1	0.38	5.14	1.96				12.35	Includes OS-1
OS-1	OS-1	4.62	0.35	14.2	1.62	5.94	10.39					Pond outfall included.
OS-2	OS-2	0.18	0.35	5.0	0.06	8.65	0.55					

Weighted Imperviousness Calculations

SUB-BASIN	AREA (SF)	AREA (Acres)	ROOF AREA	ROOF IMPERVIOUSNESS	ROOF				LANDSCAPE AREA	LANDSCAPE IMPERVIOUSNESS	LANDSCAPE				PAVEMENT AREA	PAVEMENT IMPERVIOUSNESS	PAVEMENT				WEIGHTED IMPERVIOUSNESS	WEIGHTED COEFFICIENTS			
					C2	C5	C10	C100			C2	C5	C10	C100			C2	C5	C10	C100		C2	C5	C10	C100
EX-A	670487	15.39	0	90%	0.71	0.73	0.75	0.81	15.39226	2%	0.03	0.09	0.17	0.36	0	100%	0.89	0.90	0.92	0.96	2%	0.03	0.09	0.17	0.36
OS-1	198099	4.55	0	90%	0.71	0.73	0.75	0.81	4.547727	2%	0.03	0.09	0.17	0.36	0	100%	0.89	0.90	0.92	0.96	2%	0.03	0.09	0.17	0.36
TOTAL	868,586	19.94	0.00	90%	0.71	0.73	0.75	0.81	19.94	2%	0.03	0.09	0.17	0.36	0.00	100%	0.89	0.90	0.92	0.96	2%	0.03	0.09	0.17	0.36

Tract DD, Hannah Ridge at Feathergrass Filing No. 1
Drainage Report
El Paso County, CO

SUMMARY - EXISTING RUNOFF TABLE						
DESIGN POINT	BASIN DESIGNATION	BASIN AREA (ACRES)	DIRECT 5-YR RUNOFF (CFS)	DIRECT 100-YR RUNOFF (CFS)	CUMULATIVE 5-YR RUNOFF (CFS)	CUMULATIVE 100-YR RUNOFF (CFS)
1	EX-A	15.39	4.41	29.59	5.69	37.64
2	OS-1	4.55	1.28	8.04	1.28	8.04

**Tract DD, Hannah Ridge at Feathergrass Filing No. 1
Drainage Report
El Paso County, CO**

Akers Road - Drainage Report Proposed Runoff Calculations Time of Concentration																
Watercourse Coefficient Forest & Meadow 2.50 Short Grass Pasture & Lawns 7.00 Grassed Waterway 15.00 Fallow or Cultivation 5.00 Nearly Bare Ground 10.00 Paved Area & Shallow Gutter 20.00																
DESIGN POINT	SUB-BASIN DATA				INITIAL / OVERLAND TIME			TRAVEL TIME T(t)					T(c) CHECK (URBANIZED BASINS)			FINAL T(c) min.
	DRAIN BASIN	AREA sq. ft.	AREA ac.	C(5)	Length ft.	Slope %	T(i) min	Length ft.	Slope %	Coeff.	Velocity fps	T(t) min.	COMP. T(c)	TOTAL LENGTH	L/180+10	
1	EX-A	670,487	15.39	0.09	100	2.0%	14.7	1287	1.0%	10.00	1.0	21.5	36.2	1387	17.7	17.7
2	OS-1	198,099	4.55	0.09	100	3.5%	12.2	1937	2.0%	10.00	1.4	22.8	35.0	2037	21.3	21.3

Tract DD, Hannah Ridge at Feathergrass Filing No. 1
Drainage Report
El Paso County, CO

Akers Road - Drainage Report Proposed Runoff Calculations												
(Rational Method Procedure)												
Design Storm 5 Year												
BASIN INFORMATION				DIRECT RUNOFF				CUMULATIVE RUNOFF				NOTES
DESIGN POINT	DRAIN BASIN	AREA ac.	RUNOFF COEFF	T(c) min	C x A	I in/hr	Q cfs	T(c) min	C x A	I in/hr	Q cfs	
1	EX-A	15.39	0.09	17.7	1.39	3.18	4.41				5.69	
2	OS-1	4.55	0.09	21.3	0.41	2.89	1.28				1.28	Additional 0.1 CFS from pond included.

Tract DD, Hannah Ridge at Feathergrass Filing No. 1
Drainage Report
El Paso County, CO

Akers Road - Drainage Report Proposed Runoff Calculations (Rational Method Procedure)												
BASIN INFORMATION				DIRECT RUNOFF				CUMULATIVE RUNOFF				NOTES
DESIGN POINT	DRAIN BASIN	AREA ac.	RUNOFF COEFF	T(c) min	C x A	I in/hr	Q cfs	T(c) min	C x A	I in/hr	Q cfs	
1	EX-A	15.39	0.36	17.7	5.54	5.34	29.59				37.64	
2	OS-1	4.55	0.36	21.3	1.64	4.85	8.04				8.04	Additional 0.1 CFS from pond included.

APPENDIX C: HYDRAULICS

Curb Cut - Design Point B4 - 5-yr

Project Description	
Friction Method	Manning Formula
Solve For	Normal Depth
Input Data	
Roughness Coefficient	0.013
Channel Slope	0.006 ft/ft
Bottom Width	3.00 ft
Discharge	1.08 cfs
Results	
Normal Depth	1.8 in
Flow Area	0.5 ft ²
Wetted Perimeter	3.3 ft
Hydraulic Radius	1.7 in
Top Width	3.00 ft
Critical Depth	1.9 in
Critical Slope	0.005 ft/ft
Velocity	2.37 ft/s
Velocity Head	0.09 ft
Specific Energy	0.24 ft
Froude Number	1.071
Flow Type	Supercritical
GVF Input Data	
Downstream Depth	0.0 in
Length	0.0 ft
Number Of Steps	0
GVF Output Data	
Upstream Depth	0.0 in
Profile Description	N/A
Profile Headloss	0.00 ft
Downstream Velocity	Infinity ft/s
Upstream Velocity	Infinity ft/s
Normal Depth	1.8 in
Critical Depth	1.9 in
Channel Slope	0.006 ft/ft
Critical Slope	0.005 ft/ft

Curb Cut - Design Point B4 - 100-yr

Project Description	
Friction Method	Manning Formula
Solve For	Normal Depth
Input Data	
Roughness Coefficient	0.013
Channel Slope	0.006 ft/ft
Bottom Width	3.00 ft
Discharge	1.93 cfs
Results	
Normal Depth	2.6 in
Flow Area	0.7 ft ²
Wetted Perimeter	3.4 ft
Hydraulic Radius	2.3 in
Top Width	3.00 ft
Critical Depth	2.8 in
Critical Slope	0.005 ft/ft
Velocity	2.94 ft/s
Velocity Head	0.13 ft
Specific Energy	0.35 ft
Froude Number	1.107
Flow Type	Supercritical
GVF Input Data	
Downstream Depth	0.0 in
Length	0.0 ft
Number Of Steps	0
GVF Output Data	
Upstream Depth	0.0 in
Profile Description	N/A
Profile Headloss	0.00 ft
Downstream Velocity	Infinity ft/s
Upstream Velocity	Infinity ft/s
Normal Depth	2.6 in
Critical Depth	2.8 in
Channel Slope	0.006 ft/ft
Critical Slope	0.005 ft/ft

Curb Cut - Design Point B9 - 5-yr

Project Description	
Friction Method	Manning Formula
Solve For	Normal Depth
Input Data	
Roughness Coefficient	0.013
Channel Slope	0.022 ft/ft
Bottom Width	9.00 ft
Discharge	16.87 cfs
Results	
Normal Depth	3.3 in
Flow Area	2.5 ft ²
Wetted Perimeter	9.5 ft
Hydraulic Radius	3.1 in
Top Width	9.00 ft
Critical Depth	5.7 in
Critical Slope	0.004 ft/ft
Velocity	6.86 ft/s
Velocity Head	0.73 ft
Specific Energy	1.00 ft
Froude Number	2.315
Flow Type	Supercritical
GVF Input Data	
Downstream Depth	0.0 in
Length	0.0 ft
Number Of Steps	0
GVF Output Data	
Upstream Depth	0.0 in
Profile Description	N/A
Profile Headloss	0.00 ft
Downstream Velocity	Infinity ft/s
Upstream Velocity	Infinity ft/s
Normal Depth	3.3 in
Critical Depth	5.7 in
Channel Slope	0.022 ft/ft
Critical Slope	0.004 ft/ft

Curb Cut - Design Point B9 - 100-yr

Project Description	
Friction Method	Manning Formula
Solve For	Normal Depth
Input Data	
Roughness Coefficient	0.013
Channel Slope	0.022 ft/ft
Bottom Width	9.00 ft
Discharge	30.19 cfs
Results	
Normal Depth	4.7 in
Flow Area	3.5 ft ²
Wetted Perimeter	9.8 ft
Hydraulic Radius	4.3 in
Top Width	9.00 ft
Critical Depth	8.5 in
Critical Slope	0.003 ft/ft
Velocity	8.57 ft/s
Velocity Head	1.14 ft
Specific Energy	1.53 ft
Froude Number	2.416
Flow Type	Supercritical
GVF Input Data	
Downstream Depth	0.0 in
Length	0.0 ft
Number Of Steps	0
GVF Output Data	
Upstream Depth	0.0 in
Profile Description	N/A
Profile Headloss	0.00 ft
Downstream Velocity	Infinity ft/s
Upstream Velocity	Infinity ft/s
Normal Depth	4.7 in
Critical Depth	8.5 in
Channel Slope	0.022 ft/ft
Critical Slope	0.003 ft/ft

HY-8 Culvert Analysis Report

Crossing Discharge Data

Discharge Selection Method: Specify Minimum, Design, and Maximum Flow

Minimum Flow: 0.8 cfs

Design Flow: 3.11 cfs

Maximum Flow: 10 cfs

Table 1 - Summary of Culvert Flows at Crossing: Crossing 1

Headwater Elevation (ft)	Total Discharge (cfs)	Culvert 1 Discharge (cfs)	Roadway Discharge (cfs)	Iterations
6448.44	0.80	0.80	0.00	1
6448.66	1.72	1.72	0.00	1
6448.85	2.64	2.64	0.00	1
6448.94	3.11	3.11	0.00	1
6449.19	4.48	4.48	0.00	1
6449.34	5.40	5.40	0.00	1
6449.49	6.32	6.32	0.00	1
6449.65	7.24	7.24	0.00	1
6449.83	8.16	8.16	0.00	1
6450.03	9.08	9.08	0.00	1
6450.24	10.00	10.00	0.00	1
6451.00	12.65	12.65	0.00	Overtopping

Rating Curve Plot for Crossing: Crossing 1

Total Rating Curve

Crossing: Crossing 1

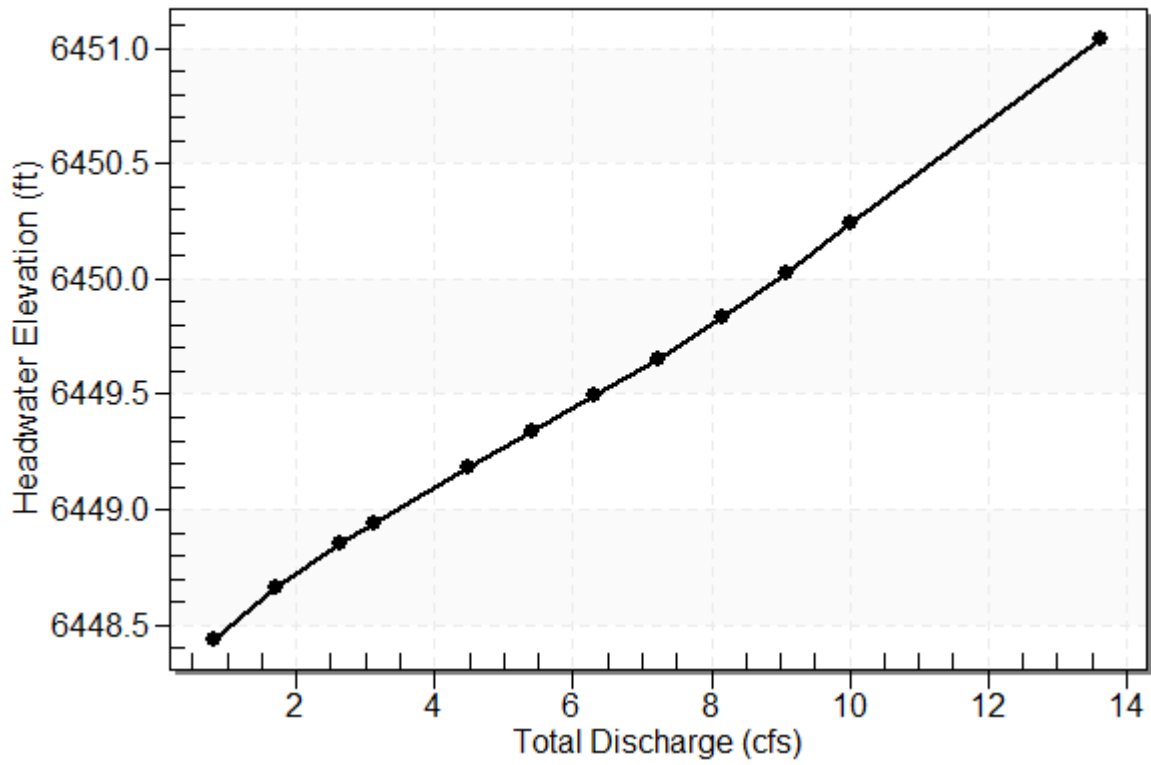

Table 2 - Culvert Summary Table: Culvert 1

Total Discharge (cfs)	Culvert Discharge (cfs)	Headwater Elevation (ft)	Inlet Control Depth (ft)	Outlet Control Depth (ft)	Flow Type	Normal Depth (ft)	Critical Depth (ft)	Outlet Depth (ft)	Tailwater Depth (ft)	Outlet Velocity (ft/s)	Tailwater Velocity (ft/s)
0.80	0.80	6448.44	0.441	0.0*	1-S2n	0.202	0.333	0.202	0.352	5.614	1.395
1.72	1.72	6448.66	0.660	0.0*	1-S2n	0.294	0.493	0.294	0.469	7.035	1.690
2.64	2.64	6448.85	0.850	0.0*	1-S2n	0.364	0.616	0.364	0.551	7.967	1.881
3.11	3.11	6448.94	0.944	0.0*	1-S2n	0.395	0.671	0.395	0.586	8.350	1.959
4.48	4.48	6449.19	1.187	0.0*	1-S2n	0.477	0.812	0.485	0.672	9.066	2.147
5.40	5.40	6449.34	1.338	0.0*	1-S2n	0.527	0.895	0.527	0.720	9.755	2.249
6.32	6.32	6449.49	1.492	0.0*	1-S2n	0.573	0.972	0.584	0.764	9.923	2.339
7.24	7.24	6449.65	1.654	0.0*	5-S2n	0.617	1.042	0.617	0.804	10.564	2.420
8.16	8.16	6449.83	1.830	0.0*	5-S2n	0.660	1.106	0.678	0.841	10.524	2.494
9.08	9.08	6450.03	2.026	0.0*	5-S2n	0.701	1.165	0.701	0.875	11.212	2.561
10.00	10.00	6450.24	2.242	0.0*	5-S2n	0.741	1.219	0.741	0.908	11.491	2.624

* Full Flow Headwater elevation is below inlet invert.

Straight Culvert

Inlet Elevation (invert): 6448.00 ft, Outlet Elevation (invert): 6444.88 ft

Culvert Length: 83.06 ft, Culvert Slope: 0.0376

Culvert Performance Curve Plot: Culvert 1

Performance Curve

Culvert: Culvert 1

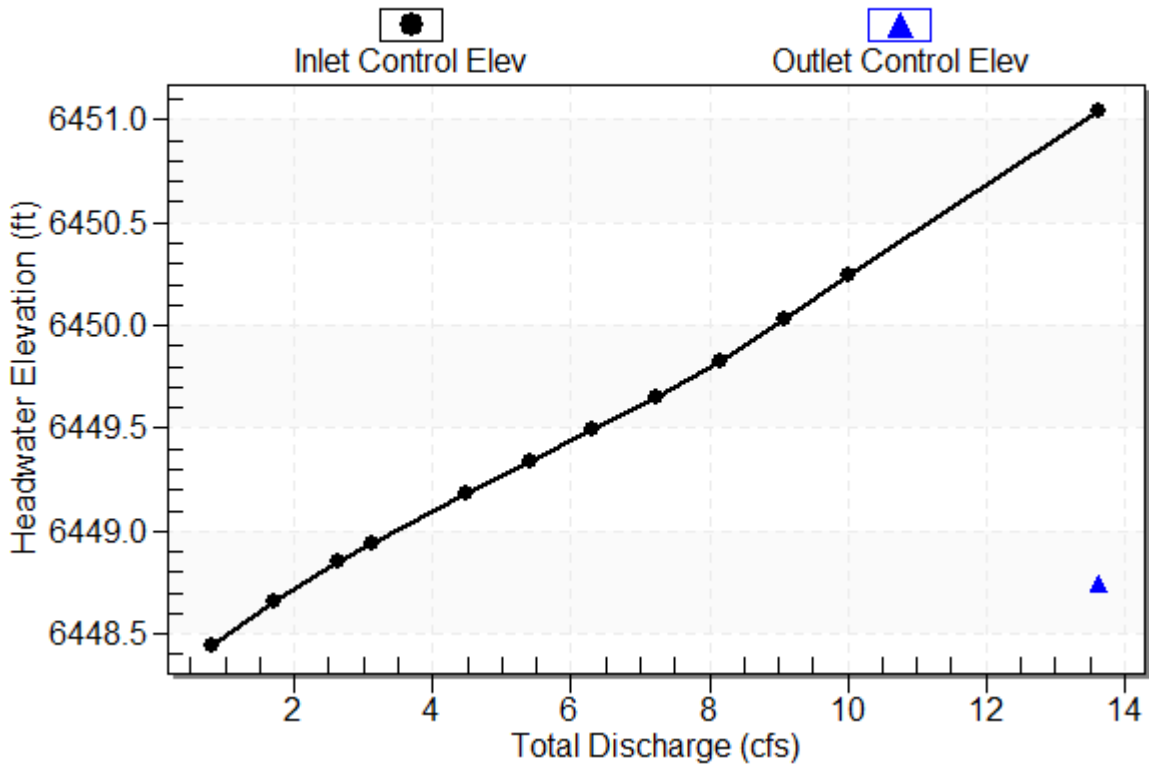

Water Surface Profile Plot for Culvert: Culvert 1

Crossing - Crossing 1, Design Discharge - 3.1 cfs

Culvert - Culvert 1, Culvert Discharge - 3.1 cfs

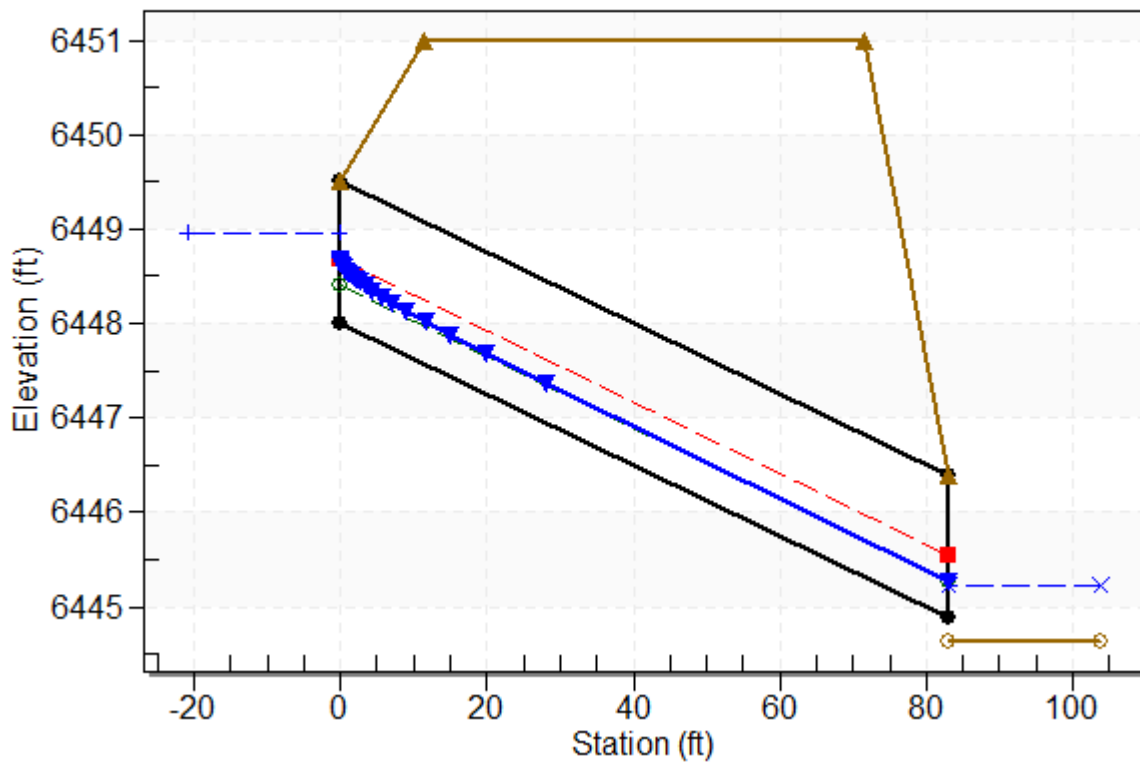

Site Data - Culvert 1

Site Data Option: Culvert Invert Data

Inlet Station: 0.00 ft

Inlet Elevation: 6448.00 ft

Outlet Station: 83.00 ft

Outlet Elevation: 6444.88 ft

Number of Barrels: 1

Culvert Data Summary - Culvert 1

Barrel Shape: Circular

Barrel Diameter: 1.50 ft

Barrel Material: Concrete

Embedment: 0.00 in

Barrel Manning's n: 0.0130

Culvert Type: Straight

Inlet Configuration: Square Edge with Headwall

Inlet Depression: None

Table 3 - Downstream Channel Rating Curve (Crossing: Crossing 1)

Flow (cfs)	Water Surface Elev (ft)	Depth (ft)	Velocity (ft/s)	Shear (psf)	Froude Number
0.80	6444.99	0.35	1.40	0.18	0.59
1.72	6445.11	0.47	1.69	0.24	0.61
2.64	6445.19	0.55	1.88	0.29	0.63
3.11	6445.23	0.59	1.96	0.30	0.64
4.48	6445.31	0.67	2.15	0.35	0.65
5.40	6445.36	0.72	2.25	0.37	0.66
6.32	6445.40	0.76	2.34	0.40	0.67
7.24	6445.44	0.80	2.42	0.42	0.67
8.16	6445.48	0.84	2.49	0.44	0.68
9.08	6445.52	0.88	2.56	0.45	0.68
10.00	6445.55	0.91	2.62	0.47	0.69

Tailwater Channel Data - Crossing 1

Tailwater Channel Option: Irregular Channel

Roadway Data for Crossing: Crossing 1

Roadway Profile Shape: Constant Roadway Elevation

Crest Length: 30.00 ft

Crest Elevation: 6451.00 ft

Roadway Surface: Paved

Roadway Top Width: 60.00 ft

Worksheet for Swale B2 - 100-yr

Project Description	
Friction Method	Manning Formula
Solve For	Normal Depth
Input Data	
Channel Slope	0.069 ft/ft
Discharge	3.11 cfs

Section Definitions

Station (ft)	Elevation (ft)
0+00	6,453.25
0+12	6,451.98
0+20	6,451.92
0+28	6,452.06
0+62	6,452.39
0+72	6,452.74
0+84	6,455.67
0+85	6,455.62

Roughness Segment Definitions

Start Station	Ending Station	Roughness Coefficient
(0+00, 6,453.25)	(0+85, 6,455.62)	0.030

Options

Current Roughness Weighted Method	Pavlovskii's Method
Open Channel Weighting Method	Pavlovskii's Method
Closed Channel Weighting Method	Pavlovskii's Method

Results

Normal Depth	1.6 in
Roughness Coefficient	0.030
Elevation	6,452.05 ft
Elevation Range	6,451.9 to 6,455.7 ft
Flow Area	1.3 ft ²
Wetted Perimeter	16.1 ft
Hydraulic Radius	1.0 in
Top Width	16.09 ft
Normal Depth	1.6 in
Critical Depth	1.9 in
Critical Slope	0.029 ft/ft
Velocity	2.41 ft/s
Velocity Head	0.09 ft

Worksheet for Swale B2 - 100-yr

Results

Specific Energy	0.22 ft
Froude Number	1.502
Flow Type	Supercritical

GVF Input Data

Downstream Depth	0.0 in
Length	0.0 ft
Number Of Steps	0

GVF Output Data

Upstream Depth	0.0 in
Profile Description	N/A
Profile Headloss	0.00 ft
Downstream Velocity	Infinity ft/s
Upstream Velocity	Infinity ft/s
Normal Depth	1.6 in
Critical Depth	1.9 in
Channel Slope	0.069 ft/ft
Critical Slope	0.029 ft/ft

Worksheet for Swale B5 - 100-yr

Project Description	
Friction Method	Manning Formula
Solve For	Normal Depth
Input Data	
Channel Slope	0.008 ft/ft
Discharge	3.50 cfs

Section Definitions

Station (ft)	Elevation (ft)
0+00	6,450.19
0+29	6,444.64
0+37	6,446.64

Roughness Segment Definitions

Start Station	Ending Station	Roughness Coefficient
(0+00, 6,450.19)	(0+37, 6,446.64)	0.030

Options

Current Roughness Weighted Method	Pavlovskii's Method
Open Channel Weighting Method	Pavlovskii's Method
Closed Channel Weighting Method	Pavlovskii's Method

Results

Normal Depth	7.4 in
Roughness Coefficient	0.030
Elevation	6,445.26 ft
Elevation Range	6,444.6 to 6,450.2 ft
Flow Area	1.8 ft ²
Wetted Perimeter	5.8 ft
Hydraulic Radius	3.6 in
Top Width	5.70 ft
Normal Depth	7.4 in
Critical Depth	6.2 in
Critical Slope	0.021 ft/ft
Velocity	1.99 ft/s
Velocity Head	0.06 ft
Specific Energy	0.68 ft
Froude Number	0.632
Flow Type	Subcritical

GVF Input Data

Worksheet for Swale B5 - 100-yr

GVF Input Data

Downstream Depth	0.0 in
Length	0.0 ft
Number Of Steps	0

GVF Output Data

Upstream Depth	0.0 in
Profile Description	N/A
Profile Headloss	0.00 ft
Downstream Velocity	0.00 ft/s
Upstream Velocity	0.00 ft/s
Normal Depth	7.4 in
Critical Depth	6.2 in
Channel Slope	0.008 ft/ft
Critical Slope	0.021 ft/ft

Worksheet for Swale B10 - 100-yr

Project Description

Friction Method	Manning
	Formula
Solve For	Normal Depth

Input Data

Channel Slope	0.026 ft/ft
Discharge	4.01 cfs

Section Definitions

	Station (ft)	Elevation (ft)	
	0+00		6,451.28
	0+25		6,449.17
	0+49		6,450.29

Roughness Segment Definitions

Start Station	Ending Station	Roughness Coefficient	
(0+00, 6,451.28)	(0+49, 6,450.29)		0.030

Options

Current Roughness Weighted Method	Pavlovskii's Method
Open Channel Weighting Method	Pavlovskii's Method
Closed Channel Weighting Method	Pavlovskii's Method

Results

Normal Depth	3.8 in
Roughness Coefficient	0.030
Elevation	6,449.49 ft
Elevation Range	6,449.2 to 6,451.3 ft
Flow Area	1.7 ft ²
Wetted Perimeter	10.6 ft
Hydraulic Radius	1.9 in
Top Width	10.62 ft
Normal Depth	3.8 in
Critical Depth	3.9 in
Critical Slope	0.024 ft/ft
Velocity	2.36 ft/s
Velocity Head	0.09 ft
Specific Energy	0.41 ft
Froude Number	1.037
Flow Type	Supercritical

GVF Input Data

Worksheet for Swale B10 - 100-yr

GVF Input Data

Downstream Depth	0.0 in
Length	0.0 ft
Number Of Steps	0

GVF Output Data

Upstream Depth	0.0 in
Profile Description	N/A
Profile Headloss	0.00 ft
Downstream Velocity	Infinity ft/s
Upstream Velocity	Infinity ft/s
Normal Depth	3.8 in
Critical Depth	3.9 in
Channel Slope	0.026 ft/ft
Critical Slope	0.024 ft/ft

Worksheet for Swale B15 - 100-yr

Project Description	
Friction Method	Manning Formula
Solve For	Normal Depth

Input Data	
Channel Slope	0.018 ft/ft
Discharge	3.93 cfs

Section Definitions

Station (ft)	Elevation (ft)
0+00	6,457.79
0+35	6,450.55
0+59	6,453.92

Roughness Segment Definitions

Start Station	Ending Station	Roughness Coefficient
(0+00, 6,457.79)	(0+59, 6,453.92)	0.030

Options

Current Roughness Weighted Method	Pavlovskii's Method
Open Channel Weighting Method	Pavlovskii's Method
Closed Channel Weighting Method	Pavlovskii's Method

Results

Normal Depth	6.0 in
Roughness Coefficient	0.030
Elevation	6,451.05 ft
Elevation Range	6,450.6 to 6,457.8 ft
Flow Area	1.5 ft ²
Wetted Perimeter	6.1 ft
Hydraulic Radius	3.0 in
Top Width	6.00 ft
Normal Depth	6.0 in
Critical Depth	5.8 in
Critical Slope	0.021 ft/ft
Velocity	2.62 ft/s
Velocity Head	0.11 ft
Specific Energy	0.61 ft
Froude Number	0.922
Flow Type	Subcritical

GVF Input Data

Worksheet for Swale B15 - 100-yr

GVF Input Data

Downstream Depth	0.0 in
Length	0.0 ft
Number Of Steps	0

GVF Output Data

Upstream Depth	0.0 in
Profile Description	N/A
Profile Headloss	0.00 ft
Downstream Velocity	0.00 ft/s
Upstream Velocity	0.00 ft/s
Normal Depth	6.0 in
Critical Depth	5.8 in
Channel Slope	0.018 ft/ft
Critical Slope	0.021 ft/ft

Worksheet for Swale B18 - 100-yr

Project Description	
Friction Method	Manning Formula
Solve For	Normal Depth

Input Data	
Channel Slope	0.010 ft/ft
Discharge	12.35 cfs

Section Definitions

Station (ft)	Elevation (ft)
0+04	6,457.41
0+19	6,452.38
0+29	6,453.11

Roughness Segment Definitions

Start Station	Ending Station	Roughness Coefficient
(0+04, 6,457.41)	(0+29, 6,453.11)	0.030

Options	
Current Roughness Weighted Method	Pavlovskii's Method
Open Channel Weighting Method	Pavlovskii's Method
Closed Channel Weighting Method	Pavlovskii's Method

Results	
Normal Depth	9.0 in
Roughness Coefficient	0.030
Elevation	6,453.13 ft
Elevation Range	6,452.4 to 6,457.4 ft
Flow Area	4.8 ft ²
Wetted Perimeter	12.5 ft
Hydraulic Radius	4.6 in
Top Width	12.38 ft
Normal Depth	9.0 in
Critical Depth	8.0 in
Critical Slope	0.019 ft/ft
Velocity	2.59 ft/s
Velocity Head	0.10 ft
Specific Energy	0.86 ft
Froude Number	0.738
Flow Type	Subcritical

GVF Input Data

Worksheet for Swale B18 - 100-yr

GVF Input Data

Downstream Depth	0.0 in
Length	0.0 ft
Number Of Steps	0

GVF Output Data

Upstream Depth	0.0 in
Profile Description	N/A
Profile Headloss	0.00 ft
Downstream Velocity	0.00 ft/s
Upstream Velocity	0.00 ft/s
Normal Depth	9.0 in
Critical Depth	8.0 in
Channel Slope	0.010 ft/ft
Critical Slope	0.019 ft/ft

Worksheet for Type 13 Design Point B10

Project Description	
Solve For	Spread
Input Data	
Discharge	4.01 cfs
Left Side Slope	4.000 H:V
Right Side Slope	4.000 H:V
Bottom Width	3.33 ft
Grate Width	1.91 ft
Grate Length	3.3 ft
Local Depression	0.0 in
Local Depression Width	23.0 in
Grate Type	Curved Vaned
Clogging	50.0 %
Results	
Spread	6.9 ft
Depth	5.4 in
Wetted Perimeter	7.0 ft
Top Width	6.92 ft
Open Grate Area	1.1 ft ²
Active Grate Weir Length	8.6 ft

Worksheet for Type 13 Design Point B15

Project Description	
Solve For	Spread
Input Data	
Discharge	3.93 cfs
Left Side Slope	4.000 H:V
Right Side Slope	4.000 H:V
Bottom Width	3.33 ft
Grate Width	1.91 ft
Grate Length	3.3 ft
Local Depression	0.0 in
Local Depression Width	23.0 in
Grate Type	Curved Vaned
Clogging	50.0 %
Results	
Spread	6.8 ft
Depth	5.2 in
Wetted Perimeter	6.9 ft
Top Width	6.78 ft
Open Grate Area	1.1 ft ²
Active Grate Weir Length	8.6 ft

ALLOWABLE CAPACITY FOR ONE-HALF OF STREET (Minor & Major Storm)

(Based on Regulated Criteria for Maximum Allowable Flow Depth and Spread)

Project: _____
 Inlet ID: _____ **Inlet B5**

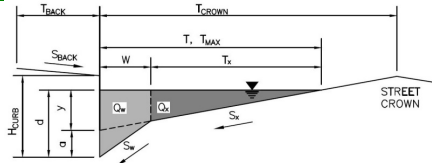

Gutter Geometry (Enter data in the blue cells)									
Maximum Allowable Width for Spread Behind Curb	$T_{BACK} = $ <input style="width: 50px;" type="text" value="0.0"/> ft								
Side Slope Behind Curb (leave blank for no conveyance credit behind curb)	$S_{BACK} = $ <input style="width: 50px;" type="text" value=""/> ft/ft								
Manning's Roughness Behind Curb (typically between 0.012 and 0.020)	$n_{BACK} = $ <input style="width: 50px;" type="text" value="0.020"/>								
Height of Curb at Gutter Flow Line	$H_{CURB} = $ <input style="width: 50px;" type="text" value="6.00"/> inches								
Distance from Curb Face to Street Crown	$T_{CROWN} = $ <input style="width: 50px;" type="text" value="35.0"/> ft								
Gutter Width	$W = $ <input style="width: 50px;" type="text" value="2.00"/> ft								
Street Transverse Slope	$S_x = $ <input style="width: 50px;" type="text" value="0.014"/> ft/ft								
Gutter Cross Slope (typically 2 inches over 24 inches or 0.083 ft/ft)	$S_w = $ <input style="width: 50px;" type="text" value="0.083"/> ft/ft								
Street Longitudinal Slope - Enter 0 for sump condition	$S_o = $ <input style="width: 50px;" type="text" value="0.000"/> ft/ft								
Manning's Roughness for Street Section (typically between 0.012 and 0.020)	$n_{STREET} = $ <input style="width: 50px;" type="text" value="0.016"/>								
Max. Allowable Spread for Minor & Major Storm	<table style="width: 100%; border-collapse: collapse;"> <tr> <th style="width: 50%;"></th> <th style="width: 25%; text-align: center;">Minor Storm</th> <th style="width: 25%; text-align: center;">Major Storm</th> <th style="width: 10%;"></th> </tr> <tr> <td>$T_{MAX} =$</td> <td style="text-align: center;"><input style="width: 40px;" type="text" value="35.0"/></td> <td style="text-align: center;"><input style="width: 40px;" type="text" value="35.0"/></td> <td style="text-align: right;">ft</td> </tr> </table>		Minor Storm	Major Storm		$T_{MAX} = $	<input style="width: 40px;" type="text" value="35.0"/>	<input style="width: 40px;" type="text" value="35.0"/>	ft
	Minor Storm	Major Storm							
$T_{MAX} = $	<input style="width: 40px;" type="text" value="35.0"/>	<input style="width: 40px;" type="text" value="35.0"/>	ft						
Max. Allowable Depth at Gutter Flowline for Minor & Major Storm	<table style="width: 100%; border-collapse: collapse;"> <tr> <th style="width: 50%;"></th> <th style="width: 25%; text-align: center;">Minor Storm</th> <th style="width: 25%; text-align: center;">Major Storm</th> <th style="width: 10%;"></th> </tr> <tr> <td>$d_{MAX} =$</td> <td style="text-align: center;"><input style="width: 40px;" type="text" value="6.0"/></td> <td style="text-align: center;"><input style="width: 40px;" type="text" value="6.0"/></td> <td style="text-align: right;">inches</td> </tr> </table>		Minor Storm	Major Storm		$d_{MAX} = $	<input style="width: 40px;" type="text" value="6.0"/>	<input style="width: 40px;" type="text" value="6.0"/>	inches
	Minor Storm	Major Storm							
$d_{MAX} = $	<input style="width: 40px;" type="text" value="6.0"/>	<input style="width: 40px;" type="text" value="6.0"/>	inches						
Check boxes are not applicable in SUMP conditions	<table style="width: 100%; border-collapse: collapse;"> <tr> <td style="width: 50%; text-align: center;"><input type="checkbox"/></td> <td style="width: 50%; text-align: center;"><input type="checkbox"/></td> </tr> </table>	<input type="checkbox"/>	<input type="checkbox"/>						
<input type="checkbox"/>	<input type="checkbox"/>								
MINOR STORM Allowable Capacity is based on Depth Criterion									
MAJOR STORM Allowable Capacity is based on Depth Criterion	<table style="width: 100%; border-collapse: collapse;"> <tr> <th style="width: 50%;"></th> <th style="width: 25%; text-align: center;">Minor Storm</th> <th style="width: 25%; text-align: center;">Major Storm</th> <th style="width: 10%;"></th> </tr> <tr> <td>$Q_{allow} =$</td> <td style="text-align: center;"><input style="width: 40px;" type="text" value="SUMP"/></td> <td style="text-align: center;"><input style="width: 40px;" type="text" value="SUMP"/></td> <td style="text-align: right;">cfs</td> </tr> </table>		Minor Storm	Major Storm		$Q_{allow} = $	<input style="width: 40px;" type="text" value="SUMP"/>	<input style="width: 40px;" type="text" value="SUMP"/>	cfs
	Minor Storm	Major Storm							
$Q_{allow} = $	<input style="width: 40px;" type="text" value="SUMP"/>	<input style="width: 40px;" type="text" value="SUMP"/>	cfs						

INLET IN A SUMP OR SAG LOCATION

Version 4.06 Released August 2018

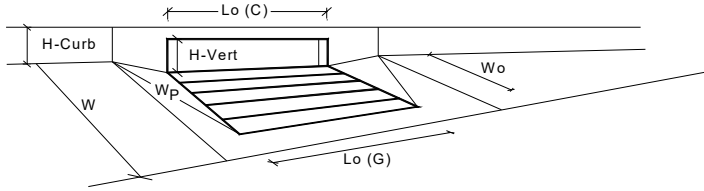

Design Information (Input)	MINOR	MAJOR	
Type of Inlet	CDOT Type R Curb Opening		
Local Depression (additional to continuous gutter depression 'a' from above)	3.00	3.00	inches
Number of Unit Inlets (Grate or Curb Opening)	6	6	
Water Depth at Flowline (outside of local depression)	6.0	6.0	inches
Grate Information	MINOR	MAJOR	<input type="checkbox"/> Override Depths
Length of a Unit Grate	N/A	N/A	feet
Width of a Unit Grate	N/A	N/A	feet
Area Opening Ratio for a Grate (typical values 0.15-0.90)	N/A	N/A	
Clogging Factor for a Single Grate (typical value 0.50 - 0.70)	N/A	N/A	
Grate Weir Coefficient (typical value 2.15 - 3.60)	N/A	N/A	
Grate Orifice Coefficient (typical value 0.60 - 0.80)	N/A	N/A	
Curb Opening Information	MINOR	MAJOR	
Length of a Unit Curb Opening	5.00	5.00	feet
Height of Vertical Curb Opening in Inches	6.00	6.00	inches
Height of Curb Orifice Throat in Inches	6.00	6.00	inches
Angle of Throat (see USDCM Figure ST-5)	63.40	63.40	degrees
Side Width for Depression Pan (typically the gutter width of 2 feet)	2.00	2.00	feet
Clogging Factor for a Single Curb Opening (typical value 0.10)	0.10	0.10	
Curb Opening Weir Coefficient (typical value 2.3-3.7)	3.60	3.60	
Curb Opening Orifice Coefficient (typical value 0.60 - 0.70)	0.67	0.67	
Low Head Performance Reduction (Calculated)	MINOR	MAJOR	
Depth for Grate Midwidth	N/A	N/A	ft
Depth for Curb Opening Weir Equation	0.33	0.33	ft
Combination Inlet Performance Reduction Factor for Long Inlets	0.57	0.57	
Curb Opening Performance Reduction Factor for Long Inlets	0.79	0.79	
Grated Inlet Performance Reduction Factor for Long Inlets	N/A	N/A	
Total Inlet Interception Capacity (assumes clogged condition)	MINOR	MAJOR	
Q_a	27.6	27.6	cfs
Q _{PEAK REQUIRED}	13.8	24.7	cfs

Inlet Capacity IS GOOD for Minor and Major Storms(>Q PEAK)

Rip-Rap Calculation

Culvert 1

Applicable Equations:

$L_p = (1/2 \tan \theta)(A_f/Y_r - D)$	Equation 9-11 per USDCM
$A_f = Q/V$	Equation 9-12 per USDCM
$\theta = \tan^{-1}(1/(2 * \text{ExpansionFactor}))$	Equation 9-13 per USDCM
$W = 2(L_p \tan \theta) + D$	Equation 9-14 per USDCM
$T = 2D_{50}$	Equation 9-15 per USDCM

Assumptions

Maximum Major Event Velocity is 7fps for FES outletting into trickle channels

Input parameters:

Description	Variable	Input	Unit
Width of the conduit (use diameter for circular conduits),	D:	1.50	ft
Rectangular conduit	H:	0.00	
HGL Elevation		6445.47	ft
Invert Elevation		6444.88	ft
Tailwater depth (ft),	Y_t :	0.59	ft
Expansion angle of the culvert flow	θ :	0.08	radians
Design discharge (cfs)*	Q:	3.11	cfs
Froude Number	F_r :	0.40	Subcritical
Unitless Variables for Tables:			
	For Figure 9-35 $Q/D^{2.5}$	1.13	
	For Figure 9-36 $Q/WH^{3/2}$	#DIV/0!	
	For Figure 9-35 Y_t/D	0.39	
	For Figure 9-38 $Q/D^{1.5}$	1.69	
	For Figure 9-38 Y_t/D	0.39	
Allowable non-eroding velocity in the downstream channel (ft/sec)	V:	5	ft/sec
Expansion Factor (Figure 9-35), $1/(2 \tan \theta)$		6.5	

Solve for:

Description	Variable	Output	Unit
1. Required area of flow at allowable velocity (ft ²)	A_c :	0.62	ft ²
2. Length of Protection	L_p :	-2.90	ft
	$L_p < 3D$?	Yes	
	L_{pmin} :	4.50	ft
3. Width of downstream riprap protection	W:	2.00	ft
4. Rip Rap Type (Figure 9-38)	-	L	
5. Rip Rap Size (Figure 8-34)	D_{50} :	9	inches

Rip Rap Summary

Length	L _p	5.00	ft
Width	W	2.00	ft
Size	D ₅₀	9	inches
Type	-	L	
Thickness	T	18	inches

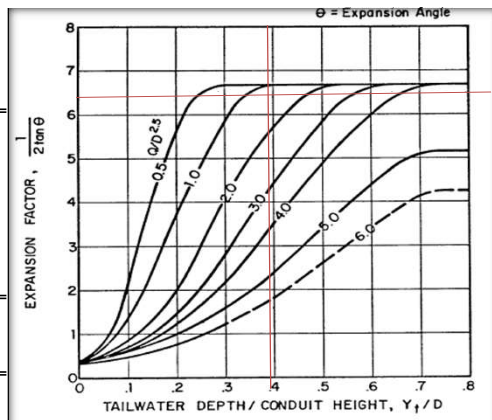

Figure 9-35. Expansion factor for circular conduits

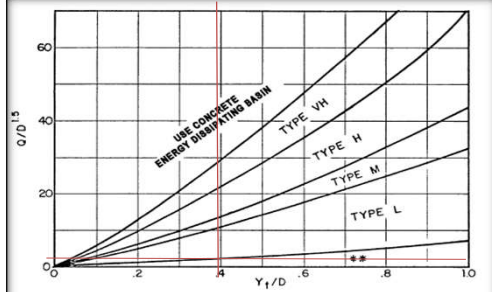

Figure 9-38. Riprap erosion protection at circular conduit outlet (valid for $Q/D^{2.5} \leq 6.0$)

RIPRAP DESIGNATION	% SMALLER THAN GIVEN SIZE BY WEIGHT	INTERMEDIATE ROCK DIMENSION (INCHES)	D ₅₀ * (INCHES)
TYPE VL	70 - 100	12	6
	50 - 70	9	
	35 - 50	6	
	2 - 10	2	
TYPE L	70 - 100	15	9
	50 - 70	12	
	35 - 50	9	
	2 - 10	3	
TYPE M	70 - 100	21	12
	50 - 70	18	
	35 - 50	12	
	2 - 10	4	
TYPE H	70 - 100	30	18
	50 - 70	24	
	35 - 50	18	
	2 - 10	6	

*D₅₀ = MEAN ROCK SIZE

Figure 8-34. Riprap and soil riprap placement and gradation (part 1 of 3)

DETENTION BASIN STAGE-STORAGE TABLE BUILDER

MHFD-Detention, Version 4.03 (May 2020)

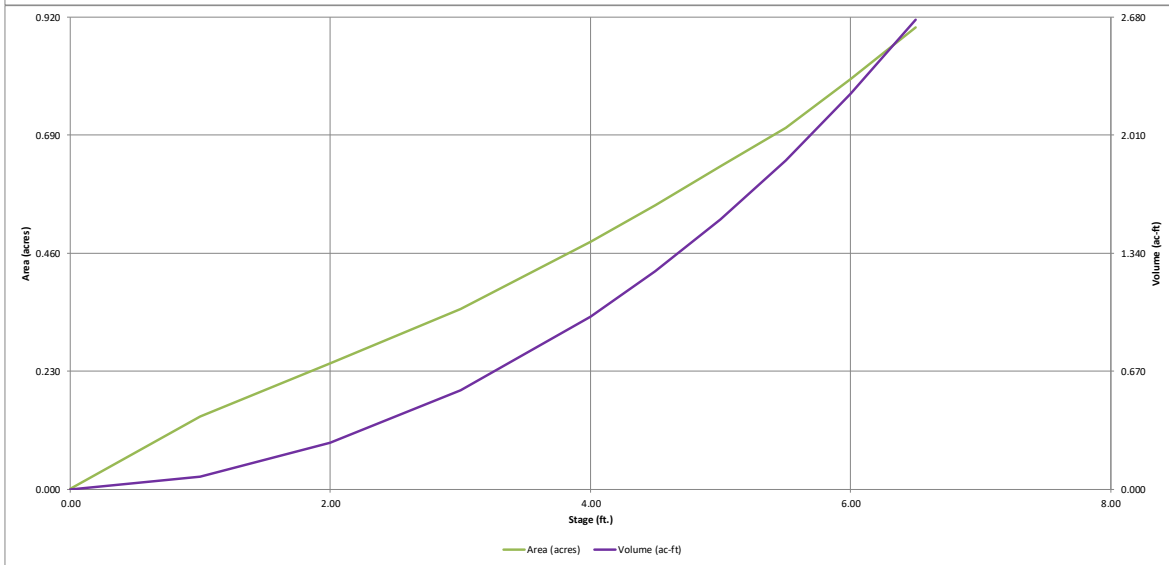
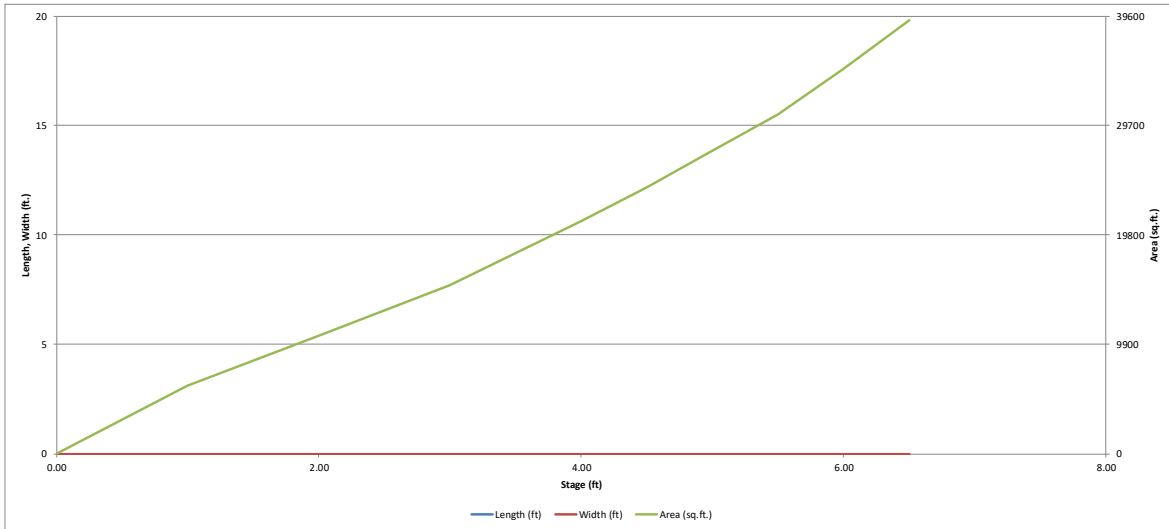

DETENTION BASIN OUTLET STRUCTURE DESIGN

MHFD-*Detention*, Version 4.03 (May 2020)

Project: Watermark at Akers

Basin ID: South Pond

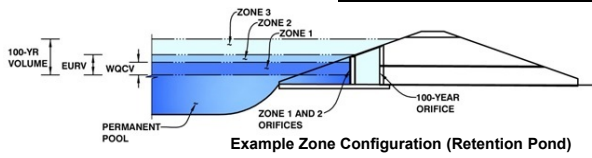

	Estimated Stage (ft)	Estimated Volume (ac-ft)	Outlet Type
Zone 1 (WQCV)	2.27	0.333	Orifice Plate
Zone 2 (EURV)	4.27	0.779	Orifice Plate
Zone 3 (100-year)	5.43	0.700	Weir&Pipe (Restrict)
Total (all zones)		1.812	

User Input: Orifice at Underdrain Outlet (typically used to drain WQCV in a Filtration BMP)

Underdrain Orifice Invert Depth = ft (distance below the filtration media surface)
 Underdrain Orifice Diameter = inches

Calculated Parameters for Underdrain
 Underdrain Orifice Area = ft²
 Underdrain Orifice Centroid = feet

User Input: Orifice Plate with one or more orifices or Elliptical Slot Weir (typically used to drain WQCV and/or EURV in a sedimentation BMP)

Invert of Lowest Orifice = ft (relative to basin bottom at Stage = 0 ft)
 Depth at top of Zone using Orifice Plate = ft (relative to basin bottom at Stage = 0 ft)
 Orifice Plate: Orifice Vertical Spacing = inches
 Orifice Plate: Orifice Area per Row = inches

Calculated Parameters for Plate
 WQ Orifice Area per Row = ft²
 Elliptical Half-Width = feet
 Elliptical Slot Centroid = feet
 Elliptical Slot Area = ft²

User Input: Stage and Total Area of Each Orifice Row (numbered from lowest to highest)

	Row 1 (required)	Row 2 (optional)	Row 3 (optional)	Row 4 (optional)	Row 5 (optional)	Row 6 (optional)	Row 7 (optional)	Row 8 (optional)
Stage of Orifice Centroid (ft)	0.00	0.60	1.60	2.40	3.20			
Orifice Area (sq. inches)	1.23	1.58	1.58	1.58	1.58			

	Row 9 (optional)	Row 10 (optional)	Row 11 (optional)	Row 12 (optional)	Row 13 (optional)	Row 14 (optional)	Row 15 (optional)	Row 16 (optional)
Stage of Orifice Centroid (ft)								
Orifice Area (sq. inches)								

User Input: Vertical Orifice (Circular or Rectangular)

Invert of Vertical Orifice = ft (relative to basin bottom at Stage = 0 ft)
 Depth at top of Zone using Vertical Orifice = ft (relative to basin bottom at Stage = 0 ft)
 Vertical Orifice Diameter = inches

Calculated Parameters for Vertical Orifice
 Vertical Orifice Area = ft²
 Vertical Orifice Centroid = feet

User Input: Overflow Weir (Dropbox with Flat or Sloped Gate and Outlet Pipe OR Rectangular/Trapezoidal Weir (and No Outlet Pipe))

	Zone 3 Weir	Not Selected	
Overflow Weir Front Edge Height, Ho =	4.30	N/A	ft (relative to basin bottom at Stage = 0 ft)
Overflow Weir Front Edge Length =	4.00	N/A	feet
Overflow Weir Gate Slope =	0.00	N/A	H:V
Horiz. Length of Weir Sides =	2.92	N/A	feet
Overflow Gate Open Area % =	70%	N/A	%, gate open area/total area
Debris Clogging % =	50%	N/A	%

Calculated Parameters for Overflow Weir
 Height of Gate Upper Edge, H₁ = feet
 Overflow Weir Slope Length = feet
 Gate Open Area / 100-yr Orifice Area = ft²
 Overflow Gate Open Area w/o Debris = ft²
 Overflow Gate Open Area w/ Debris = ft²

User Input: Outlet Pipe w/ Flow Restriction Plate (Circular Orifice, Restrictor Plate, or Rectangular Orifice)

	Zone 3 Restrictor	Not Selected	
Depth to Invert of Outlet Pipe =	0.00	N/A	ft (distance below basin bottom at Stage = 0 ft)
Outlet Pipe Diameter =	24.00	N/A	inches
Restrictor Plate Height Above Pipe Invert =	12.00		inches

Calculated Parameters for Outlet Pipe w/ Flow Restriction Plate
 Outlet Orifice Area = ft²
 Outlet Orifice Centroid = feet
 Half-Central Angle of Restrictor Plate on Pipe = radians

User Input: Emergency Spillway (Rectangular or Trapezoidal)

Spillway Invert Stage = ft (relative to basin bottom at Stage = 0 ft)
 Spillway Crest Length = feet
 Spillway End Slopes = H:V
 Freeboard above Max Water Surface = feet

Calculated Parameters for Spillway
 Spillway Design Flow Depth = feet
 Stage at Top of Freeboard = feet
 Basin Area at Top of Freeboard = acres
 Basin Volume at Top of Freeboard = acre-ft

Routed Hydrograph Results

The user can override the default CUHP hydrographs and runoff volumes by entering new values in the Inflow Hydrographs table (Columns W through AF).

	WQCV	EURV	2 Year	5 Year	10 Year	25 Year	50 Year	100 Year	500 Year
Design Storm Return Period =	N/A	N/A	1.19	1.52	1.75	2.00	2.25	2.55	3.14
One-Hour Rainfall Depth (in) =	0.333	1.112	0.865	1.162	1.391	1.827	2.179	2.693	3.626
CUHP Runoff Volume (acre-ft) =	N/A	N/A	0.865	1.162	1.391	1.827	2.179	2.693	3.626
Inflow Hydrograph Volume (acre-ft) =	N/A	N/A	0.2	0.3	1.0	5.7	8.6	13.2	21.5
CUHP Predevelopment Peak Q (cfs) =	N/A	N/A	1.0	5.7	12.3	21.4	28.9	37.6	
OPTIONAL Override Predevelopment Peak Q (cfs) =	N/A	N/A	0.05	0.30	0.64	1.12	1.51	1.97	1.12
Predevelopment Unit Peak Flow, q (cfs/acre) =	N/A	N/A	11.3	15.3	18.3	25.8	31.1	38.5	52.0
Peak Inflow Q (cfs) =	0.2	0.4	0.3	0.4	2.5	7.6	11.8	16.1	17.4
Peak Outflow Q (cfs) =	N/A	N/A	N/A	0.1	0.2	0.4	0.4	0.4	0.8
Ratio Peak Outflow to Predevelopment Q =	Plate	Plate	Plate	Plate	Overflow Weir 1	Overflow Weir 1	Overflow Weir 1	Outlet Plate 1	Outlet Plate 1
Structure Controlling Flow =	N/A	N/A	N/A	N/A	0.3	0.9	1.4	1.9	2.1
Max Velocity through Grate 1 (fps) =	N/A	N/A	N/A	N/A	N/A	N/A	N/A	N/A	N/A
Max Velocity through Grate 2 (fps) =	43	67	62	69	69	67	65	63	59
Time to Drain 97% of Inflow Volume (hours) =	47	75	69	77	78	76	75	73	71
Time to Drain 99% of Inflow Volume (hours) =	2.27	4.27	3.63	4.23	4.47	4.69	4.83	5.11	5.89
Maximum Ponding Depth (ft) =	0.27	0.52	0.43	0.51	0.55	0.58	0.60	0.64	0.78
Area at Maximum Ponding Depth (acres) =	0.334	1.114	0.809	1.093	1.221	1.339	1.422	1.597	2.148
Maximum Volume Stored (acre-ft) =									

DETENTION BASIN OUTLET STRUCTURE DESIGN

MHFD-Detention, Version 4.00 (December 2019)

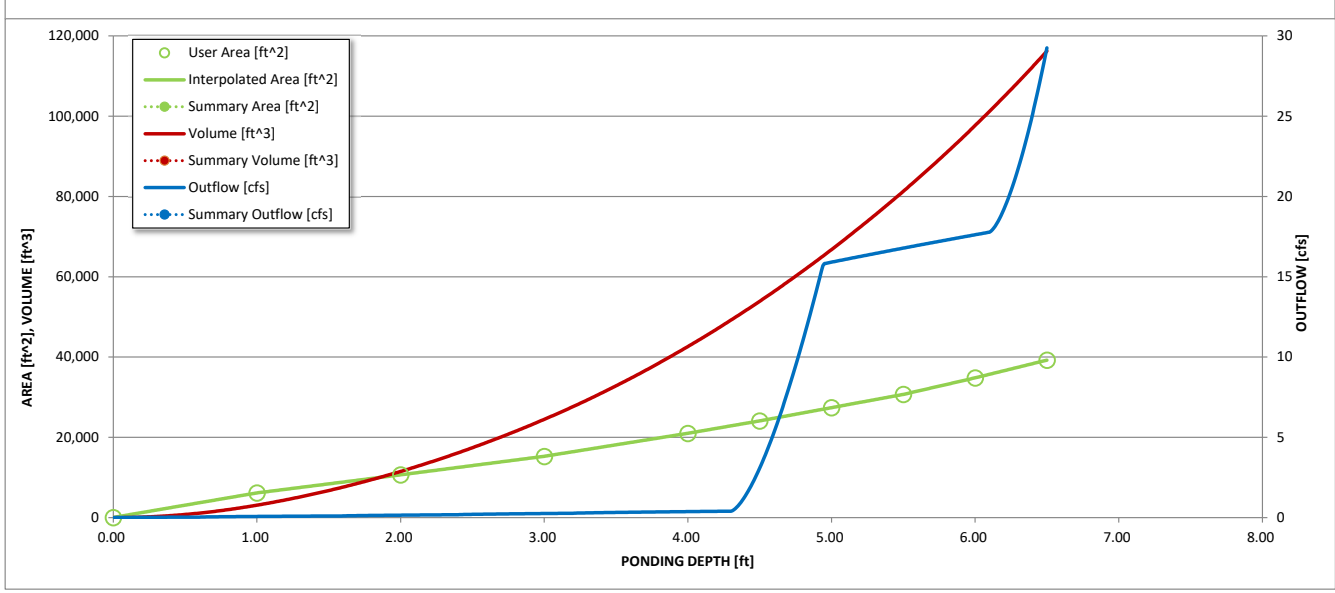
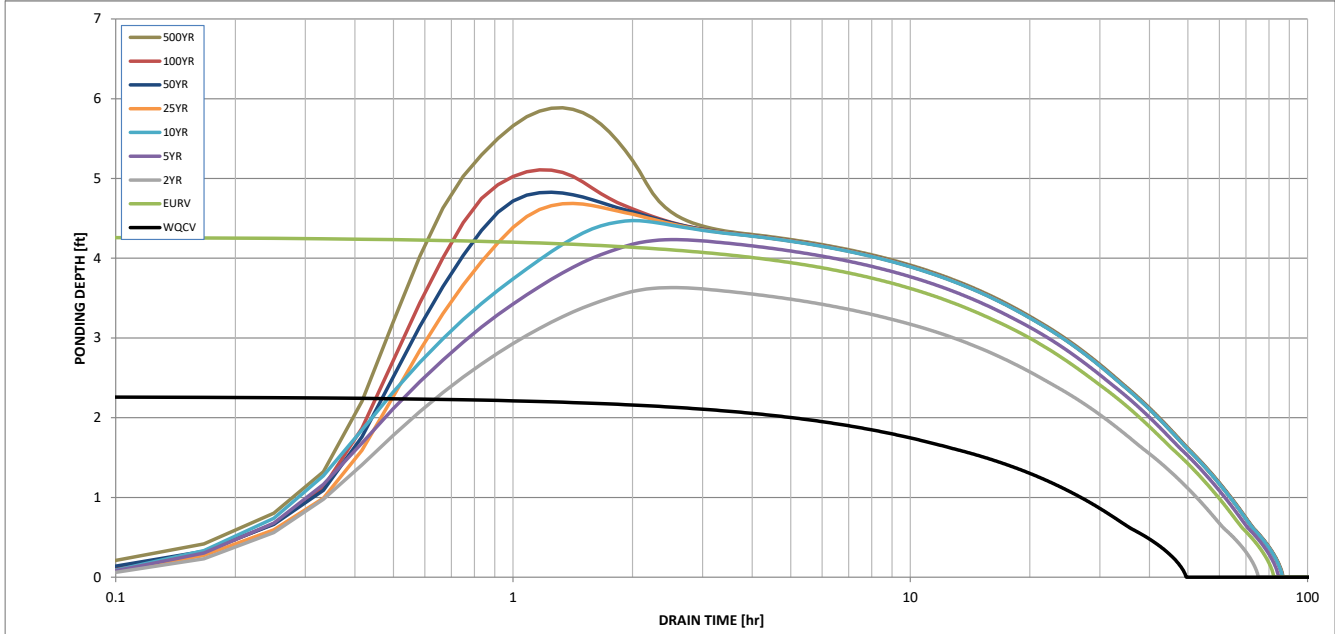
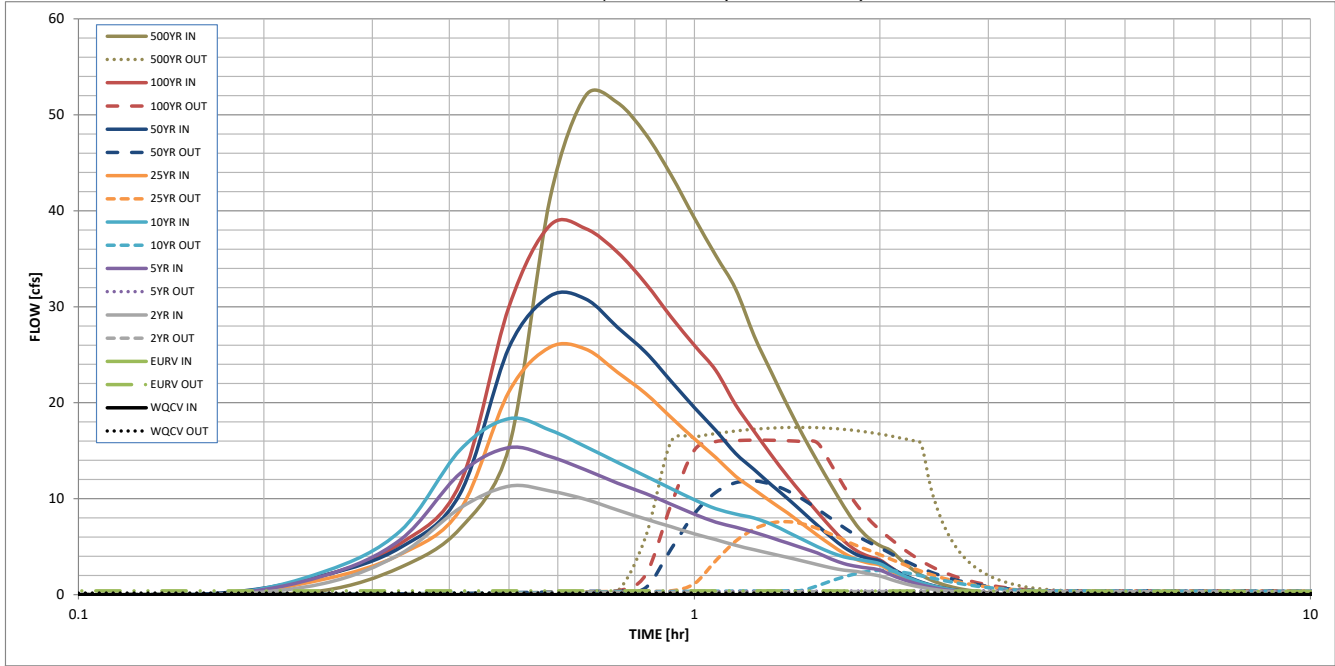

S-A-V-D Chart Axis Override	X-axis	Left Y-Axis	Right Y-Axis
minimum bound			
maximum bound			

DETENTION BASIN OUTLET STRUCTURE DESIGN

Outflow Hydrograph Workbook Filename: _____

Inflow Hydrographs

The user can override the calculated inflow hydrographs from this workbook with inflow hydrographs developed in a separate program.

Time Interval	SOURCE	CUHP	CUHP	CUHP	CUHP	CUHP	CUHP	CUHP	CUHP	CUHP	
	TIME	WQCV [cfs]	EURV [cfs]	2 Year [cfs]	5 Year [cfs]	10 Year [cfs]	25 Year [cfs]	50 Year [cfs]	100 Year [cfs]	500 Year [cfs]	
5.00 min	0:00:00	0.00	0.00	0.00	0.00	0.00	0.00	0.00	0.00	0.00	
	0:05:00	0.00	0.00	0.00	0.00	0.00	0.00	0.00	0.00	0.00	
	0:10:00	0.00	0.00	0.00	0.00	0.00	0.00	0.00	0.13	0.03	
	0:15:00	0.00	0.00	1.17	1.97	2.38	1.60	2.01	2.01	2.01	2.85
	0:20:00	0.00	0.00	4.25	5.73	6.64	4.21	4.92	5.34	5.34	6.89
	0:25:00	0.00	0.00	9.03	12.64	15.09	8.84	10.53	11.60	11.60	15.37
	0:30:00	0.00	0.00	11.31	15.32	18.34	21.16	25.75	30.02	30.02	41.32
	0:35:00	0.00	0.00	10.81	14.38	17.14	25.79	31.12	38.49	38.49	52.04
	0:40:00	0.00	0.00	9.92	12.98	15.40	25.57	30.79	38.13	38.13	51.27
	0:45:00	0.00	0.00	8.81	11.62	13.79	23.17	27.86	35.68	35.68	47.99
	0:50:00	0.00	0.00	7.88	10.54	12.35	20.95	25.26	32.43	32.43	43.73
	0:55:00	0.00	0.00	7.08	9.42	11.06	18.47	22.24	28.95	28.95	39.24
	1:00:00	0.00	0.00	6.33	8.39	9.89	16.23	19.49	25.97	25.97	35.33
	1:05:00	0.00	0.00	5.73	7.56	8.96	14.29	17.11	23.36	23.36	31.86
	1:10:00	0.00	0.00	5.15	7.03	8.40	12.34	14.72	19.79	19.79	26.97
	1:15:00	0.00	0.00	4.68	6.50	7.98	10.96	13.03	17.03	17.03	23.18
	1:20:00	0.00	0.00	4.26	5.93	7.34	9.66	11.44	14.53	14.53	19.69
	1:25:00	0.00	0.00	3.88	5.38	6.52	8.51	10.03	12.33	12.33	16.61
	1:30:00	0.00	0.00	3.50	4.85	5.73	7.32	8.58	10.40	10.40	13.91
	1:35:00	0.00	0.00	3.13	4.34	5.01	6.20	7.23	8.61	8.61	11.43
	1:40:00	0.00	0.00	2.80	3.72	4.39	5.19	6.00	6.99	6.99	9.18
	1:45:00	0.00	0.00	2.55	3.23	3.94	4.30	4.93	5.58	5.58	7.23
	1:50:00	0.00	0.00	2.42	2.94	3.69	3.66	4.18	4.58	4.58	5.91
	1:55:00	0.00	0.00	2.17	2.76	3.49	3.30	3.75	3.99	3.99	5.11
	2:00:00	0.00	0.00	1.94	2.57	3.22	3.09	3.50	3.62	3.62	4.59
	2:05:00	0.00	0.00	1.58	2.08	2.61	2.48	2.80	2.84	2.84	3.59
	2:10:00	0.00	0.00	1.25	1.64	2.07	1.93	2.18	2.17	2.17	2.72
	2:15:00	0.00	0.00	0.99	1.29	1.63	1.52	1.70	1.65	1.65	2.05
	2:20:00	0.00	0.00	0.77	1.02	1.27	1.17	1.32	1.25	1.25	1.54
	2:25:00	0.00	0.00	0.60	0.79	0.98	0.91	1.02	0.96	0.96	1.18
	2:30:00	0.00	0.00	0.47	0.60	0.75	0.69	0.78	0.73	0.73	0.90
	2:35:00	0.00	0.00	0.36	0.46	0.56	0.52	0.59	0.56	0.56	0.68
	2:40:00	0.00	0.00	0.27	0.34	0.43	0.40	0.44	0.43	0.43	0.52
	2:45:00	0.00	0.00	0.21	0.26	0.33	0.30	0.34	0.33	0.33	0.40
	2:50:00	0.00	0.00	0.15	0.18	0.24	0.22	0.25	0.24	0.24	0.29
	2:55:00	0.00	0.00	0.10	0.13	0.16	0.16	0.17	0.17	0.17	0.20
	3:00:00	0.00	0.00	0.06	0.08	0.10	0.10	0.11	0.11	0.11	0.13
	3:05:00	0.00	0.00	0.03	0.05	0.06	0.06	0.06	0.06	0.06	0.07
	3:10:00	0.00	0.00	0.01	0.02	0.02	0.02	0.03	0.03	0.03	0.03
	3:15:00	0.00	0.00	0.00	0.01	0.01	0.01	0.01	0.01	0.01	0.01
	3:20:00	0.00	0.00	0.00	0.00	0.00	0.00	0.00	0.00	0.00	0.00
	3:25:00	0.00	0.00	0.00	0.00	0.00	0.00	0.00	0.00	0.00	0.00
	3:30:00	0.00	0.00	0.00	0.00	0.00	0.00	0.00	0.00	0.00	0.00
	3:35:00	0.00	0.00	0.00	0.00	0.00	0.00	0.00	0.00	0.00	0.00
	3:40:00	0.00	0.00	0.00	0.00	0.00	0.00	0.00	0.00	0.00	0.00
	3:45:00	0.00	0.00	0.00	0.00	0.00	0.00	0.00	0.00	0.00	0.00
	3:50:00	0.00	0.00	0.00	0.00	0.00	0.00	0.00	0.00	0.00	0.00
	3:55:00	0.00	0.00	0.00	0.00	0.00	0.00	0.00	0.00	0.00	0.00
	4:00:00	0.00	0.00	0.00	0.00	0.00	0.00	0.00	0.00	0.00	0.00
	4:05:00	0.00	0.00	0.00	0.00	0.00	0.00	0.00	0.00	0.00	0.00
	4:10:00	0.00	0.00	0.00	0.00	0.00	0.00	0.00	0.00	0.00	0.00
	4:15:00	0.00	0.00	0.00	0.00	0.00	0.00	0.00	0.00	0.00	0.00
	4:20:00	0.00	0.00	0.00	0.00	0.00	0.00	0.00	0.00	0.00	0.00
	4:25:00	0.00	0.00	0.00	0.00	0.00	0.00	0.00	0.00	0.00	0.00
	4:30:00	0.00	0.00	0.00	0.00	0.00	0.00	0.00	0.00	0.00	0.00
	4:35:00	0.00	0.00	0.00	0.00	0.00	0.00	0.00	0.00	0.00	0.00
	4:40:00	0.00	0.00	0.00	0.00	0.00	0.00	0.00	0.00	0.00	0.00
	4:45:00	0.00	0.00	0.00	0.00	0.00	0.00	0.00	0.00	0.00	0.00
	4:50:00	0.00	0.00	0.00	0.00	0.00	0.00	0.00	0.00	0.00	0.00
	4:55:00	0.00	0.00	0.00	0.00	0.00	0.00	0.00	0.00	0.00	0.00
5:00:00	0.00	0.00	0.00	0.00	0.00	0.00	0.00	0.00	0.00	0.00	
5:05:00	0.00	0.00	0.00	0.00	0.00	0.00	0.00	0.00	0.00	0.00	
5:10:00	0.00	0.00	0.00	0.00	0.00	0.00	0.00	0.00	0.00	0.00	
5:15:00	0.00	0.00	0.00	0.00	0.00	0.00	0.00	0.00	0.00	0.00	
5:20:00	0.00	0.00	0.00	0.00	0.00	0.00	0.00	0.00	0.00	0.00	
5:25:00	0.00	0.00	0.00	0.00	0.00	0.00	0.00	0.00	0.00	0.00	
5:30:00	0.00	0.00	0.00	0.00	0.00	0.00	0.00	0.00	0.00	0.00	
5:35:00	0.00	0.00	0.00	0.00	0.00	0.00	0.00	0.00	0.00	0.00	
5:40:00	0.00	0.00	0.00	0.00	0.00	0.00	0.00	0.00	0.00	0.00	
5:45:00	0.00	0.00	0.00	0.00	0.00	0.00	0.00	0.00	0.00	0.00	
5:50:00	0.00	0.00	0.00	0.00	0.00	0.00	0.00	0.00	0.00	0.00	
5:55:00	0.00	0.00	0.00	0.00	0.00	0.00	0.00	0.00	0.00	0.00	
6:00:00	0.00	0.00	0.00	0.00	0.00	0.00	0.00	0.00	0.00	0.00	

APPENDIX D: DRAINAGE MAPS

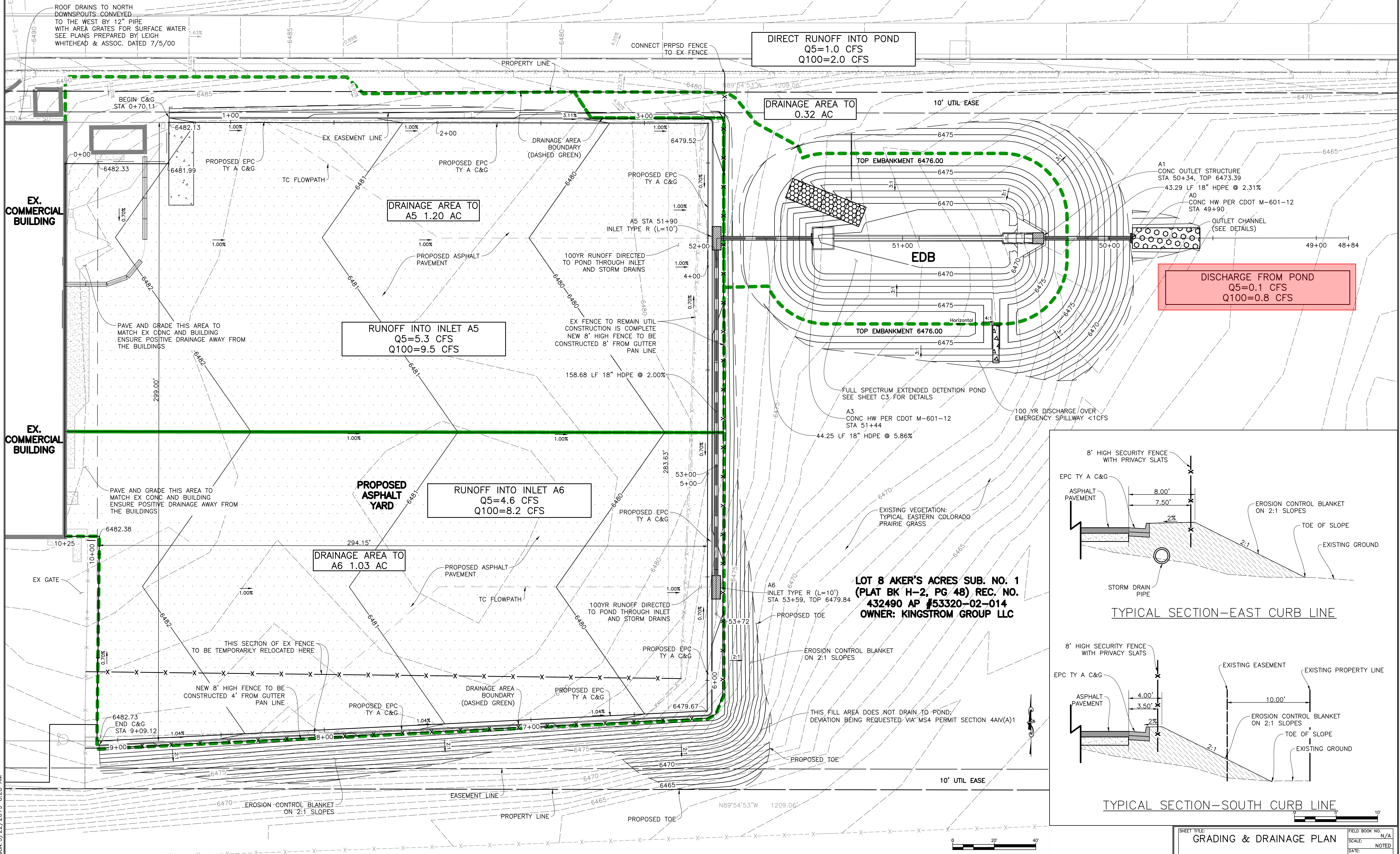

DIRECT RUNOFF INTO POND
 Q5=1.0 CFS
 Q100=2.0 CFS

DRAINAGE AREA TO
 0.32 AC

DRAINAGE AREA TO
 A5 1.20 AC

RUNOFF INTO INLET A5
 Q5=5.3 CFS
 Q100=9.5 CFS

RUNOFF INTO INLET A6
 Q5=4.6 CFS
 Q100=8.2 CFS

DRAINAGE AREA TO
 A6 1.03 AC

DISCHARGE FROM POND
 Q5=0.1 CFS
 Q100=0.8 CFS

LOT 8 AKER'S ACRES SUB. NO. 1
 (PLAT BK H-2, PG 48) REC. NO.
 432490 AP #53320-02-014
 OWNER: KINGSTROM GROUP LLC

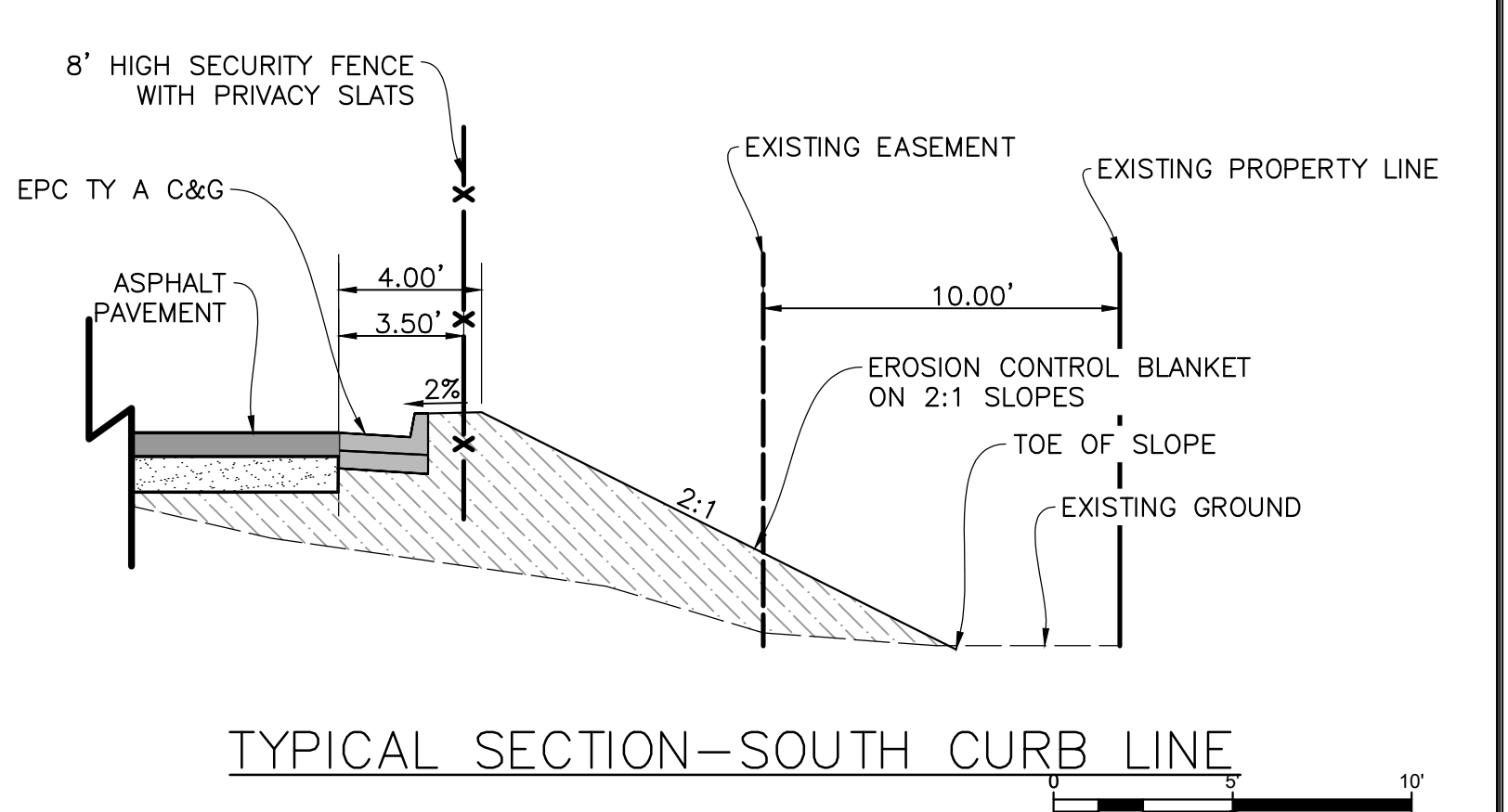
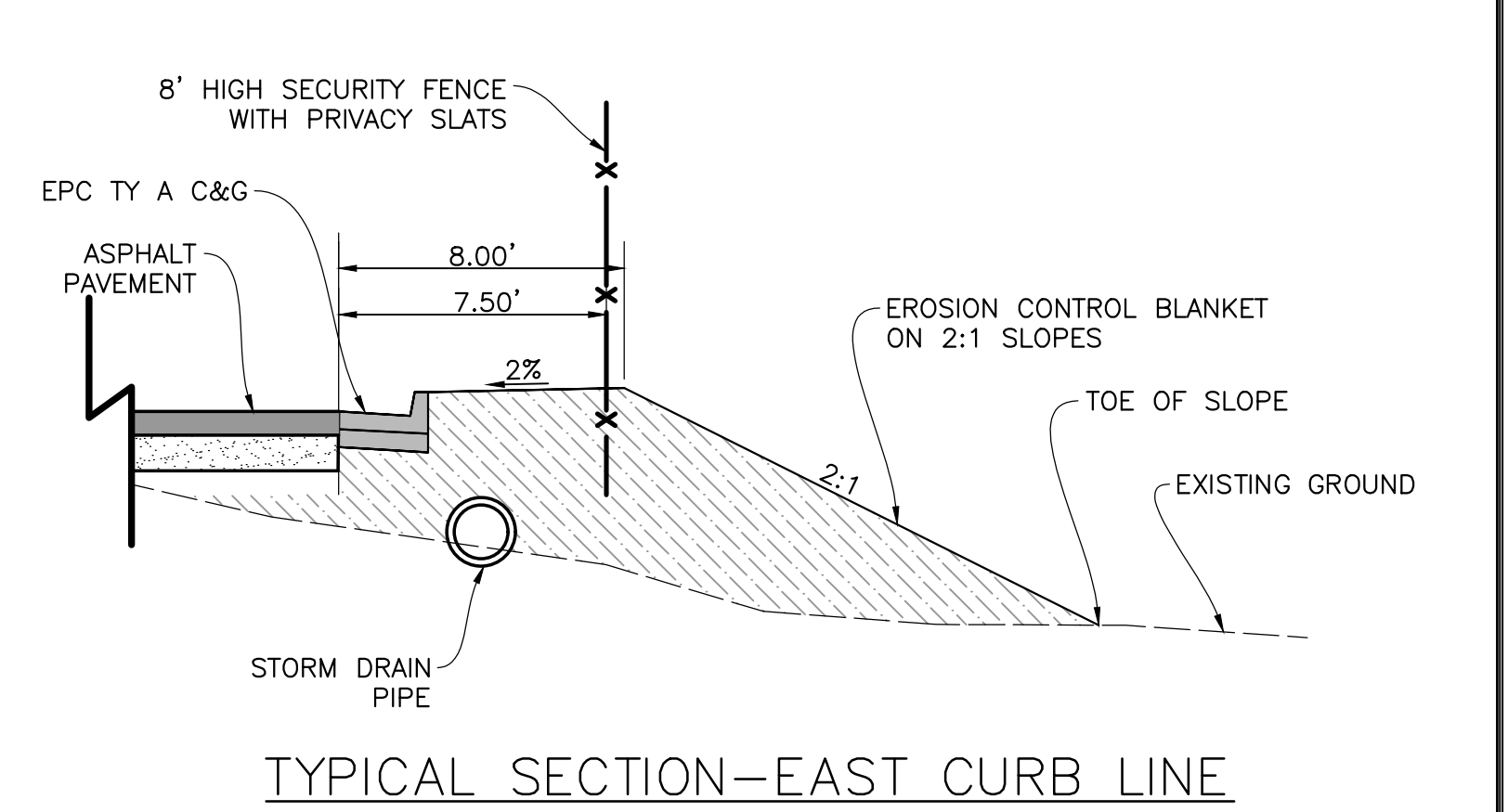

ISSUED FOR REVIEW
MAY 3, 2019

PROJECT NAME: STAGE COORDINATE IMPROVEMENTS
 CLIENT: KINGSTROM GROUP LLC
 PROJECT NO: 18020
 DATE: 5/22/2019 8:28 AM

REVIEWED FOR CONSTRUCTION:
 BY _____
 DATE _____

SCALE:
 HORIZONTAL: NOTED
 VERTICAL: _____
 BENCHMARK: _____

NO.	DATE	DESCRIPTION	BY

THIS DOCUMENT IS THE EXCLUSIVE PROPERTY OF OBERING, WURTH & ASSOCIATES. ANY REPRODUCTION, MODIFICATION OR USE OF THIS DOCUMENT FOR OTHER THAN ITS ORIGINAL INTENT WITHOUT PRIOR CONSENT OF OBERING WURTH AND ASSOCIATES IS PROHIBITED.

PCD FILE NO. PPR 1848

Know what's below.
 Call before you dig.

SHEET TITLE: GRADING & DRAINAGE PLAN	FIELD BOOK NO.: N/A
SCALE: NOTED	DATE: NOTED
PROJECT: LOT 8 AKERS ACRES COLORADO SPRINGS, COLORADO GRADING & DRAINAGE IMPROVEMENTS	DESIGNED BY: CLD
PREPARED BY: Obering, Wurth & Associates Consulting Civil Engineers Professional Land Surveyors	CHECKED BY: RGO
1042 Elkton Drive Colorado Springs, Colorado Phone (719) 531-6200 - Fax (719) 531-6286 E-mail Address: owacivil@mindspring.com	DRAWN BY: CLD
	PROJECT NO: 18022
	SHEET NO.: C2
	OF 8 SHEETS

K:\DEN_Civil\096302009_Akers Drive\CADD\PlanSheets\CD\096302009 - CD_DR.dwg Roberts, Jared 6/10/2021 11:26 AM

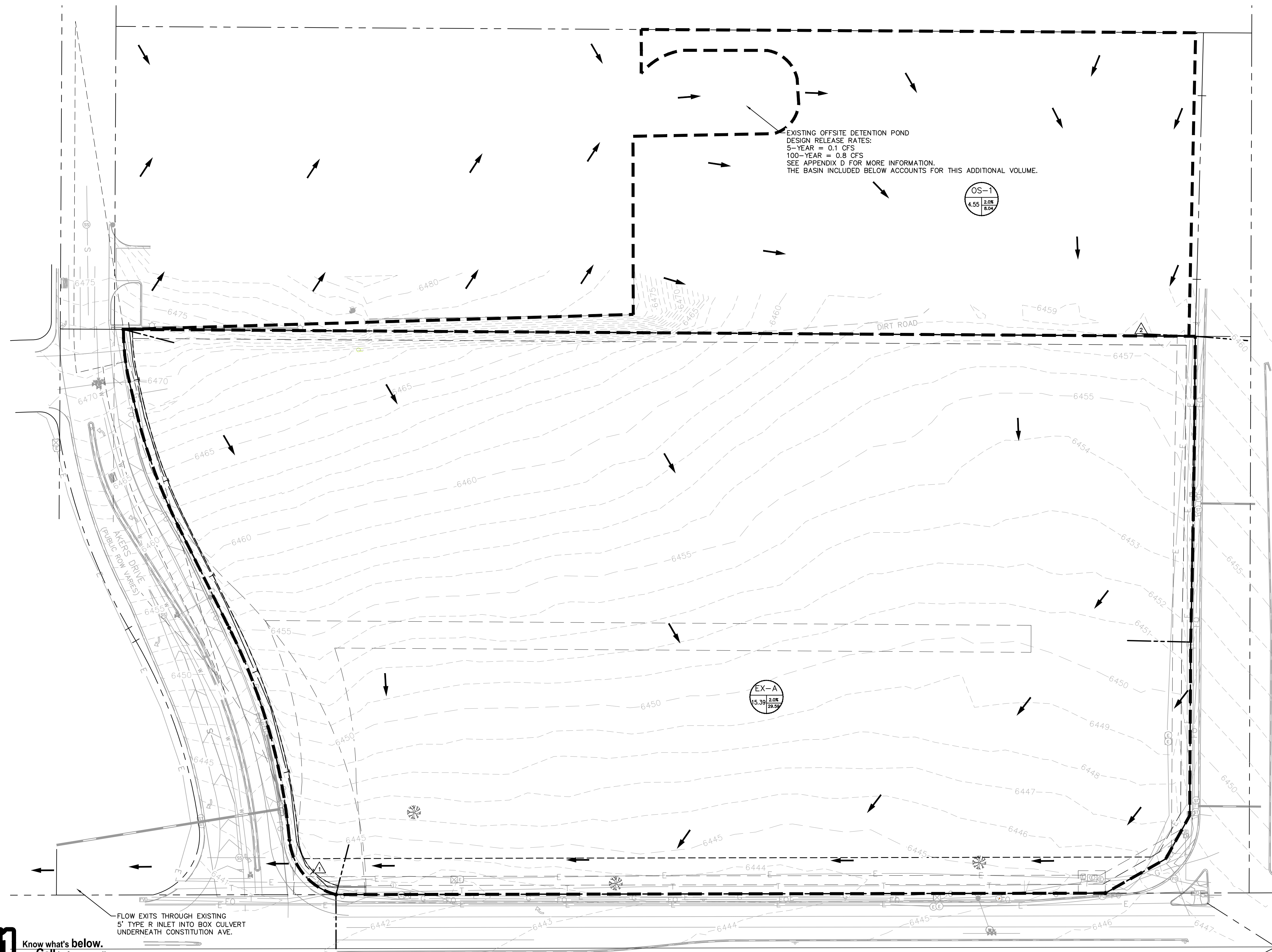

EXISTING OFFSITE DETENTION POND
DESIGN RELEASE RATES:
5-YEAR = 0.1 CFS
100-YEAR = 0.8 CFS
SEE APPENDIX D FOR MORE INFORMATION.
THE BASIN INCLUDED BELOW ACCOUNTS FOR THIS ADDITIONAL VOLUME.

LEGEND

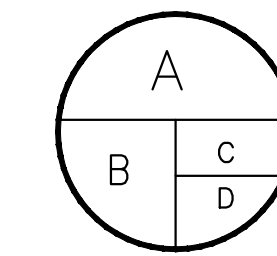

A = BASIN DESIGNATION
B = AREA (ACRES)
C = 100-YR COMPOSITE RUNOFF COEFFICIENT
D = 100-YR DESIGN STORM RUNOFF (CFS)

- DESIGN POINT
- FLOW DIRECTION
- EMERGENCY OVERFLOW PATH
- DRAINAGE BASIN BOUNDARY
- PROPERTY LINE
- PROPOSED MAJOR CONTOUR
- PROPOSED MINOR CONTOUR
- EXISTING MAJOR CONTOUR
- EXISTING MAJOR CONTOUR

NOTES

1. PLAN REVIEW BY EL PASO COUNTY IS PROVIDED ONLY FOR GENERAL CONFORMANCE WITH DESIGN CRITERIA. EL PASO COUNTY IS NOT RESPONSIBLE FOR THE ACCURACY AND ADEQUACY OF THE DESIGN, DIMENSIONS, AND/OR ELEVATIONS WHICH SHALL BE CONFIRMED AT THE JOB SITE. EL PASO COUNTY, THROUGH APPROVAL OF THIS DOCUMENT, ASSUMES NO RESPONSIBILITY FOR COMPLETENESS AND/OR ACCURACY OF THIS DOCUMENT.

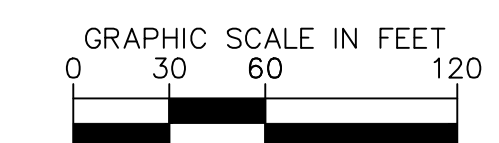
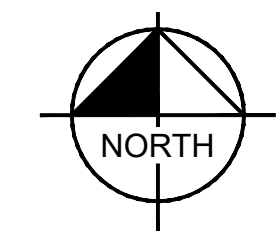

FLOW EXITS THROUGH EXISTING 5" TYPE R INLET INTO BOX CULVERT UNDERNEATH CONSTITUTION AVE.



CALL UTILITY NOTIFICATION CENTER OF COLORADO
1-800-922-1987
CALL 2-BUSINESS DAYS IN ADVANCE BEFORE YOU DIG, GRADE, OR EXCAVATE FOR THE MARKING OF UNDERGROUND MEMBER UTILITIES

CONSTITUTION AVENUE
(120' PUBLIC ROW)

SUMMARY - EXISTING RUNOFF TABLE

DESIGN POINT	BASIN DESIGNATION	BASIN AREA (ACRES)	DIRECT 5-YR RUNOFF (CFS)	DIRECT 100-YR RUNOFF (CFS)	CUMULATIVE 5-YR RUNOFF (CFS)	CUMULATIVE 100-YR RUNOFF (CFS)
1	EX-A	15.39	4.41	29.59	5.69	37.64
2	OS-1	4.55	1.28	8.04	1.28	8.04

NO.	REVISION	DATE	BY	APPR.
1	FIRST SUBMITTAL	5/19	JAR	EJC

Kimley»Horn
2021 KIMLEY-HORN AND ASSOCIATES, INC.
2 North Nevada Avenue Suite 300
Colorado Springs, Colorado 80903 (719) 453-0180

DESIGNED BY: EJC
DRAWN BY: JAR
CHECKED BY: EJC
DATE: 5/19/21

UPLAND FLATS BY WATERMARK
EL PASO COUNTY, COLORADO
CONSTRUCTION DRAWING PLANS
EXISTING DRAINAGE MAP

PRELIMINARY
FOR REVIEW ONLY
NOT FOR CONSTRUCTION
Kimley»Horn
Kimley-Horn and Associates, Inc.

PROJECT NO.
096302009
SHEET

C 700

K:\DEN_Civil\096302009_Akers Drive\CADD\PlanSheets\CD\096302009 - CD_DR.dwg Roberts, Jared 5/19/2021 3:48 PM

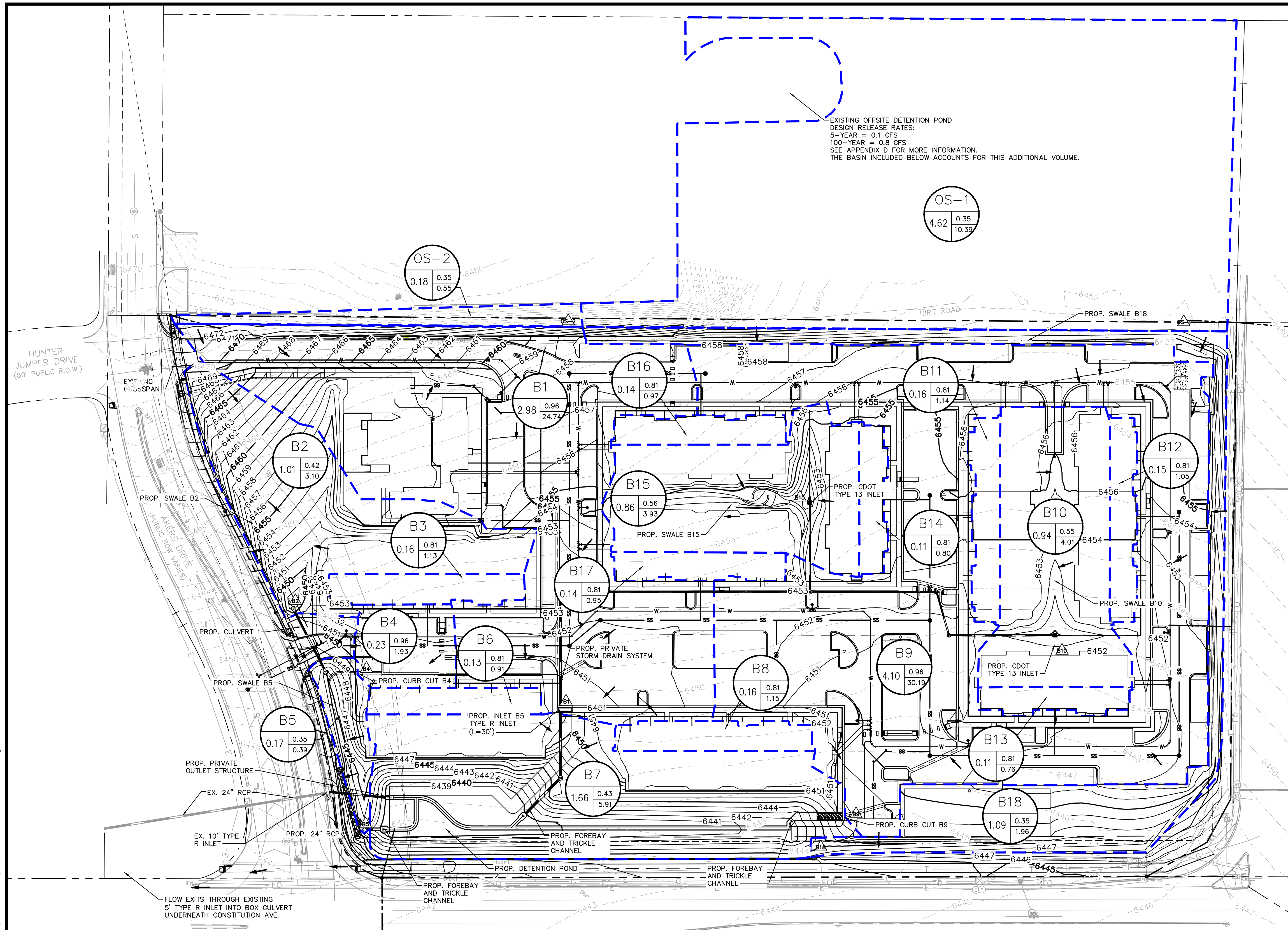

LEGEND

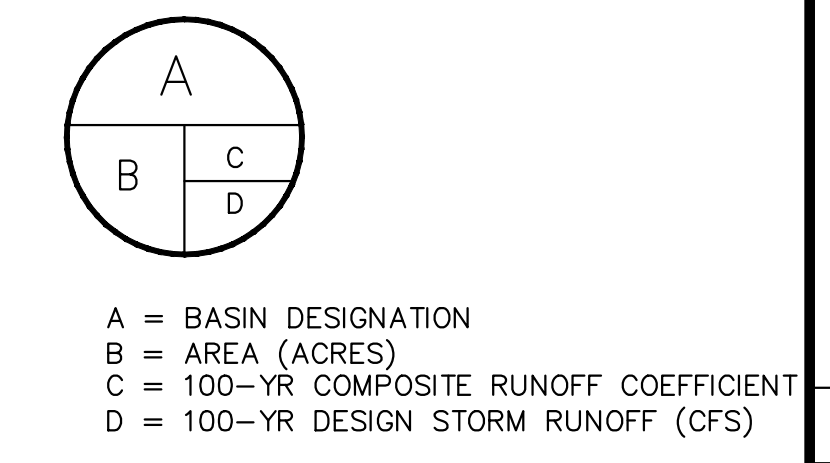

NOTES

- THESE DETAILED PLANS AND SPECIFICATIONS WERE PREPARED UNDER MY DIRECTION AND SUPERVISION. SAID DETAILED PLANS AND SPECIFICATIONS HAVE BEEN PREPARED ACCORDING TO THE ESTABLISHED CRITERIA FOR DETAILED DRAINAGE PLANS AND SPECIFICATIONS, AND SAID DETAILED PLANS AND SPECIFICATIONS ARE IN CONFORMITY WITH THE MASTER PLAN OF THE DRAINAGE BASIN. SAID DETAILED DRAINAGE PLANS AND SPECIFICATIONS MEET THE PURPOSES FOR WHICH THE PARTICULAR DRAINAGE FACILITY(S) IS DESIGNED. I ACCEPT RESPONSIBILITY FOR ANY LIABILITY CAUSED BY ANY NEGLIGENT ACTS, ERRORS OR COMMISSIONS ON MY PART IN PREPARATION OF THE DETAILED DRAINAGE PLANS AND SPECIFICATIONS.
- PLAN REVIEW BY EL PASO COUNTY IS PROVIDED ONLY FOR GENERAL CONFORMANCE WITH DESIGN CRITERIA. EL PASO COUNTY IS NOT RESPONSIBLE FOR THE ACCURACY AND ADEQUACY OF THE DESIGN, DIMENSIONS, AND/OR ELEVATIONS WHICH SHALL BE CONFIRMED AT THE JOB SITE. EL PASO COUNTY, THROUGH APPROVAL OF THIS DOCUMENT, ASSUMES NO RESPONSIBILITY FOR COMPLETENESS AND/OR ACCURACY OF THIS DOCUMENT.

SUMMARY - PROPOSED RUNOFF TABLE

DESIGN POINT	BASIN DESIGNATION	BASIN AREA (ACRES)	DIRECT 5-YR RUNOFF (CFS)	DIRECT 100-YR RUNOFF (CFS)	CUMULATIVE 5-YR RUNOFF (CFS)	CUMULATIVE 100-YR RUNOFF (CFS)
B1	B1	2.98	13.83	24.74	13.90	25.29
B2	B2	1.01	0.80	3.10	0.80	3.10
B3	B3	0.16	0.61	1.13	0.61	1.13
B4	B4	0.23	1.08	1.93	1.08	1.93
B5	B5	0.17	0.35	0.39	1.93	5.41
B6	B6	0.13	0.49	0.91	0.49	0.91
B7	B7	1.66	1.58	5.91	5.89	23.68
B8	B8	0.16	0.62	1.15	0.62	1.15
B9	B9	4.10	16.87	30.19	16.87	30.19
B10	B10	0.94	1.59	4.01	1.59	4.01
B11	B11	0.16	0.61	1.14	0.61	1.14
B12	B12	0.15	0.56	1.05	0.56	1.05
B13	B13	0.11	0.41	0.76	0.41	0.76
B14	B14	0.11	0.43	0.80	0.43	0.80
B15	B15	0.86	1.57	3.93	1.57	3.93
B16	B16	0.14	0.52	0.97	0.52	0.97
B17	B17	0.14	0.51	0.95	0.51	0.95
B18	B18	1.09	0.27	1.96	2.37	12.35
OS-1	OS-1	4.62	2.11	10.39	2.11	10.39
OS-2	OS-2	0.18	0.08	0.55	0.08	0.55

NO.	REVISION	DATE	BY	CHKD	APPR.
1	FIRST SUBMITTAL	5/19	JAR	EJC	

Kimley-Horn
 2021 KIMLEY-HORN AND ASSOCIATES, INC.
 2 North Nevada Avenue Suite 300
 Colorado Springs, Colorado 80903 (719) 453-0180

DESIGNED BY: EJC
 DRAWN BY: JAR
 CHECKED BY: EJC
 DATE: 5/19/21

UPLAND FLATS BY WATERMARK
 EL PASO COUNTY, COLORADO
 CONSTRUCTION DRAWING PLANS
 PROPOSED DRAINAGE MAP

PRELIMINARY
 FOR REVIEW ONLY
 NOT FOR
 CONSTRUCTION
Kimley-Horn
 Kimley-Horn and Associates, Inc.

PROJECT NO.
 096302009
 SHEET
C 701

811 Know what's below.
 Call before you dig.

CALL UTILITY NOTIFICATION
 CENTER OF COLORADO
 1-800-922-1987
 CALL 2-BUSINESS DAYS IN ADVANCE
 BEFORE YOU DIG, GRADE, OR EXCAVATE
 FOR THE MARKING OF UNDERGROUND
 MEMBER UTILITIES

