

Watermark at Akers Tract DD, Hannah Ridge at Feathergrass Filing No. 1, As Amended El Paso County, CO

COUNTY STORMWATER MANAGEMENT PLAN (SWMP) REPORT

Permittee:

Thompson Thrift Development, Inc.
111 Monument Circle, Suite 1500
Indianapolis, IN 46204
Contact: Monica Unger
(720)-495-3693

Preparing Engineer:

Kimley-Horn and Associates, Inc.
2 North Nevada Avenue, Suite 300
Colorado Springs, Colorado 80903
Contact: Eric Gunderson, P.E.
(719) 453-0180

Qualified Stormwater Manager:

Name:
Address:
Contact:

Contractor:

Name:
Address:
Contact:

MARCH 17, 2021

Kimley»»Horn

TABLE OF CONTENTS

CERTIFICATION / SIGNATURE BLOCKS.....	4
ENGINEER'S STATEMENT	4
OWNER'S STATEMENT.....	4
INTRODUCTION	5
INTRODUCTION AND PURPOSE	5
PERMIT COVERAGE AND APPLICATIONS.....	5
GENERAL LOCATION.....	5
PROJECT LOCATION	5
VICINITY MAP	6
SITE DESCRIPTION.....	6
GENERAL PROJECT DESCRIPTION.....	6
VEGETATION.....	7
DRAINAGE CHARACTERISTICS	7
ULTIMATE DISCHARGE	7
SITE SOILS	7
DEWATERING.....	7
AREAS AND VOLUMES	8
TIMING AND PHASING SCHEDULE	8
STORMWATER MANAGEMENT PLAN SITE MAP	10
SITE MAP MINIMUM REQUIREMENTS	10
STORMWATER MANAGEMENT CONTROLS	11
QUALIFIED STORMWATER MANAGER	11
SITE SPECIFIC POLLUTION SOURCES.....	11
IDENTIFICATION OF POLLUTANT SOURCES	11
NON-STORMWATER DISCHARGE COMPONENTS.....	13
CONTROL MEASURES FOR STORMWATER POLLUTION PREVENTION	13
OTHER POTENTIAL POLLUTION CONSIDERATIONS	15
MATERIALS HANDLING AND SPILL PREVENTION	15

VEHICLE TRACKING AND DUST CONTROL.....	16
DEDICATED CONCRETE OR ASPHALT BATCH PLANTS	17
WASTE MANAGEMENT AND DISPOSAL	17
Portable Toilets.....	17
STABILIZATION AND STORMWATER MANAGEMENT	17
TEMPORARY STABILIZATION AND SHORT-TERM STORMWATER MANAGEMENT	17
FINAL STABILIZATION AND LONG-TERM STORMWATER MANAGEMENT.....	17
INSPECTION AND MAINTENANCE	18
INSPECTION SCHEDULE REQUIREMENTS	18
INSPECTION PROCEDURES	18
CONTROL MEASURE MAINTENANCE / REPLACEMENT AND FAILED CONTROL MEASURES.....	20
DISPOSITION OF TEMPORARY MEASURES	21
PLAN MODIFICATIONS.....	21
REFERENCES	22
APPENDIX.....	23
APPENDIX A – STORMWATER MANAGEMENT PLANS / SITE MAPS	
APPENDIX B – CDPHE STORMWATER PERMIT	
APPENDIX C – FEMA FIRM MAP	
APPENDIX D – SOILS INFORMATION	
APPENDIX E – IDENTIFICATION OF POLLUTANT SOURCES	
APPENDIX F – LAND DISTURBANCE / CONTROL MEASURE / STABILIZATION LOG	
APPENDIX G – SPILL PREVENTION AND RESPONSE PLAN AND REPORTING INFORMATION	
APPENDIX H – STORM EVENT LOG	
APPENDIX I – INSPECTION AND SAMPLING REPORTS	
APPENDIX J – SWMP AMENDMENT LOG / CONTROL MEASURE DETAILS	

CERTIFICATION / SIGNATURE BLOCKS

ENGINEER'S STATEMENT

This Erosion and Stormwater Quality Control/Grading Plan was prepared under my direction and supervision and is correct to the best of my knowledge and belief. If such work is performed in accordance with the grading and erosion control plan, the work will not become a hazard to life and limb, endanger property, or adversely affect the safety, use, or stability of a public way, drainage channel, or other property.

Eric J. Gunderson, P.E.
Registered Professional Engineer
State of Colorado No. 0049487

OWNER'S STATEMENT

The owner will comply with the requirements of the Erosion and Stormwater Quality Control Plan including temporary BMP inspection requirements and final stabilization requirements. I acknowledge the responsibility to determine whether the construction activities on these plans require Colorado Discharge Permit System (CDPS) permitting for Stormwater discharges associated with Construction Activity.

Developer/Owner Signature: _____

Name of Developer/Owner: _____ Date: _____

DBA: _____ Phone: _____

Title: _____ Email: _____

Address: _____ Fax: _____

INTRODUCTION

INTRODUCTION AND PURPOSE

This Stormwater Management Report (“SWMP”) Report is provided to support the approval of the Erosion and Sediment Control Plan Construction Drawings through El Paso County (“County”) and the issuance of a CDPS General Permit through Colorado Department of Public Health and Environment (“CDPHE”) for the proposed multifamily project located at Tract DD, Hannah Ridge at Feathergrass Filing No. 1 (“Project”). This report, in conjunction with the Construction Drawings in **Appendix**, provide a site and project understanding along with guidelines for implementation and maintenance of erosion, sediment and stormwater quality control measures prior to and during construction of the Project.

The primary goal of pollution prevention efforts during Project construction is to control sediment and pollutants that originate on the site and prevent them from flowing to surface waters. A successful pollution prevention program also relies upon careful inspection and adjustments during the construction process to enhance its effectiveness. It is the intent of this plan to implement stormwater control measures, also referred to as best management practices (BMP) for enhancing the quality of stormwater discharges associated with the construction activity. Control measures designs are based on the criteria set forth by the General Permit and the El Paso County Drainage Criteria Manual Volume II and Engineering Criteria Manual.

This plan must be implemented before construction begins on the site. It primarily addresses the impact of storm rainfall and runoff on areas of the ground surface disturbed during the construction process. In addition, there are recommendations for controlling other sources of pollution that could accompany the major construction activities. Applicability of this plan shall be terminated when disturbed areas are stabilized, temporary erosion controls are removed, construction activities covered herein have ceased and the permit has been inactivated.

PERMIT COVERAGE AND APPLICATIONS

The Grading, Erosion & Sediment Control for this Project shall be approved by El Paso County prior to issuance of construction related permits.

Based upon a Site Disturbance Area of one (1) acre or more, this site requires the issuance of a Colorado Discharge Permit System (CDPS) - Stormwater Discharge Associated with Construction Activities Permit (General Permit) through the Colorado Department of Public Health and Environment (CDPHE). A copy of the CDPS General Permit Application is included in **Appendix** of this report.

GENERAL LOCATION

PROJECT LOCATION

The Project is located in the Section 32, Township 13 South, Range 65 West, 6th P.M., County of El Paso, State of Colorado (see Vicinity Map). More specifically, the site is located at Tract DD, Hannah Ridge at Feathergrass Filing No. 1.

The Project is located on approximately 15.39 acres of land consisting of vacant land with native vegetation. The proposed land use is a multifamily living area consisting of 9 multi-family buildings, 12 garage buildings, a front office building, and a clubhouse amenity space with a pool deck.

Parcels adjacent to the site include:

- North – Lot 8, Aker’s Acres Subdivision No. 1, Commercial Use
- West – Aker Drive (Public ROW)/ Tract CC Hannah Ridge at Feathergrass Filing No. 1
- South – Constitution Avenue (Public 120’ ROW)
- East – Marksheffel Road (Public ROW)

VICINITY MAP

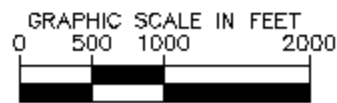
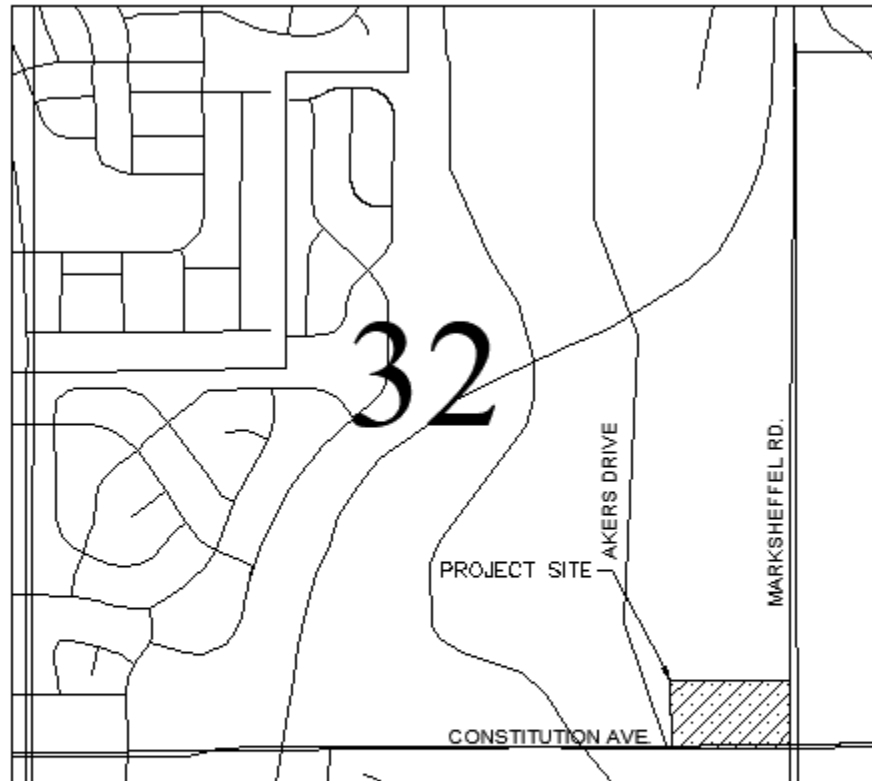

SITE DESCRIPTION

GENERAL PROJECT DESCRIPTION

The Site consists of ±15.39 acres of undeveloped land. The limits of construction are ±15.20 acres. The site is in the proposed RM-30 District. The Project will consist of grading within the limits of construction and the construction of consisting of 9 multi-family buildings, 12 garage buildings, a front office building, and a clubhouse amenity space with a pool deck, parking lot, retaining walls, utilities and adjacent landscape areas.

VEGETATION

The existing site is undeveloped, vacant land. Ground cover consists of short grasses with a few trees and an approximate density of approximately 100%. Vegetation density was confirmed through a review of photos of the Site.

DRAINAGE CHARACTERISTICS

The existing topography consists of slopes ranging from 1% to 5% and generally slopes from North to South. The site is bounded by Constitution Avenue to the south, where the majority of the site currently overland flows to, overtops the curb and gutter and flows into the storm drain system in Constitution Avenue and Akers Drive. A Full Spectrum Extended Detention Basin is proposed for the site which will release flows from the site into the existing storm system below historic levels.

The Site improvements are located in Zone X, as determined by the Flood Insurance Rate Map (FIRM) number 08041C0756G effective date, December 7, 2018. The FIRM is provided in **Appendix**.

There are no stream crossings located within the construction site boundary or limits of disturbance.

ULTIMATE DISCHARGE

The runoff generated from the roof areas are collected and conveyed via private roof drains and outfall into the proposed private storm sewer system. Other sub-basins include internal areas within the parking lot and adjacent landscape areas. Each sub-basin drains to an inlet within the parking lot and is routed to the private storm sewer system at individual design points indicated on the Proposed Drainage Exhibit. The entirety of the proposed storm sewer system is routed to a Full Spectrum Extended Detention Basin south of the parking lot on the east side of the building. The detention system will release flows into an existing curb inlet within the El Paso County MS4. The curb inlet within the MS4 will discharge to Sand Creek East Fork and then ultimately into Sand Creek.

SITE SOILS

A review of the Natural Resource Conservation Service (NRCS) Web Soil Survey determined that soils onsite are generally USCS Type A/B. The NRCS Soils map is provided in the appendix. Additionally, the Geotechnical Engineering Report by Kumar and Associates dated 09/20/2020 states “The native granular soils encountered were grouped as follows: clayey sand (SC) with silty-clayey sand (SM-SC), and poorly to well-graded sand with silt (SP-SM, SW-SM) with silty sand (SM)” The onsite soils were found to have a low to medium potential for erodibility and the Geotechnical Engineering Report suggests slopes less than 2:1. A Geotechnical Report for the site, which includes soil borings and tests, including the depth of groundwater, if encountered, has also been included in the **Appendix**.

DEWATERING

Groundwater dewatering is not anticipated per the Geotechnical Engineering Report by Kumar and Associates dated 09/20/2020. According to the Geotechnical Engineering Report, “Groundwater was not encountered at the time of drilling. When the borings were checked 8 to 9 days later, groundwater was encountered in Boring 8 at an approximate depth of 25.1 feet.” If groundwater is encountered during construction and the site must be dewatered, the operator shall file for appropriate dewatering permits (Permit No. COG070000) with the CDPHE.

If groundwater is encountered on the project site, a State of Colorado General Permit for Construction Dewater Activities will be required. The state dewatering permit application and associated information can be found at <https://www.colorado.gov/pacific/cdphe/wq-construction-general-permits>. The permit application will need to be filled out 30 days prior to the anticipated discharge. Refer to the UDFCDs detail and fact sheet for additional dewatering operations information.

AREAS AND VOLUMES

The total anticipated project disturbance area is approximately 15.20 acres. The estimated earthwork quantities are as follows:

Cut: ±34,500 cubic yards

Fill: ±13,110 cubic yards

Net: ±21,390 cubic yards CUT

TIMING AND PHASING SCHEDULE

The operator shall utilize the following general construction practices which are required throughout the project at locations shown on the Erosion and Sediment Control Plan or as dictated by construction activities.

- Materials handling and spill prevention
- Waste management and disposal
- Hazardous material storage and containment area
- Vehicle maintenance fueling and storage
- Solid waste containment facility
- Sanitary waste facility
- Street Sweeping (SS) – performed by the Operator

These practices shall remain active and operational throughout the duration of construction and be identified on the Erosion and Sediment Control Plan. Due to any phasing required for the Project, it is understood that these control measures may be relocated as needed to facilitate construction operations. The Operator shall locate and identify the original and current location of these control measures on the Erosion and Sediment Control Plan, throughout the construction of the Project. An updated copy of the Erosion and Sediment Control Plan shall be kept onsite throughout construction of the Project.

General construction sequencing and activities associated with this project are described below. They are presented in the order (or sequence) they are expected to begin, but each activity will not necessarily be completed before the next begins.

The anticipated construction start date is Fall 2021 and the anticipated construction completion date is Fall 2023.

INITIAL PHASE

The initial phase shall consist of applying for and receiving the CDPS General Permit as well as construction/installation of temporary control measures to minimize potential for erosion and sediment transfer while mobilizing and preparing the site for construction activities. The operator shall minimize site

disturbance by minimizing the extent of grading and clearing to effectively reduce sediment yield. The operator shall complete the anticipated initial phase sequencing as follows:

1. Prepare and submit the State of Colorado, Colorado Department of Public Health and Environment (CDPHE) Colorado Discharge Permit System (CDPS) General Permit. A copy of the permit shall be provided to the owner upon receipt from the CDPHE.
2. Obtain EPC ESQCP Permit, schedule Kickoff meeting with EPC, and obtain “notice to proceed” from EPC.
3. Install *Vehicle Tracking Control (VTC)* at the proposed southwest site entrance.
4. Install and denote on the plan any of the following areas: trailer, parking, lay down, porta-potty, wheel wash, concrete washout, fuel and material storage containers, solid waste containers, etc.
5. Prepare *Stabilized Staging Area (SSA)* and *Stockpile Protection (SP)*. Contractor to note the actual size and location of this area and shall minimize this area.
6. Install perimeter controls including *Silt Fence (SF)* and *Construction Fence (CF)* as shown on the Grading and Erosion Control Plans. Ensure that the limits of construction are defined as necessary and known by all parties which will be responsible for construction on the site.
7. Install *Diversion Swale (DS)* and *Check Dams (CD)* in the swales as denoted on the Grading and Erosion Control Plans.
8. Install *Inlet Protection (IP)* around all existing inlets as denoted on the Grading and Erosion Control Plans including *Temporary Outlet Protection (TOP)* at each proposed culvert.
9. Install *Rock Socks (RS)* along the curb flowline of the adjacent roadways.
10. Install *Concrete Washout Area (CWA)* prior to construction of concrete improvements.
11. Install *Temporary Sediment Basin (SB)* in the location of the permanent Full Spectrum Extended Detention Basin per the detail as denoted on the Grading and Erosion Control Plans.
12. Upon completion of the initial control measure installation the Operator shall schedule and hold a meeting with the Contractor and Inspector that shall take place prior to the Pre-Construction Meeting.
13. The Operator shall schedule a Pre-Construction Meeting with the County and Owner to confirm control measures installed are adequate prior to proceeding with additional land disturbing activities.
14. Begin clearing and grubbing of the site.

INTERIM PHASE

The interim phase shall consist of site improvements including utility installation, foundation pouring, and vertical construction. The operator shall complete the anticipated interim phase sequencing as follows:

1. Confirm existing control measures from the initial phase which are to be maintained throughout construction, are in working order and compliant with applicable regulations.
2. Repair and/or replace any existing control measures which are deemed inadequate.
3. *Temporarily Seed (TS)*, throughout construction, denuded areas that will be inactive for 14 days or more.
4. Install *Inlet Protection (IP)* around all constructed and existing inlets as denoted on the Erosion and Sediment Control Plans including *Temporary Outlet Protection (TOP)* at each proposed culvert.
5. Construct permanent Full Spectrum Extended Detention Basin

FINAL PHASE

The final phase shall consist of construction of site improvements, construction of permanent control measures, and final stabilization of the Site. The operator shall complete the anticipated final phase sequencing as follows:

1. Confirm existing control measures from the initial phase which are to be maintained throughout construction, are in working order and compliant with applicable regulations.
2. Repair and/or replace any existing control measures which are deemed inadequate.
3. *Temporarily Seed (TS)*, throughout construction, denuded areas that will be inactive for 14 days or more.
4. Complete installation of utilities and curb and gutters.
5. Permanently stabilize areas to be vegetated as they are brought to final grade.
6. Prepare site for paving.
7. Pave site, including gravel roadways, concrete sidewalk, and paved parking lot.
8. Complete grading and installation of final stabilization over all areas in accordance with the approved landscape plans for the Project.
9. Remove remaining control measures once permanent stabilization has been achieved and accepted by the County Inspector. Repair and stabilize areas disturbed through control measure removal.
10. Notify the owner of intent to file the Notice of Inactivation with CDPHE and receive Owner acceptance to proceed with Stormwater Management Close-out.
11. Proceed with filing the Notice of Inactivation with CDPHE.
12. Provide the Owner with a copy of all stormwater documentation (permits, inspection reports, logs, etc.) upon completion of Project Stormwater Notice of Inactivation.

STORMWATER MANAGEMENT PLAN SITE MAP

SITE MAP MINIMUM REQUIREMENTS

The Site Map for this project is included within **Appendix** of this report and meets the following minimum requirements:

- Construction Site Boundaries
- Flow Arrows Depicting Stormwater Flow Directions
- Identification of Ground Surface Disturbance
- Areas of Storage of Building Materials, Equipment, Soil or Waste
- Location of Dedicated Asphalt or Concrete Batch Plants (As Applicable)
- Location of Structural Control Measures
- Location of Non-Structural Control Measures
- Location of Springs, Streams, Wetlands or other Surface Waters (As Applicable)
- Location of All Stream Crossings Located Within the Construction Site Boundary (As Applicable)

STORMWATER MANAGEMENT CONTROLS

QUALIFIED STORMWATER MANAGER

The Qualified Stormwater Manager is the Operator selected for the project. The Qualified Stormwater Manager is an individual knowledgeable in the principles and practices of erosion and sediment control and pollution prevention, and with the skills to assess the effectiveness of stormwater controls implemented to meet the requirements of the General Permit. **The Qualified Stormwater Manager will be sufficiently qualified for the required duties per the ECM Appendix 1.5.** The Qualified Stormwater Manager is responsible for developing, implementing, maintaining and revising the Grading, Erosion and Sediment Control Plan. The activities and responsibilities of the Qualified Stormwater Manager shall address all aspects of the facility's Grading, Erosion and Sediment Control Plan.

Company:

Contact:

Address:

Phone:

Email:

SITE SPECIFIC POLLUTION SOURCES

Further identification of site-specific pollutants that fall within the categories outlined in the next section may be field noted using the corresponding log included in **Appendix** of this report. The logs are intended to record site specific pollutants, the date of arrival on the site, the date removed from the site, and the methods of treatment.

IDENTIFICATION OF POLLUTANT SOURCES

Evaluation of general sediment and non-sediment pollution sources associated with site construction activities, as outlined within the General Permit, consist of the following:

- **Disturbed and Stored Soils** – Earth disturbing activities (grading, excavation, etc.) will be necessary for this project; therefore, the potential exists for disturbed site soils to contribute sediment to stormwater discharges.
- **Vehicle Tracking and Sediment** – Construction traffic will be entering and exiting the Site; therefore, the potential exists for vehicle tracking to contribute sediment to stormwater discharges.
- **Management of Contaminated Soils** – Contaminated soils are not anticipated on this Site. If encountered, the Qualified Stormwater Manager shall take appropriate containment and treatment measures.
- **Loading and Unloading Operations** – Loading and unloading operations will be taking place at the Site; therefore, the potential exists for these operations to introduce sediment and non-sediment pollutants to stormwater discharges.

- **Outdoor Storage of Materials** – Limited outdoor storage of materials is anticipated with construction of this site; however, outdoor storage of chemicals, fertilizers, etc. is not anticipated.
- **Vehicle and Equipment Maintenance and Fueling** – Routine maintenance and fueling of vehicles and equipment is anticipated with this Site; therefore, the potential exists for pollutants associated with these activities to contribute pollutants to stormwater discharges.
- **Significant Dust or Particulate Generating Processes** – Earth disturbing activities (grading, excavation, etc.) will be necessary for this project; therefore, the potential exists for windblown site soils to contribute sediment to stormwater discharges.
- **Routine Maintenance** – Routine maintenance involving fertilizers, pesticides, detergents, fuels, solvents, oils, etc., other than those identified within Vehicle and Equipment Maintenance and Fueling are not anticipated with this project. If encountered, the Qualified Stormwater Manager shall take appropriate containment and treatment measures.
- **Onsite Waste Management** – Waste management consisting of solid waste piles, liquid wastes, dumpsters, etc. are anticipated onsite; therefore, the potential exists for these operations to introduce sediment and non-sediment pollutants to stormwater discharges.
- **Concrete Truck / Equipment Washing** – Concrete truck and equipment washing are not anticipated with this project. If encountered, the Qualified Stormwater Manager shall take appropriate containment and treatment measures.
- **Dedicated Asphalt and Concrete Batch Plants** – Dedicated asphalt and/or concrete batch plants are not anticipated with this project. If encountered, the Qualified Stormwater Manager shall take appropriate containment and treatment measures and document as necessary.
- **Non-Industrial Waste Sources** – Non-Industrial waste sources limited to portable sanitary facilities are anticipated with this project.
- **Additional Pollutant Sources** – Additional areas or procedures where potential spills could occur are not anticipated with this project.

Logs for the identification of pollutant sources are included in **Appendix** for reference and use.

Based on the following, the potential to contribute pollutants to stormwater discharges is not significant for most of the pollutants identified above:

- Relatively Low Frequency of the Activities
- The Ability to Schedule Activities During Dry Weather
- Existing Site Topography
- The Ability to Implement Primary and Secondary Containment for Product Storage
- The Ability to Locate Activities Away from Drainage Ways

Potential pollutant sources noted below shall be mitigated by use of Best Management Practices (BMPs) as noted in the following sections:

- Disturbed and Stored Soils
- Vehicle Tracking and Sediment
- Loading and Unloading Operations
- Outdoor Storage
- Vehicle Equipment and Maintenance Fueling
- Significant Dust or Particulate Generating Processes
- Non-Industrial Waste Sources

NON-STORMWATER DISCHARGE COMPONENTS

Only specifically authorized non-stormwater discharges are allowed to enter the storm sewer and all authorized non-stormwater discharges shall be eliminated or reduced to the extent practical. **There are no non-stormwater discharges anticipated at the Site.**

Appropriate control measures shall be used to minimize the discharge of pollutants. Such control measures will be strictly followed to ensure any impacts from non-stormwater discharges are reduced or eliminated. Appropriate control measures are:

- Emergency Fire Fighting Activities
- Uncontaminated ground water or spring water
If possible, direct uncontaminated ground water or spring water to stabilized points of discharge. If discharged to a disturbed area, assure measures to control erosive velocities and sediment control measures are implemented. Velocity control measures include riprap aprons and other conveyance measures. Sediment control measures might include stone check dams, sediment traps and basins.

If uncontaminated ground water is discharged off-site, a Construction Dewatering Permit will be required. This Permit will not apply if dewatering is not performed or if water is not discharged off-site.

- Landscape Irrigation Return Flows
Volume of water used for irrigation prior to establishment of vegetation shall be controlled to prevent excess runoff and erosion. Temporary sediment control measures shall remain in place until all upstream disturbed areas are stabilized. Sediment loss will be controlled using sediment control measures such as wattles, sediment fence, and vegetative buffers.

CONTROL MEASURES FOR STORMWATER POLLUTION PREVENTION

There are three general types of control measures that will be utilized for the Project: Erosion Control, Sediment Control, and Site/Material Management control measures. Erosion Control measures are used to limit the amount and extent of erosion. Sediment Control measures are designed to capture eroded sediments prior to their conveyance offsite. Site/Material Management control measures are related to construction access and staging. Several control measures described below may be categorized into more than one of the types described above. Also, these control measures may be categorized into one or more of the following construction phases which pertain to the phase of development in which they may be implemented. Initial Stage control measures shall be installed on existing grades at the outset of construction. Final Stage control measures shall be installed on proposed grades and drainage features after initial site grading. Construction of the identified improvements will take place under two phases of construction anticipated as identified within the construction sequencing included within this report.

Refer to the Erosion and Sediment Control Plans for the location and implementation of erosion control measures for the phases of the Project. The following is a brief description of temporary sediment and erosion control measures to be utilized on this Site and the application those control measures are treating.

EROSION CONTROL

Protection of steep slopes is not anticipated on this project. Steep slopes are defined as slopes greater than 3:1 that are higher than 5-feet vertically. Temporary slopes during construction that are greater than 3:1 need to be addressed along with any permanent slopes which are greater than 3:1. The Permittee may need to implement the use of diversion ditches to reroute the storm runoff, terrace the grades to break up the flow of incidental runoff down slopes, compost mulch to protect the exposed soil or other control measure as approved by the inspector. Slopes steeper than 3:1 shall be protected with an erosion control blanket. No un-protected final grades shall be allowed greater than 2:1.

Permanent soil erosion control measures for all slopes, channels, ditches, or any disturbed land area shall be completed within fourteen (14) calendar days after final grading or the final earth disturbances has been completed. When it is not possible to permanently stabilize a disturbed area after an earth disturbance has been completed or where significant earth disturbance activity ceases, temporary soil erosion control measures shall be implemented within fourteen (14) calendar days. All temporary soil erosion control measures shall be maintained until permanent soil erosion measures are implemented.

All disturbed areas shall be stabilized as soon as possible. Seeding and Mulching (SM), to provide protection against rain and wind erosion, shall be performed temporarily, as needed, during the pre-construction, initial, and interim phases and maintained until final stabilization is completed. Site Stabilization will be achieved through use of temporary seeding and mulching (TS) and ultimately permanent landscaping (PS). All disturbed areas which are either final graded or will remain inactive for a period of more than 30 days shall be required to be stabilized within 14 days of the completion of the grading activities.

SEDIMENT CONTROL

Silt Fence (SF) is located downstream of disturbed areas and provides a sediment barrier for runoff. SF is installed to help reduce the amount of sediment in surface runoff that will be exiting/entering the Site. SF will be installed along portions of the limits of construction line located throughout the Site as denoted on the Site Map. The SF will be installed during the initial phases of construction activities and maintained throughout construction.

SITE/MATERIAL MANAGEMENT

One construction entrance with Vehicle Tracking Control (VTC) shall be installed at the southwest entrance of the Site in an effort to reduce off-site sediment tracking. The VTC shall be installed during the initial phase of construction activities.

A Concrete Washout Area (CWA) will be installed near the VTC to help isolate concrete truck washout operations upon departure. A CWA is installed when a site anticipates the generation of concrete wash water. CWAs provide an area for the proper collection and disposal of all liquid concrete waste. The CWA will be installed during the initial phase of construction activities. Three basic approaches are available to the Contractor and include an above-grade storage area, excavation of a pit in the ground, and a prefabricated haul-away concrete washout container. All concrete washout areas shall, as a minimum adhere to the following guidelines:

- Maintain a minimum distance of 400 feet from a stream or water body.
- Maintain a minimum distance of 1,000 feet from any wells or drinking water source.
- Shall not be located in a natural draw or drainage swale.
- Shall not be located in areas of highly permeable soils, i.e., gravels and sands.

- The chosen location shall be sited so that if a failure or overtopping occurs, the flow would be directed to a flat or depressed grassy area away from any water sources.
- The use of solvents, cleaners, or hazardous materials when cleaning or removing concrete is strictly prohibited.
- Backflushing shall not be permitted on site.
- Adequate and proper disposal of contents is required once the CWA has reached ½ capacity and at the end of concrete construction activities.

A stabilized staging area (SSA) to provide an area for construction activities and material storage will be located on the north side of the Site. The SSA provides a designated area for staging of construction materials and equipment, placement of job trailer, contractor parking, etc.

Street Sweeping (SS) is necessary for any site that has track out onto adjacent sites or roadways. Paved and impervious surfaces which are adjacent to construction sites must be swept on a weekly basis or as needed during the week when sediment and other materials are tracked or discharged onto them. Either sweeping by hand or use of street sweepers is acceptable. Street sweepers using water while sweeping is preferred in order to minimize dust. Scraped or swept material shall not be deposited in the storm sewer. Materials collected by the inlet protection shall be removed and shall not be deposited in the storm sewer. Street sweeping is the responsibility of the Operator and will not be performed by the County to meet the requirements of this Plan.

OTHER POTENTIAL POLLUTION CONSIDERATIONS

MATERIALS HANDLING AND SPILL PREVENTION

Any hazardous or potentially hazardous material that is brought onto the construction site shall be handled properly to reduce the potential for stormwater pollution. In an effort to minimize the potential for a spill of petroleum product or hazardous materials to come in contact with stormwater, the following steps shall be implemented:

- Material Safety Data Sheets (MSDS) information shall be kept on site for any and all applicable materials.
- All materials with hazardous properties (such as pesticides, petroleum products, fertilizers, detergents, construction chemicals, acids, paints, paint solvents, additives for soil stabilization, concrete, curing compounds and additives, etc.) shall be stored in a secure location, under cover and in appropriate, tightly sealed containers when not in use.
- The minimum practical quantity of all such materials shall be kept on the job site and scheduled for delivery as close to time of use as practical.
- A spill control and containment kit shall be provided on the construction site and location(s) shown on Site Maps.
- All of the product in a container shall be used before the container is disposed of. All such containers shall be triple rinsed, with water prior to disposal. The rinse water used in these containers shall be disposed of in a manner in compliance with State and Federal regulations and shall not be allowed to mix with stormwater discharges.
- All products shall be stored in and used from the original container with the original product label and used in strict compliance with the instructions on the product label.
- The disposal of excess or used products shall be in strict compliance with instructions on the product label.

Fueling for construction is anticipated to be conducted with a fuel truck that will not be kept permanently on-site. If utilized, temporary onsite fuel tanks for construction vehicles shall meet all state and federal regulations. Tanks shall have approved spill containment with the capacity required by the applicable regulations. From NFPA 30: All tanks shall be provided with secondary containment (i.e. containment external to and separate from primary containment). Secondary containment shall be constructed of materials of sufficient thickness, density and composition so as not to be structurally weakened as a result of contact with the fuel stored and capable of containing discharged fuel for a period of time equal to or longer than the maximum anticipated time sufficient to allow recovery of discharged fuel. Secondary containment may only be required on larger fuel tanks and the qualified stormwater manager should familiarize themselves with and follow local and state requirements.

The tanks shall be in sound condition free of rust or other damage which might compromise containment. Fuel storage areas shall meet all Environmental Protection Agency (EPA), OSHA and other regulatory requirements for signage, fire extinguisher, etc. Hoses, valves, fittings, caps, filler nozzles and associated hardware shall be maintained in proper working condition at all times. The location of fuel tanks shall be shown on the Site Maps and shall be located to minimize exposure to weather and surface water drainage features.

The Operator shall develop and implement a Materials Handling and Spill Prevention Plan (MHSP) in accordance with the EPA and State of Colorado requirements. In the event of an accidental spill, immediate action shall be undertaken by the Operator to contain and remove the spilled material. All hazardous materials, including contaminated soil, shall be disposed of by the Operator in the manner specified by federal, state and local regulations and by the manufacturer of such products. As soon as possible, the spill shall be reported to the appropriate agencies. As required under the provisions of the Clean Water Act, any spill or discharge entering waters of the United States shall be properly reported. The Operator shall prepare a written record of any spill and associated clean-up activities of petroleum products or hazardous materials in excess of 1 gallon or reportable quantities, whichever is less. A copy of the Spill Report Form is included in **Appendix** of this report.

Accidental spills shall be handled expeditiously as outlined in CDPHE guidance. Any spills of petroleum products or hazardous materials in excess of Reportable Quantities as defined by EPA or the state or local agency regulations, shall be immediately reported to the Colorado Department of Public Health and Environment spill reporting lines.

- CDPHE Environmental Release and Incident Reporting Line (877) 518-5608.
- National Response Center - (800) 424-8802

VEHICLE TRACKING AND DUST CONTROL

Vehicle Tracking Control measures (structural and non-structural) shall be implemented in order to control potential sediment discharges from vehicle tracking. Practices shall be implemented for all areas of potential vehicle tracking which include but are not limited to reduced site access and utilization of designated haul routes.

Areas of soil that are denuded of vegetation and have little protection from particles being picked up and carried by wind should be protected with a temporary cover or kept under control with water or other soil adhering products to limit wind transported particles exiting the site perimeter.

DEDICATED CONCRETE OR ASPHALT BATCH PLANTS

Dedicated concrete or asphalt batch plants are not anticipated with this project. If encountered, the Qualified Stormwater Manager shall notify EPC immediately and take appropriate containment and treatment measures and document as necessary.

WASTE MANAGEMENT AND DISPOSAL

An effective first step towards preventing pollution in stormwater from work sites involves using a common-sense approach to improve the facility's basic housekeeping methods. Poor housekeeping practices result in increased waste and potential for stormwater contamination.

No solid materials are allowed to be discharged from the site with stormwater. All solid waste, including disposable materials incidental to the construction activities, must be collected and placed in containers. Secure covers for the containers shall be provided if required by state and local requirements. The location of solid waste receptacles shall be identified on the SWMP by the Operator.

Concrete waste is anticipated with this project; and therefore, a dedicated concrete washout is required. The Qualified Stormwater Manager shall take appropriate containment and treatment measures and document as necessary.

PORTABLE TOILETS

Portable toilets shall be provided on-site as necessary for construction personnel. Portable toilets shall be located on flat surfaces away from drainage paths. Toilets shall be located a minimum of 10 feet from stormwater inlets and 50 feet from state waters. They will be secured at all four corners to prevent overturning and cleaned on a weekly basis. They will be inspected daily for spills.

STABILIZATION AND STORMWATER MANAGEMENT

TEMPORARY STABILIZATION AND SHORT-TERM STORMWATER MANAGEMENT

The County considers the completion of over-lot grading operations, by definition, to be substantially complete; therefore, all areas that will be dormant for more than 30 days after the completion of the over-lot grading will require temporary seeding within 14 days of establishment. This does not preclude the 7-day requirement for areas fully completed in the future. At a minimum, in ensuring that this requirement is followed, adequate phasing/scheduling will be required.

FINAL STABILIZATION AND LONG-TERM STORMWATER MANAGEMENT

In the natural condition, the site soil is stabilized by means of native vegetation. The final stabilization technique to be used at this project for stabilizing soils shall be to provide a protective cover of landscaping vegetation, pavement and granular stabilization material. Seeding should be conducted after final grade is achieved and soils are prepared to take advantage of soil moisture and seed germination. Long term stabilization of the proposed extended detention basin includes this permanent seeding. The EDB provides maintenance access roads to clean sediment and debris from trickle channels and the outlet structure, which should be routinely maintained. The Qualified Stormwater Manager should evaluate the short and long-term forecasts prior to applying permanent seed.

Final site stabilization is achieved when vegetative cover provides permanent stabilization with a density greater than 70 percent of the pre-disturbance levels, or equivalent permanent, physical erosion reduction methods have been employed over the entire area to be stabilized by vegetative cover. This area is exclusive of areas that are covered with rock (crushed granite, gravel, etc.) or landscape mulch, paved or have a building or other permanent structure on them.

INSPECTION AND MAINTENANCE

Inspections shall be the responsibility of the Qualified Stormwater Manager throughout the construction process.

INSPECTION SCHEDULE REQUIREMENTS

Inspection and maintenance of erosion control measures shall comply with the criteria set forth by the General Permit (COR400000), or the following, whichever is more stringent.

The Permittee or Contractor shall produce written and signed records every seven (7) days and after within 24 hours after every significant precipitation or snow melt events that causes surface erosion. All necessary maintenance and repair shall be completed immediately. If more frequent inspections are required to ensure that control measures are properly maintained and operated, the inspection schedule shall be modified to meet this need.

When snow cover exists over the entire site for an extended period, inspections are not always feasible. This condition should be documented, including date of snowfall and date of melting conditions to bring awareness of and preparation for areas where melting conditions may pose a risk of surface erosion.

A copy of the SWMP shall be maintained at the site at all times. Any degradation of the control measures described in the SWMP or excessive accumulation of sediments shall be remedied immediately upon discovery. The Contractor shall record all storm events on the Storm Event Log included in **Appendix**.

INSPECTION PROCEDURES

The inspection shall include observations of:

- The Construction Site Perimeter and Discharge Points;
- All Disturbed Areas;
- Vehicles and Equipment;
- Areas Used for Material / Waste Storage That are Exposed to Precipitation;
- Other Areas Determined to Have a Significant Potential for Stormwater Pollution;
- Erosion and Sediment Control Measures Identified in the SWMP; and
- Any Other Structural Control Measures That May Require Maintenance.

The inspection must determine if there is evidence of, or the potential for, pollutants entering the drainage system. Control measures should be reviewed to determine if they still meet the design intent and operational criteria in the SWMP and if they continue to adequately control pollutants at the site. Any control measures not operating in accordance with the SWMP must be addressed as soon as possible, immediately in most cases, to minimize the discharge of pollutants and the SWMP must be updated and inspections must be documented.

Examples of specific items to evaluate during site inspections are listed below. This list is not intended to be comprehensive. Ultimately, it is the responsibility of the Contractor to assure the adequacy of site pollutant discharge controls. Actual physical site conditions or contractor practices could make it necessary to install more controls than are shown on the plans. Assessing the need for additional controls and implementing them or adjusting existing controls will be an ongoing requirement until the site achieves final stabilization.

1. Vehicle Tracking Control - Locations where vehicles enter and exit the site shall be inspected for evidence of offsite sediment tracking. Exits shall be maintained as necessary to prevent the release of sediment from vehicles leaving the site. Any sediment deposited on the adjacent roadway shall be removed as necessary throughout the day or at the end of every day and disposed of in an appropriate manner. Sediment shall not be washed into storm sewer systems.
2. Erosion Control Devices - Rolled erosion control products (nets, blankets, turf reinforcement mats) and marginally vegetated areas (areas not meeting required vegetative densities for final stabilization) must be inspected frequently. Rilling, rutting and other signs of erosion indicate the erosion control device is not functioning properly and additional erosion control devices are warranted.
3. Sediment Control Devices - Sediment barriers (silt fence, sediment control logs, etc.), traps and basins must be inspected, and they must be cleaned out at such time as their original capacity has been reduced by 50 percent. All material excavated from behind sediment barriers or in traps and basins shall be incorporated into onsite soils or spread out on an upland portion of the site and stabilized. To minimize the potential for sediment releases from the Project, site perimeter control devices shall be inspected with consideration given to changing up-gradient conditions.
4. Material Storage Areas - Material storage areas should be located to minimize exposure to weather. Inspections shall evaluate disturbed areas and areas used for storing materials that are exposed to rainfall for evidence of, or the potential for, pollutants entering the drainage system or discharging from the site. If necessary, the materials must be covered, or original covers must be repaired or supplemented. Also, protective berms must be constructed, if needed, in order to contain runoff from material storage areas. All state and local regulations pertaining to material storage areas shall be adhered to.
5. Vegetation - Seed/Sod shall be free of weedy species and appropriate for site soils and regional climate. Seeding, sodding, tacking, and mulching shall be completed, in accordance with the requirements outlined within the Project Manual and locations identified within the plans, immediately after topsoil is applied and final grade is reached. Grassed areas shall be inspected to confirm that a healthy stand of grass is maintained. Rip-rap, mulch, gravel, decomposed granite or other equivalent permanent stabilization measures may be employed in lieu of vegetation based on site-specific conditions and Owner approval.
6. Discharge Points - All discharge points must be inspected to determine whether erosion and sediment control measures are effective in preventing discharge of sediment from the site or impacts to receiving waters.

Based on the inspection results, all necessary maintenance and repair shall be completed immediately and in no cases longer than seventy-two (72) hours after identification. The inspection reports must be completed after each inspection. An important aspect of the inspection report is the description of additional measures that need to be taken to enhance plan effectiveness. The inspection report must identify whether the site was in compliance with the SWMP at the time of inspection and specifically identify all incidents of non-compliance.

The Qualified Stormwater Manager shall ensure that, at a minimum, the following is recorded for each inspection and kept onsite for reference:

- a. The inspector's name and signature (must be a Qualified Stormwater Manager),
- b. The date and type of the inspection (regular inspection vs. post-storm inspection),

- c. Weather conditions at the time of the inspection,
- d. Phase of construction at the time of the inspection,
- e. Estimated acreage of disturbance at the time of inspection,
- f. The minimum frequency of inspections chosen,
- g. Location(s) of discharges of sediment or other pollutants from the site,
- h. Location(s) of control measures needing maintenance,
- i. Location(s) and identification of inadequate control measures
- j. Location(s) and identification of additional control measures are needed that were not in place at the time of inspection, and
- k. Any corrective actions taken.

If repairs are needed to any control measures, they shall be completed immediately. After adequate corrective action(s) and maintenance have been taken, or where a report does not identify any incidents requiring corrective action or maintenance, the report shall contain a statement stating the following:

“I verify that, to the best of my knowledge and belief, all corrective action and maintenance items identified during the inspection are complete, and the site is currently in compliance with the permit.”

This statement must be signed by a Qualified Stormwater Manager. If it is infeasible to install or repair of control measure immediately after discovering the deficiency, the following information must be documented and kept on record:

1. Describe why it is infeasible to initiate the installation or repair immediately; and
2. Provide a schedule for installing or repairing the control measure and returning it to an effective operating condition as soon as possible.

The use and maintenance of log books, photographs, field notebooks, drawings or maps should also be included in the SWMP records when appropriate. Copies of the Inspection and Sampling Report Forms have been included in **Appendix** for reference and use.

CONTROL MEASURE MAINTENANCE / REPLACEMENT AND FAILED CONTROL MEASURES

Site inspection procedures noted above must address maintenance of control measures that are found to no longer function as needed and designed, as well as preventive measures to proactively ensure continued operation.

The Qualified Stormwater Manager shall implement a preventative maintenance program to ensure that control measure breakdowns and failures are handled proactively. Site inspections should uncover any conditions which could result in the discharge of pollutants to storm sewers and surface waters and shall be rectified. For example, sediment shall be removed from silt fences on a regular basis to prevent failure of the control measure. Sediment shall be removed to an appropriate location so that it will not become an additional pollutant source.

The inspection process must also include replacement of control measures when needed or the addition of new control measures in order to adequately manage the pollutant sources at the site.

Any control measure deficiencies, replacement or additional control measures that may be required shall be documented on the Stormwater Management Site Map and on the appropriate Inspection Form. If amendments to the SWMP are required, these amendments shall be documented on the SWMP Amendment Log included in **Appendix** for reference and use.

DISPOSITION OF TEMPORARY MEASURES

Most temporary erosion and sediment control measures must be removed within 30 days after final site stabilization is achieved. Trapped sediment and disturbed soil areas resulting from the disposal of temporary measures must be returned to final plan grades and permanently stabilized to prevent further soil erosion.

PLAN MODIFICATIONS

Plan revisions made prior to or following a change(s) onsite, including revisions to sections addressing site conditions and control measures, a notation must be included in the plan that identifies:

- Date of site change,
- The control measure removed or modified,
- The location(s) of those control measures, and
- Any changes to the control measure.

This project does not rely on control measures owned or operated by another entity.

REFERENCES

Colorado Discharge Permit System (CDPS) – Stormwater Discharge Associated with Construction Activities Application - Prepared by Water Quality Control Division, Colorado Department of Public Health and Environment; Revised April 2019.

Colorado Discharge Permit System (CDPS) General Permit – Stormwater Discharges Associated with Construction Activity - Prepared by Water Quality Control Division, Colorado Department of Public Health and Environment; signed and issued on May 31, 2007 and administratively continued effective July 1, 2012.

NRCS Web Soil Survey - Website: <http://websoilsurvey.nrcs.usda.gov>

Stormwater Discharges Associated with Construction Activity – Stormwater Management Plan Preparation Guidance - Prepared by Water Quality Control Division, Colorado Department of Public Health and Environment; Revised April 2011.

Threatened, Endangered, Candidate and Proposed Species by County - Prepared by US Department of the Interior, Fish and Wildlife Services, Ecological Services, Colorado Field Offices; printed March 2019.

Urban Storm Drainage Criteria Manual, Volume 3 – Mile High Flood District, Denver, CO.; November 2015.

APPENDIX A – STORMWATER MANAGEMENT PLANS / SITE MAPS

STANDARD NOTES FOR EL PASO COUNTY GRADING AND EROSION CONTROL PLANS:

- STORMWATER DISCHARGES FROM CONSTRUCTION SITES SHALL NOT CAUSE OR THREATEN TO CAUSE POLLUTION, CONTAMINATION, OR DEGRADATION OF STATE WATERS. ALL WORK AND EARTH DISTURBANCE SHALL BE DONE IN A MANNER THAT MINIMIZES POLLUTION OF ANY ON-SITE OR OFF-SITE WATERS, INCLUDING WETLANDS.
- NOTWITHSTANDING ANYTHING DEPICTED IN THESE PLANS IN WORDS OR GRAPHIC REPRESENTATION, ALL DESIGN AND CONSTRUCTION RELATED TO ROADS, STORM DRAINAGE AND EROSION CONTROL SHALL CONFORM TO THE STANDARDS AND REQUIREMENTS OF THE MOST RECENT VERSION OF THE RELEVANT ADOPTED EL PASO COUNTY STANDARDS, INCLUDING THE LAND DEVELOPMENT CODE, THE ENGINEERING CRITERIA MANUAL, THE DRAINAGE CRITERIA MANUAL, AND THE DRAINAGE CRITERIA MANUAL VOLUME 2. ANY DEVIATIONS TO REGULATIONS AND STANDARDS MUST BE REQUESTED, AND APPROVED, IN WRITING.
- A SEPARATE STORMWATER MANAGEMENT PLAN (SMWP) FOR THIS PROJECT SHALL BE COMPLETED AND AN EROSION AND STORMWATER QUALITY CONTROL PERMIT (ESQCP) ISSUED PRIOR TO COMMENCING CONSTRUCTION. MANAGEMENT OF THE SWMP DURING CONSTRUCTION IS THE RESPONSIBILITY OF THE DESIGNATED QUALIFIED STORMWATER MANAGER OR CERTIFIED EROSION CONTROL INSPECTOR. THE SWMP SHALL BE LOCATED ON SITE AT ALL TIMES DURING CONSTRUCTION AND SHALL BE KEPT UP TO DATE WITH WORK PROGRESS AND CHANGES IN THE FIELD.
- ONCE THE ESQCP HAS BEEN APPROVED AND A "NOTICE TO PROCEED" HAS BEEN ISSUED, THE CONTRACTOR MAY INSTALL THE INITIAL STAGE EROSION AND SEDIMENT CONTROL MEASURES AS INDICATED ON THE APPROVED GEC. A PRECONSTRUCTION MEETING BETWEEN THE CONTRACTOR, ENGINEER, AND EL PASO COUNTY WILL BE HELD PRIOR TO ANY CONSTRUCTION. IT IS THE RESPONSIBILITY OF THE APPLICANT TO COORDINATE THE MEETING TIME AND PLACE WITH COUNTY STAFF.
- CONTROL MEASURES MUST BE INSTALLED PRIOR TO COMMENCEMENT OF ACTIVITIES THAT COULD CONTRIBUTE POLLUTANTS TO STORMWATER. CONTROL MEASURES FOR ALL SLOPES, CHANNELS, DITCHES, AND DISTURBED LAND AREAS SHALL BE INSTALLED IMMEDIATELY UPON COMPLETION OF THE DISTURBANCE.
- ALL TEMPORARY SEDIMENT AND EROSION CONTROL MEASURES SHALL BE MAINTAINED AND REMAIN IN EFFECTIVE OPERATING CONDITION UNTIL PERMANENT SOIL EROSION CONTROL MEASURES ARE IMPLEMENTED AND FINAL STABILIZATION IS ESTABLISHED. ALL PERSONS ENGAGED IN LAND DISTURBANCE ACTIVITIES SHALL ASSESS THE ADEQUACY OF CONTROL MEASURES AT THE SITE AND IDENTIFY IF CHANGES TO THOSE CONTROL MEASURES ARE NEEDED TO ENSURE THE CONTINUED EFFECTIVE PERFORMANCE OF THE CONTROL MEASURES. ALL CHANGES TO TEMPORARY SEDIMENT AND EROSION CONTROL MEASURES MUST BE INCORPORATED INTO THE STORMWATER MANAGEMENT PLAN.
- TEMPORARY STABILIZATION SHALL BE IMPLEMENTED ON DISTURBED AREAS AND STOCKPILES WHERE GROUND DISTURBING CONSTRUCTION ACTIVITY HAS PERMANENTLY CEASED OR TEMPORARILY CEASED FOR LONGER THAN 14 DAYS.
- FINAL STABILIZATION MUST BE IMPLEMENTED AT ALL APPLICABLE CONSTRUCTION SITES. FINAL STABILIZATION IS ACHIEVED WHEN ALL GROUND DISTURBING ACTIVITIES ARE COMPLETE AND ALL DISTURBED AREAS EITHER HAVE A UNIFORM VEGETATIVE COVER WITH INDIVIDUAL PLAN DENSITY OF 70 PERCENT OF PRE-DISTURBANCE LEVELS ESTABLISHED OR EQUIVALENT PERMANENT ALTERNATIVE STABILIZATION METHOD IS IMPLEMENTED. ALL TEMPORARY SEDIMENT AND EROSION CONTROL MEASURES SHALL BE REMOVED UPON FINAL STABILIZATION AND BEFORE PERMIT CLOSURE.
- ALL PERMANENT STORMWATER MANAGEMENT FACILITIES SHALL BE INSTALLED AS DESIGNED IN THE APPROVED PLANS. ANY PROPOSED CHANGES THAT EFFECT THE DESIGN OR FUNCTION OF PERMANENT STORMWATER MANAGEMENT STRUCTURES MUST BE APPROVED BY THE ECM ADMINISTRATOR PRIOR TO IMPLEMENTATION.
- EARTH DISTURBANCES SHALL BE CONDUCTED IN SUCH A MANNER SO AS TO EFFECTIVELY MINIMIZE ACCELERATED SOIL EROSION AND RESULTING SEDIMENTATION. ALL DISTURBANCES SHALL BE DESIGNED, CONSTRUCTED, AND COMPLETED SO THAT THE EXPOSED AREA OF ANY DISTURBED LAND SHALL BE LIMITED TO THE SHORTEST PRACTICAL PERIOD OF TIME. PRE-EXISTING VEGETATION SHALL BE PROTECTED AND MAINTAINED WITHIN 50 HORIZONTAL FEET OF A WATERS OF THE STATE, UNLESS SHOWN TO BE INFEASIBLE AND SPECIFICALLY REQUESTED AND APPROVED.
- COMPACTION OF SOIL MUST BE PREVENTED IN AREAS DESIGNATED FOR INFILTRATION CONTROL MEASURES OR WHERE FINAL STABILIZATION WILL BE ACHIEVED BY VEGETATIVE COVER. AREAS DESIGNATED FOR INFILTRATION CONTROL SHALL ALSO BE PROTECTED FROM SEDIMENTATION DURING CONSTRUCTION UNTIL FINAL STABILIZATION IS ACHIEVED. IF COMPACTION PREVENTION IS NOT FEASIBLE DUE TO SITE CONSTRAINTS, ALL AREAS DESIGNATED FOR INFILTRATION AND VEGETATION CONTROL MEASURES MUST BE LOOSENEED PRIOR TO INSTALLATION OF THE CONTROL MEASURE(S).
- ANY TEMPORARY OR PERMANENT FACILITY DESIGNED AND CONSTRUCTED FOR THE CONVEYANCE OF STORMWATER AROUND, THROUGH, OR FROM THE EARTH DISTURBANCE AREA SHALL BE A STABILIZED CONVEYANCE DESIGNED TO MINIMIZE EROSION AND THE DISCHARGE OF SEDIMENT OFF SITE.
- CONCRETE WASH WATER SHALL BE CONTAINED AND DISPOSED OF IN ACCORDANCE WITH THE SWMP. NO WASH WATER SHALL BE DISCHARGED TO OR ALLOWED TO ENTER STATE WATERS, INCLUDING ANY SURFACE OR SUBSURFACE STORM DRAINAGE SYSTEM OR FACILITIES. CONCRETE WASHOUT SHALL NOT BE LOCATED IN AN AREA WHERE SHALLOW GROUNDWATER MAY BE PRESENT, OR WITHIN 50 FEET OF A SURFACE WATER BODY, CREEK, OR STREAM.
- DURING DEWATERING OPERATIONS OF UNCONTAMINATED GROUND WATER MAY BE DISCHARGED ON SITE, BUT SHALL NOT LEAVE THE SITE IN THE FORM OF SURFACE RUNOFF UNLESS AN APPROVED STATE DEWATERING PERMIT IS IN PLACE.
- EROSION CONTROL BLANKETING OR OTHER PROTECTIVE COVERING SHALL BE USED ON SLOPES STEEPER THAN 3:1.
- CONTRACTOR SHALL BE RESPONSIBLE FOR THE REMOVAL OF ALL WASTES FROM THE CONSTRUCTION SITE FOR DISPOSAL IN ACCORDANCE WITH LOCAL AND STATE REGULATORY REQUIREMENTS. NO CONSTRUCTION DEBRIS, TREE SLASH, BUILDING MATERIAL WASTES OR UNUSED BUILDING MATERIALS SHALL BE BURIED, DUMPED, OR DISCHARGED AT THE SITE.
- WASTE MATERIALS SHALL NOT BE TEMPORARILY PLACED OR STORED IN THE STREET, ALLEY, OR OTHER PUBLIC WAY, UNLESS IN ACCORDANCE WITH AN APPROVED TRAFFIC CONTROL PLAN. OTHER CONTROL MEASURES MAY BE REQUIRED BY EL PASO COUNTY ENGINEERING IF DEEMED NECESSARY, BASED ON SPECIFIC CONDITIONS AND CIRCUMSTANCES.
- TRACKING OF SOILS AND CONSTRUCTION DEBRIS OFF-SITE SHALL BE MINIMIZED. MATERIALS TRACKED OFF-SITE SHALL BE CLEANED UP AND PROPERLY DISPOSED OF IMMEDIATELY.
- THE OWNER/DEVELOPER SHALL BE RESPONSIBLE FOR THE REMOVAL OF ALL CONSTRUCTION DEBRIS, DIRT, TRASH, ROCK, SEDIMENT, SOIL, AND SAND THAT MAY ACCUMULATE IN ROADS, STORM DRAINS AND OTHER DRAINAGE CONVEYANCE SYSTEMS AND STORMWATER APPURTENANCES AS A RESULT OF SITE DEVELOPMENT.
- THE QUANTITY OF MATERIALS STORED ON THE PROJECT SITE SHALL BE LIMITED, AS MUCH AS PRACTICAL, TO THAT QUANTITY REQUIRED TO PERFORM THE WORK IN AN ORDERLY SEQUENCE. ALL MATERIALS STORED ON-SITE SHALL BE STORED IN A NEAT, ORDERLY MANNER, IN THEIR ORIGINAL CONTAINERS, WITH ORIGINAL MANUFACTURER'S LABELS.
- NO CHEMICAL(S) HAVING THE POTENTIAL TO BE RELEASED IN STORMWATER ARE TO BE STORED OR USED ON-SITE UNLESS PERMISSION FOR THE USE OF SUCH CHEMICAL(S) IS GRANTED IN WRITING BY THE ECM ADMINISTRATOR. IN GRANTING APPROVAL FOR THE USE OF SUCH CHEMICAL(S), SPECIAL CONDITIONS AND MONITORING MAY BE REQUIRED.

**WATERMARK AT AKERS
GRADING EROSION CONTROL PLAN**

**TRACT DD, HANNAH RIDGE AT FEATHERGRASS FILING NO. 1, AS AMENDED
SECTION 32, TOWNSHIP 13 SOUTH, RANGE 65 WEST OF THE 6TH P.M., CITY OF COLORADO
SPRINGS, COUNTY OF EL PASO, STATE OF COLORADO**

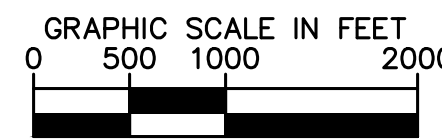
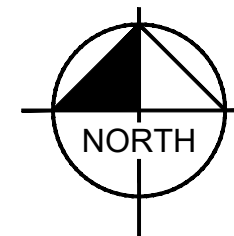
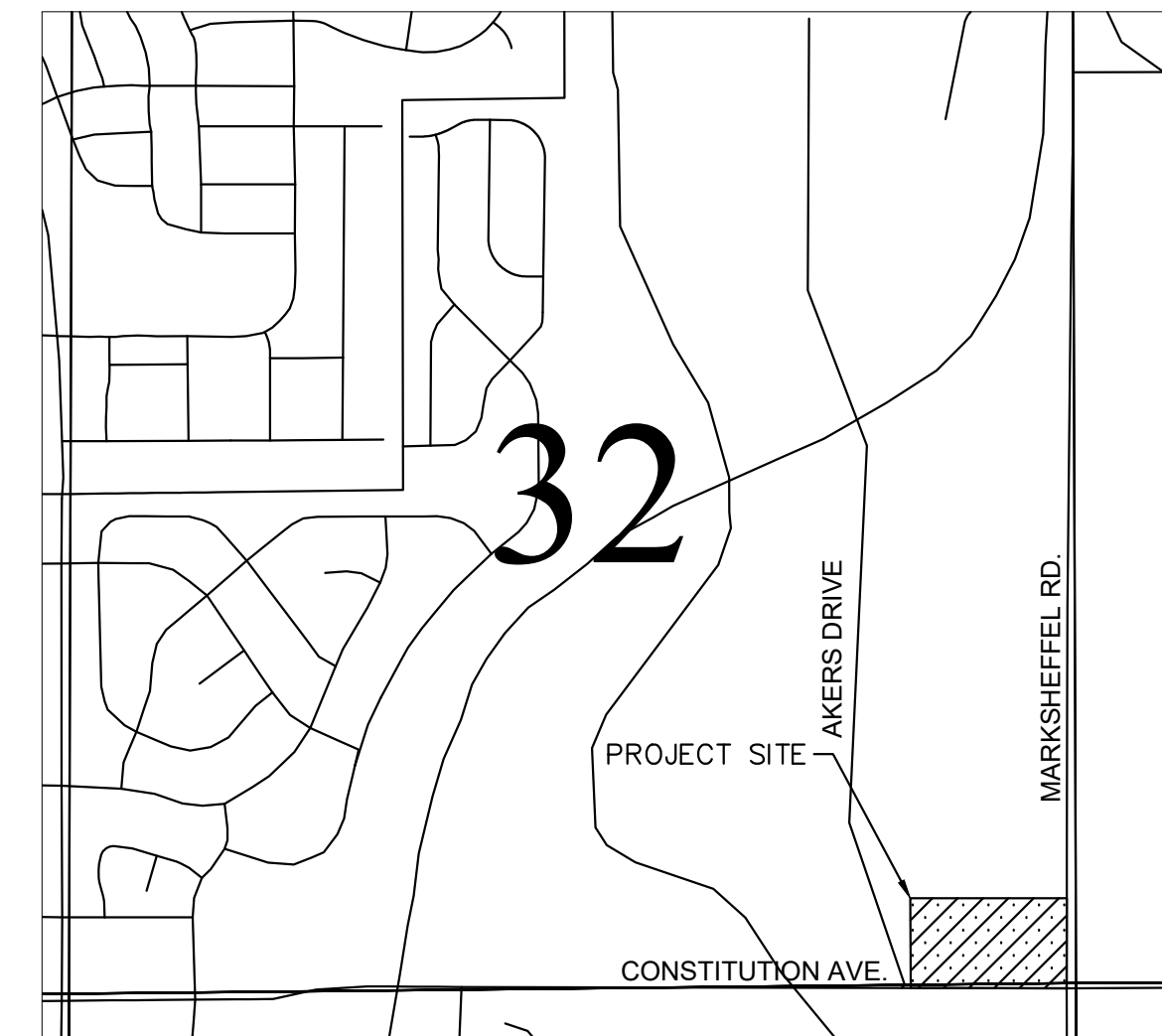

LAND AREA:

TOTAL PROPERTY AREA: +/- 15.39 ACRES

BENCHMARK:

ELEVATIONS ARE BASED UPON COLORADO SPRINGS UTILITY FIMS CONTROL POINT "BLT104", DESCRIBED AS A 2" ALUMINUM CAP SET AT THE NORTHEAST TOP OF THE NORTH HEADWALL OF A BOX CULVERT AT THE FIRST CREEK CROSSING EAST OF MARKSHEFFEL ROAD, UNDER CONSTITUTION AVENUE, APPROXIMATELY 1400' EAST AND 70' NORTH OF THE SOUTHEAST CORNER OF THE SUBJECT SECTION 32. THE ELEVATION OF SAID BENCHMARK IS 6452.43', NGVD 29 VERTICAL DATUM.

LEGAL DESCRIPTION

TRACT DD OF HANNAH RIDGE AT FEATHERGRASS FILING NO. 1, A PORTION OF THE SOUTHEAST QUARTER OF SECTION 32, TOWNSHIP 13 SOUTH, RANGE 65 WEST OF THE 6TH P.M., COUNTY OF EL PASO, STATE OF COLORADO.

SOIL TYPE:

THE SOIL ON SITE IS USGS HYDROLOGIC SOIL GROUP A/B.

FLOOD ZONE DESIGNATION

FEDERAL EMERGENCY MANAGEMENT AGENCY, FLOOD INSURANCE RATE MAP, MAP NUMBER 08041C0756G, EFFECTIVE DATE DECEMBER 7, 2018 INDICATES THIS PARCEL OF LAND IS LOCATED IN ZONE X (AREA OF MINIMAL FLOOD HAZARD).

SITE INFORMATION:

TIMING:
ANTICIPATED STARTING AND COMPLETION TIME PERIOD OF SITE GRADING:
START: FALL 2021
END: FALL 2022

EXPECTED DATE ON WHICH THE FINAL STABILIZATION WILL BE COMPLETE:
FALL 2023

AREAS:

TOTAL DISTURBED AREA: 15.05 ACRES

RECEIVING WATERS:

NAME OF RECEIVING WATERS: SAND CREEK EAST FORK, ULTIMATELY SAND CREEK

DESCRIPTION OF EXISTING VEGETATION:

THE EXISTING SITE IS CURRENTLY UNDEVELOPED AND GROUND COVER CONSISTS OF 100% WEEDS, BRUSH, GRASSES, AND TREES.

DESCRIPTION OF PERMANENT BMPS:

FULL SPECTRUM EXTENDED DETENTION BASIN

SOILS INFORMATION:

SOIL GROUP: 80% A, 20% B
SOIL SLOPES: 2.5 H: 1V OR LESS FOR ALL UN-RETAINED AREAS

OWNER'S STATEMENT

I, THE OWNER/DEVELOPER HAVE READ AND WILL COMPLY WITH THE REQUIREMENTS OF THE GRADING AND EROSION CONTROL PLAN.

OWNER SIGNATURE _____ DATE _____

ENGINEER'S STATEMENT

THIS GRADING AND EROSION CONTROL PLAN WAS PREPARED UNDER MY DIRECTION AND SUPERVISION AND IS CORRECT TO THE BEST OF MY KNOWLEDGE AND BELIEF. SAID PLAN HAS BEEN PREPARED ACCORDING TO THE CRITERIA ESTABLISHED BY THE COUNTY FOR GRADING AND EROSION CONTROL PLANS. I ACCEPT RESPONSIBILITY FOR ANY LIABILITY CAUSED BY ANY NEGLECT ACTS, ERRORS OR OMISSIONS ON MY PART IN PREPARING THIS PLAN.

ERIC GUNDERSON, PE - KIMLEY-HORN AND ASSOCIATES, INC. _____ DATE _____

EL PASO COUNTY

COUNTY PLAN REVIEW IS PROVIDED ONLY FOR GENERAL CONFORMANCE WITH COUNTY DESIGN CRITERIA. THE COUNTY IS NOT RESPONSIBLE FOR THE ACCURACY AND ADEQUACY OF THE DESIGN, DIMENSIONS, AND/OR ELEVATIONS WHICH SHALL BE CONFIRMED AT THE JOB SITE. THE COUNTY THROUGH THE APPROVAL OF THIS DOCUMENT ASSUMES NO RESPONSIBILITY FOR COMPLETENESS AND/OR ACCURACY OF THIS DOCUMENT. FILED IN ACCORDANCE WITH THE REQUIREMENTS OF THE EL PASO COUNTY LAND DEVELOPMENT CODE, DRAINAGE CRITERIA MANUAL VOLUMES 1 AND 2, AND ENGINEERING CRITERIA MANUAL, AS AMENDED.

IN ACCORDANCE WITH ECM SECTION 1.12, THESE CONSTRUCTION DOCUMENTS WILL BE VALID FOR CONSTRUCTION FOR A PERIOD OF 2 YEARS FROM THE DATE SIGNED BY THE EL PASO COUNTY ENGINEER. IF CONSTRUCTION HAS NOT STARTED WITHIN THOSE 2 YEARS, THE PLANS WILL NEED TO BE RESUBMITTED FOR APPROVAL, INCLUDING PAYMENT OF REVIEW FEES AT THE PLANNING AND COMMUNITY DEVELOPMENT DIRECTOR'S DISCRETION.

COUNTY ENGINEER/ECM ADMINISTRATOR _____ DATE _____

- BULK STORAGE OF PETROLEUM PRODUCTS OR OTHER ALLOWED LIQUID CHEMICALS IN EXCESS OF 55 GALLONS SHALL REQUIRE ADEQUATE SECONDARY CONTAINMENT PROTECTION TO CONTAIN ALL SPILLS ON-SITE AND TO PREVENT ANY SPILLED MATERIALS FROM ENTERING STATE WATERS, ANY SURFACE OR SUBSURFACE STORM DRAINAGE SYSTEM OR FACILITIES.
- NO PERSON SHALL CAUSE THE IMPEDIMENT OF STORMWATER FLOW IN THE CURB AND GUTTER OR DITCH EXCEPT WITH APPROVED SEDIMENT CONTROL MEASURES.
- OWNER/DEVELOPER AND THEIR AGENTS SHALL COMPLY WITH THE "COLORADO WATER QUALITY CONTROL ACT" (TITLE 25, ARTICLE 8, CRS), AND THE "CLEAN WATER ACT" (33 USC 1344), IN ADDITION TO THE REQUIREMENTS OF THE LAND DEVELOPMENT CODE, DCM VOLUME II AND THE ECM APPENDIX I. ALL APPROPRIATE PERMITS MUST BE OBTAINED BY THE CONTRACTOR PRIOR TO CONSTRUCTION (1041, NPDES, FLOODPLAIN, 404, FUGITIVE DUST, ETC.). IN THE EVENT OF CONFLICTS BETWEEN THESE REQUIREMENTS AND OTHER LAWS, RULES, OR REGULATIONS OF OTHER FEDERAL, STATE, LOCAL OR COUNTY AGENCIES, THE MOST RESTRICTIVE LAWS, RULES, OR REGULATIONS SHALL APPLY.
- ALL CONSTRUCTION TRAFFIC MUST ENTER/EXIT THE SITE AT APPROVED CONSTRUCTION ACCESS POINTS.
- PRIOR TO CONSTRUCTION THE PERMITEE SHALL VERIFY THE LOCATION OF EXISTING UTILITIES.
- A WATER SOURCE SHALL BE AVAILABLE ON SITE DURING EARTHWORK OPERATIONS AND SHALL BE UTILIZED AS REQUIRED TO MINIMIZE DUST FROM EARTHWORK EQUIPMENT AND WIND.
- THE SOILS REPORT FOR THIS SITE HAS BEEN PREPARED BY KUMAR AND ASSOCIATES, INC., DATED 9/20/2020 AND SHALL BE CONSIDERED A PART OF THESE PLANS.
- AT LEAST TEN (10) DAYS PRIOR TO THE ANTICIPATED START OF CONSTRUCTION, FOR PROJECTS THAT WILL DISTURB ONE (1) ACRE OR MORE, THE OWNER OR OPERATOR OF CONSTRUCTION ACTIVITY SHALL SUBMIT A PERMIT APPLICATION FOR STORMWATER DISCHARGE TO THE COLORADO DEPARTMENT OF PUBLIC HEALTH AND ENVIRONMENT, WATER QUALITY DIVISION. THE APPLICATION CONTAINS CERTIFICATION OF COMPLETION OF A STORMWATER MANAGEMENT PLAN (SWMP), OF WHICH THIS GRADING AND EROSION CONTROL PLAN MAY BE A PART. FOR INFORMATION OR APPLICATION MATERIALS CONTACT:

COLORADO DEPARTMENT OF PUBLIC HEALTH AND ENVIRONMENT
WATER QUALITY CONTROL DIVISION
WOOD -PERMITS
4300 CHERRY CREEK DRIVE SOUTH
DENVER, CO 80246-1530
ATTN: PERMITS UNIT

CONTACTS:

OWNER:
THOMPSON THRIFT DEVELOPMENT, INC.
111 MONUMENT CIRCLE, SUITE 1500
INDIANAPOLIS, IN 46204
TEL: (720) 495-3693
CONTACT: MONICA UNGER

ENGINEER:
KIMLEY-HORN AND ASSOCIATES, INC.
2 NEVADA NORTH AVE., SUITE 500
COLORADO SPRINGS, CO 80903
TEL: (719) 453-0182
CONTACT: ERIC GUNDERSON, P.E.

EL PASO COUNTY:
EL PASO COUNTY
PCD DEPARTMENT
2880 INTERNATIONAL CIRCLE, SUITE 110
COLORADO SPRINGS, CO 80910
PHONE: (719) 520-6300

SURVEYOR:
BARRON LAND, LLC
2790 N. ACADEMY BLVD. SUITE 311
COLORADO SPRINGS, CO 80917
TEL: (719) 360-6827
CONTACT: SPENCER BARRON, PLS

SHEET INDEX

SHEET NO.	SHEET TITLE
C2.0	COVER SHEET
C2.1	GEC INITIAL PLAN
C2.2	GEC INTERIM PLAN
C2.3	GEC FINAL PLAN
C2.4	GEC DETAILS
C2.5	GEC DETAILS (2)
C2.6	GEC DETAILS (3)



NO.	REVISION	DATE	BY	APPR.
1 <td>FIRST RESUBMITTAL <td>JAR 4/8/21 <td></td> <td></td> </td></td>	FIRST RESUBMITTAL <td>JAR 4/8/21 <td></td> <td></td> </td>	JAR 4/8/21 <td></td> <td></td>		

Kimley-Horn
2021 KIMLEY-HORN AND ASSOCIATES, INC.
2 North Nevada Avenue Suite 300
Colorado Springs, Colorado 80903 (719) 453-0180

DESIGNED BY: EUG
DRAWN BY: JAR
CHECKED BY: EUG
DATE: 4/8/21

WATERMARK AT AKERS
EL PASO COUNTY, COLORADO
GRADING AND EROSION CONTROL PLANS
COVER SHEET

PRELIMINARY
FOR REVIEW ONLY
NOT FOR
CONSTRUCTION
Kimley-Horn
Kimley-Horn and Associates, Inc.

PROJECT NO.
096302009

SHEET
C2.0

K:\DEN_Civil\096302009_Akers Drive\CADD\PlanSheets\SDP\096302009 - GEC_EC.dwg Roberts, Jared 4/14/2021 7:55 AM

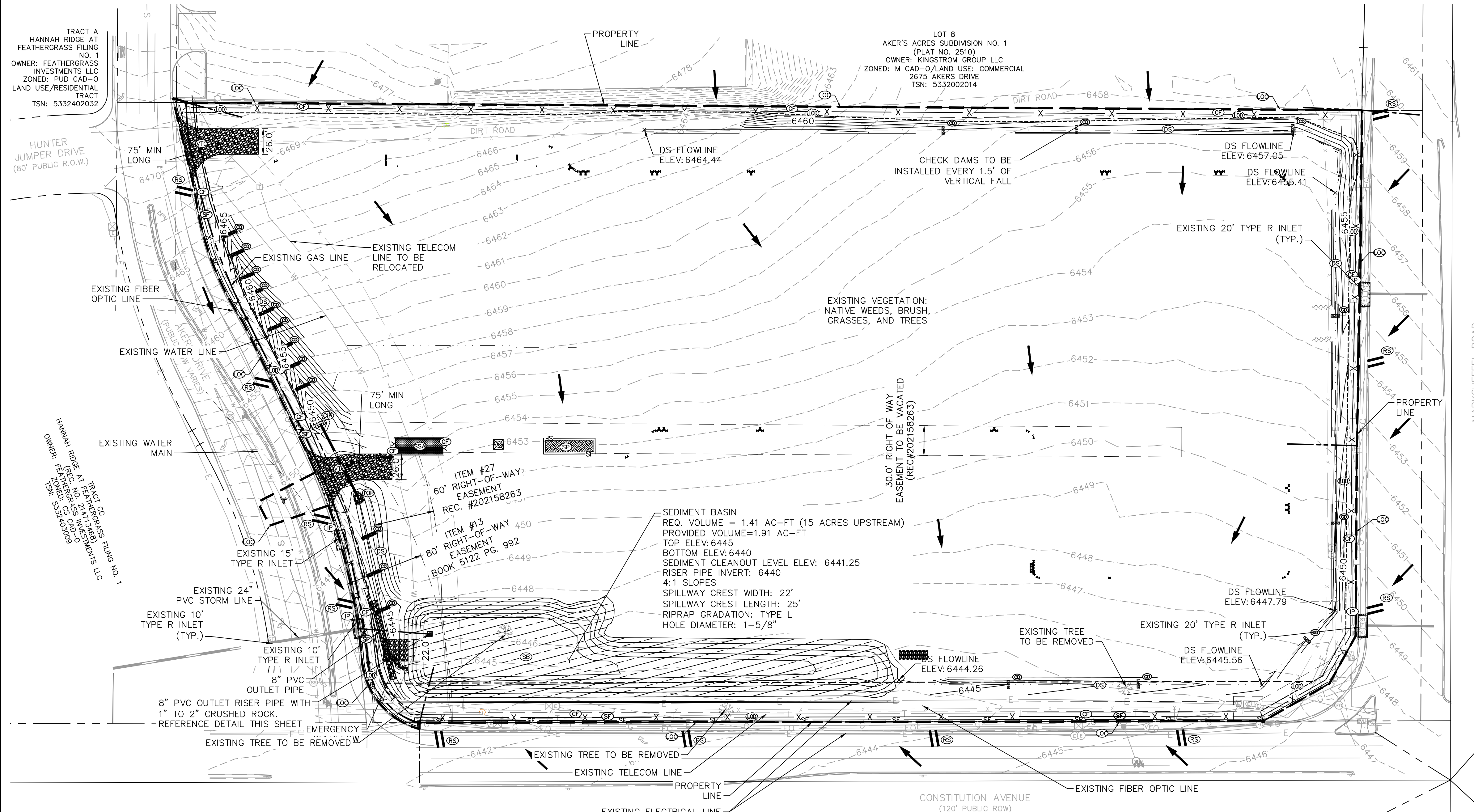

- NOTES**
- THE INTENT OF THIS PLAN IS TO IDENTIFY THE EROSION CONTROL PRACTICES RECOMMENDED. THE CONTRACTOR SHALL REFERENCE ADDITIONAL CONSTRUCTION PLANS FOR DEMOLITION OF EXISTING AND CONSTRUCTION OF PROPOSED IMPROVEMENTS.
 - ADJACENT STREETS SHALL BE KEPT CLEAN AND FREE OF SEDIMENT AND/OR DEBRIS AT ALL TIMES.
 - TEMPORARY STABILIZATION (TS) SHALL BE IMPLEMENTED WITHIN THE DISTURBED PORTIONS OF THE PROJECT SITE NO LATER THAN 14 DAYS FOLLOWING THE CEASE OF CONSTRUCTION ACTIVITIES WITHIN THE DISTURBED AREAS.
 - PERMANENT STABILIZATION (PS) MAY BE USED WITHIN AREAS OF TEMPORARY STABILIZATION (TS) AT THE CONTRACTOR'S DISCRETION. STABILIZATION SHALL BE APPLIED IN ACCORDANCE WITH APPLICABLE TEMPORARY STABILIZATION SEQUENCING REQUIREMENTS.
 - CONTRACTOR SHALL UTILIZE ROLLED EROSION CONTROL PRODUCTS ON ALL SLOPES 3H:1V OR GREATER TO ACHIEVE REQUIRED STABILIZATION.
 - CONTRACTOR SHALL MAINTAIN ACCEPTABLE EROSION CONTROL PRACTICES WITHIN THE ANTICIPATED LIMITS OF CONSTRUCTION IDENTIFIED HEREIN. BEST MANAGEMENT PRACTICES AND STABILIZATION SHALL BE COMPLETED AS IDENTIFIED HEREIN IN ACCORDANCE WITH OWNER REQUIREMENTS.
 - ALL WORK IN THE AKERS ROAD AND CONSTITUTION AVENUE ROW REQUIRES A ROW PERMIT FROM EL PASO COUNTY. CONTRACTOR IS RESPONSIBLE FOR APPLYING FOR AND OBTAINING ALL NECESSARY ROW PERMITS.
 - SILT FENCE TO BE INSTALLED PRIOR TO COMMENCEMENT OF ONSITE GRADING AND CONSTRUCTION ACTIVITIES.
 - DEMOLITION, REMOVAL, OVEREXCAVATION AND SOIL TREATMENT SHALL BE IN ACCORDANCE WITH THE GEOTECHNICAL ENGINEER RECOMMENDATIONS AS NOTED IN THE APPROVED PROJECT GEOTECHNICAL REPORT.

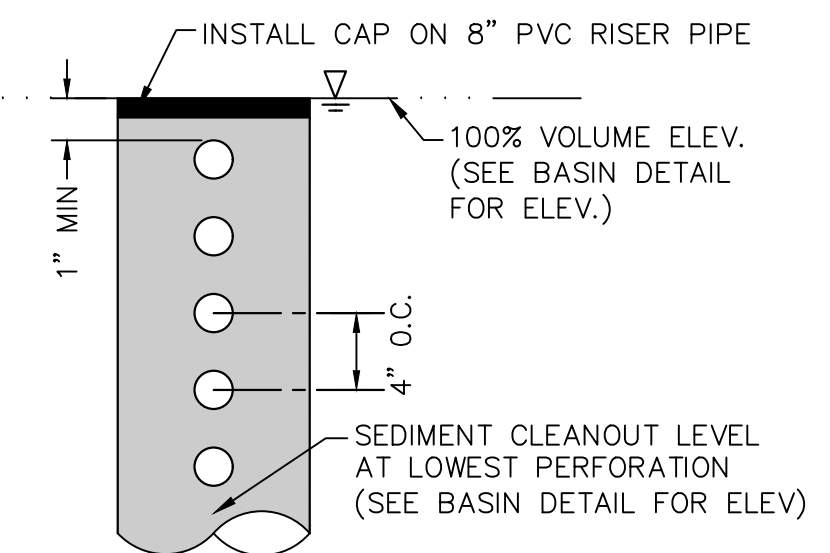

STANDARD RISER PIPE DETAIL
N.T.S.

RISER PIPE	# OF COLUMNS	# OF ROWS	HOLE DIAMETER
SB-POND	1	5	1-3/16"

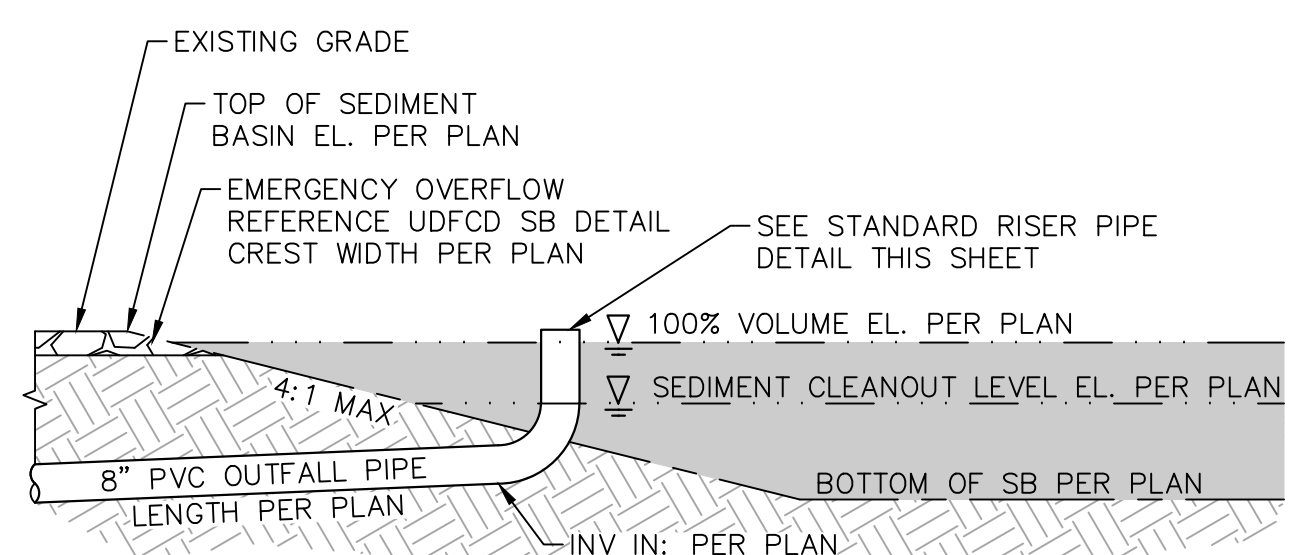

SEDIMENT BASIN DETAIL
N.T.S.

811 Know what's below. Call before you dig.

CALL UTILITY NOTIFICATION CENTER OF COLORADO
 1-800-922-1987
 CALL 2-BUSINESS DAYS IN ADVANCE BEFORE YOU DIG, GRADE, OR EXCAVATE FOR THE MARKING OF UNDERGROUND MEMBER UTILITIES

GRAPHIC SCALE IN FEET
0 30 60 120

NORTH

Kimley»Horn
 2021 KIMLEY-HORN AND ASSOCIATES, INC.
 2 North Nevada Avenue Suite 300
 Colorado Springs, Colorado 80903 (719) 453-0180

DESIGNED BY: E.J.G.
 DRAWN BY: J.A.R.
 CHECKED BY: E.J.G.
 DATE: 4/8/21

WATERMARK AT AKERS
 EL PASO COUNTY, COLORADO
 GRADING AND EROSION CONTROL PLANS
 GEC INITIAL PLAN

PRELIMINARY
 FOR REVIEW ONLY
 NOT FOR CONSTRUCTION
 Kimley»Horn
 Kimley-Horn and Associates, Inc.

PROJECT NO. 096302009
 SHEET C2.1

NO.	1	DATE	4/8/21	BY	EJG	APPR.
REVISION						

K:\DEN_Civil\096302009_Akers Drive\CADD\PlanSheets\SDP\096302009 - GEC_EC.dwg Roberts, Jared 4/14/2021 7:56 AM

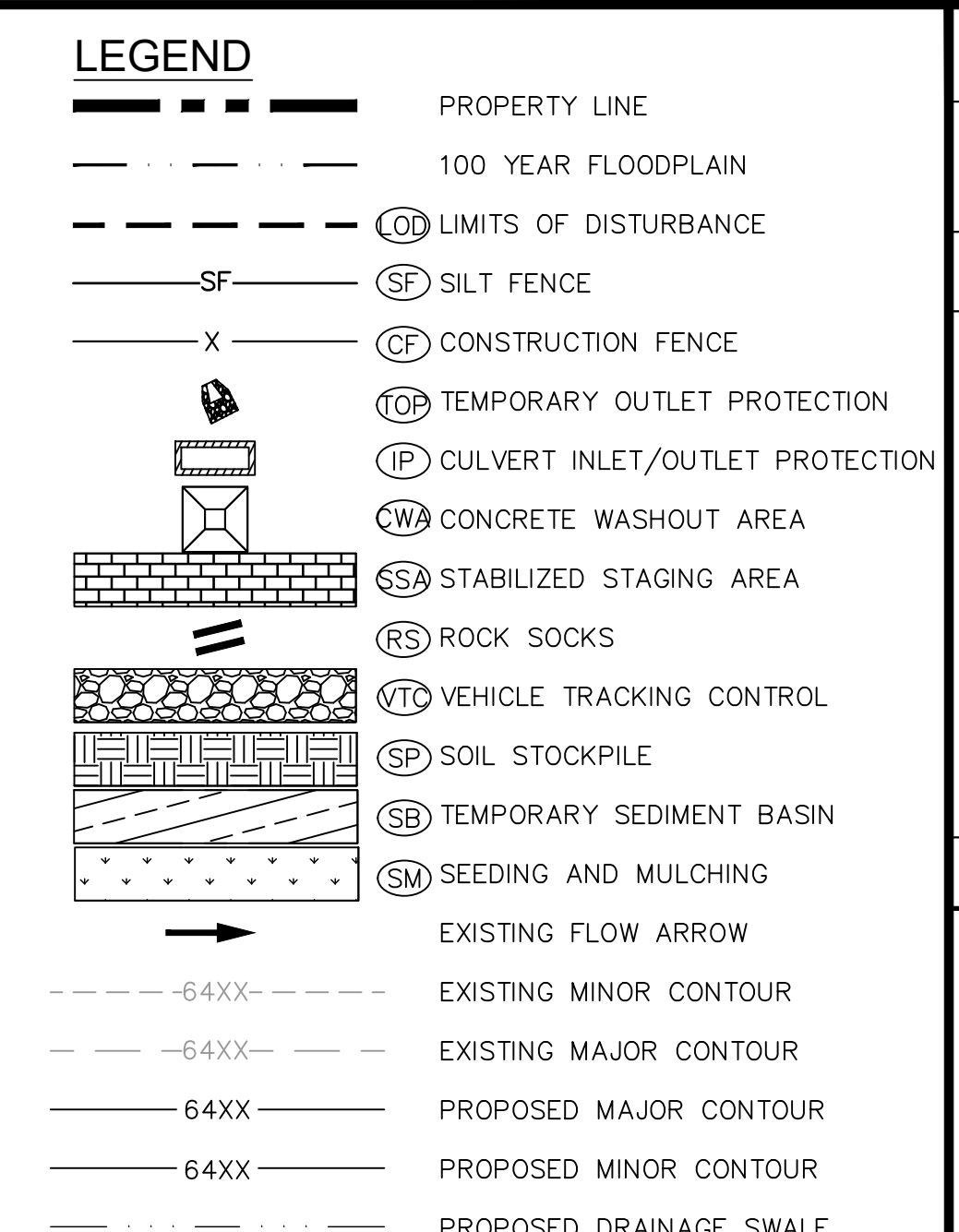
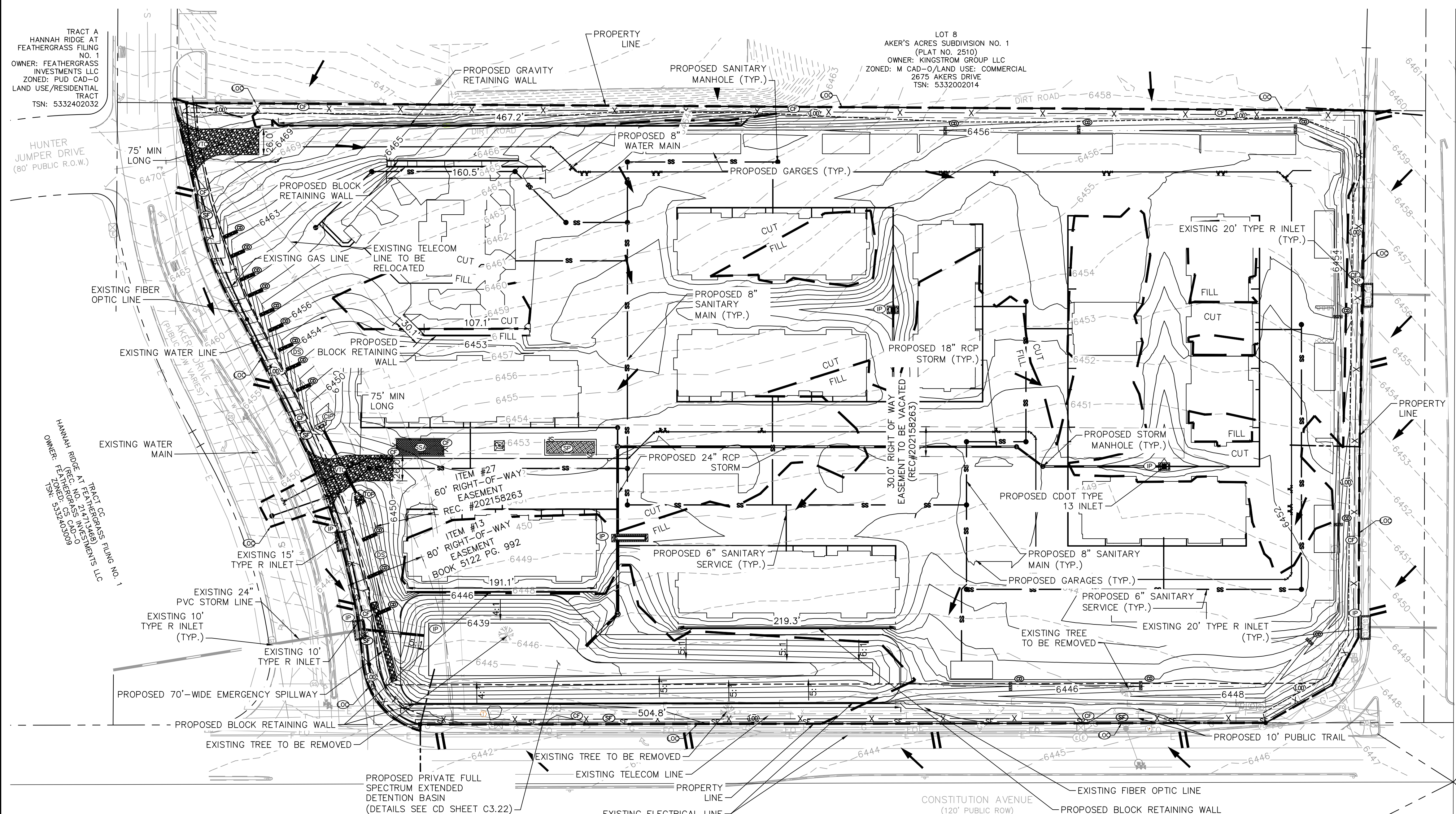

LIMITS OF CONSTRUCTION

ONSITE DISTURBANCE	= ±15.05 ACRES
OFFSITE DISTURBANCE	= ±0.15 ACRES
TOTAL	= ±15.20 ACRES

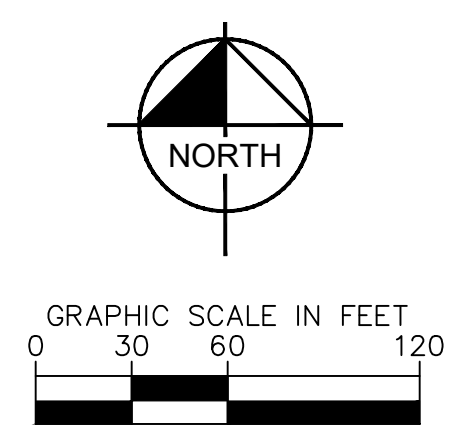

NOTES

- THE INTENT OF THIS PLAN IS TO IDENTIFY THE EROSION CONTROL PRACTICES RECOMMENDED. THE CONTRACTOR SHALL REFERENCE ADDITIONAL CONSTRUCTION PLANS FOR DEMOLITION OF EXISTING AND CONSTRUCTION OF PROPOSED IMPROVEMENTS.
- ADJACENT STREETS SHALL BE KEPT CLEAN AND FREE OF SEDIMENT AND/OR DEBRIS AT ALL TIMES.
- TEMPORARY STABILIZATION (TS) SHALL BE IMPLEMENTED WITHIN THE DISTURBED PORTIONS OF THE PROJECT SITE NO LATER THAN 14 DAYS FOLLOWING THE CEASE OF CONSTRUCTION ACTIVITIES WITHIN THE DISTURBED AREAS.
- PERMANENT STABILIZATION (PS) MAY BE USED WITHIN AREAS OF TEMPORARY STABILIZATION (TS) AT THE CONTRACTOR'S DISCRETION. STABILIZATION SHALL BE APPLIED IN ACCORDANCE WITH APPLICABLE TEMPORARY STABILIZATION SEQUENCING REQUIREMENTS.
- CONTRACTOR SHALL UTILIZE ROLLED EROSION CONTROL PRODUCTS ON ALL SLOPES 3H:1V OR GREATER TO ACHIEVE REQUIRED STABILIZATION.
- CONTRACTOR SHALL MAINTAIN ACCEPTABLE EROSION CONTROL PRACTICES WITHIN THE ANTICIPATED LIMITS OF CONSTRUCTION IDENTIFIED HEREIN. BEST MANAGEMENT PRACTICES AND STABILIZATION SHALL BE COMPLETED AS IDENTIFIED HEREIN IN ACCORDANCE WITH OWNER REQUIREMENTS.
- ALL WORK IN THE AKERS ROAD AND CONSTITUTION AVENUE ROW REQUIRES A ROW PERMIT FROM EL PASO COUNTY. CONTRACTOR IS RESPONSIBLE FOR APPLYING FOR AND OBTAINING ALL NECESSARY ROW PERMITS.
- SILT FENCE TO BE INSTALLED PRIOR TO COMMENCEMENT OF ONSITE GRADING AND CONSTRUCTION ACTIVITIES.
- DEMOLITION, REMOVAL, OVEREXCAVATION AND SOIL TREATMENT SHALL BE IN ACCORDANCE WITH THE GEOTECHNICAL ENGINEER RECOMMENDATIONS AS NOTED IN THE APPROVED PROJECT GEOTECHNICAL REPORT.

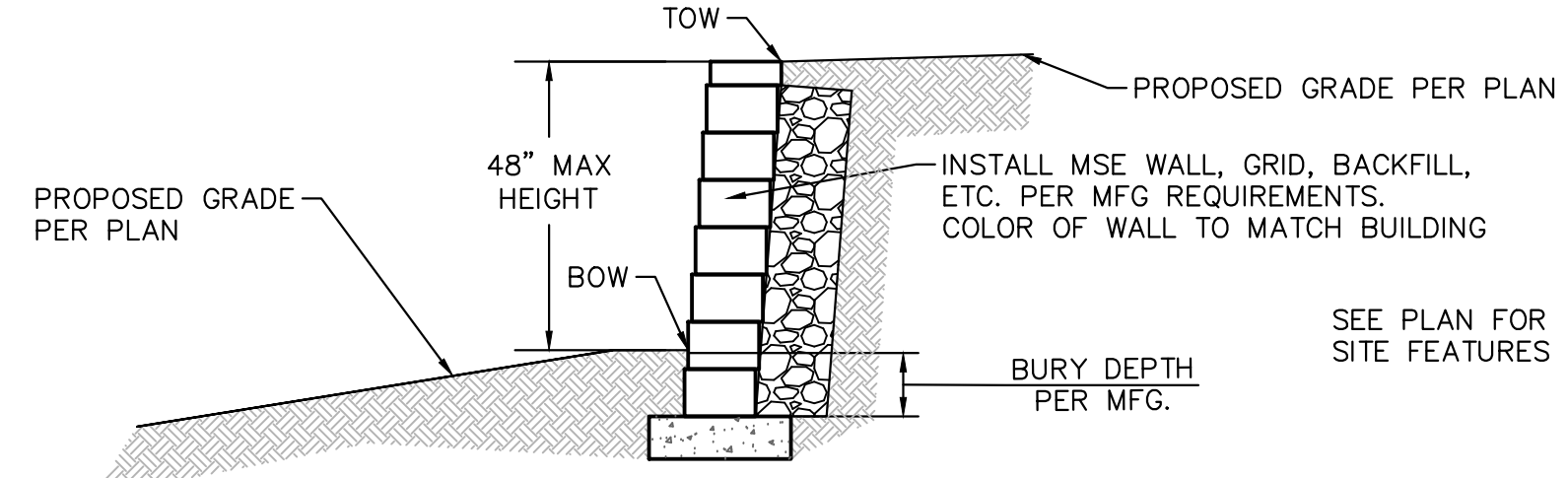

MSE BLOCK RETAINING WALL DETAIL
N.T.S.

- NOTE:
- CONTRACTOR SHALL COORDINATE WITH EL PASO COUNTY TO DETERMINE IF BUILDING PERMITS ARE REQUIRED FOR THE PROPOSED RETAINING WALLS.
 - CONTRACTOR TO PROVIDE SEALED DESIGN/SHOP DRAWINGS OF PROPOSED WALLS TO KIMLEY-HORN FOR REVIEW AND COORDINATION PRIOR TO CONSTRUCTION.
 - THIS WALL DETAIL ONLY APPLIES TO THE WALLS LESS THAN 4' IN HEIGHT. WALL MATERIAL AS SHOWN IS STANDARD AND SUBJECT TO CHANGE.

GRAVITY RETAINING WALL DETAIL

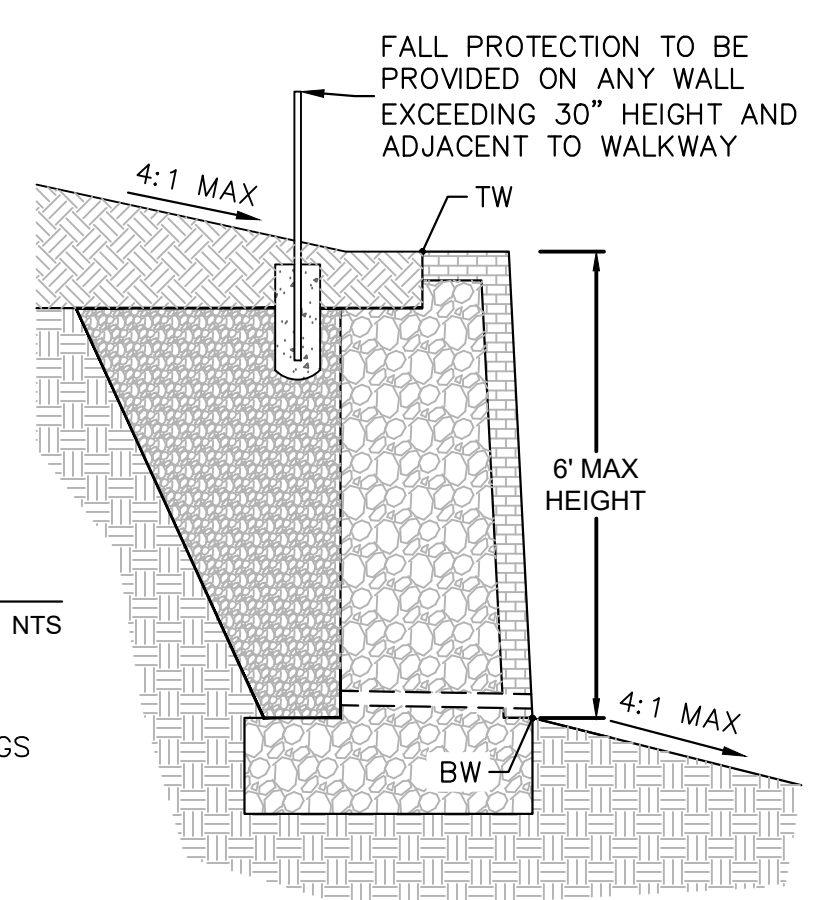

- DETAIL IS PROVIDED FOR REFERENCE TO DEPICT HORIZONTAL CROSS-SECTION (THIS SHEET).
- CONTRACTOR TO PROVIDE SEALED DESIGN/SHOP DRAWINGS OF PROPOSED WALLS TO KIMLEY-HORN FOR REVIEW AND COORDINATION PRIOR TO CONSTRUCTION.

CALL UTILITY NOTIFICATION CENTER OF COLORADO
1-800-922-1987
CALL 2-BUSINESS DAYS IN ADVANCE BEFORE YOU DIG, GRADE, OR EXCAVATE FOR THE MARKING OF UNDERGROUND MEMBER UTILITIES

NO.	REVISION	DATE	BY	APPR.
1	FIRST RESUBMITTAL	JAR 4/8/21	JAR	EJG

DESIGNED BY: EJG
DRAWN BY: JAR
CHECKED BY: EJG
DATE: 4/8/21

WATERMARK AT AKERS
EL PASO COUNTY, COLORADO
GRADING AND EROSION CONTROL PLANS
GEC INTERIM PLAN

PROJECT NO.
096302009
SHEET
C2.2

PRELIMINARY
FOR REVIEW ONLY
NOT FOR CONSTRUCTION

Kimley-Horn and Associates, Inc.

K:\DEN_Civil\096302009_Akers Drive\CADD\PlanSheets\SDP\096302009 - GEC_EC.dwg Roberts, Jared 4/14/2021 7:56 AM

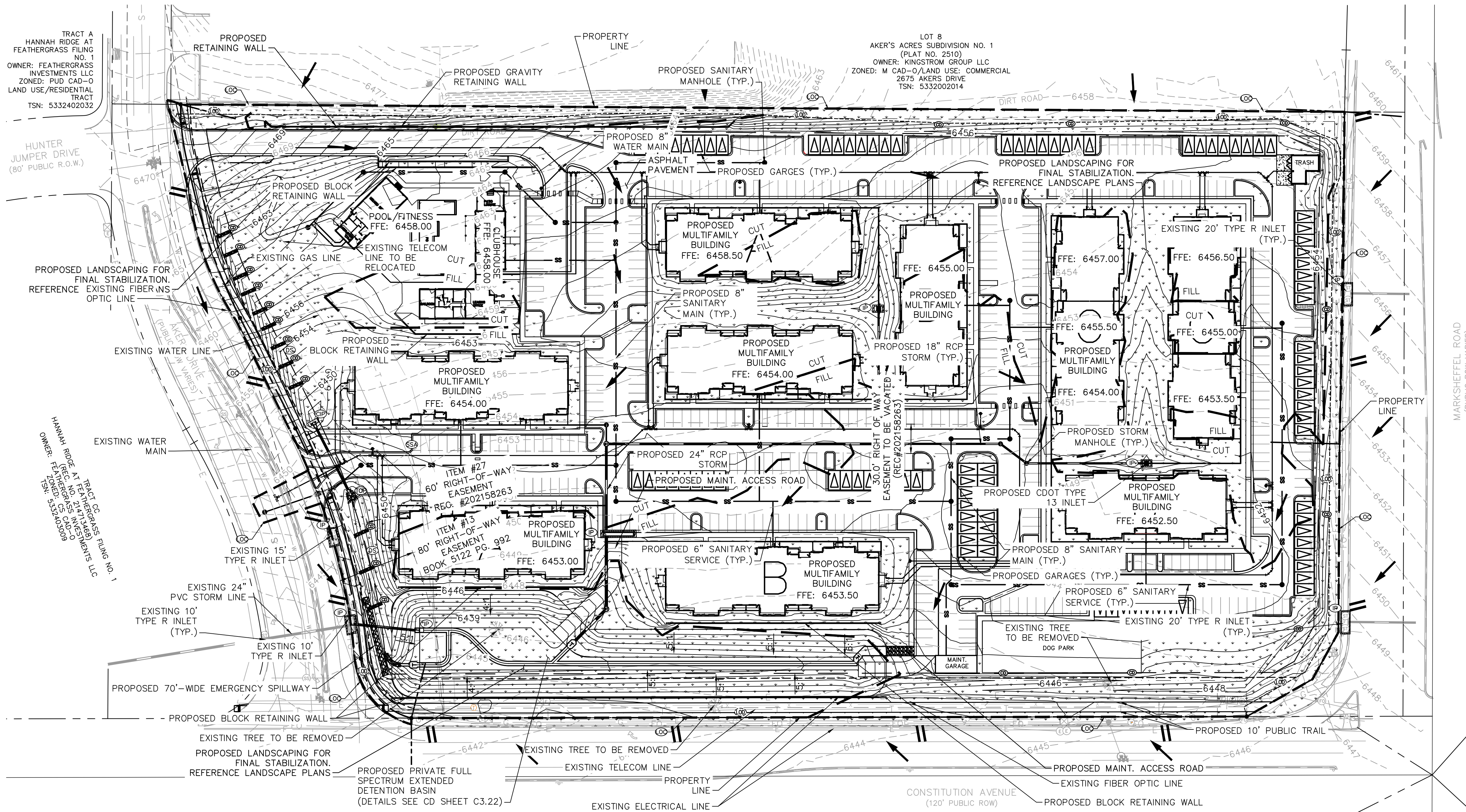

LEGEND

- — — — — PROPERTY LINE
- - - - - 100 YEAR FLOODPLAIN
- (DD) --- LIMITS OF DISTURBANCE
- (SF) --- SILT FENCE
- (CF) --- CONSTRUCTION FENCE
- (TOP) --- TEMPORARY OUTLET PROTECTION
- (IP) --- CULVERT INLET/OUTLET PROTECTION
- (CW) --- CONCRETE WASHOUT AREA
- (SSA) --- STABILIZED STAGING AREA
- (RS) --- ROCK ROCKS
- (VTC) --- VEHICLE TRACKING CONTROL
- (SP) --- SOIL STOCKPILE
- (SB) --- TEMPORARY SEDIMENT BASIN
- (SM) --- SEEDING AND MULCHING
- --- EXISTING FLOW ARROW
- 64XX- - - - - EXISTING MINOR CONTOUR
- 64XX- - - - - EXISTING MAJOR CONTOUR
- 64XX - - - - - PROPOSED MAJOR CONTOUR
- 64XX - - - - - PROPOSED MINOR CONTOUR
- - - - - PROPOSED DRAINAGE SWALE
- ▤ ▤ ▤ ▤ ▤ ▤ ▤ ▤ ▤ ▤ --- PROPOSED GARAGE BAYS

LIMITS OF CONSTRUCTION

ON-SITE DISTURBANCE	= ±15.05 ACRES
OFF-SITE DISTURBANCE	= ±0.15 ACRES
TOTAL	= ±15.20 ACRES

- NOTES**
1. THE INTENT OF THIS PLAN IS TO IDENTIFY THE EROSION CONTROL PRACTICES RECOMMENDED. THE CONTRACTOR SHALL REFERENCE ADDITIONAL CONSTRUCTION PLANS FOR DEMOLITION OF EXISTING AND CONSTRUCTION OF PROPOSED IMPROVEMENTS.
 2. ADJACENT STREETS SHALL BE KEPT CLEAN AND FREE OF SEDIMENT AND/OR DEBRIS AT ALL TIMES.
 3. TEMPORARY STABILIZATION (TS) SHALL BE IMPLEMENTED WITHIN THE DISTURBED PORTIONS OF THE PROJECT SITE NO LATER THAN 14 DAYS FOLLOWING THE CEASE OF CONSTRUCTION ACTIVITIES WITHIN THE DISTURBED AREAS.
 4. PERMANENT STABILIZATION (PS) MAY BE USED WITHIN AREAS OF TEMPORARY STABILIZATION (TS) AT THE CONTRACTOR'S DISCRETION. STABILIZATION SHALL BE APPLIED IN ACCORDANCE WITH APPLICABLE TEMPORARY STABILIZATION SEQUENCING REQUIREMENTS.
 5. CONTRACTOR SHALL UTILIZE ROLLED EROSION CONTROL PRODUCTS ON ALL SLOPES 3H:1V OR GREATER TO ACHIEVE REQUIRED STABILIZATION.
 6. CONTRACTOR SHALL MAINTAIN ACCEPTABLE EROSION CONTROL PRACTICES WITHIN THE ANTICIPATED LIMITS OF CONSTRUCTION IDENTIFIED HEREIN. BEST MANAGEMENT PRACTICES AND STABILIZATION SHALL BE COMPLETED AS IDENTIFIED HEREIN IN ACCORDANCE WITH OWNER REQUIREMENTS.
 7. ALL WORK IN THE AKERS ROAD AND CONSTITUTION AVENUE ROW REQUIRES A ROW PERMIT FROM EL PASO COUNTY. CONTRACTOR IS RESPONSIBLE FOR APPLYING FOR AND OBTAINING ALL NECESSARY ROW PERMITS.
 8. SILT FENCE TO BE INSTALLED PRIOR TO COMMENCEMENT OF ONSITE GRADING AND CONSTRUCTION ACTIVITIES.
 9. DEMOLITION, REMOVAL, OVEREXCAVATION AND SOIL TREATMENT SHALL BE IN ACCORDANCE WITH THE GEOTECHNICAL ENGINEER RECOMMENDATIONS AS NOTED IN THE APPROVED PROJECT GEOTECHNICAL REPORT.
 10. THERE WILL NOT BE ANY DEDICATED ASPHALT/CONCRETE BATCH PLANTS ONSITE.

811 Know what's below. Call before you dig.

CALL UTILITY NOTIFICATION CENTER OF COLORADO
1-800-922-1987
CALL 2-BUSINESS DAYS IN ADVANCE BEFORE YOU DIG, GRADE, OR EXCAVATE FOR THE MARKING OF UNDERGROUND MEMBER UTILITIES

NORTH

GRAPHIC SCALE IN FEET
0 30 60 120

Kimley»Horn
2021 KIMLEY-HORN AND ASSOCIATES, INC.
2 North Nevada Avenue Suite 300
Colorado Springs, Colorado 80903 (719) 453-0180

DESIGNED BY: E.J.G.
DRAWN BY: J.A.R.
CHECKED BY: E.J.G.
DATE: 4/8/21

WATERMARK AT AKERS
EL PASO COUNTY, COLORADO
GRADING AND EROSION CONTROL PLANS
GEC FINAL PLAN

PRELIMINARY
FOR REVIEW ONLY
NOT FOR CONSTRUCTION
Kimley»Horn
Kimley-Horn and Associates, Inc.

PROJECT NO.
096302009

SHEET
C2.3

NO.	REVISION	DATE	BY	E.J.G.
1	FIRST RESUBMITTAL	JAR 4/8/21	JAR	

K:\DEN_Civil\096302009 - Akers Drive\CADD\PlanSheets\SDP\096302009 - GEC_DT.dwg Roberts, Jared 4/14/2021 7:56 AM

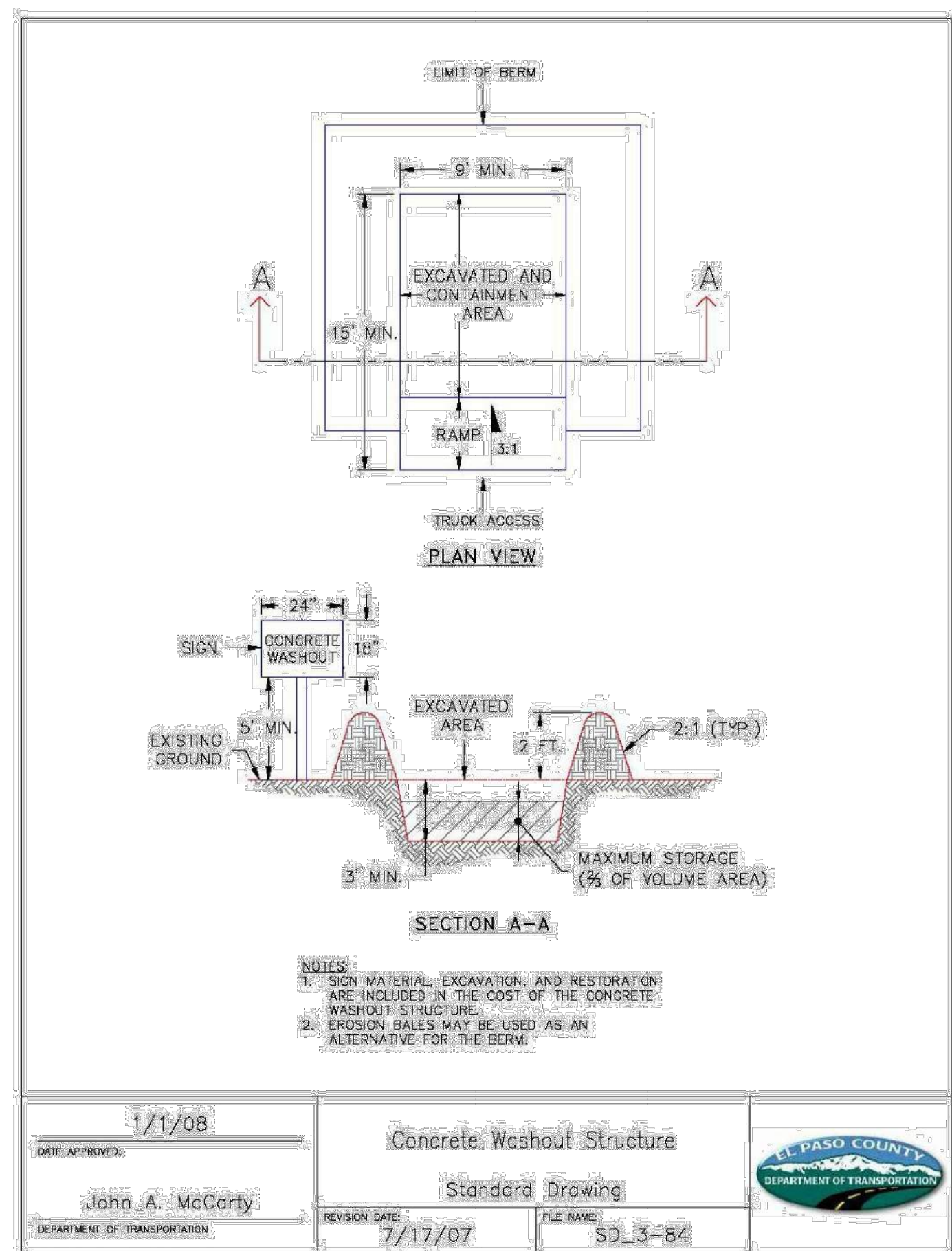

SM-3 Construction Fence (CF)

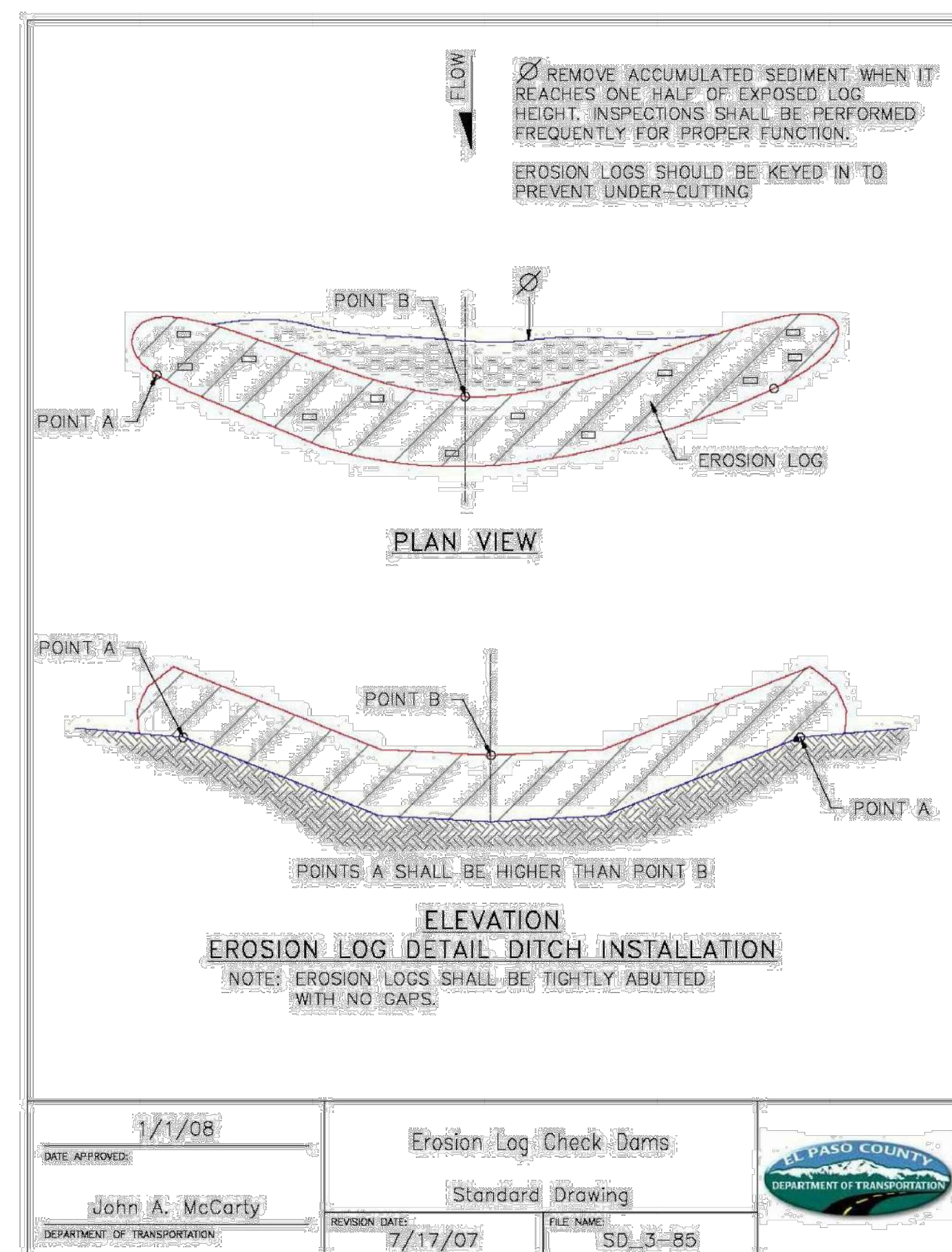

SC-1 Silt Fence (SF)

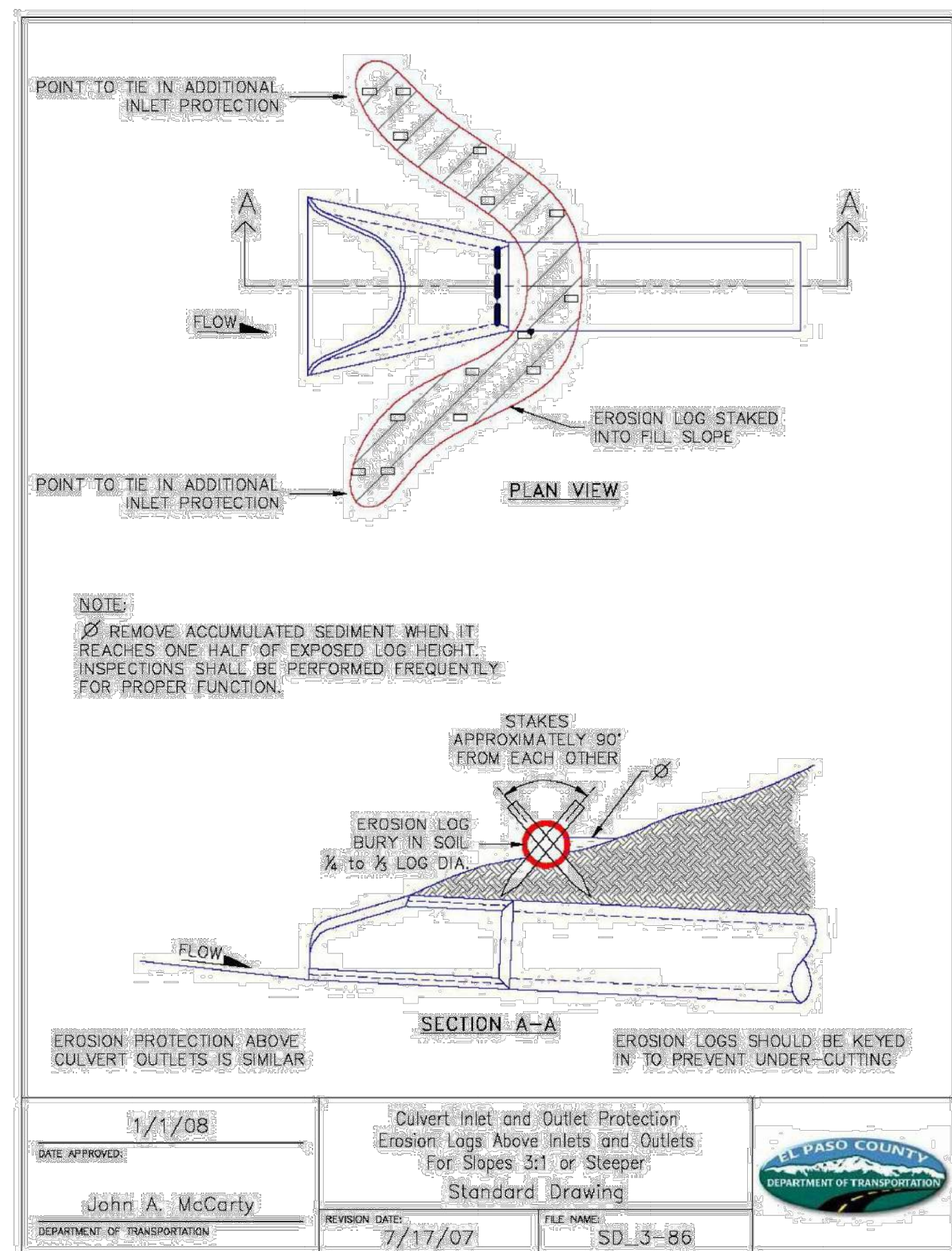

CD-1 Check Dams (CD)

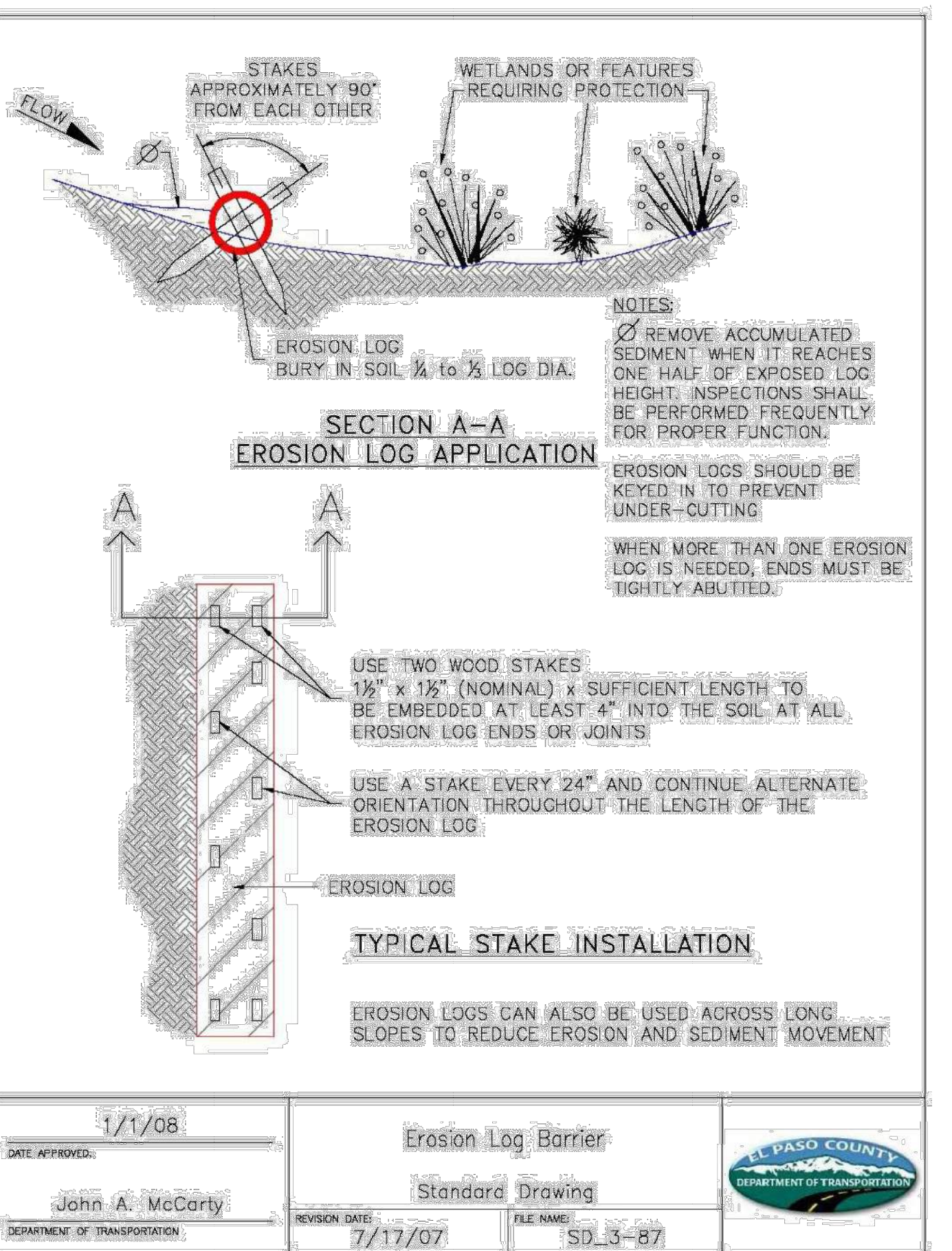

SM-6 Stabilized Staging Area (SSA)

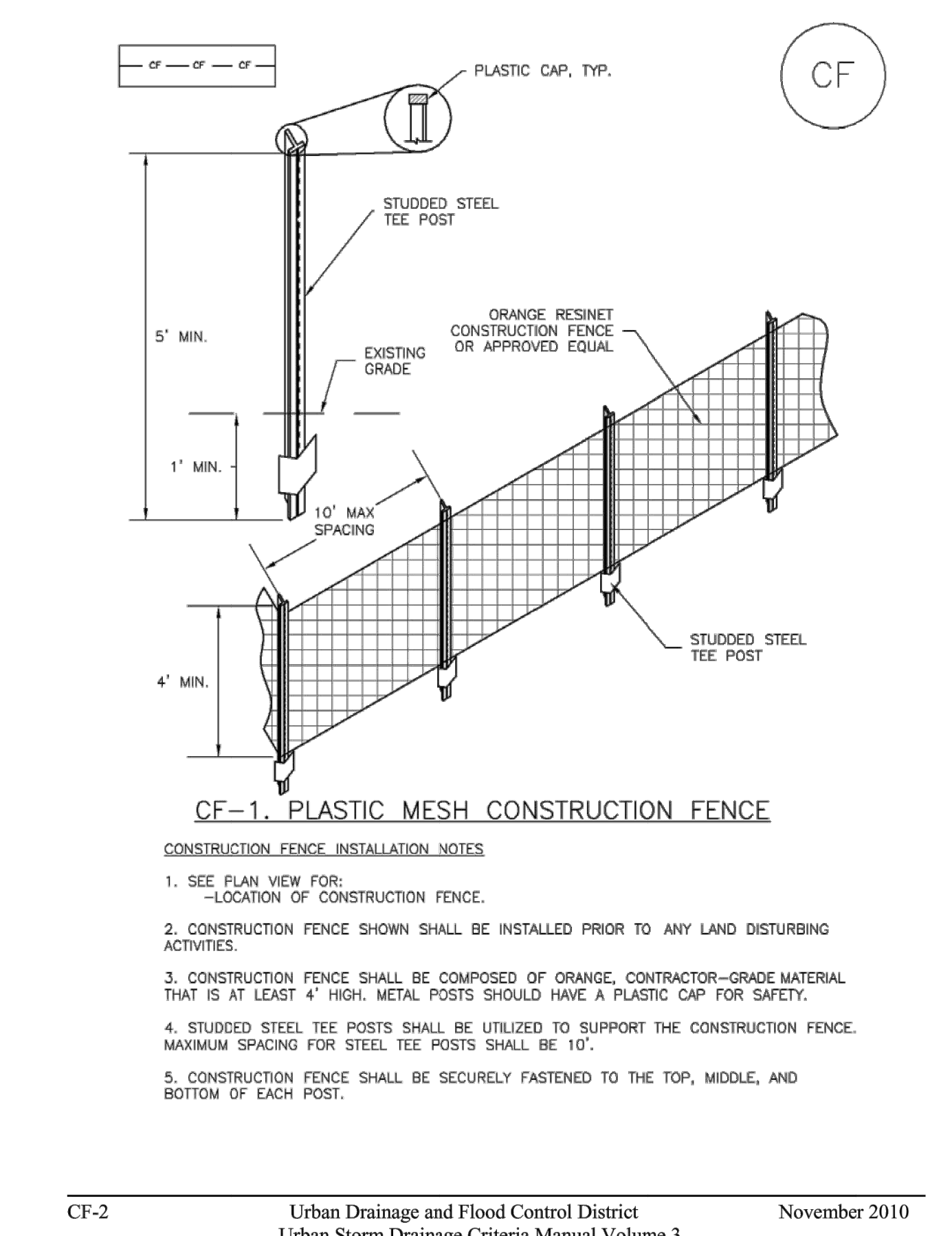

CF-1. PLASTIC MESH CONSTRUCTION FENCE

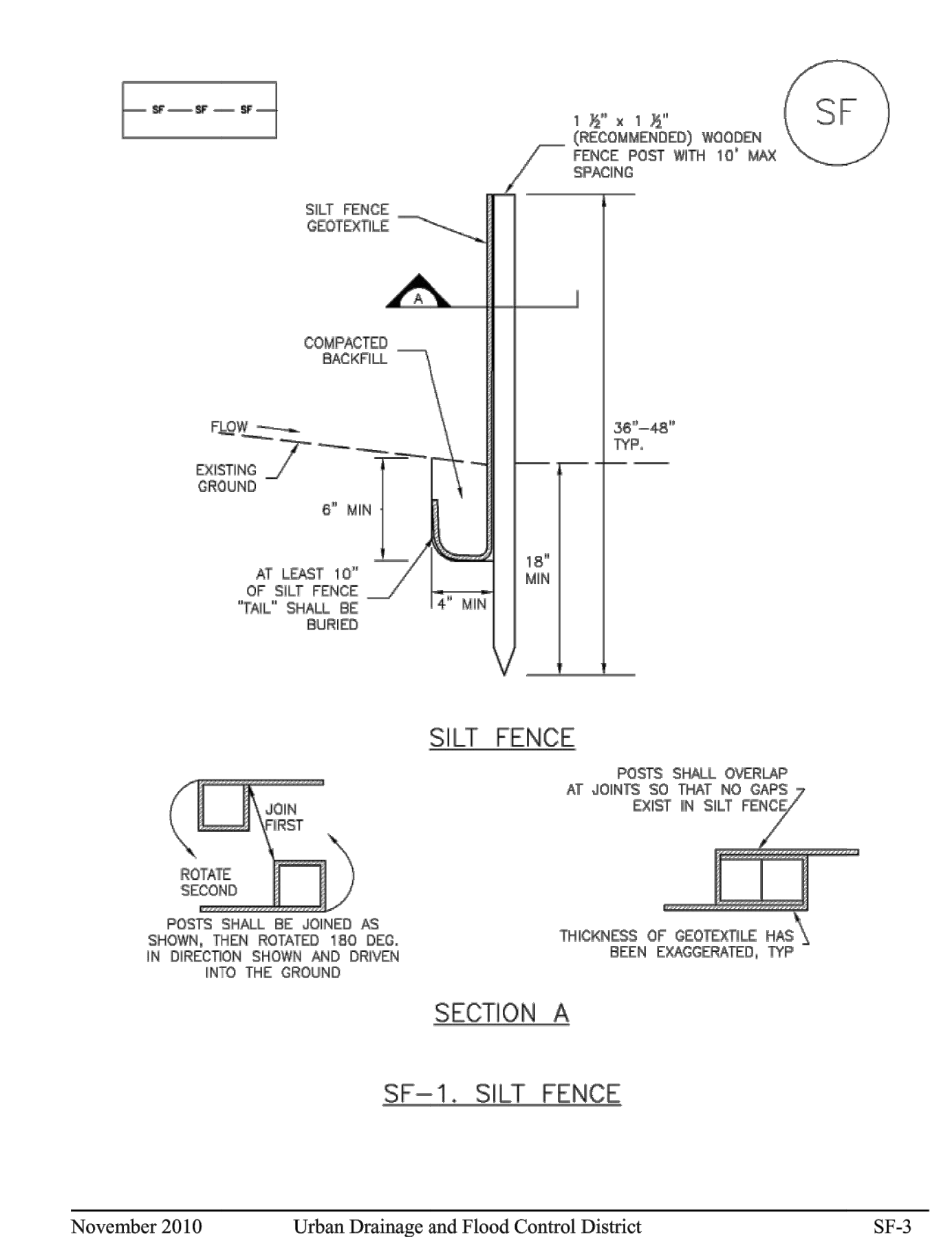

SF-1. SILT FENCE

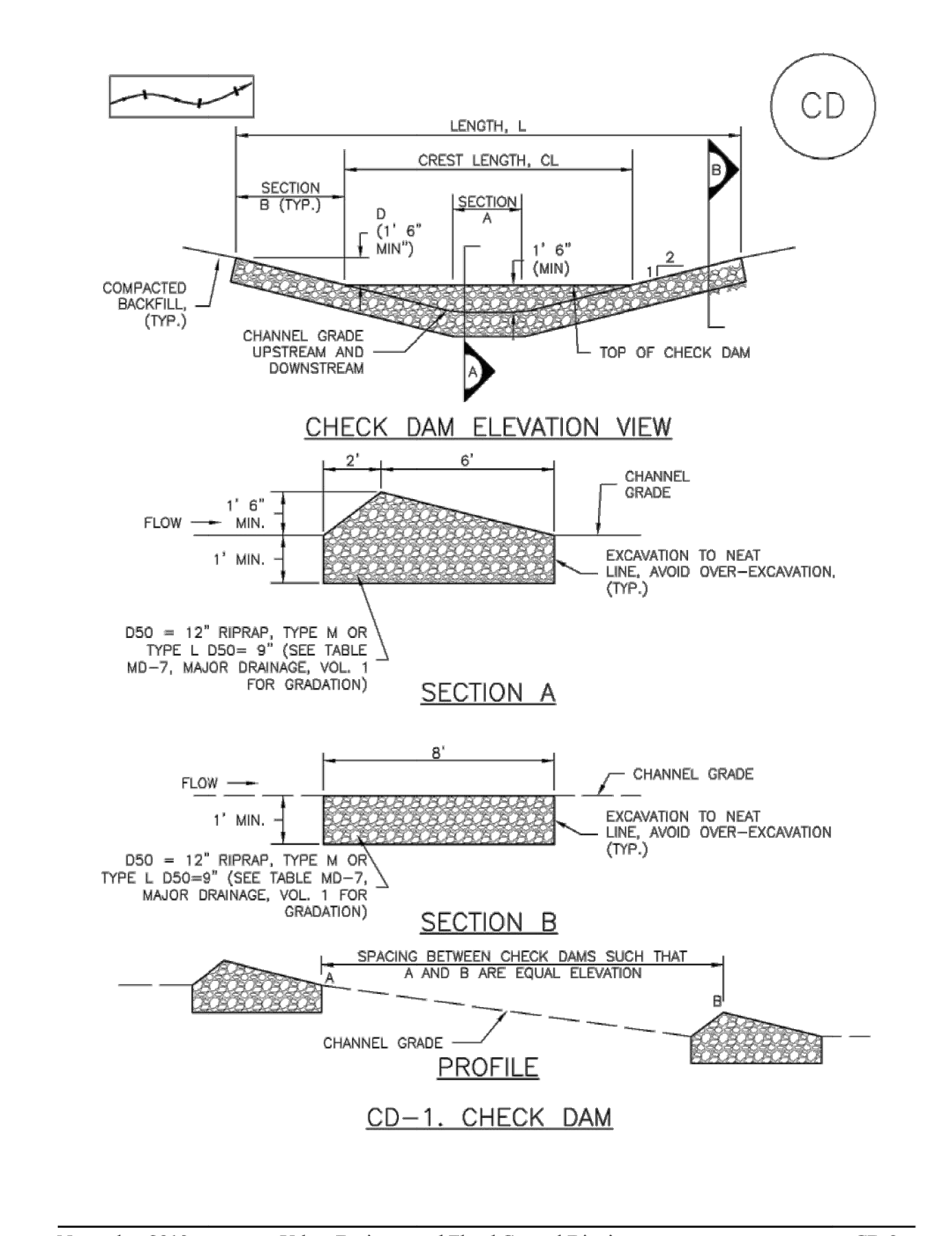

CD-1. CHECK DAM

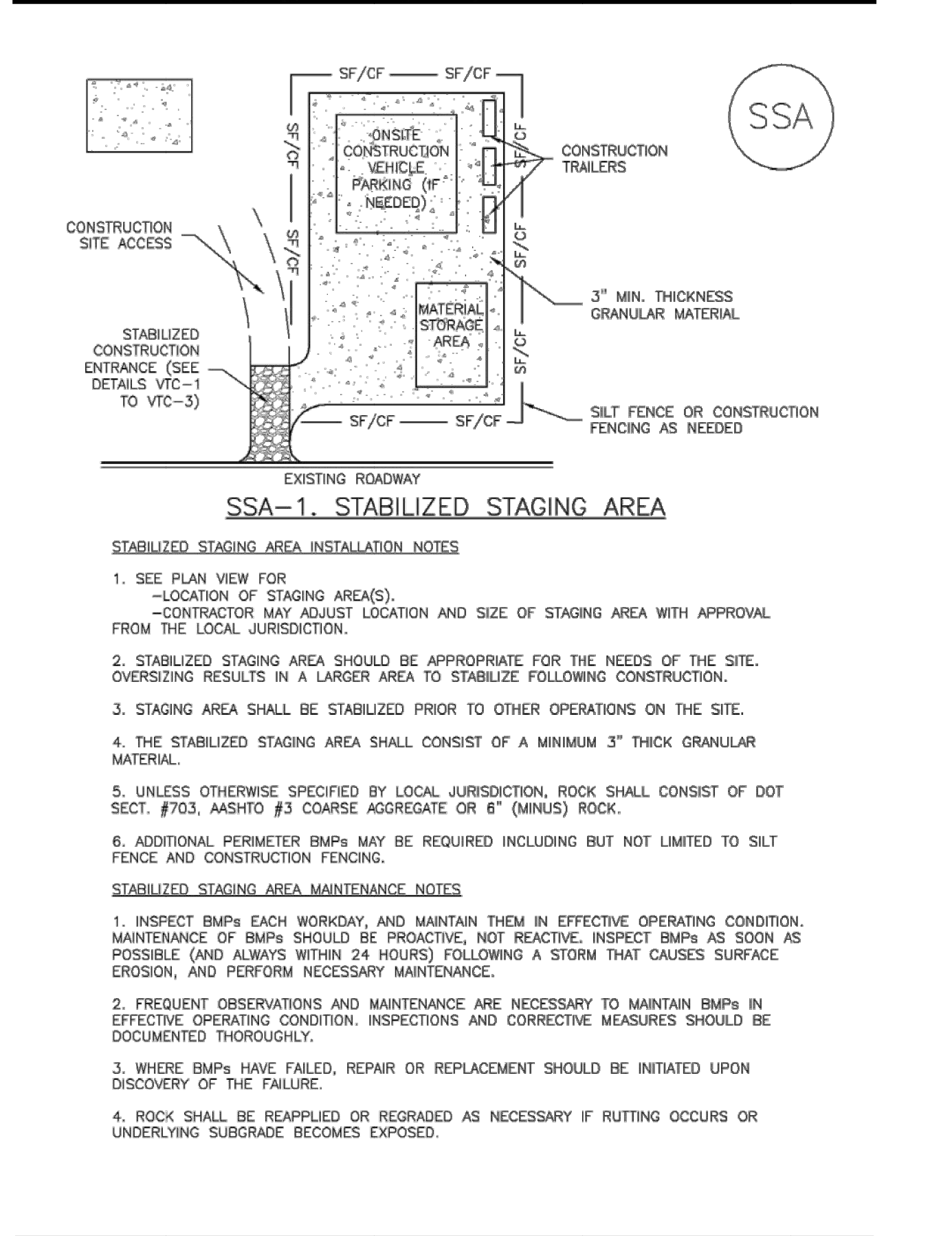

SSA-1. STABILIZED STAGING AREA

DATE APPROVED:	1/1/08	DATE APPROVED:	1/1/08	DATE APPROVED:	1/1/08	DATE APPROVED:	1/1/08
DESIGNED BY:	John A. McCarty	DESIGNED BY:	John A. McCarty	DESIGNED BY:	John A. McCarty	DESIGNED BY:	John A. McCarty
CHECKED BY:	JAR	CHECKED BY:	JAR	CHECKED BY:	JAR	CHECKED BY:	JAR
DATE:	4/8/21	DATE:	4/8/21	DATE:	4/8/21	DATE:	4/8/21
REVISION:	1	REVISION:	1	REVISION:	1	REVISION:	1
BY:	JAR	BY:	JAR	BY:	JAR	BY:	JAR
DATE:	4/8/21	DATE:	4/8/21	DATE:	4/8/21	DATE:	4/8/21

Kimley»Horn
 2021 KIMLEY-HORN AND ASSOCIATES, INC.
 2 North Nevada Avenue Suite 300
 Colorado Springs, Colorado 80903 (719) 453-0180

DESIGNED BY: E.J.G.
 DRAWN BY: JAR
 CHECKED BY: E.J.G.
 DATE: 4/8/21

WATERMARK AT AKERS
 EL PASO COUNTY, COLORADO
 GRADING AND EROSION CONTROL PLANS
 GEC DETAILS

PRELIMINARY
 FOR REVIEW ONLY
 NOT FOR CONSTRUCTION

PROJECT NO.
 096302009

SHEET
C2.4

Sediment Basin (SB)

SC-7

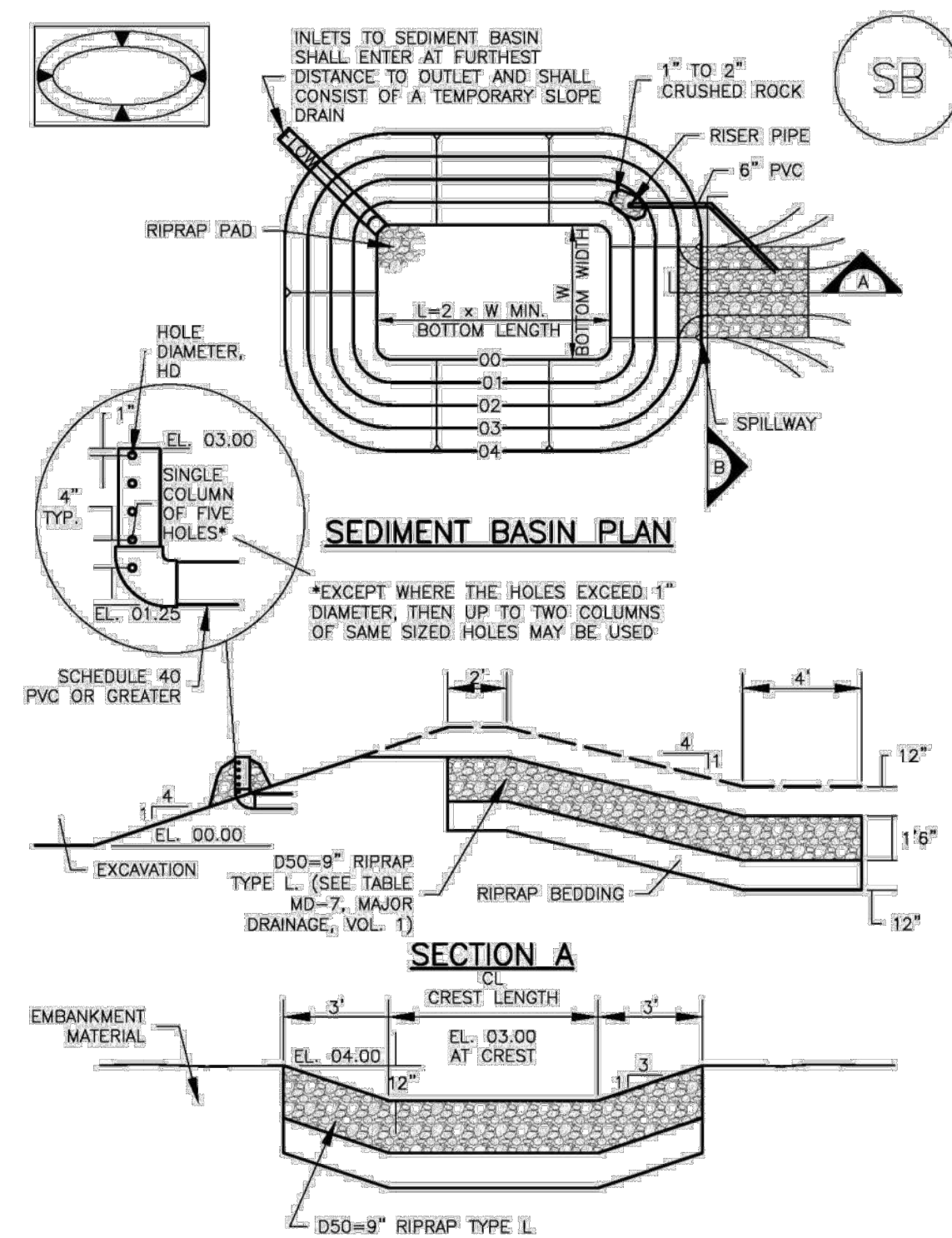

TABLE SB-1. SIZING INFORMATION FOR STANDARD SEDIMENT BASIN

Upstream Drainage Area (rounded to nearest acre), (ac)	Basin Bottom Width (W), (ft)	Spillway Crest Length (CL), (ft)	Hole Diameter (HD), (in)
1	12 1/2	2	3/8
2	21	3	1/2
3	28	5	5/8
4	33 1/2	6	3/4
5	38 1/2	8	7/8
6	43	9	1
7	47 1/2	11	1 1/8
8	51	12	1 1/4
9	55	13	1 1/2
10	58 1/2	15	1 5/8
11	61	16	1 3/4
12	64	18	1 7/8
13	67 1/2	19	2
14	70 1/2	21	2 1/8
15	73 1/2	22	2 3/8

SEDIMENT BASIN INSTALLATION NOTES

- SEE PLAN VIEW FOR:
 - LOCATION OF SEDIMENT BASIN.
 - TYPE OF BASIN (STANDARD BASIN OR NONSTANDARD BASIN).
 - FOR STANDARD BASIN, BOTTOM WIDTH W, CREST LENGTH CL, AND HOLE DIAMETER, HD.
 - FOR NONSTANDARD BASIN, SEE CONSTRUCTION DRAWINGS FOR DESIGN OF BASIN INCLUDING RISER HEIGHT H, NUMBER OF COLUMNS N, HOLE DIAMETER HD AND PIPE DIAMETER D.
- FOR STANDARD BASIN, BOTTOM DIMENSION MAY BE MODIFIED AS LONG AS BOTTOM AREA IS NOT REDUCED.
- SEDIMENT BASINS SHALL BE INSTALLED PRIOR TO ANY OTHER LAND-DISTURBING ACTIVITY THAT RELIES ON BASINS AS A STORMWATER CONTROL.
- EMBANKMENT MATERIAL SHALL CONSIST OF SOIL FREE OF DEBRIS, ORGANIC MATERIAL, AND ROCKS OR CONCRETE GREATER THAN 3 INCHES AND SHALL HAVE A MINIMUM OF 15 PERCENT BY WEIGHT PASSING THE NO. 200 SIEVE.
- EMBANKMENT MATERIAL SHALL BE COMPACTED TO AT LEAST 95 PERCENT OF MAXIMUM DENSITY IN ACCORDANCE WITH ASTM D698.
- PIPE SCH 40 OR GREATER SHALL BE USED.
- THE DETAILS SHOWN ON THESE SHEETS PERTAIN TO STANDARD SEDIMENT BASIN(S) FOR DRAINAGE AREAS LESS THAN 15 ACRES. SEE CONSTRUCTION DRAWINGS FOR EMBANKMENT, STORAGE VOLUME, SPILLWAY, OUTLET, AND OUTLET PROTECTION DETAILS FOR ANY SEDIMENT BASIN(S) THAT HAVE BEEN INDIVIDUALLY DESIGNED FOR DRAINAGE AREAS LARGER THAN 15 ACRES.

August 2013 Urban Drainage and Flood Control District SB-5
Urban Storm Drainage Criteria Manual Volume 3

Inlet Protection (IP)

SC-6

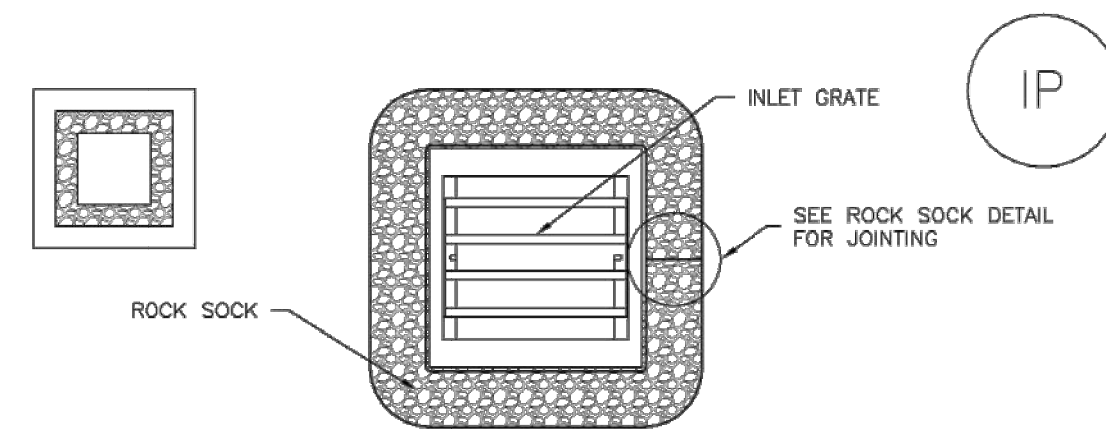

ROCK SOCK SUMP/AREA INLET PROTECTION INSTALLATION NOTES

- SEE ROCK SOCK DESIGN DETAIL FOR INSTALLATION REQUIREMENTS.
- STRAW WATTLES/SEDIMENT CONTROL LOGS MAY BE USED IN PLACE OF ROCK SOCKS FOR INLETS IN PERVIOUS AREAS. INSTALL PER SEDIMENT CONTROL LOG DETAIL.

SILT FENCE INLET PROTECTION INSTALLATION NOTES

- SEE SILT FENCE DESIGN DETAIL FOR INSTALLATION REQUIREMENTS.
- POSTS SHALL BE PLACED AT EACH CORNER OF THE INLET AND AROUND THE EDGES AT A MAXIMUM SPACING OF 3 FEET.
- STRAW WATTLES/SEDIMENT CONTROL LOGS MAY BE USED IN PLACE OF SILT FENCE FOR INLETS IN PERVIOUS AREAS. INSTALL PER SEDIMENT CONTROL LOG DETAIL.

August 2013 Urban Drainage and Flood Control District IP-5
Urban Storm Drainage Criteria Manual Volume 3

SC-7

SC-6

Sediment Basin (SB)

Stockpile Management (SP)

MM-2

Vehicle Tracking Control (VTC)

SM-4

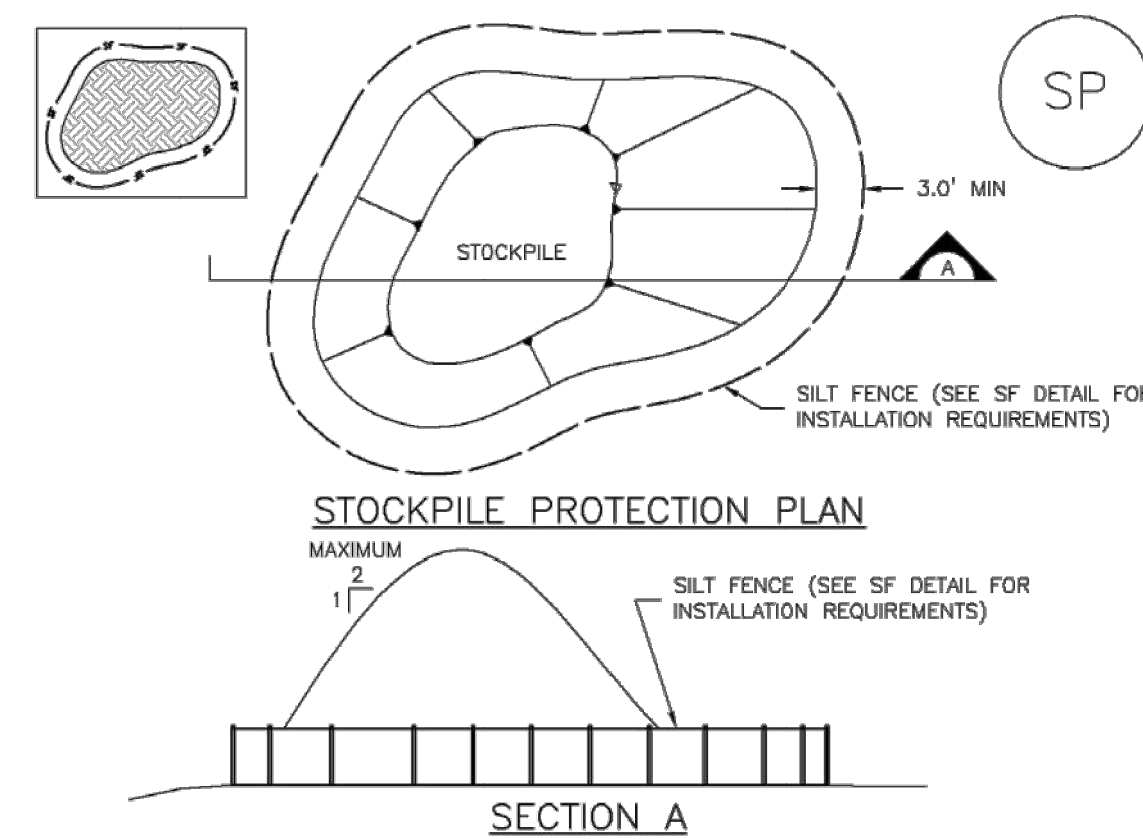

SP-1. STOCKPILE PROTECTION

STOCKPILE PROTECTION INSTALLATION NOTES

- SEE PLAN VIEW FOR:
 - LOCATION OF STOCKPILES.
 - TYPE OF STOCKPILE PROTECTION.
- INSTALL PERIMETER CONTROLS IN ACCORDANCE WITH THEIR RESPECTIVE DESIGN DETAILS. SILT FENCE IS SHOWN IN THE STOCKPILE PROTECTION DETAILS; HOWEVER, OTHER TYPES OF PERIMETER CONTROLS INCLUDING SEDIMENT CONTROL LOGS OR ROCK SOCKS MAY BE SUITABLE IN SOME CIRCUMSTANCES. CONSIDERATIONS FOR DETERMINING THE APPROPRIATE TYPE OF PERIMETER CONTROL FOR A STOCKPILE INCLUDE WHETHER THE STOCKPILE IS LOCATED ON A PERVIOUS OR IMPERVIOUS SURFACE, THE RELATIVE HEIGHTS OF THE PERIMETER CONTROL AND STOCKPILE, THE ABILITY OF THE PERIMETER CONTROL TO CONTAIN THE STOCKPILE WITHOUT FAILING IN THE EVENT THAT MATERIAL FROM THE STOCKPILE SHIFTS OR SLUMPS AGAINST THE PERIMETER, AND OTHER FACTORS.
- STABILIZE THE STOCKPILE SURFACE WITH SURFACE ROUGHENING, TEMPORARY SEEDING AND MULCHING, EROSION CONTROL BLANKETS, OR SOIL BINDERS. SOILS STOCKPILED FOR AN EXTENDED PERIOD (TYPICALLY FOR MORE THAN 60 DAYS) SHOULD BE SEEDED AND MULCHED WITH A TEMPORARY GRASS COVER ONCE THE STOCKPILE IS PLACED (TYPICALLY WITHIN 14 DAYS). USE OF MULCH ONLY OR A SOIL BINDER IS ACCEPTABLE IF THE STOCKPILE WILL BE IN PLACE FOR A MORE LIMITED TIME PERIOD (TYPICALLY 30-60 DAYS).
- FOR TEMPORARY STOCKPILES ON THE INTERIOR PORTION OF A CONSTRUCTION SITE, WHERE OTHER DOWNGRADIENT CONTROLS, INCLUDING PERIMETER CONTROL, ARE IN PLACE, STOCKPILE PERIMETER CONTROLS MAY NOT BE REQUIRED.

November 2010 Urban Drainage and Flood Control District SP-3
Urban Storm Drainage Criteria Manual Volume 3

Earth Dikes and Drainage Swales (ED/DS)

EC-10

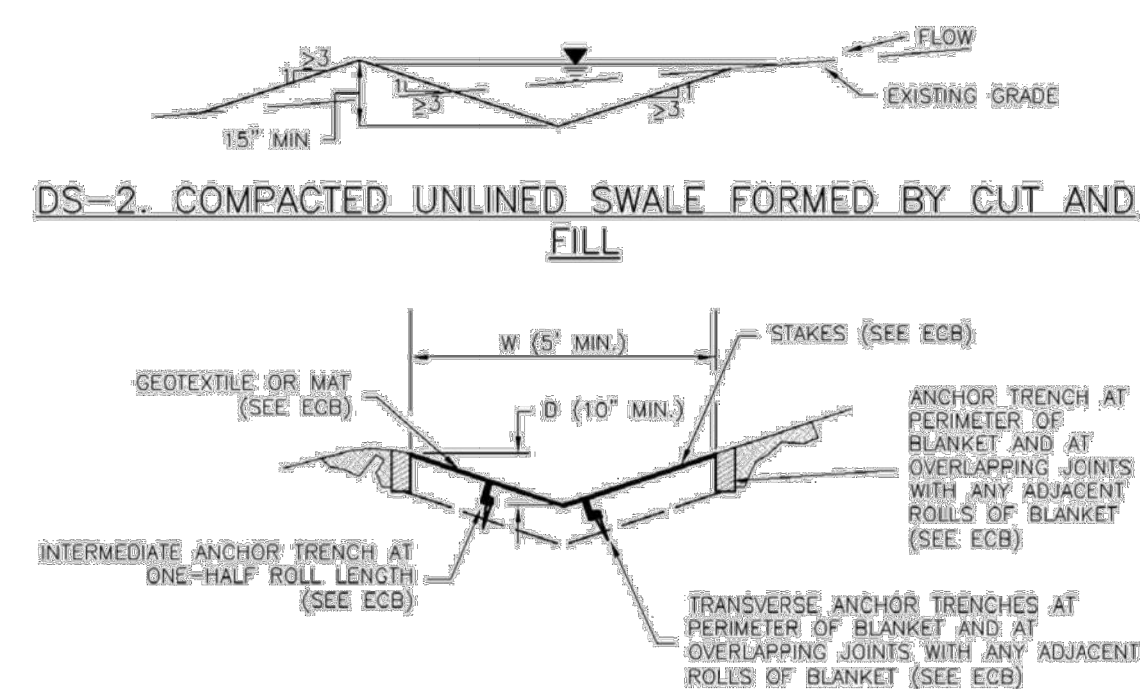
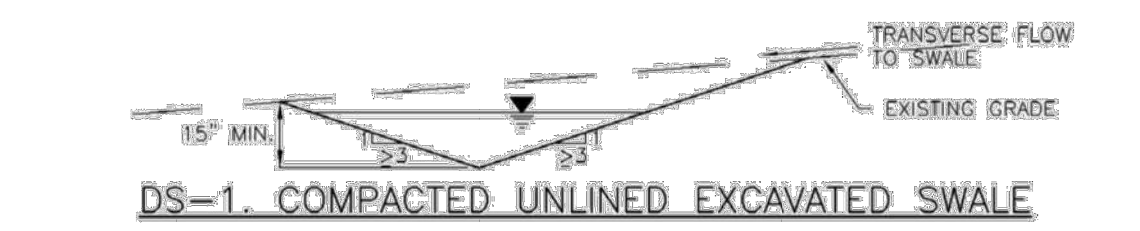
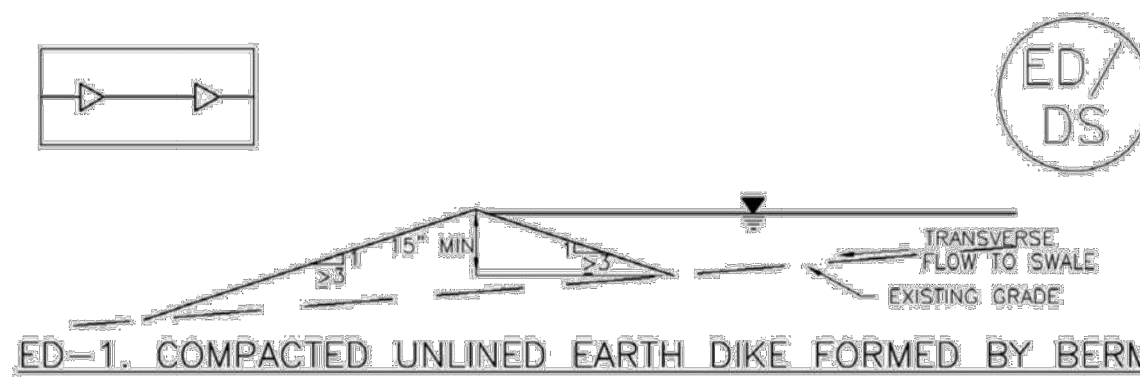

November 2010 Urban Drainage and Flood Control District ED/DS-3
Urban Storm Drainage Criteria Manual Volume 3

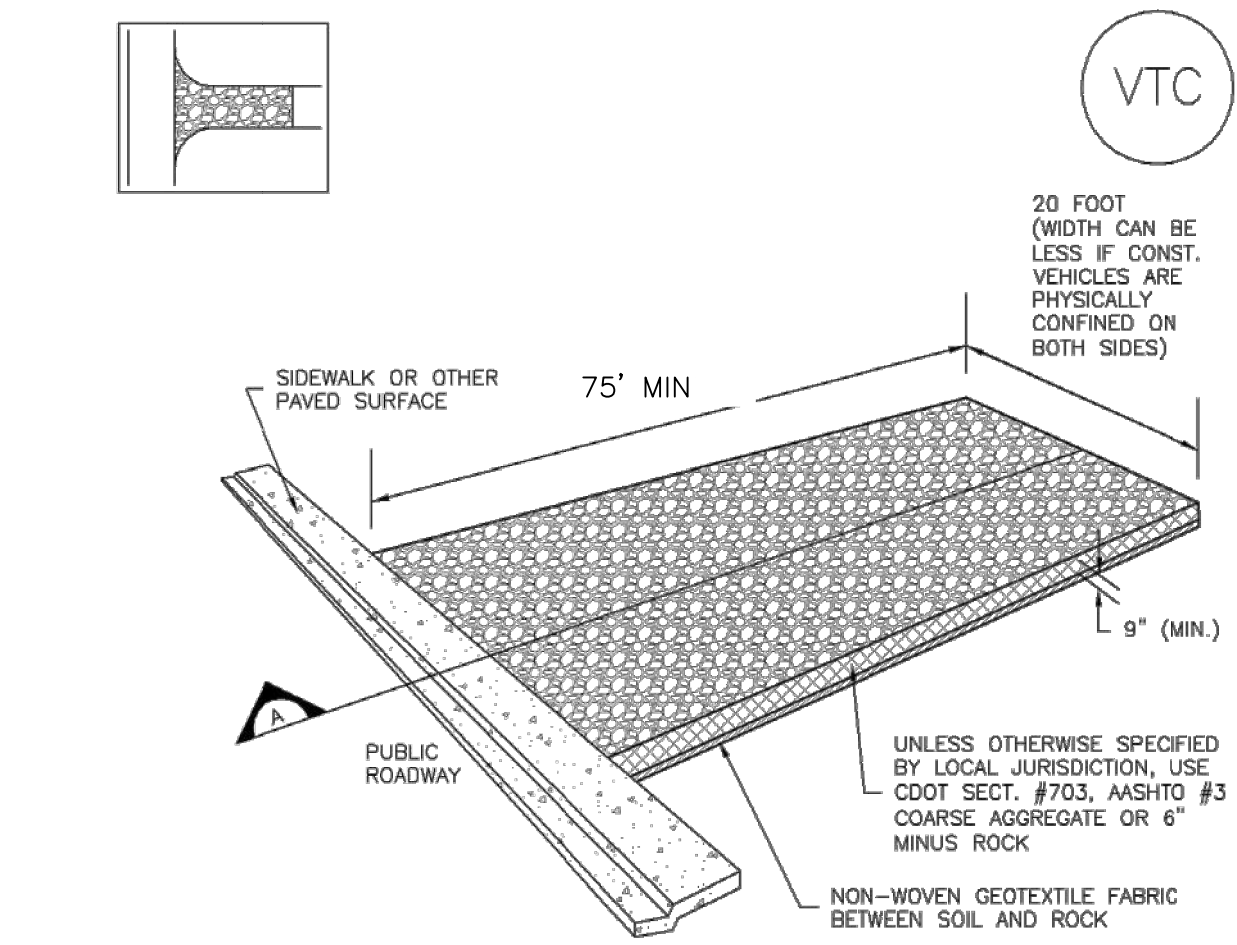

November 2010 Urban Drainage and Flood Control District VTC-3
Urban Storm Drainage Criteria Manual Volume 3

SC-5

Rock Sock (RS)

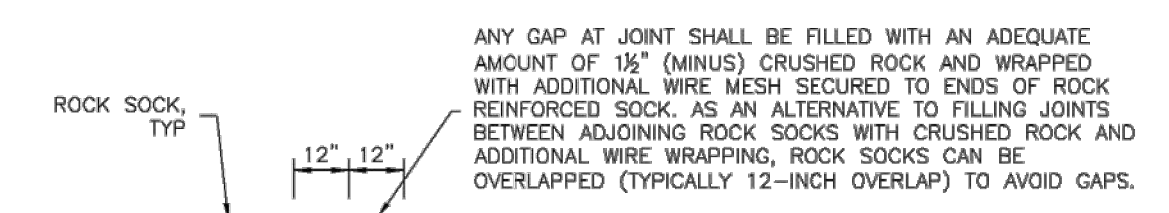
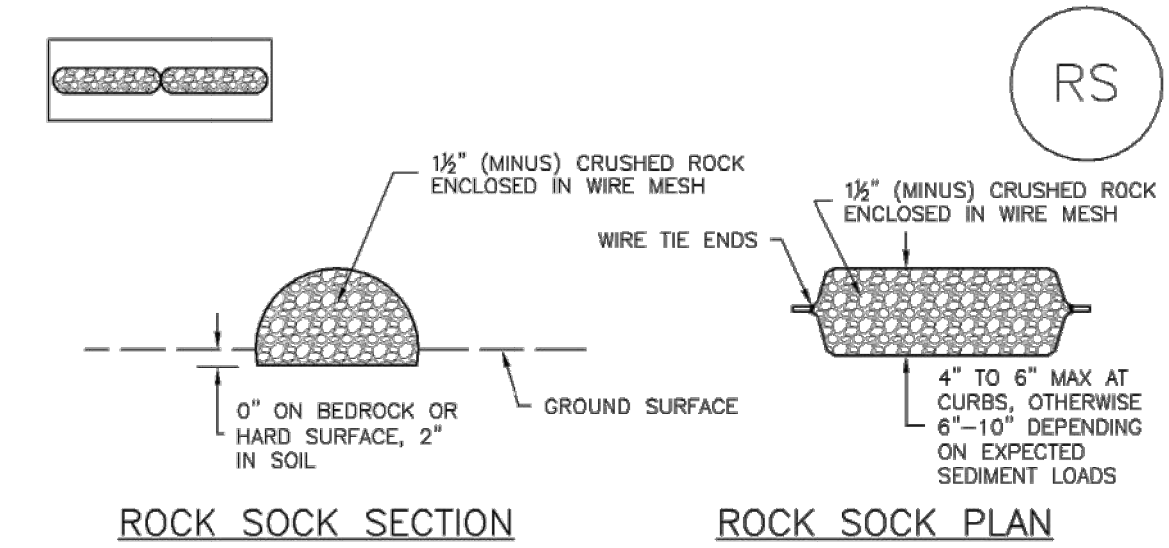

GRADATION TABLE

SIEVE SIZE	MASS PERCENT PASSING SQUARE MESH SIEVES
2"	100
1 1/2"	90 - 100
1"	20 - 55
3/4"	0 - 15
3/8"	0 - 5

MATCHES SPECIFICATIONS FOR NO. 4 COARSE AGGREGATE FOR CONCRETE PER MASHTO M43. ALL ROCK SHALL BE FRACTURED FACE, ALL SIDES.

ROCK SOCK INSTALLATION NOTES

- SEE PLAN VIEW FOR:
 - LOCATION(S) OF ROCK SOCKS.
- CRUSHED ROCK SHALL BE 1 1/2" (MINUS) IN SIZE WITH A FRACTURED FACE (ALL SIDES) AND SHALL COMPLY WITH GRADATION SHOWN ON THIS SHEET (1 1/2" MINUS).
- WIRE MESH SHALL BE FABRICATED OF 10 GAUGE POULTRY MESH, OR EQUIVALENT, WITH A MAXIMUM OPENING OF 1/2", RECOMMENDED MINIMUM ROLL WIDTH OF 48"
- WIRE MESH SHALL BE SECURED USING "HOG RINGS" OR WIRE TIES AT 6" CENTERS ALONG ALL JOINTS AND AT 2" CENTERS ON ENDS OF SOCKS.
- SOME MUNICIPALITIES MAY ALLOW THE USE OF FILTER FABRIC AS AN ALTERNATIVE TO WIRE MESH FOR THE ROCK ENCLOSURE.

November 2010 Urban Drainage and Flood Control District RS-2
Urban Storm Drainage Criteria Manual Volume 3

NO.	REVISION	DATE	BY	APPR.
1	FIRST RESUBMITTAL	JAR 4/8/21	EJG	

Kimley»Horn
2021 KIMLEY-HORN AND ASSOCIATES, INC.
2 North Nevada Avenue Suite 300
Colorado Springs, Colorado 80903 (719) 453-0180

DESIGNED BY: EJG
DRAWN BY: JAR
CHECKED BY: EJG
DATE: 4/8/21

WATERMARK AT AKERS
EL PASO COUNTY, COLORADO
GRADING AND EROSION CONTROL PLANS
GEC DETAILS (2)

PRELIMINARY
FOR REVIEW ONLY
NOT FOR CONSTRUCTION
Kimley»Horn
Kimley-Horn and Associates, Inc.

PROJECT NO.
096302009
SHEET
C2.5

K:\DEN\Civil\096302009_Akers Drive\CADD\PlanSheets\SDP\096302009 - GEC_DT.dwg Roberts, Jared 4/14/2021 7:56 AM

Temporary and Permanent Seeding (TS/PS) EC-2

Seeding dates for the highest success probability of perennial species along the Front Range are generally in the spring from April through early May and in the fall after the first of September until the ground freezes. If the area is irrigated, seeding may occur in summer months, as well. See Table TS/PS-3 for appropriate seeding dates.

Table TS/PS-1. Minimum Drill Seeding Rates for Various Temporary Annual Grasses

Species ^a (Common name)	Growth Season ^b	Pounds of Pure Live Seed (PLS)/acre ^c	Planting Depth (Inches)
1. Oats	Cool	35 - 50	1 - 2
2. Spring wheat	Cool	25 - 35	1 - 2
3. Spring barley	Cool	25 - 35	1 - 2
4. Annual ryegrass	Cool	10 - 15	½
5. Millet	Warm	3 - 15	½ - ¾
6. Sudangrass	Warm	5 - 10	½ - ¾
7. Sorghum	Warm	5 - 10	½ - ¾
8. Winter wheat	Cool	20 - 35	1 - 2
9. Winter barley	Cool	20 - 35	1 - 2
10. Winter rye	Cool	20 - 35	1 - 2
11. Triticale	Cool	25 - 40	1 - 2

^a Successful seeding of annual grass resulting in adequate plant growth will usually produce enough dead-plant residue to provide protection from wind and water erosion for an additional year. This assumes that the cover is not disturbed or mowed closer than 8 inches.

Hydraulic seeding may be substituted for drilling only where slopes are steeper than 3:1 or where access limitations exist. When hydraulic seeding is used, hydraulic mulching should be applied as a separate operation, when practical, to prevent the seeds from being encapsulated in the mulch.

^b See Table TS/PS-3 for seeding dates. Irrigation, if consistently applied, may extend the use of cool season species during the summer months.

^c Seeding rates should be doubled if seed is broadcast, or increased by 50 percent if done using a Brillion Drill or by hydraulic seeding.

EC-2 Temporary and Permanent Seeding (TS/PS)

Table TS/PS-2. Minimum Drill Seeding Rates for Perennial Grasses

Common ^a Name	Botanical Name	Growth Season ^b	Growth Form	Seeds/ Pound	Pounds of PLS/acre
Alkali Soil Seed Mix					
Alkali sacaton	<i>Sporobolus airoides</i>	Cool	Bunch	1,750,000	0.25
Basin wildrye	<i>Elymus cinereus</i>	Cool	Bunch	165,000	2.5
Sodar streambank wheatgrass	<i>Agropyron riparium 'Sodar'</i>	Cool	Sod	170,000	2.5
Jose tall wheatgrass	<i>Agropyron elongatum 'Jose'</i>	Cool	Bunch	79,000	7.0
Arriba western wheatgrass	<i>Agropyron smithii 'Arriba'</i>	Cool	Sod	110,000	5.5
Total					17.75
Fertile Loamy Soil Seed Mix					
Ephriam crested wheatgrass	<i>Agropyron cristatum 'Ephriam'</i>	Cool	Sod	175,000	2.0
Dural hard fescue	<i>Festuca ovina 'duriscusula'</i>	Cool	Bunch	565,000	1.0
Lincoln smooth brome	<i>Bromus inermis leys 'Lincoln'</i>	Cool	Sod	130,000	3.0
Sodar streambank wheatgrass	<i>Agropyron riparium 'Sodar'</i>	Cool	Sod	170,000	2.5
Arriba western wheatgrass	<i>Agropyron smithii 'Arriba'</i>	Cool	Sod	110,000	7.0
Total					15.5
High Water Table Soil Seed Mix					
Meadow foxtail	<i>Alopecurus pratensis</i>	Cool	Sod	900,000	0.5
Redtop	<i>Agrostis alba</i>	Warm	Open sod	5,000,000	0.25
Reed canarygrass	<i>Phalaris arundinacea</i>	Cool	Sod	68,000	0.5
Lincoln smooth brome	<i>Bromus inermis leys 'Lincoln'</i>	Cool	Sod	130,000	3.0
Pathfinder switchgrass	<i>Panicum virgatum 'Pathfinder'</i>	Warm	Sod	389,000	1.0
Alkar tall wheatgrass	<i>Agropyron elongatum 'Alkar'</i>	Cool	Bunch	79,000	5.5
Total					10.75
Transition Turf Seed Mix^a					
Ruebens Canadian bluegrass	<i>Poa compressa 'Ruebens'</i>	Cool	Sod	2,500,000	0.5
Dural hard fescue	<i>Festuca ovina 'duriscusula'</i>	Cool	Bunch	565,000	1.0
Citation perennial ryegrass	<i>Lolium perenne 'Citation'</i>	Cool	Sod	247,000	3.0
Lincoln smooth brome	<i>Bromus inermis leys 'Lincoln'</i>	Cool	Sod	130,000	3.0
Total					7.5

Temporary and Permanent Seeding (TS/PS) EC-2

Table TS/PS-2. Minimum Drill Seeding Rates for Perennial Grasses (cont.)

Common Name	Botanical Name	Growth Season ^b	Growth Form	Seeds/ Pound	Pounds of PLS/acre
Sandy Soil Seed Mix					
Blue grama	<i>Bouteloua gracilis</i>	Warm	Sod-forming bunchgrass	825,000	0.5
Camper little bluestem	<i>Schizachyrium scoparium 'Camper'</i>	Warm	Bunch	240,000	1.0
Prairie sandreed	<i>Calamovilfa longifolia</i>	Warm	Open sod	274,000	1.0
Sand dropseed	<i>Sporobolus cryptandrus</i>	Cool	Bunch	5,298,000	0.25
Vaughn sidecoats grama	<i>Bouteloua curtipendula 'Vaughn'</i>	Warm	Sod	191,000	2.0
Arriba western wheatgrass	<i>Agropyron smithii 'Arriba'</i>	Cool	Sod	110,000	5.5
Total					10.25
Heavy Clay, Rocky Foothill Seed Mix					
Ephriam crested wheatgrass ^d	<i>Agropyron cristatum 'Ephriam'</i>	Cool	Sod	175,000	1.5
Oahe Intermediate wheatgrass	<i>Agropyron intermedium 'Oahe'</i>	Cool	Sod	115,000	5.5
Vaughn sidecoats grama ^e	<i>Bouteloua curtipendula 'Vaughn'</i>	Warm	Sod	191,000	2.0
Lincoln smooth brome	<i>Bromus inermis leys 'Lincoln'</i>	Cool	Sod	130,000	3.0
Arriba western wheatgrass	<i>Agropyron smithii 'Arriba'</i>	Cool	Sod	110,000	5.5
Total					17.5

^a All of the above seeding mixes and rates are based on drill seeding followed by crimped straw mulch. These rates should be doubled if seed is broadcast and should be increased by 50 percent if the seeding is done using a Brillion Drill or is applied through hydraulic seeding. Hydraulic seeding may be substituted for drilling only where slopes are steeper than 3:1. If hydraulic seeding is used, hydraulic mulching should be done as a separate operation.

^b See Table TS/PS-3 for seeding dates.

^c If site is to be irrigated, the transition turf seed rates should be doubled.

^d Crested wheatgrass should not be used on slopes steeper than 6H to 1V.

^e Can substitute 0.5 lbs PLS of blue grama for the 2.0 lbs PLS of Vaughn sidecoats grama.

EC-2 Temporary and Permanent Seeding (TS/PS)

Table TS/PS-3. Seeding Dates for Annual and Perennial Grasses

Seeding Dates	Annual Grasses (Numbers in table reference species in Table TS/PS-1)		Perennial Grasses	
	Warm	Cool	Warm	Cool
January 1–March 15			✓	✓
March 16–April 30	4	1,2,3	✓	✓
May 1–May 15	4		✓	
May 16–June 30	4,5,6,7			
July 1–July 15	5,6,7			
July 16–August 31				
September 1–September 30		8,9,10,11		
October 1–December 31			✓	✓

Mulch

Cover seeded areas with mulch or an appropriate rolled erosion control product to promote establishment of vegetation. Anchor mulch by crimping, netting or use of a non-toxic tackifier. See the Mulching BMP Fact Sheet for additional guidance.

Maintenance and Removal

Monitor and observe seeded areas to identify areas of poor growth or areas that fail to germinate. Reseed and mulch these areas, as needed.

An area that has been permanently seeded should have a good stand of vegetation within one growing season if irrigated and within three growing seasons without irrigation in Colorado. Reseed portions of the site that fail to germinate or remain bare after the first growing season.

Seeded areas may require irrigation, particularly during extended dry periods. Targeted weed control may also be necessary.

Protect seeded areas from construction equipment and vehicle access.

DATE	4/8/21	EJG
BY	JAR	APPR.
REVISION		
NO.	1	FIRST RESUBMITTAL

Kimley»Horn
2021 KIMLEY-HORN AND ASSOCIATES, INC.
2 North Nevada Avenue Suite 300
Colorado Springs, Colorado 80903 (719) 453-0180

DESIGNED BY: EJG
DRAWN BY: JAR
CHECKED BY: EJG
DATE: 4/8/21

WATERMARK AT AKERS
EL PASO COUNTY, COLORADO
GRADING AND EROSION CONTROL PLANS
GEC DETAILS (3)

PRELIMINARY
FOR REVIEW ONLY
NOT FOR
CONSTRUCTION
Kimley»Horn
Kimley-Horn and Associates, Inc.

PROJECT NO.
096302009

SHEET

C2.6

APPENDIX B – CDPHE STORMWATER PERMIT





STATE OF COLORADO

COLORADO DEPARTMENT OF PUBLIC HEALTH AND ENVIRONMENT

Water Quality Control Division

CDPS GENERAL PERMIT
STORMWATER DISCHARGES ASSOCIATED WITH
CONSTRUCTION ACTIVITY
AUTHORIZATION TO DISCHARGE UNDER THE
COLORADO DISCHARGE PERMIT SYSTEM (CDPS)

In compliance with the provisions of the Colorado Water Quality Control Act, (25-8-101 et seq., CRS, 1973 as amended) and the Federal Water Pollution Control Act, as amended (33 U.S.C. 1251 et seq.; the "Act"), this permit authorizes the discharge of stormwater associated with construction activities (and specific allowable non-stormwater discharges in accordance with Part I.A.1. of the permit) certified under this permit, from those locations specified throughout the State of Colorado to specified waters of the State.

Such discharges shall be in accordance with the conditions of this permit. This permit specifically authorizes the facility listed on the certification to discharge in accordance with permit requirements and conditions set forth in Parts I and II hereof. All discharges authorized herein shall be consistent with the terms and conditions of this permit.

This permit becomes effective on April 1, 2019, and shall expire at midnight March 31, 2024.

Issued and signed this 1st day of November 2018.

COLORADO DEPARTMENT OF PUBLIC HEALTH AND ENVIRONMENT

Ellen Howard Kutzer, Permits Section Manager
Water Quality Control Division

Permit History

Originally signed and issued October 31, 2018; effective April 1, 2019.

Table of Contents

Part I	1
A. COVERAGE UNDER THIS PERMIT.....	1
1. Authorized Discharges	1
2. Limitations on Coverage.....	1
3. Permit Certification and Submittal Procedures	2
B. EFFLUENT LIMITATIONS	6
1. Requirements for Control Measures Used to Meet Effluent Limitations	6
2. Discharges to an Impaired Waterbody.....	9
3. General Requirements	10
C. STORMWATER MANAGEMENT PLAN (SWMP) REQUIREMENTS	11
1. SWMP General Requirements	11
2. SWMP Content	11
3. SWMP Review and Revisions	13
4. SWMP Availability.....	14
D. SITE INSPECTIONS.....	14
1. Person Responsible for Conducting Inspections	14
2. Inspection Frequency	14
3. Inspection Frequency for Discharges to Outstanding Waters.....	15
4. Reduced Inspection Frequency	15
5. Inspection Scope.....	16
E. DEFINITIONS	17
F. MONITORING.....	20
G. Oil and Gas Construction	21
Part II: Standard Permit Conditions.....	22
A. DUTY TO COMPLY.....	22
B. DUTY TO REAPPLY	22
C. NEED TO HALT OR REDUCE ACTIVITY NOT A DEFENSE	22
D. DUTY TO MITIGATE	22
E. PROPER OPERATION AND MAINTENANCE	22
F. PERMIT ACTIONS	22
G. PROPERTY RIGHTS	22
H. DUTY TO PROVIDE INFORMATION	23
I. INSPECTION AND ENTRY	23
J. MONITORING AND RECORDS	23
K. SIGNATORY REQUIREMENTS	24

- 1. Authorization to Sign:..... 24
- 2. Electronic Signatures 25
- 3. Change in Authorization to Sign 25
- L. REPORTING REQUIREMENTS 25
 - 1. Planned Changes..... 25
 - 2. Anticipated Non-Compliance 25
 - 3. Transfer of Ownership or Control 25
 - 4. Monitoring reports..... 26
 - 5. Compliance Schedules 26
 - 6. Twenty-four hour reporting..... 26
 - 7. Other non-compliance 27
 - 8. Other information 27
- M. BYPASS 27
 - 1. Bypass not exceeding limitations 27
 - 2. Notice of bypass 27
 - 3. Prohibition of Bypass..... 27
- N. UPSET..... 28
 - 1. Effect of an upset 28
 - 2. Conditions necessary for demonstration of an Upset 28
 - 3. Burden of Proof 28
- O. RETENTION OF RECORDS..... 28
 - 1. Post-Expiration or Termination Retention 28
 - 2. On-site Retention..... 29
- P. REOPENER CLAUSE..... 29
 - 1. Procedures for modification or revocation 29
 - 2. Water quality protection 29
- Q. SEVERABILITY..... 29
- R. NOTIFICATION REQUIREMENTS 29
 - 1. Notification to Parties 29
- S. RESPONSIBILITIES 30
 - 1. Reduction, Loss, or Failure of Treatment Facility 30
- T. Oil and Hazardous Substance Liability..... 30
- U. Emergency Powers..... 30
- V. Confidentiality 30
- W. Fees..... 30

X. Duration of Permit..... 30

Y. Section 307 Toxics..... 30

Part I

Note: At the first mention of terminology that has a specific connotation for the purposes of this permit, the terminology is electronically linked to the definitions section of the permit in Part I.E.

A. COVERAGE UNDER THIS PERMIT**1. Authorized Discharges**

This general permit authorizes [permittee\(s\)](#) to discharge the following to state waters: stormwater associated with [construction activity](#) and specified non-stormwater associated with construction activity. The following types of stormwater and non-stormwater discharges are authorized under this permit:

a. Allowable Stormwater Discharges

- i. Stormwater discharges associated with construction activity.
- ii. Stormwater discharges associated with producing earthen materials, such as soils, sand, and gravel dedicated to providing material to a single contiguous site, or within ¼ mile of a construction site (i.e. borrow or fill areas)
- iii. Stormwater discharges associated with [dedicated asphalt, concrete batch plants and masonry mixing stations](#) (Coverage under this permit is not required if alternative coverage has been obtained.)

b. Allowable Non-Stormwater Discharges

The following non-stormwater discharges are allowable under this permit if the discharges are identified in the stormwater management plan in accordance with Part I.C. and if they have appropriate [control measures](#) in accordance with Part I.B.1.

- i. Discharges from uncontaminated springs that do not originate from an area of land disturbance.
- ii. Discharges to the ground of concrete washout water associated with the washing of concrete tools and concrete mixer chutes. Discharges of concrete washout water must not leave the site as surface runoff or reach [receiving waters](#) as defined by this permit.
- iii. Discharges of landscape irrigation return flow.

c. Emergency Fire Fighting

Discharges resulting from emergency firefighting activities are authorized by this permit.

2. Limitations on Coverage

Discharges not authorized by this permit include, but are not limited to, the discharges and activities listed below. Permittees may seek individual or alternate general permit coverage for the discharges, as appropriate and available.

a. Discharges of Non-Stormwater

Discharges of non-stormwater, except the authorized non-stormwater discharges listed in Part I.A.1.b., are not eligible for coverage under this permit.

- b. Discharges Currently Covered by another Individual or General Permit
 - c. Discharges Currently Covered by a Water Quality Control Division (division) Low Risk Guidance Document
3. Permit Certification and Submittal Procedures
- a. Duty to apply
The following activities shall apply for coverage under this permit:
 - i. Construction sites that will disturb one acre or more; or
 - ii. Construction sites that are part of a [common plan of development or sale](#); or
 - iii. Stormwater discharges that are designated by the division as needing a stormwater permit because the discharge:
 - (a) Contributes to a violation of a water quality standard; or
 - (b) is a significant contributor of pollutants to state waters.
 - b. Application Requirements
To obtain authorization to discharge under this permit, applicants applying for coverage following the effective date of the renewal permit shall meet the following requirements:
 - i. Owners and operators submitting an application for permit coverage will be co-permittees subject to the same benefits, duties, and obligations under this permit.
 - ii. Signature requirements: Both the [owner](#) and [operator](#) (permittee) of the construction site, as defined in Part I.E., must agree to the terms and conditions of the permit and submit a completed application that includes the signature of both the owner and the operator. In cases where the duties of the owner and operator are managed by the owner, both application signatures may be completed by the owner. Both the owner and operator are responsible for ensuring compliance with all terms and conditions of the permit, including implementation of the stormwater management plan.
 - iii. Applicants must use the paper form provided by the division or the electronic form provided on the division's web-based application platform when applying for coverage under this permit.
 - iv. The applicant(s) must develop a stormwater management plan (SWMP) in accordance with the requirements of Part I.C. The applicant(s) must also certify that the SWMP is complete, or will be complete, prior to commencement of any construction activity.

- v. The applicant(s) must submit a complete, accurate, and signed permit application electronically, by mail or hand delivery to the division at least 10 days prior to the commencement of construction activity except that construction activities that are in response to a **public emergency related site** shall apply for coverage no later than 14 days after the commencement of construction activities. The provisions of this part in no way remove a violation of the Colorado Water Quality Control Act if a point source discharge occurs prior to the issuance of a CDPS permit.
 - vi. The application must be signed in accordance with the requirements of Part IA. Applications submitted by mail or hand delivered should be directed to:

Colorado Department of Public Health and Environment
Water Quality Control Division
Permits Section, WQCD-PS-B2
4300 Cherry Creek Drive South
Denver, CO 80246
 - vii. The applicant(s) must receive written notification that the division granted permit coverage prior to conducting construction activities except for construction activities that are in response to a public emergency related site
- c. Division Review of Permit Application
Within 10 days of receipt of the application, and following review of the application, the division may:
- i. Issue a certification of coverage;
 - ii. request additional information necessary to evaluate the discharge;
 - iii. delay the authorization to discharge pending further review;
 - iv. notify the applicant that additional terms and conditions are necessary; or
 - v. deny the authorization to discharge under this general permit.
- d. Alternative Permit Coverage
- i. Division Required Alternate Permit Coverage:
The Division may require an applicant or permittee to apply for an individual permit or an alternative general permit if it determines the discharge does not fall under the scope of this general permit. In this case, the Division will notify the applicant or permittee that an individual permit application is required.
 - ii. Permittee Request for alternate permit coverage:
A permittee authorized to discharge stormwater under this permit may request to be excluded from coverage under this general permit by applying for an individual permit. In this case, the permittee must submit an individual application, with reasons supporting the request, to the Division at least 180 days prior to any discharge. When an individual permit is issued, the permittee's authorization to discharge under this permit is terminated on the effective date of the individual permit.
- e. Submittal Signature Requirements

Documents required for submittal to the division in accordance with this permit, including applications for permit coverage and other documents as requested by the division, must include signatures by both the owner and the operator, except for instances where the duties of the owner and operator are managed by the owner.

Signatures on all documents submitted to the division as required by this permit must meet the Standard Signatory Requirements in Part II.K. of this permit in accordance with 40 C.F.R. 122.41(k).

i. Signature Certification

Any person(s) signing documents required for submittal to the Division must make the following certification:

"I certify under penalty of law that this document and all attachments were prepared under my direction or supervision in accordance with a system designed to assure that qualified personnel properly gather and evaluate the information submitted. Based on my inquiry of the person or persons who manage the system, or those persons directly responsible for gathering the information, the information submitted is, to the best of my knowledge and belief, true, accurate, and complete. I am aware that there are significant penalties for submitting false information, including the possibility of fine and imprisonment for knowing violations."

f. Compliance Document Signature Requirements

Documents which are required for compliance with the permit, but for which submittal to the division is not required unless specifically requested by the division, must be signed by the individual(s) designated as the Qualified Stormwater Manager, as defined in Part I.E.

i. Any person(s) signing inspection documents required for compliance with the permit must make the following statement:

"I verify that, to the best of my knowledge and belief, all corrective action and maintenance items identified during the inspection are complete, and the site is currently in compliance with the permit."

g. Field Wide Permit Coverage for Oil and Gas Construction

At the discretion of the division, a single permit certification may be issued to a single oil and gas permittee to cover construction activity related discharges from an oil and gas field at multiple locations that are not necessarily contiguous.

h. Permit Coverage without Application

Qualifying Local Program: When a small construction site is within the jurisdiction of a qualifying local program, the owner and operator of the construction activity are authorized to discharge stormwater associated with small construction activity under this general permit without the submittal of an application to the division. Sites covered by a qualifying local program are exempt from the following sections of this general permit:

Part I.A.3.a.; Part I.A.3.b.; Part I.A.3.c.; Part I.A.3.d.; Part I.A.3.g.; Part I.A.3.i.; Part I.A.3.j.; Part I.A.3.k.

Sites covered by a qualifying local program are subject to the following requirements:

- i. **Local Agency Authority:** This permit does not pre-empt or supersede the authority of local agencies to prohibit, restrict, or control discharges of stormwater to storm drain systems or other water courses within their jurisdiction.
 - ii. **Permit Coverage Termination:** When a site under a Qualifying Local Program is finally stabilized, coverage under this permit is automatically terminated.
 - iii. **Compliance with Qualifying Local Program:** Qualifying Local Program requirements that are equivalent to the requirements of this permit are incorporated by reference. Permittees authorized to discharge under this permit, must comply with the equivalent requirements of the Qualifying Local Program that has jurisdiction over the site as a condition of this permit.
 - iv. **Compliance with Remaining Permit Conditions.** Requirements of this permit that are in addition to or more stringent than the requirements of the Qualifying Local Program apply in addition to the requirements of the Qualifying Local Program.
 - v. **Written Authorization of Coverage:** The division or local municipality may require any permittee within the jurisdiction of a Qualifying Local Program covered under this permit to apply for, and obtain written authorization of coverage under this permit. The permittee must be notified in writing that an application for written authorization of coverage is required.
- i. **Permittee Initiated Permit Actions**
Permittee initiated permit actions, including but not limited to modifications, contact changes, transfers, reassignments, and terminations, shall be conducted following division guidance and using appropriate division-provided forms.
 - j. **Sale of Residence to Homeowner**
Residential construction sites only: The permittee may remove residential lots from permit coverage once the lot meets the following criteria:
 - i. the residential lot has been sold to the homeowner(s) for private residential use;
 - ii. a certificate of occupancy, or equivalent, is maintained on-site and is available during division inspections;
 - iii. the lot is less than one acre of disturbance;
 - iv. all construction activity conducted on the lot by the permittee is complete;
 - v. the permittee is not responsible for final stabilization of the lot; and
 - vi. the SWMP was modified to indicate the lot is no longer part of the construction activity.

If the residential lot meets the criteria listed above then activities occurring on the lot are no longer considered to be construction activities with a duty to apply and maintain permit coverage. Therefore, the permittee is not required to meet the final stabilization requirements and may terminate permit coverage for the lot.

k. Permit Expiration and Continuation of Permit Coverage

Authorization to discharge under this general permit shall expire at midnight on March 31, 2024. While Regulation 61.4 requires a permittee to submit an application for continuing permit coverage 180 days before the permit expires, the division is requiring that permittees desiring continued coverage under this general permit must reapply at least 90 days in advance of this permit expiration. The Division will determine if the permittee may continue to discharge stormwater under the terms of the general permit. An individual permit may be required for any facility not reauthorized to discharge under the reissued general permit.

If this permit is not reissued or replaced prior to the expiration date, it will be administratively continued and remain in force and effect. For permittees that have applied for continued permit coverage, discharges authorized under this permit prior to the expiration date will automatically remain covered by this permit until the earliest of:

- i. An authorization to discharge under a reissued permit, or a replacement of this permit, following the timely and appropriate submittal of a complete application requesting authorization to discharge under the new permit and compliance with the requirements of the new permit; or
- ii. The issuance and effect of a termination issued by the Division; or
- iii. The issuance or denial of an individual permit for the facility's discharges; or
- iv. A formal permit decision by the Division not to reissue this general permit, at which time the Division will identify a reasonable time period for covered dischargers to seek coverage under an alternative general permit or an individual permit. Coverage under this permit will cease when coverage under another permit is granted/authorized; or
- v. The Division has informed the permittee that discharges previously authorized under this permit are no longer covered under this permit.

B. EFFLUENT LIMITATIONS

1. Requirements for Control Measures Used to Meet Effluent Limitations

The permittee must implement control measures to **minimize** the discharge of pollutants from all potential pollutant sources at the site. Control measures must be installed prior to commencement of activities that may contribute pollutants to stormwater discharges. Control measures must be selected, designed, installed and maintained in accordance with good engineering, hydrologic and pollution control practices. Control measures implemented at the site must be designed to prevent pollution or degradation of state waters.

a. Stormwater Pollution Prevention

The permittee must implement structural and/or nonstructural control measures that effectively minimize erosion, sediment transport, and the release of other pollutants related to construction activity.

- i. Control Measures for Erosion and Sediment Control

Control measures for erosion and sediment control may include, but are not limited to, wattles/sediment control logs, silt fences, earthen dikes, drainage swales, sediment traps, subsurface drains, pipe slope drains, inlet protection, outlet protection, gabions, sediment basins, temporary vegetation, permanent vegetation, mulching, geotextiles, sod stabilization, slope roughening, maintaining existing vegetation, protection of trees, and preservation of mature vegetation. Specific non-structural control measures must meet the requirements listed below.

Specific control measures must meet the requirements listed below.

- (a) Vehicle tracking controls shall either be implemented to minimize vehicle tracking of sediment from disturbed areas, or the areas where vehicle tracking occurs shall meet subsection Part I.B.1.a.i(b);
- (b) Stormwater runoff from all disturbed areas and soil storage areas for which permanent or temporary stabilization is not implemented, must flow to at least one control measure to minimize sediment in the discharge. This may be accomplished through filtering, settling, or straining. The control measure must be selected, designed, installed and adequately sized in accordance with good engineering, hydrologic and pollution control practices. The control measure(s) must contain or filter flows in order to prevent the bypass of flows without treatment and must be appropriate for stormwater runoff from disturbed areas and for the expected flow rate, duration, and flow conditions (i.e., sheet or concentrated flow);
- (c) Outlets that withdraw water from or near the surface shall be installed when discharging from basins and impoundments, unless **infeasible**.
- (d) Maintain pre-existing vegetation or equivalent control measures for areas within 50 horizontal feet of receiving waters as defined by this permit, unless **infeasible**.
- (e) Soil compaction must be minimized for areas where infiltration control measures will occur or where **final stabilization** will be achieved through vegetative cover.
- (f) Unless **infeasible**, topsoil shall be preserved for those areas of a site that will utilize vegetative final stabilization.
- (g) Minimize the amount of soil exposed during construction activity, including the disturbance of steep slopes.

ii. Practices for Other Common Pollutants

- (a) Bulk storage, 55 gallons or greater, for petroleum products and other liquid chemicals must have secondary containment, or equivalent protection, in order to contain **spills** and to prevent spilled material from entering state waters.
- (b) Control measures designed for concrete washout waste must be implemented. This includes washout waste discharged to the ground as authorized under this permit and washout waste from concrete trucks and masonry operations contained on site. The permittee must ensure the washing activities do not contribute pollutants to stormwater runoff, or receiving waters in accordance Part I.A.1.b.ii. Discharges that may reach groundwater must flow through soil

that has buffering capacity prior to reaching groundwater, as necessary to meet the effluent limits in this permit, including Part I.B.3.a. The concrete washout location shall not be located in an area where shallow groundwater may be present and would result in buffering capacity not being adequate, such as near natural drainages, springs, or wetlands. This permit authorizes discharges to the ground of concrete washout waste.

iii. Stabilization Requirements

The following requirements must be implemented for each site.

- (a) Temporary stabilization must be implemented for earth disturbing activities on any portion of the site where ground disturbing construction activity has permanently ceased, or temporarily ceased for more than 14 calendar days. Temporary stabilization methods may include, but are not limited to, tarps, soil tackifier, and hydroseed. The permittee may exceed the 14-day schedule when either the function of the specific area of the site requires it to remain disturbed, or, physical characteristics of the terrain and climate prevent stabilization. The SWMP must document the constraints necessitating the alternative schedule, provide the alternate stabilization schedule, and identify all locations where the alternative schedule is applicable on the site map.
- (b) Final stabilization must be implemented for all construction sites. Final stabilization is reached when all ground surface disturbing activities at the construction site are complete; and, for all areas of ground surface disturbing activities, either a uniform vegetative cover with an individual plant density of at least 70 percent of pre-disturbance levels is established, or equivalent permanent alternative stabilization methods are implemented. The division may approve alternative final stabilization criteria for specific operations.
- (c) Final stabilization must be designed and installed as a permanent feature. Final stabilization measures for obtaining a vegetative cover or alternative stabilization methods include, but are not limited to, the following as appropriate:
 - (1) Seed mix selection and application methods;
 - (2) Soil preparation and amendments;
 - (3) Soil stabilization methods (e.g., crimped straw, hydro mulch or rolled erosion control products);
 - (4) Appropriate sediment control measures as needed until final stabilization is achieved;
 - (5) Permanent pavement, hardscape, xeriscape, stabilized driving surfaces;
 - (6) Other alternative stabilization practices as applicable;

(d) The permittee(s) must ensure all temporary control measures are removed from the construction site once final stabilization is achieved, except when the control measure specifications allow the control measure to be left in place (i.e., bio-degradable control measures).

b. Maintenance

The permittee must ensure that all control measures remain in effective operating condition and are protected from activities that would reduce their effectiveness. Control measures must be maintained in accordance with good engineering, hydrologic and pollution control practices. Observations leading to the required maintenance of control measures can be made during a site inspection, or during general observations of site conditions. The necessary repairs or modifications to a [control measure requiring routine maintenance](#), as defined in Part I.E., must be conducted to maintain an effective operating condition. This section is not subject to the requirements in Part I.B.1.c. below.

c. Corrective Actions

The permittee must assess the adequacy of control measures at the site, and the need for changes to those control measures, to ensure continued effective performance. When an [inadequate control measure](#), as defined in Part I.E., is identified (i.e., new or replacement control measures become necessary), the following corrective action requirements apply. The permittee is in noncompliance with the permit until the inadequate control measure is replaced or corrected and returned to effective operating condition in compliance with Part I.B.1. and the general requirements in Part I.B.3. If the inadequate control measure results in noncompliance that meets the conditions of Part II.L., the permittee must also meet the requirements of that section.

i. The permittee must take all necessary steps to minimize or prevent the discharge of pollutants, until a control measure is implemented and made operational and/or an inadequate control measure is replaced or corrected and returned to effective operating condition. If it is infeasible to install or repair of control measure immediately after discovering the deficiency, the following must be documented and kept on record in accordance with the recordkeeping requirements in Part II.

(a) Describe why it is infeasible to initiate the installation or repair immediately; and

(b) Provide a schedule for installing or repairing the control measure and returning it to an effective operating condition as soon as possible.

ii. If applicable, the permittee must remove and properly dispose of any unauthorized release or discharge (e.g., discharge of non-stormwater, spill, or leak not authorized by this permit.) The permittee must also clean up any contaminated surfaces to minimize discharges of the material in subsequent storm events.

2. Discharges to an Impaired Waterbody

a. Total Maximum Daily Load (TMDL)

If the permittee's discharge flows to or could reasonably be expected to flow to any water body for which a TMDL has been approved, and stormwater discharges

associated with construction activity were assigned a pollutant-specific Wasteload Allocation (WLA) under the TMDL, the division may:

- i. ensure the WLA is implemented properly through alternative local requirements, such as by a municipal stormwater permit; or
- ii. notify the permittee of the WLA and amend the permittee's certification to add specific effluent limits and other requirements, as appropriate. The permittee may be required to do the following:
 - (a) under the permittee's SWMP, implement specific control measures based on requirements of the WLA, and evaluate whether the requirements are met through implementation of existing stormwater control measures or if additional control measures are necessary. Document the calculations or other evidence demonstrating that the requirements are expected to be met; and
 - (b) if the evaluation shows that additional or modified control measures are necessary, describe the type and schedule for the control measure additions or modifications.
- iii. Discharge monitoring may also be required. The permittee may maintain coverage under the general permit provided they comply with the applicable requirements outlined above. The division reserves the right to require individual or alternate general permit coverage.

3. General Requirements

- a. Discharges authorized by this permit shall not cause, have the reasonable potential to cause, or measurably contribute to an exceedance of any applicable water quality standard, including narrative standards for water quality.
- b. The division may require sampling and testing, on a case-by-case basis, in the event that there is reason to suspect that the SWMP is not adequately minimizing pollutants in stormwater or in order to measure the effectiveness of the control measures in removing pollutants in the effluent. Such monitoring may include Whole Effluent Toxicity testing.
- c. The permittee must comply with the lawful requirements of federal agencies, municipalities, counties, drainage districts and other local agencies including applicable requirements in Municipal Stormwater Management Programs developed to comply with CDPS permits. The permittee must comply with local stormwater management requirements, policies and guidelines including those for erosion and sediment control.
- d. All construction site wastes must be properly managed to prevent potential pollution of state waters. This permit does not authorize on-site waste disposal.
- e. This permit does not relieve the permittee of the reporting requirements in 40 CFR 110, 40 CFR 117 or 40 CFR 302. Any discharge of hazardous material must be handled in accordance with the division's Noncompliance Notification Requirements (see Part II.L. of the permit).

C. STORMWATER MANAGEMENT PLAN (SWMP) REQUIREMENTS**1. SWMP General Requirements**

- a. A SWMP shall be developed for each construction site covered by this permit. The SWMP must be prepared in accordance with good engineering, hydrologic and pollution control practices.
 - i. For public emergency related sites a SWMP shall be created no later than 14 days after the commencement of construction activities.
- b. The permittee must implement the provisions of the SWMP as written and updated, from commencement of construction activity until final stabilization is complete. The division may review the SWMP.
- c. A copy of the SWMP must be retained onsite or be onsite when construction activities are occurring at the site unless the permittee specifies another location and obtains approval from the division.

2. SWMP Content

- a. The SWMP, at a minimum, must include the following elements.
 - i. Qualified Stormwater Manager. The SWMP must list individual(s) by title and name who are designated as the site's qualified stormwater manager(s) responsible for implementing the SWMP in its entirety. This role may be filled by more than one individual.
 - ii. Spill Prevention and Response Plan. The SWMP must have a spill prevention and response plan. The plan may incorporate by reference any part of a Spill Prevention Control and Countermeasure (SPCC) plan under section 311 of the Clean Water Act (CWA) or a Spill Prevention Plan required by a separate CDPS permit. The relevant sections of any referenced plans must be available as part of the SWMP consistent with Part I.C.4.
 - iii. Materials Handling. The SWMP must describe and locate all control measures implemented at the site to minimize impacts from handling **significant materials** that could contribute pollutants to runoff. These handling procedures can include control measures for pollutants and activities such as, exposed storage of building materials, paints and solvents, landscape materials, fertilizers or chemicals, sanitary waste material, trash and equipment maintenance or fueling procedures.
 - iv. Potential Sources of Pollution. The SWMP must list all potential sources of pollution which may reasonably be expected to affect the quality of stormwater discharges associated with construction activity from the site. This shall include, but is not limited to, the following pollutant sources:
 - (a) disturbed and stored soils;
 - (b) vehicle tracking of sediments;
 - (c) management of contaminated soils;
 - (d) loading and unloading operations;

- (e) outdoor storage activities (erodible building materials, fertilizers, chemicals, etc.);
 - (f) vehicle and equipment maintenance and fueling;
 - (g) significant dust or particulate generating processes (e.g., saw cutting material, including dust);
 - (h) routine maintenance activities involving fertilizers, pesticides, herbicides, detergents, fuels, solvents, oils, etc.;
 - (i) on-site waste management practices (waste piles, liquid wastes, dumpsters);
 - (j) concrete truck/equipment washing, including washing of the concrete truck chute and associated fixtures and equipment;
 - (k) dedicated asphalt, concrete batch plants and masonry mixing stations;
 - (l) non-industrial waste sources such as worker trash and portable toilets.
- v. Implementation of Control Measures. The SWMP must include design specifications that contain information on the implementation of the control measure in accordance with good engineering hydrologic and pollution control practices; including as applicable drawings, dimensions, installation information, materials, implementation processes, control measure-specific inspection expectations, and maintenance requirements.

The SWMP must include a documented use agreement between the permittee and the owner or operator of any control measures located outside of the permitted area, that are utilized by the permittee's construction site for compliance with this permit, but not under the direct control of the permittee. The permittee is responsible for ensuring that all control measures located outside of their permitted area, that are being utilized by the permittee's construction site, are properly maintained and in compliance with all terms and conditions of the permit. The SWMP must include all information required of and relevant to any such control measures located outside the permitted area, including location, installation specifications, design specifications and maintenance requirements.

- vi. Site Description. The SWMP must include a site description which includes, at a minimum, the following:
- (a) the nature of the construction activity at the site;
 - (b) the proposed schedule for the sequence for major construction activities and the planned implementation of control measures for each phase. (e.g.: clearing, grading, utilities, vertical, etc.);
 - (c) estimates of the total acreage of the site, and the acreage expected to be disturbed by clearing, excavation, grading, or any other construction activities;
 - (d) a summary of any existing data used in the development of the construction site plans or SWMP that describe the soil or existing potential for soil erosion;

- (e) a description of the percent of existing vegetative ground cover relative to the entire site and the method for determining the percentage;
 - (f) a description of any allowable non-stormwater discharges at the site, including those being discharged under a division low risk discharge guidance policy;
 - (g) a description of areas receiving discharge from the site. Including a description of the immediate source receiving the discharge. If the stormwater discharge is to a municipal separate storm sewer system, the name of the entity owning that system, the location of the storm sewer discharge, and the ultimate receiving water(s); and
 - (h) a description of all stream crossings located within the construction site boundary.
- vii. Site Map. The SWMP must include a site map which includes, at a minimum, the following:
- (a) construction site boundaries;
 - (b) flow arrows that depict stormwater flow directions on-site and runoff direction;
 - (c) all areas of ground disturbance including areas of borrow and fill;
 - (d) areas used for storage of soil;
 - (e) locations of all waste accumulation areas, including areas for liquid, concrete, masonry, and asphalt;
 - (f) locations of dedicated asphalt, concrete batch plants and masonry mixing stations;
 - (g) locations of all structural control measures;
 - (h) locations of all non-structural control measures;
 - (i) locations of springs, streams, wetlands and other state waters, including areas that require pre-existing vegetation be maintained within 50 feet of a receiving water, where determined feasible in accordance with Part I.B.1.a.i.(d).; and
 - (j) locations of all stream crossings located within the construction site boundary.
- viii. Final Stabilization and Long Term Stormwater Management. The SWMP must describe the practices used to achieve final stabilization of all disturbed areas at the site and any planned practices to control pollutants in stormwater discharges that will occur after construction operations are completed. Including but not limited to, detention/retention ponds, rain gardens, stormwater vaults, etc.
- ix. Inspection Reports. The SWMP must include documented inspection reports in accordance with Part ID.

3. SWMP Review and Revisions

Permittees must keep a record of SWMP changes made that includes the date and identification of the changes. The SWMP must be amended when the following occurs:

- a. a change in design, construction, operation, or maintenance of the site requiring implementation of new or revised control measures;
- b. the SWMP proves ineffective in controlling pollutants in stormwater runoff in compliance with the permit conditions;
- c. control measures identified in the SWMP are no longer necessary and are removed; and
- d. corrective actions are taken onsite that result in a change to the SWMP.

For SWMP revisions made prior to or following a change(s) onsite, including revisions to sections addressing site conditions and control measures, a notation must be included in the SWMP that identifies the date of the site change, the control measure removed, or modified, the location(s) of those control measures, and any changes to the control measure(s). The permittee must ensure the site changes are reflected in the SWMP. The permittee is noncompliant with the permit until the SWMP revisions have been made.

4. SWMP Availability

A copy of the SWMP must be provided upon request to the division, EPA, and any local agency with authority for approving sediment and erosion plans, grading plans or stormwater management plans within the time frame specified in the request. If the SWMP is required to be submitted to any of these entities, the submission must include a signed certification in accordance with Part I.A.3.e., certifying that the SWMP is complete and compliant with all terms and conditions of the permit.

All SWMPs required under this permit are considered reports that must be available to the public under Section 308(b) of the CWA and Section 61.5(4) of the CDPS regulations. The permittee must make plans available to members of the public upon request. However, the permittee may claim any portion of a SWMP as confidential in accordance with 40 CFR Part 2.

D. SITE INSPECTIONS

Site inspections must be conducted in accordance with the following requirements. The required inspection schedules are a minimum frequency and do not affect the permittee's responsibility to implement control measures in effective operating condition as prescribed in the SWMP. Proper maintenance of control measures may require more frequent inspections. Site inspections shall start within 7 calendar days of the commencement of construction activities on site.

1. Person Responsible for Conducting Inspections

The person(s) inspecting the site may be on the permittee's staff or a third party hired to conduct stormwater inspections under the direction of the permittee(s). The permittee is responsible for ensuring that the inspector is a qualified stormwater manager.

2. Inspection Frequency

Permittees must conduct site inspections in accordance with one of the following minimum frequencies, unless the site meets the requirements of Part ID.3

- a. At least one inspection every 7 calendar days. Or
- b. At least one inspection every 14 calendar days, if post-storm event inspections are conducted within 24 hours after the end of any precipitation or snowmelt event that causes surface erosion. Post-storm inspections may be used to fulfill the 14-day routine inspection requirement.
- c. When site conditions make the schedule required in this section impractical, the permittee may petition the Division to grant an alternate inspection schedule. The alternative inspection schedule may not be implemented prior to written approval by the division and incorporation into the SWMP.

3. Inspection Frequency for Discharges to Outstanding Waters

Permittees must conduct site inspections at least once every 7 calendar days for sites that discharge to a water body designated as an Outstanding Water by the Water Quality Control Commission.

4. Reduced Inspection Frequency

The permittee may perform site inspections at the following reduced frequencies when one of the following conditions exists:

a. Post-Storm Inspections at Temporarily Idle Sites

For permittees choosing to combine 14-day inspections and post-storm-event inspections, if no construction activities will occur following a storm event, post-storm event inspections must be conducted prior to re-commencing construction activities, but no later than 72 hours following the storm event. The delay of any post-storm event inspection must be documented in the inspection record. Routine inspections must still be conducted at least every 14 calendar days.

b. Inspections at Completed Sites/Areas

When the site, or portions of a site are awaiting establishment of a vegetative ground cover and final stabilization, the permittee must conduct a thorough inspection of the stormwater management system at least once every 30 days. Post-storm event inspections are not required under this schedule. This reduced inspection schedule is allowed if all of the following criteria are met:

- i. all construction activities resulting in ground disturbance are complete;
- ii. all activities required for final stabilization, in accordance with the SWMP, have been completed, with the exception of the application of seed that has not occurred due to seasonal conditions or the necessity for additional seed application to augment previous efforts; and
- iii. the SWMP has been amended to locate those areas to be inspected in accordance with the reduced schedule allowed for in this paragraph.

c. Winter Conditions Inspections Exclusion

Inspections are not required for sites that meet all of the following conditions: construction activities are temporarily halted, snow cover exists over the entire site for an extended period, and melting conditions posing a risk of surface erosion do not exist. This inspection exception is applicable only during the period where melting conditions do not exist, and applies to the routine 7-day, 14-day and monthly inspections, as well as the post-storm-event inspections. When this inspection exclusion is implemented, the following information must be documented in accordance with the requirements in Part II:

- i. dates when snow cover existed;
- ii. date when construction activities ceased; and
- iii. date melting conditions began.

5. Inspection Scope

a. Areas to be Inspected

When conducting a site inspection the following areas, if applicable, must be inspected for evidence of, or the potential for, pollutants leaving the construction site boundaries, entering the stormwater drainage system, or discharging to state waters:

- i. construction site perimeter;
- ii. all disturbed areas;
- iii. designated haul routes;
- iv. material and waste storage areas exposed to precipitation;
- v. locations where stormwater has the potential to discharge offsite; and
- vi. locations where vehicles exit the site.

b. Inspection Requirements

- i. Visually verify whether all implemented control measures are in effective operational condition and are working as designed in their specifications to minimize pollutant discharges.
- ii. Determine if there are new potential sources of pollutants.
- iii. Assess the adequacy of control measures at the site to identify areas requiring new or modified control measures to minimize pollutant discharges.
- iv. Identify all areas of non-compliance with the permit requirements and, if necessary, implement corrective action in accordance with Part IB.1.c.

c. Inspection Reports

The permittee must keep a record of all inspections conducted for each permitted site. Inspection reports must identify any incidents of noncompliance with the terms and conditions of this permit. Inspection records must be retained in accordance with Part II.O. and signed in accordance with Part I.A.3.f. At a minimum, the inspection report must include:

- i. the inspection date;

- ii. name(s) and title(s) of personnel conducting the inspection;
- iii. weather conditions at the time of inspection;
- iv. phase of construction at the time of inspection;
- v. estimated acreage of disturbance at the time of inspection
- vi. location(s) of discharges of sediment or other pollutants from the site;
- vii. location(s) of control measures needing maintenance;
- viii. location(s) and identification of inadequate control measures;
- ix. location(s) and identification of additional control measures are needed that were not in place at the time of inspection;
- x. description of the minimum inspection frequency (either in accordance with Part I.D.2., I.D.3. or I.D.4.) utilized when conducting each inspection.
- xi. deviations from the minimum inspection schedule as required in Part I.D.2.;
- xii. after adequate corrective action(s) and maintenance have been taken, or where a report does not identify any incidents requiring corrective action or maintenance, the report shall contain a statement as required in Part I.A.3.f.

E. DEFINITIONS

For the purposes of this permit:

- (1) Bypass - the intentional diversion of waste streams from any portion of a treatment facility in accordance with 40 CFR 122.41(m)(1)(i) and Regulation 61.2(12).
- (2) Common Plan of Development or Sale - A contiguous area where multiple separate and distinct construction activities may be taking place at different times on different schedules, but remain related. The Division has determined that "contiguous" means construction activities located in close proximity to each other (within ¼ mile). Construction activities are considered to be "related" if they share the same development plan, builder or contractor, equipment, storage areas, etc. "Common plan of development or sale" includes construction activities that are associated with the construction of field wide oil and gas permits for facilities that are related.
- (3) Construction Activity - Ground surface disturbing and associated activities (land disturbance), which include, but are not limited to, clearing, grading, excavation, demolition, installation of new or improved haul roads and access roads, staging areas, stockpiling of fill materials, and borrow areas. Construction does not include routine maintenance to maintain the original line and grade, hydraulic capacity, or original purpose of the facility. Activities to conduct repairs that are not part of routine maintenance or for replacement are construction activities and are not routine maintenance. Repaving activities where underlying and/or surrounding soil is exposed as part of the repaving operation are considered construction activities. Construction activity is from initial ground breaking to final stabilization regardless of ownership of the construction activities.
- (4) Control Measure - Any best management practice or other method used to prevent or reduce the discharge of pollutants to state waters. Control measures include, but are not limited to, best management practices. Control measures can include other methods such as the installation, operation, and maintenance of structural controls and treatment devices.

- (5) Control Measure Requiring Routine Maintenance - Any control measure that is still operating in accordance with its design and the requirements of this permit, but requires maintenance to prevent a breach of the control measure. See also inadequate control measure.
- (6) Dedicated Asphalt, Concrete Batch Plants and Masonry Mixing Stations - are batch plants or mixing stations located on, or within ¼ mile of, a construction site and that provide materials only to that specific construction site.
- (7) Final Stabilization - The condition reached when all ground surface disturbing activities at the site have been completed, and for all areas of ground surface disturbing activities where a uniform vegetative cover has been established with an individual plant density of at least 70 percent of pre-disturbance levels, or equivalent permanent, physical erosion reduction methods have been employed.
- (8) Good Engineering, Hydrologic and Pollution Control Practices: are methods, procedures, and practices that:
 - a. Are based on basic scientific fact(s).
 - b. Reflect best industry practices and standards.
 - c. Are appropriate for the conditions and pollutant sources.
 - d. Provide appropriate solutions to meet the associated permit requirements, including practice based effluent limits.
- (9) Inadequate Control Measure - Any control measure that is not designed or implemented in accordance with the requirements of the permit and/or any control measure that is not implemented to operate in accordance with its design. See also Control Measure Requiring Routine Maintenance.
- (10) Infeasible - Not technologically possible, or not economically practicable and achievable in light of best industry practices.
- (11) Minimize - reduce or eliminate to the extent achievable using control measures that are technologically available and economically practicable and achievable in light of best industry practice.
- (12) Municipality - A city, town, county, district, association, or other public body created by, or under, State law and having jurisdiction over disposal of sewage, industrial wastes, or other wastes, or a designated and approved management agency under section 208 of CWA (1987).
- (13) Municipal Separate Storm Sewer System (MS4) - A conveyance or system of conveyances (including roads with drainage systems, municipal streets, catch basins, curbs, gutters, ditches, man-made channels, or storm drains):
 - a) owned or operated by a State, city, town, county, district, association, or other public body (created by or pursuant to State law) having jurisdiction over disposal of sewage, industrial wastes, stormwater, or other wastes, including special districts under State law such as a sewer district, flood control district or drainage district, or similar entity, or a designated and approved management agency under section 208 of the CWA that discharges to state waters;
 - i. designed or used for collecting or conveying stormwater;
 - ii. are not a combined sewer; and
 - iii. are not part of a Publicly Owned Treatment Works (POTW). See 5 CCR 1002-61.2(62).
- (14) Municipal Stormwater Management Program - A stormwater program operated by a municipality, typically to meet the requirements of the municipalities MS4 discharge certification.

- (15) Operator - The party that has operational control over day-to-day activities at a project site which are necessary to ensure compliance with the permit. This party is authorized to direct individuals at a site to carry out activities required by the permit. (e.g. the general contractor)
- (16) Owner - The party that has overall control of the activities and that has funded the implementation of the construction plans and specifications. This is the party with ownership of, a long term lease of, or easements on the property on which the construction activity is occurring (e.g., the developer).
- (17) Permittee(s) - The owner and operator named in the discharge certification issued under this permit for the construction site specified in the certification.
- (18) Point Source - Any discernible, confined, and discrete conveyance, including, but not limited to, any pipe, ditch, channel, tunnel, conduit, well, discrete fissure, container, rolling stock, concentrated animal feeding operation, or vessel or other floating craft, from which pollutants are or may be discharged. Point source does not include irrigation return flow. See 5 CCR 102-61.2(75).
- (19) Pollutant - Dredged spoil, dirt, slurry, solid waste, incinerator residue, sewage, sewage sludge, garbage, trash, chemical waste, biological nutrient, biological material, radioactive material, heat, wrecked or discarded equipment, rock, sand, or any industrial, municipal or agricultural waste. See 5 CCR 1002-61.2(76).
- (20) Presentation of credentials - a government issued form of identification, if in person; or (ii) providing name, position and purpose of inspection if request to enter is made via telephone, email or other form of electronic communication. A Permittee's non-response to a request to enter upon presentation of credentials constitutes a denial to such request, and may result in violation of the Permit.
- (21) Process Water - Any water which, during manufacturing or processing, comes into contact with or results from the production of any raw material, intermediate product, finished product, by product or waste product.
- (22) Public Emergency Related Site - a project initiated in response to an unanticipated emergency (e.g., mud slides, earthquake, extreme flooding conditions, disruption in essential public services), for which the related work requires immediate authorization to avoid imminent endangerment to human health or the environment, or to reestablish essential public services.
- (23) Qualified Stormwater Manager - An individual knowledgeable in the principles and practices of erosion and sediment control and pollution prevention, and with the skills to assess conditions at construction sites that could impact stormwater quality and to assess the effectiveness of stormwater controls implemented to meet the requirements of this permit.
- (24) Qualifying Local Program - A municipal program for stormwater discharges associated with small construction activity that was formally approved by the division as a qualifying local program.
- (25) Receiving Water - Any classified or unclassified surface water segment (including tributaries) in the State of Colorado into which stormwater associated with construction activities discharges. This definition includes all water courses, even if they are usually dry, such as borrow ditches, arroyos, and other unnamed waterways.
- (26) Severe Property Damage - substantial physical damage to property, damage to the treatment facilities which causes them to become inoperable, or substantial and permanent loss of natural resources which can reasonably be expected to occur in the absence of a bypass. Severe property damage does not mean economic loss caused by delays in production. See 40 CFR 122.41(m)(1)(ii).

- (27) Significant Materials - Include, but not limited to, raw materials; fuels; materials such as solvents, detergents, and plastic pellets; finished materials such as metallic products; raw materials used in food processing or production; hazardous substances designated under section 101(14) of CERCLA; any chemical the permittee is required to report under section 313 of Title III of the Superfund Amendments and Reauthorization Act (SARA); fertilizers; pesticides; and waste products such as ashes, slag and sludge that have the potential to be released with stormwater discharges.
- (28) Small Construction Activity - The discharge of stormwater from construction activities that result in land disturbance of equal to, or greater than, one acre and less than five acres. Small construction activity also includes the disturbance of less than one acre of total land area that is part of a larger common plan of development or sale, if the larger common plan ultimately disturbs equal to, or greater than, one acre and less than five acres.
- (29) Spill - An unintentional release of solid or liquid material which may pollute state waters.
- (30) State Waters - means any and all surface and subsurface waters which are contained in or flow in or through this state, but does not include waters in sewage systems, waters in treatment works of disposal systems, waters in potable water distribution systems, and all water withdrawn for use until use and treatment have been completed.
- (31) Steep Slopes: where a local government, or industry technical manual (e.g., stormwater BMP manual) has defined what is to be considered a "steep slope", this permit's definition automatically adopts that definition. Where no such definition exists, steep slopes are automatically defined as those that are 3:1 or greater.
- (32) Stormwater - Precipitation runoff, snow melt runoff, and surface runoff and drainage. See 5 CCR 1002-61.2(103).
- (33) Total Maximum Daily Loads (TMDLs) -The sum of the individual wasteload allocations (WLA) for point sources and load allocations (LA) for nonpoint sources and natural background. For the purposes of this permit, a TMDL is a calculation of the maximum amount of a pollutant that a waterbody can receive and still meet water quality standards, and an allocation of that amount to the pollutant's sources. A TMDL includes WLAs, LAs, and must include a margin of safety (MOS), and account for seasonal variations. See section 303(d) of the CWA and 40 C.F.R. 130.2 and 130.7.
- (34) Upset - an exceptional incident in which there is unintentional and temporary noncompliance with permit effluent limitations because of factors beyond the reasonable control of the permittee. An upset does not include noncompliance to the extent caused by operational error, improperly designed treatment facilities, inadequate treatment facilities, lack of preventative maintenance, or careless or improper operation in accordance with 40 CFR 122.41(n) and Regulation 61.2(114).

F. MONITORING

The division may require sampling and testing, on a case-by-case basis. If the division requires sampling and testing, the division will send a notification to the permittee. Reporting procedures for any monitoring data collected will be included in the notification.

If monitoring is required, the following applies:

1. the thirty (30) day average must be determined by the arithmetic mean of all samples collected during a thirty (30) consecutive-day period; and
2. a grab sample, for monitoring requirements, is a single "dip and take" sample.

G. Oil and Gas Construction

Stormwater discharges associated with construction activities directly related to oil and gas exploration, production, processing, and treatment operations or transmission facilities are regulated under the Colorado Discharge Permit System Regulations (5 CCR 1002-61), and require coverage under this permit in accordance with that regulation. However, references in this permit to specific authority under the CWA do not apply to stormwater discharges associated with these oil and gas related construction activities, to the extent that the references are limited by the federal Energy Policy Act of 2005.

Part II: Standard Permit Conditions

A. DUTY TO COMPLY

The permittee must comply with all conditions of this permit. Any permit noncompliance constitutes a violation of the Water Quality Control Act and is grounds for:

- a. enforcement action;
- b. permit termination, revocation and reissuance, or modification; or
- c. denial of a permit renewal application.

B. DUTY TO REAPPLY

If the permittee wishes to continue an activity regulated by this permit after the expiration date of this permit, the permittee must apply for and obtain authorization as required by Part I.A.3.k. of the permit.

C. NEED TO HALT OR REDUCE ACTIVITY NOT A DEFENSE

It shall not be a defense for a permittee in an enforcement action that it would have been necessary to halt or reduce the permitted activity in order to maintain compliance with the conditions of this permit.

D. DUTY TO MITIGATE

A permittee must take all reasonable steps to minimize or prevent any discharge in violation of this permit which has a reasonable likelihood of adversely affecting human health or the environment.

E. PROPER OPERATION AND MAINTENANCE

A permittee must at all times properly operate and maintain all facilities and systems of treatment and control (and related appurtenances) that are installed or used by the permittee to achieve compliance with the conditions of this permit. Proper operation and maintenance also includes adequate laboratory controls and appropriate quality assurance procedures. This provision requires the operation of backup or auxiliary facilities or similar systems which are installed by the permittee only when the operation is necessary to achieve compliance with the conditions of this permit. This requirement can be met by meeting the requirements for Part I.B., I.C., and I.D. above. See also 40 C.F.R. § 122.41(e).

F. PERMIT ACTIONS

This permit may be modified, revoked and reissued, or terminated for cause. The permittee request for a permit modification, revocation and reissuance, or termination, or a notification of planned changes or anticipated noncompliance does not stay any permit condition. Any request for modification, revocation, reissuance, or termination under this permit must comply with all terms and conditions of Regulation 61.8(8).

G. PROPERTY RIGHTS

In accordance with 40 CFR 122.41(g) and 5 CCR 1002-61, 61.8(9):

1. The issuance of a permit does not convey any property or water rights in either real or personal property, or stream flows or any exclusive privilege.

2. The issuance of a permit does not authorize any injury to person or property or any invasion of personal rights, nor does it authorize the infringement of federal, state, or local laws or regulations.
3. Except for any toxic effluent standard or prohibition imposed under Section 307 of the Federal act or any standard for sewage sludge use or disposal under Section 405(d) of the Federal act, compliance with a permit during its term constitutes compliance, for purposes of enforcement, with Sections 301, 302, 306, 318, 403, and 405(a) and (b) of the Federal act. However, a permit may be modified, revoked and reissued, or terminated during its term for cause as set forth in Section 61.8(8) of the Colorado Discharge Permit System Regulations.

H. DUTY TO PROVIDE INFORMATION

The permittee shall furnish to the division, within a reasonable time, any information which the division may request to determine whether cause exists for modifying, revoking and reissuing, or terminating this permit, or to determine compliance with this permit. The permittee shall also furnish to the division, upon request, copies of records required to be kept by this permit in accordance with 40 CFR 122.41(h) and/or Regulation 61.8(3)(q).

I. INSPECTION AND ENTRY

The permittee shall allow the division and the authorized representative, upon the presentation of credentials as required by law, to allow for inspections to be conducted in accordance with 40 CFR 122.41(i), Regulation 61.8(3), and Regulation 61.8(4):

1. to enter upon the permittee's premises where a regulated facility or activity is located or in which any records are required to be kept under the terms and conditions of this permit;
2. at reasonable times to have access to and copy any records required to be kept under the terms and conditions of this permit;
3. at reasonable times, inspect any monitoring equipment or monitoring method required in the permit; and
4. to enter upon the permittee's premises in a reasonable manner and at a reasonable time to inspect or investigate, any actual, suspected, or potential source of water pollution, or any violation of the Colorado Water Quality Control Act. The investigation may include: sampling of any discharges, stormwater or process water, taking of photographs, interviewing site staff on alleged violations and other matters related to the permit, and assessing any and all facilities or areas within the site that may affect discharges, the permit, or an alleged violation.

The permittee shall provide access to the division or other authorized representatives upon presentation of proper credentials. A permittee's non-response to a request to enter upon presentation of credentials constitutes a denial of such request, and may result in a violation of the permit.

J. MONITORING AND RECORDS

1. Samples and measurements taken for the purpose of monitoring must be representative of the volume and nature of the monitored activity.

2. The permittee must retain records of all monitoring information, including all calibration and maintenance records and all original strip chart recordings for continuous monitoring instrumentation, copies of all reports required by this permit, and records of all data used to complete the application for this permit, for a period of at least three years from the date the permit expires or the date the permittee's authorization is terminated. This period may be extended by request of the division at any time.
3. Records of monitoring information must include:
 - a. The date, exact place, and time of sampling or measurements;
 - b. The individual(s) who performed the sampling or measurements;
 - c. The date(s) analyses were performed
 - d. The individual(s) who performed the analyses;
 - e. The analytical techniques or methods used; and
 - f. The results of such analyses.
4. Monitoring must be conducted according to test procedures approved under 40 CFR Part 136, unless other test procedures have been specified in the permit.

K. SIGNATORY REQUIREMENTS

1. Authorization to Sign:

All documents required to be submitted to the division by the permit must be signed in accordance with the following criteria:

- a. For a corporation: By a responsible corporate officer. For the purpose of this subsection, a responsible corporate officer means:
 - i. a president, secretary, treasurer, or vice president of the corporation in charge of a principal business function, or any other person who performs similar policy- or decision-making functions for the corporation, or
 - ii. the manager of one or more manufacturing, production, or operating facilities, provided, the manager is authorized to make management decisions which govern the operation of the regulated facility including having the explicit or implicit duty of making major capital investment recommendations, and initiating and directing other comprehensive measures to assure long term environmental compliance with environmental laws and regulations; the manager can ensure that the necessary systems are established or actions taken to gather complete and accurate information for permit application requirements; and where authority to sign documents has been assigned or delegated to the manager in accordance with corporate procedures.
- b. For a partnership or sole proprietorship: By a general partner or the proprietor, respectively; or
- c. For a municipality, state, federal, or other public agency: By either a principal executive officer or ranking elected official. For purposes of this subsection, a principal executive officer of a federal agency includes
 - i. (i) the chief executive officer of the agency, or

- ii. (ii) a senior executive officer having responsibility for the overall operations of a principal geographic unit of the agency. (e.g., Regional Administrator of EPA)

2. Electronic Signatures

For persons signing applications for coverage under this permit electronically, in addition to meeting other applicable requirements stated above, such signatures must meet the same signature, authentication, and identity-proofing standards set forth at 40 CFR § 3.2000(b) for electronic reports (including robust second-factor authentication). Compliance with this requirement can be achieved by submitting the application using the Colorado Environmental Online Service (CEOS) system.

3. Change in Authorization to Sign

If an authorization is no longer accurate because a different individual or position has responsibility for the overall operation of the facility, a new authorization must be submitted to the division, prior to the re-authorization, or together with any reports, information, or applications to be signed by an authorized representative.

L. REPORTING REQUIREMENTS

1. Planned Changes

The permittee shall give advance notice to the division, in writing, of any planned physical alterations or additions to the permitted facility in accordance with 40 CFR 122.41(l) and Regulation 61.8(5)(a). Notice is required only when:

- a. The alteration or addition to a permitted facility may meet one of the criteria for determining whether a facility is a new source in 40 CFR 122.29(b); or
- b. The alteration or addition could significantly change the nature or increase the quantity of pollutants discharged. This notification applies to pollutants which are subject neither to effluent limitations in the permit, nor to notification requirements under 40 CFR 122.41(a)(1).

2. Anticipated Non-Compliance

The permittee shall give advance notice to the division, in writing, of any planned changes in the permitted facility or activity that may result in noncompliance with permit requirements. The timing of notification requirements differs based on the type of non-compliance as described in subparagraphs 5, 6, 7, and 8 below.

3. Transfer of Ownership or Control

The permittee shall notify the division, in writing, ten (10) calendar days in advance of a proposed transfer of the permit. This permit is not transferable to any person except after notice is given to the division.

- a. Where a facility wants to change the name of the permittee, the original permittee (the first owner or operators) must submit a Notice of Termination.
- b. The new owner or operator must submit an application. See also signature requirements in Part II.K, above.
- c. A permit may be automatically transferred to a new permittee if:
 - i. The current permittee notifies the Division in writing 30 calendar days in advance of the proposed transfer date; and
 - ii. The notice includes a written agreement between the existing and new permittee(s) containing a specific date for transfer of permit responsibility, coverage and liability between them; and
 - iii. The division does not notify the existing permittee and the proposed new permittee of its intent to modify, or revoke and reissue the permit.
 - iv. Fee requirements of the Colorado Discharge Permit System Regulations, Section 61.15, have been met.

4. Monitoring reports

Monitoring results must be reported at the intervals specified in this permit per the requirements of 40 CFR 122.41(l)(4).

5. Compliance Schedules

Reports of compliance or noncompliance with, or any progress reports on, interim and final requirements contained in any compliance schedule in the permit, shall be submitted on the date listed in the compliance schedule section. The fourteen (14) calendar day provision in Regulation 61.8(4)(n)(i) has been incorporated into the due date.

6. Twenty-four hour reporting

In addition to the reports required elsewhere in this permit, the permittee shall report the following circumstances orally within twenty-four (24) hours from the time the permittee becomes aware of the circumstances, and shall mail to the division a written report containing the information requested within five (5) working days after becoming aware of the following circumstances:

- a. Circumstances leading to any noncompliance which may endanger health or the environment regardless of the cause of the incident;
- b. Circumstances leading to any unanticipated bypass which exceeds any effluent limitations in the permit;
- c. Circumstances leading to any upset which causes an exceedance of any effluent limitation in the permit;

- d. Daily maximum violations for any of the pollutants limited by Part I of this permit. This includes any toxic pollutant or hazardous substance or any pollutant specifically identified as the method to control any toxic pollutant or hazardous substance.
- e. The division may waive the written report required under subparagraph 6 of this section if the oral report has been received within 24 hours.

7. Other non-compliance

A permittee must report all instances of noncompliance at the time monitoring reports are due. If no monitoring reports are required, these reports are due at least annually in accordance with Regulation 61.8(4)(p). The annual report must contain all instances of non-compliance required under either subparagraph 5 or subparagraph 6 of this subsection.

8. Other information

Where a permittee becomes aware that it failed to submit any relevant facts in a permit application, or submitted incorrect information in a permit application, or in any report to the Permitting Authority, it has a duty to promptly submit such facts or information.

M. BYPASS

1. Bypass not exceeding limitations

The permittees may allow any bypass to occur which does not cause effluent limitations to be exceeded, but only if it also is for essential maintenance to assure efficient operation. These bypasses are not subject to the provisions of Part II.M.2 of this permit. See 40 CFR 122.41(m)(2).

2. Notice of bypass

- a. Anticipated bypass. If the permittee knows in advance of the need for a bypass, the permittee must submit prior notice, if possible at least ten days before the date of the bypass. See 40 CFR §122.41(m)(3)(i) and/or Regulation 61.9(5)(c).
- b. Unanticipated bypass. The permittee must submit notice of an unanticipated bypass in accordance with Part II.L.6. See 40 CFR §122.41(m)(3)(ii) .

3. Prohibition of Bypass

Bypasses are prohibited and the division may take enforcement action against the permittee for bypass, unless:

- i. the bypass is unavoidable to prevent loss of life, personal injury, or severe property damage;

- ii. There were no feasible alternatives to the bypass, such as the use of auxiliary treatment facilities, retention of untreated wastes, or maintenance during normal periods of equipment downtime. This condition is not satisfied if adequate backup equipment should have been installed in the exercise of reasonable engineering judgment to prevent a bypass which occurred during normal periods of equipment downtime or preventive maintenance; and
- iii. proper notices were submitted to the division.

N. UPSET

1. Effect of an upset

An upset constitutes an affirmative defense to an action brought for noncompliance with permit effluent limitations if the requirements of Part II.N.2. of this permit are met. No determination made during administrative review of claims that noncompliance was caused by upset, and before an action for noncompliance, is final administrative action subject to judicial review in accordance with Regulation 61.8(3)(j).

2. Conditions necessary for demonstration of an Upset

A permittee who wishes to establish the affirmative defense of upset shall demonstrate through properly signed contemporaneous operating logs, or other relevant evidence that

- a. an upset occurred and the permittee can identify the specific cause(s) of the upset;
- b. the permitted facility was at the time being properly operated and maintained; and
- c. the permittee submitted proper notice of the upset as required in Part II.L.6. (24-hour notice); and
- d. the permittee complied with any remedial measure necessary to minimize or prevent any discharge or sludge use or disposal in violation of this permit which has a reasonable likelihood of adversely affecting human health or the environment. In addition to the demonstration required above, a permittee who wishes to establish the affirmative defense of upset for a violation of effluent limitations based upon water quality standards shall also demonstrate through monitoring, modeling or other methods that the relevant standards were achieved in the receiving water.

3. Burden of Proof

In any enforcement proceeding, the permittee seeking to establish the occurrence of an upset has the burden of proof.

O. RETENTION OF RECORDS

1. Post-Expiration or Termination Retention

Copies of documentation required by this permit, including records of all data used to complete the application for permit coverage to be covered by this permit, must be

retained for at least three years from the date that permit coverage expires or is terminated. This period may be extended by request of EPA at any time.

2. On-site Retention

The permittee must retain an electronic version or hardcopy of the SWMP at the construction site from the date of the initiation of construction activities to the date of expiration or inactivation of permit coverage; unless another location, specified by the permittee, is approved by the division.

P. REOPENER CLAUSE

1. Procedures for modification or revocation

Permit modification or revocation of this permit or coverage under this permit will be conducted according to Regulation 61.8(8).

2. Water quality protection

If there is evidence indicating that the stormwater discharges authorized by this permit cause, have the reasonable potential to cause or contribute to an excursion above any applicable water quality standard, the permittee may be required to obtain an individual permit, or the permit may be modified to include different limitations and/or requirements.

Q. SEVERABILITY

The provisions of this permit are severable. If any provisions or the application of any provision of this permit to any circumstances, is held invalid, the application of such provision to other circumstances and the application of the remainder of this permit shall not be affected.

R. NOTIFICATION REQUIREMENTS

1. Notification to Parties

All notification requirements, excluding information submitted using the CEOS portal, shall be directed as follows:

a. Oral Notifications, during normal business hours shall be to:

Clean Water Compliance Section
Water Quality Control Division
Telephone: (303) 692-3500

b. Written notification shall be to:

Clean Water Compliance Section
Water Quality Control Division
Colorado Department of Public Health and Environment
WQCD-WQP-B2
4300 Cherry Creek Drive South
Denver, CO 80246-1530

S. RESPONSIBILITIES**1. Reduction, Loss, or Failure of Treatment Facility**

The permittee has the duty to halt or reduce any activity if necessary to maintain compliance with the effluent limitations of the permit. It shall not be a defense for a permittee in an enforcement action that it would be necessary to halt or reduce the permitted activity in order to maintain compliance with the conditions of this permit.

T. Oil and Hazardous Substance Liability

Nothing in this permit shall be construed to preclude the institution of any legal action or relieve the permittee from any responsibilities, liabilities, or penalties to which the permittee is or may be subject to under Section 311 (Oil and Hazardous Substance Liability) of the CWA.

U. Emergency Powers

Nothing in this permit shall be construed to prevent or limit application of any emergency power of the division.

V. Confidentiality

Any information relating to any secret process, method of manufacture or production, or sales or marketing data which has been declared confidential by the permittee, and which may be acquired, ascertained, or discovered, whether in any sampling investigation, emergency investigation, or otherwise, shall not be publicly disclosed by any member, officer, or employee of the Water Quality Control Commission or the division, but shall be kept confidential. Any person seeking to invoke the protection of of this section shall bear the burden of proving its applicability. This section shall never be interpreted as preventing full disclosure of effluent data.

W. Fees

The permittee is required to submit payment of an annual fee as set forth in the 2016 amendments to the Water Quality Control Act. Section 25-8-502 (1.1) (b), and the Colorado Discharge Permit System Regulations 5 CCR 1002-61, Section 61.15 as amended. Failure to submit the required fee when due and payable is a violation of the permit and will result in enforcement action pursuant to Section 25-8-601 et. seq., C.R.S.1973 as amended.

X. Duration of Permit

The duration of a permit shall be for a fixed term and shall not exceed five (5) years. If the permittee desires to continue to discharge, a permit renewal application shall be submitted at least ninety (90) calendar days before this permit expires. Filing of a timely and complete application shall cause the expired permit to continue in force to the effective date of the new permit. The permit's duration may be extended only through administrative extensions and not through interim modifications. If the permittee anticipates there will be no discharge after the expiration date of this permit, the division should be promptly notified so that it can terminate the permit in accordance with Part I.A.3.i.

Y. Section 307 Toxics

If a toxic effluent standard or prohibition, including any applicable schedule of compliance specified, is established by regulation pursuant to Section 307 of the Federal Act for a toxic pollutant which is present in the permittee's discharge and such standard or prohibition is more stringent than any limitation upon such pollutant in the discharge permit, the division

shall institute proceedings to modify or revoke and reissue the permit to conform to the toxic effluent standard or prohibition

APPENDIX C – FEMA FIRM MAP



ff1



(1) 6 8 8 (8) 8 8 8

	LWKRW %DHJRRGOHMDLRLQ % -FCH\$ 9 \$
	LWK%RU#BVK -FCH\$ 9 9 \$
	#HODWRAJRRGD

	\$DDO &OOHJRRG EPUG \$H/D/ R DDDO FROFHJRRG ZWKDHUDH G-BVKOHV WKOQRHRRW RU ZWKGDLOO DJH/D R OHW WKOQRHVDOUHOH#CH;
	XWXUH&GL WLRLQ/\$DDO &OOHJRRG EPUG -FCH;
	\$HJZWK\$GTHGJRRG LNGHWR HHH GH RVH -FCH;
	\$HJZWKJRRG LNGHWRHHH -FCH

	\$HJDR OQLBO JRRG EPUG -FCH;
	(HFWLYH#
	\$HJDR OGWVHJRGJRRG EPUG -FCH
	&OQD &OYUW RU OVRUR#ZU
	HHH LNH RU JRRGZOO

	\$JRW O FVLRQ/ ZWKSDDO &OOH
	DVHU OUIDFOHMDLRLQ
	&DWDJ TUDQFW
	%DHJRRGOHMDLRLQLQ %
	LEW R O VVG
	-XULVL FVLRQ%ROOEU
	&DWDJ TUDQFW %DHLQH
	URLOH%DHLQH
	URUDSLFJ#DVUH

	LJLWDO DWD\$DLOOEOH
	RLLWDO DWD\$DLOOEOH
	OOSS-G

7HSLQGL VSDHGRQWKHBSLV DQDSURLBWH
SRLQV VHOHFWHGE WKH XHU DQG GRV CRV UHSHU
DQDWRULWDLV YHSURSUW ODFDLRLQ

7LV BSBOLHV ZWKJW WDOOJG/IRU WKH XHR
GLJWDO IO RRG B/LI LW LV CRV YRLGDV GHVULB#G#ORZ
7HEDHBS VGRQFBOLHV ZWKJW EDHBS
DFXDF WDOOJG/

7HIO RRGKQJGL QRUBMLRQLV GHLYHGLUHFWOIURVWKH
DVKRULWDLV YH#ZEVUYLHV SURLGH#G# 7LV BSB
ZV HSRUWHGRQ DV 3 DQG GRV CRV
UHOFRV RQJHV RU DQGRQW VEHIXQV VRWKL V GMDH DQ
WLF 7HJ DQGH IIFWLYHLQRUBMLRQ B RQJHRU
BFRFVSHUV#G#G#QZDQVDRYHU WLF

7LV BSLBHLV YRLGLI WKHQHRU RUHR WKHIOORZ QJBS
HOFRWV GRQRV DSB#DJ EDHBSLBHU IO RRG JROHDFHV
OHJOG VROHEDU BSRUHWDLRLQDWH FRQLWALGQMLLHV
)SSQD QEHU DQGH OHHIIFWLYHGDVH DSLBHVIRU
XOBS#G DQGRG#UQLJGDUJH FQGRV BHXV#GIRU
UHODWRU#SUSRVH

674 DWL RQD OS DW R DHU DWDPUSU H HGRV RSH ed October, 2020.



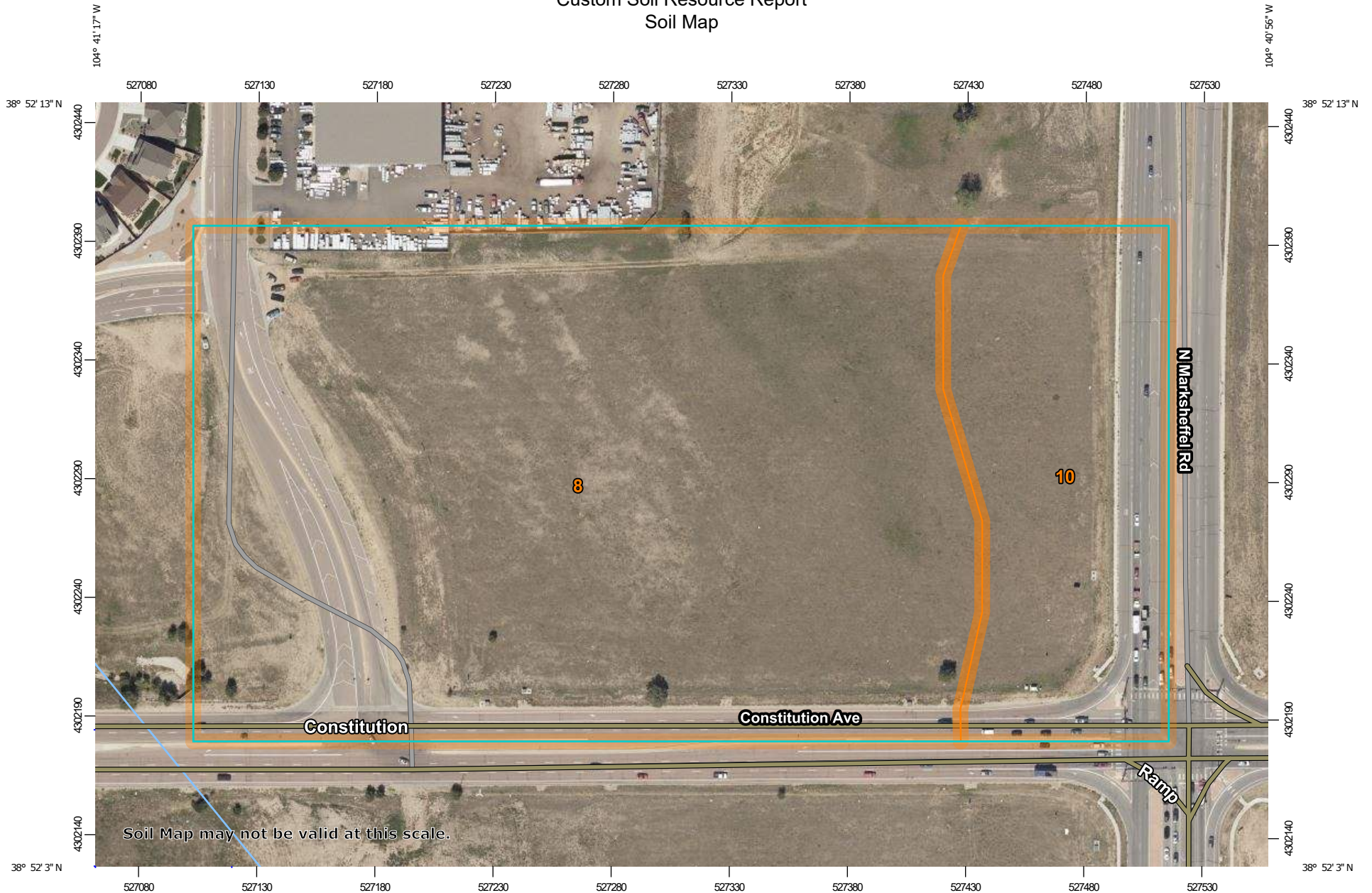



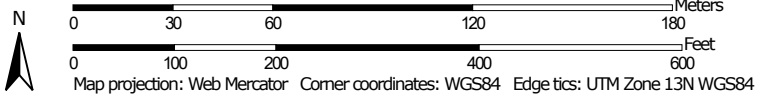





























Custom Soil Resource Report Soil Map



Map Scale: 1:2,270 if printed on A landscape (11" x 8.5") sheet.



MAP LEGEND

- Area of Interest (AOI)**
 -  Area of Interest (AOI)
- Soils**
 -  Soil Map Unit Polygons
 -  Soil Map Unit Lines
 -  Soil Map Unit Points
- Special Point Features**
 -  Blowout
 -  Borrow Pit
 -  Clay Spot
 -  Closed Depression
 -  Gravel Pit
 -  Gravelly Spot
 -  Landfill
 -  Lava Flow
 -  Marsh or swamp
 -  Mine or Quarry
 -  Miscellaneous Water
 -  Perennial Water
 -  Rock Outcrop
 -  Saline Spot
 -  Sandy Spot
 -  Severely Eroded Spot
 -  Sinkhole
 -  Slide or Slip
 -  Sodic Spot
- Water Features**
 -  Streams and Canals
- Transportation**
 -  Rails
 -  Interstate Highways
 -  US Routes
 -  Major Roads
 -  Local Roads
- Background**
 -  Aerial Photography
-  Spoil Area
-  Stony Spot
-  Very Stony Spot
-  Wet Spot
-  Other
-  Special Line Features

MAP INFORMATION

The soil surveys that comprise your AOI were mapped at 1:24,000.

Warning: Soil Map may not be valid at this scale.

Enlargement of maps beyond the scale of mapping can cause misunderstanding of the detail of mapping and accuracy of soil line placement. The maps do not show the small areas of contrasting soils that could have been shown at a more detailed scale.

Please rely on the bar scale on each map sheet for map measurements.

Source of Map: Natural Resources Conservation Service
 Web Soil Survey URL:
 Coordinate System: Web Mercator (EPSG:3857)

Maps from the Web Soil Survey are based on the Web Mercator projection, which preserves direction and shape but distorts distance and area. A projection that preserves area, such as the Albers equal-area conic projection, should be used if more accurate calculations of distance or area are required.

This product is generated from the USDA-NRCS certified data as of the version date(s) listed below.

Soil Survey Area: El Paso County Area, Colorado
 Survey Area Data: Version 18, Jun 5, 2020

Soil map units are labeled (as space allows) for map scales 1:50,000 or larger.

Date(s) aerial images were photographed: Aug 19, 2018—Sep 23, 2018

The orthophoto or other base map on which the soil lines were compiled and digitized probably differs from the background imagery displayed on these maps. As a result, some minor shifting of map unit boundaries may be evident.

Map Unit Legend

Map Unit Symbol	Map Unit Name	Acres in AOI	Percent of AOI
8	Blakeland loamy sand, 1 to 9 percent slopes	17.5	78.8%
10	Blendon sandy loam, 0 to 3 percent slopes	4.7	21.2%
Totals for Area of Interest		22.3	100.0%

Map Unit Descriptions

The map units delineated on the detailed soil maps in a soil survey represent the soils or miscellaneous areas in the survey area. The map unit descriptions, along with the maps, can be used to determine the composition and properties of a unit.

A map unit delineation on a soil map represents an area dominated by one or more major kinds of soil or miscellaneous areas. A map unit is identified and named according to the taxonomic classification of the dominant soils. Within a taxonomic class there are precisely defined limits for the properties of the soils. On the landscape, however, the soils are natural phenomena, and they have the characteristic variability of all natural phenomena. Thus, the range of some observed properties may extend beyond the limits defined for a taxonomic class. Areas of soils of a single taxonomic class rarely, if ever, can be mapped without including areas of other taxonomic classes. Consequently, every map unit is made up of the soils or miscellaneous areas for which it is named and some minor components that belong to taxonomic classes other than those of the major soils.

Most minor soils have properties similar to those of the dominant soil or soils in the map unit, and thus they do not affect use and management. These are called noncontrasting, or similar, components. They may or may not be mentioned in a particular map unit description. Other minor components, however, have properties and behavioral characteristics divergent enough to affect use or to require different management. These are called contrasting, or dissimilar, components. They generally are in small areas and could not be mapped separately because of the scale used. Some small areas of strongly contrasting soils or miscellaneous areas are identified by a special symbol on the maps. If included in the database for a given area, the contrasting minor components are identified in the map unit descriptions along with some characteristics of each. A few areas of minor components may not have been observed, and consequently they are not mentioned in the descriptions, especially where the pattern was so complex that it was impractical to make enough observations to identify all the soils and miscellaneous areas on the landscape.

The presence of minor components in a map unit in no way diminishes the usefulness or accuracy of the data. The objective of mapping is not to delineate pure taxonomic classes but rather to separate the landscape into landforms or landform segments that have similar use and management requirements. The delineation of such segments on the map provides sufficient information for the development of resource plans. If intensive use of small areas is planned, however,

Custom Soil Resource Report

onsite investigation is needed to define and locate the soils and miscellaneous areas.

An identifying symbol precedes the map unit name in the map unit descriptions. Each description includes general facts about the unit and gives important soil properties and qualities.

Soils that have profiles that are almost alike make up a *soil series*. Except for differences in texture of the surface layer, all the soils of a series have major horizons that are similar in composition, thickness, and arrangement.

Soils of one series can differ in texture of the surface layer, slope, stoniness, salinity, degree of erosion, and other characteristics that affect their use. On the basis of such differences, a soil series is divided into *soil phases*. Most of the areas shown on the detailed soil maps are phases of soil series. The name of a soil phase commonly indicates a feature that affects use or management. For example, Alpha silt loam, 0 to 2 percent slopes, is a phase of the Alpha series.

Some map units are made up of two or more major soils or miscellaneous areas. These map units are complexes, associations, or undifferentiated groups.

A *complex* consists of two or more soils or miscellaneous areas in such an intricate pattern or in such small areas that they cannot be shown separately on the maps. The pattern and proportion of the soils or miscellaneous areas are somewhat similar in all areas. Alpha-Beta complex, 0 to 6 percent slopes, is an example.

An *association* is made up of two or more geographically associated soils or miscellaneous areas that are shown as one unit on the maps. Because of present or anticipated uses of the map units in the survey area, it was not considered practical or necessary to map the soils or miscellaneous areas separately. The pattern and relative proportion of the soils or miscellaneous areas are somewhat similar. Alpha-Beta association, 0 to 2 percent slopes, is an example.

An *undifferentiated group* is made up of two or more soils or miscellaneous areas that could be mapped individually but are mapped as one unit because similar interpretations can be made for use and management. The pattern and proportion of the soils or miscellaneous areas in a mapped area are not uniform. An area can be made up of only one of the major soils or miscellaneous areas, or it can be made up of all of them. Alpha and Beta soils, 0 to 2 percent slopes, is an example.

Some surveys include *miscellaneous areas*. Such areas have little or no soil material and support little or no vegetation. Rock outcrop is an example.

El Paso County Area, Colorado

8—Blakeland loamy sand, 1 to 9 percent slopes

Map Unit Setting

National map unit symbol: 369v
Elevation: 4,600 to 5,800 feet
Mean annual precipitation: 14 to 16 inches
Mean annual air temperature: 46 to 48 degrees F
Frost-free period: 125 to 145 days
Farmland classification: Not prime farmland

Map Unit Composition

Blakeland and similar soils: 98 percent
Minor components: 2 percent
Estimates are based on observations, descriptions, and transects of the mapunit.

Description of Blakeland

Setting

Landform: Hills, flats
Landform position (three-dimensional): Side slope, talf
Down-slope shape: Linear
Across-slope shape: Linear
Parent material: Alluvium derived from sedimentary rock and/or eolian deposits derived from sedimentary rock

Typical profile

A - 0 to 11 inches: loamy sand
AC - 11 to 27 inches: loamy sand
C - 27 to 60 inches: sand

Properties and qualities

Slope: 1 to 9 percent
Depth to restrictive feature: More than 80 inches
Drainage class: Somewhat excessively drained
Runoff class: Low
Capacity of the most limiting layer to transmit water (Ksat): High to very high (5.95 to 19.98 in/hr)
Depth to water table: More than 80 inches
Frequency of flooding: None
Frequency of ponding: None
Calcium carbonate, maximum content: 5 percent
Available water capacity: Low (about 4.5 inches)

Interpretive groups

Land capability classification (irrigated): 3e
Land capability classification (nonirrigated): 6e
Hydrologic Soil Group: A
Ecological site: R049XB210CO - Sandy Foothill
Hydric soil rating: No

Minor Components

Pleasant

Percent of map unit: 1 percent

Custom Soil Resource Report

Landform: Depressions
Hydric soil rating: Yes

Other soils

Percent of map unit: 1 percent
Hydric soil rating: No

10—Blendon sandy loam, 0 to 3 percent slopes

Map Unit Setting

National map unit symbol: 3671
Elevation: 6,000 to 6,800 feet
Mean annual precipitation: 14 to 16 inches
Mean annual air temperature: 46 to 48 degrees F
Frost-free period: 125 to 145 days
Farmland classification: Not prime farmland

Map Unit Composition

Blendon and similar soils: 98 percent
Minor components: 2 percent
Estimates are based on observations, descriptions, and transects of the mapunit.

Description of Blendon

Setting

Landform: Terraces, alluvial fans
Down-slope shape: Linear
Across-slope shape: Linear
Parent material: Sandy alluvium derived from arkose

Typical profile

A - 0 to 10 inches: sandy loam
Bw - 10 to 36 inches: sandy loam
C - 36 to 60 inches: gravelly sandy loam

Properties and qualities

Slope: 0 to 3 percent
Depth to restrictive feature: More than 80 inches
Drainage class: Well drained
Runoff class: Low
Capacity of the most limiting layer to transmit water (Ksat): Moderately high to high
(0.60 to 2.00 in/hr)
Depth to water table: More than 80 inches
Frequency of flooding: None
Frequency of ponding: None
Calcium carbonate, maximum content: 2 percent
Available water capacity: Moderate (about 6.2 inches)

Interpretive groups

Land capability classification (irrigated): None specified
Land capability classification (nonirrigated): 3e

Custom Soil Resource Report

Hydrologic Soil Group: B

Ecological site: R049XB210CO - Sandy Foothill

Hydric soil rating: No

Minor Components

Pleasant

Percent of map unit: 1 percent

Landform: Depressions

Hydric soil rating: Yes

Other soils

Percent of map unit: 1 percent

Hydric soil rating: No

References

- American Association of State Highway and Transportation Officials (AASHTO). 2004. Standard specifications for transportation materials and methods of sampling and testing. 24th edition.
- American Society for Testing and Materials (ASTM). 2005. Standard classification of soils for engineering purposes. ASTM Standard D2487-00.
- Cowardin, L.M., V. Carter, F.C. Golet, and E.T. LaRoe. 1979. Classification of wetlands and deep-water habitats of the United States. U.S. Fish and Wildlife Service FWS/OBS-79/31.
- Federal Register. July 13, 1994. Changes in hydric soils of the United States.
- Federal Register. September 18, 2002. Hydric soils of the United States.
- Hurt, G.W., and L.M. Vasilas, editors. Version 6.0, 2006. Field indicators of hydric soils in the United States.
- National Research Council. 1995. Wetlands: Characteristics and boundaries.
- Soil Survey Division Staff. 1993. Soil survey manual. Soil Conservation Service. U.S. Department of Agriculture Handbook 18. http://www.nrcs.usda.gov/wps/portal/nrcs/detail/national/soils/?cid=nrcs142p2_054262
- Soil Survey Staff. 1999. Soil taxonomy: A basic system of soil classification for making and interpreting soil surveys. 2nd edition. Natural Resources Conservation Service, U.S. Department of Agriculture Handbook 436. http://www.nrcs.usda.gov/wps/portal/nrcs/detail/national/soils/?cid=nrcs142p2_053577
- Soil Survey Staff. 2010. Keys to soil taxonomy. 11th edition. U.S. Department of Agriculture, Natural Resources Conservation Service. http://www.nrcs.usda.gov/wps/portal/nrcs/detail/national/soils/?cid=nrcs142p2_053580
- Tiner, R.W., Jr. 1985. Wetlands of Delaware. U.S. Fish and Wildlife Service and Delaware Department of Natural Resources and Environmental Control, Wetlands Section.
- United States Army Corps of Engineers, Environmental Laboratory. 1987. Corps of Engineers wetlands delineation manual. Waterways Experiment Station Technical Report Y-87-1.
- United States Department of Agriculture, Natural Resources Conservation Service. National forestry manual. http://www.nrcs.usda.gov/wps/portal/nrcs/detail/soils/home/?cid=nrcs142p2_053374
- United States Department of Agriculture, Natural Resources Conservation Service. National range and pasture handbook. <http://www.nrcs.usda.gov/wps/portal/nrcs/detail/national/landuse/rangepasture/?cid=stelprdb1043084>

Custom Soil Resource Report

United States Department of Agriculture, Natural Resources Conservation Service. National soil survey handbook, title 430-VI. http://www.nrcs.usda.gov/wps/portal/nrcs/detail/soils/scientists/?cid=nrcs142p2_054242

United States Department of Agriculture, Natural Resources Conservation Service. 2006. Land resource regions and major land resource areas of the United States, the Caribbean, and the Pacific Basin. U.S. Department of Agriculture Handbook 296. http://www.nrcs.usda.gov/wps/portal/nrcs/detail/national/soils/?cid=nrcs142p2_053624

United States Department of Agriculture, Soil Conservation Service. 1961. Land capability classification. U.S. Department of Agriculture Handbook 210. http://www.nrcs.usda.gov/Internet/FSE_DOCUMENTS/nrcs142p2_052290.pdf

APPENDIX E – IDENTIFICATION OF POLLUTANT SOURCES

APPENDIX F – LAND DISTURBANCE / CONTROL MEASURE /
STABILIZATION LOG



APPENDIX G – SPILL PREVENTION AND RESPONSE PLAN AND REPORTING INFORMATION

Spill Prevention and Response Plan

(Sample Plan – This plan has been produced to assist the General Contractor. This plan shall be revised and updated as needed by the contractor to fit the specific needs of the construction site and may need to be updated to reflect different type of materials and chemicals).

General Spill Control Practices

Any hazardous or potentially hazardous material that is brought onto the construction site shall be handled properly to reduce the potential for stormwater pollution. In an effort to minimize the potential for a spill of petroleum product or hazardous materials to come in contact with stormwater, the following steps shall be implemented:

- Material Safety Data Sheets (MSDS) information shall be kept on site for any and all applicable materials.
- A spill control and containment kit shall be provided on the construction site
- All materials with hazardous properties (such as pesticides, petroleum products, fertilizers, detergents, construction chemicals, acids, paints, paint solvents, additives for soil stabilization, concrete, curing compounds and additives, etc.) shall be stored in a secure location, under cover and in appropriate, tightly sealed containers when not in use.
- The minimum practical quantity of all such materials shall be kept on the job site and scheduled for delivery as close to time of use as practical.
- All products shall be stored in and used from the original container with the original product label and used in strict compliance with the instructions on the product label.
- All of the product in a container shall be used before the container is disposed of. All such containers shall be triple rinsed, with water prior to disposal. The rinse water used in these containers shall be disposed of in a manner in compliance with State and Federal regulations and shall not be allowed to mix with stormwater discharges. The disposal of excess or used products shall be in strict compliance with instructions on the product label.
- If utilized, temporary onsite fuel tanks for construction vehicles shall meet all state and federal regulations. Tanks shall have approved spill containment with the capacity required by the applicable regulations. The tanks shall be in sound condition free of rust or other damage which might compromise containment. All tanks in excess of 50 gallons shall be provided with secondary containment (i.e. containment external to and separate from primary containment). Secondary containment shall be constructed of materials of sufficient thickness, density and composition so as not to be structurally weakened as a result of contact with the fuel stored and capable of containing discharged fuel for a period of time equal to or longer than the maximum anticipated time sufficient to allow recovery of discharged fuel. The operator / qualified stormwater manager should familiarize themselves with and follow local and state requirements.

Spill Response Plan

In the event of an accidental spill, immediate action shall be undertaken by the Operator to contain and remove the spilled material.

- All hazardous materials, including contaminated soil, shall be disposed of by the Operator in the manner specified by federal, state and local regulations and by the manufacturer of such products.
- Spilled materials shall be cleaned-up by following the procedures outlined by the MSDS.
- As soon as possible, the spill shall be reported to the appropriate agencies as required by law. As required under the provisions of the Clean Water Act, any spill or discharge entering waters of the United States shall be properly reported. Any spills of petroleum products or hazardous materials in excess of Reportable Quantities as defined by EPA or the state or local agency regulations, shall be immediately reported to the Colorado Department of Public Health and Environment (CDPHE) spill reporting lines.
 - CDPHE Environmental Release and Incident Reporting Line (877) 518-5608.
 - National Response Center - (800) 424-8802
- The Operator shall prepare a written record of any spill and associated clean-up activities of petroleum products or hazardous materials in excess of 1 gallon or reportable quantities, whichever is less. At a minimum, the following shall be documented: Nature of spill, quantity of spill, date/time spill occurred, agency notification if necessary, clean-up procedures used, daily monitoring (for the following 7 days), photographs, and interview(s) with any witnesses of the event.



Environmental Spill Reporting

*24–Hour Emergency and Incident Reporting Line
Office of Emergency Preparedness & Response*

1-877-518-5608

Updated: June, 2018

Reporting chemical spills and releases in Colorado

General

For all hazardous substance incidents, local emergency response agencies must be notified.

Releases from fixed facilities

The Superfund Amendments and Reauthorization Act (SARA) Title III, requires reporting releases from fixed facilities

Refer to the SARA Title III List of Lists, available from the Environmental Protection Agency (EPA), for the reportable quantity.

The party that owns the spilled material must immediately notify the following agencies or organizations:

- National Response Center (NRC) 1-800-424-8802;
- Colorado Emergency Planning Committee (CEPC), represented by the Colorado Department of Public Health and Environment (CDPHE) 1-877-518-5608; and
- Local Emergency Planning Committee (LEPC) 1-720-852-6600.

In addition to telephone notification, the responsible party must also send written notification describing the release and associated emergency response to both the CEPC (in this case, CDPHE) and the LEPC.

Releases from RCRA facilities

Emergency releases from facilities permitted under the Resource Conservation and Recovery Act (RCRA) are reportable according to the permit requirements.

The permit often requires reporting to CDPHE, even if the amount of the release is less than a reportable quantity under SARA Title III (6 CCR 1007-3 Part 264).

Permitted facilities and generators and transporters of hazardous waste are required to have and implement a contingency plan that describes the actions facility personnel must take in response to fires, explosions or any unplanned sudden or non-sudden release of hazardous waste or hazardous waste constituents to air, soil, surface or ground water at the facility (6 CCR 1007-3 Sections 261, 262, 263, 264 and 265).

Whenever there is an imminent or actual emergency situation, appropriate state or local agencies, with designated response roles as described in the contingency plan, must be notified immediately.

The National Response Center or government official designated as the regional on-scene coordinator must be notified immediately if it is determined that the facility has had a release, fire or explosion that could threaten human health or the environment outside the facility.

CDPHE and local authorities must be notified when the facility is back in compliance and ready to resume operations. In addition, the facility must send a written report to CDPHE within 15 days of any incident that requires implementation of the contingency plan. The contingency plan should include current contact information for notification and submittal of written reports.

Permitted facilities, generators and transporters that store hazardous waste must notify CDPHE within 24 hours of any release to the environment that is greater than one (1) pound and must submit a written report to CDPHE within 30 days of the release (6 CCR 1007-3).

Transportation accidents

Transportation accidents that require reporting:

- Result in a spill or release of a hazardous substance in excess of the reportable quantity (40 CFR Part 302.6)
- Cause injury or death or cause estimated property damage exceeding \$50,000.
- Cause an evacuation of the general public lasting one or more hours.

Those that close or shut down one or more major transportation arteries or facilities or result in fire, breakage, spillage, or suspected contamination from radioactive or infectious substances must immediately be reported to the National Response Center.

Refer to the EPA SARA Title III List of Lists for those substances that have reportable quantities.

In addition to the NRC being notified, the local emergency number (9-1-1) must be called and CDPHE should be notified.

Written notification of any transportation accident involving a release of hazardous materials must be provided to the U.S. Department of Transportation within 30 days (49 CFR Part 171.16)

Since hazardous waste is a subset of hazardous materials, transporters who have discharged hazardous waste must notify the NRC and provide a written report to the US Department of Transportation as noted in the above reporting requirements.

The transporter must give immediate notice to the nearest Colorado State Patrol office (8 CCR 1507-8 HMP 5) and the nearest law enforcement agency if the accident or spill involved a vehicle (42-20-113(3) CRS).

Notification and a written report detailing the ultimate disposition of the discharge of hazardous waste must also be provided to CDPHE (6 CCR 1007-2 Section 263.30). This may be a duplicate copy of the US Department of Transportation report

In the event of a spill or discharge of hazardous waste at a transfer facility, the transporter must notify CDPHE within 24 hours if the spill exceeds 55 gallons or if there is a fire or explosion.

Within 15 days of a reportable incident, the transporter must submit a written report of the incident to CDPHE, including the final disposition of the material (6 CCR 1007-2 Section 263.40).

Releases of hazardous waste at a transfer facility may also require notification to the National Response Center and a written report to the U.S. Department of Transportation.

Releases to water

A release of any chemical, oil, petroleum product, sewage, etc., which may enter waters of the State of Colorado (which include surface water, ground water and dry gullies or storm sewers leading to surface water) must be reported to CDPHE immediately (25-8-601 CRS).

Written notification to CDPHE must follow within five (5) days (5 CCR 1002-61, Section 61.8(5)(d)).

Any accidental discharge to the sanitary sewer system must be reported immediately to the local sewer authority and the affected wastewater treatment plant.

Releases of petroleum products and certain hazardous substances listed under the Federal Clean Water Act (40 CFR Part 116) must be reported to the National Response Center as well as to CDPHE (1-877-518-5608) as required under the Clean Water Act and the Oil Pollution Act.

Releases to air

Any unpredictable failure of air pollution control or process equipment that results in the violation of emission

control regulations should be reported CDPHE by 10 a.m. of the following working day, followed by a written notice explaining the cause of the occurrence and describing action that has been or is being taken to correct the condition causing the violation and to prevent such excess emissions in the future (5 CCR 1001-2 Common Provisions Regulations Section II.E).

If emergency conditions cause excess emissions at a permitted facility, the owner/operator must provide notice to CDPHE no later than noon of the next working day following the emergency, and follow by written notice within one month of the time when emission limitations were exceeded due to the emergency (5 CCR 1001-5, Regulation 3 Part C, Section VII.C.4).

Releases from oil and gas wells

All spills or releases of exploration and production wastes or produced fluids which meet the reporting thresholds of the Colorado Oil and Gas Conservation Commission (COGCC) Rule 906 shall be reported verbally to the COGCC within 24 hours of discovery and on the COGCC Spill/Release Report Form 19 within 72 hours of discovery.

Spills or releases are reportable to the COGCC in the following circumstances:

- 1) the spill or release impacts or threatens to impact any waters of the state, (which include surface water, ground water and dry gullies or storm sewers leading to surface water), a residence or occupied structure, livestock or a public byway;
- 2) a spill or release in which 1 barrel or more is released outside of berms or other secondary containment; or
- 3) any spill or release of 5 barrels or more.

COGCC also requires reportable spills or releases be reported to the surface owner and local government. Whether or not they are reportable, spills or releases of any size must be stopped, cleaned up, and investigated as soon as practicable.

If the spill or release impacts or threatens to impact waters of the state, it must also be reported immediately to CDPHE (25-8-601 CRS).

Releases from storage tanks

Petroleum releases of 25 gallons or more (or any size that causes a sheen on nearby surface waters) from regulated aboveground and underground fuel storage tanks must be reported to the Division of Oil and Public Safety (303-318-8547) within 24 hours. If the report is made after business hours, please leave a message on the technical assistance line for the Division of Oil and Public Safety, and contact the 24 hour CDPHE Emergency and Incident Reporting Line. This includes spills from fuel dispensers.

Spills or releases of hazardous substances from regulated storage tanks in excess of the reportable quantity (40 CFR Part 302.6) must be reported to the National Response Center and the local fire authority immediately, and to the Division of Oil and Public Safety within 24 hours. (8-20.5-208 CRS and 7 CCR 1101-14 Article 4).

Owners/operators of regulated storage tanks must contain and immediately clean up a spill or overflow of less than 25 gallons of petroleum and a spill or overflow of a hazardous substance that is less than the reportable quantity.

If cleanup cannot be accomplished within 24 hours, the Division of Oil and Public Safety must be notified immediately (7 CCR 1101-14 Article 4-4).

CDPHE should also be notified in the case of hazardous substance releases as cleanup activities may be covered by state solid or hazardous waste requirements (6 CCR 1007-2, 6 CCR 1007-3).

Any release that has or may impact waters of the state (which include surface water, ground water and dry

gullies or storm sewers leading to surface water), no matter how small, must be reported immediately to CDPHE (25-8-601 CRS).

Releases from pipelines

Releases of five or more gallons of hazardous liquids or carbon dioxide from a pipeline that result in explosion or fire, cause injury or death or cause estimated property damage (including cost of clean-up and recovery, value of lost product and property damage) exceeding \$50,000 must be reported immediately to the US Department of Transportation Office of Pipeline Safety (49 CFR Part 195 Subpart B) and the National Response Center.

Releases of five or more gallons of hazardous liquids or carbon dioxide from interstate pipelines that do not involve explosion or fire, injury or death or property damage exceeding \$50,000 should be reported to the US Department of Transportation Office of Pipeline Safety within 30 days after the incident.

Releases of natural gas from intrastate pipelines that cause injury or death, property damage in excess of \$50,000 (including the cost of lost product), closure of a public road, or evacuation of 50 or more people must be reported immediately to the Colorado Public Utilities Commission, Pipeline Safety Group (4 CCR 723-11-2).

Releases of natural gas or liquefied natural gas (LNG) from interstate pipelines that cause injury or death, property damage in excess of \$50,000 (including the cost of lost product), or results in an emergency shutdown of the facility must be reported immediately to the National Response Center and the US Dept of Transportation Office of Pipeline Safety.

Releases of oil, petroleum products or other hazardous liquids from interstate and intrastate pipelines that have or may enter waters of the State of Colorado (which include surface water, ground water and dry gullies or storm sewers leading to surface water) must be reported to CDPHE immediately (25-8-601 CRS). CDPHE should also be notified of releases to soil, as cleanup activities may be covered by state solid or hazardous waste requirements (6 CCR 1007-2, 6 CCR 1007-3).

Radiological accidents, incidents, and events

CDPHE must be notified of any condition that has caused or threatens to cause an event, which meets or exceeds the criteria specified in (6 CCR 1007-1) RH 4.51 and RH 4.52 of the State of Colorado *Rules and Regulations Pertaining to Radiation Control*. Reportable events include lost radioactive materials, lost radiation producing machines, over-exposures to persons, contamination events and fires or explosions involving radioactive materials.

Depending upon the severity of the event, notification may be required immediately, within 24 hours, or within 30 days. In most cases, a written follow-up report is also required.

If you are unsure of the proper notification requirement, please contact CDPHE immediately. Telephone event notifications can be made to the CDPHE Radiation Program at any time by calling 1-303-877-9757.

Notification Numbers

Colorado Department of Public Health and Environment toll-free 24-hour environmental emergency and incident reporting line: (877) 518-5608 (24-hour)

National Response Center
(800) 424-8802 (24-hour)

State Oil Inspector (Colorado Division of Oil & Public Safety-Above & Underground Storage Tank Regulators)
(303) 318-8547

APPENDIX H – STORM EVENT LOG



APPENDIX I – INSPECTION AND SAMPLING REPORTS

CONSTRUCTION STORMWATER SITE INSPECTION REPORT

Facility Name		Permittee					
Date of Inspection		Weather Conditions					
Permit Certification #		Disturbed Acreage					
Phase of Construction		Inspector Title					
Inspector Name							
Is the above inspector a qualified stormwater manager? (permittee is responsible for ensuring that the inspector is a qualified stormwater manager)			<table border="1" style="width: 100%; border-collapse: collapse;"> <tr> <td style="width: 50%; text-align: center;">YES</td> <td style="width: 50%; text-align: center;">NO</td> </tr> <tr> <td style="text-align: center;"><input type="checkbox"/></td> <td style="text-align: center;"><input type="checkbox"/></td> </tr> </table>	YES	NO	<input type="checkbox"/>	<input type="checkbox"/>
YES	NO						
<input type="checkbox"/>	<input type="checkbox"/>						

INSPECTION FREQUENCY					
Check the box that describes the minimum inspection frequency utilized when conducting each inspection					
At least one inspection every 7 calendar days	<input type="checkbox"/>				
At least one inspection every 14 calendar days, with post-storm event inspections conducted within 24 hours after the end of any precipitation or snowmelt event that causes surface erosions	<input type="checkbox"/>				
<ul style="list-style-type: none"> • This is this a post-storm event inspection. Event Date: _____ 	<input type="checkbox"/>				
Reduced inspection frequency - Include site conditions that warrant reduced inspection frequency	<input type="checkbox"/>				
<ul style="list-style-type: none"> • Post-storm inspections at temporarily idle sites 	<input type="checkbox"/>				
<ul style="list-style-type: none"> • Inspections at completed sites/area 	<input type="checkbox"/>				
<ul style="list-style-type: none"> • Winter conditions exclusion 	<input type="checkbox"/>				
Have there been any deviations from the minimum inspection schedule? If yes, describe below.	<table border="1" style="width: 100%; border-collapse: collapse;"> <tr> <td style="width: 50%; text-align: center;">YES</td> <td style="width: 50%; text-align: center;">NO</td> </tr> <tr> <td style="text-align: center;"><input type="checkbox"/></td> <td style="text-align: center;"><input type="checkbox"/></td> </tr> </table>	YES	NO	<input type="checkbox"/>	<input type="checkbox"/>
YES	NO				
<input type="checkbox"/>	<input type="checkbox"/>				

INSPECTION REQUIREMENTS*
i. Visually verify all implemented control measures are in effective operational condition and are working as designed in the specifications
ii. Determine if there are new potential sources of pollutants
iii. Assess the adequacy of control measures at the site to identify areas requiring new or modified control measures to minimize pollutant discharges
iv. Identify all areas of non-compliance with the permit requirements, and if necessary, implement corrective action
*Use the attached Control Measures Requiring Routine Maintenance and Inadequate Control Measures Requiring Corrective Action forms to document results of this assessment that trigger either maintenance or corrective actions

AREAS TO BE INSPECTED			
Is there evidence of, or the potential for, pollutants leaving the construction site boundaries, entering the stormwater drainage system or discharging to state waters at the following locations?			
	NO	YES	If "YES" describe discharge or potential for discharge below. Document related maintenance, inadequate control measures and corrective actions Inadequate Control Measures Requiring Corrective Action form
Construction site perimeter	<input type="checkbox"/>	<input type="checkbox"/>	
All disturbed areas	<input type="checkbox"/>	<input type="checkbox"/>	
Designated haul routes	<input type="checkbox"/>	<input type="checkbox"/>	
Material and waste storage areas exposed to precipitation	<input type="checkbox"/>	<input type="checkbox"/>	
Locations where stormwater has the potential to discharge offsite	<input type="checkbox"/>	<input type="checkbox"/>	
Locations where vehicles exit the site	<input type="checkbox"/>	<input type="checkbox"/>	
Other: _____	<input type="checkbox"/>	<input type="checkbox"/>	

REPORTING REQUIREMENTS

The permittee shall report the following circumstances orally within twenty-four (24) hours from the time the permittee becomes aware of the circumstances, and shall mail to the division a written report containing the information requested within five (5) working days after becoming aware of the following circumstances. The division may waive the written report required if the oral report has been received within 24 hours.

All Noncompliance Requiring 24-Hour Notification per Part II.L.6 of the Permit		
a. Endangerment to Health or the Environment Circumstances leading to any noncompliance which may endanger health or the environment regardless of the cause of the incident (See Part II.L.6.a of the Permit) <i>This category would primarily result from the discharge of pollutants in violation of the permit</i>		
b. Numeric Effluent Limit Violations <ul style="list-style-type: none"> o Circumstances leading to any unanticipated bypass which exceeds any effluent limitations (See Part II.L.6.b of the Permit) o Circumstances leading to any upset which causes an exceedance of any effluent limitation (See Part II.L.6.c of the Permit) o Daily maximum violations (See Part II.L.6.d of the Permit) <i>Numeric effluent limits are very uncommon in certifications under the COR400000 general permit. This category of noncompliance only applies if numeric effluent limits are included in a permit certification.</i>		

Has there been an incident of noncompliance requiring 24-hour notification?	NO	YES	
	<input type="checkbox"/>	<input type="checkbox"/>	If "YES" document below

Date and Time of Incident	Location	Description of Noncompliance	Description of Corrective Action	Date and Time of 24 Hour Oral Notification	Date of 5 Day Written Notification *

*Attach copy of 5 day written notification to report. Indicate if written notification was waived, including the name of the division personnel who granted waiver.

After adequate corrective action(s) and maintenance have been taken, or where a report does not identify any incidents requiring corrective action or maintenance, the individual(s) designated as the Qualified Stormwater Manager, shall sign and certify the below statement:

"I verify that, to the best of my knowledge and belief, all corrective action and maintenance items identified during the inspection are complete, and the site is currently in compliance with the permit."

Name of Qualified Stormwater Manager

Title of Qualified Stormwater Manager

Signature of Qualified Stormwater Manager

Date

Notes/Comments

APPENDIX J – SWMP AMENDMENT LOG / CONTROL MEASURE DETAILS



APPENDIX K – SOIL BORINGS / TEST (GEOTECH REPORT)



Kumar & Associates, Inc.®
Geotechnical and Materials Engineers
and Environmental Scientists

6735 Kumar Heights
Colorado Springs, CO 80918
phone: (719) 632-7009
fax: (719) 632-1049
email: kacolospgs@kumarusa.com
www.kumarusa.com

An Employee Owned Company

Office Locations: Denver (HQ), Parker, Colorado Springs, Fort Collins, Glenwood Springs, and Summit County, Colorado

PRELIMINARY GEOTECHNICAL ENGINEERING STUDY
WATERMARK AT COLORADO SPRINGS
AKERS DRIVE APARTMENTS
NWC OF CONSTITUTION AVE & MARKSHEFFEL RD
COLORADO SPRINGS, COLORADO

Prepared by:
Duane P. Craft, P.E.



Reviewed by:

Arben F. Kalaveshi, P.E.

Prepared for:

Thompson Thrift Development, Inc.
Chase Tower
111 Monument Circle, Suite 1600
Indianapolis, IN 46204

Attn: Mr. Pat Smith

TABLE OF CONTENTS

SUMMARY	1
PURPOSE AND SCOPE OF STUDY	1
PROPOSED CONSTRUCTION	2
SITE CONDITIONS	2
FIELD EXPLORATION PROGRAM	2
LABORATORY TESTING	3
SUBSURFACE CONDITIONS	3
GEOTECHNICAL ENGINEERING CONSIDERATIONS	5
FOUNDATION RECOMMENDATIONS	8
SITE SEISMIC CRITERIA	11
FLOOR SLABS	11
FOUNDATION WALLS AND RETAINING STRUCTURES	13
EXTERIOR FLATWORK	14
WATER SOLUBLE SULFATES	15
SWIMMING POOL	15
UNDERDRAIN SYSTEM	16
SURFACE DRAINAGE	16
PAVEMENT DESIGN	18
SITE GRADING AND EARTHWORK	20
DESIGN AND SUPPORT SERVICES	24
LIMITATIONS	24
FIG. 1 - LOCATION OF EXPLORATORY BORINGS	
FIGS. 2 THRU 4 - LOGS OF EXPLORATORY BORINGS	
FIG. 5 - LEGEND AND NOTES	
FIGS. 6 THRU 10 – SWELL-CONSOLIDATION TEST RESULTS	
FIGS. 11 THRU 16 - GRADATION TEST RESULTS	
TABLE I - SUMMARY OF LABORATORY TEST RESULTS	

SUMMARY

1. Beneath a layer of topsoil (root zone), the generalized subsurface profile encountered in the borings consisted of a combination of granular and cohesive overburden soils underlain by claystone and sandstone bedrock. Man-placed fill was encountered in one of the borings. Considering the wide spacings of the borings drilled for this study, it is possible for existing fill to be present elsewhere on site. Swell-consolidation tests indicate the tested samples of clay varied from having a nil to high swell potential to a low potential for compression, when wetted under a 1,000 psf surcharge.
2. Groundwater was not encountered at the time of drilling. When the borings were checked 8 to 9 days later, groundwater was encountered in one of the borings at a depth approximately 25.1 feet. Fluctuations in the water level may occur with time, particularly during wetter seasons and after precipitation events.
3. Considering the data obtained from the field and laboratory studies and the nature of the proposed construction, it is our opinion that a shallow foundation system with a partial overexcavation of the underlying expansive materials, and complete overexcavation of any existing fill would perform adequately if the recommendations provided in this report are followed. The risk for excessive foundation movements is estimated to be relatively low for a shallow foundation system supported by nonexpansive material. The use of a post-tensioned slab foundation will result in the reduced risk of associated distress from foundation movement as compared to a conventional spread footing foundation system, given the foundation systems ability to be rigid and withstand differential movements. Foundation recommendations included in this report include post tensioned (PT) slabs and spread footings based on our understanding of the owner's preferences.
4. The on-site soils and sandstone bedrock will be suitable for reuse as nonexpansive structural fill, including for compacted fill beneath foundations, exterior flatwork and pavements. The existing fill encountered is also suitable for reuse, minus any deleterious materials. Claystone should be considered unsuitable for use as structural fill. Overlot grading compaction specification recommendations are included in the report.
5. We recommend drive lanes be constructed with 7 inches of full-depth asphalt pavement or a composite section consisting of 5 inches of asphalt over 7 inches of aggregate base course. We recommend parking stalls and other areas restricted to auto traffic be constructed with 6 inches of full-depth asphalt pavement or a composite section consisting of 4 inches of asphalt over 7 inches of base course. We recommend trash collection areas and other areas that may have concentrated truck turning movements be paved with a 6-inch thick portland cement concrete pavement section.

PURPOSE OF STUDY

This report presents the results of a preliminary geotechnical engineering study for the proposed apartment development in Colorado Springs, Colorado. The study was conducted for the purpose of developing preliminary recommendations for site grading, foundations and pavements. The project site is shown on the attached Fig. 1. The study was performed in accordance with our Proposal No. C20-163R, dated August 4, 2020.

This report has been prepared to summarize the data obtained during this study and to present our conclusions and preliminary recommendations based on the proposed construction and the subsurface conditions encountered. Design parameters and a discussion of geotechnical engineering considerations related to the proposed construction are included in the report. Once details regarding the proposed construction have been finalized, to include the site layout and planned grading, additional study with supplemental field exploration and lab testing will be required to develop a report with final recommendations. It should be noted that even if the proposed construction does not change from that described herein, it is still possible for the recommendations to change if the supplemental field and lab data significantly differs.

PROPOSED CONSTRUCTION

We understand the proposed construction will include nine separate three-story apartment buildings, a clubhouse with pool, a rental office, and potential garage pods or covered parking areas. Paved access roadways and parking stalls will also be constructed throughout the site. The preliminary site layout plan provided (dated 7/28/20) is shown on Fig. 1. The planned site grading had not been determined at the time of our study; however, we have assumed it would be relatively minor, with cuts and fills on the order of approximately 2 to 4 feet or less. If the proposed construction varies significantly from that described above or depicted herein, we should be notified to reevaluate the recommendations provided herein.

SITE CONDITIONS

The subject site consists of vacant, undeveloped land, bound by Akers Drive to the west, Constitution Avenue to the south, and Marksheffel Road to the east. Additional vacant land and commercial development is located to the north. The site slopes gently down to the southeast, and there was roughly 25 feet of elevation different across the property. The site appeared relatively undisturbed; however, review of historic aerial photographs indicates some potential site grading and unknown land use occurred in the 1970's and 80's. The site was vegetated with natural grasses, weeds, yucca, and cacti. There were some deciduous trees along the south property line.

FIELD EXPLORATION

The field exploration of subsurface conditions consisted of drilling a total of 18 borings at the approximate locations shown on Fig. 1. The borings were drilled on August 24 and 25, 2020. The locations of the borings were approximated using a handheld GPS unit, and the elevations were measured using a hand level. The boring logs are presented on Figs. 2 thru 4, and corresponding legend and notes are presented on Fig. 5.

The borings were drilled with 4-inch diameter continuous flight augers and were logged by a representative of Kumar & Associates, Inc. Samples of the soils and bedrock were taken with a 2-inch I.D. California sampler. The sampler was driven into the various strata with blows from a 140-pound hammer falling 30 inches. Penetration resistance values, when properly evaluated, provide an indication of the relative density or consistency of the soils. Depths at which the samples were taken and the penetration resistance values are shown on the boring logs.

LABORATORY TESTING

Samples obtained from the exploratory borings were visually classified in the laboratory by the project engineer and samples were selected for laboratory testing. Laboratory testing included index property tests such as in-situ moisture content and dry unit weight, grain size analysis, and Atterberg limits. Additional testing included in-situ swell-consolidation and concentration of water soluble sulfates. The testing was conducted in general accordance with recognized test procedures, primarily those of the American Society for Testing of Materials (ASTM). Results of the laboratory testing program are shown on Figs. 2 thru 4, and 6 thru 16, and are summarized on Table I.

SUBSURFACE CONDITIONS

Beneath a layer of topsoil (root zone), the generalized subsurface profile encountered in the borings consisted of a combination of granular and cohesive overburden soils, underlain by claystone and sandstone bedrock. Man-placed fill was encountered in one of the borings. Given the wide spacings of the borings drilled for this study, it is possible for existing fill to be present elsewhere on site. The following subsurface descriptions are of a generalized nature to highlight the soil and bedrock types encountered in the borings drilled for this study. The boring logs should be reviewed for more detailed information.

Existing Fill: In Boring 11, man-placed fill was encountered to an approximate depth of 7 feet. The fill consisted of a mixture of clayey sand (SC) and sandy silty clay (CL-ML), and appeared to consist of reworked on-site soils. Due to the similarity of the natural soil and fill materials, it was not possible to clearly differentiate between fill and native soils. The fill was slightly moist to moist, and light brown to brown in color. Our study did not determine the exact lateral or vertical extent of the fill. Swell-consolidation test results presented on Fig. 9 indicate the tested sample of sandy silty clay fill had a low swell potential when wetted under a 1,000 psf surcharge.

Native Granular Soils: The native granular soils encountered were grouped as follows: clayey sand (SC) with silty-clayey sand (SM-SC), and poorly to well-graded sand with silt (SP-SM, SW-SM) with silty sand (SM) and occasional gravel. These soils were encountered in 17 of the 18 borings, beginning at depths ranging from near surface (below topsoil layer) to 10 feet, and extending to depths ranging from 4 to 22 feet in 10 of the borings, and to the maximum 15 to 30-foot depths explored in seven of the borings. The native granular soils were slightly moist to very moist, and tan to brown in color. Sampler penetration blow counts indicate the granular soils are generally medium dense to very dense. The exception was Boring 9 at a depth of 9 feet, where the granular soils were very loose (blow count of 3).

Native Clay Soils: Native lean clay (CL) soil with varied amounts of sand were encountered in 15 of the 18 borings. These soils were encountered beginning at depths ranging from near surface (below topsoil layer) to 13 feet, and extending to depths ranging from 4.5 feet to 26 feet in 13 of the borings, and to the maximum 20-foot depth explored in two of the borings. The native clay soils were slightly moist to moist, and brown, dark brown, and gray in color. Sampler penetration blow counts indicate the clay soils are medium stiff to hard in consistency. Swell-consolidation test results presented on Figs. 6 thru 10 indicate the tested samples of clay varied from having a nil to high swell potential to a low potential for compression, when wetted under a 1,000 psf surcharge.

Bedrock: Sandstone and/or claystone bedrock was encountered in 9 of the borings, beginning at depths of 9 to 26 feet, and extending to the maximum 15 to 30-foot depths explored. In two of these borings, the upper few feet of claystone was weathered. The sandstone was poorly cemented, moist and brown in color. The claystone was slightly moist to moist, and brown to gray in color. Sampler penetration blow counts indicate the non-weathered bedrock is hard to very hard, and the weathered claystone is very stiff to hard. Swell-consolidation testing was not performed on the claystone due to the depth encountered, however, based on our experience in the area, we recognize that it typically has a similar potential for swell as the tested overburden clay soils.

Groundwater: Groundwater was not encountered at the time of drilling. When the borings were checked 8 to 9 days later, groundwater was encountered in Boring 8 at an approximate depth of 25.1 feet. Fluctuations in the water level may occur with time, particularly during wetter seasons and after precipitation events. The borings were backfilled with auger cuttings upon completion of water level measurements.

GEOTECHNICAL ENGINEERING CONSIDERATIONS

The site subsurface conditions generally consist of variable depths of granular and clay overburden soils underlain by sandstone and claystone bedrock. Existing fill was encountered in one of the borings. The existing fill and the expansive clay and claystone materials are considered unsuitable as discussed in the paragraphs that follow. Shallow foundations (PT-slab and spread footings) and slabs placed directly on or near these materials can experience differential movement or excessive settlement (in the case of existing fill) causing distress if the materials are subjected to changes in moisture content. The natural granular soils and sandstone encountered are considered suitable for support of shallow foundations and slabs.

Existing fill: As discussed, it appears that previous land usage has occurred on the site, and it is unclear as to the extent of site grading that may have occurred. Existing fill was encountered in one of the borings, and sampler penetration blow counts suggest the fill is relatively compact. Given the unknown history of the fill, it is our opinion that it should be considered unsuitable for support of the proposed development unless documentation is available stating the site fills were properly controlled to the compaction criteria presented in this report. Foundations, floor slabs and pavements placed on uncontrolled fill can experience large total and differential movement resulting structural distress, particularly if debris or loose zones are present within the existing fill zone. We recommend the existing fill, where present in these areas, be overexcavated, moisture conditioned, and placed back properly compacted. The intent of this recommendation is to provide a low risk of settlement more than about 1 inch. Based on the properties of the existing fill encountered, it is our opinion it would be suitable for reuse as structural fill if it is processed and moisture conditioned.

Expansive Soil/Bedrock Considerations: Clay overburden soil varied from having a nil to high swell potential to a low potential for compression, and was encountered in several of the borings within the assumed elevation of construction. With the given conditions, the foundation option which would allow for the least amount of risk of overall movement would be to support the structures with a deep foundation system end bearing in the underlying bedrock and to use a structurally supported floor. However, bedrock was not encountered in many of the borings within the 20 to 30-foot depths explored, suggesting that a deep foundation may be a cost prohibitive option for portions of the site. Additional field exploration would be required to develop criteria for a deep foundation option.

Considering the data obtained from the field and laboratory studies and the nature of the proposed construction, it is expected that a shallow foundation system with a partial overexcavation of the underlying expansive materials would perform adequately if the recommendations provided in this

report are followed. The risk for excessive foundation movements is estimated to be relatively low for a shallow foundation system supported by nonexpansive material. It is anticipated that providing separation from the expansive materials with a zone of nonexpansive fill will result in a low risk of swell-related heave of about 1-1/2 inches or less unless extreme wetting of the subgrade occurs.

The use of a post-tensioned slab foundation will result in the reduced risk of associated distress from foundation movement as compared to a conventional spread footing foundation system, given the foundation systems ability to be rigid and withstand differential movements. As requested, the foundation recommendations that follow include PT-slabs and spread footings based on our understanding of the owner's preferences.

Acceptable performance of a PT-slab or spread footing foundation will rely on maintaining a relatively stable moisture content, and minimizing water infiltration into the underlying expansive clay by providing good surface and subsurface drainage, and using prudent landscaping and irrigation practices. The use of PT slab foundations or spread footing foundations with slab-on-grade floors should only be considered if the owner understands and accepts the risk of distress resulting from some foundation movement even though mitigation measures are used to reduce the potential for building and foundation distress resulting from ground heave.

Potential Heave: The following discussion presents estimates of ground heave to aid in the decision making process for selecting a depth of subgrade preparation. The risk of ground heave and its effect on the foundation can be reduced by providing a zone of compacted nonexpansive fill directly beneath foundations and floor slabs. Heave estimate calculations can be useful in evaluating the relative effectiveness of varying the thickness of this prepared fill zone. However, such calculations cannot address the uncertainty in the potential depth and degree of wetting or drying that may occur beneath the buildings or the variable swell potential across the site.

We have performed calculations for a range of scenarios of depth of wetting and overexcavation and backfill combinations to demonstrate the potential for ground heave if the expansive materials beneath the buildings should be thoroughly wetted to a significant depth, including below the depth of the prepared fill zone. Fills should consist of the on-site soils, sandstone bedrock or similar imported nonexpansive materials. The following table presents estimates of potential heave based on the results of swell-consolidation tests using test and analysis methods generally accepted in the Colorado Front Range. Both depth of wetting and depth of the prepared nonexpansive fill were considered as variables in the analysis.

Calculated Ground Heave (in.)			
ALTERNATIVE	Assumed Depth of Wetting (ft.)		
	5 ft	10 ft	15 ft
No Treatment	2.7	4.3	5.7
3' Overexcavation	0.8	2.4	3.7
4' Overexcavation	0.3	1.9	3.3
5' Overexcavation	0	1.6	2.9

The heave estimate calculations demonstrate that significant heave should be expected if thorough wetting of the expansive materials below the bottom of the prepared fill zone occurs, particularly if wetting extends to significant depths. However, our experience indicates the natural materials underlying the foundations on the large majority of sites with similar subsurface conditions do not experience extreme moisture increases to significant depth provided that good surface and subsurface drainage is designed, constructed and maintained, and that good irrigation practices are followed. The risk could be further reduced by eliminating landscape irrigation within about 15 to 20 feet of the buildings and limiting irrigation elsewhere on site. Wetting can also occur as a result of unforeseeable influences such as plumbing leaks or breaks, or adverse surface or subsurface drainage from adjacent future developments.

With proper site preparation, PT slabs, and shallow spread footing foundations with slab-on-grade floors should be feasible. Proper site preparation should include complete removal of topsoil and organic materials, and existing non-engineered fills where present within the proposed building footprints and beneath other structures, down to the natural soils or bedrock and replacement with nonexpansive structural fill. Any clay or claystone bedrock encountered within 5 feet of the base of spread footing foundations and floor slabs and within 4 feet of PT slab foundations (as referenced from the bottom the lowest portion of the foundation element/rib) should be removed and replaced with a suitable structural fill. The approximate limits of overexcavation should be evaluated once the site layout and proposed grading have been determined.

The on-site native soils and sandstone bedrock will be suitable for reuse as nonexpansive fill, including structural fill beneath foundations, exterior flatwork, pool and pavements. The existing fill encountered is also suitable for reuse, minus any deleterious materials. The "Site Grading and Earthwork" section of the report provides additional discussion.

FOUNDATION RECOMMENDATIONS

PT-Slab Foundations: We assume the PT-slab foundation will be designed in accordance with the Post-Tensioning Institute's (PTI) publication "Design of Post-Tensioned Slabs-On-Ground (Third Edition, 2004)" with the 2008 supplement. The design method is empirical and was developed in other parts of the country based on assumptions relating clay mineralogy and climate to the soil swell characteristics. Using the PTI design procedure, the PT-slab foundations are designed for differential uplift and settlement of the slab edges, relative to the slab center, caused by seasonal swelling and shrinking cycles of the clay soils supporting the slab.

The PTI design method does not take into account the swell characteristics of highly overconsolidated clay materials, including soils found along the Colorado front range, which are prone to swell but are rarely observed to shrink. Nor does the method use direct measurement of the material swell characteristics, as is routinely done for foundation design in the Colorado front range area. However, our experience indicates that PT-slabs designed using the PTI design methods perform well when the slabs are supported on a layer of fill consisting of on-site or imported moisture-conditioned materials. Because the thickness of the moisture-conditioned fill generally does not extend to the anticipated depth of potential wetting and uplift, the remaining untreated expansive materials have the potential to cause uplift. However, the contribution of the remaining deeper expansive materials to differential uplift is considered to be significantly less than the shallower materials.

The design and construction criteria presented below should be observed for a PT-slab foundation. The construction details should be considered when preparing project documents.

1. We recommend that PT-slab foundations be supported on the native granular soils, sandstone bedrock, or properly compacted nonexpansive fill. Clay or claystone encountered within 4 feet of the base of the foundation should be removed and replaced with suitable structural fill in accordance with the criteria presented in the "Site Grading and Earthwork" section of the report. The base of the foundation should be defined as the bottom of the lowest element of the PT-slab (the bottom of the foundation ribs would be considered the lowest point).
2. Any areas of existing fill, loose or soft material encountered within the foundation excavation should be removed and replaced with structural fill meeting the material and placement requirements outlined in the "Site Grading and Earthwork" section of this report. New

structural fill should extend down from the edges of the foundations at a 1 horizontal to 1 vertical projection.

3. PT-slab foundations bearing on compacted suitable fill material placed as recommended herein should be designed for a maximum allowable bearing pressure of 2,500 psf.
4. Based on the method in PTI's Third Edition, the PT-slabs should be designed using the following criteria:

Criteria	Center Lift	Edge Lift
Moisture variation (e_m) (ft.)	5.3	2.6
Differential swell (y_m) (in.)	0.19	0.43

5. The parameters used to calculate these values include a soil suction (pF) of 3.9 and a Mineral Classification of Zone III. These parameters were selected from the PTI design manual based on soil index parameters; they are not actual measurements or estimates of soil suction and soil moisture distributions across the site.
6. PT-slab beam elements around the slab perimeters and beneath unheated areas should be provided with adequate soil cover above their bearing elevation for frost protection. A cover of at least 30 inches is typically used in this area.
7. Once the building pad area has been prepared as described above, it should be protected from excessive wetting or drying until after the foundation has been completed.
8. Proper construction is essential for the adequate performance of a PT-slab foundation. We recommend a contractor experienced in PT-slab construction in this area be retained.
9. A representative of the geotechnical engineer should confirm proper subgrade preparations have been met prior to placing foundation formwork. Loose or disturbed material should be removed from the slab subgrade prior to placement of concrete. Placement of structural fill should be observed and tested by a representative of the geotechnical engineer. In addition, representatives of the geotechnical and/or structural engineer should check reinforcement placement immediately prior to concrete placement.

Spread Footings: As discussed previously, it is our opinion that the proposed buildings may be founded on spread footings bearing on the native granular soils, sandstone or properly compacted structural fill. Existing fill and expansive clay and claystone materials will require overexcavation as discussed in the "Site Grading and Earthwork" section. The design and construction criteria presented below should be observed for a spread footing foundation system. The construction details should be considered when preparing project documents.

1. We recommend that spread footing foundations be supported on the native granular soils, sandstone bedrock, or properly compacted nonexpansive fill. Clay or claystone encountered within 5 feet of the foundation bearing elevation should be removed and replaced with structural fill in accordance with the criteria presented in the "Site Grading and Earthwork" section of the report.
2. Any areas of existing fill, loose or soft material encountered within the foundation excavation should be removed and replaced with structural fill meeting the material and placement requirements outlined in the "Site Grading and Earthwork" section of this report. New structural fill should extend down from the edges of the foundations at a 1 horizontal to 1 vertical projection.
3. Footings supported on the native granular materials or properly compacted structural fill as recommended herein should be designed for an allowable soil bearing pressure of 2,500 psf.
4. The footings for buildings in areas requiring overexcavation of the clay or claystone should also be designed for a minimum dead load pressure of 800 psf. In order to satisfy the minimum dead load pressure and minimum footing width criteria, it may be necessary to concentrate loads by using a grade beam and pad or similar foundation design. If this system is used, a void should be provided beneath the grade beams between pads. Wall-on-grade construction is not acceptable to achieve the minimum dead load.
5. Spread footings should have a minimum footing width of 16 inches for continuous footings and of 24 inches for isolated pads.

6. Exterior footings and footings beneath unheated areas should be provided with adequate soil cover above their bearing elevation for frost protection. Placement of foundations at least 30 inches below the exterior grade is typically used in this area.
7. Criteria for the lateral resistance of a spread footing placed on native granular materials or properly compacted structural fill is presented in the "Foundation Walls & Retaining Structures" section of this report.
8. Continuous foundation walls should be reinforced top and bottom to span an unsupported length of at least 10 feet.
9. Granular foundation soils should be densified with a smooth vibratory compactor prior to placement of formwork and reinforcing steel.
10. A representative of the geotechnical engineer should confirm proper subgrade preparations have been met prior to placing foundation formwork. Loose disturbed material should be removed from the foundation subgrade prior to placement of concrete. Placement of structural fill should be observed and tested by a representative of the geotechnical engineer. In addition, representatives of the geotechnical and/or structural engineer should check reinforcement placement immediately prior to concrete placement.

SITE SEISMIC CRITERIA

Using estimated shear wave velocities for the subgrade materials encountered based on standard penetration testing, calculations indicate a design Site Class D per the International Building Code (IBC). Based on the subsurface profile and the anticipated ground conditions, liquefaction is not a design consideration.

FLOOR SLABS

The native granular soils, sandstone bedrock, or reconditioned fill are suitable to support light to moderately loaded slab-on-grade construction. Where shallow expansive clay or claystone is present near the proposed floor slab elevation, floor slabs will present a difficult problem because sufficient dead load cannot be imposed on them to resist the uplift pressure generated when the materials are wetted and expand. The most positive method to avoid damage as a result of floor slab movement is to construct a structural floor above a well-ventilated crawl space. Based on the moisture-volume change characteristics of the materials encountered, we believe slab-on-ground construction may be

used in conjunction with buildings that will utilize spread footing foundations, provided the risk of distress resulting from slab movement is accepted by the owner. The “Geotechnical Considerations” section discusses the anticipated movement potential.

The following measures should be taken to reduce the damage which could result from movement should the underslab materials be subjected to moisture changes.

1. Existing fill, clay and claystone, where encountered below the floor slab, should be overexcavated and replaced with suitable nonexpansive fill per the depths and criteria presented in the “Site Grading and Earthwork” section of the report.
2. Floor slabs should be separated from all bearing walls and columns with expansion joints which allow unrestrained vertical movement.
3. Applicable for buildings that will require overexcavation of clay or claystone, interior non-bearing partitions resting on floor slabs should be provided with slip joints at the bottoms so that, if the slabs move, the movement cannot be transmitted to the upper structure. This detail is also important for wallboards, stairways and door frames. Slip joints which will allow at least 2 inches of vertical movement are recommended.
4. Floor slabs should not extend beneath exterior doors or over foundation grade beams, unless saw cut at the beam after construction.
5. Floor slab control joints should be used to reduce damage due to shrinkage cracking. The appropriate joint spacing is dependent on slab thickness, concrete aggregate size and slump, and should be consistent with recognized guidelines such as those of the Portland Cement Association (PCA) or American Concrete Institute (ACI). The joint spacing and any requirements for slab reinforcement should be established by the designer based on experience and the intended slab use.
6. If moisture-sensitive floor coverings will be used, mitigation of moisture penetration into the slabs, such as by use of a vapor barrier, may be required. If an impervious vapor barrier membrane is used, special precautions will be required to reduce potential differential curing problems which could cause the slabs to warp. Section 302.1R of the ACI Manual of Concrete Practice addresses this topic.

7. All plumbing lines should be tested before operation. Where plumbing lines or other slab protrusions enter through the floor, a positive bond break should be provided. Flexible connections should be provided for slab-bearing mechanical equipment.

The precautions and recommendations itemized above will not prevent the movement of floor slabs if the underlying expansive materials are subjected to alternate wetting and drying cycles. However, the precautions should reduce the damage if such movement occurs.

FOUNDATION WALLS AND RETAINING STRUCTURES

Foundation walls and retaining structures which are laterally supported and can be expected to undergo only a moderate amount of deflection should be designed for a lateral earth pressure computed on the basis of an equivalent fluid unit weight of 55 pcf for backfill consisting of the on-site granular soils, or 50 pcf if a imported CDOT Class I structural backfill is used. Cantilevered retaining structures which can be expected to deflect sufficiently to mobilize the full active earth pressure condition should be designed for a lateral earth pressure computed on the basis of an equivalent fluid unit weight of 45 pcf for backfill consisting of the on-site granular soils, or 40 pcf for CDOT Class I structural backfill.

All foundation and retaining structures should be designed for appropriate hydrostatic and surcharge pressures such as adjacent buildings, traffic, construction materials and equipment. The pressures recommended above assume drained conditions behind the walls and a horizontal backfill surface. The buildup of water behind a wall or an upward sloping backfill surface will increase the lateral pressure imposed on a foundation wall or retaining structure.

The lateral resistance of a foundation or retaining wall footing placed on undisturbed native granular soils or properly compacted structural fill material will be a combination of the sliding resistance of the foundation on the foundation materials and passive earth pressure against the side of the footing. Resistance to sliding at the bottoms of the footings may be calculated based on an allowable coefficient of friction of 0.3. Passive pressure against the sides of the footings may be calculated using an allowable equivalent fluid unit weight of 180 pcf.

The onsite soils, minus any clay soils or claystone, are suitable for use as wall backfill. Imported granular wall back fill, if used, should meet the requirements of a CDOT Class I structural backfill with less than 20% passing the No. 200 sieve. Proposed material should be approved by the geotechnical engineer prior to use.

The granular backfill behind foundation and retaining walls should be sloped from the base of the wall at an angle of at least 45 degrees from the vertical. Backfill should be placed in uniform lifts and compacted to the criteria presented in the "Site Grading and Earthwork" section of the report. Care should be taken not to overcompact the backfill since this could cause excessive lateral pressure on the walls. Some settlement of deep foundation wall backfills will occur even if the material is placed properly.

EXTERIOR FLATWORK

The following discussion applies to areas where shallow expansive clay or claystone is present near the proposed foundation, floor slab, pavement or pool grades. The limits should be evaluated once the site layout and proposed grading have been determined.

It is extremely important that exterior flatwork and pavements be isolated from the building foundations and other structures. Many problems associated with expansive materials are related to ineffective isolation between pavements and exterior slabs relative to foundation-supported components of structures. Careful design detailing is necessary at locations such as exterior stairway landings and entry points.

We recommend subgrade preparation beneath exterior flatwork immediately adjacent to the buildings and pool, and within a 10-foot zone around the perimeter of the buildings and pool including sidewalks and patio areas, where reduction of heave potential is considered critical be done to the same requirement of overexcavation required for the structure, including depth of overexcavation and backfilling with compacted fill.

In pavement areas, we recommend the clay and claystone materials be removed and replaced with nonexpansive fill where encountered within 2 feet of the pavement grade. If the client can tolerate a greater risk of movement, subgrade preparation for exterior flatwork may be done as per the pavement subgrade requirements. Reference the "Pavement Design" section of this report for additional discussion. Proper surface drainage measures as recommended in "Surface Drainage" section of this report are also critical to reducing moisture or frost-related movement.

Upward heave-related movement or settlement of fill of exterior flatwork adjacent to the building or pool may result in adverse drainage conditions with runoff directed toward the structure. In addition, upward movement of exterior flatwork may restrict movement of outward swinging doors. Site grading and drainage design should consider those possibilities, particularly at entryways. Positive drainage and grades should be maintained throughout the life of the facility.

WATER SOLUBLE SULFATES

The concentration of water soluble sulfates measured in samples of the on-site soils obtained from the borings ranged from less than 0.01% to approximately 0.03%. These concentrations of water soluble sulfates represent Class 0 severity exposures to sulfate attack on concrete exposed to these materials. The degree of attack is based on a range of Class 0, Class 1, Class 2, and Class 3 severity exposure as presented in ACI 201. Based on the laboratory data and our experience, we believe special sulfate resistant cement will not be required for concrete exposed to the on-site soils. Concrete containing Type I or I/II cement is commonly used in the area, and is recommended for this project due to its availability.

SWIMMING POOL

Boring 1 was drilled in the vicinity of pool area, and encountered granular soil types to a depth of 13 feet, followed by clay and claystone. The granular soils are considered to be suitable for the proposed construction. Any clay or claystone encountered within 5 feet of the pool will require overexcavation and replacement with nonexpansive fill as described below. Proper design and construction of below-ground pool structures is critical to their satisfactory performance. Based on the subsurface conditions, we suggest the following precautions be taken in the design and construction of the proposed pool.

1. The pool should be designed and constructed to withstand some differential movement without serious cracking.
2. Clay and claystone encountered within 5 feet beneath the pool bottom should be removed and replaced with a suitable nonexpansive fill, compacted in accordance with the "Site Grading and Earthwork" section of this report. The determined overexcavation depth should be uniform within the pool footprint to reduce the potential for excessive differential settlements. The overexcavation limits should also follow the criteria discussed in the "Exterior Flatwork" section of the report, as applicable for the deck and any adjacent flatwork.
3. A minimum 6-inch free-draining gravel layer above a bituminous liner or equivalent impermeable membrane should be placed beneath the pools. The drainage layer should slope to a drain line or collection point from which water can be removed by pumping or gravity drainage. The pool should be designed to resist hydrostatic uplift forces. The pool designer should determine the suitability/ requirements of any underdrain systems.

4. A water-tight joint should be provided between the pool and deck so that water splashed from the pool will not infiltrate into the pool backfill soils. The deck should be properly maintained, including sealing of cracks which develop on the deck while the pool is in service, to mitigate water infiltration.
5. The pool deck and adjoining area should be sloped to drain away from the pool and to minimize ponding and infiltration of moisture into the subsoils. Lawn irrigation should be kept to a minimum adjacent to the pool. Landscape not requiring irrigation may be considered as an alternative to lawn in areas surrounding the pool.

The above measures will not eliminate the risk of damage to the pool and deck due to movement of subgrade materials, but should reduce the amount of subsurface materials becoming wetted, which should help reduce potential movement due to wetting of the subgrade materials.

UNDERDRAIN SYSTEM

For Below Grade Space: Based on our understanding that there will be no basement or below grade space, it is our opinion an underdrain system will not be necessary for the apartment buildings and other on-site buildings. If the proposed construction differs from our assumptions, we should be consulted to reevaluate the recommendations for an underdrain in these areas.

For Building Pads Requiring Overexcavation: Depending on the final site layout and grading, for buildings that will require overexcavation of the expansive clay or claystone materials, the base of the fill zone may require an underdrain system. If the overexcavation is limited to only a portion of the building footprint, or if the remaining thickness of native clay is limited below the overexcavation zone, it is our opinion an underdrain would not be necessary. This should be evaluated as part of the final design.

SURFACE DRAINAGE

Proper surface drainage is very important for acceptable performance of the buildings during construction and after the construction has been completed. Drainage recommendations provided by local, state and national entities should be followed based on the intended use. The following recommendations should be used as guidelines and changes should be made only after consultation with the geotechnical engineer.

1. Excessive wetting or drying of foundation and slab subgrades should be avoided during construction.
2. The prepared subgrade will have an increased swell potential if it is allowed to dry between completion of the subgrade preparation and when it is covered with concrete and/or backfilled. We recommend the surface of the subgrade be protected with a loose soil layer to reduce drying. Subgrade that is exposed for extended periods of time should be scarified, moisture conditioned and removed/recompacted as necessary prior to placement of concrete.
3. The ground surface surrounding the exterior of the buildings and other structures should be sloped to drain away from the foundations in all directions. We recommend a minimum slope of 12 inches in the first 10 feet in unpaved areas. Site drainage beyond the 10-foot zone should be designed to promote runoff and reduce infiltration. A minimum slope of 3 inches in the first 10 feet is recommended in the paved areas. These slopes may be changed as required for handicap access points in accordance with the Americans with Disabilities Act.
4. Ponding of water should not be allowed in backfill material or in a zone within 10 feet of foundations or foundation walls, whichever is greater.
5. Roof downspouts and drains should discharge well beyond the limits of all backfill.
6. Lawn sprinkler heads and landscaping which requires typical irrigation should be located at least 10 feet from foundations. Irrigation schemes are available which allow placement of lightly irrigated landscape near foundations in moisture sensitive soil areas. Drip irrigation heads with main lines located at least 10 feet from the foundations are acceptable provided irrigation quantities are limited.
7. Plastic membranes should not be used to cover the ground surface adjacent to foundation walls. A pervious geotextile may be used to inhibit weed growth.
8. Raised landscape edging should have periodic openings to prevent ponding of water.

9. If the nearby ground surface slopes towards a building, we recommend a swale be constructed to intercept and redirect surface runoff around and away from the building. The swale should be located a minimum of 10 feet from the foundation, and should be graded at a minimum 2% slope.

PAVEMENT DESIGN

Subgrade Materials: Based on the results of the field exploration and laboratory testing programs, the pavement subgrade materials encountered at the site classify as A-1-a, A-1-b, A-2-4, A-4, A-6 and A-7-6 with group indices ranging from 0 to 20 in accordance with the American Association of State Highway and Transportation Officials (AASHTO) soil classification system. An R-value of 5 and a resilient modulus value of 3,025 psi were assumed for design of flexible pavements, and a subgrade modulus of 50 pci was assumed for design of rigid pavements. The pavement design has also assumed any clay and claystone materials encountered within 2 feet of pavement grade would be removed and replaced with suitable nonexpansive fill.

Design Traffic: We have not been provided with site specific traffic numbers for the planned pavement areas. For pavement thickness design calculations, we have assumed an equivalent 18-kip daily load application (EDLA) of 15 for drive lanes subject to vehicle traffic and infrequent moderate to heavy vehicles, such as fire trucks and trash trucks, and an EDLA of 5 for the parking stalls restricted to automobile traffic. If it is determined that actual traffic is significantly different, we should be contacted to reevaluate the pavement thickness design.

Pavement Sections: Asphalt pavement sections were determined in accordance with the 1993 AASHTO pavement design procedures. Based on this procedure, we recommend drive lanes be constructed with 7 inches of full-depth asphalt pavement or a composite section consisting of 5 inches of asphalt over 7 inches of aggregate base course. We recommend parking stalls restricted to auto traffic be constructed with 6 inches of full-depth asphalt pavement or a composite section consisting of 4 inches of asphalt over 7 inches of base course.

We recommend trash collection areas and other areas that may have concentrated truck turning movements be paved with a 6-inch thick portland cement concrete pavement section. The use of a flexible pavement in these areas could result in pavement fatigue cracking and/or rutting/shoving of the pavement due to the concentrated wheel loads. A 6-inch portland cement concrete pavement section may also be considered in lieu of an asphalt pavement section for other pavements in the development.

Subgrade Preparation: Fill placed for support of pavements should meet the material and compaction requirements for structural fill presented in the "Site Grading and Earthwork" section of this report.

To reduce the potential magnitude of pavement heave and distress caused by swelling of the clays and shallow claystone bedrock, we recommend these materials be removed and replaced with nonexpansive fill where encountered within 2 feet of the pavement grade. At the base of the overexcavation, the entire subgrade area should be overexcavated scarified to a depth of 12 inches, moisture conditioned as necessary, and compacted to 95% of the standard Proctor (ASTM D698) maximum dry density. Increasing the depth of moisture conditioning would further reduce the magnitude of potential movements.

The pavement subgrade should be proofrolled with a heavily loaded pneumatic-tired vehicle or a heavy, smooth drum roller compactor. Pavement design procedures assume a stable subgrade. Areas that deform excessively under heavy wheel loads are not stable and should be removed and replaced to achieve a stable subgrade prior to paving.

Drainage: The collection and diversion of surface drainage away from paved areas is extremely important to the satisfactory performance of pavement. Drainage design should provide for the removal of water from paved areas and prevent the wetting of the subgrade soils.

Pavement Materials: The asphalt pavement should consist of a bituminous material which meets the requirements of the Pikes Peak Region Asphalt Paving Specifications. Given the assumed traffic loading, we recommend the mix have a binder grade of PG 58-28 or PG 64-22, and a design gyrations (Ndes) of 75. In the event that a PG 64-22 asphalt binder is used in the mix, the asphalt section will provide adequate structural support but will be subject to a higher potential for low temperature related transverse cracking. The mix grading should consist of a Grading S for the lower lifts, and a grading SX for the top lift. Grading S may also be acceptable for the top lift.

Aggregate base course should be a Class 6 material conforming to the requirements presented in Section 703.03 of the CDOT Standard Specifications for Road and Bridge Construction.

Concrete pavement should meet the requirements of a Class P Mix, per Section 601 of the CDOT Standard Specifications, and should be based on a mix design established by a qualified engineer. The concrete should contain transverse joints not greater than 12 to 15 feet on centers and

longitudinal joints no greater than 14 feet. The joints should be hand formed, sawed or formed by premolded filler. The joints should be at least 1/4 of the slab thickness. Expansion joints should be provided at the end of each construction sequence and between the concrete slab and adjacent structures. Expansion joints where required, should be filled with a 1/2 inch-thick asphalt impregnated fiber. Concrete should be cured by protecting against loss of moisture, rapid temperature changes and mechanical injury for at least three days after placement. The concrete sections presented above are assumed to be unreinforced. Providing dowels at construction joints would help reduce the risk of differential movements between panel sections. Providing a grid mat of deformed rebar or welded wire mesh within the concrete pavement section would assist in mitigating corner breaks and differential panel movements. If a rebar mat is installed, we recommend that the bars be placed in the lower half of the pavement section. Also, if reinforcing is used, we have commonly seen No. 4 rebar placed at 24-inch center in each direction, however, we recommend that a structural engineer evaluate the placement and spacing of rebar if needed.

Maintenance: Periodic maintenance of paved areas is critical to achieve the design life of the pavement. Crack sealing should be performed annually as new cracks appear. Chip seals, fog seals, or slurry seals applied at approximate intervals of 3 to 5 years are usually necessary for asphalt. As conditions warrant, it may be necessary to perform patching and overlay at approximate 10-year intervals.

SITE GRADING AND EARTHWORK

Temporary Excavations: We recommend temporary excavation slopes be constructed in accordance with OSHA regulations. In accordance with OSHA criteria, the on-site native granular soils and existing fill should be considered a Type C soil due to the variability of material properties. The native clay soils classify as a Type B material, however, considering the intermittent occurrence of the clays, we recommend the overburden soils as a whole be considered a Type C material. The sandstone and claystone should be considered a Type B material. Temporary unretained excavations should have slopes no steeper than 1.5:1 (H:V) in Type C soils and 1:1 in Type B materials. A properly braced excavation or the use of a trench box should be used where the indicated unretained slopes cannot be accommodated. Flatter slopes will be required where groundwater seepage is encountered. OSHA regulations require that excavations greater than 20 feet in depth be designed by a professional engineer. If soils different from those indicated in this report are encountered, the OSHA soil type may vary and the required cut slopes may need to be adjusted. A contractor's competent person should make decisions regarding cut slopes.

Excavated slopes may soften or loosen due to construction traffic and erode from surface runoff. Measures to keep surface runoff from excavation slopes, including diversion berms, should be considered.

Excavation Considerations: In our opinion, the overburden soils and near surface bedrock encountered in the exploratory borings drilled for this study can be excavated with heavy-duty construction equipment with rippers. It is possible that localized, harder lenses of bedrock may be encountered within the excavation in portions of the site, and in particular confined excavations such as trench cuts. If harder rock is encountered, hydraulic chiseling may be required. Based on the subsurface conditions encountered, we do not anticipate dewatering to be necessary during construction.

Cut and Fill Slopes: Permanent cut and fill slopes should not be steeper than 3:1 (horizontal to vertical). Slopes will generally be stable at 2:1; however, 2:1 slopes will be prone to increased surface erosion and it will be difficult to maintain vegetation on them. The risk of slope instability will be significantly increased if seepage is encountered in cuts. If seepage is encountered in permanent excavations, an investigation should be conducted to determine if the seepage will adversely affect the cut stability.

Good surface drainage should be provided for all permanent cuts and fills to direct the surface runoff away from the slope faces. Permanent cut and fill slopes and other stripped areas should be protected against erosion by revegetation or other means. Fills should be benched into hillsides exceeding 4 horizontal to 1 vertical. Site grading should be planned to provide positive surface drainage away from all building and pavement areas.

No formal stability analyses were performed to evaluate the slopes recommended above. Published literature and our experience with similar cuts and fills indicate the recommended slopes should have adequate factors of safety. If a detailed stability analysis is required, we should be notified.

Fill Material: Unless specifically modified in the preceding sections of this report, the following recommended material and compaction requirements are presented for structural fills on the project site. A geotechnical engineer should evaluate the suitability of all proposed fill materials for the project prior to placement.

1. *Nonexpansive Structural Fill:* With proper moisture conditioning, the on-site native granular soils, clay soils, and sandstone bedrock will be suitable for reuse as nonexpansive fill, including structural fill beneath foundations, exterior flatwork, pool and pavements. The existing fill encountered is also suitable for reuse, minus any deleterious materials. Claystone should be considered unsuitable for use as structural fill. New fill should extend down from the edge of footings at a minimum 1:1 horizontal to vertical projection.

Imported structural fill, if required, should consist of nonexpansive soil material having a maximum of 50% passing the No. 200 sieve, and a maximum plasticity index of 15. (We recognize that some of the tested samples of the onsite soils do not meet these specifications; however, given the properties, it is our opinion they would be acceptable for reuse as structural fill, if properly moisture conditioned.) Import fill source materials not meeting the above liquid limit and plasticity index criteria may be acceptable (provided the minimum percentage passing the No. 200 sieve is satisfied) if the swell potential when remolded to 98% of the ASTM D 698 (standard Proctor) maximum dry density at optimum moisture content under a 200 psf surcharge pressure does not exceed 1%. Evaluation of potential sources would then require determination of laboratory moisture-density relationships and swell consolidation tests on remolded samples, thereby adding time and cost to evaluate proposed fill materials.

2. *Reuse of Claystone Bedrock:* The claystone will be expansive when placed in a compacted condition and are not suitable for use as nonexpansive fill. Placement of excavated claystone should be limited to nonstructural areas such as landscape areas to the extent practical. If necessary elsewhere, placement of these materials should be limited to deeper fills, and placed at depths 5 feet or greater from the base of foundation in building/structure locations, and 2 feet or greater in pavement areas. Claystone placed as fill should only be used if it is processed into a soil like material, with a maximum particle size of 2 inches.
3. *Utility Trench Backfill:* Materials excavated from the utility trenches may be used for trench backfill above the pipe zone fill provided they do not contain unsuitable material or particles larger than 4 inches.

4. *Material Suitability:* All fill material should be free of vegetation, brush, sod, trash and debris, and other deleterious substances, and should not contain rocks or lumps having a diameter of more than 6 inches.
5. *Subgrade Preparation:* The ground surface shall be stripped of vegetation/organics prior to fill placement. The resulting ground surface should be scarified to a depth of 12 inches, moisture conditioned as necessary, and compacted in a manner specified below for the subsequent layers of fill. Loose or unstable soils shall be removed, where present, in order to provide a stable platform prior to placement of fill.
6. *Existing Fill:* Existing fill was encountered in one of borings (Boring 11) to an approximate depth of 7 feet. Any existing fill encountered should be considered unsuitable for support of foundations, floor slabs, retaining walls and pavements, unless documentation can be provided stating it was properly compacted. We recommend the existing fill, where present in these areas, be overexcavated, moisture conditioned, and placed back properly compacted.
7. *Overexcavation of Expansive Clay and Claystone:* We recommend the expansive clays and claystone bedrock be overexcavated and replaced with a nonexpansive structural fill where present within 5 feet of the bottom of spread footing foundations, floor slabs and the pool. For PT slab foundations, we recommend a 4-foot overexcavation, as referenced from the bottom the lowest portion of the foundation element/rib. As discussed in the "Exterior Flatwork" section, the overexcavation zone should also extend 10 feet beyond each building where exterior flatwork is located, including sidewalks and patio areas, and where reduction of heave potential is considered critical. Depending on the amount of site grading planned, partial or no overexcavation may be applicable provided there is adequate separation between the foundation bearing elevation and the expansive materials. For pavement areas and other areas with movement sensitive exterior flatwork, we recommend a minimum 2-foot overexcavation and replacement. The anticipated areas that may require overexcavation should be evaluated during the final study once the site layout and proposed grading has been determined. It is expected that once grading and excavations begin, we are present on site to observe test pits and assist the contractor in determining the limits of overexcavation that will be required.

Compaction Requirements: A representative of the geotechnical engineer should observe fill placement operations on a full-time basis. We recommend the following minimum compaction criteria be used on the project.

Area	Percentage of Standard Proctor Maximum Dry Density (ASTM D 698)
Building Pads and all areas with fill depths greater than 10 feet	100%
Floor Slab Subgrade	98%
Foundation Wall Backfill	95%
Swimming Pool Subgrade	98%
Beneath Pavement Areas/Exterior Flatwork/Utility Trenches	95%
Retaining Wall Subgrade	98%
Retaining Wall Backfill	95%
Landscape and Other Misc. Overlot Fill Areas	95%
Compaction of granular soils should be achieved at a moisture content within +/- 2% of the optimum. Clay and claystone materials should be placed at a moisture content within 0% to +4% of the optimum.	

DESIGN AND CONSTRUCTION SUPPORT SERVICES

Kumar & Associates, Inc. should be retained to review the project plans and specifications for conformance with the recommendations provided in our report. We are also available to assist the design team in preparing specifications for geotechnical aspects of the project, and performing additional studies if necessary to accommodate possible changes in the proposed construction.

We recommend that Kumar & Associates, Inc. be retained to provide construction observation and testing services to document that the intent of this report and the requirements of the plans and specifications are being followed during construction. This will allow us to identify possible variations in subsurface conditions from those encountered during this study and to allow us to re-evaluate our recommendations, if needed. We will not be responsible for implementation of the recommendations presented in this report by others, if we are not retained to provide construction observation and testing services.

LIMITATIONS

This study has been conducted for exclusive use by the client for preliminary geotechnical related design and construction criteria for the project. The conclusions and recommendations submitted in

this report are based upon the data obtained from the exploratory borings at the locations indicated on Fig. 1 or as described in the report, and the proposed type of construction. This report may not reflect subsurface variations that occur, and the nature and extent of variations across the site may not become evident until site grading and excavations are performed. If during construction, fill, soil, rock or water conditions appear to be different from those described herein, Kumar & Associates, Inc. should be advised at once so that a re-evaluation of the recommendations presented in this report can be made. Kumar & Associates, Inc. is not responsible for liability associated with interpretation of subsurface data by others.

The scope of services for this project does not include identification of contaminated or hazardous materials or conditions. If the owner is concerned about the potential for such contamination, other studies should be undertaken.

Swelling soils occur on this site. Such materials are stable at their natural moisture content but will undergo high volume changes with changes in moisture content. The extent and amount of perched water beneath the building site as a result of area irrigation and inadequate surface drainage is difficult, if not impossible, to foresee.

The recommendations presented in this report are based on current theories and experience of our engineers on the behavior of swelling soil in this area. Standards of practice in this area evolve over time. The owner should be aware that there is a risk in constructing a building in an expansive soil area. Following the recommendations given by a geotechnical engineer, careful construction practice and prudent maintenance by the owner can, however, decrease the risk of foundation movement due to expansive soils.

DPC:bj

September 08, 2020 - 03:41pm
V:\Projects\2020\20-2-194-Watermark at Colorado Springs-Akers Drive\Drafting\202194-01.dwg

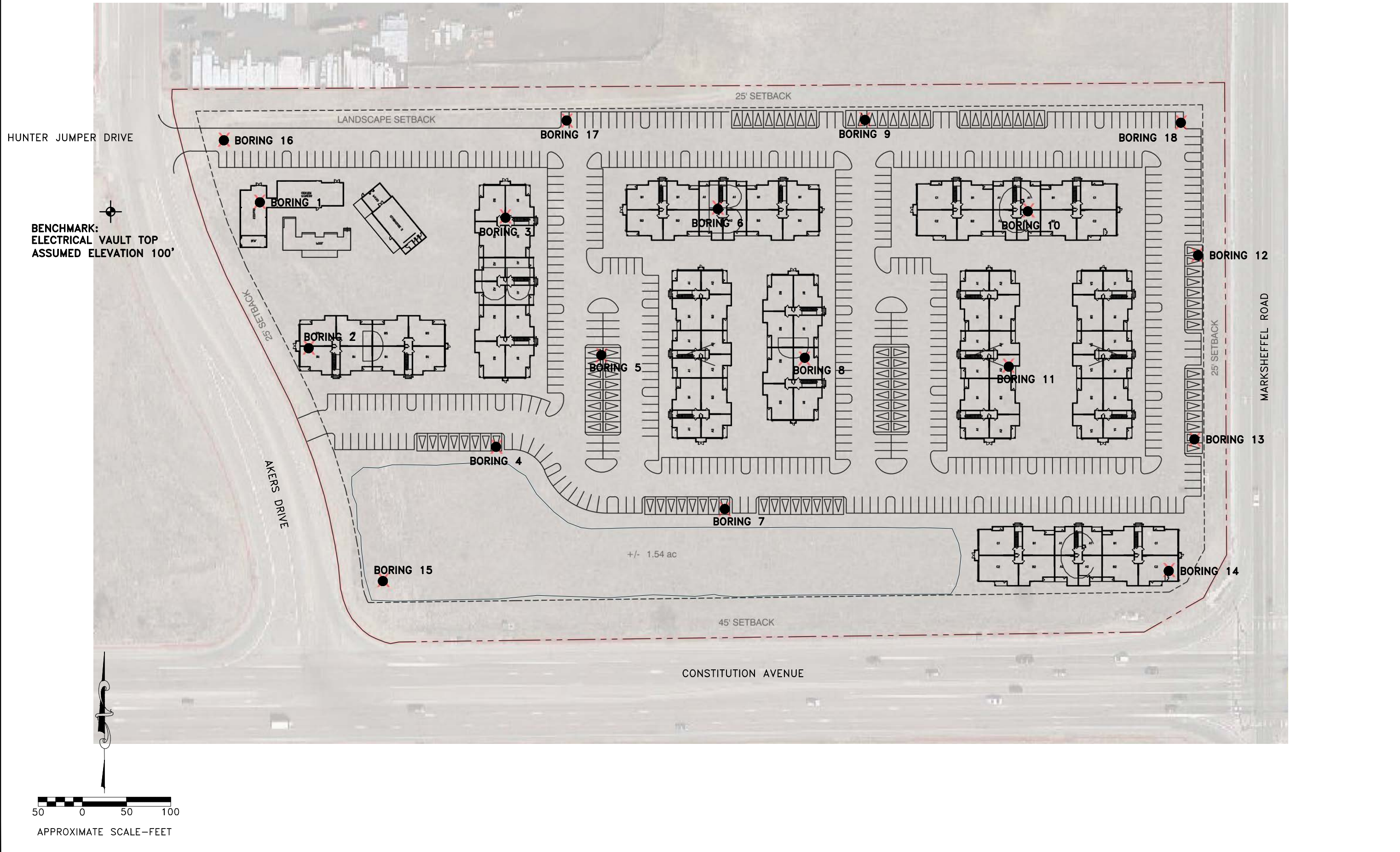

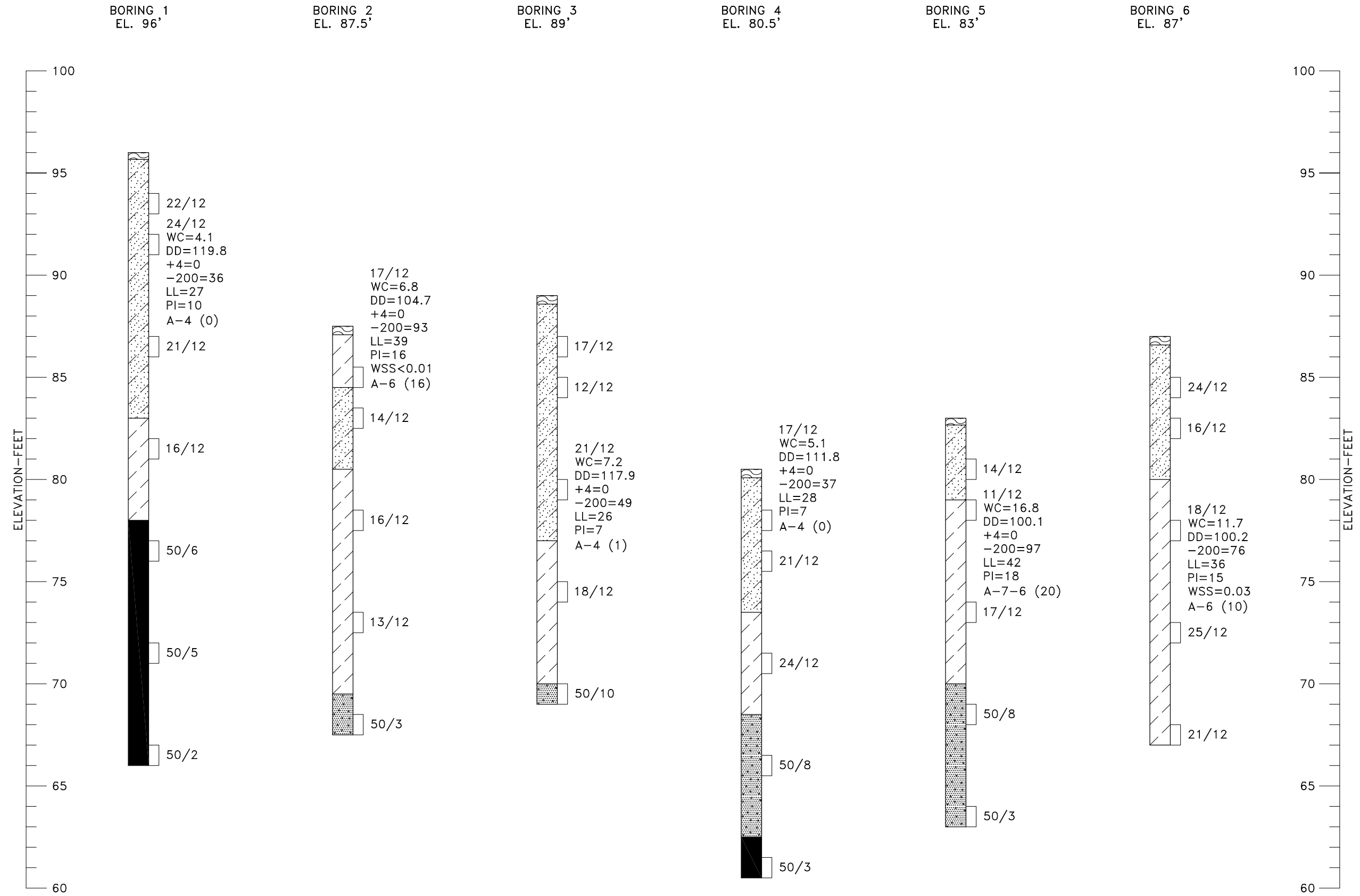

Sep 06, 2017 15:42pm
 C:\Users\mromero\AppData\Local\Temp\AcPublish_25964\202194-02 to 05.dwg

BORING 7
EL. 78'

BORING 8
EL. 81.5'

BORING 9
EL. 85.5'

BORING 10
EL. 82'

BORING 11
EL. 79'

BORING 12
EL. 82'

BORING 13
EL. 79'

ELEVATION - FEET

ELEVATION - FEET

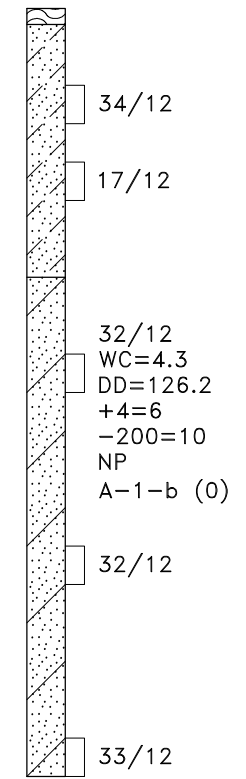
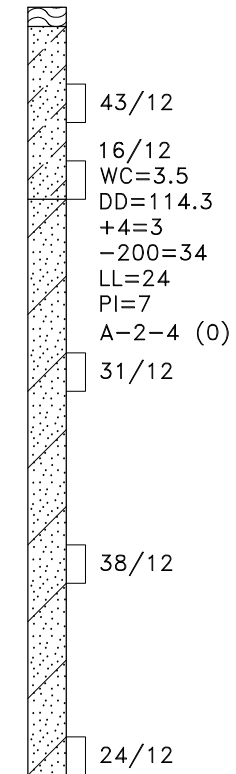
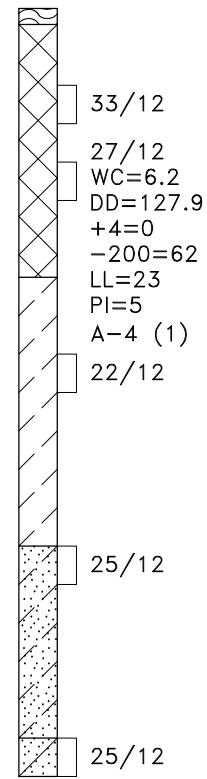
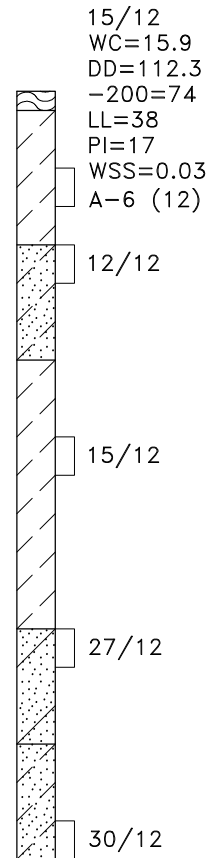
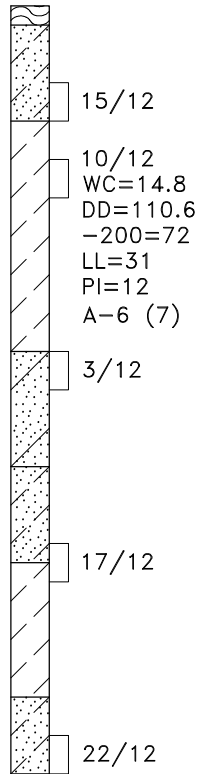
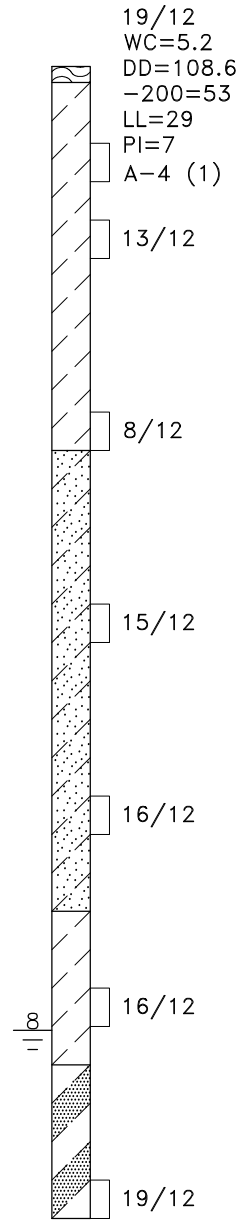
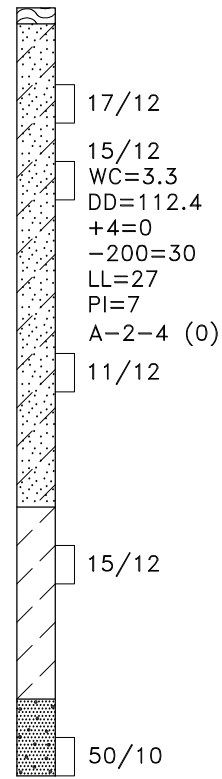

Sep 08, 2011 15:42pm
C:\Users\mromero\AppData\Local\Temp\AcPublish_25964\202194-02 to 05.dwg

BORING 14
EL. 75'

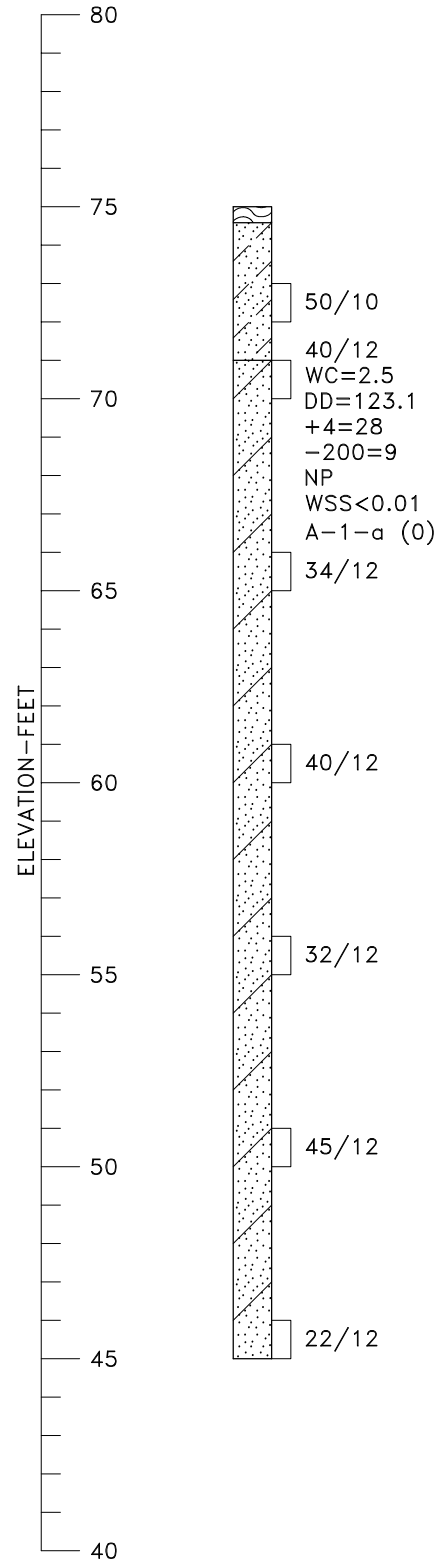

BORING 15
EL. 80'

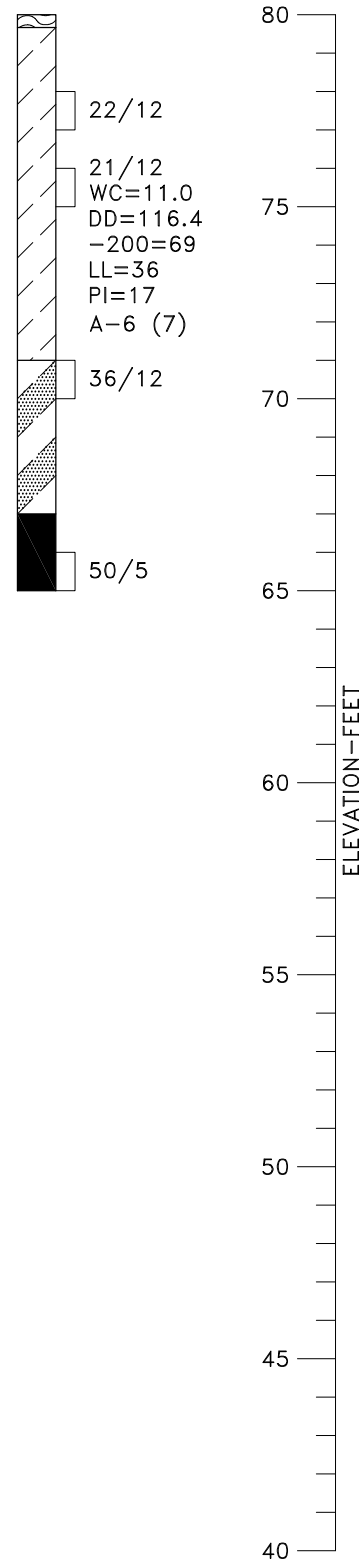

BORING 16
EL. 99'

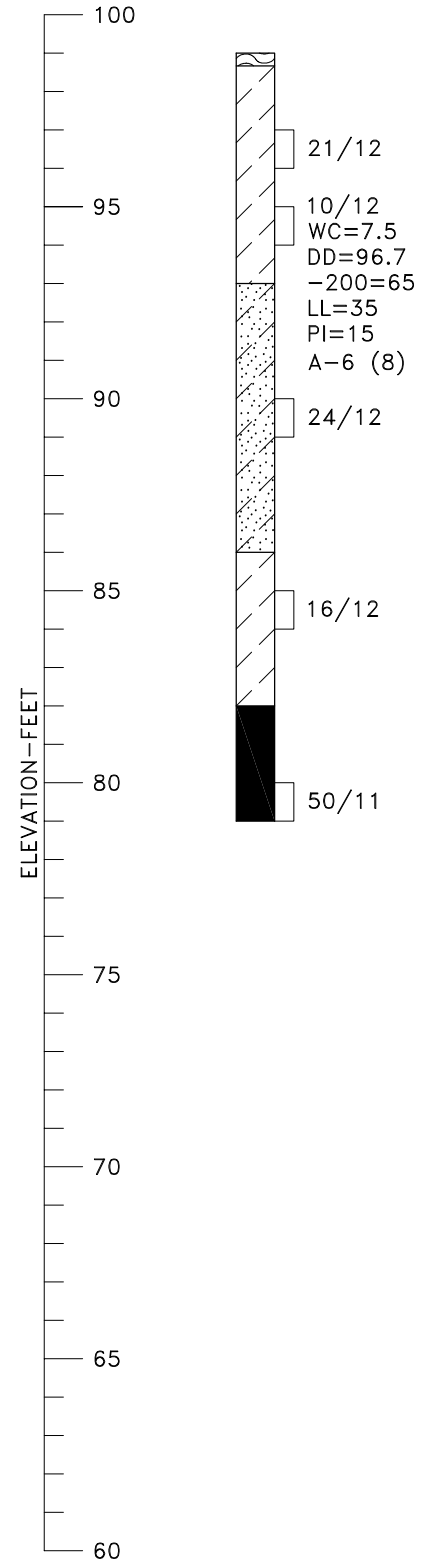

BORING 17
EL. 87'

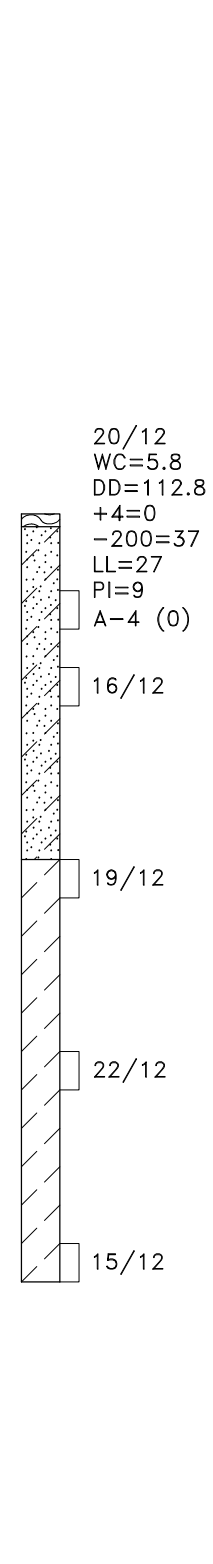



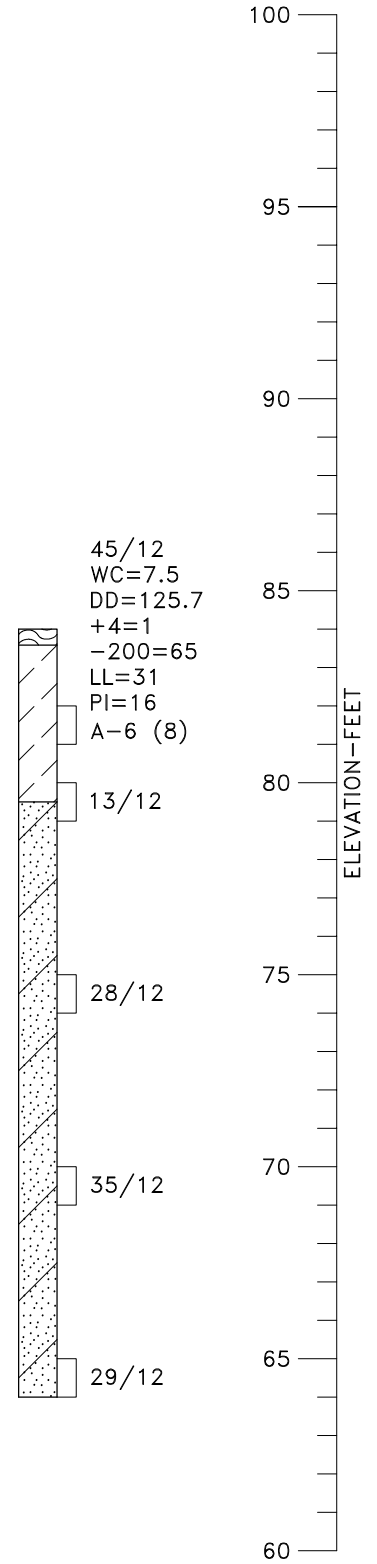







BORING 18
EL. 84'



Sep 08, 2011 15:42pm C:\Users\mromero\AppData\Local\Temp\AcPublish_25964\202194-02 to 05.dwg

LEGEND

-  TOPSOIL.
-  FILL: CLAYEY SAND (SC) AND SANDY-SILTY CLAY (CL-ML), SLIGHTLY MOIST TO MOIST, LIGHT BROWN TO BROWN.
-  CLAYEY SAND (SC) AND SILTY-CLAYEY SAND (SC-SM), MEDIUM DENSE TO VERY DENSE, SLIGHTLY MOIST TO MOIST, TAN TO BROWN.
-  LEAN CLAY WITH VARIED AMOUNTS OF SAND (CL), WITH OCCASIONAL CLAYEY SAND (SC) LAYERS, MEDIUM STIFF TO HARD, SLIGHTLY MOIST TO MOIST, BROWN, DARK BROW AND GRAY.
-  POORLY TO WELL GRADED SAND WITH SILT (SP-SM, SW-SM), AND SILTY SAND (SM), WITH OCCASIONAL GRAVEL, VERY LOOSE TO DENSE, MOIST TO VERY MOIST, TAN TO BROWN.
-  SANDSTONE BEDROCK, POORLY CEMENTED, HARD TO VERY HARD, MOIST, BROWN.
-  WEATHERED CLAYSTONE BEDROCK, VERY STIFF TO HARD, SLIGHTLY MOIST TO MOIST, BROWN TO GRAY.
-  CLAYSTONE BEDROCK, SANDY, HARD TO VERY HARD, SLIGHTLY MOIST TO MOIST, BROWN TO DARK BROWN, AND GRAY TO DARK GRAY.
-  DRIVE SAMPLE, 2-INCH I.D. CALIFORNIA LINER SAMPLE.
-  DISTURBED BULK SAMPLE.
- 22/12 DRIVE SAMPLE BLOW COUNT. INDICATES THAT 22 BLOWS OF A 140-POUND HAMMER FALLING 30 INCHES WERE REQUIRED TO DRIVE THE SAMPLER 12 INCHES.
- $\frac{8}{1}$ DEPTH TO WATER LEVEL AND NUMBER OF DAYS AFTER DRILLING MEASUREMENT WAS MADE.

NOTES

1. THE EXPLORATORY BORINGS WERE DRILLED ON AUGUST 24 AND 25, 2020 WITH A 4-INCH-DIAMETER CONTINUOUS-FLIGHT POWER AUGER.
2. THE LOCATIONS OF THE EXPLORATORY BORINGS WERE APPROXIMATED USING A HANDHELD GPS UNIT.
3. THE ELEVATIONS OF THE EXPLORATORY BORINGS WERE MEASURED BY HAND LEVEL AND REFER TO THE BENCHMARK ON FIG. 1.
4. THE EXPLORATORY BORING LOCATIONS AND ELEVATIONS SHOULD BE CONSIDERED ACCURATE ONLY TO THE DEGREE IMPLIED BY THE METHOD USED.
5. THE LINES BETWEEN MATERIALS SHOWN ON THE EXPLORATORY BORING LOGS REPRESENT THE APPROXIMATE BOUNDARIES BETWEEN MATERIAL TYPES AND THE TRANSITIONS MAY BE GRADUAL.
6. GROUNDWATER LEVELS SHOWN ON THE LOGS WERE MEASURED AT THE TIME AND UNDER CONDITIONS INDICATED. FLUCTUATIONS IN THE WATER LEVEL MAY OCCUR WITH TIME.
7. LABORATORY TEST RESULTS:
 WC = WATER CONTENT (%) (ASTM D2216);
 DD = DRY DENSITY (pcf) (ASTM D2216);
 +4 = PERCENTAGE RETAINED ON NO. 4 SIEVE (ASTM D6913);
 -200 = PERCENTAGE PASSING NO. 200 SIEVE (ASTM D1140);
 LL = LIQUID LIMIT (ASTM D4318);
 PI = PLASTICITY INDEX (ASTM D4318);
 NP = NON-PLASTIC (ASTM D 4318);
 WSS = WATER SOLUBLE SULFATES (%) (CP-L 2103);
 A-4 (0) = AASHTO CLASSIFICATION (GROUP INDEX) (AASHTO M145).

September 05, 2020 03:45pm
VA\Projects\2020\20-2-194 Watermark at Colorado Springs-Akers Drive\Drafting\202194-06 to 10.dwg

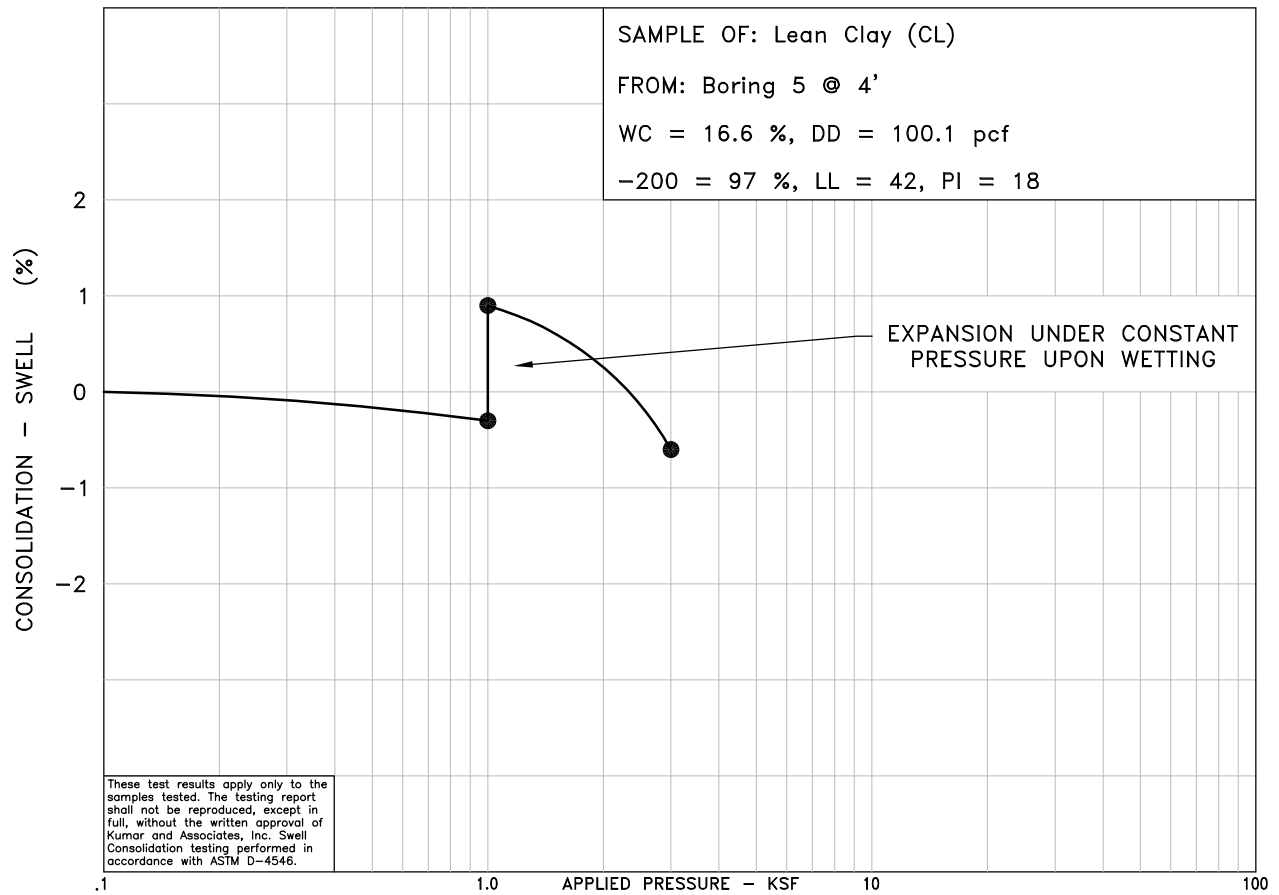
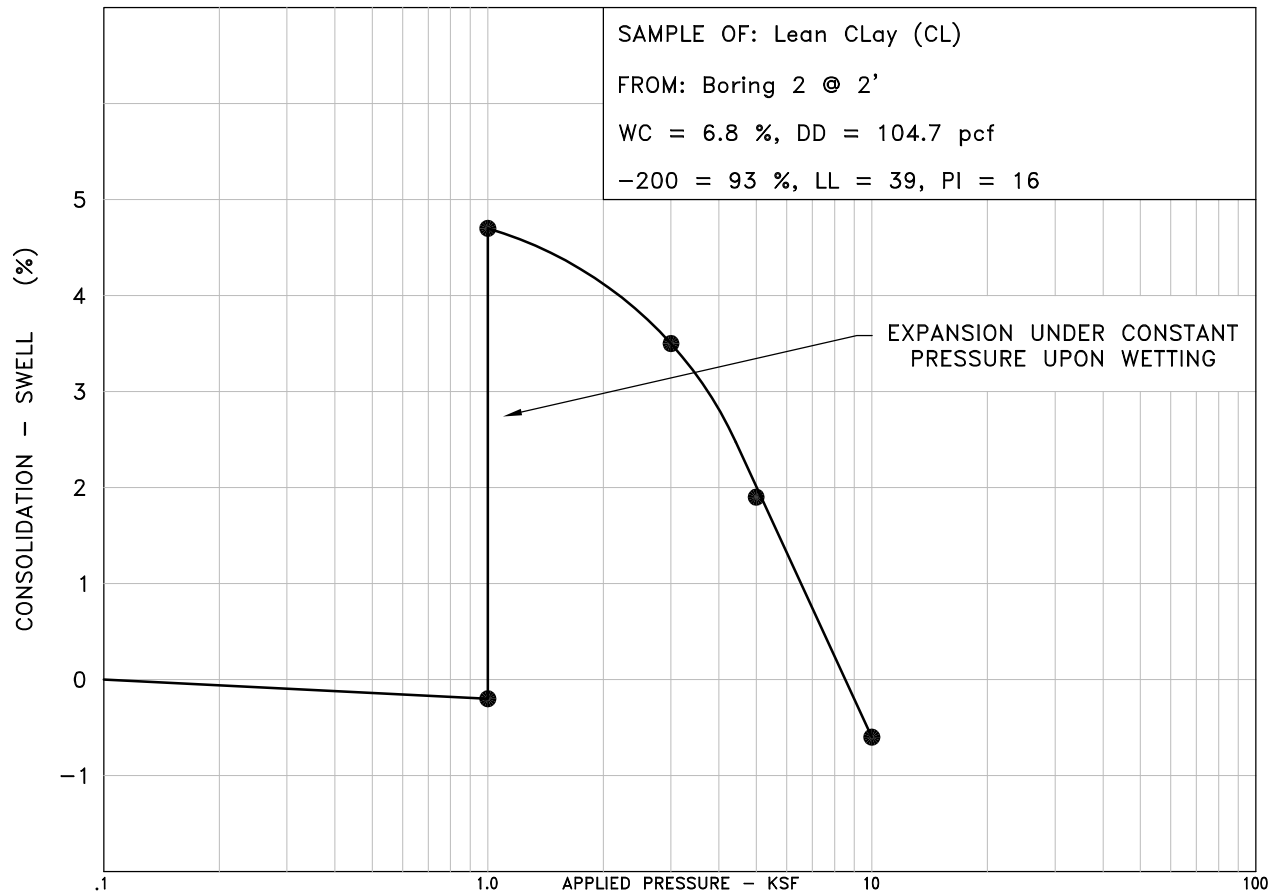

These test results apply only to the samples tested. The testing report shall not be reproduced, except in full, without the written approval of Kumar and Associates, Inc. Swell Consolidation testing performed in accordance with ASTM D-4546.

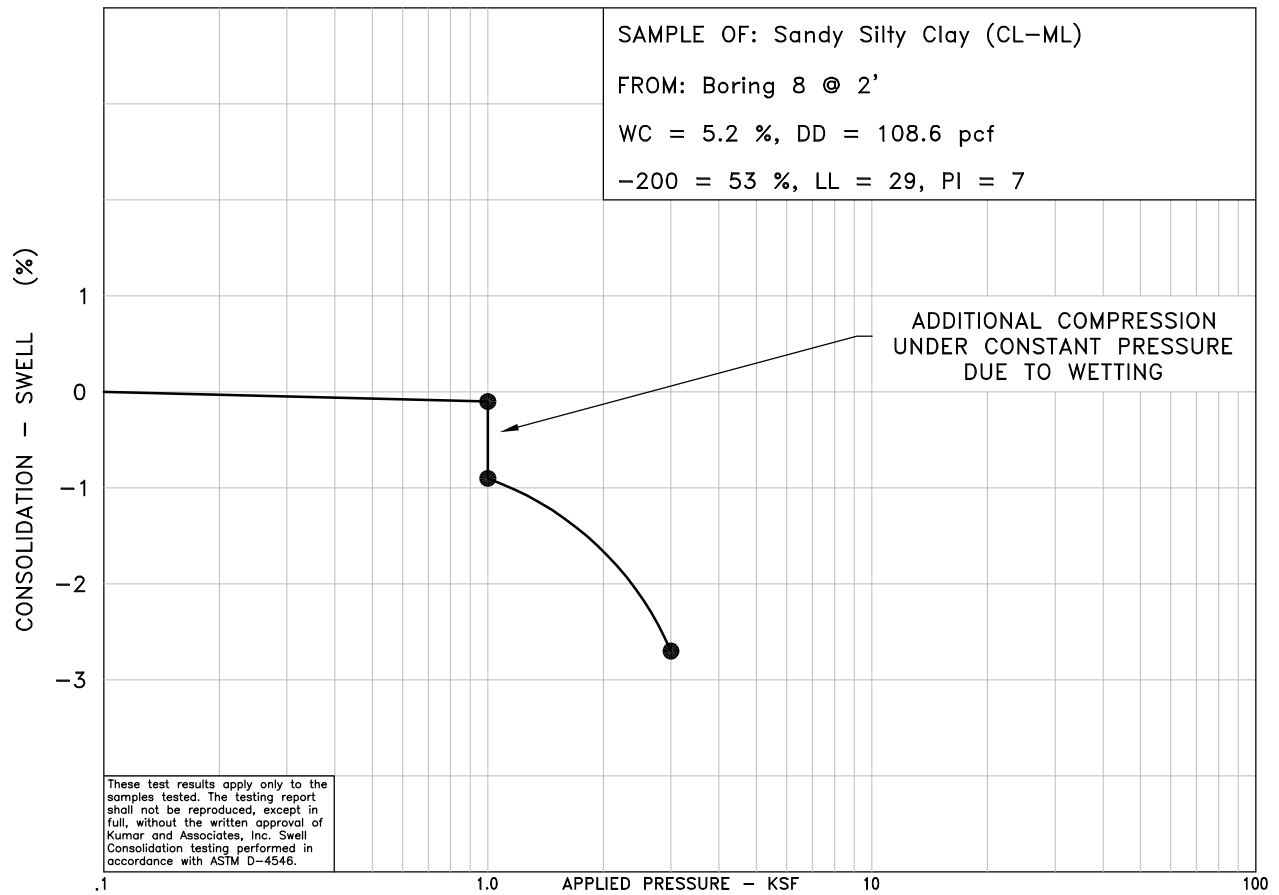
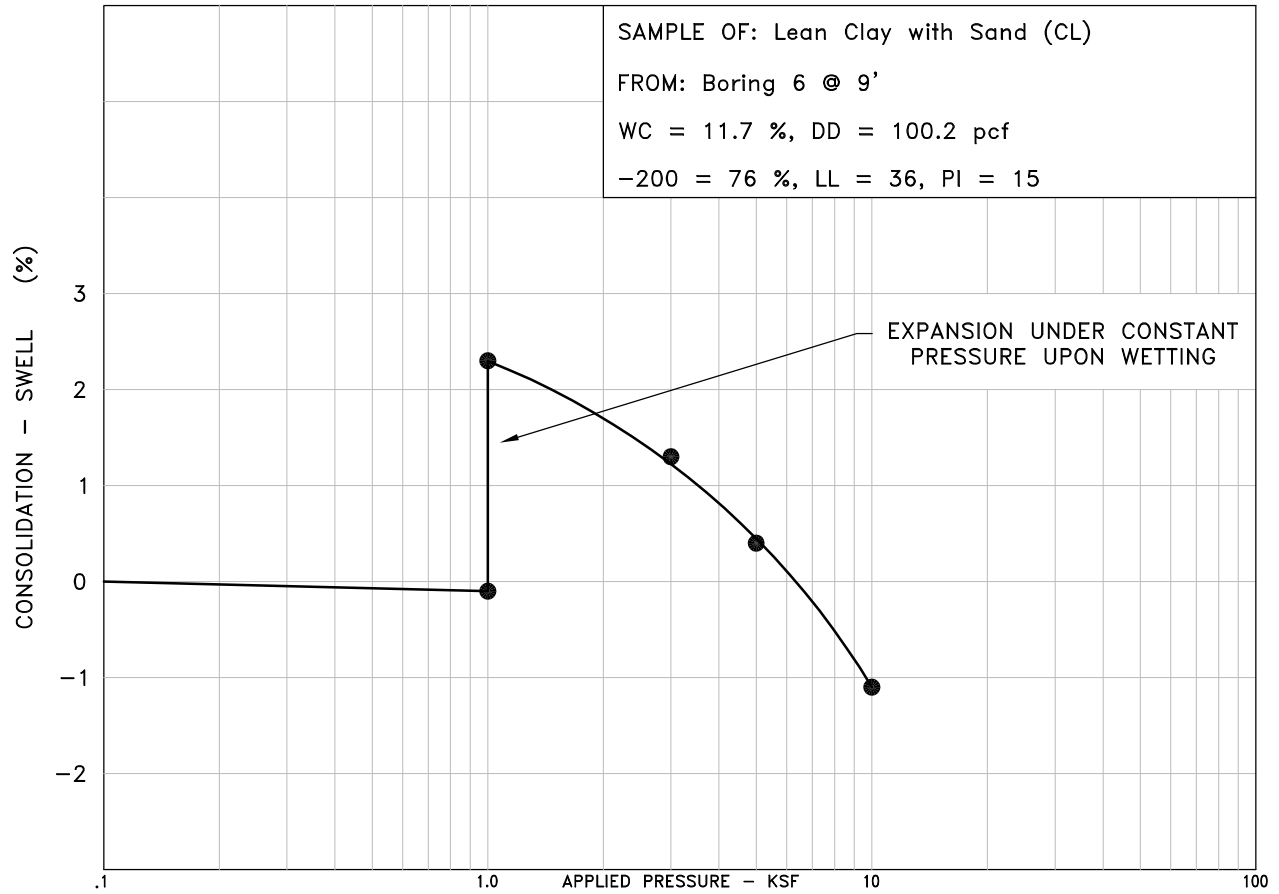

These test results apply only to the samples tested. The testing report shall not be reproduced, except in full, without the written approval of Kumar and Associates, Inc. Swell Consolidation testing performed in accordance with ASTM D-4546.

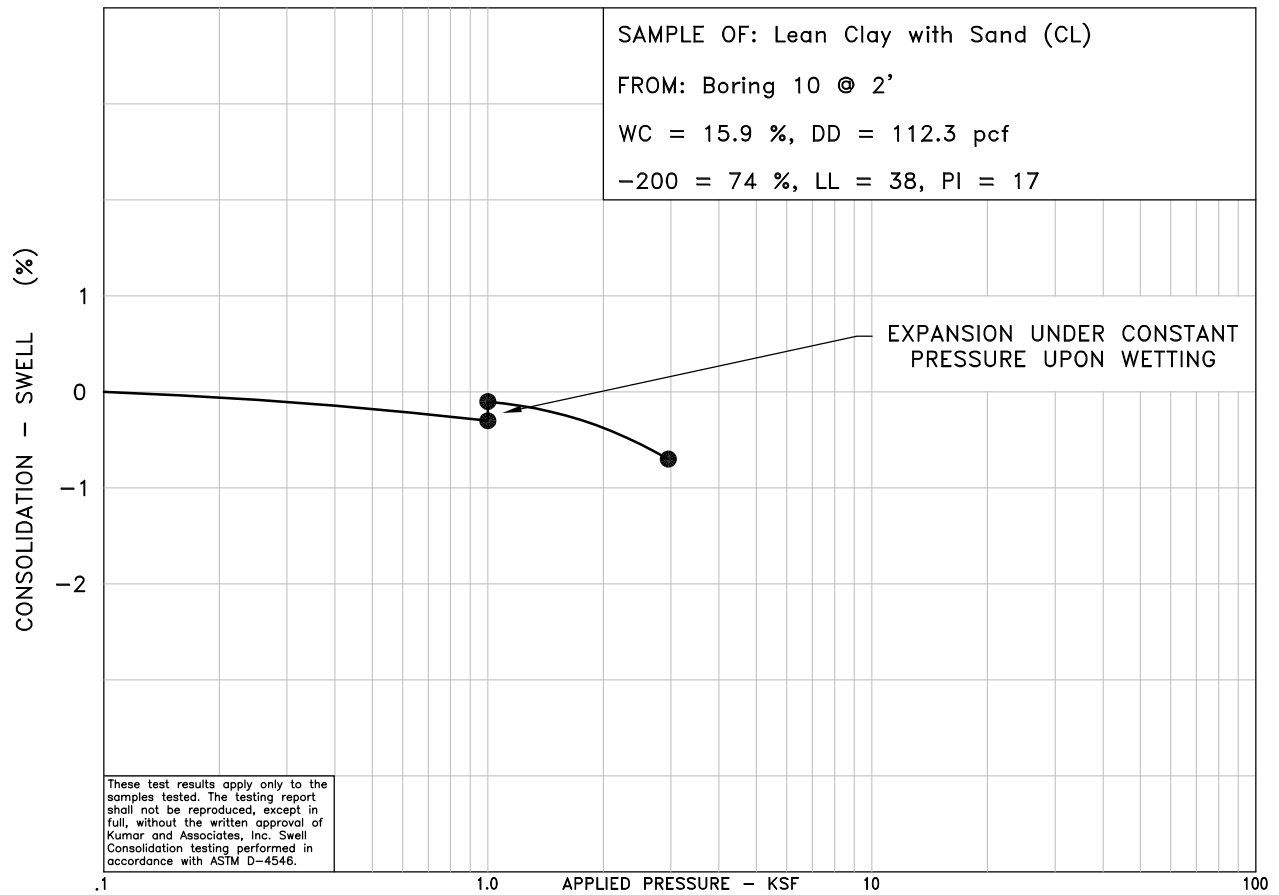
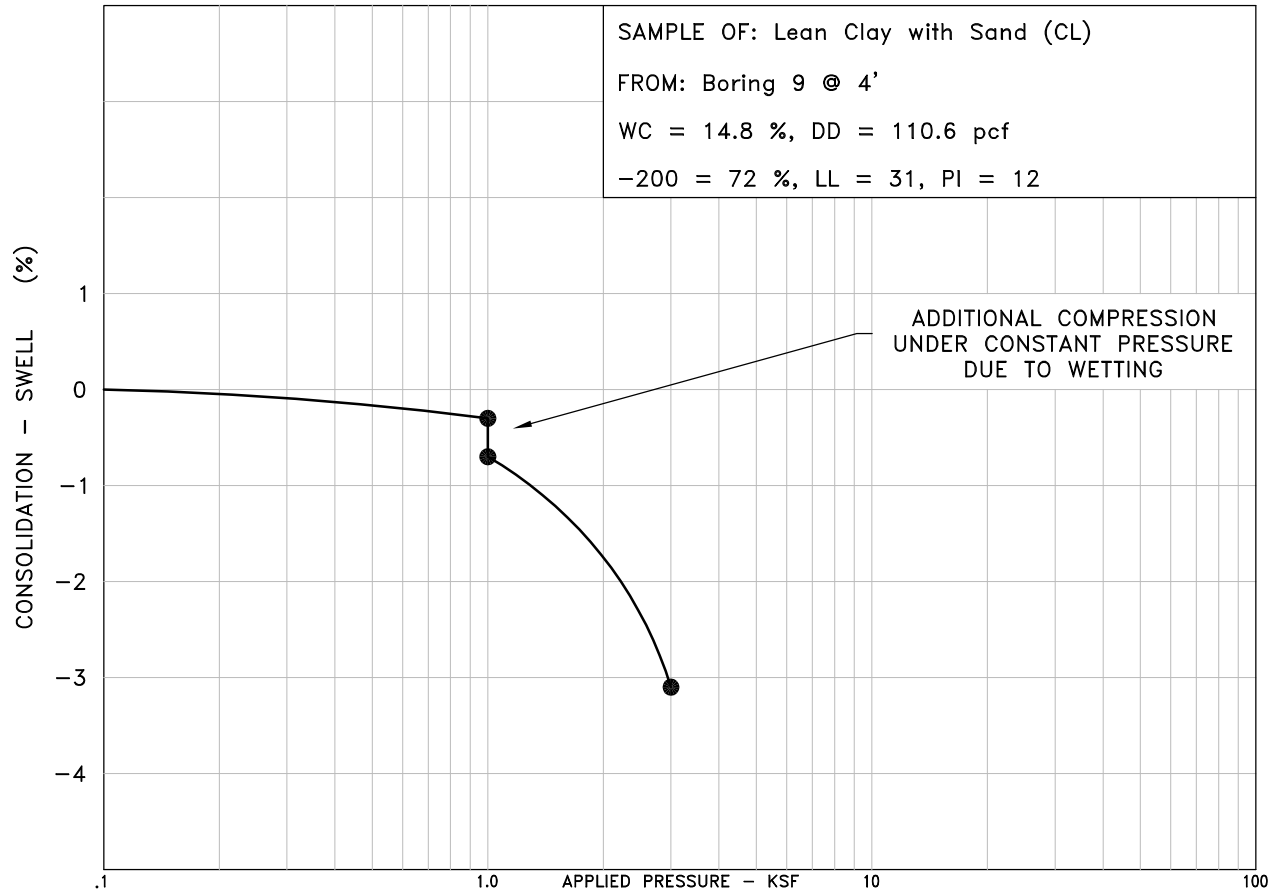

These test results apply only to the samples tested. The testing report shall not be reproduced, except in full, without the written approval of Kumar and Associates, Inc. Swell Consolidation testing performed in accordance with ASTM D-4546.

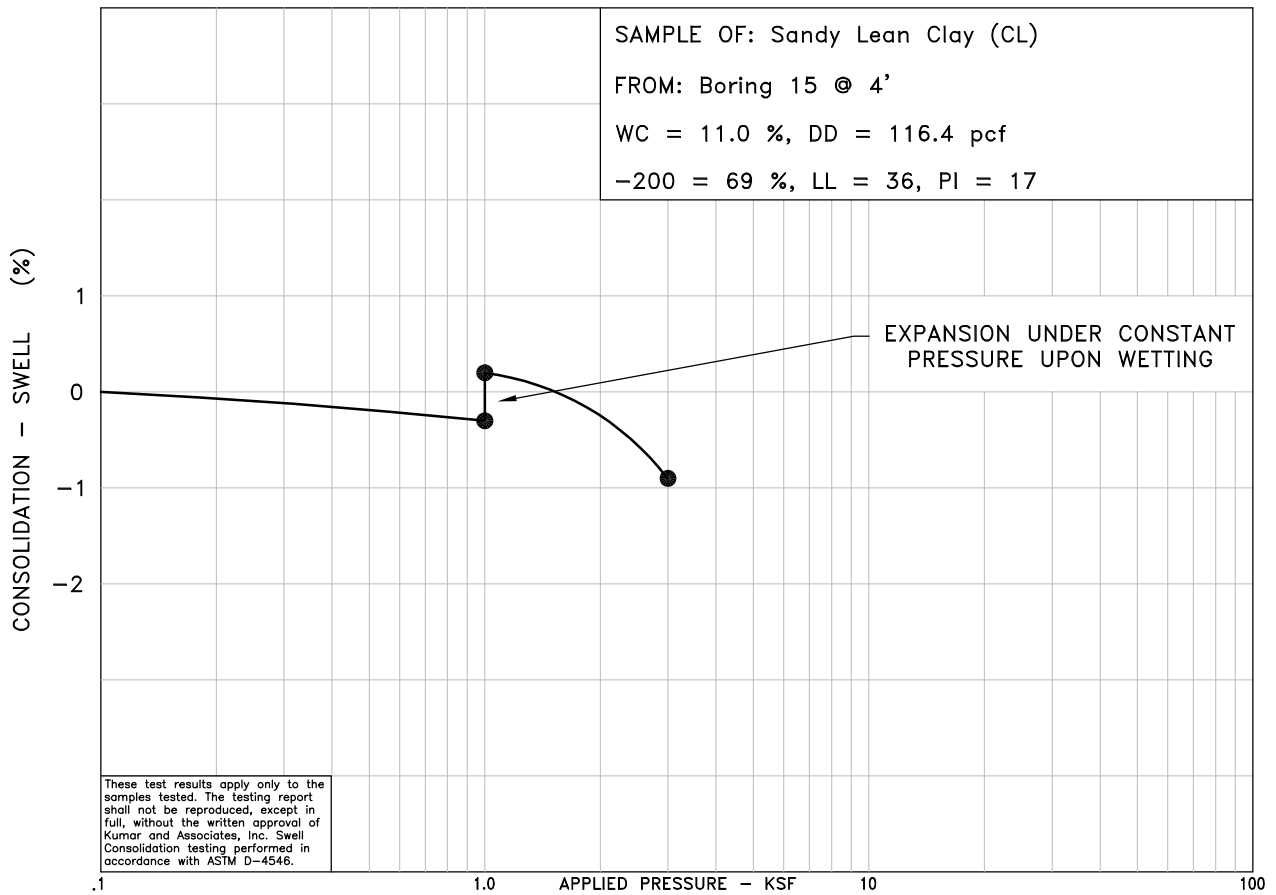
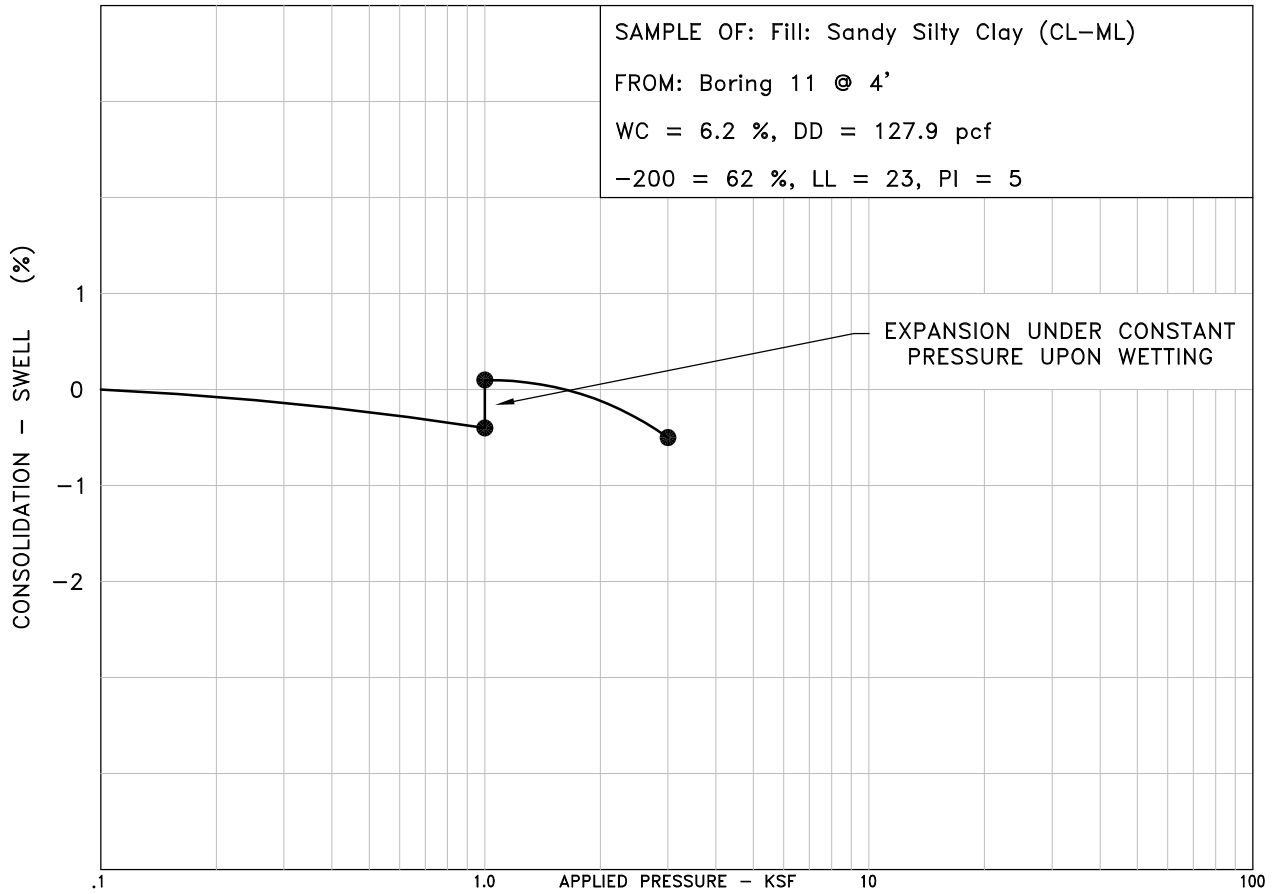

These test results apply only to the samples tested. The testing report shall not be reproduced, except in full, without the written approval of Kumar and Associates, Inc. Swell Consolidation testing performed in accordance with ASTM D-4546.

SAMPLE OF: Sandy Lean Clay (CL)
 FROM: Boring 16 @ 4'
 WC = 7.5 %, DD = 96.7 pcf
 -200 = 65 %, LL = 35, PI = 15

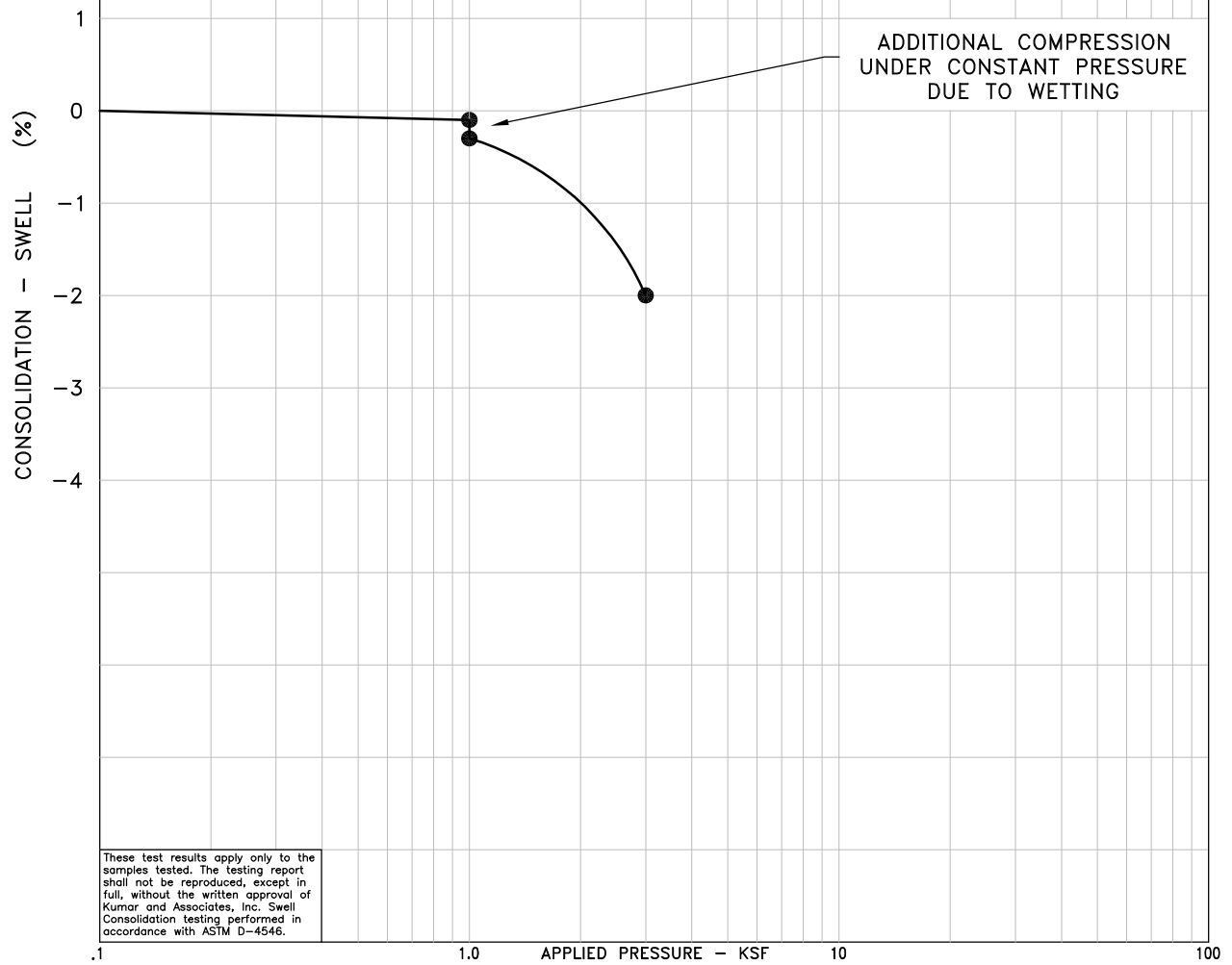

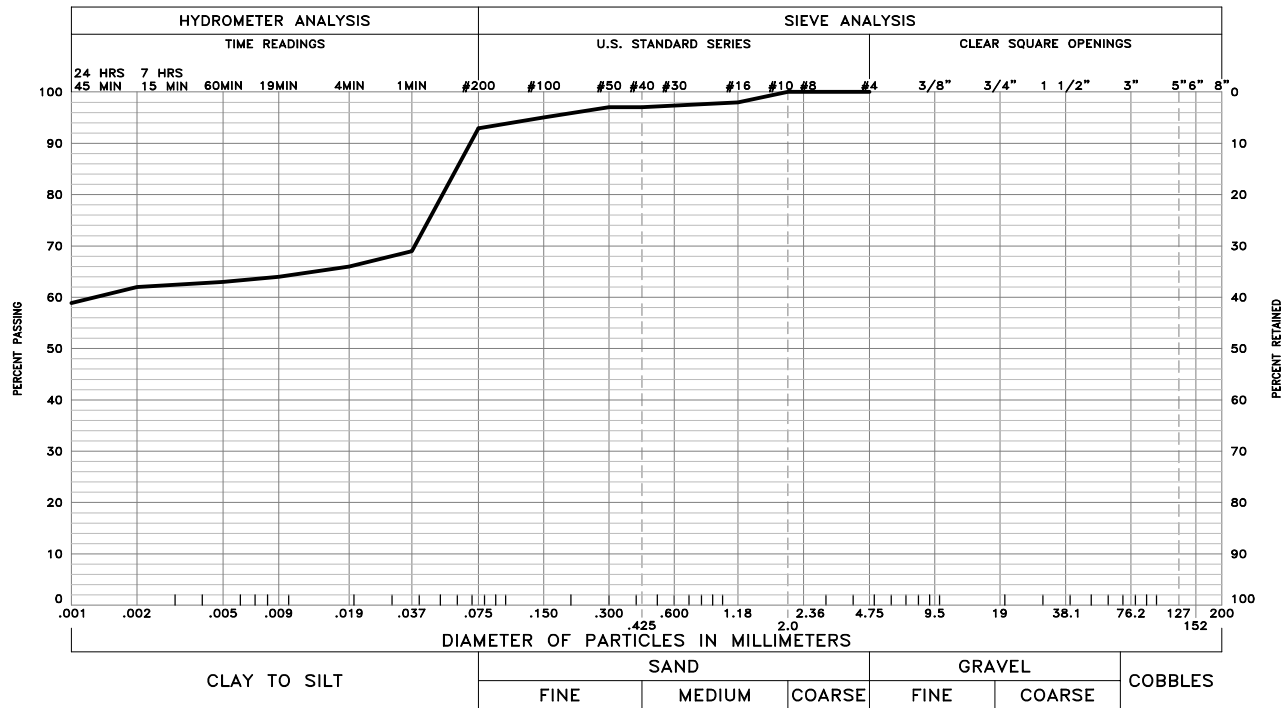
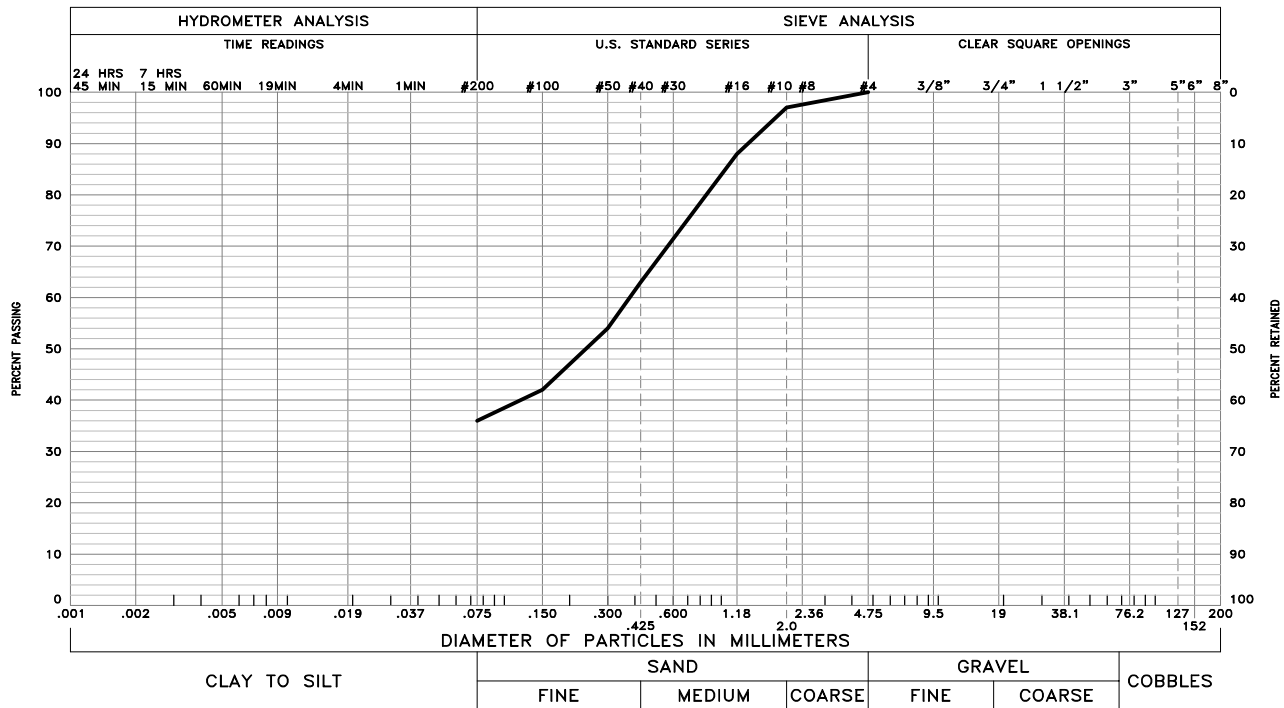

These test results apply only to the samples which were tested. The testing report shall not be reproduced, except in full, without the written approval of Kumar & Associates, Inc. Sieve analysis testing is performed in accordance with ASTM D6913, ASTM D7928, ASTM C136 and/or ASTM D1140.

September 06, 2020 - 05:45pm
 V:\Projects\2020\20-2-194 - Watermark at Colorado Springs - Akers Drive\Drafting\202104-11 to 16.dwg

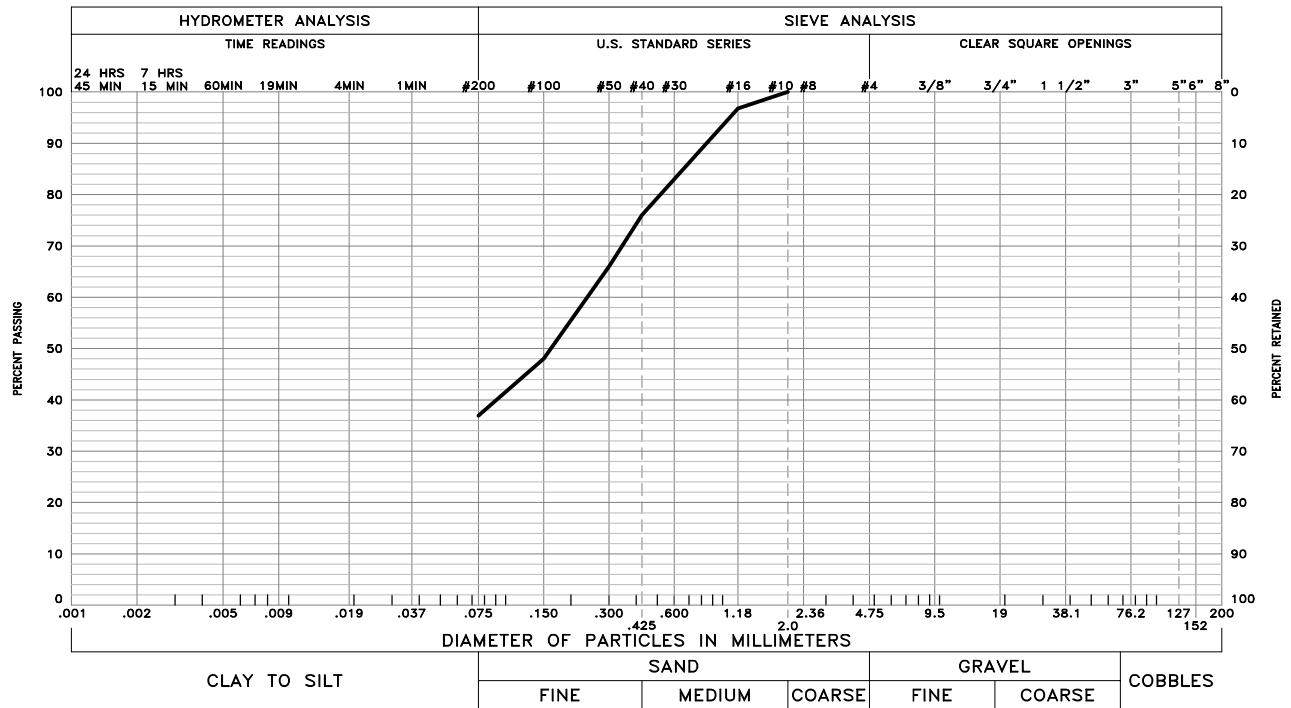
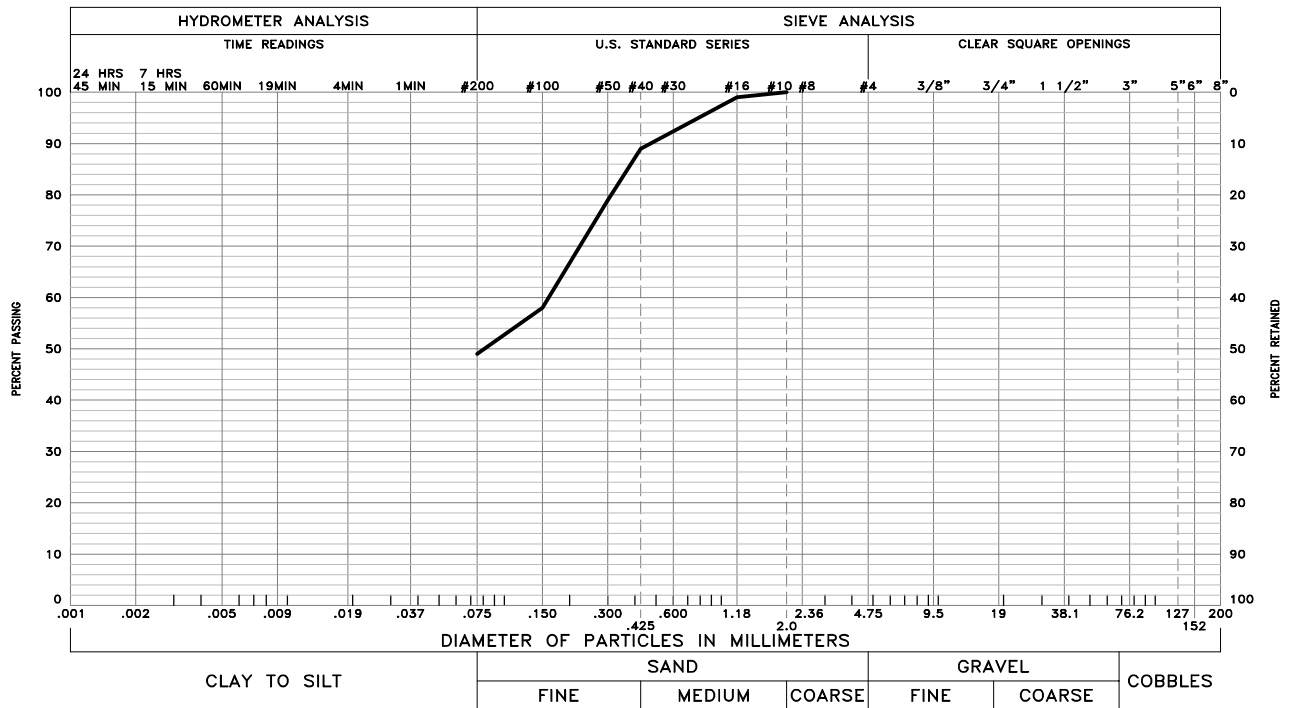

These test results apply only to the samples which were tested. The testing report shall not be reproduced, except in full, without the written approval of Kumar & Associates, Inc. Sieve analysis testing is performed in accordance with ASTM D6913, ASTM D7928, ASTM C136 and/or ASTM D1140.

September 06, 2020 - 05:45pm
 V:\Projects\2020\20-2-194 - Watermark at Colorado Springs-Akers Drive\Drafting\202194-11 to 16.dwg

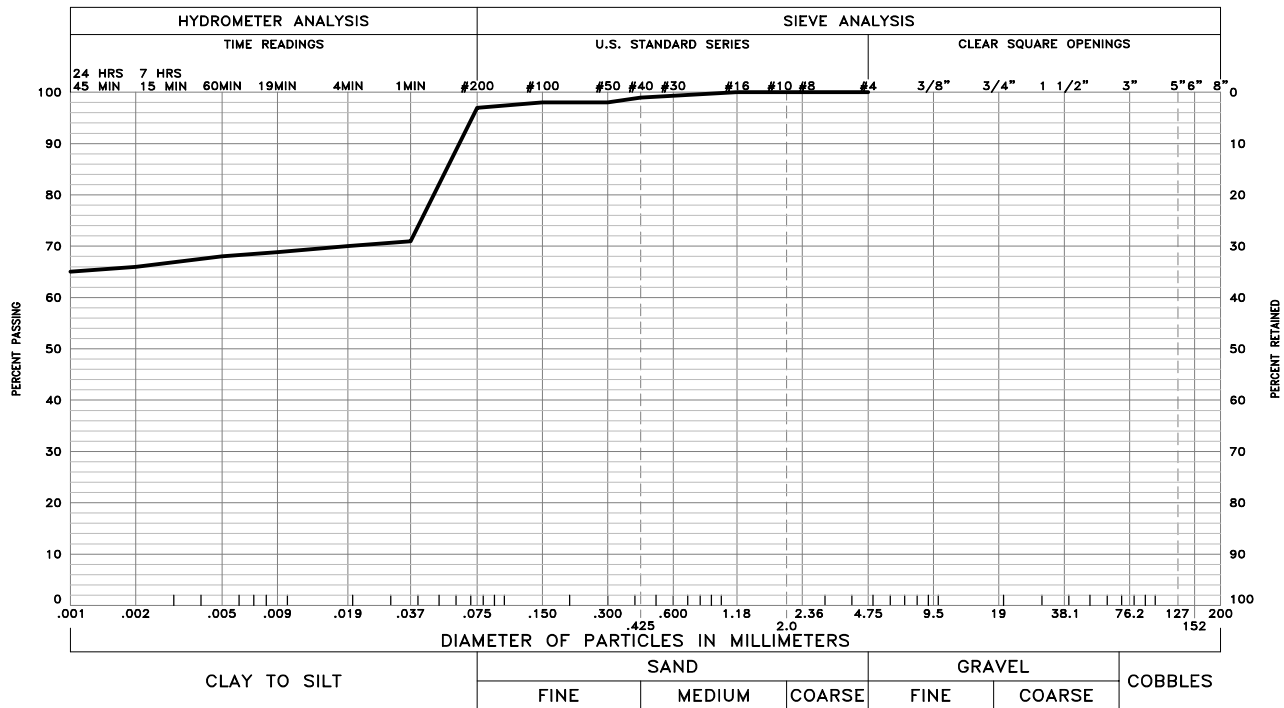

GRAVEL 0 % SAND 3 % SILT AND CLAY 97 %
 LIQUID LIMIT 42 PLASTICITY INDEX 18
 SAMPLE OF: Lean Clay (CL) FROM: Boring 5 @ 4'

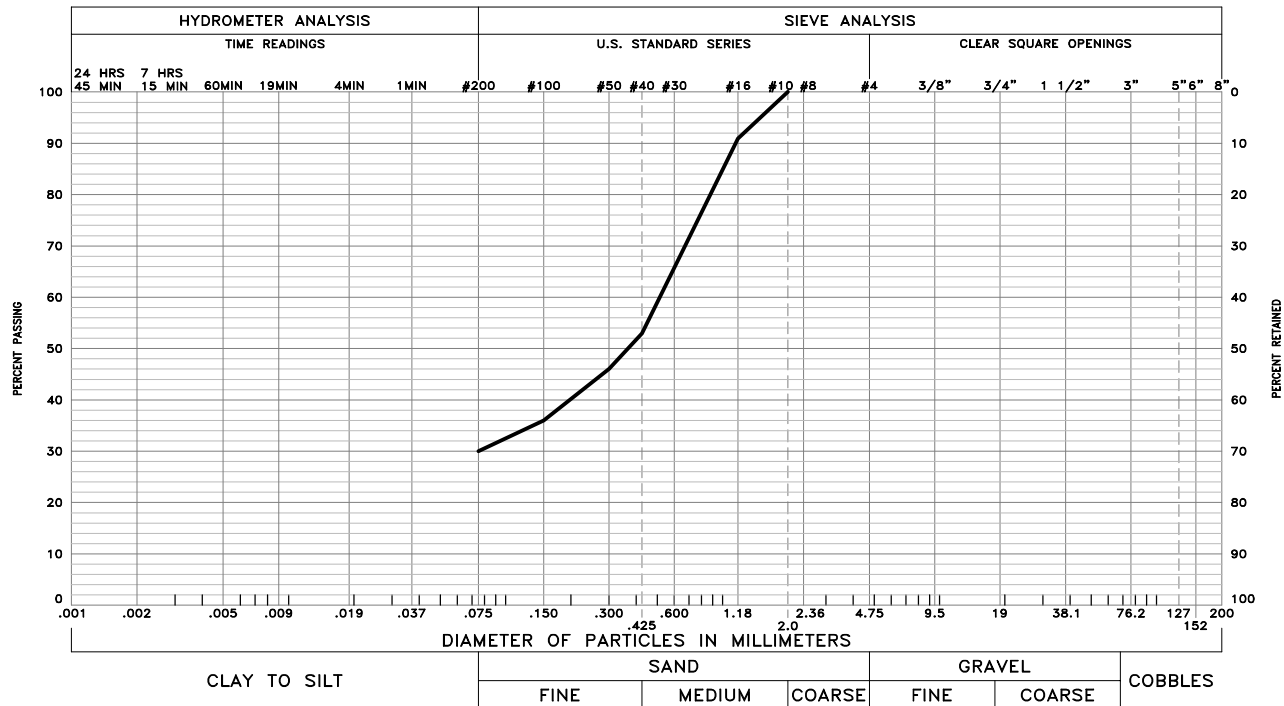

GRAVEL 0 % SAND 70 % SILT AND CLAY 30 %
 LIQUID LIMIT 27 PLASTICITY INDEX 7
 SAMPLE OF: silty Clayey Sand (SC-SM) FROM: Boring 7 @ 4'

These test results apply only to the samples which were tested. The testing report shall not be reproduced, except in full, without the written approval of Kumar & Associates, Inc. Sieve analysis testing is performed in accordance with ASTM D6913, ASTM D7928, ASTM C136 and/or ASTM D1140.

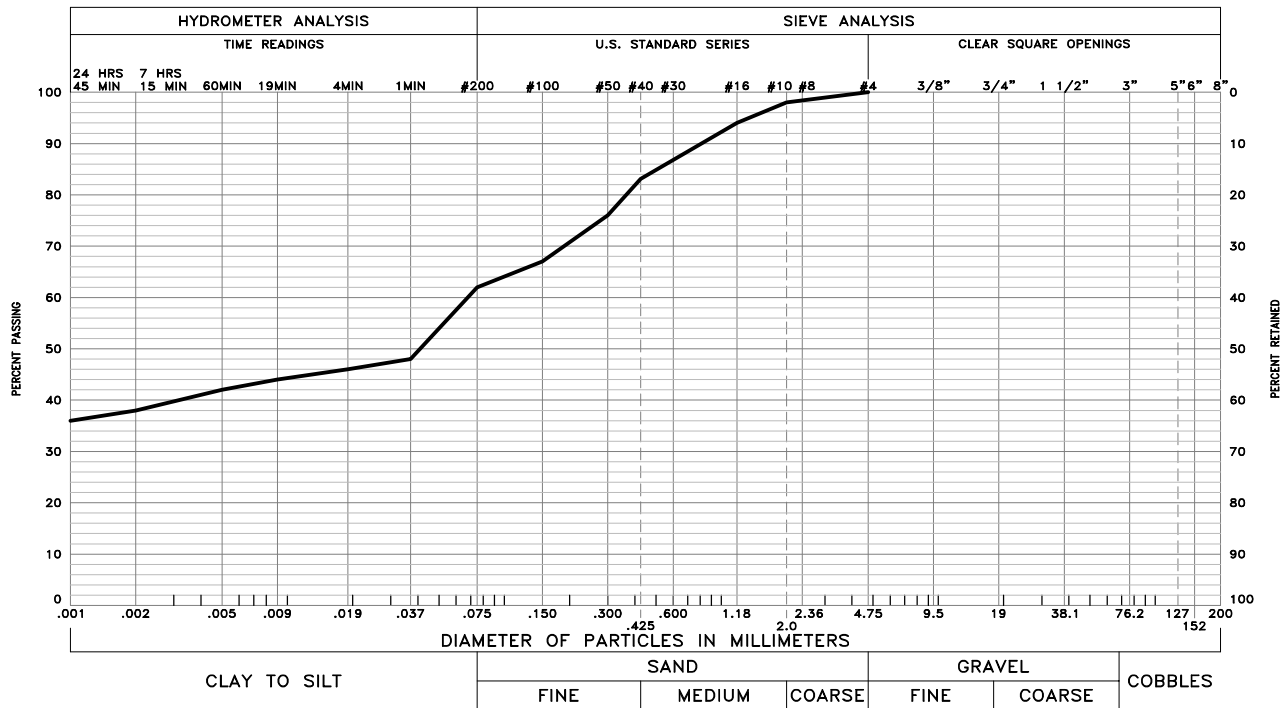

GRAVEL 0 % SAND 38 % SILT AND CLAY 62 %
 LIQUID LIMIT 23 PLASTICITY INDEX 5
 SAMPLE OF: Fill: Sandy Silty Clay (CL-ML) FROM: Boring 11 @ 4'

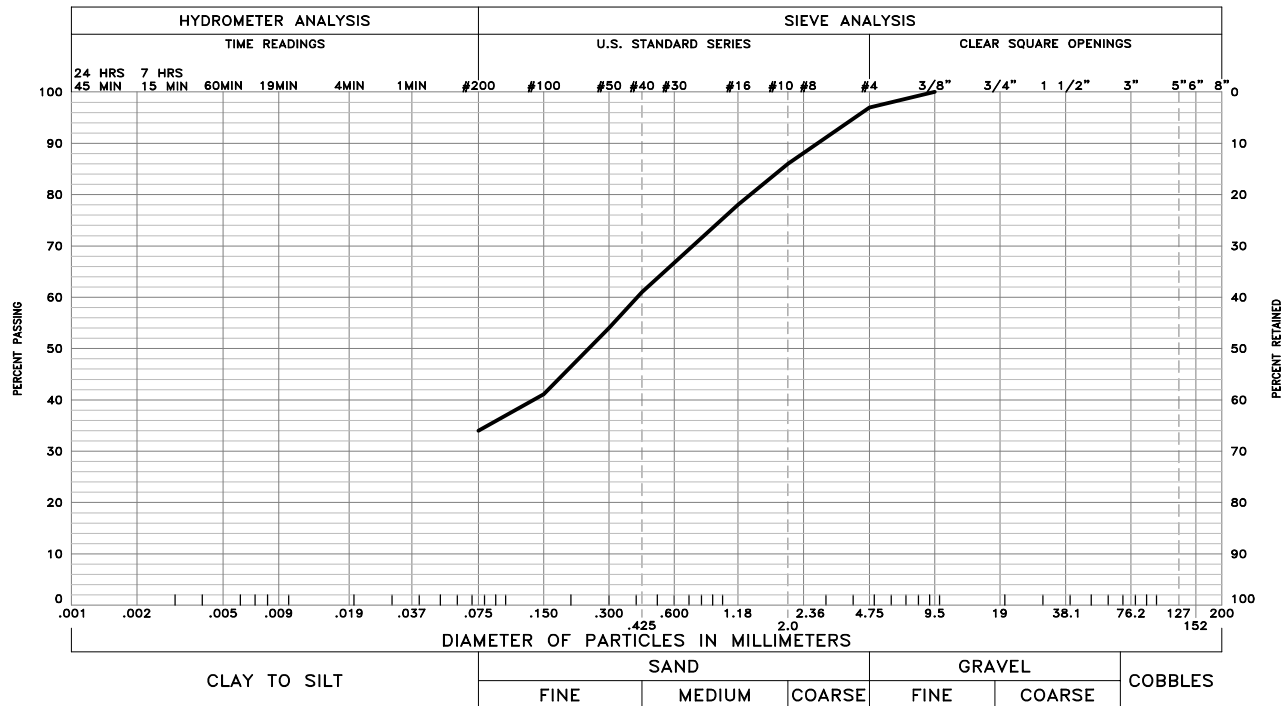

GRAVEL 3 % SAND 63 % SILT AND CLAY 34 %
 LIQUID LIMIT 24 PLASTICITY INDEX 7
 SAMPLE OF: Silty Clayey Sand (SC-SM) FROM: Boring 12 @ 4'

These test results apply only to the samples which were tested. The testing report shall not be reproduced, except in full, without the written approval of Kumar & Associates, Inc. Sieve analysis testing is performed in accordance with ASTM D6913, ASTM D7928, ASTM C136 and/or ASTM D1140.

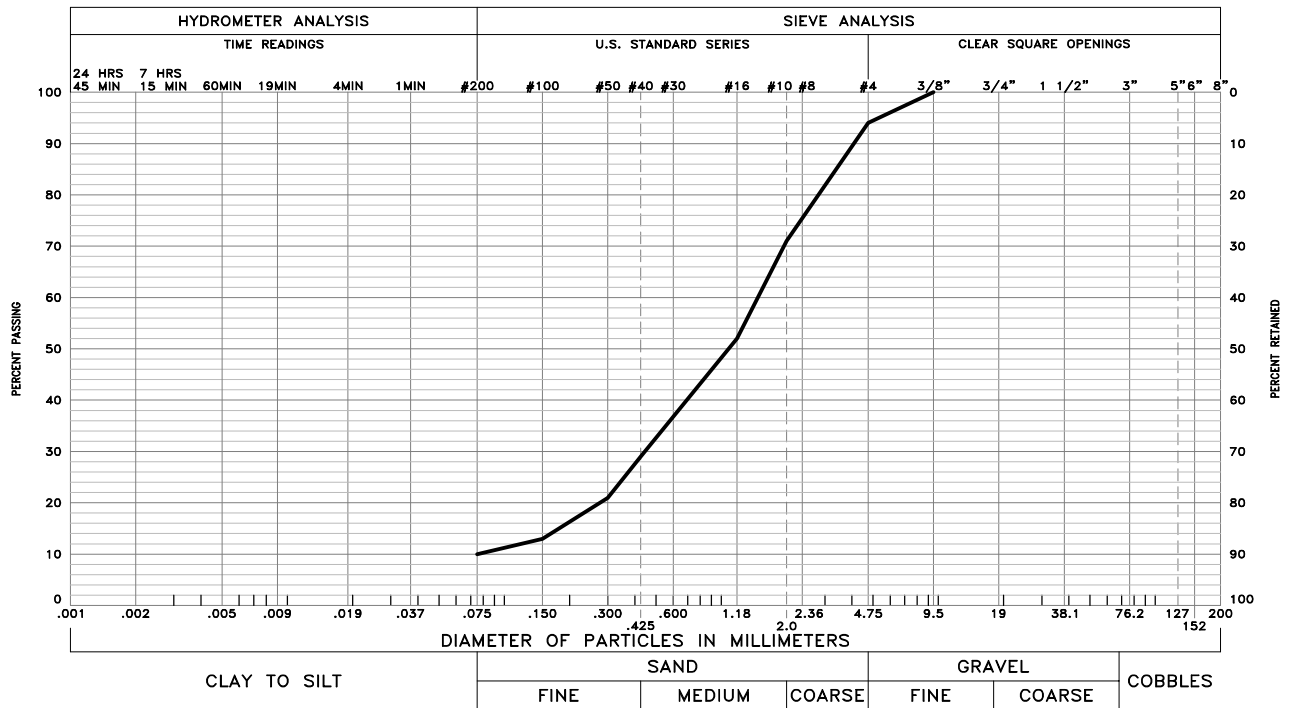

GRAVEL 6 % SAND 84 % SILT AND CLAY 10 %

LIQUID LIMIT PLASTICITY INDEX NP

SAMPLE OF: Well Graded Sand with Silt (SW-SM) FROM: Boring 13 @ 9'

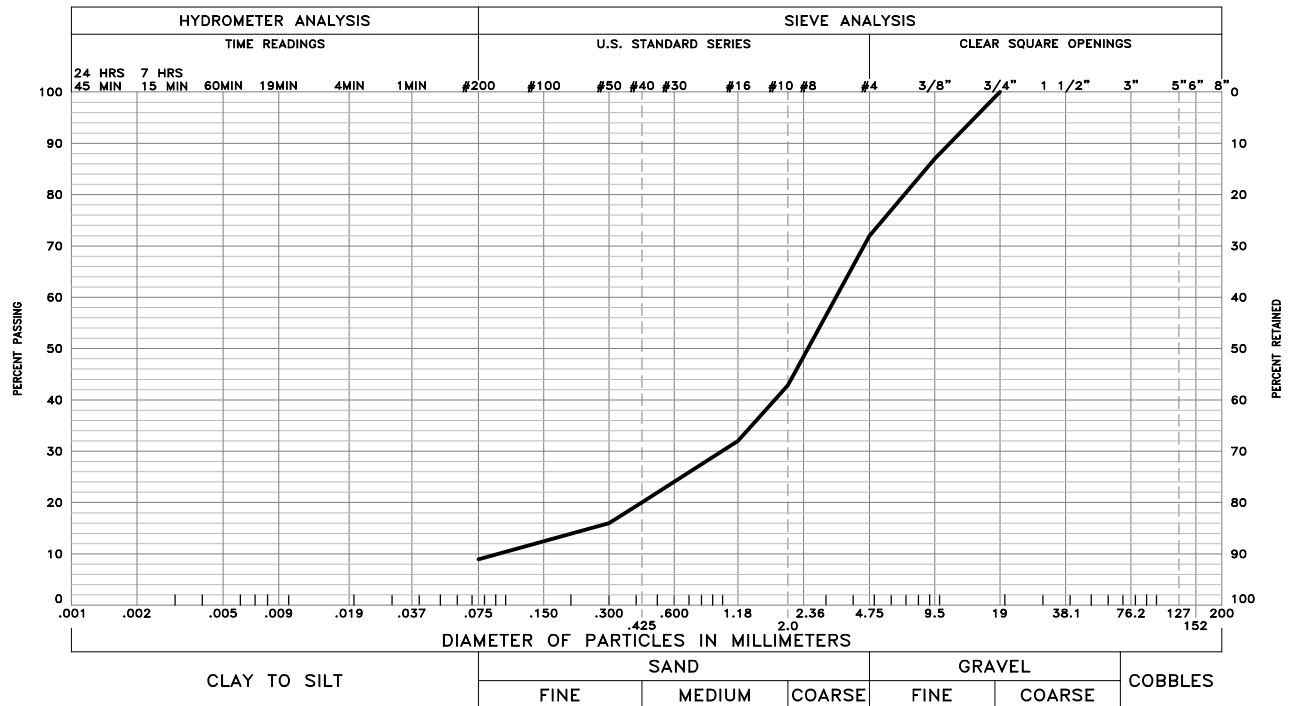

GRAVEL 28 % SAND 63 % SILT AND CLAY 9 %

LIQUID LIMIT PLASTICITY INDEX NP

SAMPLE OF: Well Graded Sand with Silt and Gravel (SW-SM) FROM: Boring 14 @ 4'

These test results apply only to the samples which were tested. The testing report shall not be reproduced, except in full, without the written approval of Kumar & Associates, Inc. Sieve analysis testing is performed in accordance with ASTM D6913, ASTM D7928, ASTM C136 and/or ASTM D1140.

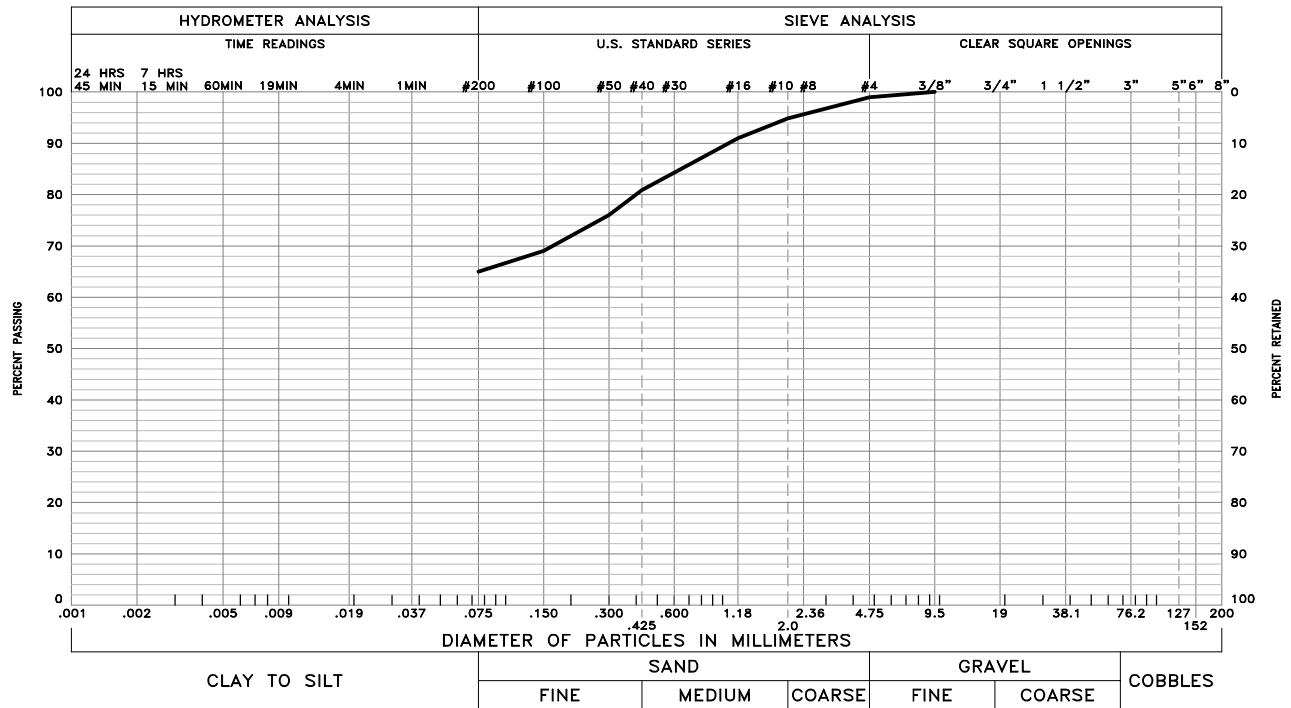
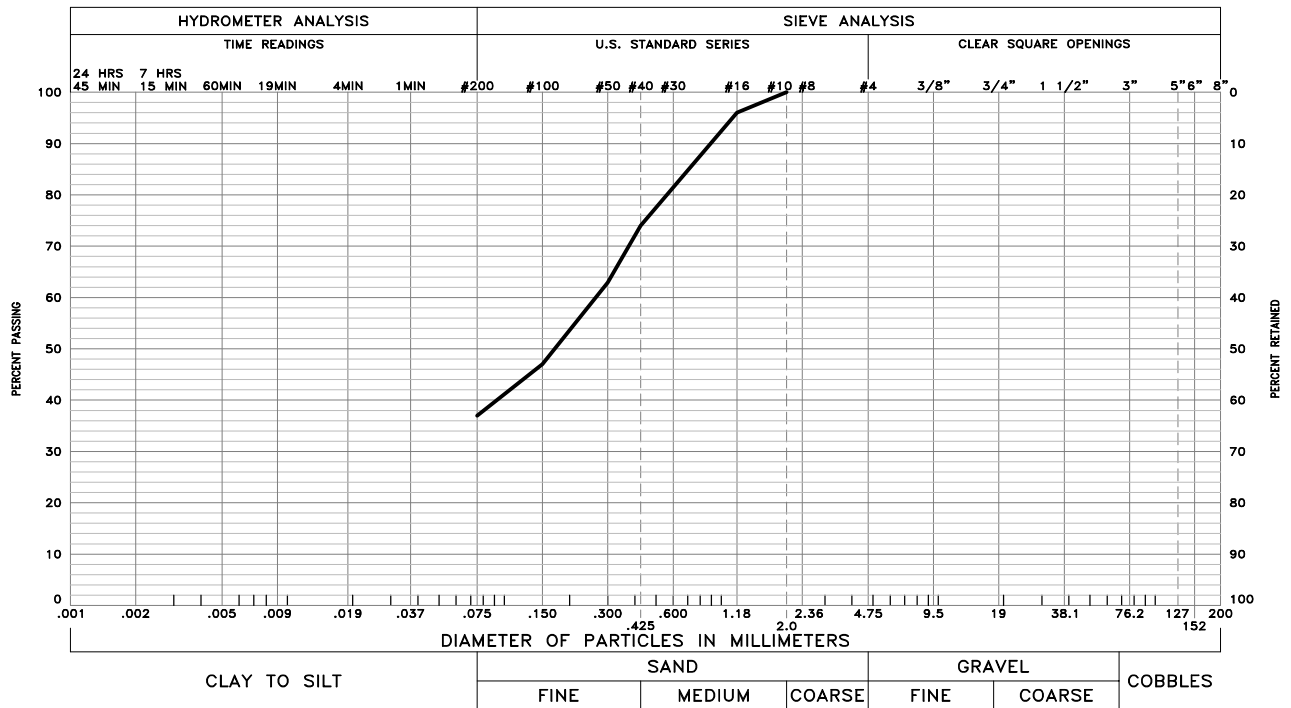

These test results apply only to the samples which were tested. The testing report shall not be reproduced, except in full, without the written approval of Kumar & Associates, Inc. Sieve analysis testing is performed in accordance with ASTM D6913, ASTM D7928, ASTM C136 and/or ASTM D1140.

Kumar and Associates, Inc.

**TABLE I
SUMMARY OF LABORATORY TEST RESULTS**

Project No.: 20-2-194

Project Name: Watermark Apartments - Akers Drive, Colorado Springs, CO

Date Sampled: 8/24/2020 and 8/25/2020

Date Received: 8/24/2020 and 8/25/2020

SAMPLE LOCATION		DATE TESTED	NATURAL MOISTURE CONTENT (%)	NATURAL DRY DENSITY (pcf)	GRADATION		PERCENT PASSING NO. 200 SIEVE	PERCENT PASSING 0.002 mm	ATTERBERG LIMITS		WATER SOLUBLE SULFATES (%)	AASHTO CLASSIFICATION (Group Index)	SOIL OR BEDROCK TYPE (Unified Soil Classification)
BORING	DEPTH (ft)				GRAVEL (%)	SAND (%)			LIQUID LIMIT	PLASTICITY INDEX			
1	4	9/2/20	4.1	119.8	0	64	36		27	10		A-4 (0)	Clayey Sand (SC)
2	2	9/2/20	6.8	104.7	0	7	93	62	39	16	<0.01	A-6 (16)	Lean Clay (CL)
3	9	9/2/20	7.2	117.9	0	51	49		26	7		A-4 (1)	Silty Clayey Sand (SC-SM)
4	2	9/2/20	5.1	111.8	0	63	37		28	7		A-4 (0)	Silty Clayey Sand (SC-SM)
5	4	9/2/20	16.6	100.1	0	3	97	66	42	18		A-7-6 (20)	Lean Clay (CL)
6	9	9/2/20	11.7	100.2			76		36	15	0.03	A-6 (10)	Lean Clay with Sand (CL)
7	4	9/2/20	3.3	112.4	0	70	30		27	7		A-2-4 (0)	Silty Clayey Sand (SC-SM)
8	2	9/2/20	5.2	108.6			53		29	7		A-4 (1)	Sandy Silty Clay (CL-ML)
9	4	9/2/20	14.8	110.6			72		31	12		A-6 (7)	Lean Clay with Sand (CL)
10	2	9/2/20	15.9	112.3			74		38	17	0.03	A-6 (12)	Lean Clay with Sand (CL)
11	4	9/2/20	6.2	127.9	0	38	62	38	23	5		A-4 (1)	Fill: Sandy Silty Clay (CL-ML)

Kumar and Associates, Inc.

**TABLE I
SUMMARY OF LABORATORY TEST RESULTS**

Project No.: 20-2-194

Project Name: Watermark Apartments - Akers Drive, Colorado Springs, CO

Date Sampled: 8/24/2020 and 8/25/2020

Date Received: 8/24/2020 and 8/25/2020

SAMPLE LOCATION		DATE TESTED	NATURAL MOISTURE CONTENT (%)	NATURAL DRY DENSITY (pcf)	GRADATION		PERCENT PASSING NO. 200 SIEVE	PERCENT PASSING 0.002 mm	ATTERBERG LIMITS		WATER SOLUBLE SULFATES (%)	AASHTO CLASSIFICATION (Group Index)	SOIL OR BEDROCK TYPE (Unified Soil Classification)
BORING	DEPTH (ft)				GRAVEL (%)	SAND (%)			LIQUID LIMIT	PLASTICITY INDEX			
12	4	9/2/20	3.5	114.3	3	63	34		24	7		A-2-4 (0)	Silty Clayey Sand (SC-SM)
13	9	9/2/20	4.3	126.2	6	84	10			NP		A-1-b (0)	Well Graded Sand with Silt (SW-SM)
14	4	9/2/20	2.5	123.1	28	63	9			NP	<0.01	A-1-a (0)	Well Graded Sand with Silt and Gravel (SW-SM)
15	4	9/2/20	11.0	116.4			69		36	17		A-6 (7)	Sandy Lean Clay (CL)
16	4	9/2/20	7.5	96.7			65		35	15		A-6 (8)	Sandy Lean Clay (CL)
17	2	9/2/20	5.8	112.8	0	63	37		27	9		A-4 (0)	Clayey Sand (SC)
18	2	9/2/20	7.5	125.7	1	34	65		31	16		A-6 (8)	Sandy Lean Clay (CL)