

Z:\0001-Dakota Springs\02-Waterview Partners\19-06ns Roy D S\CAD\Plans\02-Preliminary\19-06ns Prelim - Tract Map.dwg

CS
WATERVIEW COMMERCIAL INVESTORS, LLC
5509200004

PUD
COLA, LLC
5509301134

EX. LEGACY HILL DR.
(120' ROW - URBAN COLLECTOR)

EX. BRADLEY RD.
(210' ROW - ARTERIAL)

EX. FRONTSIDE DR.
(80' ROW - URBAN COLLECTOR)

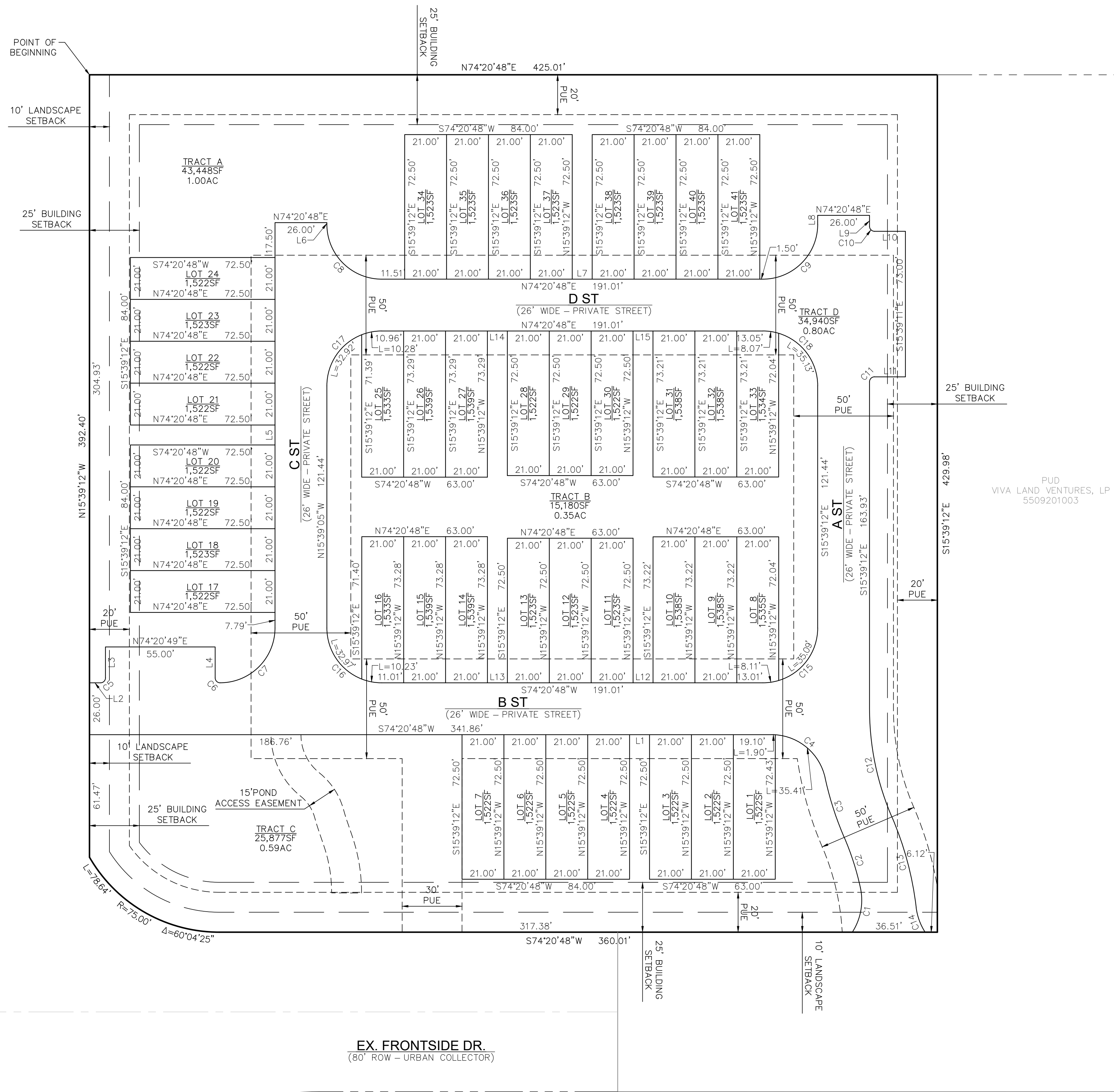

LEGEND

PROPERTY BOUNDARY	———
PROPOSED LOT LINE	———
EXISTING LOT LINE	———
EXISTING RIGHT-OF-WAY	———
EXISTING CENTERLINE	———
EASEMENT LINE	———
SETBACK LINE	———

TRACT LIST

TRACT #	AREA	USE
TRACT A	43,448SF	LANDSCAPE/OPEN SPACE
TRACT B	15,180SF	LANDSCAPE/OPEN SPACE
TRACT C	25,877SF	LANDSCAPE/OPEN SPACE & DETENTION
TRACT D	34,940SF	ACCESS/PARKING

LINE TABLE

LINE #	LENGTH	BEARING
L1	10.00'	S74°20'48"W
L2	5.50'	N74°20'48"E
L3	15.50'	N15°39'11"W
L4	15.50'	S15°39'11"E
L5	10.00'	N15°39'12"W
L6	0.85'	S15°39'19"E
L7	10.00'	N74°20'48"E
L8	4.50'	N15°39'12"W
L9	5.50'	S15°39'12"E
L10	15.50'	N74°20'49"E
L11	15.50'	S74°20'49"W
L12	10.00'	S74°20'48"W
L13	10.00'	S74°20'48"W
L14	10.00'	N74°20'48"E
L15	10.00'	N74°20'48"E

CURVE TABLE

CURVE #	LENGTH	RADIUS	DELTA
C1	23.19'	29.50'	45°01'52"
C2	26.61'	137.00'	110°07'41"
C3	31.42'	163.00'	110°02'46"
C4	37.31'	27.50'	77°43'31"
C5	3.93'	2.50'	89°59'10"
C6	3.93'	2.50'	90°00'00"
C7	43.20'	27.50'	90°00'33"
C8	43.20'	27.50'	90°00'00"
C9	43.20'	27.50'	90°00'00"
C10	3.93'	2.50'	90°00'00"
C11	3.93'	2.50'	90°00'00"
C12	55.76'	137.00'	23°19'14"
C13	47.07'	163.00'	16°32'47"
C14	13.42'	29.50'	26°04'16"
C15	43.20'	27.50'	90°00'00"
C16	43.20'	27.50'	89°59'59"
C17	43.20'	27.50'	90°00'00"
C18	43.20'	27.50'	90°00'00"

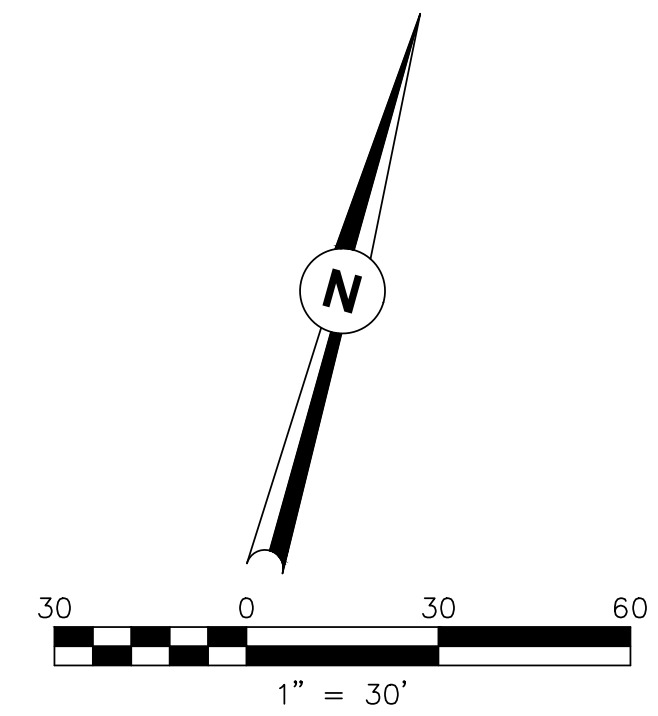

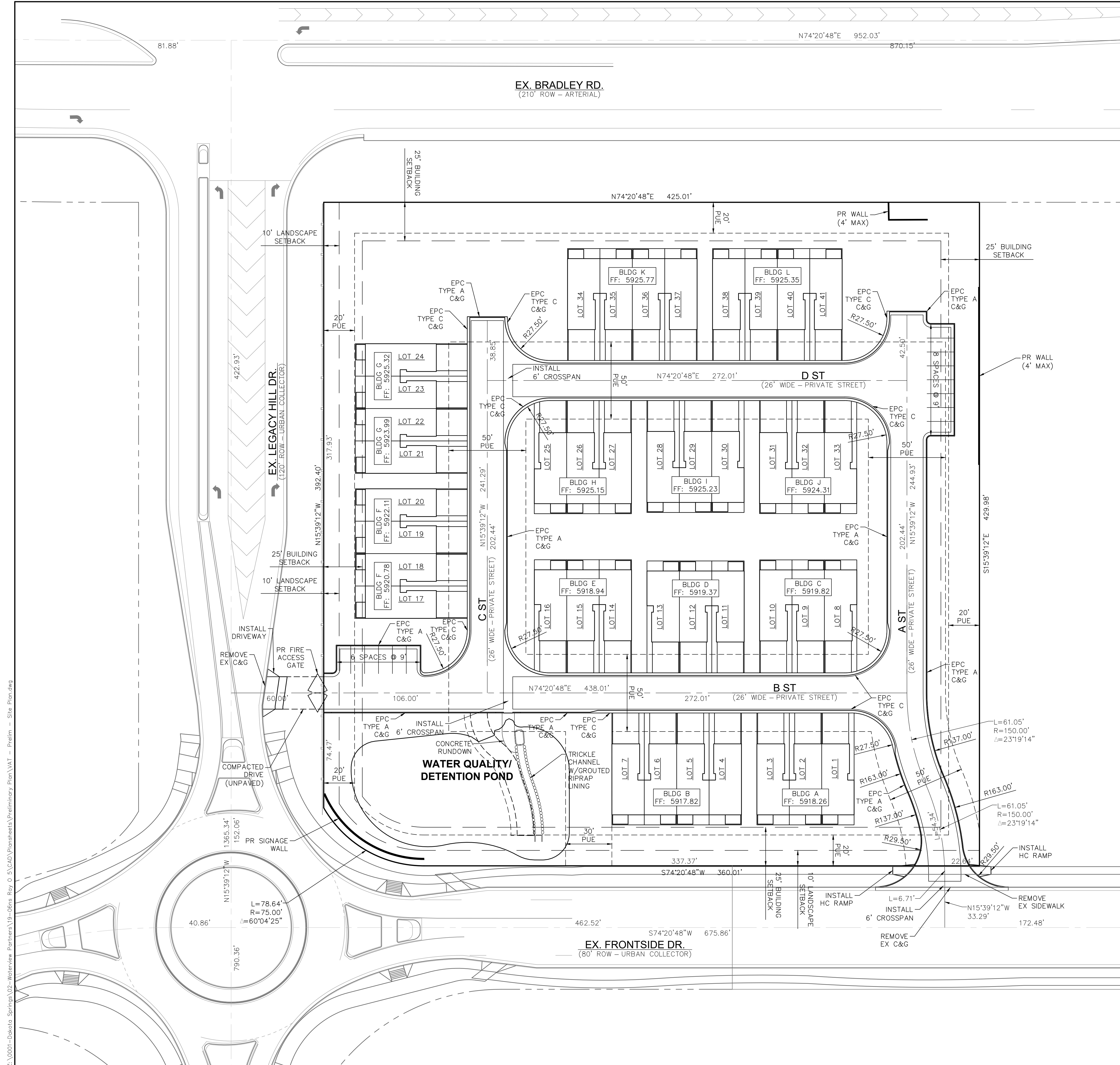

OPEN SPACE CALCULATIONS

PROVIDED OPEN SPACE	182,038 SF
TOTAL AREA =	62,593 SF (34.4%)
UNIT/LOT AREA =	34,940 SF (19.2%)
DRIVE AND PARKING =	84,505 SF (46.4%)
TOTAL OPEN SPACE =	

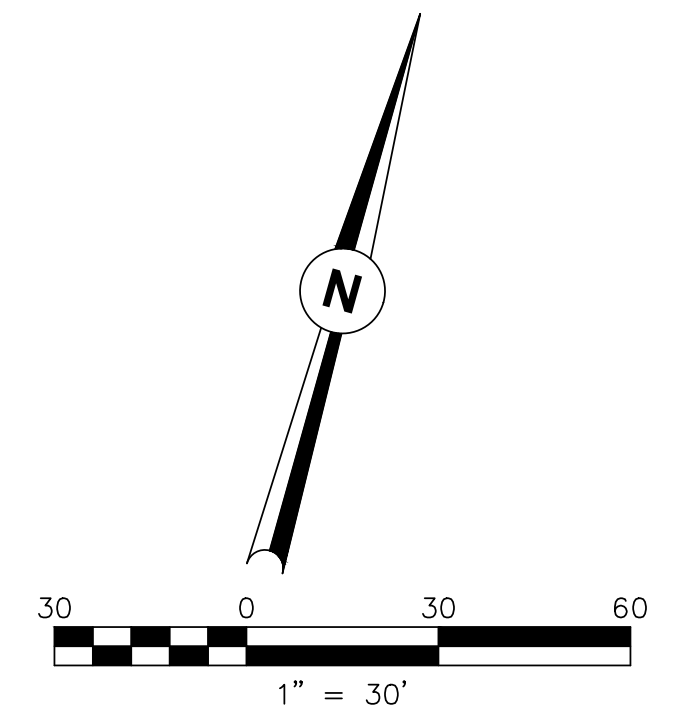
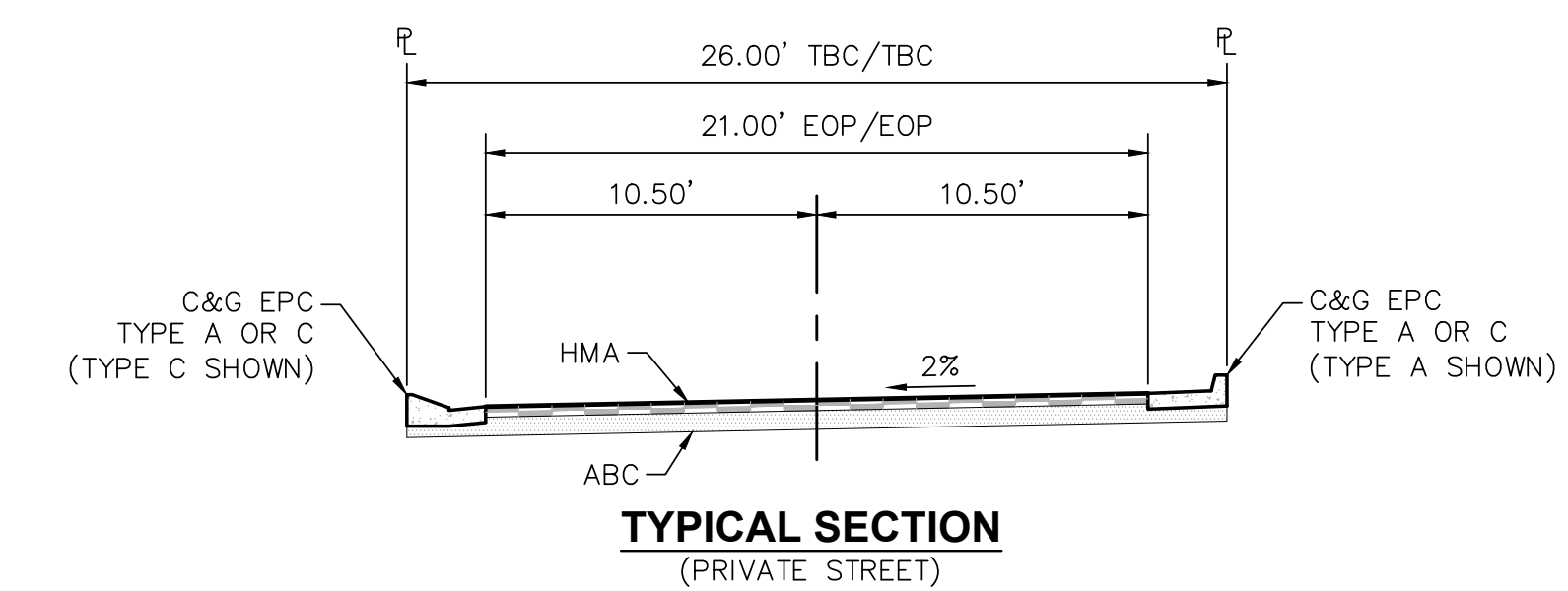

REVISIONS:	DATE
NO. DESCRIPTION	
PROJECT NUMBER:	0219-06
SHEET	3 OF 8

Z:\0001-Dakota Springs\02-Waterview Partners\19-06ns Roy D S\CAD\Plans\02\19-06ns Roy D S - Prelim - Site Plan.dwg

Z:\0001-Dakota Springs\02-Water\Partners\19-06ns Roy D S\CAD\Plansheets\Preliminary Plan\VA1 - Prelim - Grading Plan.dwg



LEGEND

- PROPERTY BOUNDARY
- PROPOSED LOT LINE
- PROPOSED CENTERLINE
- EXISTING LOT LINE
- EXISTING RIGHT-OF-WAY
- EXISTING CENTERLINE
- EASEMENT LINE
- SETBACK LINE
- LIMITS OF CONSTRUCTION /DISTURBANCE
- PR MAJOR CONTOUR
- PR MINOR CONTOUR
- EX MAJOR CONTOUR
- EX MINOR CONTOUR
- PROPOSED FLOW PATH
- PROPOSED RCP STORM
- EXISTING RCP STORM

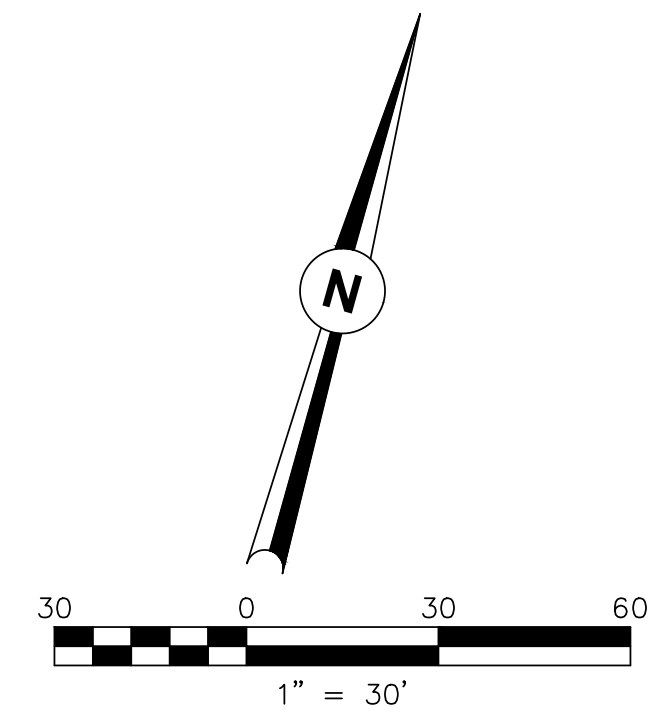

Dakota Springs Engineering
Engineering Consultants
 31 N. TEJON ST. SUITE 518
 COLORADO SPRINGS, CO 80903
 P: (719) 227-7388 F: (719) 227-7392

JCAD
 719-377-0002

DESIGNED BY: JJM DATE: 10.22.22
 DRAWN BY: JJM DATE: 11.27.23
 CHECKED BY: DATE:

VILLAS AT ASPEN TRAILS

PRELIMINARY PLAN
GRADING PLAN

NO.	DESCRIPTION	DATE

PROJECT NUMBER: 0219-06
 SHEET 4 OF 8

SP-23-004

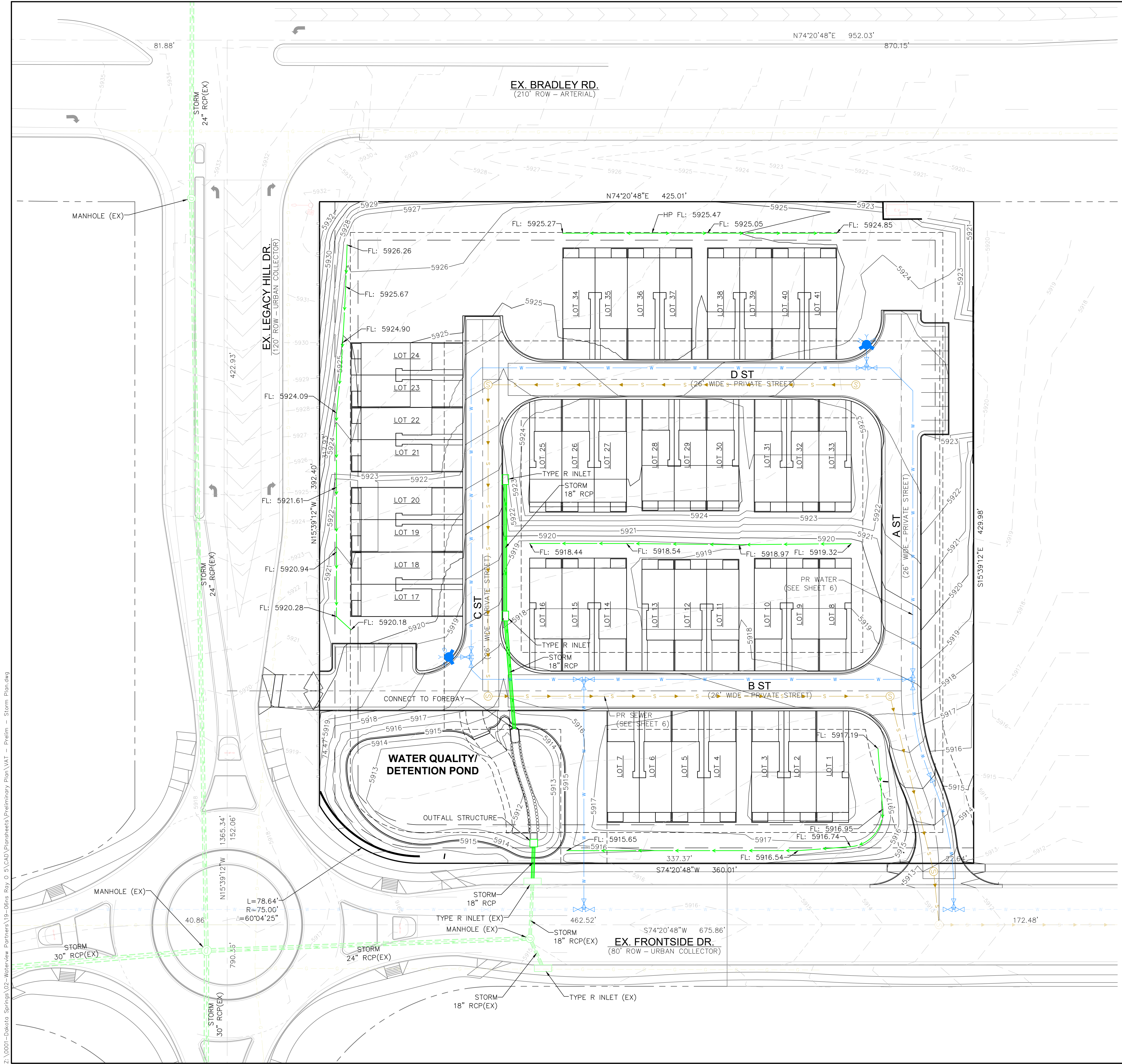

- LEGEND**
- PROPERTY BOUNDARY
 - PROPOSED LOT LINE
 - PROPOSED CENTERLINE
 - EXISTING LOT LINE
 - EXISTING RIGHT-OF-WAY
 - EXISTING CENTERLINE
 - EASEMENT LINE
 - SETBACK LINE
 - PR MAJOR CONTOUR
 - PR MINOR CONTOUR
 - EX MAJOR CONTOUR
 - EX MINOR CONTOUR
 - PROPOSED FLOW PATH
 - PROPOSED RCP STORM
 - EXISTING RCP STORM
 - PROPOSED SEWER
 - EXISTING SEWER
 - PROPOSED WATER
 - EXISTING WATER

Dakota Springs Engineering
 Engineering Consultants
 31 N. TEJON ST. SUITE 518
 COLORADO SPRINGS, CO 80903
 P: (719) 227-7388 F: (719) 227-7392

811 Know what's below. Call 811 before you dig.
 SCALE: 1" = 30'
 VERT: JMM
 STATION: FROM: TO:
 JCAD 719-377-0002

DESIGNED BY: JMM DATE: 10.22.22
 DRAWN BY: JMM DATE: 11.27.23
 CHECKED BY: DATE:

VILLAS AT ASPEN TRAILS
 PRELIMINARY PLAN
 STORM PLAN

REVISIONS:	DATE
NO. DESCRIPTION	
PROJECT NUMBER:	0219-06
SHEET	5 OF 8

Z:\0001-Dakota Springs\02-Waterview Partners\19-06ns Roy D S\CAD\Plansheets\Preliminary Plan\VA1 - Prelim - Storm Plan.dwg

