

**STORMWATER MANAGEMENT PLAN (SWMP)  
STORMWATER BEST MANAGEMENT PRACTICES**

**For:**

**PAINT BRUSH HILLS FIL. 14**

**Located at:**

**~Northwest of Londonderry Drive & Rockingham Drive**

**Prepared For:**

**Developer: Landhuis Co, 212 N Wahsatch Ave, Ste 301, Colorado Springs, CO  
80903, Contact: Jeff Mark, 719-635-3200**

**Contractor: TBD**

**Stormwater Manger: Landhuis Co, 212 N Wahsatch Ave, Ste 301, Colorado  
Springs, CO 80903, Contact: Jeff Mark, 719-635-3200**

**Prepared For:**

**Landhuis Company**

**212 N Wahsatch Ave, Ste 301**

**Colorado Springs, CO 80903**

**Contact: Jeff Mark**

**719-635-3200**

**Prepared by:**



**CIVIL CONSULTANTS, INC.**

**M&S Civil Consultants, Inc.**

**102 E. Pikes Peak, Suite 500**

**Colorado Springs, CO 80903**

**Job. No. 10-014**

**Project #SF**

**SP-20-006**

**SF-20-024**

# TABLE OF CONTENTS

Table of Contents	1
General Site Description	2
Existing Site Conditions	2
Soils	2
Soil Erosion Potential	3
Phasing Plan	3
Water Quality	3
Narrative Description of BMP Control Measures	4
Timing Schedule	5
Areas of Disturbance	5
Permanent Stabilization	5
Owners Inspections and Maintenance of BMP's	5
Soils Borings / Test and Groundwater	6
Site Run-off Characteristics	6
Introduction	7
Floodplain Statement	7
Receiving Waters Descriptions	7
Existing Vegetation Description	8
Potential Pollution Sources	8
Anticipated Non-Stormwater Discharges	8
Proposed Sequence of Construction Activities	8
Structural Practices	9
Non-Structural Practices	9
Materials Handling and Spill Practices	9
Revising BMP's and SWMP	10
Selecting Post-Construction BMPs	10
Inspections	11
Record Keeping	11

## **APPENDICES**

Copy of CDPHE Application
Vicinity Map
Grading, Erosion, Stormwater Inspection Checklist
Spill Cleanup Instructions and Report Form
BMP Construction Details
SWMP Grading and Erosion Control Plans

# **STORMWATER MANAGEMENT PLAN (SWMP)**

## ***General Site Description***

Paint Brush Hills Filing No. 14 is an 88.631 acre site consisting of single-family residential units. The site is located off of Londonderry Dr in El Paso County. The parcel is bound to the north, south and east by single family residential developments. West of the site are two rural and undeveloped parcels which is tributary to the Falcon Drainage Basin passing through both parcels and approaching the southwest boundary of the site. Drainage is directed south and southwest to an Extended Detention Basin (EDB) Pond C and subsequently southeasterly to the Chico Creek receiving waters. Drainage along the northeast portion of the site, the two northeastern cul-de-sacs, are directed to the east where runoff enters a drainage swale and is routed south to EDB Pond D.

Pond C is located within the Paint Brush Hills Filing No. 12 subdivision. Improvements to the Pond C will be required per the development of Paint Brush Hills Filing No. 14.

Paint Brush Hills Filing No. 14 presently undeveloped. Vegetation is sparse, consisting of native grasses. Existing site terrain generally slopes from north to southwest at grade rates that vary between 2% and 4%.

Land use for Paint Brush Hills Filing No. 14 is currently listed as AG (Grazing Land). Improvements proposed for the site include paved streets, trails, a full spectrum detention pond (off-site), and utilities as normally constructed for a residential development.

## ***Existing Site Conditions***

The overall existing drainage for the Paint Brush Hills Filing No. 14 site is generally from north to south via existing natural drainage swales. Offsite flows tributary to some of these natural drainage swales are contributed from the Paint Brush Hills Filing No. 3 residential rural development north of the site. Slopes across the development typically range between 2% to 4%. A majority of the site consists of native grasses and weeds with no trees present. An existing detention facility (Pond C) is located at the southwest boundary of the site and improvements will be required upon development of the proposed Paint Brush Hills Filing No. 14 site.

## ***Soils***

Soils for this project have been delineated by the map in the appendix, as Pring Coarse Sandy Loam (71) and is characterized as Hydrologic Soil Type "B". Soils in the study area are shown as mapped by S.C.S. in the "Soils Survey of El Paso County Area." Vegetation is sparse, consisting of native grasses and weeds.

### ***Soil Erosion Potential***

The proposed onsite construction activities anticipate the potential for soil erosion. Onsite stormwater BMP management facilities are proposed to minimize and aid in soil erosion. Group B soils have a moderate infiltration rate when thoroughly wet. These consist chiefly of moderate deep or deep, moderately well drained or well drained soils that have moderately fine texture to moderately coarse texture. These soils have a moderate rate of water transmission, and thus have a moderate potential for erosion. The impact on discharge for the soil erosion potential is moderate. The existing vegetation is sparse, consisting of prairie grasses and shrubs. A post construction comparison can be made from the adjacent undeveloped property to determine the percent of vegetation versus bare soil.

### ***Phasing Plan***

This section can be removed. See comment on Page 4.

Paint Brush Hills Filing No. 14 is not a phased project. The entire development will be constructed in the normal sequence of a single-family development.

### ***Water Quality***

**Detention Pond C**, has combined upstream developed runoff of  $Q_5=102.2$  cfs and  $Q_{100}=287.8$  cfs. The proposed Detention Pond functions to provide full spectrum detention and water quality for runoff calculated onsite. The pond is designed to treat approx 123.51 acres, and provide 1.724 ac-ft of water quality storage, 4.945 ac-ft of EURV storage and 9.490 ac-ft of 100-year storage. The proposed full spectrum detention basin will be private and shall be maintained by the Paint Brush Hills Metropolitan District. Access shall be granted to the District and El Paso County for access and maintenance of the private WQCV facility. A private maintenance agreement document shall accompany this report submittal.

## ***Narrative Description of BMP Control Measures***

This is your phasing plan.

Installations of BMPs are staged in order to minimize the potential for pollutants in the stormwater discharge. The following stages will be used: establishment of perimeter controls, installation of temporary BMPs during soil disturbance and then finally installation of permanent controls. Descriptions of some of the available BMPs are listed in below stages:

Only clearing necessary for the installation of perimeter controls should be employed in the first stage of temporary BMPs installation. Silt fence and vehicle tracking should be installed as shown on the Grading & Erosion Control Plan. At this time, the El Paso County inspector should be notified to schedule an initial inspection. Rough grading of the site will precede construction of proposed underground utilities.

Once utilities and storm drain infrastructure have been constructed, installation of temporary BMPs will commence. Temporary BMPs for this site consist of Inlet Protection. Locations for a concrete washout area and temporary stockpile location will also be established. These locations are likely to be different than what is shown on the Grading and Erosion Control Plan that accompanies this report. Once these locations have been established, they should be added and denoted on the copy of the plan that will be kept with the site administrator. The final stage is the installation of permanent BMPs where no further disturbance is anticipated. Upon completion of the permanent BMPs and all grading activities are completed, all disturbed areas not sodded or developed will be mulched and reseeded with native seed mix and may be watered until vegetative cover has been fully re-instated. At this point, the person responsible for inspection and maintenance can begin to address requirements for final stabilization. See construction details for installation and maintenance.

**Specifically, the proposed project will use silt fence, a vehicle tracking control pad, concrete washout area, inlet protection, mulching and reseeded to mitigate the potential for erosion across the site.**

No ground water, springs, or irrigation of non-stormwater discharge covered by CDPHE low risk guidance are known for this project.

No additional areas for storage of building materials, soil stockpiles or wastes are proposed for this project. Access for the project for construction equipment will be along the construction corridor. Construction vehicles (trucks) will access the site from adjacent public roadways.

There are no dedicated asphalt or concrete batch plants associated with this project.

This project does not rely on control measures owned or operated by another entity. There are no offsite stormwater control measures proposed for use by the project that are not under the direct control of the owner or contractor.

Removal of temporary control measures can be completed once the downstream drainage systems are complete, completion of upstream development, and vegetative cover has been established. See **Permanent Stabilization**.

### ***Timing Schedule***

Anticipated Starting and Completion Time Period of Grading Activities:  
**Initial Stage - July 2020**

**Substantial Completion Stage - September 2021**

Expected Date on which the Final Stabilization Stage will be completed:  
**August 2021**

update schedule

Removal of Temporary BMP's, (ex. Silt Fence, Inlet protection...)

**Upon completion of all upstream development and 70% or more vegetation establishment**

### ***Areas of Disturbance***

Total subject property site acreage: **88.631 AC**

Total disturbed area of subject property: **~72.18 AC**

### ***Permanent Stabilization***

Final stabilization is reached when all soil-disturbing activities at the site have been completed, and uniform vegetative cover has been established by drill seeding and crimping with a density of at least 70% of pre-disturbance levels or equivalent permanent physical erosion reduction methods have been employed. The CDPHE Water Quality Division may, after consultation with the permittee and upon good cause, amend the final stabilization criteria for specific operations. At this time, the El Paso County inspector should be notified to schedule a final inspection. The conditions of the SWMP and General Permit for Stormwater Discharges associated with Construction Activity will remain in effect until Final Stabilization is achieved and a notice of inactivation is sent by the applicant to CDPHE Stormwater Quality Division. All pertinent records must be kept on file for at least 3 years from the date the site is finally stabilized. Post Construction BMPs; Rock and revegetation including seeding, mulching and erosion control blanket will be the final BMP's. Permanent stabilization will be achieved with 70% vegetative establishment.

### ***Owner Inspections and Maintenance of BMP's***

1. Make thorough inspection of the stormwater management system at least every 14 days. and/or snow melt
2. Make thorough inspection of the stormwater management system after each precipitation event that causes runoff.
3. If any deficiencies are noted, they must be corrected immediately after being noted.
4. Records of the signed site inspections or modifications must be kept at the site unless alternate place is approved by the El Paso County inspector and must be made available upon request.
5. Inspections must take place where construction activity is complete, but lot is not sold add "and removed from the ESQCP" or something along those lines.
6. Monthly inspections must take place on site where construction activity is complete, but vegetative cover is still being established.

### ***Soil Borings / Test and Groundwater***

A Geotechnical Investigation has been completed for the overall Paintbrush Hills development which is inclusive of Paint Brush Hills Filing No.14 site, titled Geologic Hazard Evaluation Paintbrush Hills, EL Paso County Colorado, by CTL Thompson Inc. dated January 20, 2009.

### ***Site Run-Off Characteristics***

The site runoff coefficients are:	Minor Storm	Major Storm
-Historic existing Conditions	0.09	0.36
-Roofs, sidewalks, paved areas	0.90	0.96
-Landscaped and undeveloped areas	0.25	0.35

### ***Introduction***

**To: Site Inspector responsible for all Colorado Department of Public Health and Environment and El Paso County**

### **Requirements:**

The following stormwater management plan (SWMP) is a required item under the Construction Stormwater Discharge Permit. The primary goal for a SWMP is to improve water quality by reducing pollutants in stormwater discharges. Construction dewatering is a separate issue, and must be covered by the CDPHE Stormwater Quality Division's general permit for construction dewatering (regardless of the size of the construction project). Stormwater that mixes with ground water in an excavation is subject to the controls of a Construction Dewatering Permit. The SWMP will be completed and implemented at the time the project breaks ground, and will be revised if necessary as construction proceeds. This document must be kept at the construction site at all times and be made available to the public and any representative of any Water Quality Control Divisions if requested. Inspection guidance can be found at [www.cdphe.state.co.us](http://www.cdphe.state.co.us) and El Paso County and City of Colorado Springs Storm Drainage Design Criteria. The inspections should be made at least every 14 days and after any precipitation or snowmelt event that causes surface erosion. El Paso County requires that the inspector must be contacted 48 hours prior to initial and final inspections. An inspection log entry should be completed with each inspection performed. The inspection log should be kept with the SWMP. The conditions of the SWMP and General Permit for Stormwater Discharges associated with the construction activity will remain in effect until final stabilization is achieved, and a notice of inactivation is sent to CDPHE Stormwater Quality Division. All pertinent records must be kept for at least 3 years from date the site is stabilized or sold.

### ***Floodplain Statement***

No portion of this site is within a designated F.E.M.A. floodplain as determined by the Federal Emergency Management Agency (FEMA) Flood Insurance Rate Map (FIRM) Panel No. 08041C0535G, effective date December 7, 2018 and revised to reflect LOMR, 12-08-0579P, dated February 28, 2013.

### ***Receiving Water Description***

The site is located within the Falcon Drainage Basin and is tributary to the Chico Creek Channel. No stream crossings are proposed for this project.



### **Existing Vegetation Description**

Paint Brush Hills Filing No. 14 consists of 88.631 acres and is presently undeveloped. Vegetation is sparse, consisting of native grasses and shrubs. Existing site terrain generally slopes from north to southwest at grade rates that vary between 2% and 6%. Land use for Paint Brush Hills Filing No. 14 is currently listed as AG (Grazing Land). The existing vegetation should be visually inspected prior to disturbance and cataloged to compare with post construction vegetation. Adjacent undisturbed land can also be used to compare the post-construction to the pre-disturbed condition.

Leave space to fill the % ground cover and method of determination at a later date.

### **Potential Pollution Sources**

Construction activities that will take place at this site may have an impact on the stormwater quality. These include, but are not limited to, portable toilets, materials storage, vehicle fueling, maintenance and vehicle tracking, dust, waste piles, significant dust generating processes, routine maintenance activities involving fertilizers, pesticides, herbicides, detergents, fuels, solvents, oils, loading and unloading areas, dumpsters, etc.... The location of any of these activities not included on the initial site map should be added along with a description of the measures used to prevent the discharge of these materials from the site. See construction details for installation and maintenance. All trash and debris should be removed from the site on a regular basis and disposed of properly.

### **Anticipated Non-Stormwater Discharges**

Non-stormwater discharges are caused by activities other than direct runoff from precipitation events. These include, but are not limited to natural springs, irrigation. Any non-stormwater discharges that are not included in the initial map should be added along with a description of measures used to handle it. There are no known natural springs, temporary or permanent irrigation that would cause erosion on this project site.

### **Proposed Sequence of Construction Activities**

1. Notify the inspector for initial inspection.
2. Clearing for necessary for perimeter controls.
3. Construct vehicle traffic control pad at entrance/exit of construction site.
4. Install lot perimeter controls, including silt fence, delineating project site as indicated on Site Map.
5. Complete remaining clearing and grubbing for project area. Install additional BMPs, as indicated on Site Map.
6. Final grade site as indicated on Site Map.
7. Achieve Final Stabilization, as outlined in SWMP. Send inactivation notice to CDPHE.
8. See Construction Details for BMP Installation and Maintenance.

Any stockpile areas are to be contained with silt fence, or other acceptable measures to prevent erosion and sediment from leaving the area. All BMP's that may be in place need to be inspected and cleaned if sediment should leave the site and enter the streets. Erosion control measures shall be implemented in a manner that will protect properties

and public facilities from the adverse effect of erosion and sedimentation as a result of construction and earthwork activities. The following practices are to be implemented for this site:

### ***Structural Practices***

In areas of sheet flow running off-site and at the top and bottom of steep slopes, silt fence will be used to trap sediment. Silt fence should be placed on the contour and in areas where the tributary area is less than one-quarter acre per 100' of silt fence. A vehicle traffic control pad will be installed at the entrance/exit of the site to reduce sediment tracking off-site.

Practices may include, but are not limited to straw bales, wattles/sediment control logs, silt fences, earth dikes, drainage swales, sediment traps, subsurface drains, pipe slope drains, inlet protection, outlet protection, gabions, and temporary or permanent sediment basins. All roads will be inspected to ensure that sediment from on-site construction activity is not being discharged with the stormwater. Sediment and debris that have been tracked off-site should be removed daily by shoveling or sweeping. See construction details for installation and maintenance.

### ***Non-Structural Practices***

Surface roughening may be used to reduce the amount of runoff and wind erosion from any given areas. Once the existing vegetation is cleared, watering should occur to help control fugitive dust. Disturbed areas where work is temporarily halted shall be temporarily stabilized within 21 calendar days after activity has ceased unless work is to be resumed within 30 calendar days after the activity has ceased. Other Non-Structural Practices may include soils erosion control measures for all slopes, channels, ditches, or any disturbed land area shall be completed within 21 calendar days after final grade, or final earth disturbance, has been completed. Disturbed areas and stockpiles, which are not at final grade but will remain dormant for longer than 30 days, shall also be mulched within 21 days after interim grading. An area that is going to remain in an interim state for more than 60 days shall also be seeded. All temporary soil erosion control measures and BMPs shall be maintained until permanent soil erosion control measures are implemented. See construction details for installation and maintenance.

### ***Materials Handling and Spill Practices***

Any substances with potential to contaminate either the ground or ground surface water shall be cleaned up immediately after discovery or contained until appropriate cleanup methods can be employed. Manufacturer's recommended methods for clean up shall be followed, along with proper disposal methods. Any discharge of hazardous materials must be handled in accordance with the Divisions Notification Requirement. All waste and debris created by construction activities at the site or removed from the site shall be disposed of in compliance with all laws, regulations and ordinances of the federal, state and local agencies. See construction details for Materials Handling and Spills.

## **Revising BMP's and SWMP**

1. The plans must be amended, by the contractor whenever there is a change in design, construction operation or maintenance that could have a significant effect on the potential for the discharge of pollutants to State Waters. It also must be amended if it is found to be ineffective in controlling pollutants present in stormwater.

2. Permittees are required to amend, adapt, and adjust their SWMP to accurately reflect phased construction changes and current conditions at the site. Plan modifications are broken into major and minor modifications which have differing requirements.

Major Modifications: Major modifications are changes to the SWMP that remove or add area to the project, modify the final hydrology or drainage of the final design, replace approved SWMP, or otherwise expand or contract the scope of the approved project. A revised SWMP and any revised supporting documents require review and approval of the local agency.

Minor Modifications: Minor modifications are changes to the SWMP that do not increase the scope or change hydrology of the project but; modify or improve specific BMPs in use at the site, indicate progression in phasing of the project, or specify relocation of previously approved BMPs within the project. Minor modifications can be made in the field by the permittee if the permittee can demonstrate that the modified soil erosion controls are equivalent to, or better than, the originally approved BMPs. Minor modifications must be thoroughly documented in the permittee's SWMP narrative, drawings and specifications.

3. The SWMP should be viewed as a "living document" throughout the lifetime of the project.

4. The plan must be signed in accordance with the general permit.

5. The plan must be made available, upon request, to CDPHE, United States Environmental Protection Agency, or operator of the local municipal storm sewer system, if applicable.

6. The following documents must be kept in a field office, trailer, shed, or vehicle that is onsite during normal working hours;

1. The permit coverage letter from the Colorado Department of Public Health and Environment (CDPHE)
2. The Stormwater Management Plan
3. Site Inspection Records
4. A copy of the Colorado General Permit for Stormwater Discharges from Construction Activities.

## **Selecting Post-Construction BMPs**

Post Construction BMPs; FSD Pond (Off-Site), Rip Rap and revegetation including seeding, mulching and erosion control blanket will be the final BMP's. Permanent stabilization will be achieved with 70% vegetative establishment.

## Inspections

Inspections should occur at least every 14 days and within 24 hours of a rainfall event producing runoff, usually this occurs with precipitation of 1/4 inch of rain or more. The local news weather report gives general rainfall amounts each day or snow melt

The inspection schedule should be routinely accomplished every 14 days and within 24 hours of the end of a storm event for the entire site with all BMP's evaluated for performance and need. Any BMP found to be ineffective should be re-accomplished or replaced with a new BMP to provide the level of protection needed. BMP's found to be no longer needed can be removed. Inspections should also be accomplished as soon as practical, at the end of a rain event causing surface erosion. The general procedure for correcting problems when identified should be documented in a log and a solution to correct the problem as soon as possible.

## Record Keeping

Records should be retained for a minimum period of at least 3 years after the permit is terminated. Sign and date the inspection log sheets provided in the Appendix of this report. The inspection logs and location of SWMP records should be kept onsite.

## APPENDICES

COPY OF CDPHE APPLICATION



# COLORADO

Department of Public Health & Environment

Dedicated to protecting and improving the health and environment of the people of Colorado

ASSIGNED PERMIT NUMBER

Date Received \_\_\_\_/\_\_\_\_/\_\_\_\_  
MM DD YYYY  
Revised: 10-2017

## STORMWATER DISCHARGE ASSOCIATED WITH CONSTRUCTION ACTIVITIES APPLICATION COLORADO DISCHARGE PERMIT SYSTEM (CDPS)

**PHOTO COPIES, FAXED COPIES, PDF COPIES OR EMAILS WILL NOT BE ACCEPTED.**

**For Applications submitted on paper - Please print or type. Original signatures are required.**

All items must be completed accurately and in their entirety for the application to be deemed complete. Incomplete applications will not be processed until all information is received which will ultimately delay the issuance of a permit. If more space is required to answer any question, please attach additional sheets to the application form. Applications or signature pages for the application may be submitted by mail or hand delivered to:

Colorado Department of Public Health and Environment, 4300 Cherry Creek Drive South, WQCD-P-B2, Denver, CO 80246-1530

**For Applications submitted electronically**

Please note that you can ONLY complete the feedback form by downloading it to a PC or Mac/Apple computer and opening the Application with Adobe Reader or a similar PDF reader. The form will NOT work with web browsers, Google preview, Mac preview software or on mobile devices using iOS or Android operating systems.

If application is submitted electronically, processing of the application will begin at that time and not be delayed for receipt of the signed document.

Any additional information that you would like the Division to consider in developing the permit should be provided with the application. Examples include effluent data and/or modeling and planned pollutant removal strategies.

**Beginning July 1, 2016, invoices will be based on acres disturbed.**

**DO NOT PAY THE FEES NOW - Invoices will be sent after the receipt of the application.**

Disturbed Acreage for this application (see page 4)

- Less than 1 acre (\$83 initial fee, \$165 annual fee)
- 1-30 acres (\$175 initial fee, \$350 annual fee)
- Greater than 30 acres (\$270 initial fee, \$540 annual fee)

### PERMIT INFORMATION

Reason for Application:  NEW CERT  RENEW CERT EXISTING CERT# \_\_\_\_\_

Applicant is:  Property Owner  Contractor/Operator

### A. CONTACT INFORMATION - \*indicates required

\* PERMITTED ORGANIZATION FORMAL NAME: Rice & Rice, Inc.

1) \* PERMIT OPERATOR - the party that has operational control over day to day activities - may be the same as owner.

Responsible Person (Title): Owner/Manager

Currently Held By (Person): First Name: Tyrone Last Name: Rice

Telephone: 719-392-5311 Email Address: trice@riceandriceinc.com

Organization: Rice & Rice, Inc.

Mailing Address: 8150 Rice Lane

City: Fountain State: CO Zip Code: 80817

**Per Regulation 61** : All reports required by permits, and other information requested by the Division shall be signed by the permittee or by a duly authorized representative of that person. A person is a duly authorized representative only if:

- (i) The authorization is made in writing by the permittee
- (ii) The authorization specifies either an individual or a position having responsibility for the overall operation of the regulated facility or activity such as the position of plant manager, operator of a well or a well field, superintendent, position of equivalent responsibility, or an individual or position having overall responsibility for environmental matters for the company. (A duly authorized representative may thus be either a named individual or any individual occupying a named position); and
- (iii) The written authorization is submitted to the Division

2) **OWNER - party has ownership or long term lease of property - may be the same as the operator.**

Same as 1) Permit Operator

Responsible Person (Title): Owner/Manager  
Currently Held By (Person): First Name: Jeff Last Name: Mark  
Telephone: 719-635-3200 Email Address: jmark@landhuisco.com  
Organization: The Landhuis Company  
Mailing Address: 212 N. Wahsatch Avenue, Suite 301  
City: Colorado Springs State: CO Zip Code: 80903

**Per Regulation 61** : All reports required by permits, and other information requested by the Division shall be signed by the permittee or by a duly authorized representative of that person. A person is a duly authorized representative only if:

- i. The authorization is made in writing by the permittee.
- ii. The authorization specifies either an individual or a position having responsibility for the overall operation of the regulated facility or activity such as the position of plant manager, operator of a well or a well field, superintendent, position of equivalent responsibility, or an individual or position having overall responsibility for environmental matters for the company. (A duly authorized representative may thus be either a **named individual** or any individual occupying a **named position**); and
- iii. The written authorization is submitted to the Division.

3) **\*SITE CONTACT** local contact for questions relating to the facility & discharge authorized by this permit for the facility

Same as 1) Permit Operator

Responsible Person (Title): Owner/Manager  
Currently Held By (Person): First Name: Tyrone Last Name: Rice  
Telephone: 719-392-5311 Email Address: trice@riceandriceinc.com  
Organization: Rice & Rice, Inc.  
Mailing Address: 8150 Rice Lane  
City: Fountain State: CO Zip Code: 80817

4) **\*BILLING CONTACT** if different than the permittee.

Same as 1) Permit Operator

Responsible Person (Title): Owner/Manager  
Currently Held By (Person): First Name: Tyrone Last Name: Rice  
Telephone: 719-392-5311 Email Address: trice@riceandriceinc.com  
Organization: Rice & Rice, Inc.  
Mailing Address: 8150 Rice Lane  
City: Fountain State: CO Zip Code: 80817

5) **OTHER CONTACT TYPES (check below) Add pages if necessary:**

Responsible Person (Title): \_\_\_\_\_  
Currently Held By (Person): First Name: \_\_\_\_\_ Last Name: \_\_\_\_\_  
Telephone: \_\_\_\_\_ Email Address: \_\_\_\_\_  
Organization: \_\_\_\_\_  
Mailing Address: \_\_\_\_\_  
City: \_\_\_\_\_ State: \_\_\_\_\_ Zip Code: \_\_\_\_\_

- |  |   |   |
|--|---|---|
| <input type="checkbox"/> Environmental Contact       | <input type="checkbox"/> Consultant         | <input type="checkbox"/> Stormwater MS4 Responsible Person    |
| <input type="checkbox"/> Inspection Facility Contact | <input type="checkbox"/> Compliance Contact | <input type="checkbox"/> Stormwater Authorized Representative |



**B) PERMITTED PROJECT/FACILITY INFORMATION**

Project/Facility Name Paint Brush Hills Filing No.14

Street Address or Cross Streets Northwest of the Londonderry Drive/Rockingham Drive intersection.

(e.g., Park St and 5 Ave; CR 21 and Hwy 10; 44 Ave and Clear Creek) ; A street name without an address, intersection, mile marker, or other identifying information describing the location of the project is not adequate. For **linear projects**, the route of the project should be described as best as possible using the starting point for the address and latitude and longitude - more clearly defined in the required map )

City: Colorado Springs County: El Paso Zip Code: 80831

**Facility Latitude/Longitude** - List the latitude and longitude of the excavation(s) resulting in the discharge(s). If the exact soil disturbing location(s) are not known, list the latitude and longitude of the center point of the construction project. If using the center point, be sure to specify that it is the center point of construction activity. The preferred method is GPS and Decimal Degrees.

Latitude 38 981091 Longitude -104 634060 (e.g., 39.70312°, 104.93348°)  
Decimal Degrees (to 5 decimal places) Decimal Degrees (to 5 decimal places)

This information may be obtained from a variety of sources, including:

- **Surveyors or engineers** for the project should have, or be able to calculate, this information.
- **U.S. Geological Survey topographical map(s)**, available at area map stores.
- Using a **Global Positioning System (GPS) unit** to obtain a direct reading.
- **Google** - enter address in search engine, select the map, right click on location, and select "what's here".

*Note: the latitude/longitude required above is not the directional degrees, minutes, and seconds provided on a site legal description to define property boundaries.*

**C) MAP (Attachment) If no map is submitted, the application cannot be submitted.**

**Map:** Attach a map that indicates the site location and that CLEARLY shows the boundaries of the area that will be disturbed. A vicinity map is not adequate for this purpose.

**D) LEGAL DESCRIPTION - only for Subdivisions**

**Legal description:** If subdivided, provide the legal description below, or indicate that it is not applicable (**do not** supply Township/Range/Section or metes and bounds description of site)

Subdivision(s): \_\_\_\_\_ Lot(s): \_\_\_\_\_ Block(s) \_\_\_\_\_

OR  Not applicable (site has not been subdivided)

**E) AREA OF CONSTRUCTION SITE - SEE PAGE 1 - WILL DETERMINE FEE**

Provide both the total area of the construction site, and the area that will undergo disturbance, in acres.

Total area of project disturbance site (acres): 88.632

**Note:** aside from clearing, grading and excavation activities, disturbed areas also include areas receiving overburden (e.g., stockpiles), demolition areas, and areas with heavy equipment/vehicle traffic and storage that disturb existing vegetative cover.

Part of Larger Common Plan of Development or Sale, (i.e., total, including all phases, filings, lots, and infrastructure not covered by this application)

**F) NATURE OF CONSTRUCTION ACTIVITY**

Check the appropriate box(es) or provide a brief description that indicates the general nature of the construction activities. (The full description of activities must be included in the Stormwater Management Plan.)

Commercial Development

Residential Development

Highway and Transportation Development

Pipeline and Utilities (including natural gas, electricity, water, and communications)

Oil and Gas Exploration and Well Pad Development

Non-structural and other development (i.e. parks, trails, stream realignment, bank stabilization, demolition, etc.)

**G) ANTICIPATED CONSTRUCTION SCHEDULE**

Construction Start Date: July 2018 Final Stabilization Date: September 2020

- *Construction Start Date* - This is the day you expect to begin ground disturbing activities, including grubbing, stockpiling, excavating, demolition, and grading activities.
- *Final Stabilization Date* - in terms of permit coverage, this is when the site is finally stabilized. This means that all ground surface disturbing activities at the site have been completed, and all disturbed areas have been either built on, paved, or a uniform vegetative cover has been established with an individual plant density of at least 70 percent of pre-disturbance levels. **Permit coverage must be maintained until the site is finally stabilized. Even if you are only doing one part of the project, the estimated final stabilization date must be for the overall project.** If permit coverage is still required once your part is completed, the permit certification may be transferred or reassigned to a new responsible entity(s).

**H) RECEIVING WATERS (If discharge is to a ditch or storm sewer, include the name of the ultimate receiving waters)**

Immediate Receiving Water(s): Black Squirrel Creek

Ultimate Receiving Water(s): Chico Creek

Identify the receiving water of the stormwater from your site. Receiving waters are any waters of the State of Colorado. This includes all water courses, even if they are usually dry. If stormwater from the construction site enters a ditch or storm sewer system, identify that system and indicate the ultimate receiving water for the ditch or storm sewer. **Note:** a stormwater discharge permit does not allow a discharge into a ditch or storm sewer system without the approval of the owner/operator of that system.

**I) SIGNATURE PAGE**

1. You may print and sign this document and mail the hard copy to the State along with required documents (address on page one).

**2. Electronic Submission Signature**

You may choose to submit your application electronically, along with required attachments. To do so, click the SUBMIT button below which will direct you, via e-mail, to sign the document electronically using the DocuSign Electronic Signature process. Once complete, you will receive via e-mail, an electronically stamped Adobe pdf of this application. Print the signature page from the electronically stamped pdf, sign it and mail it to the WQCD Permits Section to complete the application process (address is on page one of the application).

- The Division encourages use of the electronic submission of the application and electronic signature. This method meets signature requirements as required by the State of Colorado.
- The ink signed copy of the electronically stamped pdf signature page is also required to meet Federal EPA Requirements.
- Processing of the application will begin with the receipt of the valid electronic signature.

**STORMWATER MANAGEMENT PLAN CERTIFICATION**

By checking this box "I certify under penalty of law that a complete Stormwater Management Plan, as described in the stormwater management plan guidance, has been pre-pared for my activity. Based on my inquiry of the person or persons who manage the system, or those persons directly responsible for gathering the information, the Stormwater Management Plan is, to the best of my knowledge and belief, true, accurate, and complete. I am aware that there are significant penalties for falsely certifying the completion of said SWMP, including the possibility of fine and imprisonment for knowing violations."

"I certify under penalty of law that this document and all attachments were prepared under my direction or supervision in accordance with a system designed to assure that qualified personnel properly gather and evaluate the information submitted. Based on my inquiry of the person or persons who manage the system, or those persons directly responsible for gathering the information, the information submitted is to the best of my knowledge and belief, true, accurate and complete. I am aware that there are significant penalties for submitting false information, including the possibility of fine and imprisonment for knowing violations."

"I understand that submittal of this application is for coverage under the State of Colorado General Permit for Stormwater Discharges Associated with Construction Activity for the entirety of the construction site/project described and applied for, until such time as the application is amended or the certification is transferred, inactivated, or expired." [Reg 61.4(1)(h)]

For DocuSign  
Electronic Signature \_\_\_\_\_ Ink Signature \_\_\_\_\_ Date: \_\_\_\_\_

Signature of Legally Responsible Person or Authorized Agent (submission must include original signature)

Tyrone Rice

Owner/Manager

Name (printed)

Title

**Signature:** The applicant must be either the owner and operator of the construction site. Refer to Part B of the instructions for additional information.

The application must be signed by the applicant to be considered complete. In all cases, it shall be signed as follows:

(Regulation 61.4 (1e))

- In the case of corporations, by the responsible corporate officer is responsible for the overall operation of the facility from which the discharge described in the form originates
- In the case of a partnership, by a general partner.
- In the case of a sole proprietorship, by the proprietor.
- In the case of a municipal, state, or other public facility, by either a principal executive officer, ranking elected official, (a principal executive officer has responsibility for the overall operation of the facility from which the discharge originates).

**3rd Party Preparer:** If this form was prepared by an authorized agent on behalf of the Permittee, please complete the field below.

Preparer Name (printed)

Email Address

**DO NOT INCLUDE A COPY OF THE STORMWATER MANAGEMENT PLAN  
DO NOT INCLUDE PAYMENT—AN INVOICE WILL BE SENT AFTER THE CERTIFICATION IS ISSUED.**

<input type="text"/>	<b>Attach Map</b>
<input type="text"/>	<b>Attach File</b>
<input type="text"/>	<b>Attach File</b>
<input type="text"/>	<b>Attach File</b>
<input type="text"/>	<b>Attach File</b>

VICINITY MAP

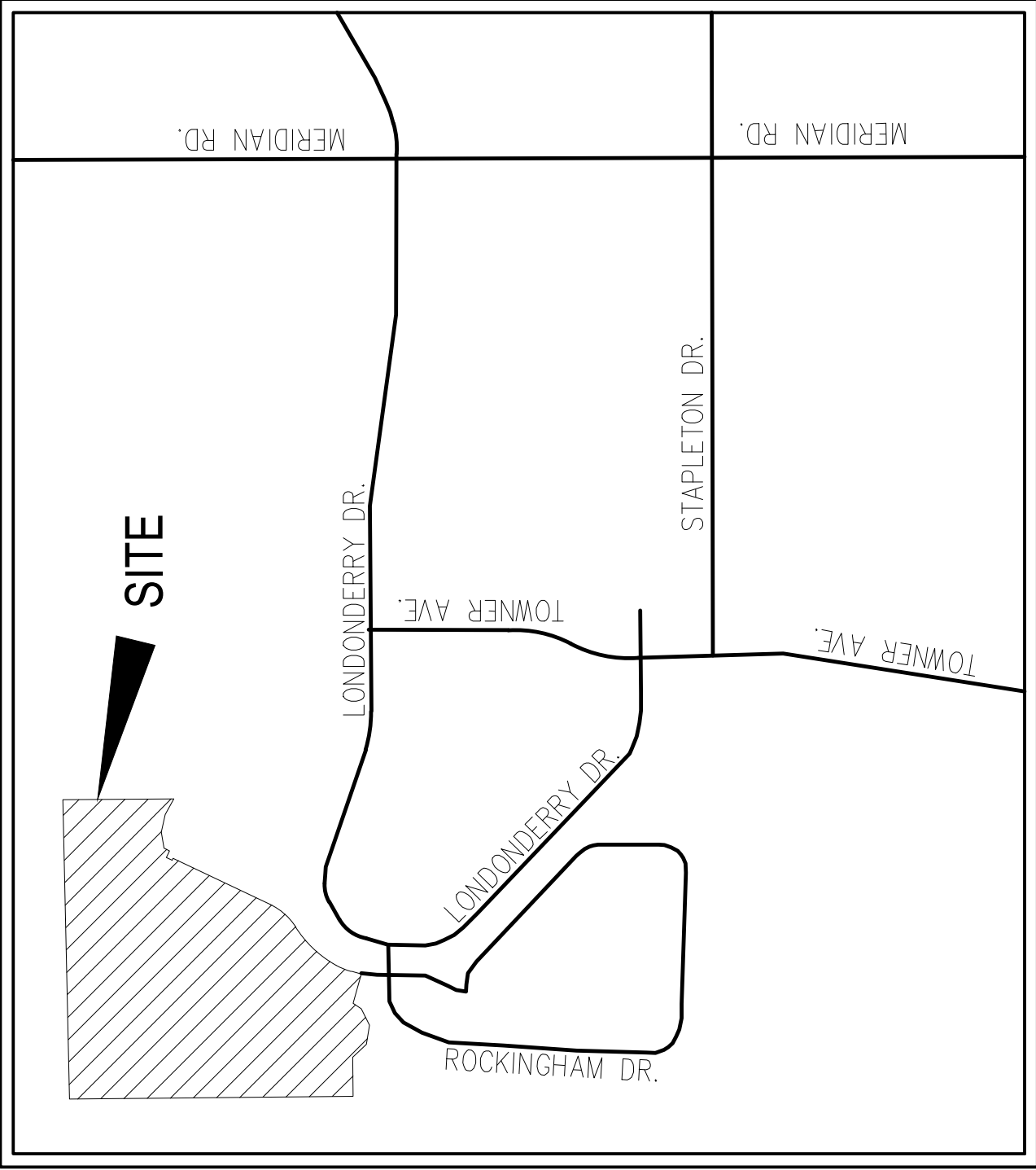

# VICINITY MAP

N.T.S.

GRADING, EROSION, STORMWATER  
INSPECTION CHECKLIST

# Appendix C Inspection Checklist – Grading Erosion, and Stormwater Quality Controls

## CITY OF COLORADO SPRINGS

DATE/TIME:
INSPECTOR:
TYPE OF INSPECTION: Self-Monitoring_____
Initial _____ Compliance_____ Follow-Up_____
Reconnaissance_____ Complaint_____ Final_____

SITE:	DATE OF PERMIT:
ADDRESS:	
CONTRACTOR:	OWNER/OWNER'S REPRESENTATIVE:
CONTACT:	CONTACT:
PHONE:	PHONE:
STAGE OF CONSTRUCTION: Initial BMP Installation/Prior to Construction_____ Clearing & Grubbing_____	
Rough Grading_____ Finish Grading_____ Utility Construction_____ Building Construction_____	
Final Stabilization_____	

OVERALL SITE INSPECTION	YES/NO/N.A.	REMARKS/ACTIONS
Is there any evidence of sediment leaving the construction site? If so, note areas.		
Have any adverse impacts such as flooding, structural damage, erosion, spillage, or accumulation of sediment, debris or litter occurred on or within public or private property, wetlands or surface waters –to include intermittent drainageways and the City's stormwater system (storm sewers, gutters, ditches, etc.)?		
Are the BMPs properly installed and maintained?		
Have the BMPs been placed as shown on approved plans?		
Are the BMPs functioning as intended?		
Is work being done according to approved plans and any phased construction schedule?		
Is the construction schedule on track?		
Are drainage channels and outlets adequately stabilized?		
Is there any evidence of discharges or spills of fuels, lubricants, chemicals, etc.?		

<b>BMP MAINTENANCE CHECKLIST</b>	<b>YES/NO/N.A.</b>	<b>REMARKS/ACTIONS NECESSARY</b>
<p>CHECK DAM</p> <p>Has accumulated sediment and debris been removed per maintenance requirements?</p>		
<p>EROSION CONTROL BLANKET</p> <p>Is fabric damaged, loose or in need of repairs?</p>		
<p>INLET PROTECTION</p> <p>Is the inlet protection damaged, ineffective or in need of repairs?</p> <p>Has sediment been removed per maintenance requirements?</p>		
<p>MULCHING</p> <p>Distributed uniformly on all disturbed areas?</p> <p>Is the application rate adequate?</p> <p>Any evidence of mulch being blown or washed away?</p> <p>Has the mulched area been seeded, if necessary?</p>		
<p>SEDIMENT BASIN</p> <p>Is the sediment basin properly constructed and operational?</p> <p>Has sediment and debris been cleaned out of the basin?</p>		
<p>SILT FENCE</p> <p>Is the fence damaged, collapsed, unentrenched or ineffective?</p> <p>Has sediment been removed per maintenance requirements?</p> <p>Is the silt fence properly located?</p>		
<p>SLOPE DRAIN</p> <p>Is water bypassing or undercutting the inlet or pipe?</p> <p>Is erosion occurring at the outlet of the pipe?</p>		
<p>STRAW BALE BARRIER</p> <p>Are the straw bales damaged, ineffective or unentrenched?</p> <p>Has sediment been removed per maintenance requirements?</p> <p>Are the bales installed and positioned correctly?</p>		



<b>BMP MAINTENANCE CHECKLIST</b>	<b>YES/NO/N.A.</b>	<b>REMARKS/ACTIONS NECESSARY</b>
<p><b>SURFACE ROUGHENING</b></p> <p>Is the roughening consistent/uniform on slopes??</p> <p>Any evidence of erosion?</p>		
<p><b>TEMPORARY SEEDING</b></p> <p>Are the seedbeds protected by mulch?</p> <p>Has any erosion occurred in the seeded area?</p> <p>Any evidence of vehicle tracking on seeded areas?</p>		
<p><b>TEMPORARY SWALES</b></p> <p>Has any sediment or debris been deposited within the swales?</p> <p>Have the slopes of the swale eroded or has damage occurred to the lining?</p> <p>Are the swales properly located?</p>		
<p><b>VEHICLE TRACKING</b></p> <p>Is gravel surface clogged with mud or sediment?</p> <p>Is the gravel surface sinking into the ground?</p> <p>Has sediment been tracked onto any roads and has it been cleaned up?</p> <p>Is inlet protection placed around curb inlets near construction entrance?</p>		
<p><b>OTHER</b></p>		

FINAL INSPECTION CHECKLIST	YES/NO/N.A.	REMARKS/ACTIONS NECESSARY
Has all grading been completed in compliance with the approved Plan, and all stabilization completed, including vegetation, retaining walls or other approved measures?		
Has final stabilization been achieved – uniform vegetative cover with a density of at least 70 percent of pre-disturbance levels, and cover capable of adequately controlling soil erosion; or permanent, physical erosion methods?		
Have all temporary measures been removed?		
Have all stockpiles, construction materials and construction equipment been removed?		
Are all paved surfaces clean (on-site and off-site)?		
Has sediment and debris been removed from drainage facilities (on-site and off-site) and other off-site property, including proper restoration of any damaged property?		
Have all permanent stormwater quality BMPs been installed and completed?		

ADDITIONAL COMMENTS:          
--

The items noted as needing action must be remedied no later than \_\_\_\_\_.

The contractor shall notify the inspector when all the items noted above have been addressed.

By signing this inspection form, the owner/owner's representative and the contractor acknowledge that they have received a copy of the inspection report and are aware it is their responsibility to take corrective actions by the date noted above. Failure to sign does not relieve the contractor and owner/owner's representative of their responsibility to take the necessary corrective action and of their liability for any damages that have occurred or may occur.

INSPECTOR'S SIGNATURE:	DATE:
OWNER/OWNER'S REPRESENTATIVE SIGNATURE:	DATE:
CONTRACTOR'S SIGNATURE:	DATE:

**SPILL CLEANUP INSTRUCTIONS AND REPORT FORM**

involving a radioactive or infectious material, or there is a release of a marine pollutant.

Spills and incidents that have or may result in a spill along a highway must be reported to the nearest law enforcement agency immediately. The Colorado State Patrol and CDPHE must also be notified as soon as possible. In the event of a spill of hazardous waste at a transfer facility, the transporter must notify CDPHE within 24 hours if the spill exceeds 55 gallons or if there is a fire or explosion.

The National Response Center should be notified as soon as possible after discovery of a release of a hazardous liquid or carbon dioxide from a pipeline system if a person is killed or injured, there is a fire or explosion, there is property damage of \$50,000 or more, or any nearby water body is contaminated.

The National Response Center and the Colorado Public Utilities Commission Gas Pipeline Safety Section must be notified as soon as possible, but not more than two hours after discovery of a release of gas from a natural gas pipeline or liquefied natural gas facility if a person is killed or injured, there is an emergency shutdown of the facility, or there is property damage of \$50,000 or more. The Colorado Public Utilities Commission should also be notified if there is a gas leak from a pipeline, liquefied natural gas system, master meter system or a propane system that results in the evacuation of 50 or more people from an occupied building or the closure of a roadway.

### **Oil and Gas Exploration**

All Class I major events on federal lands, including releases of hazardous substances in excess of the CERCLA reportable quantity and spills of more than 100 barrels of fluid and/or 500 MCF of gas released, must be reported to the Bureau of Land Management (BLM) immediately. Spills of oil, gas, salt water, toxic liquids and waste materials must also be reported to the BLM and the surface management agency.

Spills of exploration and production (E&P) waste on state or private lands in excess of 20 barrels, and spills of any size that impact or threaten to impact waters of the state, an occupied structure, or public byway must be reported to the Colorado Oil and Gas Conservation Commission as soon as practicable, but not more than 24 hours after discovery. Spills of any

size that impact or threaten to impact waters of the state must be reported to CDPHE immediately. Spills that impact or threaten to impact a surface water intake must be reported to the emergency contact for that facility immediately after discovery. Spills of more than five (5) barrels of E&P waste must be reported in writing to the Oil and Gas Conservation Commission within 10 days of discovery.

### **REPORTING NUMBERS**

National Response Center (24-hour)  
**1-800-424-8802**

CDPHE Colorado Environmental Release and Incident Reporting Line (24-hour)  
**1-877-518-5608**

Radiation Incident Reporting Line (24-hour)  
**303-877-9757**

Colorado State Patrol (24-hour)  
**303-239-4501**

Division of Oil and Public Safety  
(business hours)  
**303-318-8547**

Oil and Gas Conservation Commission  
(business hours)  
**303-894-2100**

Colorado Public Utilities Commission Gas Pipeline Safety Section (business hours)  
**303-894-2851**

Local Emergency Planning Committees  
(to obtain list, business hours)  
**720-852-6603**



Colorado Department  
of Public Health  
and Environment

# *Environmental Spill Reporting*

Colorado Department of Public  
Health and Environment  
4300 Cherry Creek Drive South  
Denver, CO 80246-1530

<http://www.colorado.gov/cdphe>

January 2009

When a release of a hazardous material or other substance occurs to the environment, there are a number of reporting and notification requirements that must be followed by the company or individual responsible for the release. Most spills are covered by more than one reporting requirement, and **all** requirements must be met. In addition to verbal notification, written reports are generally required. This brochure briefly explains the major requirements. A more detailed description is provided in the "Reporting Environmental Releases in Colorado" Guidance Document, available on the web.

Releases that must be reported to the Colorado Department of Public Health and Environment (CDPHE) may be reported to the Colorado Environmental Release and Incident Reporting Line.

## ENVIRONMENTAL SPILL REPORTING

### CERCLA, EPCRA and RCRA

The Comprehensive Environmental Response, Compensation and Liability Act (CERCLA) and the Emergency Planning and Community Right-to-Know Act (EPCRA) require that a release of a reportable quantity or more of a hazardous substance to the environment be reported immediately to the appropriate authorities when the release is discovered.

Under CERCLA, reportable quantities were established for hazardous substances listed or designated under other environmental statutes. These include:

- all hazardous air pollutants (HAPs) listed under Section 112(b) of the Clean Air Act.
- all toxic pollutants designated under Section 307(a) or Section 311(b)(2)(A) of the Clean Water Act.
- all Resource Conservation and Recovery Act (RCRA) characteristic and listed hazardous wastes.
- any element, compound, or substance designated under Section 102 of CERCLA.

EPCRA established a list of extremely hazardous substances (EHS) that could cause serious irreversible health effects from accidental releases. Many substances appear on both the CERCLA and EPCRA lists. EPCRA extremely hazardous substances that are also CERCLA hazardous substances have the same reportable quantity (RQ) as under CERCLA. EPCRA extremely hazardous substances that are not listed under CERCLA have a reportable quantity that is equal to their threshold planning quantity (TPQ). A list of CERCLA reportable quantities is included in 40 CFR Section 302.4. A list of EPCRA threshold planning quantities is included in 40 CFR Part 355 Appendices A & B.

CERCLA-reportable releases must be reported immediately to the National Response Center (NRC), while EPCRA-reportable releases must be reported immediately to the National Response Center, the State Emergency Response Commission (SERC) and the affected Local Emergency Planning Committee (LEPC). If the release is an EPCRA extremely

hazardous substance, but not a CERCLA hazardous substance, and there is absolutely no potential to affect off-site persons, then only the State Emergency Planning Commission (represented by CDPHE for reporting purposes) and the Local Emergency Planning Committee need to be notified.

In the case of a release of hazardous waste stored in tanks, RCRA-permitted facilities and large quantity generators must also notify CDPHE within 24 hours of any release to the environment that is greater than one (1) pound.

### Radiation Control

Each licensee or registrant must report to the Radiation Incident Reporting Line in the event of lost, stolen or missing licensed or registered radioactive materials or radiation machines, releases of radioactive materials, contamination events, and fires or explosions involving radioactive materials. Releases of radionuclides are reportable under CERCLA.

### Clean Water Act

The Clean Water Act requires the person in charge of a facility or vessel to immediately report to the National Response Center all discharges of oil or designated hazardous substances to water. Oil means oil of any kind or form. Designated hazardous substances are included in the CERCLA list.

The Clean Water Act also requires that facilities with a National Pollutant Discharge Elimination System (NPDES) permit report to the National Response Center within 24 hours of becoming aware of any unanticipated bypasses or upsets that cause an exceedance of the effluent limits in their permit and any violations of their maximum daily discharge limits for pollutants listed in their permit.

A release of any chemical, oil, petroleum product, sewage, etc., which may enter waters of the state of Colorado (which include surface water, ground water and dry gullies and storm sewers leading to surface water) must be reported immediately to CDPHE. Any accidental discharge to the sanitary sewer system must be reported immediately to the local sewer authority and the affected wastewater treatment plant. For additional reporting releases to water, please see "Guidance for Reporting Spills under the Colorado

Water Quality Control Act and Colorado Discharge Permits" at <http://www.cdphe.state.co.us/op/wqcc/Resources/Guidance/spillage.pdf>.

### Clean Air Act

Hazardous air pollutants (HAPs) are designated as hazardous substances under CERCLA. If a facility has an air permit but the permit does not allow for or does not specify the release of a substance, or if the facility does not have an air permit, then all releases in excess of the CERCLA / EPCRA reportable quantity for that substance must be reported to the National Response Center and CDPHE. If the facility releases more of a substance than is allowed under its air permit, the facility must also report the release. Discharges of a substance that are within the allowable limits specified in the facility's permit do not need to be reported.

### Regulated Storage Tanks

Owners and operators of regulated storage tank systems must report a release or suspected release of regulated substances to the Division of Oil and Public Safety at the Colorado Department of Labor and Employment within 24 hours. Under this program, the reportable quantity for petroleum releases is 25 gallons or more, or any amount that causes a sheen on nearby surface water. Spills of less than 25 gallons of petroleum must be immediately contained and cleaned up. If cleanup cannot be accomplished within 24 hours, the Division of Oil and Public Safety must be notified immediately.

Spills of hazardous substances from tanks in excess of the CERCLA or EPCRA reportable quantity must be reported immediately to the National Response Center, CDPHE and the local fire authority, and to the Division of Oil and Public Safety within 24 hours.

### Transportation and Pipelines

The person in physical possession of a hazardous material must notify the National Response Center as soon as practical, but not to exceed 12 hours after the incident, if as a direct result of the hazardous material, a person is killed or injured, there is an evacuation of the general public lasting more than an hour, a major transportation artery is shut down for an hour or more, the flight pattern of an aircraft is altered, there is fire, spillage or suspected contamination

WATER QUALITY  
CONTROL  
DIVISION

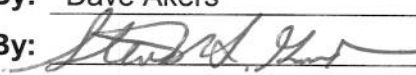
Policy No: WQE-10  
Initiated By: Dave Akers  
Approved By:   
Effective Date: 3/1/08  
Revision No.: \_\_\_\_\_  
Revision Date: \_\_\_\_\_

**Guidance for Reporting Spills under the Colorado Water Quality  
Control Act and Colorado Discharge Permits**

**I. Purpose**

To provide guidance on applicable Colorado reporting requirements pursuant to § 25-8-601(2), C.R.S., that pertains to spills or discharges that may cause pollution of State waters. This guidance does not relieve an entity of any other statutory or regulatory requirements applicable to a spill. Facilities possessing a Colorado Discharge Permit System (CDPS) permit should follow applicable permit terms and conditions regarding spill reporting and response. This guidance is not intended to supersede or modify such permit terms and conditions or the applicable statute and regulations. This guidance does not limit the existing rights or responsibilities of persons with respect to spill reporting. For example, persons retain the right and responsibility to determine in the first instance whether a particular spill is covered by an existing permit or may cause pollution to State waters (i.e., surface or ground waters).

**II. Statutory Requirement Addressed**

Colorado Water Quality Control Act - Spill Reporting Requirements - § 25-8-601(2), C.R.S.

“Any person engaged in any operation or activity which results in a spill or discharge of oil or other substance which may cause pollution of the waters of the state contrary to the provisions of this article as soon as he has knowledge thereof, shall notify the division of such discharge.”

State waters means any and all surface and subsurface waters which are contained in or flow in or through this state, but does not include waters in sewage systems, waters in treatment works of disposal systems, waters in potable water distribution systems, and all water withdrawn for use until use and treatment have been completed (§ 25-8-103 (19), C.R.S.).

Examples of State waters include, but are not limited to, perennial streams, intermittent or ephemeral gulches and arroyos, ponds, lakes, reservoirs, irrigation canals or ditches, wetlands, stormwater conveyances (when they discharge to a surface water), and groundwater.

**III. Policy/Applicability**

The Division distinguishes between reporting requirements for spills that occur with respect to activities that result in a discharge that is authorized under a CDPS permit and those that are not. For non-permitted activities, or in the case of an activity where a permit does not address reporting of or response to a given spill, the Division recommends that the responsible person(s) take the following actions:

1. Immediately report spills that may result in a non-permitted discharge of pollutants to State waters to the Environmental Release and Incident Reporting Line at 1-877-518-5608;
2. Include the following information, if available, when notifying the Division of a spill:
  - a. The name of the responsible person and, if not reported by that person, the name of the person reporting the spill and the name of the responsible person if known;
  - b. An estimate of the date and time that the spill began or the actual date and time, if known;

**WATER QUALITY  
CONTROL  
DIVISION**

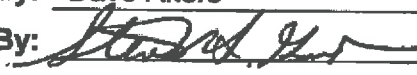
**Policy No:** WQE-10  
**Initiated By:** Dave Akers  
**Approved By:**   
**Effective Date:** 3/1/08  
**Revision No.:** \_\_\_\_\_  
**Revision Date:** \_\_\_\_\_

**Guidance for Reporting Spills under the Colorado Water Quality  
Control Act and Colorado Discharge Permits**

**I. Purpose**

To provide guidance on applicable Colorado reporting requirements pursuant to § 25-8-601(2), C.R.S., that pertains to spills or discharges that may cause pollution of State waters. This guidance does not relieve an entity of any other statutory or regulatory requirements applicable to a spill. Facilities possessing a Colorado Discharge Permit System (CDPS) permit should follow applicable permit terms and conditions regarding spill reporting and response. This guidance is not intended to supersede or modify such permit terms and conditions or the applicable statute and regulations. This guidance does not limit the existing rights or responsibilities of persons with respect to spill reporting. For example, persons retain the right and responsibility to determine in the first instance whether a particular spill is covered by an existing permit or may cause pollution to State waters (i.e., surface or ground waters).

**II. Statutory Requirement Addressed**

Colorado Water Quality Control Act - Spill Reporting Requirements - § 25-8-601(2), C.R.S.

"Any person engaged in any operation or activity which results in a spill or discharge of oil or other substance which may cause pollution of the waters of the state contrary to the provisions of this article as soon as he has knowledge thereof, shall notify the division of such discharge."

State waters means any and all surface and subsurface waters which are contained in or flow in or through this state, but does not include waters in sewage systems, waters in treatment works of disposal systems, waters in potable water distribution systems, and all water withdrawn for use until use and treatment have been completed (§ 25-8-103 (19), C.R.S.).

Examples of State waters include, but are not limited to, perennial streams, intermittent or ephemeral gulches and arroyos, ponds, lakes, reservoirs, irrigation canals or ditches, wetlands, stormwater conveyances (when they discharge to a surface water), and groundwater.

**III. Policy/Applicability**

The Division distinguishes between reporting requirements for spills that occur with respect to activities that result in a discharge that is authorized under a CDPS permit and those that are not. For non-permitted activities, or in the case of an activity where a permit does not address reporting of or response to a given spill, the Division recommends that the responsible person(s) take the following actions:

1. Immediately report spills that may result in a non-permitted discharge of pollutants to State waters to the Environmental Release and Incident Reporting Line at 1-877-518-5608;
2. Include the following information, if available, when notifying the Division of a spill:
  - a. The name of the responsible person and, if not reported by that person, the name of the person reporting the spill and the name of the responsible person if known;
  - b. An estimate of the date and time that the spill began or the actual date and time, if known;

- c. The location of the spill, its source (e.g., manhole, tanker truck), and identification of the type of material spilled (e.g., untreated wastewater, biosolids, specific chemical);
- d. The estimated volume of the spill and, if known, the actual date and time the spill was fully controlled/stopped.
- e. Whether the spill is ongoing and, if it is, the rate of flow and an estimate of the time that the spill will be fully controlled, if known;
- f. Measures that are being or have been taken to contain, reduce, and/or clean up the spill;
- g. A list of any potentially affected area and any known downstream water uses (e.g., public water supplies, irrigation diversions, public use areas such as parks or swim beaches) that will be or have been notified; and
- h. A phone number and e-mail to contact a representative of the responsible person that is in charge of the response. Where a non-responsible person is reporting the spill, they are encouraged, but not required, to provide contact information.

Reporting and management of spills that occur with respect to activities resulting in a discharge authorized under a permit should be performed in accordance with the specific requirements of that permit. If the permit does not provide specific reporting or management response requirements for a given spill that may pollute State waters, the Division recommends that the responsible person report the spill in accordance with the procedures listed above.

This guidance only addresses reporting requirements under the Division's authority. The person or entity engaged in any operation or activity that results in a spill is responsible for any other applicable reporting requirements associated with the spill to other regulatory agencies.

Section 25-8-601(2), C.R.S. only addresses spill reporting to the Division. Section 25-8-202(7), C.R.S. provides certain water quality responsibilities to other state "implementing agencies." The Division's position is that, where a spill to the ground that may impact ground water only is fully and timely reported to an implementing agency having jurisdiction over that spill, the intent of section 601(2) has been fulfilled, and the spill need not also be reported to the Division. The Division suggests that the responsible person confirm with the implementing agency that a spill falls under the jurisdiction of the implementing agency at the time it is reported in order to avoid possible legal liability should it fall under the Division's jurisdiction.

#### **IV. Division Examples of Non-Reportable Spills**

The Division has identified the following examples of types of spills that are considered "non-reportable" under § 25-8-601(2), C.R.S. Documentation of such spills, including the information listed in section III.2.a – III.2.f above, should be maintained by the responsible person for Division review for a period of three years.

1. A spill to a generally impervious surface or structure (e.g., paved street/parking lot, storm sewer, warehouse floor, manhole, vault, concrete basement), or onto soils, that is fully contained in/on the impervious surface/structure or soils, or that is managed in a manner so that it will not reach State waters at the time of the spill or in the future. Such spills that are cleaned up within 24 hours will be considered by the Division to have no potential to reach State waters. However, even if such spills are not cleaned up within 24 hours, the responsible person may be able to "fully contain" or otherwise manage a spill such that it will not reach State waters. Where there is a sump pump present in a basement to which a spill occurred, the responsible person must establish that the pump did not discharge to State waters during the time between the start of the spill and the completion of clean-up in accordance with best management practices.
2. A spill or discharge that is managed consistent with best management practices that are established in accordance with a CDPS discharge permit or any Water Quality Control Commission-adopted control regulation related to spill management or reporting.
3. A spill of potable water from a public water system that does not reach surface waters.



<input checked="" type="checkbox"/> Field Services - Grand Junction 222 South 6th Street, Room 232 Grand Junction, CO 81501 Telephone: 970-248-7150 Fax: 970-248-7198 Contact email: <a href="mailto:michelle.thiebaud@state.co.us">michelle.thiebaud@state.co.us</a>	<input type="checkbox"/> Field Services - Pueblo 140 Central Main, Suite 300 Pueblo, CO 81003 Telephone: 719-295-5060 Fax: 719-543-8441 Contact email: <a href="mailto:carol.keever@state.co.us">carol.keever@state.co.us</a>	<input type="checkbox"/> Field Services - Denver 4300 Cherry Creek Dr. South, B2 Denver, Colorado 80246-1530 Phone: 303-692-3650 Fax: 303-782-0390 Contact email: <a href="mailto:annemarie.goolsby@state.co.us">annemarie.goolsby@state.co.us</a>
---	---	--

**Reporting Form: Incident / Spill / Sanitary Sewer Overflow (SSO)**

The Water Quality Control Division distinguishes between reporting requirements for spills that occur with respect to activities that result in a discharge that is authorized under a CDPS permit and those that are not. Reporting and management of spills that occur with respect to activities resulting in a discharge authorized under a permit should be performed in accordance with the specific requirements of that permit. If the permit does not require a 5-day report, please provide the information below in writing. For non-permitted activities, or in the case of an activity where a permit does not address reporting of or response to a given spill, please submit this written response to the Water Quality Control Division within five (5) working days of the date of the event. If sufficient space is not provided, please attach other sheets. Please send the completed form with signature via fax or email to the Division's Field Services office indicated above. If you have any questions please contact the Division's Field Services Engineer at your earliest convenience. The Field Services County list is available at: <http://www.colorado.gov/cdphe/wqcd> (Contacts, Inspection services contacts, then Field services contacts).

Prior to the five (5) working day deadline, you may request an extension to submit the report if sample analyses justifiably are going to require more time to analyze than the reporting time allows. To request an extension please send an email to the Division's Field Services Engineer for the County that the incident / spill / SSO took place or to the email listed above.

Incident Background Information			
County			
Incident / Spill Number (Division provided) and Spill Date			
Type of Incident / Spill / SSO (check one)	<input type="checkbox"/> Sanitary Sewer Overflow/Reuse	<input type="checkbox"/> Petroleum Product	<input type="checkbox"/> Chemical
	<input type="checkbox"/> WW Treatment Plant Bypass or Upset (through an authorized outfall point)	<input type="checkbox"/> WW Treatment Plant Spill or Overflow (other than outfall)	<input type="checkbox"/> Biosolids
	<input type="checkbox"/> Unplanned potable water release (e.g., water line break)		<input type="checkbox"/> Other
Contact Information			
Potentially Responsible Party (PRP): Contact Name		Potentially Responsible Party (PRP): Company / Agency	
PRP Phone / Fax	Phone: Fax:	PRP email address	
CDPS Permit Number:		CDPS Permittee Name:	
Reported by (if not PRP): Contact Name		Reported by (if not PRP): Company / Agency	
Reported by (if not PRP): Phone / Fax	Phone: Fax:	Reported by (if not PRP): email address	
Incident Information: Please provide the following information.			
A	Incident / spill / SSO source, cause, and event description.		
	Response:		
B	Material released (e.g., untreated wastewater, biosolids, specific chemicals or products) and estimated total quantity (e.g., gallons). Please attach MSDS for any and all chemicals or products involved in spill or release.		
	Response:		
C	Actual or estimated dates and times of the event, including duration and actual date and time spill was fully controlled/stopped. If release is still occurring, the date and time the release is expected to be stopped.		
	Response:		

D	Location of release (e.g., address, lat/long, road name and mile marker).
	Response:
E	Describe measures taken or planned to contain, reduce, and clean up spill or release.
	Response:
F	Steps taken or planned to prevent reoccurrence of the event.
	Response:

**Incident Impact to State Waters (As defined in § 25-8-103(19), C.R.S.).**

*Examples of State waters include: perennial streams, intermittent or ephemeral gulches, ditches, ponds, lakes, reservoirs, irrigation canals, wetlands, stormwater conveyances (when they discharge to surface water), and groundwater.*

G	Did flow or materials reach surface waters of the State? If so, please describe the path of flow to State waters and which State water body was impacted (e.g., spill impacted a storm drain which was directly connected to Cherry Creek, Colorado River, etc.). If yes, what quantity of material (e.g., gallons) reached the surface water and what was the resulting impact?
	Response:
H	Were any water quality samples or other samples taken? If so, please describe sampling process and attached results.
	Response:
I	Did flow or materials reach groundwater of the State? If so, please describe the path of flow to State waters and which State water body impacted (e.g., spill soaked into ground and wet soil was not excavated). If yes, what quantity of material (e.g., gallons) reached the ground or groundwater and what was the resulting impact?
	Response:
J	Did the incident include any of the following (check if yes)? If so, please include additional details below.
	<input type="checkbox"/> Toxic Chemical Release
	<input type="checkbox"/> Fish Kill
Response:	

**Incident Impact to Areas or Water Users**

K	Did the incident / spill / SSO impact any areas (e.g., public use areas including parks or swim beaches) or downstream water users (e.g., public water suppliers, irrigation diversions)? Please list impacted areas and/or users, their location, and potential impacts.
	Response:
L	How were the impacted area users (e.g., park patrons) and downstream water users notified (e.g., signs posted, list downstream users contact via phone).
	Response:

I hereby certify that the information presented above is accurate and complete.

Date	Company	Typed Name and Title	Signature

- c. The location of the spill, its source (e.g., manhole, tanker truck), and identification of the type of material spilled (e.g., untreated wastewater, biosolids, specific chemical);
- d. The estimated volume of the spill and, if known, the actual date and time the spill was fully controlled/stopped.
- e. Whether the spill is ongoing and, if it is, the rate of flow and an estimate of the time that the spill will be fully controlled, if known;
- f. Measures that are being or have been taken to contain, reduce, and/or clean up the spill;
- g. A list of any potentially affected area and any known downstream water uses (e.g., public water supplies, irrigation diversions, public use areas such as parks or swim beaches) that will be or have been notified; and
- h. A phone number and e-mail to contact a representative of the responsible person that is in charge of the response. Where a non-responsible person is reporting the spill, they are encouraged, but not required, to provide contact information.

Reporting and management of spills that occur with respect to activities resulting in a discharge authorized under a permit should be performed in accordance with the specific requirements of that permit. If the permit does not provide specific reporting or management response requirements for a given spill that may pollute State waters, the Division recommends that the responsible person report the spill in accordance with the procedures listed above.

This guidance only addresses reporting requirements under the Division's authority. The person or entity engaged in any operation or activity that results in a spill is responsible for any other applicable reporting requirements associated with the spill to other regulatory agencies.

Section 25-8-601(2), C.R.S. only addresses spill reporting to the Division. Section 25-8-202(7), C.R.S. provides certain water quality responsibilities to other state "implementing agencies." The Division's position is that, where a spill to the ground that may impact ground water only is fully and timely reported to an implementing agency having jurisdiction over that spill, the intent of section 601(2) has been fulfilled, and the spill need not also be reported to the Division. The Division suggests that the responsible person confirm with the implementing agency that a spill falls under the jurisdiction of the implementing agency at the time it is reported in order to avoid possible legal liability should it fall under the Division's jurisdiction.

#### **IV. Division Examples of Non-Reportable Spills**

The Division has identified the following examples of types of spills that are considered "non-reportable" under § 25-8-601(2), C.R.S. Documentation of such spills, including the information listed in section III.2.a – III.2.f above, should be maintained by the responsible person for Division review for a period of three years.

1. A spill to a generally impervious surface or structure (e.g., paved street/parking lot, storm sewer, warehouse floor, manhole, vault, concrete basement), or onto soils, that is fully contained in/on the impervious surface/structure or soils, or that is managed in a manner so that it will not reach State waters at the time of the spill or in the future. Such spills that are cleaned up within 24 hours will be considered by the Division to have no potential to reach State waters. However, even if such spills are not cleaned up within 24 hours, the responsible person may be able to "fully contain" or otherwise manage a spill such that it will not reach State waters. Where there is a sump pump present in a basement to which a spill occurred, the responsible person must establish that the pump did not discharge to State waters during the time between the start of the spill and the completion of clean-up in accordance with best management practices.
2. A spill or discharge that is managed consistent with best management practices that are established in accordance with a CDPS discharge permit or any Water Quality Control Commission-adopted control regulation related to spill management or reporting.
3. A spill of potable water from a public water system that does not reach surface waters.

## BMP CONSTRUCTION DETAILS

Provide inlet protection detail.

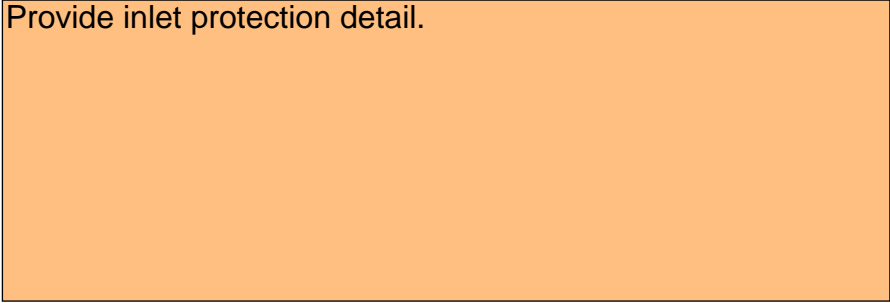

# Vehicle Tracking Control (VTC)

SM-4

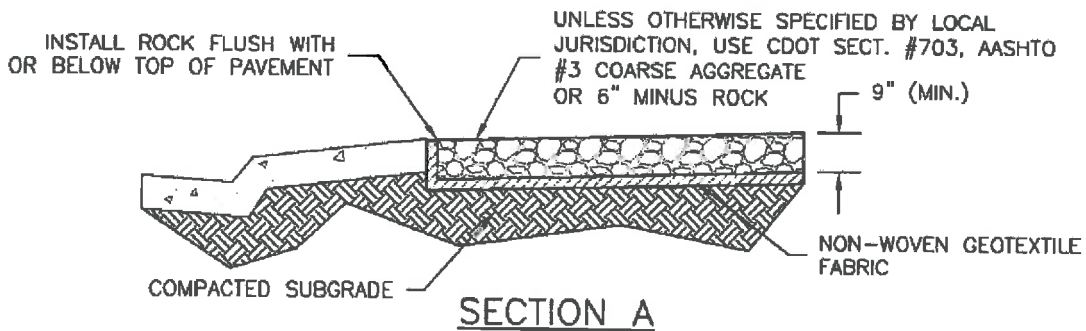
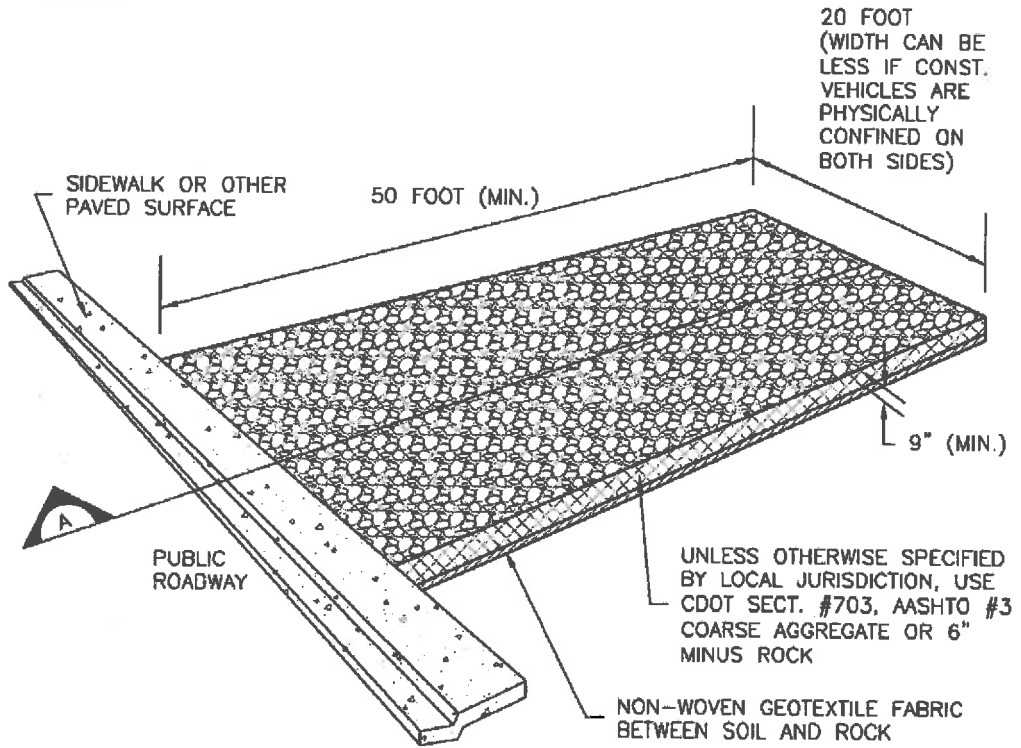
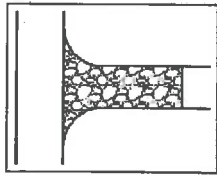

## VTC-1. AGGREGATE VEHICLE TRACKING CONTROL

Provide details of temporary sediment basin, including riser pipe perforation sizing, number of rows, required volume, and tributary area to the sediment basin.

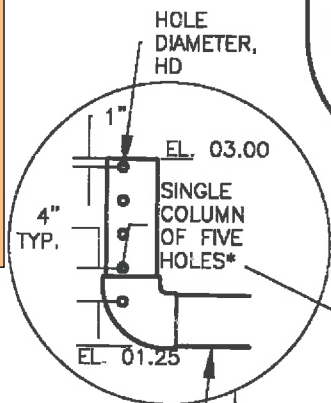
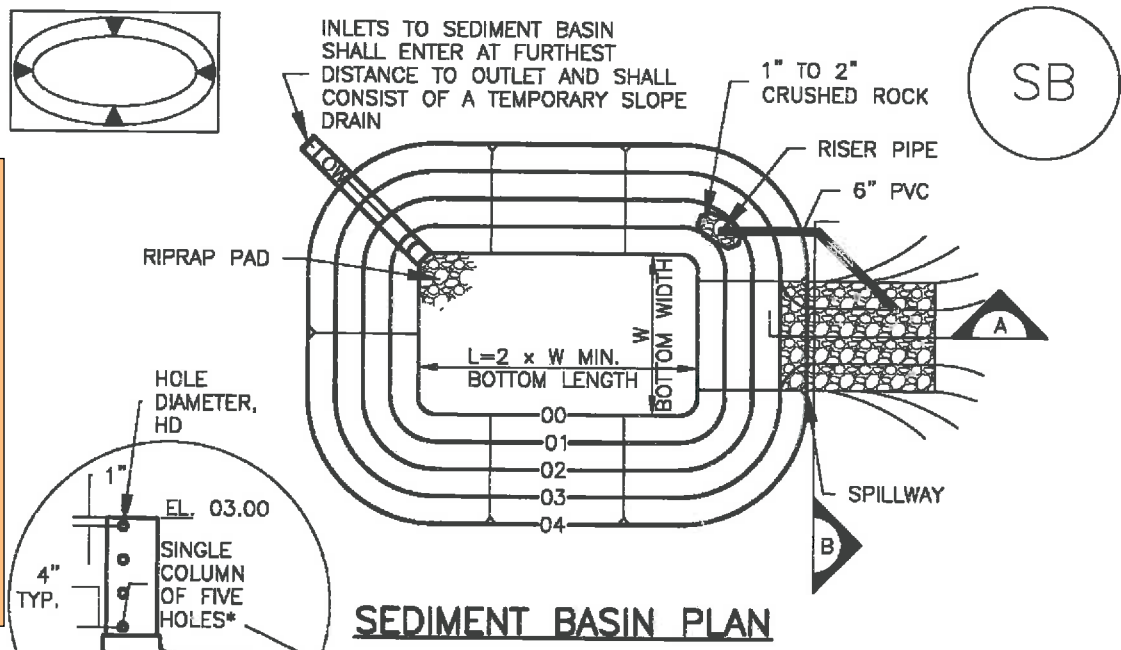

\*EXCEPT WHERE THE HOLES EXCEED 1" DIAMETER, THEN UP TO TWO COLUMNS OF SAME SIZED HOLES MAY BE USED

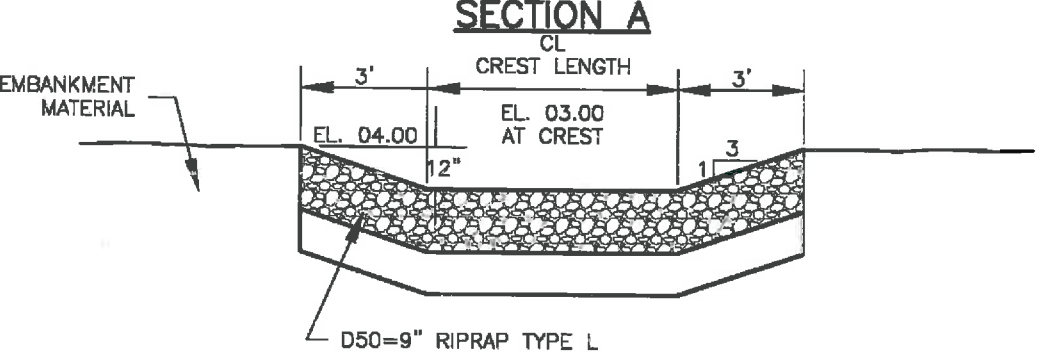
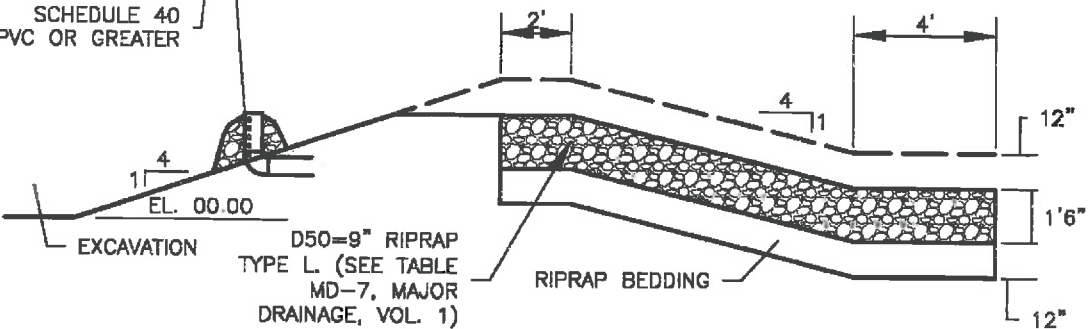

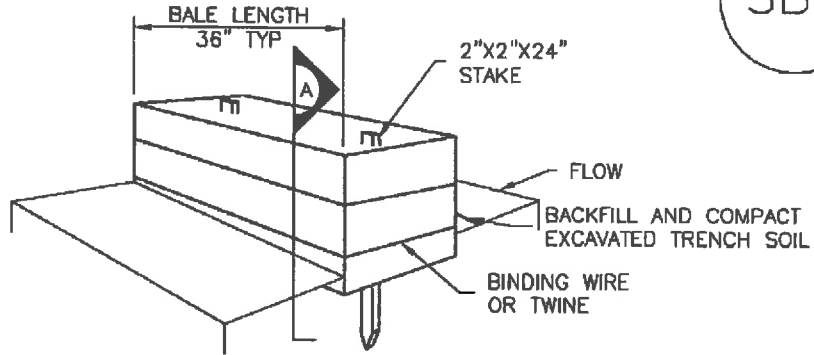
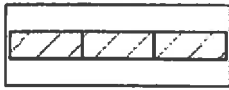

STRAW BALE

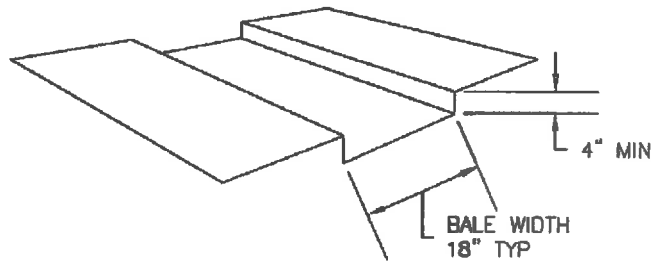

TRENCH FOR STRAW BALE

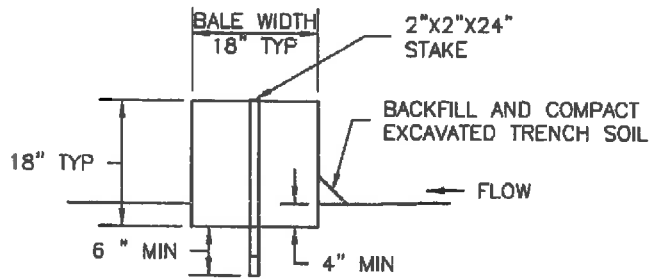

SECTION A

SBB-1. STRAW BALE

B

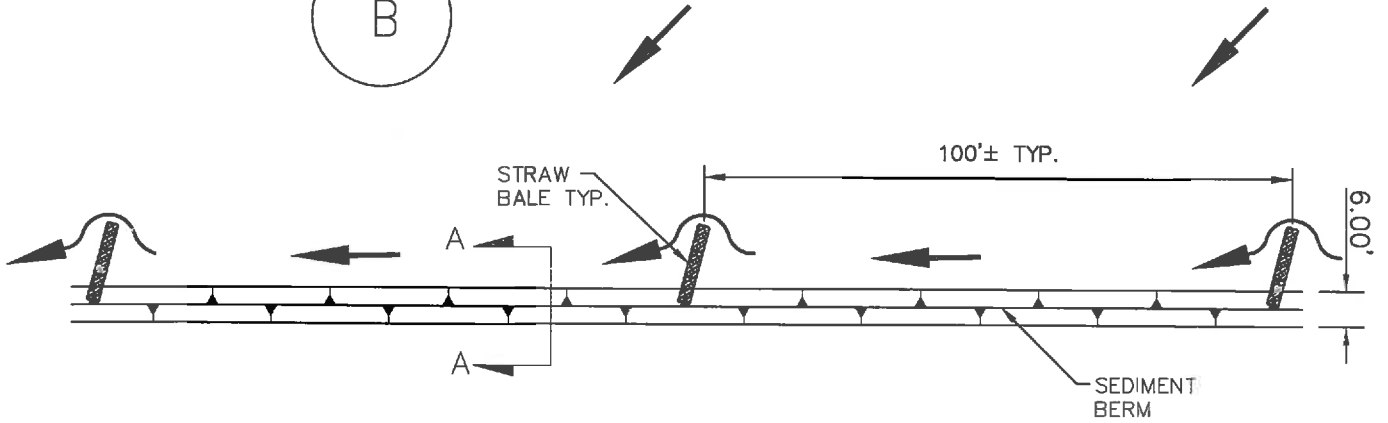

**SEDIMENT BERM**  
NTS

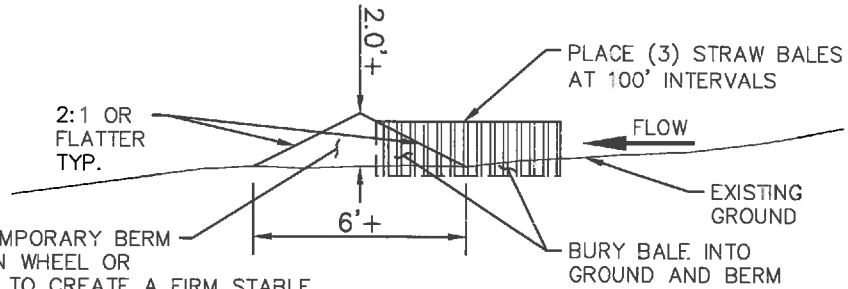

ROLLER COMPACT TEMPORARY BERM USING A COMPACTION WHEEL OR SHEEPSFOOT ROLLER TO CREATE A FIRM STABLE EMBANKMENT. DIMENSIONS SHOWN ARE POST COMPACTION. COMPACTION TESTING IS NOT REQUIRED FOR THIS ITEM.

**SECTION A-A**  
NTS



## SEEDING GUIDELINES:

### SEEDBED PREPARATION

1. THE SEEDBED SHOULD BE WELL-SETTLED AND FIRM, BUT FRIABLE ENOUGH THAT THE SEED CAN BE PLACED AT THE SPECIFIED DEPTHS. COMPETITIVE STANDS OF WEEDS THAT ARE PRESENT BEFORE SEEDING MUST BE CONTROLLED BY SHALLOW TILLAGE OR BY APPLICATION OF HERBICIDES. SOILS THAT HAVE BEEN OVER-COMPACTED BY TRAFFIC OR EQUIPMENT, ESPECIALLY WHEN WET, SHOULD BE TILLED TO BREAK UP ROOTING-RESTRICTIVE LAYERS, THAN HARROWED, ROLLED, OR PACKED TO PREPARE THE REQUIRED FIRM SEEDBED.

### FERTILIZER

2. FERTILIZER SHOULD BE APPLIED AT A RATE OF 50 POUNDS OF AVAILABLE NITROGEN PER ACRE AND 40 POUNDS OF AVAILABLE PHOSPHATE PER ACRE. THE TIMING OF APPLICATION SHOULD BE IMMEDIATELY PRIOR TO SEEDING, AT THE TIME OF SEEDING, OR IMMEDIATELY FOLLOWING SEEDING, DEPENDING ON THE KIND OF FERTILIZER AND TYPE OF EQUIPMENT USED.

### SEEDING

3. SEED SHOULD BE PLANTED WITH A GRASS DRILL ON ALL SLOPES OF 33% (3:1) OR FLATTER. SEED MAY BE BROADCAST BY HAND, BY MECHANICAL SPREADER, OR BY HYDRAULIC EQUIPMENT ON AREAS THAT ARE SMALL, TOO STEEP, OR NOT ACCESSIBLE FOR SEED DRILL OPERATIONS. SEED PLANTED WITH A DRILL SHOULD BE COVERED WITH SOIL TO A DEPTH OF 1/4 TO 3/4 INCH. SEED PLANTED BY THE BROADCAST METHOD SHALL BE INCORPORATED INTO THE SOIL SURFACE, NOT TO EXCEED A DEPTH OF 3/4 INCH, BY RAKING, HARROWING, OR OTHER PROVEN METHOD.

THE TIMING OF SEEDING IS FROM OCTOBER 15TH – MAY 31ST. SEED PLANTED IN THE LATE FALL WILL REMAIN DORMANT UNTIL SPRING, WHEN IT WILL GERMINATE.

### MULCHING

4. SEEDED AREAS SHOULD BE MULCHED TO CONSERVE MOISTURE; PREVENT SURFACE COMPACTION OR CRUSTING; REDUCE RUNOFF AND EROSION; CONTROL INSECTS; AND HELP ESTABLISH PLANT COVER.

NATIVE HAY OR STRAW SHOULD BE APPLIED AT A RATE OF 4,000 POUNDS PER ACRE AND CRIMPED INTO THE GROUND. ON SLOPES GREATER THAN 3:1, AN AGRONOMY BLANKET SHOULD BE USED.

### SUPPLEMENTAL WATER

5. IN LOW RAINFALL AREAS, WHERE WATER IS AVAILABLE AND WHERE RAPID ESTABLISHMENT IS NEEDED, IRRIGATION OF NEW SEEDING SHOULD BE PERFORMED DURING THE FIRST GROWING SEASON. WATER SHOULD BE APPLIED AT APPROXIMATELY ONE WEEK INTERVALS, AT A RATE OF 3/4 TO 1 INCH PER APPLICATION, WHEN RAINFALL IS DEFICIENT FOR PLANT DEVELOPMENT.

## EROSION CONTROL CRITERIA:

EROSION CONTROL MEASURES SHALL BE IMPLEMENTED IN A MANNER THAT WILL PROTECT PROPERTIES AND PUBLIC FACILITIES FROM THE ADVERSE EFFECTS OF EROSION AND SEDIMENTATION AS A RESULT OF CONSTRUCTION AND EARTHWORK ACTIVITIES WITHIN THE PROJECT SITE.

1. PRIOR TO START OF GRADING OPERATIONS, LOCATE AND SET THE SILT FENCE AND VEHICLE TRACKING CONTROL AS SHOWN ON THE EROSION CONTROL PLAN.
2. THE SILT FENCE SHALL BE KEPT IN PLACE AND MAINTAINED UNTIL EROSION AND SEDIMENTATION POTENTIAL IS MITIGATED. REMOVAL OF SILT AND SEDIMENT COLLECTED BY THE SILT FENCES IS REQUIRED ONCE IT REACHES HALF THE HEIGHT OF THE SILT FENCES.
3. EROSION CONTROL DEVICES SHOULD BE CHECKED AFTER EVERY STORM OR NOT MORE THAN EVERY 14 DAYS. REPAIRS OR REPLACEMENT SHOULD BE MADE AS NECESSARY TO MAINTAIN PROPER PROTECTION.

SOIL EROSION CONTROL MEASURES FOR ALL SLOPES, CHANNELS, DITCHES, OR ANY DISTURBED LAND AREA SHALL BE COMPLETED WITHIN TWENTY-ONE (21) CALENDAR DAYS AFTER FINAL GRADING, OR FINAL EARTH DISTURBANCE HAS BEEN COMPLETED. DISTURBED AREAS AND STOCKPILES WHICH ARE NOT AT THE FINAL GRADE BUT WILL REMAIN DORMANT FOR LONGER THAN 30 DAYS SHALL ALSO BE MULCHED WITHIN 21 DAYS AFTER INTERIM GRADING. AN AREA THAT IS GOING TO REMAIN IN AN INTERIM STATE FOR MORE THAN 60 DAYS SHALL ALSO BE SEEDED. ALL TEMPORARY SOIL EROSION CONTROL MEASURES AND BMP'S SHALL BE MAINTAINED UNTIL PERMANENT SOIL EROSION CONTROL MEASURES ARE IMPLEMENTED.

# EROSION PROTECTION & REVEGETATION REQUIREMENTS "PER U.S.D.A. SOIL CONSERVATION SERVICE GUIDELINES"

1. PRACTICE NO. & NAME \_\_\_\_\_ 342 - CRITICAL AREA TREATMENT  
RANGE SITE \_\_\_\_\_ SANDY FOOTHILLS

2. PLANNED:

SEEDED PREP:

A METHOD \_\_\_\_\_  
B DATES \_\_\_\_\_ OCT 15 - MAY 31  
C CLEAN TILLED \_\_\_\_\_ XX  
FIRM SEEDBED \_\_\_\_\_ XX  
STUBBLE COVER \_\_\_\_\_  
INTERSEED \_\_\_\_\_  
OTHER \_\_\_\_\_

SEEDING OPERATION:

A METHOD:  
DRILL \_\_\_\_\_ XX  
INTERSEED \_\_\_\_\_  
BROADCAST \_\_\_\_\_  
B DRILL SPACING \_\_\_\_\_ 6-12"  
TYPE \_\_\_\_\_ GRASS W/AGITATOR  
C DATE \_\_\_\_\_ OCT 15 - MAY 31  
D PLANTING DEPTH \_\_\_1/4 - 1/2"

FERTILIZER:

POUNDS ACTUAL PER  
ACRE N2 \_\_\_\_\_  
(AVAILABLE)  
P205 \_\_\_\_\_  
K \_\_\_\_\_

WEED CONTROL: N/A

MOWING \_\_\_\_\_  
CHEMICAL \_\_\_\_\_  
DATES \_\_\_\_\_

SEE S.C.S. FOR SPECIFIC RECOMMENDATIONS  
AT HERBICIDE APPLICATION TIME.

MULCH:

KIND \_\_\_\_\_ LONG - STEM NATIVE HAY  
AMOUNT \_\_\_\_\_ 4,000 POUNDS/ACRE  
HOW APPLIED \_\_\_\_\_ N/A  
HOW ANCHORED \_\_\_\_\_ CRIMPED  
ANCHORAGE DEPTH \_\_\_\_\_ 4"

SEED:

VARIETY	SPECIES	REQUIRED PLS RATES PER ACRES (100%)		
EL RENO	SIDEOATS GRAMMA	3.0		
BARTON	WESTERN WHEATGRASS	2.5		
NATIVE	SLENDER WHEATGRASS	2.0		
PASTURA	LITTLE BLUESTEM	2.0		
NATIVE	SAND DROPSEED	0.5		
NEBRASKA 28	SWITCH GRASS	3.0		
MORPHA	WEEPING LOVE GRASS	1.0		
(2) % OF SPECIES IN MIXTURE	PLS SEEDING RATE PER SPECIES/ACRE (1) X (2) = (3)	(4) PLANNED ACRE	(5) TOTAL PLS LBS/ (3) X (4)	
21	0.63	72.18	45.5	
18	0.45	72.18	32.5	
14	0.28	72.18	20.2	
14	0.28	72.18	20.2	
4	0.02	72.18	1.4	
21	0.63	72.18	45.5	
7	0.07	72.18	5.1	

## GRADING AND EROSION CONTROL PLANS

# PAINT BRUSH HILLS FILING NO. 14

## COUNTY OF EL PASO, STATE OF COLORADO

# EARLY GRADING/EROSION CONTROL PLANS

JULY 2020

### STANDARD CONSTRUCTION NOTES:

- ALL DRAINAGE AND ROADWAY CONSTRUCTION SHALL MEET THE STANDARDS AND SPECIFICATIONS OF THE CITY OF COLORADO SPRINGS/EL PASO COUNTY DRAINAGE CRITERIA MANUAL VOLUMES 1 AND 2, AND THE EL PASO COUNTY ENGINEERING CRITERIA MANUAL.
- CONTRACTOR SHALL BE RESPONSIBLE FOR THE NOTIFICATION AND FIELD LOCATION OF ALL EXISTING UTILITIES, WHETHER SHOWN ON THE PLANS OR NOT, BEFORE BEGINNING CONSTRUCTION. LOCATION OF EXISTING UTILITIES SHALL BE VERIFIED BY THE CONTRACTOR PRIOR TO CONSTRUCTION. CALL 811 TO CONTACT THE UTILITY NOTIFICATION CENTER OF COLORADO SPRINGS.
- CONTRACTOR SHALL KEEP A COPY OF THESE APPROVED PLANS, THE GRADING AND EROSION CONTROL PLAN, THE STORMWATER MANAGEMENT PLAN (SWMP), THE SOILS AND GEOTECHNICAL REPORT AND THE APPROPRIATE DESIGN AND CONSTRUCTION STANDARDS AND SPECIFICATIONS AT THE JOB SITE AT ALL TIME INCLUDING THE FOLLOWING:
  - EL PASO COUNTY ENGINEERING CRITERIA MANUAL (ECM)
  - CITY OF COLORADO SPRINGS/EL PASO COUNTY ENGINEERING CRITERIA MANUAL, VOLUMES 1 AND 2.
  - COLORADO DEPARTMENT OF TRANSPORTATION (CDOT) STANDARDS SPECIFICATION FOR ROAD AND BRIDGE CONSTRUCTION.
  - CDOT M&S STANDARDS.
- IT IS THE DESIGN ENGINEERS RESPONSIBILITY TO ACCURACY SHOW EXISTING CONDITION BOTH ONSITE AND OFFSITE ON THE CONSTRUCTION PLANS. ANY MODIFICATION NECESSARY DUE TO CONFLICT OMISSIONS OR CHANGED CONDITIONS WILL BE ENTIRELY THE DEVELOPERS RESPONSIBILITY TO RECTIFY.
- ONCE THE ESQCP HAS BEEN ISSUED, THE CONTRACTOR MAY INSTALL THE INITIAL STAGE EROSION AND SEDIMENT CONTROL BMPs AS INDICATED ON THE GEC. A PRECONSTRUCTION MEETING BETWEEN THE CONTRACTOR, ENGINEER, AND EL PASO COUNTY WILL BE HELD PRIOR TO ANY CONSTRUCTION. IT IS THE RESPONSIBILITY OF THE APPLICANT TO COORDINATE THE MEETING TIME AND PLACE WITH COUNTY PCD INSPECTIONS STAFF.
- IT IS THE CONTRACTORS RESPONSIBILITY TO UNDERSTAND THE REQUIREMENTS OF ALL JURISDICTIONAL AGENCIES AND TO OBTAIN ALL REQUIRED PERMITS, INCLUDING BUT NOT LIMITED TO EL PASO COUNTY EROSION AND STORM WATER QUALITY CONTROL PERMIT (ESQCP), US ARMY CORPS OF ENGINEER ISSUED 401 AND/OR 404 PERMITS AND COUNTY AND STATE FUGITIVE DUST PERMITS.
- ALL CONSTRUCTION TRAFFIC MUST ENTER/EXIT THE CONSTRUCTION SITE AT APPROVED CONSTRUCTION ACCESS POINTS.
- ANY TEMPORARY SIGNAGE AND STRIPING SHALL COMPLY WITH EL PASO COUNTY DOW AND MUTCD CRITERIA.
- CONTRACTOR SHALL OBTAIN ANY PERMITS REQUIRE BY EL PASO COUNTY DOT INCLUDING WORK WITHIN THE RIGHT-OF-WAY AND SPECIAL TRANSPORT PERMITS.
- THE LIMITS OF CONSTRUCTION SHALL REMAIN WITHIN THE PROPERTY LINE UNLESS OTHERWISE NOTED. THE OWNER/DEVELOPER SHALL OBTAIN WRITTEN PERMISSION AND EASEMENTS, WHERE REQUIRED, FROM ADJOINING PROPERTY OWNER(S) PRIOR TO ANY OFFSITE DISTURBANCE GRADING, OR CONSTRUCTION.

### GRADING AND EROSION CONTROL NOTES:

- STORMWATER DISCHARGES FROM CONSTRUCTION SITES SHALL NOT CAUSE OR THREATEN TO CAUSE POLLUTION, CONTAMINATION, OR DEGRADATION OF STATE WATERS. ALL WORK AND EARTH DISTURBANCE SHALL BE DONE IN A MANNER THAT MINIMIZES POLLUTION OF ANY ON-SITE OR OFF-SITE WATERS, INCLUDING WETLANDS.
- NOTWITHSTANDING ANYTHING DEPICTED IN THESE PLANS IN WORDS OR GRAPHIC REPRESENTATION, ALL DESIGN AND CONSTRUCTION RELATED TO ROADS, STORM DRAINAGE AND EROSION CONTROL SHALL CONFORM TO THE STANDARDS AND REQUIREMENTS OF THE MOST RECENT VERSION OF THE RELEVANT ADOPTED EL PASO COUNTY STANDARDS, INCLUDING THE LAND DEVELOPMENT CODE, THE ENGINEERING CRITERIA MANUAL, THE DRAINAGE CRITERIA MANUAL, AND THE DRAINAGE CRITERIA MANUAL VOLUME 2. ANY DEVIATIONS FROM REGULATIONS AND STANDARDS MUST BE REQUESTED, AND APPROVED, IN WRITING.
- A SEPARATE STORMWATER MANAGEMENT PLAN (SWMP) FOR THIS PROJECT SHALL BE COMPLETED AND AN EROSION AND STORMWATER QUALITY CONTROL PERMIT (ESQCP) ISSUED PRIOR TO COMMENCING CONSTRUCTION. MANAGEMENT OF THE SWMP DURING CONSTRUCTION IS THE RESPONSIBILITY OF THE DESIGNATED QUALIFIED STORMWATER MANAGER OR CERTIFIED EROSION CONTROL INSPECTOR. THE SWMP SHALL BE LOCATED ON SITE AT ALL TIMES DURING CONSTRUCTION AND SHALL BE KEPT UP TO DATE WITH WORK PROGRESS AND CHANGES IN THE FIELD.
- ONCE THE ESQCP IS APPROVED AND A "NOTICE TO PROCEED" HAS BEEN ISSUED, THE CONTRACTOR MAY INSTALL THE INITIAL STAGE EROSION AND SEDIMENT CONTROL MEASURES AS INDICATED ON THE APPROVED GEC. A PRECONSTRUCTION MEETING BETWEEN THE CONTRACTOR, ENGINEER, AND EL PASO COUNTY WILL BE HELD PRIOR TO ANY CONSTRUCTION. IT IS THE RESPONSIBILITY OF THE APPLICANT TO COORDINATE THE MEETING TIME AND PLACE WITH COUNTY STAFF.
- CONTROL MEASURES MUST BE INSTALLED PRIOR TO COMMENCEMENT OF ACTIVITIES THAT COULD CONTRIBUTE POLLUTANTS TO STORMWATER. CONTROL MEASURES FOR ALL SLOPES, CHANNELS, DITCHES, AND DISTURBED LAND AREAS SHALL BE INSTALLED IMMEDIATELY UPON COMPLETION OF THE DISTURBANCE.
- ALL TEMPORARY SEDIMENT AND EROSION CONTROL MEASURES SHALL BE MAINTAINED AND REMAIN IN EFFECTIVE OPERATING CONDITION UNTIL PERMANENT SOIL EROSION CONTROL MEASURES ARE IMPLEMENTED AND FINAL STABILIZATION IS ESTABLISHED. ALL PERSONS ENGAGED IN LAND DISTURBANCE ACTIVITIES SHALL ASSESS THE ADEQUACY OF CONTROL MEASURES AT THE SITE AND IDENTIFY IF CHANGES TO THOSE CONTROL MEASURES ARE NEEDED TO ENSURE THE CONTINUED EFFECTIVE PERFORMANCE OF THE CONTROL MEASURES. ALL CHANGES TO TEMPORARY SEDIMENT AND EROSION CONTROL MEASURES MUST BE INCORPORATED INTO THE STORMWATER MANAGEMENT PLAN.
- TEMPORARY STABILIZATION SHALL BE IMPLEMENTED ON DISTURBED AREAS AND STOCKPILES WHERE GROUND DISTURBING CONSTRUCTION ACTIVITY HAS PERMANENTLY CEASED OR TEMPORARILY CEASED FOR LONGER THAN 14 DAYS.
- FINAL STABILIZATION MUST BE IMPLEMENTED AT ALL APPLICABLE CONSTRUCTION SITES. FINAL STABILIZATION IS ACHIEVED WHEN ALL GROUND DISTURBING ACTIVITIES ARE COMPLETE AND ALL DISTURBED AREAS EITHER HAVE A UNIFORM VEGETATIVE COVER WITH INDIVIDUAL PLANT DENSITY OF 70 PERCENT OF PRE-DISTURBANCE LEVELS ESTABLISHED OR EQUIVALENT PERMANENT ALTERNATIVE STABILIZATION METHOD IS IMPLEMENTED. ALL TEMPORARY SEDIMENT AND EROSION CONTROL MEASURES SHALL BE REMOVED UPON FINAL STABILIZATION AND BEFORE PERMIT CLOSURE.
- ALL PERMANENT STORMWATER MANAGEMENT FACILITIES SHALL BE INSTALLED AS DESIGNED IN THE APPROVED PLANS. ANY PROPOSED CHANGES THAT EFFECT THE DESIGN OR FUNCTION OF PERMANENT STORMWATER MANAGEMENT STRUCTURES MUST BE APPROVED BY THE ECM ADMINISTRATOR PRIOR TO IMPLEMENTATION.
- EARTH DISTURBANCES SHALL BE CONDUCTED IN SUCH A MANNER SO AS TO EFFECTIVELY MINIMIZE ACCELERATED SOIL EROSION AND RESULTING SEDIMENTATION. ALL DISTURBANCES SHALL BE DESIGNED, CONSTRUCTED, AND COMPLETED SO THAT THE EXPOSED AREA OF ANY DISTURBED LAND SHALL BE LIMITED TO THE SHORTEST PRACTICAL PERIOD OF TIME. PRE-EXISTING VEGETATION SHALL BE PROTECTED AND MAINTAINED WITHIN 50 HORIZONTAL FEET OF A WATERS OF THE STATE UNLESS SHOWN TO BE INFEASIBLE AND SPECIFICALLY REQUESTED AND APPROVED.
- COMPACTION OF SOIL MUST BE PREVENTED IN AREAS DESIGNATED FOR INFILTRATION CONTROL MEASURES OR WHERE FINAL STABILIZATION WILL BE ACHIEVED BY VEGETATIVE COVER. AREAS DESIGNATED FOR INFILTRATION CONTROL MEASURES SHALL ALSO BE PROTECTED FROM SEDIMENTATION DURING CONSTRUCTION UNTIL FINAL STABILIZATION IS ACHIEVED. IF COMPACTION PREVENTION IS NOT FEASIBLE DUE TO SITE CONSTRAINTS, ALL AREAS DESIGNATED FOR INFILTRATION AND VEGETATION CONTROL MEASURES MUST BE LOOSEEN PRIOR TO INSTALLATION OF THE CONTROL MEASURES(S).
- ANY TEMPORARY OR PERMANENT FACILITY DESIGNED AND CONSTRUCTED FOR THE CONVEYANCE OF STORMWATER AROUND, THROUGH, OR FROM THE EARTH DISTURBANCE AREA SHALL BE A STABILIZED CONVEYANCE DESIGNED TO MINIMIZE EROSION AND THE DISCHARGE OF SEDIMENT OFF SITE.
- CONCRETE WASH WATER SHALL BE CONTAINED AND DISPOSED OF IN ACCORDANCE WITH THE SWMP. NO WASH WATER SHALL BE DISCHARGED TO OR ALLOWED TO ENTER STATE WATERS, INCLUDING ANY SURFACE OR SUBSURFACE STORM DRAINAGE SYSTEM OR FACILITIES. CONCRETE WASHOUTS SHALL NOT BE LOCATED IN AN AREA WHERE SHALLOW GROUNDWATER MAY BE PRESENT, OR WITHIN 50 FEET OF A SURFACE WATER BODY, CREEK OR STREAM.
- DURING DEWATERING OPERATIONS OF UNCONTAMINATED GROUND WATER MAY BE DISCHARGED ON SITE, BUT SHALL NOT LEAVE THE SITE IN THE FORM OF SURFACE RUNOFF UNLESS AN APPROVED STABILIZATION PERMIT IS IN PLACE.
- EROSION CONTROL, BLANKETTING OR OTHER PROTECTIVE COVERING SHALL BE USED ON SLOPES STEEPER THAN 3:1.
- CONTRACTOR SHALL BE RESPONSIBLE FOR THE REMOVAL OF ALL WASTES FROM THE CONSTRUCTION SITE FOR DISPOSAL IN ACCORDANCE WITH LOCAL AND STATE REGULATORY REQUIREMENTS. NO CONSTRUCTION DEBRIS, TREE SLASH, BUILDING MATERIAL WASTES OR UNUSED BUILDING MATERIALS SHALL BE BURIED, DUMPED, OR DISCHARGED AT THE SITE.
- WASTE MATERIALS SHALL NOT BE TEMPORARILY PLACED OR STORED IN THE STREET, ALLEY, OR OTHER PUBLIC WAY, UNLESS IN ACCORDANCE WITH AN APPROVED TRAFFIC CONTROL PLAN. CONTROL MEASURES MAY BE REQUIRED BY EL PASO COUNTY ENGINEERING IF DEEMED NECESSARY, BASED ON SPECIFIC CONDITIONS AND CIRCUMSTANCES.
- TRACKING OF SOILS AND CONSTRUCTION DEBRIS OFF-SITE SHALL BE MINIMIZED. MATERIALS TRACKED OFF-SITE SHALL BE CLEANED UP AND PROPERLY DISPOSED OF IMMEDIATELY.
- THE OWNER/DEVELOPER SHALL BE RESPONSIBLE FOR THE REMOVAL OF ALL CONSTRUCTION DEBRIS, DIRT, TRASH, ROCK, SEDIMENT, SOIL, AND SAND THAT MAY ACCUMULATE IN ROADS, STORM DRAINS AND OTHER DRAINAGE CONVEYANCE SYSTEMS AND STORMWATER APPURTENANCES AS A RESULT OF SITE DEVELOPMENT.
- THE QUANTITY OF MATERIALS STORED ON THE PROJECT SITE SHALL BE LIMITED, AS MUCH AS PRACTICAL, TO THAT QUANTITY REQUIRED TO PERFORM THE WORK IN AN ORDERLY SEQUENCE. ALL MATERIALS STORED ON-SITE SHALL BE STORED IN A NEAT, ORDERLY MANNER, IN THEIR ORIGINAL CONTAINERS, WITH ORIGINAL MANUFACTURER'S LABELS.
- NO CHEMICAL(S) HAVING THE POTENTIAL TO BE RELEASED IN STORMWATER ARE TO BE STORED OR USED ONSITE UNLESS PERMISSION FOR THE USE OF SUCH CHEMICAL(S) IS GRANTED IN WRITING BY THE ECM ADMINISTRATOR. IN GRANTING APPROVAL FOR THE USE OF SUCH CHEMICAL(S), SPECIAL CONDITIONS AND MONITORING MAY BE REQUIRED.
- BULK STORAGE OF ALLOWED PETROLEUM PRODUCTS OR OTHER ALLOWED LIQUID CHEMICALS IN EXCESS OF 55 GALLONS SHALL REQUIRE ADEQUATE SECONDARY CONTAINMENT PROTECTION TO CONTAIN ALL SPILLS ONSITE AND TO PREVENT ANY SPILLED MATERIALS FROM ENTERING STATE WATERS, ANY SURFACE OR SUBSURFACE STORM DRAINAGE SYSTEM OR OTHER FACILITIES.
- NO PERSON SHALL CAUSE THE IMPEDIMENT OF STORMWATER FLOW IN THE CURB AND GUTTER OR DITCH EXCEPT WITH APPROVED SEDIMENT CONTROL MEASURES.
- OWNER/DEVELOPER AND THEIR AGENTS SHALL COMPLY WITH THE "COLORADO WATER QUALITY CONTROL ACT" (TITLE 25, ARTICLE 8, (CRS)), AND THE "CLEAN WATER ACT" (33 USC 1344) IN ADDITION TO THE REQUIREMENTS OF THE LAND DEVELOPMENT CODE, DCM VOLUME 1 AND THE ECM APPENDIX I. ALL APPROPRIATE PERMITS MUST BE OBTAINED BY THE CONTRACTOR PRIOR TO CONSTRUCTION (1041, NPDES, FLOODPLAIN, 404, FUGITIVE DUST, ETC.), IN THE EVENT OF CONFLICTS BETWEEN THESE REQUIREMENTS AND OTHER LAWS, RULES, OR REGULATIONS OF OTHER FEDERAL, STATE, LOCAL, OR COUNTY AGENCIES, THE MOST RESTRICTIVE LAWS, RULES, OR REGULATIONS SHALL APPLY.
- ALL CONSTRUCTION TRAFFIC MUST ENTER/EXIT THE SITE ONLY AT APPROVED CONSTRUCTION ACCESS POINTS.
- PRIOR TO CONSTRUCTION THE PERMITTEE SHALL VERIFY THE LOCATION OF EXISTING UTILITIES.
- A WATER SOURCE SHALL BE AVAILABLE ON SITE DURING EARTHWORK OPERATIONS AND SHALL BE UTILIZED AS REQUIRED TO MINIMIZE DUST FROM EARTHWORK EQUIPMENT AND WIND.
- THE SOILS REPORT FOR THIS SITE HAS BEEN PREPARED BY ENTECH ENGINEERING, INC., ENTITLED GEOLOGIC HAZARD/LAND STUDY AND PRELIMINARY SUBSURFACE SOIL INVESTIGATION STERLING RANCH, DATED OCTOBER 31, 2006, AND SHALL BE CONSIDERED A PART OF THESE PLANS.
- AT LEAST TEN (10) DAYS PRIOR TO THE ANTICIPATED START OF CONSTRUCTION, FOR PROJECTS THAT WILL DISTURB ONE (1) ACRE OR MORE, THE OWNER OR OPERATOR OF CONSTRUCTION ACTIVITY SHALL SUBMIT A PERMIT APPLICATION FOR STORMWATER DISCHARGE TO THE COLORADO DEPARTMENT OF PUBLIC HEALTH AND ENVIRONMENT, WATER QUALITY DIVISION. THE APPLICATION CONTAINS CERTIFICATION OF COMPLETION OF A STORMWATER MANAGEMENT PLAN (SWMP), OF WHICH THIS GRADING AND EROSION CONTROL PLAN MAY BE A PART. FOR INFORMATION OR APPLICATION MATERIALS CONTACT:  
COLORADO DEPARTMENT OF PUBLIC HEALTH AND ENVIRONMENT  
WATER QUALITY DIVISION  
WOOD - PERMITS  
4300 CHERRY CREEK DRIVE SOUTH  
DENVER, CO 80246-1530  
ATTN: PERMITS UNIT

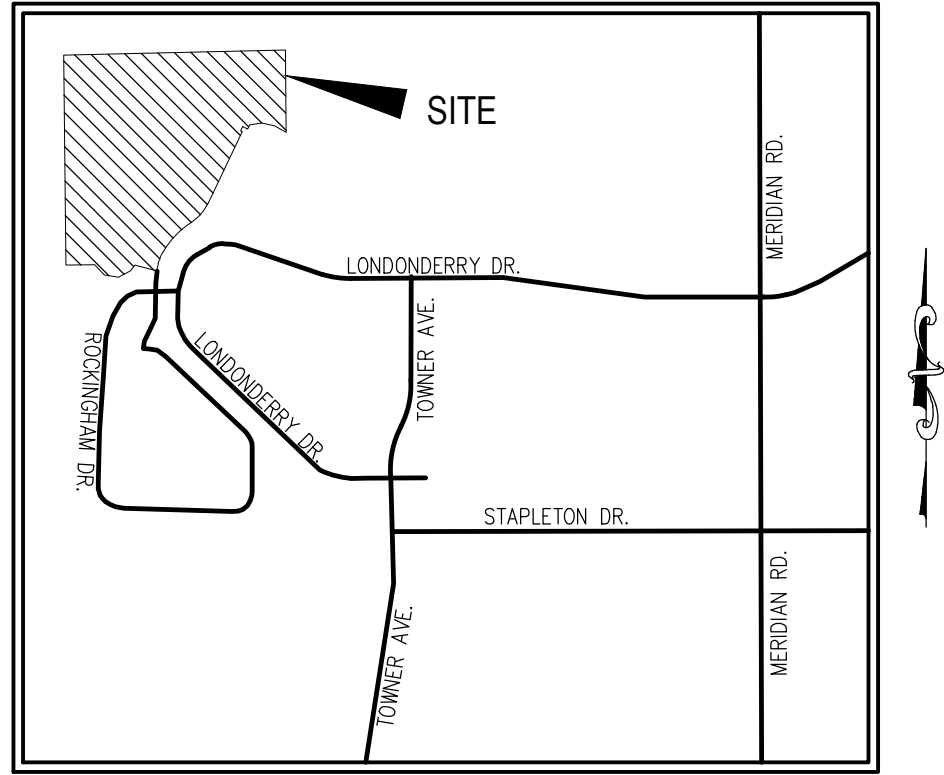

VICINITY MAP  
N.T.S.



SITE MAP  
N.T.S.

### ADDITIONAL NOTES:

STAGING AREA TO BE DETERMINED BY CONTRACTOR IN THE FIELD. THE LOCATIONS SHALL BE DELINEATED ON THIS PLAN BY THE CONTRACTOR.

THE EROSION CONTROL DELINEATED ON THIS PLAN SHALL BE REGULARLY UPDATED BY THE CONTRACTOR.

TEMPORARY SEDIMENT TRAP LOCATIONS WILL BE DETERMINED BY THE CONTRACTOR IN THE FIELD.

EXISTING SITE TERRAIN GENERALLY SLOPES FROM NORTH TO SOUTHWEST AT GRADE RATES THAT VARY BETWEEN 2% TO 6%.

THERE ARE NO BATCH PLANTS ON SITE.

AREAS LEFT OPEN FOR 30 DAYS OR MORE, OTHER THAN FOR UTILITY AND DRAINAGE CONSTRUCTION SHALL BE SEEDED AND/OR MULCHED.

NO PORTION OF THIS PROPERTY IS LOCATED WITHIN A DESIGNATED FEMA FLOODPLAIN IN ACCORDANCE WITH FLOOD INSURANCE RATE MAPS (FIRM) 08041C0535G, EFFECTIVE DATE DECEMBER 7, 2018.

**EXISTING VEGETATION:** THE SITE ORIGINALLY CONSISTED OF PRAIRIE GRASSES AND SHRUBS. NO OTHER NOTABLE VEGETATION EXISTED. THE SITE IS PROPOSED FOR A SINGLE FAMILY SUBDIVISION. IF THE SUBDIVISION IS NOT COMPLETED, THE ENTIRE SITE SHOULD BE RESEEDED PER EPC SPECIFICATIONS. FOR AREAS OUTSIDE OF THE DEVELOPED LOTS, THE GROUND SHOULD BE RESEEDED PER EPC CRITERIA AS SHOWN ON THE GRADING AND EROSION CONTROL PLAN. THE VEGETATION SHOULD BE VISUALLY INSPECTED TO EXCEED THE AMOUNT OF VEGETATION THAT EXISTS IN NON-DISTURBED AREAS AROUND THE SITE.

### AGENCIES

OWNER/DEVELOPER: THE LANDHUIS COMPANY  
212 N. WAHSATCH AVE, SUITE 301  
COLORADO SPRINGS, CO 80903  
JEFF MARK (719) 635-3200

CIVIL ENGINEER: M & S CIVIL CONSULTANTS, INC.  
102 E. PIKES PEAK, SUITE 110  
COLORADO SPRINGS, CO 80903  
VIRGIL A. SANCHEZ P.E. (719) 955-5485

COUNTY ENGINEERING: EL PASO COUNTY PLANNING AND COMMUNITY DEVELOPMENT  
2880 INTERNATIONAL CIRCLE, SUITE 110  
COLORADO SPRINGS, CO 80910  
MR. GILBERT LAFORCE (719) 520-7945

METRO DISTRICT: PAINT BRUSH HILLS METRO DISTRICT  
9830 LIBERTY GROVE DR.  
FALCON, CO 80831  
MR. LEON GOMES (719) 495-8188

TRAFFIC ENGINEERING: EL PASO COUNTY DEPARTMENT OF PUBLIC WORKS  
3275 AKERS DRIVE  
COLORADO SPRINGS, CO 80922  
JENNIFER IRVINE, P.E. (719) 520-6460

FIRE DEPARTMENT: FALCON FIRE PROTECTION DISTRICT  
7030 N. MERIDIAN RD.  
FALCON, CO 80831  
CHIEF HARMIG (719) 495-4050

GAS DEPARTMENT: BLACKHILLS ENERGY  
37 WIDFIELD BOULEVARD  
WIDFIELD, CO 80911  
MR. GEORGE M. PETERSON (719) 392-3491

ELECTRIC DEPARTMENT: MOUNTAIN VIEW ELECTRIC  
11140 E. WOODMEN ROAD  
FALCON, CO 80831  
(719) 495-2283

TELEPHONE COMPANY: CENTURY LINK  
(LOCATORS) 811  
AT&T  
(LOCATORS) 811

### ENGINEER'S STATEMENT:

THIS GRADING AND EROSION CONTROL PLAN WAS PREPARED UNDER MY DIRECTION AND SUPERVISION AND IS CORRECT TO THE BEST OF MY KNOWLEDGE AND BELIEF. SAID PLAN HAS BEEN PREPARED ACCORDING TO THE CRITERIA ESTABLISHED BY THE COUNTY FOR GRADING AND EROSION CONTROL PLANS. I ACCEPT RESPONSIBILITY FOR ANY LIABILITY CAUSED BY NEGLIGENT ACTS, ERRORS OR OMISSIONS ON MY PART IN PREPARING THIS PLAN.

VIRGIL A. SANCHEZ, COLORADO P.E. NO. 37160 \_\_\_\_\_ DATE  
FOR AND ON BEHALF OF M&S CIVIL CONSULTANTS, INC.

### DEVELOPER'S STATEMENT:

THE OWNER WILL COMPLY WITH THE REQUIREMENTS OF THE GRADING AND EROSION CONTROL PLAN.

JEFF MARK, LANDHUIS COMPANY \_\_\_\_\_ DATE  
PRESIDENT

### EL PASO COUNTY:

COUNTY PLAN REVIEW IS PROVIDED ONLY FOR GENERAL CONFORMANCE WITH COUNTY DESIGN CRITERIA. THE COUNTY IS NOT RESPONSIBLE FOR THE ACCURACY AND ADEQUACY OF THE DESIGN, DIMENSIONS, AND/OR ELEVATIONS WHICH SHALL BE CONFIRMED AT THE JOB SITE. THE COUNTY THROUGH THE APPROVAL OF THIS DOCUMENT ASSUMES NO RESPONSIBILITY FOR COMPLETENESS AND/OR ACCURACY OF THIS DOCUMENT.

FILED IN ACCORDANCE WITH THE REQUIREMENTS OF THE EL PASO COUNTY LAND DEVELOPMENT CODE, DRAINAGE CRITERIA MANUAL VOLUMES 1 AND 2, AND ENGINEERING CRITERIA MANUAL AS AMENDED.

IN ACCORDANCE WITH ECM SECTION 1.12, THESE CONSTRUCTION DOCUMENTS WILL BE VALID FOR CONSTRUCTION FOR A PERIOD OF 2 YEARS FROM THE DATE SIGNED BY THE EL PASO COUNTY ENGINEER. IF CONSTRUCTION HAS NOT STARTED WITHIN THOSE 2 YEARS, THE PLANS WILL NEED TO BE RESUBMITTED FOR APPROVAL, INCLUDING PAYMENT OF REVIEW FEES AT THE PLANNING AND COMMUNITY DEVELOPMENT DIRECTOR'S DISCRETION.

JENNIFER IRVINE, P.E. \_\_\_\_\_ DATE  
COUNTY ENGINEER/ECM ADMINISTRATOR

### SHEET INDEX

SHEET 1 TITLE SHEET  
SHEET 2 EARLY GRADING PLAN  
SHEET 3 EARLY GRADING PLAN DETAILS

### BENCHMARKS

- SOUTH 1/4 CORNER OF SECTION 26, TOP OF 2 1/2" ALUMINUM CAP.  
ELEV. = 7140.91  
VERTICAL DATUM = NGVD 1929
- SOUTHWEST CORNER OF SECTION 25, TOP OF 3 1/2" ALUMINUM CAP.  
ELEV. = 7136.34  
VERTICAL DATUM = NGVD 1929

### BASIS OF BEARINGS:

THE SOUTH LINE OF THE SOUTHWEST QUARTER OF SECTION 26, TOWNSHIP 12 SOUTH, RANGE 65 WEST OF THE SIXTH PRINCIPAL MERIDIAN BEING MONUMENTED AT THE EAST BY A 3.25" ALUMINUM CAP STAMPED P.L.S. 12103, PRINCIPAL MERIDIAN AND AT THE WEST END BY A NO. 6 BEAR WITH 2.5" ALUMINUM CAP STAMPED P.L.S. 4842, ASSUMED TO BEAR N89°02'00"W, A DISTANCE OF 2614.11 FEET AS SHOWN ON A LAND SURVEY PLAT BY W. K. CLARK AND ASSOCIATES, DATED AUGUST 13, 1999.

EL PASO COUNTY FILE NO. CDR XX-XXX

PAINT BRUSH HILLS FILING NO. 14  
EARLY GRADING AND EROSION CONTROL PLAN  
PROJECT NO. 10-014 FILE: \\smy\c\06086\c\8187\086\1004-ear\p\pdp\pdp.dwg  
DATE: 06/24/2020  
SCALE: N/A  
DESIGNED BY: JWP  
DRAWN BY: JWP  
CHECKED BY: DLM  
SHEET 1 OF 3  
EGP-1

20 BOLDER CREEK, SUITE 110  
COLORADO SPRINGS, CO 80903  
PHONE: 719.555.5485

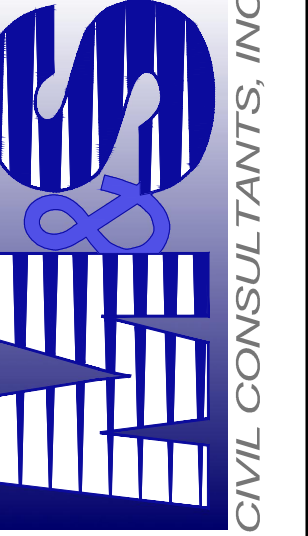

FOR AND ON BEHALF OF M&S CIVIL CONSULTANTS, INC.

VIRGIL A. SANCHEZ, COLORADO P.E. NO. 37160

NO.	DATE	DESCRIPTION

THE ENGINEER PREPARES THESE PLANS AND MUST BE RESPONSIBLE FOR UNAUTHORIZED CHANGES TO OR USES OF THESE PLANS. ALL CHANGES TO THE PLANS MUST BE IN WRITING AND MUST BE APPROVED BY THE PREPARED OF THESE PLANS.

FOR LOCATING & MARKING EXISTING UTILITIES, ELECTRICAL, WATER & TELEPHONE LINES  
FOR BURIED UTILITY INFORMATION  
48 HRS BEFORE YOU DIG  
CALL 1-800-922-1987

\*PAINT BRUSH HILLS FILING NO. 3\*  
BOOK U.3, PAGE 79

FOR LOCATING & MARKING GAS, ELECTRIC, WATER & TELEPHONE LINES  
FOR BURIED UTILITY INFORMATION  
48 HRS BEFORE YOU DIG  
CALL 1-800-922-1987

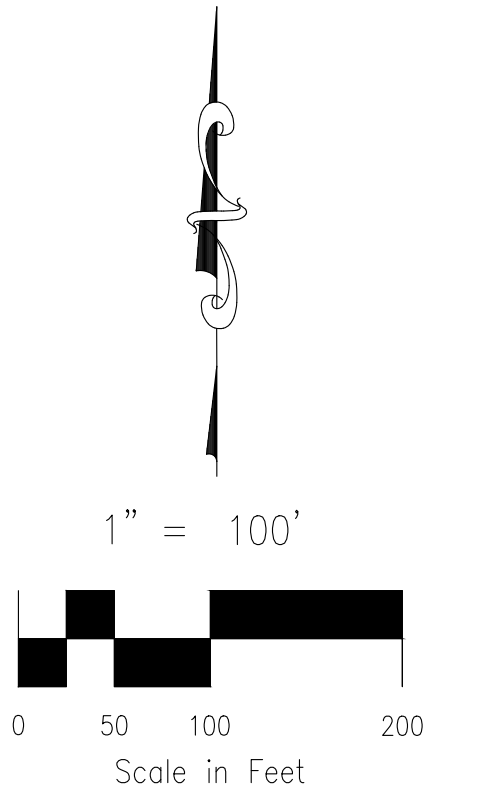

**LEGEND**

- (7260) --- EXISTING MAJOR CONTOUR
- (7262) --- EXISTING MINOR CONTOUR
- 7260 --- PROPOSED MAJOR CONTOUR
- 7262 --- PROPOSED MINOR CONTOUR
- FILING BOUNDARY LINE
- CONST BOUNDARY/LIMITS OF DISTURBANCE
- L.P./H.P. (2.0%) LOW POINT/HIGH POINT
- FLOW DIRECTION & SLOPE
- FLOW DIRECTION ARROW/ EMERGENCY OVERFLOW
- EXISTING FLOW DIRECTION ARROW
- EMERGENCY OVERFLOW DIRECTION
- SBB STRAW BALE DITCH CHECK
- VTC VEHICLE TRACKING CONTROL
- SB#1 TEMPORARY SEDIMENT BASIN
- B EARTH BERM

**ADDITIONAL NOTES:**

STAGING, STORAGE AND STOCKPILE AREAS TO BE DETERMINED BY CONTRACTOR IN THE FIELD. THE LOCATIONS SHALL BE DELINEATED ON THIS PLAN BY THE CONTRACTOR.

THE EROSION CONTROL DELINEATED ON THIS PLAN SHALL BE REGULARLY UPDATED BY THE CONTRACTOR.

ALL TEMPORARY OR PERMANENT GRADING DISTURBANCES SHALL BE RE-SEEDDED AND MULCHED PER EL PASO COUNTY CRITERIA AND SPECIFICATIONS.

PROPOSED SLOPES SHALL BE 3:1 OR LESS.

THE CONTRACTOR SHALL OBTAIN A COPY OF THE GEOTECHNICAL ENGINEERING REPORT AND KEEP A COPY ON SITE DURING ALL EARTHWORK OPERATIONS

NO OFFSITE GRADING IS TO OCCUR.

THE CONTRACTOR SHALL PROTECT ALL AREAS OUTSIDE OF THE CONSTRUCTION LIMITS WITH SILT FENCE OR OTHER METHOD TO PROTECT UNDISTURBED AREAS FROM EROSION.

**SEDIMENT BASIN TABLE**

SEDIMENT BASIN NO.	REQ'D VOLUME C.F.	BASIN WIDTH FT.	BASIN LENGTH FT.	ANTIC WATER FT.	MAX WATER HT FT.	SPILLWAY LENGTH FT.	HOLE DIA. IN.	ROWS OF HOLES IN STANDPIPE
1	7,500	30.0	60.0	4	6	9/16	1	
2	7,500	30.0	60.0	4	6	9/16	1	
3	57,600	74.0	148.0	4	22	1 3/16	1	
4	57,600	74.0	148.0	4	22	1 3/16	1	
5	43,200	64.0	128.0	4	18	1	1	
6	21,600	43.0	86.0	4	9	21/32	1	
7	46,800	68.0	136.0	4	19	1 1/16	1	
8	21,600	43.0	86.0	4	9	21/32	1	

\*UNPLATTED\* TRUSTEE'S DEED RECEPTION NO. 202190199

\*UNPLATTED\* TRUSTEE'S DEED RECEPTION NO. 202190199

\*EXISTING PAINT BRUSH HILLS FILING NO. 12\* REC. NO. 205077511

\*EXISTING PAINT BRUSH HILLS FILING NO. 13D\* REC. NO. 218714078

PAINT BRUSH HILLS FILING NO. 14  
EARLY GRADING AND EROSION CONTROL PLAN  
PROJECT NO. 10-014 FILE: \\ms\c\users\j\j\1014-earlygrading.dwg  
DESIGNED BY: JWP SCALE: DATE: 06/24/2020



FOR AND ON BEHALF OF M&S CIVIL ENGINEERS, INC.

VIRGIL A. SANCHEZ, COLORADO P.E. NO. 37160

APPROV. BY: DATE:

NO.	DATE	BY	DESCRIPTION

**Vehicle Tracking Control (VTC) SM-4**

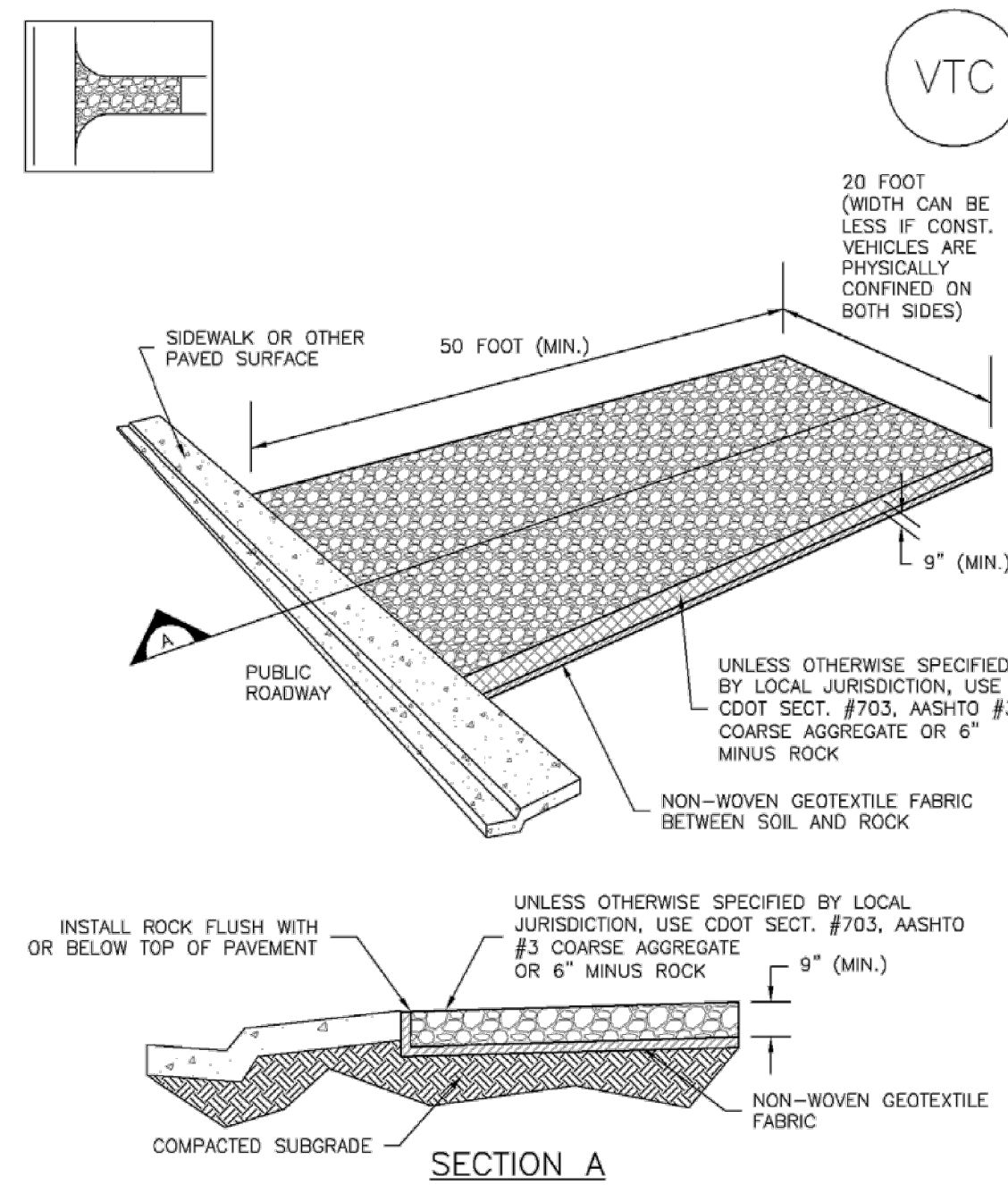

VTC-1. AGGREGATE VEHICLE TRACKING CONTROL

November 2010 Urban Drainage and Flood Control District Urban Storm Drainage Criteria Manual Volume 3 VTC-3

**SC-3 Straw Bale Barrier (SBB)**

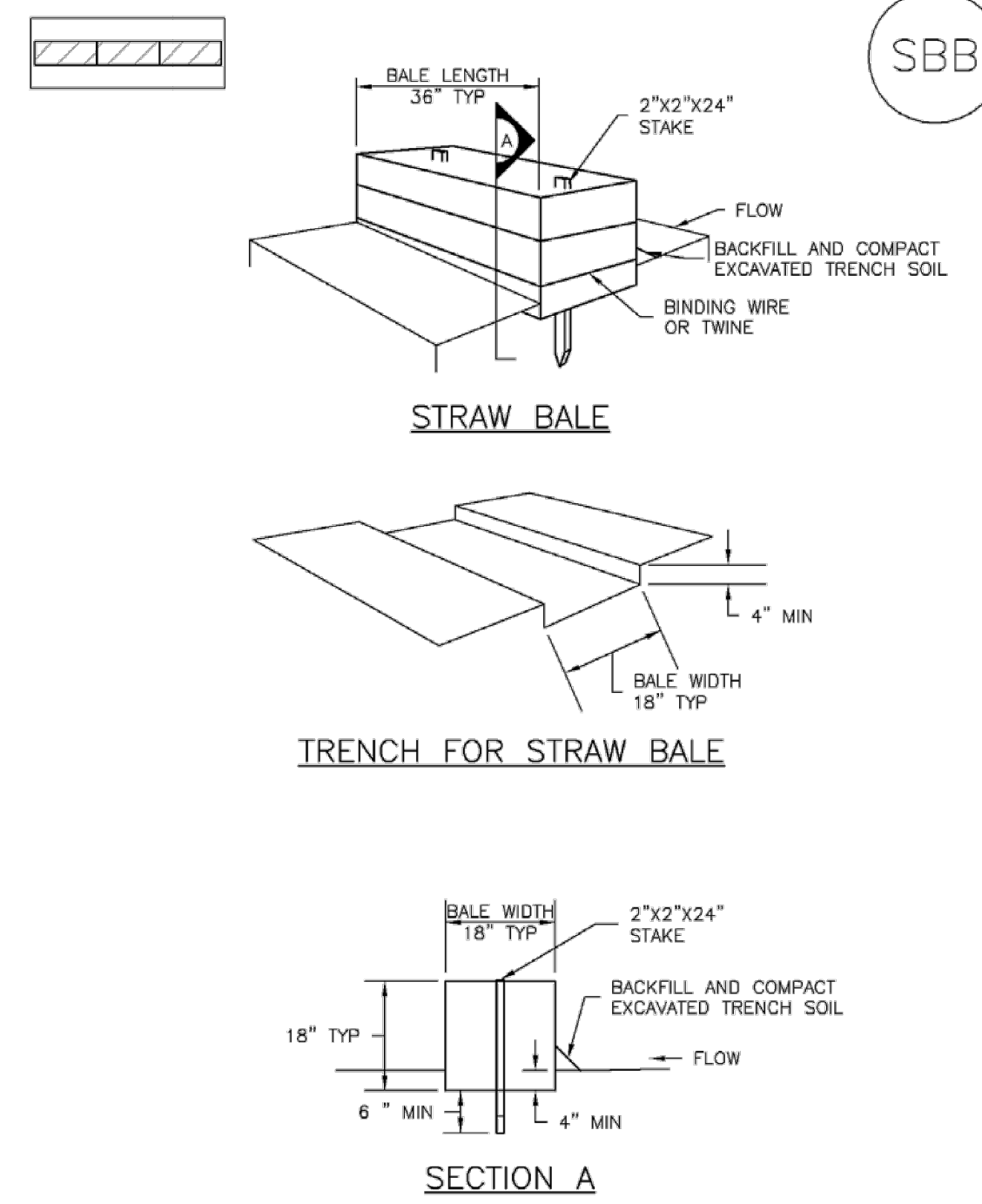

SBB-1. STRAW BALE

SBB-2 Urban Drainage and Flood Control District Urban Storm Drainage Criteria Manual Volume 3 November 2010

**EROSION PROTECTION & REVEGETATION REQUIREMENTS "PER U.S.D.A. SOIL CONSERVATION SERVICE GUIDELINES"**

1. PRACTICE NO. & NAME: 342 - CRITICAL AREA TREATMENT SANDY FOOTHILLS  
RANGE SITE: SANDY FOOTHILLS

2. PLANNED:

<b>SEEDING METHOD:</b>	A. METHOD: DRILL INTERSEED XX
<b>B. DATES:</b>	OCT 15 - MAY 31
<b>C. CLEAN TILLED:</b>	XX
<b>FIRM SEEDBED:</b>	XX
<b>STUBBLE COVER:</b>	6-12"
<b>INTERSEED TYPE:</b>	GRASS W/AGITATOR
<b>OTHER:</b>	OCT 15 - MAY 31
	D. PLANTING DEPTH: 1/4 - 1/2"

<b>FERTILIZER:</b>	<b>WEED CONTROL:</b> N/A
<b>POUNDS ACTUAL PER ACRE N2 (AVAILABLE):</b>	4,000 POUNDS/ACRE
<b>P2O5:</b>	
<b>K:</b>	

<b>MULCH:</b>	<b>LONG - STEM NATIVE HAY</b>
<b>KIND:</b>	4,000 POUNDS/ACRE
<b>AMOUNT:</b>	
<b>HOW APPLIED:</b>	N/A
<b>HOW ANCHORED:</b>	CRIMPED
<b>ANCHORAGE DEPTH:</b>	4"

<b>SEED:</b>	<b>SPECIES</b>	<b>REQUIRED PLS RATES PER ACRE (100%)</b>
EL RENO	SIDEATS GRAMMA	3.0
BARTON	WESTERN WHEATGRASS	2.5
NATIVE	SLENDER WHEATGRASS	2.0
PASTURA	LITTLE BLUESTEM	2.0
NATIVE	SAND DROPSSEED	0.5
NEBRASKA 28	SWITCH GRASS	3.0
MORPHA	WEEPING LOVE GRASS	1.0

(2) % OF SPECIES IN MIXTURE	PLS SEEDING RATE PER SPECIES/ACRE (1) X (2) = (3)	(4) PLANNED ACRE	(5) TOTAL PLS LBS/ (3) X (4)
21	0.63	72.18	45.5
18	0.45	72.18	32.5
14	0.28	72.18	20.2
14	0.28	72.18	20.2
4	0.02	72.18	1.4
21	0.63	72.18	45.5
7	0.07	72.18	5.1

**SEEDING GUIDELINES:**

- SEEDBED PREPARATION:** THE SEEDBED SHOULD BE WELL-SETTLED AND FIRM, BUT FRIABLE ENOUGH THAT THE SEED CAN BE PLACED AT THE SPECIFIED DEPTHS. COMPETITIVE STANDS OF WEEDS THAT ARE PRESENT BEFORE SEEDING MUST BE CONTROLLED BY SHALLOW TILLAGE OR BY APPLICATION OF HERBICIDES. SOILS THAT HAVE BEEN OVER-COMPACTED BY TRAFFIC OR EQUIPMENT, ESPECIALLY WHEN WET, SHOULD BE TILLED TO BREAK UP ROOTING-RESTRICTIVE LAYERS, THAN HARROWED, ROLLED, OR PACKED TO PREPARE THE REQUIRED FIRM SEEDBED.
- FERTILIZER:** FERTILIZER SHOULD BE APPLIED AT A RATE OF 50 POUNDS OF AVAILABLE NITROGEN PER ACRE AND 40 POUNDS OF AVAILABLE PHOSPHATE PER ACRE. THE TIMING OF APPLICATION SHOULD BE IMMEDIATELY PRIOR TO SEEDING, AT THE TIME OF SEEDING, OR IMMEDIATELY FOLLOWING SEEDING, DEPENDING ON THE KIND OF FERTILIZER AND TYPE OF EQUIPMENT USED.
- SEEDING:** SEED SHOULD BE PLANTED WITH A GRASS DRILL ON ALL SLOPES OF 3:3% (3:1) OR FLATTER. SEED MAY BE BROADCAST BY HAND, BY MECHANICAL SPREADER, OR BY HYDRAULIC EQUIPMENT ON AREAS THAT ARE SMALL, TOO STEEP, OR NOT ACCESSIBLE FOR SEED DRILL OPERATIONS. SEED PLANTED WITH A DRILL SHOULD BE COVERED WITH SOIL TO A DEPTH OF 1/4 TO 3/4 INCH. SEED PLANTED BY THE BROADCAST METHOD SHALL BE INCORPORATED INTO THE SOIL SURFACE, NOT TO EXCEED A DEPTH OF 3/4 INCH, BY RAKING, HARROWING, OR OTHER PROVEN METHOD. THE TIMING OF SEEDING IS FROM OCTOBER 15TH - MAY 31ST. SEED PLANTED IN THE LATE FALL WILL REMAIN DORMANT UNTIL SPRING, WHEN IT WILL GERMINATE.
- MULCHING:** SEEDING AREAS SHOULD BE MULCHED TO CONSERVE MOISTURE; PREVENT SURFACE COMPACTION OR CRUSTING; REDUCE RUNOFF AND EROSION; CONTROL INSECTS; AND HELP ESTABLISH PLANT COVER. NATIVE HAY OR STRAW SHOULD BE APPLIED AT A RATE OF 4,000 POUNDS PER ACRE AND CRIMPED INTO THE GROUND. ON SLOPES GREATER THAN 3:1, AN AGRONOMY BLANKET SHOULD BE USED.
- SUPPLEMENTAL WATER:** IN LOW RAINFALL AREAS, WHERE WATER IS AVAILABLE AND WHERE RAPID ESTABLISHMENT IS NEEDED, IRRIGATION OF NEW SEEDING SHOULD BE PERFORMED DURING THE FIRST GROWING SEASON. WATER SHOULD BE APPLIED AT APPROXIMATELY ONE WEEK INTERVALS, AT A RATE OF 3/4 TO 1 INCH PER APPLICATION, WHEN RAINFALL IS DEFICIENT FOR PLANT DEVELOPMENT.

**EROSION CONTROL CRITERIA:**

- EROSION CONTROL MEASURES SHALL BE IMPLEMENTED IN A MANNER THAT WILL PROTECT PROPERTIES AND PUBLIC FACILITIES FROM THE ADVERSE EFFECTS OF EROSION AND SEDIMENTATION AS A RESULT OF CONSTRUCTION AND EARTHWORK ACTIVITIES WITHIN THE PROJECT SITE.
- PRIOR TO START OF GRADING OPERATIONS, LOCATE AND SET THE SILT FENCE AND VEHICLE TRACKING CONTROL AS SHOWN ON THE EROSION CONTROL PLAN.
  - THE SILT FENCE SHALL BE KEPT IN PLACE AND MAINTAINED UNTIL EROSION AND SEDIMENTATION POTENTIAL IS MITIGATED. REMOVAL OF SILT AND SEDIMENT COLLECTED BY THE SILT FENCES IS REQUIRED ONCE IT REACHES HALF THE HEIGHT OF THE SILT FENCES.
  - EROSION CONTROL DEVICES SHOULD BE CHECKED AFTER EVERY STORM OR NOT MORE THAN EVERY 14 DAYS. REPAIRS OR REPLACEMENT SHOULD BE MADE AS NECESSARY TO MAINTAIN PROPER PROTECTION.

SOIL EROSION CONTROL MEASURES FOR ALL SLOPES, CHANNELS, DITCHES, OR ANY DISTURBED LAND AREA SHALL BE COMPLETED WITHIN TWENTY-ONE (21) CALENDAR DAYS AFTER FINAL GRADING, OR FINAL EARTH DISTURBANCE HAS BEEN COMPLETED. DISTURBED AREAS AND STOCKPILES WHICH ARE NOT AT THE FINAL GRADE BUT WILL REMAIN DORMANT FOR LONGER THAN 30 DAYS SHALL ALSO BE MULCHED WITHIN 21 DAYS AFTER INTERM GRADING. AN AREA THAT IS GOING TO REMAIN IN AN INTERM STATE FOR MORE THAN 60 DAYS SHALL ALSO BE SEED. ALL TEMPORARY SOIL EROSION CONTROL MEASURES AND BMP'S SHALL BE MAINTAINED UNTIL PERMANENT SOIL EROSION CONTROL MEASURES ARE IMPLEMENTED.

**NOTE**  
SEE URBAN DRAINAGE CRITERIA MANUAL (VOL. 3) FOR INSTALLATION AND MAINTENANCE (TYP)

**Sediment Basin (SB) SC-7**

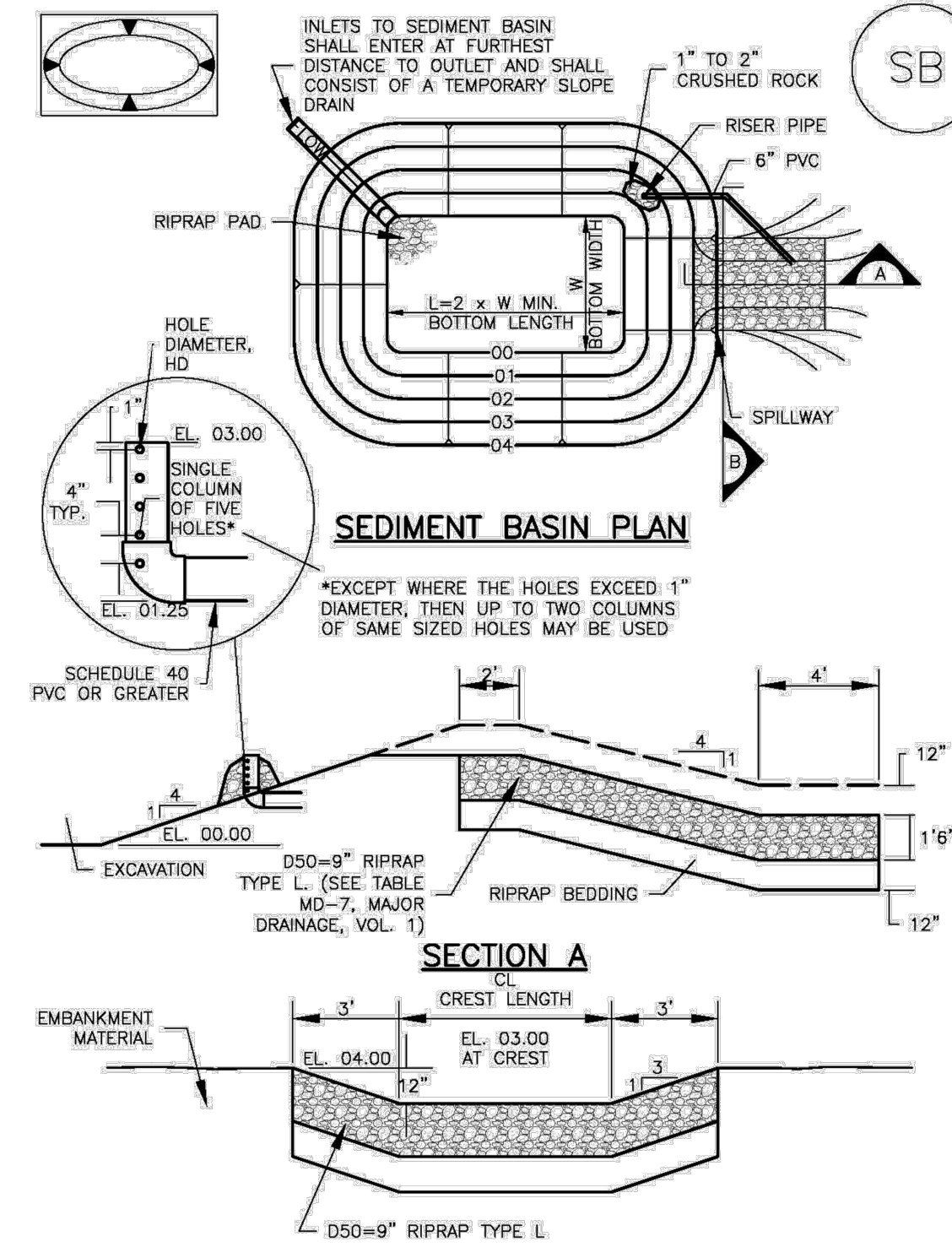

August 2013 Urban Drainage and Flood Control District Urban Storm Drainage Criteria Manual Volume 3 SB-5

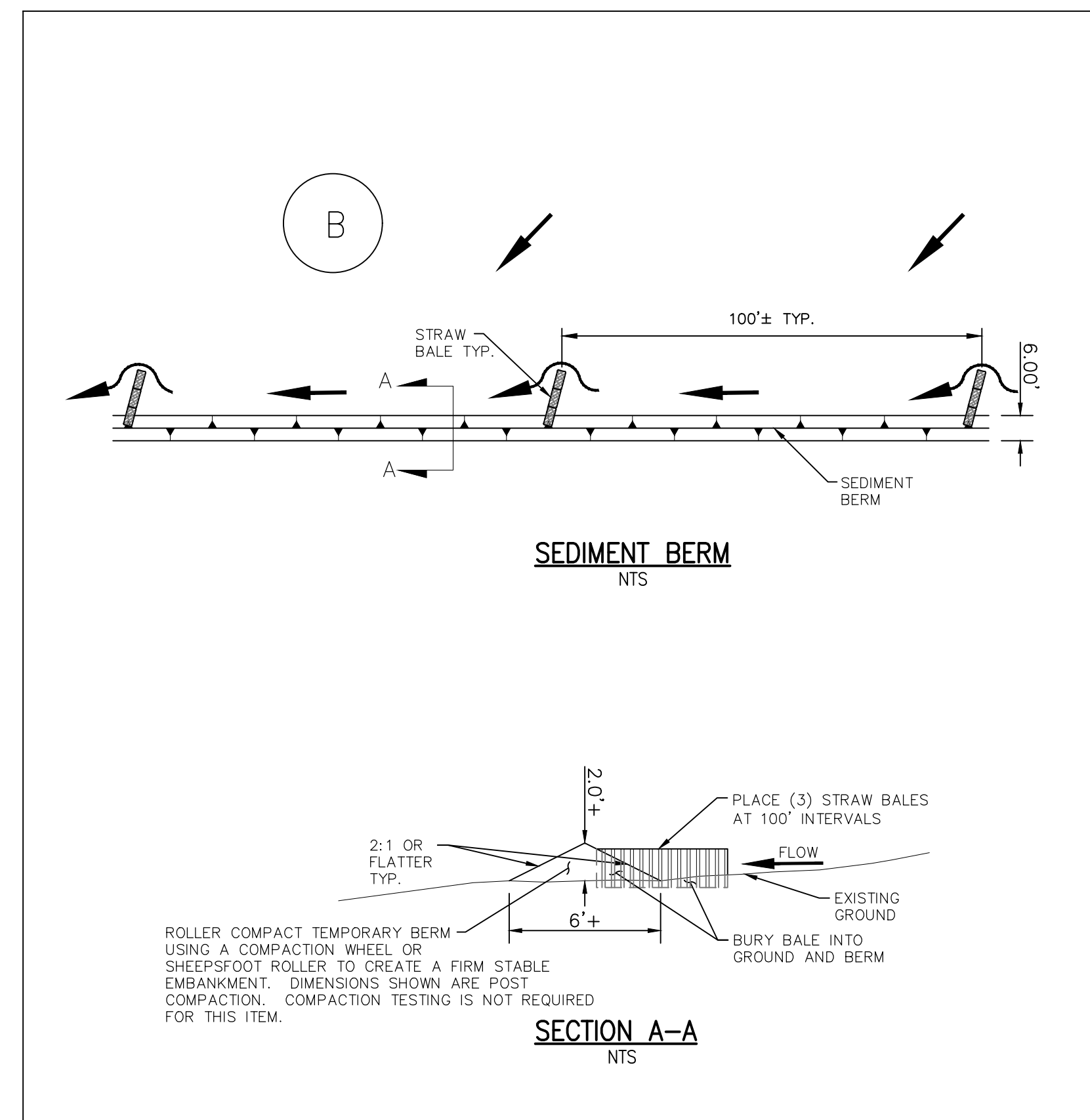

NO.	DATE	BY	DESCRIPTION