

LEGEND

PROPERTY LINE	---
LOT LINE	----
CURB & GUTTER	=====
SIDEWALK	=====
PRO. WATER LINE	—R—
PRO. FIRE HYDRANT	—H—
PRO. RAW WATER	—W—
PRO. SANITARY SEWER	—SS—
PRO. STORM SEWER	—S—
EX. OVERHEAD ELECTRIC	—OE—
EX. SANITARY SEWER	—SS—
EX. GAS	—G—

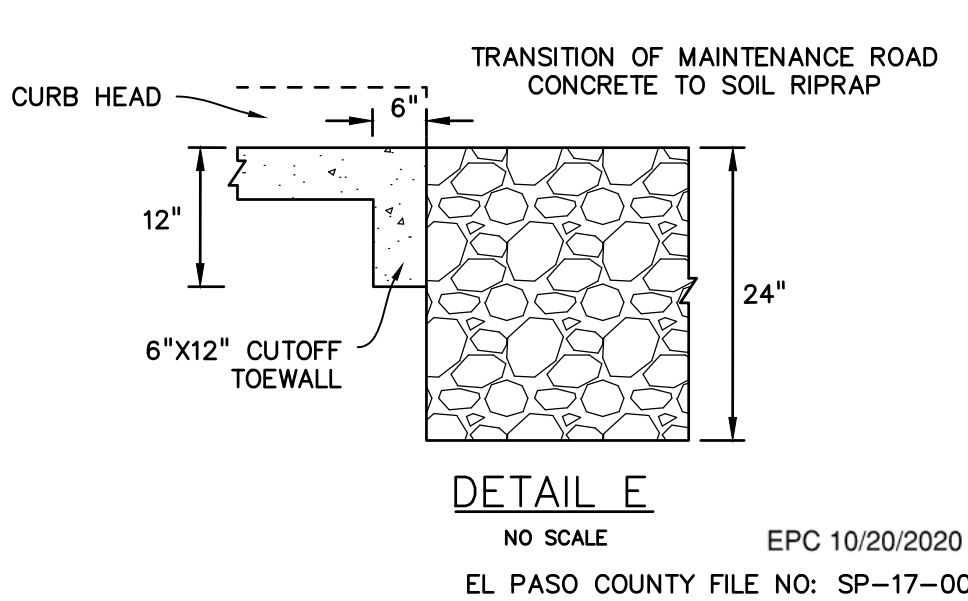
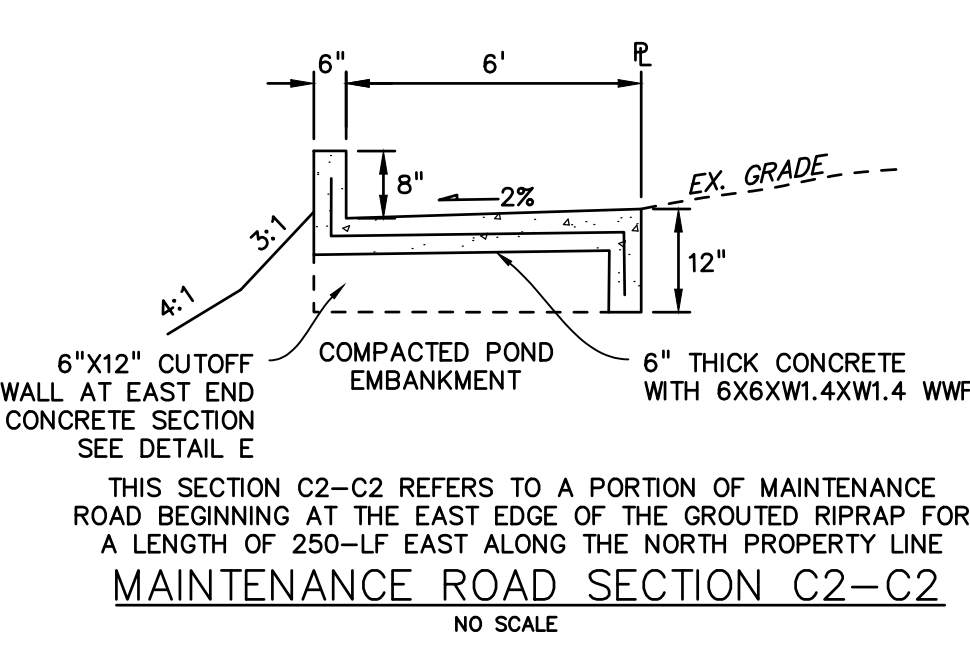
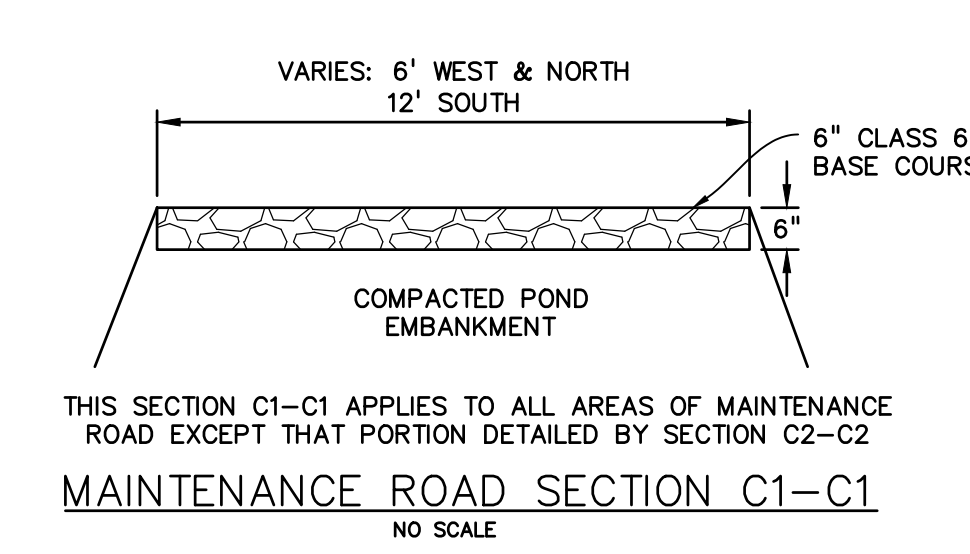
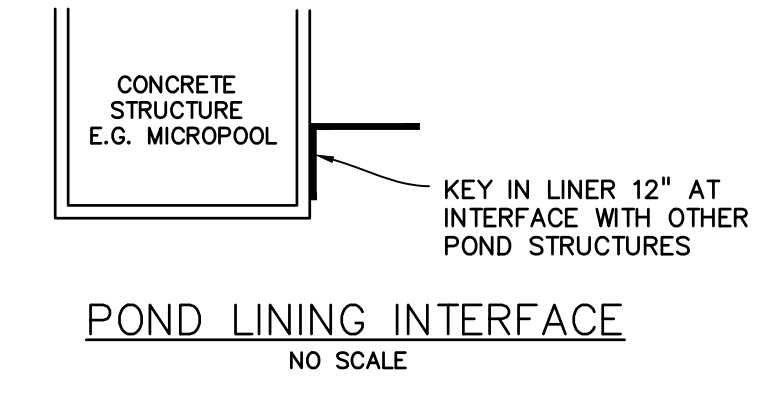
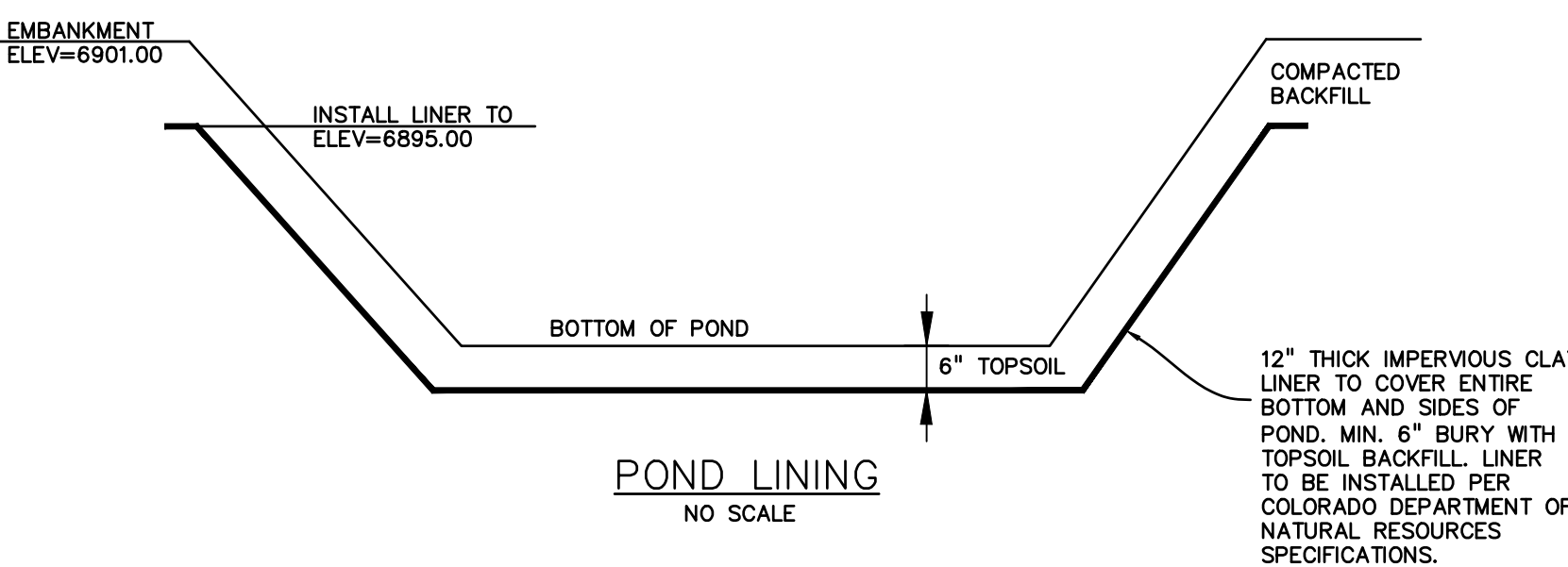

PREPARED BY:

DREXEL, BARRELL & CO.
Engineers-Surveyors
3 SOUTH 7TH STREET
COLORADO SPGS, COLORADO 80905
CONTACT: TIM D. McCONNELL, P.E.
(719)260-0887
BOULDER • COLORADO SPRINGS

CLIENT:
HUMMEL INVESTMENTS, LLC
8117 PRESTON ROAD, SUITE 120
DALLAS, TEXAS 75225
(214) 416-9820

OVERLOT GRADING, POND SR4 & UTILITY
CONSTRUCTION DRAWINGS FOR
**FALCON
MARKETPLACE**
FALCON, COLORADO

ISSUE	DATE
1ST SUBMITTAL	6-20-17
RESUBMITTAL	9-6-18
REVISED	7-24-20

DESIGNED BY: TDM
DRAWN BY: KGV
CHECKED BY: TDM
FILE NAME:



PREPARED UNDER MY DIRECT
SUPERVISION FOR AND ON BEHALF
OF DREXEL, BARRELL & CO.
DRAWING SCALE:
HORIZONTAL: 1"=40'
VERTICAL: N/A

**SUB-REGIONAL
POND #1 (SR4)**
PROJECT NO. 20988-00CSCV
DRAWING NO.

C7.2
SHEET: 9 OF 12