

**PRELIMINARY/FINAL
DRAINAGE REPORT**

FOR

SOUTH ACADEMY BUSINESS CENTER

**Prepared For:
#9 Properties
3325 Clubview Tr
Colorado Springs, CO 80906**

**Prepared By:
Associated Design Professionals, Inc.
3520 Austin Bluffs Parkway, Suite 102
Colorado Springs, CO 80918
(719) 266-5212
Project No. 161103
March, 2021
PCD Project No 17-004**





ENGINEER'S STATEMENT:

The attached drainage plan and report were prepared under my direction and supervision and are correct to the best of my knowledge and belief. Said drainage report has been prepared according to the criteria established by the city/county for drainage reports, and said report is in conformity with the master plan of the drainage basin. I accept responsibility for any liability caused by any negligent acts, errors or omissions on my part in preparing this report.

Michael A. Bartusek, P.E. #23329



DEVELOPER'S STATEMENT:

I, the Developer, have read and will comply with all of the requirements specified in this drainage report and plan.

By:
Mr. Barry Helton

Title: Manager

Address: #9 Properties
3325 Clubview Tr
Colorado Springs, CO 80937

EL PASO COUNTY:

Filed in accordance with the El Paso County Land Development Code; the Drainage Criteria Manual, Volumes 1 and 2; and the Engineering Criteria Manual, as amended.

Jennifer Irvine, P.E., County Engineer
ECM Administrator
Conditions:

APPROVED
Engineering Department
03/15/2021 12:27:21 PM

EPC Planning & Community
Development Department



PROJECT DESCRIPTION

This proposed project is contained within a new subdivision named the South Academy Business Center. This currently vacant lot consists of 7.60 acres. It is located in the Southeast Quarter of Section 3, Township 15 South, Range 66 West of the Sixth Principal Meridian, County of El Paso, State of Colorado. The site is located on a narrow strip of land which is bordered on the west by State Highway 85/87 and on the east by the Denver and Rio Grande Western Railroad. Its northern boundary is situated on the south boundary line of the South Academy Boulevard right-of-way.

FLOODPLAIN STATEMENT

This site does not lie within a designated 100-year floodplain as delineated on 08-0318G, dated December 7, 2018. It is located within the West Little Johnson drainage basin. The drainage basin map shows a split in the property between the Little Johnson and West Little Johnson Basins. However, field verification revealed that all of the property was located within the West Little Johnson Basin.

SOILS

The soils on the northern site are classified as Blakeland loamy sand by the USDA Soil Conservation Service. This soil is further classified as Hydrologic Soil Group "A". The soils on the proposed site are classified as Nunn clay loam by the USDA Soil Conservation Service. This soil is further classified as Hydrologic Soil Group "C".

METHOD OF COMPUTATION

The methodology utilized for this report is in accordance with *City/County Drainage Criteria Manual*. The Rational Method for computation of runoff was used for determining on-site flows.

$Q = c ia$

Where

- Q = maximum rate of runoff in cubic feet per second
- c = runoff coefficient representing drainage area characteristics
- i = average rainfall intensity, in inches per hour, for the duration required for the runoff to become established
- a = drainage basin size in acres

Off-site flows were determined using the TR20 hydrologic program for project hydrology by the Soil Conservation Service.

EXISTING DRAINAGE CHARACTERISTICS

This project is located along the north side of State Highway 85/87 just south of the Academy Blvd. crossing. The area is covered with Rangeland grasses with a slope of approximately 0.7%. The drainage flows in an easterly direction with on-site flows traveling south within a broad grassed swale and large part of the off-site flows traveling south within a swale located within the railroad Right-of-Way. This previously unplatted site was included in the *Little Johnson/West Little Johnson Drainage Basin Planning Study* prepared by Simons, Li & Associates in 1987.

Sub-basin OS1 contains 46.9 acres and is located north of the site much of the land lies north of the proposed project lies within either the Rocky Mountain Materials property or the Stephen



Schnurr Living Trust. Flows from these properties are released at historic levels onto the site to its south. This vacant land is just north of the proposed project and is covered with rangeland grasses. The tributary area slopes generally southwest at an average slope of 0.7 percent.

According to the analysis performed by Simons, Li & Associates, the runoff produced by Sub-basin OS1 would result in no flow for the ten-year storm event and 1.0 cfs for the 100-year storm event. The low runoff amounts were due to the Type "A" soils and the long overland flow times. Using the Rational Method the off-site area produced the following flow of 3.7 cfs for the five-year storm and 28.0 cfs for the 100-year storm. These off-site flows travel to the southeast and flow onto the parcel.

An analysis of the South Academy Business Center site using the Rational Method produced the following flow rates: Sub-Basin Aex, which drains toward the interior of the parcel and produces 1.6 cfs for the five-year storm and 9.2 cfs for the 100-year storm. The flows from Sub-basin Aex combine with the flows from OS1 at DP1 to produce total flows on through the site of 4.6 cfs for the five-year storm and 33.4 cfs for the 100-year storm.

Sub-Basin Bex, which drains a portion of the property which currently flows into the ditch along SH 85/87 produces a flow of 0.4 cfs for the five-year storm and 2.1 cfs for the 100-year storm.

Sub-Basin OS2, which drains to a ditch along SH 85/87 produces a flow of 1.6 cfs for the five-year storm and 3.9 cfs for the 100-year storm. The flows from Sub-basin Bex combine with the flows from OS2 at DP2 to produce total flows on through the site of 1.7 cfs for the five-year storm and 5.2 cfs for the 100-year storm.

DEVELOPED DRAINAGE CHARACTERISTICS

The proposed development of 7.6 acres will be a storage facility comprised of 8' x 40' and 8'x20' containers placed on the site with loose gravel placed over the site.

Runoff from Sub-Basin OS1 which contains 46.9 acres is located northwest of the site and produces historic flows of 3.7 cfs for the five-year storm and 28.0 cfs for the 100-year storm. These flows are drained through the berm and under a trailer which will be raised 12" above the ground. The flows will continue through the site and combines with the flows from Sub-Basin A. These flows continue through the site to the detention basin and continue flowing south.

Runoff from Sub-Basin A which contains 7.6 acres will be directed in a southeasterly direction toward the south property line. Based on the proposed developed conditions, Sub-Basin A will produce flows of 3.9 cfs for the five-year storm and 13.7 cfs for the 100-year storm. The combined flows into the detention basin will be 3.9 cfs for the five-year storm and 13.7 cfs for the 100-year storm. The detained flows from the Water Quality/Detention Basin will be 0.2 cfs for the five-year storm and 10.7 cfs for the 100-year storm. These detained flows will be directed into an existing grass swale just east of the basin. The existing broad, grassed swale continues flowing to the east at a 0.7% slope with 10:1 side slopes. The 100 year outflow will produce a flow depth of 0.6 ft and a velocity of 1.5 fps.



Runoff from Sub-Basin OS2 which contains 1.37 acres is located northwest of the site and produces historic flows of 1.6 cfs for the five-year storm and 3.9 cfs for the 100-year storm. These flows drain into the existing ditch along Hwy 85/87 and were used to size the approved culvert under the access road for CDOT.

No flows from this property or the property north of our site along Hwy 85/87 are being directed onto the railroad property east of our site.

WATER QUALITY/DETENTION REQUIREMENTS

In accordance with current NPDES, stormwater quality BMPs will be provided for this site when it is developed. Based on actual calculations, the commercial development combined with the historic imperviousness from the upstream property will produce an imperviousness of 4.5 percent. The water quality component is accomplished by a 2.74' deep 0.898 acre foot private extended detention facility located at the south end of the project. The facility will be maintained by the owner

DRAINAGE BASIN FEE

The proposed development is located within the West Little Johnson drainage basin. The 2017 drainage basin fee calculation is as follows:

Impervious Coverage	=	41.37%
Area Subject to Fee	=	0.4137 x 7.6 acres = 3.144 acre
West Little Johnson Basin Fee	=	\$1,072/acre
Drainage Basin Fee	=	\$1,072 x 3.144 = \$3,370

There are no associated Bridge Fees for the West Little Johnson drainage basin. These fees were paid at the time of platting.

PRIVATE DRAINAGE FACILITIES

Item	Unit	Quantity	Unit Cost	Total Cost
18" RCP FES	EA	1	\$500	\$ 600
18" HDPE	LF	15	\$84	\$ 1,260
Detention Outlet Structure	EA	1	\$3,000	\$ 5,000
Emergency Spillway	EA	1	\$1,000	\$ 1,500
			Sub-Total	\$8,360
			15% Contingency & Engineering	\$ 1,254
			TOTAL	\$9,614

CONCLUSION

Storm runoff from this property will not adversely affect downstream properties or facilities. Grading will take place on the property; therefore, appropriate erosion control measures will be



implemented to will include a water quality basin. An on-site detention basin will be incorporated into the parcel to reduce developed flows to historic levels.

Step 1: Runoff has been reduced by disconnecting impervious areas where possible, eliminating "unnecessary" impervious areas and encouraging infiltration into suitable soils.

Step 2: All drainageways, ditches and channels have been stabilized by the following methods:

- New swales within the site are broad and covered with gravel and with a slope of about 0.7% no erosion will take place
- An existing roadside ditch will be enhanced as part of the proposed development.

Step 3: The proposed development will disturb approximately 7.6 acres.

Step 4: The development of this project will not affect sensitive waters.

The development of this site will have little impact on downstream properties once the water quality/detention basin is constructed.

REFERENCES

1. City of Colorado Springs and El Paso County (1994). *Drainage Criteria Manual Volume 1* (DCM).
2. City of Colorado Springs and El Paso County (1994). *Drainage Criteria Manual Volume II* (DCM).
3. Soil Survey of El Paso County Area, Colorado by USDA, NRCS.
4. *El Paso County (January 2006) Engineering Criteria Manual*.
5. Urban Drainage and Flood Control District (June 2011). *Urban Storm Drainage Criteria Manual, Volume 1-3*.
6. Little Johnson/west Little Johnson Drainage Basin Planning Study prepared by Simons, Li Associates (1987)



APPENDIX A MAPS & EXHIBITS

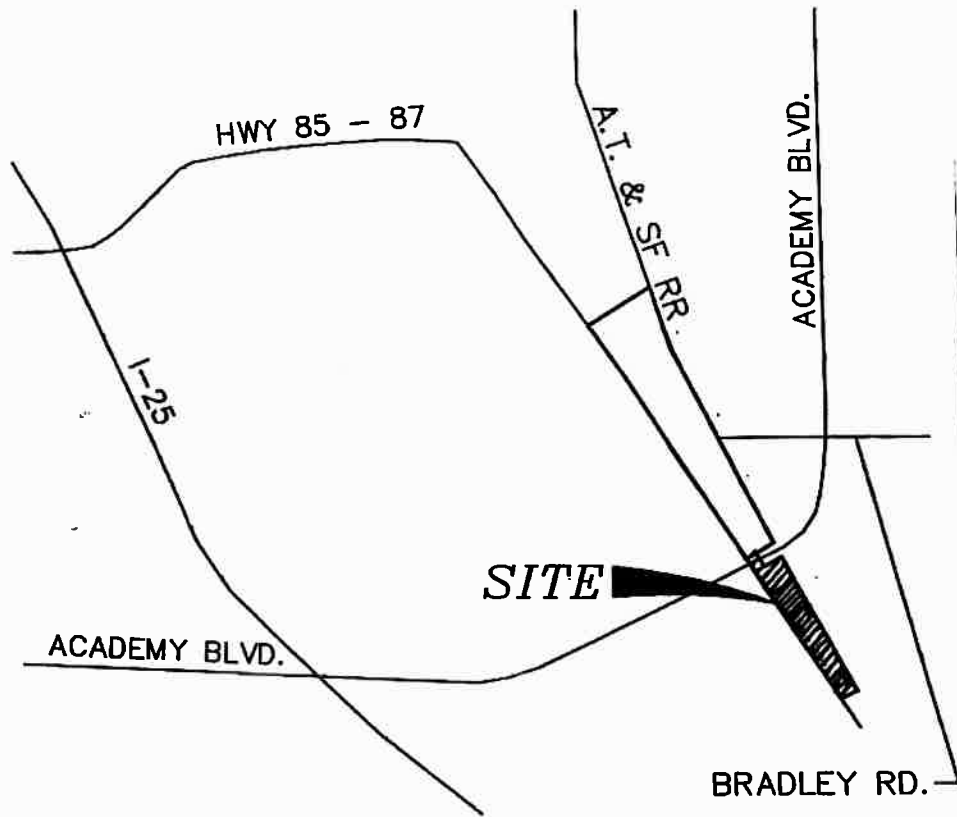

VICINITY MAP

N.T.S.

ADP CIVIL
ENGINEERING FOR THE FUTURE

3520 Austin Bluffs Pkwy, Suite 102
Colorado Springs, CO 80918
(719) 266-5212
fax: (719) 266-5341

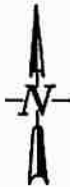

SOILS MAP

N.T.S.

ADPCIVIL
ENGINEERING FOR THE FUTURE

3520 Austin Bluffs Pkwy, Suite 102
Colorado Springs, CO 80918
(719) 266-5212
fax: (719) 266-5341

National Flood Hazard Layer FIRMette



38°46'12.94"N
104°45'49.54"W

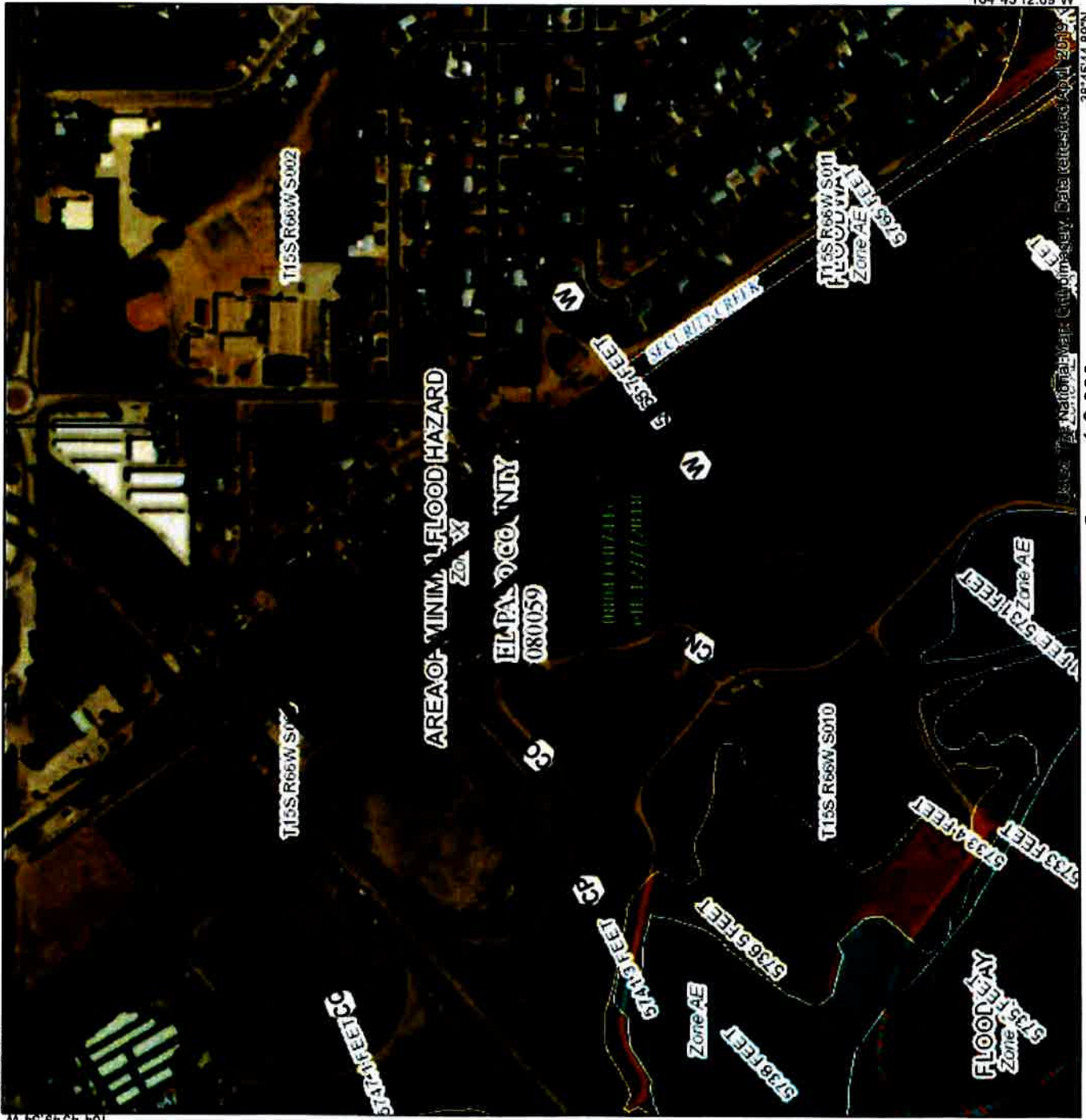

Legend

SEE FIS REPORT FOR DETAILED LEGEND AND INDEX MAP FOR FIRM PANEL LAYOUT

SPECIAL FLOOD HAZARD AREAS

- Without Base Flood Elevation (BFE) Zone A, V, AH
- With BFE or Depth Zone AE, AO, AV, AR
- Regulatory Floodway

0.2% Annual Chance Flood Hazard. Areas of 1% annual chance flood with average depth less than one foot or with drainage areas of less than one square mile Zone X

Future Conditions 1% Annual Chance Flood Hazard Zone X

Area with Reduced Flood Risk due to Levee. See Notes. Zone X

Area with Flood Risk due to Levee Zone D

Area of Minimal Flood Hazard Zone X

Effective LOMRs

Area of Undetermined Flood Hazard Zone D

Channel, Culvert, or Storm Sewer Levee, Dike, or Floodwall

Cross Sections with 1% Annual Chance Water Surface Elevation

Coastal Transect

Base Flood Elevation Line (BFE)

Limit of Study

Jurisdiction Boundary

Coastal Transect Baseline

Profile Baseline

Hydrographic Feature

Digital Data Available

No Digital Data Available

Unmapped



The pin displayed on the map is an approximate point selected by the user and does not represent an authoritative property location.

This map complies with FEMA's standards for the use of digital flood maps if it is not void as described below. The basemap shown complies with FEMA's basemap accuracy standards

The flood hazard information is derived directly from the authoritative NFHL web services provided by FEMA. This map was exported on 3/13/2020 at 11:49:59 AM and does not reflect changes or amendments subsequent to this date and time. The NFHL and effective information may change or become superseded by new data over time.

This map image is void if the one or more of the following map elements do not appear: basemap imagery, flood zone labels, legend, scale bar, map creation date, community identifiers, FIRM panel number, and FIRM effective date. Map images for unmapped and unmodernized areas cannot be used for regulatory purposes.



1:6,000

104°45'12.09"W
38°45'44.89"N



APPENDIX B DRAINAGE CALCULATIONS



SBA46: 1" = 400'

DESIGNED BY
MAB
PROJECT ENGINEER
MAB
PROJECT MANAGER
MAB
HORZ. N/A
VERT. N/A

DATE: 2/26/13
JOB NO. 111001
CAD FILE NO.
OFFSITE.DWG
DRAWN BY JRH

PREPARED BY:

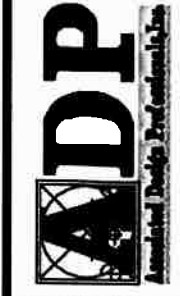

4800 Austin, Suite 100
Colorado Springs, CO 80901
(719) 594-1111
Fax: (719) 594-1111

NO.	DATE	REVISION	BY

SOUTH ACADEMY BUSINESS PARK
EL PASO COUNTY, COLORADO
OFFSITE HISTORIC CONDITIONS

SOUTH ACADEMY BUSINESS CENTER

C FACTOR CALCULATION SHEET

RUNOFF COEFICIENT

TYPE C SOILS

LAND USE	5 YR	100 YR
UNDEV & LOOSE GRAVEL	0.15	0.5
STREETS/PARKING GRAVEL	0.63	0.74
ROOFS/ PAVED AREAS	0.75	0.83

Historic Conditions

AREA	TOTAL AREA	SURFACE CONDITION AREAS			CALCULATED C	
		UNDEV	STREETS/ PARKING GRAVEL	ROOFS/ PAVED AREAS	5 YR	100 YR
DESIG.	(acre)					
Aex	6.40	6.40			0.15	0.50
Bex	1.30	1.30			0.15	0.50

RUNOFF COEFICIENT

TYPE C SOILS

LAND USE	5 YR	100 YR
UNDEV & LOOSE GRAVEL	0.15	0.5
STREETS/PARKING GRAVEL	0.63	0.74
ROOFS/ PAVED AREAS	0.75	0.83

Developed Conditions

AREA	TOTAL AREA	SURFACE CONDITION AREAS			CALCULATED C	
		UNDEV	LOOSE GRAVEL	ROOFS/ PAVED AREAS	5 YR	100 YR
DESIG.	(acre)					
A	7.60	1.90	3.97	1.73	0.29	0.58

IMPERVIOUS

COVERAGE	ACREAGE	% IMP
Undev	1.90	0
Loose Grav	3.97	0.4
Trailers	1.73	0.9
	7.60	3.15

		TOTAL IMP	41.38%			
OFF-SITE AREA						
TYPE A SOILS						
LAND USE			5 YR	100 YR		
UNDEV & LOOSE GRAVEL			0.08	0.35		
Historic Conditions						
	TOTAL	SURFACE CONDITION AREAS			CALCULATED C	
AREA	AREA	UNDEV	STREETS/ PARKING	ROOFS/ PAVED	5	100
DESIG.	(acre)		GRAVEL	AREAS	YR	YR
OS1	46.90	46.90	0.00	0.00	0.08	0.35

SOUTH ACADEMY BUSINESS CENTER																			
DRAINAGE CALCULATION SHEET																			
file:lock - load dr																			
06/09/17 Rev 9/8/20																			
AREA	AREA (acre)	C5 (5 yr)	C100 (100 yr)	C5 X A	C100 X A	L (ft)	Initial Tci Slope (%)	ti (min)	L (ft)	Slope (%)	V (fps)	Tt (min)	TC (min)	I5 (in/hr)	I100 (in/hr)	Q5 (cfs)	Q100 (cfs)	AREA DESIG.	
CURRENT CONDITIONS																			
OS1	46.90	0.08	0.35	3.75	16.42	100	1.50	16.69	5000	0.70	0.90	92.59	109.28	0.98	1.71	3.66	27.99	OS1	
Aex	6.30	0.15	0.50	0.95	3.15	100	1.50	15.54	1900	0.70	0.90	35.19	50.73	1.67	2.91	1.58	9.18	Aex	
OS1	46.90	0.08	0.35	3.75	16.42	100	1.50	16.69	5000	0.70	0.90	92.59	109.28	0.98	1.71	3.66	27.99	OS1	
DP1	53.20			4.70	19.57								109.28	0.98	1.71	4.59	33.37	DP1	
Bex	1.30	0.15	0.50	0.20	0.65	15	1.00	6.88	1900	0.70	0.90	35.19	42.07	1.88	3.29	0.37	2.14	Bex	
OS2	1.40	0.49	0.67	0.68	0.94	50	2.00	6.46	1200	0.70	0.90	22.22	28.68	2.38	4.16	1.62	3.89	OS2	
DP2	2.70			0.88	1.59								42.07	1.88	3.29	1.65	5.21	DP2	
DEVELOPED CONDITIONS																			
OS1	46.90	0.08	0.35	3.75	16.42	100	1.50	16.69	5000	0.70	0.90	92.59	109.28	0.98	1.71	3.66	27.99	OS1	
A	7.60	0.29	0.58	2.20	4.41	50	1.00	10.71	1900	0.70	0.90	35.19	45.90	1.78	3.11	3.92	13.71	A	
DP1	54.50			5.96	20.82								109.28	0.98	1.71	5.82	35.51	DP1	
OS2	1.40	0.49	0.67	0.68	0.94	50	2.00	6.46	1200	0.70	0.90	22.22	28.68	2.38	4.16	1.62	3.89	OS2	
														$ti = (0.395 * (1.1 - C5) * L^{0.5}) / S^{0.33}$ [EQ 6-8] V from Fig 6-25 $Tt = LV/60$ $TC = ti + Tt$					
ACCESS ROAD CULVERT CAPACITY CALCULATION SHEET																			
25"X15" CMP ARCH @ 0.5% CAPACITY = 3.9 CFS = 100YR STORM																			
DITCH CAPACITY CALCULATION SHEET																			
														Froude # D ft					
Swale Location	Q5 cfs	Q100 cfs	S %	B ft	Z	d100 ft	V fps												
Outlet Swale	0.20	10.80	0.70	0.00	10:1	0.76	1.90												
Spillway	3.90	13.70	1.00	10.00	4:1	0.50	2.20												

FOREBAY CALCULATION SHEET (Per Table EDB-4)																				
RELEASE RATE	OPENING	VOLUME	FOREBAY DEPTH	TRICKLE CHAN CAP																
2% 100 yr stm	$Q = C \times W \times D^{3/2}$	2% WQCV	D = 6"	OUTLET Q = 0.71 cfs																
0.02 X 35.5 = 0.71 cfs	@W = 0.67'	0.02 X 0.149 ac ft = 0.003 ac ft		@d = 4", b = 1', s = 0.5%																
	Q = 0.71 cfs	0.002 ac ft x 43560 = 129.8 cf		MAX Q = 0.79 cfs																

CULVERT DESIGN FORM

STATION: _____ OF _____ SHEET _____

DESIGNER / DATE: _____ / _____ REVIEWER / DATE: _____ / _____

ROADWAY ELEVATION: _____ (11)

HYDROLOGICAL DATA
 METHOD: RAT. O. & A.
 DRAINAGE AREA: 46.9 STREAM SLOPE: 0.7%
 CHANNEL SHAPE: TRAP - B' B&T
 ROUTING: OTHER: _____

DESIGN FLOWS/TAILWATER
 R 1 (YEARS) 5 FLOW (cfs) 3.7 TW (11) _____
100 28.0

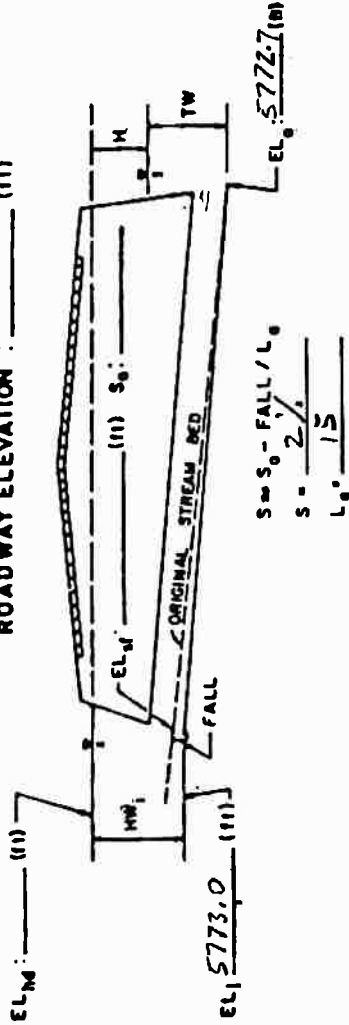

HEADWATER CALCULATIONS

CULVERT DESCRIPTION: MATERIAL - SHAPE - SIZE - ENTRANCE	TOTAL FLOW Q (cfs)	FLOW PER CHANNEL Q/N	INLET CONTROL			OUTLET CONTROL			HEADWATER CONTROL ELEVATION	OUTLET VELOCITY	COMMENTS			
			HW ₁ /D	FALL	EL _{H1}	TW	d _c	h ₀				H		
2-18" NDS - PROJ	28.0	14.0	2.10	3.6	0.3	76.3	1.8	1.4	1.45	1.8	75.90	76.30		
"	3.7	1.85	0.85	0.75	0.3	73.45	0.7	0.6	1.05	0.5	73.95	73.95		

TECHNICAL FOOTNOTES:
 (1) USE Q/NB FOR BOX CULVERTS
 (2) HW₁/D - HW₁/D OR HW₁/D FROM DESIGN CHARTS
 (3) FALL - HW₁ - (EL_{H0} - EL_{H1}); FALL IS ZERO FOR CULVERTS ON GRADE
 (4) EL_M = HW₁ + EL_i (INVERT OF INLET CONTROL SECTION)
 (5) TW BASED ON DOWN STREAM CONTROL OR FLOW DEPTH IN CHANNEL.
 (6) h₀ = TW or (d_c * D / 2) (WHICHEVER IS GREATER)
 (7) H = [1 + h₀ * (29 * n² * L) / R^{1.33}] * V² / 2g
 (8) EL_{H0} = EL₀ + H * h₀

COMMENTS / DISCUSSION:

SUBSCRIPT DEFINITIONS:
 0. APPROXIMATE
 1. CULVERT FACE
 2. DESIGN HEADWATER
 3. HEADWATER IN INLET CONTROL
 4. HEADWATER IN OUTLET CONTROL
 5. INLET CONTROL SECTION
 6. OUTLET
 7. STREAMBED AT CULVERT FACE
 8. TAILWATER

CULVERT BARREL SELECTED:

SIZE: _____
 SHAPE: _____
 MATERIAL: _____
 ENTRANCE: _____

CULVERT DESIGN FORM

STATION : _____ OF _____
 SHEET _____ OF _____

DESIGNER / DATE : _____ / _____
 REVIEWER / DATE : _____ / _____

ROADWAY ELEVATION : 5768.0 (111)

HYDROLOGICAL DATA
 METHOD: RATIONAL
 DRAINAGE AREA: 1.4 STREAM SLOPE: 0.7%
 CHANNEL SHAPE: V-SHAPE
 ROUTING: OTHER: _____

DESIGN FLOWS/TAILWATER
 R.I. (YEARS) _____ FLOW (cfs) _____ TW (ft) _____
5 1.6
100 3.9

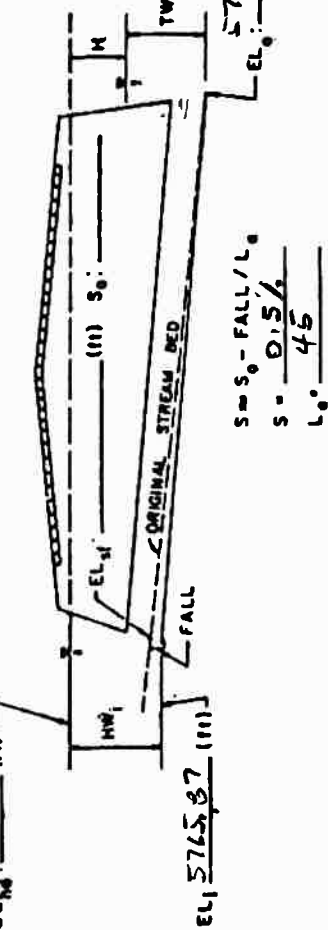

$S = S_0 - \text{FALL} / L$
 $S = 0.5\%$
 $L = 45$

CULVERT DESCRIPTION: MATERIAL - SHAPE - SIZE - ENTRANCE	TOTAL FLOW Q (cfs)	FLOW PER BARREL Q/N (1)	HEADWATER CALCULATIONS								COMMENTS				
			INLET CONTROL				OUTLET CONTROL								
			HW ₁ /D (2)	HW ₁ (3)	FALL (4)	EL ₁ (5)	TW (6)	d _c (7)	h ₀ (8)	h ₀ (9)		EL ₀ (10)			
25" X 15" C&G ARCH - PROF	3.9	3.9	0.67	0.84	0.25	66.46	0.7	0.53	0.93	0.2	0.9	1.13	66.75	66.75	
"	1.6	1.6	0.36	0.45	0.25	66.07	0.5	0.2	0.73	0.1	0.9	0.83	66.45	66.45	

TECHNICAL FOOTNOTES:
 (1) USE Q/NB FOR BOX CULVERTS
 (2) HW₁/D = HW₁/D OR HW₁/D FROM DESIGN CHARTS
 (3) FALL = HW₁ - (EL_{RD} - EL₀); FALL IS ZERO FOR CULVERTS ON GRADE
 (4) EL_{RD} = HW₁; EL₁ (INVERT OF INLET CONTROL SECTION)
 (5) TW BASED ON DOWN STREAM CONTROL OR FLOW DEPTH IN CHANNEL.
 (6) h₀ = TW OR (d_c + D/2) (WHICHEVER IS GREATER)
 (7) h₀ = [1 + h₀ + (29n²L) / R<sup>(33)] V² / 2g
 (8) EL₀ = EL₁ + H + h₀</sup>

SUBSCRIPT DEFINITIONS:
 0 - APPROXIMATE
 1 - CULVERT FACE
 2 - DESIGN HEADWATER
 3 - HEADWATER IN INLET CONTROL
 4 - HEADWATER IN OUTLET CONTROL
 5 - INLET CONTROL SECTION
 6 - OUTLET
 7 - STREAMBED AT CULVERT FACE
 8 - TAILWATER

COMMENTS / DISCUSSION:

CULVERT BARREL SELECTED:
 SIZE: _____
 SHAPE: _____
 MATERIAL: _____
 ENTRANCE: _____

DETENTION BASIN STAGE-STORAGE TABLE BUILDER

UD Detention, Version 3.07 (February 2017)

Project: **S Academy Bulldogs Ct**

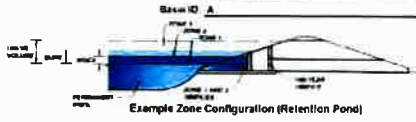

Example Zone Configuration (Retention Pond)

Required Volume Calculation

Select RMP 1-yr	EDR	
Watershed Area	54.50	acres
Watershed Length	7,000	ft
Watershed Slope	0.007	ft/ft
Watershed Imperviousness	4.50%	percent
Percentage Hydraulic Soil Group A	87.0%	percent
Percentage Hydraulic Soil Group B	0.0%	percent
Percentage Hydraulic Soil Group C/D	13.0%	percent
Desired WOCV Drain Time	40.0	hours
Location for 1-yr Rainfall Depth	Denver - Capital Building	
Water Quality Capture Volume (WQCV)	0.149	acre-feet
Excess Urban Runoff Volume (EURV)	0.150	acre-feet
2-yr Runoff Volume (P1 = 1.18 in.)	0.100	acre-feet
5-yr Runoff Volume (P1 = 1.5 in.)	0.182	acre-feet
10-yr Runoff Volume (P1 = 1.75 in.)	0.342	acre-feet
25-yr Runoff Volume (P1 = 2 in.)	0.707	acre-feet
50-yr Runoff Volume (P1 = 2.25 in.)	1.257	acre-feet
100-yr Runoff Volume (P1 = 2.52 in.)	2.480	acre-feet
500-yr Runoff Volume (P1 = 3.01 in.)	5.082	acre-feet
Approximate 2-yr Detention Volume	0.082	acre-feet
Approximate 5-yr Detention Volume	0.176	acre-feet
Approximate 10-yr Detention Volume	0.243	acre-feet
Approximate 25-yr Detention Volume	0.320	acre-feet
Approximate 50-yr Detention Volume	0.457	acre-feet
Approximate 100-yr Detention Volume	0.598	acre-feet

Stage-Storage Calculation

Zone 1 Volume (WQCV)	0.149	acre-feet
Zone 2 Volume (EURV - Zone 1)	0.001	acre-feet
Zone 3 Volume (100-year Zones 1 & 2)	0.747	acre-feet
Total Detention Basin Volume	0.898	acre-feet
Initial Surcharge Volume (ISV)	0.000	acre-feet
Initial Surcharge Depth (ISD)	0.000	ft
Total Available Detention Depth (H _{total})	0.000	ft
Depth of Trickle Channel (H _{trickle})	0.000	ft
Slope of Trickle Channel (S _{trickle})	0.000	ft/ft
Slopes of Main Basin Sides (S _{main})	0.000	H:V
Basin Length-to-Width Ratio (R _{basin})	0.000	
Initial Surcharge Area (A _{ISV})	0.000	sq-ft
Surcharge Volume Length (L _{ISV})	0.000	ft
Surcharge Volume Width (W _{ISV})	0.000	ft
Depth of Basin Floor (H _{basin})	0.000	ft
Length of Basin Floor (L _{basin})	0.000	ft
Width of Basin Floor (W _{basin})	0.000	ft
Area of Basin Floor (A _{basin})	0.000	sq-ft
Volume of Basin Floor (V _{basin})	0.000	cu-ft
Depth of Main Basin (H _{main})	0.000	ft
Length of Main Basin (L _{main})	0.000	ft
Width of Main Basin (W _{main})	0.000	ft
Area of Main Basin (A _{main})	0.000	sq-ft
Volume of Main Basin (V _{main})	0.000	cu-ft
Calculated Total Basin Volume (V _{total})	0.000	acre-feet

Stage - Storage Description	Stage (ft)	Initial Surcharge Stage (ft)	Length (ft)	Width (ft)	Area (sq-ft)	Volume (cu-ft)	Area (acres)	Volume (ac-ft)
Top of Micropool	0.00				7,645	0.176		
	0.15				8,767	0.192	2.716	0.067
	0.30				9,890	0.223	4.882	0.112
	0.45				10,990	0.249	7.135	0.164
	0.60				12,133	0.278	9.634	0.221
	0.75				13,300	0.308	12.475	0.286
	0.90				14,487	0.339	15.857	0.359
	1.05				15,693	0.360	19.181	0.440
	1.20				16,917	0.381	23.563	0.541
	1.35				18,159	0.402	28.059	0.667
	1.50				19,427	0.423	32.706	0.813
	1.65				20,711	0.444	37.556	0.978
	1.80				22,011	0.465	42.624	1.163

Detention Basin Outlet Structure Design

UD-Detention, Version 3.07 (February 2017)

Project: **Academy Business Ctr**

Basin ID: **A**

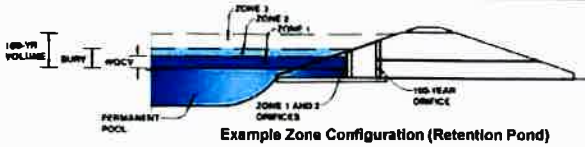

Example Zone Configuration (Retention Pond)

	Stage (ft)	Zone Volume (ac-ft)	Outlet Type
Zone 1 (WQCV)	0.77	0.149	Orifice Plate
Zone 2 (EURV)	0.78	0.001	Orifice Plate
Zone 3 (100-year)	2.74	0.747	Weir & Pipe (Restrict)
		0.898	Total

User Input: Orifice at Underdrain Outlet (typically used to drain WQCV in a Filtration BMP)

Underdrain Orifice Invert Depth = ft (distance below the filtration media surface)
 Underdrain Orifice Diameter = inches

Calculated Parameters for Underdrain

Underdrain Orifice Area = ft²
 Underdrain Orifice Centroid = feet

User Input: Orifice Plate with one or more orifices or Elliptical Slot Weir (typically used to drain WQCV and/or EURV in a sedimentation BMP)

Invert of Lowest Orifice = ft (relative to basin bottom at Stage = 0 ft)
 Depth at top of Zone using Orifice Plate = ft (relative to basin bottom at Stage = 0 ft)
 Orifice Plate: Orifice Vertical Spacing = inches
 Orifice Plate: Orifice Area per Row = inches

Calculated Parameters for Plate

WQ Orifice Area per Row = ft²
 Elliptical Half-Width = feet
 Elliptical Slot Centroid = feet
 Elliptical Slot Area = ft²

User Input: Stage and Total Area of Each Orifice Row (numbered from lowest to highest)

	Row 1 (required)	Row 2 (optional)	Row 3 (optional)	Row 4 (optional)	Row 5 (optional)	Row 6 (optional)	Row 7 (optional)	Row 8 (optional)
Stage of Orifice Centroid (ft)	0.00	0.28	0.52	0.00	0.00	0.00	0.00	0.00
Orifice Area (sq inches)	2.00	2.00	4.00					

	Row 9 (optional)	Row 10 (optional)	Row 11 (optional)	Row 12 (optional)	Row 13 (optional)	Row 14 (optional)	Row 15 (optional)	Row 16 (optional)
Stage of Orifice Centroid (ft)	0.00	0.00	0.00	0.00	0.00	0.00	0.00	0.00
Orifice Area (sq inches)								

User Input: Vertical Orifice (Circular or Rectangular)

	Not Selected	Not Selected	
Invert of Vertical Orifice =	<input type="text" value="N/A"/>	<input type="text" value="N/A"/>	ft (relative to basin bottom at Stage = 0 ft)
Depth at top of Zone using Vertical Orifice =	<input type="text" value="N/A"/>	<input type="text" value="N/A"/>	ft (relative to basin bottom at Stage = 0 ft)
Vertical Orifice Diameter =	<input type="text" value="N/A"/>	<input type="text" value="N/A"/>	inches

Calculated Parameters for Vertical Orifice

	Not Selected	Not Selected	
Vertical Orifice Area =	<input type="text" value="N/A"/>	<input type="text" value="N/A"/>	ft ²
Vertical Orifice Centroid =	<input type="text" value="N/A"/>	<input type="text" value="N/A"/>	feet

User Input: Overflow Weir (Dropbox) and Grate (Flat or Sloped)

	Zone 3 Weir	Not Selected	
Overflow Weir Front Edge Height, H _o =	<input type="text" value="1.50"/>	<input type="text" value="N/A"/>	ft (relative to basin bottom at Stage = 0 ft)
Overflow Weir Front Edge Length =	<input type="text" value="3.00"/>	<input type="text" value="N/A"/>	feet
Overflow Weir Slope =	<input type="text" value="0.00"/>	<input type="text" value="N/A"/>	H:V (enter zero for flat grate)
Horiz. Length of Weir Sides =	<input type="text" value="3.00"/>	<input type="text" value="N/A"/>	feet
Overflow Grate Open Area % =	<input type="text" value="70%"/>	<input type="text" value="N/A"/>	% grate open area/total area
Debris Clogging % =	<input type="text" value="50%"/>	<input type="text" value="N/A"/>	%

Calculated Parameters for Overflow Weir

	Zone 3 Weir	Not Selected	
Height of Grate Upper Edge, H _g =	<input type="text" value="1.50"/>	<input type="text" value="N/A"/>	feet
Overflow Weir Slope Length =	<input type="text" value="3.00"/>	<input type="text" value="N/A"/>	feet
Grate Open Area / 100-yr Orifice Area =	<input type="text" value="6.93"/>	<input type="text" value="N/A"/>	should be > 4
Overflow Grate Open Area w/o Debris =	<input type="text" value="6.30"/>	<input type="text" value="N/A"/>	ft ²
Overflow Grate Open Area w/ Debris =	<input type="text" value="3.15"/>	<input type="text" value="N/A"/>	ft ²

User Input: Outlet Pipe w/ Flow Restriction Plate (Circular Orifice, Restrictor Plate, or Rectangular Orifice)

	Zone 3 Restrictor	Not Selected	
Depth to Invert of Outlet Pipe =	<input type="text" value="0.00"/>	<input type="text" value="N/A"/>	ft (distance below basin bottom at Stage = 0 ft)
Outlet Pipe Diameter =	<input type="text" value="18.00"/>	<input type="text" value="N/A"/>	inches
Restrictor Plate Height Above Pipe Invert =	<input type="text" value="9.20"/>	<input type="text" value="N/A"/>	inches

Calculated Parameters for Outlet Pipe w/ Flow Restriction Plate

	Zone 3 Restrictor	Not Selected	
Outlet Orifice Area =	<input type="text" value="0.91"/>	<input type="text" value="N/A"/>	ft ²
Outlet Orifice Centroid =	<input type="text" value="0.44"/>	<input type="text" value="N/A"/>	feet
Half-Central Angle of Restrictor Plate on Pipe =	<input type="text" value="1.59"/>	<input type="text" value="N/A"/>	radians

User Input: Emergency Spillway (Rectangular or Trapezoidal)

Spillway Invert Stage =	<input type="text" value="2.42"/>	ft (relative to basin bottom at Stage = 0 ft)
Spillway Crest Length =	<input type="text" value="8.00"/>	feet
Spillway End Slopes =	<input type="text" value="4.00"/>	H:V
Freeboard above Max Water Surface =	<input type="text" value="1.00"/>	feet

Calculated Parameters for Spillway

Spillway Design Flow Depth =	<input type="text" value="0.48"/>	feet
Stage at Top of Freeboard =	<input type="text" value="3.90"/>	feet
Basin Area at Top of Freeboard =	<input type="text" value="0.77"/>	acres

Routed Hydrograph Results

	WQCV	EURV	2 Year	5 Year	10 Year	25 Year	50 Year	100 Year	500 Year
Design Storm Return Period =									
One-Hour Rainfall Depth (in)	0.53	1.07	1.19	1.50	1.75	2.00	2.25	2.52	3.01
Calculated Runoff Volume (acre-ft)	0.149	0.150	0.100	0.182	0.342	0.707	1.257	2.480	5.082
OPTIONAL Override Runoff Volume (acre-ft) =									
Inflow Hydrograph Volume (acre-ft) =	0.148	0.150	0.100	0.181	0.341	0.706	1.256	2.479	5.081
Predevelopment Unit Peak Flow, q (cfs/acre) =	0.00	0.00	0.00	0.01	0.03	0.07	0.17	0.33	0.66
Predevelopment Peak Q (cfs) =	0.0	0.0	0.1	0.6	1.6	4.0	9.4	18.1	36.2
Peak Inflow Q (cfs) =	1.0	1.0	0.7	1.2	2.3	4.7	8.2	16.1	32.6
Peak Outflow Q (cfs) =	0.1	0.1	0.1	0.2	0.3	2.6	5.4	10.7	27.6
Ratio Peak Outflow to Predevelopment Q =	N/A	N/A	N/A	0.3	0.2	0.7	0.6	0.6	0.8
Structure Controlling Flow =	Plate	Plate	Plate	Plate	Plate	Overflow Grate 1	Outlet Plate 1	Spillway	Spillway
Max Velocity through Grate 1 (fps) =	N/A	N/A	N/A	N/A	N/A	0.3	0.8	1.0	1.1
Max Velocity through Grate 2 (fps) =	N/A	N/A	N/A	N/A	N/A	N/A	N/A	N/A	N/A
Time to Drain 97% of Inflow Volume (hours) =	40	40	37	41	44	41	34	24	16
Time to Drain 99% of Inflow Volume (hours) =	44	44	41	46	51	50	46	40	30
Maximum Ponding Depth (ft) =	0.62	0.63	0.44	0.74	1.29	1.70	1.96	2.71	3.17
Area at Maximum Ponding Depth (acres) =	0.20	0.20	0.20	0.21	0.27	0.32	0.38	0.63	0.76
Maximum Volume Stored (acre-ft) =	0.118	0.118	0.080	0.143	0.270	0.391	0.480	0.874	1.202

Detention Basin Outlet Structure Design

UD-Detention, Version 3.07 (February 2017)

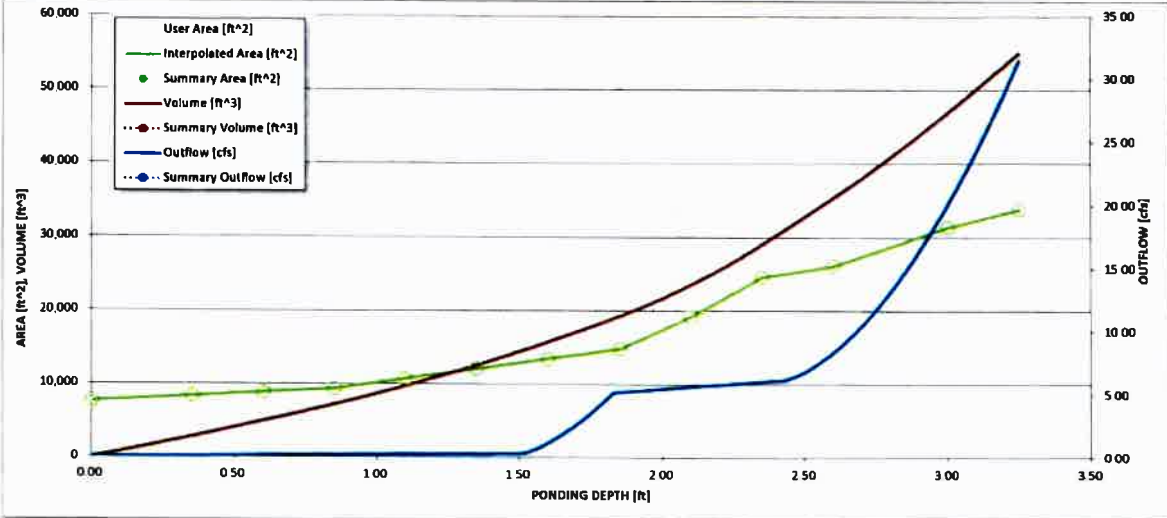
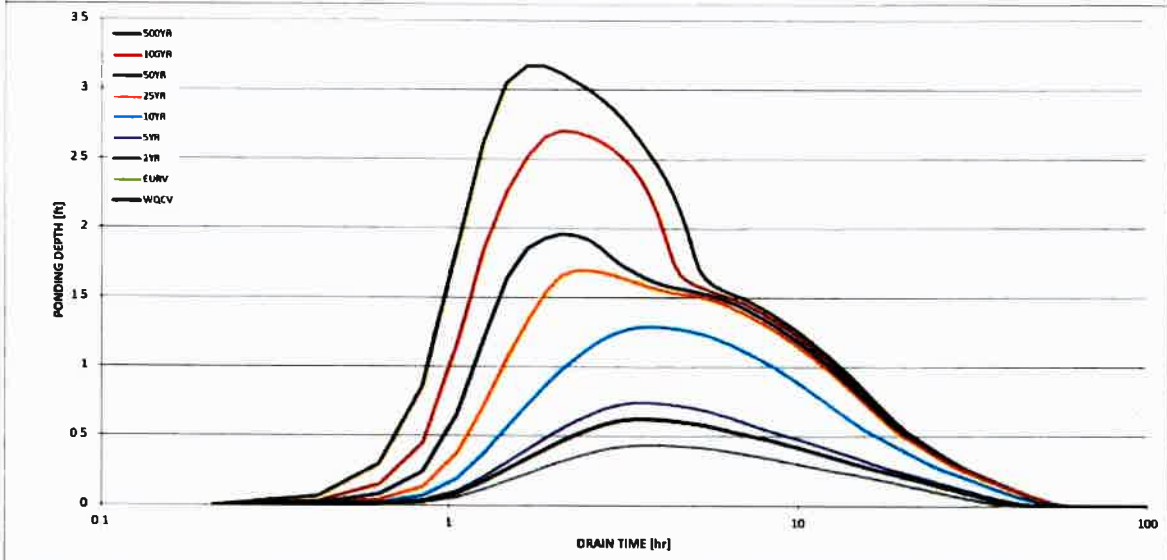
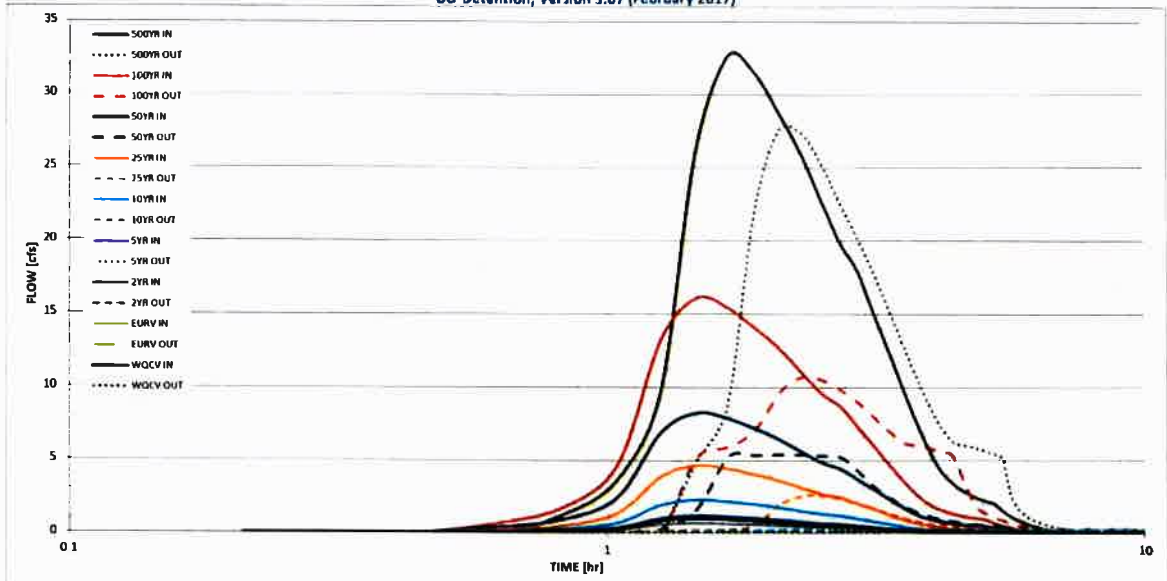

S-A-V-D Chart Axis Override

	X-axis	Left Y-Axis	Right Y-Axis
minimum bound			
maximum bound			

DETENTION BASIN STAGE-STORAGE TABLE BUILDER

UD-Detention, Version 3.07 (February 2017)

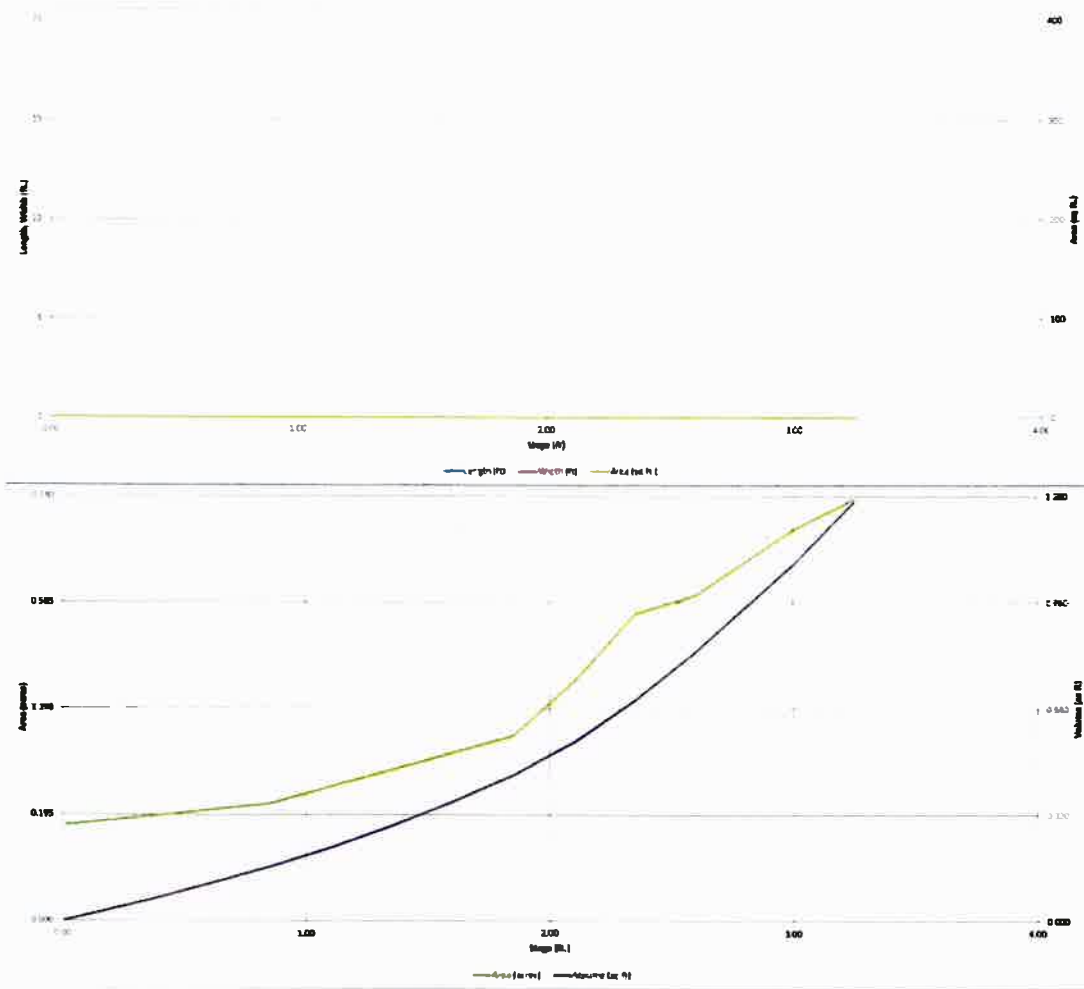



APPENDIX C CDOT PERMIT

SPECIAL USE PERMIT 2190120

PERMITTEE Name: Load and Lock Storage	APPLICANT Name:	DEPARTMENT USE ONLY Date Issued:		
REP: Barry Helton	REP: Michael Bartusek	Permit # 2190120	Milepost(s)	Side(s)
Address: 4425 Hwy 85/87 Colorado Springs, Colorado 80910	Address:	S.H.# 085	135.000	
		Region: 2		
Email: bhelton9@aol.com	Email: mbartusek@adpcivil.com	S.H. Section : A		
Telephone: 719-338-3813	Telephone: 719-266-5212	Patrol: Brad Bauer		

NOTICE TO PERMITTEE: For underground facility location information, contact the Utility Notification Center of Colorado (UNCC). Pursuant to 9-1.5-103 C.R.S. you shall not make or begin excavation without first notifying the UNCC and if necessary, then notifying the tier two members having underground facilities in the area of such excavation. Notification shall also be given to the CDOT regional permitting office, or as otherwise directed by this Permit's Special Provisions. Notice of the commencement, extent and duration of the excavation work shall be given at least two business days prior thereto, not including the day of actual notice. The UNCC may be called at 1-800-922-1987. **FOR CDOT FIBER LOCATES CONTACT REGION 2 TRAFFIC AT 719-546-5418**

ACTIVITY DESCRIPTION (Furnished by Permittee)

PURPOSE Installation Adjustment Removal Relocation SUE/Other Maintenance of Existing Facility
FACILITY Grading for an earth berm
DESCRIPTION OF WORK: Install earth berm approximately 200" east of Hwy 85. Contractor to install drainage culvert at the south end of the earth berm. Trash collector to be installed over culvert end.
NATURE OF INSTALLATION: Longitudinal Transverse (Crossing) Buried Aerial/Ground-mounted
LOCATION: east of milepost 135
 County: **El Paso County** City/Town:
ADDITIONAL REMARKS:

SPECIAL PROVISIONS (completed by the Department) The Special Provisions are terms and conditions of this permit.

Any work shall only be in accordance with the approved plans and special provisions as set forth in this permit and its attachments.
 The CDOT Utility Coordinator is Ron Young. Please contact with start date of project prior to work and for final inspection.
 Telephone: (719) 289-8718. E-mail: ronaldr.young@state.co.us

- Permittee is responsible for the installation and maintenance of the earth berm.
- All work shall comply with the plans submitted and that are on file with the Colorado Department of Transportation.
- Submit any and all as built plans with utility conflicts no later than 45 days after project is completed.
- It is the responsibility of the permittee to comply with the subsurface utility engineering requirements as defined in Senate Bill 18-167.
- All utilities conflicts must be positively identified (potholing). Pothole data must be in as-built plans.
- *The permittee shall contact local law enforcement and fire department to ensure traffic control does not interfere with an emergency route. The contractor working within CDOT right-of-way shall make a conservative effort when constructing not to block or interfere with business or residential access*

Work is to be completed on or before: 2/1/2020
 Work time restrictions: **No work in adverse weather conditions.**
 Designated minimum cover is N/A Designated overhead clearance is N/A
 (ALSO SEE ATTACHED STANDARD PROVISIONS, AND ADDITIONAL SPECIAL PROVISIONS), (TRAFFIC CONTROL MUST CONFORM TO THE MUTCD)
 Other: **Permit and traffic control must be on site.**

Permittee is prohibited from commencing any work within highway ROW prior to issuance of a fully endorsed and validated permit. Permit, plan exhibit, insurance certificate(s), and traffic control plan must be available on site during work. High visibility vests are required at all times during working hours.

1. Your request to use and/or occupy state highway system rights of way as described above is granted subject to the terms and conditions of this permit, including the Standard and Special Provisions as shown on the permit and all attachments hereto.
2. To the extent authorized by law, Permittee hereby assumes, releases and agrees to indemnify, defend, protect, and save the State of Colorado harmless from and against any loss and/or damages to the property of the State of Colorado, third parties or the Permittee's facilities, and all loss and/or damage on account of injury to or death of any person whomsoever, arising at any time, caused by or growing out of the occupation of Colorado State Highway rights of way by Permittee's facilities or any part thereof, including but not limited to installation, adjustment, relocation, maintenance or operation, or removal of existing facilities, unless such loss and/or damage arises from the sole negligence or willful conduct of the State of Colorado or its employees or agents.
3. Failure by the Permittee to comply with any of the included terms or conditions may subject this permit to suspension or cancellation, at the discretion of the Department of Transportation.
4. **THIS PERMIT IS NOT VALID UNTIL FULLY ENDORSED BY ALL PARTIES, WITH DATE OF ISSUE AFFIXED BY AN AUTHORIZED REPRESENTATIVE OF THE DEPARTMENT. A FULLY EXECUTED COPY OF THIS PERMIT MUST BE ON FILE AT THE TRANSPORTATION REGION OFFICE.**
5. In accepting this permit the undersigned, representing the Permittee, verifies that he or she has the authority to sign for and bind the Permittee, and that he or she has read, understands and accepts all the included conditions.

CDOT Signature:	Date	Permittee Signature	Date
COLORADO DEPARTMENT OF TRANSPORTATION Chief Engineer, Regional Transportation Director or Designee		Print Name/Title	

Distribution: Region File (Original)
 Permittee/Applicant
 Mtce Patrol Supvr.

Mtce Landscaping Supvr
 Inspector

CDOT Form # 0333 01/09
 Previous versions are obsolete and should not be used.

The following Standard Provisions are terms and conditions of this permit:

Effective March 1, 2006

Utility work authorized under this permit shall comply with the requirements of the State Highway Utility Accommodation Code, and applicable federal, state, local, and industry codes and regulations.

Construction of any portion of the highway facility, including the pavement structure, subsurface support, drainage, landscaping elements and all appurtenant features, shall comply with the provisions of the CDOT Standard Specifications for Road and Bridge Construction, and with the Colorado Standard Plans (M & S Standards).

1. COMMENCEMENT AND COMPLETION

Work on highway Right of Way (ROW) shall not commence prior to issuance of a fully endorsed and validated permit.

Permittee shall notify the CDOT inspector:

- a. At least 2 working days prior to commencing work, or resuming operations which have been suspended for five or more consecutive working days
- b. When suspending operations for 5 or more working days
- c. Upon completion of work.

Work shall not proceed beyond a completion date specified in the Special Provisions without written approval of the Department.

2. PLANS, PLAN REVISIONS, ALTERED WORK

Plans or work sketch (EXHIBIT A) are subject to CDOT approval. A copy of the approved plans or sketch must be available on site during work. Plan revisions or altered work differing in scope or nature from that authorized under this permit, are subject to CDOT prior approval. Permittee shall promptly notify the CDOT inspector of changed or unforeseen conditions, which may occur on the job.

3. INSURANCE

Insurance Requirements for Utility and Special-Use Permits (Revised 7-05 per State Requirements)

- A. The Permittee shall obtain, and maintain at all times during the performance of work authorized by this Permit, insurance in the following kinds and amounts. The Permittee shall require any Contractor working for them within the State Highway Right of Way to obtain like coverage. The Permittee shall also require any Contractor or Consultant performing work described in subparagraph 4) below, to obtain Professional Liability Insurance.
 - 1) Workers' Compensation Insurance as required by state statute, and Employer's Liability Insurance covering all employees acting within the course and scope of their employment and work on the activities authorized by this Permit.
 - 2) Commercial General Liability Insurance written on ISO occurrence form CG 00 01 10/93 or equivalent, covering premises operations, fire damage, independent Consultants, products and completed operations, blanket contractual liability, personal injury, and advertising liability with minimum limits as follows:
 - a. \$1,000,000 each occurrence;
 - b. \$2,000,000 general aggregate;
 - c. \$2,000,000 products and completed operations aggregate; and
 - d. \$50,000 any one fire.
 - e. For any permanent Permittee-owned installations located within the State Highway Right of Way, highway repairs, or site restoration, Completed Operations coverage shall be provided for a minimum period of one year following final acceptance of work.

If any aggregate limit is reduced below 1,000,000 because of claims made or paid, the Permittee, or as applicable - their Contractor, shall immediately

aggregate limit and furnish to CDOT a certificate or other document satisfactory to CDOT showing compliance with this provision.

- 3) Automobile Liability Insurance covering any auto (including owned, hired and non-owned autos) with a minimum limit as follows: \$1,000,000 each accident combined single limit.
- 4) For any: a) engineering design; b) construction inspection; or, c) traffic control plans approved by a Traffic Control Supervisor; done in association with the operations or installations authorized by this permit, Professional Liability Insurance with minimum limits of liability of not less than \$1,000,000 Each Claim and \$1,000,000 Annual Aggregate. If the policy is written on a Claims Made form, the Permittee, or, as applicable - their Consultant or Contractor, shall renew and maintain Professional Liability Insurance for a minimum of two years following final acceptance of the work, or provide a project specific Policy with a two year extended reporting provision.
- 5) Pollution Legal Liability Insurance with minimum limits of liability of \$1,000,000 Each Claim and \$1,000,000 Annual Aggregate. CDOT shall be named as an additional insured to the Pollution Legal Liability policy. If the Policy is a component of the Professional Liability Policy, the Additional Insured requirement is waived, and the Policy shall be written on a Claims Made form, with an extended reporting period of at least two year following final acceptance of the work.
- 6) Umbrella or Excess Liability Insurance with minimum limits of \$1,000,000. This policy shall become primary (drop down) in the event the primary Liability Policy limits are impaired or exhausted. The Policy shall be written on an Occurrence form and shall be following form of the primary. The following form Excess Liability shall include CDOT as an additional insured.

- B. CDOT shall be named as additional insured on the Commercial General Liability and Automobile Liability Insurance policies. Completed operations additional insured coverage shall be on endorsements CG 2010 11/85, CG 2037, or equivalent. Coverage required by the Permit will be primary over any insurance or self-insurance program carried by the State of Colorado.
- C. The Insurance shall include provisions preventing cancellation or non-renewal without at least 30 days prior notice to CDOT by certified mail.
- D. The Permittee, or, as applicable - their Contractor or Consultant, will require all insurance policies in any way related to the Permit and secured and maintained by the Permittee, Contractor or Consultant, to include clauses stating that each carrier will waive all rights of recovery, under subrogation or otherwise, against CDOT, its agencies, institutions, organizations, officers, agents, employees and volunteers.
- E. All policies evidencing the insurance coverages required hereunder shall be issued by insurance companies satisfactory to CDOT.
- F. The Permittee, or, as applicable - their Contractor or Consultant, shall provide certificates showing insurance coverage required by this Permit to CDOT prior to commencing work. No later than 15 days prior to the expiration date of any such coverage, the Permittee, Contractor or Consultant, shall deliver CDOT certificates of insurance evidencing renewals thereof. At any time during the term of this contract, CDOT may request in writing, and the Permittee, Contractor or Consultant, shall thereupon within 10 days supply to CDOT, evidence satisfactory to CDOT of compliance with the provisions of this section.
- G. Notwithstanding subsection A of this section, if the Permittee is a "public entity" within the meaning of the Colorado Governmental Immunity Act CRS 24-10-101, et seq., as amended ("Act"), the Permittee shall at all times during the term of this permit maintain only such liability insurance, by commercial policy or self-insurance, as is necessary to meet its liabilities under the Act. Upon request by CDOT, the Permittee shall show proof of such insurance satisfactory to CDOT. Public entity Permittees are not required to name CDOT as an Additional Insured.
- H. If the Permittee engages a Contractor and/or Consultant to act

CDOT UTILITY/RELOCATION/SPECIAL USE PERMIT STANDARD PROVISIONS

Contractor and/or Consultant shall be required to provide an endorsement naming CDOT as an Additional Insured on their Commercial General Liability, Auto Liability, Pollution Legal Liability and Umbrella or Excess Liability policies.

4. WORK WHERE DEPARTMENT LACKS AUTHORITY

Utility work within municipal boundaries (pursuant to 43-2-135 CRS), on certain public lands, or on private property, may require separate approval of the appropriate jurisdictional agency or property owner.

5. INSTALLATIONS ON FREEWAYS

CDOT may permit utility accommodations on freeways, including but not limited to the Interstate System, only in accordance with Utility Accommodation Code provisions. Special case exceptions as defined therein may be permitted only in accordance with FHWA-approved Departmental policy.

6. JOINT USE ALTERNATIVES

As directed or approved by CDOT, if necessary for the safe and efficient use of the ROW, Permittee shall utilize joint use facilities such as the placement of two or more separate lines in a common trench, or attachment to the same overhead support. The Permittee will be responsible for proper coordination with other affected utilities.

7. ATTACHMENT TO HIGHWAY STRUCTURES

Permittee is responsible for designing structure attachments, subject to the approval of the CDOT Staff Bridge Design Engineer.

8. DRAINAGEWAYS AND WATERCOURSES

The flow of water shall not ever be impaired or interrupted. Where possible, crossings of ditches, canals or water-carrying structures shall be bored or jacked beneath. Irrigation ditch or canal crossings require approval of the ditch company or owner. Permittee shall repair damage to any drainage facility to the satisfaction of the owner.

9. TRAFFIC CONTROL PLAN

- a. Prior to commencing work, the Permittee shall develop and submit to the Department for acceptance, a Traffic Control Plan (TCP) for any accommodation work that will affect traffic movement or safety. The Permittee shall implement the TCP and utilize traffic control devices as necessary to ensure the safe and expeditious movement of traffic around and through the work site.
- b. The Permittee shall develop the TCP, and Methods of Handling Traffic (MHT's) included therein, in conformance with the Manual on Uniform Traffic Control Devices (MUTCD), the Colorado Supplement thereto adopted by the Commission pursuant to sections 42-4-104 and 42-4-105 CRS, the Department's standard specifications for temporary traffic control and the Department's standard plans for signing - Standard Plans S 630-1 and S 630-2. The TCP shall include provisions for the passage of emergency vehicles through the work zone, and shall conform to the requirements of the Americans with Disabilities Act. The TCP and MHT's shall contain sufficient detail to demonstrate conformity with all applicable requirements.
- c. The Permittee shall have a competent person at the work site at all times in responsible charge of temporary traffic control. In situations where the TCP goes beyond any Typical Application shown in the MUTCD, or particularly dangerous roadway or traffic conditions exist, the Department may require the Permittee to have a Traffic Control Supervisor (TCS) develop or approve the TCP or to have a TCS on-site during work. The TCS shall be certified as a worksite traffic supervisor by either the American Traffic Safety Services Association (ATSSA) or the Colorado Contractors Association (CCA), and shall have a current CDOT flaggers' certification card. The TCS shall be responsible for the planning,

preparation, coordination, implementation, and inspection of the TCP.

- d. The Permittee shall not start the permitted work before the Department accepts the TCP.
- e. The Department may review and order changes to the TCP and MHT's during performance of the work, as required.
- f. The Permittee shall comply with the TCP at all times during performance of the work.
- g. The Permittee shall keep a copy of the TCP at the work site at all times during performance of the work for inspection.
- h. The TCP shall ensure that closure of intersecting streets, road approaches and other access points is minimized. On heavily traveled highways, the Department will not permit operations that interfere with traffic during periods of peak traffic flow.
- i. When Permittee operations coincide with highway construction or maintenance operations, the Permittee shall develop and implement the TCP in cooperation and coordination with the highway agency and/or its contractors and as otherwise directed by the Department in the permit.
- j. All flaggers shall have a current CDOT flagger certification card and shall be capable of communicating with the traveling public and others at the work site.

10. NCHRP 350 CRASHWORTHINESS REQUIREMENTS FOR WORK ZONE TRAFFIC CONTROL DEVICES

Work zone devices designated by FHWA as: Category I, including but not limited to single-piece drums, tubes, cones and delineators; Category II, including but not limited to barricades, vertical panels with light, drums or cones with light, portable sign supports, intrusion detectors and type III barricades; or as Category III, including but not limited to concrete barriers, fixed sign supports, crash cushions, and other work zone devices not meeting the definitions of Category I or II; shall meet NCHRP 350 crash test requirements. The Permittee, or their contractor shall obtain and make available upon request, the manufacturer's written NCHRP 350 certification, or as applicable, the FHWA Acceptance Letter, for each type of device. FHWA Acceptance Letters for Category II or Category III Work Zone Devices may be accessed through the FHWA website at http://safety.fhwa.dot.gov/roadway_dept/road_hardware/wzd.htm

11. WORKER SAFETY AND HEALTH

- a. All workers within the State Highway right of way shall comply with their employer's safety and health policies/procedures and all applicable U.S. Occupational Safety and Health Administration (OSHA) regulations - including, but not limited to the applicable sections of 29 CFR Part 1910 - Occupational Safety and Health Standards and 29 CFR Part 1926 - Safety and Health Regulations for Construction.
- b. Personal protective equipment (PPE) (e.g. head protection, footwear, high visibility apparel, safety glasses, hearing protection, respirators, gloves, etc.) shall be worn as appropriate for the work being performed, and as specified in regulation. At a minimum, all workers in the SH ROW, except when in their vehicles, shall wear the following personal protective equipment:
 - 1) Head protection that complies with the ANSI Z89.1 standard;
 - 2) At all construction sites or whenever there is danger of injury to feet, workers shall comply with OSHA's PPE requirements for foot protection per 29 CFR 1910.136, 1926.95, and 1926.96. If required, such footwear shall meet the requirements of ANSI Z41;
 - 3) High visibility apparel, which shall, at a minimum comply with the Class 2 specifications of the ANSI/ISEA 107 standard.

CDOT UTILITY/RELOCATION/SPECIAL USE PERMIT STANDARD PROVISIONS

Class 3 apparel shall be considered for use at night or in particularly hazardous situations.

- 4) The most recent version of the ANSI standards listed above shall apply.

12. ADA REQUIREMENTS

The Permittee shall comply with the applicable provisions of the Americans With Disabilities Act, with respect to both permanent facilities installations and temporary work zones.

13. CLEAR ROADSIDE CONSIDERATIONS

- a. CDOT is committed to provide a roadside area that is as free as practical from nontraverseable hazards and fixed objects ("clear zone"). New above ground installations may be permitted within the clear zone only upon a showing that no feasible alternate locations exist. Permittee must utilize appropriate countermeasures to minimize hazards.
- b. Permittee shall remove materials and equipment from the highway ROW at the close of daily operations. The traffic control plan must include protective measures where materials and equipment may be stored on ROW. Protection of open trenches and other excavations within highway ROW shall be addressed in the Permittee's traffic control plan. All excavations shall be closed at the end of daily operations, and no open excavation will be allowed in the clear zone after dark. The Permittee agrees to promptly undertake mitigating or corrective actions acceptable to the Department upon notification by CDOT that the installation permitted herein has resulted in a hazardous situation for highway users.

14. GENERAL CONSTRUCTION REQUIREMENTS

- a. Work shall not be performed at night or on Saturdays, Sundays, or holidays without prior authorization or unless otherwise specified in this permit. CDOT may restrict work on ROW during adverse weather conditions or during periods of high traffic volume.
- b. Those areas within ROW, which must be disturbed by permit operations, shall be kept to a practical minimum. Permittee shall not spray, cut, or trim trees or other landscaping elements within highway ROW, unless such work is otherwise specified in this permit, or clearly indicated on the approved plans. Cleated or tracked equipment shall not work on or move over paved surfaces without mats, or pads on tracks.
- c. Material removed from any portion of the roadway prism must be replaced in like kind with equal or better compaction. Segregation of material is not permitted. The permitted facility shall be of durable materials in conformity with accepted practice or industry standards, designed for long service life, and relatively free from routine servicing or maintenance.
- d. Construction or compaction by means of jetting, puddling, or water flooding is prohibited within all highway ROW.
- e. Thrust blocks are required on all vertical and horizontal bends in pressure pipes.
- f. Meters shall not be placed on highway ROW except within corporate limits where municipal regulations allow such use.

15. ALIGNMENT, COVER, CLEARANCE

- a. Location and alignment of Permittee's facilities shall only be as specified in this permit or as otherwise indicated in the approved plans or work sketch (EXHIBIT A).
- b. Parallel installations will not be permitted within roadways (including curbing and/or shoulders) or median areas, except within corporate boundaries, subject to municipal regulations.

- c. Parallel installations should be located as near as practicable to the ROW line. Crossings shall be as nearly perpendicular to the highway as feasible.
- d. Where no feasible alternate locations exist, the Department may permit parallel installations along roadside areas within 15 feet from edge of shoulder or back of curb. In these cases, the facility must be so located and safeguarded as to avoid potential conflict with necessary highway appurtenances (signs, guard rail, delineators, etc.). Specific safeguards such as increasing depth of cover to 60 inches, capping, or encasement, shall be specified in this permit's Special Provisions.
- e. Parallel installations shall follow a uniform alignment, wherever practical. Due consideration must be given to conserving space available for future utility accommodations. The standard allowable deviation from the approved horizontal alignment is ± 18 inches.
- f. Minimum cover shall conform to the Special Provisions. Normal specified cover will be 48 inches or greater; reduced cover may be approved where site conditions warrant, subject to other safeguards as may be specified or approved in the permit. Minimum overhead clearance shall conform to the Special Provisions, consistent with Utility Accommodation Code criteria.

16. PAVEMENT CUTS AND REPAIRS

Paved surfaces shall not be cut unless otherwise specified in this permit. No more than one half the width of the roadbed may be opened at a time, when otherwise permitted. Pavement shall be sawed or wheel-cut to a neat line. Pavement shall be replaced to a design equal to or greater than that of the surrounding undisturbed pavement structure. Pavement repair shall conform to the Special Provisions or the approved plans.

17. BORING, JACKING, ENCASEMENT

Unless otherwise specified, buried crossings shall be bored or jacked beneath the roadway, at least from toe of slope to toe of opposite slope. Portals for untrenched crossings more than 5 feet in depth shall be bulk headed in conformance with OSHA construction and safety standards. Portal limits of untrenched crossings shall be established safely beyond the highway surface and clear zone and in no case shall the lateral distance from the surfaced area of the highway to the boring or jacking pit be less than the vertical difference in elevation between such surface and the bottom of the pit. Water jetting or tunneling is not permitted. Water assisted boring may be permitted as determined by the CDOT Inspector. Boring hole shall be oversized to the minimum amount required to allow pull-through of the conduit being installed. Resultant voids shall be grouted or otherwise backfilled, subject to CDOT approval. Ends of bored sections shall not be covered before being inspected. Encasement shall be consistent with Utility Accommodation Code provisions. CDOT may require protective casing for shallow installations or certain conduit materials. Encased crossings shall extend at least from toe of slope to toe of slope, or the full width between access-control lines on freeways, including the Interstate System.

18. INSPECTION AND ACCEPTANCE

- a. CDOT will determine the extent of inspection services necessary for a given installation. Permittee shall attend final inspection as may be required. If the initial performance of permitted work was unacceptable, as determined by the Department, the Permittee shall perform any reconstruction or improvement of that work as ordered by the Department, in a timely manner and prior to any further construction. If permitted operations are not being carried out in compliance with the terms and conditions of this permit, the Department may order the Permittee to perform whatever corrective measures are necessary to attain compliance with the permit. If there is an immediate danger to the public's health, safety or welfare, the Department may order the Permittee to cease all operations and if necessary, to remove all equipment and facilities from the SHROW.
- b. Final acceptance does not relieve Permittee of maintenance obligations toward those elements of the highway facility

CDOT UTILITY/RELOCATION/SPECIAL USE PERMIT STANDARD PROVISIONS

constructed under this permit. Final acceptance begins the two-year warranty period (see requirement under "Operation and Maintenance" below).

19. ENVIRONMENTAL CLEARANCES/PERMITS

- a. It is the responsibility of the Permittee to determine which environmental clearances and/or regulations apply to their activities and to obtain any clearances that are required directly from the appropriate regulatory agency prior to commencing work. Please refer to or request a copy of the "CDOT Environmental Clearance Information Summary" (ECIS) for details. The ECIS may be obtained from CDOT Permitting Offices or may be accessed via the CDOT webpage at <http://www.dot.state.co.us/UtilityProgram/Forms.cfm>. Failure to comply with regulatory requirements may result in suspension or revocation of your CDOT permit, or enforcement actions by other agencies.
- b. The Special Provisions of this permit shall list any specific environmental clearances or permits that the Department has been notified by the Permittee or by the administering regulatory agency apply to the operations authorized by this permit. The Special Provisions shall require the Permittee obtain the listed environmental clearances/permits prior to beginning work.
- c. The Permittee shall comply with all requirements described in the CDOT Environmental Clearances Information Summary, including those pertaining to:
 - 1) Ecological Resources
 - 2) Cultural Resources
 - 3) Discharges of Stormwater or Process Water
 - 4) Hazardous Materials
 - 5) Discharges of Dredged or Fill Material
 - 6) Erosion and Sediment Control
 - 7) Disposal of Drilling Fluids
 - 8) Concrete Washout
 - 9) Spill Reporting
 - 10) Transportation of Hazardous Materials
- d. Disturbance of any wildlife shall be avoided to the maximum extent practicable. If threatened or endangered species or archeological or historical artifacts are encountered during the progress of a project, work in the subject area shall be halted and the CDOT regional permitting office shall be contacted immediately for direction as to how to proceed.
- e. All discharges of stormwater or process water are subject to the applicable provisions of the Colorado Water Quality Control Act and the Colorado Discharge Permit Regulations.
- f. There shall be no disposal of hazardous materials in the state highway right of way. Solid waste shall be removed from the state highway right of way and disposed of at a permitted facility or designated collection point (such as the Permittee's own dumpster). Drilling fluids must be disposed of as described in the ECIS.
- g. If pre-existing solid waste or hazardous materials contamination (including oil or gasoline contaminated soil, asbestos, chemicals, mine tailings, etc.) are encountered during the performance of work, the Permittee shall halt work in the affected area and immediately contact the CDOT regional permitting office for direction as to how to proceed.
- h. Spills shall be reported immediately using the CDOT Illicit Discharge Hotline (303) 512-4446. Spills on the highway, into waterways, or that may otherwise present an immediate danger to the public, shall be reported by calling 911 or the Colorado State Patrol at (303) 239-4501, and the Colorado Department of Public Health and Environment at 1-(877) 518-5608.

20. RESTORATION OF RIGHT OF WAY

Prior to final acceptance, all disturbed portions of highway right of way shall be cleaned up and restored to their original condition, subject to CDOT approval. Seeding, sodding, and planting shall be as specified, or otherwise approved by CDOT. Construction, maintenance and watering requirements shall conform to the CDOT Standard Specifications. Where landscape restoration must be delayed due to seasonal requirements, such work may be authorized by separate permit. Permittee shall use only certified weed-free seed and mulch. Permittee shall clean equipment before transporting it into or out of the state to prevent the migration of noxious weeds.

21. OPERATION AND MAINTENANCE

- a. Permittee agrees to own and maintain the installation permitted herein. The facility shall be kept in an adequate state of repair and maintained in such a manner as to cause the least interference with the normal operation and maintenance of the highway.
- b. If any element of the transportation facility, constructed or replaced as a condition of this permit, fails within 24 months due to improper construction or materials. Permittee shall make all repairs immediately as notified in writing by CDOT.
- c. Routine, periodic maintenance and emergency repairs may be performed under the general terms and conditions of this permit. CDOT shall be given proper advance notice whenever maintenance work will affect the movement or safety of traffic. In an emergency, the CDOT Region office and the State Patrol shall immediately be notified of possible traffic hazards. Emergency procedures shall be coordinated beforehand, where possible.
- d. Maintenance activities requiring new excavation or other disturbance within highway ROW may require separate permit. Where highway construction or maintenance operations so require, Permittee will shut off lines, remove all combustible materials from the highway right of way, or provide other temporary safeguards.

22. MARKERS, LOCATION AIDS, LOCATION ASSISTANCE

- a. The utility shall take all practical measures to ensure that buried utility facilities are surface-detectable by standard geophysical methods. Where the utility facilities, by the nature of their material properties, burial depth or other factors, may by themselves not be surface-detectable, the utility shall, where feasible, incorporate detection wire or other detection aids in the installation of those facilities. In instances where detection aids are not feasible or would be ineffective and surface-detectability cannot be ensured, surface markers shall be installed as directed by the Department and as-constructed plans and showing the accurate horizontal and vertical location of the buried facilities shall be provided to the Department.
- b. All plowed or trenched installations must include color-coded (using the American Public Works Association color coding system) warning tape placed not less than 12 inches vertically above the top of the line. The warning tape shall be surface-detectable if needed to facilitate detection of the line.
- c. The utility shall place readily identifiable markers at the right of way line where it is crossed by pipelines carrying transmittants which are flammable, corrosive, expansive, energized, or unstable, particularly if carried at high pressure or potential, except where a vent will serve as a marker.
- d. The utility shall place markers for longitudinal underground facilities vertically above the facilities or at a known horizontal offset, unless otherwise approved in writing by the Department. Each marker shall provide a fore- and backsight to succeeding and preceding markers. Markers shall be installed at suitable intervals along tangent sections, at angle points or points of curvature and at reasonable intervals along curves.
- e. The utility shall maintain any markers required by this Code for the life of the installation.

CDOT UTILITY/RELOCATION/SPECIAL USE PERMIT STANDARD PROVISIONS

- f. The Department may require the utility to submit "as-constructed" plans. The Department may enter into an agreement with the utility whereby the Department can rely on those plans for the exact location of the utility for any future excavations, and need not give notice to the utility under Article 1.5 of Title 9, C.R.S.
 - 4) requesting entity whether or not the subject facilities are retired or abandoned.
 - perform any other actions as deemed necessary by the Department to protect the transportation facility and/or the traveling public.
- g. The utility will comply with the applicable requirements of Article 1.5 of Title 9 C.R.S., including any requirement to participate in the State's Notification Association pursuant to 9-1.5-105 C.R.S.. All owners of underground utilities within the SHROW, with the exception of the Department itself, must become members of the UNCC Notification Association.
- h. In addition to complying with the provisions of Article 1.5 of Title 9 C.R.S (One-Call Statute) in response to the Department's notification of planned excavations, utility owners shall surface-mark their buried utility facilities that are located within the SHROW in order to facilitate Departmental engineering and design activities, upon reasonable request from the Department, and at no cost to the Department. The Permittee shall respond to such request within a reasonable timeframe acceptable to the Department, but no longer than 14 calendar days from the date of request, and the accuracy of the surface marking shall be within 18 inches of either side of the actual location of the buried facility.

23. ADJUSTMENTS DUE TO HIGHWAY CONSTRUCTION

If for any transportation purpose it becomes necessary to remove, adjust, or relocate this facility, Permittee will do so promptly, at no cost to the CDOT except as provided by law, upon written notice from CDOT and in accordance with the utility relocation permit issued to cover the necessary work. The utility shall perform the relocation at or within a time convenient to and in proper coordination with the project or transportation-related activity, to minimize public inconvenience and cost, as directed by the Department in the permit authorizing the relocation. The utility company shall pay for damages caused by the company's delay in the performance of utility relocation work or interference with the performance of transportation project work done by others. Such damages include, but are not limited to, payments made by the Department to any third party based on a claim that performance of the transportation project work was delayed or interfered with as a direct result of the utility company's failure to timely perform the utility relocation work. Damages resulting from delays in the performance of the utility relocation work or interference with the transportation project work that are caused by events beyond the utility company's ability to reasonably foresee or control (a force majeure) shall not be charged to the utility company.

24. ABANDONMENT, RETIREMENT, CHANGE IN OWNERSHIP

- a. The Permittee shall notify the Department in writing of the planned retirement or abandonment of its facility or any portion thereof. The Department will notify the Permittee in writing if it determines that the facilities may be retired or abandoned in place, along with any special conditions that may apply.
- b. Retired facilities shall remain the Permittee's sole responsibility, subject to all provisions of the Utility Accommodation Code and all of the terms and conditions of the permit issued for that facility, including maintenance and relocation requirements.
- c. The Permittee shall promptly remove all abandoned facilities from the SH ROW and promptly restore the SH ROW to pre-existing or other conditions prescribed by the Department unless the Department in writing expressly allows the facility to remain in place. Written notice from the Department, allowing an abandoned facility to remain in place, may include special conditions.
- d. If utility facilities are retired or abandoned in place, the utility shall comply with that decision if directed by the Department:
 - 1) cap, plug or fill lines,
 - 2) furnish suitable location records for any such buried facilities,
 - 3) maintain its own records of such facilities and respond to locate notices/requests from the UNCC and/or excavators. In providing such locates, the utility will indicate to the

25. SUSPENSION AND CANCELLATION

- a. The CDOT inspector may suspend operation due to:
 - 1) Non compliance with the provisions of this permit
 - 2) Adverse weather or traffic conditions
 - 3) Concurrent transportation construction or maintenance operations in conflict with the permitted work.
 - 4) Any condition deemed unsafe for workers or for the general public.
- b. Work may resume when grounds for suspension no longer exist.

This permit is subject to cancellation due to:

 - 1) Persistent noncompliance with permit provisions
 - 2) Abandonment or transfer of ownership
 - 3) Superseded by new permit covering the same installation
 - 4) Conflict with necessary planned transportation construction.
- c. Permittee must promptly terminate occupancy upon notice of cancellation of permit, unless a new permit is applied for and granted.
- d. Where Permittee does not fulfill an obligation to repair or maintain any portion of the highway facility, or control and safely maintain the flow of traffic thereon, CDOT reserves the right, in lieu of canceling this permit, to accomplish the required work by any other appropriate means, and Permittee shall be liable for the actual costs thereof.

COLORADO DEPARTMENT OF TRANSPORTATION Environmental Clearances Information Summary

PURPOSE - This summary is intended to inform entities external to CDOT that may be entering the state highway right-of-way to perform work related to their own facilities (such as Utility, Special Use or Access Permittees), about some of the more commonly encountered environmental permits/clearances that may apply to their activities. This listing is not all-inclusive - additional environmental or cultural resource permits/clearances may be required in certain instances. Appropriate local, state and federal agencies should be contacted for additional information if there is any uncertainty about what permits/clearances are required for a specific activity. **IMPORTANT – Please Review The Following Information Carefully – Failure to Comply With Regulatory Requirements May Result In Suspension or Revocation of Your CDOT Permit, Or Enforcement Actions By Other Agencies.**

CLEARANCE CONTACTS - As indicated in the permit/clearance descriptions listed below, the following individuals or agencies may be contacted for additional information:

- Colorado Department of Public Health and Environment (CDPHE): General Information – (303) 692-2035
Water Quality Control Division (WQCD): (303) 692-3500
Environmental Permitting Website <https://www.colorado.gov/pacific/cdphe/all-permits>
- CDOT Water Quality Program Manager: (303) 757-9343 <https://www.codot.gov/programs/environmental/water-quality>
- CDOT Asbestos Project Manager: Phil Kangas, (303) 512-5519
- Colorado Office of Archaeology and Historic Preservation: (303) 866-5216
- U.S. Army Corps of Engineers, District Regulatory Offices:
 - Omaha District (NE CO), Denver Office (303) 979-4120
<http://www.nwo.usace.army.mil/Missions/RegulatoryProgram/Colorado.aspx>
 - Sacramento Dist. (Western CO), Grand Junction Office (970) 243-1199
<http://www.spk.usace.army.mil/Missions/Regulatory.aspx>
 - Albuquerque District (SE CO), Pueblo Office (719)-543-9459
<http://www.spa.usace.army.mil/Missions/RegulatoryProgramandPermits.aspx>
- CDOT Utilities, Special Use and Access Permitting: (303) 757-9654 <https://www.codot.gov/business/permits>

Wildlife Resources - Disturbance of wildlife shall be avoided to the maximum extent practicable. Entry into areas of known or suspected threatened or endangered species habitat will require special authorization from the CDOT permitting office. If any threatened or endangered species are encountered during the progress of the permitted work, work in the subject area shall be halted and the CDOT Regional Permitting Office and Region Planning and Environmental Manager shall be contacted immediately. Authorization must be provided by CDOT prior to the continuation of work. Information about threatened or endangered species may be obtained from the CDOT website, <http://www.codot.gov/programs/environmental/wildlife/guidelines>, or the Colorado Parks and Wildlife (CPW) website, <http://www.cpw.state.co.us/learn/Pages/SOC-ThreatenedEndangeredList.aspx>. Additional guidance may be provided by the appropriate Region Planning and Environmental Manager (RPEM).

Cultural Resources - The applicant must request a file search of the permit area through the Colorado Office of Archaeology and Historic Preservation (OAHP), Denver, to ascertain if historic or archaeological resources have previously been identified (<http://www.historycolorado.org/oaHP/file-search>). Inventory of the permit area by a qualified cultural resources specialist may be necessary, per the recommendation of CDOT. If archaeological sites/artifacts or historic resources are known to exist prior to the initiation of the permitted work or are encountered as the project progresses, all work in the subject area shall be halted and the CDOT Regional Permitting Office and Region Planning and Environmental Manager shall be contacted immediately. Authorization must be provided by CDOT prior to the continuation of work. Additional guidance may be provided by the Regional Permitting Office and RPEM. **Contact Information:** Contact the OAHP for file searches at (303) 866-5216.

Paleontological Resources - The applicant must request a fossil locality file search through the University of Colorado Museum, Boulder (<https://cumuseum.colorado.edu/research/paleontology/vertebrates/policies>), and the Denver Museum of Nature and Science (<http://www.dmns.org/science/collections/earth-science-collections/>) to ascertain if paleontological resources have been previously identified in or near the permit area. Inventory of the permit area by a qualified paleontologist may be necessary, per the recommendation of CDOT. If fossils are encountered during the permitted work, all work in the subject area shall be halted and the CDOT Regional Permitting Office and Region Planning and Environmental Manager shall be contacted immediately. Authorization must be provided by CDOT prior to the continuation of work. Additional guidance may be provided by the Regional Permitting Office in the Permit Special Provisions. **Contact Information:** See the museum websites listed above for Paleontological Collections Manager contact information. Contact the CDOT Paleontologist for further information at nicole.peavey@state.co.us or (303) 757-9632. The CDOT Paleontologist will not conduct a comprehensive file search independently of the museums.

Hazardous Materials, Solid Waste - The Solid Wastes Disposal Sites and Facilities Act C.R.S. 30-20-100, et al, and Regulations Pertaining to Solid Waste Disposal Sites and Facilities (6 CCR 1007-2), prohibit solid waste disposal without an approved Certificate of Designation (a landfill permit). The Colorado Hazardous Waste Act C.R.S. 25-15-301 et al, and the Colorado Hazardous Waste Regulations (6 CCR 1007-3) prohibit the transfer, storage or disposal (TSD) of hazardous waste except at permitted TSD sites. There are no permitted landfills or TSD sites within the State Highway Right of Way. Therefore, all solid or hazardous wastes that might be generated by the activities of entities entering the State Highway Right of Way must be removed from the ROW and disposed of at a permitted facility or designated collection point (e.g., for solid waste, a utility or construction company's own dumpster). If pre-existing solid waste or hazardous materials contamination (including oil or petroleum contaminated soil, asbestos, chemicals, mine tailings, etc.) is encountered during the performance of work, the permittee shall halt work in the affected area and immediately contact the CDOT Regional Permitting Office for direction as to how to proceed. **Contact Information:** Theresa Santangelo-Dreiling, CDOT Hazardous Materials Management Supervisor: (303) 512-5524.

Asbestos Containing Materials, Asbestos Contaminated Soil - All work on asbestos containing materials (ACM) must comply with the applicable requirements of the CDPHE Air Pollution Control Division's (APCD) Regulation 8. Disposal of ACM, and work done in asbestos-contaminated soil, must comply with the CDPHE Hazardous Materials and Waste Management Division's (HMWMD) Solid

Waste Regulations. The application for any CDOT permit must specifically identify any ACM involved in the work for which authorization is being requested. Additional guidance or requirements may be specified in the permit special provisions. **Contact Info:** CDPHE APCD and HMWMD Regulations can be accessed via the CDPHE Environmental Permitting Website listed above. Additional information concerning clearance on CDOT projects is available from the CDOT Asbestos Project Manager (303) 512-5519, or Theresa Santangelo-Dreiling, Hazardous Materials Management Supervisor: (303) 512-5524.

Transportation of Hazardous Materials - No person may offer or accept a hazardous material for transportation in commerce unless that person is registered in conformance with the United States Department of Transportation regulations at 49 CFR, Part 171. The hazardous material must be properly classed, described, packaged, marked, labeled, and in condition for shipment as required or authorized by applicable requirements, or an exemption, approval or registration has been issued. Vehicles requiring a placard, must obtain authorization and a State HAZMAT Permit from the Colorado Public Utilities Commission. **Contact Information:** For authorization and more info call the Federal Motor Safety Carrier Administration, US DOT for inter- and intra-state HAZMAT Registration (303) 969-6748. Colorado Public Utilities Commission: (303) 894-2868.

Discharge of Dredged or Fill Material – 404 Permits Administered By the U.S. Army Corps of Engineers, and Section 401 Water Quality Certifications Issued by the CDPHE WQCD - Corps of Engineers 404 permits are required for the discharge of dredged or fill materials into waters of the United States, including wetlands. There are various types of 404 permits, including nationwide permits, which are issued for activities with relatively minor impacts. For example, there is a nationwide permit for utility line activities (nwp #12). Depending upon the specific circumstances, it is possible that either a "general" or "individual" 404 permit would be required. If an individual 404 permit is required, section 401 water quality certification from the CDPHE WQCD is also required. Contact the appropriate Corps District Regulatory Office for information about what type of 404 permit may be required (contact information above). Contact the CDPHE Water Quality Control Division at (303) 692-3500.

Working on or in any stream or its bank - In order to protect and preserve the state's fish and wildlife resources from actions that may obstruct, diminish, destroy, change, modify, or vary a natural existing stream or its banks or tributaries, it may be necessary to obtain a Senate Bill 40 certification from the Colorado Department of Natural Resources. A stream is defined as 1) represented by a solid blue line on USGS 7.5' quadrangle maps; and/or 2) intermittent streams providing live water beneficial to fish and wildlife; and/or 3) segments of streams supporting 25% or more cover within 100 yards upstream or downstream of the project; and/or 4) segments of streams having wetlands present within 200 yards upstream or downstream of the project measured by valley length. The CPW application, as per guidelines agreed upon by CDOT and CPW, can be accessed at <https://www.codot.gov/programs/environmental/wildlife/guidelines>.

Stormwater Construction Permit (SCP) and Stormwater Discharge From Industrial Facilities - Discharges of stormwater runoff from construction sites disturbing one acre or more - or certain types of industrial facilities, such as concrete batch plants - require a CDPS Stormwater Permit. **Contact Information:** Contact the CDPHE Water Quality Control Division at (303) 692-3500. Website: <https://www.colorado.gov/pacific/cdphe/wq-construction-general-permits> and <https://colorado.gov/pacific/cdphe/wq-commerce-and-industry-permits>.

Construction Dewatering (Discharge or Infiltration) and Remediation Activities - Discharges of water encountered during excavation or work in wet areas may require a Construction Dewatering or Remediation Activities Discharge Permit. **Contact Information:** For Construction Dewatering and Remediation Activities Discharge Permits, contact the CDPHE WQCD at (303) 692-3500. For Applications and Instructions (CDPHE website): <https://www.colorado.gov/pacific/cdphe/wq-construction-general-permits>.

Municipal Separate Storm Sewer System (MS4) Discharge Permit - Discharges from the storm sewer systems of larger municipalities, and from the CDOT highway drainage system that lies within those municipalities, are subject to MS4 Permits issued by the CDPHE WQCD. For facilities that lie within the boundaries of a municipality that is subject to an MS4 permit, the owner of such facility should contact the municipality regarding stormwater related clearances that may have been established under that municipality's MS4 permit. All discharges to the CDOT highway drainage system or within the Right of Way (ROW) must comply with the applicable provisions of the Colorado Water Quality Control Act, the Water Quality Control Commission (WQCC) Regulations (<https://www.colorado.gov/pacific/cdphe/wqcc-regulations-and-policies-and-water-quality-statutes>) and the CDOT MS4 Permit # COS-000005 (<https://www.codot.gov/programs/environmental/water-quality/documents>). Discharges are subject to inspection by CDOT and CDPHE. Contact the CDPHE Water Quality Control Division at (303) 692-3500 for a listing of municipalities required to obtain MS4 Permits, or go to <https://www.colorado.gov/pacific/cdphe/wq-municipal-ms4-permits>. For CDOT-related MS4 regulations, go to: <https://www.codot.gov/programs/environmental/water-quality/stormwater-programs.html>.

General Prohibition – Discharges - All discharges are subject to the provisions of the Colorado Water Quality Control Act and the Colorado Discharge Permit Regulations. Prohibited discharges include, but are not limited to, substances such as wash water, paint, automotive fluids, solvents, oils or soaps and sediment. **Contact Information:** Contact the CDPHE Water Quality Control Division at (303) 692-3500.

General Authorization - Allowable Non-Stormwater Discharges - Unless otherwise identified by CDOT or the WQCD as significant sources of pollutants to the waters of the State, the following discharges to stormwater systems are allowed without a Colorado Discharge Permit System permit: landscape irrigation, diverted stream flows, uncontaminated ground water infiltration to separate storm sewers, discharges from potable water sources, foundation drains, air conditioning condensation, irrigation water, uncontaminated springs, footing drains, water line flushing, flows from riparian habitats and wetlands, and flow from firefighting activities. Allowable non-stormwater discharges can be found under Illicit Discharge PDD at: <https://www.codot.gov/programs/environmental/water-quality/stormwater-programs.html>. **Contact Information:** The CDPHE Water Quality Control Division (telephone #'s listed above).

Erosion and Sediment Control Practices - For activities requiring a Stormwater Construction Permit, erosion control requirements will be specified in that permit. In situations where a stormwater permit is not required, all reasonable measures should be taken to minimize erosion and sedimentation according to CDOT Standard Specifications 107.25, 208, 213 and 216 (<https://www.codot.gov/business/designsupport/2011-construction-specifications/2011-Specs/2011-specs-book>). All disturbances require a stabilization plan, native seeding or landscape design plan according to applicable CDOT Standard Specifications 212-217 and 623. The CDOT Erosion Control and Stormwater Quality Guide (available from the Bid Plans Office at (303) 757-9313) should be used to design erosion controls and restore disturbed vegetation.

Disposal of Drilling Fluids - Drilling fluids used in operations such as Horizontal Directional Drilling may be classified as "discharges" or "solid wastes," and in general, should be pumped or vacuumed from the construction area, removed from the State Highway Right of Way, and disposed of at permitted facilities that specifically accept such wastes. Disposal of drilling fluids into storm drains, storm sewers, roadside ditches or any other type of man-made or natural waterway is prohibited by Water Quality Control and/or Solid Waste regulations. Small quantities of drilling fluid solids (less than 1 cubic yard of solids) may be left on-site after either being separated from fluids or after infiltration of the water, provided: 1) the drilling fluid consists of only water and bentonite clay, or, if required for proper drilling properties, small quantities of polymer additives that are approved for use in drinking water well drilling; 2) the solids are fully contained in a pit, and are not likely to pose a nuisance to future work in the area, 3) the solids are covered and the area restored as required by CDOT permit requirements (Utility, Special Use, or Access Permits, etc.). **Contact Information:** Contact CDPHE (telephone #'s listed above).

Noxious Weeds and Invasive Species Management Plan - Noxious Weeds and Invasive Species guidance can be found by contacting the Colorado Department of Agriculture (<https://www.colorado.gov/pacific/agconservation/noxiousweeds>) and the Colorado Division of Parks and Wildlife (<http://cpw.state.co.us/aboutus/Pages/RS-NoxiousWeeds.aspx>). In either case, management plans involving the control of noxious weeds associated with the permitted activity and cleaning of equipment will be required.

Concrete Washout - Waste generated from concrete activities shall NOT be allowed to flow into the drainage ways, inlets, receiving waters, or in the CDOT ROW. Concrete waste shall be placed in a temporary concrete washout facility and must be located a minimum of 50 feet from state waters, drainageways, and inlets. Concrete washout shall only be performed as specified by the CDOT Environmental Program and shall be in accordance to CDOT specifications and guidelines. **Contact Information:** Contact CDPHE or find additional information on the CDOT website: <https://www.codot.gov/business/designsupport/2011-construction-specifications/2011-Specs> and refer to the specifications and their revisions for sections 101, 107 and 208.

Spill Reporting - Spills shall be contained and cleaned up as soon as possible. Spills shall NOT be washed down into the storm drain or buried. All spills shall be reported to the CDOT Illicit Discharge Hotline at (303) 512-4446 (4H20), as well as the Regional Permitting Office and Regional Maintenance Supervisor. Spills on highways, into waterways, any spill in the highway right-of-way exceeding 25 gallons, or that may otherwise present an immediate danger to the public shall be reported by calling 911, and shall also be reported to the CDPHE at 1-877-518-5608. More information can be found at <https://www.colorado.gov/pacific/cdphe/emergency-reporting-line>.



APPENDIX D DESIGN CHARTS

Table 6-6. Runoff Coefficients for Rational Method
(Source: UDFCD 2001)

Land Use or Surface Characteristics	Percent Impervious	Runoff Coefficients											
		2-year		5-year		10-year		25-year		50-year		100-year	
		HSG A&B	HSG C&D	HSG A&B	HSG C&D	HSG A&B	HSG C&D	HSG A&B	HSG C&D	HSG A&B	HSG C&D	HSG A&B	HSG C&D
Business													
Commercial Areas	95	0.79	0.80	0.81	0.82	0.83	0.84	0.85	0.87	0.87	0.88	0.88	0.89
Neighborhood Areas	70	0.45	0.49	0.49	0.53	0.53	0.57	0.58	0.62	0.60	0.65	0.62	0.68
Residential													
1/8 Acre or less	65	0.41	0.45	0.45	0.49	0.49	0.54	0.54	0.59	0.57	0.62	0.59	0.65
1/4 Acre	40	0.23	0.28	0.30	0.35	0.36	0.42	0.42	0.50	0.46	0.54	0.50	0.58
1/3 Acre	30	0.18	0.22	0.25	0.30	0.32	0.38	0.39	0.47	0.43	0.52	0.47	0.57
1/2 Acre	25	0.15	0.20	0.22	0.28	0.30	0.36	0.37	0.46	0.41	0.51	0.46	0.56
1 Acre	20	0.12	0.17	0.20	0.26	0.27	0.34	0.35	0.44	0.40	0.50	0.44	0.55
Industrial													
Light Areas	80	0.57	0.60	0.59	0.63	0.63	0.66	0.66	0.70	0.68	0.72	0.70	0.74
Heavy Areas	90	0.71	0.73	0.73	0.75	0.75	0.77	0.78	0.80	0.80	0.82	0.81	0.83
Parks and Cemeteries													
Parks and Cemeteries	7	0.05	0.09	0.12	0.19	0.20	0.29	0.30	0.40	0.34	0.46	0.39	0.52
Playgrounds	13	0.07	0.13	0.16	0.23	0.24	0.31	0.32	0.42	0.37	0.48	0.41	0.54
Railroad Yard Areas	40	0.23	0.28	0.30	0.35	0.36	0.42	0.42	0.50	0.46	0.54	0.50	0.58
Undeveloped Areas													
Historic Flow Analysis—Greenbelts, Agriculture	2	0.03	0.05	0.09	0.16	0.17	0.26	0.26	0.38	0.31	0.45	0.36	0.51
Pasture/Meadow	0	0.02	0.04	0.08	0.15	0.15	0.25	0.25	0.37	0.30	0.44	0.35	0.50
Forest	0	0.02	0.04	0.08	0.15	0.15	0.25	0.25	0.37	0.30	0.44	0.35	0.50
Exposed Rock	100	0.89	0.89	0.90	0.90	0.92	0.92	0.94	0.94	0.95	0.95	0.96	0.96
Offsite Flow Analysis (when land use is undefined)	45	0.26	0.31	0.32	0.37	0.38	0.44	0.44	0.51	0.48	0.55	0.51	0.59
Streets													
Paved	100	0.89	0.89	0.90	0.90	0.92	0.92	0.94	0.94	0.95	0.95	0.96	0.96
Gravel	80	0.57	0.60	0.59	0.63	0.63	0.66	0.66	0.70	0.68	0.72	0.70	0.74
Drive and Walks													
Drive and Walks	100	0.89	0.89	0.90	0.90	0.92	0.92	0.94	0.94	0.95	0.95	0.96	0.96
Roofs	90	0.71	0.73	0.73	0.75	0.75	0.77	0.78	0.80	0.80	0.82	0.81	0.83
Lawns	0	0.02	0.04	0.08	0.15	0.15	0.25	0.25	0.37	0.30	0.44	0.35	0.50

Figure 6-25. Estimate of Average Concentrated Shallow Flow

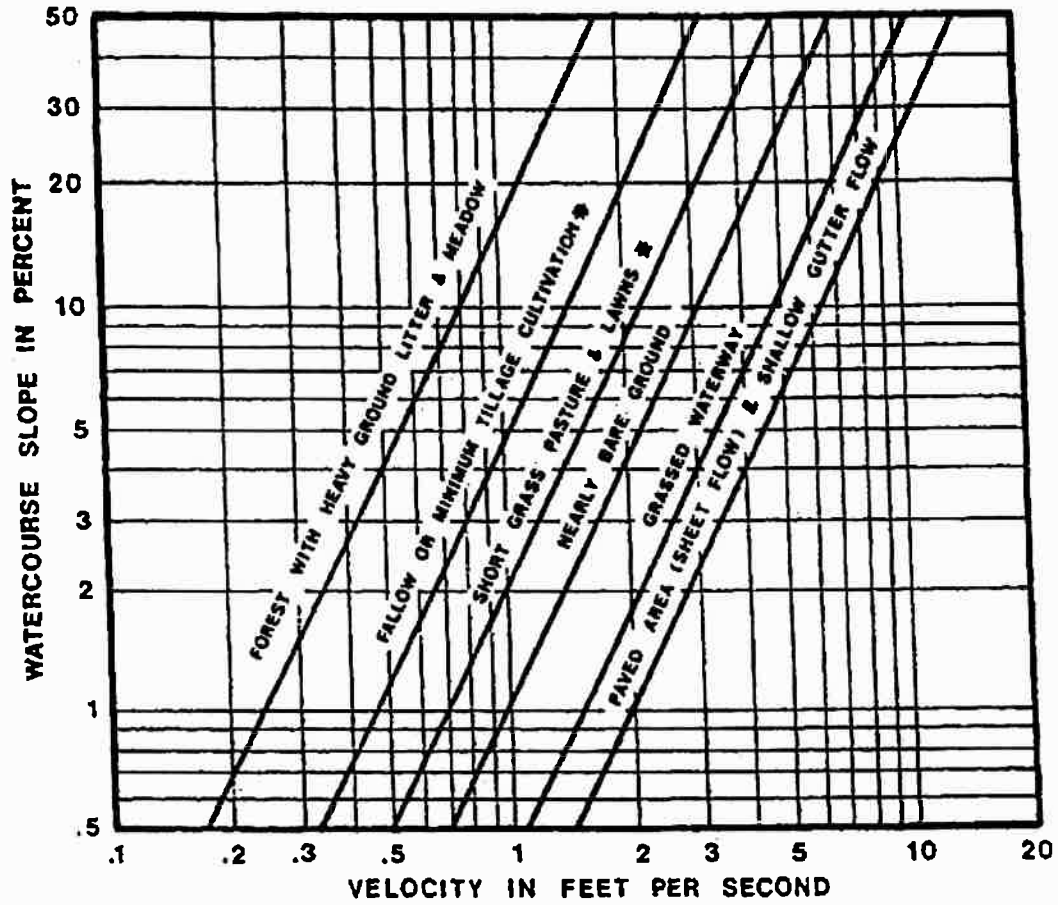
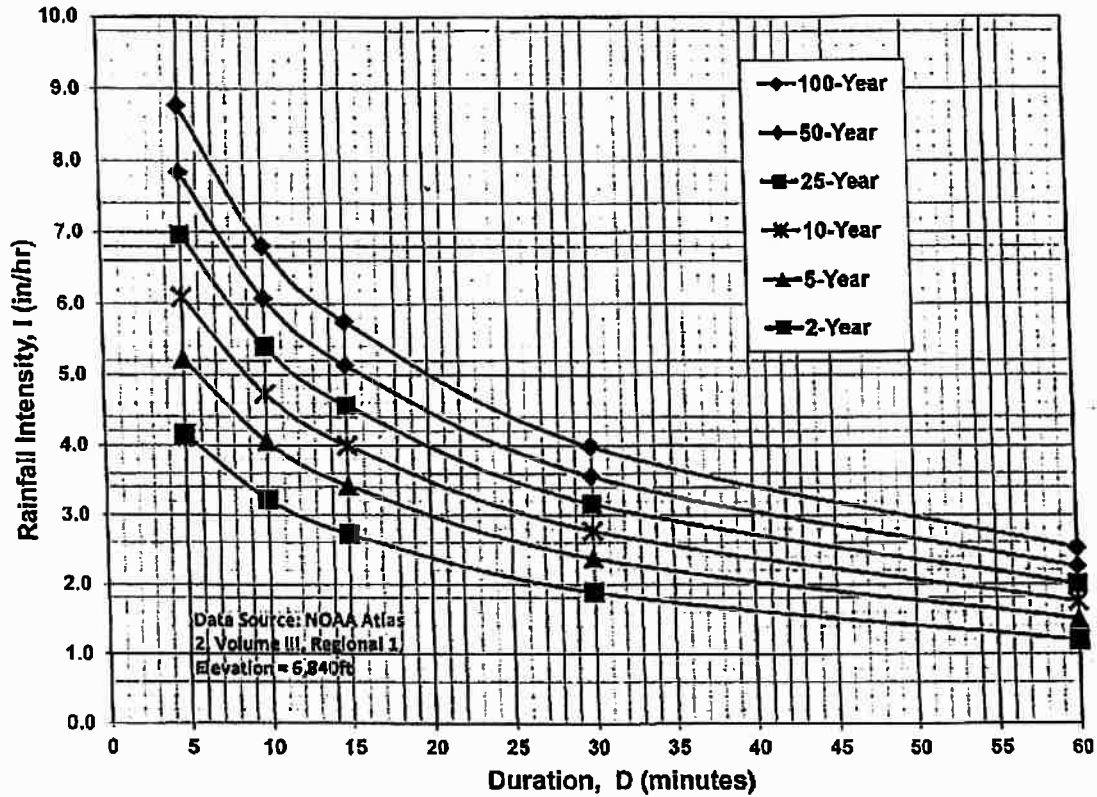

Figure 6-5. Colorado Springs Rainfall Intensity Duration Frequency



IDF Equations

$$I_{100} = -2.52 \ln(D) + 12.735$$

$$I_{50} = -2.25 \ln(D) + 11.375$$

$$I_{25} = -2.00 \ln(D) + 10.111$$

$$I_{10} = -1.75 \ln(D) + 8.847$$

$$I_5 = -1.50 \ln(D) + 7.583$$

$$I_2 = -1.19 \ln(D) + 6.035$$

Note: Values calculated by equations may not precisely duplicate values read from figure.

M:\LAND PROJECTS\2016\161103-Drainage.dwg Mike Bartusek Wed, 09/29/20 11:32 AM

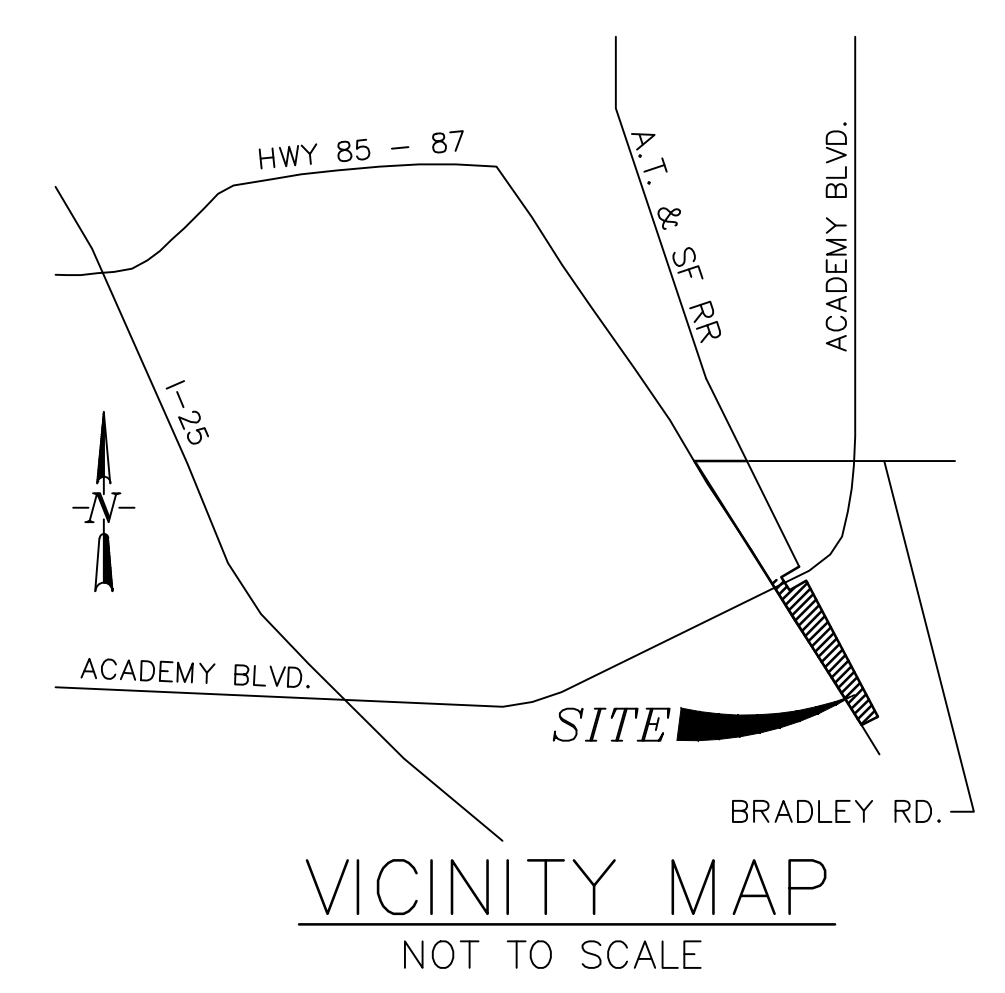

LEGEND

- BASIN DESIGNATION
- BASIN AREA, ACRES
- 5 YEAR STORM, CFS
- 100 YEAR STORM, CFS
- 5 YEAR ACCUMULATED FLOW, CFS
100 YEAR ACCUMULATED FLOW, CFS
- SUB-BASIN BOUNDARY
- DIRECTION OF DRAINAGE FLOW

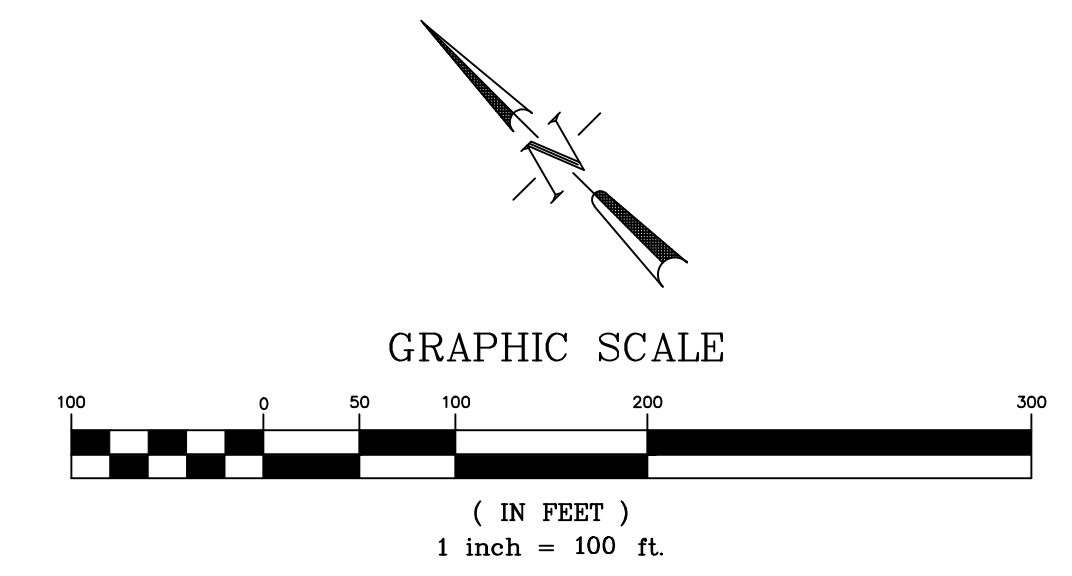
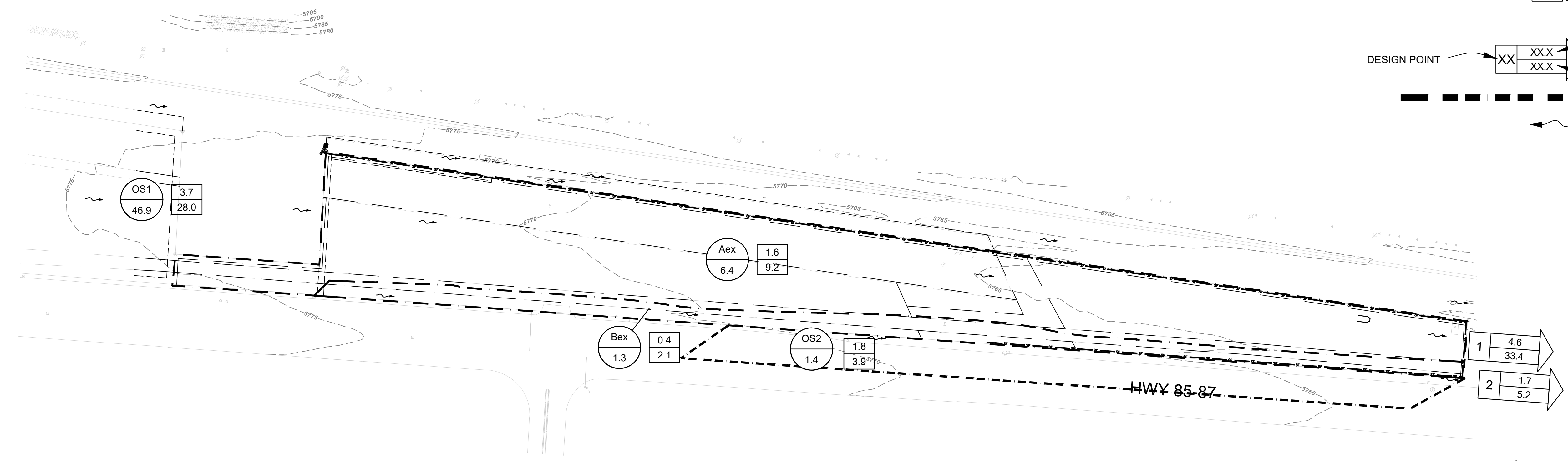

ASSOCIATED DESIGN PROFESSIONALS
 PREPARED UNDER MY DIRECT SUPERVISION FOR AND ON THE BEHALF OF ASSOCIATED DESIGN PROFESSIONALS, INC.

 MICHAEL BARTUSEK, COLORADO P.E. #23329

 DATE

DESIGNED BY	MAB
PROJECT ENGINEER	MAB
PROJECT MANAGER	MAB
DATE:	09/17/20
JOB NO.	161103
CAD FILE NO.	161103-Drainage
DRAWN BY	HUG
SCALE:	1"=100'
VERT.	N/A

SOUTH ACADEMY BUSINESS CENTER
4425 HWY 85-87
EL PASO COUNTY, COLORADO
DRAINAGE PLAN - EXISTING CONDITIONS

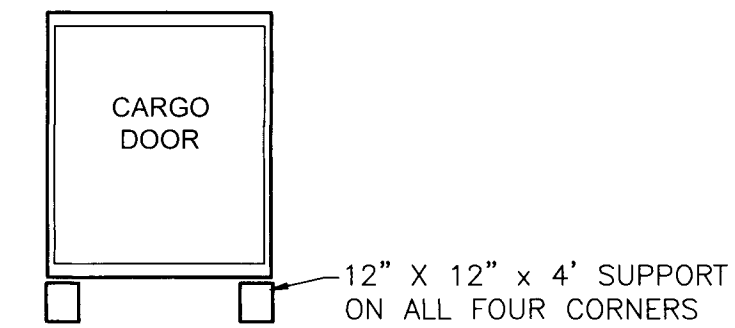

TRAILER AT BERM OPENING
SUPPORT DETAIL

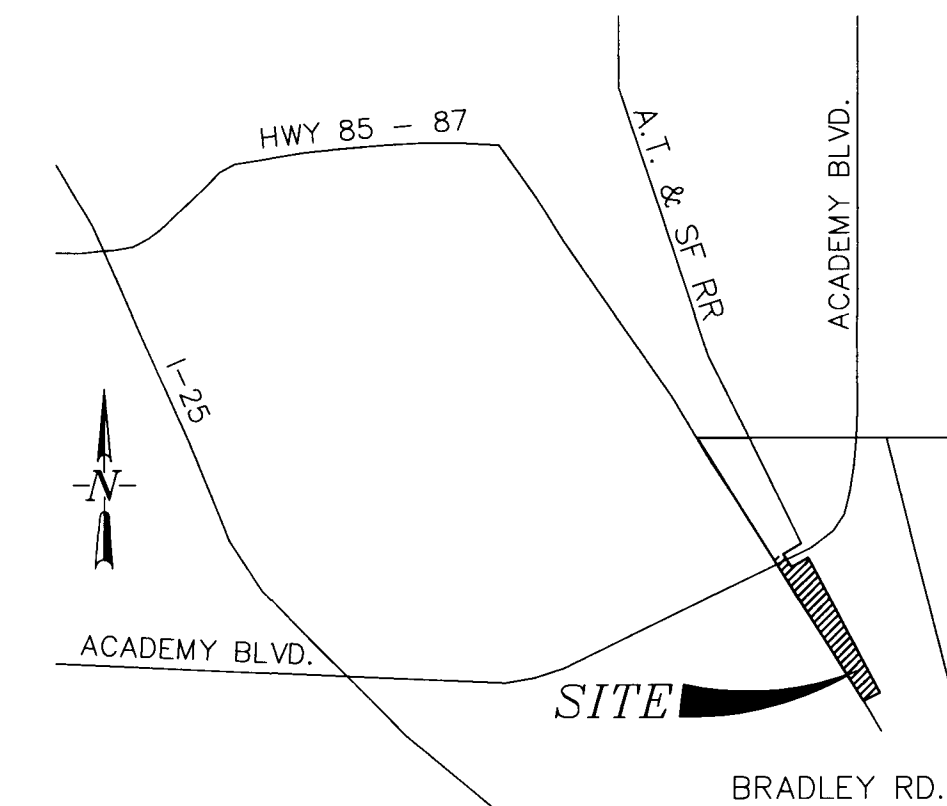

VICINITY MAP
NOT TO SCALE

LEGEND

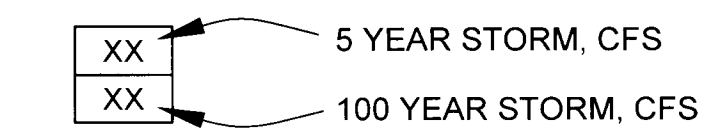
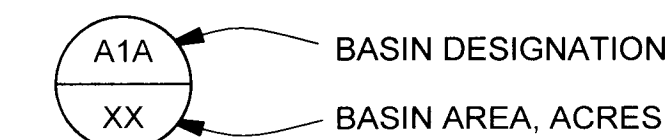

NOTE:
BERM IN THIS AREA IS
A CONTINUATION OF
BERM FROM ADJACENT
PROPERTY AND KEEPS
FLOWS IN THE RR
DITCH

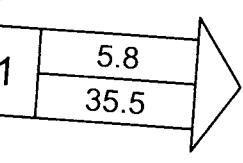
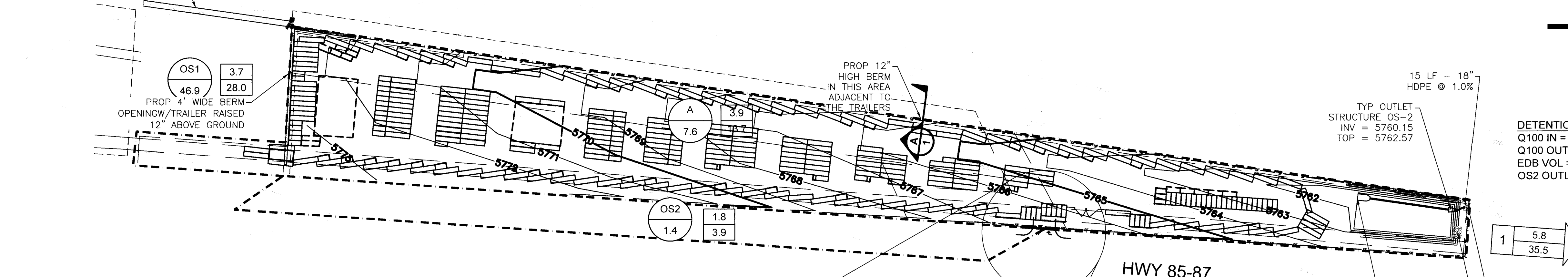
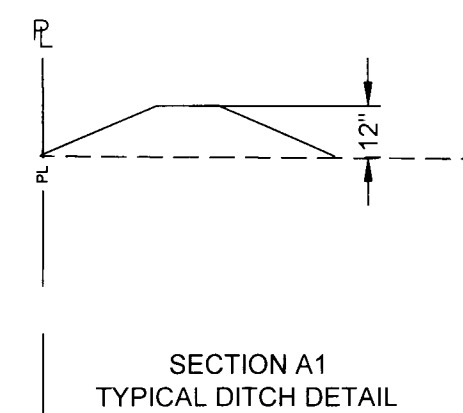

DETENTION BASIN:
Q100 IN = 16.1 CFS
Q100 OUT = 10.7 CFS
EDB VOL = 0.898AF
OS2 OUTLET

15 LF - 18"
HDPE @ 1.0%

TYP OUTLET
STRUCTURE OS-2
INV = 5760.15
TOP = 5762.57

5' X 5' OUTLET PROTECTION,
6" RIPRAP, 12" THICK W/
FILTER FABRIC

8 FT EMERGENCY
SPILLWAY, 6" RIPRAP,
12" THICK W/ FILTER
FABRIC
ELEV 5762.89
TOP OF BERM 5764.37

129.8 CF FOREBAY
6" HIGH W/0.71
OUTLET

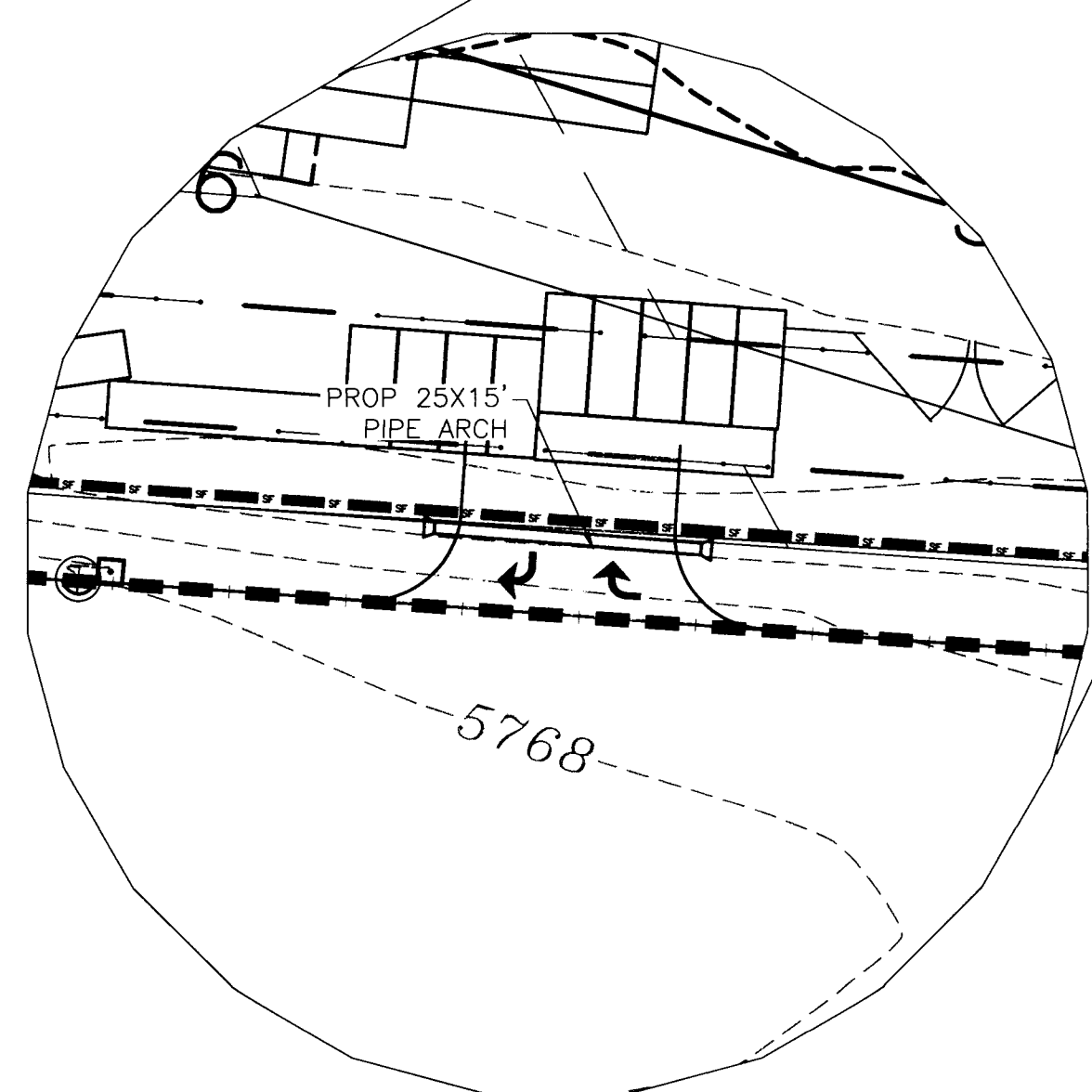

DETAIL - DRAINAGE AREA 'B'

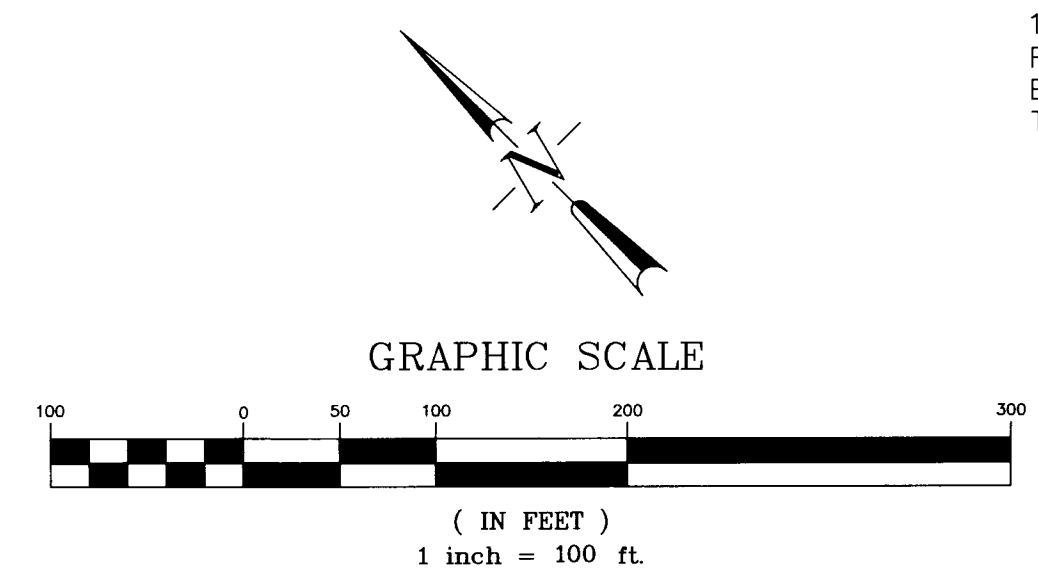

NOTE:
DETENTION POND AREA TO BE UTILIZED AS A
SEDIMENTATION BASIN UNTIL EARTH MOVING
IS COMPLETED AND THE GROUND STABILIZED,
AT WHICH TIME IT WILL BE CLEANED OUT AND
THE DETENTION POND STRUCTURES ADDED.

ASSOCIATED DESIGN PROFESSIONALS

PREPARED UNDER MY DIRECT SUPERVISION FOR AND ON THE BEHALF OF ASSOCIATED DESIGN PROFESSIONALS, INC.
MICHAEL BARTUSEK, COLORADO P.E. #23329

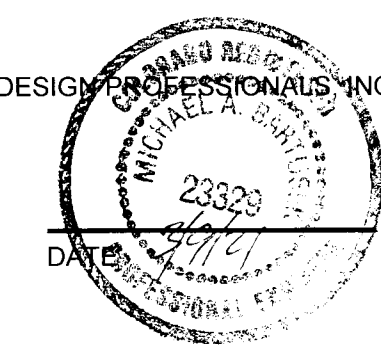

DESIGNED BY: MAB
PROJECT ENGINEER: MAB
JOB NO.: 16103
PROJECT MANAGER: MAB
CAD FILE NO.: 16103-Drainage
DRAWN BY: HUG
SCALE: 1"=100'
HORZ.: VERT.: N/A

PREPARED BY:
ADPCIVIL
ENGINEERING FOR THE FUTURE

3520 Austin Bluffs Parkway
Suite 102
Colorado Springs, CO 80918
(719) 266-5212
fax: (719) 266-5341

NO.	DATE	REVISION	BY

SOUTH ACADEMY BUSINESS CENTER
4425 HWY 85-87
EL PASO COUNTY, COLORADO
DRAINAGE PLAN - PROPOSED CONDITIONS