

**FINAL DRAINAGE REPORT**  
**PIKE SOLAR PLUS STORAGE PROJECT**  
**EL PASO COUNTY, COLORADO**

*Prepared for:*

**JSI Construction Group, LLC**  
1710 29<sup>th</sup> Street, Suite 1068  
Boulder, CO 80301  
Contact: Brian Vickers  
Phone: (720) 838-2302

*Prepared by:*



CORE Consultants, Inc.  
3473 S. Broadway  
Englewood, CO 80113  
Phone: 303-703-4444  
Contact: Rob Hansen, PE, CFM  
CORE Project Number: 20-194

July 2022

PPR-22-008

## TABLE OF CONTENTS

---

I. GENERAL LOCATION AND DESCRIPTION .....	1
A. Site Location.....	1
B. Description of Property .....	1
II. DRAINAGE BASINS AND SUBBASINS .....	1
III. DRAINAGE DESIGN CRITERIA .....	8
A. Regulations .....	8
B. Drainage Studies, Master Plans, and Site Constraints.....	8
C. Hydrology .....	8
D. Hydraulics .....	9
E. The Four Step Process.....	9
IV. DRAINAGE FACILITY DESIGN .....	9
A. General Concept.....	9
B. Specific Details.....	10
C. Floodplain Modification.....	10
D. Runoff Reduction and Water Quality.....	11
E. Additional Permitting Requirements .....	11
V. RESULTS AND CONCLUSIONS .....	11
A. CUHP-SWMM Results.....	11
B. Compliance with Standards .....	11
C. Variances .....	11

## **Appendices**

---

### **Appendix A – Maps**

- Vicinity & Effective FIRM Panel Map
- Subbasin Map

### **Appendix B – Hydrologic Calculations**

- USDA Web Soil Survey Report
- NOAA Atlas 14 Point Precipitation Table
- Table 5-1 of EPC DCM (2018)
- Table 6-3 of MHFD USDCM Volume I (2018)
- Percent Imperviousness Calculations for Existing Condition
- Percent Imperviousness Calculations for Proposed Condition
- CUHP Input Parameters for Existing Condition
- CUHP Calculated Parameters for 5-Year Existing Condition
- CUHP Calculated Parameters for 100-Year Existing Condition
- CUHP Input Parameters for Proposed Condition
- CUHP Calculated Parameters for 5-Year Proposed Condition
- CUHP Calculated Parameters for 100-Year Proposed Condition
- SWMM Summary Report for 5-Year Existing Condition
- SWMM Summary Report for 100-Year Existing Condition
- SWMM Summary Report for 5-Year Proposed Condition
- SWMM Summary Report for 100-Year Proposed Condition
- 5- & 100-Year Peak Flow Rate Comparison Table

### **Appendix C – Hydraulic Calculations**

- Swale Capacity Calculations
- Culvert Capacity Calculations
- Runoff Reduction Calculations

### **Appendix D – Hydrologic Calculations**

- No-Rise Report

### **Appendix E – Reference Material**

- “Hydraulic Response of Solar Farms”  
Cost Opinion

### **Appendix F – Maps**

- Drainage Maps
- Runoff Reduction Maps

**Approval Blocks**

**Design Engineer's Statement:**

The attached drainage plan and report were prepared under my direction and supervision and are correct to the best of my knowledge and belief. Said drainage report has been prepared according to the criteria established by the County for drainage reports and said report is in conformity with the applicable master plan of the drainage basin. I accept responsibility for any liability caused by any negligent acts, errors or omissions on my part in preparing this report.



8/25/2022

Rob Hansen, P.E. #50417

Date

**EPC Contractor/Developer's Statement:**

I, the owner/developer have read and will comply with all of the requirements specified in this drainage report and plan.



8/26/2022

Brian Vickers, authorized person  
JSI Construction Group, LLC  
1710 29<sup>th</sup> Street, Suite 1068  
Boulder, CO 80301

Date

**El Paso County:**

Filed in accordance with the requirements of the Drainage Criteria Manual, Volumes 1 and 2, El Paso County Engineering Criteria Manual and Land Development Code as amended.

Joshua Palmer, P.E.  
County Engineer / ECM Administrator

APPROVED  
Engineering Review

10/03/2022 3:28:14 PM  
dsdrice

JeffRice@elpasoco.com  
(719) 520-7877

EPC Planning & Community  
Development Department

Date

Conditions:

## **I. GENERAL LOCATION AND DESCRIPTION**

### **A. Site Location**

The following final drainage report details the hydrologic assessment conducted for the proposed Pike Solar Project (the “Project”). The Project will be a 175 megawatt (MW) photovoltaic solar facility consisting of photovoltaic modules aligned in arrays and affixed to a single-axis tracking system. Although the property boundary area encompasses a total of 4,050 acres in El Paso County, Colorado, the Project will only be constructed on approximately 1,240 acres of the property.

As shown on the Vicinity and Effective FIRM Panel Map in Appendix A, the property lies just to the southeast of the City of Fountain and is bound by Squirrel Creek Road to the north, Hammer Road to the east, Hanover Road to the south, and Old Pueblo Road to the west (the “Site”). Specifically, the proposed Site is located in Sections 1, 11, 12, 13, 14, 23, 24, 25, 26, 35, and 36, Township 16 South, Range 65 West of the 6<sup>th</sup> Principal Meridian and Sections 6, 7, 18, 30, and 31, Township 16 South, Range 64 West of the 6<sup>th</sup> Principal Meridian, El Paso County, Colorado.

### **B. Description of Property**

Currently the Site is undeveloped with shortgrass prairies and rangelands covering the landscape. For this reason, the site has been primarily utilized for cattle grazing to date. Williams Creek and its tributaries weave in and out of the project boundary before exiting and flowing approximately 6 miles before ultimately reaching its confluence with Fountain Creek. Since the site is situated towards the central portion of the Williams Creek drainage basin, the natural slopes range from flat to 8.35 percent to include numerous ridges as well and more gently sloping overland flow paths. The soils within the site vary throughout and include Ascalon Sandy Loam, Blendon Sandy Loam, Heldt Clay Loam, Midway Clay Loam, Nelson-Tassel Fine Sandy Loam, Olney Sandy Loam, Razor-Midway Complex, Ustic Torrifluvents, Wilid Silt Loam, Wiley Silt Loam, Fort Loam, Fort Sandy Loam, and Manzanola Silty Clay Loam. These soil types encompass hydrologic soil groups (HSGs) B, C, and D. Additional detail regarding the on-site soils can be found in the USDA Web Soil Survey report included in Appendix B.

All mapped drainageways within the Project site are currently mapped as Zone A, indicating an area of 1% annual flood hazard without determined base flood elevations (BFEs), as shown on the Vicinity and Effective FIRM Panel Map in Appendix A.

## **II. DRAINAGE BASINS AND SUBBASINS**

### **A. Major Drainage Basins**

The Site is situated near the center of the Williams Creek sub-watershed, and due to the configuration of the project, most of the on-site runoff enters Williams Creek before ultimately exiting the property. Still, the Site represents only a small portion of the total drainage area of Williams Creek, with the total contributing area for runoff being approximately eight times greater than the property boundary area.

The Site falls within five (5) FEMA Flood Insurance Rate Map (FIRM) panels: 08041C0967G, 08041C0970G, 08041C1000G, 08041C1160G, and 08041C1180G. All of Williams Creek and its major tributary that fall within the project site are mapped as Zone A, while the remaining minor tributaries and the remainder of the site are mapped as Zone X floodplain, indicating an area of minimal flood hazard. The effective flood hazard areas are shown on the Vicinity and FIRM Panel Map included in Appendix A.

There are no nearby irrigation facilities or other obstructions which could influence or be influenced by the local drainage of the Site.

## **B. Minor Drainage Basins**

It is not anticipated that significant grading that will alter the historic drainage flow paths within the Site will be needed for construction of the Project. All minor drainage basins (subbasins) for both the existing and proposed field conditions were delineated using a composite terrain surface based on 2020 survey data collected by Clark Land Survey, Inc. within the project boundary, supplemented by USGS 3DEP 1/3 arc second seamless products outside of the project boundary. All elevation data utilized for this study was processed in ArcGIS 10.8 into a single composite 1-foot resolution gridded raster from which a supplementary 5-foot contour dataset was created. The composite surface contours are shown on the Drainage Plan and Subbasin Map in Appendix A. The following sections detail the minor drainage basins delineated for the proposed condition of the study.

### **Subbasin A1.0**

Subbasin A1.0 is situated in the northern-most portion of the Site within Area Array #2. This subbasin is the largest subbasin within Array Area #2 and drains from the northeastern edge to the southern edge of the array. This subbasin will include a solar panel array, inverters, staging area, and gravel access road. All runoff from this subbasin flows through Subbasin A1.1 to one of the unnamed tributaries before ultimately reaching Williams Creek.

### **Subbasin A1.1**

Subbasin A1.1 is situated in the southern-most portion of the Site within Area Array #2, just south of Subbasin A1.0. This subbasin will include a solar panel array, inverters, and gravel access roads. All runoff from this subbasin flows south to one of the unnamed tributaries before ultimately reaching Williams Creek.

### **Subbasin A2.0**

Subbasin A2.0 is situated in the northern-most portion of the Site along the eastern edge of Array Area #2 and just southeast of Subbasin A1.0. This subbasin will include a solar panel array, inverters, staging area, and gravel access roads. All runoff from this subbasin flows to the east to one of the unnamed tributaries before ultimately reaching Williams Creek.

### **Subbasin A3.0**

Subbasin A3.0 is situated in the northern-most portion of the Site in the southeastern corner of Array Area #2 and just southwest of Subbasin A2.0. This subbasin will include a solar panel array, inverters, staging area, and gravel access roads. All runoff from this subbasin flows to the south to one of the unnamed tributaries before ultimately reaching Williams Creek.

### **Subbasin A4.0**

Subbasin A4.0 is situated in the northern-most portion of the Site in the southwestern corner of Array Area #2 and west of Subbasins A1.1 and A3.0. This subbasin will include a solar panel arrays and gravel access road. All runoff from this subbasin flows to the south directly to Williams Creek.

### **Subbasin A5.0**

Subbasin A5.0 is situated in the northern-most portion of the Site along the western edge of Array Area #2 just north of Subbasin A4.0. This subbasin will include a solar panel array, inverters, and gravel access roads. All runoff from this subbasin flows to the northwest directly to Williams Creek.

**Subbasin A6.0**

Subbasin A6.0 is situated in the northern-most portion of the Site along the western edge of Array Area #2 and north of Subbasin A5.0. This subbasin will include a solar panel array, inverters, and gravel access roads. All runoff from this subbasin flows to the west directly to Williams Creek.

**Subbasin A7.0**

Subbasin A7.0 is situated in the northern-most portion of the Site along the western edge of Array Area #2 just north of Subbasin A6.0. This subbasin will include a solar panel array, inverters, and gravel access roads. All runoff from this subbasin flows to the west directly to Williams Creek.

**Subbasin A8.0**

Subbasin A8.0 is situated in the northern-most portion of the Site in the northwestern corner of Array Area #2 and northwest of Subbasin A7.0. This subbasin will include solar panel arrays. All runoff from this subbasin flows to the west directly to Williams Creek.

**Subbasin A9.0**

Subbasin A9.0 is situated in the northern-most portion of the Site in the northwestern corner of Array Area #2 and north of Subbasin A7.0. This subbasin will include solar panel arrays. All runoff from this subbasin flows to the northwest directly to Williams Creek.

**Subbasin A10.0**

Subbasin A10.0 is situated in the northern-most portion of the Site in the northeastern corner of Array Area #2 and north of Subbasin A1.0. This subbasin will include solar panel arrays. All runoff from this subbasin flows to the northwest to Williams Creek.

**Subbasin B1.0**

Subbasin B1.0 is situated in the northern portion of the Site along the eastern side of Array Area #1. This subbasin will include solar panel arrays. All runoff from this subbasin flows north to one of the unnamed tributaries before ultimately reaching Williams Creek.

**Subbasin B2.0**

Subbasin B2.0 is situated in the northern portion of the Site along the eastern side of Array Area #1 and south of Subbasin B1.0. This subbasin will include solar panel arrays. All runoff from this subbasin flows south to one of the unnamed tributaries before ultimately reaching Williams Creek.

**Subbasin B3.0**

Subbasin B3.0 is situated in the northern portion of the Site along the southern edge of Array Area #1 just southwest of Subbasin B2.0. This subbasin will include solar panel arrays. All runoff from this subbasin flows south to one of the unnamed tributaries before ultimately reaching Williams Creek.

**Subbasin B4.0**

Subbasin B4.0 is situated in the northern portion of the Site along the southern edge of Array Area #1 and west of Subbasin B3.0. This subbasin will include a solar panel array, inverters, and gravel access roads. All runoff from this subbasin flows southwest to one of the unnamed tributaries before ultimately reaching Williams Creek.

**Subbasin B5.0**

Subbasin B5.0 is situated in the northern portion of the Site along the western side of Array Area #1 just northwest of Subbasin B4.0. This subbasin will include a solar panel array and gravel access roads. All runoff from this subbasin flows southwest to one of the unnamed tributaries before ultimately reaching Williams Creek.

**Subbasin B6.0**

Subbasin B6.0 is situated in the northern portion of the Site along the northwestern side of Array Area #1 and north of Subbasins B4.0 and B5.0. This subbasin will include a solar panel array, inverters, staging area, and gravel access roads. All runoff from this subbasin flows northwest to one of the unnamed tributaries before ultimately reaching Williams Creek.

**Subbasin B7.0**

Subbasin B7.0 is situated in the northern portion of the Site along the northern edge of Array Area #1 and north of Subbasins B6.0. This subbasin will include a solar panel array, inverters, staging area, and gravel access roads. All runoff from this subbasin flows northwest to one of the unnamed tributaries before ultimately reaching Williams Creek.

**Subbasin B8.0**

Subbasin B8.0 is situated in the northern portion of the Site along the northern side of Array Area #1 just north of Subbasins B2.0 and B3.0. This subbasin will include a solar panel array, inverters, and gravel access roads. All runoff from this subbasin flows north to one of the unnamed tributaries before ultimately reaching Williams Creek.

**Subbasin C1.0**

Subbasin C1.0 is situated in the central portion of the Site in the northwestern corner of Array Area #3. This subbasin will include a solar panel array. All runoff from this subbasin flows north to one of the unnamed tributaries before ultimately reaching Williams Creek.

**Subbasin C2.0**

Subbasin C2.0 is situated in the central portion of the Site in the northwestern corner of Array Area #3 and east of Subbasin C1.0. This subbasin will include solar panel array. All runoff from this subbasin flows north to one of the unnamed tributaries before ultimately reaching Williams Creek.

**Subbasin C3.0**

Subbasin C3.0 is situated in the central portion of the Site in the northeastern corner of Array Area #3 and east of Subbasin C2.0. This subbasin will include a solar panel array. All runoff from this subbasin flows northeast to one of the unnamed tributaries before ultimately reaching Williams Creek.

**Subbasin C4.0**

Subbasin C4.0 is situated in the central portion of the Site along the western edge of Array Area #3 and south of Subbasins C1.0, C2.0, and C3.0. This subbasin will include a solar panel array, inverters, and gravel access roads. All runoff from this subbasin flows northeast through Subbasin C4.1 to one of the unnamed tributaries before ultimately reaching Williams Creek.

**Subbasin C4.1**

Subbasin C4.1 is situated in the central portion of the Site along the eastern edge of Array Area #3 and south of Subbasin C4.2. This subbasin will include a solar panel array, staging area, and



gravel access roads. All runoff from this subbasin flows northeast to one of the unnamed tributaries before ultimately reaching Williams Creek.

#### **Subbasin C4.2**

Subbasin C4.2 is situated in the central portion of the Site along the eastern edge of Array Area #3 just southeast of Subbasin C3.0. This subbasin will include a solar panel array, inverters, staging area, and gravel access roads. All runoff from this subbasin flows northeast to one of the unnamed tributaries before ultimately reaching Williams Creek.

#### **Subbasin C5.0**

Subbasin C5.0 is situated in the central portion of the Site near the southeastern corner of Array Area #3 just east of Subbasin C4.0. This subbasin will include solar panel arrays. All runoff from this subbasin flows northeast to one of the unnamed tributaries before ultimately reaching Williams Creek.

#### **Subbasin C6.0**

Subbasin C6.0 is situated in the central portion of the Site just south of Subbasins C4.0 and C5.0 and includes portions of Array Area #3 and Array Area #4. This subbasin will include a solar panel array, inverters, and gravel access roads. All runoff from this subbasin flows east to one of the unnamed tributaries before ultimately reaching Williams Creek.

#### **Subbasin C7.0**

Subbasin C7.0 is situated in the central portion of the Site along the southern edge of Array Area #4 and just south of Subbasin C6.0. This subbasin will include a solar panel array, inverters, and gravel access roads. All runoff from this subbasin flows south through Subbasin 7.1 via one of the unnamed tributaries.

#### **Subbasin C7.1**

Subbasin C7.1 is situated in the central portion of the Site just south of Subbasin C6.0 and 7.0 and includes portion of Array Areas #4, #5, and #6. This subbasin will include a solar panel array, inverters, staging areas, and gravel access roads. All runoff from this subbasin flows southeast through Subbasin C7.4 via one of the unnamed tributaries.

#### **Subbasin C7.2**

Subbasin C7.2 is situated in the central portion of the Site near the center of Array Area #6 just east of Subbasin C8.0. This subbasin will include a solar panel array, inverters, and gravel access roads. All runoff from this subbasin flows southeast through Subbasin C7.1 via one of the unnamed tributaries.

#### **Subbasin C7.3**

Subbasin C7.3 is situated in the central portion of the Site near the center of Array Area #6 just south of Subbasin C7.2. This subbasin will include a solar panel array, inverters, and gravel access roads. All runoff from this subbasin flows south through Subbasin C7.4 via one of the unnamed tributaries.

#### **Subbasin C7.4**

Subbasin C7.4 is situated in the southern portion of the Site just south of Subbasin C7.1 and includes the southern portion of Array Area #6. This subbasin will include a solar panel array, inverters, staging areas, and gravel access roads. All runoff from this subbasin flows south through Subbasin C7.7 before ultimately reaching Williams Creek.

**Subbasin C7.5**

Subbasin C7.5 is situated in the southern portion of the Site just south of Subbasin C7.3 and includes a small portion of Array Area #7. This subbasin will include a solar panel array and gravel access roads. All runoff from this subbasin flows south through Subbasin C7.7 via one of the unnamed tributaries before ultimately reaching Williams Creek.

**Subbasin C7.6**

Subbasin C7.6 is situated in the southern portion of the Site just east of Subbasin C7.4. This subbasin will include only gravel access roads. All runoff from this subbasin flows south through Subbasin C7.7 to Williams Creek.

**Subbasin C7.7**

Subbasin C7.7 is situated in the southern portion of the Site just south of Subbasins C7.4 and C7.5 and includes the majority of Array Area #7. This subbasin will include a solar panel array, inverters, staging areas, and gravel access roads. The majority of runoff from this subbasin will flow to the south through one of the unnamed tributaries before ultimately reaching Williams Creek. A small portion of runoff from this subbasin flows south directly to Williams Creek. A small portion

**Subbasin C8.0**

Subbasin C8.0 is situated in the central portion of the Site just south of Subbasin C6.0 and includes the majority of Array Area #5. This subbasin will include a solar panel array, inverters, staging area the substation, and gravel access roads. All runoff from this subbasin flows south through Subbasin 8.1 via one of the unnamed tributaries before ultimately reaching Williams Creek.

**Subbasin C8.1**

Subbasin C8.1 is situated in the southern portion of the Site just south of Subbasin C8.0 and includes the western edge of Array Area #7. This subbasin will include solar panel arrays and gravel access roads. All runoff from this subbasin flows south to one of the unnamed tributaries before ultimately reaching Williams Creek.

**Subbasin D1.0**

Subbasin D1.0 is located in the southern portion of the Site at the northern end of Array Area #8. This subbasin will include a solar panel array, inverters, and gravel access roads. All runoff from this subbasin flows west to Subbasin O5.0 where it enters one of the unnamed tributaries before ultimately reaching Williams Creek.

**Subbasin D2.0**

Subbasin D2.0 is located in the southern portion of the Site near the northern end of Array Area #8 just south of Subbasin D1.0. This subbasin will include a solar panel array, inverters, and gravel access roads. All runoff from this subbasin flows west to Subbasin O5.0 where it enters one of the unnamed tributaries before ultimately reaching Williams Creek.

**Subbasin D3.0**

Subbasin D3.0 is located in the southern portion of the Site in the central section of Array Area #8 just south of Subbasin D2.0. This subbasin will include a solar panel array, inverters, and gravel access roads. All runoff from this subbasin flows to the west directly to Williams Creek.

**Subbasin D4.0**

Subbasin D4.0 is located in the southern portion of the Site in the central section of Array Area #8 just south of Subbasin D3.0. This subbasin will include a solar panel array, inverters, and

gravel access roads. All runoff from this subbasin flows to the southwest directly to Williams Creek beyond the Site.

#### **Subbasin D5.0**

Subbasin D5.0 is located in the southern portion of the Site near the southern end of Array Area #8 just south of Subbasin D4.0. This subbasin will include a solar panel array, inverters, staging areas, and gravel access roads. All runoff from this subbasin flows to the southwest directly to Williams Creek beyond the site.

#### **Subbasin D6.0**

Subbasin D6.0 is located in the southern portion of the Site near the southern end of Array Area #8 just southeast of Subbasin D5.0. This subbasin will include a solar panel array. All runoff from this subbasin flows southeast offsite to one of the unnamed tributaries before ultimately reaching Williams Creek.

#### **Subbasin D7.0**

Subbasin D7.0 is located in the southern portion of the Site near the southern end of Array Area #8 just south of Subbasin D5.0. This subbasin will include a solar panel array, staging areas, and gravel access roads. All runoff from this subbasin flows south offsite to one of the unnamed tributaries before ultimately reaching Williams Creek.

#### **Subbasin O1.0**

Subbasin O1.0 is located northeast of Array Areas #1 and #2. This subbasin includes a portion of the offsite area draining from the north onto the Site. This subbasin will include a gravel access road. All runoff from this subbasin flows southwest to one of the unnamed tributaries before ultimately reaching Williams Creek.

#### **Subbasin O2.0**

Subbasin O2.0 is located northwest of Array Area #3. This subbasin includes the majority of the offsite area draining from the north onto the Site. This subbasin will include a gravel access road. All runoff from this subbasin flows south directly to Williams Creek.

#### **Subbasin O3.0**

Subbasin O3.0 is located north of Array Areas #2 and #3. This subbasin will include gravel access road. All runoff from this subbasin flows southeast to one of the unnamed tributaries before ultimately reaching Williams Creek.

#### **Subbasin O4.0**

Subbasin O4.0 is located near the central portion of the Site between Array Areas #1, #2, #4, #5 and #6. This subbasin mainly includes offsite area which receives runoff from the Project Site at the northern end of the subbasin and then drains back into the Project Site at the southern end of the subbasin. This subbasin does not include any of the development associated with the project. All runoff from this subbasin flows to the south directly to Williams Creek.

#### **Subbasin O5.0**

Subbasin O5.0 is located near the central portion of the Site, with Array Area #1 to the north and Array Area #8 to the south. This subbasin mainly includes offsite area draining from the east onto the Project Site. This subbasin will include gravel access roads. All runoff from this subbasin flows to the south directly to Williams Creek.

### III. DRAINAGE DESIGN CRITERIA

#### A. Regulations

This final drainage report is in accordance with the *Drainage Criteria Manual* (El Paso County, Colorado, 2018) and the *Urban Storm Drainage Criteria Manual* (Mile High Flood district [MHFD] 2018, 2017, and 2010). These manuals were used as a basis for this hydrologic assessment of the minor (5-year) and major (100-year) design storm events.

#### B. Drainage Studies, Master Plans, and Site Constraints

There are no previous drainage studies, master plans, or site constraints for the Project site.

#### C. Hydrology

An integrated Colorado Unit Hydrograph Procedure (CUHP) 2005 v. 2.0.1 and Environmental Protection Agency Storm Water Management Model (EPA SWMM) 5.1 analysis was developed for the Pike Solar Project final drainage assessment. This assessment models the on-site and off-site contributing runoff areas for both the existing and proposed field conditions at key locations of interest. Resulting peak flow rates associated with the design storm events were then compared to quantify if there are any significant hydrologic impacts caused by the increased imperviousness associated with the proposed solar panel development.

The CUHP is a unit hydrograph-based rainfall-runoff analysis calibrated for the Colorado Front Range by the MHFD. Both precipitation depth and subbasin characteristics are required to complete the CUHP calculations.

The temporal distribution calibrated for the Front Range within the CUHP model is a 2-hour design storm developed from embedded National Oceanic and Atmospheric Administration (NOAA) Atlas 14 1-hour point precipitation values. For this study, the NOAA 1-hour point precipitation for the 5-year and 100-year recurrence intervals were determined to be 1.29 and 2.79 inches, respectively, as shown in the NOAA Atlas 14 Point Precipitation Table for the Site in Appendix B. All pertinent CUHP model files have been included with this submittal and the proposed condition subbasins analyzed for this study are shown on the Drainage Plan and Subbasin Map in Appendix A.

Within the CUHP interface, model subcatchments are used to represent the various subbasins within a given watershed of interest. Subcatchment characteristics, including area, shape, slope, imperviousness, storage capacity, and infiltration capacity, are all used to determine the effective rainfall and unit hydrograph transformation for each subbasin, from which the final output hydrograph is calculated. Topographic characteristics of each subcatchment considered for this study were determined from the aforementioned composite surface, which is based on 2020 field survey information collected by Clark Land Survey, Inc. for the Site and the available USGS 3DEP seamless products. All soil characteristics were determined from the United States Department of Agriculture (USDA) Web Soils Survey (WSS) and the resulting summary report is included in Appendix B. Percent imperviousness values were determined according to Table 5-1 of the *Drainage Criteria Manual* (El Paso County, Colorado, 2018). Table 6.3 of the MHFD Urban Storm Drainage Criteria Manual (2018) was used as a secondary reference for all other land use conditions not listed in Table 5-1. Both Table 5-1 and 6.3 are included in Appendix B.

The resulting CUHP output hydrographs were then loaded into the EPA SWMM 5.1 model to appropriately route the hydrographs through the site. SWMM requires landscape characteristics such as topography, flow path cross-sectional geometry, and landcover roughness to correctly route the hydrographs. These parameters were determined using the composite surface and USDA National

Agriculture Imagery Program (NAIP) aerial photography. All pertinent SWMM model files have been included with this submittal.

#### **D. Hydraulics**

All drainage ditch sizing was performed using the Hydraflow Express add-on for Civil 3D (2018), while all culvert sizing was performed using the MHFD-Culvert v.4.00 workbook (released May 2020). Street and inlet capacity were not necessary for this project, and therefore are not included with this submittal.

#### **E. The Four Step Process**

The Project was designed in accordance with the four-step process to minimize adverse impacts of urbanization, as outlined in Chapter I Section 4.0 of the City of Colorado Springs and El Paso County “Drainage Criteria Manual (DCM)”.

**Step 1. Employ Runoff Reduction Practices** – The Project was designed to conserve as much of the existing vegetation as possible and to minimize the extent of disturbance. All the disturbed area beneath the solar arrays will be replanted with native grasses. The proposed roadways will be constructed with aggregate base to minimize impervious surfaces. All impervious areas will drain over pervious areas to reduce runoff and provide water quality.

**Step 2. Stabilize Drainageways** – The Project is part of the Williams Creek basin. The Project does not alter the existing drainage patterns in Williams Creek. Concentrated flows are not discharged into the existing drainageway.

**Step 3. Implement BMP's That Provide a Water Quality Capture Volume with Slow Release** – Permanent detention facilities will not be necessary for the Project. Runoff reduction techniques will be used to provide water quality treatment, permanent BMPs that require maintenance are not required. See Section IV.D. for additional information. Temporary water quality and erosion control measures will be provided during construction to prevent sediment laden water from discharging from the Site. Permanent check dams will be constructed throughout the site in areas where concentrated flows could affect graded areas.

**Step 4. Implement Site Specific and Other Source Control BMP's** – The erosion control construction BMP's of the Project were designed to reduce site erosion and sediment transfer during Site construction. Source control BMP's include the use of vehicle tracking, culvert protection and stabilized staging areas.

### **IV. DRAINAGE FACILITY DESIGN**

#### **A. General Concept**

The general concept for the proposed drainage design is to maintain the historic drainage patterns of the Site. Only micro-grading will be required in select areas throughout the site to facilitate the clearance tolerances of the solar array system. It should be noted that areas that would have required more extensive grading have been avoided. Therefore, the proposed site grading will generally not alter the historic drainage patterns to Williams Creek. Native seed and vegetation will be established under the solar array system such that the overall impervious area of the Site will not increase except for the addition of gravel access roads. Gravel access roads have been kept to a minimum within the Site and a more permeable gravel type (Class 5 or 6) will be utilized to minimize the impact of the access roads on the overall Site infiltration capacity.

Detention are not provided for the Site per justification provided in the “Hydrologic Response of Solar Farms” ASCE white paper prepared by Lauren M. Cook and Richard H. McCuen at the

University of Maryland, dated May 2013 (the “white paper”). A copy is provided in Appendix C. The white paper outlines the hydrologic effects of solar panels and the applicability of stormwater management on solar sites to control runoff volumes and rates. The white paper concluded that “The addition of solar panels over a grassy field does not have a much of an effect on the volume of runoff, the peak discharge, nor the time to peak. With each analysis, the runoff volume increased slightly but not enough to require storm-water management facilities.” The white paper then goes on to emphasize the impact that native ground cover - which will be undisturbed or revegetated at the Site - has on runoff volume, peak discharge, and time to peak. Gravel or pavement underneath the solar panels would increase the volume of runoff significantly and therefore will not be used at the Site in this manner. Minimizing grading to leave native vegetation undisturbed, combined with revegetation, will result in proposed runoff and infiltration similar to existing conditions. 'The solar panels are impervious to rainwater; however, they are mounted on metal rods and placed over pervious land,' as stated in the white paper. For this reason, the Project does not provide detention as the Project is not significantly increasing the imperviousness of the Site or developed flows.

Supporting calculations and result summaries for the CUHP-SWMM hydrologic analysis of the existing and proposed site conditions are included in Appendix B. Additionally, design calculations for the proposed stormwater conveyance infrastructure are included in Appendix C.

Water quality address MS4 permit requirements is addressed through runoff reduction practices by allowing the minimal areas of added imperviousness to flow over pervious areas. Additional information is provided in Section IV. D.

### **B. Specific Details**

Two (2) drainage ditches were designed to convey runoff around the proposed solar panel posts in Array 3 and 7 in order to mitigate erosion concerns, as shown on the Drainage Plan included in Appendix A. Both ditches are designed as simple trapezoidal channels sized to adequately convey the 100-year storm event, while maintaining a minimum freeboard of 1-foot. Due to increasing flows within Array 7, the ditch transitions to a larger cross-section in order to maintain capacity and freeboard. All ditch capacity design calculations were completed via the Hydraflow Express add-on for Civil 3D (2018) and are included in Appendix C of this report.

A total of nine (9) culvert crossings were designed to allow vehicular access to the solar arrays, as shown on the Drainage Plan included in Appendix A. Each culvert was designed to adequately convey the 5-year storm event peak flow rate determined at the corresponding design point. For the 100-year event, each roadway will overtop and effectively act as a broad-crested weir to pass excess flow to the outlet. All culvert design calculations were completed utilizing MHFD-Culvert design spreadsheet and included in Appendix C.

It should be noted that three (3) access road culvert crossings will span across streams which are currently mapped as Zone A floodplain on the effective FIRM panels. For this reason, an additional no-rise analysis was conducted for these three crossings to verify that the Pike Solar project does not impact the existing floodplain water surface elevations. The associated floodplain use memorandum and no-rise calculations are included in Appendix D of this report.

The estimated opinion of probable cost for the stormwater infrastructure is \$236,899. An opinion of the cost is provided in Appendix E.

There are no drainage or bridge fees associated with the project.

### **C. Floodplain Modification**

The Project will have three low-water crossings through the floodplain. The crossings will be constructed so that no fill will be placed within the floodplain. The corresponding floodplain use memorandum and no-rise calculations are included in Appendix D.

#### **D. Runoff Reduction and Water Quality**

The project is using the Runoff Reduction Standard to address MS4 water quality requirements. Areas within the project with added imperviousness are the aggregate base access road, operations and maintenance area and the substation area. The solar array areas are supported by posts, as discussed within Section A, these posts add a very minimal area of impervious area and are connected to large pervious areas by comparison and separate runoff reduction calculations are not appropriate.

The MHFD BMP Spreadsheet was used to determine the minimum size of the receiving pervious areas (RPA). The access drives within the site are typically 16ft wide with some bump out areas at 20ft wide. A typical access drive calculation was provided by using a 100ft long section of 20ft wide access road and assuming worst case soils, Type D and worst-case slope of 5%. This calculation indicates that a 18ft wide pervious area adjacent to the roadway is necessary to fully provide water quality for the 20ft wide access drive. This typical calculation is applied throughout the site and 18ft wide pervious areas have been identified adjacent to the access drives throughout the site. See Runoff Reduction Maps in Appendix F. Calculations and RPAs have been identified for the Operations and Maintenance Areas and the substation.

The RPAs identified on the Runoff Reduction Maps are to remain pervious and vegetated after construction is completed. Overall, the project has ample pervious areas available to receive runoff from the minor increase in pervious areas which meet the MS4 water quality requirements.

#### **E. Additional Permitting Requirements**

The following are other permits the project will be obtaining:

- Areas and Activities of State Interest (1041)
- Colorado Department of Public Health & Environment (CDPHE) Construction Stormwater Permitting
- El Paso County Stormwater Permitting

## **V. RESULTS AND CONCLUSIONS**

#### **A. CUHP-SWMM Results**

A comparison table of modeled peak flows is provided for both the 5- and 100-year in Appendix B. Due to the relatively minimal change in impervious area and minor grading associated with the proposed solar panel development, the peak flow rates determined for each subbasin did not significantly differ between the existing and proposed conditions of the model for both storm events of interest. Therefore, this hydrologic assessment shows that the proposed Pike Solar Project does not cause any considerable change to the local hydrology.

#### **B. Compliance with Standards**

This drainage assessment for the Pike Solar Project satisfies the requirements outlined in the *Drainage Criteria Manual* (El Paso County, Colorado, 2018) and the *Urban Storm Drainage Criteria Manual* (MHFD 2018, 2017, and 2010) where applicable.

#### **C. Variances**

No variances associated with the proposed drainage design are being requested.

## **REFERENCES**

1. The City of Colorado Springs/El Paso County Drainage Criteria Manual, October 2018.
2. Urban Storm Drainage Criteria Manual, MHFD, January 2021.

### Computer Programs:

1. CUHP 2005 by MHFD, V.2.0.1.
2. EPA SWMM 5.1 by USEPA.
3. Hydraflow Express Extension for Autodesk Civil 3D by Autodesk, Version 2018.
4. MHFD-Culvert Spreadsheet by MHFD, V 4.00.
5. "Hydrologic Response of Solar Farms" ASCE white paper prepared by Lauren M. Cook and Richard H. McCuen at the University of Maryland, dated May 2013.



**APPENDIX A**  
**GENERAL MAPS**

VICINITY & EFFECTIVE FLOOD INSURANCE RATE MAP (FIRM) PANEL MAP  
SUBBASIN MAP

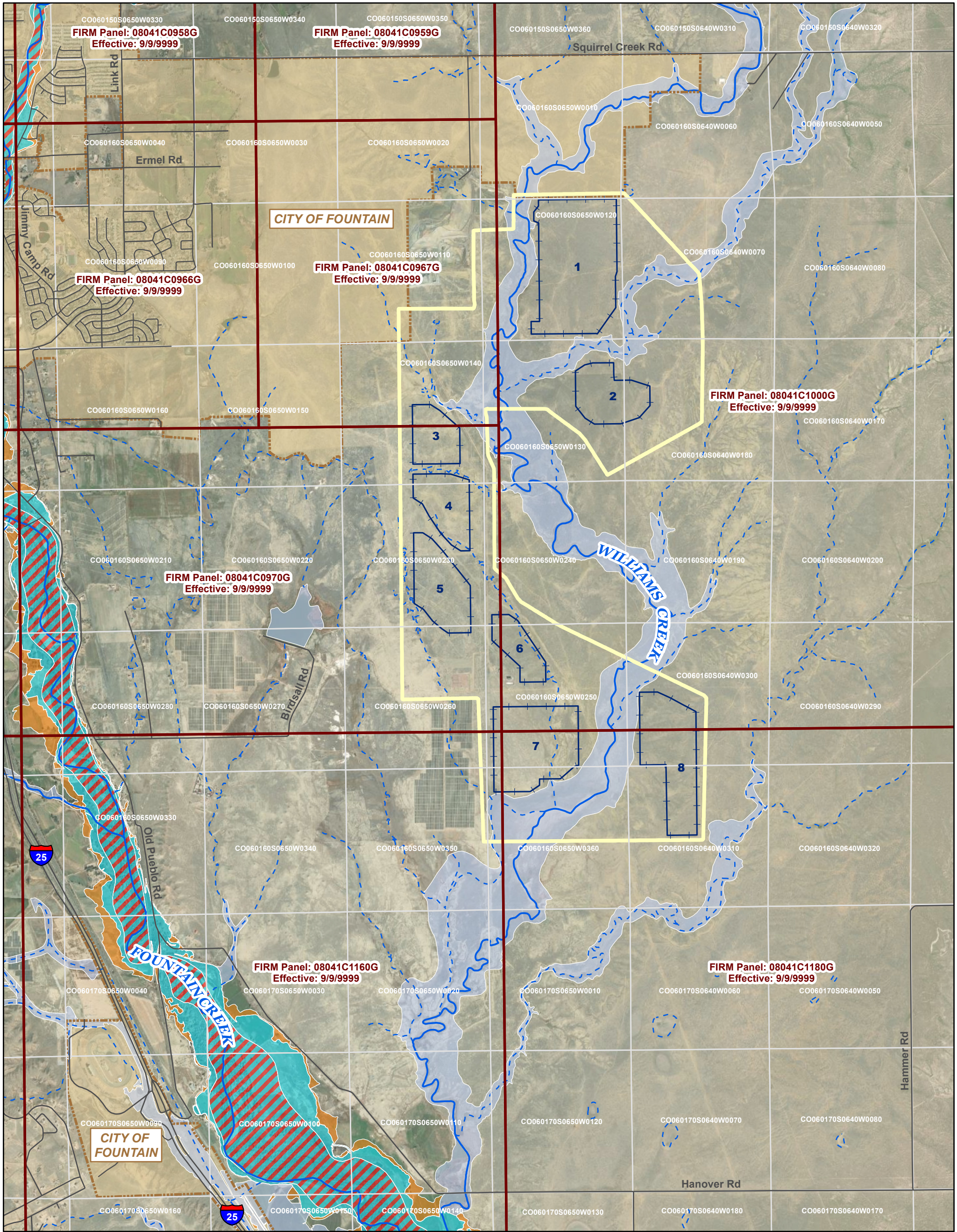

# Pike Solar Development

## Vicinity and Effective FIRM Map

El Paso County, CO

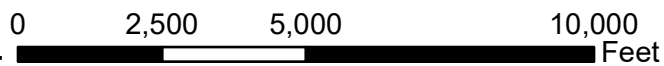

1:40,000



Project #: 20-194  
Date: 1/31/2022

### Legend

- Property Boundary
- Proposed Fence Boundary
- City Limits
- PLSS Grid
- Road
- FEMA FIRM Panel

### FEMA Flowline

- Major Stream
- Minor Tributary

### FEMA Flood Hazard Area

- 0.2% Annual Chance Flood Hazard (Zone X)
- 1% Annual Chance Flood Hazard (Zone A)
- 1% Annual Chance Flood Hazard with BFEs (Zone AE)
- Regulatory Floodway

Subbasin ID	Corresponding SWMM Node	Existing Condition		Proposed Condition	
		5-Year	100-Year	5-Year	100-Year
A1.0	Outlet_A1.0	13.79	173.24	14.85	174.18
A1.1	A1.1	4.40	35.74	4.69	36.01
A2.0	Outlet_A2.0	10.01	72.71	10.39	73.02
A3.0	A3.0	4.70	40.40	5.10	40.78
A4.0	Outlet_A4.0	7.06	54.72	7.22	54.85
A5.0	A5.0	2.15	32.00	2.81	32.70
A6.0	A6.0	11.40	102.64	11.87	102.99
A7.0	A7.0	5.43	55.20	6.14	55.86
A8.0	A8.0	0.85	12.94	0.85	12.94
A9.0	A9.0	0.86	14.41	0.86	14.41
A10.0	Outlet_A10.0.1	1.51	20.68	1.51	20.68
B1.0, B8.0	Outlet_B1.0&8.0	3.50	29.81	3.77	30.07
B2.0, B3.0	Outlet_B2.0&3.0	3.72	51.46	3.72	51.46
B4.0, B5.0	Outlet_B4.0&5.0	9.50	69.50	9.91	69.84
B6.0	B6.0	14.49	113.48	15.08	114.05
B7.0	B7.0	2.83	23.62	3.14	23.92
C1.0, C2.0, & C3.0	Outlet_C1.0.2.0&3.0	5.68	43.12	5.68	43.12
C4.0	Outlet_C4.0	11.28	89.36	11.56	89.58
C4.1	C4.1	1.87	15.07	1.91	15.10
C4.2	C4.2	0.53	4.30	0.64	4.43
C5.0	Outlet_C5.0	4.73	34.07	4.73	34.07
C6.0	C6.0	25.19	207.27	25.65	207.60
C7.0	Outlet_C7.0	3.61	29.29	3.93	29.62
C7.1	C7.1	39.54	336.41	39.90	336.65
C7.2	Outlet_C7.2	2.33	20.34	2.43	20.44
C7.3	C7.3	2.19	17.70	2.19	17.70
C7.4	C7.4	36.14	286.03	36.88	286.64
C7.5	Outlet_C7.5	2.43	17.46	2.63	17.73
C7.6	Outlet_C7.6	16.12	132.91	16.36	133.11
C7.7	C7.7	36.38	319.90	38.30	321.39
C8.0	Outlet_C8.0	67.57	585.56	69.31	587.18
C8.1	C8.1	42.06	388.72	42.16	388.82
D1.0	D1.0	2.84	44.10	3.16	44.37
D2.0	D2.0	4.29	60.22	4.51	60.41
D3.0	Outlet_D3.0	8.50	109.06	9.22	109.60
D4.0	Outlet_D4.0	4.60	61.59	4.92	61.89
D5.0	Outlet_D5.0	4.29	50.71	5.03	51.33
D6.0	Outlet_D6.0	1.43	22.07	1.43	22.07
D7.0	Outlet_D7.0	0.27	4.20	0.40	4.32
O1.0	O1.0	87.21	1857.86	87.26	1857.91
O2.0	O2.0	145.11	3741.45	145.34	3741.77
O3.0	O3.0	99.11	989.85	100.60	990.25
O4.0	O4.0	58.36	639.02	58.61	639.26
O5.0	O5.0	105.56	1098.89	105.71	1099.01
All (Except D6.0-7.0)	Outlet_C8.1	300.62	6013.05	309.59	6013.08

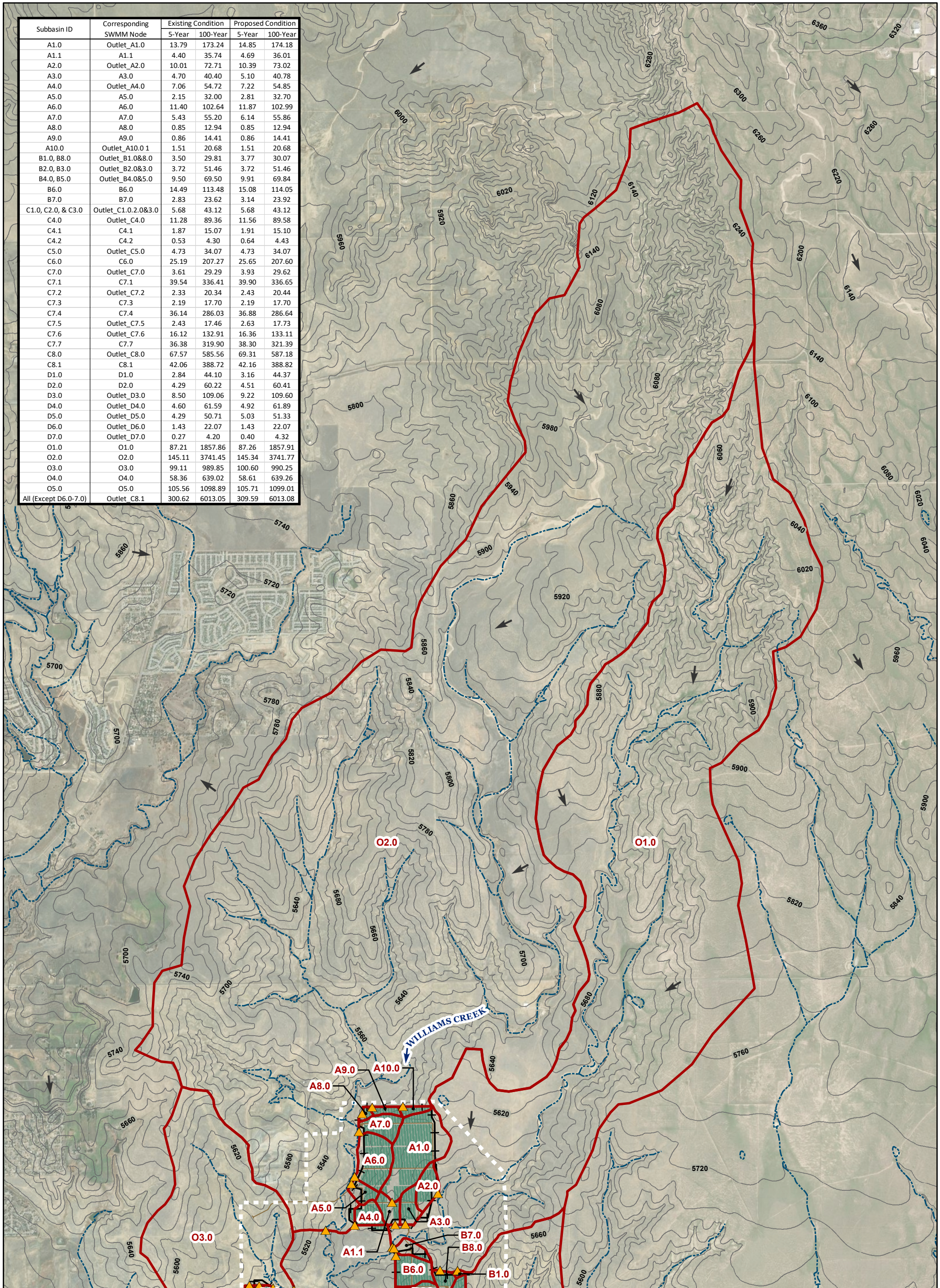

**Pike Solar Development**  
**Proposed Conditions**  
**Drainage Map**  
 Sheet 1 of 2  
 El Paso County, CO

**Legend**

- Project Site
- Drainage Subbasin
- Proposed Fence
- Drainage Subbasin Outlet
- Proposed Road
- Streamline
- Proposed Solar Panel
- 20-foot Contours

0 2,000  
 Feet  
 1:45,000

Project #: 20-194  
 Date: 7/29/2021

**CORE** LAND DEVELOPMENT  
 ENERGY  
 PUBLIC INFRASTRUCTURE

Subbasin ID	Corresponding SWMM Node	Existing Condition		Proposed Condition	
		5-Year	100-Year	5-Year	100-Year
A1.0	Outlet_A1.0	13.79	173.24	14.85	174.18
A1.1	A1.1	4.40	35.74	4.69	36.01
A2.0	Outlet_A2.0	10.01	72.71	10.39	73.02
A3.0	A3.0	4.70	40.40	5.10	40.78
A4.0	Outlet_A4.0	7.06	54.72	7.22	54.85
A5.0	A5.0	2.15	32.00	2.81	32.70
A6.0	A6.0	11.40	102.64	11.87	102.99
A7.0	A7.0	5.43	55.20	6.14	55.86
A8.0	A8.0	0.85	12.94	0.85	12.94
A9.0	A9.0	0.86	14.41	0.86	14.41
A10.0	Outlet_A10.0.1	1.51	20.68	1.51	20.68
B1.0, B8.0	Outlet_B1.0&8.0	3.50	29.81	3.77	30.07
B2.0, B3.0	Outlet_B2.0&3.0	3.72	51.46	3.72	51.46
B4.0, B5.0	Outlet_B4.0&5.0	9.50	69.50	9.91	69.84
B6.0	B6.0	14.49	113.48	15.08	114.05
B7.0	B7.0	2.83	23.62	3.14	23.92
C1.0, C2.0, & C3.0	Outlet_C1.0,2.0&3.0	5.68	43.12	5.68	43.12
C4.0	Outlet_C4.0	11.28	89.36	11.56	89.58
C4.1	C4.1	1.87	15.07	1.91	15.10
C4.2	C4.2	0.53	4.30	0.64	4.43
C5.0	Outlet_C5.0	4.73	34.07	4.73	34.07
C6.0	C6.0	25.19	207.27	25.65	207.60
C7.0	Outlet_C7.0	3.61	29.29	3.93	29.62
C7.1	C7.1	39.54	336.41	39.90	336.65
C7.2	Outlet_C7.2	2.33	20.34	2.43	20.44
C7.3	C7.3	2.19	17.70	2.19	17.70
C7.4	C7.4	36.14	286.03	36.88	286.64
C7.5	Outlet_C7.5	2.43	17.46	2.63	17.73
C7.6	Outlet_C7.6	16.12	132.91	16.36	133.11
C7.7	C7.7	36.38	319.90	38.30	321.39
C8.0	Outlet_C8.0	67.57	585.56	69.31	587.18
C8.1	C8.1	42.06	388.72	42.16	388.82
D1.0	D1.0	2.84	44.10	3.16	44.37
D2.0	D2.0	4.29	60.22	4.51	60.41
D3.0	Outlet_D3.0	8.50	109.06	9.22	109.60
D4.0	Outlet_D4.0	4.60	61.59	4.92	61.89
D5.0	Outlet_D5.0	4.29	50.71	5.03	51.33
D6.0	Outlet_D6.0	1.43	22.07	1.43	22.07
D7.0	Outlet_D7.0	0.27	4.20	0.40	4.32
O1.0	O1.0	87.21	1857.86	87.26	1857.91
O2.0	O2.0	145.11	3741.45	145.34	3741.77
O3.0	O3.0	99.11	989.85	100.60	990.25
O4.0	O4.0	58.36	639.02	58.61	639.26
O5.0	O5.0	105.56	1098.89	105.71	1099.01
All (Except D6.0-7.0)	Outlet_C8.1	300.62	6013.05	309.59	6013.08

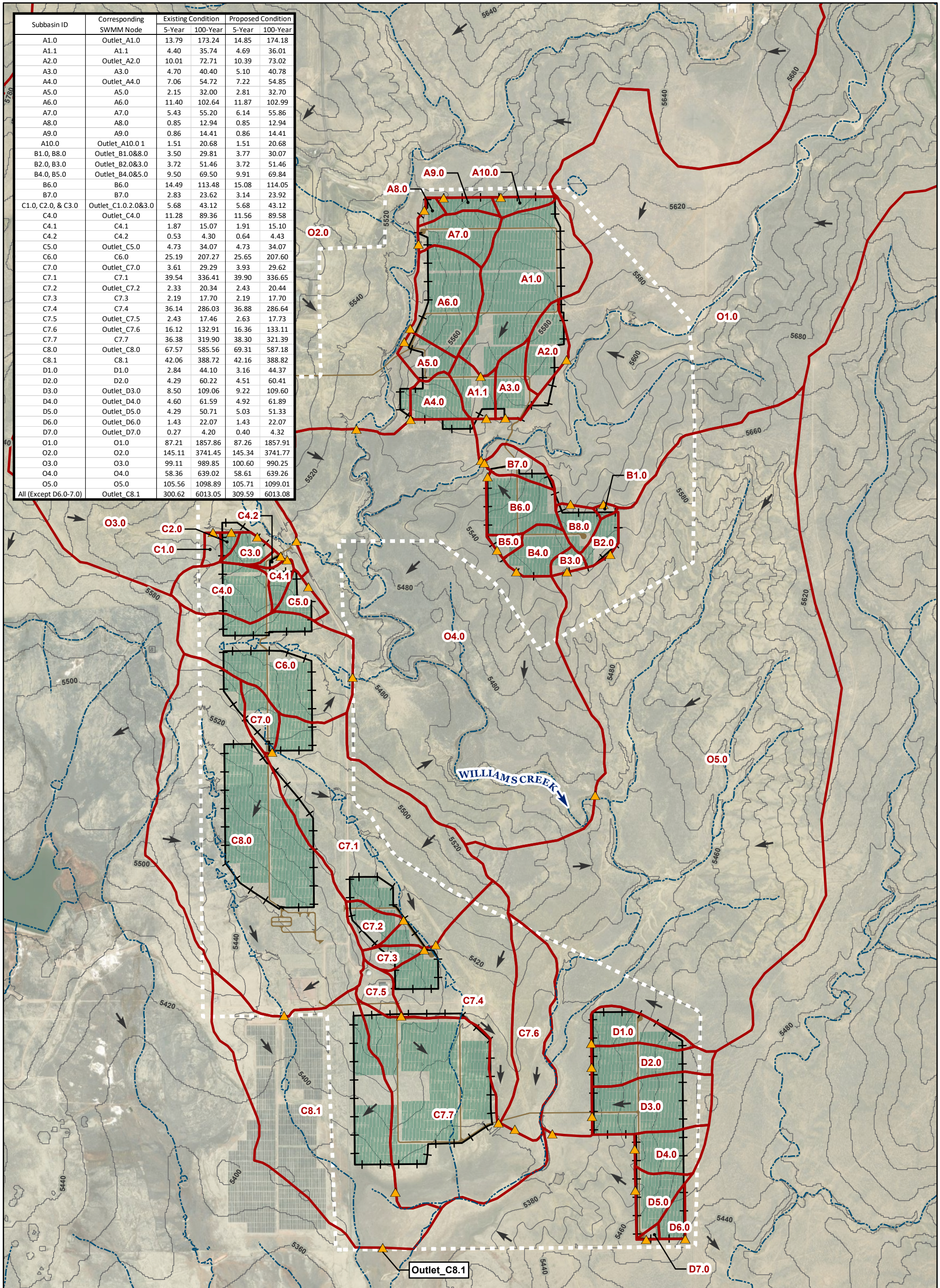

**Pike Solar Development**  
**Proposed Conditions**  
**Drainage Map**  
 Sheet 2 of 2  
 El Paso County, CO

**Legend**

- Project Site
- Drainage Subbasin
- Proposed Fence
- Drainage Subbasin Outlet
- Proposed Road
- Streamline
- Proposed Solar Panel
- 20-foot Contours

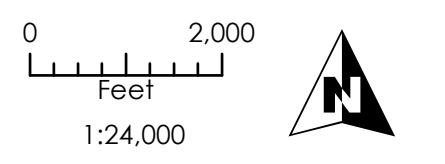

Project #: 20-194  
 Date: 7/29/2021



## **APPENDIX B HYDROLOGIC CALCULATIONS**

USDA WEB SOIL SURVEY REPORT

NOAA ATLAS 14 POINT PRECIPITATION TABLE

TABLE 5-1 OF EPC DCM (2018)

TABLE 6-3 OF MHFD USDCM VOLUME 1 (2018)

PERCENT IMPERVIOUSNESS CALCULATIONS FOR EXISTING CONDITION

PERCENT IMPERVIOUSNESS CALCULATIONS FOR PROPOSED CONDITION

CUHP INPUT PARAMETERS FOR EXISTING CONDITION

CUHP CALCULATED PARAMETERS FOR 5-YEAR EXISTING CONDITION

CUHP CALCULATED PARAMETERS FOR 100-YEAR EXISTING CONDITION

CUHP INPUT PARAMETERS FOR PROPOSED CONDITION

CUHP CALCULATED PARAMETERS FOR 5-YEAR PROPOSED CONDITION

CUHP CALCULATED PARAMETERS FOR 100-YEAR PROPOSED CONDITION

SWMM SUMMARY REPORT FOR 5-YEAR EXISTING CONDITION

SWMM SUMMARY REPORT FOR 100-YEAR EXISTING CONDITION

SWMM SUMMARY REPORT FOR 5-YEAR PROPOSED CONDITION

SWMM SUMMARY REPORT FOR 100-YEAR PROPOSED CONDITION

5- & 100-YEAR PEAK FLOW RATE COMPARISON TABLE

# Custom Soil Resource Report Map—Hydrologic Soil Group

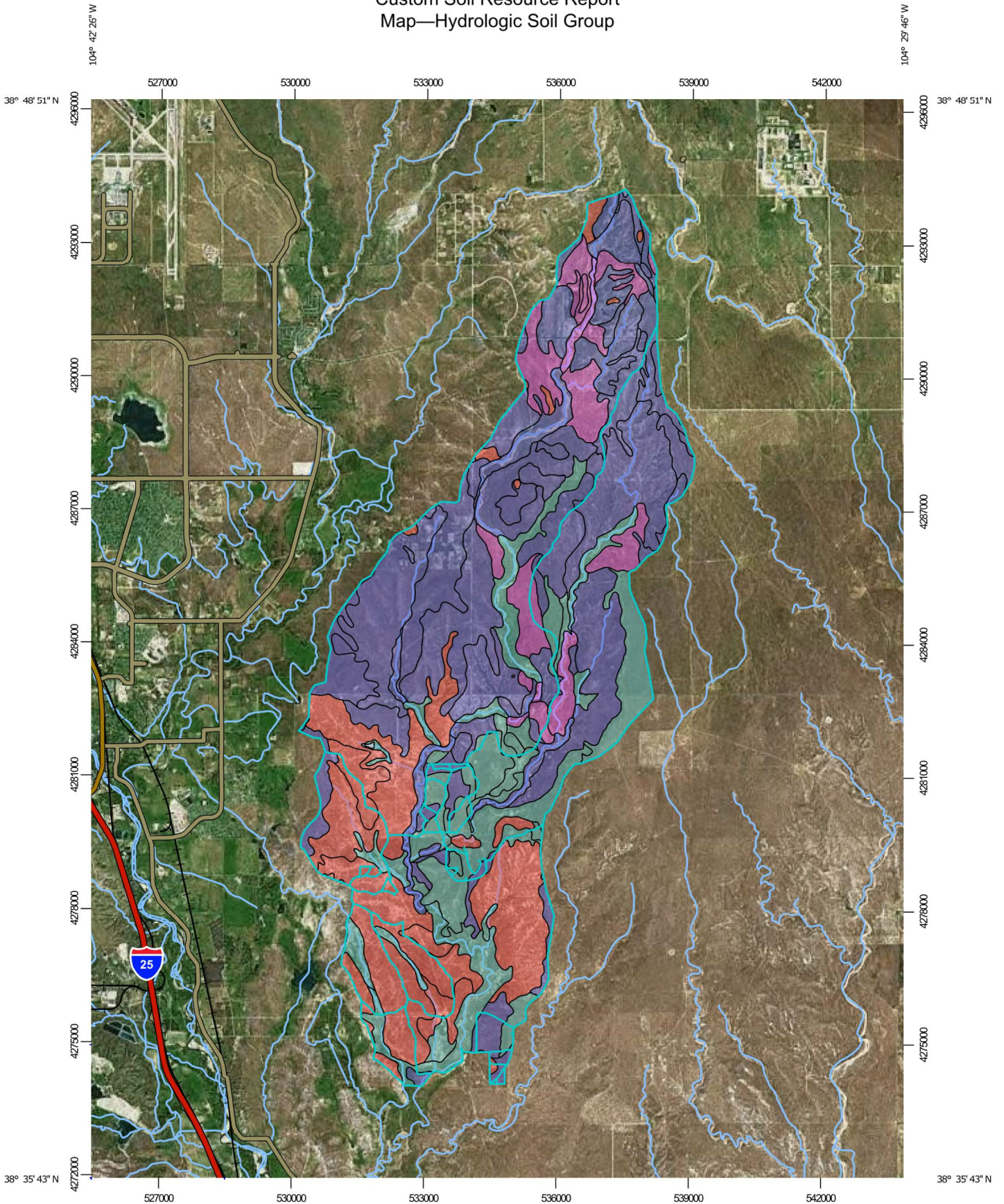



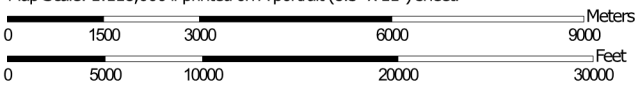

























































Map Scale: 1:118,000 if printed on A portrait (8.5" x 11") sheet.



Map projection: Web Mercator Corner coordinates: WGS84 Edge tics: UTM Zone 13N WGS84



## MAP LEGEND

	Area of Interest (AOI)		C
	Area of Interest (AOI)		C/D
	Area of Interest (AOI)		D
	Area of Interest (AOI)		Not rated or not available
<b>Soils</b>			
	Soil Rating Polygons		Not rated or not available
	A		
	A/D		
	B		
	B/D		
	C		
	C/D		
	D		
	Not rated or not available		
<b>Soil Rating Lines</b>			
	A		
	A/D		
	B		
	B/D		
	C		
	C/D		
	D		
	Not rated or not available		
<b>Water Features</b>			
	Streams and Canals		
<b>Transportation</b>			
	Interstate Highways		
	US Routes		
	Major Roads		
	Local Roads		
	Local Roads		
	Local Roads		
	Local Roads		
	Aerial Photography		

## MAP INFORMATION

The soil surveys that comprise your AOI were mapped at 1:24,000.

Please rely on the bar scale on each map sheet for map measurements.

Source of Map: Natural Resources Conservation Service  
 Web Soil Survey URL:  
 Coordinate System: Web Mercator (EPSG:3857)

Maps from the Web Soil Survey are based on the Web Mercator projection, which preserves direction and shape but distorts distance and area. A projection that preserves area, such as the Albers equal-area conic projection, should be used if more accurate calculations of distance or area are required.

This product is generated from the USDA-NRCS certified data as of the version date(s) listed below.

Soil Survey Area: El Paso County Area, Colorado  
 Survey Area Data: Version 18, Jun 5, 2020

Soil map units are labeled (as space allows) for map scales 1:50,000 or larger.

Date(s) aerial images were photographed: Apr 12, 2017—May 26, 2019

The orthophoto or other base map on which the soil lines were compiled and digitized probably differs from the background imagery displayed on these maps. As a result, some minor shifting of map unit boundaries may be evident.

Custom Soil Resource Report

**Table—Hydrologic Soil Group**

Map unit symbol	Map unit name	Rating	Acres in AOI	Percent of AOI
2	Ascalon sandy loam, 1 to 3 percent slopes	B	223.1	1.0%
3	Ascalon sandy loam, 3 to 9 percent slopes	B	48.3	0.2%
10	Blendon sandy loam, 0 to 3 percent slopes	B	28.3	0.1%
28	Ellicott loamy coarse sand, 0 to 5 percent slopes	A	138.9	0.6%
30	Fort Collins loam, 0 to 3 percent slopes	B	193.6	0.8%
31	Fort Collins loam, 3 to 8 percent slopes	B	122.2	0.5%
33	Heldt clay loam, 0 to 3 percent slopes	C	495.8	2.2%
39	Keith silt loam, 0 to 3 percent slopes	C	827.0	3.6%
52	Manzanst clay loam, 0 to 3 percent slopes	C	784.1	3.4%
54	Midway clay loam, 3 to 25 percent slopes	D	1,959.9	8.5%
56	Nelson-Tassel fine sandy loams, 3 to 18 percent slopes	B	3,416.0	14.9%
61	Olney sandy loam, 3 to 8 percent slopes	B	50.6	0.2%
70	Pits, gravel	A	0.8	0.0%
73	Razor clay loam, 3 to 9 percent slopes	D	200.9	0.9%
75	Razor-Midway complex	D	2,779.2	12.1%
78	Sampson loam, 0 to 3 percent slopes	B	123.9	0.5%
84	Stapleton sandy loam, 8 to 15 percent slopes	B	68.2	0.3%
86	Stoneham sandy loam, 3 to 8 percent slopes	B	280.8	1.2%
89	Tassel fine sandy loam, 3 to 18 percent slopes	D	30.5	0.1%
96	Truckton sandy loam, 0 to 3 percent slopes	A	35.1	0.2%
101	Ustic Torrifluvents, loamy	B	718.5	3.1%
102	Valent sand, 1 to 12 percent slopes, dry	A	73.7	0.3%
104	Vona sandy loam, warm, 0 to 3 percent slopes	A	841.6	3.7%



## Custom Soil Resource Report

Map unit symbol	Map unit name	Rating	Acres in AOI	Percent of AOI
105	Vona sandy loam, warm, 3 to 6 percent slopes	A	960.4	4.2%
107	Wilid silt loam, 0 to 3 percent slopes	C	1,071.4	4.7%
108	Wiley silt loam, 3 to 9 percent slopes	B	4,642.7	20.2%
111	Water		4.6	0.0%
116	Udic Haplusterts	D	7.0	0.0%
118	Fort loam, 1 to 5 percent slopes, cool	C	471.3	2.1%
119	Fort sandy loam, 1 to 8 percent slopes, cool	B	938.2	4.1%
120	Fort sandy loam, 8 to 15 percent slopes, cool	B	44.7	0.2%
125	Olrest sandy loam, 3 to 8 percent slopes	B	574.6	2.5%
HeA	Chromic Haplotorrerts, 0 to 1 percent slopes, ponded	D	6.3	0.0%
MzA	Manzanola silty clay loam, saline, 0 to 2 percent slopes	C	778.6	3.4%
<b>Totals for Area of Interest</b>			<b>22,941.3</b>	<b>100.0%</b>

### Rating Options—Hydrologic Soil Group

*Aggregation Method: Dominant Condition*

*Component Percent Cutoff: None Specified*

*Tie-break Rule: Higher*



**NOAA Atlas 14, Volume 8, Version 2**  
**Location name: Colorado Springs, Colorado, USA\***  
**Latitude: 38.6378°, Longitude: -104.6347°**  
**Elevation: 5459.49 ft\*\***



\* source: ESRI Maps  
 \*\* source: USGS

**POINT PRECIPITATION FREQUENCY ESTIMATES**

Sanja Perica, Deborah Martin, Sandra Pavlovic, Ishani Roy, Michael St. Laurent, Carl Trypaluk, Dale Unruh, Michael Yekta, Geoffery Bonnin

NOAA, National Weather Service, Silver Spring, Maryland

[PF\\_tabular](#) | [PF\\_graphical](#) | [Maps & aerals](#)

**PF tabular**

<b>PDS-based point precipitation frequency estimates with 90% confidence intervals (in inches)<sup>1</sup></b>										
Duration	Average recurrence interval (years)									
	1	2	5	10	25	50	100	200	500	1000
5-min	0.257 (0.207-0.325)	0.309 (0.248-0.390)	0.401 (0.322-0.509)	0.486 (0.388-0.620)	0.616 (0.477-0.827)	0.725 (0.545-0.985)	0.842 (0.609-1.17)	0.970 (0.669-1.39)	1.15 (0.760-1.70)	1.30 (0.829-1.93)
10-min	0.376 (0.303-0.475)	0.452 (0.364-0.571)	0.588 (0.471-0.745)	0.712 (0.568-0.907)	0.902 (0.699-1.21)	1.06 (0.798-1.44)	1.23 (0.892-1.72)	1.42 (0.979-2.04)	1.69 (1.11-2.49)	1.90 (1.21-2.83)
15-min	0.459 (0.370-0.580)	0.551 (0.444-0.696)	0.717 (0.575-0.908)	0.869 (0.692-1.11)	1.10 (0.852-1.48)	1.30 (0.973-1.76)	1.50 (1.09-2.10)	1.73 (1.19-2.48)	2.06 (1.36-3.03)	2.32 (1.48-3.45)
30-min	0.660 (0.532-0.833)	0.790 (0.636-0.999)	1.03 (0.823-1.30)	1.24 (0.990-1.58)	1.57 (1.22-2.11)	1.85 (1.39-2.52)	2.15 (1.56-3.00)	2.48 (1.71-3.56)	2.95 (1.95-4.35)	3.33 (2.12-4.95)
60-min	0.847 (0.683-1.07)	0.999 (0.805-1.26)	1.29 (1.03-1.63)	1.56 (1.25-1.99)	2.00 (1.56-2.70)	2.37 (1.79-3.24)	2.79 (2.02-3.90)	3.24 (2.24-4.67)	3.91 (2.58-5.77)	4.45 (2.84-6.61)
2-hr	1.03 (0.837-1.30)	1.21 (0.979-1.52)	1.55 (1.25-1.95)	1.89 (1.51-2.38)	2.42 (1.90-3.27)	2.89 (2.20-3.94)	3.42 (2.50-4.76)	4.00 (2.79-5.74)	4.86 (3.24-7.15)	5.57 (3.58-8.22)
3-hr	1.13 (0.917-1.41)	1.31 (1.06-1.63)	1.66 (1.35-2.09)	2.03 (1.63-2.55)	2.62 (2.07-3.54)	3.15 (2.41-4.28)	3.74 (2.75-5.22)	4.41 (3.10-6.32)	5.40 (3.63-7.94)	6.23 (4.03-9.16)
6-hr	1.28 (1.05-1.59)	1.47 (1.20-1.83)	1.86 (1.51-2.31)	2.26 (1.82-2.83)	2.93 (2.34-3.94)	3.53 (2.73-4.78)	4.22 (3.13-5.85)	4.99 (3.54-7.11)	6.15 (4.17-8.98)	7.12 (4.65-10.4)
12-hr	1.42 (1.17-1.75)	1.65 (1.35-2.03)	2.09 (1.71-2.59)	2.53 (2.06-3.15)	3.24 (2.60-4.31)	3.88 (3.01-5.19)	4.58 (3.42-6.29)	5.38 (3.84-7.58)	6.54 (4.47-9.47)	7.51 (4.96-10.9)
24-hr	1.59 (1.31-1.95)	1.86 (1.53-2.28)	2.36 (1.94-2.91)	2.85 (2.33-3.52)	3.60 (2.89-4.73)	4.26 (3.32-5.64)	4.99 (3.74-6.77)	5.79 (4.16-8.07)	6.95 (4.79-9.96)	7.90 (5.27-11.4)
2-day	1.78 (1.48-2.17)	2.12 (1.75-2.58)	2.72 (2.24-3.32)	3.26 (2.68-4.00)	4.09 (3.28-5.28)	4.78 (3.73-6.25)	5.52 (4.16-7.41)	6.33 (4.58-8.73)	7.47 (5.19-10.6)	8.40 (5.66-12.0)
3-day	1.92 (1.60-2.33)	2.27 (1.88-2.75)	2.89 (2.39-3.51)	3.46 (2.85-4.23)	4.33 (3.49-5.57)	5.06 (3.97-6.59)	5.84 (4.43-7.81)	6.70 (4.87-9.21)	7.92 (5.54-11.2)	8.91 (6.04-12.7)
4-day	2.06 (1.72-2.49)	2.40 (2.00-2.91)	3.03 (2.52-3.68)	3.62 (2.99-4.41)	4.51 (3.65-5.80)	5.27 (4.15-6.85)	6.09 (4.64-8.13)	6.99 (5.10-9.59)	8.28 (5.81-11.7)	9.33 (6.35-13.3)
7-day	2.47 (2.07-2.97)	2.83 (2.37-3.41)	3.49 (2.92-4.22)	4.11 (3.41-4.98)	5.06 (4.11-6.46)	5.87 (4.65-7.58)	6.74 (5.16-8.94)	7.71 (5.67-10.5)	9.08 (6.43-12.7)	10.2 (7.01-14.4)
10-day	2.83 (2.37-3.38)	3.23 (2.71-3.87)	3.95 (3.31-4.75)	4.62 (3.84-5.58)	5.62 (4.58-7.14)	6.48 (5.14-8.32)	7.39 (5.68-9.75)	8.39 (6.19-11.4)	9.81 (6.97-13.7)	11.0 (7.56-15.4)
20-day	3.72 (3.14-4.42)	4.30 (3.63-5.12)	5.29 (4.45-6.31)	6.14 (5.14-7.37)	7.37 (6.00-9.20)	8.36 (6.66-10.6)	9.39 (7.24-12.2)	10.5 (7.77-14.0)	11.9 (8.55-16.5)	13.1 (9.15-18.4)
30-day	4.45 (3.77-5.27)	5.17 (4.38-6.13)	6.37 (5.37-7.57)	7.37 (6.18-8.81)	8.76 (7.14-10.8)	9.85 (7.85-12.4)	11.0 (8.47-14.1)	12.1 (8.99-16.1)	13.6 (9.76-18.6)	14.7 (10.3-20.5)
45-day	5.39 (4.58-6.37)	6.27 (5.32-7.40)	7.68 (6.50-9.10)	8.83 (7.44-10.5)	10.4 (8.47-12.7)	11.6 (9.25-14.4)	12.7 (9.88-16.3)	13.9 (10.4-18.4)	15.4 (11.1-21.0)	16.6 (11.7-23.0)
60-day	6.23 (5.31-7.33)	7.21 (6.13-8.49)	8.76 (7.43-10.4)	10.0 (8.46-11.9)	11.7 (9.54-14.3)	12.9 (10.4-16.0)	14.1 (11.0-18.0)	15.3 (11.5-20.1)	16.8 (12.2-22.8)	17.9 (12.7-24.8)

<sup>1</sup> Precipitation frequency (PF) estimates in this table are based on frequency analysis of partial duration series (PDS). Numbers in parenthesis are PF estimates at lower and upper bounds of the 90% confidence interval. The probability that precipitation frequency estimates (for a given duration and average recurrence interval) will be greater than the upper bound (or less than the lower bound) is 5%. Estimates at upper bounds are not checked against probable maximum precipitation (PMP) estimates and may be higher than currently valid PMP values. Please refer to NOAA Atlas 14 document for more information.

[Back to Top](#)

**PF graphical**

PDS-based depth-duration-frequency (DDF) curves

Latitude: 38.6378°, Longitude: -104.6347°

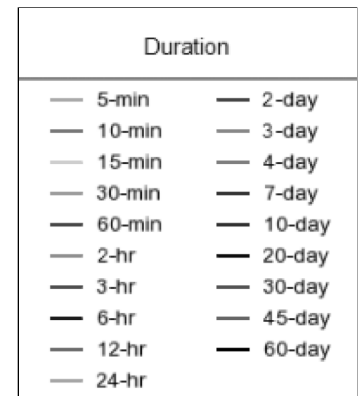
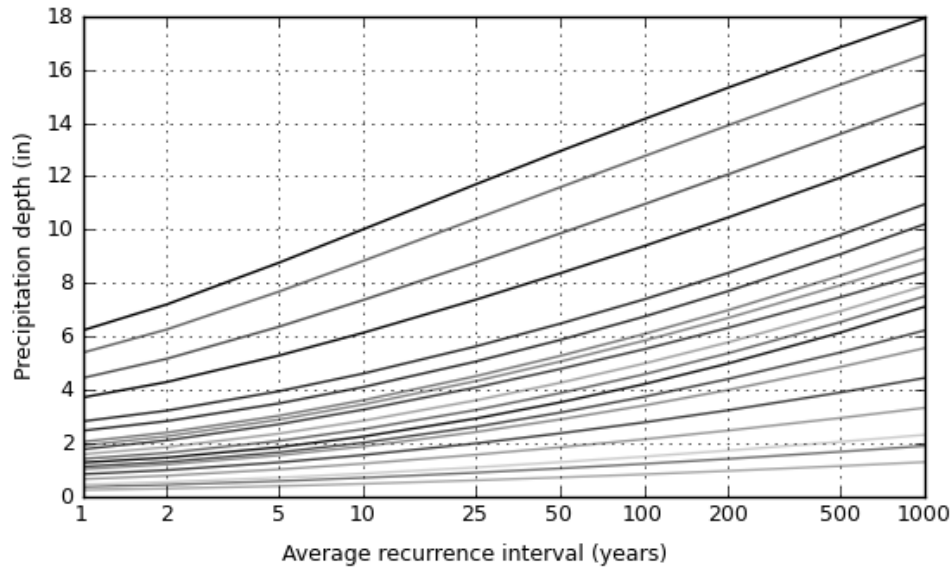
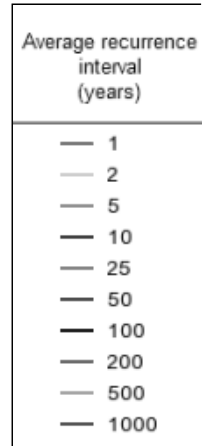
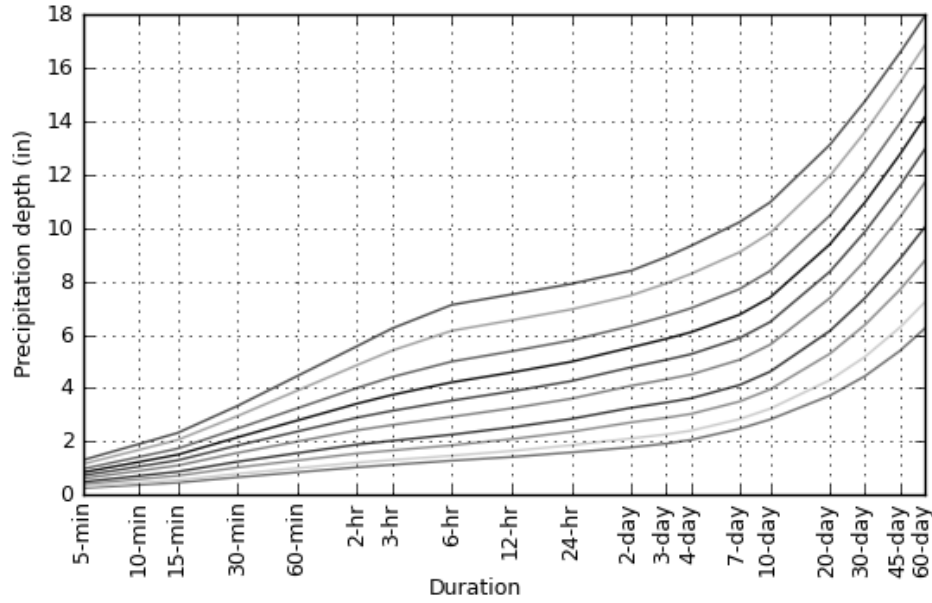

**Maps & aerials**

**Small scale terrain**

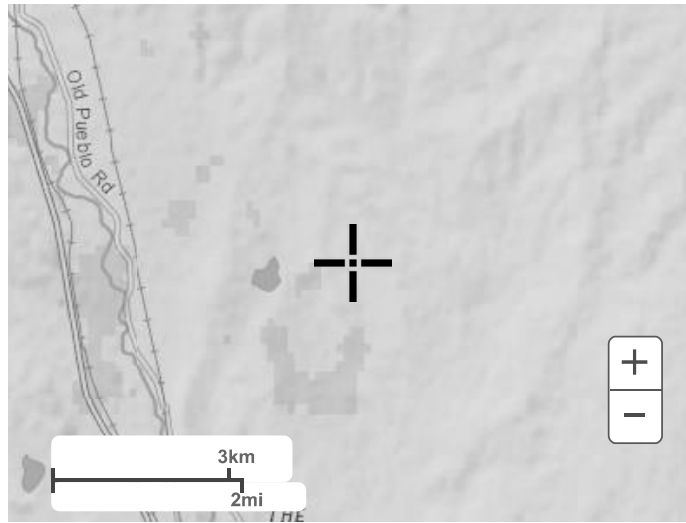

Large scale terrain



Large scale map

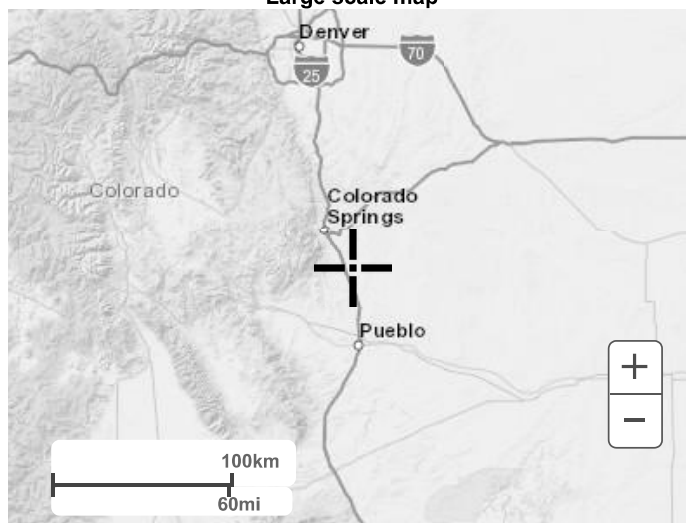

Large scale aerial

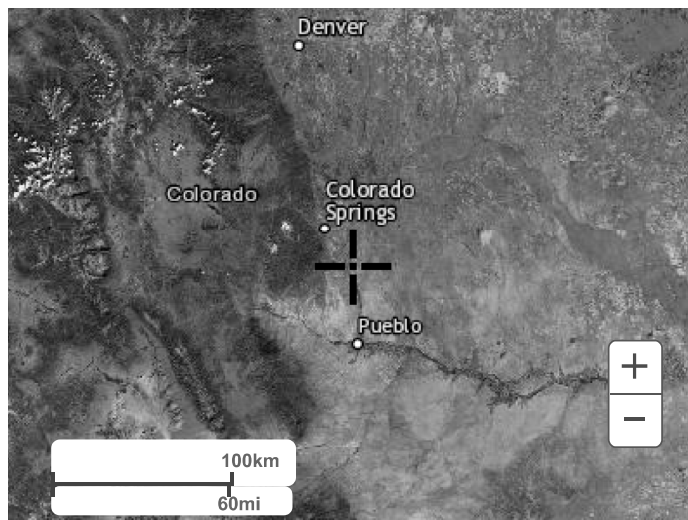

[Back to Top](#)

---

[US Department of Commerce](#)  
[National Oceanic and Atmospheric Administration](#)  
[National Weather Service](#)  
[National Water Center](#)  
1325 East West Highway  
Silver Spring, MD 20910  
Questions?: [HDSC.Questions@noaa.gov](mailto:HDSC.Questions@noaa.gov)

[Disclaimer](#)

Percent Imperviousness Calculations for Proposed Condition

Subcatchment Name	Total Area (mi <sup>2</sup> )	Landuse Area (mi <sup>2</sup> )					Subcatchment Composite Percent Imperviousness (%)
		Undeveloped	Residential Lot >2.5 Acres	Gravel	Roof	Paved	
		(2% Impervious)*	(12% Impervious)**	(80% Impervious)*	(90% Impervious)*	(100% Impervious)*	
A1.0	0.224	0.221	0.000	0.003	0.000	0.000	3.10
A1.1	0.035	0.035	0.000	0.001	0.000	0.000	3.62
A2.0	0.048	0.048	0.000	0.001	0.000	0.000	3.07
A3.0	0.040	0.039	0.000	0.001	0.000	0.000	3.95
A4.0	0.038	0.037	0.000	0.000	0.000	0.000	2.59
A5.0	0.030	0.029	0.000	0.001	0.000	0.000	5.38
A6.0	0.109	0.107	0.000	0.001	0.000	0.000	2.87
A7.0	0.055	0.053	0.000	0.002	0.000	0.000	4.37
A8.0	0.008	0.008	0.000	0.000	0.000	0.000	2.00
A9.0	0.015	0.015	0.000	0.000	0.000	0.000	2.00
A10.0	0.015	0.015	0.000	0.000	0.000	0.000	2.00
B1.0	0.004	0.004	0.000	0.000	0.000	0.000	2.00
B2.0	0.022	0.022	0.000	0.000	0.000	0.000	2.00
B3.0	0.012	0.012	0.000	0.000	0.000	0.000	2.00
B4.0	0.040	0.040	0.000	0.001	0.000	0.000	3.34
B5.0	0.010	0.010	0.000	0.000	0.000	0.000	2.54
B6.0	0.067	0.066	0.000	0.001	0.000	0.000	3.11
B7.0	0.028	0.027	0.000	0.001	0.000	0.000	4.61
B8.0	0.026	0.025	0.000	0.001	0.000	0.000	4.17
C1.0	0.010	0.010	0.000	0.000	0.000	0.000	2.00
C2.0	0.006	0.006	0.000	0.000	0.000	0.000	2.00
C3.0	0.019	0.019	0.000	0.000	0.000	0.000	2.00
C4.0	0.084	0.083	0.000	0.001	0.000	0.000	2.63
C4.1	0.016	0.016	0.000	0.000	0.000	0.000	2.48
C4.2	0.005	0.005	0.000	0.000	0.000	0.000	7.34
C5.0	0.024	0.024	0.000	0.000	0.000	0.000	2.39
C6.0	0.240	0.237	0.000	0.003	0.000	0.000	3.09
C7.0	0.032	0.031	0.000	0.001	0.000	0.000	4.17
C7.1	0.468	0.460	0.000	0.007	0.000	0.000	3.19
C7.2	0.031	0.030	0.000	0.000	0.000	0.000	3.05
C7.3	0.019	0.019	0.000	0.000	0.000	0.000	2.00
C7.4	0.250	0.248	0.000	0.002	0.000	0.000	2.51
C7.5	0.028	0.025	0.000	0.002	0.001	0.000	10.79
C7.6	0.143	0.142	0.000	0.001	0.000	0.000	2.37
C7.7	0.416	0.409	0.000	0.007	0.000	0.000	3.23
C8.0	0.815	0.800	0.000	0.015	0.000	0.000	3.41
C8.1	0.577	0.571	0.000	0.007	0.000	0.000	2.91
D1.0	0.052	0.051	0.000	0.001	0.000	0.000	3.24
D2.0	0.071	0.070	0.000	0.001	0.000	0.000	2.64
D3.0	0.117	0.116	0.000	0.002	0.000	0.000	3.13
D4.0	0.053	0.052	0.000	0.001	0.000	0.000	2.84
D5.0	0.040	0.039	0.000	0.001	0.000	0.000	4.50
D6.0	0.018	0.018	0.000	0.000	0.000	0.000	2.00
D7.0	0.004	0.003	0.000	0.000	0.000	0.000	6.90
O1.0	8.461	8.446	0.000	0.015	0.000	0.000	2.14
O2.0	17.312	16.489	0.591	0.207	0.003	0.022	3.42
O3.0	1.390	1.376	0.000	0.014	0.000	0.000	2.77
O4.0	1.626	1.625	0.000	0.002	0.000	0.000	2.07
O5.0	2.696	2.695	0.000	0.001	0.000	0.000	2.02

\* El Paso County Drainage Criteria Manual, Table 5-1

\*\* Mile High Flood District Urban Storm Drainage Criteria Manual Volume 1, Table 6-3

**TABLE 5-1 RECOMMENDED AVERAGE RUNOFF COEFFICIENTS AND PERCENT IMPERVIOUS**  
 (DRAINAGE CRITERIA MANUAL COUNTY OF EL PASO, COLORADO, OCT 2018)

LAND USE OR SURFACE CHARACTERISTICS	PERCENT IMPERVIOUS	"C" FREQUENCY			
		10		100	
		A&B*	C&D*	A&B*	C&D*
Business					
Commercial Areas	95	0.90	0.90	0.90	0.90
Neighborhood Areas	70	0.75	0.75	0.80	0.80
Residential					
1/8 Acre or less	65	0.60	0.70	0.70	0.80
1/4 Acre	40	0.50	0.60	0.60	0.70
1/3 Acre	30	0.40	0.50	0.55	0.60
1/2 Acre	25	0.35	0.45	0.45	0.55
1 Acre	20	0.30	0.40	0.40	0.50
Industrial					
Light Areas	80	0.70	0.70	0.80	0.80
Heavy Areas	90	0.80	0.80	0.90	0.90
Parks and Cemeteries	7	0.30	0.35	0.55	0.60
Playgrounds	13	0.30	0.35	0.60	0.65
Railroad Yard Areas	40	0.50	0.55	0.60	0.65
Undeveloped Areas					

# El Paso County Drainage Criteria Manual - Percent Imperviousness Table

LAND USE OR SURFACE CHARACTERISTICS	PERCENT IMPERVIOUS	"C" FREQUENCY			
		10		100	
		A&B*	C&D*	A&B*	C&D*
Historic Flow Analysis- Greenbelts, Agricultural	2	0.15	0.25	0.20	0.30
Pasture/Meadow	0	0.25	0.30	0.35	0.45
Forest	0	0.10	0.15	0.15	0.20
Exposed Rock	100	0.90	0.90	0.95	0.95
Offsite Flow Analysis (when land use not defined)	45	0.55	0.60	0.65	0.70
Streets					
Paved	100	0.90	0.90	0.95	0.95
Gravel	80	0.80	0.80	0.85	0.85
Drive and Walks	100	0.90	0.90	0.95	0.95
Roofs	90	0.90	0.90	0.95	0.95
Lawns	0	0.25	0.30	0.35	0.45
*Hydrologic Soil Group					



**Table 6-3. Recommended percentage imperviousness values**

Land Use or Surface Characteristics	Percentage Imperviousness (%)
<b>Business:</b>	
Downtown Areas	95
Suburban Areas	75
<b>Residential lots (lot area only):</b>	
Single-family	
2.5 acres or larger	12
0.75 – 2.5 acres	20
0.25 – 0.75 acres	30
0.25 acres or less	45
Apartments	75
<b>Industrial:</b>	
Light areas	80
Heavy areas	90
<b>Parks, cemeteries</b>	10
<b>Playgrounds</b>	25
<b>Schools</b>	55
<b>Railroad yard areas</b>	50
<b>Undeveloped Areas:</b>	
Historic flow analysis	2
Greenbelts, agricultural	2
Off-site flow analysis (when land use not defined)	45
<b>Streets:</b>	
Paved	100
Gravel (packed)	40
Drive and walks	90
Roofs	90
Lawns, sandy soil	2
Lawns, clayey soil	2

Percent Imperviousness Calculations for Existing Condition

Subcatchment Name	Total Area (mi <sup>2</sup> )	Landuse Area (mi <sup>2</sup> )					Subcatchment Composite Percent Imperviousness (%)
		Undeveloped	Residential Lot >2.5 Acres	Gravel	Roof	Paved	
		(2% Impervious)*	(12% Impervious)**	(80% Impervious)*	(90% Impervious)*	(100% Impervious)*	
A1.0	0.224	0.224	0.000	0.000	0.000	0.000	2.00
A1.1	0.035	0.035	0.000	0.000	0.000	0.000	2.00
A2.0	0.048	0.048	0.000	0.000	0.000	0.000	2.00
A3.0	0.040	0.040	0.000	0.000	0.000	0.000	2.00
A4.0	0.038	0.038	0.000	0.000	0.000	0.000	2.00
A5.0	0.030	0.030	0.000	0.000	0.000	0.000	2.00
A6.0	0.109	0.109	0.000	0.000	0.000	0.000	2.00
A7.0	0.055	0.055	0.000	0.000	0.000	0.000	2.00
A8.0	0.008	0.008	0.000	0.000	0.000	0.000	2.00
A9.0	0.015	0.015	0.000	0.000	0.000	0.000	2.00
A10.0	0.015	0.015	0.000	0.000	0.000	0.000	2.00
B1.0	0.004	0.004	0.000	0.000	0.000	0.000	2.00
B2.0	0.022	0.022	0.000	0.000	0.000	0.000	2.00
B3.0	0.012	0.012	0.000	0.000	0.000	0.000	2.00
B4.0	0.040	0.040	0.000	0.000	0.000	0.000	2.00
B5.0	0.010	0.010	0.000	0.000	0.000	0.000	2.00
B6.0	0.067	0.067	0.000	0.000	0.000	0.000	2.00
B7.0	0.028	0.028	0.000	0.000	0.000	0.000	2.00
B8.0	0.026	0.026	0.000	0.000	0.000	0.000	2.00
C1.0	0.010	0.010	0.000	0.000	0.000	0.000	2.00
C2.0	0.006	0.006	0.000	0.000	0.000	0.000	2.00
C3.0	0.019	0.019	0.000	0.000	0.000	0.000	2.00
C4.0	0.084	0.084	0.000	0.000	0.000	0.000	2.00
C4.1	0.016	0.016	0.000	0.000	0.000	0.000	2.00
C4.2	0.005	0.005	0.000	0.000	0.000	0.000	2.00
C5.0	0.024	0.024	0.000	0.000	0.000	0.000	2.39
C6.0	0.240	0.238	0.000	0.002	0.000	0.000	2.65
C7.0	0.032	0.032	0.000	0.000	0.000	0.000	2.00
C7.1	0.468	0.462	0.000	0.006	0.000	0.000	2.97
C7.2	0.031	0.031	0.000	0.000	0.000	0.000	2.00
C7.3	0.019	0.019	0.000	0.000	0.000	0.000	2.00
C7.4	0.250	0.250	0.000	0.000	0.000	0.000	2.00
C7.5	0.028	0.026	0.000	0.001	0.001	0.000	8.59
C7.6	0.143	0.143	0.000	0.000	0.000	0.000	2.00
C7.7	0.416	0.416	0.000	0.000	0.000	0.000	2.00
C8.0	0.815	0.807	0.000	0.008	0.000	0.000	2.79
C8.1	0.577	0.571	0.000	0.006	0.000	0.000	2.86
D1.0	0.052	0.052	0.000	0.000	0.000	0.000	2.00
D2.0	0.071	0.071	0.000	0.000	0.000	0.000	2.00
D3.0	0.117	0.117	0.000	0.000	0.000	0.000	2.00
D4.0	0.053	0.053	0.000	0.000	0.000	0.000	2.00
D5.0	0.040	0.040	0.000	0.000	0.000	0.000	2.00
D6.0	0.018	0.018	0.000	0.000	0.000	0.000	2.00
D7.0	0.004	0.004	0.000	0.000	0.000	0.000	2.00
O1.0	8.461	8.446	0.000	0.015	0.000	0.000	2.14
O2.0	17.312	16.491	0.591	0.205	0.003	0.022	3.41
O3.0	1.390	1.381	0.000	0.009	0.000	0.000	2.48
O4.0	1.626	1.626	0.000	0.000	0.000	0.000	2.00
O5.0	2.696	2.696	0.000	0.000	0.000	0.000	2.00

\* El Paso County Drainage Criteria Manual, Table 5-1

\*\* Mile High Flood District Urban Storm Drainage Criteria Manual Volume 1, Table 6-3

Percent Imperviousness Calculations for Proposed Condition

Subcatchment Name	Total Area (mi <sup>2</sup> )	Landuse Area (mi <sup>2</sup> )					Subcatchment Composite Percent Imperviousness (%)
		Undeveloped	Residential Lot >2.5 Acres	Gravel	Roof	Paved	
		(2% Impervious)*	(12% Impervious)**	(80% Impervious)*	(90% Impervious)*	(100% Impervious)*	
A1.0	0.224	0.221	0.000	0.003	0.000	0.000	3.10
A1.1	0.035	0.035	0.000	0.001	0.000	0.000	3.62
A2.0	0.048	0.048	0.000	0.001	0.000	0.000	3.07
A3.0	0.040	0.039	0.000	0.001	0.000	0.000	3.95
A4.0	0.038	0.037	0.000	0.000	0.000	0.000	2.59
A5.0	0.030	0.029	0.000	0.001	0.000	0.000	5.38
A6.0	0.109	0.107	0.000	0.001	0.000	0.000	2.87
A7.0	0.055	0.053	0.000	0.002	0.000	0.000	4.37
A8.0	0.008	0.008	0.000	0.000	0.000	0.000	2.00
A9.0	0.015	0.015	0.000	0.000	0.000	0.000	2.00
A10.0	0.015	0.015	0.000	0.000	0.000	0.000	2.00
B1.0	0.004	0.004	0.000	0.000	0.000	0.000	2.00
B2.0	0.022	0.022	0.000	0.000	0.000	0.000	2.00
B3.0	0.012	0.012	0.000	0.000	0.000	0.000	2.00
B4.0	0.040	0.040	0.000	0.001	0.000	0.000	3.34
B5.0	0.010	0.010	0.000	0.000	0.000	0.000	2.54
B6.0	0.067	0.066	0.000	0.001	0.000	0.000	3.11
B7.0	0.028	0.027	0.000	0.001	0.000	0.000	4.61
B8.0	0.026	0.025	0.000	0.001	0.000	0.000	4.17
C1.0	0.010	0.010	0.000	0.000	0.000	0.000	2.00
C2.0	0.006	0.006	0.000	0.000	0.000	0.000	2.00
C3.0	0.019	0.019	0.000	0.000	0.000	0.000	2.00
C4.0	0.084	0.083	0.000	0.001	0.000	0.000	2.63
C4.1	0.016	0.016	0.000	0.000	0.000	0.000	2.48
C4.2	0.005	0.005	0.000	0.000	0.000	0.000	7.34
C5.0	0.024	0.024	0.000	0.000	0.000	0.000	2.39
C6.0	0.240	0.237	0.000	0.003	0.000	0.000	3.09
C7.0	0.032	0.031	0.000	0.001	0.000	0.000	4.17
C7.1	0.468	0.460	0.000	0.007	0.000	0.000	3.19
C7.2	0.031	0.030	0.000	0.000	0.000	0.000	3.05
C7.3	0.019	0.019	0.000	0.000	0.000	0.000	2.00
C7.4	0.250	0.248	0.000	0.002	0.000	0.000	2.51
C7.5	0.028	0.025	0.000	0.002	0.001	0.000	10.79
C7.6	0.143	0.142	0.000	0.001	0.000	0.000	2.37
C7.7	0.416	0.409	0.000	0.007	0.000	0.000	3.23
C8.0	0.815	0.800	0.000	0.015	0.000	0.000	3.41
C8.1	0.577	0.571	0.000	0.007	0.000	0.000	2.91
D1.0	0.052	0.051	0.000	0.001	0.000	0.000	3.24
D2.0	0.071	0.070	0.000	0.001	0.000	0.000	2.64
D3.0	0.117	0.116	0.000	0.002	0.000	0.000	3.13
D4.0	0.053	0.052	0.000	0.001	0.000	0.000	2.84
D5.0	0.040	0.039	0.000	0.001	0.000	0.000	4.50
D6.0	0.018	0.018	0.000	0.000	0.000	0.000	2.00
D7.0	0.004	0.003	0.000	0.000	0.000	0.000	6.90
O1.0	8.461	8.446	0.000	0.015	0.000	0.000	2.14
O2.0	17.312	16.489	0.591	0.207	0.003	0.022	3.42
O3.0	1.390	1.376	0.000	0.014	0.000	0.000	2.77
O4.0	1.626	1.625	0.000	0.002	0.000	0.000	2.07
O5.0	2.696	2.695	0.000	0.001	0.000	0.000	2.02

\* El Paso County Drainage Criteria Manual, Table 5-1

\*\* Mile High Flood District Urban Storm Drainage Criteria Manual Volume 1, Table 6-3

## CUHP SUBCATCHMENTS - EXISTING CONDITION

Columns with this color heading are for required user-input  
Columns with this color heading are for optional override values  
Columns with this color heading are for program-calculated values

Subcatchment Name	EPA SWMM Target Node	Raingage	Area (mi <sup>2</sup> )	Length to Centroid (mi)	Length (mi)	Slope (ft/ft)	Percent Imperviousness	Maximum Depression Storage (Watershed inches)		Horton's Infiltration Parameters			DCIA Level 0, 1, or 2
								Pervious	Impervious	Initial Rate (in/hr)	Decay Coefficient (1/seconds)	Final Rate (in/hr)	
A1.0	A1.0	Design Storm	0.2239	0.4630	0.8182	0.0185	2.00	0.4	0.1	3.78	0.0018	0.55	0
A1.1	A1.1	Design Storm	0.0353	0.1465	0.3126	0.0315	2.00	0.4	0.1	3.04	0.0018	0.50	0
A2.0	A2.0	Design Storm	0.0485	0.0984	0.2082	0.0391	2.00	0.4	0.1	3.02	0.0018	0.50	0
A3.0	A3.0	Design Storm	0.0405	0.1534	0.3612	0.0339	2.00	0.4	0.1	3.17	0.0018	0.51	0
A4.0	A4.0	Design Storm	0.0378	0.0955	0.2160	0.0546	2.00	0.4	0.1	3.15	0.0018	0.51	0
A5.0	A5.0	Design Storm	0.0302	0.1455	0.2455	0.0542	2.00	0.4	0.1	4.35	0.0018	0.59	0
A6.0	A6.0	Design Storm	0.1085	0.2267	0.6403	0.0253	2.00	0.4	0.1	3.21	0.0018	0.51	0
A7.0	A7.0	Design Storm	0.0545	0.1923	0.3763	0.0392	2.00	0.4	0.1	3.50	0.0018	0.53	0
A8.0	A8.0	Design Storm	0.0083	0.0272	0.0885	0.0366	2.00	0.4	0.1	4.50	0.0018	0.60	0
A9.0	A9.0	Design Storm	0.0152	0.0951	0.2438	0.0448	2.00	0.4	0.1	4.50	0.0018	0.60	0
A10.0	A10.0	Design Storm	0.0149	0.0488	0.1346	0.0398	2.00	0.4	0.1	4.34	0.0018	0.59	0
B1.0	B1.0	Design Storm	0.0040	0.0904	0.0646	0.0410	2.00	0.4	0.1	3.60	0.0018	0.54	0
B2.0	B2.0	Design Storm	0.0218	0.0289	0.1661	0.0578	2.00	0.4	0.1	4.50	0.0018	0.60	0
B3.0	B3.0	Design Storm	0.0118	0.0958	0.1279	0.0462	2.00	0.4	0.1	3.78	0.0018	0.55	0
B4.0	B4.0	Design Storm	0.0403	0.0429	0.3274	0.0257	2.00	0.4	0.1	3.00	0.0018	0.50	0
B5.0	B5.0	Design Storm	0.0100	0.1323	0.1348	0.0382	2.00	0.4	0.1	3.00	0.0018	0.50	0
B6.0	B6.0	Design Storm	0.0669	0.0476	0.3986	0.0375	2.00	0.4	0.1	3.18	0.0018	0.51	0
B7.0	B7.0	Design Storm	0.0284	0.1725	0.3976	0.0347	2.00	0.4	0.1	3.00	0.0018	0.50	0
B8.0	B8.0	Design Storm	0.0257	0.1618	0.2110	0.0312	2.00	0.4	0.1	3.09	0.0018	0.51	0
C1.0	C1.0	Design Storm	0.0098	0.0756	0.1652	0.0460	2.00	0.4	0.1	3.00	0.0018	0.50	0
C2.0	C2.0	Design Storm	0.0063	0.0522	0.1383	0.0463	2.00	0.4	0.1	3.00	0.0018	0.50	0
C3.0	C3.0	Design Storm	0.0191	0.0670	0.1977	0.0441	2.00	0.4	0.1	3.00	0.0018	0.50	0
C4.0	C4.0	Design Storm	0.0838	0.2163	0.4311	0.0321	2.00	0.4	0.1	3.00	0.0018	0.50	0
C4.1	C4.1	Design Storm	0.0159	0.1047	0.2488	0.0327	2.00	0.4	0.1	3.00	0.0018	0.50	0
C4.2	C4.2	Design Storm	0.0050	0.0579	0.2024	0.0375	2.00	0.4	0.1	3.00	0.0018	0.50	0
C5.0	C5.0	Design Storm	0.0240	0.0661	0.1892	0.0404	2.39	0.4	0.1	3.00	0.0018	0.50	0
C6.0	C6.0	Design Storm	0.2400	0.3914	0.8912	0.0206	2.65	0.4	0.1	3.00	0.0018	0.50	0
C7.0	C7.0	Design Storm	0.0323	0.1647	0.3423	0.0306	2.00	0.4	0.1	3.00	0.0018	0.50	0
C7.1	C7.1	Design Storm	0.4676	0.7020	1.2373	0.0183	2.97	0.4	0.1	3.00	0.0018	0.50	0
C7.2	C7.2	Design Storm	0.0307	0.5497	0.2695	0.0396	2.00	0.4	0.1	3.00	0.0018	0.50	0
C7.3	C7.3	Design Storm	0.0193	0.1429	0.2740	0.0420	2.00	0.4	0.1	3.00	0.0018	0.50	0
C7.4	C7.4	Design Storm	0.2498	0.1481	1.0895	0.0212	2.00	0.4	0.1	3.00	0.0018	0.50	0
C7.5	C7.5	Design Storm	0.0281	0.6788	0.2592	0.0371	8.59	0.4	0.1	3.00	0.0018	0.50	0
C7.6	C7.6	Design Storm	0.1431	0.1728	1.0079	0.0175	2.00	0.4	0.1	3.00	0.0018	0.50	0
C7.7	C7.7	Design Storm	0.4159	0.4585	1.2494	0.0139	2.00	0.4	0.1	3.02	0.0018	0.50	0
C8.0	C8.0	Design Storm	0.8148	0.7558	1.6417	0.0174	2.79	0.4	0.1	3.00	0.0018	0.50	0
C8.1	C8.1	Design Storm	0.5774	0.6638	1.4767	0.0127	2.86	0.4	0.1	3.13	0.0018	0.51	0
D1.0	D1.0	Design Storm	0.0516	0.1807	0.4799	0.0315	2.00	0.4	0.1	4.32	0.0018	0.59	0
D2.0	D2.0	Design Storm	0.0707	0.2315	0.5432	0.0323	2.00	0.4	0.1	4.13	0.0018	0.58	0
D3.0	D3.0	Design Storm	0.1174	0.2811	0.5696	0.0312	2.00	0.4	0.1	3.98	0.0018	0.57	0
D4.0	D4.0	Design Storm	0.0529	0.1539	0.2714	0.0398	2.00	0.4	0.1	4.17	0.0018	0.58	0
D5.0	D5.0	Design Storm	0.0398	0.0950	0.2589	0.0391	2.00	0.4	0.1	3.98	0.0018	0.57	0
D6.0	D6.0	Design Storm	0.0178	0.0753	0.1289	0.0306	2.00	0.4	0.1	4.50	0.0018	0.60	0
D7.0	D7.0	Design Storm	0.0036	0.0240	0.0746	0.0178	2.00	0.4	0.1	4.50	0.0018	0.60	0
O1.0	O1.0	Design Storm	8.4607	5.6183	10.0105	0.0122	2.14	0.4	0.1	4.06	0.0017	0.60	0
O2.0	O2.0	Design Storm	17.3124	6.5830	12.9757	0.0117	3.41	0.4	0.1	4.29	0.0016	0.64	0
O3.0	O3.0	Design Storm	1.3898	0.9602	1.9721	0.0209	2.48	0.4	0.1	3.26	0.0018	0.52	0
O4.0	O4.0	Design Storm	1.6261	1.5447	3.1918	0.0063	2.00	0.4	0.1	3.25	0.0018	0.52	0
O5.0	O5.0	Design Storm	2.6961	2.2964	4.0217	0.0136	2.00	0.4	0.1	3.16	0.0018	0.51	0

5-Year Existing Condition Model

Summary of Unit Hydrograph Parameters Used By Program and Calculated Results (Version 2.0.1)

Catchment Name/ID	User Comment for Catchment	Unit Hydrograph Parameters and Results									Excess Precip.		Storm Hydrograph			
		CT	Cp	W50 (min.)	W50 Before Peak	W75 (min.)	W75 Before Peak	Time to Peak (min.)	Peak (cfs)	Volume (c.f)	Excess (inches)	Excess (c.f.)	Time to Peak (min.)	Peak Flow (cfs)	Total Volume (c.f.)	Runoff per Unit Area (cfs/acre)
A1.0		0.157	0.231	52.2	10.75	27.1	7.60	17.9	129	520,217	0.12	59,895	50.0	14	59,878	0.10
A1.1		0.157	0.104	36.8	4.45	19.1	3.15	7.4	29	82,047	0.17	14,315	40.0	4	14,279	0.19
A2.0		0.157	0.120	20.6	3.40	10.7	2.41	5.7	71	112,670	0.18	19,960	35.0	10	19,801	0.32
A3.0		0.157	0.111	37.3	4.68	19.4	3.31	7.8	33	94,057	0.16	15,340	40.0	5	15,301	0.18
A4.0		0.157	0.108	21.3	3.26	11.1	2.31	5.4	53	87,726	0.16	14,442	35.0	7	14,301	0.29
A5.0		0.157	0.097	30.8	3.80	16.0	2.69	6.3	29	70,113	0.08	5,856	35.0	2	5,832	0.11
A6.0		0.157	0.173	40.7	6.91	21.2	4.88	11.5	80	252,108	0.16	40,120	40.0	11	40,124	0.16
A7.0		0.157	0.127	35.8	4.99	18.6	3.53	8.3	46	126,679	0.13	16,805	40.0	5	16,769	0.16
A8.0		0.157	0.055	16.6	2.19	8.6	1.55	3.7	15	19,308	0.08	1,452	35.0	1	1,389	0.16
A9.0		0.157	0.072	35.7	3.46	18.5	2.45	5.8	13	35,319	0.08	2,659	35.0	1	2,648	0.09
A10.0		0.157	0.071	20.2	2.60	10.5	1.84	4.3	22	34,656	0.08	2,918	35.0	2	2,845	0.16
B1.0		0.157	0.039	34.3	2.53	17.8	1.79	4.2	3	9,271	0.13	1,159	35.0	0	1,140	0.15
B2.0		0.157	0.084	13.4	2.37	7.0	1.67	3.9	49	50,631	0.08	3,813	35.0	3	3,616	0.18
B3.0		0.157	0.064	29.3	2.93	15.2	2.07	4.9	12	27,322	0.12	3,151	35.0	1	3,117	0.16
B4.0		0.157	0.111	20.6	3.26	10.7	2.30	5.4	59	93,678	0.18	16,731	35.0	8	16,573	0.32
B5.0		0.157	0.059	39.5	3.29	20.5	2.33	5.5	8	23,214	0.18	4,144	40.0	1	4,125	0.19
B6.0		0.157	0.139	17.4	3.35	9.0	2.37	5.6	116	155,369	0.16	25,101	35.0	14	24,830	0.34
B7.0		0.157	0.095	48.2	5.00	25.0	3.53	8.3	18	65,928	0.18	11,775	40.0	3	11,751	0.16
B8.0		0.157	0.090	36.9	4.07	19.2	2.87	6.8	21	59,767	0.17	10,186	40.0	3	10,160	0.19
C1.0		0.157	0.059	32.0	2.94	16.7	2.08	4.9	9	22,842	0.18	4,078	35.0	1	4,034	0.22
C2.0		0.157	0.048	30.0	2.61	15.6	1.84	4.3	6	14,644	0.18	2,614	35.0	1	2,570	0.23
C3.0		0.157	0.079	24.7	3.00	12.8	2.12	5.0	23	44,309	0.18	7,914	35.0	3	7,815	0.28
C4.0		0.157	0.154	34.9	5.63	18.2	3.98	9.4	72	194,700	0.18	34,774	40.0	11	34,731	0.21
C4.1		0.157	0.073	39.9	3.73	20.8	2.64	6.2	12	36,840	0.18	6,580	40.0	2	6,560	0.18
C4.2		0.157	0.043	44.4	2.97	23.1	2.10	5.0	3	11,518	0.18	2,056	40.0	1	2,042	0.17
C5.0		0.156	0.087	22.1	2.98	11.5	2.11	5.0	33	55,826	0.18	10,190	35.0	5	10,033	0.31
C6.0		0.155	0.233	47.8	10.05	24.9	7.10	16.7	151	557,577	0.19	103,262	45.0	25	103,178	0.16
C7.0		0.157	0.100	42.6	4.78	22.2	3.38	8.0	23	75,022	0.18	13,399	40.0	4	13,373	0.17
C7.1		0.154	0.282	62.4	15.03	32.4	10.62	25.1	225	1,086,369	0.19	204,732	55.0	40	204,721	0.13
C7.2		0.157	0.098	65.2	6.40	33.9	4.53	10.7	14	71,274	0.18	12,730	45.0	2	12,730	0.12
C7.3		0.157	0.079	41.8	4.05	21.8	2.86	6.8	14	44,787	0.18	7,999	40.0	2	7,979	0.18
C7.4		0.157	0.238	32.4	7.44	16.9	5.26	12.4	231	580,279	0.18	103,639	40.0	36	103,567	0.23
C7.5		0.137	0.083	73.9	6.20	38.4	4.38	10.3	11	65,328	0.25	16,086	50.0	2	16,088	0.14
C7.6		0.157	0.196	42.9	7.95	22.3	5.62	13.2	100	332,521	0.18	59,389	45.0	16	59,318	0.18
C7.7		0.157	0.278	56.6	13.57	29.4	9.59	22.6	220	966,197	0.18	170,916	55.0	36	170,881	0.14
C8.0		0.155	0.335	63.5	17.83	33.0	12.60	29.7	385	1,893,039	0.19	353,310	60.0	68	353,086	0.13
C8.1		0.154	0.302	67.7	17.19	35.2	12.15	28.7	256	1,341,301	0.17	234,588	60.0	42	234,584	0.11
D1.0		0.157	0.124	42.2	5.52	21.9	3.90	9.2	37	119,896	0.09	10,194	40.0	3	10,184	0.09
D2.0		0.157	0.143	43.5	6.27	22.6	4.43	10.4	49	164,327	0.10	15,764	40.0	4	15,767	0.09
D3.0		0.157	0.179	39.2	6.90	20.4	4.88	11.5	90	272,746	0.10	28,387	40.0	9	28,396	0.11
D4.0		0.157	0.125	27.8	4.17	14.4	2.95	7.0	57	122,997	0.09	11,518	35.0	5	11,473	0.14
D5.0		0.157	0.110	24.6	3.58	12.8	2.53	6.0	49	92,468	0.10	9,611	35.0	4	9,563	0.17
D6.0		0.157	0.077	24.0	2.91	12.5	2.06	4.9	22	41,382	0.08	3,115	35.0	1	3,066	0.13
D7.0		0.157	0.037	25.0	2.22	13.0	1.57	3.7	4	8,287	0.08	623	35.0	0	604	0.12
O1.0		0.157	0.685	213.9	74.86	111.2	50.05	190.2	1,187	19,655,897	0.07	1,455,817	220.0	87	1,455,821	0.02
O2.0		0.153	0.832	212.6	74.40	110.5	49.74	228.8	2,443	40,220,276	0.06	2,418,766	255.0	145	2,418,733	0.01
O3.0		0.156	0.395	63.4	20.76	33.0	14.67	34.6	657	3,228,832	0.16	514,523	60.0	99	514,462	0.11
O4.0		0.157	0.418	127.5	42.45	66.3	30.00	70.8	383	3,777,804	0.16	585,852	100.0	58	585,840	0.06
O5.0		0.157	0.487	123.3	43.17	64.1	28.86	79.3	656	6,263,644	0.16	1,026,023	105.0	106	1,025,889	0.06

100-Year Existing Condition Model

Summary of Unit Hydrograph Parameters Used By Program and Calculated Results (Version 2.0.1)

Catchment Name/ID	User Comment for Catchment	Unit Hydrograph Parameters and Results										Excess Precip.		Storm Hydrograph			
		CT	Cp	W50 (min.)	W50 Before Peak	W75 (min.)	W75 Before Peak	Time to Peak (min.)	Peak (cfs)	Volume (c.f)	Excess (inches)	Excess (c.f.)	Time to Peak (min.)	Peak Flow (cfs)	Total Volume (c.f.)	Runoff per Unit Area (cfs/acre)	
A1.0		0.156	0.230	52.1	10.70	27.1	7.56	17.8	129	520,217	1.66	866,097	55.0	173	865,843	1.21	
A1.1		0.156	0.104	36.8	4.44	19.1	3.14	7.4	29	82,047	1.75	143,928	45.0	36	143,566	1.58	
A2.0		0.156	0.120	20.6	3.40	10.7	2.40	5.7	71	112,670	1.76	198,040	40.0	73	196,456	2.34	
A3.0		0.156	0.110	37.3	4.66	19.4	3.29	7.8	33	94,057	1.74	163,605	45.0	40	163,187	1.56	
A4.0		0.156	0.107	21.3	3.25	11.1	2.30	5.4	53	87,726	1.74	152,768	40.0	55	151,265	2.26	
A5.0		0.156	0.097	30.8	3.79	16.0	2.68	6.3	29	70,113	1.60	112,262	40.0	32	111,796	1.66	
A6.0		0.156	0.172	40.7	6.88	21.2	4.86	11.5	80	252,108	1.73	437,228	50.0	103	437,278	1.48	
A7.0		0.156	0.126	35.8	4.97	18.6	3.51	8.3	46	126,679	1.70	215,244	45.0	55	214,777	1.58	
A8.0		0.157	0.054	16.6	2.19	8.6	1.55	3.7	15	19,308	1.59	30,643	35.0	13	29,302	2.43	
A9.0		0.156	0.071	35.7	3.45	18.5	2.44	5.7	13	35,319	1.59	56,052	45.0	14	55,820	1.48	
A10.0		0.156	0.071	20.2	2.59	10.5	1.83	4.3	22	34,656	1.60	55,530	40.0	21	54,131	2.17	
B1.0		0.156	0.039	34.3	2.53	17.8	1.79	4.2	3	9,271	1.69	15,636	45.0	4	15,374	1.56	
B2.0		0.156	0.084	13.4	2.36	7.0	1.67	3.9	49	50,631	1.59	80,355	35.0	39	76,191	2.81	
B3.0		0.156	0.063	29.3	2.92	15.2	2.07	4.9	12	27,322	1.67	45,504	40.0	13	44,993	1.76	
B4.0		0.156	0.110	20.6	3.25	10.7	2.29	5.4	59	93,678	1.76	164,834	40.0	60	163,257	2.33	
B5.0		0.156	0.059	39.4	3.28	20.5	2.32	5.5	8	23,214	1.76	40,846	45.0	10	40,653	1.49	
B6.0		0.156	0.138	17.4	3.35	9.0	2.36	5.6	116	155,369	1.74	269,944	35.0	113	267,002	2.65	
B7.0		0.156	0.094	48.2	4.98	25.0	3.52	8.3	18	65,928	1.76	116,006	50.0	24	115,768	1.30	
B8.0		0.156	0.090	36.9	4.06	19.2	2.87	6.8	21	59,767	1.75	104,530	45.0	26	104,258	1.57	
C1.0		0.156	0.058	32.0	2.94	16.7	2.08	4.9	9	22,842	1.76	40,192	40.0	11	39,756	1.71	
C2.0		0.156	0.048	30.0	2.60	15.6	1.84	4.3	6	14,644	1.76	25,767	40.0	7	25,332	1.78	
C3.0		0.156	0.079	24.7	2.99	12.8	2.12	5.0	23	44,309	1.76	77,966	40.0	25	76,977	2.06	
C4.0		0.156	0.153	34.9	5.61	18.2	3.97	9.4	72	194,700	1.76	342,590	45.0	89	342,162	1.67	
C4.1		0.156	0.072	39.9	3.72	20.7	2.63	6.2	12	36,840	1.76	64,822	45.0	15	64,629	1.48	
C4.2		0.156	0.043	44.4	2.96	23.1	2.09	4.9	3	11,518	1.76	20,266	45.0	4	20,120	1.36	
C5.0		0.155	0.087	22.1	2.97	11.5	2.10	5.0	33	55,826	1.76	98,481	40.0	34	96,950	2.22	
C6.0		0.154	0.231	47.8	9.99	24.9	7.06	16.7	151	557,577	1.77	985,291	55.0	207	984,531	1.35	
C7.0		0.156	0.100	42.6	4.77	22.2	3.37	7.9	23	75,022	1.76	132,007	45.0	29	131,753	1.42	
C7.1		0.153	0.281	62.4	14.94	32.4	10.56	24.9	225	1,086,369	1.77	1,923,746	65.0	336	1,923,599	1.12	
C7.2		0.156	0.098	65.2	6.38	33.9	4.51	10.6	14	71,274	1.76	125,412	55.0	20	125,410	1.04	
C7.3		0.156	0.079	41.8	4.04	21.8	2.86	6.7	14	44,787	1.76	78,806	45.0	18	78,608	1.43	
C7.4		0.156	0.237	32.4	7.41	16.9	5.24	12.3	231	580,279	1.76	1,021,046	45.0	286	1,020,376	1.79	
C7.5		0.134	0.081	73.7	6.11	38.3	4.32	10.2	11	65,328	1.84	119,937	60.0	17	119,936	0.97	
C7.6		0.156	0.195	42.8	7.92	22.3	5.59	13.2	100	332,521	1.76	585,097	50.0	133	584,420	1.45	
C7.7		0.156	0.276	56.6	13.52	29.4	9.55	22.5	221	966,197	1.76	1,697,956	60.0	320	1,697,605	1.20	
C8.0		0.154	0.333	63.5	17.72	33.0	12.52	29.5	385	1,893,039	1.77	3,348,283	65.0	586	3,345,908	1.12	
C8.1		0.153	0.300	67.7	17.09	35.2	12.07	28.5	256	1,341,301	1.75	2,351,830	65.0	389	2,351,782	1.05	
D1.0		0.156	0.123	42.2	5.49	21.9	3.88	9.2	37	119,896	1.60	192,280	50.0	44	192,078	1.34	
D2.0		0.156	0.142	43.5	6.24	22.6	4.41	10.4	49	164,327	1.62	266,734	50.0	60	266,795	1.33	
D3.0		0.156	0.179	39.2	6.87	20.4	4.86	11.5	90	272,746	1.64	447,543	50.0	109	447,698	1.45	
D4.0		0.156	0.125	27.8	4.16	14.4	2.94	6.9	57	122,997	1.62	199,071	40.0	62	198,291	1.82	
D5.0		0.156	0.110	24.6	3.57	12.8	2.52	6.0	49	92,468	1.64	151,702	40.0	51	150,935	1.99	
D6.0		0.156	0.076	23.9	2.91	12.5	2.05	4.8	22	41,382	1.59	65,674	40.0	22	64,631	1.94	
D7.0		0.157	0.037	25.0	2.21	13.0	1.56	3.7	4	8,287	1.59	13,151	40.0	4	12,746	1.84	
O1.0		0.156	0.682	213.8	74.85	111.2	50.04	189.1	1,187	19,655,897	1.58	31,110,953	225.0	1,858	31,110,125	0.34	
O2.0		0.152	0.824	212.5	74.36	110.5	49.71	226.5	2,445	40,220,276	1.55	62,219,901	260.0	3,741	62,219,268	0.34	
O3.0		0.155	0.393	63.4	20.65	33.0	14.59	34.4	657	3,228,832	1.73	5,598,187	70.0	990	5,597,588	1.11	
O4.0		0.156	0.416	127.5	42.26	66.3	29.86	70.4	383	3,777,804	1.73	6,531,881	105.0	639	6,531,664	0.61	
O5.0		0.156	0.484	123.3	43.16	64.1	28.86	79.0	656	6,263,644	1.74	10,900,963	115.0	1,099	10,899,743	0.64	

## CUHP SUBCATCHMENTS - PROPOSED CONDITION

Columns with this color heading are for required user-input  
 Columns with this color heading are for optional override values  
 Columns with this color heading are for program-calculated values

Subcatchment Name	EPA SWMM Target Node	Raingage	Area (mi <sup>2</sup> )	Length to Centroid (mi)	Length (mi)	Slope (ft/ft)	Percent Imperviousness	Maximum Depression Storage (Watershed inches)		Horton's Infiltration Parameters			DCIA Level 0, 1, or 2
								Pervious	Impervious	Initial Rate (in/hr)	Decay Coefficient (1/seconds)	Final Rate (in/hr)	
A1.0	A1.0	Design Storm	0.2239	0.4630	0.8182	0.0185	3.10	0.4	0.1	3.78	0.0018	0.55	0
A1.1	A1.1	Design Storm	0.0353	0.1465	0.3126	0.0315	3.62	0.4	0.1	3.04	0.0018	0.50	0
A2.0	A2.0	Design Storm	0.0485	0.0984	0.2082	0.0391	3.07	0.4	0.1	3.02	0.0018	0.50	0
A3.0	A3.0	Design Storm	0.0405	0.1534	0.3612	0.0339	3.95	0.4	0.1	3.17	0.0018	0.51	0
A4.0	A4.0	Design Storm	0.0378	0.0955	0.2160	0.0546	2.59	0.4	0.1	3.15	0.0018	0.51	0
A5.0	A5.0	Design Storm	0.0302	0.1455	0.2455	0.0542	5.38	0.4	0.1	4.35	0.0018	0.59	0
A6.0	A6.0	Design Storm	0.1085	0.2267	0.6403	0.0253	2.87	0.4	0.1	3.21	0.0018	0.51	0
A7.0	A7.0	Design Storm	0.0545	0.1923	0.3763	0.0392	4.37	0.4	0.1	3.50	0.0018	0.53	0
A8.0	A8.0	Design Storm	0.0083	0.0272	0.0885	0.0366	2.00	0.4	0.1	4.50	0.0018	0.60	0
A9.0	A9.0	Design Storm	0.0152	0.0951	0.2438	0.0448	2.00	0.4	0.1	4.50	0.0018	0.60	0
A10.0	A10.0	Design Storm	0.0149	0.0488	0.1346	0.0398	2.00	0.4	0.1	4.34	0.0018	0.59	0
B1.0	B1.0	Design Storm	0.0040	0.0904	0.0646	0.0410	2.00	0.4	0.1	3.60	0.0018	0.54	0
B2.0	B2.0	Design Storm	0.0218	0.0289	0.1661	0.0578	2.00	0.4	0.1	4.50	0.0018	0.60	0
B3.0	B3.0	Design Storm	0.0118	0.0958	0.1279	0.0462	2.00	0.4	0.1	3.78	0.0018	0.55	0
B4.0	B4.0	Design Storm	0.0403	0.0429	0.3274	0.0257	3.34	0.4	0.1	3.00	0.0018	0.50	0
B5.0	B5.0	Design Storm	0.0100	0.1323	0.1348	0.0382	2.54	0.4	0.1	3.00	0.0018	0.50	0
B6.0	B6.0	Design Storm	0.0669	0.0476	0.3986	0.0375	3.11	0.4	0.1	3.18	0.0018	0.51	0
B7.0	B7.0	Design Storm	0.0284	0.1725	0.3976	0.0347	4.61	0.4	0.1	3.00	0.0018	0.50	0
B8.0	B8.0	Design Storm	0.0257	0.1618	0.2110	0.0312	4.17	0.4	0.1	3.09	0.0018	0.51	0
C1.0	C1.0	Design Storm	0.0098	0.0756	0.1652	0.0460	2.00	0.4	0.1	3.00	0.0018	0.50	0
C2.0	C2.0	Design Storm	0.0063	0.0522	0.1383	0.0463	2.00	0.4	0.1	3.00	0.0018	0.50	0
C3.0	C3.0	Design Storm	0.0191	0.0670	0.1977	0.0441	2.00	0.4	0.1	3.00	0.0018	0.50	0
C4.0	C4.0	Design Storm	0.0838	0.2163	0.4311	0.0321	2.63	0.4	0.1	3.00	0.0018	0.50	0
C4.1	C4.1	Design Storm	0.0159	0.1047	0.2488	0.0327	2.48	0.4	0.1	3.00	0.0018	0.50	0
C4.2	C4.2	Design Storm	0.0050	0.0579	0.2024	0.0375	7.34	0.4	0.1	3.00	0.0018	0.50	0
C5.0	C5.0	Design Storm	0.0240	0.0661	0.1892	0.0404	2.39	0.4	0.1	3.00	0.0018	0.50	0
C6.0	C6.0	Design Storm	0.2400	0.3914	0.8912	0.0206	3.09	0.4	0.1	3.00	0.0018	0.50	0
C7.0	C7.0	Design Storm	0.0323	0.1647	0.3423	0.0306	4.17	0.4	0.1	3.00	0.0018	0.50	0
C7.1	C7.1	Design Storm	0.4676	0.7020	1.2373	0.0183	3.19	0.4	0.1	3.00	0.0018	0.50	0
C7.2	C7.2	Design Storm	0.0307	0.5497	0.2695	0.0396	3.05	0.4	0.1	3.00	0.0018	0.50	0
C7.3	C7.3	Design Storm	0.0193	0.1429	0.2740	0.0420	2.00	0.4	0.1	3.00	0.0018	0.50	0
C7.4	C7.4	Design Storm	0.2498	0.1481	1.0895	0.0212	2.51	0.4	0.1	3.00	0.0018	0.50	0
C7.5	C7.5	Design Storm	0.0281	0.6788	0.2592	0.0371	10.79	0.4	0.1	3.00	0.0018	0.50	0
C7.6	C7.6	Design Storm	0.1431	0.1728	1.0079	0.0175	2.37	0.4	0.1	3.00	0.0018	0.50	0
C7.7	C7.7	Design Storm	0.4159	0.4585	1.2494	0.0139	3.23	0.4	0.1	3.02	0.0018	0.50	0
C8.0	C8.0	Design Storm	0.8148	0.7558	1.6417	0.0174	3.41	0.4	0.1	3.00	0.0018	0.50	0
C8.1	C8.1	Design Storm	0.5774	0.6638	1.4767	0.0127	2.91	0.4	0.1	3.13	0.0018	0.51	0
D1.0	D1.0	Design Storm	0.0516	0.1807	0.4799	0.0315	3.24	0.4	0.1	4.32	0.0018	0.59	0
D2.0	D2.0	Design Storm	0.0707	0.2315	0.5432	0.0323	2.64	0.4	0.1	4.13	0.0018	0.58	0
D3.0	D3.0	Design Storm	0.1174	0.2811	0.5696	0.0312	3.13	0.4	0.1	3.98	0.0018	0.57	0
D4.0	D4.0	Design Storm	0.0529	0.1539	0.2714	0.0398	2.84	0.4	0.1	4.17	0.0018	0.58	0
D5.0	D5.0	Design Storm	0.0398	0.0950	0.2589	0.0391	4.50	0.4	0.1	3.98	0.0018	0.57	0
D6.0	D6.0	Design Storm	0.0178	0.0753	0.1289	0.0306	2.00	0.4	0.1	4.50	0.0018	0.60	0
D7.0	D7.0	Design Storm	0.0036	0.0240	0.0746	0.0178	6.90	0.4	0.1	4.50	0.0018	0.60	0
O1.0	O1.0	Design Storm	8.4607	5.6183	10.0105	0.0122	2.14	0.4	0.1	4.06	0.0017	0.60	0
O2.0	O2.0	Design Storm	17.3124	6.5830	12.9757	0.0117	3.42	0.4	0.1	4.29	0.0016	0.64	0
O3.0	O3.0	Design Storm	1.3898	0.9602	1.9721	0.0209	2.77	0.4	0.1	3.26	0.0018	0.52	0
O4.0	O4.0	Design Storm	1.6261	1.5447	3.1918	0.0063	2.07	0.4	0.1	3.25	0.0018	0.52	0
O5.0	O5.0	Design Storm	2.6961	2.2964	4.0217	0.0136	2.02	0.4	0.1	3.16	0.0018	0.51	0

5-Year Proposed Condition Model

Summary of Unit Hydrograph Parameters Used By Program and Calculated Results (Version 2.0.1)

Catchment Name/ID	User Comment for Catchment	Unit Hydrograph Parameters and Results									Excess Precip.		Storm Hydrograph			
		CT	Cp	W50 (min.)	W50 Before Peak	W75 (min.)	W75 Before Peak	Time to Peak (min.)	Peak (cfs)	Volume (c.f)	Excess (inches)	Excess (c.f.)	Time to Peak (min.)	Peak Flow (cfs)	Total Volume (c.f.)	Runoff per Unit Area (cfs/acre)
A1.0		0.154	0.226	52.1	10.56	27.1	7.46	17.6	129	520,217	0.13	65,781	45.0	15	65,759	0.10
A1.1		0.152	0.101	36.8	4.36	19.1	3.08	7.3	29	82,047	0.19	15,664	40.0	5	15,625	0.21
A2.0		0.154	0.118	20.6	3.36	10.7	2.38	5.6	71	112,670	0.19	21,182	35.0	10	21,007	0.33
A3.0		0.151	0.107	37.2	4.56	19.3	3.22	7.6	33	94,057	0.18	17,212	40.0	5	17,168	0.20
A4.0		0.155	0.106	21.3	3.24	11.1	2.29	5.4	53	87,726	0.17	14,972	35.0	7	14,823	0.30
A5.0		0.147	0.092	30.7	3.66	15.9	2.59	6.1	30	70,113	0.12	8,273	35.0	3	8,236	0.15
A6.0		0.154	0.170	40.7	6.82	21.2	4.82	11.4	80	252,108	0.17	42,362	40.0	12	42,368	0.17
A7.0		0.150	0.122	35.7	4.83	18.6	3.41	8.1	46	126,679	0.16	19,919	40.0	6	19,875	0.18
A8.0		0.157	0.055	16.6	2.19	8.6	1.55	3.7	15	19,308	0.08	1,452	35.0	1	1,389	0.16
A9.0		0.157	0.072	35.7	3.46	18.5	2.45	5.8	13	35,319	0.08	2,659	35.0	1	2,648	0.09
A10.0		0.157	0.071	20.2	2.60	10.5	1.84	4.3	22	34,656	0.08	2,918	35.0	2	2,845	0.16
B1.0		0.157	0.039	34.3	2.53	17.8	1.79	4.2	3	9,271	0.13	1,159	35.0	0	1,140	0.15
B2.0		0.157	0.084	13.4	2.37	7.0	1.67	3.9	49	50,631	0.08	3,813	35.0	3	3,616	0.18
B3.0		0.157	0.064	29.3	2.93	15.2	2.07	4.9	12	27,322	0.12	3,151	35.0	1	3,117	0.16
B4.0		0.153	0.108	20.6	3.21	10.7	2.27	5.3	59	93,678	0.19	18,002	35.0	9	17,821	0.34
B5.0		0.155	0.059	39.4	3.27	20.5	2.31	5.5	8	23,214	0.18	4,274	40.0	1	4,253	0.19
B6.0		0.154	0.136	17.3	3.31	9.0	2.34	5.5	116	155,369	0.17	26,857	35.0	15	26,554	0.35
B7.0		0.149	0.090	48.0	4.82	25.0	3.41	8.0	18	65,928	0.21	13,524	40.0	3	13,496	0.17
B8.0		0.150	0.087	36.9	3.96	19.2	2.80	6.6	21	59,767	0.19	11,504	40.0	3	11,474	0.21
C1.0		0.157	0.059	32.0	2.94	16.7	2.08	4.9	9	22,842	0.18	4,078	35.0	1	4,034	0.22
C2.0		0.157	0.048	30.0	2.61	15.6	1.84	4.3	6	14,644	0.18	2,614	35.0	1	2,570	0.23
C3.0		0.157	0.079	24.7	3.00	12.8	2.12	5.0	23	44,309	0.18	7,914	35.0	3	7,815	0.28
C4.0		0.155	0.152	34.9	5.58	18.2	3.94	9.3	72	194,700	0.18	36,014	40.0	12	35,968	0.22
C4.1		0.156	0.072	39.9	3.71	20.7	2.62	6.2	12	36,840	0.18	6,759	40.0	2	6,738	0.19
C4.2		0.140	0.039	44.0	2.82	22.9	1.99	4.7	3	11,518	0.23	2,686	40.0	1	2,661	0.20
C5.0		0.156	0.087	22.1	2.98	11.5	2.11	5.0	33	55,826	0.18	10,190	35.0	5	10,033	0.31
C6.0		0.154	0.231	47.8	9.97	24.9	7.05	16.6	151	557,577	0.19	105,732	45.0	26	105,652	0.17
C7.0		0.150	0.096	42.5	4.64	22.1	3.28	7.7	23	75,022	0.20	15,048	40.0	4	15,018	0.19
C7.1		0.153	0.281	62.4	14.97	32.4	10.58	25.0	225	1,086,369	0.19	207,108	55.0	40	207,095	0.13
C7.2		0.154	0.096	65.2	6.31	33.9	4.46	10.5	14	71,274	0.19	13,484	45.0	2	13,484	0.12
C7.3		0.157	0.079	41.8	4.05	21.8	2.86	6.8	14	44,787	0.18	7,999	40.0	2	7,979	0.18
C7.4		0.155	0.236	32.4	7.38	16.9	5.21	12.3	231	580,279	0.18	106,621	40.0	37	106,557	0.23
C7.5		0.129	0.079	73.3	5.96	38.1	4.21	9.9	12	65,328	0.27	17,618	50.0	3	17,617	0.15
C7.6		0.156	0.195	42.8	7.90	22.3	5.58	13.2	100	332,521	0.18	60,624	45.0	16	60,555	0.18
C7.7		0.153	0.271	56.5	13.28	29.4	9.39	22.1	221	966,197	0.19	182,965	50.0	38	182,928	0.14
C8.0		0.153	0.331	63.5	17.63	33.0	12.46	29.4	385	1,893,039	0.19	365,098	60.0	69	364,841	0.13
C8.1		0.154	0.301	67.7	17.18	35.2	12.14	28.6	256	1,341,301	0.18	235,276	60.0	42	235,273	0.11
D1.0		0.154	0.121	42.1	5.42	21.9	3.83	9.0	37	119,896	0.10	11,703	40.0	3	11,689	0.10
D2.0		0.155	0.141	43.4	6.21	22.6	4.39	10.4	49	164,327	0.10	16,826	40.0	5	16,829	0.10
D3.0		0.154	0.176	39.1	6.79	20.4	4.79	11.3	90	272,746	0.12	31,543	40.0	9	31,557	0.12
D4.0		0.155	0.124	27.7	4.13	14.4	2.92	6.9	57	122,997	0.10	12,570	35.0	5	12,520	0.15
D5.0		0.150	0.105	24.5	3.48	12.7	2.46	5.8	49	92,468	0.13	11,987	35.0	5	11,919	0.20
D6.0		0.157	0.077	24.0	2.91	12.5	2.06	4.9	22	41,382	0.08	3,115	35.0	1	3,066	0.13
D7.0		0.143	0.034	24.8	2.15	12.9	1.52	3.6	4	8,287	0.13	1,038	35.0	0	1,005	0.17
O1.0		0.157	0.685	213.9	74.86	111.2	50.05	190.2	1,187	19,655,897	0.07	1,456,671	220.0	87	1,456,675	0.02
O2.0		0.153	0.831	212.6	74.40	110.5	49.74	228.7	2,443	40,220,276	0.06	2,422,531	255.0	145	2,422,500	0.01
O3.0		0.155	0.393	63.4	20.66	33.0	14.60	34.4	657	3,228,832	0.16	523,856	60.0	101	523,800	0.11
O4.0		0.157	0.418	127.5	42.40	66.3	29.96	70.7	383	3,777,804	0.16	588,647	100.0	59	588,633	0.06
O5.0		0.157	0.486	123.3	43.17	64.1	28.86	79.3	656	6,263,644	0.16	1,027,537	105.0	106	1,027,405	0.06



100-Year Proposed Condition Model

Summary of Unit Hydrograph Parameters Used By Program and Calculated Results (Version 2.0.1)

Catchment Name/ID	User Comment for Catchment	Unit Hydrograph Parameters and Results									Excess Precip.		Storm Hydrograph			
		CT	Cp	W50 (min.)	W50 Before Peak	W75 (min.)	W75 Before Peak	Time to Peak (min.)	Peak (cfs)	Volume (c.f)	Excess (inches)	Excess (c.f.)	Time to Peak (min.)	Peak Flow (cfs)	Total Volume (c.f.)	Runoff per Unit Area (cfs/acre)
A1.0		0.153	0.225	52.1	10.49	27.1	7.41	17.5	129	520,217	1.68	873,028	55.0	174	872,707	1.22
A1.1		0.151	0.100	36.7	4.33	19.1	3.06	7.2	29	82,047	1.77	145,464	45.0	36	145,111	1.59
A2.0		0.153	0.117	20.6	3.35	10.7	2.37	5.6	71	112,670	1.77	199,432	40.0	73	197,758	2.35
A3.0		0.150	0.106	37.2	4.53	19.3	3.20	7.5	33	94,057	1.76	165,742	45.0	41	165,317	1.57
A4.0		0.154	0.106	21.3	3.23	11.1	2.28	5.4	53	87,726	1.75	153,374	40.0	55	151,824	2.27
A5.0		0.145	0.090	30.6	3.63	15.9	2.56	6.0	30	70,113	1.64	115,219	40.0	33	114,692	1.69
A6.0		0.153	0.169	40.7	6.78	21.1	4.79	11.3	80	252,108	1.74	439,793	50.0	103	439,865	1.48
A7.0		0.148	0.120	35.7	4.79	18.5	3.39	8.0	46	126,679	1.73	218,822	45.0	56	218,325	1.60
A8.0		0.157	0.054	16.6	2.19	8.6	1.55	3.7	15	19,308	1.59	30,643	35.0	13	29,302	2.43
A9.0		0.156	0.071	35.7	3.45	18.5	2.44	5.7	13	35,319	1.59	56,052	45.0	14	55,820	1.48
A10.0		0.156	0.071	20.2	2.59	10.5	1.83	4.3	22	34,656	1.60	55,530	40.0	21	54,131	2.17
B1.0		0.156	0.039	34.3	2.53	17.8	1.79	4.2	3	9,271	1.69	15,636	45.0	4	15,374	1.56
B2.0		0.156	0.084	13.4	2.36	7.0	1.67	3.9	49	50,631	1.59	80,355	35.0	39	76,191	2.81
B3.0		0.156	0.063	29.3	2.92	15.2	2.07	4.9	12	27,322	1.67	45,504	40.0	13	44,993	1.76
B4.0		0.152	0.107	20.6	3.20	10.7	2.26	5.3	59	93,678	1.78	166,281	40.0	61	164,573	2.35
B5.0		0.154	0.058	39.4	3.26	20.5	2.31	5.4	8	23,214	1.77	40,992	45.0	10	40,792	1.49
B6.0		0.153	0.135	17.3	3.30	9.0	2.33	5.5	116	155,369	1.75	271,950	35.0	114	268,843	2.66
B7.0		0.147	0.089	48.0	4.78	24.9	3.38	8.0	18	65,928	1.79	117,993	50.0	24	117,748	1.32
B8.0		0.149	0.086	36.8	3.94	19.2	2.78	6.6	21	59,767	1.77	106,031	45.0	26	105,751	1.59
C1.0		0.156	0.058	32.0	2.94	16.7	2.08	4.9	9	22,842	1.76	40,192	40.0	11	39,756	1.71
C2.0		0.156	0.048	30.0	2.60	15.6	1.84	4.3	6	14,644	1.76	25,767	40.0	7	25,332	1.78
C3.0		0.156	0.079	24.7	2.99	12.8	2.12	5.0	23	44,309	1.76	77,966	40.0	25	76,977	2.06
C4.0		0.154	0.151	34.9	5.56	18.2	3.93	9.3	72	194,700	1.77	344,004	45.0	90	343,554	1.67
C4.1		0.155	0.072	39.9	3.70	20.7	2.61	6.2	12	36,840	1.77	65,026	45.0	15	64,830	1.49
C4.2		0.138	0.038	43.9	2.79	22.8	1.97	4.7	3	11,518	1.82	20,977	45.0	4	20,775	1.40
C5.0		0.155	0.087	22.1	2.97	11.5	2.10	5.0	33	55,826	1.76	98,481	40.0	34	96,950	2.22
C6.0		0.153	0.229	47.8	9.91	24.8	7.00	16.5	151	557,577	1.77	988,102	55.0	208	987,395	1.35
C7.0		0.149	0.095	42.5	4.61	22.1	3.26	7.7	23	75,022	1.78	133,882	45.0	30	133,610	1.43
C7.1		0.152	0.279	62.3	14.87	32.4	10.51	24.8	225	1,086,369	1.77	1,926,449	65.0	337	1,926,265	1.12
C7.2		0.153	0.095	65.1	6.27	33.9	4.43	10.5	14	71,274	1.77	126,271	55.0	20	126,270	1.04
C7.3		0.156	0.079	41.8	4.04	21.8	2.86	6.7	14	44,787	1.76	78,806	45.0	18	78,608	1.43
C7.4		0.155	0.235	32.4	7.34	16.9	5.19	12.2	231	580,279	1.77	1,024,446	45.0	287	1,023,879	1.79
C7.5		0.126	0.078	73.0	5.85	38.0	4.13	9.7	12	65,328	1.86	121,637	60.0	18	121,621	0.99
C7.6		0.155	0.194	42.8	7.87	22.3	5.56	13.1	100	332,521	1.76	586,505	50.0	133	585,861	1.45
C7.7		0.152	0.270	56.5	13.20	29.4	9.32	22.0	221	966,197	1.77	1,711,683	60.0	321	1,711,364	1.21
C8.0		0.152	0.329	63.4	17.50	33.0	12.37	29.2	385	1,893,039	1.78	3,361,685	65.0	587	3,359,424	1.13
C8.1		0.153	0.299	67.7	17.07	35.2	12.06	28.4	256	1,341,301	1.75	2,352,616	65.0	389	2,352,565	1.05
D1.0		0.152	0.120	42.1	5.39	21.9	3.81	9.0	37	119,896	1.62	194,132	50.0	44	193,890	1.34
D2.0		0.154	0.140	43.4	6.18	22.6	4.37	10.3	49	164,327	1.63	268,026	50.0	60	268,079	1.33
D3.0		0.153	0.174	39.1	6.74	20.3	4.76	11.2	90	272,746	1.65	451,328	50.0	110	451,529	1.46
D4.0		0.154	0.123	27.7	4.11	14.4	2.91	6.9	57	122,997	1.63	200,354	40.0	62	199,550	1.83
D5.0		0.148	0.104	24.5	3.46	12.7	2.45	5.8	49	92,468	1.67	154,543	40.0	51	153,638	2.02
D6.0		0.156	0.076	23.9	2.91	12.5	2.05	4.8	22	41,382	1.59	65,674	40.0	22	64,631	1.94
D7.0		0.140	0.034	24.7	2.14	12.9	1.51	3.6	4	8,287	1.65	13,660	40.0	4	13,217	1.89
O1.0		0.156	0.682	213.8	74.85	111.2	50.04	189.0	1,187	19,655,897	1.58	31,112,017	225.0	1,858	31,111,167	0.34
O2.0		0.152	0.824	212.5	74.36	110.5	49.71	226.5	2,445	40,220,276	1.55	62,224,722	260.0	3,742	62,224,080	0.34
O3.0		0.154	0.391	63.4	20.53	33.0	14.51	34.2	658	3,228,832	1.74	5,608,869	70.0	990	5,608,320	1.11
O4.0		0.156	0.416	127.5	42.19	66.3	29.82	70.3	383	3,777,804	1.73	6,535,085	105.0	639	6,534,838	0.61
O5.0		0.156	0.484	123.3	43.16	64.1	28.86	78.9	656	6,263,644	1.74	10,902,696	115.0	1,099	10,901,489	0.64

Scenario ID = 5-Year\_Ex\_5yr\_0mi^2\_PikeSolar

\*\*\*\*\*  
NOTE: The summary statistics displayed in this report are based on results found at every computational time step, not just on results from each reporting time step.  
\*\*\*\*\*

\*\*\*\*\*  
Analysis Options  
\*\*\*\*\*  
Flow Units ..... CFS  
Process Models:  
  Rainfall/Runoff ..... NO  
  RDII ..... NO  
  Snowmelt ..... NO  
  Groundwater ..... NO  
  Flow Routing ..... YES  
  Ponding Allowed ..... NO  
  Water Quality ..... NO  
Flow Routing Method ..... KINWAVE  
Starting Date ..... 01/01/2005 00:00:00  
Ending Date ..... 01/01/2005 23:59:00  
Antecedent Dry Days ..... 0.0  
Report Time Step ..... 00:15:00  
Routing Time Step ..... 30.00 sec

\*\*\*\*\*

	Volume	Volume
Flow Routing Continuity	acre-feet	10 <sup>6</sup> gal
*****	-----	-----
Dry Weather Inflow .....	0.000	0.000
Wet Weather Inflow .....	0.000	0.000
Groundwater Inflow .....	0.000	0.000
RDII Inflow .....	0.000	0.000
External Inflow .....	176.659	57.567
External Outflow .....	181.592	59.175
Flooding Loss .....	0.000	0.000
Evaporation Loss .....	0.000	0.000
Exfiltration Loss .....	0.000	0.000
Initial Stored Volume ....	0.000	0.000
Final Stored Volume .....	0.453	0.148
Continuity Error (%) .....	-3.049	

\*\*\*\*\*  
Highest Flow Instability Indexes  
\*\*\*\*\*  
Link 03.0Channel2 (1)

\*\*\*\*\*  
Routing Time Step Summary  
\*\*\*\*\*  
Minimum Time Step : 29.00 sec  
Average Time Step : 30.00 sec  
Maximum Time Step : 30.00 sec  
Percent in Steady State : 0.00  
Average Iterations per Step : 1.00  
Percent Not Converging : 0.00

\*\*\*\*\*  
Node Depth Summary  
\*\*\*\*\*

Node	Type	Average Depth Feet	Maximum Depth Feet	Maximum HGL Feet	Time of Max Occurrence days hr:min	Reported Max Depth Feet
A1.0	JUNCTION	0.00	0.00	5621.00	0 00:00	0.00
A4.0	JUNCTION	0.00	0.00	5578.00	0 00:00	0.00
A3.0	JUNCTION	0.00	0.00	5580.30	0 00:00	0.00
A2.0	JUNCTION	0.00	0.00	5587.40	0 00:00	0.00
A5.0	JUNCTION	0.00	0.00	5578.00	0 00:00	0.00
A6.0	JUNCTION	0.00	0.00	5590.00	0 00:00	0.00
A7.0	JUNCTION	0.00	0.00	5601.00	0 00:00	0.00
A10.0	JUNCTION	0.00	0.00	5621.00	0 00:00	0.00
A9.0	JUNCTION	0.00	0.00	5601.00	0 00:00	0.00
A8.0	JUNCTION	0.00	0.00	5558.00	0 00:00	0.00
B6.0	JUNCTION	0.00	0.00	5584.40	0 00:00	0.00
B5.0	JUNCTION	0.00	0.00	5572.00	0 00:00	0.00
B4.0	JUNCTION	0.00	0.00	5586.90	0 00:00	0.00
B2.0	JUNCTION	0.00	0.00	5598.40	0 00:00	0.00
B3.0	JUNCTION	0.00	0.00	5586.20	0 00:00	0.00
B1.0	JUNCTION	0.00	0.00	5600.60	0 00:00	0.00
C4.1	JUNCTION	0.00	0.00	5544.90	0 00:00	0.00
C3.0	JUNCTION	0.00	0.00	5556.70	0 00:00	0.00
C2.0	JUNCTION	0.00	0.00	5556.70	0 00:00	0.00
C1.0	JUNCTION	0.00	0.00	5565.10	0 00:00	0.00
C5.0	JUNCTION	0.00	0.00	5544.40	0 00:00	0.00
C8.0	JUNCTION	0.00	0.00	5566.50	0 00:00	0.00
C7.1	JUNCTION	0.00	0.00	5568.00	0 00:00	0.00
Outlet_C8.0	JUNCTION	0.03	0.33	5407.03	0 01:00	0.33
C7.4	JUNCTION	0.00	0.00	5472.00	0 00:00	0.00
D3.0	JUNCTION	0.00	0.00	5503.60	0 00:00	0.00
D2.0	JUNCTION	0.00	0.00	5496.50	0 00:00	0.00
D1.0	JUNCTION	0.00	0.00	5480.00	0 00:00	0.00
D7.0	JUNCTION	0.00	0.00	5478.60	0 00:00	0.00
D4.0	JUNCTION	0.00	0.00	5487.70	0 00:00	0.00
D6.0	JUNCTION	0.00	0.00	5485.20	0 00:00	0.00
D5.0	JUNCTION	0.00	0.00	5488.00	0 00:00	0.00
C8.1	JUNCTION	0.00	0.00	5465.90	0 00:00	0.00
Outlet_C7.7	JUNCTION	0.31	0.60	5369.60	0 03:06	0.60
C7.4.1	JUNCTION	0.15	1.34	5417.94	0 01:30	1.34
O3.0	JUNCTION	0.00	0.00	5716.50	0 00:00	0.00
O4.0	JUNCTION	0.00	0.00	5555.00	0 00:00	0.00
O5.0	JUNCTION	0.00	0.00	5681.10	0 00:00	0.00
O1.0	JUNCTION	0.00	0.00	6147.50	0 00:00	0.00
O2.0	JUNCTION	0.00	0.00	6281.20	0 00:00	0.00
Outlet_A6.0&5.0	JUNCTION	0.07	0.66	5500.56	0 00:45	0.66
Outlet_A7.0	JUNCTION	0.02	0.21	5515.11	0 00:40	0.21
Outlet_A9.0&8.0	JUNCTION	0.01	0.08	5522.98	0 00:35	0.07
Outlet_O2.0	JUNCTION	0.72	2.37	5485.97	0 04:26	2.36
Outlet_A10.0_2	JUNCTION	0.02	0.20	5540.50	0 00:53	0.20
Outlet_O4.0	JUNCTION	0.45	1.27	5423.17	0 04:37	1.27
Outlet_O3.0	JUNCTION	0.09	0.97	5496.17	0 01:00	0.97
Outlet_C1.0.2.0&3.0	JUNCTION	0.02	0.37	5519.37	0 00:35	0.34
C5.0&03.0	JUNCTION	0.99	3.08	5468.78	0 04:28	3.08
Outlet_C5.0	JUNCTION	0.01	0.21	5502.11	0 00:35	0.19
Outlet_B4.0&5.0	JUNCTION	0.01	0.16	5539.46	0 00:35	0.15
B4.0.5.0&03.0	JUNCTION	0.49	1.23	5449.03	0 04:39	1.23
Outlet_O5.0	JUNCTION	1.15	2.84	5382.84	0 05:16	2.84
Outlet_B2.0&3.0	JUNCTION	0.01	0.07	5550.07	0 00:35	0.06
Outlet_O1.0	JUNCTION	0.60	1.92	5490.92	0 03:40	1.92
Outlet_A2.0	JUNCTION	0.02	0.49	5533.45	0 00:35	0.43
Outlet_A2.0.B1.0&8.0	JUNCTION	0.04	0.39	5519.58	0 00:55	0.39
B7.0	JUNCTION	0.00	0.00	5572.00	0 00:00	0.00
B8.0	JUNCTION	0.00	0.00	5600.20	0 00:00	0.00
Outlet_B1.0&8.0	JUNCTION	0.01	0.11	5552.29	0 00:40	0.10

01.0&2.0	JUNCTION	1.04	3.25	5474.25	0	04:37	3.24
Outlet_D1.0&D2.0	JUNCTION	1.14	2.84	5389.24	0	05:15	2.84
Outlet_A4.0	JUNCTION	0.01	0.13	5510.93	0	00:35	0.11
Outlet_A10.0_1	JUNCTION	0.00	0.05	5589.65	0	00:35	0.04
C6.0	JUNCTION	0.00	0.00	5585.20	0	00:00	0.00
Outlet_C6.0	JUNCTION	0.65	1.79	5455.79	0	04:31	1.79
02.0&A4.0	JUNCTION	0.98	3.25	5476.25	0	04:32	3.25
Outlet_C7.4	JUNCTION	0.16	1.08	5379.98	0	01:28	1.07
C7.7.1	JUNCTION	0.41	1.07	5373.27	0	01:48	1.07
C7.7	JUNCTION	0.00	0.00	5459.00	0	00:00	0.00
Outlet_C7.1	JUNCTION	0.14	1.44	5419.34	0	00:55	1.44
C7.6	JUNCTION	0.00	0.00	5475.30	0	00:00	0.00
Outlet_C7.6	JUNCTION	0.01	0.19	5382.09	0	00:45	0.19
C7.5	JUNCTION	0.00	0.00	5484.30	0	00:00	0.00
C7.3	JUNCTION	0.00	0.00	5488.00	0	00:00	0.00
C7.2	JUNCTION	0.00	0.00	5493.00	0	00:00	0.00
Outlet_C7.2	JUNCTION	0.02	0.20	5436.60	0	00:45	0.20
Outlet_C7.5	JUNCTION	0.02	0.15	5425.65	0	00:50	0.15
C7.0	JUNCTION	0.00	0.00	5567.50	0	00:00	0.00
Outlet_C7.0	JUNCTION	0.04	0.26	5511.46	0	00:40	0.26
C4.2	JUNCTION	0.00	0.00	5538.50	0	00:00	0.00
C4.0	JUNCTION	0.00	0.00	5586.60	0	00:00	0.00
Outlet_C4.0	JUNCTION	0.01	0.11	5513.61	0	00:40	0.11
A1.1	JUNCTION	0.00	0.00	5575.80	0	00:00	0.00
Outlet_A1.0	JUNCTION	0.03	0.22	5540.32	0	00:50	0.22
Outlet_D3.0	JUNCTION	0.01	0.17	5391.17	0	00:40	0.17
Outlet_D4.0	JUNCTION	0.00	0.09	5426.89	0	00:35	0.09
Outlet_D5.0	JUNCTION	0.00	0.09	5434.29	0	00:35	0.08
Outlet_C8.1	OUTFALL	0.15	0.35	5362.35	0	03:15	0.35
Outlet_D6.0	OUTFALL	0.00	0.00	5459.80	0	00:00	0.00
Outlet_D7.0	OUTFALL	0.00	0.00	5471.10	0	00:00	0.00

\*\*\*\*\*  
Node Inflow Summary  
\*\*\*\*\*

Node	Type	Maximum Lateral Inflow CFS	Maximum Total Inflow CFS	Time of Max Occurrence days hr:min	Lateral Inflow Volume 10^6 gal	Total Inflow Volume 10^6 gal	Flow Balance Error Percent
A1.0	JUNCTION	13.79	13.79	0 00:50	0.448	0.448	0.000
A4.0	JUNCTION	7.06	7.06	0 00:35	0.107	0.107	0.000
A3.0	JUNCTION	4.70	4.70	0 00:40	0.114	0.114	0.000
A2.0	JUNCTION	10.01	10.01	0 00:35	0.148	0.148	0.000
A5.0	JUNCTION	2.15	2.15	0 00:35	0.0436	0.0436	0.000
A6.0	JUNCTION	11.40	11.40	0 00:40	0.3	0.3	0.000
A7.0	JUNCTION	5.43	5.43	0 00:40	0.125	0.125	0.000
A10.0	JUNCTION	1.51	1.51	0 00:35	0.0213	0.0213	0.000
A9.0	JUNCTION	0.86	0.86	0 00:35	0.0198	0.0198	0.000
A8.0	JUNCTION	0.85	0.85	0 00:35	0.0104	0.0104	0.000
B6.0	JUNCTION	14.49	14.49	0 00:35	0.186	0.186	0.000
B5.0	JUNCTION	1.19	1.19	0 00:40	0.0309	0.0309	0.000
B4.0	JUNCTION	8.35	8.35	0 00:35	0.124	0.124	0.000
B2.0	JUNCTION	2.52	2.52	0 00:35	0.0271	0.0271	0.000
B3.0	JUNCTION	1.19	1.19	0 00:35	0.0233	0.0233	0.000
B1.0	JUNCTION	0.38	0.38	0 00:35	0.00853	0.00853	0.000
C4.1	JUNCTION	1.87	1.87	0 00:40	0.0491	0.0491	0.000
C3.0	JUNCTION	3.37	3.37	0 00:35	0.0585	0.0585	0.000
C2.0	JUNCTION	0.93	0.93	0 00:35	0.0192	0.0192	0.000
C1.0	JUNCTION	1.38	1.38	0 00:35	0.0302	0.0302	0.000
C5.0	JUNCTION	4.73	4.73	0 00:35	0.0751	0.0751	0.000
C8.0	JUNCTION	67.57	67.57	0 01:00	2.64	2.64	0.000
C7.1	JUNCTION	39.54	39.54	0 00:55	1.53	1.53	0.000
Outlet_C8.0	JUNCTION	0.00	67.57	0 01:00	0	2.64	0.000
C7.4	JUNCTION	36.14	36.14	0 00:40	0.775	0.775	0.000
D3.0	JUNCTION	8.50	8.50	0 00:40	0.212	0.212	0.000

D2.0	JUNCTION	4.29	4.29	0	00:40	0.118	0.118	0.000
D1.0	JUNCTION	2.84	2.84	0	00:40	0.0762	0.0762	0.000
D7.0	JUNCTION	0.27	0.27	0	00:35	0.00452	0.00452	0.000
D4.0	JUNCTION	4.60	4.60	0	00:35	0.0858	0.0858	0.000
D6.0	JUNCTION	1.43	1.43	0	00:35	0.0229	0.0229	0.000
D5.0	JUNCTION	4.29	4.29	0	00:35	0.0715	0.0715	0.000
C8.1	JUNCTION	42.06	42.06	0	01:00	1.75	1.75	0.000
Outlet_C7.7	JUNCTION	0.00	269.64	0	03:04	0	54.2	0.000
C7.4.1	JUNCTION	0.00	39.37	0	01:23	0	1.91	0.000
O3.0	JUNCTION	99.11	99.11	0	01:00	3.85	3.85	0.000
O4.0	JUNCTION	58.36	58.36	0	01:40	4.38	4.38	0.000
O5.0	JUNCTION	105.56	105.56	0	01:45	7.67	7.67	0.000
O1.0	JUNCTION	87.21	87.21	0	03:40	10.9	10.9	0.000
O2.0	JUNCTION	145.11	145.11	0	04:15	18.1	18.1	0.000
Outlet_A6.0&5.0	JUNCTION	0.00	13.95	0	00:45	0	0.494	0.000
Outlet_A7.0	JUNCTION	0.00	5.53	0	00:40	0	0.154	0.000
Outlet_A9.0&8.0	JUNCTION	0.00	1.70	0	00:35	0	0.0316	0.000
Outlet_O2.0	JUNCTION	0.00	147.02	0	04:26	0	18.6	0.000
Outlet_A10.0_2	JUNCTION	0.00	0.99	0	00:53	0	0.0231	0.000
Outlet_O4.0	JUNCTION	0.00	243.06	0	04:37	0	40.3	0.000
Outlet_O3.0	JUNCTION	0.00	114.32	0	01:00	0	4.31	0.000
Outlet_C1.0.2.0&3.0	JUNCTION	0.00	5.68	0	00:35	0	0.108	0.000
C5.0&03.0	JUNCTION	0.00	229.82	0	04:20	0	35.2	0.000
Outlet_C5.0	JUNCTION	0.00	4.73	0	00:35	0	0.0751	0.000
Outlet_B4.0&5.0	JUNCTION	0.00	9.50	0	00:35	0	0.155	0.000
B4.0.5.0&03.0	JUNCTION	0.00	228.87	0	04:39	0	36.3	0.000
Outlet_O5.0	JUNCTION	0.00	256.36	0	05:16	0	49.2	-0.000
Outlet_B2.0&3.0	JUNCTION	0.00	3.72	0	00:35	0	0.0504	0.000
Outlet_O1.0	JUNCTION	0.00	87.22	0	03:40	0	12	0.000
Outlet_A2.0	JUNCTION	0.00	10.01	0	00:35	0	0.148	0.000
Outlet_A2.0.B1.0&8.0	JUNCTION	0.00	9.85	0	00:55	0	0.253	-0.000
B7.0	JUNCTION	2.83	2.83	0	00:40	0.0879	0.0879	0.000
B8.0	JUNCTION	3.12	3.12	0	00:40	0.076	0.076	0.000
Outlet_B1.0&8.0	JUNCTION	0.00	3.50	0	00:40	0	0.0845	0.000
O1.0&2.0	JUNCTION	0.00	225.70	0	04:17	0	30.8	0.000
Outlet_D1.0&D2.0	JUNCTION	0.00	237.82	0	05:15	0	41.1	0.000
Outlet_A4.0	JUNCTION	0.00	7.06	0	00:35	0	0.107	0.000
Outlet_A10.0_1	JUNCTION	0.00	1.51	0	00:35	0	0.0213	0.000
C6.0	JUNCTION	25.19	25.19	0	00:45	0.772	0.772	0.000
Outlet_C6.0	JUNCTION	0.00	229.51	0	04:31	0	36.1	0.000
O2.0&A4.0	JUNCTION	0.00	146.24	0	04:32	0	18.8	0.000
Outlet_C7.4	JUNCTION	0.00	47.52	0	01:28	0	2.71	0.000
C7.7.1	JUNCTION	0.00	268.70	0	02:48	0	52.8	0.000
C7.7	JUNCTION	36.38	36.38	0	00:55	1.28	1.28	0.000
Outlet_C7.1	JUNCTION	0.00	43.98	0	00:55	0	1.7	0.000
C7.6	JUNCTION	16.12	16.12	0	00:45	0.444	0.444	0.000
Outlet_C7.6	JUNCTION	0.00	16.12	0	00:45	0	0.444	0.000
C7.5	JUNCTION	2.43	2.43	0	00:50	0.12	0.12	0.000
C7.3	JUNCTION	2.19	2.19	0	00:40	0.0597	0.0597	0.000
C7.2	JUNCTION	2.33	2.33	0	00:45	0.0952	0.0952	0.000
Outlet_C7.2	JUNCTION	0.00	2.33	0	00:45	0	0.0952	0.000
Outlet_C7.5	JUNCTION	0.00	2.43	0	00:50	0	0.12	0.000
C7.0	JUNCTION	3.61	3.61	0	00:40	0.1	0.1	0.000
Outlet_C7.0	JUNCTION	0.00	3.61	0	00:40	0	0.1	0.000
C4.2	JUNCTION	0.53	0.53	0	00:40	0.0153	0.0153	0.000
C4.0	JUNCTION	11.28	11.28	0	00:40	0.26	0.26	0.000
Outlet_C4.0	JUNCTION	0.00	11.28	0	00:40	0	0.26	0.000
A1.1	JUNCTION	4.40	4.40	0	00:40	0.107	0.107	0.000
Outlet_A1.0	JUNCTION	0.00	13.79	0	00:50	0	0.448	0.000
Outlet_D3.0	JUNCTION	0.00	8.50	0	00:40	0	0.212	0.000
Outlet_D4.0	JUNCTION	0.00	4.60	0	00:35	0	0.0858	0.000
Outlet_D5.0	JUNCTION	0.00	4.29	0	00:35	0	0.0715	0.000
Outlet_C8.1	OUTFALL	0.00	300.62	0	03:10	0	59.1	0.000
Outlet_D6.0	OUTFALL	0.00	1.43	0	00:35	0	0.0229	0.000
Outlet_D7.0	OUTFALL	0.00	0.27	0	00:35	0	0.00452	0.000

\*\*\*\*\*  
Node Flooding Summary  
\*\*\*\*\*

No nodes were flooded.

\*\*\*\*\*  
Outfall Loading Summary  
\*\*\*\*\*

Outfall Node	Flow Freq Pcmt	Avg Flow CFS	Max Flow CFS	Total Volume 10^6 gal
Outlet_C8.1	99.20	92.32	300.62	59.143
Outlet_D6.0	10.15	0.35	1.43	0.023
Outlet_D7.0	8.23	0.08	0.27	0.005
System	39.19	92.75	300.62	59.170

\*\*\*\*\*  
Link Flow Summary  
\*\*\*\*\*

Link	Type	Maximum  Flow  CFS	Time of Max Occurrence days hr:min	Maximum  Veloc  ft/sec	Max/ Full Flow	Max/ Full Depth
A1.0	DUMMY	13.79	0 00:50			
A3.0	DUMMY	4.70	0 00:40			
A2.0	DUMMY	10.01	0 00:35			
A4.0	DUMMY	7.06	0 00:35			
A5.0	DUMMY	2.15	0 00:35			
A6.0	DUMMY	11.40	0 00:40			
A7.0	DUMMY	5.43	0 00:40			
A9.0	DUMMY	0.86	0 00:35			
A8.0	DUMMY	0.85	0 00:35			
A10.0	DUMMY	1.51	0 00:35			
C7.7Channel1	CONDUIT	268.70	0 03:15	1.50	0.02	0.10
C8.0Channel	CHANNEL	42.75	0 01:54	2.17	0.00	0.01
C8.1	DUMMY	42.06	0 01:00			
C8.0	DUMMY	67.57	0 01:00			
C7.4	DUMMY	36.14	0 00:40			
C5.0	DUMMY	4.73	0 00:35			
C4.1	DUMMY	1.87	0 00:40			
C3.0	DUMMY	3.37	0 00:35			
C2.0	DUMMY	0.93	0 00:35			
C1.0	DUMMY	1.38	0 00:35			
B5.0	DUMMY	1.19	0 00:40			
B4.0	DUMMY	8.35	0 00:35			
B3.0	DUMMY	1.19	0 00:35			
B1.0	DUMMY	0.38	0 00:35			
B2.0	DUMMY	2.52	0 00:35			
B6.0	DUMMY	14.49	0 00:35			
D1.0	DUMMY	2.84	0 00:40			
D2.0	DUMMY	4.29	0 00:40			
D3.0	DUMMY	8.50	0 00:40			
D4.0	DUMMY	4.60	0 00:35			
D5.0	DUMMY	4.29	0 00:35			
D6.0	DUMMY	1.43	0 00:35			
D7.0	DUMMY	0.27	0 00:35			
C7.1&C7.5Channe12	CHANNEL	38.56	0 01:37	2.66	0.00	0.03
C7.1	DUMMY	39.54	0 00:55			
O2.0	DUMMY	145.11	0 04:15			
A10.0Channe12	CHANNEL	0.23	0 01:20	0.30	0.00	0.00

A9.0&8.0Channel	CHANNEL	0.77	0	01:20	0.36	0.00	0.00
A7.0Channel	CHANNEL	3.40	0	01:20	0.87	0.00	0.01
A6.0&5.0Channel	CHANNEL	10.69	0	01:23	2.95	0.00	0.02
O3.0	DUMMY	99.11	0	01:00			
C1.0.2.0&3.0Channel	CHANNEL	4.48	0	00:54	1.96	0.00	0.03
O3.0Channel1	CHANNEL	113.32	0	01:07	4.36	0.01	0.12
C5.0Channel	CHANNEL	3.91	0	00:47	1.84	0.00	0.05
B4.0&5.0Channel	CHANNEL	6.34	0	00:55	2.17	0.00	0.00
O3.0Channel2	CHANNEL	229.51	0	04:31	3.07	0.00	0.05
O4.0	DUMMY	58.36	0	01:40			
O4.0Channel1	CHANNEL	237.82	0	05:15	3.21	0.00	0.04
O5.0	DUMMY	105.56	0	01:45			
B2.0&3.0Channel	CHANNEL	0.47	0	00:56	0.26	0.00	0.00
A2.0Channel	CHANNEL	6.92	0	00:55	1.82	0.00	0.02
A2.0.B1.0&8.0	CHANNEL	6.93	0	01:21	1.36	0.00	0.01
B7.0	DUMMY	2.83	0	00:40			
O1.0	DUMMY	87.21	0	03:40			
B8.0	DUMMY	3.12	0	00:40			
B1.0&8.0Channel	CHANNEL	2.95	0	00:53	1.89	0.00	0.00
O2.0Channel1	CHANNEL	146.21	0	04:32	3.56	0.00	0.08
O1.0Channel	CHANNEL	87.05	0	03:49	3.67	0.00	0.06
O2.0Channel3	CHANNEL	225.51	0	04:28	4.01	0.00	0.11
A4.0Channel	CHANNEL	4.74	0	01:00	1.79	0.00	0.06
A10.0Channel1	CHANNEL	0.99	0	00:53	0.99	0.00	0.01
C6.0	DUMMY	25.19	0	00:45			
O2.0Channel2	CHANNEL	146.09	0	04:37	2.62	0.00	0.17
O3.0Channel3	CHANNEL	228.87	0	04:39	2.11	0.00	0.04
C74&C7.6Channel1	CHANNEL	265.17	0	03:06	1.01	0.02	0.15
C7.1Channel1	CHANNEL	37.23	0	01:30	1.09	0.00	0.06
C7.6	DUMMY	16.12	0	00:45			
C7.4Channel1	CHANNEL	46.48	0	01:48	1.91	0.01	0.31
C7.6Channel1	CHANNEL	11.57	0	01:15	2.99	0.00	0.03
C7.7	DUMMY	36.38	0	00:55			
C7.5	DUMMY	2.43	0	00:50			
C7.2	DUMMY	2.33	0	00:45			
C7.2Channel1	CHANNEL	2.23	0	00:59	1.57	0.00	0.02
C7.3	DUMMY	2.19	0	00:40			
C7.0Channel1	CHANNEL	1.35	0	01:29	1.00	0.00	0.00
C7.0	DUMMY	3.61	0	00:40			
C4.2	DUMMY	0.53	0	00:40			
C4.0Channel1	CHANNEL	9.39	0	00:56	1.14	0.00	0.01
C4.0	DUMMY	11.28	0	00:40			
C7.5Channel1	CHANNEL	2.30	0	01:23	0.90	0.00	0.01
D1.0&D2.0Channel1	CHANNEL	237.53	0	05:16	4.04	0.03	0.22
O5.0Channel1	CHANNEL	254.11	0	05:41	1.27	0.03	0.21
O3.0Channel4	CHANNEL	228.86	0	04:40	6.99	0.00	0.01
A1.1	DUMMY	4.40	0	00:40			
A1.0Channel1	CHANNEL	12.42	0	01:02	2.66	0.00	0.01
D3.0Channel1	CONDUIT	7.83	0	00:52	1.35	0.01	0.05
D4.0Channel1	CONDUIT	3.42	0	00:55	1.29	0.00	0.03
D5.0Channel1	CONDUIT	2.85	0	00:58	1.26	0.00	0.02

\*\*\*\*\*  
 Conduit Surcharge Summary  
 \*\*\*\*\*

No conduits were surcharged.

Analysis begun on: Wed Jul 28 16:20:16 2021  
 Analysis ended on: Wed Jul 28 16:20:17 2021  
 Total elapsed time: 00:00:01

-----  
 Scenario ID = 100-Year\_Ex\_100yr\_0mi^2\_PikeSolar

\*\*\*\*\*  
 NOTE: The summary statistics displayed in this report are based on results found at every computational time step, not just on results from each reporting time step.  
 \*\*\*\*\*

\*\*\*\*\*

Analysis Options

\*\*\*\*\*

Flow Units ..... CFS  
 Process Models:  
   Rainfall/Runoff ..... NO  
   RDII ..... NO  
   Snowmelt ..... NO  
   Groundwater ..... NO  
   Flow Routing ..... YES  
   Ponding Allowed ..... NO  
   Water Quality ..... NO  
 Flow Routing Method ..... KINWAVE  
 Starting Date ..... 01/01/2005 00:00:00  
 Ending Date ..... 01/01/2005 23:59:00  
 Antecedent Dry Days ..... 0.0  
 Report Time Step ..... 00:15:00  
 Routing Time Step ..... 30.00 sec

	Volume	Volume
Flow Routing Continuity	acre-feet	10 <sup>6</sup> gal
*****	-----	-----
Dry Weather Inflow .....	0.000	0.000
Wet Weather Inflow .....	0.000	0.000
Groundwater Inflow .....	0.000	0.000
RDII Inflow .....	0.000	0.000
External Inflow .....	3075.469	1002.187
External Outflow .....	3101.710	1010.738
Flooding Loss .....	0.000	0.000
Evaporation Loss .....	0.000	0.000
Exfiltration Loss .....	0.000	0.000
Initial Stored Volume ....	0.000	0.000
Final Stored Volume .....	0.730	0.238
Continuity Error (%) .....	-0.877	

\*\*\*\*\*

Highest Flow Instability Indexes

\*\*\*\*\*

Link 03.0Channel3 (1)  
 Link 02.0Channel3 (1)  
 Link 03.0Channel2 (1)  
 Link C74&C7.6Channel1 (1)  
 Link 05.0Channel1 (1)

\*\*\*\*\*

Routing Time Step Summary

\*\*\*\*\*

Minimum Time Step : 29.00 sec  
 Average Time Step : 30.00 sec  
 Maximum Time Step : 30.00 sec  
 Percent in Steady State : 0.00  
 Average Iterations per Step : 1.00  
 Percent Not Converging : 0.00



\*\*\*\*\*  
Node Depth Summary  
\*\*\*\*\*

Node	Type	Average Depth Feet	Maximum Depth Feet	Maximum HGL Feet	Time of Max Occurrence days hr:min	Reported Max Depth Feet
A1.0	JUNCTION	0.00	0.00	5621.00	0 00:00	0.00
A4.0	JUNCTION	0.00	0.00	5578.00	0 00:00	0.00
A3.0	JUNCTION	0.00	0.00	5580.30	0 00:00	0.00
A2.0	JUNCTION	0.00	0.00	5587.40	0 00:00	0.00
A5.0	JUNCTION	0.00	0.00	5578.00	0 00:00	0.00
A6.0	JUNCTION	0.00	0.00	5590.00	0 00:00	0.00
A7.0	JUNCTION	0.00	0.00	5601.00	0 00:00	0.00
A10.0	JUNCTION	0.00	0.00	5621.00	0 00:00	0.00
A9.0	JUNCTION	0.00	0.00	5601.00	0 00:00	0.00
A8.0	JUNCTION	0.00	0.00	5558.00	0 00:00	0.00
B6.0	JUNCTION	0.00	0.00	5584.40	0 00:00	0.00
B5.0	JUNCTION	0.00	0.00	5572.00	0 00:00	0.00
B4.0	JUNCTION	0.00	0.00	5586.90	0 00:00	0.00
B2.0	JUNCTION	0.00	0.00	5598.40	0 00:00	0.00
B3.0	JUNCTION	0.00	0.00	5586.20	0 00:00	0.00
B1.0	JUNCTION	0.00	0.00	5600.60	0 00:00	0.00
C4.1	JUNCTION	0.00	0.00	5544.90	0 00:00	0.00
C3.0	JUNCTION	0.00	0.00	5556.70	0 00:00	0.00
C2.0	JUNCTION	0.00	0.00	5556.70	0 00:00	0.00
C1.0	JUNCTION	0.00	0.00	5565.10	0 00:00	0.00
C5.0	JUNCTION	0.00	0.00	5544.40	0 00:00	0.00
C8.0	JUNCTION	0.00	0.00	5566.50	0 00:00	0.00
C7.1	JUNCTION	0.00	0.00	5568.00	0 00:00	0.00
Outlet_C8.0	JUNCTION	0.10	0.94	5407.64	0 01:05	0.92
C7.4	JUNCTION	0.00	0.00	5472.00	0 00:00	0.00
D3.0	JUNCTION	0.00	0.00	5503.60	0 00:00	0.00
D2.0	JUNCTION	0.00	0.00	5496.50	0 00:00	0.00
D1.0	JUNCTION	0.00	0.00	5480.00	0 00:00	0.00
D7.0	JUNCTION	0.00	0.00	5478.60	0 00:00	0.00
D4.0	JUNCTION	0.00	0.00	5487.70	0 00:00	0.00
D6.0	JUNCTION	0.00	0.00	5485.20	0 00:00	0.00
D5.0	JUNCTION	0.00	0.00	5488.00	0 00:00	0.00
C8.1	JUNCTION	0.00	0.00	5465.90	0 00:00	0.00
Outlet_C7.7	JUNCTION	1.01	2.57	5371.57	0 05:44	2.57
C7.4.1	JUNCTION	0.41	2.99	5419.59	0 01:28	2.99
O3.0	JUNCTION	0.00	0.00	5716.50	0 00:00	0.00
O4.0	JUNCTION	0.00	0.00	5555.00	0 00:00	0.00
O5.0	JUNCTION	0.00	0.00	5681.10	0 00:00	0.00
O1.0	JUNCTION	0.00	0.00	6147.50	0 00:00	0.00
O2.0	JUNCTION	0.00	0.00	6281.20	0 00:00	0.00
Outlet_A6.0&5.0	JUNCTION	0.20	1.94	5501.84	0 01:03	1.94
Outlet_A7.0	JUNCTION	0.08	0.92	5515.82	0 01:05	0.92
Outlet_A9.0&8.0	JUNCTION	0.04	0.59	5523.49	0 01:14	0.59
Outlet_O2.0	JUNCTION	3.19	9.83	5493.43	0 04:20	9.82
Outlet_A10.0_2	JUNCTION	0.04	0.69	5540.99	0 00:47	0.69
Outlet_O4.0	JUNCTION	2.24	7.54	5429.44	0 04:27	7.54
Outlet_O3.0	JUNCTION	0.30	3.09	5498.29	0 01:07	3.04
Outlet_C1.0.2.0&3.0	JUNCTION	0.06	1.15	5520.15	0 00:40	1.14
C5.0&O3.0	JUNCTION	3.15	7.31	5473.01	0 04:20	7.29
Outlet_C5.0	JUNCTION	0.03	0.55	5502.45	0 00:40	0.54
Outlet_B4.0&5.0	JUNCTION	0.03	0.53	5539.83	0 00:40	0.52
B4.0.5.0&O3.0	JUNCTION	2.07	6.54	5454.34	0 04:27	6.54
Outlet_O5.0	JUNCTION	4.38	11.49	5391.49	0 05:34	11.32
Outlet_B2.0&3.0	JUNCTION	0.01	0.26	5550.26	0 00:35	0.24
Outlet_O1.0	JUNCTION	2.74	9.15	5498.15	0 03:40	9.15
Outlet_A2.0	JUNCTION	0.06	1.39	5534.35	0 00:40	1.35
Outlet_A2.0.B1.0&8.0	JUNCTION	0.08	1.32	5520.51	0 00:52	1.27
B7.0	JUNCTION	0.00	0.00	5572.00	0 00:00	0.00
B8.0	JUNCTION	0.00	0.00	5600.20	0 00:00	0.00
Outlet_B1.0&8.0	JUNCTION	0.02	0.34	5552.52	0 00:45	0.34

O1.0&2.0	JUNCTION	3.92	10.50	5481.50	0	04:30	10.50
Outlet_D1.0&D2.0	JUNCTION	4.37	11.49	5397.89	0	05:32	11.46
Outlet_A4.0	JUNCTION	0.01	0.24	5511.04	0	00:40	0.24
Outlet_A10.0_1	JUNCTION	0.01	0.21	5589.81	0	00:40	0.21
C6.0	JUNCTION	0.00	0.00	5585.20	0	00:00	0.00
Outlet_C6.0	JUNCTION	2.58	7.30	5461.30	0	04:24	7.29
O2.0&A4.0	JUNCTION	3.85	10.50	5483.50	0	04:27	10.50
Outlet_C7.4	JUNCTION	0.33	1.97	5380.87	0	01:22	1.96
C7.7.1	JUNCTION	1.14	2.73	5374.93	0	05:40	2.71
C7.7	JUNCTION	0.00	0.00	5459.00	0	00:00	0.00
Outlet_C7.1	JUNCTION	0.37	3.06	5420.96	0	01:05	3.05
C7.6	JUNCTION	0.00	0.00	5475.30	0	00:00	0.00
Outlet_C7.6	JUNCTION	0.03	0.43	5382.33	0	00:50	0.42
C7.5	JUNCTION	0.00	0.00	5484.30	0	00:00	0.00
C7.3	JUNCTION	0.00	0.00	5488.00	0	00:00	0.00
C7.2	JUNCTION	0.00	0.00	5493.00	0	00:00	0.00
Outlet_C7.2	JUNCTION	0.06	0.51	5436.91	0	00:55	0.51
Outlet_C7.5	JUNCTION	0.05	0.43	5425.93	0	01:00	0.43
C7.0	JUNCTION	0.00	0.00	5567.50	0	00:00	0.00
Outlet_C7.0	JUNCTION	0.06	0.58	5511.78	0	00:45	0.57
C4.2	JUNCTION	0.00	0.00	5538.50	0	00:00	0.00
C4.0	JUNCTION	0.00	0.00	5586.60	0	00:00	0.00
Outlet_C4.0	JUNCTION	0.02	0.37	5513.87	0	00:45	0.36
A1.1	JUNCTION	0.00	0.00	5575.80	0	00:00	0.00
Outlet_A1.0	JUNCTION	0.08	0.91	5541.01	0	00:55	0.90
Outlet_D3.0	JUNCTION	0.05	0.76	5391.76	0	00:50	0.76
Outlet_D4.0	JUNCTION	0.02	0.44	5427.24	0	00:40	0.44
Outlet_D5.0	JUNCTION	0.02	0.40	5434.60	0	00:40	0.39
Outlet_C8.1	OUTFALL	0.77	2.20	5364.20	0	05:48	2.19
Outlet_D6.0	OUTFALL	0.00	0.00	5459.80	0	00:00	0.00
Outlet_D7.0	OUTFALL	0.00	0.00	5471.10	0	00:00	0.00

\*\*\*\*\*  
Node Inflow Summary  
\*\*\*\*\*

Node	Type	Maximum Lateral Inflow CFS	Maximum Total Inflow CFS	Time of Max Occurrence days hr:min	Lateral Inflow Volume 10^6 gal	Total Inflow Volume 10^6 gal	Flow Balance Error Percent
A1.0	JUNCTION	173.24	173.24	0 00:55	6.48	6.48	0.000
A4.0	JUNCTION	54.72	54.72	0 00:40	1.13	1.13	0.000
A3.0	JUNCTION	40.40	40.40	0 00:45	1.22	1.22	0.000
A2.0	JUNCTION	72.71	72.71	0 00:40	1.47	1.47	0.000
A5.0	JUNCTION	32.00	32.00	0 00:40	0.836	0.836	0.000
A6.0	JUNCTION	102.64	102.64	0 00:50	3.27	3.27	0.000
A7.0	JUNCTION	55.20	55.20	0 00:45	1.61	1.61	0.000
A10.0	JUNCTION	20.68	20.68	0 00:40	0.405	0.405	0.000
A9.0	JUNCTION	14.41	14.41	0 00:45	0.418	0.418	0.000
A8.0	JUNCTION	12.94	12.94	0 00:35	0.219	0.219	0.000
B6.0	JUNCTION	113.48	113.48	0 00:35	2	2	0.000
B5.0	JUNCTION	9.53	9.53	0 00:45	0.304	0.304	0.000
B4.0	JUNCTION	60.25	60.25	0 00:40	1.22	1.22	0.000
B2.0	JUNCTION	39.20	39.20	0 00:35	0.57	0.57	0.000
B3.0	JUNCTION	13.22	13.22	0 00:40	0.337	0.337	0.000
B1.0	JUNCTION	3.97	3.97	0 00:45	0.115	0.115	0.000
C4.1	JUNCTION	15.07	15.07	0 00:45	0.483	0.483	0.000
C3.0	JUNCTION	25.17	25.17	0 00:40	0.576	0.576	0.000
C2.0	JUNCTION	7.19	7.19	0 00:40	0.189	0.189	0.000
C1.0	JUNCTION	10.76	10.76	0 00:40	0.297	0.297	0.000
C5.0	JUNCTION	34.07	34.07	0 00:40	0.725	0.725	0.000
C8.0	JUNCTION	585.56	585.56	0 01:05	25	25	0.000
C7.1	JUNCTION	336.41	336.41	0 01:05	14.4	14.4	0.000
Outlet_C8.0	JUNCTION	0.00	585.56	0 01:05	0	25	-0.000
C7.4	JUNCTION	286.03	286.03	0 00:45	7.63	7.63	0.000
D3.0	JUNCTION	109.06	109.06	0 00:50	3.35	3.35	0.000

D2.0	JUNCTION	60.22	60.22	0	00:50	2	2	0.000
D1.0	JUNCTION	44.10	44.10	0	00:50	1.44	1.44	0.000
D7.0	JUNCTION	4.20	4.20	0	00:40	0.0953	0.0953	0.000
D4.0	JUNCTION	61.59	61.59	0	00:40	1.48	1.48	0.000
D6.0	JUNCTION	22.07	22.07	0	00:40	0.483	0.483	0.000
D5.0	JUNCTION	50.71	50.71	0	00:40	1.13	1.13	0.000
C8.1	JUNCTION	388.72	388.72	0	01:05	17.6	17.6	0.000
Outlet_C7.7	JUNCTION	0.00	6010.33	0	05:44	0	966	0.000
C7.4.1	JUNCTION	0.00	371.85	0	01:28	0	18.5	0.000
O3.0	JUNCTION	989.85	989.85	0	01:10	41.9	41.9	0.000
O4.0	JUNCTION	639.02	639.02	0	01:45	48.9	48.9	0.000
O5.0	JUNCTION	1098.89	1098.89	0	01:55	81.5	81.5	0.000
O1.0	JUNCTION	1857.86	1857.86	0	03:45	233	233	0.000
O2.0	JUNCTION	3741.45	3741.45	0	04:20	465	465	0.000
Outlet_A6.0&5.0	JUNCTION	0.00	184.62	0	01:03	0	6.92	0.000
Outlet_A7.0	JUNCTION	0.00	74.71	0	01:05	0	2.74	0.000
Outlet_A9.0&8.0	JUNCTION	0.00	32.45	0	01:05	0	1.07	-0.000
Outlet_O2.0	JUNCTION	0.00	3745.18	0	04:20	0	473	0.000
Outlet_A10.0_2	JUNCTION	0.00	19.74	0	00:47	0	0.415	0.000
Outlet_O4.0	JUNCTION	0.00	5763.78	0	04:27	0	827	0.000
Outlet_O3.0	JUNCTION	0.00	1116.59	0	01:07	0	46.2	0.000
Outlet_C1.0.2.0&3.0	JUNCTION	0.00	43.12	0	00:40	0	1.06	0.000
C5.0&03.0	JUNCTION	0.00	5578.03	0	04:20	0	768	0.000
Outlet_C5.0	JUNCTION	0.00	34.07	0	00:40	0	0.725	0.000
Outlet_B4.0&5.0	JUNCTION	0.00	69.50	0	00:40	0	1.53	0.000
B4.0.5.0&03.0	JUNCTION	0.00	5572.08	0	04:27	0	777	0.000
Outlet_O5.0	JUNCTION	0.00	6096.37	0	05:34	0	920	0.000
Outlet_B2.0&3.0	JUNCTION	0.00	51.46	0	00:35	0	0.906	0.000
Outlet_O1.0	JUNCTION	0.00	1869.24	0	03:40	0	247	0.000
Outlet_A2.0	JUNCTION	0.00	72.71	0	00:40	0	1.47	0.000
Outlet_A2.0.B1.0&8.0	JUNCTION	0.00	95.31	0	00:51	0	2.43	0.000
B7.0	JUNCTION	23.62	23.62	0	00:50	0.866	0.866	0.000
B8.0	JUNCTION	25.83	25.83	0	00:45	0.78	0.78	0.000
Outlet_B1.0&8.0	JUNCTION	0.00	29.81	0	00:45	0	0.895	0.000
O1.0&2.0	JUNCTION	0.00	5538.01	0	04:18	0	721	0.000
Outlet_D1.0&D2.0	JUNCTION	0.00	5913.87	0	05:32	0	833	0.000
Outlet_A4.0	JUNCTION	0.00	54.72	0	00:40	0	1.13	0.000
Outlet_A10.0_1	JUNCTION	0.00	20.68	0	00:40	0	0.405	0.000
C6.0	JUNCTION	207.27	207.27	0	00:55	7.36	7.36	0.000
Outlet_C6.0	JUNCTION	0.00	5573.85	0	04:24	0	775	0.000
O2.0&A4.0	JUNCTION	0.00	3741.54	0	04:27	0	474	0.000
Outlet_C7.4	JUNCTION	0.00	505.73	0	01:22	0	26.2	0.000
C7.7.1	JUNCTION	0.00	6044.50	0	05:40	0	952	0.000
C7.7	JUNCTION	319.90	319.90	0	01:00	12.7	12.7	0.000
Outlet_C7.1	JUNCTION	0.00	389.96	0	01:05	0	16.9	0.000
C7.6	JUNCTION	132.91	132.91	0	00:50	4.37	4.37	0.000
Outlet_C7.6	JUNCTION	0.00	132.91	0	00:50	0	4.37	0.000
C7.5	JUNCTION	17.46	17.46	0	01:00	0.897	0.897	0.000
C7.3	JUNCTION	17.70	17.70	0	00:45	0.588	0.588	0.000
C7.2	JUNCTION	20.34	20.34	0	00:55	0.938	0.938	0.000
Outlet_C7.2	JUNCTION	0.00	20.34	0	00:55	0	0.938	0.000
Outlet_C7.5	JUNCTION	0.00	17.46	0	01:00	0	0.897	0.000
C7.0	JUNCTION	29.29	29.29	0	00:45	0.986	0.986	0.000
Outlet_C7.0	JUNCTION	0.00	29.29	0	00:45	0	0.986	0.000
C4.2	JUNCTION	4.30	4.30	0	00:45	0.15	0.15	0.000
C4.0	JUNCTION	89.36	89.36	0	00:45	2.56	2.56	0.000
Outlet_C4.0	JUNCTION	0.00	89.36	0	00:45	0	2.56	0.000
A1.1	JUNCTION	35.74	35.74	0	00:45	1.07	1.07	0.000
Outlet_A1.0	JUNCTION	0.00	173.24	0	00:55	0	6.48	0.000
Outlet_D3.0	JUNCTION	0.00	109.06	0	00:50	0	3.35	-0.000
Outlet_D4.0	JUNCTION	0.00	61.59	0	00:40	0	1.48	0.000
Outlet_D5.0	JUNCTION	0.00	50.71	0	00:40	0	1.13	0.000
Outlet_C8.1	OUTFALL	0.00	6013.05	0	05:48	0	1.01e+03	0.000
Outlet_D6.0	OUTFALL	0.00	22.07	0	00:40	0	0.483	0.000
Outlet_D7.0	OUTFALL	0.00	4.20	0	00:40	0	0.0953	0.000

\*\*\*\*\*  
Node Flooding Summary  
\*\*\*\*\*

No nodes were flooded.

\*\*\*\*\*  
Outfall Loading Summary  
\*\*\*\*\*

Outfall Node	Flow Freq Pcmt	Avg Flow CFS	Max Flow CFS	Total Volume 10^6 gal
Outlet_C8.1	99.27	1575.52	6013.05	1010.085
Outlet_D6.0	12.44	6.02	22.07	0.483
Outlet_D7.0	10.77	1.37	4.20	0.095
System	40.83	1582.91	6013.05	1010.663

\*\*\*\*\*  
Link Flow Summary  
\*\*\*\*\*

Link	Type	Maximum  Flow  CFS	Time of Max Occurrence days hr:min	Maximum  Veloc  ft/sec	Max/ Full Flow	Max/ Full Depth
A1.0	DUMMY	173.24	0 00:55			
A3.0	DUMMY	40.40	0 00:45			
A2.0	DUMMY	72.71	0 00:40			
A4.0	DUMMY	54.72	0 00:40			
A5.0	DUMMY	32.00	0 00:40			
A6.0	DUMMY	102.64	0 00:50			
A7.0	DUMMY	55.20	0 00:45			
A9.0	DUMMY	14.41	0 00:45			
A8.0	DUMMY	12.94	0 00:35			
A10.0	DUMMY	20.68	0 00:40			
C7.7Channel1	CONDUIT	6000.83	0 05:48	4.75	0.44	0.63
C8.0Channel	CHANNEL	491.68	0 01:39	3.17	0.00	0.03
C8.1	DUMMY	388.72	0 01:05			
C8.0	DUMMY	585.56	0 01:05			
C7.4	DUMMY	286.03	0 00:45			
C5.0	DUMMY	34.07	0 00:40			
C4.1	DUMMY	15.07	0 00:45			
C3.0	DUMMY	25.17	0 00:40			
C2.0	DUMMY	7.19	0 00:40			
C1.0	DUMMY	10.76	0 00:40			
B5.0	DUMMY	9.53	0 00:45			
B4.0	DUMMY	60.25	0 00:40			
B3.0	DUMMY	13.22	0 00:40			
B1.0	DUMMY	3.97	0 00:45			
B2.0	DUMMY	39.20	0 00:35			
B6.0	DUMMY	113.48	0 00:35			
D1.0	DUMMY	44.10	0 00:50			
D2.0	DUMMY	60.22	0 00:50			
D3.0	DUMMY	109.06	0 00:50			
D4.0	DUMMY	61.59	0 00:40			
D5.0	DUMMY	50.71	0 00:40			
D6.0	DUMMY	22.07	0 00:40			
D7.0	DUMMY	4.20	0 00:40			
C7.1&C7.5Channe12	CHANNEL	370.60	0 01:34	5.93	0.00	0.11
C7.1	DUMMY	336.41	0 01:05			
O2.0	DUMMY	3741.45	0 04:20			
A10.0Channel2	CHANNEL	14.95	0 01:14	2.15	0.00	0.02

A9.0&8.0Channel	CHANNEL	31.24	0	01:15	1.32	0.00	0.02
A7.0Channel	CHANNEL	73.17	0	01:17	2.69	0.00	0.03
A6.0&5.0Channel	CHANNEL	179.38	0	01:16	3.40	0.00	0.06
O3.0	DUMMY	989.85	0	01:10			
C1.0.2.0&3.0Channel	CHANNEL	40.92	0	00:53	3.73	0.00	0.10
O3.0Channel1	CHANNEL	1117.30	0	01:11	9.11	0.08	0.39
C5.0Channel	CHANNEL	33.06	0	00:46	3.42	0.00	0.15
B4.0&5.0Channel	CHANNEL	64.68	0	00:50	4.35	0.00	0.02
O3.0Channel2	CHANNEL	5573.83	0	04:24	7.86	0.01	0.22
O4.0	DUMMY	639.02	0	01:45			
O4.0Channel1	CHANNEL	5913.87	0	05:32	8.08	0.01	0.25
O5.0	DUMMY	1098.89	0	01:55			
B2.0&3.0Channel	CHANNEL	29.60	0	01:20	3.09	0.00	0.00
A2.0Channel	CHANNEL	65.91	0	00:52	3.15	0.00	0.05
A2.0.B1.0&8.0	CHANNEL	87.50	0	01:05	3.48	0.00	0.02
B7.0	DUMMY	23.62	0	00:50			
O1.0	DUMMY	1857.86	0	03:45			
B8.0	DUMMY	25.83	0	00:45			
B1.0&8.0Channel	CHANNEL	29.43	0	00:51	3.34	0.00	0.01
O2.0Channel1	CHANNEL	3741.46	0	04:27	6.47	0.01	0.34
O1.0Channel	CHANNEL	1867.11	0	04:11	7.71	0.00	0.26
O2.0Channel3	CHANNEL	5536.32	0	04:21	5.43	0.02	0.26
A4.0Channel	CHANNEL	46.06	0	00:58	2.40	0.01	0.14
A10.0Channel1	CHANNEL	19.74	0	00:47	2.57	0.00	0.03
C6.0	DUMMY	207.27	0	00:55			
O2.0Channel2	CHANNEL	3740.65	0	04:30	5.00	0.08	0.54
O3.0Channel3	CHANNEL	5572.08	0	04:27	6.33	0.02	0.19
C74&C7.6Channel1	CHANNEL	6010.33	0	05:44	2.88	0.38	0.64
C7.1Channel1	CHANNEL	356.36	0	01:28	1.52	0.00	0.14
C7.6	DUMMY	132.91	0	00:50			
C7.4Channel1	CHANNEL	499.33	0	01:31	2.23	0.12	0.57
C7.6Channel1	CHANNEL	121.99	0	01:10	2.99	0.00	0.08
C7.7	DUMMY	319.90	0	01:00			
C7.5	DUMMY	17.46	0	01:00			
C7.2	DUMMY	20.34	0	00:55			
C7.2Channel1	CHANNEL	20.18	0	01:06	2.26	0.00	0.04
C7.3	DUMMY	17.70	0	00:45			
C7.0Channel1	CHANNEL	23.12	0	01:25	3.49	0.00	0.01
C7.0	DUMMY	29.29	0	00:45			
C4.2	DUMMY	4.30	0	00:45			
C4.0Channel1	CHANNEL	86.74	0	00:53	2.29	0.00	0.05
C4.0	DUMMY	89.36	0	00:45			
C7.5Channel1	CHANNEL	17.37	0	01:09	1.86	0.00	0.03
D1.0&D2.0Channel1	CHANNEL	5911.46	0	05:34	10.66	0.78	0.88
O5.0Channel1	CHANNEL	6037.25	0	05:40	3.63	0.61	0.80
O3.0Channel4	CHANNEL	5572.06	0	04:28	16.60	0.00	0.05
A1.1	DUMMY	35.74	0	00:45			
A1.0Channel1	CHANNEL	171.28	0	01:02	5.04	0.00	0.02
D3.0Channel1	CONDUIT	108.87	0	00:52	3.37	0.08	0.25
D4.0Channel1	CONDUIT	59.39	0	00:51	3.58	0.03	0.14
D5.0Channel1	CONDUIT	47.40	0	00:51	3.28	0.02	0.13

\*\*\*\*\*  
 Conduit Surcharge Summary  
 \*\*\*\*\*

No conduits were surcharged.

Analysis begun on: Wed Jul 28 16:21:17 2021  
 Analysis ended on: Wed Jul 28 16:21:18 2021  
 Total elapsed time: 00:00:01

Scenario ID = 5-Year\_Fut\_5yr\_0mi^2\_PikeSolar

\*\*\*\*\*  
NOTE: The summary statistics displayed in this report are based on results found at every computational time step, not just on results from each reporting time step.  
\*\*\*\*\*

\*\*\*\*\*  
Analysis Options  
\*\*\*\*\*  
Flow Units ..... CFS  
Process Models:  
  Rainfall/Runoff ..... NO  
  RDII ..... NO  
  Snowmelt ..... NO  
  Groundwater ..... NO  
  Flow Routing ..... YES  
  Ponding Allowed ..... NO  
  Water Quality ..... NO  
Flow Routing Method ..... KINWAVE  
Starting Date ..... 01/01/2005 00:00:00  
Ending Date ..... 01/01/2005 23:59:00  
Antecedent Dry Days ..... 0.0  
Report Time Step ..... 00:15:00  
Routing Time Step ..... 30.00 sec

\*\*\*\*\*

	Volume	Volume
Flow Routing Continuity	acre-feet	10 <sup>6</sup> gal
*****	-----	-----
Dry Weather Inflow .....	0.000	0.000
Wet Weather Inflow .....	0.000	0.000
Groundwater Inflow .....	0.000	0.000
RDII Inflow .....	0.000	0.000
External Inflow .....	178.773	58.256
External Outflow .....	183.883	59.921
Flooding Loss .....	0.000	0.000
Evaporation Loss .....	0.000	0.000
Exfiltration Loss .....	0.000	0.000
Initial Stored Volume ....	0.000	0.000
Final Stored Volume .....	0.453	0.148
Continuity Error (%) .....	-3.112	

\*\*\*\*\*  
Highest Flow Instability Indexes  
\*\*\*\*\*  
Link 03.0Channel2 (1)

\*\*\*\*\*  
Routing Time Step Summary  
\*\*\*\*\*  
Minimum Time Step : 29.00 sec  
Average Time Step : 30.00 sec  
Maximum Time Step : 30.00 sec  
Percent in Steady State : 0.00  
Average Iterations per Step : 1.00  
Percent Not Converging : 0.00

\*\*\*\*\*  
Node Depth Summary  
\*\*\*\*\*

Node	Type	Average Depth Feet	Maximum Depth Feet	Maximum HGL Feet	Time of Max Occurrence days hr:min	Reported Max Depth Feet
A1.0	JUNCTION	0.00	0.00	5621.00	0 00:00	0.00
A4.0	JUNCTION	0.00	0.00	5578.00	0 00:00	0.00
A3.0	JUNCTION	0.00	0.00	5580.30	0 00:00	0.00
A2.0	JUNCTION	0.00	0.00	5587.40	0 00:00	0.00
A5.0	JUNCTION	0.00	0.00	5578.00	0 00:00	0.00
A6.0	JUNCTION	0.00	0.00	5590.00	0 00:00	0.00
A7.0	JUNCTION	0.00	0.00	5601.00	0 00:00	0.00
A10.0	JUNCTION	0.00	0.00	5621.00	0 00:00	0.00
A9.0	JUNCTION	0.00	0.00	5601.00	0 00:00	0.00
A8.0	JUNCTION	0.00	0.00	5558.00	0 00:00	0.00
B6.0	JUNCTION	0.00	0.00	5584.40	0 00:00	0.00
B5.0	JUNCTION	0.00	0.00	5572.00	0 00:00	0.00
B4.0	JUNCTION	0.00	0.00	5586.90	0 00:00	0.00
B2.0	JUNCTION	0.00	0.00	5598.40	0 00:00	0.00
B3.0	JUNCTION	0.00	0.00	5586.20	0 00:00	0.00
B1.0	JUNCTION	0.00	0.00	5600.60	0 00:00	0.00
C4.1	JUNCTION	0.00	0.00	5544.90	0 00:00	0.00
C3.0	JUNCTION	0.00	0.00	5556.70	0 00:00	0.00
C2.0	JUNCTION	0.00	0.00	5556.70	0 00:00	0.00
C1.0	JUNCTION	0.00	0.00	5565.10	0 00:00	0.00
C5.0	JUNCTION	0.00	0.00	5544.40	0 00:00	0.00
C8.0	JUNCTION	0.00	0.00	5566.50	0 00:00	0.00
C7.1	JUNCTION	0.00	0.00	5568.00	0 00:00	0.00
Outlet_C8.0	JUNCTION	0.03	0.33	5407.03	0 01:00	0.33
C7.4	JUNCTION	0.00	0.00	5472.00	0 00:00	0.00
D3.0	JUNCTION	0.00	0.00	5503.60	0 00:00	0.00
D2.0	JUNCTION	0.00	0.00	5496.50	0 00:00	0.00
D1.0	JUNCTION	0.00	0.00	5480.00	0 00:00	0.00
D7.0	JUNCTION	0.00	0.00	5478.60	0 00:00	0.00
D4.0	JUNCTION	0.00	0.00	5487.70	0 00:00	0.00
D6.0	JUNCTION	0.00	0.00	5485.20	0 00:00	0.00
D5.0	JUNCTION	0.00	0.00	5488.00	0 00:00	0.00
C8.1	JUNCTION	0.00	0.00	5465.90	0 00:00	0.00
Outlet_C7.7	JUNCTION	0.31	0.61	5369.61	0 03:06	0.61
C7.4.1	JUNCTION	0.16	1.34	5417.94	0 01:23	1.33
O3.0	JUNCTION	0.00	0.00	5716.50	0 00:00	0.00
O4.0	JUNCTION	0.00	0.00	5555.00	0 00:00	0.00
O5.0	JUNCTION	0.00	0.00	5681.10	0 00:00	0.00
O1.0	JUNCTION	0.00	0.00	6147.50	0 00:00	0.00
O2.0	JUNCTION	0.00	0.00	6281.20	0 00:00	0.00
Outlet_A6.0&5.0	JUNCTION	0.07	0.69	5500.59	0 00:45	0.69
Outlet_A7.0	JUNCTION	0.02	0.22	5515.12	0 00:40	0.22
Outlet_A9.0&8.0	JUNCTION	0.01	0.08	5522.98	0 00:35	0.07
Outlet_O2.0	JUNCTION	0.73	2.37	5485.97	0 04:28	2.37
Outlet_A10.0_2	JUNCTION	0.02	0.20	5540.50	0 00:53	0.20
Outlet_O4.0	JUNCTION	0.45	1.27	5423.17	0 04:38	1.27
Outlet_O3.0	JUNCTION	0.09	0.98	5496.18	0 01:00	0.98
Outlet_C1.0.2.0&3.0	JUNCTION	0.02	0.37	5519.37	0 00:35	0.34
C5.0&O3.0	JUNCTION	0.99	3.08	5468.78	0 04:24	3.08
Outlet_C5.0	JUNCTION	0.01	0.21	5502.11	0 00:35	0.19
Outlet_B4.0&5.0	JUNCTION	0.01	0.17	5539.47	0 00:35	0.15
B4.0.5.0&O3.0	JUNCTION	0.49	1.24	5449.04	0 04:39	1.23
Outlet_O5.0	JUNCTION	1.15	2.84	5382.84	0 05:16	2.84
Outlet_B2.0&3.0	JUNCTION	0.01	0.07	5550.07	0 00:35	0.06
Outlet_O1.0	JUNCTION	0.60	1.93	5490.93	0 03:26	1.92
Outlet_A2.0	JUNCTION	0.02	0.50	5533.46	0 00:35	0.44
Outlet_A2.0.B1.0&8.0	JUNCTION	0.04	0.40	5519.59	0 00:55	0.40
B7.0	JUNCTION	0.00	0.00	5572.00	0 00:00	0.00
B8.0	JUNCTION	0.00	0.00	5600.20	0 00:00	0.00
Outlet_B1.0&8.0	JUNCTION	0.01	0.11	5552.29	0 00:40	0.11

01.0&2.0	JUNCTION	1.04	3.26	5474.26	0	04:28	3.25
Outlet_D1.0&D2.0	JUNCTION	1.14	2.85	5389.25	0	05:15	2.85
Outlet_A4.0	JUNCTION	0.01	0.13	5510.93	0	00:35	0.12
Outlet_A10.0_1	JUNCTION	0.00	0.05	5589.65	0	00:35	0.04
C6.0	JUNCTION	0.00	0.00	5585.20	0	00:00	0.00
Outlet_C6.0	JUNCTION	0.65	1.80	5455.80	0	04:28	1.79
02.0&A4.0	JUNCTION	0.98	3.25	5476.25	0	04:33	3.25
Outlet_C7.4	JUNCTION	0.16	1.10	5380.00	0	01:28	1.10
C7.7.1	JUNCTION	0.41	1.08	5373.28	0	01:48	1.08
C7.7	JUNCTION	0.00	0.00	5459.00	0	00:00	0.00
Outlet_C7.1	JUNCTION	0.14	1.45	5419.35	0	00:55	1.44
C7.6	JUNCTION	0.00	0.00	5475.30	0	00:00	0.00
Outlet_C7.6	JUNCTION	0.01	0.19	5382.09	0	00:45	0.19
C7.5	JUNCTION	0.00	0.00	5484.30	0	00:00	0.00
C7.3	JUNCTION	0.00	0.00	5488.00	0	00:00	0.00
C7.2	JUNCTION	0.00	0.00	5493.00	0	00:00	0.00
Outlet_C7.2	JUNCTION	0.02	0.21	5436.61	0	00:45	0.21
Outlet_C7.5	JUNCTION	0.02	0.15	5425.65	0	00:50	0.15
C7.0	JUNCTION	0.00	0.00	5567.50	0	00:00	0.00
Outlet_C7.0	JUNCTION	0.04	0.27	5511.47	0	00:40	0.27
C4.2	JUNCTION	0.00	0.00	5538.50	0	00:00	0.00
C4.0	JUNCTION	0.00	0.00	5586.60	0	00:00	0.00
Outlet_C4.0	JUNCTION	0.01	0.11	5513.61	0	00:40	0.11
A1.1	JUNCTION	0.00	0.00	5575.80	0	00:00	0.00
Outlet_A1.0	JUNCTION	0.03	0.22	5540.32	0	00:45	0.22
Outlet_D3.0	JUNCTION	0.01	0.18	5391.18	0	00:40	0.18
Outlet_D4.0	JUNCTION	0.00	0.10	5426.90	0	00:35	0.09
Outlet_D5.0	JUNCTION	0.00	0.10	5434.30	0	00:35	0.09
Outlet_C8.1	OUTFALL	0.15	0.36	5362.36	0	03:14	0.36
Outlet_D6.0	OUTFALL	0.00	0.00	5459.80	0	00:00	0.00
Outlet_D7.0	OUTFALL	0.00	0.00	5471.10	0	00:00	0.00

\*\*\*\*\*  
Node Inflow Summary  
\*\*\*\*\*

Node	Type	Maximum Lateral Inflow CFS	Maximum Total Inflow CFS	Time of Max Occurrence days hr:min	Lateral Inflow Volume 10^6 gal	Total Inflow Volume 10^6 gal	Flow Balance Error Percent
A1.0	JUNCTION	14.85	14.85	0 00:45	0.492	0.492	0.000
A4.0	JUNCTION	7.22	7.22	0 00:35	0.111	0.111	0.000
A3.0	JUNCTION	5.10	5.10	0 00:40	0.128	0.128	0.000
A2.0	JUNCTION	10.39	10.39	0 00:35	0.157	0.157	0.000
A5.0	JUNCTION	2.81	2.81	0 00:35	0.0616	0.0616	0.000
A6.0	JUNCTION	11.87	11.87	0 00:40	0.317	0.317	0.000
A7.0	JUNCTION	6.14	6.14	0 00:40	0.149	0.149	0.000
A10.0	JUNCTION	1.51	1.51	0 00:35	0.0213	0.0213	0.000
A9.0	JUNCTION	0.86	0.86	0 00:35	0.0198	0.0198	0.000
A8.0	JUNCTION	0.85	0.85	0 00:35	0.0104	0.0104	0.000
B6.0	JUNCTION	15.08	15.08	0 00:35	0.199	0.199	0.000
B5.0	JUNCTION	1.21	1.21	0 00:40	0.0318	0.0318	0.000
B4.0	JUNCTION	8.73	8.73	0 00:35	0.133	0.133	0.000
B2.0	JUNCTION	2.52	2.52	0 00:35	0.0271	0.0271	0.000
B3.0	JUNCTION	1.19	1.19	0 00:35	0.0233	0.0233	0.000
B1.0	JUNCTION	0.38	0.38	0 00:35	0.00853	0.00853	0.000
C4.1	JUNCTION	1.91	1.91	0 00:40	0.0504	0.0504	0.000
C3.0	JUNCTION	3.37	3.37	0 00:35	0.0585	0.0585	0.000
C2.0	JUNCTION	0.93	0.93	0 00:35	0.0192	0.0192	0.000
C1.0	JUNCTION	1.38	1.38	0 00:35	0.0302	0.0302	0.000
C5.0	JUNCTION	4.73	4.73	0 00:35	0.0751	0.0751	0.000
C8.0	JUNCTION	69.31	69.31	0 01:00	2.73	2.73	0.000
C7.1	JUNCTION	39.90	39.90	0 00:55	1.55	1.55	0.000
Outlet_C8.0	JUNCTION	0.00	69.31	0 01:00	0	2.73	0.000
C7.4	JUNCTION	36.88	36.88	0 00:40	0.797	0.797	0.000
D3.0	JUNCTION	9.22	9.22	0 00:40	0.236	0.236	0.000



D2.0	JUNCTION	4.51	4.51	0	00:40	0.126	0.126	0.000
D1.0	JUNCTION	3.16	3.16	0	00:40	0.0874	0.0874	0.000
D7.0	JUNCTION	0.40	0.40	0	00:35	0.00752	0.00752	0.000
D4.0	JUNCTION	4.92	4.92	0	00:35	0.0937	0.0937	0.000
D6.0	JUNCTION	1.43	1.43	0	00:35	0.0229	0.0229	0.000
D5.0	JUNCTION	5.03	5.03	0	00:35	0.0892	0.0892	0.000
C8.1	JUNCTION	42.16	42.16	0	01:00	1.76	1.76	0.000
Outlet_C7.7	JUNCTION	0.00	277.59	0	03:04	0	54.9	0.000
C7.4.1	JUNCTION	0.00	39.87	0	01:22	0	1.97	0.000
O3.0	JUNCTION	100.60	100.60	0	01:00	3.92	3.92	0.000
O4.0	JUNCTION	58.61	58.61	0	01:40	4.4	4.4	0.000
O5.0	JUNCTION	105.71	105.71	0	01:45	7.68	7.68	0.000
O1.0	JUNCTION	87.26	87.26	0	03:40	10.9	10.9	0.000
O2.0	JUNCTION	145.34	145.34	0	04:15	18.1	18.1	0.000
Outlet_A6.0&5.0	JUNCTION	0.00	15.27	0	00:45	0	0.553	0.000
Outlet_A7.0	JUNCTION	0.00	6.23	0	00:40	0	0.177	0.000
Outlet_A9.0&8.0	JUNCTION	0.00	1.70	0	00:35	0	0.0316	0.000
Outlet_O2.0	JUNCTION	0.00	146.79	0	04:28	0	18.7	0.000
Outlet_A10.0_2	JUNCTION	0.00	0.99	0	00:53	0	0.0231	0.000
Outlet_O4.0	JUNCTION	0.00	243.57	0	04:38	0	40.6	0.000
Outlet_O3.0	JUNCTION	0.00	116.19	0	01:00	0	4.39	0.000
Outlet_C1.0.2.0&3.0	JUNCTION	0.00	5.68	0	00:35	0	0.108	0.000
C5.0&03.0	JUNCTION	0.00	230.26	0	04:20	0	35.5	0.000
Outlet_C5.0	JUNCTION	0.00	4.73	0	00:35	0	0.0751	0.000
Outlet_B4.0&5.0	JUNCTION	0.00	9.91	0	00:35	0	0.165	0.000
B4.0.5.0&03.0	JUNCTION	0.00	229.41	0	04:39	0	36.7	0.000
Outlet_O5.0	JUNCTION	0.00	261.13	0	02:23	0	49.6	0.000
Outlet_B2.0&3.0	JUNCTION	0.00	3.72	0	00:35	0	0.0504	0.000
Outlet_O1.0	JUNCTION	0.00	87.64	0	03:26	0	12.2	0.000
Outlet_A2.0	JUNCTION	0.00	10.39	0	00:35	0	0.157	0.000
Outlet_A2.0.B1.0&8.0	JUNCTION	0.00	10.45	0	00:54	0	0.272	0.000
B7.0	JUNCTION	3.14	3.14	0	00:40	0.101	0.101	0.000
B8.0	JUNCTION	3.40	3.40	0	00:40	0.0858	0.0858	0.000
Outlet_B1.0&8.0	JUNCTION	0.00	3.77	0	00:40	0	0.0944	0.000
O1.0&2.0	JUNCTION	0.00	226.06	0	04:17	0	31.1	0.000
Outlet_D1.0&D2.0	JUNCTION	0.00	238.33	0	05:15	0	41.5	0.000
Outlet_A4.0	JUNCTION	0.00	7.22	0	00:35	0	0.111	0.000
Outlet_A10.0_1	JUNCTION	0.00	1.51	0	00:35	0	0.0213	0.000
C6.0	JUNCTION	25.65	25.65	0	00:45	0.79	0.79	0.000
Outlet_C6.0	JUNCTION	0.00	229.96	0	04:28	0	36.4	0.000
O2.0&A4.0	JUNCTION	0.00	146.12	0	04:33	0	18.9	0.000
Outlet_C7.4	JUNCTION	0.00	48.55	0	01:28	0	2.8	0.000
C7.7.1	JUNCTION	0.00	276.26	0	02:47	0	53.3	0.000
C7.7	JUNCTION	38.30	38.30	0	00:50	1.37	1.37	0.000
Outlet_C7.1	JUNCTION	0.00	44.54	0	00:55	0	1.75	0.000
C7.6	JUNCTION	16.36	16.36	0	00:45	0.453	0.453	0.000
Outlet_C7.6	JUNCTION	0.00	16.36	0	00:45	0	0.453	0.000
C7.5	JUNCTION	2.63	2.63	0	00:50	0.132	0.132	0.000
C7.3	JUNCTION	2.19	2.19	0	00:40	0.0597	0.0597	0.000
C7.2	JUNCTION	2.43	2.43	0	00:45	0.101	0.101	0.000
Outlet_C7.2	JUNCTION	0.00	2.43	0	00:45	0	0.101	0.000
Outlet_C7.5	JUNCTION	0.00	2.63	0	00:50	0	0.132	0.000
C7.0	JUNCTION	3.93	3.93	0	00:40	0.112	0.112	0.000
Outlet_C7.0	JUNCTION	0.00	3.93	0	00:40	0	0.112	0.000
C4.2	JUNCTION	0.64	0.64	0	00:40	0.0199	0.0199	0.000
C4.0	JUNCTION	11.56	11.56	0	00:40	0.269	0.269	0.000
Outlet_C4.0	JUNCTION	0.00	11.56	0	00:40	0	0.269	0.000
A1.1	JUNCTION	4.69	4.69	0	00:40	0.117	0.117	0.000
Outlet_A1.0	JUNCTION	0.00	14.85	0	00:45	0	0.492	0.000
Outlet_D3.0	JUNCTION	0.00	9.22	0	00:40	0	0.236	0.000
Outlet_D4.0	JUNCTION	0.00	4.92	0	00:35	0	0.0937	0.000
Outlet_D5.0	JUNCTION	0.00	5.03	0	00:35	0	0.0892	0.000
Outlet_C8.1	OUTFALL	0.00	309.59	0	03:10	0	59.9	0.000
Outlet_D6.0	OUTFALL	0.00	1.43	0	00:35	0	0.0229	0.000
Outlet_D7.0	OUTFALL	0.00	0.40	0	00:35	0	0.00752	0.000

\*\*\*\*\*  
Node Flooding Summary  
\*\*\*\*\*

No nodes were flooded.

\*\*\*\*\*  
Outfall Loading Summary  
\*\*\*\*\*

Outfall Node	Flow Freq Pcmt	Avg Flow CFS	Max Flow CFS	Total Volume 10^6 gal
Outlet_C8.1	99.24	93.44	309.59	59.886
Outlet_D6.0	10.15	0.35	1.43	0.023
Outlet_D7.0	10.67	0.11	0.40	0.008
System	40.02	93.90	309.60	59.916

\*\*\*\*\*  
Link Flow Summary  
\*\*\*\*\*

Link	Type	Maximum  Flow  CFS	Time of Max Occurrence days hr:min	Maximum  Veloc  ft/sec	Max/ Full Flow	Max/ Full Depth
A1.0	DUMMY	14.85	0 00:45			
A3.0	DUMMY	5.10	0 00:40			
A2.0	DUMMY	10.39	0 00:35			
A4.0	DUMMY	7.22	0 00:35			
A5.0	DUMMY	2.81	0 00:35			
A6.0	DUMMY	11.87	0 00:40			
A7.0	DUMMY	6.14	0 00:40			
A9.0	DUMMY	0.86	0 00:35			
A8.0	DUMMY	0.85	0 00:35			
A10.0	DUMMY	1.51	0 00:35			
C7.7Channel1	CONDUIT	276.68	0 03:14	1.52	0.02	0.10
C8.0Channel	CHANNEL	44.18	0 01:53	2.18	0.00	0.01
C8.1	DUMMY	42.16	0 01:00			
C8.0	DUMMY	69.31	0 01:00			
C7.4	DUMMY	36.88	0 00:40			
C5.0	DUMMY	4.73	0 00:35			
C4.1	DUMMY	1.91	0 00:40			
C3.0	DUMMY	3.37	0 00:35			
C2.0	DUMMY	0.93	0 00:35			
C1.0	DUMMY	1.38	0 00:35			
B5.0	DUMMY	1.21	0 00:40			
B4.0	DUMMY	8.73	0 00:35			
B3.0	DUMMY	1.19	0 00:35			
B1.0	DUMMY	0.38	0 00:35			
B2.0	DUMMY	2.52	0 00:35			
B6.0	DUMMY	15.08	0 00:35			
D1.0	DUMMY	3.16	0 00:40			
D2.0	DUMMY	4.51	0 00:40			
D3.0	DUMMY	9.22	0 00:40			
D4.0	DUMMY	4.92	0 00:35			
D5.0	DUMMY	5.03	0 00:35			
D6.0	DUMMY	1.43	0 00:35			
D7.0	DUMMY	0.40	0 00:35			
C7.1&C7.5Channel2	CHANNEL	38.92	0 01:37	2.66	0.00	0.03
C7.1	DUMMY	39.90	0 00:55			
O2.0	DUMMY	145.34	0 04:15			
A10.0Channel2	CHANNEL	0.23	0 01:20	0.30	0.00	0.00

A9.0&8.0Channel	CHANNEL	0.77	0	01:20	0.36	0.00	0.00
A7.0Channel	CHANNEL	4.00	0	01:20	0.94	0.00	0.01
A6.0&5.0Channel	CHANNEL	12.20	0	01:21	2.96	0.00	0.02
O3.0	DUMMY	100.60	0	01:00			
C1.0.2.0&3.0Channel	CHANNEL	4.48	0	00:54	1.96	0.00	0.03
O3.0Channel1	CHANNEL	115.15	0	01:07	4.38	0.01	0.12
C5.0Channel	CHANNEL	3.91	0	00:47	1.84	0.00	0.05
B4.0&5.0Channel	CHANNEL	6.69	0	00:55	2.22	0.00	0.00
O3.0Channel2	CHANNEL	229.96	0	04:28	3.07	0.00	0.05
O4.0	DUMMY	58.61	0	01:40			
O4.0Channel1	CHANNEL	238.33	0	05:15	3.21	0.00	0.04
O5.0	DUMMY	105.71	0	01:45			
B2.0&3.0Channel	CHANNEL	0.47	0	00:56	0.26	0.00	0.00
A2.0Channel	CHANNEL	7.24	0	00:55	1.83	0.00	0.02
A2.0.B1.0&8.0	CHANNEL	7.45	0	01:21	1.41	0.00	0.01
B7.0	DUMMY	3.14	0	00:40			
O1.0	DUMMY	87.26	0	03:40			
B8.0	DUMMY	3.40	0	00:40			
B1.0&8.0Channel	CHANNEL	3.23	0	00:53	1.94	0.00	0.00
O2.0Channel1	CHANNEL	146.09	0	04:33	3.56	0.00	0.08
O1.0Channel	CHANNEL	87.17	0	03:48	3.67	0.00	0.06
O2.0Channel3	CHANNEL	225.85	0	04:24	4.01	0.00	0.11
A4.0Channel	CHANNEL	4.88	0	01:00	1.79	0.00	0.06
A10.0Channel1	CHANNEL	0.99	0	00:53	0.99	0.00	0.01
C6.0	DUMMY	25.65	0	00:45			
O2.0Channel2	CHANNEL	146.52	0	04:28	2.63	0.00	0.17
O3.0Channel3	CHANNEL	229.41	0	04:39	2.11	0.00	0.04
C74&C7.6Channel1	CHANNEL	272.71	0	03:06	1.02	0.02	0.15
C7.1Channel1	CHANNEL	37.58	0	01:23	1.07	0.00	0.06
C7.6	DUMMY	16.36	0	00:45			
C7.4Channel1	CHANNEL	47.25	0	01:48	1.89	0.01	0.31
C7.6Channel1	CHANNEL	11.77	0	01:15	2.99	0.00	0.03
C7.7	DUMMY	38.30	0	00:50			
C7.5	DUMMY	2.63	0	00:50			
C7.2	DUMMY	2.43	0	00:45			
C7.2Channel1	CHANNEL	2.34	0	00:59	1.56	0.00	0.02
C7.3	DUMMY	2.19	0	00:40			
C7.0Channel1	CHANNEL	1.66	0	01:45	1.20	0.00	0.00
C7.0	DUMMY	3.93	0	00:40			
C4.2	DUMMY	0.64	0	00:40			
C4.0Channel1	CHANNEL	9.66	0	00:56	1.15	0.00	0.01
C4.0	DUMMY	11.56	0	00:40			
C7.5Channel1	CHANNEL	2.36	0	01:11	0.92	0.00	0.01
D1.0&D2.0Channel1	CHANNEL	238.08	0	05:16	4.04	0.03	0.22
O5.0Channel1	CHANNEL	254.76	0	05:40	1.27	0.03	0.21
O3.0Channel4	CHANNEL	229.41	0	04:40	6.99	0.00	0.01
A1.1	DUMMY	4.69	0	00:40			
A1.0Channel1	CHANNEL	13.49	0	01:01	2.74	0.00	0.01
D3.0Channel1	CONDUIT	8.54	0	00:51	1.39	0.01	0.06
D4.0Channel1	CONDUIT	3.69	0	00:55	1.33	0.00	0.03
D5.0Channel1	CONDUIT	3.45	0	00:57	1.32	0.00	0.03

\*\*\*\*\*  
 Conduit Surcharge Summary  
 \*\*\*\*\*

No conduits were surcharged.

Analysis begun on: Wed Jul 28 16:08:48 2021  
 Analysis ended on: Wed Jul 28 16:08:49 2021  
 Total elapsed time: 00:00:01

Scenario ID = 100-Year\_Fut\_100yr\_0mi^2\_PikeSolar

\*\*\*\*\*  
NOTE: The summary statistics displayed in this report are based on results found at every computational time step, not just on results from each reporting time step.  
\*\*\*\*\*

\*\*\*\*\*

Analysis Options

\*\*\*\*\*

Flow Units ..... CFS  
Process Models:  
  Rainfall/Runoff ..... NO  
  RDII ..... NO  
  Snowmelt ..... NO  
  Groundwater ..... NO  
  Flow Routing ..... YES  
  Ponding Allowed ..... NO  
  Water Quality ..... NO  
Flow Routing Method ..... KINWAVE  
Starting Date ..... 01/01/2005 00:00:00  
Ending Date ..... 01/01/2005 23:59:00  
Antecedent Dry Days ..... 0.0  
Report Time Step ..... 00:15:00  
Routing Time Step ..... 30.00 sec

\*\*\*\*\*

	Volume	Volume
	acre-feet	10 <sup>6</sup> gal
*****	-----	-----
Dry Weather Inflow .....	0.000	0.000
Wet Weather Inflow .....	0.000	0.000
Groundwater Inflow .....	0.000	0.000
RDII Inflow .....	0.000	0.000
External Inflow .....	3077.908	1002.982
External Outflow .....	3104.233	1011.561
Flooding Loss .....	0.000	0.000
Evaporation Loss .....	0.000	0.000
Exfiltration Loss .....	0.000	0.000
Initial Stored Volume ....	0.000	0.000
Final Stored Volume .....	0.728	0.237
Continuity Error (%) .....	-0.879	

\*\*\*\*\*

Highest Flow Instability Indexes

\*\*\*\*\*

Link 03.0Channel3 (1)  
Link 02.0Channel3 (1)  
Link 03.0Channel2 (1)  
Link 05.0Channel1 (1)

\*\*\*\*\*

Routing Time Step Summary

\*\*\*\*\*

Minimum Time Step : 29.00 sec  
Average Time Step : 30.00 sec  
Maximum Time Step : 30.00 sec  
Percent in Steady State : 0.00  
Average Iterations per Step : 1.00  
Percent Not Converging : 0.00

\*\*\*\*\*  
Node Depth Summary  
\*\*\*\*\*

Node	Type	Average Depth Feet	Maximum Depth Feet	Maximum HGL Feet	Time of Max Occurrence days hr:min	Reported Max Depth Feet
A1.0	JUNCTION	0.00	0.00	5621.00	0 00:00	0.00
A4.0	JUNCTION	0.00	0.00	5578.00	0 00:00	0.00
A3.0	JUNCTION	0.00	0.00	5580.30	0 00:00	0.00
A2.0	JUNCTION	0.00	0.00	5587.40	0 00:00	0.00
A5.0	JUNCTION	0.00	0.00	5578.00	0 00:00	0.00
A6.0	JUNCTION	0.00	0.00	5590.00	0 00:00	0.00
A7.0	JUNCTION	0.00	0.00	5601.00	0 00:00	0.00
A10.0	JUNCTION	0.00	0.00	5621.00	0 00:00	0.00
A9.0	JUNCTION	0.00	0.00	5601.00	0 00:00	0.00
A8.0	JUNCTION	0.00	0.00	5558.00	0 00:00	0.00
B6.0	JUNCTION	0.00	0.00	5584.40	0 00:00	0.00
B5.0	JUNCTION	0.00	0.00	5572.00	0 00:00	0.00
B4.0	JUNCTION	0.00	0.00	5586.90	0 00:00	0.00
B2.0	JUNCTION	0.00	0.00	5598.40	0 00:00	0.00
B3.0	JUNCTION	0.00	0.00	5586.20	0 00:00	0.00
B1.0	JUNCTION	0.00	0.00	5600.60	0 00:00	0.00
C4.1	JUNCTION	0.00	0.00	5544.90	0 00:00	0.00
C3.0	JUNCTION	0.00	0.00	5556.70	0 00:00	0.00
C2.0	JUNCTION	0.00	0.00	5556.70	0 00:00	0.00
C1.0	JUNCTION	0.00	0.00	5565.10	0 00:00	0.00
C5.0	JUNCTION	0.00	0.00	5544.40	0 00:00	0.00
C8.0	JUNCTION	0.00	0.00	5566.50	0 00:00	0.00
C7.1	JUNCTION	0.00	0.00	5568.00	0 00:00	0.00
Outlet_C8.0	JUNCTION	0.10	0.94	5407.64	0 01:05	0.93
C7.4	JUNCTION	0.00	0.00	5472.00	0 00:00	0.00
D3.0	JUNCTION	0.00	0.00	5503.60	0 00:00	0.00
D2.0	JUNCTION	0.00	0.00	5496.50	0 00:00	0.00
D1.0	JUNCTION	0.00	0.00	5480.00	0 00:00	0.00
D7.0	JUNCTION	0.00	0.00	5478.60	0 00:00	0.00
D4.0	JUNCTION	0.00	0.00	5487.70	0 00:00	0.00
D6.0	JUNCTION	0.00	0.00	5485.20	0 00:00	0.00
D5.0	JUNCTION	0.00	0.00	5488.00	0 00:00	0.00
C8.1	JUNCTION	0.00	0.00	5465.90	0 00:00	0.00
Outlet_C7.7	JUNCTION	1.01	2.57	5371.57	0 05:44	2.57
C7.4.1	JUNCTION	0.41	3.00	5419.60	0 01:28	3.00
O3.0	JUNCTION	0.00	0.00	5716.50	0 00:00	0.00
O4.0	JUNCTION	0.00	0.00	5555.00	0 00:00	0.00
O5.0	JUNCTION	0.00	0.00	5681.10	0 00:00	0.00
O1.0	JUNCTION	0.00	0.00	6147.50	0 00:00	0.00
O2.0	JUNCTION	0.00	0.00	6281.20	0 00:00	0.00
Outlet_A6.0&5.0	JUNCTION	0.20	1.95	5501.85	0 01:03	1.95
Outlet_A7.0	JUNCTION	0.08	0.93	5515.83	0 01:05	0.92
Outlet_A9.0&8.0	JUNCTION	0.04	0.59	5523.49	0 01:14	0.59
Outlet_O2.0	JUNCTION	3.19	9.83	5493.43	0 04:20	9.82
Outlet_A10.0_2	JUNCTION	0.04	0.69	5540.99	0 00:47	0.69
Outlet_O4.0	JUNCTION	2.24	7.54	5429.44	0 04:27	7.54
Outlet_O3.0	JUNCTION	0.30	3.10	5498.30	0 01:06	3.04
Outlet_C1.0.2.0&3.0	JUNCTION	0.06	1.15	5520.15	0 00:40	1.14
C5.0&O3.0	JUNCTION	3.15	7.31	5473.01	0 04:20	7.29
Outlet_C5.0	JUNCTION	0.03	0.55	5502.45	0 00:40	0.54
Outlet_B4.0&5.0	JUNCTION	0.03	0.53	5539.83	0 00:40	0.52
B4.0.5.0&O3.0	JUNCTION	2.07	6.54	5454.34	0 04:27	6.54
Outlet_O5.0	JUNCTION	4.38	11.49	5391.49	0 05:34	11.32
Outlet_B2.0&3.0	JUNCTION	0.01	0.26	5550.26	0 00:35	0.24
Outlet_O1.0	JUNCTION	2.74	9.15	5498.15	0 03:40	9.15
Outlet_A2.0	JUNCTION	0.06	1.39	5534.35	0 00:40	1.35
Outlet_A2.0.B1.0&8.0	JUNCTION	0.08	1.32	5520.51	0 00:52	1.27
B7.0	JUNCTION	0.00	0.00	5572.00	0 00:00	0.00
B8.0	JUNCTION	0.00	0.00	5600.20	0 00:00	0.00

Outlet_B1.0&8.0	JUNCTION	0.02	0.34	5552.52	0	00:45	0.34
01.0&2.0	JUNCTION	3.92	10.50	5481.50	0	04:30	10.50
Outlet_D1.0&D2.0	JUNCTION	4.37	11.49	5397.89	0	05:32	11.46
Outlet_A4.0	JUNCTION	0.01	0.24	5511.04	0	00:40	0.24
Outlet_A10.0_1	JUNCTION	0.01	0.21	5589.81	0	00:40	0.21
C6.0	JUNCTION	0.00	0.00	5585.20	0	00:00	0.00
Outlet_C6.0	JUNCTION	2.58	7.30	5461.30	0	04:24	7.29
02.0&A4.0	JUNCTION	3.85	10.50	5483.50	0	04:27	10.50
Outlet_C7.4	JUNCTION	0.33	1.98	5380.88	0	01:22	1.96
C7.7.1	JUNCTION	1.14	2.73	5374.93	0	05:40	2.71
C7.7	JUNCTION	0.00	0.00	5459.00	0	00:00	0.00
Outlet_C7.1	JUNCTION	0.37	3.06	5420.96	0	01:05	3.05
C7.6	JUNCTION	0.00	0.00	5475.30	0	00:00	0.00
Outlet_C7.6	JUNCTION	0.03	0.43	5382.33	0	00:50	0.42
C7.5	JUNCTION	0.00	0.00	5484.30	0	00:00	0.00
C7.3	JUNCTION	0.00	0.00	5488.00	0	00:00	0.00
C7.2	JUNCTION	0.00	0.00	5493.00	0	00:00	0.00
Outlet_C7.2	JUNCTION	0.06	0.52	5436.92	0	00:55	0.51
Outlet_C7.5	JUNCTION	0.05	0.43	5425.93	0	01:00	0.43
C7.0	JUNCTION	0.00	0.00	5567.50	0	00:00	0.00
Outlet_C7.0	JUNCTION	0.06	0.58	5511.78	0	00:45	0.58
C4.2	JUNCTION	0.00	0.00	5538.50	0	00:00	0.00
C4.0	JUNCTION	0.00	0.00	5586.60	0	00:00	0.00
Outlet_C4.0	JUNCTION	0.02	0.37	5513.87	0	00:45	0.37
A1.1	JUNCTION	0.00	0.00	5575.80	0	00:00	0.00
Outlet_A1.0	JUNCTION	0.08	0.91	5541.01	0	00:55	0.90
Outlet_D3.0	JUNCTION	0.05	0.77	5391.77	0	00:50	0.76
Outlet_D4.0	JUNCTION	0.02	0.44	5427.24	0	00:40	0.44
Outlet_D5.0	JUNCTION	0.02	0.40	5434.60	0	00:40	0.39
Outlet_C8.1	OUTFALL	0.77	2.20	5364.20	0	05:48	2.19
Outlet_D6.0	OUTFALL	0.00	0.00	5459.80	0	00:00	0.00
Outlet_D7.0	OUTFALL	0.00	0.00	5471.10	0	00:00	0.00

\*\*\*\*\*  
Node Inflow Summary  
\*\*\*\*\*

Node	Type	Maximum Lateral Inflow CFS	Maximum Total Inflow CFS	Time of Max Occurrence days hr:min	Lateral Inflow Volume 10^6 gal	Total Inflow Volume 10^6 gal	Flow Balance Error Percent
A1.0	JUNCTION	174.18	174.18	0 00:55	6.53	6.53	0.000
A4.0	JUNCTION	54.85	54.85	0 00:40	1.14	1.14	0.000
A3.0	JUNCTION	40.78	40.78	0 00:45	1.24	1.24	0.000
A2.0	JUNCTION	73.02	73.02	0 00:40	1.48	1.48	0.000
A5.0	JUNCTION	32.70	32.70	0 00:40	0.858	0.858	0.000
A6.0	JUNCTION	102.99	102.99	0 00:50	3.29	3.29	0.000
A7.0	JUNCTION	55.86	55.86	0 00:45	1.63	1.63	0.000
A10.0	JUNCTION	20.68	20.68	0 00:40	0.405	0.405	0.000
A9.0	JUNCTION	14.41	14.41	0 00:45	0.418	0.418	0.000
A8.0	JUNCTION	12.94	12.94	0 00:35	0.219	0.219	0.000
B6.0	JUNCTION	114.05	114.05	0 00:35	2.01	2.01	0.000
B5.0	JUNCTION	9.56	9.56	0 00:45	0.305	0.305	0.000
B4.0	JUNCTION	60.56	60.56	0 00:40	1.23	1.23	0.000
B2.0	JUNCTION	39.20	39.20	0 00:35	0.57	0.57	0.000
B3.0	JUNCTION	13.22	13.22	0 00:40	0.337	0.337	0.000
B1.0	JUNCTION	3.97	3.97	0 00:45	0.115	0.115	0.000
C4.1	JUNCTION	15.10	15.10	0 00:45	0.485	0.485	0.000
C3.0	JUNCTION	25.17	25.17	0 00:40	0.576	0.576	0.000
C2.0	JUNCTION	7.19	7.19	0 00:40	0.189	0.189	0.000
C1.0	JUNCTION	10.76	10.76	0 00:40	0.297	0.297	0.000
C5.0	JUNCTION	34.07	34.07	0 00:40	0.725	0.725	0.000
C8.0	JUNCTION	587.18	587.18	0 01:05	25.1	25.1	0.000
C7.1	JUNCTION	336.65	336.65	0 01:05	14.4	14.4	0.000
Outlet_C8.0	JUNCTION	0.00	587.18	0 01:05	0	25.1	0.000
C7.4	JUNCTION	286.64	286.64	0 00:45	7.66	7.66	0.000

D3.0	JUNCTION	109.60	109.60	0	00:50	3.38	3.38	0.000
D2.0	JUNCTION	60.41	60.41	0	00:50	2.01	2.01	0.000
D1.0	JUNCTION	44.37	44.37	0	00:50	1.45	1.45	0.000
D7.0	JUNCTION	4.32	4.32	0	00:40	0.0989	0.0989	0.000
D4.0	JUNCTION	61.89	61.89	0	00:40	1.49	1.49	0.000
D6.0	JUNCTION	22.07	22.07	0	00:40	0.483	0.483	0.000
D5.0	JUNCTION	51.33	51.33	0	00:40	1.15	1.15	0.000
C8.1	JUNCTION	388.82	388.82	0	01:05	17.6	17.6	0.000
Outlet_C7.7	JUNCTION	0.00	6010.16	0	05:44	0	966	0.000
C7.4.1	JUNCTION	0.00	372.83	0	01:28	0	18.5	0.000
O3.0	JUNCTION	990.25	990.25	0	01:10	42	42	0.000
O4.0	JUNCTION	639.26	639.26	0	01:45	48.9	48.9	0.000
O5.0	JUNCTION	1099.01	1099.01	0	01:55	81.5	81.5	0.000
O1.0	JUNCTION	1857.91	1857.91	0	03:45	233	233	0.000
O2.0	JUNCTION	3741.77	3741.77	0	04:20	465	465	0.000
Outlet_A6.0&5.0	JUNCTION	0.00	186.17	0	01:03	0	6.99	0.000
Outlet_A7.0	JUNCTION	0.00	75.25	0	01:05	0	2.77	0.000
Outlet_A9.0&8.0	JUNCTION	0.00	32.45	0	01:05	0	1.07	-0.000
Outlet_O2.0	JUNCTION	0.00	3745.53	0	04:20	0	473	0.000
Outlet_A10.0_2	JUNCTION	0.00	19.74	0	00:47	0	0.415	0.000
Outlet_O4.0	JUNCTION	0.00	5764.65	0	04:27	0	827	0.000
Outlet_O3.0	JUNCTION	0.00	1118.14	0	01:06	0	46.3	0.000
Outlet_C1.0.2.0&3.0	JUNCTION	0.00	43.12	0	00:40	0	1.06	0.000
C5.0&03.0	JUNCTION	0.00	5578.73	0	04:20	0	768	0.000
Outlet_C5.0	JUNCTION	0.00	34.07	0	00:40	0	0.725	0.000
Outlet_B4.0&5.0	JUNCTION	0.00	69.84	0	00:40	0	1.54	0.000
B4.0.5.0&03.0	JUNCTION	0.00	5572.90	0	04:27	0	777	0.000
Outlet_O5.0	JUNCTION	0.00	6096.06	0	05:34	0	921	0.000
Outlet_B2.0&3.0	JUNCTION	0.00	51.46	0	00:35	0	0.906	0.000
Outlet_O1.0	JUNCTION	0.00	1869.38	0	03:40	0	247	0.000
Outlet_A2.0	JUNCTION	0.00	73.02	0	00:40	0	1.48	0.000
Outlet_A2.0.B1.0&8.0	JUNCTION	0.00	95.90	0	00:51	0	2.45	0.000
B7.0	JUNCTION	23.92	23.92	0	00:50	0.881	0.881	0.000
B8.0	JUNCTION	26.10	26.10	0	00:45	0.791	0.791	0.000
Outlet_B1.0&8.0	JUNCTION	0.00	30.07	0	00:45	0	0.906	0.000
O1.0&2.0	JUNCTION	0.00	5538.72	0	04:18	0	721	0.000
Outlet_D1.0&D2.0	JUNCTION	0.00	5914.01	0	05:32	0	833	0.000
Outlet_A4.0	JUNCTION	0.00	54.85	0	00:40	0	1.14	0.000
Outlet_A10.0_1	JUNCTION	0.00	20.68	0	00:40	0	0.405	0.000
C6.0	JUNCTION	207.60	207.60	0	00:55	7.39	7.39	0.000
Outlet_C6.0	JUNCTION	0.00	5574.66	0	04:24	0	776	-0.000
O2.0&A4.0	JUNCTION	0.00	3741.88	0	04:27	0	474	0.000
Outlet_C7.4	JUNCTION	0.00	507.25	0	01:22	0	26.2	0.000
C7.7.1	JUNCTION	0.00	6044.35	0	05:40	0	953	0.000
C7.7	JUNCTION	321.39	321.39	0	01:00	12.8	12.8	0.000
Outlet_C7.1	JUNCTION	0.00	390.67	0	01:05	0	16.9	0.000
C7.6	JUNCTION	133.11	133.11	0	00:50	4.38	4.38	0.000
Outlet_C7.6	JUNCTION	0.00	133.11	0	00:50	0	4.38	0.000
C7.5	JUNCTION	17.73	17.73	0	01:00	0.91	0.91	0.000
C7.3	JUNCTION	17.70	17.70	0	00:45	0.588	0.588	0.000
C7.2	JUNCTION	20.44	20.44	0	00:55	0.944	0.944	0.000
Outlet_C7.2	JUNCTION	0.00	20.44	0	00:55	0	0.944	0.000
Outlet_C7.5	JUNCTION	0.00	17.73	0	01:00	0	0.91	0.000
C7.0	JUNCTION	29.62	29.62	0	00:45	0.999	0.999	0.000
Outlet_C7.0	JUNCTION	0.00	29.62	0	00:45	0	0.999	0.000
C4.2	JUNCTION	4.43	4.43	0	00:45	0.155	0.155	0.000
C4.0	JUNCTION	89.58	89.58	0	00:45	2.57	2.57	0.000
Outlet_C4.0	JUNCTION	0.00	89.58	0	00:45	0	2.57	0.000
A1.1	JUNCTION	36.01	36.01	0	00:45	1.09	1.09	0.000
Outlet_A1.0	JUNCTION	0.00	174.18	0	00:55	0	6.53	0.000
Outlet_D3.0	JUNCTION	0.00	109.60	0	00:50	0	3.38	0.000
Outlet_D4.0	JUNCTION	0.00	61.89	0	00:40	0	1.49	0.000
Outlet_D5.0	JUNCTION	0.00	51.33	0	00:40	0	1.15	0.000
Outlet_C8.1	OUTFALL	0.00	6013.08	0	05:48	0	1.01e+03	0.000
Outlet_D6.0	OUTFALL	0.00	22.07	0	00:40	0	0.483	0.000
Outlet_D7.0	OUTFALL	0.00	4.32	0	00:40	0	0.0989	0.000

\*\*\*\*\*

Node Flooding Summary  
 \*\*\*\*\*

No nodes were flooded.

\*\*\*\*\*  
 Outfall Loading Summary  
 \*\*\*\*\*

Outfall Node	Flow Freq Pcnt	Avg Flow CFS	Max Flow CFS	Total Volume 10^6 gal
Outlet_C8.1	99.27	1576.80	6013.08	1010.903
Outlet_D6.0	12.44	6.02	22.07	0.483
Outlet_D7.0	12.44	1.23	4.32	0.099
System	41.38	1584.05	6013.08	1011.486

\*\*\*\*\*  
 Link Flow Summary  
 \*\*\*\*\*

Link	Type	Maximum  Flow  CFS	Time of Max Occurrence days hr:min	Maximum  Veloc  ft/sec	Max/ Full Flow	Max/ Full Depth
A1.0	DUMMY	174.18	0 00:55			
A3.0	DUMMY	40.78	0 00:45			
A2.0	DUMMY	73.02	0 00:40			
A4.0	DUMMY	54.85	0 00:40			
A5.0	DUMMY	32.70	0 00:40			
A6.0	DUMMY	102.99	0 00:50			
A7.0	DUMMY	55.86	0 00:45			
A9.0	DUMMY	14.41	0 00:45			
A8.0	DUMMY	12.94	0 00:35			
A10.0	DUMMY	20.68	0 00:40			
C7.7Channel1	CONDUIT	6000.84	0 05:48	4.75	0.44	0.63
C8.0Channel	CHANNEL	493.38	0 01:39	3.16	0.00	0.03
C8.1	DUMMY	388.82	0 01:05			
C8.0	DUMMY	587.18	0 01:05			
C7.4	DUMMY	286.64	0 00:45			
C5.0	DUMMY	34.07	0 00:40			
C4.1	DUMMY	15.10	0 00:45			
C3.0	DUMMY	25.17	0 00:40			
C2.0	DUMMY	7.19	0 00:40			
C1.0	DUMMY	10.76	0 00:40			
B5.0	DUMMY	9.56	0 00:45			
B4.0	DUMMY	60.56	0 00:40			
B3.0	DUMMY	13.22	0 00:40			
B1.0	DUMMY	3.97	0 00:45			
B2.0	DUMMY	39.20	0 00:35			
B6.0	DUMMY	114.05	0 00:35			
D1.0	DUMMY	44.37	0 00:50			
D2.0	DUMMY	60.41	0 00:50			
D3.0	DUMMY	109.60	0 00:50			
D4.0	DUMMY	61.89	0 00:40			
D5.0	DUMMY	51.33	0 00:40			
D6.0	DUMMY	22.07	0 00:40			
D7.0	DUMMY	4.32	0 00:40			
C7.1&C7.5Channe12	CHANNEL	371.57	0 01:34	5.93	0.00	0.11
C7.1	DUMMY	336.65	0 01:05			
O2.0	DUMMY	3741.77	0 04:20			
A10.0Channel12	CHANNEL	14.95	0 01:14	2.15	0.00	0.02
A9.0&8.0Channel	CHANNEL	31.24	0 01:15	1.32	0.00	0.02



A7.0Channel	CHANNEL	73.72	0	01:16	2.70	0.00	0.03
A6.0&5.0Channel	CHANNEL	180.97	0	01:16	3.41	0.00	0.06
03.0	DUMMY	990.25	0	01:10			
C1.0.2.0&3.0Channel	CHANNEL	40.92	0	00:53	3.73	0.00	0.10
03.0Channel1	CHANNEL	1118.43	0	01:11	9.12	0.08	0.39
C5.0Channel	CHANNEL	33.06	0	00:46	3.42	0.00	0.15
B4.0&5.0Channel	CHANNEL	65.02	0	00:50	4.35	0.00	0.02
03.0Channel2	CHANNEL	5574.63	0	04:24	7.86	0.01	0.22
04.0	DUMMY	639.26	0	01:45			
04.0Channel1	CHANNEL	5914.01	0	05:32	8.08	0.01	0.25
05.0	DUMMY	1099.01	0	01:55			
B2.0&3.0Channel	CHANNEL	29.60	0	01:20	3.09	0.00	0.00
A2.0Channel	CHANNEL	66.22	0	00:52	3.16	0.00	0.05
A2.0.B1.0&8.0	CHANNEL	88.06	0	01:05	3.49	0.00	0.02
B7.0	DUMMY	23.92	0	00:50			
01.0	DUMMY	1857.91	0	03:45			
B8.0	DUMMY	26.10	0	00:45			
B1.0&8.0Channel	CHANNEL	29.70	0	00:51	3.35	0.00	0.01
02.0Channel1	CHANNEL	3741.80	0	04:27	6.47	0.01	0.34
01.0Channel	CHANNEL	1867.22	0	04:11	7.71	0.00	0.26
02.0Channel3	CHANNEL	5536.99	0	04:21	5.43	0.02	0.26
A4.0Channel	CHANNEL	46.19	0	00:58	2.34	0.01	0.14
A10.0Channel1	CHANNEL	19.74	0	00:47	2.57	0.00	0.03
C6.0	DUMMY	207.60	0	00:55			
02.0Channel2	CHANNEL	3740.99	0	04:30	4.99	0.08	0.54
03.0Channel3	CHANNEL	5572.90	0	04:27	6.33	0.02	0.19
C74&C7.6Channel1	CHANNEL	6010.16	0	05:44	2.88	0.38	0.64
C7.1Channel1	CHANNEL	357.12	0	01:28	1.52	0.00	0.14
C7.6	DUMMY	133.11	0	00:50			
C7.4Channel1	CHANNEL	500.87	0	01:31	2.23	0.12	0.57
C7.6Channel1	CHANNEL	122.22	0	01:09	2.99	0.00	0.08
C7.7	DUMMY	321.39	0	01:00			
C7.5	DUMMY	17.73	0	01:00			
C7.2	DUMMY	20.44	0	00:55			
C7.2Channel1	CHANNEL	20.28	0	01:06	2.27	0.00	0.04
C7.3	DUMMY	17.70	0	00:45			
C7.0Channel1	CHANNEL	23.42	0	01:24	3.49	0.00	0.01
C7.0	DUMMY	29.62	0	00:45			
C4.2	DUMMY	4.43	0	00:45			
C4.0Channel1	CHANNEL	86.99	0	00:53	2.29	0.00	0.05
C4.0	DUMMY	89.58	0	00:45			
C7.5Channel1	CHANNEL	17.64	0	01:09	1.87	0.00	0.03
D1.0&D2.0Channel1	CHANNEL	5911.14	0	05:34	10.65	0.78	0.88
05.0Channel1	CHANNEL	6037.12	0	05:40	3.63	0.61	0.80
03.0Channel14	CHANNEL	5572.88	0	04:28	16.60	0.00	0.05
A1.1	DUMMY	36.01	0	00:45			
A1.0Channel1	CHANNEL	172.15	0	01:01	5.05	0.00	0.02
D3.0Channel1	CONDUIT	109.49	0	00:52	3.37	0.08	0.25
D4.0Channel1	CONDUIT	59.67	0	00:50	3.58	0.03	0.14
D5.0Channel1	CONDUIT	48.03	0	00:51	3.30	0.02	0.13

\*\*\*\*\*  
Conduit Surcharge Summary  
\*\*\*\*\*

No conduits were surcharged.

Analysis begun on: Wed Jul 28 16:09:49 2021  
Analysis ended on: Wed Jul 28 16:09:50 2021  
Total elapsed time: 00:00:01

### Existing & Proposed Hydrology Comparison Table

Subbasin ID	Corresponding SWMM Node	Existing Condition		Proposed Condition		Difference (Proposed - Existing)			
		5-Year	100-Year	5-Year	100-Year	5-Year (cfs)	5-Year (%)	100-Year (cfs)	100-Year (%)
A1.0	Outlet_A1.0	13.79	173.24	14.85	174.18	1.06	7.7%	0.94	0.5%
A1.1	A1.1	4.40	35.74	4.69	36.01	0.29	6.6%	0.27	0.8%
A2.0	Outlet_A2.0	10.01	72.71	10.39	73.02	0.38	3.8%	0.31	0.4%
A3.0	A3.0	4.70	40.40	5.10	40.78	0.40	8.5%	0.38	0.9%
A4.0	Outlet_A4.0	7.06	54.72	7.22	54.85	0.16	2.3%	0.13	0.2%
A5.0	A5.0	2.15	32.00	2.81	32.70	0.66	30.7%	0.70	2.2%
A6.0	A6.0	11.40	102.64	11.87	102.99	0.47	4.1%	0.35	0.3%
A7.0	A7.0	5.43	55.20	6.14	55.86	0.71	13.1%	0.66	1.2%
A8.0	A8.0	0.85	12.94	0.85	12.94	0.00	0.0%	0.00	0.0%
A9.0	A9.0	0.86	14.41	0.86	14.41	0.00	0.0%	0.00	0.0%
A10.0	Outlet_A10.0 1	1.51	20.68	1.51	20.68	0.00	0.0%	0.00	0.0%
B1.0, B8.0	Outlet_B1.0&8.0	3.50	29.81	3.77	30.07	0.27	7.7%	0.26	0.9%
B2.0, B3.0	Outlet_B2.0&3.0	3.72	51.46	3.72	51.46	0.00	0.0%	0.00	0.0%
B4.0, B5.0	Outlet_B4.0&5.0	9.50	69.50	9.91	69.84	0.41	4.3%	0.34	0.5%
B6.0	B6.0	14.49	113.48	15.08	114.05	0.59	4.1%	0.57	0.5%
B7.0	B7.0	2.83	23.62	3.14	23.92	0.31	11.0%	0.30	1.3%
C1.0, C2.0, & C3.0	Outlet_C1.0.2.0&3.0	5.68	43.12	5.68	43.12	0.00	0.0%	0.00	0.0%
C4.0	Outlet_C4.0	11.28	89.36	11.56	89.58	0.28	2.5%	0.22	0.2%
C4.1	C4.1	1.87	15.07	1.91	15.10	0.04	2.1%	0.03	0.2%
C4.2	C4.2	0.53	4.30	0.64	4.43	0.11	20.8%	0.13	3.0%
C5.0	Outlet_C5.0	4.73	34.07	4.73	34.07	0.00	0.0%	0.00	0.0%
C6.0	C6.0	25.19	207.27	25.65	207.60	0.46	1.8%	0.33	0.2%
C7.0	Outlet_C7.0	3.61	29.29	3.93	29.62	0.32	8.9%	0.33	1.1%
C7.1	C7.1	39.54	336.41	39.90	336.65	0.36	0.9%	0.24	0.1%
C7.2	Outlet_C7.2	2.33	20.34	2.43	20.44	0.10	4.3%	0.10	0.5%
C7.3	C7.3	2.19	17.70	2.19	17.70	0.00	0.0%	0.00	0.0%
C7.4	C7.4	36.14	286.03	36.88	286.64	0.74	2.0%	0.61	0.2%
C7.5	Outlet_C7.5	2.43	17.46	2.63	17.73	0.20	8.2%	0.27	1.5%
C7.6	Outlet_C7.6	16.12	132.91	16.36	133.11	0.24	1.5%	0.20	0.2%
C7.7	C7.7	36.38	319.90	38.30	321.39	1.92	5.3%	1.49	0.5%
C8.0	Outlet_C8.0	67.57	585.56	69.31	587.18	1.74	2.6%	1.62	0.3%
C8.1	C8.1	42.06	388.72	42.16	388.82	0.10	0.2%	0.10	0.0%
D1.0	D1.0	2.84	44.10	3.16	44.37	0.32	11.3%	0.27	0.6%
D2.0	D2.0	4.29	60.22	4.51	60.41	0.22	5.1%	0.19	0.3%
D3.0	Outlet_D3.0	8.50	109.06	9.22	109.60	0.72	8.5%	0.54	0.5%
D4.0	Outlet_D4.0	4.60	61.59	4.92	61.89	0.32	7.0%	0.30	0.5%
D5.0	Outlet_D5.0	4.29	50.71	5.03	51.33	0.74	17.2%	0.62	1.2%
D6.0	Outlet_D6.0	1.43	22.07	1.43	22.07	0.00	0.0%	0.00	0.0%
D7.0	Outlet_D7.0	0.27	4.20	0.40	4.32	0.13	48.1%	0.12	2.9%
O1.0	O1.0	87.21	1857.86	87.26	1857.91	0.05	0.1%	0.05	0.0%
O2.0	O2.0	145.11	3741.45	145.34	3741.77	0.23	0.2%	0.32	0.0%
O3.0	O3.0	99.11	989.85	100.60	990.25	1.49	1.5%	0.40	0.0%
O4.0	O4.0	58.36	639.02	58.61	639.26	0.25	0.4%	0.24	0.0%
O5.0	O5.0	105.56	1098.89	105.71	1099.01	0.15	0.1%	0.12	0.0%
All (Except D6.0-7.0)	Outlet_C8.1	300.62	6013.05	309.59	6013.08	8.97	3.0%	0.03	0.0%

**APPENDIX C**  
**HYDRAULIC CALCULATIONS**

DRAINAGE DITCH CAPACITY CALCULATIONS  
CULVERT CAPACITY CALCULATIONS  
RUNOFF REDUCTION CALCULATIONS

# Channel Report

## Channel #1 (Channel before Area 3 - Crossing 1)

### Trapezoidal

Bottom Width (ft) = 10.00  
Side Slopes (z:1) = 10.00, 14.00  
Total Depth (ft) = 2.00  
Invert Elev (ft) = 5515.00  
Slope (%) = 2.32  
N-Value = 0.030

### Highlighted

Depth (ft) = 0.86  
Q (cfs) = 89.60  
Area (sqft) = 17.48  
Velocity (ft/s) = 5.13  
Wetted Perim (ft) = 30.71  
Crit Depth, Yc (ft) = 0.95  
Top Width (ft) = 30.64  
EGL (ft) = 1.27

### Calculations

Compute by: Known Q  
Known Q (cfs) = 89.60

Check dams will be used  
for erosive velocity.

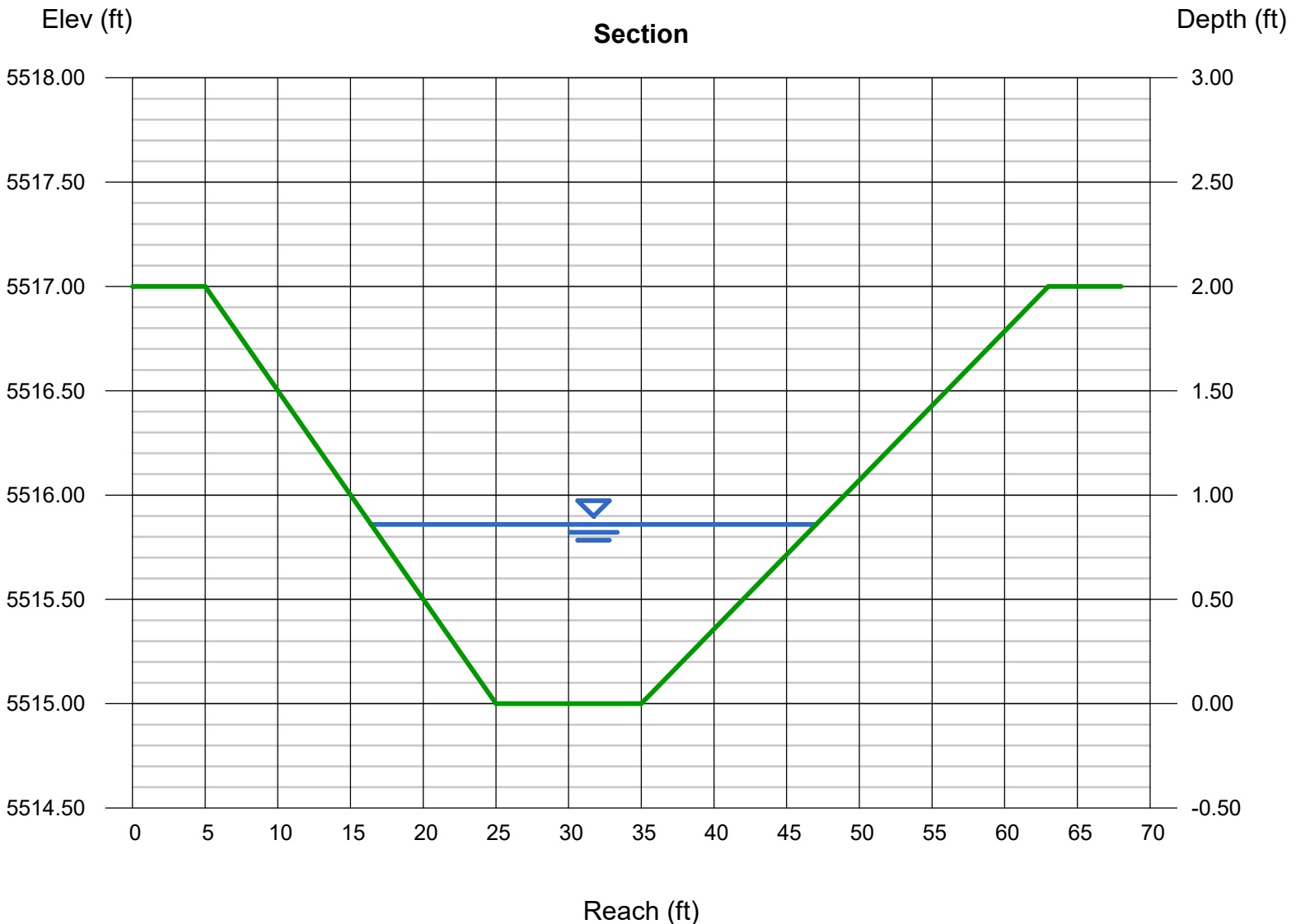

# Channel Report

## Channel #2 (Before Area 7 - Crossing 1)

### Trapezoidal

Bottom Width (ft) = 12.00  
Side Slopes (z:1) = 4.00, 8.00  
Total Depth (ft) = 2.00  
Invert Elev (ft) = 5425.50  
Slope (%) = 1.00  
N-Value = 0.030

### Highlighted

Depth (ft) = 0.46  
Q (cfs) = 17.70  
Area (sqft) = 6.79  
Velocity (ft/s) = 2.61  
Wetted Perim (ft) = 17.61  
Crit Depth, Yc (ft) = 0.39  
Top Width (ft) = 17.52  
EGL (ft) = 0.57

### Calculations

Compute by: Known Q  
Known Q (cfs) = 17.70

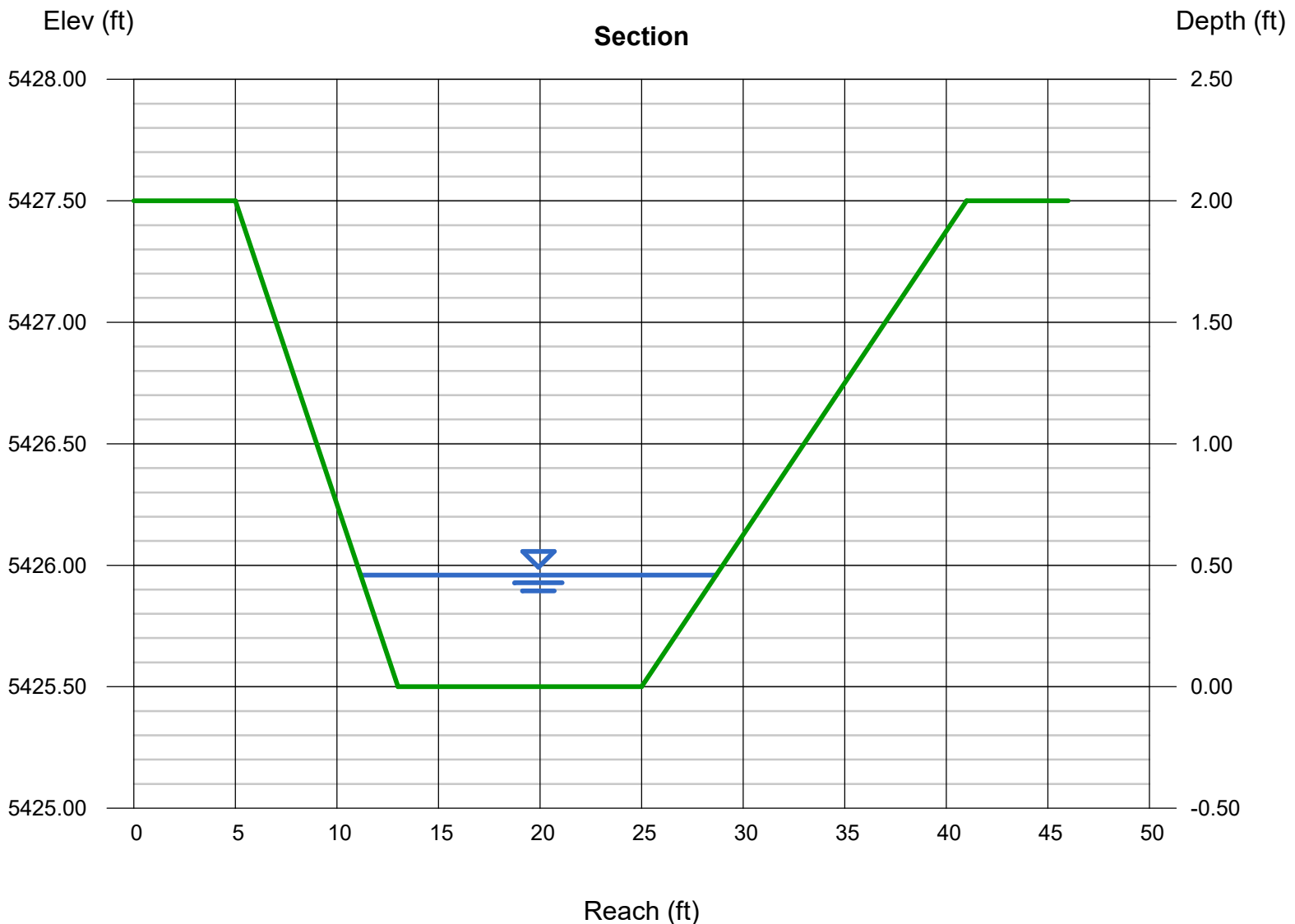

# Channel Report

## Channel #3 (Before Area 7 - Crossing 2)

### Trapezoidal

Bottom Width (ft) = 35.00  
Side Slopes (z:1) = 4.00, 4.00  
Total Depth (ft) = 3.00  
Invert Elev (ft) = 5380.00  
Slope (%) = 0.67  
N-Value = 0.030

### Highlighted

Depth (ft) = 1.48  
Q (cfs) = 286.60  
Area (sqft) = 60.56  
Velocity (ft/s) = 4.73  
Wetted Perim (ft) = 47.20  
Crit Depth, Yc (ft) = 1.22  
Top Width (ft) = 46.84  
EGL (ft) = 1.83

### Calculations

Compute by: Known Q  
Known Q (cfs) = 286.60

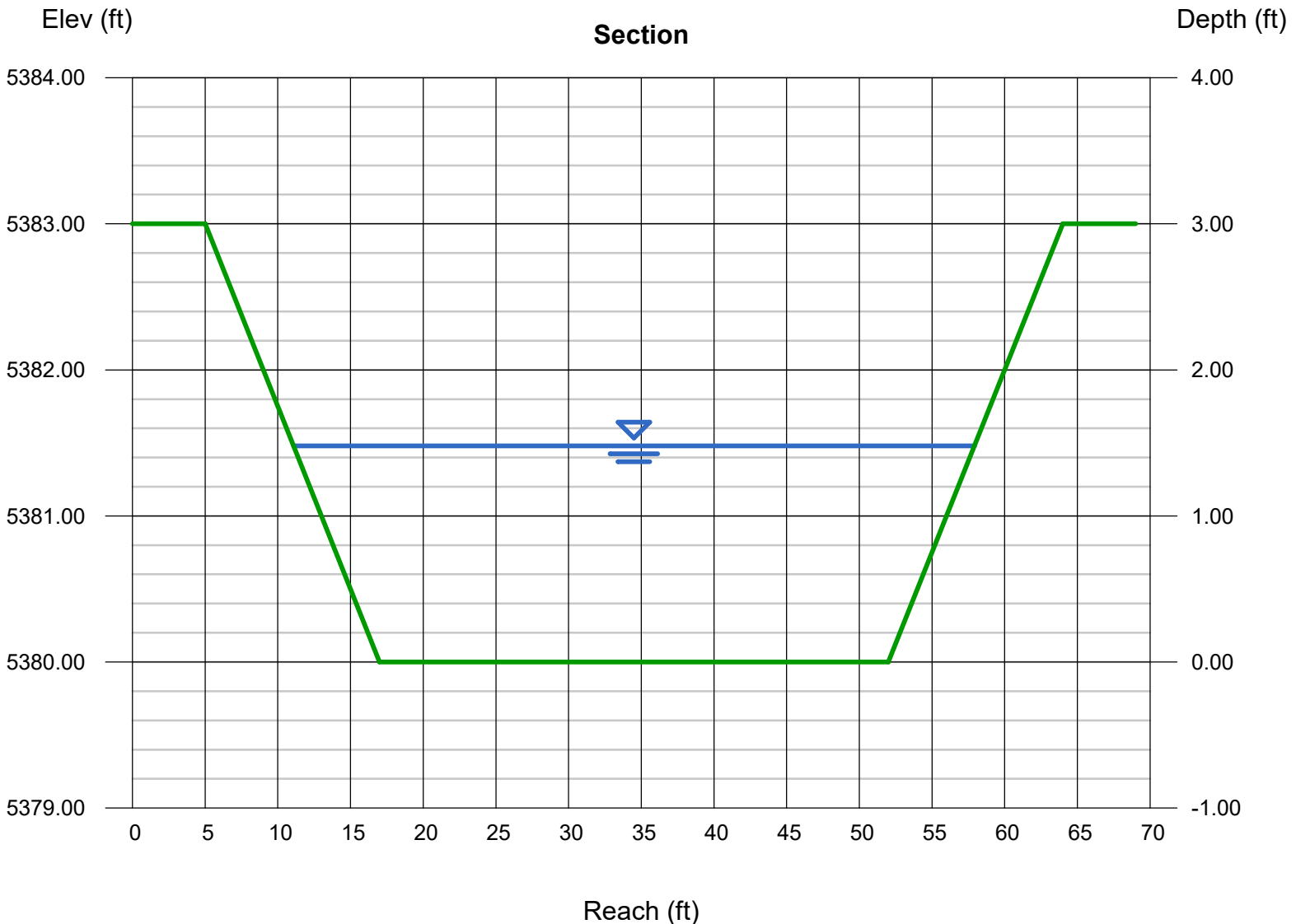

# Culvert Report

## Culvert #1 (Area 2 - Crossing 1)

Invert Elev Dn (ft)	= 5537.98
Pipe Length (ft)	= 23.61
Slope (%)	= 2.08
Invert Elev Up (ft)	= 5538.47
Rise (in)	= 18.0
Shape	= Circular
Span (in)	= 18.0
No. Barrels	= 2
n-Value	= 0.013
Culvert Type	= Circular Concrete
Culvert Entrance	= Square edge w/headwall (C)
Coeff. K,M,c,Y,k	= 0.0098, 2, 0.0398, 0.67, 0.5

<b>Embankment</b>	
Top Elevation (ft)	= 5540.66
Top Width (ft)	= 16.00
Crest Width (ft)	= 23.60

<b>Calculations</b>	
Qmin (cfs)	= 14.90
Qmax (cfs)	= 14.90
Tailwater Elev (ft)	= 0.00

<b>Highlighted</b>	
Qtotal (cfs)	= 14.90
Qpipe (cfs)	= 14.90
Qovertop (cfs)	= 0.00
Veloc Dn (ft/s)	= 7.71
Veloc Up (ft/s)	= 5.60
HGL Dn (ft)	= 5538.79
HGL Up (ft)	= 5539.53
Hw Elev (ft)	= 5540.17
Hw/D (ft)	= 1.14
Flow Regime	= Inlet Control

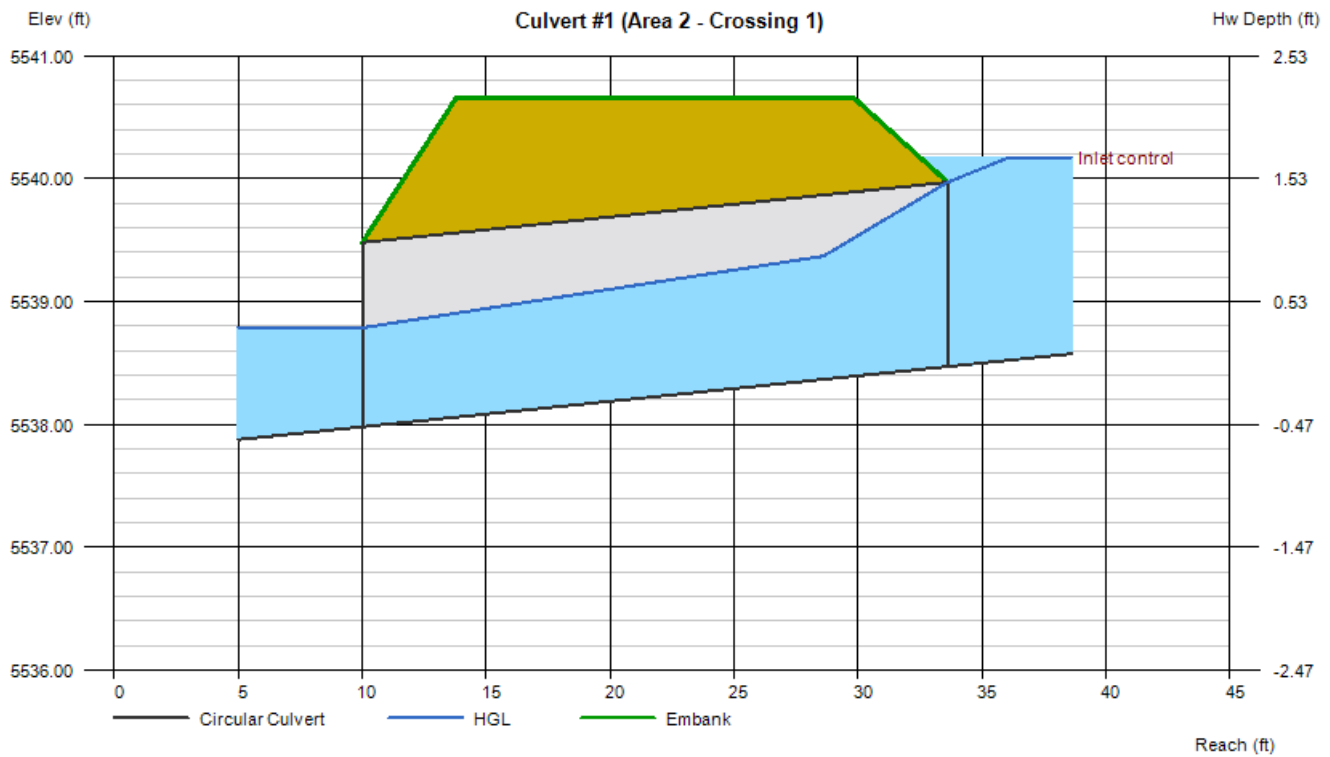

# DETERMINATION OF CULVERT HEADWATER AND OUTLET PROTECTION

*MHFD-Culvert, Version 4.00 (May 2020)*

**Project:** Pike Solar  
**ID:** Culvert #1 (Area 2, Crossing 1)

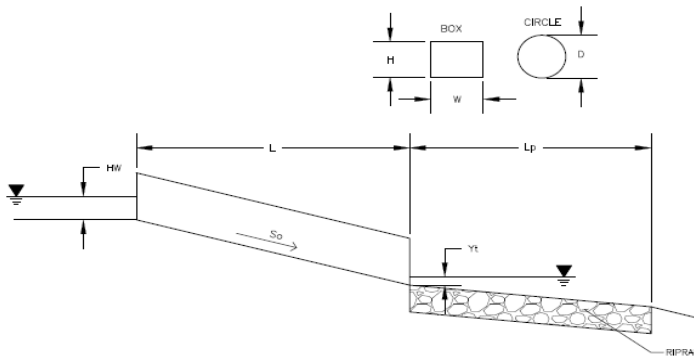

**Soil Type:**

Choose One:

- Sandy  
 Non-Sandy

**Supercritical Flow! Using Adjusted Diameter to calculate protection type.**

Design Information:	
Design Discharge	Q = <input style="width: 100px;" type="text" value="14.9"/> cfs
<b>Circular Culvert:</b>	
Barrel Diameter in Inches	D = <input style="width: 100px;" type="text" value="18"/> inches
Inlet Edge Type (Choose from pull-down list)	Square Edge with Headwall
<b>OR:</b>	
<b>Box Culvert:</b>	
Barrel Height (Rise) in Feet	H (Rise) = <input style="width: 100px;" type="text"/> ft
Barrel Width (Span) in Feet	W (Span) = <input style="width: 100px;" type="text"/> ft
Inlet Edge Type (Choose from pull-down list)	OR
Number of Barrels	# Barrels = <input style="width: 100px;" type="text" value="2"/>
Inlet Elevation	Elev IN = <input style="width: 100px;" type="text" value="5538.47"/> ft
Outlet Elevation <b>OR</b> Slope	Elev OUT = <input style="width: 100px;" type="text" value="5537.98"/> ft
Culvert Length	L = <input style="width: 100px;" type="text" value="23.61"/> ft
Manning's Roughness	n = <input style="width: 100px;" type="text" value="0.013"/>
Bend Loss Coefficient	k <sub>b</sub> = <input style="width: 100px;" type="text" value="0"/>
Exit Loss Coefficient	k <sub>x</sub> = <input style="width: 100px;" type="text" value="1"/>
Tailwater Surface Elevation	Y <sub>t</sub> , Elevation = <input style="width: 100px;" type="text" value="5538.79"/> ft
Max Allowable Channel Velocity	V = <input style="width: 100px;" type="text" value="7.64"/> ft/s
Calculated Results:	
Culvert Cross Sectional Area Available	A = <input style="width: 100px;" type="text" value="1.77"/> ft <sup>2</sup>
Culvert Normal Depth	Y <sub>n</sub> = <input style="width: 100px;" type="text" value="0.74"/> ft
Culvert Critical Depth	Y <sub>c</sub> = <input style="width: 100px;" type="text" value="1.06"/> ft
Froude Number	Fr = <input style="width: 100px;" type="text" value="1.98"/> <span style="color: red; font-weight: bold;">Supercritical!</span>
Entrance Loss Coefficient	k <sub>e</sub> = <input style="width: 100px;" type="text" value="0.50"/>
Friction Loss Coefficient	k <sub>f</sub> = <input style="width: 100px;" type="text" value="0.43"/>
Sum of All Loss Coefficients	k <sub>s</sub> = <input style="width: 100px;" type="text" value="1.93"/> ft
<b>Headwater:</b>	
Inlet Control Headwater	HW <sub>I</sub> = <input style="width: 100px;" type="text" value="1.71"/> ft
Outlet Control Headwater	HW <sub>O</sub> = <input style="width: 100px;" type="text" value="1.32"/> ft
<b>Design Headwater Elevation</b>	<b>HW = <input style="width: 100px;" type="text" value="5540.18"/> ft</b>
<b>Headwater/Diameter <b>OR</b> Headwater/Rise Ratio</b>	<b>HW/D = <input style="width: 100px;" type="text" value="1.14"/></b>
<b>Outlet Protection:</b>	
Flow/(Diameter <sup>2.5</sup> )	Q/D <sup>2.5</sup> = <input style="width: 100px;" type="text" value="2.70"/> ft <sup>0.5</sup> /s
Tailwater Surface Height	Y <sub>t</sub> = <input style="width: 100px;" type="text" value="0.81"/> ft
Tailwater/Diameter	Y <sub>t</sub> /D = <input style="width: 100px;" type="text" value="0.54"/>
Expansion Factor	1/(2*tan(Θ)) = <input style="width: 100px;" type="text" value="6.38"/>
Flow Area at Max Channel Velocity	A <sub>t</sub> = <input style="width: 100px;" type="text" value="1.95"/> ft <sup>2</sup>
Width of Equivalent Conduit for Multiple Barrels	W <sub>eq</sub> = <input style="width: 100px;" type="text" value="3.00"/> ft
<b>Length of Riprap Protection</b>	<b>L<sub>p</sub> = <input style="width: 100px;" type="text" value="5"/> ft</b>
<b>Width of Riprap Protection at Downstream End</b>	<b>T = <input style="width: 100px;" type="text" value="4"/> ft</b>
<b>Adjusted Diameter for Supercritical Flow</b>	
Minimum Theoretical Riprap Size	D <sub>a</sub> = <input style="width: 100px;" type="text" value="1.12"/> ft
Nominal Riprap Size	d <sub>50 min</sub> = <input style="width: 100px;" type="text" value="3"/> in
<b>MHFD Riprap Type</b>	d <sub>50 nominal</sub> = <input style="width: 100px;" type="text" value="6"/> in
	<b>Type = <input style="width: 100px;" type="text" value="VL"/></b>



# Culvert Report

## Culvert #2 (Area 3 - Crossing 1)

Invert Elev Dn (ft)	= 5511.00
Pipe Length (ft)	= 46.65
Slope (%)	= 0.86
Invert Elev Up (ft)	= 5511.40
Rise (in)	= 18.0
Shape	= Circular
Span (in)	= 18.0
No. Barrels	= 1
n-Value	= 0.013
Culvert Type	= Circular Concrete
Culvert Entrance	= Square edge w/headwall (C)
Coeff. K,M,c,Y,k	= 0.0098, 2, 0.0398, 0.67, 0.5

<b>Embankment</b>	
Top Elevation (ft)	= 5514.83
Top Width (ft)	= 16.00
Crest Width (ft)	= 46.65

<b>Calculations</b>	
Qmin (cfs)	= 11.60
Qmax (cfs)	= 11.60
Tailwater Elev (ft)	= (dc+D)/2

<b>Highlighted</b>	
Qtotal (cfs)	= 11.60
Qpipe (cfs)	= 11.60
Qovertop (cfs)	= 0.00
Veloc Dn (ft/s)	= 6.76
Veloc Up (ft/s)	= 6.56
HGL Dn (ft)	= 5512.40
HGL Up (ft)	= 5512.97
Hw Elev (ft)	= 5514.11
Hw/D (ft)	= 1.81
Flow Regime	= Inlet Control

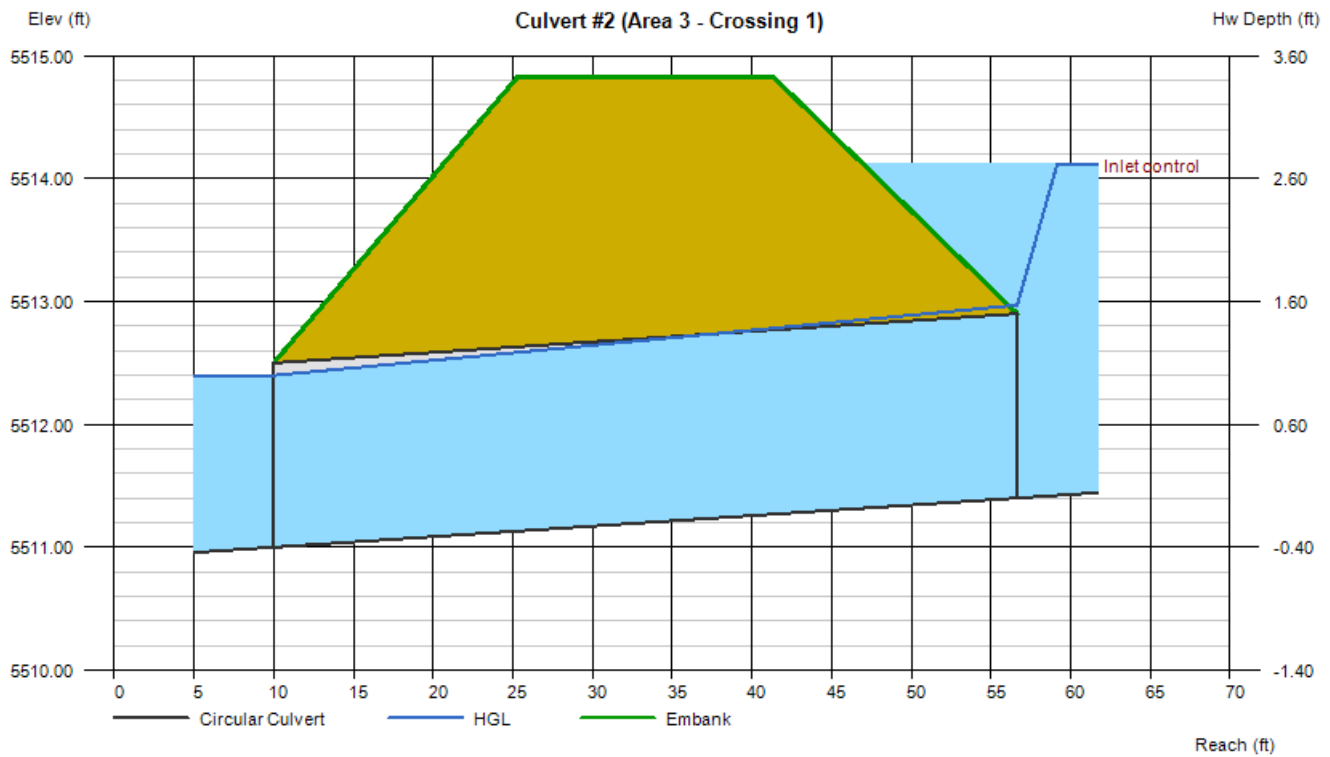

# DETERMINATION OF CULVERT HEADWATER AND OUTLET PROTECTION

*MHFD-Culvert, Version 4.00 (May 2020)*

**Project:** Pike Solar  
**ID:** Culvert #2 (Area 3, Crossing 1)

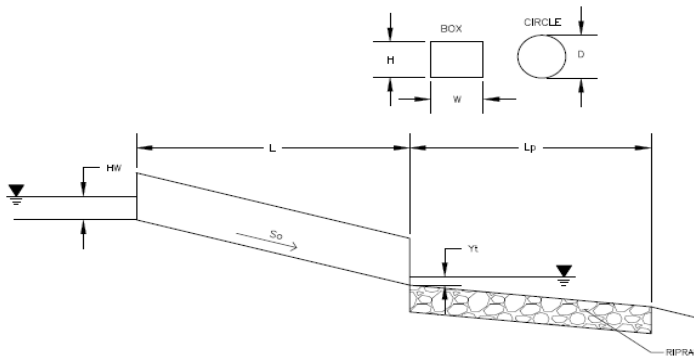

**Soil Type:**

Choose One:

- Sandy  
 Non-Sandy

**Design Information:**

Design Discharge	Q = <input type="text" value="11.6"/> cfs
Circular Culvert:	
Barrel Diameter in Inches	D = <input type="text" value="18"/> inches
Inlet Edge Type (Choose from pull-down list)	Square Edge with Headwall
<b>OR:</b>	
Box Culvert:	
Barrel Height (Rise) in Feet	H (Rise) = <input type="text" value="OR"/> ft
Barrel Width (Span) in Feet	W (Span) = <input type="text" value="OR"/> ft
Inlet Edge Type (Choose from pull-down list)	
Number of Barrels	# Barrels = <input type="text" value="1"/>
Inlet Elevation	Elev IN = <input type="text" value="5511.4"/> ft
Outlet Elevation <b>OR</b> Slope	Elev OUT = <input type="text" value="5511"/> ft
Culvert Length	L = <input type="text" value="46.65"/> ft
Manning's Roughness	n = <input type="text" value="0.013"/>
Bend Loss Coefficient	k <sub>b</sub> = <input type="text" value="0"/>
Exit Loss Coefficient	k <sub>x</sub> = <input type="text" value="1"/>
Tailwater Surface Elevation	Y <sub>t</sub> , Elevation = <input type="text" value="5512.4"/> ft
Max Allowable Channel Velocity	V = <input type="text" value="6.04"/> ft/s

**Calculated Results:**

Culvert Cross Sectional Area Available	A = <input type="text" value="1.77"/> ft <sup>2</sup>
Culvert Normal Depth	Y <sub>n</sub> = <input type="text" value="1.50"/> ft
Culvert Critical Depth	Y <sub>c</sub> = <input type="text" value="1.30"/> ft
Froude Number	Fr = <input type="text" value="-"/> <b>Pressure flow!</b>
Entrance Loss Coefficient	k <sub>e</sub> = <input type="text" value="0.50"/>
Friction Loss Coefficient	k <sub>f</sub> = <input type="text" value="0.85"/>
Sum of All Loss Coefficients	k <sub>s</sub> = <input type="text" value="2.35"/> ft
Headwater:	
Inlet Control Headwater	HW <sub>I</sub> = <input type="text" value="2.70"/> ft
Outlet Control Headwater	HW <sub>O</sub> = <input type="text" value="2.57"/> ft
<b>Design Headwater Elevation</b>	<b>HW = <input type="text" value="5514.10"/> ft</b>
<b>Headwater/Diameter <b>OR</b> Headwater/Rise Ratio</b>	<b>HW/D = <input type="text" value="1.80"/> <b>HW/D &gt; 1.5!</b></b>
Outlet Protection:	
Flow/(Diameter <sup>2.5</sup> )	Q/D <sup>2.5</sup> = <input type="text" value="4.21"/> ft <sup>0.5</sup> /s
Tailwater Surface Height	Y <sub>t</sub> = <input type="text" value="1.40"/> ft
Tailwater/Diameter	Y <sub>t</sub> /D = <input type="text" value="0.93"/>
Expansion Factor	1/(2*tan(Θ)) = <input type="text" value="6.38"/>
Flow Area at Max Channel Velocity	A <sub>t</sub> = <input type="text" value="1.92"/> ft <sup>2</sup>
Width of Equivalent Conduit for Multiple Barrels	W <sub>eq</sub> = <input type="text" value="-"/> ft
<b>Length of Riprap Protection</b>	<b>L<sub>p</sub> = <input type="text" value="5"/> ft</b>
<b>Width of Riprap Protection at Downstream End</b>	<b>T = <input type="text" value="3"/> ft</b>
Adjusted Diameter for Supercritical Flow	Da = <input type="text" value="-"/> ft
Minimum Theoretical Riprap Size	d <sub>50 min</sub> = <input type="text" value="2"/> in
Nominal Riprap Size	d <sub>50 nominal</sub> = <input type="text" value="6"/> in
<b>MHFD Riprap Type</b>	<b>Type = <input type="text" value="VL"/></b>

# Culvert Report

## Culvert #3 (Area 3 - Crossing 2)

Invert Elev Dn (ft)	= 5498.00
Pipe Length (ft)	= 39.62
Slope (%)	= 2.47
Invert Elev Up (ft)	= 5498.98
Rise (in)	= 24.0
Shape	= Circular
Span (in)	= 24.0
No. Barrels	= 1
n-Value	= 0.013
Culvert Type	= Circular Concrete
Culvert Entrance	= Square edge w/headwall (C)
Coeff. K,M,c,Y,k	= 0.0098, 2, 0.0398, 0.67, 0.5

<b>Embankment</b>	
Top Elevation (ft)	= 5502.15
Top Width (ft)	= 16.00
Crest Width (ft)	= 39.62

<b>Calculations</b>	
Qmin (cfs)	= 14.10
Qmax (cfs)	= 14.10
Tailwater Elev (ft)	= (dc+D)/2

<b>Highlighted</b>	
Qtotal (cfs)	= 14.10
Qpipe (cfs)	= 14.10
Qovertop (cfs)	= 0.00
Veloc Dn (ft/s)	= 5.02
Veloc Up (ft/s)	= 6.24
HGL Dn (ft)	= 5499.68
HGL Up (ft)	= 5500.33
Hw Elev (ft)	= 5501.11
Hw/D (ft)	= 1.06
Flow Regime	= Inlet Control

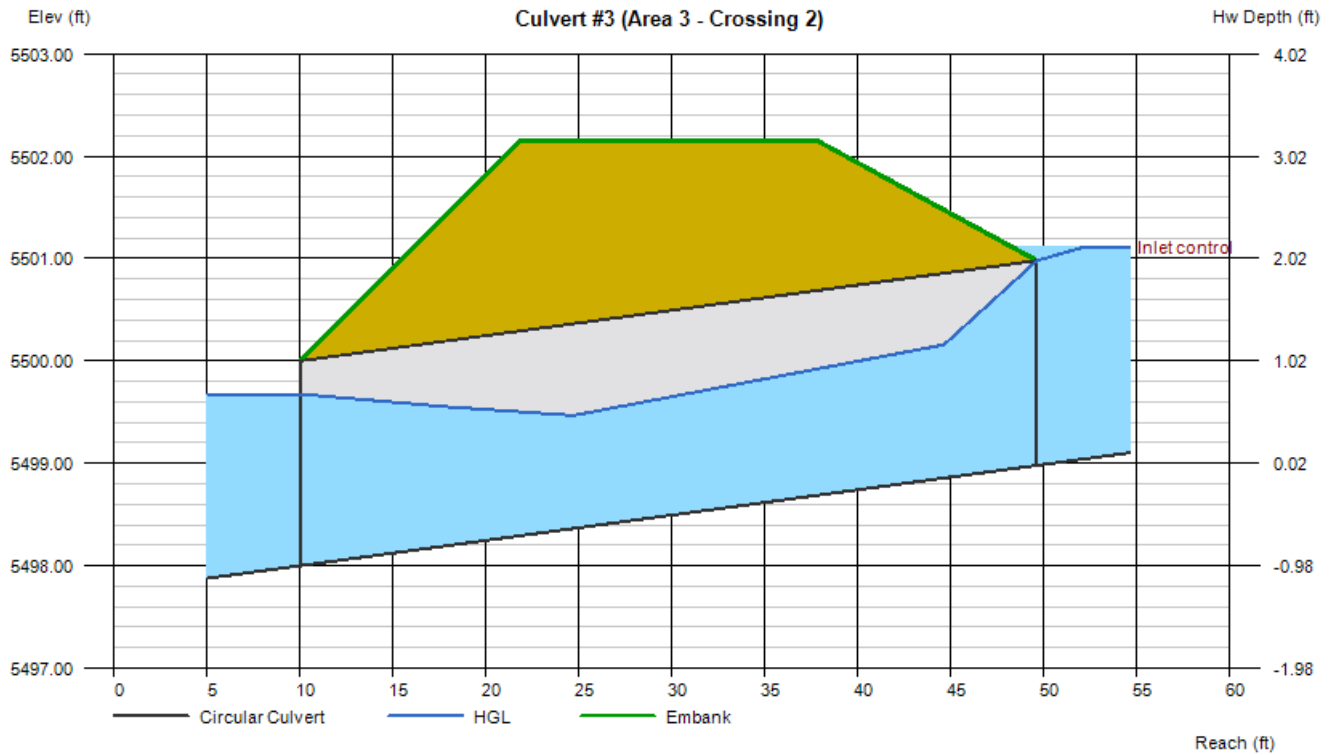

# DETERMINATION OF CULVERT HEADWATER AND OUTLET PROTECTION

MHFD-Culvert, Version 4.00 (May 2020)

**Project:** Pike Solar  
**ID:** Culvert #3 (Area 3, Crossing 2)

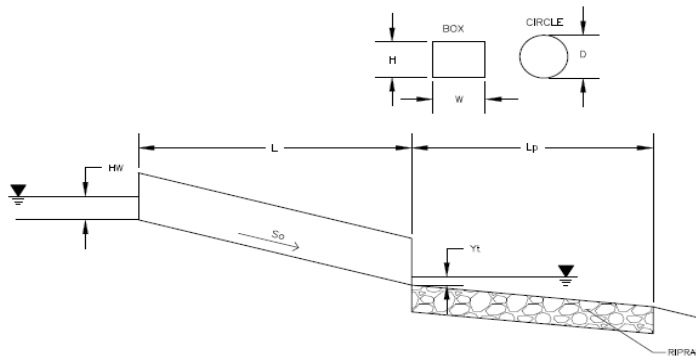

**Soil Type:**  
 Choose One:  
 Sandy  
 Non-Sandy

**Supercritical Flow! Using Adjusted Diameter to calculate protection type.**

Design Information:	
Design Discharge	Q = <input type="text" value="14.1"/> cfs
<b>Circular Culvert:</b>	
Barrel Diameter in Inches	D = <input type="text" value="24"/> inches
Inlet Edge Type (Choose from pull-down list)	Square Edge with Headwall
<b>OR:</b>	
<b>Box Culvert:</b>	
Barrel Height (Rise) in Feet	H (Rise) = <input type="text"/> ft
Barrel Width (Span) in Feet	W (Span) = <input type="text"/> ft
Inlet Edge Type (Choose from pull-down list)	
Number of Barrels	# Barrels = <input type="text" value="1"/>
Inlet Elevation	Elev IN = <input type="text" value="5498.98"/> ft
Outlet Elevation <b>OR</b> Slope	Elev OUT = <input type="text" value="5498"/> ft
Culvert Length	L = <input type="text" value="39.62"/> ft
Manning's Roughness	n = <input type="text" value="0.013"/>
Bend Loss Coefficient	k <sub>b</sub> = <input type="text" value="0"/>
Exit Loss Coefficient	k <sub>x</sub> = <input type="text" value="1"/>
Tailwater Surface Elevation	Y <sub>t</sub> , Elevation = <input type="text" value="5499.68"/> ft
Max Allowable Channel Velocity	V = <input type="text" value="4.69"/> ft/s
Calculated Results:	
Culvert Cross Sectional Area Available	A = <input type="text" value="3.14"/> ft <sup>2</sup>
Culvert Normal Depth	Y <sub>n</sub> = <input type="text" value="0.87"/> ft
Culvert Critical Depth	Y <sub>c</sub> = <input type="text" value="1.35"/> ft
Froude Number	Fr = <input type="text" value="2.31"/> <span style="color: red;">Supercritical!</span>
Entrance Loss Coefficient	k <sub>e</sub> = <input type="text" value="0.50"/>
Friction Loss Coefficient	k <sub>f</sub> = <input type="text" value="0.49"/>
Sum of All Loss Coefficients	k <sub>s</sub> = <input type="text" value="1.99"/> ft
<b>Headwater:</b>	
Inlet Control Headwater	HW <sub>I</sub> = <input type="text" value="2.13"/> ft
Outlet Control Headwater	HW <sub>O</sub> = <input type="text" value="N/A"/> ft
<b>Design Headwater Elevation</b>	<b>HW = <input type="text" value="5501.11"/> ft</b>
<b>Headwater/Diameter OR Headwater/Rise Ratio</b>	<b>HW/D = <input type="text" value="1.06"/></b>
<b>Outlet Control Headwater Approximation Method Inaccurate for Low Flow - Backwater Calculations Required</b>	
<b>Outlet Protection:</b>	
Flow/(Diameter <sup>2.5</sup> )	Q/D <sup>2.5</sup> = <input type="text" value="2.49"/> ft <sup>0.5</sup> /s
Tailwater Surface Height	Y <sub>t</sub> = <input type="text" value="1.68"/> ft
Tailwater/Diameter	Y <sub>t</sub> /D = <input type="text" value="0.84"/>
Expansion Factor	1/(2*tan(θ)) = <input type="text" value="6.70"/>
Flow Area at Max Channel Velocity	A <sub>t</sub> = <input type="text" value="3.01"/> ft <sup>2</sup>
Width of Equivalent Conduit for Multiple Barrels	W <sub>eq</sub> = <input type="text" value="-"/> ft
<b>Length of Riprap Protection</b>	<b>L<sub>p</sub> = <input type="text" value="6"/> ft</b>
<b>Width of Riprap Protection at Downstream End</b>	<b>T = <input type="text" value="3"/> ft</b>
Adjusted Diameter for Supercritical Flow	Da = <input type="text" value="1.44"/> ft
Minimum Theoretical Riprap Size	d <sub>50</sub> min = <input type="text" value="2"/> in
Nominal Riprap Size	d <sub>50</sub> nominal = <input type="text" value="6"/> in
<b>MHFD Riprap Type</b>	<b>Type = <input type="text" value="VL"/></b>

# Culvert Report

## Culvert #4 (Area 3-4 - Crossing 1)

Invert Elev Dn (ft)	= 5519.00
Pipe Length (ft)	= 39.85
Slope (%)	= 1.25
Invert Elev Up (ft)	= 5519.50
Rise (in)	= 18.0
Shape	= Circular
Span (in)	= 18.0
No. Barrels	= 2
n-Value	= 0.013
Culvert Type	= Circular Concrete
Culvert Entrance	= Square edge w/headwall (C)
Coeff. K,M,c,Y,k	= 0.0098, 2, 0.0398, 0.67, 0.5

<b>Calculations</b>	
Qmin (cfs)	= 25.70
Qmax (cfs)	= 25.70
Tailwater Elev (ft)	= (dc+D)/2

<b>Highlighted</b>	
Qtotal (cfs)	= 25.70
Qpipe (cfs)	= 25.70
Qovertop (cfs)	= 0.00
Veloc Dn (ft/s)	= 7.42
Veloc Up (ft/s)	= 7.68
HGL Dn (ft)	= 5520.42
HGL Up (ft)	= 5520.85
Hw Elev (ft)	= 5522.60
Hw/D (ft)	= 2.07
Flow Regime	= Inlet Control

<b>Embankment</b>	
Top Elevation (ft)	= 5523.38
Top Width (ft)	= 16.00
Crest Width (ft)	= 39.85

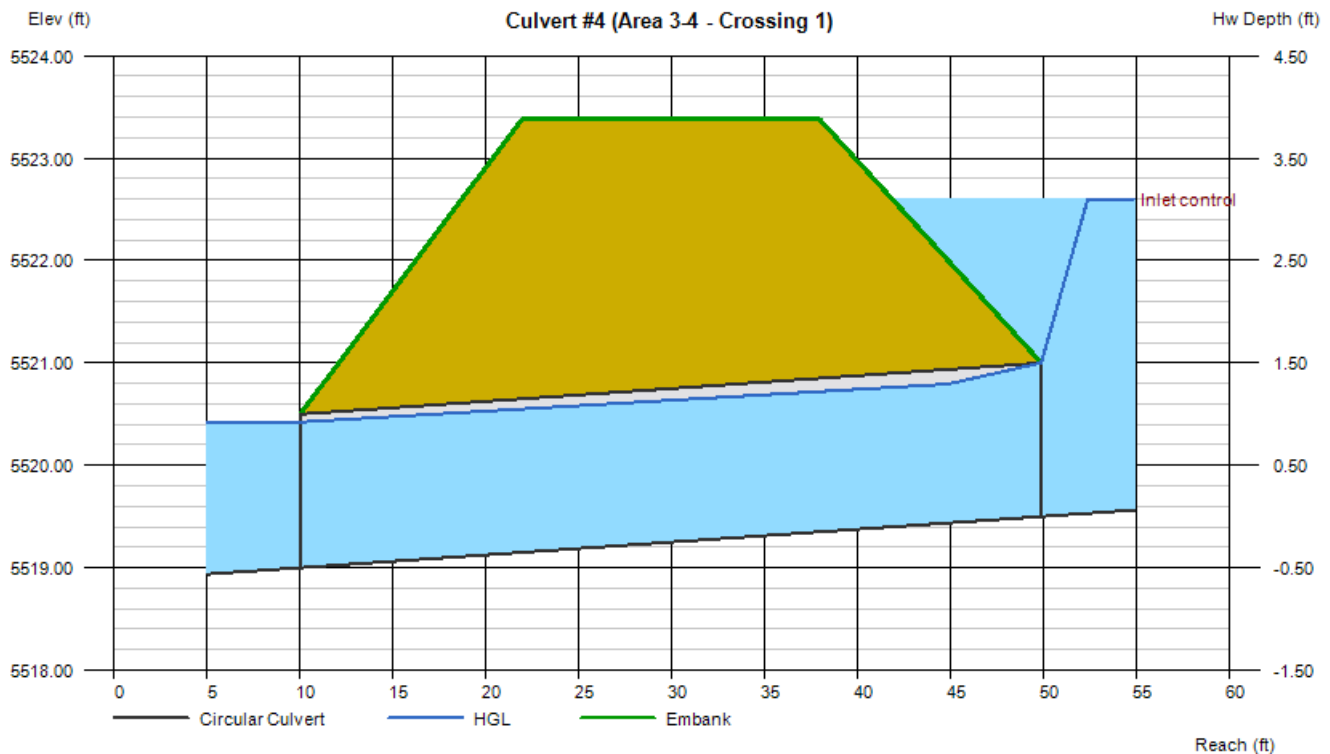

# DETERMINATION OF CULVERT HEADWATER AND OUTLET PROTECTION

*MHFD-Culvert, Version 4.00 (May 2020)*

**Project:** Pike Solar  
**ID:** Culvert #4 (Area 3-4, Crossing 1)

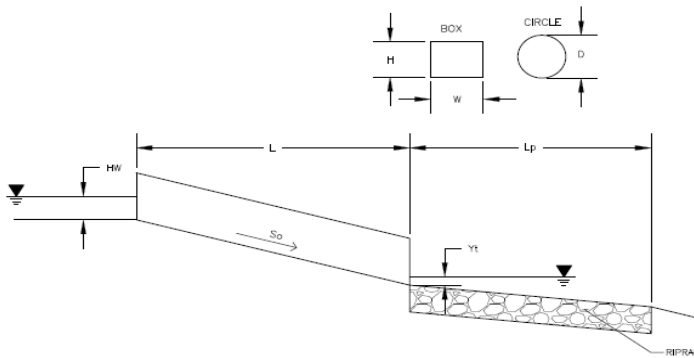

**Soil Type:**  
 Choose One:  
 Sandy  
 Non-Sandy

**Design Information:**

Design Discharge	Q = <input type="text" value="25.7"/> cfs
<b>Circular Culvert:</b>	
Barrel Diameter in Inches	D = <input type="text" value="18"/> inches
Inlet Edge Type (Choose from pull-down list)	Square Edge with Headwall
<b>OR:</b>	
<b>Box Culvert:</b>	
Barrel Height (Rise) in Feet	H (Rise) = <input type="text"/> ft
Barrel Width (Span) in Feet	W (Span) = <input type="text"/> ft
Inlet Edge Type (Choose from pull-down list)	
<b>OR:</b>	
Number of Barrels	# Barrels = <input type="text" value="2"/>
Inlet Elevation	Elev IN = <input type="text" value="5519.5"/> ft
Outlet Elevation <b>OR</b> Slope	Elev OUT = <input type="text" value="5519"/> ft
Culvert Length	L = <input type="text" value="39.85"/> ft
Manning's Roughness	n = <input type="text" value="0.013"/>
Bend Loss Coefficient	k <sub>b</sub> = <input type="text" value="0"/>
Exit Loss Coefficient	k <sub>x</sub> = <input type="text" value="1"/>
Tailwater Surface Elevation	Y <sub>t</sub> , Elevation = <input type="text" value="5520.42"/> ft
Max Allowable Channel Velocity	V = <input type="text" value="6.96"/> ft/s

**Calculated Results:**

Culvert Cross Sectional Area Available	A = <input type="text" value="1.77"/> ft <sup>2</sup>
Culvert Normal Depth	Y <sub>n</sub> = <input type="text" value="1.50"/> ft
Culvert Critical Depth	Y <sub>c</sub> = <input type="text" value="1.35"/> ft
Froude Number	Fr = <input type="text" value="-"/> <b>Pressure flow!</b>
Entrance Loss Coefficient	k <sub>e</sub> = <input type="text" value="0.50"/>
Friction Loss Coefficient	k <sub>f</sub> = <input type="text" value="0.72"/>
Sum of All Loss Coefficients	k <sub>s</sub> = <input type="text" value="2.22"/> ft
<b>Headwater:</b>	
Inlet Control Headwater	HW <sub>I</sub> = <input type="text" value="3.08"/> ft
Outlet Control Headwater	HW <sub>O</sub> = <input type="text" value="2.75"/> ft
<b>Design Headwater Elevation</b>	<b>HW = <input type="text" value="5522.58"/> ft</b>
<b>Headwater/Diameter OR Headwater/Rise Ratio</b>	<b>HW/D = <input type="text" value="2.06"/> <b>HW/D &gt; 1.5!</b></b>
<b>Outlet Protection:</b>	
Flow/(Diameter <sup>2.5</sup> )	Q/D <sup>2.5</sup> = <input type="text" value="4.66"/> ft <sup>0.5</sup> /s
Tailwater Surface Height	Y <sub>t</sub> = <input type="text" value="1.42"/> ft
Tailwater/Diameter	Y <sub>t</sub> /D = <input type="text" value="0.95"/>
Expansion Factor	1/(2*tan(Θ)) = <input type="text" value="5.67"/>
Flow Area at Max Channel Velocity	A <sub>t</sub> = <input type="text" value="3.69"/> ft <sup>2</sup>
Width of Equivalent Conduit for Multiple Barrels	W <sub>eq</sub> = <input type="text" value="3.00"/> ft
<b>Length of Riprap Protection</b>	<b>L<sub>p</sub> = <input type="text" value="5"/> ft</b>
<b>Width of Riprap Protection at Downstream End</b>	<b>T = <input type="text" value="4"/> ft</b>
<b>Adjusted Diameter for Supercritical Flow</b>	
Minimum Theoretical Riprap Size	Da = <input type="text" value="-"/> ft
Nominal Riprap Size	d <sub>50</sub> min = <input type="text" value="2"/> in
<b>MHFD Riprap Type</b>	d <sub>50</sub> nominal = <input type="text" value="6"/> in
	<b>Type = <input type="text" value="VL"/></b>

# Culvert Report

## Culvert #5 (Area 4 - Crossing 1)

Invert Elev Dn (ft)	= 5510.25
Pipe Length (ft)	= 28.95
Slope (%)	= 0.48
Invert Elev Up (ft)	= 5510.39
Rise (in)	= 18.0
Shape	= Circular
Span (in)	= 18.0
No. Barrels	= 1
n-Value	= 0.013
Culvert Type	= Circular Concrete
Culvert Entrance	= Square edge w/headwall (C)
Coeff. K,M,c,Y,k	= 0.0098, 2, 0.0398, 0.67, 0.5

<b>Embankment</b>	
Top Elevation (ft)	= 5512.86
Top Width (ft)	= 16.00
Crest Width (ft)	= 28.95

<b>Calculations</b>	
Qmin (cfs)	= 3.90
Qmax (cfs)	= 3.90
Tailwater Elev (ft)	= (dc+D)/2

<b>Highlighted</b>	
Qtotal (cfs)	= 3.90
Qpipe (cfs)	= 3.90
Qovertop (cfs)	= 0.00
Veloc Dn (ft/s)	= 2.74
Veloc Up (ft/s)	= 4.38
HGL Dn (ft)	= 5511.38
HGL Up (ft)	= 5511.15
Hw Elev (ft)	= 5511.49
Hw/D (ft)	= 0.73
Flow Regime	= Inlet Control

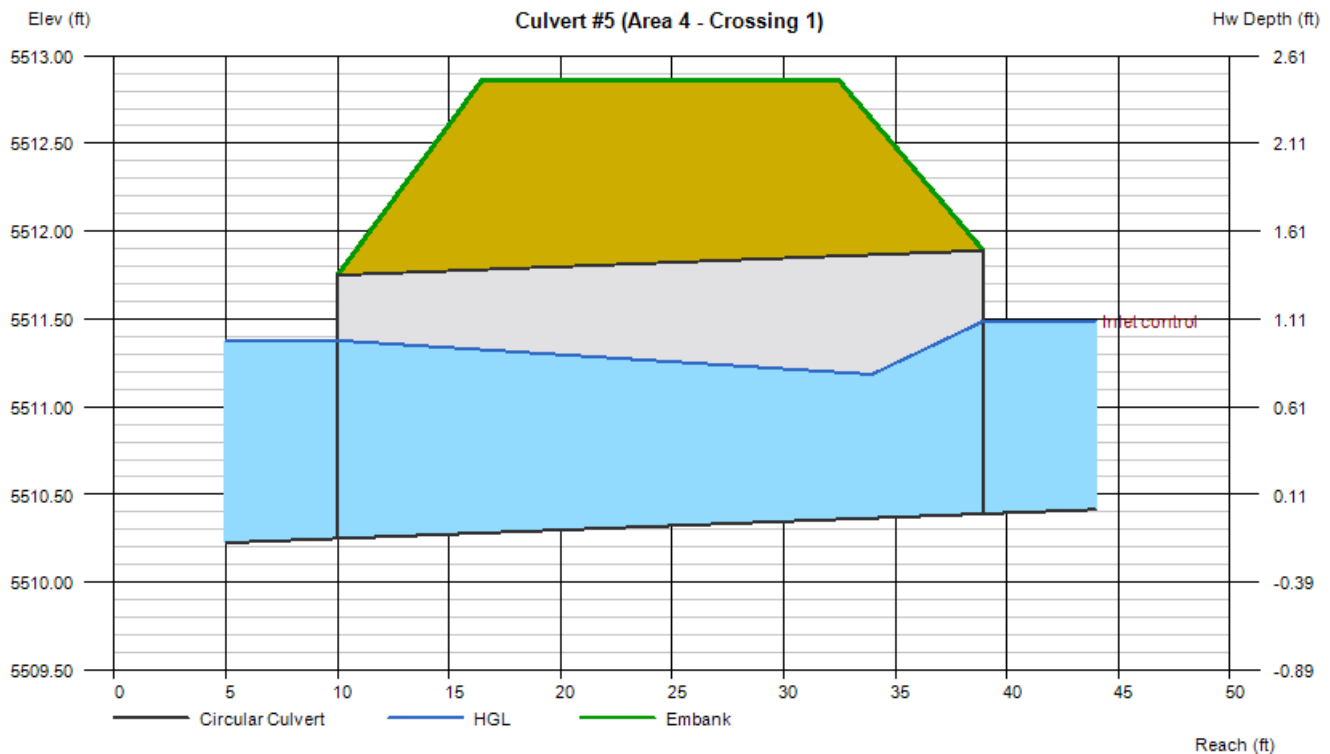

# DETERMINATION OF CULVERT HEADWATER AND OUTLET PROTECTION

*MHFD-Culvert, Version 4.00 (May 2020)*

**Project:** Pike Solar  
**ID:** Culvert #5 (Culvert 4, Crossing 1)

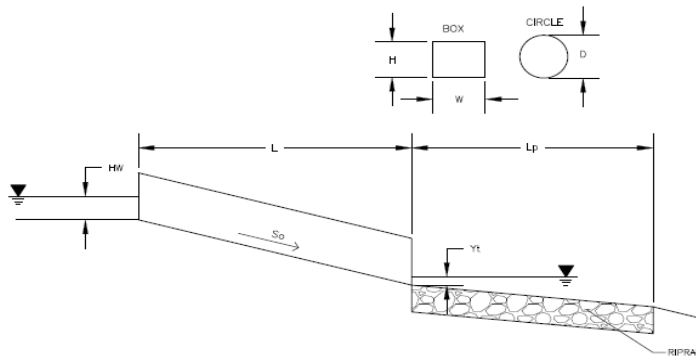

**Soil Type:**

Choose One:

Sandy

Non-Sandy

**Design Information:**

Design Discharge	Q = <input type="text" value="3.9"/> cfs
<b>Circular Culvert:</b>	
Barrel Diameter in Inches	D = <input type="text" value="18"/> inches
Inlet Edge Type (Choose from pull-down list)	
<b>OR:</b>	
<b>Box Culvert:</b>	
Barrel Height (Rise) in Feet	H (Rise) = <input type="text"/> ft
Barrel Width (Span) in Feet	W (Span) = <input type="text"/> ft
Inlet Edge Type (Choose from pull-down list)	
Number of Barrels	# Barrels = <input type="text" value="1"/>
Inlet Elevation	Elev IN = <input type="text" value="5510.39"/> ft
Outlet Elevation <b>OR</b> Slope	Elev OUT = <input type="text" value="5510.25"/> ft
Culvert Length	L = <input type="text" value="28.95"/> ft
Manning's Roughness	n = <input type="text" value="0.013"/>
Bend Loss Coefficient	k <sub>b</sub> = <input type="text" value="0"/>
Exit Loss Coefficient	k <sub>x</sub> = <input type="text" value="1"/>
Tailwater Surface Elevation	Y <sub>t</sub> , Elevation = <input type="text" value="5511.38"/> ft
Max Allowable Channel Velocity	V = <input type="text" value="2.2"/> ft/s

**Calculated Results:**

Culvert Cross Sectional Area Available	A = <input type="text" value="1.77"/> ft <sup>2</sup>
Culvert Normal Depth	Y <sub>n</sub> = <input type="text" value="0.78"/> ft
Culvert Critical Depth	Y <sub>c</sub> = <input type="text" value="0.76"/> ft
Froude Number	Fr = <input type="text" value="0.94"/>
Entrance Loss Coefficient	k <sub>e</sub> = <input type="text" value="0.50"/>
Friction Loss Coefficient	k <sub>f</sub> = <input type="text" value="0.52"/>
Sum of All Loss Coefficients	k <sub>s</sub> = <input type="text" value="2.02"/> ft
<b>Headwater:</b>	
Inlet Control Headwater	HW <sub>I</sub> = <input type="text" value="1.11"/> ft
Outlet Control Headwater	HW <sub>O</sub> = <input type="text" value="1.14"/> ft
<b>Design Headwater Elevation</b>	<b>HW = <input type="text" value="5511.53"/> ft</b>
<b>Headwater/Diameter OR Headwater/Rise Ratio</b>	<b>HW/D = <input type="text" value="0.76"/></b>
<b>Outlet Protection:</b>	
Flow/(Diameter <sup>2.5</sup> )	Q/D <sup>2.5</sup> = <input type="text" value="1.42"/> ft <sup>0.5</sup> /s
Tailwater Surface Height	Y <sub>t</sub> = <input type="text" value="1.13"/> ft
Tailwater/Diameter	Y <sub>t</sub> /D = <input type="text" value="0.75"/>
Expansion Factor	1/(2*tan(Θ)) = <input type="text" value="6.70"/>
Flow Area at Max Channel Velocity	A <sub>t</sub> = <input type="text" value="1.77"/> ft <sup>2</sup>
Width of Equivalent Conduit for Multiple Barrels	W <sub>eq</sub> = <input type="text" value="-"/> ft
<b>Length of Riprap Protection</b>	<b>L<sub>p</sub> = <input type="text" value="5"/> ft</b>
<b>Width of Riprap Protection at Downstream End</b>	<b>T = <input type="text" value="3"/> ft</b>
Adjusted Diameter for Supercritical Flow	Da = <input type="text" value="-"/> ft
Minimum Theoretical Riprap Size	d <sub>50 min</sub> = <input type="text" value="1"/> in
Nominal Riprap Size	d <sub>50 nominal</sub> = <input type="text" value="6"/> in
<b>MHFD Riprap Type</b>	<b>Type = <input type="text" value="VL"/></b>



# Culvert Report

## Culvert #6 (Area 6 - Crossing 1)

Invert Elev Dn (ft)	= 5433.00
Pipe Length (ft)	= 29.96
Slope (%)	= 0.50
Invert Elev Up (ft)	= 5433.15
Rise (in)	= 18.0
Shape	= Circular
Span (in)	= 18.0
No. Barrels	= 1
n-Value	= 0.013
Culvert Type	= Circular Concrete
Culvert Entrance	= Square edge w/headwall (C)
Coeff. K,M,c,Y,k	= 0.0098, 2, 0.0398, 0.67, 0.5

<b>Embankment</b>	
Top Elevation (ft)	= 5436.32
Top Width (ft)	= 16.00
Crest Width (ft)	= 29.96

<b>Calculations</b>	
Qmin (cfs)	= 2.40
Qmax (cfs)	= 2.40
Tailwater Elev (ft)	= (dc+D)/2

<b>Highlighted</b>	
Qtotal (cfs)	= 2.40
Qpipe (cfs)	= 2.40
Qovertop (cfs)	= 0.00
Veloc Dn (ft/s)	= 1.83
Veloc Up (ft/s)	= 3.75
HGL Dn (ft)	= 5434.04
HGL Up (ft)	= 5433.74
Hw Elev (ft)	= 5433.97
Hw/D (ft)	= 0.55
Flow Regime	= Inlet Control

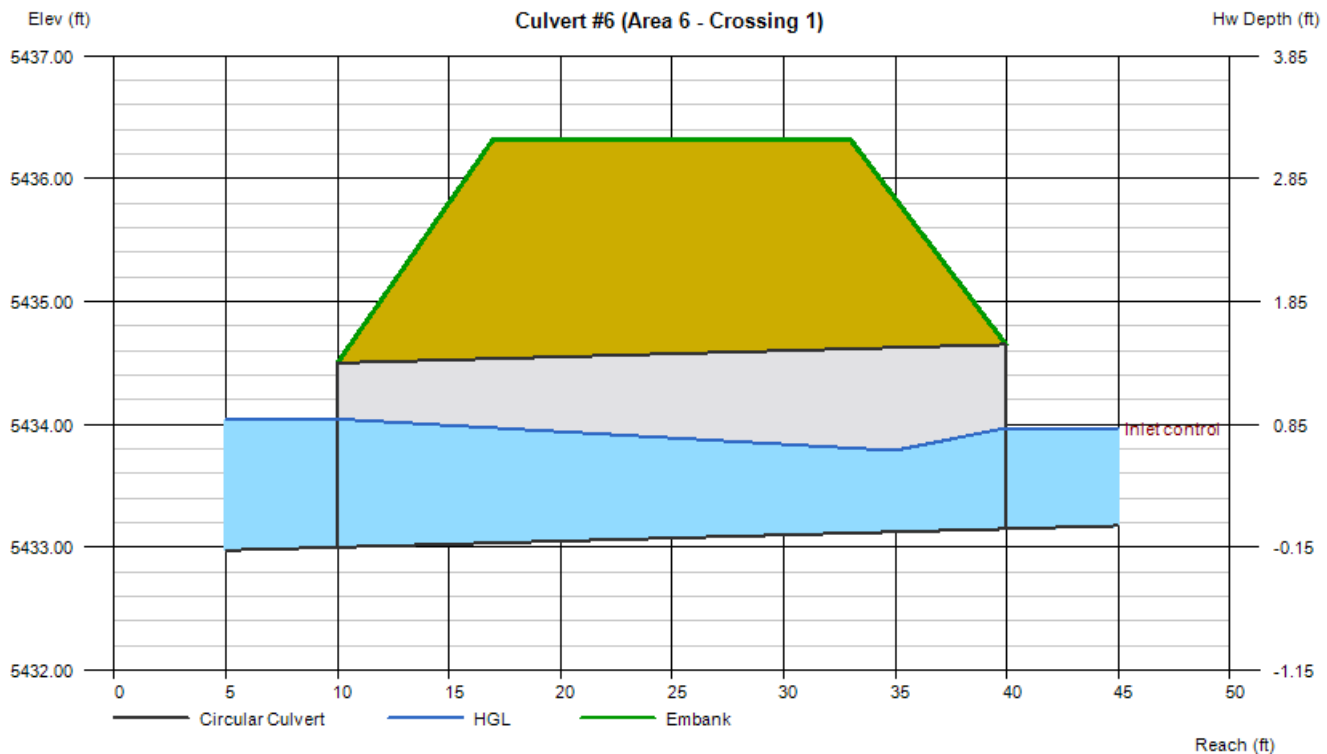

# DETERMINATION OF CULVERT HEADWATER AND OUTLET PROTECTION

MHFD-Culvert, Version 4.00 (May 2020)

**Project:** Pike Solar  
**ID:** Culvert #6 (Area 6, Crossing 1)

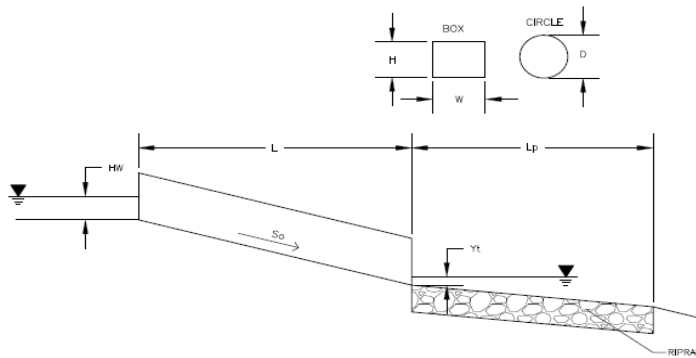

**Soil Type:**

Choose One:

- Sandy  
 Non-Sandy

**Supercritical Flow! Using Adjusted Diameter to calculate protection type.**

Design Information:	
Design Discharge	Q = <input type="text" value="2.4"/> cfs
<b>Circular Culvert:</b>	
Barrel Diameter in Inches	D = <input type="text" value="18"/> inches
Inlet Edge Type (Choose from pull-down list)	
<b>OR:</b>	
<b>Box Culvert:</b>	
Barrel Height (Rise) in Feet	H (Rise) = <input type="text"/> ft
Barrel Width (Span) in Feet	W (Span) = <input type="text"/> ft
Inlet Edge Type (Choose from pull-down list)	
Number of Barrels	# Barrels = <input type="text" value="1"/>
Inlet Elevation	Elev IN = <input type="text" value="5433.15"/> ft
Outlet Elevation <b>OR</b> Slope	Elev OUT = <input type="text" value="5433"/> ft
Culvert Length	L = <input type="text" value="29.96"/> ft
Manning's Roughness	n = <input type="text" value="0.013"/>
Bend Loss Coefficient	k <sub>b</sub> = <input type="text" value="0"/>
Exit Loss Coefficient	k <sub>x</sub> = <input type="text" value="1"/>
Tailwater Surface Elevation	Y <sub>t</sub> , Elevation = <input type="text" value="5424.04"/> ft
Max Allowable Channel Velocity	V = <input type="text" value="1.57"/> ft/s

**Tailwater ELEVATION is less than outlet elevation, using 0.4 x Rise as Yt.**

Calculated Results:	
Culvert Cross Sectional Area Available	A = <input type="text" value="1.77"/> ft <sup>2</sup>
Culvert Normal Depth	Y <sub>n</sub> = <input type="text" value="0.59"/> ft
Culvert Critical Depth	Y <sub>c</sub> = <input type="text" value="0.59"/> ft
Froude Number	Fr = <input type="text" value="1.00"/> <b>Supercritical!</b>
Entrance Loss Coefficient	k <sub>e</sub> = <input type="text" value="0.50"/>
Friction Loss Coefficient	k <sub>f</sub> = <input type="text" value="0.54"/>
Sum of All Loss Coefficients	k <sub>s</sub> = <input type="text" value="2.04"/> ft
<b>Headwater:</b>	
Inlet Control Headwater	HW <sub>I</sub> = <input type="text" value="0.82"/> ft
Outlet Control Headwater	HW <sub>O</sub> = <input type="text" value="N/A"/> ft
<b>Design Headwater Elevation</b>	<b>HW = <input type="text" value="N/A"/> ft</b>
<b>Headwater/Diameter OR Headwater/Rise Ratio</b>	<b>HW/D = <input type="text" value="N/A"/></b>
<b>Outlet Control Headwater Approximation Method Inaccurate for Low Flow - Backwater Calculations Required</b>	
<b>Outlet Protection:</b>	
Flow/(Diameter <sup>2.5</sup> )	Q/D <sup>2.5</sup> = <input type="text" value="0.87"/> ft <sup>0.5</sup> /s
Tailwater Surface Height	Y <sub>t</sub> = <input type="text" value="0.60"/> ft
Tailwater/Diameter	Y <sub>t</sub> /D = <input type="text" value="0.40"/>
Expansion Factor	1/(2*tan(θ)) = <input type="text" value="6.70"/>
Flow Area at Max Channel Velocity	A <sub>t</sub> = <input type="text" value="1.53"/> ft <sup>2</sup>
Width of Equivalent Conduit for Multiple Barrels	W <sub>eq</sub> = <input type="text" value="-"/> ft
<b>Length of Riprap Protection</b>	<b>L<sub>p</sub> = <input type="text" value="8"/> ft</b>
<b>Width of Riprap Protection at Downstream End</b>	<b>T = <input type="text" value="3"/> ft</b>
Adjusted Diameter for Supercritical Flow	Da = <input type="text" value="1.04"/> ft
Minimum Theoretical Riprap Size	d <sub>50</sub> min = <input type="text" value="1"/> in
Nominal Riprap Size	d <sub>50</sub> nominal = <input type="text" value="6"/> in
<b>MHFD Riprap Type</b>	<b>Type = <input type="text" value="VL"/></b>

# Culvert Report

## Culvert #7 (Area 6 - Crossing 2)

Invert Elev Dn (ft)	= 5423.00
Pipe Length (ft)	= 48.24
Slope (%)	= 0.50
Invert Elev Up (ft)	= 5423.24
Rise (in)	= 18.0
Shape	= Circular
Span (in)	= 18.0
No. Barrels	= 1
n-Value	= 0.013
Culvert Type	= Circular Concrete
Culvert Entrance	= Square edge w/headwall (C)
Coeff. K,M,c,Y,k	= 0.0098, 2, 0.0398, 0.67, 0.5

<b>Embankment</b>	
Top Elevation (ft)	= 5426.16
Top Width (ft)	= 16.00
Crest Width (ft)	= 48.24

<b>Calculations</b>	
Qmin (cfs)	= 2.20
Qmax (cfs)	= 2.20
Tailwater Elev (ft)	= (dc+D)/2

<b>Highlighted</b>	
Qtotal (cfs)	= 2.20
Qpipe (cfs)	= 2.20
Qovertop (cfs)	= 0.00
Veloc Dn (ft/s)	= 1.70
Veloc Up (ft/s)	= 3.66
HGL Dn (ft)	= 5424.03
HGL Up (ft)	= 5423.80
Hw Elev (ft)	= 5424.02
Hw/D (ft)	= 0.52
Flow Regime	= Inlet Control

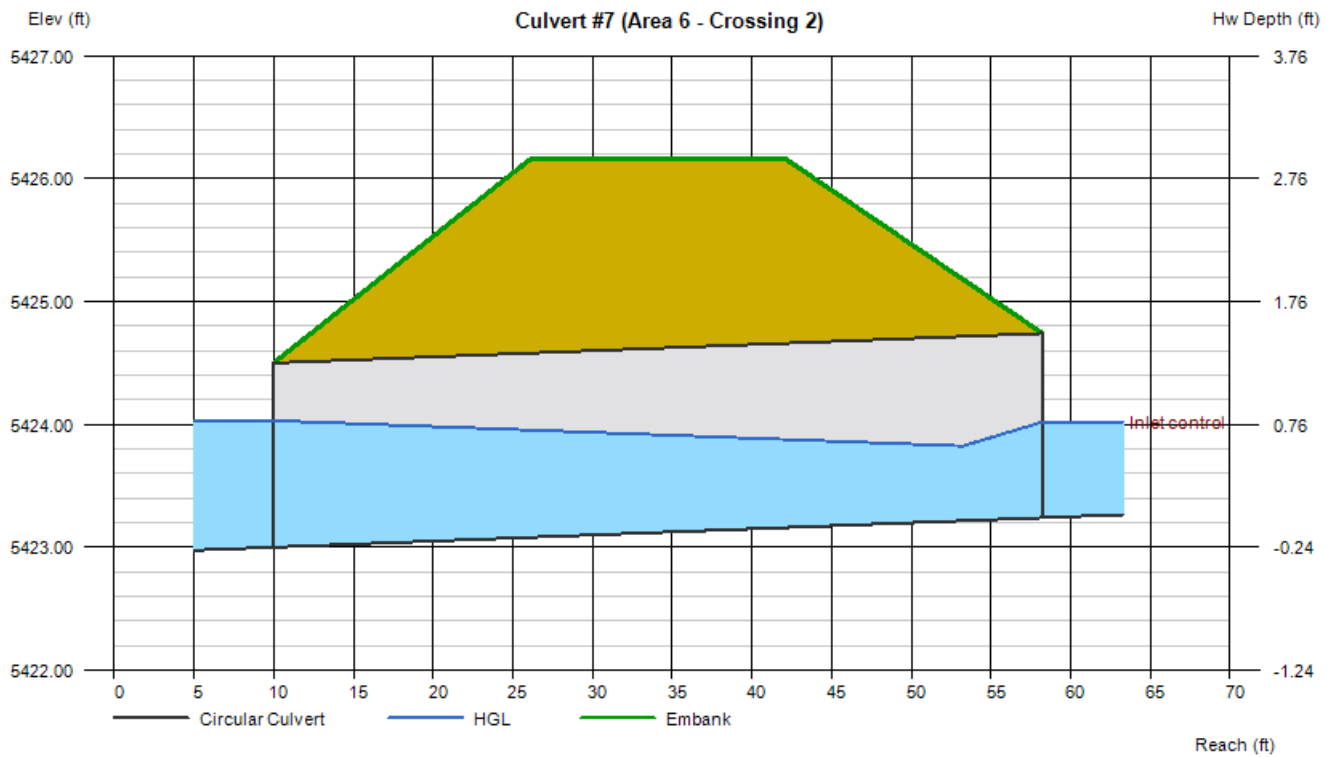

# DETERMINATION OF CULVERT HEADWATER AND OUTLET PROTECTION

MHFD-Culvert, Version 4.00 (May 2020)

**Project:** Pike Solar  
**ID:** Culvert #7 (Area 6, Crossing 2)

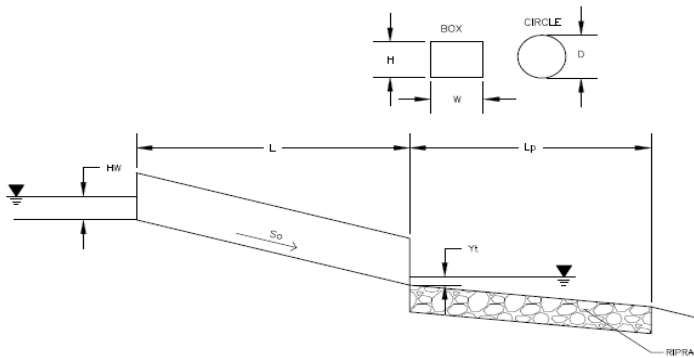

**Soil Type:**

Choose One:

- Sandy  
 Non-Sandy

**Supercritical Flow! Using Adjusted Diameter to calculate protection type.**

Design Information:	
Design Discharge	Q = <input type="text" value="2.2"/> cfs
<b>Circular Culvert:</b>	
Barrel Diameter in Inches	D = <input type="text" value="18"/> inches
Inlet Edge Type (Choose from pull-down list)	
<b>OR:</b>	
<b>Box Culvert:</b>	
Barrel Height (Rise) in Feet	H (Rise) = <input type="text"/> ft
Barrel Width (Span) in Feet	W (Span) = <input type="text"/> ft
Inlet Edge Type (Choose from pull-down list)	
Number of Barrels	# Barrels = <input type="text" value="1"/>
Inlet Elevation	Elev IN = <input type="text" value="5423.24"/> ft
Outlet Elevation <b>OR</b> Slope	Elev OUT = <input type="text" value="5423"/> ft
Culvert Length	L = <input type="text" value="48.24"/> ft
Manning's Roughness	n = <input type="text" value="0.013"/>
Bend Loss Coefficient	k <sub>b</sub> = <input type="text" value="0"/>
Exit Loss Coefficient	k <sub>x</sub> = <input type="text" value="1"/>
Tailwater Surface Elevation	Y <sub>t</sub> , Elevation = <input type="text" value="5424.03"/> ft
Max Allowable Channel Velocity	V = <input type="text" value="1.57"/> ft/s
Calculated Results:	
Culvert Cross Sectional Area Available	A = <input type="text" value="1.77"/> ft <sup>2</sup>
Culvert Normal Depth	Y <sub>n</sub> = <input type="text" value="0.56"/> ft
Culvert Critical Depth	Y <sub>c</sub> = <input type="text" value="0.56"/> ft
Froude Number	Fr = <input type="text" value="1.00"/> <span style="color: red;">Supercritical!</span>
Entrance Loss Coefficient	k <sub>e</sub> = <input type="text" value="0.50"/>
Friction Loss Coefficient	k <sub>f</sub> = <input type="text" value="0.87"/>
Sum of All Loss Coefficients	k <sub>s</sub> = <input type="text" value="2.37"/> ft
<b>Headwater:</b>	
Inlet Control Headwater	HW <sub>I</sub> = <input type="text" value="0.78"/> ft
Outlet Control Headwater	HW <sub>O</sub> = <input type="text" value="N/A"/> ft
<b>Design Headwater Elevation</b>	<b>HW = <input type="text" value="N/A"/> ft</b>
<b>Headwater/Diameter OR Headwater/Rise Ratio</b>	<b>HW/D = <input type="text" value="N/A"/></b>
<b>Outlet Control Headwater Approximation Method Inaccurate for Low Flow - Backwater Calculations Required</b>	
<b>Outlet Protection:</b>	
Flow/(Diameter <sup>2.5</sup> )	Q/D <sup>2.5</sup> = <input type="text" value="0.80"/> ft <sup>0.5</sup> /s
Tailwater Surface Height	Y <sub>t</sub> = <input type="text" value="1.03"/> ft
Tailwater/Diameter	Y <sub>t</sub> /D = <input type="text" value="0.69"/>
Expansion Factor	1/(2*tan(Θ)) = <input type="text" value="6.70"/>
Flow Area at Max Channel Velocity	A <sub>t</sub> = <input type="text" value="1.40"/> ft <sup>2</sup>
Width of Equivalent Conduit for Multiple Barrels	W <sub>eq</sub> = <input type="text" value="-"/> ft
<b>Length of Riprap Protection</b>	<b>L<sub>p</sub> = <input type="text" value="5"/> ft</b>
<b>Width of Riprap Protection at Downstream End</b>	<b>T = <input type="text" value="3"/> ft</b>
Adjusted Diameter for Supercritical Flow	Da = <input type="text" value="1.03"/> ft
Minimum Theoretical Riprap Size	d <sub>50</sub> min = <input type="text" value="1"/> in
Nominal Riprap Size	d <sub>50</sub> nominal = <input type="text" value="6"/> in
<b>MHFD Riprap Type</b>	<b>Type = <input type="text" value="VL"/></b>

# Culvert Report

## Culvert #8 (Area 7 - Crossing 1)

Invert Elev Dn (ft)	= 5425.04
Pipe Length (ft)	= 32.48
Slope (%)	= 1.42
Invert Elev Up (ft)	= 5425.50
Rise (in)	= 18.0
Shape	= Circular
Span (in)	= 18.0
No. Barrels	= 1
n-Value	= 0.013
Culvert Type	= Circular Concrete
Culvert Entrance	= Square edge w/headwall (C)
Coeff. K,M,c,Y,k	= 0.0098, 2, 0.0398, 0.67, 0.5

### Embankment

Top Elevation (ft)	= 5428.86
Top Width (ft)	= 16.00
Crest Width (ft)	= 32.48

### Calculations

Qmin (cfs)	= 2.60
Qmax (cfs)	= 2.60
Tailwater Elev (ft)	= (dc+D)/2

### Highlighted

Qtotal (cfs)	= 2.60
Qpipe (cfs)	= 2.60
Qovertop (cfs)	= 0.00
Veloc Dn (ft/s)	= 1.96
Veloc Up (ft/s)	= 3.85
HGL Dn (ft)	= 5426.10
HGL Up (ft)	= 5426.11
Hw Elev (ft)	= 5426.35
Hw/D (ft)	= 0.57
Flow Regime	= Inlet Control

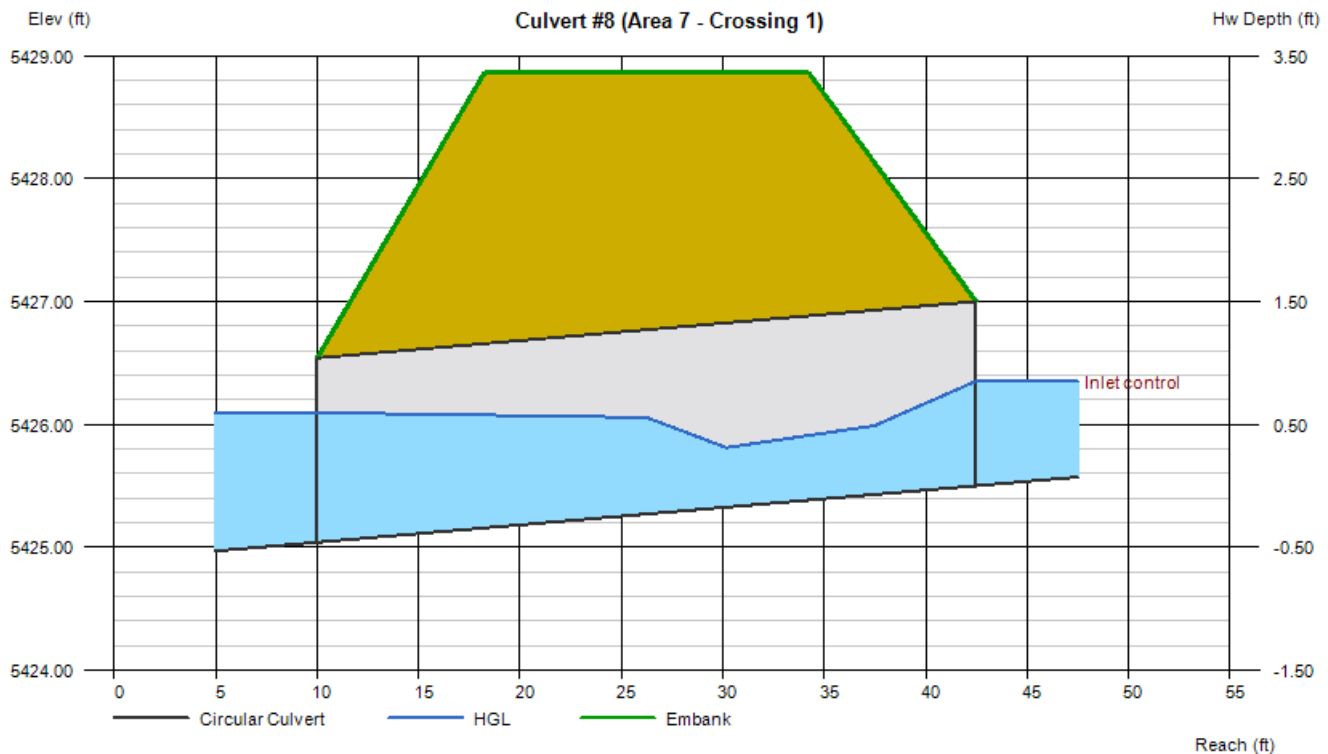

# DETERMINATION OF CULVERT HEADWATER AND OUTLET PROTECTION

MHFD-Culvert, Version 4.00 (May 2020)

**Project:** Pike Solar  
**ID:** Culvert #8 (Area 7, Crossing 1)

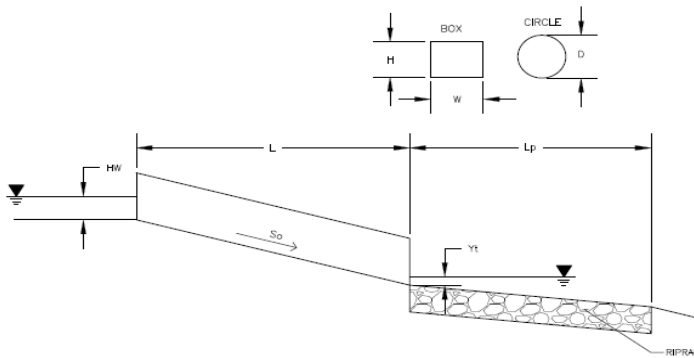

**Soil Type:**

Choose One:

- Sandy  
 Non-Sandy

**Supercritical Flow! Using Adjusted Diameter to calculate protection type.**

Design Information:	
Design Discharge	Q = <input type="text" value="2.6"/> cfs
<b>Circular Culvert:</b>	
Barrel Diameter in Inches	D = <input type="text" value="18"/> inches
Inlet Edge Type (Choose from pull-down list)	
<b>OR:</b>	
<b>Box Culvert:</b>	
Barrel Height (Rise) in Feet	H (Rise) = <input type="text"/> ft
Barrel Width (Span) in Feet	W (Span) = <input type="text"/> ft
Inlet Edge Type (Choose from pull-down list)	
Number of Barrels	# Barrels = <input type="text" value="1"/>
Inlet Elevation	Elev IN = <input type="text" value="5425.5"/> ft
Outlet Elevation <b>OR</b> Slope	Elev OUT = <input type="text" value="5425.04"/> ft
Culvert Length	L = <input type="text" value="32.48"/> ft
Manning's Roughness	n = <input type="text" value="0.013"/>
Bend Loss Coefficient	k <sub>b</sub> = <input type="text" value="0"/>
Exit Loss Coefficient	k <sub>x</sub> = <input type="text" value="1"/>
Tailwater Surface Elevation	Y <sub>t</sub> , Elevation = <input type="text" value="5426.1"/> ft
Max Allowable Channel Velocity	V = <input type="text" value="1.57"/> ft/s
Calculated Results:	
Culvert Cross Sectional Area Available	A = <input type="text" value="1.77"/> ft <sup>2</sup>
Culvert Normal Depth	Y <sub>n</sub> = <input type="text" value="0.46"/> ft
Culvert Critical Depth	Y <sub>c</sub> = <input type="text" value="0.61"/> ft
Froude Number	Fr = <input type="text" value="1.70"/> <span style="color: red; font-weight: bold;">Supercritical!</span>
Entrance Loss Coefficient	k <sub>e</sub> = <input type="text" value="0.50"/>
Friction Loss Coefficient	k <sub>f</sub> = <input type="text" value="0.59"/>
Sum of All Loss Coefficients	k <sub>s</sub> = <input type="text" value="2.09"/> ft
<b>Headwater:</b>	
Inlet Control Headwater	HW <sub>I</sub> = <input type="text" value="0.86"/> ft
Outlet Control Headwater	HW <sub>O</sub> = <input type="text" value="N/A"/> ft
<b>Design Headwater Elevation</b>	<b>HW = <input type="text" value="N/A"/> ft</b>
<b>Headwater/Diameter OR Headwater/Rise Ratio</b>	<b>HW/D = <input type="text" value="N/A"/></b>
Outlet Control Headwater Approximation Method Inaccurate for Low Flow - Backwater Calculations Required	
<b>Outlet Protection:</b>	
Flow/(Diameter <sup>2.5</sup> )	Q/D <sup>2.5</sup> = <input type="text" value="0.94"/> ft <sup>0.5</sup> /s
Tailwater Surface Height	Y <sub>t</sub> = <input type="text" value="1.06"/> ft
Tailwater/Diameter	Y <sub>t</sub> /D = <input type="text" value="0.71"/>
Expansion Factor	1/(2*tan(Θ)) = <input type="text" value="6.70"/>
Flow Area at Max Channel Velocity	A <sub>t</sub> = <input type="text" value="1.66"/> ft <sup>2</sup>
Width of Equivalent Conduit for Multiple Barrels	W <sub>eq</sub> = <input type="text" value="-"/> ft
<b>Length of Riprap Protection</b>	<b>L<sub>p</sub> = <input type="text" value="5"/> ft</b>
<b>Width of Riprap Protection at Downstream End</b>	<b>T = <input type="text" value="3"/> ft</b>
Adjusted Diameter for Supercritical Flow	Da = <input type="text" value="0.98"/> ft
Minimum Theoretical Riprap Size	d <sub>50</sub> min = <input type="text" value="1"/> in
Nominal Riprap Size	d <sub>50</sub> nominal = <input type="text" value="6"/> in
<b>MHFD Riprap Type</b>	<b>Type = <input type="text" value="VL"/></b>

# Culvert Report

## Culvert #9 (Area 7 - Crossing 2)

Invert Elev Dn (ft)	= 5378.43
Pipe Length (ft)	= 29.19
Slope (%)	= 0.89
Invert Elev Up (ft)	= 5378.69
Rise (in)	= 18.0
Shape	= Circular
Span (in)	= 18.0
No. Barrels	= 3
n-Value	= 0.013
Culvert Type	= Circular Concrete
Culvert Entrance	= Square edge w/headwall (C)
Coeff. K,M,c,Y,k	= 0.0098, 2, 0.0398, 0.67, 0.5

<b>Embankment</b>	
Top Elevation (ft)	= 5381.72
Top Width (ft)	= 16.00
Crest Width (ft)	= 29.19

<b>Calculations</b>	
Qmin (cfs)	= 36.90
Qmax (cfs)	= 36.90
Tailwater Elev (ft)	= (dc+D)/2

<b>Highlighted</b>	
Qtotal (cfs)	= 36.90
Qpipe (cfs)	= 36.90
Qovertop (cfs)	= 0.00
Veloc Dn (ft/s)	= 7.13
Veloc Up (ft/s)	= 6.96
HGL Dn (ft)	= 5379.84
HGL Up (ft)	= 5380.25
Hw Elev (ft)	= 5381.62
Hw/D (ft)	= 1.95
Flow Regime	= Inlet Control

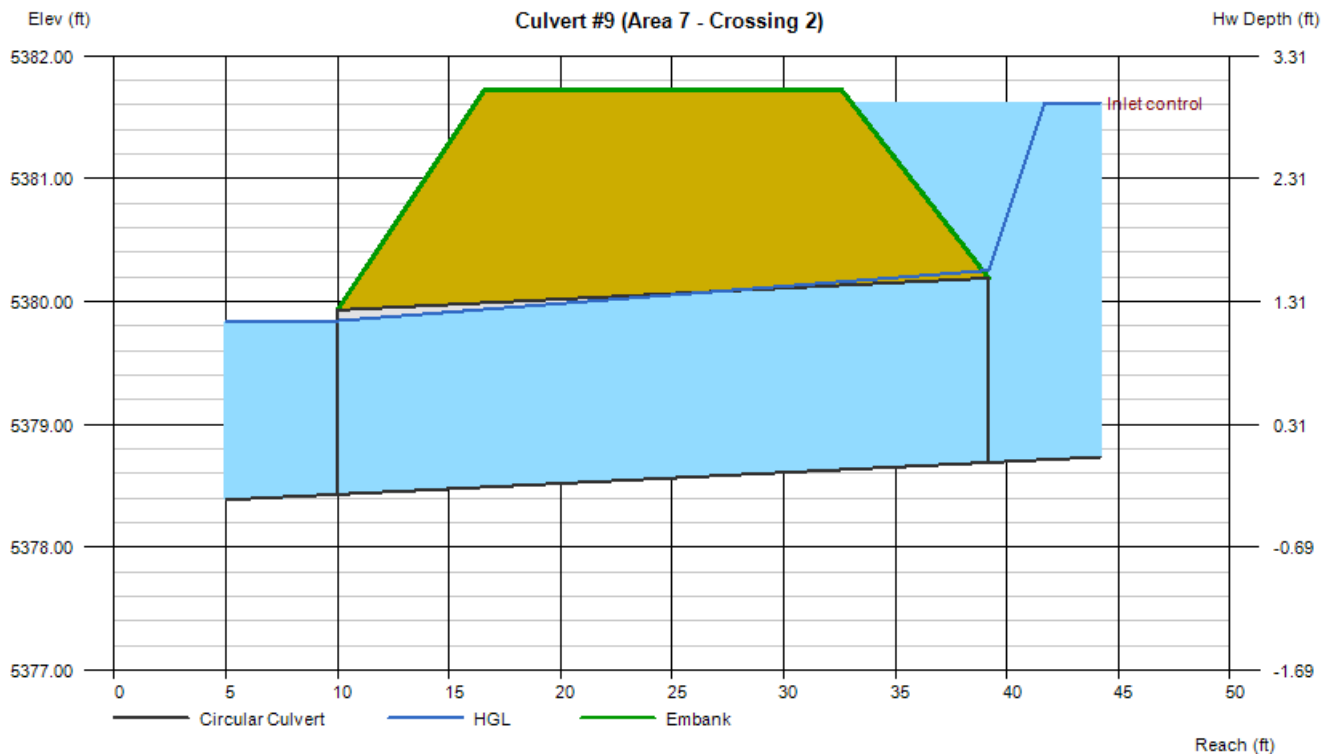

# DETERMINATION OF CULVERT HEADWATER AND OUTLET PROTECTION

*MHFD-Culvert, Version 4.00 (May 2020)*

**Project:** Pike Solar  
**ID:** Culvert #9 (Area 7, Crossing 2)

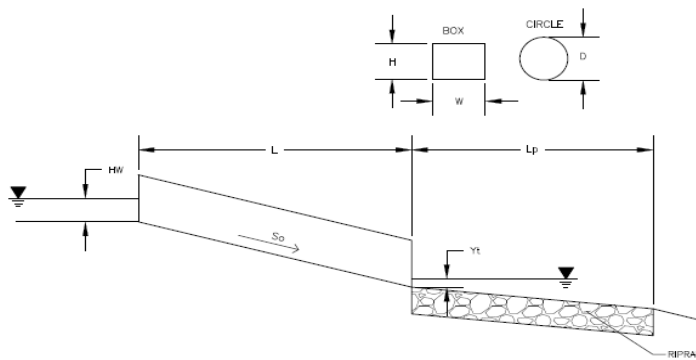

**Soil Type:**

Choose One:

- Sandy  
 Non-Sandy

**Design Information:**

Design Discharge	Q = <input type="text" value="36.9"/> cfs
<b>Circular Culvert:</b>	
Barrel Diameter in Inches	D = <input type="text" value="18"/> inches
Inlet Edge Type (Choose from pull-down list)	
<b>OR:</b>	
<b>Box Culvert:</b>	
Barrel Height (Rise) in Feet	H (Rise) = <input type="text"/> ft
Barrel Width (Span) in Feet	W (Span) = <input type="text"/> ft
Inlet Edge Type (Choose from pull-down list)	
Number of Barrels	# Barrels = <input type="text" value="3"/>
Inlet Elevation	Elev IN = <input type="text" value="5378.69"/> ft
Outlet Elevation <b>OR</b> Slope	Elev OUT = <input type="text" value="5378.43"/> ft
Culvert Length	L = <input type="text" value="29.19"/> ft
Manning's Roughness	n = <input type="text" value="0.013"/>
Bend Loss Coefficient	k <sub>b</sub> = <input type="text" value="0"/>
Exit Loss Coefficient	k <sub>x</sub> = <input type="text" value="1"/>
Tailwater Surface Elevation	Y <sub>t</sub> , Elevation = <input type="text" value="5379.84"/> ft
Max Allowable Channel Velocity	V = <input type="text" value="6.97"/> ft/s

**Calculated Results:**

Culvert Cross Sectional Area Available	A = <input type="text" value="1.77"/> ft <sup>2</sup>
Culvert Normal Depth	Y <sub>n</sub> = <input type="text" value="1.50"/> ft
Culvert Critical Depth	Y <sub>c</sub> = <input type="text" value="1.33"/> ft
Froude Number	Fr = <input type="text" value="-"/> <b>Pressure flow!</b>
Entrance Loss Coefficient	k <sub>e</sub> = <input type="text" value="0.50"/>
Friction Loss Coefficient	k <sub>f</sub> = <input type="text" value="0.53"/>
Sum of All Loss Coefficients	k <sub>s</sub> = <input type="text" value="2.03"/> ft
<b>Headwater:</b>	
Inlet Control Headwater	HW <sub>I</sub> = <input type="text" value="2.91"/> ft
Outlet Control Headwater	HW <sub>O</sub> = <input type="text" value="2.68"/> ft
<b>Design Headwater Elevation</b>	<b>HW = <input type="text" value="5381.60"/> ft</b>
<b>Headwater/Diameter OR Headwater/Rise Ratio</b>	<b>HW/D = <input type="text" value="1.94"/> <b>HW/D &gt; 1.5!</b></b>
<b>Outlet Protection:</b>	
Flow/(Diameter <sup>2.5</sup> )	Q/D <sup>2.5</sup> = <input type="text" value="4.46"/> ft <sup>0.5</sup> /s
Tailwater Surface Height	Y <sub>t</sub> = <input type="text" value="1.41"/> ft
Tailwater/Diameter	Y <sub>t</sub> /D = <input type="text" value="0.94"/>
Expansion Factor	1/(2*tan(θ)) = <input type="text" value="5.98"/>
Flow Area at Max Channel Velocity	A <sub>t</sub> = <input type="text" value="5.29"/> ft <sup>2</sup>
Width of Equivalent Conduit for Multiple Barrels	W <sub>eq</sub> = <input type="text" value="4.50"/> ft
<b>Length of Riprap Protection</b>	<b>L<sub>p</sub> = <input type="text" value="5"/> ft</b>
<b>Width of Riprap Protection at Downstream End</b>	<b>T = <input type="text" value="6"/> ft</b>
Adjusted Diameter for Supercritical Flow	Da = <input type="text" value="-"/> ft
Minimum Theoretical Riprap Size	d <sub>50</sub> min = <input type="text" value="2"/> in
Nominal Riprap Size	d <sub>50</sub> nominal = <input type="text" value="6"/> in
<b>MHFD Riprap Type</b>	<b>Type = <input type="text" value="VL"/></b>



## Design Procedure Form: Runoff Reduction

UD-BMP (Version 3.07, March 2018)

Sheet 1 of 1

**Designer:** Rob Hansen  
**Company:** CORE Consultants  
**Date:** August 25, 2022  
**Project:** Pike Solar  
**Location:** El Paso County

### SITE INFORMATION (User Input in Blue Cells)

WQCV Rainfall Depth = 0.60 inches  
 Depth of Average Runoff Producing Storm,  $d_6$  = 0.43 inches (for Watersheds Outside of the Denver Region, Figure 3-1 in USDCM V

Area Type	UIA:RPA	UIA:RPA	UIA:RPA	UIA:RPA	UIA:RPA			
Area ID	Typ.	O&M	Substation 1	Substation 2	Substation 3			
Downstream Design Point ID	Typ.	O&M	SUB	SUB	SUB			
Downstream BMP Type	None	None	None	None	None			
DCIA (ft <sup>2</sup> )	--	--	--	--	--			
UIA (ft <sup>2</sup> )	2,000	4,819	42,000	9,318	2,202			
RPA (ft <sup>2</sup> )	1,800	4,329	32,809	8,173	3,470			
SPA (ft <sup>2</sup> )	--	--	--	--	--			
HSG A (%)	0%	0%	0%	0%	0%			
HSG B (%)	0%	0%	0%	0%	0%			
HSG C/D (%)	100%	100%	100%	100%	100%			
Average Slope of RPA (ft/ft)	0.050	0.050	0.030	0.040	0.040			
UIA:RPA Interface Width (ft)	100.00	144.00	298.26	326.90	138.80			

### CALCULATED RUNOFF RESULTS

Area ID	Typ.	O&M	Substation 1	Substation 2	Substation 3			
UIA:RPA Area (ft <sup>2</sup> )	3,800	9,148	74,809	17,491	5,672			
L / W Ratio	0.38	0.44	0.84	0.16	0.29			
UIA / Area	0.5263	0.5268	0.5614	0.5327	0.3882			
Runoff (in)	0.00	0.00	0.00	0.00	0.00			
Runoff (ft <sup>3</sup> )	0	0	0	0	0			
Runoff Reduction (ft <sup>3</sup> )	83	201	1750	388	92			

### CALCULATED WQCV RESULTS

Area ID	Typ.	O&M	Substation 1	Substation 2	Substation 3			
WQCV (ft <sup>3</sup> )	83	201	1750	388	92			
WQCV Reduction (ft <sup>3</sup> )	83	201	1750	388	92			
WQCV Reduction (%)	100%	100%	100%	100%	100%			
Untreated WQCV (ft <sup>3</sup> )	0	0	0	0	0			

### CALCULATED DESIGN POINT RESULTS (sums results from all columns with the same Downstream Design Point ID)

Downstream Design Point ID	Typ.	O&M	SUB					
DCIA (ft <sup>2</sup> )	0	0	0					
UIA (ft <sup>2</sup> )	2,000	4,819	53,520					
RPA (ft <sup>2</sup> )	1,800	4,329	44,451					
SPA (ft <sup>2</sup> )	0	0	0					
Total Area (ft <sup>2</sup> )	3,800	9,148	97,971					
Total Impervious Area (ft <sup>2</sup> )	2,000	4,819	53,520					
WQCV (ft <sup>3</sup> )	83	201	2,230					
WQCV Reduction (ft <sup>3</sup> )	83	201	2,230					
WQCV Reduction (%)	100%	100%	100%					
Untreated WQCV (ft <sup>3</sup> )	0	0	0					

### CALCULATED SITE RESULTS (sums results from all columns in worksheet)

Total Area (ft <sup>2</sup> )	110,919
Total Impervious Area (ft <sup>2</sup> )	60,339
WQCV (ft <sup>3</sup> )	2,514
WQCV Reduction (ft <sup>3</sup> )	2,514
WQCV Reduction (%)	100%
Untreated WQCV (ft <sup>3</sup> )	0

**APPENDIX D**  
**FLOODPLAIN USE MEMORANDUM & NO-RISE ANALYSIS**



April 6, 2021

Keith Curtis  
Pikes Peak Regional Building Department  
2800 International Circle  
Colorado Springs, Colorado 80910

**RE: Pike Solar Project – Floodplain Use Permit**

Dear Mr. Curtis:

This letter has been prepared to provide information in support of the issuance of a Floodplain Use Permit for the Pike Solar Project (the "Project"). The Project is currently a vacant site located on approximately 1,240 acres southeast of City of Fountain in El Paso County, Colorado and is bound by Squirrel Creek Road to the north, Hammer Road to the east, Hanover Road to the south, and Old Pueblo Road to the west. The proposed improvements to the site consist of 175 megawatt (MW) photovoltaic solar facility and up to 50 MW battery energy storage system consisting of photovoltaic modules aligned in arrays and affixed to a single-axis tracking system. The project is tributary to Williams Creek with portions of the site falling within Zone A on the Federal Emergency Management Agency (FEMA) Flood Insurance Rate Map (FIRM) panels 08041C0967G, 08041C0970G, 08041C1000G, 08041C1160G, and 08041C1180G.

Construction activities that would occur in the mapped floodplain consist of three separate access road crossings within the floodplain boundary. The access road crossings will be cut into the existing topography, guaranteeing that no fill will be placed within the mapped floodplain. In accordance with Pikes Peak Regional Building Department (PPRBD) guidelines for solar array projects within a mapped Zone A, the following basic design requirements have been met.

1. The mapped floodplain within the project boundary have been determined and are represented in the Preliminary Drainage Report and Wind/Solar Energy Generation Overlay (WSE-O) Plan.
2. Grading along site boundaries will be constructed at or below grades and will be compatible with upstream and downstream conditions.
3. Access drives across the mapped floodplain will be constructed at or below existing grades.
4. All electrical service equipment will be buried under the floodplain. There will be no permanent vertical structures, but there will be concrete low water crossings within the floodplain.
5. Access drives across the mapped floodplain will be constructed at or below existing grades.
6. There are no Regulated Riparian Habitats present on site.

I certify that I am a duly qualified registered Professional Engineer licensed in the state of Colorado. Using standard Engineering practice, I have evaluated the unstudied A zone

floodplain in the area of the proposed project, and I have determined pre-project 100-year flood depths. I certify that the cumulative effects of the proposed project Pike Solar as detailed on construction drawing sheets 49-51 will result in less than one foot rise in the 100-year flood elevations that I have determined for Williams Creek and Unnamed Tributary, which is shown on FEMA map 08041C0967G, 08041C1000G, and 08041C1180G. This certification is intended as proof of meeting the requirements set forth in the Federal Code 44CFR Chp. 1, 60.3.c.10.

I offer the following documentation in accordance with standard Engineering practice to support my findings:

- a) Cross Section 1 – 5 year – Existing
- b) Cross Section 1 – 5 year – Proposed
- c) Cross Section 1 – 100 year – Existing
- d) Cross Section 1 – 100 year – Proposed
- e) Cross Section 2 – 5 year – Existing
- f) Cross Section 2 – 5 year – Proposed
- g) Cross Section 2 – 100 year – Existing
- h) Cross Section 2 – 100 year – Proposed
- i) Cross Section 3 – 5 year – Existing
- j) Cross Section 3 – 5 year – Proposed
- k) Cross Section 3 – 100 year – Existing
- l) Cross Section 3 – 100 year – Proposed
- m) Pike Solar Construction Documents

CORE consultants believes that the proposed Pike Solar Project meets PPRBD's basic design requirements for Solar Array Projects and respectfully requests the issuance of a Floodplain Use Permit. All required WSE-O submittal documents and exhibits are being submitted along with this letter to El Paso County Development Services Department.

If you have any questions, please do not hesitate to call me at 303.730.5974.

Sincerely,  
**CORE Consultants, Inc.**



**David Bacci**  
Senior Project Engineer

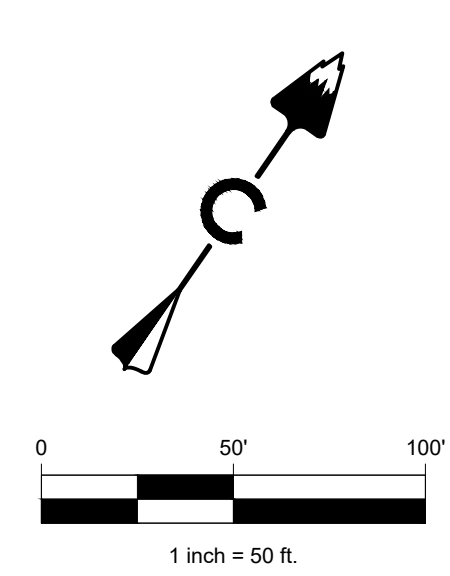
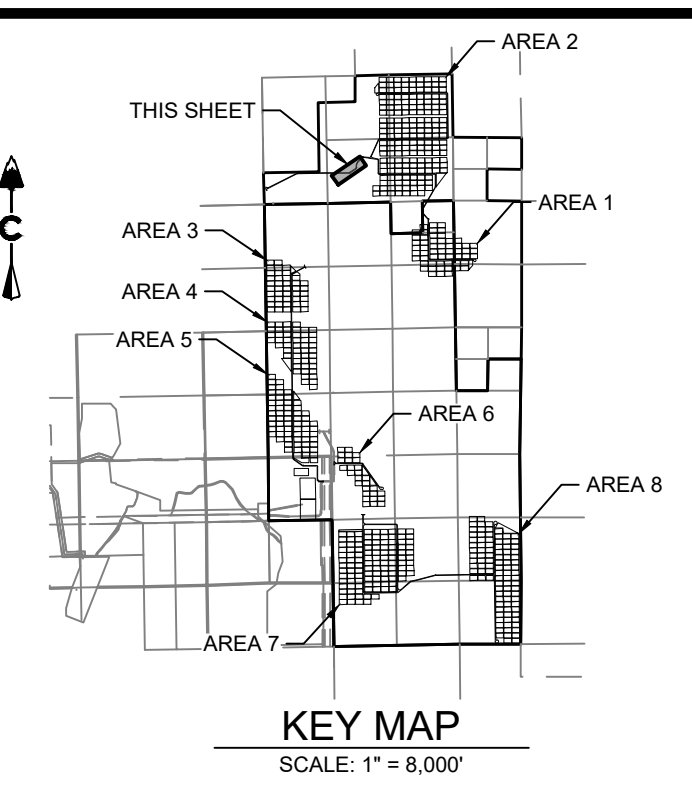
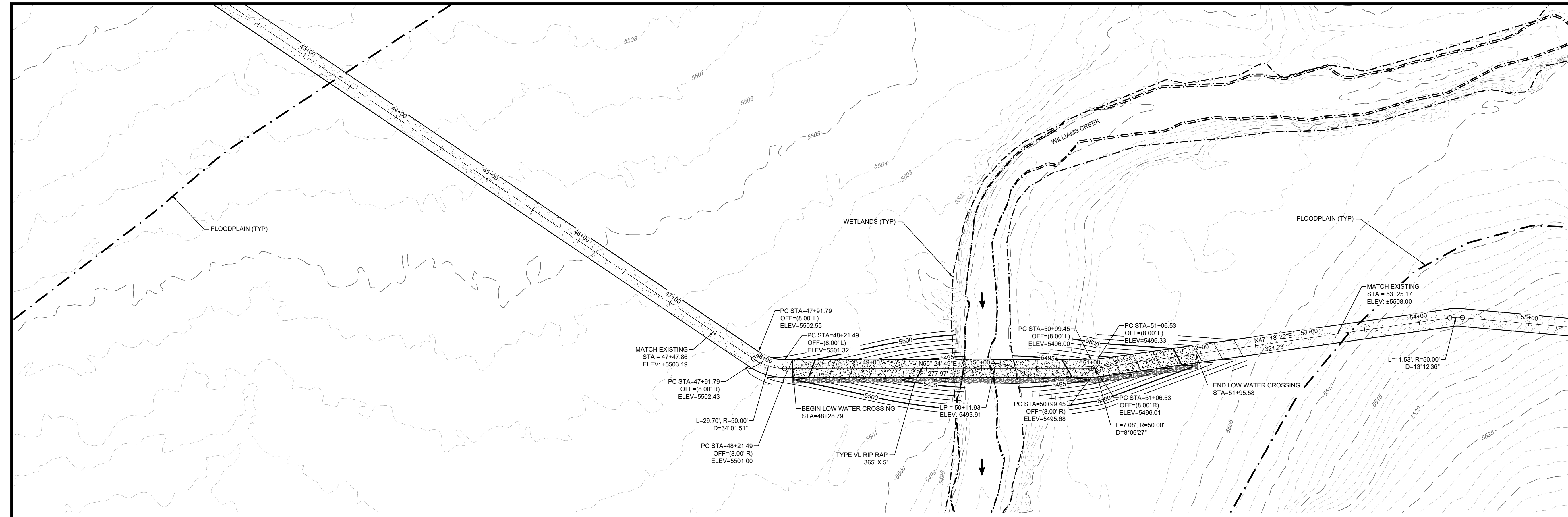

### FLOODPLAIN CROSSING #1 (43+00-54+00)

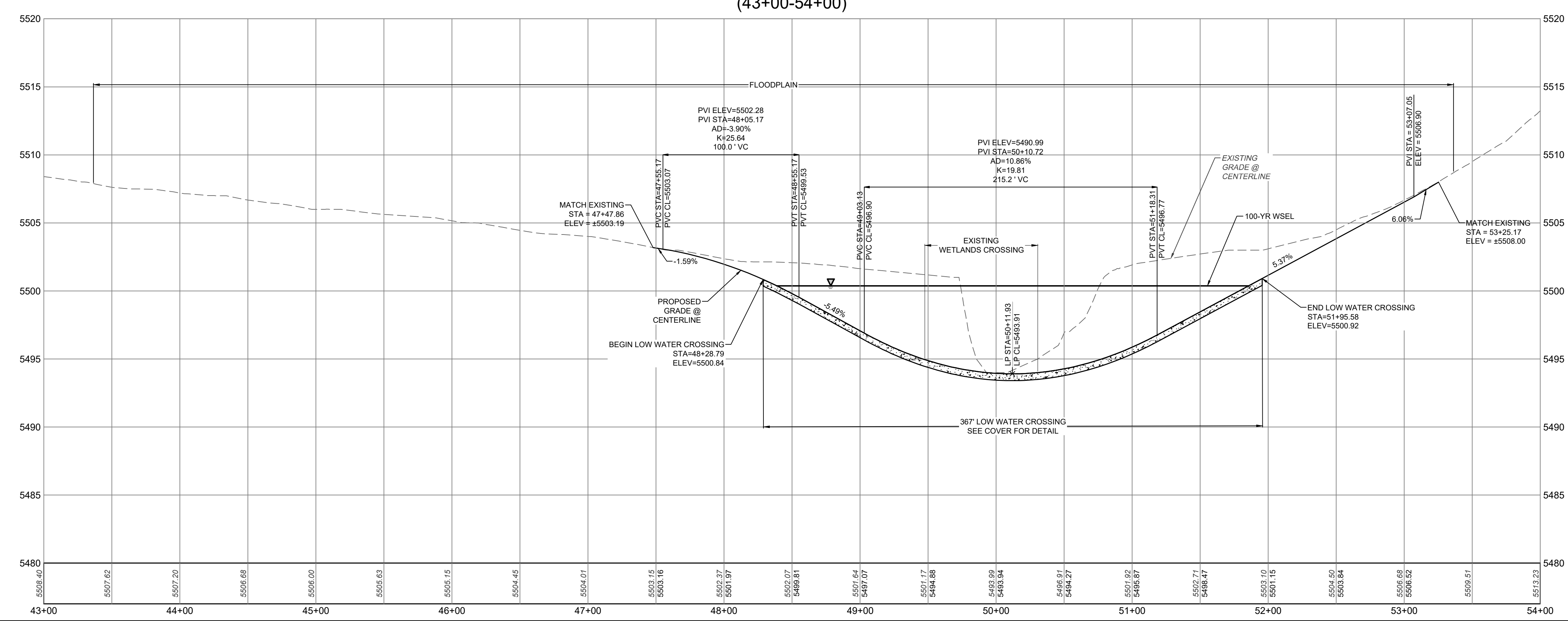

**LEGEND**

	EXISTING MAJOR CONTOUR
	EXISTING MINOR CONTOUR
	PROPOSED MAJOR CONTOUR
	PROPOSED MINOR CONTOUR
	PROJECT BOUNDARY
	CENTERLINE
	PROPOSED SOLAR TRACKER
	PROPOSED INVERTER
	PROPOSED FENCE
	EXISTING FENCE
	POWER POLES
	GUY WIRE
	WATER VALVES
	FIRE HYDRANTS
	EXISTING STORM MANHOLES
	EXISTING STORM & STUB OUT
	FLOODPLAIN
	JURISDICTIONAL WATER FEATURES
	WILLIAMS CREEK RES. EXPANSION
	EXISTING STORM
	EXISTING WATER
	EXISTING ELECTRIC
	EXISTING TELEPHONE
	EXISTING FIBER OPTIC
	EXISTING GAS
	EXISTING OVER HEAD ELECTRIC

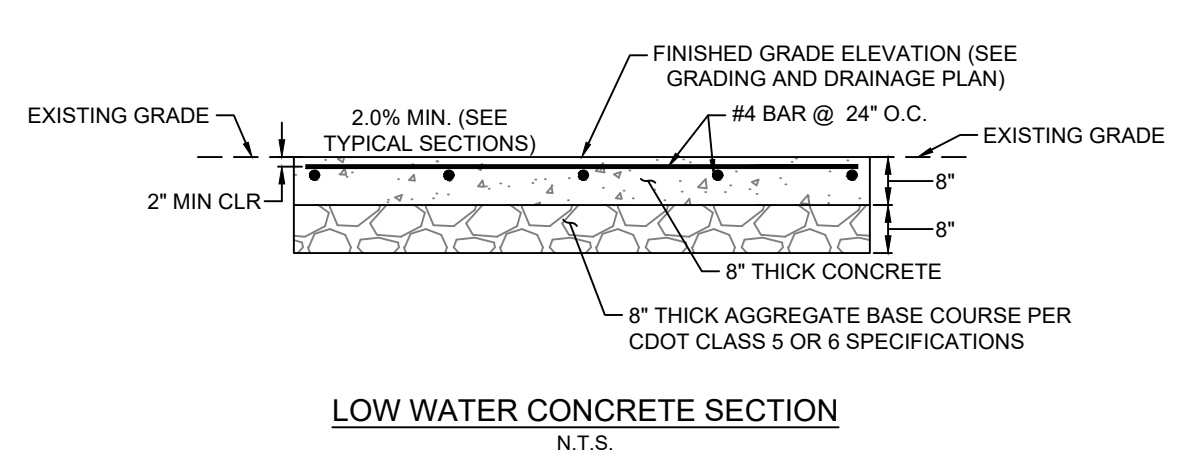

CORE CONSULTANTS, INC.  
 3473 S. BROADWAY  
 DENVER, CO 80113  
 303.703.4444  
 LIVEYOURCORE.COM

**CORE**  
 LAND DEVELOPMENT  
 ENERGY  
 PUBLIC INFRASTRUCTURE

Know what's below.  
 Call before you dig.  
**811**

#	REVISION DESCRIPTION	DATE	BY
1	SIGNATURE SET	08/25/22	RH

**PIKE SOLAR**  
 EL PASO COUNTY, COLORADO  
 CONSTRUCTION DOCUMENTS  
 FLOOD PLAN CROSSINGS #1 P&P

DESIGNED BY: BB  
 DRAWN BY: TP  
 CHECKED BY: DB

JOB NO.  
 20-194  
 SHEET  
 50 OF 67

02/22/2022 2:52 PM X:\20-194 PIKE SOLAR\CIVIL\CAD\PLANS\FILING\1CDS\FLOOD PLAN CROSSINGS.DWG

# Channel Report

## Cross Section 1 - 5 year - Existing

### User-defined

Invert Elev (ft) = 5494.00  
 Slope (%) = 0.10  
 N-Value = 0.030

### Highlighted

Depth (ft) = 1.88  
 Q (cfs) = 135.30  
 Area (sqft) = 77.13  
 Velocity (ft/s) = 1.75  
 Wetted Perim (ft) = 64.39  
 Crit Depth, Yc (ft) = 0.98  
 Top Width (ft) = 64.12  
 EGL (ft) = 1.93

### Calculations

Compute by: Known Q  
 Known Q (cfs) = 135.30

### (Sta, El, n)-(Sta, El, n)...

( 0.00, 5509.00, 0.030)-(97.00, 5508.00, 0.030)-(172.00, 5507.00, 0.030)-(242.00, 5506.00, 0.030)-(294.00, 5505.00, 0.030)-(342.00, 5504.00, 0.030)-(388.00, 5503.00, 0.030)-  
 -(452.00, 5502.00, 0.030)-(502.00, 5501.45, 0.030)-(551.00, 5501.00, 0.030)-(562.00, 5496.00, 0.030)-(570.00, 5494.00, 0.030)-(587.00, 5494.00, 0.030)-(609.00, 5494.00, 0.030)-  
 -(629.00, 5496.00, 0.030)-(665.00, 5501.00, 0.030)-(684.00, 5502.00, 0.030)-(743.00, 5503.00, 0.030)-(787.00, 5503.00, 0.030)-(808.00, 5504.00, 0.030)-(823.00, 5504.00, 0.030)-  
 -(837.00, 5506.00, 0.030)-(850.00, 5507.00, 0.030)-(865.00, 5508.00, 0.030)

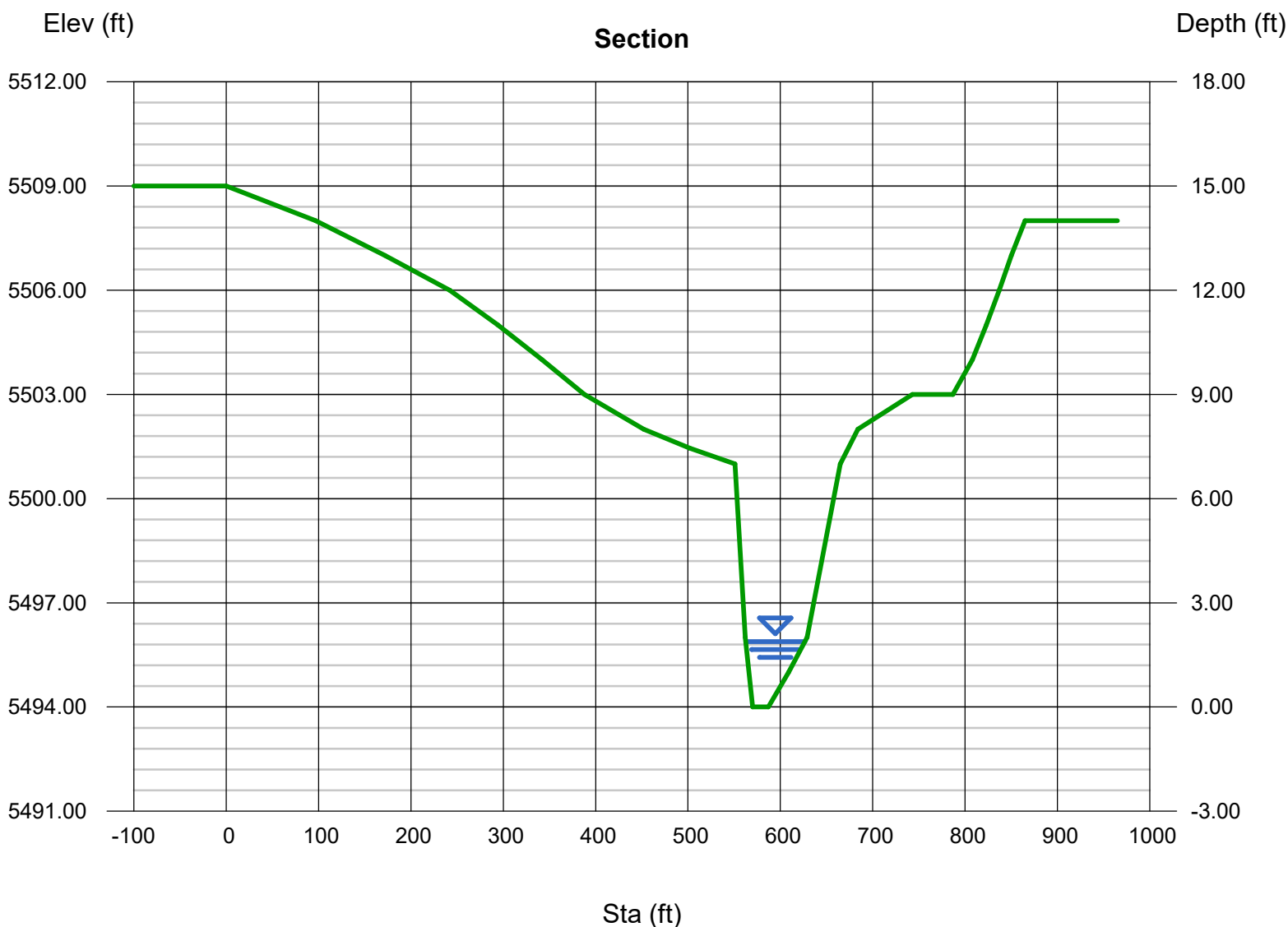

# Channel Report

## Cross Section 1 - 5 year - Proposed

### User-defined

Invert Elev (ft) = 5493.81  
 Slope (%) = 0.10  
 N-Value = 0.030

### Highlighted

Depth (ft) = 1.21  
 Q (cfs) = 135.30  
 Area (sqft) = 104.50  
 Velocity (ft/s) = 1.29  
 Wetted Perim (ft) = 138.98  
 Crit Depth, Yc (ft) = 0.63  
 Top Width (ft) = 138.95  
 EGL (ft) = 1.24

### Calculations

Compute by: Known Q  
 Known Q (cfs) = 135.30

### (Sta, El, n)-(Sta, El, n)...

( 0.00, 5509.00)-(97.00, 5508.00, 0.030)-(172.00, 5507.00, 0.030)-(242.00, 5506.00, 0.030)-(294.00, 5505.00, 0.030)-(342.00, 5504.00, 0.030)-(388.00, 5503.00, 0.030)  
 -(452.00, 5502.00, 0.030)-(472.00, 5501.00, 0.030)-(495.00, 5496.00, 0.030)-(503.00, 5495.85, 0.030)-(523.00, 5495.00, 0.030)-(565.00, 5494.00, 0.030)-(591.00, 5493.81, 0.030)  
 -(620.00, 5494.00, 0.030)-(661.00, 5495.00, 0.030)-(685.00, 5496.00, 0.030)-(703.00, 5497.00, 0.030)-(721.00, 5498.00, 0.030)-(739.00, 5499.00, 0.030)-(743.00, 5500.00, 0.030)  
 -(757.00, 5500.00, 0.030)-(773.00, 5503.00, 0.030)-(787.00, 5503.00, 0.030)-(808.00, 5504.00, 0.030)-(823.00, 5505.00, 0.030)-(838.00, 5506.00, 0.030)-(850.00, 5507.00, 0.030)  
 -(865.00, 5508.13, 0.030)

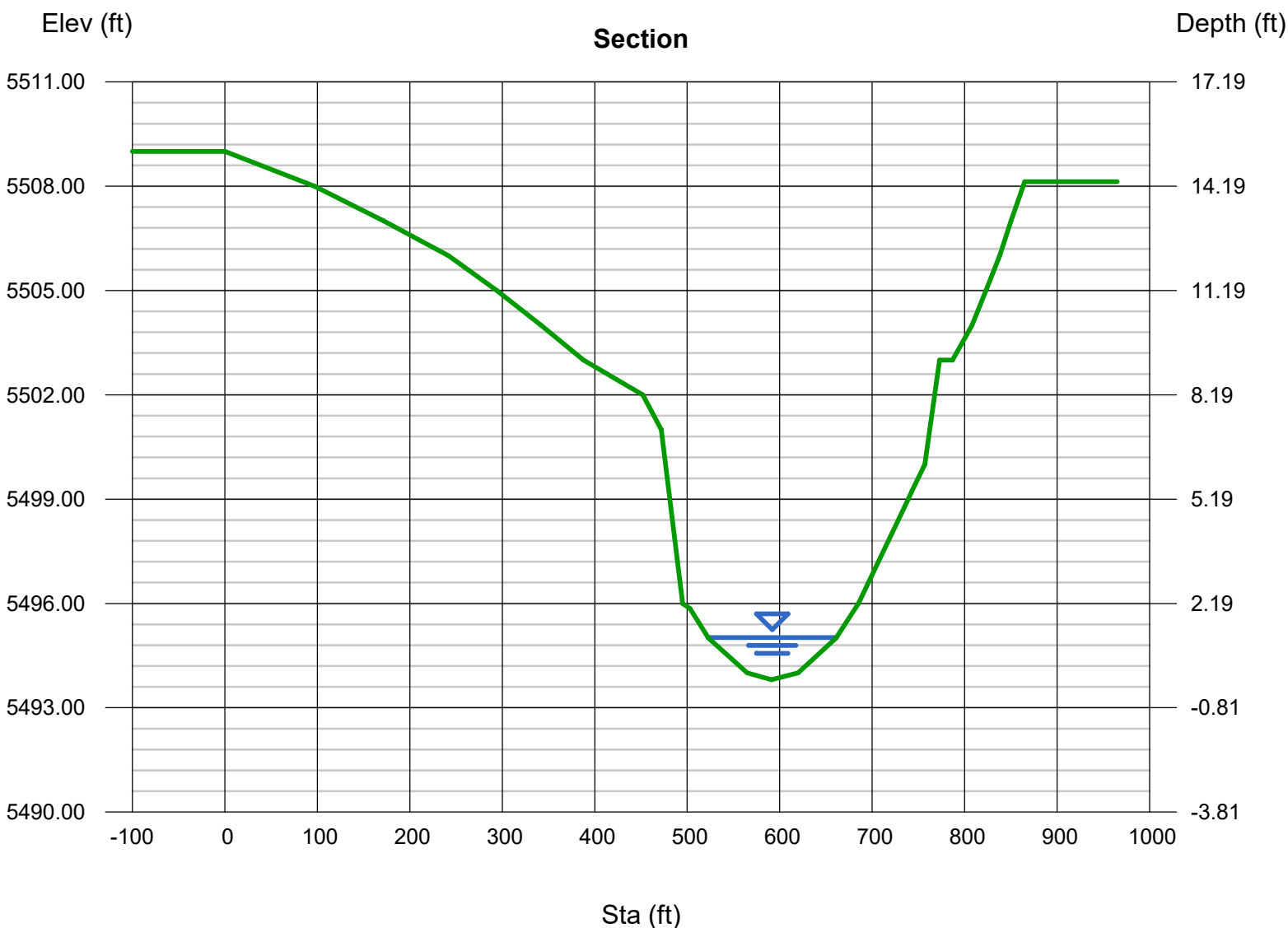

# Channel Report

## Cross Section 1 - 100 year - Existing

### User-defined

Invert Elev (ft) = 5494.00  
 Slope (%) = 0.10  
 N-Value = 0.030

### Highlighted

Depth (ft) = 10.33  
 Q (cfs) = 5,503  
 Area (sqft) = 1595.96  
 Velocity (ft/s) = 3.45  
 Wetted Perim (ft) = 488.61  
 Crit Depth, Yc (ft) = 6.37  
 Top Width (ft) = 486.79  
 EGL (ft) = 10.52

### Calculations

Compute by: Known Q  
 Known Q (cfs) = 5503.46

### (Sta, El, n)-(Sta, El, n)...

( 0.00, 5509.00)-(97.00, 5508.00, 0.030)-(172.00, 5507.00, 0.030)-(242.00, 5506.00, 0.030)-(294.00, 5505.00, 0.030)-(342.00, 5504.00, 0.030)-(388.00, 5503.00, 0.030)-  
 -(452.00, 5502.00, 0.030)-(502.00, 5501.45, 0.030)-(551.00, 5501.00, 0.030)-(562.00, 5496.00, 0.030)-(570.00, 5494.00, 0.030)-(587.00, 5494.00, 0.030)-(609.00, 5494.00, 0.030)-  
 -(629.00, 5496.00, 0.030)-(665.00, 5501.00, 0.030)-(684.00, 5502.00, 0.030)-(743.00, 5503.00, 0.030)-(787.00, 5503.00, 0.030)-(808.00, 5504.00, 0.030)-(823.00, 5504.00, 0.030)-  
 -(837.00, 5506.00, 0.030)-(850.00, 5507.00, 0.030)-(865.00, 5508.00, 0.030)

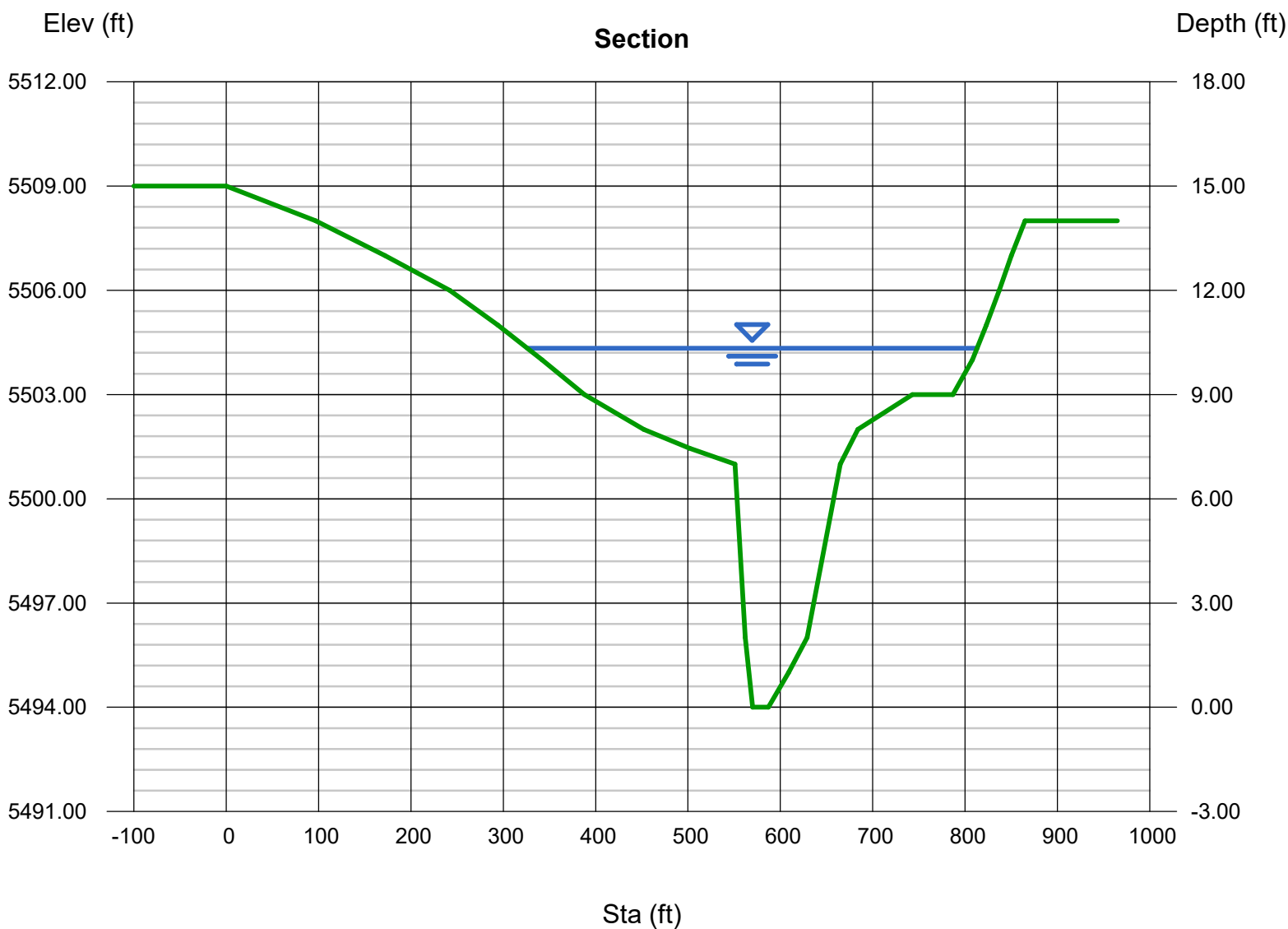



# Channel Report

## Cross Section 1 - 100 year - Proposed

### User-defined

Invert Elev (ft) = 5493.81  
 Slope (%) = 0.10  
 N-Value = 0.030

### Highlighted

Depth (ft) = 6.47  
 Q (cfs) = 5,503  
 Area (sqft) = 1283.53  
 Velocity (ft/s) = 4.29  
 Wetted Perim (ft) = 283.85  
 Crit Depth, Yc (ft) = 3.80  
 Top Width (ft) = 283.18  
 EGL (ft) = 6.76

### Calculations

Compute by: Known Q  
 Known Q (cfs) = 5503.46

### (Sta, El, n)-(Sta, El, n)...

( 0.00, 5509.00)-(97.00, 5508.00, 0.030)-(172.00, 5507.00, 0.030)-(242.00, 5506.00, 0.030)-(294.00, 5505.00, 0.030)-(342.00, 5504.00, 0.030)-(388.00, 5503.00, 0.030)  
 -(452.00, 5502.00, 0.030)-(472.00, 5501.00, 0.030)-(495.00, 5496.00, 0.030)-(503.00, 5495.85, 0.030)-(523.00, 5495.00, 0.030)-(565.00, 5494.00, 0.030)-(591.00, 5493.81, 0.030)  
 -(620.00, 5494.00, 0.030)-(661.00, 5495.00, 0.030)-(685.00, 5496.00, 0.030)-(703.00, 5497.00, 0.030)-(721.00, 5498.00, 0.030)-(739.00, 5499.00, 0.030)-(743.00, 5500.00, 0.030)  
 -(757.00, 5500.00, 0.030)-(773.00, 5503.00, 0.030)-(787.00, 5503.00, 0.030)-(808.00, 5504.00, 0.030)-(823.00, 5505.00, 0.030)-(838.00, 5506.00, 0.030)-(850.00, 5507.00, 0.030)  
 -(865.00, 5508.13, 0.030)

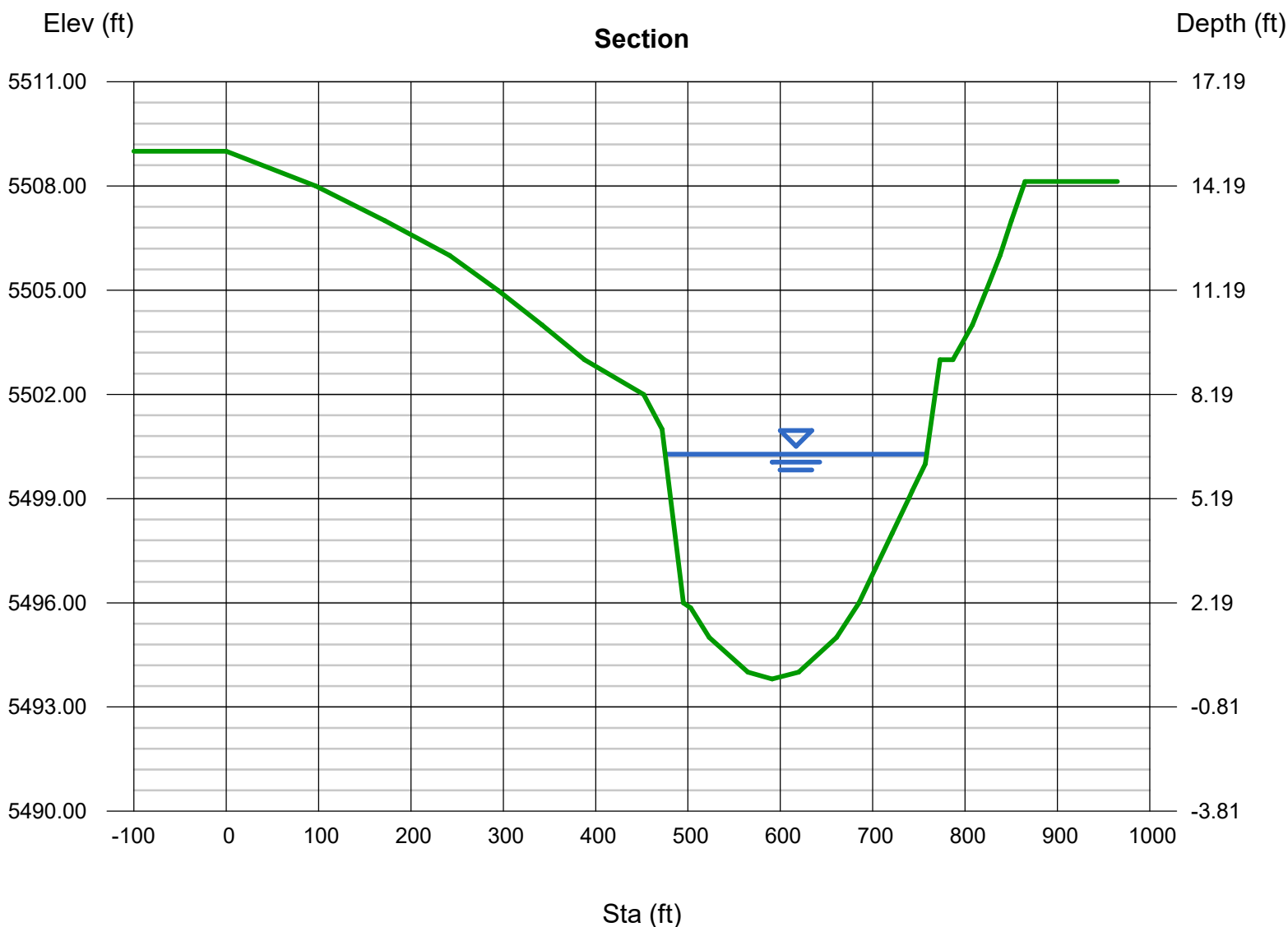

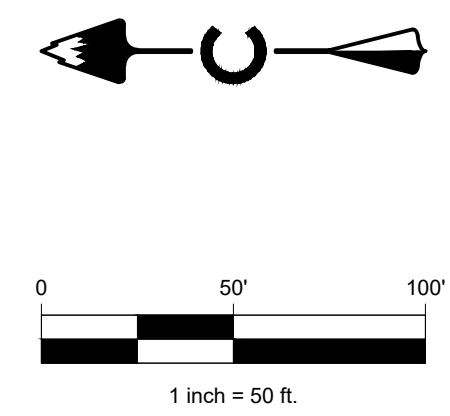
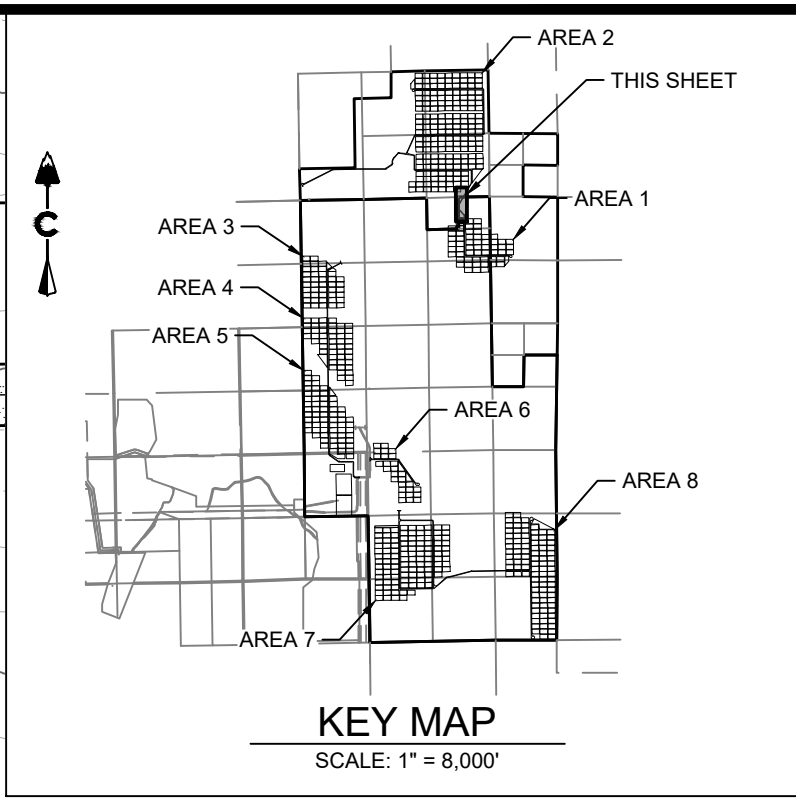
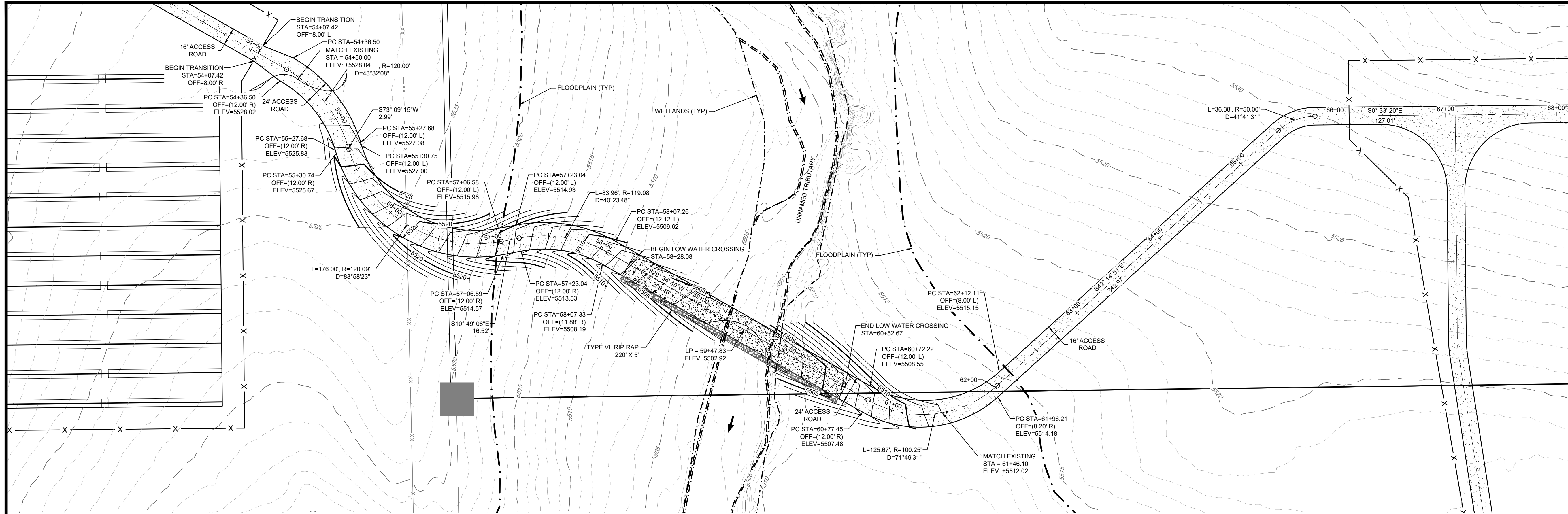

**LEGEND**

	EXISTING MAJOR CONTOUR
	EXISTING MINOR CONTOUR
	PROPOSED MAJOR CONTOUR
	PROPOSED MINOR CONTOUR
	PROJECT BOUNDARY
	CENTERLINE
	PROPOSED SOLAR TRACKER
	PROPOSED INVERTER
	PROPOSED FENCE
	EXISTING FENCE
	POWER POLES
	GUY WIRE
	WATER VALVES
	FIRE HYDRANTS
	EXISTING STORM MANHOLES
	EXISTING STORM & STUB OUT
	FLOODPLAIN
	JURISDICTIONAL WATER FEATURES
	WILLIAMS CREEK RES. EXPANSION
	EXISTING STORM
	EXISTING WATER
	EXISTING ELECTRIC
	EXISTING TELEPHONE
	EXISTING FIBER OPTIC
	EXISTING GAS
	EXISTING OVER HEAD ELECTRIC

**FLOODPLAIN CROSSING #2**  
(54+00-64+00)

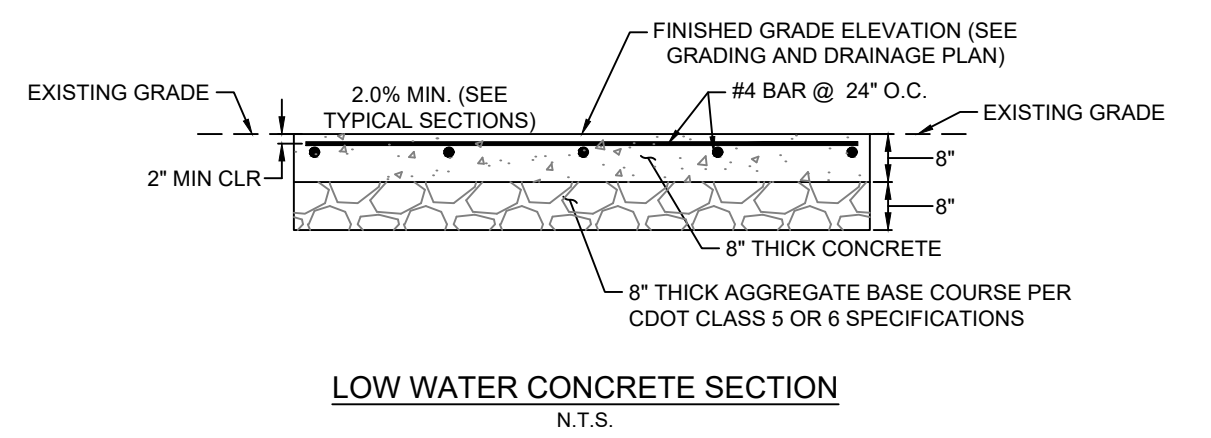
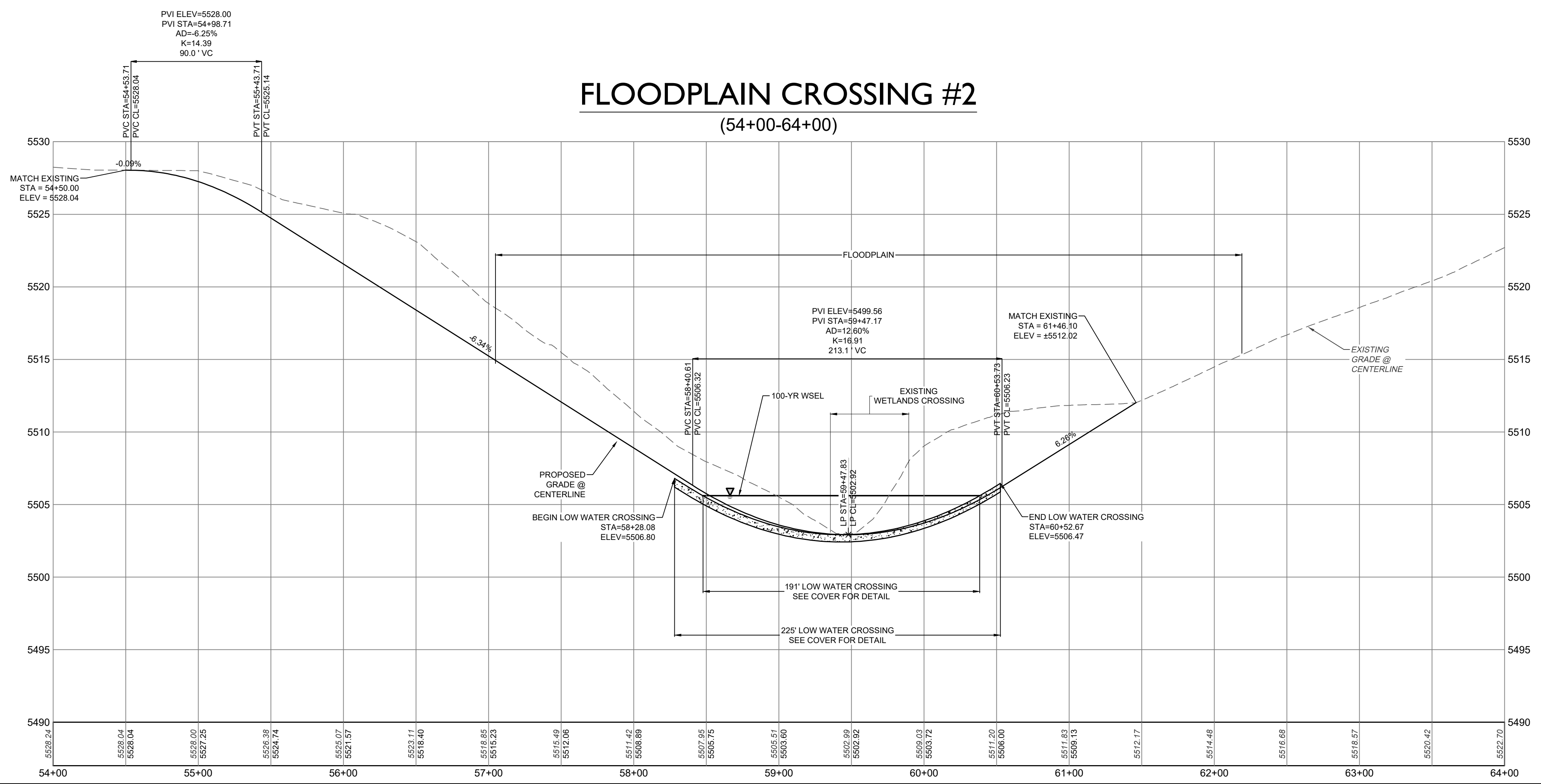

LAND DEVELOPMENT  
ENERGY  
PUBLIC INFRASTRUCTURE

CORE CONSULTANTS, INC.  
3473 S. BROADWAY  
DENVER, CO 80113  
303.703.4444  
LIVE@CORE.COM

**CORE**

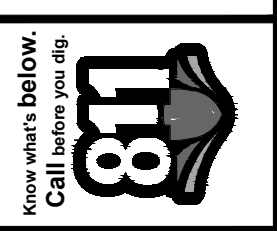

#	REVISION DESCRIPTION	DATE	BY
1	SIGNATURE SET	08/25/22	RH

**PIKE SOLAR**  
EL PASO COUNTY, COLORADO  
CONSTRUCTION DOCUMENTS  
FLOOD PLAN CROSSINGS #2 P&P

DESIGNED BY: BB  
DRAWN BY: TP  
CHECKED BY: DB

JOB NO.  
20-194  
SHEET  
51 OF 67

08/25/2022 2:52 PM X:\03-164 PIKE SOLAR\CHILCAD\PLANS\FILING 1\CDS\FLOOD PLAN CROSSINGS.DWG

# Channel Report

## Cross Section 2 - 5 year - Existing

### User-defined

Invert Elev (ft) = 5503.00  
 Slope (%) = 0.50  
 N-Value = 0.030

### Highlighted

Depth (ft) = 1.10  
 Q (cfs) = 87.09  
 Area (sqft) = 31.44  
 Velocity (ft/s) = 2.77  
 Wetted Perim (ft) = 44.28  
 Crit Depth, Yc (ft) = 0.84  
 Top Width (ft) = 44.20  
 EGL (ft) = 1.22

### Calculations

Compute by: Known Q  
 Known Q (cfs) = 87.09

### (Sta, El, n)-(Sta, El, n)...

(0.00, 5519.21)-(50.00, 5515.37, 0.030)-(100.00, 5511.25, 0.030)-(150.00, 5507.86, 0.030)-(170.32, 5506.97, 0.030)-(200.00, 5505.40, 0.030)-(208.04, 5504.95, 0.030)  
 -(220.59, 5504.02, 0.030)-(237.78, 5503.00, 0.030)-(250.00, 5503.00, 0.030)-(262.96, 5504.00, 0.030)-(270.36, 5504.99, 0.030)-(275.97, 5506.00, 0.030)-(282.27, 5507.00, 0.030)  
 -(287.77, 5508.02, 0.030)-(300.00, 5509.16, 0.030)-(312.55, 5509.91, 0.030)-(350.00, 5511.89, 0.030)-(400.00, 5514.19, 0.030)-(446.31, 5517.29, 0.030)

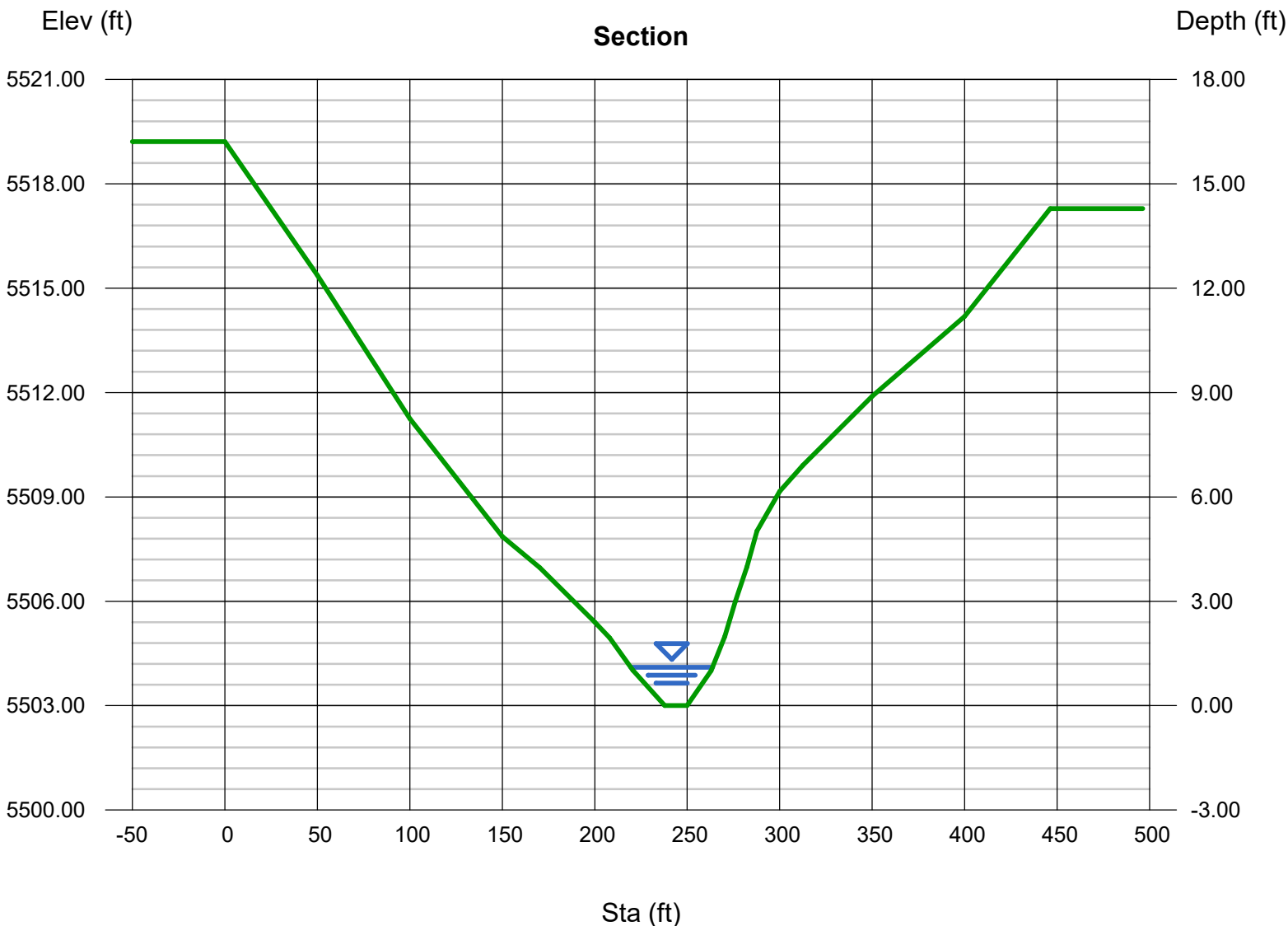

# Channel Report

## Cross Section 2 - 5 year - Proposed

### User-defined

Invert Elev (ft) = 5503.00  
Slope (%) = 0.50  
N-Value = 0.030

### Highlighted

Depth (ft) = 0.68  
Q (cfs) = 87.09  
Area (sqft) = 43.75  
Velocity (ft/s) = 1.99  
Wetted Perim (ft) = 97.67  
Crit Depth, Yc (ft) = 0.49  
Top Width (ft) = 97.66  
EGL (ft) = 0.74

### Calculations

Compute by: Known Q  
Known Q (cfs) = 87.09

### (Sta, El, n)-(Sta, El, n)...

(0.00, 5519.21)-(73.00, 5513.58, 0.030)-(102.00, 5508.01, 0.030)-(111.00, 5507.00, 0.030)-(129.00, 5506.00, 0.030)-(148.00, 5505.00, 0.030)-(174.00, 5504.00, 0.030)  
-(223.00, 5503.00, 0.030)-(254.00, 5503.00, 0.030)-(303.00, 5504.00, 0.030)-(313.00, 5504.34, 0.030)-(324.00, 5504.99, 0.030)-(353.00, 5512.00, 0.030)-(380.00, 5517.29, 0.030)  
-(447.00, 5517.29, 0.030)

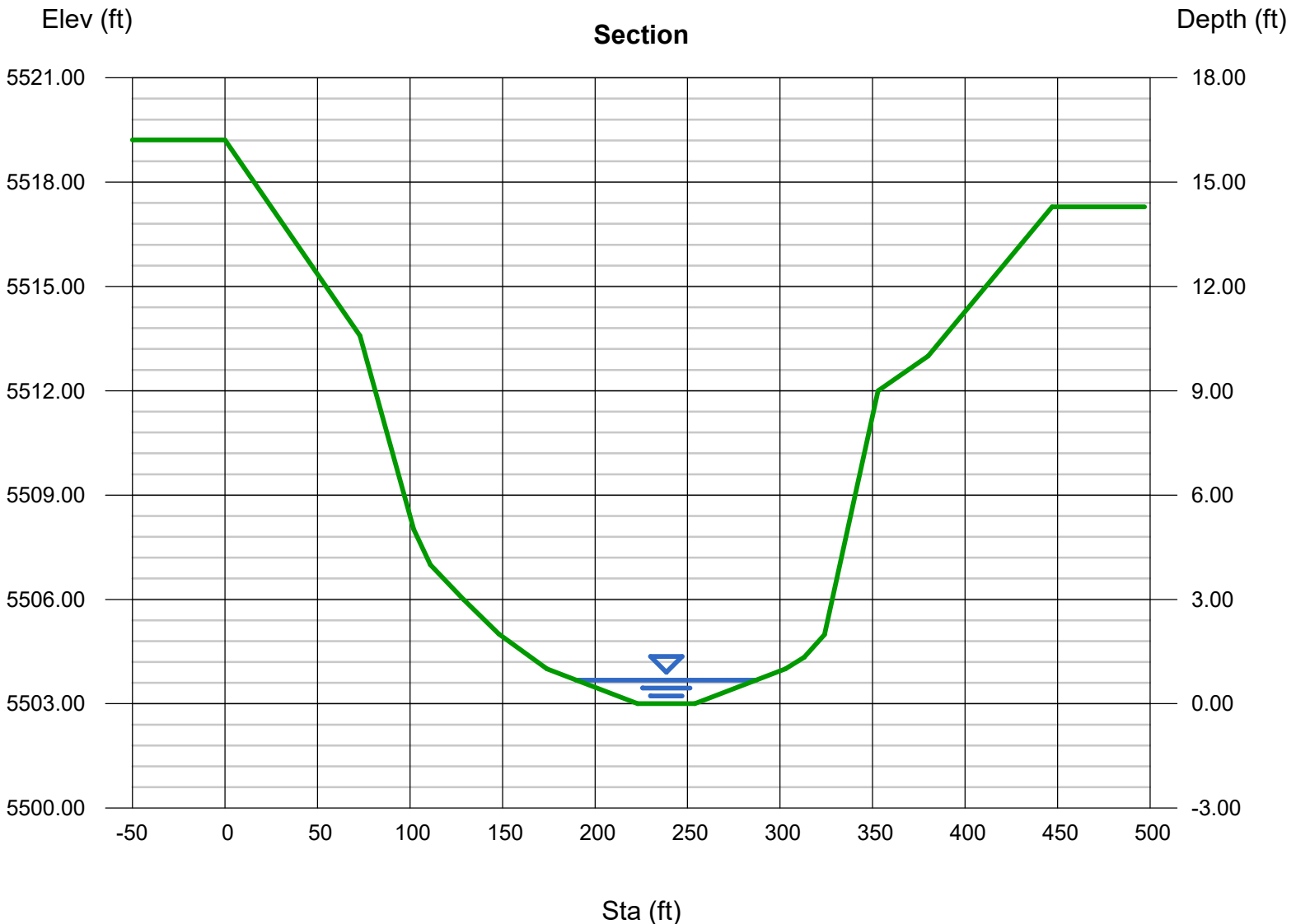

# Channel Report

## Cross Section 2 - 100 year - Existing

### User-defined

Invert Elev (ft) = 5503.00  
Slope (%) = 0.50  
N-Value = 0.030

### Highlighted

Depth (ft) = 4.36  
Q (cfs) = 1,869  
Area (sqft) = 297.20  
Velocity (ft/s) = 6.29  
Wetted Perim (ft) = 123.26  
Crit Depth, Yc (ft) = 3.74  
Top Width (ft) = 122.82  
EGL (ft) = 4.97

### Calculations

Compute by: Known Q  
Known Q (cfs) = 1868.62

### (Sta, El, n)-(Sta, El, n)...

( 0.00, 5519.21)-(50.00, 5515.37, 0.030)-(100.00, 5511.25, 0.030)-(150.00, 5507.86, 0.030)-(170.32, 5506.97, 0.030)-(200.00, 5505.40, 0.030)-(208.04, 5504.95, 0.030)  
-(220.59, 5504.02, 0.030)-(237.78, 5503.00, 0.030)-(250.00, 5503.00, 0.030)-(262.96, 5504.00, 0.030)-(270.36, 5504.99, 0.030)-(275.97, 5506.00, 0.030)-(282.27, 5507.00, 0.030)  
-(287.77, 5508.02, 0.030)-(300.00, 5509.16, 0.030)-(312.55, 5509.91, 0.030)-(350.00, 5511.89, 0.030)-(400.00, 5514.19, 0.030)-(446.31, 5517.29, 0.030)

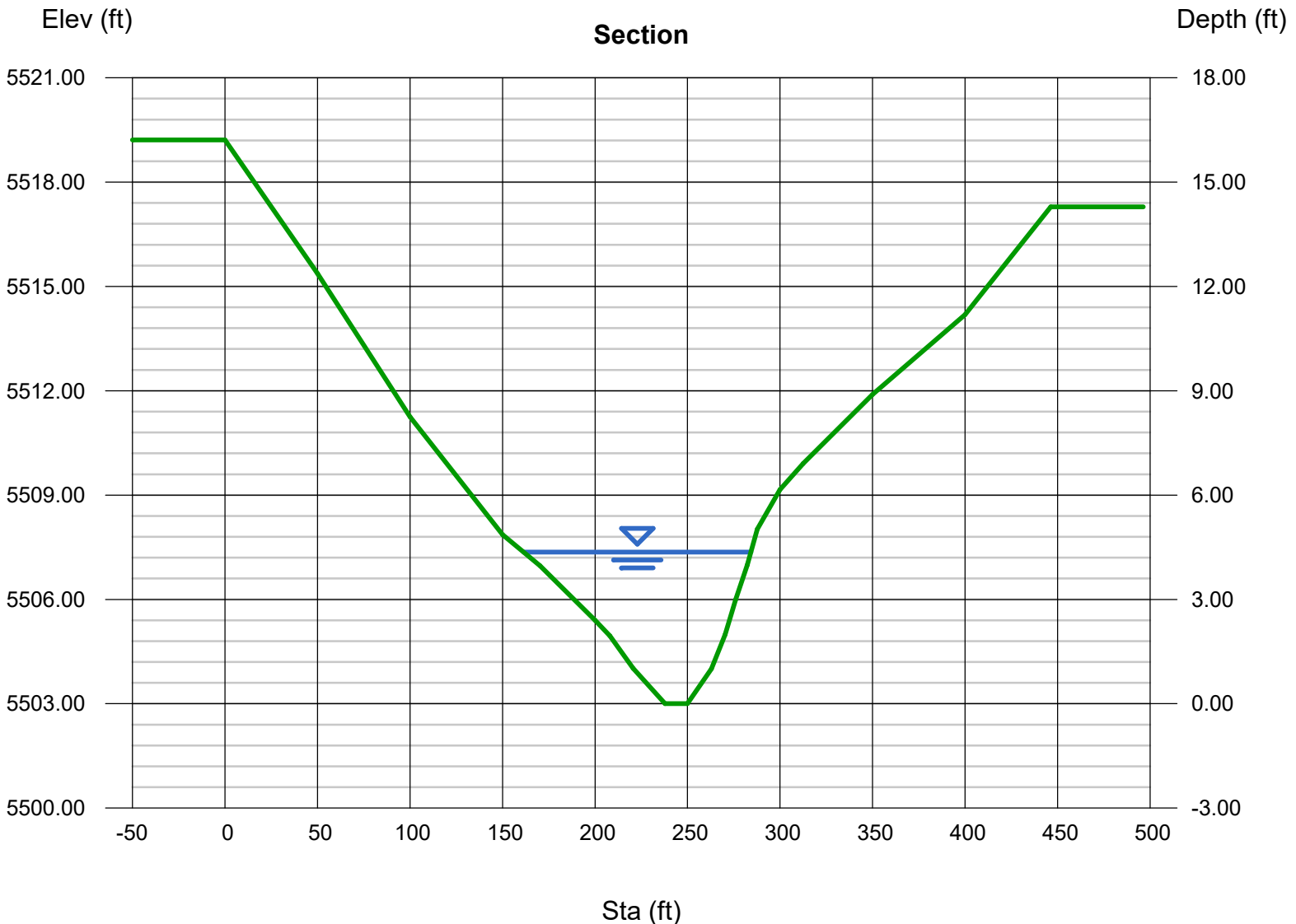

# Channel Report

## Cross Section 2 - 100 year - Proposed

### User-defined

Invert Elev (ft) = 5503.00  
Slope (%) = 0.50  
N-Value = 0.030

### Highlighted

Depth (ft) = 2.66  
Q (cfs) = 1,869  
Area (sqft) = 355.24  
Velocity (ft/s) = 5.26  
Wetted Perim (ft) = 191.48  
Crit Depth, Yc (ft) = 2.21  
Top Width (ft) = 191.31  
EGL (ft) = 3.09

### Calculations

Compute by: Known Q  
Known Q (cfs) = 1868.62

### (Sta, El, n)-(Sta, El, n)...

( 0.00, 5519.21)-(73.00, 5513.58, 0.030)-(102.00, 5508.01, 0.030)-(111.00, 5507.00, 0.030)-(129.00, 5506.00, 0.030)-(148.00, 5505.00, 0.030)-(174.00, 5504.00, 0.030)  
-(223.00, 5503.00, 0.030)-(254.00, 5503.00, 0.030)-(303.00, 5504.00, 0.030)-(313.00, 5504.34, 0.030)-(324.00, 5504.99, 0.030)-(353.00, 5512.00, 0.030)-(380.00, 5517.29, 0.030)  
-(447.00, 5517.29, 0.030)

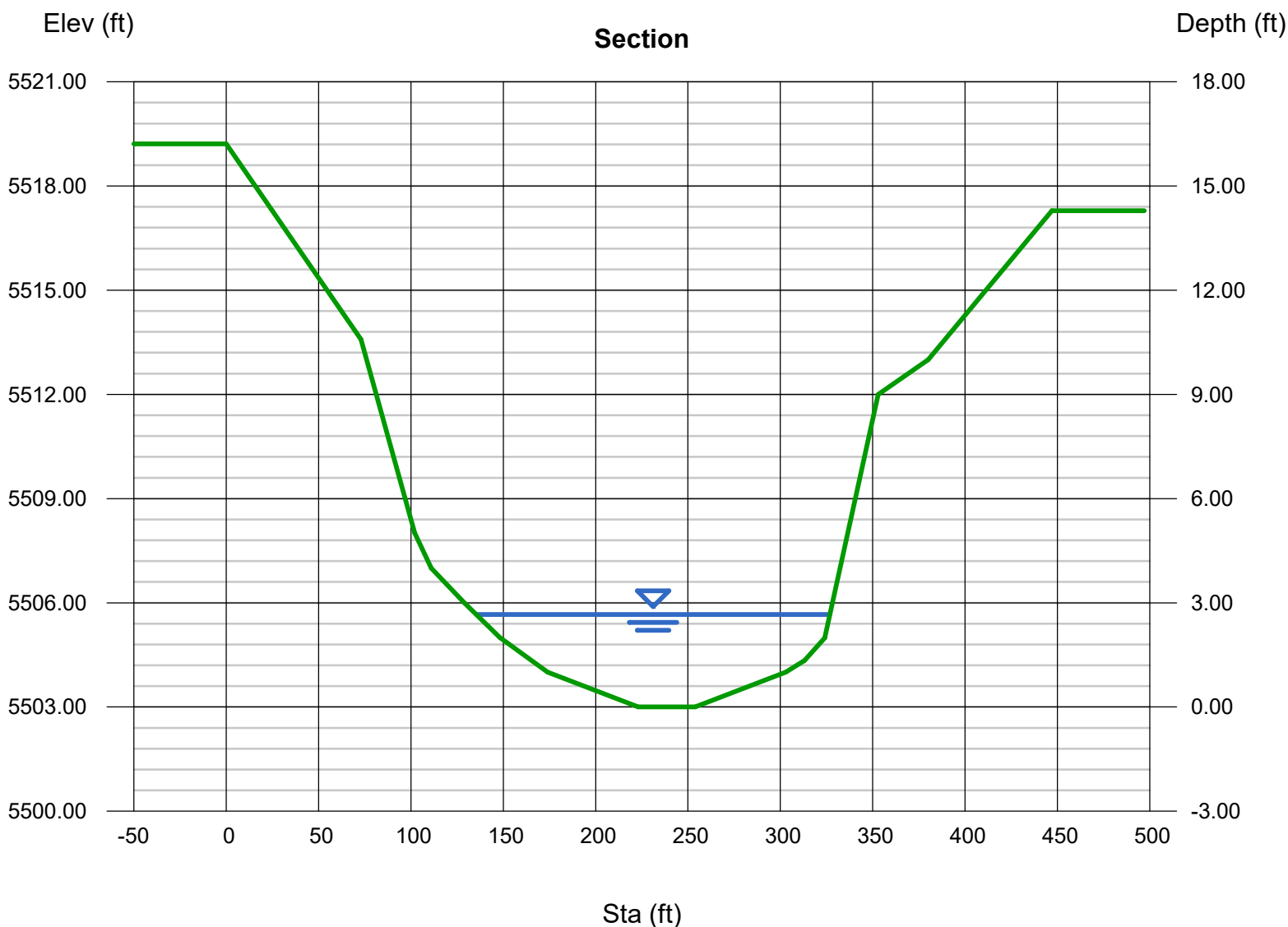

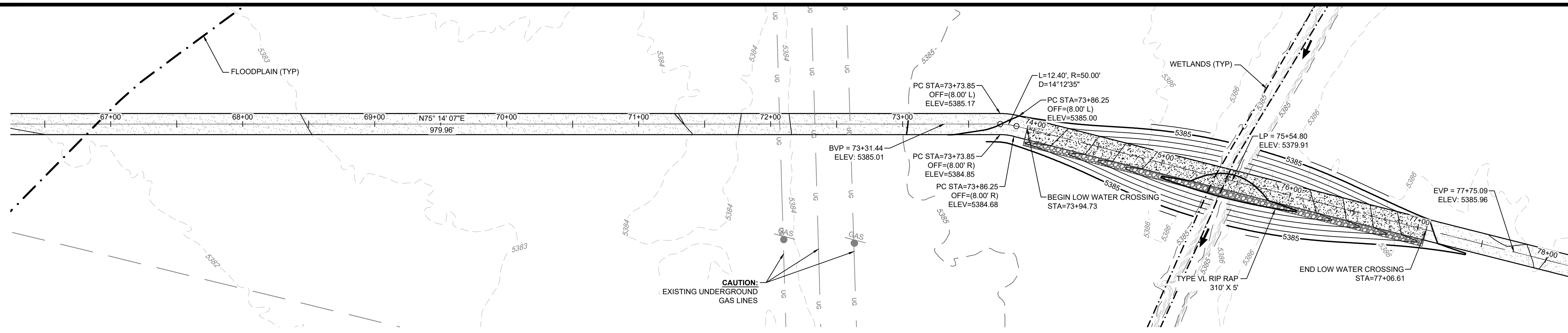

**FLOODPLAIN CROSSING #3**  
(66+50-78+00)

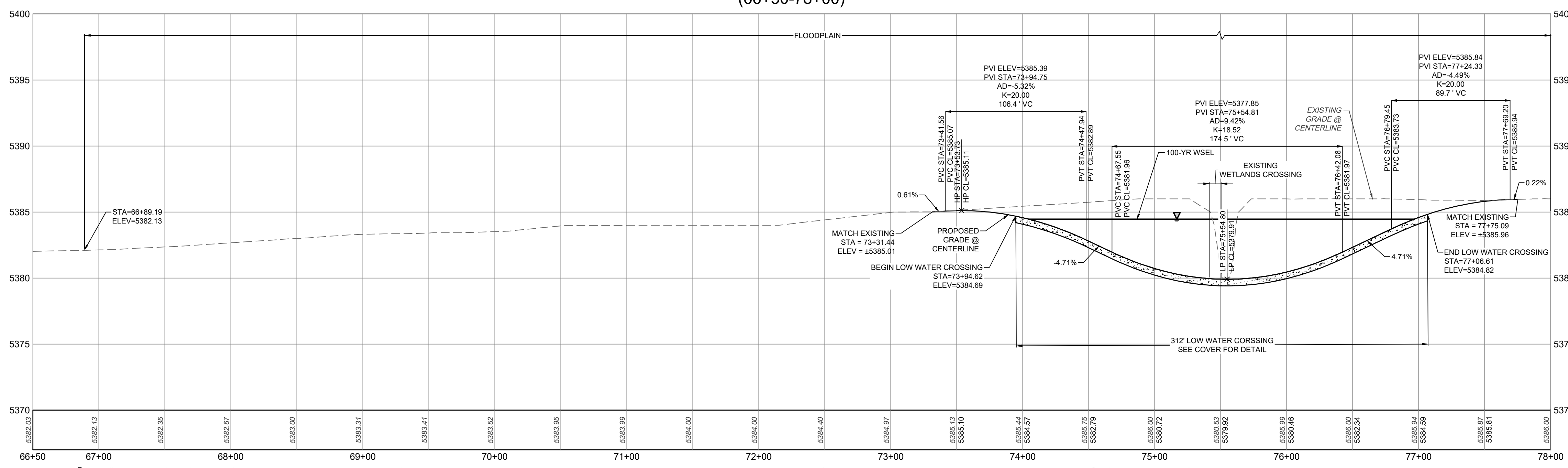

**FLOODPLAIN CROSSING #3**  
(78+00-86+00)

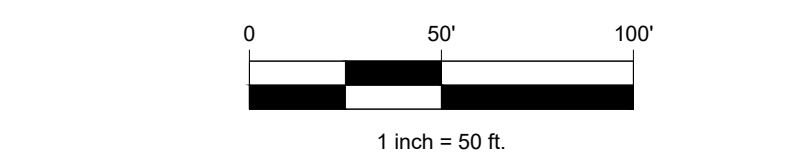
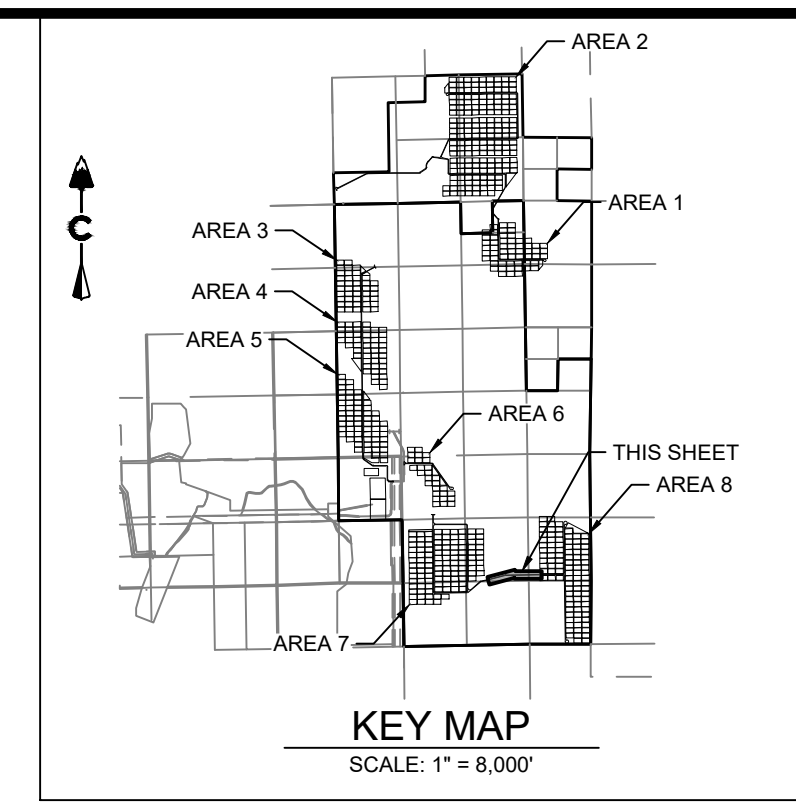
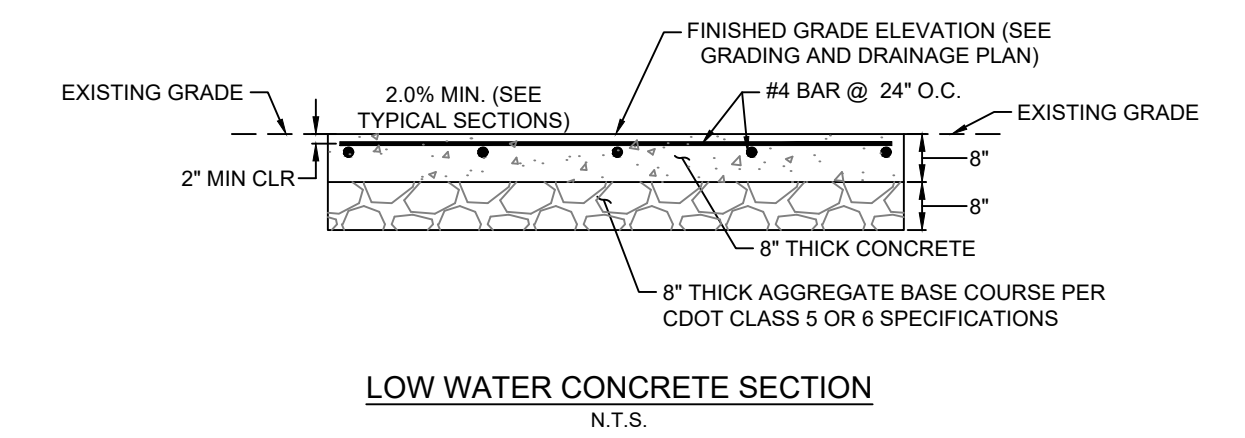
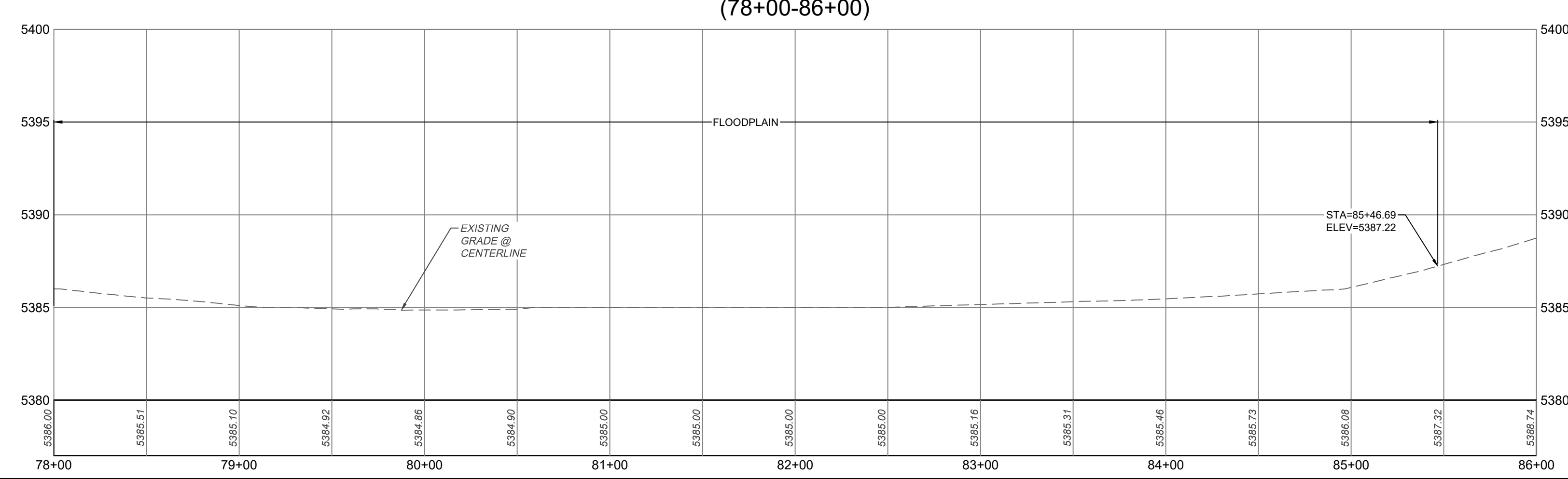

**LEGEND**

---	EXISTING MAJOR CONTOUR
---	EXISTING MINOR CONTOUR
---	PROPOSED MAJOR CONTOUR
---	PROPOSED MINOR CONTOUR
---	PROJECT BOUNDARY
---	CENTERLINE
---	PROPOSED SOLAR TRACKER
---	PROPOSED INVERTER
---	PROPOSED FENCE
---	EXISTING FENCE
---	POWER POLES
---	GUY WIRE
---	WATER VALVES
---	FIRE HYDRANTS
---	EXISTING STORM MANHOLES
---	EXISTING STORM & STUB OUT
---	FLOODPLAIN
---	JURISDICTIONAL WATER FEATURES
---	WILLIAMS CREEK RES. EXPANSION
---	EXISTING STORM
---	EXISTING WATER
---	EXISTING ELECTRIC
---	EXISTING TELEPHONE
---	EXISTING FIBER OPTIC
---	EXISTING GAS
---	EXISTING OVER HEAD ELECTRIC

**CORE**  
CORE CONSULTANTS, INC.  
3473 S. BROADWAY  
DENVER, CO 80113  
303.703.4444  
LIVE@CORE.COM

**PIKE SOLAR**  
EL PASO COUNTY, COLORADO  
CONSTRUCTION DOCUMENTS  
FLOOD PLAIN CROSSINGS #3 P&P

#	REVISION DESCRIPTION	DATE	BY
1 <td>SIGNATURE SET <td>09/25/22</td> <td>RH</td> </td>	SIGNATURE SET <td>09/25/22</td> <td>RH</td>	09/25/22	RH

DESIGNED BY: BB  
DRAWN BY: TP  
CHECKED BY: DB

JOB NO. 20-194  
SHEET 52 OF 67

9/25/2022 2:53 PM X:\25-194 PIKE SOLAR\CHILCAD\PLANS\FILING 1\CD\5\FLOOD PLAN CROSSINGS.DWG

# Channel Report

## Existing Floodplain Crossing 3 - 5 year

### User-defined

Invert Elev (ft) = 5380.00  
 Slope (%) = 0.50  
 N-Value = 0.030

### Highlighted

Depth (ft) = 2.49  
 Q (cfs) = 107.79  
 Area (sqft) = 22.99  
 Velocity (ft/s) = 4.69  
 Wetted Perim (ft) = 14.85  
 Crit Depth, Yc (ft) = 1.95  
 Top Width (ft) = 13.47  
 EGL (ft) = 2.83

### Calculations

Compute by: Known Q  
 Known Q (cfs) = 107.79

### (Sta, El, n)-(Sta, El, n)...

( 0.00, 5386.05)-(50.00, 5384.96, 0.030)-(100.00, 5384.26, 0.030)-(150.00, 5383.69, 0.030)-(200.00, 5383.38, 0.030)-(250.00, 5383.32, 0.030)-(300.00, 5383.22, 0.030)-  
 -(350.00, 5383.27, 0.030)-(400.00, 5383.36, 0.030)-(450.00, 5383.43, 0.030)-(500.00, 5383.86, 0.030)-(550.00, 5384.47, 0.030)-(600.00, 5384.99, 0.030)-(650.00, 5385.50, 0.030)-  
 -(700.00, 5385.90, 0.030)-(750.00, 5385.90, 0.030)-(800.00, 5386.00, 0.030)-(850.00, 5385.99, 0.030)-(888.00, 5386.00, 0.030)-(898.00, 5385.00, 0.030)-(905.00, 5384.00, 0.030)-  
 -(910.00, 5380.00, 0.030)-(920.00, 5385.00, 0.030)-(950.00, 5386.00, 0.030)-(1000.00, 5385.82, 0.030)-(1050.00, 5385.51, 0.030)-(1100.00, 5385.24, 0.030)-(1150.00, 5385.00, 0.030)-  
 -(1200.00, 5384.95, 0.030)-(1250.00, 5384.55, 0.030)-(1300.00, 5384.48, 0.030)-(1350.00, 5384.87, 0.030)-(1400.00, 5385.15, 0.030)-(1450.00, 5385.54, 0.030)-(1500.00, 5386.00, 0.030)-  
 -(1536.76, 5386.77, 0.030)

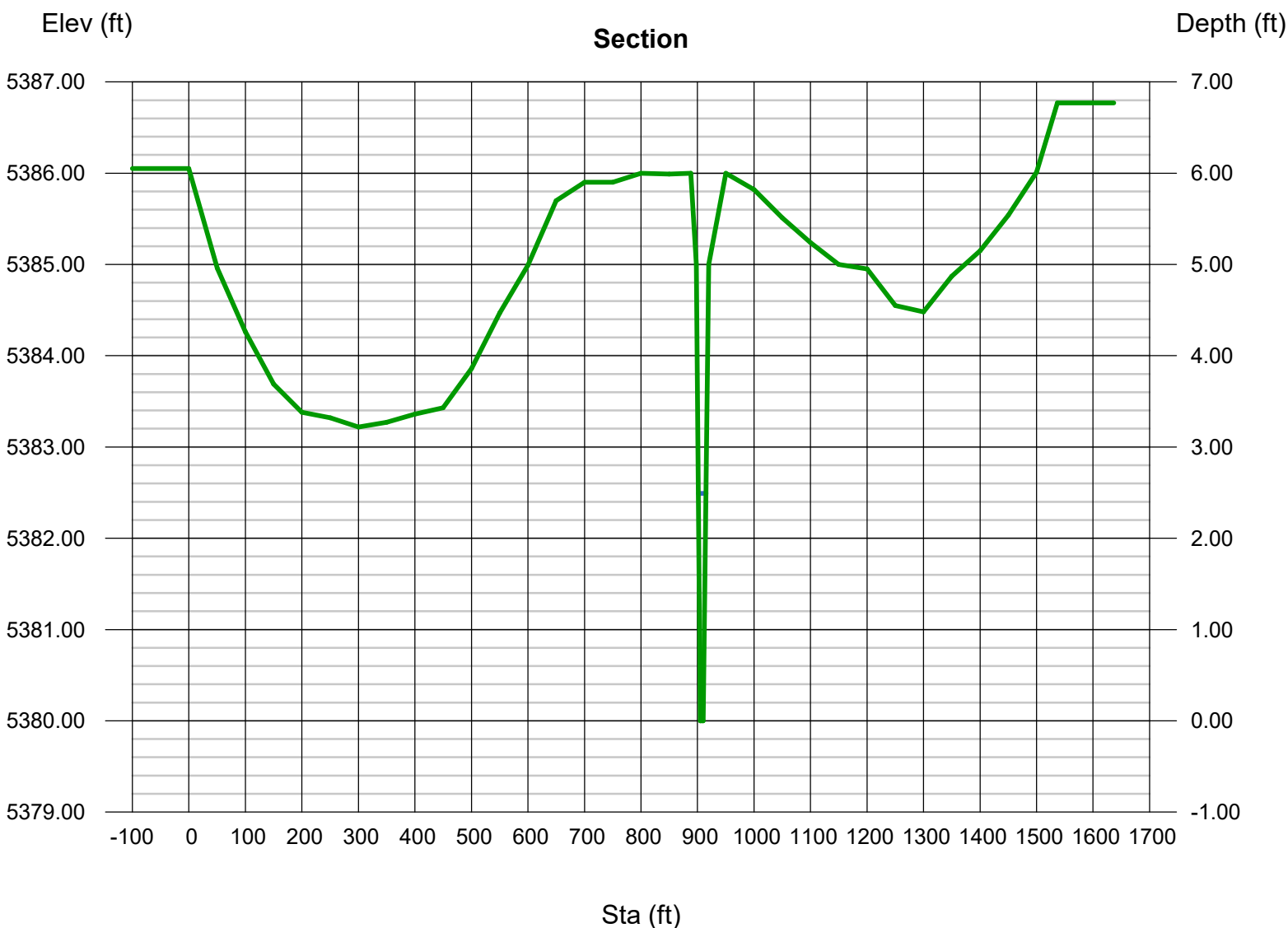



# Channel Report

## Proposed Floodplain Crossing 3 - 5 year

### User-defined

Invert Elev (ft) = 5379.91  
 Slope (%) = 0.50  
 N-Value = 0.030

### Highlighted

Depth (ft) = 0.76  
 Q (cfs) = 107.79  
 Area (sqft) = 50.11  
 Velocity (ft/s) = 2.15  
 Wetted Perim (ft) = 102.32  
 Crit Depth, Yc (ft) = 0.57  
 Top Width (ft) = 102.30  
 EGL (ft) = 0.83

### Calculations

Compute by: Known Q  
 Known Q (cfs) = 107.79

### (Sta, El, n)-(Sta, El, n)...

( 0.00, 5386.05)-(50.00, 5384.96, 0.030)-(100.00, 5384.26, 0.030)-(150.00, 5383.69, 0.030)-(200.00, 5383.38, 0.030)-(250.00, 5383.32, 0.030)-(300.00, 5383.22, 0.030)-  
 -(350.00, 5383.27, 0.030)-(400.00, 5383.36, 0.030)-(450.00, 5383.43, 0.030)-(500.00, 5383.86, 0.030)-(550.00, 5384.47, 0.030)-(600.00, 5384.99, 0.030)-(650.00, 5385.50, 0.030)-  
 -(700.00, 5385.90, 0.030)-(750.00, 5384.96, 0.030)-(800.00, 5382.35, 0.030)-(850.00, 5380.76, 0.030)-(888.00, 5380.00, 0.030)-(898.00, 5379.93, 0.030)-(905.00, 5379.91, 0.030)-  
 -(910.00, 5379.91, 0.030)-(920.00, 5379.95, 0.030)-(950.00, 5380.42, 0.030)-(1000.00, 5382.26, 0.030)-(1050.00, 5384.27, 0.030)-(1100.00, 5385.24, 0.030)-(1150.00, 5385.54, 0.030)-  
 -(1200.00, 5384.95, 0.030)-(1250.00, 5384.55, 0.030)-(1300.00, 5384.48, 0.030)-(1350.00, 5384.87, 0.030)-(1400.00, 5385.15, 0.030)-(1450.00, 5385.54, 0.030)-(1500.00, 5386.05, 0.030)-  
 -(1536.76, 5386.77, 0.030)

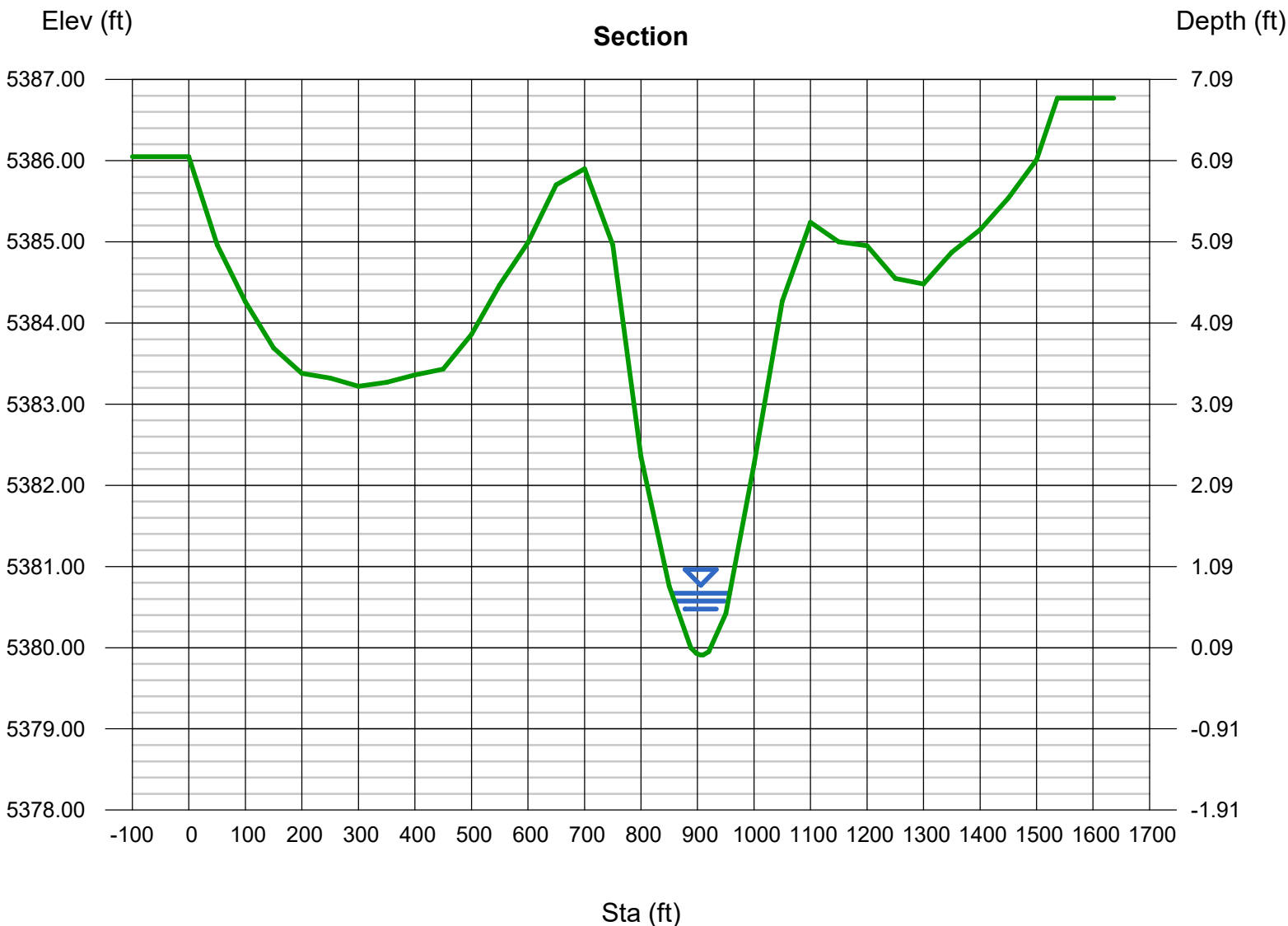

# Channel Report

## Existing Floodplain Crossing 3 - 100 year

### User-defined

Invert Elev (ft) = 5380.00  
 Slope (%) = 0.50  
 N-Value = 0.030

### Highlighted

Depth (ft) = 5.58  
 Q (cfs) = 5,541  
 Area (sqft) = 1359.62  
 Velocity (ft/s) = 4.08  
 Wetted Perim (ft) = 1083.65  
 Crit Depth, Yc (ft) = 5.16  
 Top Width (ft) = 1080.79  
 EGL (ft) = 5.84

### Calculations

Compute by: Known Q  
 Known Q (cfs) = 5540.82

### (Sta, El, n)-(Sta, El, n)...

( 0.00, 5386.05)-(50.00, 5384.96, 0.030)-(100.00, 5384.26, 0.030)-(150.00, 5383.69, 0.030)-(200.00, 5383.38, 0.030)-(250.00, 5383.32, 0.030)-(300.00, 5383.22, 0.030)  
 -(350.00, 5383.27, 0.030)-(400.00, 5383.36, 0.030)-(450.00, 5383.43, 0.030)-(500.00, 5383.86, 0.030)-(550.00, 5384.47, 0.030)-(600.00, 5384.99, 0.030)-(650.00, 5385.00, 0.030)  
 -(700.00, 5385.90, 0.030)-(750.00, 5385.90, 0.030)-(800.00, 5386.00, 0.030)-(850.00, 5385.99, 0.030)-(888.00, 5386.00, 0.030)-(898.00, 5385.00, 0.030)-(905.00, 5385.00, 0.030)  
 -(910.00, 5380.00, 0.030)-(920.00, 5385.00, 0.030)-(950.00, 5386.00, 0.030)-(1000.00, 5385.82, 0.030)-(1050.00, 5385.51, 0.030)-(1100.00, 5385.24, 0.030)-(1150.00, 5385.24, 0.030)  
 -(1200.00, 5384.95, 0.030)-(1250.00, 5384.55, 0.030)-(1300.00, 5384.48, 0.030)-(1350.00, 5384.87, 0.030)-(1400.00, 5385.15, 0.030)-(1450.00, 5385.54, 0.030)-(1500.00, 5386.00, 0.030)  
 -(1536.76, 5386.77, 0.030)

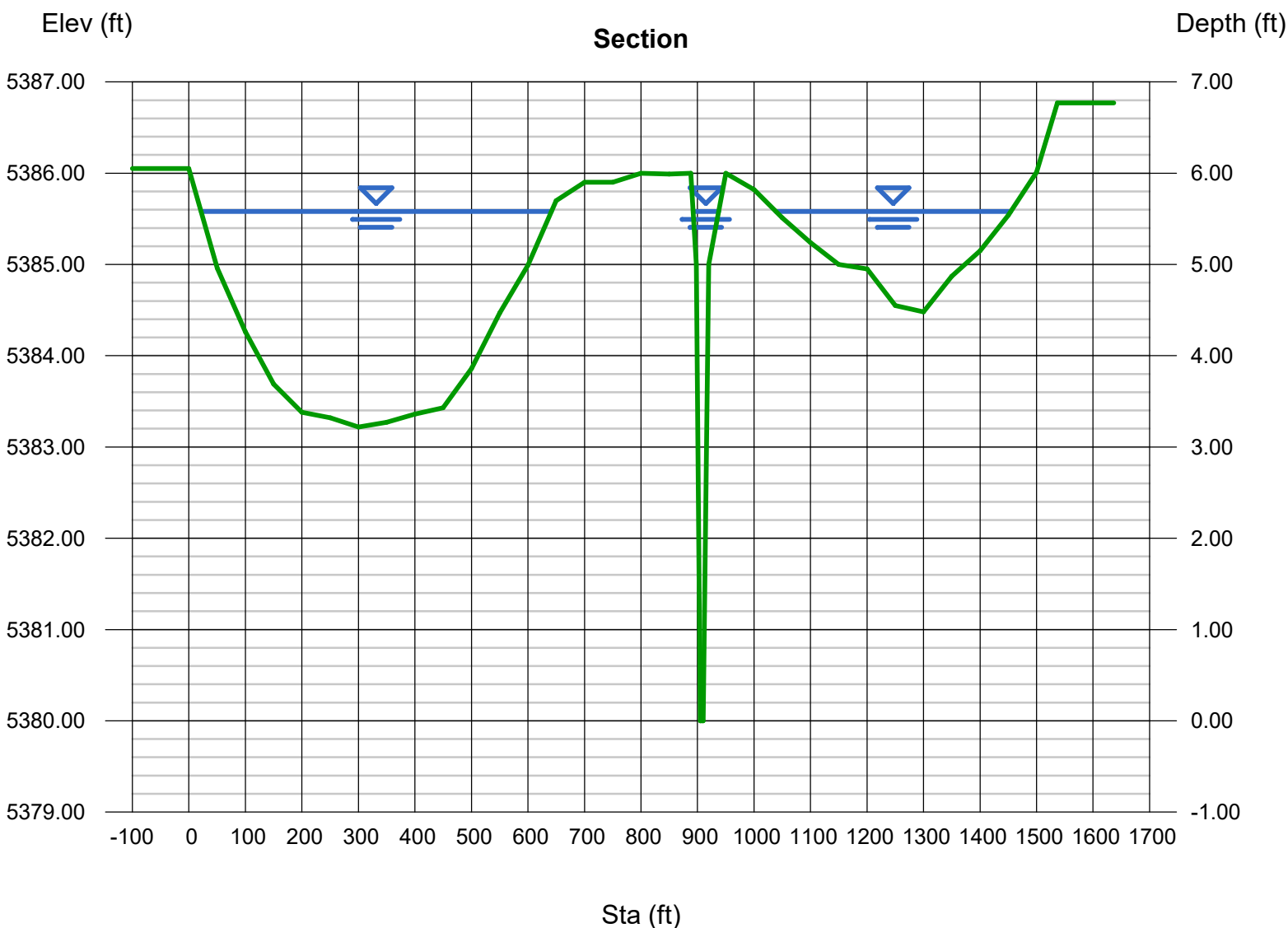

# Channel Report

## Proposed Floodplain Crossing 3 - 100 year

### User-defined

Invert Elev (ft) = 5379.91  
 Slope (%) = 0.50  
 N-Value = 0.030

### Highlighted

Depth (ft) = 4.45  
 Q (cfs) = 5,541  
 Area (sqft) = 1171.37  
 Velocity (ft/s) = 4.73  
 Wetted Perim (ft) = 741.53  
 Crit Depth, Yc (ft) = 3.99  
 Top Width (ft) = 741.35  
 EGL (ft) = 4.80

### Calculations

Compute by: Known Q  
 Known Q (cfs) = 5540.82

### (Sta, El, n)-(Sta, El, n)...

( 0.00, 5386.05)-(50.00, 5384.96, 0.030)-(100.00, 5384.26, 0.030)-(150.00, 5383.69, 0.030)-(200.00, 5383.38, 0.030)-(250.00, 5383.32, 0.030)-(300.00, 5383.22, 0.030)-  
 -(350.00, 5383.27, 0.030)-(400.00, 5383.36, 0.030)-(450.00, 5383.43, 0.030)-(500.00, 5383.86, 0.030)-(550.00, 5384.47, 0.030)-(600.00, 5384.99, 0.030)-(650.00, 5385.32, 0.030)-  
 -(700.00, 5385.90, 0.030)-(750.00, 5384.96, 0.030)-(800.00, 5382.35, 0.030)-(850.00, 5380.76, 0.030)-(888.00, 5380.00, 0.030)-(898.00, 5379.93, 0.030)-(905.00, 5380.00, 0.030)-  
 -(910.00, 5379.91, 0.030)-(920.00, 5379.95, 0.030)-(950.00, 5380.42, 0.030)-(1000.00, 5382.26, 0.030)-(1050.00, 5384.27, 0.030)-(1100.00, 5385.24, 0.030)-(1150.00, 5385.54, 0.030)-  
 -(1200.00, 5384.95, 0.030)-(1250.00, 5384.55, 0.030)-(1300.00, 5384.48, 0.030)-(1350.00, 5384.87, 0.030)-(1400.00, 5385.15, 0.030)-(1450.00, 5385.54, 0.030)-(1500.00, 5386.05, 0.030)-  
 -(1536.76, 5386.77, 0.030)

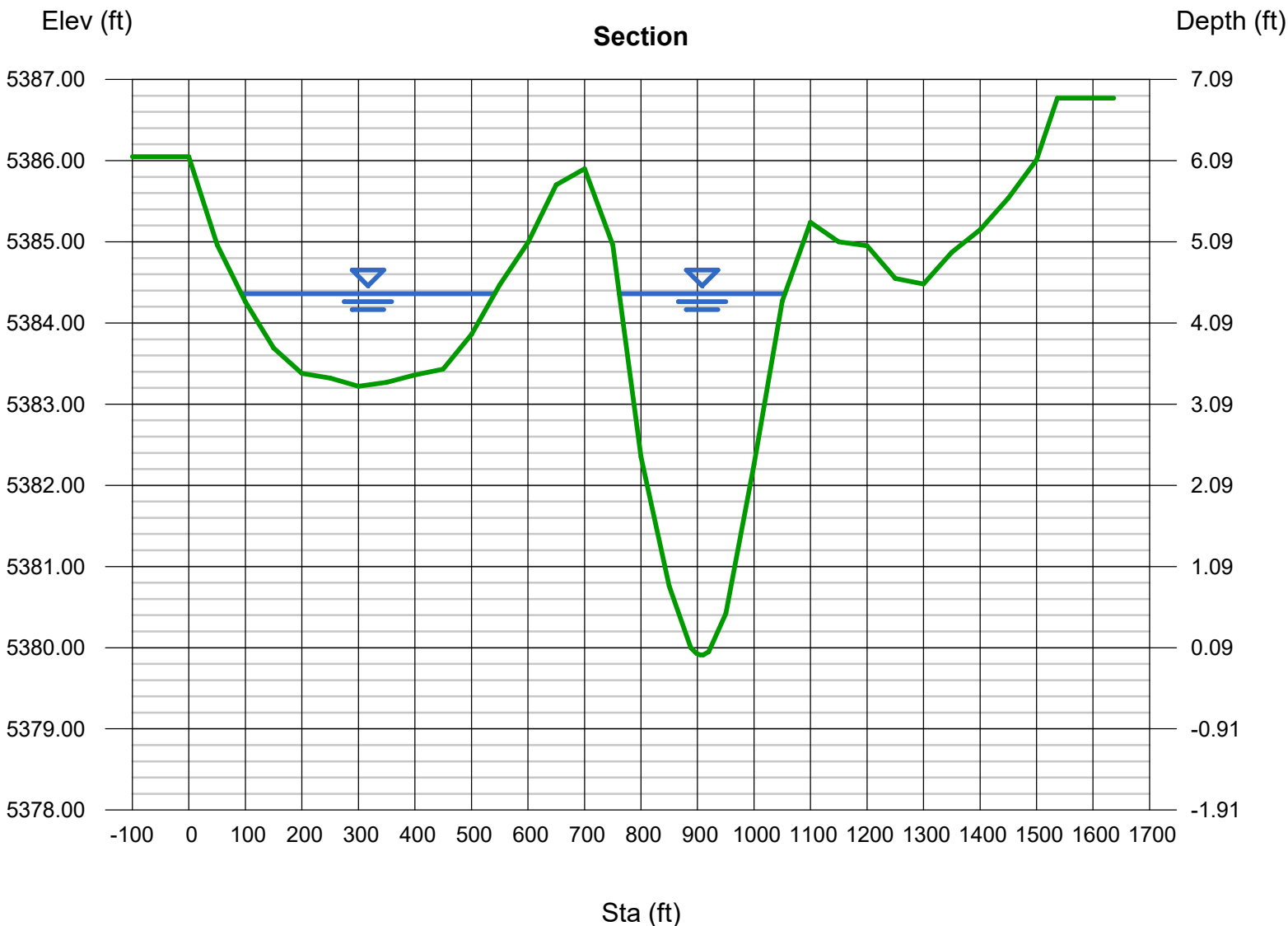

**APPENDIX E**  
**REFERENCE MATERIALS**

“HYDRAULIC RESPONSE OF SOLAR FARMS”  
COST OPINION

# Hydrologic Response of Solar Farms

Lauren M. Cook, S.M.ASCE<sup>1</sup>; and Richard H. McCuen, M.ASCE<sup>2</sup>

**Abstract:** Because of the benefits of solar energy, the number of solar farms is increasing; however, their hydrologic impacts have not been studied. The goal of this study was to determine the hydrologic effects of solar farms and examine whether or not storm-water management is needed to control runoff volumes and rates. A model of a solar farm was used to simulate runoff for two conditions: the pre- and postpaneled conditions. Using sensitivity analyses, modeling showed that the solar panels themselves did not have a significant effect on the runoff volumes, peaks, or times to peak. However, if the ground cover under the panels is gravel or bare ground, owing to design decisions or lack of maintenance, the peak discharge may increase significantly with storm-water management needed. In addition, the kinetic energy of the flow that drains from the panels was found to be greater than that of the rainfall, which could cause erosion at the base of the panels. Thus, it is recommended that the grass beneath the panels be well maintained or that a buffer strip be placed after the most downgradient row of panels. This study, along with design recommendations, can be used as a guide for the future design of solar farms. DOI: 10.1061/(ASCE)HE.1943-5584.0000530. © 2013 American Society of Civil Engineers.

**CE Database subject headings:** Hydrology; Land use; Solar power; Floods; Surface water; Runoff; Stormwater management.

**Author keywords:** Hydrology; Land use change; Solar energy; Flooding; Surface water runoff; Storm-water management.

## Introduction

Storm-water management practices are generally implemented to reverse the effects of land-cover changes that cause increases in volumes and rates of runoff. This is a concern posed for new types of land-cover change such as the solar farm. Solar energy is a renewable energy source that is expected to increase in importance in the near future. Because solar farms require considerable land, it is necessary to understand the design of solar farms and their potential effect on erosion rates and storm runoff, especially the impact on offsite properties and receiving streams. These farms can vary in size from 8 ha (20 acres) in residential areas to 250 ha (600 acres) in areas where land is abundant.

The solar panels are impervious to rain water; however, they are mounted on metal rods and placed over pervious land. In some cases, the area below the panel is paved or covered with gravel. Service roads are generally located between rows of panels. Although some panels are stationary, others are designed to move so that the angle of the panel varies with the angle of the sun. The angle can range, depending on the latitude, from 22° during the summer months to 74° during the winter months. In addition, the angle and direction can also change throughout the day. The issue posed is whether or not these rows of impervious panels will change the runoff characteristics of the site, specifically increase runoff volumes or peak discharge rates. If the increases are hydrologically significant, storm-water management facilities may be needed. Additionally, it is possible that the velocity of water

draining from the edge of the panels is sufficient to cause erosion of the soil below the panels, especially where the maintenance roadways are bare ground.

The outcome of this study provides guidance for assessing the hydrologic effects of solar farms, which is important to those who plan, design, and install arrays of solar panels. Those who design solar farms may need to provide for storm-water management. This study investigated the hydrologic effects of solar farms, assessed whether or not storm-water management might be needed, and if the velocity of the runoff from the panels could be sufficient to cause erosion of the soil below the panels.

## Model Development

Solar farms are generally designed to maximize the amount of energy produced per unit of land area, while still allowing space for maintenance. The hydrologic response of solar farms is not usually considered in design. Typically, the panels will be arrayed in long rows with separations between the rows to allow for maintenance vehicles. To model a typical layout, a unit width of one panel was assumed, with the length of the downgradient strip depending on the size of the farm. For example, a solar farm with 30 rows of 200 panels each could be modeled as a strip of 30 panels with space between the panels for maintenance vehicles. Rainwater that drains from the upper panel onto the ground will flow over the land under the 29 panels on the downgradient strip. Depending on the land cover, infiltration losses would be expected as the runoff flows to the bottom of the slope.

To determine the effects that the solar panels have on runoff characteristics, a model of a solar farm was developed. Runoff in the form of sheet flow without the addition of the solar panels served as the prepaneled condition. The paneled condition assumed a downgradient series of cells with one solar panel per ground cell. Each cell was separated into three sections: wet, dry, and spacer.

The dry section is that portion directly underneath the solar panel, unexposed directly to the rainfall. As the angle of the panel from the horizontal increases, more of the rain will fall directly onto

<sup>1</sup>Research Assistant, Dept. of Civil and Environmental Engineering, Univ. of Maryland, College Park, MD 20742-3021.

<sup>2</sup>The Ben Dyer Professor, Dept. of Civil and Environmental Engineering, Univ. of Maryland, College Park, MD 20742-3021 (corresponding author). E-mail: rhmccuen@eng.umd.edu

Note. This manuscript was submitted on August 12, 2010; approved on October 20, 2011; published online on October 24, 2011. Discussion period open until October 1, 2013; separate discussions must be submitted for individual papers. This paper is part of the *Journal of Hydrologic Engineering*, Vol. 18, No. 5, May 1, 2013. © ASCE, ISSN 1084-0699/2013/5-536-541/\$25.00.

the ground; this section of the cell is referred to as the wet section. The spacer section is the area between the rows of panels used by maintenance vehicles. Fig. 1 is an image of two solar panels and the spacer section allotted for maintenance vehicles. Fig. 2 is a schematic of the wet, dry, and spacer sections with their respective dimensions. In Fig. 1, tracks from the vehicles are visible on what is modeled within as the spacer section. When the solar panel is horizontal, then the length longitudinal to the direction that runoff will occur is the length of the dry and wet sections combined. Runoff from a dry section drains onto the downgradient spacer section. Runoff from the spacer section flows to the wet section of the next downgradient cell. Water that drains from a solar panel falls directly onto the spacer section of that cell.

The length of the spacer section is constant. During a storm event, the loss rate was assumed constant for the 24-h storm because a wet antecedent condition was assumed. The lengths of the wet and dry sections changed depending on the angle of the solar panel. The total length of the wet and dry sections was set



**Fig. 1.** Maintenance or “spacer” section between two rows of solar panels (photo by John E. Showler, reprinted with permission)

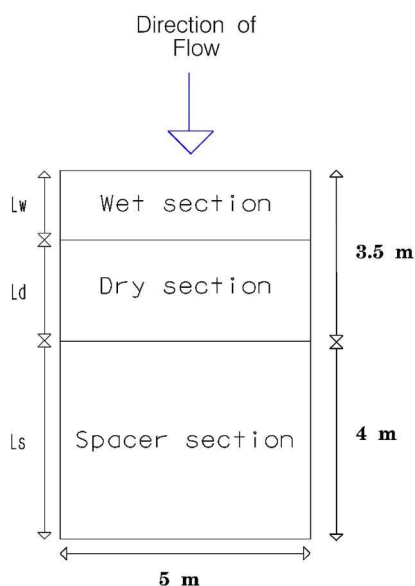

**Fig. 2.** Wet, dry, and spacer sections of a single cell with lengths  $L_w$ ,  $L_s$ , and  $L_d$  with the solar panel covering the dry section

equal to the length of one horizontal solar panel, which was assumed to be 3.5 m. When a solar panel is horizontal, the dry section length would equal 3.5 m and the wet section length would be zero. In the paneled condition, the dry section does not receive direct rainfall because the rain first falls onto the solar panel then drains onto the spacer section. However, the dry section does infiltrate some of the runoff that comes from the upgradient wet section. The wet section was modeled similar to the spacer section with rain falling directly onto the section and assuming a constant loss rate.

For the presolar panel condition, the spacer and wet sections are modeled the same as in the paneled condition; however, the cell does not include a dry section. In the prepaneled condition, rain falls directly onto the entire cell. When modeling the prepaneled condition, all cells receive rainfall at the same rate and are subject to losses. All other conditions were assumed to remain the same such that the prepaneled and paneled conditions can be compared.

Rainfall was modeled after a natural resources conservation service (NRCS) Type II Storm (McCuen 2005) because it is an accurate representation of actual storms of varying characteristics that are imbedded in intensity-duration-frequency (IDF) curves. For each duration of interest, a dimensionless hyetograph was developed using a time increment of 12 s over the duration of the storm (see Fig. 3). The depth of rainfall that corresponds to each storm magnitude was then multiplied by the dimensionless hyetograph. For a 2-h storm duration, depths of 40.6, 76.2, and 101.6 mm were used for the 2-, 25-, and 100-year events. The 2- and 6-h duration hyetographs were developed using the center portion of the 24-h storm, with the rainfall depths established with the Baltimore IDF curve. The corresponding depths for a 6-h duration were 53.3, 106.7, and 132.1 mm, respectively. These magnitudes were chosen to give a range of storm conditions.

During each time increment, the depth of rain is multiplied by the cell area to determine the volume of rain added to each section of each cell. This volume becomes the storage in each cell. Depending on the soil group, a constant volume of losses was subtracted from the storage. The runoff velocity from a solar panel was calculated using Manning's equation, with the hydraulic radius for sheet flow assumed to equal the depth of the storage on the panel (Bedient and Huber 2002). Similar assumptions were made to compute the velocities in each section of the surface sections.

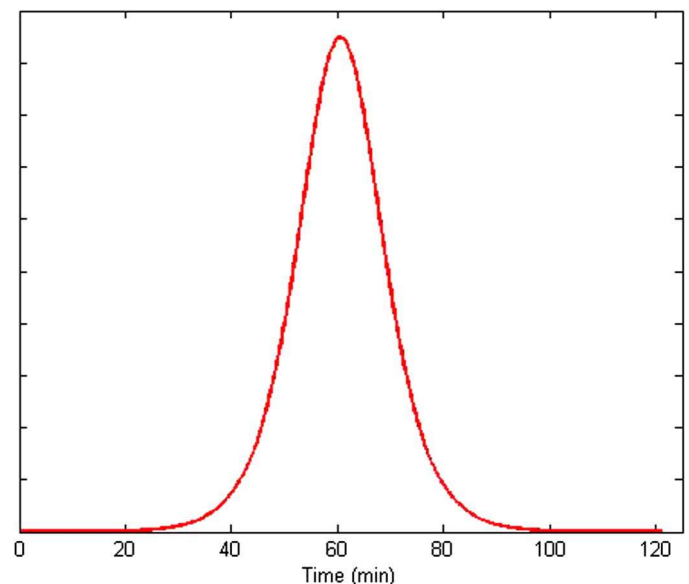

**Fig. 3.** Dimensionless hyetograph of 2-h Type II storm

Runoff from one section to the next and then to the next downgradient cell was routed using the continuity of mass. The routing coefficient depended on the depth of flow in storage and the velocity of runoff. Flow was routed from the wet section to the dry section to the spacer section, with flow from the spacer section draining to the wet section of the next cell. Flow from the most downgradient cell was assumed to be the outflow. Discharge rates and volumes from the most downgradient cell were used for comparisons between the prepaneled and paneled conditions.

## Alternative Model Scenarios

To assess the effects of the different variables, a section of 30 cells, each with a solar panel, was assumed for the base model. Each cell was separated individually into wet, dry, and spacer sections. The area had a total ground length of 225 m with a ground slope of 1% and width of 5 m, which was the width of an average solar panel. The roughness coefficient (Engman 1986) for the silicon solar panel was assumed to be that of glass, 0.01. Roughness coefficients of 0.15 for grass and 0.02 for bare ground were also assumed. Loss rates of 0.5715 cm/h (0.225 in./h) and 0.254 cm/h (0.1 in./h) for B and C soils, respectively, were assumed.

The prepaneled condition using the 2-h, 25-year rainfall was assumed for the base condition, with each cell assumed to have a good grass cover condition. All other analyses were made assuming a paneled condition. For most scenarios, the runoff volumes and peak discharge rates from the paneled model were not significantly greater than those for the prepaneled condition. Over a total length of 225 m with 30 solar panels, the runoff increased by 0.26 m<sup>3</sup>, which was a difference of only 0.35%. The slight increase in runoff volume reflects the slightly higher velocities for the paneled condition. The peak discharge increased by 0.0013 m<sup>3</sup>, a change of only 0.31%. The time to peak was delayed by one time increment, i.e., 12 s. Inclusion of the panels did not have a significant hydrologic impact.

### Storm Magnitude

The effect of storm magnitude was investigated by changing the magnitude from a 25-year storm to a 2-year storm. For the 2-year storm, the rainfall and runoff volumes decreased by approximately 50%. However, the runoff from the paneled watershed condition increased compared to the prepaneled condition by approximately the same volume as for the 25-year analysis, 0.26 m<sup>3</sup>. This increase represents only a 0.78% increase in volume. The peak discharge and the time to peak did not change significantly. These results reflect runoff from a good grass cover condition and indicated that the general conclusion of very minimal impacts was the same for different storm magnitudes.

### Ground Slope

The effect of the downgradient ground slope of the solar farm was also examined. The angle of the solar panels would influence the velocity of flows from the panels. As the ground slope was increased, the velocity of flow over the ground surface would be closer to that on the panels. This could cause an overall increase in discharge rates. The ground slope was changed from 1 to 5%, with all other conditions remaining the same as the base conditions.

With the steeper incline, the volume of losses decreased from that for the 1% slope, which is to be expected because the faster velocity of the runoff would provide less opportunity for infiltration. However, between the prepaneled and paneled conditions, the increase in runoff volume was less than 1%. The peak discharge

and the time to peak did not change. Therefore, the greater ground slope did not significantly influence the response of the solar farm.

### Soil Type

The effect of soil type on the runoff was also examined. The soil group was changed from B soil to C soil by varying the loss rate. As expected, owing to the higher loss rate for the C soil, the depths of runoff increased by approximately 7.5% with the C soil when compared with the volume for B soils. However, the runoff volume for the C soil condition only increased by 0.17% from the prepaneled condition to the paneled condition. In comparison with the B soil, a difference of 0.35% in volume resulted between the two conditions. Therefore, the soil group influenced the actual volumes and rates, but not the relative effect of the paneled condition when compared to the prepaneled condition.

### Panel Angle

Because runoff velocities increase with slope, the effect of the angle of the solar panel on the hydrologic response was examined. Analyses were made for angles of 30° and 70° to test an average range from winter to summer. The hydrologic response for these angles was compared to that of the base condition angle of 45°. The other site conditions remained the same. The analyses showed that the angle of the panel had only a slight effect on runoff volumes and discharge rates. The lower angle of 30° was associated with an increased runoff volume, whereas the runoff volume decreased for the steeper angle of 70° when compared with the base condition of 45°. However, the differences (~0.5%) were very slight. Nevertheless, these results indicate that, when the solar panel was closer to horizontal, i.e., at a lower angle, a larger difference in runoff volume occurred between the prepaneled and paneled conditions. These differences in the response result are from differences in loss rates.

The peak discharge was also lower at the lower angle. At an angle of 30°, the peak discharge was slightly lower than at the higher angle of 70°. For the 2-h storm duration, the time to peak of the 30° angle was 2 min delayed from the time to peak of when the panel was positioned at a 70° angle, which reflects the longer travel times across the solar panels.

### Storm Duration

To assess the effect of storm duration, analyses were made for 6-h storms, testing magnitudes for 2-, 25-, and 100-year return periods, with the results compared with those for the 2-h rainfall events. The longer storm duration was tested to determine whether a longer duration storm would produce a different ratio of increase in runoff between the prepaneled and paneled conditions. When compared to runoff volumes from the 2-h storm, those for the 6-h storm were 34% greater in both the paneled and prepaneled cases. However, when comparing the prepaneled to the paneled condition, the increase in the runoff volume with the 6-h storm was less than 1% regardless of the return period. The peak discharge and the time-to-peak did not differ significantly between the two conditions. The trends in the hydrologic response of the solar farm did not vary with storm duration.

### Ground Cover

The ground cover under the panels was assumed to be a native grass that received little maintenance. For some solar farms, the area beneath the panel is covered in gravel or partially paved because the panels prevent the grass from receiving sunlight. Depending on the

volume of traffic, the spacer cell could be grass, patches of grass, or bare ground. Thus, it was necessary to determine whether or not these alternative ground-cover conditions would affect the runoff characteristics. This was accomplished by changing the Manning's  $n$  for the ground beneath the panels. The value of  $n$  under the panels, i.e., the dry section, was set to 0.015 for gravel, with the value for the spacer or maintenance section set to 0.02, i.e., bare ground. These can be compared to the base condition of a native grass ( $n = 0.15$ ). A good cover should promote losses and delay the runoff.

For the smoother surfaces, the velocity of the runoff increased and the losses decreased, which resulted in increasing runoff volumes. This occurred both when the ground cover under the panels was changed to gravel and when the cover in the spacer section was changed to bare ground. Owing to the higher velocities of the flow, runoff rates from the cells increased significantly such that it was necessary to reduce the computational time increment. Fig. 4(a) shows the hydrograph from a 30-panel area with a time increment of 12 s. With a time increment of 12 s, the water in each cell is discharged at the end of every time increment, which results in no attenuation of the flow; thus, the undulations shown in Fig. 4(a) result. The time increment was reduced to 3 s for the 2-h storm, which resulted in watershed smoothing and a rational hydrograph shape [Fig. 4(b)]. The results showed that the storm runoff

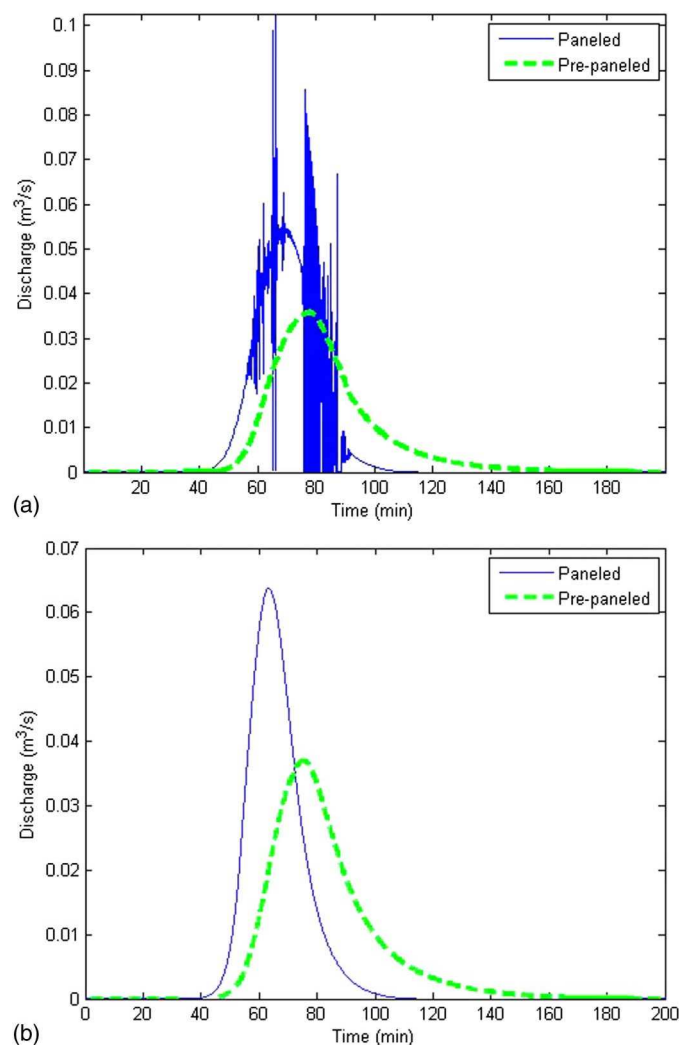

**Fig. 4.** Hydrograph with time increment of (a) 12 s; (b) 3 s with Manning's  $n$  for bare ground

increased by 7% from the grass-covered scenario to the scenario with gravel under the panel. The peak discharge increased by 73% for the gravel ground cover when compared with the grass cover without the panels. The time to peak was 10 min less with the gravel than with the grass, which reflects the effect of differences in surface roughness and the resulting velocities.

If maintenance vehicles used the spacer section regularly and the grass cover was not adequately maintained, the soil in the spacer section would be compacted and potentially the runoff volumes and rates would increase. Grass that is not maintained has the potential to become patchy and turn to bare ground. The grass under the panel may not get enough sunlight and die. Fig. 1 shows the result of the maintenance trucks frequently driving in the spacer section, which diminished the grass cover.

The effect of the lack of solar farm maintenance on runoff characteristics was modeled by changing the Manning's  $n$  to a value of 0.02 for bare ground. In this scenario, the roughness coefficient for the ground under the panels, i.e., the dry section, as well as in the spacer cell was changed from grass covered to bare ground ( $n = 0.02$ ). The effects were nearly identical to that of the gravel. The runoff volume increased by 7% from the grass-covered to the bare-ground condition. The peak discharge increased by 72% when compared with the grass-covered condition. The runoff for the bare-ground condition also resulted in an earlier time to peak by approximately 10 min. Two other conditions were also modeled, showing similar results. In the first scenario, gravel was placed directly under the panel, and healthy grass was placed in the spacer section, which mimics a possible design decision. Under these conditions, the peak discharge increased by 42%, and the volume of runoff increased by 4%, which suggests that storm-water management would be necessary if gravel is placed anywhere.

Fig. 5 shows two solar panels from a solar farm in New Jersey. The bare ground between the panels can cause increased runoff rates and reductions in time of concentration, both of which could necessitate storm-water management. The final condition modeled involved the assumption of healthy grass beneath the panels and bare ground in the spacer section, which would simulate the condition of unmaintained grass resulting from vehicles that drive over the spacer section. Because the spacer section is 53% of the cell, the change in land cover to bare ground would reduce losses and decrease runoff travel times, which would cause runoff to amass as it



**Fig. 5.** Site showing the initiation of bare ground below the panels, which increases the potential for erosion (photo by John Showler, reprinted with permission)



moves downgradient. With the spacer section as bare ground, the peak discharge increased by 100%, which reflected the increases in volume and decrease in timing. These results illustrate the need for maintenance of the grass below and between the panels.

## Design Suggestions

With well-maintained grass underneath the panels, the solar panels themselves do not have much effect on total volumes of the runoff or peak discharge rates. Although the panels are impervious, the rainwater that drains from the panels appears as runoff over the downgradient cells. Some of the runoff infiltrates. If the grass cover of a solar farm is not maintained, it can deteriorate either because of a lack of sunlight or maintenance vehicle traffic. In this case, the runoff characteristics can change significantly with both runoff rates and volumes increasing by significant amounts. In addition, if gravel or pavement is placed underneath the panels, this can also contribute to a significant increase in the hydrologic response.

If bare ground is foreseen to be a problem or gravel is to be placed under the panels to prevent erosion, it is necessary to counteract the excess runoff using some form of storm-water management. A simple practice that can be implemented is a buffer strip (Dabney et al. 2006) at the downgradient end of the solar farm. The buffer strip length must be sufficient to return the runoff characteristics with the panels to those of runoff experienced before the gravel and panels were installed. Alternatively, a detention basin can be installed.

A buffer strip was modeled along with the panels. For approximately every 200 m of panels, or 29 cells, the buffer must be 5 cells long (or 35 m) to reduce the runoff volume to that which occurred before the panels were added. Even if a gravel base is not placed under the panels, the inclusion of a buffer strip may be a good practice when grass maintenance is not a top funding priority. Fig. 6 shows the peak discharge from the graveled surface versus the length of the buffer needed to keep the discharge to prepaneled peak rate.

Water draining from a solar panel can increase the potential for erosion of the spacer section. If the spacer section is bare ground, the high kinetic energy of water draining from the panel can cause soil detachment and transport (Garde and Raju 1977; Beuselinck et al. 2002). The amount and risk of erosion was modeled using the velocity of water coming off a solar panel compared with the velocity and intensity of the rainwater. The velocity of panel

runoff was calculated using Manning's equation, and the velocity of falling rainwater was calculated using the following:

$$V_t = 120 d_r^{0.35} \quad (1)$$

where  $d_r$  = diameter of a raindrop, assumed to be 1 mm. The relationship between kinetic energy and rainfall intensity is

$$K_e = 916 + 330 \log_{10} i \quad (2)$$

where  $i$  = rainfall intensity (in./h) and  $K_e$  = kinetic energy (ft-tons per ac-in. of rain) of rain falling onto the wet section and the panel, as well as the water flowing off of the end of the panel (Wischmeier and Smith 1978). The kinetic energy (Salles et al. 2002) of the rainfall was greater than that coming off the panel, but the area under the panel (i.e., the product of the length, width, and cosine of the panel angle) is greater than the area under the edge of the panel where the water drains from the panel onto the ground. Thus, dividing the kinetic energy by the respective areas gives a more accurate representation of the kinetic energy experienced by the soil. The energy of the water draining from the panel onto the ground can be nearly 10 times greater than the rain itself falling onto the ground area. If the solar panel runoff falls onto an unsealed soil, considerable detachment can result (Motha et al. 2004). Thus, because of the increased kinetic energy, it is possible that the soil is much more prone to erosion with the panels than without. Where panels are installed, methods of erosion control should be included in the design.

## Conclusions

Solar farms are the energy generators of the future; thus, it is important to determine the environmental and hydrologic effects of these farms, both existing and proposed. A model was created to simulate storm-water runoff over a land surface without panels and then with solar panels added. Various sensitivity analyses were conducted including changing the storm duration and volume, soil type, ground slope, panel angle, and ground cover to determine the effect that each of these factors would have on the volumes and peak discharge rates of the runoff.

The addition of solar panels over a grassy field does not have much of an effect on the volume of runoff, the peak discharge, nor the time to peak. With each analysis, the runoff volume increased slightly but not enough to require storm-water management facilities. However, when the land-cover type was changed under the panels, the hydrologic response changed significantly. When gravel or pavement was placed under the panels, with the spacer section left as patchy grass or bare ground, the volume of the runoff increased significantly and the peak discharge increased by approximately 100%. This was also the result when the entire cell was assumed to be bare ground.

The potential for erosion of the soil at the base of the solar panels was also studied. It was determined that the kinetic energy of the water draining from the solar panel could be as much as 10 times greater than that of rainfall. Thus, because the energy of the water draining from the panels is much higher, it is very possible that soil below the base of the solar panel could erode owing to the concentrated flow of water off the panel, especially if there is bare ground in the spacer section of the cell. If necessary, erosion control methods should be used.

Bare ground beneath the panels and in the spacer section is a realistic possibility (see Figs. 1 and 5). Thus, a good, well-maintained grass cover beneath the panels and in the spacer section is highly recommended. If gravel, pavement, or bare ground is

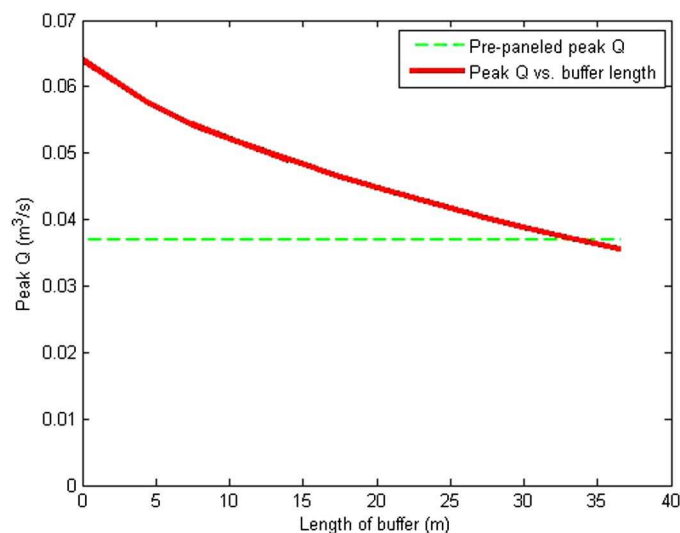

Fig. 6. Peak discharge over gravel compared with buffer length

deemed unavoidable below the panels or in the spacer section, it may necessary to add a buffer section to control the excess runoff volume and ensure adequate losses. If these simple measures are taken, solar farms will not have an adverse hydrologic impact from excess runoff or contribute eroded soil particles to receiving streams and waterways.

## Acknowledgments

The authors appreciate the photographs (Figs. 1 and 5) of Ortho Clinical Diagnostics, 1001 Route 202, North Raritan, New Jersey, 08869, provided by John E. Showler, Environmental Scientist, New Jersey Department of Agriculture. The extensive comments of reviewers resulted in an improved paper.

## References

Bedient, P. B., and Huber, W. C. (2002). *Hydrology and floodplain analysis*, Prentice-Hall, Upper Saddle River, NJ.

- Beuselinck, L., Govers, G., Hairsince, P. B., Sander, G. C., and Breynaert, M. (2002). "The influence of rainfall on sediment transport by overland flow over areas of net deposition." *J. Hydrol.*, 257(1–4), 145–163.
- Dabney, S. M., Moore, M. T., and Locke, M. A. (2006). "Integrated management of in-field, edge-of-field, and after-field buffers." *J. Amer. Water Resour. Assoc.*, 42(1), 15–24.
- Engman, E. T. (1986). "Roughness coefficients for routing surface runoff." *J. Irrig. Drain. Eng.*, 112(1), 39–53.
- Garde, R. J., and Raju, K. G. (1977). *Mechanics of sediment transportation and alluvial stream problems*, Wiley, New York.
- McCuen, R. H. (2005). *Hydrologic analysis and design*, 3rd Ed., Pearson/Prentice-Hall, Upper Saddle River, NJ.
- Motha, J. A., Wallbrink, P. J., Hairsine, P. B., and Grayson, R. B. (2004). "Unsealed roads as suspended sediment sources in agricultural catchment in south-eastern Australia." *J. Hydrol.*, 286(1–4), 1–18.
- Salles, C., Poesen, J., and Sempere-Torres, D. (2002). "Kinetic energy of rain and its functional relationship with intensity." *J. Hydrol.*, 257(1–4), 256–270.
- Wischmeier, W. H., and Smith, D. D. (1978). *Predicting rainfall erosion losses: A guide to conservation planning, USDA Handbook 537*, U.S. Government Printing Office, Washington, DC.

# 2022 Financial Assurance Estimate Form (with pre-plat construction)

Updated: 11/4/2021

PROJECT INFORMATION			
Pike Solar	7/19/2022	PPR-22-008	
Project Name	Date	PCD File No.	

Description	Quantity	Units	Unit Cost		Total	(with Pre-Plat Construction)		
						% Complete	Remaining	
<b>SECTION 1 - GRADING AND EROSION CONTROL (Construction and Permanent BMPs)</b>								
* Earthwork								
less than 1,000; \$5,300 min		CY	\$ 8.00	=	\$ -		\$ -	
1,000-5,000; \$8,000 min		CY	\$ 6.00	=	\$ -		\$ -	
5,001-20,000; \$30,000 min		CY	\$ 5.00	=	\$ -		\$ -	
20,001-50,000; \$100,000 min		CY	\$ 3.50	=	\$ -		\$ -	
50,001-200,000; \$175,000 min	99,507	CY	\$ 2.50	=	\$ 248,767.50		\$ 248,767.50	
greater than 200,000; \$500,000 min		CY	\$ 2.00	=	\$ -		\$ -	
* Permanent Seeding (inc. noxious weed mgmnt.)	169	AC	\$ 886.00	=	\$ 149,734.00		\$ 149,734.00	
* Mulching		AC	\$ 831.00	=	\$ -		\$ -	
* Permanent Erosion Control Blanket		SY	\$ 7.00	=	\$ -		\$ -	
* Permanent Pond/BMP Construction		CY	\$ 22.00	=	\$ -		\$ -	
* Permanent Pond/BMP (provide engineer's estimate)		EA		=	\$ -		\$ -	
		EA		=	\$ -		\$ -	
Safety Fence		LF	\$ 3.00	=	\$ -		\$ -	
Temporary Erosion Control Blanket	3,642	SY	\$ 3.00	=	\$ 10,926.00		\$ 10,926.00	
Vehicle Tracking Control	7	EA	\$ 2,625.00	=	\$ 18,375.00		\$ 18,375.00	
Silt Fence	53,580	LF	\$ 3.00	=	\$ 160,740.00		\$ 160,740.00	
Temporary Seeding		AC	\$ 695.00	=	\$ -		\$ -	
Temporary Mulch		AC	\$ 831.00	=	\$ -		\$ -	
Erosion Bales		EA	\$ 28.00	=	\$ -		\$ -	
Erosion Logs/Straw Wattles	416	LF	\$ 6.00	=	\$ 2,496.00		\$ 2,496.00	
Rock Check Dams	27	EA	\$ 554.00	=	\$ 14,958.00		\$ 14,958.00	
Inlet Protection		EA	\$ 185.00	=	\$ -		\$ -	
Sediment Basin	4	EA	\$ 1,952.00	=	\$ 7,808.00		\$ 7,808.00	
Concrete Washout Basin	3	EA	\$ 997.00	=	\$ 2,991.00		\$ 2,991.00	
<i>Diversion Ditch</i>	1,205	LF	\$ 1.00	=	\$ 1,205.00		\$ 1,205.00	
<i>Rock Sock</i>	96	LF	\$ 6.00	=	\$ 576.00		\$ 576.00	
<i>Sediment Traps</i>	38	EA	\$ 300.00	=	\$ 11,400.00		\$ 11,400.00	
<i>Temporary Stream Crossings</i>		EA	\$ 3,000.00	=	\$ -		\$ -	
<i>[insert items not listed but part of construction plans]</i>				=	\$ -		\$ -	
<b>MAINTENANCE (35% of Construction BMPs)</b>					=	\$ 81,016.25		\$ 81,016.25
<b>Section 1 Subtotal</b>					=	<b>\$ 710,992.75</b>		<b>\$ 710,992.75</b>

<b>SECTION 2 - PUBLIC IMPROVEMENTS *</b>							
--	--	--	--	--	--	--	--

ROADWAY IMPROVEMENTS							
Construction Traffic Control		LS		=	\$ -		\$ -
Aggregate Base Course (135 lbs/cf)		Tons	\$ 31.00	=	\$ -		\$ -
Aggregate Base Course (135 lbs/cf)		CY	\$ 56.00	=	\$ -		\$ -
Asphalt Pavement (3" thick)		SY	\$ 16.00	=	\$ -		\$ -
Asphalt Pavement (4" thick)		SY	\$ 21.00	=	\$ -		\$ -
Asphalt Pavement (6" thick)		SY	\$ 32.00	=	\$ -		\$ -
Asphalt Pavement (147 lbs/cf) ___" thick		Tons	\$ 97.00	=	\$ -		\$ -
Raised Median, Paved		SF	\$ 9.00	=	\$ -		\$ -
Regulatory Sign/Advisory Sign		EA	\$ 333.00	=	\$ -		\$ -
Guide/Street Name Sign		EA		=	\$ -		\$ -
Epoxy Pavement Marking		SF	\$ 15.00	=	\$ -		\$ -
Thermoplastic Pavement Marking		SF	\$ 26.00	=	\$ -		\$ -
Barricade - Type 3		EA	\$ 221.00	=	\$ -		\$ -
Delineator - Type I		EA	\$ 27.00	=	\$ -		\$ -
Curb and Gutter, Type A (6" Vertical)		LF	\$ 32.00	=	\$ -		\$ -
Curb and Gutter, Type B (Median)		LF	\$ 32.00	=	\$ -		\$ -
Curb and Gutter, Type C (Ramp)		LF	\$ 32.00	=	\$ -		\$ -
4" Sidewalk (common areas only)		SY	\$ 53.00	=	\$ -		\$ -
5" Sidewalk		SY	\$ 66.00	=	\$ -		\$ -
6" Sidewalk		SY	\$ 80.00	=	\$ -		\$ -
8" Sidewalk		SY	\$ 106.00	=	\$ -		\$ -
Pedestrian Ramp		EA	\$ 1,273.00	=	\$ -		\$ -
Cross Pan, local (8" thick, 6' wide to include return)		LF	\$ 67.00	=	\$ -		\$ -
Cross Pan, collector (9" thick, 8' wide to include return)		LF	\$ 102.00	=	\$ -		\$ -
Curb Chase		EA	\$ 1,639.00	=	\$ -		\$ -
Guardrail Type 3 (W-Beam)		LF	\$ 55.00	=	\$ -		\$ -
Guardrail Type 7 (Concrete)		LF	\$ 80.00	=	\$ -		\$ -
Guardrail End Anchorage		EA	\$ 2,324.00	=	\$ -		\$ -
Guardrail Impact Attenuator		EA	\$ 4,172.00	=	\$ -		\$ -
Sound Barrier Fence (CMU block, 6' high)		LF	\$ 87.00	=	\$ -		\$ -

**PROJECT INFORMATION**

<b>Pike Solar</b>	<b>7/19/2022</b>	<b>PPR-22-008</b>
<b>Project Name</b>	<b>Date</b>	<b>PCD File No.</b>

Description	Quantity	Units	Unit Cost		Total	(with Pre-Plat Construction)	
						% Complete	Remaining
Sound Barrier Fence (panels, 6' high)		LF	\$ 89.00	=	\$ -		\$ -
Electrical Conduit, Size =		LF	\$ 18.00	=	\$ -		\$ -
Traffic Signal, complete intersection		EA	\$ 470,666	=	\$ -		\$ -
<i>[insert items not listed but part of construction plans]</i>				=	\$ -		\$ -
<b>STORM DRAIN IMPROVEMENTS</b>							
Concrete Box Culvert (M Standard), Size ( W x H )		LF		=	\$ -		\$ -
18" Reinforced Concrete Pipe		LF	\$ 70.00	=	\$ -		\$ -
24" Reinforced Concrete Pipe		LF	\$ 83.00	=	\$ -		\$ -
30" Reinforced Concrete Pipe		LF	\$ 104.00	=	\$ -		\$ -
36" Reinforced Concrete Pipe		LF	\$ 128.00	=	\$ -		\$ -
42" Reinforced Concrete Pipe		LF	\$ 171.00	=	\$ -		\$ -
48" Reinforced Concrete Pipe		LF	\$ 209.00	=	\$ -		\$ -
54" Reinforced Concrete Pipe		LF	\$ 272.00	=	\$ -		\$ -
60" Reinforced Concrete Pipe		LF	\$ 319.00	=	\$ -		\$ -
66" Reinforced Concrete Pipe		LF	\$ 368.00	=	\$ -		\$ -
72" Reinforced Concrete Pipe		LF	\$ 421.00	=	\$ -		\$ -
18" Corrugated Steel Pipe		LF	\$ 90.00	=	\$ -		\$ -
24" Corrugated Steel Pipe		LF	\$ 103.00	=	\$ -		\$ -
30" Corrugated Steel Pipe		LF	\$ 131.00	=	\$ -		\$ -
36" Corrugated Steel Pipe		LF	\$ 157.00	=	\$ -		\$ -
42" Corrugated Steel Pipe		LF	\$ 180.00	=	\$ -		\$ -
48" Corrugated Steel Pipe		LF	\$ 190.00	=	\$ -		\$ -
54" Corrugated Steel Pipe		LF	\$ 278.00	=	\$ -		\$ -
60" Corrugated Steel Pipe		LF	\$ 300.00	=	\$ -		\$ -
66" Corrugated Steel Pipe		LF	\$ 364.00	=	\$ -		\$ -
72" Corrugated Steel Pipe		LF	\$ 428.00	=	\$ -		\$ -
78" Corrugated Steel Pipe		LF	\$ 492.00	=	\$ -		\$ -
84" Corrugated Steel Pipe		LF	\$ 588.00	=	\$ -		\$ -
Flared End Section (FES) RCP Size = <i>(unit cost = 6x pipe unit cost)</i>		EA		=	\$ -		\$ -
Flared End Section (FES) CSP Size = <i>(unit cost = 6x pipe unit cost)</i>		EA		=	\$ -		\$ -
End Treatment- Headwall		EA		=	\$ -		\$ -
End Treatment- Wingwall		EA		=	\$ -		\$ -
End Treatment - Cutoff Wall		EA		=	\$ -		\$ -
Curb Inlet (Type R) L=5', Depth < 5'		EA	\$ 6,138.00	=	\$ -		\$ -
Curb Inlet (Type R) L=5', 5' ≤ Depth < 10'		EA	\$ 7,981.00	=	\$ -		\$ -
Curb Inlet (Type R) L =5', 10' ≤ Depth < 15'		EA	\$ 9,242.00	=	\$ -		\$ -
Curb Inlet (Type R) L =10', Depth < 5'		EA	\$ 8,447.00	=	\$ -		\$ -
Curb Inlet (Type R) L =10', 5' ≤ Depth < 10'		EA	\$ 8,706.00	=	\$ -		\$ -
Curb Inlet (Type R) L =10', 10' ≤ Depth < 15'		EA	\$ 10,898.00	=	\$ -		\$ -
Curb Inlet (Type R) L =15', Depth < 5'		EA	\$ 10,984.00	=	\$ -		\$ -
Curb Inlet (Type R) L =15', 5' ≤ Depth < 10'		EA	\$ 11,775.00	=	\$ -		\$ -
Curb Inlet (Type R) L =15', 10' ≤ Depth < 15'		EA	\$ 12,876.00	=	\$ -		\$ -
Curb Inlet (Type R) L =20', Depth < 5'		EA	\$ 11,706.00	=	\$ -		\$ -
Curb Inlet (Type R) L =20', 5' ≤ Depth < 10'		EA	\$ 12,920.00	=	\$ -		\$ -
Grated Inlet (Type C), Depth < 5'		EA	\$ 5,138.00	=	\$ -		\$ -
Grated Inlet (Type D), Depth < 5'		EA	\$ 6,347.00	=	\$ -		\$ -
Storm Sewer Manhole, Box Base		EA	\$ 12,876.00	=	\$ -		\$ -
Storm Sewer Manhole, Slab Base		EA	\$ 7,082.00	=	\$ -		\$ -
Geotextile (Erosion Control)		SY	\$ 7.00	=	\$ -		\$ -
Rip Rap, d50 size from 6" to 24"		Tons	\$ 89.00	=	\$ -		\$ -
Rip Rap, Grouted		Tons	\$ 105.00	=	\$ -		\$ -
Drainage Channel Construction, Size ( W x H )		LF	\$ -	=	\$ -		\$ -
Drainage Channel Lining, Concrete		CY	\$ 631.00	=	\$ -		\$ -
Drainage Channel Lining, Rip Rap		CY	\$ 124.00	=	\$ -		\$ -
Drainage Channel Lining, Grass		AC	\$ 1,626.00	=	\$ -		\$ -
Drainage Channel Lining, Other Stabilization				=	\$ -		\$ -
<i>[insert items not listed but part of construction plans]</i>				=	\$ -		\$ -
				<b>Section 2 Subtotal</b>	<b>=</b>	<b>\$ -</b>	<b>\$ -</b>

\* - Subject to defect warranty financial assurance. A minimum of 20% shall be retained until final acceptance (MAXIMUM OF 80% COMPLETE ALLOWED)

PROJECT INFORMATION		
Pike Solar	7/19/2022	PPR-22-008
Project Name	Date	PCD File No.

Description	Quantity	Units	Unit Cost		Total	(with Pre-Plat Construction)	
						% Complete	Remaining
<b>SECTION 3 - COMMON DEVELOPMENT IMPROVEMENTS (Private or District and NOT Maintained by EPC)**</b>							
<b>ROADWAY IMPROVEMENTS</b>							
				=	\$ -		\$ -
				=	\$ -		\$ -
				=	\$ -		\$ -
				=	\$ -		\$ -
				=	\$ -		\$ -
				=	\$ -		\$ -
<b>STORM DRAIN IMPROVEMENTS</b> (Exception: Permanent Pond/BMP shall be itemized under Section 1)							
				=	\$ -		\$ -
				=	\$ -		\$ -
				=	\$ -		\$ -
				=	\$ -		\$ -
				=	\$ -		\$ -
				=	\$ -		\$ -
<b>WATER SYSTEM IMPROVEMENTS</b>							
Water Main Pipe (PVC), Size 8"		LF	\$ 71.00	=	\$ -		\$ -
Water Main Pipe (Ductile Iron), Size 8"		LF	\$ 83.00	=	\$ -		\$ -
Gate Valves, 8"		EA	\$ 2,058.00	=	\$ -		\$ -
Fire Hydrant Assembly, w/ all valves		EA	\$ 7,306.00	=	\$ -		\$ -
Water Service Line Installation, inc. tap and valves		EA	\$ 1,466.00	=	\$ -		\$ -
Fire Cistern Installation, complete		EA		=	\$ -		\$ -
				=	\$ -		\$ -
<i>[insert items not listed but part of construction plans]</i>							
				=	\$ -		\$ -
<b>SANITARY SEWER IMPROVEMENTS</b>							
Sewer Main Pipe (PVC), Size 8"		LF	\$ 71.00	=	\$ -		\$ -
Sanitary Sewer Manhole, Depth < 15 feet		EA	\$ 4,858.00	=	\$ -		\$ -
Sanitary Service Line Installation, complete		EA	\$ 1,553.00	=	\$ -		\$ -
Sanitary Sewer Lift Station, complete		EA		=	\$ -		\$ -
				=	\$ -		\$ -
<i>[insert items not listed but part of construction plans]</i>							
				=	\$ -		\$ -
<b>LANDSCAPING IMPROVEMENTS</b> (For subdivision specific condition of approval, or PUD)							
*Wildlife Exclusionary Fencing	1	EA	\$ 1,081,000.00	=	\$ 1,081,000.00		\$ 1,081,000.00
		EA		=	\$ -		\$ -
		EA		=	\$ -		\$ -
		EA		=	\$ -		\$ -
		EA		=	\$ -		\$ -
<b>Section 3 Subtotal</b>				=	<b>\$ 1,081,000.00</b>		<b>\$ 1,081,000.00</b>

\*\* - Section 3 is not subject to defect warranty requirements



**PROJECT INFORMATION**

<b>Pike Solar</b>	<b>7/19/2022</b>	<b>PPR-22-008</b>
<b>Project Name</b>	<b>Date</b>	<b>PCD File No.</b>

Description	Quantity	Units	Unit Cost	Total	(with Pre-Plat Construction)	
					% Complete	Remaining
AS-BUILT PLANS (Public Improvements inc. Permanent WQCV BMPs)		LS	= \$	-	\$	-
POND/BMP CERTIFICATION (inc. elevations and volume calculations)		LS	= \$	-	\$	-
<b>Total Construction Financial Assurance</b>					<b>\$</b>	<b>1,791,992.75</b>
(Sum of all section subtotals plus as-builts and pond/BMP certification)						
<b>Total Remaining Construction Financial Assurance (with Pre-Plat Construction)</b>					<b>\$</b>	<b>1,791,992.75</b>
(Sum of all section totals less credit for items complete plus as-builts and pond/BMP certification)						
<b>Total Defect Warranty Financial Assurance</b>					<b>\$</b>	<b>295,900.30</b>
(20% of all items identified as (*). To be collateralized at time of preliminary acceptance)						

**Approvals**

I hereby certify that this is an accurate and complete estimate of costs for the work as shown on the Grading and Erosion Control Plan and Construction Drawings associated with the Project.

Engineer (P.E. Seal Required)

Approved by Owner / Applicant

Date

Approved by El Paso County Engineer / ECM Administrator

Date

**APPENDIX F**  
**MAPS**

DRAINAGE MAPS  
RUNOFF REDUCTION MAPS

7/19/2022 7:42 AM, X:\20-194 PIKE SOLAR\CD\PLANS\FINAL\DRAINAGE MAP\DRAINAGE MAP.DWG

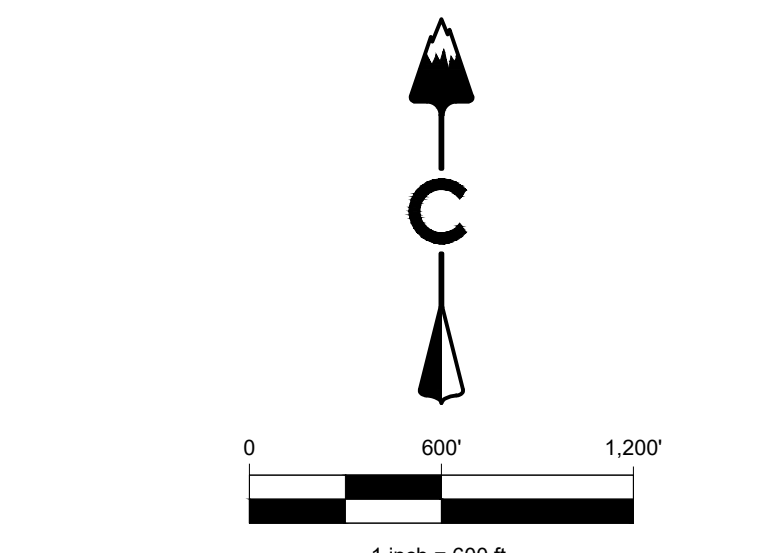
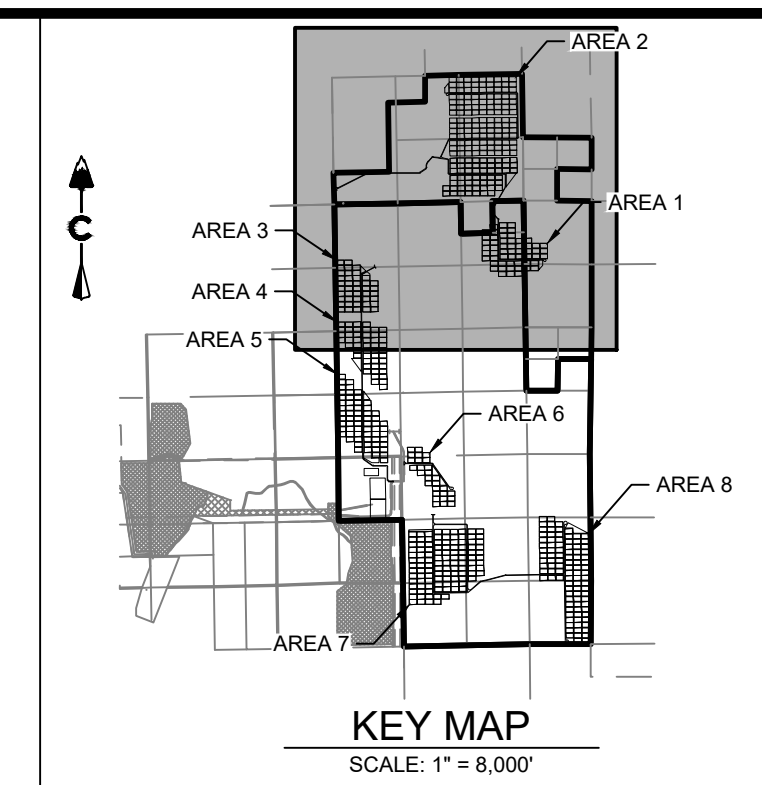
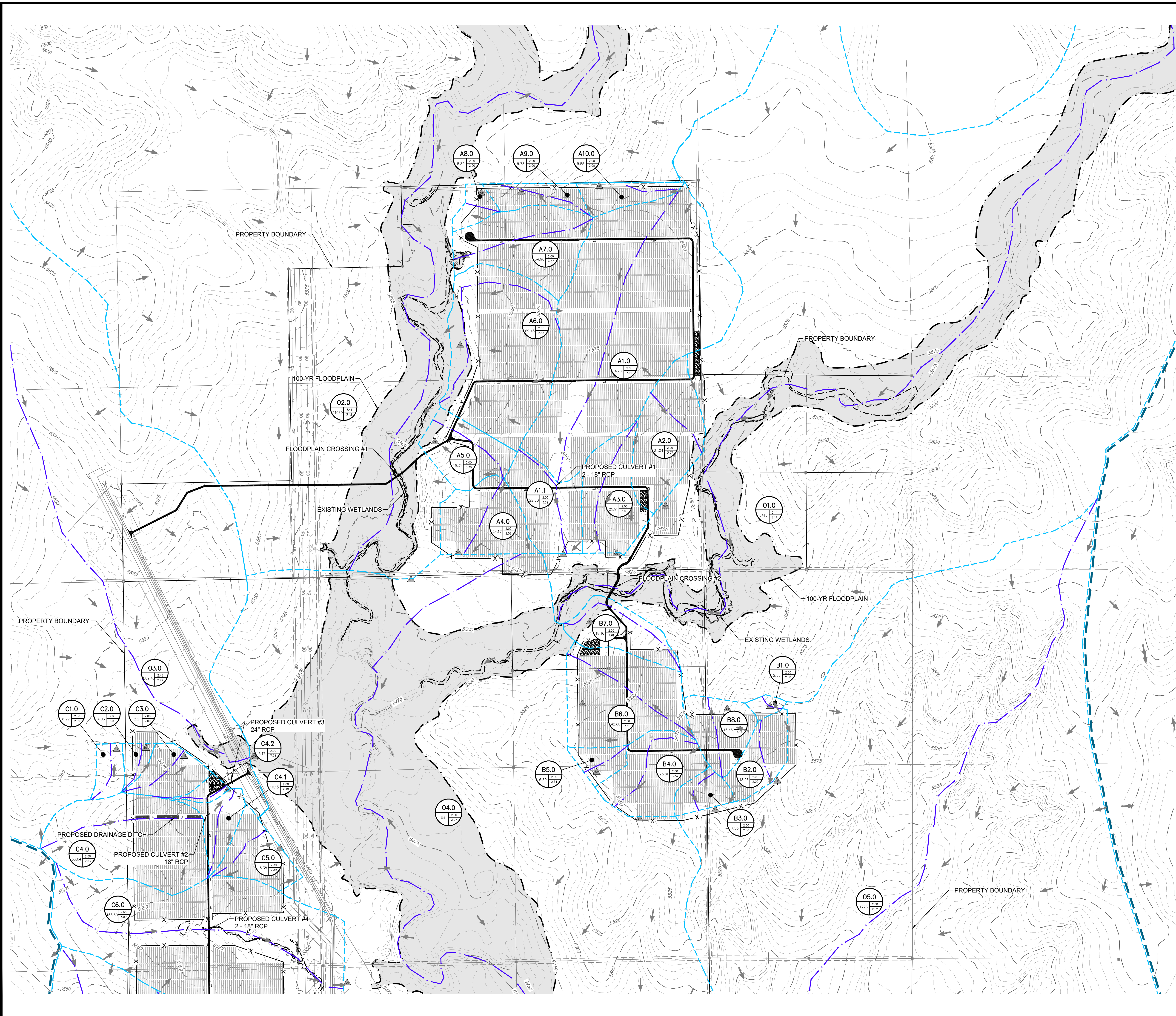

**LEGEND**

- X BASIN DESIGNATION
- AREA XXX 0.45 EXISTING IMPERVIOUS
- 0.60 PROPOSED IMPERVIOUS
- 100-YR FLOODPLAIN
- EXISTING WETLANDS
- EXISTING MAJOR CONTOUR (5280)
- EXISTING MINOR CONTOUR (5275)
- SUBBASIN BOUNDARY
- MAJOR BASIN BOUNDARY
- SUBCATCHMENT LENGTH
- DRAINAGE DITCH
- DIRECTIONAL FLOW ARROW
- DESIGN POINT

Subbasin ID	Existing Condition		Proposed Condition	
	5-Year	100-Year	5-Year	100-Year
A1.0	13.8	173.2	14.9	174.2
A1.1	4.4	35.7	4.7	36.0
A2.0	10.0	72.7	10.4	73.0
A3.0	4.7	40.4	5.1	40.8
A4.0	7.1	54.7	7.2	54.9
A5.0	2.2	32.0	2.8	32.7
A6.0	11.4	102.6	11.9	103.0
A7.0	5.4	55.2	6.1	55.9
A8.0	0.9	12.9	0.9	12.9
A9.0	0.9	14.4	0.9	14.4
A10.0	1.5	20.7	1.5	20.7
B6.0	14.5	113.5	15.1	114.1
B7.0	2.8	23.6	3.1	23.9
C4.0	11.3	89.4	11.6	89.6
C4.1	1.9	15.1	1.9	15.1
C4.2	0.5	4.3	0.6	4.4
C5.0	4.7	34.1	4.7	34.1
C6.0	25.2	207.3	25.7	207.6
C7.0	3.6	29.3	3.9	29.6
C7.1	39.5	336.4	39.9	336.7
C7.2	2.3	20.3	2.4	20.4
C7.3	2.2	17.7	2.2	17.7
C7.4	36.1	286.0	36.9	286.6
C7.5	2.4	17.5	2.6	17.7
C7.6	16.1	132.9	16.4	133.1
C7.7	36.4	319.9	38.3	321.4
C8.0	67.6	585.6	69.3	587.2
C8.1	42.1	388.7	42.2	388.8
D1.0	2.8	44.1	3.2	44.4
D2.0	4.3	60.2	4.5	60.4
D3.0	8.5	109.1	9.2	109.6
D4.0	4.6	61.6	4.9	61.9
D5.0	4.3	50.7	5.0	51.3
D6.0	1.4	22.1	1.4	22.1
D7.0	0.3	4.2	0.4	4.3
O1.0	87.2	1857.9	87.3	1857.9
O2.0	145.1	3741.5	145.3	3741.8
O3.0	99.1	989.9	100.6	990.3
O4.0	58.4	639.0	58.6	639.3
O5.0	105.6	1098.9	105.7	1099.0

CIVIL ENGINEERING  
WATER RESOURCES  
LAND SURVEYING  
DEVELOPMENT SERVICES  
303.703.4441 | corechil.com  
3473 S. Broadway  
Englewood, CO 80113

**CORE**  
CONSULTANTS

CALL BUSINESS DAYS IN ADVANCE BEFORE YOU DIG, GRADE, OR EXCAVATE FOR THE MARKING OF UNDERGROUND UTILITIES.  
CORE ASSUMES NO RESPONSIBILITY FOR EXISTING UTILITY UTILITIES SHOWN ON THIS DRAWING HAVE BEEN LOCATED FOR THE BEST AVAILABLE INFORMATION. TO SHOW THE LOCATION OF ALL UTILITIES PRIOR TO THE COMMENCEMENT OF ANY CONSTRUCTION ACTIVITIES.

811  
Know what's below.  
Call before you dig.

#	REVISION DESCRIPTION	DATE BY
1	SUBMITTAL	02/04/22 RH

**PIKE SOLAR PROJECT**  
EL PASO COUNTY, COLORADO  
FINAL DRAINAGE REPORT  
DRAINAGE PLAN

DESIGNED BY: CS  
DRAWN BY: TP  
CHECKED BY: RH

JOB NO.  
20-194  
SHEET  
1 OF 2



7/19/2022 7:43 AM, X:\20-194 PIKE SOLAR\CD\PLANS\FINALS\DRAINAGE MAP\DRAINAGE MAP.DWG

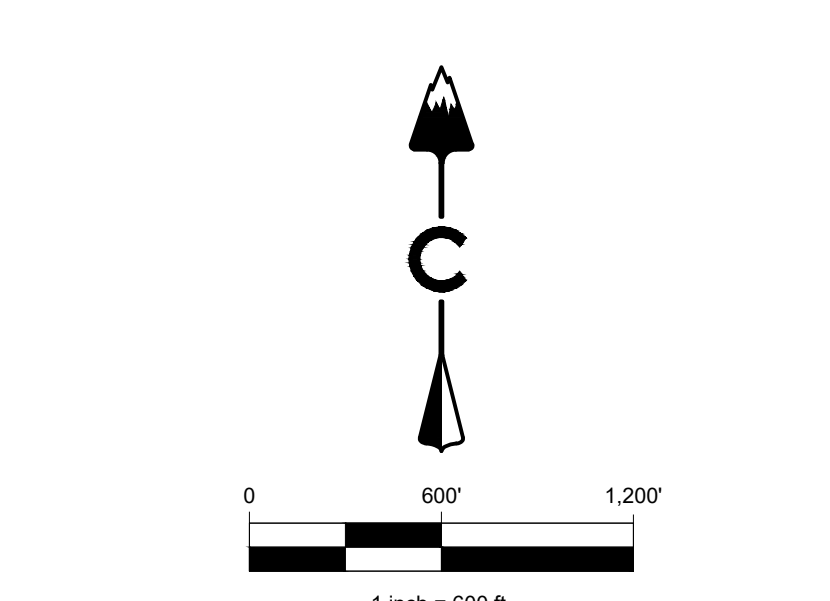
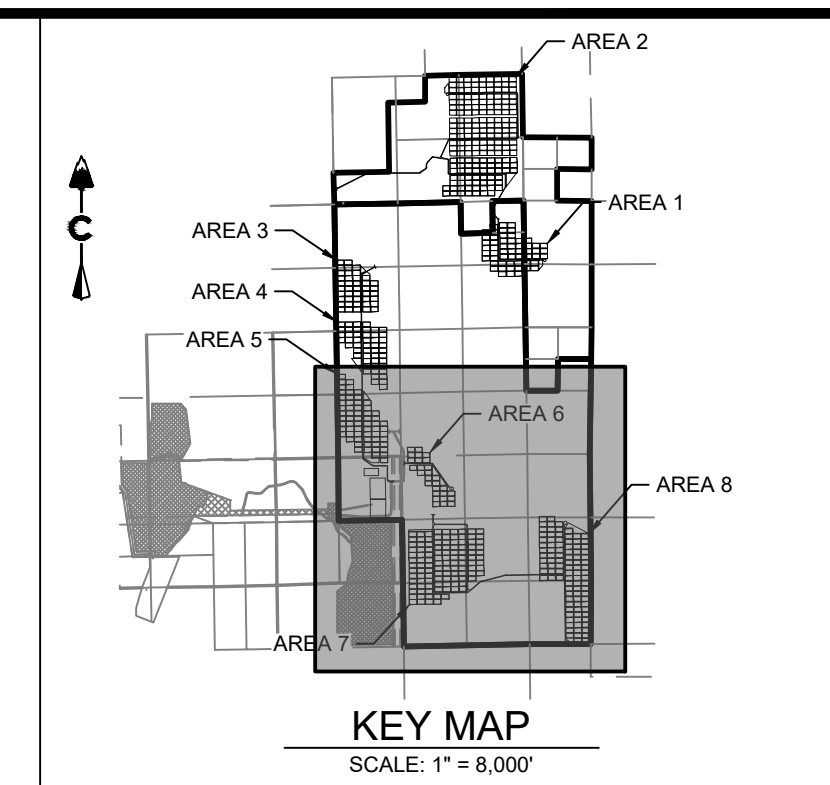
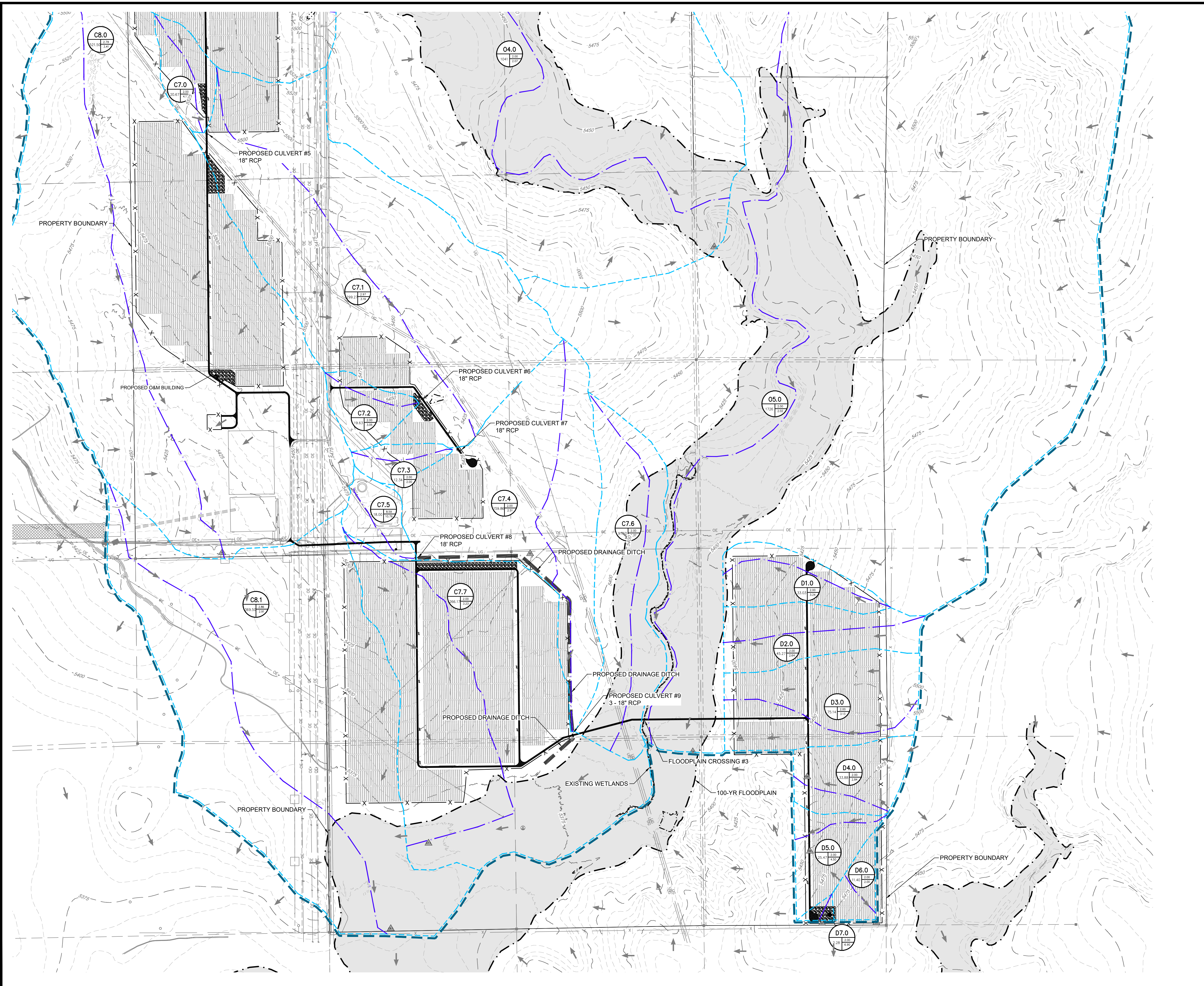

**LEGEND**

- X BASIN DESIGNATION
- AREA XXX 0.45  
0.60 EXISTING IMPERVIOUS
- PROPOSED IMPERVIOUS
- 100-YR FLOODPLAIN
- EXISTING WETLANDS
- EXISTING MAJOR CONTOUR
- EXISTING MINOR CONTOUR
- SUBBASIN BOUNDARY
- MAJOR BASIN BOUNDARY
- SUBCATCHMENT LENGTH
- DRAINAGE DITCH
- DIRECTIONAL FLOW ARROW
- DESIGN POINT

Subbasin ID	Existing Condition		Proposed Condition	
	5-Year	100-Year	5-Year	100-Year
A1.0	13.8	173.2	14.9	174.2
A1.1	4.4	35.7	4.7	36.0
A2.0	10.0	72.7	10.4	73.0
A3.0	4.7	40.4	5.1	40.8
A4.0	7.1	54.7	7.2	54.9
A5.0	2.2	32.0	2.8	32.7
A6.0	11.4	102.6	11.9	103.0
A7.0	5.4	55.2	6.1	55.9
A8.0	0.9	12.9	0.9	12.9
A9.0	0.9	14.4	0.9	14.4
A10.0	1.5	20.7	1.5	20.7
B6.0	14.5	113.5	15.1	114.1
B7.0	2.8	23.6	3.1	23.9
C4.0	11.3	89.4	11.6	89.6
C4.1	1.9	15.1	1.9	15.1
C4.2	0.5	4.3	0.6	4.4
C5.0	4.7	34.1	4.7	34.1
C6.0	25.2	207.3	25.7	207.6
C7.0	3.6	29.3	3.9	29.6
C7.1	39.5	336.4	39.9	336.7
C7.2	2.3	20.3	2.4	20.4
C7.3	2.2	17.7	2.2	17.7
C7.4	36.1	286.0	36.9	286.6
C7.5	2.4	17.5	2.6	17.7
C7.6	16.1	132.9	16.4	133.1
C7.7	36.4	319.9	38.3	321.4
C8.0	67.6	585.6	69.3	587.2
C8.1	42.1	388.7	42.2	388.8
D1.0	2.8	44.1	3.2	44.4
D2.0	4.3	60.2	4.5	60.4
D3.0	8.5	109.1	9.2	109.6
D4.0	4.6	61.6	4.9	61.9
D5.0	4.3	50.7	5.0	51.3
D6.0	1.4	22.1	1.4	22.1
D7.0	0.3	4.2	0.4	4.3
O1.0	87.2	1857.9	87.3	1857.9
O2.0	145.1	3741.5	145.3	3741.8
O3.0	99.1	989.9	100.6	990.3
O4.0	58.4	639.0	58.6	639.3
O5.0	105.6	1098.9	105.7	1099.0

CIVIL ENGINEERING  
 WATER RESOURCES  
 SURVEYING  
 DEVELOPMENT SERVICES  
 303.703.4441 | corechil.com  
 3473 S. Broadway  
 Englewood, CO 80113

CORE CONSULTANTS

CALL 2 BUSINESS DAYS IN ADVANCE BEFORE YOU DIG, GRADE, OR EXCAVATE FOR THE MARKING OF UNDERGROUND UTILITIES.  
 CORE ASSUMES NO RESPONSIBILITY FOR EXISTING UTILITY UTILITIES SHOWN ON THIS DRAWING HAVE BEEN LOCATED FOR THE BEST AVAILABLE INFORMATION. TO SHOW THE LOCATION OF ALL UTILITIES PRIOR TO THE COMMENCEMENT OF ANY CONSTRUCTION ACTIVITIES.

# REVISION DESCRIPTION  
 1 SUBMITTAL

DATE BY  
 02/04/22 RH

PIKE SOLAR PROJECT  
EL PASO COUNTY, COLORADO  
FINAL DRAINAGE REPORT  
DRAINAGE PLAN

DESIGNED BY: CS  
 DRAWN BY: TP  
 CHECKED BY: RH

JOB NO.  
 20-194  
 SHEET  
 2 OF 2

# LEGEND

-  RECEIVING PERVIOUS AREA (RPA) (18FT WIDE)
-  FLOW DIRECTION

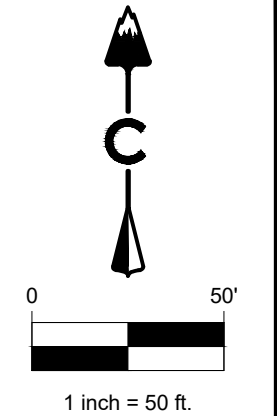

LAND DEVELOPMENT  
ENERGY  
PUBLIC INFRASTRUCTURE

CORE CONSULTANTS, INC.  
3472 S. BROADWAY  
DENVER, CO 80113  
303.703.4444  
LIVE@OURCORE.COM



RUNOFF REDUCTION

PIKE SOLAR

DATE: 07/15/22  
CREATED BY: TP  
JOB NO.  
20-194  
SHEET  
1

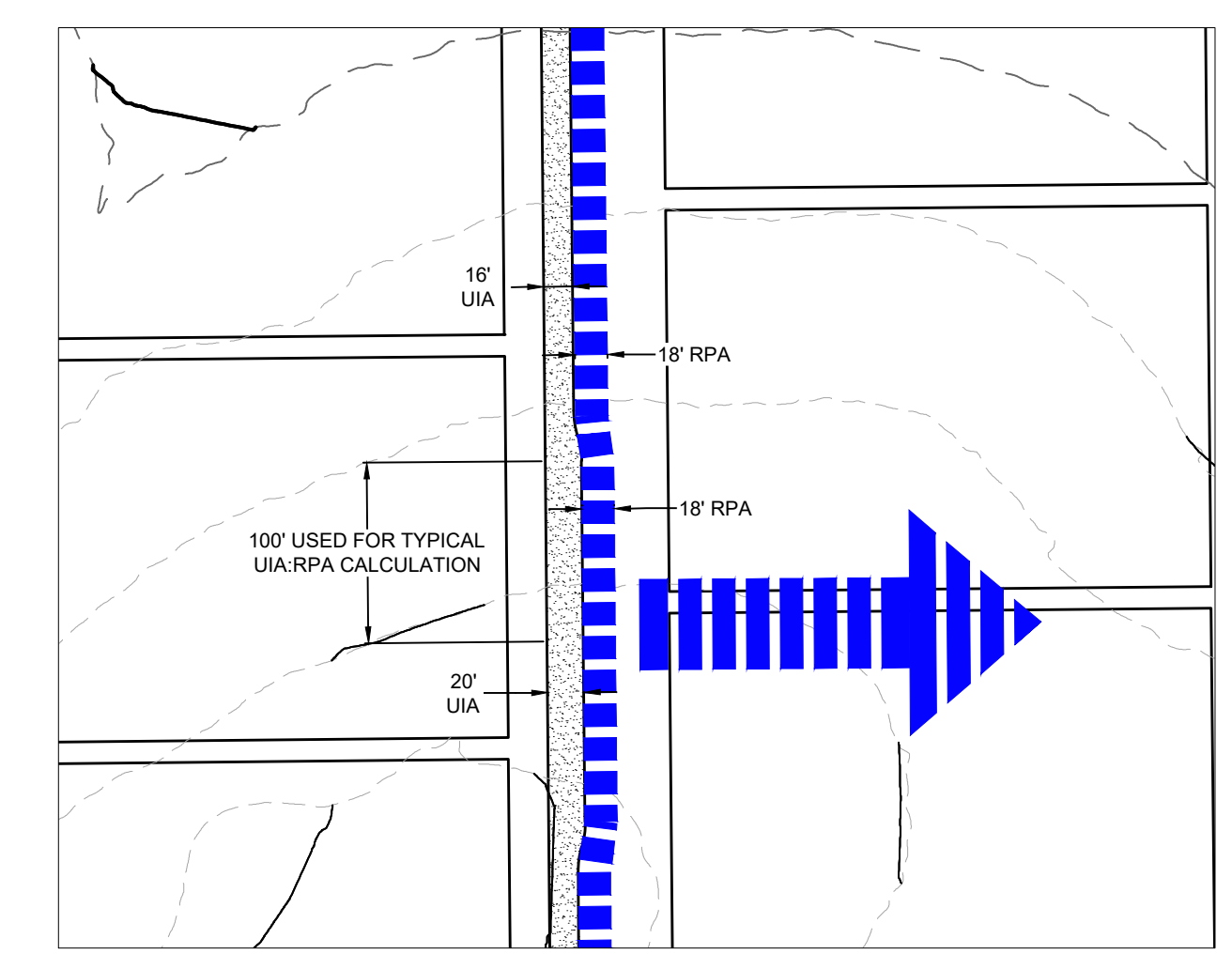
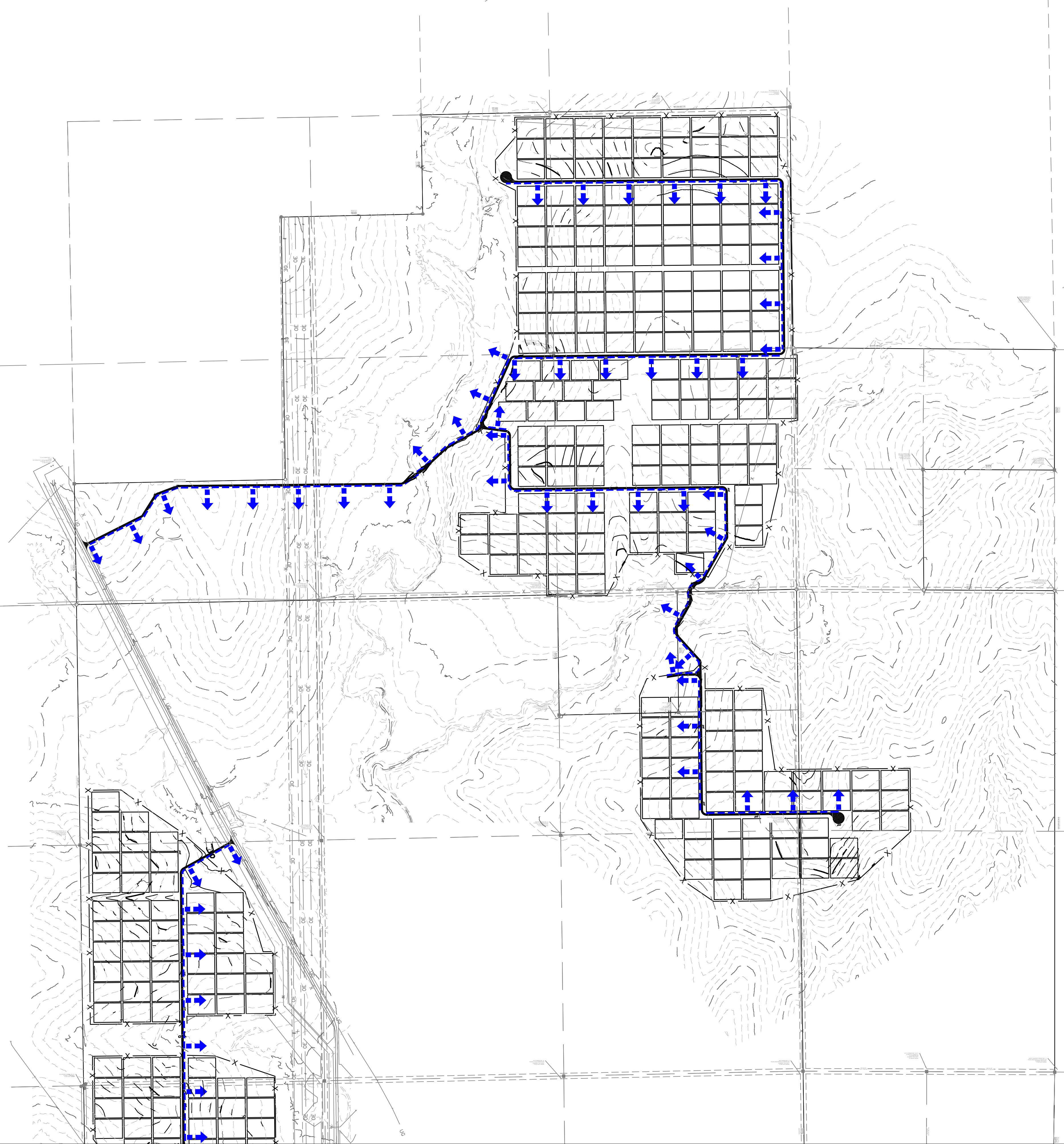

TYPICAL DETAIL

SCALE: 1"=100'

NOTES:

1. THE IDENTIFIED RECEIVING PERVIOUS AREA (RPA) ARE TO REMAIN PERVIOUS AND VEGETATED AFTER CONSTRUCTION IS COMPLETED.
2. AN 18' WIDE RECEIVING PERVIOUS AREA (RPA) WILL BE PROVIDED ADJACENT TO ALL ROADWAYS.

Design Procedure Form: Runoff Reduction

UD-BMP (Version 3.07, March 2018) Sheet 1 of 1

Designer: Rob Hansen  
Company: CORE Consultants  
Date: July 17, 2022  
Project: Pike Solar  
Location: El Paso County

[Clear Worksheet](#)

SITE INFORMATION (User Input in Blue Cells)

WQCV Rainfall Depth: 0.60 inches  
Depth of Average Runoff Producing Storm,  $d_s$ : 0.43 inches (for Watersheds Outside of the Denver Region, Figure 3-1 in USDC)

Area Type	UIA RPA	UIA RPA	UIA RPA	UIA RPA	UIA RPA
Area ID	Typ	O&M	Substation 1	Substation 2	Substation 3
Downstream Design Point ID	Typ	O&M	SUB	SUB	SUB
Downstream BMP Type	None	None	None	None	None
DCIA (ft <sup>2</sup> )	--	--	--	--	--
UIA (ft <sup>2</sup> )	2,000	4,338	42,000	9,318	2,202
RPA (ft <sup>2</sup> )	1,800	4,329	32,809	8,173	3,470
SPA (ft <sup>2</sup> )	--	--	--	--	--
HSG A (%)	0%	0%	0%	0%	0%
HSG B (%)	0%	0%	0%	0%	0%
HSG C/D (%)	100%	100%	100%	100%	100%
Average Slope of RPA (ft/ft)	0.050	0.050	0.030	0.040	0.040
UIA/RPA Interface Width (ft)	100.00	144.00	298.26	326.90	138.80

CALCULATED RUNOFF RESULTS

Area ID	Typ	O&M	Substation 1	Substation 2	Substation 3
UIA/RPA Area (ft <sup>2</sup> )	3,800	8,667	74,809	17,491	5,672
L / W Ratio	0.38	0.42	0.84	0.16	0.29
UIA / Area	0.5263	0.5005	0.5614	0.5327	0.3882
Runoff (in)	0.00	0.00	0.00	0.00	0.00
Runoff (ft <sup>3</sup> )	0	0	0	0	0
Runoff Reduction (ft <sup>3</sup> )	83	181	1750	388	92

CALCULATED WQCV RESULTS

Area ID	Typ	O&M	Substation 1	Substation 2	Substation 3
WQCV (ft <sup>3</sup> )	83	181	1750	388	92
WQCV Reduction (ft <sup>3</sup> )	83	181	1750	388	92
WQCV Reduction (%)	100%	100%	100%	100%	100%
Untreated WQCV (ft <sup>3</sup> )	0	0	0	0	0

CALCULATED DESIGN POINT RESULTS (sums results from all columns with the same Downstream Design Point ID)

Downstream Design Point ID	Typ	O&M	SUB
DCIA (ft <sup>2</sup> )	0	0	0
UIA (ft <sup>2</sup> )	2,000	4,338	53,520
RPA (ft <sup>2</sup> )	1,800	4,329	44,451
SPA (ft <sup>2</sup> )	0	0	0
Total Area (ft <sup>2</sup> )	3,800	8,667	97,971
Total Impervious Area (ft <sup>2</sup> )	2,000	4,338	53,520
WQCV (ft <sup>3</sup> )	83	181	2,230
WQCV Reduction (ft <sup>3</sup> )	83	181	2,230
WQCV Reduction (%)	100%	100%	100%
Untreated WQCV (ft <sup>3</sup> )	0	0	0

2021-09-11 (4:25 PM) Trent Powell X:\20-194 Pike Solar\Civil\CAD\Plans\Filing\_1\Drainage Map Runoff Reduction.dwg

2021-09-11 (4:25 PM) Trent Powell X:\120-194 Pike Solar\Civil\CAD\Plans\Filing\_1\Drainage Map Runoff Reduction.dwg

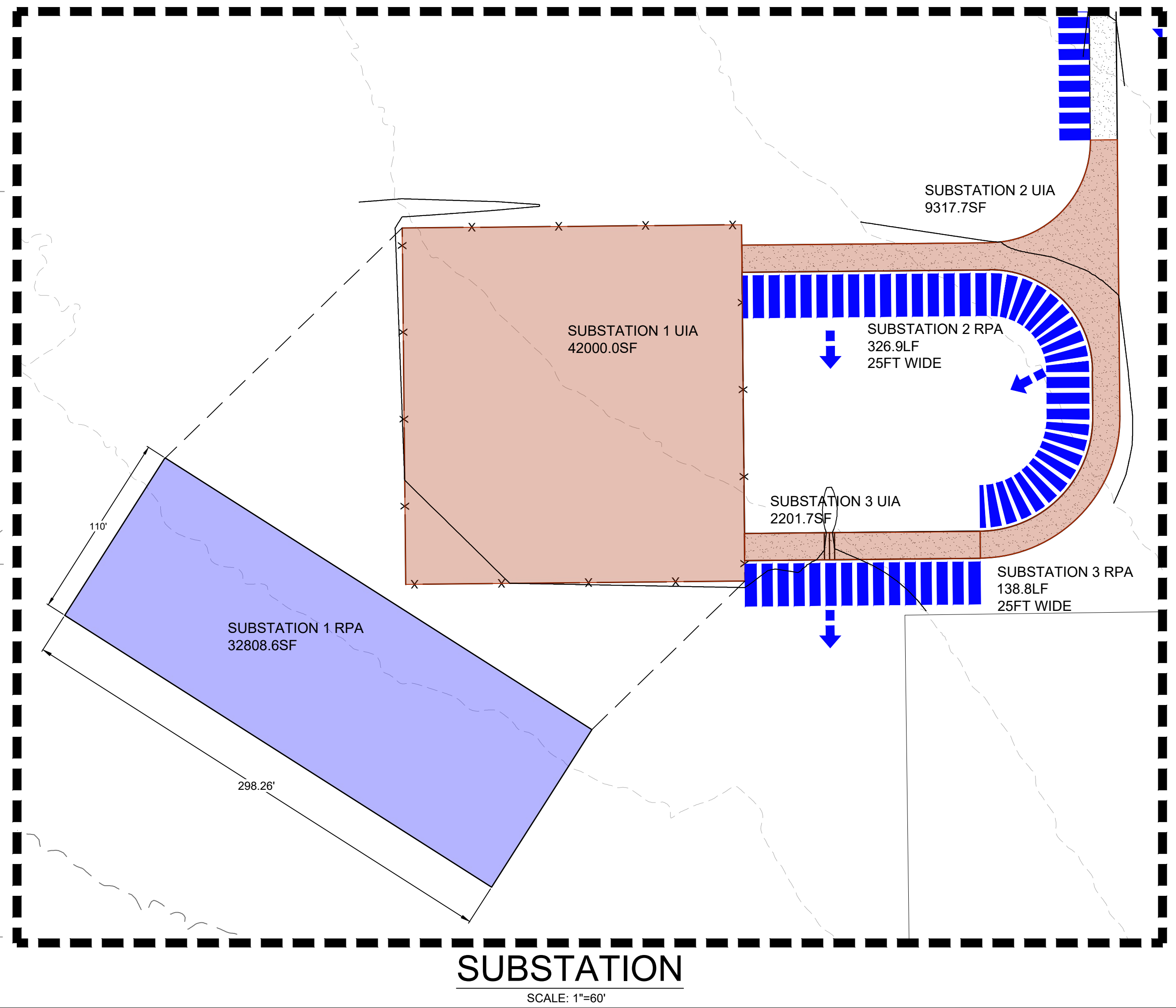
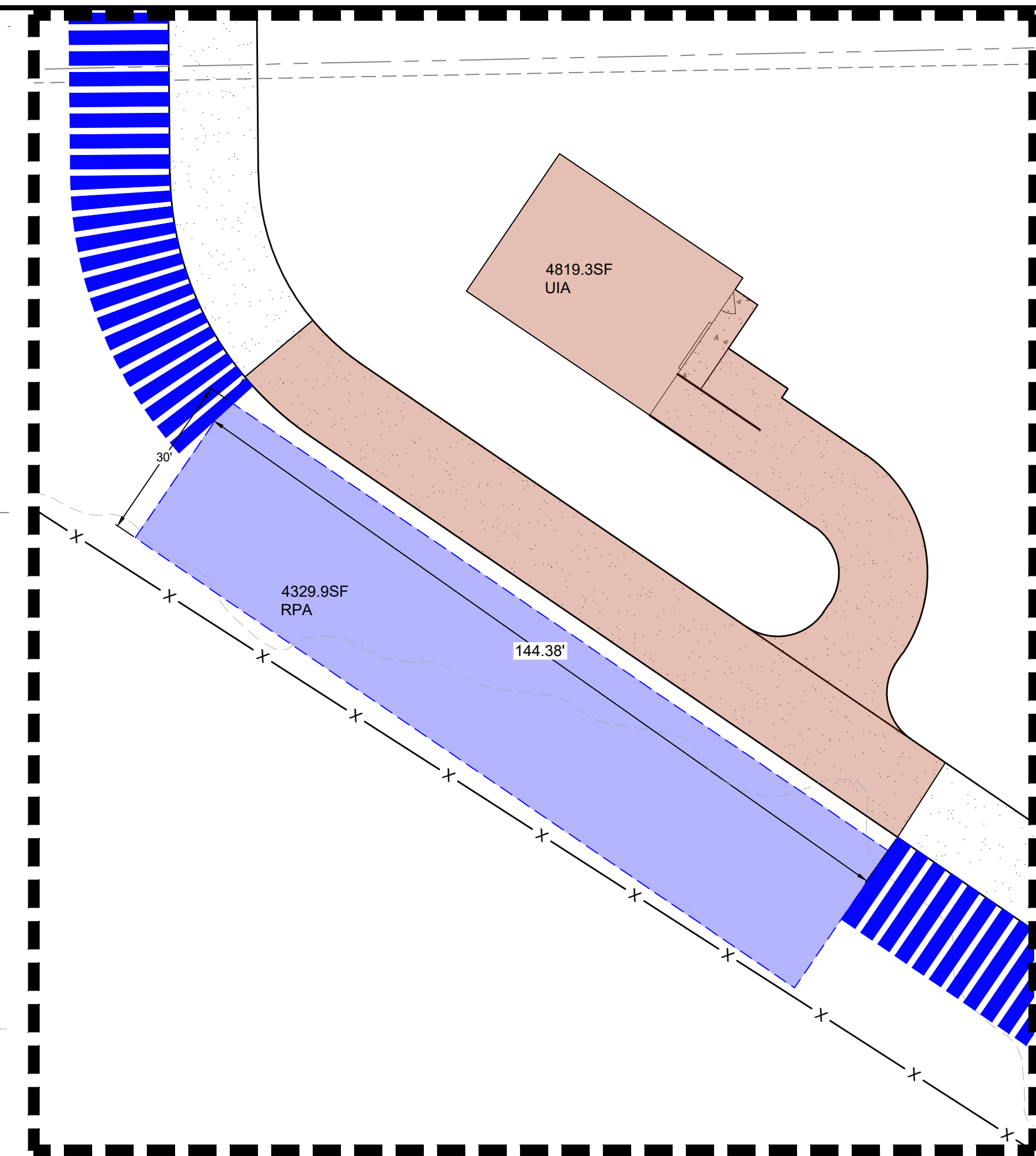
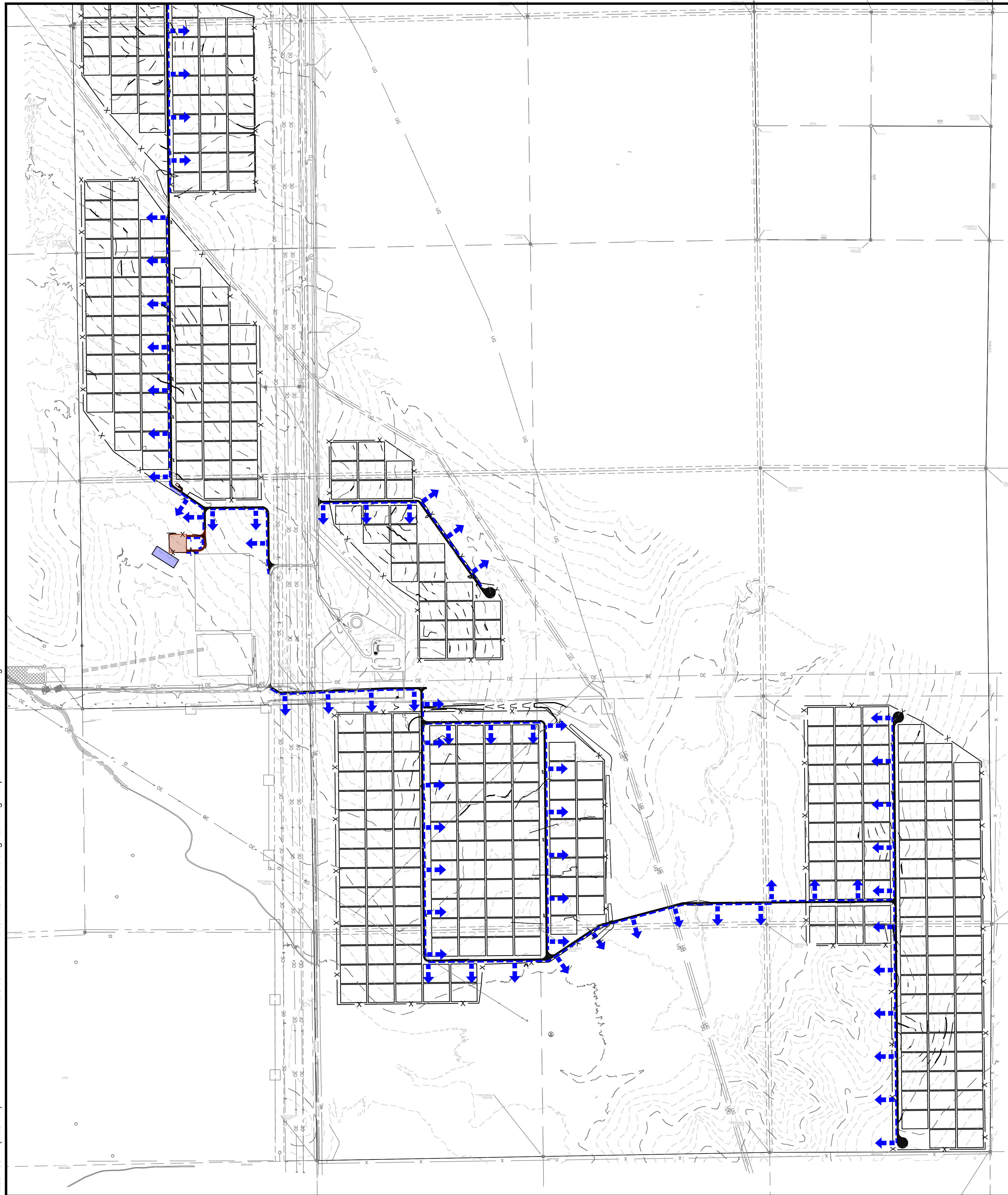

**LEGEND**

- DRAINAGE WAY
- FLOW DIRECTION

- NOTES:**
1. THE IDENTIFIED RECEIVING PERVIOUS AREA (RPA) ARE TO REMAIN PERVIOUS AND VEGETATED AFTER CONSTRUCTION IS COMPLETED.
  2. AN 18' WIDE RECEIVING PERVIOUS AREA (RPA) WILL BE PROVIDED ADJACENT TO ALL ROADWAYS.

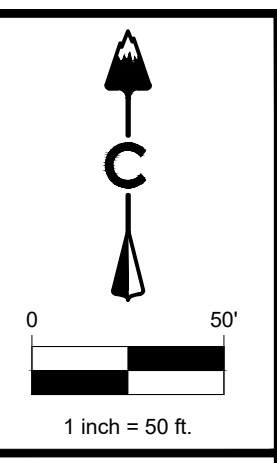

LAND DEVELOPMENT  
ENERGY  
PUBLIC INFRASTRUCTURE

CORE CONSULTANTS, INC.  
3472 S. BROADWAY  
DENVER, CO 80113  
303.703.4444  
LIVE@OURCORE.COM



RUNOFF REDUCTION

PIKE SOLAR

DATE: 09/11/21
CREATED BY: TP
JOB NO. 20-194
SHEET 2