

PRELIMINARY DRAINAGE REPORT
for
FALCON MARKETPLACE

El Paso County, Colorado

January 17, 2017
Revised: June 18, 2018

Prepared for:

Hummel Investments, LLC
8117 Preston Road, Suite 120
Dallas, TX 75225
Contact: Steve Meier
(214) 416-9820

Prepared by:

Drexel, Barrell & Co.
3 South Seventh Street
Colorado Springs, CO 80905
Contact: Tim McConnell, P.E.
(719) 260-0887

TABLE OF CONTENTS

1.0 CERTIFICATION STATEMENTS III

2.0 PURPOSE 1

3.0 GENERAL SITE DESCRIPTION 1

4.0 DBPS ANALYSIS 3

5.0 EXISTING CONDITION HYDROLOGY SUMMARY 7

6.0 PROPOSED HYDROLOGY (RATIONAL METHOD) & HYDRAULIC SUMMARY 8

7.0 PROPOSED DETENTION/WATER QUALITY FACILITIES 11

8.0 FOUR-STEP PROCESS 11

9.0 GEOTECHNICAL HAZARDS 12

10.0 EXISTING ONSITE UTILITY INFRASTRUCTURE 12

11.0 CONDITIONAL LETTER OF MAP REVISION (CLOMR) 13

12.0 DRAINAGE/BRIDGE FEES 13

13.0 CONCLUSIONS 14

14.0 REFERENCES 14

APPENDICES

VICINITY MAP
SOILS MAP
FLOODPLAIN MAP
HYDROLOGY CALCULATIONS
HYDRAULIC CALCULATIONS
DRAINAGE MAP
DBPS EXCERPTS
CLOMR EXCERPTS

PRELIMINARY DRAINAGE REPORT
for
FALCON MARKETPLACE
Falcon, Colorado

1.0 CERTIFICATION STATEMENTS

ENGINEER'S STATEMENT

The attached drainage plan and report were prepared under my direction and supervision and are correct to the best of my knowledge and belief. Said drainage report has been prepared according to the criteria established by El Paso County for drainage reports, and said report is in conformity with the master plan of the drainage basin. I accept responsibility for any liability caused by any negligent acts, errors or omission on my part in preparing this report.

Tim D. McConnell, P.E. Date
Colorado P.E. License No. 33797
For and on Behalf of Drexel, Barrell & Co.

DEVELOPER'S STATEMENT

I, the developer have read and will comply with all the requirements specified in this drainage report and plan.

Business Name: Hummel Investments, LLC

By: Date
Steve Meier
Title: Development Partner
Address: 8117 Preston Road, Suite 120
Dallas, TX 75225

EL PASO COUNTY

Filed in accordance with the requirements of the El Paso County Land Development Code, Drainage Criteria Manual Volumes 1 and 2, and the Engineering Criteria Manual, as amended.

For the County Engineer Date
CONDITIONS:

PRELIMINARY DRAINAGE REPORT
for
FALCON MARKETPLACE
Falcon, Colorado

2.0 PURPOSE

This report is prepared by Drexel, Barrel & Co in support of the Falcon Marketplace project. The purpose of this report is to identify onsite and offsite drainage patterns, storm sewer, inlet locations, and areas tributary to the site, and to safely route developed storm water runoff to adequate outfall facilities.

3.0 GENERAL SITE DESCRIPTION

Location

The site is located at the northwest corner of E. Woodmen Road and Meridian Road - the SE 1/4 of the SE 1/4 of Section 1, Township 13 S, Range 65 W of the 6th P.M., El Paso County, Colorado.

There is one existing home on the site, and several out buildings. The site is bounded on the north by Falcon Ranchettes single family residential, the west by Courtyards at Woodmen Hills West single family residential, the east by Meridian Road, and on the south by E. Woodmen Road.

There are no existing irrigation facilities on the project site.

Existing Site Conditions

The site is approximately 36.4 acres in size and is proposed as commercial use, with one large anchor lot and several smaller outlying lots. The majority of the site is currently undeveloped and is covered with native grass and vegetation. It is gently sloping from the north to south. Offsite flows concentrate into the Unnamed Tributary to Black Squirrel Creek (UTBSC) through the center of the site, and on to a double set of triple 48" diameter culverts under E. Woodmen Road.

Proposed Site Conditions

Falcon Marketplace is a proposed commercial development, consisting of a main anchor, junior anchor and several outlying lots. Falcon Market Place bisects the project, providing access from E. Woodmen Road, Woodmen Frontage Road and Eastonville Road to the north east.

Soils

According to the Soil Survey of El Paso County Area, Colorado, prepared by the U.S. Department of Agriculture Soil Conservation Service, the site is partially underlain by the Blakeland loamy sand (Soil No. 8), and predominantly by the Blakeland-Fluvaquentic Haplaquolis (Soil No. 9), and the Columbine gravelly sandy loam (Soil No. 19). All soils are type 'A' hydrologic soil group. See appendix for map.

Climate

This area of El Paso County can be described as the foothills, with total precipitation amounts typical of a semi-arid region. Winters are generally cold and dry, and summers relatively warm and dry. Precipitation ranges from 12 to 14 inches per year, with the majority of this moisture occurring in the spring and summer in the form of rainfall. Thunderstorms are common during the summer months.

Floodplain Statement

The effective floodplain, Zone A limits, for the Unnamed Tributary to Black Squirrel Creek (UTBSC), in the vicinity of the Falcon Marketplace project, are defined on the FIRM for El Paso County, Colorado and Unincorporated Areas, Map Number 8041CO575F, Effective Date March 17, 1997.

The effective floodplain, Zone A limits, for the UTBSC, in the vicinity of the Falcon Marketplace development, were modified by a LOMR, Case No. 12-08-0579P, Woodmen Road Widening Project – Powers Boulevard to US-24, Effective Date February 28, 2013.

FEMA issued Preliminary FIS and FIRM documents for El Paso County, Colorado and Incorporated Areas dated July 29, 2015. The preliminary FIRM, Map Number 08041CO553G, incorporates the LOMR revised Zone A floodplain identified above. See appendix for supporting information.

On October 17, 2016 a CLOMR was submitted to FEMA that will significantly modify the effective/preliminary floodplain. Approval of the CLOMR will result in the revision and conversion of the approximate zone A floodplain to zone AE with base flood elevations in a few designated open flow areas. The majority of the flow will be confined within a piped storm drain system.

Provide current status of CLOMR

Previous Drainage Studies

The site is located within the Middle Tributary Basin of the Falcon Drainage Basin, as studied in the Falcon Drainage Basin Planning Study, prepared by Matrix Design Group, September, 2015. DBPS recommendations are presented later in this report.

4.0 DBPS ANALYSIS

Existing Conditions

The Falcon DBPS completed hydrologic analysis for the Falcon Basin Watershed, using HEC-HMS v.3.5 software, for historical, existing and future land use conditions by applying a 24-hour storm event with 2-, 5-, 10-, 25-, 50-, and 100-year recurrence intervals and current drainage conveyance infrastructure.

As mentioned earlier, offsite flows from two unnamed tributaries to Black Squirrel Creek (West Branch and East Branch) converge and combine with onsite flows from the Falcon Marketplace site, and travel on to a double set of triple 48" diameter culverts under E. Woodmen Road.

The following table details the HEC-HMS analysis of existing conditions across the Falcon Marketplace development.

**Peak Discharges for the Existing Condition at Points of Interest in vicinity of
Falcon Marketplace Development (DBPS)**

Location	Existing Conditions (source: Falcon Basin, Drainage Planning Study, HEC-HMS model)								
	HEC-HMS Element	Area (sq mi)	Basin/ Design Point	Peak Flow (cfs)					
				2-yr	5-yr	10-yr	25-yr	50-yr	100-yr
West Branch at North Property Line of Falcon Marketplace	RMT062	0.29	1	1	11	25	62	110	160
East Branch at North Property Line of Falcon Marketplace	RMT064	0.67	2	50	140	230	390	490	580
Local Basin	MT060	0.19	MT060	8	21	33	62	80	99
Convergence of West and East Branch at Falcon Marketplace	JMT060	1.16	3	54	160	250	450	560	670
Local Basin	MT070	0.2	MT070	10	23	34	61	77	93
E. Woodmen Road, South Property Line of Falcon Marketplace	JMT070	1.36	4	61	180	280	510	630	760

The DBPS flow rates shown in the table above were used as the basis of the existing condition analysis of the Falcon Marketplace development. Site specific basins have been allocated, and referenced on the existing conditions map in the appendix.

Future Conditions

The DBPS also studied the future condition, with the existing drainage infrastructure currently in place. To accommodate the future condition, the DBPS recommends drainage infrastructure improvements, including Sub-Regional Pond SR4 which was identified to be installed on the Falcon Marketplace property. Pond SR4 will be renamed Pond #1 for the purposes of this report, and was conceptually sized with the parameters shown below:

Falcon DBPS, Pond #1 (SR4) – Sizing Parameters

Parameter	Value
100-year storage volume	19 ac-ft
Q _{2in}	130 cfs
Q _{2out}	27 cfs
Q _{100in}	1,000 cfs
Q _{100out}	730 cfs

The DBPS model was updated to reflect the proposed site design and Pond #1's stage/storage/discharge characteristics were updated using Urban Drainage UD-Detention software. This analysis was then input into the HEC-HMS hydrologic model.

Peak Discharges for the Future Developed Conditions at Points of Interest in vicinity of Falcon Marketplace Development (DBPS)

Location	Future Conditions, with existing drainage infrastructure and Pond SR4 (Pond #1) (source: Falcon Basin, DBPS, HEC-HMS model)								
	HEC-HMS Element	Area (sq mi)	Basin/Design Point	Peak Flow (cfs)					
				2-yr	5-yr	10-yr	25-yr	50-yr	100-yr
West Branch at North Property Line of Falcon Marketplace	RMT062	0.29	1	5	21	34	64	81	99
East Branch at North Property Line of Falcon Marketplace	RMT064	0.67	2	121	273	373	591	712	847
Local Basin	MT060	0.19	MT060	30	59	83	137	167	199
Sub Regional Pond SR4 (Pond #1) Inflow		1.16		133	310	431	697	847	1016
Sub Regional Pond SR4 (Pond #1) Outflow	JMT060	1.16	3	27	142	246	467	595	727
Local Basin	MT070	0.2	MT070	25	50	69	114	139	165
E. Woodmen Road, South Property Line of Falcon Marketplace	JMT070	1.36	4	31	162	281	535	685	844

As shown in the above table, the 100-year discharge to E. Woodmen Road at the south property line, with pond #1 is 844-cfs. To be in conformance with the DBPS recommendations, the allowable 100-year discharge from the Falcon Marketplace development can be no greater than 844-cfs.

Proposed Development & CLOMR Study

On October 17, 2016 a CLOMR, prepared by Drexel, Barrell & Co., was submitted to FEMA. The CLOMR specifically details how the Falcon Marketplace development proposes filling the site and rerouting the UTBSC. This will be accomplished by intercepting the existing creek at the north property line and conveying it via a rundown into a sub-regional detention pond (SR4 - Pond #1), as recommended by the DBPS.

Pond #1 Inflow/Outflow/Stage/Storage Parameters

Recurrence Interval	Pond Inflow (cfs)	Pond Outflow (cfs)	Water Surface Elevation (ft)	Storage Volume (ac-ft)
100-year	1,016	644	6897.0	26.6
50-year	847	481	6896.4	24.5
25-year	697	338	6895.8	22.5
10-year	431	106	6894.6	18.3
5-year	310	52	6894.2	17.0
2-year	133	12	6891.8	10.0

Peak discharges resulting from proposed Pond #1 are summarized above.

Pond #1 will discharge to a new 96" RCP storm drainage system which will flow from south to east across the property and discharge to a section of grass-lined channel that parallels the south perimeter of the property.

Onsite runoff generated from the site, represented as a portion of MT070 in the HEC-HMS model, will be conveyed via curb and gutter, and storm sewer to proposed water quality basins at the south end of the site. The water quality basins will discharge into the open grass-lined channel along the south perimeter of the site.

Specific developed runoff quantities for the site were determined using the Rational Method and are discussed further in section 5.0 of this report.

The open grass-lined channel will then discharge into two sets of existing triple 48" culverts under E. Woodmen Road. Detention pond #1, 96" pipe and open channel are all designed to convey the full 100-year discharge.

No changes to the existing culverts under E. Woodmen Road are proposed. HY-8 software was used to quantify a 765-cfs total capacity of the existing culverts with the culvert headwater at the elevation of the north edge of the roadway pavement.

Specific developed runoff quantities for the site were determined using the Rational Method and are discussed further in section 5.0 of this report.

Peak Discharges at Points of Interest of Falcon Marketplace

Location	Future Conditions, with existing drainage infrastructure + Falcon Marketplace Development (Source: Falcon Marketplace, HEC-HMS model)							
	HEC-HMS Element	Area (sq mi)	Peak Flow (cfs)					
			2-yr	5-yr	10-yr	25-yr	50-yr	100-yr
West branch at North Property Line of Falcon Marketplace	RMT062	0.29	5	21	34	64	81	99
East branch at North Property Line of Falcon Marketplace	RMT064	0.67	121	273	373	591	712	847
Local Basin	MT060	0.19	30	59	83	137	167	199
Sub Regional Pond SR4 Inflow	-	1.16	133	310	431	697	847	1016
Sub Regional Pond SR4 Outflow	JMT060	1.16	12	52	106	338	481	644
Local Basin	MT070	0.20	30	57	79	129	157	186
E. Woodmen Road, South Property Line of Falcon Marketplace	JMT070	1.36	32	62	119	398	562	757

Per the above table, the 100-year discharge at the south property line is 757-cfs, which is less than the capacity of the existing culverts (765-cfs), and also less than the maximum allowable 100-year discharge (844-cfs) identified by the DBPS.

5.0 EXISTING CONDITION HYDROLOGY SUMMARY

In addition to the DBPS, a site specific analysis of the existing conditions was completed. The flows determined by the DBPS for the creek tributary entering the site from the north, were used in combination with rational method analysis for the surrounding onsite/offsite flows.

O1 represents the easterly boundary of the Courtyards at Woodmen Hills West is graded to discharge to the east, onto the Falcon Marketplace site as overland flow. In addition, a swale along their northern boundary captures runoff from the north, and discharges a flow of $Q_5=8.9$ cfs and $Q_{100}=21.8$ cfs on to the northwest corner of the Falcon Marketplace site.

Basin O2 covers the westerly lanes of Meridian Road that discharge into a roadside swale and travel southerly towards a curb cut. The curb cut discharges into the SE corner of the Falcon Marketplace site.

Existing storm sewer infrastructure in the median of Meridian Road was identified as part of this project. Currently, flows generated in the Meridian Road median travel in open landscaped swales, and culverts under roadway intersections, from Woodmen Hills Road to approximately 500 ft north of E. Woodmen Road. The flow approaching E. Woodmen Road is intercepted by a Type D inlet and piped to the south.

Basin O3 generates flows along E. Woodmen Road adjacent to the Falcon Marketplace project site, and from a high point approximately 500 ft to the west, traveling easterly via roadside ditch towards the existing triple 48" culverts.

Existing Design Point 1 combines the flows, to result in $Q_5=196.7$ cfs and $Q_{100}=780.4$ cfs culminating at the existing triple 48" culverts under E. Woodmen Road. This value is comparable to the DBPS determined $Q_{100}=757$ cfs determined for the same location.

The two sets of existing triple 48" RCP culverts discharge to the south across E. Woodmen Road, into an existing storm sewer system. A Type D grate inlet in the median of E. Woodmen Road intercepts median flows and also discharges to the south.

6.0 PROPOSED HYDROLOGY (RATIONAL METHOD) & HYDRAULIC SUMMARY

For the purposes of site specific analysis, the project site has been divided into several grouped drainage basins as shown on the proposed drainage plan. Five Design Points have been analyzed for sizing of the drainage facilities.

The Rational Method was used to determine runoff quantities for the 5- and 100-year storm recurrence intervals. Urban Drainage UD-Detention, UD-Inlet and HydraFlow were also used to identify pond and storm system sizing (see appendix for calculations), and below for a summary runoff table.

Rational Method Runoff Summary

BASIN	Area (Ac.)	Q₅ (CFS)	Q₁₀₀ (CFS)
A1	0.69	0.2	1.4
A2	1.50	5.2	10.2
A3	4.82	1.2	8.8
A4	1.52	5.6	10.2
B1	0.54	2.4	4.3
B2	1.18	4.9	8.9
B3	1.17	4.3	7.9
B4	3.32	9.6	17.6
B5	0.32	1.5	2.6
B6	0.31	1.4	2.5
B7	0.72	3.0	5.4
B8	0.17	0.8	1.4
B9	2.25	8.8	16.1
B10	0.18	0.8	1.5
B11	0.20	0.9	1.6
B12	1.76	6.1	11.2
B13	0.21	1.0	1.7
B14	4.34	16.2	29.6
B15	0.16	0.7	1.3
B16	0.34	1.5	2.6

BASIN	Area (Ac.)	Q₅ (CFS)	Q₁₀₀ (CFS)
B17	2.16	8.9	16.2
B18	2.90	11.3	20.7
B19	2.02	5.4	11.1
B20	1.65	0.4	3.3
C1	4.88	8.2	19.1
C2	0.24	1.1	2.0
C3	0.64	0.5	1.7
C4	0.09	0.0	0.2
C5	0.12	0.5	1.0
C6	0.16	0.7	1.3
C7	1.13	2.9	6.1
C8	3.33	5.0	11.8
DP	Area (Ac.)	Q₅ (CFS)	Q₁₀₀ (CFS)
DP1	2.89	10.9	19.8
DP2	1.03	4.4	8.0
DP3	2.43	9.6	16.1
DP4	25.90	66.3	124.3
DP5	45.02	-	754.0

A-group basins represent flows at the northern portion of the site that will be intercepted by Pond #1, and the 96" outfall. Flows generated from offsite basins have already been established by the aforementioned CLOMR study.

At-grade 10' Type R Inlet IA1 is located at the NW corner of the Meridian Road and Eastonville Road intersection, and is sized to intercept flows from Basin A2. Bypass flows from Inlet IA1, combine with flow from Basin A1 and continue on to 10' Type R sump Inlet IA2. Type C Area Inlet IA3 is designed to intercept runoff generated by the depressed roundabout circle, the intention is to utilize the circle for snow stockpiling during winter storms.

As discussed, a 10' swale along the Courtyards at Woodmen Hills West northern boundary discharges offsite flows (Q₅=8.9 cfs and Q₁₀₀=21.8 cfs) onto the Falcon Marketplace site. These flows will be directed into the sub-regional pond #1 via concrete swale rundown.

B-group basins represent the bulk of the site, with flows generally travelling southwards via curb and gutter, and storm sewer towards Pond #2. Pond #2 has been designed as a 1.1 ac-ft basin, sufficient to detain and release the WQCV generated by the site.

DP1 ($Q_5 = 10.9$ cfs, $Q_{100} = 19.8$ cfs) is located at the confluence of basins B1-B3 to determine the required size of at-grade 10' Type R Inlet IB1. At-grade 10' Type R Inlet IB2 intercepts flow from Basin B5.

DP2 ($Q_5 = 4.4$ cfs, $Q_{100} = 8.0$ cfs) is located further south down Falcon Market Place, and along with bypass flow from Inlet IB1, is used to determine at-grade 10' Type R Inlet IB3 sizing. At-grade 10' Type R Inlet IB4 intercepts flow from Basin B8, and bypass flow from Inlet IB2.

DP3 ($Q_5 = 9.6$ cfs, $Q_{100} = 16.1$ cfs) is used to determine 10' Type R sump Inlet sizing, and 24" storm stub sizing to the north. 10' Type R sump Inlet IB6 intercepts flows from Basin B11 and bypass from Inlet IB3. 10' Type R at-grade inlet IB7 with a 24" storm stub to the north, intercepts flow from Basin B12 and B13. 10' Type R sump inlet IB8 with a 24" storm stub to the north, intercepts bypass from Inlet IB7 and flow from Basin B14 and B15. 10' Type R sump Inlet IB9 intercepts flow from Basin B16. Flows continue via storm sewer system on to Water Quality Pond #2 to the south. DP4 ($Q_5 = 66.3$ cfs, $Q_{100} = 124.3$ cfs) is located at Water Quality Pond #2.

Flows generated by Meridian Road, basin B19 ($Q_5 = 5.4$ cfs, $Q_{100} = 11.1$ cfs) will be intercepted via a relocated curb cut, and directed to Pond #2 via riprap swale/rundown.

C-group basins cover the western and southern portions of the site, along with flows off E. Woodmen Road that will discharge into the open channel. Flows from Basin C1 converge at a small water quality basin (Pond #3 - 0.20 ac-ft). Basin C2 flows will be intercepted by a 10' Type R sump Inlet IC1 that will discharge into Pond #3.

Runoff from Basin C3 will be intercepted by an open 18" FES, discharging into Pond #3 for Water Quality. Outflow from Pond #3 enters a 24" RCP storm sewer and discharges into the 96" line, ultimately reaching the open channel. Type C area Inlet IC3 is located in the depressed roundabout circle, as with the roundabout to the NE the intention is to utilize the circle for snow stockpiling during winter storms. 5' Type R at-grade Inlet IC4 collects flow from Basin C5, and 10' Type R sump Inlet IC5 intercepts flows from Basin C6. Both inlets discharge to the east.

The HEC-HMS study determined that allowable flow generated by the site (B & C-group basins) cannot exceed $Q_{100} = 113$ -cfs. This represents the difference between the open channel flow and discharge from the 96" pipe (757 cfs - 644 cfs = 113 cfs).

Design Point 5 ($Q_{100} = 754.0$ cfs) represents the entirety of the site flow reaching the culverts under E. Woodmen Road. Outflow from the 96" storm pipe, and discharge from Ponds 2 & 3 are combined with basins C3-6, to generate flows of 754 cfs. This flow is within the HEC-HMS design parameter of 757 cfs and as such will not negatively impact the downstream facilities.

HY-8 software was used to analyze the hydraulic performance of the existing culverts. The table below lists the discharge/headwater relationship for the two sets of culverts, and identifies the assumed maximum allowable discharge through each of the two sets of culverts assuming the maximum allowable headwater elevation is equal to the elevation of the edge of roadway asphalt along the north side of E. Woodmen Road.

E. Woodmen Road Culverts, Headwater/Discharge Data

West Set of 3-48" RCP Culverts		East Set of 3-48" RCP Culverts	
Headwater Elevation (ft)	Total Discharge (cfs)	Headwater Elevation (ft)	Total Discharge (cfs)
6871.20	0	6867.80	0
6873.04	50	6869.44	50
6873.88	100	6870.26	100
6874.60	150	6870.95	150
6875.27	200	6871.58	200
6875.96	250	6872.41	250
6876.84	300	6873.01	300
6877.87	350	6873.88	350
6877.99	355	6875.00	400
6878.0*	355.5*	6875.12	405
6878.59	450	6875.2*	408.4*
6878.80	500	6875.78	500

* maximum allowable discharge through each of the two sets of culverts assuming the maximum allowable headwater elevation is equal to the elevation of the edge of roadway asphalt along the north side of E. Woodmen Road.

The proposed grass-lined channel, which parallels the south property line, contains a check dam, located immediately downstream (east) of the westerly set of 3-48" culverts under E. Woodmen Road. The check dam will help to more evenly divide flows between the westerly and easterly sets of 3-48" culverts. The check dam will be constructed of earthen material armored with riprap. The check dam was modeled as an obstruction at CLOMR XS535 with a crest elevation of 6875.9 which was chosen to maximize flow to the westerly set of culverts without exceeding the allowable headwater elevation. The HEC-RAS model results indicate that of the total 100-year discharge = 757 cfs, in the main channel, 351 cfs is diverted to the westerly set of culverts and 406 cfs remain in the main channel. See appendix for supporting information.

In addition to the onsite storm sewer system, a proposed 24" RCP line is to be installed between the existing grate inlet at the Meridian Road/Eastonville Road intersection and the existing grate inlet approximately 600 ft to the south. Median grading in Meridian Road necessitates replacing the existing landscaped median flow with pipe in this location. The southerly inlet will be replaced with a storm sewer manhole.

Private maintenance agreements will be established for the private storm system, prior to Final Plat.

7.0 PROPOSED DETENTION/WATER QUALITY FACILITIES

As previously mentioned, three separate detention/water quality facilities are proposed with this development:

Pond #1 (DBPS – SR4), a 26.7 ac-ft sub-regional detention facility is proposed along the northern boundary of the project site, to intercept flows from the UTBSC, and release it at a reduced flow rate into the 96" pipe. In accordance with El Paso County criteria, a 12'x8' modified type D outlet structure with a permanent micropool will release the WQCV over a 40-hour period. A gravel maintenance access road will be constructed in to, and around the entire perimeter of the pond. Pond #1 will be owned and maintained by El Paso County.

Pond #2, a 1.1 ac-ft water-quality basin will intercept the flows generated by the site, south of the proposed sub-regional pond #1. As with pond #1, in accordance with El Paso County criteria, an outlet structure with permanent micropool will release the WQCV over a 40-hour period, to the open channel along E. Woodmen Road. A gravel maintenance access road will be constructed in to, and around the southern perimeter of the pond.

Pond #3, is a small 0.20 ac-ft water-quality basin intended to intercept the flows generated by the western portion of the site. As with pond #1, in accordance with El Paso County criteria, an outlet structure with permanent micropool will release the WQCV over a 40-hour period. Flows will discharge into the 96" RCP, and ultimately reach the open channel along E. Woodmen Road.

Private maintenance agreements and O&M manuals will be established for Ponds 2 and 3, prior to Final Plat.

8.0 FOUR-STEP PROCESS

In conformance with the Four-Step Process, outlined in the DCM, Volume 2, the site development design is focused on reducing runoff volumes, treating the water quality capture volume, and creating stabilized drainage ways. Methods will be discussed further in the Final Drainage Report.

Proposed sub-regional pond SR4 (Pond #1), and both onsite water quality facilities (Ponds #2 & #3) will capture and slowly release the WQCV, aiding in water quality treatment.

Construction and stabilization of a natural channel along E. Woodmen Road will also take place, allowing water quality benefits, through infiltration and vegetation pollutant uptake. A proposed grade structure will also reduce channel velocities and assist in preventing bed and bank erosion.

Future individual lot owners will be required to address the four-step process, and implement further water quality features as necessary.

9.0 GEOTECHNICAL HAZARDS

In accordance with geotechnical recommendations, the project design is intended to direct runoff away from structures, and into the receiving water quality basins. This will be accomplished by a variety of means, i.e. curb and gutter and storm sewer. The individual building pads will be developed by others, and further analysis will need to be addressed in the lot-specific geotechnical reports for those lots.

After consulting with the State of Colorado Dam Safety Branch, it was determined that the design of Pond #1 (SR4) allows for the structure to be considered non-jurisdictional. Given the length of the buried outlet, the downstream toe is to be used as the datum for measuring dam height.

During construction of the embankment, settlement monitoring plates will be installed. Regular measurements will be recorded, documenting the amount of settlement in the embankment, and when it becomes negligible.

Groundwater mitigation measures for the pond, will consist of installation of a 12-inch thick impervious clay liner, to resolve the potential for vertical groundwater seepage. Liner specifications will be based on the Colorado Department of Natural Resources specifications.

10.0 EXISTING ONSITE UTILITY INFRASTRUCTURE

Along the southern site boundary, a number of existing utilities are being considered as part of the final project design. Utility providers have been consulted and communication will continue as the project design progresses.

Mountain View Electric

An existing overhead transmission line runs along Meridian Road, and continues underground along E. Woodmen Road. These lines, both overhead and underground are proposed to be relocated through the project site, following the proposed main access road.

Woodmen Hills Metropolitan District

An existing 10" sanitary sewer line runs along E. Woodmen Road, and an existing 12" sanitary sewer line runs along Meridian Road, but both are minimally impacted by the project development.

An existing 10" water main, and 6" non-potable raw water main run along the southern boundary of the site. These lines will be relocated along the project main road through the site. Existing lines will be removed when encountered during grading of the open channel.

Nustar Energy

An existing 10" high-pressure petroleum pipeline also runs along the southern boundary of the site. It is anticipated that this line will remain in place. Nustar are aware of the proposed design and as yet have not provided any official correspondence.

11.0 CONDITIONAL LETTER OF MAP REVISION (CLOMR)

As mentioned above, a Conditional Letter of Map Revision (CLOMR) was submitted to FEMA on October 17, 2016. The CLOMR proposes taking a large portion of the project site out of the floodplain, by constructing a sub-regional detention pond, and open channel along E. Woodmen Road.

Referenced portions of the CLOMR are included in the appendix.

Provide current status.

12.0 DRAINAGE/BRIDGE FEES

Drainage and Bridge Fees

The project lies within the Falcon Drainage Basin, and is previously unplatted. The following fees are required:

The percent imperviousness for this subdivision is calculated as follows:

27.7 Acres Commercial	95% Impervious
8.7 Acres Open Space	0% Impervious
<u>Weighted Average</u>	72.3% Impervious

36.4 Acres at 72.3% Impervious = 26.3 Impervious Acres

The following calculations are based on the 2017 drainage/bridge fees for the Falcon Basin:

Drainage Fees	
\$26,265 x 26.3 Impervious Ac	= \$690,770.0*
Bridge Fees	
\$3,608 x 26.3 Impervious Ac.	= \$94,890.00*
*Pond Reimbursement	

**Update to
2018 (final
plat submittal
date)**

Full reimbursement for construction of the sub-regional detention pond (Pond #1 – SR4) and outfall in accordance with DCM Section 3.3, is anticipated. Construction costs will be established in the Final Drainage Report and the drainage basin fee will be requested to be adjusted accordingly. Fees will be based upon the Final Plat submittal date.

13.0 CONCLUSIONS

The Falcon Marketplace project has been designed in accordance with El Paso County criteria. The detention pond and water quality basins have been designed to limit the release of storm runoff to historic flows. This development will not negatively impact the downstream facilities.

A portion of the site will remain in the 100-year floodplain after grading is complete. A LOMR will be submitted to FEMA after construction to revise the FIRM map and remove the majority of the site from the floodplain. Future buildings will not be constructed in the floodplain, or downstream of the Pond SR4 spillway in the potential overtopping inundation area.

14.0 REFERENCES

The sources of information used in the development of this study are listed below:

1. City of Colorado Springs/El Paso County Drainage Criteria Manual, May 2014.
2. Urban Storm Drainage Criteria Manuals, Urban Drainage and Flood Control District. June 2001, Revised April 2008.
3. Request for Conditional Letter of Map Revision, Unnamed Tributary to Black Squirrel Creek, Falcon Marketplace. Prepared by Drexel, Barrell & Co., October 17, 2016.
4. Final Drainage & Erosion Control Plan for The Courtyards at Woodmen Hills West. Prepared by JDS-Hydro, December 1, 2003.
5. Natural Resources Conservation Service (NRCS) Web Soil Survey
6. Federal Emergency Management Agency, Flood Insurance Rate Map, El Paso County, Colorado and Unincorporated Areas, Map Number 8041CO575F, Effective Date March 17, 1997.
7. EL Paso County Board Resolution No 15-042: El Paso County adoption of Chapter 6 and Section 3.2.1, Chapter 13 of the City of Colorado Springs Drainage Criteria Manual, May 2014.
8. Falcon Drainage Basin Planning Study. Prepared by Matrix Design Group, September 2015.
9. Preliminary Geotechnical Investigation. Prepared by Ground Engineering, August 25, 2015, with Addenda #1, dated March 17, 2017.
10. Colorado Department of Natural Resources – Pond Liner Specifications.
11. PSI Pond Liner Memo, June 23, 2017.

Vicinity Map



Vicinity Map

NTS

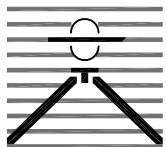

FALCON MARKETPLACE VICINITY MAP

Drexel, Barrell & Co.
Engineers • Surveyors

DATE:
8/18/16

DWG. NO.

JOB NO:
20988-00

VMAP

SHEET 1 OF 1

Soils Map

Custom Soil Resource Report Soil Map



Map Scale: 1:3,170 if printed on A landscape (11" x 8.5") sheet.

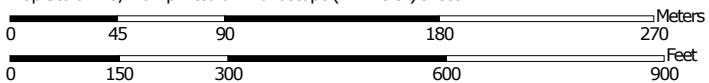

Map projection: Web Mercator Corner coordinates: WGS84 Edge tics: UTM Zone 13N WGS84



MAP LEGEND

Area of Interest (AOI)

 Area of Interest (AOI)

Soils

 Soil Map Unit Polygons

 Soil Map Unit Lines

 Soil Map Unit Points

Special Point Features

 Blowout

 Borrow Pit

 Clay Spot

 Closed Depression

 Gravel Pit

 Gravelly Spot

 Landfill

 Lava Flow

 Marsh or swamp

 Mine or Quarry

 Miscellaneous Water

 Perennial Water

 Rock Outcrop

 Saline Spot

 Sandy Spot

 Severely Eroded Spot

 Sinkhole

 Slide or Slip

 Sodic Spot

 Spoil Area

 Stony Spot

 Very Stony Spot

 Wet Spot

 Other

 Special Line Features

Water Features

 Streams and Canals

Transportation

 Rails

 Interstate Highways

 US Routes

 Major Roads

 Local Roads

Background

 Aerial Photography

MAP INFORMATION

The soil surveys that comprise your AOI were mapped at 1:24,000.

Warning: Soil Map may not be valid at this scale.

Enlargement of maps beyond the scale of mapping can cause misunderstanding of the detail of mapping and accuracy of soil line placement. The maps do not show the small areas of contrasting soils that could have been shown at a more detailed scale.

Please rely on the bar scale on each map sheet for map measurements.

Source of Map: Natural Resources Conservation Service
 Web Soil Survey URL: <http://websoilsurvey.nrcs.usda.gov>
 Coordinate System: Web Mercator (EPSG:3857)

Maps from the Web Soil Survey are based on the Web Mercator projection, which preserves direction and shape but distorts distance and area. A projection that preserves area, such as the Albers equal-area conic projection, should be used if more accurate calculations of distance or area are required.

This product is generated from the USDA-NRCS certified data as of the version date(s) listed below.

Soil Survey Area: El Paso County Area, Colorado
 Survey Area Data: Version 13, Sep 22, 2015

Soil map units are labeled (as space allows) for map scales 1:50,000 or larger.

Date(s) aerial images were photographed: Apr 15, 2011—Sep 22, 2011

The orthophoto or other base map on which the soil lines were compiled and digitized probably differs from the background imagery displayed on these maps. As a result, some minor shifting of map unit boundaries may be evident.

Map Unit Legend

El Paso County Area, Colorado (CO625)			
Map Unit Symbol	Map Unit Name	Acres in AOI	Percent of AOI
8	Blakeland loamy sand, 1 to 9 percent slopes	1.2	3.2%
9	Blakeland-Fluvaquentic Haplaquolls	16.3	43.9%
19	Columbine gravelly sandy loam, 0 to 3 percent slopes	19.6	52.9%
Totals for Area of Interest		37.1	100.0%

Map Unit Descriptions

The map units delineated on the detailed soil maps in a soil survey represent the soils or miscellaneous areas in the survey area. The map unit descriptions, along with the maps, can be used to determine the composition and properties of a unit.

A map unit delineation on a soil map represents an area dominated by one or more major kinds of soil or miscellaneous areas. A map unit is identified and named according to the taxonomic classification of the dominant soils. Within a taxonomic class there are precisely defined limits for the properties of the soils. On the landscape, however, the soils are natural phenomena, and they have the characteristic variability of all natural phenomena. Thus, the range of some observed properties may extend beyond the limits defined for a taxonomic class. Areas of soils of a single taxonomic class rarely, if ever, can be mapped without including areas of other taxonomic classes. Consequently, every map unit is made up of the soils or miscellaneous areas for which it is named and some minor components that belong to taxonomic classes other than those of the major soils.

Most minor soils have properties similar to those of the dominant soil or soils in the map unit, and thus they do not affect use and management. These are called noncontrasting, or similar, components. They may or may not be mentioned in a particular map unit description. Other minor components, however, have properties and behavioral characteristics divergent enough to affect use or to require different management. These are called contrasting, or dissimilar, components. They generally are in small areas and could not be mapped separately because of the scale used. Some small areas of strongly contrasting soils or miscellaneous areas are identified by a special symbol on the maps. If included in the database for a given area, the contrasting minor components are identified in the map unit descriptions along with some characteristics of each. A few areas of minor components may not have been observed, and consequently they are not mentioned in the descriptions, especially where the pattern was so complex that it was impractical to make enough observations to identify all the soils and miscellaneous areas on the landscape.

The presence of minor components in a map unit in no way diminishes the usefulness or accuracy of the data. The objective of mapping is not to delineate pure taxonomic classes but rather to separate the landscape into landforms or landform segments that have similar use and management requirements. The delineation of such segments

Custom Soil Resource Report

on the map provides sufficient information for the development of resource plans. If intensive use of small areas is planned, however, onsite investigation is needed to define and locate the soils and miscellaneous areas.

An identifying symbol precedes the map unit name in the map unit descriptions. Each description includes general facts about the unit and gives important soil properties and qualities.

Soils that have profiles that are almost alike make up a *soil series*. Except for differences in texture of the surface layer, all the soils of a series have major horizons that are similar in composition, thickness, and arrangement.

Soils of one series can differ in texture of the surface layer, slope, stoniness, salinity, degree of erosion, and other characteristics that affect their use. On the basis of such differences, a soil series is divided into *soil phases*. Most of the areas shown on the detailed soil maps are phases of soil series. The name of a soil phase commonly indicates a feature that affects use or management. For example, Alpha silt loam, 0 to 2 percent slopes, is a phase of the Alpha series.

Some map units are made up of two or more major soils or miscellaneous areas. These map units are complexes, associations, or undifferentiated groups.

A *complex* consists of two or more soils or miscellaneous areas in such an intricate pattern or in such small areas that they cannot be shown separately on the maps. The pattern and proportion of the soils or miscellaneous areas are somewhat similar in all areas. Alpha-Beta complex, 0 to 6 percent slopes, is an example.

An *association* is made up of two or more geographically associated soils or miscellaneous areas that are shown as one unit on the maps. Because of present or anticipated uses of the map units in the survey area, it was not considered practical or necessary to map the soils or miscellaneous areas separately. The pattern and relative proportion of the soils or miscellaneous areas are somewhat similar. Alpha-Beta association, 0 to 2 percent slopes, is an example.

An *undifferentiated group* is made up of two or more soils or miscellaneous areas that could be mapped individually but are mapped as one unit because similar interpretations can be made for use and management. The pattern and proportion of the soils or miscellaneous areas in a mapped area are not uniform. An area can be made up of only one of the major soils or miscellaneous areas, or it can be made up of all of them. Alpha and Beta soils, 0 to 2 percent slopes, is an example.

Some surveys include *miscellaneous areas*. Such areas have little or no soil material and support little or no vegetation. Rock outcrop is an example.

El Paso County Area, Colorado

8—Blakeland loamy sand, 1 to 9 percent slopes

Map Unit Setting

National map unit symbol: 369v
Elevation: 4,600 to 5,800 feet
Mean annual precipitation: 14 to 16 inches
Mean annual air temperature: 46 to 48 degrees F
Frost-free period: 125 to 145 days
Farmland classification: Not prime farmland

Map Unit Composition

Blakeland and similar soils: 85 percent
Estimates are based on observations, descriptions, and transects of the mapunit.

Description of Blakeland

Setting

Landform: Flats, hills
Landform position (three-dimensional): Side slope, talf
Down-slope shape: Linear
Across-slope shape: Linear
Parent material: Alluvium derived from sedimentary rock and/or eolian deposits derived from sedimentary rock

Typical profile

A - 0 to 11 inches: loamy sand
AC - 11 to 27 inches: loamy sand
C - 27 to 60 inches: sand

Properties and qualities

Slope: 1 to 9 percent
Depth to restrictive feature: More than 80 inches
Natural drainage class: Somewhat excessively drained
Runoff class: Low
Capacity of the most limiting layer to transmit water (Ksat): High to very high (5.95 to 19.98 in/hr)
Depth to water table: More than 80 inches
Frequency of flooding: None
Frequency of ponding: None
Calcium carbonate, maximum in profile: 5 percent
Available water storage in profile: Low (about 4.5 inches)

Interpretive groups

Land capability classification (irrigated): 3e
Land capability classification (nonirrigated): 6e
Hydrologic Soil Group: A
Ecological site: Sandy Foothill (R049BY210CO)

Minor Components

Other soils

Percent of map unit:

Pleasant

Percent of map unit:

Landform: Depressions

9—Blakeland-Fluvaquentic Haplaquolls

Map Unit Setting

National map unit symbol: 36b6

Elevation: 3,500 to 5,800 feet

Mean annual precipitation: 13 to 17 inches

Mean annual air temperature: 46 to 55 degrees F

Frost-free period: 110 to 165 days

Farmland classification: Not prime farmland

Map Unit Composition

Blakeland and similar soils: 60 percent

Fluvaquentic haplaquolls and similar soils: 30 percent

Estimates are based on observations, descriptions, and transects of the mapunit.

Description of Blakeland

Setting

Landform: Flats, hills

Landform position (three-dimensional): Side slope, talf

Down-slope shape: Linear

Across-slope shape: Linear

Parent material: Sandy alluvium derived from arkose and/or eolian deposits derived from arkose

Typical profile

A - 0 to 11 inches: loamy sand

AC - 11 to 27 inches: loamy sand

C - 27 to 60 inches: sand

Properties and qualities

Slope: 1 to 9 percent

Depth to restrictive feature: More than 80 inches

Natural drainage class: Somewhat excessively drained

Runoff class: Low

Capacity of the most limiting layer to transmit water (Ksat): High to very high (5.95 to 19.98 in/hr)

Depth to water table: More than 80 inches

Frequency of flooding: None

Frequency of ponding: None

Calcium carbonate, maximum in profile: 5 percent

Available water storage in profile: Low (about 4.5 inches)

Interpretive groups

Land capability classification (irrigated): 3e

Land capability classification (nonirrigated): 6e

Custom Soil Resource Report

Hydrologic Soil Group: A
Ecological site: Sandy Foothill (R049BY210CO)

Description of Fluvaquentic Haplaquolls

Setting

Landform: Swales
Down-slope shape: Linear
Across-slope shape: Linear
Parent material: Alluvium

Typical profile

H1 - 0 to 12 inches: variable

Properties and qualities

Slope: 1 to 2 percent
Depth to restrictive feature: More than 80 inches
Natural drainage class: Poorly drained
Runoff class: Very high
Capacity of the most limiting layer to transmit water (Ksat): Moderately high to high
(0.20 to 6.00 in/hr)
Depth to water table: About 0 to 24 inches
Frequency of flooding: Occasional
Frequency of ponding: None
Salinity, maximum in profile: Nonsaline to slightly saline (0.0 to 4.0 mmhos/cm)

Interpretive groups

Land capability classification (irrigated): 6w
Land capability classification (nonirrigated): 6w
Hydrologic Soil Group: D

Minor Components

Other soils

Percent of map unit:

Pleasant

Percent of map unit:
Landform: Depressions

19—Columbine gravelly sandy loam, 0 to 3 percent slopes

Map Unit Setting

National map unit symbol: 367p
Elevation: 6,500 to 7,300 feet
Mean annual precipitation: 14 to 16 inches
Mean annual air temperature: 46 to 50 degrees F
Frost-free period: 125 to 145 days
Farmland classification: Not prime farmland

Map Unit Composition

Columbine and similar soils: 85 percent

Estimates are based on observations, descriptions, and transects of the mapunit.

Description of Columbine

Setting

Landform: Fans, flood plains, fan terraces

Down-slope shape: Linear

Across-slope shape: Linear

Parent material: Alluvium

Typical profile

A - 0 to 14 inches: gravelly sandy loam

C - 14 to 60 inches: very gravelly loamy sand

Properties and qualities

Slope: 0 to 3 percent

Depth to restrictive feature: More than 80 inches

Natural drainage class: Well drained

Runoff class: Very low

Capacity of the most limiting layer to transmit water (Ksat): High to very high (5.95 to 19.98 in/hr)

Depth to water table: More than 80 inches

Frequency of flooding: None

Frequency of ponding: None

Available water storage in profile: Very low (about 2.5 inches)

Interpretive groups

Land capability classification (irrigated): 4e

Land capability classification (nonirrigated): 6e

Hydrologic Soil Group: A

Ecological site: Gravelly Foothill (R049BY214CO)

Minor Components

Fluvaquentic haplaquolls

Percent of map unit:

Landform: Swales

Other soils

Percent of map unit:

Pleasant

Percent of map unit:

Landform: Depressions

Floodplain Map

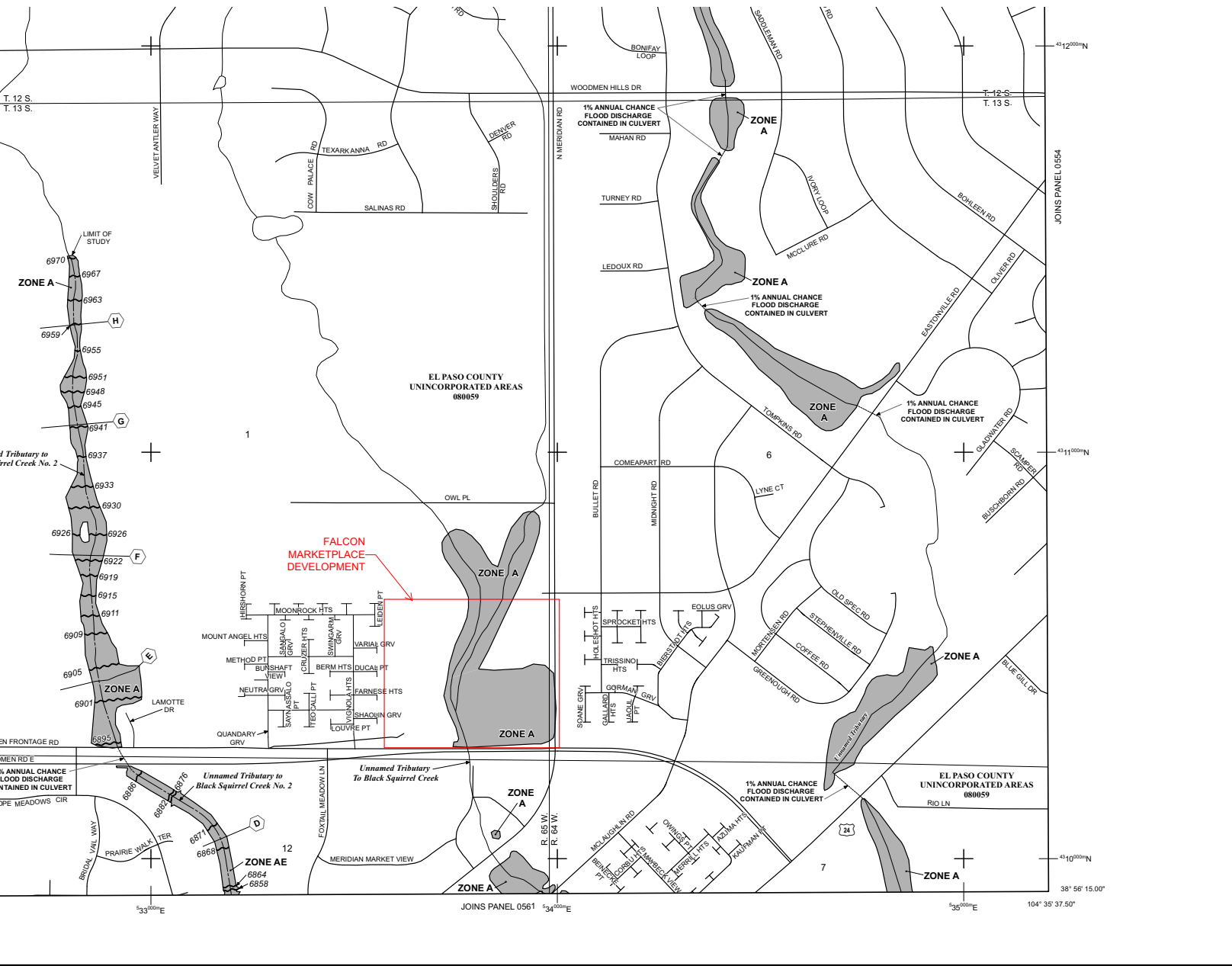

(EL 987) Base Flood Elevation value where uniform within zone; elevation in feet*

* Referenced to the North American Vertical Datum of 1988 (NAVD 88)

A Cross section line

23-----**23** Transsect line

97° 07' 30.00"
32' 22" 30.00"
475⁰⁰⁰N
1000-meter Universal Transverse Mercator grid ticks, zone 13

6000000 FT 5000-foot grid ticks: Colorado State Plane coordinate system, central zone (FIPSZONE 0502), Lambert Conformal Conic Projection

DX5510, X Bench mark (see explanation in Notes to Users section of this FIRM panel)

● M1.5 River Mile

MAP REPOSITORIES
Refer to Map Repositories list on Map Index

EFFECTIVE DATE OF COUNTYWIDE FLOOD INSURANCE RATE MAP
MARCH 17, 1997

EFFECTIVE DATE(S) OF REVISION(S) TO THIS PANEL

[MAP REVISED DATE] - to update corporate limits, to change Base Flood Elevations and Special Flood Hazard Areas, to update map format, to add roads and road names, and to incorporate previously issued Letters of Map Revision.

For community map revision history prior to countywide mapping, refer to the Community Map History Table located in the Flood Insurance Study report for this jurisdiction.

To determine if flood insurance is available in this community, contact your insurance agent or call the National Flood Insurance Program at 1-800-638-6620.

MAP SCALE 1" = 500'

250 0 500 1000 FEET
150 0 150 300 METERS

NATIONAL FLOOD INSURANCE PROGRAM

PANEL 0553G

FIRM
FLOOD INSURANCE RATE MAP
EL PASO COUNTY,
COLORADO
AND INCORPORATED AREAS

PANEL 553 OF 1300
(SEE MAP INDEX FOR FIRM PANEL LAYOUT)

CONTAINS:
COMMUNITY NUMBER PANEL SUFFIX
EL PASO COUNTY 080059 0553 G

PRELIMINARY
JULY 29, 2015

Notice to User: The Map Number shown below should be used when placing map orders: the Community Number shown above should be used on insurance applications for the subject community.

MAP NUMBER
08041C0553G

MAP REVISED

Federal Emergency Management Agency

Hydrology Calculations

PROJECT INFORMATION

PROJECT: Falcon Marketplace
 PROJECT NO: 20988-00CSCV
 DESIGN BY: KGV
 REV. BY: TDM
 AGENCY: El Paso County
 REPORT TYPE: Preliminary
 DATE: 4/28/2017



Drexel, Barrell & Co.

	C2*	C5*	C10*	C100*	% IMPERV
Commercial Development		0.81		0.88	95
Open Space		0.08		0.35	0
Asphalt Roadway		0.90		0.96	100

*C-Values and Basin Imperviousness based on Table 5-1, City of Colorado Springs and El Paso County "Drainage Criteria Manual"

SUB-BASIN	SURFACE DESIGNATION	AREA ACRE	COMPOSITE RUNOFF COEFFICIENTS				% IMPERV
			C2	C5	C10	C100	
O1	Commercial Development	0.00		0.81		0.88	95
	Open Space	2.06		0.08		0.35	0
	Asphalt Roadway	0.00		0.90		0.96	100
TOTAL A1	<i>WEIGHTED AVERAGE</i>	2.06		0.08		0.35	0
O2	Commercial Development	0.00		0.81		0.88	95
	Open Space	0.00		0.08		0.35	0
	Asphalt Roadway	2.21		0.90		0.96	100
TOTAL A2	<i>WEIGHTED AVERAGE</i>	2.21		0.90		0.96	100
O3	Commercial Development	0.00		0.81		0.88	95
	Open Space	0.00		0.08		0.35	0
	Asphalt Roadway	4.46		0.90		0.96	100
TOTAL A3	<i>WEIGHTED AVERAGE</i>	4.46		0.90		0.96	100
E1	Commercial Development	0.00		0.81		0.88	95
	Open Space	35.70		0.08		0.35	0
	Asphalt Roadway	0.00		0.90		0.96	100
TOTAL A4	<i>WEIGHTED AVERAGE</i>	35.70		0.08		0.35	0

PROJECT INFORMATION

PROJECT: Falcon Marketplace
 PROJECT NO: 20988-00CSCV
 DESIGN BY: KGV
 REV. BY: TDM
 AGENCY: El Paso County
 REPORT TYPE: Preliminary
 DATE: 4/28/2017



Drexel, Barrell & Co.

RATIONAL METHOD CALCULATIONS FOR STORM WATER RUNOFF EXISTING

SUB-BASIN DATA				INITIAL/OVERLAND TIME (t_i)			TRAVEL TIME (t_t)					TIME OF CONC. t_c		FINAL t_c
BASIN	DESIGN PT:	C_5	C_{100}	AREA	LENGTH	SLOPE	t_i	LENGTH	SLOPE	VEL.	t_t	COMP.	<i>MINIMUM</i>	
				Ac	Ft	%	Min	Ft	%	FPS	Min	t_c	t_c	Min
	(1)	(2)		(3)	(4)	(5)	(6)	(7)	(8)	(9)*	(11)	(12)	(13)	(14)
O1		0.08	0.35	2.06	80	5.0	10.0	0	0.0	0.0	0.0	10.0	5.0	10.0
O2		0.90	0.96	2.21	50	2.0	2.1	1700	2.0	2.1	13.4	15.5	5.0	15.5
O3		0.90	0.96	4.46	50	2.0	2.1	1500	2.0	2.1	11.8	13.9	5.0	13.9
E1		0.08	0.35	35.70	200	1.0	27.0	1100	2.0	2.8	6.5	33.5	5.0	33.5

PROJECT INFORMATION

PROJECT: Falcon Marketplace
PROJECT NO: 20988-00CSCV
DESIGN BY: KGV
REV. BY: TDM
AGENCY: El Paso County
REPORT TYPE: Preliminary
DATE: 4/28/2017



RATIONAL METHOD CALCULATIONS FOR STORM WATER RUNOFF

EXISTING RUNOFF 5 YR STORM P1= 1.50

BASIN (S)	DIRECT RUNOFF								TOTAL RUNOFF			
	DESIGN POINT	AREA	AREA (AC)	RUNOFF COEFF	t _c (MIN)	C * A	I (IN/HR)	Q (CFS)	t _c (MIN)	S (C * A)	I (IN/HR)	Q (CFS)
	(2)	(3)	(4)	(5)	(6)	(7)	(8)	(9)	(10)	(11)	(12)	(13)
O1			2.06	0.08	10.0	0.16	4.06	0.7				
O2			2.21	0.90	15.5	1.99	3.36	6.7				
O3			4.46	0.90	13.9	4.01	3.53	14.2				
E1			35.70	0.08	33.5	2.86	2.21	6.3				
DBPS OFFSITE NORTH								160.0				
COURTYARDS SWALE OFFSITE NW								8.9				
	DP1							196.7				

PROJECT INFORMATION

PROJECT: Falcon Marketplace
 PROJECT NO: 20988-00CSCV
 DESIGN BY: KGV
 REV. BY: TDM
 AGENCY: El Paso County
 REPORT TYPE: Preliminary
 DATE: 4/28/2017



RATIONAL METHOD CALCULATIONS FOR STORM WATER RUNOFF

EXISTING RUNOFF 100 YR STORM P1= **2.52**

BASIN (S)	DIRECT RUNOFF								TOTAL RUNOFF			
	DESIGN POINT	AREA	AREA (AC)	RUNOFF COEFF	t _c (MIN)	C * A	I (IN/HR)	Q (CFS)	t _c (MIN)	S (C * A)	I (IN/HR)	Q (CFS)
	(2)	(3)	(4)	(5)	(6)	(7)	(8)	(9)	(10)	(11)	(12)	(13)
O1			2.06	0.35	10.0	0.72	6.82	4.9				
O2			2.21	0.96	15.5	2.12	5.64	12.0				
O3			4.46	0.96	13.9	4.28	5.93	25.4				
E1			35.70	0.35	33.5	12.50	3.70	46.3				
DBPS OFFSITE NORTH								670.0				
COURTYARDS SWALE OFFSITE NW								21.8				
	DP1							780.4				

PROJECT INFORMATION

PROJECT: Falcon Marketplace
 PROJECT NO: 20988-00CSCV
 DESIGN BY: KGV
 REV. BY: TDM
 AGENCY: El Paso County
 REPORT TYPE: Preliminary
 DATE: 3/21/2017



	C2*	C5*	C10*	C100*	% IMPERV
Commercial Development		0.81		0.88	95
Open Space		0.08		0.35	0
Asphalt Roadway		0.90		0.96	100

*C-Values and Basin Imperviousness based on Table 5-1, City of Colorado Springs and El Paso County "Drainage Criteria Manual"

SUB-BASIN	SURFACE DESIGNATION	AREA ACRE	COMPOSITE RUNOFF COEFFICIENTS				% IMPERV
			C2	C5	C10	C100	
A1	Commercial Development	0.00		0.81		0.88	95
	Open Space	0.69		0.08		0.35	0
	Asphalt Roadway	0.00		0.90		0.96	100
TOTAL A1	WEIGHTED AVERAGE	0.69		0.08		0.35	0
A2	Commercial Development	0.00		0.81		0.88	95
	Open Space	0.40		0.08		0.35	0
	Asphalt Roadway	1.10		0.90		0.96	100
TOTAL A2	WEIGHTED AVERAGE	1.50		0.68		0.80	73
A3	Commercial Development	0.00		0.81		0.88	95
	Open Space	4.82		0.08		0.35	0
	Asphalt Roadway	0.00		0.90		0.96	100
TOTAL A3	WEIGHTED AVERAGE	4.82		0.08		0.35	0
A4	Commercial Development	1.52		0.81		0.88	95
	Open Space	0.00		0.08		0.35	0
	Asphalt Roadway	0.00		0.90		0.96	100
TOTAL A4	WEIGHTED AVERAGE	1.52		0.81		0.88	95
B1	Commercial Development	0.00		0.81		0.88	95
	Open Space	0.00		0.08		0.35	0
	Asphalt Roadway	0.54		0.90		0.96	100
TOTAL B1	WEIGHTED AVERAGE	0.54		0.90		0.96	100
B2	Commercial Development	1.18		0.81		0.88	95
	Open Space	0.00		0.08		0.35	0
	Asphalt Roadway	0.00		0.90		0.96	100
TOTAL B2	WEIGHTED AVERAGE	1.18		0.81		0.88	95
B3	Commercial Development	1.17		0.81		0.88	95
	Open Space	0.00		0.08		0.35	0
	Asphalt Roadway	0.00		0.90		0.96	100
TOTAL B3	WEIGHTED AVERAGE	1.17		0.81		0.88	95
B4	Commercial Development	3.32		0.81		0.88	95
	Open Space	0.00		0.08		0.35	0
	Asphalt Roadway	0.00		0.90		0.96	100
TOTAL B4	WEIGHTED AVERAGE	3.32		0.81		0.88	95
B5	Commercial Development	0.00		0.81		0.88	95
	Open Space	0.00		0.08		0.35	0
	Asphalt Roadway	0.32		0.90		0.96	100
TOTAL B5	WEIGHTED AVERAGE	0.32		0.90		0.96	100
B6	Commercial Development	0.00		0.81		0.88	95
	Open Space	0.00		0.08		0.35	0
	Asphalt Roadway	0.31		0.90		0.96	100
TOTAL B6	WEIGHTED AVERAGE	0.31		0.90		0.96	100
B7	Commercial Development	0.72		0.81		0.88	95

PROJECT INFORMATION

PROJECT: Falcon Marketplace
 PROJECT NO: 20988-00CSCV
 DESIGN BY: KGV
 REV. BY: TDM
 AGENCY: El Paso County
 REPORT TYPE: Preliminary
 DATE: 3/21/2017



	C2*	C5*	C10*	C100*	% IMPERV
Commercial Development		0.81		0.88	95
Open Space		0.08		0.35	0
Asphalt Roadway		0.90		0.96	100

*C-Values and Basin Imperviousness based on Table 5-1, City of Colorado Springs and El Paso County "Drainage Criteria Manual"

	Open Space	0.00		0.08		0.35	0
	Asphalt Roadway	0.00		0.90		0.96	100
TOTAL B7	<i>WEIGHTED AVERAGE</i>	0.72		0.81		0.88	95
B8	Commercial Development	0.00		0.81		0.88	95
	Open Space	0.00		0.08		0.35	0
	Asphalt Roadway	0.17		0.90		0.96	100
TOTAL B8	<i>WEIGHTED AVERAGE</i>	0.17		0.90		0.96	100
B9	Commercial Development	2.25		0.81		0.88	95
	Open Space	0.00		0.08		0.35	0
	Asphalt Roadway	0.00		0.90		0.96	100
TOTAL B9	<i>WEIGHTED AVERAGE</i>	2.25		0.81		0.88	95
B10	Commercial Development	0.00		0.81		0.88	95
	Open Space	0.00		0.08		0.35	0
	Asphalt Roadway	0.18		0.90		0.96	100
TOTAL B10	<i>WEIGHTED AVERAGE</i>	0.18		0.90		0.96	100
B11	Commercial Development	0.00		0.81		0.88	95
	Open Space	0.00		0.08		0.35	0
	Asphalt Roadway	0.20		0.90		0.96	100
TOTAL B11	<i>WEIGHTED AVERAGE</i>	0.20		0.90		0.96	100
B12	Commercial Development	1.76		0.81		0.88	95
	Open Space	0.00		0.08		0.35	0
	Asphalt Roadway	0.00		0.90		0.96	100
TOTAL B12	<i>WEIGHTED AVERAGE</i>	1.76		0.81		0.88	95
B13	Commercial Development	0.00		0.81		0.88	95
	Open Space	0.00		0.08		0.35	0
	Asphalt Roadway	0.21		0.90		0.96	100
TOTAL B13	<i>WEIGHTED AVERAGE</i>	0.21		0.90		0.96	100
B14	Commercial Development	4.34		0.81		0.88	95
	Open Space	0.00		0.08		0.35	0
	Asphalt Roadway	0.00		0.90		0.96	100
TOTAL B14	<i>WEIGHTED AVERAGE</i>	4.34		0.81		0.88	95
B15	Commercial Development	0.00		0.81		0.88	95
	Open Space	0.00		0.08		0.35	0
	Asphalt Roadway	0.16		0.90		0.96	100
TOTAL B15	<i>WEIGHTED AVERAGE</i>	0.16		0.90		0.96	100
B16	Commercial Development	0.00		0.81		0.88	95
	Open Space	0.00		0.08		0.35	0
	Asphalt Roadway	0.34		0.90		0.96	100
TOTAL B16	<i>WEIGHTED AVERAGE</i>	0.34		0.90		0.96	100
B17	Commercial Development	2.16		0.81		0.88	95
	Open Space	0.00		0.08		0.35	0
	Asphalt Roadway	0.00		0.90		0.96	100
TOTAL B17	<i>WEIGHTED AVERAGE</i>	2.16		0.81		0.88	95
B18	Commercial Development	2.90		0.81		0.88	95

PROJECT INFORMATION

PROJECT: Falcon Marketplace
 PROJECT NO: 20988-00CSCV
 DESIGN BY: KGV
 REV. BY: TDM
 AGENCY: El Paso County
 REPORT TYPE: Preliminary
 DATE: 3/21/2017



	C2*	C5*	C10*	C100*	% IMPERV
Commercial Development		0.81		0.88	95
Open Space		0.08		0.35	0
Asphalt Roadway		0.90		0.96	100

*C-Values and Basin Imperviousness based on Table 5-1, City of Colorado Springs and El Paso County "Drainage Criteria Manual"

	Open Space	0.00		0.08		0.35	0
	Asphalt Roadway	0.00		0.90		0.96	100
TOTAL B18	<i>WEIGHTED AVERAGE</i>	2.90		0.81		0.88	95
B19	Commercial Development	0.00		0.81		0.88	95
	Open Space	0.73		0.08		0.35	0
	Asphalt Roadway	1.29		0.90		0.96	100
TOTAL B19	<i>WEIGHTED AVERAGE</i>	2.02		0.60		0.74	64
B20	Commercial Development	0.00		0.81		0.88	95
	Open Space	1.63		0.08		0.35	0
	Asphalt Roadway	0.00		0.90		0.96	100
TOTAL B20	<i>WEIGHTED AVERAGE</i>	1.63		0.08		0.35	0
C1	Commercial Development	2.75		0.81		0.88	95
	Open Space	2.05		0.08		0.35	0
	Asphalt Roadway	0.00		0.90		0.96	100
TOTAL C1	<i>WEIGHTED AVERAGE</i>	4.80		0.50		0.65	54
C2	Commercial Development	0.00		0.81		0.88	95
	Open Space	0.25		0.08		0.35	0
	Asphalt Roadway	0.09		0.90		0.96	100
TOTAL C2	<i>WEIGHTED AVERAGE</i>	0.34		0.30		0.51	26
C3	Commercial Development	0.00		0.81		0.88	95
	Open Space	0.27		0.08		0.35	0
	Asphalt Roadway	0.70		0.90		0.96	100
TOTAL C3	<i>WEIGHTED AVERAGE</i>	0.97		0.67		0.79	72
C4	Commercial Development	0.00		0.81		0.88	95
	Open Space	0.00		0.08		0.35	0
	Asphalt Roadway	0.45		0.90		0.96	100
TOTAL C4	<i>WEIGHTED AVERAGE</i>	0.45		0.90		0.96	100
C5	Commercial Development	0.00		0.81		0.88	95
	Open Space	2.17		0.08		0.35	0
	Asphalt Roadway	1.94		0.90		0.96	100
TOTAL C5	<i>WEIGHTED AVERAGE</i>	4.11		0.47		0.64	47

PROJECT INFORMATION

PROJECT: Falcon Marketplace
 PROJECT NO: 20988-00CSCV
 DESIGN BY: KGV
 REV. BY: TDM
 AGENCY: El Paso County
 REPORT TYPE: Preliminary
 DATE: 3/21/2017



Drexel, Barrell & Co.

RATIONAL METHOD CALCULATIONS FOR STORM WATER RUNOFF

DEVELOPED TIME OF CONCENTRATION STANDARD FORM SF-2

SUB-BASIN DATA				INITIAL/OVERLAND TIME (t _i)			TRAVEL TIME (t _t)				TIME OF CONC. t _c		FINAL t _c	
BASIN	DESIGN PT:	C ₅	C ₁₀₀	AREA	LENGTH	SLOPE	t _i		SLOPE	C _v	t _t	COMP.	MINIMUM	
				Ac	Ft	%	Min		%	COEFF	Min	t _c	t _c	Min
	(1)	(2)		(3)	(4)	(5)	(6)		(8)	(10)	(11)	(12)	(13)	(14)
A1		0.08	0.35	0.69	65	2.0	12.2		2.0	20	3.3	15.5	5.0	15.5
A2		0.68	0.80	1.50	50	2.7	4.0	2	2.7	10	0.8	4.7	5.0	5.0
A3	POND 1	0.08	0.35	4.82	70	25.0	5.5		0.5	15	12.6	18.0	5.0	18.0
A4		0.81	0.88	1.52	50	0.7	4.3	2	0.7	20	3.1	7.4	5.0	7.4
B1		0.90	0.96	0.54	30	1.8	1.7	11	1.8	20	3.7	5.4	5.0	5.4
B2		0.81	0.88	1.18	50	20.0	1.4	4	1.1	20	2.7	4.1	5.0	5.0
B3		0.81	0.88	1.17	50	0.5	4.8	3	1.1	20	2.4	7.2	5.0	7.2
B4		0.81	0.88	3.32	50	0.5	4.8	2	0.3	20	8.7	13.5	5.0	13.5
B5		0.90	0.96	0.32	40	20.0	0.9	6	1.6	20	2.4	3.3	5.0	5.0
B6		0.90	0.96	0.31	25	2.0	1.5	4	1.3	20	2.4	3.9	5.0	5.0
B7		0.81	0.88	0.72	0	1.0	0.0	2	1.0	20	1.7	1.7	5.0	5.0
B8		0.90	0.96	0.17	30	2.0	1.6	4	1.7	20	1.5	3.1	5.0	5.0
B9		0.81	0.88	2.25	25	2.0	2.2	9	1.6	20	3.8	6.0	5.0	6.0

B10		0.90	0.96	0.18	25	2.0	1.5	4	1.8	20	1.4	2.9	5.0	5.0
B11		0.90	0.96	0.20	25	2.0	1.5	4	1.6	20	1.6	3.1	5.0	5.0
B12		0.81	0.88	1.76	30	0.5	3.7	8	1.2	20	4.9	8.6	5.0	8.6
B13		0.90	0.96	0.21	25	2.0	1.5	5	2.0	20	1.5	3.0	5.0	5.0
B14		0.81	0.88	4.34	30	1.0	3.0	10	1.6	20	4.0	7.0	5.0	7.0
B15		0.90	0.96	0.16	25	2.0	1.5	2	1.0	20	1.7	3.2	5.0	5.0
B16		0.90	0.96	0.34	25	2.0	1.5	6	1.0	20	4.7	6.2	5.0	6.2
B17		0.81	0.88	2.16	50	20.0	1.4	3	1.1	20	2.3	3.7	5.0	5.0
B18		0.81	0.88	2.90	30	2.0	2.4	5	1.1	20	3.7	6.0	5.0	6.0
B19		0.60	0.74	2.02	50	2.0	5.2		2.5	20	2.7	7.9	5.0	7.9
B20	POND 2	0.08	0.35	1.63	50	25.0	4.6	0	0.5	20	10.6	15.2	5.0	15.2
C1		0.50	0.65	4.80	100	10.0	5.2	15	1.7	20	0.1	5.4	5.0	5.4
C2		0.30	0.51	0.34	50	2.0	8.4	1	5.0	20	1.6	10.0	5.0	10.0
C3		0.67	0.79	0.97	50	2.0	4.5	4	1.0	20	3.0	7.5	5.0	7.5
C4		0.90	0.96	0.45	25	2.0	1.5	4	1.1	20	7.9	9.4	5.0	9.4
C5	CHANNEL	0.47	0.64	4.11	100	10.0	5.5		1.0	15	9.3	14.8	5.0	14.8

DP1	B1+B2+B3	0.83	0.89	2.89										7.2
DP2	B6+B7	0.84	0.90	1.03										5.0
DP3	B9+B10	0.82	0.89	2.43										6.0
DP4	Pond 2	0.76	0.84	25.88		B4	13.5		1.0		1.7	15.2	5.0	15.2
DP5	Channel	0.62	0.74	45.08										5.0

PROJECT INFORMATION

PROJECT: Falcon Marketplace
 PROJECT NO: 20988-00CSCV
 DESIGN BY: KGV
 REV. BY: TDM
 AGENCY: El Paso County
 REPORT TYPE: Preliminary
 DATE: 3/21/2017



RATIONAL METHOD CALCULATIONS FOR STORM WATER RUNOFF

DEVELOPED RUNOFF 5 YR STORM P1= 1.50

BASIN (S)	DIRECT RUNOFF								TOTAL RUNOFF			
	DESIGN POINT	AREA	AREA (AC)	RUNOFF COEFF	t _c (MIN)	C * A	I (IN/HR)	Q (CFS)	t _c (MIN)	S (C * A)	I (IN/HR)	Q (CFS)
	(2)	(3)	(4)	(5)	(6)	(7)	(8)	(9)	(10)	(11)	(12)	(13)
A1			0.69	0.08	15.5	0.06	3.35	0.2				
A2			1.50	0.68	5.0	1.02	5.09	5.2				
A3			4.82	0.08	18.0	0.39	3.11	1.2				
A4			1.52	0.81	7.4	1.23	4.53	5.6				
B1			0.54	0.90	5.4	0.49	4.99	2.4				
B2			1.18	0.81	5.0	0.96	5.09	4.9				
B3			1.17	0.81	7.2	0.95	4.57	4.3				
B1+B2+B3	DP1	2.89		0.83					7.2	2.4	4.6	10.9
B4			3.32	0.81	13.5	2.69	3.58	9.6				
B5			0.32	0.90	5.0	0.29	5.09	1.5				
B6			0.31	0.90	5.0	0.28	5.09	1.4				
B7			0.72	0.81	5.0	0.58	5.09	3.0				
B6+B7	DP2	1.03		0.84					5.0	0.9	5.1	4.4
B8			0.17	0.90	5.0	0.15	5.09	0.8				
B9			2.25	0.81	6.0	1.82	4.84	8.8				
B10			0.18	0.90	5.0	0.16	5.09	0.8				

B9+B10	DP3	2.43		0.82					6.0	2.0	4.8	9.6
B11			0.20	0.90	5.0	0.18	5.09	0.9				
B12			1.76	0.81	8.6	1.43	4.29	6.1				
B13			0.21	0.90	5.0	0.19	5.09	1.0				
B14			4.34	0.81	7.0	3.52	4.61	16.2				
B15			0.16	0.90	5.0	0.14	5.09	0.7				
B16			0.34	0.90	6.2	0.31	4.79	1.5				
B17			2.16	0.81	5.0	1.75	5.09	8.9				
B18			2.90	0.81	6.0	2.35	4.83	11.3				
B19			2.02	0.60	7.9	1.22	4.42	5.4				
B20			1.63	0.08	15.2	0.13	3.38	0.4				
(POND 2)	DP4	25.88		0.76					15.2	19.6	3.4	66.3
C1			4.80	0.50	5.4	2.39	5.00	11.9				
C2			0.34	0.30	10.0	0.10	4.06	0.4				
C3			0.97	0.67	7.5	0.65	4.51	2.9				
C5			0.45	0.90	9.4	0.41	4.16	1.7				
C6			4.11	0.47	14.8	1.92	3.42	6.6				
(CHANNEL)	DP5	45.08		0.62								0.0

PROJECT INFORMATION

PROJECT: Falcon Marketplace
 PROJECT NO: 20988-00CSCV
 DESIGN BY: KGV
 REV. BY: TDM
 AGENCY: El Paso County
 REPORT TYPE: Preliminary
 DATE: 3/21/2017



RATIONAL METHOD CALCULATIONS FOR STORM WATER RUNOFF

DEVELOPED RUNOFF 100 YR STORM P1= **2.52**

BASIN (S)	DIRECT RUNOFF								TOTAL RUNOFF			
	DESIGN POINT	AREA	AREA (AC)	RUNOFF COEFF	t _c (MIN)	C * A	I (IN/HR)	Q (CFS)	t _c (MIN)	S (C * A)	I (IN/HR)	Q (CFS)
	(2)	(3)	(4)	(5)	(6)	(7)	(8)	(9)	(10)	(11)	(12)	(13)
A1			0.69	0.35	15.5	0.24	5.63	1.4				
A2			1.50	0.80	5.0	1.20	8.55	10.2				
A3			4.82	0.35	18.0	1.69	5.23	8.8				
A4			1.52	0.88	7.4	1.34	7.61	10.2				
B1			0.54	0.96	5.4	0.52	8.38	4.3				
B2			1.18	0.88	5.0	1.04	8.55	8.9				
B3			1.17	0.88	7.2	1.03	7.67	7.9				
B1+B2+B3	DP1	2.89		0.89					7.2	2.6	7.7	19.8
B4			3.32	0.88	13.5	2.92	6.01	17.6				
B5			0.32	0.96	5.0	0.31	8.55	2.6				
B6			0.31	0.96	5.0	0.30	8.55	2.5				
B7			0.72	0.88	5.0	0.63	8.55	5.4				
B6+B7	DP2	1.03		0.90					5.0	0.9	8.5	8.0
B8			0.17	0.96	5.0	0.16	8.55	1.4				
B9			2.25	0.88	6.0	1.98	8.13	16.1				
B10			0.18	0.96	5.0	0.17	8.55	1.5				

B9+B10	DP3	2.43		0.82					6.0	2.0	8.1	16.1
B11			0.20	0.96	5.0	0.19	8.55	1.6				
B12			1.76	0.88	8.6	1.55	7.21	11.2				
B13			0.21	0.96	5.0	0.20	8.55	1.7				
B14			4.34	0.88	7.0	3.82	7.75	29.6				
B15			0.16	0.96	5.0	0.15	8.55	1.3				
B16			0.34	0.96	6.2	0.33	8.06	2.6				
B17			2.16	0.88	5.0	1.90	8.55	16.2				
B18			2.90	0.88	6.0	2.55	8.11	20.7				
B19			2.02	0.74	7.9	1.49	7.42	11.1				
B20			1.63	0.35	15.2	0.57	5.68	3.2				
(POND 2)	DP4	25.88		0.84					15.2	21.8	5.7	124.2
C1			4.80	0.65	5.4	3.14	8.39	26.3				
C2			0.34	0.51	10.0	0.17	6.82	1.2				
C3			0.97	0.79	7.5	0.77	7.57	5.8				
C5			0.45	0.96	9.4	0.43	7.00	3.0				
C6			4.11	0.64	14.8	2.62	5.75	15.1				
(CHANNEL)	DP5	45.08		0.74								754.0

Hydraulic Calculations

Hydraflow Storm Sewers Extension for Autodesk® AutoCAD® Civil 3D® Plan

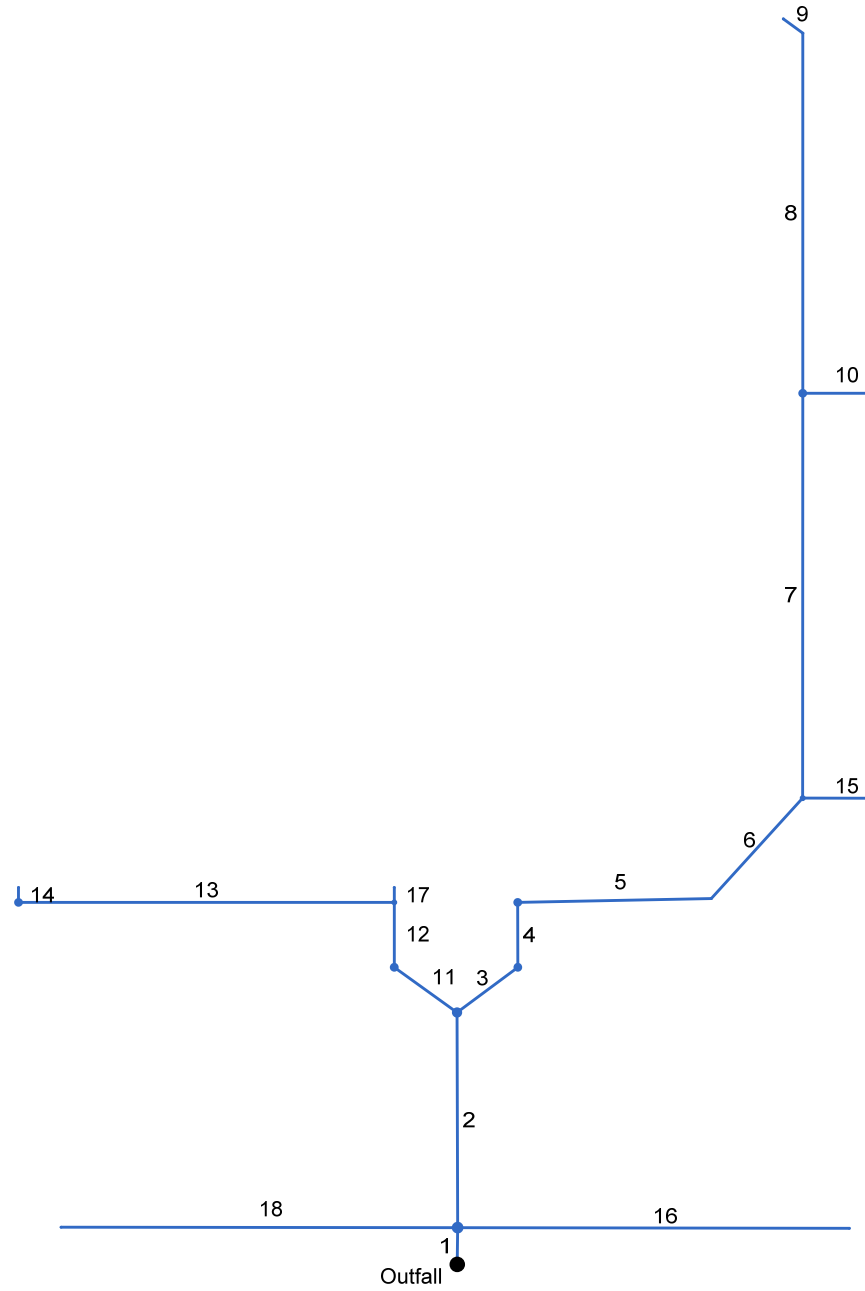

Project File: FM 3-7-17 HF.stm

Number of lines: 18

Date: 3/16/2017

Storm Sewer Inventory Report

Line No.	Alignment				Flow Data				Physical Data								Line ID
	Dnstr Line No.	Line Length (ft)	Defl angle (deg)	Junc Type	Known Q (cfs)	Drng Area (ac)	Runoff Coeff (C)	Inlet Time (min)	Invert El Dn (ft)	Line Slope (%)	Invert El Up (ft)	Line Size (in)	Line Shape	N Value (n)	J-Loss Coeff (K)	Inlet/ Rim El (ft)	
1	End	25.128	-89.363	MH	0.00	0.00	0.00	0.0	6874.00	0.99	6874.25	48	Cir	0.012	1.00	6882.05	PB16
2	1	146.947	-0.786	MH	0.00	0.00	0.00	0.0	6874.25	1.00	6875.72	48	Cir	0.012	0.84	6883.35	PB13
3	2	51.602	53.397	Curb	14.30	0.00	0.00	0.0	6876.22	1.01	6876.74	42	Cir	0.012	1.25	6883.20	PB7
4	3	44.332	-53.375	Curb	11.20	0.00	0.00	0.0	6877.24	0.99	6877.68	36	Cir	0.012	1.50	6883.20	PB6
5	4	131.739	88.983	None	0.00	0.00	0.00	0.0	6877.68	1.00	6879.00	36	Cir	0.012	0.77	6884.84	PB5B
6	5	92.553	-46.653	Curb	1.40	0.00	0.00	0.0	6879.00	0.99	6879.92	36	Cir	0.012	1.17	6886.62	PB5A
7	6	276.549	-42.201	Curb	2.60	0.00	0.00	0.0	6880.42	1.00	6883.19	30	Cir	0.012	1.50	6890.30	PB3
8	7	245.950	0.000	None	0.00	0.00	0.00	0.0	6883.69	1.00	6886.15	24	Cir	0.012	0.84	6893.40	PB1B
9	8	16.464	-53.625	None	17.60	0.00	0.00	0.0	6886.15	0.97	6886.31	24	Cir	0.012	1.00	6893.70	PB1A
10	7	44.336	89.981	Curb	9.30	0.00	0.00	0.0	6884.19	0.99	6884.63	18	Cir	0.012	1.00	6890.30	PB2
11	2	52.706	-53.988	Curb	9.40	0.00	0.00	0.0	6876.22	1.01	6876.75	42	Cir	0.012	1.26	6883.04	PB12
12	11	44.330	54.116	Curb	9.40	0.00	0.00	0.0	6877.25	0.99	6877.69	36	Cir	0.012	1.50	6883.04	PB11
13	12	255.617	-89.979	Curb	1.70	0.00	0.00	0.0	6878.69	1.00	6881.25	24	Cir	0.012	1.50	6885.40	PB9
14	13	10.167	89.940	None	11.20	0.00	0.00	0.0	6881.25	0.98	6881.35	24	Cir	0.012	1.00	6885.60	PB8
15	6	44.335	47.813	Curb	9.10	0.00	0.00	0.0	6881.42	0.99	6881.86	18	Cir	0.012	1.00	6886.88	PB4
16	1	266.443	89.475	None	20.70	0.00	0.00	0.0	6876.25	1.00	6878.92	24	Cir	0.012	1.00	6882.04	PB15
17	12	10.167	-0.039	None	29.60	0.00	0.00	0.0	6878.19	0.98	6878.29	30	Cir	0.012	1.00	6883.24	PB10
18	1	269.817	-90.576	None	16.20	0.00	0.00	0.0	6876.25	1.00	6878.95	24	Cir	0.012	1.00	6882.06	PB14

Project File: FM 3-7-17 HF.stm

Number of lines: 18

Date: 3/16/2017

Structure Report

Struct No.	Structure ID	Junction Type	Rim Elev (ft)	Structure			Line Out			Line In		
				Shape	Length (ft)	Width (ft)	Size (in)	Shape	Invert (ft)	Size (in)	Shape	Invert (ft)
1	MB2	Manhole	6882.05	Cir	6.00	6.00	48	Cir	6874.25	48 24 24	Cir Cir Cir	6874.25 6876.25 6876.25
2	MB1	Manhole	6883.35	Cir	5.00	5.00	48	Cir	6875.72	42 42	Cir Cir	6876.22 6876.22
3	IB6	Curb-	6883.20	Cir	4.00	4.00	42	Cir	6876.74	36	Cir	6877.24
4	IB5	Curb-	6883.20	Cir	4.00	4.00	36	Cir	6877.68	36	Cir	6877.68
5	NB3	None	6884.84	n/a	n/a	n/a	36	Cir	6879.00	36	Cir	6879.00
6	IB4	Curb-	6886.62	Cir	2.00	2.00	36	Cir	6879.92	30 18	Cir Cir	6880.42 6881.42
7	IB2	Curb-	6890.30	Cir	4.00	4.00	30	Cir	6883.19	24 18	Cir Cir	6883.69 6884.19
8	NB2	None	6893.40	n/a	n/a	n/a	24	Cir	6886.15	24	Cir	6886.15
9	NB1	None	6893.70	n/a	n/a	n/a	24	Cir	6886.31			
10	IB1	Curb-	6890.30	Cir	2.00	2.00	18	Cir	6884.63			
11	IB9	Curb-	6883.04	Cir	4.00	4.00	42	Cir	6876.75	36	Cir	6877.25
12	IB8	Curb-	6883.04	Cir	2.00	2.00	36	Cir	6877.69	24 30	Cir Cir	6878.69 6878.19
13	IB7	Curb-	6885.40	Cir	4.00	4.00	24	Cir	6881.25	24	Cir	6881.25
14	NB4	None	6885.60	n/a	n/a	n/a	24	Cir	6881.35			
15	IB3	Curb-	6886.88	Cir	2.00	2.00	18	Cir	6881.86			
16	NB7	None	6882.04	n/a	n/a	n/a	24	Cir	6878.92			
17	NB5	None	6883.24	n/a	n/a	n/a	30	Cir	6878.29			
18	NB6	None	6882.06	n/a	n/a	n/a	24	Cir	6878.95			

Storm Sewer Summary Report

Line No.	Line ID	Flow rate (cfs)	Line Size (in)	Line shape	Line length (ft)	Invert EL Dn (ft)	Invert EL Up (ft)	Line Slope (%)	HGL Down (ft)	HGL Up (ft)	Minor loss (ft)	HGL Junct (ft)	Dns Line No.	Junction Type
1	PB16	163.7	48	Cir	25.128	6874.00	6874.25	0.995	6877.69	6877.94	n/a	6877.94	End	Manhole
2	PB13	126.8	48	Cir	146.947	6874.25	6875.72	1.001	6877.94	6879.10	1.64	6879.10	1	Manhole
3	PB7	65.50	42	Cir	51.602	6876.22	6876.74	1.008	6879.10	6879.28	1.50	6879.28	2	Curb-
4	PB6	51.20	36	Cir	44.332	6877.24	6877.68	0.992	6879.28	6880.01	n/a	6880.01	3	Curb-
5	PB5B	40.00	36	Cir	131.739	6877.68	6879.00	1.002	6880.01	6881.06	n/a	6881.06 j	4	None
6	PB5A	40.00	36	Cir	92.553	6879.00	6879.92	0.994	6881.06	6881.98	n/a	6881.98	5	Curb-
7	PB3	29.50	30	Cir	276.549	6880.42	6883.19	1.002	6881.98	6885.04	1.34	6885.04	6	Curb-
8	PB1B	17.60	24	Cir	245.950	6883.69	6886.15	1.000	6885.04	6887.66	n/a	6887.66	7	None
9	PB1A	17.60	24	Cir	16.464	6886.15	6886.31	0.973	6887.66	6887.82	n/a	6887.82	8	None
10	PB2	9.30	18	Cir	44.336	6884.19	6884.63	0.992	6885.22	6885.81	n/a	6885.81	7	Curb-
11	PB12	61.30	42	Cir	52.706	6876.22	6876.75	1.005	6879.10	6879.20	n/a	6879.20	2	Curb-
12	PB11	51.90	36	Cir	44.330	6877.25	6877.69	0.992	6879.20	6880.03	n/a	6880.03	11	Curb-
13	PB9	12.90	24	Cir	255.617	6878.69	6881.25	1.002	6880.03	6882.54	n/a	6882.54 j	12	Curb-
14	PB8	11.20	24	Cir	10.167	6881.25	6881.35	0.985	6882.54	6882.55	n/a	6882.55	13	None
15	PB4	9.10	18	Cir	44.335	6881.42	6881.86	0.992	6882.44	6883.03	0.59	6883.03	6	Curb-
16	PB15	20.70	24	Cir	266.443	6876.25	6878.92	1.002	6877.94	6880.55	n/a	6880.55 j	1	None
17	PB10	29.60	30	Cir	10.167	6878.19	6878.29	0.985	6880.03	6880.14	0.89	6880.14	12	None
18	PB14	16.20	24	Cir	269.817	6876.25	6878.95	1.001	6877.94	6880.40	n/a	6880.40 j	1	None

Project File: FM 3-7-17 HF.stm

Number of lines: 18

Run Date: 3/16/2017

NOTES: Known Qs only ; j - Line contains hyd. jump.

Storm Sewer Tabulation

Station		Len (ft)	Drng Area		Rnoff coeff (C)	Area x C		Tc		Rain (l) (in/hr)	Total flow (cfs)	Cap full (cfs)	Vel (ft/s)	Pipe		Invert Elev		HGL Elev		Grnd / Rim Elev		Line ID
Line	To Line		Incr (ac)	Total (ac)		Incr	Total	Inlet (min)	Syst (min)					Size (in)	Slope (%)	Dn (ft)	Up (ft)	Dn (ft)	Up (ft)	Dn (ft)	Up (ft)	
1	End	25.128	0.00	0.00	0.00	0.00	0.00	0.0	2.7	0.0	163.7	155.2	13.51	48	0.99	6874.00	6874.25	6877.69	6877.94	6878.66	6882.05	PB16
2	1	146.947	0.00	0.00	0.00	0.00	0.00	0.0	2.4	0.0	126.8	155.7	10.84	48	1.00	6874.25	6875.72	6877.94	6879.10	6882.05	6883.35	PB13
3	2	51.602	0.00	0.00	0.00	0.00	0.00	0.0	2.3	0.0	65.50	109.4	8.26	42	1.01	6876.22	6876.74	6879.10	6879.28	6883.35	6883.20	PB7
4	3	44.332	0.00	0.00	0.00	0.00	0.00	0.0	2.2	0.0	51.20	71.98	9.37	36	0.99	6877.24	6877.68	6879.28	6880.01	6883.20	6883.20	PB6
5	4	131.739	0.00	0.00	0.00	0.00	0.00	0.0	1.8	0.0	40.00	72.32	7.27	36	1.00	6877.68	6879.00	6880.01	6881.06	6883.20	6884.84	PB5B
6	5	92.553	0.00	0.00	0.00	0.00	0.00	0.0	1.5	0.0	40.00	72.03	7.74	36	0.99	6879.00	6879.92	6881.06	6881.98	6884.84	6886.62	PB5A
7	6	276.549	0.00	0.00	0.00	0.00	0.00	0.0	0.8	0.0	29.50	44.47	8.38	30	1.00	6880.42	6883.19	6881.98	6885.04	6886.62	6890.30	PB3
8	7	245.950	0.00	0.00	0.00	0.00	0.00	0.0	0.0	0.0	17.60	24.50	7.36	24	1.00	6883.69	6886.15	6885.04	6887.66	6890.30	6893.40	PB1B
9	8	16.464	0.00	0.00	0.00	0.00	0.00	0.0	0.0	0.0	17.60	24.17	6.92	24	0.97	6886.15	6886.31	6887.66	6887.82	6893.40	6893.70	PB1A
10	7	44.336	0.00	0.00	0.00	0.00	0.00	0.0	0.0	0.0	9.30	11.33	6.70	18	0.99	6884.19	6884.63	6885.22	6885.81	6890.30	6890.30	PB2
11	2	52.706	0.00	0.00	0.00	0.00	0.00	0.0	1.2	0.0	61.30	109.3	7.88	42	1.01	6876.22	6876.75	6879.10	6879.20	6883.35	6883.04	PB12
12	11	44.330	0.00	0.00	0.00	0.00	0.00	0.0	1.1	0.0	51.90	71.98	9.72	36	0.99	6877.25	6877.69	6879.20	6880.03	6883.04	6883.04	PB11
13	12	255.617	0.00	0.00	0.00	0.00	0.00	0.0	0.0	0.0	12.90	24.52	5.89	24	1.00	6878.69	6881.25	6880.03	6882.54	6883.04	6885.40	PB9
14	13	10.167	0.00	0.00	0.00	0.00	0.00	0.0	0.0	0.0	11.20	24.31	5.46	24	0.98	6881.25	6881.35	6882.54	6882.55	6885.40	6885.60	PB8
15	6	44.335	0.00	0.00	0.00	0.00	0.00	0.0	0.0	0.0	9.10	11.33	6.65	18	0.99	6881.42	6881.86	6882.44	6883.03	6886.62	6886.88	PB4
16	1	266.443	0.00	0.00	0.00	0.00	0.00	0.0	0.0	0.0	20.70	24.53	7.43	24	1.00	6876.25	6878.92	6877.94	6880.55	6882.05	6882.04	PB15
17	12	10.167	0.00	0.00	0.00	0.00	0.00	0.0	0.0	0.0	29.60	44.09	7.61	30	0.98	6878.19	6878.29	6880.03	6880.14	6883.04	6883.24	PB10
18	1	269.817	0.00	0.00	0.00	0.00	0.00	0.0	0.0	0.0	16.20	24.51	6.18	24	1.00	6876.25	6878.95	6877.94	6880.40	6882.05	6882.06	PB14

Project File: FM 3-7-17 HF.stm

Number of lines: 18

Run Date: 3/16/2017

NOTES: Known Qs only ; c = cir e = ellip b = box

Inlet Report

Line No	Inlet ID	Q = CIA (cfs)	Q carry (cfs)	Q capt (cfs)	Q Byp (cfs)	Junc Type	Curb Inlet		Grate Inlet			Gutter						Inlet			Byp Line No	
							Ht (in)	L (ft)	Area (sqft)	L (ft)	W (ft)	So (ft/ft)	W (ft)	Sw (ft/ft)	Sx (ft/ft)	n	Depth (ft)	Spread (ft)	Depth (ft)	Spread (ft)		Depr (in)
1	MB2	0.00	0.00	0.00	0.00	MH	0.0	0.00	0.00	0.00	0.00	Sag	0.00	0.000	0.000	0.013	0.00	0.00	0.00	0.00	0.0	Off
2	MB1	0.00	0.00	0.00	0.00	MH	0.0	0.00	0.00	0.00	0.00	Sag	0.00	0.000	0.000	0.013	0.00	0.00	0.00	0.00	0.0	Off
3	IB6	14.30*	0.00	14.30	0.00	Curb	6.0	10.00	0.00	0.00	0.00	Sag	2.00	0.083	0.020	0.013	0.61	24.20	0.61	24.20	0.0	Off
4	IB5	11.20*	0.00	11.20	0.00	Curb	6.0	10.00	0.00	0.00	0.00	Sag	2.00	0.083	0.020	0.013	0.52	19.62	0.52	19.62	0.0	Off
5	NB3	0.00	0.00	0.00	0.00	None	0.0	0.00	0.00	0.00	0.00	0.000	0.00	0.000	0.000	0.013	0.00	0.00	0.00	0.00	0.0	Off
6	IB4	1.40*	0.00	1.40	0.00	Curb	6.0	10.00	0.00	0.00	0.00	0.010	2.00	0.083	0.020	0.013	0.25	5.95	0.01	0.12	0.0	Off
7	IB2	2.60*	0.00	2.31	0.29	Curb	6.0	10.00	0.00	0.00	0.00	0.010	2.00	0.083	0.020	0.013	0.29	8.35	0.15	1.81	0.0	Off
8	NB2	0.00	0.00	0.00	0.00	None	0.0	0.00	0.00	0.00	0.00	0.000	0.00	0.000	0.000	0.013	0.00	0.00	0.00	0.00	0.0	Off
9	NB1	17.60*	0.00	0.00	17.60	None	0.0	0.00	0.00	0.00	0.00	0.000	0.00	0.000	0.000	0.013	0.00	0.00	0.00	0.00	0.0	Off
10	IB1	9.30*	0.00	4.91	4.39	Curb	6.0	10.00	0.00	0.00	0.00	0.010	2.00	0.083	0.020	0.013	0.42	14.70	0.34	10.70	0.0	Off
11	IB9	9.40*	0.00	9.40	0.00	Curb	6.0	10.00	0.00	0.00	0.00	Sag	2.00	0.050	0.020	0.013	0.46	20.06	0.46	20.06	0.0	Off
12	IB8	9.40*	0.00	9.40	0.00	Curb	6.0	10.00	0.00	0.00	0.00	Sag	2.00	0.083	0.020	0.013	0.46	16.76	0.46	16.76	0.0	Off
13	IB7	1.70*	0.00	1.67	0.03	Curb	6.0	10.00	0.00	0.00	0.00	0.010	2.00	0.083	0.020	0.013	0.26	6.70	0.07	0.84	0.0	Off
14	NB4	11.20*	0.00	0.00	11.20	None	0.0	0.00	0.00	0.00	0.00	0.000	0.00	0.000	0.000	0.013	0.00	0.00	0.00	0.00	0.0	Off
15	IB3	9.10*	0.00	4.85	4.25	Curb	6.0	10.00	0.00	0.00	0.00	0.010	2.00	0.083	0.020	0.013	0.42	14.55	0.34	10.70	0.0	Off
16	NB7	20.70*	0.00	0.00	20.70	None	0.0	0.00	0.00	0.00	0.00	0.000	0.00	0.000	0.000	0.013	0.00	0.00	0.00	0.00	0.0	Off
17	NB5	29.60*	0.00	0.00	29.60	None	0.0	0.00	0.00	0.00	0.00	0.000	0.00	0.000	0.000	0.013	0.00	0.00	0.00	0.00	0.0	Off
18	NB6	16.20*	0.00	0.00	16.20	None	0.0	0.00	0.00	0.00	0.00	0.000	0.00	0.000	0.000	0.013	0.00	0.00	0.00	0.00	0.0	Off

Project File: FM 3-7-17 HF.stm

Number of lines: 18

Run Date: 3/16/2017

NOTES: Inlet N-Values = 0.016; Known Qs only; * Indicates Known Q added. All curb inlets are throat.

FL-DOT Report

Line No	To Line	Type of struc	n - Value	Len (ft)	Drainage Area			Time of conc (min)	Time of Flow in sect (min)	Inten (l) (in/hr)	Total CA	Add Q (cfs)	Inlet elev (ft)	Elev of HGL			Rise	HGL	ADD		Date: 3/16/2017
					Increment (ac)	Sub-Total (ac)	Sum CA							Elev of Crown			Span	Pipe	Full Flow		Frequency: (n/a)
														Elev of Invert			Size (in)	Slope (%)	Vel (ft/s)	Cap (cfs)	Proj: FM 3-7-17 HF.stm
														Up (ft)	Down (ft)	Fall (ft)					
1	End	MH	0.012	25.128	0.00 0.00 0.00	0.00 0.00 0.00	0.00 0.00 0.00	2.68	0.03	0.00	0.00	0.00 163.7	6882.05	6877.94 6878.25 6874.25	6877.69 6878.00 6874.00	0.25	48 48 Cir	0.99 0.99	13.51 12.35	163.7 155.2	PB16
2	1	MH	0.012	146.947	0.00 0.00 0.00	0.00 0.00 0.00	0.00 0.00 0.00	2.44	0.24	0.00	0.00	0.00 126.8	6883.35	6879.10 6879.72 6875.72	6877.94 6878.25 6874.25	1.16	48 48 Cir	0.79 1.00	10.84 12.39	126.8 155.7	PB13
3	2	Curb	0.012	51.602	0.00 0.00 0.00	0.00 0.00 0.00	0.00 0.00 0.00	2.31	0.13	0.00	0.00	14.30 65.50	6883.20	6879.28 6880.24 6876.74	6879.10 6879.72 6876.22	0.18	42 42 Cir	0.35 1.01	8.26 11.37	65.50 109.4	PB7
4	3	Curb	0.012	44.332	0.00 0.00 0.00	0.00 0.00 0.00	0.00 0.00 0.00	2.21	0.10	0.00	0.00	11.20 51.20	6883.20	6880.01 6880.68 6877.68	6879.28 6880.24 6877.24	0.73	36 36 Cir	1.65 0.99	9.37 10.18	51.20 71.98	PB6
5	4	None	0.012	131.739	0.00 0.00 0.00	0.00 0.00 0.00	0.00 0.00 0.00	1.82	0.39	0.00	0.00	0.00 40.00	6884.84	6881.06 6882.00 6879.00	6880.01 6880.68 6877.68	1.05	36 36 Cir	0.80 1.00	7.27 10.23	40.00 72.32	PB5B
6	5	Curb	0.012	92.553	0.00 0.00 0.00	0.00 0.00 0.00	0.00 0.00 0.00	1.55	0.27	0.00	0.00	1.40 40.00	6886.62	6881.98 6882.92 6879.92	6881.06 6882.00 6879.00	0.92	36 36 Cir	0.99 0.99	7.74 10.19	40.00 72.03	PB5A
7	6	Curb	0.012	276.549	0.00 0.00 0.00	0.00 0.00 0.00	0.00 0.00 0.00	0.78	0.77	0.00	0.00	2.60 29.50	6890.30	6885.04 6885.69 6883.19	6881.98 6882.92 6880.42	3.06	30 30 Cir	1.11 1.00	8.38 9.06	29.50 44.47	PB3
8	7	None	0.012	245.950	0.00 0.00 0.00	0.00 0.00 0.00	0.00 0.00 0.00	0.05	0.73	0.00	0.00	0.00 17.60	6893.40	6887.66 6888.15 6886.15	6885.04 6885.69 6883.69	2.62	24 24 Cir	1.07 1.00	7.36 7.80	17.60 24.50	PB1B
9	8	None	0.012	16.464	0.00 0.00 0.00	0.00 0.00 0.00	0.00 0.00 0.00	0.00	0.05	0.00	0.00	17.60 17.60	6893.70	6887.82 6888.31 6886.31	6887.66 6888.15 6886.15	0.16	24 24 Cir	0.97 0.97	6.92 7.69	17.60 24.17	PB1A
10	7	Curb	0.012	44.336	0.00 0.00 0.00	0.00 0.00 0.00	0.00 0.00 0.00	0.00	0.14	0.00	0.00	9.30 9.30	6890.30	6885.81 6886.13 6884.63	6885.22 6885.69 6884.19	0.58	18 18 Cir	1.32 0.99	6.70 6.41	9.30 11.33	PB2

NOTES: Known Qs only ; Time of flow in section is based on full flow.

Project File: FM 3-7-17 HF.stm

FL-DOT Report

Line No	To Line	Type of struc	n - Value	Len (ft)	Drainage Area			Time of conc (min)	Time of Flow in sect (min)	Inten (l) (in/hr)	Total CA	Add Q (cfs)	Inlet elev (ft)	Elev of HGL			Rise	HGL	ADD		Date: 3/16/2017
					Increment (ac)	Sub-Total (ac)	Sum CA							Elev of Crown			Span	Pipe	Full Flow	Frequency: (n/a)	
														Elev of Invert							
														Up (ft)	Down (ft)	Fall (ft)	Size (in)	Slope (%)	Vel (ft/s)	Cap (cfs)	Line description
11	2	Curb	0.012	52.706	0.00 0.00 0.00	0.00 0.00 0.00	0.00 0.00 0.00	1.19	0.14	0.00	0.00	9.40 61.30	6883.04	6879.20 6880.25 6876.75	6879.10 6879.72 6876.22	0.11 0.53	42 42 Cir	0.20 1.01	7.88 11.36	61.30 109.3	PB12
12	11	Curb	0.012	44.330	0.00 0.00 0.00	0.00 0.00 0.00	0.00 0.00 0.00	1.09	0.10	0.00	0.00	9.40 51.90	6883.04	6880.03 6880.69 6877.69	6879.20 6880.25 6877.25	0.83 0.44	36 36 Cir	1.87 0.99	9.72 10.18	51.90 71.98	PB11
13	12	Curb	0.012	255.617	0.00 0.00 0.00	0.00 0.00 0.00	0.00 0.00 0.00	0.05	1.04	0.00	0.00	1.70 12.90	6885.40	6882.54 6883.25 6881.25	6880.03 6880.69 6878.69	2.51 2.56	24 24 Cir	0.98 1.00	5.89 7.81	12.90 24.52	PB9
14	13	None	0.012	10.167	0.00 0.00 0.00	0.00 0.00 0.00	0.00 0.00 0.00	0.00	0.05	0.00	0.00	11.20 11.20	6885.60	6882.55 6883.35 6881.35	6882.54 6883.25 6881.25	0.01 0.10	24 24 Cir	0.08 0.98	5.46 7.74	11.20 24.31	PB8
15	6	Curb	0.012	44.335	0.00 0.00 0.00	0.00 0.00 0.00	0.00 0.00 0.00	0.00	0.14	0.00	0.00	9.10 9.10	6886.88	6883.03 6883.36 6881.86	6882.44 6882.92 6881.42	0.59 0.44	18 18 Cir	1.33 0.99	6.65 6.41	9.10 11.33	PB4
16	1	None	0.012	266.443	0.00 0.00 0.00	0.00 0.00 0.00	0.00 0.00 0.00	0.00	0.67	0.00	0.00	20.70 20.70	6882.04	6880.55 6880.92 6878.92	6877.94 6878.25 6876.25	2.61 2.67	24 24 Cir	0.98 1.00	7.43 7.81	20.70 24.53	PB15
17	12	None	0.012	10.167	0.00 0.00 0.00	0.00 0.00 0.00	0.00 0.00 0.00	0.00	0.03	0.00	0.00	29.60 29.60	6883.24	6880.14 6880.79 6878.29	6880.03 6880.69 6878.19	0.11 0.10	30 30 Cir	1.11 0.98	7.61 8.98	29.60 44.09	PB10
18	1	None	0.012	269.817	0.00 0.00 0.00	0.00 0.00 0.00	0.00 0.00 0.00	0.00	0.87	0.00	0.00	16.20 16.20	6882.06	6880.40 6880.95 6878.95	6877.94 6878.25 6876.25	2.46 2.70	24 24 Cir	0.91 1.00	6.18 7.80	16.20 24.51	PB14

NOTES: Known Qs only ; Time of flow in section is based on full flow.

Project File: FM 3-7-17 HF.stm

Line No.	Area Dn (sqft)	Area Up (sqft)	By Ln No	Coeff C1 (C)	Coeff C2 (C)	Coeff C3 (C)	Capac Full (cfs)	Crit Depth (ft)	Cross SI, Sw (ft/ft)	Cross SI, Sx (ft/ft)	Curb Len (ft)	Defl Ang (Deg)	Depth Dn (ft)	Depth Up (ft)	DnStm Ln No	Drng Area (ac)	Easting X (ft)	EGL Dn (ft)	EGL Up (ft)	Energy Loss (ft)
1	12.12	12.11	n/a	0.20	0.50	0.90	155.22	3.69	-89.363	3.69	3.69**	Outfall	0.00	9422.28	6880.53	6880.78	0.000
2	11.31	11.31	n/a	0.20	0.50	0.90	155.66	3.37	-0.786	3.69	3.37**	1	0.00	9421.90	6879.89	6881.05	0.000
3	7.46	7.46	Sag	0.20	0.50	0.90	109.41	2.53	0.083	0.020	10.00	53.397	2.87	2.54**	2	0.00	9463.25	6880.29	6880.47	0.000
4	5.11	5.88	Sag	0.20	0.50	0.90	71.98	2.33	0.083	0.020	10.00	-53.375	2.04	2.33**	3	0.00	9463.15	6880.46	6881.19	0.000
5	5.17	5.17	n/a	0.20	0.50	0.90	72.32	2.06	88.983	2.33	2.06**	4	0.00	9594.86	6880.94	6881.99	0.000
6	5.17	5.17	Offsite	0.20	0.50	0.90	72.03	2.06	0.083	0.020	10.00	-46.653	2.06	2.06**	5	0.00	9657.03	6881.99	6882.91	0.000
7	3.21	3.89	Offsite	0.20	0.50	0.90	44.47	1.85	0.083	0.020	10.00	-42.201	1.56	1.85**	6	0.00	9657.04	6882.87	6885.93	0.000
8	2.26	2.55	n/a	0.20	0.50	0.90	24.50	1.51	0.000	1.35	1.51**	7	0.00	9657.05	6885.78	6888.40	0.000
9	2.55	2.55	n/a	0.20	0.50	0.90	24.17	1.51	-53.625	1.51	1.51**	8	0.00	9643.80	6888.40	6888.56	0.000
10	1.30	1.49	Offsite	0.20	0.50	0.90	11.33	1.18	0.083	0.020	10.00	89.981	1.03	1.18**	7	0.00	9701.38	6885.83	6886.42	0.000
11	7.20	7.20	Sag	0.20	0.50	0.90	109.27	2.45	0.050	0.020	10.00	-53.988	2.87	2.45**	2	0.00	9379.19	6880.22	6880.33	0.000
12	4.87	5.92	Sag	0.20	0.50	0.90	71.98	2.34	0.083	0.020	10.00	54.116	1.95	2.34**	11	0.00	9379.17	6880.40	6881.23	0.000
13	2.14	2.14	Offsite	0.20	0.50	0.90	24.52	1.29	0.083	0.020	10.00	-89.979	1.34	1.29**	12	0.00	9123.56	6880.59	6883.10	0.000
14	1.97	1.97	n/a	0.20	0.50	0.90	24.31	1.20	89.940	1.29	1.20**	13	0.00	9123.54	6883.05	6883.05	0.000
15	1.28	1.47	Offsite	0.20	0.50	0.90	11.33	1.17	0.083	0.020	10.00	47.813	1.02	1.17**	6	0.00	9701.37	6883.03	6883.62	0.000
16	2.74	2.74	n/a	0.20	0.50	0.90	24.53	1.63	89.475	1.69	1.63**	1	0.00	9688.73	6878.83	6881.44	0.000
17	3.87	3.90	n/a	0.20	0.50	0.90	44.09	1.85	-0.039	1.84	1.85**	12	0.00	9379.16	6880.93	6881.04	0.000
18	2.44	2.44	n/a	0.20	0.50	0.90	24.51	1.45	-90.576	1.69	1.45**	1	0.00	9152.47	6878.63	6881.09	0.000

Project File: FM 3-7-17 HF.stm

Number of lines: 18

Date: 3/16/2017

NOTES: ** Critical depth

MyReport

Flow Rate	Sf Ave	Sf Dn	Grate Area	Grate Len	Grate Width	Gnd/Rim El Dn	Gnd/Rim El Up	Gutter Depth	Gutter Slope	Gutter Spread	Gutter Width	HGL Dn	HGL Up	HGL Jnct	HGL Jmp Dn	HGL Jmp Up	Incr CxA	Incr Q	Inlet Depth	Inlet Eff
(cfs)	(ft/ft)	(ft/ft)	(sqft)	(ft)	(ft)	(ft)	(ft)	(ft)	(ft/ft)	(ft)	(ft)	(ft)	(ft)	(ft)	(ft)	(ft)		(cfs)	(ft)	(%)
163.70	0.000	0.000	6878.66	6882.05	6877.69	6877.94	6877.94	0.00	0.00
126.80	0.000	0.000	6882.05	6883.35	6877.94	6879.10	6879.10	0.00	0.00
65.50	0.000	0.000	6883.35	6883.20	0.61	Sag	24.20	2.00	6879.10	6879.28	6879.28	0.00	14.30	0.61	100
51.20	0.000	0.000	6883.20	6883.20	0.52	Sag	19.62	2.00	6879.28	6880.01	6880.01	0.00	11.20	0.52	100
40.00	0.000	0.000	6883.20	6884.84	6880.01	6881.06 j	6881.06	6879.88	6879.75	0.00	0.00
40.00	0.000	0.000	6884.84	6886.62	0.25	0.010	5.95	2.00	6881.06	6881.98	6881.98	0.00	1.40	0.25	100
29.50	0.000	0.000	6886.62	6890.30	0.29	0.010	8.35	2.00	6881.98	6885.04	6885.04	0.00	2.60	0.29	89
17.60	0.000	0.000	6890.30	6893.40	6885.04	6887.66	6887.66	0.00	0.00
17.60	0.000	0.000	6893.40	6893.70	6887.66	6887.82	6887.82	0.00	17.60
9.30	0.000	0.000	6890.30	6890.30	0.42	0.010	14.70	2.00	6885.22	6885.81	6885.81	0.00	9.30	0.42	53
61.30	0.000	0.000	6883.35	6883.04	0.46	Sag	20.06	2.00	6879.10	6879.20	6879.20	0.00	9.40	0.46	100
51.90	0.000	0.000	6883.04	6883.04	0.46	Sag	16.76	2.00	6879.20	6880.03	6880.03	0.00	9.40	0.46	100
12.90	0.000	0.000	6883.04	6885.40	0.26	0.010	6.70	2.00	6880.03	6882.54 j	6882.54	6880.24	6880.10	0.00	1.70	0.26	98
11.20	0.000	0.000	6885.40	6885.60	6882.54	6882.55	6882.55	0.00	11.20
9.10	0.000	0.000	6886.62	6886.88	0.42	0.010	14.55	2.00	6882.44	6883.03	6883.03	0.00	9.10	0.42	53
20.70	0.000	0.000	6882.05	6882.04	6877.94	6880.55 j	6880.55	6878.15	6878.06	0.00	20.70
29.60	0.000	0.000	6883.04	6883.24	6880.03	6880.14	6880.14	0.00	29.60
16.20	0.000	0.000	6882.05	6882.06	6877.94	6880.40 j	6880.40	6877.97	6877.83	0.00	16.20

Project File: FM 3-7-17 HF.stm

Number of lines: 18

Date: 3/16/2017

NOTES: ** Critical depth

Inlet ID	Inlet Loc	(ft)	Inlet Time (min)	i Sys (in/hr)	i Inlet (in/hr)	Invert Dn (ft)	Invert Up (ft)	Jump Loc (ft)	Jump Len (ft)	Vel Hd Jmp Dn (ft)	Vel Hd Jmp Up (ft)	J-Loss Coeff	Junct Type	Known Q (cfs)	Cost RCP	Cost CMP	Cost PVC	Line ID
MB2	Sag		0.0	0.00	0.00	6874.00	6874.25	0.00	0.00	1.00 z	MH	0.00	1,646	1,481	1,399	PB16
MB1	Sag		0.0	0.00	0.00	6874.25	6875.72	0.00	0.00	0.84 z	MH	0.00	9,506	8,555	8,080	PB13
IB6	Sag		0.0	0.00	0.00	6876.22	6876.74	0.00	0.00	1.25 z	Curb	14.30	3,323	2,991	2,825	PB7
IB5	Sag		0.0	0.00	0.00	6877.24	6877.68	0.00	0.00	1.50 z	Curb	11.20	2,408	2,167	2,047	PB6
NB3	On Grade		0.0	0.00	0.00	6877.68	6879.00	13.17	10.32	0.92	1.21	0.77 z	None	0.00	6,958	6,262	5,914	PB5B
IB4	On Grade		0.0	0.00	0.00	6879.00	6879.92	0.00	0.00	1.17 z	Curb	1.40	5,544	4,990	4,712	PB5A
IB2	On Grade		0.0	0.00	0.00	6880.42	6883.19	0.00	0.00	1.50 z	Curb	2.60	15,614	14,053	13,272	PB3
NB2	On Grade		0.0	0.00	0.00	6883.69	6886.15	0.00	0.00	0.84 z	None	0.00	12,896	11,606	10,962	PB1B
NB1	On Grade		0.0	0.00	0.00	6886.15	6886.31	0.00	0.00	1.00 z	None	17.60	962	866	818	PB1A
IB1	On Grade		0.0	0.00	0.00	6884.19	6884.63	0.00	0.00	1.00 z	Curb	9.30	1,935	1,742	1,645	PB2
IB9	Sag		0.0	0.00	0.00	6876.22	6876.75	0.00	0.00	1.26 z	Curb	9.40	3,385	3,047	2,877	PB12
IB8	Sag		0.0	0.00	0.00	6877.25	6877.69	0.00	0.00	1.50 z	Curb	9.40	2,408	2,167	2,047	PB11
IB7	On Grade		0.0	0.00	0.00	6878.69	6881.25	25.56	6.46	0.56	0.86	1.50 z	Curb	1.70	11,362	10,226	9,658	PB9
NB4	On Grade		0.0	0.00	0.00	6881.25	6881.35	0.00	0.00	1.00 z	None	11.20	560	504	476	PB8
IB3	On Grade		0.0	0.00	0.00	6881.42	6881.86	0.00	0.00	1.00 z	Curb	9.10	1,880	1,692	1,598	PB4
NB7	On Grade		0.0	0.00	0.00	6876.25	6878.92	26.64	8.15	0.89	1.11	1.00 z	None	20.70	11,104	9,994	9,438	PB15
NB5	On Grade		0.0	0.00	0.00	6878.19	6878.29	0.00	0.00	1.00 z	None	29.60	600	540	510	PB10
NB6	On Grade		0.0	0.00	0.00	6876.25	6878.95	26.98	7.25	0.69	0.97	1.00 z	None	16.20	11,246	10,121	9,559	PB14

Project File: FM 3-7-17 HF.stm

Number of lines: 18

Date: 3/16/2017

NOTES: Known Qs only. ; ** Critical depth

Line Length	Line Size	Line Slope	Line Type	Local Depr	n-val Gutter	n-val Pipe	Minor Loss	Northing Y	Pipe Travel	Q Byp	Q Capt	Q Carry	Line Rise	Runoff Coeff	Line Span	Area A1	Area A2	Area A3	Tc	Throat Ht	Total Area	Total CxA
(ft)	(in)	(%)		(in)			(ft)	(ft)	(min)	(cfs)	(cfs)	(cfs)	(in)	(C)	(in)	(ac)	(ac)	(ac)	(min)	(in)	(ac)	
25.128	48	0.99	Cir	0.012	n/a	15205.44	0.03	48	0.00	48	0.00	0.00	0.00	2.7	0.00	0.00
146.947	48	1.00	Cir	0.012	1.64	15352.39	0.24	48	0.00	48	0.00	0.00	0.00	2.4	0.00	0.00
51.602	42	1.01	Cir	0.0	0.012	1.50	15383.27	0.13	0.00	14.30	0.00	42	0.00	42	0.00	0.00	0.00	2.3	6.0	0.00	0.00
44.332	36	0.99	Cir	0.0	0.012	n/a	15427.60	0.10	0.00	11.20	0.00	36	0.00	36	0.00	0.00	0.00	2.2	6.0	0.00	0.00
131.739	36	1.00	Cir	0.012	n/a	15430.23	0.39	36	0.00	36	0.00	0.00	0.00	1.8	0.00	0.00
92.553	36	0.99	Cir	0.0	0.013	0.012	n/a	15498.79	0.27	0.00	1.40	0.00	36	0.00	36	0.00	0.00	0.00	1.5	6.0	0.00	0.00
276.549	30	1.00	Cir	0.0	0.013	0.012	1.34	15775.34	0.77	0.29	2.31	0.00	30	0.00	30	0.00	0.00	0.00	0.8	6.0	0.00	0.00
245.950	24	1.00	Cir	0.012	n/a	16021.29	0.73	24	0.00	24	0.00	0.00	0.00	0.0	0.00	0.00
16.464	24	0.97	Cir	0.012	n/a	16031.05	0.05	24	0.00	24	0.00	0.00	0.00	0.0	0.00	0.00
44.336	18	0.99	Cir	0.0	0.013	0.012	n/a	15775.35	0.14	4.39	4.91	0.00	18	0.00	18	0.00	0.00	0.00	0.0	6.0	0.00	0.00
52.706	42	1.01	Cir	0.0	0.012	n/a	15383.27	0.14	0.00	9.40	0.00	42	0.00	42	0.00	0.00	0.00	1.2	6.0	0.00	0.00
44.330	36	0.99	Cir	0.0	0.012	n/a	15427.60	0.10	0.00	9.40	0.00	36	0.00	36	0.00	0.00	0.00	1.1	6.0	0.00	0.00
255.617	24	1.00	Cir	0.0	0.013	0.012	n/a	15427.60	1.04	0.03	1.67	0.00	24	0.00	24	0.00	0.00	0.00	0.0	6.0	0.00	0.00
10.167	24	0.98	Cir	0.012	n/a	15437.77	0.05	24	0.00	24	0.00	0.00	0.00	0.0	0.00	0.00
44.335	18	0.99	Cir	0.0	0.013	0.012	0.59	15498.78	0.14	4.25	4.85	0.00	18	0.00	18	0.00	0.00	0.00	0.0	6.0	0.00	0.00
266.443	24	1.00	Cir	0.012	n/a	15204.93	0.67	24	0.00	24	0.00	0.00	0.00	0.0	0.00	0.00
10.167	30	0.98	Cir	0.012	0.89	15437.77	0.03	30	0.00	30	0.00	0.00	0.00	0.0	0.00	0.00
269.817	24	1.00	Cir	0.012	n/a	15205.73	0.87	24	0.00	24	0.00	0.00	0.00	0.0	0.00	0.00

Project File: FM 3-7-17 HF.stm

Number of lines: 18

Date: 3/16/2017

NOTES: ** Critical depth

Total Runoff	Vel Ave	Vel Dn	Vel Hd Dn	Vel Hd Up	Vel Up	Cover Dn	Cover Up	Storage	
(cfs)	(ft/s)	(ft/s)	(ft)	(ft)	(ft/s)	(ft)	(ft)	(cft)	
0.00	13.51	13.51	2.84	2.84	13.51	0.66	3.80	304.43	
0.00	10.84	10.47	1.95	1.95	11.21	3.80	3.63	1723.89	
0.00	8.26	7.75	1.20	1.20	8.78	3.63	2.96	411.33	
0.00	9.37	10.03	1.18	1.18	8.71	2.96	2.52	243.81	
0.00	7.27	6.80	0.93	0.93	7.74	2.52	2.84	728.38	
0.00	7.74	7.74	0.93	0.93	7.74	2.84	3.70	478.15	
0.00	8.38	9.18	0.89	0.89	7.57	3.70	4.61	984.74	
0.00	7.36	7.80	0.74	0.74	6.92	4.61	5.25	590.95	
0.00	6.92	6.92	0.74	0.74	6.92	5.25	5.39	41.90	
0.00	6.70	7.16	0.61	0.61	6.25	4.61	4.17	61.86	
0.00	7.88	7.25	1.13	1.13	8.52	3.63	2.79	413.49	
0.00	9.72	10.66	1.20	1.20	8.77	2.79	2.35	239.62	
0.00	5.89	5.76	0.56	0.56	6.02	2.35	2.15	560.42	
0.00	5.46	5.22	0.50	0.50	5.70	2.15	2.25	20.90	
0.00	6.65	7.13	0.59	0.59	6.17	3.70	3.52	61.05	
0.00	7.43	7.31	0.89	0.89	7.55	3.80	1.12	742.30	
0.00	7.61	7.64	0.89	0.89	7.59	2.35	2.45	39.52	
0.00	6.18	5.72	0.69	0.69	6.64	3.80	1.11	712.62	

Project File: FM 3-7-17 HF.stm	Number of lines: 18	Date: 3/16/2017
--------------------------------	---------------------	-----------------

NOTES: ** Critical depth

Storm Sewer Inlet Time Tabulation

Line No.	Line ID	Tc Method	Sheet Flow					Shallow Concentrated Flow					Channel Flow						Total Travel Time (min)	
			n-Value	flow Length (ft)	2-yr 24h P (in)	Land Slope (%)	Travel Time (min)	flow Length (ft)	Water Slope (%)	Surf Descr	Ave Vel (ft/s)	Travel Time (min)	X-sec Area (sqft)	Wetted Perim (ft)	Chan Slope (%)	n-Value	Vel	flow Length (ft)		Travel Time (min)
1	PB16	User																		0.00
2	PB13	User																		0.00
3	PB7	User																		0.00
4	PB6	User																		0.00
5	PB5B	User																		0.00
6	PB5A	User																		0.00
7	PB3	User																		0.00
8	PB1B	User																		0.00
9	PB1A	User																		0.00
10	PB2	User																		0.00
11	PB12	User																		0.00
12	PB11	User																		0.00
13	PB9	User																		0.00
14	PB8	User																		0.00
15	PB4	User																		0.00
16	PB15	User																		0.00
17	PB10	User																		0.00
18	PB14	User																		0.00
Project File: FM 3-7-17 HF.stm					Min. Tc used for intensity calculations = 5 min					Number of lines: 18					Date: 3/16/2017					

Hydraulic Grade Line Computations

Line	Size	Q	Downstream								Len	Upstream								Check		JL coeff	Minor loss
			Invert elev (ft)	HGL elev (ft)	Depth (ft)	Area (sqft)	Vel (ft/s)	Vel head (ft)	EGL elev (ft)	Sf (%)		Invert elev (ft)	HGL elev (ft)	Depth (ft)	Area (sqft)	Vel (ft/s)	Vel head (ft)	EGL elev (ft)	Sf (%)	Ave Sf (%)	Enrgy loss (ft)		
(1)	(in) (2)	(cfs) (3)	(4)	(5)	(6)	(7)	(8)	(9)	(10)	(11)	(ft) (12)	(13)	(14)	(15)	(16)	(17)	(18)	(19)	(20)	(21)	(22)	(K) (23)	(ft) (24)
1	48	163.7	6874.00	6877.69	3.69	12.12	13.51	2.84	6880.53	0.000	25.128	6874.25	6877.94	3.69**	12.11	13.51	2.84	6880.78	0.000	0.000	n/a	1.00	n/a
2	48	126.8	6874.25	6877.94	3.69	11.31	10.47	1.95	6879.89	0.000	146.947	6875.72	6879.10	3.37**	11.31	11.21	1.95	6881.05	0.000	0.000	n/a	0.84	1.64
3	42	65.50	6876.22	6879.10	2.87	7.46	7.75	1.20	6880.29	0.000	51.602	6876.74	6879.28	2.54**	7.46	8.78	1.20	6880.47	0.000	0.000	n/a	1.25	1.50
4	36	51.20	6877.24	6879.28	2.04	5.11	10.03	1.18	6880.46	0.000	44.332	6877.68	6880.01	2.33**	5.88	8.71	1.18	6881.19	0.000	0.000	n/a	1.50	n/a
5	36	40.00	6877.68	6880.01	2.33	5.17	6.80	0.93	6880.94	0.000	131.739	6879.00	6881.06 j	2.06**	5.17	7.74	0.93	6881.99	0.000	0.000	n/a	0.77	n/a
6	36	40.00	6879.00	6881.06	2.06*	5.17	7.74	0.93	6881.99	0.000	92.553	6879.92	6881.98	2.06**	5.17	7.74	0.93	6882.91	0.000	0.000	n/a	1.17	n/a
7	30	29.50	6880.42	6881.98	1.56	3.21	9.18	0.89	6882.87	0.000	276.549	6883.19	6885.04	1.85**	3.89	7.57	0.89	6885.93	0.000	0.000	n/a	1.50	1.34
8	24	17.60	6883.69	6885.04	1.35	2.26	7.80	0.74	6885.78	0.000	245.950	6886.15	6887.66	1.51**	2.55	6.92	0.74	6888.40	0.000	0.000	n/a	0.84	n/a
9	24	17.60	6886.15	6887.66	1.51*	2.55	6.92	0.74	6888.40	0.000	16.464	6886.31	6887.82	1.51**	2.55	6.92	0.74	6888.56	0.000	0.000	n/a	1.00	n/a
10	18	9.30	6884.19	6885.22	1.03*	1.30	7.16	0.61	6885.83	0.000	44.336	6884.63	6885.81	1.18**	1.49	6.25	0.61	6886.42	0.000	0.000	n/a	1.00	n/a
11	42	61.30	6876.22	6879.10	2.87	7.20	7.25	1.13	6880.22	0.000	52.706	6876.75	6879.20	2.45**	7.20	8.52	1.13	6880.33	0.000	0.000	n/a	1.26	n/a
12	36	51.90	6877.25	6879.20	1.95	4.87	10.66	1.20	6880.40	0.000	44.330	6877.69	6880.03	2.34**	5.92	8.77	1.20	6881.23	0.000	0.000	n/a	1.50	n/a
13	24	12.90	6878.69	6880.03	1.34	2.14	5.76	0.56	6880.59	0.000	255.617	6881.25	6882.54 j	1.29**	2.14	6.02	0.56	6883.10	0.000	0.000	n/a	1.50	0.84
14	24	11.20	6881.25	6882.54	1.29	1.97	5.22	0.50	6883.05	0.000	10.167	6881.35	6882.55	1.20**	1.97	5.70	0.50	6883.05	0.000	0.000	n/a	1.00	n/a
15	18	9.10	6881.42	6882.44	1.02*	1.28	7.13	0.59	6883.03	0.000	44.335	6881.86	6883.03	1.17**	1.47	6.17	0.59	6883.62	0.000	0.000	n/a	1.00	0.59
16	24	20.70	6876.25	6877.94	1.69	2.74	7.31	0.89	6878.83	0.000	266.443	6878.92	6880.55 j	1.63**	2.74	7.55	0.89	6881.44	0.000	0.000	n/a	1.00	n/a
17	30	29.60	6878.19	6880.03	1.84	3.87	7.64	0.89	6880.93	0.000	10.167	6878.29	6880.14	1.85**	3.90	7.59	0.89	6881.04	0.000	0.000	n/a	1.00	0.89
18	24	16.20	6876.25	6877.94	1.69	2.44	5.72	0.69	6878.63	0.000	269.817	6878.95	6880.40 j	1.45**	2.44	6.64	0.69	6881.09	0.000	0.000	n/a	1.00	n/a

Project File: FM 3-7-17 HF.stm

Number of lines: 18

Run Date: 3/16/2017

Notes: * depth assumed; ** Critical depth.; j-Line contains hyd. jump ; c = cir e = ellip b = box

General Procedure:

Hydraflow computes the HGL using the Bernoulli energy equation. Manning's equation is used to determine energy losses due to pipe friction. In a standard step, iterative procedure, Hydraflow assumes upstream HGLs until the energy equation balances. If the energy equation cannot balance, supercritical flow exists and critical depth is temporarily assumed at the upstream end. A supercritical flow Profile is then computed using the same procedure in a downstream direction using momentum principles.

Col. 1 The line number being computed. Calculations begin at Line 1 and proceed upstream.

Col. 2 The line size. In the case of non-circular pipes, the line rise is printed above the span.

Col. 3 Total flow rate in the line.

Col. 4 The elevation of the downstream invert.

Col. 5 Elevation of the hydraulic grade line at the downstream end. This is computed as the upstream HGL + Minor loss of this line's downstream line.

Col. 6 The downstream depth of flow inside the pipe (HGL - Invert elevation) but not greater than the line size.

Col. 7 Cross-sectional area of the flow at the downstream end.

Col. 8 The velocity of the flow at the downstream end, (Col. 3 / Col. 7).

Col. 9 Velocity head (Velocity squared / 2g).

Col. 10 The elevation of the energy grade line at the downstream end, HGL + Velocity head, (Col. 5 + Col. 9).

Col. 11 The friction slope at the downstream end (the S or Slope term in Manning's equation).

Col. 12 The line length.

Col. 13 The elevation of the upstream invert.

Col. 14 Elevation of the hydraulic grade line at the upstream end.

Col. 15 The upstream depth of flow inside the pipe (HGL - Invert elevation) but not greater than the line size.

Col. 16 Cross-sectional area of the flow at the upstream end.

Col. 17 The velocity of the flow at the upstream end, (Col. 3 / Col. 16).

Col. 18 Velocity head (Velocity squared / 2g).

Col. 19 The elevation of the energy grade line at the upstream end, HGL + Velocity head, (Col. 14 + Col. 18) .

Col. 20 The friction slope at the upstream end (the S or Slope term in Manning's equation).

Col. 21 The average of the downstream and upstream friction slopes.

Col. 22 Energy loss. Average $Sf/100 \times \text{Line Length}$ (Col. 21/100 x Col. 12). Equals (EGL upstream - EGL downstream) +/- tolerance.

Col. 23 The junction loss coefficient (K).

Col. 24 Minor loss. (Col. 23 x Col. 18). Is added to upstream HGL and used as the starting HGL for the next upstream line(s).

ALLOWABLE CAPACITY FOR ONE-HALF OF STREET (Minor & Major Storm)

(Based on Regulated Criteria for Maximum Allowable Flow Depth and Spread)

Project: FALCON MARKETPLACE
 Inlet ID: IB1

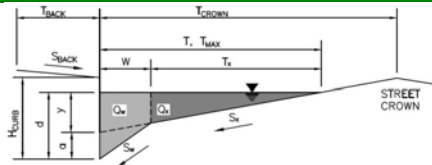

Gutter Geometry (Enter data in the blue cells)							
Maximum Allowable Width for Spread Behind Curb	$T_{BACK} = 7.0$ ft						
Side Slope Behind Curb (leave blank for no conveyance credit behind curb)	$S_{BACK} = 0.020$ ft/ft						
Manning's Roughness Behind Curb (typically between 0.012 and 0.020)	$n_{BACK} = 0.020$						
Height of Curb at Gutter Flow Line	$H_{CURB} = 6.00$ inches						
Distance from Curb Face to Street Crown	$T_{CROWN} = 20.0$ ft						
Gutter Width	$W = 2.00$ ft						
Street Transverse Slope	$S_X = 0.020$ ft/ft						
Gutter Cross Slope (typically 2 inches over 24 inches or 0.083 ft/ft)	$S_W = 0.083$ ft/ft						
Street Longitudinal Slope - Enter 0 for sump condition	$S_O = 0.010$ ft/ft						
Manning's Roughness for Street Section (typically between 0.012 and 0.020)	$n_{STREET} = 0.013$						
Max. Allowable Spread for Minor & Major Storm	<table border="1"> <thead> <tr> <th>Minor Storm</th> <th>Major Storm</th> <th>ft</th> </tr> </thead> <tbody> <tr> <td>$T_{MAX} = 20.0$</td> <td>$T_{MAX} = 20.0$</td> <td></td> </tr> </tbody> </table>	Minor Storm	Major Storm	ft	$T_{MAX} = 20.0$	$T_{MAX} = 20.0$	
Minor Storm	Major Storm	ft					
$T_{MAX} = 20.0$	$T_{MAX} = 20.0$						
Max. Allowable Depth at Gutter Flowline for Minor & Major Storm	<table border="1"> <thead> <tr> <th>Minor Storm</th> <th>Major Storm</th> <th>inches</th> </tr> </thead> <tbody> <tr> <td>$d_{MAX} = 6.0$</td> <td>$d_{MAX} = 7.5$</td> <td></td> </tr> </tbody> </table>	Minor Storm	Major Storm	inches	$d_{MAX} = 6.0$	$d_{MAX} = 7.5$	
Minor Storm	Major Storm	inches					
$d_{MAX} = 6.0$	$d_{MAX} = 7.5$						
Allow Flow Depth at Street Crown (leave blank for no)	<input type="checkbox"/> <input type="checkbox"/> check = yes						
MINOR STORM Allowable Capacity is based on Depth Criterion							
MAJOR STORM Allowable Capacity is based on Spread Criterion							
Minor storm max. allowable capacity GOOD - greater than the design flow given on sheet 'Inlet Management'	<table border="1"> <thead> <tr> <th>Minor Storm</th> <th>Major Storm</th> <th>cfs</th> </tr> </thead> <tbody> <tr> <td>$Q_{allow} = 17.0$</td> <td>$Q_{allow} = 20.1$</td> <td></td> </tr> </tbody> </table>	Minor Storm	Major Storm	cfs	$Q_{allow} = 17.0$	$Q_{allow} = 20.1$	
Minor Storm	Major Storm	cfs					
$Q_{allow} = 17.0$	$Q_{allow} = 20.1$						
Major storm max. allowable capacity GOOD - greater than the design flow given on sheet 'Inlet Management'							

INLET ON A CONTINUOUS GRADE

Version 4.04 Released November 2016

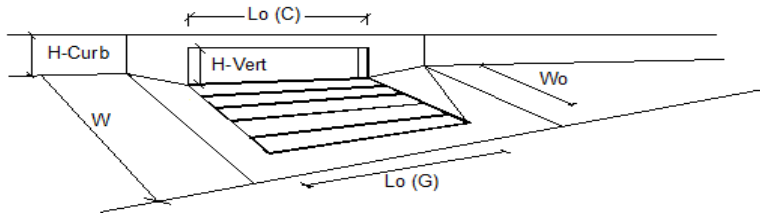

Design Information (Input)	MINOR	MAJOR	
Type of Inlet	CDOT Type R Curb Opening		
Local Depression (additional to continuous gutter depression 'a')	3.0	3.0	inches
Total Number of Units in the Inlet (Grate or Curb Opening)	1	1	
Length of a Single Unit Inlet (Grate or Curb Opening)	10.00	10.00	ft
Width of a Unit Grate (cannot be greater than W, Gutter Width)	N/A	N/A	ft
Clogging Factor for a Single Unit Grate (typical min. value = 0.5)	N/A	N/A	
Clogging Factor for a Single Unit Curb Opening (typical min. value = 0.1)	0.10	0.10	
Street Hydraulics: OK - Q < Allowable Street Capacity*			
Total Inlet Interception Capacity	7.0	9.3	cfs
Total Inlet Carry-Over Flow (flow bypassing inlet)	3.9	10.5	cfs
Capture Percentage = Q_i/Q_o =	64	47	%

ALLOWABLE CAPACITY FOR ONE-HALF OF STREET (Minor & Major Storm)

(Based on Regulated Criteria for Maximum Allowable Flow Depth and Spread)

Project: FALCON MARKETPLACE
 Inlet ID: IB2

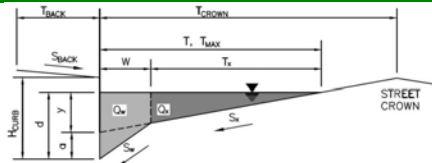

Gutter Geometry (Enter data in the blue cells)							
Maximum Allowable Width for Spread Behind Curb	$T_{BACK} = 7.0$ ft						
Side Slope Behind Curb (leave blank for no conveyance credit behind curb)	$S_{BACK} = 0.020$ ft/ft						
Manning's Roughness Behind Curb (typically between 0.012 and 0.020)	$n_{BACK} = 0.020$						
Height of Curb at Gutter Flow Line	$H_{CURB} = 6.00$ inches						
Distance from Curb Face to Street Crown	$T_{CROWN} = 20.0$ ft						
Gutter Width	$W = 2.00$ ft						
Street Transverse Slope	$S_x = 0.020$ ft/ft						
Gutter Cross Slope (typically 2 inches over 24 inches or 0.083 ft/ft)	$S_w = 0.083$ ft/ft						
Street Longitudinal Slope - Enter 0 for sump condition	$S_o = 0.010$ ft/ft						
Manning's Roughness for Street Section (typically between 0.012 and 0.020)	$n_{STREET} = 0.013$						
Max. Allowable Spread for Minor & Major Storm	<table border="1"> <thead> <tr> <th>Minor Storm</th> <th>Major Storm</th> <th>ft</th> </tr> </thead> <tbody> <tr> <td>20.0</td> <td>20.0</td> <td></td> </tr> </tbody> </table>	Minor Storm	Major Storm	ft	20.0	20.0	
Minor Storm	Major Storm	ft					
20.0	20.0						
Max. Allowable Depth at Gutter Flowline for Minor & Major Storm	<table border="1"> <thead> <tr> <th>Minor Storm</th> <th>Major Storm</th> <th>inches</th> </tr> </thead> <tbody> <tr> <td>6.0</td> <td>7.5</td> <td></td> </tr> </tbody> </table>	Minor Storm	Major Storm	inches	6.0	7.5	
Minor Storm	Major Storm	inches					
6.0	7.5						
Allow Flow Depth at Street Crown (leave blank for no)	<input type="checkbox"/> <input type="checkbox"/> check = yes						
MINOR STORM Allowable Capacity is based on Depth Criterion							
MAJOR STORM Allowable Capacity is based on Spread Criterion							
Minor storm max. allowable capacity GOOD - greater than the design flow given on sheet 'Inlet Management'	<table border="1"> <thead> <tr> <th>Minor Storm</th> <th>Major Storm</th> <th>cfs</th> </tr> </thead> <tbody> <tr> <td>17.0</td> <td>20.1</td> <td></td> </tr> </tbody> </table>	Minor Storm	Major Storm	cfs	17.0	20.1	
Minor Storm	Major Storm	cfs					
17.0	20.1						
Major storm max. allowable capacity GOOD - greater than the design flow given on sheet 'Inlet Management'							

INLET ON A CONTINUOUS GRADE

Version 4.04 Released November 2016

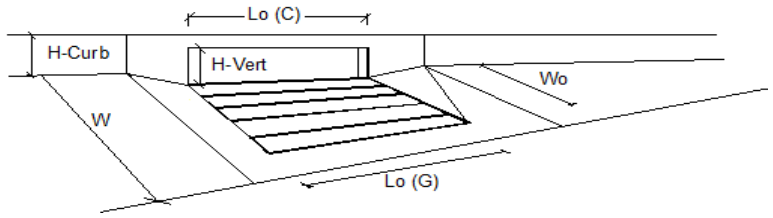

Design Information (Input)	MINOR	MAJOR	
Type of Inlet	CDOT Type R Curb Opening		
Local Depression (additional to continuous gutter depression 'a')	3.0	3.0	inches
Total Number of Units in the Inlet (Grate or Curb Opening)	1	1	
Length of a Single Unit Inlet (Grate or Curb Opening)	10.00	10.00	ft
Width of a Unit Grate (cannot be greater than W, Gutter Width)	N/A	N/A	ft
Clogging Factor for a Single Unit Grate (typical min. value = 0.5)	N/A	N/A	
Clogging Factor for a Single Unit Curb Opening (typical min. value = 0.1)	0.10	0.10	
Street Hydraulics: OK - Q < Allowable Street Capacity			
Total Inlet Interception Capacity	1.5	2.6	cfs
Total Inlet Carry-Over Flow (flow bypassing inlet)	0.0	0.0	cfs
Capture Percentage = Q_i/Q_o =	100	100	%

ALLOWABLE CAPACITY FOR ONE-HALF OF STREET (Minor & Major Storm)

(Based on Regulated Criteria for Maximum Allowable Flow Depth and Spread)

Project: FALCON MARKETPLACE
 Inlet ID: IB3

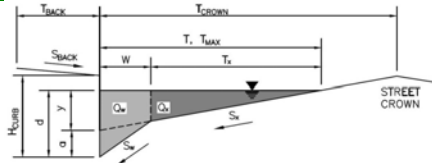

Gutter Geometry (Enter data in the blue cells)							
Maximum Allowable Width for Spread Behind Curb	$T_{BACK} = 7.0$ ft						
Side Slope Behind Curb (leave blank for no conveyance credit behind curb)	$S_{BACK} = 0.020$ ft/ft						
Manning's Roughness Behind Curb (typically between 0.012 and 0.020)	$n_{BACK} = 0.020$						
Height of Curb at Gutter Flow Line	$H_{CURB} = 6.00$ inches						
Distance from Curb Face to Street Crown	$T_{CROWN} = 20.0$ ft						
Gutter Width	$W = 2.00$ ft						
Street Transverse Slope	$S_x = 0.020$ ft/ft						
Gutter Cross Slope (typically 2 inches over 24 inches or 0.083 ft/ft)	$S_w = 0.083$ ft/ft						
Street Longitudinal Slope - Enter 0 for sump condition	$S_o = 0.010$ ft/ft						
Manning's Roughness for Street Section (typically between 0.012 and 0.020)	$n_{STREET} = 0.013$						
Max. Allowable Spread for Minor & Major Storm	<table border="1"> <tr> <th>Minor Storm</th> <th>Major Storm</th> <th>ft</th> </tr> <tr> <td>$T_{MAX} = 20.0$</td> <td>$T_{MAX} = 20.0$</td> <td></td> </tr> </table>	Minor Storm	Major Storm	ft	$T_{MAX} = 20.0$	$T_{MAX} = 20.0$	
Minor Storm	Major Storm	ft					
$T_{MAX} = 20.0$	$T_{MAX} = 20.0$						
Max. Allowable Depth at Gutter Flowline for Minor & Major Storm	<table border="1"> <tr> <th>Minor Storm</th> <th>Major Storm</th> <th>inches</th> </tr> <tr> <td>$d_{MAX} = 6.0$</td> <td>$d_{MAX} = 7.5$</td> <td></td> </tr> </table>	Minor Storm	Major Storm	inches	$d_{MAX} = 6.0$	$d_{MAX} = 7.5$	
Minor Storm	Major Storm	inches					
$d_{MAX} = 6.0$	$d_{MAX} = 7.5$						
Allow Flow Depth at Street Crown (leave blank for no)	<table border="1"> <tr> <td><input type="checkbox"/></td> <td><input type="checkbox"/></td> <td>check = yes</td> </tr> </table>	<input type="checkbox"/>	<input type="checkbox"/>	check = yes			
<input type="checkbox"/>	<input type="checkbox"/>	check = yes					
MINOR STORM Allowable Capacity is based on Depth Criterion							
MAJOR STORM Allowable Capacity is based on Spread Criterion							
Minor storm max. allowable capacity GOOD - greater than the design flow given on sheet 'Inlet Management'	<table border="1"> <tr> <th>Minor Storm</th> <th>Major Storm</th> <th>cfs</th> </tr> <tr> <td>$Q_{allow} = 17.0$</td> <td>$Q_{allow} = 20.1$</td> <td></td> </tr> </table>	Minor Storm	Major Storm	cfs	$Q_{allow} = 17.0$	$Q_{allow} = 20.1$	
Minor Storm	Major Storm	cfs					
$Q_{allow} = 17.0$	$Q_{allow} = 20.1$						
Major storm max. allowable capacity GOOD - greater than the design flow given on sheet 'Inlet Management'							

INLET ON A CONTINUOUS GRADE

Version 4.04 Released November 2016

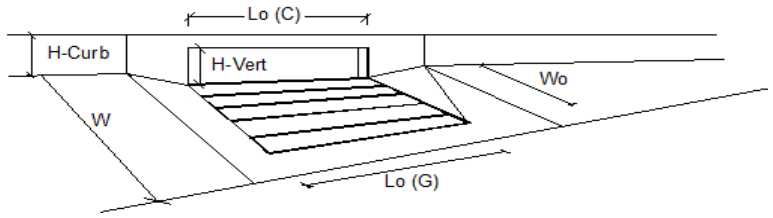

Design Information (Input)	MINOR	MAJOR	
Type of Inlet	CDOT Type R Curb Opening		
Local Depression (additional to continuous gutter depression 'a')	3.0	3.0	inches
Total Number of Units in the Inlet (Grate or Curb Opening)	1	1	
Length of a Single Unit Inlet (Grate or Curb Opening)	10.00	10.00	ft
Width of a Unit Grate (cannot be greater than W, Gutter Width)	N/A	N/A	ft
Clogging Factor for a Single Unit Grate (typical min. value = 0.5)	N/A	N/A	
Clogging Factor for a Single Unit Curb Opening (typical min. value = 0.1)	0.10	0.10	
Street Hydraulics: OK - Q < Allowable Street Capacity*			
Total Inlet Interception Capacity	6.2	9.1	cfs
Total Inlet Carry-Over Flow (flow bypassing inlet)	2.3	10.0	cfs
Capture Percentage = Q_i/Q_o =	73	48	%

ALLOWABLE CAPACITY FOR ONE-HALF OF STREET (Minor & Major Storm)

(Based on Regulated Criteria for Maximum Allowable Flow Depth and Spread)

Project: FALCON MARKETPLACE
 Inlet ID: IB4

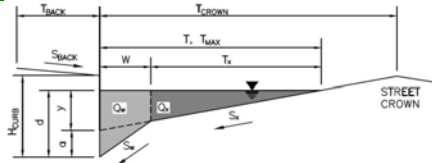

Gutter Geometry (Enter data in the blue cells)							
Maximum Allowable Width for Spread Behind Curb	$T_{BACK} = $ <input style="width: 50px;" type="text" value="7.0"/> ft						
Side Slope Behind Curb (leave blank for no conveyance credit behind curb)	$S_{BACK} = $ <input style="width: 50px;" type="text" value="0.020"/> ft/ft						
Manning's Roughness Behind Curb (typically between 0.012 and 0.020)	$n_{BACK} = $ <input style="width: 50px;" type="text" value="0.020"/>						
Height of Curb at Gutter Flow Line	$H_{CURB} = $ <input style="width: 50px;" type="text" value="6.00"/> inches						
Distance from Curb Face to Street Crown	$T_{CROWN} = $ <input style="width: 50px;" type="text" value="20.0"/> ft						
Gutter Width	$W = $ <input style="width: 50px;" type="text" value="2.00"/> ft						
Street Transverse Slope	$S_X = $ <input style="width: 50px;" type="text" value="0.020"/> ft/ft						
Gutter Cross Slope (typically 2 inches over 24 inches or 0.083 ft/ft)	$S_W = $ <input style="width: 50px;" type="text" value="0.083"/> ft/ft						
Street Longitudinal Slope - Enter 0 for sump condition	$S_O = $ <input style="width: 50px;" type="text" value="0.010"/> ft/ft						
Manning's Roughness for Street Section (typically between 0.012 and 0.020)	$n_{STREET} = $ <input style="width: 50px;" type="text" value="0.013"/>						
Max. Allowable Spread for Minor & Major Storm	<table border="1" style="display: inline-table; border-collapse: collapse;"> <thead> <tr> <th style="width: 50px;">Minor Storm</th> <th style="width: 50px;">Major Storm</th> <th style="width: 20px;"></th> </tr> </thead> <tbody> <tr> <td style="text-align: center;"><input style="width: 50px;" type="text" value="20.0"/></td> <td style="text-align: center;"><input style="width: 50px;" type="text" value="20.0"/></td> <td style="text-align: right;">ft</td> </tr> </tbody> </table>	Minor Storm	Major Storm		<input style="width: 50px;" type="text" value="20.0"/>	<input style="width: 50px;" type="text" value="20.0"/>	ft
Minor Storm	Major Storm						
<input style="width: 50px;" type="text" value="20.0"/>	<input style="width: 50px;" type="text" value="20.0"/>	ft					
Max. Allowable Depth at Gutter Flowline for Minor & Major Storm	<table border="1" style="display: inline-table; border-collapse: collapse;"> <thead> <tr> <th style="width: 50px;">Minor Storm</th> <th style="width: 50px;">Major Storm</th> <th style="width: 20px;"></th> </tr> </thead> <tbody> <tr> <td style="text-align: center;"><input style="width: 50px;" type="text" value="6.0"/></td> <td style="text-align: center;"><input style="width: 50px;" type="text" value="7.5"/></td> <td style="text-align: right;">inches</td> </tr> </tbody> </table>	Minor Storm	Major Storm		<input style="width: 50px;" type="text" value="6.0"/>	<input style="width: 50px;" type="text" value="7.5"/>	inches
Minor Storm	Major Storm						
<input style="width: 50px;" type="text" value="6.0"/>	<input style="width: 50px;" type="text" value="7.5"/>	inches					
Allow Flow Depth at Street Crown (leave blank for no)	<table border="1" style="display: inline-table; border-collapse: collapse;"> <thead> <tr> <th style="width: 50px;">Minor Storm</th> <th style="width: 50px;">Major Storm</th> <th style="width: 20px;"></th> </tr> </thead> <tbody> <tr> <td style="text-align: center;"><input type="checkbox"/></td> <td style="text-align: center;"><input type="checkbox"/></td> <td style="text-align: right;">check = yes</td> </tr> </tbody> </table>	Minor Storm	Major Storm		<input type="checkbox"/>	<input type="checkbox"/>	check = yes
Minor Storm	Major Storm						
<input type="checkbox"/>	<input type="checkbox"/>	check = yes					
MINOR STORM Allowable Capacity is based on Depth Criterion							
MAJOR STORM Allowable Capacity is based on Spread Criterion							
Minor storm max. allowable capacity GOOD - greater than the design flow given on sheet 'Inlet Management'	$Q_{allow} = $ <table border="1" style="display: inline-table; border-collapse: collapse;"> <thead> <tr> <th style="width: 50px;">Minor Storm</th> <th style="width: 50px;">Major Storm</th> <th style="width: 20px;"></th> </tr> </thead> <tbody> <tr> <td style="text-align: center;"><input style="width: 50px;" type="text" value="17.0"/></td> <td style="text-align: center;"><input style="width: 50px;" type="text" value="20.1"/></td> <td style="text-align: right;">cfs</td> </tr> </tbody> </table>	Minor Storm	Major Storm		<input style="width: 50px;" type="text" value="17.0"/>	<input style="width: 50px;" type="text" value="20.1"/>	cfs
Minor Storm	Major Storm						
<input style="width: 50px;" type="text" value="17.0"/>	<input style="width: 50px;" type="text" value="20.1"/>	cfs					
Major storm max. allowable capacity GOOD - greater than the design flow given on sheet 'Inlet Management'							

INLET ON A CONTINUOUS GRADE

Version 4.04 Released November 2016

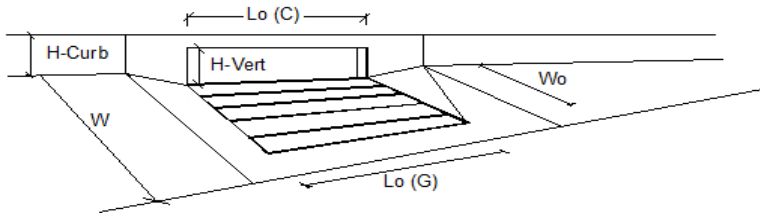

Design Information (Input)	MINOR	MAJOR	
Type of Inlet	CDOT Type R Curb Opening		
Local Depression (additional to continuous gutter depression 'a')	3.0	3.0	inches
Total Number of Units in the Inlet (Grate or Curb Opening)	1	1	
Length of a Single Unit Inlet (Grate or Curb Opening)	10.00	10.00	ft
Width of a Unit Grate (cannot be greater than W, Gutter Width)	N/A	N/A	ft
Clogging Factor for a Single Unit Grate (typical min. value = 0.5)	N/A	N/A	
Clogging Factor for a Single Unit Curb Opening (typical min. value = 0.1)	0.10	0.10	
Street Hydraulics: OK - Q < Allowable Street Capacity			
Total Inlet Interception Capacity	0.8	1.4	cfs
Total Inlet Carry-Over Flow (flow bypassing inlet)	0.0	0.0	cfs
Capture Percentage = Q_i/Q_o =	100	100	%

ALLOWABLE CAPACITY FOR ONE-HALF OF STREET (Minor & Major Storm)

(Based on Regulated Criteria for Maximum Allowable Flow Depth and Spread)

Project: FALCON MARKETPLACE
 Inlet ID: IB5

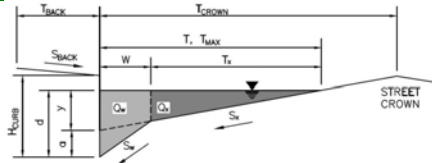

Gutter Geometry (Enter data in the blue cells)							
Maximum Allowable Width for Spread Behind Curb	$T_{BACK} = $ <input style="width: 50px;" type="text" value="7.0"/> ft						
Side Slope Behind Curb (leave blank for no conveyance credit behind curb)	$S_{BACK} = $ <input style="width: 50px;" type="text" value="0.020"/> ft/ft						
Manning's Roughness Behind Curb (typically between 0.012 and 0.020)	$n_{BACK} = $ <input style="width: 50px;" type="text" value="0.020"/>						
Height of Curb at Gutter Flow Line	$H_{CURB} = $ <input style="width: 50px;" type="text" value="6.00"/> inches						
Distance from Curb Face to Street Crown	$T_{CROWN} = $ <input style="width: 50px;" type="text" value="20.0"/> ft						
Gutter Width	$W = $ <input style="width: 50px;" type="text" value="2.00"/> ft						
Street Transverse Slope	$S_X = $ <input style="width: 50px;" type="text" value="0.020"/> ft/ft						
Gutter Cross Slope (typically 2 inches over 24 inches or 0.083 ft/ft)	$S_W = $ <input style="width: 50px;" type="text" value="0.083"/> ft/ft						
Street Longitudinal Slope - Enter 0 for sump condition	$S_O = $ <input style="width: 50px;" type="text" value="0.000"/> ft/ft						
Manning's Roughness for Street Section (typically between 0.012 and 0.020)	$n_{STREET} = $ <input style="width: 50px;" type="text" value="0.013"/>						
Max. Allowable Spread for Minor & Major Storm	<table border="1" style="display: inline-table; border-collapse: collapse;"> <thead> <tr> <th style="width: 50px;">Minor Storm</th> <th style="width: 50px;">Major Storm</th> <th style="width: 20px;">ft</th> </tr> </thead> <tbody> <tr> <td style="text-align: center;"><input style="width: 40px;" type="text" value="20.0"/></td> <td style="text-align: center;"><input style="width: 40px;" type="text" value="20.0"/></td> <td></td> </tr> </tbody> </table>	Minor Storm	Major Storm	ft	<input style="width: 40px;" type="text" value="20.0"/>	<input style="width: 40px;" type="text" value="20.0"/>	
Minor Storm	Major Storm	ft					
<input style="width: 40px;" type="text" value="20.0"/>	<input style="width: 40px;" type="text" value="20.0"/>						
Max. Allowable Depth at Gutter Flowline for Minor & Major Storm	<table border="1" style="display: inline-table; border-collapse: collapse;"> <thead> <tr> <th style="width: 50px;">Minor Storm</th> <th style="width: 50px;">Major Storm</th> <th style="width: 20px;">inches</th> </tr> </thead> <tbody> <tr> <td style="text-align: center;"><input style="width: 40px;" type="text" value="6.0"/></td> <td style="text-align: center;"><input style="width: 40px;" type="text" value="7.5"/></td> <td></td> </tr> </tbody> </table>	Minor Storm	Major Storm	inches	<input style="width: 40px;" type="text" value="6.0"/>	<input style="width: 40px;" type="text" value="7.5"/>	
Minor Storm	Major Storm	inches					
<input style="width: 40px;" type="text" value="6.0"/>	<input style="width: 40px;" type="text" value="7.5"/>						
Allow Flow Depth at Street Crown (leave blank for no)	<input type="checkbox"/> <input type="checkbox"/> check = yes						
MINOR STORM Allowable Capacity is based on Depth Criterion							
MAJOR STORM Allowable Capacity is based on Depth Criterion	<table border="1" style="display: inline-table; border-collapse: collapse;"> <thead> <tr> <th style="width: 50px;">Minor Storm</th> <th style="width: 50px;">Major Storm</th> <th style="width: 20px;">cfs</th> </tr> </thead> <tbody> <tr> <td style="text-align: center;"><input style="width: 40px;" type="text" value="SUMP"/></td> <td style="text-align: center;"><input style="width: 40px;" type="text" value="SUMP"/></td> <td></td> </tr> </tbody> </table>	Minor Storm	Major Storm	cfs	<input style="width: 40px;" type="text" value="SUMP"/>	<input style="width: 40px;" type="text" value="SUMP"/>	
Minor Storm	Major Storm	cfs					
<input style="width: 40px;" type="text" value="SUMP"/>	<input style="width: 40px;" type="text" value="SUMP"/>						

INLET IN A SUMP OR SAG LOCATION

Version 4.04 Released November 2016

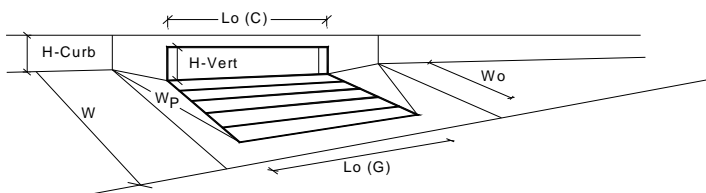

Design Information (Input)	MINOR	MAJOR	
Type of Inlet	CDOT Type R Curb Opening		
Local Depression (additional to continuous gutter depression 'a' from 'Q-Allow')	3.00	3.00	inches
Number of Unit Inlets (Grate or Curb Opening)	1	1	
Water Depth at Flowline (outside of local depression)	6.0	6.3	inches
Grate Information	MINOR	MAJOR	<input checked="" type="checkbox"/> Override Depths
Length of a Unit Grate	N/A	N/A	feet
Width of a Unit Grate	N/A	N/A	feet
Area Opening Ratio for a Grate (typical values 0.15-0.90)	N/A	N/A	
Clogging Factor for a Single Grate (typical value 0.50 - 0.70)	N/A	N/A	
Grate Weir Coefficient (typical value 2.15 - 3.60)	N/A	N/A	
Grate Orifice Coefficient (typical value 0.60 - 0.80)	N/A	N/A	
Curb Opening Information	MINOR	MAJOR	
Length of a Unit Curb Opening	15.00	15.00	feet
Height of Vertical Curb Opening in Inches	6.00	6.00	inches
Height of Curb Orifice Throat in Inches	6.00	6.00	inches
Angle of Throat (see USDCM Figure ST-5)	63.40	63.40	degrees
Side Width for Depression Pan (typically the gutter width of 2 feet)	2.00	2.00	feet
Clogging Factor for a Single Curb Opening (typical value 0.10)	0.10	0.10	
Curb Opening Weir Coefficient (typical value 2.3-3.7)	3.60	3.60	
Curb Opening Orifice Coefficient (typical value 0.60 - 0.70)	0.67	0.67	
Low Head Performance Reduction (Calculated)	MINOR	MAJOR	
Depth for Grate Midwidth	N/A	N/A	ft
Depth for Curb Opening Weir Equation	0.33	0.36	ft
Combination Inlet Performance Reduction Factor for Long Inlets	0.57	0.60	
Curb Opening Performance Reduction Factor for Long Inlets	0.79	0.81	
Grated Inlet Performance Reduction Factor for Long Inlets	N/A	N/A	
Total Inlet Interception Capacity (assumes clogged condition)	MINOR	MAJOR	
Q_a	9.7	11.2	cfs
Q_{PEAK REQUIRED}	9.6	17.5	cfs

WARNING: Inlet Capacity less than Q Peak for Major Storm

ALLOWABLE CAPACITY FOR ONE-HALF OF STREET (Minor & Major Storm)

(Based on Regulated Criteria for Maximum Allowable Flow Depth and Spread)

Project: FALCON MARKETPLACE
 Inlet ID: IB6

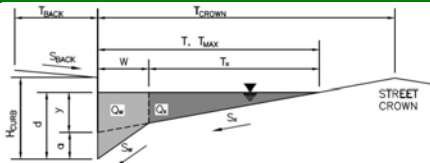

Gutter Geometry (Enter data in the blue cells)									
Maximum Allowable Width for Spread Behind Curb	$T_{BACK} = $ <input style="width: 50px;" type="text" value="7.0"/> ft								
Side Slope Behind Curb (leave blank for no conveyance credit behind curb)	$S_{BACK} = $ <input style="width: 50px;" type="text" value="0.020"/> ft/ft								
Manning's Roughness Behind Curb (typically between 0.012 and 0.020)	$n_{BACK} = $ <input style="width: 50px;" type="text" value="0.020"/>								
Height of Curb at Gutter Flow Line	$H_{CURB} = $ <input style="width: 50px;" type="text" value="6.00"/> inches								
Distance from Curb Face to Street Crown	$T_{CROWN} = $ <input style="width: 50px;" type="text" value="20.0"/> ft								
Gutter Width	$W = $ <input style="width: 50px;" type="text" value="2.00"/> ft								
Street Transverse Slope	$S_X = $ <input style="width: 50px;" type="text" value="0.020"/> ft/ft								
Gutter Cross Slope (typically 2 inches over 24 inches or 0.083 ft/ft)	$S_W = $ <input style="width: 50px;" type="text" value="0.083"/> ft/ft								
Street Longitudinal Slope - Enter 0 for sump condition	$S_O = $ <input style="width: 50px;" type="text" value="0.000"/> ft/ft								
Manning's Roughness for Street Section (typically between 0.012 and 0.020)	$n_{STREET} = $ <input style="width: 50px;" type="text" value="0.013"/>								
Max. Allowable Spread for Minor & Major Storm	<table style="width: 100%; border: none;"> <tr> <td style="text-align: center; border: none;">$T_{MAX} =$</td> <td style="text-align: center; border: none;">Minor Storm</td> <td style="text-align: center; border: none;">Major Storm</td> <td style="border: none;"></td> </tr> <tr> <td style="border: 1px solid black; width: 50px;"></td> <td style="border: 1px solid black; width: 50px; text-align: center;">20.0</td> <td style="border: 1px solid black; width: 50px; text-align: center;">20.0</td> <td style="border: none;">ft</td> </tr> </table>	$T_{MAX} = $	Minor Storm	Major Storm			20.0	20.0	ft
$T_{MAX} = $	Minor Storm	Major Storm							
	20.0	20.0	ft						
Max. Allowable Depth at Gutter Flowline for Minor & Major Storm	<table style="width: 100%; border: none;"> <tr> <td style="text-align: center; border: none;">$d_{MAX} =$</td> <td style="text-align: center; border: none;">Minor Storm</td> <td style="text-align: center; border: none;">Major Storm</td> <td style="border: none;"></td> </tr> <tr> <td style="border: 1px solid black; width: 50px;"></td> <td style="border: 1px solid black; width: 50px; text-align: center;">6.0</td> <td style="border: 1px solid black; width: 50px; text-align: center;">7.5</td> <td style="border: none;">inches</td> </tr> </table>	$d_{MAX} = $	Minor Storm	Major Storm			6.0	7.5	inches
$d_{MAX} = $	Minor Storm	Major Storm							
	6.0	7.5	inches						
Allow Flow Depth at Street Crown (leave blank for no)	<table style="width: 100%; border: none;"> <tr> <td style="text-align: center; border: none;"><input type="checkbox"/></td> <td style="text-align: center; border: none;"><input type="checkbox"/></td> <td style="border: none;">check = yes</td> </tr> </table>	<input type="checkbox"/>	<input type="checkbox"/>	check = yes					
<input type="checkbox"/>	<input type="checkbox"/>	check = yes							
MINOR STORM Allowable Capacity is based on Depth Criterion									
MAJOR STORM Allowable Capacity is based on Depth Criterion	<table style="width: 100%; border: none;"> <tr> <td style="text-align: center; border: none;">$Q_{allow} =$</td> <td style="text-align: center; border: none;">Minor Storm</td> <td style="text-align: center; border: none;">Major Storm</td> <td style="border: none;"></td> </tr> <tr> <td style="border: 1px solid black; width: 50px;"></td> <td style="border: 1px solid black; width: 50px; text-align: center;">SUMP</td> <td style="border: 1px solid black; width: 50px; text-align: center;">SUMP</td> <td style="border: none;">cfs</td> </tr> </table>	$Q_{allow} = $	Minor Storm	Major Storm			SUMP	SUMP	cfs
$Q_{allow} = $	Minor Storm	Major Storm							
	SUMP	SUMP	cfs						

INLET IN A SUMP OR SAG LOCATION

Version 4.04 Released November 2016

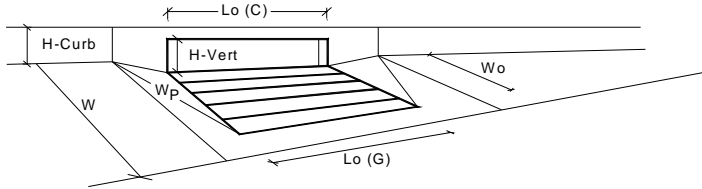

Design Information (Input)	MINOR	MAJOR	
Type of Inlet	CDOT Type R Curb Opening		
Local Depression (additional to continuous gutter depression 'a' from 'Q-Allow')	3.00	3.00	inches
Number of Unit Inlets (Grate or Curb Opening)	1	1	
Water Depth at Flowline (outside of local depression)	6.0	7.5	inches
Grate Information	MINOR	MAJOR	<input checked="" type="checkbox"/> Override Depths
Length of a Unit Grate	N/A	N/A	feet
Width of a Unit Grate	N/A	N/A	feet
Area Opening Ratio for a Grate (typical values 0.15-0.90)	N/A	N/A	
Clogging Factor for a Single Grate (typical value 0.50 - 0.70)	N/A	N/A	
Grate Weir Coefficient (typical value 2.15 - 3.60)	N/A	N/A	
Grate Orifice Coefficient (typical value 0.60 - 0.80)	N/A	N/A	
Curb Opening Information	MINOR	MAJOR	
Length of a Unit Curb Opening	10.00	10.00	feet
Height of Vertical Curb Opening in Inches	6.00	6.00	inches
Height of Curb Orifice Throat in Inches	6.00	6.00	inches
Angle of Throat (see USDCM Figure ST-5)	63.40	63.40	degrees
Side Width for Depression Pan (typically the gutter width of 2 feet)	2.00	2.00	feet
Clogging Factor for a Single Curb Opening (typical value 0.10)	0.10	0.10	
Curb Opening Weir Coefficient (typical value 2.3-3.7)	3.60	3.60	
Curb Opening Orifice Coefficient (typical value 0.60 - 0.70)	0.67	0.67	
Low Head Performance Reduction (Calculated)	MINOR	MAJOR	
Depth for Grate Midwidth	N/A	N/A	ft
Depth for Curb Opening Weir Equation	0.33	0.46	ft
Combination Inlet Performance Reduction Factor for Long Inlets	0.57	0.71	
Curb Opening Performance Reduction Factor for Long Inlets	0.93	1.00	
Grated Inlet Performance Reduction Factor for Long Inlets	N/A	N/A	
Total Inlet Interception Capacity (assumes clogged condition)	MINOR	MAJOR	
Q_a	8.3	14.3	cfs
Q _{PEAK REQUIRED}	3.2	11.6	cfs

Inlet Capacity IS GOOD for Minor and Major Storms(>Q PEAK)

ALLOWABLE CAPACITY FOR ONE-HALF OF STREET (Minor & Major Storm)

(Based on Regulated Criteria for Maximum Allowable Flow Depth and Spread)

Project: FALCON MARKETPLACE
 Inlet ID: IB7

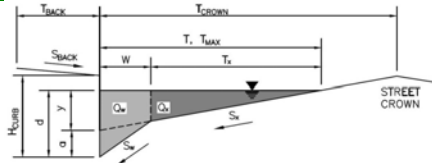

Gutter Geometry (Enter data in the blue cells)							
Maximum Allowable Width for Spread Behind Curb	$T_{BACK} = 7.0$ ft						
Side Slope Behind Curb (leave blank for no conveyance credit behind curb)	$S_{BACK} = 0.020$ ft/ft						
Manning's Roughness Behind Curb (typically between 0.012 and 0.020)	$n_{BACK} = 0.020$						
Height of Curb at Gutter Flow Line	$H_{CURB} = 6.00$ inches						
Distance from Curb Face to Street Crown	$T_{CROWN} = 20.0$ ft						
Gutter Width	$W = 2.00$ ft						
Street Transverse Slope	$S_X = 0.020$ ft/ft						
Gutter Cross Slope (typically 2 inches over 24 inches or 0.083 ft/ft)	$S_W = 0.083$ ft/ft						
Street Longitudinal Slope - Enter 0 for sump condition	$S_O = 0.010$ ft/ft						
Manning's Roughness for Street Section (typically between 0.012 and 0.020)	$n_{STREET} = 0.013$						
Max. Allowable Spread for Minor & Major Storm	<table border="1"> <thead> <tr> <th>Minor Storm</th> <th>Major Storm</th> <th>ft</th> </tr> </thead> <tbody> <tr> <td>$T_{MAX} = 20.0$</td> <td>$T_{MAX} = 20.0$</td> <td></td> </tr> </tbody> </table>	Minor Storm	Major Storm	ft	$T_{MAX} = 20.0$	$T_{MAX} = 20.0$	
Minor Storm	Major Storm	ft					
$T_{MAX} = 20.0$	$T_{MAX} = 20.0$						
Max. Allowable Depth at Gutter Flowline for Minor & Major Storm	<table border="1"> <thead> <tr> <th>Minor Storm</th> <th>Major Storm</th> <th>inches</th> </tr> </thead> <tbody> <tr> <td>$d_{MAX} = 6.0$</td> <td>$d_{MAX} = 7.5$</td> <td></td> </tr> </tbody> </table>	Minor Storm	Major Storm	inches	$d_{MAX} = 6.0$	$d_{MAX} = 7.5$	
Minor Storm	Major Storm	inches					
$d_{MAX} = 6.0$	$d_{MAX} = 7.5$						
Allow Flow Depth at Street Crown (leave blank for no)	<input type="checkbox"/> <input type="checkbox"/> check = yes						
MINOR STORM Allowable Capacity is based on Depth Criterion							
MAJOR STORM Allowable Capacity is based on Spread Criterion							
Minor storm max. allowable capacity GOOD - greater than the design flow given on sheet 'Inlet Management'	<table border="1"> <thead> <tr> <th>Minor Storm</th> <th>Major Storm</th> <th>cfs</th> </tr> </thead> <tbody> <tr> <td>$Q_{allow} = 17.0$</td> <td>$Q_{allow} = 20.1$</td> <td></td> </tr> </tbody> </table>	Minor Storm	Major Storm	cfs	$Q_{allow} = 17.0$	$Q_{allow} = 20.1$	
Minor Storm	Major Storm	cfs					
$Q_{allow} = 17.0$	$Q_{allow} = 20.1$						
Major storm max. allowable capacity GOOD - greater than the design flow given on sheet 'Inlet Management'							

INLET ON A CONTINUOUS GRADE

Version 4.04 Released November 2016

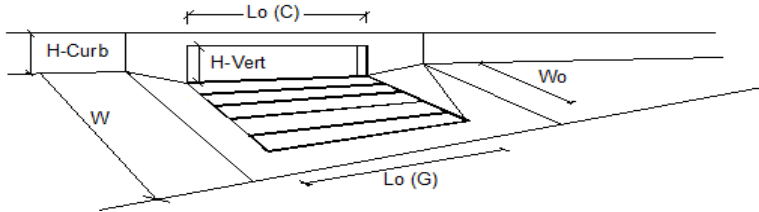

Design Information (Input)	MINOR	MAJOR	
Type of Inlet	CDOT Type R Curb Opening		
Local Depression (additional to continuous gutter depression 'a')	3.0	3.0	inches
Total Number of Units in the Inlet (Grate or Curb Opening)	1	1	
Length of a Single Unit Inlet (Grate or Curb Opening)	10.00	10.00	ft
Width of a Unit Grate (cannot be greater than W, Gutter Width)	N/A	N/A	ft
Clogging Factor for a Single Unit Grate (typical min. value = 0.5)	N/A	N/A	
Clogging Factor for a Single Unit Curb Opening (typical min. value = 0.1)	0.10	0.10	
Street Hydraulics: OK - Q < Allowable Street Capacity			
Total Inlet Interception Capacity	1.0	1.7	cfs
Total Inlet Carry-Over Flow (flow bypassing inlet)	0.0	0.0	cfs
Capture Percentage = Q_i/Q_o =	100	100	%

ALLOWABLE CAPACITY FOR ONE-HALF OF STREET (Minor & Major Storm)

(Based on Regulated Criteria for Maximum Allowable Flow Depth and Spread)

Project: FALCON MARKETPLACE
 Inlet ID: IB8

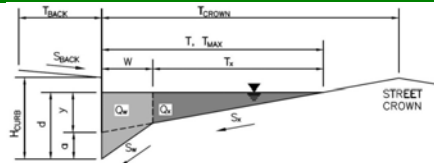

Gutter Geometry (Enter data in the blue cells)							
Maximum Allowable Width for Spread Behind Curb	$T_{BACK} = $ <input style="width: 50px;" type="text" value="7.0"/> ft						
Side Slope Behind Curb (leave blank for no conveyance credit behind curb)	$S_{BACK} = $ <input style="width: 50px;" type="text" value="0.020"/> ft/ft						
Manning's Roughness Behind Curb (typically between 0.012 and 0.020)	$n_{BACK} = $ <input style="width: 50px;" type="text" value="0.020"/>						
Height of Curb at Gutter Flow Line	$H_{CURB} = $ <input style="width: 50px;" type="text" value="6.00"/> inches						
Distance from Curb Face to Street Crown	$T_{CROWN} = $ <input style="width: 50px;" type="text" value="20.0"/> ft						
Gutter Width	$W = $ <input style="width: 50px;" type="text" value="2.00"/> ft						
Street Transverse Slope	$S_X = $ <input style="width: 50px;" type="text" value="0.020"/> ft/ft						
Gutter Cross Slope (typically 2 inches over 24 inches or 0.083 ft/ft)	$S_W = $ <input style="width: 50px;" type="text" value="0.083"/> ft/ft						
Street Longitudinal Slope - Enter 0 for sump condition	$S_O = $ <input style="width: 50px;" type="text" value="0.000"/> ft/ft						
Manning's Roughness for Street Section (typically between 0.012 and 0.020)	$n_{STREET} = $ <input style="width: 50px;" type="text" value="0.013"/>						
Max. Allowable Spread for Minor & Major Storm	<table border="1" style="display: inline-table; border-collapse: collapse;"> <thead> <tr> <th style="width: 50px;">Minor Storm</th> <th style="width: 50px;">Major Storm</th> <th style="width: 20px;">ft</th> </tr> </thead> <tbody> <tr> <td style="text-align: center;">$T_{MAX} =$ <input style="width: 40px;" type="text" value="20.0"/></td> <td style="text-align: center;"><input style="width: 40px;" type="text" value="20.0"/></td> <td></td> </tr> </tbody> </table>	Minor Storm	Major Storm	ft	$T_{MAX} = $ <input style="width: 40px;" type="text" value="20.0"/>	<input style="width: 40px;" type="text" value="20.0"/>	
Minor Storm	Major Storm	ft					
$T_{MAX} = $ <input style="width: 40px;" type="text" value="20.0"/>	<input style="width: 40px;" type="text" value="20.0"/>						
Max. Allowable Depth at Gutter Flowline for Minor & Major Storm	<table border="1" style="display: inline-table; border-collapse: collapse;"> <thead> <tr> <th style="width: 50px;">Minor Storm</th> <th style="width: 50px;">Major Storm</th> <th style="width: 20px;">inches</th> </tr> </thead> <tbody> <tr> <td style="text-align: center;">$d_{MAX} =$ <input style="width: 40px;" type="text" value="6.0"/></td> <td style="text-align: center;"><input style="width: 40px;" type="text" value="7.5"/></td> <td></td> </tr> </tbody> </table>	Minor Storm	Major Storm	inches	$d_{MAX} = $ <input style="width: 40px;" type="text" value="6.0"/>	<input style="width: 40px;" type="text" value="7.5"/>	
Minor Storm	Major Storm	inches					
$d_{MAX} = $ <input style="width: 40px;" type="text" value="6.0"/>	<input style="width: 40px;" type="text" value="7.5"/>						
Allow Flow Depth at Street Crown (leave blank for no)	<input type="checkbox"/> <input type="checkbox"/> check = yes						
MINOR STORM Allowable Capacity is based on Depth Criterion							
MAJOR STORM Allowable Capacity is based on Depth Criterion	<table border="1" style="display: inline-table; border-collapse: collapse;"> <thead> <tr> <th style="width: 50px;">Minor Storm</th> <th style="width: 50px;">Major Storm</th> <th style="width: 20px;">cfs</th> </tr> </thead> <tbody> <tr> <td style="text-align: center;">$Q_{allow} =$ <input style="width: 40px;" type="text" value="SUMP"/></td> <td style="text-align: center;"><input style="width: 40px;" type="text" value="SUMP"/></td> <td></td> </tr> </tbody> </table>	Minor Storm	Major Storm	cfs	$Q_{allow} = $ <input style="width: 40px;" type="text" value="SUMP"/>	<input style="width: 40px;" type="text" value="SUMP"/>	
Minor Storm	Major Storm	cfs					
$Q_{allow} = $ <input style="width: 40px;" type="text" value="SUMP"/>	<input style="width: 40px;" type="text" value="SUMP"/>						

INLET IN A SUMP OR SAG LOCATION

Version 4.04 Released November 2016

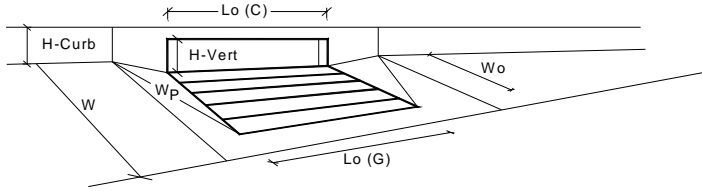

Design Information (Input)	MINOR	MAJOR	
Type of Inlet	CDOT Type R Curb Opening		
Local Depression (additional to continuous gutter depression 'a' from 'Q-Allow')	3.00	3.00	inches
Number of Unit Inlets (Grate or Curb Opening)	1	1	
Water Depth at Flowline (outside of local depression)	6.0	6.3	inches
Grate Information	MINOR	MAJOR	<input type="checkbox"/> Override Depths
Length of a Unit Grate	N/A	N/A	feet
Width of a Unit Grate	N/A	N/A	feet
Area Opening Ratio for a Grate (typical values 0.15-0.90)	N/A	N/A	
Clogging Factor for a Single Grate (typical value 0.50 - 0.70)	N/A	N/A	
Grate Weir Coefficient (typical value 2.15 - 3.60)	N/A	N/A	
Grate Orifice Coefficient (typical value 0.60 - 0.80)	N/A	N/A	
Curb Opening Information	MINOR	MAJOR	
Length of a Unit Curb Opening	10.00	10.00	feet
Height of Vertical Curb Opening in Inches	6.00	6.00	inches
Height of Curb Orifice Throat in Inches	6.00	6.00	inches
Angle of Throat (see USDCM Figure ST-5)	63.40	63.40	degrees
Side Width for Depression Pan (typically the gutter width of 2 feet)	2.00	2.00	feet
Clogging Factor for a Single Curb Opening (typical value 0.10)	0.10	0.10	
Curb Opening Weir Coefficient (typical value 2.3-3.7)	3.60	3.60	
Curb Opening Orifice Coefficient (typical value 0.60 - 0.70)	0.67	0.67	
Low Head Performance Reduction (Calculated)	MINOR	MAJOR	
Depth for Grate Midwidth	N/A	N/A	ft
Depth for Curb Opening Weir Equation	0.33	0.36	ft
Combination Inlet Performance Reduction Factor for Long Inlets	0.57	0.60	
Curb Opening Performance Reduction Factor for Long Inlets	0.93	0.95	
Grated Inlet Performance Reduction Factor for Long Inlets	N/A	N/A	
Total Inlet Interception Capacity (assumes clogged condition)	MINOR	MAJOR	
Q_a	8.3	9.4	cfs
Q_{PEAK REQUIRED}	2.1	6.4	cfs

Inlet Capacity IS GOOD for Minor and Major Storms(>Q PEAK)

ALLOWABLE CAPACITY FOR ONE-HALF OF STREET (Minor & Major Storm)

(Based on Regulated Criteria for Maximum Allowable Flow Depth and Spread)

Project: FALCON MARKETPLACE
 Inlet ID: IB9

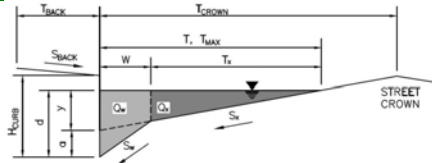

Gutter Geometry (Enter data in the blue cells)													
Maximum Allowable Width for Spread Behind Curb	$T_{BACK} = $ <input style="width: 50px;" type="text" value="7.0"/> ft												
Side Slope Behind Curb (leave blank for no conveyance credit behind curb)	$S_{BACK} = $ <input style="width: 50px;" type="text" value="0.020"/> ft/ft												
Manning's Roughness Behind Curb (typically between 0.012 and 0.020)	$n_{BACK} = $ <input style="width: 50px;" type="text" value="0.020"/>												
Height of Curb at Gutter Flow Line	$H_{CURB} = $ <input style="width: 50px;" type="text" value="6.00"/> inches												
Distance from Curb Face to Street Crown	$T_{CROWN} = $ <input style="width: 50px;" type="text" value="20.0"/> ft												
Gutter Width	$W = $ <input style="width: 50px;" type="text" value="2.00"/> ft												
Street Transverse Slope	$S_X = $ <input style="width: 50px;" type="text" value="0.020"/> ft/ft												
Gutter Cross Slope (typically 2 inches over 24 inches or 0.083 ft/ft)	$S_W = $ <input style="width: 50px;" type="text" value="0.083"/> ft/ft												
Street Longitudinal Slope - Enter 0 for sump condition	$S_O = $ <input style="width: 50px;" type="text" value="0.000"/> ft/ft												
Manning's Roughness for Street Section (typically between 0.012 and 0.020)	$n_{STREET} = $ <input style="width: 50px;" type="text" value="0.013"/>												
Max. Allowable Spread for Minor & Major Storm	<table style="width: 100%; border-collapse: collapse;"> <tr> <th style="width: 50%;"></th> <th style="width: 25%; text-align: center;">Minor Storm</th> <th style="width: 25%; text-align: center;">Major Storm</th> <th style="width: 10%;"></th> </tr> <tr> <td style="padding: 5px;">$T_{MAX} =$</td> <td style="text-align: center;"><input style="width: 50px;" type="text" value="20.0"/></td> <td style="text-align: center;"><input style="width: 50px;" type="text" value="20.0"/></td> <td style="text-align: right;">ft</td> </tr> <tr> <td style="padding: 5px;">$d_{MAX} =$</td> <td style="text-align: center;"><input style="width: 50px;" type="text" value="6.0"/></td> <td style="text-align: center;"><input style="width: 50px;" type="text" value="7.5"/></td> <td style="text-align: right;">inches</td> </tr> </table>		Minor Storm	Major Storm		$T_{MAX} = $	<input style="width: 50px;" type="text" value="20.0"/>	<input style="width: 50px;" type="text" value="20.0"/>	ft	$d_{MAX} = $	<input style="width: 50px;" type="text" value="6.0"/>	<input style="width: 50px;" type="text" value="7.5"/>	inches
	Minor Storm	Major Storm											
$T_{MAX} = $	<input style="width: 50px;" type="text" value="20.0"/>	<input style="width: 50px;" type="text" value="20.0"/>	ft										
$d_{MAX} = $	<input style="width: 50px;" type="text" value="6.0"/>	<input style="width: 50px;" type="text" value="7.5"/>	inches										
Max. Allowable Depth at Gutter Flowline for Minor & Major Storm													
Allow Flow Depth at Street Crown (leave blank for no)	<table style="width: 100%; border-collapse: collapse;"> <tr> <td style="width: 50%; text-align: center;"><input type="checkbox"/></td> <td style="width: 50%; text-align: center;"><input type="checkbox"/></td> <td style="text-align: right;">check = yes</td> </tr> </table>	<input type="checkbox"/>	<input type="checkbox"/>	check = yes									
<input type="checkbox"/>	<input type="checkbox"/>	check = yes											
MINOR STORM Allowable Capacity is based on Depth Criterion													
MAJOR STORM Allowable Capacity is based on Depth Criterion	<table style="width: 100%; border-collapse: collapse;"> <tr> <th style="width: 50%;"></th> <th style="width: 25%; text-align: center;">Minor Storm</th> <th style="width: 25%; text-align: center;">Major Storm</th> <th style="width: 10%;"></th> </tr> <tr> <td style="padding: 5px;">$Q_{allow} =$</td> <td style="text-align: center;"><input style="width: 50px;" type="text" value="SUMP"/></td> <td style="text-align: center;"><input style="width: 50px;" type="text" value="SUMP"/></td> <td style="text-align: right;">cfs</td> </tr> </table>		Minor Storm	Major Storm		$Q_{allow} = $	<input style="width: 50px;" type="text" value="SUMP"/>	<input style="width: 50px;" type="text" value="SUMP"/>	cfs				
	Minor Storm	Major Storm											
$Q_{allow} = $	<input style="width: 50px;" type="text" value="SUMP"/>	<input style="width: 50px;" type="text" value="SUMP"/>	cfs										

INLET IN A SUMP OR SAG LOCATION

Version 4.04 Released November 2016

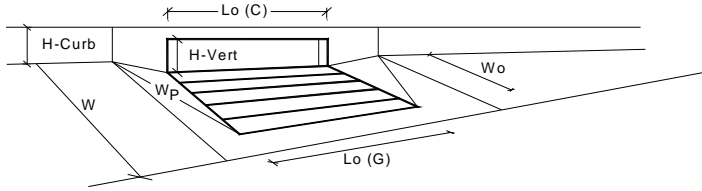

Design Information (Input)	MINOR	MAJOR	
Type of Inlet	CDOT Type R Curb Opening		
Local Depression (additional to continuous gutter depression 'a' from 'Q-Allow')	3.00	3.00	inches
Number of Unit Inlets (Grate or Curb Opening)	1	1	
Water Depth at Flowline (outside of local depression)	6.0	6.3	inches
Grate Information	MINOR	MAJOR	<input type="checkbox"/> Override Depths
Length of a Unit Grate	N/A	N/A	feet
Width of a Unit Grate	N/A	N/A	feet
Area Opening Ratio for a Grate (typical values 0.15-0.90)	N/A	N/A	
Clogging Factor for a Single Grate (typical value 0.50 - 0.70)	N/A	N/A	
Grate Weir Coefficient (typical value 2.15 - 3.60)	N/A	N/A	
Grate Orifice Coefficient (typical value 0.60 - 0.80)	N/A	N/A	
Curb Opening Information	MINOR	MAJOR	
Length of a Unit Curb Opening	10.00	10.00	feet
Height of Vertical Curb Opening in Inches	6.00	6.00	inches
Height of Curb Orifice Throat in Inches	6.00	6.00	inches
Angle of Throat (see USDCM Figure ST-5)	63.40	63.40	degrees
Side Width for Depression Pan (typically the gutter width of 2 feet)	2.00	2.00	feet
Clogging Factor for a Single Curb Opening (typical value 0.10)	0.10	0.10	
Curb Opening Weir Coefficient (typical value 2.3-3.7)	3.60	3.60	
Curb Opening Orifice Coefficient (typical value 0.60 - 0.70)	0.67	0.67	
Low Head Performance Reduction (Calculated)	MINOR	MAJOR	
Depth for Grate Midwidth	N/A	N/A	ft
Depth for Curb Opening Weir Equation	0.33	0.36	ft
Combination Inlet Performance Reduction Factor for Long Inlets	0.57	0.60	
Curb Opening Performance Reduction Factor for Long Inlets	0.93	0.95	
Grated Inlet Performance Reduction Factor for Long Inlets	N/A	N/A	
Total Inlet Interception Capacity (assumes clogged condition)	MINOR	MAJOR	
Q_a	8.3	9.4	cfs
Q _{PEAK REQUIRED}	1.5	2.6	cfs

Inlet Capacity IS GOOD for Minor and Major Storms(>Q PEAK)

ALLOWABLE CAPACITY FOR ONE-HALF OF STREET (Minor & Major Storm)

(Based on Regulated Criteria for Maximum Allowable Flow Depth and Spread)

Project: FALCON MARKETPLACE
 Inlet ID: IB10

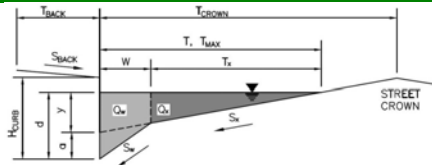

Gutter Geometry (Enter data in the blue cells)							
Maximum Allowable Width for Spread Behind Curb	$T_{BACK} = 10.0$ ft						
Side Slope Behind Curb (leave blank for no conveyance credit behind curb)	$S_{BACK} = 0.020$ ft/ft						
Manning's Roughness Behind Curb (typically between 0.012 and 0.020)	$n_{BACK} = 0.020$						
Height of Curb at Gutter Flow Line	$H_{CURB} = 6.00$ inches						
Distance from Curb Face to Street Crown	$T_{CROWN} = 24.0$ ft						
Gutter Width	$W = 2.00$ ft						
Street Transverse Slope	$S_X = 0.020$ ft/ft						
Gutter Cross Slope (typically 2 inches over 24 inches or 0.083 ft/ft)	$S_W = 0.083$ ft/ft						
Street Longitudinal Slope - Enter 0 for sump condition	$S_O = 0.010$ ft/ft						
Manning's Roughness for Street Section (typically between 0.012 and 0.020)	$n_{STREET} = 0.013$						
Max. Allowable Spread for Minor & Major Storm	<table border="1"> <thead> <tr> <th>Minor Storm</th> <th>Major Storm</th> <th>ft</th> </tr> </thead> <tbody> <tr> <td>24.0</td> <td>24.0</td> <td></td> </tr> </tbody> </table>	Minor Storm	Major Storm	ft	24.0	24.0	
Minor Storm	Major Storm	ft					
24.0	24.0						
Max. Allowable Depth at Gutter Flowline for Minor & Major Storm	<table border="1"> <thead> <tr> <th>Minor Storm</th> <th>Major Storm</th> <th>inches</th> </tr> </thead> <tbody> <tr> <td>6.0</td> <td>8.0</td> <td></td> </tr> </tbody> </table>	Minor Storm	Major Storm	inches	6.0	8.0	
Minor Storm	Major Storm	inches					
6.0	8.0						
Allow Flow Depth at Street Crown (leave blank for no)	<table border="1"> <thead> <tr> <th>Minor Storm</th> <th>Major Storm</th> <th>check = yes</th> </tr> </thead> <tbody> <tr> <td><input type="checkbox"/></td> <td><input type="checkbox"/></td> <td></td> </tr> </tbody> </table>	Minor Storm	Major Storm	check = yes	<input type="checkbox"/>	<input type="checkbox"/>	
Minor Storm	Major Storm	check = yes					
<input type="checkbox"/>	<input type="checkbox"/>						
MINOR STORM Allowable Capacity is based on Depth Criterion							
MAJOR STORM Allowable Capacity is based on Spread Criterion							
Minor storm max. allowable capacity GOOD - greater than the design flow given on sheet 'Inlet Management'	<table border="1"> <thead> <tr> <th>Minor Storm</th> <th>Major Storm</th> <th>cfs</th> </tr> </thead> <tbody> <tr> <td>17.0</td> <td>32.3</td> <td></td> </tr> </tbody> </table>	Minor Storm	Major Storm	cfs	17.0	32.3	
Minor Storm	Major Storm	cfs					
17.0	32.3						
Major storm max. allowable capacity GOOD - greater than the design flow given on sheet 'Inlet Management'							

INLET ON A CONTINUOUS GRADE

Version 4.04 Released November 2016

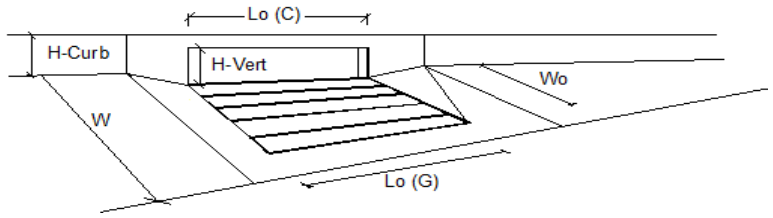

Design Information (Input)	MINOR	MAJOR	
Type of Inlet	CDOT Type R Curb Opening		
Local Depression (additional to continuous gutter depression 'a')	3.0	3.0	inches
Total Number of Units in the Inlet (Grate or Curb Opening)	1	1	
Length of a Single Unit Inlet (Grate or Curb Opening)	10.00	10.00	ft
Width of a Unit Grate (cannot be greater than W, Gutter Width)	N/A	N/A	ft
Clogging Factor for a Single Unit Grate (typical min. value = 0.5)	N/A	N/A	
Clogging Factor for a Single Unit Curb Opening (typical min. value = 0.1)	0.10	0.10	
Street Hydraulics: OK - Q < Allowable Street Capacity			
Total Inlet Interception Capacity	4.1	6.2	cfs
Total Inlet Carry-Over Flow (flow bypassing inlet)	0.2	2.3	cfs
Capture Percentage = Q_i/Q_o =	95	73	%

ALLOWABLE CAPACITY FOR ONE-HALF OF STREET (Minor & Major Storm)

(Based on Regulated Criteria for Maximum Allowable Flow Depth and Spread)

Project: FALCON MARKETPLACE
 Inlet ID: IA1

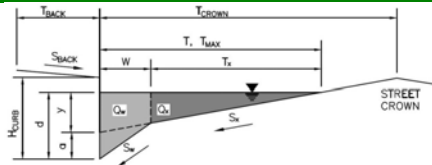

Gutter Geometry (Enter data in the blue cells)							
Maximum Allowable Width for Spread Behind Curb	$T_{BACK} = 10.0$ ft						
Side Slope Behind Curb (leave blank for no conveyance credit behind curb)	$S_{BACK} = 0.020$ ft/ft						
Manning's Roughness Behind Curb (typically between 0.012 and 0.020)	$n_{BACK} = 0.020$						
Height of Curb at Gutter Flow Line	$H_{CURB} = 6.00$ inches						
Distance from Curb Face to Street Crown	$T_{CROWN} = 24.0$ ft						
Gutter Width	$W = 2.00$ ft						
Street Transverse Slope	$S_x = 0.020$ ft/ft						
Gutter Cross Slope (typically 2 inches over 24 inches or 0.083 ft/ft)	$S_w = 0.083$ ft/ft						
Street Longitudinal Slope - Enter 0 for sump condition	$S_o = 0.010$ ft/ft						
Manning's Roughness for Street Section (typically between 0.012 and 0.020)	$n_{STREET} = 0.013$						
Max. Allowable Spread for Minor & Major Storm	<table border="1"> <tr> <th>Minor Storm</th> <th>Major Storm</th> <th>ft</th> </tr> <tr> <td>$T_{MAX} = 24.0$</td> <td>$T_{MAX} = 24.0$</td> <td></td> </tr> </table>	Minor Storm	Major Storm	ft	$T_{MAX} = 24.0$	$T_{MAX} = 24.0$	
Minor Storm	Major Storm	ft					
$T_{MAX} = 24.0$	$T_{MAX} = 24.0$						
Max. Allowable Depth at Gutter Flowline for Minor & Major Storm	<table border="1"> <tr> <th>Minor Storm</th> <th>Major Storm</th> <th>inches</th> </tr> <tr> <td>$d_{MAX} = 6.0$</td> <td>$d_{MAX} = 8.0$</td> <td></td> </tr> </table>	Minor Storm	Major Storm	inches	$d_{MAX} = 6.0$	$d_{MAX} = 8.0$	
Minor Storm	Major Storm	inches					
$d_{MAX} = 6.0$	$d_{MAX} = 8.0$						
Allow Flow Depth at Street Crown (leave blank for no)	<table border="1"> <tr> <td><input type="checkbox"/></td> <td><input type="checkbox"/></td> <td>check = yes</td> </tr> </table>	<input type="checkbox"/>	<input type="checkbox"/>	check = yes			
<input type="checkbox"/>	<input type="checkbox"/>	check = yes					
MINOR STORM Allowable Capacity is based on Depth Criterion							
MAJOR STORM Allowable Capacity is based on Spread Criterion							
Minor storm max. allowable capacity GOOD - greater than the design flow given on sheet 'Inlet Management'	<table border="1"> <tr> <th>Minor Storm</th> <th>Major Storm</th> <th>cfs</th> </tr> <tr> <td>$Q_{allow} = 17.0$</td> <td>$Q_{allow} = 32.3$</td> <td></td> </tr> </table>	Minor Storm	Major Storm	cfs	$Q_{allow} = 17.0$	$Q_{allow} = 32.3$	
Minor Storm	Major Storm	cfs					
$Q_{allow} = 17.0$	$Q_{allow} = 32.3$						
Major storm max. allowable capacity GOOD - greater than the design flow given on sheet 'Inlet Management'							

INLET ON A CONTINUOUS GRADE

Version 4.04 Released November 2016

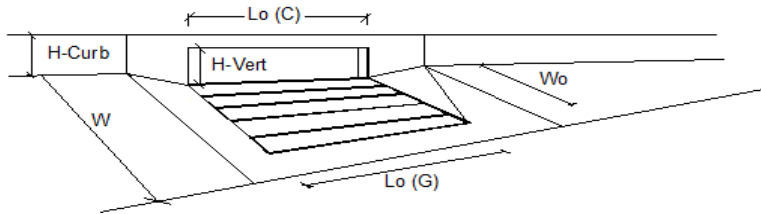

Design Information (Input)	MINOR	MAJOR	
Type of Inlet	CDOT Type R Curb Opening		
Local Depression (additional to continuous gutter depression 'a')	3.0	3.0	inches
Total Number of Units in the Inlet (Grate or Curb Opening)	1	1	
Length of a Single Unit Inlet (Grate or Curb Opening)	10.00	10.00	ft
Width of a Unit Grate (cannot be greater than W, Gutter Width)	N/A	N/A	ft
Clogging Factor for a Single Unit Grate (typical min. value = 0.5)	N/A	N/A	
Clogging Factor for a Single Unit Curb Opening (typical min. value = 0.1)	0.10	0.10	
Street Hydraulics: OK - Q < Allowable Street Capacity*			
Total Inlet Interception Capacity	2.4	4.7	cfs
Total Inlet Carry-Over Flow (flow bypassing inlet)	0.0	0.6	cfs
Capture Percentage = Q_i/Q_o =	100	89	%

ALLOWABLE CAPACITY FOR ONE-HALF OF STREET (Minor & Major Storm)

(Based on Regulated Criteria for Maximum Allowable Flow Depth and Spread)

Project: FALCON MARKETPLACE
 Inlet ID: IA2

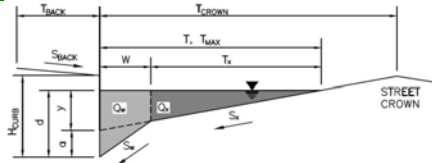

Gutter Geometry (Enter data in the blue cells)							
Maximum Allowable Width for Spread Behind Curb	$T_{BACK} = 5.0$ ft						
Side Slope Behind Curb (leave blank for no conveyance credit behind curb)	$S_{BACK} = 0.020$ ft/ft						
Manning's Roughness Behind Curb (typically between 0.012 and 0.020)	$n_{BACK} = 0.020$						
Height of Curb at Gutter Flow Line	$H_{CURB} = 6.00$ inches						
Distance from Curb Face to Street Crown	$T_{CROWN} = 28.0$ ft						
Gutter Width	$W = 2.00$ ft						
Street Transverse Slope	$S_X = 0.020$ ft/ft						
Gutter Cross Slope (typically 2 inches over 24 inches or 0.083 ft/ft)	$S_W = 0.083$ ft/ft						
Street Longitudinal Slope - Enter 0 for sump condition	$S_O = 0.000$ ft/ft						
Manning's Roughness for Street Section (typically between 0.012 and 0.020)	$n_{STREET} = 0.013$						
Max. Allowable Spread for Minor & Major Storm	<table border="1"> <tr> <th>Minor Storm</th> <th>Major Storm</th> <th>ft</th> </tr> <tr> <td>$T_{MAX} = 28.0$</td> <td>$T_{MAX} = 28.0$</td> <td></td> </tr> </table>	Minor Storm	Major Storm	ft	$T_{MAX} = 28.0$	$T_{MAX} = 28.0$	
Minor Storm	Major Storm	ft					
$T_{MAX} = 28.0$	$T_{MAX} = 28.0$						
Max. Allowable Depth at Gutter Flowline for Minor & Major Storm	<table border="1"> <tr> <th>Minor Storm</th> <th>Major Storm</th> <th>inches</th> </tr> <tr> <td>$d_{MAX} = 6.0$</td> <td>$d_{MAX} = 7.5$</td> <td></td> </tr> </table>	Minor Storm	Major Storm	inches	$d_{MAX} = 6.0$	$d_{MAX} = 7.5$	
Minor Storm	Major Storm	inches					
$d_{MAX} = 6.0$	$d_{MAX} = 7.5$						
Allow Flow Depth at Street Crown (leave blank for no)	<input type="checkbox"/> <input type="checkbox"/> check = yes						
MINOR STORM Allowable Capacity is based on Depth Criterion							
MAJOR STORM Allowable Capacity is based on Depth Criterion							
	<table border="1"> <tr> <th>Minor Storm</th> <th>Major Storm</th> <th>cfs</th> </tr> <tr> <td>$Q_{allow} = \text{SUMP}$</td> <td>$Q_{allow} = \text{SUMP}$</td> <td></td> </tr> </table>	Minor Storm	Major Storm	cfs	$Q_{allow} = \text{SUMP}$	$Q_{allow} = \text{SUMP}$	
Minor Storm	Major Storm	cfs					
$Q_{allow} = \text{SUMP}$	$Q_{allow} = \text{SUMP}$						

INLET IN A SUMP OR SAG LOCATION

Version 4.04 Released November 2016

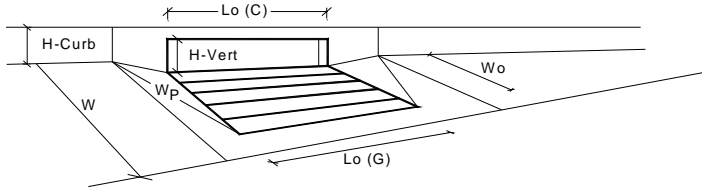

Design Information (Input)	MINOR	MAJOR	
Type of Inlet	CDOT Type R Curb Opening		
Local Depression (additional to continuous gutter depression 'a' from 'Q-Allow')	3.00	3.00	inches
Number of Unit Inlets (Grate or Curb Opening)	1	1	
Water Depth at Flowline (outside of local depression)	6.0	7.5	inches
Grate Information	MINOR	MAJOR	<input type="checkbox"/> Override Depths
Length of a Unit Grate	N/A	N/A	feet
Width of a Unit Grate	N/A	N/A	feet
Area Opening Ratio for a Grate (typical values 0.15-0.90)	N/A	N/A	
Clogging Factor for a Single Grate (typical value 0.50 - 0.70)	N/A	N/A	
Grate Weir Coefficient (typical value 2.15 - 3.60)	N/A	N/A	
Grate Orifice Coefficient (typical value 0.60 - 0.80)	N/A	N/A	
Curb Opening Information	MINOR	MAJOR	
Length of a Unit Curb Opening	10.00	10.00	feet
Height of Vertical Curb Opening in Inches	6.00	6.00	inches
Height of Curb Orifice Throat in Inches	6.00	6.00	inches
Angle of Throat (see USDCM Figure ST-5)	63.40	63.40	degrees
Side Width for Depression Pan (typically the gutter width of 2 feet)	2.00	2.00	feet
Clogging Factor for a Single Curb Opening (typical value 0.10)	0.10	0.10	
Curb Opening Weir Coefficient (typical value 2.3-3.7)	3.60	3.60	
Curb Opening Orifice Coefficient (typical value 0.60 - 0.70)	0.67	0.67	
Low Head Performance Reduction (Calculated)	MINOR	MAJOR	
Depth for Grate Midwidth	N/A	N/A	ft
Depth for Curb Opening Weir Equation	0.33	0.46	ft
Combination Inlet Performance Reduction Factor for Long Inlets	0.57	0.71	
Curb Opening Performance Reduction Factor for Long Inlets	0.93	1.00	
Grated Inlet Performance Reduction Factor for Long Inlets	N/A	N/A	
Total Inlet Interception Capacity (assumes clogged condition)	MINOR	MAJOR	
Q_a	8.3	14.3	cfs
Q _{PEAK REQUIRED}	2.0	4.6	cfs

Inlet Capacity IS GOOD for Minor and Major Storms(>Q PEAK)

ALLOWABLE CAPACITY FOR ONE-HALF OF STREET (Minor & Major Storm)

(Based on Regulated Criteria for Maximum Allowable Flow Depth and Spread)

Project: FALCON MARKETPLACE
 Inlet ID: IC1

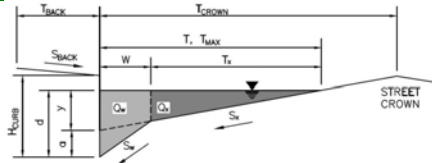

Gutter Geometry (Enter data in the blue cells)							
Maximum Allowable Width for Spread Behind Curb	$T_{BACK} = $ <input style="width: 60px;" type="text" value="10.0"/> ft						
Side Slope Behind Curb (leave blank for no conveyance credit behind curb)	$S_{BACK} = $ <input style="width: 60px;" type="text" value="0.200"/> ft/ft						
Manning's Roughness Behind Curb (typically between 0.012 and 0.020)	$n_{BACK} = $ <input style="width: 60px;" type="text" value="0.020"/>						
Height of Curb at Gutter Flow Line	$H_{CURB} = $ <input style="width: 60px;" type="text" value="6.00"/> inches						
Distance from Curb Face to Street Crown	$T_{CROWN} = $ <input style="width: 60px;" type="text" value="20.0"/> ft						
Gutter Width	$W = $ <input style="width: 60px;" type="text" value="2.00"/> ft						
Street Transverse Slope	$S_X = $ <input style="width: 60px;" type="text" value="0.020"/> ft/ft						
Gutter Cross Slope (typically 2 inches over 24 inches or 0.083 ft/ft)	$S_W = $ <input style="width: 60px;" type="text" value="0.083"/> ft/ft						
Street Longitudinal Slope - Enter 0 for sump condition	$S_O = $ <input style="width: 60px;" type="text" value="0.000"/> ft/ft						
Manning's Roughness for Street Section (typically between 0.012 and 0.020)	$n_{STREET} = $ <input style="width: 60px;" type="text" value="0.013"/>						
Max. Allowable Spread for Minor & Major Storm	<table style="width: 100%; border-collapse: collapse;"> <tr> <td style="text-align: center; border-bottom: 1px solid black;">Minor Storm</td> <td style="text-align: center; border-bottom: 1px solid black;">Major Storm</td> <td></td> </tr> <tr> <td style="border: 1px solid black;">$T_{MAX} =$ <input style="width: 60px;" type="text" value="20.0"/></td> <td style="border: 1px solid black;"><input style="width: 60px;" type="text" value="20.0"/></td> <td style="text-align: right;">ft</td> </tr> </table>	Minor Storm	Major Storm		$T_{MAX} = $ <input style="width: 60px;" type="text" value="20.0"/>	<input style="width: 60px;" type="text" value="20.0"/>	ft
Minor Storm	Major Storm						
$T_{MAX} = $ <input style="width: 60px;" type="text" value="20.0"/>	<input style="width: 60px;" type="text" value="20.0"/>	ft					
Max. Allowable Depth at Gutter Flowline for Minor & Major Storm	<table style="width: 100%; border-collapse: collapse;"> <tr> <td style="text-align: center; border-bottom: 1px solid black;">Minor Storm</td> <td style="text-align: center; border-bottom: 1px solid black;">Major Storm</td> <td></td> </tr> <tr> <td style="border: 1px solid black;">$d_{MAX} =$ <input style="width: 60px;" type="text" value="6.0"/></td> <td style="border: 1px solid black;"><input style="width: 60px;" type="text" value="8.0"/></td> <td style="text-align: right;">inches</td> </tr> </table>	Minor Storm	Major Storm		$d_{MAX} = $ <input style="width: 60px;" type="text" value="6.0"/>	<input style="width: 60px;" type="text" value="8.0"/>	inches
Minor Storm	Major Storm						
$d_{MAX} = $ <input style="width: 60px;" type="text" value="6.0"/>	<input style="width: 60px;" type="text" value="8.0"/>	inches					
Allow Flow Depth at Street Crown (leave blank for no)	<table style="width: 100%; border-collapse: collapse;"> <tr> <td style="text-align: center; border-bottom: 1px solid black;">Minor Storm</td> <td style="text-align: center; border-bottom: 1px solid black;">Major Storm</td> <td></td> </tr> <tr> <td style="border: 1px solid black;"><input type="checkbox"/></td> <td style="border: 1px solid black;"><input type="checkbox"/></td> <td style="text-align: right;">check = yes</td> </tr> </table>	Minor Storm	Major Storm		<input type="checkbox"/>	<input type="checkbox"/>	check = yes
Minor Storm	Major Storm						
<input type="checkbox"/>	<input type="checkbox"/>	check = yes					
MINOR STORM Allowable Capacity is based on Depth Criterion	$Q_{allow} = $ <input style="width: 60px;" type="text" value="SUMP"/>						
MAJOR STORM Allowable Capacity is based on Depth Criterion	<input style="width: 60px;" type="text" value="SUMP"/> cfs						

INLET IN A SUMP OR SAG LOCATION

Version 4.04 Released November 2016

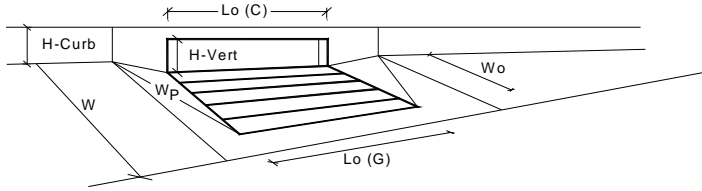

Design Information (Input)	CDOT Type R Curb Opening	
Type of Inlet	Type = CDOT Type R Curb Opening	
Local Depression (additional to continuous gutter depression 'a' from 'Q-Allow')	$a_{local} = 3.00$	3.00 inches
Number of Unit Inlets (Grate or Curb Opening)	No = 1	1
Water Depth at Flowline (outside of local depression)	Ponding Depth = 6.0	7.5 inches
Grate Information	MINOR	MAJOR <input checked="" type="checkbox"/> Override Depths
Length of a Unit Grate	$L_o (G) = N/A$	N/A feet
Width of a Unit Grate	$W_o = N/A$	N/A feet
Area Opening Ratio for a Grate (typical values 0.15-0.90)	$A_{ratio} = N/A$	N/A
Clogging Factor for a Single Grate (typical value 0.50 - 0.70)	$C_l (G) = N/A$	N/A
Grate Weir Coefficient (typical value 2.15 - 3.60)	$C_w (G) = N/A$	N/A
Grate Orifice Coefficient (typical value 0.60 - 0.80)	$C_o (G) = N/A$	N/A
Curb Opening Information	MINOR	MAJOR
Length of a Unit Curb Opening	$L_o (C) = 15.00$	15.00 feet
Height of Vertical Curb Opening in Inches	$H_{vert} = 6.00$	6.00 inches
Height of Curb Orifice Throat in Inches	$H_{throat} = 6.00$	6.00 inches
Angle of Throat (see USDCM Figure ST-5)	$\theta = 63.40$	63.40 degrees
Side Width for Depression Pan (typically the gutter width of 2 feet)	$W_p = 2.00$	2.00 feet
Clogging Factor for a Single Curb Opening (typical value 0.10)	$C_l (C) = 0.10$	0.10
Curb Opening Weir Coefficient (typical value 2.3-3.7)	$C_w (C) = 3.60$	3.60
Curb Opening Orifice Coefficient (typical value 0.60 - 0.70)	$C_o (C) = 0.67$	0.67
Low Head Performance Reduction (Calculated)	MINOR	MAJOR
Depth for Grate Midwidth	$d_{grate} = N/A$	N/A ft
Depth for Curb Opening Weir Equation	$d_{curb} = 0.33$	0.46 ft
Combination Inlet Performance Reduction Factor for Long Inlets	$RF_{Combination} = 0.57$	0.71
Curb Opening Performance Reduction Factor for Long Inlets	$RF_{Curb} = 0.79$	0.87
Grated Inlet Performance Reduction Factor for Long Inlets	$RF_{Grate} = N/A$	N/A
Total Inlet Interception Capacity (assumes clogged condition)	MINOR	MAJOR
	$Q_a = 9.7$	17.3 cfs
WARNING: Inlet Capacity less than Q Peak for Major Storm	$Q_{PEAK REQUIRED} = 9.3$	20.6 cfs

ALLOWABLE CAPACITY FOR ONE-HALF OF STREET (Minor & Major Storm)

(Based on Regulated Criteria for Maximum Allowable Flow Depth and Spread)

Project: FALCON MARKETPLACE
 Inlet ID: IC2

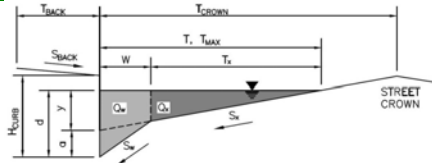

Gutter Geometry (Enter data in the blue cells)													
Maximum Allowable Width for Spread Behind Curb	T _{BACK} = <input style="width: 50px;" type="text" value="7.0"/> ft												
Side Slope Behind Curb (leave blank for no conveyance credit behind curb)	S _{BACK} = <input style="width: 50px;" type="text" value="0.020"/> ft/ft												
Manning's Roughness Behind Curb (typically between 0.012 and 0.020)	n _{BACK} = <input style="width: 50px;" type="text" value="0.020"/>												
Height of Curb at Gutter Flow Line	H _{CURB} = <input style="width: 50px;" type="text" value="6.00"/> inches												
Distance from Curb Face to Street Crown	T _{CROWN} = <input style="width: 50px;" type="text" value="20.0"/> ft												
Gutter Width	W = <input style="width: 50px;" type="text" value="2.00"/> ft												
Street Transverse Slope	S _X = <input style="width: 50px;" type="text" value="0.020"/> ft/ft												
Gutter Cross Slope (typically 2 inches over 24 inches or 0.083 ft/ft)	S _W = <input style="width: 50px;" type="text" value="0.083"/> ft/ft												
Street Longitudinal Slope - Enter 0 for sump condition	S _O = <input style="width: 50px;" type="text" value="0.000"/> ft/ft												
Manning's Roughness for Street Section (typically between 0.012 and 0.020)	n _{STREET} = <input style="width: 50px;" type="text" value="0.013"/>												
Max. Allowable Spread for Minor & Major Storm	<table border="1" style="display: inline-table; border-collapse: collapse;"> <thead> <tr> <th style="width: 50px;"></th> <th style="width: 50px; text-align: center;">Minor Storm</th> <th style="width: 50px; text-align: center;">Major Storm</th> <th style="width: 20px;"></th> </tr> </thead> <tbody> <tr> <td>T_{MAX} =</td> <td style="text-align: center;"><input style="width: 40px;" type="text" value="20.0"/></td> <td style="text-align: center;"><input style="width: 40px;" type="text" value="20.0"/></td> <td style="text-align: right;">ft</td> </tr> <tr> <td>d_{MAX} =</td> <td style="text-align: center;"><input style="width: 40px;" type="text" value="6.0"/></td> <td style="text-align: center;"><input style="width: 40px;" type="text" value="7.5"/></td> <td style="text-align: right;">inches</td> </tr> </tbody> </table>		Minor Storm	Major Storm		T _{MAX} =	<input style="width: 40px;" type="text" value="20.0"/>	<input style="width: 40px;" type="text" value="20.0"/>	ft	d _{MAX} =	<input style="width: 40px;" type="text" value="6.0"/>	<input style="width: 40px;" type="text" value="7.5"/>	inches
	Minor Storm	Major Storm											
T _{MAX} =	<input style="width: 40px;" type="text" value="20.0"/>	<input style="width: 40px;" type="text" value="20.0"/>	ft										
d _{MAX} =	<input style="width: 40px;" type="text" value="6.0"/>	<input style="width: 40px;" type="text" value="7.5"/>	inches										
Max. Allowable Depth at Gutter Flowline for Minor & Major Storm	<table border="1" style="display: inline-table; border-collapse: collapse;"> <thead> <tr> <th style="width: 50px;"></th> <th style="width: 50px; text-align: center;">Minor Storm</th> <th style="width: 50px; text-align: center;">Major Storm</th> <th style="width: 20px;"></th> </tr> </thead> <tbody> <tr> <td>d_{MAX} =</td> <td style="text-align: center;"><input style="width: 40px;" type="text" value="6.0"/></td> <td style="text-align: center;"><input style="width: 40px;" type="text" value="7.5"/></td> <td style="text-align: right;">inches</td> </tr> </tbody> </table>		Minor Storm	Major Storm		d _{MAX} =	<input style="width: 40px;" type="text" value="6.0"/>	<input style="width: 40px;" type="text" value="7.5"/>	inches				
	Minor Storm	Major Storm											
d _{MAX} =	<input style="width: 40px;" type="text" value="6.0"/>	<input style="width: 40px;" type="text" value="7.5"/>	inches										
Allow Flow Depth at Street Crown (leave blank for no)	<input type="checkbox"/> <input type="checkbox"/> check = yes												
MINOR STORM Allowable Capacity is based on Depth Criterion	<table border="1" style="display: inline-table; border-collapse: collapse;"> <thead> <tr> <th style="width: 50px;"></th> <th style="width: 50px; text-align: center;">Minor Storm</th> <th style="width: 50px; text-align: center;">Major Storm</th> <th style="width: 20px;"></th> </tr> </thead> <tbody> <tr> <td>Q_{allow} =</td> <td style="text-align: center;"><input style="width: 40px;" type="text" value="SUMP"/></td> <td style="text-align: center;"><input style="width: 40px;" type="text" value="SUMP"/></td> <td style="text-align: right;">cfs</td> </tr> </tbody> </table>		Minor Storm	Major Storm		Q _{allow} =	<input style="width: 40px;" type="text" value="SUMP"/>	<input style="width: 40px;" type="text" value="SUMP"/>	cfs				
	Minor Storm	Major Storm											
Q _{allow} =	<input style="width: 40px;" type="text" value="SUMP"/>	<input style="width: 40px;" type="text" value="SUMP"/>	cfs										
MAJOR STORM Allowable Capacity is based on Depth Criterion													

INLET IN A SUMP OR SAG LOCATION

Version 4.04 Released November 2016

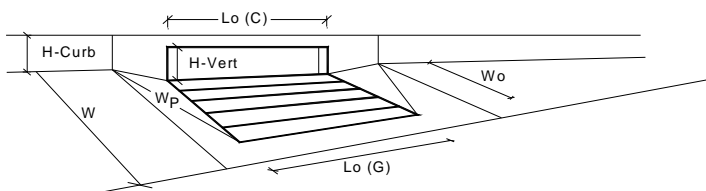

Design Information (Input)	MINOR	MAJOR	
Type of Inlet	CDOT Type R Curb Opening		
Local Depression (additional to continuous gutter depression 'a' from 'Q-Allow')	3.00	3.00	inches
Number of Unit Inlets (Grate or Curb Opening)	1	1	
Water Depth at Flowline (outside of local depression)	6.0	6.3	inches
Grate Information	MINOR	MAJOR	<input type="checkbox"/> Override Depths
Length of a Unit Grate	N/A	N/A	feet
Width of a Unit Grate	N/A	N/A	feet
Area Opening Ratio for a Grate (typical values 0.15-0.90)	N/A	N/A	
Clogging Factor for a Single Grate (typical value 0.50 - 0.70)	N/A	N/A	
Grate Weir Coefficient (typical value 2.15 - 3.60)	N/A	N/A	
Grate Orifice Coefficient (typical value 0.60 - 0.80)	N/A	N/A	
Curb Opening Information	MINOR	MAJOR	
Length of a Unit Curb Opening	10.00	10.00	feet
Height of Vertical Curb Opening in Inches	6.00	6.00	inches
Height of Curb Orifice Throat in Inches	6.00	6.00	inches
Angle of Throat (see USDCM Figure ST-5)	63.40	63.40	degrees
Side Width for Depression Pan (typically the gutter width of 2 feet)	2.00	2.00	feet
Clogging Factor for a Single Curb Opening (typical value 0.10)	0.10	0.10	
Curb Opening Weir Coefficient (typical value 2.3-3.7)	3.60	3.60	
Curb Opening Orifice Coefficient (typical value 0.60 - 0.70)	0.67	0.67	
Low Head Performance Reduction (Calculated)	MINOR	MAJOR	
Depth for Grate Midwidth	N/A	N/A	ft
Depth for Curb Opening Weir Equation	0.33	0.36	ft
Combination Inlet Performance Reduction Factor for Long Inlets	0.57	0.60	
Curb Opening Performance Reduction Factor for Long Inlets	0.93	0.95	
Grated Inlet Performance Reduction Factor for Long Inlets	N/A	N/A	
Total Inlet Interception Capacity (assumes clogged condition)	MINOR	MAJOR	
Q_a	8.3	9.4	cfs
Q _{PEAK REQUIRED}	0.4	5.7	cfs

Inlet Capacity IS GOOD for Minor and Major Storms(>Q PEAK)

ALLOWABLE CAPACITY FOR ONE-HALF OF STREET (Minor & Major Storm)

(Based on Regulated Criteria for Maximum Allowable Flow Depth and Spread)

Project: FALCON MARKETPLACE
 Inlet ID: IC3

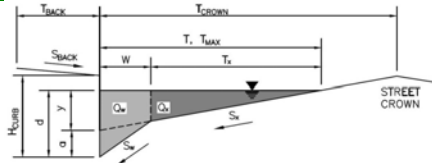

Gutter Geometry (Enter data in the blue cells)							
Maximum Allowable Width for Spread Behind Curb	$T_{BACK} = 7.0$ ft						
Side Slope Behind Curb (leave blank for no conveyance credit behind curb)	$S_{BACK} = 0.020$ ft/ft						
Manning's Roughness Behind Curb (typically between 0.012 and 0.020)	$n_{BACK} = 0.020$						
Height of Curb at Gutter Flow Line	$H_{CURB} = 6.00$ inches						
Distance from Curb Face to Street Crown	$T_{CROWN} = 20.0$ ft						
Gutter Width	$W = 2.00$ ft						
Street Transverse Slope	$S_X = 0.020$ ft/ft						
Gutter Cross Slope (typically 2 inches over 24 inches or 0.083 ft/ft)	$S_W = 0.083$ ft/ft						
Street Longitudinal Slope - Enter 0 for sump condition	$S_O = 0.000$ ft/ft						
Manning's Roughness for Street Section (typically between 0.012 and 0.020)	$n_{STREET} = 0.013$						
Max. Allowable Spread for Minor & Major Storm	<table border="1" style="display: inline-table; border-collapse: collapse;"> <thead> <tr> <th style="padding: 2px;">Minor Storm</th> <th style="padding: 2px;">Major Storm</th> <th style="padding: 2px;">ft</th> </tr> </thead> <tbody> <tr> <td style="padding: 2px;">$T_{MAX} = 20.0$</td> <td style="padding: 2px;">20.0</td> <td style="padding: 2px;"></td> </tr> </tbody> </table>	Minor Storm	Major Storm	ft	$T_{MAX} = 20.0$	20.0	
Minor Storm	Major Storm	ft					
$T_{MAX} = 20.0$	20.0						
Max. Allowable Depth at Gutter Flowline for Minor & Major Storm	<table border="1" style="display: inline-table; border-collapse: collapse;"> <thead> <tr> <th style="padding: 2px;">Minor Storm</th> <th style="padding: 2px;">Major Storm</th> <th style="padding: 2px;">inches</th> </tr> </thead> <tbody> <tr> <td style="padding: 2px;">$d_{MAX} = 6.0$</td> <td style="padding: 2px;">7.5</td> <td style="padding: 2px;"></td> </tr> </tbody> </table>	Minor Storm	Major Storm	inches	$d_{MAX} = 6.0$	7.5	
Minor Storm	Major Storm	inches					
$d_{MAX} = 6.0$	7.5						
Allow Flow Depth at Street Crown (leave blank for no)	<input type="checkbox"/> <input type="checkbox"/> check = yes						
MINOR STORM Allowable Capacity is based on Depth Criterion							
MAJOR STORM Allowable Capacity is based on Depth Criterion	<table border="1" style="display: inline-table; border-collapse: collapse;"> <thead> <tr> <th style="padding: 2px;">Minor Storm</th> <th style="padding: 2px;">Major Storm</th> <th style="padding: 2px;">cfs</th> </tr> </thead> <tbody> <tr> <td style="padding: 2px;">$Q_{allow} = \text{SUMP}$</td> <td style="padding: 2px;">SUMP</td> <td style="padding: 2px;"></td> </tr> </tbody> </table>	Minor Storm	Major Storm	cfs	$Q_{allow} = \text{SUMP}$	SUMP	
Minor Storm	Major Storm	cfs					
$Q_{allow} = \text{SUMP}$	SUMP						

INLET IN A SUMP OR SAG LOCATION

Version 4.04 Released November 2016

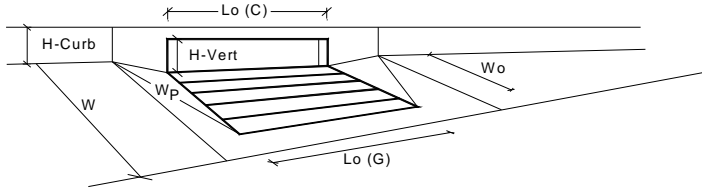

Design Information (Input)	MINOR	MAJOR	
Type of Inlet	CDOT Type R Curb Opening		
Local Depression (additional to continuous gutter depression 'a' from 'Q-Allow')	3.00	3.00	inches
Number of Unit Inlets (Grate or Curb Opening)	1	1	
Water Depth at Flowline (outside of local depression)	6.0	6.3	inches
Grate Information	MINOR	MAJOR	<input type="checkbox"/> Override Depths
Length of a Unit Grate	N/A	N/A	feet
Width of a Unit Grate	N/A	N/A	feet
Area Opening Ratio for a Grate (typical values 0.15-0.90)	N/A	N/A	
Clogging Factor for a Single Grate (typical value 0.50 - 0.70)	N/A	N/A	
Grate Weir Coefficient (typical value 2.15 - 3.60)	N/A	N/A	
Grate Orifice Coefficient (typical value 0.60 - 0.80)	N/A	N/A	
Curb Opening Information	MINOR	MAJOR	
Length of a Unit Curb Opening	10.00	10.00	feet
Height of Vertical Curb Opening in Inches	6.00	6.00	inches
Height of Curb Orifice Throat in Inches	6.00	6.00	inches
Angle of Throat (see USDCM Figure ST-5)	63.40	63.40	degrees
Side Width for Depression Pan (typically the gutter width of 2 feet)	2.00	2.00	feet
Clogging Factor for a Single Curb Opening (typical value 0.10)	0.10	0.10	
Curb Opening Weir Coefficient (typical value 2.3-3.7)	3.60	3.60	
Curb Opening Orifice Coefficient (typical value 0.60 - 0.70)	0.67	0.67	
Low Head Performance Reduction (Calculated)	MINOR	MAJOR	
Depth for Grate Midwidth	N/A	N/A	ft
Depth for Curb Opening Weir Equation	0.33	0.36	ft
Combination Inlet Performance Reduction Factor for Long Inlets	0.57	0.60	
Curb Opening Performance Reduction Factor for Long Inlets	0.93	0.95	
Grated Inlet Performance Reduction Factor for Long Inlets	N/A	N/A	
Total Inlet Interception Capacity (assumes clogged condition)	MINOR	MAJOR	
Q_a	8.3	9.4	cfs
Q_{PEAK REQUIRED}	2.1	3.7	cfs

Inlet Capacity IS GOOD for Minor and Major Storms(>Q PEAK)

DETENTION VOLUME BY THE FULL SPECTRUM METHOD

Project: _____
 Basin ID: _____

* User input data shown in blue.

Area of Watershed (acres)	740.00	
Subwatershed Imperviousness	15.0%	
Level of Minimizing Directly Connected Impervious Area (MDCIA)	0	0 ▼
Effective Imperviousness ¹	15.0%	
Hydrologic Soil Type	Percentage of Area	Area (acres)
Type A	100.0%	740.0
Type B		0.0
Type C or D		0.0

Recommended Horton's Equation Parameters for CUHP		
Infiltration (inches per hour)		Decay Coefficient-- α
Initial-- f_i	Final-- f_o	
5	1.0	0.0007
Detention Volumes ^{2,5}		
(watershed inches)	(acre-feet)	Maximum Allowable Release Rate, cfs ³
0.22	13.30	Design Outlet to Empty EURV in 72 Hours
0.32	19.72	370.00

Excess Urban Runoff Volume⁴

100-year Detention Volume Including WQCV⁵

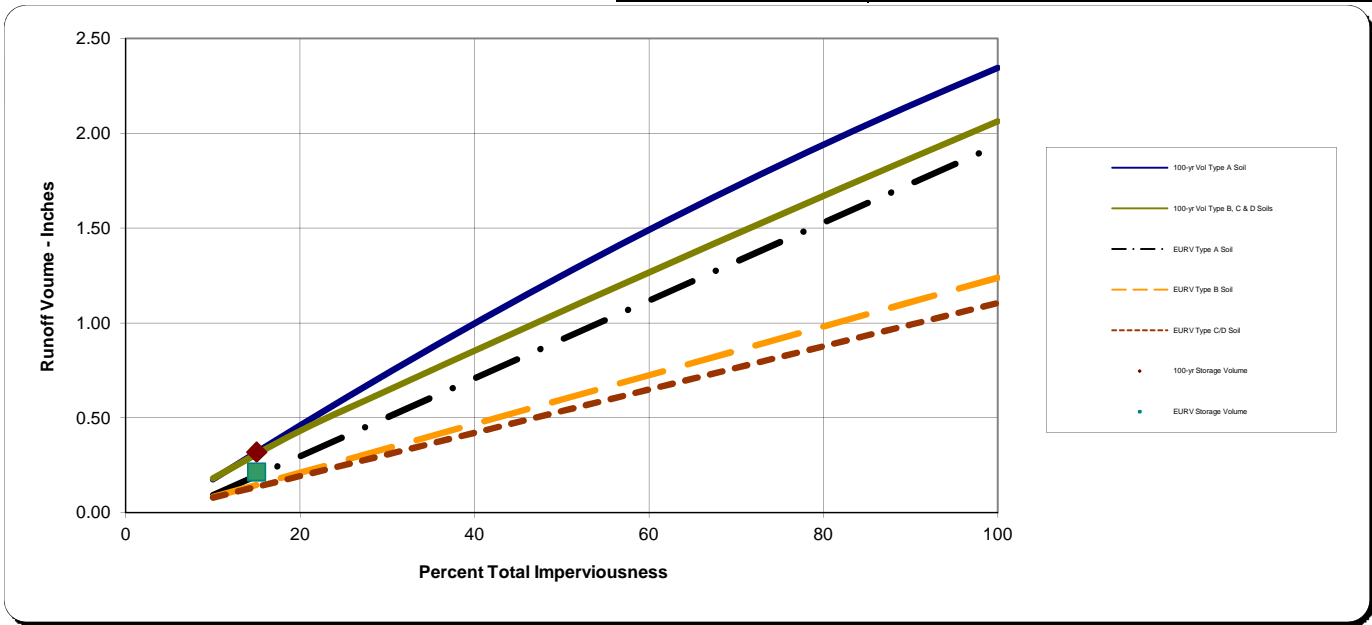

Notes:

- 1) Effective imperviousness is based on Figure ND-1 of the Urban Storm Drainage Criteria Manual (USDCM).
- 2) Results shown reflect runoff reduction from Level 1 or 2 MDCIA and are plotted at the watershed's total imperviousness value; the impact of MDCIA is reflected by the results being below the curves.
- 3) Maximum allowable release rates for 100-year event are based on Table SO-1. Outlet for the Excess Urban Runoff Volume (EURV) to be designed to empty out the EURV in 72 hours. Outlet design is similar to one for the WQCV outlet of an extended detention basin (i.e., perforated plate with a micro-pool) and extends to top of EURV water surface elevation.
- 4) EURV approximates the difference between developed and pre-developed runoff volume.
- 5) 100-yr detention volume includes EURV. No need to add more volume for WQCV or EURV

STAGE-STORAGE SIZING FOR DETENTION BASINS

Project: _____
Basin ID: _____

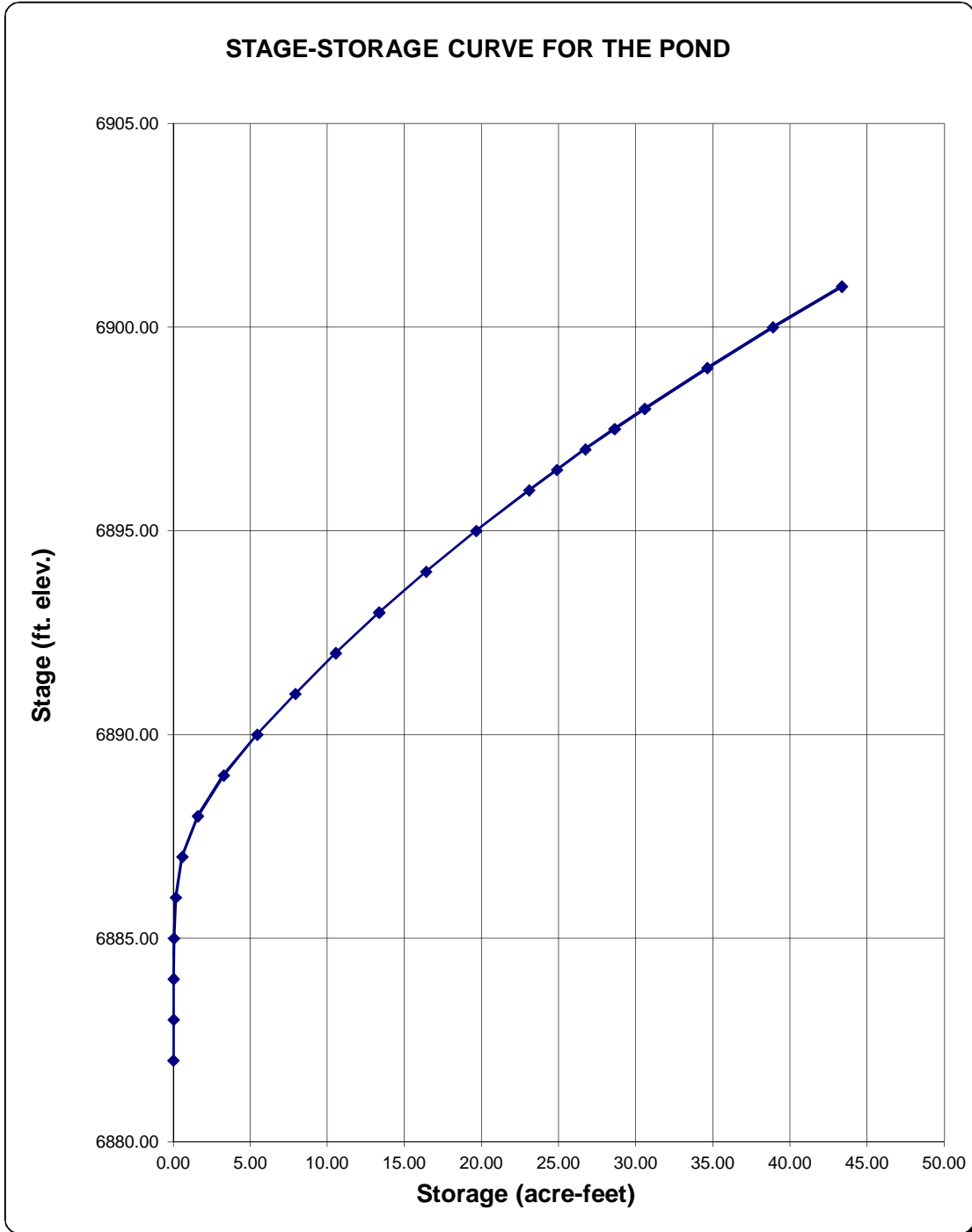

STAGE-DISCHARGE SIZING OF THE WATER QUALITY CAPTURE VOLUME (WQCV) OUTLET

Project: **FALCON MARKETPLACE**

Basin ID: **NORTH POND #1**

WQCV Design Volume (Input):

Catchment Imperviousness, I _p = <u>15.0</u> percent	Diameter of holes, D = <u>9.500</u> inches
Catchment Area, A = <u>740.00</u> acres	Number of holes per row, N = <u>1</u>
Depth at WQCV outlet above lowest perforation, H = <u>8</u> feet	OR
Vertical distance between rows, h = <u>30.00</u> inches	Height of slot, H = <u> </u> inches
Number of rows, NL = <u>3.00</u>	Width of slot, W = <u> </u> inches
Orifice discharge coefficient, C _d = <u>0.50</u>	
Slope of Basin Trickle Channel, S = <u>0.005</u> ft / ft	
Time to Drain the Pond = <u>40</u> hours	

Watershed Design Information (Input):

Percent Soil Type A = 100 %
 Percent Soil Type B = %
 Percent Soil Type C/D = %

Outlet Design Information (Output):

Excess Urban Runoff Volume (From 'Full-Spectrum Sheet') = 0.216 watershed inches
 = N/A

Excess Urban Runoff Volume (From 'Full-Spectrum Sheet') = 13.300 acre-feet

Outlet area per row, A_o = 69.21 square inches
 Total opening area at each row based on user-input above, A_o = 70.88 square inches
 Total opening area at each row based on user-input above, A_o = 0.492 square feet

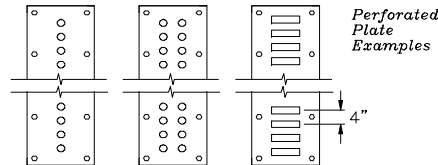

3

Central Elevations of Rows of Holes in feet																							Σ Flow		
Row 1	Row 2	Row 3	Row 4	Row 5	Row 6	Row 7	Row 8	Row 9	Row 10	Row 11	Row 12	Row 13	Row 14	Row 15	Row 16	Row 17	Row 18	Row 19	Row 20	Row 21	Row 22	Row 23		Row 23	
6885.00	6887.50	6890.00																							
Collection Capacity for Each Row of Holes in cfs																									
6882.00	0.0000	0.0000	0.0000																					0.00	
6883.00	0.0000	0.0000	0.0000																						0.00
6884.00	0.0000	0.0000	0.0000																						0.00
6885.00	0.0000	0.0000	0.0000																						0.00
6886.00	1.9751	0.0000	0.0000																						1.98
6887.00	2.7932	0.0000	0.0000																						2.79
6888.00	3.4210	1.3966	0.0000																						4.82
6889.00	3.9502	2.4190	0.0000																						6.37
6890.00	4.4164	3.1229	0.0000																						7.54
6891.00	4.8380	3.6951	1.9751																						10.51
6892.00	5.2256	4.1898	2.7932																						12.21
6893.00	5.5864	4.6320	3.4210																						13.64
6894.00	5.9253	5.0355	3.9502																						14.91
6895.00	6.2458	5.4090	4.4164																						16.07
6896.00	6.5506	5.7583	4.8380																						17.15
6896.50	6.6979	5.9253	5.0355																						17.66
6897.00	6.8419	6.0876	5.2256																						18.16
6897.50	6.9830	6.2458	5.4090																						18.64
6898.00	7.1213	6.4000	5.5864																						19.11
6899.00	7.3901	6.6979	5.9253																						20.01
6900.00	7.6495	6.9830	6.2458																						20.88
6901.00	7.9004	7.2570	6.5506																						21.71
	#N/A	#N/A	#N/A																						#N/A
	#N/A	#N/A	#N/A																						#N/A
	#N/A	#N/A	#N/A																						#N/A
	#N/A	#N/A	#N/A																						#N/A
	#N/A	#N/A	#N/A																						#N/A
	#N/A	#N/A	#N/A																						#N/A
	#N/A	#N/A	#N/A																						#N/A
	#N/A	#N/A	#N/A																						#N/A
	#N/A	#N/A	#N/A																						#N/A
	#N/A	#N/A	#N/A																						#N/A
	#N/A	#N/A	#N/A																						#N/A
	#N/A	#N/A	#N/A																						#N/A
	#N/A	#N/A	#N/A																						#N/A
	#N/A	#N/A	#N/A																						#N/A
	#N/A	#N/A	#N/A																						#N/A
	#N/A	#N/A	#N/A																						#N/A
	#N/A	#N/A	#N/A																						#N/A
	#N/A	#N/A	#N/A																						#N/A
Override Area Row 1	Override Area Row 2	Override Area Row 3	Override Area Row 4	Override Area Row 5	Override Area Row 6	Override Area Row 7	Override Area Row 8	Override Area Row 9	Override Area Row 10	Override Area Row 11	Override Area Row 12	Override Area Row 13	Override Area Row 14	Override Area Row 15	Override Area Row 16	Override Area Row 17	Override Area Row 18	Override Area Row 19	Override Area Row 20	Override Area Row 21	Override Area Row 22	Override Area Row 23	Override Area Row 24		

STAGE-DISCHARGE SIZING OF THE WATER QUALITY CAPTURE VOLUME (WQCV) OUTLET

Worksheet Protected

Project: FALCON MARKETPLACE

Basin ID: NORTH POND #1

STAGE-DISCHARGE CURVE FOR THE WQCV OUTLET STRUCTURE

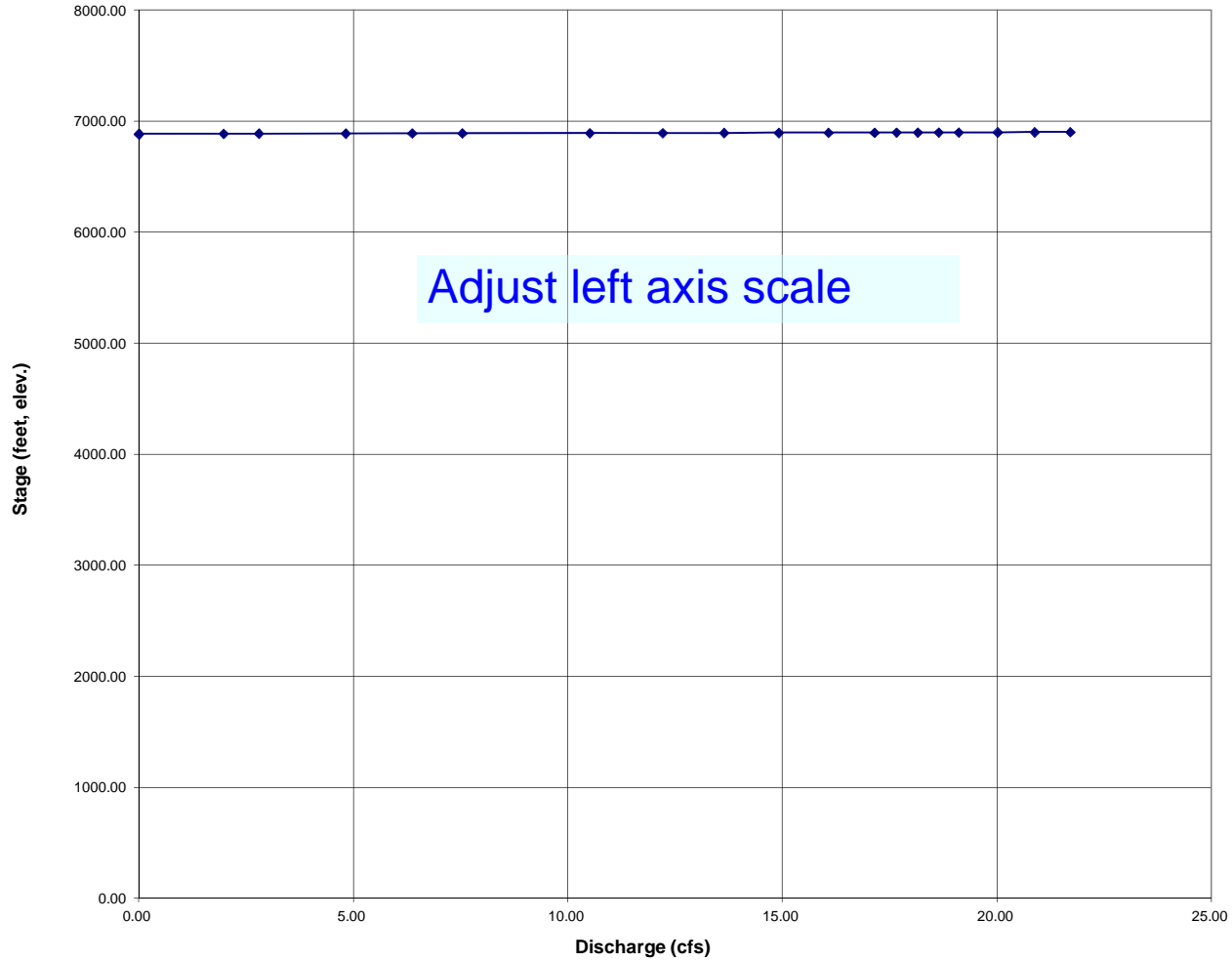

STAGE-DISCHARGE SIZING OF THE WEIRS AND ORIFICES (INLET CONTROL)

Project: Falcon Marketplace #1
Basin ID: NORTH POND #1

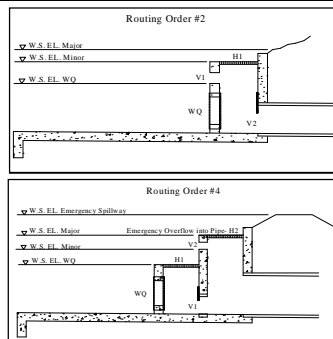
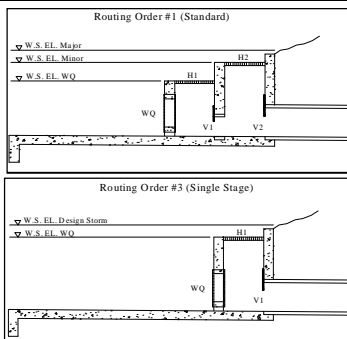

Current Routing Order is #3

Design Information (Input):

Circular Opening: Diameter in Inches
 OR
 Rectangular Opening: Width in Feet
 Length (Height for Vertical)

Percentage of Open Area After Trash Rack Reduction
 Orifice Coefficient
 Weir Coefficient
 Orifice Elevation (Bottom for Vertical)

Dia. =	#1 Horiz.	#2 Horiz.	#1 Vert.	#2 Vert.	inches
W =	8.00				ft.
L or H =	12.00				ft.
% open =	80		100		%
C _o =	0.75		0.75		
C _w =	3.00				
E _o =	6893.80		6.881.97		ft.

Calculation of Collection Capacity:

Net Opening Area (after Trash Rack Reduction)
 OPTIONAL: User-Override Net Opening Area
 Perimeter as Weir Length
 OPTIONAL: User-Override Weir Length

A _o =	76.80	50.27	sq. ft.
A _o =			sq. ft.
L _w =	36.80		ft.
L _w =			ft.
Top Elevation of Vertical Orifice Opening, Top =	6889.97		ft.
Center Elevation of Vertical Orifice Opening, Cen =	6885.97		ft.

Routing 3: Single Stage - Water flows through WQCV plate and #1 horizontal opening into #1 vertical opening. This flow will be applied to culvert sheet (#2 vertical & horizontal openings is not used).

Labels for WQCV, Minor, & Major Storage W.S. Elevations (input)	Water Surface Elevation ft (linked)	WQCV Plate/Riser Flow cfs (User-linked)	Horizontal Orifices				Vertical Orifices		Total Collection Capacity cfs (output)	Target Volumes for WQCV, Minor, & Major Storage Volumes (link for goal seek)
			#1 Horiz. Weir Flow cfs (output)	#1 Horiz. Orifice Flow cfs (output)	#2 Horiz. Weir Flow cfs (output)	#2 Horiz. Orifice Flow cfs (output)	#1 Vert. Collection Capacity cfs (output)	#2 Vert. Collection Capacity cfs (output)		
	6882.00	0.00	0.00	0.00	0.00	0.00	0.14	0.00	0.00	
	6883.00	0.00	0.00	0.00	0.00	0.00	27.95	0.00	0.00	
	6884.00	0.00	0.00	0.00	0.00	0.00	77.34	0.00	0.00	
	6885.00	0.00	0.00	0.00	0.00	0.00	141.04	0.00	0.00	
	6886.00	1.98	0.00	0.00	0.00	0.00	216.33	0.00	1.98	
	6887.00	2.79	0.00	0.00	0.00	0.00	301.66	0.00	2.79	
	6888.00	4.82	0.00	0.00	0.00	0.00	395.95	0.00	4.82	
	6889.00	6.37	0.00	0.00	0.00	0.00	498.43	0.00	6.37	
	6890.00	7.54	0.00	0.00	0.00	0.00	607.33	0.00	7.54	
	6891.00	10.51	0.00	0.00	0.00	0.00	678.51	0.00	10.51	
	6892.00	12.21	0.00	0.00	0.00	0.00	742.90	0.00	12.21	
	6893.00	13.64	0.00	0.00	0.00	0.00	802.14	0.00	13.64	
	6894.00	14.91	9.87	206.72	0.00	0.00	857.30	0.00	24.79	
	6895.00	16.07	145.12	506.36	0.00	0.00	909.11	0.00	161.20	
	6896.00	17.15	360.25	685.61	0.00	0.00	958.13	0.00	377.40	
	6896.50	17.66	489.80	759.53	0.00	0.00	981.72	0.00	507.45	
	6897.00	18.16	631.97	826.88	0.00	0.00	1004.76	0.00	650.12	
	6897.50	18.64	785.73	889.13	0.00	0.00	1027.28	0.00	804.36	
	6898.00	19.11	950.26	947.31	0.00	0.00	1049.32	0.00	966.41	
	6899.00	20.01	1309.10	1054.06	0.00	0.00	1092.06	0.00	1074.08	
	6900.00	20.88	1704.34	1150.96	0.00	0.00	1133.19	0.00	1133.19	
	6901.00	21.71	2132.89	1240.31	0.00	0.00	1172.88	0.00	1172.88	
		#N/A	#N/A	#N/A	#N/A	#N/A	#N/A	0.00	#N/A	
		#N/A	#N/A	#N/A	#N/A	#N/A	#N/A	0.00	#N/A	
		#N/A	#N/A	#N/A	#N/A	#N/A	#N/A	0.00	#N/A	
		#N/A	#N/A	#N/A	#N/A	#N/A	#N/A	0.00	#N/A	
		#N/A	#N/A	#N/A	#N/A	#N/A	#N/A	0.00	#N/A	
		#N/A	#N/A	#N/A	#N/A	#N/A	#N/A	0.00	#N/A	
		#N/A	#N/A	#N/A	#N/A	#N/A	#N/A	0.00	#N/A	
		#N/A	#N/A	#N/A	#N/A	#N/A	#N/A	0.00	#N/A	
		#N/A	#N/A	#N/A	#N/A	#N/A	#N/A	0.00	#N/A	
		#N/A	#N/A	#N/A	#N/A	#N/A	#N/A	0.00	#N/A	
		#N/A	#N/A	#N/A	#N/A	#N/A	#N/A	0.00	#N/A	
		#N/A	#N/A	#N/A	#N/A	#N/A	#N/A	0.00	#N/A	
		#N/A	#N/A	#N/A	#N/A	#N/A	#N/A	0.00	#N/A	
		#N/A	#N/A	#N/A	#N/A	#N/A	#N/A	0.00	#N/A	
		#N/A	#N/A	#N/A	#N/A	#N/A	#N/A	0.00	#N/A	
		#N/A	#N/A	#N/A	#N/A	#N/A	#N/A	0.00	#N/A	
		#N/A	#N/A	#N/A	#N/A	#N/A	#N/A	0.00	#N/A	
		#N/A	#N/A	#N/A	#N/A	#N/A	#N/A	0.00	#N/A	
		#N/A	#N/A	#N/A	#N/A	#N/A	#N/A	0.00	#N/A	
		#N/A	#N/A	#N/A	#N/A	#N/A	#N/A	0.00	#N/A	
		#N/A	#N/A	#N/A	#N/A	#N/A	#N/A	0.00	#N/A	
		#N/A	#N/A	#N/A	#N/A	#N/A	#N/A	0.00	#N/A	
		#N/A	#N/A	#N/A	#N/A	#N/A	#N/A	0.00	#N/A	
		#N/A	#N/A	#N/A	#N/A	#N/A	#N/A	0.00	#N/A	
		#N/A	#N/A	#N/A	#N/A	#N/A	#N/A	0.00	#N/A	
		#N/A	#N/A	#N/A	#N/A	#N/A	#N/A	0.00	#N/A	
		#N/A	#N/A	#N/A	#N/A	#N/A	#N/A	0.00	#N/A	
		#N/A	#N/A	#N/A	#N/A	#N/A	#N/A	0.00	#N/A	

STAGE-DISCHARGE SIZING OF THE WEIRS AND ORIFICES (INLET CONTROL)

Project: Falcon Marketplace #1
Basin ID: NORTH POND #1

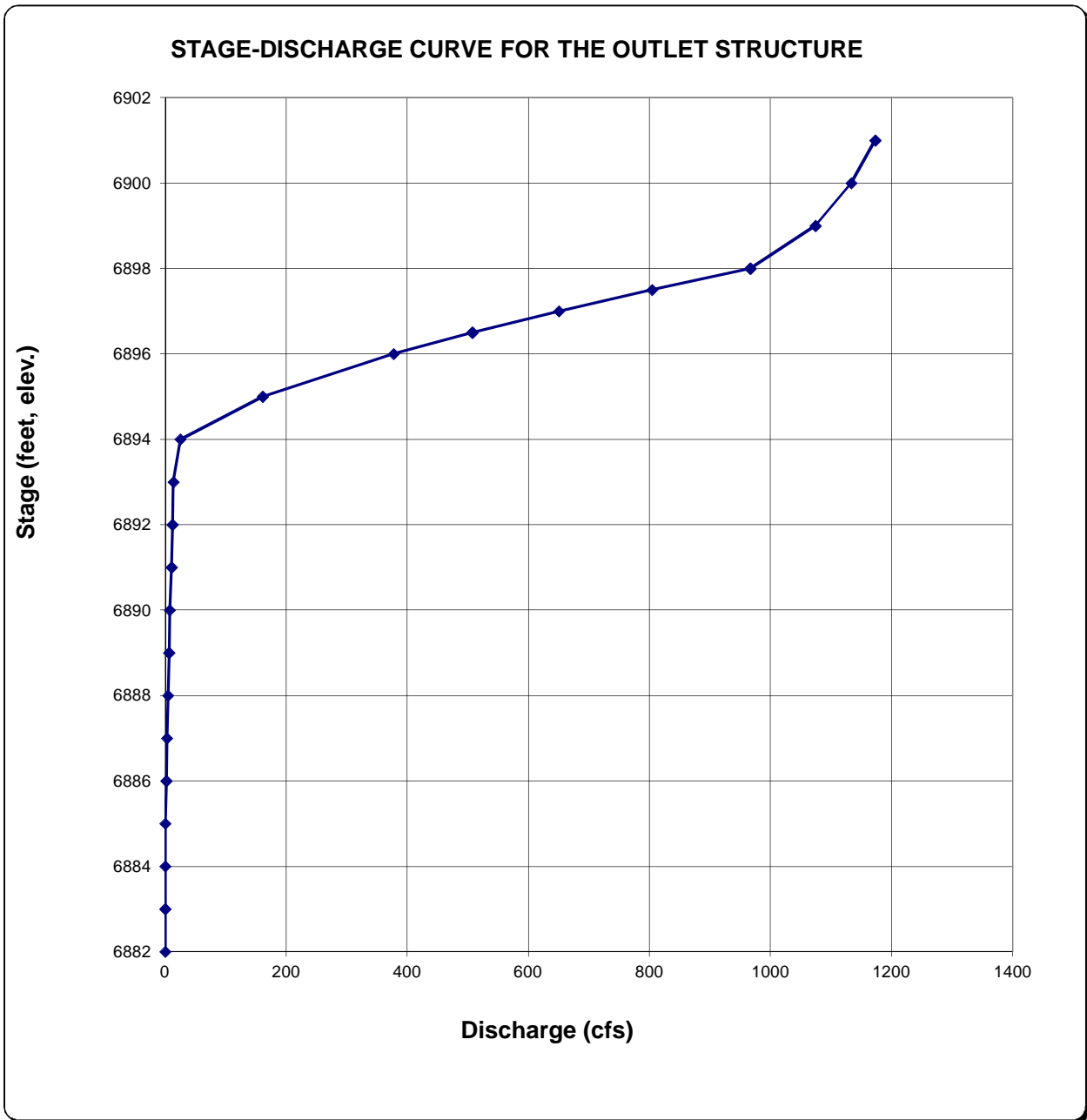

STAGE-DISCHARGE SIZING OF THE OUTLET CULVERT (INLET vs. OUTLET CONTROL WITH TAILWATER EFFECTS)

Project: FALCON MARKETPLACE
Basin ID: NORTH POND #1

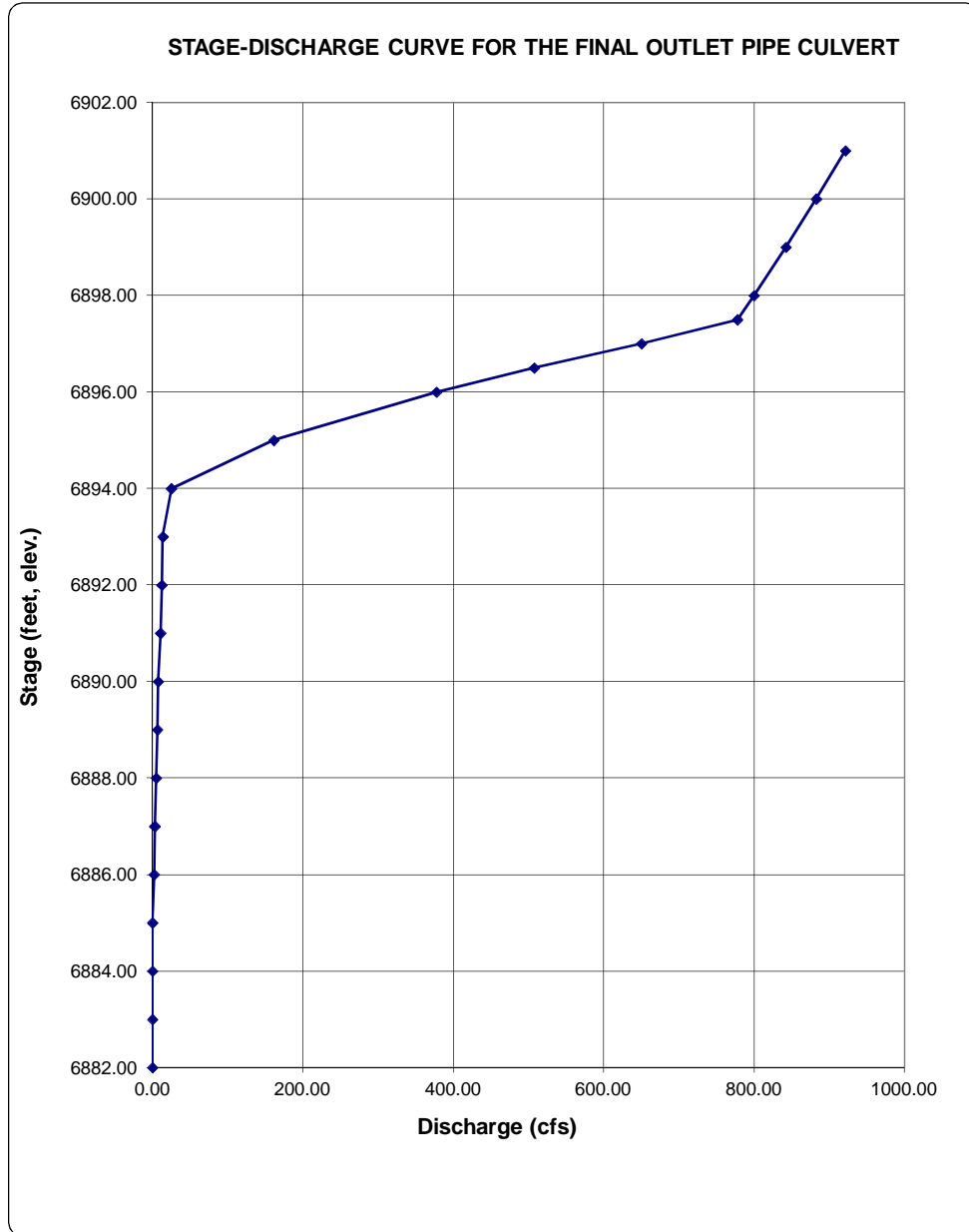

PROJECT INFORMATION

PROJECT: Falcon Marketplace
PROJECT NO: 20988-00CSCV
DESIGN BY: KGV
REV. BY: TDM
AGENCY: El Paso County
REPORT TYPE: Preliminary
DATE: 6/19/2017



SPILLWAY CALCULATIONS

$$Q=CL(H^{2/3})$$

Weir coefficient C: 3.5
Depth H, ft: 1.5
Flowrate Q. cfs: 1016

Required L, ft: 158.01

STAGE-DISCHARGE SIZING OF THE SPILLWAY

Project: FALCON MARKETPLACE
 Basin ID: NORTH POND #1

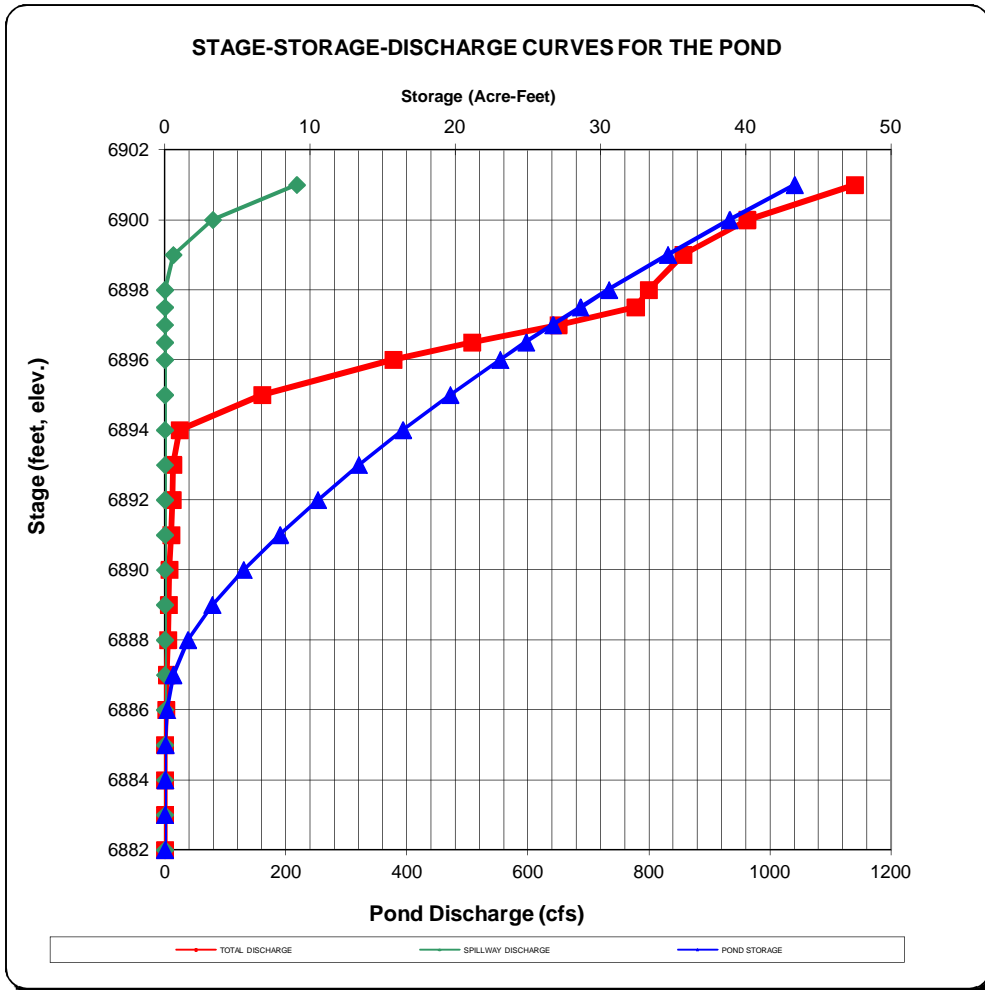

Aluminum Bar Grating

RECTANGULAR BAR SWAGE-LOCKED 1-3/16" C/C Bearing Bars

PRESS-LOCKED 1-3/16" C/C Bearing Bars

19-SR-4



Cross Rods 4" C/C

19-SR-2



Cross Rods 2" C/C

19-AP-4



Cross Bars 4" C/C

19-AP-2



Cross Bars 2" C/C

NON-SERRATED & SERRATED

LOAD & DEFLECTION TABLE

Bar Size	Symbol	Approx. Weight psf	Sec. Mod Per Ft. of Width	SPAN (Direction of Bearing Bar)					
				24"	30"	36"	42"	48"	
3/4" x 1/8"	19-SR-4	1.4	0.118	U	237	152	105	77	
	19-SR-2	1.6		D	0.192	0.300	0.432	0.588	
	19-AP-4	1.5		C	237	189	158	135	
3/4" x 3/16"	19-AP-2	1.8	0.178	D	0.154	0.240	0.346	0.470	
	19-SR-4	1.9		U	355	227	158	116	
	19-SR-2	2.1		D	0.192	0.300	0.432	0.588	
1" x 1/8"	19-AP-4	2.2	0.211	C	355	284	237	203	
	19-AP-2	2.7		D	0.154	0.240	0.346	0.470	
	19-SR-4	1.7		U	421	269	187	137	105
1" x 3/16"	19-SR-2	1.9	0.316	D	0.144	0.225	0.324	0.441	0.576
	19-AP-4	1.8		C	421	337	281	241	211
	19-AP-2	2.2		D	0.115	0.180	0.259	0.353	0.461
1-1/4" x 1/8"	19-SR-4	2.5	0.329	U	632	404	281	206	158
	19-SR-2	2.7		D	0.144	0.225	0.324	0.441	0.576
	19-AP-4	2.8		C	632	505	421	361	316
1-1/4" x 3/16"	19-AP-2	3.3	0.493	D	0.115	0.180	0.259	0.353	0.461
	19-SR-4	2.1		U	658	421	292	215	164
	19-SR-2	2.3		D	0.115	0.180	0.259	0.353	0.461
1-1/2" x 1/8"	19-AP-4	2.4	0.474	C	658	526	439	376	329
	19-AP-2	2.8		D	0.092	0.144	0.207	0.282	0.369
	19-SR-4	3.1		U	987	632	439	322	247
1-1/2" x 3/16"	19-SR-2	3.3	0.711	D	0.115	0.180	0.259	0.353	0.461
	19-AP-4	3.5		C	987	789	658	564	493
	19-AP-2	4.2		D	0.092	0.144	0.207	0.282	0.369
1-1/2" x 3/16"	19-SR-4	2.5	0.967	U	947	606	421	309	237
	19-SR-2	2.7		D	0.096	0.150	0.216	0.294	0.384
	19-AP-4	2.8		C	947	758	632	541	474
1-3/4" x 3/16"	19-AP-2	3.2	1.263	D	0.077	0.120	0.173	0.235	0.307
	19-SR-4	3.7		U	1421	909	632	464	355
	19-SR-2	3.9		D	0.096	0.150	0.216	0.294	0.384
2" x 3/16"	19-AP-4	4.1	1.599	C	1421	1137	947	812	711
	19-AP-2	4.8		D	0.077	0.120	0.173	0.235	0.307
	19-SR-4	4.2		U	1934	1238	860	632	484
2-1/4" x 3/16"	19-SR-2	4.4	1.974	D	0.082	0.129	0.185	0.252	0.329
	19-AP-4	4.7		C	1934	1547	1289	1105	967
	19-AP-2	5.3		D	0.066	0.103	0.148	0.202	0.263
2-1/2" x 3/16"	19-SR-4	4.8	1.974	U	2526	1617	1123	825	632
	19-SR-2	5.0		D	0.072	0.113	0.162	0.221	0.288
	19-AP-4	5.3		C	2526	2021	1684	1444	1263
2-1/2" x 3/16"	19-AP-2	5.9	1.974	D	0.058	0.090	0.130	0.176	0.230
	19-SR-4	5.4		U	3197	2046	1421	1044	799
	19-SR-2	5.6		D	0.064	0.100	0.144	0.196	0.256
2-1/2" x 3/16"	19-AP-4	5.8	1.974	C	3197	2558	2132	1827	1599
	19-AP-2	6.5		D	0.051	0.080	0.115	0.157	0.205
	19-SR-4	5.9		U	3947	2526	1754	1289	987
2-1/2" x 3/16"	19-SR-2	6.1	1.974	D	0.058	0.090	0.130	0.176	0.230
	19-AP-4	6.4		C	3947	3158	2632	2256	1974
	19-AP-2	7.1		D	0.046	0.072	0.104	0.141	0.184

U = safe uniform load, psf (page 93)
 C = safe concentrated load, psf (page 93)
 D = deflection, inches
 E = modulus of elasticity, 10,000,000 psi
 F = fiber stress, 12,000 psi
Material: ASTM B-221, 6063 or 6061
Deflection: Spans and loads to the right of the bold line exceed 1/4" deflection for uniform load of 100 psf which provides safe pedestrian comfort. These can be exceeded for other types of loads with engineer's approval.
Serrated Bars: For serrated grating, the depth of grating required for a specified load is 1/4" deeper than that shown in the table.
General: Loads and deflections are theoretical and based on static loading.
Finish: Mill finish unless otherwise specified.

FALCON MARKETPLACE
 15-FT Head x 62-4 = 936 psf
 Verify compliance with flow velocity considerations for safety (<2.5 ft/sec.)
 Reference UDFCD vs. T-12/OS-3.

SR/AP-19 PANEL WIDTH (inches)

No. of Bars	2	3	4	5	6	7	8	9	10	11	12	13	14	15	16
1/8" Bar	19 ^{1/16}	23 ^{1/4}	31 ^{5/16}	51 ^{1/8}	65 ^{1/16}	71 ^{1/2}	81 ^{1/16}	97 ^{1/8}	111 ^{1/16}	121 ^{1/4}	137 ^{1/16}	145 ^{1/8}	151 ^{3/16}	17	18 ^{3/16}
3/16" Bar	15 ^{1/8}	21 ^{3/16}	4	5 ^{3/16}	6 ^{3/8}	7 ^{9/16}	8 ^{3/4}	9 ^{15/16}	11 ^{1/8}	12 ^{5/16}	13 ^{1/2}	14 ^{11/16}	15 ^{7/8}	17 ^{1/16}	18 ^{1/4}
No. of Bars	17	18	19	20	21	22	23	24	25	26	27	28	29	30	31
1/8" Bar	19 ^{3/8}	20 ^{9/16}	21 ^{3/4}	22 ^{15/16}	24 ^{1/8}	25 ^{5/16}	26 ^{1/2}	27 ^{11/16}	28 ^{7/8}	30 ^{1/16}	31 ^{1/4}	32 ^{7/16}	33 ^{3/8}	34 ^{13/16}	36
3/16" Bar	19 ^{7/16}	20 ^{5/8}	21 ^{13/16}	23	24 ^{3/16}	25 ^{3/8}	26 ^{9/16}	27 ^{3/4}	28 ^{15/16}	30 ^{1/8}	31 ^{1/16}	32 ^{1/2}	33 ^{11/16}	34 ^{7/8}	36 ^{1/16}

Note: Includes 1/4" (1/8" each side) for extended cross rods on swage-locked (SR) and extended cross bars on press-locked (AP).

Isn't span 8'? (current plan). This does not match plan labels of standard grate.

DETENTION BASIN STAGE-STORAGE TABLE BUILDER

UD-Detention, Version 3.07 (February 2017)

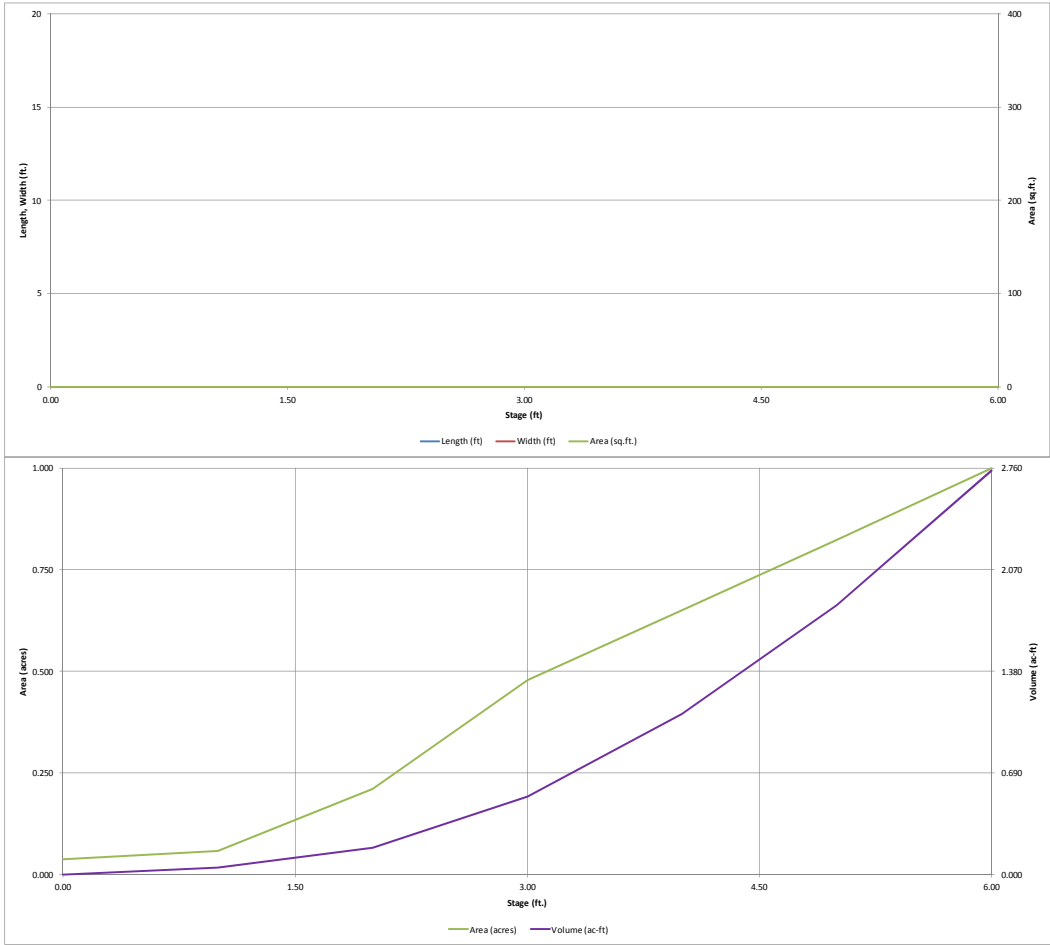

Detention Basin Outlet Structure Design

UD-Detention, Version 3.07 (February 2017)

Project: **Falcon Marketplace Pond #2**

Basin ID: _____

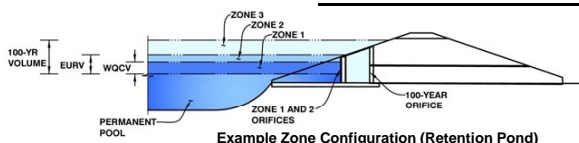

Example Zone Configuration (Retention Pond)

	Stage (ft)	Zone Volume (ac-ft)	Outlet Type
Zone 1 (WQCV)	3.38	0.718	Orifice Plate
Zone 2			Weir&Pipe (Circular)
Zone 3			
		0.718	Total

User Input: Orifice at Underdrain Outlet (typically used to drain WQCV in a Filtration BMP)

Underdrain Orifice Invert Depth = ft (distance below the filtration media surface)
 Underdrain Orifice Diameter = inches

Calculated Parameters for Underdrain

Underdrain Orifice Area = ft²
 Underdrain Orifice Centroid = feet

User Input: Orifice Plate with one or more orifices or Elliptical Slot Weir (typically used to drain WQCV and/or EURV in a sedimentation BMP)

Invert of Lowest Orifice = ft (relative to basin bottom at Stage = 0 ft)
 Depth at top of Zone using Orifice Plate = ft (relative to basin bottom at Stage = 0 ft)
 Orifice Plate: Orifice Vertical Spacing = inches
 Orifice Plate: Orifice Area per Row = sq. inches (diameter = 1-13/16 inches)

Calculated Parameters for Plate

WQ Orifice Area per Row = ft²
 Elliptical Half-Width = feet
 Elliptical Slot Centroid = feet
 Elliptical Slot Area = ft²

User Input: Stage and Total Area of Each Orifice Row (numbered from lowest to highest)

	Row 1 (required)	Row 2 (optional)	Row 3 (optional)	Row 4 (optional)	Row 5 (optional)	Row 6 (optional)	Row 7 (optional)	Row 8 (optional)
Stage of Orifice Centroid (ft)	0.00	1.20	2.40					
Orifice Area (sq. inches)	2.69	2.69	2.69					

	Row 9 (optional)	Row 10 (optional)	Row 11 (optional)	Row 12 (optional)	Row 13 (optional)	Row 14 (optional)	Row 15 (optional)	Row 16 (optional)
Stage of Orifice Centroid (ft)								
Orifice Area (sq. inches)								

User Input: Vertical Orifice (Circular or Rectangular)

Invert of Vertical Orifice = ft (relative to basin bottom at Stage = 0 ft)
 Depth at top of Zone using Vertical Orifice = ft (relative to basin bottom at Stage = 0 ft)
 Vertical Orifice Diameter = inches

Calculated Parameters for Vertical Orifice

Vertical Orifice Area = ft²
 Vertical Orifice Centroid = feet

User Input: Overflow Weir (Dropbox) and Grate (Flat or Sloped)

	Zone 2 Weir	Not Selected	
Overflow Weir Front Edge Height, H _o =	3.38		ft (relative to basin bottom at Stage = 0 ft)
Overflow Weir Front Edge Length =	7.00		feet
Overflow Weir Slope =	0.00		H:V (enter zero for flat grate)
Horiz. Length of Weir Sides =	5.00		feet
Overflow Grate Open Area % =	70%		%, grate open area/total area
Debris Clogging % =	50%		%

Calculated Parameters for Overflow Weir

	Zone 2 Weir	Not Selected	
Height of Grate Upper Edge, H ₁ =	3.38		feet
Over Flow Weir Slope Length =	5.00		feet
Grate Open Area / 100-yr Orifice Area =	4.99		should be ≥ 4
Overflow Grate Open Area w/o Debris =	24.50		ft ²
Overflow Grate Open Area w/ Debris =	12.25		ft ²

User Input: Outlet Pipe w/ Flow Restriction Plate (Circular Orifice, Restrictor Plate, or Rectangular Orifice)

	Zone 2 Circular	Not Selected	
Depth to Invert of Outlet Pipe =	0.00		ft (distance below basin bottom at Stage = 0 ft)
Circular Orifice Diameter =	30.00		inches

Calculated Parameters for Outlet Pipe w/ Flow Restriction Plate

	Zone 2 Circular	Not Selected	
Outlet Orifice Area =	4.91		ft ²
Outlet Orifice Centroid =	1.25		feet
Half-Central Angle of Restrictor Plate on Pipe =	N/A	N/A	radians

User Input: Emergency Spillway (Rectangular or Trapezoidal)

Spillway Invert Stage = ft (relative to basin bottom at Stage = 0 ft)
 Spillway Crest Length = feet
 Spillway End Slopes = H:V
 Freeboard above Max Water Surface = feet

Calculated Parameters for Spillway

Spillway Design Flow Depth = feet
 Stage at Top of Freeboard = feet
 Basin Area at Top of Freeboard = acres

Routed Hydrograph Results

	WQCV	EURV	2 Year	5 Year	10 Year	25 Year	50 Year	100 Year	500 Year
Design Storm Return Period =									
One-Hour Rainfall Depth (in) =	0.53	1.07	0.95	1.22	1.48	1.86	2.19	2.54	3.46
Calculated Runoff Volume (acre-ft) =	0.718	2.706	1.498	1.979	2.476	3.204	3.826	4.561	6.456
OPTIONAL Override Runoff Volume (acre-ft) =									
Inflow Hydrograph Volume (acre-ft) =	0.717	2.703	1.496	1.976	2.473	3.200	3.821	4.556	6.445
Predevelopment Unit Peak Flow, q (cfs/acre) =	0.00	0.00	0.00	0.01	0.01	0.03	0.26	0.65	1.56
Predevelopment Peak Q (cfs) =	0.0	0.0	0.0	0.1	0.3	0.8	6.2	15.4	37.2
Peak Inflow Q (cfs) =	14.9	55.3	30.8	40.6	50.6	65.3	77.7	92.3	129.6
Peak Outflow Q (cfs) =	0.4	35.1	13.8	22.2	31.2	41.3	43.6	46.3	103.3
Ratio Peak Outflow to Predevelopment Q =	N/A	N/A	N/A	165.0	95.6	51.7	7.0	3.0	2.8
Structure Controlling Flow =	Plate	Overflow Grate 1	Overflow Grate 1	Overflow Grate 1	Overflow Grate 1	Outlet Plate 1	Outlet Plate 1	Outlet Plate 1	Spillway
Max Velocity through Grate 1 (fps) =	N/A	1.43	0.53	0.9	1.3	1.7	1.8	1.9	1.9
Max Velocity through Grate 2 (fps) =	N/A	N/A	N/A	N/A	N/A	N/A	N/A	N/A	N/A
Time to Drain 97% of Inflow Volume (hours) =	37	31	35	33	32	30	29	28	24
Time to Drain 99% of Inflow Volume (hours) =	40	38	40	39	39	37	36	35	33
Maximum Ponding Depth (ft) =	3.29	4.15	3.78	3.94	4.09	4.30	4.65	5.09	5.38
Area at Maximum Ponding Depth (acres) =	0.53	0.67	0.61	0.64	0.66	0.70	0.76	0.84	0.89
Maximum Volume Stored (acre-ft) =	0.669	1.185	0.954	1.054	1.145	1.288	1.544	1.904	2.155

Detention Basin Outlet Structure Design

UD-Detention, Version 3.07 (February 2017)

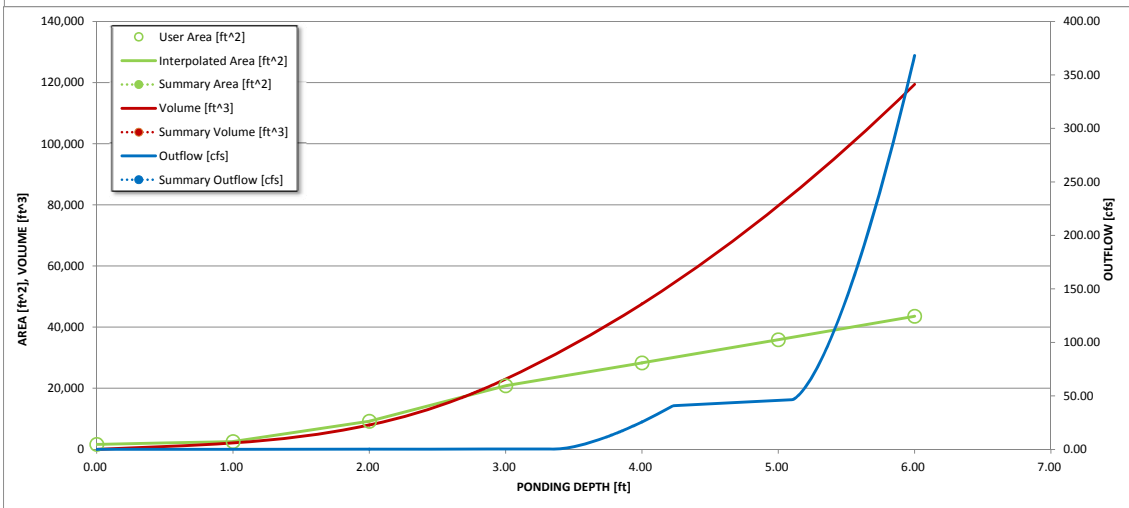
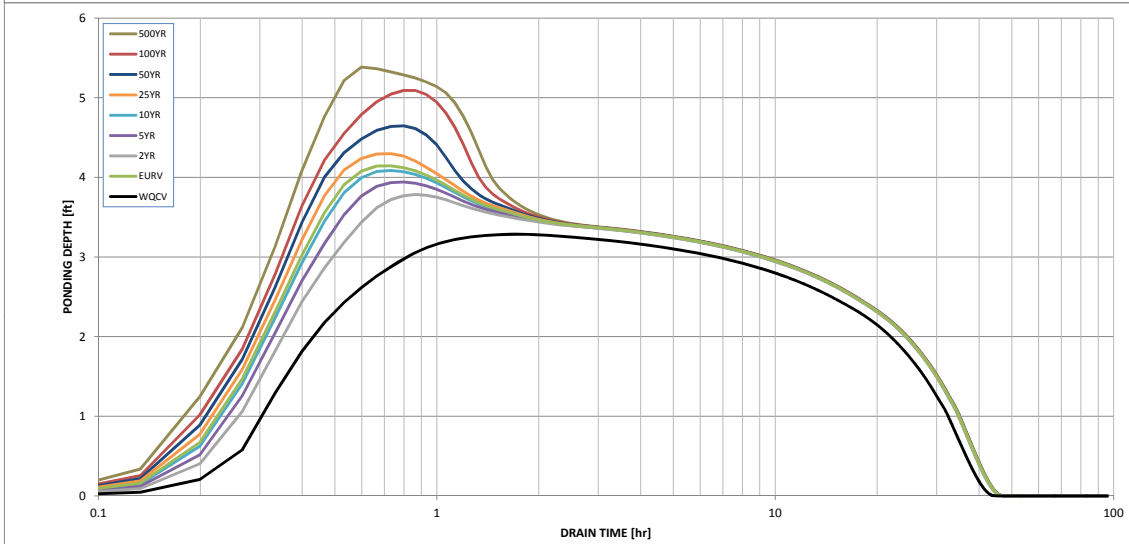
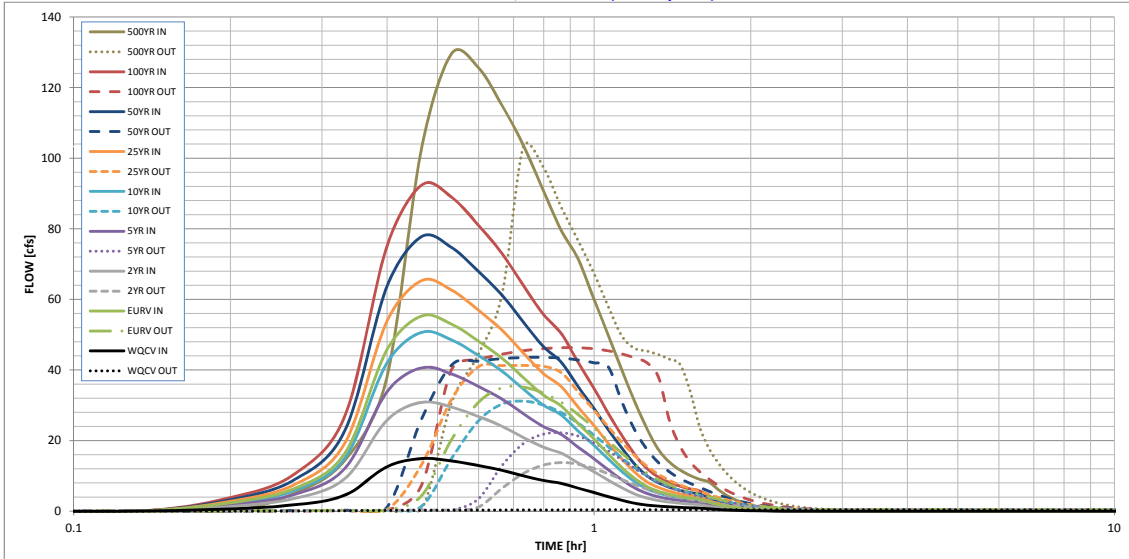

S-A-V-D Chart Axis Override	X-axis	Left Y-Axis	Right Y-Axis
minimum bound			
maximum bound			

DETENTION BASIN STAGE-STORAGE TABLE BUILDER

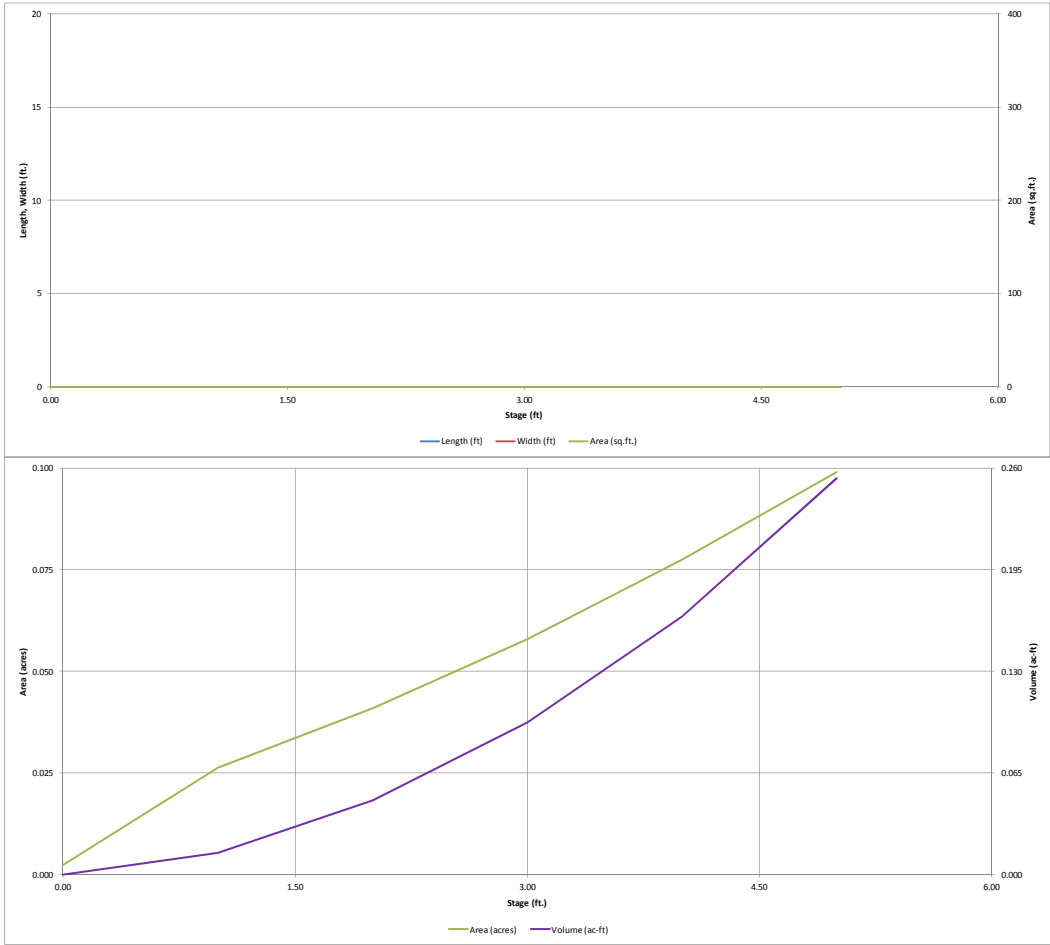

Detention Basin Outlet Structure Design

Project: **FALCON MARKETPLACE**
Basin ID: **POND #3**

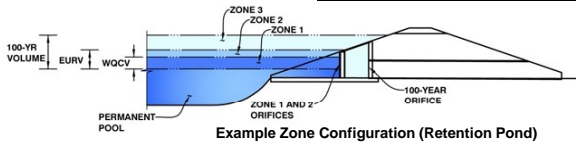

	Stage (ft)	Zone Volume (ac-ft)	Outlet Type
Zone 1 (WQCV)	2.89	0.091	Orifice Plate
Zone 2			Weir&Pipe (Circular)
Zone 3			
		0.091	Total

User Input: Orifice at Underdrain Outlet (typically used to drain WQCV in a Filtration BMP)

Underdrain Orifice Invert Depth = ft (distance below the filtration media surface)
Underdrain Orifice Diameter = inches

Calculated Parameters for Underdrain

Underdrain Orifice Area = ft²
Underdrain Orifice Centroid = feet

User Input: Orifice Plate with one or more orifices or Elliptical Slot Weir (typically used to drain WQCV and/or EURV in a sedimentation BMP)

Invert of Lowest Orifice = ft (relative to basin bottom at Stage = 0 ft)
Depth at top of Zone using Orifice Plate = ft (relative to basin bottom at Stage = 0 ft)
Orifice Plate: Orifice Vertical Spacing = inches
Orifice Plate: Orifice Area per Row = sq. inches (diameter = 3/4 inch)

Calculated Parameters for Plate

WQ Orifice Area per Row = ft²
Elliptical Half-Width = feet
Elliptical Slot Centroid = feet
Elliptical Slot Area = ft²

User Input: Stage and Total Area of Each Orifice Row (numbered from lowest to highest)

	Row 1 (required)	Row 2 (optional)	Row 3 (optional)	Row 4 (optional)	Row 5 (optional)	Row 6 (optional)	Row 7 (optional)	Row 8 (optional)
Stage of Orifice Centroid (ft)	0.00	0.96	1.93					
Orifice Area (sq. inches)	0.43	0.43	0.43					

	Row 9 (optional)	Row 10 (optional)	Row 11 (optional)	Row 12 (optional)	Row 13 (optional)	Row 14 (optional)	Row 15 (optional)	Row 16 (optional)
Stage of Orifice Centroid (ft)								
Orifice Area (sq. inches)								

User Input: Vertical Orifice (Circular or Rectangular)

	Not Selected	Not Selected	
Invert of Vertical Orifice =			ft (relative to basin bottom at Stage = 0 ft)
Depth at top of Zone using Vertical Orifice =			ft (relative to basin bottom at Stage = 0 ft)
Vertical Orifice Diameter =			inches

Calculated Parameters for Vertical Orifice

	Not Selected	Not Selected	
Vertical Orifice Area =			ft ²
Vertical Orifice Centroid =			feet

User Input: Overflow Weir (Dropbox) and Grate (Flat or Sloped)

	Zone 2 Weir	Not Selected	
Overflow Weir Front Edge Height, H _o =	3.00		ft (relative to basin bottom at Stage = 0 ft)
Overflow Weir Front Edge Length =	3.00		feet
Overflow Weir Slope =	0.00		H:V (enter zero for flat grate)
Horiz. Length of Weir Sides =	3.00		feet
Overflow Grate Open Area % =	70%		% grate open area/total area
Debris Clogging % =	50%		%

Calculated Parameters for Overflow Weir

	Zone 2 Weir	Not Selected	
Height of Grate Upper Edge, H ₁ =	3.00		feet
Over Flow Weir Slope Length =	3.00		feet
Grate Open Area / 100-yr Orifice Area =	3.57		should be ≥ 4
Overflow Grate Open Area w/o Debris =	6.30		ft ²
Overflow Grate Open Area w/ Debris =	3.15		ft ²

User Input: Outlet Pipe w/ Flow Restriction Plate (Circular Orifice, Restrictor Plate, or Rectangular Orifice)

	Zone 2 Circular	Not Selected	
Depth to Invert of Outlet Pipe =	0.00		ft (distance below basin bottom at Stage = 0 ft)
Circular Orifice Diameter =	18.00		inches

Calculated Parameters for Outlet Pipe w/ Flow Restriction Plate

	Zone 2 Circular	Not Selected	
Outlet Orifice Area =	1.77		ft ²
Outlet Orifice Centroid =	0.75		feet
Half-Central Angle of Restrictor Plate on Pipe =	N/A	N/A	radians

User Input: Emergency Spillway (Rectangular or Trapezoidal)

Spillway Invert Stage = ft (relative to basin bottom at Stage = 0 ft)
Spillway Crest Length = feet
Spillway End Slopes = H:V
Freeboard above Max Water Surface = feet

Calculated Parameters for Spillway

Spillway Design Flow Depth = feet
Stage at Top of Freeboard = feet
Basin Area at Top of Freeboard = acres

Routed Hydrograph Results

	WQCV	EURV	2 Year	5 Year	10 Year	25 Year	50 Year	100 Year	500 Year
Design Storm Return Period =									
One-Hour Rainfall Depth (in) =	0.53	1.07	0.95	1.34	1.64	2.02	2.32	2.61	3.29
Calculated Runoff Volume (acre-ft) =	0.091	0.312	0.160	0.239	0.323	0.484	0.591	0.710	0.986
OPTIONAL Override Runoff Volume (acre-ft) =									
Inflow Hydrograph Volume (acre-ft) =	0.090	0.311	0.159	0.239	0.322	0.483	0.591	0.710	0.985
Predevelopment Unit Peak Flow, q (cfs/acre) =	0.00	0.00	0.00	0.01	0.01	0.16	0.33	0.54	0.99
Predevelopment Peak Q (cfs) =	0.0	0.0	0.0	0.0	0.1	0.8	1.7	2.8	5.1
Peak Inflow Q (cfs) =	1.6	5.5	2.8	4.2	5.7	8.6	10.5	12.6	17.4
Peak Outflow Q (cfs) =	0.1	4.9	1.3	3.4	5.6	8.4	10.6	13.8	19.4
Ratio Peak Outflow to Predevelopment Q =	N/A	N/A	N/A	81.9	81.7	10.4	6.3	5.0	3.8
Structure Controlling Flow =	Plate	Overflow Grate 1	Overflow Grate 1	Overflow Grate 1	Overflow Grate 1	Overflow Grate 1	Overflow Grate 1	Overflow Grate 1	Spillway
Max Velocity through Grate 1 (fps) =	N/A	0.78	0.19	0.5	0.9	1.3	1.7	2.2	2.4
Max Velocity through Grate 2 (fps) =	N/A	N/A	N/A	N/A	N/A	N/A	N/A	N/A	N/A
Time to Drain 97% of Inflow Volume (hours) =	37	34	38	36	34	29	27	26	22
Time to Drain 99% of Inflow Volume (hours) =	40	41	43	41	40	39	37	36	34
Maximum Ponding Depth (ft) =	2.71	3.33	3.13	3.25	3.36	3.47	3.55	3.71	3.84
Area at Maximum Ponding Depth (acres) =	0.05	0.06	0.06	0.06	0.06	0.07	0.07	0.07	0.07
Maximum Volume Stored (acre-ft) =	0.081	0.117	0.105	0.113	0.119	0.126	0.132	0.143	0.153

Detention Basin Outlet Structure Design

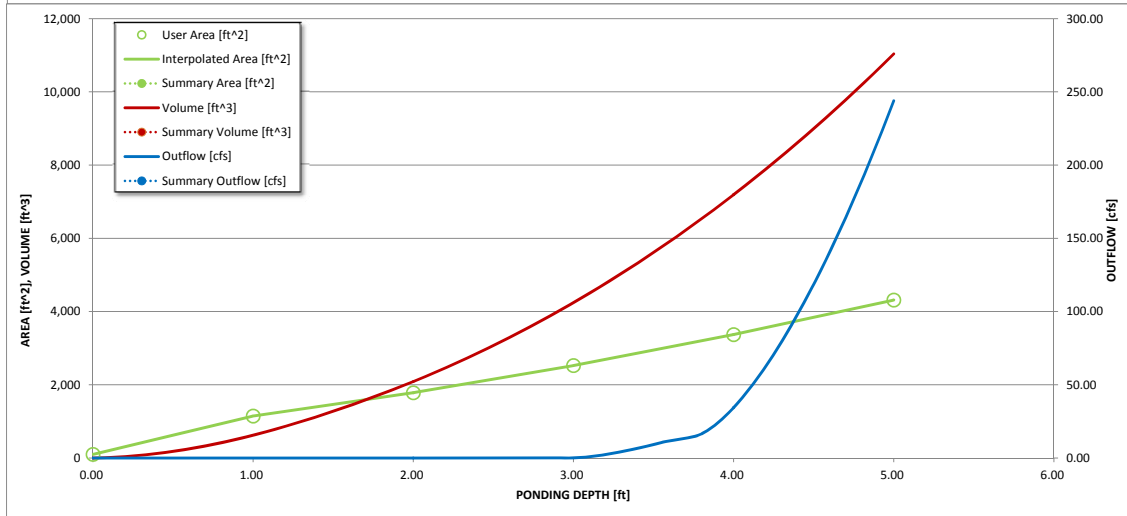
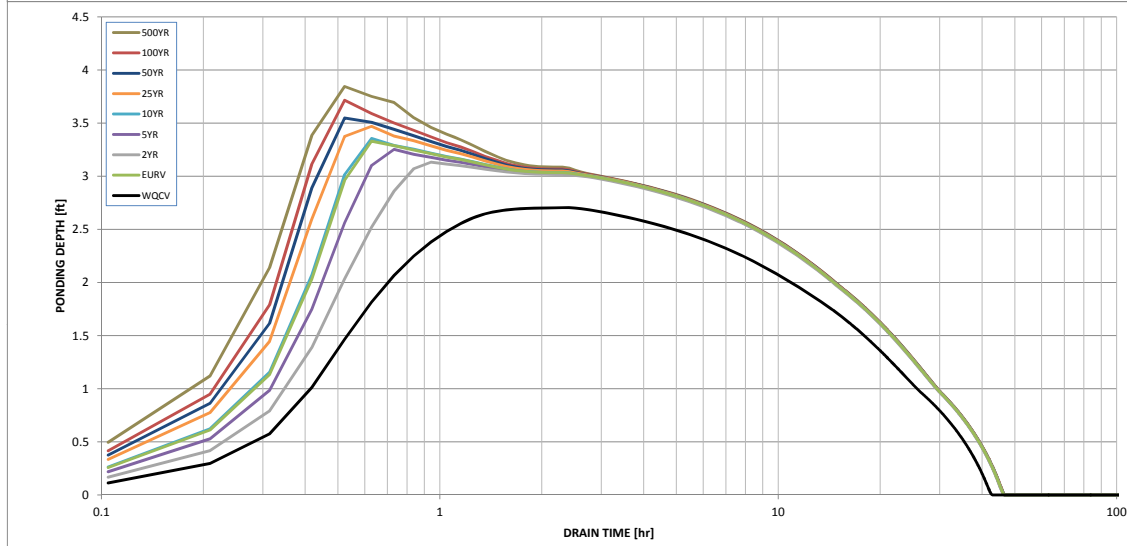
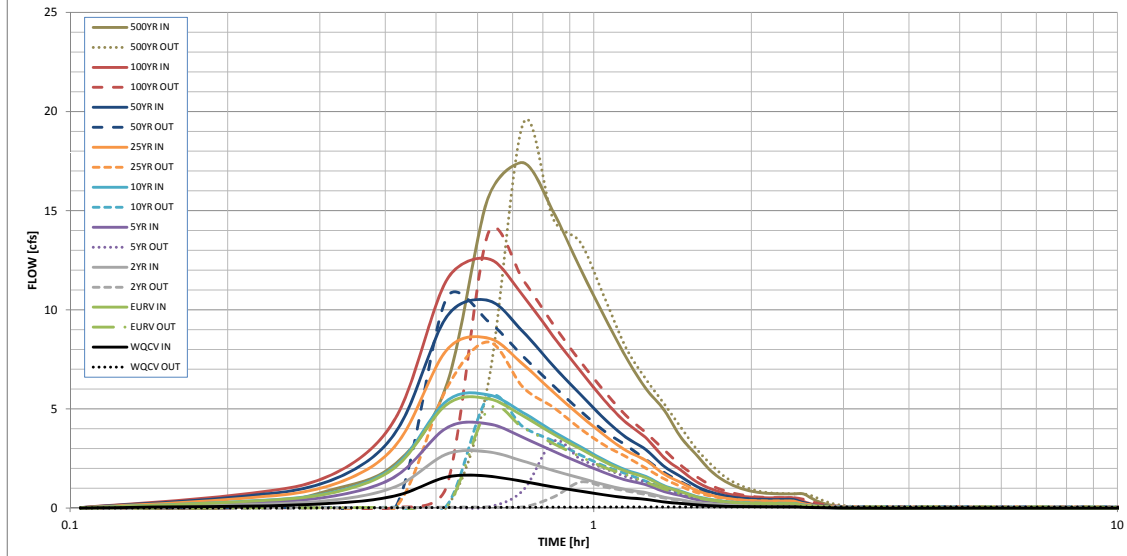

S-A-V-D Chart Axis Override

	X-axis	Left Y-Axis	Right Y-Axis
minimum bound			
maximum bound			

CLOMR Excerpts

Provide all, from previous version of this report.
(See previous redline pdf pgs 12-18?)

① Schematic

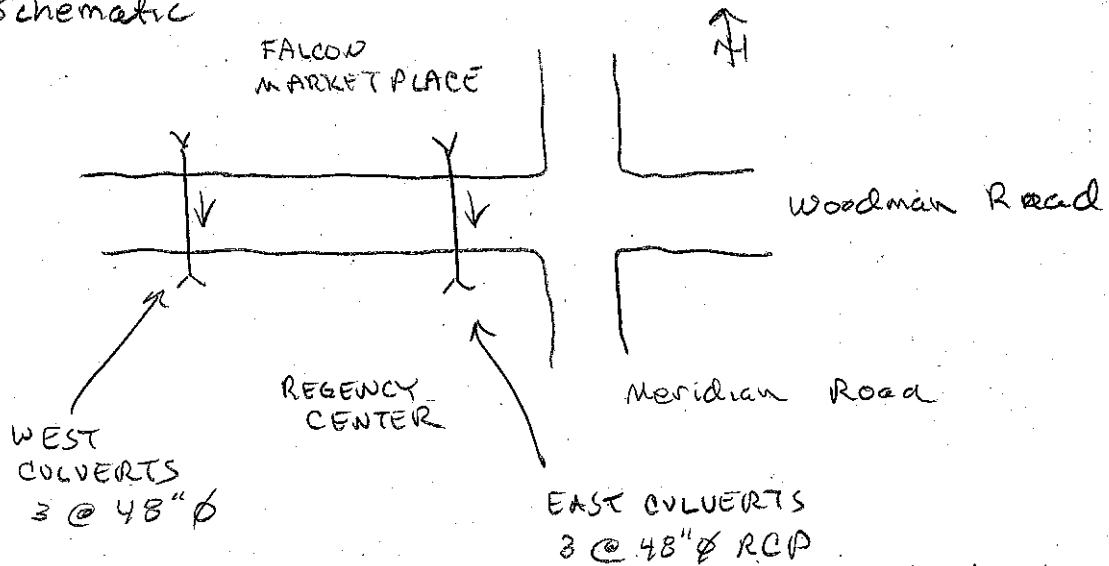

② USE FHWA HY-8 software to check culvert capacity

③ Model input based on 3 sources of information

a) project surveys by DBC for Falcon Marketplace
email 9/26/16

b) Design drawing from Regency Center
URS 8/24/04

c) Design drawing for culvert extension on north side of Woodman
DMJM Harris/AECOM 9/11/2007

d) see HY8 model output files
file: HY-8-Woodman Culverts.hy8

e) Design flow rate varied until allowable headwater elevation reached. Allowable headwater elevation = to north edge of Woodman Road Asphalt.

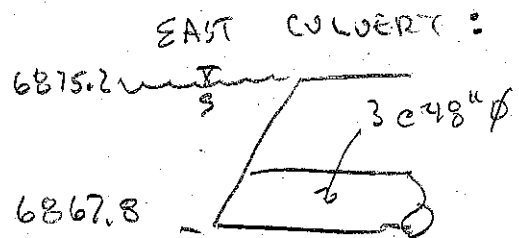
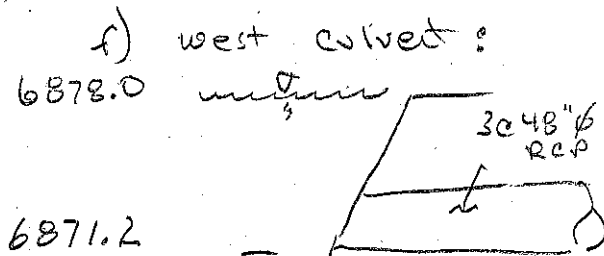

g) The Woodman Road culverts discharge to large 84" culvert & 8' x 8' culvert on the Regency Center property that are @ a significantly lower elevation.

than the invert of the 48" ϕ pipes;
 therefore inlet control conditions are
 anticipate w/ no backwater from
 downstream

④ see HY-8 output

a) west Culvert: $Q_{cap} = 355$ cfs w/ HW @ 6877.99
 ≈ 6878

b) East Culvert: $Q_{cap} = 405$ cfs w/ HW @ 6875.12
 ≈ 6875.2

c) Total Capacity 760 cfs

d) Also looked @ capacity of both
 culverts with the lower allowable
 headwater elevation

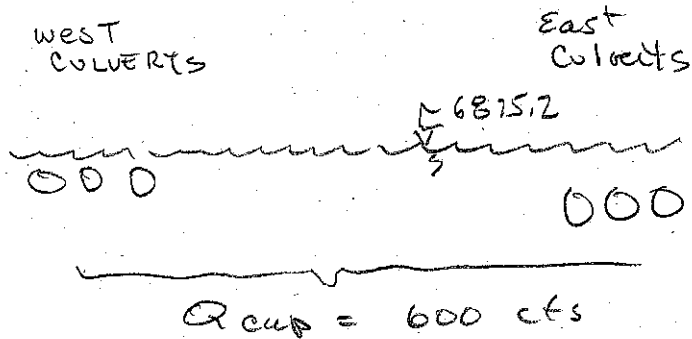

HY-8 Culvert Analysis Report

Project Notes

Project Title:

Designer:

Project Date: Wednesday, September 28, 2016

Notes:

Project Units: U.S. Customary Units

Outlet Control Option: Profiles

Exit Loss Option: Standard Method

Crossing Notes: East Culvert

Table 1 - Summary of Culvert Flows at Crossing: East Culvert

Headwater Elevation (ft)	Total Discharge (cfs)	East Discharge (cfs)	Roadway Discharge (cfs)	Iterations
6867.80	0.00	0.00	0.00	1
6869.44	50.00	50.00	0.00	1
6870.26	100.00	100.00	0.00	1
6870.95	150.00	150.00	0.00	1
6871.58	200.00	200.00	0.00	1
6872.41	250.00	250.00	0.00	1
6873.01	300.00	300.00	0.00	1
6873.88	350.00	350.00	0.00	1
6875.00	400.00	400.00	0.00	1
6875.12	405.00	405.00	0.00	1
6875.78	500.00	432.38	67.60	5
6875.20	408.39	408.39	0.00	Overtopping

Rating Curve Plot for Crossing: East Culvert

Total Rating Curve

Crossing: East Culvert

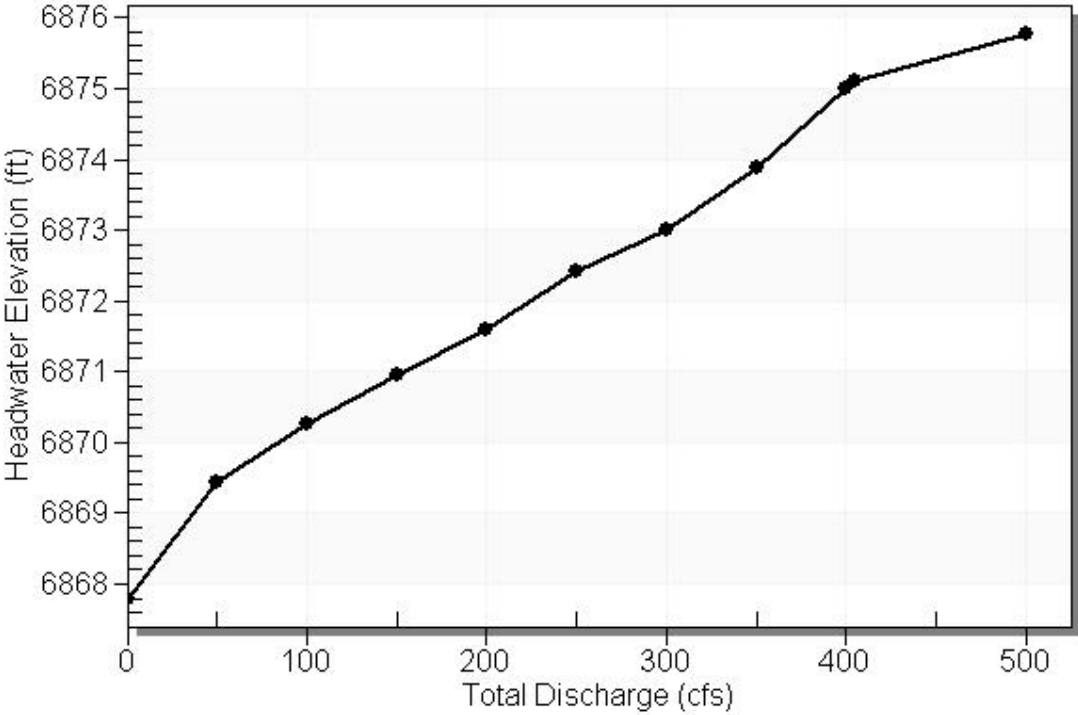

Crossing Front View (Roadway Profile): East Culvert

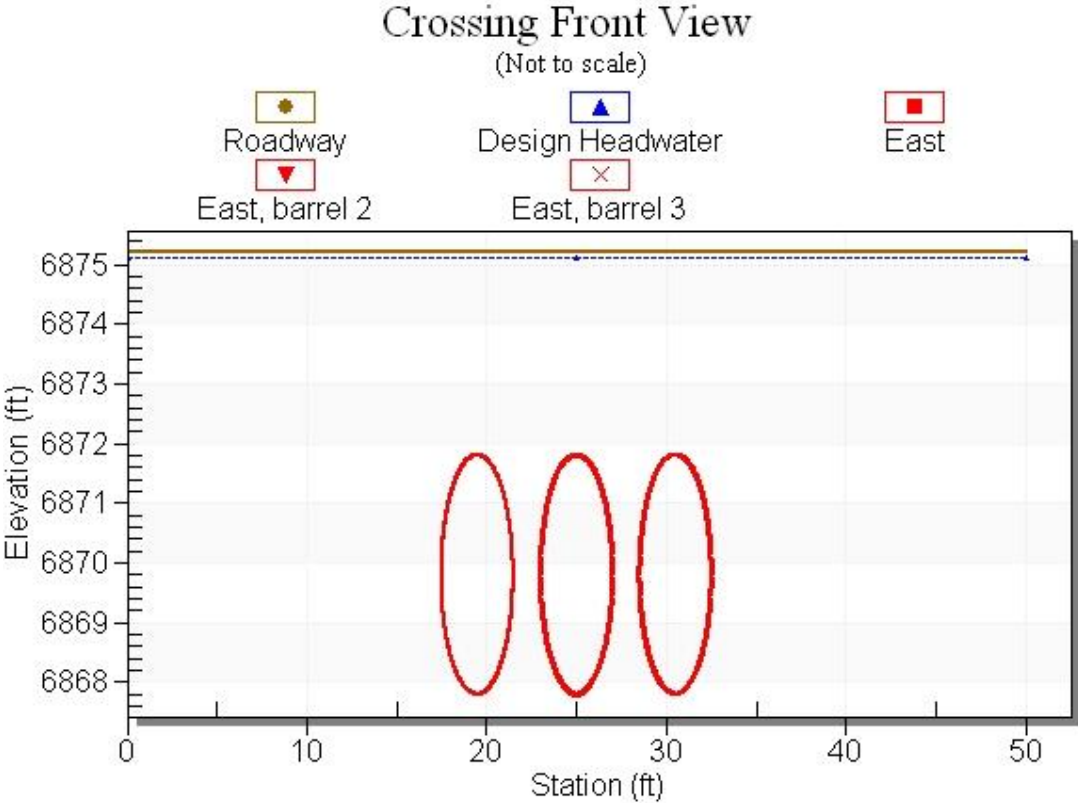

Culvert Notes: East

Table 2 - Culvert Summary Table: East

Total Discharge (cfs)	Culvert Discharge (cfs)	Headwater Elevation (ft)	Inlet Control Depth (ft)	Outlet Control Depth (ft)	Flow Type	Normal Depth (ft)	Critical Depth (ft)	Outlet Depth (ft)	Tailwater Depth (ft)	Outlet Velocity (ft/s)	Tailwater Velocity (ft/s)
0.00	0.00	6867.80	0.000	0.0*	0-NF	0.000	0.000	0.000	0.000	0.000	0.000
50.00	50.00	6869.44	1.645	0.0*	1-S2n	1.114	1.197	1.117	0.745	5.778	8.385
100.00	100.00	6870.26	2.457	0.0*	1-S2n	1.620	1.708	1.622	1.169	6.978	10.692
150.00	150.00	6870.95	3.153	0.0*	1-S2n	2.042	2.114	2.043	1.532	7.747	12.238
200.00	200.00	6871.58	3.785	0.0*	1-S2n	2.445	2.461	2.445	1.864	8.280	13.414
250.00	250.00	6872.41	4.445	4.610	2-M2c	2.874	2.763	2.766	2.175	8.989	14.366
300.00	300.00	6873.01	5.196	5.208	2-M2c	3.464	3.018	3.030	2.473	9.792	15.165
350.00	350.00	6873.88	6.077	6.001	2-M2c	4.000	3.246	3.258	2.760	10.663	15.852
400.00	400.00	6875.00	7.109	7.200	7-M2c	4.000	3.420	3.447	3.039	11.579	16.454
405.00	405.00	6875.12	7.221	7.318	7-M2c	4.000	3.437	3.464	3.066	11.676	16.509
500.00	432.38	6875.78	7.861	7.984	7-M2c	4.000	3.533	3.544	3.578	12.241	17.466

* theoretical depth is impractical. Depth reported is corrected.

Inlet Elevation (invert): 6867.80 ft, Outlet Elevation (invert): 6866.90 ft
Culvert Length: 200.00 ft, Culvert Slope: 0.0045

Culvert Performance Curve Plot: East

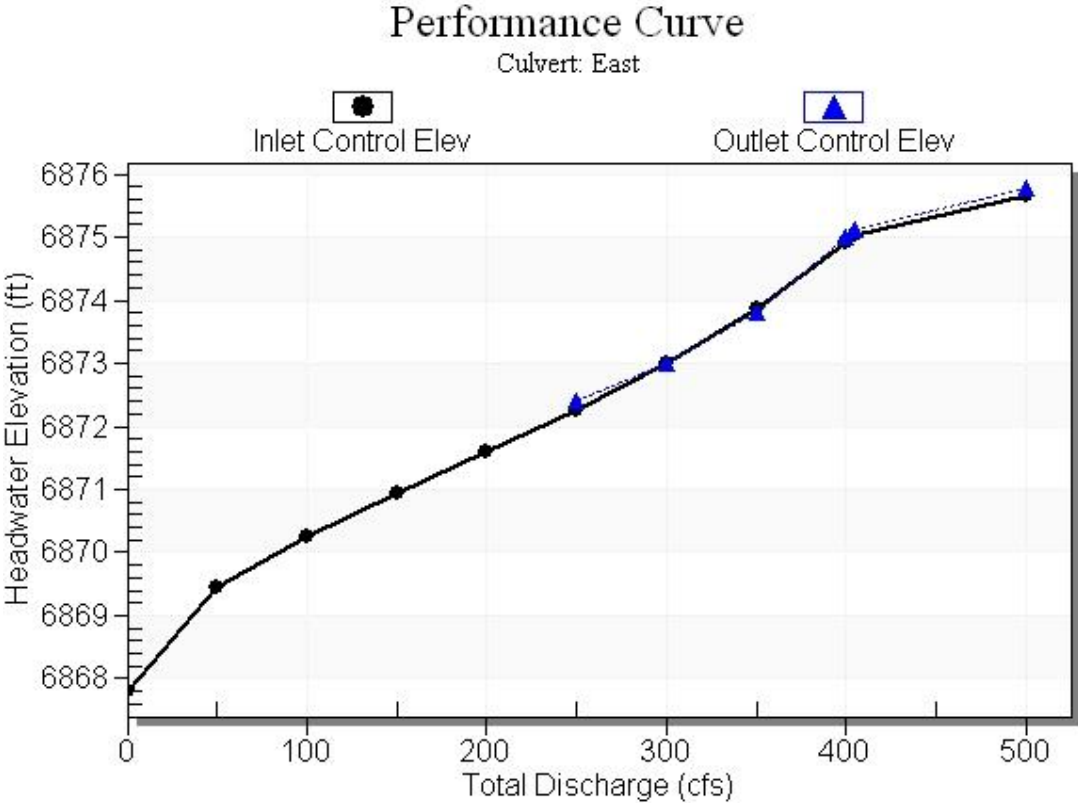

Water Surface Profile Plot for Culvert: East

Crossing - East Culvert , Design Discharge - 405.0 cfs

Culvert - East, Culvert Discharge - 405.0 cfs

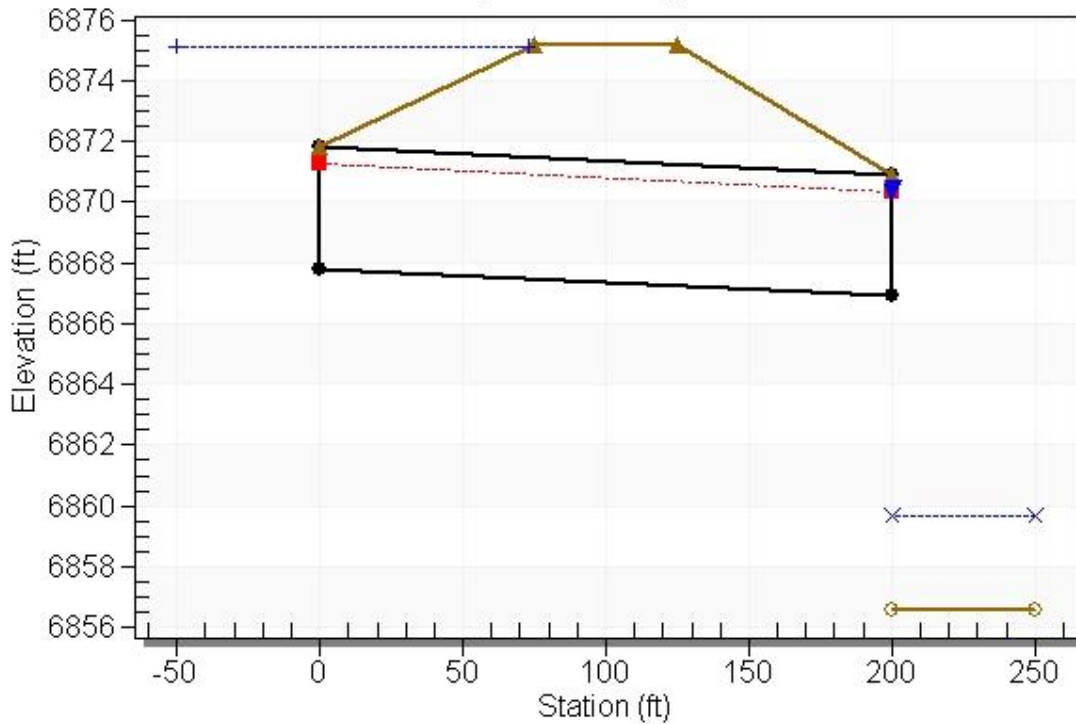

Site Data - East

Site Data Option: Culvert Invert Data

Inlet Station: 0.00 ft

Inlet Elevation: 6867.80 ft

Outlet Station: 200.00 ft

Outlet Elevation: 6866.90 ft

Number of Barrels: 3

Culvert Data Summary - East

Barrel Shape: Circular

Barrel Diameter: 4.00 ft

Barrel Material: Concrete

Embedment: 0.00 in

Barrel Manning's n: 0.0130

Inlet Type: Conventional

Inlet Edge Condition: Square Edge with Headwall

Inlet Depression: NONE

Table 3 - Downstream Channel Rating Curve (Crossing: East Culvert)

Flow (cfs)	Water Surface Elev (ft)	Depth (ft)	Velocity (ft/s)	Shear (psf)	Froude Number
0.00	6856.60	0.00	0.00	0.00	0.00
50.00	6857.35	0.75	8.39	0.47	1.71
100.00	6857.77	1.17	10.69	0.73	1.74
150.00	6858.13	1.53	12.24	0.96	1.74
200.00	6858.46	1.86	13.41	1.16	1.73
250.00	6858.78	2.18	14.37	1.36	1.72
300.00	6859.07	2.47	15.17	1.54	1.70
350.00	6859.36	2.76	15.85	1.72	1.68
400.00	6859.64	3.04	16.45	1.90	1.66
405.00	6859.67	3.07	16.51	1.91	1.66
500.00	6860.18	3.58	17.47	2.23	1.63

Tailwater Channel Data - East Culvert

Tailwater Channel Option: Rectangular Channel

Bottom Width: 8.00 ft

Channel Slope: 0.0100

Channel Manning's n: 0.0130

Channel Invert Elevation: 6856.60 ft

Tailwater Rating Curve Plot for Crossing: East Culvert

Downstream Channel Rating Curve

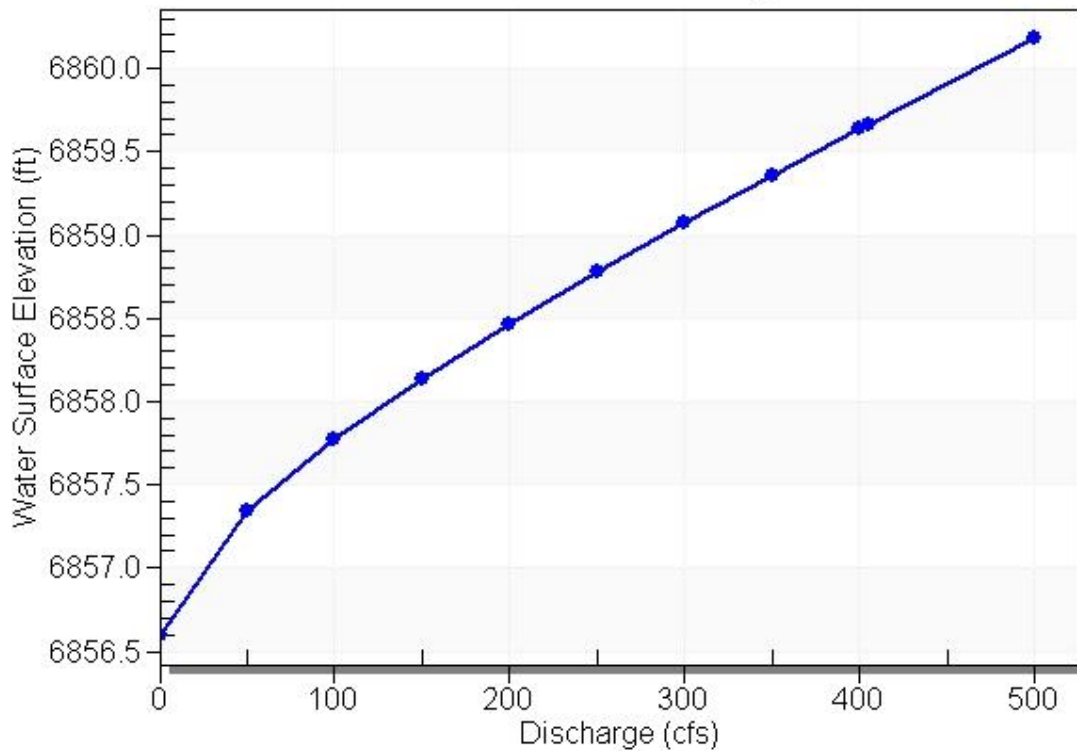

Roadway Data for Crossing: East Culvert

Roadway Profile Shape: Irregular Roadway Shape (coordinates)

Irregular Roadway Cross-Section:

Coord No.	Station (ft)	Elevation (ft)
0	0.00	6875.20
1	25.00	6875.20
2	50.00	6875.20

Roadway Surface: Paved

Roadway Top Width: 50.00 ft

HY-8 Culvert Analysis Report

Project Notes

Project Title:

Designer:

Project Date: Wednesday, September 28, 2016

Notes:

Project Units: U.S. Customary Units

Outlet Control Option: Profiles

Exit Loss Option: Standard Method

Crossing Notes: West Culvert

Table 1 - Summary of Culvert Flows at Crossing: West Culvert

Headwater Elevation (ft)	Total Discharge (cfs)	West Discharge (cfs)	Roadway Discharge (cfs)	Iterations
6871.20	0.00	0.00	0.00	1
6873.04	50.00	50.00	0.00	1
6873.88	100.00	100.00	0.00	1
6874.60	150.00	150.00	0.00	1
6875.27	200.00	200.00	0.00	1
6875.96	250.00	250.00	0.00	1
6876.84	300.00	300.00	0.00	1
6877.87	350.00	350.00	0.00	1
6877.99	355.00	355.00	0.00	1
6878.59	450.00	381.65	68.32	5
6878.80	500.00	390.91	108.90	4
6878.00	355.54	355.54	0.00	Overtopping

Rating Curve Plot for Crossing: West Culvert

Total Rating Curve

Crossing: West Culvert

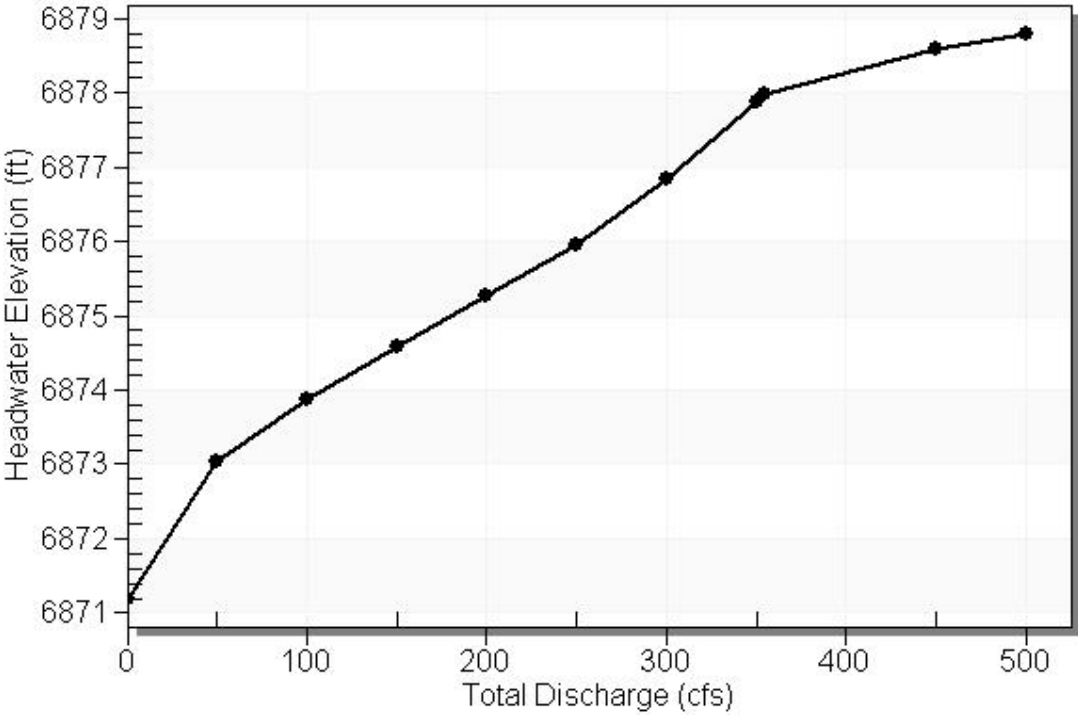

Crossing Front View (Roadway Profile): West Culvert

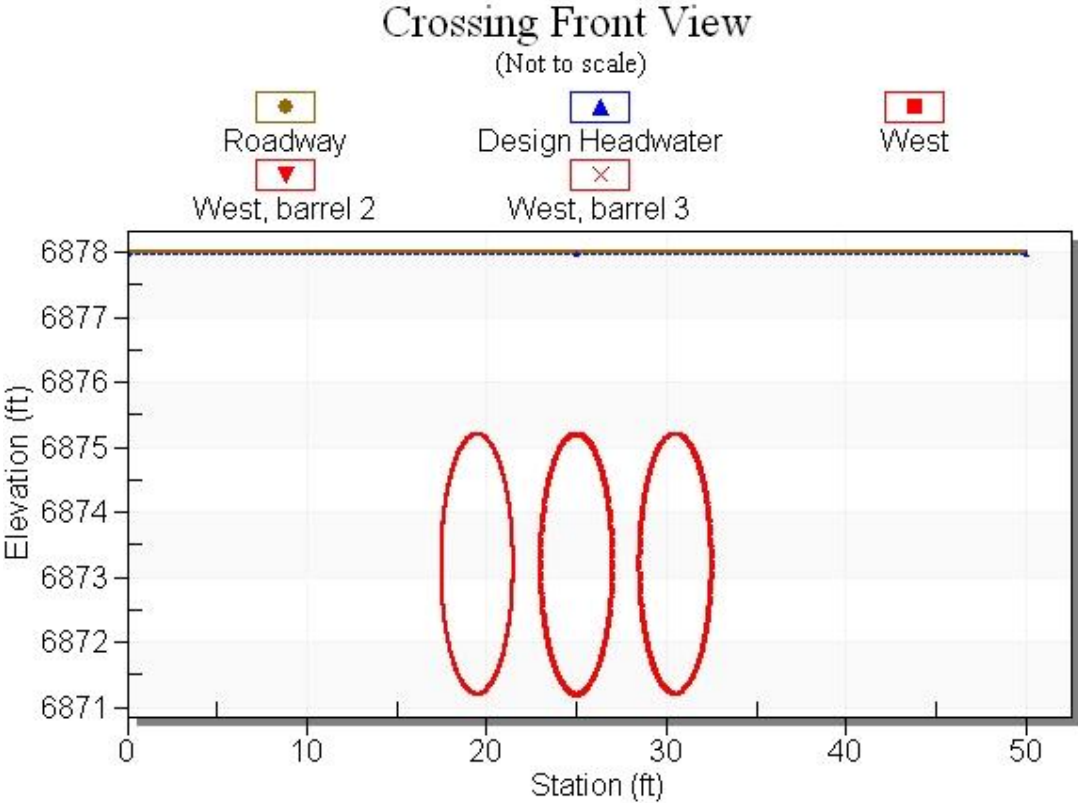

Culvert Notes: West

Table 2 - Culvert Summary Table: West

Total Discharge (cfs)	Culvert Discharge (cfs)	Headwater Elevation (ft)	Inlet Control Depth (ft)	Outlet Control Depth (ft)	Flow Type	Normal Depth (ft)	Critical Depth (ft)	Outlet Depth (ft)	Tailwater Depth (ft)	Outlet Velocity (ft/s)	Tailwater Velocity (ft/s)
0.00	0.00	6871.20	0.000	0.0*	0-NF	0.000	0.000	0.000	0.000	0.000	0.000
50.00	50.00	6873.04	1.649	1.836	2-M2c	1.492	1.197	1.197	0.821	5.273	8.705
100.00	100.00	6873.88	2.463	2.685	2-M2c	2.228	1.708	1.716	1.297	6.473	11.017
150.00	150.00	6874.60	3.159	3.396	2-M2c	2.970	2.114	2.121	1.709	7.390	12.536
200.00	200.00	6875.27	3.791	4.071	2-M2c	4.000	2.461	2.465	2.090	8.203	13.674
250.00	250.00	6875.96	4.451	4.755	2-M2c	4.000	2.763	2.766	2.449	8.989	14.582
300.00	300.00	6876.84	5.202	5.642	7-M2c	4.000	3.018	3.030	2.795	9.792	15.335
350.00	350.00	6877.87	6.083	6.665	7-M2c	4.000	3.246	3.258	3.130	10.646	15.976
355.00	355.00	6877.99	6.179	6.787	7-M2c	4.000	3.264	3.278	3.163	10.735	16.035
450.00	381.65	6878.59	6.718	7.388	7-M2c	4.000	3.356	3.380	3.777	11.230	17.019
500.00	390.91	6878.80	6.916	7.602	7-M2c	4.000	3.388	3.413	4.093	11.410	17.453

* theoretical depth is impractical. Depth reported is corrected.

Inlet Elevation (invert): 6871.20 ft, Outlet Elevation (invert): 6870.90 ft
Culvert Length: 200.00 ft, Culvert Slope: 0.0015

Culvert Performance Curve Plot: West

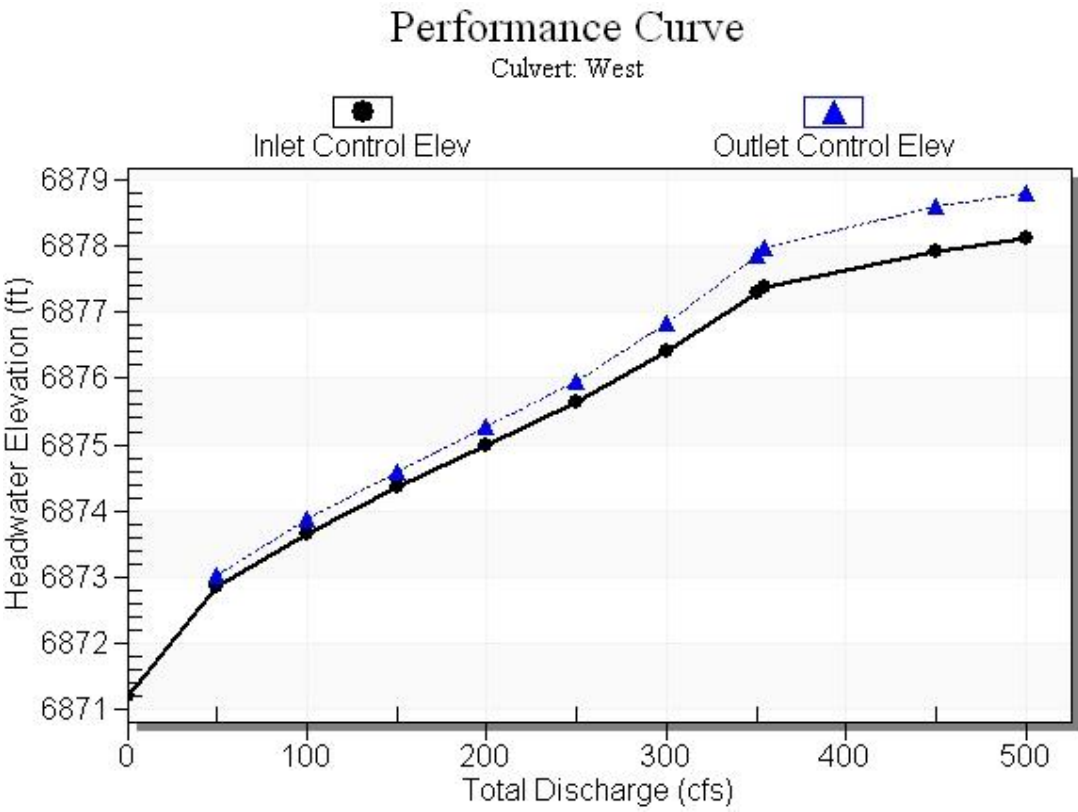

Water Surface Profile Plot for Culvert: West

Crossing - West Culvert, Design Discharge - 355.0 cfs

Culvert - West, Culvert Discharge - 355.0 cfs

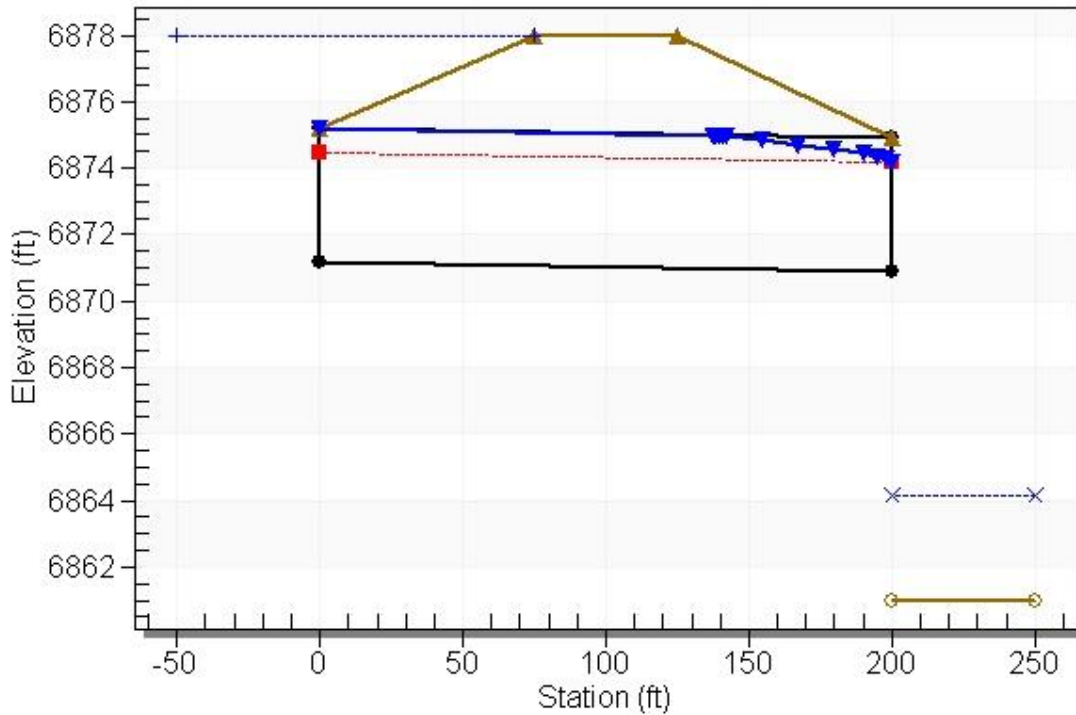

Site Data - West

Site Data Option: Culvert Invert Data

Inlet Station: 0.00 ft

Inlet Elevation: 6871.20 ft

Outlet Station: 200.00 ft

Outlet Elevation: 6870.90 ft

Number of Barrels: 3

Culvert Data Summary - West

Barrel Shape: Circular

Barrel Diameter: 4.00 ft

Barrel Material: Concrete

Embedment: 0.00 in

Barrel Manning's n: 0.0130

Inlet Type: Conventional

Inlet Edge Condition: Square Edge with Headwall

Inlet Depression: NONE

Table 3 - Downstream Channel Rating Curve (Crossing: West Culvert)

Flow (cfs)	Water Surface Elev (ft)	Depth (ft)	Velocity (ft/s)	Shear (psf)	Froude Number
0.00	6861.00	0.00	0.00	0.00	0.00
50.00	6861.82	0.82	8.71	0.51	1.69
100.00	6862.30	1.30	11.02	0.81	1.71
150.00	6862.71	1.71	12.54	1.07	1.69
200.00	6863.09	2.09	13.67	1.30	1.67
250.00	6863.45	2.45	14.58	1.53	1.64
300.00	6863.79	2.79	15.34	1.74	1.62
350.00	6864.13	3.13	15.98	1.95	1.59
355.00	6864.16	3.16	16.03	1.97	1.59
450.00	6864.78	3.78	17.02	2.36	1.54
500.00	6865.09	4.09	17.45	2.55	1.52

Tailwater Channel Data - West Culvert

Tailwater Channel Option: Rectangular Channel

Bottom Width: 7.00 ft

Channel Slope: 0.0100

Channel Manning's n: 0.0130

Channel Invert Elevation: 6861.00 ft

Tailwater Rating Curve Plot for Crossing: West Culvert

Downstream Channel Rating Curve

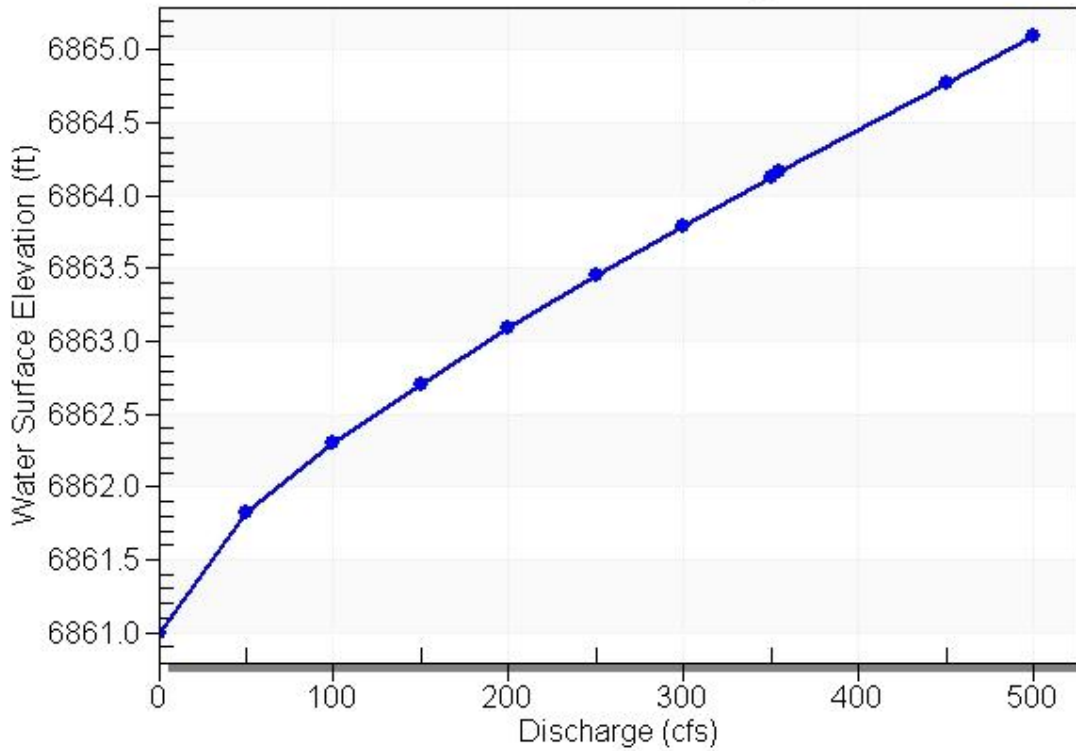

Roadway Data for Crossing: West Culvert

Roadway Profile Shape: Irregular Roadway Shape (coordinates)

Irregular Roadway Cross-Section:

Coord No.	Station (ft)	Elevation (ft)
0	0.00	6878.00
1	25.00	6878.00
2	50.00	6878.00

Roadway Surface: Paved

Roadway Top Width: 50.00 ft

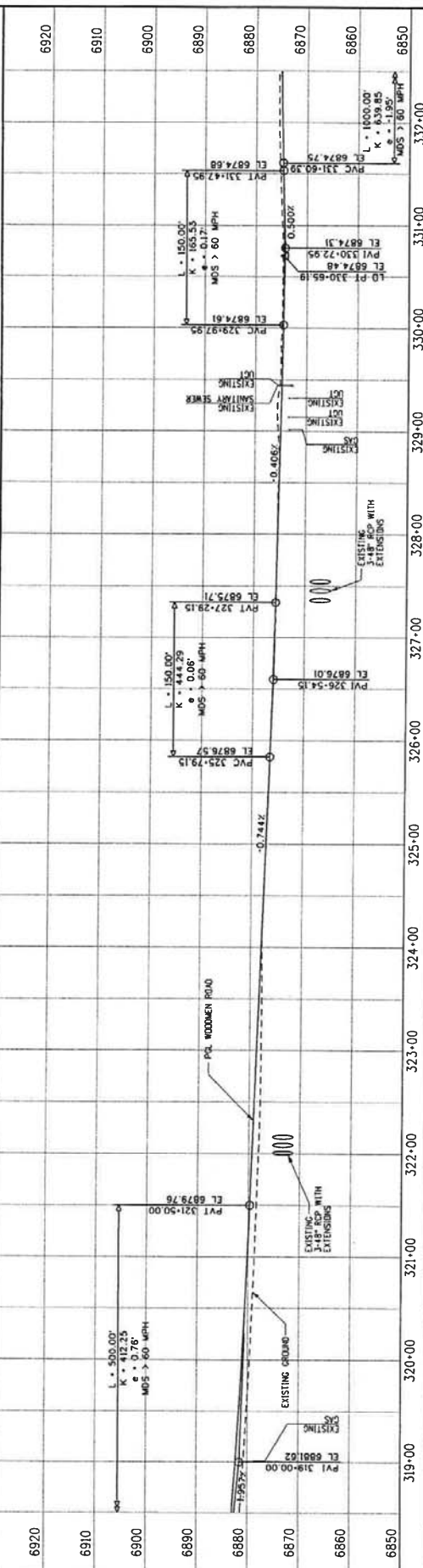
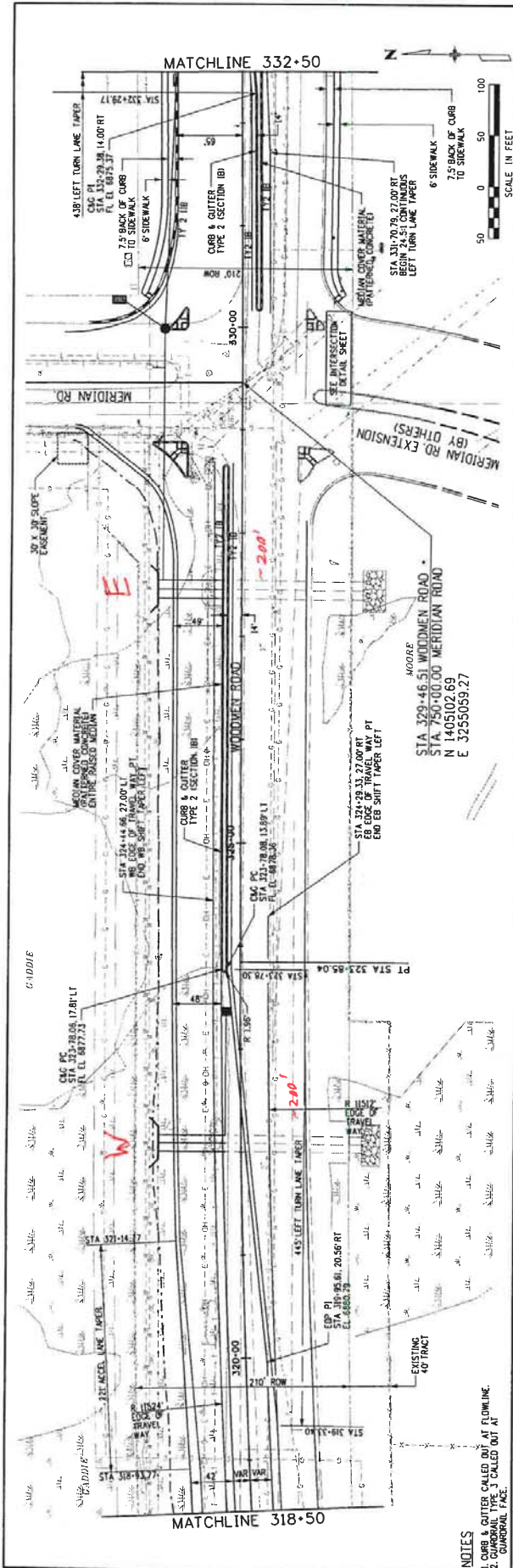

Computer File Information		Sheet Revisions		As Constructed		Project No./Code	
Creditor Date:	02/07/06	Initials:	LPS	No Revisions:	-	WOODMEN ROAD	
Last Modification Date:	9/11/2007	Initials:	LPS	Revised:	-	PLAN & PROFILE - WOODMEN ROAD	
Full Path:	V:\P24\1954_0804\Roadway\RDPP2.dgn	Drawn:	LPS	Void:	-	STU M240-062	
Drawing Scale:	1"=50'	Detailer:	LPS	Structure Numbers:	13263		
Units:	ENGLISH	Sheet Subject:	ROADWAY	Subst. Sheets:	RDPP23 of 38		
Ver. Ver.:	08.00.01.19					Sheet Number	

- NOTES**
- CURB & GUTTER CALLED OUT AT FLOWLINE.
 - GUARDRAIL TYPE 3 CALLED OUT AT GUARDRAIL FACE.

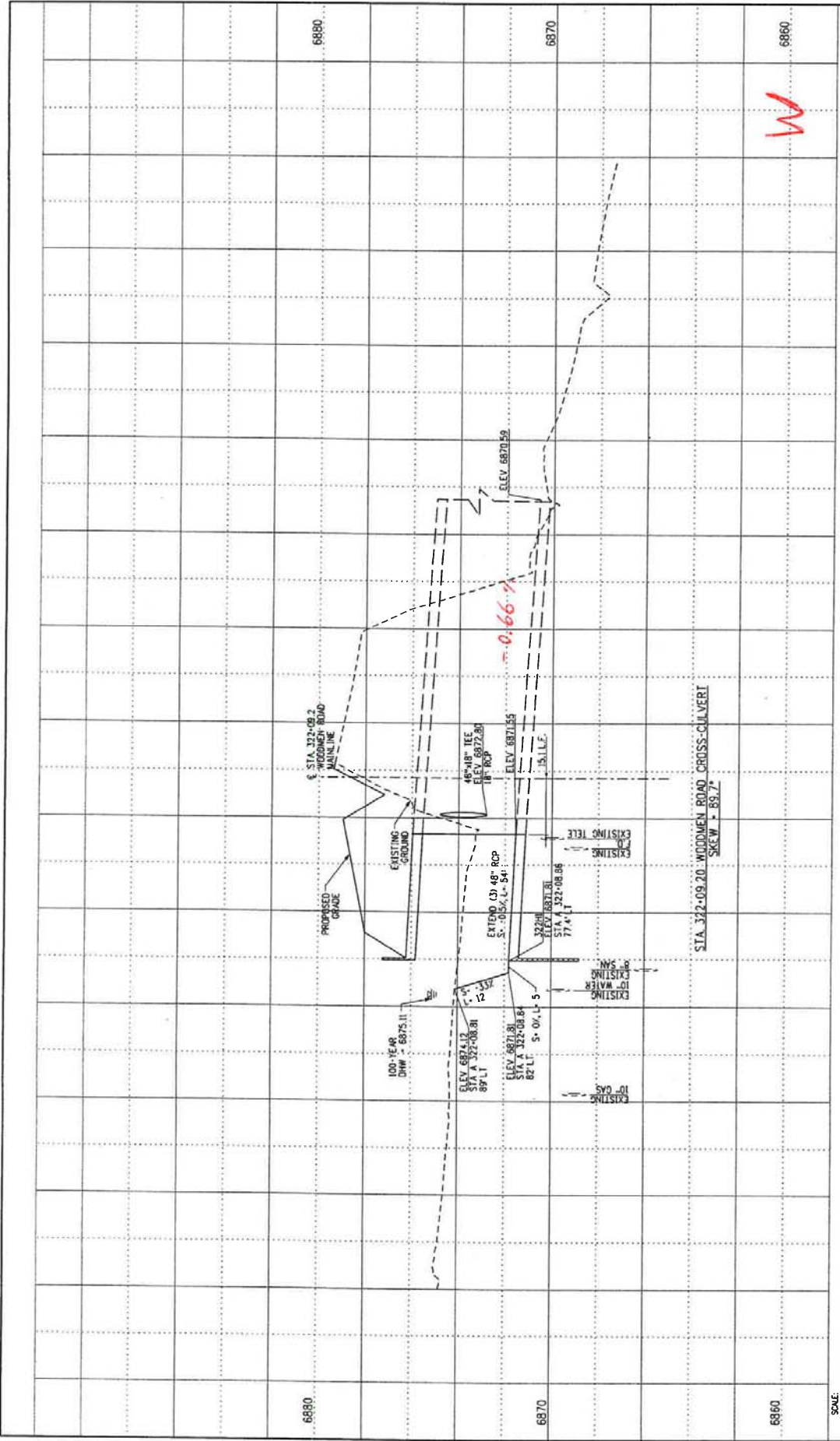

W

SCALE: 1" = 40' HORIZONTAL 1" = 4' VERTICAL		Computer File Information Creation Date: 02/20/06 Initials: LPS Last Modification Date: 9/17/2007 Initials: LPS Full Path: C:\V854\V854_0604\wood\Woodmen\44PRSTR45.dgn Drawing Scale: 1=20 VB Ver.: 08.00.01.19 Units: ENGLISH		Sheet Revisions <table border="1"> <tr><td> </td><td> </td><td> </td><td> </td><td> </td></tr> <tr><td> </td><td> </td><td> </td><td> </td><td> </td></tr> <tr><td> </td><td> </td><td> </td><td> </td><td> </td></tr> <tr><td> </td><td> </td><td> </td><td> </td><td> </td></tr> </table>																						DMJM HARRIS AECOM 2850 Professional Place Denver, Colorado 80204 Phone: (303) 386-8000 Fax: (303) 386-8008				As Constructed No Revisions: - Revised: - Void: -		WOODMEN ROAD STORM SEWER PROFILE - WOODMEN RD. STA. 322+09.20 Designer: LPS Checker: LPS Sheet Subset: DMMAN02 Sheet Sheets: DR45 of 50		Project No./Code STU M240-062 13263 Sheet Number 193	

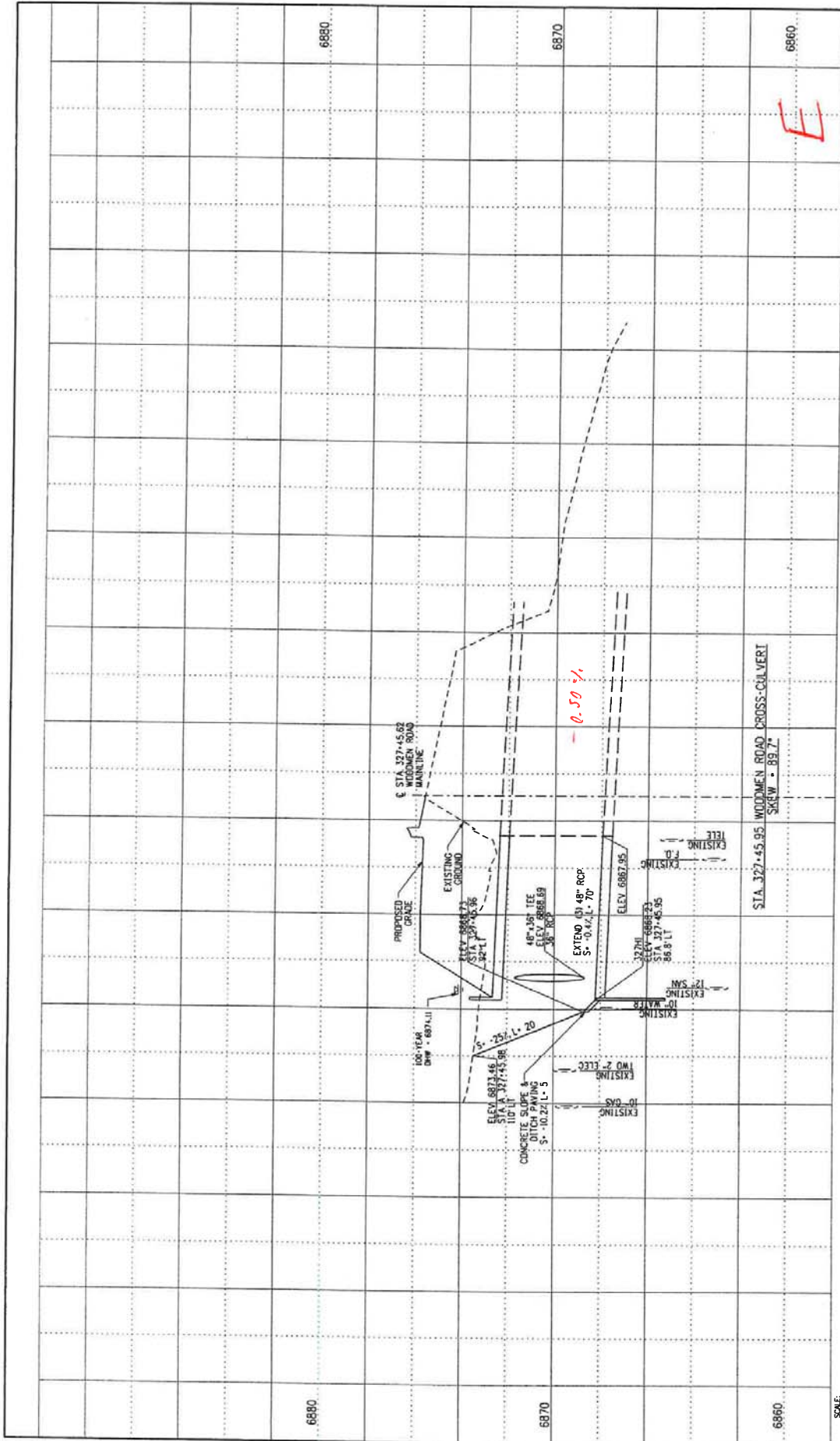

SCALE:
 1" = 40' HORIZONTAL
 1" = 4' VERTICAL

Computer File Information		Sheet Revisions		As Constructed		WOODMEN ROAD STORM SEWER PROFILE - WOODMEN RD STA 327+45.95		Project No./Code	
Creation Date:	07/20/06	Initials:	LPS	No Revisions:	-	STU M240-062	Decision:	13263	Sheet No. / Code
Last Modification Date:	10/11/2007	Initials:	LPS	Revised:	-	Decision:	13263	Sheet Number	
Full Path:	E:\655A\655A_060A\Local\Drawings\4485STR17.dwg	Initials:	LPS	Void:	-	Decision:	13263		
Drawing Scale:	1"=20'	Units:	ENGLISH	Sheet Subject:	DOWNWELL	Sheet Sheets:	DR47	of 50	



DMJM HARRIS AECOM
 9950 Perimeter Road
 Colorado Springs, Colorado 80904
 Phone: (719) 386-8300 Fax: (719) 386-8338

00000

Falcon DBPS Excerpts

Provide peak flow table and Figure 5-3 and/or corrected Figure 6-1.

Verify Pond SR4 inlet covers this area or re-model.

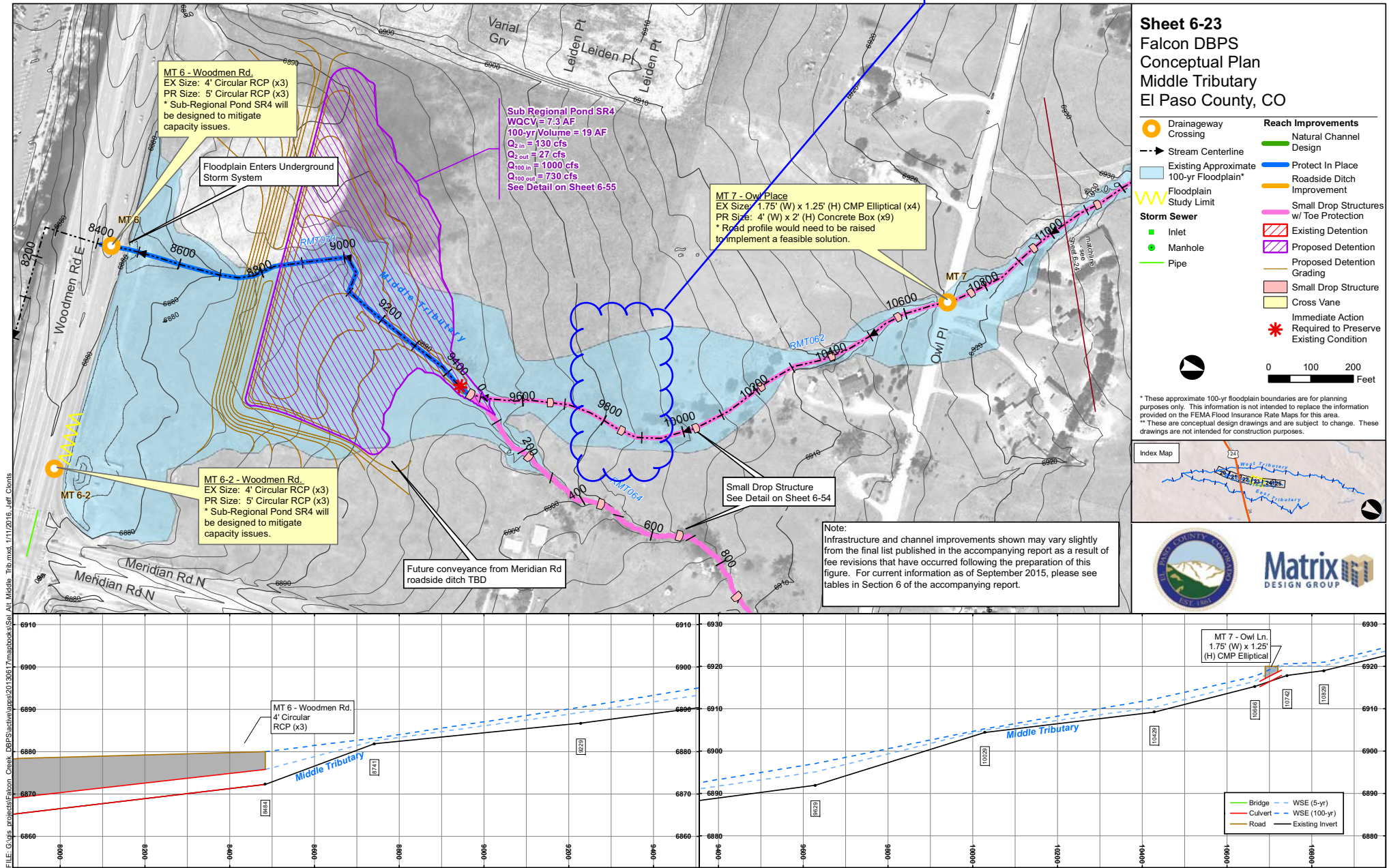

FILE: G:\gis_projects\Falcon_Creek_DBPS\active\appa\20130817\mapbooks\SaI Middle Trib.mxd, 1/11/2016, Jeff Cobits

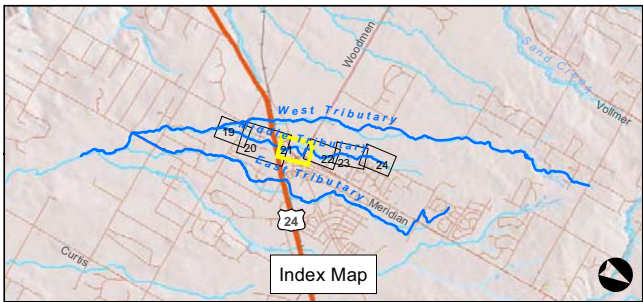
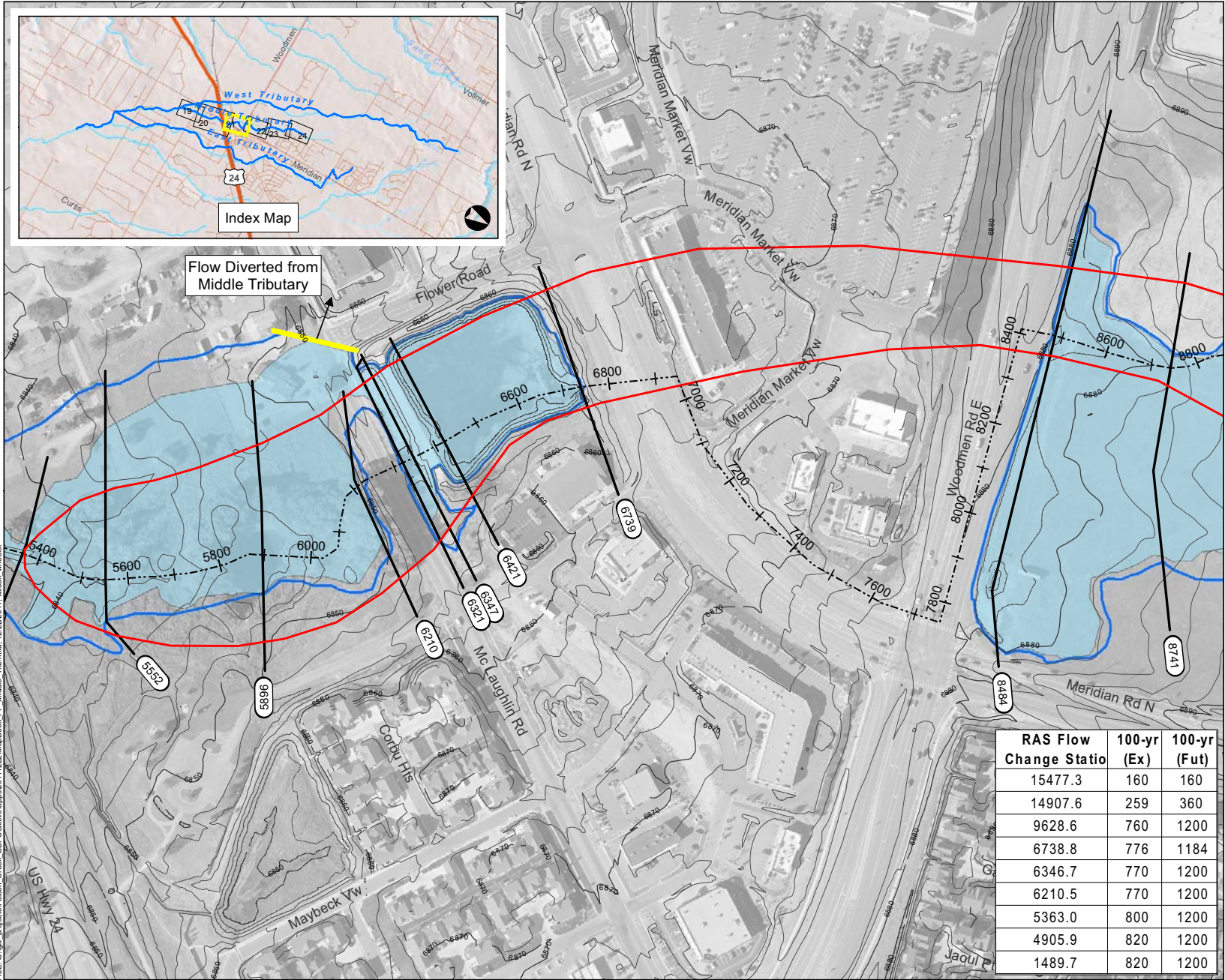

Flow Diverted from Middle Tributary

Sheet 4-21

Middle Tributary Floodplain Falcon DBPS El Paso County, CO

- Legend**
- Approximate 100-yr Floodplain Existing
 - Approximate 100-yr Floodplain Existing (Based on Assumed Split Flow Condition)
 - Approximate 100-yr Floodplain Future
 - Approximate 100-yr Floodplain Future (Based on Assumed Split Flow Condition)
 - Shallow Flooding
 - HEC-RAS Centerline
 - XSCutLines (Middle Trib)
 - FEMA Regulatory Floodplain (Effective as of 1999)*
 - Study Limit

*Letters of Map Change completed after 1999 are not shown

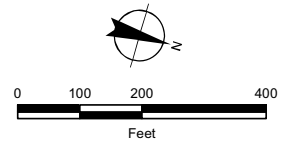

RAS Flow Change Statio	100-yr (Ex)	100-yr (Fut)
15477.3	160	160
14907.6	259	360
9628.6	760	1200
6738.8	776	1184
6346.7	770	1200
6210.5	770	1200
5363.0	800	1200
4905.9	820	1200
1489.7	820	1200

FILE:G:\gis_projects\Falcon Creek_DBPS\active\apps\20111221_MapBook_FP_Middle_Trib.mxd, 12/22/2011, wslon_wheeler



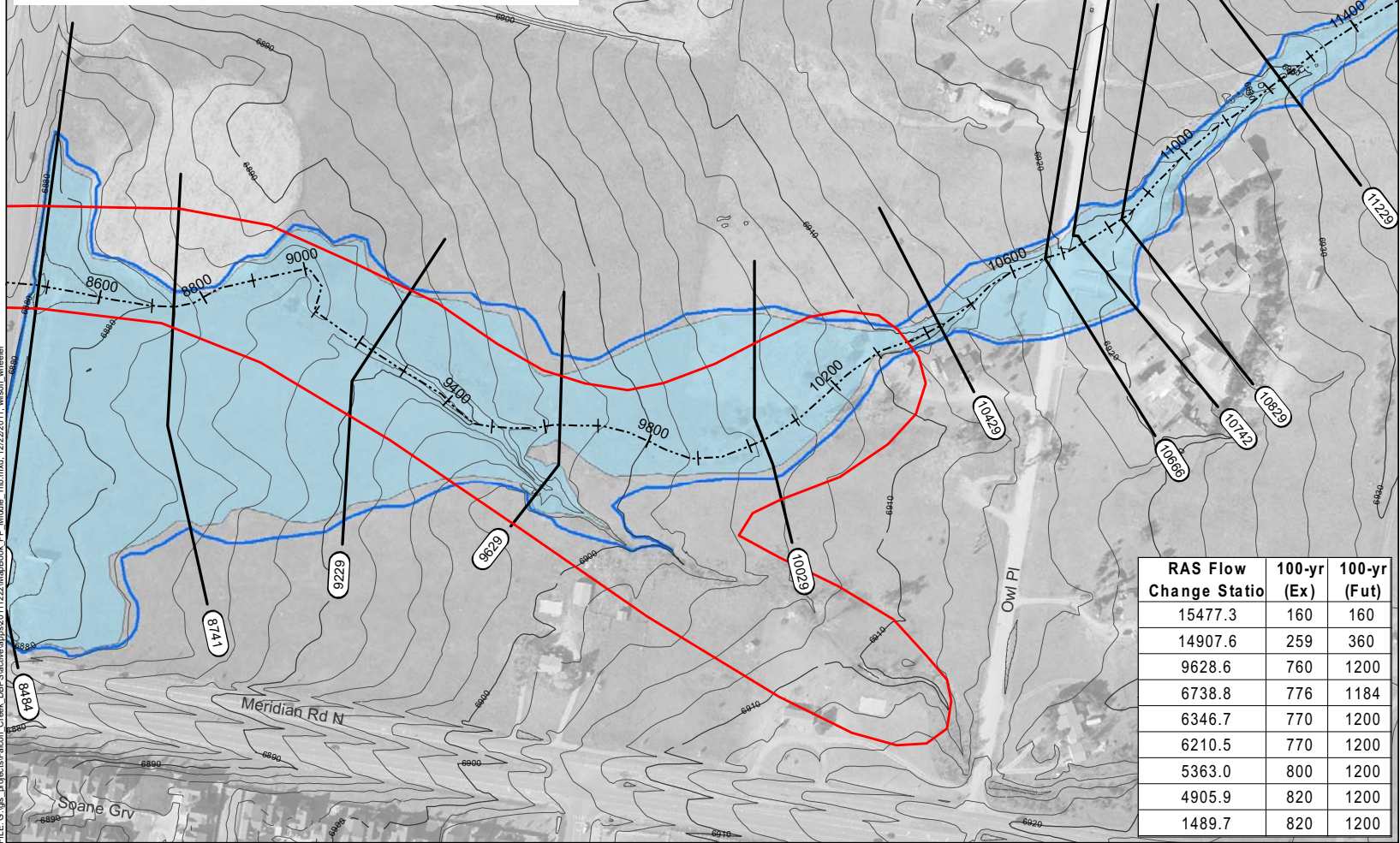
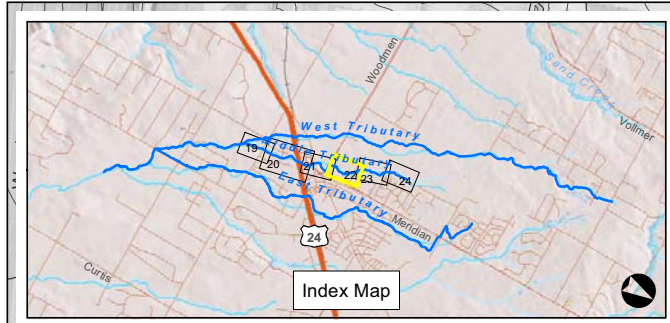

Sheet 4-22

Middle Tributary Floodplain Falcon DBPS El Paso County, CO

- Legend**
- Approximate 100-yr Floodplain Existing
 - Approximate 100-yr Floodplain Existing (Based on Assumed Split Flow Condition)
 - Approximate 100-yr Floodplain Future
 - Approximate 100-yr Floodplain Future (Based on Assumed Split Flow Condition)
 - Shallow Flooding
 - HEC-RAS Centerline
 - XSCutLines (Middle Trib)
 - FEMA Regulatory Floodplain (Effective as of 1999)*
 - Study Limit

*Letters of Map Change completed after 1999 are not shown

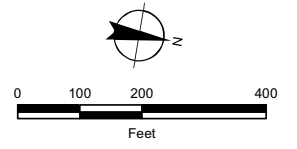

RAS Flow Change Statio	100-yr (Ex)	100-yr (Fut)
15477.3	160	160
14907.6	259	360
9628.6	760	1200
6738.8	776	1184
6346.7	770	1200
6210.5	770	1200
5363.0	800	1200
4905.9	820	1200
1489.7	820	1200



FILE:G:\vis_projects\Falcon_Creek_DBPS\active\apps201122\MapBook_FP_Middle_Trib.mxd, 12/22/2011, wslon_wheeler

Drainage Map

Show and label all offsite design points and sub-basins.

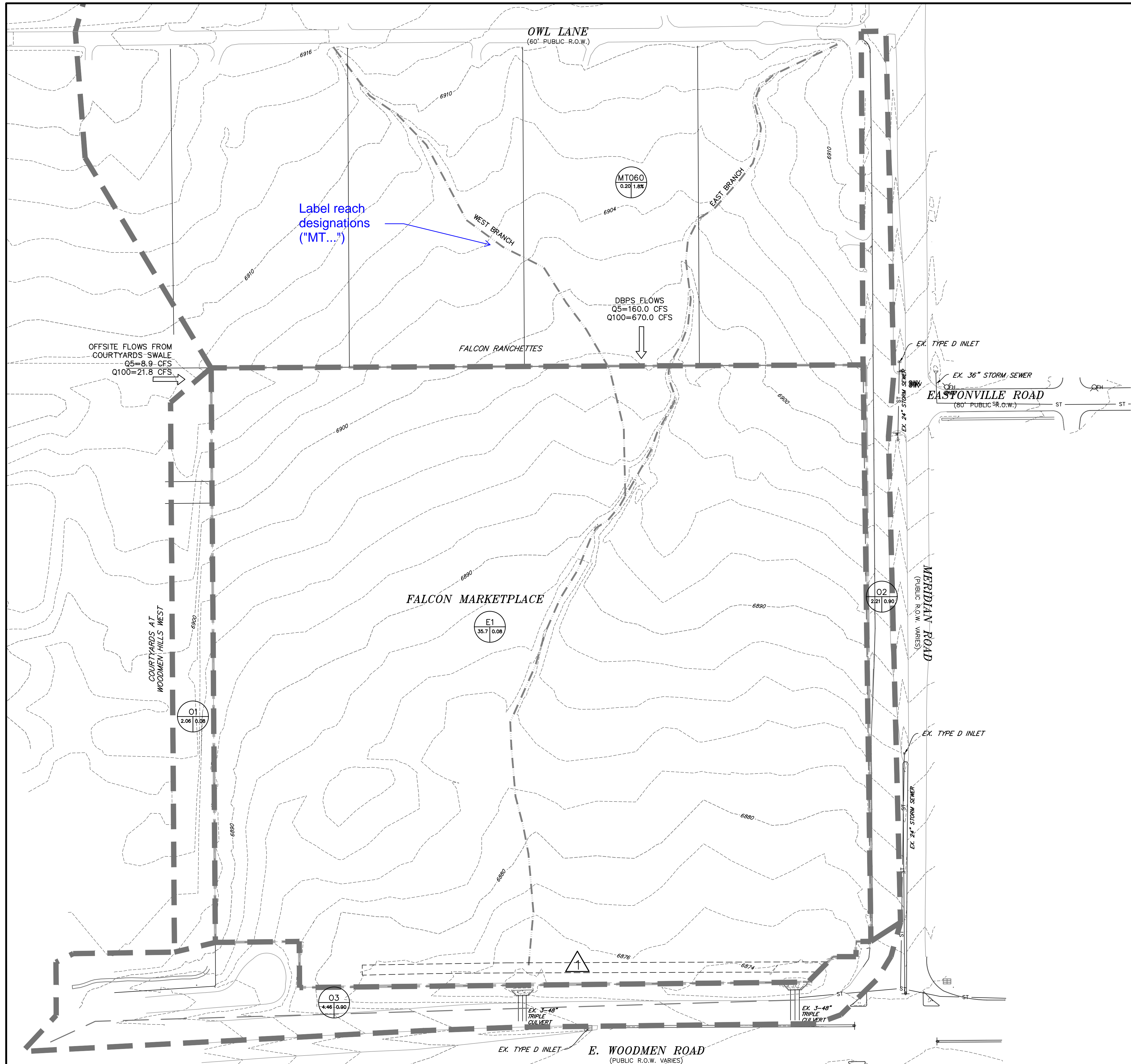

LEGEND

- PROPERTY LINE: - - - - -
- EX. MINOR CONTOUR: - - - - -
- EX. MAJOR CONTOUR: - - - - - 6800 - - - - -
- BASIN BOUNDARY: - - - - -
- FLOW DIRECTION: - - - - -
- DESIGN POINT: (X)

BASIN DESCRIPTION FROM FALCON BASIN DBPS

BASIN AREA (SQ. MILES)	BASIN IMPERVIOUS COVERAGE PERCENTAGE
(X)	(X)

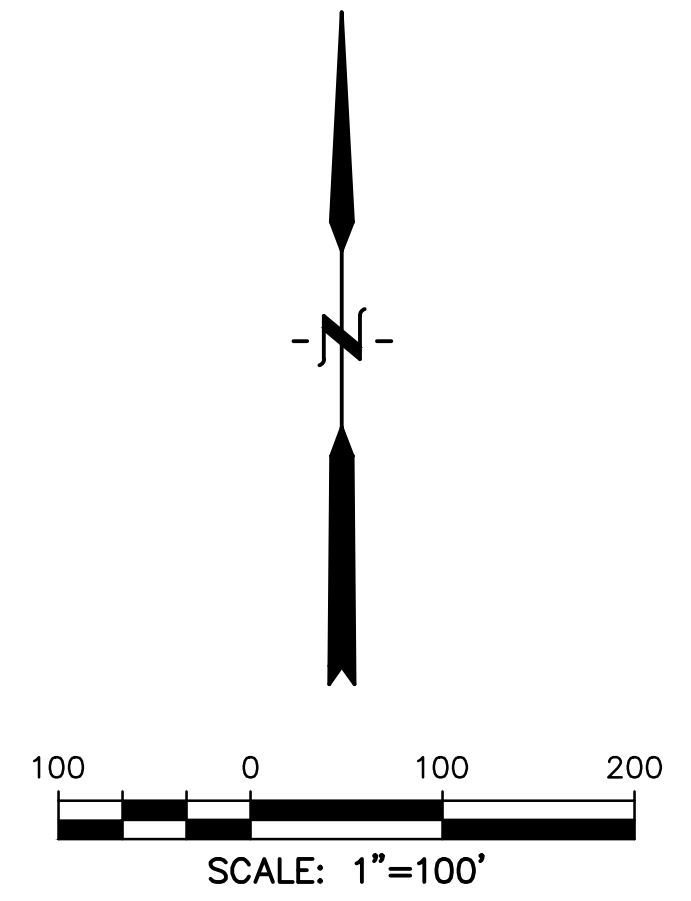

RUNOFF SUMMARY

BASIN	Area (Ac.)	Q ₂ (CFS)	Q ₁₀₀ (CFS)
O1	2.06	0.7	4.9
O2	2.21	6.7	12.0
O3	4.46	14.2	25.4
E1	35.70	6.3	46.3
DBPS (N)			
		160.0	670.0
COURTYARDS (NW)			
		8.9	21.8
DP1			
		196.7	780.4

PREPARED BY:

DREXEL, BARRELL & CO.
 Engineers-Surveyors
 3 SOUTH 7TH STREET
 COLORADO SPGS, COLORADO 80905
 CONTACT: TIM D. McCONNELL, P.E.
 (719)260-0887
 BOULDER • COLORADO SPRINGS

CLIENT:
HUMMEL INVESTMENTS, LLC
 8117 PRESTON ROAD, SUITE 120
 DALLAS, TEXAS 75225
 (214) 416-9820

PRELIMINARY PLAN FOR
FALCON MARKETPLACE
 FALCON, COLORADO

ISSUE	DATE
INITIAL ISSUE	3-23-17
EG SUBMITTAL	4-28-17
3rd SUBMITTAL	5-19-17

DESIGNED BY: TDM
 DRAWN BY: KGV
 CHECKED BY: TDM
 FILE NAME:

PREPARED UNDER MY DIRECT SUPERVISION FOR AND ON BEHALF OF DREXEL, BARRELL & CO.
 DRAWING SCALE:
 HORIZONTAL: 1"=100'
 VERTICAL: N/A

EXISTING DRAINAGE CONDITIONS
 PROJECT NO. 20988-00CSCV
 DRAWING NO.

ED-1
 SHEET: 1 OF 1

Provide detail showing grading to get swale into pond.

Show and label all offsite design points and sub-basins.

Provide calculations showing width and depth of flows entering pond at all applicable locations.

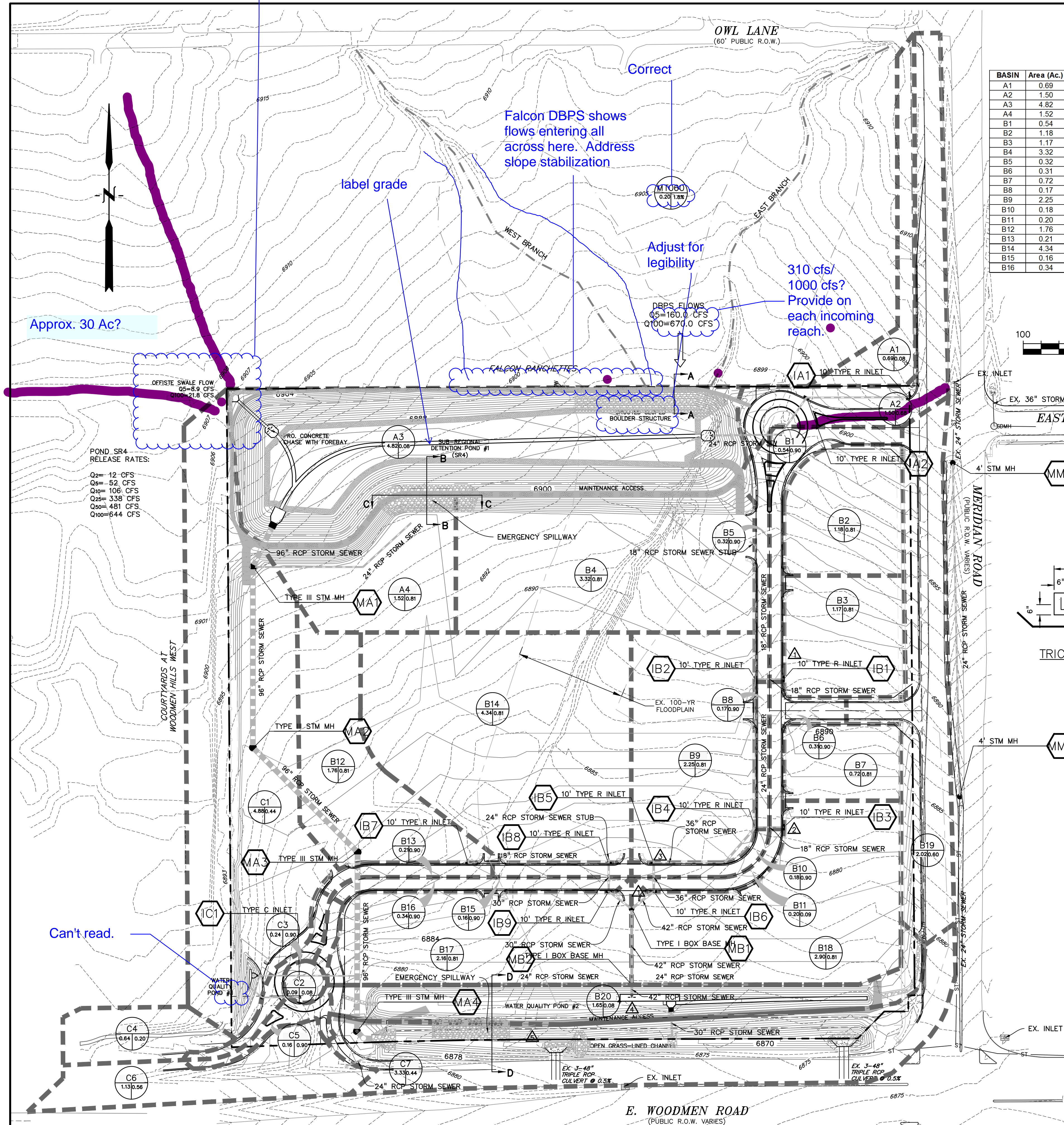

RUNOFF SUMMARY

BASIN	Area (Ac.)	Q ₂ (CFS)	Q ₁₀₀ (CFS)	BASIN	Area (Ac.)	Q ₂ (CFS)	Q ₁₀₀ (CFS)
A1	0.89	0.2	1.4	B17	2.16	8.9	16.2
A2	1.50	5.2	10.2	B18	2.90	11.3	20.7
A3	4.82	1.2	8.8	B19	2.02	5.4	11.1
A4	1.52	5.6	10.2	B20	1.65	0.4	3.3
B1	0.54	2.4	4.3	C1	4.88	8.2	19.1
B2	1.18	4.9	8.9	C2	0.24	1.1	2.0
B3	1.17	4.3	7.9	C3	0.64	0.5	1.7
B4	3.32	9.6	17.6	C4	0.09	0.0	0.2
B5	0.32	1.5	2.6	C5	0.12	0.5	1.0
B6	0.31	1.4	2.5	C6	0.16	0.7	1.3
B7	0.72	3.0	5.4	C7	1.13	2.9	6.1
B8	0.17	0.8	1.4	C8	3.33	5.0	11.8
B9	2.25	8.8	16.1				
B10	0.18	0.8	1.5				
B11	0.20	0.9	1.6				
B12	1.76	6.1	11.2				
B13	0.21	1.0	1.7				
B14	4.34	16.2	29.6				
B15	0.16	0.7	1.3				
B16	0.34	1.5	2.6				

DP	Area (Ac.)	Q ₂ (CFS)	Q ₁₀₀ (CFS)
DP1	2.89	10.9	19.8
DP2	1.03	4.4	8.0
DP3	2.43	9.6	16.1
DP4	25.90	66.3	124.3
DP5	45.02	-	754.0

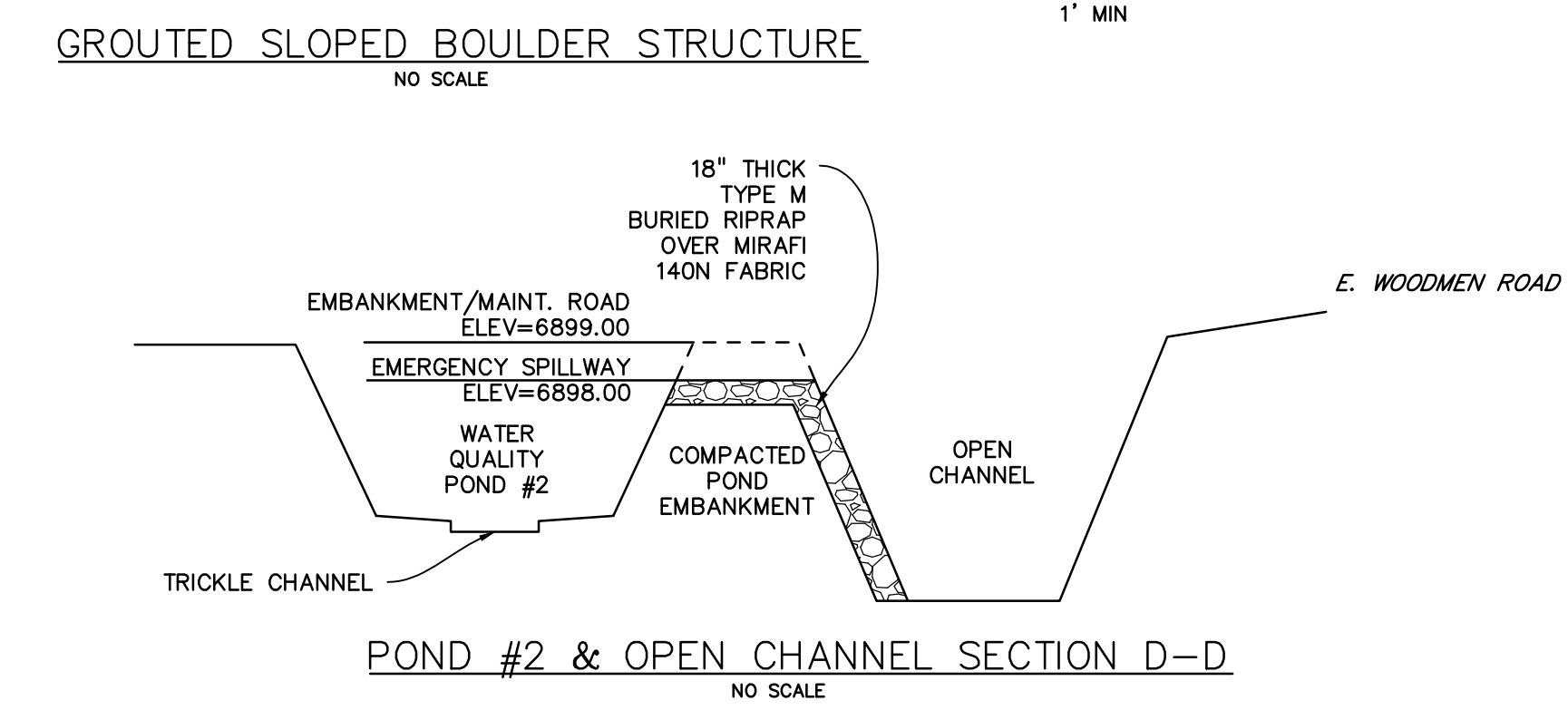
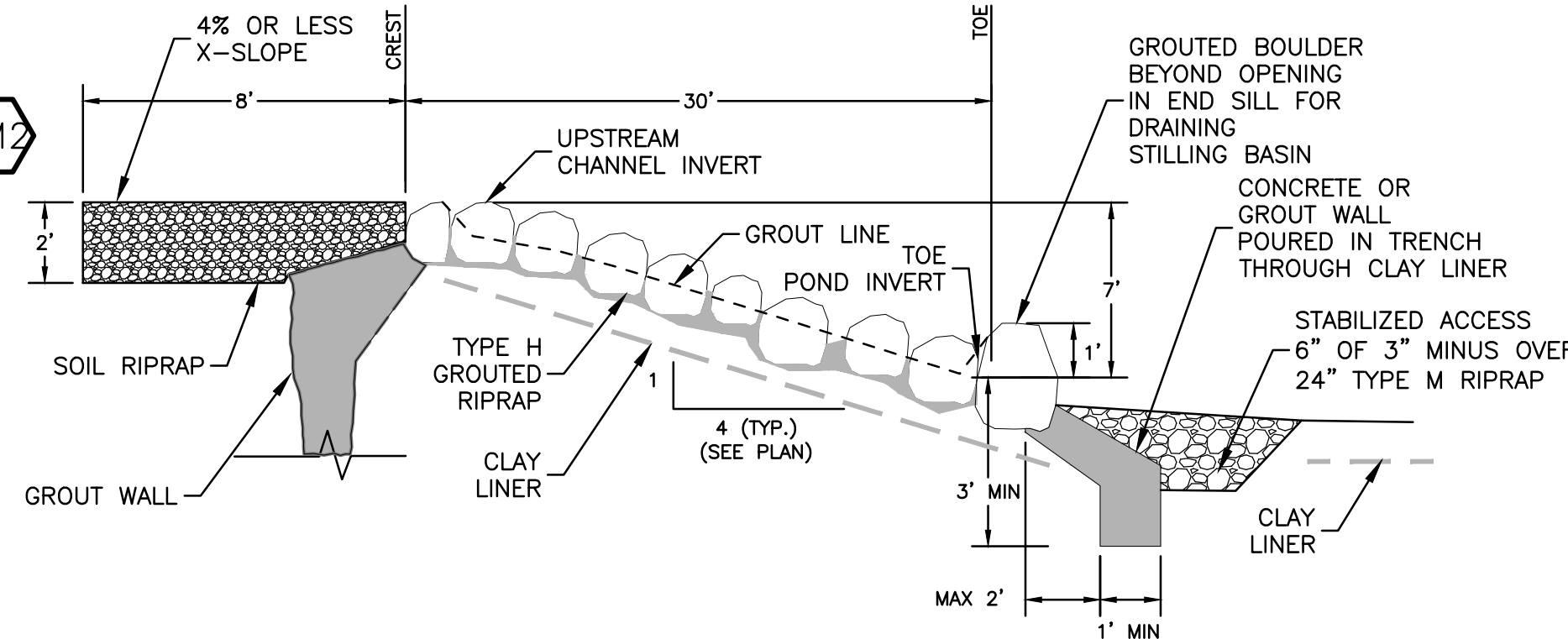
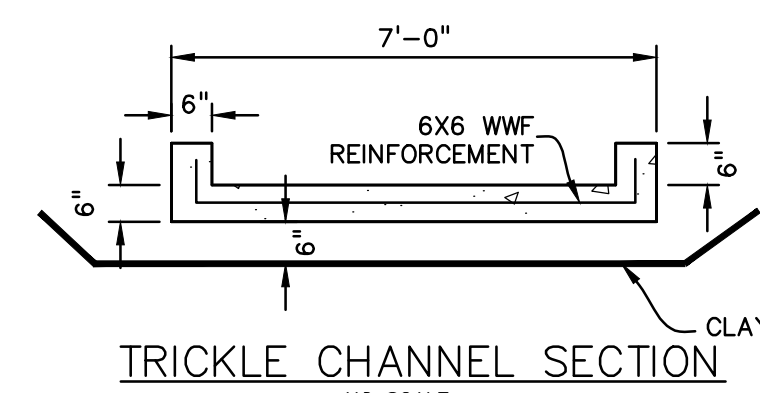
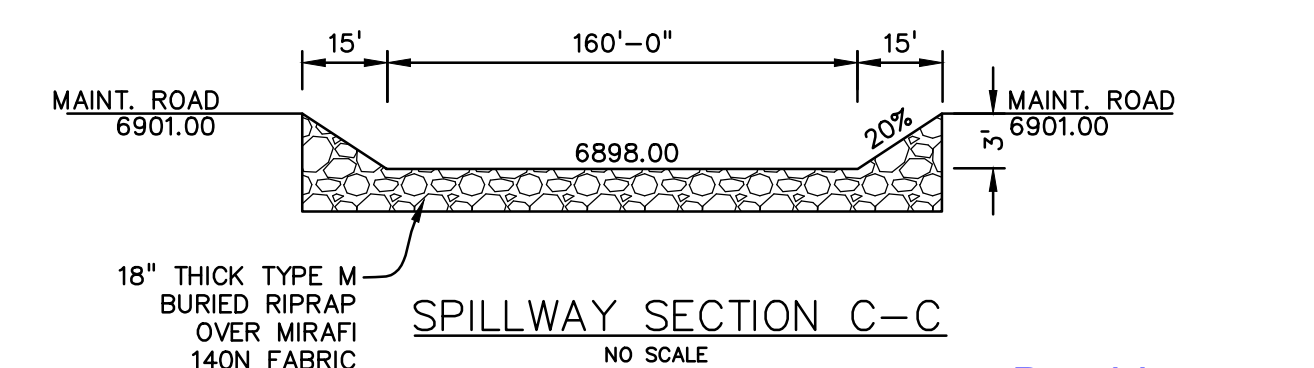
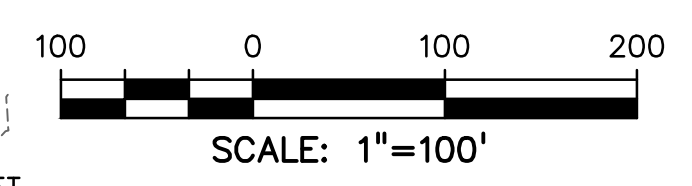
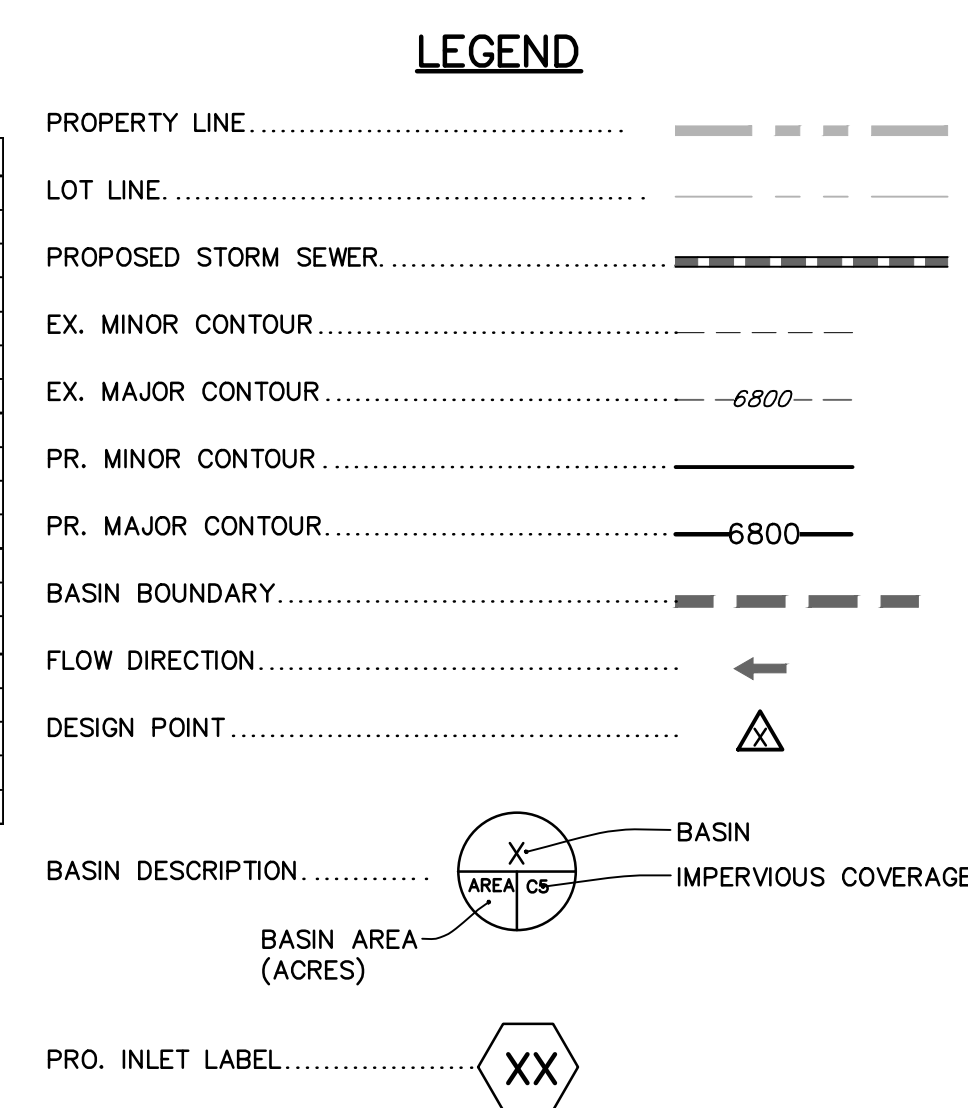

POND SR4 RELEASE RATES:
 Q₂= 12 CFS
 Q₅= 52 CFS
 Q₁₀= 106 CFS
 Q₂₅= 338 CFS
 Q₅₀= 481 CFS
 Q₁₀₀= 644 CFS

Approx. 30 Ac?

label grade

Falcon DBPS shows flows entering all across here. Address slope stabilization

Correct

Adjust for legibility

310 cfs/1000 cfs? Provide on each incoming reach.

DBPS FLOWS
 Q₅=160.0 CFS
 Q₁₀₀=670.0 CFS

Provide dimension

concrete?

Can't read.

PREPARED BY:

 DREXEL, BARRELL & CO.
 Engineers-Surveyors
 3 SOUTH 7TH STREET
 COLORADO SPRGS, COLORADO 80905
 CONTACT: TIM D. MCCONNELL, P.E.
 (719)260-0887
 BOULDER • COLORADO SPRINGS

CLIENT:
 HUMMEL INVESTMENTS, LLC
 8117 PRESTON ROAD, SUITE 120
 DALLAS, TEXAS 75225
 (214) 416-9820

PRELIMINARY PLAN FOR
FALCON MARKETPLACE
 FALCON, COLORADO

ISSUE	DATE
INITIAL ISSUE	1-17-17
RESUBMITTAL	6-18-18

DESIGNED BY: TDM
 DRAWN BY: KGV
 CHECKED BY: TDM
 FILE NAME:

PREPARED UNDER MY DIRECT SUPERVISION FOR AND ON BEHALF OF DREXEL, BARRELL & CO.
 DRAWING SCALE:
 HORIZONTAL: 1"=100'
 VERTICAL: N/A

PROPOSED DRAINAGE CONDITIONS

PROJECT NO. 20988-00CSCV
 DRAWING NO.

D-1
 SHEET: 1 OF 1