



STORMWATER MANAGEMENT PLAN (SWMP)

FOR

MAYBERRY, COLORADO SPRINGS – FILING NO. 2A

PREPARED FOR:

**COLORADO SPRINGS MAYBERRY, LLC
3296 DEVINE HEIGHTS #208
COLORADO SPRINGS, CO 80922**

PREPARED BY:

**R & R ENGINEERS - SURVEYORS, INC.
1635 W. 13TH AVE, SUITE 310
DENVER, CO 80204
CONTACT: CLIF DAYTON, P.E.
(303) 753-6730**

SWMP Checklist Item 1 - put QSM and Contractor info on cover/title sheet (if TBD leave a placeholder)

QSM and Contractor info now provided.

**R&R JOB #MC22199
EPC PROJECT No. SF1910**

ORIGINAL SUBMITTAL: SEPTEMBER 2023

TABLE OF CONTENTS

	<u>PAGE</u>
1. APPLICANT/CONTACT INFORMATION.....	1
2. SITE DESCRIPTION.....	1
3. SITE MAP.....	2
4. BMP'S FOR STORMWATER POLLUTION PREVENTION.....	2
5. FINAL STABILIZATION AND LONG-TERM STORMWATER MANAGEMENT.....	5
6. OTHER CONTROLS.....	6
7. INSPECTION AND MAINTENANCE.....	6

APPENDICES

<u>APPENDIX A</u>	SITE MAP
<u>APPENDIX B</u>	SOILS MAP
<u>APPENDIX C</u>	SITE GRADING & EROSION CONTROL PLAN
<u>APPENDIX D</u>	EROSION CONTROL NOTES & DETAILS

**MAYBERRY – FILING 2A
SWMP REPORT**

1. APPLICANT/CONTACT INFORMATION

Developer: Colorado Springs Mayberry, LLC
3296 Devine Heights #208
Colorado Springs, CO 80922

Engineer: R & R Engineers - Surveyors, Inc.
1635 W. 13th Ave, Suite 310
Denver, CO 80204

Contractor: Raw Land Detailing
10475 Accipiter Dr.
Peyton, CO 80831
Attn: Larry Lee (719)-495-7770

2. SITE DESCRIPTION

- a. Ellicott Town Center is a proposed subdivision located west of Ellicott, Colorado in El Paso County. The development is located on the south side of State Highway 94, approximately 1-1/2 miles west of Ellicott Highway. The approved Ellicott Town Center PUD includes a total of 1,048 single-family dwelling units and 32 acres of commercial space. Colorado Springs Mayberry, LLC is moving forward with development of Ellicott Town Center Filing No. 1, consisting of 98 single-family residential lots near the north boundary of the project. Ellicott Town Center Filing No. 2 consisted of a replat of Tract L and Tract Q of Ellicott Town Center Filing No. 1, creating 3 commercial lots along the previous extension of Cattlemen Run on the west side of Springs Road. Filing No. 2A consists of a re-plat of Filing No. 2, as Cattlemen Run no longer extends and a new road, Business Park Avenue, will be proposed which ends in a cul-de-sac. The boundary of Lots 1, 2, and 3 have been slightly modified with this change.
- b. There are no stream crossings in the project area.
- c. The proposed development consists of three commercial lots and a proposed street, Business Park Avenue, which ends in a cul-del-sac. A portion of the north curb and gutter has been built per the original Filing No. 2 construction plans completed and designed by JPS Engineering. The site development activities will include site grading, pavement, curb and gutter, and related site improvements.
- d. Proposed sequence of major activities:
 - Mobilization/implementation of BMP's
 - Clearing and grubbing
 - Rough grading
 - Roadway grading/paving

SWMP Checklist Item 6 - Provide construction schedule for major completion dates.

Construction schedule added as section 3 in the report.

**MAYBERRY – FILING 2A
SWMP REPORT**

percent cover refers to the amount of vegetal cover within pervious areas (not the percent of the site that is pervious). 10% is very low. If site was previously graded or land use was such that there is no or minimal vegetation, the % cover required for final stabilization should then be based on neighboring properties to show natural native vegetative cover (ie: an adequate reference site). If surrounding sites are also being developed, use historic aerial photos to make determination.

- e. Total site area = 4.48 acres (Filing No. 2A); Proposed disturbed area = 0.58 acres (only the cul-de-sac and associated grading)
- f. Historic runoff coefficient, C = 0.35
Developed runoff coefficient, C = 0.88
- g. Existing vegetation on site on site: existing gravel, native meadow grasses (approx. 10% coverage).
- h. Potential pollution sources: vehicle emissions.
- i. Non-stormwater components of discharge: none anticipated.
- j. Receiving water: Surface drainage from this site will flow southeasterly to existing natural drainage swales flowing to the West Fork of Black Squirrel Creek located east of this parcel between the site and Ellicott Highway. Black Squirrel Creek ultimately outfalls into the Arkansas River.
- k. Erosion potential and potential impacts upon discharge: According to the Web Soil Survey by the Natural Resources Conservation Service, on-site soils are comprised primarily of Truckton loamy sand and Blakeland loamy sand which are both classified as soil Group A. Group A soils have a high infiltration rate with a moderate rate of water transmission. The erosion factor K for these soils are 0.24 and 0.10 respectively. Uncontrolled soil erosion may adversely affect downstream drainageways; on-site BMP's will be provided and maintained to mitigate impacts. See soils map in appendices.

This percent coverage of existing vegetation has been verified and revised to 60%.

There will be more potential pollution sources rather than just vehicle emissions. IE off-site soil tracking, waste disposal, etc. Verify all sources of potential pollution include sedimentation are accounted for. Provide general location as well to satisfy SWMP Checklist Item 10.

3. SITE MAP

See Site Map in appendices.

4. BMP'S FOR STORMWATER POLLUTION PREVENTION

Phase

Clearing and grubbing necessary for perimeter	MP TC's
Initiation of perimeter controls	SCL
Remaining clearing and grubbing	
Site grading	RS/SCL
Stabilization	SM
Removal of erosion control measures	

A separate section dedicated to potential pollutants has been added as section #4.

A. Erosion and Sediment Controls

1) Structural Practices:

- Vehicle Tracking Control (VTC) pad at construction entry. This will be used from Filing 3's construction entrance.
- Sediment Control Logs (SCL) at toe of slope along downstream limits of disturbance
- Inlet protection (IP) in Filing 3, downstream of Filing 2A, shall remain in place until the completion of Filing 2A.

MAYBERRY – FILING 2A
SWMP REPORT

2) Non-Structural Practices:

- Preserve existing vegetation beyond limits of work
- Temporary seeding of areas to remain disturbed for significant periods of time.
- Permanent seeding/mulching (SM) upon completion of rough grading.

B. Materials Handling and Spill Prevention

- General Materials Handling Practices:
 - Potential pollutants shall be stored and used in a manner consistent with the manufacturer's instructions in a secure location. To the extent practical, material storage areas should not be located near storm drain inlets and should be equipped with covers, roofs, or secondary containment as required to prevent storm water from contacting stored materials. Chemicals that are not compatible shall be stored and segregated areas so that spilled materials cannot combine and react.
 - Disposal of materials shall be in accordance with the manufacturer's instructions and applicable local, state, and federal regulations.
 - Materials no longer required for construction shall be removed from the site as soon as possible.
- Adequate garbage, construction waste, and sanitary waste handling and disposal facilities shall be provided as necessary to keep the site clear of obstruction and BMPs clear and functional.
- Specific Materials Handling Practices:
 - All pollutants, including waste materials and demolition debris, that occur on-site during construction shall be handled in a way that does not contaminate storm water.
 - All chemicals including liquid products, petroleum products, water treatment chemicals, and wastes stored on site shall be covered and contained and protected from vandalism.
 - Maintenance and repair of all equipment and vehicles involving oil changes, hydraulic system drain down, de-greasing operations, fuel tank drain down and removal, and other activities which may result in the accidental release of contaminants, shall be conducted under cover during wet weather and on an impervious surface to prevent release of contaminants onto the ground. Materials spilled during maintenance operations shall be cleaned up immediately and properly disposed of.
 - Wheel wash water shall be settled and discharged on site by infiltration. Wheel wash water shall not be discharged to the storm water system.
 - Application of agricultural chemicals, including fertilizers and pesticides, shall be conducted in a manner and at application rates that will not result in loss of

MAYBERRY – FILING 2A
SWMP REPORT

chemical to storm water runoff. Follow manufacturer's recommendations for application rates and procedures.

- pH-modifying sources shall be managed to prevent contamination of runoff and storm water collected on site. The most common sources of pH-modifying materials are bulk cement, cement kiln dust (CKD), fly ash, new concrete washing and curing waters, waste streams generated from concrete grinding and sawing, exposed aggregate processes, and concrete pumping and mixer washout waters.
- Equipment maintenance and fueling: Contractor shall implement appropriate spill prevention and response procedures
- Spill Prevention and Response Procedures:
 - The primary objective in responding to a spill is to quickly contain the material(s) and prevent or minimize their migration into storm water runoff and conveyance systems. If the release has impacted on-site storm water, it is critical to contain the released materials on site and prevent their release into receiving waters.
 - Spill Response Procedures:
 - Notify site superintendent immediately when a spill, or the threat of a spill, is observed. The superintendent shall assess the situation and determine the appropriate response.
 - If spills represent an imminent threat of escaping on-site facilities and entering the receiving waters, site personnel shall respond immediately to contain the release and notify the superintendent after the situation has stabilized.
 - The site superintendent, or his designee, shall be responsible for completing a spill reporting form and for reporting the spill to the appropriate agency.
 - Spill response equipment shall be inspected and maintained as necessary to replace any materials used in spill response activities.
 - Spill kits shall be on-hand at all fueling sites. Spill kit location(s) shall be reported to the SWMP Administrator.
 - Absorbent materials shall be on-hand at all fueling areas for use in containing inadvertent spills. Containers shall be on-hand at all fueling sites for disposal of used absorbents.
 - Recommended components of spill kits include the following:
 - Oil absorbent pads (one bale)
 - Oil absorbent booms (40 feet)
 - 55-gallon drums (2)
 - 9-mil plastic bags (10)
 - Personal protective equipment including gloves and goggles

MAYBERRY – FILING 2A
SWMP REPORT

- Concrete Wash Water: Unless confined in a pre-defined, bermed containment area, the cleaning of concrete truck delivery chutes is prohibited at the job site. The discharge of water containing waste cement to the storm drainage system is prohibited.
- Concrete Batch Plant: This project will not have an on-site dedicated batch plant.
- Notification Procedures:
 - In the event of an accident or spill, the SWMP Administrator shall be notified as a minimum.
 - Depending on the nature of the spill material involved, the Colorado Department of Public Health and Environment (24-hour spill reporting line: 877-518-5608), downstream water users, or other agencies may also need to be notified.
 - Any spill of oil which 1) violates water quality standards, 2) produces a “sheen” on a surface water, or 3) causes a sludge or emulsion, or any hazardous substance release, or hazardous waste release which exceeds the reportable quantity, must be reported immediately by telephone to the National Response Center Hotline at (800)-424-8802.

SWMP Checklist Item 26 - Provide a statement clarifying if the project relies on control measures owned/operated by another entity.

The last bullet point of this section, Section #6B, provides a statement that this project does not rely on control measures owned or operated by another entity.

STABILIZATION AND LONG-TERM STORMWATER MANAGEMENT

- Permanent seeding will be provided to achieve long-term stabilization of the site.
 - Mix: “Foothills Mix” or approved equal:
 - Application Rate: Drill seed 0.25” to 0.5” into the soil. In small areas not accessible to a drill, hand broadcast at double the rate and rake 0.25” to 0.5” into the soil. Apply seed at the following rates:
 - Dryland: 20-25 lbs/acre
 - Irrigated: 40 lbs/acre
- Soil Stabilization Practices:
 - Mulching Application: Apply 1-1/2 tons of certified weed free hay per acre mechanically crimped into the soil in combination with tackifier. On slopes and ditches requiring a blanket in lieu of much and mulch tackifier.
- Soil Conditioning and Fertilizer Requirements:
 - Soil conditioner, organic amendment shall be applied to all seeded areas at 3 CY / 1000 SF.
 - Fertilizer shall consist of 90% fungal biomass (mycelium) and 10% potassium-magnesia with a grade of 6-1-3 or approved equal. Fertilizer shall be applied as recommended by seed supplier.
- Final stabilization is reached when all soil-disturbing activities at the site have been completed, and uniform vegetative cover has been established with an individual plant density of at least 70 percent of pre-disturbance levels, or equivalent permanent, physical erosion reduction methods have been employed.

Discuss long-term SW Management - the site drains to an existing pond. Provide the pond identifier, EPC project and filing it was constructed with, and verify it is functioning as intended.

The last bullet point of this section, Section #7, describes the existing pond accordingly.

MAYBERRY – FILING 2A
SWMP REPORT

6. OTHER CONTROLS

- Contractor shall dispose of all waste materials at a permitted off-site disposal site.
- Vehicle tracking pads from Mayberry Filing No. 3 BMP's will remain in place to limit off-site soil tracking.

7. INSPECTION AND MAINTENANCE

A. Inspection Schedules:

- Contractor shall inspect BMPs bi-weekly as a minimum, and immediately (within 24 hours) after any precipitation or snowmelt event that causes surface erosion (i.e. that results in stormwater running across the ground), to ensure that BMPs are maintained in effective operating condition.

B. Inspection Procedures:

1. Site Inspection / Observation Items:

- Construction site perimeter and discharge points (including discharges into a storm sewer system)
- All disturbed areas
- Areas used for material / waste storage that are exposed to precipitation
- Other areas having a significant potential for stormwater pollution, such as demolition areas or concrete washout locations, or locations where vehicles enter or leave the site
- Erosion and sediment control measures identified in the SWMP
- Any other structural BMPs that may require maintenance, such as secondary containment around fuel tanks, or the condition of spill response kits.

2. Inspection requirements:

- Determine if there is any evidence of, or potential for, pollutants entering the drainage system.
- Review BMPs to determine if they still meet design and operational criteria in the SWMP, and if they continue to adequately control pollutants at the site.
- Upgrade and/or revise any BMPs not operating in accordance with the SWMP and update the SWMP to reflect any revisions.

C. BMP Maintenance / Replacement and Failed BMPs:

- Contractor shall remove sediment that has been collected by perimeter controls, such as silt fence and inlet protection, on a regular basis to prevent failure of BMPs, and remove potential of sediment from being discharged from the site in the event of BMP failure.

Text added that the SWMP is a living document that is continuously being reviewed and modified.

SWMP Checklist Item 21. Add text stating that the SWMP should be viewed as a “living document” that is continuously being reviewed and modified as a part of the overall process of evaluating and managing SW quality issues at the site. The QSM shall amend the SWMP when there is a change in design, construction, O&M of the site which would require the implementation of new or revised BMPs or if the SWMP proves to be ineffective in achieving the general objectives of controlling pollutants in SW discharges associated with construction activity or when BMPs are no longer necessary and are removed.

MAYBERRY – FILING 2A
SWMP REPORT

- Removed sediment must be moved to an appropriate location where it will not become an additional pollutant source, and should never be placed in ditches or streams.
 - Contractor shall update Erosion Control Plans as required with any new BMPs added during the construction period.
 - Contractor shall address BMPs that have failed or have the potential to fail without maintenance or modifications, as soon as possible, immediately in most cases, to prevent discharge of pollutants.
- D. Record Keeping and Documenting Inspections:
- Contractor shall maintain records of all inspection reports, including signed inspection logs, at the project site.
 - Permittee shall document inspection results and maintain a record of the results for a period of 3 years following expiration or inactivation of permit coverage.
 - Site inspection records shall include the following:
 - Inspection date
 - Name and title of personnel making the inspection
 - Location of discharges of sediment or other pollutants from the site
 - Location(s) of BMPs that need to be maintained
 - Location(s) of BMPs that failed to operate as designed or proved inadequate for a particular location
 - Location(s) where additional BMPs are needed that were not in place at the time of inspection
 - Deviations from the minimum inspection schedule

APPENDIX A – SITE MAP

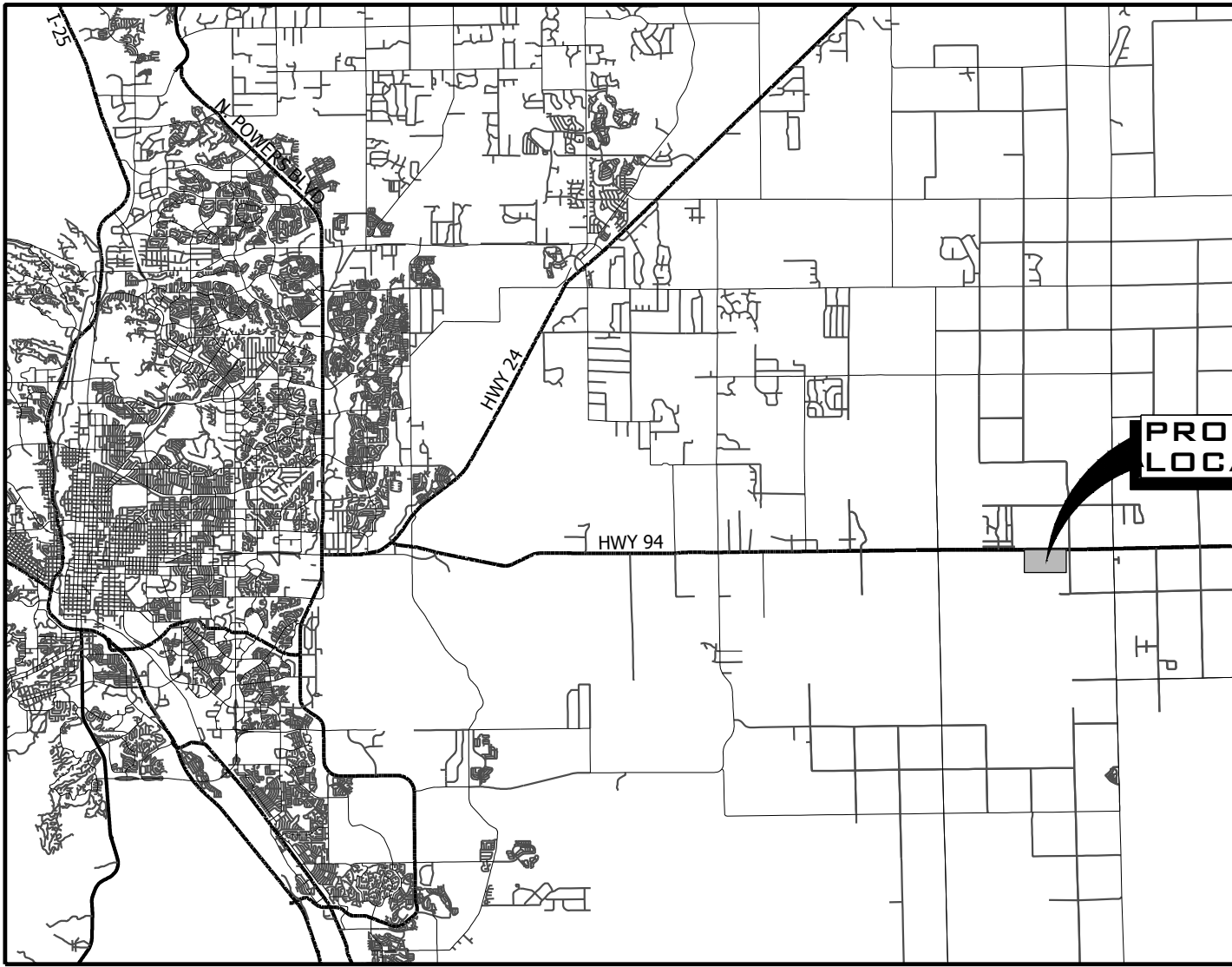

VICINITY MAP
SCALE 1" = 20,000'

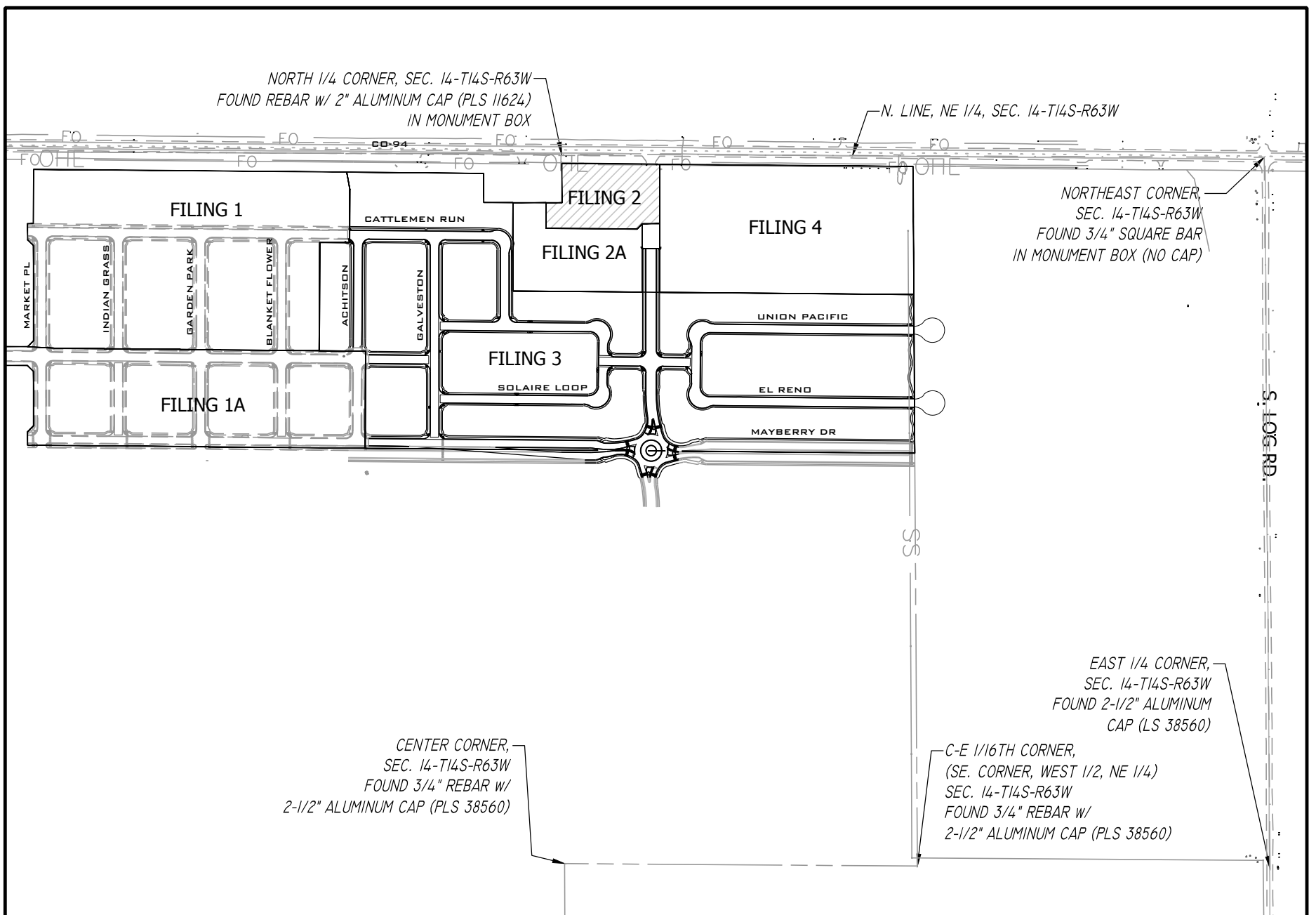

SITE MAP
SCALE 1" = 500'

REVISIONS			

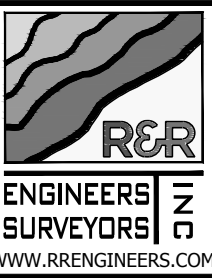

SITE MAP

MAYBERRY FILING NO. 2A

3296 DEVINE HEIGHTS #208
COLORADO SPRINGS, CO 80922

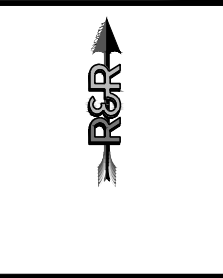

JOB NO.	MC22199
DATE	12-16-2022
DRN	LAO CHK CD
EXHIBIT NAME	SITE MAP
SHEET NO.	1 OF 1

APPENDIX B – SOILS MAP

Hydrologic Soil Group—El Paso County Area, Colorado
(Mayberry Filing No. 2A)

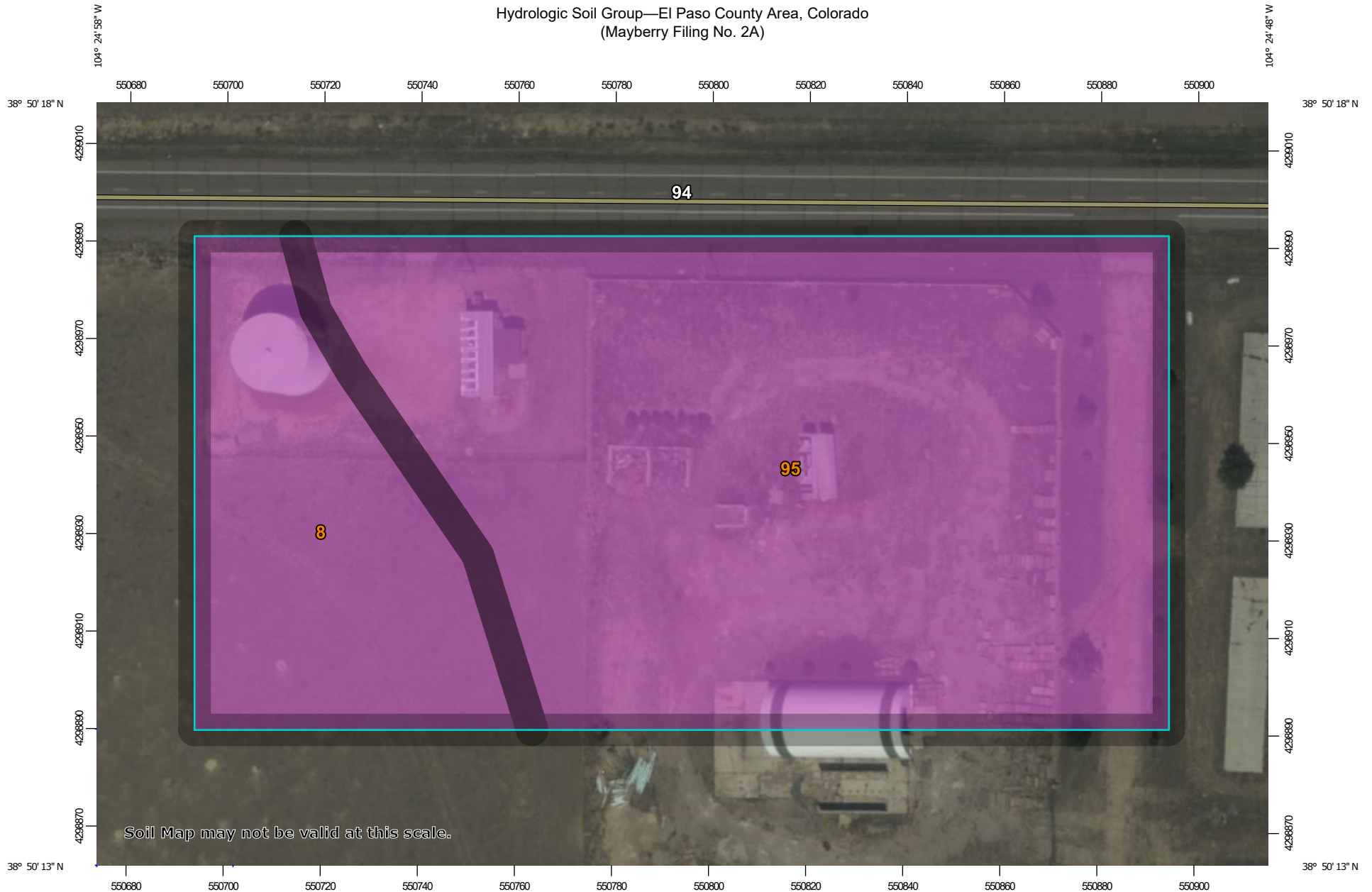

Soil Map may not be valid at this scale.

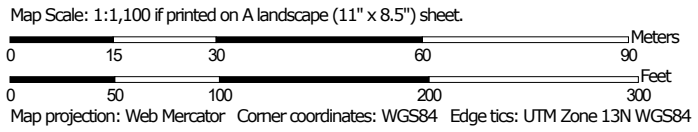

MAP LEGEND

Area of Interest (AOI)









 Area of Interest (AOI)

Soils

Soil Rating Polygons





 A
 A/D
 B
 B/D
 C
 C/D
 D
 Not rated or not available

Soil Rating Lines

 A
 A/D
 B
 B/D
 C
 C/D
 D
 Not rated or not available

Soil Rating Points



 A
 A/D
 B
 B/D

 C
 C/D
 D
 Not rated or not available

Water Features

 Streams and Canals

Transportation

 Rails
 Interstate Highways
 US Routes
 Major Roads
 Local Roads

Background

 Aerial Photography

MAP INFORMATION

The soil surveys that comprise your AOI were mapped at 1:24,000.

Warning: Soil Map may not be valid at this scale.

Enlargement of maps beyond the scale of mapping can cause misunderstanding of the detail of mapping and accuracy of soil line placement. The maps do not show the small areas of contrasting soils that could have been shown at a more detailed scale.

Please rely on the bar scale on each map sheet for map measurements.

Source of Map: Natural Resources Conservation Service
 Web Soil Survey URL:
 Coordinate System: Web Mercator (EPSG:3857)

Maps from the Web Soil Survey are based on the Web Mercator projection, which preserves direction and shape but distorts distance and area. A projection that preserves area, such as the Albers equal-area conic projection, should be used if more accurate calculations of distance or area are required.

This product is generated from the USDA-NRCS certified data as of the version date(s) listed below.

Soil Survey Area: El Paso County Area, Colorado
 Survey Area Data: Version 20, Sep 2, 2022

Soil map units are labeled (as space allows) for map scales 1:50,000 or larger.

Date(s) aerial images were photographed: Sep 11, 2018—Oct 20, 2018

The orthophoto or other base map on which the soil lines were compiled and digitized probably differs from the background imagery displayed on these maps. As a result, some minor shifting of map unit boundaries may be evident.

Hydrologic Soil Group

Map unit symbol	Map unit name	Rating	Acres in AOI	Percent of AOI
8	Blakeland loamy sand, 1 to 9 percent slopes	A	1.2	23.2%
95	Truckton loamy sand, 1 to 9 percent slopes	A	3.9	76.8%
Totals for Area of Interest			5.0	100.0%

Description

Hydrologic soil groups are based on estimates of runoff potential. Soils are assigned to one of four groups according to the rate of water infiltration when the soils are not protected by vegetation, are thoroughly wet, and receive precipitation from long-duration storms.

The soils in the United States are assigned to four groups (A, B, C, and D) and three dual classes (A/D, B/D, and C/D). The groups are defined as follows:

Group A. Soils having a high infiltration rate (low runoff potential) when thoroughly wet. These consist mainly of deep, well drained to excessively drained sands or gravelly sands. These soils have a high rate of water transmission.

Group B. Soils having a moderate infiltration rate when thoroughly wet. These consist chiefly of moderately deep or deep, moderately well drained or well drained soils that have moderately fine texture to moderately coarse texture. These soils have a moderate rate of water transmission.

Group C. Soils having a slow infiltration rate when thoroughly wet. These consist chiefly of soils having a layer that impedes the downward movement of water or soils of moderately fine texture or fine texture. These soils have a slow rate of water transmission.

Group D. Soils having a very slow infiltration rate (high runoff potential) when thoroughly wet. These consist chiefly of clays that have a high shrink-swell potential, soils that have a high water table, soils that have a claypan or clay layer at or near the surface, and soils that are shallow over nearly impervious material. These soils have a very slow rate of water transmission.

If a soil is assigned to a dual hydrologic group (A/D, B/D, or C/D), the first letter is for drained areas and the second is for undrained areas. Only the soils that in their natural condition are in group D are assigned to dual classes.

Rating Options

Aggregation Method: Dominant Condition

Component Percent Cutoff: None Specified

Tie-break Rule: Higher

K Factor, Whole Soil—El Paso County Area, Colorado
(Mayberry Filing No. 2A)

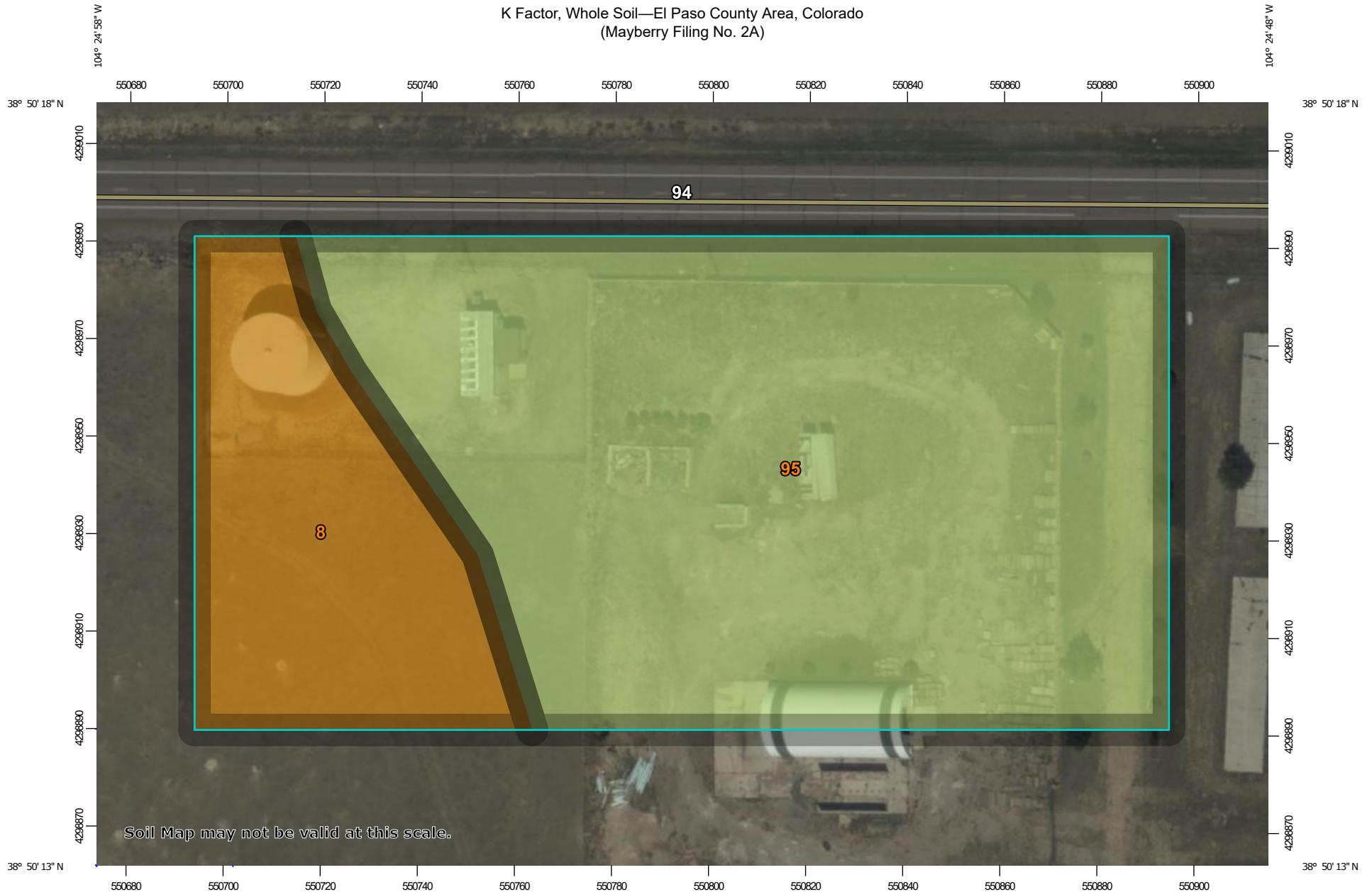

Soil Map may not be valid at this scale.

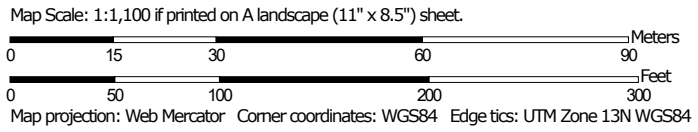















MAP LEGEND

Area of Interest (AOI)







 Area of Interest (AOI)









Soils

Soil Rating Polygons















-  .02
-  .05
-  .10
-  .15
-  .17
-  .20
-  .24
-  .28
-  .32
-  .37
-  .43
-  .49
-  .55
-  .64
-  Not rated or not available

Soil Rating Lines







-  .02
-  .05
-  .10
-  .15
-  .17
-  .20

-  .24
-  .28
-  .32
-  .37
-  .43
-  .49
-  .55
-  .64
-  Not rated or not available

Soil Rating Points

-  .02
-  .05
-  .10
-  .15
-  .17
-  .20
-  .24
-  .28
-  .32
-  .37
-  .43
-  .49
-  .55
-  .64
-  Not rated or not available

Water Features

-  Streams and Canals
- Transportation**
-  Rails
-  Interstate Highways
-  US Routes
-  Major Roads
-  Local Roads
- Background**
-  Aerial Photography

MAP INFORMATION

The soil surveys that comprise your AOI were mapped at 1:24,000.

Warning: Soil Map may not be valid at this scale.
Enlargement of maps beyond the scale of mapping can cause misunderstanding of the detail of mapping and accuracy of soil line placement. The maps do not show the small areas of contrasting soils that could have been shown at a more detailed scale.

Please rely on the bar scale on each map sheet for map measurements.

Source of Map: Natural Resources Conservation Service
Web Soil Survey URL:
Coordinate System: Web Mercator (EPSG:3857)

Maps from the Web Soil Survey are based on the Web Mercator projection, which preserves direction and shape but distorts distance and area. A projection that preserves area, such as the Albers equal-area conic projection, should be used if more accurate calculations of distance or area are required.

This product is generated from the USDA-NRCS certified data as of the version date(s) listed below.

Soil Survey Area: El Paso County Area, Colorado
Survey Area Data: Version 20, Sep 2, 2022

Soil map units are labeled (as space allows) for map scales 1:50,000 or larger.

Date(s) aerial images were photographed: Sep 11, 2018—Oct 20, 2018

The orthophoto or other base map on which the soil lines were compiled and digitized probably differs from the background imagery displayed on these maps. As a result, some minor shifting of map unit boundaries may be evident.

K Factor, Whole Soil

Map unit symbol	Map unit name	Rating	Acres in AOI	Percent of AOI
8	Blakeland loamy sand, 1 to 9 percent slopes	.10	1.2	23.2%
95	Truckton loamy sand, 1 to 9 percent slopes	.24	3.9	76.8%
Totals for Area of Interest			5.0	100.0%

Description

Erosion factor K indicates the susceptibility of a soil to sheet and rill erosion by water. Factor K is one of six factors used in the Universal Soil Loss Equation (USLE) and the Revised Universal Soil Loss Equation (RUSLE) to predict the average annual rate of soil loss by sheet and rill erosion in tons per acre per year. The estimates are based primarily on percentage of silt, sand, and organic matter and on soil structure and saturated hydraulic conductivity (Ksat). Values of K range from 0.02 to 0.69. Other factors being equal, the higher the value, the more susceptible the soil is to sheet and rill erosion by water.

"Erosion factor Kw (whole soil)" indicates the erodibility of the whole soil. The estimates are modified by the presence of rock fragments.

Factor K does not apply to organic horizons and is not reported for those layers.

Rating Options

Aggregation Method: Dominant Condition

Component Percent Cutoff: None Specified

Tie-break Rule: Higher

Layer Options (Horizon Aggregation Method): Surface Layer (Not applicable)

APPENDIX C – EROSION CONTROL PLAN



Know what's below.
Call before you dig.

NO.	REVISION	BY	DATE

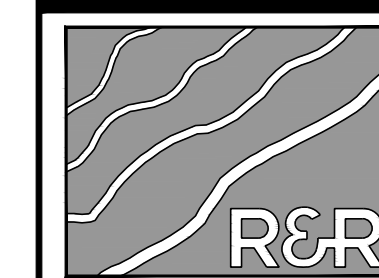

ENGINEERS
SURVEYORS

R&R ENGINEERS-SURVEYORS, INC.
1635 WEST 13TH AVENUE, SUITE 310
DENVER, COLORADO 80204
PHONE: 303-753-6730

WWW.RRENINEERS.COM

MAYBERRY PUD PH1 - FILING NO. 2A
SITE ADDRESS: MAYBERRY, COLORADO SPRINGS
EL PASO COUNTY
PREPARED FOR: MAYBERRY COMMUNITIES, LLC
3296 DEVINE HEIGHTS #208
COLORADO SPRINGS, CO 80922

CONSTRUCTION DOCUMENTS			
JOB NO.	MC22199	DATE	09/25/2023
ORG. SUBM. DATE	09/25/2023	CHKD.	TW
DWN.	LO	NAME	

INITIAL EROSION CONTROL MEASURES

NO. **9**

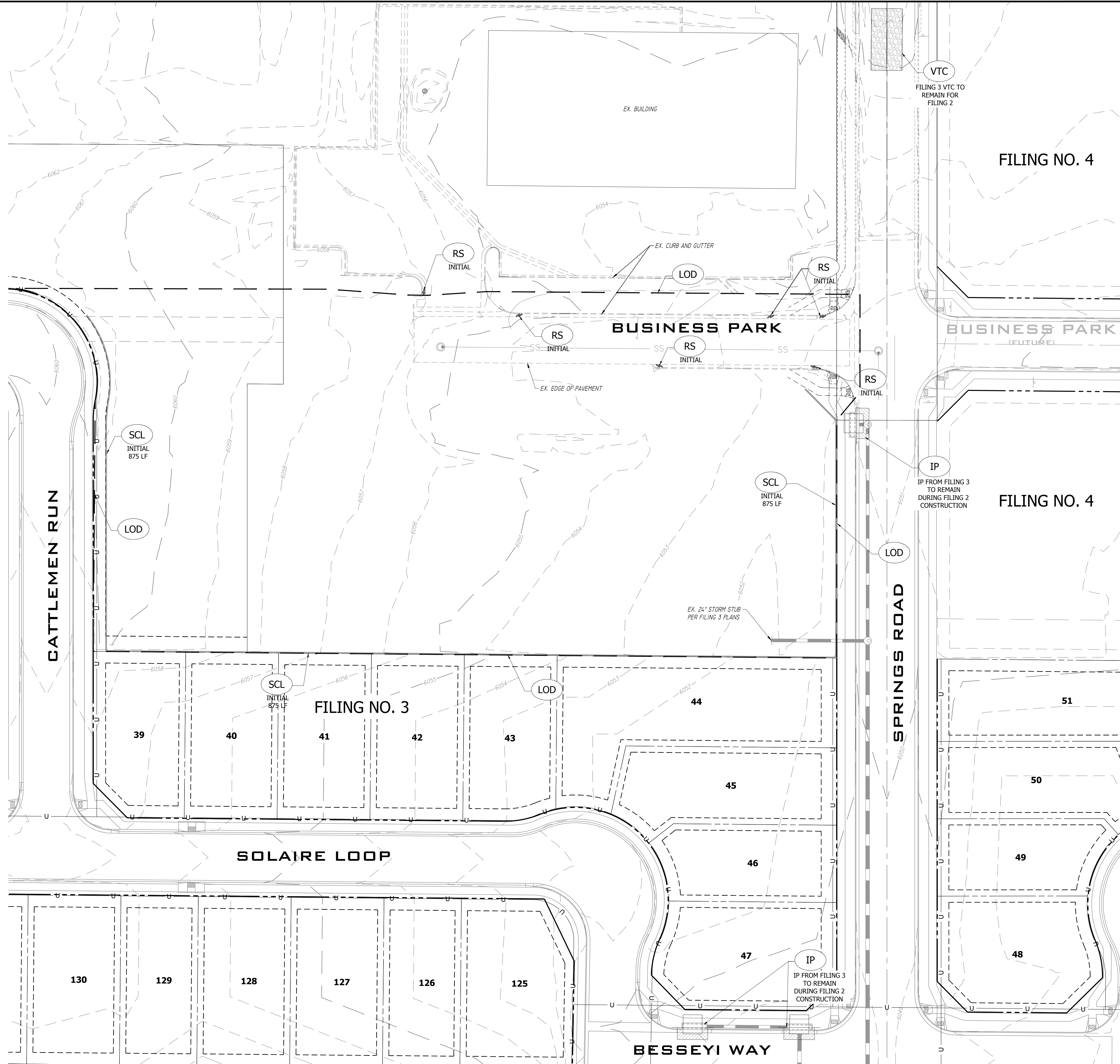

BMP LEGEND

	LOD	LIMITS OF DISTURBANCE
	SCL	SEDIMENT CONTROL LOG
	RS	ROCK SOCK
	IP	INLET PROTECTION
	VTC	VEHICLE TRACKING CONTROL
	RRC	REINFORCED CHECK DAM FOR CULVERT PROTECTION
		PROP. CUT/FILL BOUNDARY

SCHEDULE OF ACTIVITIES/SEQUENCE

INITIAL PHASE

1. INSTALL EROSION CONTROL MEASURES
2. CLEAR & GRUB, GRADING

INTERIM PHASE

1. GRADE AREA FOR NEW PARKING LOT CONFIGURATION.
2. INSTALL DETENTION VAULT SYSTEM
3. PAVE PARKING LOT

FINAL PHASE

1. LANDSCAPING
2. SITE CLEAN UP
3. REMOVE EROSION CONTROL MEASURES

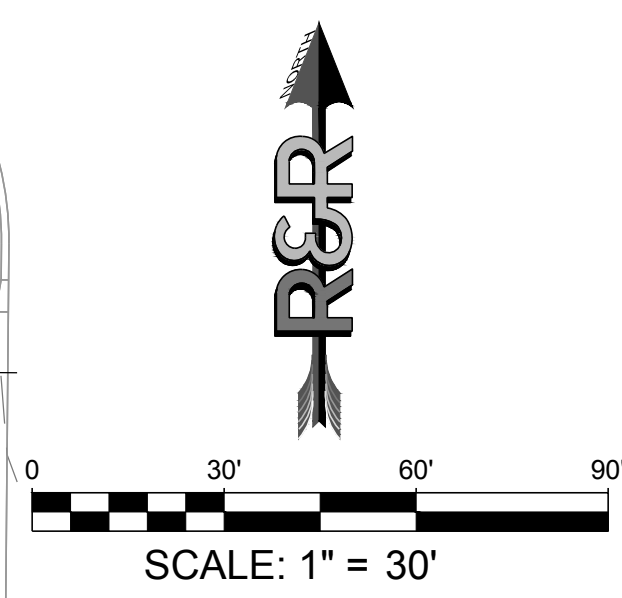

P:\PLANS\22199\MAYBERRY PUD PH1 - FILING NO. 2A\LOTS 2 & 3\ENGINEERING\DRAWINGS\PLANS\MCD199_CUL DE SAC EROSION CONTROL MEASURES 9/25/2023 2:22:48 PM BY: JRM, GORDY



Know what's below.
Call before you dig.

CHEROKEE WATER &
SANITATION DISTRICT
BK. 5527, PG. 376

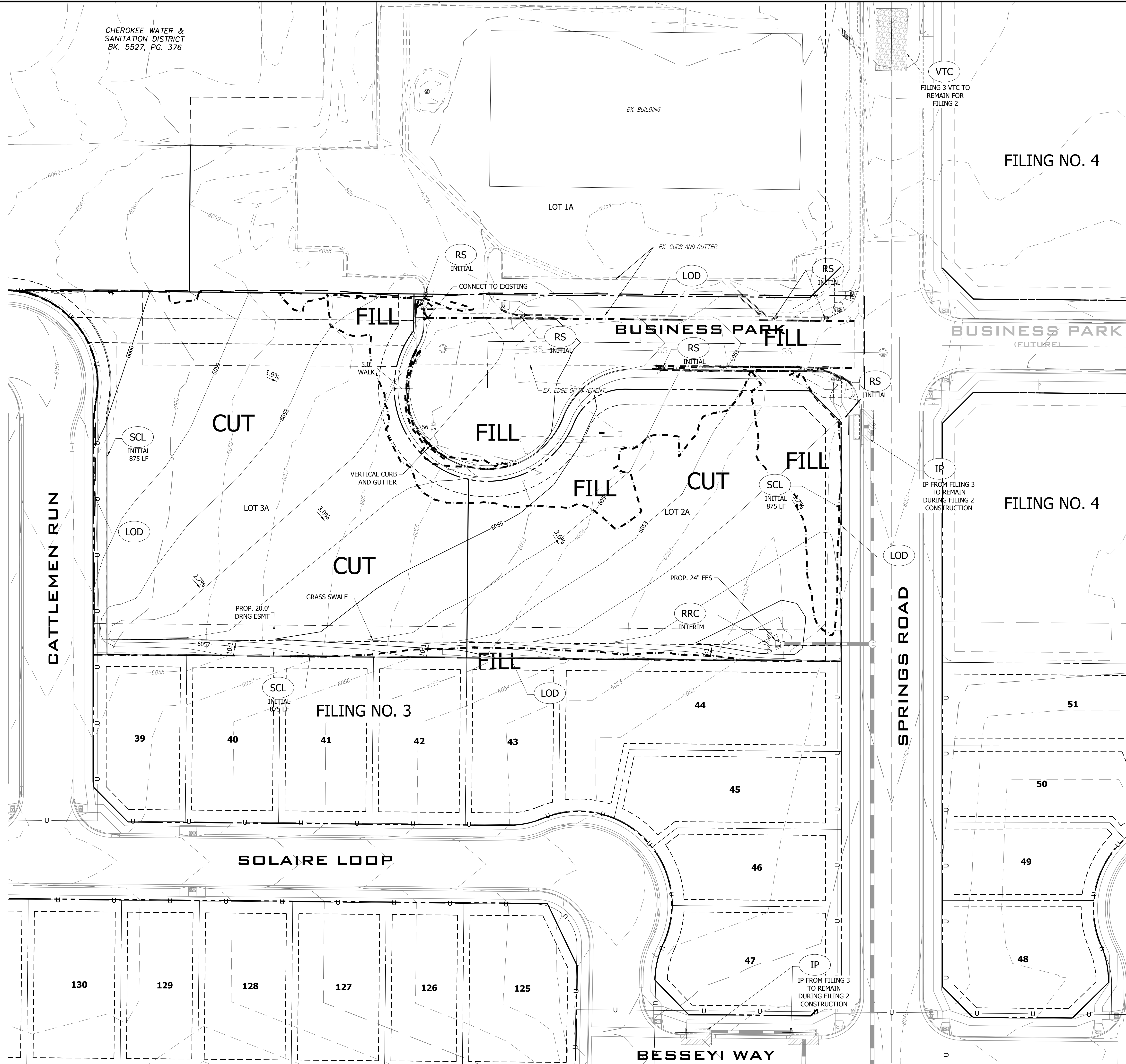

FILING NO. 4

FILING NO. 4

FILING NO. 3

- BMP LEGEND**
- LIMITS OF DISTURBANCE
 - SEDIMENT CONTROL LOG
 - ROCK SOCK
 - INLET PROTECTION
 - VEHICLE TRACKING CONTROL
 - REINFORCED CHECK DAM FOR CULVERT PROTECTION
 - PROP. CUT/FILL BOUNDARY

- SCHEDULE OF ACTIVITIES/SEQUENCE**
- INITIAL PHASE**
1. INSTALL EROSION CONTROL MEASURES
 2. CLEAR & GRUB, GRADING
- INTERIM PHASE**
1. GRADE AREA FOR NEW PARKING LOT CONFIGURATION.
 2. INSTALL DETENTION VAULT SYSTEM
 3. PAVE PARKING LOT
- FINAL PHASE**
1. LANDSCAPING
 2. SITE CLEAN UP
 3. REMOVE EROSION CONTROL MEASURES

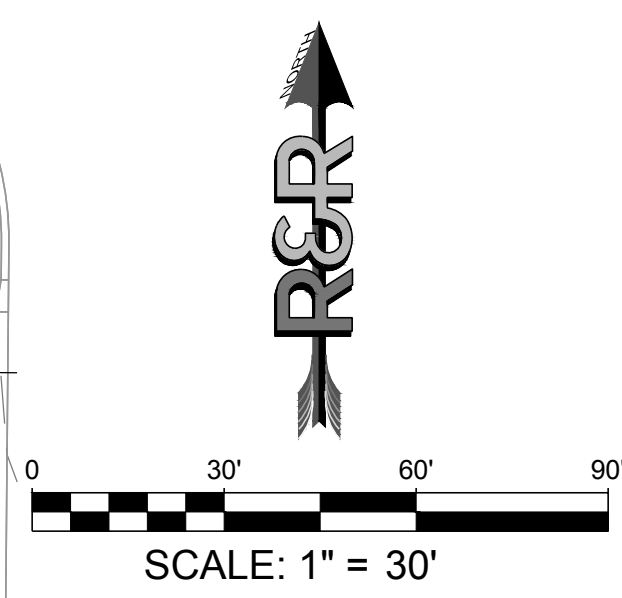

NO.	REVISION	BY	DATE

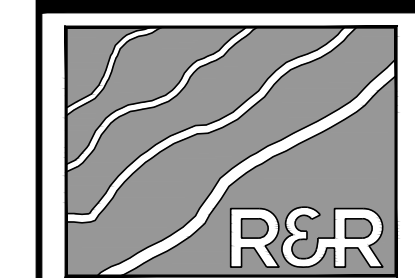

ENGINEERS
SURVEYORS

R&R ENGINEERS-SURVEYORS, INC.
1635 WEST 13TH AVENUE, SUITE 310
DENVER, COLORADO 80204
PHONE: 303-753-6730

WWW.RRENINEERS.COM

MAYBERRY PUD PH1 - FILING NO. 2A

SITE ADDRESS: MAYBERRY, COLORADO SPRINGS
EL PASO COUNTY

PREPARED FOR: MAYBERRY COMMUNITIES, LLC
3296 DEVINE HEIGHTS #208
COLORADO SPRINGS, CO 80922

CONSTRUCTION DOCUMENTS			
JOB NO.	MC22199	DATE	09/25/2023
ORG. SUBM. DATE	09/25/2023	CHKD.	TW
DWN.	LO	DATE	
NAME			

INTERIM EROSION CONTROL MEASURES

NO. 10

P:\P\1\MC22199_MAYBERRY_PUD_PH1 - FILING NO. 2A - LOTS 2 & 3\ENGINEERING\DRAWINGS\PLANS\MC22199_CUL DE SAC EROSION CONTROL MEASURES.dwg PLOT DATE: 09/25/2023 2:23:06 PM BY: DINA CORADO

P:\P\1\222109 MAYBERRY FILING NO. 2 LOTS 2 & 3\ENGINEERING DRAWINGS\PLANS\WC2109 CUL DE SAC EROSION CONTROL MEASURES 09/25/2023 2:21:13 PM BY: JLN, C:GRADY

CHEROKEE WATER & SANITATION DISTRICT
BK. 5527, PG. 376



Know what's below.
Call before you dig.

NO.	REVISION	BY	DATE

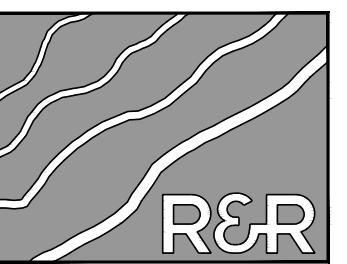

ENGINEERS
SURVEYORS

R&R ENGINEERS-SURVEYORS, INC.
1635 WEST 13TH AVENUE, SUITE 310
DENVER, COLORADO 80204
PHONE: 303-753-6730

WWW.RRENINEERS.COM

MAYBERRY PUD PH1 - FILING NO. 2A
SITE ADDRESS: MAYBERRY, COLORADO SPRINGS
EL PASO COUNTY
PREPARED FOR: MAYBERRY COMMUNITIES, LLC
3296 DEVINE HEIGHTS #208
COLORADO SPRINGS, CO 80922

CONSTRUCTION DOCUMENTS			
JOB NO.	MC22199	DATE	09/25/2023
ORG. SUBM. DATE	09/25/2023	CHKD.	TW
DWN.	LO	NAME	

FINAL EROSION CONTROL MEASURES

NO. 11

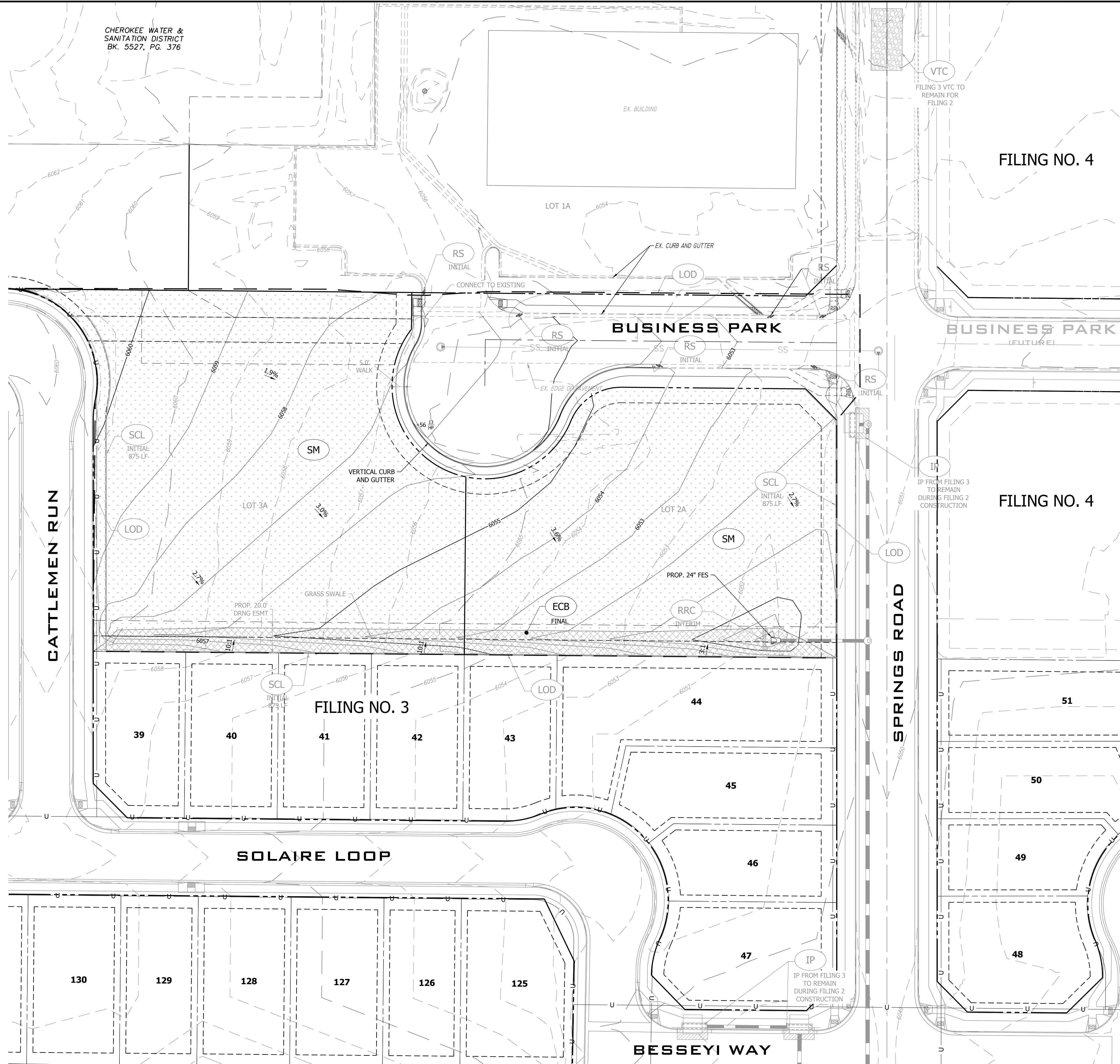

BMP LEGEND

	LOD	LIMITS OF DISTURBANCE
	SCL	SEDIMENT CONTROL LOG
	RS	ROCK SOCK
	IP	INLET PROTECTION
	VTC	VEHICLE TRACKING CONTROL
	RRC	REINFORCED CHECK DAM FOR CULVERT PROTECTION
		PROP. CUT/FILL BOUNDARY

SCHEDULE OF ACTIVITIES/SEQUENCE

INITIAL PHASE

1. INSTALL EROSION CONTROL MEASURES
2. CLEAR & GRUB, GRADING

INTERIM PHASE

1. GRADE AREA FOR NEW PARKING LOT CONFIGURATION.
2. INSTALL DETENTION VAULT SYSTEM
3. PAVE PARKING LOT

FINAL PHASE

1. LANDSCAPING
2. SITE CLEAN UP
3. REMOVE EROSION CONTROL MEASURES

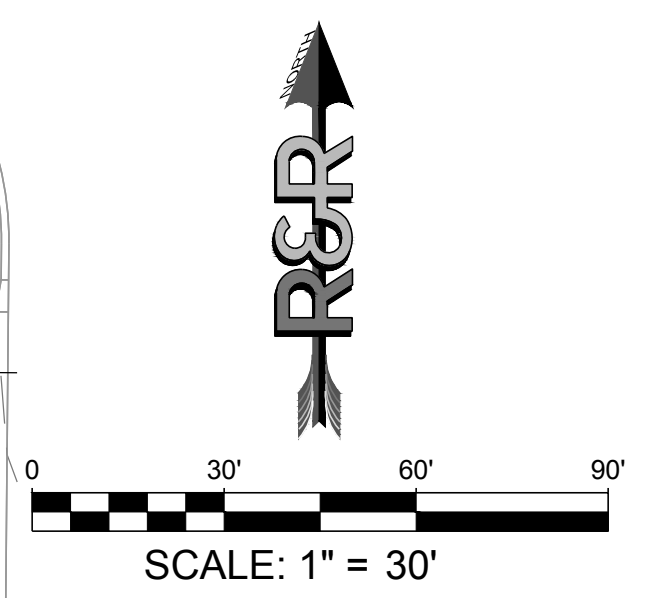

APPENDIX D – BMP DETAILS

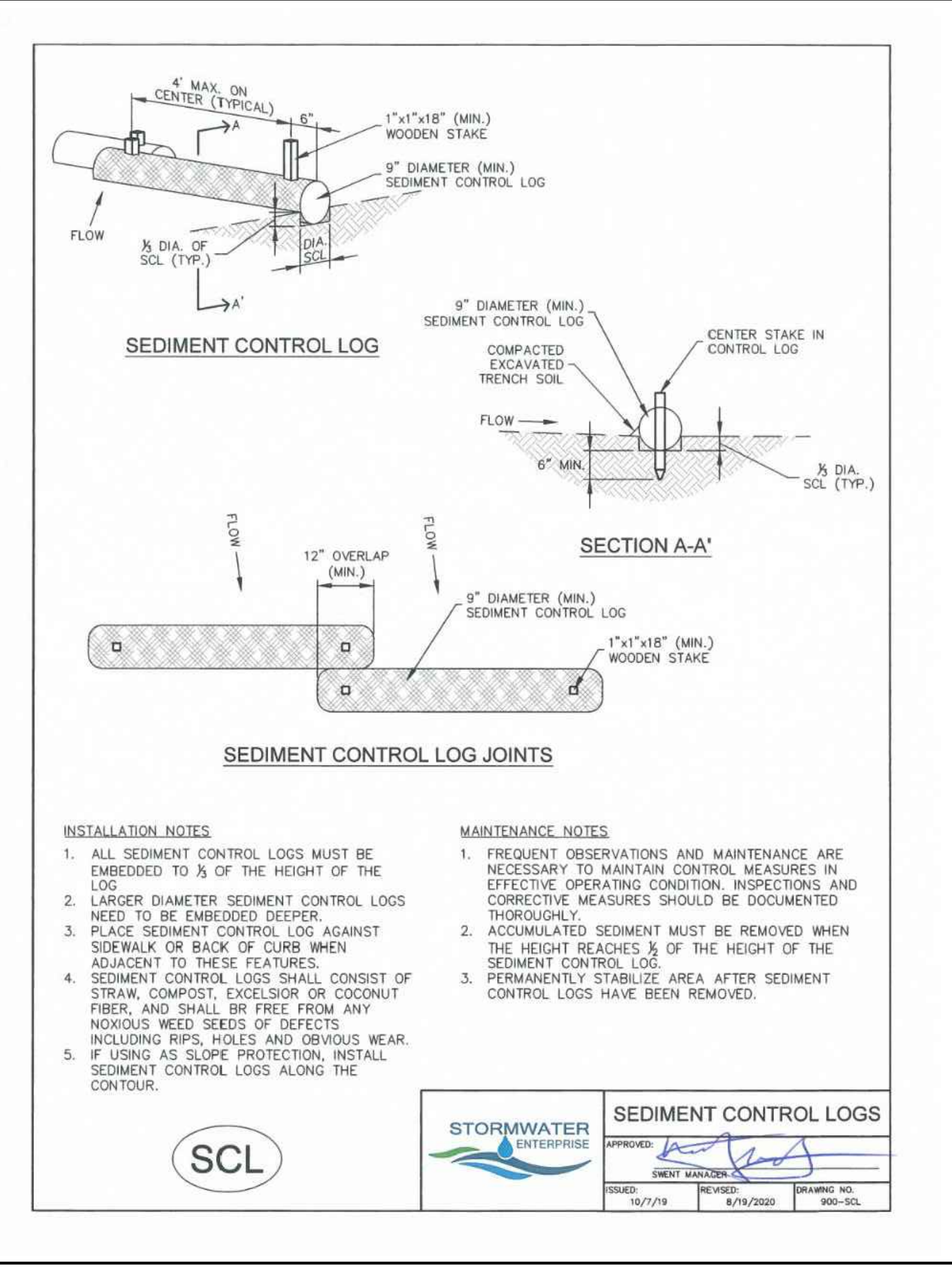
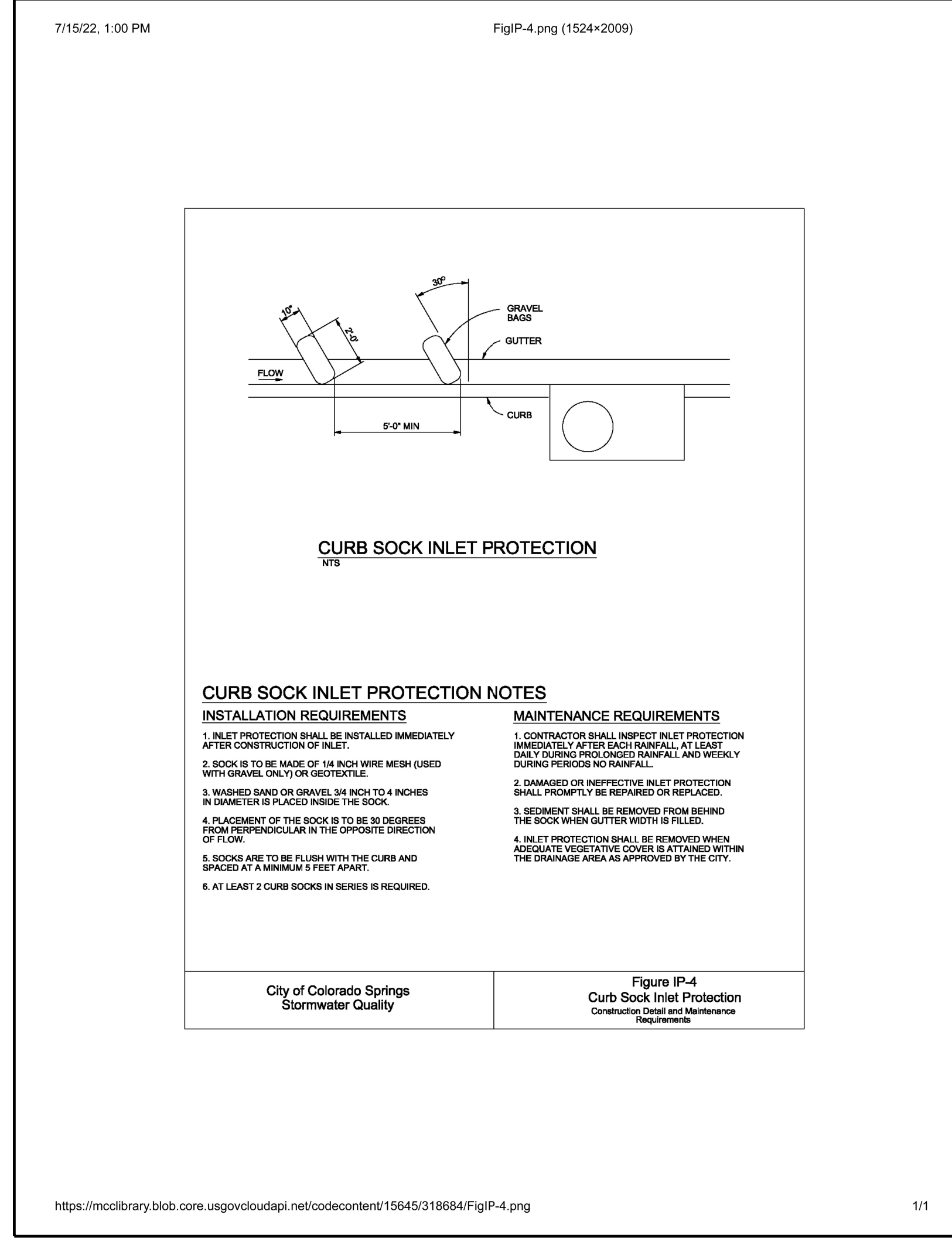
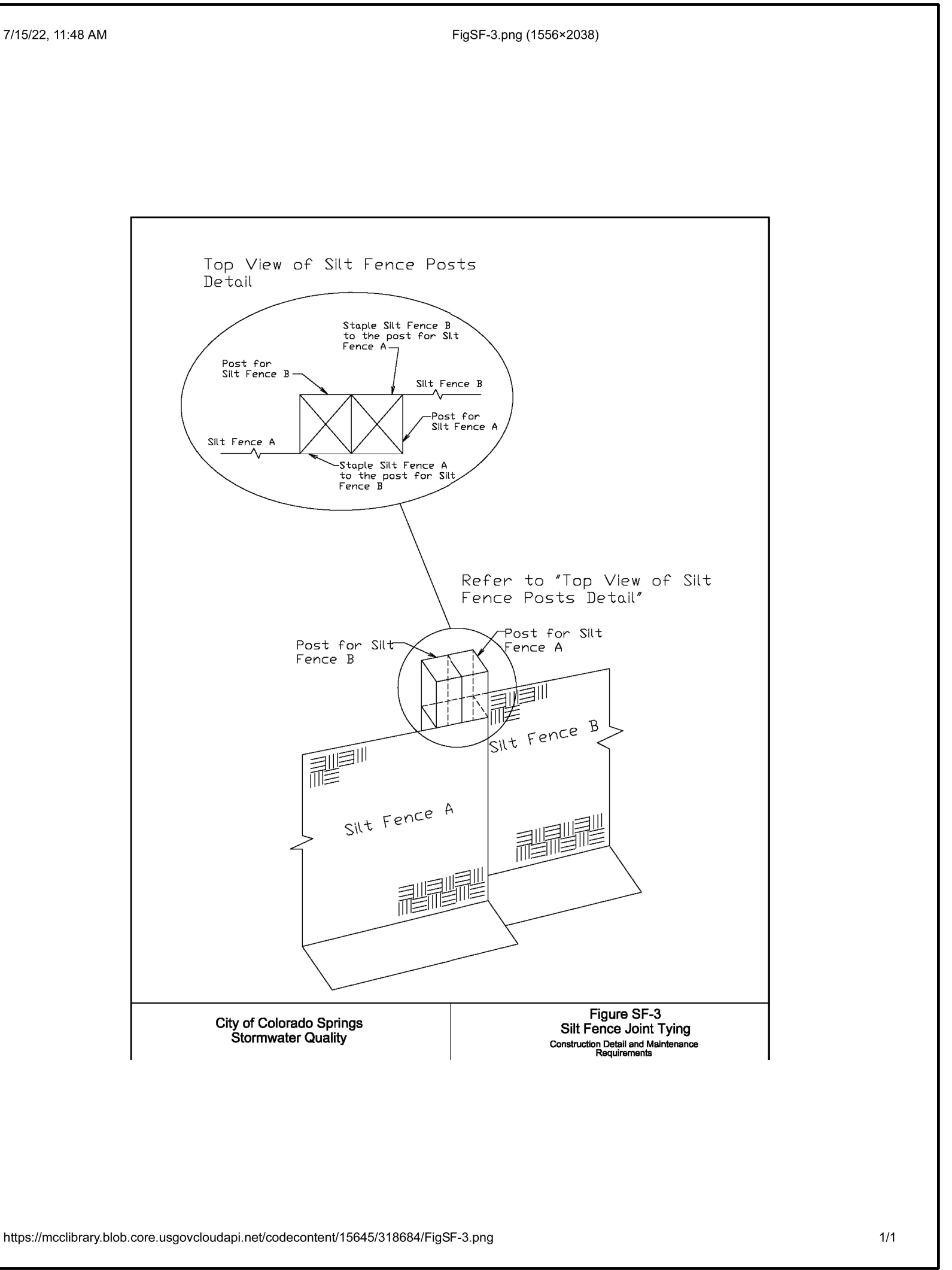
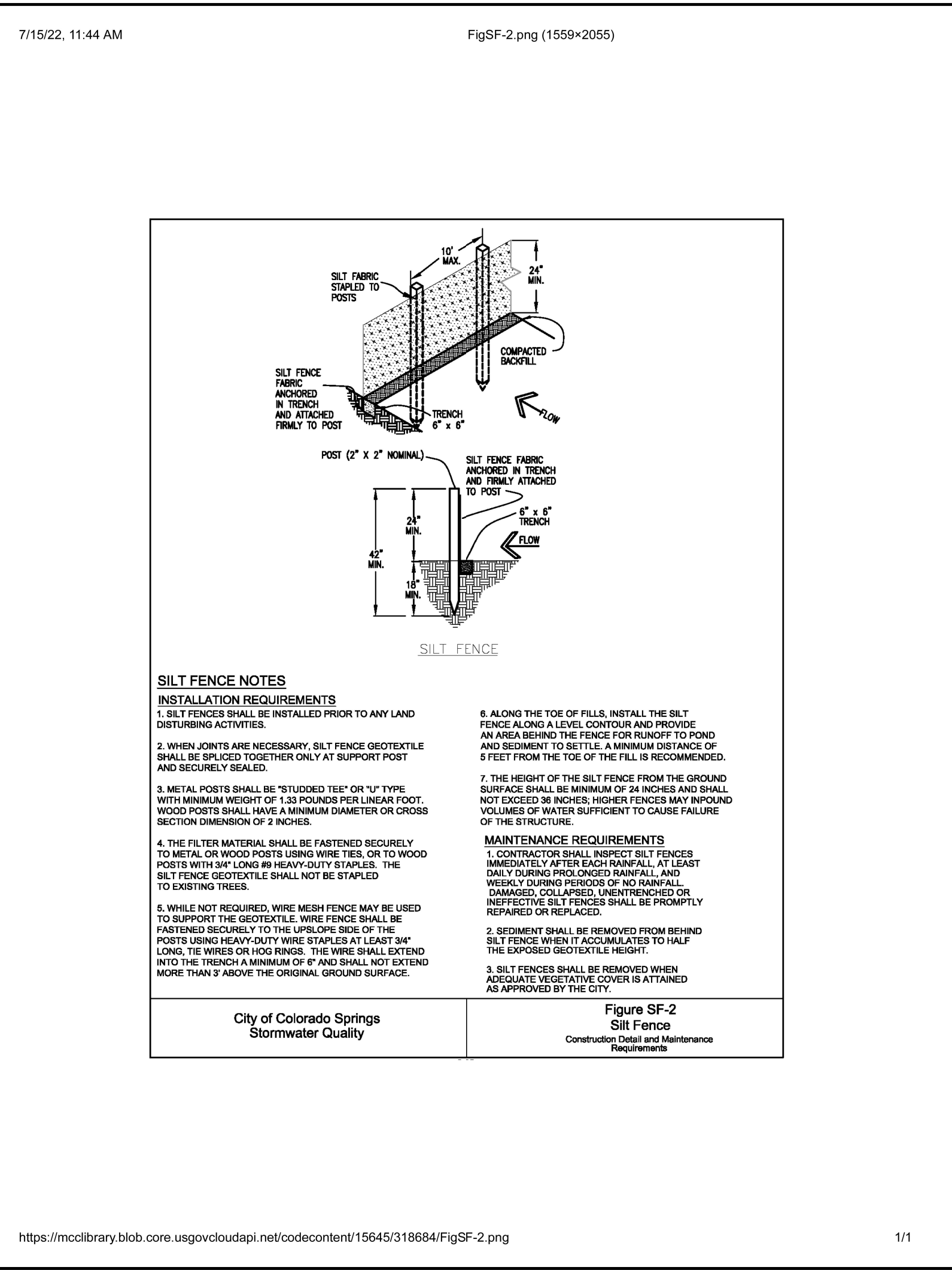
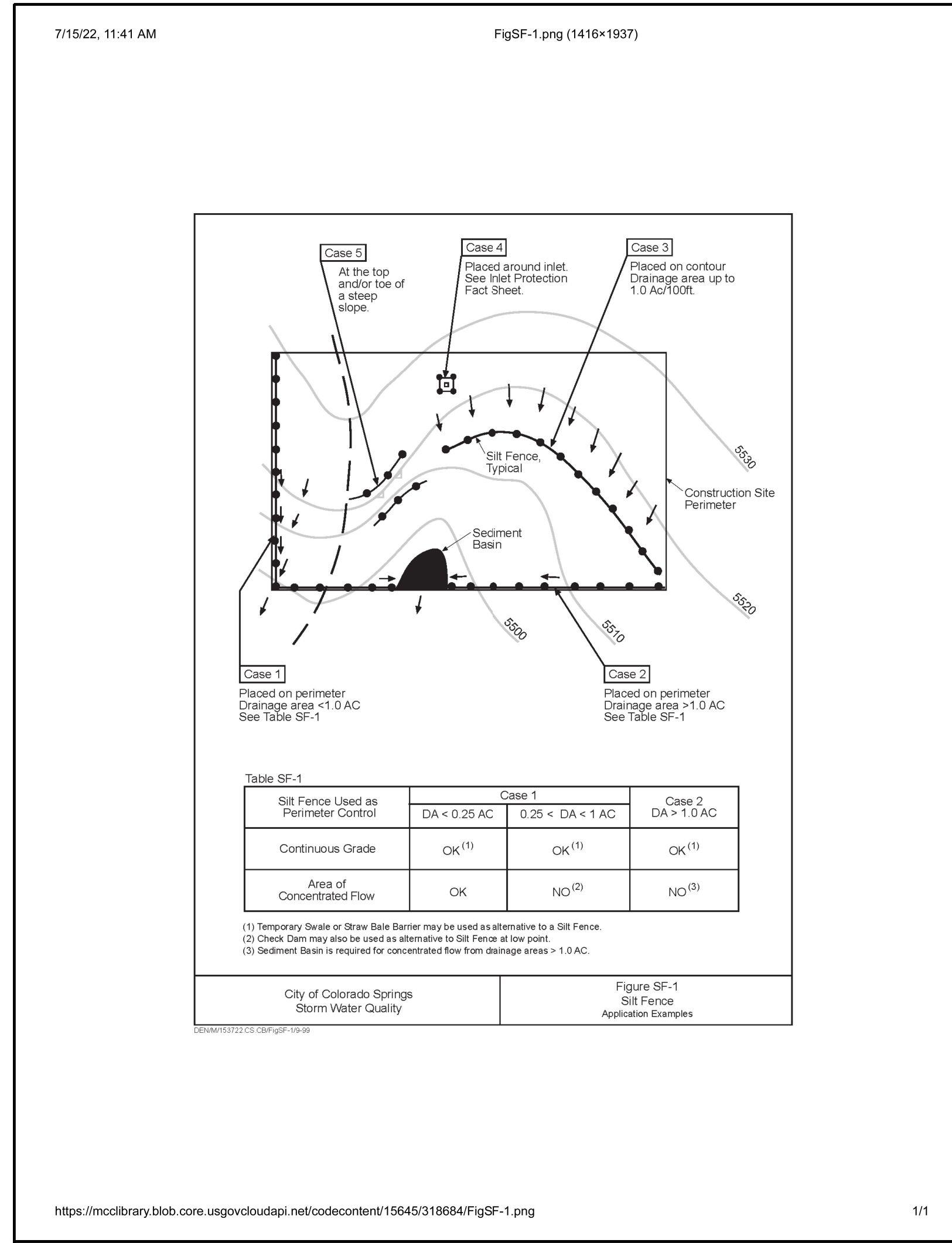

NO.	REVISION	BY	DATE

R&R ENGINEERS-SURVEYORS, INC.
1635 WEST 13TH AVENUE, SUITE 310
DENVER, COLORADO 80204
PHONE: 303-753-6730

WWW.RRENGINEERS.COM

MAYBERRY PUD PH 1 - FILING NO. 2

SITE ADDRESS: MAYBERRY, COLORADO SPRINGS EL PASO COUNTY

PREPARED FOR: MAYBERRY COMMUNITIES, LLC 3296 DEVINE HEIGHTS #208 COLORADO SPRINGS, CO 80922

CONSTRUCTION DOCUMENTS

JOB NO. MC22199

ORG. SUBM. DATE XX/XX/XXXX

DWN: JMP CHKD: CJD

NAME

DETAILS

NO. 6

PATH: P:\MC22199\MAYBERRY PUD PH 1 - FILING NO. 2 - LOTS 2 & 3\ENGINEERING\DRAWINGS\PLANS\MC22199 - DETAILS.DWG: PLOT DATE: 12/7/2022 9:11:25 AM BY: LNU, G36ADY