

McLaughlin Office Building

Transportation Memorandum

SF-20-022

Prepared for:
Darin C. Weiss, Architect AIA
Design and Development Consultants
T-Bone Construction
1310 Ford Street
Colorado Springs, CO 80915

NOVEMBER 30, 2020

LSC Transportation Consultants
Prepared by: Colleen Guillotte, P.E., PTOE, RSP
Reviewed by: Jeffrey C. Hodsdon, P.E.

LSC #204590



CONTENTS

REPORT CONTENTS	1
PREVIOUS TRAFFIC STUDIES	2
LAND USE AND ACCESS	2
Land Use	2
Access & Circulation	2
INTERSECTION SIGHT DISTANCE	2
ROAD AND TRAFFIC CONDITIONS.....	3
Area Roads	3
Traffic Volumes	3
TRIP GENERATION	3
BACKGROUND TRAFFIC	4
TRIP DISTRIBUTION AND ASSIGNMENT	5
Trip Directional Distribution	5
Site-Generated Traffic	5
Short-Term Total Traffic Volumes.....	5
Long-Term Total Traffic Volumes.....	5
LEVEL OF SERVICE ANALYSIS.....	5
McLaughlin Road/Midnight Road	6
Site Accesses	7
AUXILIARY TURN LANES	7
VEHICLE QUEUING	7
MTCP ROADWAY IMPROVEMENTS.....	7
PEDESTRIAN AND BICYCLE ACCOMMODATION	8
COUNTY ROAD IMPROVEMENT FEE PROGRAM.....	8
Transportation Impact Fees.....	8
Reimbursable MTCP Improvements	8
FINDINGS AND CONCLUSIONS.....	8
Trip Generation	8
Recommendations	8
Auxiliary Lanes	9

Enclosures:.....9

Tables 4-5

Figures 1-8

Traffic Counts

Level of Service Reports



LSC TRANSPORTATION CONSULTANTS, INC.
2504 East Pikes Peak Avenue, Suite 304
Colorado Springs, CO 80909
(719) 633-2868
FAX (719) 633-5430
E-mail: lsc@lsctrans.com
Website: <http://www.lsctrans.com>

November 30, 2020

Darin C. Weiss, Architect AIA
Design and Development Consultants
T-Bone Construction
1310 Ford Street
Colorado Springs, CO 80915

RE: McLaughlin Office Building
Transportation Memorandum
El Paso County, Colorado
LSC #204590

Dear Mr. Weiss:

LSC Transportation Consultants, Inc. has prepared this transportation memorandum for the proposed development planned to be located east of the intersection of McLaughlin Road/Midnight Road in El Paso County, Colorado. A 4,200-square-foot medical office building is proposed for the western portion of the parcel (parcel number 4306301002). This report has been prepared for submittal to El Paso County.

REPORT CONTENTS

The preparation of this report included the following:

- Inventory of the existing adjacent and nearby roadway system. This includes functional classifications, street widths, lane configurations, intersection traffic control, posted speed limits, pavement markings, intersection and access spacing, roadway and intersection alignments, auxiliary left- and right-turn lanes, intersection sight distances, etc.;
- A review of the proposed site land use and access locations;
- Morning and evening peak-hour traffic volumes at the intersection of McLaughlin Road/Midnight Road and the Safeway access;
- Estimates of short- and long-term background traffic volumes and total traffic (site traffic plus background traffic). Forecasts include buildout of adjacent proposed developments;
- Estimates of the daily and peak-hour trip generation for the proposed land use;
- The estimated directional distribution of site-generated vehicle trips on the study-area roadway system;

- Projections of peak-hour site-generated turning-movement traffic volumes at the study-area intersections;
- Level of service (LOS) analysis at the study-area intersections;
- Evaluation of the short-term and long-term projected intersection volumes to determine the potential need for any new auxiliary right-/left-turn lanes and/or the adequacy of existing lanes at the site access-point intersections and the other study-area intersections; and
- Findings and recommendations.

PREVIOUS TRAFFIC STUDIES

Reports completed in the past five years in the vicinity of the study area include:

- Falcon Marketplace
- Meadowlake Ranch
- Judge Orr/Eastonville (northeast corner)
- The Ranch
- US Highway Planning and Environment Linkage Study
- Falcon Highland Taco Bell deviation request memo
- Falcon Field
- Meridian Crossing

LAND USE AND ACCESS

Figure 1 shows the site location relative to the adjacent and nearby roadways. The site plan is shown in Figure 2

Land Use

As shown in Figure 2, the development is proposed to include a 4,200-square-foot office building on the west portion of the parcel. This office building may be expanded up to an additional 1,400 square feet for a total of 5,600 square feet.

Access & Circulation

As shown, the site is planned to access the service drive which provides access to the rear of the Safeway store and other businesses to the east. The access configuration is shown in Figure 2.

INTERSECTION SIGHT DISTANCE

The development will use an existing shopping center access to McLaughlin Road. The required intersection sight distance for this access, per the El Paso County Engineering Criteria Manual (ECM) and based on Table 2-35, is 250 feet for passenger vehicles. There is also sufficient stopping sight distance along McLaughlin for entering trucks. This access meets this minimum sight-distance criterion. The intersection line of sight “triangles” will need to be kept free of site improvements

(that would limit the line of sight needed to maintain ECM prescribed sight distance). Examples of site improvements include landscaping, monument signs, parking areas, berms, etc. Obstruction height to maintain passenger car line of sight is about 18 inches. Obstruction height to maintain truck line of sight is higher as the truck “driver’s eye” is significantly higher than the “driver’s eye” for a two-passenger vehicle.

ROAD AND TRAFFIC CONDITIONS

Area Roads

Figure 1 shows the streets in the vicinity of the site. The streets adjacent to the site are identified below, followed by a brief description of each:

- **McLaughlin Road** is a two-lane, non-residential Collector road that extends north from Rolling Thunder Avenue to Eastonville Road. The roadway provides retail and residential access both north and south of Woodmen Road. The posted speed limit is 25 miles per hour (mph).
- **Midnight Road** is a two-lane, non-residential Collector road that extends north from McLaughlin Road west to Eastonville Road, where it then becomes a north/south road and is classified as a Local road.

Traffic Volumes

Traffic counts were conducted in September 2020 at the study intersections. Figure 3 provides the peak-hour traffic. These volumes may be lower than Pre-COVID-19 levels.

TRIP GENERATION

Estimates of the vehicle trips projected to be generated by the proposed development have been made using the nationally published trip-generation rates from *Trip Generation, 10th Edition, 2017* by the Institute of Transportation Engineers (ITE). The ITE land use Medical Office Building (IE Code 720) was used for the analysis. As mentioned previously, the building will initially be constructed as a 4,200-square-foot building, but may be expanded to 5,600 square feet in the future.

Table 1, below, presents a summary of the estimated site trip generation on a typical weekday during phase 1. Phase 1 is the initial construction of the building with a square footage of 4,200 square feet. Table 2 provides a summary of the estimated trip generation, if the building is expanded in the future (Buildout). The detailed trip-generation estimate for the development, including ITE rates for the proposed land use, is presented in Table 4.

With the initial construction, approximately 74 total vehicle trips are projected to enter and exit the site at the access point (“driveway trips”) on the average weekday during a 24-hour period. During the morning peak hour, approximately 10 vehicles would enter and 6 vehicles would exit the site. During the evening peak hour, approximately 6 vehicles would enter and 9 vehicles would exit the site.

Table 1: Phase 1 Estimated External Site Vehicle-Trip Generation (Vehicles per Hour)

Analysis Period	Total Trips		
	In	Out	Total
A.M. Peak Hour	10	6	16
P.M. Peak Hour	6	9	15
Daily/24-Hour	37	37	74

Table 2: Buildout Estimated External Site Vehicle-Trip Generation (Vehicles per Hour)

Analysis Period	Total Trips		
	In	Out	Total
A.M. Peak Hour	14	8	22
P.M. Peak Hour	7	12	19
Daily/24-Hour	64	64	128

BACKGROUND TRAFFIC

Background traffic includes growth that is projected to occur on the study roadways, due to future development in the area. Background volumes do not include projected traffic to be generated by the proposed development.

Long-term volumes have been projected assuming two percent growth per year for the through volumes on McLaughlin Road. However, changes in the area are worth noting. The area is growing and the transportation system is changing to have less emphasis on McLaughlin as a through route. Area changes include the planned new Meridian connection to US Highway 24 and removal of the signal at US Highway 24/“Old” Meridian Road. Also, a signal will be installed soon at Meridian/Eastonville Road.

There are undeveloped parcels within the shopping center. The east half of the site is not being developed with this project. In the long-term background, it was assumed the east half of the parcel would be developed as a 2,086-square-foot fast-food restaurant and use the same access as the proposed development. The parcel to the southwest of the site was assumed to be a shopping center land use with trips using both shopping center accesses along McLaughlin Road. The vacant parcel at the south corner of the shopping center was not included because it was assumed that trips to/from this parcel would use the south access to the shopping center and not impact the study intersections. Table 5 provides the trip generation assumptions for the vacant parcels. Figure 4 shows the projected 20-year background traffic volumes for the year 2040.

TRIP DISTRIBUTION AND ASSIGNMENT

Trip Directional Distribution

Estimation of the directional distribution of site-generated vehicle trips to the study-area roads and intersections is a necessary component in determining the site's traffic impacts. Figure 5 shows the directional distribution estimates for the proposed development. Estimates were based on the following factors: existing traffic counts, existing area development, and the area roadway system.

Site-Generated Traffic

Site-generated traffic volumes at the study intersections have been calculated by applying the directional-distribution percentages estimated by LSC to the trip-generation estimates (from Table 2). To be conservative, the buildout trip generation that includes the potential future expansion was used for the analysis. Figure 5 provides the site-generated traffic for the site.

Short-Term Total Traffic Volumes

Figure 6 shows the sum of the existing traffic volumes (from Figure 3) and the site-generated peak-hour traffic volumes for the development (shown in Figure 5). These volumes represent the projected short-term total traffic following construction of the development.

Long-Term Total Traffic Volumes

Figure 7 shows the projected 2040 total traffic volumes, which are the sum of 2040 background traffic volumes (from Figure 4) plus the site-generated traffic volumes (from Figure 5).

LEVEL OF SERVICE ANALYSIS

Level of service (LOS) is a quantitative measure of the level of congestion or delay at an intersection and is indicated on a scale from "A" to "F." LOS A is indicative of little congestion or delay. LOS F indicates a high level of congestion or delay. Table 3 shows the level of service delay ranges for signalized and unsignalized intersections.

Table 3: Intersection Levels of Service Delay Ranges

Level of Service	Signalized Intersections	Unsignalized Intersections
	Average Control Delay (seconds per vehicle)	Average Control Delay (seconds per vehicle) ⁽¹⁾
A	10.0 sec or less	10.0 sec or less
B	10.1-20.0 sec	10.1-15.0 sec
C	20.1-35.0 sec	15.1-25.0 sec
D	35.1-55.0 sec	25.1-35.0 sec
E	55.1-80.0 sec	35.1-50.0 sec
F	80.1 sec or more	50.1 sec or more

(1) For unsignalized intersections if V/C ratio is greater than 1.0 the level of service is LOS F regardless of the projected average control delay per vehicle.

The study intersections and the site access point have been analyzed to determine the projected control delay and corresponding levels of service for turning movements. Figure 3 provides the existing levels of service. Figure 4 provides the background levels of service for the long-term scenarios. Figure 6 and Figure 7 provide the levels of service for the short-term and long-term total traffic scenarios, respectively.

McLaughlin Road/Midnight Road

All yielding turning movements at the unsignalized intersection of McLaughlin Road/Midnight Road currently operate at LOS D or better during both peak hours, with the exception of the westbound left-turning movement. This movement currently operates at LOS F during the afternoon peak hour. In all future scenarios, this movement is expected to continue to operate at LOS F with potentially increasing delay and queues. In addition, the westbound through/right movement is expected to operate at LOS E in the long-term total traffic scenario.

This intersection is not expected to meet signal warrants during the morning peak hour (see Figure 8 for four-hour signal warrant chart). If the westbound delay or queuing (see section on Vehicle Queuing) is found to be a significant problem in the long term, then a potential traffic-control change to all-way stop or a mini roundabout/roundabout are options for consideration. Figure 7 shows the levels of service for roundabout and all-way-stop-control alternatives. As shown, all movements are anticipated to operate at LOS D or better with an all-way stop in the long-term with the exception of the northbound through/right, which is expected to operate at LOS E. All approaches are expected to operate at LOS B or better during both peak hours in the long-term total traffic scenario, if the intersection is reconstructed as a roundabout.

It should be noted that this intersection is just one of two exits from the shopping center onto McLaughlin Road. Therefore, any change at this access would likely affect volumes at the south access and vice versa. All long-term solutions should consider both access points. While this study

only looked at the north access, installing all-way stop control or constructing a roundabout at one of the access points could potentially improve operations at the other as well.

Site Accesses

In all future scenarios, the access to the office building and the access to the parking lot are projected to have all movements operate at LOS B or better.

AUXILIARY TURN LANES

No additional auxiliary lanes are necessary with this proposed development.

VEHICLE QUEUING

The first internal access east of the McLaughlin Road intersection is approximately 110 feet to the east of Midnight/McLaughlin (queuing distance between the intersections), with the second access (to the south) located approximately 225 feet to the east. The westbound left turn at the intersection of McLaughlin Road/Midnight Road currently has a 150-foot 95th-percentile queue during the afternoon peak hour (Synchro-calculated). With the addition of the site, the queue is projected to extend to 175 feet. In the existing and short-term total scenarios, the queue length indicated the potential to block the existing service drive access during the afternoon peak hour.

In the long-term background, the 95th-percentile queue is expected to be 300 feet. With the addition of the site-generated traffic, this queue is projected to be 325 feet. In both scenarios, the projected queue length indicated the potential to block both accesses points during the afternoon peak hour. It should be noted that this condition is expected to exist both with and without the proposed development. In the short term, a "Do Not Block Intersection" sign (R10-7) could be placed just east of the access for westbound traffic that may be queuing for the McLaughlin Road/Midnight Road intersection. Pavement markings could also be added to encourage motorists to leave a gap at the access for entering traffic to turn left into this access.

As mentioned previously, the McLaughlin Road/Midnight Road intersection is not expected to meet signal warrants during the morning peak hour. The afternoon peak is expected to meet the four-hour signal warrant. There is the potential for the warrant thresholds to be met during the other afternoon hours outside of the one-hour peak. An all-way stop would reduce queuing to prevent the access from being blocked, but will cause queuing and delay on the northbound and southbound major street approaches. Potential future modification of the intersection to a mini roundabout/roundabout would reduce queuing on all approaches to 75 feet or less.

MTCP ROADWAY IMPROVEMENTS

The 2016 El Paso County Major Transportation Corridor Plan does not show any planned improvements in the study area.

PEDESTRIAN AND BICYCLE ACCOMMODATION

There are currently sidewalks along McLaughlin Road adjacent to the site and along the south boundary of the parcel.

COUNTY ROAD IMPROVEMENT FEE PROGRAM

Transportation Impact Fees

Per ECM Appendix B: *State what the current applicable Transportation Impact Fees are and what option the developer will be selecting for payment.*

The applicant intends to opt out of the PID options and will pay the full-fee amount at the time of building permit. The current "full fee" is \$3,180 per 1,000 square feet of office building floor area. The total fee amount for the proposed development is \$13,356 for the initial 4,200 square foot office.

Reimbursable MTCP Improvements

There are no apparent reimbursable improvements programmed in the MTCP in the general vicinity of this site.

FINDINGS AND CONCLUSIONS

Trip Generation

- The development is expected to generate approximately 74 vehicle trips on the average weekday with approximately 16 trips occurring during the morning peak hour and 15 trips during the evening peak hour when first constructed.
-
- If the building is expanded to 5,600 square feet, the development would generate approximately 128 vehicle trips on the average weekday with approximately 22 trips occurring during the morning peak hour and 19 trips during the evening peak hour

Recommendations

- In the short-term future, no additional improvements should be necessary to accommodate the trips generated by this project. The westbound left at the intersection of McLaughlin Road/Midnight Road is projected to continue to operate at LOS F during the afternoon peak hour with the addition of the site-generated traffic. However, the movement will continue to have a V/C ratio below 1.0 indicating the movement is below capacity.
-
- Should queues periodically extend across the first internal shopping center access, a "Do Not Block Intersection" sign (R10-7) could be placed just east of this internal access for westbound

traffic that may be queuing for the McLaughlin Road/Midnight Road intersection. Pavement markings could also be added to encourage motorists to leave a gap at the access for entering traffic to turn left into this access.

-
- In the future, the delay for vehicles exiting the shopping center (as indicated by the LOS F for the left-turn movement at the north access) during the afternoon peak hour has the potential to increase to levels deemed unacceptable for a higher percentage of patrons and employees. The LOS F (existing and projected) typically requires mitigation by El Paso County. This project and associated trip generation adds a relatively minor level of additional traffic to the McLaughlin/Midnight/north shopping center access intersection. However, this project in conjunction with developers of other vacant lots could potentially be part of a future solution to improve exiting level of service that could be programmed for implementation should delays and queues increase at either or both access points.
- As this north access intersection is only one of two exits from the greater shopping center, improving either exit could potentially result in improved levels of service and operations at both. Two potential methods for mitigating F level of service for the exiting left turn at this north access intersection are conversion to all-way stop control (AWSC) or mini-roundabout/roundabout traffic control. A future traffic signal may also be a consideration.

•

Auxiliary Lanes

- No additional auxiliary lanes along McLaughlin Road are required for the proposed development.

* * * * *

Please contact me if you have any questions regarding this report.

Respectfully Submitted,

LSC TRANSPORTATION CONSULTANTS, INC.

By: Colleen Guillotte, P.E., PTOE, RSP
Project Manager

JCH:jas

Enclosures: Tables 4-5
Figures 1-8
Traffic Counts
Level of Service Reports

Tables



Table 4: Detailed Site Trip Generation Estimate (Lot 1)

Land Use Code	Land Use Description	Trip Generation Units	Trip Generation Rates ⁽¹⁾				Total Trips Generated					
			Average Weekday Traffic ⁽²⁾	Morning Peak Hour In	Morning Peak Hour Out	Afternoon Peak Hour In	Afternoon Peak Hour Out	Average Weekday Traffic	Morning Peak Hour In	Morning Peak Hour Out	Afternoon Peak Hour In	Afternoon Peak Hour Out
Lot 1												
Phase 1												
720	Medical/Dental Office Building	4.2 KSF ⁽²⁾	17.56	2.41	1.48	1.32	2.06	74	10	6	6	9
Phase 1 Plus Potential Future Building Addition												
720	Medical/Dental Office Building	5.6 KSF	22.77	2.41	1.48	1.32	2.06	128	14	8	7	12
Lot 2												
Please refer to Table 5 - Background Trip Generation												
Notes:												
(1) Source: "Trip Generation, 10th Edition, 2017" by the Institute of Transportation Engineers (ITE)												
(2) KSF = thousand square feet												
Source: LSC Transportation Consultants, Inc.										Rev 11-12-20		

Table 5: Detailed Trip Generation Estimate – Background Traffic

Land Use Code	Land Use Description	Trip Generation Units	Trip Generation Rates ⁽¹⁾				Total Trips Generated					
			Average Weekday Traffic ⁽²⁾	Morning Peak Hour		Afternoon Peak Hour		Average Weekday Traffic	Morning Peak Hour		Afternoon Peak Hour	
				In	Out	In	Out		In	Out	In	Out
Background												
934	Fast Food Restaurant w/Drive Thru	2.09 KSF	465.00	20.13	19.65	16.78	15.34	970	42	41	35	32
820	Shopping Center	5.0 KSF	37.75	1.62	1.38	2.11	2.11	189	8	7	11	11
Notes:												
(1) Source: "Trip Generation, 10th Edition, 2017" by the Institute of Transportation Engineers (ITE)												
(2) KSF = thousand square feet												
Source: LSC Transportation Consultants, Inc.											Rev. 11/23/2020	

Figures





Not to scale

Figure 1

Vicinity

McLaughlin Office Building (LSC# 204590)

GREENOUGH ROAD
60' ROW



Not to scale

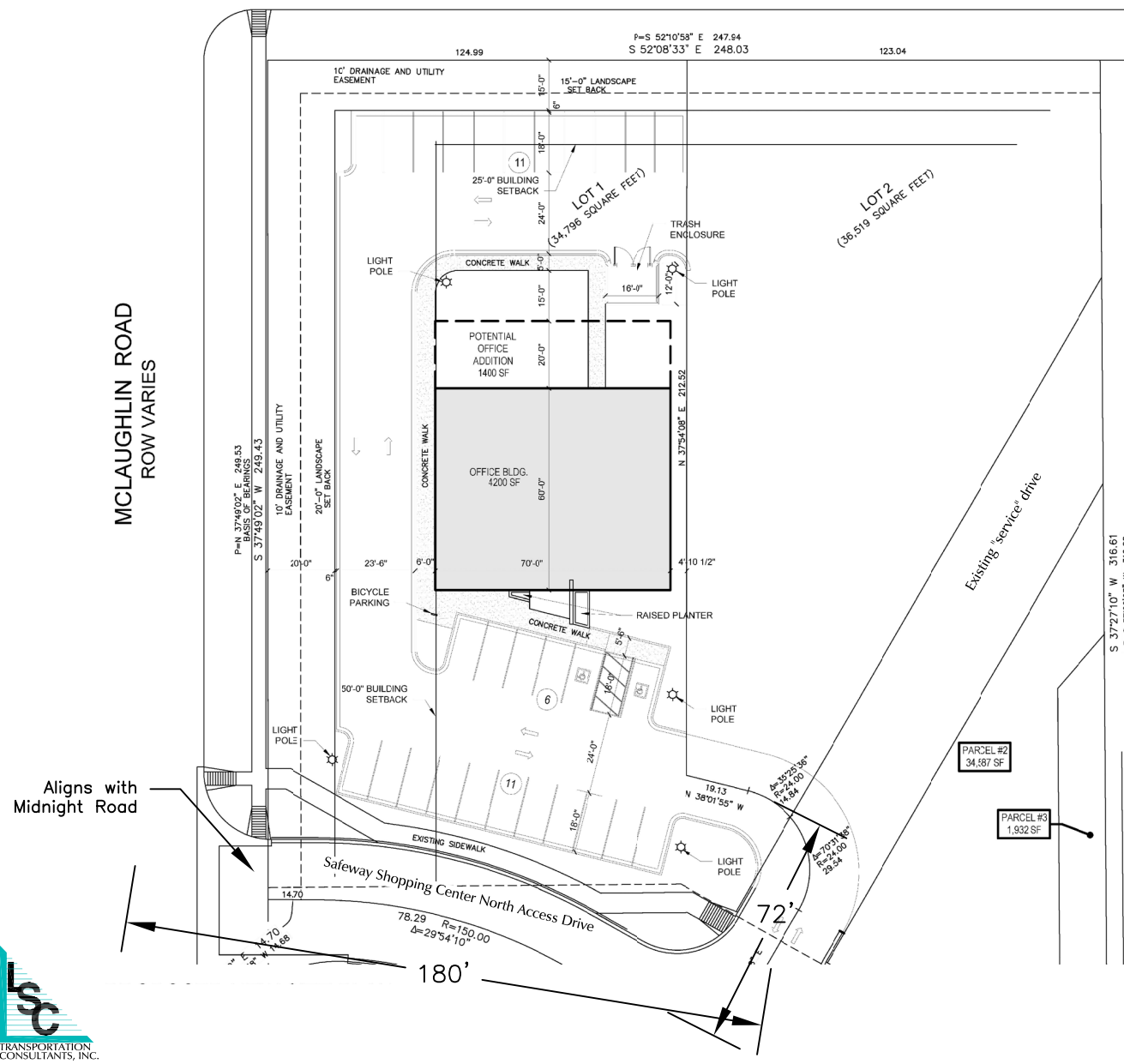

MCLAUGHLIN ROAD
ROW VARIES

Aligns with
Midnight Road

Figure 2
Site Plan

McLaughlin Office Building (LSC# 204590)



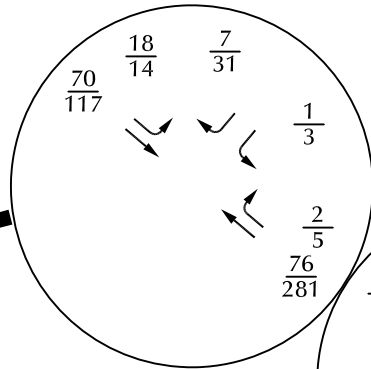
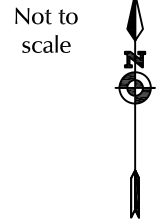
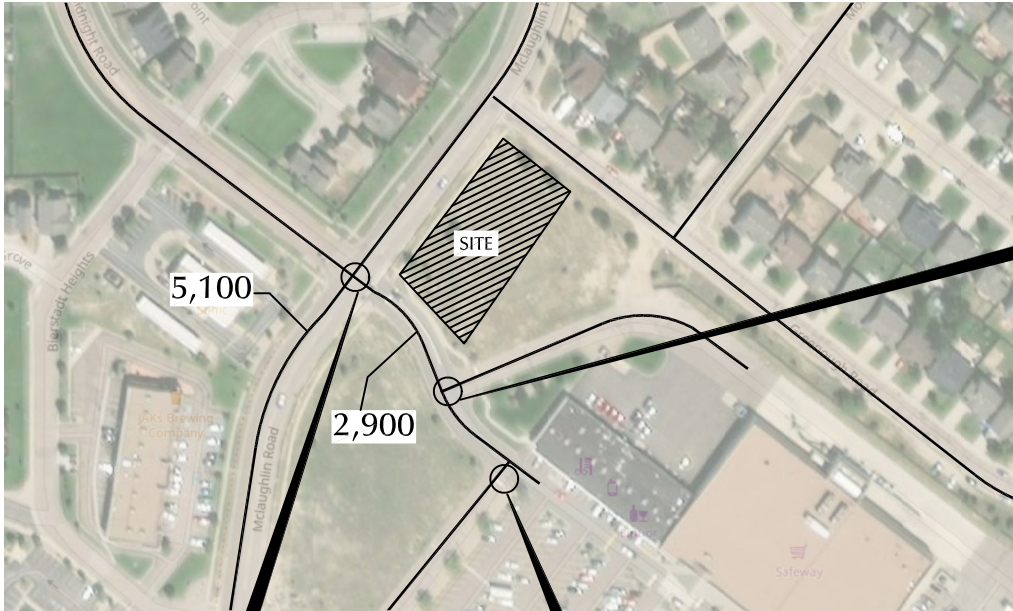

Peak Hours:
8:00–9:00 am
4:30–5:30 pm

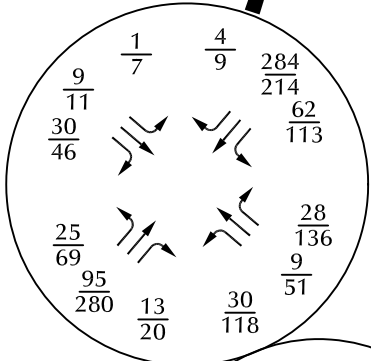
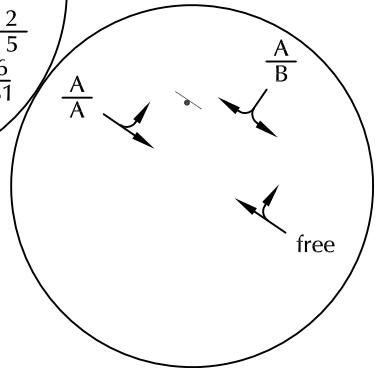

Peak Hours:
7:30–8:30 am
4:15–5:15 pm

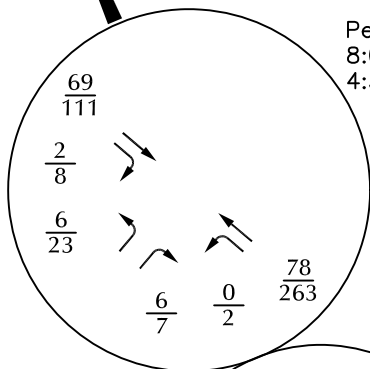
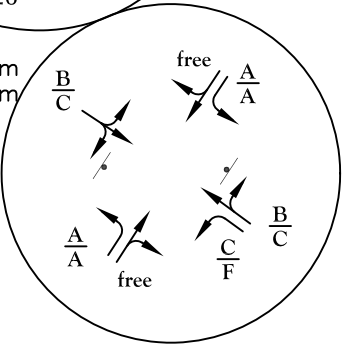

Peak Hours:
8:00–9:00 am
4:30–5:30 pm

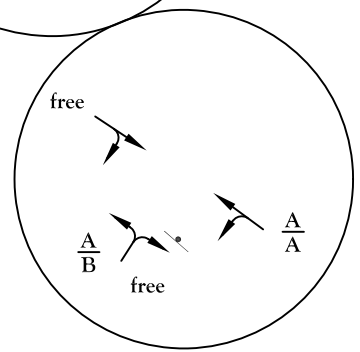

LEGEND:

$\frac{XX}{XX}$ = AM Peak-Hour Traffic (veh/hr)
 $\frac{XX}{XX}$ = PM Peak-Hour Traffic (veh/hr)

XXX = Average Weekday Daily Traffic (vehicles per day)

= Traffic Signal = Stop Sign

$\frac{A}{B}$ = $\frac{\text{AM Individual Movement Peak-Hour Level of Service}}{\text{PM Individual Movement Peak-Hour Level of Service}}$

Counted by LSC – September 2020

Existing Traffic Conditions

McLaughlin Office Building (LSC# 204590)



Figure 3

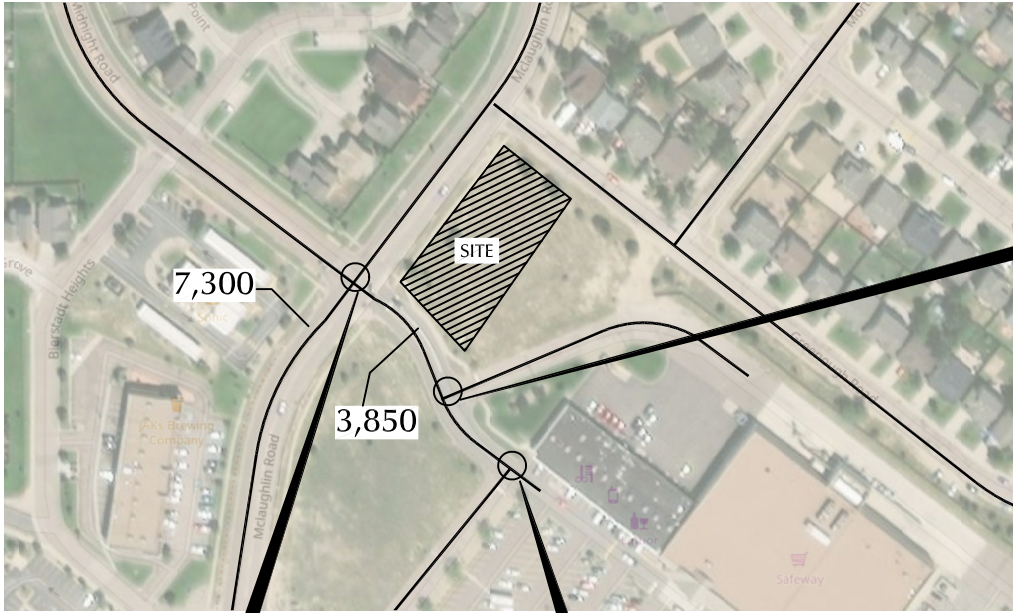

Not to scale

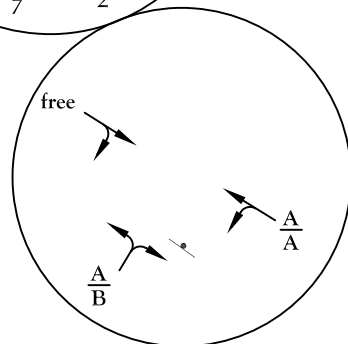
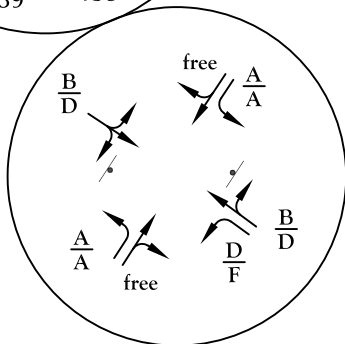
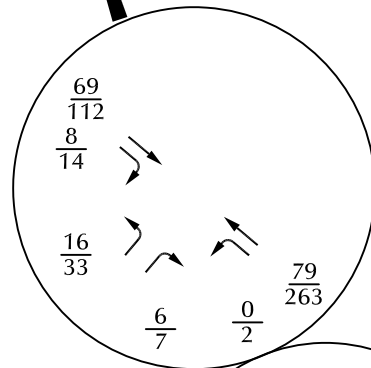
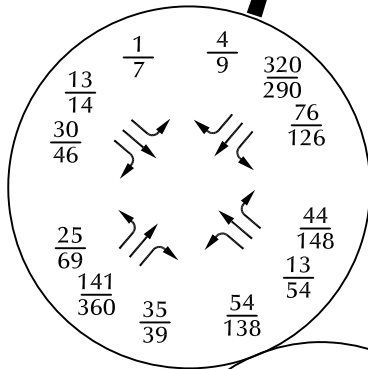
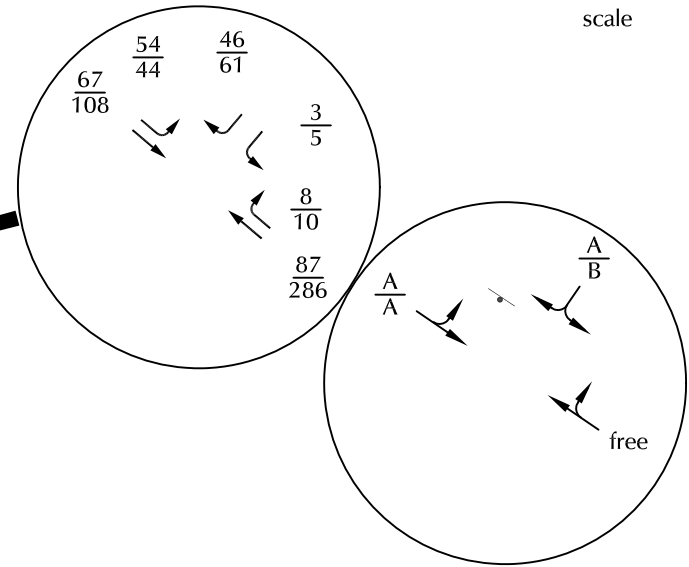

LEGEND:

$\frac{XX}{XX}$ = AM Peak-Hour Traffic (veh/hr)
 $\frac{XX}{XX}$ = PM Peak-Hour Traffic (veh/hr)

XXX = Average Weekday Daily Traffic (vehicles per day)

= Traffic Signal = Stop Sign

$\frac{A}{B}$ = $\frac{\text{AM Individual Movement Peak-Hour Level of Service}}{\text{PM Individual Movement Peak-Hour Level of Service}}$

Figure 4

Long-Term Background Traffic Conditions

McLaughlin Office Building (LSC# 204590)

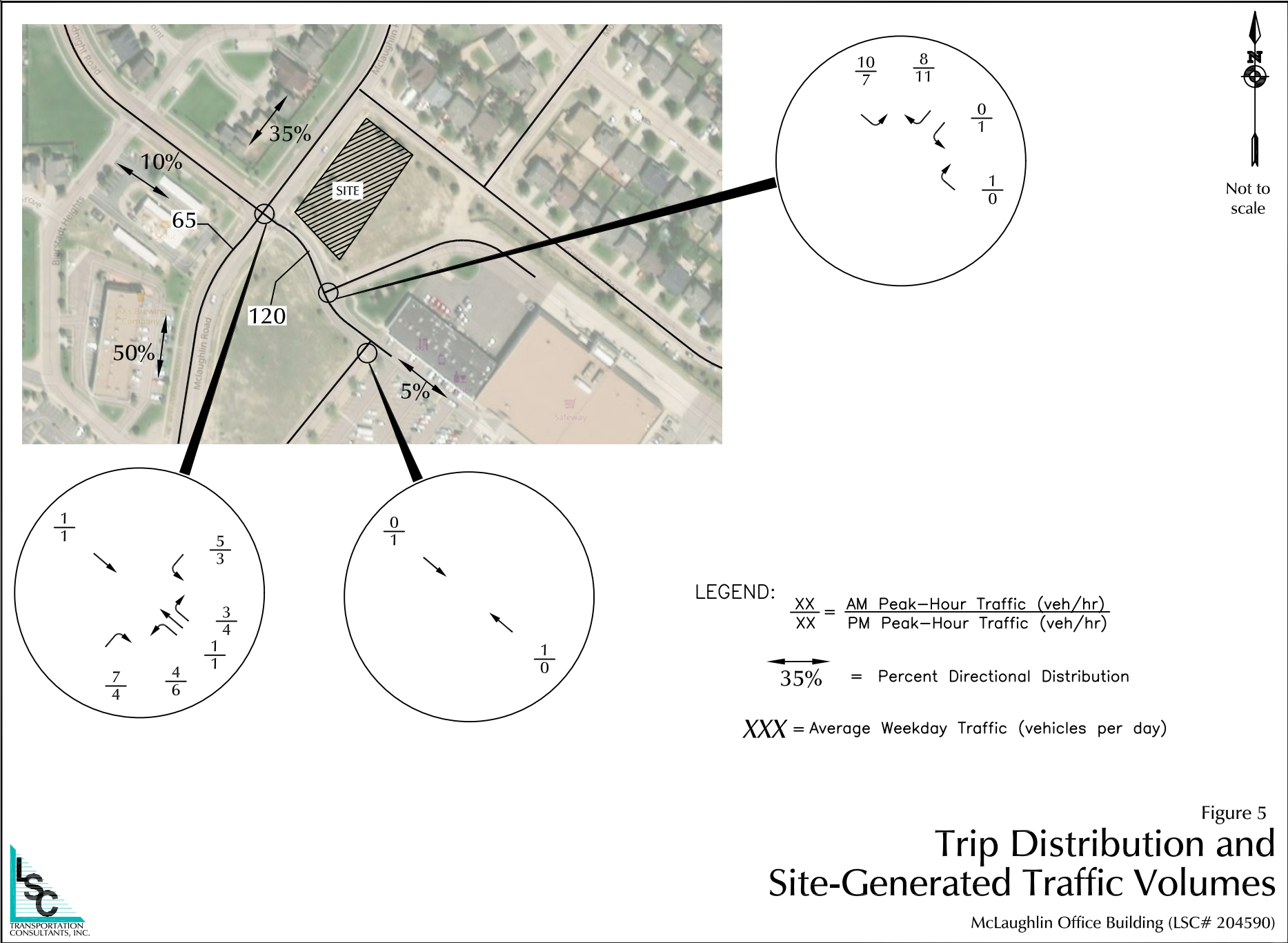

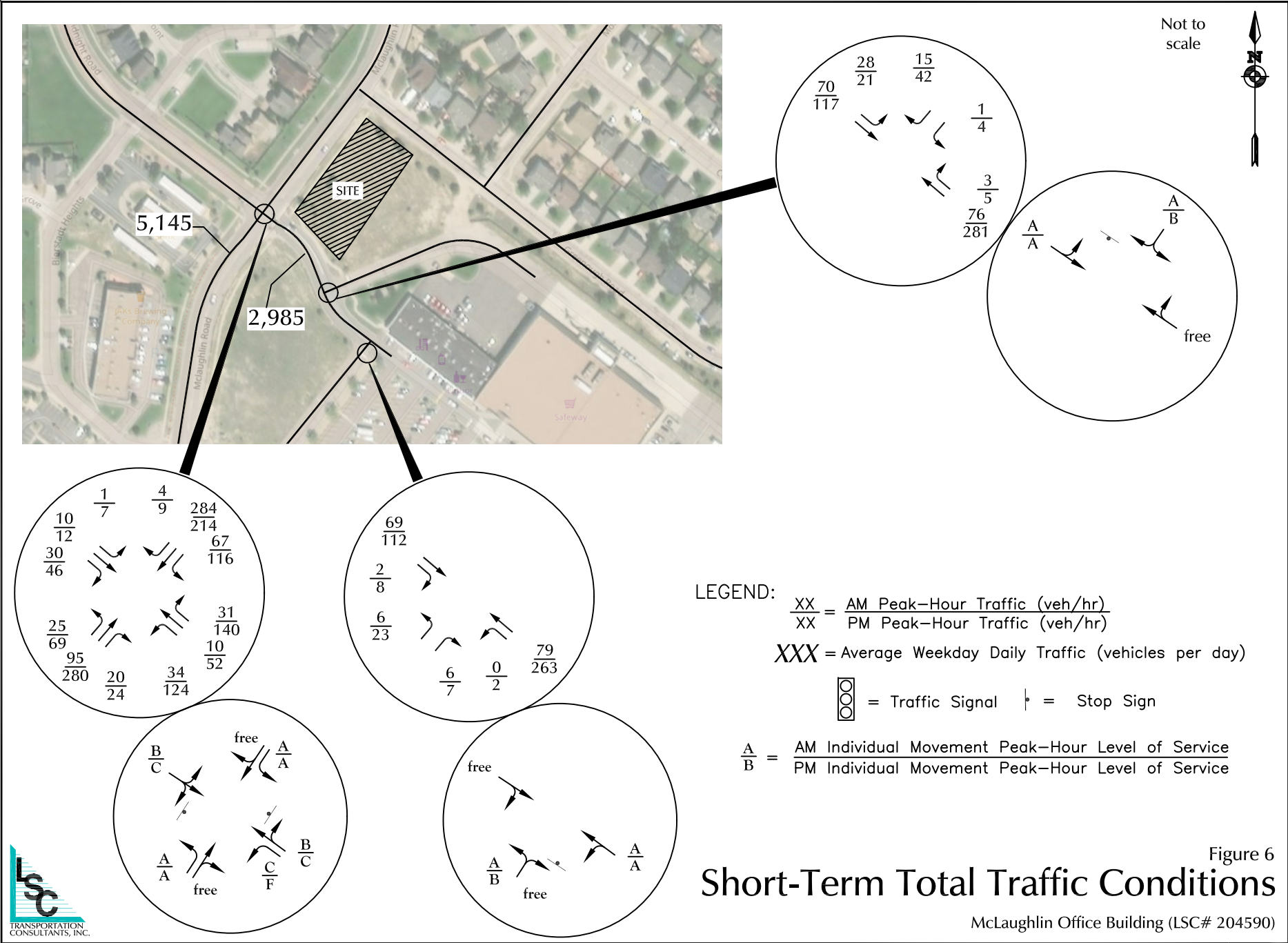

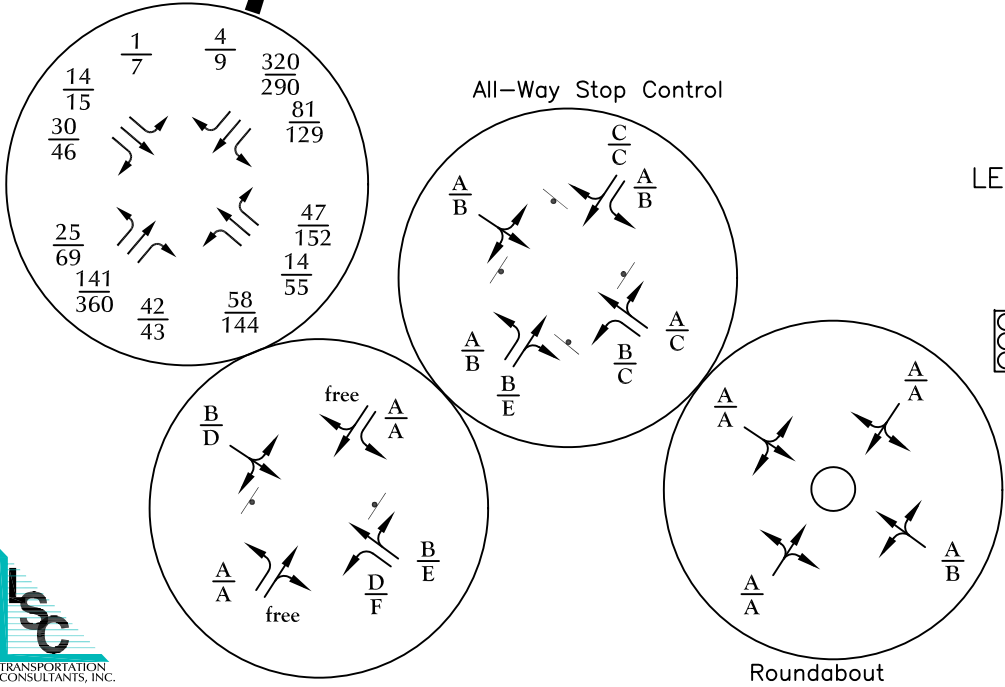
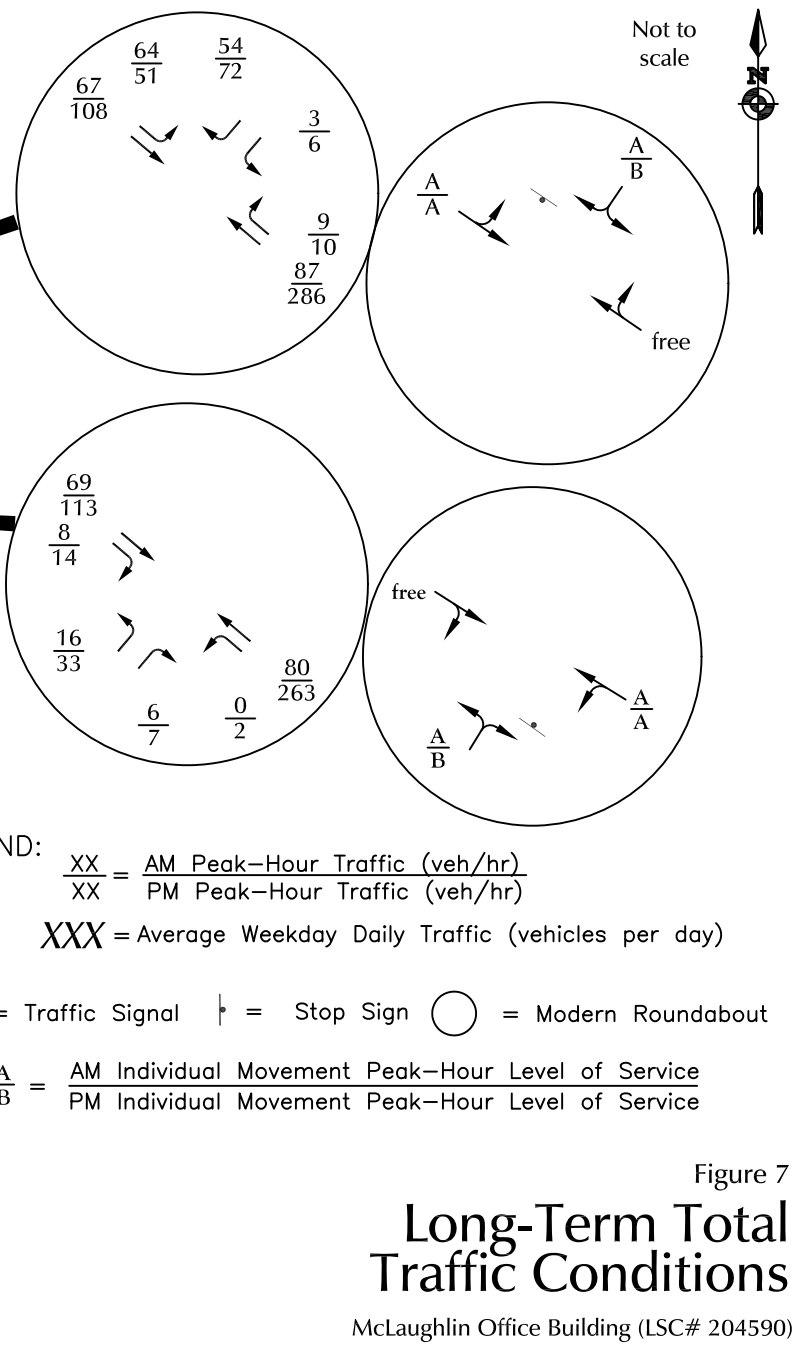
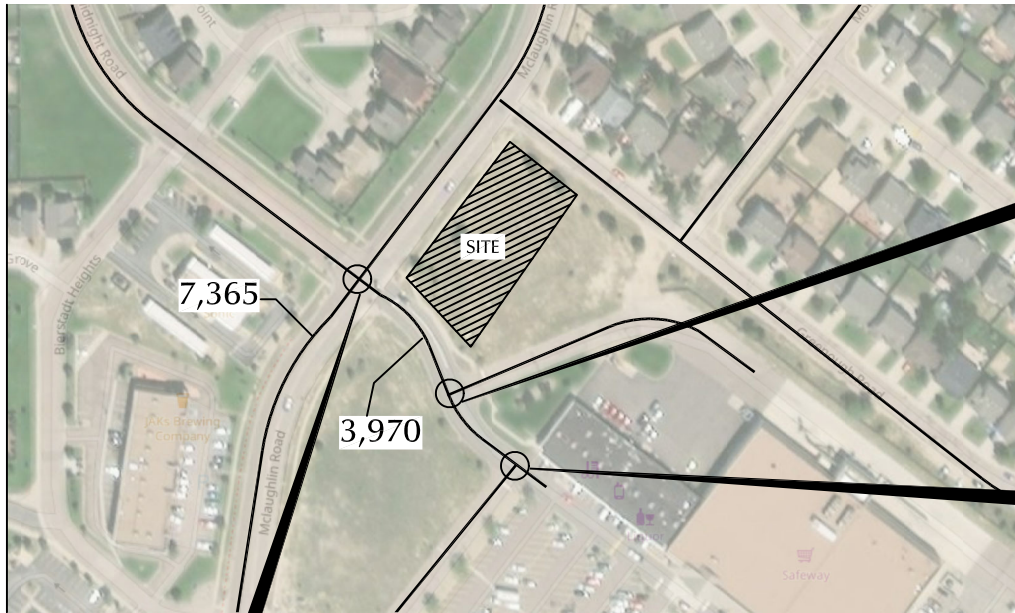

Figure 7
Long-Term Total Traffic Conditions
 McLaughlin Office Building (LSC# 204590)

McLaughlin Road/Midnight Road
 Figure 4C-1. Warrant 2, Four-Hour Vehicular Volume

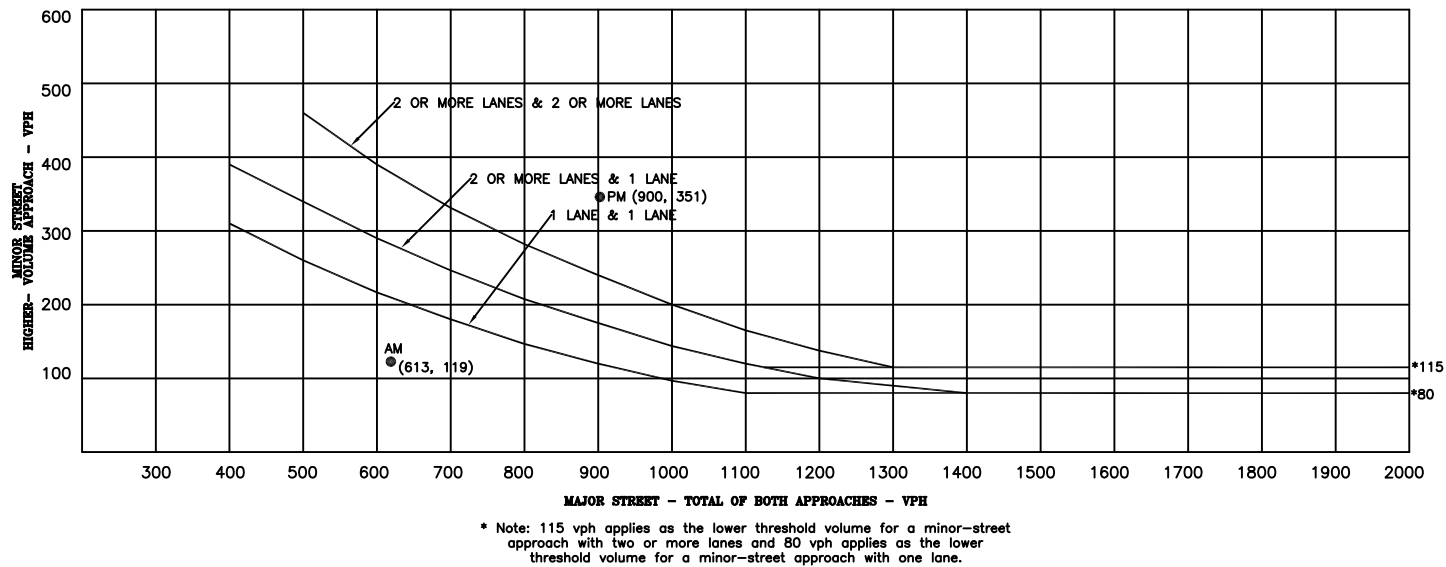

Figure 8

Traffic Signal Warrant Analysis McLaughlin Road/Midnight Road Long Term Total Traffic

McLaughlin Office Building (LSC# 204590)



Traffic Counts



LSC Transportation Consultants, Inc.

545 E Pikes Peak Ave, Suite 210
 Colorado Springs, CO 80905
 719-633-2868

File Name : McLaughlin Rd - Midnight Rd AM
 Site Code : 00204590
 Start Date : 9/15/2020
 Page No : 1

Groups Printed- Unshifted

Start Time	McLaughlin Rd Southbound					NE Safeway Access Westbound					McLaughlin Rd Northbound					Midnight Rd Eastbound					Int. Total
	L	T	R	U	App. Total	L	T	R	U	App. Total	L	T	R	U	App. Total	L	T	R	U	App. Total	
07:00 AM	12	70	0	0	82	5	0	5	0	10	2	24	2	0	28	1	1	8	0	10	130
07:15 AM	11	81	2	0	94	7	0	2	0	9	2	15	4	0	21	0	4	9	0	13	137
07:30 AM	11	90	0	0	101	6	3	10	0	19	6	21	4	0	31	0	1	6	0	7	158
07:45 AM	14	78	0	0	92	8	4	8	0	20	4	23	3	0	30	0	3	9	0	12	154
Total	48	319	2	0	369	26	7	25	0	58	14	83	13	0	110	1	9	32	0	42	579
08:00 AM	10	38	0	0	48	6	2	8	0	16	6	30	3	0	39	1	3	7	0	11	114
08:15 AM	27	78	4	0	109	10	0	2	0	12	9	21	3	0	33	0	2	8	0	10	164
08:30 AM	14	42	2	0	58	14	3	14	0	31	4	15	4	0	23	2	2	8	0	12	124
08:45 AM	12	39	0	0	51	14	4	10	0	28	7	19	5	0	31	2	3	6	0	11	121
Total	63	197	6	0	266	44	9	34	0	87	26	85	15	0	126	5	10	29	0	44	523
Grand Total	111	516	8	0	635	70	16	59	0	145	40	168	28	0	236	6	19	61	0	86	1102
Apprch %	17.5	81.3	1.3	0		48.3	11	40.7	0		16.9	71.2	11.9	0		7	22.1	70.9	0		
Total %	10.1	46.8	0.7	0	57.6	6.4	1.5	5.4	0	13.2	3.6	15.2	2.5	0	21.4	0.5	1.7	5.5	0	7.8	

LSC Transportation Consultants, Inc.

545 E Pikes Peak Ave, Suite 210
 Colorado Springs, CO 80905
 719-633-2868

File Name : McLaughlin Rd - Midnight Rd AM
 Site Code : 00204590
 Start Date : 9/15/2020
 Page No : 2

Start Time	Mclaughlin Rd Southbound					NE Safeway Access Westbound					McLaughlin Rd Northbound					Midnight Rd Eastbound					Int. Total
	L	T	R	U	App. Total	L	T	R	U	App. Total	L	T	R	U	App. Total	L	T	R	U	App. Total	
Peak Hour Analysis From 7:00:00 AM to 8:45:00 AM - Peak 1 of 1																					
Peak Hour for Entire Intersection Begins at 7:30:00 AM																					
7:30:00 AM	11	90	0	0	101	6	3	10	0	19	6	21	4	0	31	0	1	6	0	7	158
7:45:00 AM	14	78	0	0	92	8	4	8	0	20	4	23	3	0	30	0	3	9	0	12	154
8:00:00 AM	10	38	0	0	48	6	2	8	0	16	6	30	3	0	39	1	3	7	0	11	114
8:15:00 AM	27	78	4	0	109	10	0	2	0	12	9	21	3	0	33	0	2	8	0	10	164
Total Volume	62	284	4	0	350	30	9	28	0	67	25	95	13	0	133	1	9	30	0	40	590
% App. Total	17.7	81.1	1.1	0		44.8	13.4	41.8	0		18.8	71.4	9.8	0		2.5	22.5	75	0		
PHF	.574	.789	.250	.000	.803	.750	.563	.700	.000	.838	.694	.792	.813	.000	.853	.250	.750	.833	.000	.833	.899

LSC Transportation Consultants, Inc.

545 E Pikes Peak Ave, Suite 210
 Colorado Springs, CO 80905
 719-633-2868

File Name : McLaughlin Rd - Midnight Rd AM
 Site Code : 00204590
 Start Date : 9/15/2020
 Page No : 3

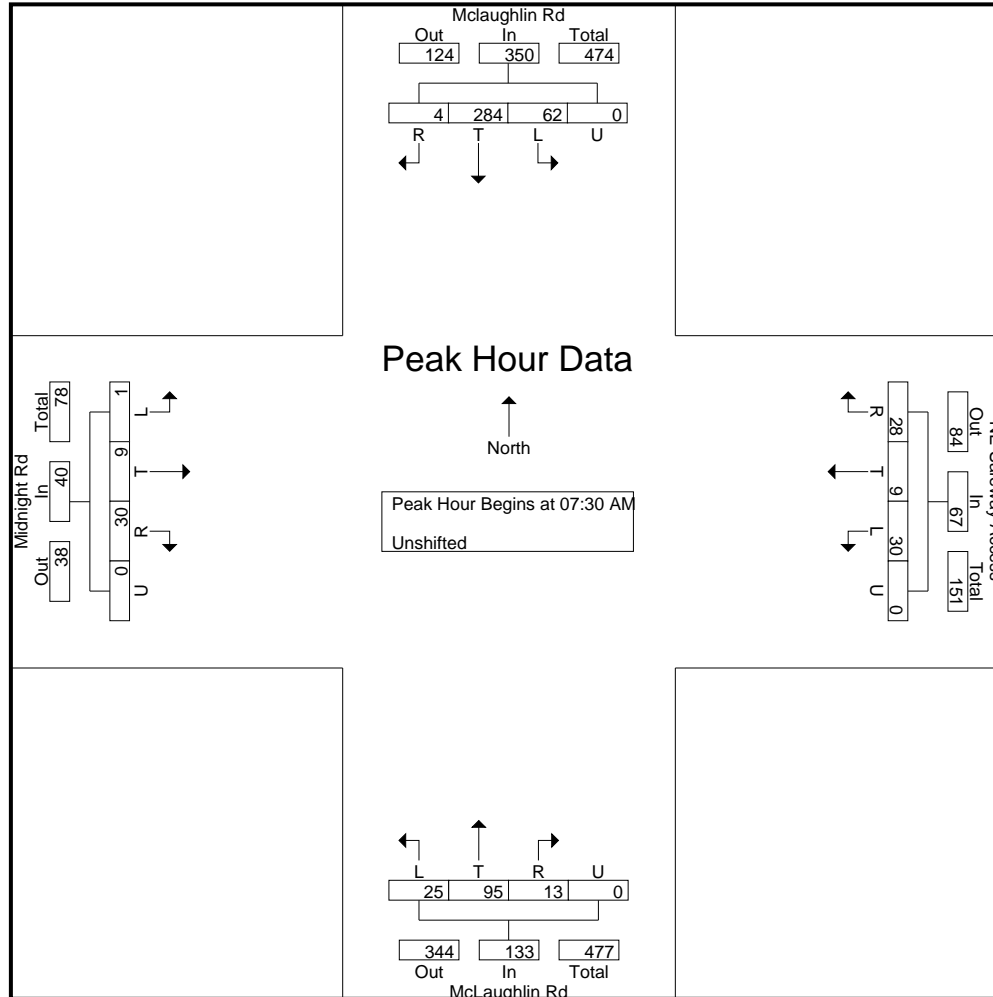

LSC Transportation Consultants, Inc.

545 E Pikes Peak Ave, Suite 210
 Colorado Springs, CO 80905
 719-633-2868

File Name : McLaughlin Rd - Midnight Rd AM
 Site Code : 00204590
 Start Date : 9/15/2020
 Page No : 4

Start Time	Mclaughlin Rd Southbound					NE Safeway Access Westbound					McLaughlin Rd Northbound					Midnight Rd Eastbound					Int. Total
	L	T	R	U	App. Total	L	T	R	U	App. Total	L	T	R	U	App. Total	L	T	R	U	App. Total	
Peak Hour Analysis From 7:00:00 AM to 8:45:00 AM - Peak 1 of 1																					
Peak Hour for Each Approach Begins at:																					
	7:00:00 AM					8:00:00 AM					7:30:00 AM					7:45:00 AM					
+0 mins.	12	70	0	0	82	6	2	8	0	16	6	21	4	0	31	0	3	9	0	12	
+5 mins.	11	81	2	0	94	10	0	2	0	12	4	23	3	0	30	1	3	7	0	11	
+10 mins.	11	90	0	0	101	14	3	14	0	31	6	30	3	0	39	0	2	8	0	10	
+15 mins.	14	78	0	0	92	14	4	10	0	28	9	21	3	0	33	2	2	8	0	12	
Total Volume	48	319	2	0	369	44	9	34	0	87	25	95	13	0	133	3	10	32	0	45	
% App. Total	13	86.4	0.5	0		50.6	10.3	39.1	0		18.8	71.4	9.8	0		6.7	22.2	71.1	0		
PHF	.857	.886	.250	.000	.913	.786	.563	.607	.000	.702	.694	.792	.813	.000	.853	.375	.833	.889	.000	.938	

LSC Transportation Consultants, Inc.

545 E Pikes Peak Ave, Suite 210
 Colorado Springs, CO 80905
 719-633-2868

File Name : McLaughlin Rd - Midnight Rd AM
 Site Code : 00204590
 Start Date : 9/15/2020
 Page No : 5

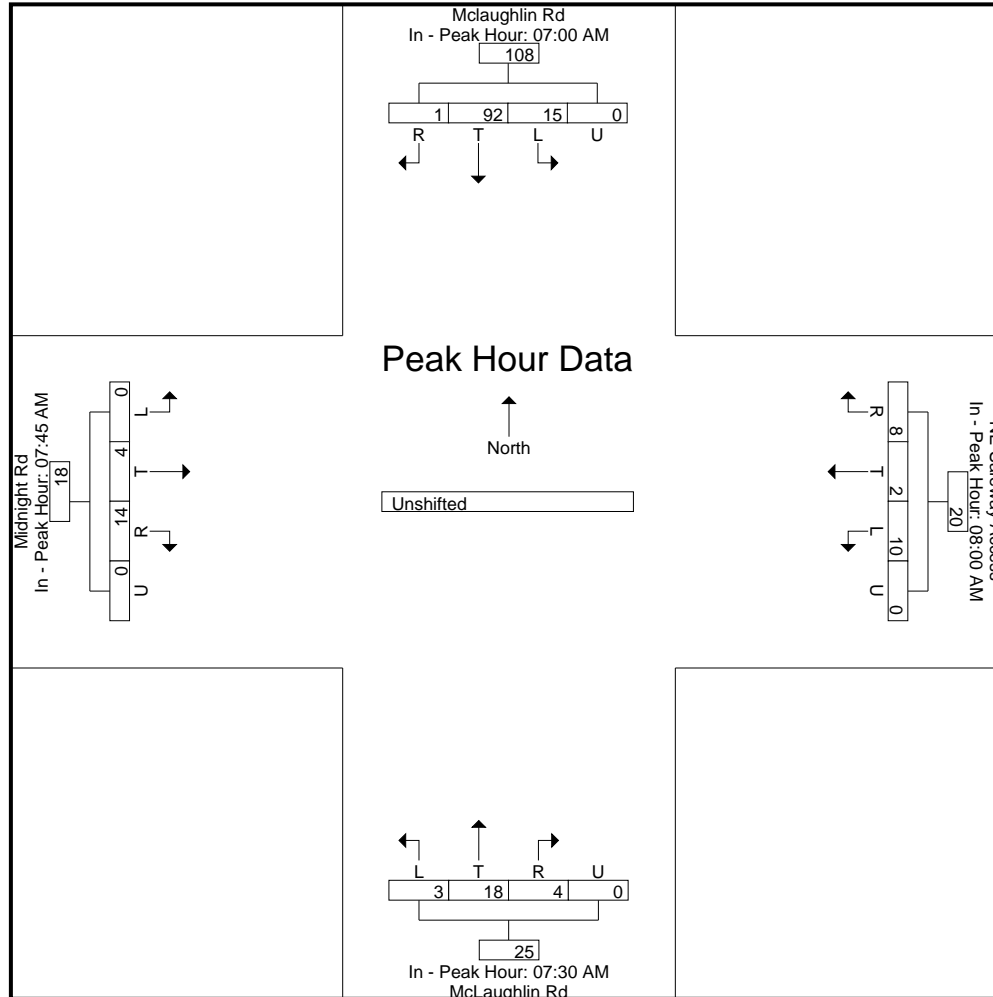

LSC Transportation Consultants, Inc.

545 E Pikes Peak Ave, Suite 210
 Colorado Springs, CO 80905
 719-633-2868

File Name : McLaughlin Rd - Midnight Rd PM
 Site Code : 00204590
 Start Date : 9/15/2020
 Page No : 1

Groups Printed- Unshifted

Start Time	McLaughlin Rd Southbound					NE SafeWay Access Westbound					McLaughlin Rd Northbound					Midnight Rd Eastbound					Int. Total
	L	T	R	U	App. Total	L	T	R	U	App. Total	L	T	R	U	App. Total	L	T	R	U	App. Total	
04:00 PM	28	56	2	0	86	29	7	21	0	57	23	55	9	0	87	2	3	11	0	16	246
04:15 PM	30	57	1	0	88	25	15	31	0	71	10	69	7	0	86	0	1	13	0	14	259
04:30 PM	26	56	1	0	83	38	7	30	0	75	15	70	5	0	90	2	6	13	0	21	269
04:45 PM	30	50	1	0	81	20	23	48	0	91	19	66	3	0	88	1	2	10	0	13	273
Total	114	219	5	0	338	112	52	130	0	294	67	260	24	0	351	5	12	47	0	64	1047
05:00 PM	27	51	6	0	84	35	6	27	0	68	25	75	5	0	105	4	2	10	0	16	273
05:15 PM	26	47	1	0	74	32	14	34	0	80	16	62	2	0	80	3	4	10	0	17	251
05:30 PM	24	41	3	0	68	19	9	37	0	65	27	64	8	0	99	1	6	7	0	14	246
05:45 PM	30	34	3	0	67	18	11	36	0	65	17	64	8	0	89	2	6	9	0	17	238
Total	107	173	13	0	293	104	40	134	0	278	85	265	23	0	373	10	18	36	0	64	1008
Grand Total	221	392	18	0	631	216	92	264	0	572	152	525	47	0	724	15	30	83	0	128	2055
Apprch %	35	62.1	2.9	0		37.8	16.1	46.2	0		21	72.5	6.5	0		11.7	23.4	64.8	0		
Total %	10.8	19.1	0.9	0	30.7	10.5	4.5	12.8	0	27.8	7.4	25.5	2.3	0	35.2	0.7	1.5	4	0	6.2	

LSC Transportation Consultants, Inc.

545 E Pikes Peak Ave, Suite 210
 Colorado Springs, CO 80905
 719-633-2868

File Name : McLaughlin Rd - Midnight Rd PM
 Site Code : 00204590
 Start Date : 9/15/2020
 Page No : 2

Start Time	McLaughlin Rd Southbound					NE SafeWay Access Westbound					McLaughlin Rd Northbound					Midnight Rd Eastbound					Int. Total
	L	T	R	U	App. Total	L	T	R	U	App. Total	L	T	R	U	App. Total	L	T	R	U	App. Total	
Peak Hour Analysis From 4:00:00 PM to 4:30:00 PM - Peak 1 of 1																					
Peak Hour for Entire Intersection Begins at 4:00:00 PM																					
4:00:00 PM	28	56	2	0	86	29	7	21	0	57	23	55	9	0	87	2	3	11	0	16	246
4:15:00 PM	30	57	1	0	88	25	15	31	0	71	10	69	7	0	86	0	1	13	0	14	259
4:30:00 PM	20	32	1	0	53	24	6	21	0	51	8	47	3	0	58	0	4	10	0	14	176
04:15 PM	0	0	0	0	0	0	0	0	0	0	0	0	0	0	0	0	0	0	0	0	0
Total Volume	78	145	4	0	227	78	28	73	0	179	41	171	19	0	231	2	8	34	0	44	681
% App. Total	34.4	63.9	1.8	0		43.6	15.6	40.8	0		17.7	74	8.2	0		4.5	18.2	77.3	0		
PHF	.650	.636	.500	.000	.645	.672	.467	.589	.000	.630	.446	.620	.528	.000	.664	.250	.500	.654	.000	.688	.657

LSC Transportation Consultants, Inc.

545 E Pikes Peak Ave, Suite 210
 Colorado Springs, CO 80905
 719-633-2868

File Name : McLaughlin Rd - Midnight Rd PM
 Site Code : 00204590
 Start Date : 9/15/2020
 Page No : 3

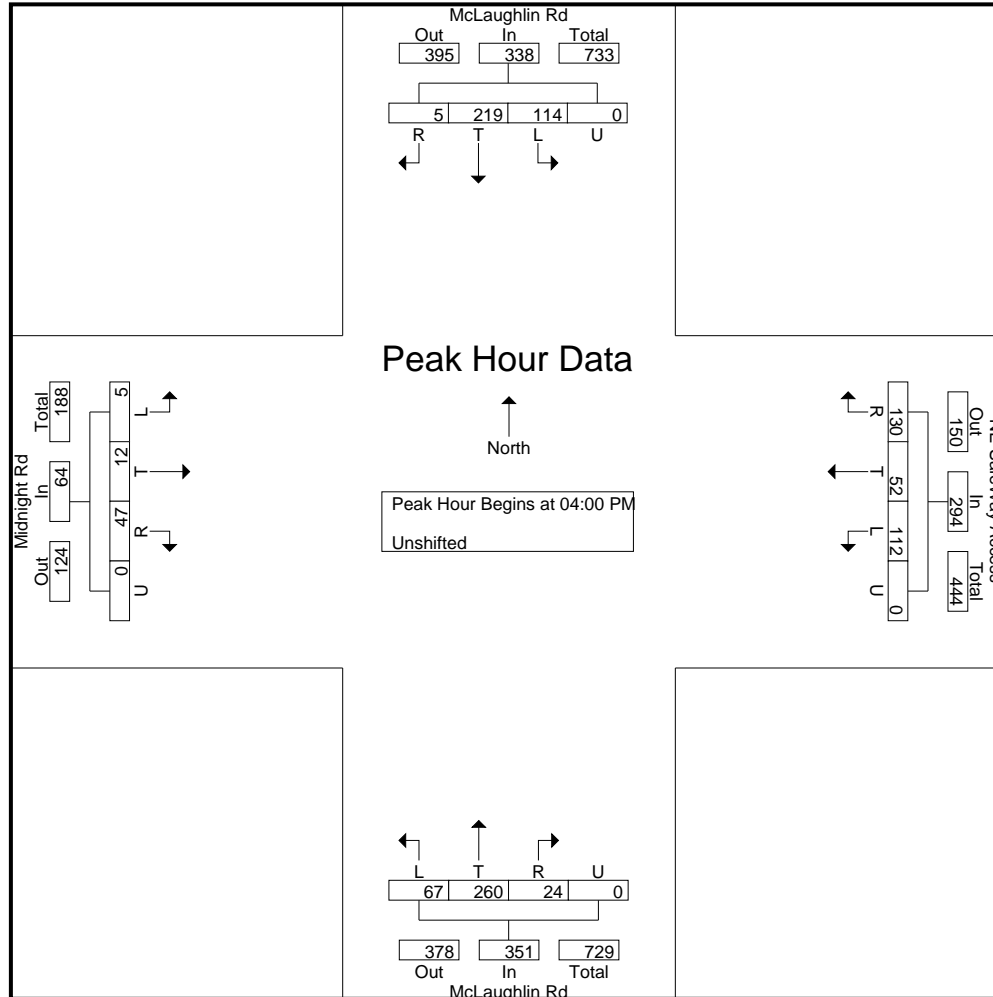

LSC Transportation Consultants, Inc.

545 E Pikes Peak Ave, Suite 210
 Colorado Springs, CO 80905
 719-633-2868

File Name : McLaughlin Rd - Midnight Rd PM
 Site Code : 00204590
 Start Date : 9/15/2020
 Page No : 4

Start Time	McLaughlin Rd Southbound					NE SafeWay Access Westbound					McLaughlin Rd Northbound					Midnight Rd Eastbound					Int. Total
	L	T	R	U	App. Total	L	T	R	U	App. Total	L	T	R	U	App. Total	L	T	R	U	App. Total	
Peak Hour Analysis From 4:00:00 PM to 4:30:00 PM - Peak 1 of 1																					
Peak Hour for Each Approach Begins at:																					
	4:00:00 PM					4:00:00 PM					4:00:00 PM					4:00:00 PM					
+0 mins.	28	56	2	0	86	29	7	21	0	57	23	55	9	0	87	2	3	11	0	16	
+5 mins.	30	57	1	0	88	25	15	31	0	71	10	69	7	0	86	0	1	13	0	14	
+10 mins.	20	32	1	0	53	24	6	21	0	51	8	47	3	0	58	0	4	10	0	14	
+15 mins.	0	0	0	0	0	0	0	0	0	0	0	0	0	0	0	0	0	0	0	0	
Total Volume	78	145	4	0	227	78	28	73	0	179	41	171	19	0	231	2	8	34	0	44	
% App. Total	34.4	63.9	1.8	0		43.6	15.6	40.8	0		17.7	74	8.2	0		4.5	18.2	77.3	0		
PHF	.650	.636	.500	.000	.645	.672	.467	.589	.000	.630	.446	.620	.528	.000	.664	.250	.500	.654	.000	.688	

LSC Transportation Consultants, Inc.

545 E Pikes Peak Ave, Suite 210
 Colorado Springs, CO 80905
 719-633-2868

File Name : McLaughlin Rd - Midnight Rd PM
 Site Code : 00204590
 Start Date : 9/15/2020
 Page No : 5

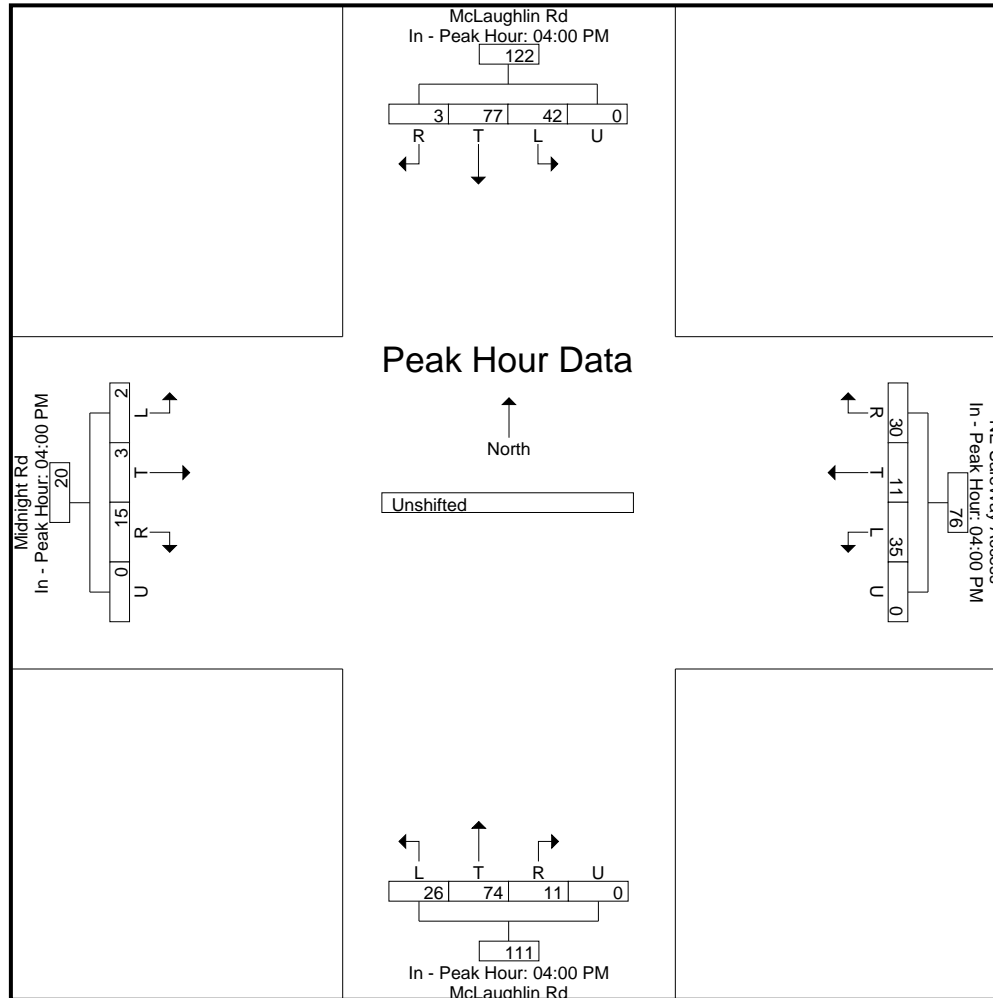

LSC Transportation Consultants, Inc.

545 E Pikes Peak Ave, Suite 210
 Colorado Springs, CO 80905
 719-633-2868

File Name : Falcon Safeway East Access AM
 Site Code : 00204590
 Start Date : 9/15/2020
 Page No : 1

Groups Printed- Bank 1

Start Time	Rear Store Access Southbound					In Front of Store Access Westbound					Gas and Retail Access Northbound					Safeway Access Eastbound					Int. Total
	L	T	R	U	App. Total	L	T	R	U	App. Total	L	T	R	U	App. Total	L	T	R	U	App. Total	
07:00 AM	0	0	0	0	0	1	9	0	0	10	1	0	3	0	4	2	10	2	0	14	28
07:15 AM	0	0	2	0	2	1	7	0	0	8	0	0	0	0	0	3	15	0	0	18	28
07:30 AM	0	0	0	0	0	1	15	0	0	16	3	0	1	0	4	1	13	2	0	16	36
07:45 AM	0	1	2	0	3	1	17	0	0	18	1	0	0	0	1	7	12	1	0	20	42
Total	0	1	4	0	5	4	48	0	0	52	5	0	4	0	9	13	50	5	0	68	134
08:00 AM	0	0	0	0	0	0	13	1	0	14	1	0	1	0	2	3	12	1	0	16	32
08:15 AM	0	0	0	0	0	0	12	1	0	13	1	0	0	0	1	4	28	0	0	32	46
08:30 AM	0	0	4	0	4	0	24	0	0	24	3	0	2	0	5	6	14	0	0	20	53
08:45 AM	1	0	3	0	4	0	23	0	0	23	1	0	3	0	4	5	14	1	0	20	51
Total	1	0	7	0	8	0	72	2	0	74	6	0	6	0	12	18	68	2	0	88	182
Grand Total	1	1	11	0	13	4	120	2	0	126	11	0	10	0	21	31	118	7	0	156	316
Apprch %	7.7	7.7	84.6	0		3.2	95.2	1.6	0		52.4	0	47.6	0		19.9	75.6	4.5	0		
Total %	0.3	0.3	3.5	0	4.1	1.3	38	0.6	0	39.9	3.5	0	3.2	0	6.6	9.8	37.3	2.2	0	49.4	

LSC Transportation Consultants, Inc.

545 E Pikes Peak Ave, Suite 210
 Colorado Springs, CO 80905
 719-633-2868

File Name : Falcon Safeway East Access AM
 Site Code : 00204590
 Start Date : 9/15/2020
 Page No : 2

Start Time	Rear Store Access Southbound					In Front of Store Access Westbound					Gas and Retail Access Northbound					Safeway Access Eastbound					Int. Total
	L	T	R	U	App. Total	L	T	R	U	App. Total	L	T	R	U	App. Total	L	T	R	U	App. Total	
Peak Hour Analysis From 7:00:00 AM to 8:45:00 AM - Peak 1 of 1																					
Peak Hour for Entire Intersection Begins at 8:00:00 AM																					
8:00:00 AM	0	0	0	0	0	0	13	1	0	14	1	0	1	0	2	3	12	1	0	16	32
8:15:00 AM	0	0	0	0	0	0	12	1	0	13	1	0	0	0	1	4	28	0	0	32	46
8:30:00 AM	0	0	4	0	4	0	24	0	0	24	3	0	2	0	5	6	14	0	0	20	53
8:45:00 AM	1	0	3	0	4	0	23	0	0	23	1	0	3	0	4	5	14	1	0	20	51
Total Volume	1	0	7	0	8	0	72	2	0	74	6	0	6	0	12	18	68	2	0	88	182
% App. Total	12.5	0	87.5	0		0	97.3	2.7	0		50	0	50	0		20.5	77.3	2.3	0		
PHF	.250	.000	.438	.000	.500	.000	.750	.500	.000	.771	.500	.000	.500	.000	.600	.750	.607	.500	.000	.688	.858

LSC Transportation Consultants, Inc.

545 E Pikes Peak Ave, Suite 210
 Colorado Springs, CO 80905
 719-633-2868

File Name : Falcon Safeway East Access AM
 Site Code : 00204590
 Start Date : 9/15/2020
 Page No : 3

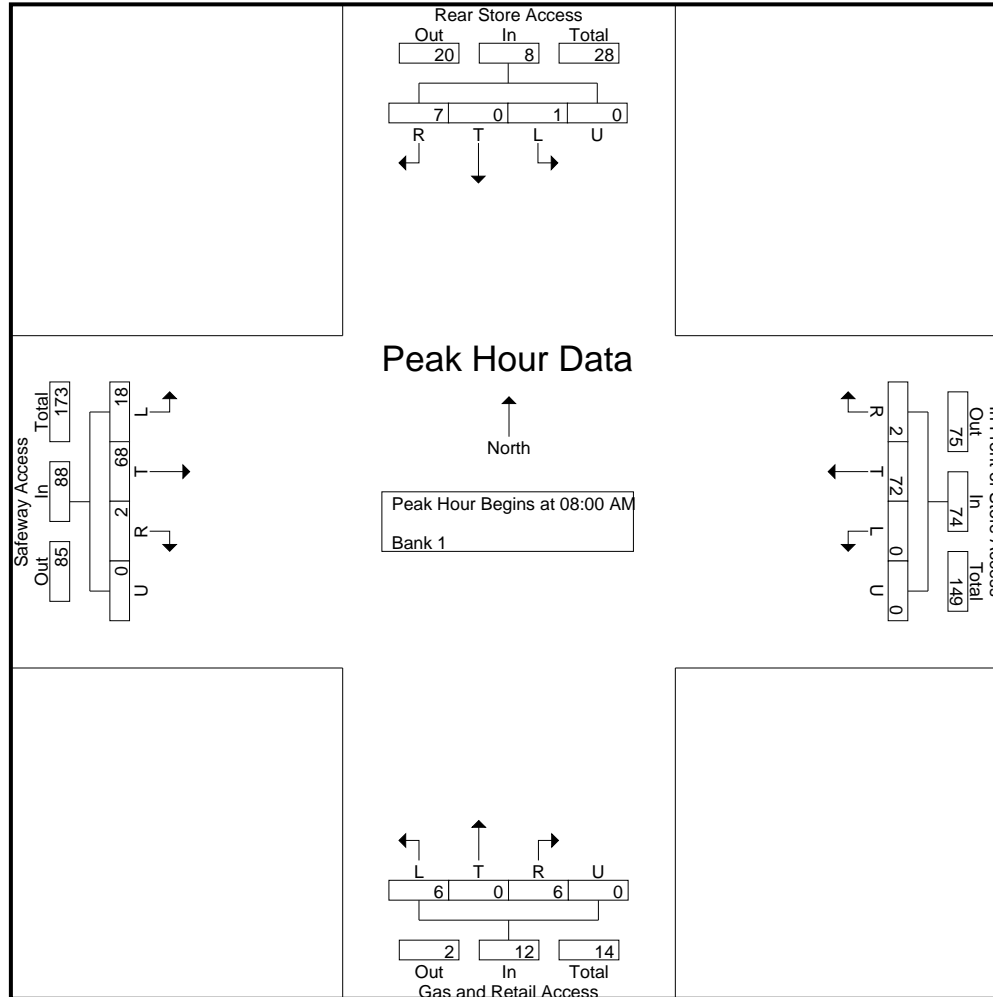

LSC Transportation Consultants, Inc.

545 E Pikes Peak Ave, Suite 210
 Colorado Springs, CO 80905
 719-633-2868

File Name : Falcon Safeway East Access AM
 Site Code : 00204590
 Start Date : 9/15/2020
 Page No : 4

Start Time	Rear Store Access Southbound					In Front of Store Access Westbound					Gas and Retail Access Northbound					Safeway Access Eastbound					Int. Total
	L	T	R	U	App. Total	L	T	R	U	App. Total	L	T	R	U	App. Total	L	T	R	U	App. Total	
Peak Hour Analysis From 7:00:00 AM to 8:45:00 AM - Peak 1 of 1																					
Peak Hour for Each Approach Begins at:																					
	8:00:00 AM					8:00:00 AM					8:00:00 AM					7:45:00 AM					
+0 mins.	0	0	0	0	0	0	13	1	0	14	1	0	1	0	2	7	12	1	0	20	
+5 mins.	0	0	0	0	0	0	12	1	0	13	1	0	0	0	1	3	12	1	0	16	
+10 mins.	0	0	4	0	4	0	24	0	0	24	3	0	2	0	5	4	28	0	0	32	
+15 mins.	1	0	3	0	4	0	23	0	0	23	1	0	3	0	4	6	14	0	0	20	
Total Volume	1	0	7	0	8	0	72	2	0	74	6	0	6	0	12	20	66	2	0	88	
% App. Total	12.5	0	87.5	0		0	97.3	2.7	0		50	0	50	0		22.7	75	2.3	0		
PHF	.250	.000	.438	.000	.500	.000	.750	.500	.000	.771	.500	.000	.500	.000	.600	.714	.589	.500	.000	.688	

LSC Transportation Consultants, Inc.

545 E Pikes Peak Ave, Suite 210
Colorado Springs, CO 80905
719-633-2868

File Name : Falcon Safeway East Access AM
Site Code : 00204590
Start Date : 9/15/2020
Page No : 5

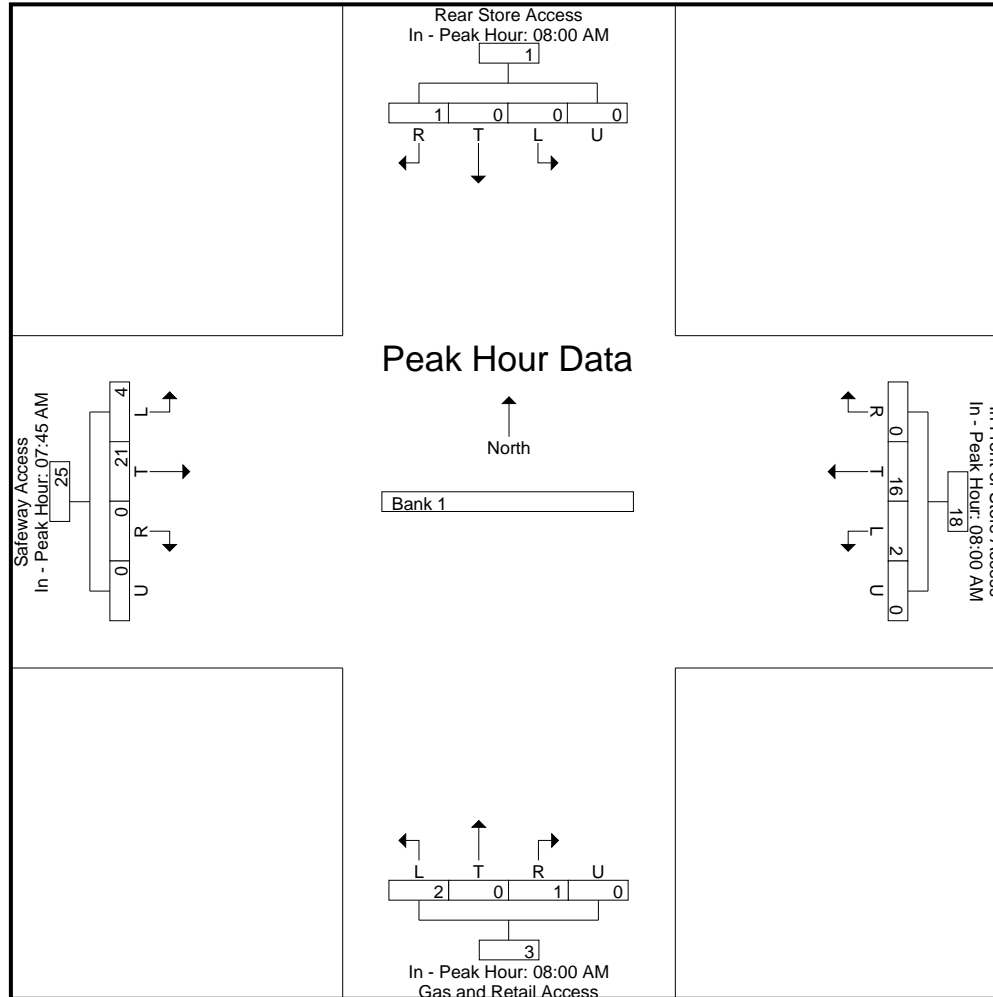

LSC Transportation Consultants, Inc.

545 E Pikes Peak Ave, Suite 210
 Colorado Springs, CO 80905
 719-633-2868

File Name : Falcon Safeway East Access PM
 Site Code : 00204590
 Start Date : 9/15/2020
 Page No : 1

Groups Printed- Bank 1

Start Time	Behind Safeway Southbound					In Front Of Safeway Westbound					Gas & Retail Store access Northbound					Safeway Access Eastbound					Int. Total
	L	T	R	U	App. Total	L	T	R	U	App. Total	L	T	R	U	App. Total	L	T	R	U	App. Total	
04:00 PM	0	0	3	0	3	0	44	0	0	44	5	0	4	0	9	3	29	2	0	34	90
04:15 PM	0	0	8	0	8	0	49	0	0	49	10	0	2	0	12	6	27	3	0	36	105
04:30 PM	1	0	7	0	8	1	69	1	0	71	5	1	1	0	7	3	27	3	0	33	119
04:45 PM	2	0	7	0	9	1	73	1	0	75	9	0	0	0	9	2	32	1	0	35	128
Total	3	0	25	0	28	2	235	2	0	239	29	1	7	0	37	14	115	9	0	138	442
05:00 PM	0	0	9	0	9	0	53	2	0	55	3	0	2	0	5	6	25	1	0	32	101
05:15 PM	0	0	8	0	8	0	64	0	0	64	5	0	4	0	9	3	25	3	0	31	112
05:30 PM	1	0	8	0	9	0	53	4	0	57	3	0	1	0	4	1	31	1	0	33	103
05:45 PM	2	0	6	0	8	0	51	1	0	52	6	0	2	0	8	1	40	3	0	44	112
Total	3	0	31	0	34	0	221	7	0	228	17	0	9	0	26	11	121	8	0	140	428
Grand Total	6	0	56	0	62	2	456	9	0	467	46	1	16	0	63	25	236	17	0	278	870
Apprch %	9.7	0	90.3	0		0.4	97.6	1.9	0		73	1.6	25.4	0		9	84.9	6.1	0		
Total %	0.7	0	6.4	0	7.1	0.2	52.4	1	0	53.7	5.3	0.1	1.8	0	7.2	2.9	27.1	2	0	32	

LSC Transportation Consultants, Inc.

545 E Pikes Peak Ave, Suite 210
 Colorado Springs, CO 80905
 719-633-2868

File Name : Falcon Safeway East Access PM
 Site Code : 00204590
 Start Date : 9/15/2020
 Page No : 2

Start Time	Behind Safeway Southbound					In Front Of Safeway Westbound					Gas & Retail Store access Northbound					Safeway Access Eastbound					Int. Total
	L	T	R	U	App. Total	L	T	R	U	App. Total	L	T	R	U	App. Total	L	T	R	U	App. Total	
Peak Hour Analysis From 4:00:00 PM to 5:45:00 PM - Peak 1 of 1																					
Peak Hour for Entire Intersection Begins at 4:30:00 PM																					
4:30:00 PM	1	0	7	0	8	1	69	1	0	71	5	1	1	0	7	3	27	3	0	33	119
4:45:00 PM	2	0	7	0	9	1	73	1	0	75	9	0	0	0	9	2	32	1	0	35	128
5:00:00 PM	0	0	9	0	9	0	53	2	0	55	3	0	2	0	5	6	25	1	0	32	101
5:15:00 PM	0	0	8	0	8	0	64	0	0	64	5	0	4	0	9	3	25	3	0	31	112
Total Volume	3	0	31	0	34	2	259	4	0	265	22	1	7	0	30	14	109	8	0	131	460
% App. Total	8.8	0	91.2	0		0.8	97.7	1.5	0		73.3	3.3	23.3	0		10.7	83.2	6.1	0		
PHF	.375	.000	.861	.000	.944	.500	.887	.500	.000	.883	.611	.250	.438	.000	.833	.583	.852	.667	.000	.936	.898

LSC Transportation Consultants, Inc.

545 E Pikes Peak Ave, Suite 210
 Colorado Springs, CO 80905
 719-633-2868

File Name : Falcon Safeway East Access PM
 Site Code : 00204590
 Start Date : 9/15/2020
 Page No : 3

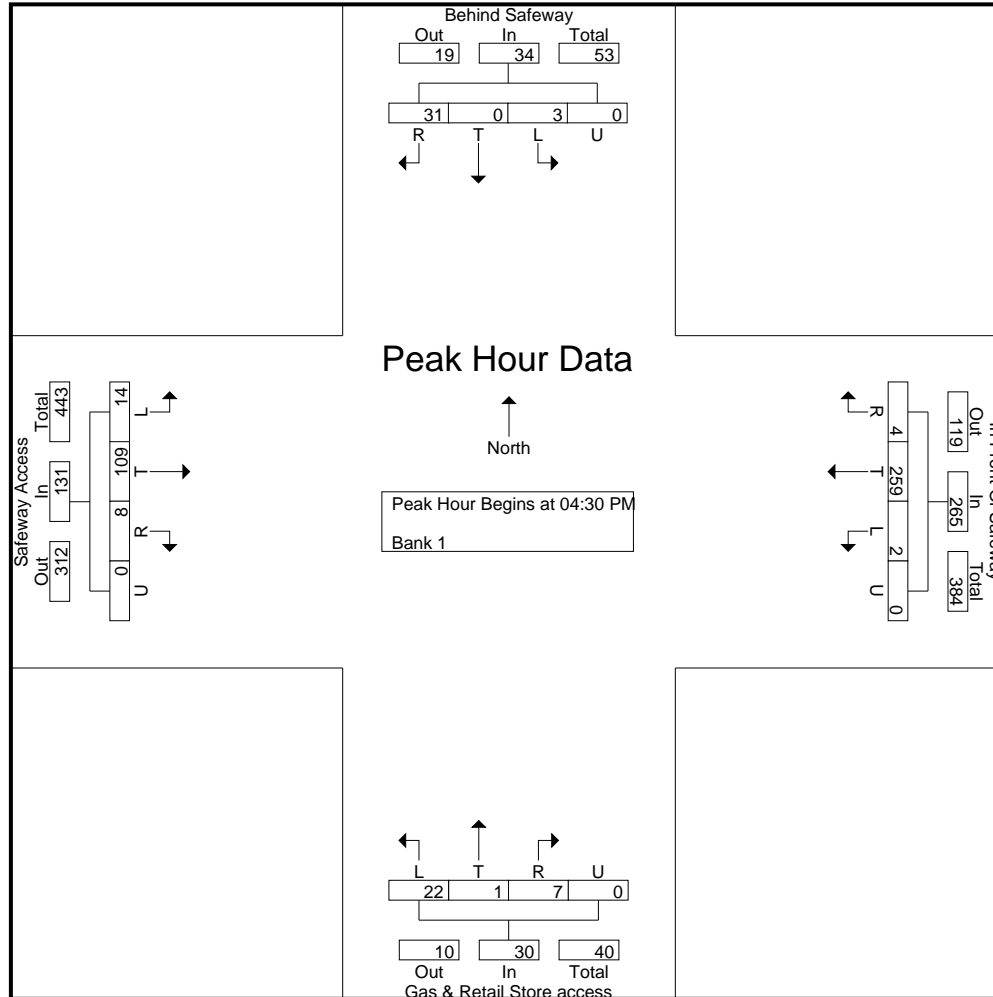

LSC Transportation Consultants, Inc.

545 E Pikes Peak Ave, Suite 210
 Colorado Springs, CO 80905
 719-633-2868

File Name : Falcon Safeway East Access PM
 Site Code : 00204590
 Start Date : 9/15/2020
 Page No : 4

Start Time	Behind Safeway Southbound					In Front Of Safeway Westbound					Gas & Retail Store access Northbound					Safeway Access Eastbound					Int. Total
	L	T	R	U	App. Total	L	T	R	U	App. Total	L	T	R	U	App. Total	L	T	R	U	App. Total	
Peak Hour Analysis From 4:00:00 PM to 5:45:00 PM - Peak 1 of 1																					
Peak Hour for Each Approach Begins at:																					
	4:45:00 PM					4:30:00 PM					4:00:00 PM					5:00:00 PM					
+0 mins.	2	0	7	0	9	1	69	1	0	71	5	0	4	0	9	6	25	1	0	32	
+5 mins.	0	0	9	0	9	1	73	1	0	75	10	0	2	0	12	3	25	3	0	31	
+10 mins.	0	0	8	0	8	0	53	2	0	55	5	1	1	0	7	1	31	1	0	33	
+15 mins.	1	0	8	0	9	0	64	0	0	64	9	0	0	0	9	1	40	3	0	44	
Total Volume	3	0	32	0	35	2	259	4	0	265	29	1	7	0	37	11	121	8	0	140	
% App. Total	8.6	0	91.4	0		0.8	97.7	1.5	0		78.4	2.7	18.9	0		7.9	86.4	5.7	0		
PHF	.375	.000	.889	.000	.972	.500	.887	.500	.000	.883	.725	.250	.438	.000	.771	.458	.756	.667	.000	.795	

LSC Transportation Consultants, Inc.

545 E Pikes Peak Ave, Suite 210
 Colorado Springs, CO 80905
 719-633-2868

File Name : Falcon Safeway East Access PM
 Site Code : 00204590
 Start Date : 9/15/2020
 Page No : 5

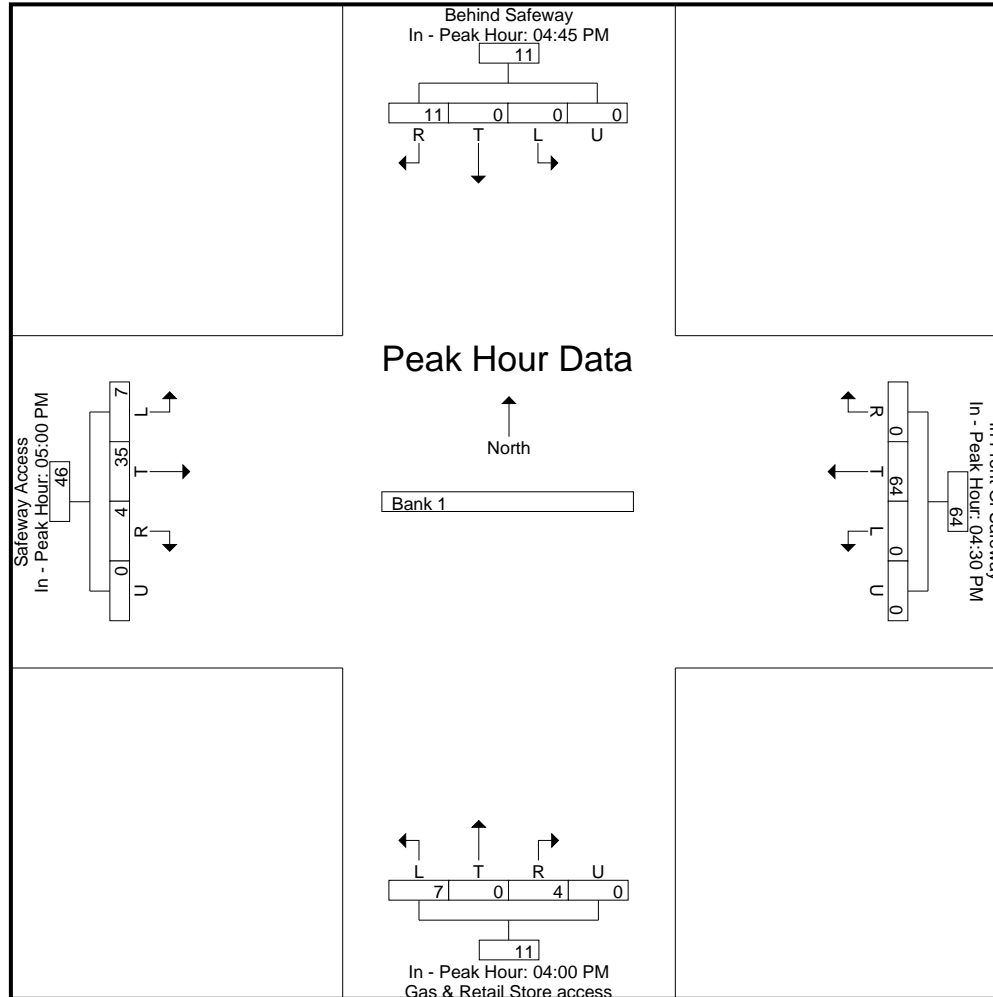

Levels of Service



HCM 6th TWSC
1: McLaughlin Rd & Midnight Rd

Existing
AM Peak Hour

Intersection												
Int Delay, s/veh	3.5											
Movement	EBL	EBT	EBR	WBL	WBT	WBR	NBL	NBT	NBR	SBL	SBT	SBR
Lane Configurations		↕		↕	↕		↕	↕		↕	↕	
Traffic Vol, veh/h	1	9	30	30	9	28	25	95	13	62	284	4
Future Vol, veh/h	1	9	30	30	9	28	25	95	13	62	284	4
Conflicting Peds, #/hr	0	0	0	0	0	0	0	0	0	0	0	0
Sign Control	Stop	Stop	Stop	Stop	Stop	Stop	Free	Free	Free	Free	Free	Free
RT Channelized	-	-	None	-	-	None	-	-	None	-	-	None
Storage Length	-	-	-	0	-	-	0	-	-	0	-	-
Veh in Median Storage, #	-	0	-	-	0	-	-	0	-	-	0	-
Grade, %	-	0	-	-	0	-	-	0	-	-	0	-
Peak Hour Factor	83	83	83	84	84	84	100	85	85	80	80	80
Heavy Vehicles, %	2	2	2	2	2	2	2	2	2	2	2	2
Mvmt Flow	1	11	36	36	11	33	25	112	15	78	355	5

Major/Minor	Minor2		Minor1		Major1		Major2					
Conflicting Flow All	706	691	358	707	686	120	360	0	0	127	0	0
Stage 1	514	514	-	170	170	-	-	-	-	-	-	-
Stage 2	192	177	-	537	516	-	-	-	-	-	-	-
Critical Hdwy	7.12	6.52	6.22	7.12	6.52	6.22	4.12	-	-	4.12	-	-
Critical Hdwy Stg 1	6.12	5.52	-	6.12	5.52	-	-	-	-	-	-	-
Critical Hdwy Stg 2	6.12	5.52	-	6.12	5.52	-	-	-	-	-	-	-
Follow-up Hdwy	3.518	4.018	3.318	3.518	4.018	3.318	2.218	-	-	2.218	-	-
Pot Cap-1 Maneuver	351	368	686	350	370	931	1199	-	-	1459	-	-
Stage 1	543	535	-	832	758	-	-	-	-	-	-	-
Stage 2	810	753	-	528	534	-	-	-	-	-	-	-
Platoon blocked, %								-	-	-	-	-
Mov Cap-1 Maneuver	312	341	686	306	343	931	1199	-	-	1459	-	-
Mov Cap-2 Maneuver	312	341	-	306	343	-	-	-	-	-	-	-
Stage 1	532	507	-	815	742	-	-	-	-	-	-	-
Stage 2	754	737	-	463	506	-	-	-	-	-	-	-

Approach	EB		WB		NB		SB	
HCM Control Delay, s	12.2		14.2		1.3		1.3	
HCM LOS	B		B					

Minor Lane/Major Mvmt	NBL	NBT	NBR	EBLn1	WBLn1	WBLn2	SBL	SBT	SBR
Capacity (veh/h)	1199	-	-	545	306	657	1459	-	-
HCM Lane V/C Ratio	0.021	-	-	0.088	0.117	0.067	0.053	-	-
HCM Control Delay (s)	8.1	-	-	12.2	18.3	10.9	7.6	-	-
HCM Lane LOS	A	-	-	B	C	B	A	-	-
HCM 95th %tile Q(veh)	0.1	-	-	0.3	0.4	0.2	0.2	-	-

HCM 6th TWSC
2: Safeway Back Access

Existing
AM Peak Hour

Intersection						
Int Delay, s/veh	1.4					
Movement	EBL	EBT	WBT	WBR	SBL	SBR
Lane Configurations		↶	↷		↶	
Traffic Vol, veh/h	18	70	76	2	1	7
Future Vol, veh/h	18	70	76	2	1	7
Conflicting Peds, #/hr	0	0	0	0	0	0
Sign Control	Free	Free	Free	Free	Stop	Stop
RT Channelized	-	None	-	None	-	None
Storage Length	-	-	-	-	0	-
Veh in Median Storage, #	-	0	0	-	0	-
Grade, %	-	0	0	-	0	-
Peak Hour Factor	69	69	77	77	50	50
Heavy Vehicles, %	2	2	2	2	2	2
Mvmt Flow	26	101	99	3	2	14

Major/Minor	Major1	Major2	Minor2		
Conflicting Flow All	102	0	-	0	254 101
Stage 1	-	-	-	-	101 -
Stage 2	-	-	-	-	153 -
Critical Hdwy	4.12	-	-	-	6.42 6.22
Critical Hdwy Stg 1	-	-	-	-	5.42 -
Critical Hdwy Stg 2	-	-	-	-	5.42 -
Follow-up Hdwy	2.218	-	-	-	3.518 3.318
Pot Cap-1 Maneuver	1490	-	-	-	735 954
Stage 1	-	-	-	-	923 -
Stage 2	-	-	-	-	875 -
Platoon blocked, %		-	-	-	
Mov Cap-1 Maneuver	1490	-	-	-	722 954
Mov Cap-2 Maneuver	-	-	-	-	722 -
Stage 1	-	-	-	-	906 -
Stage 2	-	-	-	-	875 -

Approach	EB	WB	SB
HCM Control Delay, s	1.5	0	9
HCM LOS			A

Minor Lane/Major Mvmt	EBL	EBT	WBT	WBR	SBLn1
Capacity (veh/h)	1490	-	-	-	917
HCM Lane V/C Ratio	0.018	-	-	-	0.017
HCM Control Delay (s)	7.5	0	-	-	9
HCM Lane LOS	A	A	-	-	A
HCM 95th %tile Q(veh)	0.1	-	-	-	0.1

HCM 6th TWSC
3: Safeway E Access

Existing
AM Peak Hour

Intersection						
Int Delay, s/veh	0.8					
Movement	EBT	EBR	WBL	WBT	NBL	NBR
Lane Configurations	↔			↔	↔	
Traffic Vol, veh/h	69	2	0	78	6	6
Future Vol, veh/h	69	2	0	78	6	6
Conflicting Peds, #/hr	0	0	0	0	0	0
Sign Control	Free	Free	Free	Free	Stop	Stop
RT Channelized	-	None	-	None	-	None
Storage Length	-	-	-	-	0	-
Veh in Median Storage, #	0	-	-	0	0	-
Grade, %	0	-	-	0	0	-
Peak Hour Factor	69	69	77	77	60	60
Heavy Vehicles, %	2	2	2	2	2	2
Mvmt Flow	100	3	0	101	10	10

Major/Minor	Major1	Major2	Minor1		
Conflicting Flow All	0	0	103	0	203
Stage 1	-	-	-	-	102
Stage 2	-	-	-	-	101
Critical Hdwy	-	-	4.12	-	6.42
Critical Hdwy Stg 1	-	-	-	-	5.42
Critical Hdwy Stg 2	-	-	-	-	5.42
Follow-up Hdwy	-	-	2.218	-	3.518
Pot Cap-1 Maneuver	-	-	1489	-	786
Stage 1	-	-	-	-	922
Stage 2	-	-	-	-	923
Platoon blocked, %	-	-	-	-	-
Mov Cap-1 Maneuver	-	-	1489	-	786
Mov Cap-2 Maneuver	-	-	-	-	786
Stage 1	-	-	-	-	922
Stage 2	-	-	-	-	923

Approach	EB	WB	NB
HCM Control Delay, s	0	0	9.3
HCM LOS			A

Minor Lane/Major Mvmt	NBLn1	EBT	EBR	WBL	WBT
Capacity (veh/h)	861	-	-	1489	-
HCM Lane V/C Ratio	0.023	-	-	-	-
HCM Control Delay (s)	9.3	-	-	0	-
HCM Lane LOS	A	-	-	A	-
HCM 95th %tile Q(veh)	0.1	-	-	0	-

HCM 6th TWSC
1: McLaughlin Rd & Midnight Rd

Existing
PM Peak Hour

Intersection												
Int Delay, s/veh	15.4											
Movement	EBL	EBT	EBR	WBL	WBT	WBR	NBL	NBT	NBR	SBL	SBT	SBR
Lane Configurations		↕		↕	↕		↕	↕		↕	↕	
Traffic Vol, veh/h	7	11	46	118	51	136	69	280	20	113	214	9
Future Vol, veh/h	7	11	46	118	51	136	69	280	20	113	214	9
Conflicting Peds, #/hr	0	0	0	0	0	0	0	0	0	0	0	0
Sign Control	Stop	Stop	Stop	Stop	Stop	Stop	Free	Free	Free	Free	Free	Free
RT Channelized	-	-	None	-	-	None	-	-	None	-	-	None
Storage Length	-	-	-	0	-	-	0	-	-	0	-	-
Veh in Median Storage, #	-	0	-	-	0	-	-	0	-	-	0	-
Grade, %	-	0	-	-	0	-	-	0	-	-	0	-
Peak Hour Factor	76	76	76	84	84	84	88	88	88	95	95	95
Heavy Vehicles, %	2	2	2	2	2	2	2	2	2	2	2	2
Mvmt Flow	9	14	61	140	61	162	78	318	23	119	225	9

Major/Minor	Minor2		Minor1		Major1		Major2					
Conflicting Flow All	1065	965	230	991	958	330	234	0	0	341	0	0
Stage 1	468	468	-	486	486	-	-	-	-	-	-	-
Stage 2	597	497	-	505	472	-	-	-	-	-	-	-
Critical Hdwy	7.12	6.52	6.22	7.12	6.52	6.22	4.12	-	-	4.12	-	-
Critical Hdwy Stg 1	6.12	5.52	-	6.12	5.52	-	-	-	-	-	-	-
Critical Hdwy Stg 2	6.12	5.52	-	6.12	5.52	-	-	-	-	-	-	-
Follow-up Hdwy	3.518	4.018	3.318	3.518	4.018	3.318	2.218	-	-	2.218	-	-
Pot Cap-1 Maneuver	200	255	809	225	257	712	1333	-	-	1218	-	-
Stage 1	575	561	-	563	551	-	-	-	-	-	-	-
Stage 2	490	545	-	549	559	-	-	-	-	-	-	-
Platoon blocked, %								-	-	-	-	-
Mov Cap-1 Maneuver	108	216	809	175	218	712	1333	-	-	1218	-	-
Mov Cap-2 Maneuver	108	216	-	175	218	-	-	-	-	-	-	-
Stage 1	541	506	-	530	518	-	-	-	-	-	-	-
Stage 2	315	513	-	445	504	-	-	-	-	-	-	-

Approach	EB	WB	NB	SB
HCM Control Delay, s	17.5	43.3	1.5	2.8
HCM LOS	C	E		

Minor Lane/Major Mvmt	NBL	NBT	NBR	EBLn1	WBLn1	WBLn2	SBL	SBT	SBR
Capacity (veh/h)	1333	-	-	371	175	440	1218	-	-
HCM Lane V/C Ratio	0.059	-	-	0.227	0.803	0.506	0.098	-	-
HCM Control Delay (s)	7.9	-	-	17.5	78.1	21.3	8.3	-	-
HCM Lane LOS	A	-	-	C	F	C	A	-	-
HCM 95th %tile Q(veh)	0.2	-	-	0.9	5.4	2.8	0.3	-	-

HCM 6th TWSC
2: Safeway Back Access

Existing
PM Peak Hour

Intersection						
Int Delay, s/veh	1					
Movement	EBL	EBT	WBT	WBR	SBL	SBR
Lane Configurations		↔	↔		↔	
Traffic Vol, veh/h	14	117	281	5	3	31
Future Vol, veh/h	14	117	281	5	3	31
Conflicting Peds, #/hr	0	0	0	0	0	0
Sign Control	Free	Free	Free	Free	Stop	Stop
RT Channelized	-	None	-	None	-	None
Storage Length	-	-	-	-	0	-
Veh in Median Storage, #	-	0	0	-	0	-
Grade, %	-	0	0	-	0	-
Peak Hour Factor	92	92	88	88	92	92
Heavy Vehicles, %	2	2	2	2	2	2
Mvmt Flow	15	127	319	6	3	34

Major/Minor	Major1	Major2	Minor2		
Conflicting Flow All	325	0	-	0	479 322
Stage 1	-	-	-	-	322 -
Stage 2	-	-	-	-	157 -
Critical Hdwy	4.12	-	-	-	6.42 6.22
Critical Hdwy Stg 1	-	-	-	-	5.42 -
Critical Hdwy Stg 2	-	-	-	-	5.42 -
Follow-up Hdwy	2.218	-	-	-	3.518 3.318
Pot Cap-1 Maneuver	1235	-	-	-	545 719
Stage 1	-	-	-	-	735 -
Stage 2	-	-	-	-	871 -
Platoon blocked, %		-	-	-	
Mov Cap-1 Maneuver	1235	-	-	-	538 719
Mov Cap-2 Maneuver	-	-	-	-	538 -
Stage 1	-	-	-	-	725 -
Stage 2	-	-	-	-	871 -

Approach	EB	WB	SB
HCM Control Delay, s	0.8	0	10.4
HCM LOS			B

Minor Lane/Major Mvmt	EBL	EBT	WBT	WBR	SBLn1
Capacity (veh/h)	1235	-	-	-	698
HCM Lane V/C Ratio	0.012	-	-	-	0.053
HCM Control Delay (s)	8	0	-	-	10.4
HCM Lane LOS	A	A	-	-	B
HCM 95th %tile Q(veh)	0	-	-	-	0.2

HCM 6th TWSC
3: Safeway E Access

Existing
PM Peak Hour

Intersection						
Int Delay, s/veh	0.9					
Movement	EBT	EBR	WBL	WBT	NBL	NBR
Lane Configurations						
Traffic Vol, veh/h	111	8	2	263	22	7
Future Vol, veh/h	111	8	2	263	22	7
Conflicting Peds, #/hr	0	0	0	0	0	0
Sign Control	Free	Free	Free	Free	Stop	Stop
RT Channelized	-	None	-	None	-	None
Storage Length	-	-	-	-	0	-
Veh in Median Storage, #	0	-	-	0	0	-
Grade, %	0	-	-	0	0	-
Peak Hour Factor	92	92	88	88	83	83
Heavy Vehicles, %	2	2	2	2	2	2
Mvmt Flow	121	9	2	299	27	8

Major/Minor	Major1	Major2	Minor1		
Conflicting Flow All	0	0	130	0	429
Stage 1	-	-	-	-	126
Stage 2	-	-	-	-	303
Critical Hdwy	-	-	4.12	-	6.42
Critical Hdwy Stg 1	-	-	-	-	5.42
Critical Hdwy Stg 2	-	-	-	-	5.42
Follow-up Hdwy	-	-	2.218	-	3.518
Pot Cap-1 Maneuver	-	-	1455	-	583
Stage 1	-	-	-	-	900
Stage 2	-	-	-	-	749
Platoon blocked, %	-	-	-	-	-
Mov Cap-1 Maneuver	-	-	1455	-	582
Mov Cap-2 Maneuver	-	-	-	-	582
Stage 1	-	-	-	-	900
Stage 2	-	-	-	-	748

Approach	EB	WB	NB
HCM Control Delay, s	0	0.1	11
HCM LOS			B

Minor Lane/Major Mvmt	NBLn1	EBT	EBR	WBL	WBT
Capacity (veh/h)	639	-	-	1455	-
HCM Lane V/C Ratio	0.055	-	-	0.002	-
HCM Control Delay (s)	11	-	-	7.5	0
HCM Lane LOS	B	-	-	A	A
HCM 95th %tile Q(veh)	0.2	-	-	0	-

HCM 6th TWSC
1: McLaughlin Rd & Midnight Rd

Short Term Total
AM Peak Hour

Intersection												
Int Delay, s/veh	3.7											
Movement	EBL	EBT	EBR	WBL	WBT	WBR	NBL	NBT	NBR	SBL	SBT	SBR
Lane Configurations		↕		↕	↕		↕	↕		↕	↕	
Traffic Vol, veh/h	1	10	30	34	10	31	25	95	20	67	284	4
Future Vol, veh/h	1	10	30	34	10	31	25	95	20	67	284	4
Conflicting Peds, #/hr	0	0	0	0	0	0	0	0	0	0	0	0
Sign Control	Stop	Stop	Stop	Stop	Stop	Stop	Free	Free	Free	Free	Free	Free
RT Channelized	-	-	None	-	-	None	-	-	None	-	-	None
Storage Length	-	-	-	0	-	-	0	-	-	0	-	-
Veh in Median Storage, #	-	0	-	-	0	-	-	0	-	-	0	-
Grade, %	-	0	-	-	0	-	-	0	-	-	0	-
Peak Hour Factor	83	83	83	84	84	84	100	85	85	80	80	80
Heavy Vehicles, %	2	2	2	2	2	2	2	2	2	2	2	2
Mvmt Flow	1	12	36	40	12	37	25	112	24	84	355	5

Major/Minor	Minor2		Minor1		Major1		Major2					
Conflicting Flow All	725	712	358	724	702	124	360	0	0	136	0	0
Stage 1	526	526	-	174	174	-	-	-	-	-	-	-
Stage 2	199	186	-	550	528	-	-	-	-	-	-	-
Critical Hdwy	7.12	6.52	6.22	7.12	6.52	6.22	4.12	-	-	4.12	-	-
Critical Hdwy Stg 1	6.12	5.52	-	6.12	5.52	-	-	-	-	-	-	-
Critical Hdwy Stg 2	6.12	5.52	-	6.12	5.52	-	-	-	-	-	-	-
Follow-up Hdwy	3.518	4.018	3.318	3.518	4.018	3.318	2.218	-	-	2.218	-	-
Pot Cap-1 Maneuver	340	358	686	341	362	927	1199	-	-	1448	-	-
Stage 1	535	529	-	828	755	-	-	-	-	-	-	-
Stage 2	803	746	-	519	528	-	-	-	-	-	-	-
Platoon blocked, %								-	-	-	-	-
Mov Cap-1 Maneuver	299	330	686	296	334	927	1199	-	-	1448	-	-
Mov Cap-2 Maneuver	299	330	-	296	334	-	-	-	-	-	-	-
Stage 1	524	498	-	811	739	-	-	-	-	-	-	-
Stage 2	743	730	-	452	497	-	-	-	-	-	-	-

Approach	EB		WB		NB		SB	
HCM Control Delay, s	12.5		14.7		1.3		1.4	
HCM LOS	B		B					

Minor Lane/Major Mvmt	NBL	NBT	NBR	EBLn1	WBLn1	WBLn2	SBL	SBT	SBR
Capacity (veh/h)	1199	-	-	530	296	647	1448	-	-
HCM Lane V/C Ratio	0.021	-	-	0.093	0.137	0.075	0.058	-	-
HCM Control Delay (s)	8.1	-	-	12.5	19.1	11	7.6	-	-
HCM Lane LOS	A	-	-	B	C	B	A	-	-
HCM 95th %tile Q(veh)	0.1	-	-	0.3	0.5	0.2	0.2	-	-

HCM 6th TWSC
2: Safeway Back Access

Short Term Total
AM Peak Hour

Intersection						
Int Delay, s/veh	2.1					
Movement	EBL	EBT	WBT	WBR	SBL	SBR
Lane Configurations		↶	↷		↶	
Traffic Vol, veh/h	28	70	76	3	1	15
Future Vol, veh/h	28	70	76	3	1	15
Conflicting Peds, #/hr	0	0	0	0	0	0
Sign Control	Free	Free	Free	Free	Stop	Stop
RT Channelized	-	None	-	None	-	None
Storage Length	-	-	-	-	0	-
Veh in Median Storage, #	-	0	0	-	0	-
Grade, %	-	0	0	-	0	-
Peak Hour Factor	69	69	77	77	50	50
Heavy Vehicles, %	2	2	2	2	2	2
Mvmt Flow	41	101	99	4	2	30

Major/Minor	Major1	Major2	Minor2		
Conflicting Flow All	103	0	-	0	284 101
Stage 1	-	-	-	-	101 -
Stage 2	-	-	-	-	183 -
Critical Hdwy	4.12	-	-	-	6.42 6.22
Critical Hdwy Stg 1	-	-	-	-	5.42 -
Critical Hdwy Stg 2	-	-	-	-	5.42 -
Follow-up Hdwy	2.218	-	-	-	3.518 3.318
Pot Cap-1 Maneuver	1489	-	-	-	706 954
Stage 1	-	-	-	-	923 -
Stage 2	-	-	-	-	848 -
Platoon blocked, %		-	-	-	
Mov Cap-1 Maneuver	1489	-	-	-	686 954
Mov Cap-2 Maneuver	-	-	-	-	686 -
Stage 1	-	-	-	-	896 -
Stage 2	-	-	-	-	848 -

Approach	EB	WB	SB
HCM Control Delay, s	2.1	0	9
HCM LOS			A

Minor Lane/Major Mvmt	EBL	EBT	WBT	WBR	SBLn1
Capacity (veh/h)	1489	-	-	-	931
HCM Lane V/C Ratio	0.027	-	-	-	0.034
HCM Control Delay (s)	7.5	0	-	-	9
HCM Lane LOS	A	A	-	-	A
HCM 95th %tile Q(veh)	0.1	-	-	-	0.1

HCM 6th TWSC
3: Safeway E Access

Short Term Total
AM Peak Hour

Intersection						
Int Delay, s/veh	0.8					
Movement	EBT	EBR	WBL	WBT	NBL	NBR
Lane Configurations	↔			↔	↔	
Traffic Vol, veh/h	69	2	0	79	6	6
Future Vol, veh/h	69	2	0	79	6	6
Conflicting Peds, #/hr	0	0	0	0	0	0
Sign Control	Free	Free	Free	Free	Stop	Stop
RT Channelized	-	None	-	None	-	None
Storage Length	-	-	-	-	0	-
Veh in Median Storage, #	0	-	-	0	0	-
Grade, %	0	-	-	0	0	-
Peak Hour Factor	69	69	77	77	60	60
Heavy Vehicles, %	2	2	2	2	2	2
Mvmt Flow	100	3	0	103	10	10

Major/Minor	Major1	Major2	Minor1		
Conflicting Flow All	0	0	103	0	205 102
Stage 1	-	-	-	-	102 -
Stage 2	-	-	-	-	103 -
Critical Hdwy	-	-	4.12	-	6.42 6.22
Critical Hdwy Stg 1	-	-	-	-	5.42 -
Critical Hdwy Stg 2	-	-	-	-	5.42 -
Follow-up Hdwy	-	-	2.218	-	3.518 3.318
Pot Cap-1 Maneuver	-	-	1489	-	783 953
Stage 1	-	-	-	-	922 -
Stage 2	-	-	-	-	921 -
Platoon blocked, %	-	-	-	-	-
Mov Cap-1 Maneuver	-	-	1489	-	783 953
Mov Cap-2 Maneuver	-	-	-	-	783 -
Stage 1	-	-	-	-	922 -
Stage 2	-	-	-	-	921 -

Approach	EB	WB	NB
HCM Control Delay, s	0	0	9.3
HCM LOS			A

Minor Lane/Major Mvmt	NBLn1	EBT	EBR	WBL	WBT
Capacity (veh/h)	860	-	-	1489	-
HCM Lane V/C Ratio	0.023	-	-	-	-
HCM Control Delay (s)	9.3	-	-	0	-
HCM Lane LOS	A	-	-	A	-
HCM 95th %tile Q(veh)	0.1	-	-	0	-

HCM 6th TWSC
1: McLaughlin Rd & Midnight Rd

Short Term Total
PM Peak Hour

Intersection												
Int Delay, s/veh	17.4											
Movement	EBL	EBT	EBR	WBL	WBT	WBR	NBL	NBT	NBR	SBL	SBT	SBR
Lane Configurations		↕		↕	↕		↕	↕		↕	↕	
Traffic Vol, veh/h	7	12	46	124	52	140	69	280	24	116	214	9
Future Vol, veh/h	7	12	46	124	52	140	69	280	24	116	214	9
Conflicting Peds, #/hr	0	0	0	0	0	0	0	0	0	0	0	0
Sign Control	Stop	Stop	Stop	Stop	Stop	Stop	Free	Free	Free	Free	Free	Free
RT Channelized	-	-	None	-	-	None	-	-	None	-	-	None
Storage Length	-	-	-	0	-	-	0	-	-	0	-	-
Veh in Median Storage, #	-	0	-	-	0	-	-	0	-	-	0	-
Grade, %	-	0	-	-	0	-	-	0	-	-	0	-
Peak Hour Factor	76	76	76	84	84	84	88	88	88	95	95	95
Heavy Vehicles, %	2	2	2	2	2	2	2	2	2	2	2	2
Mvmt Flow	9	16	61	148	62	167	78	318	27	122	225	9

Major/Minor	Minor2		Minor1		Major1		Major2					
Conflicting Flow All	1076	975	230	1000	966	332	234	0	0	345	0	0
Stage 1	474	474	-	488	488	-	-	-	-	-	-	-
Stage 2	602	501	-	512	478	-	-	-	-	-	-	-
Critical Hdwy	7.12	6.52	6.22	7.12	6.52	6.22	4.12	-	-	4.12	-	-
Critical Hdwy Stg 1	6.12	5.52	-	6.12	5.52	-	-	-	-	-	-	-
Critical Hdwy Stg 2	6.12	5.52	-	6.12	5.52	-	-	-	-	-	-	-
Follow-up Hdwy	3.518	4.018	3.318	3.518	4.018	3.318	2.218	-	-	2.218	-	-
Pot Cap-1 Maneuver	197	251	809	222	255	710	1333	-	-	1214	-	-
Stage 1	571	558	-	561	550	-	-	-	-	-	-	-
Stage 2	486	543	-	545	556	-	-	-	-	-	-	-
Platoon blocked, %								-	-	-	-	-
Mov Cap-1 Maneuver	104	213	809	171	216	710	1333	-	-	1214	-	-
Mov Cap-2 Maneuver	104	213	-	171	216	-	-	-	-	-	-	-
Stage 1	537	502	-	528	518	-	-	-	-	-	-	-
Stage 2	308	511	-	439	500	-	-	-	-	-	-	-

Approach	EB		WB		NB		SB	
HCM Control Delay, s	18.1		48.9		1.5		2.8	
HCM LOS	C		E					

Minor Lane/Major Mvmt	NBL	NBT	NBR	EBLn1	WBLn1	WBLn2	SBL	SBT	SBR
Capacity (veh/h)	1333	-	-	360	171	438	1214	-	-
HCM Lane V/C Ratio	0.059	-	-	0.238	0.863	0.522	0.101	-	-
HCM Control Delay (s)	7.9	-	-	18.1	90.8	21.8	8.3	-	-
HCM Lane LOS	A	-	-	C	F	C	A	-	-
HCM 95th %tile Q(veh)	0.2	-	-	0.9	6.1	2.9	0.3	-	-

HCM 6th TWSC
2: Safeway Back Access

Short Term Total
PM Peak Hour

Intersection						
Int Delay, s/veh	1.4					
Movement	EBL	EBT	WBT	WBR	SBL	SBR
Lane Configurations		↶	↷		↶	↷
Traffic Vol, veh/h	21	117	281	5	4	42
Future Vol, veh/h	21	117	281	5	4	42
Conflicting Peds, #/hr	0	0	0	0	0	0
Sign Control	Free	Free	Free	Free	Stop	Stop
RT Channelized	-	None	-	None	-	None
Storage Length	-	-	-	-	0	-
Veh in Median Storage, #	-	0	0	-	0	-
Grade, %	-	0	0	-	0	-
Peak Hour Factor	92	92	88	88	92	92
Heavy Vehicles, %	2	2	2	2	2	2
Mvmt Flow	23	127	319	6	4	46

Major/Minor	Major1	Major2	Minor2		
Conflicting Flow All	325	0	-	0	495 322
Stage 1	-	-	-	-	322 -
Stage 2	-	-	-	-	173 -
Critical Hdwy	4.12	-	-	-	6.42 6.22
Critical Hdwy Stg 1	-	-	-	-	5.42 -
Critical Hdwy Stg 2	-	-	-	-	5.42 -
Follow-up Hdwy	2.218	-	-	-	3.518 3.318
Pot Cap-1 Maneuver	1235	-	-	-	534 719
Stage 1	-	-	-	-	735 -
Stage 2	-	-	-	-	857 -
Platoon blocked, %		-	-	-	
Mov Cap-1 Maneuver	1235	-	-	-	523 719
Mov Cap-2 Maneuver	-	-	-	-	523 -
Stage 1	-	-	-	-	720 -
Stage 2	-	-	-	-	857 -

Approach	EB	WB	SB
HCM Control Delay, s	1.2	0	10.6
HCM LOS			B

Minor Lane/Major Mvmt	EBL	EBT	WBT	WBR	SBLn1
Capacity (veh/h)	1235	-	-	-	696
HCM Lane V/C Ratio	0.018	-	-	-	0.072
HCM Control Delay (s)	8	0	-	-	10.6
HCM Lane LOS	A	A	-	-	B
HCM 95th %tile Q(veh)	0.1	-	-	-	0.2

HCM 6th TWSC
3: Safeway E Access

Short Term Total
PM Peak Hour

Intersection						
Int Delay, s/veh	0.9					
Movement	EBT	EBR	WBL	WBT	NBL	NBR
Lane Configurations						
Traffic Vol, veh/h	112	8	2	263	23	7
Future Vol, veh/h	112	8	2	263	23	7
Conflicting Peds, #/hr	0	0	0	0	0	0
Sign Control	Free	Free	Free	Free	Stop	Stop
RT Channelized	-	None	-	None	-	None
Storage Length	-	-	-	-	0	-
Veh in Median Storage, #	0	-	-	0	0	-
Grade, %	0	-	-	0	0	-
Peak Hour Factor	92	92	88	88	83	83
Heavy Vehicles, %	2	2	2	2	2	2
Mvmt Flow	122	9	2	299	28	8

Major/Minor	Major1	Major2	Minor1		
Conflicting Flow All	0	0	131	0	430
Stage 1	-	-	-	-	127
Stage 2	-	-	-	-	303
Critical Hdwy	-	-	4.12	-	6.42
Critical Hdwy Stg 1	-	-	-	-	5.42
Critical Hdwy Stg 2	-	-	-	-	5.42
Follow-up Hdwy	-	-	2.218	-	3.518
Pot Cap-1 Maneuver	-	-	1454	-	582
Stage 1	-	-	-	-	899
Stage 2	-	-	-	-	749
Platoon blocked, %	-	-	-	-	-
Mov Cap-1 Maneuver	-	-	1454	-	581
Mov Cap-2 Maneuver	-	-	-	-	581
Stage 1	-	-	-	-	899
Stage 2	-	-	-	-	748

Approach	EB	WB	NB
HCM Control Delay, s	0	0.1	11
HCM LOS			B

Minor Lane/Major Mvmt	NBLn1	EBT	EBR	WBL	WBT
Capacity (veh/h)	636	-	-	1454	-
HCM Lane V/C Ratio	0.057	-	-	0.002	-
HCM Control Delay (s)	11	-	-	7.5	0
HCM Lane LOS	B	-	-	A	A
HCM 95th %tile Q(veh)	0.2	-	-	0	-

Intersection												
Int Delay, s/veh	4.6											
Movement	EBL	EBT	EBR	WBL	WBT	WBR	NBL	NBT	NBR	SBL	SBT	SBR
Lane Configurations		↕		↕	↕		↕	↕		↕	↕	
Traffic Vol, veh/h	1	13	30	54	13	44	25	141	35	76	320	4
Future Vol, veh/h	1	13	30	54	13	44	25	141	35	76	320	4
Conflicting Peds, #/hr	0	0	0	0	0	0	0	0	0	0	0	0
Sign Control	Stop	Stop	Stop	Stop	Stop	Stop	Free	Free	Free	Free	Free	Free
RT Channelized	-	-	None	-	-	None	-	-	None	-	-	None
Storage Length	-	-	-	0	-	-	0	-	-	0	-	-
Veh in Median Storage, #	-	0	-	-	0	-	-	0	-	-	0	-
Grade, %	-	0	-	-	0	-	-	0	-	-	0	-
Peak Hour Factor	83	83	83	84	84	84	100	85	85	80	80	80
Heavy Vehicles, %	2	2	2	2	2	2	2	2	2	2	2	2
Mvmt Flow	1	16	36	64	15	52	25	166	41	95	400	5

Major/Minor	Minor2		Minor1		Major1		Major2					
Conflicting Flow All	863	850	403	856	832	187	405	0	0	207	0	0
Stage 1	593	593	-	237	237	-	-	-	-	-	-	-
Stage 2	270	257	-	619	595	-	-	-	-	-	-	-
Critical Hdwy	7.12	6.52	6.22	7.12	6.52	6.22	4.12	-	-	4.12	-	-
Critical Hdwy Stg 1	6.12	5.52	-	6.12	5.52	-	-	-	-	-	-	-
Critical Hdwy Stg 2	6.12	5.52	-	6.12	5.52	-	-	-	-	-	-	-
Follow-up Hdwy	3.518	4.018	3.318	3.518	4.018	3.318	2.218	-	-	2.218	-	-
Pot Cap-1 Maneuver	275	298	647	278	305	855	1154	-	-	1364	-	-
Stage 1	492	493	-	766	709	-	-	-	-	-	-	-
Stage 2	736	695	-	476	492	-	-	-	-	-	-	-
Platoon blocked, %								-	-	-	-	-
Mov Cap-1 Maneuver	230	271	647	234	278	855	1154	-	-	1364	-	-
Mov Cap-2 Maneuver	230	271	-	234	278	-	-	-	-	-	-	-
Stage 1	481	458	-	749	693	-	-	-	-	-	-	-
Stage 2	661	680	-	404	458	-	-	-	-	-	-	-

Approach	EB		WB		NB		SB	
HCM Control Delay, s	14.2		18.9		0.9		1.5	
HCM LOS	B		C					

Minor Lane/Major Mvmt	NBL	NBT	NBR	EBLn1	WBLn1	WBLn2	SBL	SBT	SBR
Capacity (veh/h)	1154	-	-	446	234	580	1364	-	-
HCM Lane V/C Ratio	0.022	-	-	0.119	0.275	0.117	0.07	-	-
HCM Control Delay (s)	8.2	-	-	14.2	26.1	12	7.8	-	-
HCM Lane LOS	A	-	-	B	D	B	A	-	-
HCM 95th %tile Q(veh)	0.1	-	-	0.4	1.1	0.4	0.2	-	-

Intersection						
Int Delay, s/veh	3.8					
Movement	EBL	EBT	WBT	WBR	SBL	SBR
Lane Configurations		↶	↷		↶	↷
Traffic Vol, veh/h	54	67	87	8	3	46
Future Vol, veh/h	54	67	87	8	3	46
Conflicting Peds, #/hr	0	0	0	0	0	0
Sign Control	Free	Free	Free	Free	Stop	Stop
RT Channelized	-	None	-	None	-	None
Storage Length	-	-	-	-	0	-
Veh in Median Storage, #	-	0	0	-	0	-
Grade, %	-	0	0	-	0	-
Peak Hour Factor	69	69	77	77	50	50
Heavy Vehicles, %	2	2	2	2	2	2
Mvmt Flow	78	97	113	10	6	92

Major/Minor	Major1	Major2	Minor2		
Conflicting Flow All	123	0	-	0	371 118
Stage 1	-	-	-	-	118 -
Stage 2	-	-	-	-	253 -
Critical Hdwy	4.12	-	-	-	6.42 6.22
Critical Hdwy Stg 1	-	-	-	-	5.42 -
Critical Hdwy Stg 2	-	-	-	-	5.42 -
Follow-up Hdwy	2.218	-	-	-	3.518 3.318
Pot Cap-1 Maneuver	1464	-	-	-	630 934
Stage 1	-	-	-	-	907 -
Stage 2	-	-	-	-	789 -
Platoon blocked, %		-	-	-	
Mov Cap-1 Maneuver	1464	-	-	-	595 934
Mov Cap-2 Maneuver	-	-	-	-	595 -
Stage 1	-	-	-	-	856 -
Stage 2	-	-	-	-	789 -

Approach	EB	WB	SB
HCM Control Delay, s	3.4	0	9.5
HCM LOS			A

Minor Lane/Major Mvmt	EBL	EBT	WBT	WBR	SBLn1
Capacity (veh/h)	1464	-	-	-	903
HCM Lane V/C Ratio	0.053	-	-	-	0.109
HCM Control Delay (s)	7.6	0	-	-	9.5
HCM Lane LOS	A	A	-	-	A
HCM 95th %tile Q(veh)	0.2	-	-	-	0.4

Intersection						
Int Delay, s/veh	1.4					
Movement	EBT	EBR	WBL	WBT	NBL	NBR
Lane Configurations						
Traffic Vol, veh/h	69	8	0	79	16	6
Future Vol, veh/h	69	8	0	79	16	6
Conflicting Peds, #/hr	0	0	0	0	0	0
Sign Control	Free	Free	Free	Free	Stop	Stop
RT Channelized	-	None	-	None	-	None
Storage Length	-	-	-	-	0	-
Veh in Median Storage, #	0	-	-	0	0	-
Grade, %	0	-	-	0	0	-
Peak Hour Factor	69	69	77	77	60	60
Heavy Vehicles, %	2	2	2	2	2	2
Mvmt Flow	100	12	0	103	27	10

Major/Minor	Major1	Major2	Minor1		
Conflicting Flow All	0	0	112	0	209
Stage 1	-	-	-	-	106
Stage 2	-	-	-	-	103
Critical Hdwy	-	-	4.12	-	6.42
Critical Hdwy Stg 1	-	-	-	-	5.42
Critical Hdwy Stg 2	-	-	-	-	5.42
Follow-up Hdwy	-	-	2.218	-	3.518
Pot Cap-1 Maneuver	-	-	1478	-	779
Stage 1	-	-	-	-	918
Stage 2	-	-	-	-	921
Platoon blocked, %	-	-	-	-	-
Mov Cap-1 Maneuver	-	-	1478	-	779
Mov Cap-2 Maneuver	-	-	-	-	779
Stage 1	-	-	-	-	918
Stage 2	-	-	-	-	921

Approach	EB	WB	NB
HCM Control Delay, s	0	0	9.6
HCM LOS			A

Minor Lane/Major Mvmt	NBLn1	EBT	EBR	WBL	WBT
Capacity (veh/h)	819	-	-	1478	-
HCM Lane V/C Ratio	0.045	-	-	-	-
HCM Control Delay (s)	9.6	-	-	0	-
HCM Lane LOS	A	-	-	A	-
HCM 95th %tile Q(veh)	0.1	-	-	0	-

Intersection												
Int Delay, s/veh	41.2											
Movement	EBL	EBT	EBR	WBL	WBT	WBR	NBL	NBT	NBR	SBL	SBT	SBR
Lane Configurations		↕		↕	↕		↕	↕		↕	↕	
Traffic Vol, veh/h	7	14	46	138	54	148	69	360	39	126	290	9
Future Vol, veh/h	7	14	46	138	54	148	69	360	39	126	290	9
Conflicting Peds, #/hr	0	0	0	0	0	0	0	0	0	0	0	0
Sign Control	Stop	Stop	Stop	Stop	Stop	Stop	Free	Free	Free	Free	Free	Free
RT Channelized	-	-	None	-	-	None	-	-	None	-	-	None
Storage Length	-	-	-	0	-	-	0	-	-	0	-	-
Veh in Median Storage, #	-	0	-	-	0	-	-	0	-	-	0	-
Grade, %	-	0	-	-	0	-	-	0	-	-	0	-
Peak Hour Factor	76	76	76	84	84	84	88	88	88	95	95	95
Heavy Vehicles, %	2	2	2	2	2	2	2	2	2	2	2	2
Mvmt Flow	9	18	61	164	64	176	78	409	44	133	305	9

Major/Minor	Minor2		Minor1		Major1			Major2				
Conflicting Flow All	1283	1185	310	1202	1167	431	314	0	0	453	0	0
Stage 1	576	576	-	587	587	-	-	-	-	-	-	-
Stage 2	707	609	-	615	580	-	-	-	-	-	-	-
Critical Hdwy	7.12	6.52	6.22	7.12	6.52	6.22	4.12	-	-	4.12	-	-
Critical Hdwy Stg 1	6.12	5.52	-	6.12	5.52	-	-	-	-	-	-	-
Critical Hdwy Stg 2	6.12	5.52	-	6.12	5.52	-	-	-	-	-	-	-
Follow-up Hdwy	3.518	4.018	3.318	3.518	4.018	3.318	2.218	-	-	2.218	-	-
Pot Cap-1 Maneuver	142	189	730	~ 161	194	624	1246	-	-	1108	-	-
Stage 1	503	502	-	496	497	-	-	-	-	-	-	-
Stage 2	426	485	-	479	500	-	-	-	-	-	-	-
Platoon blocked, %								-	-	-	-	-
Mov Cap-1 Maneuver	61	156	730	~ 117	160	624	1246	-	-	1108	-	-
Mov Cap-2 Maneuver	61	156	-	~ 117	160	-	-	-	-	-	-	-
Stage 1	471	442	-	465	466	-	-	-	-	-	-	-
Stage 2	247	454	-	370	440	-	-	-	-	-	-	-

Approach	EB	WB	NB	SB
HCM Control Delay, s	27	139.6	1.2	2.6
HCM LOS	D	F		

Minor Lane/Major Mvmt	NBL	NBT	NBR	EBLn1	WBLn1	WBLn2	SBL	SBT	SBR
Capacity (veh/h)	1246	-	-	250	117	352	1108	-	-
HCM Lane V/C Ratio	0.063	-	-	0.353	1.404	0.683	0.12	-	-
HCM Control Delay (s)	8.1	-	-	27	293.2	34.6	8.7	-	-
HCM Lane LOS	A	-	-	D	F	D	A	-	-
HCM 95th %tile Q(veh)	0.2	-	-	1.5	11.3	4.8	0.4	-	-

Notes
 ~: Volume exceeds capacity \$: Delay exceeds 300s +: Computation Not Defined *: All major volume in platoon

Intersection						
Int Delay, s/veh	2					
Movement	EBL	EBT	WBT	WBR	SBL	SBR
Lane Configurations		↶	↷		↶	
Traffic Vol, veh/h	44	108	286	10	5	61
Future Vol, veh/h	44	108	286	10	5	61
Conflicting Peds, #/hr	0	0	0	0	0	0
Sign Control	Free	Free	Free	Free	Stop	Stop
RT Channelized	-	None	-	None	-	None
Storage Length	-	-	-	-	0	-
Veh in Median Storage, #	-	0	0	-	0	-
Grade, %	-	0	0	-	0	-
Peak Hour Factor	92	92	88	88	92	92
Heavy Vehicles, %	2	2	2	2	2	2
Mvmt Flow	48	117	325	11	5	66

Major/Minor	Major1	Major2	Minor2		
Conflicting Flow All	336	0	-	0	544 331
Stage 1	-	-	-	-	331 -
Stage 2	-	-	-	-	213 -
Critical Hdwy	4.12	-	-	-	6.42 6.22
Critical Hdwy Stg 1	-	-	-	-	5.42 -
Critical Hdwy Stg 2	-	-	-	-	5.42 -
Follow-up Hdwy	2.218	-	-	-	3.518 3.318
Pot Cap-1 Maneuver	1223	-	-	-	500 711
Stage 1	-	-	-	-	728 -
Stage 2	-	-	-	-	823 -
Platoon blocked, %		-	-	-	
Mov Cap-1 Maneuver	1223	-	-	-	479 711
Mov Cap-2 Maneuver	-	-	-	-	479 -
Stage 1	-	-	-	-	697 -
Stage 2	-	-	-	-	823 -

Approach	EB	WB	SB
HCM Control Delay, s	2.3	0	10.9
HCM LOS			B

Minor Lane/Major Mvmt	EBL	EBT	WBT	WBR	SBLn1
Capacity (veh/h)	1223	-	-	-	686
HCM Lane V/C Ratio	0.039	-	-	-	0.105
HCM Control Delay (s)	8.1	0	-	-	10.9
HCM Lane LOS	A	A	-	-	B
HCM 95th %tile Q(veh)	0.1	-	-	-	0.3

Intersection						
Int Delay, s/veh	1					
Movement	EBT	EBR	WBL	WBT	NBL	NBR
Lane Configurations						
Traffic Vol, veh/h	112	13	2	263	27	7
Future Vol, veh/h	112	13	2	263	27	7
Conflicting Peds, #/hr	0	0	0	0	0	0
Sign Control	Free	Free	Free	Free	Stop	Stop
RT Channelized	-	None	-	None	-	None
Storage Length	-	-	-	-	0	-
Veh in Median Storage, #	0	-	-	0	0	-
Grade, %	0	-	-	0	0	-
Peak Hour Factor	92	92	88	88	83	83
Heavy Vehicles, %	2	2	2	2	2	2
Mvmt Flow	122	14	2	299	33	8

Major/Minor	Major1	Major2	Minor1	Minor2	Minor3
Conflicting Flow All	0	0	136	0	432
Stage 1	-	-	-	-	129
Stage 2	-	-	-	-	303
Critical Hdwy	-	-	4.12	-	6.42
Critical Hdwy Stg 1	-	-	-	-	5.42
Critical Hdwy Stg 2	-	-	-	-	5.42
Follow-up Hdwy	-	-	2.218	-	3.518
Pot Cap-1 Maneuver	-	-	1448	-	581
Stage 1	-	-	-	-	897
Stage 2	-	-	-	-	749
Platoon blocked, %	-	-	-	-	-
Mov Cap-1 Maneuver	-	-	1448	-	580
Mov Cap-2 Maneuver	-	-	-	-	580
Stage 1	-	-	-	-	897
Stage 2	-	-	-	-	748

Approach	EB	WB	NB
HCM Control Delay, s	0	0.1	11.1
HCM LOS			B

Minor Lane/Major Mvmt	NBLn1	EBT	EBR	WBL	WBT
Capacity (veh/h)	628	-	-	1448	-
HCM Lane V/C Ratio	0.065	-	-	0.002	-
HCM Control Delay (s)	11.1	-	-	7.5	0
HCM Lane LOS	B	-	-	A	A
HCM 95th %tile Q(veh)	0.2	-	-	0	-

HCM 6th TWSC
1: McLaughlin Rd & Midnight Rd

Long Term Total
AM Peak Hour

Intersection												
Int Delay, s/veh	4.9											
Movement	EBL	EBT	EBR	WBL	WBT	WBR	NBL	NBT	NBR	SBL	SBT	SBR
Lane Configurations		↕		↕	↕		↕	↕		↕	↕	
Traffic Vol, veh/h	1	14	30	58	14	47	25	141	42	81	320	4
Future Vol, veh/h	1	14	30	58	14	47	25	141	42	81	320	4
Conflicting Peds, #/hr	0	0	0	0	0	0	0	0	0	0	0	0
Sign Control	Stop	Stop	Stop	Stop	Stop	Stop	Free	Free	Free	Free	Free	Free
RT Channelized	-	-	None	-	-	None	-	-	None	-	-	None
Storage Length	-	-	-	0	-	-	0	-	-	0	-	-
Veh in Median Storage, #	-	0	-	-	0	-	-	0	-	-	0	-
Grade, %	-	0	-	-	0	-	-	0	-	-	0	-
Peak Hour Factor	83	83	83	84	84	84	100	85	85	80	80	80
Heavy Vehicles, %	2	2	2	2	2	2	2	2	2	2	2	2
Mvmt Flow	1	17	36	69	17	56	25	166	49	101	400	5

Major/Minor	Minor2		Minor1		Major1		Major2					
Conflicting Flow All	882	870	403	872	848	191	405	0	0	215	0	0
Stage 1	605	605	-	241	241	-	-	-	-	-	-	-
Stage 2	277	265	-	631	607	-	-	-	-	-	-	-
Critical Hdwy	7.12	6.52	6.22	7.12	6.52	6.22	4.12	-	-	4.12	-	-
Critical Hdwy Stg 1	6.12	5.52	-	6.12	5.52	-	-	-	-	-	-	-
Critical Hdwy Stg 2	6.12	5.52	-	6.12	5.52	-	-	-	-	-	-	-
Follow-up Hdwy	3.518	4.018	3.318	3.518	4.018	3.318	2.218	-	-	2.218	-	-
Pot Cap-1 Maneuver	267	290	647	271	298	851	1154	-	-	1355	-	-
Stage 1	485	487	-	762	706	-	-	-	-	-	-	-
Stage 2	729	689	-	469	486	-	-	-	-	-	-	-
Platoon blocked, %								-	-	-	-	-
Mov Cap-1 Maneuver	221	262	647	226	270	851	1154	-	-	1355	-	-
Mov Cap-2 Maneuver	221	262	-	226	270	-	-	-	-	-	-	-
Stage 1	474	450	-	745	690	-	-	-	-	-	-	-
Stage 2	650	674	-	394	450	-	-	-	-	-	-	-

Approach	EB		WB		NB		SB	
HCM Control Delay, s	14.6		19.8		0.9		1.6	
HCM LOS	B		C					

Minor Lane/Major Mvmt	NBL	NBT	NBR	EBLn1	WBLn1	WBLn2	SBL	SBT	SBR
Capacity (veh/h)	1154	-	-	431	226	570	1355	-	-
HCM Lane V/C Ratio	0.022	-	-	0.126	0.306	0.127	0.075	-	-
HCM Control Delay (s)	8.2	-	-	14.6	27.8	12.2	7.9	-	-
HCM Lane LOS	A	-	-	B	D	B	A	-	-
HCM 95th %tile Q(veh)	0.1	-	-	0.4	1.2	0.4	0.2	-	-

Intersection						
Int Delay, s/veh	4.2					
Movement	EBL	EBT	WBT	WBR	SBL	SBR
Lane Configurations		↶	↷		↶	↷
Traffic Vol, veh/h	64	67	87	9	3	54
Future Vol, veh/h	64	67	87	9	3	54
Conflicting Peds, #/hr	0	0	0	0	0	0
Sign Control	Free	Free	Free	Free	Stop	Stop
RT Channelized	-	None	-	None	-	None
Storage Length	-	-	-	-	0	-
Veh in Median Storage, #	-	0	0	-	0	-
Grade, %	-	0	0	-	0	-
Peak Hour Factor	69	69	77	77	50	50
Heavy Vehicles, %	2	2	2	2	2	2
Mvmt Flow	93	97	113	12	6	108

Major/Minor	Major1	Major2	Minor2		
Conflicting Flow All	125	0	-	0	402 119
Stage 1	-	-	-	-	119 -
Stage 2	-	-	-	-	283 -
Critical Hdwy	4.12	-	-	-	6.42 6.22
Critical Hdwy Stg 1	-	-	-	-	5.42 -
Critical Hdwy Stg 2	-	-	-	-	5.42 -
Follow-up Hdwy	2.218	-	-	-	3.518 3.318
Pot Cap-1 Maneuver	1462	-	-	-	604 933
Stage 1	-	-	-	-	906 -
Stage 2	-	-	-	-	765 -
Platoon blocked, %		-	-	-	
Mov Cap-1 Maneuver	1462	-	-	-	564 933
Mov Cap-2 Maneuver	-	-	-	-	564 -
Stage 1	-	-	-	-	845 -
Stage 2	-	-	-	-	765 -

Approach	EB	WB	SB
HCM Control Delay, s	3.7	0	9.6
HCM LOS			A

Minor Lane/Major Mvmt	EBL	EBT	WBT	WBR	SBLn1
Capacity (veh/h)	1462	-	-	-	902
HCM Lane V/C Ratio	0.063	-	-	-	0.126
HCM Control Delay (s)	7.6	0	-	-	9.6
HCM Lane LOS	A	A	-	-	A
HCM 95th %tile Q(veh)	0.2	-	-	-	0.4

HCM 6th TWSC
3: Safeway E Access

Long Term Total
AM Peak Hour

Intersection						
Int Delay, s/veh	1.4					
Movement	EBT	EBR	WBL	WBT	NBL	NBR
Lane Configurations						
Traffic Vol, veh/h	69	8	0	80	16	6
Future Vol, veh/h	69	8	0	80	16	6
Conflicting Peds, #/hr	0	0	0	0	0	0
Sign Control	Free	Free	Free	Free	Stop	Stop
RT Channelized	-	None	-	None	-	None
Storage Length	-	-	-	-	0	-
Veh in Median Storage, #	0	-	-	0	0	-
Grade, %	0	-	-	0	0	-
Peak Hour Factor	69	69	77	77	60	60
Heavy Vehicles, %	2	2	2	2	2	2
Mvmt Flow	100	12	0	104	27	10

Major/Minor	Major1	Major2	Minor1		
Conflicting Flow All	0	0	112	0	210
Stage 1	-	-	-	-	106
Stage 2	-	-	-	-	104
Critical Hdwy	-	-	4.12	-	6.42
Critical Hdwy Stg 1	-	-	-	-	5.42
Critical Hdwy Stg 2	-	-	-	-	5.42
Follow-up Hdwy	-	-	2.218	-	3.518
Pot Cap-1 Maneuver	-	-	1478	-	778
Stage 1	-	-	-	-	918
Stage 2	-	-	-	-	920
Platoon blocked, %	-	-	-	-	-
Mov Cap-1 Maneuver	-	-	1478	-	778
Mov Cap-2 Maneuver	-	-	-	-	778
Stage 1	-	-	-	-	918
Stage 2	-	-	-	-	920

Approach	EB	WB	NB
HCM Control Delay, s	0	0	9.6
HCM LOS			A

Minor Lane/Major Mvmt	NBLn1	EBT	EBR	WBL	WBT
Capacity (veh/h)	818	-	-	1478	-
HCM Lane V/C Ratio	0.045	-	-	-	-
HCM Control Delay (s)	9.6	-	-	0	-
HCM Lane LOS	A	-	-	A	-
HCM 95th %tile Q(veh)	0.1	-	-	0	-

HCM 6th Roundabout
1: McLaughlin Rd & Midnight Rd

Long Term Total - Roundabout
AM Peak Hour

Intersection				
Intersection Delay, s/veh	6.1			
Intersection LOS	A			
Approach	EB	WB	NB	SB
Entry Lanes	1	1	1	1
Conflicting Circle Lanes	1	1	1	1
Adj Approach Flow, veh/h	54	142	240	506
Demand Flow Rate, veh/h	55	144	245	516
Vehicles Circulating, veh/h	581	195	121	112
Vehicles Exiting, veh/h	47	170	515	227
Ped Vol Crossing Leg, #/h	0	0	0	0
Ped Cap Adj	1.000	1.000	1.000	1.000
Approach Delay, s/veh	5.6	4.3	4.8	7.2
Approach LOS	A	A	A	A
Lane	Left	Left	Left	Left
Designated Moves	LTR	LTR	LTR	LTR
Assumed Moves	LTR	LTR	LTR	LTR
RT Channelized				
Lane Util	1.000	1.000	1.000	1.000
Follow-Up Headway, s	2.609	2.609	2.609	2.609
Critical Headway, s	4.976	4.976	4.976	4.976
Entry Flow, veh/h	55	144	245	516
Cap Entry Lane, veh/h	763	1131	1220	1231
Entry HV Adj Factor	0.976	0.984	0.978	0.981
Flow Entry, veh/h	54	142	240	506
Cap Entry, veh/h	744	1113	1193	1207
V/C Ratio	0.072	0.127	0.201	0.419
Control Delay, s/veh	5.6	4.3	4.8	7.2
LOS	A	A	A	A
95th %tile Queue, veh	0	0	1	2

Intersection	
Intersection Delay, s/veh	13.1
Intersection LOS	B

Movement	EBL	EBT	EBR	WBL	WBT	WBR	NBL	NBT	NBR	SBL	SBT	SBR
Lane Configurations		↕		↕	↕		↕	↕		↕	↕	
Traffic Vol, veh/h	1	14	30	58	14	47	25	141	42	81	320	4
Future Vol, veh/h	1	14	30	58	14	47	25	141	42	81	320	4
Peak Hour Factor	0.83	0.83	0.83	0.84	0.84	0.84	1.00	0.85	0.85	0.80	0.80	0.80
Heavy Vehicles, %	2	2	2	2	2	2	2	2	2	2	2	2
Mvmt Flow	1	17	36	69	17	56	25	166	49	101	400	5
Number of Lanes	0	1	0	1	1	0	1	1	0	1	1	0

Approach	EB	WB	NB	SB
Opposing Approach	WB	EB	SB	NB
Opposing Lanes	2	1	2	2
Conflicting Approach Left	SB	NB	EB	WB
Conflicting Lanes Left	2	2	1	2
Conflicting Approach Right	NB	SB	WB	EB
Conflicting Lanes Right	2	2	2	1
HCM Control Delay	10	10.2	11	15.2
HCM LOS	A	B	B	C

Lane	NBLn1	NBLn2	EBLn1	WBLn1	WBLn2	SBLn1	SBLn2
Vol Left, %	100%	0%	2%	100%	0%	100%	0%
Vol Thru, %	0%	77%	31%	0%	23%	0%	99%
Vol Right, %	0%	23%	67%	0%	77%	0%	1%
Sign Control	Stop	Stop	Stop	Stop	Stop	Stop	Stop
Traffic Vol by Lane	25	183	45	58	61	81	324
LT Vol	25	0	1	58	0	81	0
Through Vol	0	141	14	0	14	0	320
RT Vol	0	42	30	0	47	0	4
Lane Flow Rate	25	215	54	69	73	101	405
Geometry Grp	7	7	6	7	7	7	7
Degree of Util (X)	0.044	0.336	0.095	0.135	0.121	0.168	0.616
Departure Headway (Hd)	6.284	5.616	6.32	7.047	5.994	5.987	5.474
Convergence, Y/N	Yes	Yes	Yes	Yes	Yes	Yes	Yes
Cap	571	642	567	509	598	602	664
Service Time	4.013	3.344	4.364	4.787	3.733	3.687	3.174
HCM Lane V/C Ratio	0.044	0.335	0.095	0.136	0.122	0.168	0.61
HCM Control Delay	9.3	11.2	10	10.9	9.6	9.9	16.5
HCM Lane LOS	A	B	A	B	A	A	C
HCM 95th-tile Q	0.1	1.5	0.3	0.5	0.4	0.6	4.2

HCM 6th TWSC
1: McLaughlin Rd & Midnight Rd

Long Term Total
PM Peak Hour

Intersection												
Int Delay, s/veh	47.4											
Movement	EBL	EBT	EBR	WBL	WBT	WBR	NBL	NBT	NBR	SBL	SBT	SBR
Lane Configurations		↕		↕	↕		↕	↕		↕	↕	
Traffic Vol, veh/h	7	15	46	144	55	152	69	360	43	129	290	9
Future Vol, veh/h	7	15	46	144	55	152	69	360	43	129	290	9
Conflicting Peds, #/hr	0	0	0	0	0	0	0	0	0	0	0	0
Sign Control	Stop	Stop	Stop	Stop	Stop	Stop	Free	Free	Free	Free	Free	Free
RT Channelized	-	-	None	-	-	None	-	-	None	-	-	None
Storage Length	-	-	-	0	-	-	50	-	-	50	-	-
Veh in Median Storage, #	-	0	-	-	0	-	-	0	-	-	0	-
Grade, %	-	0	-	-	0	-	-	0	-	-	0	-
Peak Hour Factor	76	76	76	84	84	84	88	88	88	95	95	95
Heavy Vehicles, %	2	2	2	2	2	2	2	2	2	2	2	2
Mvmt Flow	9	20	61	171	65	181	78	409	49	136	305	9

Major/Minor	Minor2		Minor1		Major1			Major2				
Conflicting Flow All	1295	1196	310	1212	1176	434	314	0	0	458	0	0
Stage 1	582	582	-	590	590	-	-	-	-	-	-	-
Stage 2	713	614	-	622	586	-	-	-	-	-	-	-
Critical Hdwy	7.12	6.52	6.22	7.12	6.52	6.22	4.12	-	-	4.12	-	-
Critical Hdwy Stg 1	6.12	5.52	-	6.12	5.52	-	-	-	-	-	-	-
Critical Hdwy Stg 2	6.12	5.52	-	6.12	5.52	-	-	-	-	-	-	-
Follow-up Hdwy	3.518	4.018	3.318	3.518	4.018	3.318	2.218	-	-	2.218	-	-
Pot Cap-1 Maneuver	139	186	730	~ 159	191	622	1246	-	-	1103	-	-
Stage 1	499	499	-	494	495	-	-	-	-	-	-	-
Stage 2	423	483	-	474	497	-	-	-	-	-	-	-
Platoon blocked, %								-	-	-	-	-
Mov Cap-1 Maneuver	58	153	730	~ 114	157	622	1246	-	-	1103	-	-
Mov Cap-2 Maneuver	58	153	-	~ 114	157	-	-	-	-	-	-	-
Stage 1	468	438	-	463	464	-	-	-	-	-	-	-
Stage 2	241	453	-	364	436	-	-	-	-	-	-	-

Approach	EB		WB		NB		SB	
HCM Control Delay, s	28.5		159.2		1.2		2.6	
HCM LOS	D		F					

Minor Lane/Major Mvmt	NBL	NBT	NBR	EBLn1	WBLn1	WBLn2	SBL	SBT	SBR
Capacity (veh/h)	1246	-	-	241	114	348	1103	-	-
HCM Lane V/C Ratio	0.063	-	-	0.371	1.504	0.708	0.123	-	-
HCM Control Delay (s)	8.1	-	-	28.5	334.9	36.9	8.7	-	-
HCM Lane LOS	A	-	-	D	F	E	A	-	-
HCM 95th %tile Q(veh)	0.2	-	-	1.6	12.4	5.2	0.4	-	-

Notes
 ~: Volume exceeds capacity \$: Delay exceeds 300s +: Computation Not Defined *: All major volume in platoon

Intersection						
Int Delay, s/veh	2.3					
Movement	EBL	EBT	WBT	WBR	SBL	SBR
Lane Configurations		↕	↕		↕	
Traffic Vol, veh/h	51	108	286	10	6	72
Future Vol, veh/h	51	108	286	10	6	72
Conflicting Peds, #/hr	0	0	0	0	0	0
Sign Control	Free	Free	Free	Free	Stop	Stop
RT Channelized	-	None	-	None	-	None
Storage Length	-	-	-	-	0	-
Veh in Median Storage, #	-	0	0	-	0	-
Grade, %	-	0	0	-	0	-
Peak Hour Factor	92	92	88	88	92	92
Heavy Vehicles, %	2	2	2	2	2	2
Mvmt Flow	55	117	325	11	7	78

Major/Minor	Major1	Major2	Minor2		
Conflicting Flow All	336	0	-	0	558 331
Stage 1	-	-	-	-	331 -
Stage 2	-	-	-	-	227 -
Critical Hdwy	4.12	-	-	-	6.42 6.22
Critical Hdwy Stg 1	-	-	-	-	5.42 -
Critical Hdwy Stg 2	-	-	-	-	5.42 -
Follow-up Hdwy	2.218	-	-	-	3.518 3.318
Pot Cap-1 Maneuver	1223	-	-	-	491 711
Stage 1	-	-	-	-	728 -
Stage 2	-	-	-	-	811 -
Platoon blocked, %		-	-	-	
Mov Cap-1 Maneuver	1223	-	-	-	467 711
Mov Cap-2 Maneuver	-	-	-	-	467 -
Stage 1	-	-	-	-	693 -
Stage 2	-	-	-	-	811 -

Approach	EB	WB	SB
HCM Control Delay, s	2.6	0	11
HCM LOS			B

Minor Lane/Major Mvmt	EBL	EBT	WBT	WBR	SBLn1
Capacity (veh/h)	1223	-	-	-	684
HCM Lane V/C Ratio	0.045	-	-	-	0.124
HCM Control Delay (s)	8.1	0	-	-	11
HCM Lane LOS	A	A	-	-	B
HCM 95th %tile Q(veh)	0.1	-	-	-	0.4

HCM 6th TWSC
3: Safeway E Access

Long Term Total
PM Peak Hour

Intersection						
Int Delay, s/veh	1.2					
Movement	EBT	EBR	WBL	WBT	NBL	NBR
Lane Configurations						
Traffic Vol, veh/h	113	14	2	263	33	7
Future Vol, veh/h	113	14	2	263	33	7
Conflicting Peds, #/hr	0	0	0	0	0	0
Sign Control	Free	Free	Free	Free	Stop	Stop
RT Channelized	-	None	-	None	-	None
Storage Length	-	-	-	-	0	-
Veh in Median Storage, #	0	-	-	0	0	-
Grade, %	0	-	-	0	0	-
Peak Hour Factor	92	92	88	88	83	83
Heavy Vehicles, %	2	2	2	2	2	2
Mvmt Flow	123	15	2	299	40	8

Major/Minor	Major1	Major2	Minor1	Minor2	Minor3
Conflicting Flow All	0	0	138	0	434
Stage 1	-	-	-	-	131
Stage 2	-	-	-	-	303
Critical Hdwy	-	-	4.12	-	6.42
Critical Hdwy Stg 1	-	-	-	-	5.42
Critical Hdwy Stg 2	-	-	-	-	5.42
Follow-up Hdwy	-	-	2.218	-	3.518
Pot Cap-1 Maneuver	-	-	1446	-	579
Stage 1	-	-	-	-	895
Stage 2	-	-	-	-	749
Platoon blocked, %	-	-	-	-	-
Mov Cap-1 Maneuver	-	-	1446	-	578
Mov Cap-2 Maneuver	-	-	-	-	578
Stage 1	-	-	-	-	895
Stage 2	-	-	-	-	748

Approach	EB	WB	NB
HCM Control Delay, s	0	0.1	11.3
HCM LOS			B

Minor Lane/Major Mvmt	NBLn1	EBT	EBR	WBL	WBT
Capacity (veh/h)	618	-	-	1446	-
HCM Lane V/C Ratio	0.078	-	-	0.002	-
HCM Control Delay (s)	11.3	-	-	7.5	0
HCM Lane LOS	B	-	-	A	A
HCM 95th %tile Q(veh)	0.3	-	-	0	-

HCM 6th Roundabout
1: McLaughlin Rd & Midnight Rd

Long Term Total - Roundabout
PM Peak Hour

Intersection				
Intersection Delay, s/veh	9.4			
Intersection LOS	A			
Approach	EB	WB	NB	SB
Entry Lanes	1	1	1	1
Conflicting Circle Lanes	1	1	1	1
Adj Approach Flow, veh/h	90	417	536	450
Demand Flow Rate, veh/h	91	425	547	459
Vehicles Circulating, veh/h	624	506	168	320
Vehicles Exiting, veh/h	155	209	547	611
Ped Vol Crossing Leg, #/h	0	0	0	0
Ped Cap Adj	1.000	1.000	1.000	1.000
Approach Delay, s/veh	6.3	11.7	8.3	9.1
Approach LOS	A	B	A	A
Lane	Left	Left	Left	Left
Designated Moves	LTR	LTR	LTR	LTR
Assumed Moves	LTR	LTR	LTR	LTR
RT Channelized				
Lane Util	1.000	1.000	1.000	1.000
Follow-Up Headway, s	2.609	2.609	2.609	2.609
Critical Headway, s	4.976	4.976	4.976	4.976
Entry Flow, veh/h	91	425	547	459
Cap Entry Lane, veh/h	730	824	1163	996
Entry HV Adj Factor	0.985	0.980	0.980	0.980
Flow Entry, veh/h	90	417	536	450
Cap Entry, veh/h	719	808	1139	976
V/C Ratio	0.125	0.516	0.471	0.461
Control Delay, s/veh	6.3	11.7	8.3	9.1
LOS	A	B	A	A
95th %tile Queue, veh	0	3	3	2

Intersection	
Intersection Delay, s/veh	27.1
Intersection LOS	D

Movement	EBL	EBT	EBR	WBL	WBT	WBR	NBL	NBT	NBR	SBL	SBT	SBR
Lane Configurations		↕		↕	↕		↕	↕		↕	↕	
Traffic Vol, veh/h	7	15	46	144	55	152	69	360	43	129	290	9
Future Vol, veh/h	7	15	46	144	55	152	69	360	43	129	290	9
Peak Hour Factor	0.76	0.76	0.76	0.84	0.84	0.84	0.88	0.88	0.88	0.95	0.95	0.95
Heavy Vehicles, %	2	2	2	2	2	2	2	2	2	2	2	2
Mvmt Flow	9	20	61	171	65	181	78	409	49	136	305	9
Number of Lanes	0	1	0	1	1	0	1	1	0	1	1	0

Approach	EB	WB	NB	SB
Opposing Approach	WB	EB	SB	NB
Opposing Lanes	2	1	2	2
Conflicting Approach Left	SB	NB	EB	WB
Conflicting Lanes Left	2	2	1	2
Conflicting Approach Right	NB	SB	WB	EB
Conflicting Lanes Right	2	2	2	1
HCM Control Delay	13.8	16.8	43	20.2
HCM LOS	B	C	E	C

Lane	NBLn1	NBLn2	EBLn1	WBLn1	WBLn2	SBLn1	SBLn2
Vol Left, %	100%	0%	10%	100%	0%	100%	0%
Vol Thru, %	0%	89%	22%	0%	27%	0%	97%
Vol Right, %	0%	11%	68%	0%	73%	0%	3%
Sign Control	Stop	Stop	Stop	Stop	Stop	Stop	Stop
Traffic Vol by Lane	69	403	68	144	207	129	299
LT Vol	69	0	7	144	0	129	0
Through Vol	0	360	15	0	55	0	290
RT Vol	0	43	46	0	152	0	9
Lane Flow Rate	78	458	89	171	246	136	315
Geometry Grp	7	7	6	7	7	7	7
Degree of Util (X)	0.169	0.913	0.21	0.395	0.497	0.3	0.648
Departure Headway (Hd)	7.771	7.181	8.43	8.3	7.258	7.945	7.409
Convergence, Y/N	Yes	Yes	Yes	Yes	Yes	Yes	Yes
Cap	461	504	424	434	495	452	488
Service Time	5.53	4.94	6.519	6.061	5.018	5.708	5.171
HCM Lane V/C Ratio	0.169	0.909	0.21	0.394	0.497	0.301	0.645
HCM Control Delay	12.1	48.3	13.8	16.4	17	14.1	22.9
HCM Lane LOS	B	E	B	C	C	B	C
HCM 95th-tile Q	0.6	10.6	0.8	1.9	2.7	1.2	4.5



LSC TRANSPORTATION CONSULTANTS, INC.
2504 East Pikes Peak Avenue, Suite 304
Colorado Springs, CO 80909
(719) 633-2868
FAX (719) 633-5430
E-mail: lsc@lsctrans.com
Website: <http://www.lsctrans.com>

McLaughlin Office Building
Transportation Memorandum
(LSC #204590)
SF-20-022
November 30, 2020

Traffic Engineer's Statement

This traffic report and supporting information were prepared under my responsible charge and they comport with the standard of care. So far as is consistent with the standard of care, said report was prepared in general conformance with the criteria established by the County for traffic reports.



Developer's Statement

I, the Developer, have read and will comply with all commitments made on my behalf within this report.

A handwritten signature in black ink, consisting of a series of loops and a final flourish, positioned above a horizontal line.

3-2-2021
Date