

OFFICE WAREHOUSE DEVELOPMENT PLAN MINOR AMENDMENT

9495 PEACEFUL VALLEY ROAD
COLORADO SPRINGS, COLORADO 80925

John P. Nelson
associates
1626 E. Fillmore Peak, Colorado Springs, CO 80905
Phone: (719) 631-9384
John@jpnelson.com (719) 631-1181 FAX

SITE / LANDSCAPE PLAN

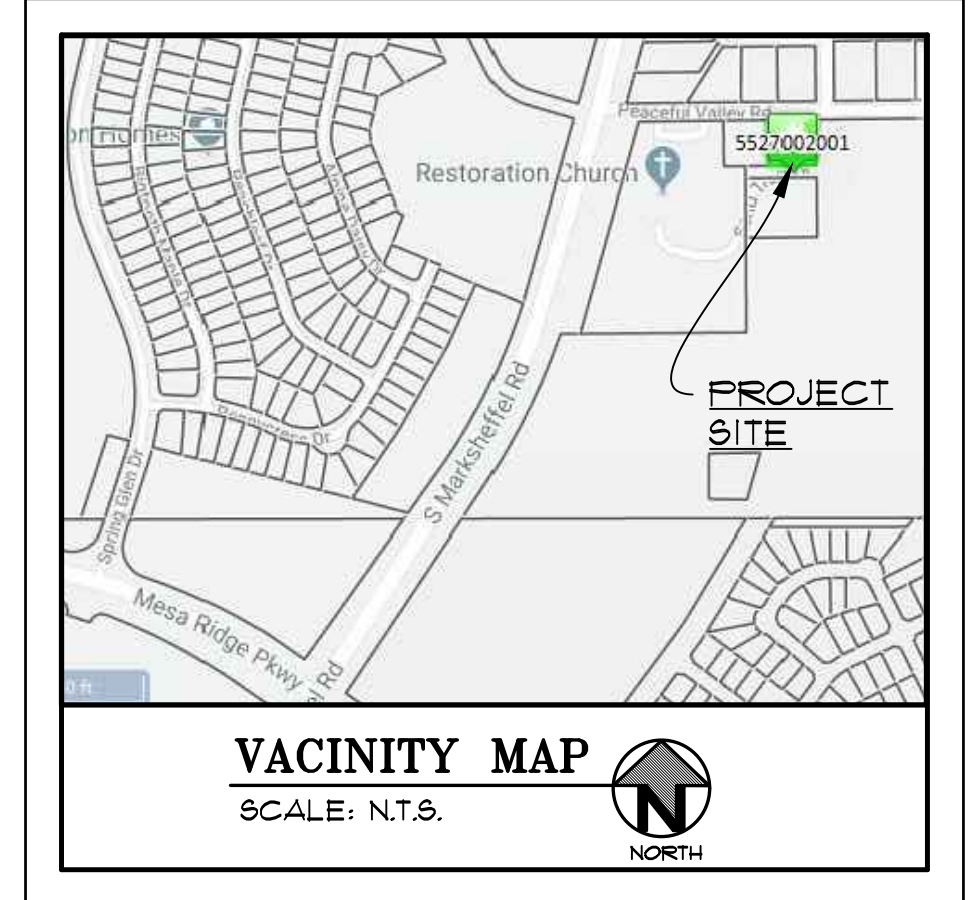
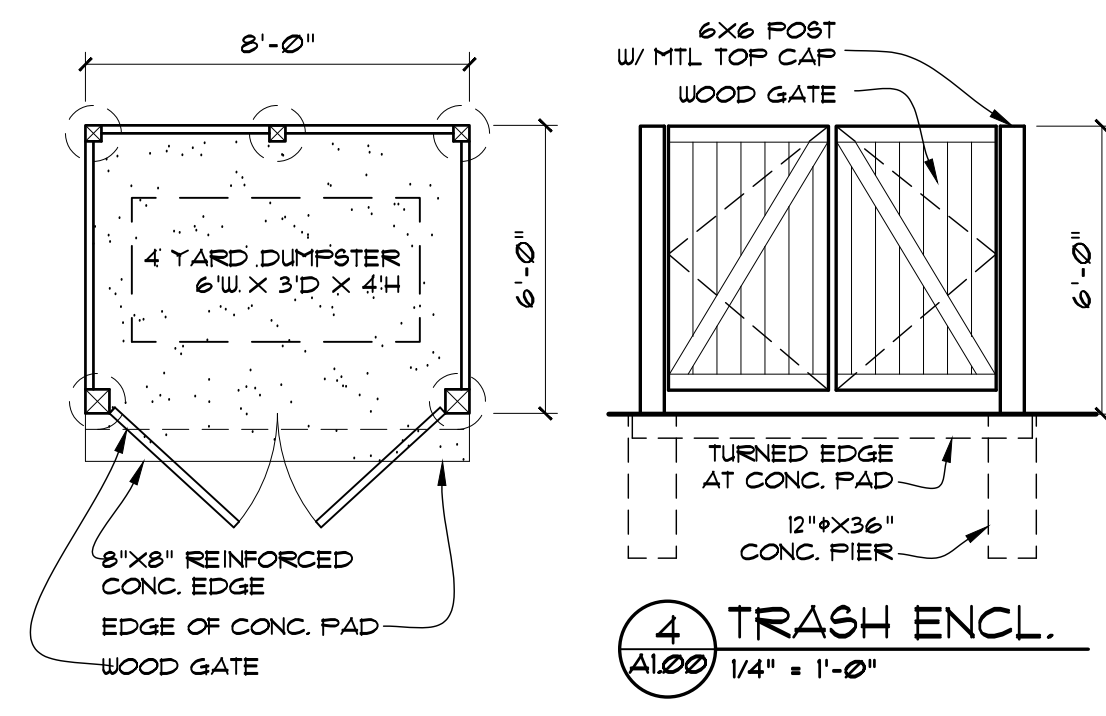
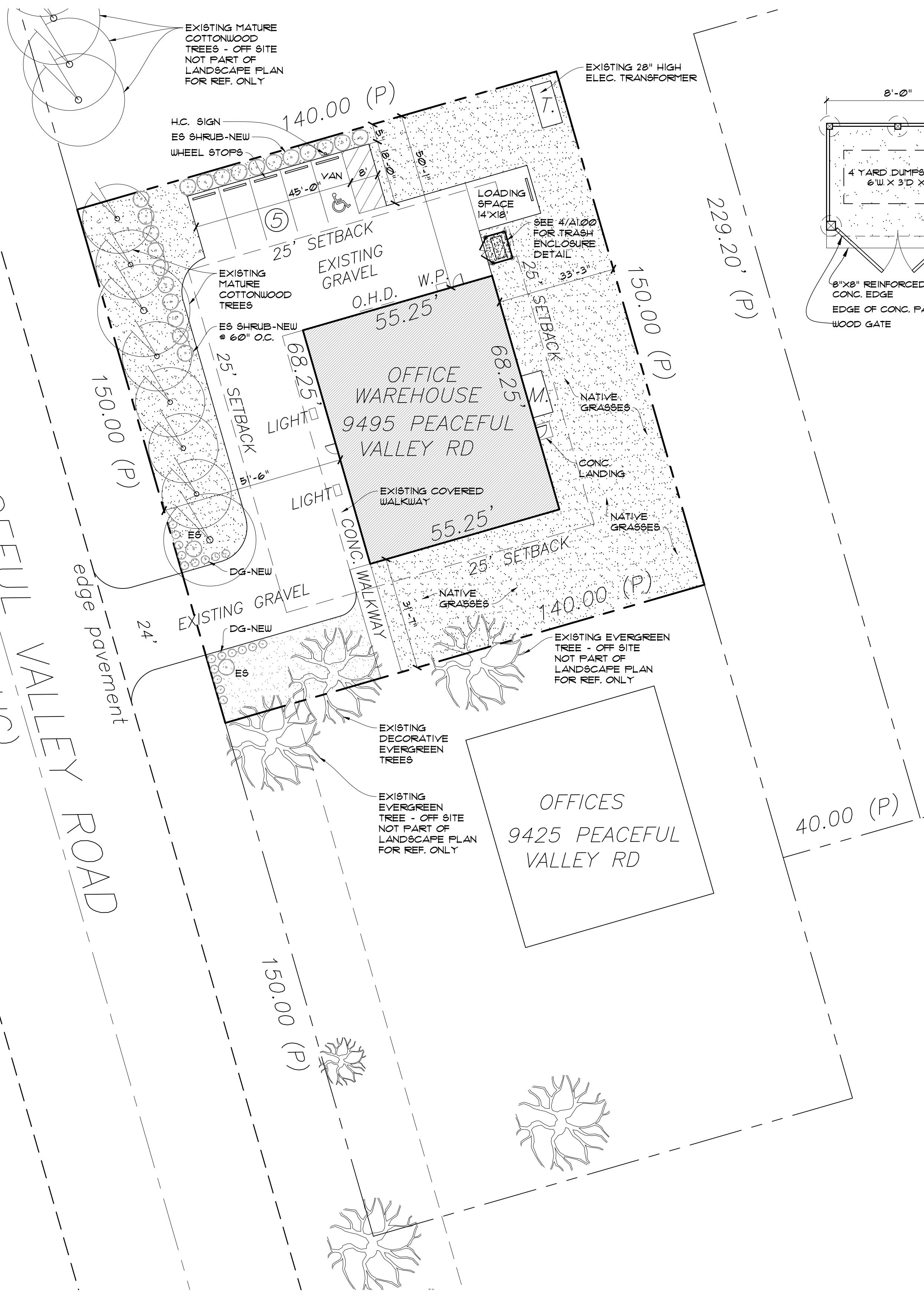
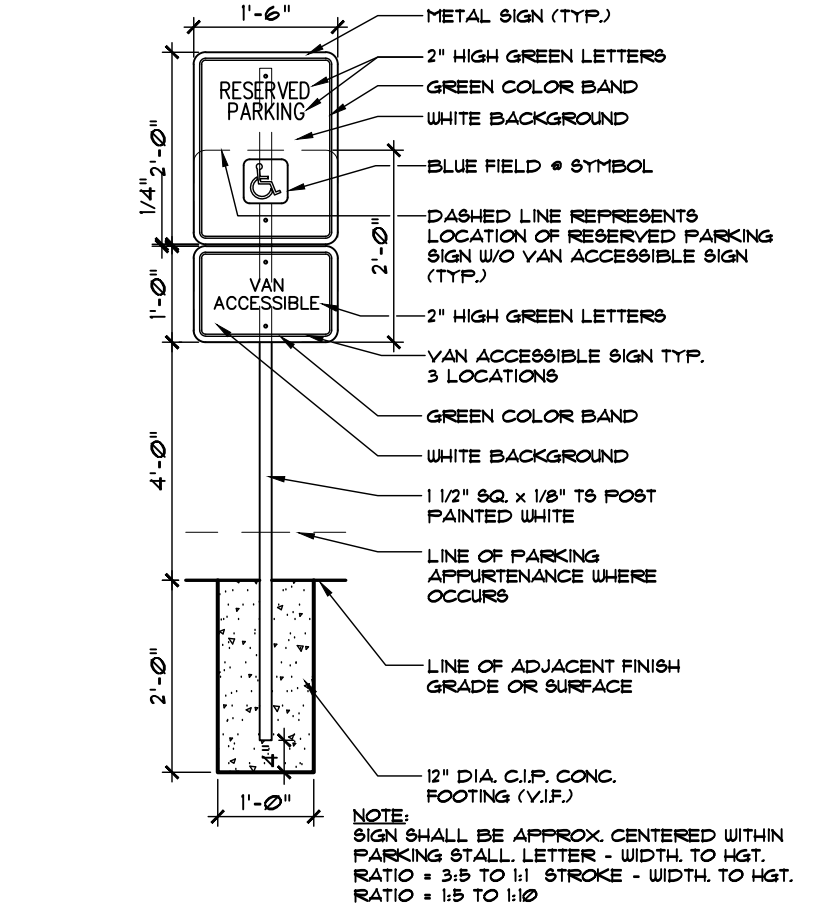
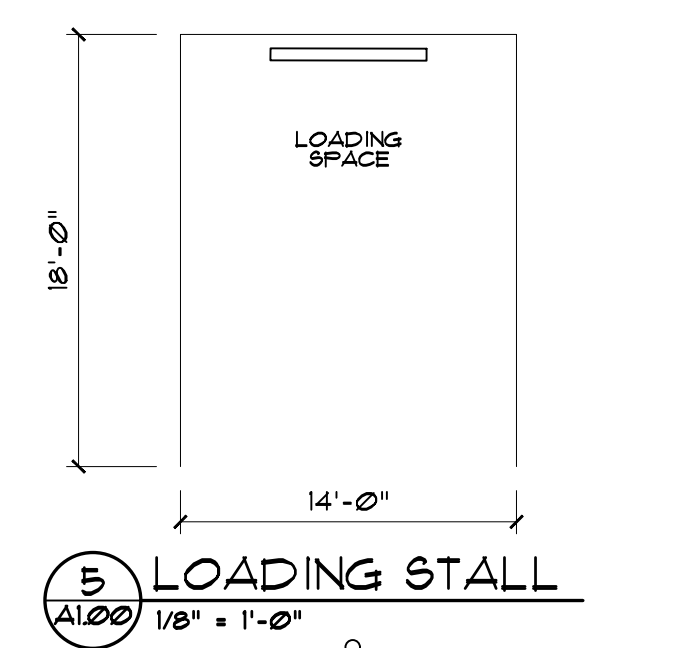

LEGAL DESCRIPTION:
LOT 1 PEACEFUL VALLEY SHOPETTE NOI

LOT SETBACKS:
Lot 1: Front - 25' from lot line
Side - 25' from lot line
Rear - 25' from lot line

LANDSCAPE:
OWNER RESPONSIBLE: THE OWNER IS RESPONSIBLE FOR ALL REGULAR AND NORMAL MAINTENANCE OF REQUIRED LANDSCAPING INCLUDING WEEDING, IRRIGATION, FERTILIZING, PRUNING AND MOWING.

PARKING SUMMARY:
3768 SF. FOOTPRINT (3560 SF. CONDITIONED)
1/1000 WAREHOUSE (2630 SF.) = 2.6 SPACES
1/300 OFFICE (500 SF.) = 1.6 SPACES
1/1000 SERVICE (430 SF.) = .43 SPACES
TOTAL PARKING REQUIRED: 4.63 = 5
1-5 PARKING: GRAVEL ALLOWED = OK

PROJECT DATA

OWNER: RESTORATION CHURCH ASSEMBLY OF GOD 9355 PEACEFUL VALLEY RD COLORADO SPRINGS, CO. 80925-9593	TAX ID#: 5521002001 ZONING: CC
PROJECT SITE: 9495 PEACEFUL VALLEY RD COLORADO SPRINGS, CO	PROPOSED BUILDING USE: NO CHANGE IN USE: OFFICE WAREHOUSE
LOT SIZE (SF): 22,651 SF	EXISTING LOT COVERAGE: 16.6% PROPOSED LOT COVERAGE: NO CHANGE

ADA PROFESSIONAL STANDARDS
THE DESIGN PROFESSIONAL RESPONSIBLE FOR THE PLAN HAS FAMILIARIZED THEMSELVES WITH ALL CURRENT ADA CRITERIA AND SPECIFICATIONS, AND THE PROPOSED PLAN REFLECTS REQUIRED SITE ELEMENTS. SEE "2010 ADA STANDARDS FOR ACCESSIBLE DESIGN", AS PUBLISHED BY THE DEPARTMENT OF JUSTICE (DOJ).

AVIGATION EASEMENT, GIVEN TO THE CITY OF COLORADO SPRINGS, RECORDED FEBRUARY 3, 1972 IN BOOK 2465 AT PAGE 481 AND IN BOOK 2465 AT PAGE 759 AND IN BOOK 3635 AT PAGE 688. SAID EASEMENT CONTAINS RESTRICTIONS WHICH INCLUDE RESTRICTION AGAINST INTERFERENCE WITH AIRCRAFT AND AIRPORTS AND THEIR PERFORMANCE AND NECESSARY FUNCTIONS.

LANDSCAPE KEY

EXISTING, COTTONWOOD TREE SEE NOTES ON PLAN	EXISTING, EVERGREEN TREE	EXISTING, NATIVE GRASSES	
KEY	NEW PLANT MATERIALS	SIZE	QTY.
DG	DECORATIVE GRASSES KARL FOERSTER 3 GAL. @ 36" C/C	MATURE HEIGHT 36"	19
ES	DECORATIVE EVERGREEN SHRUB - DWARF GLOBE BLUE SPRUCE - 60" C/C	MATURE SIZE 36"H X 60"W	23

OFFICE WAREHOUSE
INTERIOR REMODEL
9495 PEACEFUL VALLEY ROAD
COLORADO SPRINGS, COLORADO 80925

PROJECT NO.
DRN. BY: L. ROSS
REVISIONS:
STATE OF COLORADO
JOHN P. NELSON
260976
LICENSED ARCHITECT

ISSUE DATE: 5-25-2019
SHEET:

A1.00