

DRAINAGE LETTER

for

**Lot 12 - Rolling Thunder Business Park
10707 Maltese Pt.
Peyton, Colorado**

SK Project No. 24-105

June 21, 2024

**Prepared for:
WT Holdings, LLC.**

William Tibbitt
30 E. Uintah St.
Colorado Springs, CO 80903
Phone: 719-492-0084
Email: BTibbit@wdconstruct.com

Prepared by:

SK Design Group, Inc.
333 Perry Street #209
Castle Rock, CO 80104
Email: amahobian@skdg.com, eprskalo@skdg.com

PPR2414

TABLE OF CONTENTS

DESCRIPTION	PAGE
ENGINEER'S STATEMENT	1
DEVELOPER'S STATEMENT	1
EL PASO COUNTY	1
LOCATION AND DESCRIPTION	2
FLOODPLAIN STATEMENT	2
DESCRIPTION OF RUNOFF	2
RATIONAL METHOD & INFILTRATION CALCULATION SUMMARY	4
FEES	6
FOUR STEP PROCESS.....	6
SUMMARY	7
REFERENCES.....	7

APPENDIX

A – VICINITY MAP

B – SOIL MAP

C – NOAA ATLAS 14 RAINFALL DATA

D – FEMA FIRMETTE

E – CALCULATIONS

F – REFERENCE DOCUMENTS

G – EXISTING AND PROPOSED DRAINAGE MAPS



1. Engineer's Statement:

The attached drainage maps and letter were prepared under my direction and supervision and are correct to the best of my knowledge and belief. Said drainage letter has been prepared according to the criteria established by the County for drainage letters and said report is in conformity with the master plan of the drainage basin. I accept responsibility for any liability caused by any negligent acts, errors or omissions on my part in preparing this report.

Sassan Mahobian (PE.58090)

(Seal)

2. Developer's Statement:

I, _____ the owner/developer have read and will comply with all of the requirements specified in this drainage letter and plan.

Business Name

By: _____

Title: _____

Address: _____

3. El Paso County:

Filed in accordance with the requirements of the Drainage Criteria Manual, Volumes 1 and 2, El Paso County Engineering Criteria Manual and Land Development Code as amended.

Joshua Palmer, P.E.
County Engineer / ECM Administrator
Conditions:

Date

4. Location and Description:

Lot 12 of Rolling Thunder Business Park is located northwest of the intersection of Rolling Thunder Way and Firehouse View, and south of Maltese Point. The property is located in a portion of the NE ¼ of Section 11, Township 13 South, Range 65 West of the 6th P.M. in El Paso County, Colorado. The lot area is 1.17 acres. This project is proposing to construct a commercial building on the site. A Vicinity Map showing the Site location is included in Appendix A.

5. Floodplain Statement:

This development is not within the limits of a designated floodplain or flood hazard area, per FEMA panel no. 08041C0535G dated December 7, 2018. The site is designated as Zone X, which is identified as an area of minimal flood hazard. The FEMA FIRMette is included in Appendix D.

6. Description of Runoff:

a. Existing Conditions:

This Site was platted as Lot 12 of the Rolling Thunder Business Park in 2008. Rolling Thunder Business Park Preliminary/Final Drainage Report (EDARP #SF07019) (hereafter referred to as the Rolling Thunder FDR), dated September 2008, was approved by El Paso County on 10-16-08. Lot 12 was rough graded with runoff generally directed south and east, to Tank water quality pond, which was constructed and designed as a part of the Rolling Thunder FDR. Tank pond was recently cleaned/maintained by the metro district and appears to be in good working order, operating as originally intended. There is an existing combined landscape, utility, and drainage easement at the south of the property, this was intended to service the future development of the site and allow for runoff to be directed to Tank water quality pond in the developed condition. Access to this easement has since been blocked by grading, landscaping, paving and fencing on Lot 13. Due to the Lot 13 development, the Lot 12 Site is not draining as originally intended with the Rolling Thunder FDR. Currently, a majority of the Site runoff, as well as the runoff from the western half of the building on Lot 13 are routed overland to the curb and gutter of Rolling Thunder Way, bypassing the Tank water quality pond. This existing condition has existed since 2008.

b. Proposed Conditions

Per the original Rolling Thunder FDR, the entire Lot 12 Site was intended to be treated for water quality at Tank water quality pond. However, due to the development of Lot 13 blocking access to Tank pond, this Site has been sub-divided into 3 basins. Photos of the existing condition of the Site and the Lot 13 approved plan are included in Appendix G. An infiltration basin, hereafter referred to as Pond A, has been designed to treat the WQCV that would have been treated at Tank pond. Pond A ensures the water quality

needs of the proposed development are met. In order to follow the original plan laid out in the Rolling Thunder FDR, with all runoff being treated at Tank pond, the entire grading of the site would have had to been reversed due to Lot 13 blocking the drainage easement and access to Tank pond. The northern area of the Site drains to Tank pond, as intended with the Rolling Thunder FDR. The entire Site is within Basin D-12 of the Rolling Thunder FDR, which assumed a percent impervious of 85% and consisted of the entire Lot 12 area, approximately 0.91 acres per the Rolling Thunder FDR. The area of the Site discharging to Tank pond is 0.25 acres and the percent impervious of that area is 41.5%. Since only a portion of the Site is able to discharge into Tank pond, and the impervious percentage of that area is less than what was assumed with the Rolling Thunder FDR, Tank pond has adequate capacity to accept and treat runoff from the Site.

Basin A (0.25 acres, Q5: 0.12CFS, Q100: 0.35CFS)

Basin A consists of the northern landscape area of Lot 12, roughly 66% of the roof area of the proposed building, and a small area in the northeast corner of the site. Runoff for Basin A is conveyed via overland flow, as well as roof drains and a concrete channel to the north. Runoff discharges into the existing curb and gutter of Maltese Point and is then conveyed east to an existing curb cut and channel that routes runoff to Tank water quality pond, which was intended to service the entire area of Lot 12.

Basin B (0.52 acres, Q5: 0.50CFS, Q100: 1.15CFS)

Basin B consists of the parking lot and southern roof drainage areas. Basin B is treated for water quality on-site at Pond A. Full infiltration of the required WQCV is achieved within Pond A. This is achieved by excavating a minimum of 2' below the pond bottom and replacing the native soils with AASHTO Type M43 Fine Aggregate Filter Sand to enhance the infiltration capacity of the pond bottom. Infiltration calculations for Pond A are included in Appendix E. Runoff in excess of the WQCV overtops the infiltration pond via a riprap lined spillway and flows overland to the drainage channel along the eastern property boundary of the Site. Overflows are then discharged to the curb and gutter of Rolling Thunder Way, following the existing drainage pattern of the Site.

Basin C (0.18 acres, Q5: 0.06CFS, Q100: 0.25CFS)

Basin C generally consists of landscape areas adjacent to Fire House View and Rolling Thunder Way, as well as the area where the adjacent building on Lot 13 is discharging runoff onto the Lot 12 site. Runoff from the landscape areas adjacent to the existing roadways is routed overland to existing curb and gutter, where it is captured at the existing inlet in Rolling Thunder Way. Runoff from the adjacent building and a portion of the area in the southwest corner of the Site is captured and conveyed by a

grass-lined drainage channel. This development is proposing a sidewalk chase and concrete pan at the southwest corner of the Site which allows runoff to reach the curb and gutter of Rolling Thunder Way and maintain the existing drainage patterns of the Site. This basin bypasses water quality treatment and makes up 19% of the total disturbance area. A significant portion of the runoff associated with this basin is not being treated for water quality due to the existing conditions imposed on the Site by the existing Lot 13 development.

Off-Site Basin (0.13 acres, Q5: 0.12CFS, Q100: 0.27CFS)

There is only one off-site basin associated with this development. The building on the adjacent Lot 13 of the Rolling Thunder Business Park discharges runoff directly onto the Lot 12 Site via the roof drains/downspouts on the west side of the building. These downspouts will be shortened, and all runoff from the existing building currently being discharged onto the Lot 12 Site will be picked up by a grass lined swale and conveyed south to the curb and gutter of Rolling Thunder Way, maintaining the existing drainage pattern in this area.

7. Rational Method & Infiltration Pond A Calculation Summary:

Table 1: Existing Conditions Rational Method Summary

Rational Method Summary - Existing					
Basin ID	Area (acres)	Percent Impervious (%)	Q ₅ (cfs)	Q ₁₀ (cfs)	Q ₁₀₀ (cfs)
EX-1	0.95	2.0	0.11	0.24	0.87
EX-2 (OS-1)	0.13	90.0	0.12	0.14	0.27
Existing Basin Total	1.08	0.0	0.22	0.38	1.14

Table 2: Proposed Conditions Rational Method Summary

Rational Method Summary - Proposed					
Basin ID	Area (acres)	Percent Impervious (%)	Q ₅ (cfs)	Q ₁₀ (cfs)	Q ₁₀₀ (cfs)
Basin A-1	0.22	42.1	0.10	0.14	0.32
Basin A-2	0.03	36.1	0.01	0.02	0.04
Basin A Total	0.25	41.5	0.12	0.16	0.35
Basin B-1	0.47	85.3	0.45	0.56	1.05
Basin B-2	0.05	90.0	0.05	0.06	0.10
Basin B Total	0.52	85.7	0.50	0.62	1.15
Basin C-1	0.11	20.5	0.03	0.05	0.13
Basin C-2	0.08	17.9	0.02	0.03	0.09
Basin C Total	0.18	19.4	0.05	0.08	0.22
Basin EX-2 (OS-1)	0.13	90.0	0.12	0.14	0.27

Table 3: WQCV and Infiltration Rate Summary

WQCV and Infiltration Rate Summary	
	Infiltration Basin
WQCV (cf)	559
¹ WQCV Depth (ft)	0.55
² 12-hr Infiltration Rate (in/hr)	1.63
¹ Refer to WSEL calculations in the appendices of this letter	
² Based on AASHTO M43 Fine aggregate filter sand	

Table 4: Infiltration Rate and Drain Time Calculation

Infiltration Rate and Drain Time Calculation			
Stage (ft)	Area (sf)	Volume (cf)	¹ Time (hr)
0	875	0	0.00
0.5	1204	520	3.68
0.55	1245	581	4.05
0.7	1486	777	5.15
¹ Time = Stage(in.) / (12-hr Infiltration Rate (in./hr))			
Time required to infiltrate WQCV = 4.05hr			
Infiltration rate required to drain WQCV in 12hr = 0.55in/hr			
² Infiltration rate required to drain WQCV in 12hr = 1.10in/hr < 1.63in/hr			

Tables 1 and 2 summarize the results of the rational method calculations used to determine peak flows for the proposed development. Tables 3 and 4 relate to the infiltration calculations that were done for Infiltration Pond A. WQCV measured in watershed inches was determined using the UD-BMP spreadsheet for sand filter basins. The tributary areas effective impervious percentage and contributing watershed area were then applied to the calculated WQCV to determine a volume of 559 cu-ft. The design of Pond A means that this WQCV occurs at roughly 0.55 feet of depth (581 cu-ft @ 0.5'). To meet requirements for full infiltration, soils must have an infiltration rate which is double the rate required to infiltrate the full WQCV in less than 12 hours. The native soils in the area of Pond A do not meet this requirement for full infiltration. The soils at the bottom of Pond A are therefore being amended to meet the requirements to infiltrate at the desired rate. The amended soils will meet the depth and gradation requirements recommended by the Geotechnical Engineer, described in MHFD Volume 3 Table 4-5 (Gradation Specifications for AASHTO M43 Fine Aggregate (Filter Sand)). This infiltration testing report performed by Entech Engineering, Inc. is included

within this report's appendix. With the amendment of the soils at the bottom of Pond A, the infiltration rate is determined to be 1.63 in/hr, which is consistent with the amended soils type and gradation. This is the updated infiltration rate used for Pond A. With the amended soils and new infiltration rate, it has been determined that Pond A will meet the requirements for full infiltration.

8. Fees:

The Site is within the Sand Creek Drainage Basin. It was previously platted, and drainage fees were previously paid with the Rolling Thunder Business Park Development. Excerpts from the Rolling Thunder FDR showing the original fee calculations are included in Appendix G. The Rolling Thunder Business Park development assumed a percent impervious value of 85% for the area encompassing Lot 12 (Basin D-12 in the Rolling Thunder FDR). Since this development was previously platted, fees are calculated using the increase in impervious cover. The total developed area associated with this project is 0.95 acres. A summary of the calculation for impervious area is shown below.

Total Developed Area: 0.95 acres

Landscaped Area: 0.324 acres 34%

Impervious Area: 66%

Due to the impervious area not being increased when compared to the original plat and fees calculated with the overall development, there are no drainage fees associated with the proposed development of Lot 12.

9. Four Step Process

a. Step 1: Employ Runoff Reduction Practices

Directly connected impervious areas are minimized to the extent possible, with runoff from the sidewalk, east of the proposed building, and runoff from the existing building on the adjacent lot being conveyed via grass swale. Runoff is concentrated along the curb and gutter of the proposed parking lot and then released into the proposed infiltration basin within the proposed development.

b. Step 2: Stabilize Drainageways

The development of this project does not create drainageways and does not anticipate having any negative effects on existing downstream drainageways.

c. Step 3: Provide Water Quality Capture Volume

The limit of disturbance for the proposed construction is 0.95 acres. Only water quality is required and necessary. An infiltration basin is proposed to capture the WQCV for Basin B due to Lot 13 blocking drainage to Tank water quality pond. Basin A WQCV will be

captured by the existing Tank water quality pond.

d. Step 4: Consider Need for Industrial and Commercial BMPs

This submittal provides a final grading and erosion control plan with BMPs in place. The proposed project will use silt fence, a vehicle tracking control pad, concrete washout area, stabilized staging area, erosion control blankets and rock socks, reseeding and landscaping to mitigate the potential for erosion across the site. The proposed BMPs are fully adequate for this development.

10. Summary

The proposed development of Lot 12 Rolling Thunder Business Park shall not adversely affect adjacent or downstream properties and is consistent with the Rolling Thunder FDR. The proposed improvements will overcome the hardship caused by the development of adjacent Lot 13 that blocked the previously planned drainage easement and path to the existing Tank water quality pond, by adding an infiltration basin on the Site. All drainage facilities outlined in this document and depicted in the drawings are susceptible to modifications based on final design and development of construction documents. This letter has been prepared in accordance with the El Paso Land Development Code, Drainage Criteria Manual Volumes 1 and 2, and the Engineering Criteria Manual, as amended.

11. References

- a. Drainage Criteria Manual County of El Paso, Colorado, Volume 1 and Volume 2, Version: October 31, 2018 (current).
- b. Engineering Criteria Manual County of El Paso, Colorado, Adopted: December 23, 2004, Revised: December 13, 2016.
- c. Urban Storm Drainage Criteria Manual: Volume 3, Stormwater Best Management Practices, Mile High Flood District (MHFD), latest version.
- d. Rolling Thunder Business Park Preliminary/Final Drainage Report, Springs Engineering, September, 2008.
- e. Rolling Thunder – Lot 13 Civil Plot Plan, Sheet 1 of 8, Springs Engineering, Date: 2-17-09.
- f. Geotechnical and Pavement Design Report – 10707 Maltese Point Peyton, Colorado, by Entech Engineering, Inc., Date: March 25, 2024.
- g. Infiltration Rate Testing (Percolation Test Method) – 10707 Maltese Point Peyton, Colorado by Entech Engineering, Inc., Date: June 13, 2024

S K D E S I G N G R O U P , I N C .

C I V I L E N G I N E E R S S I N C E 1 9 8 9



APPENDIX A – VICINITY MAP

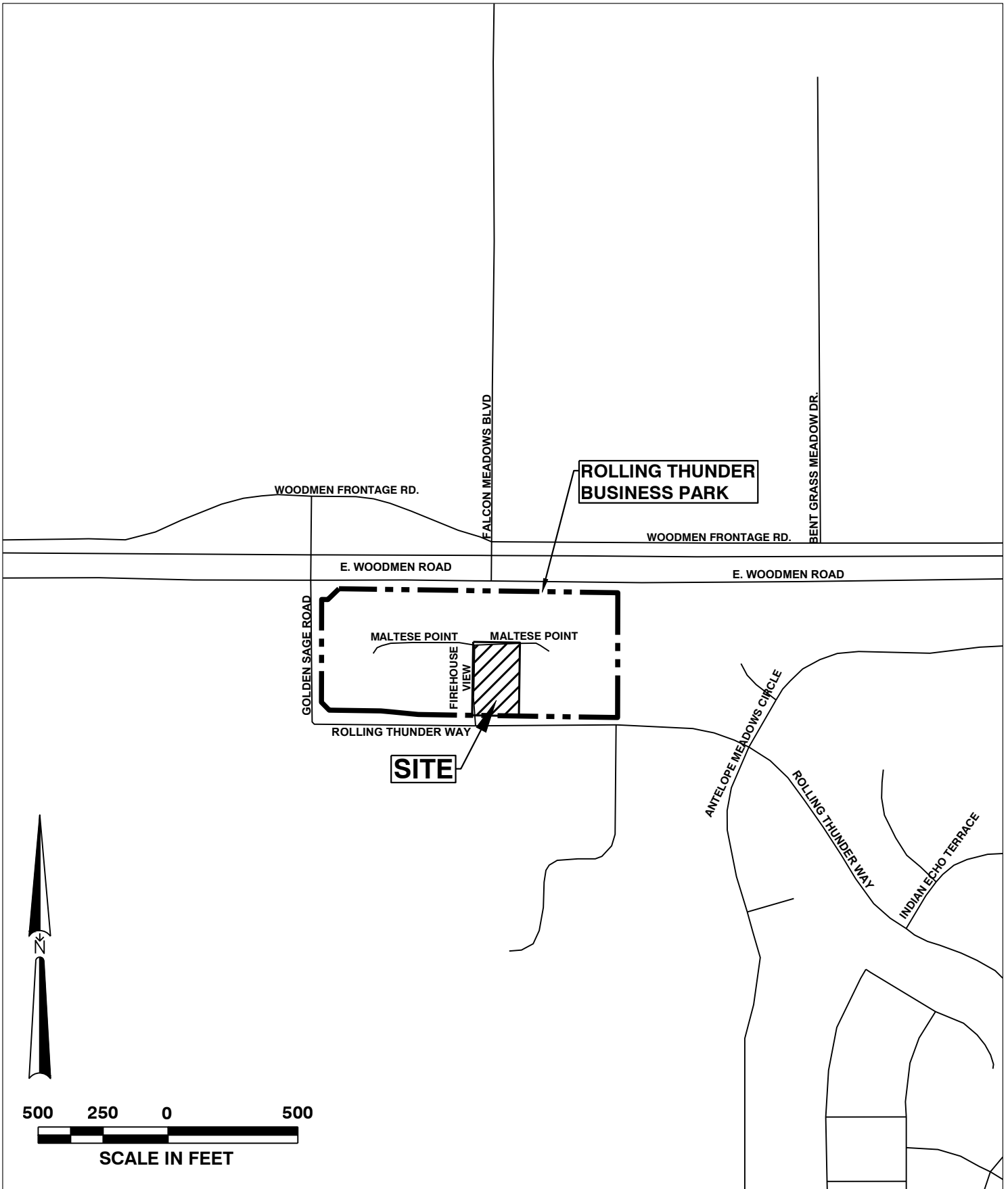

**ROLLING THUNDER
BUSINESS PARK**

SITE



333 Perry St.,
Suite 209
Castle Rock, Colorado 80104
Tel: 913-451-1818
Fax: 913-451-7599

VICINITY MAP

**ROLLING THUNDER BUSINESS PARK - LOT 12
10701 MALTESE PT, EL PASO COUNTY,
PEYTON, CO**

EXHIBIT

APRIL, 2024

S K D E S I G N G R O U P , I N C .

C I V I L E N G I N E E R S S I N C E 1 9 8 9



APPENDIX B – SOIL MAP

Hydrologic Soil Group—El Paso County Area, Colorado

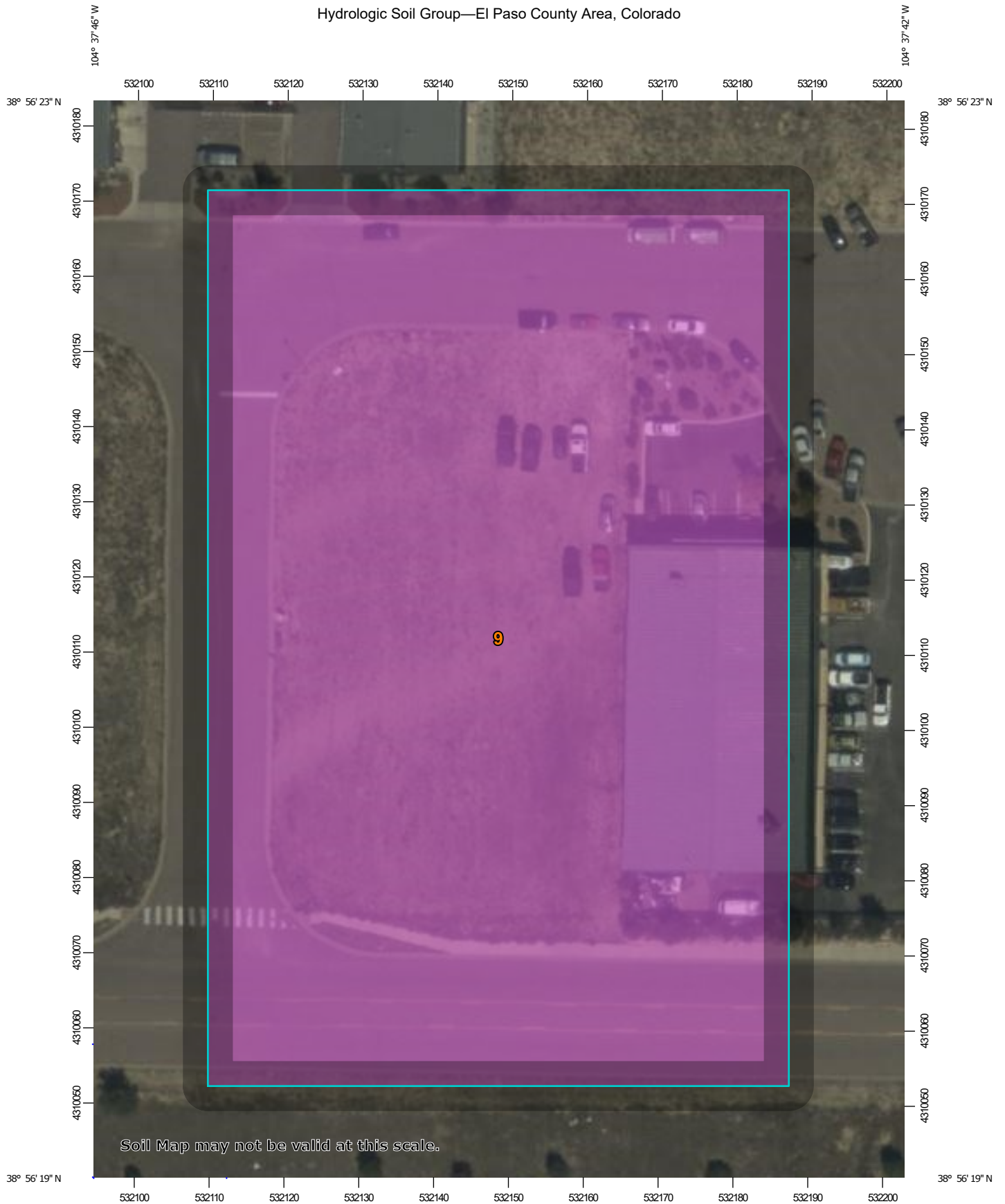

Map Scale: 1:699 if printed on A portrait (8.5" x 11") sheet.



Map projection: Web Mercator Corner coordinates: WGS84 Edge tics: UTM Zone 13N WGS84



MAP LEGEND

Area of Interest (AOI)









 Area of Interest (AOI)

Soils

Soil Rating Polygons





-  A
-  A/D
-  B
-  B/D
-  C
-  C/D
-  D
-  Not rated or not available

Soil Rating Lines

-  A
-  A/D
-  B
-  B/D
-  C
-  C/D
-  D
-  Not rated or not available

Soil Rating Points





-  A
-  A/D
-  B
-  B/D

-  C
-  C/D
-  D
-  Not rated or not available

Water Features

 Streams and Canals

Transportation

-  Rails
-  Interstate Highways
-  US Routes
-  Major Roads
-  Local Roads

Background

 Aerial Photography

MAP INFORMATION

The soil surveys that comprise your AOI were mapped at 1:24,000.

Warning: Soil Map may not be valid at this scale.

Enlargement of maps beyond the scale of mapping can cause misunderstanding of the detail of mapping and accuracy of soil line placement. The maps do not show the small areas of contrasting soils that could have been shown at a more detailed scale.

Please rely on the bar scale on each map sheet for map measurements.

Source of Map: Natural Resources Conservation Service
 Web Soil Survey URL:
 Coordinate System: Web Mercator (EPSG:3857)

Maps from the Web Soil Survey are based on the Web Mercator projection, which preserves direction and shape but distorts distance and area. A projection that preserves area, such as the Albers equal-area conic projection, should be used if more accurate calculations of distance or area are required.

This product is generated from the USDA-NRCS certified data as of the version date(s) listed below.

Soil Survey Area: El Paso County Area, Colorado
 Survey Area Data: Version 21, Aug 24, 2023

Soil map units are labeled (as space allows) for map scales 1:50,000 or larger.

Date(s) aerial images were photographed: Sep 11, 2018—Oct 20, 2018

The orthophoto or other base map on which the soil lines were compiled and digitized probably differs from the background imagery displayed on these maps. As a result, some minor shifting of map unit boundaries may be evident.

Hydrologic Soil Group

Map unit symbol	Map unit name	Rating	Acres in AOI	Percent of AOI
9	Blakeland-Fluvaquentic Haplaquolls	A	2.3	100.0%
Totals for Area of Interest			2.3	100.0%

Description

Hydrologic soil groups are based on estimates of runoff potential. Soils are assigned to one of four groups according to the rate of water infiltration when the soils are not protected by vegetation, are thoroughly wet, and receive precipitation from long-duration storms.

The soils in the United States are assigned to four groups (A, B, C, and D) and three dual classes (A/D, B/D, and C/D). The groups are defined as follows:

Group A. Soils having a high infiltration rate (low runoff potential) when thoroughly wet. These consist mainly of deep, well drained to excessively drained sands or gravelly sands. These soils have a high rate of water transmission.

Group B. Soils having a moderate infiltration rate when thoroughly wet. These consist chiefly of moderately deep or deep, moderately well drained or well drained soils that have moderately fine texture to moderately coarse texture. These soils have a moderate rate of water transmission.

Group C. Soils having a slow infiltration rate when thoroughly wet. These consist chiefly of soils having a layer that impedes the downward movement of water or soils of moderately fine texture or fine texture. These soils have a slow rate of water transmission.

Group D. Soils having a very slow infiltration rate (high runoff potential) when thoroughly wet. These consist chiefly of clays that have a high shrink-swell potential, soils that have a high water table, soils that have a claypan or clay layer at or near the surface, and soils that are shallow over nearly impervious material. These soils have a very slow rate of water transmission.

If a soil is assigned to a dual hydrologic group (A/D, B/D, or C/D), the first letter is for drained areas and the second is for undrained areas. Only the soils that in their natural condition are in group D are assigned to dual classes.

Rating Options

Aggregation Method: Dominant Condition

Component Percent Cutoff: None Specified

Tie-break Rule: Higher

S K D E S I G N G R O U P , I N C .

C I V I L E N G I N E E R S S I N C E 1 9 8 9



APPENDIX C – NOAA ATLAS 14 RAINFALL DATA



POINT PRECIPITATION FREQUENCY ESTIMATES

Sanja Perica, Deborah Martin, Sandra Pavlovic, Ishani Roy, Michael St. Laurent, Carl Trypaluk, Dale Unruh, Michael Yekta, Geoffery Bonnin

NOAA, National Weather Service, Silver Spring, Maryland

[PF_tabular](#) | [PF_graphical](#) | [Maps_&_aerials](#)

PF tabular

PDS-based point precipitation frequency estimates with 90% confidence intervals (in inches) ¹										
Duration	Average recurrence interval (years)									
	1	2	5	10	25	50	100	200	500	1000
5-min	0.237 (0.193-0.294)	0.289 (0.235-0.358)	0.379 (0.307-0.470)	0.458 (0.369-0.571)	0.574 (0.449-0.748)	0.669 (0.510-0.882)	0.769 (0.565-1.04)	0.876 (0.616-1.21)	1.02 (0.691-1.46)	1.14 (0.748-1.64)
10-min	0.348 (0.283-0.430)	0.423 (0.344-0.524)	0.555 (0.450-0.689)	0.671 (0.540-0.836)	0.841 (0.658-1.10)	0.980 (0.746-1.29)	1.13 (0.827-1.52)	1.28 (0.901-1.78)	1.50 (1.01-2.14)	1.67 (1.10-2.41)
15-min	0.424 (0.345-0.525)	0.516 (0.420-0.640)	0.676 (0.548-0.840)	0.818 (0.659-1.02)	1.02 (0.802-1.34)	1.20 (0.910-1.58)	1.37 (1.01-1.85)	1.56 (1.10-2.17)	1.83 (1.23-2.60)	2.04 (1.34-2.93)
30-min	0.615 (0.500-0.761)	0.748 (0.608-0.926)	0.978 (0.793-1.22)	1.18 (0.952-1.47)	1.48 (1.16-1.93)	1.72 (1.31-2.27)	1.98 (1.45-2.67)	2.25 (1.58-3.12)	2.63 (1.78-3.75)	2.94 (1.92-4.22)
60-min	0.795 (0.647-0.984)	0.949 (0.772-1.18)	1.23 (0.994-1.52)	1.48 (1.19-1.85)	1.87 (1.47-2.45)	2.20 (1.68-2.91)	2.55 (1.88-3.46)	2.93 (2.07-4.08)	3.48 (2.35-4.97)	3.92 (2.57-5.64)
2-hr	0.975 (0.800-1.20)	1.15 (0.942-1.41)	1.48 (1.20-1.82)	1.78 (1.45-2.21)	2.26 (1.80-2.96)	2.67 (2.06-3.52)	3.12 (2.32-4.21)	3.62 (2.57-5.01)	4.33 (2.95-6.15)	4.91 (3.24-7.02)
3-hr	1.07 (0.884-1.31)	1.25 (1.03-1.53)	1.58 (1.30-1.94)	1.92 (1.56-2.36)	2.44 (1.96-3.20)	2.91 (2.26-3.84)	3.43 (2.56-4.62)	4.00 (2.87-5.54)	4.84 (3.33-6.88)	5.54 (3.67-7.88)
6-hr	1.24 (1.03-1.51)	1.43 (1.19-1.74)	1.80 (1.49-2.20)	2.18 (1.79-2.66)	2.79 (2.26-3.65)	3.34 (2.62-4.39)	3.96 (2.99-5.32)	4.65 (3.36-6.41)	5.68 (3.93-8.02)	6.53 (4.36-9.23)
12-hr	1.43 (1.20-1.72)	1.65 (1.38-1.99)	2.09 (1.74-2.53)	2.52 (2.09-3.06)	3.22 (2.63-4.16)	3.84 (3.03-4.99)	4.52 (3.44-6.02)	5.29 (3.85-7.22)	6.41 (4.47-8.98)	7.34 (4.95-10.3)
24-hr	1.64 (1.39-1.96)	1.93 (1.62-2.30)	2.45 (2.06-2.94)	2.95 (2.46-3.55)	3.72 (3.04-4.73)	4.38 (3.48-5.63)	5.11 (3.91-6.72)	5.90 (4.32-7.97)	7.05 (4.95-9.78)	7.99 (5.43-11.1)
2-day	1.90 (1.62-2.25)	2.25 (1.91-2.66)	2.87 (2.43-3.41)	3.43 (2.89-4.10)	4.27 (3.50-5.35)	4.97 (3.97-6.30)	5.72 (4.40-7.44)	6.54 (4.81-8.73)	7.68 (5.43-10.6)	8.61 (5.90-11.9)
3-day	2.09 (1.79-2.46)	2.47 (2.11-2.91)	3.13 (2.66-3.70)	3.73 (3.15-4.43)	4.61 (3.80-5.75)	5.35 (4.29-6.74)	6.13 (4.74-7.93)	6.98 (5.16-9.27)	8.16 (5.80-11.2)	9.12 (6.28-12.6)
4-day	2.25 (1.93-2.65)	2.64 (2.26-3.11)	3.33 (2.84-3.93)	3.95 (3.35-4.68)	4.87 (4.02-6.04)	5.63 (4.52-7.07)	6.44 (4.99-8.30)	7.31 (5.43-9.69)	8.54 (6.08-11.6)	9.52 (6.58-13.1)
7-day	2.67 (2.30-3.11)	3.08 (2.66-3.60)	3.81 (3.28-4.47)	4.47 (3.82-5.26)	5.45 (4.53-6.71)	6.26 (5.07-7.81)	7.13 (5.56-9.12)	8.06 (6.02-10.6)	9.36 (6.72-12.7)	10.4 (7.25-14.3)
10-day	3.03 (2.63-3.52)	3.48 (3.02-4.05)	4.27 (3.69-4.98)	4.98 (4.27-5.83)	6.01 (5.02-7.36)	6.87 (5.58-8.52)	7.78 (6.09-9.90)	8.75 (6.56-11.5)	10.1 (7.28-13.6)	11.2 (7.82-15.3)
20-day	4.06 (3.55-4.68)	4.67 (4.08-5.38)	5.69 (4.95-6.58)	6.57 (5.68-7.64)	7.82 (6.55-9.44)	8.82 (7.20-10.8)	9.84 (7.76-12.4)	10.9 (8.23-14.1)	12.4 (8.96-16.5)	13.5 (9.52-18.3)
30-day	4.90 (4.30-5.62)	5.64 (4.95-6.48)	6.87 (6.00-7.91)	7.89 (6.86-9.12)	9.30 (7.80-11.1)	10.4 (8.52-12.6)	11.5 (9.10-14.4)	12.6 (9.56-16.2)	14.1 (10.3-18.7)	15.3 (10.8-20.6)
45-day	5.94 (5.24-6.78)	6.84 (6.04-7.82)	8.30 (7.29-9.51)	9.49 (8.28-10.9)	11.1 (9.32-13.1)	12.3 (10.1-14.8)	13.5 (10.7-16.7)	14.6 (11.1-18.7)	16.2 (11.8-21.3)	17.3 (12.3-23.2)
60-day	6.82 (6.04-7.75)	7.84 (6.94-8.93)	9.48 (8.35-10.8)	10.8 (9.45-12.4)	12.5 (10.5-14.7)	13.8 (11.4-16.5)	15.0 (11.9-18.5)	16.2 (12.4-20.6)	17.7 (13.0-23.2)	18.8 (13.5-25.2)

¹ Precipitation frequency (PF) estimates in this table are based on frequency analysis of partial duration series (PDS). Numbers in parenthesis are PF estimates at lower and upper bounds of the 90% confidence interval. The probability that precipitation frequency estimates (for a given duration and average recurrence interval) will be greater than the upper bound (or less than the lower bound) is 5%. Estimates at upper bounds are not checked against probable maximum precipitation (PMP) estimates and may be higher than currently valid PMP values. Please refer to NOAA Atlas 14 document for more information.

[Back to Top](#)

PF graphical

PDS-based depth-duration-frequency (DDF) curves

Latitude: 38.9394°, Longitude: -104.6292°

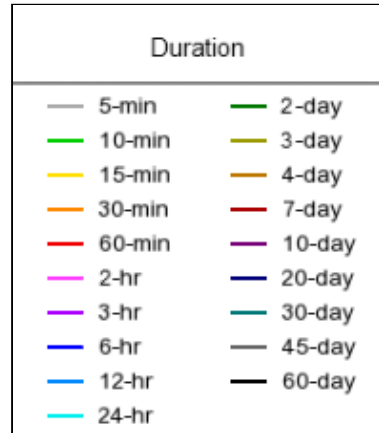
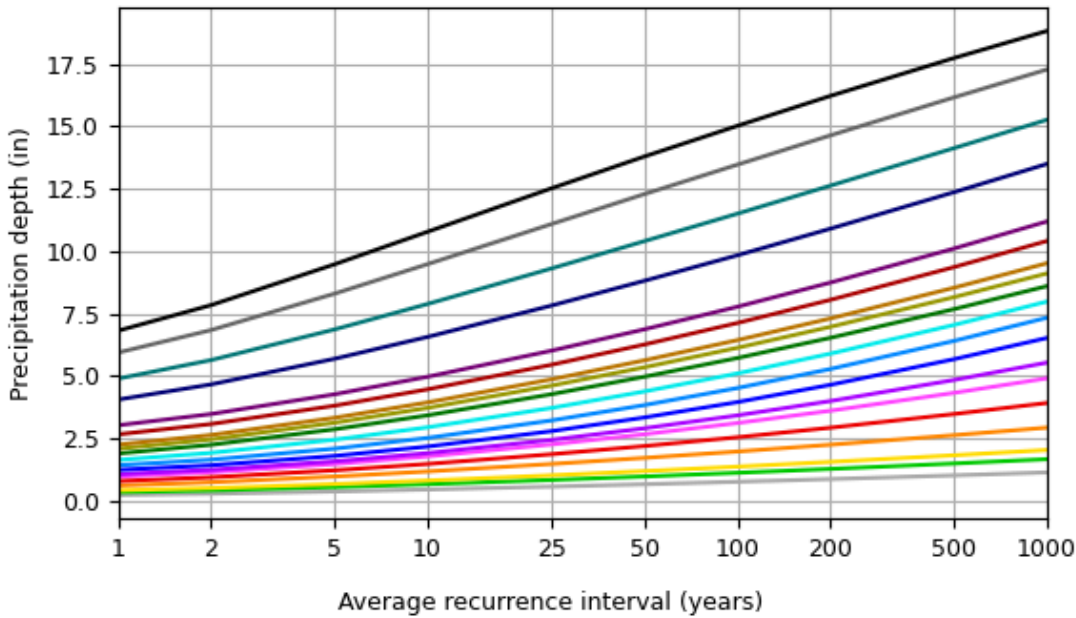
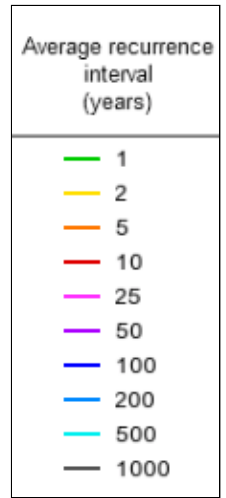
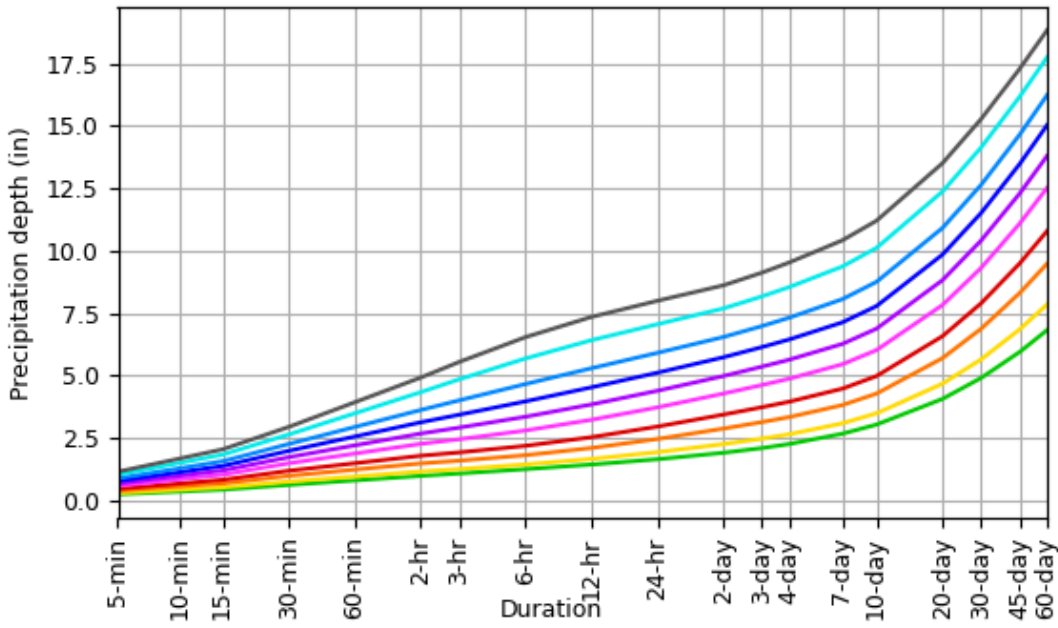

[Back to Top](#)

Maps & aerials

Small scale terrain



Large scale terrain



Large scale map



Large scale aerial



[Back to Top](#)

[US Department of Commerce](#)
[National Oceanic and Atmospheric Administration](#)
[National Weather Service](#)
[National Water Center](#)
1325 East West Highway
Silver Spring, MD 20910
Questions?: HDSC.Questions@noaa.gov

[Disclaimer](#)

S K D E S I G N G R O U P , I N C .

C I V I L E N G I N E E R S S I N C E 1 9 8 9



APPENDIX D – FEMA FIRMETTE

National Flood Hazard Layer FIRMMette



104°38'4"W 38°56'36"N

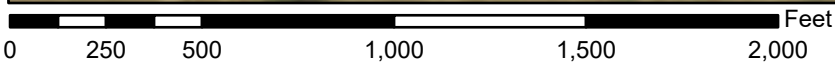

1:6,000

104°37'26"W 38°56'8"N

Basemap Imagery Source: USGS National Map 2023

Legend

SEE FIS REPORT FOR DETAILED LEGEND AND INDEX MAP FOR FIRM PANEL LAYOUT

- | | | |
|------------------------------------|--|--|
| SPECIAL FLOOD HAZARD AREAS | | Without Base Flood Elevation (BFE)
<i>Zone A, V, A99</i> |
| | | With BFE or Depth <i>Zone AE, AO, AH, VE, AR</i> |
| | | Regulatory Floodway |
| OTHER AREAS OF FLOOD HAZARD | | 0.2% Annual Chance Flood Hazard, Areas of 1% annual chance flood with average depth less than one foot or with drainage areas of less than one square mile <i>Zone X</i> |
| | | Future Conditions 1% Annual Chance Flood Hazard <i>Zone X</i> |
| | | Area with Reduced Flood Risk due to Levee. See Notes. <i>Zone X</i> |
| | | Area with Flood Risk due to Levee <i>Zone D</i> |
| OTHER AREAS | | NO SCREEN Area of Minimal Flood Hazard <i>Zone X</i> |
| | | Effective LOMRs |
| | | Area of Undetermined Flood Hazard <i>Zone D</i> |
| GENERAL STRUCTURES | | Channel, Culvert, or Storm Sewer |
| | | Levee, Dike, or Floodwall |
| OTHER FEATURES | | 20.2 Cross Sections with 1% Annual Chance Water Surface Elevation |
| | | 17.5 Cross Sections with 1% Annual Chance Water Surface Elevation |
| | | Coastal Transect |
| | | Base Flood Elevation Line (BFE) |
| | | Limit of Study |
| | | Jurisdiction Boundary |
| | | Coastal Transect Baseline |
| | | Profile Baseline |
| | | Hydrographic Feature |
| MAP PANELS | | Digital Data Available |
| | | No Digital Data Available |
| | | Unmapped |



The pin displayed on the map is an approximate point selected by the user and does not represent an authoritative property location.

This map complies with FEMA's standards for the use of digital flood maps if it is not void as described below. The basemap shown complies with FEMA's basemap accuracy standards

The flood hazard information is derived directly from the authoritative NFHL web services provided by FEMA. This map was exported on 3/27/2024 at 6:53 PM and does not reflect changes or amendments subsequent to this date and time. The NFHL and effective information may change or become superseded by new data over time.

This map image is void if the one or more of the following map elements do not appear: basemap imagery, flood zone labels, legend, scale bar, map creation date, community identifiers, FIRM panel number, and FIRM effective date. Map images for unmapped and unmodernized areas cannot be used for regulatory purposes.



APPENDIX E – CALCULATIONS



Comp C and i%

Project: Rolling Thunder Business Park, Lot 12

Location: Peyton, CO

Date: 2024-06-21

Calculated By: EP

Checked By: AM

Basin ID	Areas				Total Area (acres)	Comp i%	Comp C		
	Historic Flow Analysis (sf)	Drives and Walks (sf)	Roofs (sf)	Lawns (sf)		Percent Imperviousness (%)	C ₅	C ₁₀	C ₁₀₀
EX-1	41368	0	0	0	0.950	2.0	0.09	0.17	0.36
EX-2 (OS-1)	0	0	5613	0	0.129	90.0	0.73	0.75	0.81
Basin A-1	0	104	4352	5084	0.219	42.1	0.39	0.43	0.57
Basin A-2	0	414	0	733	0.026	36.1	0.38	0.43	0.57
Basin B-1	0	17580	0	3034	0.473	85.3	0.78	0.81	0.87
Basin B-2	0	0	2201	0	0.051	90.0	0.73	0.75	0.81
Basin C-1	0	956	0	3716	0.107	20.5	0.25	0.31	0.47
Basin C-2	0	593	0	2712	0.076	17.9	0.23	0.29	0.46
Basin A Total	0	518	4352	5817	0.245	41.5	0.38	0.43	0.57
Basin B Total	0	17580	2201	3034	0.524	85.7	0.77	0.80	0.86
Basin C Total	0	1549	0	6428	0.183	19.4	0.24	0.30	0.47
Site Total	0	19647	6553	15279	0.952	61.6	0.57	0.61	0.71



Standard Form SF-1. Time of Concentration
Project: Rolling Thunder Business Park, Lot 12
Location: Peyton, CO
Date: 2024-06-21
Calculated By: EP
Checked By: AM

Sub-Basin			Initial/Overland Time (T _i)			Travel Time (T _t)					T _c Check (Urbanized Basin)		Final T _c	Notes
Basin ID	⁵ C _s	Area (ac)	Length (ft)	Slope (ft/ft)	¹ T _i (min)	Length (ft)	Slope (%)	³ C _v	² V (ft/s)	T _t (min)	Total Length (ft)	⁴ T _c (min)	T _c (min)	
EX-1	0.09	0.95	65	0.004	19.9	170	0.02	10	1.4	2.0	235	11.3	11.3	
EX-2 (OS-1)	0.73	0.13	40	0.05	2.5	185	0.02	10	1.4	2.2	225	11.3	11.3	
Basin A-1	0.39	0.22	60	0.02	7.9	100	0.005	20	1.4	1.2	160	10.9	9.1	
Basin A-2	0.38	0.03	25	0.02	5.2	60	0.02	20	2.8	0.4	85	10.5	5.6	
Basin B-1	0.78	0.47	45	0.03	2.7	240	0.005	20	1.4	2.8	285	11.6	5.5	
Basin B-2	0.73	0.05	60	0.02	4.1	75	0.03	20	3.5	0.4	135	10.8	10.8	
Basin C-1	0.25	0.11	15	0.05	3.5	450	0.01	20	2.0	3.8	465	12.6	7.3	
Basin C-2	0.23	0.08	15	0.08	3.1	180	0.01	20	2.0	1.5	195	11.1	11.1	

¹ Drainage Criteria Manual, Volume 1 Update, El Paso County, Eq. 6-8
² Drainage Criteria Manual, Volume 1 Update, El Paso County, Eq. 6-9
³ Drainage Criteria Manual, Volume 1 Update, El Paso County, Table 6-7
⁴ Drainage Criteria Manual, Volume 1 Update, El Paso County, Eq. 6-7
⁵ Drainage Criteria Manual, Volume 1 Update, El Paso County, Table 6-6



Standard Form SF-2. Storm Drainage System Design (Rational Method Procedure)

Project: Rolling Thunder Business Park, Lot 12

Location: Peyton, CO

Date: 2024-06-21

Calculated By: EP

Checked By: AM

Design Storm: 5 -YR

Point Precipitation Frequency Estimates, 1-hr Duration							
NOAA Atlas 14, Volume 8, Version 2							
Average Recurrence Interval (years)							
1	2	5	10	25	50	100	
Point Based Precipitation Frequency (inches)							
0.80	0.95	1.23	1.48	1.87	2.20	2.55	

Design Point	Direct Runoff							Total Runoff				Street		Pipe			Travel Time			Notes
	Area Designation	Area (A) (ac)	Runoff Coeff. (C)	T _c (min)	Total CA	I ¹ (in/hr)	Q (cfs)	T _c (min)	Total CA	I ¹ (in/hr)	Q (cfs)	Slope (%)	Street Flow	Design Flow (cfs)	Slope (%)	Pipe Size (in)	Length (ft)	Velocity (ft/sec)	T ₁ (min)	
EX-1		0.95	0.09	11.3	0.09	1.23	0.11													
EX-2 (OS-1)		0.13	0.73	11.3	0.09	1.23	0.12													
Basin A-1		0.22	0.38	9.1	0.08	1.23	0.10													
Basin A-2		0.03	0.38	5.6	0.01	1.23	0.01													
Basin B-1		0.47	0.78	5.5	0.37	1.23	0.45													
Basin B-2		0.05	0.73	10.8	0.04	1.23	0.05													
Basin C-1		0.11	0.25	7.3	0.03	1.23	0.03													
Basin C-2		0.08	0.23	11.1	0.02	1.23	0.02													

¹ Drainage Criteria Manual, Volume 1 Update, El Paso County, Table 6-6



Standard Form SF-2. Storm Drainage System Design (Rational Method Procedure)

Project: Rolling Thunder Business Park, Lot 12

Location: Peyton, CO

Date: 2024-06-21

Calculated By: EP

Checked By: AM

Design Storm: 10 -YR

Point Precipitation Frequency Estimates, 1-hr Duration							
NOAA Atlas 14, Volume 8, Version 2							
Average Recurrence Interval (years)	1	2	5	10	25	50	100
Point Based Precipitation Frequency (inches)	0.80	0.95	1.23	1.48	1.87	2.20	2.55

Design Point	Direct Runoff							Total Runoff				Street		Pipe			Travel Time			Notes
	Area Designation	Area (A) (ac)	Runoff Coeff. (C)	T _c (min)	Total CA	I ¹ (in/hr)	Q (cfs)	T _c (min)	Total CA	I ¹ (in/hr)	Q (cfs)	Slope (%)	Street Flow	Design Flow (cfs)	Slope (%)	Pipe Size (in)	Length (ft)	Velocity (ft/sec)	T ₁ (min)	
	EX-1	0.95	0.17	11.3	0.16	1.48	0.24													
	EX-2 (OS-1)	0.13	0.75	11.3	0.10	1.48	0.14													
	Basin A-1	0.22	0.43	9.1	0.09	1.48	0.14													
	Basin A-2	0.03	0.43	5.6	0.01	1.48	0.02													
	Basin B-1	0.47	0.81	5.5	0.38	1.48	0.56													
	Basin B-2	0.05	0.75	10.8	0.04	1.48	0.06													
	Basin C-1	0.11	0.31	7.3	0.03	1.48	0.05													
	Basin C-2	0.08	0.29	11.1	0.02	1.48	0.03													

¹ Drainage Criteria Manual, Volume 1 Update, El Paso County, Table 6-6



Standard Form SF-2. Storm Drainage System Design (Rational Method Procedure)

Project: Rolling Thunder Business Park, Lot 12

Location: Peyton, CO

Date: 2024-06-21

Calculated By: EP

Checked By: AM

Design Storm: 100 -YR

Point Precipitation Frequency Estimates, 1-hr Duration							
NOAA Atlas 14, Volume 8, Version 2							
Average Recurrence Interval (years)	1	2	5	10	25	50	100
Point Based Precipitation Frequency (inches)	0.80	0.95	1.23	1.48	1.87	2.20	2.55

Design Point	Direct Runoff						Total Runoff				Street		Pipe			Travel Time			Notes
	Area Designation	Area (A) (ac)	Runoff Coeff. (C)	T _r (min)	Total CA	Q (cfs)	T _r (min)	Total CA	Q (cfs)	Slope (%)	Street Flow	Design Flow (cfs)	Slope (%)	Pipe Size (in)	Length (ft)	Velocity (ft/sec)	T _t (min)		
EX-1		0.95	0.36	11.3	0.34	2.55			0.87										
EX-2 (OS-1)		0.13	0.81	11.3	0.10	2.55			0.27										
Basin A-1		0.22	0.57	9.1	0.12	2.55			0.32										
Basin A-2		0.03	0.57	5.6	0.02	2.55			0.04										
Basin B-1		0.47	0.87	5.5	0.41	2.55			1.05										
Basin B-2		0.05	0.81	10.8	0.04	2.55			0.10										
Basin C-1		0.11	0.47	7.3	0.05	2.55			0.13										
Basin C-2		0.08	0.46	11.1	0.03	2.55			0.09										

¹ Drainage Criteria Manual, Volume 1 Update, El Paso County, Table 6-6

Design Procedure Form: Sand Filter (SF)

UD-BMP (Version 3.07, March 2018)

Sheet 1 of 2

Designer: EP
Company: SK Design Group
Date: June 21, 2024
Project: Roling Thunder Business Park, Lot 12
Location: Peyton, CO

<p>1. Basin Storage Volume</p> <p>A) Effective Imperviousness of Tributary Area, I_a (100% if all paved and roofed areas upstream of sand filter)</p> <p>B) Tributary Area's Imperviousness Ratio ($i = I_a/100$)</p> <p>C) Water Quality Capture Volume (WQCV) Based on 12-hour Drain Time $WQCV = 0.8 * (0.91 * i^3 - 1.19 * i^2 + 0.78 * i)$</p> <p>D) Contributing Watershed Area (including sand filter area)</p> <p>E) Water Quality Capture Volume (WQCV) Design Volume $V_{WQCV} = WQCV / 12 * Area$</p> <p>F) For Watersheds Outside of the Denver Region, Depth of Average Runoff Producing Storm</p> <p>G) For Watersheds Outside of the Denver Region, Water Quality Capture Volume (WQCV) Design Volume</p> <p>H) User Input of Water Quality Capture Volume (WQCV) Design Volume (Only if a different WQCV Design Volume is desired)</p>	<p>$I_a =$ <input type="text" value="85.7"/> %</p> <p>$i =$ <input type="text" value="0.857"/></p> <p>WQCV = <input type="text" value="0.29"/> watershed inches</p> <p>Area = <input type="text" value="22,815"/> sq ft</p> <p>$V_{WQCV} =$ <input type="text" value="559"/> cu ft</p> <p>$d_e =$ <input type="text"/> in</p> <p>$V_{WQCV\ OTHER} =$ <input type="text"/> cu ft</p> <p>$V_{WQCV\ USER} =$ <input type="text"/> cu ft</p>
<p>2. Basin Geometry</p> <p>A) WQCV Depth</p> <p>B) Sand Filter Side Slopes (Horizontal distance per unit vertical, 4:1 or flatter preferred). Use "0" if sand filter has vertical walls.</p> <p>C) Minimum Filter Area (Flat Surface Area)</p> <p>D) Actual Filter Area</p> <p>E) Volume Provided</p>	<p>$D_{WQCV} =$ <input type="text" value="0.6"/> ft</p> <p>$Z =$ <input type="text" value="3.00"/> ft / ft DIFFICULT TO MAINTAIN, INCREASE WHERE POSSIBLE</p> <p>$A_{Min} =$ <input type="text" value="244"/> sq ft</p> <p>$A_{Actual} =$ <input type="text" value="875"/> sq ft</p> <p>$V_T =$ <input type="text" value="777"/> cu ft</p>
<p>3. Filter Material</p>	<p>Choose One</p> <div style="border: 1px solid black; padding: 5px;"> <p><input checked="" type="radio"/> 18" CDOT Class B or C Filter Material</p> <p><input type="radio"/> Other (Explain):</p> </div> <p>_____</p> <p>_____</p>
<p>4. Underdrain System</p> <p>A) Are underdrains provided?</p> <p>B) Underdrain system orifice diameter for 12 hour drain time</p> <p style="margin-left: 20px;">i) Distance From Lowest Elevation of the Storage Volume to the Center of the Orifice</p> <p style="margin-left: 20px;">ii) Volume to Drain in 12 Hours</p> <p style="margin-left: 20px;">iii) Orifice Diameter, 3/8" Minimum</p>	<p>Choose One</p> <div style="border: 1px solid black; padding: 5px;"> <p><input type="radio"/> YES</p> <p><input checked="" type="radio"/> NO</p> </div> <p>$y =$ <input type="text" value="N/A"/> ft</p> <p>$Vol_{12} =$ <input type="text" value="N/A"/> cu ft</p> <p>$D_o =$ <input type="text" value="N/A"/> in</p>

Design Procedure Form: Sand Filter (SF)

Sheet 2 of 2

Designer: EP
Company: SK Design Group
Date: June 21, 2024
Project: Roling Thunder Business Park, Lot 12
Location: Peyton, CO

5. Impermeable Geomembrane Liner and Geotextile Separator Fabric

A) Is an impermeable liner provided due to proximity of structures or groundwater contamination?

Choose One

YES NO

6. Inlet / Outlet Works

A) Describe the type of energy dissipation at inlet points and means of conveying flows in excess of the WQCV through the outlet

Energy dissipation is achieved with Type VL riprap at all inflow and outflow locations.

Notes: Runoff beyond the required WQCV is released via riprap lined overflow channel.
WQCV is infiltrated, all other flows are bypassed to an on-site drainage channel and discharged to existing curb and gutter.



WQCV & Drain Time Calculation

Project: Rolling Thunder Business Park, Lot 12

Location: Peyton, CO

Date: 2024-06-21

Calculated By: EP

Checked By: AM

WQCV and Infiltration Rate Summary	
	Infiltration Basin
WQCV (cf)	559
¹ WQCV Depth (ft)	0.55
² 12-hr Infiltration Rate (in/hr)	1.63
¹ Refer to WSEL calculations in the appendices of this letter	
² Based on AASHTO M43 Fine aggregate filter sand	

Infiltration Rate and Drain Time Calculation			
Stage (ft)	Area (sf)	Volume (cf)	¹ Time (hr)
0	875	0	0.00
0.5	1204	520	3.68
0.55	1245	581	4.05
0.7	1486	777	5.15
¹ Time = Stage(in.) / (12-hr Infiltration Rate (in./hr))			
Time required to infiltrate WQCV = 4.05hr			
Infiltration rate required to drain WQCV in 12hr = 0.55in/hr			
² *Infiltration rate required to drain WQCV in 12hr = 1.10in/hr < 1.63in/hr			

Channel Report

Grass Lined Channel - Section A-A - 100-YR

User-defined

Invert Elev (ft) = 6897.10
Slope (%) = 1.00
N-Value = 0.020

Highlighted

Depth (ft) = 0.11
Q (cfs) = 0.380
Area (sqft) = 0.27
Velocity (ft/s) = 1.41
Wetted Perim (ft) = 2.95
Crit Depth, Yc (ft) = 0.10
Top Width (ft) = 2.92
EGL (ft) = 0.14

Calculations

Compute by: Known Q
Known Q (cfs) = 0.38

(Sta, El, n)-(Sta, El, n)...

(0.00, 6900.00)-(5.00, 6900.00, 0.020)-(10.50, 6899.90, 0.020)-(11.50, 6899.90, 0.020)-(11.50, 6898.63, 0.020)-(16.50, 6897.10, 0.020)-(18.50, 6897.10, 0.020)
-(23.00, 6897.98, 0.020)

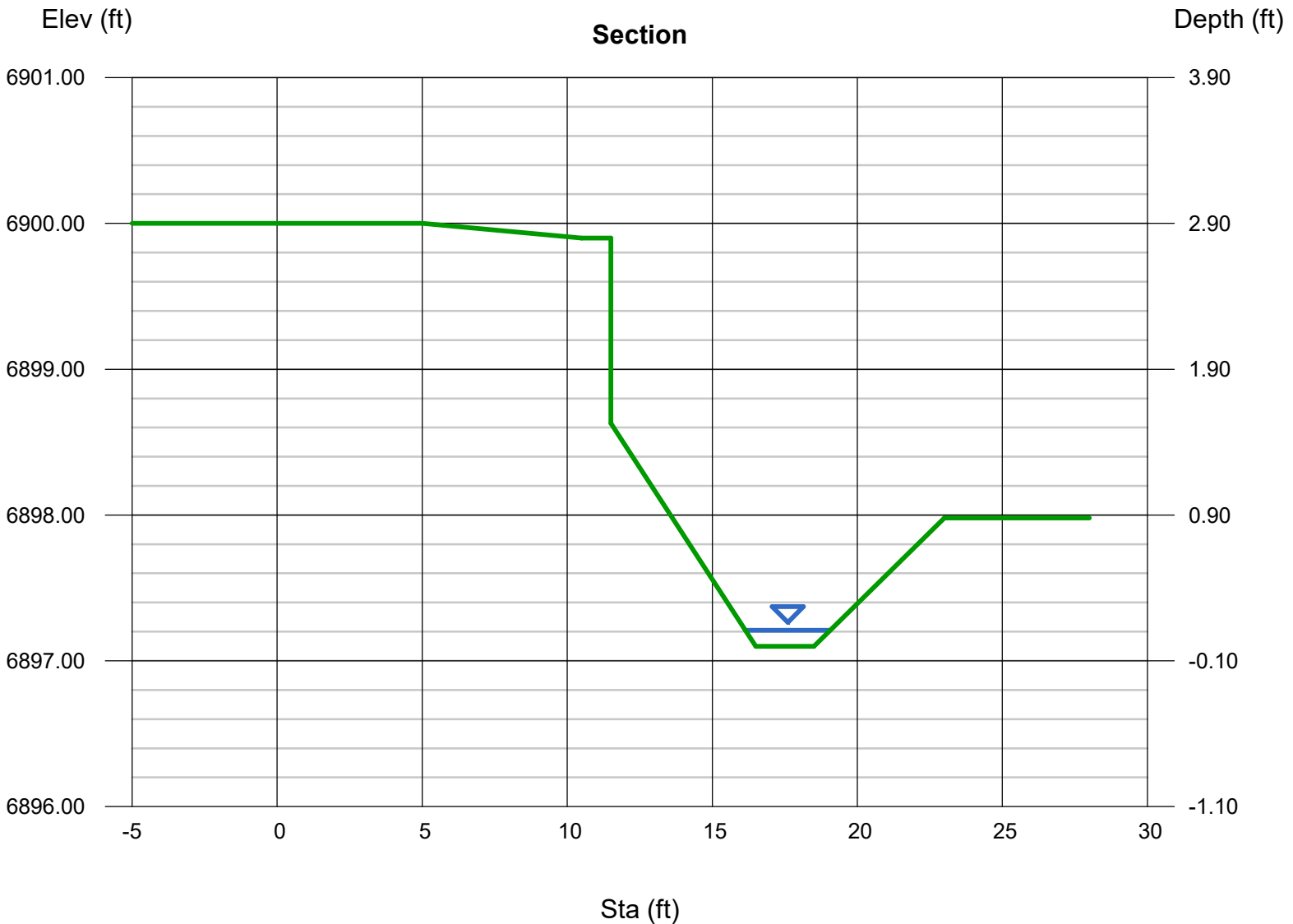

Weir Report

Pond A - Overflow Weir - SECTION B-B - 100-YR

Trapezoidal Weir

Crest = Sharp
Bottom Length (ft) = 4.80
Total Depth (ft) = 0.30
Side Slope (z:1) = 0.30

Highlighted

Depth (ft) = 0.19
Q (cfs) = 1.150
Area (sqft) = 0.92
Velocity (ft/s) = 1.25
Top Width (ft) = 4.91

Calculations

Weir Coeff. Cw = 3.10
Compute by: Known Q
Known Q (cfs) = 1.15

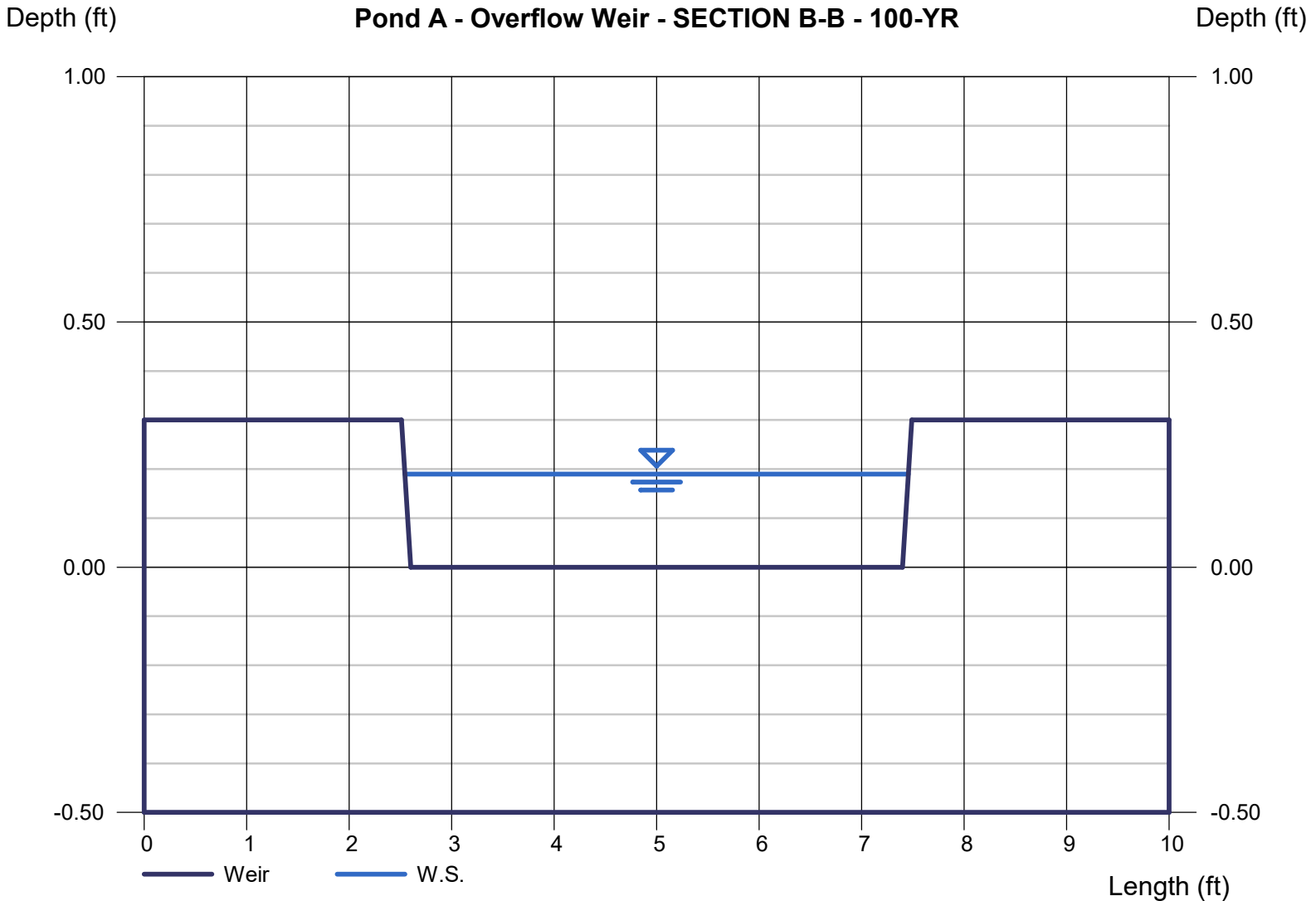

Channel Report

Sidewalk Chase Section - 100-yr Runoff from Basins B-1, B-2, C-2, & OS-1

Rectangular

Bottom Width (ft) = 2.00
Total Depth (ft) = 0.50

Invert Elev (ft) = 6894.70
Slope (%) = 2.09
N-Value = 0.012

Calculations

Compute by: Known Q
Known Q (cfs) = 1.53

Highlighted

Depth (ft) = 0.17
Q (cfs) = 1.530
Area (sqft) = 0.34
Velocity (ft/s) = 4.50
Wetted Perim (ft) = 2.34
Crit Depth, Yc (ft) = 0.27
Top Width (ft) = 2.00
EGL (ft) = 0.48

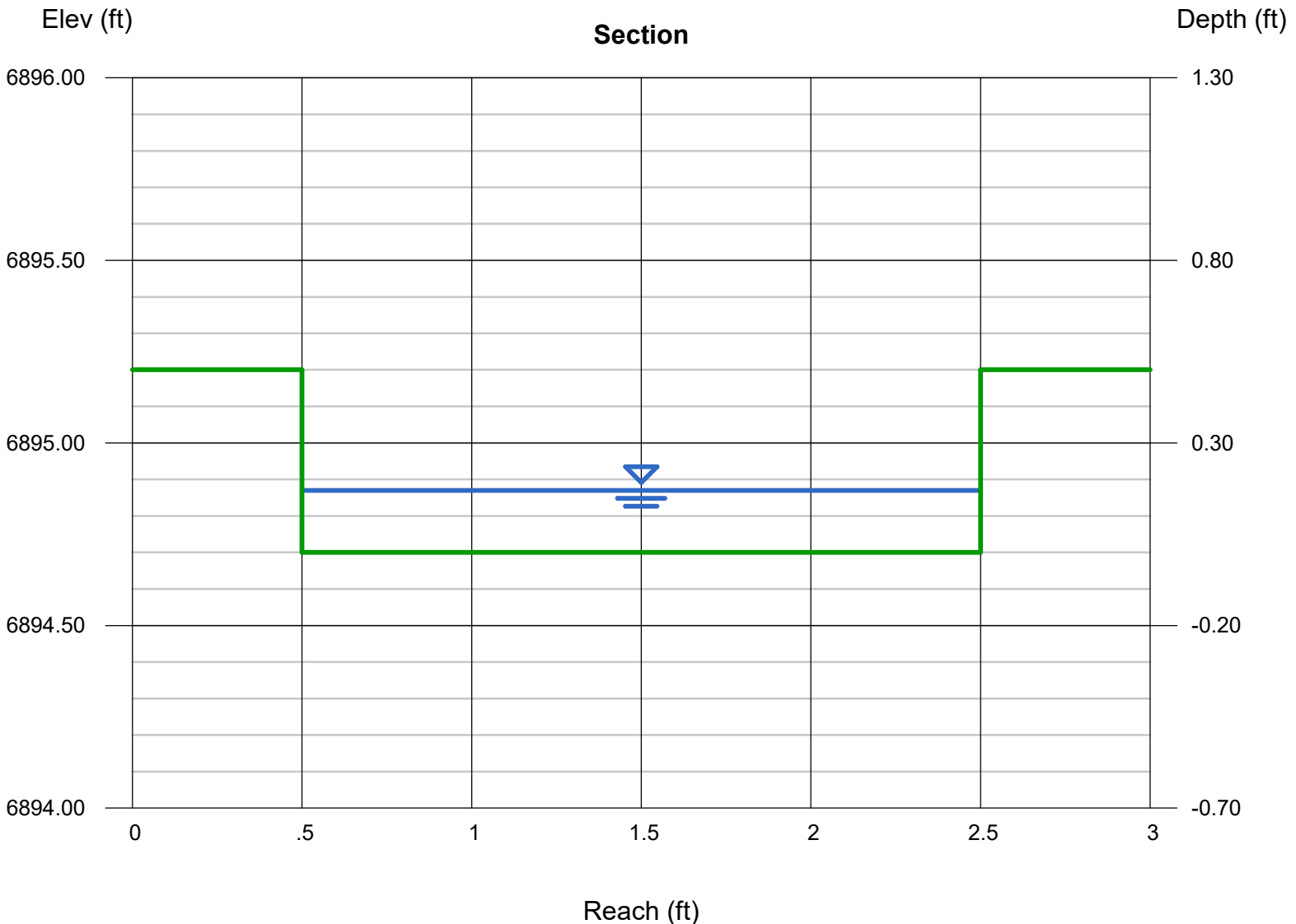



APPENDIX F – REFERENCE MATERIALS



ROLLING THUNDER
BUSINESS PARK
PRELIMINARY/FINAL
DRAINAGE REPORT
EL PASO COUNTY, COLORADO

September 2008

PREPARED FOR:

Foursome Development LLC

31 N. Tejon Street, Suite 500
Colorado Springs, CO 80903

PREPARED BY:

Springs Engineering

31 N. Tejon Street, Suite 315
Colorado Springs, CO 80903
719.227.7388

PROJECT NO. 06-0041

- Basin D-11 (5.33 acres) consists of the area to the east of the proposed site. This area is undeveloped. Flows continue on their existing path, through a shallow, wide bottom natural swale to the twin existing 48-inch culverts under Rolling Thunder Way. This flow combines with the onsite flow from the east portion of the site at Design Point 10. Flows generated by this basin are 8.2 cfs and 19.4 cfs for the 5 and 100-year storms. Offsite flows are released into this basin by an existing 48-inch rcp under Woodmen Road.
- Basin D-12 (1.58 acres) contains the area south of Maltese Point, situated between Firehouse View and the existing tank site. This basin will sheetflow to the south and east where it will be directed to the tank water quality pond. This flow is then released from the pond outlet structure and combines with flows at Design Point 10. This basin generates 7.3 cfs for the 5-year event and 13.6 cfs for the 100-year event.

Design Points

- DP-14 ($Q_5=7.3$, $Q_{100}=13.6$, $A=1.58$ acres) consists of Basin D-7a. A 5-foot curb cut will be placed at the low point in the west end cul-de-sac. These flows will be directed through a proposed swale to the southwest pond.
- DP-1 ($Q_5=20.7$, $Q_{100}=38.9$, $A=4.72$ acres) combines the released flows from the Southwest Pond and the Firehouse Pond in Basins D-7, D-7a and D-8. This flow enters the existing storm sewer system under Rolling Thunder Way between Golden Sage and Firehouse View. Individual storm systems are discussed in the following section.
- DP-2 ($Q_5=7.6$, $Q_{100}=14.3$, $A=1.98$ acres) combines flow from Basins D-2 and D-3. It is located at the intersection of Rolling Thunder Way and Golden Sage. An existing sump inlet is located at this location to intercept the street flow.
- DP-3 ($Q_5=3.2$, $Q_{100}=6.1$, $A=0.70$ acres) consists of Basin D-1. An existing at-grade inlet intercepts this flow. The inlet flow combines with the flow from DP-2 and is released into an existing swale which conveys the runoff to the west and an existing drainage channel.
- DP-4 ($Q_5=1.0$, $Q_{100}=2.5$) consists of the released flow from the inlet located at DP-3. This flow is released into an existing drainage swale and releases into an existing drainage channel west of the proposed site.
- DP-5 ($Q_5=3.1$, $Q_{100}=5.8$, $A=0.74$ acres) consists of Basin D-4. This is the street flow from this basin and is released on the curb return of Rolling Thunder Way.
- DP-6 ($Q_5=5.4$, $Q_{100}=10.2$, $A=1.48$ acres) contains Basin D-5. A sump inlet on the north side of Rolling Thunder Way intercepts this flow. The inlet connects to an existing 48-inch rcp under the roadway.
- DP-7 ($Q_5=5.2$, $Q_{100}=9.7$, $A=1.25$ acres) contains Basin D-6. A sump inlet on the south side of Rolling Thunder Way intercepts the street flow from this basin. This flow is also released into the existing 48-inch rcp under the roadway, along with the flow from DP-6. Individual storm sewers are discussed in the following section.

- DP-8 ($Q_5=16.5$, $Q_{100}=31.0$, $A=4.94$ acres) contains Basin D-9. This flow is conveyed as street flow along Maltese Point to a low point in the east cul-de-sac. At this location a curb cut will be installed to release the flow. A drainage swale will then convey the flow to the Tank Pond, a water quality pond on the water tank site. Swales and channels are discussed in a later section.
- DP-9 ($Q_5=27.3$, $Q_{100}=51.2$, $A=8.67$ acres) consists of Basins D-10 and D-12 and DP-8. This flow is released directly into the proposed Tank water quality pond at the southeast corner of the site. These flows will be released over a 40-hour drain time. Refer to water quality pond design in Appendix F. These flows will be released into a proposed storm system which will convey flows to the east towards the existing culverts at DP-10.
- DP-10 ($Q_5=133.7$, $Q_{100}=254.6$, $A=14.00$ acres) combines Basin D-11 with the flow from DP-10. This design point is located at the set of existing twin 48-inch rcp's. The flow entering these structures is the flow from Basin D-11 along with the released flow from the Tank Pond. Flows released from these structures will continue to the south and follow existing drainage patterns. The existing structures were designed in the MDDP and FDR for Falcon Highlands Filing No. 1. Based on the MDDP/PDR/FDR this design point also combines 200 cfs from an offsite basin north of Woodmen Road. Flow from Basin D-11 and the tank pond will have already passed as the flow from the offsite basin reaches the existing culverts under Rolling Thunder Way. The analysis of these structures, refer to Appendix D and Appendix E, shows the structures still function as designed in the approved FDR for Falcon Highlands Filing No. 1. The existing structures (culverts and channel) were designed for the offsite flow of 200 cfs in the MDDP/PDR/FDR for Falcon Highlands Filing No. 1. The current analysis on both was performed with the overall flow of 254 cfs, even though the 200 cfs is the maximum major flow through these structures (offsite flow reaches structures after flow from D-11 and Tank Pond have already passed).
- DP-11 ($Q_5=141.9$, $Q_{100}=270.1$, $A=16.73$ acres) combines the flow from DP-10 with the intercepted flow from the existing inlets at DP-6 and DP-7. This is the flow released at the end of the existing culverts under Rolling Thunder Way. A discussion of this storm system is included under the heading "Storm Systems". The analysis of these existing structures is included in Appendix D.
- DP-12 ($Q_5=11.3$, $Q_{100}=21.7$, $A=2.68$ acres) combines the intercepted inlet flows from DP-2 and DP-3 the flow-by associated with DP-4. This flow is released into a minor swale which conveys the flow towards the existing drainage channel west of the site. The swale was designed as part of the FDR for Golden Sage/Rolling Thunder Way. This temporary swale was not reanalyzed as there was no change to the release flow in the storm system. There is an analysis of the storm system located in Appendix D.
- DP-13 ($Q_5=32.2$, $Q_{100}=61.1$, $A=5.82$ acres) combines flow from DP-12 with DP-5 and DP-1. This is the flow from the site which enters the existing drainage channel west of the site. There was no previous analysis of this channel, so there are no flows or recommendations for this facility. An analysis was performed on the channel based on the flows being released into the channel. The channel is more than adequate to handle the flows from the proposed site. See Appendix E for channel analysis.

The third pond has been designed as a porous landscape detention facility (PLD). Calculations for the pond volumes, 2-year water quality release and major storm release rates have been included in the appendix. Two of the water quality capture ponds (WQCP) will be extended detention basins with a 40-hour drain time. The outlet will be a structure with orifice holes, which will extend the emptying time of the pond to allow for pollutants to settle out prior to being released from the pond. The third pond will be a porous landscape detention area which will drain through a sand filter bottom and a 3-inch perforated pvc pipe along the bottom of the facility. The Southwest pond is required to hold a volume of 0.17 ac-ft and the second pond (Tank Pond) located at the southeast corner of the site near the water tanks is required to hold a volume of 0.33 ac-ft. The Firehouse Pond is required to hold a volume of 1,312 cubic feet. The outlet will consist of a 3" perforated pvc underdrain and sand bottom for exfiltration. The PLD provides filtering absorption and biological uptake of constituents in storm water.

Downstream Facilities

The downstream facilities analyzed for this report are the existing channel which runs alongside the west property line of the site and the existing channel downstream of the twin 48-inch rcp's to the east and south of the site. Calculations on these channels have been included in Appendix E. This site is located within the Sand Creek DBPS, however, there are no facilities in the vicinity of the area which were analyzed in this report. The existing channels, which continue south to Dublin Avenue, do not start any analysis until well over a mile past the proposed site. The analysis of the existing channels show that they are more than adequate to handle the developed flows. There are no negative impacts to downstream structures or facilities.

DRAINAGE FEES, COST ESTIMATE & MAINTENANCE

Maintenance

The streets and major improvements within this site will be maintained by the Rolling Thunder Business Park Property Owners Association (POA) for ownership and maintenance. This includes the roads, drainage facilities, and water quality ponds. The Falcon Highlands Metropolitan District will own and operate water and wastewater systems. The remaining utilities (gas, phone, electric, cable, etc) will be owned and maintained by their respective companies. Easements will be issued to ensure each entity is able to access and maintain their facilities.

Drainage Fees

The proposed development falls within the Sand Creek Drainage Basin. The entire development occupies approximately 12.42 acres. Fees will be based on 11.13 acres for the business park. This area was determined by removing the existing tank site. Right-of-way adjacent to the site is 3.48 acres. Based on an 85% impervious area for the site, the area which the fees will be based on is 9.46 acres for the business park and 2.96 acres for the right-of-way.

Since the development is commercial and roadway, the actual imperviousness of the area was calculated for use in calculating drainage and bridge fees. Drainage fees in the Sand Creek basin are \$15,000 and bridge fees \$1,982.

	<u>Acres</u>	<u>Acreage for fees</u>	<u>Impervious Acres</u>
Rolling Thunder Bus. Park	12.42	11.13	9.46

Right-of-Way (Rolling Thunder & Golden Sage)

3.48

2.96

The calculated fees due will be as follows:

Drainage Fees:	Business Park	\$141,900
	Right-of-Way	44,400
	Total Drainage Fee	\$186,300
Bridge Fees:	Business Park	\$18,750
	Right-of-Way	5,867
	Total Bridge Fee	\$24,617

The developer of Rolling Thunder Business Park has credits within the Sand Creek Basin, as generated from the Constitution LID. Drainage credits are \$182,375 and bridge credits are \$433,789.

Proposed Facilities Estimate

ITEM	UNITS	UNIT COST	QUANTITY	ITEM COST
DRAINAGE				
24" RCP	LF	\$ 50.00	228	\$ 11,400
30" RCP	LF	\$ 55.00	254	\$ 13,970
36" RCP	LF	\$ 65.00	8	\$ 520
WATER QUALITY PONDS	EA	\$ 3,000.00	3	\$ 9,000
5' STORM MANHOLE	EA	\$ 2,800.00	3	\$ 8,400
3' x 3' CONCRETE BOX	EA	\$ 4,500.00	2	\$ 9,000
TYPE C INLET	EA	\$ 4,000.00	1	\$ 4,000
RIPRAP	CY	\$ 45.00	22	\$ 990
SUBTOTAL DRAINAGE				\$ 74,680
GRADING AND EROSION CONTROL				
CLEARING AND GRUBBING	AC	\$ 800.00	13	\$ 10,400
EARTHWORK	CY	\$ 3.50	500	\$ 46,550
CURB BACKFILL	LF	\$ 2.50	1,325	\$ 3,313
MISC SEEDING AND MULCH	AC	\$ 3,500.00	2	\$ 7,000
HAY BALE CHECKS	EA	\$ 10.00	190	\$ 1,900
VEHICLE TRACKING CONTROL	EA	\$ 1,500.00	1	\$ 1,500
SILT FENCING	LF	\$ 5.00	3166	\$ 15,830
SUBTOTAL GRADING & EROSION CONTROL				\$ 86,493
SUBTOTAL DRAINAGE & GRADING/EROSION CONTROL				\$ 161,173
ENGINEERING (10%)				\$ 16,117
CONTINGENCY (25%)				\$ 40,293
TOTAL				\$ 217,583

WOODMEN ROAD

GOLDEN SAGE

FALCON HIGHLANDS
PLANNING NO. 1

ROLLING GAP

THUNDER WAY



BASIN
Os | O100
AREA

DESIGN POINT	Q (5)	Q (100)
DP-14	7.3	13.6
DP-1	20.7	38.9
DP-2	7.6	14.3
DP-3	3.2	6.1
DP-4	1.0	2.5
DP-5	3.1	5.8
DP-6	5.4	10.2
DP-7	5.2	9.7
DP-8	16.5	31.0
DP-9	27.3	51.2
DP-10	133.7	254.6
DP-11	141.9	270.1
DP-12	11.3	21.7
DP-13	32.2	61.1

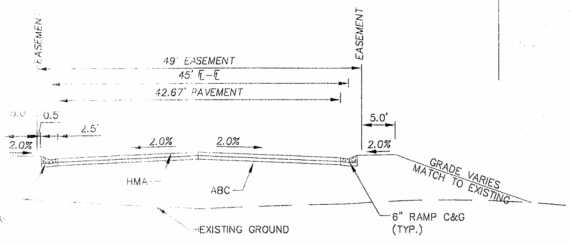

TYPICAL SECTION
(NON RESIDENTIAL COLLECTOR - MODIFIED)
PRIVATE ROAD
SCALE: N.T.S.

REVISIONS:		
NO.	DESCRIPTION	DATE

ENGINEER:
DESIGNED BY: CMS DATE: 10/03/06
DRAWN BY: CMS DATE: 10/03/06
CHECKED BY: _____ DATE: _____
48 HOURS BEFORE YOU DIG,
CALL UTILITY LOCATORS
1-800-922-1987
CITY OF COLORADO SPRINGS DEPT. OF UTILITIES
GAS, ELECTRIC, WATER AND WASTEWATER

SE Springs Engineering
31 N. TEJON, SUITE 315
COLORADO SPRINGS, CO 80903
P: (719) 227-7388
F: (719) 227-7392
PROJECT: ROLLING THUNDER BUSINESS PARK
SHEET TITLE: PROPOSED DRAINAGE PLAN
FROM: N/A TO: N/A
JOB NO. 08-0041 SHEET 1 OF 1



LOT 8
PUD

**DOWNSPOUTS
EXTEND ~6'
BEYOND LOT 13
PROPERTY LINE
AND DISCHARGE
WITHIN LOT 12
PROPERTY, NOT
SHOWN ON LOT 13
APPROVED PLANS**

**ACCESS TO DRAINAGE
EASEMENT TO ALLOW LOT
12 TO DRAIN TO TANK POND
FOR WQ TREATMENT
BLOCKED BY EXISTING LOT
13 LANDSCAPING**

100' BUILDING SETBACK FOR SITE 2009-001
SETBACKS
FRONT 20
SIDE 0
REAR 25
BUILDING AREA: 11,200 S.F. PHASE 1
2,448 S.F. PHASE 2
BUILDING(S) COLOR SCHEME: OPTION B
PARKING REQUIRED: REPAIR GARAGE
1 SPACE PER PLUS 3 SPACES
5 BAYS
5 EMPLOYEES
20 REQUIRED
PARKING PROVIDED: 20 PROVIDED
1 BICYCLE SPACE
HANDICAP: 1 SPACE REQUIRED/1 SPACE
LOT COVERAGE:
EX. PAVEMENT 24.0%
NEW PAVEMENT 22.7%
BUILDING PHASE 1 22.0%
BUILDING PHASE 2 4.8%
TOTAL 76.5%
DEVELOPMENT SCHEDULE
GRADING - MARCH 2009
UTILITY INSTALLATION - APRIL 2009
CONSTRUCTION - APRIL 2009
FINAL GRADING - JUNE 2009

NOTE:
• ALL RADI EDGE OF ASPHALT
• ALL DIMENSIONS IN PARKING AREA TO EDGE OF ASPHALT

EL PASO COUNTY CONSTRUCTION PLANS STANDARD NOTES

- ALL DRAINAGE AND ROADWAY CONSTRUCTION SHALL MEET THE STANDARDS AND SPECIFICATIONS OF THE CITY OF COLORADO SPRINGS/EL PASO COUNTY DRAINAGE CRITERIA MANUAL, VOLUMES 1 AND 2, AND THE EL PASO COUNTY ENGINEERING CRITERIA MANUAL.
- CONTRACTOR SHALL BE RESPONSIBLE FOR THE NOTIFICATION AND FIELD NOTIFICATION OF ALL EXISTING UTILITIES, WHETHER SHOWN ON THE PLANS OR NOT, BEFORE BEGINNING CONSTRUCTION. LOCATION OF EXISTING UTILITIES SHALL BE VERIFIED BY THE CONTRACTOR PRIOR TO CONSTRUCTION. CALL 811 TO CONTACT THE UTILITY NOTIFICATION CENTER OF COLORADO (UNCC).
- CONTRACTOR SHALL KEEP A COPY OF THESE APPROVED PLANS, THE GRADING AND EROSION CONTROL PLAN, THE STORMWATER MANAGEMENT PLAN (SWMP), THE SOILS AND GEOTECHNICAL REPORT, AND THE APPROPRIATE DESIGN AND CONSTRUCTION STANDARDS AND SPECIFICATIONS AT THE JOB SITE AT ALL TIMES, INCLUDING THE FOLLOWING:
a. EL PASO COUNTY ENGINEERING CRITERIA MANUAL (ECM)
b. CITY OF COLORADO SPRINGS/EL PASO COUNTY DRAINAGE CRITERIA MANUAL, VOLUMES 1 AND 2
c. COLORADO DEPARTMENT OF TRANSPORTATION (CDOT) STANDARD SPECIFICATIONS FOR ROAD AND BRIDGE CONSTRUCTION
d. CDOT M & S STANDARDS
- NOTWITHSTANDING ANYTHING DEPICTED IN THESE PLANS IN WORDS OR GRAPHIC REPRESENTATION, ALL DESIGN AND CONSTRUCTION RELATED TO ROADS, STORM DRAINAGE AND EROSION CONTROL, SHALL CONFORM TO THE STANDARDS AND REQUIREMENTS OF THE MOST RECENT VERSION OF THE RELEVANT ADOPTED EL PASO COUNTY STANDARDS, INCLUDING THE LAND DEVELOPMENT CODE, THE ENGINEERING CRITERIA MANUAL, THE DRAINAGE CRITERIA MANUAL, AND THE DRAINAGE CRITERIA MANUAL VOLUME 2. ANY DEVIATIONS FROM REGULATORY STANDARDS MUST BE REQUESTED, AND APPROVED, IN WRITING. ANY MODIFICATIONS NECESSARY TO MEET CRITERIA AFTER-THE-FACT WILL BE ENTIRELY THE DEVELOPER'S RESPONSIBILITY TO RECTIFY.
- IT IS THE DESIGN ENGINEER'S RESPONSIBILITY TO ACCURATELY SHOW EXISTING CONDITIONS, BOTH ONSITE AND OFFSITE, ON THE CONSTRUCTION PLANS. ANY MODIFICATIONS NECESSARY DUE TO CONFLICTS, OMISSIONS, OR CHANGED CONDITIONS WILL BE ENTIRELY THE DEVELOPER'S RESPONSIBILITY TO RECTIFY.
- CONTRACTOR SHALL SCHEDULE A PRE-CONSTRUCTION MEETING WITH EL PASO COUNTY DEVELOPMENT SERVICES DEPARTMENT (DSD) INSPECTIONS, PRIOR TO STARTING CONSTRUCTION.
- IT IS THE CONTRACTOR'S RESPONSIBILITY TO UNDERSTAND THE REQUIREMENTS OF ALL JURISDICTIONAL AGENCIES AND TO OBTAIN ALL REQUIRED PERMITS, INCLUDING BUT NOT LIMITED TO EL PASO COUNTY EROSION AND STORMWATER QUALITY CONTROL PERMIT (ESQCP), REGIONAL BUILDING FLOORPLAN DEVELOPMENT PERMIT, U.S. ARMY CORPS OF ENGINEERS-ISSUED 401 AND/OR 404 PERMITS, AND COUNTY AND STATE FUGITIVE DUST PERMITS.
- CONTRACTOR SHALL NOT DEVIATE FROM THE PLANS WITHOUT FIRST OBTAINING WRITTEN APPROVAL FROM THE DESIGN ENGINEER AND DSD. CONTRACTOR SHALL NOTIFY THE DESIGN ENGINEER IMMEDIATELY UPON DISCOVERY OF ANY ERRORS OR INCONSISTENCIES.
- ALL STORM DRAIN PIPE SHALL BE CLASS III ROP UNLESS OTHERWISE NOTED AND APPROVED BY DSD.
- CONTRACTOR SHALL COORDINATE GEOTECHNICAL TESTING PER EGM STANDARDS. PAVEMENT DESIGN SHALL BE APPROVED BY EL PASO COUNTY DSD PRIOR TO PLACEMENT OF CURB AND GUTTER AND PAVEMENT.
- ALL CONSTRUCTION TRAFFIC MUST ENTER/EXIT THE SITE AT APPROVED CONSTRUCTION ACCESS POINTS.
- SIGHT VISIBILITY TRIANGLES AS IDENTIFIED IN THE PLANS SHALL BE PROVIDED AT ALL INTERSECTIONS. OBSTRUCTIONS GREATER THAN 18 INCHES ABOVE FLOWLINE ARE NOT ALLOWED WITHIN SIGHT TRIANGLES.
- SIGNING AND STRIPING SHALL COMPLY WITH EL PASO COUNTY DOT AND MUTCD CRITERIA. (IF APPLICABLE, ADDITIONAL SIGNING AND STRIPING NOTES WILL BE PROVIDED.)
- CONTRACTOR SHALL OBTAIN ANY PERMITS REQUIRED BY EL PASO COUNTY DOT, INCLUDING WORK WITHIN THE RIGHT-OF-WAY AND SPECIAL TRANSPORT PERMITS.
- THE LIMITS OF CONSTRUCTION SHALL REMAIN WITHIN THE PROPERTY LINE UNLESS OTHERWISE NOTED. THE OWNER/DEVELOPER SHALL OBTAIN WRITTEN PERMISSION AND EASEMENTS, WHERE REQUIRED, FROM ADJOINING PROPERTY OWNER(S) PRIOR TO ANY OFF-SITE DISTURBANCE, GRADING, OR CONSTRUCTION.

APPROVED FOR THE CITY OF EL PASO
NOTES: 1. BY E. 1/11/09
2. BY E. 1/11/09

EL PASO COUNTY
DEVELOPMENT SERVICES

Division of Planning and Development
upon compliance with all applicable codes on the recorded plat.

An access permit must be granted by the Development Services Engineering Division prior to the establishment of any driveway onto a County Road.

Division of Public Works Engineering Division

RECEIVED
BY: [Signature]
DATE: 2/11/09

ANY APPROVAL GIVEN BY EL PASO COUNTY ENGINEER DOES NOT CONSTITUTE A GUARANTEE OF THE ACCURACY OF THE INFORMATION PROVIDED HEREON OR THE COMPLIANCE WITH APPLICABLE FEDERAL, STATE OR LOCAL LAWS AND/OR REGULATIONS

REVIEWED FOR GENERAL COMPLIANCE WITH EL PASO COUNTY ENGINEERING CRITERIA
BY: [Signature]
DATE: 6/24/09

16. 6' OPAQUE CHAIN WITH VINYL SLATS TO BE INSTALLED FROM TO C/O. LANDSCAPE TO BE BETWEEN FENCE AND ROLLING THUNDER WAY.

SHEET INDEX

- PLOT PLAN
- GRADING & EROSION CONTROL
- MASTERS UTILITY PLAN
- LANDSCAPING PLAN
- LANDSCAPING DETAILS
- BODY SHOP BUILDING ELEVATION
- ACCESSORY BUILDING ELEVATION
- PHOTOMETRIC PLAN

REVISIONS:		
NO.	DESCRIPTION	DATE

ENGINEER: _____ DATE: 2-17-09
DESIGNED BY: TWR DATE: 2-17-09
DRAWN BY: TWR DATE: 2-17-09
CHECKED BY: WDC DATE: 2-17-09

48 HOURS BEFORE YOU DIG,
CALL UTILITY LOCATORS
1-800-922-1987
CITY OF COLORADO SPRINGS DEPT. OF UTILITIES
GAS, ELECTRIC, WATER AND WASTEWATER

SE Springs Engineering
31 N. TEJON, SUITE 315
COLORADO SPRINGS, CO 80903
P: (719) 227-7269
F: (719) 227-7392

PROJECT: ROLLING THUNDER - LOT 13
SHEET TITLE: CIVIL PLOT PLAN
FROM: n/a TO: n/a
JOB NO.: 083-08-026 SHEET 1 OF 8

RECEIVED
FEB 18 2009
EPC DEVELOPMENT SERVICES



ENTECH
ENGINEERING, INC.

505 ELKTON DRIVE
COLORADO SPRINGS, CO 80907
PHONE (719) 531-5599

**GEOTECHNICAL AND PAVEMENT DESIGN REPORT
10707 MALTESE POINT
PEYTON, COLORADO**

Prepared for:
WD Construction
919 W. Cucharras Street, Suite 100
Colorado Springs, CO 80905

Attn: Bill Tibbit

March 25, 2024

Respectfully Submitted,

ENTECH ENGINEERING, INC.

Stuart Wood
Geologist

Reviewed by:

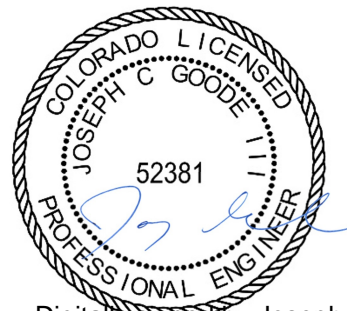

Digitally signed by Joseph C Goode III
Date: 03/25/24

Joseph C. Goode III, P.E.
Sr. Engineer

SW:JCG/

Entech Job No. 240324

1 Introduction

Entech Engineering Inc. (Entech) completed this geotechnical and pavement design report for a new building and associated site improvements located at 10707 Maltese Point in Peyton, Colorado. This report describes the subsurface exploration program conducted at the site and provides recommendations for foundation design, pavement design sections, and construction considerations. Our services were completed for WD Construction in accordance with our geotechnical and pavement design service agreement dated February 9, 2024. The contents of this report, including the geotechnical evaluation and recommendations, are subject to the limitations and assumptions presented in Section 8.

2 Project and Site Description

We understand that the project will consist of the construction of a new 8,950 square foot metal frame structure and associated site improvements to be located at 10707 Maltese Point in Peyton, Colorado. The location of the project site is shown on the Vicinity Map (Figure 1). Site improvements include an access lane and passenger vehicle parking lot to be paved with asphalt.

At the time of drilling, the property was a large flat vacant lot. Vegetation consists of sparse native grass and weeds. Building loads are expected to be light to moderate. The property is surrounded by large vacant to commercial lots. We understand that a detention pond will be located at the south side of the property.

3 Subsurface Explorations and Laboratory Testing

3.1 Subsurface Exploration Program

Subsurface conditions at the project site were explored by five test borings, designated TB-1 through TB-5, drilled on March 6, 2024 at the approximate locations shown on the Site and Exploration Plan (Figure 2). Three of the borings were drilled within the footprint of the proposed building. Two additional borings were drilled in the parking lot and access drive to provide pavement design recommendations. The borings in the building footprints were drilled to depths of 20 feet below the existing ground surface (bgs), the borings drilled in the parking and drive areas were drilled to depths of 10 feet bgs. The drilling was performed using a truck-mounted, continuous flight auger drill rig supplied and operated by Entech. Descriptive boring logs providing

the lithologies of the subsurface conditions encountered during drilling are presented in Appendix A. Groundwater levels were measured in each of the open boreholes at the conclusion of drilling.

Soil and bedrock samples were obtained from the borings utilizing the Standard Penetration Test (ASTM D1586) using a split-barrel California sampler. Results of the Standard Penetration Test (SPT) are included on the boring logs in terms of N-values expressed in blows per foot (bpf). Soil and bedrock samples recovered from the borings were visually classified and recorded on the boring logs. The soil and bedrock classifications were later verified utilizing laboratory testing and grouped by soil type. The soil and bedrock type numbers are included on the boring logs. It should be understood that the soil and bedrock descriptions shown on the boring logs may vary between boring locations and sample depths. It should also be noted that the lines of stratigraphic separation shown on the boring logs represent approximate boundaries between soil and bedrock types and the actual stratigraphic transitions may be more gradual or variable with location.

3.2 Geotechnical Index and Engineering Property Testing

Water content testing (ASTM D2216) was performed on the samples recovered from the borings and the results are shown on the boring logs. Grain-Size Analysis (ASTM D422) and Atterberg Limits testing (ASTM D4318) were performed on selected samples to assist in classifying the materials encountered in the borings. One-dimensional swell or collapse testing (ASTM D4546) was performed to evaluate the expansive characteristics and collapse potential of the soil. Soluble sulfate testing was performed on select soil samples to evaluate the potential for below-grade degradation of concrete due to sulfate attack.

For pavement design, a Modified Proctor (ASTM D1557) and California Bearing Ratio (CBR) test (ASTM D1883) were completed on a bulk sample from the roadway subgrade. The Laboratory Testing Results are presented in Appendix B and summarized in Table B-1.

4 Subsurface Conditions

Two primary soil types and two bedrock types were encountered in the test borings drilled for the subsurface exploration program. Each soil and bedrock type was classified in accordance with the Unified Soil Classification System (USCS) and the American Association of State Highway and Transportation Officials (AASHTO) soil classification system using the laboratory testing results and the observations made during drilling.

4.1 Soil and Bedrock

Subsurface conditions for the proposed project site consisted of native loose to medium dense silty sand to sand with silt (Soil Type 1) encountered in all the test borings from the existing ground surface and extended to depths of 7 to 13 feet bgs. Hard sandy clay (Soil Type 2) was encountered below the Soil Type 1 sands in three of the test borings at 7 to 9 feet and extended to depths of 12 to 14 feet or to the termination of the boring at 10 feet. Sandstone bedrock, or very dense clayey sand when classified as a soil (Soil Type 3), was encountered in borings TB-1, TB-2, and TB-3 at depths ranging from 13 to 18 feet and extended to the termination of the borings (20 feet). Claystone bedrock, or hard sandy clay when classified as a soil (Soil Type 4) was encountered overlying the sandstone bedrock in TB-2 and TB-3 beginning at 12 to 14 feet and extended to 16 to 18 feet. The AASHTO soil classifications of the subgrade Soil Type 1 was A-1-b, and A-4.

Swell or collapse testing on samples of the site clayey soils resulted in a volume change of 0.5%. The results indicate a low expansion potential. One dimensional swell or collapse testing on the claystone bedrock resulted in a volume change of 1.2% indicating a low to moderate expansion potential.

4.2 Groundwater

Depth to groundwater was measured in each of the borings at the conclusion of drilling. Groundwater was encountered in TB-1 at 5 feet and in TB-2 at 9 feet during, or subsequent to, drilling. It should be noted that groundwater levels could change due to seasonal variations, changes in land runoff characteristics, and future development of nearby areas.

5 Geotechnical Evaluation and Recommendations

The following discussion is based on the subsurface conditions encountered in the borings drilled in the planned lot for construction. If subsurface conditions different from those described herein are encountered during construction, or if the project elements change from those described, Entech Engineering, Inc. should be notified so that the evaluation and recommendations presented can be reviewed and revised if necessary.

As discussed in Section 2, we understand that the site will be developed with the construction of a new large metal building. The proposed building is expected to have a shallow foundation and slab on grade floors.

Exhibit 1: Foundation Design Parameters

Design Parameter	Value
Allowable Bearing Capacity ¹	
Recompacted site sands or granular fill	2,000 psf
Lateral Earth Pressure Equivalent Fluid Density ²	
Active Conditions - Granular Backfill	40 pcf

pcf = pounds per cubic foot; psf = pounds per square foot

Notes:

1. Assumes a minimum embedment of 30 inches for frost protection.
2. Assumes level backfill conditions.

5.2 On-Grade Floor Slabs

On-grade floor slabs for the planned structure should be supported on moisture-conditioned, compacted, site granular soils, or imported granular fill prepared in accordance with Section 7.1.1. Any loose soils or uncontrolled fill encountered will require removal according to Section 7.1.1.

Grade-supported floor slabs should be separated from other building structural components and utility penetrations to allow for possible future vertical movement. Interior partition walls should be constructed in such a manner so as not to transfer slab movement into the overlying floor(s) and/or roof members, should slab movement occur. Control joints in grade-supported slabs are recommended at 10- to 15-foot perpendicular spacings to control cracking. If slab movement cannot be tolerated, a structural floor system should be used.

5.3 Detention Pond

We understand that a detention pond will be located on the south side of the project site. Based on boring TB-5 we anticipate silty sands to a depth of 9 feet overlying clayey sand. We recommend that detention pond slopes be constructed at 3H:1V (horizontal to vertical).

5.4 Seismic Site Classification

Based on the subsurface conditions encountered at the site, and in accordance with Section 1613 of the 2021 *International Building Code* (IBC), the site meets the conditions of Site Class D.

5.5 Surface and Subsurface Drainage

Positive surface drainage is recommended around the building's perimeter to minimize infiltration of surface water into the supporting foundation soils. A minimum ground surface slope of 5% in the first 10 feet adjacent to exterior foundation walls is recommended for unpaved areas. For paved areas and other impervious surfaces, a minimum slope of 2% is adequate. All roof drains and gutter downspouts should be extended to discharge well beyond the building's foundation backfill zone or be connected to a storm sewer system.

To help minimize infiltration of water into the foundation zone, vegetative plantings placed close to foundation walls should be limited to those species having low watering requirements and irrigated grass should not be located within 5 feet of the foundation. Similarly, sprinklers are not recommended to discharge water within 5 feet of foundations. Irrigation near foundations should be limited to the minimum amount sufficient to maintain vegetation. Application of more irrigation water than necessary can increase the potential for slab and foundation movement.

Perimeter drains are recommended for usable space below grade (areas where the interior slab or bottom of the crawl space is below the exterior grade). A typical perimeter drain detail is shown in Figure 3.

6 Pavement Design Recommendations

Pavement design recommendations were made based on guidance from the *Pavement Design Criteria for El Paso County*. We understand that the access lane and passenger vehicle parking lot will be paved with asphalt.

6.1 Pavement Subgrade Conditions

Two test borings (TB-4 and TB-5) were drilled to depths of approximately 10 feet in the parking lot and access road areas. The soils at the roadway subgrade depth consisted of silty sand. Soil Type 1 was used to evaluate the subgrade support characteristics of pavement based on laboratory testing. The Type 1 subgrade soils classified as A-1-b, and A-4 using the AASHTO classification system.

California Bearing Ratio (CBR) testing was performed on a representative bulk sample of the silty sand (Soil Type 1) from TB-4 to determine the support characteristics of the subgrade soils for

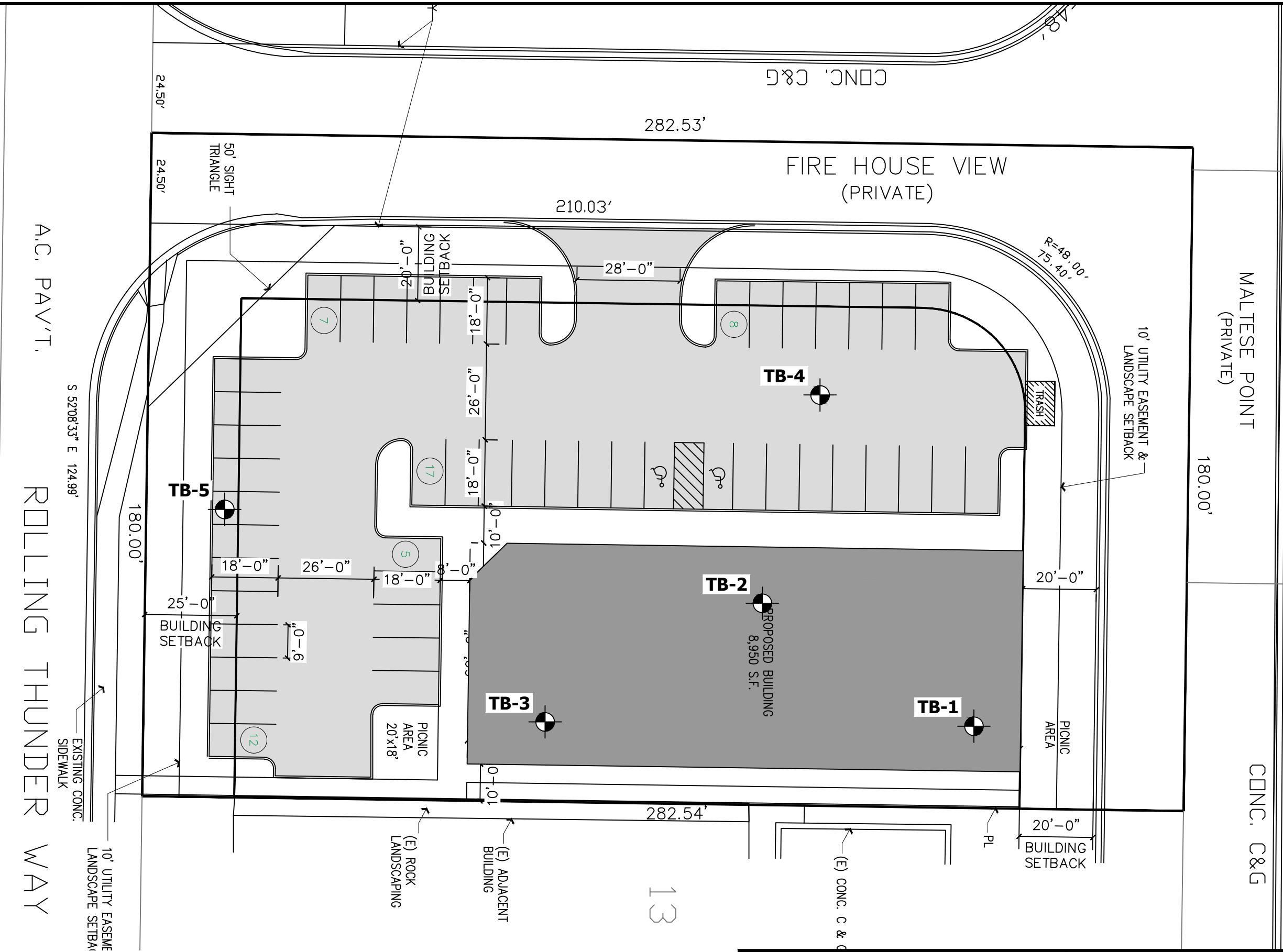

A.C. PAV'T.
 ROLLING THUNDER WAY

R.D.W. VARIES
 CONC. S/W

MALTESE POINT
 (PRIVATE)

180.00'

CONC. C&G

5

6

282.53'

210.03'

24.50'

24.50'

180.00'

282.54'

CONC. C&G

FIRE HOUSE VIEW
 (PRIVATE)

R=48.00'
 75.40'

10' UTILITY EASEMENT &
 LANDSCAPE SETBACK

PICNIC
 AREA

20'-0"
 BUILDING
 SETBACK

PROPOSED BUILDING
 8,950 S.F.

(E) ROCK
 LANDSCAPING

(E) ADJACENT
 BUILDING

(E) CONC. C & G

S 52°08'33" E 124.99'

EXISTING CONC.
 SIDEWALK
 10' UTILITY EASEMENT
 LANDSCAPE SETBACK

50' SIGHT
 TRIANGLE

24.50'

24.50'

24.50'

24.50'

24.50'

24.50'

24.50'

24.50'

24.50'

24.50'

24.50'

24.50'

24.50'

24.50'

24.50'

24.50'

24.50'

TB- APPROXIMATE TEST BORING LOCATION AND NUMBER

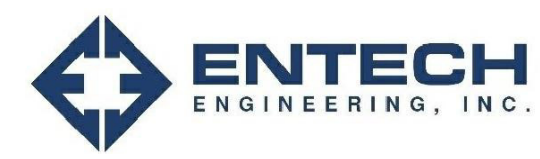

SITE AND EXPLORATION PLAN
 10707 MALTESE POINT
 WD CONSTRUCTION

JOB NO.
 240324
FIG. 2

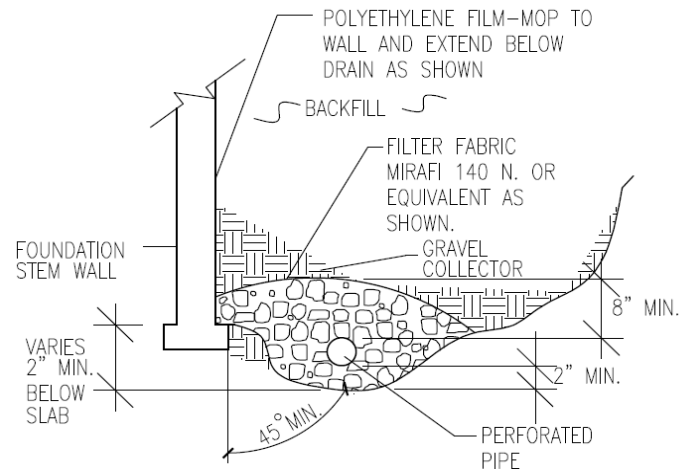
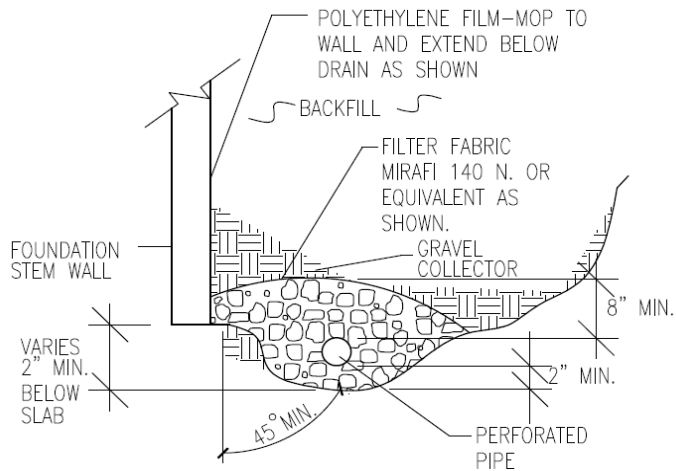

NOTES:

-GRAVEL SIZE IS RELATED TO DIAMETER OF PIPE PERFORATIONS-85% GRAVEL GREATER THAN 2x PERFORATION DIAMETER.

-PIPE DIAMETER DEPENDS UPON EXPECTED SEEPAGE. 4-INCH DIAMETER IS MOST OFTEN USED.

-ALL PIPE SHALL BE PERFORATED PLASTIC. THE DISCHARGE PORTION OF THE PIPE SHOULD BE NON-PERFORATED PIPE.

-FLEXIBLE PIPE MAY BE USED UP TO 8 FEET IN DEPTH, IF SUCH PIPE IS DESIGNED TO WITHSTAND THE PRESSURES. RIGID PLASTIC PIPE WOULD OTHERWISE BE REQUIRED.

-MINIMUM GRADE FOR DRAIN PIPE TO BE 1% OR 3 INCHES OF FALL IN 25 FEET.

-DRAIN TO BE PROVIDED WITH A FREE GRAVITY OUTFALL, IF POSSIBLE. A SUMP AND PUMP MAY BE USED IF GRAVITY OUTFALL IS NOT AVAILABLE.



PERIMETER DRAIN DETAIL

10707 MALTESE POINT
WD CONSTRUCTION

JOB NO.
240324

FIG. 3



APPENDIX A: Test Boring Logs

TABLE A-1
DEPTH TO GROUNDWATER & BEDROCK

TEST BORING	DEPTH TO GROUNDWATER (ft.)	DEPTH TO BEDROCK (ft.)
1	5	13
2	9	14
3	>20	12
4	>10	>10
5	>10	>10

TEST BORING 1
 DATE DRILLED 3/6/2024

TEST BORING 2
 DATE DRILLED 3/6/2024

REMARKS

REMARKS

WATER @ 5', 3/6/24

WATER @ 9', 3/6/24

SAND, SILTY to WITH SILT, TAN to BROWN, MEDIUM DENSE, DRY to WET

SAND, SILTY, BROWN, LOOSE to MEDIUM DENSE, MOIST

SANDSTONE, VERY WEAK, GRAY, HIGHLY WEATHERED (SAND, CLAYEY, VERY DENSE, MOIST)

CLAY, SANDY, BROWN, HARD, MOIST

CLAYSTONE, VERY WEAK, GRAY, MODERATELY WEATHERED (CLAY, SANDY, HARD, MOIST)

SANDSTONE, VERY WEAK, GRAY, COMPLETELY WEATHERED (SAND, CLAYEY, VERY DENSE, MOIST)

Depth (ft)	Symbol	Samples	Blows per foot	Watercontent %	Soil Type	Depth (ft)	Symbol	Samples	Blows per foot	Watercontent %	Soil Type
5			16	2.6	1	5			5	8.1	1
5			11	13.1	1	5			17	7.6	1
10			29	13.6	1	10			40	9.0	2
15			50	9.9	3	15			50	11.9	4
			11"						10"		
20			50	11.3	3	20			50	10.4	3
			9"						8"		



TEST BORING LOGS

10707 MALTESE POINT
 WD CONSTRUCTION

JOB NO.
 240324

FIG. A-1

TEST BORING 3
 DATE DRILLED 3/6/2024

TEST BORING 4
 DATE DRILLED 3/6/2024

REMARKS

REMARKS

DRY TO 20', 3/6/24

18" TOPSOIL
 SAND, SILTY to SLIGHTLY SILTY,
 LIGHT BROWN, LOOSE to
 MEDIUM DENSE, MOIST

CLAY, SANDY, BROWN, HARD,
 MOIST

CLAYSTONE, VERY WEAK, GRAY,
 MODERATELY WEATHERED
 (CLAY, SANDY, HARD, MOIST)

SANDSTONE, VERY WEAK, GRAY,
 COMPLETELY WEATHERED
 (SAND, CLAYEY, VERY DENSE,
 MOIST)

Depth (ft)	Symbol	Samples	Blows per foot	Watercontent %	Soil Type
0					
1.8			9	4.6	1
5			28	8.2	1
10			39	9.2	2
15			50	12.6	4
15			10"		
20			50	11.1	3
20			7"		

DRY TO 10', 3/6/24

12" TOPSOIL
 SAND, SILTY, DARK BROWN to
 BROWN, LOOSE to MEDIUM
 DENSE, MOIST

Depth (ft)	Symbol	Samples	Blows per foot	Watercontent %	Soil Type
0					
1.2			7	11.7	1
5			7	7.0	1
10			22	10.9	1
15					
20					



TEST BORING LOGS

10707 MALTESE POINT
 WD CONSTRUCTION

JOB NO.
 240324

FIG. A-2

TEST BORING 5
 DATE DRILLED 3/6/2024

REMARKS

DRY TO 10', 3/6/24

SAND, SILTY, TAN to BROWN,
 MEDIUM DENSE to DENSE, DRY
 to MOIST

CLAY, SANDY, GRAY, HARD,
 MOIST

Depth (ft)	Symbol	Samples	Blows per foot	Watercontent %	Soil Type
0 - 5	(Dotted pattern)		15	2.6	1
5 - 10	(Dotted pattern)		33	6.8	1
10 - 11	(Hatched pattern)		44	9.2	2
11 - 15	(Dotted pattern)				
15 - 20	(Dotted pattern)				



TEST BORING LOGS

10707 MALTESE POINT
 WD CONSTRUCTION

JOB NO.
 240324

FIG. A-3



APPENDIX B: Laboratory Test Results

**TABLE B-1
SUMMARY OF LABORATORY TEST RESULTS**

SOIL TYPE	TEST BORING NO.	DEPTH (FT)	WATER (%)	DRY DENSITY (PCF)	PASSING NO. 200 SIEVE (%)	LIQUID LIMIT	PLASTIC LIMIT	PLASTIC INDEX	SULFATE (WT %)	AASHTO CLASS.	SWELL/ CONSOL (%)	USCS	SOIL DESCRIPTION
1, CBR	4	0-3			23.8	NV	NP	NP	<0.01	A-1-b		SM	SAND, SILTY
1	1	2-3			7.2	NV	NP	NP	0.00			SW-SM	SAND, WITH SILT
1	4	1-2			36.8	NV	NP	NP	0.00	A-4		SM	SAND, SILTY
1	5	1-2			3.8	NV	NP	NP		A-1-b		SW	SAND, SLIGHTLY SILTY
2	2	10	13.8	118.8	51.3	26	17	9	<0.01		0.5	CL	CLAY, SANDY
3	1	15			27.9	29	20	9	<0.01			SC	SANDSTONE (SAND, CLAYEY)
4	3	15	13.1	113.4	52.7	36	24	12	0.00		1.2	CL	CLAYSTONE (CLAY, SANDY)

TEST BORING 4
 DEPTH (FT) 0-3

SOIL DESCRIPTION SAND, SILTY
 SOIL TYPE 1, CBR

**Sieve Analysis
 Grain Size Distribution**

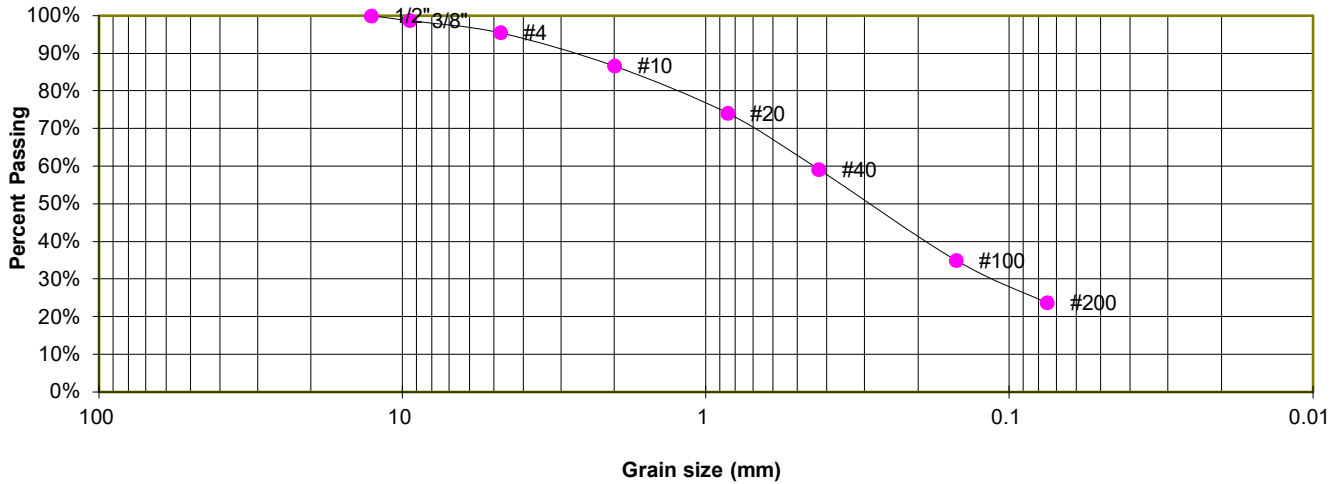

GRAIN SIZE ANALYSIS

U.S. Sieve #	Percent Finer
3"	
1 1/2"	
3/4"	
1/2"	100.0%
3/8"	98.7%
4	95.5%
10	86.7%
20	74.1%
40	59.2%
100	35.0%
200	23.8%

ATTERBERG LIMITS

Plastic Limit	NP
Liquid Limit	NV
Plastic Index	NP

SOIL CLASSIFICATION

USCS CLASSIFICATION: SM
 AASHTO CLASSIFICATION: A-1-b
 AASHTO GROUP INDEX: 0



LABORATORY TEST RESULTS

10707 MALTESE POINT
 WD CONSTRUCTION

JOB NO.
 240324

FIG. B-1

TEST BORING 1
 DEPTH (FT) 2-3

SOIL DESCRIPTION SAND, WITH SILT
 SOIL TYPE 1

**Sieve Analysis
 Grain Size Distribution**

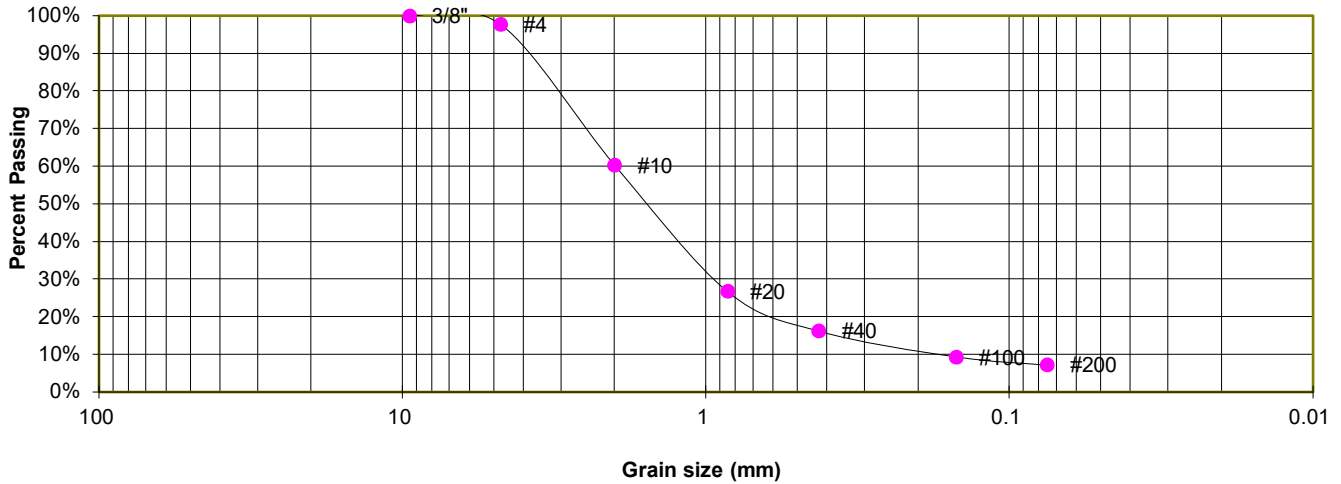

GRAIN SIZE ANALYSIS

U.S. Sieve #	Percent Finer
3"	
1 1/2"	
3/4"	
1/2"	
3/8"	100.0%
4	97.7%
10	60.3%
20	26.8%
40	16.2%
100	9.3%
200	7.2%

ATTERBERG LIMITS

Plastic Limit	NP
Liquid Limit	NV
Plastic Index	NP

SOIL CLASSIFICATION

USCS CLASSIFICATION: SW-SM



LABORATORY TEST RESULTS

10707 MALTESE POINT
 WD CONSTRUCTION

JOB NO.
 240324

FIG. B-2

TEST BORING 4
 DEPTH (FT) 1-2

SOIL DESCRIPTION SAND, SILTY
 SOIL TYPE 1

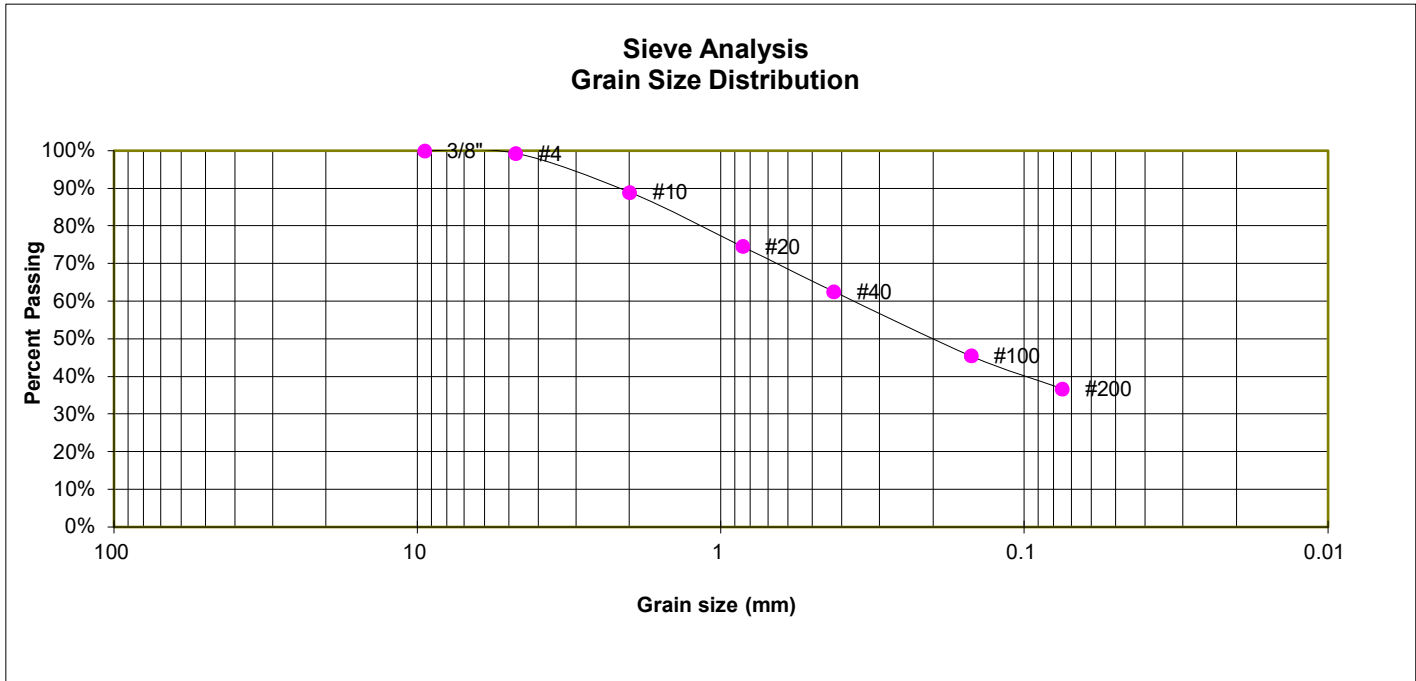

GRAIN SIZE ANALYSIS

U.S. Sieve #	Percent Finer
3"	
1 1/2"	
3/4"	
1/2"	
3/8"	100.0%
4	99.3%
10	89.0%
20	74.6%
40	62.6%
100	45.5%
200	36.8%

ATTERBERG LIMITS

Plastic Limit	NP
Liquid Limit	NV
Plastic Index	NP

SOIL CLASSIFICATION

USCS CLASSIFICATION:	SM
AASHTO CLASSIFICATION:	A-4
AASHTO GROUP INDEX:	0



LABORATORY TEST RESULTS

10707 MALTESE POINT
 WD CONSTRUCTION

JOB NO.
 240324

FIG. B-3

TEST BORING 5
 DEPTH (FT) 1-2

SOIL DESCRIPTION SAND, SLIGHTLY SILTY
 SOIL TYPE 1

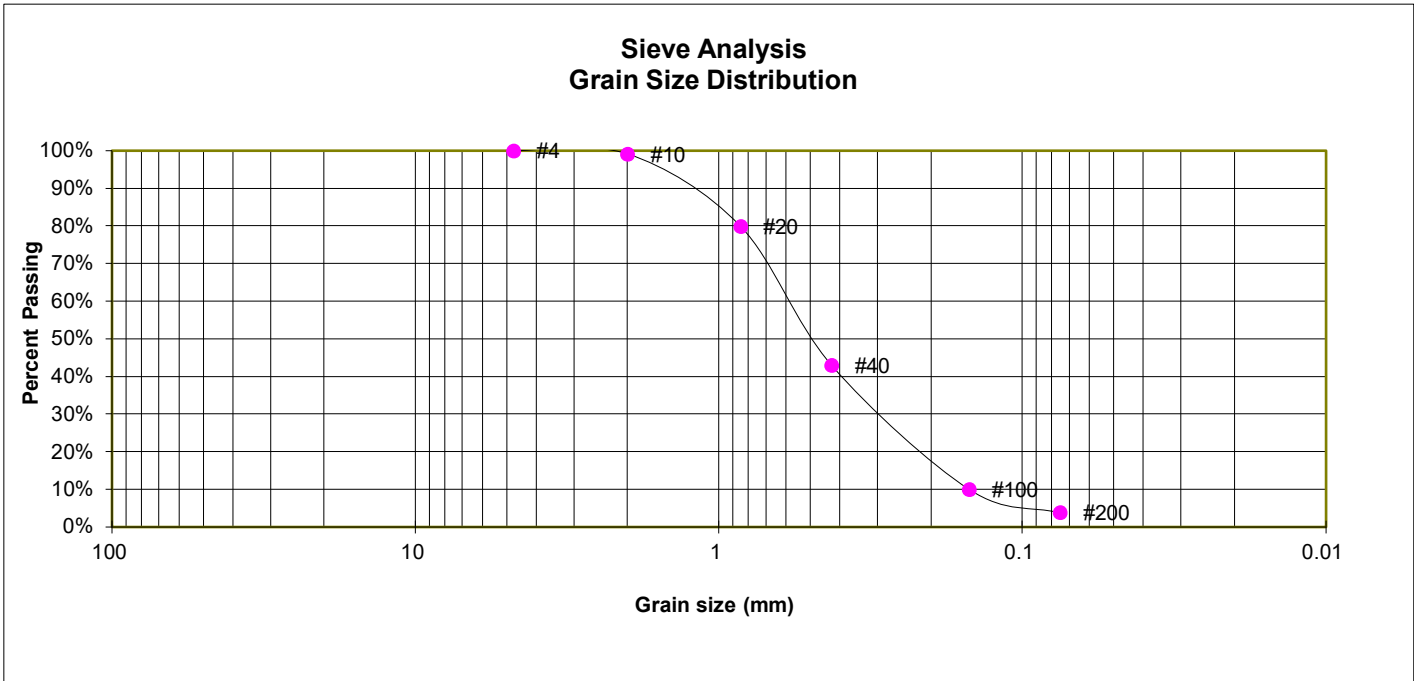

GRAIN SIZE ANALYSIS

U.S. Sieve #	Percent Finer
3"	
1 1/2"	
3/4"	
1/2"	
3/8"	
4	100.0%
10	99.2%
20	79.9%
40	43.0%
100	10.0%
200	3.8%

ATTERBERG LIMITS

Plastic Limit	NP
Liquid Limit	NV
Plastic Index	NP

SOIL CLASSIFICATION

USCS CLASSIFICATION: SW
 AASHTO CLASSIFICATION: A-1-b
 AASHTO GROUP INDEX: 0



LABORATORY TEST RESULTS

10707 MALTESE POINT
 WD CONSTRUCTION

JOB NO.
 240324

FIG. B-4

TEST BORING 2
 DEPTH (FT) 10

SOIL DESCRIPTION CLAY, SANDY
 SOIL TYPE 2

**Sieve Analysis
 Grain Size Distribution**

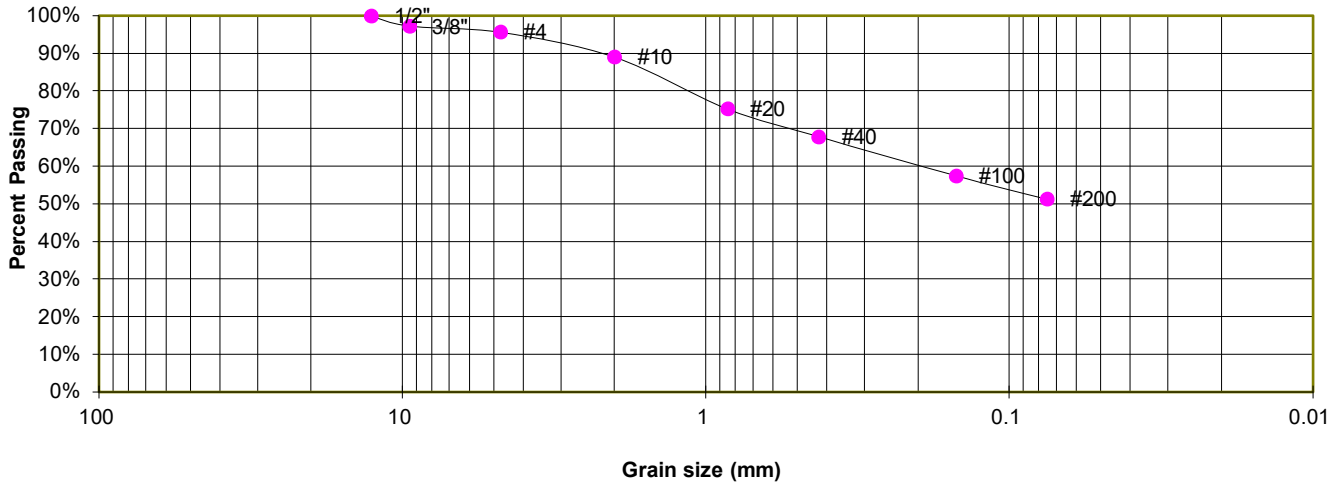

GRAIN SIZE ANALYSIS

U.S. Sieve #	Percent Finer
3"	
1 1/2"	
3/4"	
1/2"	100.0%
3/8"	97.3%
4	95.7%
10	89.0%
20	75.3%
40	67.8%
100	57.5%
200	51.3%

ATTERBERG LIMITS

Plastic Limit	17
Liquid Limit	26
Plastic Index	9

SOIL CLASSIFICATION

USCS CLASSIFICATION: CL



LABORATORY TEST RESULTS

10707 MALTESE POINT
 WD CONSTRUCTION

JOB NO.
 240324

FIG. B-5

TEST BORING 1
 DEPTH (FT) 15

SOIL DESCRIPTION SANDSTONE (SAND, CLAYEY)
 SOIL TYPE 3

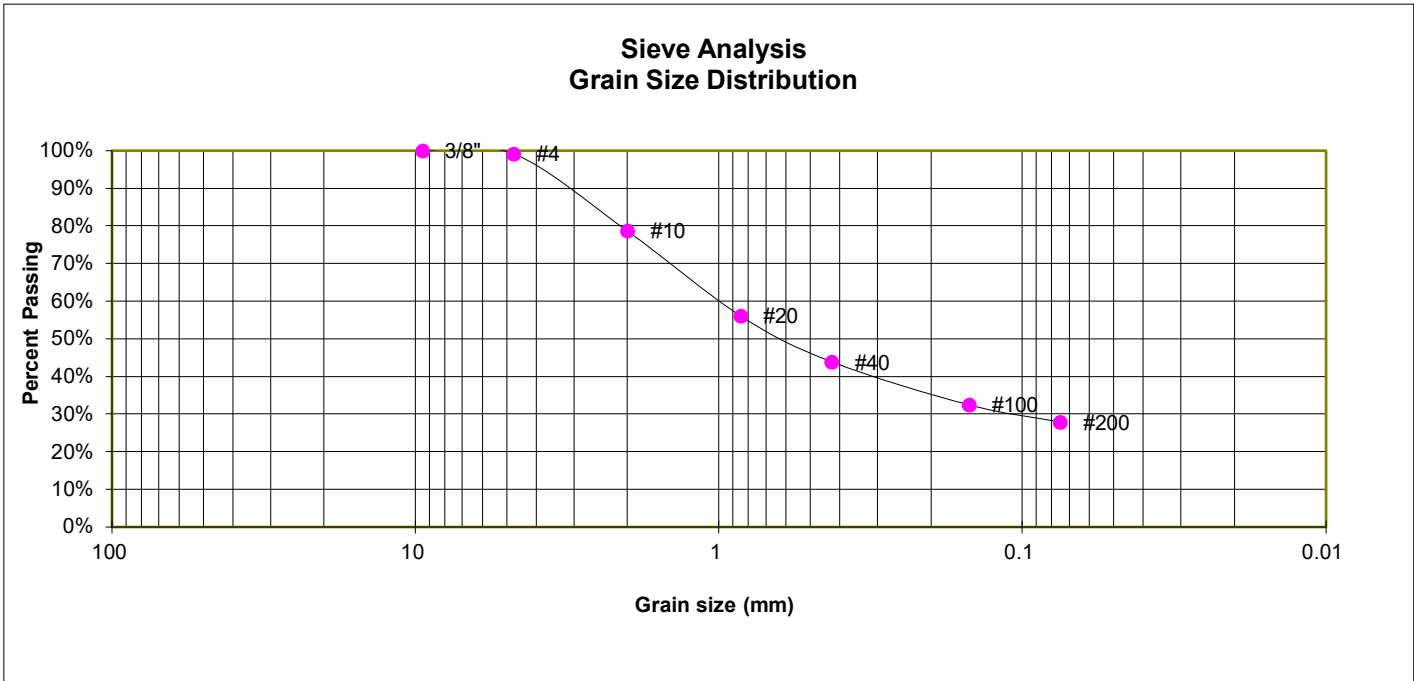

GRAIN SIZE ANALYSIS

U.S. Sieve #	Percent Finer
3"	
1 1/2"	
3/4"	
1/2"	
3/8"	100.0%
4	99.2%
10	78.7%
20	56.2%
40	43.9%
100	32.5%
200	27.9%

ATTERBERG LIMITS

Plastic Limit	20
Liquid Limit	29
Plastic Index	9

SOIL CLASSIFICATION

USCS CLASSIFICATION: SC



LABORATORY TEST RESULTS

10707 MALTESE POINT
 WD CONSTRUCTION

JOB NO.
 240324

FIG. B-6

TEST BORING 3
 DEPTH (FT) 15

SOIL DESCRIPTION CLAYSTONE (CLAY, SANDY)
 SOIL TYPE 4

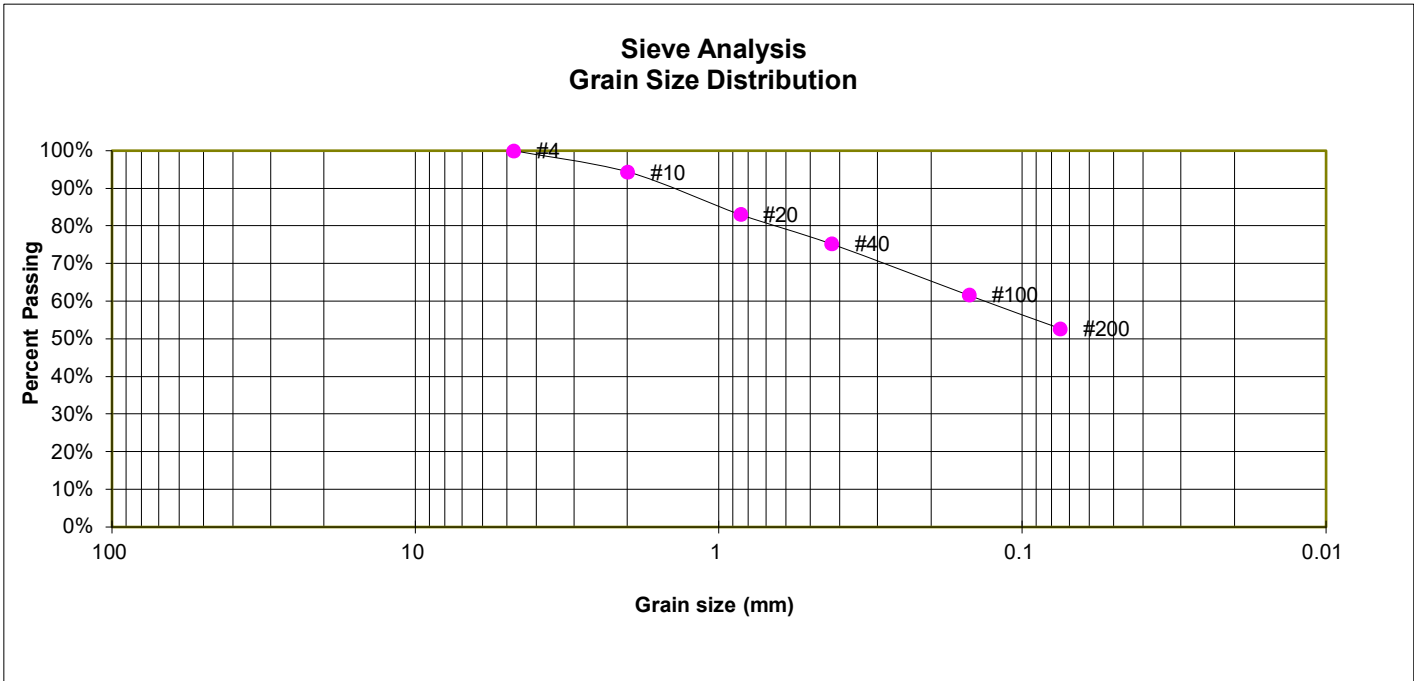

GRAIN SIZE ANALYSIS

U.S. Sieve #	Percent Finer
3"	
1 1/2"	
3/4"	
1/2"	
3/8"	
4	100.0%
10	94.4%
20	83.1%
40	75.2%
100	61.7%
200	52.7%

ATTERBERG LIMITS

Plastic Limit	24
Liquid Limit	36
Plastic Index	12

SOIL CLASSIFICATION

USCS CLASSIFICATION: CL



LABORATORY TEST RESULTS

10707 MALTESE POINT
 WD CONSTRUCTION

JOB NO.
 240324

FIG. B-7

TEST BORING 2
DEPTH (FT) 10

SOIL DESCRIPTION CLAY, SANDY
SOIL TYPE 2



SWELL/COLLAPSE TEST RESULTS

NATURAL UNIT DRY WEIGHT (PCF): 119
NATURAL MOISTURE CONTENT: 13.8%
SWELL/COLLAPSE (%): 0.5%



SWELL TEST RESULTS

10707 MALTESE POINT
WD CONSTRUCTION

JOB NO.
240324

FIG. B-8

TEST BORING 3
DEPTH (FT) 15

SOIL DESCRIPTION CLAYSTONE (CLAY, SANDY)
SOIL TYPE 4

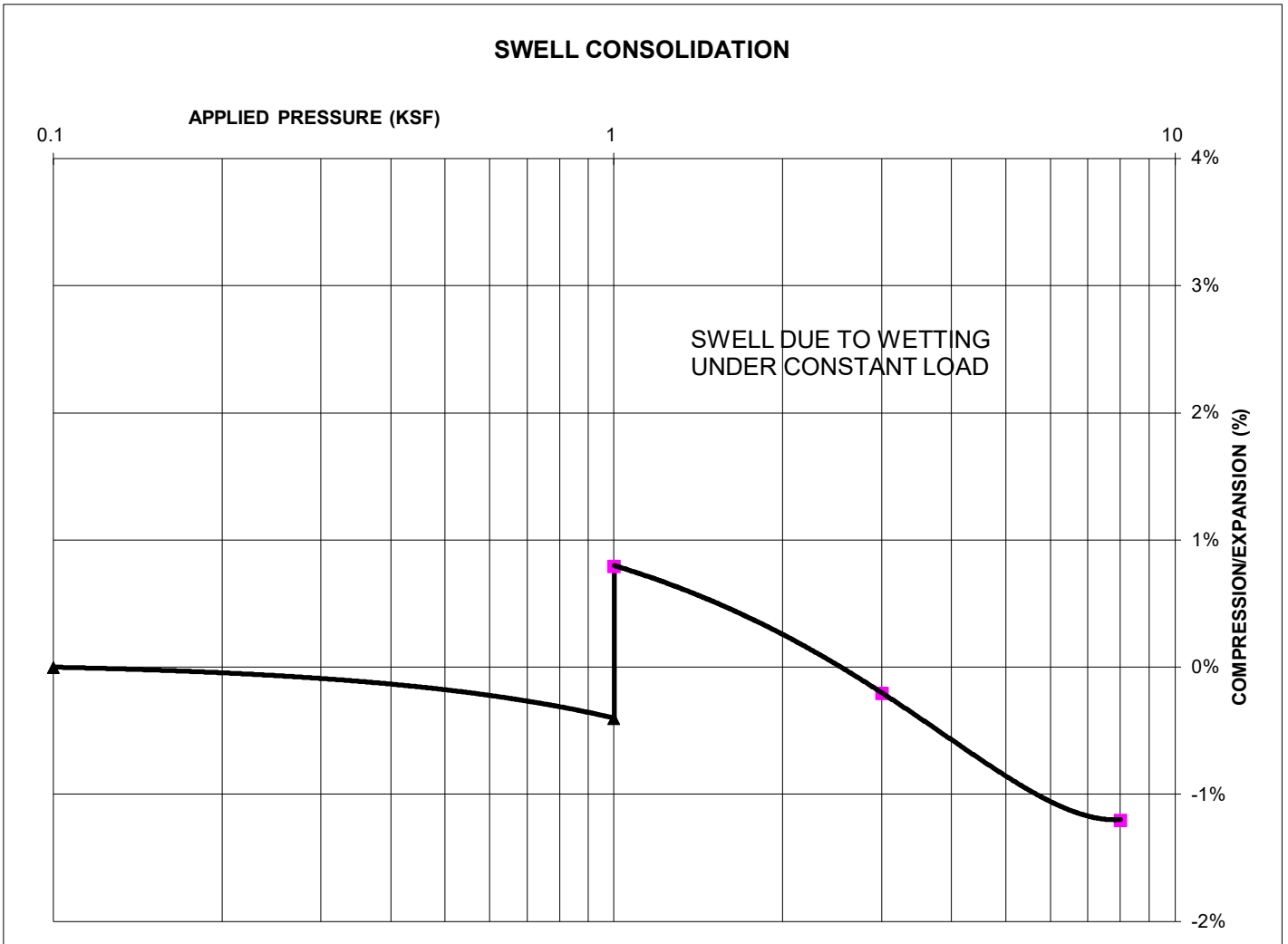

SWELL/COLLAPSE TEST RESULTS

NATURAL UNIT DRY WEIGHT (PCF): 113
NATURAL MOISTURE CONTENT: 13.1%
SWELL/COLLAPSE (%): 1.2%



SWELL TEST RESULTS

10707 MALTESE POINT
WD CONSTRUCTION

JOB NO.
240324

FIG. B-9

SAMPLE LOCATION TB-4 @ 0-3'

SOIL DESCRIPTION SAND, SILTY, BROWN
SOIL TYPE 1

PROCTOR DATA

IDENTIFICATION: SM
PROCTOR TEST #: 1
TEST BY: DK
TEST DESIGNATION: ASTM-1557-A
MAXIMUM DRY DENSITY (PCF): 124.9
OPTIMUM MOISTURE: 8.6

Compaction Curve

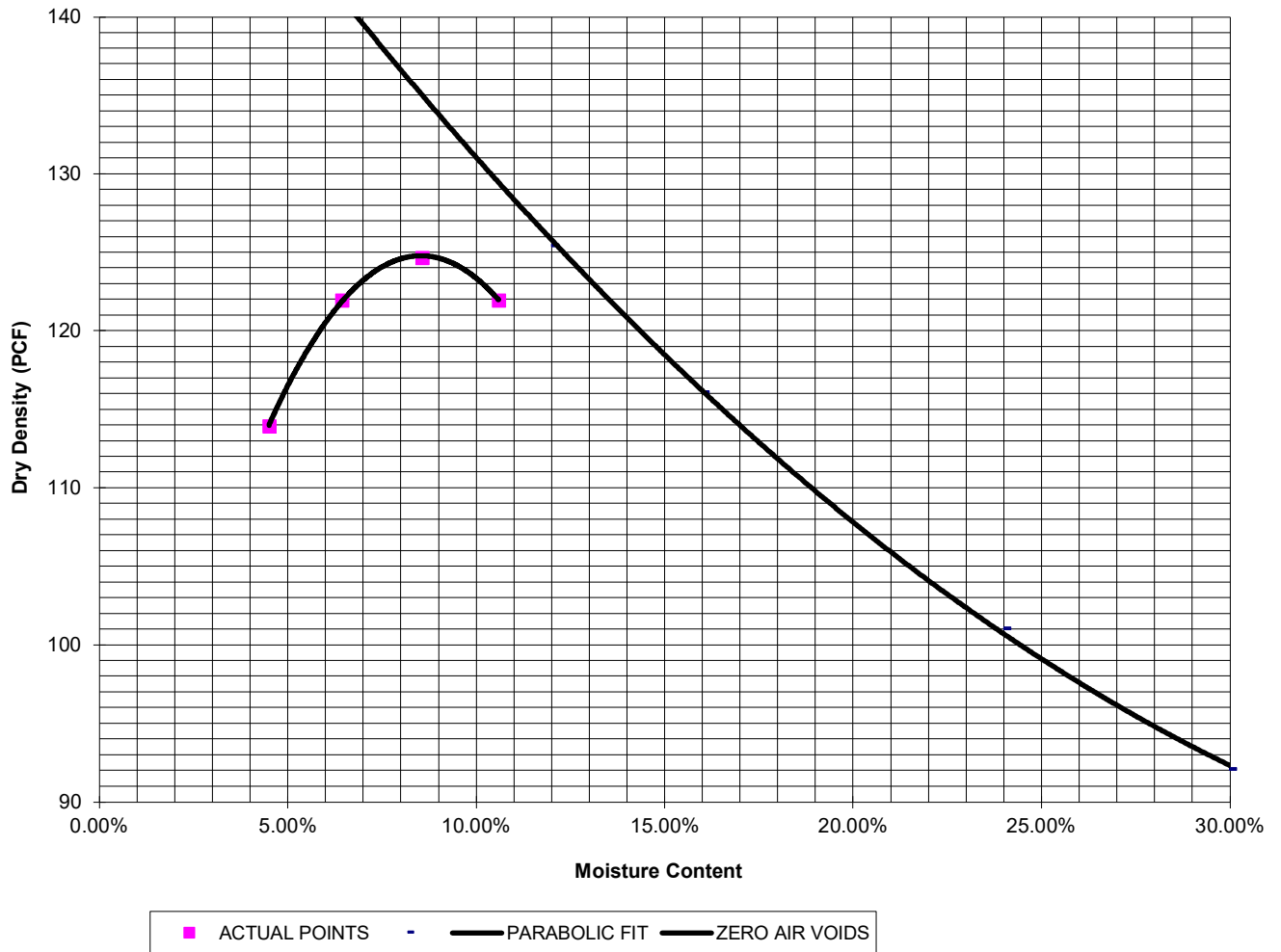

LABORATORY TEST RESULTS

10707 MALTESE POINT
WD CONSTRUCTION

JOB NO.
240324

FIG. B-10

SAMPLE LOCATION TB-4 @ 0-3'
DEPTH (FT) 0

SOIL DESCRIPTION SAND, SILTY, BROWN
SOIL TYPE 1

CBR TEST LOAD DATA

Piston Diameter (cm): 4.958
Piston Area (in²): 2.993

Penetration Depth (inches)	10 BLOWS Mold # 1		25 BLOWS Mold # 2		56 BLOWS Mold # 3	
	Load (lbs)	Stress (psi)	Load (lbs)	Stress (psi)	Load (lbs)	Stress (psi)
0.000	0	0.00	0	0.00	0	0.00
0.025	199	66.50	422	141.02	590	197.16
0.050	274	91.56	668	223.22	1213	405.35
0.075	335	111.95	829	277.03	1711	571.76
0.100	393	131.33	1055	352.55	2425	810.36
0.125	465	155.39	1264	422.39	2868	958.39
0.150	530	177.11	1429	477.53	3238	1082.04
0.175	585	195.49	1578	527.32	3529	1179.28
0.200	628	209.86	1688	564.08	3799	1269.50
0.300	775	258.98	2121	708.77	4618	1543.19
0.400	884	295.40	2332	779.28	4738	1583.29
0.500	1015	339.18	2694	900.25	5114	1708.93

MOISTURE AND DENSITY DATA

	Mold # 1	Mold # 2	Mold # 3
Can #	399	400	41
Wt. Can	8.39	8.36	8.31
Wt. Can+Wet	301.02	322.9	292.73
Wt. Can+Dry	266.35	288.51	263.96
Wt. H2O	34.67	34.39	28.77
Wt. Dry Soil	257.96	280.15	255.65
Moisture Content	13.44%	12.28%	11.25%
Wet Density (PCF)	121.6	128.1	133.3
Dry Density (PCF)	112.0	117.9	122.7
% Compaction	90%	94%	98%
CBR	13.13	35.25	81.04

PROCTOR DATA

Maximum Dry Density (pcf) 124.9
Optimum Moisture 8.6
90% of Max. Dry Density (pcf) 112.4
95% of Max. Dry Density (pcf) 118.7

CBR at 90% of Max. Density = 14.74 ~ R VALUE 45
CBR at 95% of Max. Density = 42.18 ~ R VALUE 75



LABORATORY TEST RESULTS

10707 MALTESE POINT
WD CONSTRUCTION

JOB NO.
240324

FIG. B-11

SAMPLE LOCATION TB-4 @ 0-3'
DEPTH (FT) 0

SOIL DESCRIPTION SAND, SILTY, BROWN
SOIL TYPE 0

Stress VS Penetration

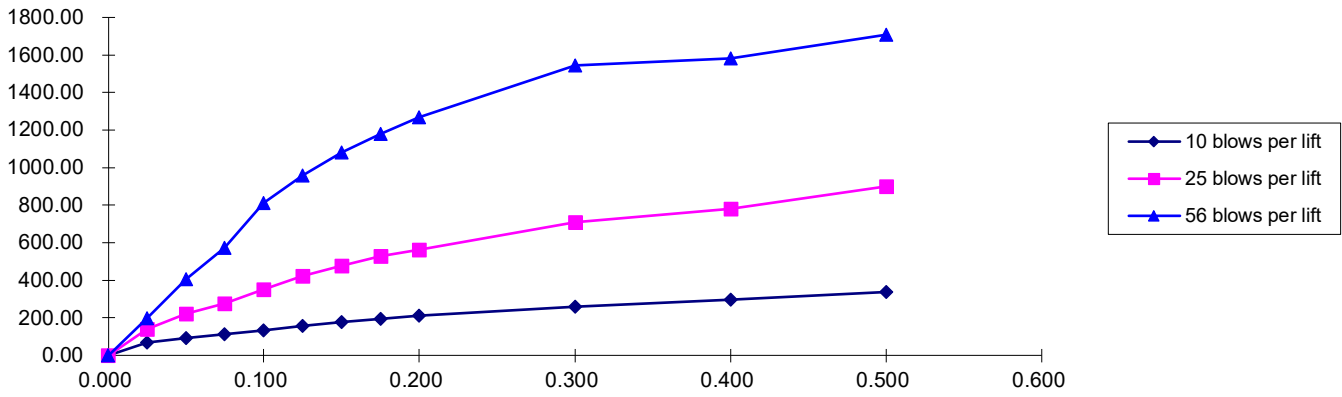

Bearing Ratio VS Dry Density

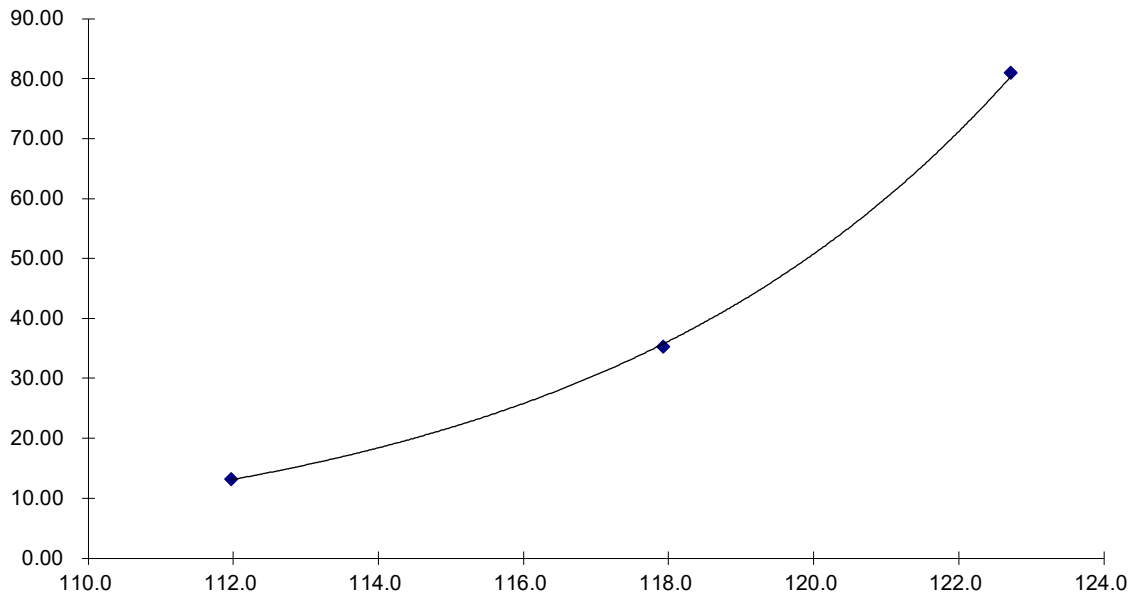

LABORATORY TEST RESULTS

10707 MALTESE POINT
WD CONSTRUCTION

JOB NO.
240324

FIG. B-12



ENTECH
ENGINEERING, INC.

505 ELKTON DRIVE
COLORADO SPRINGS, CO 80907
PHONE (719) 531-5599

June 13, 2024

WD Construction
919 W. Cucharras Street, Suite 100
Colorado Springs, Colorado 80905

Attn: Bill Tibbit

Re: Infiltration Rate Testing (Percolation Test Method)
10707 Maltese Point
El Paso County, Colorado
Entech Job No. 240324

Dear Mr. Tibbit:

As requested, personnel of Entech Engineering, Inc. have performed percolation testing at the above referenced site to evaluate the site soils to determine the infiltration rates for the proposed infiltration garden.

The testing was performed on June 6, 2024. The test locations are shown on Figure 1. The profile hole was placed in the center of the proposed infiltration garden, and the percolation holes (P1 and P2) were placed in the eastern and western sides of the infiltration garden. The Site and Exploration Plan is shown on Figure 1, the profile hole log, laboratory test results, and percolation test results, and infiltration rates are shown in Figures 2 through 5. Soils encountered in the profile and percolation holes consisted of silty sand overlying sand clay. Bedrock and groundwater were not encountered in the profile hole which was drilled to approximately 10 feet.

P1 – Infiltration Rate: the average percolation rate was 27 minutes/inch for P1, the percolation rates correspond to adjusted Infiltration Rate of 0.325 inches/hour. P2 – Infiltration Rate: the average percolation rate was 20 minutes/inch for P2, the percolation rates correspond to adjusted Infiltration Rate of 0.390 inches/hour. An overall average infiltration rate of 0.358 inches/hour should be used for the design of the infiltration garden. To achieve higher infiltration rates the use of a sand filter (minimum depth of 2') could be considered. For material specifications refer to Mile High Flood District – Urban Storm Drainage Criteria Manual Volume 3, Table 4-5 (Gradation Specifications for AASHTO M 43 Fine Aggregate (Filter Sand) https://mhfd.org/wp-content/uploads/2024/06/01_USDCM-Volume-3.pdf .

We trust that this has provided you with the information you required. If you have any questions or need additional information, please do not hesitate to contact us.

Respectfully Submitted,

ENTECH ENGINEERING, INC.

Logan L. Langford, P.G.
Sr. Geologist

Reviewed by:



Digitally signed by Joseph C. Goode Jr.
Date: 06/13/24

Joseph C. Goode, Jr., P.E.
President

PROFILE HOLE 1
 DATE DRILLED 6/6/2024

REMARKS

DRY TO 10', 6/6/24

12" TOPSOIL

SAND, SILTY, BROWN to LIGHT
 BROWN, DENSE to MEDIUM
 DENSE, MOIST

CLAY, SANDY, GRAY, HARD,
 MOIST

Depth (ft)	Symbol	Samples	Blows per foot	Watercontent %
0 - 1.2	(Dotted pattern)			
1.2 - 1.8	(Dotted pattern)		34	3.9
1.8 - 2.4	(Dotted pattern)		21	7.7
2.4 - 10.0	(Dotted pattern)			
10.0 - 10.2	(Diagonal hatching)		38	14.4
10.2 - 20.0	(Dotted pattern)			



PROFILE HOLE LOG

10707 MALTESE POINT
 WD CONSTRUCTION

JOB NO.
 240324

FIG. 2

TEST BORING 1
DEPTH (FT) 2-3

SOIL DESCRIPTION SAND, SILTY

Sieve Analysis Grain Size Distribution

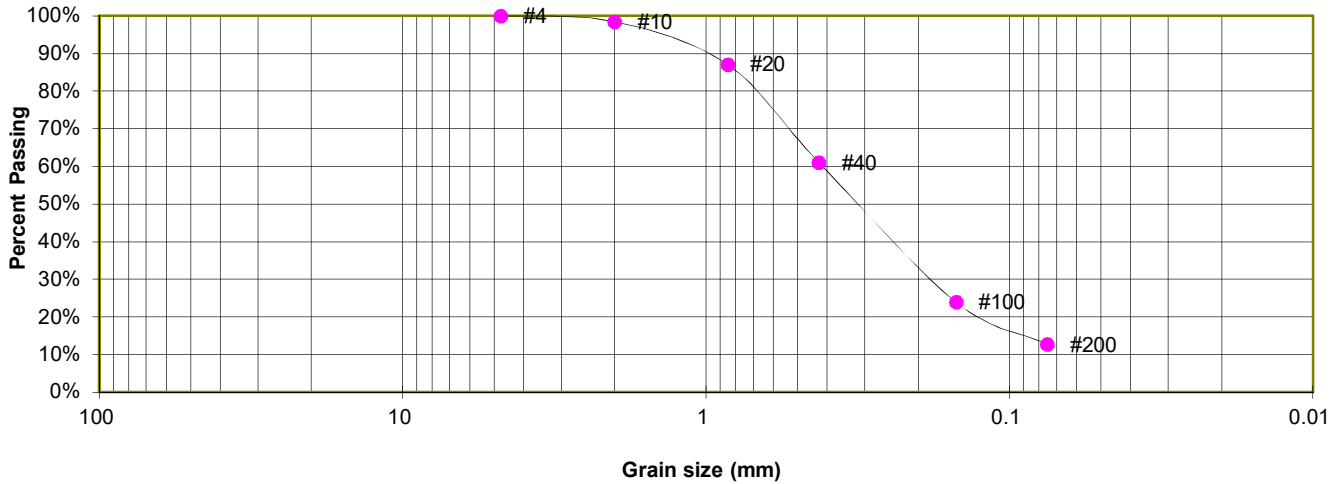

GRAIN SIZE ANALYSIS

U.S. Sieve #	Percent Finer
3"	
1 1/2"	
3/4"	
1/2"	
3/8"	
4	100.0%
10	98.5%
20	87.1%
40	61.1%
100	23.9%
200	12.7%

SOIL CLASSIFICATION

USCS CLASSIFICATION: SM

OL



LABORATORY TEST RESULTS

10707 MALTESE POINT
WD CONSTRUCTION

JOB NO.
240324

FIG. 3

Client: WD Construction
Test Location: 10707 Maltese Point

Job Number: 240324

PERCOLATION HOLES

Date Holes Prepared: 6/6/2024

Hole No. 1
Depth: 29"

Hole No. 2
Depth: 29"

	Time	Water		Time	Water
<u>Trial</u>	<u>(min.)</u>	<u>Level</u>	<u>Trial</u>	<u>(min.)</u>	<u>Level</u>
		<u>Change (in.)</u>			<u>Change (in.)</u>
1	10	1/2	1	10	1/2
2	10	3/8	2	10	1/2
3	10	3/8	3	10	1/2

Perc Rate (min./in.): 27

Perc Rate (min./in.) 20

Average Perc Rate (min./in.) 24

PROFILE HOLE

Date Profile Hole Completed: 6/6/2024

<u>Depth</u>	<u>Visual Classification</u>	<u>Remarks</u>
0-9'	Sand, silty, brown to light brown	
9-10'	Clay, sandy, gray	No Bedrock No Groundwater

34 Blows / ft. @ 2'
21 Blows / ft. @ 4'
38 Blows / ft. @ 9'

Observer: L. Langford



PERCOLATION TEST RESULTS
10707 MALTESE POINT
WD CONSTRUCTION

JOB NO.
240324

FIG. 4

Client: WD Construction
Test Location: 10707 Maltese Point

Job Number 240324

Infiltration Rate (I) = Percolation Rate (P) / Reduction Factor (R_f)
I = P / R_f

$$R_f = [(2d_1 - \Delta d) / \text{dia}] + 1$$

d₁ = initial water depth (in.)

Δd = final water level drop (in.)

dia = diameter of the percolation hole (in.)

Test No. P1 (PH-1)

Perc Rate 2.22 in/hr
diameter 8

P1 (inches)

d₁ = 23.5

Δd = 0.38

R_f = 6.8

Test No. P2 (PH-1)

Perc Rate 3 in/hr
diameter 8

P2 (inches)

d₁ = 27.0

Δd = 0.50

R_f = 7.7

I = 0.325 in/hr

I = 0.390 in/hr

I AVG = 0.358 in/hr



PERCOLATION TEST RESULTS
10707 MALTESE POINT
WD CONSTRUCTION

JOB NO.
240324

FIG. 5



APPENDIX G – EXISTING AND PROPOSED DRAINAGE MAPS

PROPOSED DRAINAGE MAP LEGEND:

	EXISTING CONTOURS
	PROPOSED CONTOURS
	PROPERTY LINE
	ROADWAY CENTERLINE
	EXISTING WATER LINE
	EXISTING SANITARY SEWER
	EXISTING FIRE HYDRANT
	EXISTING WATER VALVE
	EXISTING SANITARY MANHOLE
	EXISTING STREET LIGHT
	EXISTING SIGN
	PROPOSED EPC TYPE A CURB
	PROPOSED EPC TYPE B CURB
	PROPOSED SPILL CURB & LEVEL SPREADER
	PROPOSED RETAINING WALL (MAX HEIGHT 1.5')
	DRAINAGE CHANNEL FLOW LINE
	PROPOSED DOWNSPOUT & PVC STORM DRAIN
	PROPOSED CONCRETE DRAINAGE CHANNEL
	PROPOSED SIDEWALK CHASE
	PROPOSED CONCRETE CURB STOP
	PROPOSED REINFORCED CONCRETE
	PROPOSED DRAINAGE FLOW ARROW
	PROPOSED DRAINAGE BASIN BOUNDARY
	PROPOSED OVERLAND/CHANNELIZED FLOW PATH

REVISIONS

NO.	DATE	REVISION

ROLLING THUNDER BUSINESS PARK - LOT 12
10707 MALTESE PT. PEYTON, CO

SK
SK Design Group, Inc.
333 Perry St.
Suite 209
Castle Rock, Colorado 80104
Phone: 913-451-1818
Fax: 913-451-7599

SK JOB NUMBER: 24-105	DESIGNED: AM	CHECKED: SM	APPROVED:
DATE: 02-22-2024	DETAILED: EP		

PROPOSED DRAINAGE MAP

SHEET 2 OF 2

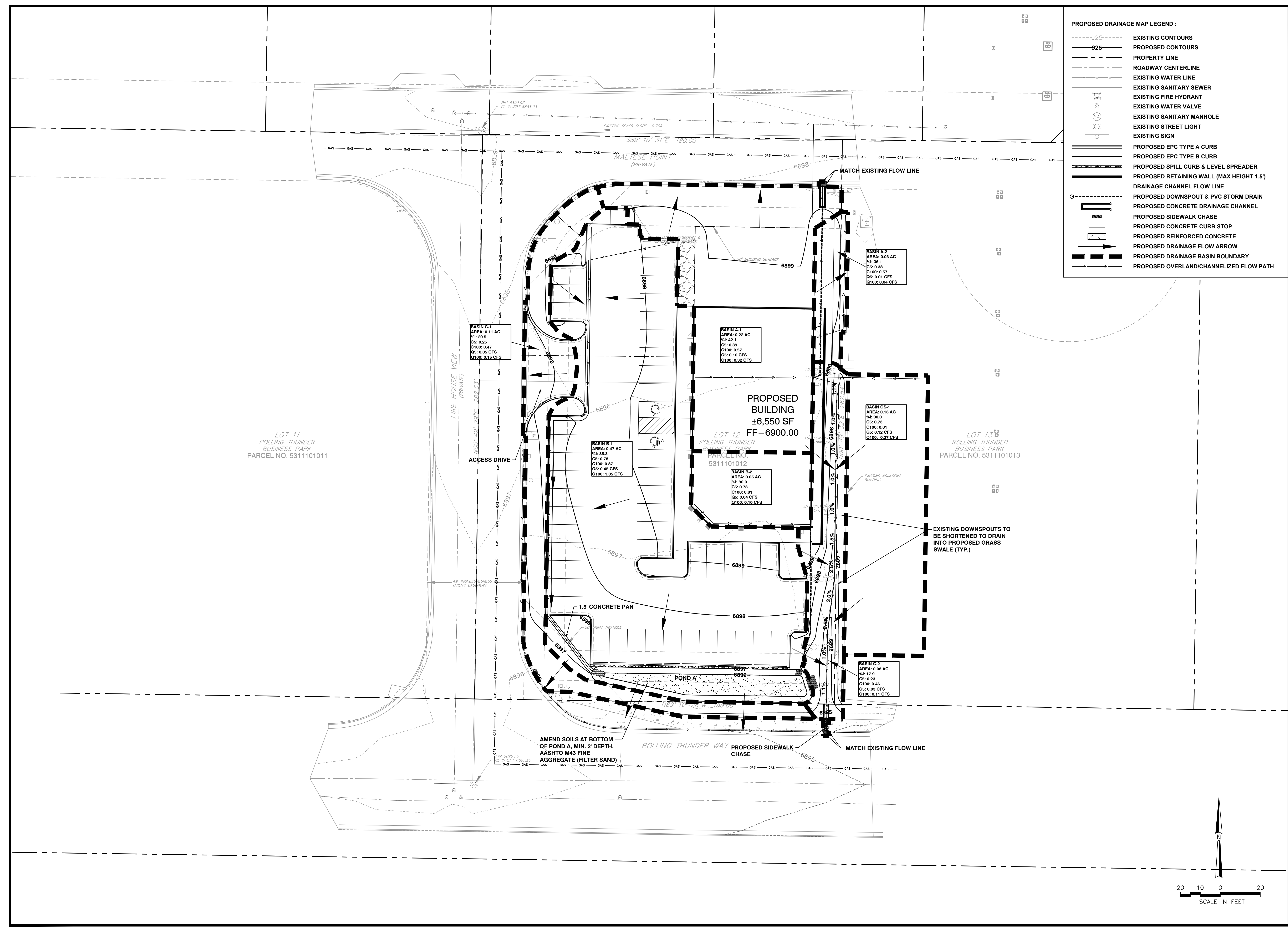

BASIN C-1
AREA: 0.11 AC
H: 20.9
CS: 0.25
C100: 0.47
Q5: 0.05 CFS
Q100: 0.15 CFS

BASIN A-1
AREA: 0.22 AC
H: 42.1
CS: 0.39
C100: 0.57
Q5: 0.10 CFS
Q100: 0.32 CFS

BASIN A-2
AREA: 0.03 AC
H: 36.1
CS: 0.38
C100: 0.57
Q5: 0.01 CFS
Q100: 0.04 CFS

BASIN C-1
AREA: 0.13 AC
H: 90.0
CS: 0.73
C100: 0.81
Q5: 0.12 CFS
Q100: 0.27 CFS

BASIN B-1
AREA: 0.47 AC
H: 85.3
CS: 0.78
C100: 0.87
Q5: 0.45 CFS
Q100: 1.05 CFS

BASIN B-2
AREA: 0.05 AC
H: 90.0
CS: 0.73
C100: 0.81
Q5: 0.04 CFS
Q100: 0.10 CFS

BASIN C-2
AREA: 0.08 AC
H: 17.5
CS: 0.23
C100: 0.46
Q5: 0.03 CFS
Q100: 0.11 CFS

AMEND SOILS AT BOTTOM OF POND A, MIN. 2' DEPTH. AASHTO M43 FINE AGGREGATE (FILTER SAND)

EXISTING DOWNSPOUTS TO BE SHORTENED TO DRAIN INTO PROPOSED GRASS SWALE (TYP.)