

LOT 1, BLOCK 1, JOHNSONS VACATION

A PORTION OF THE SE ¼ OF SECTION 1, TOWNSHIP 13S, RANGE 65W OF THE 6TH P.M. OLD MERIDIAN RD., FALCON, COLORADO

GRADING & EROSION CONTROL DOCUMENTS

STANDARD NOTES FOR EL PASO COUNTY GRADING AND EROSION CONTROL PLANS

1. STORMWATER DISCHARGES FROM CONSTRUCTION SITES SHALL NOT CAUSE OR THREATEN TO CAUSE POLLUTION, CONTAMINATION, OR DEGRADATION OF STATE WATERS. ALL WORK AND EARTH DISTURBANCE SHALL BE DONE IN A MANNER THAT MINIMIZES POLLUTION OF ANY ON-SITE OR OFF SITE WATERS, INCLUDING WETLANDS.
2. NOTWITHSTANDING ANYTHING DEPICTED IN THESE PLANS IN WORDS OR GRAPHIC REPRESENTATION, ALL DESIGN AND CONSTRUCTION RELATED TO ROADS, STORM DRAINAGE AND EROSION CONTROL SHALL CONFORM TO THE STANDARDS AND REQUIREMENTS OF THE MOST RECENT VERSION OF THE RELEVANT ADOPTED EL PASO COUNTY STANDARDS, INCLUDING THE LAND DEVELOPMENT CODE, THE ENGINEERING CRITERIA MANUAL, THE DRAINAGE CRITERIA MANUAL, AND THE DRAINAGE CRITERIA MANUAL VOLUME 2. ANY DEVIATIONS TO REGULATIONS AND STANDARDS MUST BE REQUESTED, AND APPROVED, IN WRITING.
3. A SEPARATE STORMWATER MANAGEMENT PLAN (SWMP) FOR THIS PROJECT SHALL BE COMPLETED AND AN EROSION AND STORMWATER QUALITY CONTROL PERMIT (ESQCP) ISSUED PRIOR TO COMMENCING CONSTRUCTION. MANAGEMENT OF THE SWMP DURING CONSTRUCTION IS THE RESPONSIBILITY OF THE DESIGNATED QUALIFIED STORMWATER MANAGER OR CERTIFIED EROSION CONTROL INSPECTOR. THE SWMP SHALL BE LOCATED ON-SITE AT ALL TIMES DURING CONSTRUCTION AND SHALL BE KEPT UP TO DATE WITH WORK PROGRESS AND CHANGES IN THE FIELD.
4. ONCE THE ESQCP IS APPROVED AND A "NOTICE TO PROCEED" HAS BEEN ISSUED, THE CONTRACTOR MAY INSTALL THE INITIAL STAGE EROSION AND SEDIMENT CONTROL BMPS AS INDICATED ON THE GEC. A PRECONSTRUCTION MEETING BETWEEN THE CONTRACTOR, ENGINEER, AND EL PASO COUNTY WILL BE HELD PRIOR TO ANY CONSTRUCTION. IT IS THE RESPONSIBILITY OF THE APPLICANT TO COORDINATE THE MEETING TIME AND PLACE WITH COUNTY STAFF.
5. CONTROL MEASURES MUST BE INSTALLED PRIOR TO COMMENCEMENT OF ACTIVITIES THAT COULD CONTRIBUTE POLLUTANTS TO STORMWATER. CONTROL MEASURES FOR ALL SLOPES, CHANNELS, DITCHES, AND DISTURBED LAND AREAS SHALL BE INSTALLED IMMEDIATELY UPON COMPLETION OF THE DISTURBANCE.
6. ALL TEMPORARY SEDIMENT AND EROSION CONTROL MEASURES SHALL BE MAINTAINED AND REMAIN IN EFFECTIVE OPERATING CONDITION UNTIL PERMANENT SOIL EROSION CONTROL MEASURES ARE IMPLEMENTED AND FINAL STABILIZATION IS ESTABLISHED. ALL PERSONS ENGAGED IN LAND DISTURBANCE ACTIVITIES SHALL ASSESS THE ADEQUACY OF CONTROL MEASURES AT THE SITE AND IDENTIFY IF CHANGES TO THOSE CONTROL MEASURES ARE NEEDED TO ENSURE THE CONTINUED EFFECTIVE PERFORMANCE OF THE CONTROL MEASURES. ALL CHANGES TO TEMPORARY SEDIMENT AND EROSION CONTROL MEASURES MUST BE INCORPORATED INTO THE STORMWATER MANAGEMENT PLAN.
7. TEMPORARY STABILIZATION SHALL BE IMPLEMENTED ON DISTURBED AREAS AND STOCKPILES WHERE GROUND DISTURBING CONSTRUCTION ACTIVITY HAS PERMANENTLY CEASED OR TEMPORARILY CEASED FOR LONGER THAN 14 DAYS.
8. FINAL STABILIZATION MUST BE IMPLEMENTED AT ALL APPLICABLE CONSTRUCTION SITES. FINAL STABILIZATION IS ACHIEVED WHEN ALL GROUND DISTURBING ACTIVITIES ARE COMPLETE AND ALL DISTURBED AREAS EITHER HAVE A UNIFORM VEGETATIVE COVER WITH INDIVIDUAL PLANT DENSITY OF 70 PERCENT OF PRE-DISTURBANCE LEVELS ESTABLISHED OR EQUIVALENT PERMANENT ALTERNATIVE STABILIZATION METHOD IS IMPLEMENTED. ALL TEMPORARY SEDIMENT AND EROSION CONTROL MEASURES SHALL BE REMOVED UPON FINAL STABILIZATION AND BEFORE PERMIT CLOSURE.
9. ALL PERMANENT STORMWATER MANAGEMENT FACILITIES SHALL BE INSTALLED AS DESIGNED IN THE APPROVED PLANS. ANY PROPOSED CHANGES THAT EFFECT THE DESIGN OR FUNCTION OF PERMANENT STORMWATER MANAGEMENT STRUCTURES MUST BE APPROVED BY THE ECM ADMINISTRATOR PRIOR TO IMPLEMENTATION.
10. EARTH DISTURBANCES SHALL BE CONDUCTED IN SUCH A MANNER SO AS TO EFFECTIVELY MINIMIZE ACCELERATED SOIL EROSION AND RESULTING SEDIMENTATION. ALL DISTURBANCES SHALL BE DESIGNED, CONSTRUCTED, AND COMPLETED SO THAT THE EXPOSED AREA OF ANY DISTURBED LAND SHALL BE LIMITED TO THE SHORTEST PRACTICAL PERIOD OF TIME. PRE-EXISTING VEGETATION SHALL BE PROTECTED AND MAINTAINED WITHIN 50 HORIZONTAL FEET OF A WATERS OF THE STATE UNLESS SHOWN TO BE INFEASIBLE AND SPECIFICALLY REQUESTED AND APPROVED.
11. COMPACTION OF SOIL MUST BE PREVENTED IN AREAS DESIGNATED FOR INFILTRATION CONTROL MEASURES OR WHERE FINAL STABILIZATION WILL BE ACHIEVED BY VEGETATIVE COVER. AREAS DESIGNATED FOR INFILTRATION CONTROL MEASURES SHALL ALSO BE PROTECTED FROM SEDIMENTATION DURING CONSTRUCTION UNTIL FINAL STABILIZATION IS ACHIEVED. IF COMPACTION PREVENTION IS NOT FEASIBLE DUE TO SITE CONSTRAINTS, ALL AREAS DESIGNATED FOR INFILTRATION AND VEGETATION CONTROL MEASURES MUST BE LOOSENEED PRIOR TO INSTALLATION OF THE CONTROL MEASURE(S).
12. ANY TEMPORARY OR PERMANENT FACILITY DESIGNED AND CONSTRUCTED FOR THE CONVEYANCE OF STORMWATER AROUND, THROUGH, OR FROM THE EARTH DISTURBANCE AREA SHALL BE A STABILIZED CONVEYANCE DESIGNED TO MINIMIZE EROSION AND THE DISCHARGE OF SEDIMENT OFF-SITE.
13. CONCRETE WASH WATER SHALL BE CONTAINED AND DISPOSED OF IN ACCORDANCE WITH THE SWMP. NO WASH WATER SHALL BE DISCHARGED TO OR ALLOWED TO ENTER STATE WATERS, INCLUDING ANY SURFACE OR SUBSURFACE STORM DRAINAGE SYSTEM OR FACILITIES. CONCRETE WASHOUTS SHALL NOT BE LOCATED IN AN AREA WHERE SHALLOW GROUNDWATER MAY BE PRESENT, OR WITHIN 50 FEET OF A SURFACE WATER BODY, CREEK OR STREAM.
14. DURING DEWATERING OPERATIONS, UNCONTAMINATED GROUNDWATER MAY BE DISCHARGED ON-SITE, BUT SHALL NOT LEAVE THE SITE IN THE FORM OF SURFACE RUNOFF UNLESS AN APPROVED STATE DEWATERING PERMIT IS IN PLACE.
15. EROSION CONTROL BLANKETING OR OTHER PROTECTIVE COVERING SHALL BE USED ON SLOPES STEEPER THAN 3:1.
16. CONTRACTOR SHALL BE RESPONSIBLE FOR THE REMOVAL OF ALL WASTES FROM THE CONSTRUCTION SITE FOR DISPOSAL IN ACCORDANCE WITH LOCAL AND STATE REGULATORY REQUIREMENTS: NO CONSTRUCTION DEBRIS, TREE SLASH, BUILDING MATERIAL WASTES OR UNUSED BUILDING MATERIALS SHALL BE BURIED, DUMPED, OR DISCHARGED AT THE SITE.
17. WASTE MATERIALS SHALL NOT BE TEMPORARILY PLACED OR STORED IN THE STREET, ALLEY, OR OTHER PUBLIC WAY, UNLESS IN ACCORDANCE WITH AN APPROVED TRAFFIC CONTROL PLAN. CONTROL MEASURES MAY BE REQUIRED BY EL PASO COUNTY ENGINEERING IF DEEMED NECESSARY, BASED ON SPECIFIC CONDITIONS AND CIRCUMSTANCES.
18. TRACKING OF SOILS AND CONSTRUCTION DEBRIS OFF-SITE SHALL BE MINIMIZED. MATERIALS TRACKED OFF-SITE SHALL BE CLEANED UP AND PROPERLY DISPOSED OF IMMEDIATELY.
19. THE OWNER/DEVELOPER SHALL BE RESPONSIBLE FOR THE REMOVAL OF ALL CONSTRUCTION DEBRIS, DIRT, TRASH, ROCK, SEDIMENT, SOIL, AND SAND THAT MAY ACCUMULATE IN ROADS, STORM DRAINS AND OTHER DRAINAGE CONVEYANCE SYSTEMS AND STORMWATER APPURTENANCES AS A RESULT OF SITE DEVELOPMENT.
20. THE QUANTITY OF MATERIALS STORED ON THE PROJECT SITE SHALL BE LIMITED, AS MUCH AS PRACTICAL, TO THAT QUANTITY REQUIRED TO PERFORM THE WORK IN AN ORDERLY SEQUENCE. ALL MATERIALS STORED ON-SITE SHALL BE STORED IN A NEAT, ORDERLY MANNER, IN THEIR ORIGINAL CONTAINERS, WITH ORIGINAL MANUFACTURER'S LABELS.
21. NO CHEMICAL(S) HAVING THE POTENTIAL TO BE RELEASED IN STORMWATER ARE TO BE STORED OR USED ON-SITE UNLESS PERMISSION FOR THE USE OF SUCH CHEMICAL(S) IS GRANTED IN WRITING BY THE ECM ADMINISTRATOR. IN GRANTING APPROVAL FOR THE USE OF SUCH CHEMICAL(S), SPECIAL CONDITIONS AND MONITORING MAY BE REQUIRED.

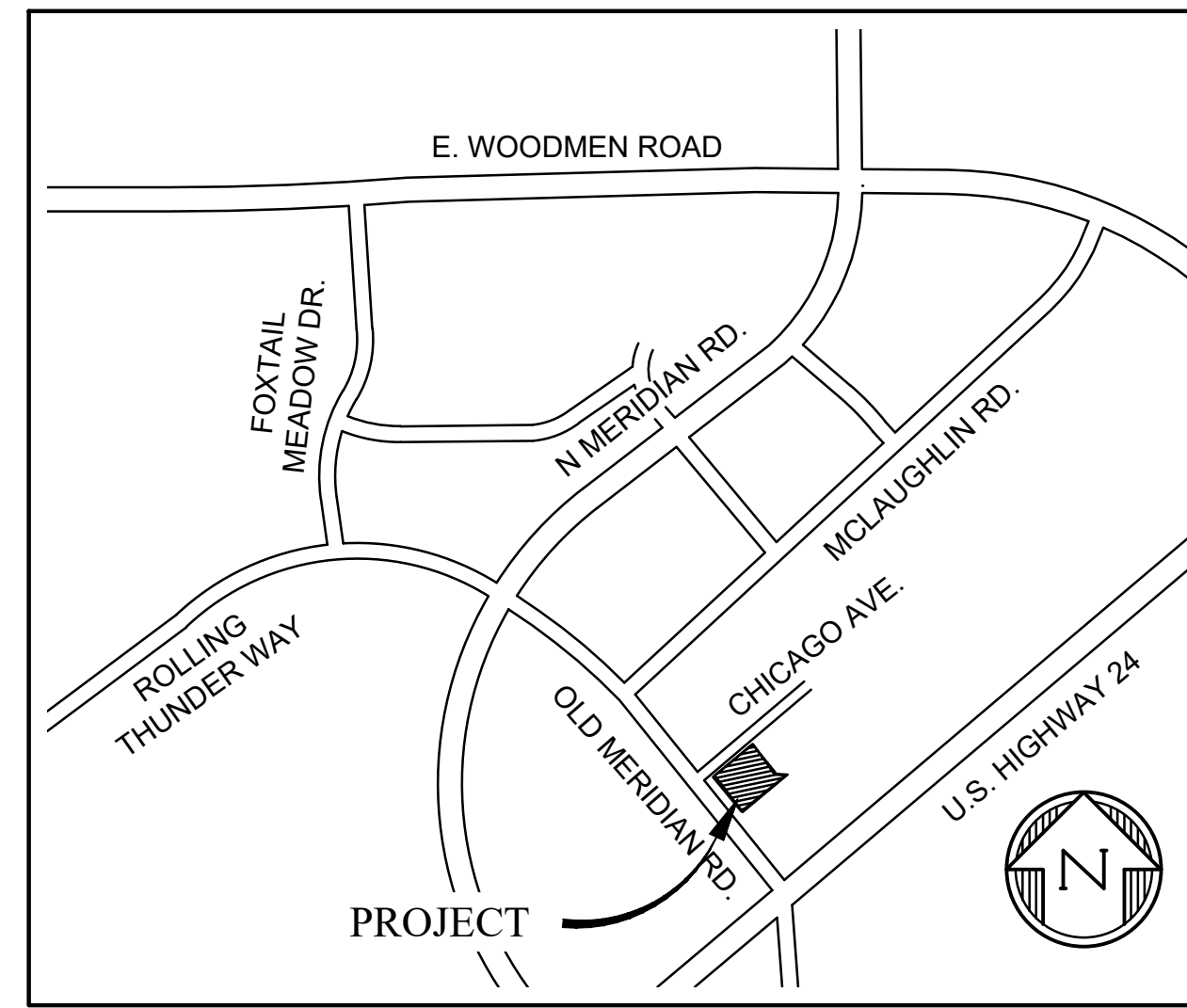

VICINITY MAP
SCALE: NTS

CONTACTS:

OWNER/DEVELOPER:	HESED LLC 10308 MT EVANS DR. PEYTON, CO 80831 DAVID CABAN	ELECTRIC:	MVEA 11140 E. WOODMEN RD. FALCON, CO 80831 719-495-2283
ARCHITECT:	JOHN DAVIS DESIGN GROUP 176 TALAMINE COURT, SUITE #100 COLORADO SPRINGS, CO 80907 719-528-1177	FIRE PREVENTION	FALCON FIRE DEPARTMENT 7030 OLD MERIDIAN RD. PEYTON, CO 80831 CHIEF TRENT HARWIG 719-495-4050
CIVIL ENGINEER:	DREXEL BARRELL & CO. 3 SOUTH 7TH STREET COLORADO SPRINGS, CO 80905 TIM D. MCCONNELL, P.E. 719-260-0887	TELEPHONE:	CENTURY LINK 303 E. PIKES PEAK AVENUE COLORADO SPRINGS, CO. 80903 PAT NEELY 719-636-4859
GAS:	COLORADO SPRINGS UTILITIES 7710 DURANT DRIVE COLORADO SPRINGS, CO 80920 TIM WENDT 719-668-4962	WATER & WASTEWATER:	WOODMEN HILLS METRO DISTRICT 8046 EASTONVILLE RD PEYTON, CO 80831 CODY RITTER 719-495-2500

SHEET INDEX

1	CV	COVER SHEET
2	EC1	INITIAL GRADING & EROSION CONTROL PLAN
3	EC2	INTERIM/FINAL GRADING & EROSION CONTROL PLAN
4	DT1	EROSION CONTROL DETAILS
5	DT2	EROSION CONTROL DETAILS

DESIGN ENGINEER'S STATEMENT

THIS GRADING AND EROSION CONTROL PLAN WAS PREPARED UNDER MY DIRECTION AND SUPERVISION AND IS CORRECT TO THE BEST OF MY KNOWLEDGE AND BELIEF. SAID PLAN HAS BEEN PREPARED ACCORDING TO THE CRITERIA ESTABLISHED BY THE COUNTY FOR GRADING AND EROSION CONTROL PLANS. I ACCEPT RESPONSIBILITY FOR ANY LIABILITY CAUSED BY ANY NEGLIGENT ACTS, ERRORS OR OMISSIONS ON MY PART IN PREPARING THIS PLAN.

Katherine Varnum
KATHERINE VARNUM
P.E.# 53459
5/18/2023
DATE

OWNER'S STATEMENT

I, THE OWNER/DEVELOPER HAVE READ AND WILL COMPLY WITH THE REQUIREMENTS OF THE GRADING AND EROSION CONTROL PLAN

David Caban
OWNER
5/30/2023
DATE

EL PASO COUNTY

COUNTY PLAN REVIEW IS PROVIDED ONLY FOR GENERAL CONFORMANCE WITH COUNTY DESIGN CRITERIA. THE COUNTY IS NOT RESPONSIBLE FOR THE ACCURACY AND ADEQUACY OF THE DESIGN, DIMENSIONS, AND/OR ELEVATIONS WHICH SHALL BE CONFIRMED AT THE JOB SITE. THE COUNTY THROUGH THE APPROVAL OF THIS DOCUMENT ASSUMES NO RESPONSIBILITY FOR COMPLETENESS AND/OR ACCURACY OF THIS DOCUMENT.

FILED IN ACCORDANCE WITH THE REQUIREMENTS OF THE EL PASO COUNTY LAND DEVELOPMENT CODE, DRAINAGE CRITERIA MANUAL VOLUMES 1 AND 2, AND ENGINEERING CRITERIA MANUAL, AS AMENDED.

IN ACCORDANCE WITH ECM SECTION 1.12, THESE CONSTRUCTION DOCUMENTS WILL BE VALID FOR CONSTRUCTION FOR A PERIOD OF 2 YEARS FROM THE DATE SIGNED BY THE EL PASO COUNTY ENGINEER. IF CONSTRUCTION HAS NOT STARTED WITHIN THOSE 2 YEARS, THE PLANS WILL NEED TO BE RESUBMITTED FOR APPROVAL, INCLUDING PAYMENT OF REVIEW FEES AT THE PLANNING AND COMMUNITY DEVELOPMENT DIRECTOR'S DISCRETION.

JOSHUA PALMER, P.E.
COUNTY ENGINEER/ECM ADMINISTRATOR
DATE

PREPARED BY:



CLIENT:

HESED LLC

10308 MT. EVANS DR.
PEYTON, CO 80831

DEVELOPMENT PLANS FOR:
**LOT 1, BLOCK 1,
JOHNSONS VACATION**
OLD MERIDIAN ROAD
FALCON, COLORADO

ISSUE	DATE
INITIAL ISSUE	10/17/21
RESUBMITTAL	5/18/23
DESIGNED BY:	KGV
DRAWN BY:	SDM
CHECKED BY:	TDW
FILE NAME:	21496-01-ECCV



PREPARED UNDER MY DIRECT SUPERVISION FOR AND ON BEHALF OF DREXEL, BARRELL & CO.

DRAWING SCALE:
HORIZONTAL: N/A
VERTICAL: N/A

**GRADING &
EROSION CONTROL
COVER SHEET**

PROJECT NO. 21496-01CSCV
DRAWING NO.

CV

SHEET: 1 OF 5

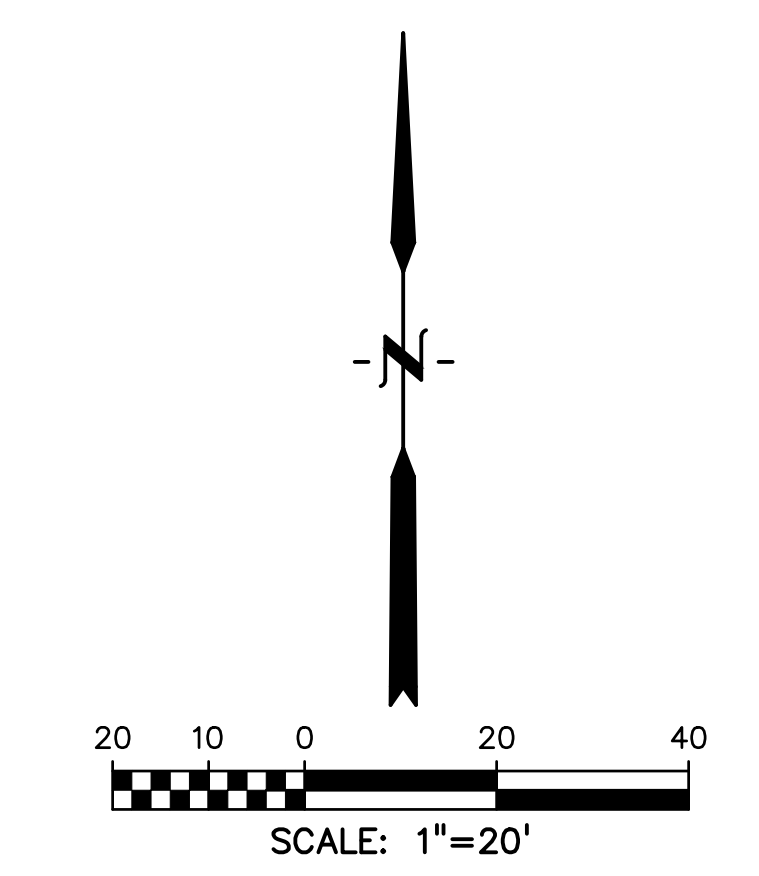
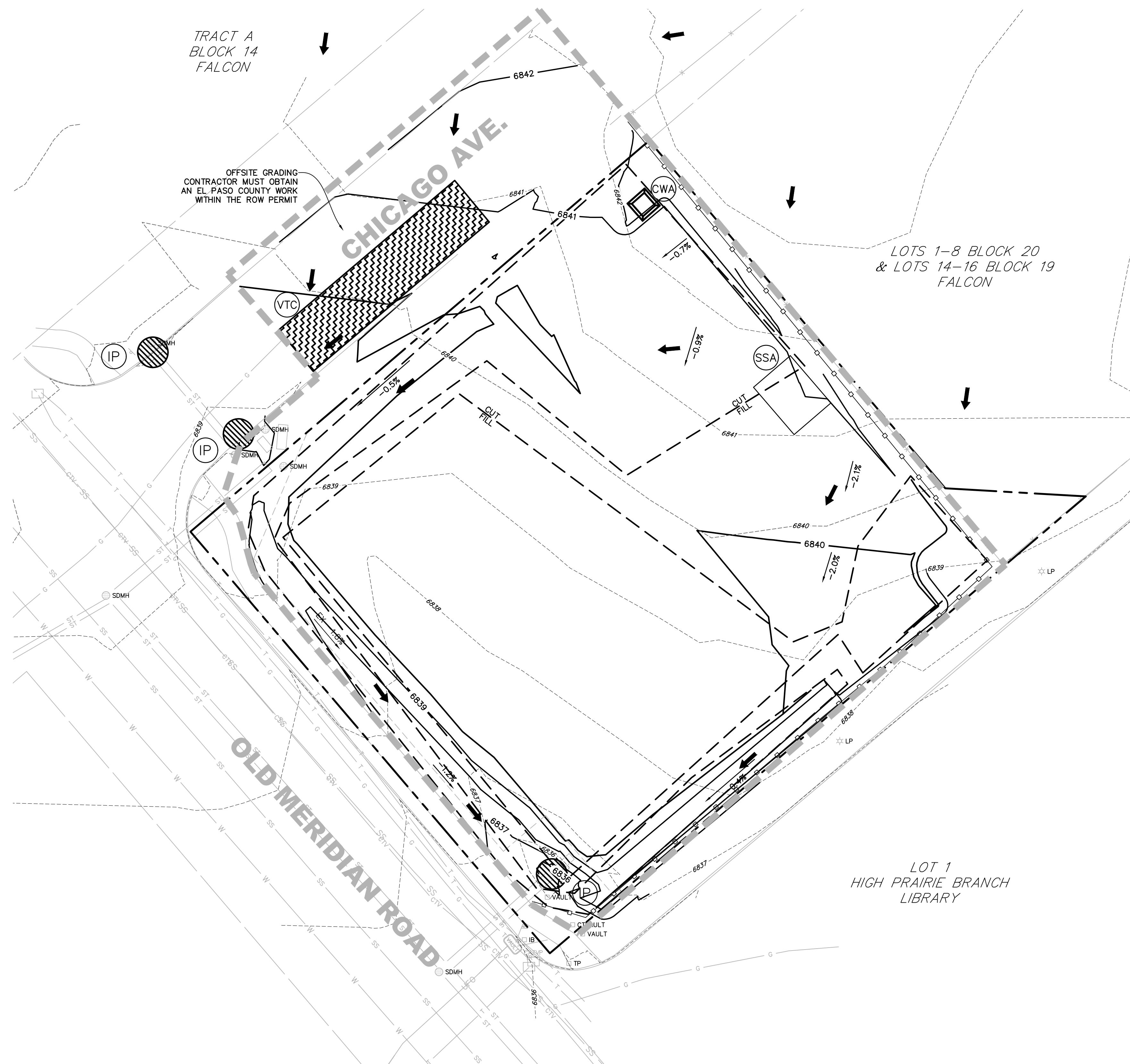

LEGEND

PROJECT BOUNDARY/PROPERTY LINE
EASEMENT
EX INTERMEDIATE CONTOUR 6203
EX INDEX CONTOUR 6205
MINOR CONTOUR 6203
MAJOR CONTOUR 6205
EXISTING SLOPE GRADE & DIRECTION OF FLOW	EX -2.0%
PROPOSED SLOPE GRADE & DIRECTION OF FLOW	-2.0%
HIGH POINT	HP
LOW POINT	LP
PROPOSED INLET	■
PROPOSED MANHOLE	●
INITIAL LIMITS OF DISTURBANCE/ CONSTRUCTION SITE BOUNDARY
CUT/FILL LINE CUT FILL
FINAL SEEDING/MULCHING/LANDSCAPING (SEE DETAIL SHEET 4)	SM
INTERIM/FINAL INLET PROTECTION (SEE DETAIL SHEET 3)	IP
INITIAL/INTERIM SILT FENCE (SEE DETAIL SHEET 4)	SF
NOTE: FIBER ROLL EROSION LOG CAN BE UTILIZED AS AN ALTERNATIVE TO SILT FENCING OR STRAW BALES.	
INITIAL/INTERIM CONCRETE WASHOUT AREA (SEE DETAIL SHEET 4)	CWA
INITIAL/INTERIM VEHICLE TRACKING CONTROL (SEE DETAIL SHEET 3)	VTC
INITIAL/INTERIM STABILIZED STAGING AREA (SEE DETAIL SHEET 4)	SSA

- NOTES:**
1. WASTE DISPOSAL BIN LOCATIONS ARE TBD AND WILL BE ADDED TO THE SWMP ONCE DETERMINED BY THE CONTRACTOR.
 2. ONSITE LOCATION OF THE SWMP IS TBD AND WILL BE ADDED TO THE SWMP ONCE DETERMINED BY THE CONTRACTOR.
 3. THE NEED FOR DEWATERING IS NOT ANTICIPATED. IN THE EVENT THAT DEWATERING BECOMES NECESSARY THE CONTRACTOR, WITH INPUT FROM THE COUNTY STORMWATER INSPECTOR, WILL DESIGN THE LOCATIONS OF DIVERSION, PUMP & DISCHARGES.
 4. EXISTING VEGETATION IS SPARSE NATIVE GRASSES

PREPARED BY:

DREXEL, BARRELL & CO.
 Engineers • Surveyors
 3 SOUTH 7TH STREET
 COLORADO SPGS, COLORADO 80905
 CONTACT: TIM D. MCCONNELL, P.E.
 (719)260-0887
 COLORADO SPRINGS • LAFAYETTE

CLIENT:
HESED LLC
 10308 MT. EVANS DR.
 PEYTON, CO 80831

DEVELOPMENT PLANS FOR:
**LOT 1, BLOCK 1,
 JOHNSONS VACATION**
 OLD MERIDIAN ROAD
 FALCON, COLORADO

ISSUE	DATE
INITIAL ISSUE	10/17/21
RESUBMITTAL	5/18/23

DESIGNED BY: KGV
 DRAWN BY: SDM
 CHECKED BY: TDM
 FILE NAME: 21496-01EC1-2



PREPARED UNDER MY DIRECT SUPERVISION FOR AND ON BEHALF OF DREXEL, BARRELL & CO.

DRAWING SCALE:
 HORIZONTAL: 1" = 20'
 VERTICAL: N/A

**INITIAL GRADING
 & EROSION
 CONTROL PLAN**

PROJECT NO. 21496-01CSCV
 DRAWING NO.

EC1

SHEET: 2 OF 5



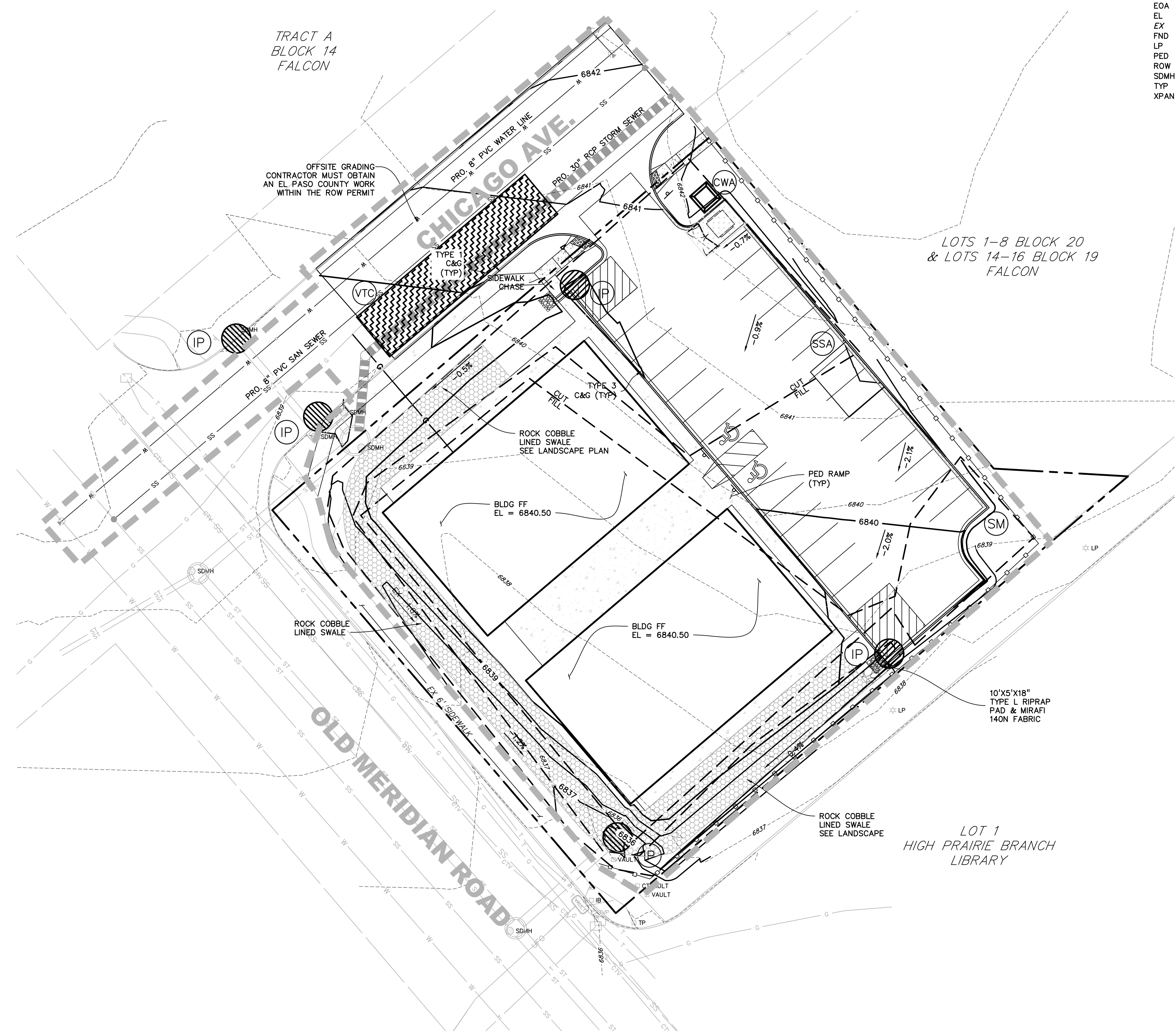

TRACT A
BLOCK 14
FALCON

LOTS 1-8 BLOCK 20
& LOTS 14-16 BLOCK 19
FALCON

LOT 1
HIGH PRAIRIE BRANCH
LIBRARY

ABBREVIATION

BLDG	BUILDING
C&G	CURB AND GUTTER
EOA	EDGE OF ASPHALT
EL	ELEVATION
EX	EXISTING
FND	FOUNDATION
LP	LIGHT POLE
PED	PEDESTRIAN
ROW	RIGHT OF WAY
SDMH	STORM DRAIN MANHOLE
TYP	TYPICAL
XPAN	CROSS PAN

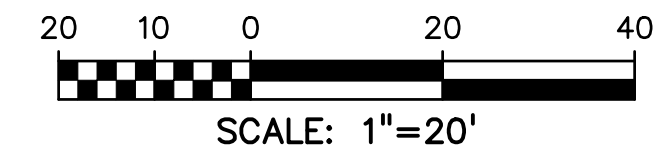
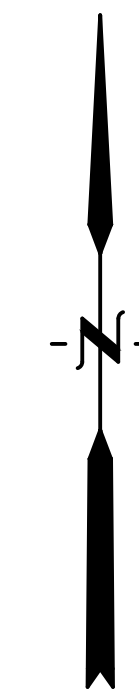

LEGEND

PROJECT BOUNDARY/PROPERTY LINE
EASEMENT
EX INTERMEDIATE CONTOUR 6203
EX INDEX CONTOUR 6205
MINOR CONTOUR 6203
MAJOR CONTOUR 6205
EXISTING SLOPE GRADE & DIRECTION OF FLOW	EX -2.0%
PROPOSED SLOPE GRADE & DIRECTION OF FLOW	-2.0%
HIGH POINT HP
LOW POINT LP
PROPOSED INLET
PROPOSED MANHOLE
LIMITS OF DISTURBANCE/ CONSTRUCTION SITE BOUNDARY
CUT/FILL LINE CUT FILL
FINAL SEEDING/MULCHING/LANDSCAPING (SM)
INTERIM/FINAL INLET PROTECTION (IP)
INTERIM/FINAL SILT FENCE (SF)
NOTE: FIBER ROLL EROSION LOG CAN BE UTILIZED AS AN ALTERNATIVE TO SILT FENCING OR STRAW BALES.	
INTERIM/FINAL CONCRETE WASHOUT AREA (CWA)
INTERIM/FINAL VEHICLE TRACKING CONTROL (VTC)
INTERIM/FINAL STABILIZED STAGING AREA (SSA)

NOTES:

1. WASTE DISPOSAL BIN LOCATIONS ARE TBD AND WILL BE ADDED TO THE SWMP ONCE DETERMINED BY THE CONTRACTOR.
2. ONSITE LOCATION OF THE SWMP IS TBD AND WILL BE ADDED TO THE SWMP ONCE DETERMINED BY THE CONTRACTOR.
3. THE NEED FOR DEWATERING IS NOT ANTICIPATED. IN THE EVENT THAT DEWATERING BECOMES NECESSARY THE CONTRACTOR, WITH INPUT FROM THE COUNTY STORMWATER INSPECTOR, WILL DESIGN THE LOCATIONS OF DIVERSION, PUMP & DISCHARGES.

PREPARED BY:



DREXEL, BARRELL & CO.
Engineers & Surveyors
3 SOUTH 7TH STREET
COLORADO SPGS, COLORADO 80905
CONTACT: TIM D. MCCONNELL, P.E.
(719)260-0887
COLORADO SPRINGS • LAFAYETTE

CLIENT:

HESED LLC
10308 MT. EVANS DR.
PEYTON, CO 80831

DEVELOPMENT PLANS FOR:
**LOT 1, BLOCK 1,
JOHNSONS VACATION**
OLD MERIDIAN ROAD
FALCON, COLORADO

ISSUE	DATE
INITIAL ISSUE	10/17/21
RESUBMITTAL	5/18/23
DESIGNED BY:	KGV
DRAWN BY:	SDM
CHECKED BY:	TDM
FILE NAME:	21496-01EC1-2



PREPARED UNDER MY DIRECT SUPERVISION FOR AND ON BEHALF OF DREXEL, BARRELL & CO.

DRAWING SCALE:
HORIZONTAL: 1" = 20'
VERTICAL: N/A

INTERIM/FINAL
GRADING/EROSION
CONTROL PLAN

PROJECT NO. 21496-01CSCV
DRAWING NO.

EC2

SHEET: 3 OF 5



EL PASO COUNTY PCD FILE NO: PPR-2167

SC-6 Inlet Protection (IP)

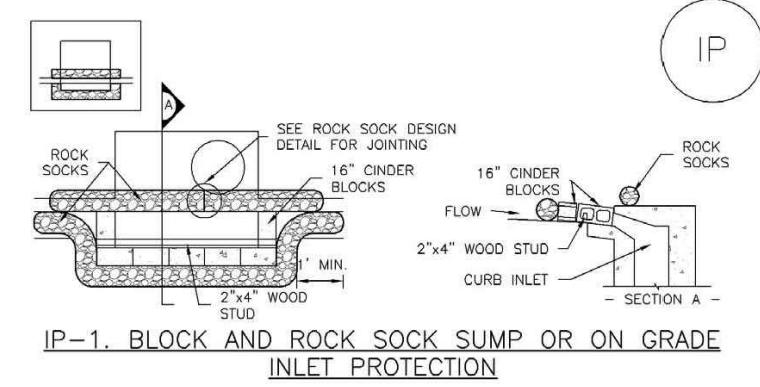

IP-1. BLOCK AND ROCK SOCK SUMP OR ON GRADE INLET PROTECTION

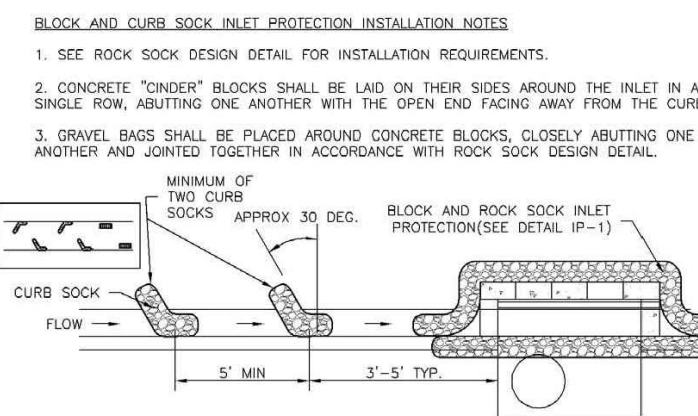

IP-2. CURB ROCK SOCKS UPSTREAM OF INLET PROTECTION

- BLOCK AND CURB ROCK SOCK INLET PROTECTION INSTALLATION NOTES**
1. SEE ROCK SOCK DESIGN DETAIL FOR INSTALLATION REQUIREMENTS.
 2. CONCRETE "CHINER" BLOCKS SHALL BE Laid ON THEIR SIDES AROUND THE INLET IN A SHAPE NOW ADJUTING ONE ANOTHER WITH THE OPEN END FACING AWAY FROM THE CURB.
 3. GRVEL BASE SHALL BE PLACED AROUND CONCRETE BLOCKS, CLOSELY ADJUTING ONE ANOTHER AND JOINED TOGETHER IN ACCORDANCE WITH ROCK SOCK DESIGN DETAIL.
- MINIMUM OF TWO CURB SOCKS APPROX 30 DEG. BLOCK AND ROCK SOCK INLET PROTECTION(SEE DETAIL IP-1)**
- CURB ROCK SOCK INLET PROTECTION INSTALLATION NOTES**
1. SEE ROCK SOCK DESIGN DETAIL INSTALLATION REQUIREMENTS.
 2. PLACEMENT OF THE SOCK SHALL BE APPROXIMATELY 30 DEGREES FROM PERPENDICULAR IN THE OPPOSITE DIRECTION OF FLOW.
 3. SOCKS ARE TO BE FLUSH WITH THE CURB AND SPACED A MINIMUM OF 3 FEET APART.
 4. AT LEAST TWO CURB SOCKS IN SERIES ARE REQUIRED UPSTREAM OF ON-GRADE INLETS.

IP-4 Urban Drainage and Flood Control District August 2013
Urban Storm Drainage Criteria Manual Volume 3

Inlet Protection (IP) SC-6

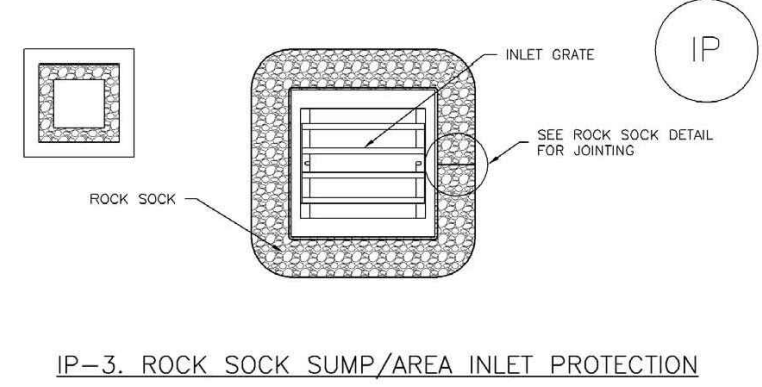

IP-3. ROCK SOCK SUMP/AREA INLET PROTECTION

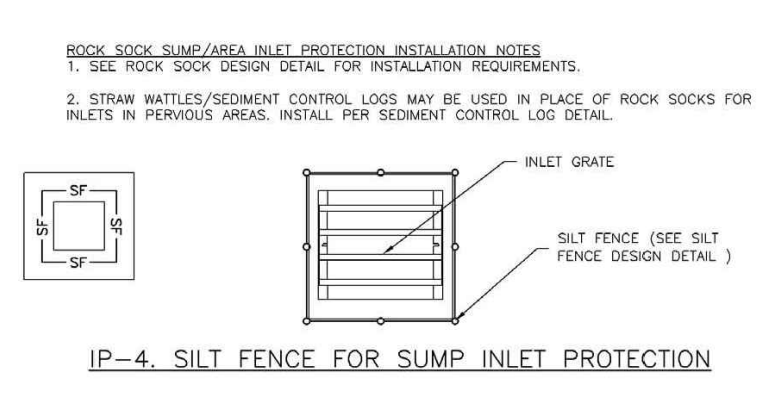

IP-4. SILT FENCE FOR SUMP INLET PROTECTION

- ROCK SOCK SUMP/AREA INLET PROTECTION INSTALLATION NOTES**
1. SEE ROCK SOCK DESIGN DETAIL FOR INSTALLATION REQUIREMENTS.
 2. STRAW MATS/SEDIMENT CONTROL LOGS MAY BE USED IN PLACE OF ROCK SOCKS FOR INLETS IN PREVIOUS AREAS. INSTALL PER SEDIMENT CONTROL LOG DETAIL.
- SILT FENCE INLET PROTECTION INSTALLATION NOTES**
1. SEE SILT FENCE DESIGN DETAIL FOR INSTALLATION REQUIREMENTS.
 2. POSTS SHALL BE PLACED AT EACH CORNER OF THE INLET AND AROUND THE EDGES AT A MAXIMUM SPACING OF 3 FEET.
 3. STRAW MATS/SEDIMENT CONTROL LOGS MAY BE USED IN PLACE OF SILT FENCE FOR INLETS IN PREVIOUS AREAS. INSTALL PER SEDIMENT CONTROL LOG DETAIL.

August 2013 Urban Drainage and Flood Control District August 2013
Urban Storm Drainage Criteria Manual Volume 3 IP-5

SC-6 Inlet Protection (IP)

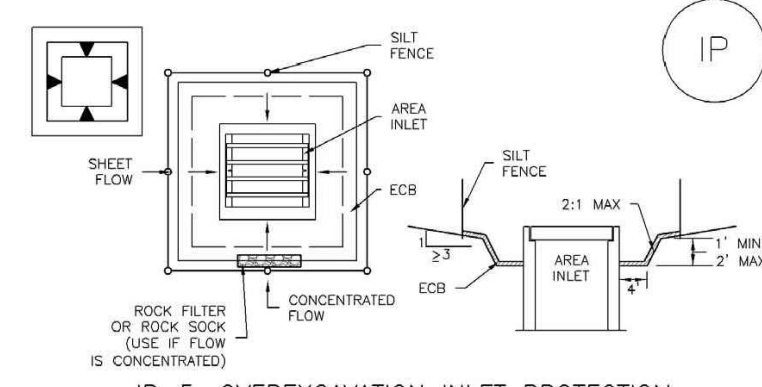

IP-5. OVEREXCAVATION INLET PROTECTION

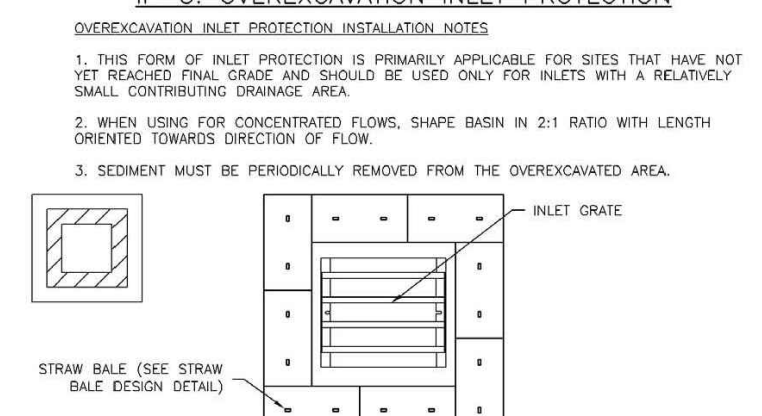

IP-6. STRAW BALE FOR SUMP INLET PROTECTION

- OVEREXCAVATION INLET PROTECTION INSTALLATION NOTES**
1. THIS FORM OF INLET PROTECTION IS PRIMARILY APPLICABLE FOR SITES THAT HAVE NOT YET REACHED FINAL GRADE AND SHOULD BE USED ONLY FOR INLETS WITH A RELATIVELY SMALL CONTRIBUTING DRAINAGE AREA.
 2. WHEN USING FOR CONCENTRATED FLOWS, SHAPE BASIN IN 2:1 RATIO WITH LENGTH ORIENTED TOWARD DIRECTION OF FLOW.
 3. SEDIMENT MUST BE PERIODICALLY REMOVED FROM THE OVEREXCAVATED AREA.
- STRAW BALE BARRIER INLET PROTECTION INSTALLATION NOTES**
1. SEE STRAW BALE DESIGN DETAIL FOR INSTALLATION REQUIREMENTS.
 2. BALES SHALL BE PLACED IN A SINGLE ROW AROUND THE INLET WITH ENDS OF BALES TIGHTLY ADJUTING ONE ANOTHER.

IP-6 Urban Drainage and Flood Control District August 2013
Urban Storm Drainage Criteria Manual Volume 3

Inlet Protection (IP) SC-6

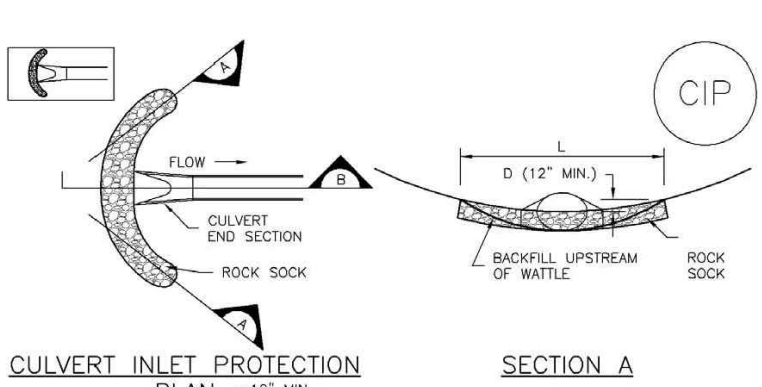

CIP-1. CULVERT INLET PROTECTION

- CULVERT INLET PROTECTION INSTALLATION NOTES**
1. SEE PLAN VIEW FOR:
 - LOCATION OF INLET PROTECTION.
 - TYPE OF INLET PROTECTION (IP-1, IP-2, IP-3, IP-4, IP-5, IP-6)
 2. INLET PROTECTION SHALL BE INSTALLED PROMPTLY AFTER INLET CONSTRUCTION OR PAVING IS COMPLETE (TYPICALLY WITHIN 48 HOURS). IF A MINOR/MAJOR EVENT IS FORECAST, INSTALL INLET PROTECTION PRIOR TO ONSET OF EVENT.
 3. MANY JURISDICTIONS HAVE BMP DETAILS THAT VARY FROM UICFD STANDARD DETAILS. CONSULT WITH LOCAL JURISDICTIONS AS TO WHICH DETAIL SHOULD BE USED WHEN DIFFERENCES ARE NOTED.
- CULVERT INLET PROTECTION MAINTENANCE NOTES**
1. INSPECT BMPs EACH WORKDAY AND MAINTAIN THEM IN EFFECTIVE OPERATING CONDITION. MAINTENANCE OF BMPs SHOULD BE PROACTIVE, NOT REACTIVE. INSPECT BMPs AS SOON AS POSSIBLE (AND ALWAYS WITHIN 24 HOURS) FOLLOWING A STORM THAT CAUSES SURFACE EROSION, AND PERFORM NECESSARY MAINTENANCE.
 2. FREQUENT OBSERVATIONS AND MAINTENANCE ARE NECESSARY TO MAINTAIN BMPs IN EFFECTIVE OPERATING CONDITION. INSPECTIONS AND CORRECTIVE MEASURES SHOULD BE DOCUMENTED THOROUGHLY.
 3. WHERE BMPs HAVE FAILED, REPAIR OR REPLACEMENT SHOULD BE INITIATED UPON DISCOVERY OF THE FAILURE.
 4. SEDIMENT ACCUMULATED UPSTREAM OF THE CULVERT SHALL BE REMOVED WHEN THE SEDIMENT DEPTH IS 2/3 THE HEIGHT OF THE ROCK SOCK.
 5. CULVERT INLET PROTECTION SHALL REMAIN IN PLACE UNTIL THE UPSTREAM DISTURBED AREA IS PERMANENTLY STABILIZED AND APPROVED BY THE LOCAL JURISDICTION.
- DETAILS ADAPTED FROM CITY OF BROOMFIELD, COLORADO. NOT AVAILABLE IN AUTOCAD.**
- NOTE: MANY JURISDICTIONS HAVE BMP DETAILS THAT VARY FROM UICFD STANDARD DETAILS. CONSULT WITH LOCAL JURISDICTIONS AS TO WHICH DETAIL SHOULD BE USED WHEN DIFFERENCES ARE NOTED.**

August 2013 Urban Drainage and Flood Control District August 2013
Urban Storm Drainage Criteria Manual Volume 3 IP-7

SC-6 Inlet Protection (IP)

- GENERAL INLET PROTECTION INSTALLATION NOTES**
1. SEE PLAN VIEW FOR:
 - LOCATION OF INLET PROTECTION.
 - TYPE OF INLET PROTECTION (IP-1, IP-2, IP-3, IP-4, IP-5, IP-6)
 2. INLET PROTECTION SHALL BE INSTALLED PROMPTLY AFTER INLET CONSTRUCTION OR PAVING IS COMPLETE (TYPICALLY WITHIN 48 HOURS). IF A MINOR/MAJOR EVENT IS FORECAST, INSTALL INLET PROTECTION PRIOR TO ONSET OF EVENT.
 3. MANY JURISDICTIONS HAVE BMP DETAILS THAT VARY FROM UICFD STANDARD DETAILS. CONSULT WITH LOCAL JURISDICTIONS AS TO WHICH DETAIL SHOULD BE USED WHEN DIFFERENCES ARE NOTED.
- INLET PROTECTION MAINTENANCE NOTES**
1. INSPECT BMPs EACH WORKDAY AND MAINTAIN THEM IN EFFECTIVE OPERATING CONDITION. MAINTENANCE OF BMPs SHOULD BE PROACTIVE, NOT REACTIVE. INSPECT BMPs AS SOON AS POSSIBLE (AND ALWAYS WITHIN 24 HOURS) FOLLOWING A STORM THAT CAUSES SURFACE EROSION, AND PERFORM NECESSARY MAINTENANCE.
 2. FREQUENT OBSERVATIONS AND MAINTENANCE ARE NECESSARY TO MAINTAIN BMPs IN EFFECTIVE OPERATING CONDITION. INSPECTIONS AND CORRECTIVE MEASURES SHOULD BE DOCUMENTED THOROUGHLY.
 3. WHERE BMPs HAVE FAILED, REPAIR OR REPLACEMENT SHOULD BE INITIATED UPON DISCOVERY OF THE FAILURE.
 4. SEDIMENT ACCUMULATED UPSTREAM OF INLET PROTECTION SHALL BE REMOVED AS NECESSARY TO MAINTAIN BMP EFFECTIVENESS, TYPICALLY WHEN SEDIMENT VOLUME REACHES 2/3 OF CAPACITY, A DEPTH OF 6" WHEN SILT FENCE IS USED, OR 2/3 OF THE HEIGHT FOR STRAW BALES.
 5. INLET PROTECTION IS TO REMAIN IN PLACE UNTIL THE UPSTREAM DISTURBED AREA IS PERMANENTLY STABILIZED. UNLESS THE LOCAL JURISDICTION APPROVES EARLIER REMOVAL OF INLET PROTECTION IN STREETS.
 6. WHEN INLET PROTECTION AT AREA INLETS IS REMOVED, THE DISTURBED AREA SHALL BE COVERED WITH TOP SOIL, SEEDS AND MULCHES, OR OTHERWISE STABILIZED IN A MANNER APPROVED BY THE LOCAL JURISDICTION.
- (DETAILS ADAPTED FROM CITY OF BROOMFIELD, COLORADO AND CITY OF AURORA, COLORADO. NOT AVAILABLE IN AUTOCAD.)**
- NOTE: MANY JURISDICTIONS HAVE BMP DETAILS THAT VARY FROM UICFD STANDARD DETAILS. CONSULT WITH LOCAL JURISDICTIONS AS TO WHICH DETAIL SHOULD BE USED WHEN DIFFERENCES ARE NOTED.**
- NOTE: THE DETAILS INCLUDED WITH THIS FACT SHEET SHOW COMMONLY USED CONVENTIONAL METHODS OF INLET PROTECTION IN THE DENVER METROPOLITAN AREA. THERE ARE MANY NON-PROPRIETARY INLET PROTECTION METHODS ON THE MARKET. DESIGN NETWORK ENGINEERS MUST DISCOURAGE USE OF PROPRIETARY INLET PROTECTION; HOWEVER, IN THE EVENT PROPRIETARY METHODS ARE USED, THE APPROPRIATE DETAIL FROM THE MANUFACTURER MUST BE INCLUDED IN THE SWP AND THE BMP MUST BE INSTALLED AND MAINTAINED AS SHOWN IN THE MANUFACTURER'S DETAILS.**
- NOTE: SOME MUNICIPALITIES DISCOURAGE OR PROHIBIT THE USE OF STRAW BALES FOR INLET PROTECTION. CHECK WITH LOCAL JURISDICTION TO DETERMINE IF STRAW BALE INLET PROTECTION IS ACCEPTABLE.**

IP-8 Urban Drainage and Flood Control District August 2013
Urban Storm Drainage Criteria Manual Volume 3

Vehicle Tracking Control (VTC) SM-4

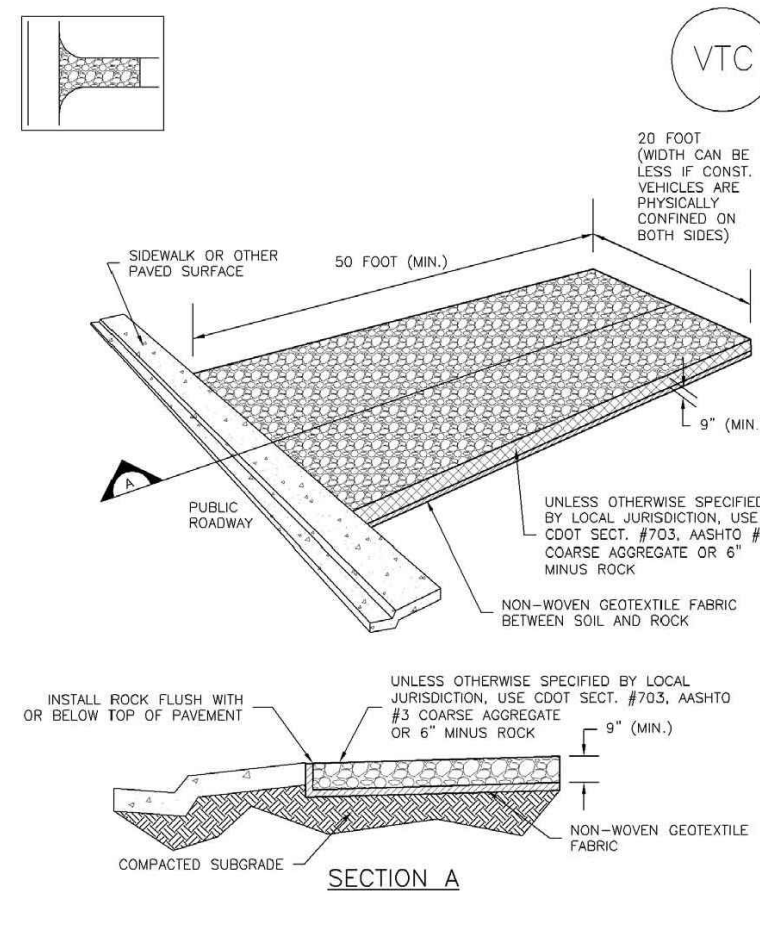

VTC-1. AGGREGATE VEHICLE TRACKING CONTROL

November 2010 Urban Drainage and Flood Control District November 2010
Urban Storm Drainage Criteria Manual Volume 3 VTC-3

SM-4 Vehicle Tracking Control (VTC)

- STABILIZED CONSTRUCTION ENTRANCE/EXIT INSTALLATION NOTES**
1. SEE PLAN VIEW FOR:
 - LOCATION OF CONSTRUCTION ENTRANCE(S)/EXIT(S)
 - TYPE OF CONSTRUCTION ENTRANCE(S)/EXIT(S) (WITH/WITHOUT WHEEL WASH, CONSTRUCTION MAT OR TRG)
 2. CONSTRUCTION MAT OR TRG STABILIZED CONSTRUCTION ENTRANCES ARE ONLY TO BE USED ON SHORT DURATION PROJECTS (TYPICALLY RANGING FROM A WEEK TO A MONTH) WHERE THERE WILL BE LIMITED VEHICULAR ACCESS.
 3. A STABILIZED CONSTRUCTION ENTRANCE/EXIT SHALL BE LOCATED AT ALL ACCESS POINTS WHERE VEHICLES ACCESS THE CONSTRUCTION SITE FROM PAVED RIGHT-OF-WAYS.
 4. STABILIZED CONSTRUCTION ENTRANCE/EXIT SHALL BE INSTALLED PRIOR TO ANY LAND DISTURBING ACTIVITIES.
 5. A NON-WOVEN GEOTEXTILE FABRIC SHALL BE PLACED UNDER THE STABILIZED CONSTRUCTION ENTRANCE/EXIT PRIOR TO THE PLACEMENT OF ROCK.
 6. UNLESS OTHERWISE SPECIFIED BY LOCAL JURISDICTION, ROCK SHALL CONSIST OF DOT SECT. #703, AASHTO #3 COARSE AGGREGATE OR 6" (MINUS) ROCK.
- STABILIZED CONSTRUCTION ENTRANCE/EXIT MAINTENANCE NOTES**
1. INSPECT BMPs EACH WORKDAY AND MAINTAIN THEM IN EFFECTIVE OPERATING CONDITION. MAINTENANCE OF BMPs SHOULD BE PROACTIVE, NOT REACTIVE. INSPECT BMPs AS SOON AS POSSIBLE (AND ALWAYS WITHIN 24 HOURS) FOLLOWING A STORM THAT CAUSES SURFACE EROSION, AND PERFORM NECESSARY MAINTENANCE.
 2. FREQUENT OBSERVATIONS AND MAINTENANCE ARE NECESSARY TO MAINTAIN BMPs IN EFFECTIVE OPERATING CONDITION. INSPECTIONS AND CORRECTIVE MEASURES SHOULD BE DOCUMENTED THOROUGHLY.
 3. WHERE BMPs HAVE FAILED, REPAIR OR REPLACEMENT SHOULD BE INITIATED UPON DISCOVERY OF THE FAILURE.
 4. ROCK SHALL BE REAPPLIED OR REGRADED AS NECESSARY TO THE STABILIZED ENTRANCE/EXIT TO MAINTAIN A CONSISTENT DEPTH.
 5. SEDIMENT TRACKED ONTO PAVED ROADS IS TO BE REMOVED THROUGHOUT THE DAY AND AT THE END OF THE DAY BY SHOVELING OR SWEEPING. SEDIMENT MAY NOT BE WASHED DOWN STORM SEWER DRAINING.
- NOTE: MANY JURISDICTIONS HAVE BMP DETAILS THAT VARY FROM UICFD STANDARD DETAILS. CONSULT WITH LOCAL JURISDICTIONS AS TO WHICH DETAIL SHOULD BE USED WHEN DIFFERENCES ARE NOTED.**
- (DETAILS ADAPTED FROM CITY OF BROOMFIELD, COLORADO. NOT AVAILABLE IN AUTOCAD.)**

VTC-6 Urban Drainage and Flood Control District November 2010
Urban Storm Drainage Criteria Manual Volume 3

PREPARED BY:

DREXEL, BARRELL & CO.
Engineers • Surveyors
3 SOUTH 7TH STREET
COLORADO SPGS, COLORADO 80905
CONTACT: TIM D. MCCONNELL, P.E.
(719)260-0887
COLORADO SPRINGS • LAFAYETTE

CLIENT:

HESED LLC

10308 MT. EVANS DR.
PEYTON, CO 80831

DEVELOPMENT PLANS FOR:

**LOT 1, BLOCK 1,
JOHNSONS VACATION**

OLD MERIDIAN ROAD
FALCON, COLORADO

ISSUE	DATE
INITIAL ISSUE	10/17/21
RESUBMITTAL	5/18/23
DESIGNED BY:	KGV
DRAWN BY:	SDM
CHECKED BY:	TDW
FILE NAME:	21496-01-DT1-2

PREPARED UNDER MY DIRECT SUPERVISION FOR AND ON BEHALF OF DREXEL, BARRELL & CO.

DRAWING SCALE:
HORIZONTAL: N/A
VERTICAL: N/A

EROSION CONTROL DETAILS

PROJECT NO. 21496-01CSCV
DRAWING NO.

DT1

SHEET: 4 OF 5

CALL 2-BUSINESS DAYS IN ADVANCE BEFORE YOU DIG, GRADE, OR EXCAVATE FOR THE MARKING OF UNDERGROUND MEMBER UTILITIES.

PREPARED BY:

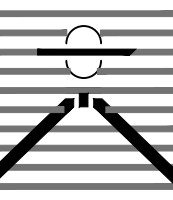

DREXEL, BARRELL & CO.
Engineers • Surveyors
3 SOUTH 7TH STREET
COLORADO SPRINGS, COLORADO 80905
CONTACT: TIM D. MCCONNELL, P.E.
(719)260-0887
COLORADO SPRINGS • LAFAYETTE

CLIENT:

HESED LLC

10308 MT. EVANS DR.
PEYTON, CO 80831

DEVELOPMENT PLANS FOR:
LOT 1, BLOCK 1,
JOHNSON'S VACATION
OLD MERIDIAN ROAD
FALCON, COLORADO

Table with 2 columns: ISSUE, DATE. Rows include INITIAL ISSUE (10/17/21) and RESUBMITTAL (5/18/23).



PREPARED UNDER MY DIRECT SUPERVISION FOR AND ON BEHALF OF DREXEL, BARRELL & CO.

DRAWING SCALE:
HORIZONTAL: N/A
VERTICAL: N/A

EROSION CONTROL DETAILS

PROJECT NO. 21496-01CSCV
DRAWING NO.

DT2

SHEET: 5 OF 5

TEMPORARY SEEDING NOTES:

- 1. SOIL IS TO BE CONDITIONED FOR PLANT GROWTH BY APPLYING TOPSOIL, FERTILIZER OR LIME.
2. SOIL IS TO BE TILLED IMMEDIATELY PRIOR TO APPLYING SEEDS. COMPACT SOILS ESPECIALLY NEED TO BE LOOSENED.
3. SEEDBED DEPTH IS TO BE 4 INCHES FOR SLOPES FLATTER THAN 2:1 AND 1 INCH FOR SLOPES STEEPER THAN 2:1.
4. ANNUAL GRASSES LISTED IN THE TABLE BELOW ARE TO BE USED FOR TEMPORARY SEEDING.
5. THE TABLE BELOW ALSO PROVIDES REQUIREMENTS FOR SEEDING RATES, SEEDING DATES, AND PLANTING DEPTHS FOR THE APPROVED TYPES OF ANNUAL GRASSES.
6. SEEDING IS TO BE APPLIED USING MECHANICAL TYPE DRILLS EXCEPT WHERE SLOPES ARE STEEP OR ACCESS IS LIMITED THEN HYDRAULIC SEEDING MAY BE USED.
7. ALL SEEDED AREAS ARE TO BE MULCHED.
8. IF HYDRAULIC SEEDING IS USED THEN HYDRAULIC MULCHING SHALL BE DONE SEPARATELY TO AVOID SEEDS BECOMING ENCAPSULATED IN THE MULCH.

MULCHING NOTES:

- 1. MATERIAL USED FOR MULCH CAN BE CERTIFIED CLEAN, WEED-AND SEED-FREE LONG STEMMED FIELD OR MARSH HAY, OR STRAW OF OATS, BARLEY, WHEAT, RYE, OR TRITICALE CERTIFIED BY THE COLORADO DEPARTMENT OF AGRICULTURE WEED FREE FORAGE CERTIFICATION PROGRAM.
2. HYDRAULIC MULCHING MATERIAL SHALL CONSIST OF VIRGIN WOOD FIBER MANUFACTURED FROM CLEAN WHOLE WOOD CHIPS. WOOD CHIPS CANNOT CONTAIN ANY GROWTH OR GERMINATION INHIBITORS OR BE PRODUCED FROM RECYCLED MATERIAL.
3. MULCH IS TO BE APPLIED EVENLY AT A RATE OF 2 TONS PER ACRE.
4. MULCH IS TO BE ANCHORED EITHER BY CRIMPING (TUCKING MULCH FIBERS 4 INCHES INTO THE SOIL), USING NETTING (USED ON SMALL AREAS WITH STEEP SLOPES) OR WITH A TACKIFIER.
5. HYDRAULIC MULCHING AND TACKIFIERS ARE NOT TO BE USED IN THE PRESENCE OF FREE SURFACE WATER.

MAINTENANCE REQUIREMENTS

- 1. REGULAR INSPECTIONS ARE TO BE MADE OF ALL MULCHED AREAS.
2. MULCH IS TO BE REPLACED IMMEDIATELY IN THOSE AREAS IT HAS BEEN REMOVED, AND IF NECESSARY THE AREA SHOULD BE RESEDED.

SEEDING PLAN

NATIVE SEEDING MIX

SOIL PREPARATION, FERTILIZER, SEEDING, MULCHING AND MULCH TACKIFIER WILL BE REQUIRED FOR DISTURBED AREAS EXCLUDING THE RIGHT-OF-WAYS.

THE FOLLOWING TYPES AND RATES SHALL BE USED:

Table with 3 columns: COMMON NAME, SCIENTIFIC NAME, LBS PLS./ACRE. Lists seed types like SAND BLUESTEM, WESTERN WHEATGRASS, etc., with their respective scientific names and rates.

Table with 2 columns: FERTILIZER, RATE PER ACRE. Lists NITROGEN (27) and PHOSPHORUS (P205) (69).

SEEDING APPLICATION: DRILL SEED 0.25"-0.5" INTO TOPSOIL. AREA NOT ACCESSIBLE TO A DRILL SEEDER AND SLOPES STEEPER THAN 2:1 SHALL BE HAND BROADCAST AT DOUBLE THE ABOVE SEED RATE AND RAKED AT 1/4 TO 1/2 INTO THE TOPSOIL.

MULCHING APPLICATION: 1 1/2 TONS CERTIFIED WEED FREE NATIVE HAY PER ACRE MECHANICALLY CRIMED IN TOPSOIL IN COMBINATION WITH AN ORGANIC MULCH TACKIFIER.

Concrete Washout Area (CWA) MM-1

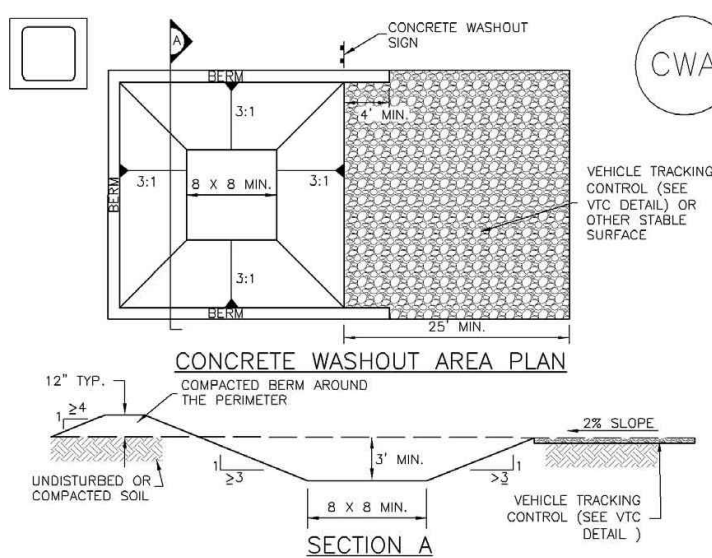

CWA-1 CONCRETE WASHOUT AREA
CWA INSTALLATION NOTES:
1. SEE PLAN VIEW FOR CWA REGULATION LOCATION.
2. DO NOT LOCATE AN UNLEAKED CWA WITHIN 400' OF ANY NATURAL DRAINAGE PATHWAY OR BACKFLOW.
3. THE CWA SHALL BE INSTALLED PRIOR TO CONCRETE PLACEMENT ON SITE.
4. CWA SHALL INCLUDE A FLAT SUBSURFACE PIT THAT IS AT LEAST 8" BY 8" SLOPES LEADING OUT OF THE SUBSURFACE PIT SHALL BE 2:1 OR FLATTER. THE PIT SHALL BE AT LEAST 3' DEEP.
5. BENTH SUBSURFACING SIDES AND BACK OF THE CWA SHALL HAVE MINIMUM HEIGHT OF 1'.
6. VEHICLE TRACKING AND SHALL BE SLOPED 2% TOWARD THE CWA.
7. SIGNS SHALL BE PLACED AT THE CONSTRUCTION ENTRANCE, AT THE CWA AND UNDERNEATH AS NECESSARY TO CLEARLY INDICATE THE LOCATION OF THE CWA TO OPERATORS OF CONCRETE, TRUCKS AND PUMP TRUCKS.
8. USE EXCAVATED MATERIAL FOR PERIMETER BERM CONSTRUCTION.

November 2010 Urban Drainage and Flood Control District
Urban Storm Drainage Criteria Manual Volume 3
November 2010 CWA-4 Urban Drainage and Flood Control District
Urban Storm Drainage Criteria Manual Volume 3

Stabilized Staging Area (SSA) SM-6

STABILIZED STAGING AREA MAINTENANCE NOTES
5. STABILIZED STAGING AREA SHALL BE ENLARGED IF NECESSARY TO CONTAIN PARKING, STORAGE, AND UNLOADING/LOADING OPERATIONS.
6. THE STABILIZED STAGING AREA SHALL BE REMOVED AT THE END OF CONSTRUCTION THE GRANULAR MATERIAL SHALL BE FINISHED OR, IF APPROVED BY THE LOCAL JURISDICTION, USED ON SITE AND THE AREA COVERED WITH TOPSOIL, SEEDED AND MULCHED OR OTHERWISE STABILIZED IN A MANNER APPROVED BY LOCAL JURISDICTION.

SSA-1 STABILIZED STAGING AREA
SSA INSTALLATION NOTES:
1. SEE PLAN VIEW FOR LOCATION OF STAGING AREA(S).
2. STABILIZED STAGING AREA SHOULD BE APPROPRIATE FOR THE NEEDS OF THE SITE.
3. STAGING AREA SHALL BE STABILIZED PRIOR TO OTHER OPERATIONS ON THE SITE.
4. THE STABILIZED STAGING AREA SHALL CONSIST OF A MINIMUM 3" THICK GRANULAR MATERIAL.
5. UNLESS OTHERWISE SPECIFIED BY LOCAL JURISDICTION, ROCK SHALL CONSIST OF DIRT SIZED FILL ABOVE 4" CONCRETE AGGREGATE OR 4" UNLEACHED ROCK.

November 2010 Urban Drainage and Flood Control District
Urban Storm Drainage Criteria Manual Volume 3
November 2010 SSA-4 Urban Drainage and Flood Control District
Urban Storm Drainage Criteria Manual Volume 3

Stabilized Staging Area (SSA) SM-6

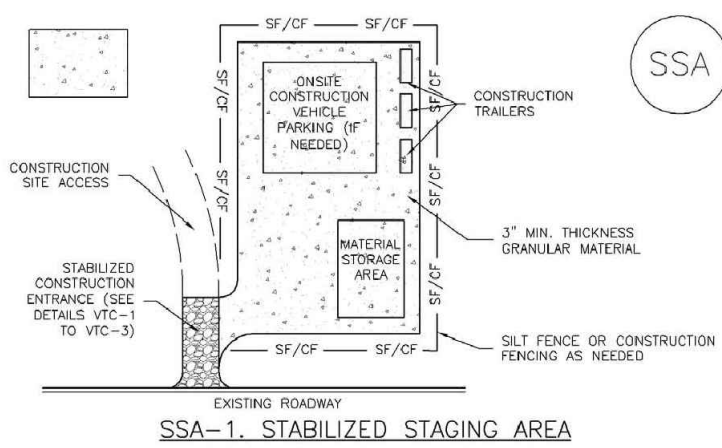

SSA-1 STABILIZED STAGING AREA
SSA INSTALLATION NOTES:
1. SEE PLAN VIEW FOR LOCATION OF STAGING AREA(S).
2. STABILIZED STAGING AREA SHOULD BE APPROPRIATE FOR THE NEEDS OF THE SITE.
3. STAGING AREA SHALL BE STABILIZED PRIOR TO OTHER OPERATIONS ON THE SITE.
4. THE STABILIZED STAGING AREA SHALL CONSIST OF A MINIMUM 3" THICK GRANULAR MATERIAL.
5. UNLESS OTHERWISE SPECIFIED BY LOCAL JURISDICTION, ROCK SHALL CONSIST OF DIRT SIZED FILL ABOVE 4" CONCRETE AGGREGATE OR 4" UNLEACHED ROCK.

November 2010 Urban Drainage and Flood Control District
Urban Storm Drainage Criteria Manual Volume 3
November 2010 SSA-3 Urban Drainage and Flood Control District
Urban Storm Drainage Criteria Manual Volume 3

Silt Fence (SF) SC-1

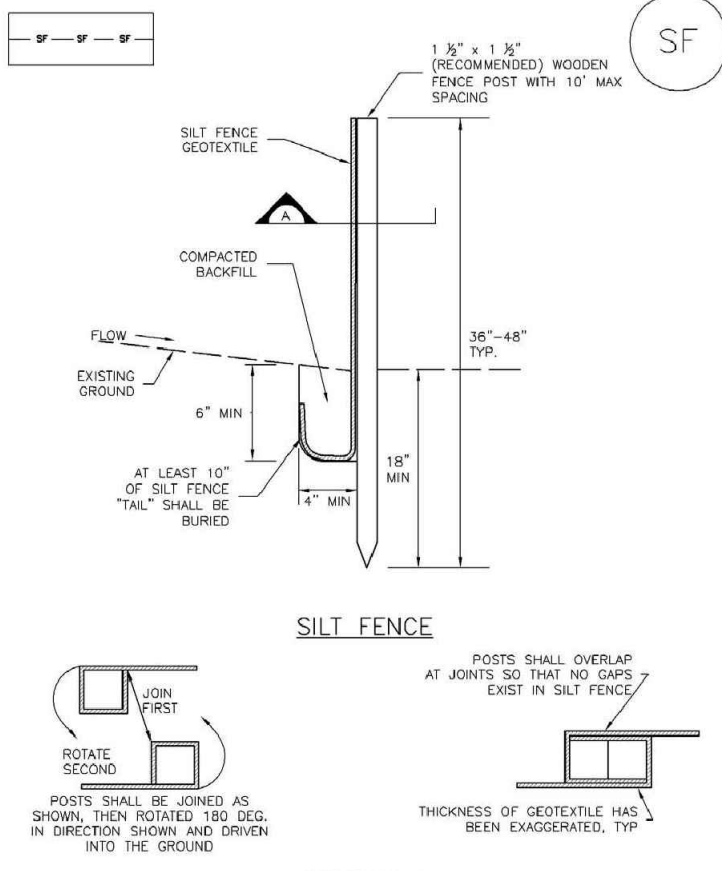

SF-1 SILT FENCE
SILT FENCE INSTALLATION NOTES:
1. SILT FENCE MUST BE FINISHED AWAY FROM THE TOE OF THE SLOPE TO ALLOW FOR WATER FORKING.
2. A MINIMUM 4" X 4" ANCHOR TRENCH SHALL BE EXCAVATED USING TRENCHER OR SILT FENCE PROTECTION DEVICE.
3. COMPACT ANCHOR TRENCH BY HAND WITH A "JUMPING JACK" OR BY WHEEL ROLLING.
4. SILT FENCE SHALL BE PULLED TIGHT AS IT IS ANCHORED TO THE STAKES.
5. SILT FENCE FABRIC SHALL BE ANCHORED TO THE STAKES USING 1" HEAVY DUTY STAPLES OR NAILS WITH 1" HEADS.
6. AT THE END OF A RUN OF SILT FENCE ALONG A CONTOUR, THE SILT FENCE SHOULD BE TYPICALLY PERPENDICULAR TO THE CONTOUR TO CREATE A "J-WALK".

November 2010 Urban Drainage and Flood Control District
Urban Storm Drainage Criteria Manual Volume 3
November 2010 SF-4 Urban Drainage and Flood Control District
Urban Storm Drainage Criteria Manual Volume 3

811 Know what's below. Call before you dig.
CALL 2-BUSINESS DAYS IN ADVANCE BEFORE YOU DIG, GRADE, OR EXCAVATE FOR THE MARKING OF UNDERGROUND MEMBER UTILITIES.
ERL PASO COUNTY PCD FILE NO: PPR-2167