

Final Bridge and Channel Design Report

Sand Creek Drainageway Sterling Ranch Road and Briargate Parkway Branding Iron at Sterling Ranch Filing 2 Homestead at Sterling Ranch Filing 2

CDR 20-004
El Paso County, Colorado

Engineering Review

11/17/2020 9:51:49 AM

dsdrice

JeffRice@elpasoco.com

(719) 520-7877

**EPC Planning & Community
Development Department**

Prepared for:
Sterling Ranch Metropolitan District
20 Boulder Crescent Suite 2nd Floor
Colorado Springs, Colorado 80903

Also see comment letter.
Blue highlights are on
areas of concern that
need to be revised or
verified.

Prepared by:

Kiowa
Engineering Corporation

1604 South 21st Street
Colorado Springs, Colorado 80904
(719) 630-7342

Kiowa Project No. 19032
October 29, 2020

	<u>Page</u>
Table of Contents	i
Engineer’s Statement	ii
I. General Location and Description	1
II. Project Background	1
III. Previous Reports and Jurisdictional Requirements	3
IV. Site Description	4
V. Hydrology	4
VI. Hydraulics	4
VII. Design Elements	7
VIII. Construction Permitting	8
IX. Drainage and Bridge Fees	8
X. Phasing	9
XI. Conclusions	10

List of Figures

Figure 1	Vicinity Map	2
Table 1	Summary of Design Discharges	5

Appendix A – Hydrologic and Hydraulic Calculations

Appendix B – Geotechnical Report and NRCS Soil Survey

Appendix C – Roadway design M & S Civil

Appendix D – Sterling Ranch 404 Permit and Wetland Mitigation Plan

Appendix E – Sand Creek DBPS Excerpts

Engineer's Statement:

The attached drainage plan and report were prepared under my direction and supervision and are correct to the best of my knowledge and belief. Said drainage report has been prepared according to the criteria established by the County for drainage reports and said report is in conformity with the master plan of the drainage basin. I accept responsibility for any liability caused by any negligent acts, errors or omissions on my part in preparing this report.

Kiowa Engineering Corporation, 1604 South 21st Street, Colorado Springs, Colorado 80904

Todd Cartwright PE
Registered Engineer #33365
For and on Behalf of Kiowa Engineering Corporation

Date

Developer's Statement:

I, the Developer, have read and will comply with all of the requirements specified in this drainage report and plan.

BY: _____

Date

James Morley
Printed

ADDRESS: Sterling Ranch Metropolitan District
20 Boulder Crescent Suite 2nd floor
Colorado Springs, Colorado 80903

El Paso County:

Filed in accordance with the requirements of the Drainage Criteria Manual Volumes 1 and 2, El Paso County Engineering Criteria Manual and Land Development Code, as amended.

Jennifer Irvine, P.E.
County Engineer/ECM Administrator

Date

what about Pond W5 outfall?

feet?

verify

I. General Location and Description

This report serves to summarize the design of the Sand Creek drainageway and for two bridges in the Sterling Ranch Development. It is proposed to construct nineteen grouted sloping boulder drops, 100-year capacity with benched overbank channel and clear span precast bridges at Sterling Ranch Road and at Briargate Boulevard. Total length of Sand Creek subject to the design is approximately 8,900 lineal feet. The work along the drainageway will begin approximately 200 feet north of the south property line of the Sterling Ranch development and ends at the north property line. The proposed drainageway and bridge improvements lie within El Paso County. The location of the site is shown on Figure 1.

Upon the completion of the drainageway facilities and acceptance by El Paso County and Sterling Ranch Metropolitan District, easements and or tracts will be dedicated for the purposes of maintenance access. Most of the channel and bridge work will occur within Tract D of Sterling Ranch Filing No. 1. The portions of the drainageway south of Sterling Ranch Road and North of Briargate Parkway will be constructed within un-platted land owned by the developer of Sterling Ranch. Operation and maintenance of the drainageway will be the responsibility of the Sterling Ranch Metropolitan District. Upon completion of a CLOMR that accounts for the channel and bridge structures subject to this design, there will be no residential lots within future Sterling Ranch Filings that will lie within the 100-year floodplain. The existing lots for Branding Iron at Sterling Ranch Filing 2 and Homestead at Sterling Ranch Filing 2 all lie outside of the effective 100-year floodplain.

The bridges over Sand Creek at Sterling Ranch Road and at Briargate Parkway are included within the design plans. The bridges will be clear-span precast structures that have the capacity to pass the 100-year discharge. The proposed road right-of-ways are 80-feet for Sterling Ranch Road and 130 feet for Briargate Parkway. The structure at Sterling Ranch Road will be 84-feet feet out-to-out. The roadway section for Sterling Ranch Road shown on the roadway design plans includes two 12-foot lanes and a 12-foot painted median, Type A curb and gutter, and 6-foot detached sidewalks. The ultimate roadway section for Briargate Parkway as shown on the roadway design plans includes four 12-foot lanes and a 16-foot raised median, 8-foot paved shoulders, Type A curb and gutter, and 6-foot detached sidewalks. Protective guardrails as shown on the drawings have been designed in conformance with Colorado Department of Transportation M-standards. The roadway design plans have been included within Appendix C of this report.

Once the bridge and roadway facilities are completed and accepted by El Paso County, El Paso County will assume maintenance responsibility for the structures and roadways. The developer intends to request reimbursement for the cost to construct the bridges and drainageway facilities, or request credit against future drainage and bridge fees. Reimbursement will be processed in accordance with sections 1.7 and 3.3 of the Drainage Criteria Manual (DCM). The drainageway facilities will be operated and maintained by the Sterling Ranch Metropolitan District

II. Project Background

until accepted by the County

Sand Creek within Sterling Ranch is a natural drainageway at this time that was shown to be stabilized in the Sterling Ranch Master Development Drainage Plan (MDDP). The MDDP as last showed Sand Creek to be reconfigured into a trapezoidal channel section capable of conveying the 100-year discharge as listed in the MDDP. The channel as proposed is a benched trapezoidal channel. This section was chosen to meet the hydraulic conditions and to conform with the Sterling Ranch 404 permit. Transitions to a trapezoidal section occurs at the crossings of the roadways. At the upstream and downstream termini of the project, the channel will be transitioned to meet the existing natural channel section. The present average slope of the drainageway within the design reach is 1.8 percent. There are short segments of the drainageway that have slopes that exceed 4 percent and some

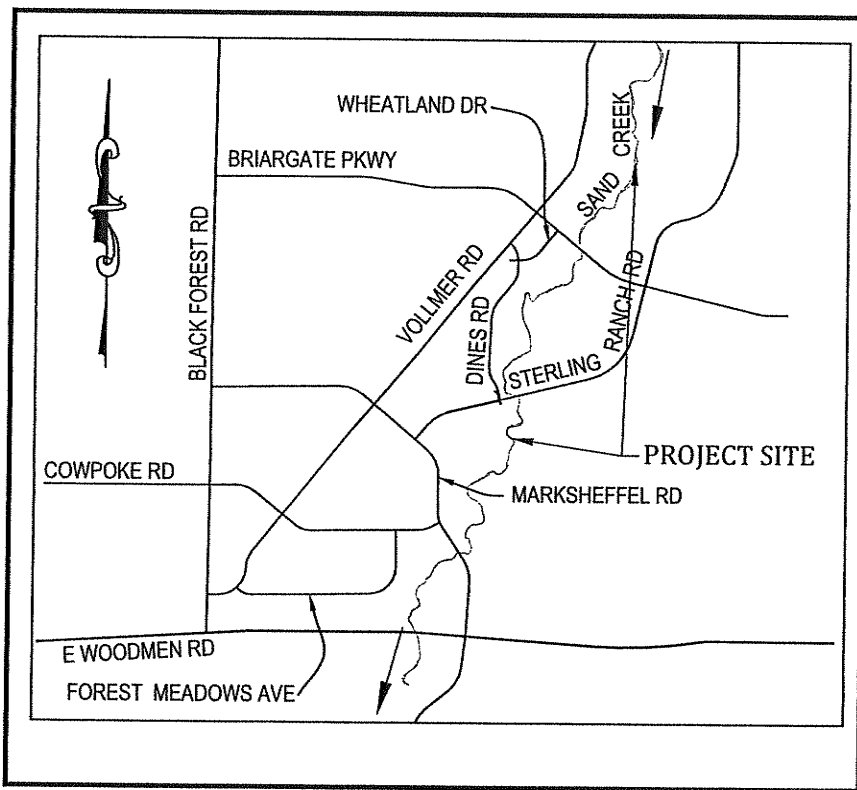

FIGURE 1
VICINITY MAP
SCALE: N.T.S.

reaches as flat as .5 percent. To create a stable invert slope capable of conveying developed runoff drop structures are necessary. For a sand bed channel, a slope of less than 1 percent is necessary to keep the flow in a sub-critical flow regime and prevent long-term degradation of the invert and the associated bank sloughing that would come from under-cutting. Drop structures for this segment of Sand Creek were identified in the MDDP as well as in the DBPPS.

III. Previous Reports and Jurisdictional Requirements

The basis for the development of the design has been developed from referencing the following reports:

1. *Sterling Ranch Master Development Drainage Plan (MDDP), prepared by M & S Civil Consultants, October 2018.*
2. *Sand Creek Drainage Basin Planning Study (DBPS), prepared by Kiowa Engineering, 1996.*
3. *City of Colorado Springs and El Paso County Drainage Criteria Manual, 1987.*
4. *El Paso County Engineering Criteria Manual, most current version.*
5. *City of Colorado Springs Drainage Criteria Manual, May 2014.*
6. *The City of Colorado Springs and El Paso County Flood Insurance Study (FIS), prepared by the Federal Emergency Management Agency, effective 2018.*
7. *Sterling Ranch Channel Improvements and Mitigation Plan, prepared by Core Consultants, October 2015.* — Filing No. 1
8. *Retreat at Timber Ridge, 2020*
— Final Drainage Report for

Reference 6 provides for the existing condition floodplain and floodway for the segment of Sand Creek subject to this design. The existing condition floodplain has been shown on the design drawings. Because the bridge structure and channel stabilization measures occur within the regulatory floodplain and floodway, a Conditional Letter of Map Revision (CLOMR) will be required to be processed through FEMA as part of gaining the necessary construction approvals for the project.

Chapter 6 and Section 3.2.1 of Chapter 13 of Reference 5 was made part of Reference 4 by El Paso County Board of County Commissioners Resolution 15-042.

Reference 7 called for a stabilized floodplain for the reach of Sand Creek in Sterling Ranch and preservation of riparian resources wherever possible. Riprap bank protection at all outside bends were called out in the DBPS. Drop structures to create a longitudinal channel slope of 1 percent were also identified for this reach of Sand Creek. The channel concept advanced in this design allow for the preservation and/or creation of riparian habitat along the channel benches. Wetland areas may develop along the low flow channel upstream of the proposed drops.

IV. Site Description

The Sand creek floodplain within the design reach is well vegetated with native grasses that are in fair to good condition that exists on the floodplain overbanks and within the greater valley in general. There is little evidence of active invert degradation or bank sloughing except for the channel bends that occur at the location of future Sterling Ranch Road. Current longitudinal slope along the project is ranges from 0.5 to 4.2 percent, with an average slope of 1.8 percent. There is presently no base flow in this segment. There is at some locations a small low flow channel that has formed and

has a top width of approximately 10 feet. Topography used in the design was compiled at a two-foot contour interval and is dated 2007. The topography does not reflect the grading that has occurred for the development Sterling Ranch Filing No, 1. There are presently no developed lots that lie within the 100-year floodplain. Lots platted for the Homestead at Sterling Ranch Filing No. 2 and Branding Iron at Sterling Ranch Filing No. 2 subdivisions will not encroach into the 100-year floodplain.

There is presently an existing sanitary sewer outfall that crosses the drainageway just upstream of the south property line of the development. A 24-inch water line is proposed cross the drainageway just upstream of future Briargate Boulevard. The water and wastewater facilities that may impact the drainageway are all owned and maintained by the Sterling Ranch Metropolitan District.

V. Hydrology

Hydrology for use in determining the typical channel sections shown on the plans were obtained from Reference 6. The 100-year discharges shown in Reference 6 is 2,600 cubic feet per second. The 100-year peak discharges from references 1 and 2 were reviewed as well. A comparison if peak discharges is presented below.

Existing Development Condition Peak Discharges Sand Creek at Sterling Ranch

Location: South Property Line (cfs)	5yr	10yr	100yr
City of Colorado Springs FIS	NR	1,200	2,600
Sand Creek DBPS	NR	770	2,620
Sterling Ranch MDDP	435	713	1,912

The above listed discharges all assume existing, or pre-development conditions. The hydrology used in the FIS was obtained from a Soil Conservation Service study conducted in 1975 for eth Sand Creek watershed using the “SCS method. The hydrology developed in the DBPS also used the SCS method and obtained similar. The MDDP used the U. S. Army Corps of Engineers HEC-1 hydrograph model and the SCS curve numbers to develop the peak discharges shown above. The MDDP applied a Type II storm distribution as proposed to the Type IIA distribution applied in the FIS and DBPS. This will typically cause peak discharges to decrease 10 to 15 percent. As the difference in the peak discharges cause relatively small differences in the hydraulic design the channel and the bridges, the FIS 100-year discharge was used in the hydraulic design of the channel and bridge improvements. According to the criteria set forth in Reference 4, the low flow channel was sized using 10 percent of the 100-year discharge, or 260 cubic feet per second.

The assumption that FSD will be required for all future development is reflected in the use of the existing development discharges in this design. There is a good correlation between the FIS and DBPS 100-year discharges for the segment of Sand Creek subject to this design. The future FSD’s within Sterling Ranch will be publicly operated and maintained facilities by the Sterling Ranch Metropolitan District.

Address the effects of diversions upstream of the confluence at DP 53. See comment letter.

VI. Hydraulics

The hydraulic design of the drainageway and bridge as presented on the plans was carried out using the US Army Corps of Engineers HEC-RAS modeling system. The HEC-RAS model was used to determine the 100-year hydraulic grade line shown on the plan and profiles. The 100-year profile for the FIS hydrology has been determined. The location for the proposed 100-year floodplain using FIS hydrology has been presented on the plan view of the design plans and on the grading plan. Contained within the Appendix A of this report are floodplain maps that show the effective regulatory 100-year floodplain. The location for selected HEC-RAS cross-sections are shown on the design profile. The HEC-RAS cross-sections are contained within Appendix A. The summary output for the 10-, 50-, 100-year and 500-year recurrence intervals have been included in the Appendix A of this report

The propose drainageway design concept put forth on the plans are 100-year benched channel section. The design slope ranges from 0.02 to 0.05 percent. The low flow area will be stabilized using soil riprap. Bottom width of the low flow is 25 feet and the top with is 40 feet. The depth of the low flow channel is 2.5 feet. Low flow channel banks will be placed at a three-to-one slopes with selective bank lining for low flow stabilization. Even with FSD implemented throughout the watershed the low flow area of the drainageway will continue to degrade to a flatter longitudinal slope. The effect of development within the watershed will be to increase the frequency and duration of base flows. Base flows will increase with the development because of discharges from future FSDs.

The channel benches will be stabilized using turf reinforcement mat (TRM). The benches range in width from 20 to 50 feet, however the predominant bench width is 35 feet. Tractive force calculations that support the use of TRM on the channel benches in contained in Appendix A. The benches will slope toward the low channel at 1 percent. Shear stress calculations were carried out for the 10- and 100-year flow conditions. Maximum 100-year shear stress on the bench was calculated at .78 pounds per square foot. Permissible shear stress for woven TRM is 1.55 pounds per square foot.

The 100-year overbank channel slopes will be placed at four -to-one and will be lined with Type M soil riprap at outside bends and grass-lied at inside bends. The depth of flow on the overbank is 3.5 feet. At a total channel depth of at 6.35 feet deep, the section provides one-foot of freeboard above the 100-year design water surface. Tractive force calculations for the grassed overbank slopes were carried out. Permissible shear stress for native vegetation with Class B retardance similar to the vegetation present at the site, is 2.1 pounds per square foot. Calculated shears stress was .52 pounds per square foot. All grass-lined overbank slopes will be temporarily cover with erosion control blanket and reseeded using native grass seed.

The existing drainageway will eventually degrade along the invert in turn causing bank sloughing to occur if grade control is not implemented. Grouted sloping boulder drops are proposed at 19 locations along the design alignment. The drops range in vertical height from 6 to 7 feet. Each drop is 70-foot long and has a 30-foot stilling basin upstream of the sills. The crests have been sized to convey the 100-year design discharge.

Nothing has changed based on EPC comments.

VII. Design Elements

Presented on the design plans associated with this design memorandum are the proposed drainageway conditions. The drops have been designed to raise the invert anywhere from two to three feet. Design criteria for the project are summarized as follows:

Channel design slope:	0.2 -0.5 percent	
Maximum low flow drop height:	7 feet	
Outside bend slopes- riprap or grass-lined	4 to 1 maximum	
Low flow channel side slopes- riprap lined	3 to 1 maximum	
Soil riprap slopes at bridge approaches and exits	3 to 1 maximum	
Low flow channel depth	2.5 feet	
Manning's n-values:	.025-.035	
Froude number-(excluding crests of drops):	.25--.75	
Minimum channel radius	150 feet	
Maximum design velocity		
Grass-lined	5 feet per second	
Reinforced turf (TRM)	7 feet per second	
Permissible shear stress: low flow channel		
TRM (curled wood mat)	1.55 psf	
Type M soil riprap	2.5 psf	
Permissible shear stress: floodplain benches and overbanks		
Class B retardance, native vegetation	2.1 psf	
TRM (curled wood mat)	1.55 psf	
Type M soil riprap	5.0 psf	

doesn't match plans

Model does not meet these?

The proposed channel alignment has been laid out to roughly follow the existing alignment to minimize disturbance. In some locations the centerline radii is less than two times the top width to more closely match the existing channel, however increasing the radii from what exists. The proposed flatness of the slope has resulted in several drop structures, the drops have been laid out to be on straight sections which results in some tighter centerline radii. The alignment was dictated in part by the 404 permit.

The drops will be constructed using grouted boulders. The selection of grouted boulders was chosen to address long-term durability of the drop. Each drop has an integral grouted boulder sill. Sheet pile cut-off walls are proposed at the crest of each drop that will extend across the entire width of the drop. The bottom depth of the sheet pile cut-off walls ranges from 6 to 7 feet. Wherever soil riprap linings are proposed, rock sizing and freeboard criteria followed is in accordance with Chapter 8 of the Urban Drainage and Flood Control Manual, equation 8-11.

A geotechnical investigation was conducted to support the design of the foundation for the bridge at Sterling Ranch Road and Briargate Parkway. The geotechnical report is included within the Appendix B. Two soil borings were drilled near the locations of the proposed footings for the bridges. Because of the depth to bedrock, deep foundations are proposed using driven H-piles at Briargate Boulevard. Bedrock is shallow at the Sterling Ranch Road and therefore it is assumed that spread

These need to be addressed if there is residential development adjacent.

footings will be used. A precast bridge section has been chosen that has a 35-foot clear span and a 10-foot, nine-inch rise. The 100-year discharge can be passed through the bridge at a headwater to depth ratio of .75. Bridge velocity during a 100-year event is estimated at between 12.5 to 12.7 feet per second. A type M riprap invert will be provided at each bridge crossing.

The construction of the improvements shown on the plans will result in a long-term stable drainageway corridor and prevent damages that could arise from bank sloughing related to the erosion of the drainageway's invert. Because the low flow channel will be stabilized both horizontally and vertically the potential for negative impacts upon the native vegetative habitat will be minimized. A stabilized floodplain corridor will result from the construction of the proposed drainageway benches and over the long term, the environmental quality of the corridor will be enhanced and preserved. The natural channel steep and potentially unstable slopes located outside of the channel improvements will be left in place and will not be impacted by construction.

Maintenance access to the proposed drops and drainageway will be provided via platted tracts within Branding Iron and Homestead subdivisions. Access trail will have an all-weather surface and be a minimum of 15-feet in width and will be continuous along overbanks of the channel. Access to the channel for maintenance in areas greater than 10-foot depth will be provided by access ramps from the maintenance trail to bottom bench of the channel located above the low flow channel. The ramps will be spaced at intervals to allow access to the channel including areas between the drop and bridge structures. However areas of the channel bench designated as wetland mitigation area not be accessible due to limitations of the 404 permit requirements.

The channel improvements were designed to include wetland mitigation elements located on the benched area of the channel bottom above the low flow channel. An overlay of the channel design will mitigation areas identified is included in the Appendix.

VIII. Construction Permitting

The following permits are anticipated to allow for the construction of the project as shown on the design plans. A copy of the Sterling Ranch 404 Permit is included within the Appendix.

USACOE notification of project in conformance with 404 permit - USACOE

Floodplain Development Permit – Regional Building Department

Grading and Erosion Control Permit (ESQCP) – El Paso County

Construction Stormwater Discharge Permit – CDPHE

Construction Dewatering Permit - CDPHE

Conditional Letter of Map Revision - FEMA

IX. Drainage and Bridge Fees

The Sterling Ranch Development and specifically Sterling Ranch East lies wholly within the Sand Creek drainage basin. Drainage and bridge fees have been established by the County for the Sand Creek drainage basin for assessment against platted land within the watershed. The drainageway structures will be public and will be maintained by the Sterling Ranch Metropolitan District. The costs for the public drainageway improvements are reimbursable or creditable against drainage and bridge fees owed when land within Sterling Ranch is platted. Reimbursement of drainage and bridge improvements require approval through the DCM reimbursement process. Construction of the bridge at Sterling Ranch Road and at Briargate Parkway will be creditable against bridge fees owed pending approval through the Drainage Board and DCM reimbursement process.

Excerpts from the 1996 Sand Creek DBPS are included in the Appendix. The recommended improvements for this reach of Sand Creek included numerous check structures and riprap lines around channel bends. The proposed channel design consists of a composite channel design with 20 GSB drop structures and two bridge crossings. The channel improvement costs will exceed the current drainage and bridge fees based on the design of the DBPS.

X. Phasing

Construction of the drainage and bridge facilities shown on the plans is to be completed all at once and no phasing of the construction is proposed. The construction will commence prior to or concurrent with the development of the Branding Iron Filing No. 2 and Homestead Filing No., 2 subdivisions.

Completion of the Briargate Parkway roadway will initially involve only the two lanes on an interim basis until such time that traffic warrants completing the full design section for Briargate Parkway. The full bridge length will be constructed as shown on the plans. The final configuration of the interim roadway section will be shown on the Briargate Boulevard design plans being prepared by others. Fine grading, paving, curb and gutter and sidewalks will be installed when the roadways are extended east from their present points of terminus.

XI. Conclusions

The development of the Branding Iron at Sterling Ranch and Homestead at Sterling Ranch subdivisions 1 requires that drainageway stabilization be implemented along Sand Creek. The stabilization measures are intended to provide protection to the residential lots from long term erosion of the banks and invert of Sand Creek. Stabilization of the drainageway to convey 100-year peak discharges will also promote better water quality to downstream reaches of Sand Creek and Fountain Creek as the potential for sediment from bank sloughing to be conveyed downstream will be eliminated. Upon construction of the drainageway stabilization measures as shown on the design plans, adjacent and downstream properties will not be adversely impacted by the runoff from these subdivisions and upstream drainage basins that will be conveyed by this segment Sand Creek.

State whether the bridges are to be constructed completely or phased.

Address MDDP recommendations, including this:

POND W3

It should be noted that after the initial run of the Proposed Condition Model, it was determined that the peak developed 100-year flow reaching the subject reach were higher than the 100-year existing condition flow rates and higher than the 100-year peak flows anticipated by the Wilson Study. To reduce the runoff, a detention facility has been added to the model upstream of Sterling Ranch Road within the Sterling Ranch Development. The incorporation of this facility when coupled with multiple Full Spectrum Detention facilities will allow the development upstream of the City/County boundary to release developed discharge at a rate this is at or below the current existing flow rates. It should be noted that the location of the facility was previously planned as a regional pond /park site in the Sterling Ranch 2010 MDDP (Draft) and Sketch Plan. Stage storage and stage volume worksheets are included in the attachments for this pond. It is anticipated that this facility can be designed without having to be jurisdiction in nature. Based upon preliminary modeling the pond will reduce 100 year peak runoff rates from 2204 to less than 1400 cfs. The pond will detain a maximum of 78 acre feet at a depth of around 10 feet. The pond embankment containing the 100 year event will be separate from Sterling Ranch Road. An exhibit detailing the concept design is provided in the appendix of this report. It is important to note that this pond will allow for the free discharge of the 2 year storm and is not intended to provide water quality and will meet the state statute regarding the allowable release times.

Design point 61 is located on the maps between Sand Creek Regional Detention Pond 3 and south boundary of Sterling Ranch just upstream of Mustang Road. Future development in the watershed should attempt to mimic the flow rates provided within the report with special consideration given to the flow at the City/County boundary line at Design Point 61. It should be noted that the hydrologic calculations contained in this memorandum are intended to aid in the design of the crossing structure at Marksheffel Road north of City Pond 3 (DP 60A) and as a planning resource to limit the amount of developed runoff discharged into the Sand Creek Channel. This report is not intended to be utilized for final design of stormwater storage facilities and infrastructure. It should also be noted, that this report did not include City Pond 3 in any of its models and was only used as a comparison point.

Appendix A Hydrologic and Hydraulic Calculations

Capacity Analysis of Composite Channel

Project: 19032 Sand Creek at Sterling Ranch

Channel ID: Q100 = 2600 (FIS) slope = 0.02% 0.2%

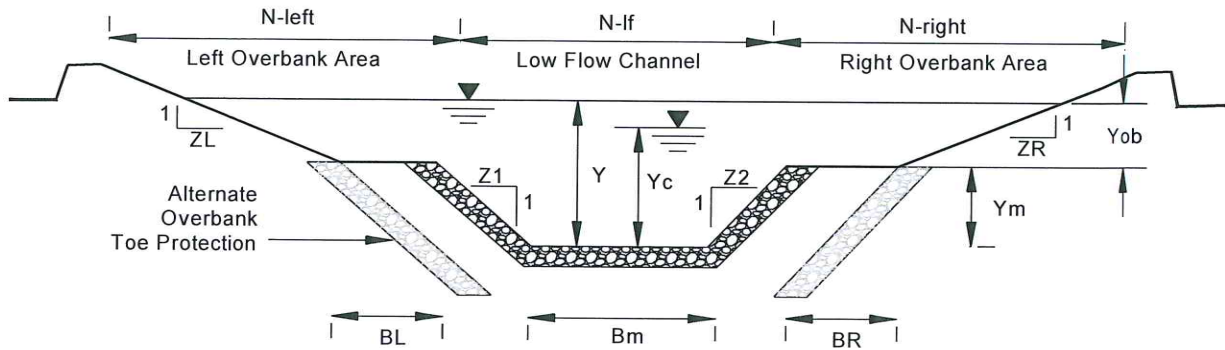

Design Information (Input)			
Channel Invert Slope	So =	0.00200 ft/ft	Left Overbank Bottom Width
			BL = 35.00 ft
Low Flow Channel Bottom Width	Bm =	25.00 ft	Left Overbank Side Slope
Low Flow Channel Left Side Slope	Z1 =	3.00 ft/ft	ZL = 4.00 ft/ft
Low Flow Channel Right Side Slope	Z2 =	3.00 ft/ft	Left Overbank Manning's n
Low Flow Channel Manning's Nn for Qd	n-lf =	0.0300	n-left = 0.0300
Low Flow Channel Manning's Nn for Q100	n-m-Q100 =	0.0350	Right Overbank Bottom Width
(See USDCM Vol. II, n vs. Depth Graph)			BR = 35.00 ft
Low Flow Channel Bank-full depth	Ym =	2.50 ft	Right Overbank Side Slope
			ZR = 4.00 ft/ft
			Right Overbank Manning's n
			n-right = 0.0300
			Overbank Flow Depth Yob (Y - Ym)
			Yob = 3.50 ft
Low Flow Channel Condition for Qd			
Top width	Tlf =	40.0 ft	Top width
Flow area	Alf =	81.3 sq ft	Flow area
Wetted perimeter	Plf =	40.8 ft	Wetted perimeter
Discharge (Calculated)	Qlf =	285.6 cfs	Discharge
Velocity	Vlf =	3.5 fps	Velocity
Froude number	Fr-lf =	0.43	Froude number
Qd Critical Velocity	Vlfc =	6.47 fps	100-Yr. Critical Velocity
Qd Critical Depth	Ylfc =	1.50 ft	100-Yr. Critical Depth
Low Flow Channel Flow Condition for Q100			
			Tm = 40.0 ft
			Am = 221.3 sq ft
			Pm = 40.8 ft
			Qm = 1,299.9 cfs
			Vm = 5.9 fps
			Frm = 0.44
			Vmc = 10.2 fps
			Ymc = 3.7 ft
Left Overbank Flow Condition for Q100			
Top width	TL =	49.0 ft	Top width
Flow area	AL =	147.0000 sq ft	Flow area
Wetted perimeter	PL =	49.4300 ft	Wetted perimeter
Discharge	QL =	675.2 cfs	Discharge
Velocity	VL =	4.6 fps	Velocity
Froude number	FrL =	0.47	Froude number
100-Yr. Critical Velocity	VLc =	7.9 fps	100-Yr. Critical Velocity
100-Yr. Critical Depth in Overbanks	YLc =	2.2 ft	100-Yr. Critical Depth in Overbanks
Right Overbank Flow Condition for Q100			
			TR = 49.0 ft
			AR = 147.0000 sq ft
			PR = 49.4300 ft
			QR = 675.2 cfs
			VR = 4.6 fps
			FrR = 0.47
			VRc = 7.9 fps
			YRc = 2.2 ft
Composite Cross-Section Flow Condition for Q100			
Top width	T =	138.0 ft	Discharge
Channel Depth Y	Y =	6.00 ft	Q = 2,650.4 cfs
Flow area	A =	515.3 sq ft	Velocity
Wetted perimeter	P =	139.7 ft	V = 5.1 fps
Cross-Sectional Manning's n (Calculated)	n =	0.0309	Froude number
			Fr = 0.47
			Vc = 8.8 fps
			Yc = 1.87 ft
			100-Yr. Critical Velocity
			100-Yr. Critical Depth in Overbanks

Capacity Analysis of Composite Channel

Project: 19032 Sand Creek at Sterling Ranch

Channel ID: Q100 = 2600 (FIS) Q LOW = 260 cfs S=0.5%

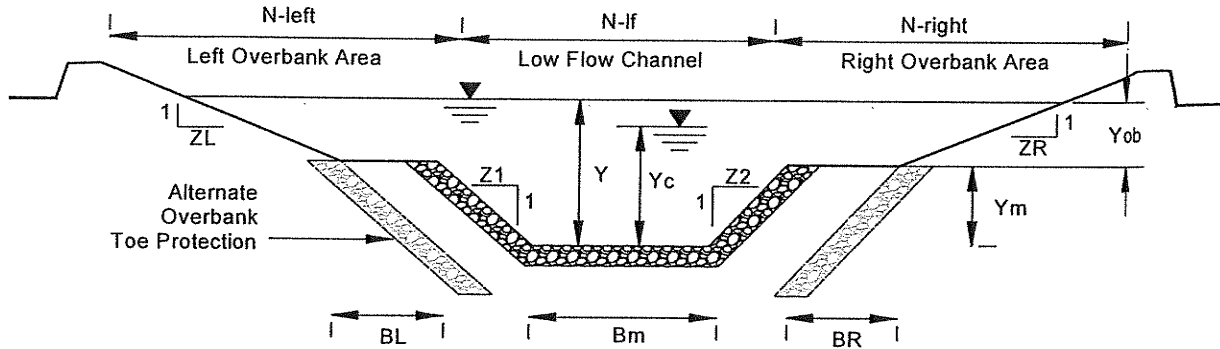

Design Information (Input)			
Channel Invert Slope	So = 0.00500 ft/ft	Left Overbank Bottom Width	BL = 35.00 ft
Low Flow Channel Bottom Width	Bm = 25.00 ft	Left Overbank Side Slope	ZL = 4.00 ft/ft
Low Flow Channel Left Side Slope	Z1 = 3.00 ft/ft	Left Overbank Manning's n	n-left = 0.0300
Low Flow Channel Right Side Slope	Z2 = 3.00 ft/ft	Right Overbank Bottom Width	BR = 35.00 ft
Low Flow Channel Manning's Nn for Qd	n-lf = 0.0300	Right Overbank Side Slope	ZR = 4.00 ft/ft
Low Flow Channel Manning's Nn for Q100 (See USDCM Vol. II, n vs. Depth Graph)	n-m-Q100 = 0.0350	Right Overbank Manning's n	n-right = 0.0300
Low Flow Channel Bank-full depth	Ym = 2.50 ft	Overbank Flow Depth Yob (Y - Ym)	Yob = 2.50 ft
Low Flow Channel Condition for Qd			
Top width	Tlf = 40.0 ft	Low Flow Channel Flow Condition for Q100	
Flow area	Alf = 81.3 sq ft	Top width	Tm = 40.0 ft
Wetted perimeter	Plf = 40.8 ft	Flow area	Am = 181.3 sq ft
Discharge (Calculated)	Qlf = 451.6 cfs	Wetted perimeter	Pm = 40.8 ft
Velocity	Vlf = 5.6 fps	Discharge	Qm = 1,474.2 cfs
Froude number	Fr-lf = 0.69	Velocity	Vm = 8.1 fps ←
Qd Critical Velocity	Vlfc = 7.33 fps	Froude number	Fr-m = 0.67
Qd Critical Depth	Ylfc = 1.99 ft	100-Yr. Critical Velocity	Vmc = 10.6 fps
Left Overbank Flow Condition for Q100		100-Yr. Critical Depth	Ymc = 3.9 ft
Top width	TL = 45.0 ft	Right Overbank Flow Condition for Q100	
Flow area	AL = 100.0000 sq ft	Top width	TR = 45.0 ft
Wetted perimeter	PL = 45.3100 ft	Flow area	AR = 100.0000 sq ft
Discharge	QL = 595.3 cfs	Wetted perimeter	PR = 45.3100 ft
Velocity	VL = 6.0 fps →	Discharge	QR = 595.3 cfs
Froude number	FrL = 0.70	Velocity	VR = 6.0 fps ←
100-Yr. Critical Velocity	VLc = 7.6 fps	Froude number	FrR = 0.70
100-Yr. Critical Depth in Overbanks	YLc = 2.0 ft	100-Yr. Critical Velocity	VRc = 7.6 fps
Composite Cross-Section Flow Condition for Q100		100-Yr. Critical Depth in Overbanks	YRc = 2.0 ft
Top width	T = 130.0 ft	Discharge	Q = 2,664.9 cfs *
Channel Depth Y	Y = 5.00 ft	Velocity	V = 7.0 fps
Flow area	A = 381.3 sq ft	Froude number	Fr = 0.72
Wetted perimeter	P = 131.4 ft	100-Yr. Critical Velocity	Vc = 8.8 fps
Cross-Sectional Manning's n (Calculated)	n = 0.0307	100-Yr. Critical Depth in Overbanks	Yc = 1.88 ft

* Q100 Design = 2600 cfs

Capacity Analysis of Composite Channel

Project: 19032 Sand Creek at Sterling Ranch

Channel ID: Q100 = 2600 (FIS) Q LOW = 260 cfs S=0.5% Benches varied 20-foot left 50 right

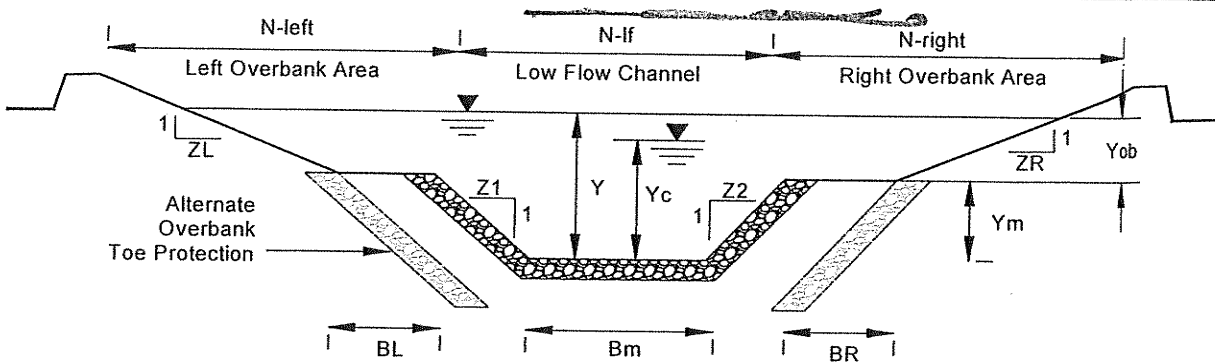

Design Information (Input)			
Channel Invert Slope	So = 0.00500 ft/ft	Left Overbank Bottom Width	BL = 20.00 ft
Low Flow Channel Bottom Width	Bm = 25.00 ft	Left Overbank Side Slope	ZL = 4.00 ft/ft
Low Flow Channel Left Side Slope	Z1 = 3.00 ft/ft	Left Overbank Manning's n	n-left = 0.0300
Low Flow Channel Right Side Slope	Z2 = 3.00 ft/ft	Right Overbank Bottom Width	BR = 50.00 ft
Low Flow Channel Manning's Nn for Qd	n-lf = 0.0300	Right Overbank Side Slope	ZR = 4.00 ft/ft
Low Flow Channel Manning's Nn for Q100 (See USDCM Vol. II, n vs. Depth Graph)	n-m-Q100 = 0.0350	Right Overbank Manning's n	n-right = 0.0300
Low Flow Channel Bank-full depth	Ym = 2.50 ft	Overbank Flow Depth Yob (Y - Ym)	Yob = 2.50 ft
Low Flow Channel Condition for Qd			
Top width	Tlf = 40.0 ft	Low Flow Channel Flow Condition for Q100	
Flow area	Alf = 81.3 sq ft	Top width	Tm = 40.0 ft
Wetted perimeter	Plf = 40.8 ft	Flow area	Am = 181.3 sq ft
Discharge (Calculated)	Qlf = 451.6 cfs	Wetted perimeter	Pm = 40.8 ft
Velocity	Vlf = 5.6 fps	Discharge	Qm = 1,474.2 cfs
Froude number	Fr-lf = 0.69	Velocity	Vm = 8.1 fps
Qd Critical Velocity	Vlfc = 7.33 fps	Froude number	Fr-m = 0.67
Qd Critical Depth	Ylfc = 1.99 ft	100-Yr. Critical Velocity	Vmc = 10.6 fps
Left Overbank Flow Condition for Q100		100-Yr. Critical Depth	Ymc = 3.9 ft
Top width	TL = 30.0 ft	Right Overbank Flow Condition for Q100	
Flow area	AL = 62.5000 sq ft	Top width	TR = 60.0 ft
Wetted perimeter	PL = 30.3100 ft	Flow area	AR = 137.5000 sq ft
Discharge	QL = 355.6 cfs	Wetted perimeter	PR = 60.3100 ft
Velocity	VL = 5.7 fps	Discharge	QR = 836.5 cfs
Froude number	FrL = 0.69	Velocity	VR = 6.1 fps
100-Yr. Critical Velocity	VLc = 7.4 fps	Froude number	FrR = 0.71
100-Yr. Critical Depth in Overbanks	YLc = 2.0 ft	100-Yr. Critical Velocity	VRc = 7.8 fps
Composite Cross-Section Flow Condition for Q100		100-Yr. Critical Depth in Overbanks	YRc = 2.0 ft
Top width	T = 130.0 ft	Discharge	Q = 2,666.3 cfs
Channel Depth Y	Y = 5.00 ft	Velocity	V = 7.0 fps
Flow area	A = 381.3 sq ft	Froude number	Fr = 0.72
Wetted perimeter	P = 131.4 ft	100-Yr. Critical Velocity	Vc = 8.8 fps
Cross-Sectional Manning's n (Calculated)	n = 0.0306	100-Yr. Critical Depth in Overbanks	Yc = 1.88 ft

* Q design = 2600 cfs

Capacity Analysis of Composite Channel

Project: 19032 Sand Creek at Sterling Ranch

Channel ID: Q100 = 2600 (FIS) Q LOW = 260 cfs S=0.85%

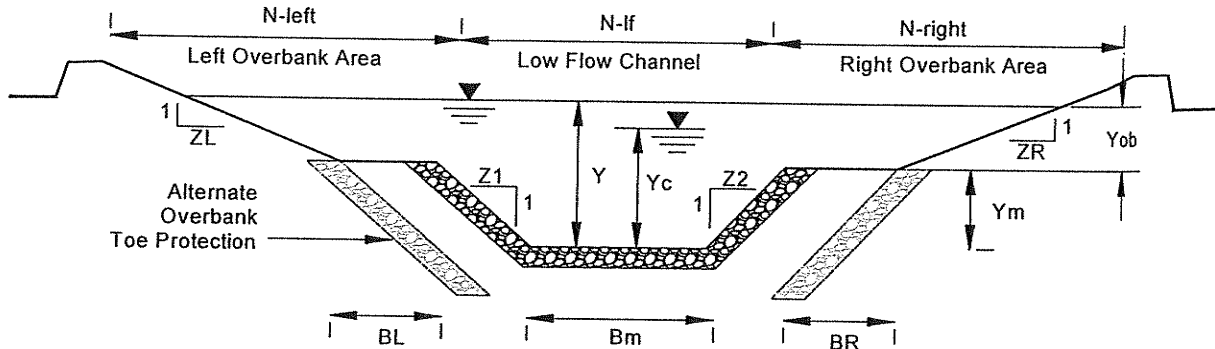

Design Information (Input)

Channel Invert Slope	So = 0.00850 ft/ft	Left Overbank Bottom Width	BL = 35.00 ft
Low Flow Channel Bottom Width	Bm = 25.00 ft	Left Overbank Side Slope	ZL = 4.00 ft/ft
Low Flow Channel Left Side Slope	Z1 = 3.00 ft/ft	Left Overbank Manning's n	n-left = 0.0300
Low Flow Channel Right Side Slope	Z2 = 3.00 ft/ft	Right Overbank Bottom Width	BR = 35.00 ft
Low Flow Channel Manning's Nn for Qd	n-lf = 0.0300	Right Overbank Side Slope	ZR = 4.00 ft/ft
Low Flow Channel Manning's Nn for Q100 (See USDCM Vol. II, n vs. Depth Graph)	n-m-Q100 = 0.0350	Right Overbank Manning's n	n-right = 0.0300
Low Flow Channel Bank-full depth	Ym = 2.50 ft	Overbank Flow Depth Yob (Y - Ym)	Yob = 2.50 ft

Low Flow Channel Condition for Qd

Top width	Tlf = 40.0 ft
Flow area	Alf = 81.3 sq ft
Wetted perimeter	Plf = 40.8 ft
Discharge (Calculated)	Qlf = 588.8 cfs
Velocity	Vlf = 7.3 fps
Froude number	Fr-lf = 0.90
Qd Critical Velocity	Vlfc = 7.86 fps
Qd Critical Depth	Ylfc = 2.34 ft

Low Flow Channel Flow Condition for Q100

Top width	Tm = 40.0 ft
Flow area	Am = 181.3 sq ft
Wetted perimeter	Pm = 40.8 ft
Discharge	Qm = 1,922.1 cfs
Velocity	Vm = 10.6 fps
Froude number	Fr-m = 0.88
100-Yr. Critical Velocity	Vmc = 11.6 fps
100-Yr. Critical Depth	Ymc = 4.6 ft

Left Overbank Flow Condition for Q100

Top width	TL = 45.0 ft
Flow area	AL = 100.0000 sq ft
Wetted perimeter	PL = 45.3100 ft
Discharge	QL = 776.2 cfs
Velocity	VL = 7.8 fps
Froude number	FrL = 0.92
100-Yr. Critical Velocity	VLc = 8.3 fps
100-Yr. Critical Depth in Overbanks	YLc = 2.4 ft

Right Overbank Flow Condition for Q100

Top width	TR = 45.0 ft
Flow area	AR = 100.0000 sq ft
Wetted perimeter	PR = 45.3100 ft
Discharge	QR = 776.2 cfs
Velocity	VR = 7.8 fps
Froude number	FrR = 0.92
100-Yr. Critical Velocity	VRc = 8.3 fps
100-Yr. Critical Depth in Overbanks	YRc = 2.4 ft

Composite Cross-Section Flow Condition for Q100

Top width	T = 130.0 ft	Discharge	Q = 3,474.5 cfs
Channel Depth Y	Y = 5.00 ft	Velocity	V = 9.1 fps
Flow area	A = 381.3 sq ft	Froude number	Fr = 0.94
Wetted perimeter	P = 131.4 ft	100-Yr. Critical Velocity	Vc = 9.5 fps
Cross-Sectional Manning's n (Calculated)	n = 0.0307	100-Yr. Critical Depth in Overbanks	Yc = 2.37 ft

Q₁₀₀ = 2600 cfs
Q_{LF} = 260 cfs

Os this sheet applicable?

① Bridges Pipe Sizing per UDFCD Eq. B-11

100% Bridge velocities (From HEC-2AS)

② Boisjoute $S = 0.85\%$
 approach 6.2 fps
 outlet 12.2 fps
 departure 10.3 fps.

$$d_{50} \geq \left[\frac{V S^{.17}}{4.5(G_s - 1)^{.66}} \right] \text{ Assume } G_s = 2.6$$

$$d_{50} \geq \frac{V S^{.17}}{6.13}$$

within bridge: inlet & outlet

$$d_{50} \geq \frac{(12.2(0.0085))^{.17}}{6.13} = .88'$$

∴ use 12" D₅₀

③ Stirling Ranch Road $S = 0.5\%$
 approach 6.4 fps
 outlet 12.7 fps
 departure 7.0 fps

$$d_{50} = \frac{12.7(0.005)^{.17}}{6.13} = .84$$

∴ use 12" D₅₀

8.1 Riprap Sizing

Procedures for sizing rock to be used in soil riprap, void-filled riprap, and riprap over bedding are the same.

8.1.1 Mild Slope Conditions

When subcritical flow conditions occur and/or slopes are mild (less than 2 percent), UDFCD recommends the following equation (Hughes, et al, 1983):

$$d_{50} \geq \left[\frac{VS^{0.17}}{4.5(G_s - 1)^{0.66}} \right]^2 \quad \text{Equation 8-11}$$

Where:

V = mean channel velocity (ft/sec)

S = longitudinal channel slope (ft/ft)

d_{50} = mean rock size (ft)

G_s = specific gravity of stone (minimum = 2.50, typically 2.5 to 2.7), Note: In this equation ($G_s - 1$) considers the buoyancy of the water, in that the specific gravity of water is subtracted from the specific gravity of the rock.

Note that Equation 8-11 is applicable for sizing riprap for channel lining with a longitudinal slope of no more than 2%. This equation is not intended for use in sizing riprap for steep slopes (typically in excess of 2 percent), rundowns, or protection downstream of culverts. Information on rundowns is provided in Section 7.0 of the *Hydraulic Structures* chapter of the USDCM, and protection downstream of culverts is discussed in the *Culverts and Bridges* chapter. For channel slopes greater than 2% use one of the methods presented in 8.1.2.

Rock size does not need to be increased for steeper channel side slopes, provided the side slopes are no steeper than 2.5H:1V (UDFCD 1982). Channel side slopes steeper than 2.5H:1V are not recommended because of stability, safety, and maintenance considerations. See Figure 8-34 for riprap placement specifications. At the upstream and downstream termination of a riprap lining, the thickness should be increased 50% for at least 3 feet to prevent undercutting.

8.1.2 Steep Slope Conditions

Steep slope rock sizing equations are used for applications where the slope is greater than 2 percent and/or flows are in the supercritical flow regime. The following rock sizing equations may be referred to for riprap design analysis on steep slopes:

- CSU Equation, *Development of Riprap Design Criteria by Riprap Testing in Flumes: Phase II* (prepared by S.R. Abt, et al, Colorado State University, 1988). This method was developed for steep slopes from 2 to 20 percent.
- USDA- Agricultural Research Service Equations, *Design of Rock Chutes* (by K.M. Robinson, et al, USDA- ARS, 1998 Transactions of ASAE) and *An Excel Program to Design Rock Chutes for Grade*

② Within drainage way

100yr Flow condition \Rightarrow Composite channel design

$$S = 0.5\%$$

Velocity in low flow during 100-year = 8.1 fps

$$d_{50} > \frac{8.1 (.005)^{.17}}{6.13} = .53 \quad \text{use } D_{50} = 9''$$

Overbank velocity during 100-year = 7.8 fps
per above calc, $d_{50} \geq .53$
use 9" D_{50}

③ Shear Stress:

Overbanks benches:

Maximum depth of flow (outside of bridges)

$$e \leq 0.5\% \quad 5.0'$$

$$\text{Maximum depth over bank} = 5.0 - 2.5 = 2.5'$$

$$\text{Shear Stress } \tau = \gamma d S = 62.4(2.5)(.005) = .78 \text{ psf}$$

Will recommend curled wood mat (TRM)
permissible $\tau = 1.55$.

Inside bends of channel

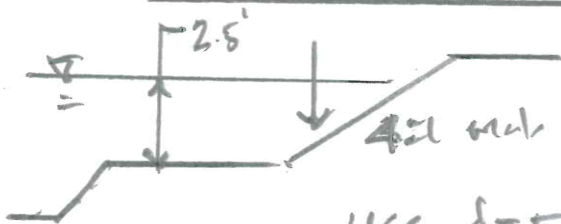

use depth @ 1/3 point of slope $\approx 1.68'$

$$\tau = 62.4(1.68)(.005) = .52 \text{ psf}$$

Recommend Erosion Control blanket (temporary)
of establishment of Class 'B' Vegetative cover

**DESIGN OF ROADSIDE CHANNELS
WITH FLEXIBLE LININGS**

Hydraulic Engineering Circular No. 15

Prepared By

Simons, Li & Associates, Inc.
3555 Stanford Road
P.O. Box 1816
Fort Collins, Colorado 80522

For

U.S. Department of Transportation
Federal Highway Administration

October 25, 1985

Table 4.1. Permissible Shear Stresses for Lining Materials.

Lining Category	Lining Type	Permissible Unit Shear Stress (lb/ft ²)
Temporary	Woven Paper Net	0.15
	Jute Net	0.45
	Fiberglass Roving*	0.75
	Straw and Erosion Net	1.45
	Curled Wood Mat (TRM)	1.55
	Nylon Mat	2.00
Vegetative	Class A	3.70
	Class B	2.10
	Class C	1.00
	Class D	0.60
	Class E	0.35
Gravel Riprap	1-inch	0.40
	2-inch	0.80
Rock Riprap	6-inch	2.50
	12-inch	5.00

* single and double applications

TABLE 3.1.--Classification of vegetal covers as to degree of retardance (6)

Note: Covers classified have been tested in experimental channels.
Covers were green and generally uniform.

Retardance	Cover	Condition
A	Weeping lovegrass	Excellent stand, tall, (average 30")
	Yellow bluestem <i>Ischaemum</i> ..	Excellent stand, tall, (average 36")
B	Kudzu	Very dense growth, uncut
	Bermudagrass	Good stand, tall (average 12")
	Native grass mixture (little bluestem, blue grama, and other long and short mid-west grasses)	Good stand, unmowed
	Weeping lovegrass	Good stand, tall, (average 24")
	Lespedeza <i>sericea</i>	Good stand, not woody, tall (average 19")
	Alfalfa	Good stand, uncut, (average 11")
	Weeping lovegrass	Good stand, mowed, (average 13")
C	Kudzu	Dense growth, uncut
	Blue grama	Good stand, uncut, (average 13")
	Crabgrass	Fair stand, uncut (10 to 48")
	Bermudagrass	Good stand, mowed (average 6")
	Common lespedeza	Good stand, uncut (average 11")
	Grass-legume mixture--summer (orchard grass, redtop, Italian ryegrass, and common lespedeza)	Good stand, uncut (6 to 8 inches)
D	Centipedegrass	Very dense cover (average 6 inches)
	Kentucky bluegrass	Good stand, headed (6 to 12 inches)
	Bermudagrass	Good stand, cut to 2.5-inch height
	Common lespedeza	Excellent stand, uncut (average 4.5")
	Buffalograss	Good stand, uncut (3 to 6 inches)
E	Grass-legume mixture--fall, spring (Orchardgrass, redtop, Italian ryegrass, and common lespedeza)	Good stand, uncut (4 to 5 inches) After cutting to 2-inch height. Very good stand before cutting.
	Lespedeza <i>sericea</i>	
E	Bermudagrass	Good stand, cut to 1.5 inches height
	Bermudagrass	Burned stubble.

Excessive velocities highlighted.



HEC-RAS Plan: PP Profiles River: Sand Creek Reach: CLOMR CL

Reach	River Sta	Profile	Q Total (cfs)	Min Ch El (ft)	W.S. Elev (ft)	Crit W.S. (ft)	E.G. Elev (ft)	E.G. Slope (ft/ft)	Vel Chnl (ft/s)	Flow Area (sq ft)	Top Width (ft)	Froude # Chl
CLOMR CL	10150	10yr	1200.00	7150.00	7154.22	7153.83	7154.74	0.010591	5.57	208.40	112.90	0.67
CLOMR CL	10150	50yr	2100.00	7150.00	7154.91	7155.67	7154.71	0.013470	7.28	299.92	151.62	0.78
CLOMR CL	10150	100yr	2600.00	7150.00	7155.17	7155.02	7156.08	0.013769	7.84	340.34	154.37	0.81
CLOMR CL	10150	500yr	3800.00	7150.00	7155.73	7155.63	7156.96	0.014098	8.91	428.81	160.19	0.84
CLOMR CL	9654	10yr	1200.00	7146.00	7149.50		7150.00	0.008634	6.03	225.36	135.18	0.64
CLOMR CL	9654	50yr	2100.00	7146.00	7150.45		7151.02	0.006771	6.50	357.97	142.81	0.59
CLOMR CL	9654	100yr	2600.00	7146.00	7150.88		7151.50	0.006414	6.80	419.15	146.20	0.59
CLOMR CL	9654	500yr	3800.00	7146.00	7151.76		7152.52	0.005875	7.41	552.23	153.31	0.58
CLOMR CL	9590	10yr	1200.00	7144.80	7149.55		7149.69	0.001568	3.29	400.72	145.19	0.29
CLOMR CL	9590	50yr	2100.00	7144.80	7150.47		7150.71	0.001953	4.21	537.22	152.52	0.33
CLOMR CL	9590	100yr	2600.00	7144.80	7150.89		7151.18	0.002110	4.63	601.98	155.88	0.35
CLOMR CL	9590	500yr	3800.00	7144.80	7151.71		7152.16	0.003161	6.22	773.69	269.75	0.44
CLOMR CL	9540	10yr	1200.00	7144.80	7148.72	7148.72	7149.47	0.010526	7.45	191.62	120.31	0.72
CLOMR CL	9540	50yr	2100.00	7144.80	7149.41	7149.41	7150.43	0.011968	9.00	276.85	126.75	0.79
CLOMR CL	9540	100yr	2600.00	7144.80	7149.74	7149.74	7150.89	0.012197	9.57	319.20	129.83	0.81
CLOMR CL	9540	500yr	3800.00	7144.80	7150.54	7150.54	7151.81	0.010998	10.17	438.03	178.02	0.79
CLOMR CL	9500	10yr	1200.00	7135.80	7142.26		7142.35	0.000594	2.45	545.66	158.90	0.19
CLOMR CL	9500	50yr	2100.00	7135.80	7143.31		7143.45	0.000827	3.26	716.55	167.28	0.23
CLOMR CL	9500	100yr	2600.00	7135.80	7143.80		7143.98	0.000916	3.60	799.85	171.22	0.24
CLOMR CL	9500	500yr	3800.00	7135.80	7144.83		7145.07	0.001058	4.24	978.10	174.94	0.26
CLOMR CL	9471	10yr	1200.00	7135.80	7142.01		7142.30	0.001025	4.67	329.73	120.89	0.36
CLOMR CL	9471	50yr	2100.00	7135.80	7142.89		7143.39	0.001530	6.31	439.26	127.94	0.45
CLOMR CL	9471	100yr	2600.00	7135.80	7143.30		7143.90	0.001740	7.02	492.34	131.21	0.48
CLOMR CL	9471	500yr	3800.00	7135.80	7144.15		7144.97	0.002126	8.41	606.64	138.01	0.54
CLOMR CL	9470	10yr	1200.00	7137.80	7141.51	7141.42	7142.26	0.004947	7.53	205.34	116.90	0.74
CLOMR CL	9470	50yr	2100.00	7137.80	7142.42		7143.34	0.004857	8.80	314.56	124.15	0.76
CLOMR CL	9470	100yr	2600.00	7137.80	7142.84		7143.85	0.004830	9.35	367.21	127.50	0.77
CLOMR CL	9470	500yr	3800.00	7137.80	7143.70		7144.93	0.004829	10.49	479.53	134.36	0.79
CLOMR CL	9420	10yr	1200.00	7137.55	7141.27	7141.17	7142.01	0.004926	7.52	205.68	116.92	0.74
CLOMR CL	9420	50yr	2100.00	7137.55	7142.18		7143.09	0.004811	8.77	315.65	124.22	0.76
CLOMR CL	9420	100yr	2600.00	7137.55	7142.60		7143.61	0.004763	9.31	369.02	127.61	0.77
CLOMR CL	9420	500yr	3800.00	7137.55	7143.45		7144.68	0.004794	10.46	480.78	134.43	0.79
CLOMR CL	9337	10yr	1200.00	7137.13	7140.92	7140.75	7141.60	0.004415	7.23	214.72	117.54	0.70
CLOMR CL	9337	50yr	2100.00	7137.13	7141.84		7142.70	0.004410	8.50	325.68	124.86	0.73
CLOMR CL	9337	100yr	2600.00	7137.13	7142.27		7143.21	0.004384	9.04	380.01	128.30	0.74
CLOMR CL	9337	500yr	3800.00	7137.13	7143.11		7144.28	0.004495	10.23	493.21	146.72	0.77
CLOMR CL	9240	10yr	1200.00	7136.65	7140.27	7140.27	7141.10	0.005649	7.90	194.75	116.17	0.78
CLOMR CL	9240	50yr	2100.00	7136.65	7141.06	7141.06	7142.17	0.006141	9.56	288.91	122.48	0.85
CLOMR CL	9240	100yr	2600.00	7136.65	7141.42	7141.42	7142.67	0.006363	10.30	332.83	125.32	0.88
CLOMR CL	9240	500yr	3800.00	7136.65	7142.18	7142.18	7143.73	0.006570	11.67	430.55	131.41	0.92
CLOMR CL	9190	10yr	1200.00	7136.40	7139.64	7139.64	7140.35	0.013603	7.09	190.71	133.11	0.79
CLOMR CL	9190	50yr	2100.00	7136.40	7140.30	7140.30	7141.25	0.014143	8.44	279.99	138.38	0.84
CLOMR CL	9190	100yr	2600.00	7136.40	7140.61	7140.61	7141.68	0.014152	8.98	323.07	140.84	0.85
CLOMR CL	9190	500yr	3800.00	7136.40	7141.22	7141.22	7142.60	0.014578	10.15	410.74	145.74	0.89
CLOMR CL	9150	10yr	1200.00	7128.40	7134.86		7134.95	0.000593	2.45	545.97	158.91	0.19
CLOMR CL	9150	50yr	2100.00	7128.40	7135.92		7136.06	0.000823	3.25	717.69	167.34	0.23
CLOMR CL	9150	100yr	2600.00	7128.40	7136.41		7136.58	0.000912	3.59	800.77	171.26	0.24
CLOMR CL	9150	500yr	3800.00	7128.40	7137.43		7137.68	0.001090	4.31	982.78	186.92	0.27
CLOMR CL	9121	10yr	1200.00	7128.40	7134.61		7134.91	0.001023	4.67	330.02	120.91	0.36
CLOMR CL	9121	50yr	2100.00	7128.40	7135.50		7135.99	0.001520	6.30	440.44	128.01	0.44
CLOMR CL	9121	100yr	2600.00	7128.40	7135.91		7136.50	0.001730	7.01	493.43	131.28	0.48
CLOMR CL	9121	500yr	3800.00	7128.40	7136.76		7137.58	0.002112	8.39	608.13	138.09	0.54
CLOMR CL	9120	10yr	1200.00	7130.40	7134.14	7134.02	7134.86	0.004727	7.41	209.05	117.15	0.72
CLOMR CL	9120	50yr	2100.00	7130.40	7135.06		7135.95	0.004655	8.66	319.42	124.46	0.75
CLOMR CL	9120	100yr	2600.00	7130.40	7135.47		7136.46	0.004689	9.25	371.07	127.74	0.76
CLOMR CL	9120	500yr	3800.00	7130.40	7136.32		7137.54	0.004730	10.41	483.01	134.57	0.79
CLOMR CL	9070	10yr	1200.00	7130.15	7133.93	7133.77	7134.62	0.004525	7.30	212.66	117.40	0.71
CLOMR CL	9070	50yr	2100.00	7130.15	7134.84		7135.71	0.004480	8.55	323.86	124.75	0.73
CLOMR CL	9070	100yr	2600.00	7130.15	7135.25		7136.22	0.004562	9.17	374.69	127.96	0.75
CLOMR CL	9070	500yr	3800.00	7130.15	7136.09		7137.29	0.004652	10.35	485.84	134.73	0.78
CLOMR CL	8990	10yr	1200.00	7129.75	7133.37	7133.37	7134.20	0.005645	7.90	194.81	116.18	0.78
CLOMR CL	8990	50yr	2100.00	7129.75	7134.16	7134.16	7135.27	0.006137	9.55	288.97	122.49	0.85
CLOMR CL	8990	100yr	2600.00	7129.75	7134.52	7134.52	7135.77	0.006367	10.31	332.77	125.32	0.88
CLOMR CL	8990	500yr	3800.00	7129.75	7135.28	7135.28	7136.83	0.006570	11.67	430.55	131.41	0.92

Please label the drop stations. All of the highlighted velocities are between drops.

HEC-RAS Plan: PP Profiles River: Sand Creek Reach: CLOMR CL (Continued)

Reach	River Sta	Profile	Q Total (cfs)	Min Ch El (ft)	W.S. Elev (ft)	Crit W.S. (ft)	E.G. Elev (ft)	E.G. Slope (ft/ft)	Vel Chnl (ft/s)	Flow Area (sq ft)	Top Width (ft)	Froude # Chl
CLOMR CL	8940	10yr	1200.00	7129.50	7132.74	7132.74	7133.45	0.013569	7.08	191.08	134.04	0.79
CLOMR CL	8940	50yr	2100.00	7129.50	7133.40	7133.40	7134.35	0.014048	8.41	281.75	140.85	0.83
CLOMR CL	8940	100yr	2600.00	7129.50	7133.71	7133.71	7134.78	0.014013	8.94	325.92	144.06	0.85
CLOMR CL	8940	500yr	3800.00	7129.50	7134.32	7134.32	7135.68	0.014449	10.11	415.40	150.34	0.88
CLOMR CL	8900	10yr	1200.00	7121.50	7127.96		7128.05	0.000595	2.45	545.58	158.89	0.19
CLOMR CL	8900	50yr	2100.00	7121.50	7129.01		7129.15	0.000828	3.26	716.14	167.26	0.23
CLOMR CL	8900	100yr	2600.00	7121.50	7129.50		7129.67	0.000919	3.60	798.77	171.17	0.24
CLOMR CL	8900	500yr	3800.00	7121.50	7130.52		7130.77	0.001060	4.24	977.01	174.47	0.27
CLOMR CL	8871	10yr	1200.00	7121.50	7127.71		7128.00	0.001026	4.67	329.67	120.89	0.36
CLOMR CL	8871	50yr	2100.00	7121.50	7128.59		7129.08	0.001535	6.32	438.76	127.91	0.45
CLOMR CL	8871	100yr	2600.00	7121.50	7128.99		7129.59	0.001750	7.04	491.25	131.15	0.48
CLOMR CL	8871	500yr	3800.00	7121.50	7129.84		7130.67	0.002139	8.43	605.29	137.93	0.54
CLOMR CL	8870	10yr	1200.00	7123.50	7127.21	7127.12	7127.96	0.004996	7.56	204.54	116.84	0.74
CLOMR CL	8870	50yr	2100.00	7123.50	7128.09	7127.91	7129.04	0.004989	8.88	311.53	123.95	0.77
CLOMR CL	8870	100yr	2600.00	7123.50	7128.51	7128.27	7129.55	0.004973	9.45	363.42	127.26	0.78
CLOMR CL	8870	500yr	3800.00	7123.50	7129.36		7130.62	0.004952	10.58	475.34	134.11	0.80
CLOMR CL	8820	10yr	1200.00	7123.25	7126.95	7126.87	7127.71	0.005010	7.57	204.31	116.83	0.74
CLOMR CL	8820	50yr	2100.00	7123.25	7127.85	7127.66	7128.79	0.004987	8.88	311.59	123.96	0.77
CLOMR CL	8820	100yr	2600.00	7123.25	7128.26		7129.30	0.004963	9.44	363.67	127.27	0.78
CLOMR CL	8820	500yr	3800.00	7123.25	7129.12		7130.37	0.004941	10.57	475.73	134.13	0.80
CLOMR CL	8700	10yr	1200.00	7122.65	7126.35	7126.27	7127.10	0.005042	7.58	203.79	116.79	0.74
CLOMR CL	8700	50yr	2100.00	7122.65	7127.26		7128.19	0.004915	8.83	313.23	124.06	0.77
CLOMR CL	8700	100yr	2600.00	7122.65	7127.68		7128.70	0.004878	9.38	365.90	127.41	0.77
CLOMR CL	8700	500yr	3800.00	7122.65	7128.55		7129.78	0.004818	10.48	479.93	134.38	0.79
CLOMR CL	8568	10yr	1200.00	7121.99	7125.78	7125.61	7126.46	0.004444	7.25	214.17	117.50	0.70
CLOMR CL	8568	50yr	2100.00	7121.99	7126.70		7127.56	0.004414	8.50	325.59	124.86	0.73
CLOMR CL	8568	100yr	2600.00	7121.99	7127.12		7128.07	0.004412	9.06	379.16	128.25	0.74
CLOMR CL	8568	500yr	3800.00	7121.99	7127.99	7127.49	7129.15	0.004442	10.19	495.18	172.64	0.76
CLOMR CL	8460	10yr	1200.00	7121.45	7125.07	7125.07	7125.90	0.005652	7.90	194.71	116.17	0.78
CLOMR CL	8460	50yr	2100.00	7121.45	7125.86	7125.86	7126.97	0.006136	9.55	288.99	122.49	0.85
CLOMR CL	8460	100yr	2600.00	7121.45	7126.21	7126.21	7127.47	0.006369	10.31	332.73	125.32	0.88
CLOMR CL	8460	500yr	3800.00	7121.45	7126.98	7126.98	7128.53	0.006558	11.66	430.83	131.43	0.91
CLOMR CL	8410	10yr	1200.00	7121.20	7124.44	7124.44	7125.15	0.013480	7.06	191.37	133.16	0.79
CLOMR CL	8410	50yr	2100.00	7121.20	7125.10	7125.10	7126.05	0.014150	8.44	279.94	138.38	0.84
CLOMR CL	8410	100yr	2600.00	7121.20	7125.41	7125.41	7126.48	0.014158	8.98	323.02	140.84	0.85
CLOMR CL	8410	500yr	3800.00	7121.20	7126.02	7126.02	7127.40	0.014583	10.15	410.69	145.74	0.89
CLOMR CL	8370	10yr	1200.00	7113.20	7119.67		7119.75	0.000593	2.45	545.99	158.92	0.19
CLOMR CL	8370	50yr	2100.00	7113.20	7120.71		7120.85	0.000830	3.26	715.60	167.24	0.23
CLOMR CL	8370	100yr	2600.00	7113.20	7121.19		7121.37	0.000922	3.61	798.04	171.14	0.24
CLOMR CL	8370	500yr	3800.00	7113.20	7122.20		7122.45	0.001077	4.27	974.26	176.65	0.27
CLOMR CL	8341	10yr	1200.00	7113.20	7119.44		7119.71	0.001291	4.51	332.88	121.11	0.34
CLOMR CL	8341	50yr	2100.00	7113.20	7120.35		7120.79	0.001842	5.97	446.17	128.37	0.42
CLOMR CL	8341	100yr	2600.00	7113.20	7120.77		7121.29	0.002055	6.59	501.55	131.78	0.45
CLOMR CL	8341	500yr	3800.00	7113.20	7121.65		7122.36	0.002435	7.78	620.52	138.63	0.50
CLOMR CL	8340	10yr	1200.00	7115.20	7119.15		7119.68	0.004494	6.45	233.50	118.81	0.61
CLOMR CL	8340	50yr	2100.00	7115.20	7120.07		7120.76	0.004538	7.58	346.49	126.19	0.64
CLOMR CL	8340	100yr	2600.00	7115.20	7120.50		7121.27	0.004546	8.07	401.32	129.62	0.65
CLOMR CL	8340	500yr	3800.00	7115.20	7121.38		7122.33	0.004624	9.10	517.40	136.60	0.67
CLOMR CL	8290	10yr	1200.00	7114.95	7118.95		7119.45	0.004186	6.29	239.66	119.23	0.59
CLOMR CL	8290	50yr	2100.00	7114.95	7119.87		7120.53	0.004342	7.46	351.86	126.53	0.62
CLOMR CL	8290	100yr	2600.00	7114.95	7120.29		7121.04	0.004381	7.97	406.46	129.94	0.64
CLOMR CL	8290	500yr	3800.00	7114.95	7121.16		7122.09	0.004515	9.02	521.61	136.84	0.66
CLOMR CL	8140	10yr	1200.00	7114.20	7117.79	7117.79	7118.60	0.007601	7.80	191.43	115.95	0.78
CLOMR CL	8140	50yr	2100.00	7114.20	7118.56	7118.56	7119.62	0.008157	9.35	282.07	122.04	0.84
CLOMR CL	8140	100yr	2600.00	7114.20	7118.89	7118.89	7120.10	0.008467	10.07	323.58	124.73	0.86
CLOMR CL	8140	500yr	3800.00	7114.20	7119.62	7119.62	7121.13	0.008693	11.35	416.89	130.58	0.90
CLOMR CL	8090	10yr	1200.00	7113.95	7117.19	7117.19	7117.90	0.013480	7.06	191.37	133.16	0.79
CLOMR CL	8090	50yr	2100.00	7113.95	7117.85	7117.85	7118.80	0.014150	8.44	279.94	138.38	0.84
CLOMR CL	8090	100yr	2600.00	7113.95	7118.16	7118.16	7119.23	0.014158	8.98	323.02	140.84	0.85
CLOMR CL	8090	500yr	3800.00	7113.95	7118.77	7118.77	7120.15	0.014583	10.15	410.69	145.74	0.89
CLOMR CL	8050	10yr	1200.00	7106.10	7112.56		7112.85	0.000594	2.45	545.89	158.91	0.19
CLOMR CL	8050	50yr	2100.00	7106.10	7113.62		7113.76	0.000822	3.25	717.77	167.34	0.23
CLOMR CL	8050	100yr	2600.00	7106.10	7114.11		7114.29	0.000911	3.59	801.36	171.29	0.24
CLOMR CL	8050	500yr	3800.00	7106.10	7115.14		7115.39	0.001055	4.24	981.39	177.03	0.26

(This page not reviewed)

HEC-RAS Plan: PP Profiles River: Sand Creek Reach: CLOMR CL (Continued)

Reach	River Sta	Profile	Q Total (cfs)	Min Ch El (ft)	W.S. Elev (ft)	Crit W.S. (ft)	E.G. Elev (ft)	E.G. Slope (ft/ft)	Vel Chnl (ft/s)	Flow Area (sq ft)	Top Width (ft)	Froude # Chl
CLOMR CL	8021	10yr	1200.00	7106.10	7112.31		7112.60	0.001024	4.67	329.96	120.91	0.36
CLOMR CL	8021	50yr	2100.00	7106.10	7113.20		7113.69	0.001518	6.30	440.57	128.02	0.44
CLOMR CL	8021	100yr	2600.00	7106.10	7113.62		7114.21	0.001723	7.00	494.14	131.32	0.48
CLOMR CL	8021	500yr	3800.00	7106.10	7114.48		7115.29	0.002093	8.36	610.01	138.11	0.54
CLOMR CL	8020	10yr	1200.00	7108.10	7111.84	7111.72	7112.56	0.004737	7.42	208.88	117.14	0.72
CLOMR CL	8020	50yr	2100.00	7108.10	7112.76		7113.65	0.004645	8.66	319.66	124.48	0.75
CLOMR CL	8020	100yr	2600.00	7108.10	7113.19		7114.17	0.004612	9.20	373.26	127.88	0.76
CLOMR CL	8020	500yr	3800.00	7108.10	7114.05		7115.25	0.004609	10.32	487.42	134.83	0.78
CLOMR CL	7970	10yr	1200.00	7107.85	7111.63	7111.47	7112.32	0.004500	7.28	213.12	117.43	0.71
CLOMR CL	7970	50yr	2100.00	7107.85	7112.56		7113.42	0.004396	8.49	326.05	124.89	0.73
CLOMR CL	7970	100yr	2600.00	7107.85	7112.99		7113.93	0.004382	9.04	380.08	128.30	0.74
CLOMR CL	7970	500yr	3800.00	7107.85	7113.85		7115.01	0.004449	10.19	493.49	135.19	0.76
CLOMR CL	7840	10yr	1200.00	7107.20	7110.82	7110.82	7111.65	0.005656	7.90	194.66	116.17	0.78
CLOMR CL	7840	50yr	2100.00	7107.20	7111.61	7111.61	7112.72	0.006136	9.55	288.99	122.49	0.85
CLOMR CL	7840	100yr	2600.00	7107.20	7111.96	7111.96	7113.22	0.006369	10.31	332.73	125.32	0.88
CLOMR CL	7840	500yr	3800.00	7107.20	7112.73	7112.73	7114.28	0.006558	11.66	430.83	131.43	0.91
CLOMR CL	7790	10yr	1200.00	7106.95	7110.19	7110.19	7110.90	0.013480	7.06	191.37	133.16	0.79
CLOMR CL	7790	50yr	2100.00	7106.95	7110.85	7110.85	7111.80	0.014150	8.44	279.94	138.38	0.84
CLOMR CL	7790	100yr	2600.00	7106.95	7111.16	7111.16	7112.23	0.014158	8.98	323.02	140.84	0.85
CLOMR CL	7790	500yr	3800.00	7106.95	7111.77	7111.77	7113.15	0.014583	10.15	410.69	145.74	0.89
CLOMR CL	7750	10yr	1200.00	7099.00	7105.45		7105.55	0.000297	2.60	543.95	158.81	0.20
CLOMR CL	7750	50yr	2100.00	7099.00	7107.35		7107.47	0.000262	2.98	860.46	174.01	0.19
CLOMR CL	7750	100yr	2600.00	7099.00	7108.60		7108.71	0.000207	2.95	1078.57	175.93	0.18
CLOMR CL	7750	500yr	3800.00	7099.00	7111.58		7111.68	0.000133	2.88	1609.51	180.53	0.15
CLOMR CL	7721	10yr	1200.00	7099.00	7105.23		7105.51	0.001014	4.65	331.26	121.00	0.35
CLOMR CL	7721	50yr	2100.00	7099.00	7107.17		7107.44	0.000728	4.84	581.44	136.54	0.32
CLOMR CL	7721	100yr	2600.00	7099.00	7108.45		7108.69	0.000532	4.61	763.12	146.74	0.28
CLOMR CL	7721	500yr	3800.00	7099.00	7111.48		7111.67	0.000295	4.20	1247.04	172.05	0.22
CLOMR CL	7720	10yr	1200.00	7101.00	7104.80	7104.62	7105.47	0.004349	7.19	215.98	117.63	0.69
CLOMR CL	7720	50yr	2100.00	7101.00	7107.10		7107.44	0.001256	5.48	507.19	136.00	0.41
CLOMR CL	7720	100yr	2600.00	7101.00	7108.42		7108.68	0.000785	4.99	692.97	146.44	0.33
CLOMR CL	7720	500yr	3800.00	7101.00	7111.47		7111.67	0.000368	4.35	1179.94	171.95	0.24
CLOMR CL	7670	10yr	1200.00	7100.75	7104.64		7105.25	0.003844	6.88	226.53	118.34	0.66
CLOMR CL	7670	50yr	2100.00	7100.75	7107.07		7107.37	0.001065	5.18	537.13	137.75	0.38
CLOMR CL	7670	100yr	2600.00	7100.75	7108.40		7108.64	0.000677	4.73	724.67	144.82	0.31
CLOMR CL	7670	500yr	3800.00	7100.75	7111.46		7111.65	0.000341	4.26	1202.87	169.86	0.23
CLOMR CL	7533	10yr	1200.00	7100.07	7104.41		7104.79	0.002186	5.63	279.90	121.89	0.50
CLOMR CL	7533	50yr	2100.00	7100.07	7107.01		7107.23	0.000680	4.43	623.27	138.55	0.31
CLOMR CL	7533	100yr	2600.00	7100.07	7108.36		7108.55	0.000464	4.15	811.03	139.79	0.26
CLOMR CL	7533	500yr	3800.00	7100.07	7111.43		7111.60	0.000291	4.10	1298.46	187.28	0.22
CLOMR CL	7400	10yr	1200.00	7099.40	7104.30		7104.54	0.001179	4.53	349.85	126.40	0.38
CLOMR CL	7400	50yr	2100.00	7099.40	7106.97		7107.14	0.000468	3.91	720.82	151.75	0.26
CLOMR CL	7400	100yr	2600.00	7099.40	7108.34		7108.48	0.000343	3.76	935.07	164.25	0.23
CLOMR CL	7400	500yr	3800.00	7099.40	7111.43		7111.55	0.000210	3.62	1519.42	216.33	0.19
CLOMR CL	7290	10yr	1200.00	7098.85	7104.25		7104.42	0.000733	3.83	413.93	130.39	0.30
CLOMR CL	7290	50yr	2100.00	7098.85	7106.95		7107.08	0.000341	3.50	794.38	148.79	0.22
CLOMR CL	7290	100yr	2600.00	7098.85	7108.32		7108.44	0.000265	3.44	1002.35	160.67	0.20
CLOMR CL	7290	500yr	3800.00	7098.85	7111.41		7111.53	0.000171	3.37	1553.14	185.66	0.17
CLOMR CL	7236	10yr	1200.00	7098.58	7103.90	7102.15	7104.34	0.001529	5.48	235.60	54.93	0.44
CLOMR CL	7236	50yr	2100.00	7098.58	7106.52	7103.31	7107.02	0.001005	5.92	378.99	54.97	0.38
CLOMR CL	7236	100yr	2600.00	7098.58	7107.84	7103.88	7108.38	0.000866	6.13	451.80	54.98	0.36
CLOMR CL	7236	500yr	3800.00	7098.58	7110.85	7105.10	7111.46	0.000662	6.52	617.14	55.02	0.33
CLOMR CL	7100		Bridge									
CLOMR CL	6990	10yr	1200.00	7096.49	7100.06	7100.06	7101.37	0.008097	9.34	135.38	50.91	0.94
CLOMR CL	6990	50yr	2100.00	7096.49	7101.25	7101.25	7103.17	0.007813	11.41	196.23	50.93	0.97
CLOMR CL	6990	100yr	2600.00	7096.49	7101.87	7101.87	7104.06	0.007480	12.21	227.66	50.94	0.97
CLOMR CL	6990	500yr	3800.00	7096.49	7103.14	7103.14	7105.98	0.007169	13.94	292.58	50.95	0.99
CLOMR CL	6950	10yr	1200.00	7096.15	7099.77	7099.77	7100.60	0.005649	7.90	194.75	116.17	0.78
CLOMR CL	6950	50yr	2100.00	7096.15	7100.56	7100.56	7101.67	0.006144	9.56	288.85	122.48	0.85
CLOMR CL	6950	100yr	2600.00	7096.15	7100.92	7100.92	7102.17	0.006363	10.30	332.83	125.32	0.88
CLOMR CL	6950	500yr	3800.00	7096.15	7101.68	7101.68	7103.23	0.006568	11.67	430.61	131.41	0.91
CLOMR CL	6820	10yr	1200.00	7095.04	7098.66	7098.66	7099.49	0.005645	7.90	194.81	116.18	0.78
CLOMR CL	6820	50yr	2100.00	7095.04	7099.45	7099.45	7100.56	0.006137	9.55	288.97	122.49	0.85
CLOMR CL	6820	100yr	2600.00	7095.04	7099.81	7099.81	7101.06	0.006367	10.31	332.77	125.32	0.88

HEC-RAS Plan: PP Profiles River: Sand Creek Reach: CLOMR CL (Continued)

Reach	River Sta	Profile	Q Total (cfs)	Min Ch El (ft)	W.S. Elev (ft)	Crit W.S. (ft)	E.G. Elev (ft)	E.G. Slope (ft/ft)	Vel Chnl (ft/s)	Flow Area (sq ft)	Top Width (ft)	Froude # Chl
CLOMR CL	6820	500yr	3800.00	7095.04	7100.57	7100.57	7102.12	0.006568	11.67	430.61	131.41	0.91
CLOMR CL	6770	10yr	1200.00	7094.62	7097.86	7097.86	7098.57	0.013603	7.09	190.71	133.11	0.79
CLOMR CL	6770	50yr	2100.00	7094.62	7098.52	7098.52	7099.47	0.014143	8.44	279.99	138.38	0.84
CLOMR CL	6770	100yr	2600.00	7094.62	7098.83	7098.83	7099.90	0.014142	8.98	323.14	140.85	0.85
CLOMR CL	6770	500yr	3800.00	7094.62	7099.44	7099.44	7100.82	0.014578	10.15	410.74	145.74	0.89
CLOMR CL	6730	10yr	1200.00	7085.70	7092.16		7092.25	0.000594	2.45	545.60	158.90	0.19
CLOMR CL	6730	50yr	2100.00	7085.70	7093.21		7093.35	0.000828	3.26	716.25	167.27	0.23
CLOMR CL	6730	100yr	2600.00	7085.70	7093.70		7093.87	0.000918	3.60	799.13	171.19	0.24
CLOMR CL	6730	500yr	3800.00	7085.70	7094.73		7094.97	0.001060	4.24	977.59	175.10	0.27
CLOMR CL	6701	10yr	1200.00	7085.70	7091.91		7092.20	0.001026	4.67	329.69	120.89	0.36
CLOMR CL	6701	50yr	2100.00	7085.70	7092.79		7093.29	0.001533	6.32	438.91	127.92	0.45
CLOMR CL	6701	100yr	2600.00	7085.70	7093.20		7093.80	0.001747	7.03	491.60	131.17	0.48
CLOMR CL	6701	500yr	3800.00	7085.70	7094.05		7094.87	0.002134	8.42	605.80	137.96	0.54
CLOMR CL	6700	10yr	1200.00	7087.70	7091.41	7091.32	7092.16	0.004957	7.54	205.18	116.89	0.74
CLOMR CL	6700	50yr	2100.00	7087.70	7092.30	7092.11	7093.24	0.004935	8.85	312.77	124.04	0.77
CLOMR CL	6700	100yr	2600.00	7087.70	7092.72		7093.75	0.004920	9.41	364.81	127.35	0.78
CLOMR CL	6700	500yr	3800.00	7087.70	7093.58		7094.82	0.004903	10.54	477.01	134.21	0.80
CLOMR CL	6650	10yr	1200.00	7087.45	7091.16	7091.07	7091.91	0.004985	7.55	204.73	116.86	0.74
CLOMR CL	6650	50yr	2100.00	7087.45	7092.05	7091.86	7092.99	0.004935	8.85	312.77	124.04	0.77
CLOMR CL	6650	100yr	2600.00	7087.45	7092.47		7093.50	0.004915	9.41	364.93	127.36	0.78
CLOMR CL	6650	500yr	3800.00	7087.45	7093.33		7094.58	0.004894	10.54	477.33	134.23	0.80
CLOMR CL	6560	10yr	1200.00	7087.00	7090.71	7090.62	7091.46	0.004992	7.56	204.59	116.85	0.74
CLOMR CL	6560	50yr	2100.00	7087.00	7091.61		7092.54	0.004894	8.82	313.71	124.09	0.76
CLOMR CL	6560	100yr	2600.00	7087.00	7092.03		7093.05	0.004843	9.36	366.84	127.47	0.77
CLOMR CL	6560	500yr	3800.00	7087.00	7092.90		7094.13	0.004829	10.49	479.53	134.36	0.79
CLOMR CL	6436	10yr	1200.00	7086.38	7090.16	7090.00	7090.85	0.004491	7.28	213.29	117.44	0.70
CLOMR CL	6436	50yr	2100.00	7086.38	7091.08		7091.94	0.004473	8.54	324.04	124.76	0.73
CLOMR CL	6436	100yr	2600.00	7086.38	7091.51		7092.46	0.004432	9.07	378.57	128.21	0.74
CLOMR CL	6436	500yr	3800.00	7086.38	7092.34		7093.53	0.004575	10.29	488.67	134.90	0.77
CLOMR CL	6340	10yr	1200.00	7085.90	7089.52	7089.52	7090.35	0.005645	7.90	194.81	116.18	0.78
CLOMR CL	6340	50yr	2100.00	7085.90	7090.31	7090.31	7091.42	0.006141	9.56	288.91	122.48	0.85
CLOMR CL	6340	100yr	2600.00	7085.90	7090.67	7090.67	7091.92	0.006367	10.31	332.77	125.32	0.88
CLOMR CL	6340	500yr	3800.00	7085.90	7091.43	7091.43	7092.98	0.006570	11.67	430.55	131.41	0.92
CLOMR CL	6290	10yr	1200.00	7085.65	7088.89	7088.89	7089.60	0.013603	7.09	190.71	133.11	0.79
CLOMR CL	6290	50yr	2100.00	7085.65	7089.55	7089.55	7090.50	0.014143	8.44	279.99	138.38	0.84
CLOMR CL	6290	100yr	2600.00	7085.65	7089.86	7089.86	7090.93	0.014152	8.98	323.07	140.84	0.85
CLOMR CL	6290	500yr	3800.00	7085.65	7090.47	7090.47	7091.85	0.014531	10.14	411.16	145.76	0.88
CLOMR CL	6250	10yr	1200.00	7076.70	7083.16		7083.25	0.000594	2.45	545.83	158.91	0.19
CLOMR CL	6250	50yr	2100.00	7076.70	7084.22		7084.36	0.000823	3.25	717.72	167.34	0.23
CLOMR CL	6250	100yr	2600.00	7076.70	7084.71		7084.89	0.000911	3.59	801.30	171.29	0.24
CLOMR CL	6250	500yr	3800.00	7076.70	7085.74		7085.99	0.001060	4.25	981.87	178.84	0.27
CLOMR CL	6221	10yr	1200.00	7076.70	7082.91		7083.20	0.001024	4.67	329.92	120.91	0.36
CLOMR CL	6221	50yr	2100.00	7076.70	7083.80		7084.29	0.001519	6.30	440.53	128.02	0.44
CLOMR CL	6221	100yr	2600.00	7076.70	7084.22		7084.81	0.001724	7.00	494.03	131.32	0.48
CLOMR CL	6221	500yr	3800.00	7076.70	7085.08		7085.89	0.002094	8.36	609.98	138.13	0.54
CLOMR CL	6220	10yr	1200.00	7078.70	7082.44	7082.32	7083.16	0.004769	7.43	208.33	117.11	0.72
CLOMR CL	6220	50yr	2100.00	7078.70	7083.36		7084.25	0.004650	8.66	319.56	124.47	0.75
CLOMR CL	6220	100yr	2600.00	7078.70	7083.78		7084.77	0.004618	9.20	373.10	127.87	0.76
CLOMR CL	6220	500yr	3800.00	7078.70	7084.65		7085.85	0.004608	10.32	487.45	134.83	0.78
CLOMR CL	6170	10yr	1200.00	7078.45	7082.23	7082.07	7082.92	0.004503	7.28	213.08	117.43	0.71
CLOMR CL	6170	50yr	2100.00	7078.45	7083.16		7084.02	0.004403	8.50	325.89	124.88	0.73
CLOMR CL	6170	100yr	2600.00	7078.45	7083.59		7084.53	0.004386	9.04	379.98	128.30	0.74
CLOMR CL	6170	500yr	3800.00	7078.45	7084.45		7085.61	0.004450	10.19	493.45	135.19	0.76
CLOMR CL	6040	10yr	1200.00	7077.80	7081.42	7081.42	7082.25	0.005649	7.90	194.75	116.17	0.78
CLOMR CL	6040	50yr	2100.00	7077.80	7082.21	7082.21	7083.32	0.006134	9.55	289.03	122.49	0.85
CLOMR CL	6040	100yr	2600.00	7077.80	7082.56	7082.56	7083.82	0.006367	10.31	332.77	125.32	0.88
CLOMR CL	6040	500yr	3800.00	7077.80	7083.33	7083.33	7084.88	0.006570	11.67	430.55	131.41	0.92
CLOMR CL	5990	10yr	1200.00	7077.55	7080.79	7080.79	7081.50	0.013603	7.09	190.71	133.11	0.79
CLOMR CL	5990	50yr	2100.00	7077.55	7081.45	7081.45	7082.40	0.014143	8.44	279.99	138.38	0.84
CLOMR CL	5990	100yr	2600.00	7077.55	7081.76	7081.76	7082.83	0.014142	8.98	323.14	140.85	0.85
CLOMR CL	5990	500yr	3800.00	7077.55	7082.37	7082.37	7083.75	0.014578	10.15	410.74	145.74	0.89
CLOMR CL	5950	10yr	1200.00	7068.60	7075.06		7075.15	0.000594	2.45	545.66	158.90	0.19
CLOMR CL	5950	50yr	2100.00	7068.60	7076.11		7076.25	0.000827	3.26	716.55	167.28	0.23
CLOMR CL	5950	100yr	2600.00	7068.60	7076.60		7076.78	0.000917	3.60	799.52	171.20	0.24

HEC-RAS Plan: PP Profiles River: Sand Creek Reach: CLOMR CL (Continued)

Reach	River Sta	Profile	Q Total (cfs)	Min Ch El (ft)	W.S. Elev (ft)	Crit W.S. (ft)	E.G. Elev (ft)	E.G. Slope (ft/ft)	Vel Chnl (ft/s)	Flow Area (sq ft)	Top Width (ft)	Froude # Chl
CLOMR CL	5950	500yr	3800.00	7068.60	7077.63		7077.87	0.001058	4.24	978.02	175.18	0.27
CLOMR CL	5921	10yr	1200.00	7068.60	7074.81		7075.10	0.001025	4.67	329.73	120.89	0.36
CLOMR CL	5921	50yr	2100.00	7068.60	7075.69		7076.19	0.001531	6.31	439.20	127.93	0.45
CLOMR CL	5921	100yr	2600.00	7068.60	7076.10		7076.70	0.001743	7.03	492.02	131.20	0.48
CLOMR CL	5921	500yr	3800.00	7068.60	7076.95		7077.77	0.002129	8.41	606.31	137.99	0.54
CLOMR CL	5920	10yr	1200.00	7070.60	7074.32	7074.22	7075.06	0.004895	7.50	206.19	116.96	0.73
CLOMR CL	5920	50yr	2100.00	7070.60	7075.21	7075.01	7076.14	0.004886	8.81	313.89	124.11	0.76
CLOMR CL	5920	100yr	2600.00	7070.60	7075.63		7076.65	0.004867	9.38	366.21	127.43	0.77
CLOMR CL	5920	500yr	3800.00	7070.60	7076.49		7077.73	0.004869	10.52	478.16	134.28	0.80
CLOMR CL	5870	10yr	1200.00	7070.35	7074.08	7073.97	7074.81	0.004837	7.47	207.16	117.02	0.73
CLOMR CL	5870	50yr	2100.00	7070.35	7074.97	7074.76	7075.89	0.004844	8.79	314.86	124.17	0.76
CLOMR CL	5870	100yr	2600.00	7070.35	7075.39		7076.41	0.004825	9.35	367.34	127.50	0.77
CLOMR CL	5870	500yr	3800.00	7070.35	7076.24		7077.48	0.004837	10.49	479.27	134.34	0.79
CLOMR CL	5800	10yr	1200.00	7070.00	7073.79	7073.62	7074.47	0.004421	7.24	214.61	117.53	0.70
CLOMR CL	5800	50yr	2100.00	7070.00	7074.67		7075.55	0.004618	8.64	320.33	124.52	0.74
CLOMR CL	5800	100yr	2600.00	7070.00	7075.08		7076.07	0.004630	9.21	372.76	127.84	0.76
CLOMR CL	5800	500yr	3800.00	7070.00	7075.92		7077.14	0.004736	10.42	482.82	134.55	0.79
CLOMR CL	5740	10yr	1200.00	7069.70	7073.32	7073.32	7074.15	0.005656	7.90	194.66	116.17	0.78
CLOMR CL	5740	50yr	2100.00	7069.70	7074.11	7074.11	7075.22	0.006136	9.55	288.99	122.49	0.85
CLOMR CL	5740	100yr	2600.00	7069.70	7074.46	7074.46	7075.72	0.006369	10.31	332.73	125.32	0.88
CLOMR CL	5740	500yr	3800.00	7069.70	7075.23	7075.23	7076.78	0.006558	11.66	430.83	131.43	0.91
CLOMR CL	5690	10yr	1200.00	7069.45	7072.69	7072.69	7073.40	0.013480	7.06	191.37	133.16	0.79
CLOMR CL	5690	50yr	2100.00	7069.45	7073.35	7073.35	7074.30	0.014150	8.44	279.94	138.38	0.84
CLOMR CL	5690	100yr	2600.00	7069.45	7073.66	7073.66	7074.73	0.014158	8.98	323.02	140.84	0.85
CLOMR CL	5690	500yr	3800.00	7069.45	7074.27	7074.27	7075.65	0.014583	10.15	410.69	145.74	0.89
CLOMR CL	5650	10yr	1200.00	7061.70	7068.16		7068.25	0.000594	2.45	545.60	158.90	0.19
CLOMR CL	5650	50yr	2100.00	7061.70	7069.21		7069.35	0.000827	3.26	716.33	167.27	0.23
CLOMR CL	5650	100yr	2600.00	7061.70	7069.70		7069.88	0.000918	3.60	799.30	171.20	0.24
CLOMR CL	5650	500yr	3800.00	7061.70	7070.72		7070.97	0.001059	4.24	977.13	174.22	0.27
CLOMR CL	5621	10yr	1200.00	7061.70	7067.91		7068.20	0.001026	4.67	329.69	120.89	0.36
CLOMR CL	5621	50yr	2100.00	7061.70	7068.79		7069.29	0.001533	6.32	438.97	127.92	0.45
CLOMR CL	5621	100yr	2600.00	7061.70	7069.20		7069.80	0.001745	7.03	491.79	131.18	0.48
CLOMR CL	5621	500yr	3800.00	7061.70	7070.04		7070.87	0.002135	8.42	605.73	138.04	0.54
CLOMR CL	5620	10yr	1200.00	7063.70	7067.41	7067.32	7068.16	0.004967	7.54	205.01	116.88	0.74
CLOMR CL	5620	50yr	2100.00	7063.70	7068.31	7068.11	7069.24	0.004925	8.84	313.01	124.05	0.77
CLOMR CL	5620	100yr	2600.00	7063.70	7068.72		7069.75	0.004903	9.40	365.25	127.38	0.78
CLOMR CL	5620	500yr	3800.00	7063.70	7069.58		7070.82	0.004905	10.54	476.94	134.21	0.80
CLOMR CL	5570	10yr	1200.00	7063.45	7067.16	7067.07	7067.91	0.004950	7.53	205.30	116.90	0.74
CLOMR CL	5570	50yr	2100.00	7063.45	7068.06	7067.86	7068.99	0.004898	8.82	313.61	124.09	0.76
CLOMR CL	5570	100yr	2600.00	7063.45	7068.48		7069.50	0.004873	9.38	366.05	127.43	0.77
CLOMR CL	5570	500yr	3800.00	7063.45	7069.33		7070.58	0.004882	10.53	477.73	134.25	0.80
CLOMR CL	5491	10yr	1200.00	7063.06	7066.77	7066.68	7067.52	0.004985	7.55	204.71	116.86	0.74
CLOMR CL	5491	50yr	2100.00	7063.06	7067.67		7068.60	0.004881	8.81	314.01	124.11	0.76
CLOMR CL	5491	100yr	2600.00	7063.06	7068.09		7069.11	0.004843	9.36	366.84	127.47	0.77
CLOMR CL	5491	500yr	3800.00	7063.06	7068.95		7070.19	0.004864	10.51	478.35	134.29	0.80
CLOMR CL	5410	10yr	1200.00	7062.65	7066.41	7066.27	7067.11	0.004633	7.36	210.71	117.27	0.72
CLOMR CL	5410	50yr	2100.00	7062.65	7067.33		7068.21	0.004553	8.60	321.97	124.63	0.74
CLOMR CL	5410	100yr	2600.00	7062.65	7067.74		7068.72	0.004569	9.17	374.51	127.95	0.75
CLOMR CL	5410	500yr	3800.00	7062.65	7068.58		7069.79	0.004683	10.38	484.72	134.67	0.78
CLOMR CL	5340	10yr	1200.00	7062.30	7065.92	7065.92	7066.75	0.005649	7.90	194.75	116.17	0.78
CLOMR CL	5340	50yr	2100.00	7062.30	7066.71	7066.71	7067.82	0.006134	9.55	289.03	122.49	0.85
CLOMR CL	5340	100yr	2600.00	7062.30	7067.06	7067.06	7068.32	0.006367	10.31	332.77	125.32	0.88
CLOMR CL	5340	500yr	3800.00	7062.30	7067.83	7067.83	7069.38	0.006570	11.67	430.55	131.41	0.92
CLOMR CL	5290	10yr	1200.00	7062.05	7065.29	7065.29	7066.07	0.006556	7.37	190.25	133.09	0.82
CLOMR CL	5290	50yr	2100.00	7062.05	7066.02	7066.02	7067.06	0.006707	8.85	290.35	138.97	0.87
CLOMR CL	5290	100yr	2600.00	7062.05	7066.36	7066.36	7067.53	0.006761	9.49	337.62	141.67	0.88
CLOMR CL	5290	500yr	3800.00	7062.05	7067.05	7067.05	7068.50	0.006906	10.79	437.27	147.19	0.92
CLOMR CL	5250	10yr	1200.00	7054.10	7060.54		7060.64	0.000300	2.61	542.24	158.73	0.20
CLOMR CL	5250	50yr	2100.00	7054.10	7061.57		7061.74	0.000446	3.57	709.37	166.94	0.25
CLOMR CL	5250	100yr	2600.00	7054.10	7062.05		7062.26	0.000508	4.00	790.33	170.77	0.27
CLOMR CL	5250	500yr	3800.00	7054.10	7063.05		7063.35	0.000615	4.82	965.16	174.96	0.30
CLOMR CL	5221	10yr	1200.00	7054.10	7060.31		7060.60	0.001026	4.67	329.67	120.89	0.36
CLOMR CL	5221	50yr	2100.00	7054.10	7061.19		7061.69	0.001535	6.32	438.76	127.91	0.45
CLOMR CL	5221	100yr	2600.00	7054.10	7061.60		7062.19	0.001748	7.04	491.44	131.16	0.48

HEC-RAS Plan: PP Profiles River: Sand Creek Reach: CLOMR CL (Continued)

Reach	River Sta	Profile	Q Total (cfs)	Min Ch El (ft)	W.S. Elev (ft)	Crit W.S. (ft)	E.G. Elev (ft)	E.G. Slope (ft/ft)	Vel Chnl (ft/s)	Flow Area (sq ft)	Top Width (ft)	Froude # Chl
CLOMR CL	5221	500yr	3800.00	7054.10	7062.44		7063.27	0.002135	8.42	605.70	137.95	0.54
CLOMR CL	5220	10yr	1200.00	7056.10	7059.81	7059.72	7060.56	0.004985	7.55	204.71	116.86	0.74
CLOMR CL	5220	50yr	2100.00	7056.10	7060.70	7060.51	7061.64	0.004965	8.86	312.08	123.99	0.77
CLOMR CL	5220	100yr	2600.00	7056.10	7061.11	7060.87	7062.15	0.004947	9.43	364.10	127.30	0.78
CLOMR CL	5220	500yr	3800.00	7056.10	7061.97		7063.22	0.004927	10.56	476.19	134.16	0.80
CLOMR CL	5170	10yr	1200.00	7055.85	7059.56	7059.47	7060.31	0.004996	7.56	204.54	116.84	0.74
CLOMR CL	5170	50yr	2100.00	7055.85	7060.45	7060.26	7061.39	0.004960	8.86	312.20	124.00	0.77
CLOMR CL	5170	100yr	2600.00	7055.85	7060.87		7061.90	0.004937	9.42	364.35	127.32	0.78
CLOMR CL	5170	500yr	3800.00	7055.85	7061.72		7062.97	0.004914	10.55	476.65	134.19	0.80
CLOMR CL	5060	10yr	1200.00	7055.30	7059.01	7058.92	7059.76	0.004982	7.55	204.76	116.86	0.74
CLOMR CL	5060	50yr	2100.00	7055.30	7059.92		7060.84	0.004870	8.80	314.26	124.13	0.76
CLOMR CL	5060	100yr	2600.00	7055.30	7060.34		7061.35	0.004832	9.35	367.15	127.49	0.77
CLOMR CL	5060	500yr	3800.00	7055.30	7061.21		7062.43	0.004784	10.45	481.11	134.45	0.79
CLOMR CL	4945	10yr	1200.00	7054.73	7058.52	7058.35	7059.20	0.004460	7.26	213.86	117.48	0.70
CLOMR CL	4945	50yr	2100.00	7054.73	7059.43		7060.29	0.004431	8.52	325.14	124.83	0.73
CLOMR CL	4945	100yr	2600.00	7054.73	7059.86		7060.81	0.004425	9.07	378.76	128.22	0.74
CLOMR CL	4945	500yr	3800.00	7054.73	7060.72		7061.89	0.004479	10.22	492.30	135.12	0.77
CLOMR CL	4840	10yr	1200.00	7054.20	7057.82	7057.82	7058.85	0.005656	7.90	194.66	116.17	0.78
CLOMR CL	4840	50yr	2100.00	7054.20	7058.61	7058.61	7059.72	0.006140	9.56	288.93	122.49	0.85
CLOMR CL	4840	100yr	2600.00	7054.20	7058.97	7058.97	7060.22	0.006366	10.30	332.79	125.32	0.88
CLOMR CL	4840	500yr	3800.00	7054.20	7059.73	7059.73	7061.28	0.006558	11.66	430.83	131.43	0.91
CLOMR CL	4790	10yr	1200.00	7053.95	7057.19	7057.19	7057.90	0.013480	7.06	191.37	133.16	0.79
CLOMR CL	4790	50yr	2100.00	7053.95	7057.85	7057.85	7058.80	0.014150	8.44	279.94	138.38	0.84
CLOMR CL	4790	100yr	2600.00	7053.95	7058.16	7058.16	7059.23	0.014158	8.98	323.02	140.84	0.85
CLOMR CL	4790	500yr	3800.00	7053.95	7058.77	7058.77	7060.15	0.014583	10.15	410.69	145.74	0.89
CLOMR CL	4750	10yr	1200.00	7046.00	7052.46		7052.55	0.000595	2.45	545.58	158.89	0.19
CLOMR CL	4750	50yr	2100.00	7046.00	7053.51		7053.65	0.000828	3.26	716.14	167.26	0.23
CLOMR CL	4750	100yr	2600.00	7046.00	7054.00		7054.17	0.000919	3.60	798.93	171.18	0.24
CLOMR CL	4750	500yr	3800.00	7046.00	7055.02		7055.27	0.001070	4.26	978.25	178.16	0.27
CLOMR CL	4721	10yr	1200.00	7046.00	7052.21		7052.50	0.001026	4.67	329.67	120.89	0.36
CLOMR CL	4721	50yr	2100.00	7046.00	7053.09		7053.58	0.001535	6.32	438.70	127.90	0.45
CLOMR CL	4721	100yr	2600.00	7046.00	7053.50		7054.09	0.001749	7.04	491.38	131.16	0.48
CLOMR CL	4721	500yr	3800.00	7046.00	7054.34		7055.17	0.002137	8.43	605.43	137.94	0.54
CLOMR CL	4720	10yr	1200.00	7048.00	7051.70	7051.62	7052.46	0.005007	7.56	204.37	116.83	0.74
CLOMR CL	4720	50yr	2100.00	7048.00	7052.60	7052.41	7053.54	0.004981	8.87	311.71	123.96	0.77
CLOMR CL	4720	100yr	2600.00	7048.00	7053.01	7052.77	7054.05	0.004959	9.44	363.79	127.28	0.78
CLOMR CL	4720	500yr	3800.00	7048.00	7053.87		7055.12	0.004937	10.57	475.86	134.14	0.80
CLOMR CL	4670	10yr	1200.00	7047.75	7051.45	7051.37	7052.20	0.005017	7.57	204.19	116.82	0.74
CLOMR CL	4670	50yr	2100.00	7047.75	7052.35	7052.16	7053.29	0.004973	8.87	311.89	123.98	0.77
CLOMR CL	4670	100yr	2600.00	7047.75	7052.76		7053.80	0.004944	9.43	364.16	127.30	0.78
CLOMR CL	4670	500yr	3800.00	7047.75	7053.62		7054.87	0.004921	10.56	476.39	134.17	0.80
CLOMR CL	4570	10yr	1200.00	7047.25	7050.96	7050.87	7051.71	0.004996	7.56	204.54	116.84	0.74
CLOMR CL	4570	50yr	2100.00	7047.25	7051.87		7052.79	0.004878	8.81	314.07	124.12	0.76
CLOMR CL	4570	100yr	2600.00	7047.25	7052.29		7053.30	0.004839	9.36	366.96	127.48	0.77
CLOMR CL	4570	500yr	3800.00	7047.25	7053.16		7054.38	0.004782	10.45	481.18	134.46	0.79
CLOMR CL	4450	10yr	1200.00	7046.65	7050.44	7050.27	7051.12	0.004439	7.25	214.26	117.51	0.70
CLOMR CL	4450	50yr	2100.00	7046.65	7051.36		7052.22	0.004406	8.50	325.81	124.87	0.73
CLOMR CL	4450	100yr	2600.00	7046.65	7051.78		7052.73	0.004401	9.05	379.51	128.27	0.74
CLOMR CL	4450	500yr	3800.00	7046.65	7052.65		7053.81	0.004449	10.19	493.49	135.19	0.76
CLOMR CL	4340	10yr	1200.00	7046.10	7049.72	7049.72	7050.55	0.005645	7.90	194.81	116.18	0.78
CLOMR CL	4340	50yr	2100.00	7046.10	7050.51	7050.51	7051.62	0.006141	9.56	288.91	122.48	0.85
CLOMR CL	4340	100yr	2600.00	7046.10	7050.87	7050.87	7052.12	0.006367	10.31	332.77	125.32	0.88
CLOMR CL	4340	500yr	3800.00	7046.10	7051.63	7051.63	7053.18	0.006570	11.67	430.55	131.41	0.92
CLOMR CL	4290	10yr	1200.00	7045.85	7049.09	7049.09	7049.80	0.013603	7.09	190.71	133.11	0.79
CLOMR CL	4290	50yr	2100.00	7045.85	7049.75	7049.75	7050.70	0.014143	8.44	279.99	138.38	0.84
CLOMR CL	4290	100yr	2600.00	7045.85	7050.06	7050.06	7051.13	0.014152	8.98	323.07	140.84	0.85
CLOMR CL	4290	500yr	3800.00	7045.85	7050.67	7050.67	7052.05	0.014578	10.15	410.74	145.74	0.89
CLOMR CL	4250	10yr	1200.00	7037.80	7044.26		7044.35	0.000595	2.45	545.58	158.89	0.19
CLOMR CL	4250	50yr	2100.00	7037.80	7045.31		7045.45	0.000828	3.26	716.14	167.26	0.23
CLOMR CL	4250	100yr	2600.00	7037.80	7045.80		7045.97	0.000920	3.61	798.80	171.16	0.24
CLOMR CL	4250	500yr	3800.00	7037.80	7046.82		7047.07	0.001061	4.25	976.76	174.73	0.27
CLOMR CL	4221	10yr	1200.00	7037.80	7044.01		7044.30	0.001026	4.67	329.67	120.89	0.36
CLOMR CL	4221	50yr	2100.00	7037.80	7044.89		7045.38	0.001535	6.32	438.70	127.90	0.45
CLOMR CL	4221	100yr	2600.00	7037.80	7045.29		7045.89	0.001752	7.04	491.06	131.14	0.48

HEC-RAS Plan: PP Profiles River: Sand Creek Reach: CLOMR CL (Continued)

Reach	River Sta	Profile	Q Total (cfs)	Min Ch El (ft)	W.S. Elev (ft)	Crit W.S. (ft)	E.G. Elev (ft)	E.G. Slope (ft/ft)	Vel Chnl (ft/s)	Flow Area (sq ft)	Top Width (ft)	Froude # Chl
CLOMR CL	4221	500yr	3800.00	7037.80	7046.14		7046.96	0.002143	8.43	604.82	137.90	0.54
CLOMR CL	4220	10yr	1200.00	7039.80	7043.50	7043.42	7044.25	0.005003	7.56	204.42	116.84	0.74
CLOMR CL	4220	50yr	2100.00	7039.80	7044.39	7044.21	7045.34	0.005003	8.89	311.23	123.93	0.77
CLOMR CL	4220	100yr	2600.00	7039.80	7044.80	7044.56	7045.85	0.004995	9.46	362.86	127.22	0.78
CLOMR CL	4220	500yr	3800.00	7039.80	7045.66		7046.92	0.004984	10.60	474.29	134.05	0.81
CLOMR CL	4170	10yr	1200.00	7039.55	7043.25	7043.17	7044.00	0.005010	7.57	204.31	116.83	0.74
CLOMR CL	4170	50yr	2100.00	7039.55	7044.14	7043.96	7045.09	0.005003	8.89	311.23	123.93	0.77
CLOMR CL	4170	100yr	2600.00	7039.55	7044.55	7044.31	7045.60	0.004992	9.46	362.92	127.23	0.78
CLOMR CL	4170	500yr	3800.00	7039.55	7045.41		7046.67	0.004980	10.60	474.42	134.05	0.81
CLOMR CL	4025	10yr	1200.00	7038.83	7042.54	7042.45	7043.29	0.005000	7.56	204.48	116.84	0.74
CLOMR CL	4025	50yr	2100.00	7038.83	7043.43	7043.24	7044.37	0.004971	8.87	311.95	123.98	0.77
CLOMR CL	4025	100yr	2600.00	7038.83	7043.84		7044.88	0.004949	9.43	364.04	127.30	0.78
CLOMR CL	4025	500yr	3800.00	7038.83	7044.70		7045.95	0.004923	10.56	476.32	134.17	0.80
CLOMR CL	3900	10yr	1200.00	7038.20	7041.91	7041.82	7042.66	0.004939	7.53	205.47	116.91	0.74
CLOMR CL	3900	50yr	2100.00	7038.20	7042.82		7043.74	0.004844	8.79	314.89	124.17	0.76
CLOMR CL	3900	100yr	2600.00	7038.20	7043.25		7044.26	0.004749	9.30	369.42	127.64	0.77
CLOMR CL	3900	500yr	3800.00	7038.20	7044.11		7045.33	0.004758	10.43	482.06	134.51	0.79
CLOMR CL	3789	10yr	1200.00	7037.65	7041.43	7041.27	7042.12	0.004491	7.28	213.29	117.44	0.70
CLOMR CL	3789	50yr	2100.00	7037.65	7042.35		7043.21	0.004463	8.54	324.28	124.77	0.73
CLOMR CL	3789	100yr	2600.00	7037.65	7042.80		7043.74	0.004318	8.99	382.08	128.43	0.73
CLOMR CL	3789	500yr	3800.00	7037.65	7043.64		7044.81	0.004488	10.22	491.97	135.10	0.77
CLOMR CL	3640	10yr	1200.00	7036.90	7040.51	7040.51	7041.35	0.005731	7.94	193.62	185.69	0.79
CLOMR CL	3640	50yr	2100.00	7036.90	7041.32	7041.32	7042.42	0.006072	9.52	290.11	196.69	0.84
CLOMR CL	3640	100yr	2600.00	7036.90	7041.64	7041.64	7042.92	0.006546	10.41	329.47	200.99	0.89
CLOMR CL	3640	500yr	3800.00	7036.90	7042.45	7042.45	7043.98	0.006457	11.60	433.18	211.88	0.91
CLOMR CL	3590	10yr	1200.00	7036.65	7039.93	7039.93	7040.60	0.012668	6.91	196.06	227.62	0.76
CLOMR CL	3590	50yr	2100.00	7036.65	7040.58	7040.58	7041.50	0.013423	8.28	285.79	248.12	0.82
CLOMR CL	3590	100yr	2600.00	7036.65	7040.88	7040.88	7041.93	0.013727	8.88	327.61	257.66	0.84
CLOMR CL	3590	500yr	3800.00	7036.65	7041.52	7041.52	7042.84	0.013717	9.93	421.48	277.11	0.86
CLOMR CL	3550	10yr	1200.00	7027.70	7034.16	7030.47	7034.25	0.000594	2.45	545.68	158.90	0.19
CLOMR CL	3550	50yr	2100.00	7027.70	7035.21	7031.57	7035.35	0.000826	3.26	716.58	167.29	0.23
CLOMR CL	3550	100yr	2600.00	7027.70	7035.70	7032.09	7035.88	0.000917	3.60	799.46	171.20	0.24
CLOMR CL	3550	500yr	3800.00	7027.70	7036.73	7033.44	7036.98	0.001090	4.31	992.98	335.51	0.27
CLOMR CL	3521	10yr	1200.00	7027.70	7033.91	7031.51	7034.20	0.001025	4.67	329.75	120.90	0.36
CLOMR CL	3521	50yr	2100.00	7027.70	7034.79	7033.47	7035.29	0.001530	6.31	439.28	127.94	0.45
CLOMR CL	3521	100yr	2600.00	7027.70	7035.20	7033.94	7035.80	0.001743	7.03	491.98	131.20	0.48
CLOMR CL	3521	500yr	3800.00	7027.70	7036.06	7034.80	7036.88	0.002117	8.40	607.55	311.48	0.54
CLOMR CL	3520	10yr	1200.00	7029.70	7033.43	7033.33	7034.16	0.004853	7.48	206.90	117.01	0.73
CLOMR CL	3520	50yr	2100.00	7029.70	7034.32	7034.13	7035.24	0.004867	8.80	314.34	124.14	0.76
CLOMR CL	3520	100yr	2600.00	7029.70	7034.73	7034.42	7035.75	0.004859	9.37	366.43	127.45	0.77
CLOMR CL	3520	500yr	3800.00	7029.70	7035.61	7035.26	7036.83	0.004769	10.44	481.66	134.49	0.79
CLOMR CL	3470	10yr	1200.00	7029.45	7033.18	7033.08	7033.91	0.004850	7.48	206.95	117.01	0.73
CLOMR CL	3470	50yr	2100.00	7029.45	7034.08	7033.88	7034.99	0.004818	8.77	315.49	124.21	0.76
CLOMR CL	3470	100yr	2600.00	7029.45	7034.49	7034.24	7035.50	0.004834	9.35	367.11	127.49	0.77
CLOMR CL	3470	500yr	3800.00	7029.45	7035.38	7035.00	7036.59	0.004693	10.38	484.36	134.65	0.78
CLOMR CL	3420	10yr	1200.00	7029.20	7032.83	7032.83	7033.65	0.005563	7.85	195.96	116.26	0.78
CLOMR CL	3420	50yr	2100.00	7029.20	7033.64	7033.64	7034.72	0.005972	9.46	291.86	122.68	0.84
CLOMR CL	3420	100yr	2600.00	7029.20	7034.00	7034.00	7035.22	0.006167	10.19	336.59	125.56	0.86
CLOMR CL	3420	500yr	3800.00	7029.20	7034.70	7034.70	7036.28	0.006742	11.78	426.66	131.18	0.93
CLOMR CL	3370	10yr	1200.00	7028.95	7032.21	7032.21	7032.97	0.006339	7.29	192.94	153.24	0.81
CLOMR CL	3370	50yr	2100.00	7028.95	7032.95	7032.95	7033.96	0.006430	8.72	294.85	168.04	0.85
CLOMR CL	3370	100yr	2600.00	7028.95	7033.29	7033.29	7034.43	0.006546	9.39	341.52	174.69	0.87
CLOMR CL	3370	500yr	3800.00	7028.95	7033.98	7033.98	7035.40	0.006696	10.68	441.97	184.42	0.91
CLOMR CL	3330	10yr	1200.00	7021.00	7027.46	7023.77	7027.55	0.000594	2.45	545.89	158.91	0.19
CLOMR CL	3330	50yr	2100.00	7021.00	7028.52	7024.87	7028.66	0.000822	3.25	717.77	189.94	0.23
CLOMR CL	3330	100yr	2600.00	7021.00	7029.01	7025.39	7029.19	0.000911	3.59	801.27	204.19	0.24
CLOMR CL	3330	500yr	3800.00	7021.00	7030.04	7026.73	7030.29	0.001048	4.23	980.72	219.98	0.26
CLOMR CL	3301	10yr	1200.00	7021.00	7027.21	7024.81	7027.50	0.001024	4.67	329.96	176.17	0.36
CLOMR CL	3301	50yr	2100.00	7021.00	7028.10	7026.75	7028.59	0.001518	6.30	440.57	197.35	0.44
CLOMR CL	3301	100yr	2600.00	7021.00	7028.52	7027.23	7029.11	0.001725	7.00	494.01	203.28	0.48
CLOMR CL	3301	500yr	3800.00	7021.00	7029.38	7028.10	7030.19	0.002094	8.36	610.08	215.71	0.54
CLOMR CL	3300	10yr	1200.00	7023.00	7026.74	7026.61	7027.46	0.004734	7.41	208.93	162.70	0.72
CLOMR CL	3300	50yr	2100.00	7023.00	7027.66	7027.42	7028.55	0.004648	8.66	319.60	187.58	0.75
CLOMR CL	3300	100yr	2600.00	7023.00	7028.08	7027.79	7029.07	0.004619	9.21	373.07	197.06	0.76

HEC-RAS Plan: PP Profiles River: Sand Creek Reach: CLOMR CL (Continued)

Reach	River Sta	Profile	Q Total (cfs)	Min Ch El (ft)	W.S. Elev (ft)	Crit W.S. (ft)	E.G. Elev (ft)	E.G. Slope (ft/ft)	Vel Chnl (ft/s)	Flow Area (sq ft)	Top Width (ft)	Froude # Chl
CLOMR CL	3300	500yr	3800.00	7023.00	7028.96	7028.55	7030.15	0.004600	10.31	487.75	209.63	0.78
CLOMR CL	3250	10yr	1200.00	7022.75	7026.54	7026.36	7027.22	0.004427	7.24	214.49	132.46	0.70
CLOMR CL	3250	50yr	2100.00	7022.75	7027.46	7027.17	7028.32	0.004399	8.49	325.99	143.36	0.73
CLOMR CL	3250	100yr	2600.00	7022.75	7027.89	7027.52	7028.83	0.004388	9.04	379.89	148.40	0.74
CLOMR CL	3250	500yr	3800.00	7022.75	7028.75	7028.25	7029.91	0.004438	10.19	493.88	158.96	0.76
CLOMR CL	3140	10yr	1200.00	7022.20	7025.82	7025.82	7026.65	0.005656	7.90	194.66	116.17	0.78
CLOMR CL	3140	50yr	2100.00	7022.20	7026.61	7026.61	7027.72	0.006136	9.55	288.99	122.49	0.85
CLOMR CL	3140	100yr	2600.00	7022.20	7026.96	7026.96	7028.22	0.006369	10.31	332.73	125.32	0.88
CLOMR CL	3140	500yr	3800.00	7022.20	7027.73	7027.73	7029.28	0.006575	11.67	430.45	131.41	0.92
CLOMR CL	3090	10yr	1200.00	7021.95	7025.19	7025.19	7025.90	0.013480	7.06	191.37	133.16	0.79
CLOMR CL	3090	50yr	2100.00	7021.95	7025.85	7025.85	7026.80	0.014150	8.44	279.94	138.38	0.84
CLOMR CL	3090	100yr	2600.00	7021.95	7026.16	7026.16	7027.23	0.014158	8.98	323.02	140.84	0.85
CLOMR CL	3090	500yr	3800.00	7021.95	7026.77	7026.77	7028.15	0.014583	10.15	410.69	145.74	0.89
CLOMR CL	3050	10yr	1200.00	7014.00	7020.46		7020.55	0.000595	2.45	545.58	158.89	0.19
CLOMR CL	3050	50yr	2100.00	7014.00	7021.51		7021.65	0.000828	3.26	716.22	167.27	0.23
CLOMR CL	3050	100yr	2600.00	7014.00	7022.00		7022.17	0.000918	3.60	799.18	171.19	0.24
CLOMR CL	3050	500yr	3800.00	7014.00	7023.03		7023.27	0.001059	4.24	977.72	174.80	0.27
CLOMR CL	3021	10yr	1200.00	7014.00	7020.21		7020.50	0.001026	4.67	329.67	120.89	0.36
CLOMR CL	3021	50yr	2100.00	7014.00	7021.09		7021.59	0.001534	6.32	438.88	127.91	0.45
CLOMR CL	3021	100yr	2600.00	7014.00	7021.50		7022.10	0.001747	7.03	491.64	131.17	0.48
CLOMR CL	3021	500yr	3800.00	7014.00	7022.35		7023.17	0.002131	8.42	606.10	137.98	0.54
CLOMR CL	3020	10yr	1200.00	7016.00	7019.70	7019.62	7020.45	0.005038	7.58	203.85	116.80	0.74
CLOMR CL	3020	50yr	2100.00	7016.00	7020.60	7020.41	7021.54	0.004944	8.85	312.56	124.02	0.77
CLOMR CL	3020	100yr	2600.00	7016.00	7021.02		7022.05	0.004916	9.41	364.91	127.35	0.78
CLOMR CL	3020	500yr	3800.00	7016.00	7021.89		7023.13	0.004869	10.52	478.16	134.28	0.80
CLOMR CL	2970	10yr	1200.00	7015.75	7019.45	7019.37	7020.20	0.005067	7.60	203.40	116.77	0.75
CLOMR CL	2970	50yr	2100.00	7015.75	7020.36		7021.29	0.004925	8.84	312.98	124.05	0.77
CLOMR CL	2970	100yr	2600.00	7015.75	7020.77		7021.80	0.004892	9.39	365.53	127.39	0.78
CLOMR CL	2970	500yr	3800.00	7015.75	7021.64		7022.88	0.004839	10.49	479.21	134.34	0.79
CLOMR CL	2850	10yr	1200.00	7015.15	7018.95		7019.62	0.004352	7.20	215.93	117.62	0.69
CLOMR CL	2850	50yr	2100.00	7015.15	7019.86		7020.72	0.004392	8.49	326.17	124.89	0.73
CLOMR CL	2850	100yr	2600.00	7015.15	7020.28		7021.23	0.004423	9.07	378.82	128.22	0.74
CLOMR CL	2850	500yr	3800.00	7015.15	7021.15		7022.31	0.004447	10.19	493.55	135.19	0.76
CLOMR CL	2740	10yr	1200.00	7014.60	7018.21	7018.21	7019.05	0.005731	7.94	193.62	185.82	0.79
CLOMR CL	2740	50yr	2100.00	7014.60	7019.02	7019.02	7020.12	0.006092	9.53	289.75	201.05	0.85
CLOMR CL	2740	100yr	2600.00	7014.60	7019.38	7019.38	7020.62	0.006238	10.23	335.22	207.97	0.87
CLOMR CL	2740	500yr	3800.00	7014.60	7020.14	7020.14	7021.68	0.006501	11.63	432.15	222.22	0.91
CLOMR CL	2690	10yr	1200.00	7014.35	7017.60	7017.60	7018.30	0.013231	7.02	192.72	188.15	0.78
CLOMR CL	2690	50yr	2100.00	7014.35	7018.24	7018.24	7019.20	0.014254	8.46	279.24	198.25	0.84
CLOMR CL	2690	100yr	2600.00	7014.35	7018.56	7018.56	7019.63	0.013999	8.94	324.24	203.47	0.84
CLOMR CL	2690	500yr	3800.00	7014.35	7019.22	7019.22	7020.55	0.013794	9.96	418.22	213.90	0.86
CLOMR CL	2650	10yr	1200.00	7006.73	7013.19		7013.28	0.000595	2.45	545.58	158.89	0.19
CLOMR CL	2650	50yr	2100.00	7006.73	7014.24		7014.38	0.000828	3.26	716.22	167.27	0.23
CLOMR CL	2650	100yr	2600.00	7006.73	7014.73		7014.90	0.000917	3.60	799.35	171.20	0.24
CLOMR CL	2650	500yr	3800.00	7006.73	7015.80		7016.04	0.001033	4.21	985.26	174.95	0.26
CLOMR CL	2621	10yr	1200.00	7006.73	7012.94		7013.23	0.001026	4.67	329.67	120.89	0.36
CLOMR CL	2621	50yr	2100.00	7006.73	7013.82		7014.32	0.001534	6.32	438.88	127.91	0.45
CLOMR CL	2621	100yr	2600.00	7006.73	7014.23		7014.83	0.001745	7.03	491.76	131.18	0.48
CLOMR CL	2621	500yr	3800.00	7006.73	7015.14		7015.94	0.002056	8.32	614.97	139.28	0.53
CLOMR CL	2620	10yr	1200.00	7008.73	7012.43	7012.35	7013.18	0.005042	7.58	203.79	116.79	0.74
CLOMR CL	2620	50yr	2100.00	7008.73	7013.33	7013.14	7014.27	0.004944	8.85	312.56	124.02	0.77
CLOMR CL	2620	100yr	2600.00	7008.73	7013.75		7014.78	0.004902	9.40	365.28	127.38	0.78
CLOMR CL	2620	500yr	3800.00	7008.73	7014.78		7015.91	0.004289	10.06	499.83	135.56	0.75
CLOMR CL	2570	10yr	1200.00	7008.48	7012.18	7012.10	7012.93	0.005067	7.60	203.40	116.77	0.75
CLOMR CL	2570	50yr	2100.00	7008.48	7013.09		7014.02	0.004925	8.84	312.98	124.05	0.77
CLOMR CL	2570	100yr	2600.00	7008.48	7013.51		7014.53	0.004874	9.38	366.03	127.42	0.77
CLOMR CL	2570	500yr	3800.00	7008.48	7014.60		7015.68	0.004053	9.87	509.78	136.15	0.73
CLOMR CL	2470	10yr	1200.00	7007.98	7011.73		7012.44	0.004659	7.37	210.25	117.23	0.72
CLOMR CL	2470	50yr	2100.00	7007.98	7012.67		7013.54	0.004501	8.56	323.31	124.71	0.73
CLOMR CL	2470	100yr	2600.00	7007.98	7013.10		7014.06	0.004461	9.09	377.70	128.15	0.74
CLOMR CL	2470	500yr	3800.00	7007.98	7014.32		7015.28	0.003438	9.32	539.89	137.91	0.68
CLOMR CL	2350	10yr	1200.00	7007.38	7011.00	7011.00	7011.83	0.005649	7.90	194.75	116.17	0.78
CLOMR CL	2350	50yr	2100.00	7007.38	7011.79	7011.79	7012.90	0.006134	9.55	289.03	122.49	0.85
CLOMR CL	2350	100yr	2600.00	7007.38	7012.15	7012.15	7013.40	0.006367	10.31	332.77	125.32	0.88

HEC-RAS Plan: PP Profiles River: Sand Creek Reach: CLOMR CL (Continued)

Reach	River Sta	Profile	Q Total (cfs)	Min Ch El (ft)	W.S. Elev (ft)	Crit W.S. (ft)	E.G. Elev (ft)	E.G. Slope (ft/ft)	Vel Chnl (ft/s)	Flow Area (sq ft)	Top Width (ft)	Froude # Chl
CLOMR CL	2350	500yr	3800.00	7007.38	7014.00		7014.88	0.003020	9.01	580.30	155.13	0.64
CLOMR CL	2300	10yr	1200.00	7007.13	7010.37	7010.37	7011.15	0.006556	7.37	190.25	133.09	0.82
CLOMR CL	2300	50yr	2100.00	7007.13	7011.10	7011.10	7012.14	0.006707	8.85	290.35	138.97	0.87
CLOMR CL	2300	100yr	2600.00	7007.13	7011.44	7011.44	7012.61	0.006761	9.49	337.62	141.67	0.88
CLOMR CL	2300	500yr	3800.00	7007.13	7014.14		7014.66	0.001586	6.69	776.21	232.41	0.47
CLOMR CL	2260	10yr	1200.00	6999.18	7007.05		7007.10	0.000113	1.88	777.05	170.15	0.13
CLOMR CL	2260	50yr	2100.00	6999.18	7009.87		7009.92	0.000084	2.04	1293.01	195.82	0.12
CLOMR CL	2260	100yr	2600.00	6999.18	7011.27		7011.32	0.000075	2.10	1574.84	208.80	0.11
CLOMR CL	2260	500yr	3800.00	6999.18	7014.46		7014.51	0.000056	2.16	2288.77	235.65	0.10
CLOMR CL	2231	10yr	1200.00	6999.18	7006.98		7007.08	0.000303	3.02	531.22	133.57	0.20
CLOMR CL	2231	50yr	2100.00	6999.18	7009.82		7009.92	0.000191	3.01	932.06	147.60	0.17
CLOMR CL	2231	100yr	2600.00	6999.18	7011.21		7011.31	0.000175	3.15	1154.83	175.67	0.17
CLOMR CL	2231	500yr	3800.00	6999.18	7014.42		7014.51	0.000120	3.08	1829.54	233.51	0.14
CLOMR CL	2230	10yr	1200.00	7001.18	7006.95		7007.08	0.000534	3.43	462.57	133.35	0.26
CLOMR CL	2230	50yr	2100.00	7001.18	7009.81		7009.92	0.000257	3.18	865.62	147.54	0.20
CLOMR CL	2230	100yr	2600.00	7001.18	7011.20		7011.31	0.000224	3.29	1088.46	175.50	0.19
CLOMR CL	2230	500yr	3800.00	7001.18	7014.41		7014.51	0.000140	3.16	1763.85	233.50	0.16
CLOMR CL	2200	10yr	1200.00	7001.12	7006.94		7007.06	0.000514	3.39	468.87	133.72	0.26
CLOMR CL	2200	50yr	2100.00	7001.12	7009.80		7009.91	0.000253	3.17	873.04	149.16	0.19
CLOMR CL	2200	100yr	2600.00	7001.12	7011.20		7011.30	0.000212	3.21	1092.19	165.93	0.18
CLOMR CL	2200	500yr	3800.00	7001.12	7014.41		7014.50	0.000141	3.18	1690.35	206.80	0.16
CLOMR CL	2136	10yr	1200.00	7000.99	7006.94		7007.02	0.000301	2.58	581.45	154.83	0.20
CLOMR CL	2136	50yr	2100.00	7000.99	7009.81		7009.88	0.000162	2.53	1075.01	189.04	0.16
CLOMR CL	2136	100yr	2600.00	7000.99	7011.21		7011.28	0.000131	2.53	1350.99	205.79	0.14
CLOMR CL	2136	500yr	3800.00	7000.99	7014.42		7014.49	0.000083	2.45	2050.54	225.10	0.12
CLOMR CL	2086	10yr	1200.00	7000.89	7006.53	7004.45	7006.96	0.001374	5.41	234.35	53.92	0.42
CLOMR CL	2086	50yr	2100.00	7000.89	7009.28	7005.71	7009.82	0.000967	6.04	369.23	53.94	0.38
CLOMR CL	2086	100yr	2600.00	7000.89	7010.62	7006.29	7011.21	0.000872	6.36	434.52	53.94	0.37
CLOMR CL	2086	500yr	3800.00	7000.89	7013.71	7007.60	7014.41	0.000701	6.91	585.80	53.96	0.35
CLOMR CL	2050	Bridge										
CLOMR CL	1992	10yr	1200.00	7000.70	7004.79	7004.20	7005.79	0.004936	8.10	152.62	44.92	0.75
CLOMR CL	1992	50yr	2100.00	7000.70	7005.55	7005.55	7007.61	0.007888	11.63	186.81	44.93	0.98
CLOMR CL	1992	100yr	2600.00	7000.70	7006.12	7006.12	7008.56	0.008020	12.71	212.10	44.94	1.01
CLOMR CL	1992	500yr	3800.00	7000.70	7007.58	7007.58	7010.64	0.007129	14.24	277.81	44.95	0.99
CLOMR CL	1942	10yr	1200.00	7000.60	7004.94		7005.33	0.002176	5.62	280.38	121.93	0.50
CLOMR CL	1942	50yr	2100.00	7000.60	7005.96		7006.49	0.002331	6.80	408.46	130.06	0.54
CLOMR CL	1942	100yr	2600.00	7000.60	7006.42		7007.03	0.002399	7.32	469.72	133.77	0.56
CLOMR CL	1942	500yr	3800.00	7000.60	7007.38		7008.15	0.002532	8.40	601.35	142.13	0.59
CLOMR CL	1847	10yr	1200.00	7000.41	7004.72		7005.12	0.002261	5.70	276.47	121.67	0.51
CLOMR CL	1847	50yr	2100.00	7000.41	7005.71		7006.26	0.002458	6.92	400.88	129.59	0.56
CLOMR CL	1847	100yr	2600.00	7000.41	7006.16		7006.79	0.002538	7.47	460.55	133.23	0.57
CLOMR CL	1847	500yr	3800.00	7000.41	7007.10		7007.90	0.002675	8.55	588.85	140.46	0.60
CLOMR CL	1755	10yr	1200.00	7000.23	7004.47		7004.90	0.002447	5.86	268.51	121.14	0.53
CLOMR CL	1755	50yr	2100.00	7000.23	7005.42		7006.02	0.002709	7.16	387.36	128.75	0.58
CLOMR CL	1755	100yr	2600.00	7000.23	7005.86		7006.54	0.002809	7.74	444.45	132.25	0.60
CLOMR CL	1755	500yr	3800.00	7000.23	7006.76		7007.63	0.003010	8.91	566.30	140.18	0.64
CLOMR CL	1640	10yr	1200.00	7000.00	7003.62	7003.62	7004.45	0.005649	7.90	194.75	116.17	0.78
CLOMR CL	1640	50yr	2100.00	7000.00	7004.41	7004.41	7005.52	0.006134	9.55	289.03	122.49	0.85
CLOMR CL	1640	100yr	2600.00	7000.00	7004.77	7004.77	7006.02	0.006367	10.31	332.77	125.32	0.88
CLOMR CL	1640	500yr	3800.00	7000.00	7005.53	7005.53	7007.08	0.006573	11.67	430.48	131.41	0.92
CLOMR CL	1590	10yr	1200.00	6999.90	7003.14	7003.14	7003.85	0.013603	7.09	190.71	133.11	0.79
CLOMR CL	1590	50yr	2100.00	6999.90	7003.80	7003.80	7004.75	0.014143	8.44	279.99	138.38	0.84
CLOMR CL	1590	100yr	2600.00	6999.90	7004.11	7004.11	7005.18	0.014152	8.98	323.07	140.84	0.85
CLOMR CL	1590	500yr	3800.00	6999.90	7004.72	7004.72	7006.10	0.014578	10.15	410.74	145.74	0.89
CLOMR CL	1550	10yr	1200.00	6992.12	6998.88		6998.95	0.000467	2.25	593.50	161.29	0.17
CLOMR CL	1550	50yr	2100.00	6992.12	7000.02		7000.14	0.000640	2.98	781.51	170.36	0.20
CLOMR CL	1550	100yr	2600.00	6992.12	7000.54		7000.69	0.000708	3.29	872.02	174.30	0.21
CLOMR CL	1550	500yr	3800.00	6992.12	7001.66		7001.87	0.000807	3.86	1070.45	179.08	0.23
CLOMR CL	1521	10yr	1200.00	6992.12	6998.69		6998.92	0.000753	4.18	373.87	123.78	0.31
CLOMR CL	1521	50yr	2100.00	6992.12	6999.72		7000.09	0.001062	5.54	504.87	131.98	0.38
CLOMR CL	1521	100yr	2600.00	6992.12	7000.19		7000.63	0.001189	6.13	568.01	135.75	0.40
CLOMR CL	1521	500yr	3800.00	6992.12	7001.20		7001.80	0.001401	7.26	710.68	146.83	0.45
CLOMR CL	1520	10yr	1200.00	6994.12	6998.55		6998.90	0.001966	5.42	291.00	122.62	0.48

Sterling
Ranch Blvd.

on a
curve

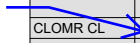

HEC-RAS Plan: PP Profiles River: Sand Creek Reach: CLOMR CL (Continued)

Reach	River Sta	Profile	Q Total (cfs)	Min Ch El (ft)	W.S. Elev (ft)	Crit W.S. (ft)	E.G. Elev (ft)	E.G. Slope (ft/ft)	Vel Chnl (ft/s)	Flow Area (sq ft)	Top Width (ft)	Froude # Chl
CLOMR CL	1520	50yr	2100.00	6994.12	6999.58		7000.07	0.002132	6.59	421.45	130.86	0.52
CLOMR CL	1520	100yr	2600.00	6994.12	7000.05		7000.62	0.002197	7.11	484.33	134.64	0.54
CLOMR CL	1520	500yr	3800.00	6994.12	7001.07		7001.78	0.002274	8.10	626.42	145.24	0.56
CLOMR CL	1470	10yr	1200.00	6994.02	6998.45		6998.81	0.001961	5.42	291.24	122.64	0.48
CLOMR CL	1470	50yr	2100.00	6994.02	6999.47		6999.96	0.002155	6.61	419.92	130.76	0.52
CLOMR CL	1470	100yr	2600.00	6994.02	6999.93		7000.50	0.002229	7.14	481.90	134.50	0.54
CLOMR CL	1470	500yr	3800.00	6994.02	7000.88		7001.66	0.002526	8.46	616.94	157.67	0.59
CLOMR CL	1210	10yr	1200.00	6993.50	6997.12	6997.12	6997.95	0.005645	7.90	194.81	116.18	0.78
CLOMR CL	1210	50yr	2100.00	6993.50	6997.91	6997.91	6999.02	0.006137	9.55	288.97	122.49	0.85
CLOMR CL	1210	100yr	2600.00	6993.50	6998.27	6998.27	6999.52	0.006367	10.31	332.77	125.32	0.88
CLOMR CL	1210	500yr	3800.00	6993.50	6999.03	6999.03	7000.58	0.006570	11.67	430.55	131.41	0.92
CLOMR CL	1160	10yr	1200.00	6993.40	6996.64	6996.64	6997.35	0.013603	7.09	190.71	133.11	0.79
CLOMR CL	1160	50yr	2100.00	6993.40	6997.30	6997.30	6998.25	0.014143	8.44	279.99	138.38	0.84
CLOMR CL	1160	100yr	2600.00	6993.40	6997.61	6997.61	6998.68	0.014152	8.98	323.07	140.84	0.85
CLOMR CL	1160	500yr	3800.00	6993.40	6998.22	6998.22	6999.60	0.014578	10.15	410.74	145.74	0.89
CLOMR CL	1120	10yr	1200.00	6986.68	6993.25		6993.33	0.000543	2.38	563.18	159.78	0.18
CLOMR CL	1120	50yr	2100.00	6986.68	6994.32		6994.45	0.000759	3.16	737.47	168.28	0.22
CLOMR CL	1120	100yr	2600.00	6986.68	6994.81		6994.98	0.000845	3.50	821.77	172.24	0.23
CLOMR CL	1120	500yr	3800.00	6986.68	6995.84		6996.07	0.000984	4.13	1001.29	175.31	0.26
CLOMR CL	1091	10yr	1200.00	6986.68	6993.03		6993.29	0.000911	4.48	346.29	121.99	0.34
CLOMR CL	1091	50yr	2100.00	6986.68	6993.94		6994.39	0.001347	6.03	461.27	129.31	0.42
CLOMR CL	1091	100yr	2600.00	6986.68	6994.37		6994.91	0.001532	6.71	516.59	132.69	0.45
CLOMR CL	1091	500yr	3800.00	6986.68	6995.24		6995.98	0.001876	8.04	635.28	139.67	0.51
CLOMR CL	1090	10yr	1200.00	6988.68	6992.78		6993.27	0.002923	6.24	251.34	120.01	0.58
CLOMR CL	1090	50yr	2100.00	6988.68	6993.68		6994.36	0.003264	7.65	362.63	127.21	0.63
CLOMR CL	1090	100yr	2600.00	6988.68	6994.10		6994.88	0.003379	8.25	416.57	130.56	0.65
CLOMR CL	1090	500yr	3800.00	6988.68	6994.96		6995.95	0.003593	9.47	531.65	137.43	0.69
CLOMR CL	1040	10yr	1200.00	6988.58	6992.19	6992.19	6993.03	0.005756	7.95	193.28	116.07	0.79
CLOMR CL	1040	50yr	2100.00	6988.58	6992.99	6992.99	6994.10	0.006137	9.55	288.97	122.49	0.85
CLOMR CL	1040	100yr	2600.00	6988.58	6993.35	6993.35	6994.60	0.006367	10.31	332.77	125.32	0.88
CLOMR CL	1040	500yr	3800.00	6988.58	6994.11	6994.11	6995.66	0.006568	11.67	430.61	131.41	0.91
CLOMR CL	644	10yr	1200.00	6982.63	6985.31	6984.70	6985.64	0.002795	4.64	266.20	141.52	0.58
CLOMR CL	644	50yr	2100.00	6982.63	6985.89	6985.33	6986.49	0.003621	6.25	349.90	146.99	0.68
CLOMR CL	644	100yr	2600.00	6982.63	6986.14	6985.64	6986.89	0.004052	7.03	386.90	148.81	0.73
CLOMR CL	644	500yr	3800.00	6982.63	6986.61	6986.30	6987.77	0.005123	8.76	457.40	151.36	0.85

Provide modeling to DP 60A
(downstream of proposed pond outfall)

Excessive
velocities
highlighted.



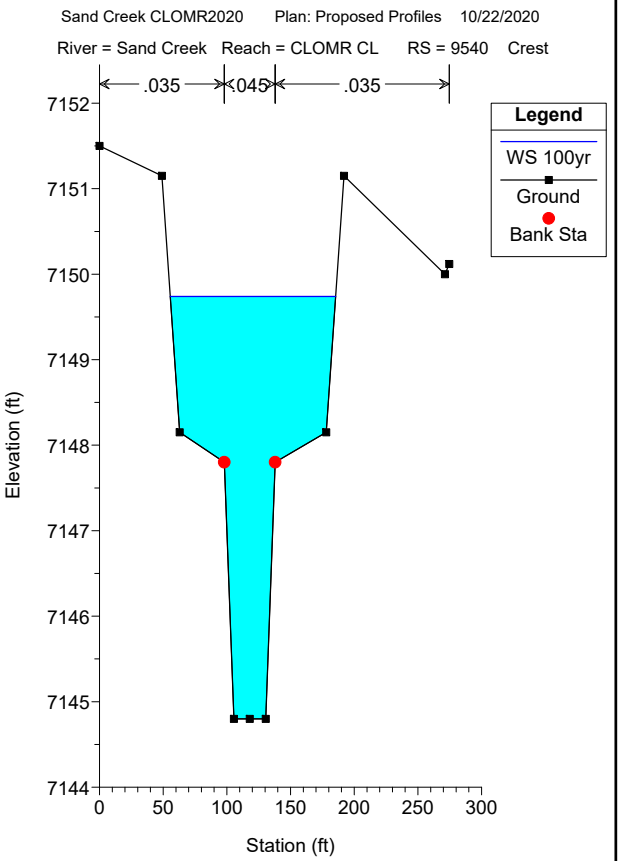
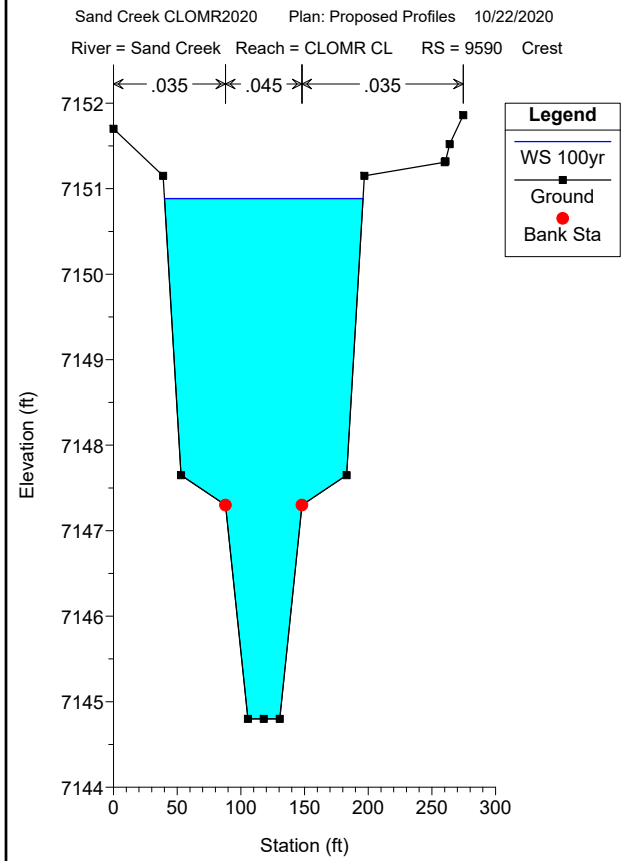
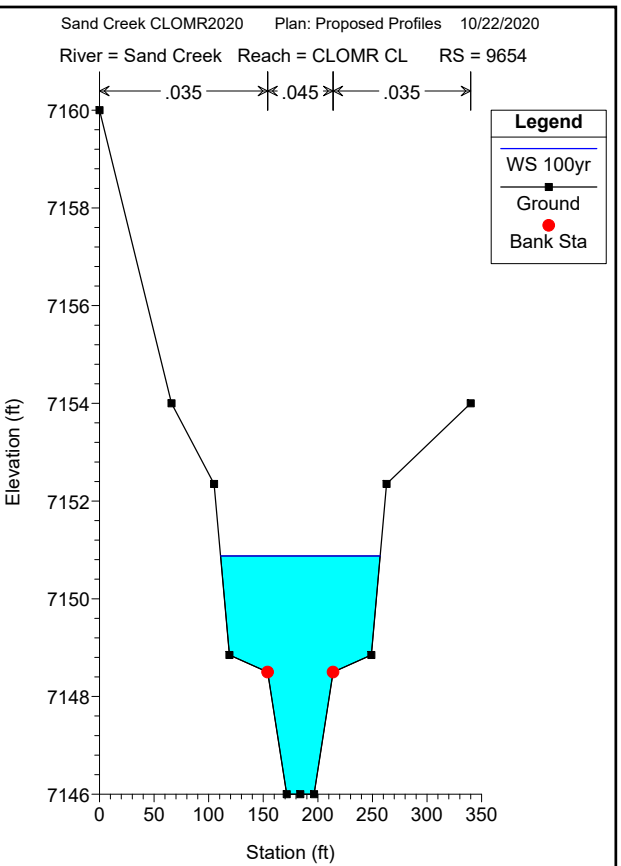
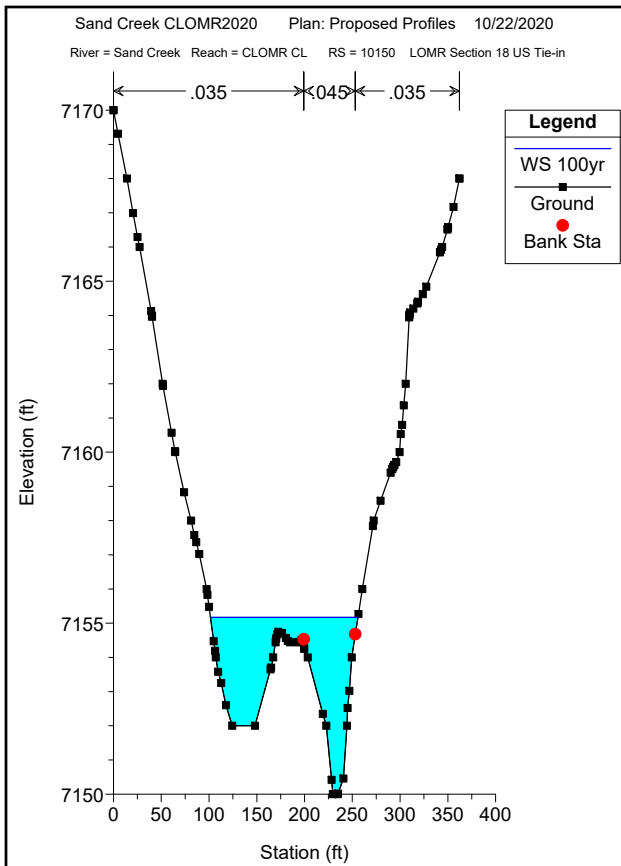

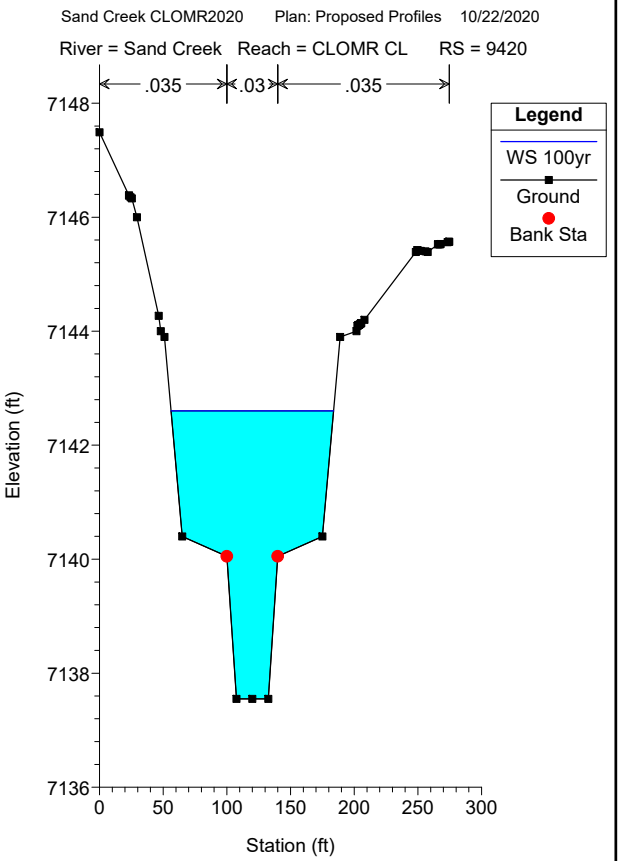
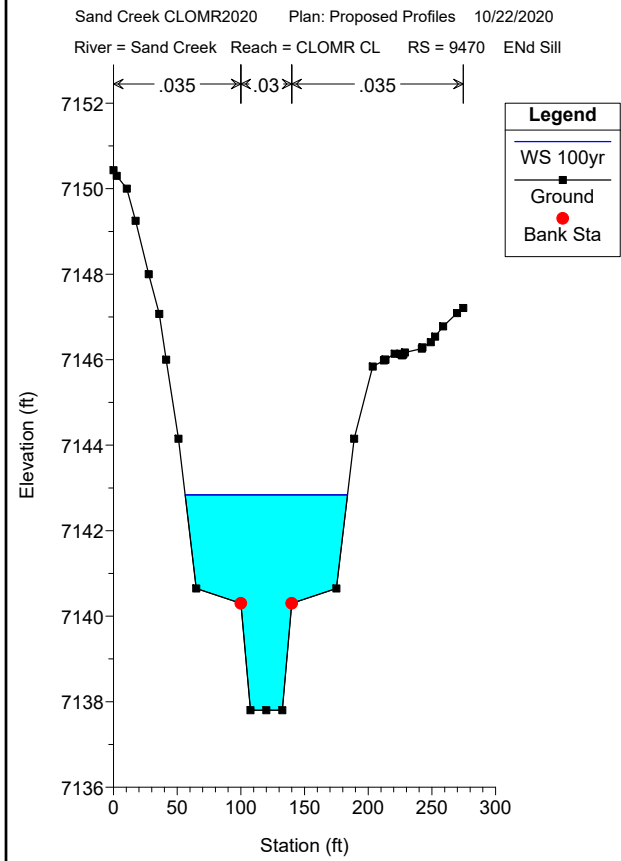
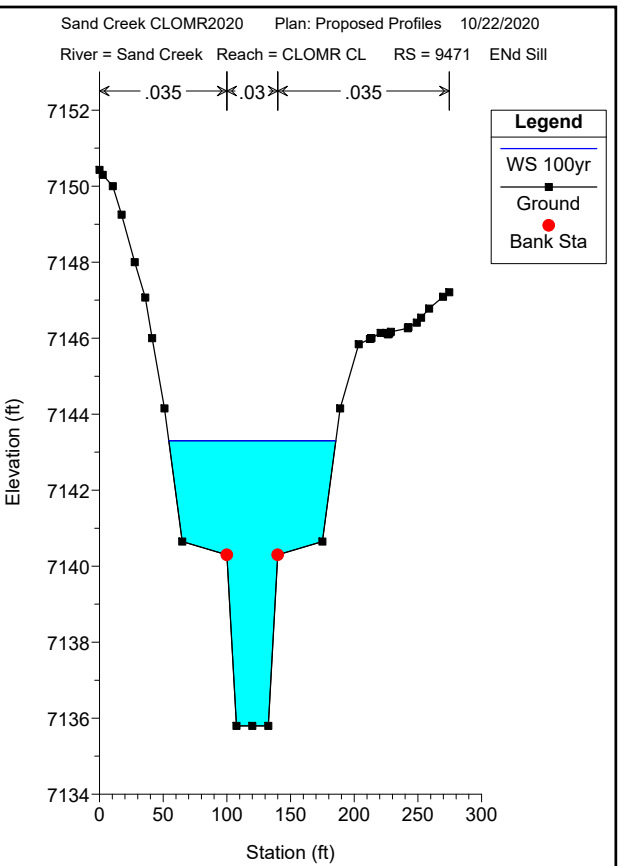
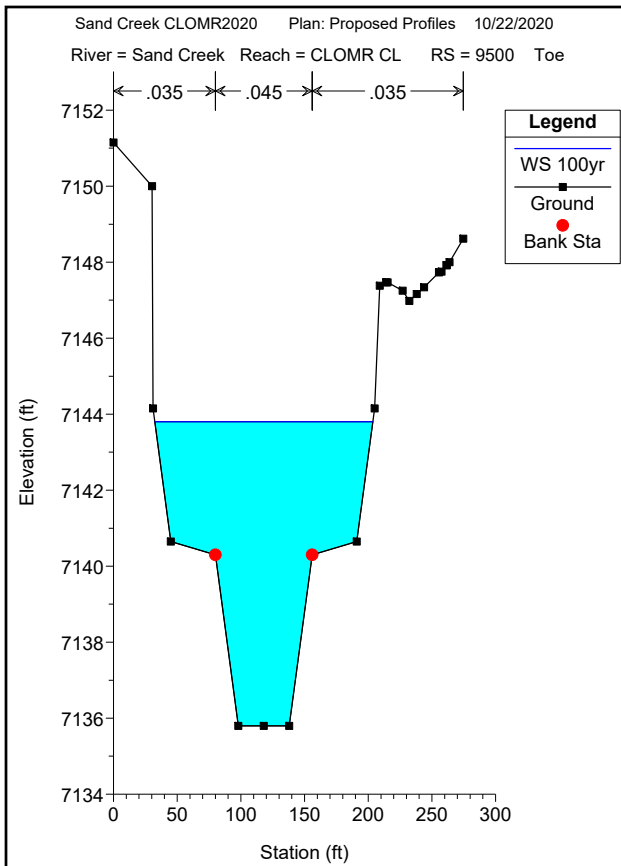

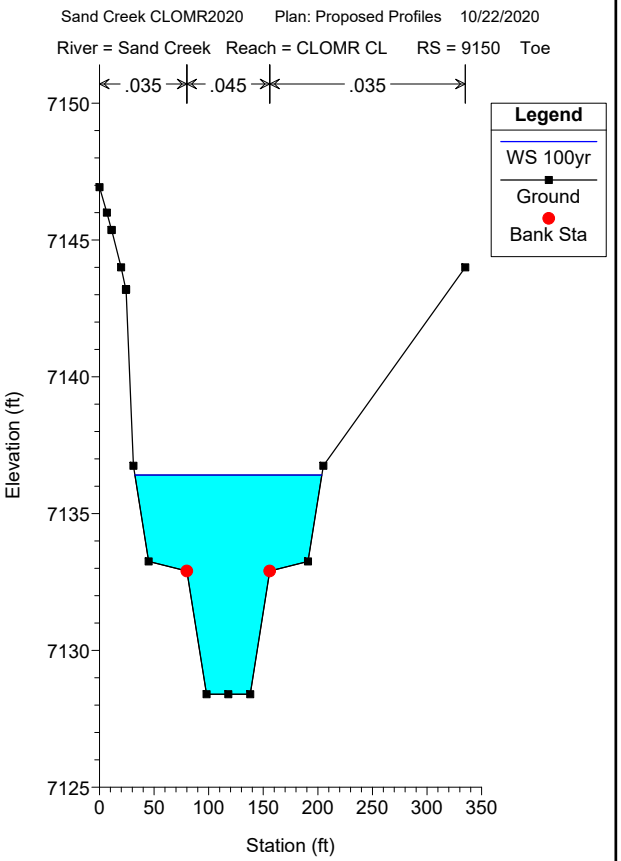
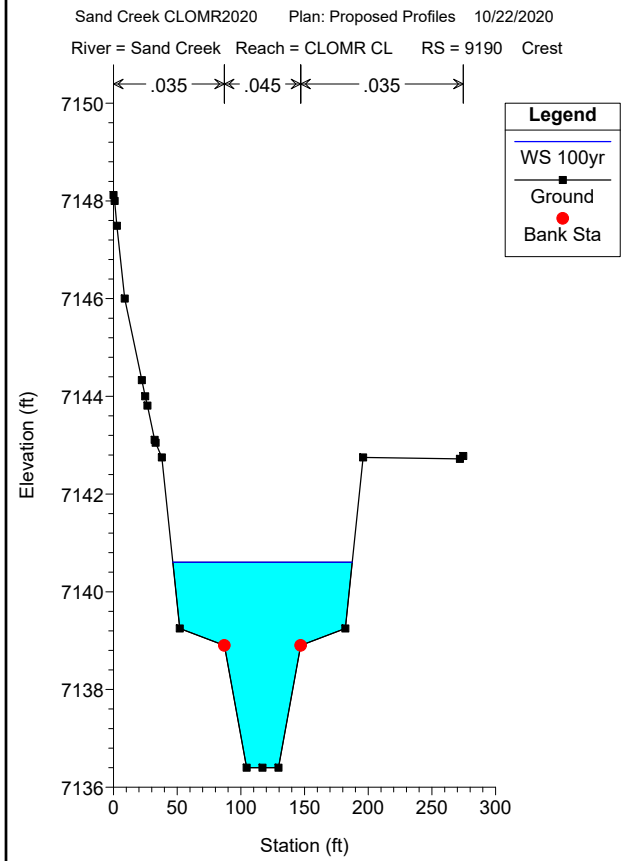
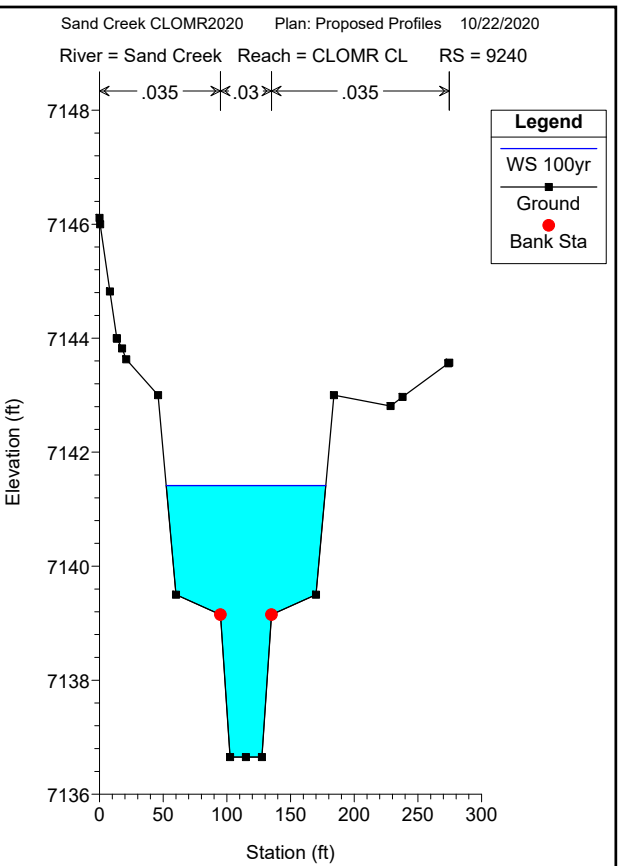
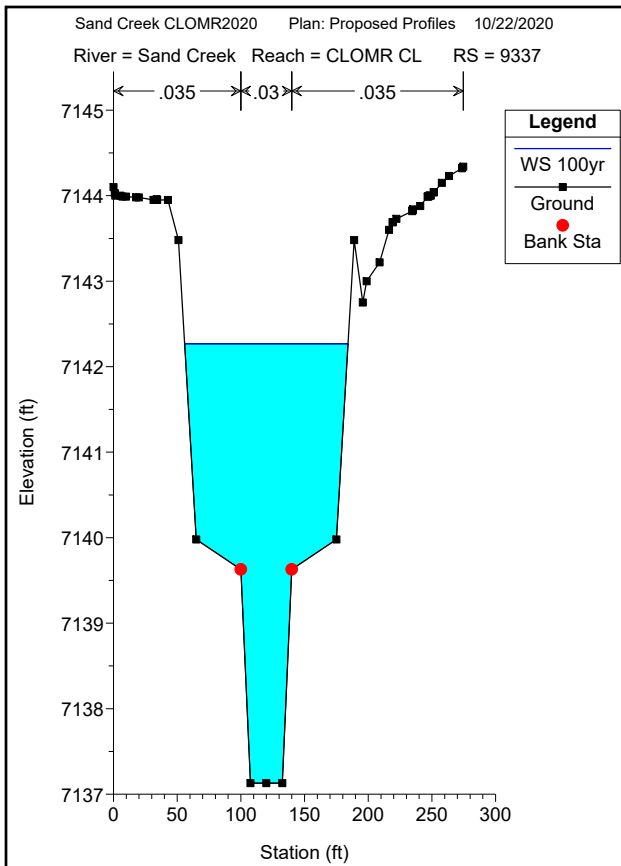

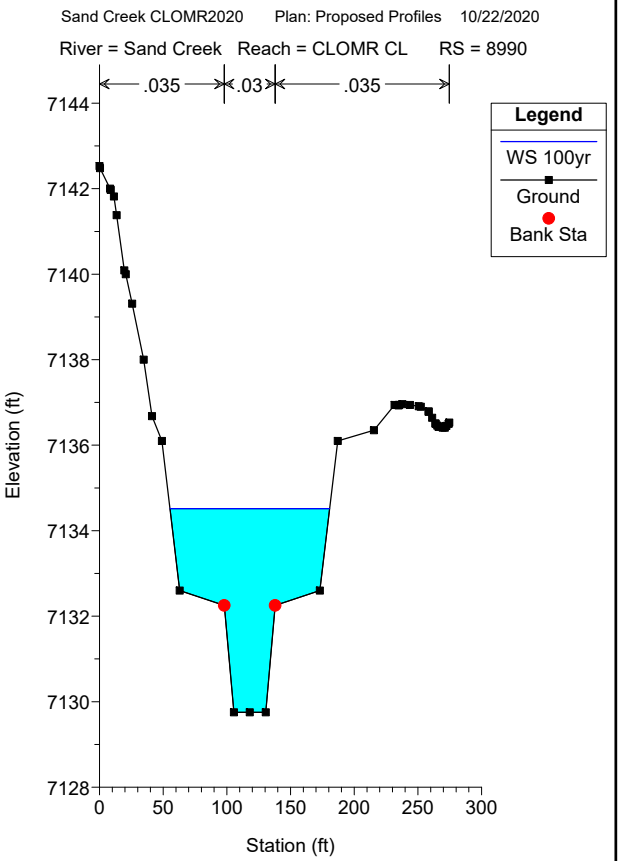
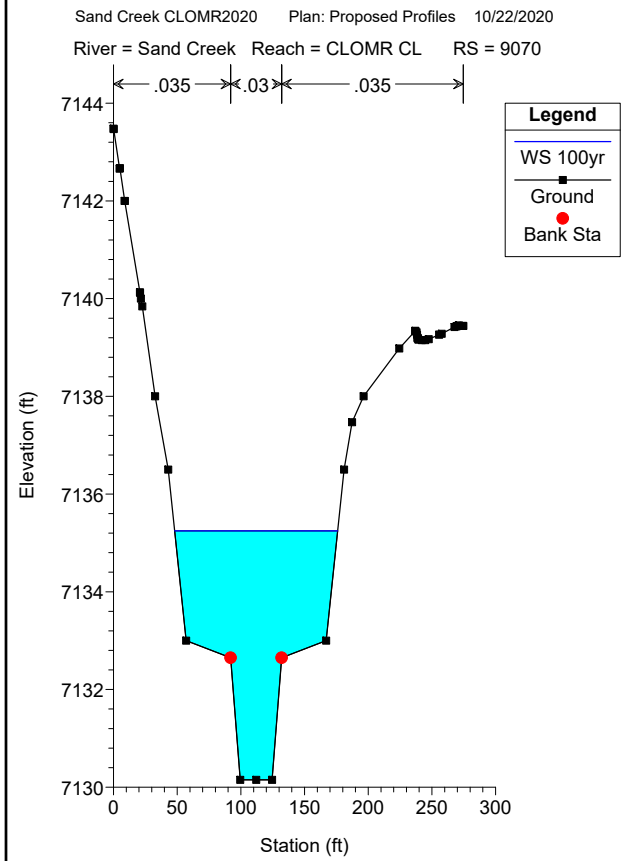
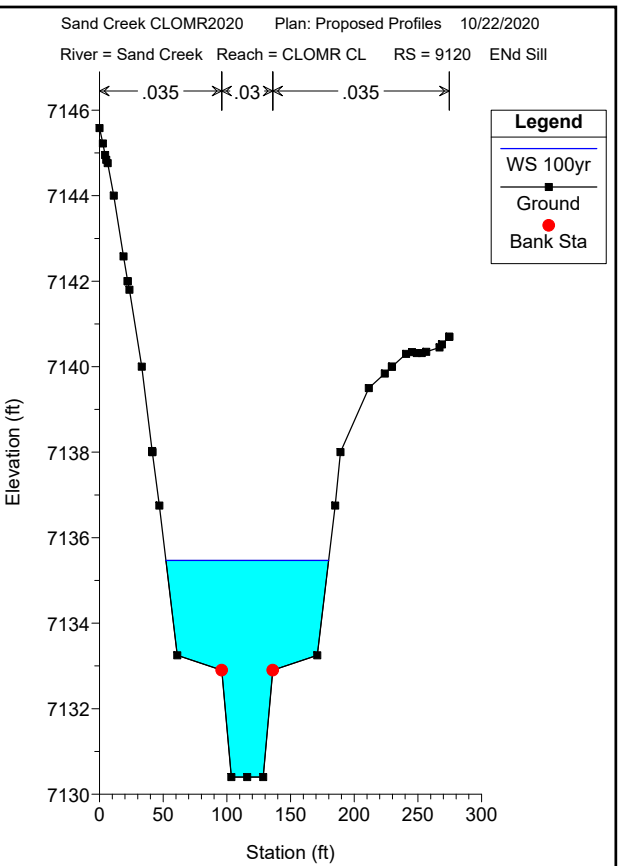
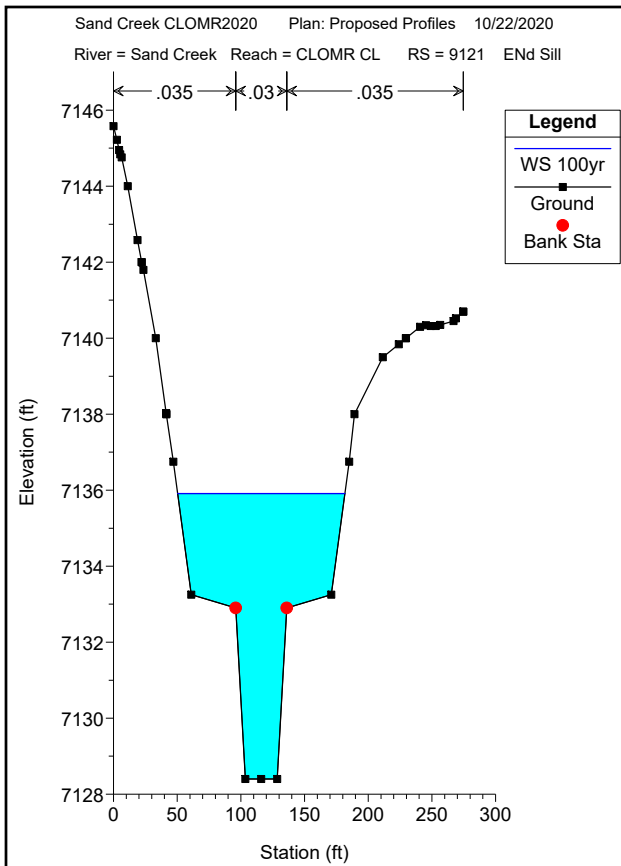

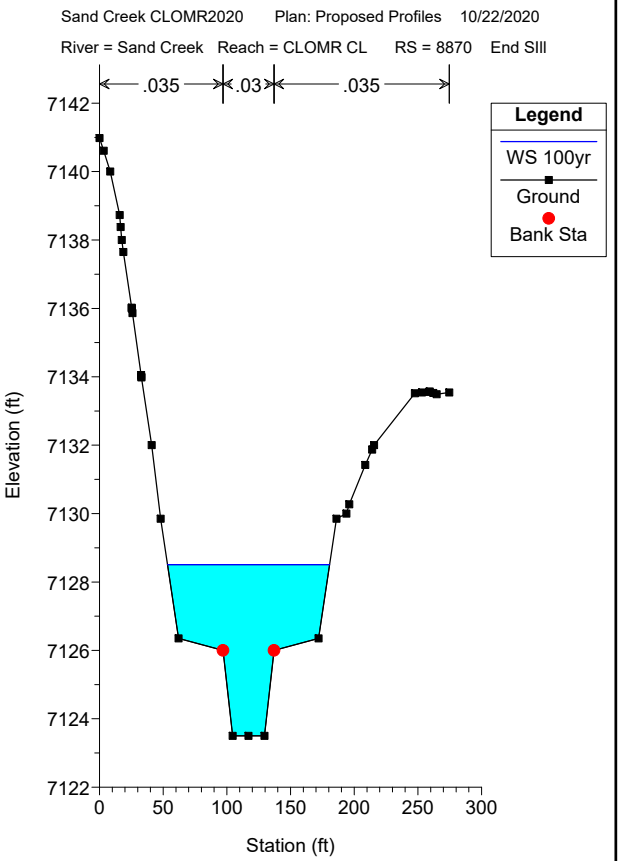
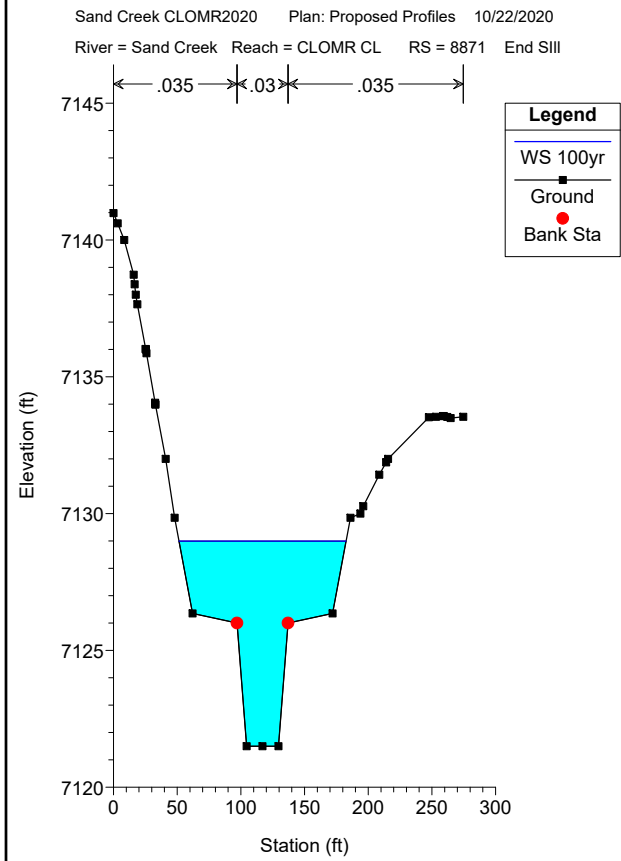
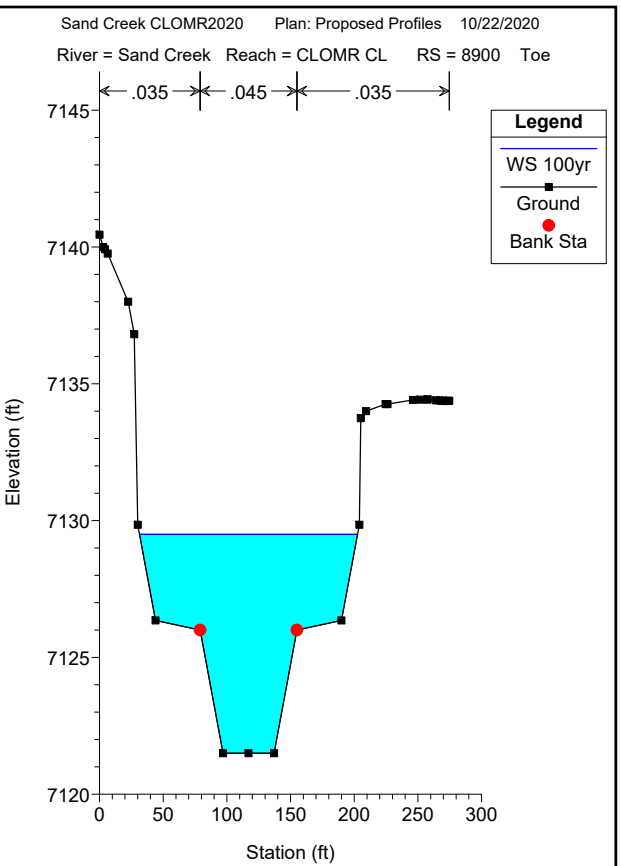
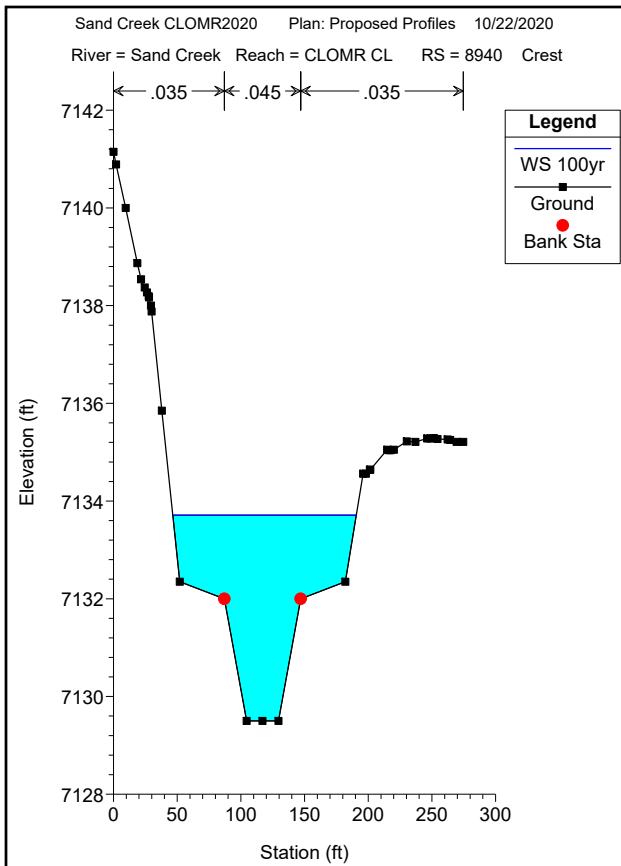

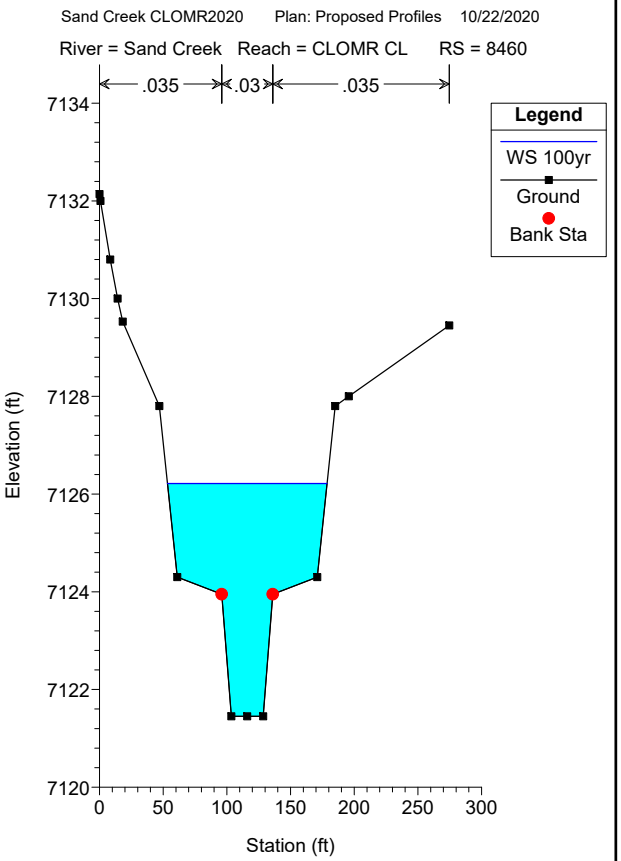
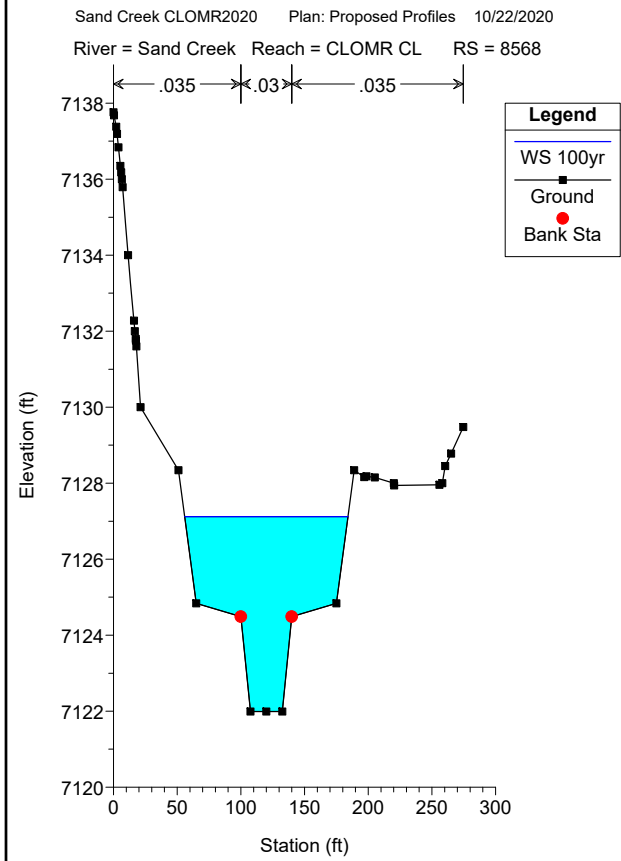
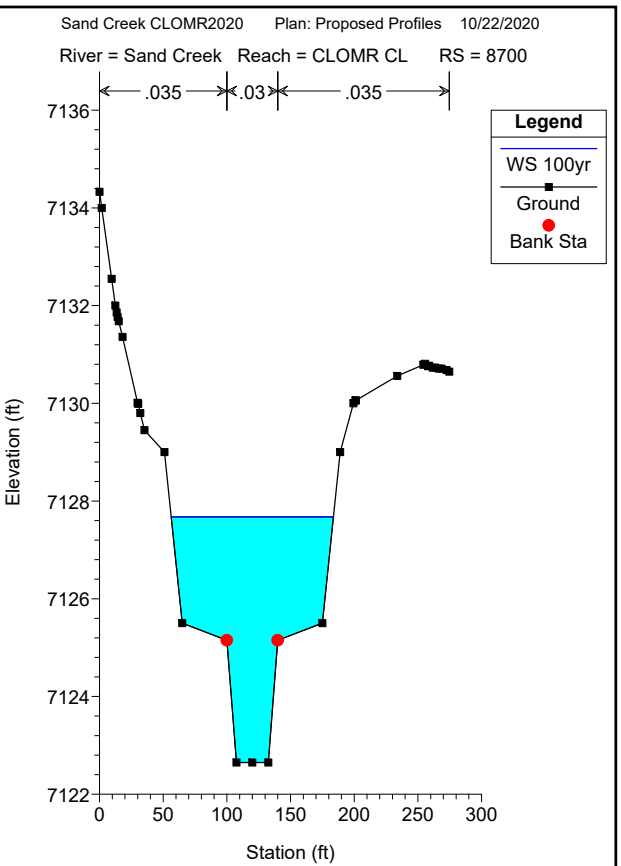
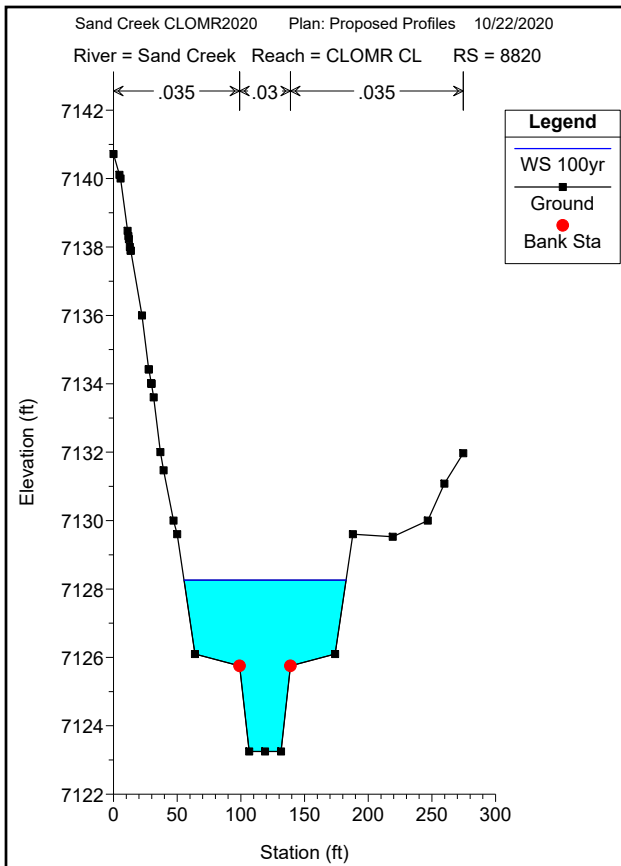

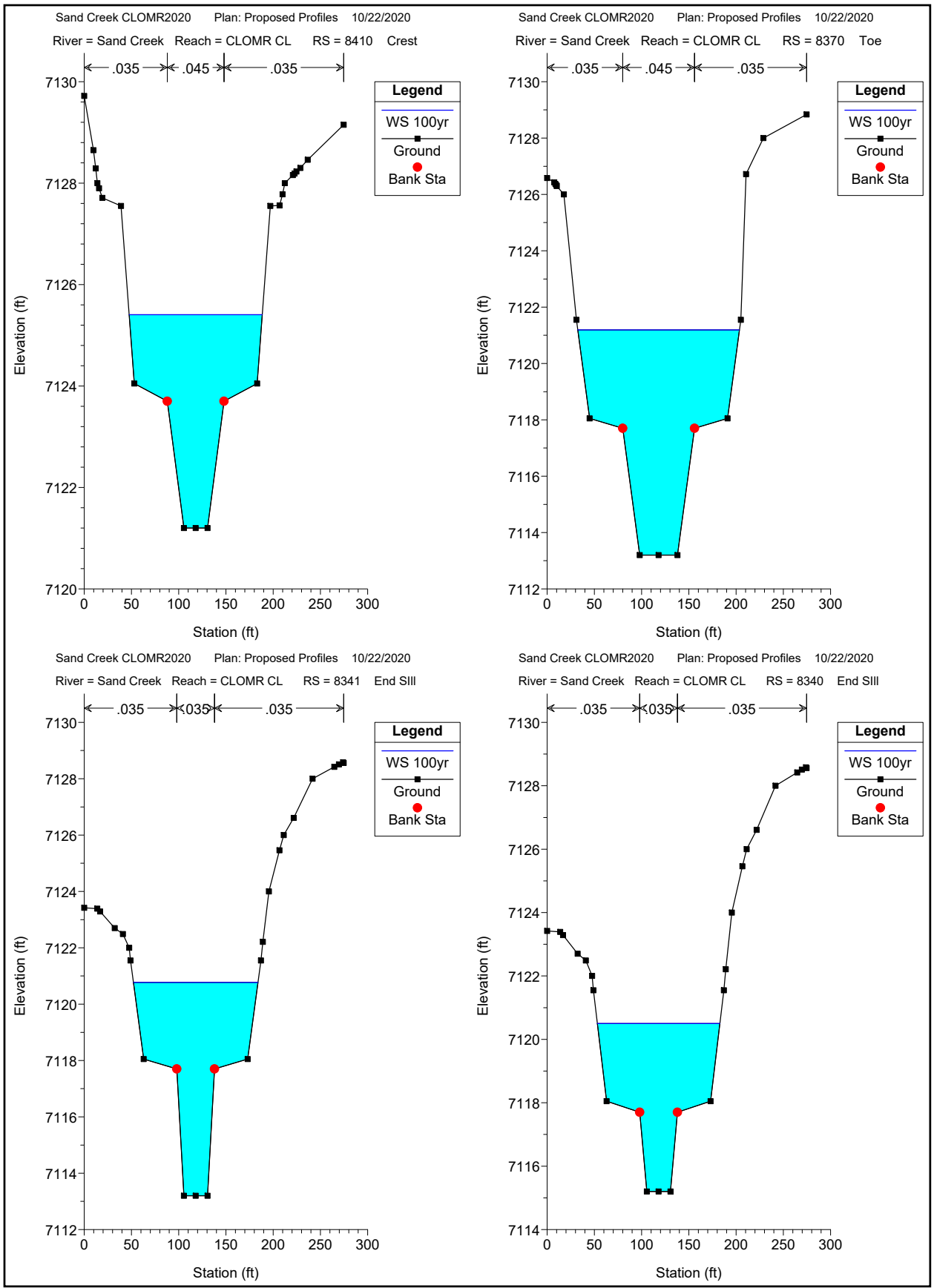

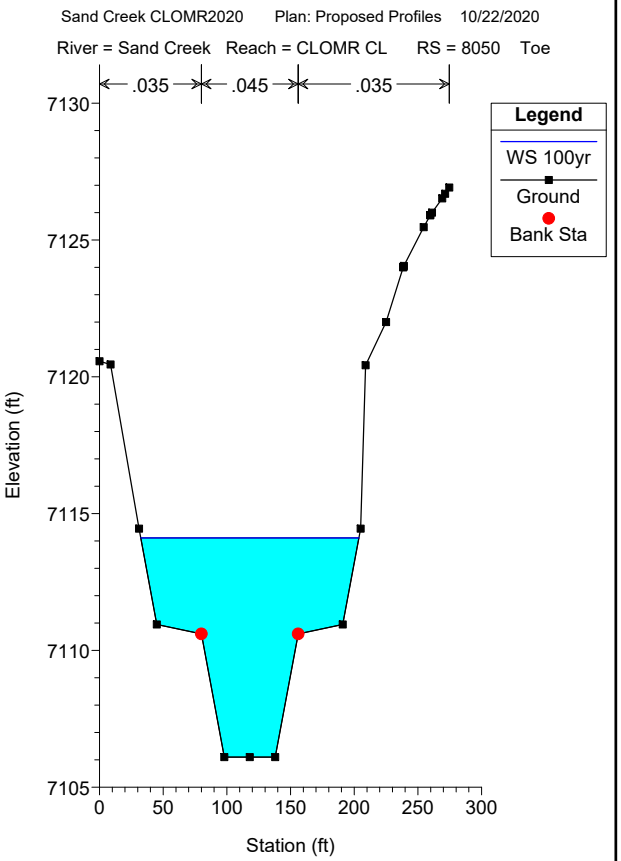
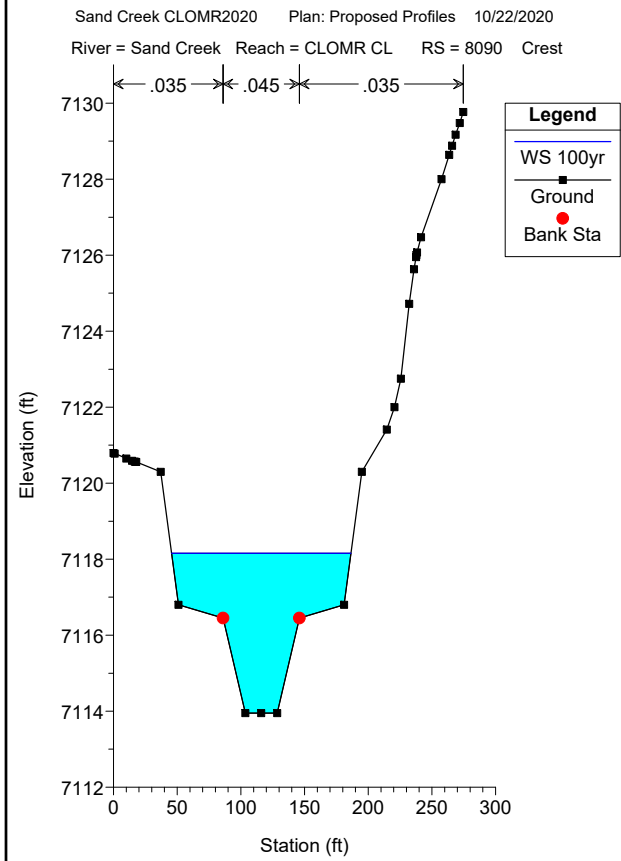
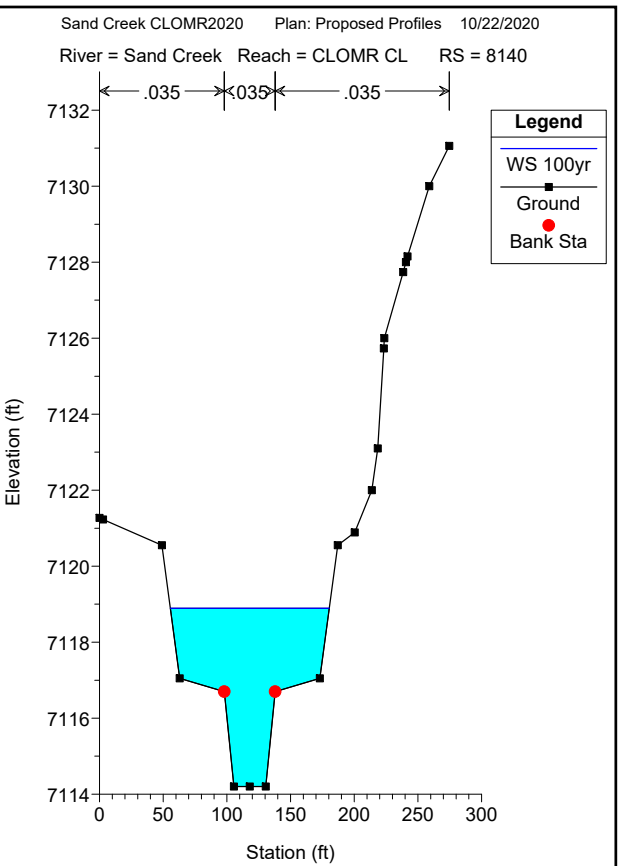
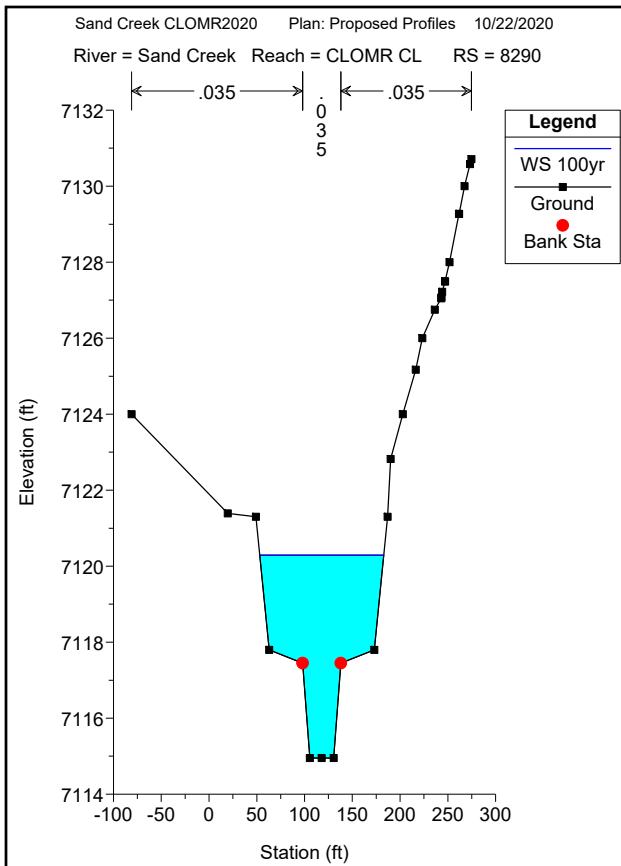

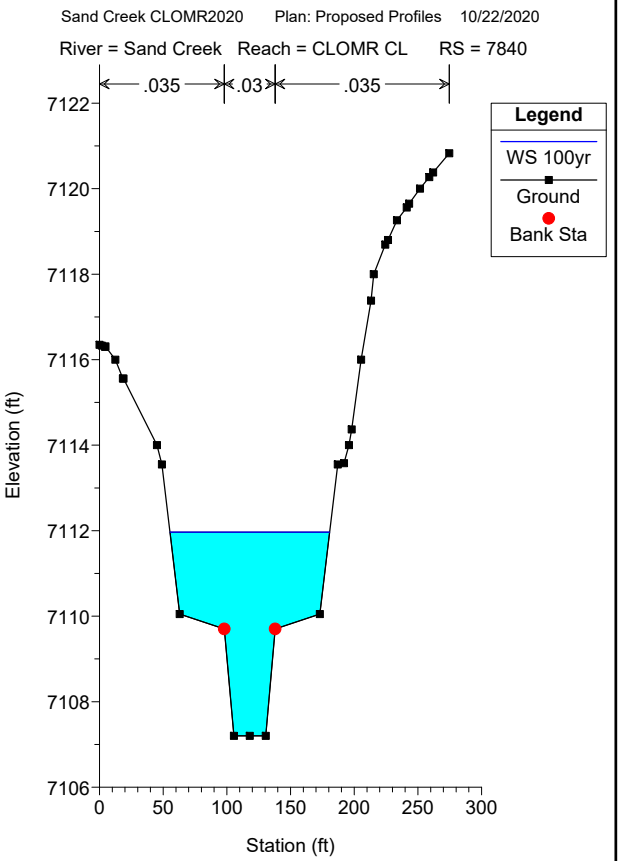
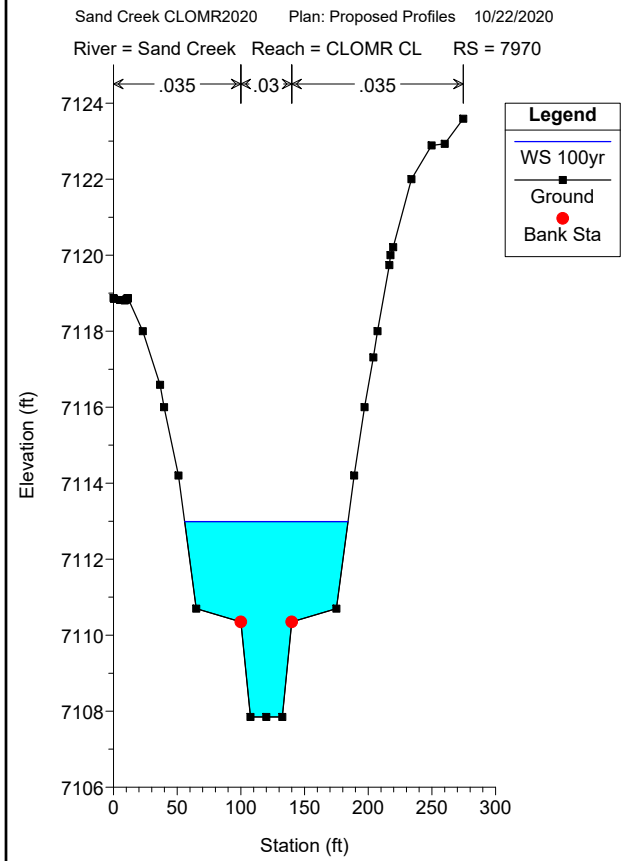
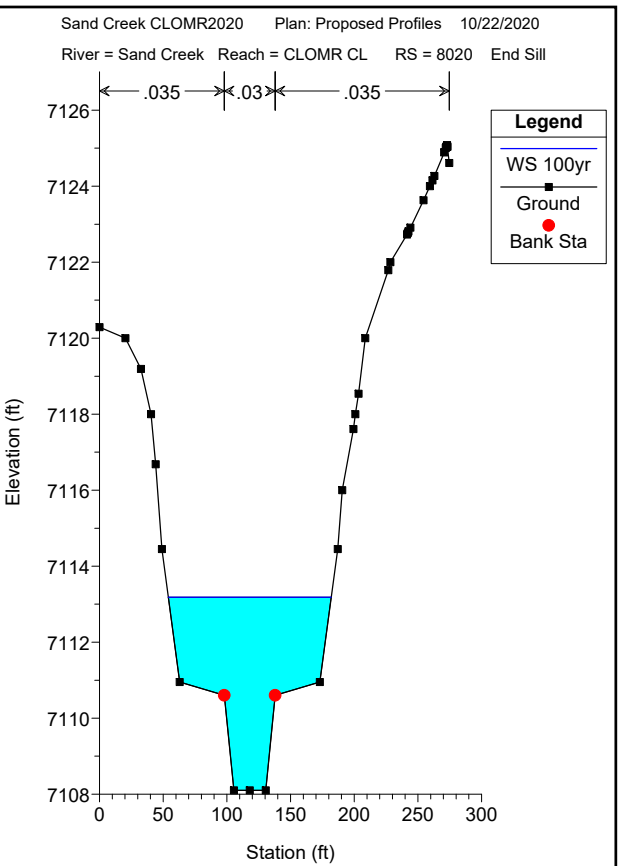
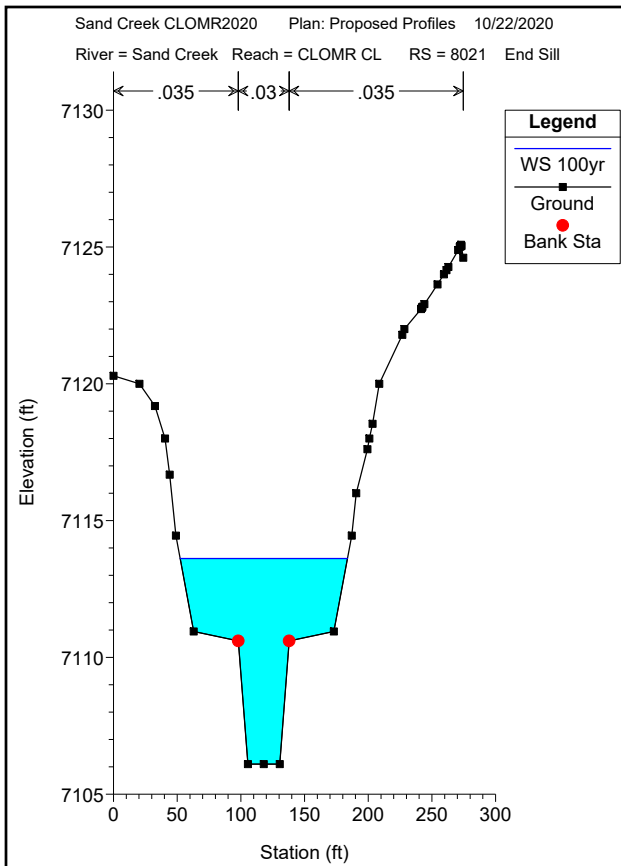

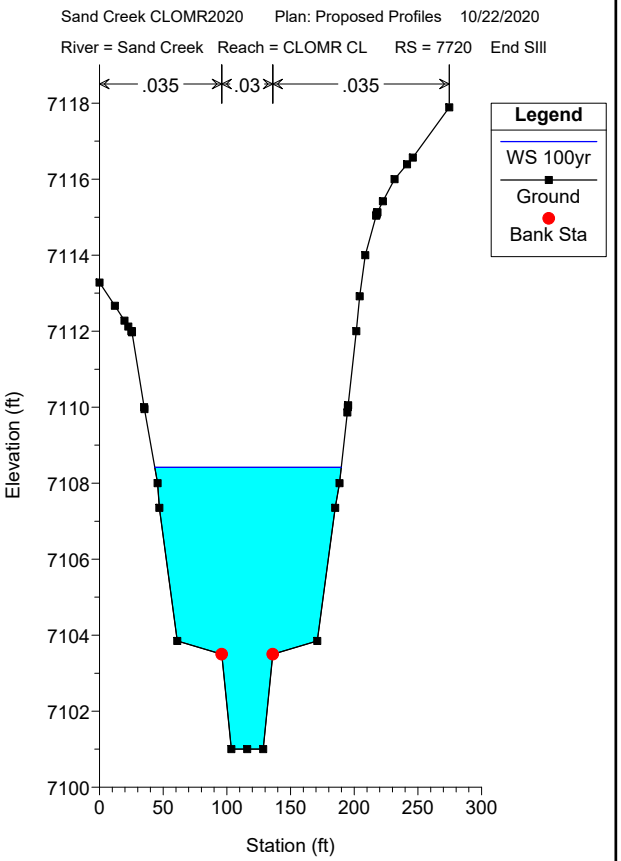
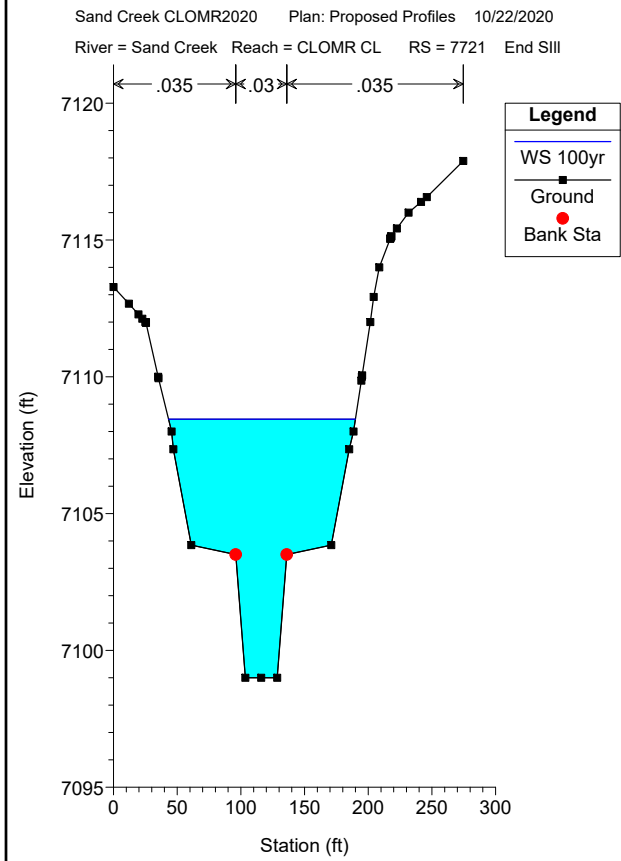
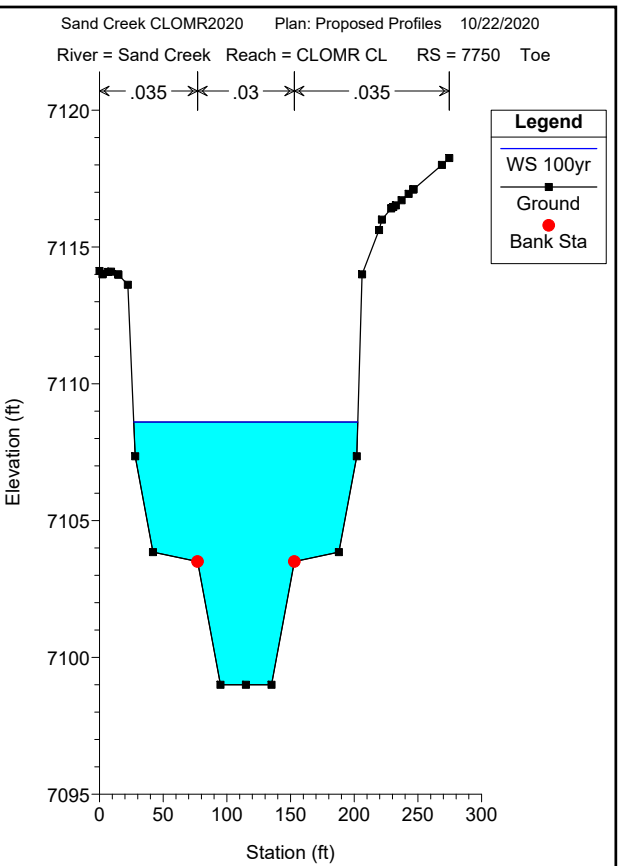
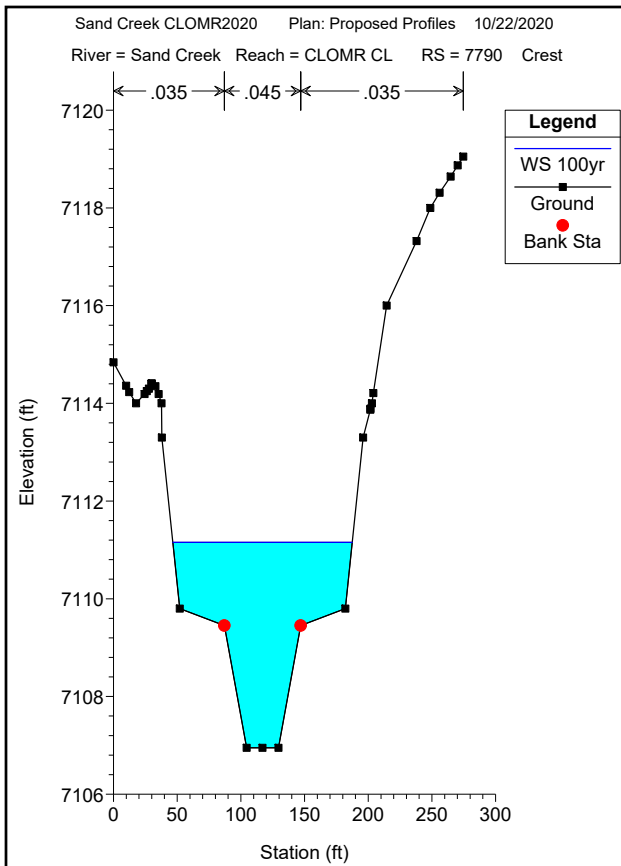

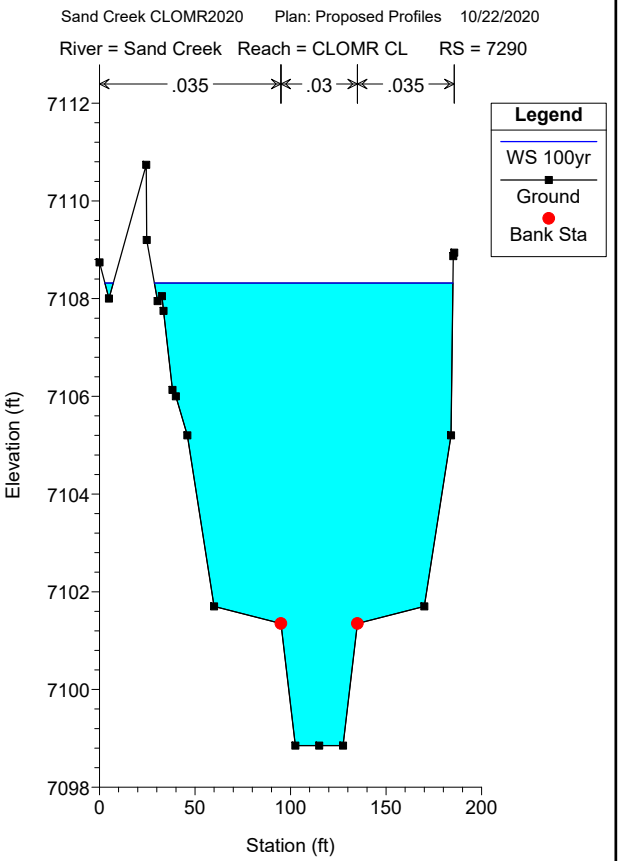
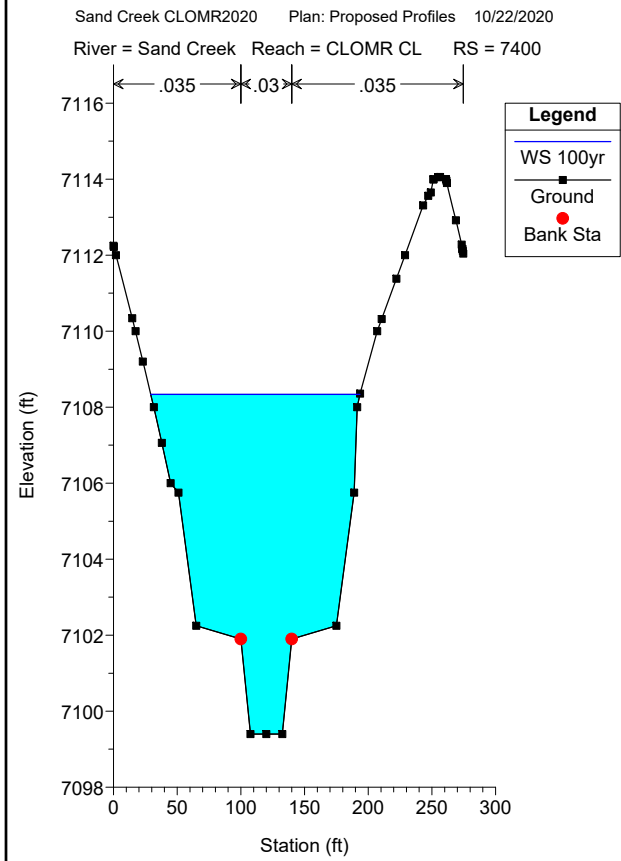
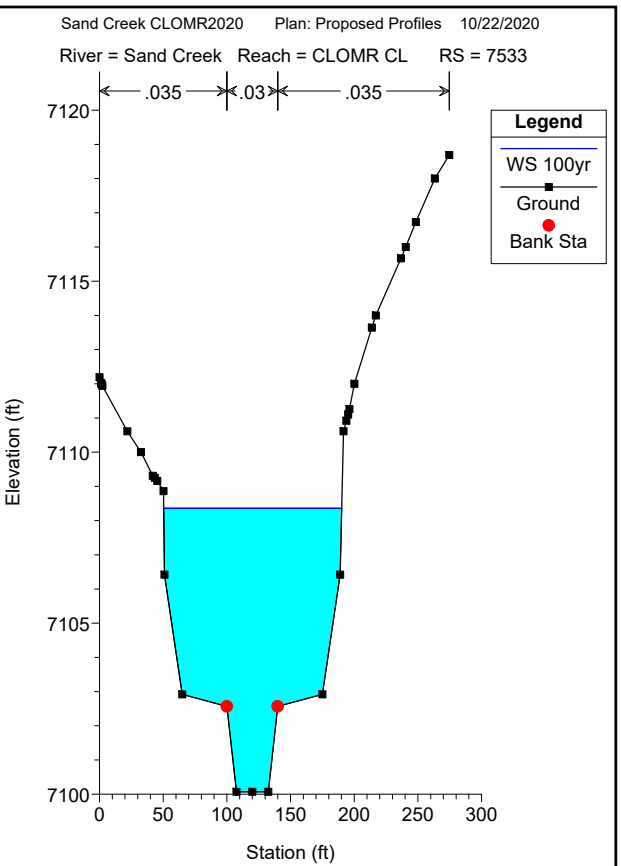
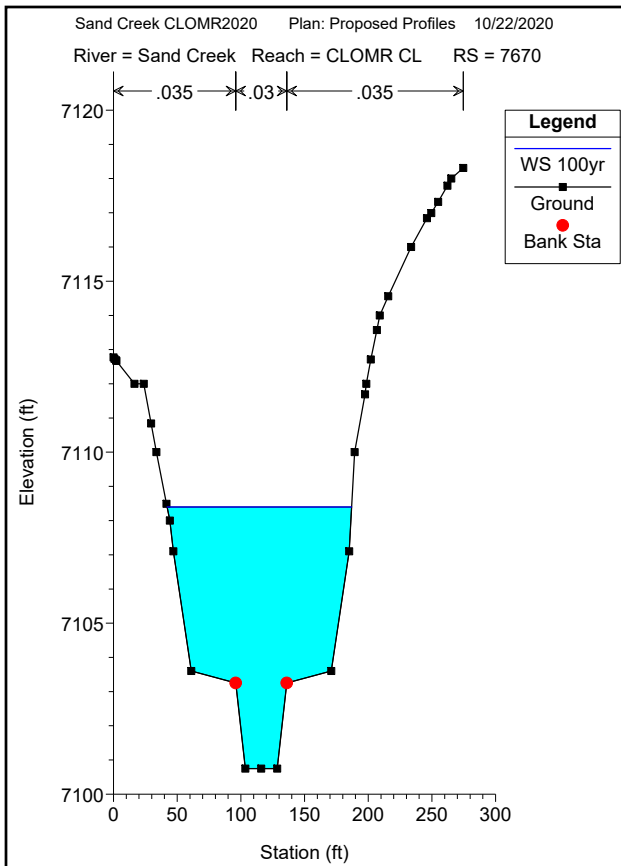

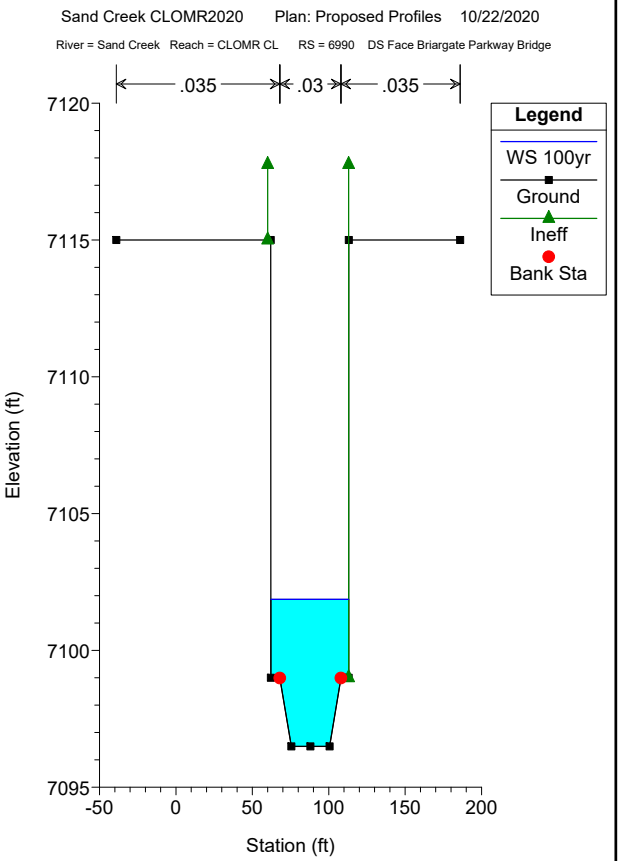
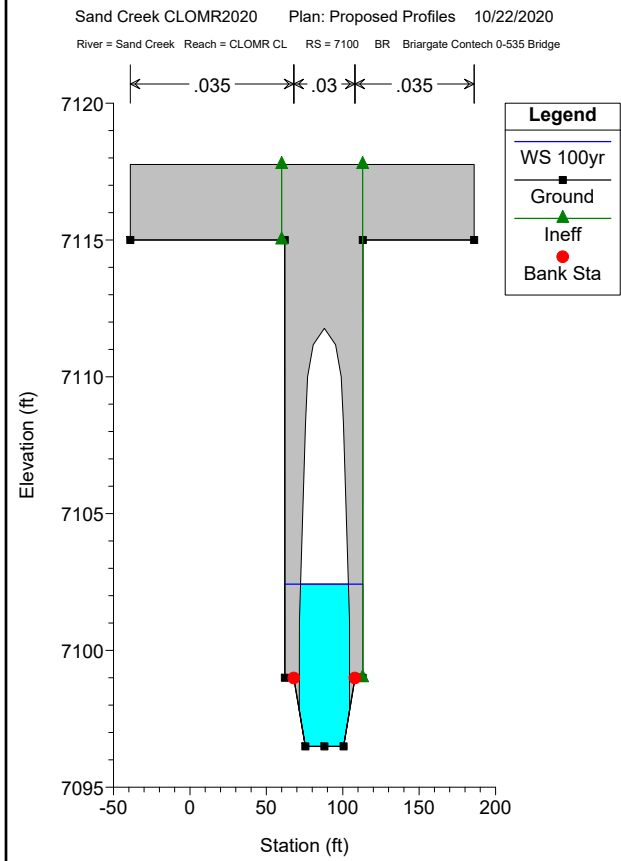
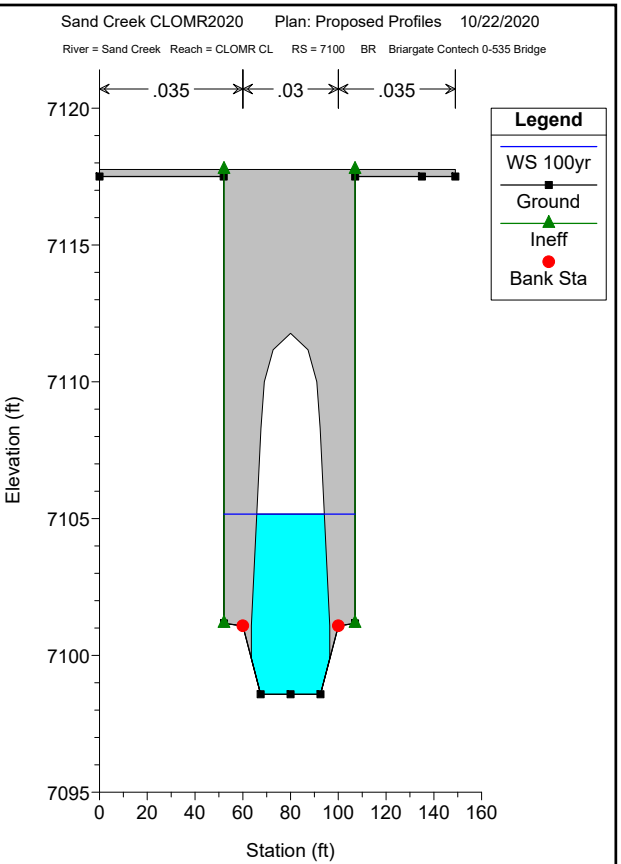
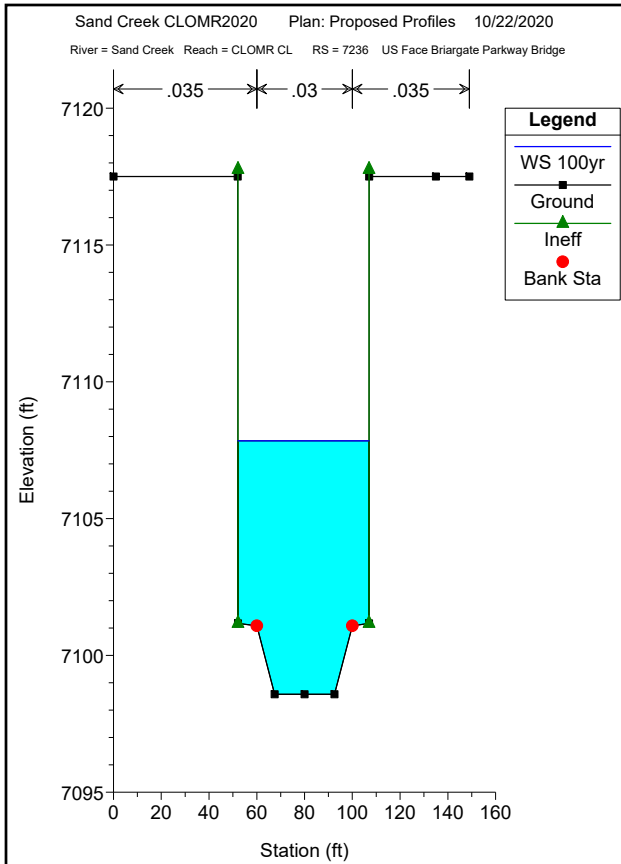

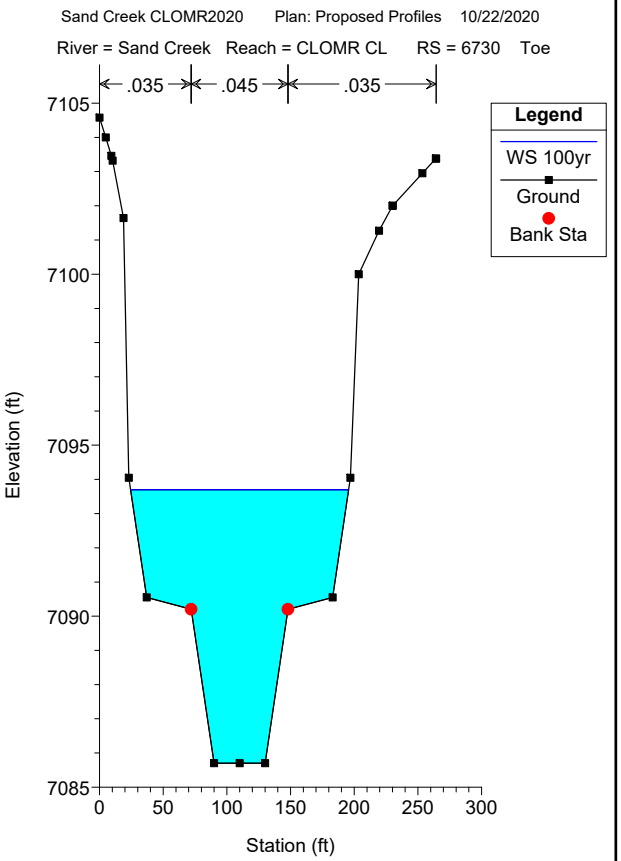
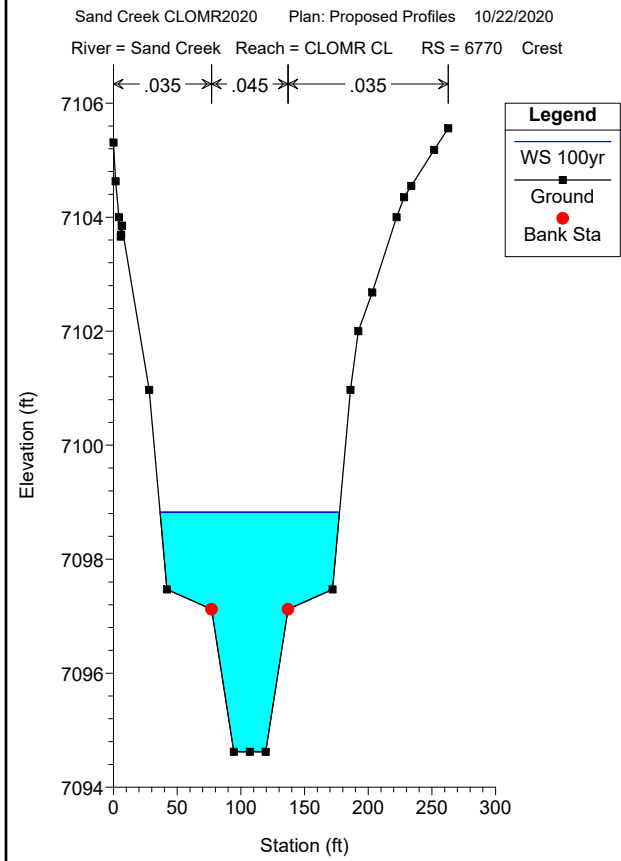
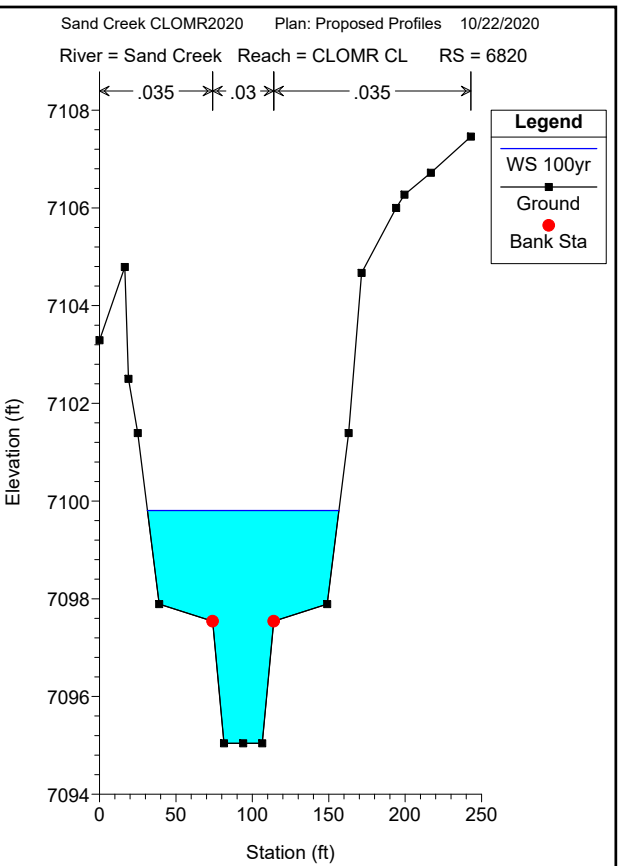
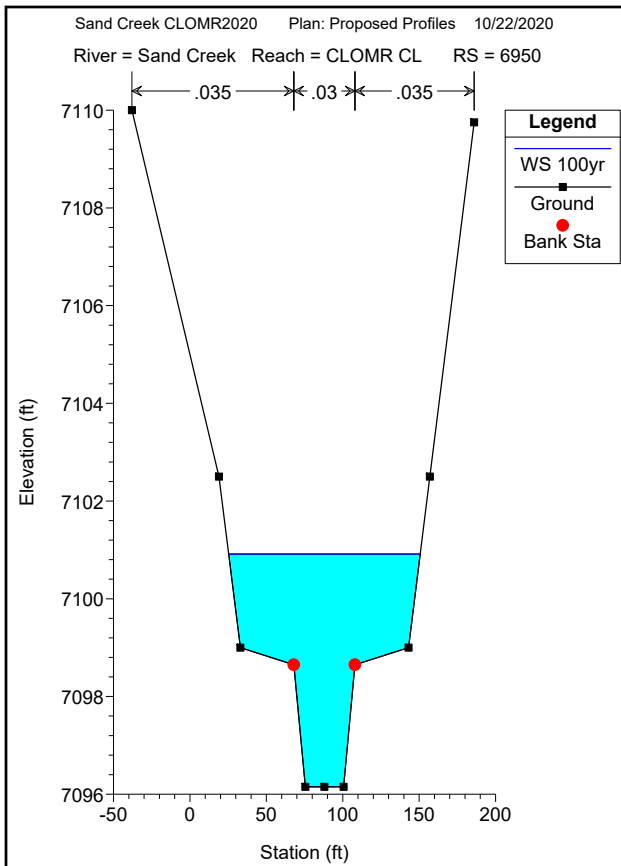

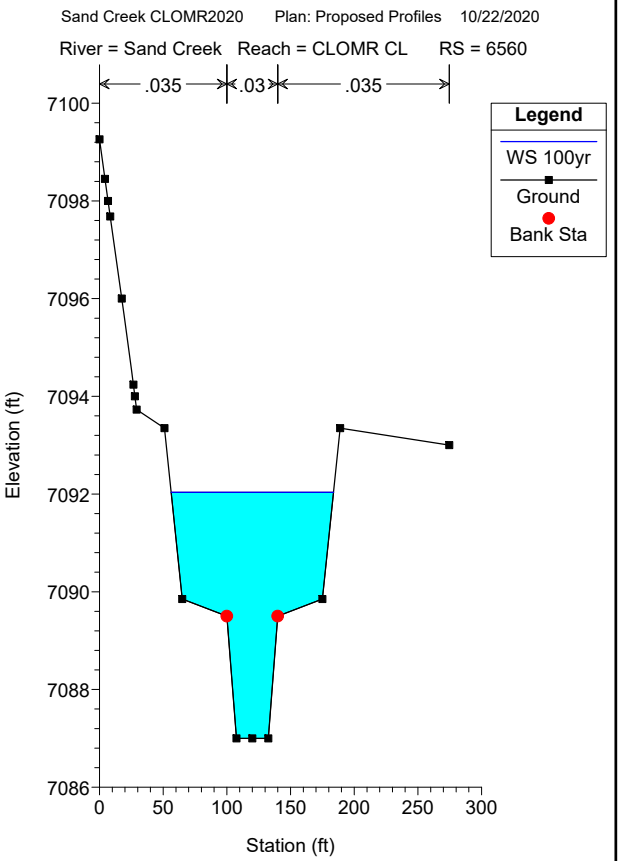
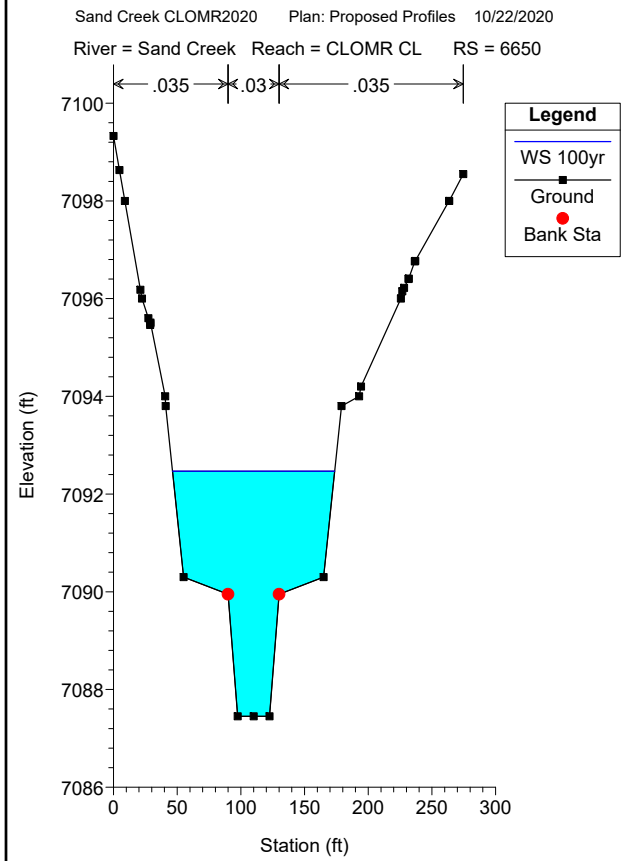
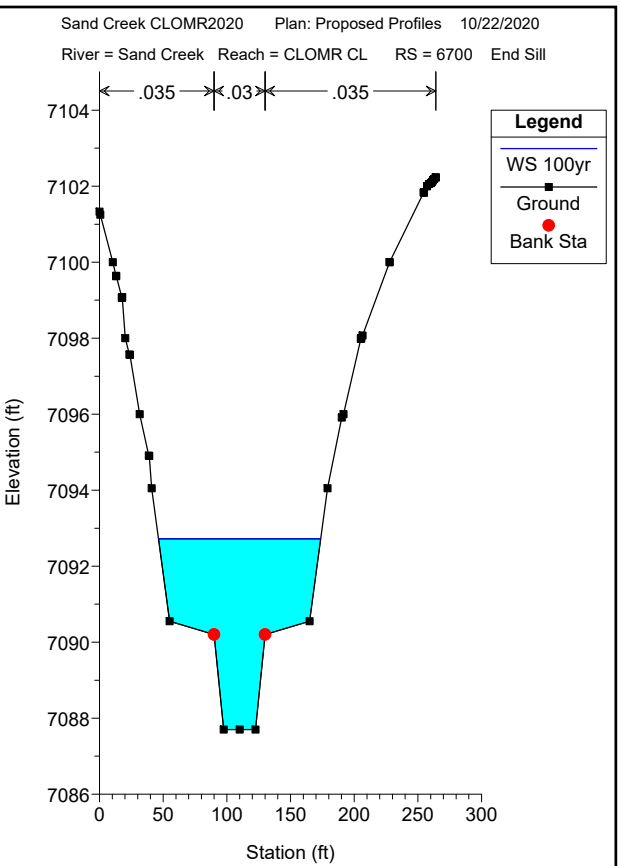
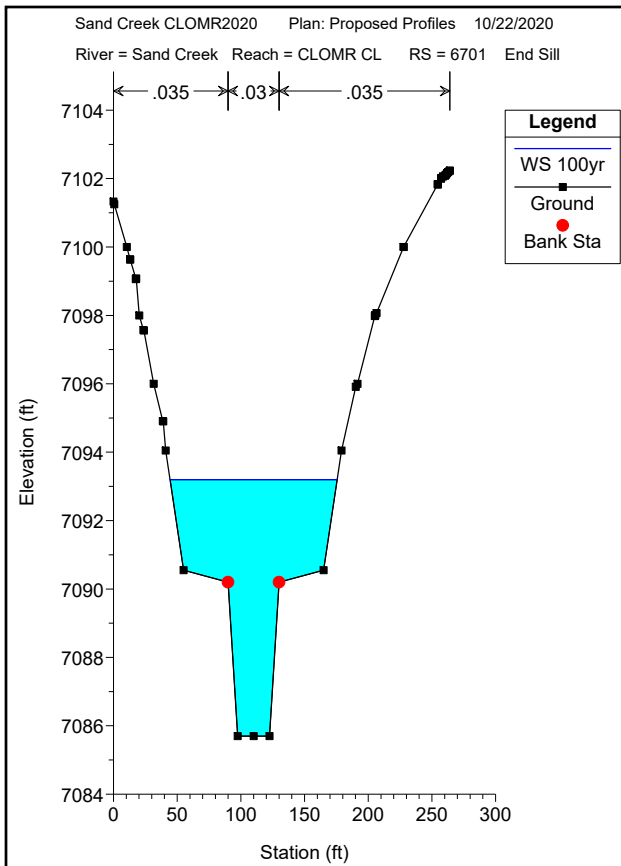

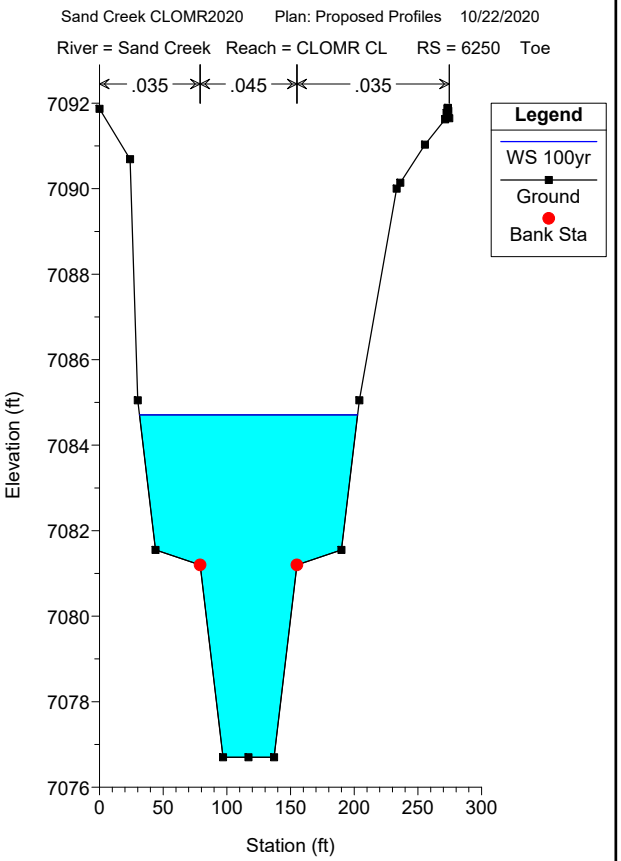
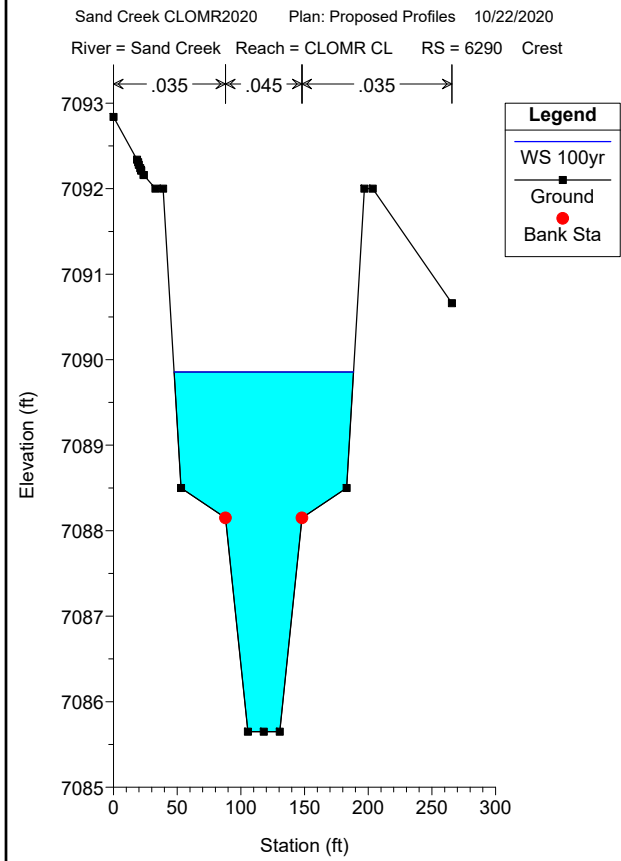
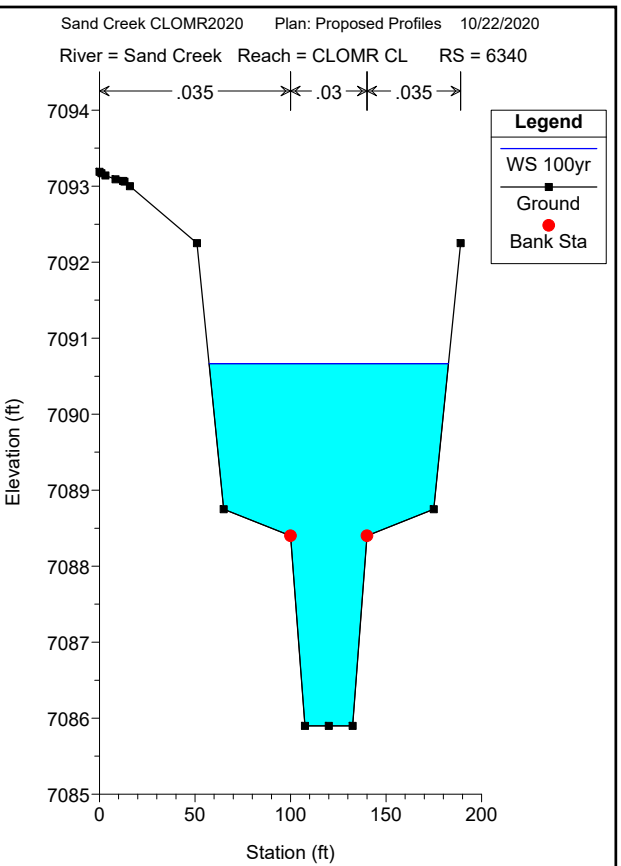
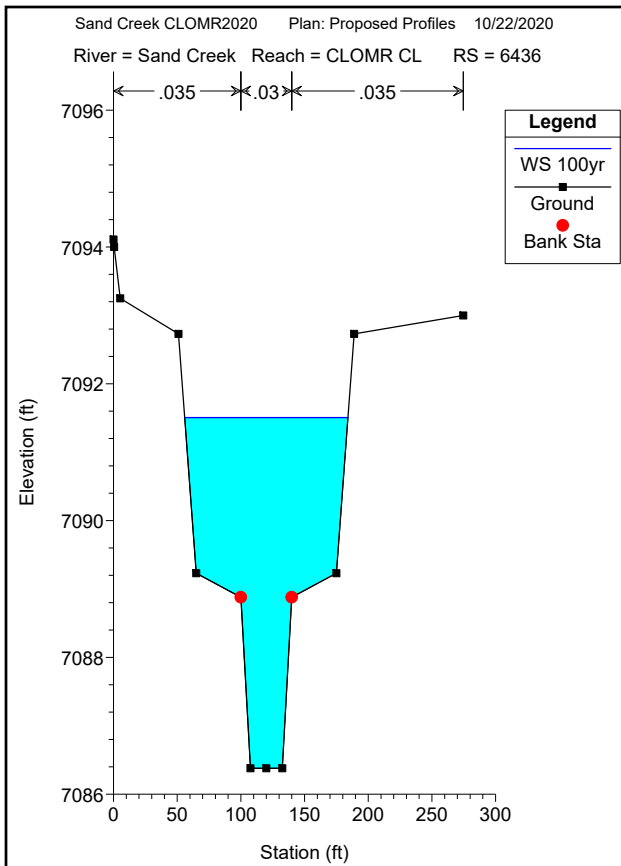

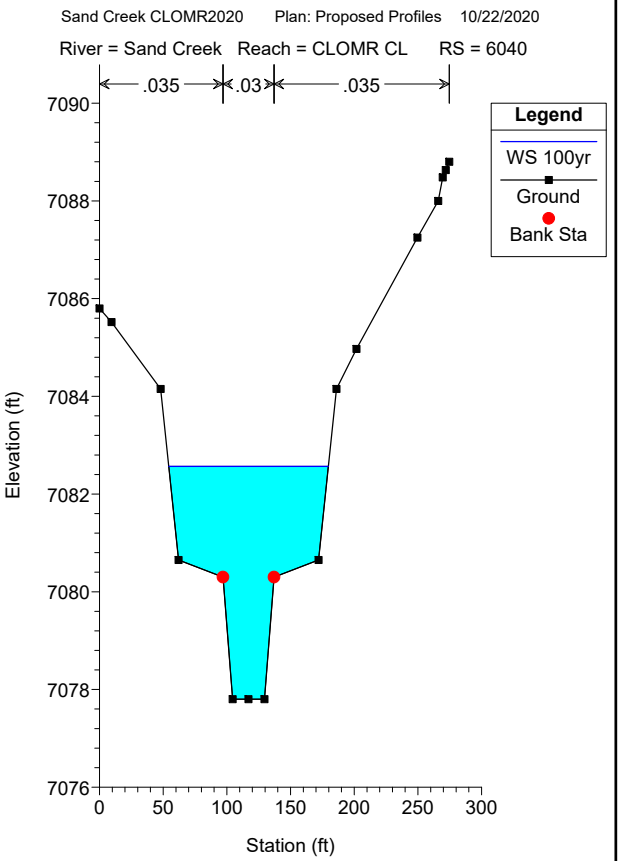
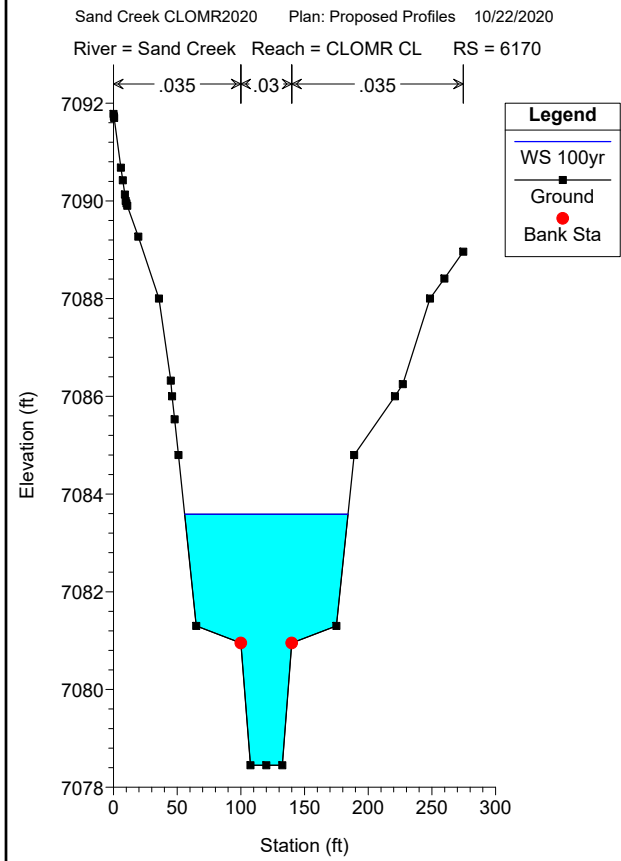
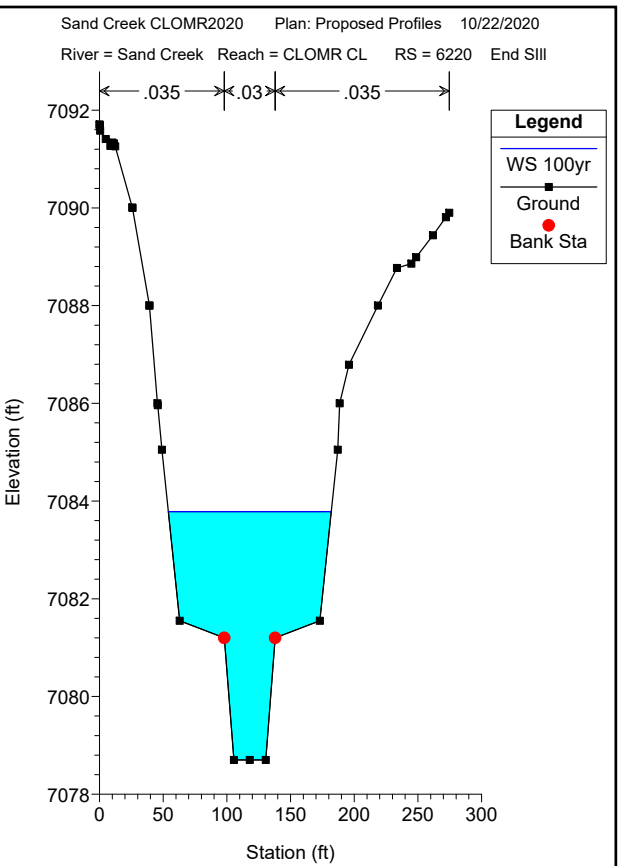
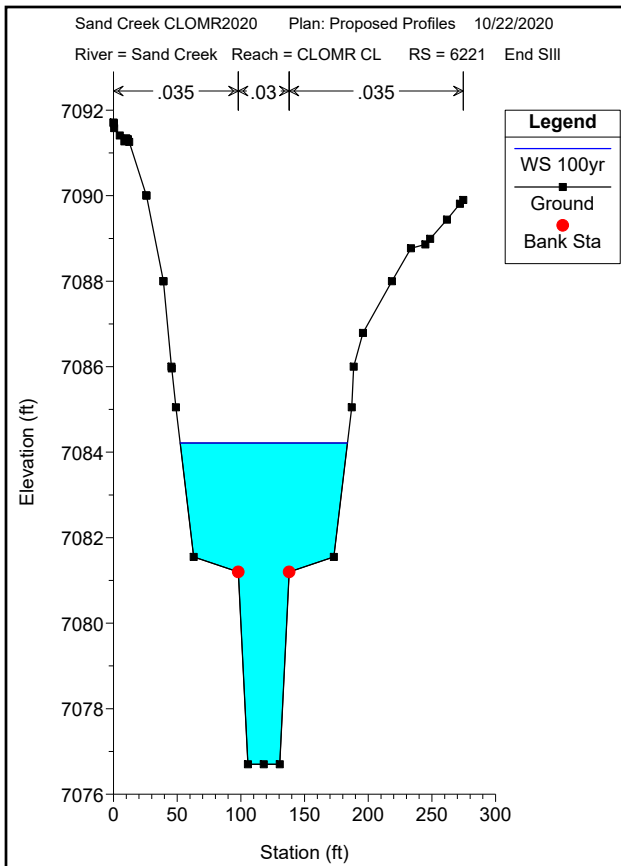

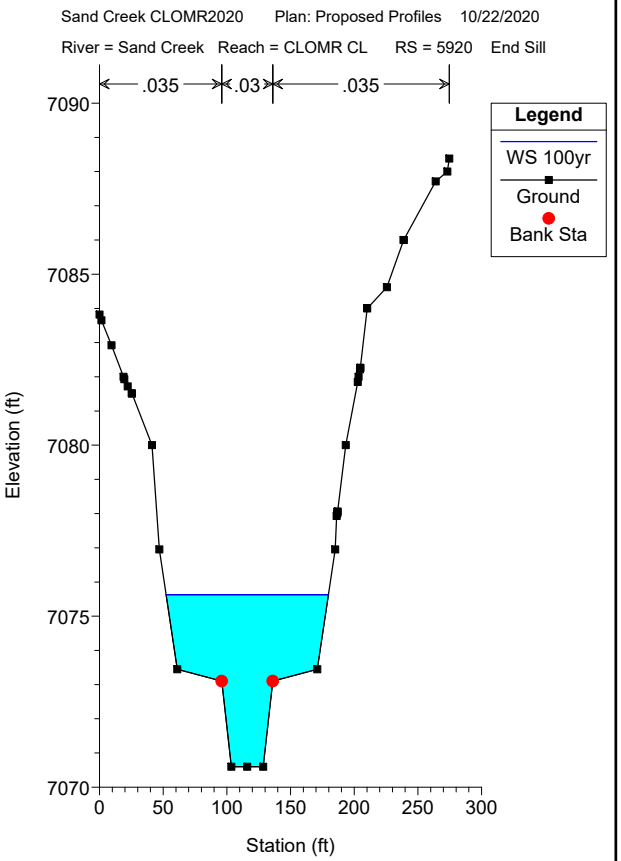
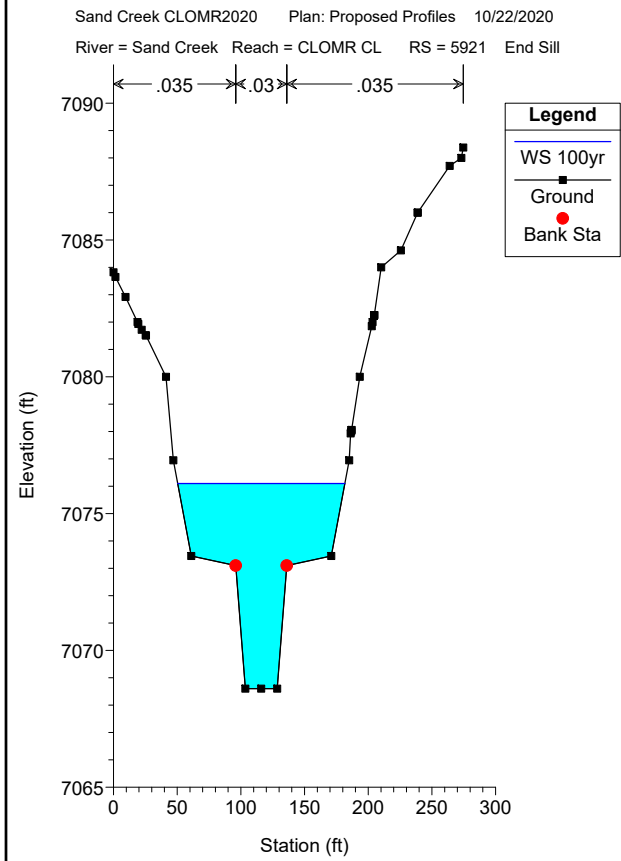
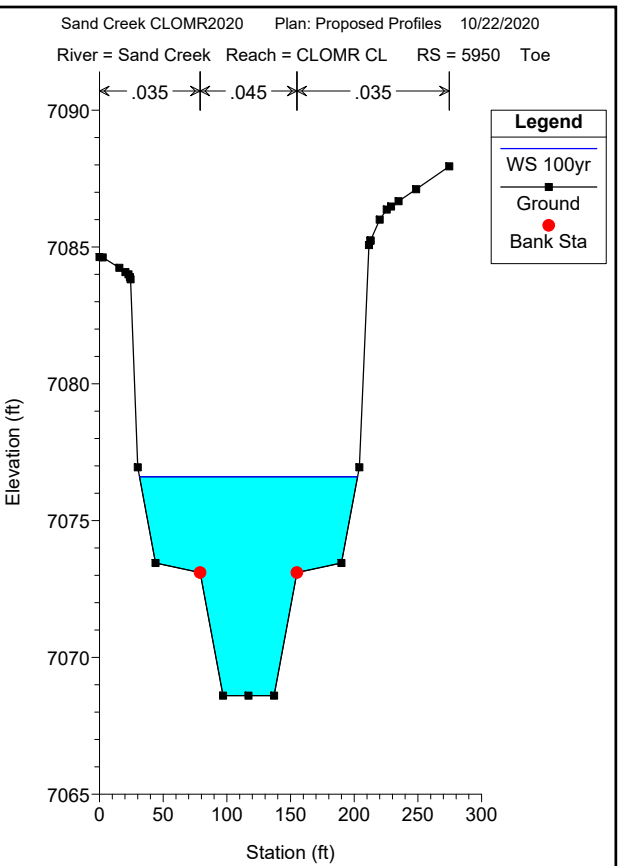
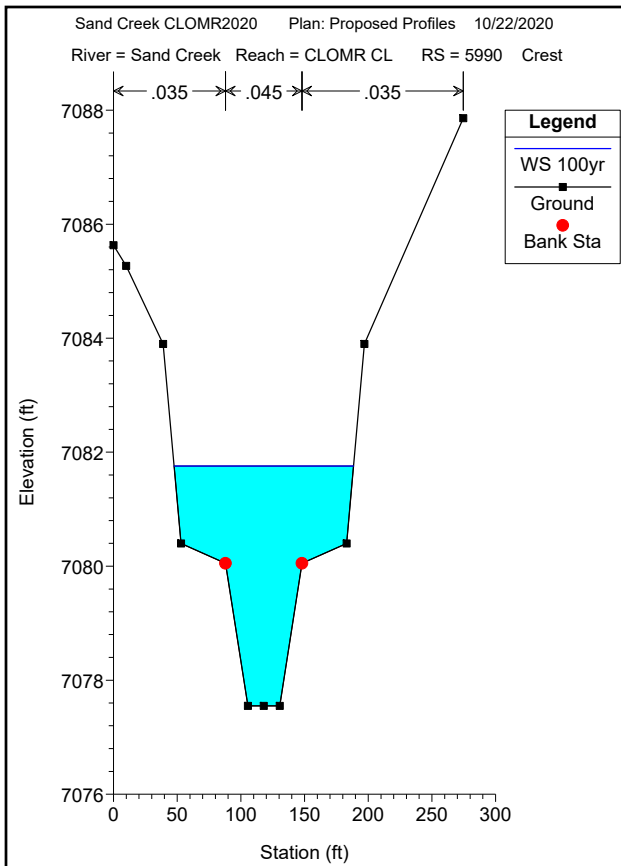

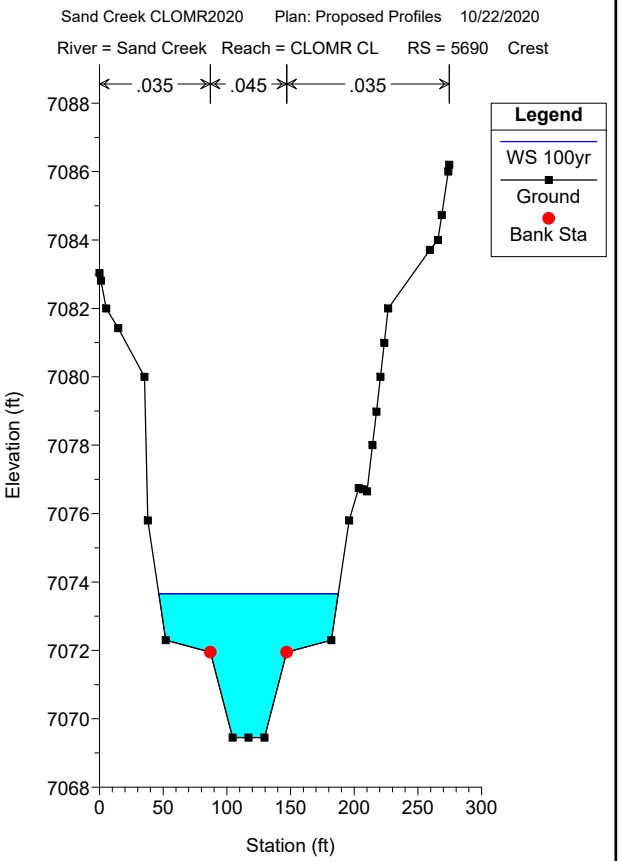
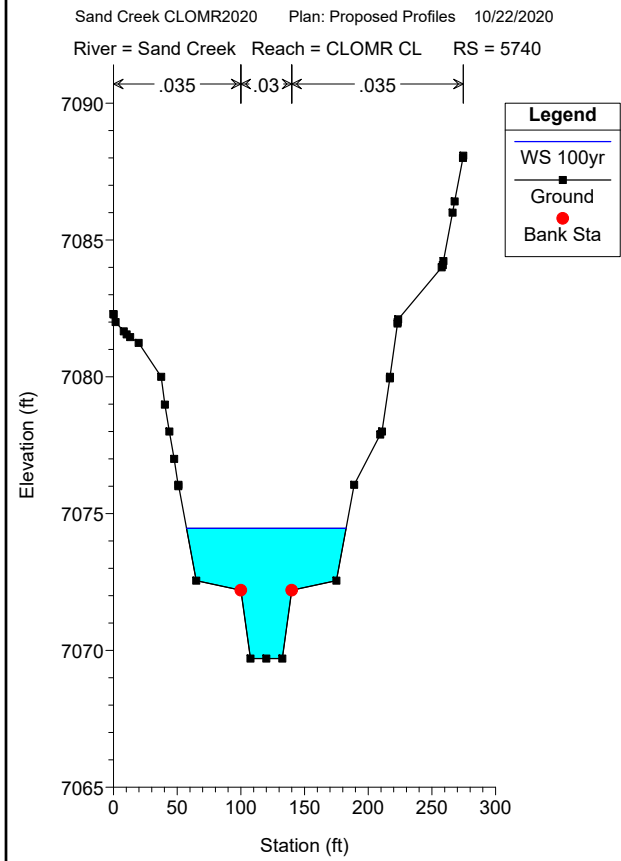
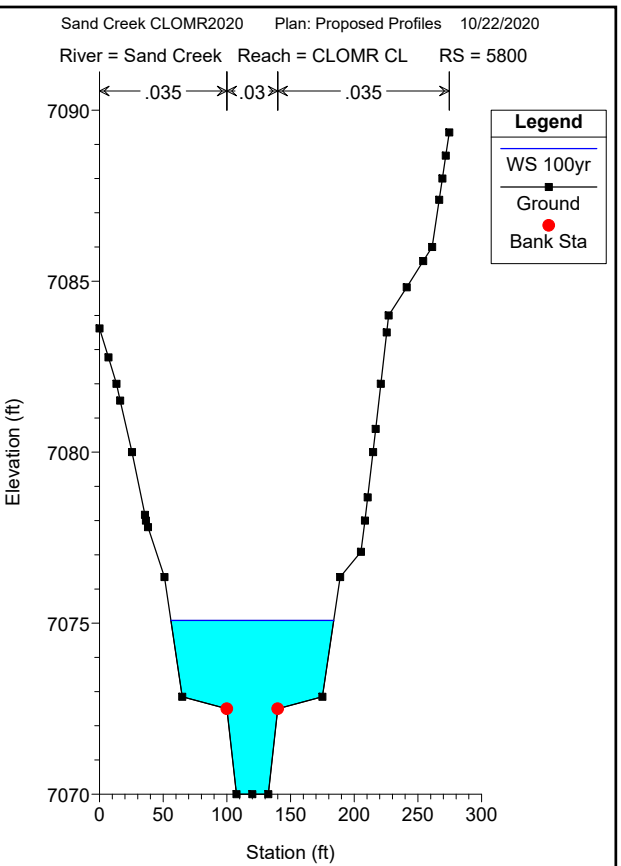
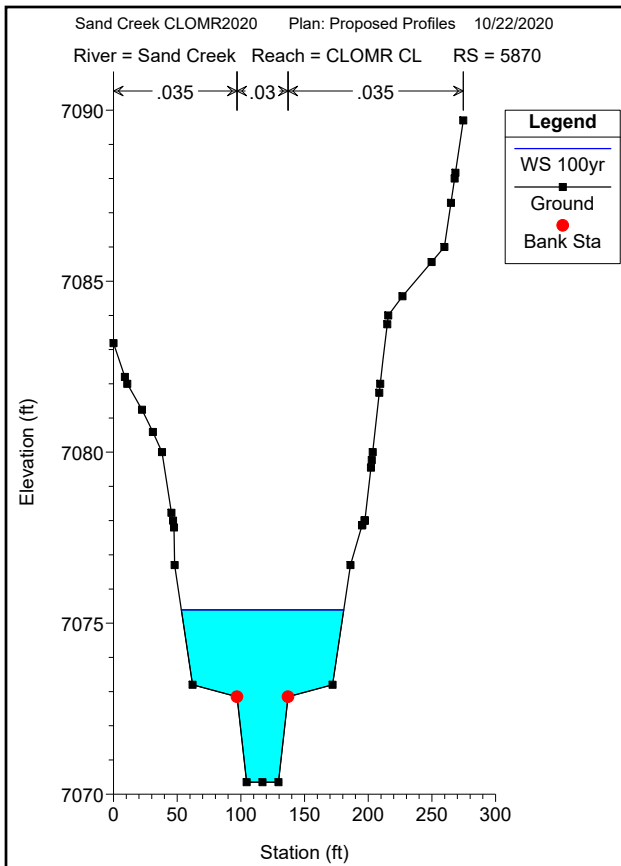

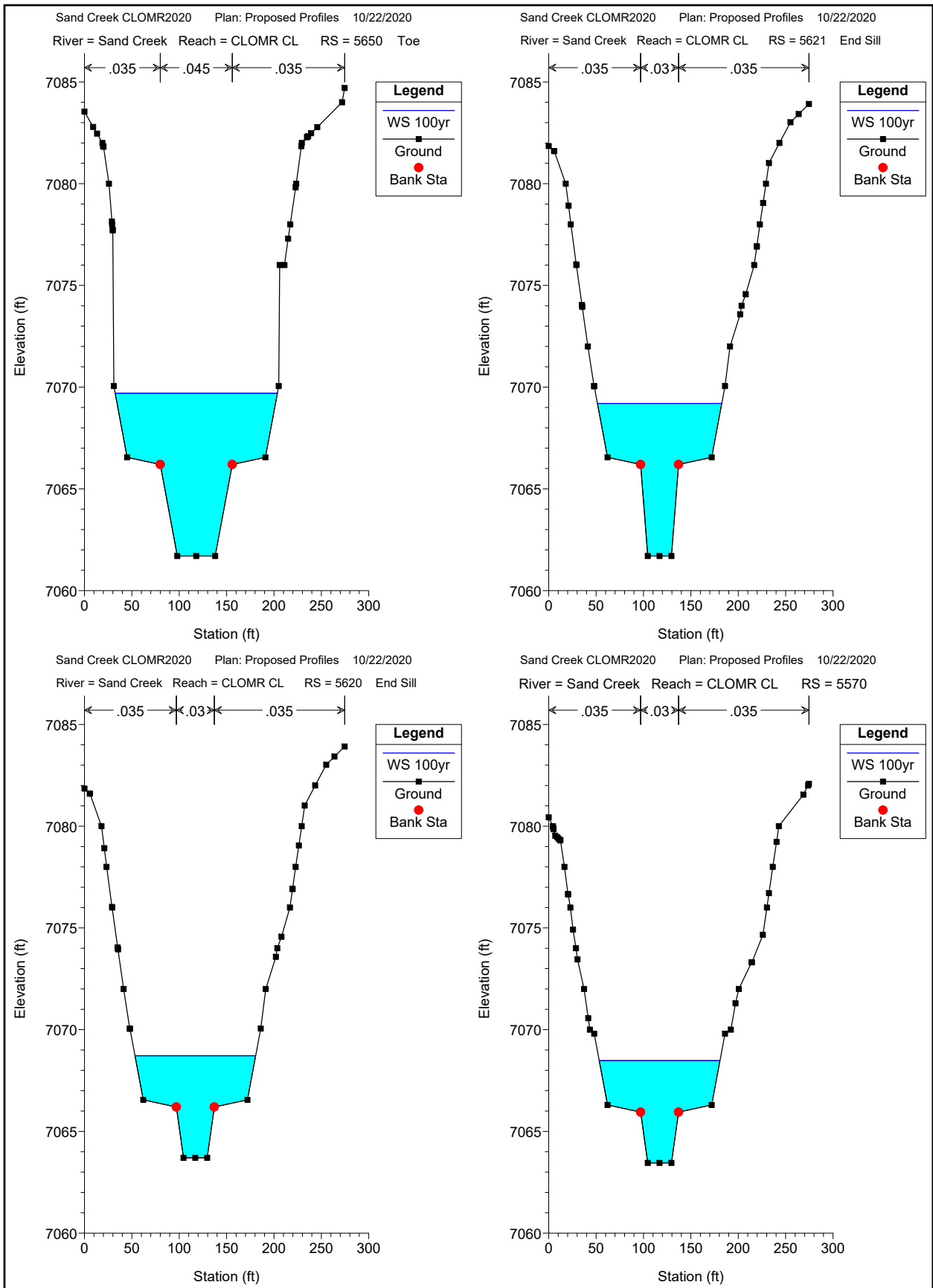

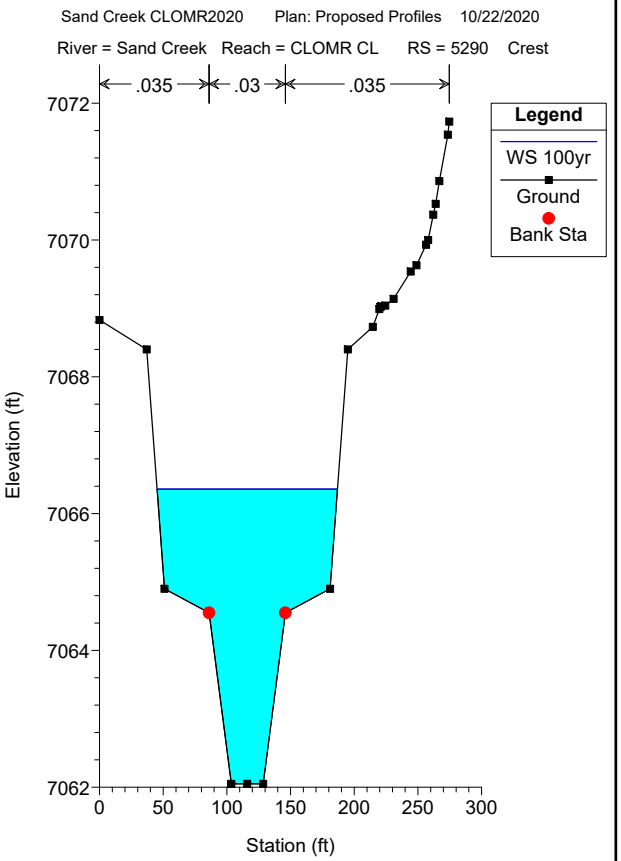
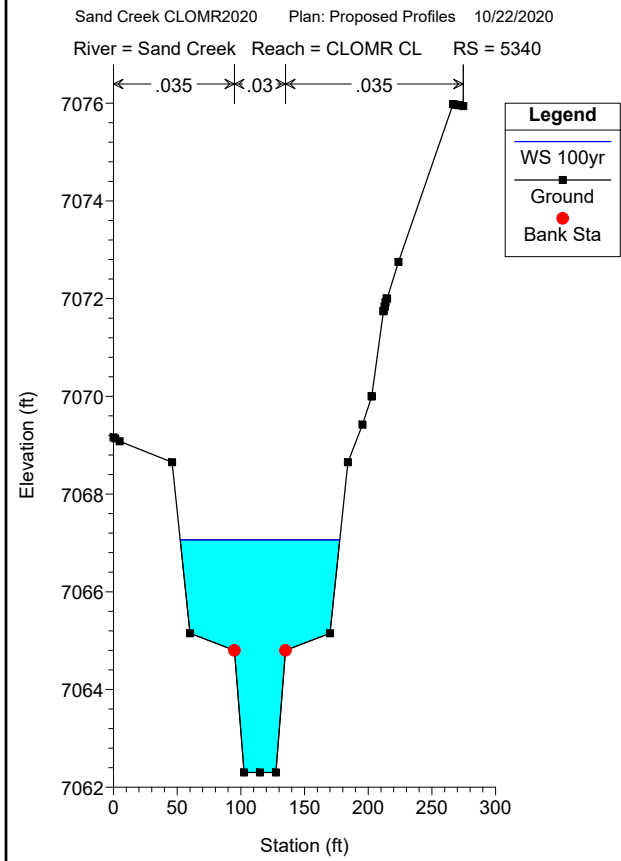
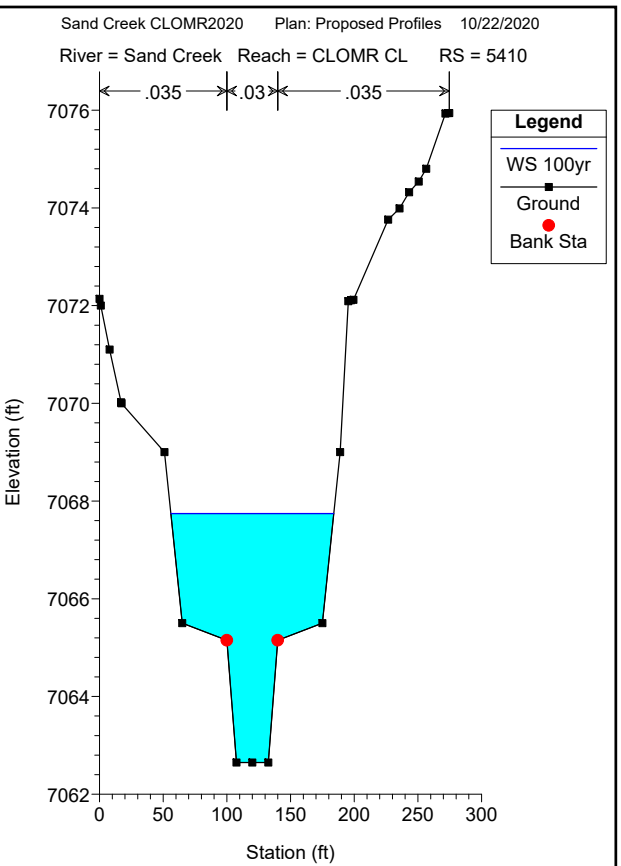
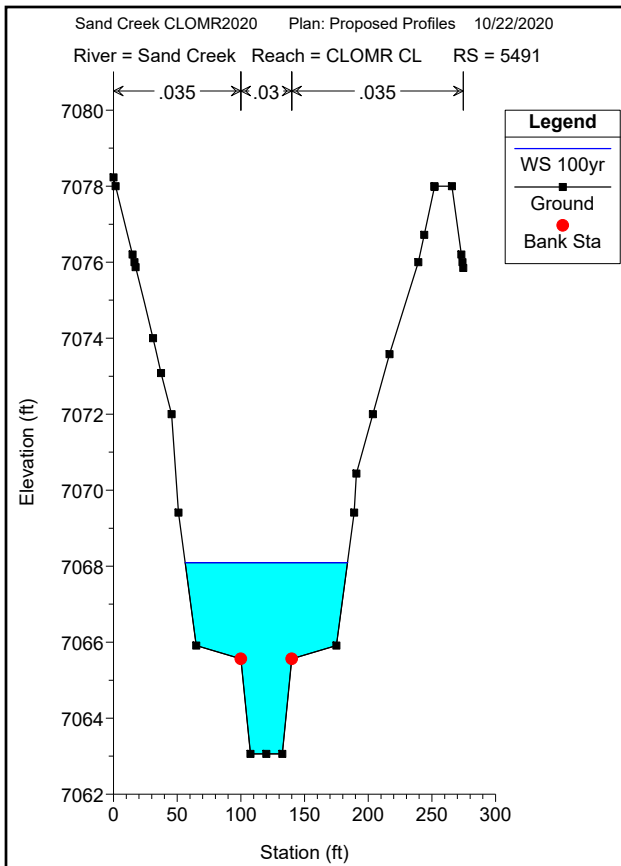

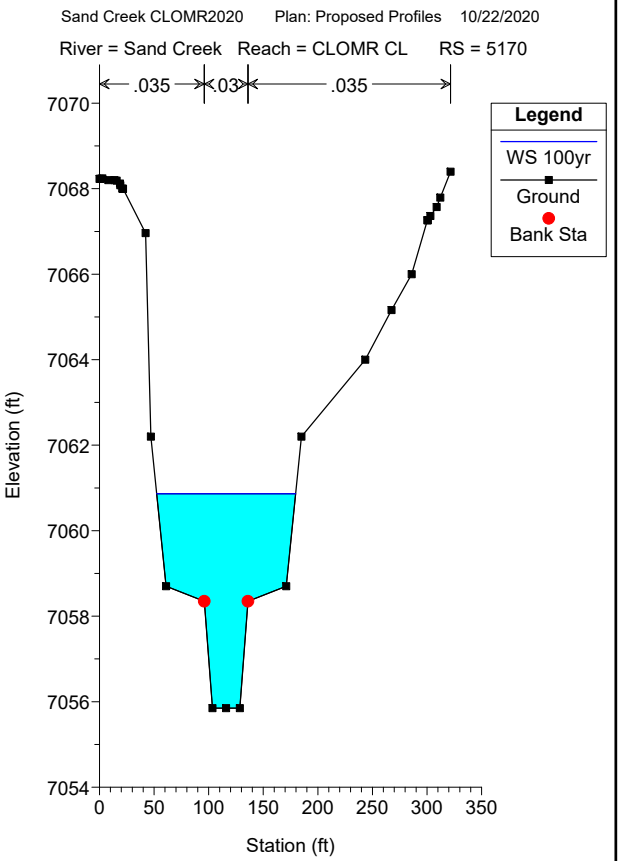
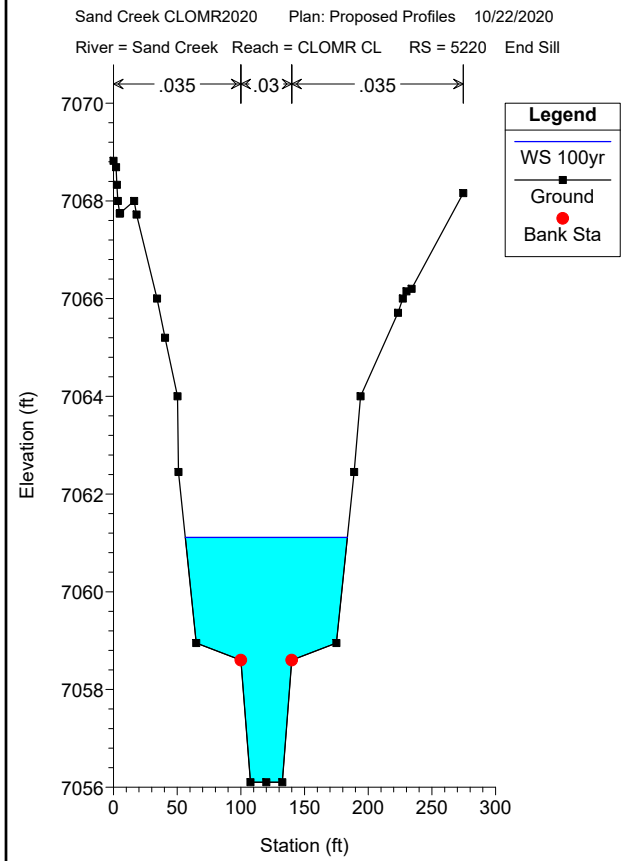
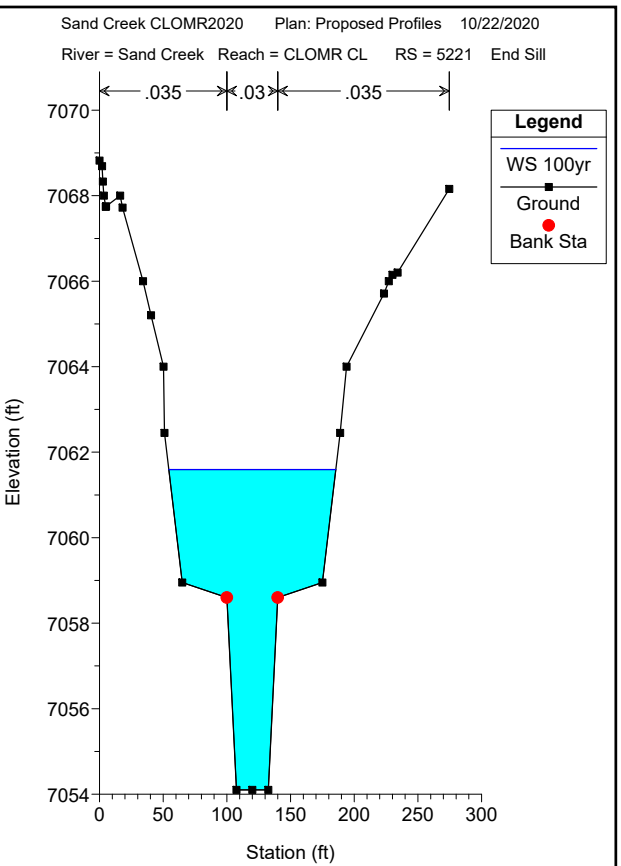
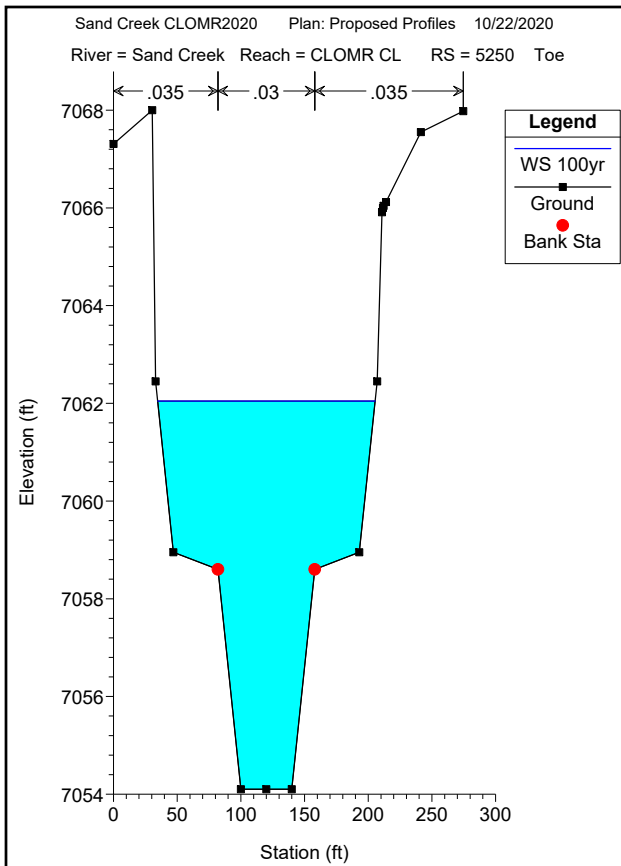

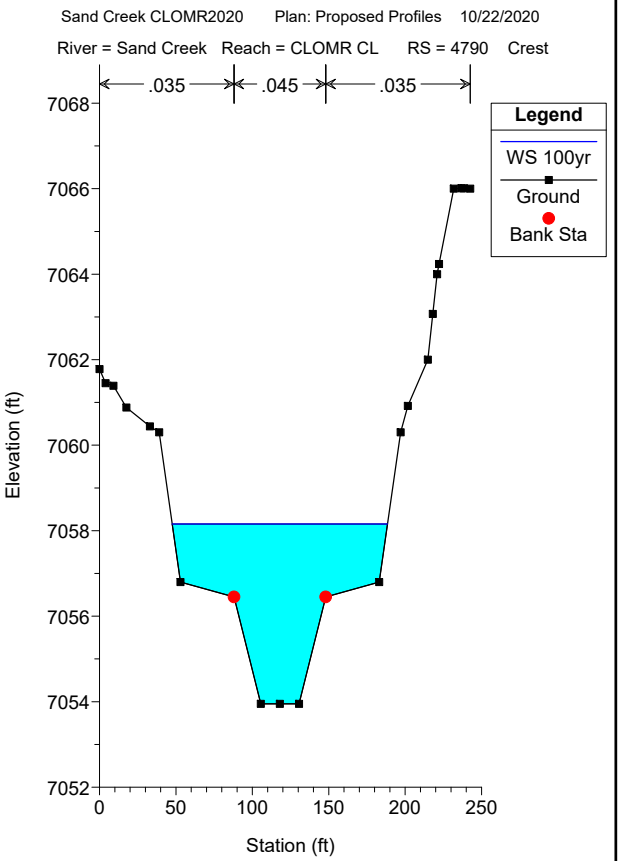
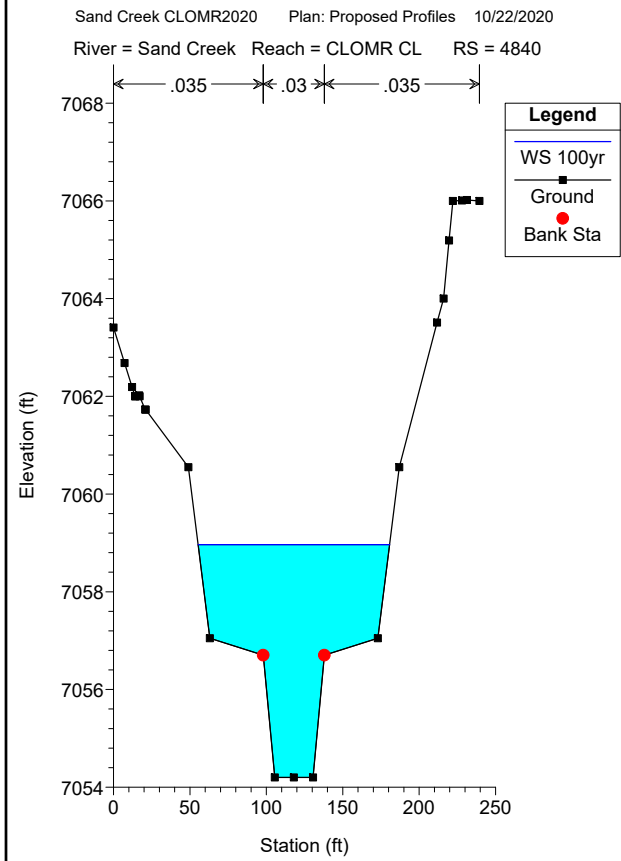
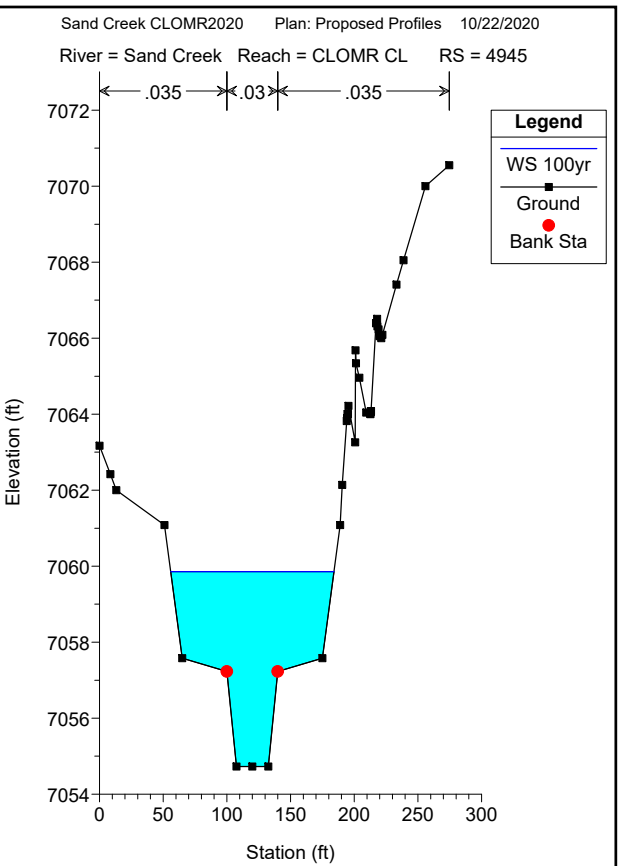
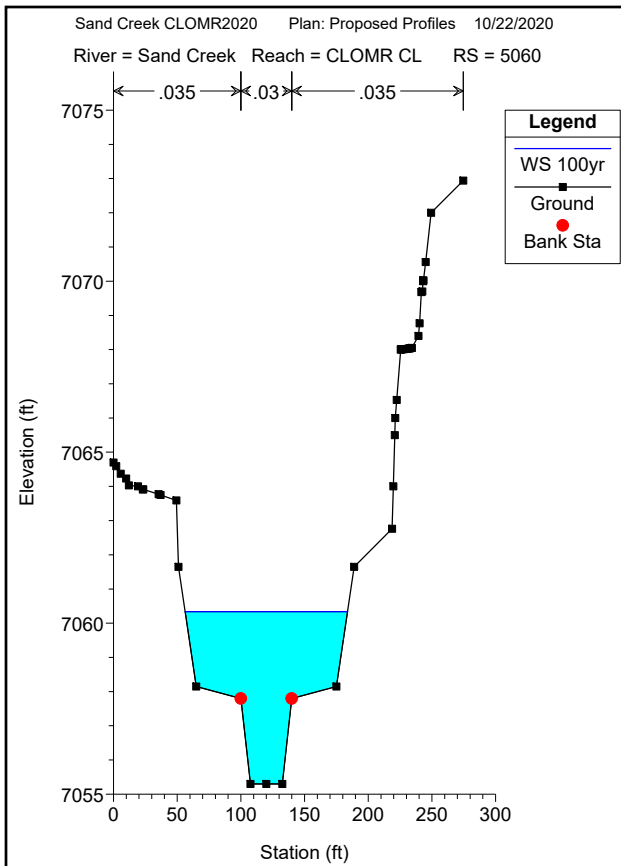

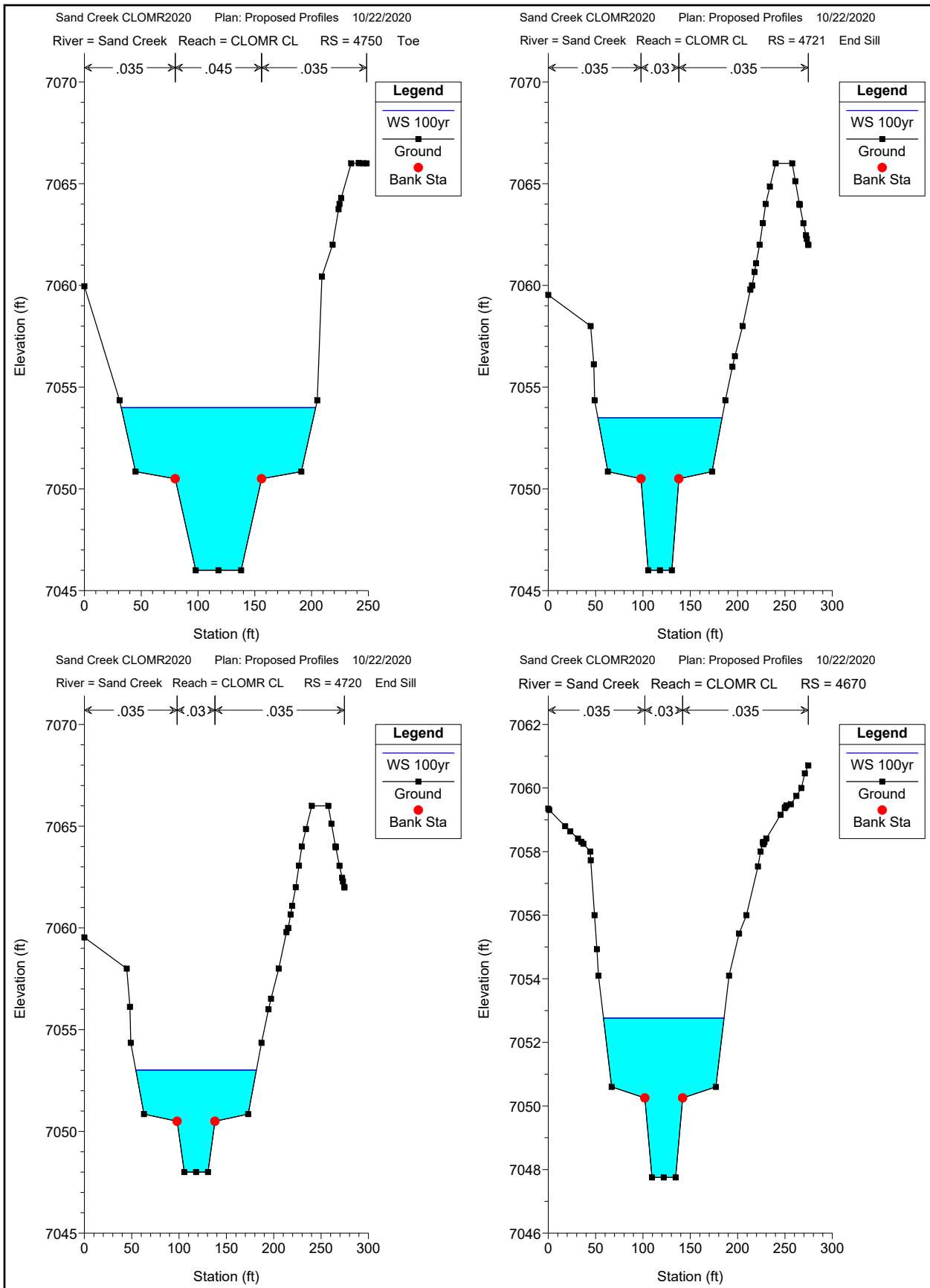

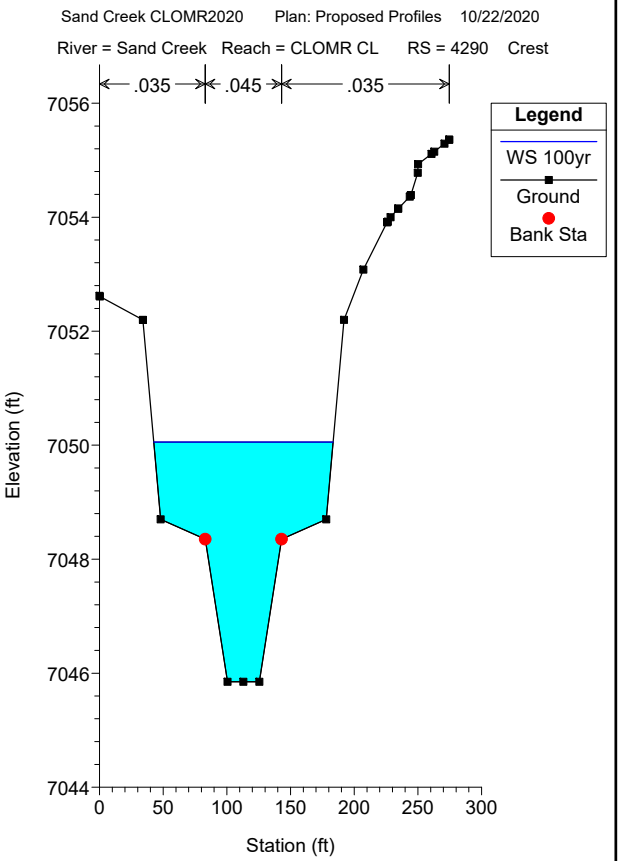
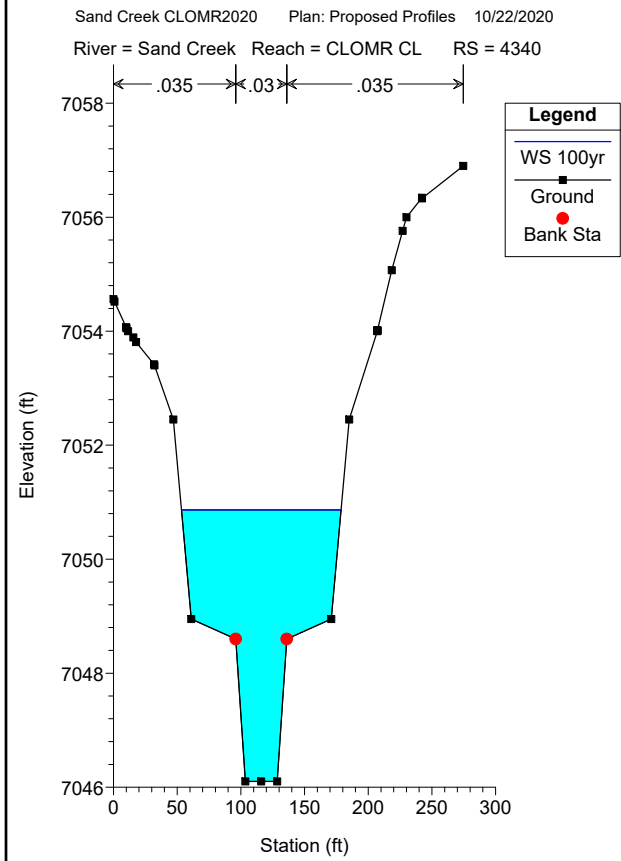
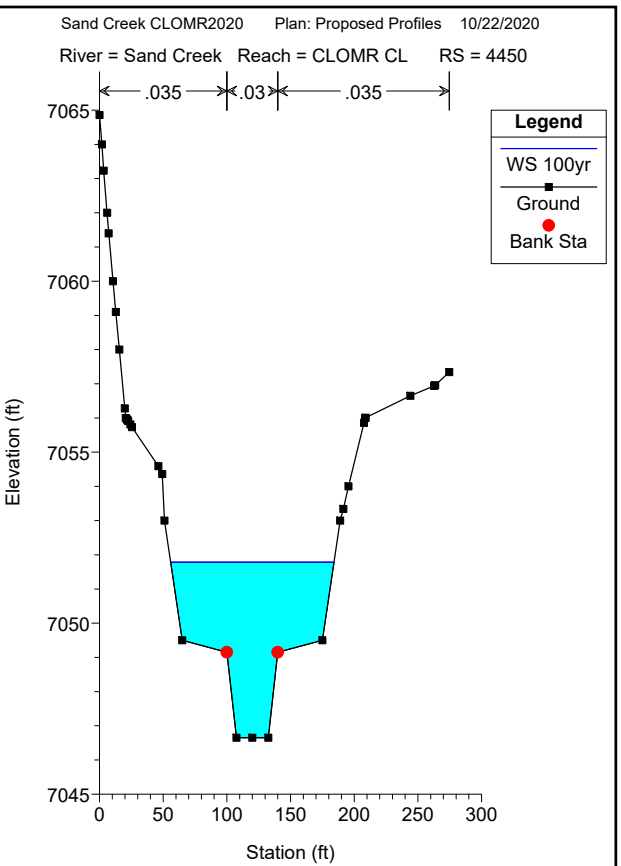
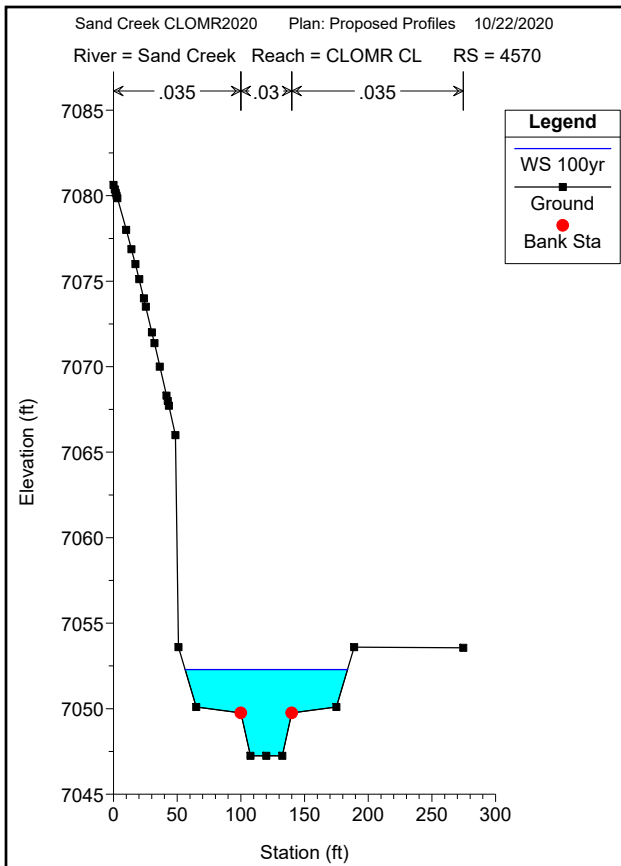

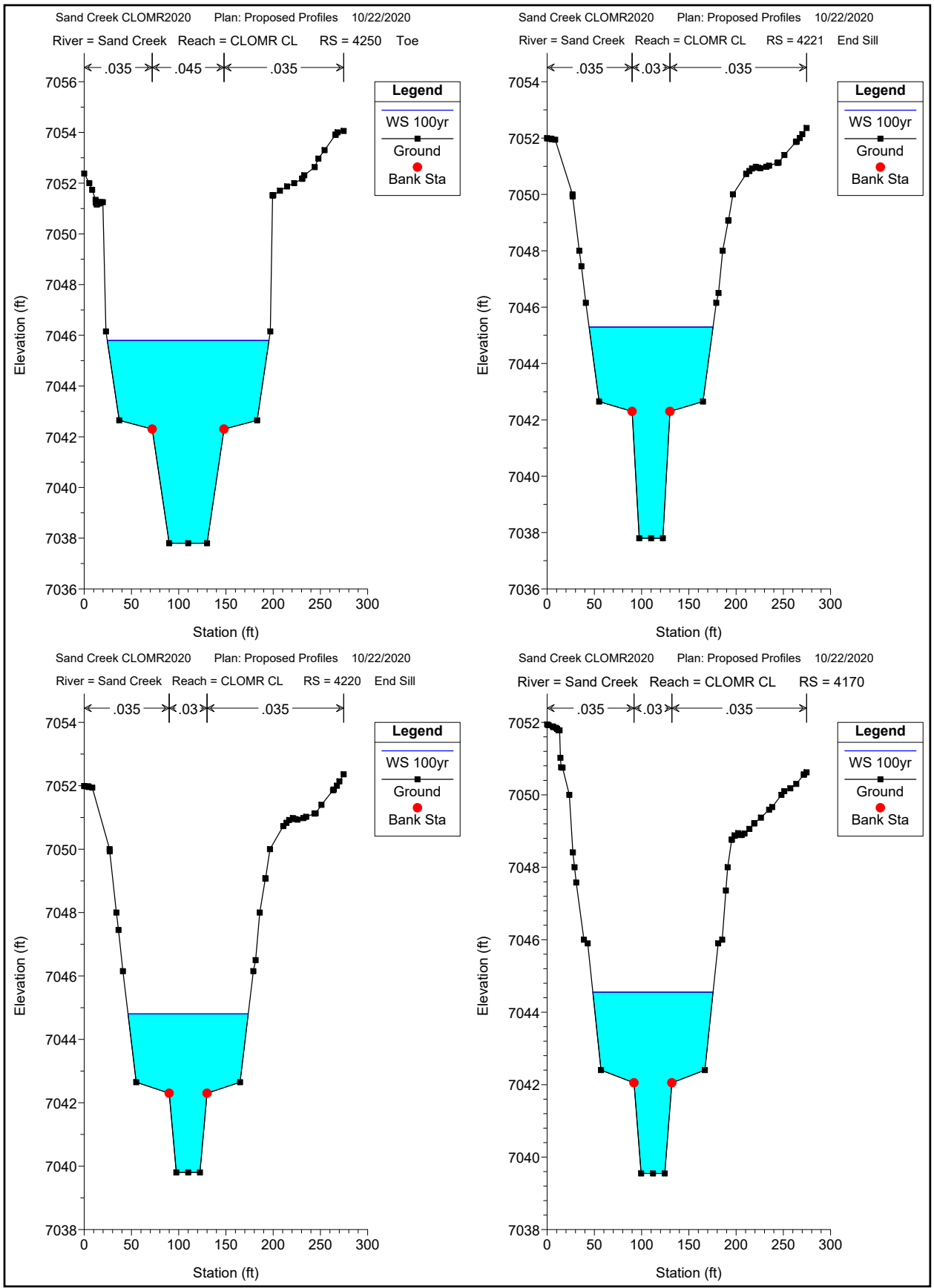

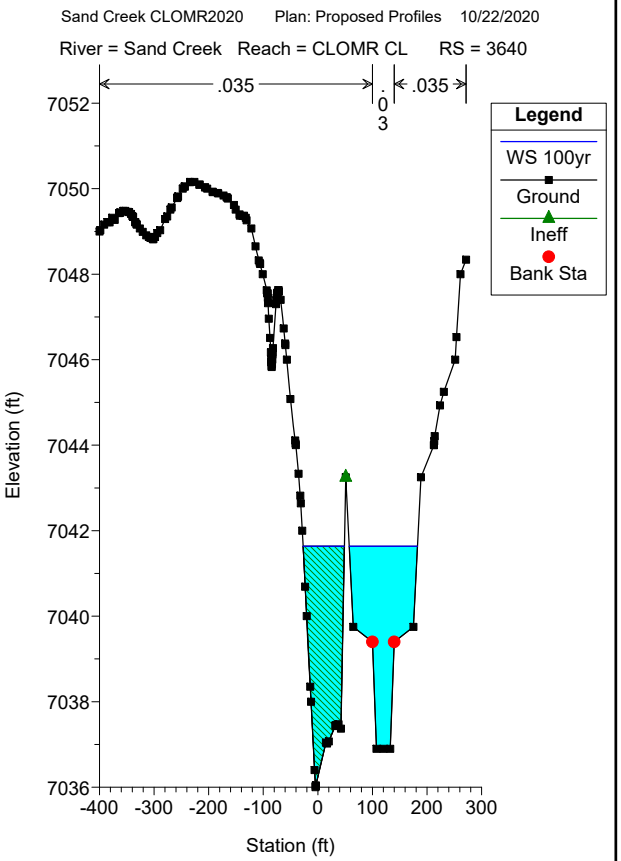
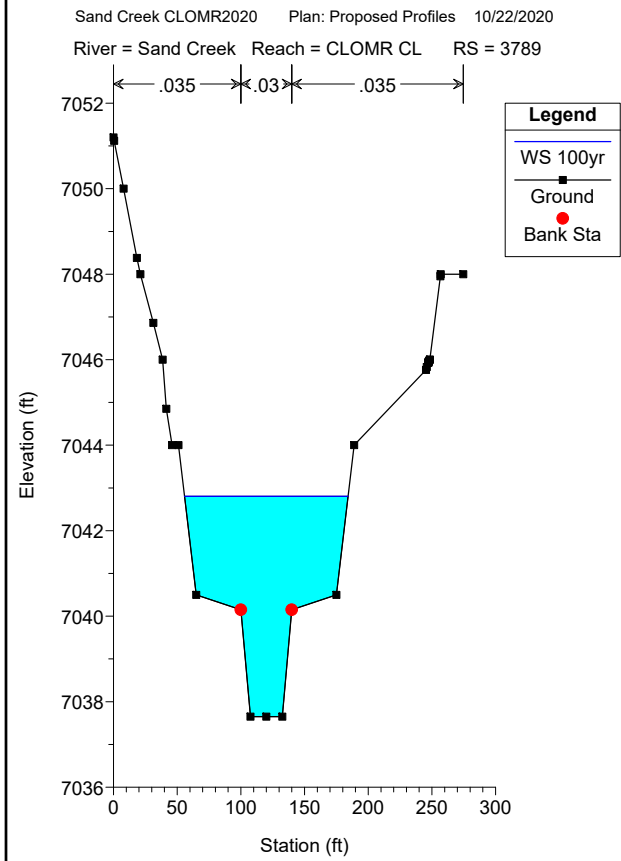
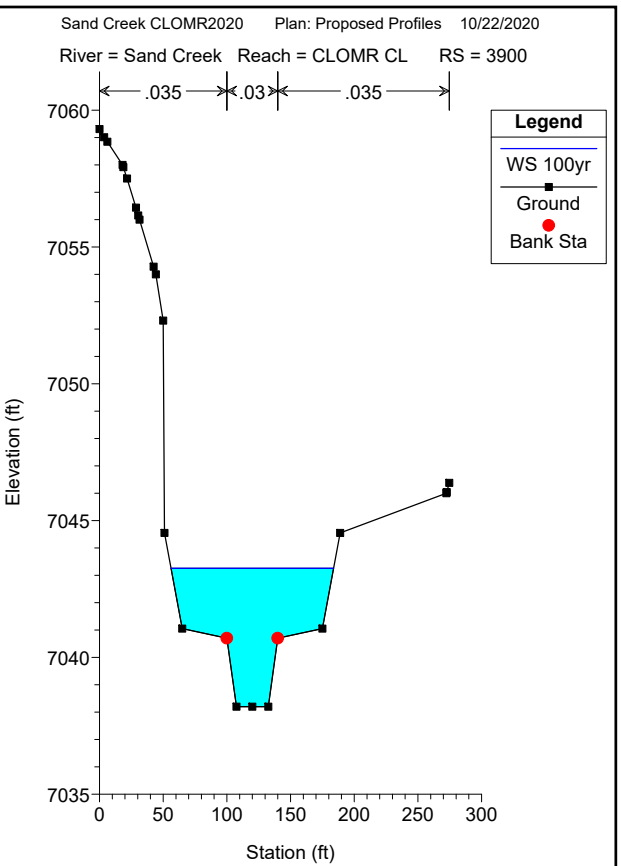
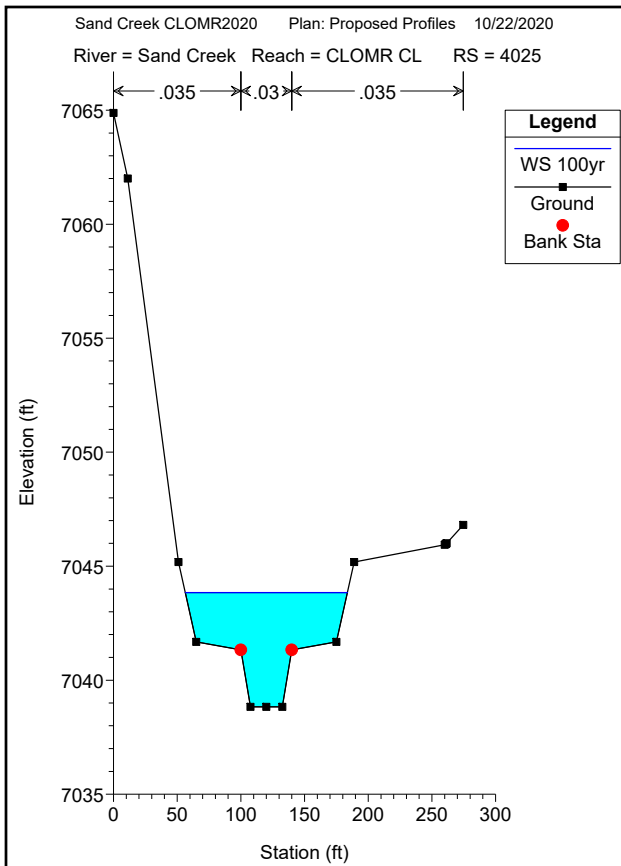

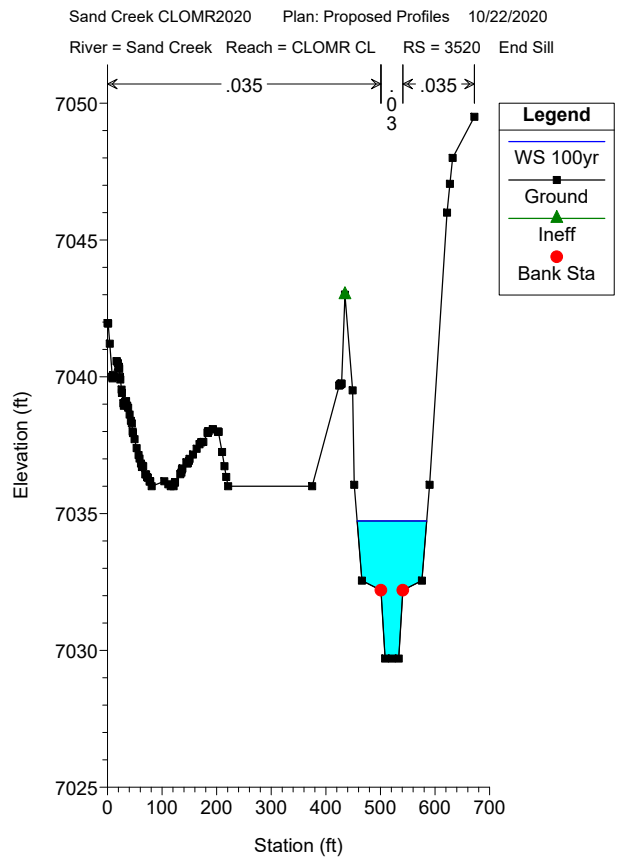
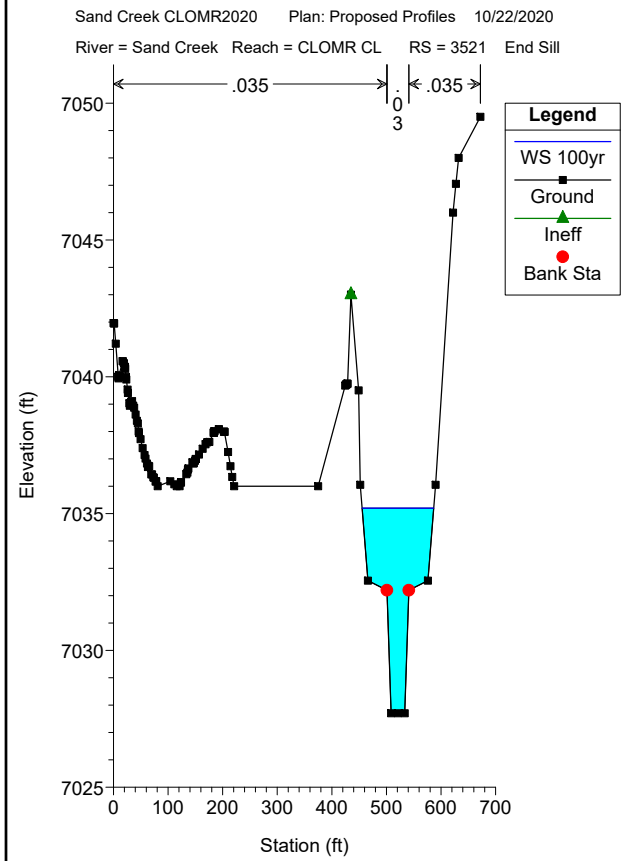
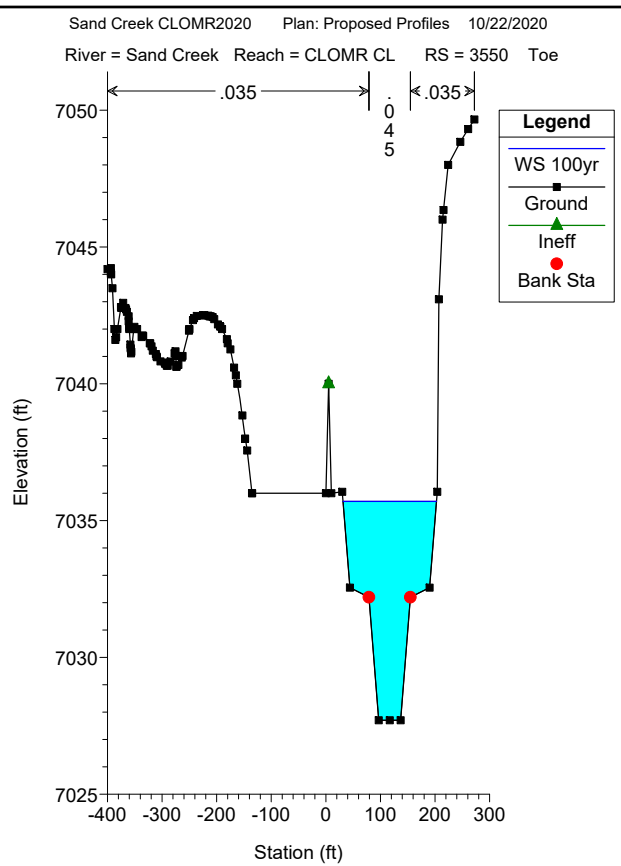
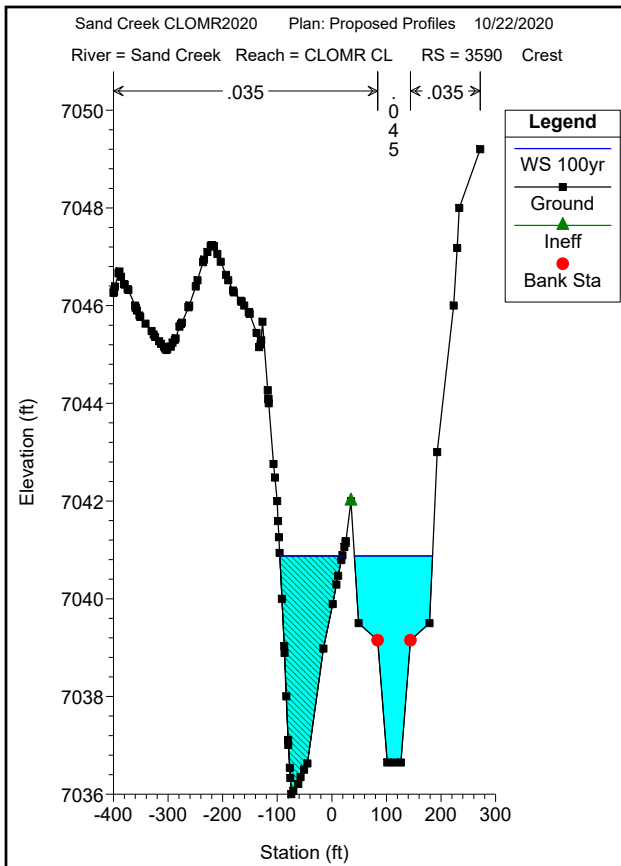

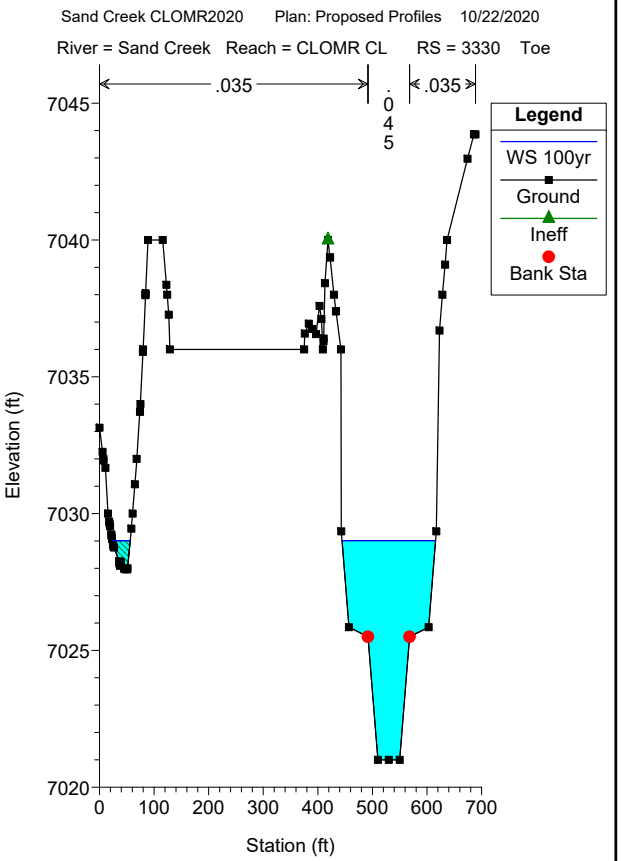
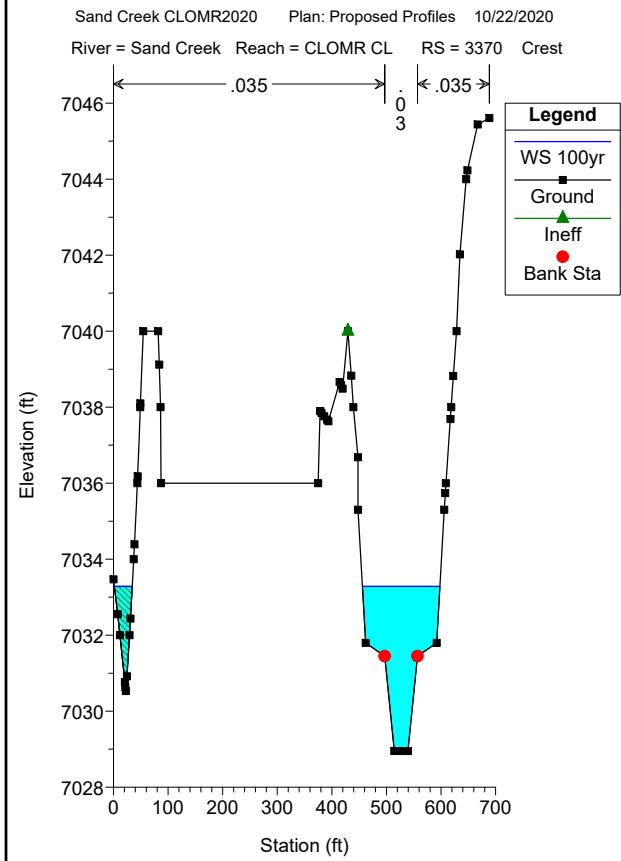
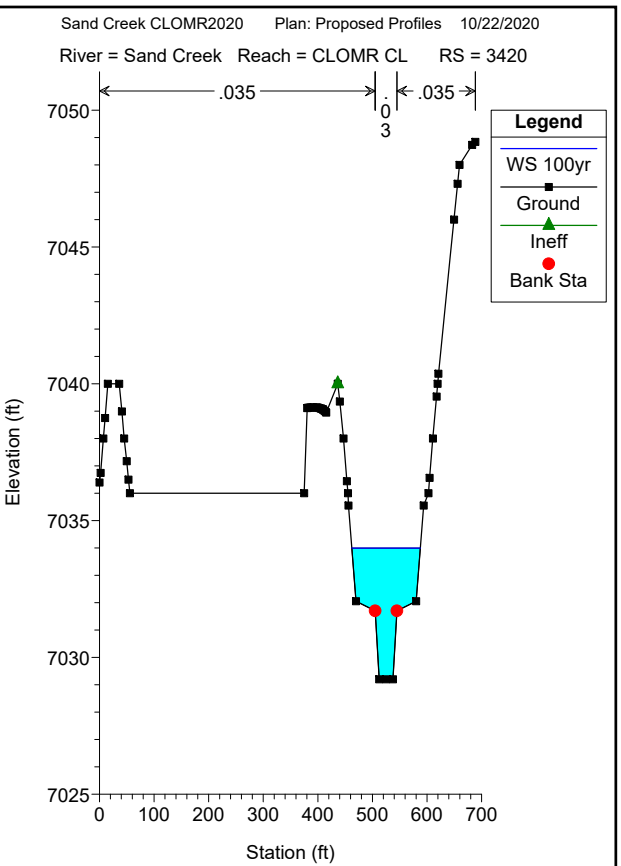
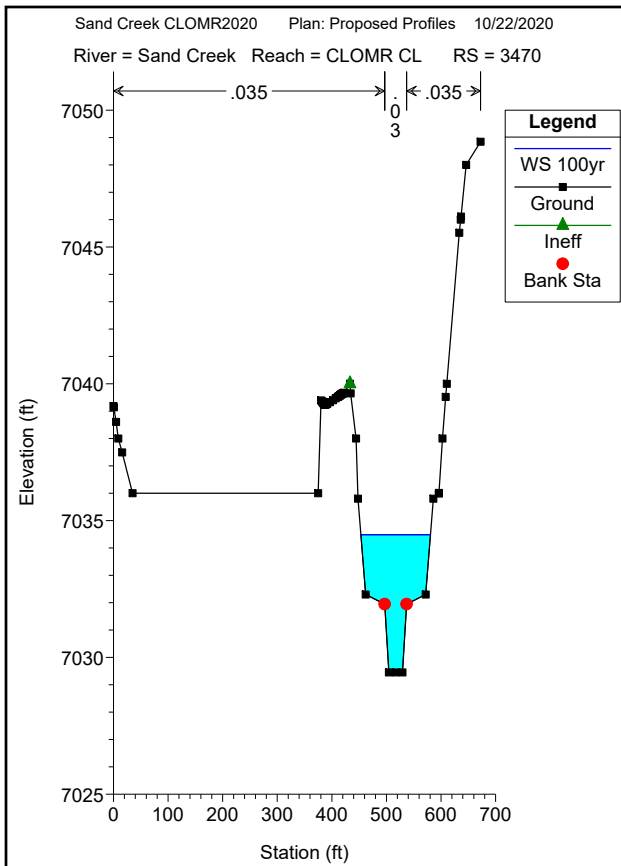

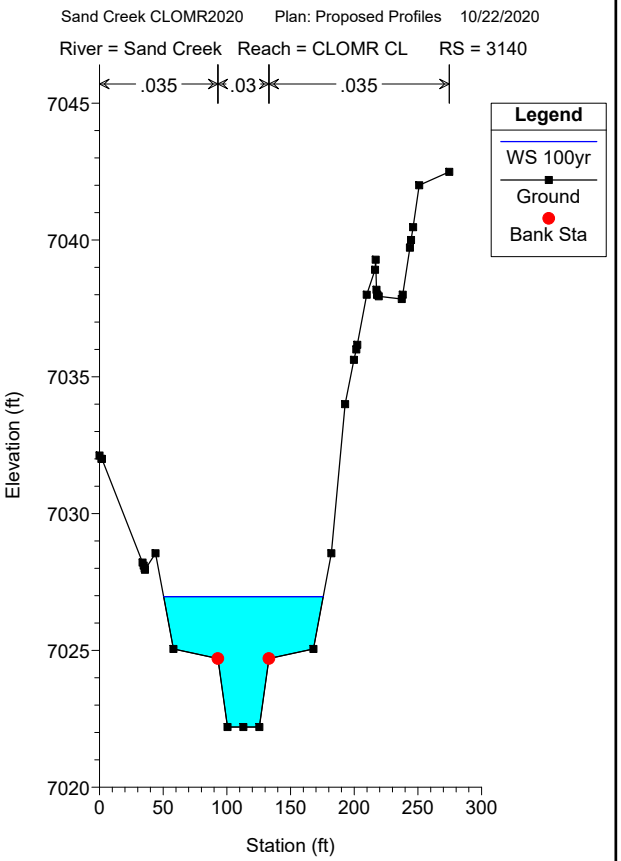
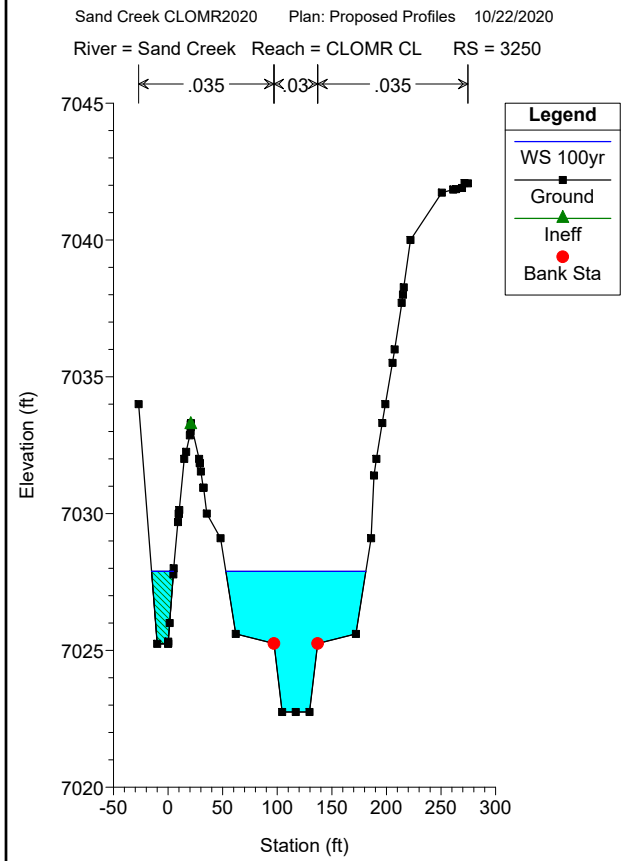
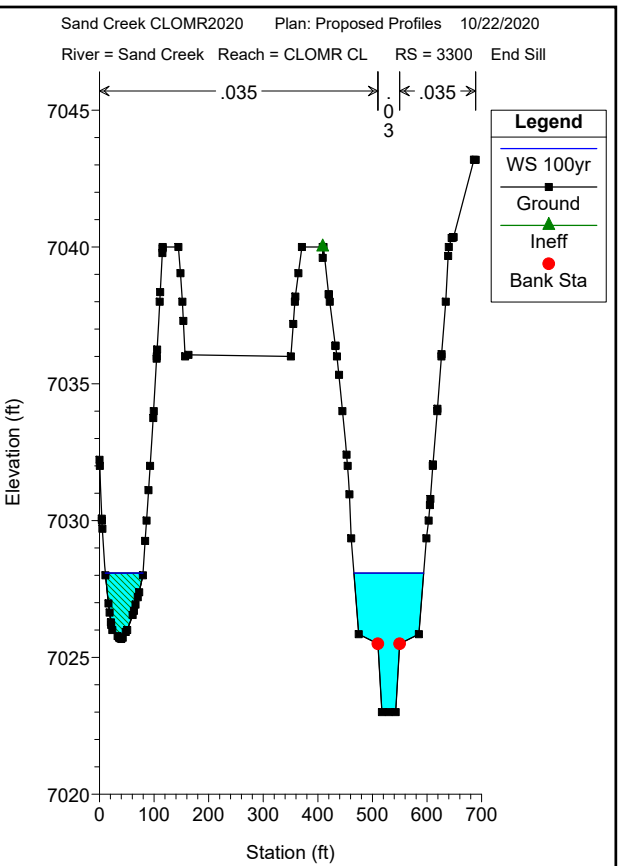
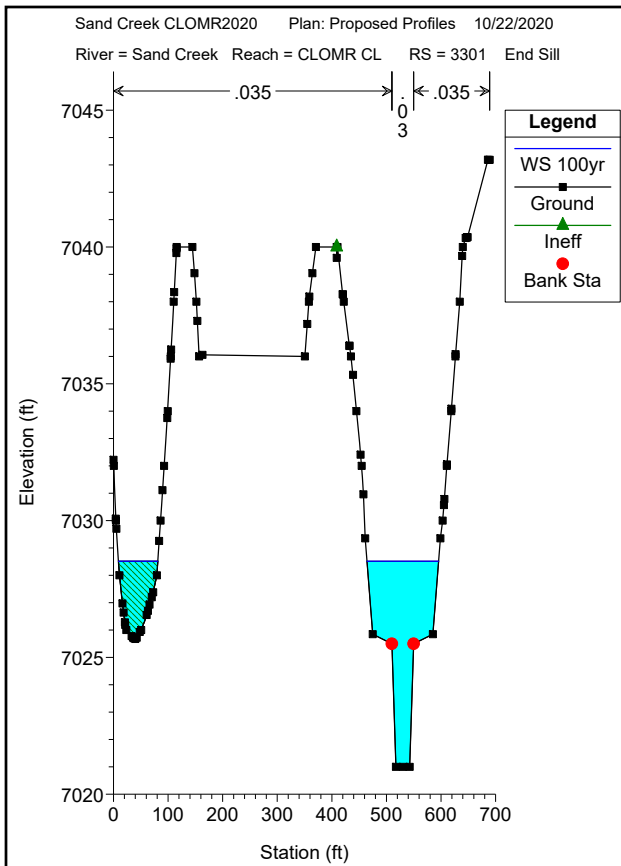

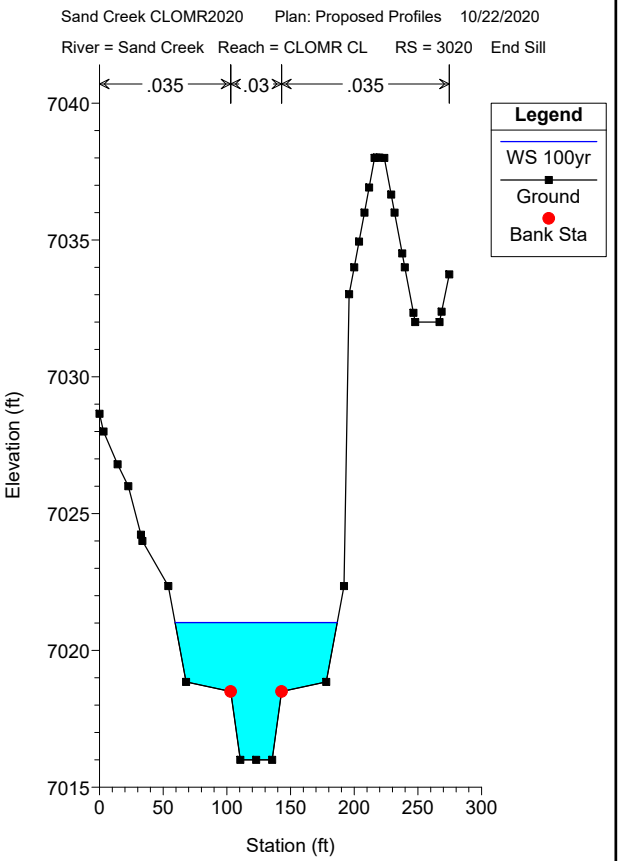
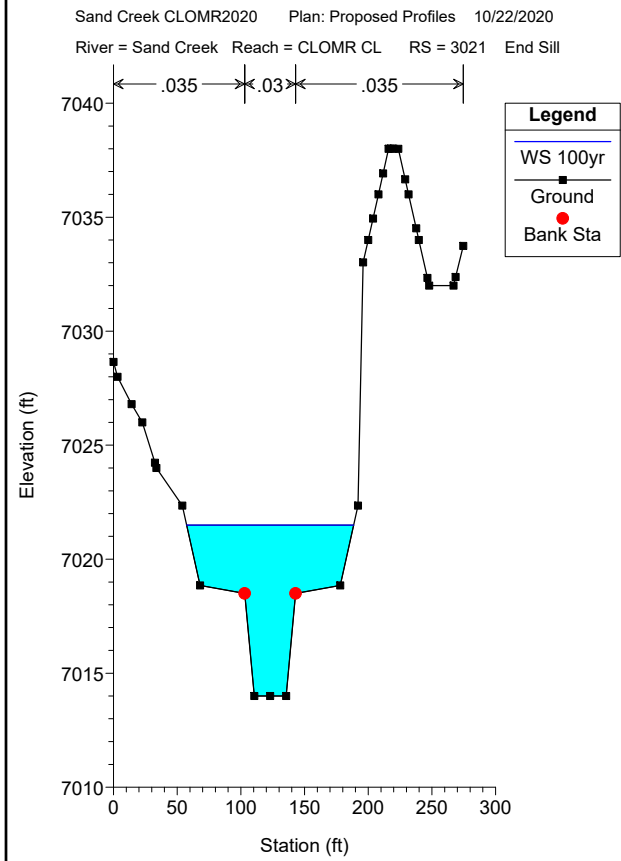
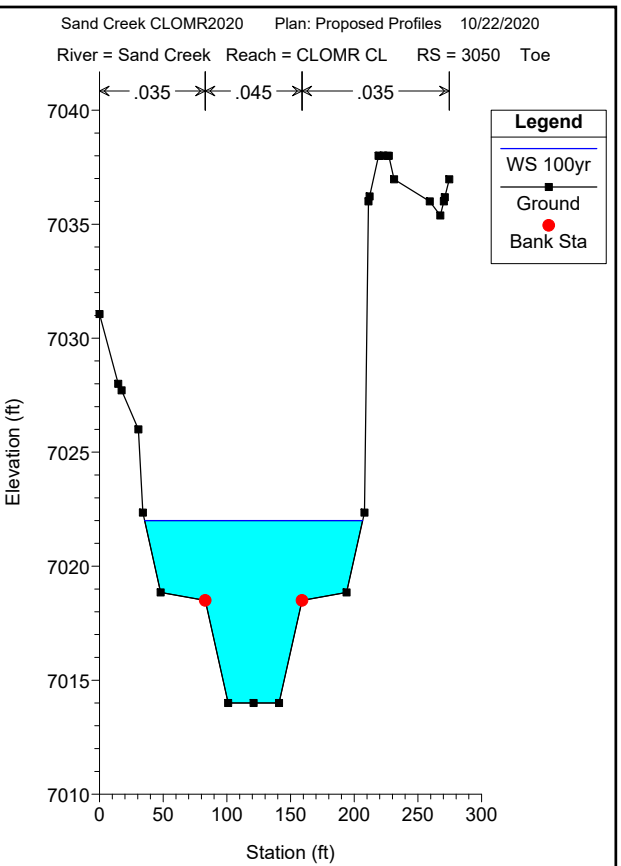
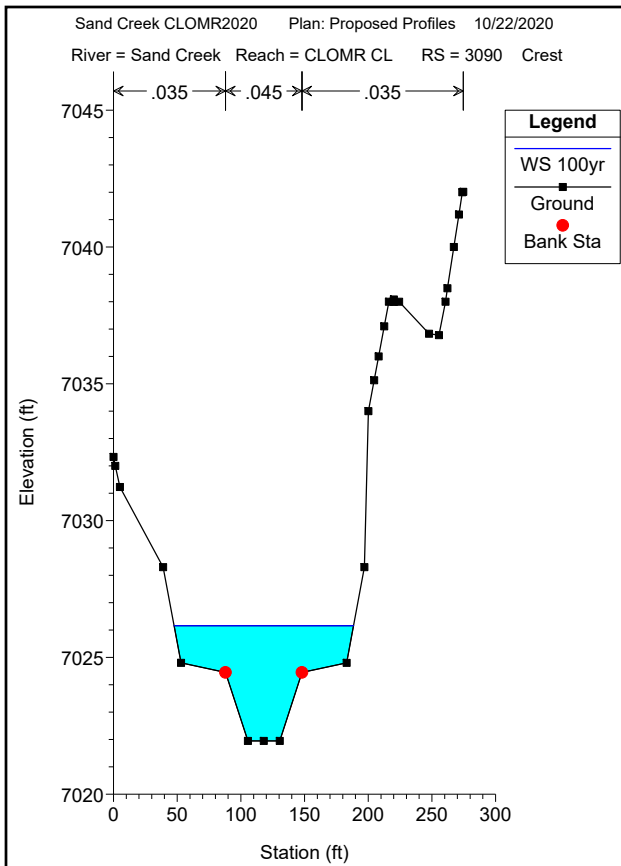

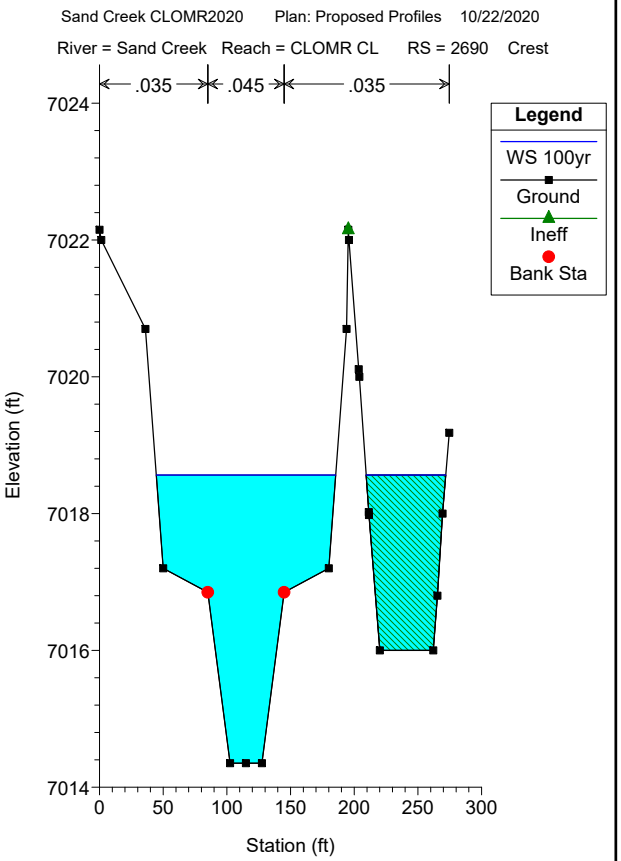
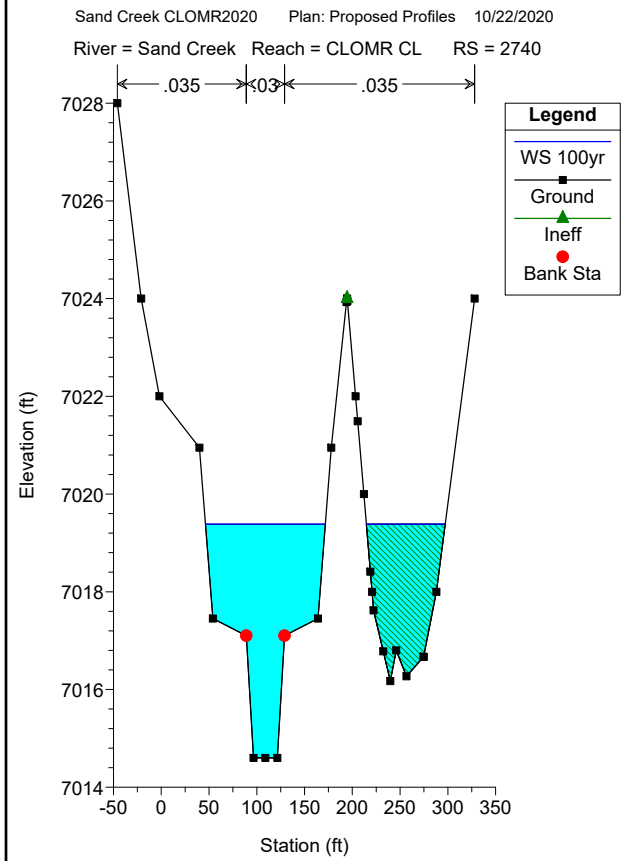
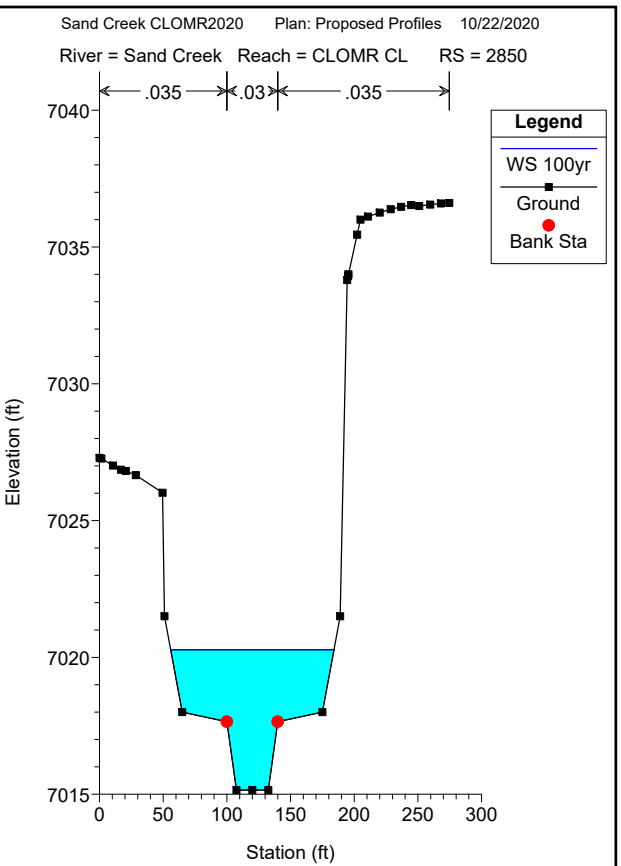
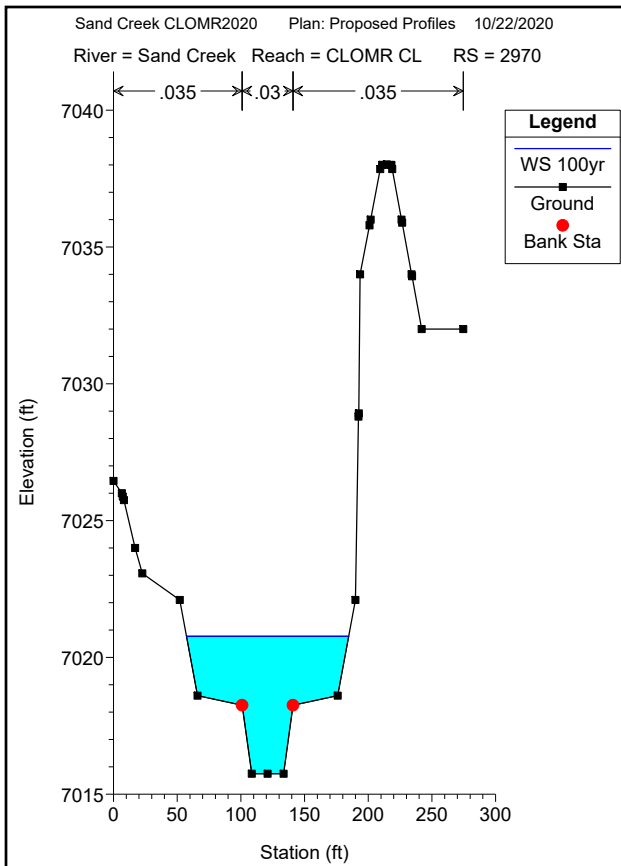

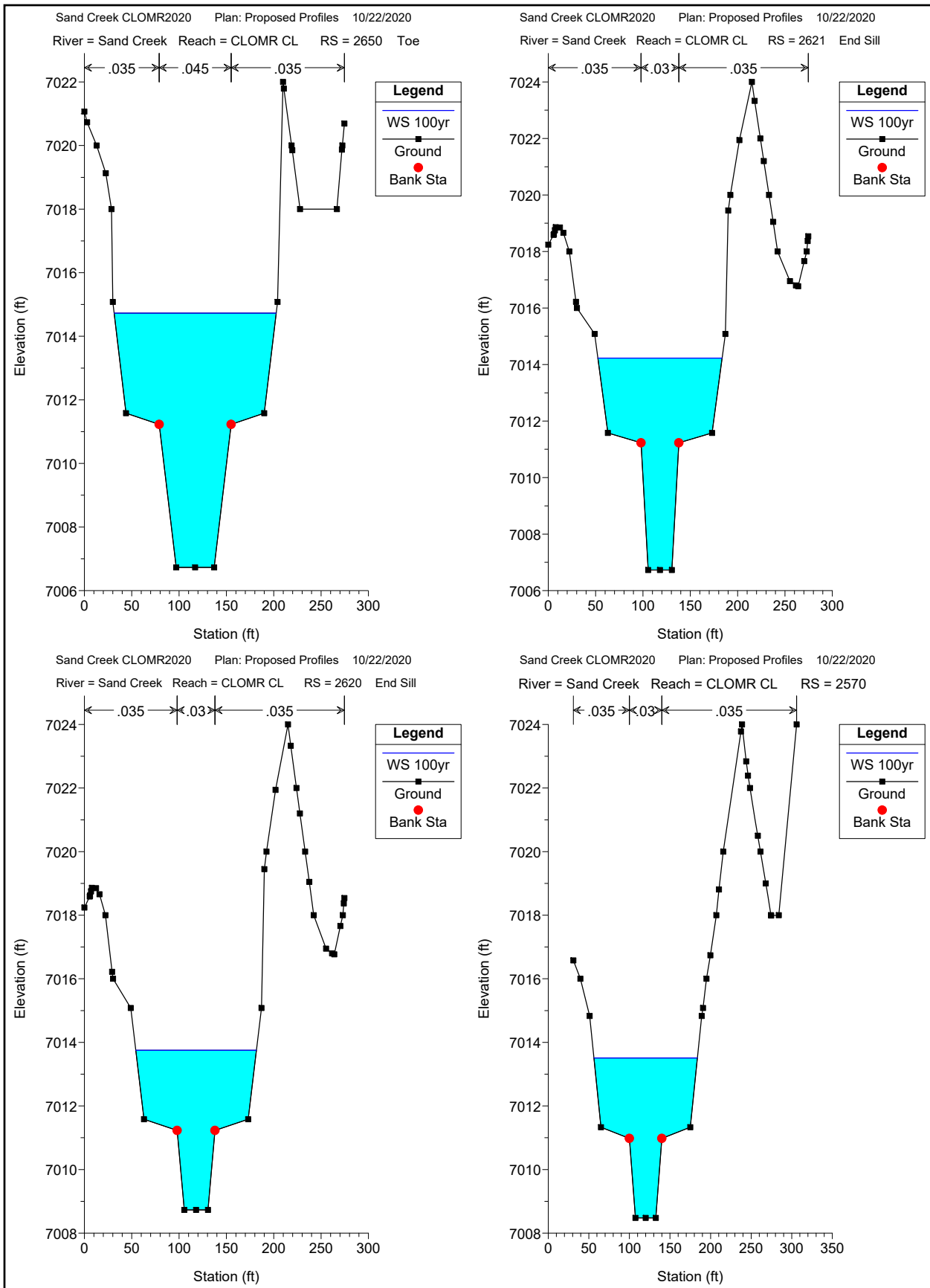

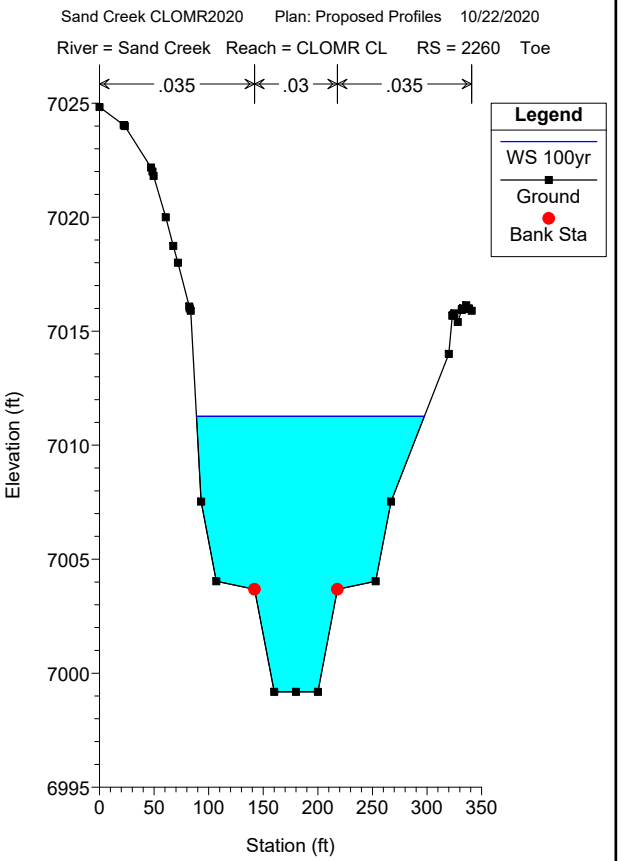
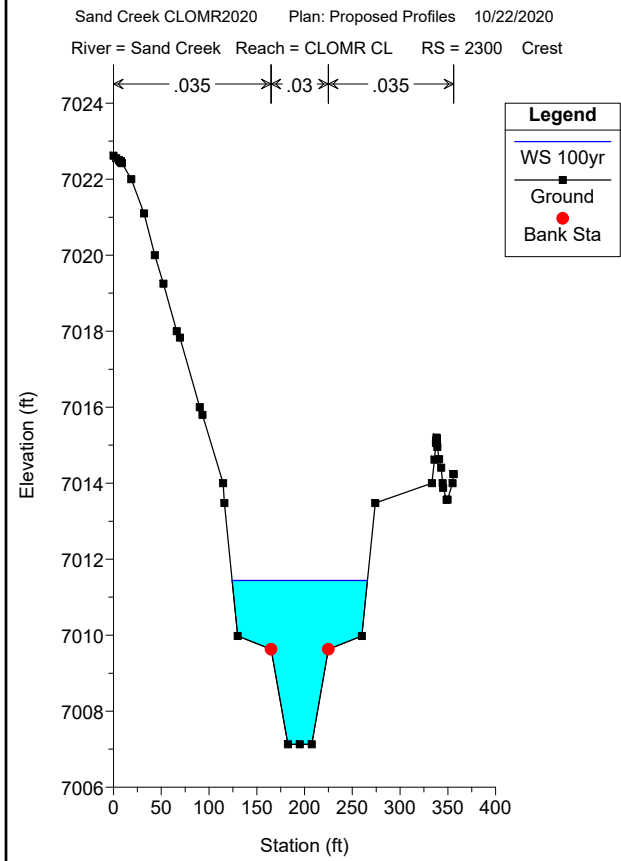
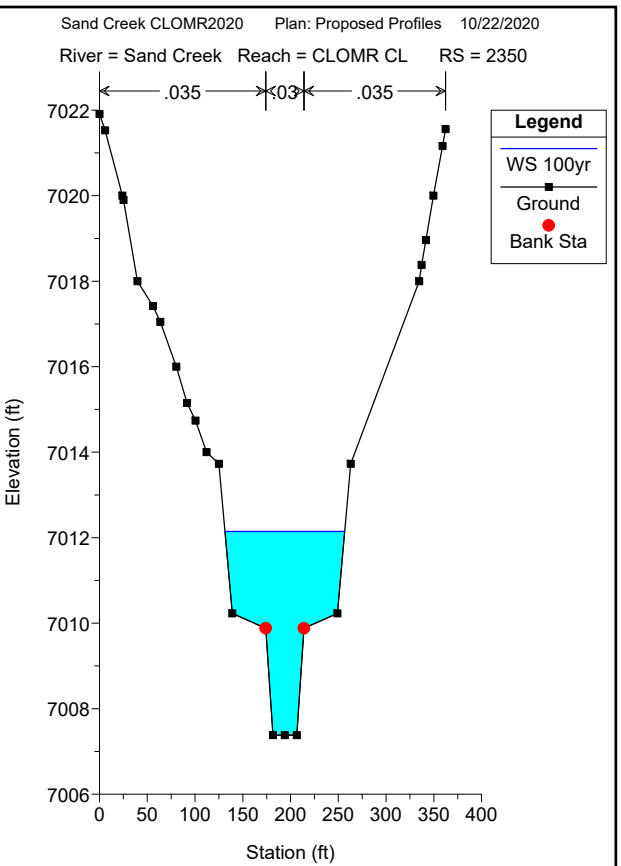
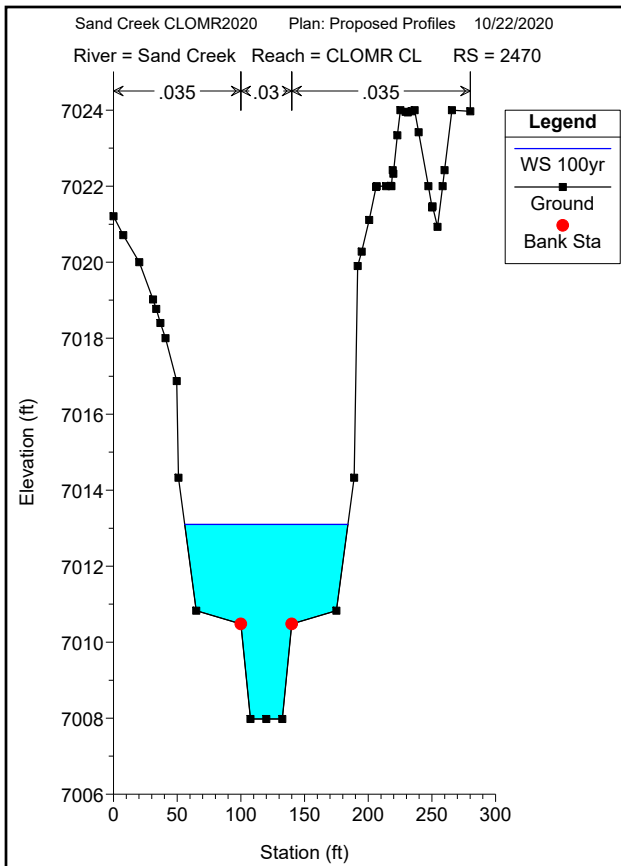

Sand Creek CLOMR2020 Plan: Proposed Profiles 10/22/2020
 River = Sand Creek Reach = CLOMR CL RS = 2231 End Sill

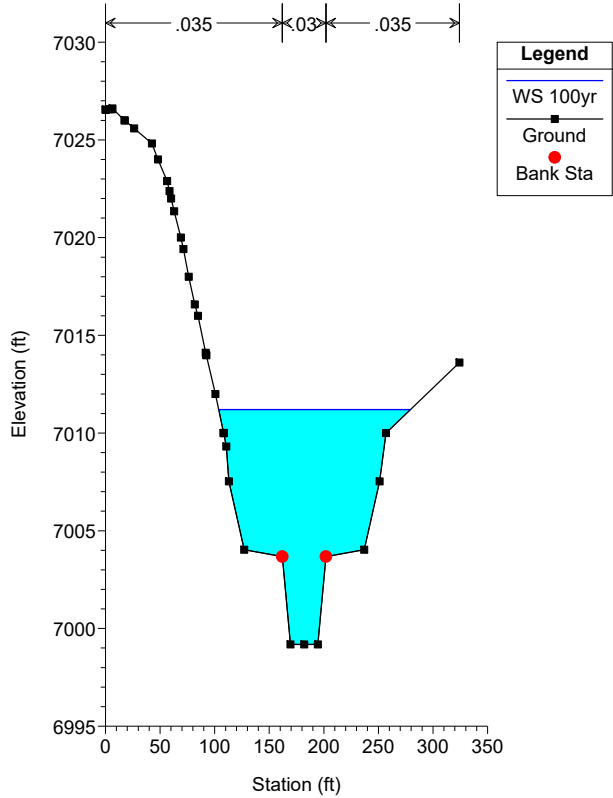

Sand Creek CLOMR2020 Plan: Proposed Profiles 10/22/2020
 River = Sand Creek Reach = CLOMR CL RS = 2230 End Sill

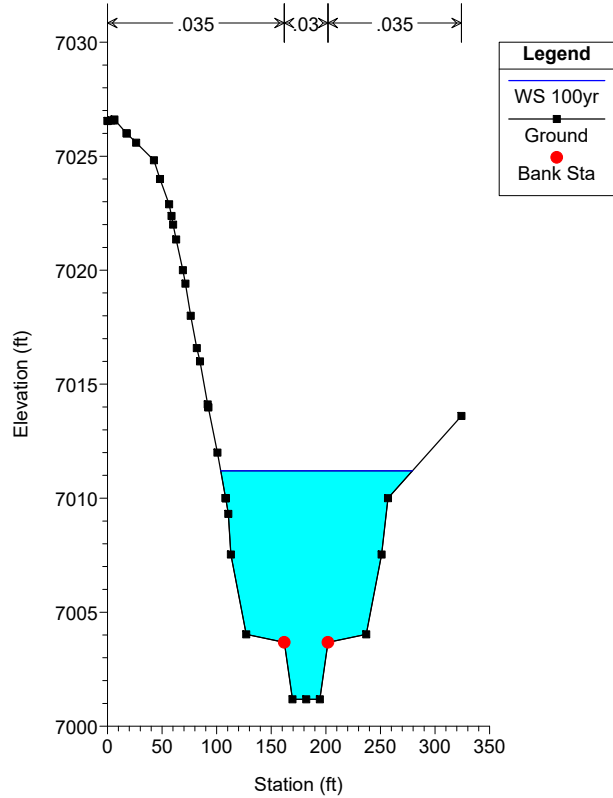

Sand Creek CLOMR2020 Plan: Proposed Profiles 10/22/2020
 River = Sand Creek Reach = CLOMR CL RS = 2200

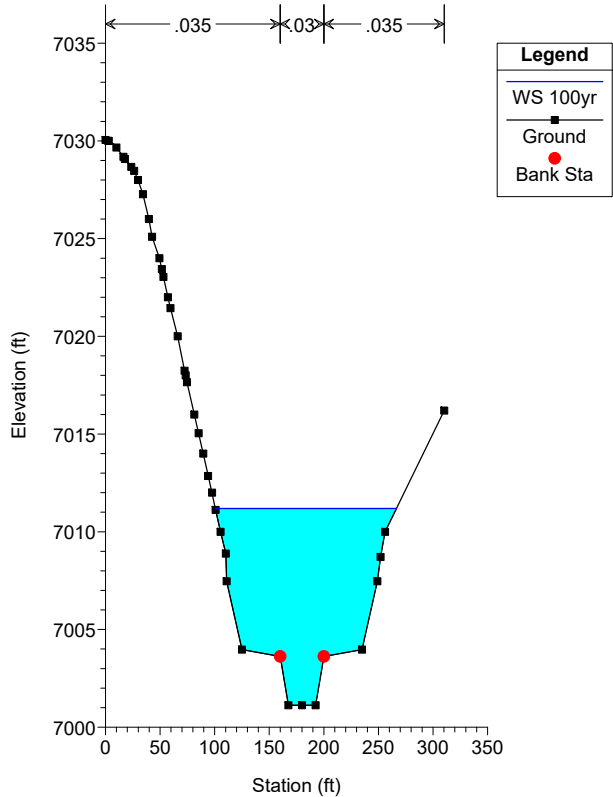

Sand Creek CLOMR2020 Plan: Proposed Profiles 10/22/2020
 River = Sand Creek Reach = CLOMR CL RS = 2136

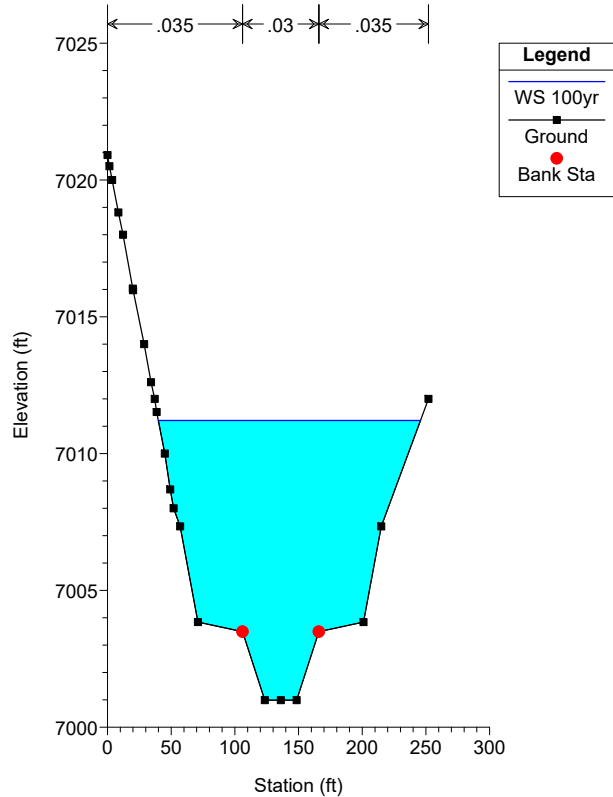

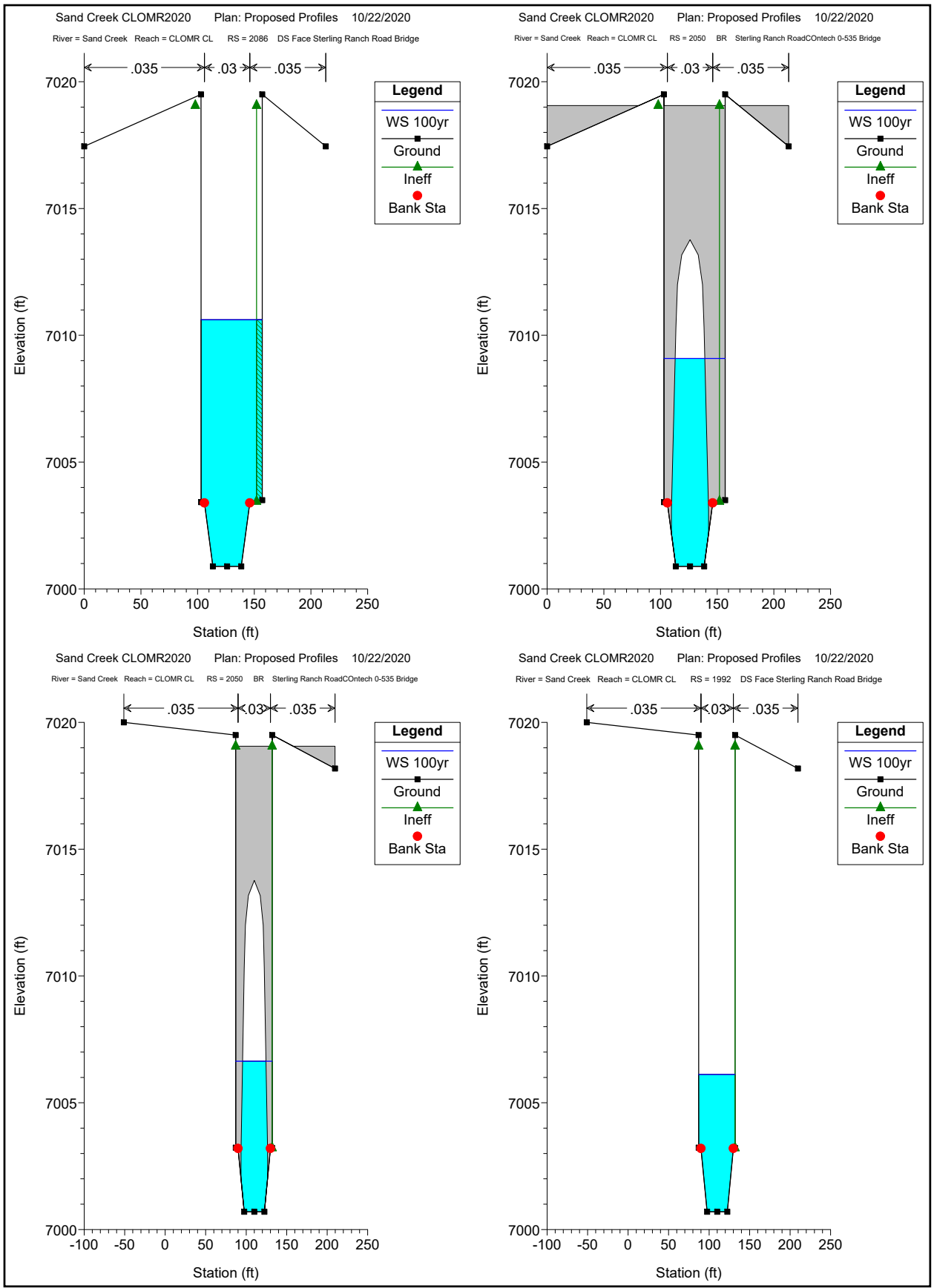

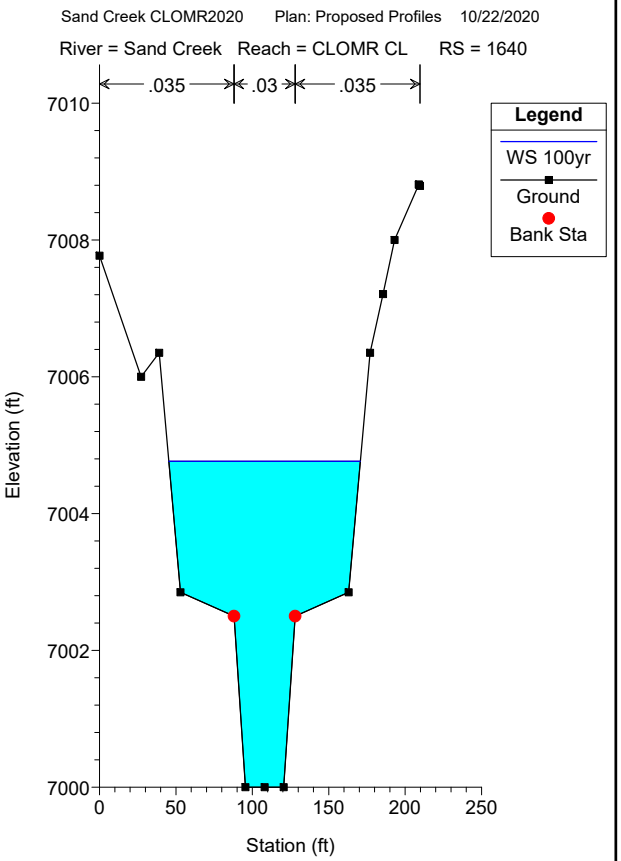
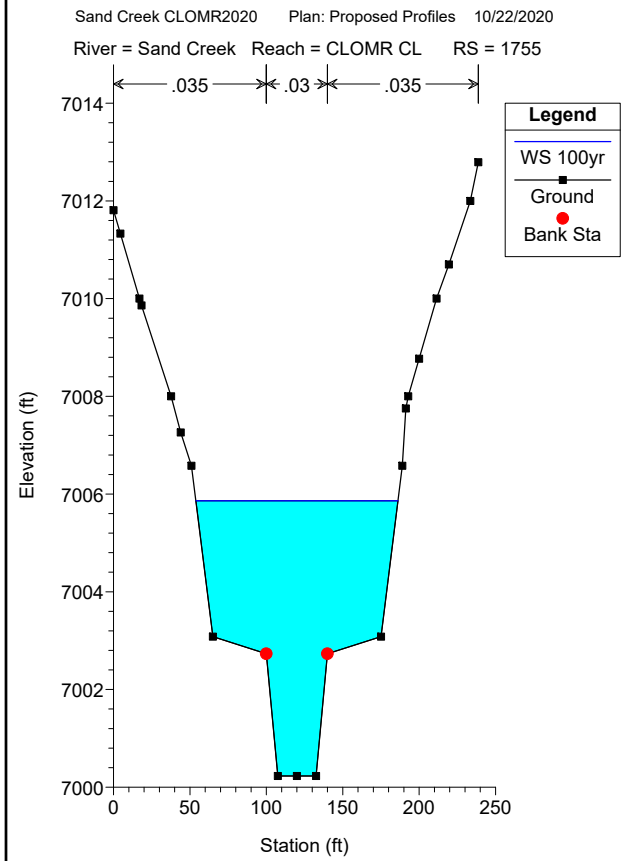
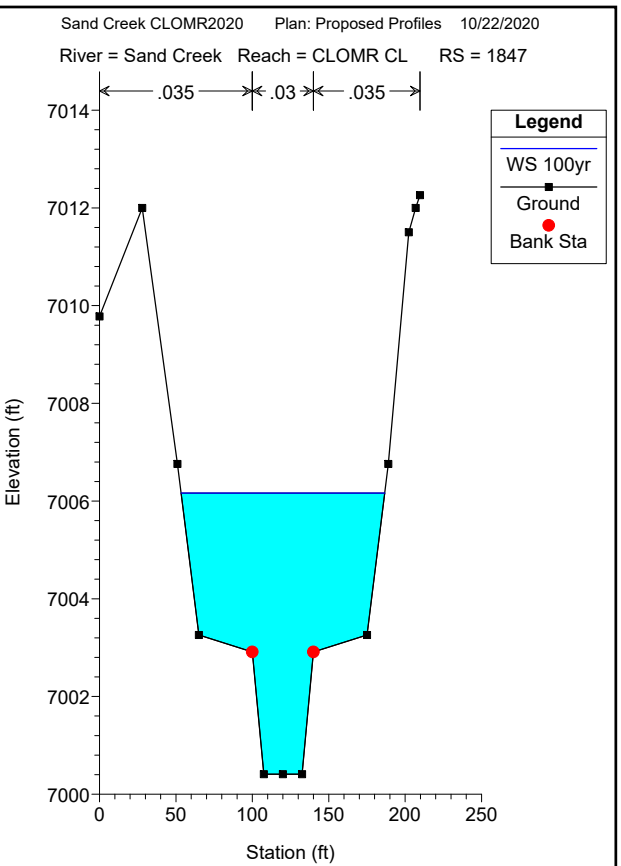
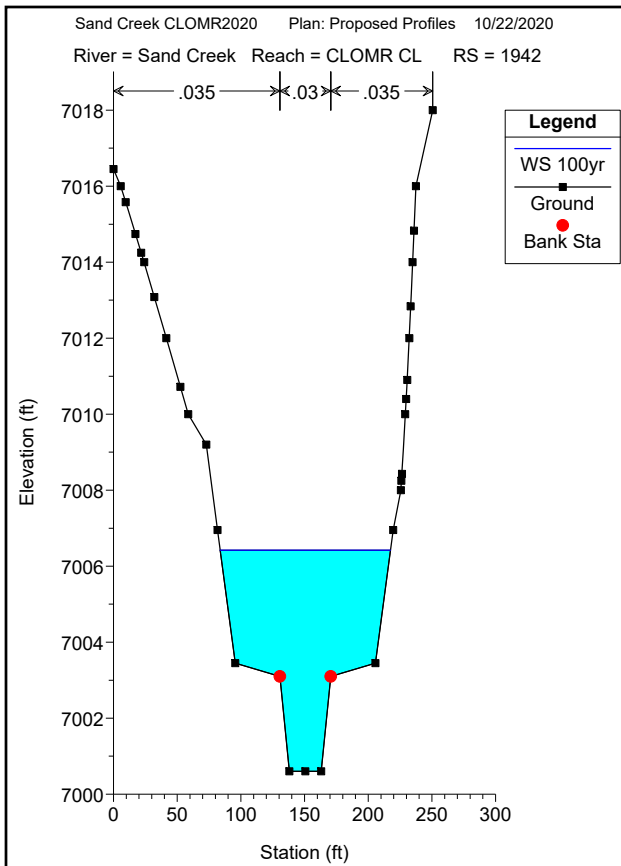

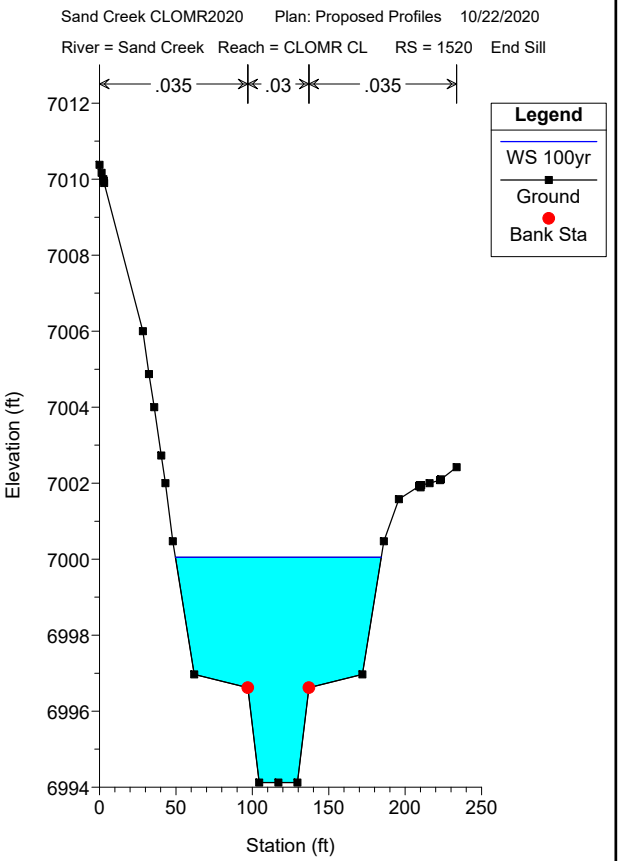
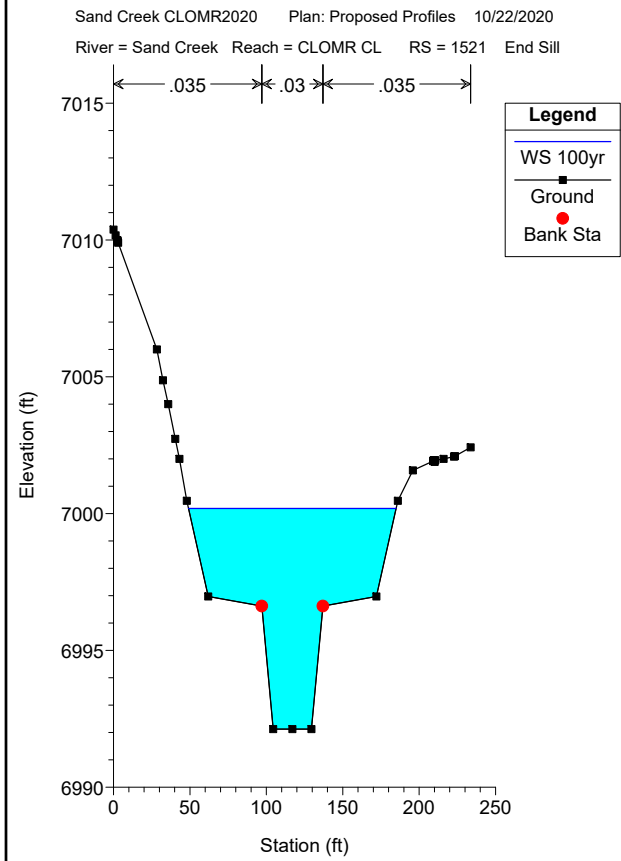
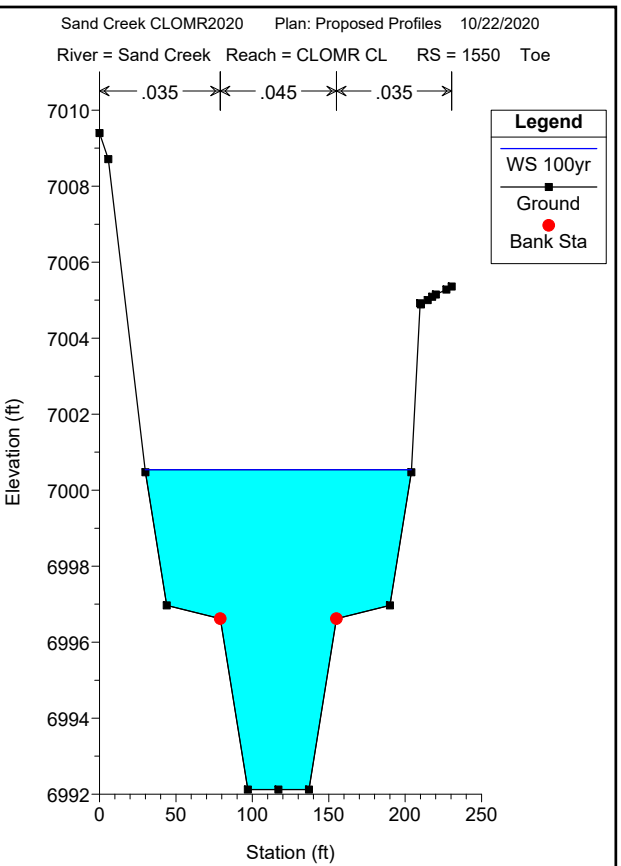
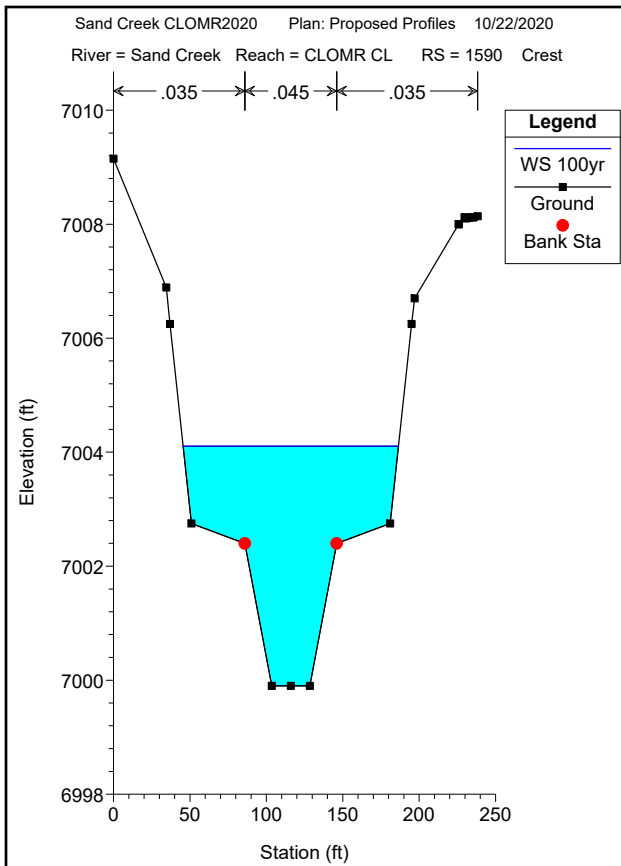

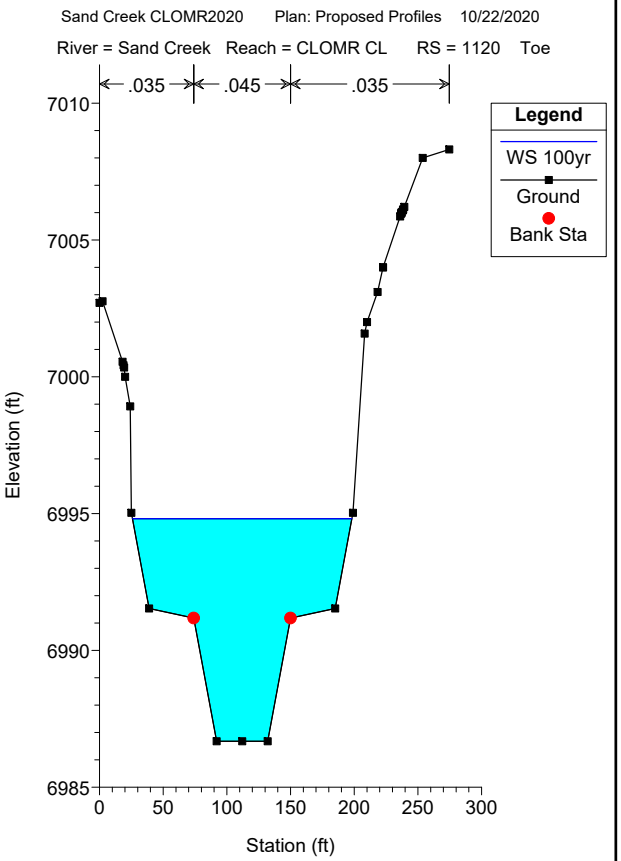
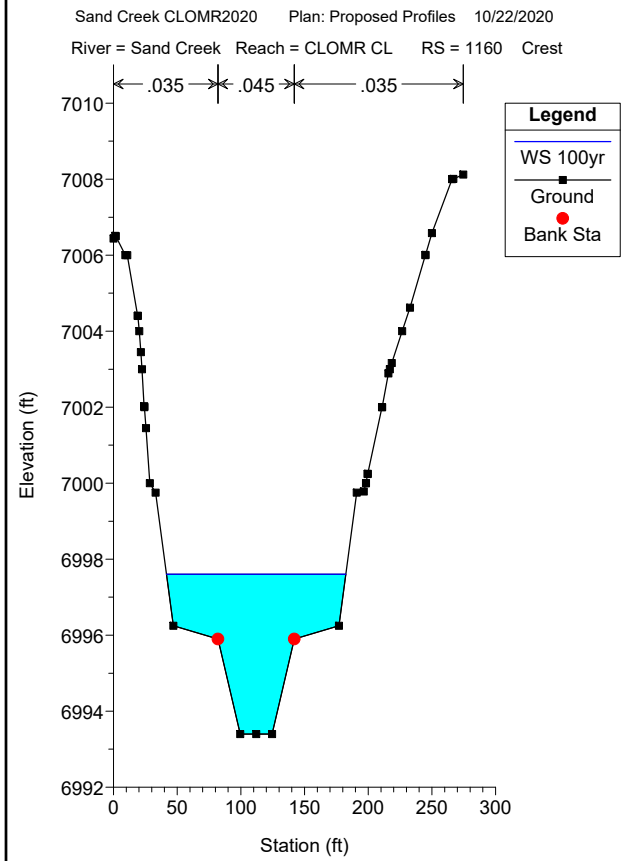
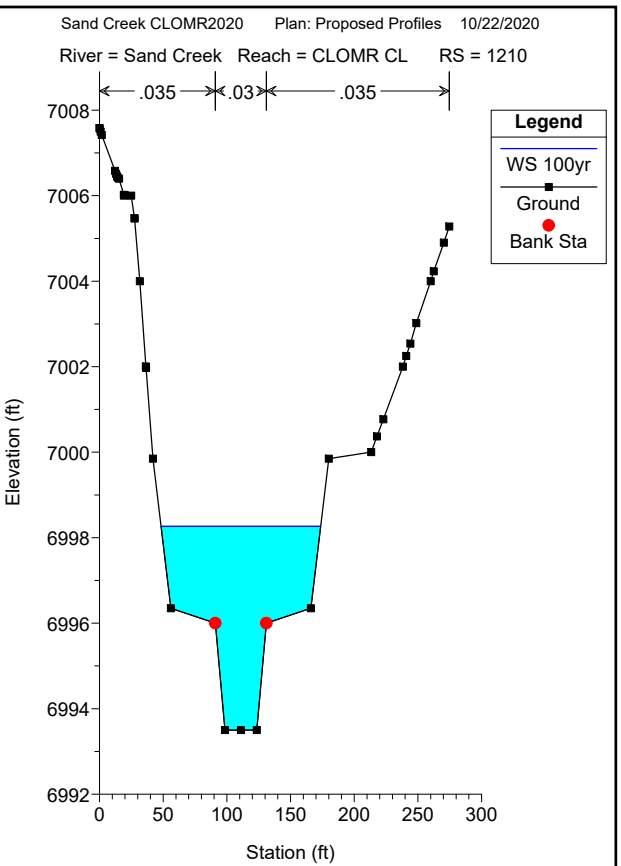
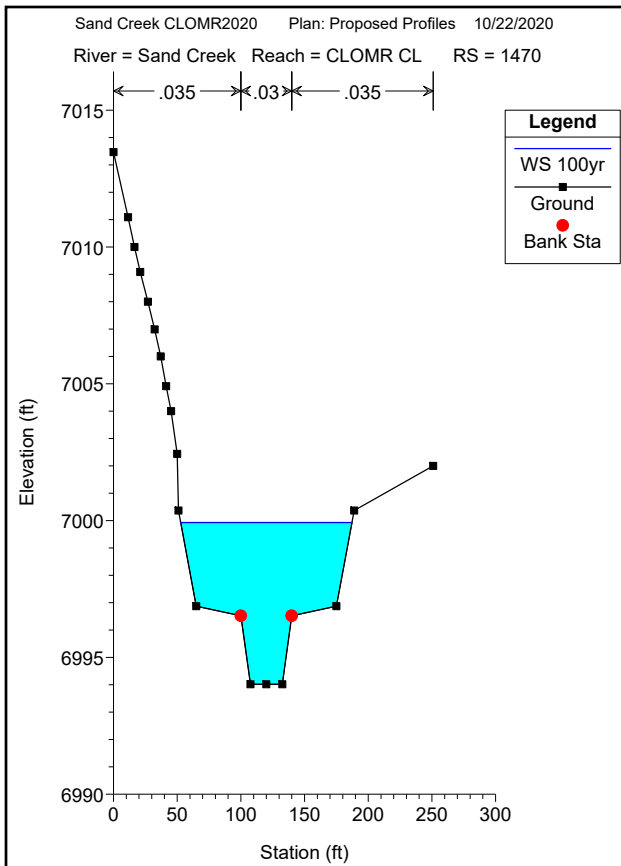

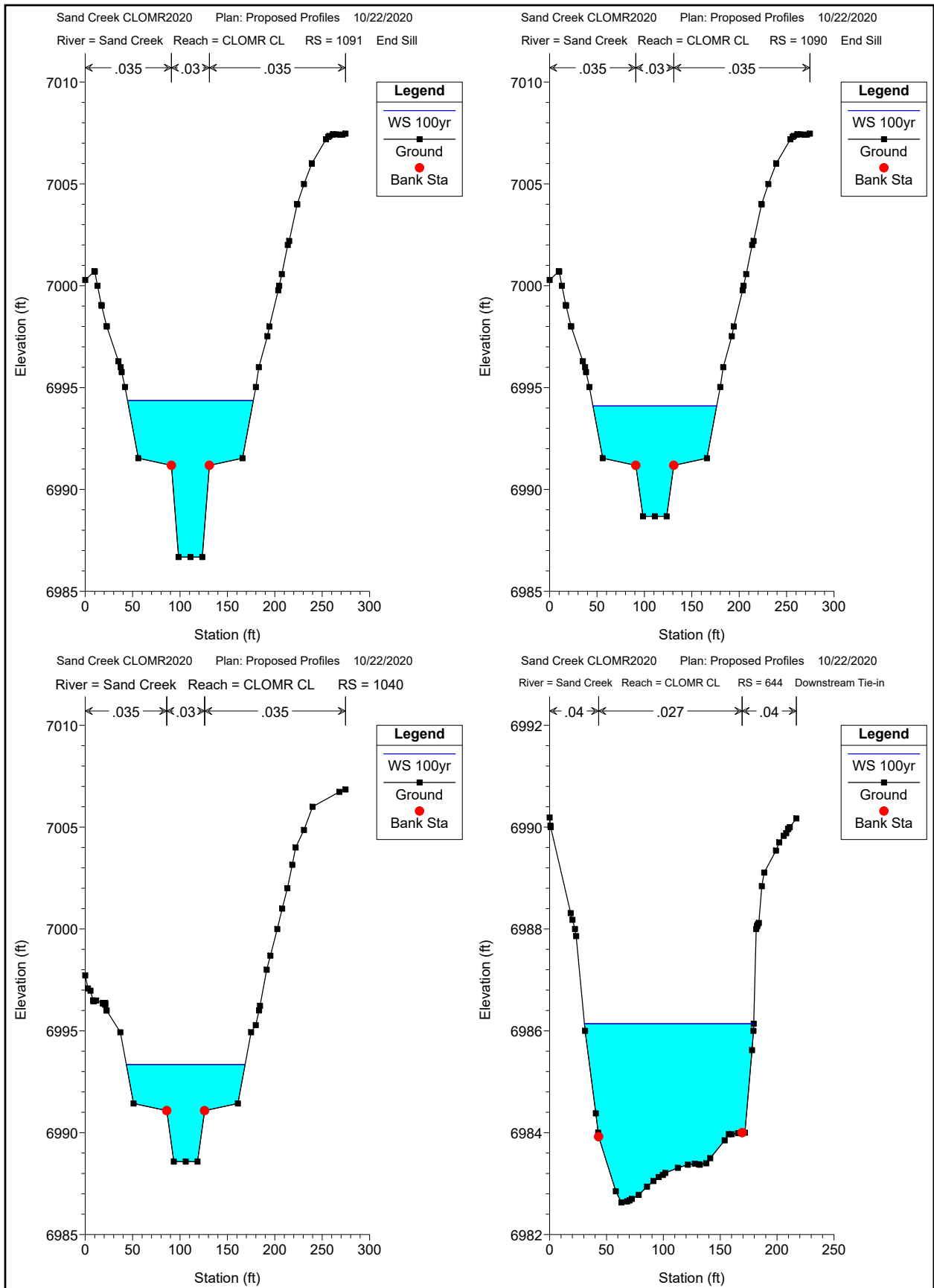

Provide modeling through the property line and downstream to DP 60A (downstream of proposed pond and diversion outfall).

National Flood Hazard Layer FIRMette



8°57'32.20"N

SEE FIS REPORT FOR DETAILED LEGEND AND INDEX MAP FOR FIRM PANEL LAYOUT

Legend

SPECIAL FLOOD HAZARD AREAS

- Without Base Flood Elevation (BFE) Zone A, V, A99
- With BFE or Depth Zone AE, AO, AH, VE, AR
- Regulatory Floodway

OTHER AREAS OF FLOOD HAZARD

- 0.2% Annual Chance Flood Hazard, Area of 1.1% annual chance flood with average depth less than one foot or with drainage areas of less than one square mile Zone 2
- Future Conditions 1% Annual Chance Flood Hazard Zone X
- Area with Reduced Flood Risk due to Levee. See Notes. Zone X
- Area with Flood Risk due to Levee Zone D

OTHER AREAS

- NO SCREEN
- Effective LOMRS
- Area of Undetermined Flood Hazard Zone A

GENERAL STRUCTURES

- Channel, Culvert, or Storm Sewer
- Levee, Dike, or Floodwall

OTHER FEATURES

- Cross Sections with 1% Annual Chance Water Surface Elevation
- Coastal Transect
- Base Flood Elevation Line (BFE)
- Limit of Study
- Jurisdiction Boundary
- Coastal Transect Baseline
- Profile Baseline
- Hydrographic Feature

MAP PANELS

- Digital Data Available
- No Digital Data Available
- Unmapped

The pin displayed on the map is an approximate point selected by the user and does not represent an authoritative property location.

This map complies with FEMA's standards for the use of digital flood maps if it is not void as described below. The basemap shown complies with FEMA's basemap accuracy standards.

The flood hazard information is derived directly from the authoritative NFHL web services provided by FEMA. This map was exported on 5/5/2020 at 1:41:59 PM and does not reflect changes or amendments subsequent to this date and time. The NFHL and effective information may change or become superseded by new data over time.

This map image is void if the one or more of the following map elements do not appear: basemap imagery, flood zone labels, legend, scale bar, map creation date, community identifiers, FIRM panel number, and FIRM effective date. Map images for unmapped and unmodernized areas cannot be used for regulatory purposes.



104°40'7.99"W

USGS The National Map: Orthoimagery. Data refreshed April, 2019. 38°57'4.22"N



National Flood Hazard Layer FIRMette



38°57'47.54"N



Legend

SEE FIS REPORT FOR DETAILED LEGEND AND INDEX MAP FOR FIRM PANEL LAYOUT

- SPECIAL FLOOD HAZARD AREAS**
 - Without Base Flood Elevation (BFE) Zone A, V, A99
 - With BFE or Depth Zone AE, AO, AH, VE, AR
 - Regulatory Floodway
- OTHER AREAS OF FLOOD HAZARD**
 - 0.2% Annual Chance Flood Hazard, Area of 1% annual chance flood with average depth less than one foot or with drainage areas of less than one square mile Zone X
 - Future Conditions 1% Annual Chance Flood Hazard Zone X
 - Area with Reduced Flood Risk due to Levee, See Notes, Zone X
 - Area with Flood Risk due to Levee Zone D
- OTHER AREAS**
 - Area of Minimal Flood Hazard Zone X
 - Effective LOMRs
 - Area of Undetermined Flood Hazard Zone X
- GENERAL STRUCTURES**
 - Channel, Culvert, or Storm Sewer
 - Levee, Dike, or Floodwall
- OTHER FEATURES**
 - Cross Sections with 1% Annual Chance Water Surface Elevation
 - Coastal Transect
 - Base Flood Elevation Line (BFE)
 - Limit of Study
 - Coastal Transect Baseline
 - Profile Baseline
 - Hydrographic Feature
- MAP PANELS**
 - Digital Data Available
 - No Digital Data Available
 - Unmapped

The pin displayed on the map is an approximate point selected by the user and does not represent an authoritative property location.

This map complies with FEMA's standards for the use of digital flood maps if it is not void as described below. The basemap shown complies with FEMA's basemap accuracy standards.

The flood hazard information is derived directly from the authoritative NFHL web services provided by FEMA. This map was exported on 5/5/2020 at 1:54:55 PM and does not reflect changes or amendments subsequent to this date and time. The NFHL and effective information may change or become superseded by new data over time.

This map image is void if the one or more of the following map elements do not appear: basemap imagery, flood zone labels, legend, scale bar, map creation date, community identifiers, FIRM panel number, and FIRM effective date. Map images for unmapped and unmodernized areas cannot be used for regulatory purposes.

National Flood Hazard Layer FIRMette



3°58'18.40"N



104°39'46.83"W

USGS The National Map: Orthoimagery. Data refreshed April, 2019. 38°57'50.43"N



Legend

SEE FIS REPORT FOR DETAILED LEGEND AND INDEX MAP FOR FIRM PANEL LAYOUT

- SPECIAL FLOOD HAZARD AREAS**
 - Without Base Flood Elevation (BFE) Zone A, V, AE, AH, AH, VE, AP
 - With BFE or Depth Zone AE, AO, AH, VE, AP
 - Regulatory Floodway
- OTHER AREAS OF FLOOD HAZARD**
 - 0.2% Annual Chance Flood Hazard, Area of 1% annual chance flood with average depth less than one foot or with draining areas of less than one square mile
 - Future Conditions 1% Annual Chance Flood Hazard Zone A
 - Area with Reduced Flood Risk due to Levee. See Notes. Zone X
 - Area with Flood Risk due to Levee Zone D
- OTHER AREAS**
 - NO SCREEN
 - Area of Minimal Flood Hazard Zone A
 - Effective LOMRS
 - Area of Undetermined Flood Hazard Zone X
- GENERAL STRUCTURES**
 - Channel, Culvert, or Storm Sewer
 - Levee, Dike, or Floodwall
- OTHER FEATURES**
 - Cross Sections with 1% Annual Chance Water Surface Elevation
 - Coastal Transect
 - Base Flood Elevation Line (BFE)
 - Limit of Study
 - Jurisdiction Boundary
 - Coastal Transect Baseline
 - Profile Baseline
 - Hydrographic Feature
- MAP PANELS**
 - Digital Data Available
 - No Digital Data Available
 - Unmapped

The pin displayed on the map is an approximate point selected by the user and does not represent an authoritative property location.

This map complies with FEMA's standards for the use of digital flood maps if it is not void as described below. The basemap shown complies with FEMA's basemap accuracy standards

The flood hazard information is derived directly from the authoritative NFHL web services provided by FEMA. This map was exported on 5/5/2020 at 1:34:46 PM and does not reflect changes or amendments subsequent to this date and time. The NFHL and effective information may change or become superseded by new data over time.

This map image is void if the one or more of the following map elements do not appear: basemap imagery, flood zone labels, legend, scale bar, map creation date, community identifiers, FIRM panel number, and FIRM effective date. Map images for unmapped and unmodernized areas cannot be used for regulatory purposes.

National Flood Hazard Layer FIRMette



38°58'37.02"N

SEE FIS REPORT FOR DETAILED LEGEND AND INDEX MAP FOR FIRM PANEL LAYOUT

- SPECIAL FLOOD HAZARD AREAS**
- Without Base Flood Elevation (BFE) Zone A, V, AE
 - With BFE or Depth Zone AE, AG, AH, VE, AR
 - Regulatory Floodway
- OTHER AREAS OF FLOOD HAZARD**
- 0.2% Annual Chance Flood Hazard, Area of 1% annual chance flood with average depth less than one foot or with drainage areas of less than one square mile Zone I
 - Future Conditions 1% Annual Chance Flood Hazard Zone X
 - Area with Reduced Flood Risk due to Levee. See Notes. Zone X
 - Area with Flood Risk due to Levee Zone D

- OTHER AREAS**
- Area of Minimal Flood Hazard Zone X
 - Effective LOWRS
 - Area of Undetermined Flood Hazard Zone X
- GENERAL STRUCTURES**
- Channel, Culvert, or Storm Sewer
 - Levee, Dike, or Floodwall

- OTHER FEATURES**
- Cross Sections with 1% Annual Chance Water Surface Elevation
 - Coastal Transect
 - Base Flood Elevation Line (BFE)
 - Limit of Study
 - Jurisdiction Boundary
 - Coastal Transect Baseline
 - Profile Baseline
 - Hydrographic Feature

- MAP PANELS**
- Digital Data Available
 - No Digital Data Available
 - Unmapped

The pin displayed on the map is an approximate point selected by the user and does not represent an authoritative property location.

This map complies with FEMA's standards for the use of digital flood maps if it is not void as described below. The basemap shown complies with FEMA's basemap accuracy standards

The flood hazard information is derived directly from the authoritative NFHL web services provided by FEMA. This map was exported on 5/5/2020 at 1:28:11 PM and does not reflect changes or amendments subsequent to this date and time. The NFHL and effective information may change or become superseded by new data over time.

This map image is void if the one or more of the following map elements do not appear: basemap imagery, flood zone labels, legend, scale bar, map creation date, community identifiers, FIRM panel number, and FIRM effective date. Map images for unmapped and unmodernized areas cannot be used for regulatory purposes.



104°39'20.96"W

USGS The National Map: Orthoimagery. Data refreshed April, 2019.

38°58'9.04"N

1:6,000



419 W. Biloc Street
 Colorado Springs, Colorado
 80905-1308
 Kiowa Engineering Corporation

**SAND CREEK DRAINAGE
 BASIN PLANNING STUDY
 PRELIMINARY DESIGN PLANS**

Project No. B.C. 04-09
 Date: 9-98
 Design: RNW
 Drawn: EAK
 Check: RNW
 Revisions:

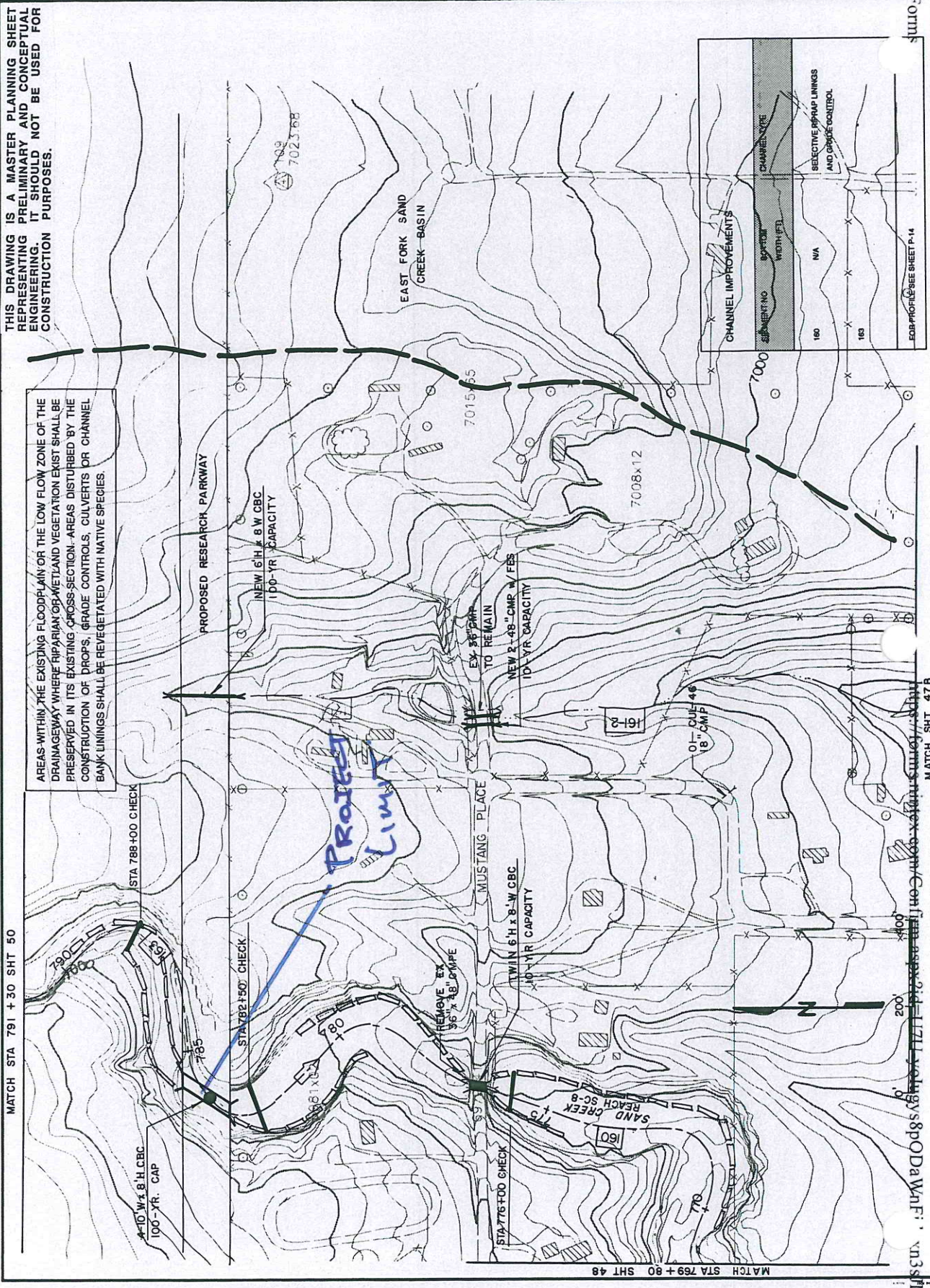

THIS DRAWING IS A MASTER PLANNING SHEET REPRESENTING PRELIMINARY AND CONCEPTUAL ENGINEERING. IT SHOULD NOT BE USED FOR CONSTRUCTION PURPOSES.

AREAS WITHIN THE EXISTING FLOODPLAIN OR THE LOW FLOW ZONE OF THE DRAINAGEWAY WHERE RIPARIAN OR WETLAND VEGETATION EXIST SHALL BE PRESERVED IN ITS EXISTING CROSS-SECTION. AREAS DISTURBED BY THE CONSTRUCTION OF DROPS, GRADE CONTROLS, CULVERTS OR CHANNEL BANK LININGS SHALL BE REVEGETATED WITH NATIVE SPECIES.

CHANNEL IMPROVEMENTS

SPACING (NO BOTTOM WIDTH FT)	CHANNEL TYPE	SELECTIVE RIPRAP LININGS AND GRADE CONTROL
180	N/A	
160		

FOR PROFILE SEE SHEET P-14

MATCH STA 791 + 30 SHT 50

MATCH STA 769 + 80 SHT 48

MATCH SHT 47B

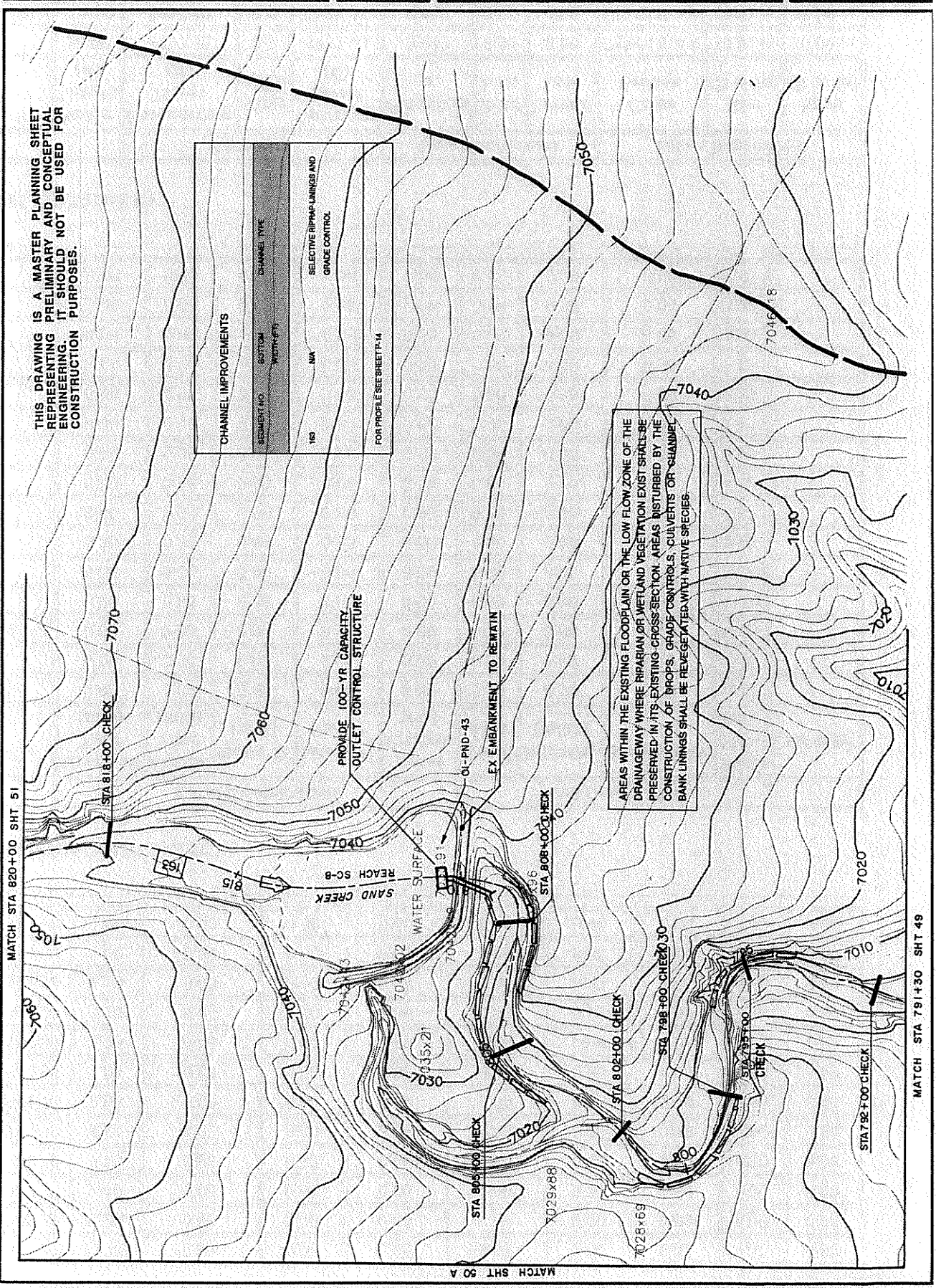

THIS DRAWING IS A MASTER PLANNING SHEET REPRESENTING PRELIMINARY AND CONCEPTUAL ENGINEERING. IT SHOULD NOT BE USED FOR CONSTRUCTION PURPOSES.

CHANNEL IMPROVEMENTS		CHANNEL TYPE
163	AMA	SELECTIVE RIPRAP LINKS AND GRADE CONTROL

FOR PROFILE SEE SHEET 14

AREAS WITHIN THE EXISTING FLOODPLAIN OR THE LOW FLOW ZONE OF THE DRAINAGEWAY WHERE RIPARIAN OR WETLAND VEGETATION EXIST SHALL BE PRESERVED IN ITS EXISTING CROSS-SECTION. AREAS DISTURBED BY THE CONSTRUCTION OF DROPS, GRADE CONTROLS, CURVERTS OR CHANNEL BANK LININGS SHALL BE REVEGETATED WITH NATIVE SPECIES.

MATCH STA 820+00 SHT 51

MATCH STA 791+30 SHT 49

MATCH SHT 50 A

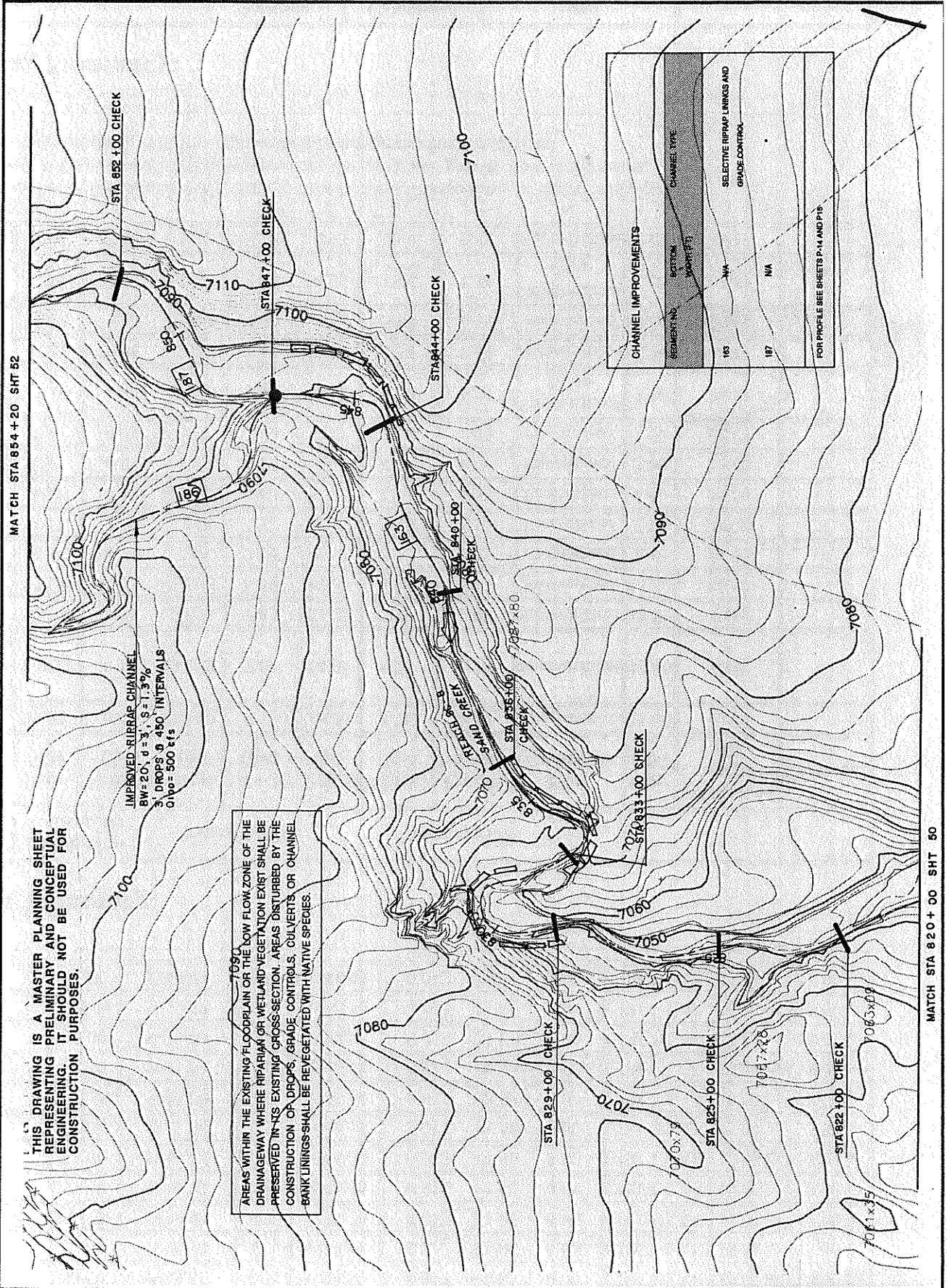

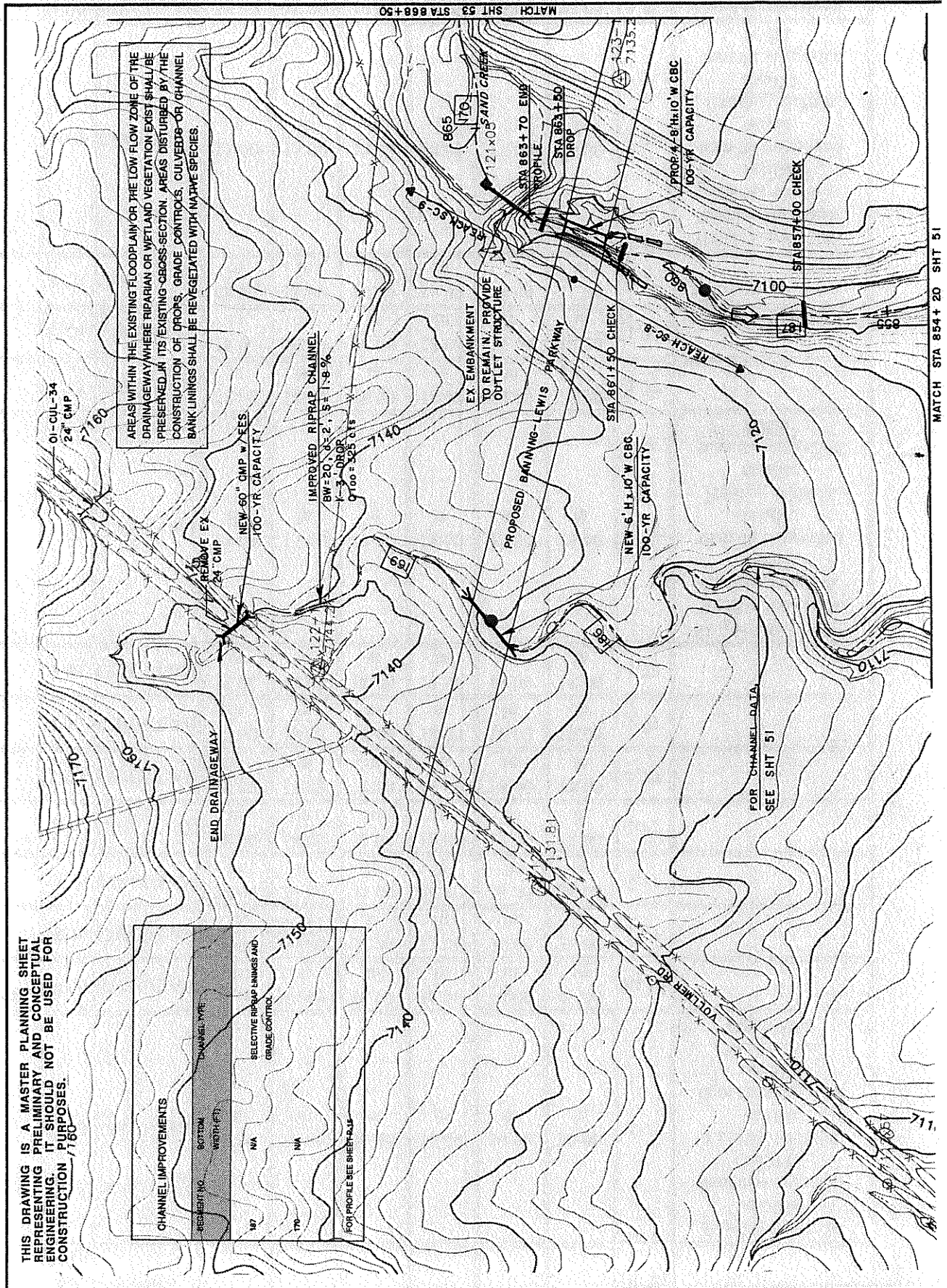

THIS DRAWING IS A MASTER PLANNING SHEET REPRESENTING PRELIMINARY AND CONCEPTUAL ENGINEERING. IT SHOULD NOT BE USED FOR CONSTRUCTION PURPOSES.

CHANNEL IMPROVEMENTS	
SHEET NO.	BOTTOM WIDTH (FT)
187	NA
188	NA

FOR PROFILE SEE SHEET 187

AREAS WITHIN THE EXISTING FLOODPLAIN OR THE LOW FLOW ZONE OF THE DRAINAGEWAY WHERE RIPARIAN OR WETLAND VEGETATION EXISTS SHALL BE PRESERVED IN ITS EXISTING CROSS-SECTION. AREAS DISTURBED BY THE CONSTRUCTION OF DROPS, GRADE CONTROLS, CULVERTS OR CHANNEL BANK LININGS SHALL BE REVEGETATED WITH NATIVE SPECIES.

IMPROVED RIPRAP CHANNEL
 BW=20', S=2.5% 1.8%
 K=3-DROPS
 @100' 325' 215'

NEW 60" CMP W/ EES
 100-YR CAPACITY

NEW 6" H.x.10" W CBC
 100-YR CAPACITY

PROF. 4'-8" H.x.10" W CBC
 100-YR CAPACITY

EX EMBANKMENT TO REMAIN. PROVIDE OUTLET STRUCTURE

PROPOSED BANNING-LEWIS PARKWAY

STA 863+70 EMS PROFILE
 STA 863+50 DROP

STA 861+50 CHECK

STA 857+00 CHECK

REACH SC-8

REACH SC-8

REACH SC-8

REACH SC-8

REACH SC-8

REACH SC-8

REACH SC-8

REACH SC-8

REACH SC-8

REACH SC-8

REACH SC-8

REACH SC-8

REACH SC-8

REACH SC-8

REACH SC-8

REACH SC-8

REACH SC-8

REACH SC-8

REACH SC-8

REACH SC-8

REACH SC-8

REACH SC-8

REACH SC-8

REACH SC-8

REACH SC-8

01-CUL-34
 24" CMP

REMOVE EX
 24" CMP

END DRAINAGEWAY

FOR CHANNEL DATA
 SEE SHT 51

FOR PROFILE SEE SHEET 187

FOR CHANNEL DATA
 SEE SHT 51

FOR CHANNEL DATA
 SEE SHT 51

FOR CHANNEL DATA
 SEE SHT 51

FOR CHANNEL DATA
 SEE SHT 51

FOR CHANNEL DATA
 SEE SHT 51

FOR CHANNEL DATA
 SEE SHT 51

FOR CHANNEL DATA
 SEE SHT 51

FOR CHANNEL DATA
 SEE SHT 51

FOR CHANNEL DATA
 SEE SHT 51

FOR CHANNEL DATA
 SEE SHT 51

FOR CHANNEL DATA
 SEE SHT 51

FOR CHANNEL DATA
 SEE SHT 51

FOR CHANNEL DATA
 SEE SHT 51

FOR CHANNEL DATA
 SEE SHT 51

FOR CHANNEL DATA
 SEE SHT 51

FOR CHANNEL DATA
 SEE SHT 51

FOR CHANNEL DATA
 SEE SHT 51

FOR CHANNEL DATA
 SEE SHT 51

FOR CHANNEL DATA
 SEE SHT 51

FOR CHANNEL DATA
 SEE SHT 51

FOR CHANNEL DATA
 SEE SHT 51

FOR CHANNEL DATA
 SEE SHT 51

FOR CHANNEL DATA
 SEE SHT 51

FOR CHANNEL DATA
 SEE SHT 51

FOR CHANNEL DATA
 SEE SHT 51

MATCH STA 854+20 SHT 51

MATCH STA 868+50 SHT 53

Project No.	90-0409
Date	9-92
Design	RNV
Drawn	EAK
Checked	RNV
Revised	

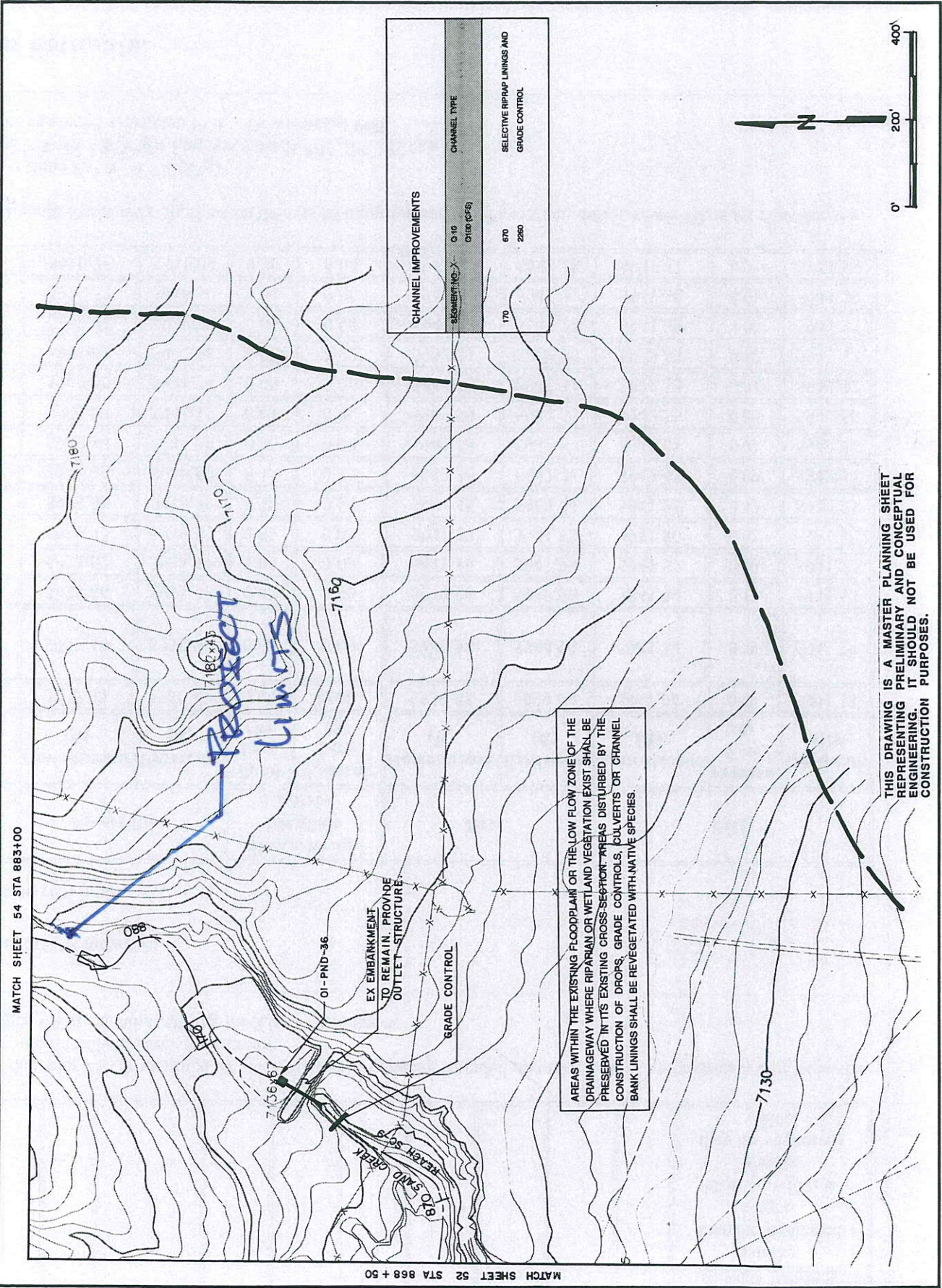

Appendix B

Sterling Ranch Road and Briargate Parkway Bridges Geotechnical Report

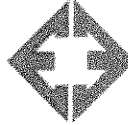

ENTECH
ENGINEERING, INC.

565 ELKTON DRIVE
COLORADO SPRINGS, CO 80907
PHONE (719) 531-5599
FAX (719) 531-5238

**SUBSURFACE SOIL INVESTIGATION
STERLING RANCH BRIDGES
STERLING RANCH ROAD OVER SAND CREEK
BRIARGATE BOULEVARD OVER SAND CREEK
COLORADO SPRINGS, COLORADO**

Prepared for:

**C&C Land
20 Boulder Crescent, 2nd Floor
Colorado Springs, Colorado 80903**

Attn: Chaz Collins

March 4, 2020

Respectfully Submitted,

ENTECH ENGINEERING, INC.

Austin M. Nossokoff, P.E.

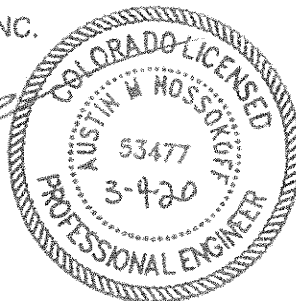

Reviewed by:

Joseph C. Goode, Jr., P.E.
President

AMN/amn

Encl.

Entech Job No. 200045

F:\AA projects\2020\200045-C&C LAnd-Sterling Ranch Bridges-220-SSI\200045 ssi.doc

Table of Contents

1.0 INTRODUCTION..... 1
2.0 PROJECT AND SITE DESCRIPTION2
3.0 SUBSURFACE EXPLORATIONS AND LABORATORY TESTING2
4.0 SUBSURFACE CONDITIONS3
 4.1 Soil and Rock3
 4.2 Groundwater.....5
5.0 GEOTECHNICAL EVALUATION AND RECOMMENDATIONS.....5
 5.1 Foundation Recommendations.....6
 5.1.1 Deep Foundation Systems (Driven H-piles).....6
 5.1.2 Shallow Foundation Parameters.....7
 5.1.3 Retaining Wall Parameters8
 5.2 Site Seismic Classification9
 5.3 Surface and Subsurface Drainage.....9
 5.4 Concrete9
 5.5 Foundation Excavation Observations 10
 5.6 Structural Fill..... 10
 5.7 Utility Trench Backfill 11
 5.8 General Backfill..... 12
 5.9 Excavation Stability..... 12
 5.10 Winter Construction 12
 5.11 Construction Observations 13
6.0 CLOSURE..... 13

Tables

- Table 1 Summary of Laboratory Test Results
- Table 2 Sterling Ranch Bridges – LPile Design Parameters

Figures

- Figure 1: Vicinity Map
- Figure 2: Site Plan/Test Boring Location Map

List of Appendices

- Appendix A Laboratory Testing Results
- Appendix B Laboratory Testing Results

**SUBSURFACE SOIL INVESTIGATION
STERLING RANCH BRIDGES
STERLING RANCH ROAD OVER SAND CREEK &
BRIARGATE BOULEVARD OVER SAND CREEK
EL PASO COUNTY, COLORADO**

1.0 INTRODUCTION

C&C Land is planning the construction of two vehicular bridges over sand creek for the proposed Sterling Ranch Road and Briargate Boulevard in El Paso County northeast of Colorado Springs, Colorado. The approximate location of the site is shown on the Vicinity Map, Figure 1. The planned layouts of the proposed bridges are shown on Figure 2, Site Plan/Test Boring Location Map.

This report describes the subsurface investigation conducted for the planned bridges and provides recommendations for foundation design and construction. The subsurface soil investigation included drilling test borings at four (4) locations within the footprints of the planned bridge foundations, collecting samples of soil, and conducting a geotechnical evaluation of the investigation findings. All drilling and subsurface investigation activities were performed by Entech Engineering, Inc. (Entech). The contents of this report, including the geotechnical evaluation and recommendations, are subject to the limitations and assumptions presented in Section 6.0.

2.0 PROJECT AND SITE DESCRIPTION

It is Entech's understanding that the project will consist of the construction of two (2) vehicular bridges spanning Sand Creek with driven H-pile foundations and associated site improvements. At the time of drilling, the sites for the proposed bridges were vacant. The crossing for the proposed Briargate Boulevard had been graded at the time of drilling. Sand Creek flows to the south. Current vegetation on the site consisted of grasses and small shrubs.

3.0 SUBSURFACE EXPLORATIONS AND LABORATORY TESTING

The subsurface conditions were investigated by drilling four (4) exploratory test borings, one at each bridge abutment. The borings were drilled to depths 20 feet below the existing ground surface using a truck-mounted continuous flight auger-drilling rig supplied and operated by Entech Engineering, Inc. Boring Logs descriptive of the subsurface conditions encountered during drilling and subsequent to drilling are presented in Appendix A. At the conclusion of drilling, observations of groundwater levels were made in each of the open borings. The approximate locations of the test borings are indicated on Figure 2.

Soil samples were obtained from the borings utilizing the Standard Penetration Test (ASTM D-1586) using a 2-inch O.D. split-barrel sampler and a California Sampler. Results of the Standard Penetration Test (SPT) are included on the Test Boring Logs in terms of N-values expressed in blows per foot (bpf). Soil samples recovered from the borings were visually classified and recorded on the Test Boring Logs. The soil classifications were later verified utilizing laboratory testing and grouped by soil type. The soil type numbers are included on the Test Boring Logs. It should be understood that the soil descriptions shown on the Test Boring Logs may vary between boring location and sample depth.

It should also be noted that the lines of stratigraphic separation shown on the Test Boring Logs represent approximate boundaries between soil types and the actual stratigraphic transitions may be more gradual and vary with location. The Test Boring Logs are presented in Appendix A.

Moisture Content, ASTM D-2216, was obtained in the laboratory for all recovered samples. Grain-Size, ASTM D-422, and Atterberg Limits, ASTM D-4318, were determined for various samples for the purpose of classification and to obtain pertinent engineering characteristics. Volume change testing was performed on selected samples using the Swell/Consolidation Test (ASTM D-4546) in order to evaluate potential expansion/consolidation characteristics of the soil and bedrock. Sulfate testing was performed on select samples to determine the corrosive characteristics of the soils. The Laboratory Test Results are included in Appendix B and summarized in Table 1.

4.0 SUBSURFACE CONDITIONS

Four (4) soil types were encountered in the borings drilled for the subsurface investigation: Type 1: silty sand fill (SM), Type 2: very silty sand (SM), Type 3: silty to very silty sandstone (SM), and Type 4: sandy to very sandy claystone (CL). The soils were classified in accordance with the Unified Soil Classification System (USCS) using the laboratory testing results and the observations made during drilling.

4.1 Soil and Rock

Soil Type 1 is a silty sand fill (SM). The sand fill was encountered in Test Boring 1 at the existing ground surface extending to a depth of 6 feet. Standard Penetration Testing conducted on the sand resulted in SPT N-values of 4 to 6 blows per foot (bpf), which indicates loose states. Moisture content and grain size testing resulted in a moisture contents of 7 to 8 percent with approximately 29 percent of the soil size particles passing the No. 200 sieve. Atterberg limit testing was performed on a sample of sand fill and resulted in a liquid limit of no value with a plastic index of non-plastic. Sulfate testing on the sand resulted in 0.00 percent soluble sulfate

by weight, indicating negligible potential for below grade concrete degradation due to sulfate attack.

Soil Type 2 is a very silty sand (SM). The sand was encountered in three (3) of the test borings at the existing ground surface extending to depths of 1 to 10 feet. Standard Penetration Testing conducted on the soil resulted in SPT N-values of 7 to 26 blows per foot (bpf), indicating the sand is loose to medium dense in terms of density. Moisture content and grain size testing resulted in moisture contents of 5 to 20 percent with approximately 40 percent of the soil size particles passing the No. 200 sieve. Atterberg limit testing was performed on a sample of sand fill and resulted in a liquid limit of 15 with a plastic index of 3. Sulfate testing on the sand resulted in less than 0.01 percent soluble sulfate by weight, indicating negligible potential for below grade concrete degradation due to sulfate attack.

Soil Type 3 is a silty to very silty sandstone (SM). The sandstone was encountered in all of the test borings at depths ranging from 1 to 10 feet bgs and extending to depths of 12 feet and the termination of the borings (20 feet). Standard Penetration Testing conducted on the soil resulted in SPT N-values of greater than 50 blows per foot (bpf), indicating the sandstone is very dense in terms of density. Moisture content and grain size testing resulted in moisture contents of 10 to 17 percent with approximately 14 to 42 percent of the soil size particles passing the No. 200 sieve. Atterberg limit testing resulted in liquid limits of no value to 32 and plastic indexes of non plastic to 6. Sulfate testing on the sandstone resulted in 0.00 to less than 0.01 percent soluble sulfate by weight, indicating negligible potential for below grade concrete degradation due to sulfate attack.

Soil Type 4 is sandy to very sandy claystone (CL). The claystone was encountered in Test Boring 1 at a depth of 12 feet bgs and extending to the termination of the boring (20 feet). Standard Penetration Testing conducted on the soil resulted in SPT N-values of greater than 50 blows per foot (bpf), indicating the soil is hard in terms of consistency. Moisture content and grain size testing resulted in moisture contents of 15 to 16 percent with approximately 59 percent of the soil size particles passing the No. 200 sieve. Atterberg limit testing resulted in a liquid limit of 35 and a plastic index of 14.

Additional descriptions and engineering properties of the soil encountered during drilling are included on the boring logs. Laboratory Testing Results are summarized on Table 1 and presented in Appendix B. It should be understood that the soil descriptions reported on the boring logs may vary between boring locations and sampling depths. Similarly, the lines of stratigraphic separation shown on the boring logs represent approximate boundaries between soil types and the actual transitions between types may be more gradual or variable.

4.2 Groundwater

Groundwater was encountered at depths ranging from 13 to 16.5 feet in Test Boring Nos. 3 and 4. Test Boring Nos. 1 and 2 were dry to 18 feet after drilling. Groundwater may affect development of significant foundation excavations or during installation of deep utilities depending on the final grading plans. Creek flow will vary due to rainfall, drainage, and other factors not readily apparent at this time. It should be noted that groundwater levels, observed at the time of the subsurface investigation, could change due to seasonal variations, changes in land runoff characteristics and future development including of nearby areas.

5.0 GEOTECHNICAL EVALUATION AND RECOMMENDATIONS

The following discussion is based on the subsurface conditions encountered in the borings drilled in the planned bridge footprints. If subsurface conditions different from those described herein are encountered during construction or if the project elements change from those described, Entech Engineering, Inc. should be notified so that the evaluation and recommendations presented can be reviewed and revised if necessary.

The site will be developed by constructing two (2) bridges over Sand Creek and associated site improvements at Sterling Ranch Road and Briargate Boulevard Crossings. The proposed bridges are expected to utilize driven H-pile foundations

Subsurface soil conditions encountered in the test borings drilled for the planned interchanges consisted of sand fill and silty to very silty sand overlying silty to very silty sandstone and sandy to very sandy claystone. Bedrock was encountered at depths of 1 to 10 feet in the test borings.

The surficial sands and sand fill were encountered in loose to medium dense states. The underlying sandstone was encountered in dense states, and the underlying claystone was encountered at hard consistencies.

5.1 Foundation Recommendations

The main purpose of the subsurface investigation was to gather soil and bedrock information for the proposed bridge abutments for use in providing foundation recommendations and design values. Recommendations for bridge supports using driven H-piles, shallow spread footings, and parameters for retaining walls are provided.

5.1.1 Deep Foundation Systems (Driven H-piles)

Based on evaluation of the site subsurface conditions, it is believed that the planned H-piles will achieve most of their compressive strength through end bearing and skin friction in the underlying sandstone and claystone bedrock (Soil Types 3 and 4). Some frictional resistance will also be developed in the overburden sand (Soil Type 1). Design parameters for use in the H-pile design, which include allowable end bearing, side resistance, and resisting factors are presented in Table 2. L Pile parameters for the sand, sandstone, and claystone are also included in Table 2. The recommendations and parameters apply to piles spaced by horizontal distances of at least 3 times the pile width. If the piles are spaced closer, reductions in the allowable pile capacity may be warranted. The following unit weights are recommended for the site soil and bedrock.

Unit weight of native overburden sand	120 pcf
Unit weight of sandstone bedrock	125 pcf
Unit weight of siltstone and claystone bedrock	125 pcf

It is recommended that full-time observation of the H-pile installation be performed to compile driving logs for each pile. At a minimum, the log should include: the driving resistance per foot of pile and per inch of pile over the last 3 inches; the pile driver make and model; rated energy; pile cushion/condition; observed damage; and final pile top location. The guidance set forth in the

State of Colorado Standard Specifications for Road and Bridge Construction, Section 502, Piling, is recommended. Piles should be driven 10 feet into bedrock or refusal.

5.1.2 Shallow Foundation Parameters

Structures associated with the bridges can be supported with shallow foundations resting on the native sands, recompacted loose sands, or sandstone. It should be noted that due to potential shallow groundwater on this site (due to the proximity to Sand Creek), extensive subgrade improvements are anticipated to support shallow foundations. The foundation members should bear on the native site sands, sandstone, or be recompacted according to the "Structural Fill" paragraph. Any topsoil must be removed and the existing subgrade cleared of any debris prior to excavation. Loose soils or uncontrolled fill material beneath foundation components will require removal and recompaction. Any expansive soils encountered beneath the foundation will require removal and replacement with non-expansive structural fill compacted according to the "Structural Fill" paragraph. Any new fill should be placed to the requirements of the "Structural Fill" paragraph. On-site granular sands may be used as structural fill as approved by Entech. Any import material should be approved by Entech prior to hauling to the site.

Provided the above recommendations are followed, an allowable bearing pressure of 2400 psf is recommended for the native sands. For recompacted sands or imported granular structural fill, an allowable bearing capacity of 3000 psf is recommended. An allowable bearing capacity of 4000 psf is recommended for undisturbed sandstone. Footings should extend a minimum of 30 inches below the adjacent exterior surface grade for frost protection. Following the above foundation subgrade preparation recommendations, and adhering to the recommended maximum allowable bearing pressure, it is expected to result in foundation designs which should limit total and differential vertical movements.

Foundation excavations are recommended to extend at least 3 feet horizontally beyond the foundation limits in order to provide adequate space for installation of drain materials (if necessary) and placement of controlled fill. All foundation excavation side slopes should be inclined at angles of 1½ horizontal to 1 vertical or flatter, as necessary, to provide for excavation sidewall stability during construction or as required by OSHA regulations.

Entech should observe overexcavated subgrades as well as the overall foundation excavation subgrade and evaluate if the exposed conditions are consistent with those described in this report. Entech should also provide recommendations for overexcavation depth and other subgrade improvements, if necessary, and the need for drain systems based on the excavation conditions observed at that time.

5.1.3 Retaining Wall Parameters

The following values are recommended for use in designing retaining walls with unbalanced lateral loading that may be associated with this project. Roadway/Vehicle surcharge loading is required for wall design.

Recommended Design Values – Lateral Loading

Equivalent fluid density for lateral earth pressure (active), pcf (site granular soils)	45
Equivalent fluid density for lateral earth pressure (passive), pcf	300
Equivalent fluid density for lateral earth pressure (at rest), pcf	60
Soil density (compacted sand), pcf	125
Angle of Internal Friction (loose silty sand and sandy clay-silt)	26°
Angle of Internal Friction (compacted silty sand)	34°
Coefficient of sliding between concrete and silty gravelly sand	0.35
Bearing capacity of sand, psf	2400 psf
Bearing capacity of sandstone, psf	3500 psi

*Note: The above lateral loading design values are for level back slope angles and no surcharge loads. If wall backfill is submerged, water pressures must be taken into account as additional wall loading. If backfill slope angles are greater than zero degrees, or if the backfill is surcharged, the design values must be adjusted to account for additional lateral loading.

5.2 Site Seismic Classification

Based on the subsurface conditions encountered at the site and in accordance with Section 1613 of the 2015 International Building Code (IBC), the site meets the conditions of a Site Class C.

5.3 Surface and Subsurface Drainage

Positive surface drainage must be maintained around structures to minimize infiltration of surface water. A minimum gradient of 5 percent in the first 10 feet adjacent to foundation components is recommended. A minimum gradient of 2 percent is recommended for paved areas. All grades should be directed away from structures.

To help minimize infiltration of water into foundation zones, vegetative plantings placed close to foundation components should be limited to those species having low watering requirements and irrigated grass should not be located within 5 feet of foundation components. Similarly, sprinklers are not recommended to discharge water within 5 feet of foundation components. Irrigation near foundations should be limited to the minimum amount sufficient to maintain vegetation. Application of more irrigation water than necessary can increase the potential for foundation movement.

5.4 Concrete

Soluble sulfate testing was conducted on three samples of the site soils to evaluate the potential for sulfate attack on concrete placed below the surface grade. The test results indicated less than 0.01 percent soluble sulfate by weight for the site soils. The test results indicate the sulfate component of the in-place site soils present a negligible exposure threat to concrete placed below grade that comes into contact with the site soils.

Type II cement is recommended for concrete at this site. To further avoid concrete degradation during construction it is recommended that concrete not be placed on frozen or wet ground. Care should be taken to prevent the accumulation or ponding of water in foundation excavations prior to the placement of concrete. If standing water is present in the foundation excavations, it should be removed by ditching to sumps and pumping the water away from the foundation area

prior to concrete placement. If concrete is placed during periods of cold temperatures, the concrete must be kept from freezing. This may require covering the concrete with insulated blankets and adding heat to prohibit freezing.

5.5 Foundation Excavation Observations

Subgrade preparation for bridge foundations and associated improvements should be observed by Entech Engineering prior to construction of the foundation elements in order to verify that (1) no anomalies are present, (2) materials of the proper bearing capacity have been encountered or placed, and (3) no soft, loose, uncontrolled fill material, expansive soil or debris are present in the foundation area prior to concrete placement or backfilling. Pile driving should be observed to verify proper embedment or refusal. Piles should be driven 10 feet into bedrock or refusal. Entech should make final recommendations for over-excavation or stabilization, if required, at the time of excavation observation, if necessary.

5.6 Structural Fill

Areas to receive fill should have all topsoil, organic material or debris removed. Fill must be properly benched. The surface should be scarified and moisture conditioned to within ± 2 percent of its optimum moisture content and compacted to 95 percent of its maximum Modified Proctor Dry Density (ASTM D-1557) beneath footings or floor slabs prior to placing new fill. New fill beneath footings should be non-expansive and be placed in thin lifts not to exceed 6 inches after compaction while maintaining at least 95 percent of its maximum Modified Proctor Dry Density (ASTM D-1557). These materials should be placed at a moisture content conducive to compaction, usually ± 2 percent of Proctor optimum moisture content. The placement and compaction of fill should be observed and tested by Entech Engineering, Inc. Imported soils should be approved by Entech Engineering, Inc. prior to being hauled to the site and on-site granular soils prior to placement.

Compacted, non-expansive granular soil, free of organics, debris and cobbles greater than 3-inches in diameter, is recommended for filling foundation components. All fill placed within the foundation areas should be non-expansive and be compacted to a minimum of 95 percent of the

soils maximum dry density as determined by the Modified Proctor Test (ASTM D-1557). Fill material placed beneath floor slabs should be compacted to a minimum of 95 percent of its maximum Modified Proctor Dry Density, ASTM D-1557. Fill material should be placed in horizontal lifts such that each finished lift has a compacted thickness of six inches or less. Fill should be placed at water contents conducive to achieving adequate compaction, usually within ± 2 percent of the optimum water content as determined by ASTM D-1557. Mechanical methods can be used for placement and compaction of fill; however, heavy equipment should be kept at distance from foundation walls and below slab infrastructure to avoid overstressing. No water flooding techniques of any type should be used for compaction or placement of foundation or floor slab fill material.

5.7 Utility Trench Backfill

Fill placed in utility trenches should be compacted to a minimum of 95 percent of its maximum dry density as determined by the Standard Proctor Test (ASTM D-698) for cohesive soils and 95 percent as determined by the Modified Proctor Test (ASTM D-1557) for cohesionless soils. Fill should be placed in horizontal lifts having a compacted thickness of six inches or less and at a water content conducive to adequate compaction, within ± 2 percent of the optimum water content. Mechanical methods should be used for fill placement; however, heavy equipment should be kept at a distance from foundation walls. No water flooding techniques of any type should be used for compaction or placement of utility trench fill.

Trench backfill placement should be performed in accordance with El Paso County specifications. All excavation and excavation shoring/bracing should be performed in accordance with OSHA guidelines.

5.8 General Backfill

Any areas to receive fill outside the foundation limits should have all topsoil, organic material, and debris removed. Fill must be properly benched into existing slopes in order to be adequately compacted. The fill receiving surface should be scarified to a depth of 12-inches and moisture conditioned to ± 2 percent of the optimum water content, and compacted to a minimum of 95 percent of the ASTM D-1557 maximum dry density before the addition of new fill. Fill should be placed in thin lifts not to exceed 6 inches in thickness after compaction while maintaining at least 95 percent of the ASTM D-1557 maximum dry density. Fill material should be free of vegetation and other unsuitable material and shall not contain rocks or fragments greater than 3-inches. Topsoil and strippings should be segregated from all other fill sources on the site. Fill placement and compaction beneath and around foundations, in utility trenches, beneath roadways or other structural features of the project should be observed and tested by Entech during construction.

5.9 Excavation Stability

Excavation sidewalls must be properly sloped, benched and/or otherwise supported in order to maintain stable conditions. All excavation openings and work completed therein shall conform to OSHA Standards as put forward in CFR 29, Part 1926.650-652, (Subpart P).

5.10 Winter Construction

In the event construction of the planned facility occurs during winter, foundations and subgrades should be protected from freezing conditions. Concrete should not be placed on frozen soil and once concrete has been placed, it should not be allowed to freeze. Similarly, once exposed, the foundation subgrade should not be allowed to freeze. During site grading and subgrade preparation, care should be taken to avoid burial of snow, ice or frozen material within the planned construction area.

5.11 Construction Observations

It is recommended that Entech observe and document the following activities during construction of the building foundations.

- Excavated subgrades and subgrade preparation.
- Drilled Pier Installation
- Placement of drains (if installed).
- Placement/compaction of fill material for the foundation components and retaining walls.
- Placement/compaction of utility bedding and trench backfill.

6.0 CLOSURE

The subsurface investigation, geotechnical evaluation and recommendations presented in this report are intended for use of C&C Land with application to the proposed bridges over Sand Creek at Sterling Ranch Road and Briargate Boulevard and their associated site improvements, in El Paso County northeast of Colorado Springs, Colorado. In conducting the subsurface investigation, laboratory testing, engineering evaluation and reporting, Entech Engineering, Inc. endeavored to work in accordance with generally accepted professional geotechnical and geologic practices and principles consistent with the level of care and skill ordinarily exercised by members of the geotechnical profession currently practicing in same locality and under similar conditions. No other warranty, expressed or implied is made. During final design and/or construction, if conditions are encountered which appear different from those described in this report, Entech Engineering, Inc. requests that it be notified so that the evaluation and recommendations presented herein can be reviewed and modified as appropriate.

If there are any questions regarding the information provided herein or if Entech Engineering, Inc. can be of further assistance, please do not hesitate to contact us.

TABLES

TABLE 1
SUMMARY OF LABORATORY TEST RESULTS

CLIENT C&C LAND
 PROJECT STERLING RANCH BRIDGES
 JOB NO. 200045

SOIL TYPE	TEST BORING NO.	DEPTH (FT)	WATER (%)	DRY DENSITY (PCF)	PASSING NO. 200 SIEVE (%)	LIQUID LIMIT (%)	PLASTIC INDEX (%)	SULFATE (WT %)	FHA SWELL (PSF)	SWELL/CONSOL (%)	UNIFIED CLASSIFICATION	SOIL DESCRIPTION
1	1	2-3			29.1	NV	NP	0.00			SM	FILL, SAND, SILTY
2	3	5			39.8	15	3	<0.01			SM	SAND, VERY SILTY
3	2	10			13.9	NV	NP	<0.01			SM	SANDSTONE, SILTY
3	4	2-3			14.7						SM	SANDSTONE, SILTY
3	4	15	17.1	110.2	42.2	32	6	0.00		1.9	SM	SANDSTONE, VERY SILTY
4	1	15	14.3	116.1						1.6	CL	CLAYSTONE, SANDY
4	1	20			58.7	35	14				CL	CLAYSTONE, VERY SANDY

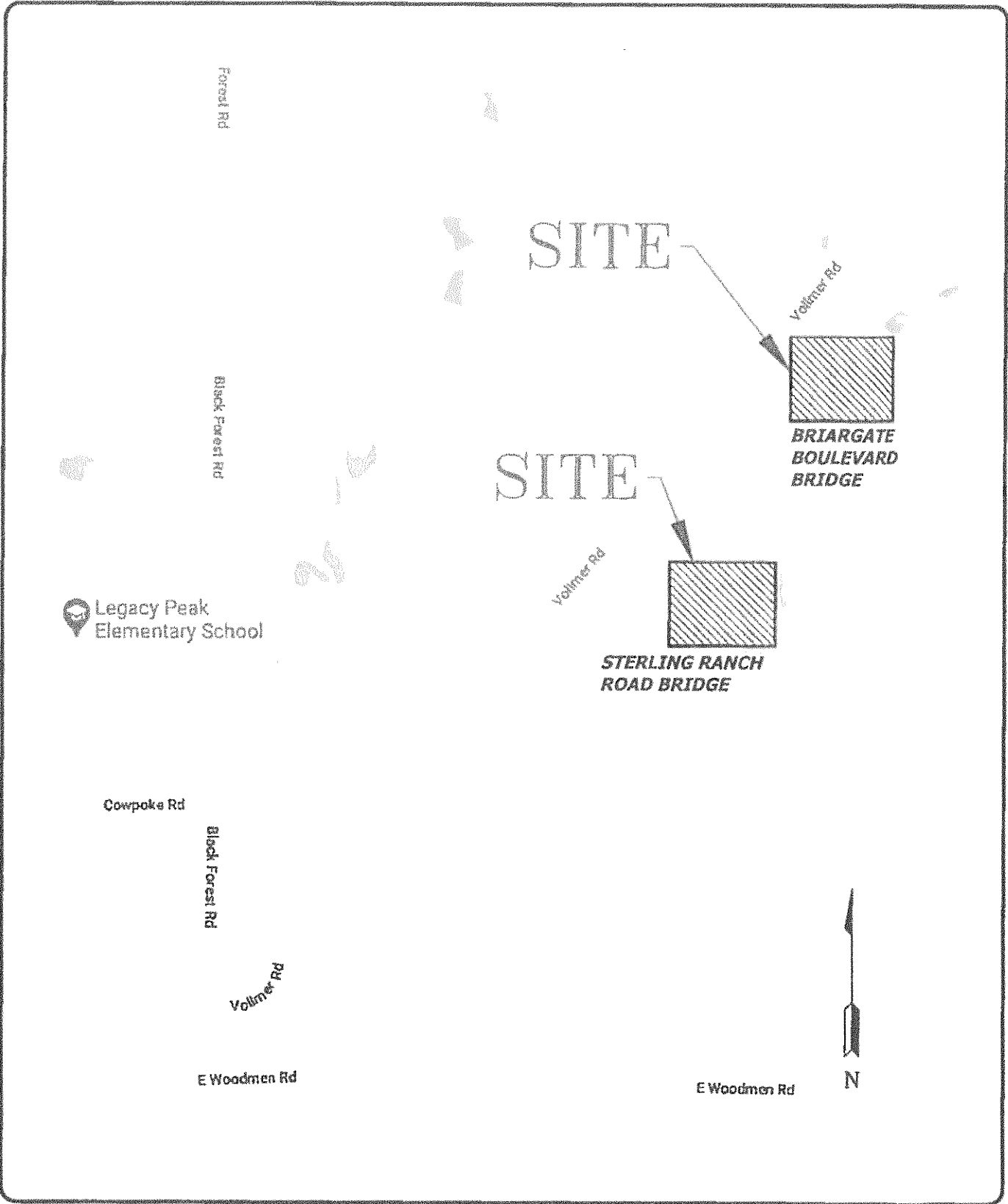

TABLE 2

Sterling Ranch Bridges - LPile Design Parameters

Depth Below Existing Ground Surface		Groundwater Elevation (ft) Below Existing Ground	Soil/Rock Description	Axial Pile Capacity Parameters		PRELIMINARY LPile Parameters						
Top	Bottom			Allowable Side Resistance (ksf)	Allowable End Bearing (ksf)	p-y Curve	Unit Weight γ^1 (pcf)	Peak Friction Angle ϕ (deg)	Initial Static Modulus of Subgrade Reaction, k (pcf)	Undrained Cohesion c_u (psf)	Strain Factor ϵ_u (in/in)	
0	6		Suitable Granular Structural Fill (Dense)	---	---	Sand	120 62 ¹	32	25 20 ¹	N/A	N/A	
0	1 to 10		Native Silty Sand	---	---	Sand	120 62 ¹	32	25 20 ¹	N/A	N/A	
1 to 10	12 to BOE	13 to 16	Silty Sandstone	3	30	Sand	125 67 ¹	34	225 125 ¹	N/A	N/A	
12	BOE		Sandy to Very Sandy Claystone	3	30	Clay	115 57 ¹	N/A	500	1500	0.005	

¹ = Submerged

FIGURES

ENTECH
ENGINEERING, INC.
305 ELKTON DRIVE
COLORADO SPRINGS, CO 80907 (719) 531-3399

Vicinity Map
Sterling Ranch Bridges
Sterling Ranch Rd & Briargate Blvd Over
Sand Creek
El Paso County, CO
For: C & C Land

DRAWN: AMN	DATE: 2/14/20	CHECKED:	DATE:
---------------	------------------	----------	-------

JOB NO.:
200045

FIG NO.:
1

⊕ TB-2- APPROXIMATE TEST BORING LOCATION AND NUMBER

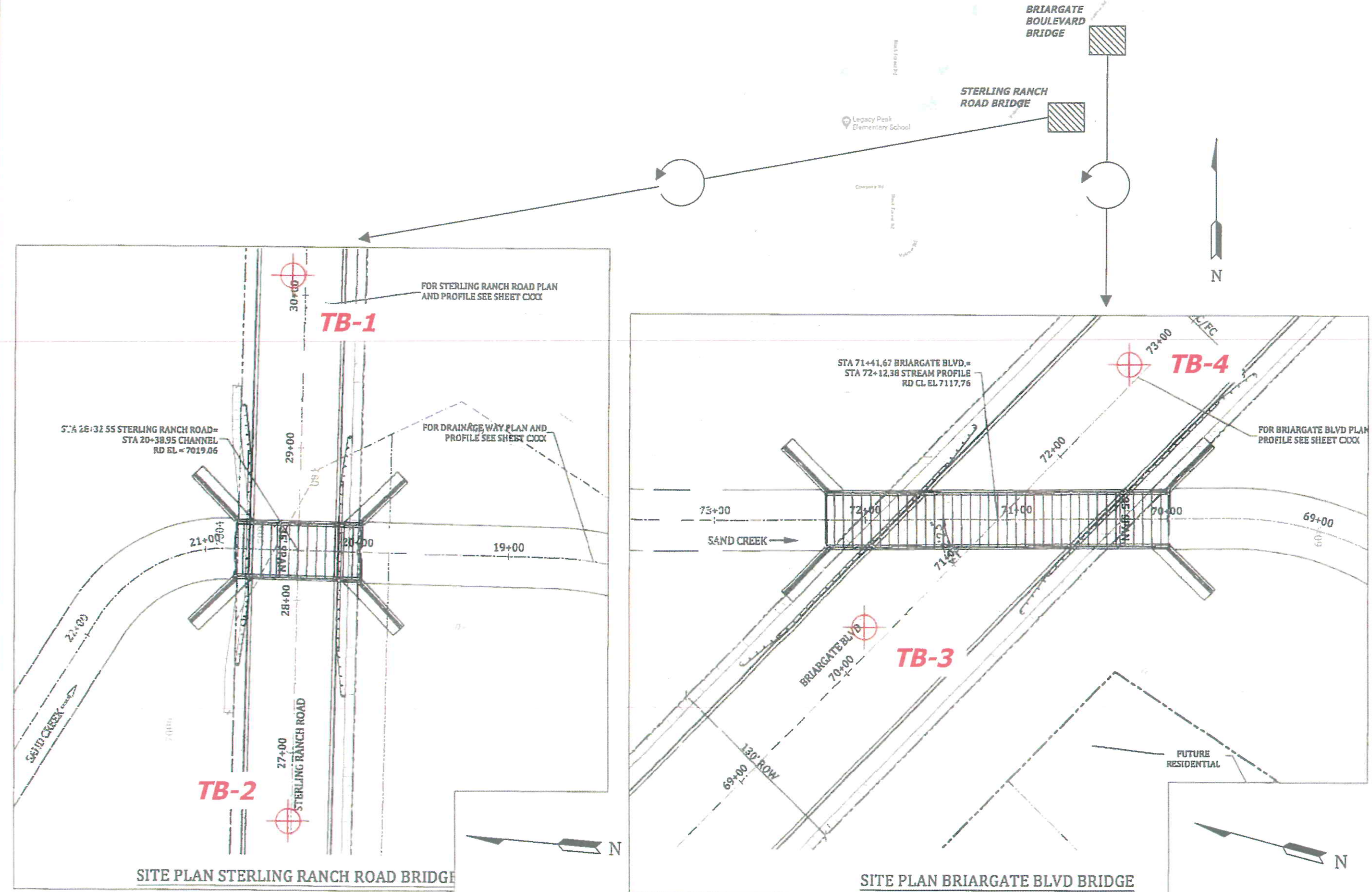

REVISIONS	BY:

ENTECH ENGINEERING, INC.
 905 ELKTON DRIVE
 COLORADO SPRINGS, CO 80907 (719) 531-5599

Site Plan/Test Boring Map
 Sterling Ranch Bridges
 Sterling Ranch Rd & Briargate Blvd
 Over Sand Creek
 El Paso County, CO
 For: C & C Land

DRAWN BY: AMY
DESIGNED BY: AMY
CHECKED BY:
DATE: 02/27/2020
SCALE: AS SHOWN
JWB NO.: 200045
FIGURE NO.:

APPENDIX A: Test Boring Logs

TEST BORING NO. 1
 DATE DRILLED 1/23/2020
 Job # 200045

TEST BORING NO. 2
 DATE DRILLED 1/23/2020
 CLIENT C&C LAND
 LOCATION STERLING RANCH BRIDGES

REMARKS

DRY TO 18', 1/28/20

FILL 0-6, SAND, SILTY, FINE TO COARSE GRAINED, BROWN, LOOSE, MOIST

SANDSTONE, SILTY, FINE GRAINED, TAN, VERY DENSE, MOIST

CLAYSTONE, SANDY TO VERY SANDY, GRAY BROWN, HARD, MOIST

Depth (ft)	Symbol	Samples	Blows per foot	Watercontent %	Soil Type
0-5	(Dotted)		6	7.7	1
5-10	(Dotted)		4	6.9	1
10-15	(Dotted)		50 7"	14.6	3
15-20	(Cross-hatched)		50 8"	15.3	4
20-25	(Cross-hatched)		50 7"	15.9	4

REMARKS

DRY TO 18', 1/28/20

SAND, SILTY, FINE TO COARSE GRAINED, TAN, MEDIUM DENSE, MOIST

SANDSTONE, SILTY, FINE GRAINED, TAN, VERY DENSE, MOIST

SANDSTONE, SILTY, FINE TO COARSE GRAINED, TAN TO GRAY BROWN, VERY DENSE, MOIST

Depth (ft)	Symbol	Samples	Blows per foot	Watercontent %	Soil Type
0-5	(Dotted)		26	5.2	2
5-10	(Dotted)		50 11"	13.5	3
10-15	(Dotted)		50 6"	10.0	3
15-20	(Dotted)		50 10"	11.2	3
20-25	(Dotted)		50 5"	12.2	3



ENTECH
 ENGINEERING, INC.

505 ELKTON DRIVE
 COLORADO SPRINGS, COLORADO 80907

TEST BORING LOG

DRAWN

DATE

CHECKED. *[Signature]*

DATE 2/10/20

JOB NO.
 200045

FIG NO.
 A-1

TEST BORING NO. 3
 DATE DRILLED 1/23/2020
 Job # 200045

TEST BORING NO. 4
 DATE DRILLED 1/23/2020
 CLIENT C&C LAND
 LOCATION STERLING RANCH BRIDGES

REMARKS

WATER @ 16.5', 1/28/20
 SAND, SILTY TO VERY SILTY,
 FINE TO COARSE GRAINED, TAN
 TO BROWN, MEDIUM DENSE TO
 LOOSE, MOIST

SANDSTONE, SILTY, FINE TO
 COARSE GRAINED, GRAY BROWN,
 VERY DENSE, MOIST TO VERY
 MOIST

Depth (ft)	Symbol	Samples	Blows per foot	Watercontent %	Soil Type
5			16	5.0	2
			7	19.7	2
10			24	15.1	2
15			50	12.7	3
			10"		
20			50	17.3	3
			10"		

REMARKS

WATER @ 13', 1/28/20
 SAND, SILTY, TAN
 SANDSTONE, SILTY, FINE TO
 COARSE GRAINED, TAN, VERY
 DENSE, MOIST

SANDSTONE, VERY SILTY, FINE
 GRAINED, GRAY BROWN, VERY
 DENSE, MOIST TO VERY MOIST

COARSE GRAINED LENSES

Depth (ft)	Symbol	Samples	Blows per foot	Watercontent %	Soil Type
5			50	7.1	3
			10"		
			50	9.2	3
			11"		
10			50	10.3	3
			9"		
15			10	16.4	3
			10"		
20			50	14.9	3
			4"		



ENTECH
 ENGINEERING, INC.
 505 ELKTON DRIVE
 COLORADO SPRINGS, COLORADO 80907

TEST BORING LOG

DRAWN _____ DATE _____ CHECKED: *L* DATE 2/10/20

JOB NO.
200045

FIG NO
A- 2

APPENDIX B: Laboratory Test Results

UNIFIED CLASSIFICATION	SM	CLIENT	C&C LAND
SOIL TYPE #	1	PROJECT	STERLING RANCH BRIDGES
TEST BORING #	1	JOB NO.	200045
DEPTH (FT)	2.3	TEST BY	BL

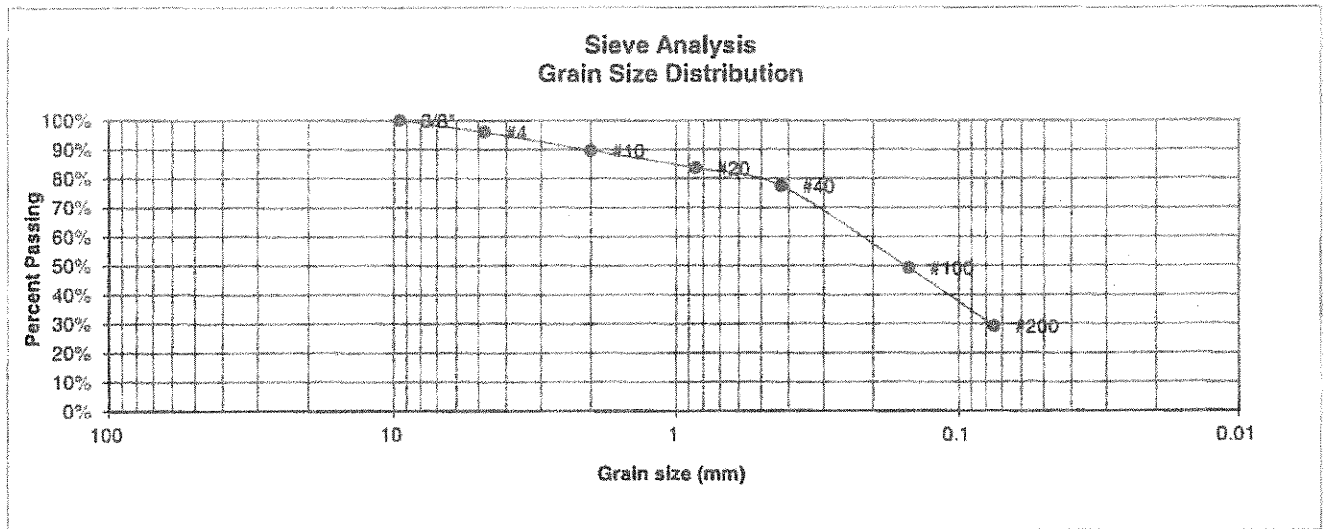

U.S. Sieve #	Percent Finer
3"	
1 1/2"	
3/4"	
1/2"	
3/8"	100.0%
4	95.9%
10	89.7%
20	83.6%
40	77.3%
100	49.2%
200	29.1%

Atterberg Limits	
Plastic Limit	NP
Liquid Limit	NV
Plastic Index	NP

Swell	
Moisture at start	
Moisture at finish	
Moisture increase	
Initial dry density (pcf)	
Swell (psf)	



**ENTECH
ENGINEERING, INC.**

505 ELKTON DRIVE
COLORADO SPRINGS, COLORADO 80907

**LABORATORY TEST
RESULTS**

DRAWN:	DATE:	CHECKED: <i>[Signature]</i>	DATE: 2/10/20
--------	-------	-----------------------------	---------------

JOB NO
200045

FIG NO
B-1

<u>UNIFIED CLASSIFICATION</u>	CL	<u>CLIENT</u>	C&C LAND
<u>SOIL TYPE #</u>	4	<u>PROJECT</u>	STERLING RANCH BRIDGES
<u>TEST BORING #</u>	1	<u>JOB NO.</u>	200045
<u>DEPTH (FT)</u>	20	<u>TEST BY</u>	BL

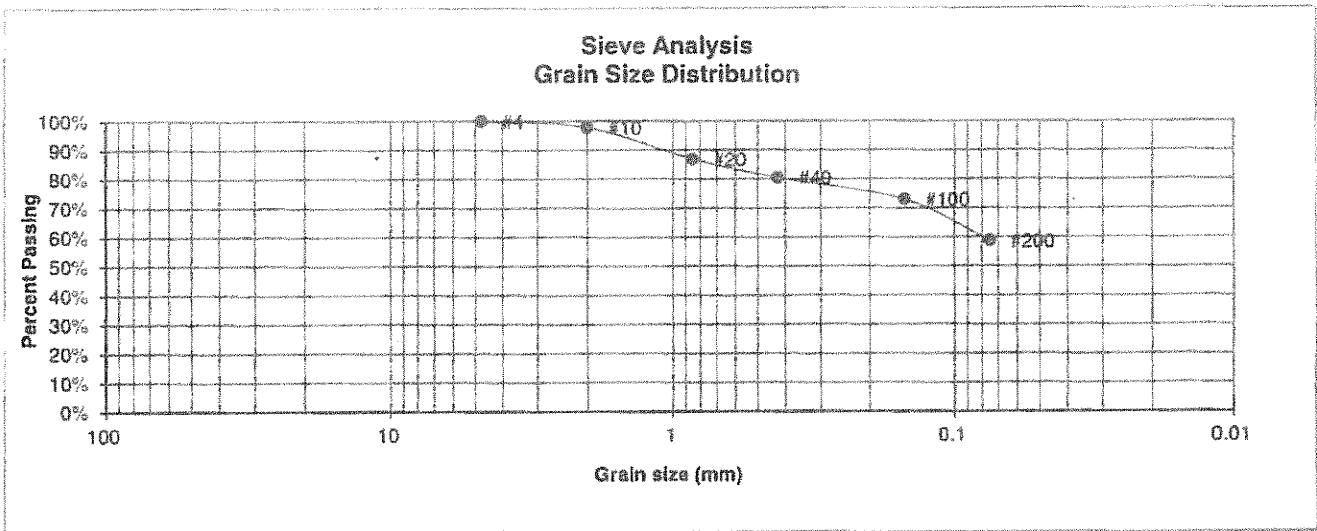

U.S. Sieve #	Percent Finer
3"	
1 1/2"	
3/4"	
1/2"	
3/8"	
4	100.0%
10	97.8%
20	86.9%
40	80.5%
100	72.9%
200	58.7%

Atterberg Limits	
Plastic Limit	21
Liquid Limit	35
Plastic Index	14

Swell	
Moisture at start	
Moisture at finish	
Moisture increase	
Initial dry density (pcf)	
Swell (psf)	



**ENTECH
ENGINEERING, INC.**

505 ELIKTON DRIVE
COLORADO SPRINGS, COLORADO 80907

**LABORATORY TEST
RESULTS**

DRAWN:

DATE:

CHECKED:

DATE

W 2/16/20

JOB NO
200045

FIG NO

B-2

<u>UNIFIED CLASSIFICATION</u>	SM	<u>CLIENT</u>	C&C LAND
<u>SOIL TYPE #</u>	3	<u>PROJECT</u>	STERLING RANCH BRIDGES
<u>TEST BORING #</u>	2	<u>JOB NO.</u>	200045
<u>DEPTH (FT)</u>	10	<u>TEST BY</u>	BL

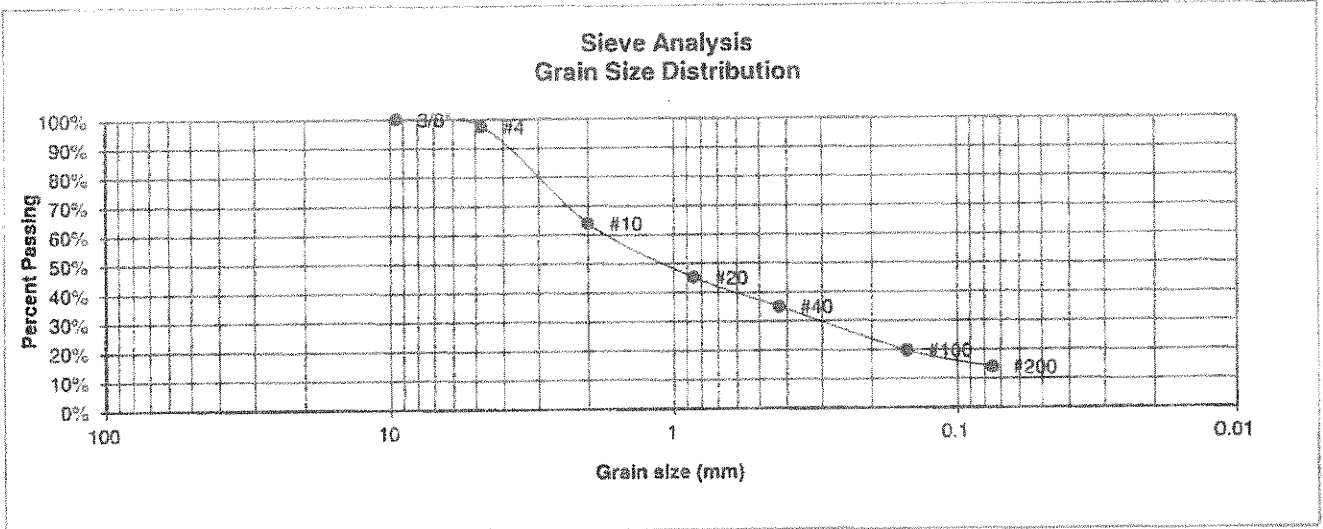

<u>U.S. Sieve #</u>	<u>Percent Finer</u>
3"	
1 1/2"	
3/4"	
1/2"	
3/8"	100.0%
4	97.4%
10	63.9%
20	45.2%
40	35.0%
100	19.7%
200	13.9%

<u>Atterberg Limits</u>	
Plastic Limit	NP
Liquid Limit	NV
Plastic Index	NP

<u>Swell</u>	
Moisture at start	
Moisture at finish	
Moisture increase	
Initial dry density (pcf)	
Swell (psf)	



ENTECH
ENGINEERING, INC.

505 ELKTON DRIVE
COLORADO SPRINGS, COLORADO 80907

**LABORATORY TEST
RESULTS**

DRAWN	DATE	CHECKED: <i>[Signature]</i>	DATE: 2/11/20
-------	------	-----------------------------	---------------

JOB NO
200045

FIG NO
B-3

<u>UNIFIED CLASSIFICATION</u>	SM	<u>CLIENT</u>	C&C LAND
<u>SOIL TYPE #</u>	2	<u>PROJECT</u>	STERLING RANCH BRIDGES
<u>TEST BORING #</u>	3	<u>JOB NO.</u>	200045
<u>DEPTH (FT)</u>	5	<u>TEST BY</u>	BL

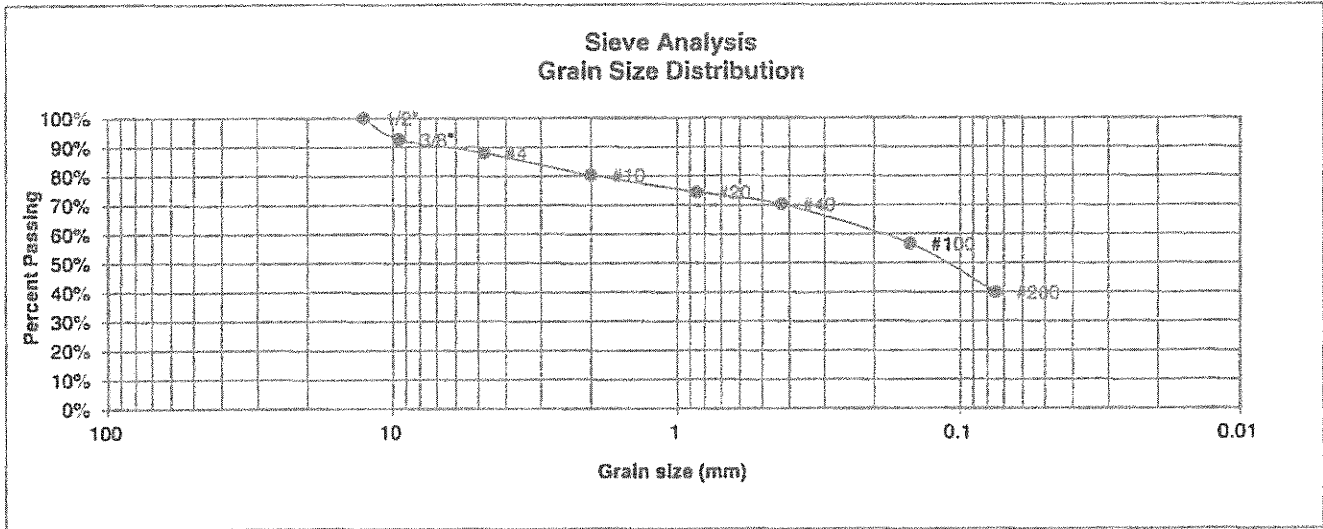

<u>U.S. Sieve #</u>	<u>Percent Finer</u>
3"	
1 1/2"	
3/4"	
1/2"	100.0%
3/8"	92.6%
4	88.0%
10	80.3%
20	74.4%
40	70.1%
100	56.5%
200	39.8%

<u>Atterberg Limits</u>	
Plastic Limit	12
Liquid Limit	15
Plastic Index	3

<u>Swell</u>	
Moisture at start	
Moisture at finish	
Moisture increase	
Initial dry density (pcf)	
Swell (psf)	



ENTECH
ENGINEERING, INC.
505 ELKTON DRIVE
COLORADO SPRINGS, COLORADO 80907

**LABORATORY TEST
RESULTS**

DRAWN:	DATE:	CHECKED: <i>MV</i>	DATE: 5-2-20
--------	-------	--------------------	--------------

JOB NO.:
200045

FIG NO
B-4

<u>UNIFIED CLASSIFICATION</u>	SM	<u>CLIENT</u>	C&C LAND
<u>SOIL TYPE #</u>	3	<u>PROJECT</u>	STERLING RANCH BRIDGES
<u>TEST BORING #</u>	4	<u>JOB NO.</u>	200045
<u>DEPTH (FT)</u>	2-3	<u>TEST BY</u>	BL

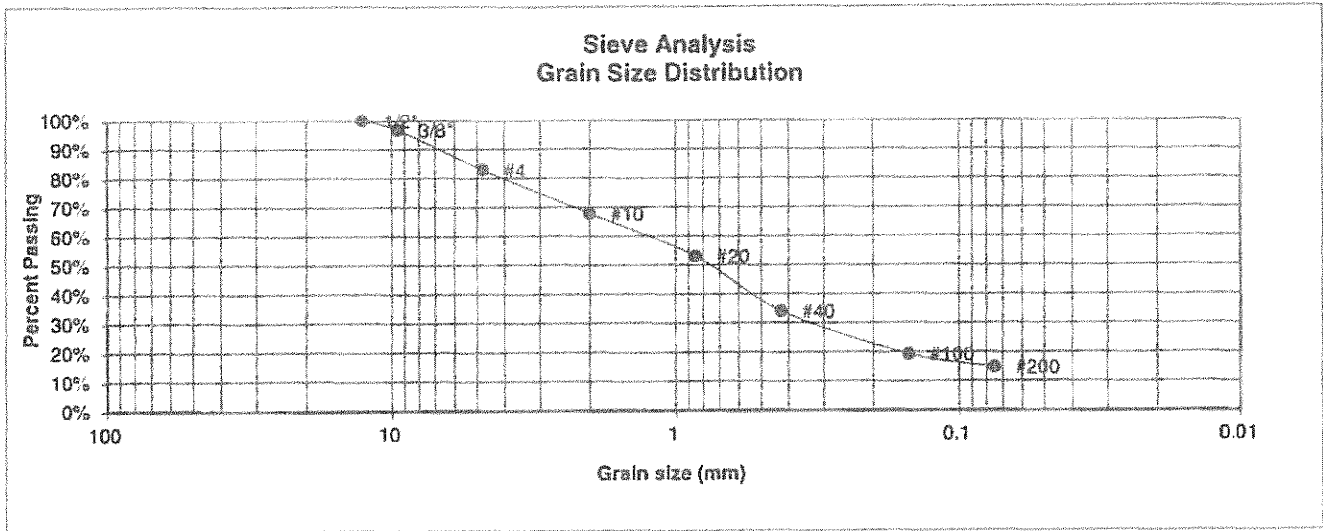

<u>U.S. Sieve #</u>	<u>Percent Finer</u>
3"	
1 1/2"	
3/4"	
1/2"	100.0%
3/8"	96.7%
4	82.8%
10	67.8%
20	53.0%
40	34.0%
100	19.2%
200	14.7%

Atterberg Limits
 Plastic Limit
 Liquid Limit
 Plastic Index

Swell
 Moisture at start
 Moisture at finish
 Moisture increase
 Initial dry density (pcf)
 Swell (psf)



ENTECH
ENGINEERING, INC.
 505 ELKTON DRIVE
 COLORADO SPRINGS, COLORADO 80907

**LABORATORY TEST
 RESULTS**

DRAWN	DATE	CHECKED	DATE
			2/10/20

JOB NO.
200045

FIG NO.
B-5

UNIFIED CLASSIFICATION	SM	CLIENT	C&C LAND
SOIL TYPE #	3	PROJECT	STERLING RANCH BRIDGES
TEST BORING #	4	JOB NO.	200045
DEPTH (FT)	15	TEST BY	BL

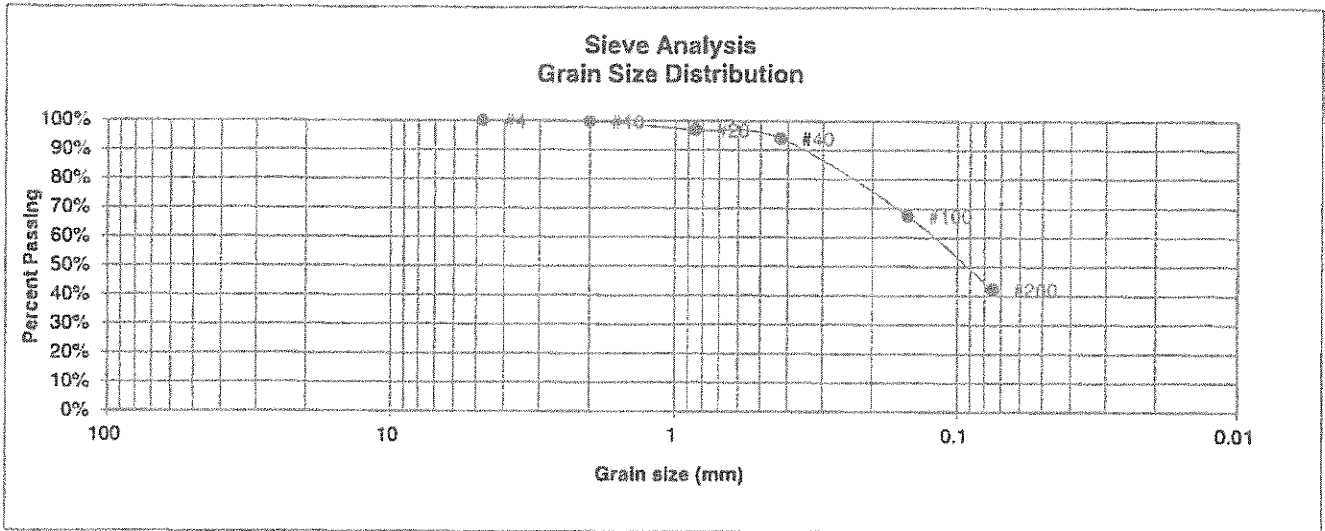

U.S. Sieve #	Percent Finer
3"	
1 1/2"	
3/4"	
1/2"	
3/8"	
4	100.0%
10	99.7%
20	96.9%
40	94.0%
100	67.4%
200	42.2%

Atterberg Limits	
Plastic Limit	26
Liquid Limit	32
Plastic Index	6

Swell	
Moisture at start	
Moisture at finish	
Moisture increase	
Initial dry density (pcf)	
Swell (psf)	



**ENTECH
ENGINEERING, INC.**

505 ELKTON DRIVE
COLORADO SPRINGS, COLORADO 80907

**LABORATORY TEST
RESULTS**

DRAWN	DATE	CHECKED	DATE
		<i>[Signature]</i>	2/10/20

JOB NO
200045

REV NO:
B-6

CONSOLIDATION TEST RESULTS

TEST BORING #	1	DEPTH(ft)	15
DESCRIPTION	CL	SOIL TYPE	4
NATURAL UNIT DRY WEIGHT (PCF)			116
NATURAL MOISTURE CONTENT			14.3%
SWELL/CONSOLIDATION (%)			1.6%

JOB NO. 200045
 CLIENT C&C LAND
 PROJECT STERLING RANCH BRIDGES

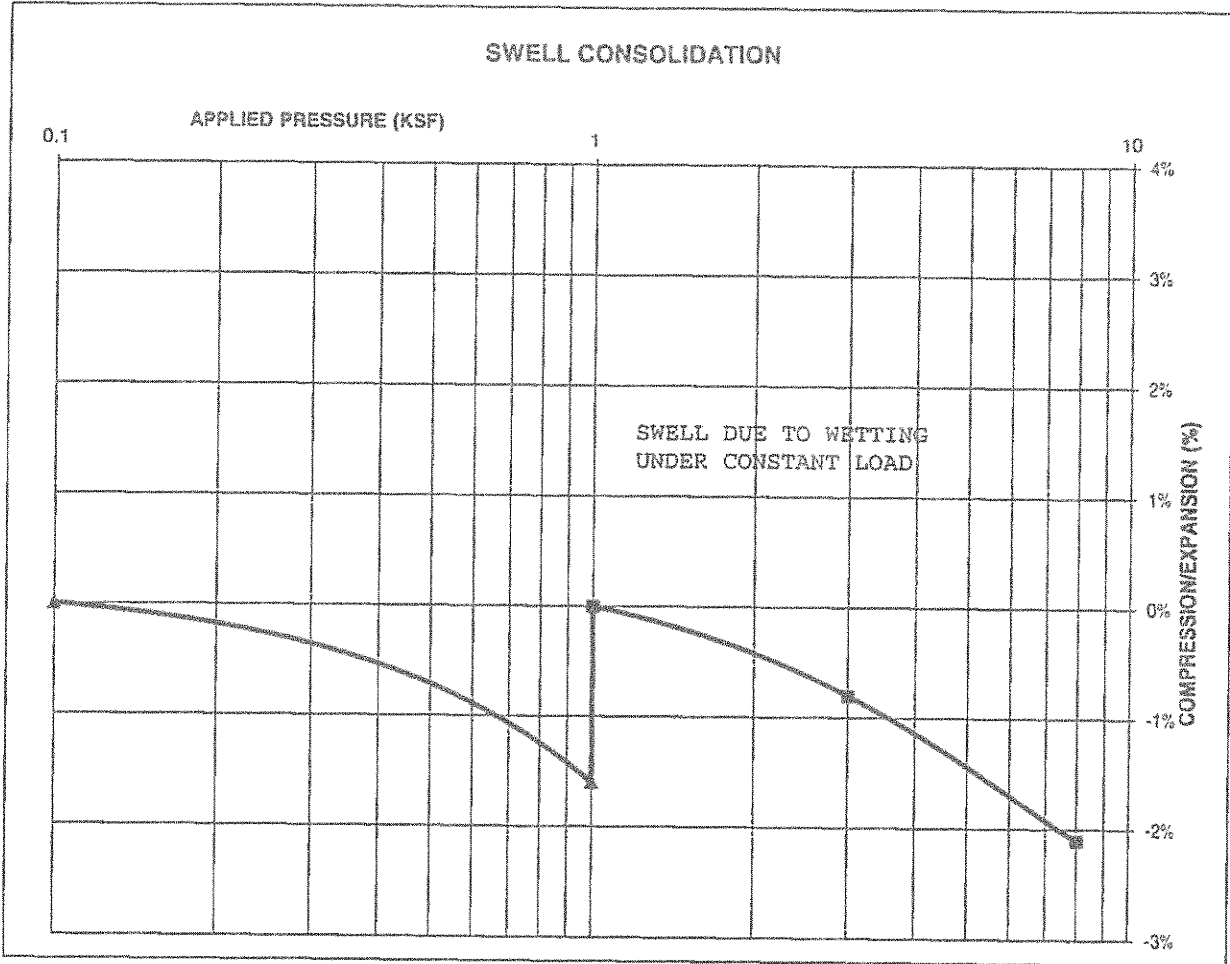

ENTECH
 ENGINEERING, INC.
 505 ELKTON DRIVE
 COLORADO SPRINGS, COLORADO 80907

SWELL CONSOLIDATION TEST RESULTS

DRAWN:

DATE:

CHECKED

DATE

Handwritten signature 2/10/20

JOB NO. 200045

FIG. NO. B-7

CONSOLIDATION TEST RESULTS

TEST BORING #	4	DEPTH(ft)	15
DESCRIPTION	SM	SOIL TYPE	3
NATURAL UNIT DRY WEIGHT (PCF)			110
NATURAL MOISTURE CONTENT			17.1%
SWELL/CONSOLIDATION (%)			1.9%

JOB NO. 200045
 CLIENT C&C LAND
 PROJECT STERLING RANCH BRIDGES

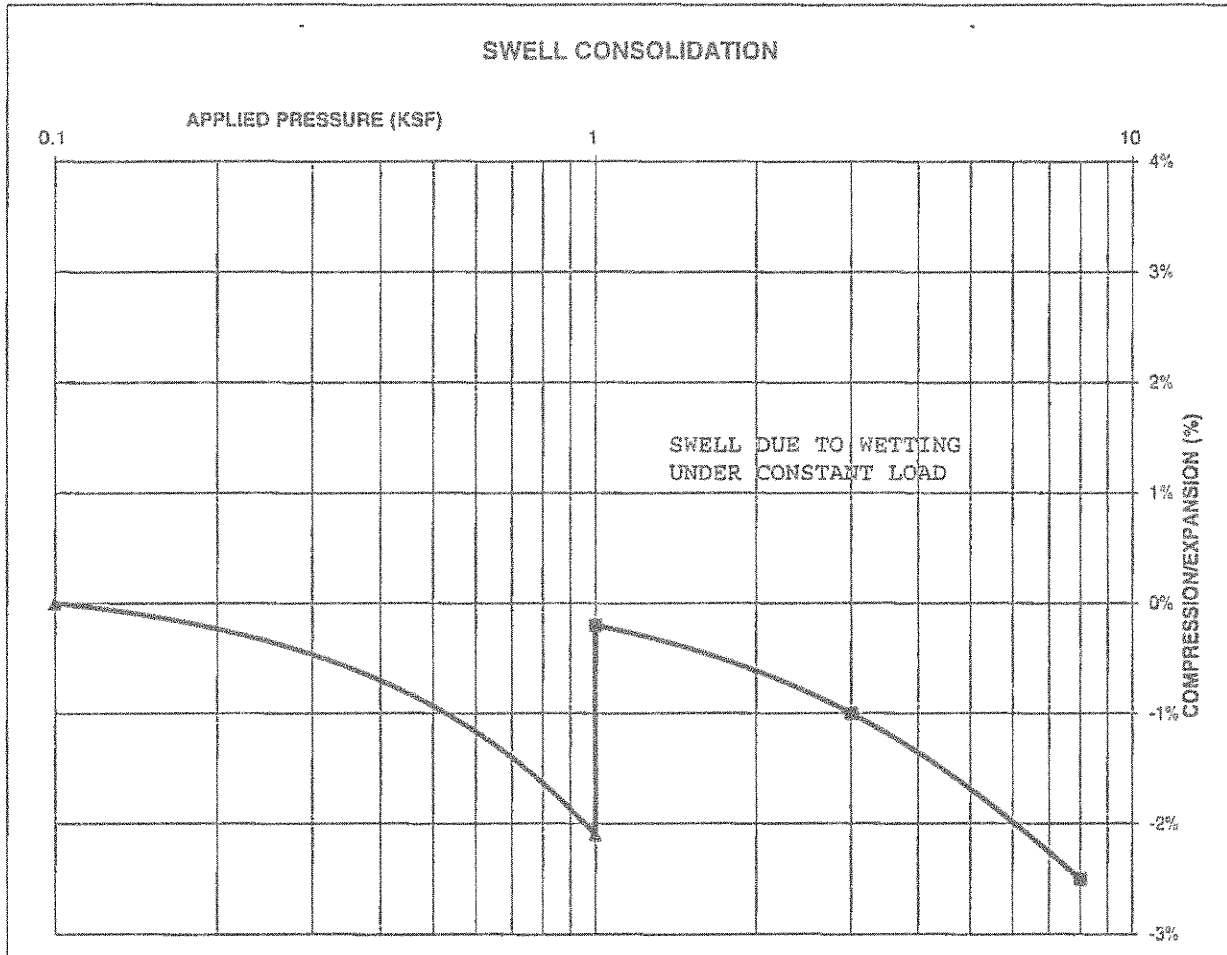

ENTECH
 ENGINEERING, INC.

505 ELKTON DRIVE
 COLORADO SPRINGS, COLORADO 80907

**SWELL CONSOLIDATION
 TEST RESULTS**

DRAWN

DATE

CHECKED: *lv*

DATE: 2/10/20

JOB NO.
 200045

FIG NO.
 B-8

CLIENT	C&C LAND	JOB NO.	200045
PROJECT	STERLING RANCH BRIDGES	DATE	2/4/2020
LOCATION	STERLING RANCH BRIDGES	TEST BY	BL

BORING NUMBER	DEPTH, (ft)	SOIL TYPE NUMBER	UNIFIED CLASSIFICATION	WATER SOLUBLE SULFATE, (wt%)
TB-1	2-3	1	SM	0.00
TB-2	10	3	SM	<0.01
TB-4	15	3	SM	0.00
TB-3	5	2	SM	<0.01

QC BLANK PASS



ENTECH
ENGINEERING, INC.
505 ELKTON DRIVE
COLORADO SPRINGS, COLORADO 80907

**LABORATORY TEST
SULFATE RESULTS**

DRAWN	DATE	CHECKED: <i>AN</i>	DATE: <i>3-2-20</i>
-------	------	--------------------	---------------------

JOB NO.
200045

FIG NO
B-9

Appendix C
Roadway Design Plans
Briargate Parkway and Sterling Ranch Road
M & S Civil

STERLING RANCH-STERLING RANCH ROAD

COUNTY OF EL PASO, STATE OF COLORADO

STREET IMPROVEMENT PLANS

DECEMBER 2017

AGENCIES

OWNER/DEVELOPER:	SR LAND, LLC 20 BOULDER CRESCENT, SUITE 201 COLORADO SPRINGS, CO 80903 JIN MORLEY (719) 471-1742	FIRE DISTRICT:	BLACK FOREST FIRE PROTECTION DISTRICT 11445 TEACHOUT ROAD COLORADO SPRINGS, CO 80908 CHIEF BRYAN JACK (719) 495-4300
CIVIL ENGINEER:	M & S CIVIL CONSULTANTS, INC. 20 BOULDER CRESCENT, SUITE 110 COLORADO SPRINGS, CO 80903 VIRGIL A. SANCHEZ P.E. (719) 955-5485	GAS DEPARTMENT:	COLORADO SPRINGS UTILITIES 7710 DURANT DR. COLORADO SPRINGS, CO 80947 TIM WENDT (719) 668-3556
COUNTY ENGINEERING:	EL PASO COUNTY DEVELOPMENT SERVICES 2880 INTERNATIONAL CIRCLE, SUITE 110 COLORADO SPRINGS, CO 80910 JENNIFER IRVINE, P.E. (719) 520-6300	ELECTRIC DEPARTMENT:	MOUNTAIN VIEW ELECTRIC 11140 E. WOODMEN ROAD FALCON, CO 80831 (719) 495-2283
TRAFFIC ENGINEERING:	EL PASO COUNTY PUBLIC SERVICES & TRANSPORTATION DEPARTMENT 3275 AKERS DRIVE COLORADO SPRINGS, CO 80922 JENNIFER IRVINE, P.E. (719) 520-6460	COMMUNICATIONS:	QWEST COMMUNICATIONS (U.N.C.C. LOCATORS) (800) 922-1987 AT&T (LOCATORS) (719) 635-3674
WATER RESOURCES:	STERLING RANCH METRO DISTRICT ENGINEERS JDS-HYDRO CONSULTANTS 545 E. FIKES PEAK AVE., SUITE 300 COLORADO SPRINGS, CO 80903 JOHN MCGINN (719) 668-8769		

BENCHMARKS

1. THE TOP OF AN ALUMINUM SURVEYORS CAP, STAMPED "9853"
NORTHING = 411416.273
EASTING = 235167.071
ELEVATION = 7023.42
2. THE TOP OF A RED PLASTIC SURVEYORS CAP, ILLEGIBLE
NORTHING = 410095.404
EASTING = 235052.131
ELEVATION = 7000.40
3. THE TOP OF A RED PLASTIC SURVEYORS CAP, STAMPED "38141"
NORTHING = 411399.962
EASTING = 233849.817
ELEVATION = 7030.82

ABBREVIATIONS

ACT	ACTUAL	FL	FLOW LINE	PT	POINT OF TANGENCY
BCR	BACK OF CURB RETURN	FT	FEET, FOOT	PROP	PROPOSED
BOV	BLOWOFF VALVE ASSEMBLY	FUT	FUTURE	REM	REMOVE
BRK	BREAK	GRD	GRADE	ROW	RIGHT OF WAY
BT	BEGINNING OF TRANSITION	HORZ	HORIZONTAL	RSNTS	RESTRAINTS
CAV	CABLE TV	HP	HIGH POINT ELEVATION	RT	RIGHT
CL	CLASS. CENTERLINE	INT	INTERSECTION	RSN	SANITARY SEWER
CLR	CLEARANCE	LP	LOW POINT ELEVATION	SD	STANDARD DETAIL
CONST	CONSTRUCT	LT	LEFT	STA	STATION
CSU	COLORADO SPRINGS UTILITIES	LOC	LOCATION	STIM	STORM
ECR	END CURB RETURN	MIN	MINIMUM	COB	TOP CORNER OF BOX
EL	ELEVATION	N.S.E.W	NORTH SOUTH EAST WEST	TELE	TELEPHONE
EDA	EDGE OF ASPHALT	NIS	NOT TO SCALE	TYP	TYPICAL
EOP	END OF PAVEMENT	PC	POINT OF CURVATURE	UNK	UNKNOWN
EPC	EL PASO COUNTY	POR	POINT OF CURB RETURN	UP	UNDERGROUND POWER
ESMT	EASMENT	PR	PROPERTY LINE CURVE	UTL	UTILITY
ET	END TRANSITION	PUB	PUBLIC	VERT	VERTICAL
EX	EXISTING	PVC	POINT OF VERTICAL INTERSECTION	WIR	WATER LINE
EX	EXISTING	PVT	POINT OF VERTICAL TANGENT	XING	CROSSING
GB	GRADE BREAK	PVT	POINT OF VERTICAL TANGENT	YD	YARD (CUBIC)

LEGEND

AIR & VACUUM VALVE STA		PROPOSED GAS SANITARY SEWER	
ANCHOR, CONC. REVERSE		PROPOSED WATER	
CENTERLINE		RIGHT-OF-WAY PROPERTY LINE	
FENCE		FIRE HYDRANT (EXISTING)	
EXISTING SANITARY SEWER		FIRE HYDRANT (PROPOSED)	
EXISTING GAS		STORM DRAIN	
EXISTING ELECTRIC (OH OR LG)		VALVE (PROPOSED)	
EXISTING TELEPHONE		VALVE (EXISTING)	
EXISTING TELEVISION		BLOWOFF ASSY. (PROPOSED)	
EXISTING FIBER OPTIC		BLOWOFF ASSY. (EXISTING)	
EXISTING WATER		PLUG (PROPOSED)	
		PLUG (EXISTING)	

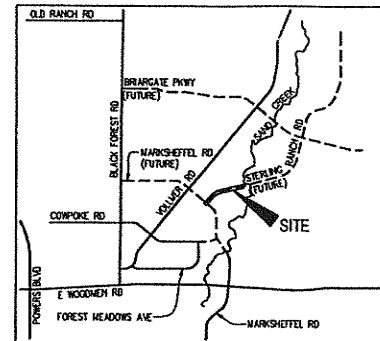

VICINITY MAP
SCALE: NTS

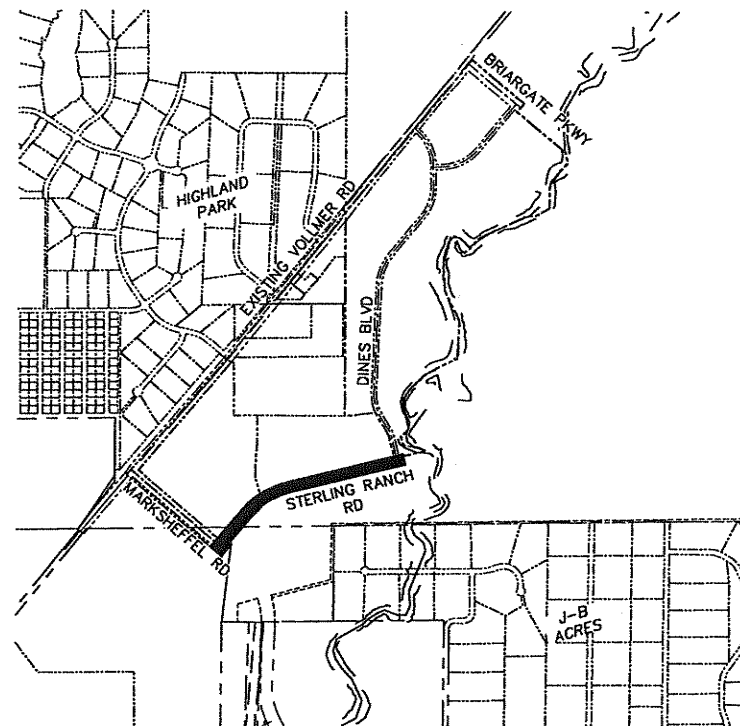

SITE MAP
SCALE: NTS

APPROVALS:

ENGINEER'S STATEMENT:

DETAILED IMPROVEMENT PLANS AND SPECIFICATIONS ENGINEER'S STATEMENT:

THESE DETAILED PLANS AND SPECIFICATIONS WERE PREPARED UNDER MY DIRECTION AND SUPERVISION. SAID DETAILED PLANS AND SPECIFICATIONS HAVE BEEN PREPARED ACCORDING TO THE CRITERIA ESTABLISHED BY THE COUNTY FOR DETAILED DRAINAGE PLANS AND SPECIFICATIONS, AND SAID DETAILED PLANS AND SPECIFICATIONS ARE IN CONFORMITY WITH THE MASTER PLAN OF THE DRAINAGE BASIN. SAID DETAILED DRAINAGE PLANS AND SPECIFICATIONS MEET THE PURPOSES FOR WHICH THE PARTICULAR DRAINAGE FACILITY(S) IS DESIGNED. I ACCEPT RESPONSIBILITY FOR ANY LIABILITY CAUSED BY ANY NEGLIGENT ACTS, ERRORS, OR OMISSIONS ON MY PART IN PREPARATION OF THE DETAILED IMPROVEMENT PLANS AND SPECIFICATIONS.

VIRGIL A. SANCHEZ, COLORADO P.E. NO. 37160
FOR AND ON BEHALF OF M&S CIVIL CONSULTANTS, INC. DATE

OWNER/DEVELOPER STATEMENT:

THE OWNER WILL COMPLY WITH THE REQUIREMENTS OF THE DRAINAGE REPORT AND PLAN AND THIS SET OF CONSTRUCTION DOCUMENTS. THE OWNER WILL COMPLY WITH THE REQUIREMENTS OF THE GRADING AND EROSION CONTROL PLAN.

SR LAND, LLC
DIRECTOR OF PLANNING AND ENGINEERING DATE

EL PASO COUNTY:

COUNTY PLAN REVIEW IS PROVIDED ONLY FOR GENERAL CONFORMANCE WITH COUNTY DESIGN CRITERIA. THE COUNTY IS NOT RESPONSIBLE FOR THE ACCURACY AND ADEQUACY OF THE DESIGN, DIMENSIONS, AND/OR ELEVATIONS WHICH SHALL BE CONFIRMED AT THE JOB SITE. THE COUNTY THROUGH APPROVAL OF THIS DOCUMENT ASSUMES NO RESPONSIBILITY FOR COMPLETENESS AND/OR ACCURACY OF THIS DOCUMENT.

FILED IN ACCORDANCE WITH THE REQUIREMENTS OF THE EL PASO COUNTY LAND DEVELOPMENT CODE, DRAINAGE CRITERIA, AND ENGINEERING CRITERIA MANUAL AS AMENDED.

JENNIFER IRVINE, P.E.
ENGINEERING MANAGER DATE

STERLING RANCH METROPOLITAN DISTRICT:

THESE DOCUMENTS HAVE BEEN REVIEWED AND APPROVED FOR STORM DRAIN AND ASSOCIATED UTILITY SERVICE CONSTRUCTION.

FOR AND ON BEHALF OF THE STERLING RANCH METRO. DISTRICT DATE

BLACK FOREST FIRE PROTECTION DISTRICT:

ALL FIRE HYDRANTS SHALL BE INSTALLED ACCORDING TO THE BLACK FOREST FIRE PROTECTION DISTRICT SPECIFICATIONS. THE NUMBER OF FIRE HYDRANTS AND HYDRANT LOCATIONS AS SHOWN ON THE WATER INSTALLATION PLAN ARE CORRECT AND ADEQUATE TO SATISFY THE FIRE PROTECTION REQUIREMENTS AS SPECIFIED BY THE BLACK FOREST FIRE PROTECTION DISTRICT.

FOR AND ON BEHALF OF THE BLACK FOREST FIRE PROTECTION DISTRICT DATE

SHEET INDEX

SHEET 1	TITLE SHEET
SHEET 2	NOTES & DETAILS SHEET
SHEET 3	PLAN & PROFILE - STA 0+00.00 TO 12+50.00
SHEET 4	PLAN & PROFILE - STA 12+50.00 TO 24+79.37
SHEET 5	SIGNAGE & STRIPING PLAN

STERLING RANCH - STERLING RANCH	
STREET IMPROVEMENT PLANS	
PROJECT NO. 09-002	DATE: 07/05/2017
DESIGNED BY: ###	HORIZONTAL: NTS
DRAWN BY: SM	VERTICAL: N/A
CHECKED BY: ###	SHEET 1 OF 5
SI01	

20 BOULDER CRESCENT, SUITE 110
COLORADO SPRINGS, CO 80903
PHONE: 719.955.5485

M&S CIVIL CONSULTANTS, INC.

VIRGIL A. SANCHEZ, COLORADO P.E. NO. 37160

FOR AND ON BEHALF OF M&S CIVIL CONSULTANTS, INC.

REVISIONS:

NO.	DATE	DESCRIPTION

FOR LOCATING & MARKING GAS, ELECTRIC, WATER & TELEPHONE LINES

FOR BURED UTILITY INFORMATION
48 HRS BEFORE YOU DIG
CALL 1-800-922-1987

THE ENGINEER PREPARING THESE PLANS WILL NOT BE RESPONSIBLE, OR LIABLE FOR, UNAUTHORIZED CHANGES TO OR USES OF THESE PLANS. ALL CHANGES TO THE PLANS MUST BE IN WRITING AND MUST BE APPROVED BY THE PREPARER OF THESE PLANS.

CAUTION

File: O:\00002A\Sterling Ranch District - Final\2\Map\Cont\Map\Sheet\Sterling Ranch_Rd\SDI.dwg PlotDate: 11/27/2017 2:35 PM

STERLING RANCH - BRIARGATE PARKWAY FROM VOLLMER ROAD - WHEATLAND DRIVE

COUNTY OF EL PASO, STATE OF COLORADO

STREET IMPROVEMENT PLANS

INCLUDING SIGNAGE AND STRIPING PLAN

JANUARY 2018

AGENCIES

OWNER/DEVELOPER: SR LAND, LLC
20 BOULDER CRESCENT, SUITE 201
COLORADO SPRINGS, CO 80903
JIM MORLEY (719) 471-1742

CIVIL ENGINEER: M & S CIVIL CONSULTANTS, INC.
20 BOULDER CRESCENT, SUITE 110
COLORADO SPRINGS, CO 80903
VIRGIL A. SANCHEZ P.E. (719) 955-5485

COUNTY ENGINEERING: EL PASO COUNTY PLANNING AND COMMUNITY DEVELOPMENT
2880 INTERNATIONAL CIRCLE, SUITE 110
COLORADO SPRINGS, CO 80910
JEFF RICE, P.E. (719) 520-6300

TRAFFIC ENGINEERING: EL PASO COUNTY DEPARTMENT OF PUBLIC WORKS
3275 AKERS DRIVE
COLORADO SPRINGS, CO 80922
JENNIFER IRVINE, P.E. (719) 520-6460

WATER RESOURCES: STERLING RANCH METRO DISTRICT ENGINEERS
J&S-HYDRO CONSULTANTS
545 E. PIKES PEAK AVE., SUITE 300
COLORADO SPRINGS, CO 80903
JOHN MCGWIN (719) 668-8769

FIRE DISTRICT: BLACK FOREST FIRE PROTECTION DISTRICT
11445 TEACOCKT ROAD
COLORADO SPRINGS, CO 80908
CHIEF BRYAN JACK (719) 495-4300

GAS DEPARTMENT: COLORADO SPRINGS UTILITIES
7710 DURANT DR.
COLORADO SPRINGS, CO 80947
TIM WENDT (719) 668-3556

ELECTRIC DEPARTMENT: MOUNTAIN VIEW ELECTRIC
11140 E. WOODMEN ROAD
FALCON, CO 80831
(719) 495-2283

COMMUNICATIONS: CENTURYLINK / COMCAST COMMUNICATIONS
(LUM.C. LOCATORS) (800) 922-1987
AT&T (LOCATORS) (719) 635-3674

BENCHMARKS:

1. THE TOP OF AN ALUMINUM SURVEYORS CAP, STAMPED "9853", AT THE SOUTHEAST BOUNDARY CORNER OF BARBARICK SUBDIVISION
NORTHING = 411416.273
EASTING = 235167.071
ELEVATION = 7023.42
2. THE TOP OF A RED PLASTIC SURVEYORS CAP, ILLEGIBLE, AT THE NORTHWEST BOUNDARY CORNER OF PAMNEE RANCHEROS SUBDIVISION
NORTHING = 410095.404
EASTING = 235052.131
ELEVATION = 7000.40
3. THE TOP OF A RED PLASTIC SURVEYORS CAP, STAMPED "38141", AT THE SOUTHWEST BOUNDARY CORNER OF BARBARICK SUBDIVISION
NORTHING = 411399.962
EASTING = 233849.817
ELEVATION = 7030.82

BASIS OF BEARINGS:

THE SOUTH LINE OF THE SOUTHWEST QUARTER (SW1/4) OF SECTION 34, TOWNSHIP 12 SOUTH, RANGE 65 WEST OF THE 6TH P.M. AS MONUMENTED AT THE SOUTHWEST CORNER OF SAID SOUTHWEST QUARTER (SW1/4) BY A 2-1/2" ALUMINUM CAP STAMPED "LS 11624" AND AT THE SOUTHEAST CORNER OF SAID SOUTHWEST QUARTER (SW1/4) BY A 2-1/2" ALUMINUM CAP STAMPED "LS 11624", SAID LINE BEARS N 89°14'14" E A DISTANCE OF 2,722.56 FEET.

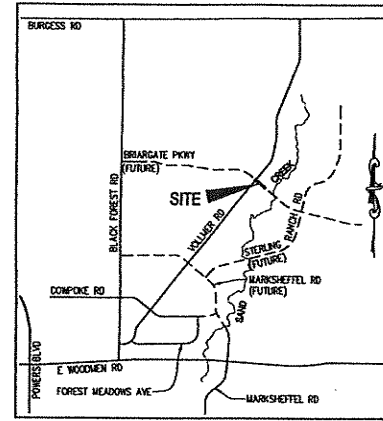

VICINITY MAP
N.T.S.

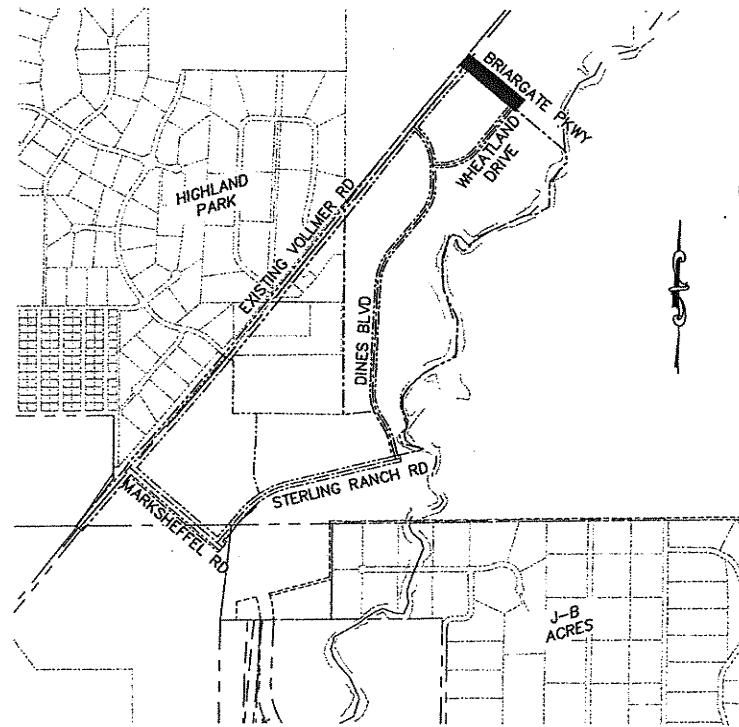

SITE MAP
N.T.S.



APPROVALS:

ENGINEER'S STATEMENT:

THESE DETAILED PLANS AND SPECIFICATIONS WERE PREPARED UNDER MY DIRECTION AND SUPERVISION. SAID DETAILED PLANS AND SPECIFICATIONS HAVE BEEN PREPARED ACCORDING TO THE CRITERIA ESTABLISHED BY THE COUNTY FOR DETAILED DRAINAGE PLANS AND SPECIFICATIONS, AND SAID DETAILED PLANS AND SPECIFICATIONS ARE IN CONFORMITY WITH THE MASTER PLAN OF THE DRAINAGE BASIN. SAID DETAILED DRAINAGE PLANS AND SPECIFICATIONS MEET THE PURPOSES FOR WHICH THE PARTICULAR DRAINAGE FACILITY(S) IS DESIGNED. I ACCEPT RESPONSIBILITY FOR ANY LIABILITY CAUSED BY ANY NEGLIGENT ACTS, ERRORS, OR OMISSIONS ON MY PART IN PREPARATION OF THE DETAILED IMPROVEMENT PLANS AND SPECIFICATIONS.

VIRGIL A. SANCHEZ, COLORADO P.E. NO. 37160
FOR AND ON BEHALF OF M&S CIVIL CONSULTANTS, INC.

DATE: 1-4-18

OWNER/DEVELOPER STATEMENT:

I, THE OWNER HAVE READ AND WILL COMPLY WITH ALL OF THE REQUIREMENTS SPECIFIED IN THESE DETAILED PLANS AND SPECIFICATIONS.

SR LAND, LLC

DATE: 1-4-18

EL PASO COUNTY:

COUNTY PLAN REVIEW IS PROVIDED ONLY FOR GENERAL CONFORMANCE WITH COUNTY DESIGN CRITERIA. THE COUNTY IS NOT RESPONSIBLE FOR THE ACCURACY AND ADEQUACY OF THE DESIGN, DIMENSIONS, AND/OR ELEVATIONS WHICH SHALL BE CONFIRMED AT THE JOB SITE. THE COUNTY THROUGH APPROVAL OF THIS DOCUMENT ASSUMES NO RESPONSIBILITY FOR COMPLETENESS AND/OR ACCURACY OF THIS DOCUMENT.

FILED IN ACCORDANCE WITH THE REQUIREMENTS OF THE EL PASO COUNTY LAND DEVELOPMENT CODE, DRAINAGE CRITERIA, AND ENGINEERING CRITERIA MANUAL AS AMENDED.

JENNIFER IRVINE, P.E.
COUNTY ENGINEER/ECM ADMINISTRATOR

DATE: 30 JAN 18

STERLING RANCH METROPOLITAN DISTRICT:

THESE DOCUMENTS HAVE BEEN REVIEWED AND APPROVED FOR STORM DRAIN AND ASSOCIATED UTILITY SERVICE CONSTRUCTION.

FOR AND ON BEHALF OF THE STERLING RANCH METRO. DISTRICT

DATE: 1-4-18

SHEET INDEX

- SHEET 1 TITLE SHEET
- SHEET 2 NOTES & DETAILS SHEET
- SHEET 3 PLAN & PROFILE - "ULTIMATE" BRIARGATE PARKWAY
- SHEET 4 PLAN & PROFILE - "INTERIM" BRIARGATE PARKWAY
- SHEET 5 SIGNAGE AND STRIPING PLAN

ABBREVIATIONS

ACT	ACTUAL	FL	FLOW LINE	PT	POINT OF TANGENCY
BCR	BACK OF CURB RETURN	FT	FEET	PROP	PROPOSED
BOV	BLOWOFF VALVE ASSEMBLY	FUT	FUTURE	REM	REMOVE
BW	BREAK	GR	GRADE	RHW	RIGHTS OF WAY
BT	BEGINNING OF TRANSITION	HORIZ	HORIZONTAL	RSMTS	RESTRAINTS
CATV	CABLE TV	HP	HIGH POINT ELEVATION	RT	RIGHT
CL	CLASS, CENTERLINE	INT	INTERSECTION	RSN	RIGHT SANITARY SEWER
CLR	CLEARANCE	LP	LOW POINT ELEVATION	SD	STANDARD DETAIL
CONSTR	CONSTRUCT	LT	LEFT	STA	STATION
CSU	COLORADO SPRINGS UTILITIES	LOC	LOCATION	STM	STORM
ECR	END CURB RETURN	MIN	MINIMUM	TCB	TOP CORNER OF BOX
E	ELEVATION	MSL	MEAN SEA LEVEL	TEL	TELEPHONE
EDA	EDGE OF ASPHALT	NIS	NOT TO SCALE	TYP	TYPICAL
EDP	END OF PAVEMENT	PC	POINT OF CURVATURE	UNK	UNKNOWN
EL	EL PASO COUNTY	PCC	POINT OF COMPOUND CURVE	UP	UNDERGROUND POWER
EASMT	EASMENT	PER	POINT OF RETURN	UTL	UTILITY
ET	END TRANSITION	PL	PROPERTY LINE	VERT	VERTICAL
EX	EXISTING	PUB	PUBLIC	WTR	WATER LINE
EX-EXIST	EXISTING	PVT	POINT OF VERTICAL INTERSECTION	XING	CROSSING
GA	GAS	PVC	POINT OF VERTICAL CURVE	YD	YARD (CUBIC)
GB	GRADE BREAK	PVT	POINT OF VERTICAL TANGENT		

LEGEND

	PROPOSED GAS		PROPOSED SANITARY SEWER
	PROPOSED WATER		RIGHT-OF-WAY
	PROPERTY LINE		CENTERLINE
	FIRE HYDRANT (EXISTING)		FIRE HYDRANT (PROPOSED)
	STORM DRAIN		VALVE (PROPOSED)
	VALVE (EXISTING)		BLOWOFF ASSY. (PROPOSED)
	BLOWOFF ASSY. (EXISTING)		PLUG (PROPOSED)
	PLUG (EXISTING)		

FOR LOCATING & MARKING
GAS,
ELECTRIC,
WATER &
TELEPHONE
LINES
FOR BURIED UTILITY INFORMATION
48 HRS BEFORE YOU DIG
CALL 1-800-922-1987

SF 16-013

STERLING RANCH - BRIARGATE PARKWAY

STREET IMPROVEMENT PLAN

PROJECT NO. 09-002 DATE: 1/3/2018

SCALE: HORIZONTAL: N/A VERTICAL: N/A

DESIGNED BY: DUM DRAWN BY: ELY CHECKED BY: WAS SHEET 1 OF 5 S101

20 BOULDER CRESCENT, SUITE 110
COLORADO SPRINGS, CO 80903
PHONE: 719/955-5485

M & S CIVIL CONSULTANTS, INC.

FOR AND ON BEHALF OF CONSULTANTS, INC.

VIRGIL A. SANCHEZ, COLORADO P.E. NO. 37160

REVISIONS:

THE ENGINEER PREPARING THESE PLANS WILL NOT BE RESPONSIBLE OR LIABLE FOR UNAUTHORIZED CHANGES TO OR USES OF THESE PLANS. ALL CHANGES TO THE PLANS MUST BE IN WRITING AND MUST BE APPROVED BY THE PREPARER OF THESE PLANS.

CAUTION

GENERAL CONSTRUCTION NOTES:

- IT SHALL BE THE RESPONSIBILITY OF THE CONTRACTOR TO VERIFY THE EXISTENCE AND LOCATION OF ALL UNDERGROUND UTILITIES ALONG THE ROUTE OF THE WORK. THE OMISSION FROM OR THE INCLUSION OF UTILITY LOCATIONS ON THE PLANS IS NOT TO BE CONSIDERED AS THE NONEXISTENCE OF OR A DEFINITE LOCATION OF EXISTING UNDERGROUND UTILITIES.
- THE CONTRACTOR WILL TAKE THE NECESSARY PRECAUTIONS TO PROTECT EXISTING UTILITIES FROM DAMAGE DUE TO THIS OPERATION. ANY DAMAGE TO THE UTILITIES WILL BE REPAIRED AT THE CONTRACTOR'S EXPENSE, AND ANY SERVICE DISRUPTION WILL BE SETTLED BY THE CONTRACTOR.
- ADDITIONAL EROSION CONTROL STRUCTURES MAY BE REQUIRED AT THE TIME OF CONSTRUCTION.
- ALL BACKFILL, SUB-BASE, AND/OR BASE COURSE (CLASS 6) MATERIAL SHALL BE COMPACTED PER THE SOILS ENGINEER'S RECOMMENDATIONS, AND APPROVED BY EL PASO COUNTY DEVELOPMENT SERVICES ENGINEERING DIVISION.
- ALL STATIONING IS CENTERLINE OF IMPROVEMENTS UNLESS OTHERWISE INDICATED. ALL ELEVATIONS ARE FLOW LINE UNLESS OTHERWISE INDICATED AS TOP BACK OF CURB (TBC), ASPHALT (ASP), OR TOP OF INLET OR BOX (TOB).
- ALL DISTURBED PAVEMENT EDGES SHALL BE CUT TO NEAT LINES. REPAIR SHALL CONFORM TO EPC ECM APPENDIX K - 1.2C.
- ALL INTERSECTION ACCESSES TO BE CONSTRUCTED WITH A 25 FOOT SIGHT VISIBILITY TRIANGLES EXCEPT [VOLLMER ROAD MARKSHEFFEL ROAD BRAIRGATE PARKWAY] WHICH IS AN ARTERIAL AND A 50 FOOT SIGHT VISIBILITY TRIANGLE IS REQUIRED AND THERE SHALL BE NO OBSTRUCTIONS GREATER THAN 18" [?] IN THIS AREA.
- ALL CULVERTS AND STORM DRAIN PIPES SHALL BE SMOOTH INTERIOR CORRUGATED POLYETHYLENE PIPE (HOPE), REINFORCED CONCRETE PIPE (RCP). ALL CULVERTS SHALL BE PLACED COMPLETE WITH FLARED END SECTIONS. ADEQUACY OF MATERIAL THICKNESS FOR ANY CSP INSTALLED SHALL BE DETERMINED BY OWNER'S GEOTECHNICAL ENGINEER TO SUPPORT MINIMUM 50 YEAR DESIGN LIFE. CULVERTS MUST CONFORM TO EPC ECM SECTION 3.32 - CULVERTS.
- ASPHALT THICKNESS AND BASE COURSE THICKNESS (COMPACTED) FOR ROADS SHALL BE PER DESIGN REPORT BY OWNER'S GEOTECHNICAL ENGINEER. OWNER'S GEOTECHNICAL ENGINEER TO BE ON SITE AT THE TIME OF ROAD CONSTRUCTION TO EVALUATE SOIL CONDITIONS AND DETERMINE IF ADDITIONAL MEASURES ARE NECESSARY TO ASSURE STABILITY OF THE NEW ROADS. PAVEMENT DESIGN SHALL BE APPROVED BY EL PASO COUNTY DEVELOPMENT SERVICES ENGINEERING DIVISION PRIOR TO CONSTRUCTION.

SIGNING AND STRIPING NOTES:

- ALL SIGNS AND PAVEMENT MARKINGS SHALL BE IN COMPLIANCE WITH THE CURRENT MANUAL ON UNIFORM TRAFFIC CONTROL DEVICES (MUTCD).
- REMOVAL OF EXISTING PAVEMENT MARKINGS SHALL BE ACCOMPLISHED BY A METHOD THAT DOES NOT MATERIALLY DAMAGE THE PAVEMENT. THE PAVEMENT MARKINGS SHALL BE REMOVED TO THE EXTENT THAT THEY WILL NOT BE VISIBLE UNDER DAY OR NIGHT CONDITIONS. AT NO TIME WILL IT BE ACCEPTABLE TO PAINT OVER EXISTING PAVEMENT MARKINGS.
- ANY DEVIATION FROM THE STRIPING AND SIGNING PLAN SHALL BE APPROVED BY EL PASO COUNTY DEVELOPMENT SERVICES.
- ALL SIGNS SHOWN ON THE SIGNING AND STRIPING PLAN SHALL BE NEW SIGNS. EXISTING SIGNS MAY REMAIN OR BE REUSED IF THEY MEET CURRENT EL PASO COUNTY AND MUTCD STANDARDS.
- STREET NAME AND REGULATORY STOP SIGNS SHALL BE ON THE SAME POST AT INTERSECTIONS.
- ALL REMOVED SIGNS SHALL BE DISPOSED OF IN A PROPER MANNER BY THE CONTRACTOR.
- ALL STREET NAME SIGNS SHALL HAVE "0" SERIES LETTERS, WITH LOCAL ROADWAY SIGNS BEING 4" UPPER-LOWER CASE LETTERING ON 8" BLANK AND NON-LOCAL ROADWAY SIGNS BEING 6" LETTERING, UPPER-LOWER CASE ON 12" BLANK, WITH A WHITE BORDER THAT IS NOT RECESSED. MULTI-LANE ROADWAYS WITH SPEED LIMITS OF 40 MPH OR HIGHER SHALL HAVE 8" UPPER-LOWER CASE LETTERING ON 18" BLANK WITH A WHITE BORDER THAT IS NOT RECESSED. THE WIDTH OF THE NON-RECESSED WHITE BORDERS SHALL MATCH PAGE 255 OF THE 2012 MUTCD "STANDARD HIGHWAY SIGNS".
- ALL TRAFFIC SIGNS SHALL HAVE A MINIMUM HIGH INTENSITY PRISMATIC GRADE SHEETING.
- ALL LOCAL RESIDENTIAL STREET SIGNS SHALL BE MOUNTED ON A 1.75" X 1.75" SQUARE TUBE SIGN POST AND STUB POST BASE. FOR OTHER APPLICATIONS, REFER TO THE CDOT STANDARD S-614-B REGARDING USE OF THE P2 TUBULAR STEEL POST SUBBASE DESIGN. ALL SIGNS SHALL BE SINGLE SHEET ALUMINUM WITH 0.100" MINIMUM THICKNESS.
- ALL LIMIT LINES/STOP LINES, CROSSWALK LINES, PAVEMENT LEGENDS, AND ARROWS SHALL BE A MINIMUM 125 MIL THICKNESS PREFORMED THERMOPLASTIC PAVEMENT MARKINGS WITH TAPERED LEADING EDGES PER CDOT STANDARD S-627-1. WORD AND SYMBOL MARKINGS SHALL BE THE NARROW TYPE. STOP BARS SHALL BE 24" IN WIDTH. CROSSWALKS LINES SHALL BE 12" WIDE AND 8' LONG PER CDOT S-627-1.
- ALL LONGITUDINAL LINES SHALL BE A MINIMUM 15MIL THICKNESS EPOXY PAINT. ALL NON-LOCAL RESIDENTIAL ROADWAYS SHALL INCLUDE BOTH RIGHT AND LEFT EDGE LINE STRIPING AND ANY ADDITIONAL STRIPING AS REQUIRED BY CDOT S-627-1.
- THE CONTRACTOR SHALL NOTIFY EL PASO COUNTY DEVELOPMENT SERVICES (719) 520-6819 PRIOR TO AND UPON COMPLETION OF SIGNING AND STRIPING.
- THE CONTRACTOR SHALL OBTAIN A WORK IN THE RIGHT OF WAY PERMIT FROM THE EL PASO COUNTY PUBLIC SERVICE DEPARTMENT (PSD) PRIOR TO ANY SIGNAGE OR STRIPING WORK WITHIN AN EXISTING EL PASO COUNTY ROADWAY.

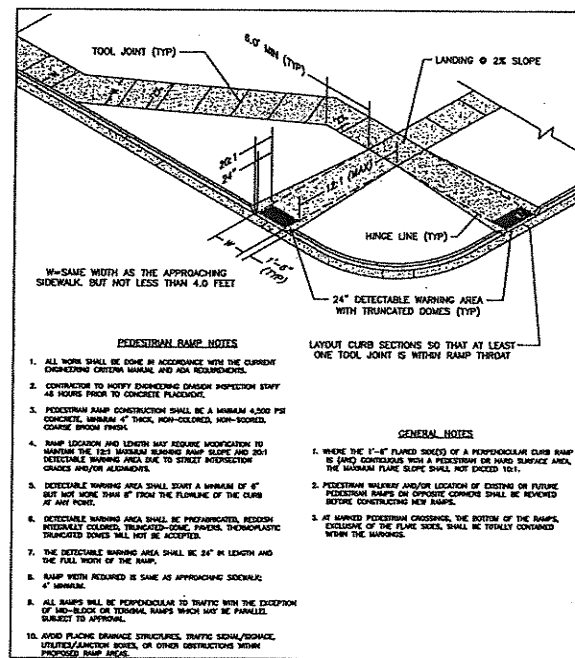

PEDESTRIAN INTERSECTION RAMP (SD 2-41)
SCALE: NTS

STANDARD NOTES FOR EL PASO COUNTY CONSTRUCTION PLANS

- ALL DRAINAGE AND ROADWAY CONSTRUCTION SHALL MEET THE STANDARDS AND SPECIFICATIONS OF THE CITY OF COLORADO SPRINGS/EL PASO COUNTY DRAINAGE CRITERIA MANUAL, VOLUMES 1 AND 2, AND THE EL PASO COUNTY ENGINEERING CRITERIA MANUAL.
- CONTRACTOR SHALL BE RESPONSIBLE FOR THE NOTIFICATION AND FIELD NOTIFICATION OF ALL EXISTING UTILITIES, WHETHER SHOWN ON THE PLANS OR NOT, BEFORE BEGINNING CONSTRUCTION. LOCATION OF EXISTING UTILITIES SHALL BE VERIFIED BY THE CONTRACTOR PRIOR TO CONSTRUCTION. CALL 811 TO CONTACT THE UTILITY NOTIFICATION CENTER OF COLORADO (UNCC).
- CONTRACTOR SHALL KEEP A COPY OF THESE APPROVED PLANS, THE GRADING AND EROSION CONTROL PLAN, THE STORMWATER MANAGEMENT PLAN (SWMP), THE SOILS AND GEOTECHNICAL REPORT, AND THE APPROPRIATE DESIGN AND CONSTRUCTION STANDARDS AND SPECIFICATIONS AT THE JOB SITE AT ALL TIMES, INCLUDING THE FOLLOWING:
 - EL PASO COUNTY ENGINEERING CRITERIA MANUAL (ECM)
 - CITY OF COLORADO SPRINGS/EL PASO COUNTY DRAINAGE CRITERIA MANUAL, VOLUMES 1 AND 2
 - COLORADO DEPARTMENT OF TRANSPORTATION (CDOT) STANDARD SPECIFICATIONS FOR ROAD AND BRIDGE CONSTRUCTION
 - CDOT M & S STANDARDS
- NOTWITHSTANDING ANYTHING DEPICTED IN THESE PLANS IN WORDS OR GRAPHIC REPRESENTATION, ALL DESIGN AND CONSTRUCTION RELATED TO ROADS, STORM DRAINAGE AND EROSION CONTROL SHALL CONFORM TO THE STANDARDS AND REQUIREMENTS OF THE MOST RECENT VERSION OF THE RELEVANT ADOPTED EL PASO COUNTY STANDARDS, INCLUDING THE LAND DEVELOPMENT CODE, THE ENGINEERING CRITERIA MANUAL, THE DRAINAGE CRITERIA MANUAL, AND THE DRAINAGE CRITERIA MANUAL VOLUME 2. ANY DEVIATIONS FROM REGULATIONS AND STANDARDS MUST BE REQUESTED, AND APPROVED, IN WRITING. ANY MODIFICATIONS NECESSARY TO MEET CRITERIA AFTER-THE-FACT WILL BE ENTIRELY THE DEVELOPER'S RESPONSIBILITY TO RECTIFY.
- IT IS THE DESIGN ENGINEER'S RESPONSIBILITY TO ACCURATELY SHOW EXISTING CONDITIONS, BOTH ONSITE AND OFFSITE, ON THE CONSTRUCTION PLANS. ANY MODIFICATIONS NECESSARY DUE TO CONFLICTS, OMISSIONS, OR CHANGED CONDITIONS WILL BE ENTIRELY THE DEVELOPER'S RESPONSIBILITY TO RECTIFY.
- CONTRACTOR SHALL SCHEDULE A PRE-CONSTRUCTION MEETING WITH EL PASO COUNTY DEVELOPMENT SERVICES DEPARTMENT (DSD) - INSPECTIONS, PRIOR TO STARTING CONSTRUCTION.
- IT IS THE CONTRACTOR'S RESPONSIBILITY TO UNDERSTAND THE REQUIREMENTS OF ALL JURISDICTIONAL AGENCIES AND TO OBTAIN ALL REQUIRED PERMITS, INCLUDING BUT NOT LIMITED TO EL PASO COUNTY EROSION AND STORMWATER QUALITY CONTROL PERMIT (ESQCP), REGIONAL BUILDING FLOODPLAIN DEVELOPMENT PERMIT, U.S. ARMY CORPS OF ENGINEERS-ISSUED 401 AND/OR 404 PERMITS, AND COUNTY AND STATE FUGITIVE DUST PERMITS.
- CONTRACTOR SHALL NOT DEVIATE FROM THE PLANS WITHOUT FIRST OBTAINING WRITTEN APPROVAL FROM THE DESIGN ENGINEER AND DSD. CONTRACTOR SHALL NOTIFY THE DESIGN ENGINEER IMMEDIATELY UPON DISCOVERY OF ANY ERRORS OR INCONSISTENCIES.
- ALL STORM DRAIN PIPE SHALL BE CLASS III RCP UNLESS OTHERWISE NOTED AND APPROVED BY DSD.
- CONTRACTOR SHALL COORDINATE GEOTECHNICAL TESTING PER ECM STANDARDS. PAVEMENT DESIGN SHALL BE APPROVED BY EL PASO COUNTY DSD PRIOR TO PLACEMENT OF CURB AND GUTTER AND PAVEMENT.
- ALL CONSTRUCTION TRAFFIC MUST ENTER/EXIT THE SITE AT APPROVED CONSTRUCTION ACCESS POINTS.
- SIGHT VISIBILITY TRIANGLES AS IDENTIFIED IN THE PLANS SHALL BE PROVIDED AT ALL INTERSECTIONS. OBSTRUCTIONS GREATER THAN 18 INCHES ABOVE FLOWLINE ARE NOT ALLOWED WITHIN SIGHT TRIANGLES.
- SIGNING AND STRIPING SHALL COMPLY WITH EL PASO COUNTY DOT AND MUTCD CRITERIA. (IF APPLICABLE, ADDITIONAL SIGNING AND STRIPING NOTES WILL BE PROVIDED.)
- CONTRACTOR SHALL OBTAIN ANY PERMITS REQUIRED BY EL PASO COUNTY DOT, INCLUDING WORK WITHIN THE RIGHT-OF-WAY AND SPECIAL TRANSPORT PERMITS.
- THE LIMITS OF CONSTRUCTION SHALL REMAIN WITHIN THE PROPERTY LINE UNLESS OTHERWISE NOTED. THE OWNER/DEVELOPER SHALL OBTAIN WRITTEN PERMISSION AND EASEMENTS, WHERE REQUIRED, FROM ADJOINING PROPERTY OWNER(S) PRIOR TO ANY OFF-SITE DISTURBANCE, GRADING, OR CONSTRUCTION.

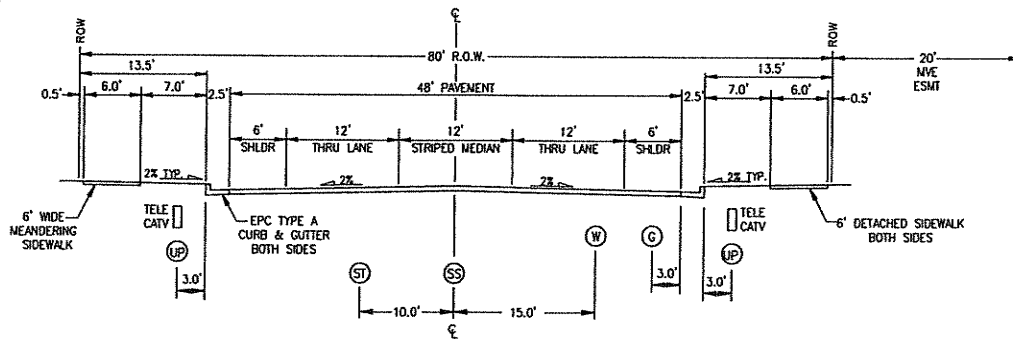

STERLING RANCH ROAD URBAN NON-RESIDENTIAL COLLECTOR
SCALE: NTS

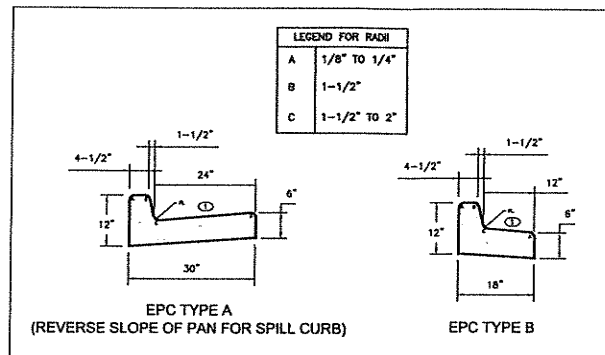

TYPICAL CURB & GUTTER DETAILS DETAIL (SD 2-20)
SCALE: NTS

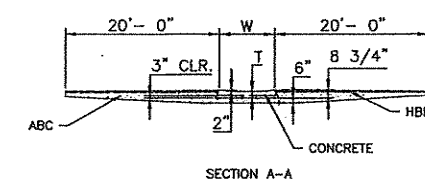
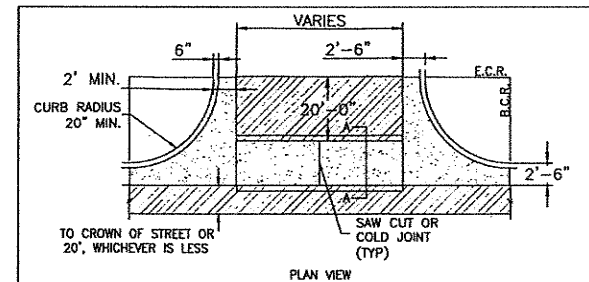

NOTES

- W - WIDTH SHALL BE 6' FOR LOCAL, 8' FOR COLLECTORS, AND 10' FOR ARTERIAL ROADS.
- T - SQUARED-OFF RETURN TO BE POURED MONOLITHICALLY, 8" PCC FOR LOCAL ROADS, 9" FOR COLLECTORS WITH 6x6 - 4.4 W.W.F. OR #4 REINFORCING BAR @ 18" EACH WAY.
- ZZZ = 3" MINIMUM ASPHALT DEPTH (2 LIFTS).
- DESIGN TO SPECIFY ELEVATIONS AT PI AND PCR.

TYPICAL CROSS PAN LAYOUT DETAIL (SD 2-26)
SCALE: NTS

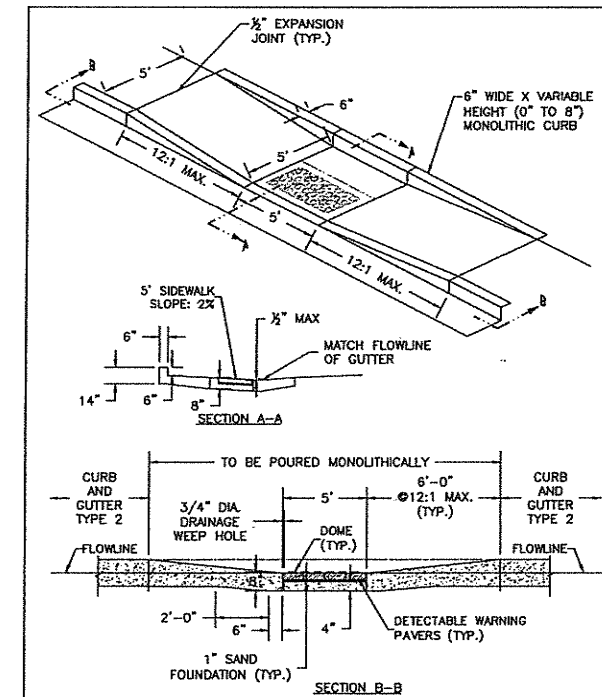

PARALLEL PEDESTRIAN RAMP DETAIL (SD 2-50)
SCALE: NTS

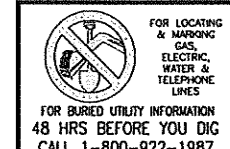

STERLING RANCH - STERLING RANCH ROAD

NOTES & DETAILS SHEET

DATE: 07/05/2017

PROJECT NO. 09-002

SCALE: HORIZONTAL: NTS
VERTICAL: N/A

DESIGNED BY: ###

DRAWN BY: SM

CHECKED BY: ###

SHEET 2 OF 5

S102

20 BOLLINGER CRESCENT, SUITE 110
DENVER, CO 80202
PHONE: 773.655.5883

CIVIL CONSULTANTS, INC.

FOR USE ON BEHALF OF MAS CIVIL CONSULTANTS, INC.

VIRGIL A. SANCHEZ, COLORADO P.E. NO. 37160

NO. DATE: DESCRIPTION:

THE ENGINEER PREPARING THESE PLANS WILL NOT BE RESPONSIBLE, OR LIABLE FOR UNAUTHORIZED CHANGES TO OR USES OF THESE PLANS. ALL CHANGES TO THE PLANS MUST BE IN WRITING AND MUST BE APPROVED BY THE PREPARER OF THESE PLANS.

CAUTION

- (a) Permanent erosion and sediment control measures that shall be installed at the earliest practicable time consistent with good construction practices and that shall be maintained and replaced as necessary throughout the life of the project.
- (b) Temporary erosion and sediment control measures that shall be coordinated with permanent measures to assure economical, effective, and continuous control throughout the construction phase and during the operation of the project.

Appendix D

**Wetland Mitigation Plan
Sterling Ranch 404 Permit**

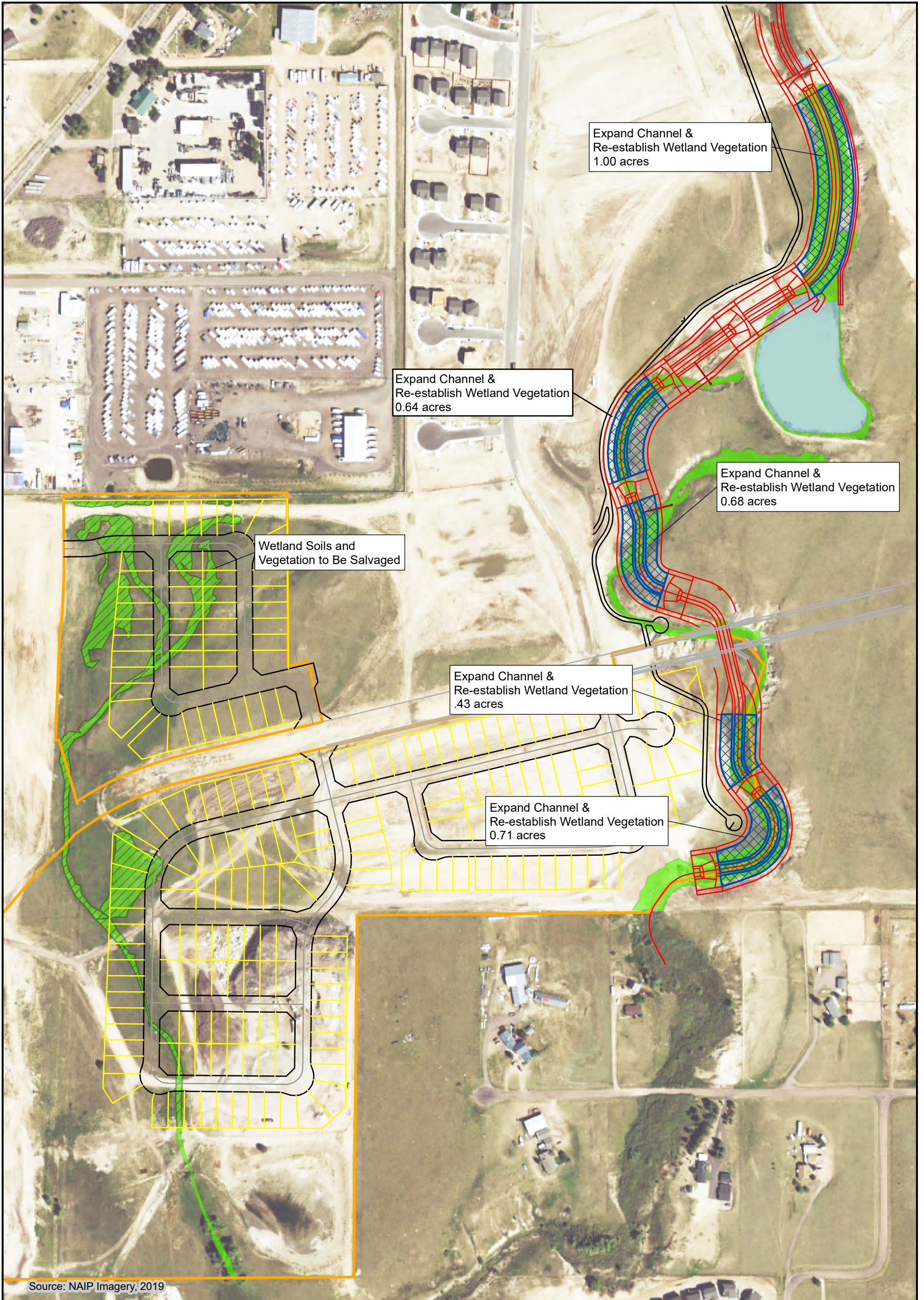

Source: NAIP Imagery, 2019



- Mitigation Area
- Project Area
- Open Water
- Wetland
- Wetland Soils and Vegetation to Be Salvaged
- Road Centerline
- Property Line
- Road ROW

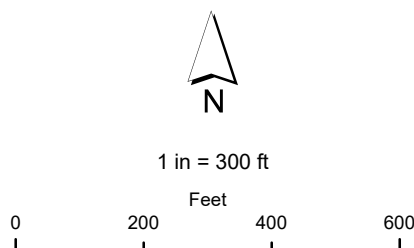

**Sterling Ranch
Phase 2**
Compensatory Mitigation Plan





REPLY TO
ATTENTION OF

DEPARTMENT OF THE ARMY
ALBUQUERQUE DISTRICT, CORPS OF ENGINEERS
200 SOUTH SANTA FE AVENUE, SUITE 301
PUEBLO, COLORADO 81003-4270

NOT SIGNED
ce-24-16

February 18, 2016

Regulatory Division

SUBJECT: Action No. SPA-2015-00428-SCO, Sterling Ranch Residential Development Project, El Paso County, Colorado

Jim Morley
SR Land, LLC
20 Boulder Crescent Suite 201
Colorado Springs, CO 80903

Mr. Morley:

Enclosed for your review and signature are two copies of the draft permit for Action No. SPA-2015-00428-SCO discharge dredged and fill material into waters of the United States.

You may either sign the permit or object to the permit and request the permit to be modified in accordance with the enclosed Notification of Administrative Appeal Options and Process and Request For Appeal (NAAOP-RFA). If you elect to object to this permit, you must complete Section II (Request for Appeal or Objections to an Initial Proffered Permit) of the enclosure and return to: U.S. Army Corps of Engineers, Attn: Mr. Tom Cavanaugh, Administrative Appeal Review Officer, 1455 Market Street, Room 1760, San Francisco, CA 94103-1399, within 60 days of the date of this letter.

If you elect to sign the permit, please ensure that both copies are signed and dated and return them to the attention of the Regulatory Division at the address above. Your signature on the permit indicates that you accept the permit in its entirety and forfeit all rights to appeal the permit or its terms and conditions, and denotes your assurance that the work will be conducted in accordance with the plans, description, and all terms and conditions of the permit.

A fee in the amount of \$100.00 for commercial project must be paid before the permit can be issued. Your check should be made payable to the "Finance and Accounting Officer, UFC, Albuquerque", and mailed to the attention of the Regulatory Division at the above address.

Within ten days, both signed copies of the accepted permit should be returned to us. One copy of the signed permit will be returned to you. The permit is not valid until signed by the U.S. Army Corps of Engineers. If you have any questions concerning this

permit, please contact me at 719-543-6915 or by e-mail at van.a.truan@usace.army.mil.

Sincerely,

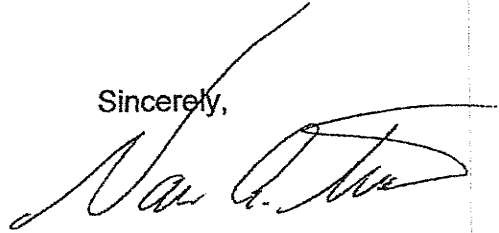
A handwritten signature in black ink, appearing to read "Van A. Truan". The signature is fluid and cursive, with a long horizontal stroke at the end.

Van Truan
Chief, Southern Colorado
Regulatory Branch

Enclosures



REPLY TO
ATTENTION OF

DEPARTMENT OF THE ARMY
ALBUQUERQUE DISTRICT, CORPS OF ENGINEERS
200 SOUTH SANTA FE AVENUE, SUITE 301
PUEBLO, COLORADO 81003-4270

SIGNED

February 29, 2016

Regulatory Division

SUBJECT: Action No. SPA-2015-00428-SCO, Sterling Ranch Residential Development Project, El Paso County, Colorado

Jim Morley
SR Land, LLC
20 Boulder Crescent Suite 201
Colorado Springs, CO 80903

Mr. Morley:

You are hereby authorized under Section 404 of the Clean Water Act to discharge dredged and fill material into waters of the United States to conduct work in associated with construction of the Sterling Ranch Residential Development in accordance with Action Number SPA-2015-00428-SCO. A copy of the permit is enclosed.

To use this permit, you must ensure that the work is conducted in accordance with the terms and conditions of the permit. You must submit revised drawings to us for approval prior to construction should any changes be found necessary in either the location or plans for the work. Approval of revised plans may be granted if they are found not contrary to the public interest.

This permit is not an approval of the project design features, nor does it imply that the construction is adequate for its intended purpose. This permit does not authorize any injury to property or invasion of rights or any infringement of Federal, state or local laws or regulations. You must possess the authority, including property rights, to undertake the proposed work.

Enclosed is a compliance certification form. Upon completion of the project, please sign and date the form and return it to this office.

If you have any questions concerning our regulatory program, please contact me at 719-543-6915 or by e-mail at van.a.truan@usace.army.mil. At your convenience,

please complete a Customer Service Survey at
<http://per2.nwp.usace.army.mil/survey.html>.

Sincerely,

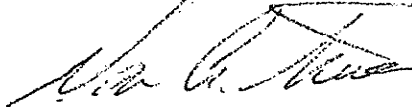
A handwritten signature in black ink, appearing to read "Van Truan", written over a horizontal line.

Van Truan
Chief, Southern Colorado
Regulatory Branch

Enclosure(s)

**Certification of Compliance
with Department of the Army Permit**

Action Number: SPA-2015-00428-SCO

Name of Permittee: SR Land, LLC

Upon completion of the activity authorized by this permit and any mitigation required by the permit, sign this certification and return it to the following address:

Van Truan
Albuquerque District, U.S. Army Corps of Engineers
200 South Santa Fe Avenue, Suite 301
Pueblo, Colorado 81003-4270

Please note that your permitted activity is subject to a compliance inspection by an U.S. Army Corps of Engineers representative. If you fail to comply with this permit, you are subject to permit suspension, modification, or revocation.

Please enclose photographs showing the completed project (if available).

I hereby certify that the work authorized by the above referenced permit has been completed in accordance with the terms and conditions of the said permit, and required mitigation was completed in accordance with the permit conditions.

Date Work Started _____

Date Work Completed _____

Date

Signature of Permittee

DEPARTMENT OF THE ARMY PERMIT

Permittee Jim Morley

Permit No. SPA-2015-00428-SCO

Issuing Office Albuquerque District, U.S. Army Corps of Engineers

NOTE: The term "you" and its derivatives, as used in this permit, means the permittee or any future transferee. The term "this office" refers to the appropriate district or division office of the Corps of Engineers having jurisdiction over the permitted activity or the appropriate official of that office acting under the authority of the commanding officer.

You are authorized to perform work in accordance with the terms and conditions specified below.

Project Description: The Sterling Ranch Residential Development Project includes installation of attendant utilities, channel improvements to the main stem of Sand Creek, three off-line stormwater detention ponds, development of two permanent residential access roads and associated culverts, and development of residential units. Permanent impacts to waters of the US will result from construction of the residential access roads and associated culverts, and construction of residential units in the unnamed western tributary to Sand Creek. Total cumulative permanent impacts from the discharge of fill material into waters/wetlands of the US from the proposed project will total 4.21 acres and 5,048 linear feet within the main channel of Sand Creek and its western tributary. The project will be constructed in accordance with the attached drawings, entitled, "Sterling Ranch Wetland Impact Location Map, Sterling Ranch Sketch Plan figure number 8, and Sterling Ranch Channel Improvements & Mitigation Plan sheets 1 through 3 dated October 13, 2015, in Sand Creek, El Paso County, Colorado, Application by Jim Morley, Application No. SPA-2015-00428-SCO".

Project Location: The project is located on 1,443.7 acres northeast of the intersection of Black Forest Road and Woodmen Road in unincorporated El Paso County, Colorado. The property is on the United States Geological Survey (USGS) Falcon Quadrangle on portions of Sections 27, 28, 32, 33, and 34 in Township 12 South, Range 65 West and the northwest portion of Section 4, Township 13 South, Range 65 West. The approximate coordinates of the project center are 39.964483 latitude and -104.664944 longitude (WGS 84 datum).

Permit Conditions: In accordance with the attached Colorado Department of Public Health and Environment Section 401 Water Quality Certification pages 1 through 6 of 6, dated February 4, 2016.

General Conditions:

1. The time limit for completing the work authorized ends on March 1, 2021. If you find that you need more time to complete the authorized activity, submit your request for a time extension to this office for consideration at least one month before the above date is reached.

2. You must maintain the activity authorized by this permit in good condition and in conformance with the terms and conditions of this permit. You are not relieved of this requirement if you abandon the permitted activity,

although you may make a good faith transfer to a third party in compliance with General Condition 4 below. Should you wish to cease to maintain the authorized activity or should you desire to abandon it without a good faith transfer, you must obtain a modification of this permit from this office, which may require restoration of the area.

3. If you discover any previously unknown historic or archeological remains while accomplishing the activity authorized by this permit, you must immediately notify this office of what you have found. We will initiate the Federal and state coordination required to determine if the remains warrant a recovery effort or if the site is eligible for listing in the National Register of Historic Places.

4. If you sell the property associated with this permit, you must obtain the signature of the new owner in the space provided and forward a copy of the permit to this office to validate the transfer of this authorization.

5. If a conditioned water quality certification has been issued for your project, you must comply with the conditions specified in the certification as special conditions to this permit. For your convenience, a copy of the certification is attached if it contains such conditions.

6. You must allow representatives from this office to inspect the authorized activity at any time deemed necessary to ensure that it is being or has been accomplished in accordance with the terms and conditions of your permit.

Special Conditions:

1. The permittee shall implement and abide by the compensatory mitigation plan titled Conceptual Mitigation Plan for Sterling Ranch Residential Development, prepared by CORE Consultants, Inc. on October 29, 2015 except where changes are necessary to comply with special conditions listed below. The permittee shall implement the mitigation plan concurrently with the construction of the project and complete the initial construction and plantings associated with the mitigation work prior to EITHER the initiation of operation OR completion of construction of the project. Completion of all elements of this mitigation plan is a requirement of this permit.

2. The permittee shall submit annual compensatory mitigation site monitoring reports to the Corps Albuquerque District Office by December 31st of each year, beginning in 2016, for a minimum of 3 years or until the Corps has determined that the mitigation performance standards and success criteria have been met. The monitoring reports shall be prepared in accordance with Corps Regulatory Guidance Letter 08-03 (Minimum Monitoring Requirements for Compensatory Mitigation Projects Involving the Restoration, Establishment, and/or Enhancement of Aquatic Resources) and current Corps Albuquerque District Mitigation Monitoring Guidelines available at <http://www.spa.usace.army.mil/Missions/RegulatoryProgramandPermits/Mitigation.aspx>. The mitigation monitoring reports shall at a minimum include the following:

a. Comparison of pre-construction site conditions to an as-built survey as submitted in accordance with Special Condition 4.

b. A map showing the wetland AND/OR Ordinary High Water Mark (OHWM) delineation, and aerial photos marked to show the wetland AND/OR OHWM boundary.

c. Photographs (minimum 5) from fixed photographic monitoring points with a location reference map and indicating camera orientation.

d. All data collected to document whether the mitigation site is achieving performance standards described in the mitigation plan and a narrative discussion of progress made toward meeting performance standards.

e. Fish and wildlife observations at the mitigation site.

f. Summary statement regarding the perceived success of the mitigation project and any potential problem areas. Suggestions and a timetable for corrections should be included if it is anticipated that project goals may not be met.

g. Date(s) of field inspection(s).

3. In order to assist the Corps in scheduling compliance inspections, the permittee shall notify the Corps Albuquerque District Office, in writing, at least 7 calendar days in advance of the initiation of mitigation construction AND no later than 15 calendar days following completion of construction activities.

4. Within 60 days after completion of construction of the mitigation project, the permittee shall submit as-built drawings and a description of the work conducted to the Corps Albuquerque District Office. The drawings shall include the following:

a. The Department of the Army Action Number.

b. A plan view drawing of the location of the authorized work footprint (as shown in permit drawings) with an overlay of the work as constructed in the same scale. The drawing should show all "earth disturbance," wetland impacts, structures, and the boundaries of any on-site and/or off-site mitigation or avoidance areas. The drawings shall contain, at a minimum, 1-foot OR greater topographic contours of the entire site.

c. Ground photographs of the completed work. The camera positions and view-angles of the ground photographs shall be identified on a map, aerial photograph, or project drawing.

d. A description of all deviations between the work as authorized by the permit and the work as constructed. Clearly indicate on the as-built drawings the location of any deviations.

5. Your responsibility to complete the required compensatory mitigation as set forth in Special Condition No. 1 will not be considered fulfilled until you have demonstrated mitigation success and have received written verification from the U.S. Army Corps of Engineers.

Further Information:

1. Congressional Authorities: You have been authorized to undertake the activity described above pursuant to:

Section 10 of the Rivers and Harbors Act of 1899 (33 U.S.C. 403).

Section 404 of the Clean Water Act (33 U.S.C. 1344).

Section 103 of the Marine Protection, Research and Sanctuaries Act of 1972 (33 U.S.C. 1413).

2. Limits of this authorization.

a. This permit does not obviate the need to obtain other Federal, state, or local authorizations required by law.

b. This permit does not grant any property rights or exclusive privileges.

c. This permit does not authorize any injury to the property or rights of others.

d. This permit does not authorize interference with any existing or proposed Federal project.

3. Limits of Federal Liability. In issuing this permit, the Federal Government does not assume any liability for the following:

a. Damages to the permitted project or uses thereof as a result of other permitted or unpermitted activities or from natural causes.

b. Damages to the permitted project or uses thereof as a result of current or future activities undertaken by or on behalf of the United States in the public interest.

c. Damages to persons, property, or to other permitted or unpermitted activities or structures caused by the activity authorized by this permit.

d. Design or construction deficiencies associated with the permitted work.

e. Damage claims associated with any future modification, suspension, or revocation of this permit.

4. Reliance on Applicant's Data: The determination of this office that issuance of this permit is not contrary to the public interest was made in reliance on the information you provided.

5. Reevaluation of Permit Decision. This office may reevaluate its decision on this permit at any time the circumstances warrant. Circumstances that could require a reevaluation include, but are not limited to, the following:

a. You fail to comply with the terms and conditions of this permit.

b. The information provided by you in support of your permit application proves to have been false, incomplete, or inaccurate (See 4 above).

c. Significant new information surfaces which this office did not consider in reaching the original public interest decision.

Such a reevaluation may result in a determination that it is appropriate to use the suspension, modification, and revocation procedures contained in 33 CFR 325.7 or enforcement procedures such as those contained in 33 CFR 326.4 and 326.5. The referenced enforcement procedures provide for the issuance of an administrative order requiring you to comply with the terms and conditions of your permit and for the initiation of legal action where appropriate. You will be required to pay for any corrective measures ordered by this office, and if you fail to comply with such directive, this office may in certain situations (such as those specified in 33 CFR 209.170) accomplish the corrective measures by contract or otherwise and bill you for the cost.

6. Extensions. General condition 1 establishes a time limit for the completion of the activity authorized by this

permit. Unless there are circumstances requiring either a prompt completion of the authorized activity or a reevaluation of the public interest decision, the Corps will normally give favorable consideration to a request for an extension of this time limit.

Your signature below, as permittee, indicates that you accept and agree to comply with the terms and conditions of this permit.

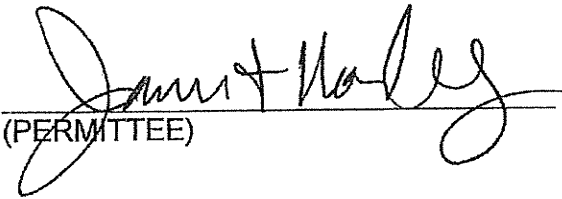
(PERMITTEE)

2/23/2016
(DATE)

This permit becomes effective when the Federal official, designated to act for the Secretary of the Army, has signed below.

(FOR THE DISTRICT ENGINEER)

29 Feb 2016
(DATE)

Patrick J. Dagon
Lieutenant Colonel, U.S. Army
District Commander

When the structures or work authorized by this permit are still in existence at the time the property is transferred, the terms and conditions of this permit will continue to be binding on the new owner(s) of the property. To validate the transfer of this permit and the associated liabilities associated with compliance with its terms and conditions, have the transferee sign and date below.

(TRANSFEREE)

(DATE)

Provide original PDF versions of these Core sheets.

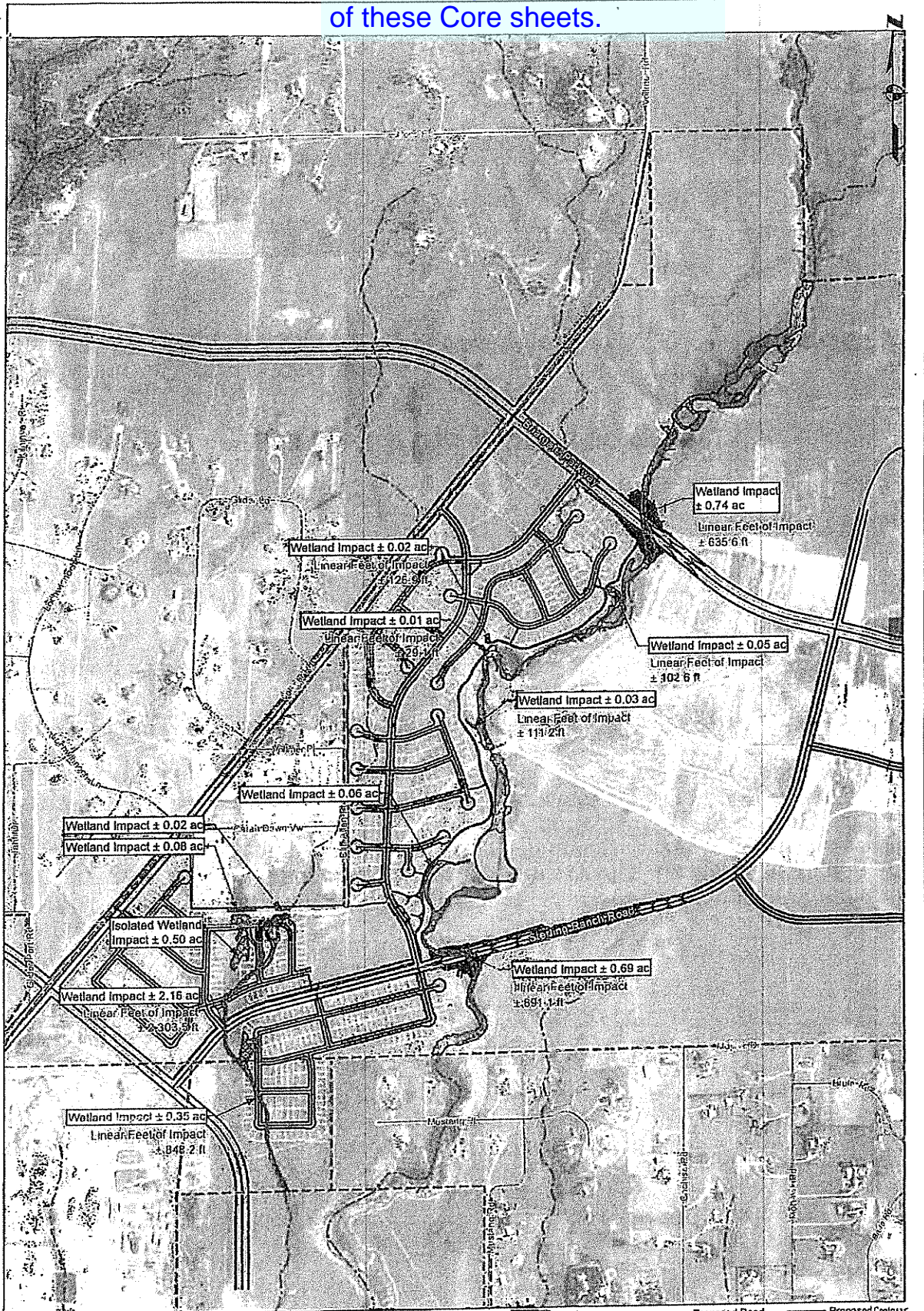

0 500 1,000
Feet

STERLING RANCH
Wetland Impact Location Map
El Paso County, Colorado

Date: 10/13/2015
Project #: 15-001



**CIVIL ENGINEERING
DEVELOPMENT CONSULTING
LAND SURVEYING**
303.703.4444
1950 W. Alameda Blvd., Ste. 102
Littleton, CO 80120

Permanent Impact Pond Proposed Road Proposed Contour
Existing Wetland Dry Wash Proposed Trail Parcel Boundary
Existing Isolated Wetland NHD Watercourse Proposed Lot Lines

LAND USE LEGEND:

[Pattern]	44 AC. RESIDENTIAL 0-3 DUVG	0 D.U.
[Pattern]	39 AC. RESIDENTIAL 0-4 DUVG	19 D.U.
[Pattern]	35 AC. RESIDENTIAL 1 DUVG	35 D.U.
[Pattern]	168 AC. RESIDENTIAL 2 DUVG	328 D.U.
[Pattern]	476 AC. RESIDENTIAL 3-6 DUVG	1,400 D.U.
[Pattern]	101 AC. RESIDENTIAL 6-9 DUVG	808 D.U.
[Pattern]	257 AC. RESIDENTIAL 9-12 DUVG	1,462 D.U.
[Pattern]	32 AC. RESIDENTIAL 12-24 DUVG	320 D.U.
[Pattern]	41 AC. RESIDENTIAL 12-24 DUVG	368 D.U.
[Pattern]	57 AC. COMMERCIAL	
[Pattern]	57 AC. ELEMENTARY / K-8 SCHOOL	
[Pattern]	18 AC. NEIGHBORHOOD PARK	
[Pattern]	30 AC. COMMUNITY PARK	
[Pattern]	57 AC. OPEN SPACE / PARK / GREENWAY	
[Pattern]	41 AC. OPEN SPACE / BUFFER	
[Pattern]	2 AC. UTILITY PACE	
TOTAL	1744 AC.	TOTAL (4,370) D.U.

SYMBOL LEGEND:

- [Line style]
- [Line style]
- [Line style]
- [Line style]
- [Line style]
- [Line style]
- [Line style]
- [Line style]
- [Line style]
- [Line style]
- [Line style]

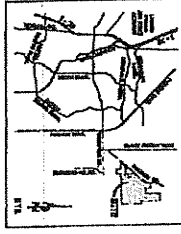

OWNER & DEVELOPER INFO:

MORLEY-BENTLEY INVESTMENTS, LLC
 20 BOLLARD CREEK DR
 COLORADO SPRINGS, CO 80903
 TEL: (719) 471-1762

NOTES:

1. LOTS, 599 AND PROPOSED CONSERVATION AND BIODIVERSITY FOUND ON PAGE 10 OF THE SKETCH PLAN REPORT.
2. NO SCHOOL SITES ARE SHOWN IN RED TO THE NOTICE OF THE USE. THE ACTIVE ADULT COMMUNITY SOCIETIES CHILDREN SCHOOL DETENTION WILL BE LAID.

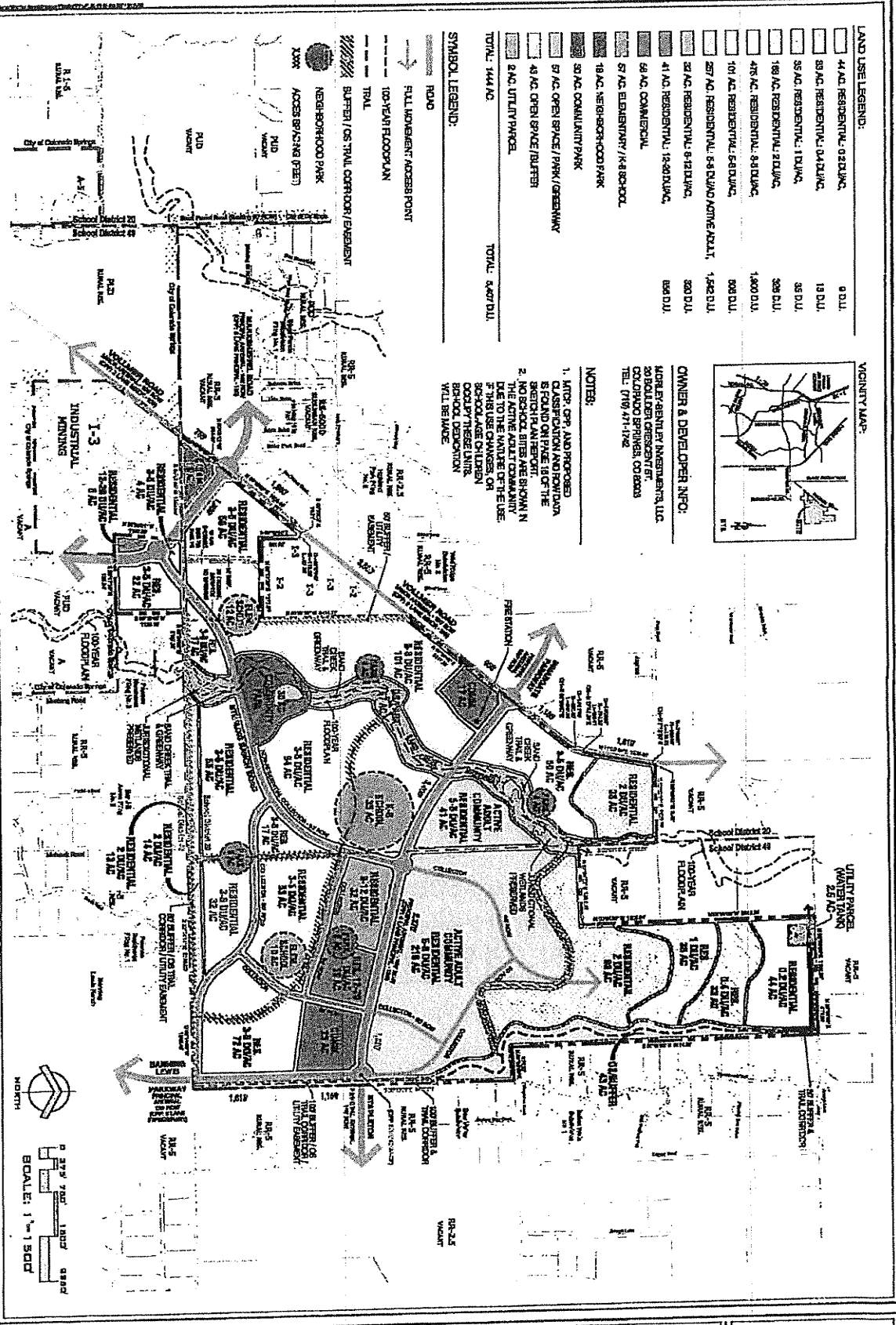

SCALE: 1" = 150'

Sterling Ranch SKETCH PLAN

MORLEY-BENTLEY INVESTMENTS, LLC.

URBAN DESIGN LAND PLANNING & LANDSCAPE ARCHITECTURE

NES is a member of the

PROJECT NO. 8
 DATE: 05/15/2008

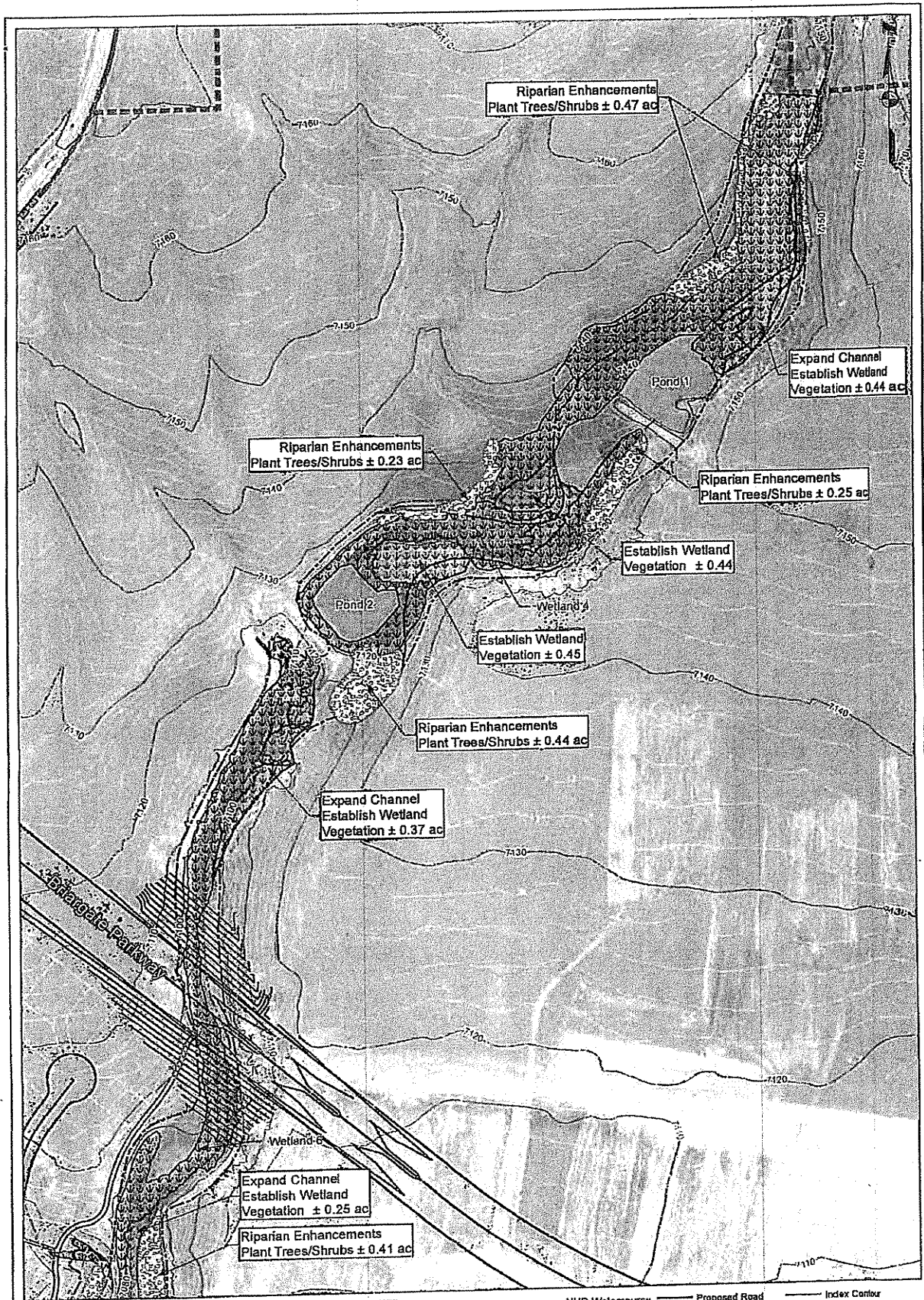

0 100 200
Feet

- | | | | | |
|-----------------------------------|---------------------------|---------------------|--------------------|----------------------|
| Potential Riparian Enhancement | Pond | NHD Watercourse | Proposed Road | Index Contour |
| Potential Wetland Mitigation Area | Dry Wash | 100-year Floodplain | Proposed Trail | Intermediate Contour |
| Existing Wetland | Existing Isolated Wetland | 500-year Floodplain | Proposed Lot Lines | Parcel Boundary |
| | | | Proposed Contour | |



CIVIL ENGINEERING
DEVELOPMENT CONSULTING
LAND SURVEYING
801.701.4444
1950 W. Littleton Blvd., Ste. 103
Littleton, CO 80120

Sterling Ranch
Channel Improvements & Mitigation Plan
Sheet 1
El Paso County, Colorado

Date: 10/13/2015
Project #: 15-001

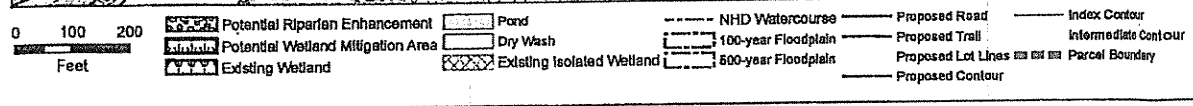
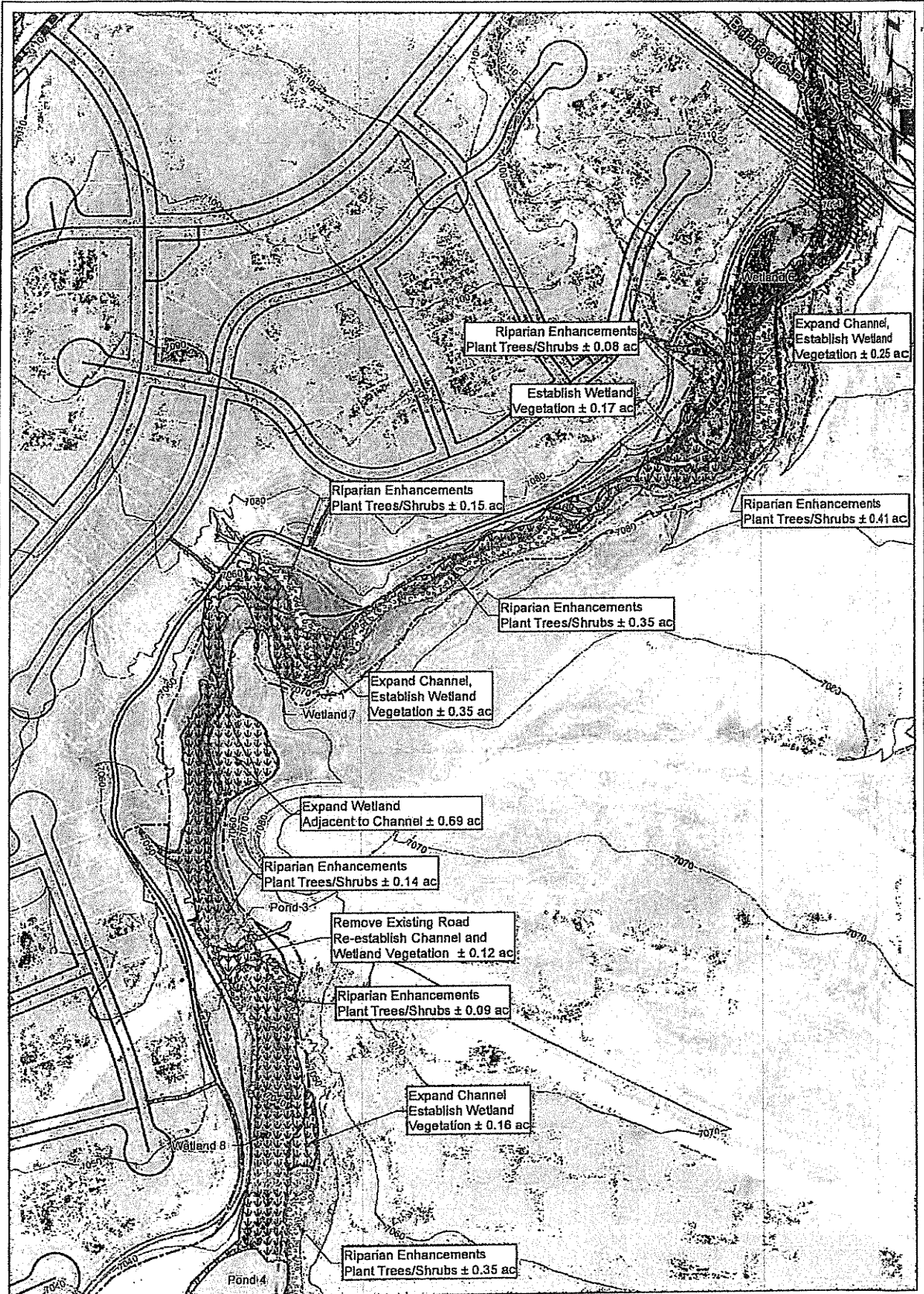

CORE
 CONSULTANTS

CIVIL ENGINEERING
 DEVELOPMENT CONSULTING
 LAND SURVEYS
 303.755.4444
 1930 W. Littleton Blvd., Ste. 109
 Littleton, CO 80120

Sterling Ranch
Channel Improvements & Mitigation Plan
Sheet 2
 El Paso County, Colorado

Date: 10/3/2015
 Project #: 15-001

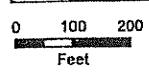
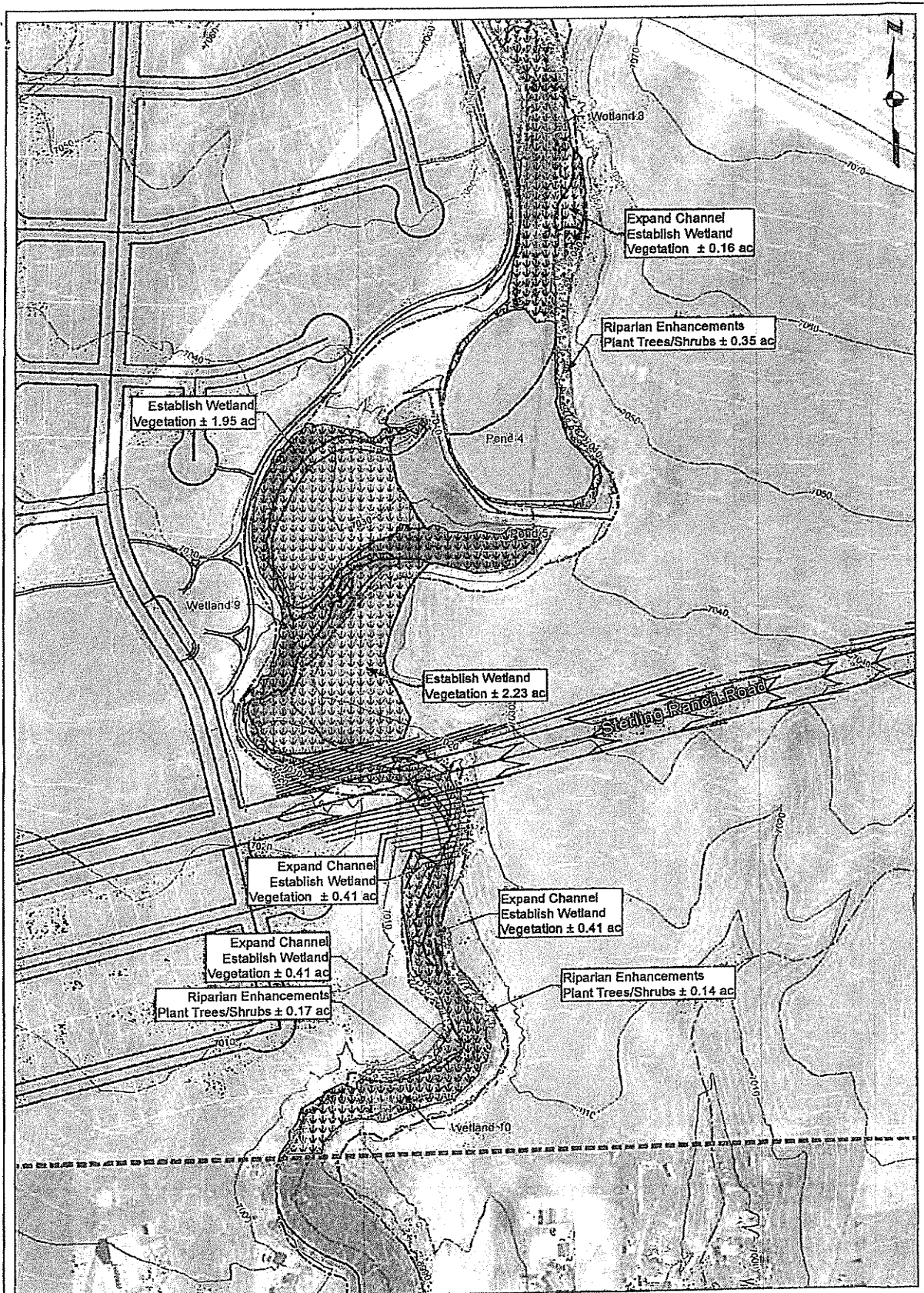

- | | | | | |
|-----------------------------------|---------------------------|---------------------|--------------------|----------------------|
| Potential Riparian Enhancement | Pond | NHD Watercourse | Proposed Road | Index Contour |
| Potential Wetland Mitigation Area | Dry Wash | 100-year Floodplain | Proposed Trail | Intermediate Contour |
| Existing Wetland | Existing Isolated Wetland | 500-year Floodplain | Proposed Lot Lines | Parcel Boundary |
| | | | Proposed Contour | |



CIVIL ENGINEERING
DEVELOPMENT CONSULTING
LAND SURVEYING
203.703.4444
1950 W. Ludman Blvd, Ste 109
Littleton, CO 80120

Sterling Ranch

Channel Improvements & Mitigation Plan

Sheet 3

El Paso County, Colorado

Date: 10/13/2015
Project #: 15-001



**US Army Corps
of Engineers®**
Albuquerque District
Project

PUBLIC NOTICE

Permit Application No.: SPA-2015-00428-SCO
Project Name: Sterling Ranch Residential
Development Project
Applicant: SR Land, LLC
Waterway: Sand Creek
Public Notice Date: December 9, 2015
Comment Due Date: January 9, 2016
USACE Contact Phone: (719) 543-8102

Reply To:

Southern Colorado Regulatory Office
US Army Corps of Engineers, Albuquerque District
200 South Santa Fe Avenue, Suite 301
Pueblo, Colorado 81003-4270

PERMIT APPLICATION UNDER SECTION 404 OF THE CLEAN WATER ACT (33 USC 1344)

Summary of Proposed Project: We are requesting public comment on the following project before the above comment due date. The application is for a permit to place dredged/fill material into waters of the US associated with the construction of a residential development in Sand Creek and one tributary located near Falcon, El Paso County, Colorado. Details of the proposed project are provided below.

Name of Applicant: SR Land, LLC, 20 Boulder Crescent, Suite 201, Colorado Springs, CO 80903.

Location: The project is located on 1,443.7 acres northeast of the intersection of Black Forest Road and Woodmen Road in unincorporated El Paso County, Colorado. The property is on the United States Geological Survey (USGS) Falcon Quadrangle on portions of Sections 27, 28, 32, 33, and 34 in Township 12 South, Range 65 West and the northwest portion of Section 4, Township 13 South, Range 65 West. The approximate coordinates of the project center are 39.964483 latitude and -104.664944 longitude (WGS 84 datum).

Description of Work: The Sterling Ranch Residential Development Project includes installation of attendant utilities, channel improvements to the main stem of Sand Creek, three off-line stormwater detention ponds, development of two permanent residential access roads and associated culverts, and development of residential units. Permanent impacts to waters of the US will result from construction of the residential access roads and associated culverts, and construction of residential units in the unnamed western

NEWS RELEASE

CESPA-RD-SC
SPA-2015-00428-SCO

tributary to Sand Creek. Total cumulative permanent impacts to waters of the US from the proposed project will total 4.21 acres and 5,048 linear feet within the main channel of Sand Creek and its western tributary.

Purpose and Need: The project purpose is twofold: (1) the development of a medium sized single-family residential development and associated facilities and infrastructure on multiple parcels of land which will be incorporated in the City of Colorado Springs; and (2) creek channel improvements for hydrology and stormwater capability through control of flood water conveyance, establishing improved grade control, and facilitating improved water quality.

Likewise, the project need is twofold: (1) to satisfy market demand for additional housing in the City of Colorado Springs, El Paso County, based on recent County and City economic development reports; and (2) to address a County-wide high-priority stormwater management project while simultaneously managing an increase in stormwater runoff to Sand Creek via channel improvements.

Mitigation: Mitigation for impacts to wetlands and waters of the US on the Sterling Ranch project site is proposed within the Middle Fountain Creek watershed and includes creation of 4.21 acres of emergent wetlands located within and adjacent to the main channel of Sand Creek, with improvements throughout to allow for construction and reestablishment of wetlands.

Plans and Data: Drawings showing the location of the work site and other data are enclosed with this notice. If additional information is desired, it may be obtained from the applicant, or from:

Christopher M. Grosso
U.S. Army Corps of Engineers
Southern Colorado Regulatory Office
200 South Santa Fe Avenue, Suite 301
Pueblo, Colorado 81003-4270
(719) 543-8102
Fax No. (719) 543-9475
E-mail: Christopher.M.Grosso@usace.army.mil

Statement of Findings: The Corps consulted district files and records, the latest version of the National Register of Historic Places (NRHP), and state records of NRHP-eligible and potentially eligible historic properties to determine if there are any historic properties that may be affected by the proposed undertaking. Based on this initial information, the Corps has made a preliminary determination that the proposed project will not affect any historic properties that meet the criteria for inclusion in the NRHP.

The Corps has reviewed the U.S. Fish and Wildlife Service's latest published version of Federally-listed endangered and threatened species located in El Paso County, Colorado to determine if any listed species or their critical habitat may occur in the proposed project area. The Corps has made a preliminary determination that the

NEWS RELEASE

CESPA-RD-SC
SPA-2015-00428-SCO

proposed project will not affect any Federally-listed endangered or threatened species or their critical habitat that are protected by the Endangered Species Act.

The applicant is required to obtain water quality certification, under Section 401 of the Clean Water Act, from the Colorado Department of Public Health and Environment. Section 401 requires that any applicant for an individual Section 404 permit provide proof of water quality certification to the Corps of Engineers prior to permit issuance.

In accordance with environmental procedures and documentation required by the National Environmental Policy Act of 1969, an environmental assessment will be prepared for this project. Upon completion, the assessment may be seen at the U.S. Army Corps of Engineers, Albuquerque District Office, at the address given above.

Comments: Any comments concerning this project should be received by the District Engineer no later than January 9, 2016. Comments received after the end of the Public Notice comment period will not be considered. However, more time may be given if a request, with a valid reason, is received prior to the suspense date. The Corps of Engineers is soliciting comments from the public; federal, state, and local agencies and officials; Indian tribes; and other interested parties in order to consider and evaluate the impacts of this proposed activity. Any comments received will be considered by the Corps of Engineers to determine whether to issue, modify, condition, or deny a permit for this proposal. To make this decision, comments are used to assess impacts on endangered species, historic properties, water quality, general environmental effects, and the other public interest factors listed below. Comments are used in the preparation of an Environmental Assessment and/or an Environmental Impact Statement pursuant to the National Environmental Policy Act. Comments are also used to determine the need for a public hearing and to determine the overall public interest of the proposed activity.

The decision whether to issue a permit will be based on an evaluation of the probable impact, including cumulative impacts, of the proposed activity on the public interest. That decision will reflect the national concern for both protection and utilization of important resources. The benefit which reasonably may be expected to accrue from the proposal must be balanced against its reasonably foreseeable detriments. The evaluation of the impact of this activity will include application of the guidelines promulgated by the Administrator, EPA, under authority of Section 404(b) of the Clean Water Act. All factors relevant to the proposal and the cumulative effects will be considered; among these are conservation, economics, aesthetics, general environmental concerns, wetlands, historic properties, fish and wildlife values, flood hazards, floodplain values, land use, navigation, shore erosion and accretion, recreation, water supply and conservation, water quality, energy needs, safety, food and fiber production, mineral needs, considerations of property ownership, and, in general, the needs and welfare of the people.

If the District Engineer determines that the project complies with the 404(b) (1) guidelines, he will grant the permit unless issuance would be contrary to the public interest.

NEWS RELEASE

CESPA-RD-SC
SPA-2015-00428-SCO

Any person may request a public hearing. The request must be submitted, in writing, to the District Engineer within 21 days of the date of this notice and must clearly set forth the reasons for holding a public hearing.

Patrick J. Dagon
Lieutenant Colonel, U.S. Army
District Commander

Enclosures:

Sheet 1 of 2 – Wetland Location Map

Sheet 2 of 2 – Wetland Impact Location Map

NEWS RELEASE

CESPA-RD-SC
SPA-2015-00428-SCO



COLORADO

Department of Public
Health & Environment

Dedicated to protecting and improving the health and environment of the people of Colorado

February 4, 2016

SR Land, LLC
Attn: Jim Morley
20 Boulder Crescent, Ste. 201
Colorado Springs, CO 80903

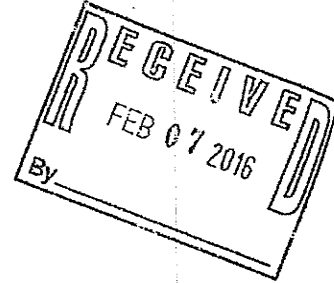

Re: Section 401 Water Quality Certification
Colorado 401 Certification No.: 4378
US Corps of Engineers 404 Permit No.: SPA-2015-00428-SCO
Description: Construction of a residential development
Location: Latitude: 38.962389, Longitude -104.675084 in El Paso County,
Colorado
Watercourse: Sand Creek and tributaries, Arkansas River Basin, Segment
COARFO04 of Fountain Creek Sub-basin
Designation: Use Protected

Dear Mr. Morley:

The Colorado Department of Public Health and Environment (CDPHE), Water Quality Control Division (Division) has completed its review of the subject Clean Water Act (CWA) Section 404 Permit Application, and our preliminary determination with the issuance of the State of Colorado 401 Certification Public Notice (5 CCR 1002-82.5(B)). This segment is designated "Use Protected" thus no antidegradation review is required (5 CCR 1002-31.8(2)).

This letter shall serve as official notification that the Division is issuing "Regular Certification" in accordance with 5 CCR 1002-82.5(A)(2).

The 401 Certification issued by the Division pursuant to 5 CCR 1002-82.3(C) shall apply to both the construction and operation of the project for which a federal license or permit is required, and shall apply to the water quality impacts associated with the project. This certification does not constitute a relinquishment of the Division's authority as defined in the Colorado Water Quality Control Act, nor does it fulfill or waive any other local, state, or federal regulations.



February 4, 2016
SR Land, LLC
Page 2

If you have any questions or need additional information, please contact me at
(303) 692-3586.

Sincerely,

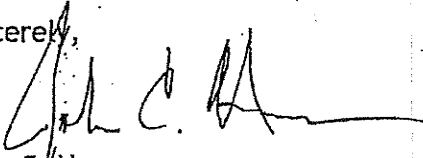

John C. Hranac
Water Quality Assessor
Environmental Data Unit
Water Quality Control Division

Attachment

cc: US Army Corps of Engineers, Southern Colorado Regulatory Office
Applicant's Agent, Mr. Chris Haas - CORE Consultants, Inc.
File

Certification Requirements:

(A) The following requirements shall apply to all certifications:

- (1) Authorized representatives from the Division shall be permitted to enter upon the site where the construction activity or operation of the project is taking place for purposes of inspection of compliance with BMPs and certification conditions.
- (2) In the event of any changes in control or ownership of facilities where the construction activity or operation of the project is taking place, the successor shall be notified in writing by his predecessor of the existence of the BMPs and certification conditions. A copy of such notification shall be provided to the Division.
- (3) If the permittee discovers that certification conditions are not being implemented as designed, or if there is an exceedance of water quality standards despite compliance with the certification conditions and there is reason to believe that the exceedance is caused, in whole or in part, by the project, the permittee shall verbally notify the Division of such failure or exceedance within two (2) working days of becoming aware of the same. Within ten (10) working days of such notification, the permittee shall provide to the Division, in writing, the following:
 - (a) In the case of the failure to comply with the certification conditions, a description of (i) the nature of such failure, (ii) any reasons for such failure, (iii) the period of non-compliance, and (iv) the measures to be taken to correct such failure to comply; and
 - (b) In the case of the exceedance of a water quality standard, (i) an explanation, to the extent known after reasonable investigation, of the relationship between the project and the exceedance, (ii) the identity of any other known contributions to the exceedance, and (iii) a proposal to modify the certification conditions so as to remedy the contribution of the project to the exceedance.
- (4) Any anticipated change in discharge location and/or quantities associated with the project which may result in water quality impacts not considered in the original certification must be reported to the Division by submission of a written notice by the permittee prior to the change. If the change is determined to be significant, the permittee will be notified within ten days, and the change will be acknowledged and approved or disapproved.
- (5) Any diversion from or bypass of facilities necessary to maintain compliance with the terms and conditions herein is prohibited, except (i) where unavoidable to prevent loss of life or severe property damage, or (ii) where excessive storm drainage or runoff would damage any facilities necessary for compliance with limitations and prohibitions herein. The Division shall be notified immediately in writing of each such diversion or bypass.

- (6) At least fifteen days prior to commencement of a project in a watercourse, which the Division has certified, or conditionally certified, the permittee shall notify the following:
- (a) Applicable local health departments;
 - (b) Owners or operators of municipal and domestic water treatment intakes which are located within twenty miles downstream from the site of the project; and
 - (c) Owners or operators of other intakes or diversions which are located within five miles downstream from the site of the project.

The permittee shall maintain a list of the persons and entities notified, including the date and form of notification.

- (7) Immediately upon discovery of any spill or other discharge to waters of the state not authorized by the applicable license or permit, the permittee shall notify the following:
- (a) Applicable local health departments;
 - (b) Owners or operators of municipal and domestic water treatment intakes which are located within twenty miles downstream from the site of the project; and
 - (c) Owners or operators of other intakes or diversions which are located within five miles downstream from the site of the project.

The permittee shall maintain a list of the persons and entities notified, including the date and form of notification.

- (8) Construction operations within watercourses and water bodies shall be restricted to only those project areas specified in the federal license or permit.
- (9) No construction equipment shall be operated below the existing water surface unless specifically authorized by the 401 certification issued by the Division.
- (10) Work should be carried out diligently and completed as soon as practicable. To the maximum extent practicable, discharges of dredged or fill material shall be restricted to those periods when impacts to designated uses are minimal.
- (11) The project shall incorporate provisions for operation, maintenance, and replacement of BMPs to assure compliance with the conditions identified in this section, and any other conditions placed in the permit or certification. All such provisions shall be identified and compiled in an operation and maintenance plan which will be retained by the project owner and available for inspection within a reasonable timeframe upon request by any authorized representative of the Division.

- (12) The use of chemicals during construction and operation shall be in accordance with the manufacturers' specifications. There shall be no excess application and introduction of chemicals into state waters.
 - (13) All solids, sludges, dredged or stockpiled materials and all fuels, lubricants, or other toxic materials shall be controlled in a manner so as to prevent such materials from entering state waters.
 - (14) All seed, mulching material and straw used in the project shall be state-certified weed-free.
 - (15) Discharges of dredged or fill material in excess of that necessary to complete the project are not permitted.
 - (16) Discharges to state waters not identified in the license or permit and not certified in accordance therewith are not allowed, subject to the terms of any 401 certification.
 - (17) Except as otherwise provided pursuant to subsection 82.7(C), no discharge shall be allowed which causes non-attainment of a narrative water quality standard identified in the Basic Standards and Methodologies for Surface Waters, Regulation #31 (5 CCR 1002-31), including, but not limited to discharges of substances in amounts, concentrations or combinations which:
 - (a) Can settle to form bottom deposits detrimental to beneficial uses; or
 - (b) Form floating debris, scum, or other surface materials sufficient to harm existing beneficial uses; or
 - (c) Produce color, odor, or other conditions in such a degree as to create a nuisance or harm existing beneficial uses or impart any undesirable taste to significant edible aquatic species, or to the water; or
 - (d) Are harmful to the beneficial uses or toxic to humans, animals, plants, or aquatic life; or
 - (e) Produce a predominance of undesirable aquatic life; or
 - (f) Cause a film on the surface or produce a deposit on shorelines.
- (B) Best Management Practices:
- (1) Best management practices are required for all projects for which Division certification is issued except for section 402 permits. Project applicants must select BMPs to be employed in their project. A listing and description of best management practices is located in Appendix I of Regulation No. 82: 401 Certification Regulation 5 CCR 1002-82.
 - (2) All requests for certifications which require BMPs shall include a map of project location, a site plan, and a listing of the selected BMPs chosen for the project. At a minimum, each project must provide for the following:

- (a) Permanent erosion and sediment control measures that shall be installed at the earliest practicable time consistent with good construction practices and that shall be maintained and replaced as necessary throughout the life of the project.
- (b) Temporary erosion and sediment control measures that shall be coordinated with permanent measures to assure economical, effective, and continuous control throughout the construction phase and during the operation of the project.

Appendix E

Sand Creek DBPS Excerpts

SAND CREEK DRAINAGE BASIN PLANNING STUDY

PRELIMINARY DESIGN REPORT

CITY OF COLORADO SPRINGS, EL PASO COUNTY, COLORADO

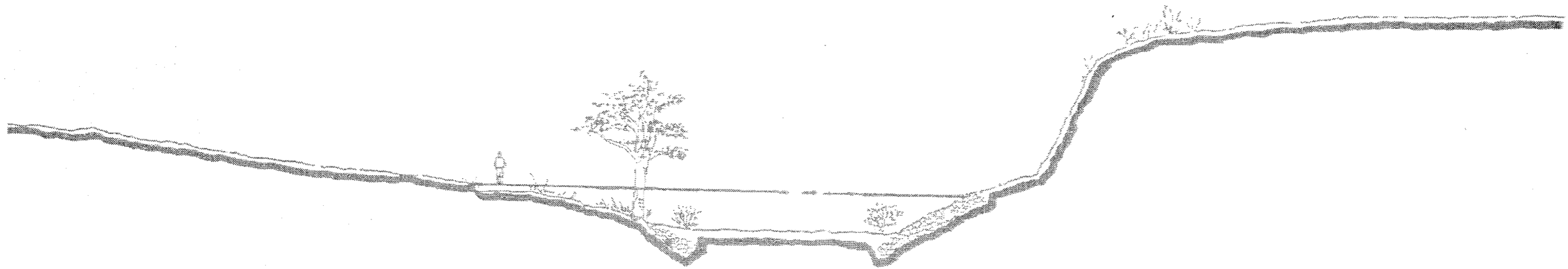

PREPARED FOR:

City of Colorado Springs
Department of Comprehensive Planning, Development and Finance
Engineering Division
30 S. Nevada
Colorado Springs, Colorado 80903

PREPARED BY:

Kiowa Engineering Corporation
1011 North Weber
Colorado Springs, CO 80903

VIII. PLAN IMPLEMENTATION

General

Many of the channel sections shown on the plans may have to be modified to fit specific site conditions. This will be particularly true in the segments where selective channel treatments are proposed. Drop and check locations are approximate and may be moved to minimize disturbances to existing vegetation, roads, trails, and utilities. Existing right-of-ways will play a key role in the location of future drainageways. Tributary channel sizes, sections and alignments will have to be verified at the time the surrounding land is proposed for development.

The detention basin locations shown on the preliminary design drawings are approximate, and will have to be verified during final design. The acquisition of property for the detention basins can proceed at any time, preferably no later than during the development planning stages of properties which lie adjacent to or surround any of the proposed sites. Sand Creek Detention basin SC#1 and SC#2 are currently sited adjacent to developing land. For the balance of the detention basins, development pressure in the vicinity of the detention sites is not eminent. The timing of construction will mainly be driven by the rate of upstream urbanization, and funding. It is recommended that funds generated within the detention basin capital cost fee be used to fund the construction of the regional detention basins. The schedule for the construction of the detention basins could be advanced by co-mingling City or County capital improvement funds with developer funds and any available detention basin capital fee funds. The City or the County may then be able to recoup its funds as the capital cost fees accumulate.

Improvements along Sand Creek within and adjacent to park areas should be completed with the following general goals in mind: (1) provide a more stable drainageway, (2) maintain and enhance the visual setting of the creek, and (3) provide multiple uses within the drainageway corridors. Construction of drops or checks could be combined with trail crossings of the creek. Low flow linings could be constructed adjacent to park activity and picnic areas in order to make the creek more visually pleasing and to protect active park facilities from damages due to frequent flooding or stream bank erosion. Localized creek improvements will be necessary as trails transition at roadway crossings, or at side tributary crossings.

In areas where the existing drainage facilities are inadequate, capital improvement projects will be necessary. This will be particularly true within the West Fork Sand Creek and Center Tributary Sand Creek basins. Several bridges are presently inadequate because of hydraulic or roadway design deficiencies. These structures will have to be funded through capital improvement or bridge replacement funds.

Cost Estimates

Presented on Table VIII-1 (at the conclusion of this section) are the unit costs used to estimate for the total construction costs for drainageway and roadway crossing improvements shown on the preliminary design plans. The cost estimates for the major drainageways, tributary drainageways, roadway culverts, regional detention basins, miscellaneous improvements and bridges are presented on Tables VIII-2 through VIII-7. The estimates represent total improvement costs for the entire Sand Creek basin, including the costs for proposed facilities in the East Fork Sand Creek basin. **No estimated costs for local or initial systems has been made, and therefore no costs attributable to local or minor drainage systems have been computed in the estimation of the drainage basin fee.** Several areas within the basin are known to have local drainage problems. In such areas, systems have been sized, however the cost for the systems have not been included within the fee calculation. Costs associated with utility relocations have not been estimated or included in the fee. A review of utility maps provided by the City Utilities Department indicated that the majority of the potential relocations occur at the roadway crossings.

The costs for habitat mitigation have been included within the drainageway improvement costs. The cost of protection and/or replacement of habitat impacted by the construction of the facilities can be minimized by paying attention to siting, construction sequencing and access.

Local drainage improvements have been sized for several areas within the City. These systems have been sized to address drainage problems which have been identified by the City through contacts with local residents. Improvements have been shown on the plans for the Monterey Drive Outfall channel, the Valli Vista Drive Outfall channel, the Serendipity Lane storm sewer and the Maizeland Drive/Turnberry Court storm sewer system. The information in this report for the above systems has been provided to assist the City in future budgeting for capital improvements.

Unplatted Acreage

Using El Paso County Tax Assessor maps, plats, and ownership records, the amount of unplatted acreage was estimated. From these records a total of 18,809 acres is unplatted, and subject to future development. Of this total, 7,497 acres lies within the unincorporated County and 11,312 lies within the City of Colorado Springs. Park areas have been excluded from the unplatted acreage total, as has City owned property within the corporate limits, and property within Peterson Air Force Base. In reviewing the unplatted acreage estimates shown in the 1985

Drainage Plan and the 1989 East Fork Sand Creek Master Drainage Plan, a close comparison was found.

Drainage and Bridge Fee Calculations

Presented on Tables VIII-8 through VIII-12 (at the conclusion of this section) are the drainage, bridge, detention basin capital construction cost, and detention basin land fees calculated for the Sand Creek Basin. Drainage basin fund deficits have been included in the drainage fee calculation, and are current as of December, 1994.

Areas of the County which are currently undeveloped and proposed for development as large lot residential have been reduced in area by 80 percent for the purposes of fee calculation. The County currently assesses the drainage fee for large residential on only 20 percent of the total acreage. For fee estimation purposes, 7,497 acres was used as the unplatted acreage shown on Tables VIII-8 and VIII-10.

The term "reimbursable costs" used on Tables VIII-2 through VIII-10 means those costs which have been used in estimation of drainage basin fees. Costs considered "non-reimbursable" are costs for the replacement of an existing, undersized culverts, or costs to rehabilitate or maintain an existing lined segment of drainageway. For the most part, all of the drainageway costs for the mainstem of Sand Creek have been considered as reimbursable. Segments of drainageway known to be funded in the future by State funds (such as the US 24 Bypass Phase II project, scheduled for completion in 1996), have not been included in the reimbursable cost estimate. Except for a short segment of the West Fork, the proposed improvements for this drainageway have not been included in the reimbursable costs since they represent existing inadequacies.

The costs associated with bridge replacement have been calculated using the guidelines set forth in City ordinances and the County's drainage basin fee resolutions, respectively, as presented in the City/County Drainage Criteria Manual. County bridge facilities which were found to be required to address existing inadequacies have been included in the bridge fee estimates in conformance with County policy. Where State and/or federal bridge funds are anticipated, only the community's share of the total construction costs have been accounted for in the bridge fee estimate.

The regional detention capital construction cost include only the cost for the construction of the embankment, water quality and outlet structures. The regional detention basin land fee has been calculated by deducting the acreage of the existing 100-year floodplain within each regional detention basin from the total 100-year storage area of the detention basin. The County does not desire to create a capital cost for the construction of detention basins within Sand Creek. The detention basin capital cost fee will be incorporated into the drainage fee whenever

assessed by the County. The County will create a detention basin land fee for the Sand Creek basin.

Table VIII-1: Unit Construction Costs

Item	Unit	Unit Cost	Comments
CHANNEL AND HYDRAULIC STRUCTURES			
Channel earthwork	CY	\$8	
Filter material	Ton	\$25	
Structural concrete	CY	\$250	
Seeding and mulching	SF	\$0.15	
Riprap Type H	CY	\$30	
Riprap Type M	CY	\$24	
12 foot wide gravel trail	LF	\$15	Maintenance trail
Erosion netting	SY	\$1.75	
Topsoil	CY	\$12	
STORM SEWERS RCP/CMP			
18-inch	LF	\$20	
24-inch	LF	\$25	
30-inch	LF	\$42	
36-inch	LF	\$58	
42-inch	LF	\$75	
48-inch	LF	\$80	
60-inch	LF	\$120	
ROADWAY CROSSINGS			
Structural Concrete, in-place	CY	\$300	
Wingwalls/headwalls	EA	\$5,000	
Bridges	SF	\$80	Based on area of roadway deck.
4' high CBC, 4'-10' wide	LF	\$210-320	
6' high CBC, 8'-12' wide	LF	\$270-510	
7' x7' CBC	LF	\$300	
Twin 4' high CBC, 4'-10' wide	LF	\$480-650	
Twin 5'x 8' CBC	LF	\$540	
Twin 6' high CBC, 8'-15' wide	LF	\$600-1200	
Twin 8'x 10' CBC	LF	\$750	
Triple 5'x 8' CBC	LF	\$900	
Triple 6'x 14' CBC	LF	\$1410	
Triple 6'x 16' CBC	LF	\$1770	
Triple 8'x 10' CBC	LF	\$1110	
Triple 10'x 10' CBC	LF	\$1260	
4-bay 5' x 8' CBC	LF	\$1200	
4-bay 8' x 10' CBC	LF	\$1560	
DETENTION BASINS			
Outlet structures, non jurisdictional	EA	\$10,000	
Outlet structures, jurisdictional	EA	\$15,000	
Unit storage cost	AF	\$10,000	
MITIGATION			
	AC	\$4,000	
LAND ACQUISITION			
Detention basins	AC	\$15,900	Based on park land fee.

THIS DRAWING IS A MASTER PLANNING SHEET REPRESENTING PRELIMINARY AND CONCEPTUAL ENGINEERING. IT SHOULD NOT BE USED FOR CONSTRUCTION PURPOSES.

AREAS WITHIN THE EXISTING FLOODPLAIN OR THE LOW FLOW ZONE OF THE DRAINAGEWAY WHERE RIPARIAN OR WETLAND VEGETATION EXIST SHALL BE PRESERVED IN ITS EXISTING CROSS-SECTION. AREAS DISTURBED BY THE CONSTRUCTION OF DROPS, GRADE CONTROLS, CULVERTS, OR CHANNEL BANK LININGS SHALL BE REVEGETATED WITH NATIVE SPECIES.

IMPROVED RIPRAP CHANNEL
 BW=20', d=3', S=1.3%
 3' DROPS @ 450' INTERVALS
 Q₁₀₀=500 cfs

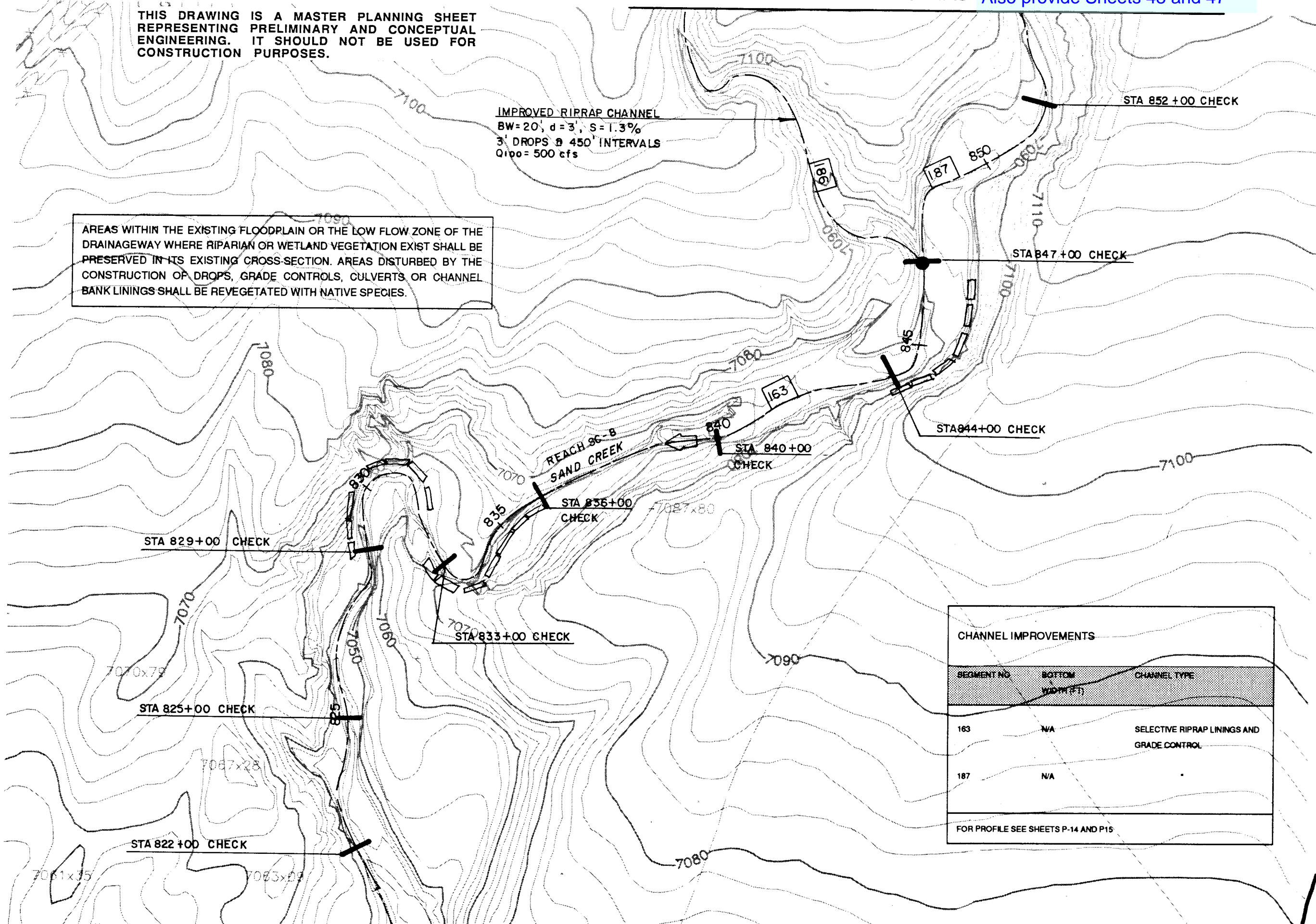

CHANNEL IMPROVEMENTS		
SEGMENT NO	BOTTOM WIDTH (FT)	CHANNEL TYPE
163	N/A	SELECTIVE RIPRAP LININGS AND GRADE CONTROL
187	N/A	

FOR PROFILE SEE SHEETS P-14 AND P15

Kiowa Engineering Corporation
 419 W. Bijou Street
 Colorado Springs, Colorado
 80905-1308

SAND CREEK DRAINAGE
 BASIN PLANNING STUDY
 PRELIMINARY DESIGN PLANS

Project No 90-04-09
 Date: 11/92
 Design: RNW
 Drawn: EAK
 Check: RNW
 Revisions:

THIS DRAWING IS A MASTER PLANNING SHEET REPRESENTING PRELIMINARY AND CONCEPTUAL ENGINEERING. IT SHOULD NOT BE USED FOR CONSTRUCTION PURPOSES.

CHANNEL IMPROVEMENTS		
SEGMENT NO.	BOTTOM WIDTH (FT)	CHANNEL TYPE
187	N/A	SELECTIVE RIPRAP LININGS AND GRADE CONTROL
170	N/A	

FOR PROFILE SEE SHEET P-15

AREAS WITHIN THE EXISTING FLOODPLAIN OR THE LOW FLOW ZONE OF THE DRAINAGEWAY WHERE RIPARIAN OR WETLAND VEGETATION EXIST SHALL BE PRESERVED IN ITS EXISTING CROSS-SECTION. AREAS DISTURBED BY THE CONSTRUCTION OF DROPS, GRADE CONTROLS, CULVERTS OR CHANNEL BANK LININGS SHALL BE REVEGETATED WITH NATIVE SPECIES.

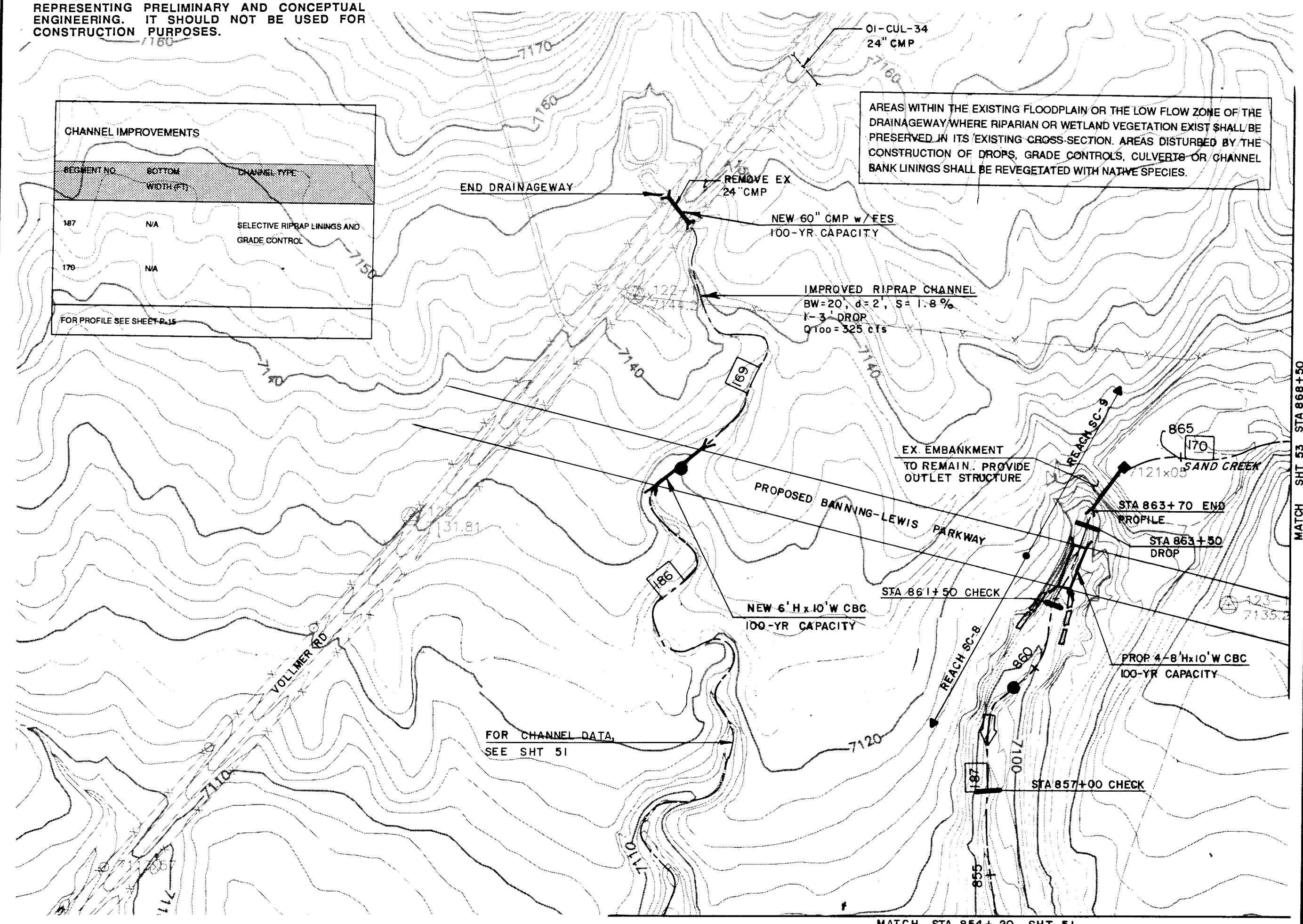

MATCH SHT 53 STA 868+50

**SAND CREEK DRAINAGE BASIN PLANNING STUDY
PRELIMINARY DESIGN PLANS**

Project No	90-04-09
Date	11/92
Design	RNW
Drawn	EAK
Check	RNW
Revisions	

Kiowa Engineering Corporation
419 W. Bijou Street
Colorado Springs, Colorado
80905-1308

THIS DRAWING IS A MASTER PLANNING SHEET REPRESENTING PRELIMINARY AND CONCEPTUAL ENGINEERING. IT SHOULD NOT BE USED FOR CONSTRUCTION PURPOSES.

CHANNEL IMPROVEMENTS		
SEGMENT NO.	BOTTOM WIDTH (FT)	CHANNEL TYPE
163	N/A	SELECTIVE RIPRAP LININGS AND GRADE CONTROL

FOR PROFILE SEE SHEET P-14

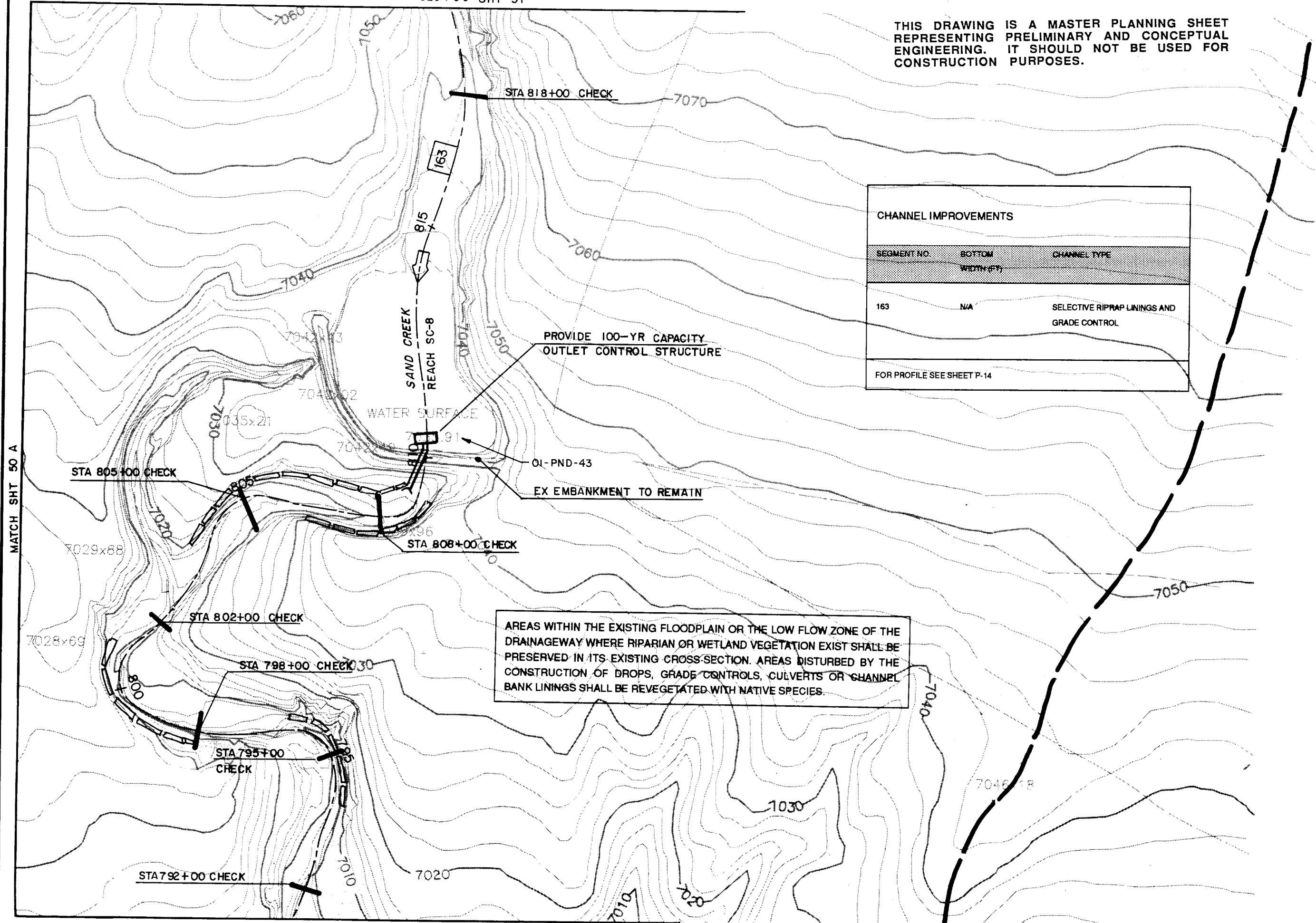

Kiowa Engineering Corporation
 419 W. Bijou Street
 Colorado Springs, Colorado
 80905-1308

SAND CREEK DRAINAGE
 BASIN PLANNING STUDY
 PRELIMINARY DESIGN PLANS

Project No	90-04-09
Date	11/92
Design	RNW
Drawn	EAK
Check	RNW
Revisions	

MATCH SHT 50 A

TABLE VIII-2: SAND CREEK DRAINAGE BASIN PLANNING STUDY
DRAINAGEWAY CONVEYANCE COST ESTIMATE
WITH SELECTED DETENTION ALTERNATIVES

SEGMENT NUMBER	REACH NUMBER	SEGMENT LENGTH (FT)	IMPROVEMENT TYPE	IMP. LENGTH (FT)	UNIT COST (\$/LF)	NUMBER OF GRADE CONTROLS	GRADE CONTROL LENGTH (FT)	TOTAL REIMBURSABL COSTS	TOTAL COST
148-2	"	2600	"	2150	127	5	620	\$384,650	\$384,650
151	SC-8	1700	10-YEAR RIPRAP	500	238	3	250	\$164,000	\$164,000
160	"	5100	SEL. LININGS (1 SIDE)	4400	127	6	720	\$688,400	\$688,400
	"		10-YR RIPRAP	600	238	0	0	\$142,800	\$142,800
163	"	6300	SEL. LININGS (1 SIDE)	2600	127	15	1200	\$546,200	\$546,200
	"		10-YR RIPRAP	350	238	0	0	\$83,300	\$83,300
187	"	1200	SEL. LININGS (1 SIDE)	0	0	2	160	\$28,800	\$28,800
170	SC-9	3200	"	0	0	4	320	\$57,600	\$57,600
171	"	5000	"	0	0	2	170	\$30,600	\$30,600
172	"	3650	"	0	0	2	150	\$27,000	\$27,000
TOTAL SAND CREEK DRAINAGEWAY								\$15,560,220	\$18,279,420