

FINAL DRAINAGE LETTER FOR LOT 4 OF CLAREMONT BUSINESS PARK 2 FILING NO. 1

EL PASO COUNTY, COLORADO

FEBRUARY 2021

Prepared for:

Hammers Construction, Inc.
1411 Woosley Heights
Colorado Springs, CO 80906
(719) 570-1599

Prepared by:



212 Wahsatch Ave., Ste. 305
Colorado Springs, CO 80903
(719) 955-5485

Project #44-037
PCD – SP 20-000

Please revise PCD
File No. to PPR2110.

**FINAL DRAINAGE LETTER FOR LOT 4 OF
CLAREMONT BUSINESS PARK 2 FILING NO. 1
EL PASO COUNTY COLORADO**

DRAINAGE PLAN STATEMENTS

ENGINEERS STATEMENT

The attached drainage plan and report was prepared under my direction and supervision and are correct to the best of my knowledge and belief. Said drainage report has been prepared according to the criteria established by the County for drainage reports and said report is in conformity with the master plan of the drainage basin. I accept responsibility for any liability caused by any negligent acts, errors or omissions on my part in preparing this report.

Darin L. Moffett, P.E. #38923
For and on Behalf of M&S Civil Consultants, Inc

DEVELOPER'S STATEMENT

I, the developer have read and will comply with all the requirements specified in this drainage report and plan.

BY: _____

TITLE: _____

DATE: _____

ADDRESS: Hammers Construction, Inc.
1411 Woosley Heights
Colorado Springs, CO 80906

EL PASO COUNTY'S STATEMENT

Filed in accordance with the requirements of El Paso County Land Development Code, Drainage Criteria Manual Volumes 1 and 2, and the Engineering Manual, as amended.

BY: _____ DATE: _____

Jennifer Irvine, P.E.
County Engineer / ECM Administrator

CONDITIONS:



February 16, 2021

El Paso County Planning & Community Development
2880 International Circle Suite 110
Colorado Springs, Colorado 80910
Attn: Jennifer Irvine P.E./County Engineer

Please include PCD File No. for both projects drainage reports are from.

RE: Drainage Letter for Lot 4 of Claremont Business Park 2 Filing No. 1

Dear Jennifer,

The following is the Drainage Letter for Lot 4 of Claremont Business Park 2 Filing No. 1. The purpose of this letter is to show general conformance with the drainage patterns established by the **Final Drainage Report for Claremont Business Park 2, Filing No. 1** (hence forth known as **FDR**). Lot 4 contains 2.677 acres and is located within the **Claremont Business Park 2 Filing No. 1** subdivision in El Paso County, Colorado. Lot 4 is bound to the east by Highway 24, to the north by Gary Watson Point and Lot 5, to the west by Lot 3 and to the south by Lot 2 Claremont Business Park Filing 1C. Lot 4 is located SE of the Gary Watson Point (Private) and Meadowbrook Pkwy (Public) intersection. The subdivision is in the NE ¼ of the NE ¼ of Section 8, Township 14 South, and Range 65 West of the 6th Principal Meridian.

The **Final Drainage Report for Claremont Business Park 2, Filing No. 1** was prepared by M&S Civil Consultants, Inc. Per the report, Lot 4 lies within Basins I and M. The flows, from the lot, are split north and south. Runoff generated by the northern portion of Lot 4, shall be conveyed to a 10' CDOT inlet in Gary Watson Point. Runoff generated by the southern portion of Lot 4, shall be conveyed via swale to the WQ Pond 2 planned within Tract A. Collected runoff will utilize a riprap rundown to enter WQ Pond 2.

Include what basin site is located in.

The site as proposed, will continue to follow the drainage patterns established by the **FDR**. As comparisons to design points within the **FDR** are not easily made. The areas and the final drainage coefficients were evaluated to determine the adequacy of the downstream facilities proposed by the previous report. The detailed calculations are as follows:

Design Point 1 consists of **Basin H3** and **Basin I6**, which contains 0.04 acres of undeveloped grassy land and 0.19 acres of landscaping bushes/grasses and a portion of Gary Watson Point, respectively. **Basin H3** has existing flows of 0.0 cfs for the minor storm event (5-year) and 0.1 cfs for the major storm event (100-year). **Basin I6** has proposed flows of 0.9 cfs for the minor storm event (5-year) and 1.6 cfs for the major storm event (100-year). The runoff shall be sheet flow to curb and gutter into Gary Watson Point, **Design Point 1** (Q5=0.8 cfs, Q100=1.6 cfs) and be routed via curb and gutter to a proposed 10' CDOT type R inlet located adjacent to Lots 1 and 2, as identified in the **FDR**. Runoff coefficients from **Basin H3** and **Basin I6** are at and/or less than those calculated in the **FDR**, therefore no negative impacts are anticipated to the downstream facilities.

The referenced FDR proposes a 15 foot type R inlet. Please confirm whether the 10 foot inlet would suffice.

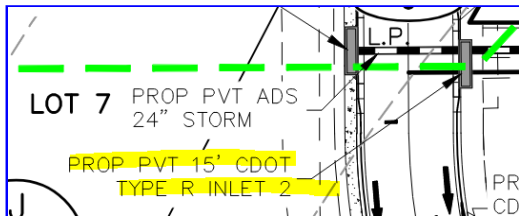

Design Point 2 consists of **Basin H4**, **Basin L** and **Basin M4**, which contains 0.10 acres of undeveloped grassy land, 1.32 acres of undeveloped grassy land and 0.98 acres of roof top, crushed asphalt paving and landscaped areas, respectively. ~~Basin H4~~ has existing flows of 0.0 cfs for the minor storm event (5-year) and 0.3 cfs for the major storm event (100-year). ~~Basin L~~ has existing flows of 0.6 cfs for the minor storm event (5-year) and 3.7 cfs for the major storm event (100-year). **Basin M4** has proposed flows of 3.5 cfs for the minor storm event (5-year) and 6.5 cfs for the major storm event (100-year). The cumulative runoff from **Basin M4**, **Basin H4** and **Basin L** will outfall into a 2' foot trapezoidal channel at the south end of the property, at **Design Point 2** (Q5=3.7 cfs, Q100=9.4 cfs). The flows will enter WQ Pond 2 via a 3' trapezoidal riprap rundown as described in the **FDR**. Runoff coefficients from **Basin H4**, **Basin L** and **Basin M4** are at and/or less than those calculated in the **FDR**, therefore no negative impacts are anticipated to the downstream improvements.

Per the proposed drainage report runoff from the western portion of the roof flow to design point 2. Please update design point 2 narrative to include any other flows that are discharging to design point 2.

All storm, street and WQ pond improvements shall be installed per the Gary Watson Point construction plans that are currently under review by El Paso County. This drainage letter includes the previously approved Proposed Drainage Map for **Final Drainage Report for Claremont Business Park 2, Filing No. 1**.

Please include a statement that discusses what party is responsible for the maintenance of the pond.

This final drainage letter for Lot 4 is in compliance with the drainage patterns and design proposals within the **FDR**; therefore no negative impacts are anticipated to the downstream improvements facilities with the approval of this drainage letter.

This site is in the Sand Creek Drainage Basin. The site has been subdivided into 11 commercial lots. Drainage fees, for these lots, were paid at the time of the previous platting as Tract C of Claremont Business Park Filing No. 2 (Reception No. 207712506), therefore no additional Drainage fees are required. See Appendix of the "Final Drainage Report for Claremont Business Park Filing No. 2", Revised November 2006, by Matrix Design Group, Inc, for previously paid drainage and bridge fees.

Revise to 10.

Respectfully,

Please update report contents to include calculations for the concrete channel between lot 3 and lot 4, per Claremont Business Park Filing no.1 Final Drainage Report.

Eugene Tellez
Project Engineer
M&S Civil Consultants, Inc.

REFERENCES

- 1.) "El Paso County and City of Colorado Springs Drainage Criteria Manual".
- 2.) "Final Drainage Report for Claremont Business Park 2 Filing No.1", dated December, 2020, by M&S Civil Consultants, Inc.
- 3.) "Final Drainage Report for Claremont Business Park Filing No. 2", dated November 2006, by Matrix Design Group, Inc.

Revise reference list to add latest version of EPC ECM date, EPC DCMs Volumes 1 and 2, and add the latest version date to the CSDCM.

ATTACHMENTS:

Vicinity map

Claremont Business Park 2 Filing No. 1 - Lot 4 Site Grading Plan

Claremont Business Park 2 Filing No. 1 - Final Plat

Excerpt of "Final Drainage Report for Claremont Business Park Filing No. 2"

Final Drainage Report Claremont Business Park 2 Filing No. 1 - Proposed Drainage Map

Hydrologic Calculations

Final Drainage Letter Claremont Business Park 2 Filing No. 1 Lot 4

– Proposed Drainage Map

ATTACHMENTS

VICINITY MAP

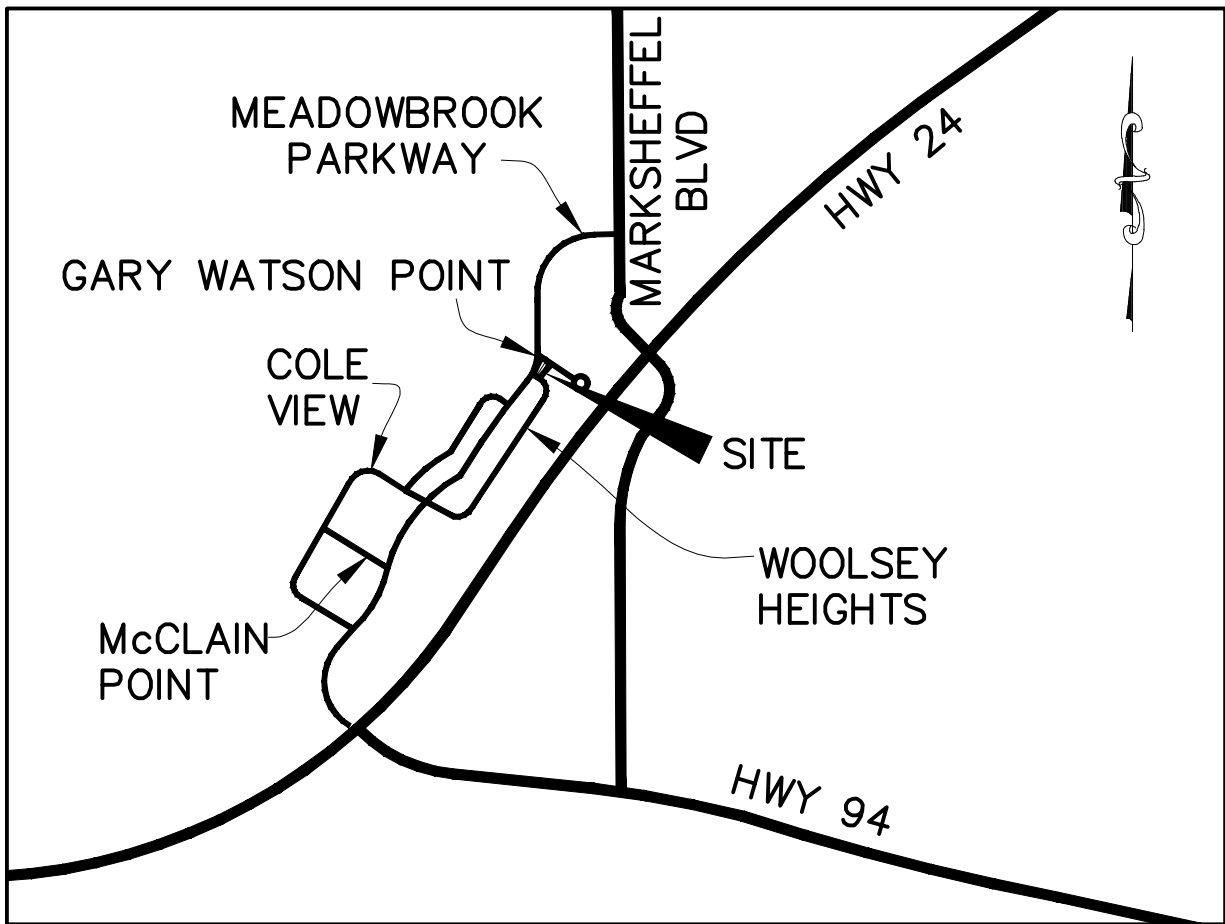

VICINITY MAP

N.T.S.

CLAREMONT BUSINESS PARK 2 FIL. NO. 1
LOT 4 SITE GRADING PLAN

CLAREMONT BUSINESS PARK 2 FIL. NO. 1 - LOT 4

FOR REFERENCE ONLY

EL PASO COUNTY, STATE OF COLORADO GRADING & EROSION CONTROL PLAN

GRADING AND EROSION CONTROL NOTES:

- STORMWATER DISCHARGES FROM CONSTRUCTION SITES SHALL NOT CAUSE OR THREATEN TO CAUSE POLLUTION, CONTAMINATION, OR DEGRADATION OF STATE WATERS. ALL WORK AND EARTH DISTURBANCE SHALL BE DONE IN A MANNER THAT MINIMIZES POLLUTION OF ANY ON-SITE OR OFF-SITE WATERS, INCLUDING WETLANDS.
- NOTWITHSTANDING ANYTHING DEPICTED IN THESE PLANS IN WORDS OR GRAPHIC REPRESENTATION, ALL DESIGN AND CONSTRUCTION RELATED TO ROADS, STORM DRAINAGE AND EROSION CONTROL SHALL CONFORM TO THE STANDARDS AND REQUIREMENTS OF THE MOST RECENT VERSION OF THE RELEVANT ADOPTED EL PASO COUNTY STANDARDS, INCLUDING THE LAND DEVELOPMENT CODE, THE ENGINEERING CRITERIA MANUAL, THE DRAINAGE CRITERIA MANUAL, AND THE DRAINAGE CRITERIA MANUAL VOLUME 2. ANY DEVIATIONS FROM REGULATIONS AND STANDARDS MUST BE REQUESTED, AND APPROVED, IN WRITING.
- A SEPARATE STORMWATER MANAGEMENT PLAN (SWMP) FOR THIS PROJECT SHALL BE COMPLETED AND AN EROSION AND STORMWATER QUALITY CONTROL PERMIT (ESQCP) ISSUED PRIOR TO COMMENCING CONSTRUCTION. MANAGEMENT OF THE SWMP DURING CONSTRUCTION IS THE RESPONSIBILITY OF THE DESIGNATED QUALIFIED STORMWATER MANAGER OR CERTIFIED EROSION CONTROL INSPECTOR. THE SWMP SHALL BE LOCATED ON SITE AT ALL TIMES DURING CONSTRUCTION AND SHALL BE KEPT UP TO DATE WITH WORK PROGRESS AND CHANGES IN THE FIELD.
- ONCE THE ESQCP IS APPROVED AND A 'NOTICE TO PROCEED' HAS BEEN ISSUED, THE CONTRACTOR MAY INSTALL THE INITIAL STAGE EROSION AND SEDIMENT CONTROL MEASURES AS INDICATED ON THE APPROVED GEC. A PRECONSTRUCTION MEETING BETWEEN THE CONTRACTOR, ENGINEER, AND EL PASO COUNTY WILL BE HELD PRIOR TO ANY CONSTRUCTION. IT IS THE RESPONSIBILITY OF THE APPLICANT TO COORDINATE THE MEETING TIME AND PLACE WITH COUNTY STAFF.
- CONTROL MEASURES MUST BE INSTALLED PRIOR TO COMMENCEMENT OF ACTIVITIES THAT COULD CONTRIBUTE POLLUTANTS TO STORMWATER. CONTROL MEASURES FOR ALL SLOPES, CHANNELS, DITCHES, AND DISTURBED LAND AREAS SHALL BE INSTALLED IMMEDIATELY UPON COMPLETION OF THE DISTURBANCE.
- ALL TEMPORARY SEDIMENT AND EROSION CONTROL MEASURES SHALL BE MAINTAINED AND REMAIN IN EFFECTIVE OPERATING CONDITION UNTIL PERMANENT SOIL EROSION CONTROL MEASURES ARE IMPLEMENTED AND FINAL STABILIZATION IS ESTABLISHED. ALL PERSONS ENGAGED IN LAND DISTURBANCE ACTIVITIES SHALL ASSESS THE ADEQUACY OF CONTROL MEASURES AT THE SITE AND IDENTIFY IF CHANGES TO THOSE CONTROL MEASURES ARE NEEDED TO ENSURE THE CONTINUED EFFECTIVE PERFORMANCE OF THE CONTROL MEASURES. ALL CHANGES TO TEMPORARY SEDIMENT AND EROSION CONTROL MEASURES MUST BE INCORPORATED INTO THE STORMWATER MANAGEMENT PLAN.
- TEMPORARY STABILIZATION SHALL BE IMPLEMENTED ON DISTURBED AREAS AND STOCKPILES WHERE GROUND DISTURBING CONSTRUCTION ACTIVITY HAS PERMANENTLY CEASED OR TEMPORARILY CEASED FOR LONGER THAN 14 DAYS.
- FINAL STABILIZATION MUST BE IMPLEMENTED AT ALL APPLICABLE CONSTRUCTION SITES. FINAL STABILIZATION IS ACHIEVED WHEN ALL GROUND DISTURBING ACTIVITIES ARE COMPLETE AND ALL DISTURBED AREAS EITHER HAVE A UNIFORM VEGETATIVE COVER WITH INDIVIDUAL PLANT DENSITY OF 70 PERCENT OF PRE-DISTURBANCE LEVELS ESTABLISHED OR EQUIVALENT PERMANENT ALTERNATIVE STABILIZATION METHOD IS IMPLEMENTED. ALL TEMPORARY SEDIMENT AND EROSION CONTROL MEASURES SHALL BE REMOVED UPON FINAL STABILIZATION AND BEFORE PERMIT CLOSURE.
- ALL PERMANENT STORMWATER MANAGEMENT FACILITIES SHALL BE INSTALLED AS DESIGNED IN THE APPROVED PLANS. ANY PROPOSED CHANGES THAT EFFECT THE DESIGN OR FUNCTION OF PERMANENT STORMWATER MANAGEMENT STRUCTURES MUST BE APPROVED BY THE EGM ADMINISTRATOR PRIOR TO IMPLEMENTATION.
- EARTH DISTURBANCES SHALL BE CONDUCTED IN SUCH A MANNER SO AS TO EFFECTIVELY MINIMIZE ACCELERATED SOIL EROSION AND RESULTING SEDIMENTATION. ALL DISTURBANCES SHALL BE DESIGNED, CONSTRUCTED, AND COMPLETED SO THAT THE EXPOSED AREA OF ANY DISTURBED LAND SHALL BE LIMITED TO THE SHORTEST PRACTICAL PERIOD OF TIME. PRE-EXISTING VEGETATION SHALL BE PROTECTED AND MAINTAINED WITHIN 50 HORIZONTAL FEET OF A WATERS OF THE STATE UNLESS SHOWN TO BE INFEASIBLE AND SPECIFICALLY REQUESTED AND APPROVED.
- COMPACTION OF SOIL MUST BE PREVENTED IN AREAS DESIGNATED FOR INFILTRATION CONTROL MEASURES OR WHERE FINAL STABILIZATION WILL BE ACHIEVED BY VEGETATIVE COVER. AREAS DESIGNATED FOR INFILTRATION CONTROL MEASURES SHALL ALSO BE PROTECTED FROM SEDIMENTATION DURING CONSTRUCTION UNTIL FINAL STABILIZATION IS ACHIEVED. IF COMPACTION PREVENTION IS NOT FEASIBLE DUE TO SITE CONSTRAINTS, ALL AREAS DESIGNATED FOR INFILTRATION AND VEGETATION CONTROL MEASURES MUST BE LOOSENED PRIOR TO INSTALLATION OF THE CONTROL MEASURE(S).
- ANY TEMPORARY OR PERMANENT FACILITY DESIGNED AND CONSTRUCTED FOR THE CONVEYANCE OF STORMWATER AROUND, THROUGH, OR FROM THE EARTH DISTURBANCE AREA SHALL BE A STABILIZED CONVEYANCE DESIGNED TO MINIMIZE EROSION AND THE DISCHARGE OF SEDIMENT OFF SITE.
- CONCRETE WASH WATER SHALL BE CONTAINED AND DISPOSED OF IN ACCORDANCE WITH THE SWMP. NO WASH WATER SHALL BE DISCHARGED TO OR ALLOWED TO ENTER STATE WATERS, INCLUDING ANY SURFACE OR SUBSURFACE STORM DRAINAGE SYSTEM OR FACILITIES. CONCRETE WASHOUTS SHALL NOT BE LOCATED IN AN AREA WHERE SHALLOW GROUNDWATER MAY BE PRESENT, OR WITHIN 50 FEET OF A SURFACE WATER BODY, CREEK OR STREAM.
- DURING DEWATERING OPERATIONS OF UNCONTAMINATED GROUND WATER MAY BE DISCHARGED ON SITE, BUT SHALL NOT LEAVE THE SITE IN THE FORM OF SURFACE RUNOFF UNLESS AN APPROVED STATE DEWATERING PERMIT IS IN PLACE.
- EROSION CONTROL BLANKETING OR OTHER PROTECTIVE COVERING SHALL BE USED ON SLOPES STEEPER THAN 3:1.
- CONTRACTOR SHALL BE RESPONSIBLE FOR THE REMOVAL OF ALL WASTES FROM THE CONSTRUCTION SITE FOR DISPOSAL IN ACCORDANCE WITH LOCAL AND STATE REGULATORY REQUIREMENTS. NO CONSTRUCTION DEBRIS, TREE SLASH, BUILDING MATERIAL WASTES OR UNUSED BUILDING MATERIALS SHALL BE BURIED, DUMPED, OR DISCHARGED AT THE SITE.
- WASTE MATERIALS SHALL NOT BE TEMPORARILY PLACED OR STORED IN THE STREET, ALLEY, OR OTHER PUBLIC WAY, UNLESS IN ACCORDANCE WITH AN APPROVED TRAFFIC CONTROL PLAN. CONTROL MEASURES MAY BE REQUIRED BY EL PASO COUNTY ENGINEERING IF DEEMED NECESSARY, BASED ON SPECIFIC CONDITIONS AND CIRCUMSTANCES.
- TRACKING OF SOILS AND CONSTRUCTION DEBRIS OFF-SITE SHALL BE MINIMIZED. MATERIALS TRACKED OFF-SITE SHALL BE CLEANED UP AND PROPERLY DISPOSED OF IMMEDIATELY.
- THE OWNER/DEVELOPER SHALL BE RESPONSIBLE FOR THE REMOVAL OF ALL CONSTRUCTION DEBRIS, DIRT, TRASH, ROCK, SEDIMENT, SOIL, AND SAND THAT MAY ACCUMULATE IN ROADS, STORM DRAINS AND OTHER DRAINAGE CONVEYANCE SYSTEMS AND STORMWATER APPURTENANCES AS A RESULT OF SITE DEVELOPMENT.
- THE QUANTITY OF MATERIALS STORED ON THE PROJECT SITE SHALL BE LIMITED, AS MUCH AS PRACTICAL, TO THAT QUANTITY REQUIRED TO PERFORM THE WORK IN AN ORDERLY SEQUENCE. ALL MATERIALS STORED ON-SITE SHALL BE STORED IN A NEAT, ORDERLY MANNER, IN THEIR ORIGINAL CONTAINERS, WITH ORIGINAL MANUFACTURER'S LABELS.
- NO CHEMICAL(S) HAVING THE POTENTIAL TO BE RELEASED IN STORMWATER ARE TO BE STORED OR USED ONSITE UNLESS PERMISSION FOR THE USE OF SUCH CHEMICAL(S) IS GRANTED IN WRITING BY THE EGM ADMINISTRATOR. IN GRANTING APPROVAL FOR THE USE OF SUCH CHEMICAL(S), SPECIAL CONDITIONS AND MONITORING MAY BE REQUIRED.
- BULK STORAGE OF ALLOWED PETROLEUM PRODUCTS OR OTHER ALLOWED LIQUID CHEMICALS IN EXCESS OF 55 GALLONS SHALL REQUIRE ADEQUATE SECONDARY CONTAINMENT PROTECTION TO CONTAIN ALL SPILLS ONSITE AND TO PREVENT ANY SPILLED MATERIALS FROM ENTERING STATE WATERS, ANY SURFACE OR SUBSURFACE STORM DRAINAGE SYSTEM OR OTHER FACILITIES.
- NO PERSON SHALL CAUSE THE IMPEDIMENT OF STORMWATER FLOW IN THE CURB AND GUTTER OR DITCH EXCEPT WITH APPROVED SEDIMENT CONTROL MEASURES.
- OWNER/DEVELOPER AND THEIR AGENTS SHALL COMPLY WITH THE 'COLORADO WATER QUALITY CONTROL ACT' (TITLE 25, ARTICLE 8, CRS), AND THE 'CLEAN WATER ACT' (33 USC 1344), IN ADDITION TO THE REQUIREMENTS OF THE LAND DEVELOPMENT CODE, DCM VOLUME II AND THE EGM APPENDIX I. ALL APPROPRIATE PERMITS MUST BE OBTAINED BY THE CONTRACTOR PRIOR TO CONSTRUCTION (1041, NPDES, FLOODPLAIN, 404, FUGITIVE DUST, ETC.). IN THE EVENT OF CONFLICTS BETWEEN THESE REQUIREMENTS AND OTHER LAWS, RULES, OR REGULATIONS OF OTHER FEDERAL, STATE, LOCAL, OR COUNTY AGENCIES, THE MOST RESTRICTIVE LAWS, RULES, OR REGULATIONS SHALL APPLY.
- ALL CONSTRUCTION TRAFFIC MUST ENTER/EXIT THE SITE ONLY AT APPROVED CONSTRUCTION ACCESS POINTS.
- PRIOR TO CONSTRUCTION THE PERMITTEE SHALL VERIFY THE LOCATION OF EXISTING UTILITIES.
- A WATER SOURCE SHALL BE AVAILABLE ON SITE DURING EARTHWORK OPERATIONS AND SHALL BE UTILIZED AS REQUIRED TO MINIMIZE DUST FROM EARTHWORK EQUIPMENT AND WIND.
- THE SOILS REPORT FOR THIS SITE HAS BEEN PREPARED BY TERRACON. #23055071 MAY 30, 2006 AND SHALL BE CONSIDERED A PART OF THESE PLANS WITH AN UPDATED LETTER JUNE 17, 2020.
- AT LEAST TEN (10) DAYS PRIOR TO THE ANTICIPATED START OF CONSTRUCTION, FOR PROJECTS THAT WILL DISTURB ONE (1) ACRE OR MORE, THE OWNER OR OPERATOR OF CONSTRUCTION ACTIVITY SHALL SUBMIT A PERMIT APPLICATION FOR STORMWATER DISCHARGE TO THE COLORADO DEPARTMENT OF PUBLIC HEALTH AND ENVIRONMENT, WATER QUALITY DIVISION. THE APPLICATION CONTAINS CERTIFICATION OF COMPLETION OF A STORMWATER MANAGEMENT PLAN (SWMP), OF WHICH THIS GRADING AND EROSION CONTROL PLAN MAY BE A PART. FOR INFORMATION OR APPLICATION MATERIALS CONTACT:

COLORADO DEPARTMENT OF PUBLIC HEALTH AND ENVIRONMENT
WATER QUALITY CONTROL DIVISION
WOOD - PERMITS
4300 CHERRY CREEK DRIVE SOUTH
DENVER, CO 80246-1530
ATTN: PERMITS UNIT

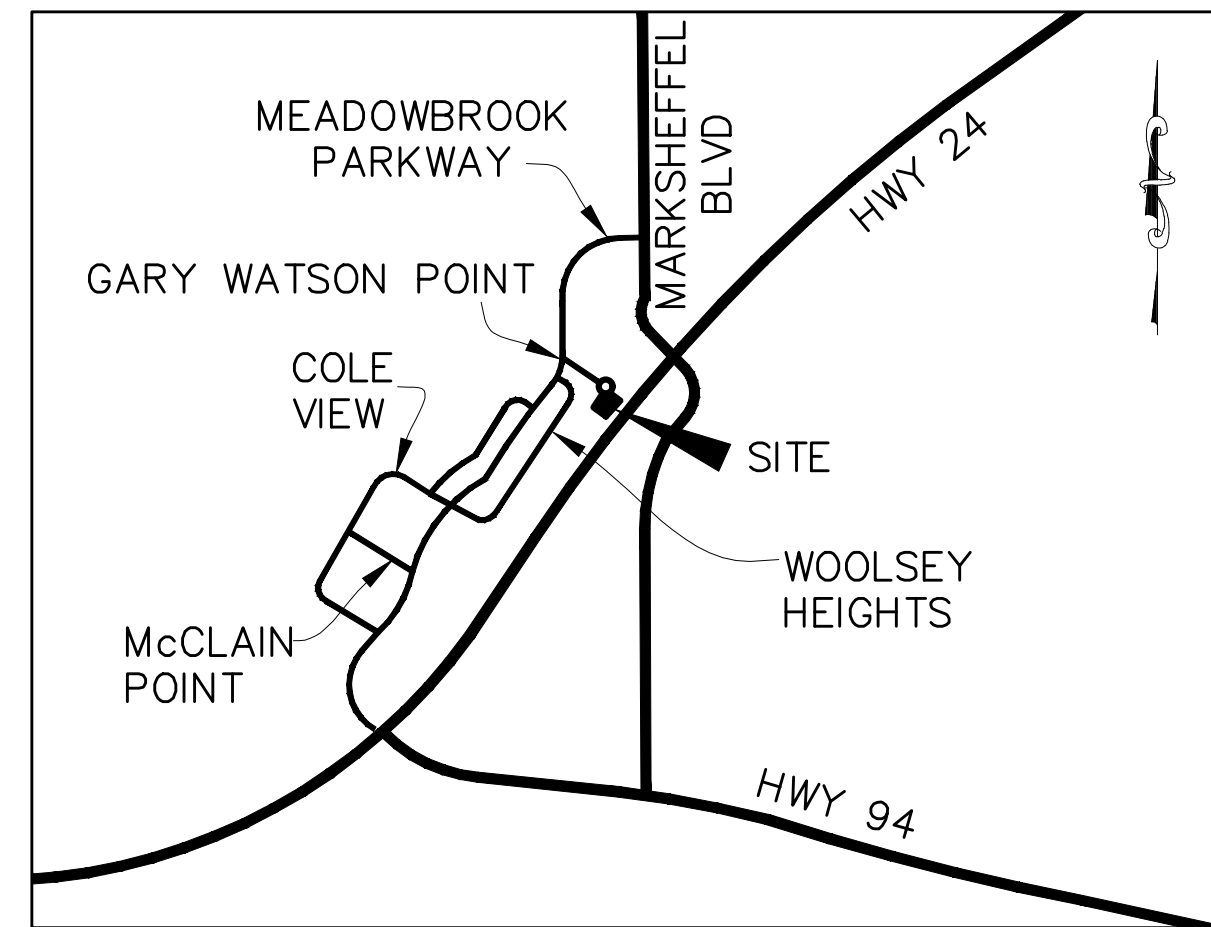

VICINITY MAP
N.T.S.

DESIGN ENGINEER'S STATEMENT

THIS GRADING AND EROSION CONTROL PLAN WAS PREPARED UNDER MY DIRECTION AND SUPERVISION AND IS CORRECT TO THE BEST OF MY KNOWLEDGE AND BELIEF. SAID PLAN HAS BEEN PREPARED ACCORDING TO THE CRITERIA ESTABLISHED BY THE COUNTY FOR GRADING AND EROSION CONTROL PLANS. I ACCEPT RESPONSIBILITY FOR ANY LIABILITY CAUSED BY NEGLIGENT ACTS, ERRORS OR OMISSIONS ON MY PART IN PREPARING THIS PLAN.

VIRGIL A. SANCHEZ, COLORADO P.E. #37160 DATE
FOR AND ON BEHALF OF M & S CIVIL CONSULTANTS, INC.

OWNER/DEVELOPER'S STATEMENT:

I, THE OWNER/DEVELOPER HAVE READ AND WILL COMPLY WITH THE REQUIREMENTS OF THE GRADING AND EROSION CONTROL PLAN.

NAME: DATE

DBA: HAMMERS CONSTRUCTION

ADDRESS: 1411 WOOLSEY HEIGHTS COLORADO SPRINGS, 80915

EL PASO COUNTY:

COUNTY PLAN REVIEW IS PROVIDED ONLY FOR GENERAL CONFORMANCE WITH COUNTY DESIGN CRITERIA. THE COUNTY IS NOT RESPONSIBLE FOR THE ACCURACY AND ADEQUACY OF THE DESIGN, DIMENSIONS, AND/OR ELEVATIONS WHICH SHALL BE CONFIRMED AT THE JOB SITE. THE COUNTY THROUGH THE APPROVAL OF THIS DOCUMENT ASSUMES NO RESPONSIBILITY FOR COMPLETENESS AND/OR ACCURACY OF THIS DOCUMENT.

FILED IN ACCORDANCE WITH THE REQUIREMENTS OF THE EL PASO COUNTY LAND DEVELOPMENT CODE, DRAINAGE CRITERIA MANUAL VOLUMES 1 AND 2, AND ENGINEERING CRITERIA MANUAL, AS AMENDED.

IN ACCORDANCE WITH EGM SECTION 1.12, THESE CONSTRUCTION DOCUMENTS WILL BE VALID FOR CONSTRUCTION FOR A PERIOD OF TWO (2) YEARS FROM THE DATE SIGNED BY EL PASO COUNTY ENGINEER. IF THE CONSTRUCTION HAS NOT STARTED WITHIN THOSE 2 YEARS, THE PLANS WILL NEED TO BE RESUBMITTED FOR APPROVAL, INCLUDING PAYMENT OF REVIEW FEES AT THE PLANNING AND COMMUNITY DEVELOPMENT DIRECTOR'S DISCRETION.

JENNIFER IRVINE, P.E. DATE
COUNTY ENGINEER / EGM ADMINISTRATOR



GRADING & EROSION CONTROL PLAN
CLAREMONT BUSINESS PARK 2 FIL. NO. 1 - LOT 4
JOB NO. 44-037
DATE PREPARED: FEBRUARY 15, 2021
DATE REVISED:

EL PASO COUNTY FILE NO. PPR 000



212 N. WAHSCATH AVE., STE 305
COLORADO SPRINGS, CO 80903
PHONE: 719.955.5485

CLAREMONT BUSINESS PARK 2 FIL. NO. 1 - LOT 4

FOR REFERENCE ONLY

EL PASO COUNTY, STATE OF COLORADO
GRADING & EROSION CONTROL PLAN

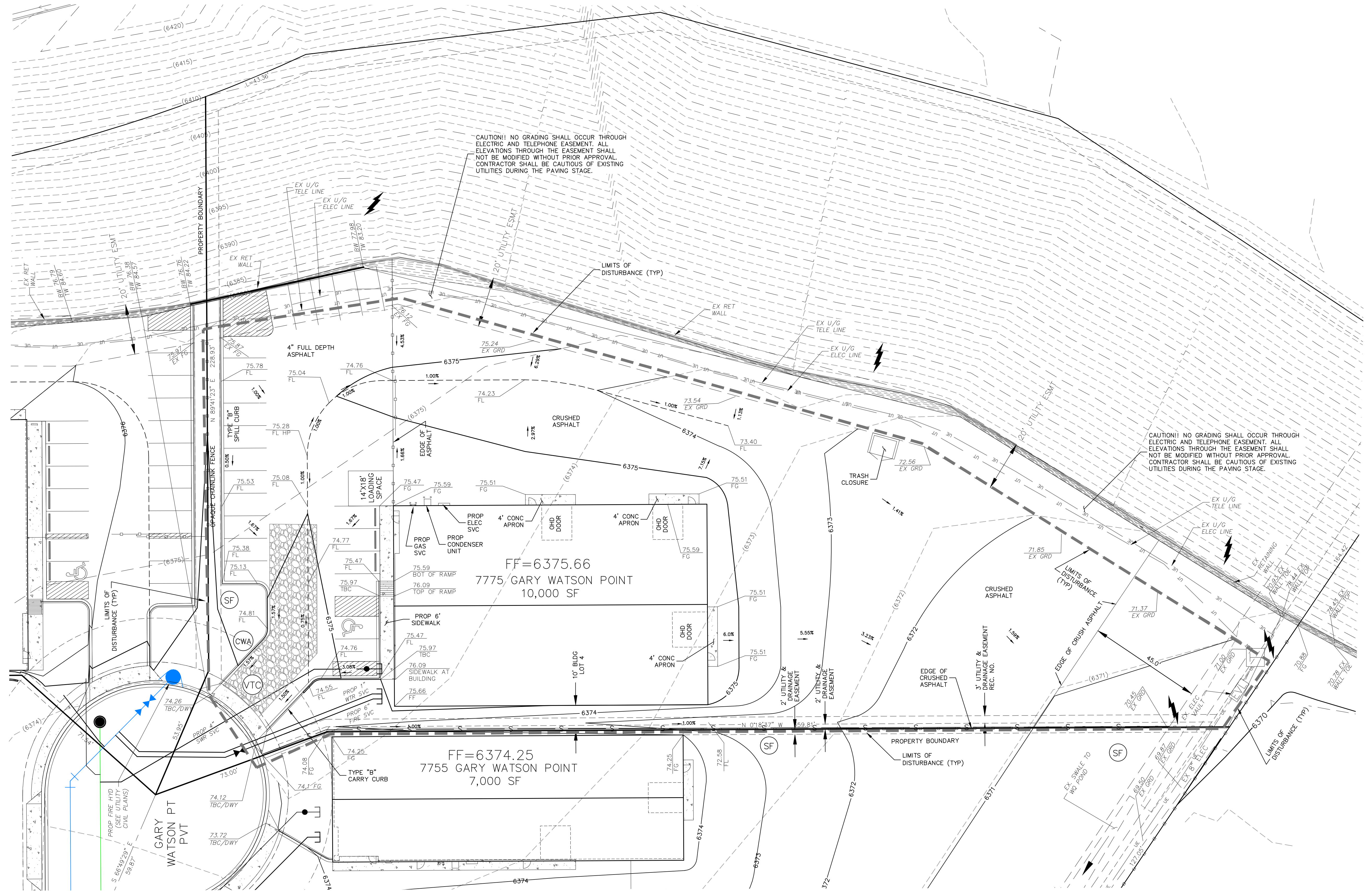

LEGEND

- EX MAJ CONT
- EX MIN CONT
- PROP MAJ CONT
- PROP MIN CONT
- LP LOW POINT
- HP HIGH POINT
- EX EXISTING
- FL FLOWLINE
- TC TOP OF CURB
- FG FINISH GRADE
- FF FINISH FLOOR
- TOF TOP OF FOOTING
- SF SILT FENCE
- VTC VEHICLE TRACKING CONTROL
- CWA CONCRETE WASH-OUT BASIN
- SSA STABILIZED STAGING AREA
- LIMITS OF DISTURBANCE

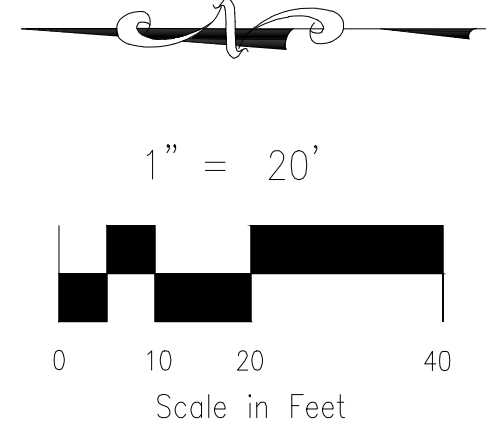

FOR BURIED UTILITY INFORMATION
48 HRS BEFORE YOU DIG
CALL 1-800-922-1987
FOR LOCATING & MARKING GAS,
ELECTRIC, WATER & TELEPHONE LINES
WATER EMERGENCIES 520-0300

CAUTION! NO GRADING SHALL OCCUR THROUGH ELECTRIC AND TELEPHONE EASEMENT. ALL ELEVATIONS THROUGH THE EASEMENT SHALL NOT BE MODIFIED WITHOUT PRIOR APPROVAL. CONTRACTOR SHALL BE CAUTIOUS OF EXISTING UTILITIES DURING THE PAVING STAGE.

CAUTION! NO GRADING SHALL OCCUR THROUGH ELECTRIC AND TELEPHONE EASEMENT. ALL ELEVATIONS THROUGH THE EASEMENT SHALL NOT BE MODIFIED WITHOUT PRIOR APPROVAL. CONTRACTOR SHALL BE CAUTIOUS OF EXISTING UTILITIES DURING THE PAVING STAGE.

FF=6375.66
7775 GARY WATSON POINT
10,000 SF

FF=6374.25
7755 GARY WATSON POINT
7,000 SF

GRADING & EROSION CONTROL PLAN
CLAREMONT BUSINESS PARK 2 FIL. NO. 1 - LOT 4
JOB NO. 44-037
DATE PREPARED: FEBRUARY 15, 2021
DATE REVISED:



212 N. WAHSATCH AVE., STE 305
COLORADO SPRINGS, CO 80903
PHONE: 719.955.5485

EL PASO COUNTY FILE NO. PPR 000

Concrete Washout Area (CWA) MM-1

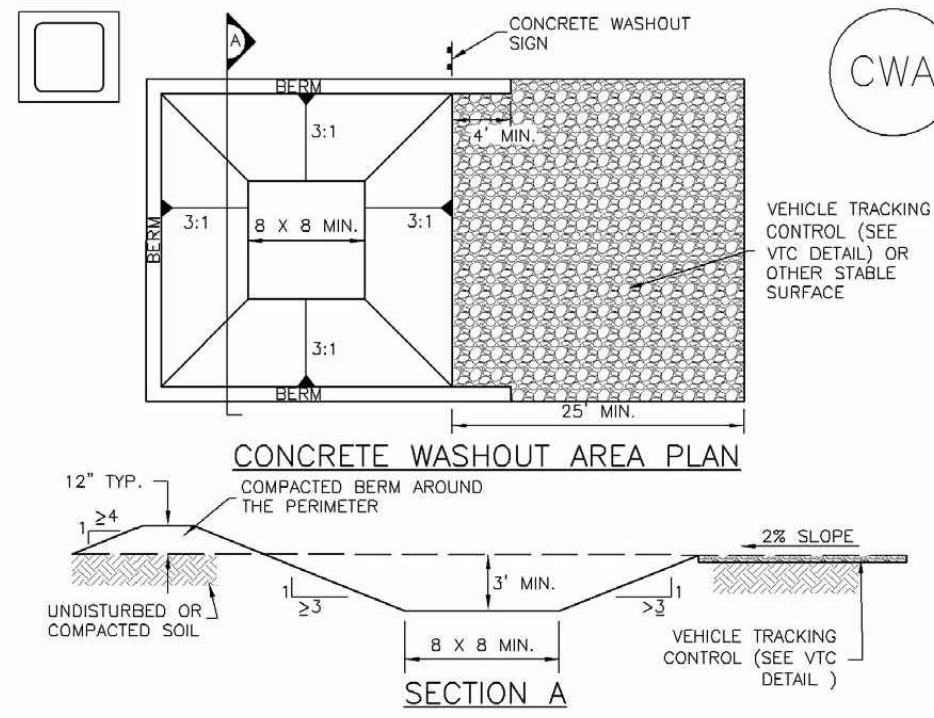

CWA-1. CONCRETE WASHOUT AREA

CWA INSTALLATION NOTES

- SEE PLAN VIEW FOR: -CWA INSTALLATION LOCATION.
- DO NOT LOCATE AN UNLINED CWA WITHIN 400' OF ANY NATURAL DRAINAGE PATHWAY OR WATERBODY. DO NOT LOCATE WITHIN 1000' OF ANY WELLS OR DRINKING WATER SOURCES IF SITE CONSTRAINTS MAKE THIS INFESIBLE, OR IF HIGHLY PERMEABLE SOILS EXIST ON SITE. THE CWA MUST BE INSTALLED WITH AN IMPERMEABLE LINER (16 MIL THICKNESS) OR SURFACE STORAGE ALTERNATIVES USING PREFABRICATED CONCRETE WASHOUT DEVICES OR A LINED ABOVE GROUND STORAGE ARE SHOULD BE USED.
- THE CWA SHALL BE INSTALLED PRIOR TO CONCRETE PLACEMENT ON SITE.
- CWA SHALL INCLUDE A FLAT SUBSURFACE PIT THAT IS AT LEAST 8' BY 8' SLOPES LEADING OUT OF THE SUBSURFACE PIT SHALL BE 3:1 OR FLATTER. THE PIT SHALL BE AT LEAST 3' DEEP.
- BERM SURROUNDING SIDES AND BACK OF THE CWA SHALL HAVE MINIMUM HEIGHT OF 1'.
- VEHICLE TRACKING PAD SHALL BE SLOPED 2% TOWARDS THE CWA.
- SIGNS SHALL BE PLACED AT THE CONSTRUCTION ENTRANCE, AT THE CWA, AND ELSEWHERE AS NECESSARY TO CLEARLY INDICATE THE LOCATION OF THE CWA TO OPERATORS OF CONCRETE TRUCKS AND PUMP TRIS.
- USE EXCAVATED MATERIAL FOR PERIMETER BERM CONSTRUCTION.

November 2010 Urban Drainage and Flood Control District Urban Storm Drainage Criteria Manual Volume 3 CWA-3

Vehicle Tracking Control (VTC) SM-4

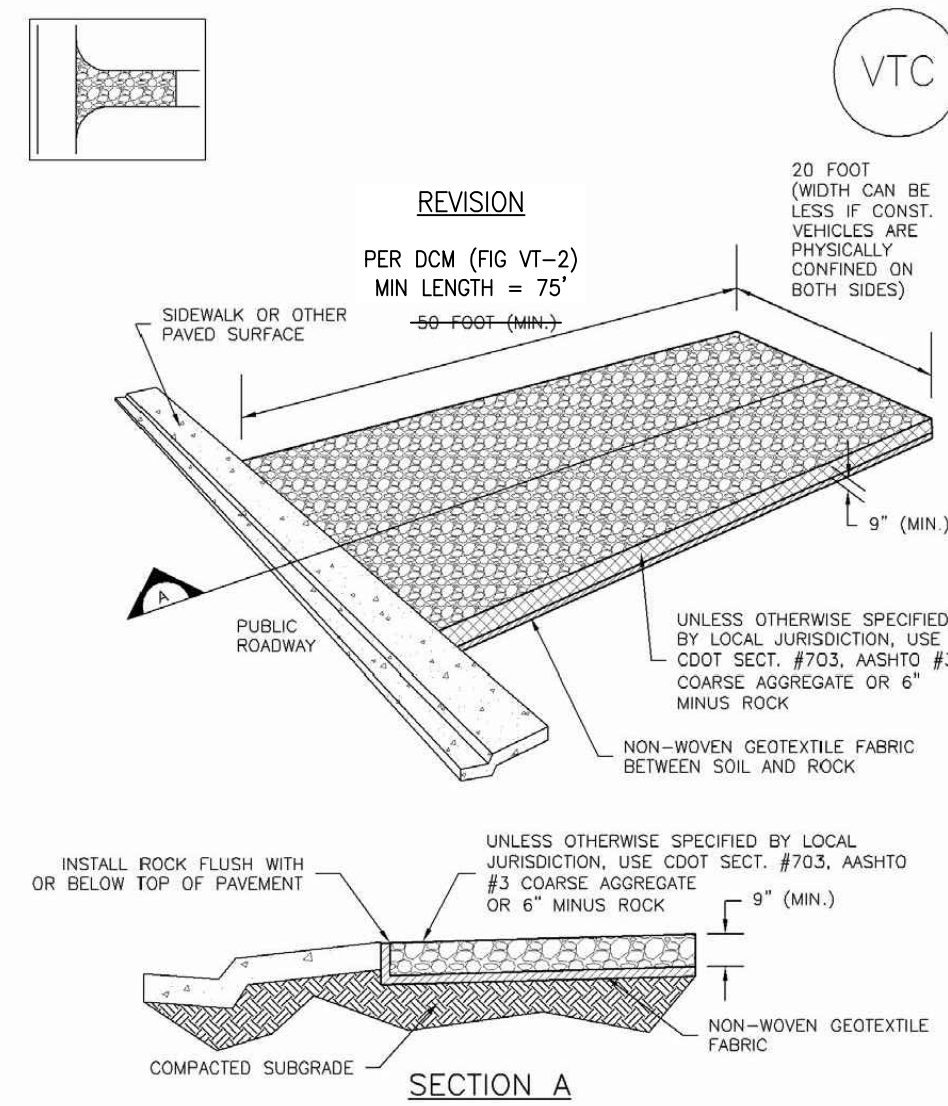

VTC-1. AGGREGATE VEHICLE TRACKING CONTROL

November 2010 Urban Drainage and Flood Control District Urban Storm Drainage Criteria Manual Volume 3 VTC-3

Silt Fence (SF) SC-1

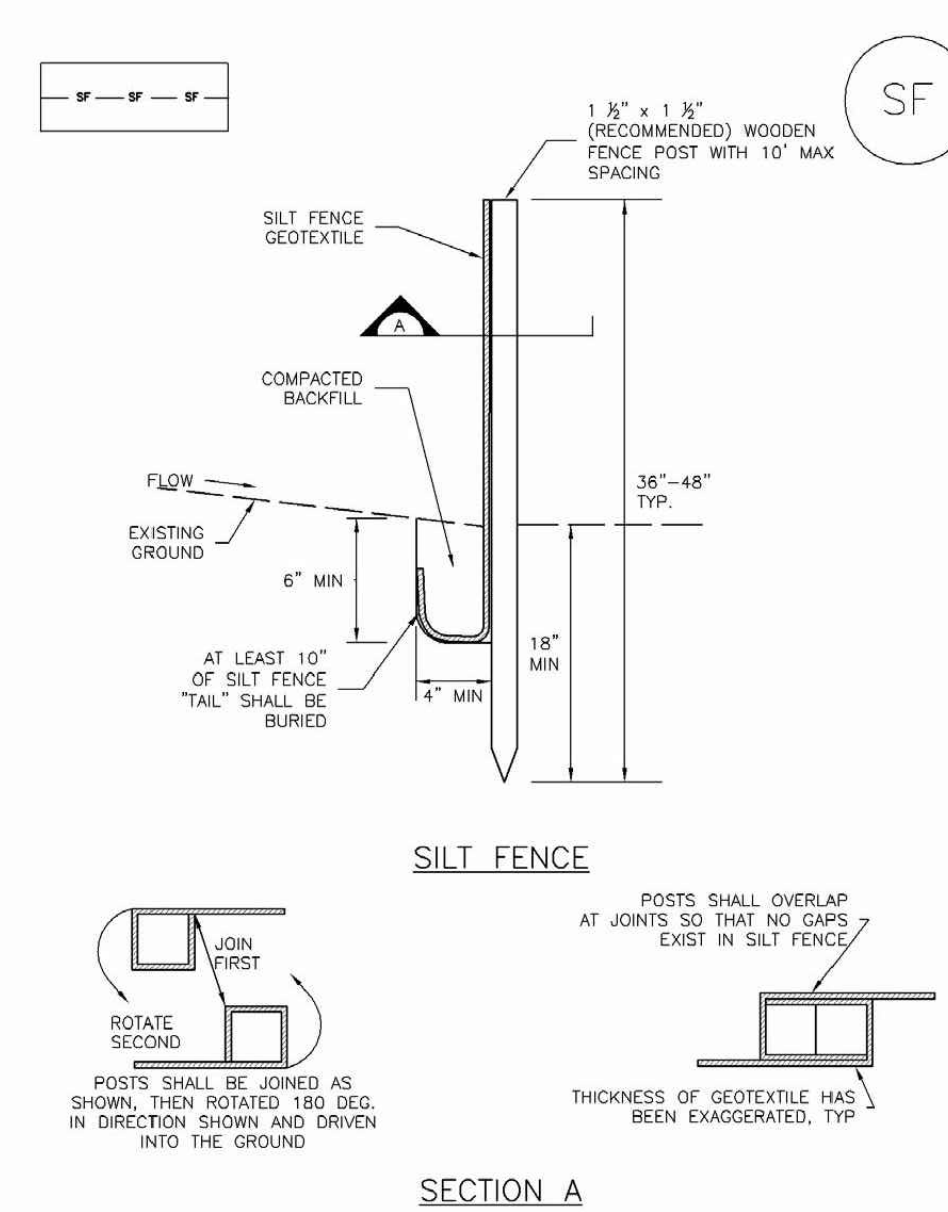

SF-1. SILT FENCE

November 2010 Urban Drainage and Flood Control District Urban Storm Drainage Criteria Manual Volume 3 SF-3

Stabilized Staging Area (SSA) SM-6

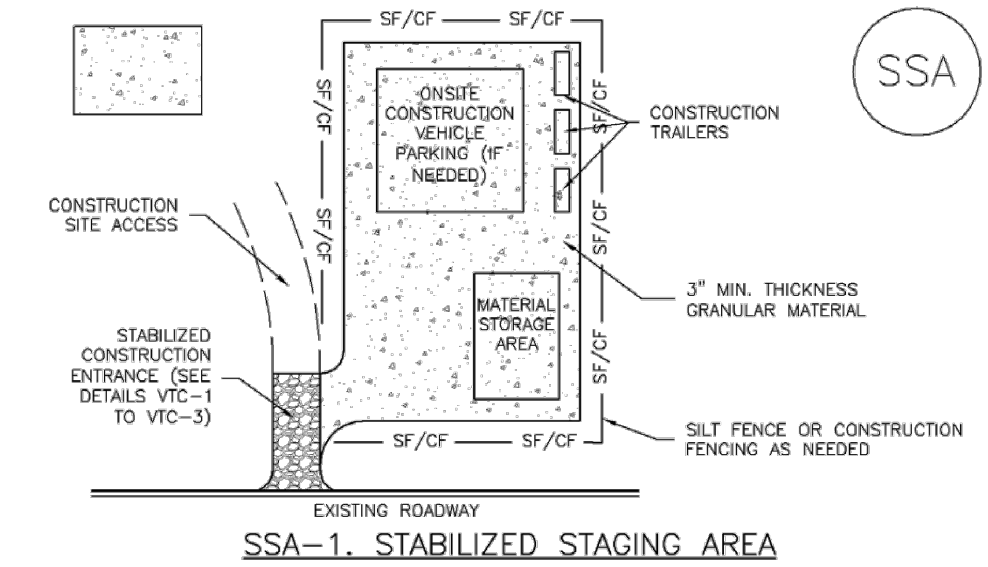

SSA-1. STABILIZED STAGING AREA

STABILIZED STAGING AREA INSTALLATION NOTES

- SEE PLAN VIEW FOR: -LOCATION OF STAGING AREA(S). -CONTRACTOR MAY ADJUST LOCATION AND SIZE OF STAGING AREA WITH APPROVAL FROM THE LOCAL JURISDICTION.
- STABILIZED STAGING AREA SHOULD BE APPROPRIATE FOR THE NEEDS OF THE SITE. OVERSIZING RESULTS IN A LARGER AREA TO STABILIZE FOLLOWING CONSTRUCTION.
- STAGING AREA SHALL BE STABILIZED PRIOR TO OTHER OPERATIONS ON THE SITE.
- THE STABILIZED STAGING AREA SHALL CONSIST OF A MINIMUM 3" THICK GRANULAR MATERIAL.
- UNLESS OTHERWISE SPECIFIED BY LOCAL JURISDICTION, ROCK SHALL CONSIST OF DOT SECT. #703, AASHTO #3 COARSE AGGREGATE OR 6" (MINUS) ROCK.
- ADDITIONAL PERIMETER BMPs MAY BE REQUIRED INCLUDING BUT NOT LIMITED TO SILT FENCE AND CONSTRUCTION FENCING.

STABILIZED STAGING AREA MAINTENANCE NOTES

- INSPECT BMPs EACH WORKDAY, AND MAINTAIN THEM IN EFFECTIVE OPERATING CONDITION. MAINTENANCE OF BMPs SHOULD BE PROACTIVE, NOT REACTIVE. INSPECT BMPs AS SOON AS POSSIBLE (AND ALWAYS WITHIN 24 HOURS) FOLLOWING A STORM THAT CAUSES SURFACE EROSION, AND PERFORM NECESSARY MAINTENANCE.
- FREQUENT OBSERVATIONS AND MAINTENANCE ARE NECESSARY TO MAINTAIN BMPs IN EFFECTIVE OPERATING CONDITION. INSPECTIONS AND CORRECTIVE MEASURES SHOULD BE DOCUMENTED THOROUGHLY.
- WHERE BMPs HAVE FAILED, REPAIR OR REPLACEMENT SHOULD BE INITIATED UPON DISCOVERY OF THE FAILURE.
- ROCK SHALL BE REAPPLIED OR REGRADED AS NECESSARY IF RUTTING OCCURS OR UNDERLYING SUBGRADE BECOMES EXPOSED.

November 2010 Urban Drainage and Flood Control District Urban Storm Drainage Criteria Manual Volume 3 SSA-3

EC-2 Temporary and Permanent Seeding (TS/PS)

Table TS/PS-2. Minimum Drill Seeding Rates for Perennial Grasses

Common Name	Botanical Name	Growth Season ¹	Growth Form	Seeds/Pound	Pounds of PLS/acre
Alkali Soil Seed Mix					
Alkali sacaton	<i>Sporobolus airoides</i>	Cool	Bunch	1,750,000	0.25
Basin wildrye	<i>Elymus cinereus</i>	Cool	Bunch	165,000	2.5
Sodar streambank wheatgrass	<i>Agropyron riparium Sodar'</i>	Cool	Sod	170,000	2.5
Tosa tall wheatgrass	<i>Agropyron elongatum Tosa'</i>	Cool	Bunch	70,000	7.0
Amba western wheatgrass	<i>Agropyron amithii 'Arbha'</i>	Cool	Sod	110,000	5.5
Total					17.75
Fertile Loamy Soil Seed Mix					
Ephraim crested wheatgrass	<i>Agropyron cristatum 'Ephraim'</i>	Cool	Sod	175,000	2.0
Dural hard fescue	<i>Festuca ovina 'Auracauda'</i>	Cool	Bunch	565,000	1.0
Lincoln smooth brome	<i>Bromus inermis leys 'Lincoln'</i>	Cool	Sod	130,000	3.0
Sodar streambank wheatgrass	<i>Agropyron riparium Sodar'</i>	Cool	Sod	170,000	2.5
Amba western wheatgrass	<i>Agropyron amithii 'Arbha'</i>	Cool	Sod	110,000	7.0
Total					15.5
High Water Table Soil Seed Mix					
Meadow foxtail	<i>Allopecurus pratensis</i>	Cool	Sod	900,000	0.5
Redtop	<i>Agrostis alba</i>	Warm	Open sod	5,000,000	0.25
Reed canarygrass	<i>Phalaris arundinacea</i>	Cool	Sod	68,000	0.5
Lincoln smooth brome	<i>Bromus inermis leys 'Lincoln'</i>	Cool	Sod	130,000	3.0
Pathfinder switchgrass	<i>Panicum virgatum 'Pathfinder'</i>	Warm	Sod	380,000	1.0
Albar tall wheatgrass	<i>Agropyron elongatum 'Albar'</i>	Cool	Bunch	79,000	5.5
Total					10.75
Transition Turf Seed Mix²					
Ruebens Canadian blugrass	<i>Poa compressa 'Ruebens'</i>	Cool	Sod	2,500,000	0.5
Dural hard fescue	<i>Festuca ovina 'Auracauda'</i>	Cool	Bunch	565,000	1.0
Citation perennial ryegrass	<i>Lolium perenne 'Citation'</i>	Cool	Sod	247,000	3.0
Lincoln smooth brome	<i>Bromus inermis leys 'Lincoln'</i>	Cool	Sod	130,000	3.0
Total					7.5

TS/PS-4 Urban Drainage and Flood Control District Urban Storm Drainage Criteria Manual Volume 3 June 2012

Temporary and Permanent Seeding (TS/PS) EC-2

Table TS/PS-2. Minimum Drill Seeding Rates for Perennial Grasses (cont.)

Common Name	Botanical Name	Growth Season ¹	Growth Form	Seeds/Pound	Pounds of PLS/acre
Sandy Soil Seed Mix					
Blue grama	<i>Bouteloua gracilis</i>	Warm	Sod-forming bunchgrass	825,000	0.5
Camper little bluestem	<i>Setchellium scoparium 'Camper'</i>	Warm	Bunch	240,000	1.0
Prairie sandreed	<i>Calamagrostis longifolia</i>	Warm	Open sod	274,000	1.0
Sand dropseed	<i>Sporobolus cryptandrus</i>	Cool	Bunch	5,298,000	0.25
Vaughn sideoats grama	<i>Bouteloua curtipendula 'Vaughn'</i>	Warm	Sod	191,000	2.0
Amba western wheatgrass	<i>Agropyron amithii 'Arbha'</i>	Cool	Sod	110,000	5.5
Total					10.25
Heavy Clay, Rocky Foothill Seed Mix					
Ephraim crested wheatgrass ³	<i>Agropyron cristatum 'Ephraim'</i>	Cool	Sod	175,000	1.5
Oshe intermediate wheatgrass	<i>Agropyron intermedium 'Oshe'</i>	Cool	Sod	115,000	5.5
Vaughn sideoats grama ⁴	<i>Bouteloua curtipendula 'Vaughn'</i>	Warm	Sod	191,000	2.0
Lincoln smooth brome	<i>Bromus inermis leys 'Lincoln'</i>	Cool	Sod	130,000	3.0
Amba western wheatgrass	<i>Agropyron amithii 'Arbha'</i>	Cool	Sod	110,000	5.5
Total					17.5

¹ All of the above seeding mixes and rates are based on drill seeding followed by crimped straw mulch. These rates should be doubled if seed is broadcast and should be increased by 50 percent if the seeding is done using a Brillion Drill or is applied through hydraulic seeding. Hydraulic seeding may be substituted for drilling only where slopes are steeper than 3:1. If hydraulic seeding is used, hydraulic mulching should be done as a separate operation.

² See Table TS/PS-3 for seeding dates.

³ If site is to be irrigated, the transition turf seed rates should be doubled.

⁴ Crested wheatgrass should not be used on slopes steeper than 6H to 1V.

⁵ Can substitute 0.5 lbs PLS of blue grama for the 2.0 lbs PLS of Vaughn sideoats grama.

June 2012 Urban Drainage and Flood Control District Urban Storm Drainage Criteria Manual Volume 3 TS/PS-5

SC-1 Silt Fence (SF)

SILT FENCE INSTALLATION NOTES

- SILT FENCE MUST BE PLACED AWAY FROM THE TOE OF THE SLOPE TO ALLOW FOR WATER PONDING. SILT FENCE AT THE TOE OF A SLOPE SHOULD BE INSTALLED IN A FLAT LOCATION AT LEAST SEVERAL FEET (2-5 FT) FROM THE TOE OF THE SLOPE TO ALLOW ROOM FOR PONDING AND DEPOSITION.
- A UNIFORM 6" X 4" ANCHOR TRENCH SHALL BE EXCAVATED USING TRENCHER OR SILT FENCE INSTALLATION DEVICE. NO ROAD GRADERS, BACKHOES, OR SIMILAR EQUIPMENT SHALL BE USED.
- COMPACT ANCHOR TRENCH BY HAND WITH A "JUMPING JACK" OR BY WHEEL ROLLING. COMPACTOR SHALL BE SUCH THAT SILT FENCE RESISTS BEING PULLED OUT OF ANCHOR TRENCH BY HAND.
- SILT FENCE SHALL BE PULLED TIGHT AS IT IS ANCHORED TO THE STAKES. THERE SHOULD BE NO NOTICEABLE SAG BETWEEN STAKES AFTER IT HAS BEEN ANCHORED TO THE STAKES.
- SILT FENCE FABRIC SHALL BE ANCHORED TO THE STAKES USING 1" HEAVY DUTY STAPLES OR NAILS WITH 1" HEADS. STAPLES AND NAILS SHOULD BE PLACED 3" ALONG THE FABRIC DOWN THE STAKE.
- AT THE END OF A RUN OF SILT FENCE ALONG A CONTOUR, THE SILT FENCE SHOULD BE TURNED PERPENDICULAR TO THE CONTOUR TO CREATE A "J-HOOK" OR "U-HOOK". THE "J-HOOK" EXTENDING PERPENDICULAR TO THE CONTOUR SHOULD BE OF SUFFICIENT LENGTH TO KEEP RUNOFF FROM FLOWING AROUND THE END OF THE SILT FENCE (TYPICALLY 10' - 20').
- SILT FENCE SHALL BE INSTALLED PRIOR TO ANY LAND DISTURBING ACTIVITIES.

SILT FENCE MAINTENANCE NOTES

- INSPECT BMPs EACH WORKDAY, AND MAINTAIN THEM IN EFFECTIVE OPERATING CONDITION. MAINTENANCE OF BMPs SHOULD BE PROACTIVE, NOT REACTIVE. INSPECT BMPs AS SOON AS POSSIBLE (AND ALWAYS WITHIN 24 HOURS) FOLLOWING A STORM THAT CAUSES SURFACE EROSION, AND PERFORM NECESSARY MAINTENANCE.
 - FREQUENT OBSERVATIONS AND MAINTENANCE ARE NECESSARY TO MAINTAIN BMPs IN EFFECTIVE OPERATING CONDITION. INSPECTIONS AND CORRECTIVE MEASURES SHOULD BE DOCUMENTED THOROUGHLY.
 - WHERE BMPs HAVE FAILED, REPAIR OR REPLACEMENT SHOULD BE INITIATED UPON DISCOVERY OF THE FAILURE.
 - SEDIMENT ACCUMULATED UPSTREAM OF THE SILT FENCE SHALL BE REMOVED AS NEEDED TO MAINTAIN THE FUNCTIONALITY OF THE BMP, TYPICALLY WHEN DEPTH OF ACCUMULATED SEDIMENTS IS APPROXIMATELY 6".
 - REPAIR OR REPLACE SILT FENCE WHEN THERE ARE SIGNS OF WEAR, SUCH AS SAGGING, TEARING, OR COLLAPSE.
 - SILT FENCE IS TO REMAIN IN PLACE UNTIL THE UPSTREAM DISTURBED AREA IS STABILIZED AND APPROVED BY THE LOCAL JURISDICTION, OR IS REPLACED BY AN EQUIVALENT PERIMETER SEDIMENT CONTROL BMP.
 - WHEN SILT FENCE IS REMOVED, ALL DISTURBED AREAS SHALL BE COVERED WITH TOPSOIL, SEEDING AND MULCHED OR OTHERWISE STABILIZED AS APPROVED BY LOCAL JURISDICTION.
- (DETAIL ADAPTED FROM TOWN OF PARKER, COLORADO AND CITY OF AURORA, NOT AVAILABLE IN AUTOCAD)
- NOTE: MANY JURISDICTIONS HAVE BMP DETAILS THAT VARY FROM LUDCO STANDARD DETAILS. CONSULT WITH LOCAL JURISDICTIONS AS TO WHICH DETAIL SHOULD BE USED WHEN DIFFERENCES ARE NOTED.

SF-4 Urban Drainage and Flood Control District Urban Storm Drainage Criteria Manual Volume 3 November 2010

SM-6 Stabilized Staging Area (SSA)

STABILIZED STAGING AREA MAINTENANCE NOTES

- STABILIZED STAGING AREA SHALL BE ENLARGED IF NECESSARY TO CONTAIN PARKING, STORAGE, AND UNLOADING/LOADING OPERATIONS.
 - THE STABILIZED STAGING AREA SHALL BE REMOVED AT THE END OF CONSTRUCTION. THE GRANULAR MATERIAL SHALL BE REMOVED OR, IF APPROVED BY THE LOCAL JURISDICTION, USED ON SITE, AND THE AREA COVERED WITH TOPSOIL, SEEDING AND MULCHED OR OTHERWISE STABILIZED IN A MANNER APPROVED BY LOCAL JURISDICTION.
- NOTE: MANY MUNICIPALITIES PROHIBIT THE USE OF RECYCLED CONCRETE AS GRANULAR MATERIAL FOR STABILIZED STAGING AREAS DUE TO DIFFICULTIES WITH RE-ESTABLISHMENT OF VEGETATION IN AREAS WHERE RECYCLED CONCRETE WAS PLACED.
- NOTE: MANY JURISDICTIONS HAVE BMP DETAILS THAT VARY FROM LUDCO STANDARD DETAILS. CONSULT WITH LOCAL JURISDICTIONS AS TO WHICH DETAIL SHOULD BE USED WHEN DIFFERENCES ARE NOTED.
- (DETAILS ADAPTED FROM DOUGLAS COUNTY, COLORADO, NOT AVAILABLE IN AUTOCAD)

SSA-4 Urban Drainage and Flood Control District Urban Storm Drainage Criteria Manual Volume 3 November 2010

**CLAREMONT BUSINESS PARK 2 FIL. NO. 1
FINAL PLAT**

CLAREMONT BUSINESS PARK 2 FILING NO. 1

A REPLAT OF TRACT A "CLAREMONT BUSINESS PARK FILING NO. 1C", AND A PORTION OF TRACT C "CLAREMONT BUSINESS PARK FILING NO. 2", BEING A TRACT OF LAND IN THE SOUTHEAST QUARTER OF THE SOUTHEAST QUARTER (SE 1/4, SE 1/4) OF SECTION 5 AND NORTHEAST QUARTER OF THE NORTHEAST QUARTER (NE 1/4, NE 1/4) OF SECTION 8, T14S, R65W, OF THE 6TH P.M., EL PASO COUNTY, COLORADO

FOR REFERENCE ONLY

BE IT KNOWN BY THESE PRESENTS:

THAT L. G. CASE (A.K.A. LENA GAIL CASE), NANCY BARBER STARR AND JON STARR, AND HAMMERS CONSTRUCTION INC., A COLORADO COMPANY, BEING THE OWNERS OF THE FOLLOWING DESCRIBED TRACT OF LAND:

LEGAL DESCRIPTION:

A PARCEL OF LAND IN THE SOUTHEAST QUARTER OF SECTION 5 AND THE NORTHEAST QUARTER OF SECTION 8, T14S, R65W OF THE 6TH P.M., EL PASO COUNTY, COLORADO CONSISTING OF TRACT A "CLAREMONT BUSINESS PARK FILING NO. 1C" AS RECORDED UNDER RECEPTION NO. 220714531 AND THAT PORTION OF TRACT C "CLAREMONT BUSINESS PARK FILING NO. 2" AS RECORDED UNDER RECEPTION NO. 207712506, AMENDED BY SPECIAL WARRANTY DEED RECORDED UNDER RECEPTION NO. 218046726, SPECIAL WARRANTY DEED RECORDED UNDER RECEPTION NO. 219078479, AND SPECIAL WARRANTY DEED RECORDED UNDER RECEPTION NO. 219160747, ALL MORE PARTICULARLY DESCRIBED AS FOLLOWS:

BEGINNING AT THE SOUTHWEST CORNER OF AFORESAID TRACT A "CLAREMONT BUSINESS PARK FILING NO. 1C"; THENCE ALONG THE EASTERLY RIGHT-OF-WAY LINE OF 80 FOOT MEADOWBROOK PARKWAY THE FOLLOWING FOUR (4) COURSES;

- 1) THENCE 207.94 FEET ALONG THE ARC OF A CURVE TO THE LEFT, SAID CURVE HAVING A RADIUS OF 605.00 FEET, A CENTRAL ANGLE OF 19°41'35", AND A CHORD OF 206.92 FEET WHICH BEARS N02°19'03"W TO A POINT OF TANGENT;
- 2) THENCE N12°09'05"W ALONG SAID TANGENT 118.69 FEET TO A POINT OF CURVE;
- 3) THENCE 932.82 FEET ALONG THE ARC OF A CURVE TO THE RIGHT, SAID CURVE HAVING A RADIUS OF 525.00 FEET, A CENTRAL ANGLE OF 101°48'12", AND A CHORD OF 814.87 FEET WHICH BEARS N38°45'53"E TO A POINT OF TANGENT;
- 4) THENCE N89°40'01"E ALONG SAID TANGENT 58.32 FEET TO THE WESTERLY RIGHT-OF-WAY LINE OF MARKSHEFFEL ROAD/U.S. HIGHWAY 24, CDOT PROJECT NO. NH 0243-058 UNIT 2;

THENCE ALONG SAID WESTERLY RIGHT-OF-WAY LINE THE FOLLOWING FIVE (5) COURSES;

- 1) THENCE S00°10'49"W A DISTANCE OF 550.15 FEET TO A POINT OF CURVE;
- 2) THENCE 264.51 FEET ALONG THE ARC OF A CURVE TO THE LEFT, SAID CURVE HAVING A RADIUS OF 605.00 FEET, A CENTRAL ANGLE OF 25°02'59", AND A CHORD OF 262.40 FEET WHICH BEARS S12°21'26"E;
- 3) THENCE S06°46'53"E NON-TANGENT TO THE PREVIOUS COURSE 142.31 FEET;
- 4) THENCE S14°56'24"W A DISTANCE OF 164.34 FEET;
- 5) THENCE S33°35'01"W A DISTANCE OF 192.22 FEET TO THE NORTHEAST CORNER OF LOT 2 "CLAREMONT BUSINESS PARK FILING NO. 1C";

THENCE N56°02'38"W ALONG THE NORTH LINES OF LOT 1 AND LOT 2, A DISTANCE OF 551.81 FEET TO THE POINT OF BEGINNING.

SAID PARCEL CONTAINS A CALCULATED AREA OF 595,013 S.F. (13.660 ACRES MORE OR LESS).

DEDICATION:

THE UNDERSIGNED OWNER HAS CAUSED SAID PARCEL TO BE PLATTED INTO LOTS, A TRACT, AND EASEMENTS, AS SHOWN ON THE PLAT. THE UNDERSIGNED DOES HEREBY DEDICATE, GRANT AND CONVEY TO EL PASO COUNTY COLORADO THOSE PUBLIC EASEMENTS AS SHOWN ON THE PLAT; AND FURTHER RESTRICTS THE USE OF ALL PUBLIC EASEMENTS TO EL PASO COUNTY AND/OR ITS ASSIGNS, PROVIDED HOWEVER, THAT THE SOLE RIGHT AND AUTHORITY TO RELEASE OR QUITCLAIM ALL OR ANY SUCH PUBLIC EASEMENTS SHALL REMAIN EXCLUSIVELY VESTED IN EL PASO COUNTY. THIS PARCEL OF LAND AS PLATTED HEREIN SHALL BE KNOWN AS "CLAREMONT BUSINESS PARK 2 FILING NO. 1", IN EL PASO COUNTY, COLORADO.

OWNER: HAMMERS CONSTRUCTION INC.
1411 WOOLSEY HEIGHTS
COLORADO SPRINGS, COLORADO 80915

BY: _____
STEVE HAMMERS, PRESIDENT

NOTARIAL:

STATE OF COLORADO }
COUNTY OF EL PASO } SS

THE ABOVE AND AFOREMENTIONED INSTRUMENT WAS ACKNOWLEDGED BEFORE ME THIS _____ DAY OF _____, 2020, A.D. BY STEVE HAMMERS, PRESIDENT, HAMMERS CONSTRUCTION, INC.

WITNESS MY HAND AND OFFICIAL SEAL:
MY COMMISSION EXPIRES: _____

NOTARY PUBLIC: _____

OWNER: L. G. CASE
2432 PARKVIEW LANE
COLORADO SPRINGS, COLORADO 80906

BY: _____
L. G. CASE, A.K.A. LENA GAIL CASE

NOTARIAL:

STATE OF COLORADO }
COUNTY OF EL PASO } SS

THE ABOVE AND AFOREMENTIONED INSTRUMENT WAS ACKNOWLEDGED BEFORE ME THIS _____ DAY OF _____, 2020, A.D. BY L. G. CASE, A.K.A. LENA GAIL CASE

WITNESS MY HAND AND OFFICIAL SEAL:
MY COMMISSION EXPIRES: _____

NOTARY PUBLIC: _____

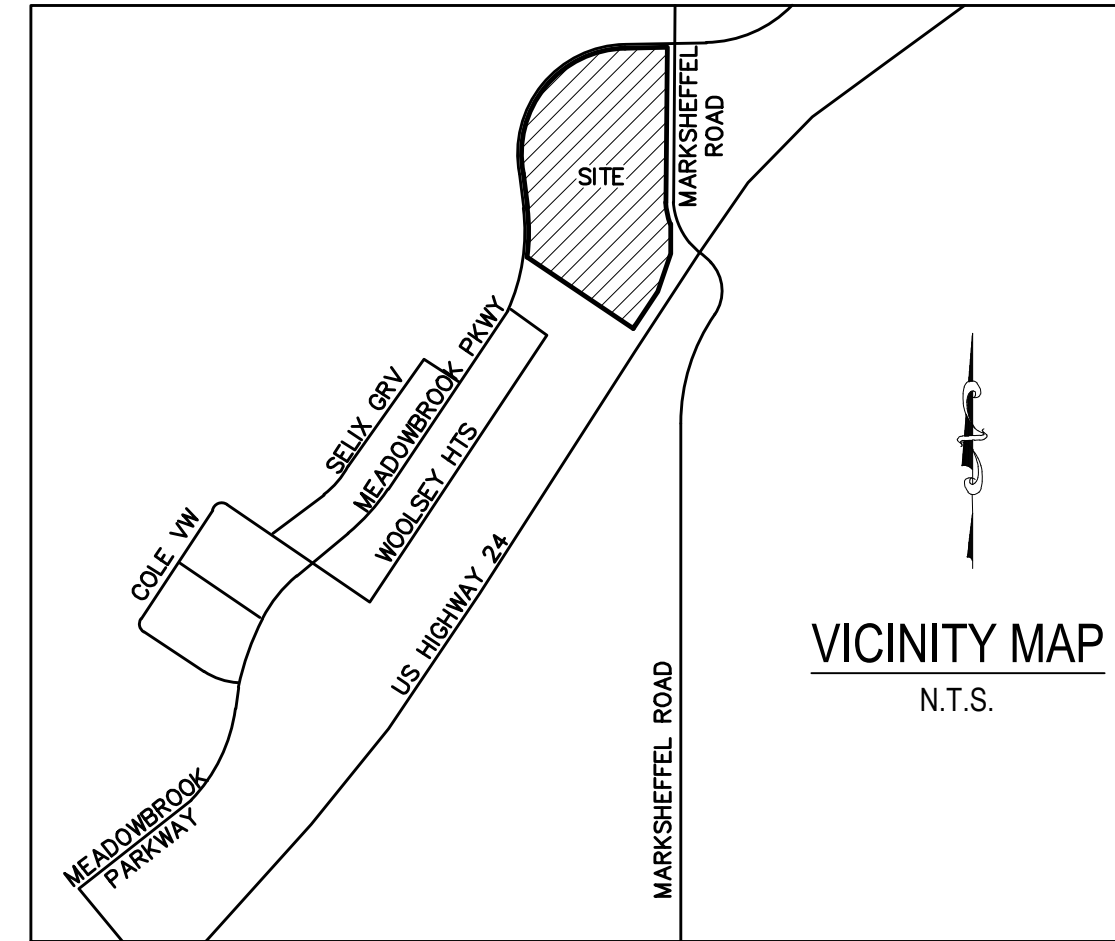

TRACT TABLE				
TRACT	SIZE (ACRES)	USE	MAINTENANCE	OWNERSHIP
A	0.489	PUBLIC AND PRIVATE UTILITIES, PUBLIC AND PRIVATE DRAINAGE, LANDSCAPING, WQ POND	OWNERS G1	OWNERS G1
B	0.425	PUBLIC AND PRIVATE UTILITIES, PUBLIC AND PRIVATE DRAINAGE, LANDSCAPING, WQ POND	OWNERS G2	OWNERS G2
C	0.202	RIGHT-OF-WAY RESERVATION, PRIVATE DRAINAGE	OWNERS G2	OWNERS G2
TOTAL	1.116	(TOTAL ACREAGE OF ALL TRACTS)		
OWNERS G1: EQUAL SHARES OF INDIVIDUAL LOT OWNERS OF LOTS 1-7				
OWNERS G2: EQUAL SHARES OF INDIVIDUAL LOT OWNERS OF LOTS 8-10				

OWNER: NANCY BARBER STARR
JON STARR
5001 S. CLINTON STREET
GREENWOOD VILLAGE, COLORADO 80111

BY: _____
NANCY BARBER STARR

BY: _____
JON STARR

NOTARIAL:

STATE OF COLORADO }
COUNTY OF EL PASO } SS

THE ABOVE AND AFOREMENTIONED INSTRUMENT WAS ACKNOWLEDGED BEFORE ME THIS _____ DAY OF _____, 2020, A.D. BY NANCY BARBER STARR AND JON STARR

WITNESS MY HAND AND OFFICIAL SEAL:
MY COMMISSION EXPIRES: _____

NOTARY PUBLIC: _____

EASEMENTS:

UNLESS OTHERWISE INDICATED, ALL SIDE, FRONT, AND REAR LOT LINES ARE HEREBY PLATTED ON EITHER SIDE WITH A 5 FOOT PUBLIC UTILITY AND DRAINAGE EASEMENT UNLESS OTHERWISE INDICATED. ALL EXTERIOR SUBDIVISION BOUNDARIES ARE HEREBY PLATTED WITH A 7 FOOT PUBLIC UTILITY AND DRAINAGE EASEMENT. THE SOLE RESPONSIBILITY FOR MAINTENANCE OF THESE EASEMENTS IS HEREBY VESTED WITH THE INDIVIDUAL PROPERTY OWNERS.

EASEMENTS ARE AS SHOWN ON SHEET 4 OF THIS PLAT.

SURVEYORS CERTIFICATE

I, VERNON P. TAYLOR, A DULY REGISTERED PROFESSIONAL LAND SURVEYOR IN THE STATE OF COLORADO, DO HEREBY CERTIFY THAT THIS PLAT TRULY AND CORRECTLY REPRESENTS THE RESULTS OF A SURVEY MADE ON DATE OF SURVEY, BY ME OR UNDER MY DIRECT SUPERVISION AND THAT ALL MONUMENTS EXIST AS SHOWN HEREON; THAT MATHEMATICAL CLOSURE ERRORS ARE LESS THAN 1:10,000; AND THAT SAID PLAT HAS BEEN PREPARED IN FULL COMPLIANCE WITH ALL APPLICABLE LAWS OF THE STATE OF COLORADO DEALING WITH MONUMENTS, SUBDIVISION, OR SURVEYING OF LAND AND ALL APPLICABLE PROVISIONS OF THE EL PASO COUNTY LAND DEVELOPMENT CODE.

I ATTEST THE ABOVE ON THIS _____ DAY OF _____, 2020.

VERNON P. TAYLOR DATE
COLORADO PLS NO. 25966, FOR AND
ON BEHALF OF M&S CIVIL CONSULTANTS, INC
20 BOULDER CRESCENT, SUITE 110
COLORADO SPRINGS, COLORADO 80903

NOTICE:

ACCORDING TO COLORADO LAW, YOU MUST COMMENCE ANY LEGAL ACTION BASED UPON ANY DEFECT IN THIS SURVEY WITHIN THREE YEARS AFTER YOU FIRST DISCOVER SUCH DEFECT. IN NO EVENT, MAY ANY ACTION BASED UPON ANY DEFECT IN THIS SURVEY BE COMMENCED MORE THAN TEN YEARS FROM THE DATE OF THE CERTIFICATION SHOWN HEREON.

PLANNING AND COMMUNITY DEVELOPMENT DEPARTMENT EXECUTIVE DIRECTOR CERTIFICATE:

THIS PLAT FOR "CLAREMONT BUSINESS PARK 2 FILING NO. 1" WAS APPROVED FOR FILING BY THE EXECUTIVE DIRECTOR OF THE EL PASO COUNTY PLANNING AND COMMUNITY DEVELOPMENT DEPARTMENT DIRECTOR ON THIS _____ DAY OF _____, 2020, SUBJECT TO ANY NOTES SPECIFIED HEREON AND ANY CONDITIONS INCLUDED IN THE RECORD OF ADMINISTRATIVE ACTION. THE DEDICATIONS OF LAND TO THE PUBLIC (STREETS AND EASEMENTS) ARE ACCEPTED, BUT PUBLIC IMPROVEMENTS THEREON WILL NOT BECOME MAINTENANCE RESPONSIBILITY OF EL PASO COUNTY UNTIL PRELIMINARY ACCEPTANCE OF THE PUBLIC IMPROVEMENTS IN ACCORDANCE WITH THE REQUIREMENTS OF THE LAND DEVELOPMENT CODE AND ENGINEERING CRITERIA MANUAL AND THE SUBDIVISION IMPROVEMENTS AGREEMENT.

EXECUTIVE DIRECTOR, PLANNING AND COMMUNITY DEVELOPMENT DEPARTMENT DATE

CLERK AND RECORDER:

STATE OF COLORADO }
COUNTY OF EL PASO } SS

I HEREBY CERTIFY THAT THIS INSTRUMENT WAS FILED FOR RECORD IN MY OFFICE AT _____ O'CLOCK _____, THIS _____ DAY OF _____, 2020, A.D., AND DULY RECORDED UNDER RECEPTION NO. _____ OF THE RECORDS OF EL PASO COUNTY, COLORADO.

FEE: _____ CHUCK BROERMAN, RECORDER

SURCHARGE: _____ BY: _____ DEPUTY

FEES:

DRAINAGE FEE: _____
BRIDGE FEE: _____
SCHOOL FEE: _____
PARK FEE: _____

SUMMARY:

10 LOTS	12.404 ACRES	90.81%
3 TRACTS	1.116 ACRES	8.17%
RIGHT-OF-WAY	0.140 ACRES	1.02%
TOTAL	13.660 ACRES	100.00%

FINAL PLAT
CLAREMONT BUSINESS PARK 2
FILING NO. 1
JOB NO. 44-037
DATE PREPARED: 04/28/2020
DATE REVISED: 10/21/2020



102 E. PIKES PEAK AVE., 5TH FLOOR
COLORADO SPRINGS, CO 80903
PHONE: 719.955.5485

CLAREMONT BUSINESS PARK 2 FILING NO. 1

FOR REFERENCE ONLY

A REPLAT OF TRACT A "CLAREMONT BUSINESS PARK FILING NO. 1C", AND A PORTION OF TRACT C "CLAREMONT BUSINESS PARK FILING NO. 2", BEING A TRACT OF LAND IN THE SOUTHEAST QUARTER OF THE SOUTHEAST QUARTER (SE 1/4, SE 1/4) OF SECTION 5 AND NORTHEAST QUARTER OF THE NORTHEAST QUARTER (NE 1/4, NE 1/4) OF SECTION 8, T14S, R65W, OF THE 6TH P.M., EL PASO COUNTY, COLORADO

GENERAL PLAT NOTES:

1. BASIS OF BEARINGS: THE CHORD OF THE WESTERLY LINE OF LOT 2 "CLAREMONT BUSINESS PARK FILING NO. 1A" UNDER RECEPTION NO. 206712398, BEING MONUMENTED AT THE SOUTHERLY END WITH A NAIL AND WASHER, PLS NO. ILLEGIBLE, AND AT THE NORTHERLY END WITH A REBAR AND ALUMINUM CAP PLS NO. 27605 IS ASSUMED TO BEAR N22°18'18"E A DISTANCE OF 218.26 U.S. SURVEY FEET.
2. THE FLOOD INSURANCE RATE MAP (FIRM) PANEL NO. 08041C0756 G, WITH AN EFFECTIVE DATE OF DECEMBER 7, 2018 SHOWS THE SUBJECT PROPERTY LIES WITHIN ZONE X (AREA OF MINIMAL FLOOD HAZARD).
3. A COMMITMENT FOR TITLE INSURANCE ISSUED BY LAND TITLE GUARANTEE COMPANY, AS AGENT FOR OLD REPUBLIC NATIONAL TITLE INSURANCE COMPANY, COMMITMENT NO. SC855084634-3, WITH AN EFFECTIVE DATE OF JULY 17, 2020, HAS BEEN EXAMINED AS IT RELATES TO THE SUBJECT PROPERTY. THE FOLLOWING EXCEPTIONS AS NUMBERED THEREIN ARE HEREBY NOTED.
 - i. (TC#9) THE PROPERTY MAY BE SUBJECT TO RESERVATION IN DEED RECORDED APRIL 10, 1919 IN BOOK 565 AT PAGE 117 OF ALL COAL UNDER SAID LANDS TOGETHER WITH THE RIGHT OF SURFACE ENTRY.
 - ii. (TC#10) THE PROPERTY MAY BE SUBJECT TO RESERVATION IN DEED RECORDED DECEMBER 9, 1920 IN BOOK 565 AT PAGE 229 OF ALL COAL UNDER SAID LANDS TOGETHER WITH THE RIGHT OF SURFACE ENTRY.
 - iii. (TC#11) THE PROPERTY MAY BE SUBJECT TO RESERVATION, IN DEED RECORDED AUGUST 9, 1939 IN BOOK 976 AT PAGE 231, AS FOLLOWS: UNDIVIDED 1/2 INTEREST IN ALL OIL, GAS AND OTHER MINERAL RIGHTS, TOGETHER WITH RIGHT OF SURFACE ENTRY.
 - iv. (TC#12) THE PROPERTY MAY BE SUBJECT TO RIGHT OF WAY AND/OR EASEMENT, GIVEN TO MOUNTAIN VIEW ELECTRIC ASSOCIATION, INCORPORATION, FOR ELECTRIC PURPOSES, THE EXACT LOCATION OF WHICH IS NOT SPECIFIED, RECORDED FEBRUARY 16, 1972 IN BOOK 2468 AT PAGE 53. RELEASE OF RIGHT OF WAY RECORDED OCTOBER 02, 2018 UNDER RECEPTION NO. 218115279.
 - v. (TC#13) THE PROPERTY MAY BE SUBJECT TO TERMS, CONDITIONS AND PROVISIONS OF AGREEMENT EVIDENCED BY MEMORANDUM OF AGREEMENT RECORDED OCTOBER 25, 2002 AT RECEPTION NO. 202185171.
 - vi. (TC#14) THE PROPERTY MAY BE SUBJECT TO THE EFFECT OF INCLUSION OF THE SUBJECT PROPERTY IN THE CENTRAL MARKSHEFFEL METROPOLITAN DISTRICT, AS EVIDENCED BY INSTRUMENTS RECORDED OCTOBER 3, 2002 UNDER RECEPTION NO. 202169647 AND RERECORDED MAY 11, 2004 UNDER RECEPTION NO. 204077221, DECEMBER 12, 2002, UNDER RECEPTION NO. 202221165 AND MAY 11, 2004 UNDER RECEPTION NO. 204077224, AND AS AMENDED BY INSTRUMENT RECORDED NOVEMBER 14, 2017 UNDER RECEPTION NO. 217138355.
 - vii. (TC#15) THE PROPERTY MAY BE SUBJECT TO TERMS, CONDITIONS, PROVISIONS, BURDENS, OBLIGATIONS AND EASEMENTS AS SET FORTH AND GRANTED IN EASEMENTS AGREEMENT RECORDED OCTOBER 01, 2004 AT RECEPTION NO. 204166012.
 - viii. (TC#16) THE PROPERTY MAY BE SUBJECT TO THE EFFECT OF RESOLUTION 04-178, REGARDING SKETCH PLAN RECORDED FEBRUARY 3, 2005 UNDER RECEPTION NO. 205016957.
 - ix. (TC#17) THE PROPERTY MAY BE SUBJECT TO THE EFFECT OF RESOLUTION NO. 05-15, REGARDING ZONING RECORDED APRIL 4, 2005 UNDER RECEPTION NO. 205047387.
 - x. (TC#18) THE PROPERTY MAY BE SUBJECT TO TERMS, CONDITIONS, PROVISIONS, BURDENS, OBLIGATIONS AND EASEMENTS AS SET FORTH AND GRANTED IN AVIGATION EASEMENT RECORDED JUNE 29, 2006 UNDER RECEPTION NO. 206095824.
 - xi. (TC#19) THE PROPERTY MAY BE SUBJECT TO RESTRICTIVE COVENANTS, WHICH DO NOT CONTAIN A FORFEITURE OR REVERTER CLAUSE, BUT OMITTING ANY COVENANTS OR RESTRICTIONS, IF ANY, BASED UPON RACE, COLOR, RELIGION, SEX, SEXUAL ORIENTATION, FAMILIAL STATUS, MARITAL STATUS, DISABILITY, HANDICAP, NATIONAL ORIGIN, ANCESTRY, OR SOURCE OF INCOME, AS SET FORTH IN APPLICABLE STATE OR FEDERAL LAWS, EXCEPT TO THE EXTENT THAT SAID COVENANT OR RESTRICTION IS PERMITTED BY APPLICABLE LAW, AS CONTAINED IN INSTRUMENT RECORDED MARCH 02, 2006, UNDER RECEPTION NO. 206031585, AND AS AMENDED IN INSTRUMENT RECORDED DECEMBER 26, 2006, UNDER RECEPTION NO. 206185249, AND AS AMENDED IN FIRST AMENDMENT TO DECLARATION IN INSTRUMENT RECORDED ON JANUARY 3, 2007 UNDER RECEPTION NO. 207001307.
 - xii. (TC#20) THE PROPERTY MAY BE SUBJECT TO EASEMENT GRANTED TO MOUNTAIN VIEW ELECTRIC ASSOCIATION, FOR UTILITIES, AND INCIDENTAL PURPOSES, BY INSTRUMENT RECORDED AUGUST 07, 2006, UNDER RECEPTION NO. 206116483.
 - xiii. (TC#21) THE PROPERTY MAY BE SUBJECT TO EASEMENTS, CONDITIONS, COVENANTS, RESTRICTIONS, RESERVATIONS AND NOTES ON THE PLAT OF CLAREMONT BUSINESS PARK FILING NO. 2 RECORDED JANUARY 4, 2007 UNDER RECEPTION NO. 207712506.
 - xiv. (TC#22) THE PROPERTY MAY BE SUBJECT TO TERMS, CONDITIONS, PROVISIONS, BURDENS AND OBLIGATIONS AS SET FORTH IN SUBDIVISION IMPROVEMENTS AGREEMENT RECORDED JANUARY 04, 2007 AT RECEPTION NO. 207001840 AND FEBRUARY 13, 2007 UNDER RECEPTION NO. 207021069.
 - xv. (TC#23) THE PROPERTY MAY BE SUBJECT TO THE EFFECT OF RESOLUTION NO. 06-362, REGARDING FINAL PLAT, RECORDED JUNE 25, 2007, UNDER RECEPTION NO. 207084816.

GENERAL PLAT NOTES: (CONT.)

- xvi. (TC#24) THE PROPERTY MAY BE SUBJECT TO THE EFFECT OF RESOLUTION NO. 19-11, APPROVE PRELIMINARY PLAN REQUEST FOR CLAREMONT COMMERCIAL FILING NO. 2 RECORDED JANUARY 10, 2019 UNDER RECEPTION NO. 219003040.
- xvii. (TC#25) THE PROPERTY MAY BE SUBJECT TO RIGHT OF WAY EASEMENT AS GRANTED TO COLORADO TELEPHONE COMPANY, FOR COMMUNICATIONS LINES AND INCIDENTAL PURPOSES, IN INSTRUMENT RECORDED MARCH 03, 1905, IN BOOK 358 AT PAGE 565.
- xviii. (TC#26) THE PROPERTY MAY BE SUBJECT TO EACH AND EVERY RIGHT OF ACCESS TO STATE HIGHWAY 24 AS CONVEYED IN WARRANTY DEED TO DEPARTMENT OF TRANSPORTATION, STATE OF COLORADO RECORDED FEBRUARY 20, 2002 UNDER RECEPTION NO. 202028680.
- xix. (TC#27) THE PROPERTY MAY BE SUBJECT TO EASEMENTS, CONDITIONS, COVENANTS, RESTRICTIONS, RESERVATIONS AND NOTES ON THE PLAT OF CLAREMONT BUSINESS PARK FILING NO. 1 RECORDED AUGUST 16, 2005 UNDER RECEPTION NO. 205127124. EL PASO COUNTY RESOLUTION NO. 05-110 IN CONNECTION THEREWITH RECORDED SEPTEMBER 23, 2005 UNDER RECEPTION NO. 205149817.
- xx. (TC#28) THE PROPERTY MAY BE SUBJECT TO TERMS, CONDITIONS, PROVISIONS, BURDENS AND OBLIGATIONS SET FORTH IN SUBDIVISION IMPROVEMENTS AGREEMENT RECORDED AUGUST 16, 2005 AT RECEPTION NO. 205127123.
- xxi. (TC#29) THE PROPERTY MAY BE SUBJECT TO EASEMENTS, CONDITIONS, COVENANTS, RESTRICTIONS, RESERVATIONS AND NOTES ON THE PLAT OF AMENDED PLAT CLAREMONT BUSINESS PARK FILING NO. 1 RECORDED SEPTEMBER 21, 2005 UNDER RECEPTION NO. 205198301. EL PASO COUNTY RESOLUTION NO. 05-314 IN CONNECTION THEREWITH RECORDED NOVEMBER 05, 2008 UNDER RECEPTION NO. 208120446.
- xxii. (TC#30) THE PROPERTY MAY BE SUBJECT TO EASEMENTS, CONDITIONS, COVENANTS, RESTRICTIONS, RESERVATIONS AND NOTES ON THE PLAT OF CLAREMONT BUSINESS PARK FILING NO. 1A RECORDED AUGUST 18, 2006 UNDER RECEPTION NO. 206712398. EL PASO COUNTY RESOLUTION NO. 06-286 IN CONNECTION THEREWITH RECORDED OCTOBER 13, 2006 UNDER RECEPTION NO. 206151738.
- xxiii. (TC#31) THE PROPERTY MAY BE SUBJECT TO TERMS, CONDITIONS, PROVISIONS, BURDENS AND OBLIGATIONS OF WATER AND SEWER SERVICE AGREEMENT RECORDED OCTOBER 20, 2006 AT RECEPTION NO. 206155229.
- xxiv. (TC#32) THE PROPERTY MAY BE SUBJECT TO TERMS, CONDITIONS AND PROVISIONS OF DECLARATION OF COVENANTS, CONDITIONS AND RESTRICTIONS AND GRANT OF EASEMENTS RECORDED JANUARY 09, 2020 AT RECEPTION NO. 220033868.
- xxv. (TC#33) THE PROPERTY MAY BE SUBJECT TO THE EFFECT OF RESOLUTION REGARDING CENTRAL MARKSHEFFEL METROPOLITAN DISTRICT RECORDED JANUARY 28, 2020, UNDER RECEPTION NO. 22012433 AND JANUARY 28, 2020, UNDER RECEPTION NO. 22012432.
- xxvi. (TC#34) THE PROPERTY MAY BE SUBJECT TO THE EFFECT OF RESOLUTION NO. 20-213, RECORDED JUNE 09, 2020, UNDER RECEPTION NO. 220079970.
- xxvii. (TC#35) THE PROPERTY MAY BE SUBJECT TO TERMS, CONDITIONS, PROVISIONS, BURDENS AND OBLIGATIONS AS SET FORTH IN EASEMENT AND RIGHT OF WAY AGREEMENT RECORDED JUNE 24, 2020 UNDER RECEPTION NO. 22088464.
- xxviii. (TC#36) THE PROPERTY MAY BE SUBJECT TO EASEMENTS, CONDITIONS, COVENANTS, RESTRICTIONS, RESERVATIONS AND NOTES ON THE PLAT OF CLAREMONT BUSINESS PARK FILING NO. 1C, RECORDED JUNE 24, 2020 UNDER RECEPTION NO. 220714531.
4. WATER AND WASTEWATER SERVICES FOR THIS SUBDIVISION ARE PROVIDED BY THE CHEROKEE METROPOLITAN DISTRICT SUBJECT TO THE DISTRICTS RULES REGULATIONS AND SPECIFICATIONS. THE OFFICE OF THE STATE ENGINEER HAS ISSUED AN OPINION OF WATER INADEQUACY BASED ON ITS ANALYSIS AND INTERPRETATION OF A STIPULATED AGREEMENT CONCERNING THE AVAILABILITY OF CERTAIN WATER RIGHTS FOR USE OUTSIDE OF THE UPPER BLACK SQUIRREL CREEK DESIGNATED BASIN, AND THUS FOUND INSUFFICIENCY OF WATER RESOURCES FOR THIS SUBDIVISION BASED ON THAT AGREEMENT. THIS INTERPRETATION DIFFERS FROM CERTAIN OPINIONS ISSUED BY THE OFFICE IN THE PAST. BASED ON ITS OWN REVIEW OF THE STIPULATED AGREEMENT AND ITS HISTORY (AND NOT ON THE AMOUNT OF WATER ACTUALLY AVAILABLE) THE BOARD OF COUNTY COMMISSIONERS IN AN OPEN AND PUBLIC HEARING DID NOT ACCEPT THE INTERPRETATION OF THE STATE ENGINEERS OFFICE. THE BOARD OF COUNTY COMMISSIONERS FOUND THAT CHEROKEE HAS COMMITTED TO PROVIDE WATER SERVICE TO THE SUBDIVISION AND ASSERTED THAT ITS LONG TERM WATER SERVICE CAPABILITIES ARE SUFFICIENT. THE BOARD OF COUNTY COMMISSIONERS MADE THIS DETERMINATION IN RELIANCE UPON THE TESTIMONY AND EXPERTISE PROVIDED BY CHEROKEE AT THE PUBLIC HEARING THEREON. AT THE HEARING, CHEROKEE ASSERTED THAT ITS PLANS AND CONTINUED FINANCIAL INVESTMENT IN INFRASTRUCTURE ARE DESIGNED TO ALLOW CHEROKEE TO CONTINUE TO PROVIDE THIS SUBDIVISION AND ITS EXISTING CUSTOMERS WITH WATER AND WASTEWATER SERVICES FOR 300 YEARS OR MORE.
5. ALL STRUCTURAL FOUNDATIONS SHALL BE LOCATED AND DESIGNED BY A PROFESSIONAL ENGINEER, CURRENTLY REGISTERED IN THE STATE OF COLORADO.
6. THE ADDRESSES EXHIBITED ON THIS PLAT ARE FOR INFORMATIONAL PURPOSES ONLY. THEY ARE NOT THE LEGAL DESCRIPTION AND ARE SUBJECT TO CHANGE.

GENERAL PLAT NOTES: (CONT.)

7. ACCESS TO MEADOWBROOK PARKWAY SHALL BE VIA EL JEFE HEIGHTS AND GARY WATSON POINT (PRIVATE ROADS). THERE SHALL BE NO DIRECT ACCESS TO MEADOWBROOK PARKWAY, MARKSHEFFEL ROAD, OR U.S. HIGHWAY 24 ALLOWED.
8. NO DRIVEWAY SHALL BE ESTABLISHED UNLESS AN ACCESS PERMIT HAS BEEN GRANTED BY EL PASO COUNTY.
9. MAILBOXES SHALL BE INSTALLED IN ACCORDANCE WITH ALL EL PASO COUNTY AND UNITED STATES POSTAL SERVICES REGULATIONS.
10. NOTICE OF POTENTIAL AIRCRAFT OVERFLIGHT AND NOISE IMPACT ASSOCIATED WITH AIRPORT: THIS SERVES AS NOTICE OF POTENTIAL AIRCRAFT OVERFLIGHT AND NOISE IMPACTS ON THIS PROPERTY DUE TO ITS CLOSE PROXIMITY TO AN AIRPORT, WHICH IS BEING DISCLOSED TO ALL PROSPECTIVE PURCHASERS CONSIDERING THE USE OF THIS PROPERTY FOR RESIDENTIAL AND OTHER PURPOSES. THIS PROPERTY IS SUBJECT TO THE OVERFLIGHT AND ASSOCIATED NOISE OF ARRIVING AND DEPARTING AIRCRAFT DURING THE COURSE OF NORMAL AIRPORT OPERATIONS. ALL PROPERTY WITHIN THIS SUBDIVISION IS SUBJECT TO AVIGATION EASEMENTS AS RECORDED AT RECEPTION NO. 203019547 AND RECEPTION NO. 206095824 OF THE RECORDS OF THE EL PASO COUNTY CLERK AND RECORDER. AS SUCH, FUTURE OWNERS SHOULD MAKE THEMSELVES FAMILIAR WITH THE FOLLOWING STIPULATIONS AND FACTS.
 - NO MAN-MADE OR NON MAN-MADE OBSTRUCTIONS SHALL BE ALLOWED TO PENETRATE THE 40: APPROACH SURFACE.
 - ALL EXTERIOR LIGHTING PLANS SHALL BE APPROVED BY THE DIRECTOR OF AVIATION TO PREVENT A HAZARD TO AIRCRAFT.
 - NO ELECTROMAGNETIC LIGHT, NOR ANY PHYSICAL EMISSIONS WHICH MAY INTERFERE WITH AIRCRAFT, AVIGATION, COMMUNICATIONS OR NAVIGATIONAL AIDS SHALL BE ALLOWED.
 - WHILE NOT A REQUIREMENT, A RECOMMENDATION IS MADE THAT A 25 DB REDUCTION IN INTERIOR NOISE (IN THE OFFICES OR ANY INHABITED WORK AREAS SUSCEPTIBLE TO AIRCRAFT NOISE) BE OBTAINED BY SOUNDPROOFING USING FAA RECOMMENDED CONSTRUCTION TECHNIQUES AND PERFORMED BY A CERTIFIED ACOUSTICAL ENGINEER.
 - IF A CRANE IS USED DURING CONSTRUCTION, AN FAA FORM 7460-1 WILL NEED TO BE FILED THROUGH THE AIRPORT OPERATIONS OFFICE AND APPROVED BY THE FEDERAL AVIATION ADMINISTRATION BEFORE ANY BUILDING PERMIT IS ISSUED BY THE CITY OR COUNTY. NORMAL TIME REQUIRED FOR APPROVAL IS 30 TO 60 WORKING DAYS.
11. ALL PROPERTY OWNERS ARE RESPONSIBLE FOR MAINTAINING PROPER STORM WATER DRAINAGE IN AND THROUGH THEIR PROPERTY. PUBLIC DRAINAGE EASEMENTS AS SPECIFICALLY NOTED ON THE PLAT SHALL BE MAINTAINED BY THE INDIVIDUAL LOT OWNERS UNLESS OTHERWISE INDICATED. STRUCTURES, FENCES, MATERIALS, OR LANDSCAPING THAT COULD IMPEDE THE FLOW OF RUNOFF SHALL NOT BE PLACED IN DRAINAGE EASEMENT.
12. THE PROPERTY IS SUBJECT TO THE DECLARATION OF COVENANTS, CONDITIONS, AND RESTRICTIONS AND GRANT OF EASEMENTS AS RECORDED AT RECEPTION NO. 206031585 OF THE RECORDS OF EL PASO COUNTY.
13. THE PRIVATE ROADS AS SHOWN ON THIS PLAT WILL NOT BE MAINTAINED BY EL PASO COUNTY UNTIL AND UNLESS THE STREETS ARE CONSTRUCTED IN CONFORMANCE WITH EL PASO COUNTY STANDARDS IN EFFECT AT THE DATE OF THE REQUEST FOR DEDICATION AND MAINTENANCE. PRIVATE ROADS ARE TO BE MAINTAINED BY THE CLAREMONT OWNER'S ASSOCIATION.
14. THE PROPERTY IS WITHIN THE SERVICE AREA OF THE CENTRAL MARKSHEFFEL METROPOLITAN DISTRICT AND, AS SUCH, IS SUBJECT TO AN ASSESSMENT FOR THE CONSTRUCTION OF MARKSHEFFEL ROAD.
15. THE FOLLOWING REPORTS HAVE BEEN SUBMITTED IN ASSOCIATION WITH THE FINAL PLAT FOR THIS SUBDIVISION AND ARE ON FILE AT THE COUNTY PLANNING AND COMMUNITY DEVELOPMENT DEPARTMENT: TRANSPORTATION IMPACT STUDY; DRAINAGE REPORT.
16. PUBLIC AND COMMON SUBDIVISION IMPROVEMENTS: NO LOT OR INTEREST THEREIN, SHALL BE SOLD, CONVEYED, OR TRANSFERRED WHETHER BY DEED OR BY CONTRACT, NOR SHALL BUILDING PERMITS BE ISSUED, UNTIL AND UNLESS EITHER THE REQUIRED PUBLIC AND COMMON DEVELOPMENT IMPROVEMENTS HAVE BEEN CONSTRUCTED AND COMPLETED AND PRELIMINARILY ACCEPTED IN ACCORDANCE WITH THE SUBDIVISION IMPROVEMENTS AGREEMENT BETWEEN THE APPLICANT/OWNER AND EL PASO COUNTY AS RECORDED UNDER RECEPTION NO. _____ IN THE OFFICE OF THE CLERK AND RECORDER OF EL PASO COUNTY, COLORADO OR, IN THE ALTERNATIVE, OTHER COLLATERAL IS PROVIDED TO MAKE PROVISION FOR THE COMPLETION OF SAID IMPROVEMENTS IN ACCORDANCE WITH THE EL PASO COUNTY LAND DEVELOPMENT CODE AND ENGINEERING CRITERIA MANUAL. ANY SUCH ALTERNATIVE COLLATERAL MUST BE APPROVED BY THE BOARD OF COUNTY COMMISSIONERS OR, IF PERMITTED BY THE SUBDIVISION IMPROVEMENTS AGREEMENT, BY THE PLANNING AND COMMUNITY DEVELOPMENT DEPARTMENT DIRECTOR AND MEET THE POLICY AND PROCEDURE REQUIREMENTS OF EL PASO COUNTY PRIOR TO THE RELEASE BY THE COUNTY OF ANY LOTS FOR SALE, CONVEYANCE OR TRANSFER. THIS PLAT RESTRICTION MAY BE REMOVED OR RESCINDED BY THE BOARD OF COUNTY COMMISSIONERS OR, IF PERMITTED BY THE SUBDIVISION IMPROVEMENTS AGREEMENT, BY THE PLANNING AND COMMUNITY DEVELOPMENT DEPARTMENT DIRECTOR UPON EITHER APPROVAL OF AN ALTERNATIVE FORM OF COLLATERAL OR COMPLETION AND PRELIMINARY ACCEPTANCE BY THE EL PASO BOARD OF COUNTY COMMISSIONERS OF ALL IMPROVEMENTS REQUIRED TO BE CONSTRUCTED AND COMPLETED IN ACCORDANCE WITH SAID SUBDIVISION IMPROVEMENTS AGREEMENT. THE PARTIAL RELEASE OF LOTS FOR SALE, CONVEYANCE OR TRANSFER MAY ONLY BE GRANTED IN ACCORDANCE WITH ANY PLANNED PARTIAL RELEASE OF LOTS AUTHORIZED BY THE SUBDIVISION IMPROVEMENTS AGREEMENT.

GENERAL PLAT NOTES: (CONT.)

17. IF IT BECOMES NECESSARY AT ANY POINT IN THE FUTURE FOR THE COUNTY TO CONSTRUCT THE ACCESS DRIVE DUE TO CLOSURE OF THE ACCESS TO MEADOWBROOK PARKWAY, THE PROPERTY OWNER SHALL GRANT TO THE COUNTY, AT NO COST TO THE COUNTY, ALL EASEMENTS NECESSARY TO CONSTRUCT SUCH IMPROVEMENTS.
18. THE INDIVIDUAL LOT PURCHASER(S) SHALL BE RESPONSIBLE FOR FINAL DESIGN, CONSTRUCTION, AND MAINTENANCE OF PRIVATE DETENTION POND/WATER QUALITY BMP(S) AS DESCRIBED IN THE APPROVED PRELIMINARY/FINAL DRAINAGE REPORT FOR THIS SUBDIVISION. FINAL DESIGN, CONSTRUCTION DRAWINGS AND DRAINAGE REPORT UPDATES FOR THE DETENTION POND/WATER QUALITY BMP(S) SERVING EACH LOT SHALL BE PROVIDED WITH SITE DEVELOPMENT PLAN SUBMITTALS. THE DETENTION POND/WATER QUALITY BMP(S) SHALL BE CONSTRUCTED AND COMPLETED PRIOR TO THE ISSUANCE OF ANY BUILDING PERMITS FOR THE SUBJECT LOTS. THE SUBDIVISION DEVELOPER IS RESPONSIBLE FOR PROVIDING FINANCIAL ASSURANCES AS INDICATED IN THE SUBDIVISION IMPROVEMENTS AGREEMENT AND ESTIMATE OF GUARANTEED FUNDS FOR ALL DETENTION PONDS/WATER QUALITY BMPS. ALL DETENTION PONDS/WATER QUALITY BMPS SHALL BE CONSTRUCTED PRIOR TO THE RELEASE OF SAID FINANCIAL ASSURANCES. INDIVIDUAL LOT PURCHASERS SHALL ENTER INTO A PRIVATE DETENTION BASIN / STORMWATER QUALITY BMP MAINTENANCE AGREEMENT AND EASEMENT (AGREEMENT) PRIOR TO THE ISSUANCE OF ANY BUILDING PERMITS FOR THE SUBJECT LOTS. IN THE CASE THAT THE DEVELOPER CONSTRUCTS THE DETENTION POND(S), THE DEVELOPER SHALL ENTER INTO AN AGREEMENT FOR EACH POND CONSTRUCTED.

APPROVED WITH SP-19-007

DEVIATION TABLE

	LDC/ECM Section	Category	Standard	Modification	Justification
1	LDC 8.4.4.E.3, LDC 8.4.4.E.2 ECM Section 2.2.4.B.6/SD-4-1	Private Road Allowances	Allowance for a Private Road	ECM Section 2.2.4.B.6/SD-4-1. The private roadway section shall meet all details of the Local Urban Road Section except requests to exclude the 5' wide sidewalk (each side) as defined in the detail and provide a 4' wide sidewalk on the one side only. (Request Gary Watson Point only).	This deviation request would provide alignment to the current characteristic design and appearance of the Claremont Business Park commercial development. Road to be maintained by Claremont Business Park HOA

WAIVER REQUESTS

1. **Private road:** Requesting a waiver to have Gary Watson Point to be a private road and owned by the property owners. The Claremont Business Park HOA has accepted this road to be maintained with in the association. This request is consistent with Claremont Business Park Filings 1 & 2.
2. **Private road:** In addition, we are requesting a waiver to deviate from ECM standards for Gary Watson Pt. The standards we are not meeting is not to have a public sidewalk on both sides of the road and to reduce the sidewalk we are installing to 4'-0" wide as defined in our deviation request.
3. **Drainage Easements:** The Preliminary Plan for this site is submitting a Waiver of the El Paso County Land Development Code to request 2' foot side lot easements for drainage. Therefore, the drainage easement being 4' foot in total width. (It is likely that some lots will have a building on each lot, 4 feet apart). A calculation sheet is included in the appendix to show the maximum capacity of a concrete drainage channel with varying slopes. The final drainage report for these lots will show the slope and total amount of drainage to be conveyed in the drainage channel. The channel is proposed to be a 6" inch tall x 3 foot wide trickle channel. The final drainage report will ensure that the maximum capacity is not exceeded.

FINAL PLAT
CLAREMONT BUSINESS PARK 2
FILING NO. 1
JOB NO. 44-037
DATE PREPARED: 04/28/2020
DATE REVISED: 10/21/2020



102 E. PIKES PEAK AVE., 5TH FLOOR
COLORADO SPRINGS, CO 80903
PHONE: 719.955.5485

CLAREMONT BUSINESS PARK 2 FILING NO. 1

FOR REFERENCE ONLY

A REPLAT OF TRACT A "CLAREMONT BUSINESS PARK FILING NO. 1C", AND A PORTION OF TRACT C "CLAREMONT BUSINESS PARK FILING NO. 2", BEING A TRACT OF LAND IN THE SOUTHEAST QUARTER OF THE SOUTHEAST QUARTER (SE 1/4, SE 1/4) OF SECTION 5 AND NORTHEAST QUARTER OF THE NORTHEAST QUARTER (NE 1/4, NE 1/4) OF SECTION 8, T14S, R65W, OF THE 6TH P.M., EL PASO COUNTY, COLORADO

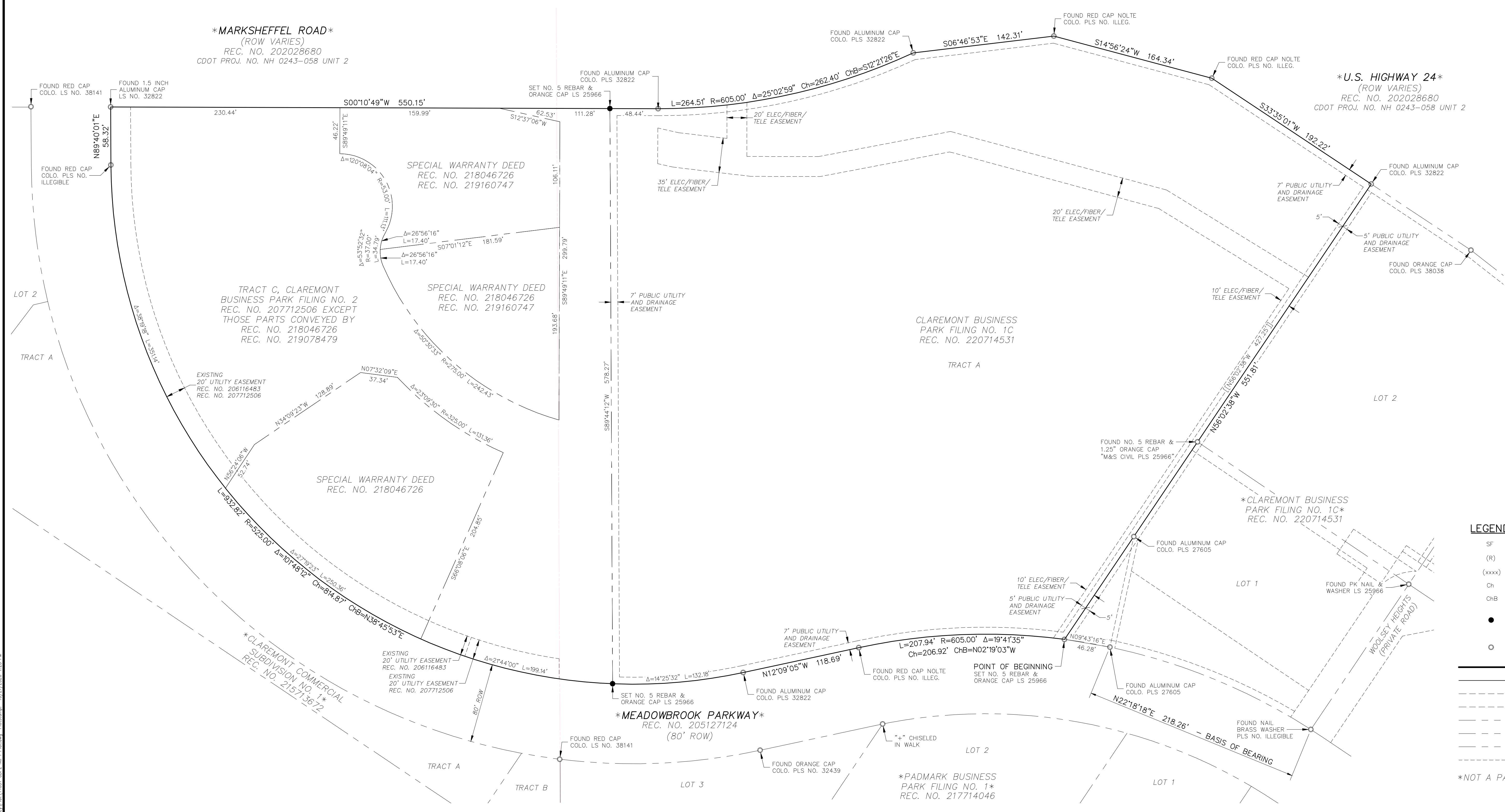

- LEGEND:**
- SF SQUARE FEET
 - (R) RADIAL BEARING
 - (xxxx) ADDRESS
 - Ch CHORD LENGTH
 - ChB CHORD BEARING
 - SET NO 5 REBAR AND 1.25" ORANGE CAP STAMPED "M&S CIVIL PLS 25966" FLUSH W/ EXISTING GRADE UNLESS NOTED OTHERWISE
 - FOUND NO 5 REBAR AND CAP AS NOTED, FLUSH W/ EXISTING GRADE UNLESS NOTED OTHERWISE
 - BOUNDARY LINE
 - PROPERTY LINE
 - - - ACCESS EASEMENT
 - - - OTHER EASEMENTS
 - - - ADJACENT SUBDIVISION LINE
 - - - ADJACENT PROPERTY LINE
 - - - EXISTING RIGHT OF WAY LINE
 - - - EXISTING EASEMENT
 - *NOT A PART* PARCELS INDICATED WITH ASTERISK "*" ARE NOT A PART OF THIS SUBDIVISION

AS PLATTED

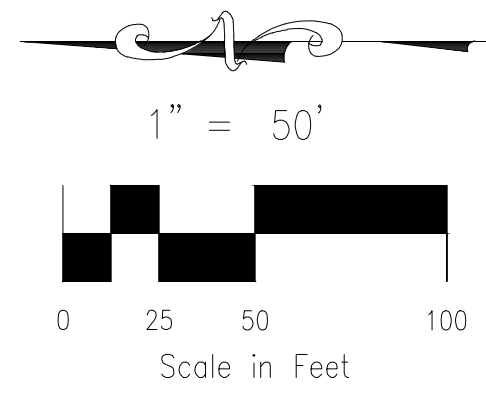

FINAL PLAT
CLAREMONT BUSINESS PARK 2
FILING NO. 1
JOB NO. 44-037
DATE PREPARED: 04/28/2020
DATE REVISED: 10/21/2020

102 E. PIKES PEAK AVE., 5TH FLOOR
COLORADO SPRINGS, CO 80903
PHONE: 719.955.5485

File: G:\44037A-CBF-F2-105-1-8\Map\Survey\Plot\44037-CBF-F2-105-1-8.dwg Plot Date: 10/27/2020 4:25 PM

CLAREMONT BUSINESS PARK 2 FILING NO. 1

FOR REFERENCE ONLY

A REPLAT OF TRACT A "CLAREMONT BUSINESS PARK FILING NO. 1C", AND A PORTION OF TRACT C "CLAREMONT BUSINESS PARK FILING NO. 2", BEING A TRACT OF LAND IN THE SOUTHEAST QUARTER OF THE SOUTHEAST QUARTER (SE 1/4, SE 1/4) OF SECTION 5 AND NORTHEAST QUARTER OF THE NORTHEAST QUARTER (NE 1/4, NE 1/4) OF SECTION 8, T14S, R65W, OF THE 6TH P.M., EL PASO COUNTY, COLORADO

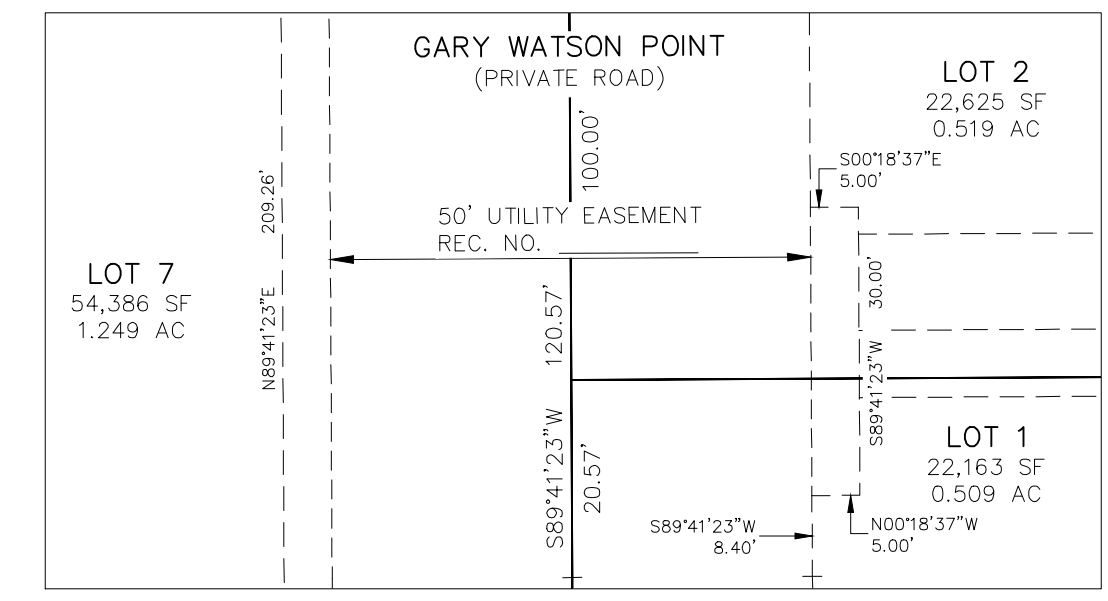
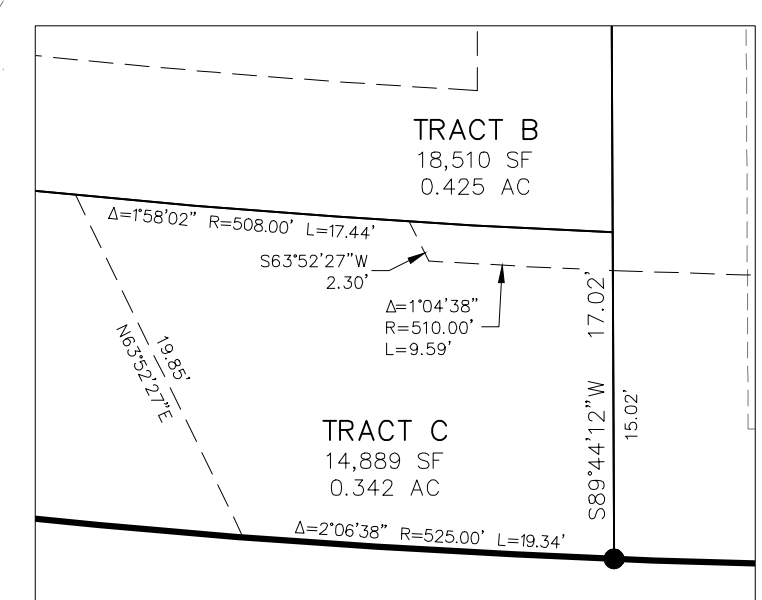
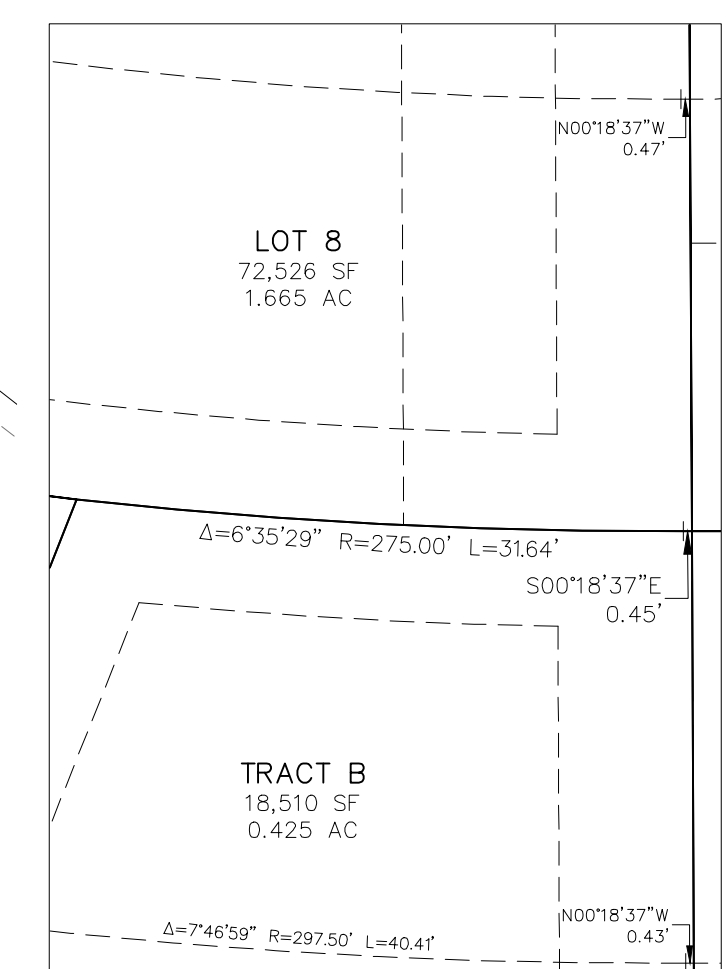
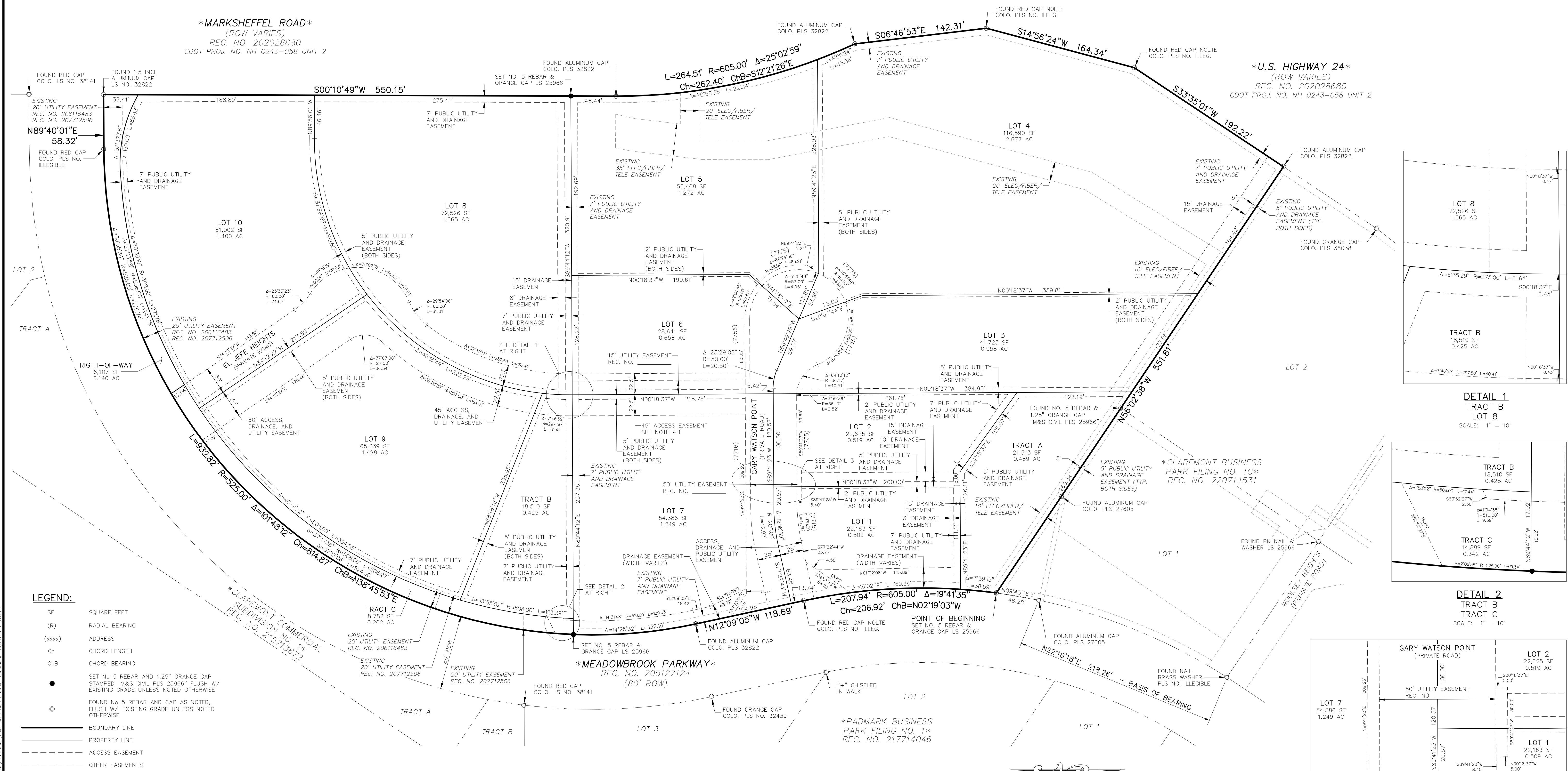

- LEGEND:**
- SF SQUARE FEET
 - (R) RADIAL BEARING
 - (xxxx) ADDRESS
 - Ch CHORD LENGTH
 - ChB CHORD BEARING
 - SET No. 5 REBAR AND 1.25" ORANGE CAP STAMPED "M&S CIVIL PLS 25966" FLUSH W/ EXISTING GRADE UNLESS NOTED OTHERWISE
 - FOUND No. 5 REBAR AND CAP AS NOTED, FLUSH W/ EXISTING GRADE UNLESS NOTED OTHERWISE
 - BOUNDARY LINE
 - - - PROPERTY LINE
 - - - ACCESS EASEMENT
 - - - OTHER EASEMENTS
 - - - ADJACENT SUBDIVISION LINE
 - - - ADJACENT PROPERTY LINE
 - - - EXISTING RIGHT OF WAY LINE
 - - - EXISTING EASEMENT
 - *NOT A PART* PARCELS INDICATED WITH ASTERISK "*" ARE NOT A PART OF THIS SUBDIVISION

SHEET NOTES:

4.1 45' ACCESS EASEMENT. ONLY LANDSCAPING WILL BE PERMITTED IN THE EASEMENT BETWEEN LOTS 6 AND 7 UNTIL SUCH TIME A ROAD CONNECTION IS REQUESTED BY EL PASO COUNTY.

AS REPLATTED

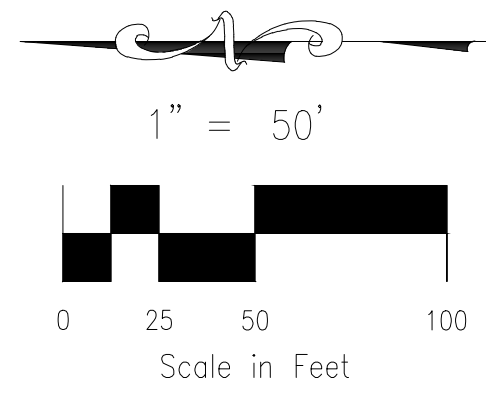

FINAL PLAT
CLAREMONT BUSINESS PARK 2
FILING NO. 1
JOB NO. 44-037
DATE PREPARED: 04/28/2020
DATE REVISED: 10/21/2020



102 E. PIKES PEAK AVE., 5TH FLOOR
COLORADO SPRINGS, CO 80903
PHONE: 719.955.5485

**EXCERPT OF “FINAL DRAINAGE REPORT FOR
CLAREMONT BUSINESS PARK FIL NO. 2 “, BY
MATRIX DESIGN DATED NOVEMBER 2006
&
EXISTING DRAINAGE MAP**



FINAL DRAINAGE REPORT

For

“Claremont Business Park Filing No. 2”

Prepared for:
El Paso County
Department of Public Works
Engineering Division

On Behalf of:
Claremont Development, Inc.

Prepared by:

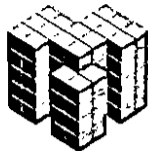

Matrix Design Group, Inc.
Integrated Design Solutions *Infrastructure Engineering*
Community Development
Program Management

2435 Research Parkway, Suite 300
Colorado Springs, CO 80920
(719) 575-0100
fax (719) 572-0208

Revised November 2006

Engineer's Statement:

The *revisions* (changes made to the base Final Drainage Report since July, 2006) to the attached drainage plan and report were prepared under my direction and supervision and are correct to the best of my knowledge and belief. The revisions encompassed adding additional right of way to the study area at the County's request, the handling of offsite drainage due to the additional right of way, a breakdown of private drainage within lot numbers 10 through 25 of Filing No. 2 due to cross-lot drainage (contrary to note # 25 on the recorded plat), profiling additional inlets along the channel edge, and rip-rap sizing for outlet structures along the channel. The Final Drainage Report dated July, 2006 was prepared under the direct supervision of Richard G. Gallegos, Jr. in July, 2006 and stamped (see next sheet).

The Final Drainage Report was prepared according to the criteria established by the County for drainage reports and said report is in conformity with the master plan of the drainage basin. I accept responsibility for any liability caused by any negligent acts, errors or omissions on my part in preparing the *revisions* to this report.

Brady A. Shyrock
Registered Professional Engineer
State of Colorado
No. 38164

SEAL



Engineer's Statement:

The attached drainage plan and report were prepared under my direction and supervision and are correct to the best of my knowledge and belief. Said drainage report has been prepared according to the criteria established by the County for drainage reports and said report is in conformity with the master plan of the drainage basin. I accept responsibility for any liability caused by any negligent acts, errors or omissions on my part in preparing this report.

SEAL

Richard G. Gallegos, Jr.
Registered Professional Engineer
State of Colorado
No. 36247

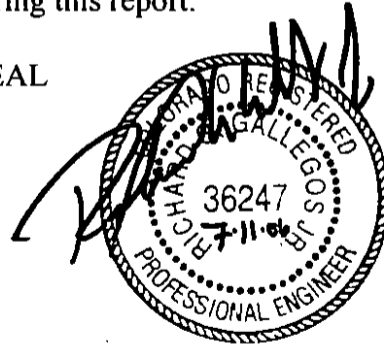

Developer's Statement:

I, the developer have read and will comply with all of the requirements specified in this drainage report and plan.

Claremont Development, Inc.
Business Name

By: _____

Title: _____

Address: 3460 Capital Drive
Colorado Springs, CO 80915

El Paso County:

Filed in accordance with Section 51.1 of the El Paso Land Development Code, as amended.

John Hamacher
Mr. John McCarty, County Engineer/Director

4/23/07
Date

Conditions:

D. Drainage and Bridge Fees

Claremont Business Park Filing No. 2 has not been previously platted. The drainage basin and bridge fees have been determined per the El Paso County Drainage Basin Fees Sheet, dated February 3, 2006, Resolution No. 06-31. The site is located entirely within the Sand Creek Drainage Basin. The fees are based upon the percent impervious of the development, which have been included within the appendix of this report. The fees due have been calculated as follows.

Claremont Business Park Filing No. 2
Final Drainage Report
Drainage and Bridge Fees

	Area (ac.)	Fee/Imp. Acre	% Imp.	Fee Due	Reimbursable Const. Costs	Fee Credit	Fee Due at Platting	Fee Credit Remaining
Drainage Fee	62.967	\$15,000.00	80%	\$755,604.00	\$0.00	\$1,225,355.45	\$0.00	\$469,751.45
Bridge Fee	62.967	\$1,503.00	80%	\$75,711.52	\$75,711.52	\$0.00	\$0.00	\$0.00
Total Fee Due at Platting							\$0.00	

The developer of Claremont Business Park is completing the construction of the channel improvements on behalf of the Central Marksheffel Metropolitan District. The construction costs for both Filing 1 and Filing 2 combined exceed the drainage fees due for the site. No drainage fees will be required at the time of platting.

It should be noted that the Central Marksheffel Business District is reimbursing the developer of Claremont Business Park Filing 2 for the construction costs of the channel minus the drainage fees due for the site. The District has \$1,225,355.45 of drainage credits available within the Sand Creek Basin. This credit amount is based upon the construction cost estimate for the channel minus the drainage fees assessed for Claremont Business Park Filing No. 1. The District will use an additional \$755,604.00 of the drainage credits for the platting of Claremont Business Park Filing No. 2. The District will have \$469,751.45 of drainage credits left within the Sand Creek Fee basin.

The Central Marksheffel Business District has also constructed the Marksheffel Road Bridge over East Fork Sand Creek. This structure has been identified as a needed public improvement within the Drainage Basin Planning Study for Sand Creek and is eligible for reimbursement. Since the construction of the Marksheffel Bridge is in excess of the \$75,711.52 in bridge fees due for this site, no bridge fees are required at the time of platting. The fee will be deducted from the eligible reimbursable construction costs of the bridge and the remaining credits will be utilized or reimbursement applied for by the Central Marksheffel Business District.

DESIGN POINT SUMMARY		
NO.	DATE	DESCRIPTION
1	08/14/2007	PRELIMINARY
2	09/11/2007	REVISED
3	10/15/2007	REVISED
4	11/15/2007	REVISED
5	01/15/2008	REVISED
6	02/15/2008	REVISED
7	03/15/2008	REVISED
8	04/15/2008	REVISED
9	05/15/2008	REVISED
10	06/15/2008	REVISED
11	07/15/2008	REVISED
12	08/15/2008	REVISED
13	09/15/2008	REVISED
14	10/15/2008	REVISED
15	11/15/2008	REVISED
16	12/15/2008	REVISED
17	01/15/2009	REVISED
18	02/15/2009	REVISED
19	03/15/2009	REVISED
20	04/15/2009	REVISED
21	05/15/2009	REVISED
22	06/15/2009	REVISED
23	07/15/2009	REVISED
24	08/15/2009	REVISED
25	09/15/2009	REVISED
26	10/15/2009	REVISED
27	11/15/2009	REVISED
28	12/15/2009	REVISED
29	01/15/2010	REVISED
30	02/15/2010	REVISED
31	03/15/2010	REVISED
32	04/15/2010	REVISED
33	05/15/2010	REVISED
34	06/15/2010	REVISED
35	07/15/2010	REVISED
36	08/15/2010	REVISED
37	09/15/2010	REVISED
38	10/15/2010	REVISED
39	11/15/2010	REVISED
40	12/15/2010	REVISED
41	01/15/2011	REVISED
42	02/15/2011	REVISED
43	03/15/2011	REVISED
44	04/15/2011	REVISED
45	05/15/2011	REVISED
46	06/15/2011	REVISED
47	07/15/2011	REVISED
48	08/15/2011	REVISED
49	09/15/2011	REVISED
50	10/15/2011	REVISED
51	11/15/2011	REVISED
52	12/15/2011	REVISED
53	01/15/2012	REVISED
54	02/15/2012	REVISED
55	03/15/2012	REVISED
56	04/15/2012	REVISED
57	05/15/2012	REVISED
58	06/15/2012	REVISED
59	07/15/2012	REVISED
60	08/15/2012	REVISED
61	09/15/2012	REVISED
62	10/15/2012	REVISED
63	11/15/2012	REVISED
64	12/15/2012	REVISED
65	01/15/2013	REVISED
66	02/15/2013	REVISED
67	03/15/2013	REVISED
68	04/15/2013	REVISED
69	05/15/2013	REVISED
70	06/15/2013	REVISED
71	07/15/2013	REVISED
72	08/15/2013	REVISED
73	09/15/2013	REVISED
74	10/15/2013	REVISED
75	11/15/2013	REVISED
76	12/15/2013	REVISED
77	01/15/2014	REVISED
78	02/15/2014	REVISED
79	03/15/2014	REVISED
80	04/15/2014	REVISED
81	05/15/2014	REVISED
82	06/15/2014	REVISED
83	07/15/2014	REVISED
84	08/15/2014	REVISED
85	09/15/2014	REVISED
86	10/15/2014	REVISED
87	11/15/2014	REVISED
88	12/15/2014	REVISED
89	01/15/2015	REVISED
90	02/15/2015	REVISED
91	03/15/2015	REVISED
92	04/15/2015	REVISED
93	05/15/2015	REVISED
94	06/15/2015	REVISED
95	07/15/2015	REVISED
96	08/15/2015	REVISED
97	09/15/2015	REVISED
98	10/15/2015	REVISED
99	11/15/2015	REVISED
100	12/15/2015	REVISED

DRAINAGE PLAN CLAREMONT BUSINESS PARK FILING NO. 2

GRAPHIC SCALE
1 inch = 100 ft.

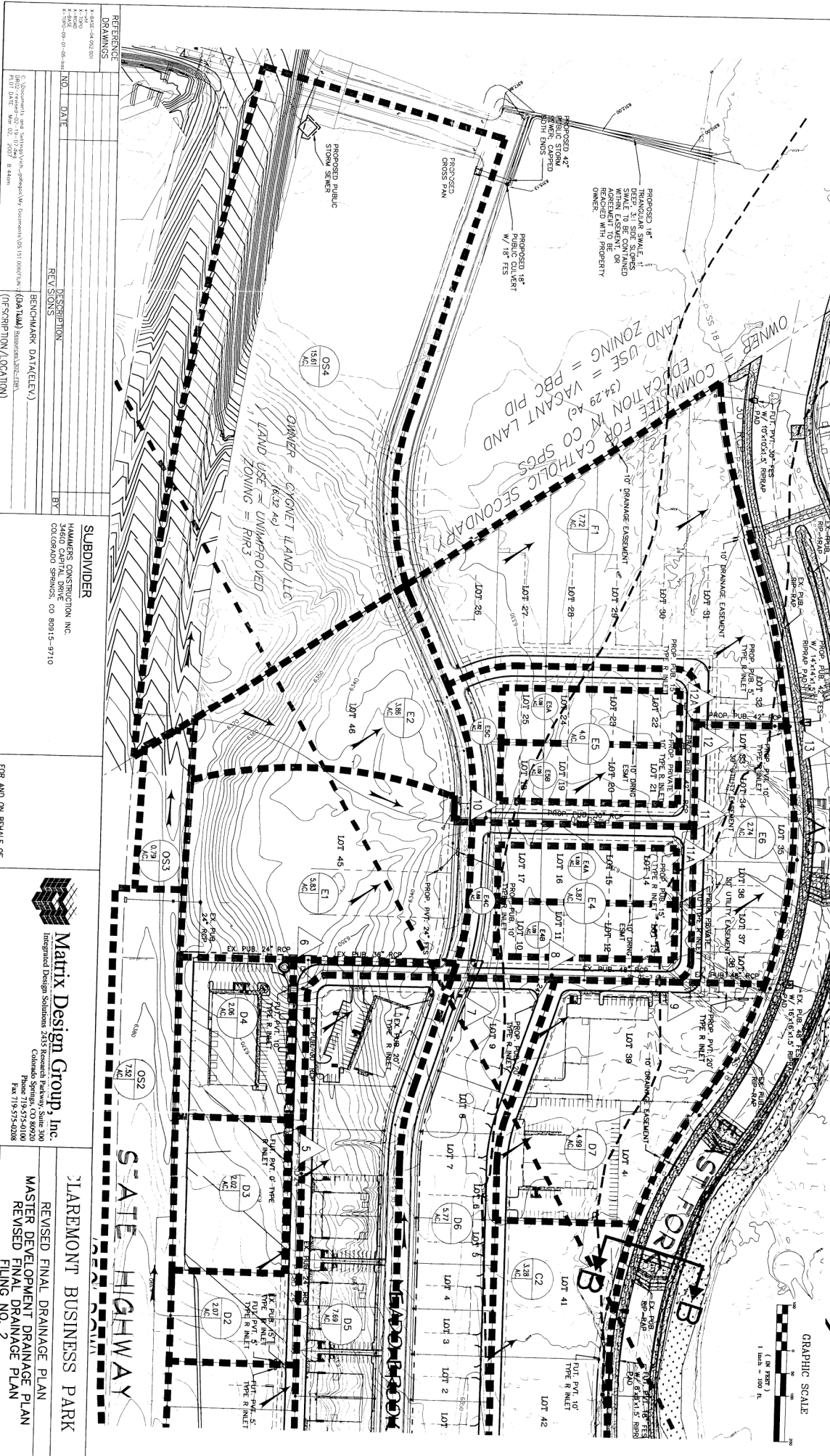

NO.	DATE	DESCRIPTION
1	08/14/2007	PRELIMINARY
2	09/11/2007	REVISED
3	10/15/2007	REVISED
4	11/15/2007	REVISED
5	01/15/2008	REVISED
6	02/15/2008	REVISED
7	03/15/2008	REVISED
8	04/15/2008	REVISED
9	05/15/2008	REVISED
10	06/15/2008	REVISED
11	07/15/2008	REVISED
12	08/15/2008	REVISED
13	09/15/2008	REVISED
14	10/15/2008	REVISED
15	11/15/2008	REVISED
16	12/15/2008	REVISED
17	01/15/2009	REVISED
18	02/15/2009	REVISED
19	03/15/2009	REVISED
20	04/15/2009	REVISED
21	05/15/2009	REVISED
22	06/15/2009	REVISED
23	07/15/2009	REVISED
24	08/15/2009	REVISED
25	09/15/2009	REVISED
26	10/15/2009	REVISED
27	11/15/2009	REVISED
28	12/15/2009	REVISED
29	01/15/2010	REVISED
30	02/15/2010	REVISED
31	03/15/2010	REVISED
32	04/15/2010	REVISED
33	05/15/2010	REVISED
34	06/15/2010	REVISED
35	07/15/2010	REVISED
36	08/15/2010	REVISED
37	09/15/2010	REVISED
38	10/15/2010	REVISED
39	11/15/2010	REVISED
40	12/15/2010	REVISED
41	01/15/2011	REVISED
42	02/15/2011	REVISED
43	03/15/2011	REVISED
44	04/15/2011	REVISED
45	05/15/2011	REVISED
46	06/15/2011	REVISED
47	07/15/2011	REVISED
48	08/15/2011	REVISED
49	09/15/2011	REVISED
50	10/15/2011	REVISED
51	11/15/2011	REVISED
52	12/15/2011	REVISED
53	01/15/2012	REVISED
54	02/15/2012	REVISED
55	03/15/2012	REVISED
56	04/15/2012	REVISED
57	05/15/2012	REVISED
58	06/15/2012	REVISED
59	07/15/2012	REVISED
60	08/15/2012	REVISED
61	09/15/2012	REVISED
62	10/15/2012	REVISED
63	11/15/2012	REVISED
64	12/15/2012	REVISED
65	01/15/2013	REVISED
66	02/15/2013	REVISED
67	03/15/2013	REVISED
68	04/15/2013	REVISED
69	05/15/2013	REVISED
70	06/15/2013	REVISED
71	07/15/2013	REVISED
72	08/15/2013	REVISED
73	09/15/2013	REVISED
74	10/15/2013	REVISED
75	11/15/2013	REVISED
76	12/15/2013	REVISED
77	01/15/2014	REVISED
78	02/15/2014	REVISED
79	03/15/2014	REVISED
80	04/15/2014	REVISED
81	05/15/2014	REVISED
82	06/15/2014	REVISED
83	07/15/2014	REVISED
84	08/15/2014	REVISED
85	09/15/2014	REVISED
86	10/15/2014	REVISED
87	11/15/2014	REVISED
88	12/15/2014	REVISED
89	01/15/2015	REVISED
90	02/15/2015	REVISED
91	03/15/2015	REVISED
92	04/15/2015	REVISED
93	05/15/2015	REVISED
94	06/15/2015	REVISED
95	07/15/2015	REVISED
96	08/15/2015	REVISED
97	09/15/2015	REVISED
98	10/15/2015	REVISED
99	11/15/2015	REVISED
100	12/15/2015	REVISED

**FINAL DRAINAGE REPORT
CLAREMONT BUSINESS PARK 2 FIL. NO. 1
PROPOSED DRAINAGE MAP**

FINAL DRAINAGE REPORT FOR CLAREMONT BUSINESS PARK 2 FILING NO.1

COUNTY OF EL PASO, STATE OF COLORADO

PROPOSED DRAINAGE MAP

AUGUST 2020

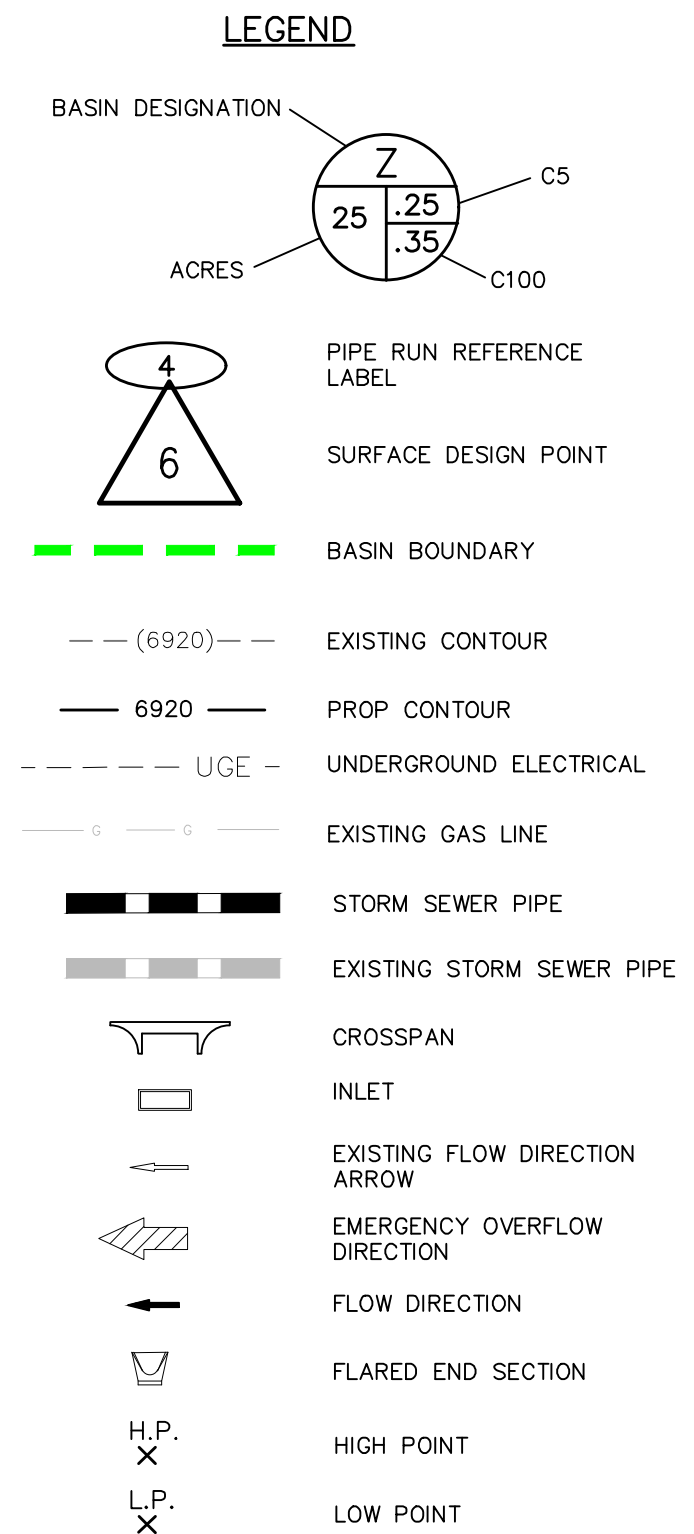
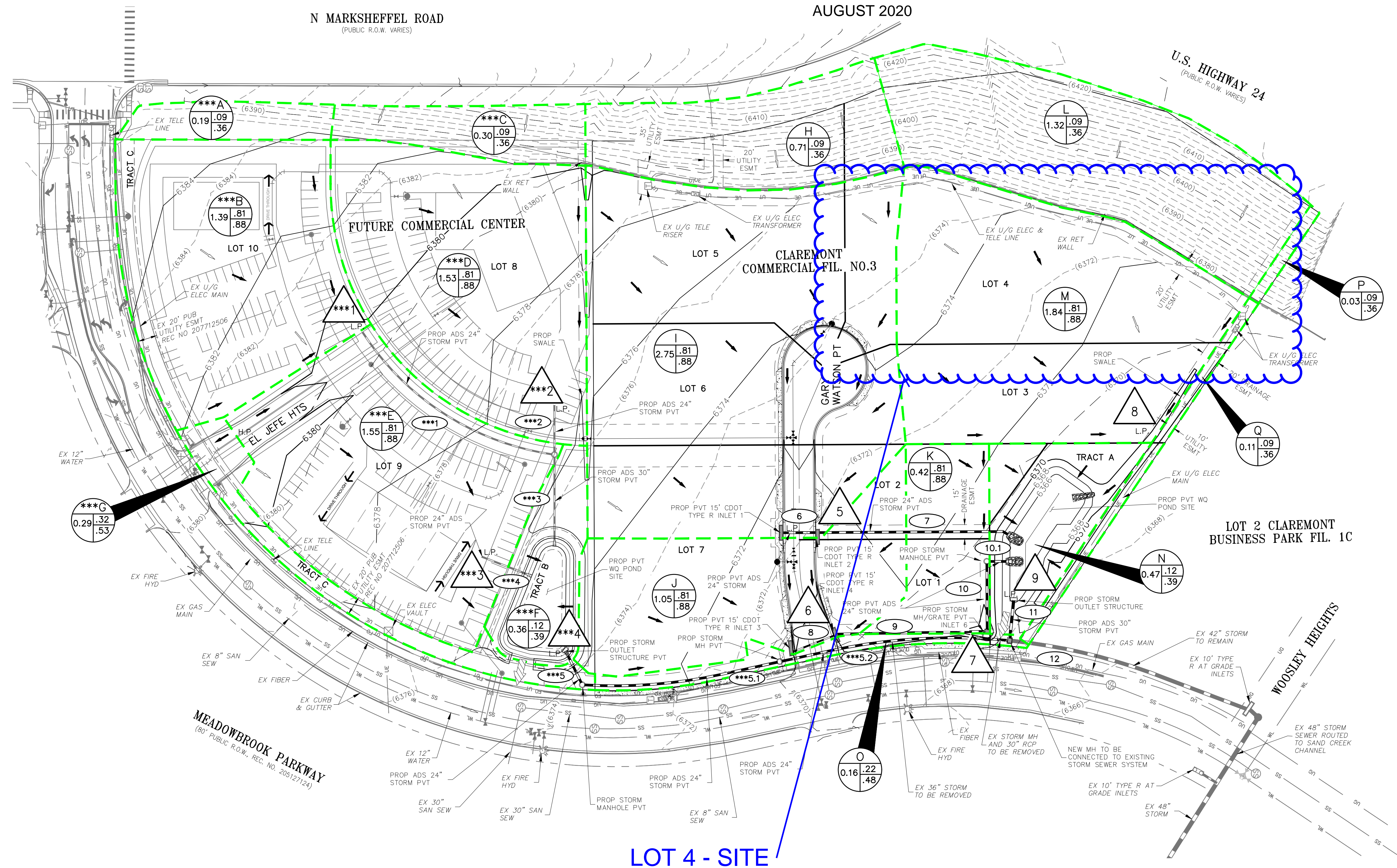

1	A	B	C	D
1	BASIN SUMMARY			
2	BASIN	AREA (ACRES)	Q ₅	Q ₁₀₀
3	***A	0.19	0.1	0.6
4	***B	1.39	5.5	10.1
5	***C	0.3	0.1	1.0
6	***D	1.53	6.3	11.5
7	***E	1.55	6.5	11.8
8	***F	0.36	0.2	1.0
9	***G	0.29	0.5	1.3
10	H	0.71	0.3	2.0
11	I	2.75	9.8	17.9
12	J	1.05	4.4	8.0
13	K	0.42	1.8	3.2
14	L	1.32	0.5	3.7
15	M	1.84	6.7	12.2
16	N	0.47	0.2	1.3
17	O	0.16	0.2	0.6
18	P	0.03	0.0	0.1
19	Q	0.11	0.0	0.3

DESIGN POINT SUMMARY

DESIGN POINT	Q ₅	Q ₁₀₀	BASIN	STRUCTURE
***1	5.6	10.6	***A, ***B	24" PP
***2	6.4	12.4	***C, ***D	24" PP
***3	6.5	11.8	***E	24" PP
***4	18.2	35.0	***F, ***G, ***H	POND 1
5	10.1	19.8	H, I	2-15" INLETS
6	4.4	9.8	J, FB05	2-15" INLETS
7	1.8	3.2	K	MH W/GRATE
8	7.2	15.7	L, M	24" PP OR SWALE
9	23.1	46.9	DP8, 7, 10, 1, N	POND 2

STORM SEWER SUMMARY

PIPE RUN	Q ₅	Q ₁₀₀	PIPE SIZE	CONTRIBUTING DP/BASIN/PIPES
***1	5.6	10.6	24"	***DP1
***2	6.4	12.4	24"	***DP2
***3	11.8	22.6	30"	***PR1, ***PR2
***4	6.5	11.8	24"	***DP3
***5	7.2	15.5	24"	POND 1 OUTFALL
***5.1	7.2	15.5	24"	***PR5
***5.2	7.2	15.5	24"	***PR5.1
6	6.4	9.1	24"	INLET 1
7	10.1	18.3	30"	PR6, INLET 2
8	3.0	4.9	18"	INLET 3
9	4.5	9.8	24"	PR8, INLET 4
10	6.3	13.0	24"	PR9, DP7
10.1	6.3	13.0	24"	PIPE 10
11	13.2	23.8	30"	POND 2 OUTFALL
12	20.4	39.3	EX42"	***PR5.2, PR11

***ULTIMATE BUILD OUT, DEVELOPED. DESIGNED TO SIZE FUTURE POND 1 AND STORM SEWER.

SF WQCV POND 1 SUMMARY

EPC/URBAN DRAINAGE SAND FILTER BASIN-SEE STD. DET.	
AREA REQUIRED	2,335 SF
AREA PROVIDED	3,690 SF

SF ELEV = 6373.00
WQCV WSE = 6374.26
100 YR SPILLWAY ELEV = 6375.00
100 YR WSE = 6375.00

SF WQCV POND 2 SUMMARY

EPC/URBAN DRAINAGE SAND FILTER BASIN-SEE STD. DET.	
AREA REQUIRED	2,962 SF
AREA PROVIDED	2,450 SF

SF ELEV = 6364.45
WQCV WSE = 6366.17
100 YR SPILLWAY ELEV = 6367.74
100 YR WSE = 6367.38

LOT 4 - SITE

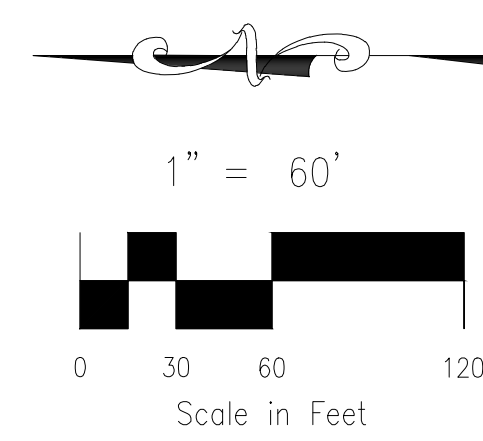

CLAREMONT BUSINESS PARK 2 FIL. NO.1
PROP. DRAINAGE OFFSITE DEVELOPED

PROJECT NO. 44-037A FILE: \dwg\Eng Exhibits\44037-FDRM-2.dwg

DESIGNED BY: ET SCALE: DATE: 08-04-2020
DRAWN BY: CLP HORIZ: 1"=60'
CHECKED BY: VAS VERT: N/A SHEET 2 OF 2 FDM02

File: 0:44037A-CBP-F2-Lots 1-8.dwg; Eng Exhibits (DR MAP, 3--20-20) 44037-FDRM-2.dwg; Plotstamp: 8/4/2020 10:55 AM

FOR LOCATING & MARKING GAS, ELECTRIC, WATER & TELEPHONE LINES

FOR BURIED UTILITY INFORMATION 48 HRS BEFORE YOU DIG CALL 1-800-922-1987

HYDROLOGIC CALCULATIONS

FINAL DRAINAGE LETTER FOR CLAREMONT BUSINESS PARK 2 FILING NO.1 - Lot 4
PROPOSED DRAINAGE CALCULATIONS
(Area Runoff Coefficient Summary)

			<i>ASPHALT DRIVES 0.90-0.96 COMMERCIAL AREAS 0.81-0.88</i>			<i>ROOFS 0.73-0.81 LIGHT INDUST AREAS 0.59-0.70</i>			<i>LANDSCAPED AREAS 0.16-0.41 GREENBELTS/AGRI. 0.09-0.36 PARKS 0.12-0.39</i>			<i>WEIGHTED</i>	
BASIN	TOTAL AREA (SF)	TOTAL AREA (Acres)	AREA (Acres)	C₅	C₁₀₀	AREA (Acres)	C₅	C₁₀₀	AREA (Acres)	C₅	C₁₀₀	C₅	C₁₀₀
<i>Portion H3</i>	1569.0	0.04	0.00	0.90	0.96	0.00	0.73	0.81	0.04	0.09	0.36	0.09	0.36
<i>Portion H4</i>	4351.0	0.10	0.00	0.90	0.96	0.00	0.73	0.81	0.10	0.09	0.36	0.09	0.36
<i>L</i>	57500.0	1.32	0.00	0.90	0.96	0.00	0.73	0.81	1.32	0.09	0.36	0.09	0.36
<i>Portion I6</i>	10171.0	0.23	0.19	0.90	0.96	0.00	0.73	0.81	0.04	0.16	0.41	0.77	0.87
<i>Portion M4</i>	42575.0	0.98	0.76	0.90	0.96	0.12	0.73	0.81	0.10	0.12	0.39	0.80	0.88

Calculated by: GT
Date: 2/15/2021
Checked by: VAS

FINAL DRAINAGE LETTER FOR CLAREMONT BUSINESS PARK 2 FILING NO.1 - Lot 4
PROPOSED DRAINAGE CALCULATIONS
(Area Drainage Summary)

From Area Runoff Coefficient Summary				OVERLAND				STREET / CHANNEL FLOW				Time of Travel (T _t)		INTENSITY *		TOTAL FLOWS	
BASIN	AREA TOTAL (Acres)	C ₅	C ₁₀₀	C ₅	Length (ft)	Height (ft)	T _c (min)	Length (ft)	Slope (%)	Velocity (fps)	T _t (min)	*TOTAL (min)	CHECK (min)	I ₅ (in/hr)	I ₁₀₀ (in/hr)	Q ₅ (c.f.s.)	Q ₁₀₀ (c.f.s.)
<i>Portion H3</i>	0.04	0.09	0.36	0.09	100	17.0	7.2	0	0.0%	0.0	0.0	7.2	10.6	4.6	7.8	0.0	0.1
<i>Portion H4</i>	0.10	0.09	0.36	0.09	100	17.0	7.2	0	0.0%	0.0	0.0	7.2	10.6	4.6	7.8	0.0	0.3
<i>L</i>	1.32	0.09	0.36	0.09	100	17.0	7.2	0	0.0%	0.0	0.0	7.2	10.6	4.6	7.8	0.6	3.7
<i>Portion I6</i>	0.23	0.77	0.87	0.77	50	0.3	5.2	133	1.1%	2.1	1.1	6.3	11.0	4.8	8.1	0.9	1.6
<i>Portion M4</i>	0.98	0.80	0.88	0.80	100	1.0	5.4	326	1.2%	2.2	2.4	7.8	12.4	4.5	7.5	3.5	6.5

* Intensity equations assume a minimum travel time of 5 minutes.

Calculated by: GT
 Date: 2/15/2021
 Checked by: VAS

FINAL DRAINAGE LETTER FOR CLAREMONT BUSINESS PARK 2 FILING NO.1 - Lot 4
PROPOSED DRAINAGE CALCULATIONS
(Basin Routing Summary)

<i>From Area Runoff Coefficient Summary</i>				OVERLAND				PIPE / CHANNEL FLOW				Time of Travel (T_t)	INTENSITY *		TOTAL FLOWS		COMMENTS
DESIGN POINT	CONTRIBUTING BASINS <i>DPS AND/OR PIPES</i>	CA ₅	CA ₁₀₀	C ₅	Length (ft)	Height (ft)	T _c (min)	Length (ft)	Slope (%)	Velocity (fps)	T _t (min)	*TOTAL (min)	I ₅ (in/hr)	I ₁₀₀ (in/hr)	Q ₅ (c.f.s.)	Q ₁₀₀ (c.f.s.)	
Lot 4 - DP 1	I6, H3	0.18	0.22	Basin H3 Tc used				183	1.1%	2.1	1.5	8.6	4.4	7.3	0.8	1.6	
Lot 4 - DP 2	M4, H4, L	0.91	1.38	Basin L Tc used				426	1.2%	2.2	3.2	10.4	4.1	6.8	3.7	9.4	

* Intensity equations assume a minimum travel time of 5 minutes.

Calculated by: GT
Date: 2/15/2021
Checked by: VAS

**FINAL DRAINAGE REPORT
CLAREMONT BUSINESS PARK 2 FIL. NO. 1 – LOT 4
PROPOSED DRAINAGE MAP**

FINAL DRAINAGE LETTER FOR CLAREMONT BUSINESS PARK 2 FILING NO. 1

COUNTY OF EL PASO, STATE OF COLORADO

PROPOSED DRAINAGE MAP - LOT 4

FEBRUARY 2021

U.S. HIGHWAY 24
(PUBLIC R.O.W. VARIES)

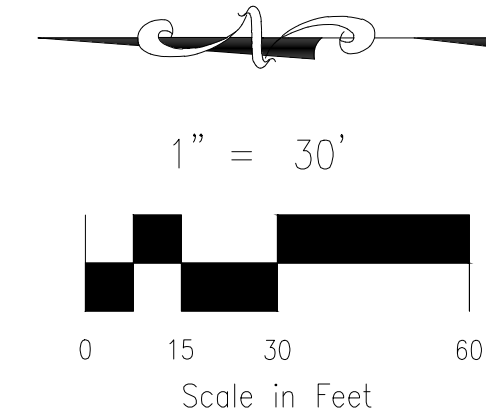

LEGEND

- BASIN DESIGNATION (CLAREMONT BUSINESS PARK 2 FILING NO.1)
- ACRES
- BASIN DESIGNATION (CLAREMONT BUSINESS PARK 2 FILING NO.1- LOTS 5, 7, 1, 2, 3)
- ACRES
- PIPE RUN REFERENCE LABEL
- SURFACE DESIGN POINT
- BASIN BOUNDARY (CLAREMONT BUSINESS PARK 2 FILING NO.1)
- BASIN BOUNDARY (CLAREMONT BUSINESS PARK 2 FILING NO.1- LOTS 5, 7, 1, 2, 3)
- BASIN BOUNDARY (CLAREMONT BUSINESS PARK 2 FILING NO.1-LOT 3)
- EXISTING CONTOUR
- PROP CONTOUR
- UNDERGROUND ELECTRICAL
- EXISTING GAS LINE
- STORM SEWER PIPE
- EXISTING STORM SEWER PIPE
- CROSSSPAN
- INLET
- EXISTING FLOW DIRECTION
- EMERGENCY OVERFLOW DIRECTION
- FLOW DIRECTION
- ROOF FLOW DIRECTION
- FLARED END SECTION
- H.P. X HIGH POINT
- L.P. X LOW POINT

The green linestyle represents basin outline of lot 3 according to legend. Please update legend so that lots match linestyles.

Update sheet to include detail of concrete channel. Also update report contents to include concrete channel calculations.

The approved SF-2014 drainage report states that calculations for this channel will be provided in the drainage letter. Please revise drainage letter contents to include concrete channel calculations.
Note: drainage runoff volume should be within drainage easement.

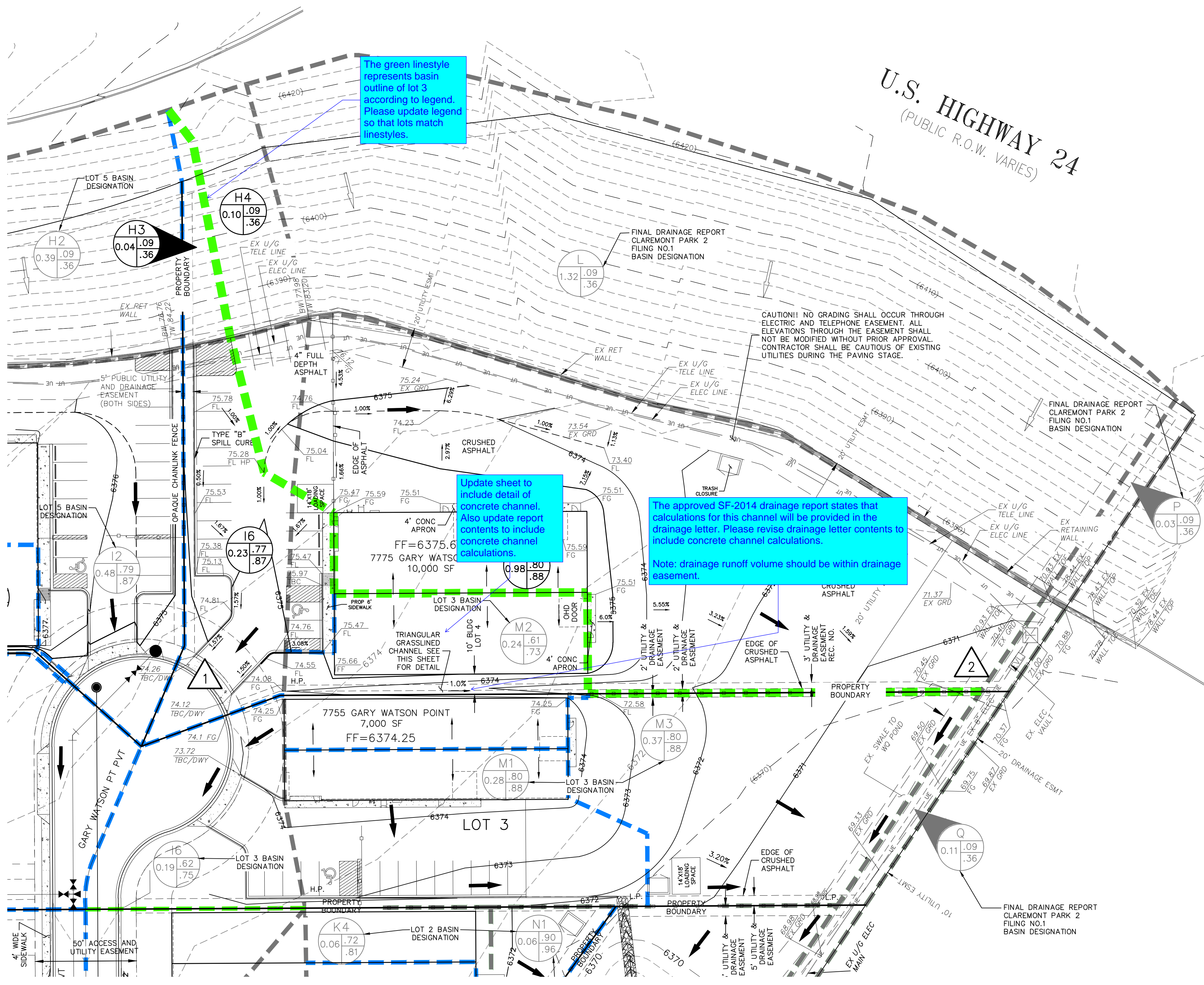

BASIN SUMMARY

BASIN	AREA (ACRES)	Q ₅	Q ₁₀₀
H3	0.04	0.0	0.1
H4	0.10	0.0	0.3
L	1.32	0.6	3.7
I6	0.23	0.9	1.6
M4	0.98	3.3	6.5

DESIGN POINT SUMMARY

DESIGN PT	BASIN	Q ₅	Q ₁₀₀
1	I6, H3	0.8	1.6
2	M4, H4, L	3.7	9.4

File: c:\44037A-CBP-F2-Lots 1-8\dwg\Const_Dwg\Individual Site Plans\Lot 4\Drainage Letter\44037-FDRM-Lot 4.dwg Plotstamp: 2/16/2021 11:00 AM

FOR LOCATING & MARKING GAS, ELECTRIC, WATER & TELEPHONE LINES
FOR BURIED UTILITY INFORMATION
48 HRS BEFORE YOU DIG
CALL 1-800-922-1987

212 N. WAHSATCH AVE., STE 305
COLORADO SPRINGS, CO 80903
PHONE: 719.955.5485

CIVIL CONSULTANTS, INC.

CLAREMONT BUSINESS PARK 2 FIL. NO.1

LOT 4

PROJECT NO. 44-037A FILE: \dwg\Eng Exhibits\44037-FDRM-Lot 4.dwg

DESIGNED BY: ET SCALE DATE: 02-15-2021

DRAWN BY: GW HORIZ: 1"=30'

CHECKED BY: VAS VERT: N/A SHEET 1 OF 1 **FDM01**