



LSC TRANSPORTATION CONSULTANTS, INC.
 2504 East Pikes Peak Avenue, Suite 304
 Colorado Springs, CO 80909
 (719) 633-2868
 FAX (719) 633-5430
 E-mail: lsc@lsctrans.com
 Website: <http://www.lsctrans.com>

Saddlehorn Ranch Filing No. 3
 Traffic Impact Study
 EPC PCD File No. SF-23-004
 (LSC #S224541)
 April 30, 2023
 w/ Minor Revisions 1-31-2024
 (prior 10-13-2023 & 12-22-2023)

Traffic Engineer's Statement

This traffic report and supporting information were prepared under my responsible charge and they comport with the standard of care. So far as is consistent with the standard of care, said report was prepared in general conformance with the criteria established by the County for traffic reports.

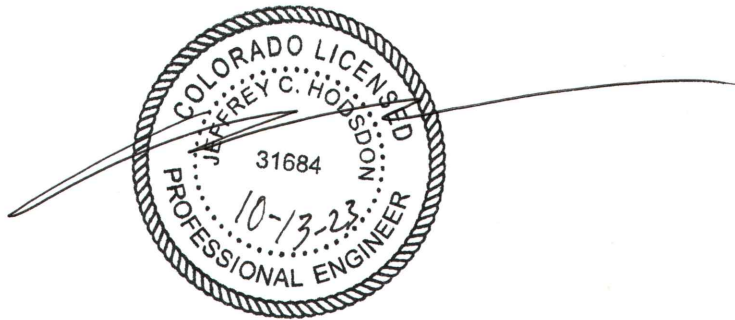

Developer's Statement

I, the Developer, have read and will comply with all commitments made on my behalf within this report.

DocuSigned by:
 Allyson Rubini manager
FCFC983D2A5748F...

10/17/2023

Gorilla Capital CO Saddlehorn Ranch, LLC

Saddlehorn Ranch Filing No. 3

Traffic Impact Study

Prepared for:
Nathan Steele
Senior Vice President of Western Region
ROI Property Group, LLC

APRIL 30, 2023
(w/Minor Revisions 1-31-2024 (prior 10-13-2023 & 12-22-2023))

LSC Transportation Consultants
Prepared by: Jeffrey C. Hodsdon, P.E.

LSC #S224541
[EPC PCD File No.: SF-23-004](#)



CONTENTS

REPORT CONTENTS	1
LIST OF OTHER TRAFFIC REPORTS USED IN THE PREPARATION OF THIS REPORT	2
LAND USE AND ACCESS	3
ROAD AND TRAFFIC CONDITIONS AND <i>MTCP</i> CLASSIFICATION	4
Existing Traffic Volumes	5
Existing Level of service	5
TRIP GENERATION.....	6
Filing No. 3	6
Prior and Future Filings and Overall Saddlehorn Buildout (for Reference)	6
Filing 4 – 42 Dwelling Units (Future – Not part of this application)	6
Filing 5 – 41 Dwelling Units (Future – Not part of this application)	7
Overall Saddlehorn Development Buildout – 218 Dwelling Units.....	7
TRIP DISTRIBUTION AND ASSIGNMENT	7
Trip Directional Distribution	7
Site-Generated Traffic.....	7
Short Term (Filing 3 Only)	7
Short Term (Filings 1-3 Combined)	7
Short Term (Filings 1-5 Combined – Saddlehorn Buildout – For Reference)	8
Long Term (Filings 1-5 Combined – Saddlehorn Buildout – For Reference)	8
Short-Term Total Traffic Volumes.....	8
2043 Background Traffic Volumes	8
2043 Total Traffic Volumes	9
LEVEL OF SERVICE ANALYSIS	9
Judge Orr Road/Barrosito Trail	9
Judge Orr Road/Del Cambre Trail	9
Curtis Road/Benito Wells Trail	9
Judge Orr Road/Curtis Road	9
Short Term	9
Long Term	10
Falcon Highway/Curtis Road	10
Short Term	10
Long Term	10
AUXILIARY TURN-LANE ANALYSIS, INTERSECTION CONFIGURATION, AND TRAFFIC CONTROL ..	10
Auxiliary Turn-Lane Requirements	10

Turn-Lane Criteria – El Paso County	11
Curtis Road/Oscuro Trail.....	11
Curtis Road/Benito Wells Trail.....	11
Southbound-Left Deceleration Lane.....	11
Northbound-Right Deceleration Lane.....	12
Judge Orr Road/Barrosito Trail	12
Judge Orr Road/Del Cambre Trail	12
Judge Orr Road/Curtis Road	12
Falcon Highway/Curtis Road.....	13
ROADWAY CLASSIFICATIONS	14
ROADWAY SEGMENT IMPROVEMENTS.....	14
Judge Orr Road Improvements.....	14
Curtis Road Improvements	15
Internal Subdivision Roadways.....	15
DEVIATIONS	16
New Deviation.....	16
Sag Vertical Curve Deviation Request (by JR Engineering).....	16
Potential Future Deviation – Not Currently Needed	16
Curtis Road & Falcon Highway Intersection - Eastbound Left Turn Lane Lengthening.....	16
Approved Deviations (Attached for Reference)	16
Curtis Road.....	16
Judge Orr Road.....	17
COUNTY ROAD IMPROVEMENT FEE PROGRAM	17
El Paso County Road Impact Fee Program.....	17
IMPROVEMENTS SUMMARY TABLE.....	17
CDOT process and requirements	18
Findings AND CONCLUSIONS	18
Enclosures:	19
Table 4 – Table 5	
Figure 1 - Figure 12	
Traffic Count Reports	
Synchro LOS Reports	
Approved Deviation (Curtis Road)(For Reference)	
Approved Deviation (Judge Orr Road) (For Reference)	



LSC TRANSPORTATION CONSULTANTS, INC.
2504 E. Pikes Peak Ave., Suite 304
Colorado Springs, CO 80909
(719) 633-2868
FAX (719) 633-5430
E-mail: lsc@lsctrans.com
Website: <http://www.lsctrans.com>

April 30, 2023
(w/Minor Revision 1-31-2024 (prior 10-13-2023 & 12-22-2023))

Nathan Steele
Senior Vice President of Western Region
ROI Property Group, LLC

RE: Saddlehorn Ranch Filing No. 3
El Paso County, CO
Traffic Impact Study
LSC #S224541
PCD File No.: [SF-23-004](#)

Dear Mr. Steele,

LSC Transportation Consultants, Inc. has prepared this traffic impact study for Saddlehorn Ranch Filing No. 3. Filing No. 3 is part of the greater 824-acre Saddlehorn Ranch residential development located southeast of the intersection of Curtis Road and Judge Orr Road in El Paso County, Colorado. The development includes 2.5-acre single-family residential lots. Figure 1 shows the location of the development. Access is proposed to Curtis Road and Judge Orr Road. This report follows our prior TIS report for the Preliminary Plan, and Filing No. 2 report, and is part of the Filing No. 3 Final Plat submittal to the County.

REPORT CONTENTS

The preparation of this report included the following:

- An inventory of existing roadway and traffic conditions on major thoroughfares adjacent to the site, including surface conditions, functional classification, widths, pavement markings, traffic control signs, posted speed limits, intersection and access spacing, roadway and intersection alignments, roadway grades, and auxiliary turn lanes;
- Review of the roadway improvement plans for the adjacent arterial roads;
- Review of other recent LSC traffic reports completed in the area;
- Updated weekday peak-hour turning-movement traffic counts at several of the major intersections in the area;
- Estimated average weekday traffic (ADT) volumes on Falcon Highway, Curtis Road, Judge Orr Road, and US Highway 24 (US Hwy 24);

- Projections of 20-year background traffic volumes at the study-area intersections and on Falcon Highway, Curtis Road, Judge Orr Road, and US Hwy 24;
- The proposed site land use and access plan;
- Estimates of average weekday and weekday peak-hour trip generation for the Filing No. 3 residential development and the estimated directional distribution of site-generated vehicle trips on roadways and intersections adjacent to and in the vicinity of the site;
- Projected site-generated and resulting total peak-hour intersection traffic volumes at the following “study-area” intersections:
 - Falcon Highway/Curtis Road
 - Curtis Road/Judge Orr Road
 - Judge Orr Road/Del Cambre Trail
 - Judge Orr/Barrosito Trail
 - Curtis Road/Benito Wells Trail
 - Curtis Road/Oscuro Trail (Filing 1 and 2 intersection)
 - US Highway 24/Stapleton Road
- Intersection level of service analysis at the study-area intersections;
- Evaluation of the short- and long-term projected intersection volumes to determine, for Filing No. 3, requirements for any auxiliary right-/left-turn lanes at the proposed site-access points, based on the criteria in El Paso County’s Engineering Criteria Manual (ECM). Also included are potential long-term lane requirements;
- Findings and recommendations for Filing No. 3 relative to those identified in the Preliminary Plan TIS. This report includes a modified version improvements table from the Preliminary Plan report. This modified version focuses on Filing No. 3 improvements;
- CDOT process and requirements for Filing No. 3, specifically for the US Hwy 24/Stapleton intersection; and
- Deviation Requests – currently proposed and previously approved.

LIST OF OTHER TRAFFIC REPORTS USED IN THE PREPARATION OF THIS REPORT

The following previously-completed traffic reports were referenced when the preparing this report:

- Saddlehorn Ranch Preliminary Plan TIS – dated March 11, 2020
- Saddlehorn Ranch (Filing 2 Memo) – dated February 6, 2023
- Meadowlake Industrial Park Rezone TIS report – dated July 29, 2022

LAND USE AND ACCESS

Figure 1 shows a vicinity map of the Filing No. 3 site location and study area. The site is located south of Judge Orr Road and east of Curtis Road. The greater 824-acre Saddlehorn Ranch development is also shown for reference. Saddlehorn at buildout of all five filings is planned to contain a total of 218 single-family residential lots. The following is a summary of the lot count by subdivision filing:

- Filing 1 – 49 dwelling units
- Filing 2 – 42 dwelling units
- Filing 3 – 44 dwelling units (this application)
- Filing 4 – 42 dwelling units
- Filing 5 – 41 dwelling units

Figure 2 shows the planned access points (subdivision road connections) to the existing, adjacent arterial roads for Filing No. 3. Four full-movement access points are planned for the overall development (not including a potential future local road connection to the parcel to the south of Saddlehorn):

- Barrosito Trail – 1,320 feet east of Curtis Road/Judge Orr
- Del Cambre Trail – 2,750 feet east of Curtis Road/Judge Orr (1,430 feet east of Barrosito Trail)
- Benito Wells Trail – 2,750 feet south of Curtis Road/Judge Orr (1,430 feet north of Oscuro Trail)
- Oscuro Trail (Primarily serving Filing Nos. 1 and 2) – 5,280 feet south of Curtis Road/Judge Orr (1,430 feet north of Richland Drive, the proposed north site access to Meadowlake Industrial Park development to the south)

Filing No. 1 has been approved and Filing No. 2 is currently in the County review process. Filing Nos. 4 and 5 are likely to be submitted in the short-term future.

Figure 3 shows the subdivision roadways to be constructed with each filing.

The proposed Filing No. 3 lot and street layout is shown in Figure 2 and generally matches/conforms to the Preliminary Plan. Filing No. 3 traffic will primarily utilize Barrosito Trail and Del Cambre Trail to access Judge Orr Road, and Benito Wells Trail to access Curtis Road. A copy of the plat is attached for reference.

Subdivision roads will be constructed to Rural Local standards, so sidewalks would not be required. No trail connections are shown on the site plan. A Park 'n Ride facility is located approximately 4.5 miles southwest of the site near US Hwy 24/New Meridian Road. The nearest school (Falcon High School) is located approximately 3.5 miles northwest of the site.

Roadway construction plans for Curtis Road adjacent to Filings 1 and 2 were previously prepared, submitted, and approved (in the case of Filing No. 1). Filing No. 3 roadway improvement plans

for the adjacent sections of Curtis Road and Judge Orr Road are included with this Filing No. 3 submittal (by JR Engineering).

Intersection sight distance must meet *ECM* criteria at all subdivision street intersections.

ROAD AND TRAFFIC CONDITIONS AND *MTCP* CLASSIFICATION

Figure 1 shows the roads adjacent to and in the vicinity of the site. Key study-area roads serving the site are identified below followed by a brief description of each:

Judge Orr Road is a two-lane roadway that extends east from Eastonville Road across most of El Paso County. It is shown on the *El Paso County 2040 Major Transportation Corridors Plan* and the *Preserved Corridor Network Plan* as a four-lane Minor Arterial west of Curtis Road. Posted speed limits range from 45 to 55 miles per hour (mph). West of Curtis Road, the speed limit is 45 mph. The limit increases to 55 mph east of Curtis Road. The intersection of Curtis Road and Judge Orr Road is two-way, stop-sign-controlled with the stop signs on the northbound and southbound approaches. The intersection of US Hwy 24/Judge Orr Road is signalized. Due to the oblique angle of this intersection, the eastbound and westbound approaches are split-phased. The *US 24 Access Control Plan/PEL Study* shows future plans for realignment of Judge Orr at US Hwy 24 to improve the intersection and provide an intersection skew angle closer to 90 degrees.

Curtis Road is a two-lane roadway that extends south from the intersection of US Hwy 24/Stapleton Road intersection to Drennan Road. It is shown as a two-lane, rural Principal Arterial on El Paso County's *2040 Major Transportation Corridors Plan* and a four-lane Principal Arterial on the *Preserved Corridor Network Plan*. Adjacent to the site, the posted speed limit is 45 mph. Both intersections of Curtis Road/Judge Orr Road and Curtis Road/Falcon Highway are two-way, stop-sign-controlled. The newer section north of Judge Orr, which connects to Stapleton Drive, was constructed to current *ECM* standards with paved shoulders, etc. Generally, Curtis Road is an "unimproved," two-lane paved road between Judge Orr and Falcon Highway. Roadway construction plans for Curtis Road adjacent to Saddlehorn have been prepared (the plans for the segment adjacent to Filing No. 1 were approved). Please refer to the "deviations" section of this report for a brief discussion of the interim cross section to be constructed.

Existing Traffic Volumes

Vehicular-turning-movement counts were conducted at the study-area intersections. Figure 4 shows these turning-movement volumes, as well as the average weekday traffic volumes (estimated based on factored peak-hour count data) on the study-area roadways. Raw count data are attached.

- Curtis Road/Falcon Highway
 - Wednesday, April 20, 2022 from 6:30 – 8:30 a.m.
 - Wednesday, April 20, 2022 from 4:00 – 6:00 p.m.
- Curtis Road/Judge Orr Road
 - Thursday, April 21, 2022 from 6:30 – 8:30 a.m.
 - Thursday, April 21, 2022 from 4:00 – 6:00 p.m.
- US Hwy 24/Judge Orr Road
 - Tuesday, May 10, 2022 from 6:30 – 8:30 a.m.
 - Tuesday, May 10, 2022 from 4:00 – 6:00 p.m.
- US Hwy 24/Stapleton Drive
 - January 10, 2023 from 6:30 – 8:30 a.m.
 - January 10, 2023 from 4:00 – 6:00 p.m.

Existing Level of service

Level of service (LOS) is a quantitative measure of the level of congestion or delay at an intersection and is indicated on a scale from “A” to “F.” LOS A is indicative of little congestion or delay. LOS F indicates a high level of congestion or delay. Table 1 shows the level of service delay ranges for signalized and unsignalized intersections.

Table 1: Intersection Levels of Service Delay Ranges

Level of Service	Signalized Intersections	Unsignalized Intersections
	Average Control Delay (seconds per vehicle)	Average Control Delay (seconds per vehicle) ⁽¹⁾
A	10.0 sec or less	10.0 sec or less
B	10.1-20.0 sec	10.1-15.0 sec
C	20.1-35.0 sec	15.1-25.0 sec
D	35.1-55.0 sec	25.1-35.0 sec
E	55.1-80.0 sec	35.1-50.0 sec
F	80.1 sec or more	50.1 sec or more

(1) For unsignalized intersections, if V/C ratio is greater than 1.0 the level of service is LOS F, regardless of the projected average control delay per vehicle.

Level of service values for existing conditions have been included on Figure 4 for each turning movement/approach during the weekday morning and evening peak hours for the proposed site-access intersections and off-site intersections in the study area. Please refer to the figure and attached LOS reports for additional detail.

TRIP GENERATION

Estimates of the vehicle trips projected to be generated by the proposed Saddlehorn Ranch Filing No. 3 have been made using the nationally published trip-generation rates for land-use code “210 – Single-Family (Detached) Housing” from *Trip Generation, 11th Edition, 2021* by the Institute of Transportation Engineers (ITE).

Filing No. 3

Forty-four dwelling units would be constructed in Filing No. 3. Resulting trip-generation estimates for Filing No. 3 are as follows:

- AM peak hour – 9 entering and 24 exiting trips
- PM peak hour – 28 entering and 16 exiting trips
- Daily 24-hour – 444 total trips, with half entering and half exiting

Table 2 below presents a summary of the estimated site trip generation for Filings 3. A detailed trip-generation estimate, including ITE rates for the proposed land use is presented in Table 5 (attached).

Table 2: Estimated Site Vehicle-Trip Generation

Filing 3			
Analysis Period	In	Out	Total
Morning Peak Hour	9	24	33
Afternoon Peak Hour	28	16	44
Daily 24-Hour	222	222	444

Prior and Future Filings and Overall Saddlehorn Buildout (for Reference)

Filing 4 – 42 Dwelling Units (Future – Not part of this application)

Filing 4 would consist of an additional 42 dwelling units to be constructed. Resulting trip-generation estimates for Filing 4 are as follows:

- AM peak hour – 8 entering and 23 exiting trips
- PM peak hour – 26 entering and 15 exiting trips
- Daily 24-hour – 424 total trips, with half entering and half exiting

Filing 5 – 41 Dwelling Units (Future – Not part of this application)

The final 41 dwelling units would be constructed during Filing 5. Resulting trip-generation estimates for Filing 5 are as follows:

- AM peak hour – 8 entering and 23 exiting trips
- PM peak hour – 26 entering and 15 exiting trips
- Daily 24-hour – 424 total trips, with half entering and half exiting

Overall Saddlehorn Development Buildout – 218 Dwelling Units

A total of 218 dwelling units are planned to be constructed by buildout of all Filings 1-5. Resulting trip-generation estimates for the residential development at buildout are as follows:

- AM peak hour – 42 entering and 120 exiting trips
- PM peak hour – 136 entering and 80 exiting trips
- Daily 24-hour – 2,200 total trips, with half entering and half exiting

A detailed trip-generation estimate, including ITE rates for all Saddlehorn filings is presented in Table 5 (attached).

TRIP DISTRIBUTION AND ASSIGNMENT

Trip Directional Distribution

Figure 5 shows the estimated percentages of the short-term and long-term site-generated vehicle trips. These percentages have been taken from the Preliminary Plan TIS report.

Site-Generated Traffic

Short Term (Filing 3 Only)

Short-term site-generated traffic volumes have been estimated at the study-area intersections by applying the short-term directional-distribution percentages estimated by LSC (from Figure 5) to the trip-generation estimates (from Table 5). Figure 6 shows projected short-term site-generated traffic volumes for Filing 3 only during the weekday morning and evening peak hours, as well as the estimated average daily traffic volumes (ADTs). The volumes shown in Figure 6 reflect Filing No. 3-specific trip routing on the area roadway system between the site and directional distribution “gates” or trip origin/destination reference points.

Short Term (Filings 1-3 Combined)

Short-term site-generated traffic volumes for Filing 3 plus Filings 1 and 2. Filings 1-3 combined traffic volumes have been estimated at the study-area intersections by applying the short-term directional-distribution percentages estimated by LSC (from Figure 5) to the trip-generation

estimates (from Table 5). Trip routing on the area roadway system between the site and directional distribution “gates” or trip origin/destination reference points is specific to each Filing. Figure 7 shows projected short-term site-generated traffic volumes for only Filings 1-3 combined during the weekday morning and evening peak hours, as well as the estimated average daily traffic volumes (ADTs). Site-generated traffic volumes in Figure 7 assume buildout of only the 135 dwelling units to be constructed during the short term for Filings 1-3 only.

Short Term (Filings 1-5 Combined – Saddlehorn Buildout – For Reference)

Short-term Saddlehorn buildout site-generated traffic volumes have been estimated at the study-area intersections by applying the short-term directional-distribution percentages estimated by LSC (from Figure 5) to the trip-generation estimates (from Table 5). Figure 8 shows projected short-term site-generated traffic volumes for all Filings 1-5 combined during the weekday morning and evening peak hours, as well as the estimated average daily traffic volumes (ADTs). Site-generated traffic volumes for Saddlehorn buildout in Figure 8 assume full buildout of all 218 dwelling units to be constructed during the short term for Filings 1-5 combined.

Long Term (Filings 1-5 Combined – Saddlehorn Buildout – For Reference)

Long-term site-generated traffic volumes have been estimated at the study-area intersections. The volumes have been calculated by applying the long-term directional-distribution percentages estimated by LSC (from Figure 5) to the trip-generation estimates (from Table 5). Figure 9 shows projected long-term site-generated traffic volumes for the weekday morning and evening peak hours. The figure also shows the estimated average daily traffic volumes (ADTs). Site-generated traffic volumes on Figure 9 assume full buildout of all 218 dwelling units during the long term.

Short-Term Total Traffic Volumes

Figure 10 shows the sum of the existing traffic volumes (from Figure 4) and short-term site-generated peak-hour traffic volumes (shown in Figure 8). These volumes represent the projected short-term total traffic following full site buildout of Filings 1-5. Laneage and traffic control at the study-area intersections following short-term site buildout are shown in Figure 10.

2043 Background Traffic Volumes

The 2043 background traffic volumes, shown in Figure 11, are generally based on the projections presented in the Preliminary Plan report, but adjustments have been made, including adjustments based on more recent traffic count data and projections in LSC’s recent *Meadowlake Industrial Park* report (dated July 29, 2022). Traffic projected for Saddlehorn Ranch (all Filings) is **not** included in the 2043 **background** traffic volumes.

2043 Total Traffic Volumes

Figure 12 shows the sum of 2043 background traffic volumes (from Figure 11) plus long-term site-generated traffic volumes (from Figure 9).

LEVEL OF SERVICE ANALYSIS

LOS values have been included on each figure for each turning movement/approach during the weekday morning and evening peak hours for the proposed site-access intersections and off-site intersections in the study area:

- Figure 4: Existing Traffic, Lane Geometry, Traffic Control, and LOS
- Figure 10: Existing + Site Traffic, Lane Geometry, Traffic Control, and LOS
- Figure 11: 2043 Background Traffic, Lane Geometry, Traffic Control, and LOS
- Figure 12: 2043 Background + Site Traffic, Lane Geometry, Traffic Control, and LOS

LOS calculations for long-term scenarios were based upon the recommended lane geometries and traffic controls outlined in the figures above.

Judge Orr Road/Barrosito Trail

All individual turning movements and approaches at this stop-sign-controlled intersection are projected to operate at LOS D or better through 2043 during both peak hours.

Judge Orr Road/Del Cambre Trail

All individual turning movements and approaches at this stop-sign-controlled intersection are projected to operate at LOS B or better through 2043 during both peak hours.

Curtis Road/Benito Wells Trail

All individual turning movements and approaches at this stop-sign-controlled intersection are projected to operate at LOS C or better through 2043 during both peak hours.

Judge Orr Road/Curtis Road

Short Term

Currently, all individual approaches/turning movements at the intersection of Judge Orr/Curtis operate at LOS B or better during both peak hours. All individual turning movements are projected to operate at LOS C or better during the short-term with the addition of Saddlehorn Filing Nos. 1-5 site-generated traffic (two-way stop-sign-controlled (TWSC) intersection).

Long Term

Assuming the intersection of Judge Orr/Curtis is converted from TWSC to a two-lane roundabout in the future, all individual turning movements would operate at LOS B or better during both peak hours of the long-term buildout scenario. This intersection improvement was previously recommended in the *Saddlehorn Ranch* traffic study. Additionally, eastbound and westbound approaches on Judge Orr Road and the southbound approach on Curtis Road are assumed to be two through lanes in each direction (per the 2040 *MTCP*).

Falcon Highway/Curtis Road

Short Term

All individual approaches/turning movements at the intersection of Falcon Highway/Curtis Road currently operate at LOS C or better and would remain LOS D or better during both peak hours with the addition of short-term site-generated traffic.

Long Term

Assuming the intersection of Falcon Highway/Curtis Road is converted from TWSC to a two-lane roundabout in the future, all individual turning movements would operate at LOS C or better during both peak hours of the long-term buildout scenario. This intersection improvement was previously recommended in the *Saddlehorn Ranch* traffic study. Additionally, the analysis assumes some two-lane approaches to the roundabout at the Falcon Highway/Curtis Road intersection proper, even though roadway links are shown to remain one through lane in each direction (per the 2040 *MTCP*).

AUXILIARY TURN-LANE ANALYSIS, INTERSECTION CONFIGURATION, AND TRAFFIC CONTROL

Please refer to the attached Roadway Improvements Table for details. The following provides a summary and discussion.

Auxiliary Turn-Lane Requirements

Auxiliary turn lanes at the access points and study-area intersections would be required to meet design criteria specified in El Paso County's *Engineering Criteria Manual* (*ECM* Tables 2-24 and 2-27) or the Colorado State Highway Access Code (CDOT) for US Hwy 24 intersections.

Turn-Lane Criteria – El Paso County

Table 3 summarizes peak-hour auxiliary left- and right-turn lane thresholds according to *ECM* criteria. Roadway classifications for key County thoroughfares in the vicinity of the site include:

- Expressway – US Highway 24
- Principal Arterial – Curtis Road
- Minor Arterial – Judge Orr Road

Table 3: ECM Auxiliary Turn-Lane Thresholds by Functional Classification

Functional Classification	Deceleration Lanes		Acceleration Lanes	
	Left	Right	Left	Right
Expressway	Required	10+ vph	*	10+ vph
Principal Arterial	10+ vph	25+ vph	*	50+ vph
Minor Arterial and Lower	25+ vph	50+ vph	*	Generally not required
* May be required if the design would benefit safety and roadway operations Note: vph = vehicles per hour				

Based on projected volumes and *ECM* criteria summarized in Table 3, auxiliary turn lanes would be required for the following turning movements at the following study-area intersections.

Note: All recommended auxiliary turn lanes at these intersections have been based on the *ECM* design speed for the roadway’s classification, with adjustments for storage lengths and/or based on the more site-specific design speed of the adjacent roadway (if different from the *ECM* design speed by general roadway classification).

Curtis Road/Oscuro Trail

Filing No. 3 is not projected to add traffic to this intersection. Please refer to the traffic report for Filing No. 2 for turn-lane recommendations specific to this intersection. The northbound right-turn deceleration lane on Curtis Road (part of Curtis Road Filing No. 1 improvement) has not yet been constructed as of the date of this report.

Curtis Road/Benito Wells Trail

Southbound-Left Deceleration Lane

The projected Filing Nos. 1, 2 and 3 site-generated traffic volumes show a southbound left-turn volume over 10 vehicles per hour at Benito Wells Trail, the proposed Filing 2/3 Curtis Road access point. This is the threshold for a left-turn lane on a Principal Arterial. Based on the Preliminary Plan TIS, the Benito Wells Trail/Curtis Road intersection (Filing 2 & 3/north Curtis Road Access) would include a southbound left-turn lane. Based on a design speed of 50 mph, this 485-foot turn

lane should consist of 235 feet of deceleration length, a 200-foot approach taper, 50 feet of storage, and a 45:1 redirect taper length. Construction plans show this auxiliary turn lane being constructed with Filing 2.

Northbound-Right Deceleration Lane

The projected northbound-right turning volume would not exceed the 25-vph threshold requiring a right-turn deceleration lane with the projected short-term, Filings 1, 2, and 3 turning-movement volumes. Construction plans show this auxiliary turn lane to be constructed with Filing No. 2. *ECM* turn-lane-length criteria based on a design speed of 50 mph shows a 435-foot turn lane consisting of 235 feet of deceleration length plus a 200-foot approach taper.

Judge Orr Road/Barrosito Trail

Based on projected short-term and long-term eastbound-right and westbound-left turning-movement volumes, no auxiliary turn lanes would be required at this proposed intersection (proposed site access). The Filing No. 3 construction plans show a right-turn deceleration lane at this intersection in case the actual volume (once developed) is higher than projected and exceeds the threshold requiring a turn lane.

Judge Orr Road/Del Cambre Trail

Based on projected short-term and long-term eastbound-right and westbound-left turning movement volumes, no auxiliary turn lanes would be required at this proposed intersection (proposed site access). The Filing No. 3 construction plans show a right-turn deceleration lane at this intersection in case the actual volume (once developed) is higher than projected and exceeds the threshold requiring a turn lane.

Judge Orr Road/Curtis Road

The intersection will likely require future improvements/upgrades, including AWSC, roundabout, or signal control, in order for all individual turning movements/approaches to operate at an acceptable level of service in the long-term. The development may be required to participate in future improvements or construct improvements. The intersection could potentially be converted to a modern roundabout in the future, as recommended in LSC's Preliminary Plan study for Saddlehorn and the *Meadowlake Industrial Park* (July 2022) traffic study.

All individual turning movements are projected to operate at LOS C or better during the short term for this project (assuming no traffic yet added by the proposed Meadowlake Industrial Park site to the southwest).

Note: The following future auxiliary turn-lane upgrade would not be required if a roundabout is selected as the ultimate traffic control in the future at the intersection of Judge Orr Road/Curtis

Road. However, this auxiliary turn lane may be needed if two-way stop control remains the intermediate traffic-control condition or with future traffic-signal control:

- Eastbound right-turn deceleration lane
 - 290-foot deceleration lane
 - 240-foot approach taper

The current eastbound AM peak-hour right-turn volume exceeds the *ECM*-threshold right-turning volume of 50 vph for which a right-turn lane is prescribed. The current eastbound PM peak-hour volume does not currently exceed this threshold. The existing-plus-Filing No. 1-5 site-generated eastbound PM peak-hour volume is not projected to exceed this threshold.

Regarding short- or intermediate-term need for this right-turn lane, Colorado State Highway Access Code Section 3.5 (5) has a provision stating:

“The auxiliary lanes required in the category design standards may be waived when the 20th year predicted roadway volumes conflicting with the turning vehicle are below the following minimum volume thresholds. The right turn deceleration lane may be dropped if the volume in the travel lane is predicted to be below 150 DHV.”

Neither the AM nor PM peak-hour eastbound through volume is currently at the 150 vph level. For the existing-plus-Filings 1-5 traffic condition, the AM peak-hour eastbound through movement is not shown to exceed 150 and the PM peak-hour eastbound right-turn movement is not projected to exceed 50. However, the background intersection traffic movements are expected to increase over time, with either the PM peak-hour right-turn volume increasing to over 50, and/or the AM peak-hour through movement increasing to over 150.

The check for these thresholds could occur with future subdivision filings and a determination could be made at that time if this project should install the turn lane (with fee-program credit per fee-program provisions). Otherwise, each filing, including Filing No. 3, should escrow for pro rata share of this future improvement.

Please refer to the attached escrow calculation table.

Falcon Highway/Curtis Road

The intersection will likely require future improvements/upgrades, including traffic control, in order for all individual turning movements/approaches to operate at an acceptable level of service in the long term. The development may be required to participate in future improvements or construct improvements. The intersection of Falcon Highway/Curtis Road could potentially be converted to a roundabout in the long term, as all approaches would operate at LOS D or better as shown in the analysis.

Note: The following auxiliary turn-lane **upgrades** would not be required if a roundabout were to be constructed at the intersection of Falcon Highway/Curtis Road. However, these auxiliary turn lanes may be needed as long as two-way stop-sign control remains the traffic control or with future traffic-signal control:

- Southbound right-turn deceleration lane (New Lane – with signal control or if needed for operations)
 - 235-foot deceleration lane
 - 200-foot approach taper
- Eastbound left-turn deceleration lane
 - 290-foot deceleration lane
 - 100 feet of storage length
 - 240-foot approach taper
 - 55:1 redirect taper length
- Westbound right-turn deceleration lane
 - 290-foot deceleration lane
 - 240-foot approach taper

Please refer to the attached Improvements Table (Table 4) for additional details.

ROADWAY CLASSIFICATIONS

All roadways within this subdivision filing should be classified as Rural Local.

ROADWAY SEGMENT IMPROVEMENTS

The segments of Curtis Road and Judge Orr Road adjacent to Filing No. 3 will be improved with this project, per the approved deviations (see the next section for details). Also, please refer to the Filing No. 3 construction plans. This project will be required to dedicate right-of-way along the east side of Curtis Road and the south side of Judge Orr Road. Details are presented in Table 4 (attached) and shown in the construction drawings.

Please refer to the Filing No. 1 and Filing No. 2 construction drawing sets for plans for upgrades to Curtis Road adjacent to those respective subdivision filings.

Judge Orr Road Improvements

The construction plans for Judge Orr show construction of an additional eastbound lane and eastbound right-turn deceleration lanes at the access points. This has been shown on the construction plans to complete the ½ section of the ultimate four-lane Minor Arterial cross section.

Curtis Road Improvements

The construction plans for Curtis Road with Filing No. 2 indicate that improvements will extend about 775 feet north of Benito Wells Trail and 1,100 feet south of Benito Wells Trail. Travel lanes will be 12-feet wide. The cross section will include an 8-foot outside paved shoulder and 2-foot gravel shoulder along the east side of Curtis Road and a 2-foot outside paved shoulder and 2-foot gravel shoulder on the west side of Curtis Road.

Auxiliary turn lanes to be constructed with Filing No. 2 at the intersection of Benito Wells Trail/Curtis Road will include a northbound right-turn deceleration lane and a southbound left-turn deceleration lane.

Adjacent to the northbound right-turn lane on the east side of the roadway, there will be a 2-foot-wide outside paved shoulder and a 2-foot-wide gravel shoulder. The Curtis Road section which will include the southbound left-turn lane will have a cross section including 2-foot outside paved shoulders (both sides) and 2-foot gravel shoulders.

Internal Subdivision Roadways

All proposed internal roadways for Filing No. 3 should be constructed to Rural Local design standards.

DEVIATIONS

New Deviation

Sag Vertical Curve Deviation Request (by JR Engineering)

A deviation from the standards of or in Section *ECM* section 2.2.4 Figure 2-4 Rural Minor Arterial of *ECM* is requested by JR Engineering for the Curtis Road cross-section. Criteria for K values of a sag curve with a design speed of 30 mph is 37, per Table 2-14 of the El Paso County *Engineering Criteria Manual*. The deviation request requests use of a K value of 20 for sag curves at intersections with stop condition.

Potential Future Deviation – Not Currently Needed

The following potential deviation is not currently needed. When warrants require improvements, the deviation will be submitted then. Also refer to Filing No. 4 TIS comments in regard to this.

Curtis Road & Falcon Highway Intersection - Eastbound Left Turn Lane Lengthening

A deviation to allow continued use of the existing lane and tapers and defer this improvement (based on short-term turning volumes /associated queue length). There is a drainage channel just to the west. The development would contribute a fair share escrow amount toward a future improvement. An Escrow Calculation Spreadsheet has been prepared and is attached to this report.

The future improvement would encompass bringing the existing turn lane up to *ECM* standards. The *ECM* criteria for turn lanes requires elements of deceleration distance plus stacking distance plus taper length. On a roadway with a 60-mph design speed (55 posted), the required full-width, left-turn lane length is 290 feet plus left-turn stacking/queuing distance. The required transition taper is 240 feet. For this turn lane, the stacking requirement would be 50 feet (100 feet based on long-term projections) and the resulting total prescribed turn lane length would be 580 feet. Redirect tapers as a ratio of 55:1 would also need to be part of the design.

Approved Deviations (Attached for Reference)

Curtis Road

A deviation (by JR Engineering, dated September 28, 2020) was approved for modification to the standard *ECM* cross section of Curtis Road, a Rural Two-Lane, Principal Arterial roadway (*ECM* Section 2.2.4 criteria). The *ECM* requires that Rural Principal Arterial cross-sections consist of 12-foot travel lanes with 8-foot paved, outside shoulders. The approved deviation shows the modified interim cross section with a 2-foot paved, outside shoulder on the west side of the roadway instead of an 8-foot shoulder, as this is the maximum that can fit within the existing western right-of-way (ROW) without needing to acquire additional ROW from the adjacent

property owners. The east side of the roadway will be constructed with an 8-foot outside shoulder. Please refer to the attached approved deviation for more information.

Judge Orr Road

A deviation (by JR Engineering, dated September 4, 2020) was approved for modification to the standard *ECM* cross section of Judge Orr Road, which has a 2040 classification of Rural Four-Lane, Minor Arterial roadway (*ECM* Section 2.2.4 criteria). Although Judge Orr Road is shown as a four-lane Rural Minor Arterial in the 2040 *MTCP*, the *ECM* does not have a standard cross-section for this type of roadway functional classification. The deviation shows an interim four-lane Rural Minor Arterial cross-section with an additional eastbound 12-foot travel lane on the south side (Saddlehorn side).

Additional ROW would be required for completion of the full 4-lane section, but additional ROW is not available (not controlled by this development) on the north side of Judge Orr Road. Currently, Saddlehorn Ranch is dedicating an additional 40 feet of ROW to facilitate this in the future. Please refer to the attached deviation and deviation exhibit for more information.

COUNTY ROAD IMPROVEMENT FEE PROGRAM

El Paso County Road Impact Fee Program

This project will be required to participate in the El Paso County Road Improvement Fee Program. Saddlehorn Filing No. 3 will select the "Opt-out" option (no PID) and would pay the "Full Fee" amount at building permit. The current (2019) fee amount associated with this option is **\$3,850** per dwelling unit (subject to change). Based on 44 lots, the total building permit fee for this plat would be \$169,400.

IMPROVEMENTS SUMMARY TABLE

Table 10 contained in the Preliminary Plan TIS report presented the roadway improvement recommendations including auxiliary turn lane needs, traffic control, anticipated right-of-way dedication, and corridor preservation. An updated/modified copy of that table, addressing items specific to the proposed Filing No. 3, is included in this report as Table 4.

Additionally, US Highway 24/Stapleton is planned to be signalized. This project will need to escrow funds for this future signal on a pro-rata basis. Curtis Road, Judge Orr Road, and Stapleton Road north of Curtis Road are shown to need roadway upgrades on the 2040 *MTCP* based on anticipated growth and the Stapleton extension to Briargate Parkway. The intersections of Curtis/Judge Orr and Curtis/Falcon Highway may need to be upgraded to roundabout or traffic-signal control by 2040. All-way, stop-sign control may be an interim option prior to ultimate signalization or roundabout control.

CDOT PROCESS AND REQUIREMENTS

- US Highway 24/Stapleton is planned to be signalized. The CDOT comment letter for Filing No. 2 indicates that the applicant will be required to escrow a fair share amount toward the future traffic signal at the US Hwy 24/Stapleton Road intersection for this subdivision filing. An access permit will be required to process the escrow.
LSC Note: There are a number of developments – in progress and future/planned - in the area which will also add traffic to this intersection and impact the four-hour warrant. As CDOT collects escrow for other developments, LSC recommends that as the collective impact trips (directly impacting the four-hour warrant volumes) by area developments begins to exceed the 60 vehicle-per-hour denominator, fair-share recalculation of pro-rata share escrow amounts and credit be provided to developments according to the updated fair-share calculations. Also, once the signal is installed, credit should be provided from the Countywide Fee Program based on a ratio of fee program unit signal cost divided by the \$700K signal cost.
- Please refer to the attached improvements table (Table 4) for detailed calculations and additional information.
- The CDOT comment letter for Filing No. 2 states the following: Section 2.6 of the State Highway Access Code, states that if changes in land use, vehicle operation and access use from a state highway increase, an updated access permit will be required for the intersection US Hwy 24/Stapleton Road.

FINDINGS AND CONCLUSIONS

- Filing No. 3 is projected to generate about 444 vehicle trips on the average weekday.
- For Filing 3, during the weekday morning peak hour of adjacent street traffic, 9 vehicles would enter the site while 24 vehicles would exit.
- For Filing 3, during the weekday evening peak hour of adjacent street traffic, 28 vehicles would enter the site while 16 vehicles would exit.
- All Filing No. 3 proposed site accesses to Curtis Road and Judge Orr Road are projected to operate at LOS D or better during both peak hours through 2043. Please refer to the level of service section for additional information. The level of service analysis analyzes potential future roundabout traffic control at the intersections of Curtis Road/Judge Orr and Falcon Highway/Curtis Road during the long term. The roundabout may be needed in the future in order for all turning movements/approaches at the intersection to operate at an acceptable level of service (LOS D or better). Signal control may also be an option. All-way, stop-sign control may be an interim option prior to ultimate signalization or roundabout control.
- Please refer to the Improvements Table for a detailed list of roadway system improvements.
- Please refer to the “Auxiliary Turn-Lane Analysis” section above and corresponding items in the improvements table for recommendations related to Filing No. 3.
- All subdivision streets within the site should be designed and constructed to meet Rural Local criteria prescribed in the ECM.

- Please refer to the “CDOT requirements” section above regarding the Stapleton/US Hwy 24 intersection.
- This project will be subject to participation in the El Paso County Road Impact Fee Program. This project will select the “Opt-out” option (no PID) and would pay the “Full Fee” amount at building permit. The current fee amount is \$3,850 per dwelling unit (subject to change). Based on 44 lots, the total building permit fee for this plat would be \$169,400.

* * * * *

Please contact me if you have any questions regarding this report.

Respectfully Submitted,

LSC TRANSPORTATION CONSULTANTS, INC.

By: Jeffrey C. Hodsdon, P.E.
Principal

JCH/JAB:jas

Enclosures: **Table 4 - Table 5**
Figure 1 - Figure 12
Traffic Count Reports
Synchro LOS Reports
Approved Deviation (Curtis Road)(For Reference)
Approved Deviation (Judge Orr Road) (For Reference)

Tables 4-5



Table 4*: Roadway Improvements			
Saddlehorn Ranch Filing No. 3			
Offsite Intersections			
Item #	Improvement	Timing	Responsibility
US Highway 24/Judge Orr Intersection			
1.1	Realignment of Judge Orr Road at US Highway 24 per CDOT Hwy 24 PEL Study	Future (the PEL study identified this as a high priority project with a time frame of less than 5 years)	CDOT
1.2	Southwest-bound right-turn deceleration lane on US Hwy 24 approaching Judge Orr Road	As required by other development(s) or with realignment of US Hwy 24/Judge Orr	CDOT or by others
1.3	Construct southwest-bound right-turn acceleration lane on US Hwy 24 at Judge Orr Road	As required by other development(s) or with realignment of US Hwy 24/Judge Orr	CDOT or by others
1.4	Eastbound left-turn lane on Judge Orr Road approaching US Hwy 24	With realignment of US Hwy 24/Judge Orr	CDOT
1.5	Westbound dual left-turn lanes on Judge Orr Road approaching US Hwy 24	With realignment of US Hwy 24/Judge Orr	CDOT
1.6	Northeast-bound right-turn deceleration lane on US 24 approaching Judge Orr Road	With realignment of US Hwy 24/Judge Orr	CDOT
1.7	Eastbound right-turn deceleration lane on Judge Orr Road approaching US Hwy 24	As required by other development(s) or with realignment of US Hwy 24/Judge Orr	CDOT or by others
US Highway 24/Stapleton Intersection			
2.1a	CDOT Escrow for Participation in the cost of future signalization - \$79,500** (Note: Opportunity for County fee Program credit/reimbursement for a portion; also opportunity for cost recovery as other area project are required to escrow funds and if/when this development's overall fair share percentage is reduced accordingly in the future.	With the Filing No. 3 Plat	Applicant
2.1b	Signalize the intersection	Once warrants are met	CDOT is collecting escrow from area developments impacting this intersection.
Curtis Road/Falcon Highway			
3.1	Filing No. 3 Escrow toward the cost of future lengthening of the eastbound left-turn lane to ECM standards on Falcon Highway approaching Curtis Road	When warrants require improvements, a deviation will be submitted. Deviation not required at this time. For Existing plus Fil. 1-5, recommended "trigger": once projected queue (95th percentile) exceeds 50'	Escrow for pro-rata share of improvement or construction at the time of Filing No. 3 development (fee program credit per fee program provisions)
3.2	Long Term: ONLY In the case of a future signalized intersection or reverse of the TWSC Stop-sign traffic control orientation- Construct southbound right-turn deceleration lane on Curtis Road approaching Falcon Highway	Upon Signalization or reversal of the Stop-sign traffic control orientation. See footnote below.	Check for either trigger with future subdivision filings and a determination could be made at that time if this project should install the turn lane (with fee program credit per fee program provisions). Otherwise, with each filing, escrow for pro-rata share of improvement or construction if warranted at the time of development (fee program credit per fee program provisions)
3.2	Long Term: Reconstruct intersection as a modern roundabout (or signalize the intersection)	Once LOS of AWSC drops below acceptable levels (roundabout); or once signal warrants are met (for conversion to a signal or roundabout)	El Paso County – This intersection will be fee-program eligible for a signal/roundabout and applicant will pay fee program traffic impact fees.
Adjacent County Arterial Roadway ROW Requirements			
4.1	Judge Orr Right-of-Way Dedication - 4 Lane Minor Arterial, Rural 130' to 150 estimated right-of-way dedication' (Note: 4-lane Rural Principal is 180')	Shown in 2040 MTCP; Dedicate adjacent ROW with the Filing No. 3 Plat	Applicant
4.2	Judge Orr - 4 Lane Minor Arterial - Beyond above dedication, no additional right-of-way preservation needed.	Shown in 2060 Corridor Pres Plan	Applicant
4.3	Curtis Road - 2 Lane Rural Principal Arterial 72' from existing centerline/section line to proposed ROW lind. This translates to 42 feet of ROW dedication. (Note: 4-lane Rural Principal is 180')	Dedicate adjacent ROW with the Filing No. 3 Plat	Applicant
4.4	Curtis Road - 4 Lane Rural Principal Arterial 180' right-of-way preservation (90 feet east of the existing centerline/section line).	Shown in 2060 Corridor Pres Plan; Reserve up to 90 feet as required with the Filing No. 3 plat.	Applicant
Roadway Segment Improvements			
5.1	Falcon Highway - Upgrade to Two-Lane Rural Minor Arterial	Shown in 2040 MTCP	MTCP Project No. U5; Details TBD; applicant will pay fee program traffic impact fees.
5.2a	Judge Orr Road (Short Term) - Filing No. 3 construction plans show widening of the south side along the site frontage to include an additional 24' of asphalt pavement, plus a two-foot gravel shoulder. Please see Filing No. 3 CDs.	With development of Filing No. 3	Applicant with potential for negotiated fee program credit based on construction of the ultimate four-lane, Rural Minor Arterial half section. This will be subject to submission and review and potential acceptance of a proposed fee program credit agreement by EPC and the Fee Program Committee.
5.2b	Judge Orr Road (Long Term) - Future widening on the north side to completed the ultimate Four Lane Rural Minor Arterial	Four-lane Rural Minor Arterial Shown in 2040 MTCP	MTCP Project No. C15; Details TBD; - applicant will pay fee program traffic impact fees.
5.3a	Short Term: Curtis Road Adjacent to Filing No. 1 - Interim upgrades to Curtis Road - to be constructed with Filing No. 1 - Please refer approved Filing No. 1 CDs.	To be constructed with Filing No. 2	Applicant with potential for negotiated fee program credit based on constructed half-section. This will be subject to submission and review and potential acceptance of a proposed fee program credit agreement by EPC and the Fee Program Committee.
5.3b	Short Term: Curtis Road Adjacent to Filing No. 2 - Interim upgrades to Curtis Road - to be constructed with Filing No. 2 - Please refer to Filing No. 2 CDs.	To be constructed with Filing No. 2	Applicant with potential for negotiated fee program credit based on constructed half-section. This will be subject to submission and review and potential acceptance of a proposed fee program credit agreement by EPC and the Fee Program Committee.
5.3c	Short Term: Curtis Road Adjacent to Filing No. 3 - Interim upgrades to Curtis Road - to be constructed with Filing No. 3 - Please refer to Filing No. 3 CDs.	To be constructed with Filing No. 3	Applicant with potential for negotiated fee program credit based on constructed half-section. This will be subject to submission and review and potential acceptance of a proposed fee program credit agreement by EPC and the Fee Program Committee.
5.3d	Long Term: Curtis Road - Upgrade to Two-Lane Rural Principal Arterial	Shown in 2040 MTCP; (Future - TBD - Limited ROW available on the west side. Please refer to approved Curtis Road Deviation). The segment from the south border of Saddlehorn and Falcon Highway is adjacent to the Meadowlake Industrial Park development. Please refer to the most recent TIS for that project for additional information.	MTCP Project No. U1; Applicant per rezone condition of approval, potentially subject to fee program credit.
Internal Subdivision Roadways			
6.1	Construct internal Filing No. 3 streets to County Rural Local Standards	Per the Filing 3 Construction Plans	Applicant
Adjacent Intersection and Access Intersections			
Judge Orr/Curtis Road Intersection			
7.1	Westbound right-turn deceleration lane	Once peak-hour westbound right-turn volume exceeds 50 vehicles per hour.	Escrow a pro-rata share for future construction with Filing No. 3 (fee program credit per fee program provisions)
7.2	Eastbound right-turn deceleration lane	Currently warranted by ECM. However, please refer to the Filing No. 2 TIS report narrative for the provision in the "State Highway Access Code" Section 3.5 (S) for low through volumes). Evaluate with future Final Plans. By Filing 5 (the last filing) a determination would be made if Saddlehorn Ranch should construct the turn lane or provide escrow toward future construction by others.	Check for eastbound through and right turning thresholds (as described in the report narrative) with future subdivision filings and a determination could be made at that time if this project should install the turn lane (with fee program credit per fee program provisions). Otherwise escrow a pro-rata share for future construction with Filing No. 3 (fee program credit per fee program provisions).
7.3	Potentially sign for all-way stop-sign control (AWSC)	Once warrants for AWSC are met	El Paso County
7.4	Long Term: Reconstruct intersection as a modern roundabout (or signalize the intersection)	Once LOS of AWSC drops below acceptable levels (roundabout); or once signal warrants are met (for conversion to a signal or roundabout)	El Paso County. This intersection will be fee-program eligible for a signal/roundabout and applicant will pay fee program traffic impact fees.
7.5	Long Term: In the case of a future signalized intersection - lengthening of northbound and southbound left-turn deceleration lanes.	As needed based on future speed limit and turning volume/stacking length criteria.	Escrow for improvement or construction if warranted at the time of development (fee program credit per fee program provisions)
7.6	Northbound Left Turn Lane - potential future lengthening (restriping)	Proposed trigger - once intersection is signalized Or if Stop signs are switched to EB and WB or while NB stop control remains, if queue reaches lengths	Escrow for improvement or construction if warranted at the time of development (fee program credit per fee program provisions)
Judge Orr/Barrosito Trail			
8.1	No Auxiliary Turn Lanes Required Construction Plans show an eastbound right-turn deceleration lane to be constructed with Filing 3	To be constructed with Filing No. 3	Applicant
Judge Orr/Del Cambre Trail			
9.1	No Auxiliary Turn Lanes Required Construction Plans show an eastbound right-turn deceleration lane to be constructed with Filing 3	To be constructed with Filing No. 3	Applicant
Curtis Road/Oscuro Trail			
10.1	Short Term Please Refer to Filing No. 2 TIS. Filing 3 is not projected to generate any left- or right-turning movements at this intersection. NOTE: The northbound right turn deceleration lane (Filing No. 1 improvement) has not yet been constructed.		
10.2	Long Term Please Refer to Filing No. 2 TIS. Filing 3 is not projected to generate any left- or right-turning movements at this intersection		
Curtis Road/Benito Wells Trail			
11.1	Short Term Construction Plans show Auxiliary Turn Lanes to be constructed with Filing 2	Construction Plans show Auxiliary Turn Lanes to be constructed with Filing 2	Applicant
11.2	Long Term Construct southbound left-turn deceleration lane on Curtis Rd approaching the site access	To be constructed with Filing No. 2	Applicant
11.3	Long Term Construct northbound right-turn deceleration lane on Curtis Rd approaching the site access	To be constructed with Filing No. 2	Applicant
* Modified version of Table 10 From the Saddlehorn Ranch Preliminary Plan TIS dated March 11, 2020.			
Note: Items with red borders - Filing No. 3 related; items in blue border - modifications associated with Filings 1 or 2.			
** Note: CDOT Formula taken from Filing No. 2 review letter: [for Filing 2] The development is required to participate in the cost of the future traffic signal at Stapleton and Hwy 24. Based on the average AM&PM site-generated passenger cars directly impacting the 4-hour warrant, the development would be responsible for ~\$75,000 [Filing 2 amount], (6.5 new vehicles / 60 vehicles-to-warrant x ~\$700K/signal cost). Filing 3 amount calculated using 44 lots/42 lots x Filing 2 amount			
Item 3.2 Note: The default ECM trigger for this potential right turn lane is 25 vph. However, since the southbound approach is currently Stop-sign controlled, the turn lane is not currently needed due to speed differential between through traffic and right turning traffic. LSC recommends the following triggers: a. Once the intersection is signalized (if as signal is the selected future traffic control instead of a modern roundabout) or b. If El Paso County switches the orientation of the stop signs such that Curtis is changed to the "major street" and Falcon Highway is changed to the "minor street" (the intersection remains two-way, stop-sign control). The check for either trigger could occur with future subdivision filings and a determination could be made at that time if this project should install the turn lane (with fee-program credit per fee program provisions). If neither trigger is met, escrow for pro-rata share of this potential improvement with each Filing. Per EPC, Saddlehorn values alone would exceed 25 vph, which could trigger the improvement LSC would suggest escrow in lieu of lane construction if the above two triggers are not met as the lane could potentially be "thrown away" if a roundabout is selected as the future traffic control. The escrow for the southbound right turn lane could potentially be returned to the applicant, as it would not be necessary with a roundabout.			
Source: LSC Transportation Consultants, Inc. REVISIONS: 1/31/2024 -see note below. Prior revisions: 2/8/2022, 11/18/2022 for Filing No. 2, 1/20/2023 and 4/30/2023 & 12/22/23 for Filing No. 3			
Note: The minor change on 1/31/2024 was to 3.1 (Timing column)			

Table 5: Detailed Trip Generation Estimate

Filing Number	Status	ITE		Inputs		Trip Generation Rates ²					Driveway Trips Generated					
		Code	Description	Values	Units ¹	Average Weekday	A.M.		P.M.		Average Weekday	A.M.		P.M.		
							In	Out	In	Out		In	Out	In	Out	
By Filing Number																
Filing 1	Approved	210	Single-Family (Detached) Housing	49	DU	10.09	0.19	0.55	0.63	0.37	494	9	27	31	18	
Filing 2	Under Review	210	Single-Family (Detached) Housing	42	DU	10.09	0.19	0.55	0.63	0.37	424	8	23	26	15	
Filing 3	This Report	210	Single-Family (Detached) Housing	44	DU	10.09	0.19	0.55	0.63	0.37	444	9	24	28	16	
Filing 4	Future	210	Single-Family (Detached) Housing	42	DU	10.09	0.19	0.55	0.63	0.37	424	8	23	26	15	
Filing 5	Future	210	Single-Family (Detached) Housing	41	DU	10.09	0.19	0.55	0.63	0.37	414	8	23	26	15	
			Total	218	DU						Total	2200	42	120	136	80
Cumulative by Filing Number																
Filing 1		210	Single-Family (Detached) Housing	49	DU	-	-	-	-	-	494	9	27	31	18	
Filings 1-2		210	Single-Family (Detached) Housing	91	DU	-	-	-	-	-	918	18	50	57	33	
Filings 1-3		210	Single-Family (Detached) Housing	135	DU	-	-	-	-	-	1362	26	74	85	50	
Filings 1-4		210	Single-Family (Detached) Housing	177	DU	-	-	-	-	-	1786	34	98	111	65	
Filings 1-5		210	Single-Family (Detached) Housing	218	DU	-	-	-	-	-	2200	42	120	136	80	
¹ DU = Dwelling Units ² Source: <i>Trip Generation, 11th Edition (2021)</i> by the Institute of Transportation Engineers (ITE)																

Figures 1-12



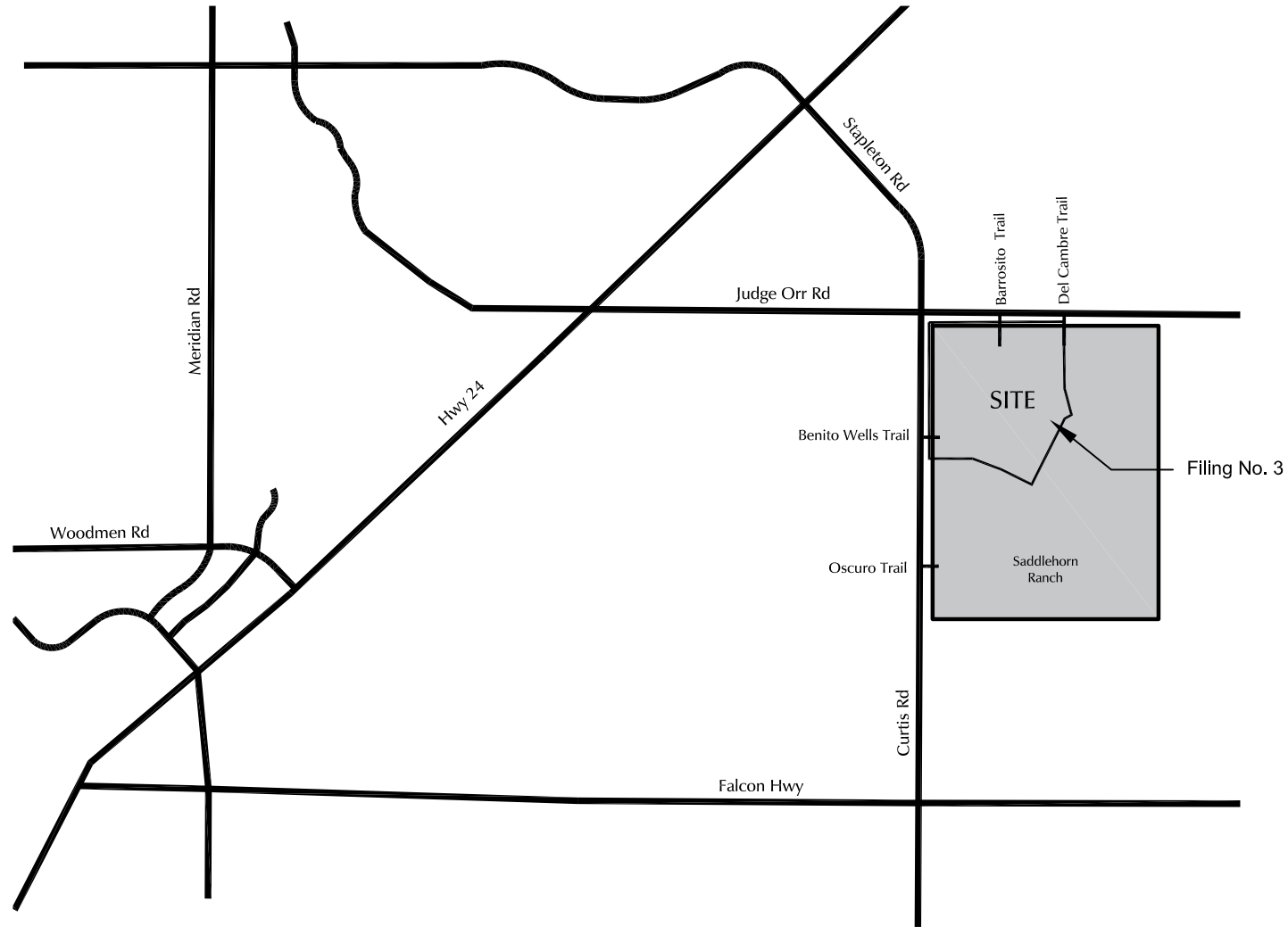

Figure 1
Vicinity Map

Saddlehorn Ranch Filing 3 (LSC # S224540)

Approximate Scale
1" = 100'



Barrosito Trail

Del Cambre Trail

1,320'

1,417'

Judge Orr Road

ROCOSO TRAIL

BARROSITO TRAIL

DEL CAMBRE TRAIL

CARRIZO SPRINGS ROAD

2,750'

Curtis Road

ESTACADO PLACE

BENITO WELLS TRAIL

SAN ISIDRO TRAIL

* SADDLEHORN RANCH

* RE

To Oscuro Trail
2,540'

 Filing No. 3

Figure 2
Site Plan

Saddlehorn Ranch Filing 3 (LSC # S224540)



- Please refer to the “CDOT requirements” section above regarding the Stapleton/US Hwy 24 intersection.
- This project will be subject to participation in the El Paso County Road Impact Fee Program. This project will select the “Opt-out” option (no PID) and would pay the “Full Fee” amount at building permit. The current fee amount is \$3,850 per dwelling unit (subject to change). Based on 44 lots, the total building permit fee for this plat would be \$169,400.

* * * * *

Please contact me if you have any questions regarding this report.

Respectfully Submitted,

LSC TRANSPORTATION CONSULTANTS, INC.

By: Jeffrey C. Hodsdon, P.E.
Principal

JCH/JAB:jas

Enclosures: **Table 4 - Table 5**
Figure 1 - Figure 12
Escrow Table w/Supplemental Figures
Traffic Count Reports
Synchro LOS Reports
Approved Deviation (Curtis Road)(For Reference)
Approved Deviation (Judge Orr Road) (For Reference)

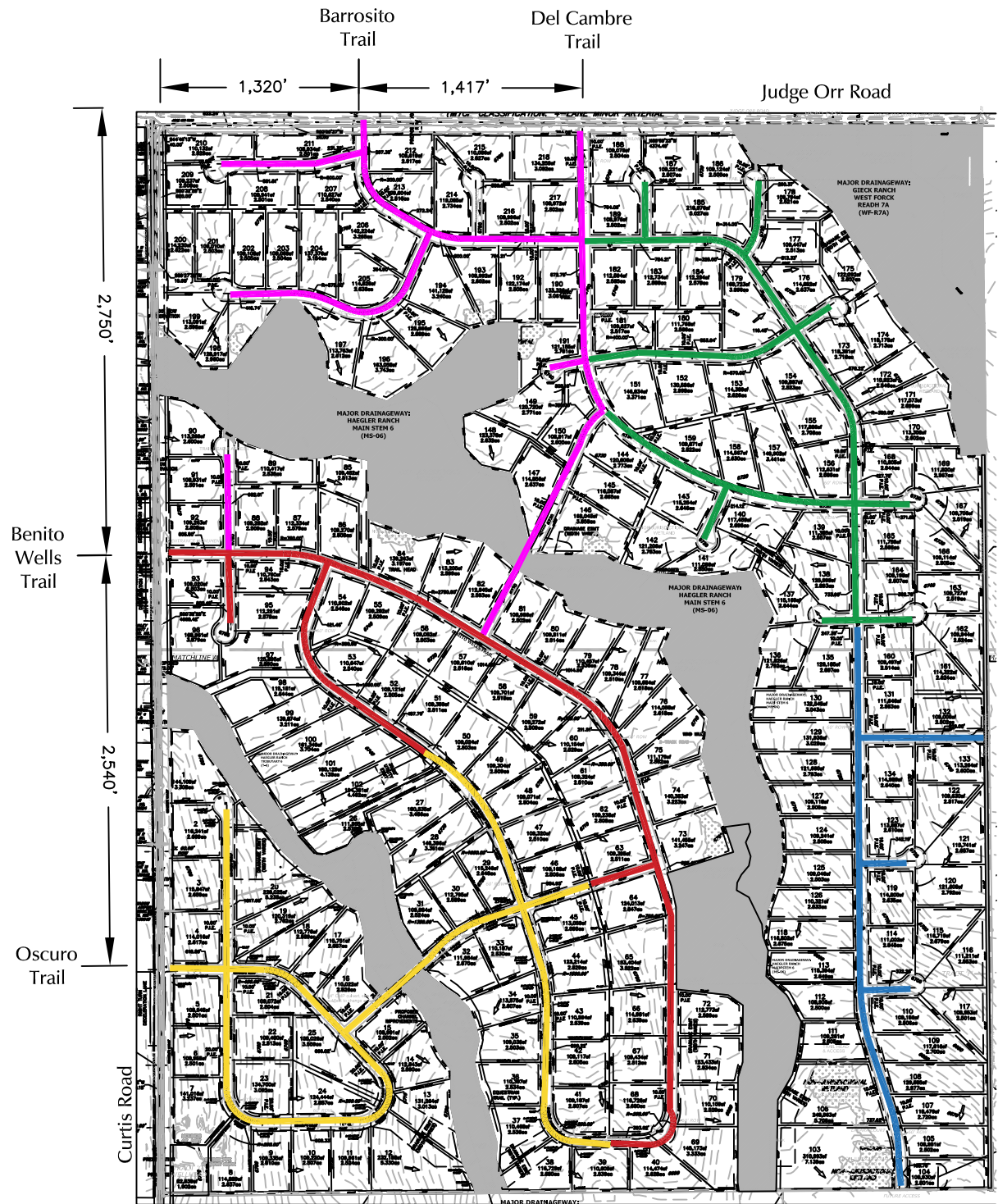

-  Filing 1
-  Filing 2
-  Filing 3
-  Filing 4
-  Filing 5

Figure 3

Roadways to be Constructed by Subdivision Filing

Saddlehorn Ranch Filing 3 (LSC # S224540)



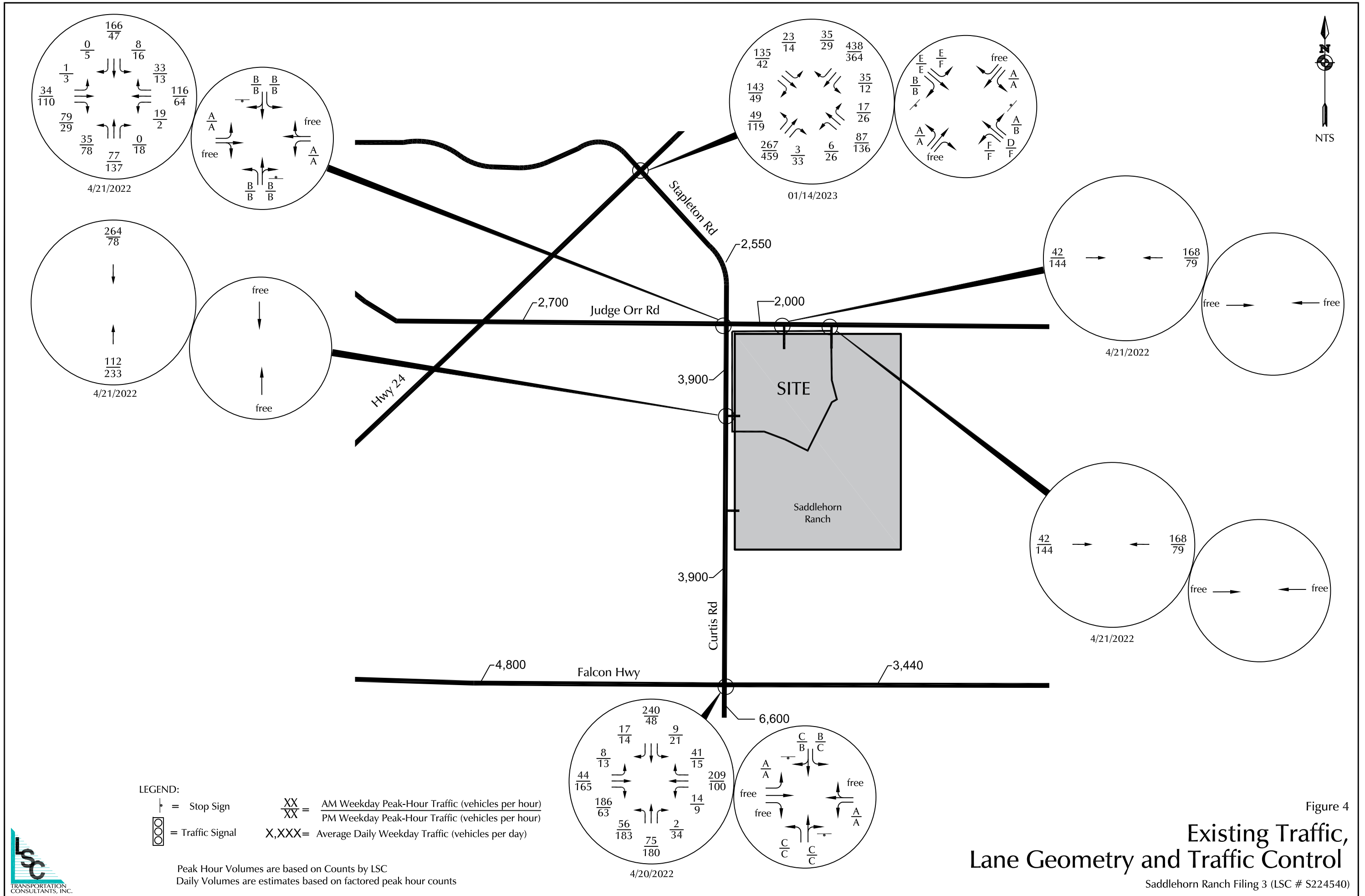

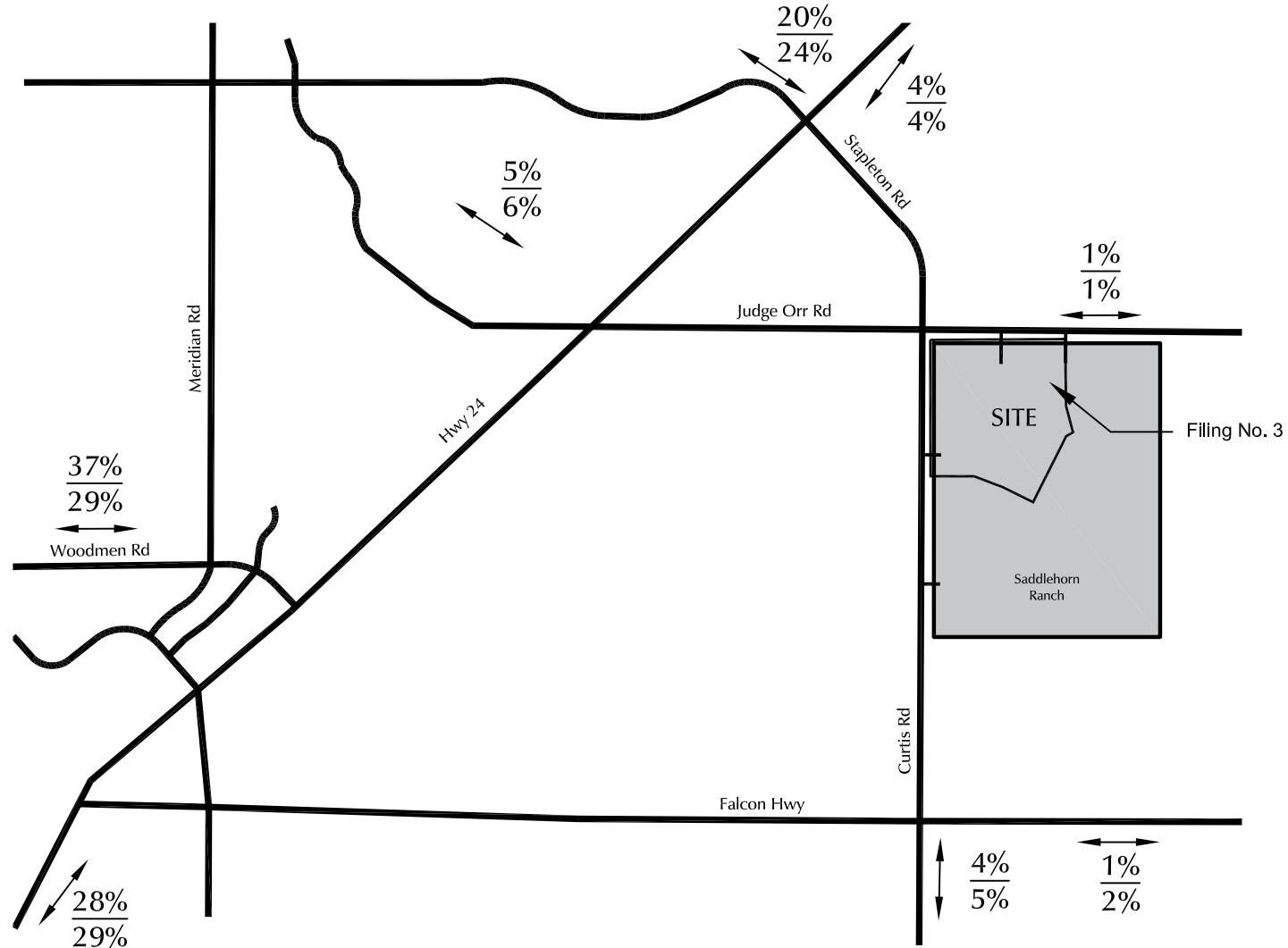

LEGEND:
 $\frac{XX\%}{XX\%} = \frac{\text{Percent Short-Term Distribution}}{\text{Percent Long-Term Distribution}}$

Estimated Directional Distribution of Site-Generated Traffic

Figure 5

Saddlehorn Ranch Filing 3 (LSC # S224540)

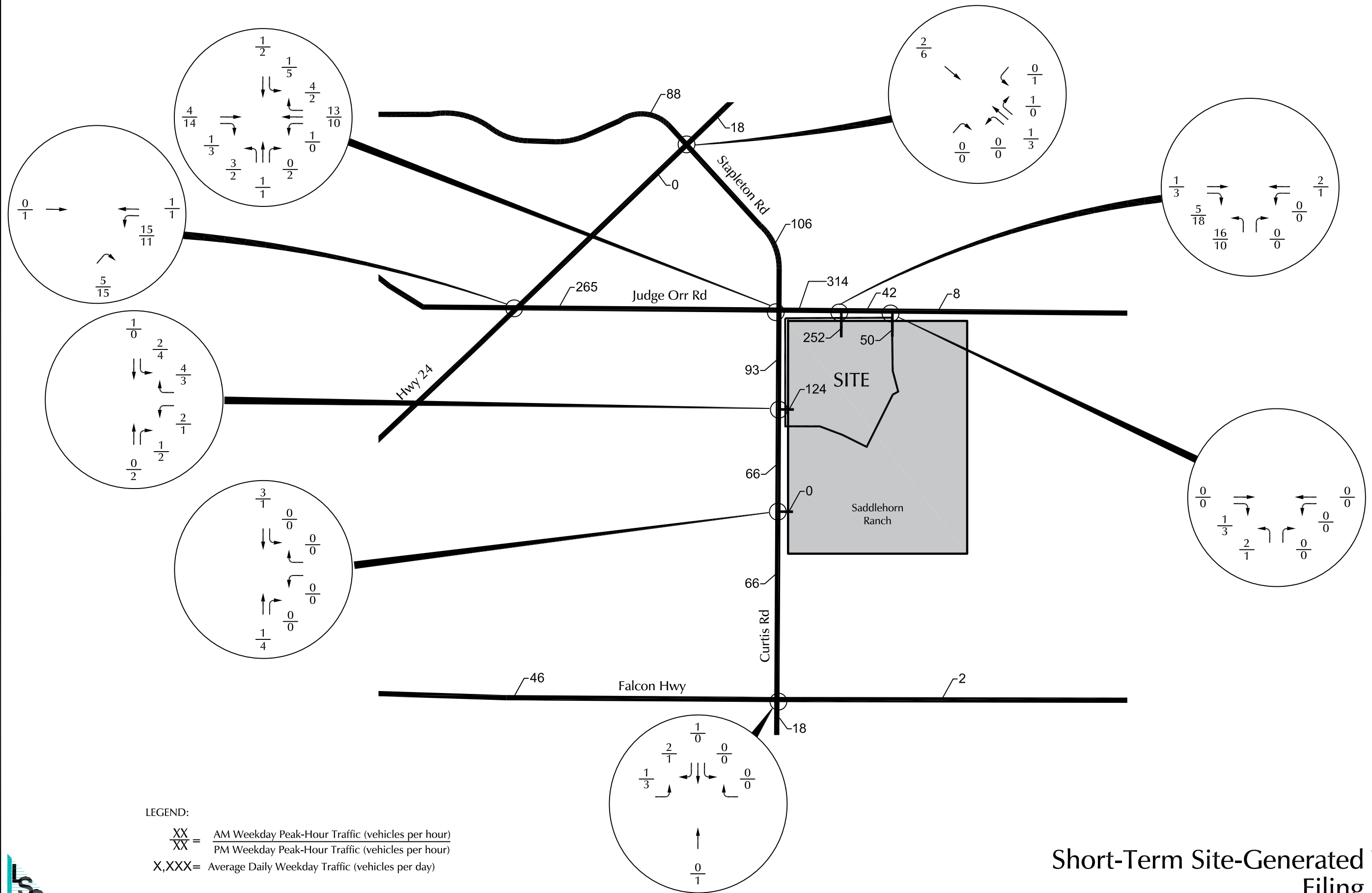

LEGEND:

- $\frac{XX}{XX}$ = AM Weekday Peak-Hour Traffic (vehicles per hour)
- $\frac{XX}{XX}$ = PM Weekday Peak-Hour Traffic (vehicles per hour)
- X,XXX= Average Daily Weekday Traffic (vehicles per day)



Figure 6
**Short-Term Site-Generated Traffic,
 Filing 3 Only**
 Saddlehorn Ranch Filing 3 (LSC # S224540)

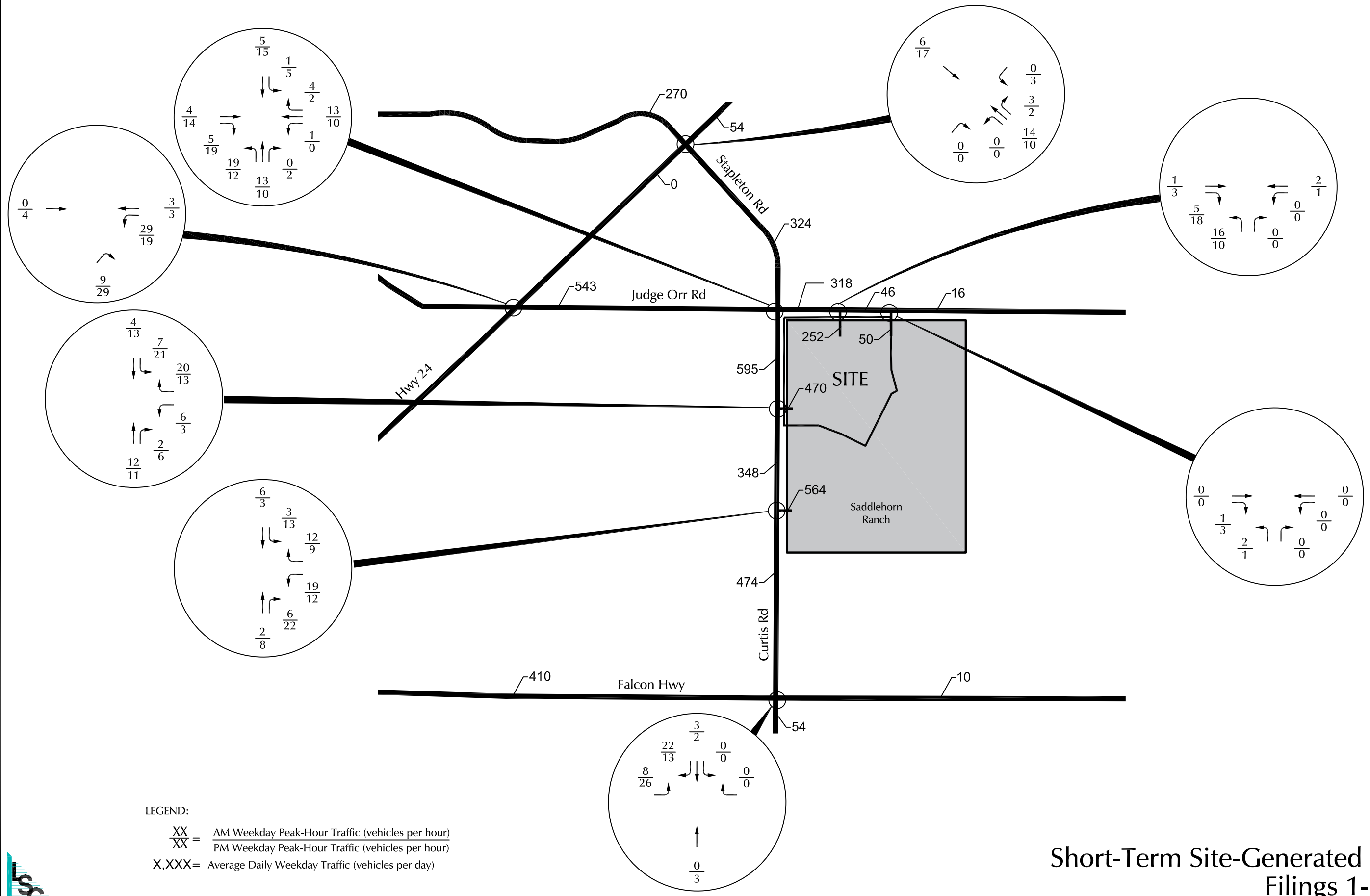

LEGEND:
 $\frac{XX}{XX}$ = AM Weekday Peak-Hour Traffic (vehicles per hour)
 $\frac{XX}{XX}$ = PM Weekday Peak-Hour Traffic (vehicles per hour)
 X,XXX= Average Daily Weekday Traffic (vehicles per day)



Figure 7
 Short-Term Site-Generated Traffic,
 Filings 1-3 Only
 Saddlehorn Ranch Filing 3 (LSC # S224540)

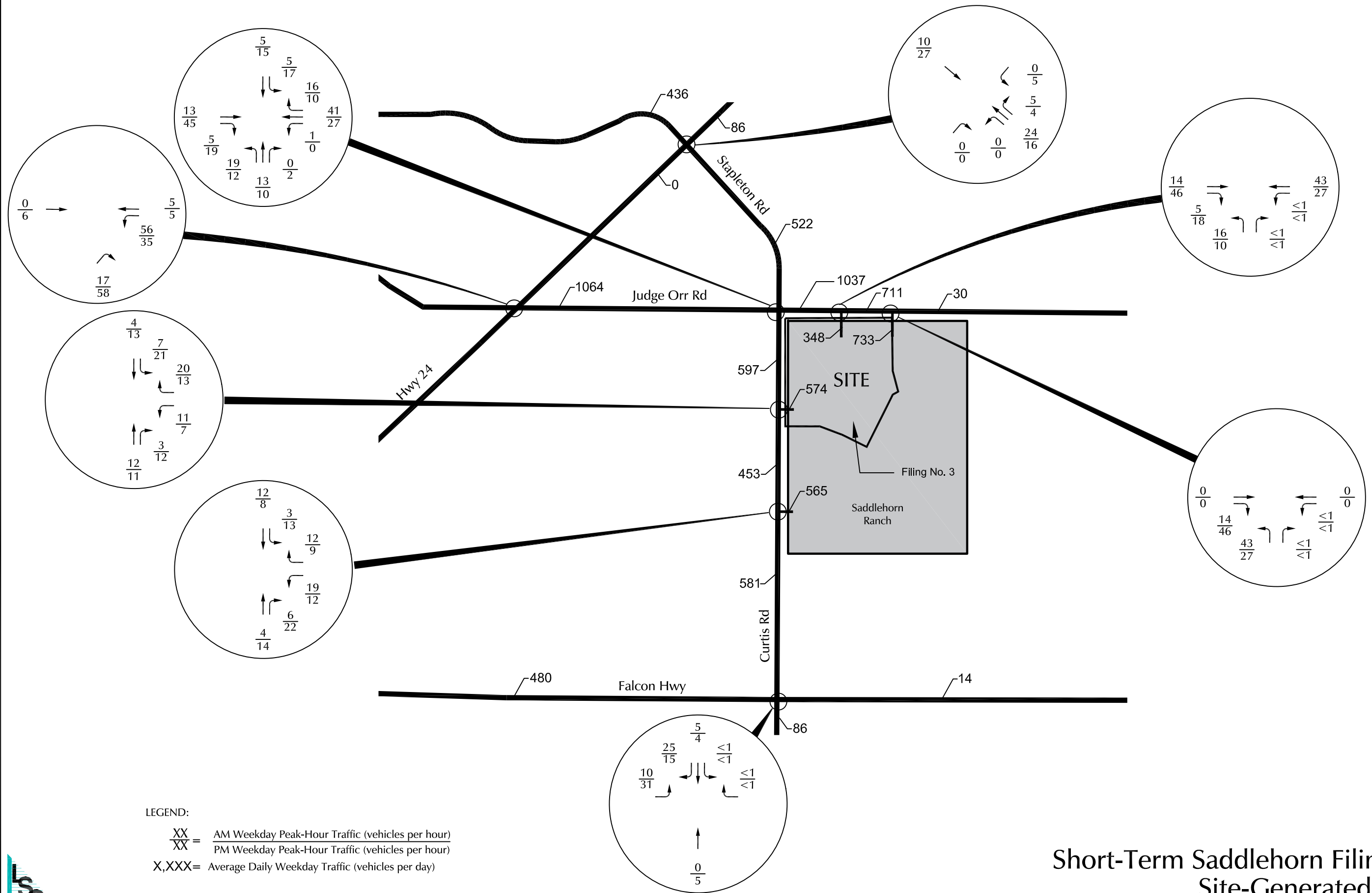

LEGEND:
 $\frac{XX}{XX}$ = AM Weekday Peak-Hour Traffic (vehicles per hour)
 $\frac{XX}{XX}$ = PM Weekday Peak-Hour Traffic (vehicles per hour)
 X,XXX= Average Daily Weekday Traffic (vehicles per day)



Figure 8
Short-Term Saddlehorn Filings 1-5
Site-Generated Traffic
 Saddlehorn Ranch Filing 3 (LSC # S224540)

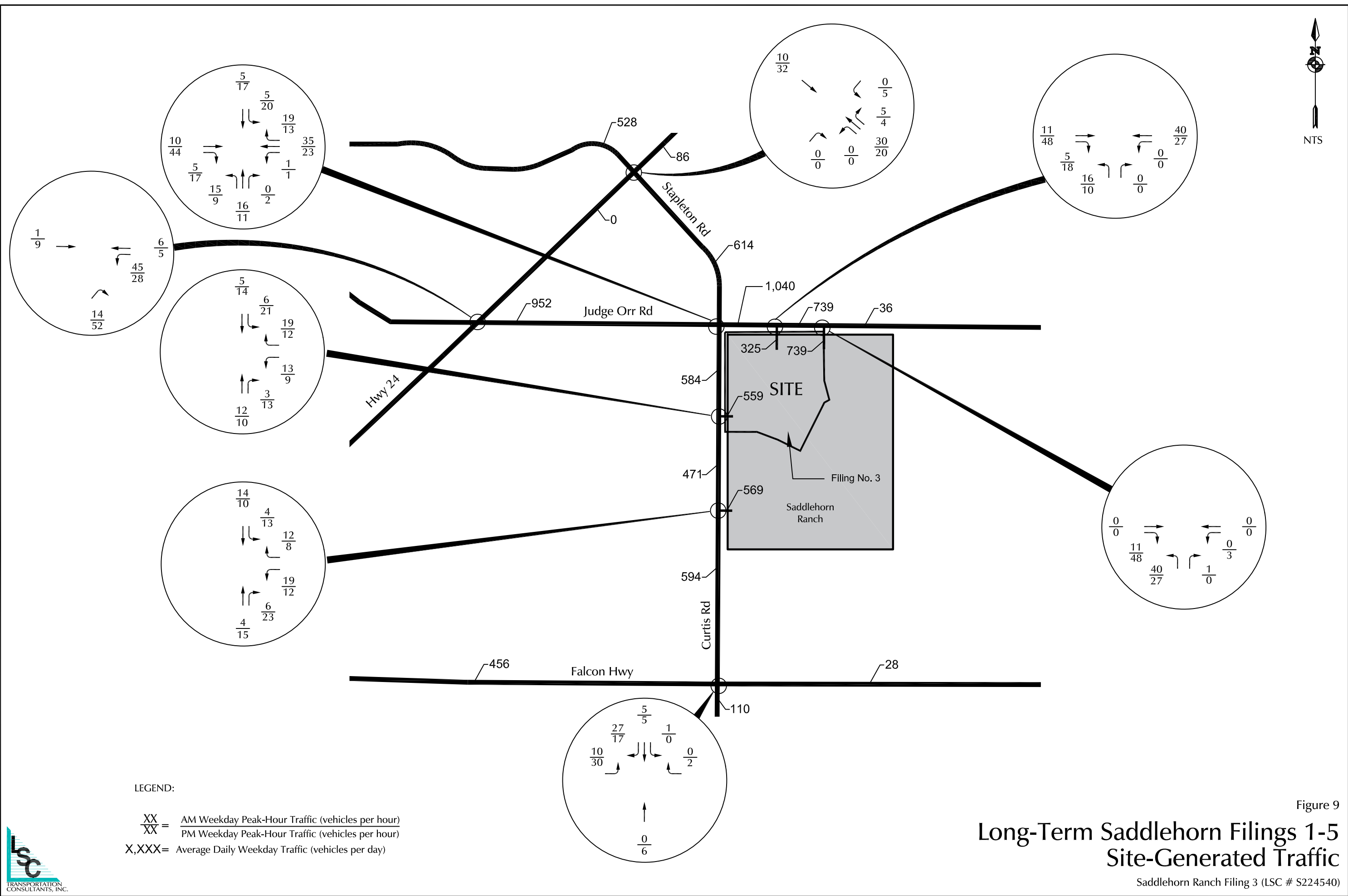

Figure 9
Long-Term Saddlehorn Filings 1-5
Site-Generated Traffic
 Saddlehorn Ranch Filing 3 (LSC # S224540)

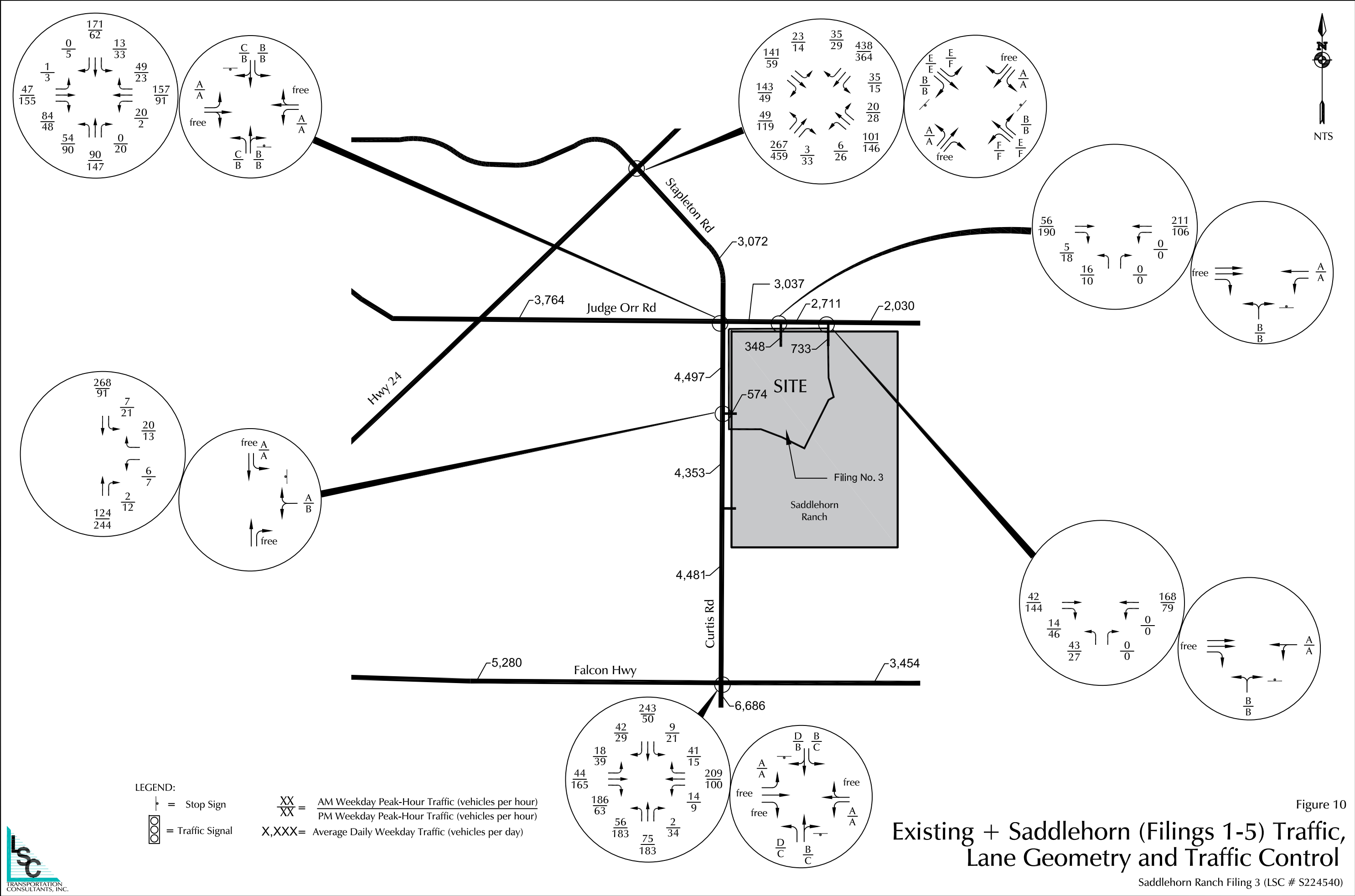
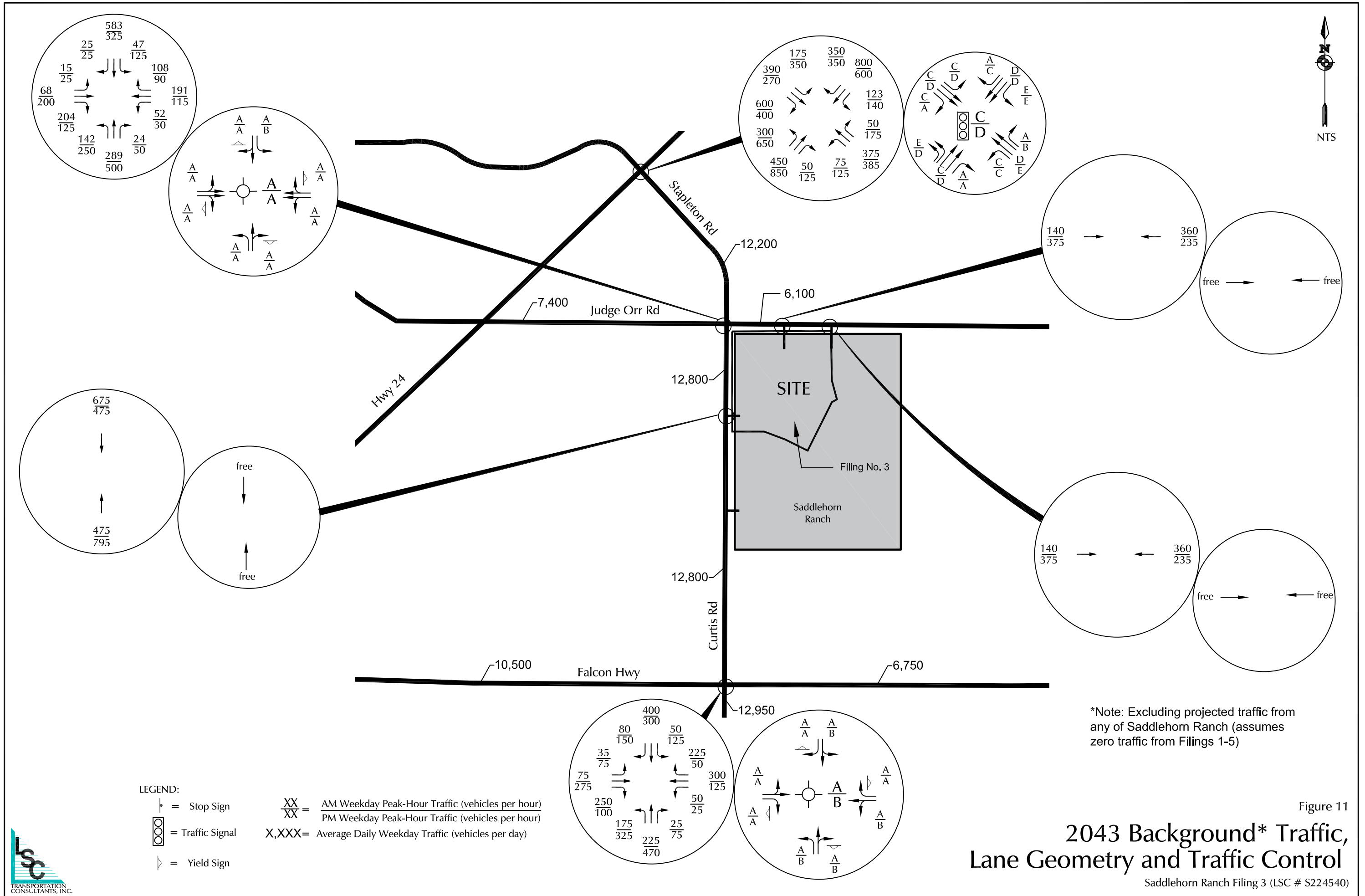

Figure 10

Existing + Saddlehorn (Filings 1-5) Traffic, Lane Geometry and Traffic Control

Saddlehorn Ranch Filing 3 (LSC # S224540)





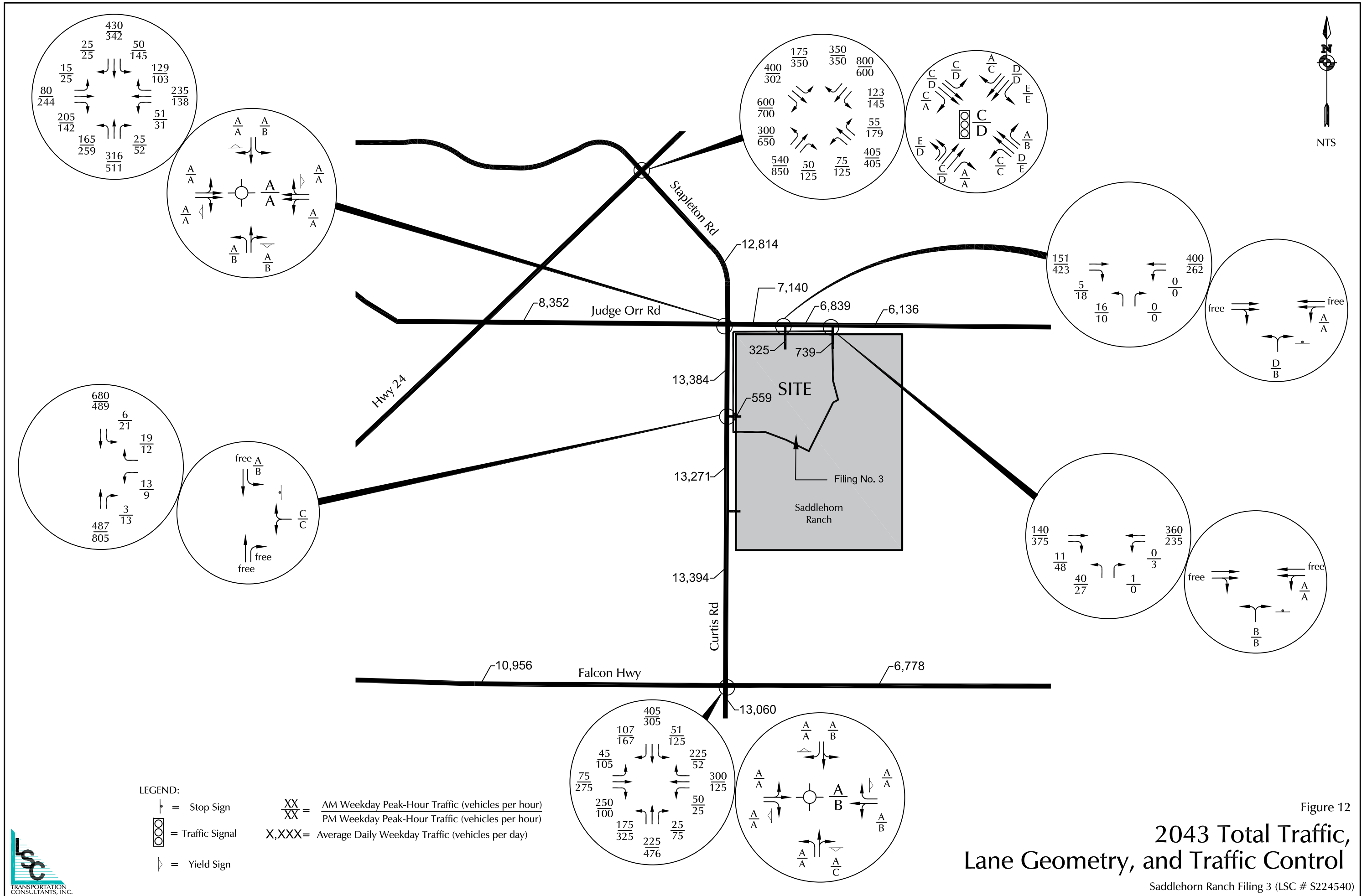

**Escrow Analysis for Off Site Improvements
Saddlehorn Ranch Filing No. 3**

Intersection Improvement	Trigger (vph)	TIS Report Short Term Site Generated Traffic Volumes				TIS Report LONG Term Site Generated Traffic Volumes				TIS Report Volumes				Percentages of Short-Term Total	Average of AM and PM Percentages	Percentages of 2043 Total	Average of AM and PM Percentages	25% of Filing No. 1 (Avg of AM and PM)	Filing No. 3 plus 25% of Filing No. 1 (Avg. or AM & PM)	Recommended Percentage for Escrow(1)	EPC Staff Override Value	Estimated Total Improvement Cost	From Filing No. 2 Dollar Amount From the Prior Table for Fil. No. 2 (to be paid)	Totals	Adjusted Totals	Remaining Amounts For Filings 4 and 5
		AM	PM	AM	PM	AM	PM	AM	PM	AM	PM	AM	PM													
		Projected Short-Term Total Traffic (TIS Fig 9)		2043 Projected Total Traffic		Percentages of Short-Term Total		Average of AM and PM Percentages		Percentages of 2043 Total		Average of AM and PM Percentages														
Judge Orr/Curtis																							Filing No. 3 + 25% of Filing No. 1 Amts.		Adjusted	
Eastbound Right Turn Deceleration Lane	50	1	3	1	3	84	48	205	142	1.2%	6.3%	3.7%	0.5%	1.9%	1.2%	2.650%	**	2.7%		\$112,623		\$3,004.62	\$3,016.69			
Northbound Left Turn Lane - potential future lengthening (restriping)	260(2)	3	2	2	2	54	90	165	259	5.6%	2.2%	3.9%	1.4%	0.6%	1.0%	0.847%	1.9%	1.9%		\$18,125		\$336.09	\$370.84			
Westbound Right Turn Deceleration Lane	50	4	2	5	3	49	23	129	103	8.2%	8.7%	8.4%	3.7%	2.5%	3.1%			3.1%		\$119,873		\$3,719.92	\$3,719.92			
TIS Figure Reference		(Figure 6)				(see attached supplemental figures)				(Figure 10)	(Figure 12)															
Filing 1 - 3																							of Filing No. 1 + Prior Filing 2 Table Amt.		Remaining Amounts For Filings 4 and 5	
Eastbound Right Turn Deceleration Lane	50	5	19	5	17	84	48	205	142	6.0%	39.6%	22.8%	2.4%	12.0%	7.2%					\$112,623	\$22,625	\$25,642	\$0			
Northbound Left Turn Lane - potential future lengthening (restriping)	260(2)	19	12	15	9	54	90	165	259	35.2%	13.3%	24.3%	9.1%	3.5%	6.3%					\$18,125	\$768	\$1,139	\$0			
Westbound Right Turn Deceleration Lane	50	4	2	5	3	49	23	129	103	8.2%	8.7%	8.4%	3.7%	2.5%	3.1%					\$119,873	\$0	\$3,720	\$12,673			
TIS Figure Reference		(Figure 7)				(see attached supplemental figures)				(Figure 10)	(Figure 12)										\$23,393	\$30,501	\$12,673			
Filing 1-5																							Filing 1-5 amts.		Remaining Amounts For Filings 4 and 5	
Eastbound Right Turn Deceleration Lane	50	5	19	5	17	84	48	205	142	6.0%	39.6%	22.8%	2.4%	12.0%	7.2%					\$112,623	\$25,642	\$25,642	\$0			
Northbound Left Turn Lane - potential future lengthening (restriping)	260(2)	19	12	15	9	54	90	165	259	35.2%	13.3%	24.3%	9.1%	3.5%	6.3%					\$18,125	\$1,463	\$1,139	\$0			
Westbound Right Turn Deceleration Lane	50	16	10	19	13	49	23	129	103	32.7%	43.5%	38.1%	14.7%	12.6%	13.7%					\$119,873	\$13,253	\$16,393	\$12,673			
TIS Figure Reference		(Figure 8)				(Figure 9)				(Figure 10)	(Figure 12)										\$40,358	\$43,173.26	\$12,673			
Falcon Highway/Curtis																							Filing No. 3 + 25% of Filing No. 1 Amts.		Adjusted	
Southbound Right Turn Deceleration Lane	25(3)	2	1	3	3	42	29	107	167	4.8%	3.4%	4.1%	2.8%	1.8%	2.3%	7.32%	9.6%	9.6%		\$99,978		\$9,617.91	\$9,617.91			
Eastbound Left turn Deceleration Lane Lengthening	50(4)	1	3	1	3	18	39	45	105	5.6%	7.7%	6.6%	2.2%	2.8%	2.5%	2.94%	5.4%	5.4%	42.7%	\$66,092		\$28,221.38	\$28,221.38			
TIS Figure Reference		(Figure 6)				(see attached supplemental figures)				(Figure 10)	(Figure 12)															
Filing 1 - 3																							of Filing No. 1 + Prior Filing 2 Table Amt.		Remaining Amounts For Filings 4 and 5	
Southbound Right Turn Deceleration Lane	25(3)	22	13	24	15	42	29	107	167	52.4%	44.8%	48.6%	22.2%	8.8%	15.5%					\$99,978	\$22,542	\$32,160	\$23,451			
Eastbound Left turn Deceleration Lane Lengthening	50(4)	8	26	8	25	18	39	45	105	44.4%	66.7%	55.6%	17.8%	24.0%	20.9%				82.2%	\$66,092	\$26,092	\$54,313	\$11,779			
TIS Figure Reference		(Figure 7)				(see attached supplemental figures)				(Figure 10)	(Figure 12)										\$48,634	\$86,473	\$35,231			
Filing 1-5																							Filing 1-5 amts.		Remaining Amounts For Filings 4 and 5	
Southbound Right Turn Deceleration Lane	25(3)	25	15	27	17	42	29	107	167	59.5%	51.7%	55.6%	25.2%	10.2%	17.7%					\$99,978	\$61,439	\$55,611	\$23,451			
Eastbound Left turn Deceleration Lane Lengthening	50(4)	10	31	10	30	18	39	45	105	55.6%	79.5%	67.5%	22.2%	28.6%	25.4%				100.0%	\$66,092	\$66,092	\$66,092	\$11,779			
TIS Figure Reference		(Figure 8)				(Figure 9)				(Figure 10)	(Figure 12)										\$127,532	\$127,532	\$127,532	\$11,779		
																							\$167,890	\$164,877		

(1) LSC General Note Regarding Escrows: There are a number of developments -- in progress and future/planned - in the area which will also add traffic to these intersection turn lanes. As El Paso County collects escrow for other developments also impacting these turning movements, LSC recommends that as the collective impact trips (directly impacting these turn movements) changes/increases, fair-share recalculation of pro-rata share escrow amounts and credit be provided to developments according to the updated fair-share calculations. Also, once the improvements are completed, applicable/allowable Countywide Fee Program credits for construction of intersection approach improvements (turn lanes) be applied based on a ratio of fee program unit cost divided by the improvement cost.

(2) 265' current length; 56/183 ex. vol.; 9/5 Fil 2 vol. 260' Stacking - future trigger... once intersection is signalized OR if stop signs are switched to EB and WB or while NB stop control remains, if queue reaches lengths that overspill the lane, at a frequency more than "infrequently."

(3) The default ECM trigger for this potential right-turn lane is 25 vph. However, since the southbound approach is currently stop-sign controlled, the turn lane is not currently needed due to speed differential between through traffic and right-turning traffic. LSC recommends the following triggers:
o Once the intersection is signalized (if as signal is the selected future traffic control instead of a modern roundabout) or
o If El Paso County switches the orientation of the stop signs such that Curtis is changed to the "major street" and Falcon Highway is changed to the "minor street" (the intersection remains two-way, stop-sign controlled).
The check for either trigger could occur with future subdivision filings and a determination could be made at that time if this project should install the turn lane (with fee-program credit per fee program provisions). If neither trigger is met, escrow for pro-rata share of this potential improvement with each Filing. Per EPC, Saddlehorn values alone would exceed 25 vph, which could trigger the improvement LSC would suggest escrow in lieu of lane construction if the above two triggers are not met, as the lane could potentially be "throw away" if a roundabout is selected as the future traffic control. The escrow for the southbound right-turn lane could potentially be returned to the applicant, as it would not be necessary with a roundabout.

(4) 290' current full-width left-turn lane length; for Existing plus Fil. 1-5, recommended "trigger:" once projected queue (95th percentile) exceeds 50'

(5) Long Term Filing 2 Percentage plus 25% of the Filing No. 1 long-term percentage (Filings 1&2 minus Filing No. 2) (25% of Filing No. 1 is to "catch up", split between Filings 2-5, since no escrow was provided with Filing No. 1)

Traffic Volume - Net New Site Trips

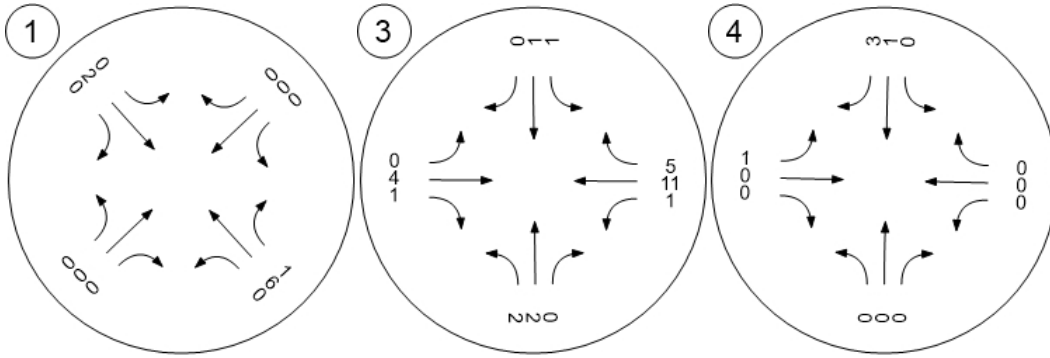

Traffic Volume - Net New Site Trips

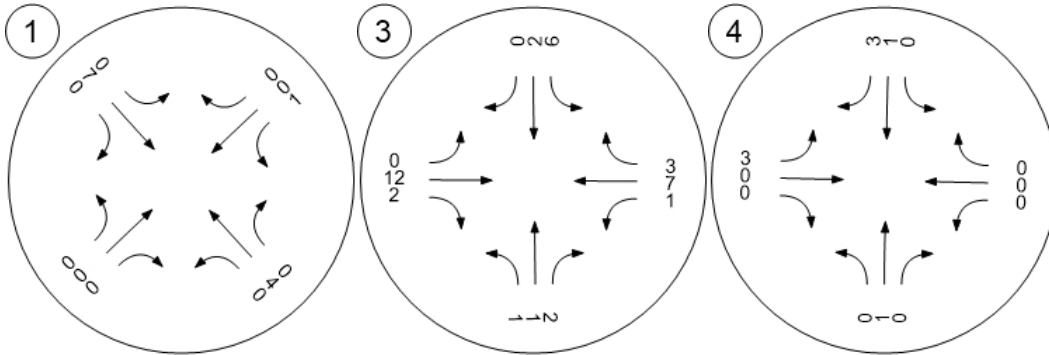

Traffic Volume - Net New Site Trips

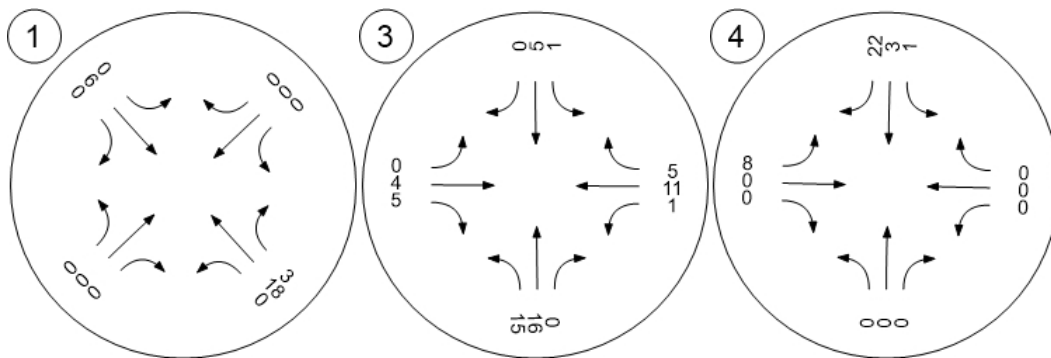

Traffic Volume - Net New Site Trips

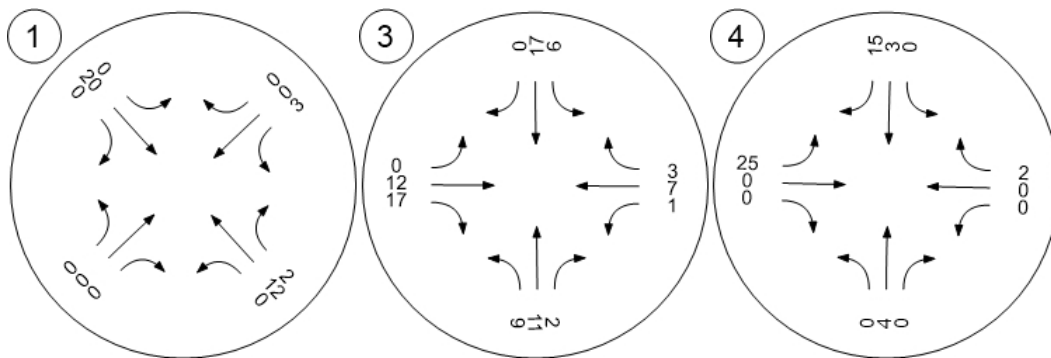

Traffic Counts



LSC Transportation Consultants, Inc.

2504 E. Pikes Peak Ave, Suite 304
 Colorado Springs, CO 80909
 719-633-2868

File Name : Hwy 24 - Stapleton Rd AM PM
 Site Code : S224640
 Start Date : 1/10/2023
 Page No : 1

Groups Printed- Unshifted

Start Time	Hwy 24 Southbound					Stapleton Dr Westbound					Hwy 24 Northbound					Stapleton Dr Eastbound					Int. Total
	Right	Thru	Left	Peds	App. Total	Right	Thru	Left	Peds	App. Total	Right	Thru	Left	Peds	App. Total	Right	Thru	Left	Peds	App. Total	
06:30	1	29	1	0	31	0	1	1	0	2	1	7	1	0	9	20	11	1	0	32	74
06:35	0	33	0	0	33	1	4	0	0	5	0	12	0	0	12	11	11	2	0	24	74
06:40	0	35	2	0	37	1	0	0	0	1	0	13	2	0	15	16	8	2	0	26	79
06:45	3	41	3	0	47	1	6	3	0	10	1	22	4	0	27	13	9	2	0	24	108
06:50	3	32	1	0	36	1	3	0	0	4	1	15	7	0	23	14	7	1	0	22	85
06:55	2	22	1	0	25	2	8	0	0	10	0	24	6	0	30	16	13	0	0	29	94
Total	9	192	8	0	209	6	22	4	0	32	3	93	20	0	116	90	59	8	0	157	514
07:00	4	35	3	0	42	2	6	0	0	8	0	29	2	0	31	7	13	1	0	21	102
07:05	4	33	4	0	41	1	10	0	0	11	0	22	4	0	26	7	11	6	0	24	102
07:10	0	33	3	0	36	4	11	1	0	16	0	30	5	0	35	15	12	2	0	29	116
07:15	2	36	2	0	40	4	14	1	0	19	0	29	7	0	36	13	15	3	0	31	126
07:20	4	46	1	0	51	1	6	0	0	7	0	30	4	0	34	11	13	1	0	25	117
07:25	5	51	8	0	64	0	7	0	0	7	0	28	0	0	28	10	7	1	0	18	117
07:30	2	34	2	0	38	0	7	0	0	7	1	16	6	0	23	9	20	2	0	31	99
07:35	6	40	5	0	51	0	9	1	0	10	0	9	2	0	11	12	7	2	0	21	93
07:40	4	31	1	0	36	0	7	2	0	9	0	9	3	0	12	5	9	0	0	14	71
07:45	1	31	1	0	33	2	5	1	0	8	0	13	6	0	19	6	17	2	0	25	85
07:50	3	21	4	0	28	0	5	0	0	5	1	18	1	0	20	10	15	2	0	27	80
07:55	2	15	3	0	20	1	1	0	0	2	0	16	4	0	20	8	5	1	0	14	56
Total	37	406	37	0	480	15	88	6	0	109	2	249	44	0	295	113	144	23	0	280	1164
08:00	3	39	2	0	44	0	6	0	0	6	0	10	5	0	15	4	10	2	0	16	81
08:05	1	30	0	0	31	1	2	1	0	4	2	19	5	0	26	4	6	4	0	14	75
08:10	2	27	2	0	31	2	2	1	0	5	0	13	4	0	17	5	6	0	0	11	64
08:15	4	31	0	0	35	5	1	2	0	8	0	7	5	0	12	8	5	2	0	15	70
08:20	5	22	3	0	30	1	7	0	0	8	0	3	3	0	6	7	4	1	0	12	56
08:25	4	34	1	0	39	0	2	0	0	2	1	14	0	0	15	4	7	5	0	16	72
*** BREAK ***																					
Total	19	183	8	0	210	9	20	4	0	33	3	66	22	0	91	32	38	14	0	84	418
*** BREAK ***																					
16:00	2	26	0	0	28	3	7	1	0	11	0	41	13	0	54	3	3	4	0	10	103
16:05	3	25	0	0	28	4	6	0	0	10	0	46	15	0	61	1	2	5	0	8	107
16:10	3	32	0	0	35	2	8	0	0	10	3	35	15	0	53	6	4	2	0	12	110
16:15	3	36	1	0	40	3	9	1	0	13	4	45	7	0	56	4	1	2	0	7	116
16:20	0	31	3	0	34	1	7	1	0	9	2	46	15	0	63	4	2	1	0	7	113
16:25	1	24	1	0	26	2	11	0	0	13	3	47	8	0	58	5	10	3	0	18	115
16:30	1	23	0	0	24	0	10	2	0	12	1	42	7	0	50	5	3	2	0	10	96
16:35	2	32	1	0	35	1	5	1	0	7	4	34	4	0	42	2	1	1	0	4	88
16:40	5	29	1	0	35	2	13	0	0	15	1	29	7	0	37	4	9	1	0	14	101
16:45	3	31	2	0	36	5	10	3	0	18	2	31	13	0	46	3	2	2	0	7	107
16:50	1	32	1	0	34	2	11	0	0	13	4	39	7	0	50	6	4	2	0	12	109

LSC Transportation Consultants, Inc.

2504 E. Pikes Peak Ave, Suite 304
 Colorado Springs, CO 80909
 719-633-2868

File Name : Hwy 24 - Stapleton Rd AM PM
 Site Code : S224640
 Start Date : 1/10/2023
 Page No : 2

Groups Printed- Unshifted

Start Time	Hwy 24 Southbound					Stapleton Dr Westbound					Hwy 24 Northbound					Stapleton Dr Eastbound					Int. Total
	Right	Thru	Left	Peds	App. Total	Right	Thru	Left	Peds	App. Total	Right	Thru	Left	Peds	App. Total	Right	Thru	Left	Peds	App. Total	
16:55	5	29	1	0	35	3	15	2	0	20	3	31	15	0	49	2	4	2	0	8	112
Total	29	350	11	0	390	28	112	11	0	151	27	466	126	0	619	45	45	27	0	117	1277
17:00	3	22	0	0	25	0	20	0	0	20	1	37	13	0	51	8	1	0	0	9	105
17:05	2	30	0	0	32	4	6	1	0	11	7	47	14	0	68	2	4	0	0	6	117
17:10	3	45	1	0	49	3	19	1	0	23	1	31	9	0	41	4	1	1	0	6	119
17:15	3	29	1	0	33	1	4	1	0	6	0	46	7	0	53	3	1	1	0	5	97
17:20	3	27	1	0	31	4	11	1	0	16	3	34	8	0	45	3	5	2	0	10	102
17:25	3	21	0	0	24	3	2	0	0	5	0	30	11	0	41	2	4	2	0	8	78
17:30	3	18	0	0	21	5	8	0	0	13	2	43	8	0	53	1	3	0	0	4	91
17:35	3	17	0	0	20	2	6	0	0	8	0	33	14	0	47	2	1	3	0	6	81
17:40	1	18	0	0	19	2	6	2	0	10	1	32	6	0	39	0	1	3	0	4	72
17:45	4	24	1	0	29	2	4	1	0	7	1	51	7	0	59	3	2	1	0	6	101
17:50	1	13	0	0	14	1	6	1	0	8	0	48	13	0	61	2	5	3	0	10	93
17:55	3	18	0	0	21	3	7	0	0	10	1	23	9	0	33	4	7	2	0	13	77
Total	32	282	4	0	318	30	99	8	0	137	17	455	119	0	591	34	35	18	0	87	1133
Grand Total	126	1413	68	0	1607	88	341	33	0	462	52	1329	331	0	1712	314	321	90	0	725	4506
Apprch %	7.8	87.9	4.2	0		19	73.8	7.1	0		3	77.6	19.3	0		43.3	44.3	12.4	0		
Total %	2.8	31.4	1.5	0	35.7	2	7.6	0.7	0	10.3	1.2	29.5	7.3	0	38	7	7.1	2	0	16.1	

LSC Transportation Consultants, Inc.

2504 E. Pikes Peak Ave, Suite 304
 Colorado Springs, CO 80909
 719-633-2868

File Name : Hwy 24 - Stapleton Rd AM PM
 Site Code : S224640
 Start Date : 1/10/2023
 Page No : 3

Start Time	Hwy 24 Southbound					Stapleton Dr Westbound					Hwy 24 Northbound					Stapleton Dr Eastbound					Int. Total
	Right	Thru	Left	Peds	App. Total	Right	Thru	Left	Peds	App. Total	Right	Thru	Left	Peds	App. Total	Right	Thru	Left	Peds	App. Total	
Peak Hour Analysis From 06:30 to 17:55 - Peak 1 of 1																					
Peak Hour for Entire Intersection Begins at 16:15																					
16:15	3	36	1	0	40	3	9	1	0	13	4	45	7	0	56	4	1	2	0	7	116
16:20	0	31	3	0	34	1	7	1	0	9	2	46	15	0	63	4	2	1	0	7	113
16:25	1	24	1	0	26	2	11	0	0	13	3	47	8	0	58	5	10	3	0	18	115
16:30	1	23	0	0	24	0	10	2	0	12	1	42	7	0	50	5	3	2	0	10	96
16:35	2	32	1	0	35	1	5	1	0	7	4	34	4	0	42	2	1	1	0	4	88
16:40	5	29	1	0	35	2	13	0	0	15	1	29	7	0	37	4	9	1	0	14	101
16:45	3	31	2	0	36	5	10	3	0	18	2	31	13	0	46	3	2	2	0	7	107
16:50	1	32	1	0	34	2	11	0	0	13	4	39	7	0	50	6	4	2	0	12	109
16:55	5	29	1	0	35	3	15	2	0	20	3	31	15	0	49	2	4	2	0	8	112
17:00	3	22	0	0	25	0	20	0	0	20	1	37	13	0	51	8	1	0	0	9	105
17:05	2	30	0	0	32	4	6	1	0	11	7	47	14	0	68	2	4	0	0	6	117
17:10	3	45	1	0	49	3	19	1	0	23	1	31	9	0	41	4	1	1	0	6	119
Total Volume	29	364	12	0	405	26	136	12	0	174	33	459	119	0	611	49	42	17	0	108	1298
% App. Total	7.2	89.9	3	0		14.9	78.2	6.9	0		5.4	75.1	19.5	0		45.4	38.9	15.7	0		
PHF	.483	.674	.333	.000	.689	.433	.567	.333	.000	.630	.393	.814	.661	.000	.749	.510	.350	.472	.000	.500	.909

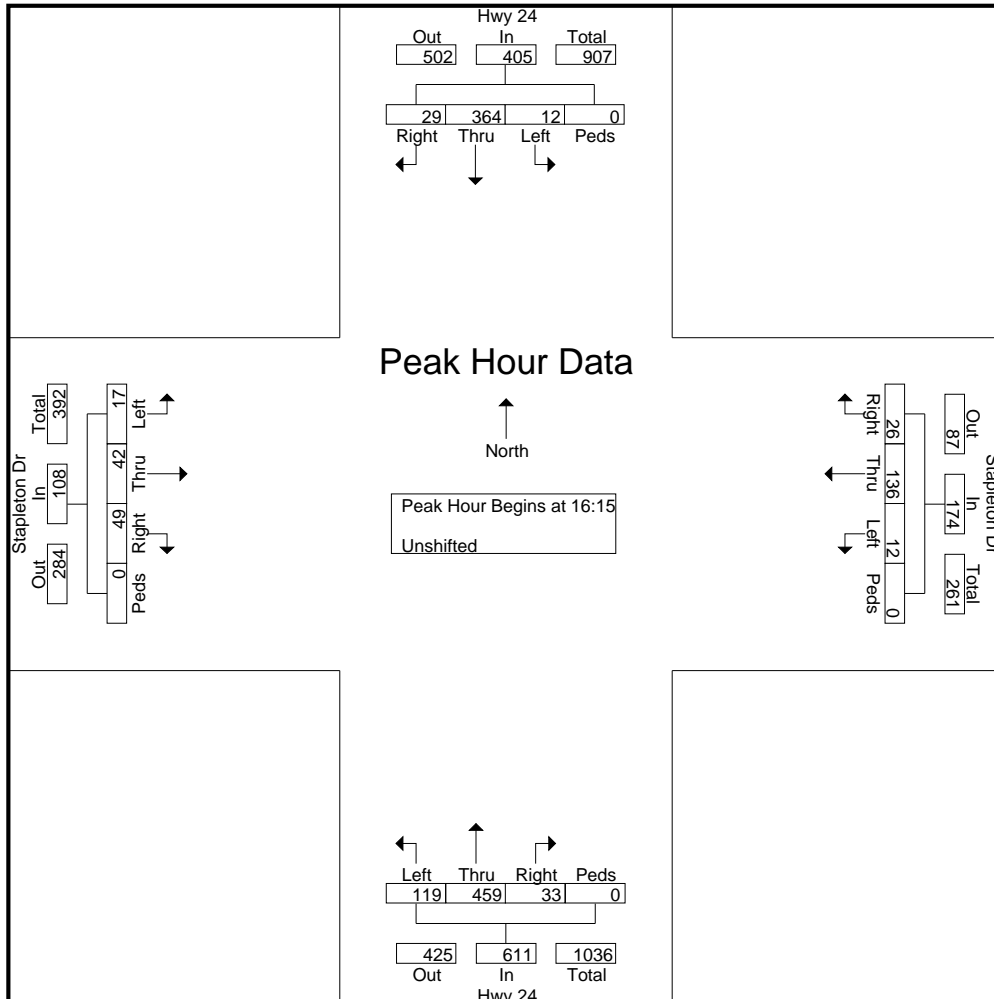

LSC Transportation Consultants, Inc.

2504 E. Pikes Peak Ave, Suite 304
 Colorado Springs, CO 80909
 719-633-2868

File Name : Hwy 24 - Stapleton Rd AM PM
 Site Code : S224640
 Start Date : 1/10/2023
 Page No : 4

Start Time	Hwy 24 Southbound					Stapleton Dr Westbound					Hwy 24 Northbound					Stapleton Dr Eastbound					Int. Total
	Right	Thru	Left	Peds	App. Total	Right	Thru	Left	Peds	App. Total	Right	Thru	Left	Peds	App. Total	Right	Thru	Left	Peds	App. Total	

Peak Hour Analysis From 06:30 to 17:55 - Peak 1 of 1
 Peak Hour for Each Approach Begins at:

	06:40					16:15					16:10					06:30				
+0 mins.	0	35	2	0	37	3	9	1	0	13	3	35	15	0	53	20	11	1	0	32
+5 mins.	3	41	3	0	47	1	7	1	0	9	4	45	7	0	56	11	11	2	0	24
+10 mins.	3	32	1	0	36	2	11	0	0	13	2	46	15	0	63	16	8	2	0	26
+15 mins.	2	22	1	0	25	0	10	2	0	12	3	47	8	0	58	13	9	2	0	24
+20 mins.	4	35	3	0	42	1	5	1	0	7	1	42	7	0	50	14	7	1	0	22
+25 mins.	4	33	4	0	41	2	13	0	0	15	4	34	4	0	42	16	13	0	0	29
+30 mins.	0	33	3	0	36	5	10	3	0	18	1	29	7	0	37	7	13	1	0	21
+35 mins.	2	36	2	0	40	2	11	0	0	13	2	31	13	0	46	7	11	6	0	24
+40 mins.	4	46	1	0	51	3	15	2	0	20	4	39	7	0	50	15	12	2	0	29
+45 mins.	5	51	8	0	64	0	20	0	0	20	3	31	15	0	49	13	15	3	0	31
+50 mins.	2	34	2	0	38	4	6	1	0	11	1	37	13	0	51	11	13	1	0	25
+55 mins.	6	40	5	0	51	3	19	1	0	23	7	47	14	0	68	10	7	1	0	18
Total Volume	35	438	35	0	508	26	136	12	0	174	35	463	125	0	623	153	130	22	0	305
% App. Total	6.9	86.2	6.9	0		14.9	78.2	6.9	0		5.6	74.3	20.1	0		50.2	42.6	7.2	0	
PHF	.486	.716	.365	.000	.661	.433	.567	.333	.000	.630	.417	.821	.694	.000	.763	.638	.722	.306	.000	.794

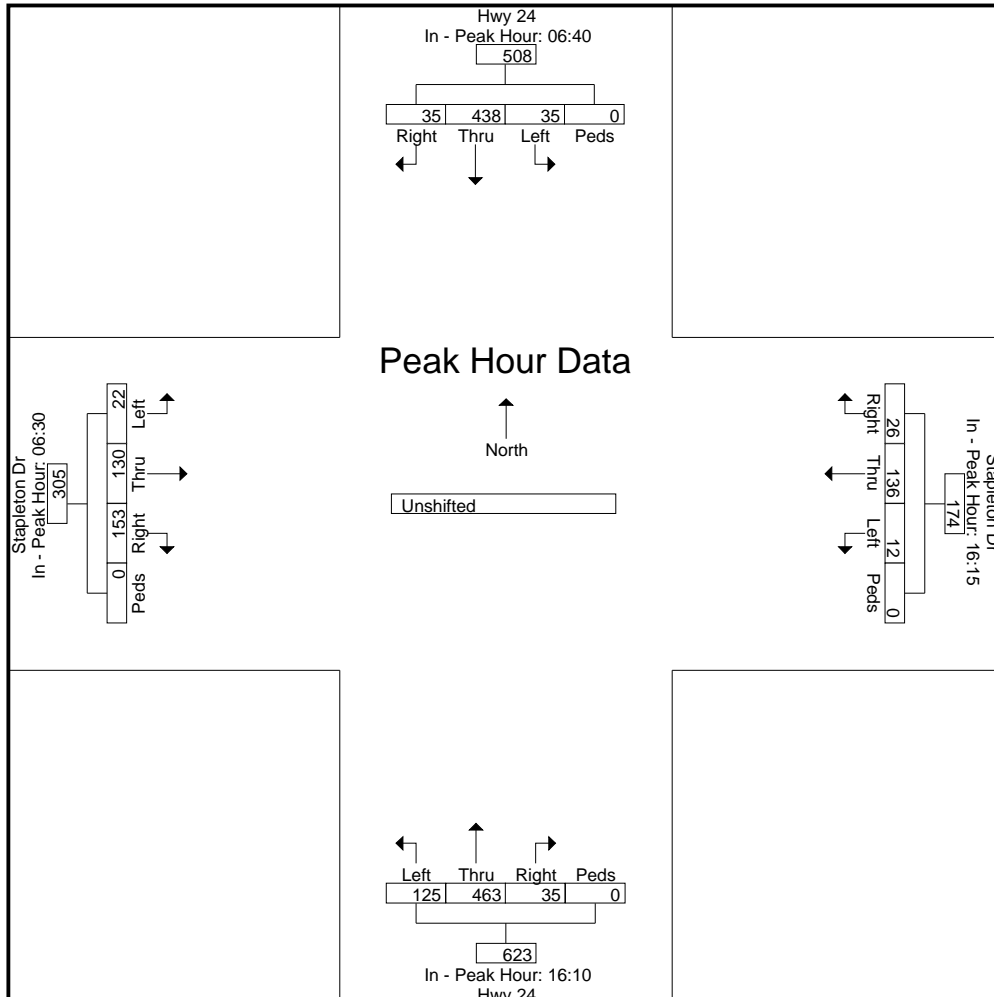

LSC Transportation Consultants, Inc.

2504 E. Pikes Peak Ave, Suite 304
 Colorado Springs, CO 80909
 719-633-2868

File Name : Curtis Rd - Falcon Hwy AM

Site Code : S214950

Start Date : 4/20/2022

Page No : 1

Groups Printed- Unshifted

Start Time	Curtis Rd Southbound					Falcon Hwy Westbound					Curtis Rd Northbound					Falcon Hwy Eastbound					Int. Total
	Right	Thru	Left	Peds	App. Total	Right	Thru	Left	Peds	App. Total	Right	Thru	Left	Peds	App. Total	Right	Thru	Left	Peds	App. Total	
06:30	0	12	0	0	12	2	15	2	0	19	0	4	4	0	8	12	1	0	0	13	52
06:35	0	14	1	0	15	1	15	2	0	18	0	3	4	0	7	13	0	0	0	13	53
06:40	0	13	0	0	13	2	14	3	0	19	0	4	5	0	9	15	1	0	0	16	57
06:45	0	20	0	0	20	1	13	1	0	15	0	4	4	0	8	6	3	0	0	9	52
06:50	0	18	0	0	18	0	15	1	0	16	0	5	4	0	9	19	1	0	0	20	63
06:55	0	15	0	0	15	5	19	2	0	26	0	7	4	0	11	16	5	0	0	21	73
Total	0	92	1	0	93	11	91	11	0	113	0	27	25	0	52	81	11	0	0	92	350
07:00	0	19	2	0	21	4	19	1	0	24	0	3	4	0	7	11	3	2	0	16	68
07:05	2	23	0	0	25	5	26	2	0	33	0	5	1	0	6	10	3	1	0	14	78
07:10	2	23	0	0	25	5	16	1	0	22	0	9	2	0	11	16	4	0	0	20	78
07:15	3	23	1	0	27	4	18	1	0	23	0	10	6	0	16	15	1	1	0	17	83
07:20	3	20	2	0	25	4	19	1	0	24	1	8	5	0	14	23	2	0	0	25	88
07:25	2	11	1	0	14	4	20	0	0	24	0	6	7	0	13	15	6	0	0	21	72
07:30	3	18	0	0	21	2	20	1	0	23	0	6	8	0	14	14	4	2	0	20	78
07:35	2	22	1	0	25	3	11	3	0	17	1	6	4	0	11	25	9	2	0	36	89
07:40	0	28	2	0	30	4	13	0	0	17	0	6	7	0	13	16	3	0	0	19	79
07:45	1	21	1	0	23	1	10	3	0	14	0	4	5	0	9	12	4	1	0	17	63
07:50	1	15	0	0	16	2	9	0	0	11	0	1	2	0	3	10	3	0	0	13	43
07:55	0	11	1	0	12	4	11	1	0	16	1	2	7	0	10	17	6	1	0	24	62
Total	19	234	11	0	264	42	192	14	0	248	3	66	58	0	127	184	48	10	0	242	881
08:00	0	19	2	0	21	0	18	0	0	18	0	2	12	0	14	13	6	0	0	19	72
08:05	2	7	2	0	11	0	15	1	0	16	1	2	2	0	5	12	5	0	0	17	49
08:10	1	14	0	0	15	1	11	1	0	13	1	2	7	0	10	10	5	3	0	18	56
08:15	0	7	0	0	7	1	8	1	0	10	0	3	4	0	7	9	6	0	0	15	39
08:20	1	8	0	0	9	2	17	1	0	20	0	3	7	0	10	11	9	0	0	20	59
08:25	0	4	0	0	4	3	9	2	0	14	0	2	6	0	8	7	7	1	0	15	41
Grand Total	23	385	16	0	424	60	361	31	0	452	5	107	121	0	233	327	97	14	0	438	1547
Apprch %	5.4	90.8	3.8	0		13.3	79.9	6.9	0		2.1	45.9	51.9	0		74.7	22.1	3.2	0		
Total %	1.5	24.9	1	0	27.4	3.9	23.3	2	0	29.2	0.3	6.9	7.8	0	15.1	21.1	6.3	0.9	0	28.3	

LSC Transportation Consultants, Inc.

2504 E. Pikes Peak Ave, Suite 304
 Colorado Springs, CO 80909
 719-633-2868

File Name : Curtis Rd - Falcon Hwy AM

Site Code : S214950

Start Date : 4/20/2022

Page No : 2

Start Time	Curtis Rd Southbound					Falcon Hwy Westbound					Curtis Rd Northbound					Falcon Hwy Eastbound					Int. Total
	Right	Thru	Left	Peds	App. Total	Right	Thru	Left	Peds	App. Total	Right	Thru	Left	Peds	App. Total	Right	Thru	Left	Peds	App. Total	
Peak Hour Analysis From 06:30 to 08:25 - Peak 1 of 1																					
Peak Hour for Entire Intersection Begins at 06:50																					
06:50	0	18	0	0	18	0	15	1	0	16	0	5	4	0	9	19	1	0	0	20	63
06:55	0	15	0	0	15	5	19	2	0	26	0	7	4	0	11	16	5	0	0	21	73
07:00	0	19	2	0	21	4	19	1	0	24	0	3	4	0	7	11	3	2	0	16	68
07:05	2	23	0	0	25	5	26	2	0	33	0	5	1	0	6	10	3	1	0	14	78
07:10	2	23	0	0	25	5	16	1	0	22	0	9	2	0	11	16	4	0	0	20	78
07:15	3	23	1	0	27	4	18	1	0	23	0	10	6	0	16	15	1	1	0	17	83
07:20	3	20	2	0	25	4	19	1	0	24	1	8	5	0	14	23	2	0	0	25	88
07:25	2	11	1	0	14	4	20	0	0	24	0	6	7	0	13	15	6	0	0	21	72
07:30	3	18	0	0	21	2	20	1	0	23	0	6	8	0	14	14	4	2	0	20	78
07:35	2	22	1	0	25	3	11	3	0	17	1	6	4	0	11	25	9	2	0	36	89
07:40	0	28	2	0	30	4	13	0	0	17	0	6	7	0	13	16	3	0	0	19	79
07:45	1	21	1	0	23	1	10	3	0	14	0	4	5	0	9	12	4	1	0	17	63
Total Volume	18	241	10	0	269	41	206	16	0	263	2	75	57	0	134	192	45	9	0	246	912
% App. Total	6.7	89.6	3.7	0		15.6	78.3	6.1	0		1.5	56	42.5	0		78	18.3	3.7	0		
PHF	.500	.717	.417	.000	.747	.683	.660	.444	.000	.664	.167	.625	.594	.000	.698	.640	.417	.375	.000	.569	.854

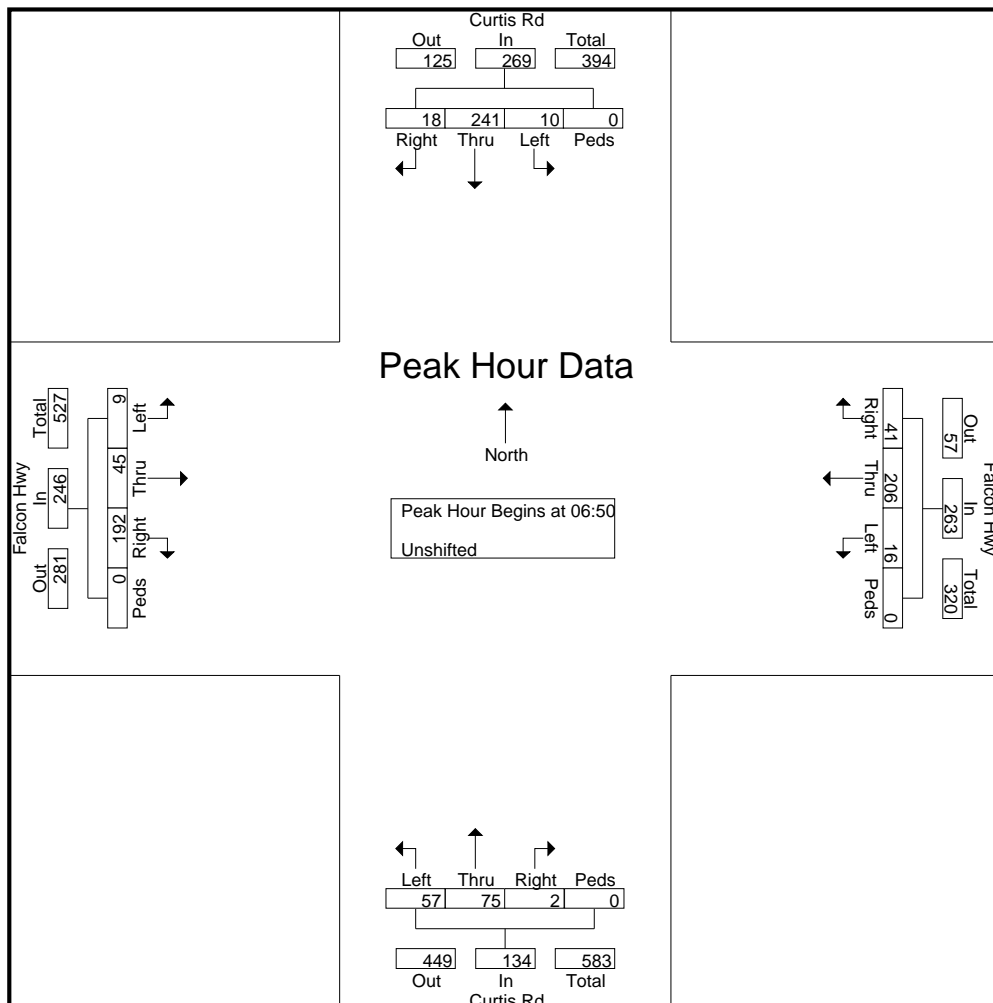

LSC Transportation Consultants, Inc.

2504 E. Pikes Peak Ave, Suite 304
 Colorado Springs, CO 80909
 719-633-2868

File Name : Curtis Rd - Falcon Hwy AM

Site Code : S214950

Start Date : 4/20/2022

Page No : 3

Start Time	Curtis Rd Southbound					Falcon Hwy Westbound					Curtis Rd Northbound					Falcon Hwy Eastbound					Int. Total
	Right	Thru	Left	Peds	App. Total	Right	Thru	Left	Peds	App. Total	Right	Thru	Left	Peds	App. Total	Right	Thru	Left	Peds	App. Total	
Peak Hour Analysis From 06:30 to 08:25 - Peak 1 of 1																					
Peak Hour for Each Approach Begins at:																					
	06:50					06:35					06:50					07:10					
+0 mins.	0	18	0	0	18	1	15	2	0	18	0	5	4	0	9	16	4	0	0	20	
+5 mins.	0	15	0	0	15	2	14	3	0	19	0	7	4	0	11	15	1	1	0	17	
+10 mins.	0	19	2	0	21	1	13	1	0	15	0	3	4	0	7	23	2	0	0	25	
+15 mins.	2	23	0	0	25	0	15	1	0	16	0	5	1	0	6	15	6	0	0	21	
+20 mins.	2	23	0	0	25	5	19	2	0	26	0	9	2	0	11	14	4	2	0	20	
+25 mins.	3	23	1	0	27	4	19	1	0	24	0	10	6	0	16	25	9	2	0	36	
+30 mins.	3	20	2	0	25	5	26	2	0	33	1	8	5	0	14	16	3	0	0	19	
+35 mins.	2	11	1	0	14	5	16	1	0	22	0	6	7	0	13	12	4	1	0	17	
+40 mins.	3	18	0	0	21	4	18	1	0	23	0	6	8	0	14	10	3	0	0	13	
+45 mins.	2	22	1	0	25	4	19	1	0	24	1	6	4	0	11	17	6	1	0	24	
+50 mins.	0	28	2	0	30	4	20	0	0	24	0	6	7	0	13	13	6	0	0	19	
+55 mins.	1	21	1	0	23	2	20	1	0	23	0	4	5	0	9	12	5	0	0	17	
Total Volume	18	241	10	0	269	37	214	16	0	267	2	75	57	0	134	188	53	7	0	248	
% App. Total	6.7	89.6	3.7	0		13.9	80.1	6	0		1.5	56	42.5	0		75.8	21.4	2.8	0		
PHF	.500	.717	.417	.000	.747	.617	.686	.444	.000	.674	.167	.625	.594	.000	.698	.627	.491	.292	.000	.574	

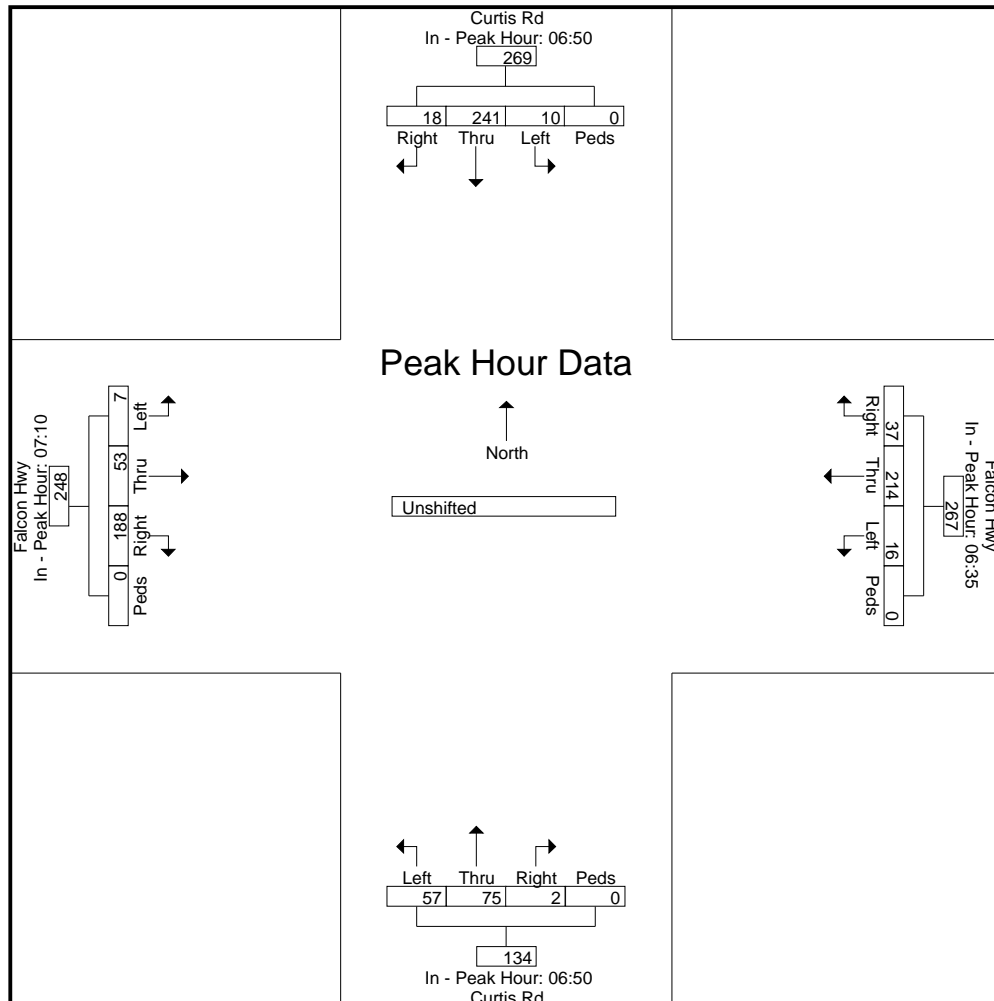

LSC Transportation Consultants, Inc.

2504 E. Pikes Peak Ave, Suite 304
 Colorado Springs, CO 80909
 719-633-2868

File Name : Curtis Rd - Falcon Hwy AM

Site Code : S214950

Start Date : 4/20/2022

Page No : 1

Groups Printed- Unshifted

Start Time	Curtis Rd Southbound					Falcon Hwy Westbound					Curtis Rd Northbound					Falcon Hwy Eastbound					Int. Total
	Right	Thru	Left	Peds	App. Total	Right	Thru	Left	Peds	App. Total	Right	Thru	Left	Peds	App. Total	Right	Thru	Left	Peds	App. Total	
06:30	0	39	1	0	40	5	44	7	0	56	0	11	13	0	24	40	2	0	0	42	162
06:45	0	53	0	0	53	6	47	4	0	57	0	16	12	0	28	41	9	0	0	50	188
Total	0	92	1	0	93	11	91	11	0	113	0	27	25	0	52	81	11	0	0	92	350
07:00	4	65	2	0	71	14	61	4	0	79	0	17	7	0	24	37	10	3	0	50	224
07:15	8	54	4	0	66	12	57	2	0	71	1	24	18	0	43	53	9	1	0	63	243
07:30	5	68	3	0	76	9	44	4	0	57	1	18	19	0	38	55	16	4	0	75	246
07:45	2	47	2	0	51	7	30	4	0	41	1	7	14	0	22	39	13	2	0	54	168
Total	19	234	11	0	264	42	192	14	0	248	3	66	58	0	127	184	48	10	0	242	881
08:00	3	40	4	0	47	1	44	2	0	47	2	6	21	0	29	35	16	3	0	54	177
08:15	1	19	0	0	20	6	34	4	0	44	0	8	17	0	25	27	22	1	0	50	139
Grand Total	23	385	16	0	424	60	361	31	0	452	5	107	121	0	233	327	97	14	0	438	1547
Apprch %	5.4	90.8	3.8	0		13.3	79.9	6.9	0		2.1	45.9	51.9	0		74.7	22.1	3.2	0		
Total %	1.5	24.9	1	0	27.4	3.9	23.3	2	0	29.2	0.3	6.9	7.8	0	15.1	21.1	6.3	0.9	0	28.3	

LSC Transportation Consultants, Inc.

2504 E. Pikes Peak Ave, Suite 304
 Colorado Springs, CO 80909
 719-633-2868

File Name : Curtis Rd - Falcon Hwy AM

Site Code : S214950

Start Date : 4/20/2022

Page No : 2

Start Time	Curtis Rd Southbound					Falcon Hwy Westbound					Curtis Rd Northbound					Falcon Hwy Eastbound					Int. Total
	Right	Thru	Left	Peds	App. Total	Right	Thru	Left	Peds	App. Total	Right	Thru	Left	Peds	App. Total	Right	Thru	Left	Peds	App. Total	
Peak Hour Analysis From 6:30:00 AM to 8:15:00 AM - Peak 1 of 1																					
Peak Hour for Entire Intersection Begins at 6:45:00 AM																					
6:45:00 AM	0	53	0	0	53	6	47	4	0	57	0	16	12	0	28	41	9	0	0	50	188
7:00:00 AM	4	65	2	0	71	14	61	4	0	79	0	17	7	0	24	37	10	3	0	50	224
7:15:00 AM	8	54	4	0	66	12	57	2	0	71	1	24	18	0	43	53	9	1	0	63	243
7:30:00 AM	5	68	3	0	76	9	44	4	0	57	1	18	19	0	38	55	16	4	0	75	246
Total Volume	17	240	9	0	266	41	209	14	0	264	2	75	56	0	133	186	44	8	0	238	901
% App. Total	6.4	90.2	3.4	0		15.5	79.2	5.3	0		1.5	56.4	42.1	0		78.2	18.5	3.4	0		
PHF	.531	.882	.563	.000	.875	.732	.857	.875	.000	.835	.500	.781	.737	.000	.773	.845	.688	.500	.000	.793	.916

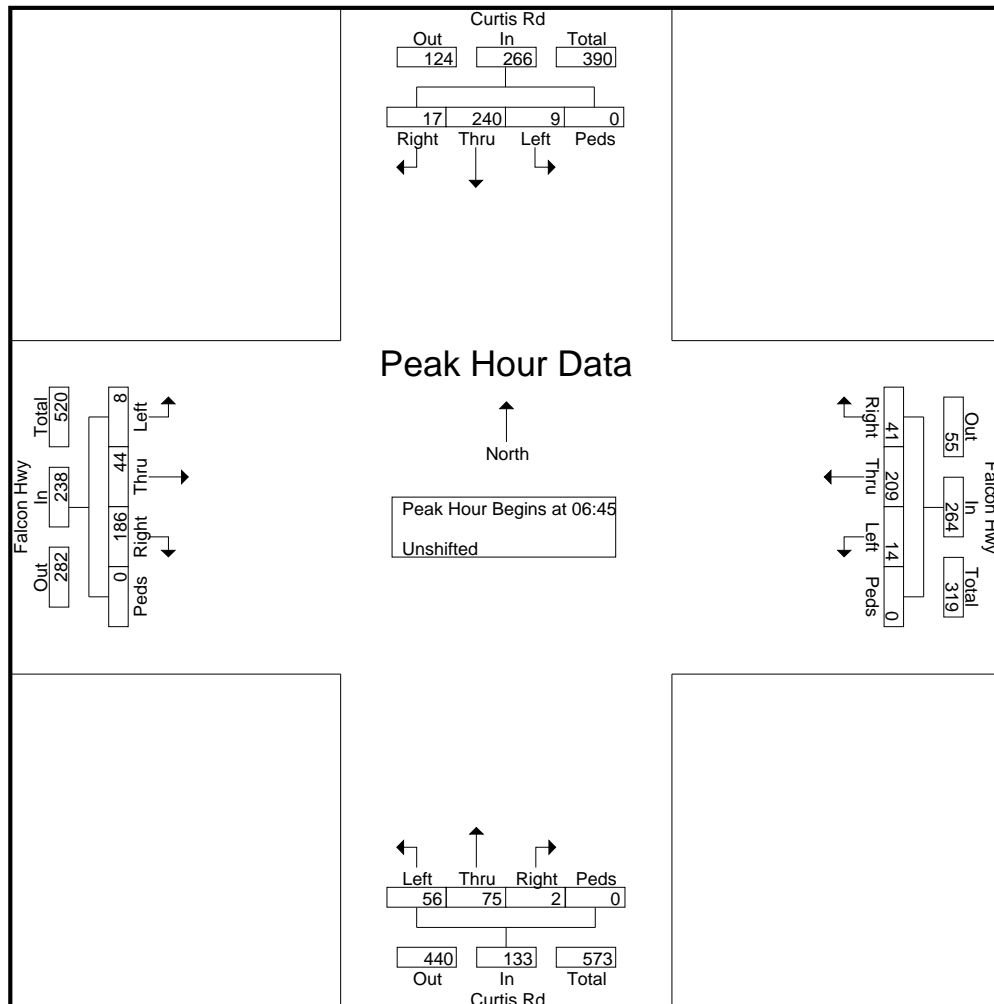

LSC Transportation Consultants, Inc.

2504 E. Pikes Peak Ave, Suite 304
 Colorado Springs, CO 80909
 719-633-2868

File Name : Curtis Rd - Falcon Hwy AM

Site Code : S214950

Start Date : 4/20/2022

Page No : 3

Start Time	Curtis Rd Southbound					Falcon Hwy Westbound					Curtis Rd Northbound					Falcon Hwy Eastbound					Int. Total
	Right	Thru	Left	Peds	App. Total	Right	Thru	Left	Peds	App. Total	Right	Thru	Left	Peds	App. Total	Right	Thru	Left	Peds	App. Total	
Peak Hour Analysis From 6:30:00 AM to 8:15:00 AM - Peak 1 of 1																					
Peak Hour for Each Approach Begins at:																					
	6:45:00 AM					6:45:00 AM					6:45:00 AM					7:15:00 AM					
+0 mins.	0	53	0	0	53	6	47	4	0	57	0	16	12	0	28	53	9	1	0	63	
+5 mins.	4	65	2	0	71	14	61	4	0	79	0	17	7	0	24	55	16	4	0	75	
+10 mins.	8	54	4	0	66	12	57	2	0	71	1	24	18	0	43	39	13	2	0	54	
+15 mins.	5	68	3	0	76	9	44	4	0	57	1	18	19	0	38	35	16	3	0	54	
Total Volume	17	240	9	0	266	41	209	14	0	264	2	75	56	0	133	182	54	10	0	246	
% App. Total	6.4	90.2	3.4	0		15.5	79.2	5.3	0		1.5	56.4	42.1	0		74	22	4.1	0		
PHF	.531	.882	.563	.000	.875	.732	.857	.875	.000	.835	.500	.781	.737	.000	.773	.827	.844	.625	.000	.820	

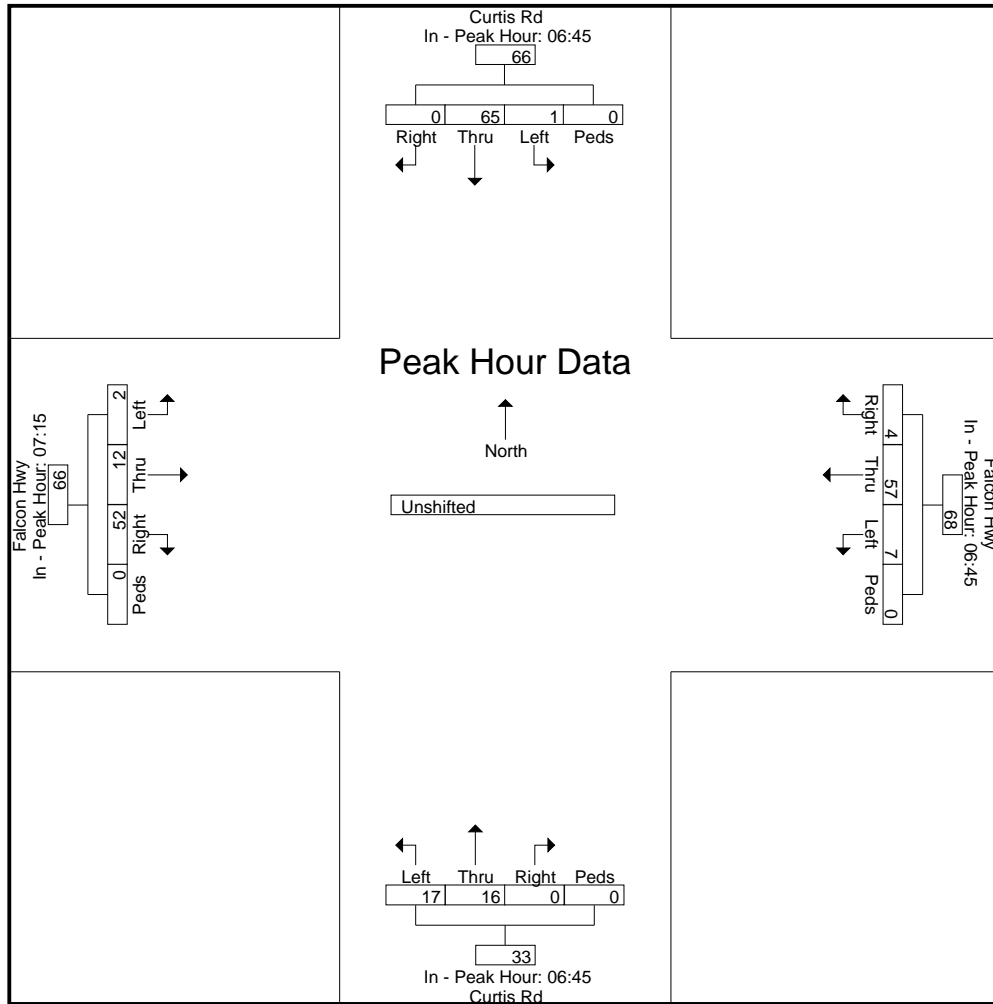

LSC Transportation Consultants, Inc.

2504 E. Pikes Peak Ave, Suite 304
 Colorado Springs, CO 80909
 719-633-2868

File Name : Curtis Rd - Falcon Hwy PM

Site Code : S214950

Start Date : 4/20/2022

Page No : 1

Groups Printed- Unshifted

Start Time	Curtis Rd Southbound					Falcon Hwy Westbound					Curtis Rd Northbound					Falcon Hwy Eastbound					Int. Total
	Right	Thru	Left	Peds	App. Total	Right	Thru	Left	Peds	App. Total	Right	Thru	Left	Peds	App. Total	Right	Thru	Left	Peds	App. Total	
16:00	1	2	1	0	4	2	6	1	0	9	1	9	12	0	22	5	13	1	0	19	54
16:05	2	9	4	0	15	1	9	0	0	10	2	11	12	0	25	6	12	1	0	19	69
16:10	1	4	3	0	8	2	8	1	0	11	2	14	9	0	25	1	12	2	0	15	59
16:15	0	7	1	0	8	0	9	0	0	9	1	13	16	0	30	3	13	0	0	16	63
16:20	1	3	0	0	4	1	5	0	0	6	4	16	14	0	34	6	11	2	0	19	63
16:25	1	6	0	0	7	2	10	1	0	13	3	18	16	0	37	5	17	1	0	23	80
16:30	2	2	1	0	5	0	7	1	0	8	6	21	20	0	47	3	12	0	0	15	75
16:35	1	6	2	0	9	2	9	3	0	14	3	17	14	0	34	13	14	1	0	28	85
16:40	1	2	1	0	4	0	15	0	0	15	3	16	19	0	38	5	13	0	0	18	75
16:45	2	3	3	0	8	1	8	0	0	9	3	10	16	0	29	9	14	2	0	25	71
16:50	2	2	3	0	7	1	7	1	0	9	3	19	18	0	40	3	21	2	0	26	82
16:55	0	2	2	0	4	3	7	1	0	11	3	16	17	0	36	4	13	1	0	18	69
Total	14	48	21	0	83	15	100	9	0	124	34	180	183	0	397	63	165	13	0	241	845
17:00	0	5	0	0	5	0	4	0	0	4	2	7	18	0	27	8	16	2	0	26	62
17:05	2	2	1	0	5	1	5	1	0	7	2	20	10	0	32	6	14	1	0	21	65
17:10	0	4	2	0	6	0	9	0	0	9	3	11	4	0	18	4	14	0	0	18	51
17:15	1	1	2	0	4	0	9	1	0	10	3	18	12	0	33	10	18	1	0	29	76
17:20	1	6	1	0	8	0	5	0	0	5	1	16	12	0	29	3	18	2	0	23	65
17:25	0	4	3	0	7	0	2	0	0	2	3	11	17	0	31	6	18	1	0	25	65
17:30	2	3	0	0	5	0	3	1	0	4	0	11	6	0	17	4	14	2	0	20	46
17:35	0	2	2	0	4	1	9	0	0	10	4	9	8	0	21	6	14	1	0	21	56
17:40	0	5	0	0	5	1	8	1	0	10	0	10	8	0	18	4	13	1	0	18	51
17:45	1	3	2	0	6	0	4	0	0	4	0	8	10	0	18	9	21	0	0	30	58
17:50	1	3	0	0	4	0	8	1	0	9	2	5	4	0	11	6	13	0	0	19	43
17:55	0	4	3	0	7	0	10	0	0	10	2	5	13	0	20	5	19	0	0	24	61
Total	8	42	16	0	66	3	76	5	0	84	22	131	122	0	275	71	192	11	0	274	699
Grand Total	22	90	37	0	149	18	176	14	0	208	56	311	305	0	672	134	357	24	0	515	1544
Apprch %	14.8	60.4	24.8	0		8.7	84.6	6.7	0		8.3	46.3	45.4	0		26	69.3	4.7	0		
Total %	1.4	5.8	2.4	0	9.7	1.2	11.4	0.9	0	13.5	3.6	20.1	19.8	0	43.5	8.7	23.1	1.6	0	33.4	

LSC Transportation Consultants, Inc.

2504 E. Pikes Peak Ave, Suite 304
 Colorado Springs, CO 80909
 719-633-2868

File Name : Curtis Rd - Falcon Hwy PM

Site Code : S214950

Start Date : 4/20/2022

Page No : 2

Start Time	Curtis Rd Southbound					Falcon Hwy Westbound					Curtis Rd Northbound					Falcon Hwy Eastbound					Int. Total
	Right	Thru	Left	Peds	App. Total	Right	Thru	Left	Peds	App. Total	Right	Thru	Left	Peds	App. Total	Right	Thru	Left	Peds	App. Total	
Peak Hour Analysis From 16:00 to 17:55 - Peak 1 of 1																					
Peak Hour for Entire Intersection Begins at 16:25																					
16:25	1	6	0	0	7	2	10	1	0	13	3	18	16	0	37	5	17	1	0	23	80
16:30	2	2	1	0	5	0	7	1	0	8	6	21	20	0	47	3	12	0	0	15	75
16:35	1	6	2	0	9	2	9	3	0	14	3	17	14	0	34	13	14	1	0	28	85
16:40	1	2	1	0	4	0	15	0	0	15	3	16	19	0	38	5	13	0	0	18	75
16:45	2	3	3	0	8	1	8	0	0	9	3	10	16	0	29	9	14	2	0	25	71
16:50	2	2	3	0	7	1	7	1	0	9	3	19	18	0	40	3	21	2	0	26	82
16:55	0	2	2	0	4	3	7	1	0	11	3	16	17	0	36	4	13	1	0	18	69
17:00	0	5	0	0	5	0	4	0	0	4	2	7	18	0	27	8	16	2	0	26	62
17:05	2	2	1	0	5	1	5	1	0	7	2	20	10	0	32	6	14	1	0	21	65
17:10	0	4	2	0	6	0	9	0	0	9	3	11	4	0	18	4	14	0	0	18	51
17:15	1	1	2	0	4	0	9	1	0	10	3	18	12	0	33	10	18	1	0	29	76
17:20	1	6	1	0	8	0	5	0	0	5	1	16	12	0	29	3	18	2	0	23	65
Total Volume	13	41	18	0	72	10	95	9	0	114	35	189	176	0	400	73	184	13	0	270	856
% App. Total	18.1	56.9	25	0		8.8	83.3	7.9	0		8.8	47.2	44	0		27	68.1	4.8	0		
PHF	.542	.569	.500	.000	.667	.278	.528	.250	.000	.633	.486	.750	.733	.000	.709	.468	.730	.542	.000	.776	.839

LSC Transportation Consultants, Inc.

2504 E. Pikes Peak Ave, Suite 304
 Colorado Springs, CO 80909
 719-633-2868

File Name : Curtis Rd - Falcon Hwy PM

Site Code : S214950

Start Date : 4/20/2022

Page No : 3

Start Time	Curtis Rd Southbound					Falcon Hwy Westbound					Curtis Rd Northbound					Falcon Hwy Eastbound					Int. Total
	Right	Thru	Left	Peds	App. Total	Right	Thru	Left	Peds	App. Total	Right	Thru	Left	Peds	App. Total	Right	Thru	Left	Peds	App. Total	
Peak Hour Analysis From 16:00 to 17:55 - Peak 1 of 1																					
Peak Hour for Each Approach Begins at:																					
	16:05					16:00					16:10					16:35					
+0 mins.	2	9	4	0	15	2	6	1	0	9	2	14	9	0	25	13	14	1	0	28	
+5 mins.	1	4	3	0	8	1	9	0	0	10	1	13	16	0	30	5	13	0	0	18	
+10 mins.	0	7	1	0	8	2	8	1	0	11	4	16	14	0	34	9	14	2	0	25	
+15 mins.	1	3	0	0	4	0	9	0	0	9	3	18	16	0	37	3	21	2	0	26	
+20 mins.	1	6	0	0	7	1	5	0	0	6	6	21	20	0	47	4	13	1	0	18	
+25 mins.	2	2	1	0	5	2	10	1	0	13	3	17	14	0	34	8	16	2	0	26	
+30 mins.	1	6	2	0	9	0	7	1	0	8	3	16	19	0	38	6	14	1	0	21	
+35 mins.	1	2	1	0	4	2	9	3	0	14	3	10	16	0	29	4	14	0	0	18	
+40 mins.	2	3	3	0	8	0	15	0	0	15	3	19	18	0	40	10	18	1	0	29	
+45 mins.	2	2	3	0	7	1	8	0	0	9	3	16	17	0	36	3	18	2	0	23	
+50 mins.	0	2	2	0	4	1	7	1	0	9	2	7	18	0	27	6	18	1	0	25	
+55 mins.	0	5	0	0	5	3	7	1	0	11	2	20	10	0	32	4	14	2	0	20	
Total Volume	13	51	20	0	84	15	100	9	0	124	35	187	187	0	409	75	187	15	0	277	
% App. Total	15.5	60.7	23.8	0		12.1	80.6	7.3	0		8.6	45.7	45.7	0		27.1	67.5	5.4	0		
PHF	.542	.472	.417	.000	.467	.417	.556	.250	.000	.689	.486	.742	.779	.000	.725	.481	.742	.625	.000	.796	

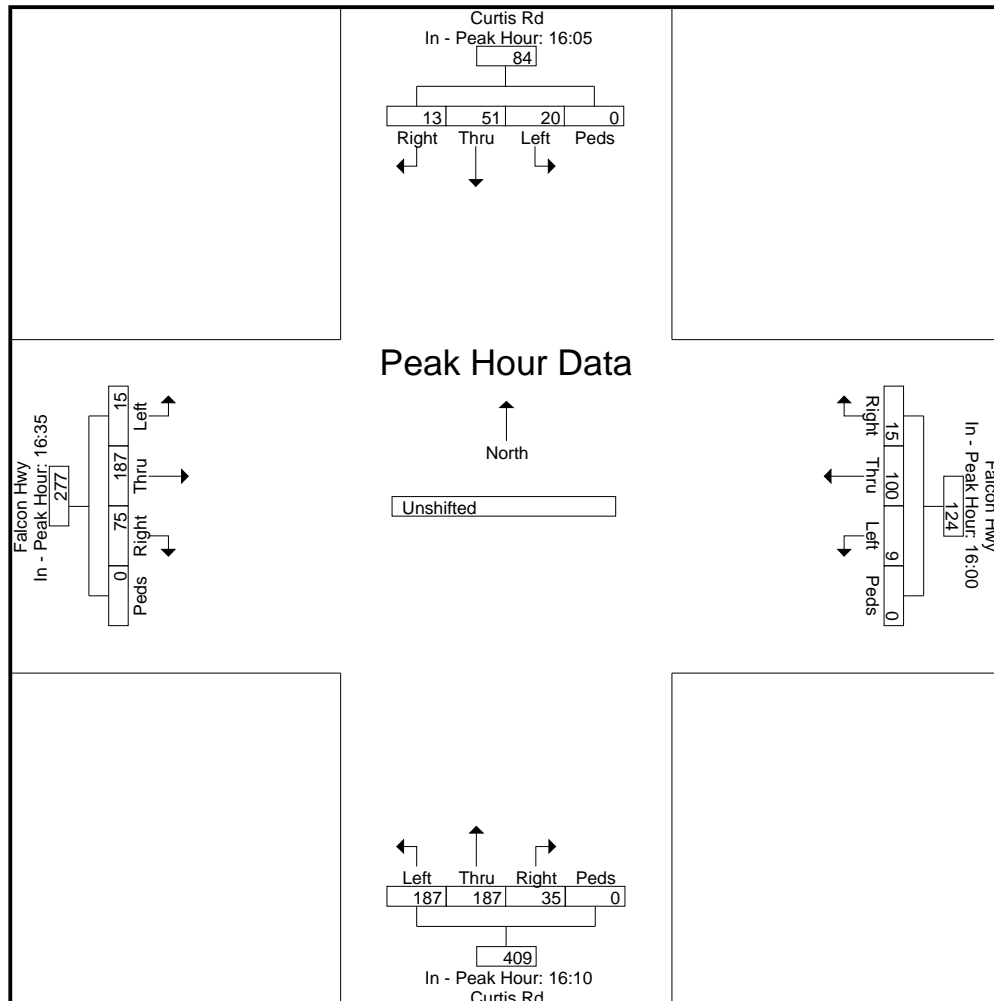

LSC Transportation Consultants, Inc.

2504 E. Pikes Peak Ave, Suite 304
 Colorado Springs, CO 80909
 719-633-2868

File Name : Curtis Rd - Falcon Hwy PM

Site Code : S214950

Start Date : 4/20/2022

Page No : 1

Groups Printed- Unshifted

Start Time	Curtis Rd Southbound					Falcon Hwy Westbound					Curtis Rd Northbound					Falcon Hwy Eastbound					Int. Total
	Right	Thru	Left	Peds	App. Total	Right	Thru	Left	Peds	App. Total	Right	Thru	Left	Peds	App. Total	Right	Thru	Left	Peds	App. Total	
16:00	4	15	8	0	27	5	23	2	0	30	5	34	33	0	72	12	37	4	0	53	182
16:15	2	16	1	0	19	3	24	1	0	28	8	47	46	0	101	14	41	3	0	58	206
16:30	4	10	4	0	18	2	31	4	0	37	12	54	53	0	119	21	39	1	0	61	235
16:45	4	7	8	0	19	5	22	2	0	29	9	45	51	0	105	16	48	5	0	69	222
Total	14	48	21	0	83	15	100	9	0	124	34	180	183	0	397	63	165	13	0	241	845
17:00	2	11	3	0	16	1	18	1	0	20	7	38	32	0	77	18	44	3	0	65	178
17:15	2	11	6	0	19	0	16	1	0	17	7	45	41	0	93	19	54	4	0	77	206
17:30	2	10	2	0	14	2	20	2	0	24	4	30	22	0	56	14	41	4	0	59	153
17:45	2	10	5	0	17	0	22	1	0	23	4	18	27	0	49	20	53	0	0	73	162
Total	8	42	16	0	66	3	76	5	0	84	22	131	122	0	275	71	192	11	0	274	699
Grand Total	22	90	37	0	149	18	176	14	0	208	56	311	305	0	672	134	357	24	0	515	1544
Apprch %	14.8	60.4	24.8	0		8.7	84.6	6.7	0		8.3	46.3	45.4	0		26	69.3	4.7	0		
Total %	1.4	5.8	2.4	0	9.7	1.2	11.4	0.9	0	13.5	3.6	20.1	19.8	0	43.5	8.7	23.1	1.6	0	33.4	

LSC Transportation Consultants, Inc.

2504 E. Pikes Peak Ave, Suite 304
 Colorado Springs, CO 80909
 719-633-2868

File Name : Curtis Rd - Falcon Hwy PM

Site Code : S214950

Start Date : 4/20/2022

Page No : 2

Start Time	Curtis Rd Southbound					Falcon Hwy Westbound					Curtis Rd Northbound					Falcon Hwy Eastbound					Int. Total
	Right	Thru	Left	Peds	App. Total	Right	Thru	Left	Peds	App. Total	Right	Thru	Left	Peds	App. Total	Right	Thru	Left	Peds	App. Total	
Peak Hour Analysis From 4:00:00 PM to 5:45:00 PM - Peak 1 of 1																					
Peak Hour for Entire Intersection Begins at 4:00:00 PM																					
4:00:00 PM	4	15	8	0	27	5	23	2	0	30	5	34	33	0	72	12	37	4	0	53	182
4:15:00 PM	2	16	1	0	19	3	24	1	0	28	8	47	46	0	101	14	41	3	0	58	206
4:30:00 PM	4	10	4	0	18	2	31	4	0	37	12	54	53	0	119	21	39	1	0	61	235
4:45:00 PM	4	7	8	0	19	5	22	2	0	29	9	45	51	0	105	16	48	5	0	69	222
Total Volume	14	48	21	0	83	15	100	9	0	124	34	180	183	0	397	63	165	13	0	241	845
% App. Total	16.9	57.8	25.3	0		12.1	80.6	7.3	0		8.6	45.3	46.1	0		26.1	68.5	5.4	0		
PHF	.875	.750	.656	.000	.769	.750	.806	.563	.000	.838	.708	.833	.863	.000	.834	.750	.859	.650	.000	.873	.899

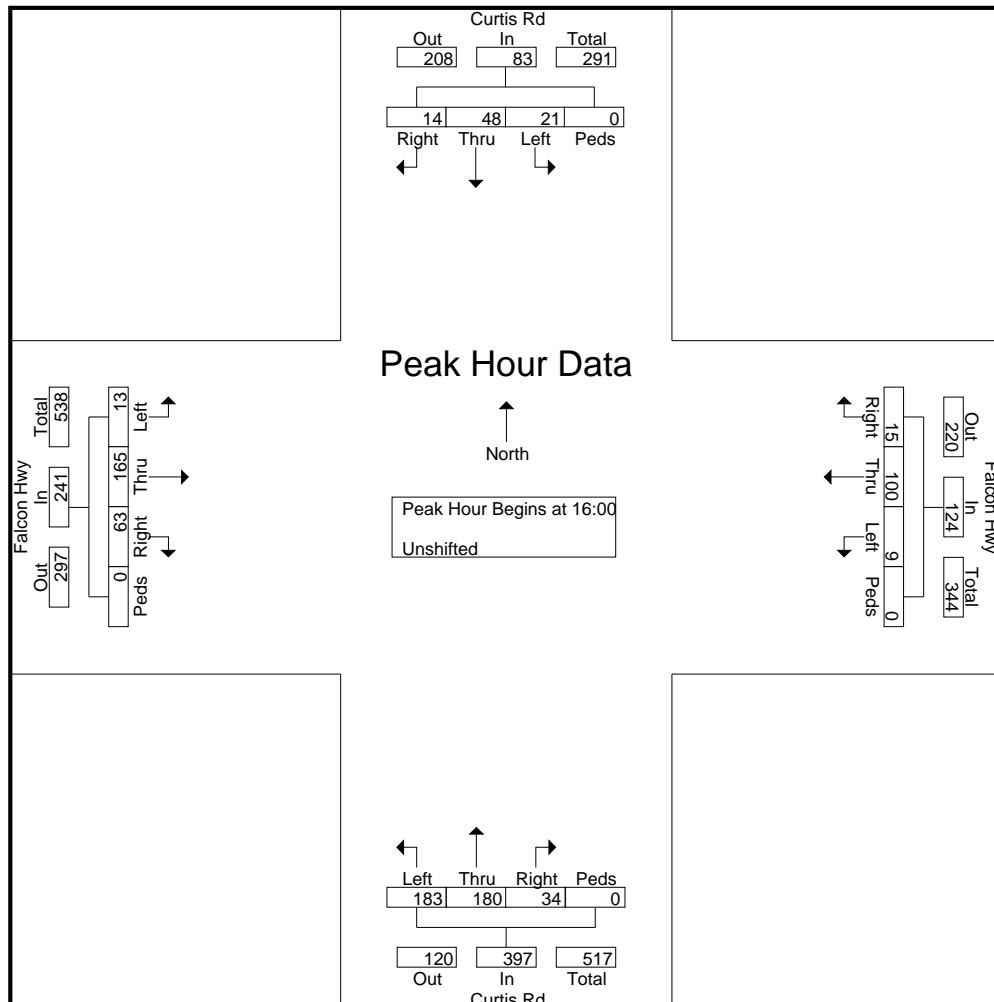

LSC Transportation Consultants, Inc.

2504 E. Pikes Peak Ave, Suite 304
Colorado Springs, CO 80909
719-633-2868

File Name : Curtis Rd - Falcon Hwy PM

Site Code : S214950

Start Date : 4/20/2022

Page No : 3

Start Time	Curtis Rd Southbound					Falcon Hwy Westbound					Curtis Rd Northbound					Falcon Hwy Eastbound					Int. Total
	Right	Thru	Left	Peds	App. Total	Right	Thru	Left	Peds	App. Total	Right	Thru	Left	Peds	App. Total	Right	Thru	Left	Peds	App. Total	
Peak Hour Analysis From 4:00:00 PM to 5:45:00 PM - Peak 1 of 1																					
Peak Hour for Each Approach Begins at:																					
	4:00:00 PM					4:00:00 PM					4:15:00 PM					5:00:00 PM					
+0 mins.	4	15	8	0	27	5	23	2	0	30	8	47	46	0	101	18	44	3	0	65	
+5 mins.	2	16	1	0	19	3	24	1	0	28	12	54	53	0	119	19	54	4	0	77	
+10 mins.	4	10	4	0	18	2	31	4	0	37	9	45	51	0	105	14	41	4	0	59	
+15 mins.	4	7	8	0	19	5	22	2	0	29	7	38	32	0	77	20	53	0	0	73	
Total Volume	14	48	21	0	83	15	100	9	0	124	36	184	182	0	402	71	192	11	0	274	
% App. Total	16.9	57.8	25.3	0		12.1	80.6	7.3	0		9	45.8	45.3	0		25.9	70.1	4	0		
PHF	.875	.750	.656	.000	.769	.750	.806	.563	.000	.838	.750	.852	.858	.000	.845	.888	.889	.688	.000	.890	

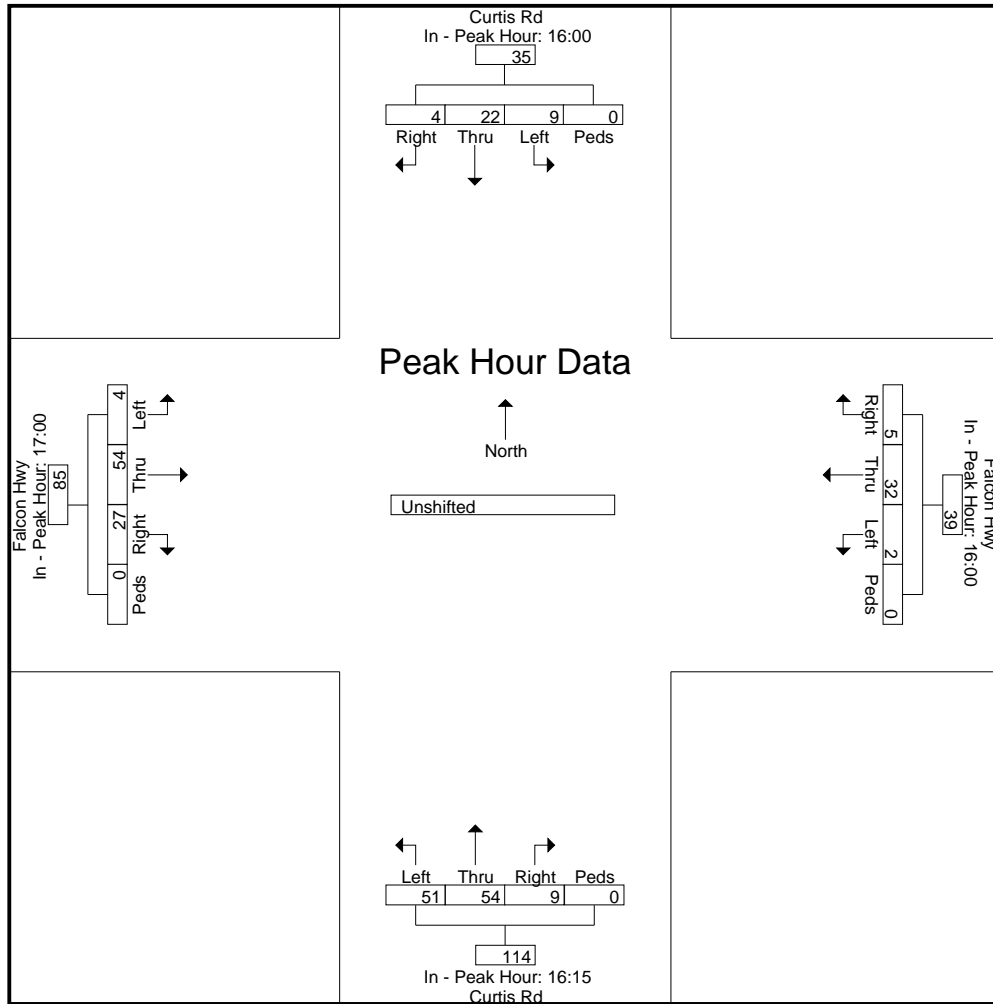

LSC Transportation Consultants, Inc.

2504 E. Pikes Peak Ave, Suite 304
 Colorado Springs, CO 80909
 719-633-2868

File Name : Curtis Rd - Judge Orr Rd AM

Site Code : S214950

Start Date : 4/21/2022

Page No : 1

Groups Printed- Unshifted

Start Time	Curtis Rd Southbound					Judge Orr Rd Westbound					Curtis Rd Northbound					Judge Orr Rd Eastbound					Int. Total
	Right	Thru	Left	Peds	App. Total	Right	Thru	Left	Peds	App. Total	Right	Thru	Left	Peds	App. Total	Right	Thru	Left	Peds	App. Total	
06:30	0	15	0	0	15	1	8	0	0	9	0	3	1	0	4	4	2	0	0	6	34
06:35	0	13	1	0	14	1	10	1	0	12	0	2	2	0	4	6	1	0	0	7	37
06:40	0	14	0	0	14	0	11	1	0	12	0	4	1	0	5	4	2	0	0	6	37
06:45	0	12	1	0	13	2	12	1	0	15	0	5	3	0	8	5	1	0	0	6	42
06:50	0	14	0	0	14	4	6	0	0	10	0	5	1	0	6	4	5	0	0	9	39
06:55	0	14	2	0	16	0	9	4	0	13	0	2	2	0	4	4	3	0	0	7	40
Total	0	82	4	0	86	8	56	7	0	71	0	21	10	0	31	27	14	0	0	41	229
07:00	0	13	0	0	13	1	9	2	0	12	0	11	2	0	13	4	4	0	0	8	46
07:05	0	13	0	0	13	5	16	2	0	23	0	6	3	0	9	6	3	0	0	9	54
07:10	0	18	0	0	18	2	9	1	0	12	0	9	4	0	13	9	3	0	0	12	55
07:15	0	16	0	0	16	6	11	4	0	21	0	9	2	0	11	7	3	0	0	10	58
07:20	0	15	0	0	15	1	9	1	0	11	0	9	4	0	13	7	3	0	0	10	49
07:25	0	9	1	0	10	5	11	1	0	17	0	7	4	0	11	8	2	0	0	10	48
07:30	0	20	0	0	20	1	8	1	0	10	0	4	2	0	6	7	4	1	0	12	48
07:35	0	9	1	0	10	3	7	2	0	12	0	5	3	0	8	9	1	0	0	10	40
07:40	0	13	3	0	16	3	9	0	0	12	0	5	5	0	10	9	2	0	0	11	49
07:45	0	18	0	0	18	1	7	1	0	9	0	3	2	0	5	5	1	1	0	7	39
07:50	0	13	1	0	14	0	12	0	0	12	0	3	1	0	4	4	2	0	0	6	36
07:55	1	11	1	0	13	2	13	1	0	16	1	5	5	0	11	3	2	0	0	5	45
Total	1	168	7	0	176	30	121	16	0	167	1	76	37	0	114	78	30	2	0	110	567
08:00	1	8	1	0	10	1	4	1	0	6	0	3	3	0	6	2	2	0	0	4	26
08:05	0	8	3	0	11	2	6	1	0	9	0	2	0	0	2	1	2	0	0	3	25
08:10	0	1	3	0	4	1	8	0	0	9	0	3	0	0	3	2	3	1	0	6	22
08:15	0	7	1	0	8	0	6	1	0	7	0	3	1	0	4	1	4	0	0	5	24
08:20	0	6	2	0	8	3	9	0	0	12	0	7	1	0	8	4	3	0	0	7	35
08:25	1	4	0	0	5	0	6	0	0	6	2	4	0	0	6	2	6	0	0	8	25
Grand Total	3	284	21	0	308	45	216	26	0	287	3	119	52	0	174	117	64	3	0	184	953
Apprch %	1	92.2	6.8	0		15.7	75.3	9.1	0		1.7	68.4	29.9	0		63.6	34.8	1.6	0		
Total %	0.3	29.8	2.2	0	32.3	4.7	22.7	2.7	0	30.1	0.3	12.5	5.5	0	18.3	12.3	6.7	0.3	0	19.3	

LSC Transportation Consultants, Inc.

2504 E. Pikes Peak Ave, Suite 304
 Colorado Springs, CO 80909
 719-633-2868

File Name : Curtis Rd - Judge Orr Rd AM

Site Code : S214950

Start Date : 4/21/2022

Page No : 2

Start Time	Curtis Rd Southbound					Judge Orr Rd Westbound					Curtis Rd Northbound					Judge Orr Rd Eastbound					Int. Total
	Right	Thru	Left	Peds	App. Total	Right	Thru	Left	Peds	App. Total	Right	Thru	Left	Peds	App. Total	Right	Thru	Left	Peds	App. Total	
Peak Hour Analysis From 06:30 to 08:25 - Peak 1 of 1																					
Peak Hour for Entire Intersection Begins at 06:45																					
06:45	0	12	1	0	13	2	12	1	0	15	0	5	3	0	8	5	1	0	0	6	42
06:50	0	14	0	0	14	4	6	0	0	10	0	5	1	0	6	4	5	0	0	9	39
06:55	0	14	2	0	16	0	9	4	0	13	0	2	2	0	4	4	3	0	0	7	40
07:00	0	13	0	0	13	1	9	2	0	12	0	11	2	0	13	4	4	0	0	8	46
07:05	0	13	0	0	13	5	16	2	0	23	0	6	3	0	9	6	3	0	0	9	54
07:10	0	18	0	0	18	2	9	1	0	12	0	9	4	0	13	9	3	0	0	12	55
07:15	0	16	0	0	16	6	11	4	0	21	0	9	2	0	11	7	3	0	0	10	58
07:20	0	15	0	0	15	1	9	1	0	11	0	9	4	0	13	7	3	0	0	10	49
07:25	0	9	1	0	10	5	11	1	0	17	0	7	4	0	11	8	2	0	0	10	48
07:30	0	20	0	0	20	1	8	1	0	10	0	4	2	0	6	7	4	1	0	12	48
07:35	0	9	1	0	10	3	7	2	0	12	0	5	3	0	8	9	1	0	0	10	40
07:40	0	13	3	0	16	3	9	0	0	12	0	5	5	0	10	9	2	0	0	11	49
Total Volume	0	166	8	0	174	33	116	19	0	168	0	77	35	0	112	79	34	1	0	114	568
% App. Total	0	95.4	4.6	0		19.6	69	11.3	0		0	68.8	31.2	0		69.3	29.8	0.9	0		
PHF	.000	.692	.222	.000	.725	.458	.604	.396	.000	.609	.000	.583	.583	.000	.718	.731	.567	.083	.000	.792	.816

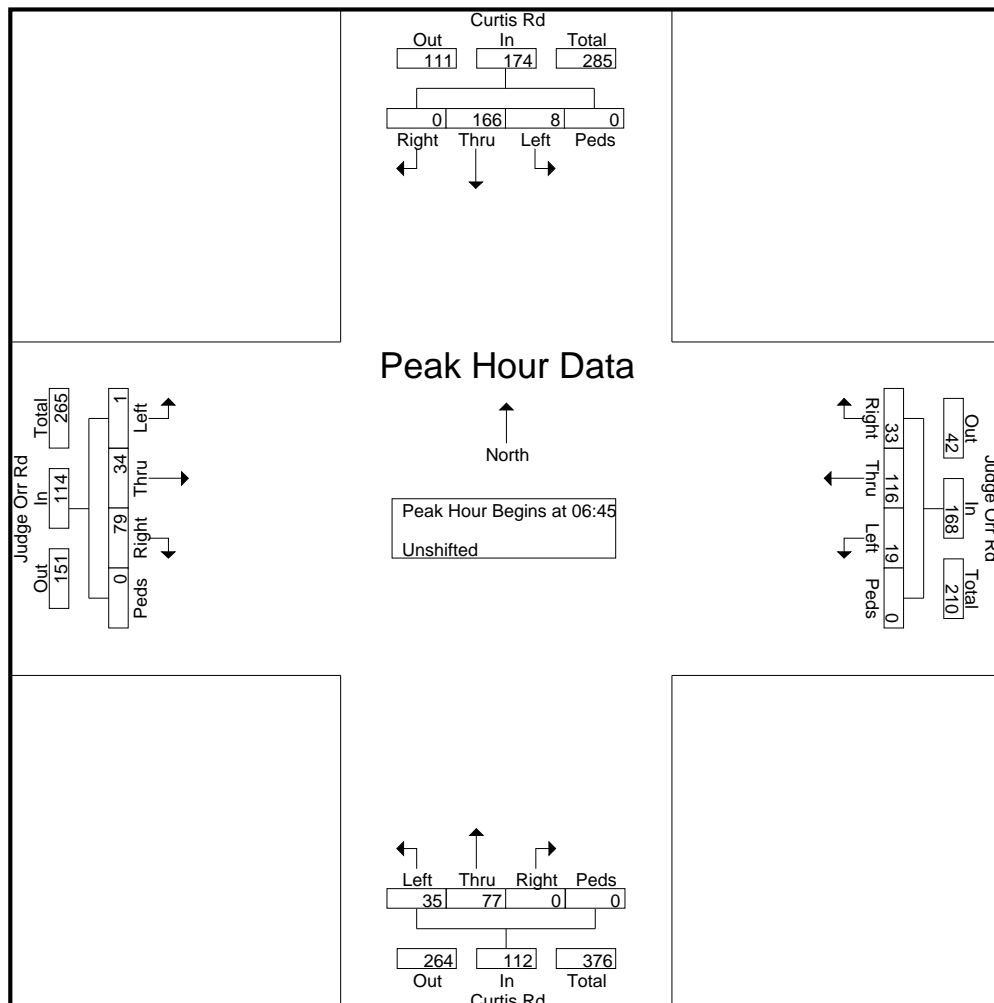

LSC Transportation Consultants, Inc.

2504 E. Pikes Peak Ave, Suite 304
 Colorado Springs, CO 80909
 719-633-2868

File Name : Curtis Rd - Judge Orr Rd AM

Site Code : S214950

Start Date : 4/21/2022

Page No : 3

Start Time	Curtis Rd Southbound					Judge Orr Rd Westbound					Curtis Rd Northbound					Judge Orr Rd Eastbound					Int. Total
	Right	Thru	Left	Peds	App. Total	Right	Thru	Left	Peds	App. Total	Right	Thru	Left	Peds	App. Total	Right	Thru	Left	Peds	App. Total	

Peak Hour Analysis From 06:30 to 08:25 - Peak 1 of 1

Peak Hour for Each Approach Begins at:

	06:50					06:35					07:00					06:50				
+0 mins.	0	14	0	0	14	1	10	1	0	12	0	11	2	0	13	4	5	0	0	9
+5 mins.	0	14	2	0	16	0	11	1	0	12	0	6	3	0	9	4	3	0	0	7
+10 mins.	0	13	0	0	13	2	12	1	0	15	0	9	4	0	13	4	4	0	0	8
+15 mins.	0	13	0	0	13	4	6	0	0	10	0	9	2	0	11	6	3	0	0	9
+20 mins.	0	18	0	0	18	0	9	4	0	13	0	9	4	0	13	9	3	0	0	12
+25 mins.	0	16	0	0	16	1	9	2	0	12	0	7	4	0	11	7	3	0	0	10
+30 mins.	0	15	0	0	15	5	16	2	0	23	0	4	2	0	6	7	3	0	0	10
+35 mins.	0	9	1	0	10	2	9	1	0	12	0	5	3	0	8	8	2	0	0	10
+40 mins.	0	20	0	0	20	6	11	4	0	21	0	5	5	0	10	7	4	1	0	12
+45 mins.	0	9	1	0	10	1	9	1	0	11	0	3	2	0	5	9	1	0	0	10
+50 mins.	0	13	3	0	16	5	11	1	0	17	0	3	1	0	4	9	2	0	0	11
+55 mins.	0	18	0	0	18	1	8	1	0	10	1	5	5	0	11	5	1	1	0	7
Total Volume	0	172	7	0	179	28	121	19	0	168	1	76	37	0	114	79	34	2	0	115
% App. Total	0	96.1	3.9	0		16.7	72	11.3	0		0.9	66.7	32.5	0		68.7	29.6	1.7	0	
PHF	.000	.717	.194	.000	.746	.389	.630	.396	.000	.609	.083	.576	.617	.000	.731	.731	.567	.167	.000	.799

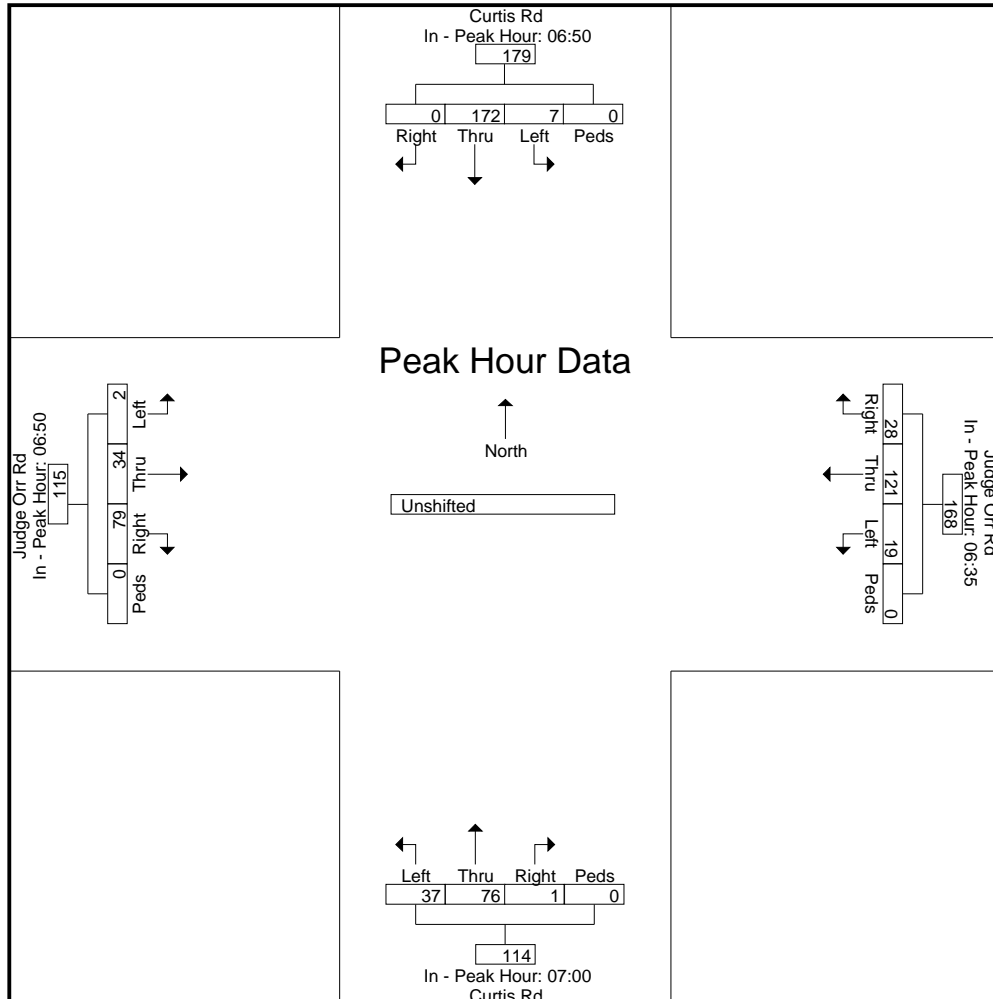

LSC Transportation Consultants, Inc.

2504 E. Pikes Peak Ave, Suite 304
 Colorado Springs, CO 80909
 719-633-2868

File Name : Curtis Rd - Judge Orr Rd AM

Site Code : S214950

Start Date : 4/21/2022

Page No : 1

Groups Printed- Unshifted

Start Time	Curtis Rd Southbound					Judge Orr Rd Westbound					Curtis Rd Northbound					Judge Orr Rd Eastbound					Int. Total
	Right	Thru	Left	Peds	App. Total	Right	Thru	Left	Peds	App. Total	Right	Thru	Left	Peds	App. Total	Right	Thru	Left	Peds	App. Total	
06:30	0	42	1	0	43	2	29	2	0	33	0	9	4	0	13	14	5	0	0	19	108
06:45	0	40	3	0	43	6	27	5	0	38	0	12	6	0	18	13	9	0	0	22	121
Total	0	82	4	0	86	8	56	7	0	71	0	21	10	0	31	27	14	0	0	41	229
07:00	0	44	0	0	44	8	34	5	0	47	0	26	9	0	35	19	10	0	0	29	155
07:15	0	40	1	0	41	12	31	6	0	49	0	25	10	0	35	22	8	0	0	30	155
07:30	0	42	4	0	46	7	24	3	0	34	0	14	10	0	24	25	7	1	0	33	137
07:45	1	42	2	0	45	3	32	2	0	37	1	11	8	0	20	12	5	1	0	18	120
Total	1	168	7	0	176	30	121	16	0	167	1	76	37	0	114	78	30	2	0	110	567
08:00	1	17	7	0	25	4	18	2	0	24	0	8	3	0	11	5	7	1	0	13	73
08:15	1	17	3	0	21	3	21	1	0	25	2	14	2	0	18	7	13	0	0	20	84
Grand Total	3	284	21	0	308	45	216	26	0	287	3	119	52	0	174	117	64	3	0	184	953
Apprch %	1	92.2	6.8	0		15.7	75.3	9.1	0		1.7	68.4	29.9	0		63.6	34.8	1.6	0		
Total %	0.3	29.8	2.2	0	32.3	4.7	22.7	2.7	0	30.1	0.3	12.5	5.5	0	18.3	12.3	6.7	0.3	0	19.3	

LSC Transportation Consultants, Inc.

2504 E. Pikes Peak Ave, Suite 304
 Colorado Springs, CO 80909
 719-633-2868

File Name : Curtis Rd - Judge Orr Rd AM

Site Code : S214950

Start Date : 4/21/2022

Page No : 2

Start Time	Curtis Rd Southbound					Judge Orr Rd Westbound					Curtis Rd Northbound					Judge Orr Rd Eastbound					Int. Total
	Right	Thru	Left	Peds	App. Total	Right	Thru	Left	Peds	App. Total	Right	Thru	Left	Peds	App. Total	Right	Thru	Left	Peds	App. Total	
Peak Hour Analysis From 6:30:00 AM to 8:15:00 AM - Peak 1 of 1																					
Peak Hour for Entire Intersection Begins at 6:45:00 AM																					
6:45:00 AM	0	40	3	0	43	6	27	5	0	38	0	12	6	0	18	13	9	0	0	22	121
7:00:00 AM	0	44	0	0	44	8	34	5	0	47	0	26	9	0	35	19	10	0	0	29	155
7:15:00 AM	0	40	1	0	41	12	31	6	0	49	0	25	10	0	35	22	8	0	0	30	155
7:30:00 AM	0	42	4	0	46	7	24	3	0	34	0	14	10	0	24	25	7	1	0	33	137
Total Volume	0	166	8	0	174	33	116	19	0	168	0	77	35	0	112	79	34	1	0	114	568
% App. Total	0	95.4	4.6	0		19.6	69	11.3	0		0	68.8	31.2	0		69.3	29.8	0.9	0		
PHF	.000	.943	.500	.000	.946	.688	.853	.792	.000	.857	.000	.740	.875	.000	.800	.790	.850	.250	.000	.864	.916

LSC Transportation Consultants, Inc.

2504 E. Pikes Peak Ave, Suite 304
 Colorado Springs, CO 80909
 719-633-2868

File Name : Curtis Rd - Judge Orr Rd AM

Site Code : S214950

Start Date : 4/21/2022

Page No : 3

Start Time	Curtis Rd Southbound					Judge Orr Rd Westbound					Curtis Rd Northbound					Judge Orr Rd Eastbound					Int. Total
	Right	Thru	Left	Peds	App. Total	Right	Thru	Left	Peds	App. Total	Right	Thru	Left	Peds	App. Total	Right	Thru	Left	Peds	App. Total	
Peak Hour Analysis From 6:30:00 AM to 8:15:00 AM - Peak 1 of 1																					
Peak Hour for Each Approach Begins at:																					
	7:00:00 AM					6:45:00 AM					7:00:00 AM					6:45:00 AM					
+0 mins.	0	44	0	0	44	6	27	5	0	38	0	26	9	0	35	13	9	0	0	22	
+5 mins.	0	40	1	0	41	8	34	5	0	47	0	25	10	0	35	19	10	0	0	29	
+10 mins.	0	42	4	0	46	12	31	6	0	49	0	14	10	0	24	22	8	0	0	30	
+15 mins.	1	42	2	0	45	7	24	3	0	34	1	11	8	0	20	25	7	1	0	33	
Total Volume	1	168	7	0	176	33	116	19	0	168	1	76	37	0	114	79	34	1	0	114	
% App. Total	0.6	95.5	4	0		19.6	69	11.3	0		0.9	66.7	32.5	0		69.3	29.8	0.9	0		
PHF	.250	.955	.438	.000	.957	.688	.853	.792	.000	.857	.250	.731	.925	.000	.814	.790	.850	.250	.000	.864	

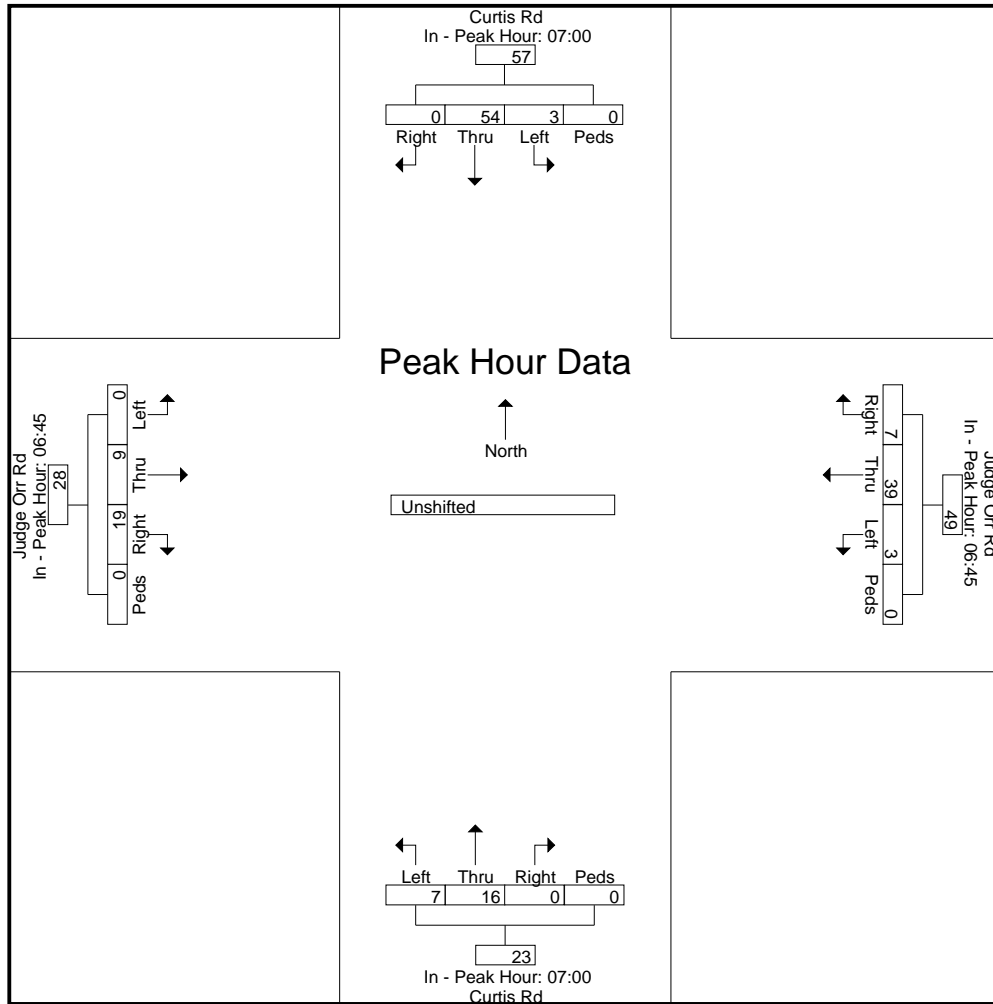

LSC Transportation Consultants, Inc.

2504 E. Pikes Peak Ave, Suite 304
 Colorado Springs, CO 80909
 719-633-2868

File Name : Curtis Rd - Judge Orr Rd PM

Site Code : S214950

Start Date : 4/21/2022

Page No : 1

Groups Printed- Unshifted

Start Time	Curtis Rd Southbound					Judge Orr Rd Westbound					Curtis Rd Northbound					Judge Orr Rd Eastbound					Int. Total
	Right	Thru	Left	Peds	App. Total	Right	Thru	Left	Peds	App. Total	Right	Thru	Left	Peds	App. Total	Right	Thru	Left	Peds	App. Total	
16:00	1	4	1	0	6	0	7	0	0	7	0	11	4	0	15	3	10	0	0	13	41
16:05	1	5	2	1	9	1	8	0	0	9	0	12	8	0	20	2	9	0	0	11	49
16:10	0	3	1	0	4	0	10	1	0	11	2	10	3	0	15	4	12	0	0	16	46
16:15	0	4	1	0	5	1	3	1	0	5	1	11	3	0	15	3	8	0	0	11	36
16:20	1	5	0	0	6	1	5	0	0	6	3	11	9	0	23	3	10	0	0	13	48
16:25	0	1	1	0	2	2	5	0	0	7	0	16	6	0	22	3	3	0	0	6	37
16:30	0	4	2	0	6	2	6	0	0	8	1	9	5	0	15	1	16	1	0	18	47
16:35	0	1	1	0	2	1	3	0	0	4	1	13	3	0	17	4	9	1	0	14	37
16:40	0	6	2	0	8	2	2	0	0	4	3	8	5	0	16	2	5	0	0	7	35
16:45	0	7	1	0	8	1	3	0	0	4	3	9	5	0	17	1	7	0	0	8	37
16:50	1	4	3	0	8	2	7	0	0	9	1	15	10	0	26	2	14	1	0	17	60
16:55	1	3	1	0	5	0	5	0	0	5	3	12	5	0	20	1	7	0	0	8	38
Total	5	47	16	1	69	13	64	2	0	79	18	137	66	0	221	29	110	3	0	142	511
17:00	0	3	2	0	5	0	4	0	0	4	2	9	3	0	14	4	11	0	0	15	38
17:05	0	2	1	0	3	4	4	0	0	8	3	21	3	0	27	0	5	0	0	5	43
17:10	0	4	1	0	5	0	2	0	0	2	1	11	5	0	17	1	16	1	0	18	42
17:15	1	7	0	0	8	0	4	0	0	4	1	8	3	0	12	2	8	0	0	10	34
17:20	0	6	2	0	8	2	5	0	0	7	1	9	3	0	13	3	8	1	0	12	40
17:25	0	2	0	0	2	1	6	0	0	7	0	6	5	0	11	3	6	0	0	9	29
17:30	0	1	2	0	3	2	3	0	0	5	0	7	1	0	8	3	15	0	0	18	34
17:35	0	5	4	0	9	1	3	0	0	4	0	7	2	0	9	3	7	0	0	10	32
17:40	1	4	3	0	8	2	5	0	0	7	2	3	3	0	8	0	14	0	0	14	37
17:45	1	4	5	0	10	0	9	0	0	9	0	7	2	0	9	3	12	0	0	15	43
17:50	0	6	2	0	8	0	7	1	0	8	0	3	2	0	5	0	4	1	0	5	26
17:55	0	3	2	0	5	0	3	0	0	3	1	8	0	0	9	0	7	0	0	7	24
Total	3	47	24	0	74	12	55	1	0	68	11	99	32	0	142	22	113	3	0	138	422
Grand Total	8	94	40	1	143	25	119	3	0	147	29	236	98	0	363	51	223	6	0	280	933
Apprch %	5.6	65.7	28	0.7		17	81	2	0		8	65	27	0		18.2	79.6	2.1	0		
Total %	0.9	10.1	4.3	0.1	15.3	2.7	12.8	0.3	0	15.8	3.1	25.3	10.5	0	38.9	5.5	23.9	0.6	0	30	

LSC Transportation Consultants, Inc.

2504 E. Pikes Peak Ave, Suite 304
 Colorado Springs, CO 80909
 719-633-2868

File Name : Curtis Rd - Judge Orr Rd PM
 Site Code : S214950
 Start Date : 4/21/2022
 Page No : 2

Start Time	Curtis Rd Southbound					Judge Orr Rd Westbound					Curtis Rd Northbound					Judge Orr Rd Eastbound					Int. Total
	Right	Thru	Left	Peds	App. Total	Right	Thru	Left	Peds	App. Total	Right	Thru	Left	Peds	App. Total	Right	Thru	Left	Peds	App. Total	
Peak Hour Analysis From 16:00 to 17:55 - Peak 1 of 1																					
Peak Hour for Entire Intersection Begins at 16:00																					
16:00	1	4	1	0	6	0	7	0	0	7	0	11	4	0	15	3	10	0	0	13	41
16:05	1	5	2	1	9	1	8	0	0	9	0	12	8	0	20	2	9	0	0	11	49
16:10	0	3	1	0	4	0	10	1	0	11	2	10	3	0	15	4	12	0	0	16	46
16:15	0	4	1	0	5	1	3	1	0	5	1	11	3	0	15	3	8	0	0	11	36
16:20	1	5	0	0	6	1	5	0	0	6	3	11	9	0	23	3	10	0	0	13	48
16:25	0	1	1	0	2	2	5	0	0	7	0	16	6	0	22	3	3	0	0	6	37
16:30	0	4	2	0	6	2	6	0	0	8	1	9	5	0	15	1	16	1	0	18	47
16:35	0	1	1	0	2	1	3	0	0	4	1	13	3	0	17	4	9	1	0	14	37
16:40	0	6	2	0	8	2	2	0	0	4	3	8	5	0	16	2	5	0	0	7	35
16:45	0	7	1	0	8	1	3	0	0	4	3	9	5	0	17	1	7	0	0	8	37
16:50	1	4	3	0	8	2	7	0	0	9	1	15	10	0	26	2	14	1	0	17	60
16:55	1	3	1	0	5	0	5	0	0	5	3	12	5	0	20	1	7	0	0	8	38
Total Volume	5	47	16	1	69	13	64	2	0	79	18	137	66	0	221	29	110	3	0	142	511
% App. Total	7.2	68.1	23.2	1.4		16.5	81	2.5	0		8.1	62	29.9	0		20.4	77.5	2.1	0		
PHF	.417	.560	.444	.083	.639	.542	.533	.167	.000	.598	.500	.714	.550	.000	.708	.604	.573	.250	.000	.657	.710

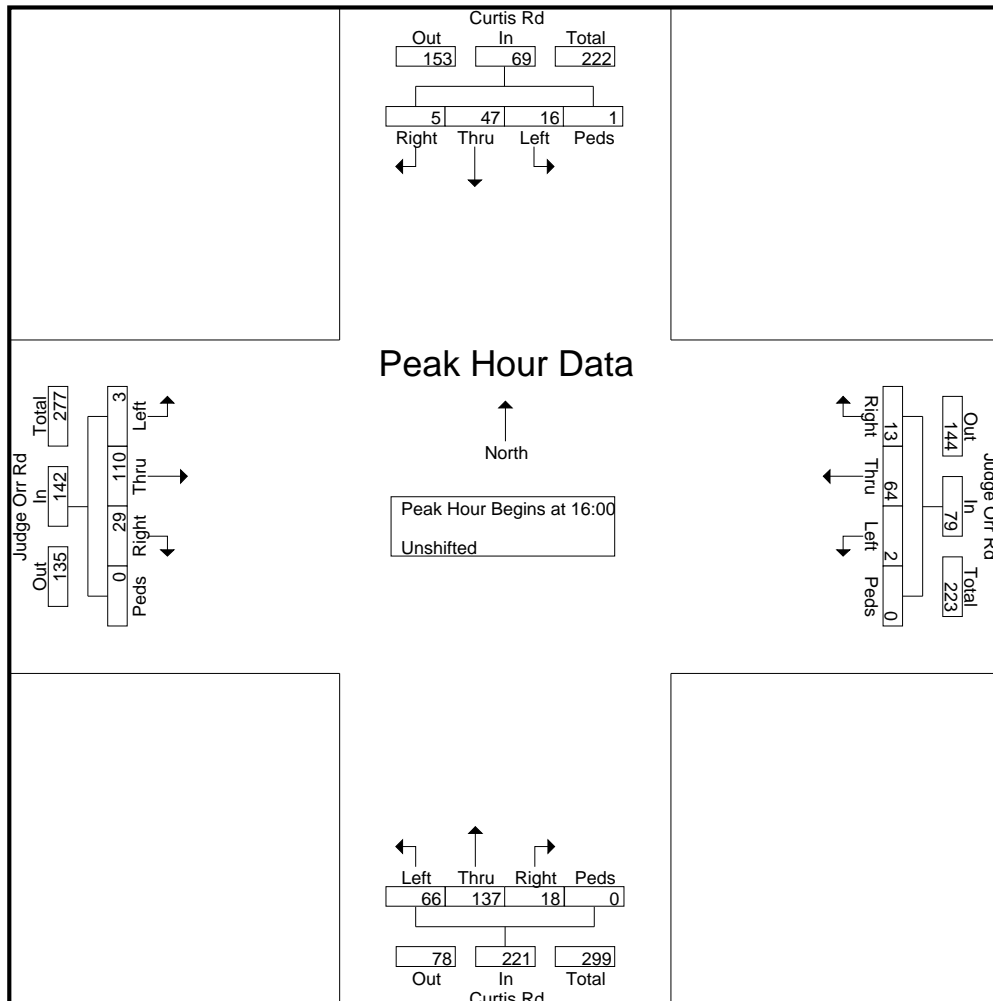

LSC Transportation Consultants, Inc.

2504 E. Pikes Peak Ave, Suite 304
 Colorado Springs, CO 80909
 719-633-2868

File Name : Curtis Rd - Judge Orr Rd PM

Site Code : S214950

Start Date : 4/21/2022

Page No : 3

Start Time	Curtis Rd Southbound					Judge Orr Rd Westbound					Curtis Rd Northbound					Judge Orr Rd Eastbound					Int. Total
	Right	Thru	Left	Peds	App. Total	Right	Thru	Left	Peds	App. Total	Right	Thru	Left	Peds	App. Total	Right	Thru	Left	Peds	App. Total	

Peak Hour Analysis From 16:00 to 17:55 - Peak 1 of 1

Peak Hour for Each Approach Begins at:

	16:50					16:00					16:15					16:50				
+0 mins.	1	4	3	0	8	0	7	0	0	7	1	11	3	0	15	2	14	1	0	17
+5 mins.	1	3	1	0	5	1	8	0	0	9	3	11	9	0	23	1	7	0	0	8
+10 mins.	0	3	2	0	5	0	10	1	0	11	0	16	6	0	22	4	11	0	0	15
+15 mins.	0	2	1	0	3	1	3	1	0	5	1	9	5	0	15	0	5	0	0	5
+20 mins.	0	4	1	0	5	1	5	0	0	6	1	13	3	0	17	1	16	1	0	18
+25 mins.	1	7	0	0	8	2	5	0	0	7	3	8	5	0	16	2	8	0	0	10
+30 mins.	0	6	2	0	8	2	6	0	0	8	3	9	5	0	17	3	8	1	0	12
+35 mins.	0	2	0	0	2	1	3	0	0	4	1	15	10	0	26	3	6	0	0	9
+40 mins.	0	1	2	0	3	2	2	0	0	4	3	12	5	0	20	3	15	0	0	18
+45 mins.	0	5	4	0	9	1	3	0	0	4	2	9	3	0	14	3	7	0	0	10
+50 mins.	1	4	3	0	8	2	7	0	0	9	3	21	3	0	27	0	14	0	0	14
+55 mins.	1	4	5	0	10	0	5	0	0	5	1	11	5	0	17	3	12	0	0	15
Total Volume	5	45	24	0	74	13	64	2	0	79	22	145	62	0	229	25	123	3	0	151
% App. Total	6.8	60.8	32.4	0		16.5	81	2.5	0		9.6	63.3	27.1	0		16.6	81.5	2	0	
PHF	.417	.536	.400	.000	.617	.542	.533	.167	.000	.598	.611	.575	.517	.000	.707	.521	.641	.250	.000	.699

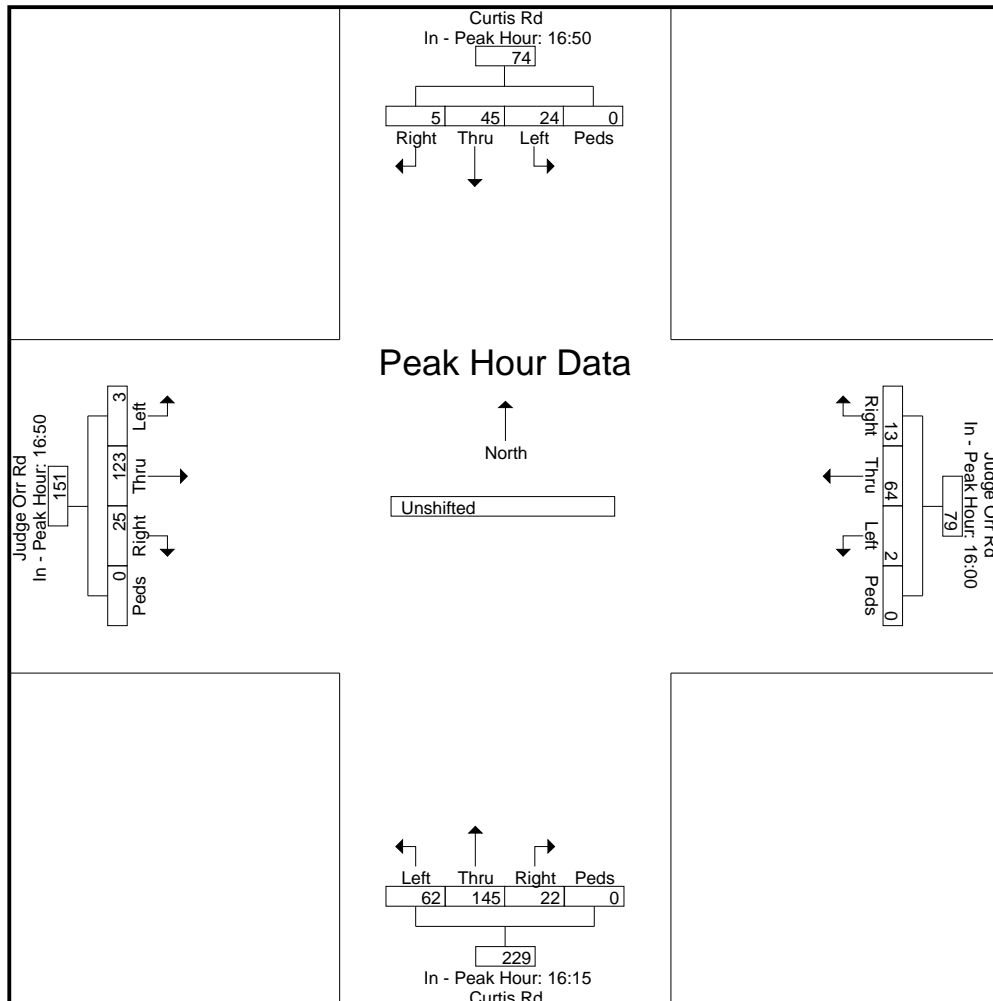

LSC Transportation Consultants, Inc.

2504 E. Pikes Peak Ave, Suite 304
 Colorado Springs, CO 80909
 719-633-2868

File Name : Curtis Rd - Judge Orr Rd PM

Site Code : S214950

Start Date : 4/21/2022

Page No : 1

Groups Printed- Unshifted

Start Time	Curtis Rd Southbound					Judge Orr Rd Westbound					Curtis Rd Northbound					Judge Orr Rd Eastbound					Int. Total
	Right	Thru	Left	Peds	App. Total	Right	Thru	Left	Peds	App. Total	Right	Thru	Left	Peds	App. Total	Right	Thru	Left	Peds	App. Total	
16:00	2	12	4	1	19	1	25	1	0	27	2	33	15	0	50	9	31	0	0	40	136
16:15	1	10	2	0	13	4	13	1	0	18	4	38	18	0	60	9	21	0	0	30	121
16:30	0	11	5	0	16	5	11	0	0	16	5	30	13	0	48	7	30	2	0	39	119
16:45	2	14	5	0	21	3	15	0	0	18	7	36	20	0	63	4	28	1	0	33	135
Total	5	47	16	1	69	13	64	2	0	79	18	137	66	0	221	29	110	3	0	142	511
17:00	0	9	4	0	13	4	10	0	0	14	6	41	11	0	58	5	32	1	0	38	123
17:15	1	15	2	0	18	3	15	0	0	18	2	23	11	0	36	8	22	1	0	31	103
17:30	1	10	9	0	20	5	11	0	0	16	2	17	6	0	25	6	36	0	0	42	103
17:45	1	13	9	0	23	0	19	1	0	20	1	18	4	0	23	3	23	1	0	27	93
Total	3	47	24	0	74	12	55	1	0	68	11	99	32	0	142	22	113	3	0	138	422
Grand Total	8	94	40	1	143	25	119	3	0	147	29	236	98	0	363	51	223	6	0	280	933
Apprch %	5.6	65.7	28	0.7		17	81	2	0		8	65	27	0		18.2	79.6	2.1	0		
Total %	0.9	10.1	4.3	0.1	15.3	2.7	12.8	0.3	0	15.8	3.1	25.3	10.5	0	38.9	5.5	23.9	0.6	0	30	

LSC Transportation Consultants, Inc.

2504 E. Pikes Peak Ave, Suite 304
 Colorado Springs, CO 80909
 719-633-2868

File Name : Curtis Rd - Judge Orr Rd PM

Site Code : S214950

Start Date : 4/21/2022

Page No : 2

Start Time	Curtis Rd Southbound					Judge Orr Rd Westbound					Curtis Rd Northbound					Judge Orr Rd Eastbound					Int. Total
	Right	Thru	Left	Peds	App. Total	Right	Thru	Left	Peds	App. Total	Right	Thru	Left	Peds	App. Total	Right	Thru	Left	Peds	App. Total	
Peak Hour Analysis From 4:00:00 PM to 5:45:00 PM - Peak 1 of 1																					
Peak Hour for Entire Intersection Begins at 4:00:00 PM																					
4:00:00 PM	2	12	4	1	19	1	25	1	0	27	2	33	15	0	50	9	31	0	0	40	136
4:15:00 PM	1	10	2	0	13	4	13	1	0	18	4	38	18	0	60	9	21	0	0	30	121
4:30:00 PM	0	11	5	0	16	5	11	0	0	16	5	30	13	0	48	7	30	2	0	39	119
4:45:00 PM	2	14	5	0	21	3	15	0	0	18	7	36	20	0	63	4	28	1	0	33	135
Total Volume	5	47	16	1	69	13	64	2	0	79	18	137	66	0	221	29	110	3	0	142	511
% App. Total	7.2	68.1	23.2	1.4		16.5	81	2.5	0		8.1	62	29.9	0		20.4	77.5	2.1	0		
PHF	.625	.839	.800	.250	.821	.650	.640	.500	.000	.731	.643	.901	.825	.000	.877	.806	.887	.375	.000	.888	.939

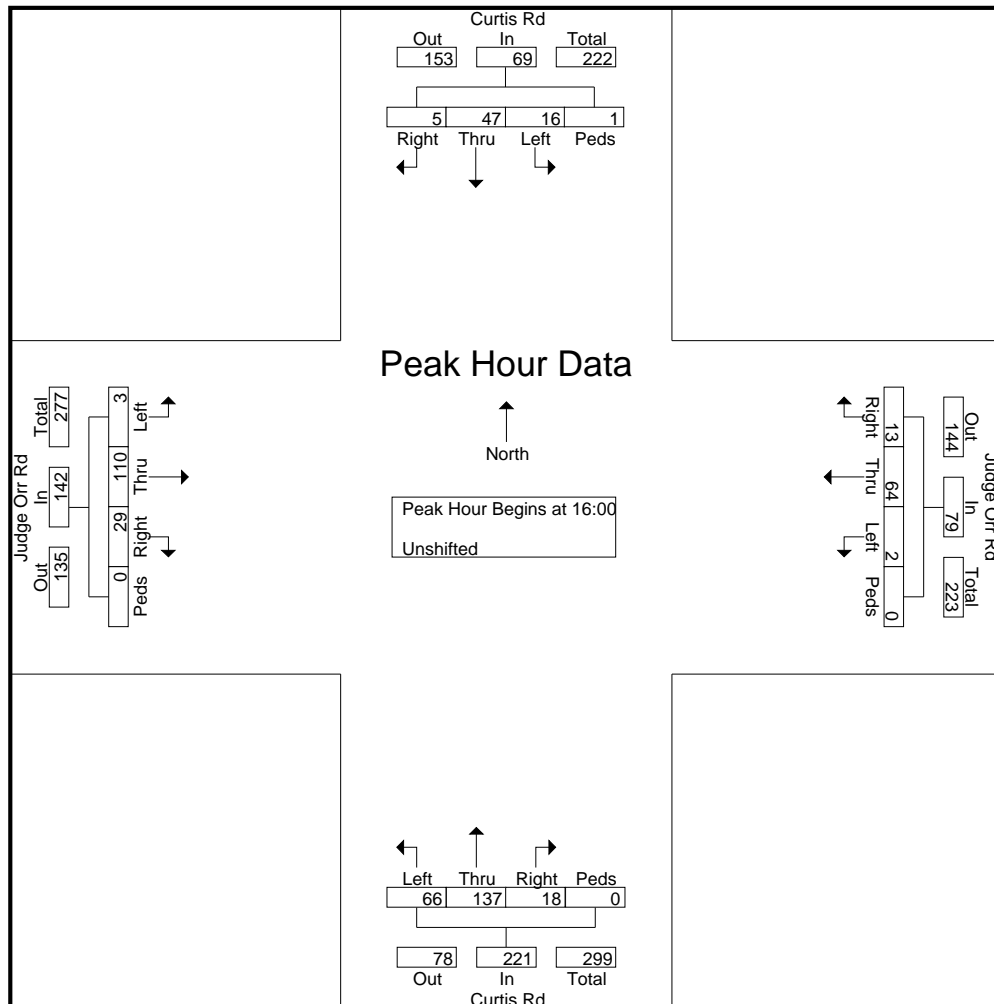

LSC Transportation Consultants, Inc.

2504 E. Pikes Peak Ave, Suite 304
 Colorado Springs, CO 80909
 719-633-2868

File Name : Curtis Rd - Judge Orr Rd PM

Site Code : S214950

Start Date : 4/21/2022

Page No : 3

Start Time	Curtis Rd Southbound					Judge Orr Rd Westbound					Curtis Rd Northbound					Judge Orr Rd Eastbound					Int. Total
	Right	Thru	Left	Peds	App. Total	Right	Thru	Left	Peds	App. Total	Right	Thru	Left	Peds	App. Total	Right	Thru	Left	Peds	App. Total	

Peak Hour Analysis From 4:00:00 PM to 5:45:00 PM - Peak 1 of 1
 Peak Hour for Each Approach Begins at:

	5:00:00 PM					4:00:00 PM					4:15:00 PM					4:45:00 PM				
+0 mins.	0	9	4	0	13	1	25	1	0	27	4	38	18	0	60	4	28	1	0	33
+5 mins.	1	15	2	0	18	4	13	1	0	18	5	30	13	0	48	5	32	1	0	38
+10 mins.	1	10	9	0	20	5	11	0	0	16	7	36	20	0	63	8	22	1	0	31
+15 mins.	1	13	9	0	23	3	15	0	0	18	6	41	11	0	58	6	36	0	0	42
Total Volume	3	47	24	0	74	13	64	2	0	79	22	145	62	0	229	23	118	3	0	144
% App. Total	4.1	63.5	32.4	0		16.5	81	2.5	0		9.6	63.3	27.1	0		16	81.9	2.1	0	
PHF	.750	.783	.667	.000	.804	.650	.640	.500	.000	.731	.786	.884	.775	.000	.909	.719	.819	.750	.000	.857

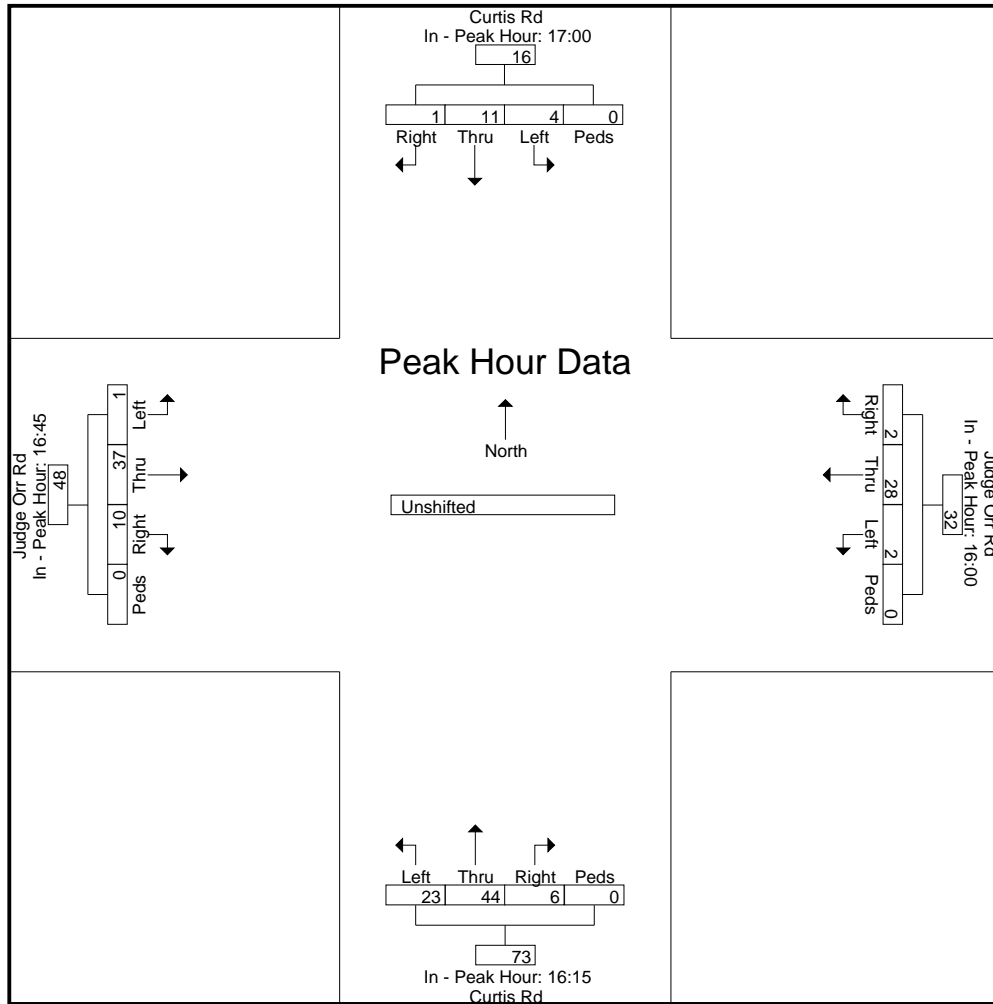

LSC Transportation Consultants, Inc.

2504 E. Pikes Peak Ave, Suite 304
 Colorado Springs, CO 80909
 719-633-2868

File Name : hwy 24 - judge orr rd am
 Site Code : S214950
 Start Date : 5/10/2022
 Page No : 1

Groups Printed- Unshifted

Start Time	Hwy 24 Southbound					Judge Orr Rd Westbound					Hwy 24 Northbound					Judge Orr Rd Eastbound					Int. Total
	Right	Thru	Left	Peds	App. Total	Right	Thru	Left	Peds	App. Total	Right	Thru	Left	Peds	App. Total	Right	Thru	Left	Peds	App. Total	
06:30	1	130	0	0	131	1	7	36	0	44	4	66	8	0	78	43	14	2	0	59	312
06:45	4	173	3	0	180	0	10	20	0	30	18	92	8	0	118	34	10	4	0	48	376
Total	5	303	3	0	311	1	17	56	0	74	22	158	16	0	196	77	24	6	0	107	688
07:00	2	132	0	0	134	3	7	39	0	49	18	98	23	0	139	50	16	9	0	75	397
07:15	3	137	2	0	142	1	23	26	0	50	19	82	18	0	119	43	16	2	0	61	372
07:30	9	137	2	0	148	0	17	30	0	47	9	71	24	0	104	51	20	0	0	71	370
07:45	1	102	1	0	104	1	15	15	0	31	21	67	17	0	105	21	15	3	0	39	279
Total	15	508	5	0	528	5	62	110	0	177	67	318	82	0	467	165	67	14	0	246	1418
08:00	2	108	1	0	111	1	8	22	0	31	23	68	12	1	104	28	20	5	0	53	299
08:15	5	96	1	0	102	2	3	29	0	34	15	70	14	0	99	15	13	4	0	32	267
Grand Total	27	1015	10	0	1052	9	90	217	0	316	127	614	124	1	866	285	124	29	0	438	2672
Apprch %	2.6	96.5	1	0		2.8	28.5	68.7	0		14.7	70.9	14.3	0.1		65.1	28.3	6.6	0		
Total %	1	38	0.4	0	39.4	0.3	3.4	8.1	0	11.8	4.8	23	4.6	0	32.4	10.7	4.6	1.1	0	16.4	

LSC Transportation Consultants, Inc.

2504 E. Pikes Peak Ave, Suite 304
 Colorado Springs, CO 80909
 719-633-2868

File Name : hwy 24 - judge orr rd am
 Site Code : S214950
 Start Date : 5/10/2022
 Page No : 2

Start Time	Hwy 24 Southbound					Judge Orr Rd Westbound					Hwy 24 Northbound					Judge Orr Rd Eastbound					Int. Total
	Right	Thru	Left	Peds	App. Total	Right	Thru	Left	Peds	App. Total	Right	Thru	Left	Peds	App. Total	Right	Thru	Left	Peds	App. Total	
Peak Hour Analysis From 6:30:00 AM to 8:15:00 AM - Peak 1 of 1																					
Peak Hour for Entire Intersection Begins at 6:45:00 AM																					
6:45:00 AM	4	173	3	0	180	0	10	20	0	30	18	92	8	0	118	34	10	4	0	48	376
7:00:00 AM	2	132	0	0	134	3	7	39	0	49	18	98	23	0	139	50	16	9	0	75	397
7:15:00 AM	3	137	2	0	142	1	23	26	0	50	19	82	18	0	119	43	16	2	0	61	372
7:30:00 AM	9	137	2	0	148	0	17	30	0	47	9	71	24	0	104	51	20	0	0	71	370
Total Volume	18	579	7	0	604	4	57	115	0	176	64	343	73	0	480	178	62	15	0	255	1515
% App. Total	3	95.9	1.2	0		2.3	32.4	65.3	0		13.3	71.5	15.2	0		69.8	24.3	5.9	0		
PHF	.500	.837	.583	.000	.839	.333	.620	.737	.000	.880	.842	.875	.760	.000	.863	.873	.775	.417	.000	.850	.954

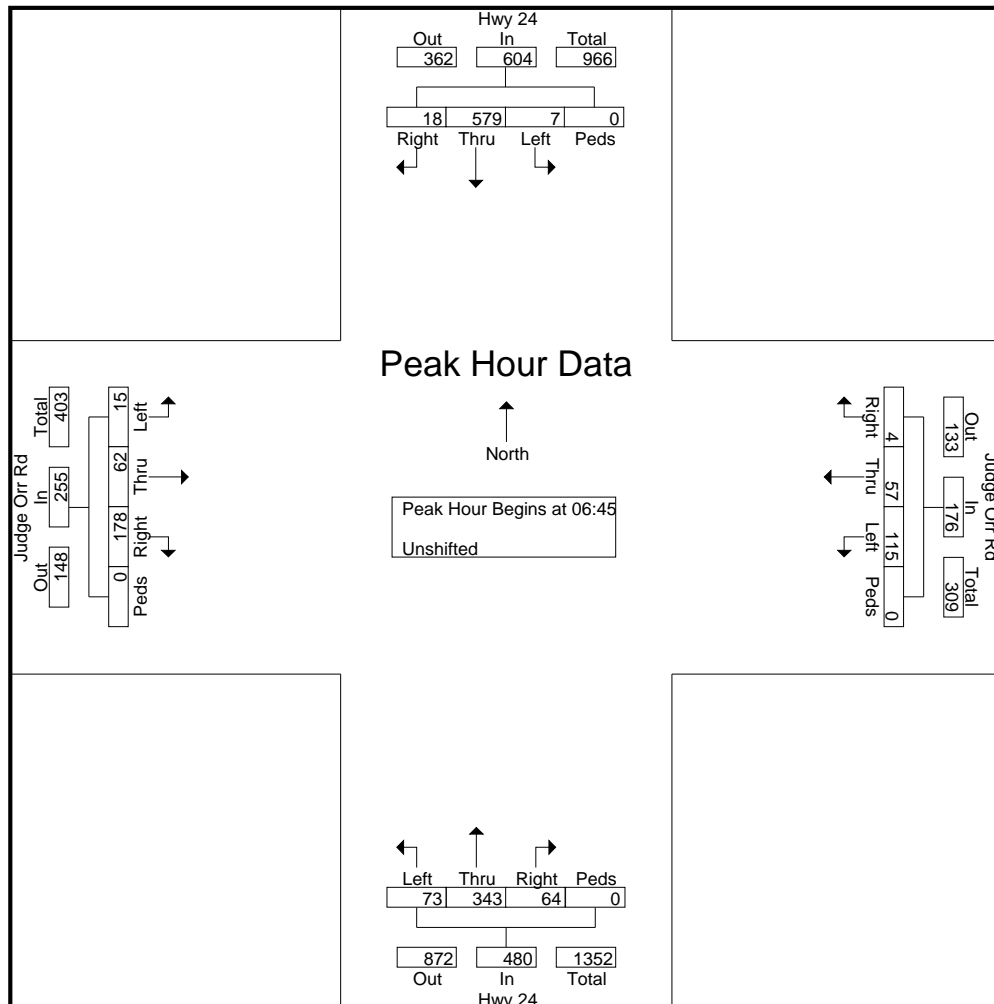

LSC Transportation Consultants, Inc.

2504 E. Pikes Peak Ave, Suite 304
 Colorado Springs, CO 80909
 719-633-2868

File Name : hwy 24 - judge orr rd am
 Site Code : S214950
 Start Date : 5/10/2022
 Page No : 3

Start Time	Hwy 24 Southbound					Judge Orr Rd Westbound					Hwy 24 Northbound					Judge Orr Rd Eastbound					Int. Total
	Right	Thru	Left	Peds	App. Total	Right	Thru	Left	Peds	App. Total	Right	Thru	Left	Peds	App. Total	Right	Thru	Left	Peds	App. Total	
Peak Hour Analysis From 6:30:00 AM to 8:15:00 AM - Peak 1 of 1																					
Peak Hour for Each Approach Begins at:																					
	6:45:00 AM					7:00:00 AM					6:45:00 AM					6:45:00 AM					
+0 mins.	4	173	3	0	180	3	7	39	0	49	18	92	8	0	118	34	10	4	0	48	
+5 mins.	2	132	0	0	134	1	23	26	0	50	18	98	23	0	139	50	16	9	0	75	
+10 mins.	3	137	2	0	142	0	17	30	0	47	19	82	18	0	119	43	16	2	0	61	
+15 mins.	9	137	2	0	148	1	15	15	0	31	9	71	24	0	104	51	20	0	0	71	
Total Volume	18	579	7	0	604	5	62	110	0	177	64	343	73	0	480	178	62	15	0	255	
% App. Total	3	95.9	1.2	0		2.8	35	62.1	0		13.3	71.5	15.2	0		69.8	24.3	5.9	0		
PHF	.500	.837	.583	.000	.839	.417	.674	.705	.000	.885	.842	.875	.760	.000	.863	.873	.775	.417	.000	.850	

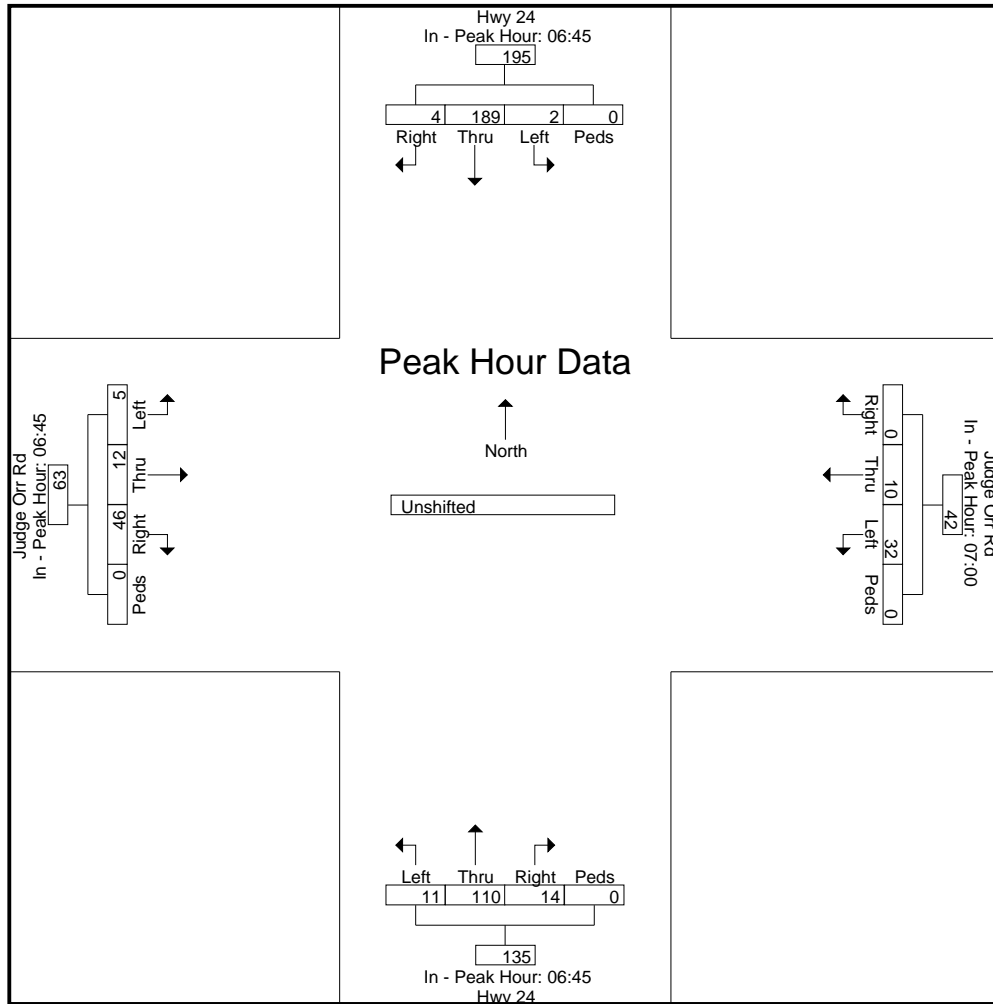

LSC Transportation Consultants, Inc.

2504 E. Pikes Peak Ave, Suite 304
 Colorado Springs, CO 80909
 719-633-2868

File Name : Hwy 24 - Judge Orr Rd PM

Site Code : S214950

Start Date : 5/10/2022

Page No : 1

Groups Printed- Unshifted

Start Time	Hwy 24 Southbound					Judge Orr Rd Westbound					Hwy 24 Northbound					Judge Orr Rd Eastbound					Int. Total
	Right	Thru	Left	Peds	App. Total	Right	Thru	Left	Peds	App. Total	Right	Thru	Left	Peds	App. Total	Right	Thru	Left	Peds	App. Total	
16:00	5	77	2	0	84	1	7	22	0	30	33	143	24	0	200	10	7	5	0	22	336
16:15	3	105	1	0	109	5	17	25	0	47	27	152	30	0	209	21	11	11	0	43	408
16:30	7	105	1	0	113	1	14	29	0	44	34	144	34	1	213	18	11	11	0	40	410
16:45	1	101	0	0	102	2	9	24	0	35	31	135	41	0	207	15	13	12	0	40	384
Total	16	388	4	0	408	9	47	100	0	156	125	574	129	1	829	64	42	39	0	145	1538
17:00	2	99	0	0	101	4	13	38	0	55	29	147	40	0	216	16	16	10	0	42	414
17:15	7	127	0	0	134	2	16	26	0	44	34	133	24	1	192	13	11	7	0	31	401
17:30	6	91	1	0	98	2	6	16	0	24	39	149	32	0	220	10	15	10	0	35	377
17:45	6	98	0	0	104	0	5	22	0	27	29	158	30	0	217	11	17	8	0	36	384
Total	21	415	1	0	437	8	40	102	0	150	131	587	126	1	845	50	59	35	0	144	1576
Grand Total	37	803	5	0	845	17	87	202	0	306	256	1161	255	2	1674	114	101	74	0	289	3114
Apprch %	4.4	95	0.6	0		5.6	28.4	66	0		15.3	69.4	15.2	0.1		39.4	34.9	25.6	0		
Total %	1.2	25.8	0.2	0	27.1	0.5	2.8	6.5	0	9.8	8.2	37.3	8.2	0.1	53.8	3.7	3.2	2.4	0	9.3	

LSC Transportation Consultants, Inc.

2504 E. Pikes Peak Ave, Suite 304
 Colorado Springs, CO 80909
 719-633-2868

File Name : Hwy 24 - Judge Orr Rd PM

Site Code : S214950

Start Date : 5/10/2022

Page No : 2

Start Time	Hwy 24 Southbound					Judge Orr Rd Westbound					Hwy 24 Northbound					Judge Orr Rd Eastbound					Int. Total
	Right	Thru	Left	Peds	App. Total	Right	Thru	Left	Peds	App. Total	Right	Thru	Left	Peds	App. Total	Right	Thru	Left	Peds	App. Total	
Peak Hour Analysis From 4:00:00 PM to 5:45:00 PM - Peak 1 of 1																					
Peak Hour for Entire Intersection Begins at 4:15:00 PM																					
4:15:00 PM	3	105	1	0	109	5	17	25	0	47	27	152	30	0	209	21	11	11	0	43	408
4:30:00 PM	7	105	1	0	113	1	14	29	0	44	34	144	34	1	213	18	11	11	0	40	410
4:45:00 PM	1	101	0	0	102	2	9	24	0	35	31	135	41	0	207	15	13	12	0	40	384
5:00:00 PM	2	99	0	0	101	4	13	38	0	55	29	147	40	0	216	16	16	10	0	42	414
Total Volume	13	410	2	0	425	12	53	116	0	181	121	578	145	1	845	70	51	44	0	165	1616
% App. Total	3.1	96.5	0.5	0		6.6	29.3	64.1	0		14.3	68.4	17.2	0.1		42.4	30.9	26.7	0		
PHF	.464	.976	.500	.000	.940	.600	.779	.763	.000	.823	.890	.951	.884	.250	.978	.833	.797	.917	.000	.959	.976

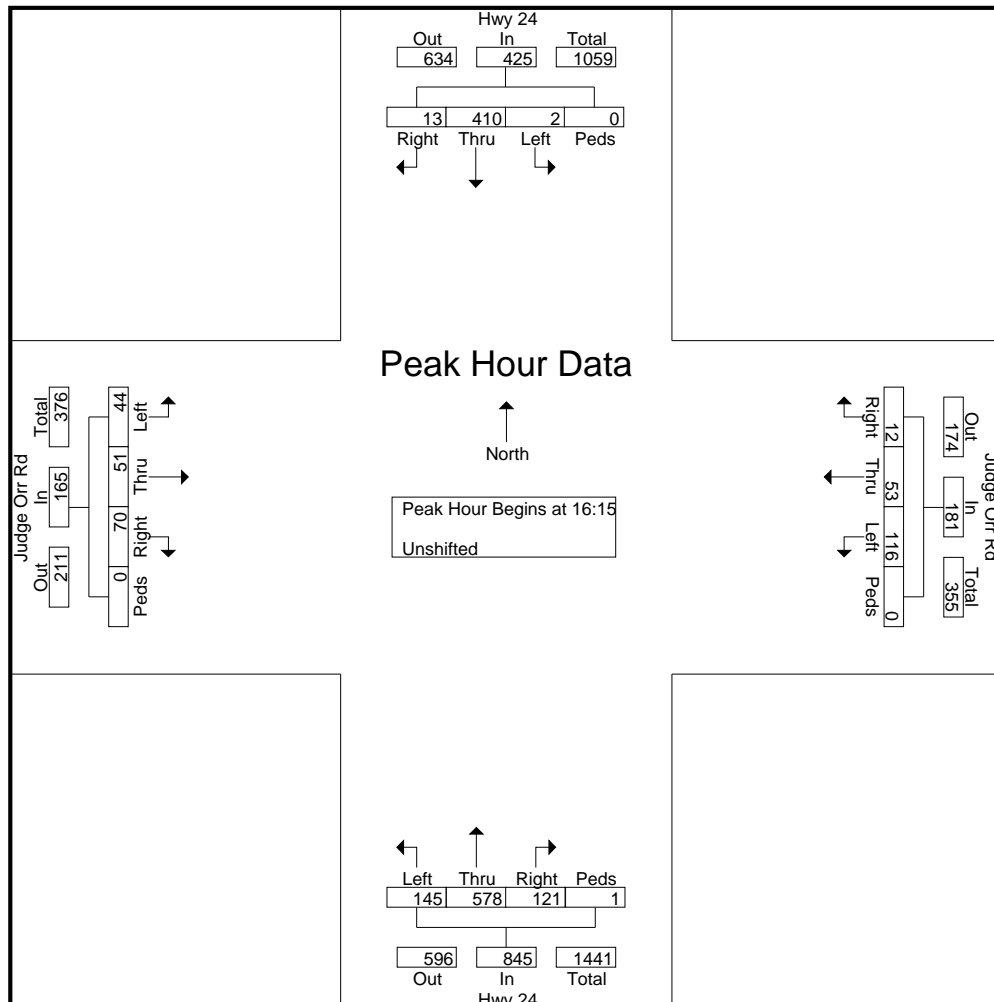

LSC Transportation Consultants, Inc.

2504 E. Pikes Peak Ave, Suite 304
 Colorado Springs, CO 80909
 719-633-2868

File Name : Hwy 24 - Judge Orr Rd PM

Site Code : S214950

Start Date : 5/10/2022

Page No : 3

Start Time	Hwy 24 Southbound					Judge Orr Rd Westbound					Hwy 24 Northbound					Judge Orr Rd Eastbound					Int. Total
	Right	Thru	Left	Peds	App. Total	Right	Thru	Left	Peds	App. Total	Right	Thru	Left	Peds	App. Total	Right	Thru	Left	Peds	App. Total	

Peak Hour Analysis From 4:00:00 PM to 5:45:00 PM - Peak 1 of 1

Peak Hour for Each Approach Begins at:

	4:30:00 PM					4:15:00 PM					4:15:00 PM					4:15:00 PM				
+0 mins.	7	105	1	0	113	5	17	25	0	47	27	152	30	0	209	21	11	11	0	43
+5 mins.	1	101	0	0	102	1	14	29	0	44	34	144	34	1	213	18	11	11	0	40
+10 mins.	2	99	0	0	101	2	9	24	0	35	31	135	41	0	207	15	13	12	0	40
+15 mins.	7	127	0	0	134	4	13	38	0	55	29	147	40	0	216	16	16	10	0	42
Total Volume	17	432	1	0	450	12	53	116	0	181	121	578	145	1	845	70	51	44	0	165
% App. Total	3.8	96	0.2	0		6.6	29.3	64.1	0		14.3	68.4	17.2	0.1		42.4	30.9	26.7	0	
PHF	.607	.850	.250	.000	.840	.600	.779	.763	.000	.823	.890	.951	.884	.250	.978	.833	.797	.917	.000	.959

LSC Transportation Consultants, Inc.

2504 E. Pikes Peak Ave, Suite 304
 Colorado Springs, CO 80909
 719-633-2868

File Name : Hwy 24 - New Meridian Rd AM
 Site Code : S214620
 Start Date : 8/5/2021
 Page No : 1

Groups Printed- Unshifted

Start Time	Hwy 24 Southbound					New Meridian Rd Westbound					Hwy 24 Northbound					New Meridian Rd Eastbound					Int. Total
	L	T	R	U	App. Total	L	T	R	U	App. Total	L	T	R	U	App. Total	L	T	R	U	App. Total	
06:30 AM	9	173	0	0	182	1	36	7	0	44	30	109	2	0	141	1	22	93	0	116	483
06:45 AM	10	213	0	0	223	0	28	10	0	38	21	109	4	0	134	0	1	120	0	121	516
Total	19	386	0	0	405	1	64	17	0	82	51	218	6	0	275	1	23	213	0	237	999
07:00 AM	3	171	0	0	174	0	44	10	0	54	15	92	4	0	111	0	4	126	1	131	470
07:15 AM	2	201	0	0	203	0	2	1	0	3	44	118	1	0	163	0	0	169	0	169	538
Grand Total	24	758	0	0	782	1	110	28	0	139	110	428	11	0	549	1	27	508	1	537	2007
Apprch %	3.1	96.9	0	0		0.7	79.1	20.1	0		20	78	2	0		0.2	5	94.6	0.2		
Total %	1.2	37.8	0	0	39	0	5.5	1.4	0	6.9	5.5	21.3	0.5	0	27.4	0	1.3	25.3	0	26.8	

LSC Transportation Consultants, Inc.

2504 E. Pikes Peak Ave, Suite 304
 Colorado Springs, CO 80909
 719-633-2868

File Name : Hwy 24 - New Meridian Rd AM
 Site Code : S214620
 Start Date : 8/5/2021
 Page No : 2

Start Time	Hwy 24 Southbound					New Meridian Rd Westbound					Hwy 24 Northbound					New Meridian Rd Eastbound					Int. Total
	L	T	R	U	App. Total	L	T	R	U	App. Total	L	T	R	U	App. Total	L	T	R	U	App. Total	
Peak Hour Analysis From 6:30:00 AM to 7:15:00 AM - Peak 1 of 1																					
Peak Hour for Entire Intersection Begins at 6:30:00 AM																					
6:30:00 AM	9	173	0	0	182	1	36	7	0	44	30	109	2	0	141	1	22	93	0	116	483
6:45:00 AM	10	213	0	0	223	0	28	10	0	38	21	109	4	0	134	0	1	120	0	121	516
7:00:00 AM	3	171	0	0	174	0	44	10	0	54	15	92	4	0	111	0	4	126	1	131	470
7:15:00 AM	2	201	0	0	203	0	2	1	0	3	44	118	1	0	163	0	0	169	0	169	538
Total Volume	24	758	0	0	782	1	110	28	0	139	110	428	11	0	549	1	27	508	1	537	2007
% App. Total	3.1	96.9	0	0		0.7	79.1	20.1	0		20	78	2	0		0.2	5	94.6	0.2		
PHF	.600	.890	.000	.000	.877	.250	.625	.700	.000	.644	.625	.907	.688	.000	.842	.250	.307	.751	.250	.794	.933

LSC Transportation Consultants, Inc.

2504 E. Pikes Peak Ave, Suite 304
 Colorado Springs, CO 80909
 719-633-2868

File Name : Hwy 24 - New Meridian Rd AM
 Site Code : S214620
 Start Date : 8/5/2021
 Page No : 3

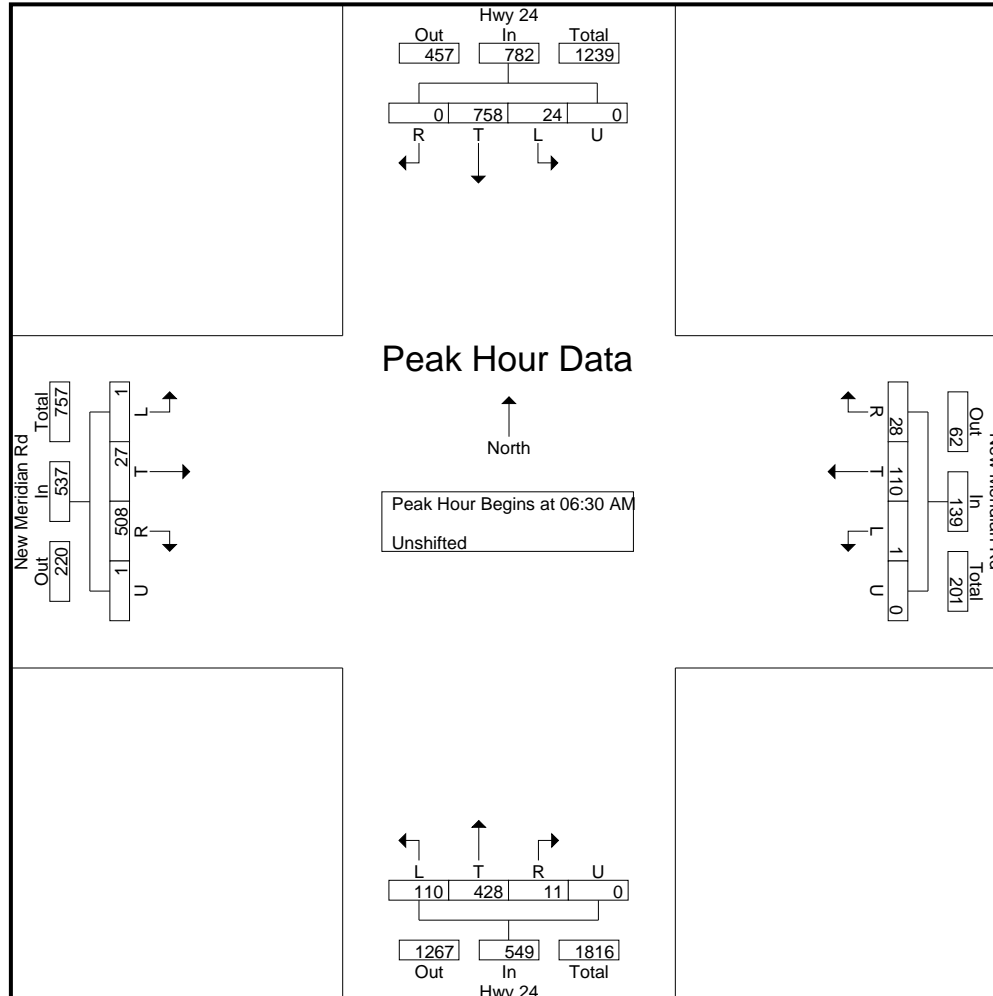

LSC Transportation Consultants, Inc.

2504 E. Pikes Peak Ave, Suite 304
 Colorado Springs, CO 80909
 719-633-2868

File Name : Hwy 24 - New Meridian Rd AM
 Site Code : S214620
 Start Date : 8/5/2021
 Page No : 4

Start Time	Hwy 24 Southbound					New Meridian Rd Westbound					Hwy 24 Northbound					New Meridian Rd Eastbound					Int. Total
	L	T	R	U	App. Total	L	T	R	U	App. Total	L	T	R	U	App. Total	L	T	R	U	App. Total	

Peak Hour Analysis From 6:30:00 AM to 7:15:00 AM - Peak 1 of 1

Peak Hour for Each Approach Begins at:

	6:30:00 AM					6:30:00 AM					6:30:00 AM					6:30:00 AM				
+0 mins.	9	173	0	0	182	1	36	7	0	44	30	109	2	0	141	1	22	93	0	116
+5 mins.	10	213	0	0	223	0	28	10	0	38	21	109	4	0	134	0	1	120	0	121
+10 mins.	3	171	0	0	174	0	44	10	0	54	15	92	4	0	111	0	4	126	1	131
+15 mins.	2	201	0	0	203	0	2	1	0	3	44	118	1	0	163	0	0	169	0	169
Total Volume	24	758	0	0	782	1	110	28	0	139	110	428	11	0	549	1	27	508	1	537
% App. Total	3.1	96.9	0	0		0.7	79.1	20.1	0		20	78	2	0		0.2	5	94.6	0.2	
PHF	.600	.890	.000	.000	.877	.250	.625	.700	.000	.644	.625	.907	.688	.000	.842	.250	.307	.751	.250	.794

LSC Transportation Consultants, Inc.

2504 E. Pikes Peak Ave, Suite 304
 Colorado Springs, CO 80909
 719-633-2868

File Name : Hwy 24 - New Meridian Rd AM
 Site Code : S214620
 Start Date : 8/5/2021
 Page No : 5

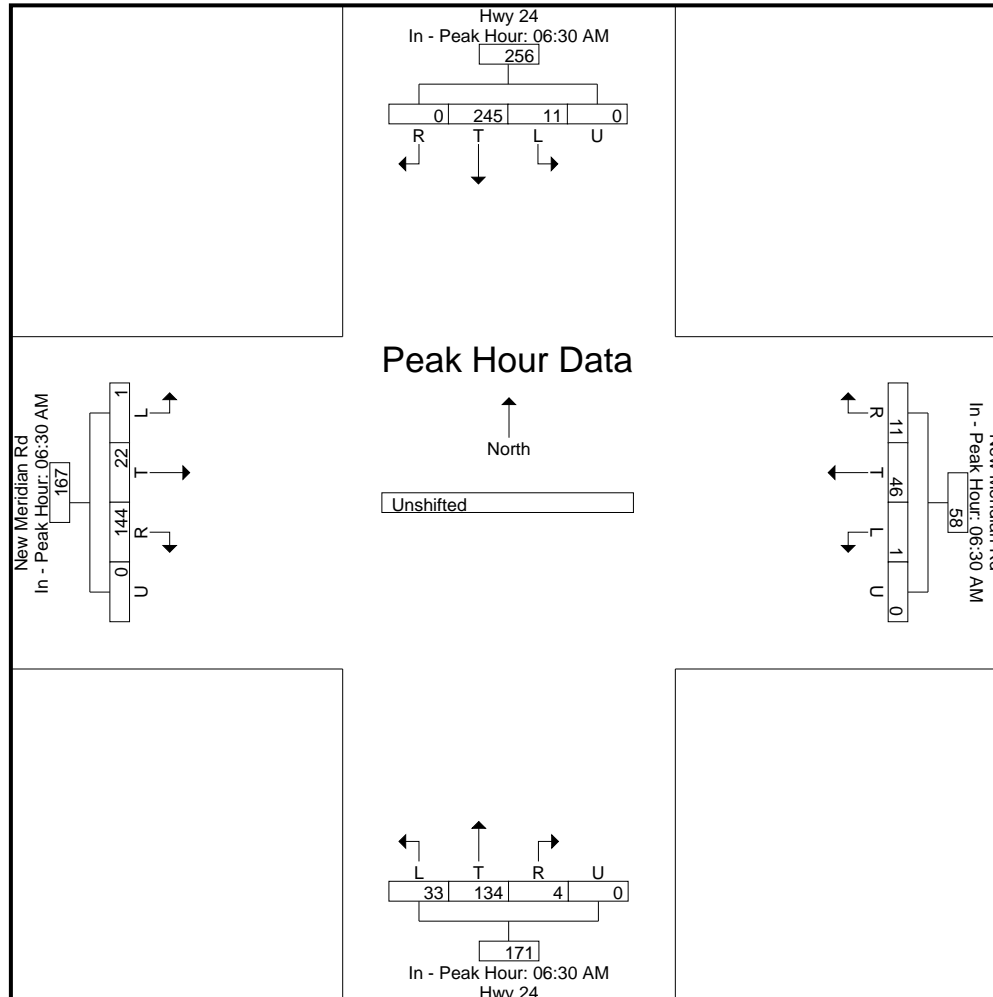

LSC Transportation Consultants, Inc.

2504 E. Pikes Peak Ave, Suite 304
 Colorado Springs, CO 80909
 719-633-2868

File Name : Hwy 24 - New Meridian Rd PM
 Site Code : S214620
 Start Date : 8/4/2021
 Page No : 1

Groups Printed- Unshifted

Start Time	Hwy 24 Southbound					New Meridian Rd Westbound					Hwy 24 Northbound					New Meridian Rd Eastbound					Int. Total
	L	T	R	U	App. Total	L	T	R	U	App. Total	L	T	R	U	App. Total	L	T	R	U	App. Total	
04:00 PM	18	138	0	0	156	1	61	22	0	84	62	156	0	0	218	4	30	43	0	77	535
04:15 PM	9	139	2	0	150	0	72	29	0	101	60	149	1	0	210	4	37	37	0	78	539
04:30 PM	17	105	1	0	123	0	91	17	0	108	88	161	0	0	249	4	40	42	0	86	566
04:45 PM	11	139	0	0	150	1	82	12	0	95	63	145	0	0	208	4	41	38	3	86	539
Total	55	521	3	0	579	2	306	80	0	388	273	611	1	0	885	16	148	160	3	327	2179
05:00 PM	14	109	0	0	123	0	91	27	0	118	79	150	0	0	229	5	41	48	0	94	564
05:15 PM	6	114	1	0	121	0	52	26	0	78	78	162	0	0	240	3	32	42	1	78	517
05:30 PM	11	89	4	0	104	1	81	14	0	96	76	156	0	0	232	1	55	44	0	100	532
05:45 PM	22	119	1	0	142	1	45	10	0	56	81	174	0	0	255	2	52	33	0	87	540
Total	53	431	6	0	490	2	269	77	0	348	314	642	0	0	956	11	180	167	1	359	2153
Grand Total	108	952	9	0	1069	4	575	157	0	736	587	1253	1	0	1841	27	328	327	4	686	4332
Apprch %	10.1	89.1	0.8	0		0.5	78.1	21.3	0		31.9	68.1	0.1	0		3.9	47.8	47.7	0.6		
Total %	2.5	22	0.2	0	24.7	0.1	13.3	3.6	0	17	13.6	28.9	0	0	42.5	0.6	7.6	7.5	0.1	15.8	

LSC Transportation Consultants, Inc.

2504 E. Pikes Peak Ave, Suite 304
 Colorado Springs, CO 80909
 719-633-2868

File Name : Hwy 24 - New Meridian Rd PM
 Site Code : S214620
 Start Date : 8/4/2021
 Page No : 2

Start Time	Hwy 24 Southbound					New Meridian Rd Westbound					Hwy 24 Northbound					New Meridian Rd Eastbound					Int. Total
	L	T	R	U	App. Total	L	T	R	U	App. Total	L	T	R	U	App. Total	L	T	R	U	App. Total	
Peak Hour Analysis From 4:00:00 PM to 5:45:00 PM - Peak 1 of 1																					
Peak Hour for Entire Intersection Begins at 4:15:00 PM																					
4:15:00 PM	9	139	2	0	150	0	72	29	0	101	60	149	1	0	210	4	37	37	0	78	539
4:30:00 PM	17	105	1	0	123	0	91	17	0	108	88	161	0	0	249	4	40	42	0	86	566
4:45:00 PM	11	139	0	0	150	1	82	12	0	95	63	145	0	0	208	4	41	38	3	86	539
5:00:00 PM	14	109	0	0	123	0	91	27	0	118	79	150	0	0	229	5	41	48	0	94	564
Total Volume	51	492	3	0	546	1	336	85	0	422	290	605	1	0	896	17	159	165	3	344	2208
% App. Total	9.3	90.1	0.5	0		0.2	79.6	20.1	0		32.4	67.5	0.1	0		4.9	46.2	48	0.9		
PHF	.750	.885	.375	.000	.910	.250	.923	.733	.000	.894	.824	.939	.250	.000	.900	.850	.970	.859	.250	.915	.975

LSC Transportation Consultants, Inc.

2504 E. Pikes Peak Ave, Suite 304
 Colorado Springs, CO 80909
 719-633-2868

File Name : Hwy 24 - New Meridian Rd PM
 Site Code : S214620
 Start Date : 8/4/2021
 Page No : 3

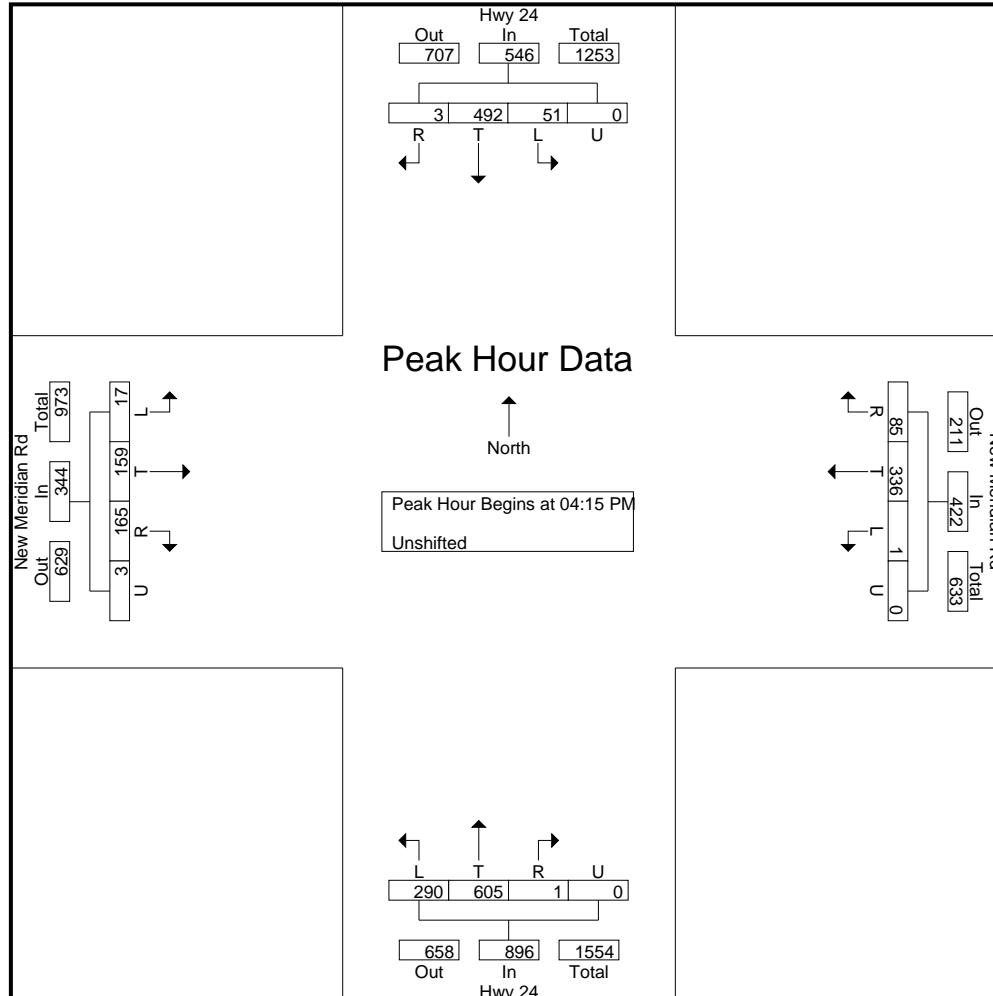

LSC Transportation Consultants, Inc.

2504 E. Pikes Peak Ave, Suite 304
 Colorado Springs, CO 80909
 719-633-2868

File Name : Hwy 24 - New Meridian Rd PM
 Site Code : S214620
 Start Date : 8/4/2021
 Page No : 4

Start Time	Hwy 24 Southbound					New Meridian Rd Westbound					Hwy 24 Northbound					New Meridian Rd Eastbound					Int. Total
	L	T	R	U	App. Total	L	T	R	U	App. Total	L	T	R	U	App. Total	L	T	R	U	App. Total	
Peak Hour Analysis From 4:00:00 PM to 5:45:00 PM - Peak 1 of 1																					
Peak Hour for Each Approach Begins at:																					
	4:00:00 PM					4:15:00 PM					5:00:00 PM					5:00:00 PM					
+0 mins.	18	138	0	0	156	0	72	29	0	101	79	150	0	0	229	5	41	48	0	94	
+5 mins.	9	139	2	0	150	0	91	17	0	108	78	162	0	0	240	3	32	42	1	78	
+10 mins.	17	105	1	0	123	1	82	12	0	95	76	156	0	0	232	1	55	44	0	100	
+15 mins.	11	139	0	0	150	0	91	27	0	118	81	174	0	0	255	2	52	33	0	87	
Total Volume	55	521	3	0	579	1	336	85	0	422	314	642	0	0	956	11	180	167	1	359	
% App. Total	9.5	90	0.5	0		0.2	79.6	20.1	0		32.8	67.2	0	0		3.1	50.1	46.5	0.3		
PHF	.764	.937	.375	.000	.928	.250	.923	.733	.000	.894	.969	.922	.000	.000	.937	.550	.818	.870	.250	.898	

LSC Transportation Consultants, Inc.

2504 E. Pikes Peak Ave, Suite 304
 Colorado Springs, CO 80909
 719-633-2868

File Name : Hwy 24 - New Meridian Rd PM
 Site Code : S214620
 Start Date : 8/4/2021
 Page No : 5

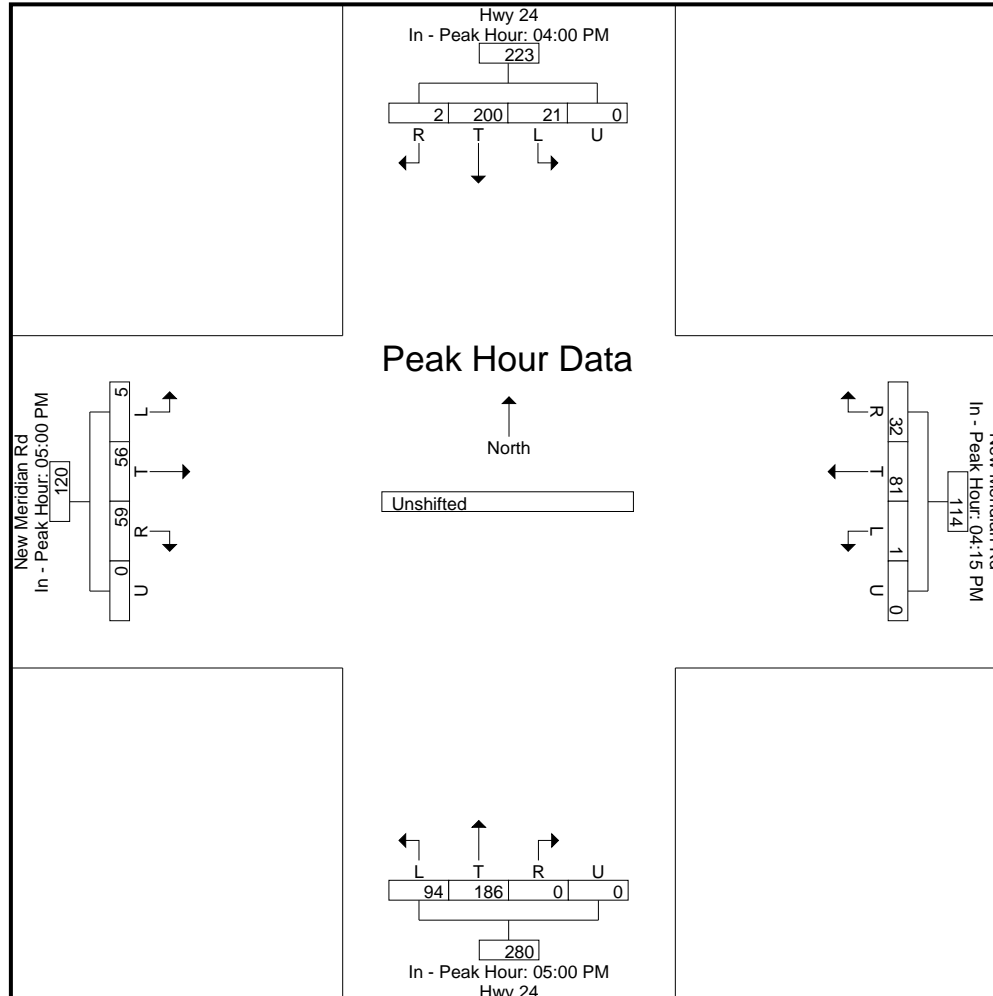

Levels of Service



Intersection												
Int Delay, s/veh	10.4											
Movement	EBL	EBT	EBR	WBL	WBT	WBR	NBL	NBT	NBR	SBL	SBT	SBR
Lane Configurations	↙	↑	↗	↙	↑	↗	↙	↑	↗	↙	↑	↗
Traffic Vol, veh/h	8	44	186	14	209	41	56	75	2	9	240	17
Future Vol, veh/h	8	44	186	14	209	41	56	75	2	9	240	17
Conflicting Peds, #/hr	0	0	0	0	0	0	0	0	0	0	0	0
Sign Control	Free	Free	Free	Free	Free	Free	Stop	Stop	Stop	Stop	Stop	Stop
RT Channelized	-	-	None	-	-	None	-	-	None	-	-	None
Storage Length	275	-	275	280	-	-	380	-	-	325	-	-
Veh in Median Storage, #	-	0	-	-	0	-	-	0	-	-	0	-
Grade, %	-	0	-	-	0	-	-	0	-	-	0	-
Peak Hour Factor	87	87	87	92	92	92	87	87	87	92	92	92
Heavy Vehicles, %	2	2	2	2	2	2	2	2	2	2	2	2
Mvmt Flow	9	51	214	15	227	45	64	86	2	10	261	18

Major/Minor	Major1			Major2			Minor1			Minor2		
Conflicting Flow All	272	0	0	265	0	0	488	371	51	500	563	250
Stage 1	-	-	-	-	-	-	69	69	-	280	280	-
Stage 2	-	-	-	-	-	-	419	302	-	220	283	-
Critical Hdwy	4.12	-	-	4.12	-	-	7.12	6.52	6.22	7.12	6.52	6.22
Critical Hdwy Stg 1	-	-	-	-	-	-	6.12	5.52	-	6.12	5.52	-
Critical Hdwy Stg 2	-	-	-	-	-	-	6.12	5.52	-	6.12	5.52	-
Follow-up Hdwy	2.218	-	-	2.218	-	-	3.518	4.018	3.318	3.518	4.018	3.318
Pot Cap-1 Maneuver	1291	-	-	1299	-	-	490	559	1017	481	435	789
Stage 1	-	-	-	-	-	-	941	837	-	727	679	-
Stage 2	-	-	-	-	-	-	612	664	-	782	677	-
Platoon blocked, %	-	-	-	-	-	-	-	-	-	-	-	-
Mov Cap-1 Maneuver	1291	-	-	1299	-	-	242	548	1017	416	427	789
Mov Cap-2 Maneuver	-	-	-	-	-	-	242	548	-	416	427	-
Stage 1	-	-	-	-	-	-	934	831	-	722	671	-
Stage 2	-	-	-	-	-	-	361	656	-	694	672	-

Approach	EB			WB			NB			SB		
HCM Control Delay, s	0.3			0.4			18			26		
HCM LOS							C			D		

Minor Lane/Major Mvmt	NBLn1	NBLn2	EBL	EBT	EBR	WBL	WBT	WBR	SBLn1	SBLn2
Capacity (veh/h)	242	555	1291	-	-	1299	-	-	416	440
HCM Lane V/C Ratio	0.266	0.159	0.007	-	-	0.012	-	-	0.024	0.635
HCM Control Delay (s)	25.2	12.7	7.8	-	-	7.8	-	-	13.9	26.4
HCM Lane LOS	D	B	A	-	-	A	-	-	B	D
HCM 95th %tile Q(veh)	1	0.6	0	-	-	0	-	-	0.1	4.3

Intersection												
Int Delay, s/veh	7											
Movement	EBL	EBT	EBR	WBL	WBT	WBR	NBL	NBT	NBR	SBL	SBT	SBR
Lane Configurations		↖	↗	↖	↗		↖	↗		↖	↗	
Traffic Vol, veh/h	1	34	79	19	116	33	35	77	0	8	166	0
Future Vol, veh/h	1	34	79	19	116	33	35	77	0	8	166	0
Conflicting Peds, #/hr	0	0	0	0	0	0	0	0	0	0	0	0
Sign Control	Free	Free	Free	Free	Free	Free	Stop	Stop	Stop	Stop	Stop	Stop
RT Channelized	-	-	None	-	-	None	-	-	None	-	-	None
Storage Length	245	-	0	235	-	-	265	-	-	265	-	-
Veh in Median Storage, #	-	0	-	-	0	-	-	0	-	-	0	-
Grade, %	-	0	-	-	0	-	-	0	-	-	0	-
Peak Hour Factor	83	83	83	87	87	87	83	83	83	87	87	87
Heavy Vehicles, %	2	2	2	2	2	2	2	2	2	2	2	2
Mvmt Flow	1	41	95	22	133	38	42	93	0	9	191	0

Major/Minor	Major1			Major2			Minor1			Minor2		
Conflicting Flow All	171	0	0	136	0	0	335	258	41	333	334	152
Stage 1	-	-	-	-	-	-	43	43	-	196	196	-
Stage 2	-	-	-	-	-	-	292	215	-	137	138	-
Critical Hdwy	4.12	-	-	4.12	-	-	7.12	6.52	6.22	7.12	6.52	6.22
Critical Hdwy Stg 1	-	-	-	-	-	-	6.12	5.52	-	6.12	5.52	-
Critical Hdwy Stg 2	-	-	-	-	-	-	6.12	5.52	-	6.12	5.52	-
Follow-up Hdwy	2.218	-	-	2.218	-	-	3.518	4.018	3.318	3.518	4.018	3.318
Pot Cap-1 Maneuver	1406	-	-	1448	-	-	619	646	1030	620	586	894
Stage 1	-	-	-	-	-	-	971	859	-	806	739	-
Stage 2	-	-	-	-	-	-	716	725	-	866	782	-
Platoon blocked, %	-	-	-	-	-	-	-	-	-	-	-	-
Mov Cap-1 Maneuver	1406	-	-	1448	-	-	455	636	1030	544	577	894
Mov Cap-2 Maneuver	-	-	-	-	-	-	455	636	-	544	577	-
Stage 1	-	-	-	-	-	-	970	858	-	805	728	-
Stage 2	-	-	-	-	-	-	520	714	-	772	781	-

Approach	EB			WB			NB			SB		
HCM Control Delay, s	0.1			0.9			12.3			14.2		
HCM LOS							B			B		

Minor Lane/Major Mvmt	NBLn1	NBLn2	EBL	EBT	EBR	WBL	WBT	WBR	SBLn1	SBLn2
Capacity (veh/h)	455	636	1406	-	-	1448	-	-	544	577
HCM Lane V/C Ratio	0.093	0.146	0.001	-	-	0.015	-	-	0.017	0.331
HCM Control Delay (s)	13.7	11.6	7.6	0	-	7.5	-	-	11.7	14.3
HCM Lane LOS	B	B	A	A	-	A	-	-	B	B
HCM 95th %tile Q(veh)	0.3	0.5	0	-	-	0	-	-	0.1	1.4

Intersection												
Int Delay, s/veh	10.3											
Movement	SEL	SET	SER	NWL	NWT	NWR	NEL	NET	NER	SWL	SWT	SWR
Lane Configurations	↖	↗	↖	↖	↗	↖	↖	↗	↖	↖	↗	↖
Traffic Vol, veh/h	23	135	143	6	87	17	49	267	3	35	438	35
Future Vol, veh/h	23	135	143	6	87	17	49	267	3	35	438	35
Conflicting Peds, #/hr	0	0	0	0	0	0	0	0	0	0	0	0
Sign Control	Stop	Stop	Stop	Stop	Stop	Stop	Free	Free	Free	Free	Free	Free
RT Channelized	-	-	None	-	-	None	-	-	None	-	-	None
Storage Length	190	-	325	215	-	-	890	-	1000	790	-	790
Veh in Median Storage, #	-	0	-	-	0	-	-	0	-	-	0	-
Grade, %	-	0	-	-	0	-	-	0	-	-	0	-
Peak Hour Factor	92	92	92	83	83	83	92	92	92	92	92	92
Heavy Vehicles, %	2	2	2	2	2	2	2	2	2	2	2	2
Mvmt Flow	25	147	155	7	105	20	53	290	3	38	476	38

Major/Minor	Minor2		Minor1		Major1			Major2				
Conflicting Flow All	1012	951	476	1118	986	290	514	0	0	293	0	0
Stage 1	552	552	-	396	396	-	-	-	-	-	-	-
Stage 2	460	399	-	722	590	-	-	-	-	-	-	-
Critical Hdwy	7.12	6.52	6.22	7.12	6.52	6.22	4.12	-	-	4.12	-	-
Critical Hdwy Stg 1	6.12	5.52	-	6.12	5.52	-	-	-	-	-	-	-
Critical Hdwy Stg 2	6.12	5.52	-	6.12	5.52	-	-	-	-	-	-	-
Follow-up Hdwy	3.518	4.018	3.318	3.518	4.018	3.318	2.218	-	-	2.218	-	-
Pot Cap-1 Maneuver	218	260	589	184	248	749	1052	-	-	1269	-	-
Stage 1	518	515	-	629	604	-	-	-	-	-	-	-
Stage 2	581	602	-	418	495	-	-	-	-	-	-	-
Platoon blocked, %	-	-	-	-	-	-	-	-	-	-	-	-
Mov Cap-1 Maneuver	128	240	589	66	229	749	1052	-	-	1269	-	-
Mov Cap-2 Maneuver	128	240	-	66	229	-	-	-	-	-	-	-
Stage 1	492	500	-	598	574	-	-	-	-	-	-	-
Stage 2	439	572	-	211	480	-	-	-	-	-	-	-

Approach	SE		NW		NE		SW	
HCM Control Delay, s	27.8		31.5		1.3		0.5	
HCM LOS	D		D					

Minor Lane/Major Mvmt	NEL	NET	NERN	NWLn1	NWLn2	NWLn3	SELn1	SELn2	SELn3	SWL	SWT	SWR
Capacity (veh/h)	1052	-	-	66	229	749	128	240	589	1269	-	-
HCM Lane V/C Ratio	0.051	-	-	0.11	0.458	0.027	0.195	0.611	0.264	0.03	-	-
HCM Control Delay (s)	8.6	-	-	66.1	33.3	9.9	39.8	41.1	13.3	7.9	-	-
HCM Lane LOS	A	-	-	F	D	A	E	E	B	A	-	-
HCM 95th %tile Q(veh)	0.2	-	-	0.4	2.2	0.1	0.7	3.6	1.1	0.1	-	-

Intersection												
Int Delay, s/veh	9											
Movement	EBL	EBT	EBR	WBL	WBT	WBR	NBL	NBT	NBR	SBL	SBT	SBR
Lane Configurations	↖	↑	↗	↖	↑	↗	↖	↑	↗	↖	↑	↗
Traffic Vol, veh/h	13	165	63	9	100	15	183	180	34	21	48	14
Future Vol, veh/h	13	165	63	9	100	15	183	180	34	21	48	14
Conflicting Peds, #/hr	0	0	0	0	0	0	0	0	0	0	0	0
Sign Control	Free	Free	Free	Free	Free	Free	Stop	Stop	Stop	Stop	Stop	Stop
RT Channelized	-	-	None	-	-	None	-	-	None	-	-	None
Storage Length	275	-	275	280	-	-	380	-	-	325	-	-
Veh in Median Storage, #	-	0	-	-	0	-	-	0	-	-	0	-
Grade, %	-	0	-	-	0	-	-	0	-	-	0	-
Peak Hour Factor	87	87	87	83	83	83	92	92	92	83	83	83
Heavy Vehicles, %	2	2	2	2	2	2	2	2	2	2	2	2
Mvmt Flow	15	190	72	11	120	18	199	196	37	25	58	17

Major/Minor	Major1			Major2			Minor1			Minor2		
Conflicting Flow All	138	0	0	262	0	0	409	380	190	524	443	129
Stage 1	-	-	-	-	-	-	220	220	-	151	151	-
Stage 2	-	-	-	-	-	-	189	160	-	373	292	-
Critical Hdwy	4.12	-	-	4.12	-	-	7.12	6.52	6.22	7.12	6.52	6.22
Critical Hdwy Stg 1	-	-	-	-	-	-	6.12	5.52	-	6.12	5.52	-
Critical Hdwy Stg 2	-	-	-	-	-	-	6.12	5.52	-	6.12	5.52	-
Follow-up Hdwy	2.218	-	-	2.218	-	-	3.518	4.018	3.318	3.518	4.018	3.318
Pot Cap-1 Maneuver	1446	-	-	1302	-	-	553	552	852	464	509	921
Stage 1	-	-	-	-	-	-	782	721	-	851	772	-
Stage 2	-	-	-	-	-	-	813	766	-	648	671	-
Platoon blocked, %	-	-	-	-	-	-	-	-	-	-	-	-
Mov Cap-1 Maneuver	1446	-	-	1302	-	-	488	542	852	315	500	921
Mov Cap-2 Maneuver	-	-	-	-	-	-	488	542	-	315	500	-
Stage 1	-	-	-	-	-	-	774	714	-	842	766	-
Stage 2	-	-	-	-	-	-	732	760	-	445	664	-

Approach	EB			WB			NB			SB		
HCM Control Delay, s	0.4			0.6			16.3			13.7		
HCM LOS							C			B		

Minor Lane/Major Mvmt	NBLn1	NBLn2	EBL	EBT	EBR	WBL	WBT	WBR	SBLn1	SBLn2
Capacity (veh/h)	488	575	1446	-	-	1302	-	-	315	558
HCM Lane V/C Ratio	0.408	0.405	0.01	-	-	0.008	-	-	0.08	0.134
HCM Control Delay (s)	17.4	15.4	7.5	-	-	7.8	-	-	17.4	12.4
HCM Lane LOS	C	C	A	-	-	A	-	-	C	B
HCM 95th %tile Q(veh)	2	1.9	0	-	-	0	-	-	0.3	0.5

Intersection												
Int Delay, s/veh	6.8											
Movement	EBL	EBT	EBR	WBL	WBT	WBR	NBL	NBT	NBR	SBL	SBT	SBR
Lane Configurations		↖	↗	↖	↗		↖	↗		↖	↗	
Traffic Vol, veh/h	3	110	29	2	64	13	78	137	18	16	47	5
Future Vol, veh/h	3	110	29	2	64	13	78	137	18	16	47	5
Conflicting Peds, #/hr	0	0	0	0	0	0	0	0	0	0	0	0
Sign Control	Free	Free	Free	Free	Free	Free	Stop	Stop	Stop	Stop	Stop	Stop
RT Channelized	-	-	None	-	-	None	-	-	None	-	-	None
Storage Length	245	-	0	235	-	-	265	-	-	265	-	-
Veh in Median Storage, #	-	0	-	-	0	-	-	0	-	-	0	-
Grade, %	-	0	-	-	0	-	-	0	-	-	0	-
Peak Hour Factor	83	83	83	83	83	83	87	87	87	83	83	83
Heavy Vehicles, %	2	2	2	2	2	2	2	2	2	2	2	2
Mvmt Flow	4	133	35	2	77	16	90	157	21	19	57	6

Major/Minor	Major1			Major2			Minor1			Minor2		
Conflicting Flow All	93	0	0	168	0	0	262	238	133	337	265	85
Stage 1	-	-	-	-	-	-	141	141	-	89	89	-
Stage 2	-	-	-	-	-	-	121	97	-	248	176	-
Critical Hdwy	4.12	-	-	4.12	-	-	7.12	6.52	6.22	7.12	6.52	6.22
Critical Hdwy Stg 1	-	-	-	-	-	-	6.12	5.52	-	6.12	5.52	-
Critical Hdwy Stg 2	-	-	-	-	-	-	6.12	5.52	-	6.12	5.52	-
Follow-up Hdwy	2.218	-	-	2.218	-	-	3.518	4.018	3.318	3.518	4.018	3.318
Pot Cap-1 Maneuver	1501	-	-	1410	-	-	691	663	916	617	640	974
Stage 1	-	-	-	-	-	-	862	780	-	918	821	-
Stage 2	-	-	-	-	-	-	883	815	-	756	753	-
Platoon blocked, %	-	-	-	-	-	-	-	-	-	-	-	-
Mov Cap-1 Maneuver	1501	-	-	1410	-	-	638	660	916	491	637	974
Mov Cap-2 Maneuver	-	-	-	-	-	-	638	660	-	491	637	-
Stage 1	-	-	-	-	-	-	859	778	-	915	820	-
Stage 2	-	-	-	-	-	-	816	814	-	588	751	-

Approach	EB			WB			NB			SB		
HCM Control Delay, s	0.2			0.2			11.9			11.4		
HCM LOS							B			B		

Minor Lane/Major Mvmt	NBLn1	NBLn2	EBL	EBT	EBR	WBL	WBT	WBR	SBLn1	SBLn2
Capacity (veh/h)	638	682	1501	-	-	1410	-	-	491	659
HCM Lane V/C Ratio	0.141	0.261	0.002	-	-	0.002	-	-	0.039	0.095
HCM Control Delay (s)	11.6	12.1	7.4	0	-	7.6	-	-	12.6	11
HCM Lane LOS	B	B	A	A	-	A	-	-	B	B
HCM 95th %tile Q(veh)	0.5	1	0	-	-	0	-	-	0.1	0.3

Intersection												
Int Delay, s/veh	25.2											
Movement	SEL	SET	SER	NWL	NWT	NWR	NEL	NET	NER	SWL	SWT	SWR
Lane Configurations	↖	↗	↖	↖	↗	↖	↖	↗	↖	↖	↗	↖
Traffic Vol, veh/h	14	42	49	26	136	26	119	459	33	12	364	29
Future Vol, veh/h	14	42	49	26	136	26	119	459	33	12	364	29
Conflicting Peds, #/hr	0	0	0	0	0	0	0	0	0	0	0	0
Sign Control	Stop	Stop	Stop	Stop	Stop	Stop	Free	Free	Free	Free	Free	Free
RT Channelized	-	-	None	-	-	None	-	-	None	-	-	None
Storage Length	190	-	325	215	-	-	890	-	1000	790	-	790
Veh in Median Storage, #	-	0	-	-	0	-	-	0	-	-	0	-
Grade, %	-	0	-	-	0	-	-	0	-	-	0	-
Peak Hour Factor	83	83	83	87	87	87	93	93	93	92	92	92
Heavy Vehicles, %	2	2	2	2	2	2	2	2	2	2	2	2
Mvmt Flow	17	51	59	30	156	30	128	494	35	13	396	32

Major/Minor	Minor2		Minor1		Major1			Major2				
Conflicting Flow All	1283	1207	396	1243	1204	494	428	0	0	529	0	0
Stage 1	422	422	-	750	750	-	-	-	-	-	-	-
Stage 2	861	785	-	493	454	-	-	-	-	-	-	-
Critical Hdwy	7.12	6.52	6.22	7.12	6.52	6.22	4.12	-	-	4.12	-	-
Critical Hdwy Stg 1	6.12	5.52	-	6.12	5.52	-	-	-	-	-	-	-
Critical Hdwy Stg 2	6.12	5.52	-	6.12	5.52	-	-	-	-	-	-	-
Follow-up Hdwy	3.518	4.018	3.318	3.518	4.018	3.318	2.218	-	-	2.218	-	-
Pot Cap-1 Maneuver	142	183	653	151	184	575	1131	-	-	1038	-	-
Stage 1	609	588	-	403	419	-	-	-	-	-	-	-
Stage 2	350	404	-	558	569	-	-	-	-	-	-	-
Platoon blocked, %								-	-	-	-	-
Mov Cap-1 Maneuver	~ 14	160	653	94	161	575	1131	-	-	1038	-	-
Mov Cap-2 Maneuver	~ 14	160	-	94	161	-	-	-	-	-	-	-
Stage 1	540	580	-	357	372	-	-	-	-	-	-	-
Stage 2	171	358	-	457	562	-	-	-	-	-	-	-

Approach	SE		NW		NE			SW			
HCM Control Delay, s	111.5		96.7		1.7			0.3			
HCM LOS	F		F								

Minor Lane/Major Mvmt	NEL	NET	NERN	NWLn1	NWLn2	NWLn3	SELn1	SELn2	SELn3	SWL	SWT	SWR
Capacity (veh/h)	1131	-	-	94	161	575	14	160	653	1038	-	-
HCM Lane V/C Ratio	0.113	-	-	0.318	0.971	0.052	1.205	0.316	0.09	0.013	-	-
HCM Control Delay (s)	8.6	-	-	60.2	119.9	11.6	684.4	37.6	11.1	8.5	-	-
HCM Lane LOS	A	-	-	F	F	B	F	E	B	A	-	-
HCM 95th %tile Q(veh)	0.4	-	-	1.2	7.4	0.2	2.7	1.3	0.3	0	-	-

Notes
 ~: Volume exceeds capacity \$: Delay exceeds 300s +: Computation Not Defined *: All major volume in platoon

HCM 6th TWSC
1: Curtis Rd & Falcon Hwy

Existing + Site
AM (Filings 1-5)

Intersection												
Int Delay, s/veh	12.1											
Movement	EBL	EBT	EBR	WBL	WBT	WBR	NBL	NBT	NBR	SBL	SBT	SBR
Lane Configurations	↙	↑	↗	↙	↑	↗	↙	↑	↗	↙	↑	↗
Traffic Vol, veh/h	16	44	186	14	209	41	56	75	2	9	243	39
Future Vol, veh/h	16	44	186	14	209	41	56	75	2	9	243	39
Conflicting Peds, #/hr	0	0	0	0	0	0	0	0	0	0	0	0
Sign Control	Free	Free	Free	Free	Free	Free	Stop	Stop	Stop	Stop	Stop	Stop
RT Channelized	-	-	None	-	-	None	-	-	None	-	-	None
Storage Length	275	-	275	280	-	-	380	-	-	325	-	-
Veh in Median Storage, #	-	0	-	-	0	-	-	0	-	-	0	-
Grade, %	-	0	-	-	0	-	-	0	-	-	0	-
Peak Hour Factor	87	87	87	92	92	92	83	83	83	92	92	92
Heavy Vehicles, %	2	2	2	2	2	2	2	2	2	2	2	2
Mvmt Flow	18	51	214	15	227	45	67	90	2	10	264	42

Major/Minor	Major1			Major2			Minor1			Minor2		
Conflicting Flow All	272	0	0	265	0	0	520	389	51	520	581	250
Stage 1	-	-	-	-	-	-	87	87	-	280	280	-
Stage 2	-	-	-	-	-	-	433	302	-	240	301	-
Critical Hdwy	4.12	-	-	4.12	-	-	7.12	6.52	6.22	7.12	6.52	6.22
Critical Hdwy Stg 1	-	-	-	-	-	-	6.12	5.52	-	6.12	5.52	-
Critical Hdwy Stg 2	-	-	-	-	-	-	6.12	5.52	-	6.12	5.52	-
Follow-up Hdwy	2.218	-	-	2.218	-	-	3.518	4.018	3.318	3.518	4.018	3.318
Pot Cap-1 Maneuver	1291	-	-	1299	-	-	467	546	1017	467	425	789
Stage 1	-	-	-	-	-	-	921	823	-	727	679	-
Stage 2	-	-	-	-	-	-	601	664	-	763	665	-
Platoon blocked, %	-	-	-	-	-	-	-	-	-	-	-	-
Mov Cap-1 Maneuver	1291	-	-	1299	-	-	212	532	1017	397	414	789
Mov Cap-2 Maneuver	-	-	-	-	-	-	212	532	-	397	414	-
Stage 1	-	-	-	-	-	-	908	811	-	717	671	-
Stage 2	-	-	-	-	-	-	341	656	-	667	656	-

Approach	EB			WB			NB			SB		
HCM Control Delay, s	0.5			0.4			20.1			29		
HCM LOS							C			D		

Minor Lane/Major Mvmt	NBLn1	NBLn2	EBL	EBT	EBR	WBL	WBT	WBR	SBLn1	SBLn2
Capacity (veh/h)	212	539	1291	-	-	1299	-	-	397	443
HCM Lane V/C Ratio	0.318	0.172	0.014	-	-	0.012	-	-	0.025	0.692
HCM Control Delay (s)	29.7	13.1	7.8	-	-	7.8	-	-	14.3	29.5
HCM Lane LOS	D	B	A	-	-	A	-	-	B	D
HCM 95th %tile Q(veh)	1.3	0.6	0	-	-	0	-	-	0.1	5.2

Intersection												
Int Delay, s/veh	7.5											
Movement	EBL	EBT	EBR	WBL	WBT	WBR	NBL	NBT	NBR	SBL	SBT	SBR
Lane Configurations		↖	↗	↖	↗		↖	↗		↖	↗	
Traffic Vol, veh/h	1	38	84	20	129	37	54	90	0	9	171	0
Future Vol, veh/h	1	38	84	20	129	37	54	90	0	9	171	0
Conflicting Peds, #/hr	0	0	0	0	0	0	0	0	0	0	0	0
Sign Control	Free	Free	Free	Free	Free	Free	Stop	Stop	Stop	Stop	Stop	Stop
RT Channelized	-	-	None	-	-	None	-	-	None	-	-	None
Storage Length	245	-	0	235	-	-	265	-	-	265	-	-
Veh in Median Storage, #	-	0	-	-	0	-	-	0	-	-	0	-
Grade, %	-	0	-	-	0	-	-	0	-	-	0	-
Peak Hour Factor	83	83	83	87	87	87	83	83	83	87	87	87
Heavy Vehicles, %	2	2	2	2	2	2	2	2	2	2	2	2
Mvmt Flow	1	46	101	23	148	43	65	108	0	10	197	0

Major/Minor	Major1			Major2			Minor1			Minor2		
Conflicting Flow All	191	0	0	147	0	0	362	285	46	369	365	170
Stage 1	-	-	-	-	-	-	48	48	-	216	216	-
Stage 2	-	-	-	-	-	-	314	237	-	153	149	-
Critical Hdwy	4.12	-	-	4.12	-	-	7.12	6.52	6.22	7.12	6.52	6.22
Critical Hdwy Stg 1	-	-	-	-	-	-	6.12	5.52	-	6.12	5.52	-
Critical Hdwy Stg 2	-	-	-	-	-	-	6.12	5.52	-	6.12	5.52	-
Follow-up Hdwy	2.218	-	-	2.218	-	-	3.518	4.018	3.318	3.518	4.018	3.318
Pot Cap-1 Maneuver	1383	-	-	1435	-	-	594	624	1023	588	563	874
Stage 1	-	-	-	-	-	-	965	855	-	786	724	-
Stage 2	-	-	-	-	-	-	697	709	-	849	774	-
Platoon blocked, %	-	-	-	-	-	-	-	-	-	-	-	-
Mov Cap-1 Maneuver	1383	-	-	1435	-	-	425	613	1023	502	553	874
Mov Cap-2 Maneuver	-	-	-	-	-	-	425	613	-	502	553	-
Stage 1	-	-	-	-	-	-	964	854	-	785	712	-
Stage 2	-	-	-	-	-	-	497	698	-	740	773	-

Approach	EB			WB			NB			SB		
HCM Control Delay, s	0.1			0.8			13.2			15		
HCM LOS							B			C		

Minor Lane/Major Mvmt	NBLn1	NBLn2	EBL	EBT	EBR	WBL	WBT	WBR	SBLn1	SBLn2
Capacity (veh/h)	425	613	1383	-	-	1435	-	-	502	553
HCM Lane V/C Ratio	0.153	0.177	0.001	-	-	0.016	-	-	0.021	0.355
HCM Control Delay (s)	15	12.1	7.6	0	-	7.5	-	-	12.3	15.1
HCM Lane LOS	C	B	A	A	-	A	-	-	B	C
HCM 95th %tile Q(veh)	0.5	0.6	0	-	-	0	-	-	0.1	1.6

Intersection												
Int Delay, s/veh	11.4											
Movement	SEL	SET	SER	NWL	NWT	NWR	NEL	NET	NER	SWL	SWT	SWR
Lane Configurations	↖	↗	↖	↖	↗	↖	↖	↗	↖	↖	↗	↖
Traffic Vol, veh/h	23	141	143	6	101	20	49	267	3	35	438	35
Future Vol, veh/h	23	141	143	6	101	20	49	267	3	35	438	35
Conflicting Peds, #/hr	0	0	0	0	0	0	0	0	0	0	0	0
Sign Control	Stop	Stop	Stop	Stop	Stop	Stop	Free	Free	Free	Free	Free	Free
RT Channelized	-	-	None	-	-	None	-	-	None	-	-	None
Storage Length	190	-	325	215	-	-	890	-	1000	790	-	790
Veh in Median Storage, #	-	0	-	-	0	-	-	0	-	-	0	-
Grade, %	-	0	-	-	0	-	-	0	-	-	0	-
Peak Hour Factor	92	92	92	83	83	83	92	92	92	92	92	92
Heavy Vehicles, %	2	2	2	2	2	2	2	2	2	2	2	2
Mvmt Flow	25	153	155	7	122	24	53	290	3	38	476	38

Major/Minor	Minor2		Minor1			Major1			Major2			
Conflicting Flow All	1023	951	476	1121	986	290	514	0	0	293	0	0
Stage 1	552	552	-	396	396	-	-	-	-	-	-	-
Stage 2	471	399	-	725	590	-	-	-	-	-	-	-
Critical Hdwy	7.12	6.52	6.22	7.12	6.52	6.22	4.12	-	-	4.12	-	-
Critical Hdwy Stg 1	6.12	5.52	-	6.12	5.52	-	-	-	-	-	-	-
Critical Hdwy Stg 2	6.12	5.52	-	6.12	5.52	-	-	-	-	-	-	-
Follow-up Hdwy	3.518	4.018	3.318	3.518	4.018	3.318	2.218	-	-	2.218	-	-
Pot Cap-1 Maneuver	214	260	589	183	248	749	1052	-	-	1269	-	-
Stage 1	518	515	-	629	604	-	-	-	-	-	-	-
Stage 2	573	602	-	416	495	-	-	-	-	-	-	-
Platoon blocked, %	-	-	-	-	-	-	-	-	-	-	-	-
Mov Cap-1 Maneuver	114	240	589	62	229	749	1052	-	-	1269	-	-
Mov Cap-2 Maneuver	114	240	-	62	229	-	-	-	-	-	-	-
Stage 1	492	500	-	598	574	-	-	-	-	-	-	-
Stage 2	415	572	-	206	480	-	-	-	-	-	-	-

Approach	SE		NW			NE			SW		
HCM Control Delay, s	29.4		34.6			1.3			0.5		
HCM LOS	D		D								

Minor Lane/Major Mvmt	NEL	NET	NERN	NWLn1	NWLn2	NWLn3	SELn1	SELn2	SELn3	SWL	SWT	SWR
Capacity (veh/h)	1052	-	-	62	229	749	114	240	589	1269	-	-
HCM Lane V/C Ratio	0.051	-	-	0.117	0.531	0.032	0.219	0.639	0.264	0.03	-	-
HCM Control Delay (s)	8.6	-	-	70.6	37.3	10	45.2	43.2	13.3	7.9	-	-
HCM Lane LOS	A	-	-	F	E	B	E	E	B	A	-	-
HCM 95th %tile Q(veh)	0.2	-	-	0.4	2.8	0.1	0.8	3.9	1.1	0.1	-	-

HCM 6th TWSC
3: Curtis & Benito Wells

Existing + Site
AM (Filings 1-5)

Intersection						
Int Delay, s/veh	0.8					
Movement	WBL	WBR	NBT	NBR	SBL	SBT
Lane Configurations	↘↙		↑	↗↘	↘↙	↑
Traffic Vol, veh/h	6	20	124	2	7	268
Future Vol, veh/h	6	20	124	2	7	268
Conflicting Peds, #/hr	0	0	0	0	0	0
Sign Control	Stop	Stop	Free	Free	Free	Free
RT Channelized	-	None	-	None	-	None
Storage Length	0	-	-	235	285	-
Veh in Median Storage, #	0	-	0	-	-	0
Grade, %	0	-	0	-	-	0
Peak Hour Factor	78	78	83	83	92	92
Heavy Vehicles, %	2	2	2	2	2	2
Mvmt Flow	8	26	149	2	8	291

Major/Minor	Minor1	Major1	Major2		
Conflicting Flow All	456	149	0	0	151
Stage 1	149	-	-	-	-
Stage 2	307	-	-	-	-
Critical Hdwy	6.42	6.22	-	-	4.12
Critical Hdwy Stg 1	5.42	-	-	-	-
Critical Hdwy Stg 2	5.42	-	-	-	-
Follow-up Hdwy	3.518	3.318	-	-	2.218
Pot Cap-1 Maneuver	562	898	-	-	1430
Stage 1	879	-	-	-	-
Stage 2	746	-	-	-	-
Platoon blocked, %			-	-	-
Mov Cap-1 Maneuver	559	898	-	-	1430
Mov Cap-2 Maneuver	559	-	-	-	-
Stage 1	879	-	-	-	-
Stage 2	742	-	-	-	-

Approach	WB	NB	SB
HCM Control Delay, s	9.8	0	0.2
HCM LOS	A		

Minor Lane/Major Mvmt	NBT	NBRWBLn1	SBL	SBT
Capacity (veh/h)	-	-	788	1430
HCM Lane V/C Ratio	-	-	0.042	0.005
HCM Control Delay (s)	-	-	9.8	7.5
HCM Lane LOS	-	-	A	A
HCM 95th %tile Q(veh)	-	-	0.1	0

Intersection						
Int Delay, s/veh	0.7					
Movement	EBT	EBR	WBL	WBT	NBL	NBR
Lane Configurations	↑↑	↑		↑	↑	
Traffic Vol, veh/h	43	5	0	170	16	0
Future Vol, veh/h	43	5	0	170	16	0
Conflicting Peds, #/hr	0	0	0	0	0	0
Sign Control	Free	Free	Free	Free	Stop	Stop
RT Channelized	-	None	-	None	-	None
Storage Length	-	200	-	-	0	-
Veh in Median Storage, #	0	-	-	0	0	-
Grade, %	0	-	-	0	0	-
Peak Hour Factor	78	78	87	87	78	78
Heavy Vehicles, %	2	2	2	2	2	2
Mvmt Flow	55	6	0	195	21	0

Major/Minor	Major1	Major2	Minor1		
Conflicting Flow All	0	0	61	0	250 28
Stage 1	-	-	-	-	55 -
Stage 2	-	-	-	-	195 -
Critical Hdwy	-	-	4.13	-	6.63 6.93
Critical Hdwy Stg 1	-	-	-	-	5.83 -
Critical Hdwy Stg 2	-	-	-	-	5.43 -
Follow-up Hdwy	-	-	2.219	-	3.519 3.319
Pot Cap-1 Maneuver	-	-	1541	-	728 1041
Stage 1	-	-	-	-	961 -
Stage 2	-	-	-	-	837 -
Platoon blocked, %	-	-	-	-	-
Mov Cap-1 Maneuver	-	-	1541	-	728 1041
Mov Cap-2 Maneuver	-	-	-	-	728 -
Stage 1	-	-	-	-	961 -
Stage 2	-	-	-	-	837 -

Approach	EB	WB	NB
HCM Control Delay, s	0	0	10.1
HCM LOS			B

Minor Lane/Major Mvmt	NBLn1	EBT	EBR	WBL	WBT
Capacity (veh/h)	728	-	-	1541	-
HCM Lane V/C Ratio	0.028	-	-	-	-
HCM Control Delay (s)	10.1	-	-	0	-
HCM Lane LOS	B	-	-	A	-
HCM 95th %tile Q(veh)	0.1	-	-	0	-

Intersection						
Int Delay, s/veh	0.1					
Movement	EBT	EBR	WBL	WBT	NBL	NBR
Lane Configurations	↑↑	↑		↑	↑	
Traffic Vol, veh/h	42	1	0	168	2	0
Future Vol, veh/h	42	1	0	168	2	0
Conflicting Peds, #/hr	0	0	0	0	0	0
Sign Control	Free	Free	Free	Free	Stop	Stop
RT Channelized	-	None	-	None	-	None
Storage Length	-	200	-	-	0	-
Veh in Median Storage, #	0	-	-	0	0	-
Grade, %	0	-	-	0	0	-
Peak Hour Factor	78	78	87	87	78	78
Heavy Vehicles, %	2	2	2	2	2	2
Mvmt Flow	54	1	0	193	3	0

Major/Minor	Major1	Major2	Minor1		
Conflicting Flow All	0	0	55	0	247 27
Stage 1	-	-	-	-	54 -
Stage 2	-	-	-	-	193 -
Critical Hdwy	-	-	4.13	-	6.63 6.93
Critical Hdwy Stg 1	-	-	-	-	5.83 -
Critical Hdwy Stg 2	-	-	-	-	5.43 -
Follow-up Hdwy	-	-	2.219	-	3.519 3.319
Pot Cap-1 Maneuver	-	-	1549	-	731 1043
Stage 1	-	-	-	-	962 -
Stage 2	-	-	-	-	839 -
Platoon blocked, %	-	-	-	-	-
Mov Cap-1 Maneuver	-	-	1549	-	731 1043
Mov Cap-2 Maneuver	-	-	-	-	731 -
Stage 1	-	-	-	-	962 -
Stage 2	-	-	-	-	839 -

Approach	EB	WB	NB
HCM Control Delay, s	0	0	9.9
HCM LOS			A

Minor Lane/Major Mvmt	NBLn1	EBT	EBR	WBL	WBT
Capacity (veh/h)	731	-	-	1549	-
HCM Lane V/C Ratio	0.004	-	-	-	-
HCM Control Delay (s)	9.9	-	-	0	-
HCM Lane LOS	A	-	-	A	-
HCM 95th %tile Q(veh)	0	-	-	0	-

HCM 6th TWSC
1: Curtis Rd & Falcon Hwy

Existing + Site
PM (Filings 1-5)

Intersection												
Int Delay, s/veh	10.1											
Movement	EBL	EBT	EBR	WBL	WBT	WBR	NBL	NBT	NBR	SBL	SBT	SBR
Lane Configurations	↙	↑	↗	↙	↑	↗	↙	↑	↗	↙	↑	↗
Traffic Vol, veh/h	39	165	63	9	100	15	183	183	34	21	50	27
Future Vol, veh/h	39	165	63	9	100	15	183	183	34	21	50	27
Conflicting Peds, #/hr	0	0	0	0	0	0	0	0	0	0	0	0
Sign Control	Free	Free	Free	Free	Free	Free	Stop	Stop	Stop	Stop	Stop	Stop
RT Channelized	-	-	None	-	-	None	-	-	None	-	-	None
Storage Length	275	-	275	280	-	-	380	-	-	325	-	-
Veh in Median Storage, #	-	0	-	-	0	-	-	0	-	-	0	-
Grade, %	-	0	-	-	0	-	-	0	-	-	0	-
Peak Hour Factor	92	92	92	83	83	83	92	92	92	83	83	83
Heavy Vehicles, %	2	2	2	2	2	2	2	2	2	2	2	2
Mvmt Flow	42	179	68	11	120	18	199	199	37	25	60	33

Major/Minor	Major1			Major2			Minor1			Minor2		
Conflicting Flow All	138	0	0	247	0	0	461	423	179	566	482	129
Stage 1	-	-	-	-	-	-	263	263	-	151	151	-
Stage 2	-	-	-	-	-	-	198	160	-	415	331	-
Critical Hdwy	4.12	-	-	4.12	-	-	7.12	6.52	6.22	7.12	6.52	6.22
Critical Hdwy Stg 1	-	-	-	-	-	-	6.12	5.52	-	6.12	5.52	-
Critical Hdwy Stg 2	-	-	-	-	-	-	6.12	5.52	-	6.12	5.52	-
Follow-up Hdwy	2.218	-	-	2.218	-	-	3.518	4.018	3.318	3.518	4.018	3.318
Pot Cap-1 Maneuver	1446	-	-	1319	-	-	511	522	864	435	484	921
Stage 1	-	-	-	-	-	-	742	691	-	851	772	-
Stage 2	-	-	-	-	-	-	804	766	-	615	645	-
Platoon blocked, %	-	-	-	-	-	-	-	-	-	-	-	-
Mov Cap-1 Maneuver	1446	-	-	1319	-	-	432	503	864	281	466	921
Mov Cap-2 Maneuver	-	-	-	-	-	-	432	503	-	281	466	-
Stage 1	-	-	-	-	-	-	720	671	-	826	766	-
Stage 2	-	-	-	-	-	-	709	760	-	402	626	-

Approach	EB			WB			NB			SB		
HCM Control Delay, s	1.1			0.6			18.4			14		
HCM LOS							C			B		

Minor Lane/Major Mvmt	NBLn1	NBLn2	EBL	EBT	EBR	WBL	WBT	WBR	SBLn1	SBLn2
Capacity (veh/h)	432	538	1446	-	-	1319	-	-	281	564
HCM Lane V/C Ratio	0.46	0.438	0.029	-	-	0.008	-	-	0.09	0.164
HCM Control Delay (s)	20.2	16.8	7.6	-	-	7.8	-	-	19.1	12.6
HCM Lane LOS	C	C	A	-	-	A	-	-	C	B
HCM 95th %tile Q(veh)	2.4	2.2	0.1	-	-	0	-	-	0.3	0.6

HCM 6th TWSC
4: Curtis Rd & Judge Orr Rd

Existing + Site
PM (Filings 1-5)

Intersection												
Int Delay, s/veh	6.9											
Movement	EBL	EBT	EBR	WBL	WBT	WBR	NBL	NBT	NBR	SBL	SBT	SBR
Lane Configurations		↖	↗	↖	↗		↖	↗		↖	↗	
Traffic Vol, veh/h	3	124	48	2	74	15	90	147	20	21	62	5
Future Vol, veh/h	3	124	48	2	74	15	90	147	20	21	62	5
Conflicting Peds, #/hr	0	0	0	0	0	0	0	0	0	0	0	0
Sign Control	Free	Free	Free	Free	Free	Free	Stop	Stop	Stop	Stop	Stop	Stop
RT Channelized	-	-	None	-	-	None	-	-	None	-	-	None
Storage Length	245	-	0	235	-	-	265	-	-	265	-	-
Veh in Median Storage, #	-	0	-	-	0	-	-	0	-	-	0	-
Grade, %	-	0	-	-	0	-	-	0	-	-	0	-
Peak Hour Factor	87	87	87	83	83	83	92	92	92	83	83	83
Heavy Vehicles, %	2	2	2	2	2	2	2	2	2	2	2	2
Mvmt Flow	3	143	55	2	89	18	98	160	22	25	75	6

Major/Minor	Major1			Major2			Minor1			Minor2		
Conflicting Flow All	107	0	0	198	0	0	292	260	143	370	306	98
Stage 1	-	-	-	-	-	-	149	149	-	102	102	-
Stage 2	-	-	-	-	-	-	143	111	-	268	204	-
Critical Hdwy	4.12	-	-	4.12	-	-	7.12	6.52	6.22	7.12	6.52	6.22
Critical Hdwy Stg 1	-	-	-	-	-	-	6.12	5.52	-	6.12	5.52	-
Critical Hdwy Stg 2	-	-	-	-	-	-	6.12	5.52	-	6.12	5.52	-
Follow-up Hdwy	2.218	-	-	2.218	-	-	3.518	4.018	3.318	3.518	4.018	3.318
Pot Cap-1 Maneuver	1484	-	-	1375	-	-	660	645	905	587	608	958
Stage 1	-	-	-	-	-	-	854	774	-	904	811	-
Stage 2	-	-	-	-	-	-	860	804	-	738	733	-
Platoon blocked, %	-	-	-	-	-	-	-	-	-	-	-	-
Mov Cap-1 Maneuver	1484	-	-	1375	-	-	593	643	905	462	606	958
Mov Cap-2 Maneuver	-	-	-	-	-	-	593	643	-	462	606	-
Stage 1	-	-	-	-	-	-	852	772	-	902	810	-
Stage 2	-	-	-	-	-	-	775	803	-	570	732	-

Approach	EB			WB			NB			SB		
HCM Control Delay, s	0.1			0.2			12.4			12		
HCM LOS							B			B		

Minor Lane/Major Mvmt	NBLn1	NBLn2	EBL	EBT	EBR	WBL	WBT	WBR	SBLn1	SBLn2
Capacity (veh/h)	593	666	1484	-	-	1375	-	-	462	623
HCM Lane V/C Ratio	0.165	0.273	0.002	-	-	0.002	-	-	0.055	0.13
HCM Control Delay (s)	12.3	12.4	7.4	0	-	7.6	-	-	13.2	11.6
HCM Lane LOS	B	B	A	A	-	A	-	-	B	B
HCM 95th %tile Q(veh)	0.6	1.1	0	-	-	0	-	-	0.2	0.4

Intersection												
Int Delay, s/veh	18.8											
Movement	SEL	SET	SER	NWL	NWT	NWR	NEL	NET	NER	SWL	SWT	SWR
Lane Configurations	↖	↗	↖	↖	↗	↖	↖	↗	↖	↖	↗	↖
Traffic Vol, veh/h	14	59	49	26	146	28	119	459	33	15	364	29
Future Vol, veh/h	14	59	49	26	146	28	119	459	33	15	364	29
Conflicting Peds, #/hr	0	0	0	0	0	0	0	0	0	0	0	0
Sign Control	Stop	Stop	Stop	Stop	Stop	Stop	Free	Free	Free	Free	Free	Free
RT Channelized	-	-	None	-	-	None	-	-	None	-	-	None
Storage Length	190	-	325	215	-	-	890	-	1000	790	-	790
Veh in Median Storage, #	-	0	-	-	0	-	-	0	-	-	0	-
Grade, %	-	0	-	-	0	-	-	0	-	-	0	-
Peak Hour Factor	83	83	83	87	87	87	93	93	93	92	92	92
Heavy Vehicles, %	2	2	2	2	2	2	2	2	2	2	2	2
Mvmt Flow	17	71	59	30	168	32	128	494	35	16	396	32

Major/Minor	Minor2		Minor1		Major1		Major2					
Conflicting Flow All	1296	1213	396	1259	1210	494	428	0	0	529	0	0
Stage 1	428	428	-	750	750	-	-	-	-	-	-	-
Stage 2	868	785	-	509	460	-	-	-	-	-	-	-
Critical Hdwy	7.12	6.52	6.22	7.12	6.52	6.22	4.12	-	-	4.12	-	-
Critical Hdwy Stg 1	6.12	5.52	-	6.12	5.52	-	-	-	-	-	-	-
Critical Hdwy Stg 2	6.12	5.52	-	6.12	5.52	-	-	-	-	-	-	-
Follow-up Hdwy	3.518	4.018	3.318	3.518	4.018	3.318	2.218	-	-	2.218	-	-
Pot Cap-1 Maneuver	139	182	653	147	183	575	1131	-	-	1038	-	-
Stage 1	605	585	-	403	419	-	-	-	-	-	-	-
Stage 2	347	404	-	547	566	-	-	-	-	-	-	-
Platoon blocked, %	-	-	-	-	-	-	-	-	-	-	-	-
Mov Cap-1 Maneuver	-	159	653	79 ~ 160	575	1131	-	-	1038	-	-	-
Mov Cap-2 Maneuver	-	159	-	79 ~ 160	-	-	-	-	-	-	-	-
Stage 1	537	576	-	357	372	-	-	-	-	-	-	-
Stage 2	159	358	-	429	558	-	-	-	-	-	-	-

Approach	SE		NW		NE		SW	
HCM Control Delay, s			115.2		1.7		0.3	
HCM LOS	-		F					

Minor Lane/Major Mvmt	NEL	NET	NERNWLn1	NWLn2	NWLn3	SELn1	SELn2	SELn3	SWL	SWT	SWR	
Capacity (veh/h)	1131	-	-	79	160	575	-	159	653	1038	-	-
HCM Lane V/C Ratio	0.113	-	-	0.378	1.049	0.056	-	0.447	0.09	0.016	-	-
HCM Control Delay (s)	8.6	-	-	76	142.1	11.6	-	44.8	11.1	8.5	-	-
HCM Lane LOS	A	-	-	F	F	B	-	E	B	A	-	-
HCM 95th %tile Q(veh)	0.4	-	-	1.5	8.4	0.2	-	2	0.3	0	-	-

Notes
 ~: Volume exceeds capacity \$: Delay exceeds 300s +: Computation Not Defined *: All major volume in platoon

HCM 6th TWSC
3: Curtis & Benito Wells

Existing + Site
PM (Filings 1-5)

Intersection						
Int Delay, s/veh	1					
Movement	WBL	WBR	NBT	NBR	SBL	SBT
Lane Configurations	↘↗		↑	↗↘	↘↗	↑
Traffic Vol, veh/h	3	13	244	6	21	91
Future Vol, veh/h	3	13	244	6	21	91
Conflicting Peds, #/hr	0	0	0	0	0	0
Sign Control	Stop	Stop	Free	Free	Free	Free
RT Channelized	-	None	-	None	-	None
Storage Length	0	-	-	235	285	-
Veh in Median Storage, #	0	-	0	-	-	0
Grade, %	0	-	0	-	-	0
Peak Hour Factor	78	78	92	92	83	83
Heavy Vehicles, %	2	2	2	2	2	2
Mvmt Flow	4	17	265	7	25	110

Major/Minor	Minor1	Major1	Major2			
Conflicting Flow All	425	265	0	0	272	0
Stage 1	265	-	-	-	-	-
Stage 2	160	-	-	-	-	-
Critical Hdwy	6.42	6.22	-	-	4.12	-
Critical Hdwy Stg 1	5.42	-	-	-	-	-
Critical Hdwy Stg 2	5.42	-	-	-	-	-
Follow-up Hdwy	3.518	3.318	-	-	2.218	-
Pot Cap-1 Maneuver	586	774	-	-	1291	-
Stage 1	779	-	-	-	-	-
Stage 2	869	-	-	-	-	-
Platoon blocked, %			-	-		-
Mov Cap-1 Maneuver	575	774	-	-	1291	-
Mov Cap-2 Maneuver	575	-	-	-	-	-
Stage 1	779	-	-	-	-	-
Stage 2	852	-	-	-	-	-

Approach	WB	NB	SB
HCM Control Delay, s	10.1	0	1.5
HCM LOS	B		

Minor Lane/Major Mvmt	NBT	NBRWBLn1	SBL	SBT
Capacity (veh/h)	-	-	727	1291
HCM Lane V/C Ratio	-	-	0.028	0.02
HCM Control Delay (s)	-	-	10.1	7.8
HCM Lane LOS	-	-	B	A
HCM 95th %tile Q(veh)	-	-	0.1	0.1

Intersection						
Int Delay, s/veh	0.4					
Movement	EBT	EBR	WBL	WBT	NBL	NBR
Lane Configurations	↑↑	↑		↑	↑	
Traffic Vol, veh/h	147	18	0	80	10	0
Future Vol, veh/h	147	18	0	80	10	0
Conflicting Peds, #/hr	0	0	0	0	0	0
Sign Control	Free	Free	Free	Free	Stop	Stop
RT Channelized	-	None	-	None	-	None
Storage Length	-	200	-	-	0	-
Veh in Median Storage, #	0	-	-	0	0	-
Grade, %	0	-	-	0	0	-
Peak Hour Factor	87	87	83	83	78	78
Heavy Vehicles, %	2	2	2	2	2	2
Mvmt Flow	169	21	0	96	13	0

Major/Minor	Major1	Major2	Minor1		
Conflicting Flow All	0	0	190	0	265
Stage 1	-	-	-	-	169
Stage 2	-	-	-	-	96
Critical Hdwy	-	-	4.13	-	6.63
Critical Hdwy Stg 1	-	-	-	-	5.83
Critical Hdwy Stg 2	-	-	-	-	5.43
Follow-up Hdwy	-	-	2.219	-	3.519
Pot Cap-1 Maneuver	-	-	1382	-	713
Stage 1	-	-	-	-	844
Stage 2	-	-	-	-	927
Platoon blocked, %	-	-	-	-	-
Mov Cap-1 Maneuver	-	-	1382	-	713
Mov Cap-2 Maneuver	-	-	-	-	713
Stage 1	-	-	-	-	844
Stage 2	-	-	-	-	927

Approach	EB	WB	NB
HCM Control Delay, s	0	0	10.1
HCM LOS			B

Minor Lane/Major Mvmt	NBLn1	EBT	EBR	WBL	WBT
Capacity (veh/h)	713	-	-	1382	-
HCM Lane V/C Ratio	0.018	-	-	-	-
HCM Control Delay (s)	10.1	-	-	0	-
HCM Lane LOS	B	-	-	A	-
HCM 95th %tile Q(veh)	0.1	-	-	0	-

Intersection						
Int Delay, s/veh	0					
Movement	EBT	EBR	WBL	WBT	NBL	NBR
Lane Configurations	↑↑	↑		↑	↑	
Traffic Vol, veh/h	144	3	0	79	1	0
Future Vol, veh/h	144	3	0	79	1	0
Conflicting Peds, #/hr	0	0	0	0	0	0
Sign Control	Free	Free	Free	Free	Stop	Stop
RT Channelized	-	None	-	None	-	None
Storage Length	-	200	-	-	0	-
Veh in Median Storage, #	0	-	-	0	0	-
Grade, %	0	-	-	0	0	-
Peak Hour Factor	83	83	83	83	78	78
Heavy Vehicles, %	2	2	2	2	2	2
Mvmt Flow	173	4	0	95	1	0

Major/Minor	Major1	Major2	Minor1		
Conflicting Flow All	0	0	177	0	268
Stage 1	-	-	-	-	173
Stage 2	-	-	-	-	95
Critical Hdwy	-	-	4.13	-	6.63
Critical Hdwy Stg 1	-	-	-	-	5.83
Critical Hdwy Stg 2	-	-	-	-	5.43
Follow-up Hdwy	-	-	2.219	-	3.519
Pot Cap-1 Maneuver	-	-	1398	-	710
Stage 1	-	-	-	-	840
Stage 2	-	-	-	-	928
Platoon blocked, %	-	-	-	-	-
Mov Cap-1 Maneuver	-	-	1398	-	710
Mov Cap-2 Maneuver	-	-	-	-	710
Stage 1	-	-	-	-	840
Stage 2	-	-	-	-	928

Approach	EB	WB	NB
HCM Control Delay, s	0	0	10.1
HCM LOS			B

Minor Lane/Major Mvmt	NBLn1	EBT	EBR	WBL	WBT
Capacity (veh/h)	710	-	-	1398	-
HCM Lane V/C Ratio	0.002	-	-	-	-
HCM Control Delay (s)	10.1	-	-	0	-
HCM Lane LOS	B	-	-	A	-
HCM 95th %tile Q(veh)	0	-	-	0	-

Lanes, Volumes, Timings
11: US 24 & Curtis/Stapleton

2042 Background
AM

Lane Group	SEL	SET	SER	NWL	NWT	NWR	NEL	NET	NER	SWL	SWT	SWR
Lane Configurations												
Traffic Volume (vph)	175	390	600	75	375	50	300	450	50	123	800	350
Future Volume (vph)	175	390	600	75	375	50	300	450	50	123	800	350
Ideal Flow (vphpl)	1900	1900	1900	1900	1900	1900	1900	1900	1900	1900	1900	1900
Storage Length (ft)	190		325	215		215	890		1000	790		790
Storage Lanes	1		1	1		0	2		1	1		1
Taper Length (ft)	240			200			190			190		
Lane Util. Factor	1.00	0.95	1.00	1.00	0.95	1.00	0.97	0.95	1.00	1.00	0.95	1.00
Frt			0.850			0.850			0.850			0.850
Flt Protected	0.950			0.950			0.950			0.950		
Satd. Flow (prot)	1770	3539	1583	1770	3539	1583	3433	3539	1583	1770	3539	1583
Flt Permitted	0.362			0.496			0.950			0.950		
Satd. Flow (perm)	674	3539	1583	924	3539	1583	3433	3539	1583	1770	3539	1583
Right Turn on Red			Yes			Yes			Yes			Yes
Satd. Flow (RTOR)			380			136			95			293
Link Speed (mph)		45		45			55			55		
Link Distance (ft)		1349		1317			1382			1435		
Travel Time (s)		20.4		20.0			17.1			17.8		
Peak Hour Factor	0.95	0.95	0.95	0.92	0.92	0.92	0.93	0.93	0.93	0.95	0.95	0.95
Adj. Flow (vph)	184	411	632	82	408	54	323	484	54	129	842	368
Shared Lane Traffic (%)												
Lane Group Flow (vph)	184	411	632	82	408	54	323	484	54	129	842	368
Enter Blocked Intersection	No	No	No	No	No	No	No	No	No	No	No	No
Lane Alignment	Left	Left	Right	Left	Left	Right	Left	Left	Right	Left	Left	Right
Median Width(ft)		12		12			24			24		
Link Offset(ft)		0		0			0			0		
Crosswalk Width(ft)		16		16			16			16		
Two way Left Turn Lane												
Headway Factor	1.00	1.00	1.00	1.00	1.00	1.00	1.00	1.00	1.00	1.00	1.00	1.00
Turning Speed (mph)	15		9	15		9	15		9	15		9
Number of Detectors	1	2	1	1	2	1	1	2	1	1	2	1
Detector Template	Left	Thru	Right	Left	Thru	Right	Left	Thru	Right	Left	Thru	Right
Leading Detector (ft)	20	100	20	20	100	20	20	100	20	20	100	20
Trailing Detector (ft)	0	0	0	0	0	0	0	0	0	0	0	0
Detector 1 Position(ft)	0	0	0	0	0	0	0	0	0	0	0	0
Detector 1 Size(ft)	20	6	20	20	6	20	20	6	20	20	6	20
Detector 1 Type	Cl+Ex	Cl+Ex	Cl+Ex	Cl+Ex	Cl+Ex	Cl+Ex	Cl+Ex	Cl+Ex	Cl+Ex	Cl+Ex	Cl+Ex	Cl+Ex
Detector 1 Channel												
Detector 1 Extend (s)	0.0	0.0	0.0	0.0	0.0	0.0	0.0	0.0	0.0	0.0	0.0	0.0
Detector 1 Queue (s)	0.0	0.0	0.0	0.0	0.0	0.0	0.0	0.0	0.0	0.0	0.0	0.0
Detector 1 Delay (s)	0.0	0.0	0.0	0.0	0.0	0.0	0.0	0.0	0.0	0.0	0.0	0.0
Detector 2 Position(ft)		94		94			94			94		
Detector 2 Size(ft)		6		6			6			6		
Detector 2 Type		Cl+Ex		Cl+Ex			Cl+Ex			Cl+Ex		
Detector 2 Channel												
Detector 2 Extend (s)		0.0		0.0			0.0			0.0		
Turn Type	pm+pt	NA	Perm	pm+pt	NA	Perm	Prot	NA	Perm	Prot	NA	Perm
Protected Phases	1	6		5	2		7	4		3	8	
Permitted Phases	6		6	2		2			4			8

Lanes, Volumes, Timings
11: US 24 & Curtis/Stapleton

2042 Background
AM



Lane Group	SEL	SET	SER	NWL	NWT	NWR	NEL	NET	NER	SWL	SWT	SWR
Detector Phase	1	6	6	5	2	2	7	4	4	3	8	8
Switch Phase												
Minimum Initial (s)	5.0	5.0	5.0	5.0	5.0	5.0	5.0	5.0	5.0	5.0	5.0	5.0
Minimum Split (s)	9.5	22.5	22.5	9.5	22.5	22.5	9.5	22.5	22.5	9.5	22.5	22.5
Total Split (s)	15.0	25.0	25.0	15.0	25.0	25.0	27.0	60.0	60.0	20.0	53.0	53.0
Total Split (%)	12.5%	20.8%	20.8%	12.5%	20.8%	20.8%	22.5%	50.0%	50.0%	16.7%	44.2%	44.2%
Maximum Green (s)	10.5	20.5	20.5	10.5	20.5	20.5	22.5	55.5	55.5	15.5	48.5	48.5
Yellow Time (s)	3.5	3.5	3.5	3.5	3.5	3.5	3.5	3.5	3.5	3.5	3.5	3.5
All-Red Time (s)	1.0	1.0	1.0	1.0	1.0	1.0	1.0	1.0	1.0	1.0	1.0	1.0
Lost Time Adjust (s)	0.0	0.0	0.0	0.0	0.0	0.0	0.0	0.0	0.0	0.0	0.0	0.0
Total Lost Time (s)	4.5	4.5	4.5	4.5	4.5	4.5	4.5	4.5	4.5	4.5	4.5	4.5
Lead/Lag	Lead	Lag	Lag	Lead	Lag	Lag	Lead	Lag	Lag	Lead	Lag	Lag
Lead-Lag Optimize?	Yes	Yes	Yes	Yes	Yes	Yes	Yes	Yes	Yes	Yes	Yes	Yes
Vehicle Extension (s)	3.0	3.0	3.0	3.0	3.0	3.0	3.0	3.0	3.0	3.0	3.0	3.0
Recall Mode	None	C-Min	C-Min	None	C-Min	C-Min	None	None	None	None	None	None
Walk Time (s)		7.0	7.0		7.0	7.0		7.0	7.0		7.0	7.0
Flash Dont Walk (s)		11.0	11.0		11.0	11.0		11.0	11.0		11.0	11.0
Pedestrian Calls (#/hr)		0	0		0	0		0	0		0	0
Act Effct Green (s)	52.1	41.2	41.2	43.8	34.8	34.8	16.5	40.8	40.8	13.1	37.4	37.4
Actuated g/C Ratio	0.43	0.34	0.34	0.36	0.29	0.29	0.14	0.34	0.34	0.11	0.31	0.31
v/c Ratio	0.45	0.34	0.80	0.20	0.40	0.10	0.68	0.40	0.09	0.67	0.76	0.53
Control Delay	27.4	33.9	24.6	24.8	38.5	0.3	56.7	30.5	1.1	68.0	41.8	9.6
Queue Delay	0.0	0.0	0.0	0.0	0.0	0.0	0.0	0.0	0.0	0.0	0.0	0.0
Total Delay	27.4	33.9	24.6	24.8	38.5	0.3	56.7	30.5	1.1	68.0	41.8	9.6
LOS	C	C	C	C	D	A	E	C	A	E	D	A
Approach Delay		28.1			32.6			38.5			35.5	
Approach LOS		C			C			D			D	
Queue Length 50th (ft)	88	126	192	37	134	0	124	151	0	97	308	42
Queue Length 95th (ft)	167	209	#502	83	213	0	167	171	6	161	345	116
Internal Link Dist (ft)		1269			1237			1302			1355	
Turn Bay Length (ft)	190		325	215		215	890		1000	790		790
Base Capacity (vph)	415	1213	792	429	1027	556	643	1636	783	228	1430	814
Starvation Cap Reductn	0	0	0	0	0	0	0	0	0	0	0	0
Spillback Cap Reductn	0	0	0	0	0	0	0	0	0	0	0	0
Storage Cap Reductn	0	0	0	0	0	0	0	0	0	0	0	0
Reduced v/c Ratio	0.44	0.34	0.80	0.19	0.40	0.10	0.50	0.30	0.07	0.57	0.59	0.45

Intersection Summary

Area Type: Other
 Cycle Length: 120
 Actuated Cycle Length: 120
 Offset: 0 (0%), Referenced to phase 2:NWTL and 6:SETL, Start of Green
 Natural Cycle: 70
 Control Type: Actuated-Coordinated
 Maximum v/c Ratio: 0.80
 Intersection Signal Delay: 33.5
 Intersection LOS: C
 Intersection Capacity Utilization 74.7%
 ICU Level of Service D
 Analysis Period (min) 15
 # 95th percentile volume exceeds capacity, queue may be longer.

Queue shown is maximum after two cycles.

Splits and Phases: 11: US 24 & Curtis/Stapleton

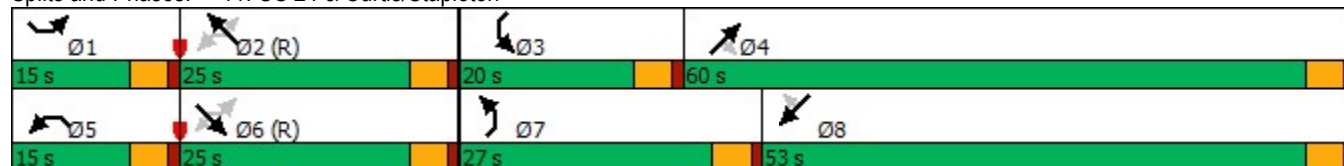

























Intersection									
Intersection Delay, s/veh	8.4								
Intersection LOS	A								
Approach	EB		WB		NB		SB		
Entry Lanes	2		2		2		2		
Conflicting Circle Lanes	1		1		1		1		
Adj Approach Flow, veh/h	392		619		462		576		
Demand Flow Rate, veh/h	400		631		472		588		
Vehicles Circulating, veh/h	554		483		178		578		
Vehicles Exiting, veh/h	612		167		776		536		
Ped Vol Crossing Leg, #/h	0		0		0		0		
Ped Cap Adj	1.000		1.000		1.000		1.000		
Approach Delay, s/veh	7.2		8.1		4.8		12.3		
Approach LOS	A		A		A		B		
Lane	Left	Right	Left	Right	Left	Right	Left	Right	
Designated Moves	LT	R	LT	R	L	TR	LT	R	
Assumed Moves	LT	R	LT	R	L	TR	LT	R	
RT Channelized									
Lane Util	0.308	0.692	0.609	0.391	0.411	0.589	0.849	0.151	
Follow-Up Headway, s	2.535	2.535	2.535	2.535	2.535	2.535	2.535	2.535	
Critical Headway, s	4.544	4.544	4.544	4.544	4.544	4.544	4.544	4.544	
Entry Flow, veh/h	123	277	384	247	194	278	499	89	
Cap Entry Lane, veh/h	858	858	915	915	1208	1208	839	839	
Entry HV Adj Factor	0.978	0.982	0.981	0.980	0.979	0.979	0.981	0.978	
Flow Entry, veh/h	120	272	377	242	190	272	489	87	
Cap Entry, veh/h	839	842	897	896	1183	1182	823	820	
V/C Ratio	0.143	0.323	0.420	0.270	0.161	0.230	0.595	0.106	
Control Delay, s/veh	5.7	7.9	9.0	6.8	4.4	5.1	13.6	5.4	
LOS	A	A	A	A	A	A	B	A	
95th %tile Queue, veh	0	1	2	1	1	1	4	0	

Intersection									
Intersection Delay, s/veh	7.3								
Intersection LOS	A								
Approach	EB		WB		NB		SB		
Entry Lanes	2		2		2		2		
Conflicting Circle Lanes	1		1		1		1		
Adj Approach Flow, veh/h	309		391		516		538		
Demand Flow Rate, veh/h	315		398		527		549		
Vehicles Circulating, veh/h	576		515		144		442		
Vehicles Exiting, veh/h	415		156		747		471		
Ped Vol Crossing Leg, #/h	0		0		0		0		
Ped Cap Adj	1.000		1.000		1.000		1.000		
Approach Delay, s/veh	6.7		6.9		5.1		10.1		
Approach LOS	A		A		A		B		
Lane	Left	Right	Left	Right	Left	Right	Left	Right	
Designated Moves	LT	R	LT	R	L	TR	L	TR	
Assumed Moves	LT	R	LT	R	L	TR	L	TR	
RT Channelized									
Lane Util	0.298	0.702	0.693	0.307	0.315	0.685	0.091	0.909	
Follow-Up Headway, s	2.535	2.535	2.535	2.535	2.535	2.535	2.535	2.535	
Critical Headway, s	4.544	4.544	4.544	4.544	4.544	4.544	4.544	4.544	
Entry Flow, veh/h	94	221	276	122	166	361	50	499	
Cap Entry Lane, veh/h	841	841	889	889	1246	1246	950	950	
Entry HV Adj Factor	0.984	0.982	0.981	0.984	0.982	0.979	0.980	0.979	
Flow Entry, veh/h	92	217	271	120	163	353	49	489	
Cap Entry, veh/h	827	826	872	874	1223	1220	931	930	
V/C Ratio	0.112	0.263	0.311	0.137	0.133	0.290	0.053	0.525	
Control Delay, s/veh	5.5	7.2	7.5	5.5	4.1	5.6	4.3	10.7	
LOS	A	A	A	A	A	A	A	B	
95th %tile Queue, veh	0	1	1	0	0	1	0	3	

Lanes, Volumes, Timings
11: US 24 & Curtis/Stapleton

2042 Background
PM

												
Lane Group	SEL	SET	SER	NWL	NWT	NWR	NEL	NET	NER	SWL	SWT	SWR
Lane Configurations												
Traffic Volume (vph)	350	270	400	125	385	175	650	850	125	140	600	350
Future Volume (vph)	350	270	400	125	385	175	650	850	125	140	600	350
Ideal Flow (vphpl)	1900	1900	1900	1900	1900	1900	1900	1900	1900	1900	1900	1900
Storage Length (ft)	190		325	215		215	890		1000	790		790
Storage Lanes	1		1	1		0	2		1	1		1
Taper Length (ft)	240			200			190			190		
Lane Util. Factor	1.00	0.95	1.00	1.00	0.95	1.00	0.97	0.95	1.00	1.00	0.95	1.00
Frt			0.850			0.850			0.850			0.850
Flt Protected	0.950			0.950			0.950			0.950		
Satd. Flow (prot)	1770	3539	1583	1770	3539	1583	3433	3539	1583	1770	3539	1583
Flt Permitted	0.201			0.574			0.950			0.950		
Satd. Flow (perm)	374	3539	1583	1069	3539	1583	3433	3539	1583	1770	3539	1583
Right Turn on Red			Yes			Yes			Yes			Yes
Satd. Flow (RTOR)			430			188			132			227
Link Speed (mph)		45			45			55			55	
Link Distance (ft)		1349			1317			1382			1435	
Travel Time (s)		20.4			20.0			17.1			17.8	
Peak Hour Factor	0.93	0.93	0.93	0.93	0.93	0.93	0.95	0.95	0.95	0.95	0.95	0.95
Adj. Flow (vph)	376	290	430	134	414	188	684	895	132	147	632	368
Shared Lane Traffic (%)												
Lane Group Flow (vph)	376	290	430	134	414	188	684	895	132	147	632	368
Enter Blocked Intersection	No	No	No	No	No	No	No	No	No	No	No	No
Lane Alignment	Left	Left	Right	Left	Left	Right	Left	Left	Right	Left	Left	Right
Median Width(ft)		12			12			24			24	
Link Offset(ft)		0			0			0			0	
Crosswalk Width(ft)		16			16			16			16	
Two way Left Turn Lane												
Headway Factor	1.00	1.00	1.00	1.00	1.00	1.00	1.00	1.00	1.00	1.00	1.00	1.00
Turning Speed (mph)	15		9	15		9	15		9	15		9
Number of Detectors	1	2	1	1	2	1	1	2	1	1	2	1
Detector Template	Left	Thru	Right	Left	Thru	Right	Left	Thru	Right	Left	Thru	Right
Leading Detector (ft)	20	100	20	20	100	20	20	100	20	20	100	20
Trailing Detector (ft)	0	0	0	0	0	0	0	0	0	0	0	0
Detector 1 Position(ft)	0	0	0	0	0	0	0	0	0	0	0	0
Detector 1 Size(ft)	20	6	20	20	6	20	20	6	20	20	6	20
Detector 1 Type	Cl+Ex	Cl+Ex	Cl+Ex	Cl+Ex	Cl+Ex	Cl+Ex	Cl+Ex	Cl+Ex	Cl+Ex	Cl+Ex	Cl+Ex	Cl+Ex
Detector 1 Channel												
Detector 1 Extend (s)	0.0	0.0	0.0	0.0	0.0	0.0	0.0	0.0	0.0	0.0	0.0	0.0
Detector 1 Queue (s)	0.0	0.0	0.0	0.0	0.0	0.0	0.0	0.0	0.0	0.0	0.0	0.0
Detector 1 Delay (s)	0.0	0.0	0.0	0.0	0.0	0.0	0.0	0.0	0.0	0.0	0.0	0.0
Detector 2 Position(ft)		94			94			94			94	
Detector 2 Size(ft)		6			6			6			6	
Detector 2 Type		Cl+Ex			Cl+Ex			Cl+Ex			Cl+Ex	
Detector 2 Channel												
Detector 2 Extend (s)		0.0			0.0			0.0			0.0	
Turn Type	pm+pt	NA	Perm	pm+pt	NA	Perm	Prot	NA	Perm	Prot	NA	Perm
Protected Phases	1	6		5	2		7	4		3	8	
Permitted Phases	6		6	2		2			4			8

Lanes, Volumes, Timings
11: US 24 & Curtis/Stapleton

2042 Background
PM



Lane Group	SEL	SET	SER	NWL	NWT	NWR	NEL	NET	NER	SWL	SWT	SWR
Detector Phase	1	6	6	5	2	2	7	4	4	3	8	8
Switch Phase												
Minimum Initial (s)	5.0	5.0	5.0	5.0	5.0	5.0	5.0	5.0	5.0	5.0	5.0	5.0
Minimum Split (s)	9.5	22.5	22.5	9.5	22.5	22.5	9.5	22.5	22.5	9.5	22.5	22.5
Total Split (s)	15.0	25.0	25.0	15.0	25.0	25.0	36.0	60.0	60.0	20.0	44.0	44.0
Total Split (%)	12.5%	20.8%	20.8%	12.5%	20.8%	20.8%	30.0%	50.0%	50.0%	16.7%	36.7%	36.7%
Maximum Green (s)	10.5	20.5	20.5	10.5	20.5	20.5	31.5	55.5	55.5	15.5	39.5	39.5
Yellow Time (s)	3.5	3.5	3.5	3.5	3.5	3.5	3.5	3.5	3.5	3.5	3.5	3.5
All-Red Time (s)	1.0	1.0	1.0	1.0	1.0	1.0	1.0	1.0	1.0	1.0	1.0	1.0
Lost Time Adjust (s)	0.0	0.0	0.0	0.0	0.0	0.0	0.0	0.0	0.0	0.0	0.0	0.0
Total Lost Time (s)	4.5	4.5	4.5	4.5	4.5	4.5	4.5	4.5	4.5	4.5	4.5	4.5
Lead/Lag	Lead	Lag	Lag	Lead	Lag	Lag	Lead	Lag	Lag	Lead	Lag	Lag
Lead-Lag Optimize?	Yes	Yes	Yes	Yes	Yes	Yes	Yes	Yes	Yes	Yes	Yes	Yes
Vehicle Extension (s)	3.0	3.0	3.0	3.0	3.0	3.0	3.0	3.0	3.0	3.0	3.0	3.0
Recall Mode	None	C-Min	C-Min	None	C-Min	C-Min	None	None	None	None	None	None
Walk Time (s)		7.0	7.0		7.0	7.0		7.0	7.0		7.0	7.0
Flash Dont Walk (s)		11.0	11.0		11.0	11.0		11.0	11.0		11.0	11.0
Pedestrian Calls (#/hr)		0	0		0	0		0	0		0	0
Act Effct Green (s)	48.4	33.8	33.8	29.5	18.5	18.5	28.2	43.5	43.5	13.7	29.0	29.0
Actuated g/C Ratio	0.40	0.28	0.28	0.25	0.15	0.15	0.24	0.36	0.36	0.11	0.24	0.24
v/c Ratio	0.83	0.29	0.57	0.41	0.76	0.47	0.85	0.70	0.20	0.73	0.74	0.66
Control Delay	47.8	37.7	7.4	30.7	57.9	10.1	54.4	35.3	4.3	71.6	47.1	20.6
Queue Delay	0.0	0.0	0.0	0.0	0.0	0.0	0.0	0.0	0.0	0.0	0.0	0.0
Total Delay	47.8	37.7	7.4	30.7	57.9	10.1	54.4	35.3	4.3	71.6	47.1	20.6
LOS	D	D	A	C	E	B	D	D	A	E	D	C
Approach Delay		29.3			40.8			40.5			41.7	
Approach LOS		C			D			D			D	
Queue Length 50th (ft)	218	94	0	66	161	0	260	311	0	110	238	96
Queue Length 95th (ft)	#539	153	97	127	216	64	322	335	36	#182	280	189
Internal Link Dist (ft)		1269			1237			1302			1355	
Turn Bay Length (ft)	190		325	215		215	890		1000	790		790
Base Capacity (vph)	455	995	754	340	604	426	901	1636	803	228	1164	673
Starvation Cap Reductn	0	0	0	0	0	0	0	0	0	0	0	0
Spillback Cap Reductn	0	0	0	0	0	0	0	0	0	0	0	0
Storage Cap Reductn	0	0	0	0	0	0	0	0	0	0	0	0
Reduced v/c Ratio	0.83	0.29	0.57	0.39	0.69	0.44	0.76	0.55	0.16	0.64	0.54	0.55

Intersection Summary

Area Type: Other

Cycle Length: 120

Actuated Cycle Length: 120

Offset: 0 (0%), Referenced to phase 2:NWTL and 6:SETL, Start of Green

Natural Cycle: 90

Control Type: Actuated-Coordinated

Maximum v/c Ratio: 0.85

Intersection Signal Delay: 38.2 Intersection LOS: D

Intersection Capacity Utilization 80.2% ICU Level of Service D

Analysis Period (min) 15

95th percentile volume exceeds capacity, queue may be longer.

Queue shown is maximum after two cycles.

Splits and Phases: 11: US 24 & Curtis/Stapleton



























Intersection									
Intersection Delay, s/veh	11.0								
Intersection LOS	B								
Approach	EB		WB		NB		SB		
Entry Lanes	2		2		2		2		
Conflicting Circle Lanes	1		1		1		1		
Adj Approach Flow, veh/h	490		230		935		618		
Demand Flow Rate, veh/h	500		235		954		630		
Vehicles Circulating, veh/h	496		955		526		533		
Vehicles Exiting, veh/h	667		525		470		657		
Ped Vol Crossing Leg, #/h	0		0		0		0		
Ped Cap Adj	1.000		1.000		1.000		1.000		
Approach Delay, s/veh	8.4		9.5		13.4		10.1		
Approach LOS	A		A		B		B		
Lane	Left	Right	Left	Right	Left	Right	Left	Right	
Designated Moves	LT	R	LT	R	L	TR	LT	R	
Assumed Moves	LT	R	LT	R	L	TR	LT	R	
RT Channelized									
Lane Util	0.778	0.222	0.753	0.247	0.373	0.627	0.740	0.260	
Follow-Up Headway, s	2.535	2.535	2.535	2.535	2.535	2.535	2.535	2.535	
Critical Headway, s	4.544	4.544	4.544	4.544	4.544	4.544	4.544	4.544	
Entry Flow, veh/h	389	111	177	58	356	598	466	164	
Cap Entry Lane, veh/h	904	904	595	595	880	880	874	874	
Entry HV Adj Factor	0.979	0.982	0.978	0.983	0.980	0.980	0.980	0.982	
Flow Entry, veh/h	381	109	173	57	349	586	457	161	
Cap Entry, veh/h	886	888	582	585	863	862	857	858	
V/C Ratio	0.430	0.123	0.297	0.097	0.405	0.680	0.533	0.188	
Control Delay, s/veh	9.2	5.2	10.3	7.3	9.0	15.9	11.6	6.1	
LOS	A	A	B	A	A	C	B	A	
95th %tile Queue, veh	2	0	1	0	2	5	3	1	

Intersection									
Intersection Delay, s/veh	8.8								
Intersection LOS	A								
Approach	EB		WB		NB		SB		
Entry Lanes	2		2		2		2		
Conflicting Circle Lanes	1		1		1		1		
Adj Approach Flow, veh/h	380		269		861		516		
Demand Flow Rate, veh/h	388		275		878		527		
Vehicles Circulating, veh/h	534		851		388		444		
Vehicles Exiting, veh/h	437		415		534		682		
Ped Vol Crossing Leg, #/h	0		0		0		0		
Ped Cap Adj	1.000		1.000		1.000		1.000		
Approach Delay, s/veh	6.8		8.3		10.4		7.7		
Approach LOS	A		A		B		A		
Lane	Left	Right	Left	Right	Left	Right	Left	Right	
Designated Moves	LT	R	LT	R	L	TR	L	TR	
Assumed Moves	LT	R	LT	R	L	TR	L	TR	
RT Channelized									
Lane Util	0.642	0.358	0.618	0.382	0.312	0.688	0.264	0.736	
Follow-Up Headway, s	2.535	2.535	2.535	2.535	2.535	2.535	2.535	2.535	
Critical Headway, s	4.544	4.544	4.544	4.544	4.544	4.544	4.544	4.544	
Entry Flow, veh/h	249	139	170	105	274	604	139	388	
Cap Entry Lane, veh/h	873	873	655	655	998	998	948	948	
Entry HV Adj Factor	0.979	0.978	0.979	0.981	0.982	0.981	0.978	0.979	
Flow Entry, veh/h	244	136	166	103	269	592	136	380	
Cap Entry, veh/h	855	855	641	642	979	978	928	928	
V/C Ratio	0.285	0.159	0.260	0.160	0.275	0.605	0.147	0.409	
Control Delay, s/veh	7.3	5.8	8.9	7.5	6.4	12.2	5.3	8.6	
LOS	A	A	A	A	A	B	A	A	
95th %tile Queue, veh	1	1	1	1	1	4	1	2	

Lanes, Volumes, Timings
11: US 24 & Curtis/Stapleton

2042 Background + Site
AM (Filings 1-5)

												
Lane Group	SEL	SET	SER	NWL	NWT	NWR	NEL	NET	NER	SWL	SWT	SWR
Lane Configurations												
Traffic Volume (vph)	175	400	600	75	405	55	300	540	50	123	800	350
Future Volume (vph)	175	400	600	75	405	55	300	540	50	123	800	350
Ideal Flow (vphpl)	1900	1900	1900	1900	1900	1900	1900	1900	1900	1900	1900	1900
Storage Length (ft)	190		325	215		215	890		1000	790		790
Storage Lanes	1		1	1		0	2		1	1		1
Taper Length (ft)	240			200			190			190		
Lane Util. Factor	1.00	0.95	1.00	1.00	0.95	1.00	0.97	0.95	1.00	1.00	0.95	1.00
Frt			0.850			0.850			0.850			0.850
Flt Protected	0.950			0.950			0.950			0.950		
Satd. Flow (prot)	1770	3539	1583	1770	3539	1583	3433	3539	1583	1770	3539	1583
Flt Permitted	0.337			0.490			0.950			0.950		
Satd. Flow (perm)	628	3539	1583	913	3539	1583	3433	3539	1583	1770	3539	1583
Right Turn on Red			Yes			Yes			Yes			Yes
Satd. Flow (RTOR)			379			136			95			289
Link Speed (mph)		45			45			55				55
Link Distance (ft)		1349			1317			1382				1435
Travel Time (s)		20.4			20.0			17.1				17.8
Peak Hour Factor	0.95	0.95	0.95	0.92	0.92	0.92	0.93	0.93	0.93	0.95	0.95	0.95
Adj. Flow (vph)	184	421	632	82	440	60	323	581	54	129	842	368
Shared Lane Traffic (%)												
Lane Group Flow (vph)	184	421	632	82	440	60	323	581	54	129	842	368
Enter Blocked Intersection	No	No	No	No	No	No	No	No	No	No	No	No
Lane Alignment	Left	Left	Right	Left	Left	Right	Left	Left	Right	Left	Left	Right
Median Width(ft)		12			12			24				24
Link Offset(ft)		0			0			0				0
Crosswalk Width(ft)		16			16			16				16
Two way Left Turn Lane												
Headway Factor	1.00	1.00	1.00	1.00	1.00	1.00	1.00	1.00	1.00	1.00	1.00	1.00
Turning Speed (mph)	15		9	15		9	15		9	15		9
Number of Detectors	1	2	1	1	2	1	1	2	1	1	2	1
Detector Template	Left	Thru	Right	Left	Thru	Right	Left	Thru	Right	Left	Thru	Right
Leading Detector (ft)	20	100	20	20	100	20	20	100	20	20	100	20
Trailing Detector (ft)	0	0	0	0	0	0	0	0	0	0	0	0
Detector 1 Position(ft)	0	0	0	0	0	0	0	0	0	0	0	0
Detector 1 Size(ft)	20	6	20	20	6	20	20	6	20	20	6	20
Detector 1 Type	Cl+Ex	Cl+Ex	Cl+Ex	Cl+Ex	Cl+Ex	Cl+Ex	Cl+Ex	Cl+Ex	Cl+Ex	Cl+Ex	Cl+Ex	Cl+Ex
Detector 1 Channel												
Detector 1 Extend (s)	0.0	0.0	0.0	0.0	0.0	0.0	0.0	0.0	0.0	0.0	0.0	0.0
Detector 1 Queue (s)	0.0	0.0	0.0	0.0	0.0	0.0	0.0	0.0	0.0	0.0	0.0	0.0
Detector 1 Delay (s)	0.0	0.0	0.0	0.0	0.0	0.0	0.0	0.0	0.0	0.0	0.0	0.0
Detector 2 Position(ft)		94			94			94				94
Detector 2 Size(ft)		6			6			6				6
Detector 2 Type		Cl+Ex			Cl+Ex			Cl+Ex				Cl+Ex
Detector 2 Channel												
Detector 2 Extend (s)		0.0			0.0			0.0				0.0
Turn Type	pm+pt	NA	Perm	pm+pt	NA	Perm	Prot	NA	Perm	Prot	NA	Perm
Protected Phases	1	6		5	2		7	4		3	8	
Permitted Phases	6		6	2		2			4			8

Lanes, Volumes, Timings
11: US 24 & Curtis/Stapleton

2042 Background + Site
AM (Filings 1-5)



Lane Group	SEL	SET	SER	NWL	NWT	NWR	NEL	NET	NER	SWL	SWT	SWR
Detector Phase	1	6	6	5	2	2	7	4	4	3	8	8
Switch Phase												
Minimum Initial (s)	5.0	5.0	5.0	5.0	5.0	5.0	5.0	5.0	5.0	5.0	5.0	5.0
Minimum Split (s)	9.5	22.5	22.5	9.5	22.5	22.5	9.5	22.5	22.5	9.5	22.5	22.5
Total Split (s)	15.0	25.0	25.0	15.0	25.0	25.0	27.0	60.0	60.0	20.0	53.0	53.0
Total Split (%)	12.5%	20.8%	20.8%	12.5%	20.8%	20.8%	22.5%	50.0%	50.0%	16.7%	44.2%	44.2%
Maximum Green (s)	10.5	20.5	20.5	10.5	20.5	20.5	22.5	55.5	55.5	15.5	48.5	48.5
Yellow Time (s)	3.5	3.5	3.5	3.5	3.5	3.5	3.5	3.5	3.5	3.5	3.5	3.5
All-Red Time (s)	1.0	1.0	1.0	1.0	1.0	1.0	1.0	1.0	1.0	1.0	1.0	1.0
Lost Time Adjust (s)	0.0	0.0	0.0	0.0	0.0	0.0	0.0	0.0	0.0	0.0	0.0	0.0
Total Lost Time (s)	4.5	4.5	4.5	4.5	4.5	4.5	4.5	4.5	4.5	4.5	4.5	4.5
Lead/Lag	Lead	Lag	Lag	Lead	Lag	Lag	Lead	Lag	Lag	Lead	Lag	Lag
Lead-Lag Optimize?	Yes	Yes	Yes	Yes	Yes	Yes	Yes	Yes	Yes	Yes	Yes	Yes
Vehicle Extension (s)	3.0	3.0	3.0	3.0	3.0	3.0	3.0	3.0	3.0	3.0	3.0	3.0
Recall Mode	None	C-Min	C-Min	None	C-Min	C-Min	None	None	None	None	None	None
Walk Time (s)		7.0	7.0		7.0	7.0		7.0	7.0		7.0	7.0
Flash Dont Walk (s)		11.0	11.0		11.0	11.0		11.0	11.0		11.0	11.0
Pedestrian Calls (#/hr)		0	0		0	0		0	0		0	0
Act Effct Green (s)	52.1	41.2	41.2	43.7	34.7	34.7	16.5	40.8	40.8	13.1	37.4	37.4
Actuated g/C Ratio	0.43	0.34	0.34	0.36	0.29	0.29	0.14	0.34	0.34	0.11	0.31	0.31
v/c Ratio	0.46	0.35	0.80	0.21	0.43	0.11	0.68	0.48	0.09	0.67	0.76	0.53
Control Delay	27.7	34.0	24.7	24.9	39.1	0.4	56.7	31.9	1.1	68.0	41.8	10.0
Queue Delay	0.0	0.0	0.0	0.0	0.0	0.0	0.0	0.0	0.0	0.0	0.0	0.0
Total Delay	27.7	34.0	24.7	24.9	39.1	0.4	56.7	31.9	1.1	68.0	41.8	10.0
LOS	C	C	C	C	D	A	E	C	A	E	D	A
Approach Delay		28.3			33.1			38.6			35.5	
Approach LOS		C			C			D			D	
Queue Length 50th (ft)	88	130	193	37	147	0	124	187	0	97	308	44
Queue Length 95th (ft)	167	214	#504	83	230	0	167	207	6	161	345	119
Internal Link Dist (ft)		1269			1237			1302			1355	
Turn Bay Length (ft)	190		325	215		215	890		1000	790		790
Base Capacity (vph)	402	1213	792	424	1021	553	643	1636	783	228	1430	811
Starvation Cap Reductn	0	0	0	0	0	0	0	0	0	0	0	0
Spillback Cap Reductn	0	0	0	0	0	0	0	0	0	0	0	0
Storage Cap Reductn	0	0	0	0	0	0	0	0	0	0	0	0
Reduced v/c Ratio	0.46	0.35	0.80	0.19	0.43	0.11	0.50	0.36	0.07	0.57	0.59	0.45

Intersection Summary

Area Type:	Other
Cycle Length:	120
Actuated Cycle Length:	120
Offset:	0 (0%), Referenced to phase 2:NWTL and 6:SETL, Start of Green
Natural Cycle:	70
Control Type:	Actuated-Coordinated
Maximum v/c Ratio:	0.80
Intersection Signal Delay:	33.7
Intersection LOS:	C
Intersection Capacity Utilization:	74.7%
ICU Level of Service:	D
Analysis Period (min):	15

95th percentile volume exceeds capacity, queue may be longer.

Queue shown is maximum after two cycles.

Splits and Phases: 11: US 24 & Curtis/Stapleton

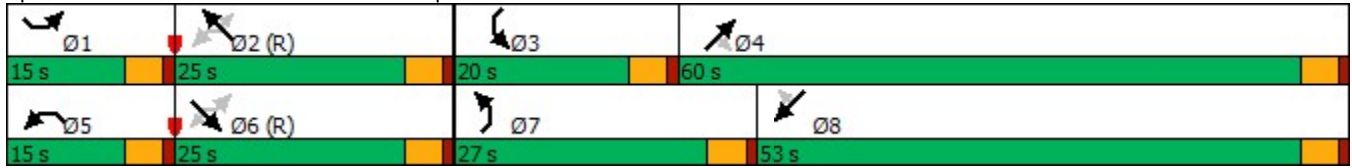

Intersection									
Intersection Delay, s/veh	8.4								
Intersection LOS	A								
Approach	EB		WB		NB		SB		
Entry Lanes	2		2		2		2		
Conflicting Circle Lanes	1		1		1		1		
Adj Approach Flow, veh/h	403		619		462		605		
Demand Flow Rate, veh/h	411		631		472		617		
Vehicles Circulating, veh/h	555		494		190		578		
Vehicles Exiting, veh/h	640		168		776		547		
Ped Vol Crossing Leg, #/h	0		0		0		0		
Ped Cap Adj	1.000		1.000		1.000		1.000		
Approach Delay, s/veh	7.3		8.3		4.9		12.1		
Approach LOS	A		A		A		B		
Lane	Left	Right	Left	Right	Left	Right	Left	Right	
Designated Moves	LT	R	LT	R	L	TR	LT	R	
Assumed Moves	LT	R	LT	R	L	TR	LT	R	
RT Channelized									
Lane Util	0.326	0.674	0.609	0.391	0.411	0.589	0.810	0.190	
Follow-Up Headway, s	2.535	2.535	2.535	2.535	2.535	2.535	2.535	2.535	
Critical Headway, s	4.544	4.544	4.544	4.544	4.544	4.544	4.544	4.544	
Entry Flow, veh/h	134	277	384	247	194	278	500	117	
Cap Entry Lane, veh/h	857	857	906	906	1195	1195	839	839	
Entry HV Adj Factor	0.980	0.982	0.981	0.980	0.979	0.979	0.981	0.983	
Flow Entry, veh/h	131	272	377	242	190	272	490	115	
Cap Entry, veh/h	840	841	888	888	1170	1169	823	825	
V/C Ratio	0.156	0.323	0.424	0.273	0.162	0.233	0.596	0.139	
Control Delay, s/veh	5.9	7.9	9.1	6.9	4.5	5.2	13.6	5.8	
LOS	A	A	A	A	A	A	B	A	
95th %tile Queue, veh	1	1	2	1	1	1	4	0	

Intersection									
Intersection Delay, s/veh	7.9								
Intersection LOS	A								
Approach	EB		WB		NB		SB		
Entry Lanes	2		2		2		2		
Conflicting Circle Lanes	1		1		1		1		
Adj Approach Flow, veh/h	326		450		549		548		
Demand Flow Rate, veh/h	332		459		561		559		
Vehicles Circulating, veh/h	587		549		160		499		
Vehicles Exiting, veh/h	471		172		759		509		
Ped Vol Crossing Leg, #/h	0		0		0		0		
Ped Cap Adj	1.000		1.000		1.000		1.000		
Approach Delay, s/veh	6.9		7.7		5.3		11.2		
Approach LOS	A		A		A		B		
Lane	Left	Right	Left	Right	Left	Right	Left	Right	
Designated Moves	LT	R	LT	R	L	TR	L	TR	
Assumed Moves	LT	R	LT	R	L	TR	L	TR	
RT Channelized									
Lane Util	0.316	0.684	0.688	0.312	0.326	0.674	0.098	0.902	
Follow-Up Headway, s	2.535	2.535	2.535	2.535	2.535	2.535	2.535	2.535	
Critical Headway, s	4.544	4.544	4.544	4.544	4.544	4.544	4.544	4.544	
Entry Flow, veh/h	105	227	316	143	183	378	55	504	
Cap Entry Lane, veh/h	832	832	862	862	1228	1228	902	902	
Entry HV Adj Factor	0.983	0.982	0.981	0.979	0.978	0.979	0.982	0.979	
Flow Entry, veh/h	103	223	310	140	179	370	54	494	
Cap Entry, veh/h	819	818	845	844	1201	1202	885	883	
V/C Ratio	0.126	0.273	0.367	0.166	0.149	0.308	0.061	0.559	
Control Delay, s/veh	5.7	7.4	8.5	5.9	4.3	5.9	4.6	11.9	
LOS	A	A	A	A	A	A	A	B	
95th %tile Queue, veh	0	1	2	1	1	1	0	4	

Intersection						
Int Delay, s/veh	0.6					
Movement	WBL	WBR	NBT	NBR	SBL	SBT
Lane Configurations	↘↙		↑	↗↘	↘↙	↑
Traffic Vol, veh/h	13	19	487	3	6	680
Future Vol, veh/h	13	19	487	3	6	680
Conflicting Peds, #/hr	0	0	0	0	0	0
Sign Control	Stop	Stop	Free	Free	Free	Free
RT Channelized	-	None	-	None	-	None
Storage Length	0	-	-	235	285	-
Veh in Median Storage, #	0	-	0	-	-	0
Grade, %	0	-	0	-	-	0
Peak Hour Factor	78	78	92	92	93	93
Heavy Vehicles, %	2	2	2	2	2	2
Mvmt Flow	17	24	529	3	6	731

Major/Minor	Minor1	Major1	Major2			
Conflicting Flow All	1272	529	0	0	532	0
Stage 1	529	-	-	-	-	-
Stage 2	743	-	-	-	-	-
Critical Hdwy	6.42	6.22	-	-	4.12	-
Critical Hdwy Stg 1	5.42	-	-	-	-	-
Critical Hdwy Stg 2	5.42	-	-	-	-	-
Follow-up Hdwy	3.518	3.318	-	-	2.218	-
Pot Cap-1 Maneuver	185	550	-	-	1036	-
Stage 1	591	-	-	-	-	-
Stage 2	470	-	-	-	-	-
Platoon blocked, %			-	-		-
Mov Cap-1 Maneuver	184	550	-	-	1036	-
Mov Cap-2 Maneuver	184	-	-	-	-	-
Stage 1	591	-	-	-	-	-
Stage 2	467	-	-	-	-	-

Approach	WB	NB	SB
HCM Control Delay, s	18.7	0	0.1
HCM LOS	C		

Minor Lane/Major Mvmt	NBT	NBRWBLn1	SBL	SBT
Capacity (veh/h)	-	-	304	1036
HCM Lane V/C Ratio	-	-	0.135	0.006
HCM Control Delay (s)	-	-	18.7	8.5
HCM Lane LOS	-	-	C	A
HCM 95th %tile Q(veh)	-	-	0.5	0

Intersection						
Int Delay, s/veh	7.1					
Movement	EBT	EBR	WBL	WBT	NBL	NBR
Lane Configurations	↑↑	↑		↑↑	↑	
Traffic Vol, veh/h	151	5	400	0	16	0
Future Vol, veh/h	151	5	400	0	16	0
Conflicting Peds, #/hr	0	0	0	0	0	0
Sign Control	Free	Free	Free	Free	Stop	Stop
RT Channelized	-	None	-	None	-	None
Storage Length	-	200	-	-	0	-
Veh in Median Storage, #	0	-	-	0	0	-
Grade, %	0	-	-	0	0	-
Peak Hour Factor	87	87	92	92	78	78
Heavy Vehicles, %	2	2	2	2	2	2
Mvmt Flow	174	6	435	0	21	0

Major/Minor	Major1	Major2	Minor1		
Conflicting Flow All	0	0	180	0	1044
Stage 1	-	-	-	-	174
Stage 2	-	-	-	-	870
Critical Hdwy	-	-	4.14	-	6.84
Critical Hdwy Stg 1	-	-	-	-	5.84
Critical Hdwy Stg 2	-	-	-	-	5.84
Follow-up Hdwy	-	-	2.22	-	3.52
Pot Cap-1 Maneuver	-	-	1393	-	225
Stage 1	-	-	-	-	839
Stage 2	-	-	-	-	370
Platoon blocked, %	-	-	-	-	-
Mov Cap-1 Maneuver	-	-	1393	-	155
Mov Cap-2 Maneuver	-	-	-	-	155
Stage 1	-	-	-	-	839
Stage 2	-	-	-	-	255

Approach	EB	WB	NB
HCM Control Delay, s	0	8.8	31.7
HCM LOS			D

Minor Lane/Major Mvmt	NBLn1	EBT	EBR	WBL	WBT
Capacity (veh/h)	155	-	-	1393	-
HCM Lane V/C Ratio	0.132	-	-	0.312	-
HCM Control Delay (s)	31.7	-	-	8.8	0
HCM Lane LOS	D	-	-	A	A
HCM 95th %tile Q(veh)	0.4	-	-	1.3	-

Intersection						
Int Delay, s/veh	1					
Movement	EBT	EBR	WBL	WBT	NBL	NBR
Lane Configurations	↑↑	↑		↑↑	↑	
Traffic Vol, veh/h	140	11	0	360	40	1
Future Vol, veh/h	140	11	0	360	40	1
Conflicting Peds, #/hr	0	0	0	0	0	0
Sign Control	Free	Free	Free	Free	Stop	Stop
RT Channelized	-	None	-	None	-	None
Storage Length	-	200	-	-	0	-
Veh in Median Storage, #	0	-	-	0	0	-
Grade, %	0	-	-	0	0	-
Peak Hour Factor	92	92	92	92	78	78
Heavy Vehicles, %	2	2	2	2	2	2
Mvmt Flow	152	12	0	391	51	1

Major/Minor	Major1	Major2	Minor1			
Conflicting Flow All	0	0	164	0	348	76
Stage 1	-	-	-	-	152	-
Stage 2	-	-	-	-	196	-
Critical Hdwy	-	-	4.14	-	6.84	6.94
Critical Hdwy Stg 1	-	-	-	-	5.84	-
Critical Hdwy Stg 2	-	-	-	-	5.84	-
Follow-up Hdwy	-	-	2.22	-	3.52	3.32
Pot Cap-1 Maneuver	-	-	1412	-	623	970
Stage 1	-	-	-	-	860	-
Stage 2	-	-	-	-	818	-
Platoon blocked, %	-	-	-	-	-	-
Mov Cap-1 Maneuver	-	-	1412	-	623	970
Mov Cap-2 Maneuver	-	-	-	-	623	-
Stage 1	-	-	-	-	860	-
Stage 2	-	-	-	-	818	-

Approach	EB	WB	NB
HCM Control Delay, s	0	0	11.3
HCM LOS			B

Minor Lane/Major Mvmt	NBLn1	EBT	EBR	WBL	WBT
Capacity (veh/h)	628	-	-	1412	-
HCM Lane V/C Ratio	0.084	-	-	-	-
HCM Control Delay (s)	11.3	-	-	0	-
HCM Lane LOS	B	-	-	A	-
HCM 95th %tile Q(veh)	0.3	-	-	0	-

Lanes, Volumes, Timings
11: US 24 & Curtis/Stapleton

2042 Background + Site
PM (Filings 1-5)

Lane Group	SEL	SET	SER	NWL	NWT	NWR	NEL	NET	NER	SWL	SWT	SWR
Lane Configurations												
Traffic Volume (vph)	350	302	400	125	405	179	650	850	125	145	600	350
Future Volume (vph)	350	302	400	125	405	179	650	850	125	145	600	350
Ideal Flow (vphpl)	1900	1900	1900	1900	1900	1900	1900	1900	1900	1900	1900	1900
Storage Length (ft)	190		325	215		215	890		1000	790		790
Storage Lanes	1		1	1		0	2		1	1		1
Taper Length (ft)	240			200			190			190		
Lane Util. Factor	1.00	0.95	1.00	1.00	0.95	1.00	0.97	0.95	1.00	1.00	0.95	1.00
Frt			0.850			0.850			0.850			0.850
Flt Protected	0.950			0.950			0.950			0.950		
Satd. Flow (prot)	1770	3539	1583	1770	3539	1583	3433	3539	1583	1770	3539	1583
Flt Permitted	0.183			0.555			0.950			0.950		
Satd. Flow (perm)	341	3539	1583	1034	3539	1583	3433	3539	1583	1770	3539	1583
Right Turn on Red			Yes			Yes			Yes			Yes
Satd. Flow (RTOR)			430			192			132			225
Link Speed (mph)		45			45			55			55	
Link Distance (ft)		1349			1317			1382			1435	
Travel Time (s)		20.4			20.0			17.1			17.8	
Peak Hour Factor	0.93	0.93	0.93	0.93	0.93	0.93	0.95	0.95	0.95	0.95	0.95	0.95
Adj. Flow (vph)	376	325	430	134	435	192	684	895	132	153	632	368
Shared Lane Traffic (%)												
Lane Group Flow (vph)	376	325	430	134	435	192	684	895	132	153	632	368
Enter Blocked Intersection	No	No	No	No	No	No	No	No	No	No	No	No
Lane Alignment	Left	Left	Right	Left	Left	Right	Left	Left	Right	Left	Left	Right
Median Width(ft)		12			12			24			24	
Link Offset(ft)		0			0			0			0	
Crosswalk Width(ft)		16			16			16			16	
Two way Left Turn Lane												
Headway Factor	1.00	1.00	1.00	1.00	1.00	1.00	1.00	1.00	1.00	1.00	1.00	1.00
Turning Speed (mph)	15		9	15		9	15		9	15		9
Number of Detectors	1	2	1	1	2	1	1	2	1	1	2	1
Detector Template	Left	Thru	Right	Left	Thru	Right	Left	Thru	Right	Left	Thru	Right
Leading Detector (ft)	20	100	20	20	100	20	20	100	20	20	100	20
Trailing Detector (ft)	0	0	0	0	0	0	0	0	0	0	0	0
Detector 1 Position(ft)	0	0	0	0	0	0	0	0	0	0	0	0
Detector 1 Size(ft)	20	6	20	20	6	20	20	6	20	20	6	20
Detector 1 Type	Cl+Ex	Cl+Ex	Cl+Ex	Cl+Ex	Cl+Ex	Cl+Ex	Cl+Ex	Cl+Ex	Cl+Ex	Cl+Ex	Cl+Ex	Cl+Ex
Detector 1 Channel												
Detector 1 Extend (s)	0.0	0.0	0.0	0.0	0.0	0.0	0.0	0.0	0.0	0.0	0.0	0.0
Detector 1 Queue (s)	0.0	0.0	0.0	0.0	0.0	0.0	0.0	0.0	0.0	0.0	0.0	0.0
Detector 1 Delay (s)	0.0	0.0	0.0	0.0	0.0	0.0	0.0	0.0	0.0	0.0	0.0	0.0
Detector 2 Position(ft)		94			94			94			94	
Detector 2 Size(ft)		6			6			6			6	
Detector 2 Type		Cl+Ex			Cl+Ex			Cl+Ex			Cl+Ex	
Detector 2 Channel												
Detector 2 Extend (s)		0.0			0.0			0.0			0.0	
Turn Type	pm+pt	NA	Perm	pm+pt	NA	Perm	Prot	NA	Perm	Prot	NA	Perm
Protected Phases	1	6		5	2		7	4		3	8	
Permitted Phases	6		6	2		2			4			8

Lanes, Volumes, Timings
11: US 24 & Curtis/Stapleton

2042 Background + Site
PM (Filings 1-5)



Lane Group	SEL	SET	SER	NWL	NWT	NWR	NEL	NET	NER	SWL	SWT	SWR
Detector Phase	1	6	6	5	2	2	7	4	4	3	8	8
Switch Phase												
Minimum Initial (s)	5.0	5.0	5.0	5.0	5.0	5.0	5.0	5.0	5.0	5.0	5.0	5.0
Minimum Split (s)	9.5	22.5	22.5	9.5	22.5	22.5	9.5	22.5	22.5	9.5	22.5	22.5
Total Split (s)	15.0	25.0	25.0	15.0	25.0	25.0	36.0	60.0	60.0	20.0	44.0	44.0
Total Split (%)	12.5%	20.8%	20.8%	12.5%	20.8%	20.8%	30.0%	50.0%	50.0%	16.7%	36.7%	36.7%
Maximum Green (s)	10.5	20.5	20.5	10.5	20.5	20.5	31.5	55.5	55.5	15.5	39.5	39.5
Yellow Time (s)	3.5	3.5	3.5	3.5	3.5	3.5	3.5	3.5	3.5	3.5	3.5	3.5
All-Red Time (s)	1.0	1.0	1.0	1.0	1.0	1.0	1.0	1.0	1.0	1.0	1.0	1.0
Lost Time Adjust (s)	0.0	0.0	0.0	0.0	0.0	0.0	0.0	0.0	0.0	0.0	0.0	0.0
Total Lost Time (s)	4.5	4.5	4.5	4.5	4.5	4.5	4.5	4.5	4.5	4.5	4.5	4.5
Lead/Lag	Lead	Lag	Lag	Lead	Lag	Lag	Lead	Lag	Lag	Lead	Lag	Lag
Lead-Lag Optimize?	Yes	Yes	Yes	Yes	Yes	Yes	Yes	Yes	Yes	Yes	Yes	Yes
Vehicle Extension (s)	3.0	3.0	3.0	3.0	3.0	3.0	3.0	3.0	3.0	3.0	3.0	3.0
Recall Mode	None	C-Min	C-Min	None	C-Min	C-Min	None	None	None	None	None	None
Walk Time (s)		7.0	7.0		7.0	7.0		7.0	7.0		7.0	7.0
Flash Dont Walk (s)		11.0	11.0		11.0	11.0		11.0	11.0		11.0	11.0
Pedestrian Calls (#/hr)		0	0		0	0		0	0		0	0
Act Effct Green (s)	48.4	33.8	33.8	29.9	18.9	18.9	28.2	43.3	43.3	14.0	29.0	29.0
Actuated g/C Ratio	0.40	0.28	0.28	0.25	0.16	0.16	0.24	0.36	0.36	0.12	0.24	0.24
v/c Ratio	0.84	0.33	0.57	0.41	0.78	0.47	0.85	0.70	0.20	0.74	0.74	0.67
Control Delay	50.3	38.1	7.4	30.7	58.9	10.0	54.4	35.5	4.3	72.8	47.1	20.9
Queue Delay	0.0	0.0	0.0	0.0	0.0	0.0	0.0	0.0	0.0	0.0	0.0	0.0
Total Delay	50.3	38.1	7.4	30.7	58.9	10.0	54.4	35.5	4.3	72.8	47.1	20.9
LOS	D	D	A	C	E	B	D	D	A	E	D	C
Approach Delay		30.5			41.6			40.7			42.1	
Approach LOS		C			D			D			D	
Queue Length 50th (ft)	226	106	0	66	169	0	260	312	0	114	238	97
Queue Length 95th (ft)	#549	171	97	127	227	64	322	335	36	#199	280	191
Internal Link Dist (ft)		1269			1237			1302			1355	
Turn Bay Length (ft)	190		325	215		215	890		1000	790		790
Base Capacity (vph)	445	995	754	337	604	429	901	1636	803	228	1164	672
Starvation Cap Reductn	0	0	0	0	0	0	0	0	0	0	0	0
Spillback Cap Reductn	0	0	0	0	0	0	0	0	0	0	0	0
Storage Cap Reductn	0	0	0	0	0	0	0	0	0	0	0	0
Reduced v/c Ratio	0.84	0.33	0.57	0.40	0.72	0.45	0.76	0.55	0.16	0.67	0.54	0.55

Intersection Summary

Area Type: Other
 Cycle Length: 120
 Actuated Cycle Length: 120
 Offset: 0 (0%), Referenced to phase 2:NWTL and 6:SETL, Start of Green
 Natural Cycle: 90
 Control Type: Actuated-Coordinated
 Maximum v/c Ratio: 0.85
 Intersection Signal Delay: 38.8
 Intersection LOS: D
 Intersection Capacity Utilization 80.7%
 ICU Level of Service D
 Analysis Period (min) 15
 # 95th percentile volume exceeds capacity, queue may be longer.

Queue shown is maximum after two cycles.

Splits and Phases: 11: US 24 & Curtis/Stapleton

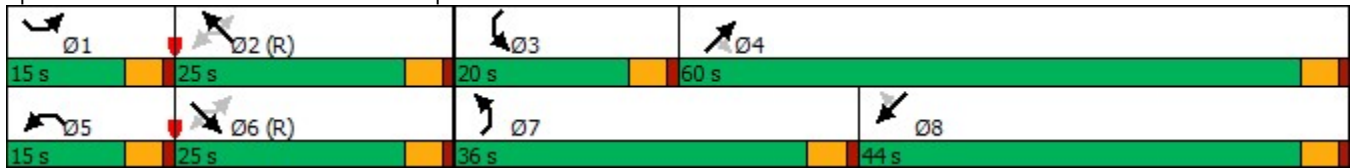

Intersection									
Intersection Delay, s/veh	11.6								
Intersection LOS	B								
Approach	EB		WB		NB		SB		
Entry Lanes	2		2		2		2		
Conflicting Circle Lanes	1		1		1		1		
Adj Approach Flow, veh/h	517		233		942		642		
Demand Flow Rate, veh/h	527		238		961		656		
Vehicles Circulating, veh/h	502		993		554		533		
Vehicles Exiting, veh/h	687		522		475		698		
Ped Vol Crossing Leg, #/h	0		0		0		0		
Ped Cap Adj	1.000		1.000		1.000		1.000		
Approach Delay, s/veh	8.9		10.0		14.4		10.2		
Approach LOS	A		A		B		B		
Lane	Left	Right	Left	Right	Left	Right	Left	Right	
Designated Moves	LT	R	LT	R	L	TR	LT	R	
Assumed Moves	LT	R	LT	R	L	TR	LT	R	
RT Channelized									
Lane Util	0.791	0.209	0.744	0.256	0.370	0.630	0.720	0.280	
Follow-Up Headway, s	2.535	2.535	2.535	2.535	2.535	2.535	2.535	2.535	
Critical Headway, s	4.544	4.544	4.544	4.544	4.544	4.544	4.544	4.544	
Entry Flow, veh/h	417	110	177	61	356	605	472	184	
Cap Entry Lane, veh/h	899	899	575	575	858	858	874	874	
Entry HV Adj Factor	0.981	0.982	0.978	0.984	0.980	0.980	0.980	0.978	
Flow Entry, veh/h	409	108	173	60	349	593	462	180	
Cap Entry, veh/h	882	883	563	566	841	840	857	855	
V/C Ratio	0.464	0.122	0.308	0.106	0.415	0.705	0.540	0.210	
Control Delay, s/veh	9.9	5.3	10.8	7.6	9.4	17.4	11.7	6.4	
LOS	A	A	B	A	A	C	B	A	
95th %tile Queue, veh	2	0	1	0	2	6	3	1	

Intersection									
Intersection Delay, s/veh	9.8								
Intersection LOS	A								
Approach	EB		WB		NB		SB		
Entry Lanes	2		2		2		2		
Conflicting Circle Lanes	1		1		1		1		
Adj Approach Flow, veh/h	446		296		883		557		
Demand Flow Rate, veh/h	455		302		901		568		
Vehicles Circulating, veh/h	575		872		459		472		
Vehicles Exiting, veh/h	465		488		571		702		
Ped Vol Crossing Leg, #/h	0		0		0		0		
Ped Cap Adj	1.000		1.000		1.000		1.000		
Approach Delay, s/veh	7.7		8.9		12.2		8.3		
Approach LOS	A		A		B		A		
Lane	Left	Right	Left	Right	Left	Right	Left	Right	
Designated Moves	LT	R	LT	R	L	TR	L	TR	
Assumed Moves	LT	R	LT	R	L	TR	L	TR	
RT Channelized									
Lane Util	0.655	0.345	0.623	0.377	0.315	0.685	0.283	0.717	
Follow-Up Headway, s	2.535	2.535	2.535	2.535	2.535	2.535	2.535	2.535	
Critical Headway, s	4.544	4.544	4.544	4.544	4.544	4.544	4.544	4.544	
Entry Flow, veh/h	298	157	188	114	284	617	161	407	
Cap Entry Lane, veh/h	841	841	642	642	935	935	924	924	
Entry HV Adj Factor	0.979	0.981	0.979	0.982	0.979	0.981	0.981	0.979	
Flow Entry, veh/h	292	154	184	112	278	605	158	399	
Cap Entry, veh/h	824	825	629	631	915	917	907	905	
V/C Ratio	0.354	0.187	0.293	0.178	0.304	0.660	0.174	0.440	
Control Delay, s/veh	8.5	6.3	9.5	7.8	7.2	14.5	5.7	9.3	
LOS	A	A	A	A	A	B	A	A	
95th %tile Queue, veh	2	1	1	1	1	5	1	2	

Intersection						
Int Delay, s/veh	0.6					
Movement	WBL	WBR	NBT	NBR	SBL	SBT
Lane Configurations	↘↗		↑	↗↘	↘↗	↑
Traffic Vol, veh/h	9	12	805	13	21	489
Future Vol, veh/h	9	12	805	13	21	489
Conflicting Peds, #/hr	0	0	0	0	0	0
Sign Control	Stop	Stop	Free	Free	Free	Free
RT Channelized	-	None	-	None	-	None
Storage Length	0	-	-	235	285	-
Veh in Median Storage, #	0	-	0	-	-	0
Grade, %	0	-	0	-	-	0
Peak Hour Factor	78	78	93	93	92	92
Heavy Vehicles, %	2	2	2	2	2	2
Mvmt Flow	12	15	866	14	23	532

Major/Minor	Minor1	Major1	Major2			
Conflicting Flow All	1444	866	0	0	880	0
Stage 1	866	-	-	-	-	-
Stage 2	578	-	-	-	-	-
Critical Hdwy	6.42	6.22	-	-	4.12	-
Critical Hdwy Stg 1	5.42	-	-	-	-	-
Critical Hdwy Stg 2	5.42	-	-	-	-	-
Follow-up Hdwy	3.518	3.318	-	-	2.218	-
Pot Cap-1 Maneuver	145	353	-	-	768	-
Stage 1	412	-	-	-	-	-
Stage 2	561	-	-	-	-	-
Platoon blocked, %			-	-		-
Mov Cap-1 Maneuver	141	353	-	-	768	-
Mov Cap-2 Maneuver	141	-	-	-	-	-
Stage 1	412	-	-	-	-	-
Stage 2	544	-	-	-	-	-

Approach	WB	NB	SB
HCM Control Delay, s	24.1	0	0.4
HCM LOS	C		

Minor Lane/Major Mvmt	NBT	NBRWBLn1	SBL	SBT
Capacity (veh/h)	-	-	215	768
HCM Lane V/C Ratio	-	-	0.125	0.03
HCM Control Delay (s)	-	-	24.1	9.8
HCM Lane LOS	-	-	C	A
HCM 95th %tile Q(veh)	-	-	0.4	0.1

Intersection						
Int Delay, s/veh	0.2					
Movement	EBT	EBR	WBL	WBT	NBL	NBR
Lane Configurations	↑↑	↑		↑↑	↑	
Traffic Vol, veh/h	423	18	0	262	10	0
Future Vol, veh/h	423	18	0	262	10	0
Conflicting Peds, #/hr	0	0	0	0	0	0
Sign Control	Free	Free	Free	Free	Stop	Stop
RT Channelized	-	None	-	None	-	None
Storage Length	-	200	-	-	0	-
Veh in Median Storage, #	0	-	-	0	0	-
Grade, %	0	-	-	0	0	-
Peak Hour Factor	92	92	92	92	78	78
Heavy Vehicles, %	2	2	2	2	2	2
Mvmt Flow	460	20	0	285	13	0

Major/Minor	Major1	Major2	Minor1		
Conflicting Flow All	0	0	480	0	603
Stage 1	-	-	-	-	460
Stage 2	-	-	-	-	143
Critical Hdwy	-	-	4.14	-	6.84
Critical Hdwy Stg 1	-	-	-	-	5.84
Critical Hdwy Stg 2	-	-	-	-	5.84
Follow-up Hdwy	-	-	2.22	-	3.52
Pot Cap-1 Maneuver	-	-	1079	-	430
Stage 1	-	-	-	-	602
Stage 2	-	-	-	-	869
Platoon blocked, %	-	-	-	-	-
Mov Cap-1 Maneuver	-	-	1079	-	430
Mov Cap-2 Maneuver	-	-	-	-	430
Stage 1	-	-	-	-	602
Stage 2	-	-	-	-	869

Approach	EB	WB	NB
HCM Control Delay, s	0	0	13.6
HCM LOS			B

Minor Lane/Major Mvmt	NBLn1	EBT	EBR	WBL	WBT
Capacity (veh/h)	430	-	-	1079	-
HCM Lane V/C Ratio	0.03	-	-	-	-
HCM Control Delay (s)	13.6	-	-	0	-
HCM Lane LOS	B	-	-	A	-
HCM 95th %tile Q(veh)	0.1	-	-	0	-

Intersection						
Int Delay, s/veh	0.7					
Movement	EBT	EBR	WBL	WBT	NBL	NBR
Lane Configurations	↑↑	↑		↑↑	↑	
Traffic Vol, veh/h	375	48	3	235	27	1
Future Vol, veh/h	375	48	3	235	27	1
Conflicting Peds, #/hr	0	0	0	0	0	0
Sign Control	Free	Free	Free	Free	Stop	Stop
RT Channelized	-	None	-	None	-	None
Storage Length	-	200	-	-	0	-
Veh in Median Storage, #	0	-	-	0	0	-
Grade, %	0	-	-	0	0	-
Peak Hour Factor	92	92	87	87	78	78
Heavy Vehicles, %	2	2	2	2	2	2
Mvmt Flow	408	52	3	270	35	1

Major/Minor	Major1	Major2	Minor1		
Conflicting Flow All	0	0	460	0	549
Stage 1	-	-	-	-	408
Stage 2	-	-	-	-	141
Critical Hdwy	-	-	4.14	-	6.84
Critical Hdwy Stg 1	-	-	-	-	5.84
Critical Hdwy Stg 2	-	-	-	-	5.84
Follow-up Hdwy	-	-	2.22	-	3.52
Pot Cap-1 Maneuver	-	-	1097	-	466
Stage 1	-	-	-	-	640
Stage 2	-	-	-	-	871
Platoon blocked, %	-	-	-	-	-
Mov Cap-1 Maneuver	-	-	1097	-	465
Mov Cap-2 Maneuver	-	-	-	-	465
Stage 1	-	-	-	-	640
Stage 2	-	-	-	-	868

Approach	EB	WB	NB
HCM Control Delay, s	0	0.1	13.3
HCM LOS			B

Minor Lane/Major Mvmt	NBLn1	EBT	EBR	WBL	WBT
Capacity (veh/h)	472	-	-	1097	-
HCM Lane V/C Ratio	0.076	-	-	0.003	-
HCM Control Delay (s)	13.3	-	-	8.3	0
HCM Lane LOS	B	-	-	A	A
HCM 95th %tile Q(veh)	0.2	-	-	0	-

Approved Deviation - Curtis Road





Planning and Community
Development Department
2880 International Circle
Colorado Springs, Colorado 80910
Phone: 719.520.6300
Fax: 719.520.6695
Website www.elpasoco.com

DEVIATION REQUEST AND DECISION FORM

Updated: 6/26/2019

PROJECT INFORMATION

Project Name : Saddlehorn Ranch – Filing 1
 Schedule No.(s) : 4300000561, 4400000562, 4300000556
 Legal Description : SEE ATTACHED – Exhibit C

APPLICANT INFORMATION

Company : WILLIAM GUMAN & ASSOCIATES
 Name : BILL GUMAN
 Owner Consultant Contractor
 Mailing Address : 731 NORTH WEBER STREET, SUITE 10, COLORADO SPRINGS, COLORADO, 80903

 Phone Number : (719) 633-9700
 FAX Number : N/A
 Email Address : BILL@GUMAN.NET

ENGINEER INFORMATION

Company : JR ENGINEERING
 Name : MIKE BRAMLETT Colorado P.E. Number : 32314
 Mailing Address : 5475 TECH CENTER DRIVE, SUITE 235, COLORADO SPRINGS, COLORADO 80919

 Phone Number : 719-593-2593
 FAX Number : N/A
 Email Address : MBRAMLETT@JRENGINEERING.COM

OWNER, APPLICANT, AND ENGINEER DECLARATION

To the best of my knowledge, the information on this application and all additional or supplemental documentation is true, factual and complete. I am fully aware that any misrepresentation of any information on this application may be grounds for denial. I have familiarized myself with the rules, regulations and procedures with respect to preparing and filing this application. I also understand that an incorrect submittal will be cause to have the project removed from the agenda of the Planning Commission, Board of County Commissioners and/or Board of Adjustment or delay review until corrections are made, and that any approval of this application is based on the representations made in the application and may be revoked on any breach of representation or condition(s) of approval.

Bill Guman FOR RO1 PROPERTY GROUP 09/28/2026
 Signature of owner (or authorized representative) Date

Engineer's Seal, Signature
And Date of Signature

Mike Bramlett



DEVIATION REQUEST (Attach diagrams, figures, and other documentation to clarify request)

A deviation from the standards of or in Section **ECM section 2.2.4 Figure 2-4 Rural Minor Arterial** of the Engineering Criteria Manual (ECM) is requested for the Curtis Road cross-section.

Identify the specific ECM standard which a deviation is requested:

ECM criteria for a rural minor arterial cross sections requires a 12' travel lane and an 8' paved shoulder. The 2040 MTCP identifies Curtis Road as a two-lane rural Principal Arterial. Since there is no standard 2-lane principal arterial cross-section this deviation will document the proposed 2040 cross-section (rural minor arterial) and reasoning for the proposed ROW dedication width

State the reason for the requested deviation:

To build the full cross-section, ROW would need to be obtained from adjacent property owners to accommodate the full 8' paved shoulder on the west side of the road. To place the burden of ROW acquisition from the adjacent property owners on the Saddlehorn development would not be fair or equitable.

While the minor arterial half-cross section could be built on the east (Saddlehorn) side of the road, it is not the appropriate time to build out the full section until traffic warrants the arterial cross-section and both sides of the road can be constructed.

Explain the proposed alternative and compare to the ECM standards (May provide applicable regional or national standards used as basis):

The proposed alternative for the west side is for the 8' paved shoulder to be reduced to a 2' paved and 2 ft gravel shoulder. This is the maximum that can fit inside the existing western ROW. Exhibit A provides the proposed cross section.

The applicant will provided a 72 foot half right of way along with an additional 18 foot ROW preservation on all plats adjacent to Curtis Road consistent with the anticipated ROW needs identified in the MTCP and the Preserved Corridor Network Plan.

The applicant is also subject to the El Paso County Road Impact Fee per resolution No. 19-471 and is therefore paying its fair and equitable share of necessary improvements identified in the MTCP.

For Curtis Road adjacent to Filing 1 east half-section, the applicant proposes to provide a 12 ft. travel lane, 2ft. asphalt shoulder and 2 ft. gravel shoulder for Filing 1 development. The proposed alternative is consistent with the ECM Table 2.5 design criteria for a rural local roadway and intersections are projected to operate at a level of service C or better with the buildout of Filing 1.

For Curtis Road adjacent to future filings, the applicant proposes to provide a 12 ft. travel lane, 8ft. asphalt shoulder and 2 ft. gravel shoulder and will retrofit the Filing 1 improvements to provide an 8 ft asphalt shoulder and 2 foot gravel shoulder on the east side. The proposed alternative is consistent with the ECM Table 2.4 design criteria for a minor arterial roadway

Per the rezoning approval, a condition was placed on Curtis Rd. requiring improvements to arterial road standards with potential reimbursement from the fee program. The condition wording is "*The adjacent portions of Curtis Road shall be improved to meet the minimum standards of an arterial roadway per the Engineering Criteria Manual. Improvements will be made as part of the Curtis Road access permitting. The necessary improvements and phasing will be clarified with the future applications for Preliminary Plan and Final Plat. The work may be subject to any reimbursement as outlined in the El Paso County Road Impact Fee Program*". The applicant is providing adequate ROW to meet this condition for Filing 1 and is proposing a reduced cross section to local road criteria for Filing 1. Future filings adjacent to Curtis Road will provide dedicate adequate ROW and will build a rural minor arterial half cross section on the east half of Curtis Rd and a rural local half cross section on the west half. Curtis can be expanded to meet the full minor arterial cross section criteria once the county has obtained the additional ROW from western parcels.

Exhibit A provides the proposed cross sections.

LIMITS OF CONSIDERATION

(At least one of the conditions listed below must be met for this deviation request to be considered.)

- The ECM standard is inapplicable to the particular situation.
- Topography, right-of-way, or other geographical conditions or impediments impose an undue hardship and an equivalent alternative that can accomplish the same design objective is available and does not compromise public safety or accessibility.
- A change to a standard is required to address a specific design or construction problem, and if not modified, the standard will impose an undue hardship on the applicant with little or no material benefit to the public.

Provide justification:

ROW must be obtained on the west side of the road for the full 8' paved shoulder to be constructed on Curtis Road. The maximum shoulder width that can be constructed inside the existing ROW is a 2' paved shoulder.

CRITERIA FOR APPROVAL

Per ECM section 5.8.7 the request for a deviation may be considered if the request is **not based exclusively on financial considerations**. The deviation must not be detrimental to public safety or surrounding property. The applicant must include supporting information demonstrating compliance with **all of the following criteria**:

The deviation will achieve the intended result with a comparable or superior design and quality of improvement.

This deviation will improve the roadway by adding a shoulder and maintain a consistent cross section until such time as the additional western ROW is acquired as part of the overall improvement of Curtis Road to minor arterial standards. This request is not based on financial considerations but the practicality of obtaining ROW from private properties.

The deviation will not adversely affect safety or operations.

This deviation will improve the safety when compared to the existing condition that has no asphalt shoulder and 11 foot travel lanes. Operations will not be impacted by the proposed cross section.

As final plats take access to Curtis Road the each intersection will be designed to accommodate the requirements listed in Table 10 Roadway Improvements of the Traffic Impact Study.

Filing 1 intersection improvements will provide a 12 foot through lane, 12 ft decell/turn lane, 2 ft paved shoulder and a 2 ft gravel shoulder.

The deviation will not adversely affect maintenance and its associated cost.

Maintenance of the roadways will not be impacted.

The deviation will not adversely affect aesthetic appearance.

The deviation has no bearing on the aesthetic appearance.

The deviation meets the design intent and purpose of the ECM standards.

Yes, the deviation meets the design intent and purpose of the ECM standards. Once ROW can be obtained, the road can be built out to the full two lane rural principal arterial section as indicated in the 2040 MTCP.

The 2040 Total ADT of 10,000 ADT is within the proposed cross section criteria. See Exhibit B for existing, Filing 1, buildout and 2040 ADT estimates from the TIS.

The deviation meets the control measure requirements of Part I.E.3 and Part I.E.4 of the County's MS4 permit, as applicable.

Yes, the deviation meets the control measure requirements of Part I.E.3 and Part I.E.4 of the County's MS4 permit, this project is proposing Water Quality facilities as required by the criteria.

REVIEW AND RECOMMENDATION:

Approved by the ECM Administrator

This request has been determined to have met the criteria for approval. A deviation from Section 2.2.4 of the ECM is hereby granted based on the justification provided.

Γ

APPROVED
Engineering Department

01/05/2021 6:09:12 PM

dsdnijkamp

**EPC Planning & Community
Development Department**

L

Denied by the ECM Administrator

This request has been determined not to have met criteria for approval. A deviation from Section _____ of the ECM is hereby denied.

Γ

Γ

L

Γ

ECM ADMINISTRATOR COMMENTS/CONDITIONS:

Construction of the cross-section as proposed is not reimbursable under the County Road Fee program.

This deviation shall be re-evaluated with the next Saddlehorn Ranch subdivision filing.

Figure 2-4. Typical Rural Principal Arterial Partial Cross-Section (4 Lane)

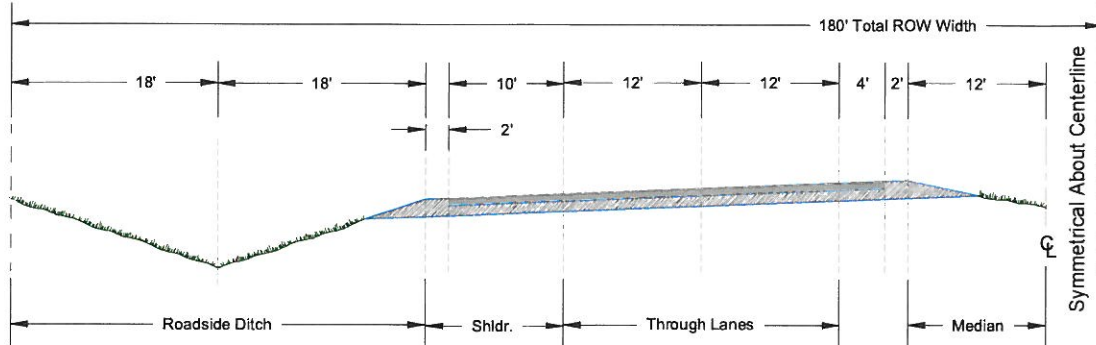

3. Minor Arterial

Minor arterials serve high-speed and high-volume traffic over medium distances, or are anticipated to serve this kind of traffic within a twenty-year period. Access is restricted through prescribed distances between intersections, use of medians, and no full movement parcel access (See Figure 2-5). Minor arterial status is assigned to rural roadways where the probability of significant travel demand in the future is high. Rights-of-way, easements, setbacks, and access limitations shall be pursued through the land development process on properties adjacent to minor arterials.

Figure 2-5. Typical Rural Minor Arterial Partial Cross Section

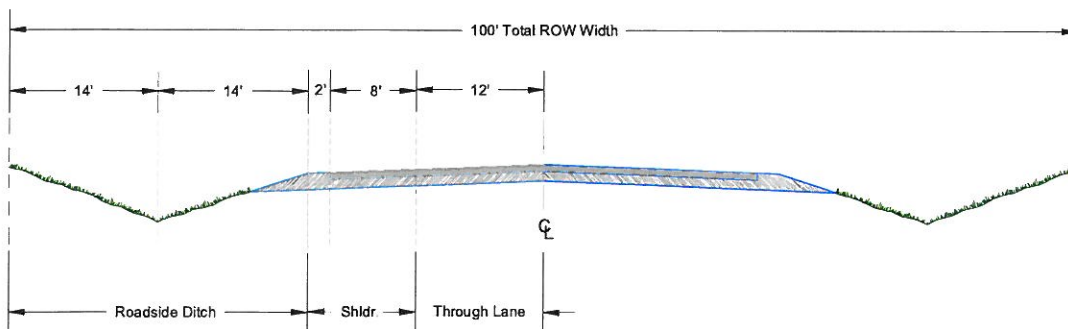

4. Major Collector

Major collectors serve as links between local access and arterial facilities over medium-to-long distances. Major collectors are managed to

Figure 2-7. Typical Rural Minor Collector Cross Section

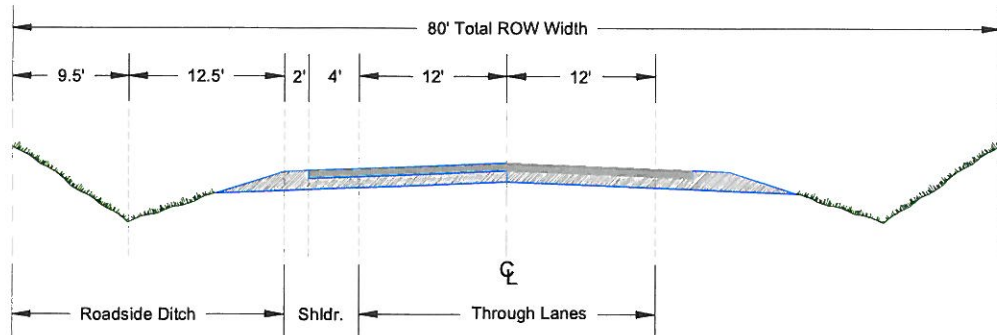

6. Local

Local roadways provide direct lot access and deliver lot-generated trips to collector roadways. Although access needs are high, accesses shall not be allowed to compromise the safety, health or welfare of roadway users (See Figure 2-8).

Figure 2-8. Typical Rural Local Cross Section

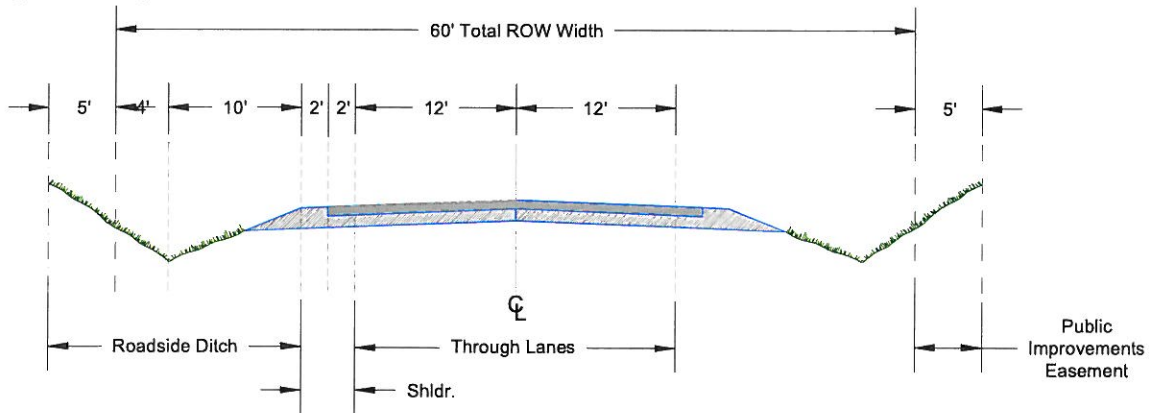

Exhibit A - cont

Table 2-3. Roadway Design Criteria Continued

Criteria	Concern	Guideline
Minimize Space Devoted to Road Use	It is desirable to minimize local road mileage, thereby reducing construction and maintenance costs, as well as permitting the most efficient use of land. Roads should also have an appearance commensurate with their function.	Roads should be designed to complement local character.
Relate Road to Topography	Local roads are more attractive and economical if constructed to closely adhere to topography (minimize cut and fill).	The important role that roads play in the overall storm drainage system can be enhanced by closely following existing topography.
Layout Road to Achieve Optimum Subdivision of Land	The arrangement of roads should allow for economical and practical patterns, shapes, and sizes of adjacent lots. Roads as a function of land use must not unduly hinder the development of land.	Distances between roads, number of roads, and related elements all have a bearing on efficient subdivision of an area. Access to adjoining properties should also be encouraged.

2.3.2 Design Standards by Functional Classification

Section 2.2.4 of these standards identifies the Roadway Functional Classifications recognized and used by the County. Table 2-4 through Table 2-7 summarize many of the minimum roadway design standards by category and functional classification. Detailed road Standard Drawings are provided in Appendix F.

Table 2-4. Roadway Design Standards for Rural Expressways and Arterials

Criteria	Expressways		Arterials		Minor
	6 Lane	4 Lane	6 Lane Principal	4 Lane Principal	
Design Speed / Posted Speed (MPH)	70 / 65	70 / 65	70 / 65	70 / 65	60 / 55
Clear Zone	34'	34'	34'	34'	30'
Minimum Centerline Curve Radius	2,050 ¹	2,050 ¹	2,050 ¹	2,050 ¹	1,505 ¹
Number of Through Lanes	6	4	6	4	2
Lane Width	12'	12'	12'	12'	12'
Right-of-Way	210'	180'	210'	180'	100'
Paved Width	56' ²	38' ²	56' ²	38' ²	40'
Median Width	24'	24'	24'	24'	n/a
Outside Shoulder Width (paved/gravel)	12'(10' ¹ / ₂)'	12'(10' ¹ / ₂)'	12'(10' ¹ / ₂)'	12'(10' ¹ / ₂)'	10'(8' ¹ / ₂)'
Inside Shoulder Width (paved/gravel)	12'(10' ¹ / ₂)'	6'(4' ¹ / ₂)'	12'(10' ¹ / ₂)'	6'(4' ¹ / ₂)'	n/a
Design ADT		48,000		40,000	10,000
Design Vehicle	WB-67	WB-67	WB-67	WB-67	WB-67
Access Permitted	No	No	No	No	No
Access Spacing	n/a	n/a	n/a	n/a	n/a
Intersection Spacing	1 mile	1 mile	½ mile	½ mile	¼ mile
Parking Permitted	No	No	No	No	No
Minimum Flowline Grade	1%	1%	1%	1%	1%

Centerline Grade (Min.-Max.)	1-5%	1-5%	1-5%	1-5%	1-6%
Intersection Grades (Min.-Max.)	1-2%	1-2%	1-3%	1-3%	1-4%

¹ Assumes 4% superelevation, 6% for 70 MPH design speeds

² Pavement width in each direction for divided roadways

Table 2-5. Roadway Design Standards for Rural Collectors and Locals

Criteria	Collectors		Local	
	Major	Minor	Local	Gravel
Design Speed / Posted Speed (MPH)	50 / 45	40 / 35	30 / 30	50/45
Clear Zone	20'	14'	7'	12'
Minimum Centerline Curve Radius	930' ²	565'	300'	As Approved
Number of Through Lanes	2	2	2	2
Lane Width	12'	12'	12'	12'
Right of Way	90'	80'	70' ³	70' ³
Paved Width	32'	32'	28'	n/a
Median Width	n/a	n/a	n/a	n/a
Outside Shoulder Width (paved/gravel)	8'(4'/4')	6'(4'/2')	4'(2'/2')	4'(0'/4')
Inside Shoulder Width (paved/gravel)	n/a	n/a	n/a	n/a
Design ADT	3,000	1,500	750	200
Design Vehicle	WB-67	WB-67	WB-50	WB-50
Access Permitted	No	Yes	Yes	Yes
Access Spacing	n/a	Frontage	Frontage	Frontage
Intersection Spacing	¼ mile	660'	330'	330'
Parking Permitted	No	Yes	Yes	No
Minimum Flowline Grade	1%	1%	1%	1%
Centerline Grade (Min.-Max.)	1-8% ¹	1-8% ¹	1-8% ¹	1-8%
Intersection Grades (Min.-Max.)	1-4%	1-4%	1-4%	1-4%

¹ 10% maximum grade permitted at the discretion of the ECM Administrator

² Assumes 4% superelevation, 6% for 70 MPH design speeds

³ 60-foot right-of-way plus two 5-foot Public Improvements Easements granted to El Paso County

EXHIBIT A

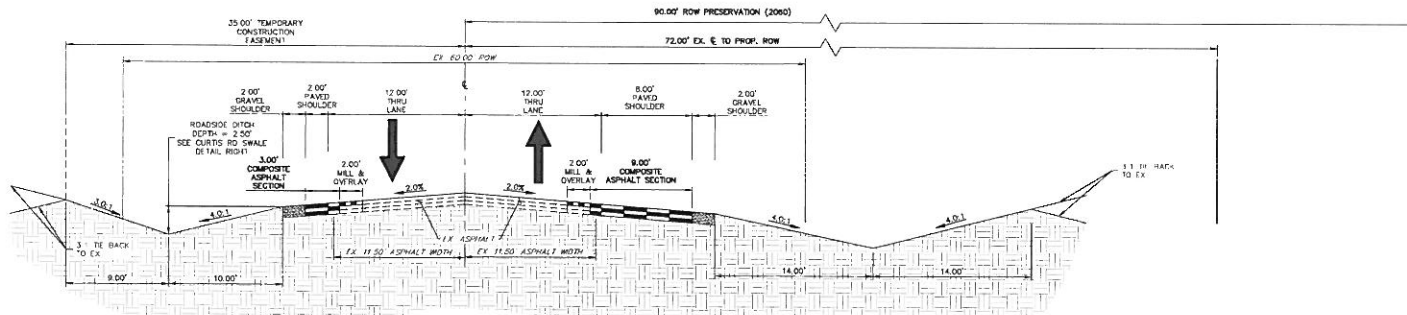

CURTIS ROAD – MODIFIED MINOR RURAL ARTERIAL – INTERIM FUTURE

STA 30+81.15 – JUDGE ORR RD/CURTIS RD INTERSECTION IMPROVEMENTS
 POSTED SPEED LIMIT = 40 MPH
 SCALE: 1" = 5'
 (LOOKING NORTH)

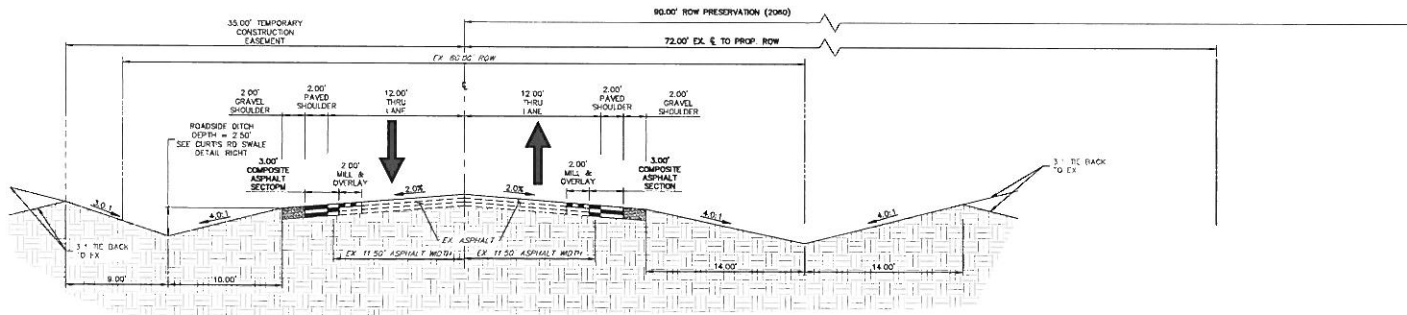

CURTIS ROAD – MODIFIED MINOR RURAL ARTERIAL – FILING 1 LIMITS

STA 14+05 – 10+143.09 & 15+82.58 – 30+81.15
 POSTED SPEED LIMIT = 45 MPH
 SCALE: 1" = 5'
 (LOOKING NORTH)

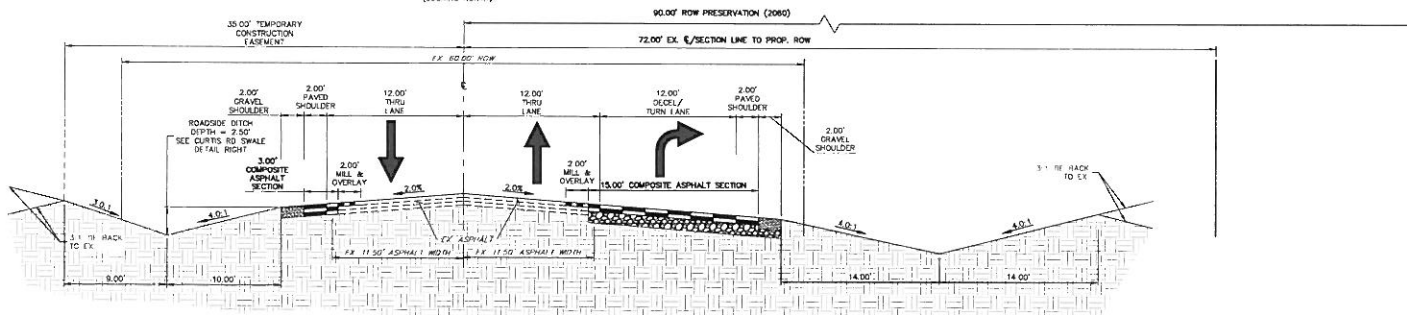

CURTIS ROAD – MODIFIED MINOR RURAL ARTERIAL

STA 12+42.36 – 14+84.72
 POSTED SPEED LIMIT = 45 MPH
 SCALE: 1" = 5'
 (LOOKING NORTH)

SADDLEHORN RANCH –
 DEVIATION REQUEST
 MODIFIED MINOR RURAL ARTERIAL
 JOB NO. 25142.02
 9/28/20
 SHEET 1 OF 1



Central 303-740-9363 • Colorado Springs 781-593-2593
 Fort Collins 970-691-9888 • www.jr-engineering.com

Exhibit B - Curtis Road ADT Volumes

Existing ADTs on Curtis Road

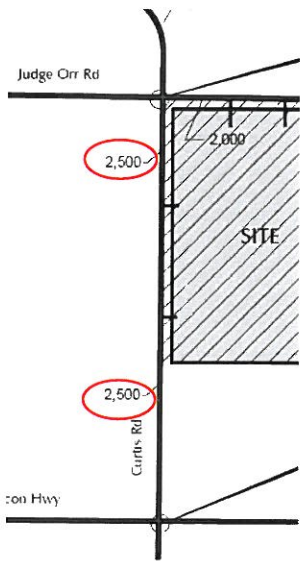

Phase 1 Site-Generated ADTs on Curtis Road

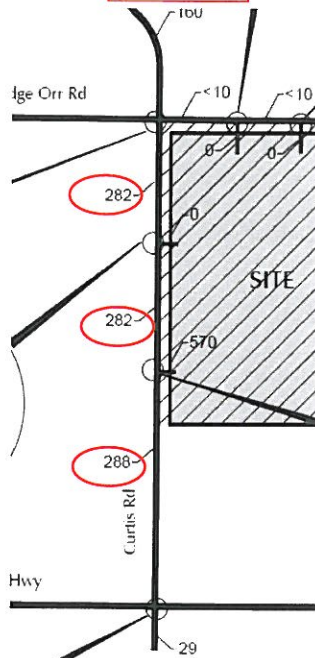

Buildout Site-Generated ADTs on Curtis Road

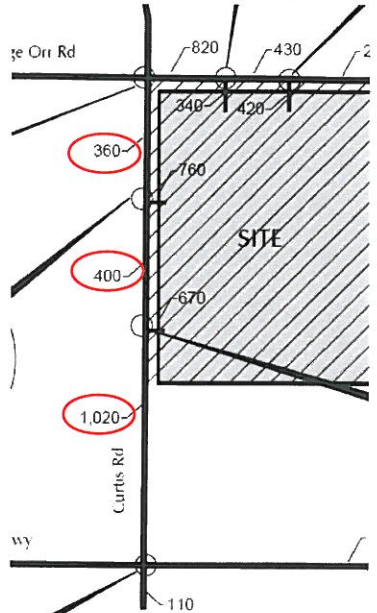

Short Term (Existing plus Site Generated) ADTs on Curtis Road

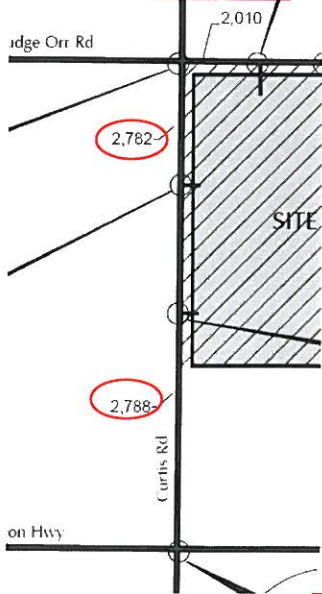

Long Term Total ADTs on Curtis Road

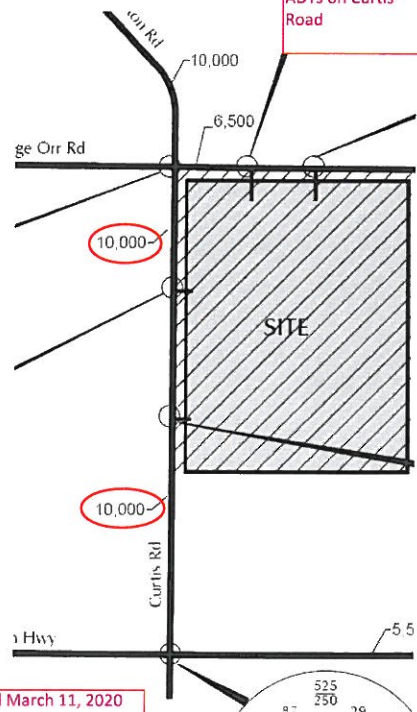

Clipped from Saddlehorn Ranch TIS dated March 11, 2020



PROPERTY DESCRIPTION:

PARCEL A:

A PARCEL OF LAND LOCATED IN SECTION 3, TOWNSHIP 13 SOUTH, RANGE 64 WEST OF THE 6TH P.M., EL PASO COUNTY, COLORADO MORE PARTICULARLY DESCRIBED AS FOLLOWS:

BEGINNING AT THE NORTHWEST CORNER OF SAID SECTION 3; THENCE S 89 DEGREES 21 MINUTES 33 SECONDS E, ALONG THE NORTH LINE OF SAID SECTION 3, 5275.27 FEET TO THE NORTHEAST CORNER THEREOF; THENCE S 00 DEGREES 04 MINUTES 45 SECONDS E, ALONG THE EAST LINE OF SAID SECTION 3, 1841.19 FEET; THENCE N 89 DEGREES 49 MINUTES 04 SECONDS W, 5280.38 FEET TO A POINT ON THE WEST LINE OF SAID SECTION 3; THENCE N 00 DEGREES 05 MINUTES 14 SECONDS E, ALONG SAID WEST LINE, 1883.39 FEET TO THE POINT OF BEGINNING.

EXCEPT THOSE PORTIONS CONVEYED TO EL PASO COUNTY BY AND THROUGH THE BOARD OF COUNTY COMMISSIONERS OF EL PASO COUNTY, COLORADO, IN SPECIAL WARRANTY DEEDS RECORDED JANUARY 29, 2015 AT RECEPTION NO. 215008985 AND RECEPTION NO. 215008986.

PARCEL B:

A PARCEL OF LAND LOCATED IN SECTION 3, TOWNSHIP 13 SOUTH, RANGE 64 WEST OF THE 6TH P.M., EL PASO COUNTY, COLORADO MORE PARTICULARLY DESCRIBED AS FOLLOWS:

COMMENCING AT THE SOUTHWEST CORNER OF SAID SECTION 3; THENCE N 00 DEGREES 05 MINUTES 14 SECONDS E, ALONG THE WEST LINE OF SAID SECTION 3, 1974.75 FEET TO THE POINT OF BEGINNING; THENCE CONTINUING ALONG SAID WEST LINE, N 00 DEGREES 05 MINUTES 14 SECONDS E, 1649.14 FEET; THENCE S 89 DEGREES 49 MINUTES 04 SECONDS E, 5280.38 FEET TO A POINT ON THE EAST LINE OF SAID SECTION 3; THENCE S 00 DEGREES 04 MINUTES 45 SECONDS E, ALONG SAID EAST LINE, 1649.15 FEET; THENCE N 89 DEGREES 49 MINUTES 04 SECONDS W, 5285.17 FEET TO THE POINT OF BEGINNING.

PARCEL C:

A PARCEL OF LAND LOCATED IN SECTION 3 AND SECTION 10, TOWNSHIP 13 SOUTH, RANGE 64 WEST, OF THE 6TH P.M., EL PASO COUNTY, COLORADO, MORE PARTICULARLY DESCRIBED AS FOLLOWS:

BEGINNING AT THE SOUTHWEST CORNER OF SAID SECTION 3; THENCE N 00 DEGREES 05 MINUTES 14 SECONDS E, ALONG THE WEST LINE OF SAID SECTION 3, 327.11 FEET; THENCE S 89 DEGREES 49 MINUTES 04 SECONDS E, 5289.95 FEET TO A POINT ON THE EAST LINE OF SAID SECTION 3; THENCE S 00 DEGREES 04 MINUTES 45 SECONDS E, ALONG SAID EAST LINE, 327.11 FEET TO THE SOUTHEAST CORNER OF SAID SECTION 3; THENCE S 00 DEGREES 57 MINUTES 38 SECONDS W, ALONG THE EAST LINE OF SAID SECTION 10, 1320.52 FEET TO THE SOUTHEAST CORNER OF THE

NORTH HALF OF THE NORTH HALF OF SAID SECTION 10; THENCE N 89 DEGREES 48 MINUTES 49 SECONDS W, ALONG THE SOUTH LINE OF SAID NORTH HALF OF THE NORTH HALF OF SAID SECTION 10, 5285.51 FEET TO THE SOUTHWEST CORNER THEREOF; THENCE N 00 DEGREES 43 MINUTES 38" SECONDS E, ALONG THE WEST LINE OF SAID SECTION 10, 1320.06 FEET TO THE POINT OF BEGINNING.

Per the Commitment for Title Insurance, issued by Westcor Land Title Insurance Company, Commitment No. 56676ECS, dated August 2, 2018.

PARCEL 21:

A PORTION OF THE SOUTH HALF OF SECTION 3, TOWNSHIP 13 SOUTH, RANGE 64 WEST OF THE 6TH PRINCIPAL MERIDIAN, COUNTY OF EL PASO, STATE OF COLORADO, BEING MORE PARTICULARLY DESCRIBED AS FOLLOWS:

COMMENCING AT THE NORTHEAST CORNER OF SAID SECTION 3; THENCE ALONG THE EAST LINE OF SAID SECTION 3, S00°42'25"E (BEARINGS ARE RELATIVE TO THE NORTH LINE OF SECTION 3, BEING MONUMENTED AT THE WESTERLY END BY A FOUND NO.6 REBAR WITH A 3-1/4" ALUMINUM CAP IN A VAULT, STAMPED "PLS 17496", AND AT THE EASTERLY END BY A FOUND NO. 6 REBAR WITH 3-1/2" ALUMINUM CAP IN A VAULT, STAMPED "LS 17496", AND MEASURED TO BEAR S89°59'26"E, A DISTANCE OF 5275.03 FEET), A DISTANCE OF 3490.37 FEET, TO THE SOUTHEAST CORNER OF THAT PARCEL DESCRIBED IN THE QUIT CLAIM DEED RECORDED AT RECEPTION NO. 213021177, IN THE OFFICIAL RECORDS OF EL PASO COUNTY; SAID CORNER ALSO BEING THE POINT OF BEGINNING; THENCE S00°42'25"E, CONTINUING ALONG THE WEST LINE OF THAT PARCEL DESCRIBED IN THE QUIT CLAIM DEED RECORDED AT RECEPTION NO.213113100, IN SAID OFFICIAL RECORDS, A DISTANCE OF 1647.65 FEET, TO THE NORTHEAST CORNER OF THAT PARCEL DESCRIBED IN THE QUIT CLAIM DEED RECORDED AT RECEPTION NO. 213043391, IN SAID OFFICIAL RECORDS; THENCE S89°33'10"W, ALONG THE NORTH LINE OF SAID PARCEL, A DISTANCE OF 5289.71 FEET, TO A POINT LYING ON THE WEST LINE OF SAID SECTION 3; THENCE ALONG SAID WEST LINE, N00°32'28"W, A DISTANCE OF 1645.40 FEET, TO THE SOUTHWEST CORNER OF SAID PARCEL, RECORDED AT RECEPTION NO. 213021177, IN SAID OFFICIAL RECORDS; THENCE N89°31'43"E, ALONG THE SOUTH LINE OF SAID PARCEL, A DISTANCE OF 5284.95 FEET, TO THE POINT OF BEGINNING.

Per the Commitment for Title Insurance, issued by Land Title Guarantee Company, Order No. SC55073032, dated October 1, 2018.

Being more particularly described by metes and bounds as follows:

COMMENCING at the Northeast Corner of Section 3, Township 13 South, Range 64 West of the 6th Principal Meridian; thence along the east line of said Section 3, S00°42'27"E (Basis of bearings is the North line of Section 3, Township 13 South, Range 64 West of the 6th Principal Meridian, monumented at the West end by a No. 6 Rebar with a 3-1/4" aluminum cap, properly marked, in a monument box, "PLS 17496" and at the East end by a No. 6 rebar with a 3-1/2" aluminum cap, properly marked, in a monument box, "PLS 17496", having a measured bearing and distance of S89°59'23"E, 5275.26'. Bearings are relative to Colorado State Plane Central Zone (0502)), a distance of 30.00 feet, to the **POINT OF BEGINNING**; thence continuing along

said east line, S00°42'27"E, a distance of 5,435.28 feet, to the Southeast Corner of said Section 3, said point also being the Northeast Corner of Section 10, Township 13 South, Range 64 West of the 6th Principal Meridian; thence along the east line of the North 1/2 of the North 1/2 of said Section 10, S00°19'54"W, a distance of 1,320.51 feet, to the North 1/16th Corner of said Section 10; thence leaving said east line and along the south line of the North 1/2 of the North 1/2 of said Section 10, S89°34'02"W, a distance of 2,642.78 feet, to the North-Center-Center 1/16th Corner of said Section 10; thence continuing along said south line, S89°34'07"W, a distance of 2,612.73 feet, to a point that is 30.00 feet distant from the North 1/16th Corner of said Section 10, said point also being a point on the east right-of-way line of Curtis Road; thence along said east right-of-way line and 30.00 feet parallel to the west line of said North 1/2 of the North 1/2 of said Section 10, N00°05'54"E, a distance of 1,319.14 feet, to a point that is 30.00 distant to the Northwest Corner of said Section 10, also being the Southwest corner of said Section 3; thence continuing along said east right-of-way line, along the following four (4) courses:

1. N00°32'28"W, a distance of 4,608.42 feet;
2. N89°27'32"E, a distance of 19.98 feet;
3. N00°32'28"W, a distance of 820.00 feet;
4. N44°46'13"E, a distance of 40.00 feet,

to a point on the south right-of-way line of Judge Orr Road, thence along said south right-of-way line, along the following three (3) courses:

1. S89°59'23"E, a distance of 822.24 feet;
2. N00°00'37"E, a distance of 20.00 feet;
3. S89°59'23"E, a distance of 4,374.49 feet,

to the **POINT OF BEGINNING**.

Containing 35,565,654 S.F. or 816.475 acres, more or less.

Approved Deviation - Judge Orr Road





Planning and Community
Development Department
2880 International Circle
Colorado Springs, Colorado 80910
Phone: 719.520.6300
Fax: 719.520.6695
Website www.elpasoco.com

DEVIATION REQUEST AND DECISION FORM

Updated: 6/26/2019

PROJECT INFORMATION

Project Name : Saddlehorn Ranch
 Schedule No.(s) : 4300000561, 4400000562, 4300000556
 Legal Description : SEE ATTACHED – Exhibit D

APPLICANT INFORMATION

Company : WILLIAM GUMAN & ASSOCIATES
 Name : BILL GUMAN
 Owner Consultant Contractor
 Mailing Address : 731 NORTH WEBER STREET, SUITE 10, COLORADO SPRINGS, COLORADO, 80903

 Phone Number : (719) 633-9700
 FAX Number : N/A
 Email Address : BILL@GUMAN.NET

ENGINEER INFORMATION

Company : JR ENGINEERING
 Name : MIKE BRAMLETT Colorado P.E. Number : 32314
 Mailing Address : 5475 TECH CENTER DRIVE, SUITE 235, COLORADO SPRINGS, COLORADO 80919

 Phone Number : 719-593-2593
 FAX Number : N/A
 Email Address : MBRAMLETT@JRENGINEERING.COM

OWNER, APPLICANT, AND ENGINEER DECLARATION

To the best of my knowledge, the information on this application and all additional or supplemental documentation is true, factual and complete. I am fully aware that any misrepresentation of any information on this application may be grounds for denial. I have familiarized myself with the rules, regulations and procedures with respect to preparing and filing this application. I also understand that an incorrect submittal will be cause to have the project removed from the agenda of the Planning Commission, Board of County Commissioners and/or Board of Adjustment or delay review until corrections are made, and that any approval of this application is based on the representations made in the application and may be revoked on any breach of representation or condition(s) of approval.

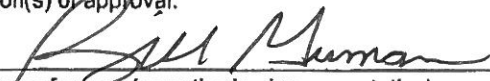
 Signature of owner (or authorized representative)

04-SEP-2020
 Date

Engineer's Seal, Signature
 And Date of Signature





DEVIATION REQUEST (Attach diagrams, figures, and other documentation to clarify request)

A deviation from the standards of or in Section **ECM section 2.2.4 Roadway Functional Classifications** of the Engineering Criteria Manual (ECM) is requested for the Judge Orr Road cross section.

Identify the specific ECM standard which a deviation is requested:

The 824 acre Curtis Road Development Traffic Impact Analysis indicates Judge Orr Road is classified as a "4 Lane Minor Arterial" in the El Paso County 2040 Major Transportation Corridors Plan. The ECM currently has no standard cross section for a 4 lane minor arterial. It is assumed that a 4 lane minor arterial (rural) cross section would add a 12 ft travel lane in each direction to Figure 2-5 Typical Rural Minor Arterial Cross Section (two lane). See Exhibit A

State the reason for the requested deviation:

The purpose of this deviation is to document the cross-section and ROW dedication necessary to be shown on the preliminary plan.

Explain the proposed alternative and compare to the ECM standards (May provide applicable regional or national standards used as basis):

See Exhibit A for available ECM cross sections and See Exhibit B for the existing Judge Orr Road cross section.

The applicant will provide a 90 foot half right of way on all plats adjacent to Judge Orr Road consistent with the anticipated ROW needs identified in the MTCP.

The applicant is also subject to the El Paso County Road Impact Fee per resolution No. 19-471 and is therefore paying its fair and equitable share of necessary improvements identified in the MTCP.

LIMITS OF CONSIDERATION

(At least one of the conditions listed below must be met for this deviation request to be considered.)

- The ECM standard is inapplicable to the particular situation.
- Topography, right-of-way, or other geographical conditions or impediments impose an undue hardship and an equivalent alternative that can accomplish the same design objective is available and does not compromise public safety or accessibility.
- A change to a standard is required to address a specific design or construction problem, and if not modified, the standard will impose an undue hardship on the applicant with little or no material benefit to the public.

Provide justification:

The MTCP minor 4-lane arterial cross-section is not provided in the Engineering Criteria Manual.

CRITERIA FOR APPROVAL

Per ECM section 5.8.7 the request for a deviation may be considered if the request is **not based exclusively on financial considerations**. The deviation must not be detrimental to public safety or surrounding property. The applicant must include supporting information demonstrating compliance with **all of the following criteria**:

The deviation will achieve the intended result with a comparable or superior design and quality of improvement.

This request is not based on financial considerations. There is not enough ROW to accommodate a 4-lane minor arterial street section. Per Table 10 of the Traffic Impact Study, Judge Orr is MTCP Project No. C15 and applicant will pay into the Fee program traffic impact fees to participate in funding the project. See Exhibit C

The deviation will not adversely affect safety or operations.

The deviation will not adversely affect safety or operations as Judge Orr Road is an existing, operable roadway
As final plats take access to Judge Orr Road the each intersection will be designed to accommodate the requirements listed in Table 10 Roadway Improvements of the Traffic Impact Study.

The deviation will not adversely affect maintenance and its associated cost.

Maintenance of the roadways will not be impacted as the existing roadway will be left in its existing condition at this time.

The deviation will not adversely affect aesthetic appearance.

The deviation has no bearing on the aesthetic appearance.

The deviation meets the design intent and purpose of the ECM standards.

Yes, the deviation meets the design intent and purpose of the ECM standards. Once ROW can be obtained, the road can be built out to the full 4-lane minor arterial street section.

The deviation meets the control measure requirements of Part I.E.3 and Part I.E.4 of the County's MS4 permit, as applicable.

Yes, the deviation meets the control measure requirements of Part I.E.3 and Part I.E.4 of the County's MS4 permit, this project is proposing Water Quality facilities as required by the criteria.

REVIEW AND RECOMMENDATION:

Approved by the ECM Administrator

This request has been determined to have met the criteria for approval. A deviation from Section 2.2.4 of the ECM is hereby granted based on the justification provided.

┌	APPROVED	┐
	Engineering Department	
	<i>01/05/2021 6:55:29 PM</i>	
	<i>dsdnijkamp</i>	
L	EPC Planning & Community Development Department	J

Denied by the ECM Administrator

This request has been determined not to have met criteria for approval. A deviation from Section _____ of the ECM is hereby denied.

┌		┐
L		J

ECM ADMINISTRATOR COMMENTS/CONDITIONS:

Exhibit A

Figure 2-4. Typical Rural Principal Arterial Partial Cross-Section (4 Lane)

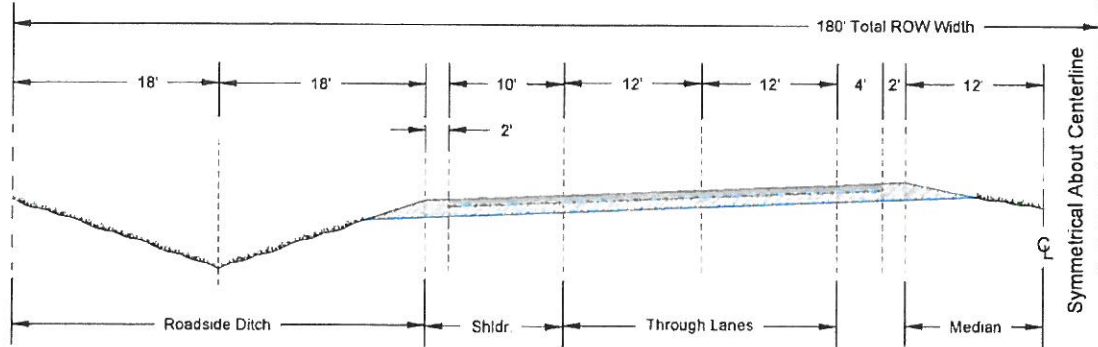

3. Minor Arterial

Minor arterials serve high-speed and high-volume traffic over medium distances, or are anticipated to serve this kind of traffic within a twenty-year period. Access is restricted through prescribed distances between intersections, use of medians, and no full movement parcel access (See Figure 2-5). Minor arterial status is assigned to rural roadways where the probability of significant travel demand in the future is high. Rights-of-way, easements, setbacks, and access limitations shall be pursued through the land development process on properties adjacent to minor arterials.

Figure 2-5. Typical Rural Minor Arterial Partial Cross Section

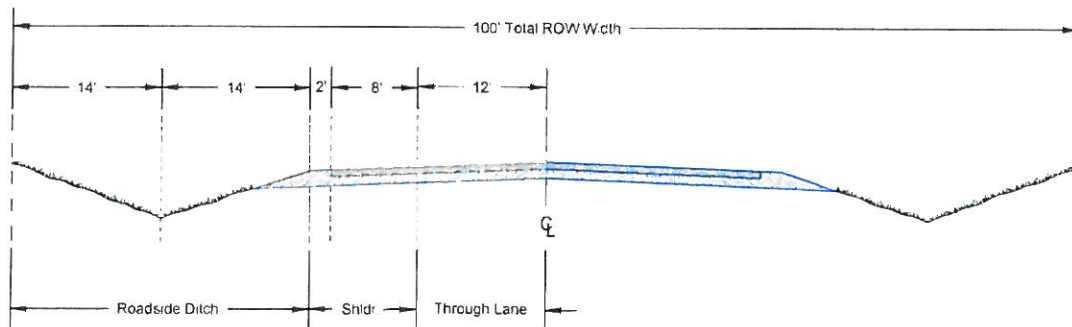

4. Major Collector

Major collectors serve as links between local access and arterial facilities over medium-to-long distances. Major collectors are managed to

Exhibit A - cont

Table 2-3. Roadway Design Criteria Continued

Criteria	Concern	Guideline
Minimize Space Devoted to Road Use	It is desirable to minimize local road mileage, thereby reducing construction and maintenance costs, as well as permitting the most efficient use of land. Roads should also have an appearance commensurate with their function.	Roads should be designed to complement local character.
Relate Road to Topography	Local roads are more attractive and economical if constructed to closely adhere to topography (minimize cut and fill).	The important role that roads play in the overall storm drainage system can be enhanced by closely following existing topography.
Layout Road to Achieve Optimum Subdivision of Land	The arrangement of roads should allow for economical and practical patterns, shapes, and sizes of adjacent lots. Roads as a function of land use must not unduly hinder the development of land.	Distances between roads, number of roads, and related elements all have a bearing on efficient subdivision of an area. Access to adjoining properties should also be encouraged.

2.3.2 Design Standards by Functional Classification

Section 2.2.4 of these standards identifies the Roadway Functional Classifications recognized and used by the County. Table 2-4 through Table 2-7 summarize many of the minimum roadway design standards by category and functional classification. Detailed road Standard Drawings are provided in Appendix F.

Table 2-4. Roadway Design Standards for Rural Expressways and Arterials

Criteria	Expressways		Arterials		Minor
	6 Lane	4 Lane	6 Lane Principal	4 Lane Principal	
Design Speed / Posted Speed (MPH)	70 / 65	70 / 65	70 / 65	70 / 65	60 / 55
Clear Zone	34'	34'	34'	34'	30'
Minimum Centerline Curve Radius	2,050 ¹	2,050 ¹	2,050 ¹	2,050 ¹	1,505 ¹
Number of Through Lanes	6	4	6	4	2
Lane Width	12'	12'	12'	12'	12'
Right-of-Way	210'	180'	210'	180'	100'
Paved Width	56 ²	38 ²	56 ²	38 ²	40'
Median Width	24'	24'	24'	24'	n/a
Outside Shoulder Width (paved/gravel)	12'(10'/2')	12'(10'/2')	12'(10'/2')	12'(10'/2')	10'(8'/2')
Inside Shoulder Width (paved/gravel)	12'(10'/2')	6'(4'/2')	12'(10'/2')	6'(4'/2')	n/a
Design ADT		48,000		40,000	10,000
Design Vehicle	WB-67	WB-67	WB-67	WB-67	WB-67
Access Permitted	No	No	No	No	No
Access Spacing	n/a	n/a	n/a	n/a	n/a
Intersection Spacing	1 mile	1 mile	½ mile	½ mile	¼ mile
Parking Permitted	No	No	No	No	No
Minimum Flowline Grade	1%	1%	1%	1%	1%

Exhibit B

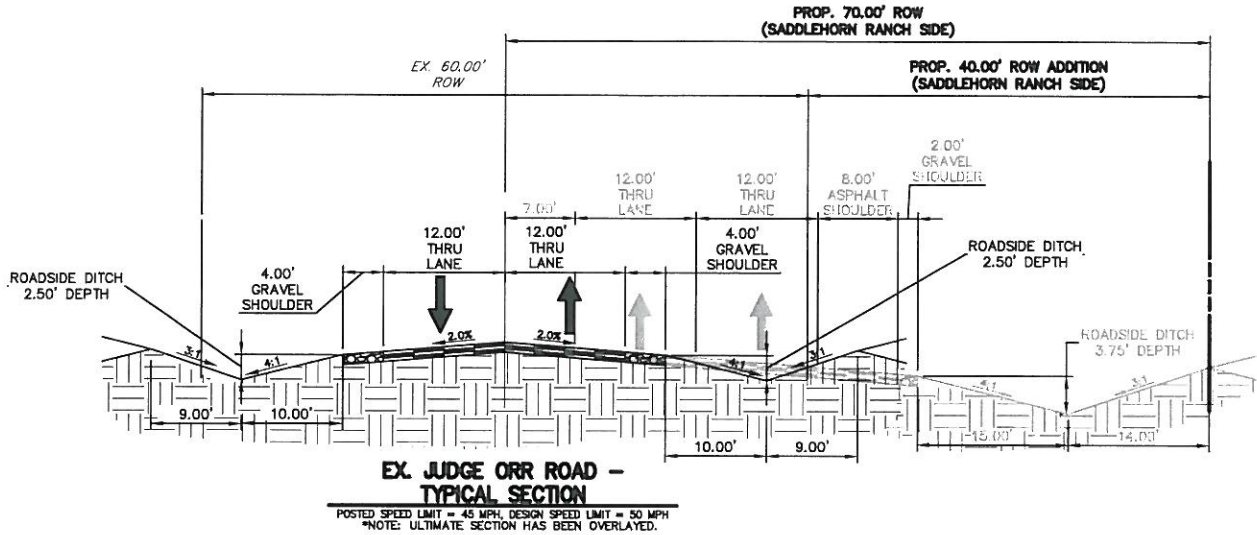

SADDLEHORN RANCH
 DEVIATION REQUEST
 EX. JUDGE ORR ROAD
 2514200
 5/4/20
 SHEET 1 OF 1

 **J·R ENGINEERING**
 A Westrian Company

Centennial 303-740-9393 • Colorado Springs 719-593-2593
 Fort Collins 970-491-9888 • www.jrengineering.com

Exhibit C

Table 10: Roadway Improvements for Saddlehorn Ranch			
Offsite Intersections			
Item #	Improvement	Timing	Responsibility
US Highway 24/Judge Orr Intersection			
1.1	Realignment of Judge Orr Road at US Highway 24 per CDOT Hwy 24 PEL Study	Future (the PEL study identified this as high priority project with a time frame of less than 5 years)	CDOT
1.2	Southwest-bound right-turn deceleration lane on US 24 approaching Judge Orr Road	As required by other development(s) or with realignment of US 24/ Judge Orr	CDOT or by others
1.3	Construct southwest-bound right-turn acceleration lane on US 24 at Judge Orr Road	As required by other development(s) or with realignment of US 24/ Judge Orr	CDOT or by others
1.4	Eastbound left-turn lane on Judge Orr Road approaching US 24	With realignment of US 24/ Judge Orr	CDOT
1.5	Westbound dual left-turn lanes on Judge Orr Road approaching US 24	With realignment of US 24/ Judge Orr	CDOT
1.6	Northeast-bound right-turn deceleration lane on US 24 approaching Judge Orr Road	With realignment of US 24/ Judge Orr	CDOT
1.7	Eastbound right-turn deceleration lane on Judge Orr Road approaching US 24	As required by other development(s) or with realignment of US 24/ Judge Orr	CDOT or by others
US Highway 24/Stapleton Intersection			
2.1	Signalize the intersection	Once warrants are met	CDOT is collecting escrow from area developments impacting this intersection with each subdivision filing
Curtis Road/Falcon Highway			
3.1	Lengthen eastbound left-turn lane to ECM standards on Falcon Highway approaching Curtis Road	Currently warranted by ECM	Escrow for pro-rata share of improvement or construction at the time of Phase 2 development (fee program credit per fee program provisions)
3.2	Long Term: In the case of a future signalized intersection - Construct southbound right-turn deceleration lane on Curtis Road approaching Falcon Highway	Upon Signalization	Escrow for pro-rata share of improvement or construction if warranted at the time of development (fee program credit per fee program provisions)
3.2	Long Term: Reconstruct intersection as a modern roundabout (or signalize the intersection)	Once LOS of AWSC drops below acceptable levels (roundabout); or once signal warrants are met (for conversion to a signal or roundabout)	El Paso County -- This intersection will be fee-program eligible for a signal/roundabout and applicant will pay fee program traffic impact fees
Adjacent County Arterial Roadway ROW Requirements			
4.1	Judge Orr Right-of-Way Dedication - 4 Lane Minor Arterial, Rural 130' to 150' estimated right-of-way dedication' (Note: 4-lane Rural Principal is 180')	Shown in 2040 MTCP	Applicant
4.2	Judge Orr - 4 Lane Minor Arterial - Beyond above dedication, no additional right-of-way preservation needed	Shown in 2060 Corridor Pres Plan	Applicant
4.3	Curtis Road - 2 Lane Rural Principal Arterial 130' to 150' estimated right-of-way dedication (Note: 4-lane Rural Principal is 180')	Shown in 2040 MTCP	Applicant
4.4	Curtis Road - 4 Lane Rural Principal Arterial 180' right-of-way preservation	Shown in 2060 Corridor Pres Plan	Applicant
Roadway Segment Improvements			
5.1	Falcon Highway - Upgrade to Two-Lane Rural Minor Arterial	Shown in 2040 MTCP	MTCP Project No. U5; Details TBD; applicant will pay fee program traffic impact fees
5.2	Judge Orr Road - Widen to Four Lane Rural Minor Arterial	Shown in 2040 MTCP	MTCP Project No. C15; Details TBD; - applicant will pay fee program traffic impact fees.
5.3	Curtis Road - Upgrade to Two-Lane Rural Principal Arterial	Shown in 2040 MTCP	MTCP Project No. U1; Applicant per rezone condition of approval, potentially subject to fee program credit.
Internal Subdivision Roadways			
6.1	Construct internal streets to County Rural Local Standards	As development occurs and as needed for access	Applicant
Adjacent Intersection and Access Intersections			
Item #	Improvement	Timing	Responsibility
Judge Orr/Curtis Road Intersection			
7.1	Westbound right-turn deceleration lane	Once peak hour westbound right turn volume exceeds 50 vehicles per hour.	Escrow for improvement or construction if warranted at the time of development (fee program credit per fee program provisions)
7.2	Eastbound right-turn deceleration lane	Currently warranted by ECM	Escrow for improvement or construction at the time of Phase 2 development (fee program credit per fee program provisions)
7.3	Potentially sign for all way stop sign control (AWSC)	Once warrants for AWSC are met	El Paso County
7.4	Long Term: Reconstruct intersection as a modern roundabout (or signalize the intersection)	Once LOS of AWSC drops below acceptable levels (roundabout); or once signal warrants are met (for conversion to a signal or roundabout)	El Paso County, This intersection will be fee-program eligible for a signal/roundabout and applicant will pay fee program traffic impact fees.
7.5	Long Term: In the case of a future signalized intersection - lengthening of northbound and southbound left-turn deceleration lanes.	As needed based on future speed limit and turning volume/stacking length criteria.	Escrow for improvement or construction if warranted at the time of development (fee program credit per fee program provisions)
Judge Orr/Barrosito Trail			
8.1	No Auxiliary Turn Lanes Required	-	-
Judge Orr/Del Cambre Trail			
9.1	No Auxiliary Turn Lanes Required	-	-
Curtis Road/Oscuro Trail			
10.1	Short Term No Auxiliary Turn Lanes Required	-	-
10.2	Long Term Construct northbound right-turn deceleration lane on Curtis Rd approaching the site access	With Phase 2/3 site development	Applicant
Curtis Road/North Site Access			
11.1	Short Term No Auxiliary Turn Lanes Required	-	-
11.2	Long Term Construct southbound left-turn deceleration lane on Curtis Rd approaching the site access	With Phase 2/3 site development	Applicant
11.3	Long Term Construct northbound right-turn deceleration lane on Curtis Rd approaching the site access	With Phase 2/3 site development	Applicant

Source: LSC Transportation Consultants, Inc.

PROPERTY DESCRIPTION: **Exhibit D**

PARCEL A:

A PARCEL OF LAND LOCATED IN SECTION 3, TOWNSHIP 13 SOUTH, RANGE 64 WEST OF THE 6TH P.M., EL PASO COUNTY, COLORADO MORE PARTICULARLY DESCRIBED AS FOLLOWS:

BEGINNING AT THE NORTHWEST CORNER OF SAID SECTION 3; THENCE S 89 DEGREES 21 MINUTES 33 SECONDS E, ALONG THE NORTH LINE OF SAID SECTION 3, 5275.27 FEET TO THE NORTHEAST CORNER THEREOF; THENCE S 00 DEGREES 04 MINUTES 45 SECONDS E, ALONG THE EAST LINE OF SAID SECTION 3, 1841.19 FEET; THENCE N 89 DEGREES 49 MINUTES 04 SECONDS W, 5280.38 FEET TO A POINT ON THE WEST LINE OF SAID SECTION 3; THENCE N 00 DEGREES 05 MINUTES 14 SECONDS E, ALONG SAID WEST LINE, 1883.39 FEET TO THE POINT OF BEGINNING.

EXCEPT THOSE PORTIONS CONVEYED TO EL PASO COUNTY BY AND THROUGH THE BOARD OF COUNTY COMMISSIONERS OF EL PASO COUNTY, COLORADO, IN SPECIAL WARRANTY DEEDS RECORDED JANUARY 29, 2015 AT RECEPTION NO. 215008985 AND RECEPTION NO. 215008986.

PARCEL B:

A PARCEL OF LAND LOCATED IN SECTION 3, TOWNSHIP 13 SOUTH, RANGE 64 WEST OF THE 6TH P.M., EL PASO COUNTY, COLORADO MORE PARTICULARLY DESCRIBED AS FOLLOWS:

COMMENCING AT THE SOUTHWEST CORNER OF SAID SECTION 3; THENCE N 00 DEGREES 05 MINUTES 14 SECONDS E, ALONG THE WEST LINE OF SAID SECTION 3, 1974.75 FEET TO THE POINT OF BEGINNING; THENCE CONTINUING ALONG SAID WEST LINE, N 00 DEGREES 05 MINUTES 14 SECONDS E, 1649.14 FEET; THENCE S 89 DEGREES 49 MINUTES 04 SECONDS E, 5280.38 FEET TO A POINT ON THE EAST LINE OF SAID SECTION 3; THENCE S 00 DEGREES 04 MINUTES 45 SECONDS E, ALONG SAID EAST LINE, 1649.15 FEET; THENCE N 89 DEGREES 49 MINUTES 04 SECONDS W, 5285.17 FEET TO THE POINT OF BEGINNING.

PARCEL C:

A PARCEL OF LAND LOCATED IN SECTION 3 AND SECTION 10, TOWNSHIP 13 SOUTH, RANGE 64 WEST, OF THE 6TH P.M., EL PASO COUNTY, COLORADO, MORE PARTICULARLY DESCRIBED AS FOLLOWS:

BEGINNING AT THE SOUTHWEST CORNER OF SAID SECTION 3; THENCE N 00 DEGREES 05 MINUTES 14 SECONDS E, ALONG THE WEST LINE OF SAID SECTION 3, 327.11 FEET; THENCE S 89 DEGREES 49 MINUTES 04 SECONDS E, 5289.95 FEET TO A POINT ON THE EAST LINE OF SAID SECTION 3; THENCE S 00 DEGREES 04 MINUTES 45 SECONDS E, ALONG SAID EAST LINE, 327.11 FEET TO THE SOUTHEAST CORNER OF SAID SECTION 3; THENCE S 00 DEGREES 57 MINUTES 38 SECONDS W, ALONG THE EAST LINE OF SAID SECTION 10, 1320.52 FEET TO THE SOUTHEAST CORNER OF THE

NORTH HALF OF THE NORTH HALF OF SAID SECTION 10; THENCE N 89 DEGREES 48 MINUTES 49 SECONDS W, ALONG THE SOUTH LINE OF SAID NORTH HALF OF THE NORTH HALF OF SAID SECTION 10, 5285.51 FEET TO THE SOUTHWEST CORNER THEREOF; THENCE N 00 DEGREES 43 MINUTES 38" SECONDS E, ALONG THE WEST LINE OF SAID SECTION 10, 1320.06 FEET TO THE POINT OF BEGINNING.

Per the Commitment for Title Insurance, issued by Westcor Land Title Insurance Company, Commitment No. 56676ECS, dated August 2, 2018.

PARCEL 21:

A PORTION OF THE SOUTH HALF OF SECTION 3, TOWNSHIP 13 SOUTH, RANGE 64 WEST OF THE 6TH PRINCIPAL MERIDIAN, COUNTY OF EL PASO, STATE OF COLORADO, BEING MORE PARTICULARLY DESCRIBED AS FOLLOWS:

COMMENCING AT THE NORTHEAST CORNER OF SAID SECTION 3; THENCE ALONG THE EAST LINE OF SAID SECTION 3, S00°42'25"E (BEARINGS ARE RELATIVE TO THE NORTH LINE OF SECTION 3, BEING MONUMENTED AT THE WESTERLY END BY A FOUND NO.6 REBAR WITH A 3-1/4" ALUMINUM CAP IN A VAULT, STAMPED "PLS 17496", AND AT THE EASTERLY END BY A FOUND NO. 6 REBAR WITH 3-1/2" ALUMINUM CAP IN A VAULT, STAMPED "LS 17496", AND MEASURED TO BEAR S89°59'26"E, A DISTANCE OF 5275.03 FEET), A DISTANCE OF 3490.37 FEET, TO THE SOUTHEAST CORNER OF THAT PARCEL DESCRIBED IN THE QUIT CLAIM DEED RECORDED AT RECEPTION NO. 213021177, IN THE OFFICIAL RECORDS OF EL PASO COUNTY; SAID CORNER ALSO BEING THE POINT OF BEGINNING; THENCE S00°42'25"E, CONTINUING ALONG THE WEST LINE OF THAT PARCEL DESCRIBED IN THE QUIT CLAIM DEED RECORDED AT RECEPTION NO.213113100, IN SAID OFFICIAL RECORDS, A DISTANCE OF 1647.65 FEET, TO THE NORTHEAST CORNER OF THAT PARCEL DESCRIBED IN THE QUIT CLAIM DEED RECORDED AT RECEPTION NO. 213043391, IN SAID OFFICIAL RECORDS; THENCE S89°33'10"W, ALONG THE NORTH LINE OF SAID PARCEL, A DISTANCE OF 5289.71 FEET, TO A POINT LYING ON THE WEST LINE OF SAID SECTION 3; THENCE ALONG SAID WEST LINE, N00°32'28"W, A DISTANCE OF 1645.40 FEET, TO THE SOUTHWEST CORNER OF SAID PARCEL, RECORDED AT RECEPTION NO. 213021177, IN SAID OFFICIAL RECORDS; THENCE N89°31'43"E, ALONG THE SOUTH LINE OF SAID PARCEL, A DISTANCE OF 5284.95 FEET, TO THE POINT OF BEGINNING.

Per the Commitment for Title Insurance, issued by Land Title Guarantee Company, Order No. SC55073032, dated October 1, 2018.

Being more particularly described by metes and bounds as follows:

COMMENCING at the Northeast Corner of Section 3, Township 13 South, Range 64 West of the 6th Principal Meridian; thence along the east line of said Section 3, S00°42'27"E (Basis of bearings is the North line of Section 3, Township 13 South, Range 64 West of the 6th Principal Meridian, monumented at the West end by a No. 6 Rebar with a 3-1/4" aluminum cap, properly marked, in a monument box, "PLS 17496" and at the East end by a No. 6 rebar with a 3-1/2" aluminum cap, properly marked, in a monument box, "PLS 17496", having a measured bearing and distance of S89°59'23"E, 5275.26'. Bearings are relative to Colorado State Plane Central Zone (0502)), a distance of 30.00 feet, to the **POINT OF BEGINNING**; thence continuing along

said east line, S00°42'27"E, a distance of 5,435.28 feet, to the Southeast Corner of said Section 3, said point also being the Northeast Corner of Section 10, Township 13 South, Range 64 West of the 6th Principal Meridian; thence along the east line of the North 1/2 of the North 1/2 of said Section 10, S00°19'54"W, a distance of 1,320.51 feet, to the North 1/16th Corner of said Section 10; thence leaving said east line and along the south line of the North 1/2 of the North 1/2 of said Section 10, S89°34'02"W, a distance of 2,642.78 feet, to the North-Center-Center 1/16th Corner of said Section 10; thence continuing along said south line, S89°34'07"W, a distance of 2,612.73 feet, to a point that is 30.00 feet distant from the North 1/16th Corner of said Section 10, said point also being a point on the east right-of-way line of Curtis Road; thence along said east right-of-way line and 30.00 feet parallel to the west line of said North 1/2 of the North 1/2 of said Section 10, N00°05'54"E, a distance of 1,319.14 feet, to a point that is 30.00 distant to the Northwest Corner of said Section 10, also being the Southwest corner of said Section 3; thence continuing along said east right-of-way line, along the following four (4) courses:

1. N00°32'28"W, a distance of 4,608.42 feet;
2. N89°27'32"E, a distance of 19.98 feet;
3. N00°32'28"W, a distance of 820.00 feet;
4. N44°46'13"E, a distance of 40.00 feet,

to a point on the south right-of-way line of Judge Orr Road, thence along said south right-of-way line, along the following three (3) courses:

1. S89°59'23"E, a distance of 822.24 feet;
2. N00°00'37"E, a distance of 20.00 feet;
3. S89°59'23"E, a distance of 4,374.49 feet,

to the **POINT OF BEGINNING**.

Containing 35,565,654 S.F. or 816.475 acres, more or less.