

Eagle HC 60M G2 315-335 Watt

MONO PERC HALF CELL MODULE

Positive power tolerance of 0~+3%

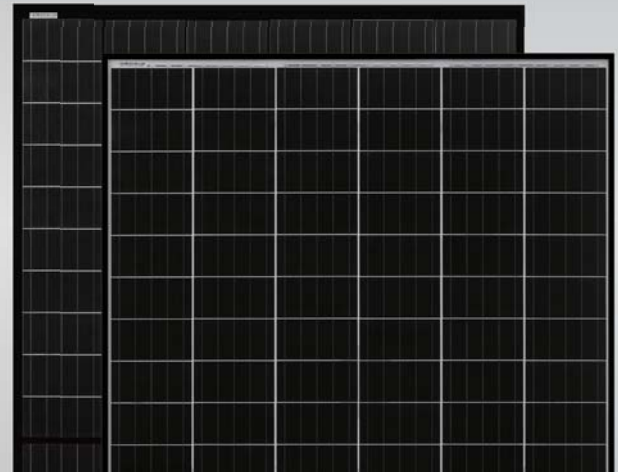

KEY FEATURES



Diamond Cell Technology

Uniquely designed high performance 5 busbar mono PERC half cell



Higher Module Power

Decrease in current loss yields higher module efficiency



Shade Tolerance

More shade tolerance due to twin arrays



PID FREE

Reinforced cell prevents potential induced degradation



Strength and Durability

Certified for high snow (5400Pa) and wind (2400 Pa) loads

- ISO9001:2008 Quality Standards
- ISO14001:2004 Environmental Standards
- OHSAS18001 Occupational Health & Safety Standards
- IEC61215, IEC61730 certified products
- UL1703 certified products

Nomenclature:

JKM335M-60HBL

Code	Cell	Code	Backsheet	Code	Cell
null	Full	null	White	null	Normal
H	Half	B	Black	L	Diamond



LINEAR PERFORMANCE WARRANTY

10 Year Product Warranty • 25 Year Linear Power Warranty

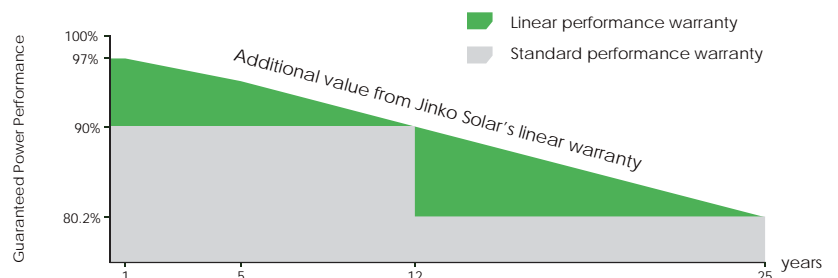

Engineering Drawings

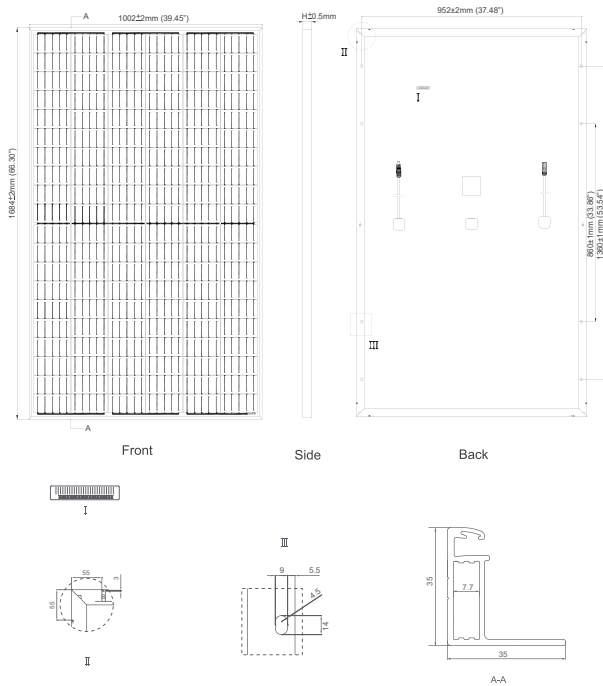

Packaging Configuration

(Two pallets = One stack)

30pcs/pallet, 60pcs/stack, 780pcs/40'HQ Container

Electrical Performance & Temperature Dependence

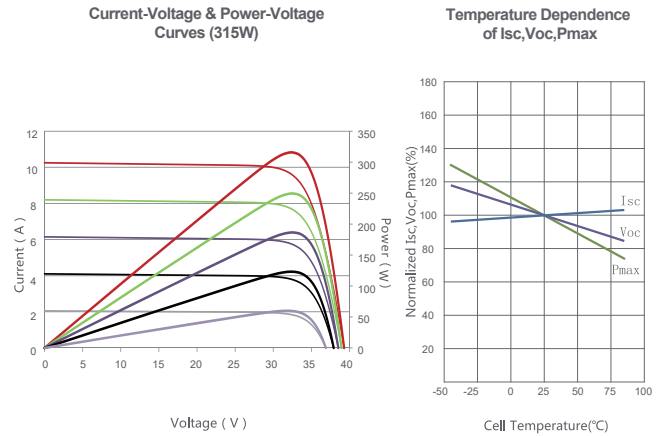

Mechanical Characteristics

Cell Type	Mono PERC Diamond Cell (158.75 x 158.75 mm)
No. of Half-cells	120 (6×20)
Dimensions	1684×1002×35mm (66.30×39.45×1.38 inch)
Weight	19.0 kg (41.9 lbs)
Front Glass	3.2mm, Anti-Reflection Coating, High Transmission, Low Iron, Tempered Glass
Frame	Anodized Aluminum Alloy
Junction Box	IP67 Rated
Output Cables	12AWG, Anode 1525mm (60.04 in), Cathode 1525mm (60.04 in) or Customized Length
Fire Type	Type 1

SPECIFICATIONS

Module Type	JKM315M-60HL		JKM320M-60HL		JKM325M-60HL		JKM330M-60HL		JKM335M-60HL	
	STC	NOCT	STC	NOCT	STC	NOCT	STC	NOCT	STC	NOCT
Maximum Power (Pmax)	315Wp	235Wp	320Wp	239Wp	325Wp	242Wp	330Wp	246Wp	335Wp	250Wp
Maximum Power Voltage (Vmp)	33.2V	31.2V	33.4V	31.4V	33.6V	31.6V	33.8V	31.8V	34.0V	32.0V
Maximum Power Current (Imp)	9.49A	7.56A	9.59A	7.62A	9.68A	7.66A	9.77A	7.74A	9.87A	7.82A
Open-circuit Voltage (Voc)	40.7V	37.6V	40.9V	37.8V	41.1V	38.0V	41.3V	38.2V	41.5V	38.4V
Short-circuit Current (Isc)	10.04A	8.33A	10.15A	8.44A	10.20A	8.54A	10.31A	8.65A	10.36A	8.74A
Module Efficiency STC (%)	18.67%		18.96%		19.26%		19.56%		19.85%	
Operating Temperature (°C)	-40°C~+85°C									
Maximum System Voltage	1000VDC(UL)/1000VDC(IEC)									
Maximum Series Fuse Rating	20A									
Power Tolerance	0~+3%									
Temperature Coefficients of Pmax	-0.36%/°C									
Temperature Coefficients of Voc	-0.28%/°C									
Temperature Coefficients of Isc	0.048%/°C									
Nominal Operating Cell Temperature (NOCT)	45±2°C									

STC: Irradiance 1000W/m² Cell Temperature 25°C AM=1.5

NOCT: Irradiance 800W/m² Ambient Temperature 20°C AM=1.5 Wind Speed 1m/s

* Power measurement tolerance: ± 3%

CAUTION: READ SAFETY AND INSTALLATION INSTRUCTIONS BEFORE USING THE PRODUCT.

© Jinko Solar Co., Ltd. All rights reserved. Specifications included in this datasheet are subject to change without notice.
JKM315-335M-60HL-A1-US

solar_{edge}

Single Phase Inverter with HD-Wave Technology for North America

SE3000H-US / SE3800H-US / SE5000H-US /
SE6000H-US / SE7600H-US / SE10000H-US / SE11400H-US

INVERTERS



Optimized installation with HD-Wave technology

- Specifically designed to work with power optimizers
- Record-breaking efficiency
- Fixed voltage inverter for longer strings
- Integrated arc fault protection and rapid shutdown for NEC 2014 and 2017, per article 690.11 and 690.12
- UL1741 SA certified, for CPUC Rule 21 grid compliance
- Extremely small
- High reliability without any electrolytic capacitors
- Built-in module-level monitoring
- Outdoor and indoor installation
- Optional: Revenue grade data, ANSI C12.20 Class 0.5 (0.5% accuracy)





Single Phase Inverter with HD-Wave Technology for North America

SE3000H-US / SE3800H-US / SE5000H-US /
SE6000H-US / SE7600H-US / SE10000H-US / SE11400H-US

	SE3000H-US	SE3800H-US	SE5000H-US	SE6000H-US	SE7600H-US	SE10000H-US	SE11400H-US		
OUTPUT									
Rated AC Power Output	3000	3800 @ 240V 3300 @ 208V	5000	6000 @ 240V 5000 @ 208V	7600	10000	11400	VA	
Max. AC Power Output	3000	3800 @ 240V 3300 @ 208V	5000	6000 @ 240V 5000 @ 208V	7600	10000	11400	VA	
AC Output Voltage Min.-Nom.-Max. (183 - 208 - 229)	-	3	-	3	-	-	-	Vac	
AC Output Voltage Min.-Nom.-Max. (211 - 240 - 264)	3	3	3	3	3	3	3	Vac	
AC Frequency (Nominal)					59.3 - 60 - 60.5 ⁽¹⁾			Hz	
Maximum Continuous Output Current 208V	-	16	-	24	-	-	-	A	
Maximum Continuous Output Current @240V	12.5	16	21	25	32	42	47.5	A	
GFDI Threshold					1			A	
Utility Monitoring, Islanding Protection, Country Configurable Thresholds					Yes				
INPUT									
Maximum DC Power @240V	4650	5900	7750	9300	11800	15500	17650	W	
Maximum DC Power @208V	-	5100	-	7750	-	-	-		
Transformer-less, Ungrounded					Yes				
Maximum Input Voltage					480			Vdc	
Nominal DC Input Voltage					380			Vdc	
Maximum Input Current 208V	-	9	-	13.5	-	-	-		
Maximum Input Current @240V	8.5	10.5	13.5	16.5	20	27	30.5	Adc	
Max. Input Short Circuit Current					45			Adc	
Reverse-Polarity Protection					Yes				
Ground-Fault Isolation Detection					600ka Sensitivity				
Maximum Inverter Efficiency	99			99.2				%	
CEC Weighted Efficiency					99			%	
Nighttime Power Consumption					< 2.5			W	
ADDITIONAL FEATURES									
Supported Communication Interfaces	RS485, Ethernet, ZigBee (optional), Cellular (optional)								
Revenue Grade Data, ANSI C12.20	Optional ⁽²⁾								
Rapid Shutdown - NEC 2014 and 2017 690.12	Automatic Rapid Shutdown upon AC Grid Disconnect								
STANDARD COMPLIANCE									
Safety	UL1741, UL1741 SA, UL1699B, CSA C22.2, Canadian AFCE according to T.I.L. M-07								
Grid Connection Standards	IEEE1547, Rule 21, Rule 14 (HI)								
Emissions	FCC Part 15 Class B								
INSTALLATION SPECIFICATIONS									
AC Output Conduit Size / AWG Range	3/4" minimum / 14-6 AWG				3/4" minimum / 14-4 AWG				
DC Input Conduit Size / # of Strings / AWG Range	3/4" minimum / 1-2 strings / 14-6 AWG				3/4" minimum / 1-3 strings / 14-6 AWG				
Dimensions with Safety Switch (HxWxD)	17.7 x 14.6 x 6.8 / 450 x 370 x 174				21.3 x 14.6 x 7.3 / 540 x 370 x 185				in / mm
Weight with Safety Switch	22 / 10	25.1 / 11.4	26.2 / 11.9					lb / kg	
Noise	< 25				< 50				dBA
Cooling	Natural Convection				Natural convection				
Operating Temperature Range	-13 to +140 / -25 to +60 ⁽³⁾ (-40°F / -40°C option) ⁽⁴⁾								
Protection Rating	NEMA 3R (Inverter with Safety Switch)								

⁽¹⁾ For other regional settings please contact SolarEdge support

⁽²⁾ Revenue grade inverter P/N: SExxxxH-US000NNC2

⁽³⁾ For power de-rating information refer to: <https://www.solaredge.com/sites/default/files/se-temperature-derating-note-na.pdf>

⁽⁴⁾ -40 version P/N: SExxxxH-US000NNU4





SolarEdge Power Optimizer

Module Add-On For North America

P320 / P370 / P400 / P405 / P505

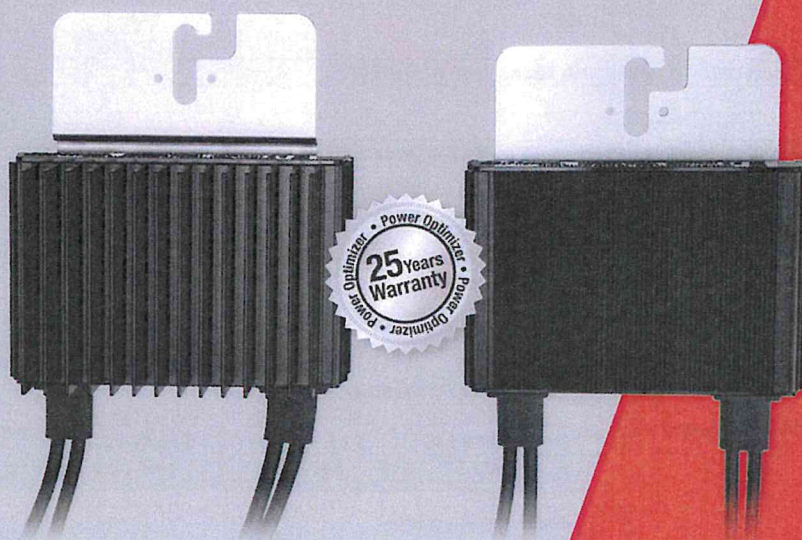

POWER OPTIMIZER

PV power optimization at the module-level

- Specifically designed to work with SolarEdge inverters
- Up to 25% more energy
- Superior efficiency (99.5%)
- Mitigates all types of module mismatch losses, from manufacturing tolerance to partial shading
- Flexible system design for maximum space utilization
- Fast installation with a single bolt
- Next generation maintenance with module-level monitoring
- Compliant with arc fault protection and rapid shutdown NEC requirements (when installed as part of the SolarEdge system)
- Module-level voltage shutdown for installer and firefighter safety



SolarEdge Power Optimizer

Module Add-On for North America

P320 / P370 / P400 / P405 / P505

OPTIMIZER MODEL (typical module compatibility)	P320 (for high-power 60-cell modules)	P370 (for higher-power 60 and 72-cell modules)	P400 (for 72 & 96-cell modules)	P405 (for thin film modules)	P505 (for higher current modules)	
INPUT						
Rated Input DC Power ⁽¹⁾	320	370	400	405	505	W
Absolute Maximum Input Voltage (Voc at lowest temperature)	48	60	80	125	83	Vdc
MPPT Operating Range	8 - 48	8 - 60	8 - 80	12.5 - 105	12.5 - 83	Vdc
Maximum Short Circuit Current (Isc)	11		10.1		14	Acd
Maximum DC Input Current	13.75		12.63		17.5	Acd
Maximum Efficiency	99.5					%
Weighted Efficiency	98.8					%
Overvoltage Category	II					
OUTPUT DURING OPERATION (POWER OPTIMIZER CONNECTED TO OPERATING SOLAREEDGE INVERTER)						
Maximum Output Current	15					Acd
Maximum Output Voltage	60			85		Vdc
OUTPUT DURING STANDBY (POWER OPTIMIZER DISCONNECTED FROM SOLAREEDGE INVERTER OR SOLAREEDGE INVERTER OFF)						
Safety Output Voltage per Power Optimizer	1 ± 0.1					Vdc
STANDARD COMPLIANCE						
EMC	FCC Part15 Class B, IEC61000-6-2, IEC61000-6-3					
Safety	IEC62109-1 (class II safety), UL1741					
RoHS	Yes					
INSTALLATION SPECIFICATIONS						
Maximum Allowed System Voltage	1000					Vdc
Compatible inverters	All SolarEdge Single Phase and Three Phase Inverters					
Dimensions (W x L x H)	128 x 152 x 28 / 5 x 5.97 x 1.1	128 x 152 x 36 / 5 x 5.97 x 1.42	128 x 152 x 50 / 5 x 5.97 x 1.96	128 x 152 x 59 / 5 x 5.97 x 2.32	1064 / 2.3	mm / in
Weight (including cables)	630 / 1.4		750 / 1.7		845 / 1.9	gr / lb
Input Connector	MC4 ⁽²⁾					
Output Wire Type / Connector	Double Insulated; MC4					
Output Wire Length	0.95 / 3.0	1.2 / 3.9				m / ft
Operating Temperature Range	-40 - +85 / -40 - +185					°C / °F
Protection Rating	IP68 / NEMA6P					
Relative Humidity	0 - 100					%

⁽¹⁾ Rated STC power of the module. Module of up to +5% power tolerance allowed.

⁽²⁾ For other connector types please contact SolarEdge

PV SYSTEM DESIGN USING A SOLAREEDGE INVERTER ⁽³⁾⁽⁴⁾		SINGLE PHASE HD-WAVE	SINGLE PHASE	THREE PHASE 208V	THREE PHASE 480V	
Minimum String Length (Power Optimizers)	P320, P370, P400	8		10	18	
	P405 / P505	6		8	14	
Maximum String Length (Power Optimizers)		25		25	50 ⁽⁵⁾	
Maximum Power per String		5700 (6000 with SE7600H-US, SE10000H-US)	5250	6000	12750	W
Parallel Strings of Different Lengths or Orientations	Yes					

⁽³⁾ For detailed string sizing information refer to: http://www.solaredge.com/sites/default/files/string_sizing_na.pdf.

⁽⁴⁾ It is not allowed to mix P405/P505 with P320/P370/P400/P600/P700/P800 in one string.

⁽⁵⁾ A string with more than 30 optimizers does not meet NEC rapid shutdown requirements; safety voltage will be above the 30V requirement



Series 200

Structural Report and Calculations



Configuration Tables

See pages 19 thru 96 for installation of racking system per wind and snow load requirements. See example below for instructions on how to read tables. All dimensions are in inches.

100 mph Wind Load 0 psf Snow																
Tilt Angle θ	Standard Installation							Braced Installation						Number of Rails Required Per Panel		
	Max (PS)		12" Dia Pier		Required Braces			Max (PS)		12" Dia Pier		Required Braces		Module Size		
	Sch 40	Sch 80	Short	Tall	A	C	D	Sch 40	Sch 80	Short	Tall	A	E	F	39" x 65"	39" x 78"
$\theta = 0$	135	154	30	30	No	Every 3rd Bay	No	180	180	30	30	Yes	Yes	Yes	2	2
$0 > \theta < 7.5$	114	130	30	30	Yes	Every 3rd Bay	No	180	180	30	31	Yes	Yes	Yes	2	2
$7.5 > \theta < 15$	107	122	30	33	Yes	Every 3rd Bay	No	180	180	30	40	Yes	Yes	Yes	2	2
$15 > \theta < 22.5$	101	115	30	38	Yes	Every 3rd Bay	Every 3rd Bay	180	180	30	47	Yes	Yes	Yes	2	2
$22.5 > \theta < 30$	96	110	30	41	Yes	Every 3rd Bay	Every 3rd Bay	180	180	30	50	Yes	Yes	Yes	2	2
$30 > \theta < 37.5$	98	112	30	51	Yes	Every 3rd Bay	Every 3rd Bay	180	180	30	63	Yes	Yes	Yes	2	2
$37.5 > \theta < 45$	101	115	30	51	Yes	Every 3rd Bay	Every 3rd Bay	180	180	30	63	Yes	Yes	Yes	2	2

Standard Installation

Tilt Angle	Tilt Angle θ	Standard Installation						
		Max (PS)		12" Dia Pier		Required Braces		
		Sch 40	Sch 80	Short	Tall	A	C	D
$\theta = 0$		135	154	30	30	No	Every 3rd Bay	No
$0 > \theta < 7.5$		114	130	30	30	Yes	Every 3rd Bay	No
$7.5 > \theta < 15$		107	122	30	33	Yes	Every 3rd Bay	No
$15 > \theta < 22.5$		101	115	30	38	Yes	Every 3rd Bay	Every 3rd Bay
$22.5 > \theta < 30$		96	110	30	41	Yes	Every 3rd Bay	Every 3rd Bay
$30 > \theta < 37.5$		98	112	30	51	Yes	Every 3rd Bay	Every 3rd Bay
$37.5 > \theta < 45$		101	115	30	51	Yes	Every 3rd Bay	Every 3rd Bay

Braced Installation

Horizontal pipe spans (in)	Footing depth at short pipe (in)	Footing depth at tall pipe (in)	Braced Installation					
			Max (PS)		12" Dia Pier		Required Braces	
			Sch 40	Sch 80	Short	Tall	A	E
180	180	30	30	Yes	Yes	Yes		
180	180	30	31	Yes	Yes	Yes		
180	180	30	40	Yes	Yes	Yes		
180	180	30	47	Yes	Yes	Yes		
180	180	30	50	Yes	Yes	Yes		
180	180	30	63	Yes	Yes	Yes		
180	180	30	63	Yes	Yes	Yes		

Number of aluminum ground rails required for either the standard or braced options per panel size. See pages C6 through C13 for 2 or 3 rail configurations.

Number of Rails Required Per Panel	
Module Size	
39" x 65"	39" x 78"
2	2
2	2
2	2
2	2
2	2
2	2
2	2

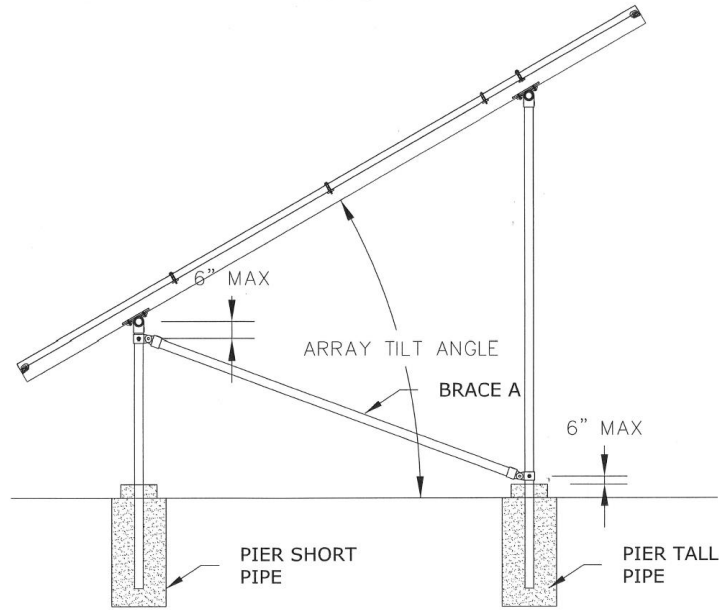

Frame Section

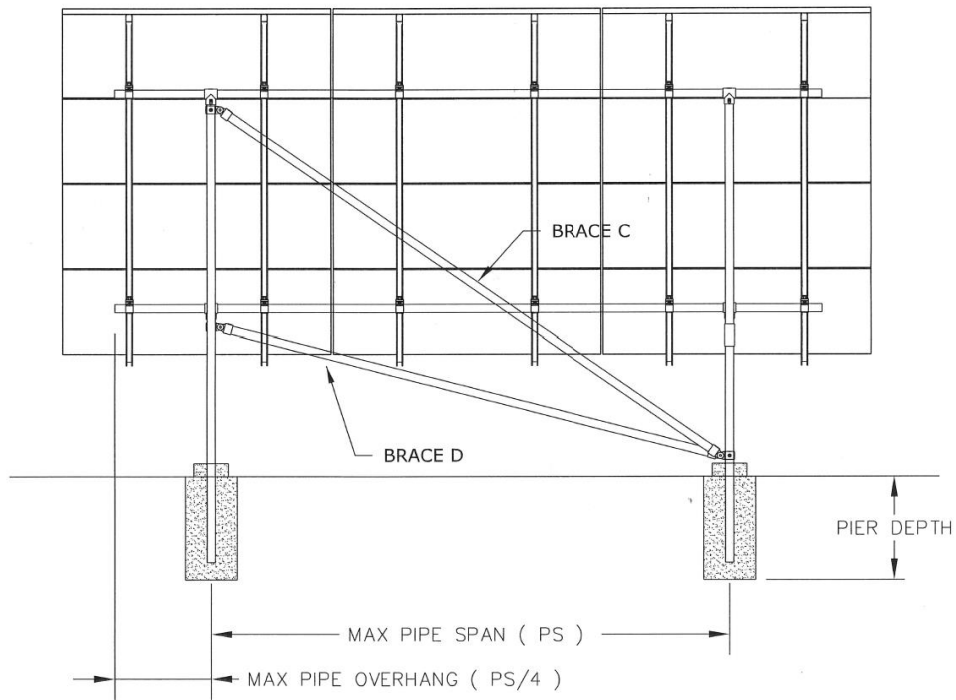

Standard Installation Rear View Bracing

Foundation Options

- Pier foundations: piers will be 12” in diameter and be at the depth required in the following charts based on wind speed, panel tilt, and snow load. The minimum depth of the footings is set to 30 inches and the concrete will be 2500 psi minimum.
- Grade beam option: a grade beam may be used in place of the pier foundations See SnapNrack’s drawing S200 D07 for grade beam configuration. Grade beams will be a minimum of 12” wide x 12” deep and will run a minimum of 12’-0” centered under the posts. Two #4 Bars will be used at the top and the bottom of the grade beam, one on each side for the vertical pipe. These must have a minimum of 3” clear concrete cover and shall be Grade 40 minimum. See table on page C16 for grade beam sizes.

SOIL BEARING CAPACITY ALLOWABLE FOUNDATION AND LATERAL PRESSURE

Class of Materials	Allowable Foundation Pressure (psf) ^d	Lateral Bearing (psf/f below natural grade) ^d	Lateral Sliding	
			Coefficient of friction	Resistance (psf) ^b
1. Crystalline bedrock	12,000	1,200	0.70	—
2. Sedimentary and foliated rock	4,000	400	0.35	—
3. Sandy gravel and/or gravel (GW and GP)	3,000	200	0.35	—
4. Sand, silty sand, clayey sand, silty gravel and clayey gravel (SW, SP, SM, SC, GM and GC)	2,000	150	0.25	—
5. Clay, sandy clay, silty clay, clayey silt, silt and sand silt (CL, ML, MH and CH)	1,500 ^c	100	—	130

Referring to page C15, this report uses 1500 pcf foundation pressure into the calculations, In addition, it uses a footing diameter of 1 ft., making the foundation pressure 1500 psf. From these calculations, which are in terms of the worst-possible conditions, any of the choices for the Class of Materials listed above in the table would work for the ground-mount solar panels.

GROUNDING MARKING DETAILS

All components included in the Ultra Rail UL 2703 Listing for grounding/bonding are packaged and marked with the UL logo, SnapNrack File E359313, and "PV Mounting System"

The SnapNrack Ground Lug is marked with the ground symbol
 IlSCO Ground Lugs have green colored set screws or bolts to indicate connection to the grounding electrode conductor

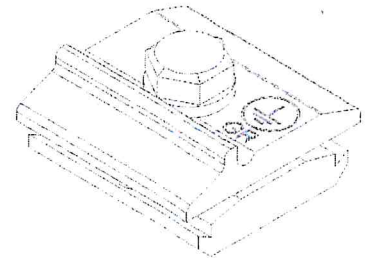
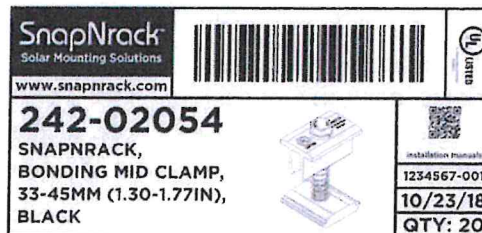

Ultra Rail has been tested with the following UL Listed modules:

The Ultra Rail System employs top-down clamps which have been evaluated for frame-to-system bonding, at specific mounting torques and with the specific modules listed below. The system has been assessed to a maximum Over-Current Device (OCD) protection level of 20 amps. The UL file number is included in parentheses below.

Hyundai Heavy Industries Co Ltd (E325005): HIS-MXXXRG where XXX is 235 to 275; HIS-SXXXRG where XXX is 245 to 295; HIS-SXXXRW where XXX is 250 to 265; HIS-MXXXMG where XXX is 210 to 270; HIS-SXXXMG where XXX is 220 to 275. All may be followed by the suffix BK or blank.

Jinko Solar (E362479): Models JKMXXXP-60, JKMXXXPP-60, JKMXXXP-60-V, JKMXXXP-60-J4, JKMXXXP-60B-J4 where XXX is 200 to 290; JKMXXXP-72, JKMXXXPP-72, JKMXXXP-72-V, JKMXXXPP-72-V where XXX is 250 to 360; JKMXXXM-60 where XXX is 200 to 305; JKMXXXM-72 where XXX is 250 to 365 JKMXXXPP-60-V where XXX is 200 to 300; JKMSXXXP-72 where XXX is 250 to 330.

Kyocera (E467150) - KU-60 1000 V Series - KUXXX, where XXX is 250 to 275, followed -6BCA, -6BFA, -6BPA, -6DCA, -6DFA, -6DPA, -6MCA, -6MPA, -6XCA, -6XPA, -6ZCA, -6ZPA, -6ZPB, -6ZCB, -6ZPC, -6ZCC, -6ZPD, -6ZCD, -6ZPE, 6ZCE, -6MPC, -6MCC, -6MPB or -6MCB; KU-80 1000 V Series - KUXXX, where XXX is 315 to 335, followed by -8BCA, -8BFA or -8BPA.

LG (E329725) - LGXXXQ1C-A5 where XXX is 340 to 385; LGXXXQ1K-A5 where XXX is 315 to 375.

Panasonic (E181540) - VBHNXXXSA16 where XXX is 320 to 335; VBHNXXXKAO1 and VBHNXXXKAO2 where XXX is 310 to 325; VBHNXXXKAO3 and VBHNXXXKAO4 where XXX is 310 to 325; VBHNXXXSA17 and VBHNXXXSA18 where XXX is 325 to 335.

REC Solar AS (E308147): RECXXX, where XXX is 214 to 270, all may be followed by PE, PE(BLK), PE-US, PE-US(BLK), PEQ2 or PEQ3.

Renesola Jiangsu Ltd (E312637): JCXXXM-24/Bb Series where XXX is 200 to 270; JCXXXM-24/BBh Series where XXX is 235 to 270.

Suniva Inc (E333709): MVX-XXX-60-5-YYY where XXX is 235 to 265 and YYY is 701 or 7B1; OPT-XXX-60-4-YYY where XXX is 250 to 275 and YYY is 800 or 8B0.

Sunpower (E246423)- Gen 3 or Gen 5 frame models SPR-XY-### where YY represents numbers 18, 19, 20 or 21, and ### represents any number from 365 to 310 and 274 to 233; Gen 3 or Gen 5 frame models SPR-EY-### where YY represents numbers 18, 19, 20 or 21, and ### represents any number from 345 to 285 and 250 to 225.

Talesun Solar (E359349) - TP660P-XXX where XXX is 235 to 285; TP660M-XXX where XXX is 240 to 300; TP672P-XXX where XXX is 280 to 345; TP672M-XXX where XXX is 290 to 360.

Trina Solar Ltd (E306515) - TSM-XXXPA05, TSM-XXXPA05.05, TSM-XXXPA05.08, where XXX is 215 to 260; TSM-XXXPD05, TSM-XXXPD05.05, TSM-XXXPD05.08 where XXX is 240 to 280; TSM-XXXPD05.08D where XXX is 245 to 275; TSM-XXXDD05A(II), TSM-XXXDD05A.05(II), TSM-XXXDD05A.08(II) where XXX is 260 to 300. All may be followed by Black or White.

Yingli Energy (China) Co Ltd (E320066) - YLXXXP-29b where XXX is 215 to 260; YLXXXA-29b where XXX is 220 to 255.

NRTL Listed PV Modules:

Boviet Solar: Models BVM6610P-XXX where XXX is 225 to 275; BVM6610M-XXX where XXX is 235 to 280; BVM6612P-XXX where XXX is 270 to 330; BVM6612M-XXX where XXX is 280 to 340.

Canadian Solar: Models CS6P-XXX-P, CS6P-XXX-M where XXX is 200 to 300; CS6P-XXX-P-SD, CS6K-XXX-P-SD where XXX is 240 to 300; CS6K-XXX-M, CS6K-XXX-MS, CS6K-XXX-M-SD where XXX is 240 to 305; CS6K-XXX-P where XXX is 220 to 300; CS6X-XXX-P where XXX is 250 to 360; CS6V-XXX-M where XXX is 215 to 225; CS6V-XXX-P where XXX is 250 to 255; CS3K-XXX-P where XXX is 250 to 310; CS3K-XXX-MS where XXX is 280 to 330; CS1K-XXX-MS where XXX is 285 to 345.

ET Solar: ET-P660XXXBB where XXX is 200 to 265; ET-P660XXXWB where XXX is 200 to 265; ET-P660XXXWW where XXX is 200 to 265; ET-P660XXXWWG where XXX is 235 to 265; P660XXXWB/WW where XXX is 200 to 265 and may be followed by WB or WW; P660XXXWWG where XXX is 240 to 250; M660XXXBB where XXX is 250 to 265; M660XXXWW where XXX is 200 to 270.

Hanwha Q Cells: B.LINE PLUS BFR-G4.1-XXX, B.LINE PRO BFR-G4.1-XXX, Q.BASE GY-XXX, Q.PEAK G4-XXX, Q.PLUS BFR-G3.1-XXX, Q.PLUS BFR-G4-XXX, Q.PLUS BFR-G4.1-XXX, Q.PLUS BFR-G4.1/TAA-XXX, Q.PLUS BRG-GY-XXX, Q.PLUS GY-XXX, Q.PLUS G4-XXX, Q.PRO BFR-G4-XXX, Q.PRO BFR-G4.1-XXX, Q.PRO BFR-G4.3-XXX, Q.PRO BFR-GY-XXX, Q.PRO BLK-GY-XX, Q.PRO G4-XXX, Q.PRO GY-XXX, Q.PRO GY/SC-XXX, where XXX is 245 to 295; Q.PEAK BLK-G3.1-XXX, Q.PEAK BLK-G4.1-XXX, Q.PEAK BLK-G4.1/TAA-XXX, Q.PEAK G3.1-XXX, Q.PEAK G4.1-XXX, Q.PEAK G4.1/MAX-XXX, Q.PEAK G4.1/TAA-XXX where XXX is 270 to 325; Q.PEAK DUO BLK-G5-XXX, Q.PEAK DUO G5-XXX where XXX is 290 to 325.

Hanwha SolarOne: Models HSL60P6-PB-X-YYYQ where X is 2 or 4, and YYY is 230 to 270, may be followed by additional suffixes.

JA Solar: Models JAP6-60-XXX/3BB where XXX is 235 to 265; JAM6-60-XXX/SI where XXX is 250 to 270; JAP72S01-XXX/SC where XXX is 315 to 335; JAP6(k)-72-XXX/4BB where XXX is 305 to 325.

LG Electronics Inc.: Models LGXXXS1C-G4 where XXX is 250 to 300; LGXXXN1K-G4 where XXX is 280 to 300; LGXXXN1C-G4 where XXX is 280 to 340; LGXXXN2C-G4, LGXXXN2W-G4, where XXX is 360 to 395; LGXXXN2K-G4, where XXX is 360 to 385; LGXXXS2C-G4, LGXXXS2W-G4, where XXX is 300 to 360; LGXXXN2C-B3, LGXXXN2W-B3, where XXX is 330 to 400; LGXXXS1C-A5 where XXX is 280 to 320; LGXXXN1C-A5 where XXX is 320 to 345; LGXXXN1K-A5 where XXX is 310 to 335.

Longi Green Energy Technology Co., Ltd.: LR6-60-XXXM, LR6-60BK-XXXM, LR60-HV-XXXM, where XXX is 270 to 300; LR6-60PB-XXXM, LR6-60PE-XXXM, LR6-60PH-XXXM, where XXX is 280 to 310.

Mission Solar: Models MSEXXXSO5T where XXX is 260 to 290; MSEXXXSO5K where XXX is 270 to 290; MSEXXXSQ5T where XXX is 280 to 300; MSEXXXSQ5K where XXX is 285 to 305; MSEXXXMM4J and MSEXXXMM6J where XXX is 320 to 330; MSEXXXSO6W where XXX is 320 to 340; MSEXXXSO4J and MSEXXXSO6J where XXX is 320 to 350; MSEXXXSQ4S and MSEXXXSQ6S where XXX is 345 to 365.

REC Solar PTE. LTD.: Models RECXXXPE where the XXX is 214 to 280; RECXXXTTP where XXX is 260 to 300; RECXXXTTP2 Series where XXX is 260 to 300; RECXXXTTP IQ where XXX is 260 to 300; All may be followed by BLK; RECXXXTTP72, where XXX is 330 to 345; RECXXX, where XXX is 285 to 325, followed by PE72, PE72BLK, PE72 Q2 or PE72 Q3; RECXXXPE72XV, where XXX is 295 to 325, followed by PE72 XV, PE72 XV Q2 or PE72 XV Q3.

Silfab: SLAXXX-M, where XXX is 280 to 300; SLGXXX-M, where XXX is 335 to 360; SLAXXX-P, where XXX is 250 to 265; SLGXXX-P, where XXX is 300 to 315; SSAXXX-M, where XXX is 280 to 300; SSGXXX-M, where XXX is 335 to 360; SSAXXX-P, where XXX is 250 to 260; SSGXXX-P, where XXX is 300 to 315.

Solar World: Models SWXXX-Mono where XXX is 200 to 300; SWXXX-Mono XL where XXX is 320 to 350. All may be followed by Black.

Suniva Inc - OPTXXX-60-4-YYY where XXX is 240 to 300 and YYY is 100; OPTXXX-60-4-YYY where XXX is 235 to 300 and YYY is 1B0.

*Trina Solar Ltd: Models TSM-XXXPD05.002, TSM-XXXPD05.082, TSM-XXXPD05.05S, TSM-XXXPD05.08S where XXX is 215 to 275; TSM-XXXDD05A.082(II) where XXX is 260 to 315; all may be followed by Black.

Mechanical Loading Specifications

The following components have been evaluated for mechanical loading:

Ultra Rail, Mid Clamp, X End Clamp, Universal End Clamp, Ultra Rail Splice, Ultra Rail Composition Mount Kits, Standard Standoff for Ultra Rail, Four Hole Standoff for Ultra Rail, Heavy Duty Standoff for Ultra Rail, Metal Roof Base Standoff for Ultra Rail, Ultra Rail Corrugated Block, Standard Base Seam Clamp for Ultra Rail, Wide Base Seam Clamp for Ultra Rail, Ultra Rail Universal Tile Hook, Ultra Rail Flat Tile Hook, Flat Tile Replacement Kit for Ultra Rail, S Tile Replacement Kit for Ultra Rail, W Tile Replacement Kit for Ultra Rail.

The UL Listing covers mechanical load ratings for the following span lengths, module orientations and downforce, uplift, and down-slope ratings:

Span	Orientation	Direction	Load Rating (lb/ft ²)
4 or 6 feet	Long Side or Short Side Mounting	Downforce	10
		Uplift	5
		Down-Slope	5

Ultra Rail has been tested with the following UL Listed modules:

The Ultra Rail System has been evaluated for mechanical loading for its top-down clamps with the specific modules listed below. The UL file number is included in parentheses below. *(The following modules were also evaluated for bonding. Please see Grounding Specifications section.)*

Hyundai Heavy Industries Co Ltd (E325005): HiS-MXXXRG where XXX is 235 to 275; HiS-SXXXRG where xxx is 245 to 295; HiS-SXXXRW where xxx is 250 to 265.

JA Solar (E328263): JAP6-60-XXX/3BB where XXX is 235 to 250.

Jinko Solar (E362479): JKMXXXP-60, JKMXXXPP-60, JKMXXXP-60-J4, JKMXXXP-60B-J4 where XXX is 200 to 290; JKMXXXM-60 where XXX is 200 to 305

Panasonic (E181540) - VBHNXXXSA16 where XXX is 320 to 335; VBHNXXXKA01 and VBHNXXXKA02 where XXX is 310 to 325; VBHNXXXKA03 and VBHNXXXKA04 where XXX is 310 to 325; VBHNXXXSA17 and VBHNXXXSA18 where XXX is 325 to 335.

ReneSola (E312637): Models JCXXXM-24/Bbh where XXX is 235 to 270.

Trina Solar (E306515): TSM-XXXPD05, TSM-XXXPD05.05 and TSM-XXXPD05.08, where XXX 240 to 280; TSM-XXXDD05A(II), TSM-XXXDD05A.05(II), TSM-XXXDD05A.08(II) where XXX is 260 to 300.

Yingli Solar (E357540): Models YLXXXP-29b where XXX is 215 to 265.

NRTL Listed PV Modules:

Boviet Solar: Models BVM6610P-XXX where XXX is 225 to 275; BVM6610M-XXX where XXX is 235 to 280.

Canadian Solar: Models CS6P-XXX-P, CS6P-XXX-M where XXX is 200 to 300; CS6P-XXX-P-SD, CS6K-XXX-P-SD where XXX is 240 to 300; CS6K-XXX-M, CS6K-XXX-M-SD where XXX is 240 to 305; CS6K-XXX-P where XXX is 220 to 300.

ET Solar: Models ET-P660XXXBB where XXX is 200 to 265; ET-P660XXXWB where XXX is 200 to 265; ET-P660XXXWW where XXX is 200 to 265; ET-P660XXXWWG where XXX is 235 to 265.

Mechanical Loading Specifications

snapnrack.com

Hanwha Q Cells: Q.PRO BFR-G4-XXX, Q.PRO BFR-G4.1-XXX; Q.PLUS BFR-G4-XXX; Q.PLUS BFR-G4.1-XXX, Q.PLUS BFR-G3.1-XXX where XXX is 245 to 295; Q.PEAK-G3.1-XXX and Q.PEAK BLK-G3.1-XXX where XXX is 270 to 325.

LG Electronics: Models LGXXXN1C-G4 where XXX is 280 to 340; LGXXXS1C-G4 where XXX is 250 to 300; LGXXXN1K-G4 where xxx is 280 to 330; LGXXXN1K-A5 where XXX is 310 to 350.

Longi Green Energy Technology Co., Ltd.: LR6-60-XXXM, LR6-60BK-XXXM, LR60-HV-XXXM, where XXX is 270 to 300.

REC Solar PTE, LTD: Models RECxxxPE or RECXXXPE-BLK Series where XXX is 214 to 270; RECxxxTP RECXXXTP-BLK Series, where the xxx is 260 to 300; RECXXTP2 or RECXXTP2-BLK Series where XXX is 260 to 300.

SolarWorld: Models SW XXX mono where XXX is 200 to 300, may additionally be followed by "black".

Talesun: Models TP660P-XXX where XXX is 215 to 285; TP660M-XXX where XXX is 210 to 300.

snapnrack.com