

Venture on Venetucci
El Paso County, Colorado,
COUNTY STORMWATER MANAGEMENT PLAN (SWMP) REPORT
PCD FILING NO.: TBD **SF2431 & PPR2444**

Permittee:

Thompson Thrift Development, LLC
Donald Dungu
111 Monument Circle
Suite 1500
Indianapolis, IN 46204
(336) 609-2131

Preparing Engineer:

Kimley-Horn and Associates, Inc.
6200 S. Syracuse Way, Suite 300
Greenwood Village, CO 80111
Contact: Michael Hart, P.E.
(720)-943-9966

Qualified Stormwater Manager: TBD

Name:
Address:
Contact:

Contractor: TBD

Name:
Address:
Contact:

NOVEMBER 12, 2024

Kimley»»Horn

TABLE OF CONTENTS

CERTIFICATION / SIGNATURE BLOCKS.....	4
ENGINEER'S STATEMENT	4
OWNER'S STATEMENT	4
INTRODUCTION	5
INTRODUCTION AND PURPOSE	5
PERMIT COVERAGE AND APPLICATIONS	5
GENERAL LOCATION.....	6
PROJECT LOCATION	6
VICINITY MAP	6
SITE DESCRIPTION.....	7
GENERAL PROJECT DESCRIPTION	7
VEGETATION	7
DRAINAGE CHARACTERISTICS	7
ULTIMATE DISCHARGE	7
SITE SOILS.....	7
DEWATERING	8
AREAS AND VOLUMES.....	8
TIMING AND PHASING SCHEDULE	8
STORMWATER MANAGEMENT PLAN SITE MAP	11
SITE MAP MINIMUM REQUIREMENTS	11
STORMWATER MANAGEMENT CONTROLS	11
QUALIFIED STORMWATER MANAGER.....	11
SITE SPECIFIC POLLUTION SOURCES	11
IDENTIFICATION OF POLLUTANT SOURCES	12
NON-STORMWATER DISCHARGE COMPONENTS	13
CONTROL MEASURES FOR STORMWATER POLLUTION PREVENTION	13
OTHER POTENTIAL POLLUTION CONSIDERATIONS.....	16
MATERIALS HANDLING AND SPILL PREVENTION	16

VEHICLE TRACKING AND DUST CONTROL.....	17
DEDICATED CONCRETE OR ASPHALT BATCH PLANTS.....	17
WASTE MANAGEMENT AND DISPOSAL.....	17
Portable Toilets	18
STABILIZATION AND STORMWATER MANAGEMENT	18
TEMPORARY STABILIZATION AND SHORT-TERM STORMWATER MANAGEMENT	18
FINAL STABILIZATION AND LONG-TERM STORMWATER MANAGEMENT	18
INSPECTION AND MAINTENANCE	18
INSPECTION SCHEDULE REQUIREMENTS	18
INSPECTION PROCEDURES.....	19
CONTROL MEASURE MAINTENANCE / REPLACEMENT AND FAILED CONTROL MEASURES	21
DISPOSITION OF TEMPORARY MEASURES.....	21
PLAN MODIFICATIONS	21
REFERENCES	22
APPENDIX.....	23
APPENDIX A – GRADING AND EROSION CONTROL PLANS	
APPENDIX B – CDPHE STORMWATER PERMIT	
APPENDIX C – FEMA FIRM MAP	
APPENDIX D – SOILS INFORMATION	
APPENDIX E – IDENTIFICATION OF POLLUTANT SOURCES	
APPENDIX F – LAND DISTURBANCE / CONTROL MEASURE / STABILIZATION LOG	
APPENDIX G – SPILL PREVENTION AND RESPONSE PLAN AND REPORTING INFORMATION	
APPENDIX H – STORM EVENT LOG	
APPENDIX I – INSPECTION AND SAMPLING REPORTS	
APPENDIX J – SWMP AMENDMENT LOG / CONTROL MEASURE DETAILS	
APPENDIX K – GEOTECH REPORT	

CERTIFICATION / SIGNATURE BLOCKS

ENGINEER'S STATEMENT

This Erosion and Stormwater Quality Control/Grading Plan was prepared under my direction and supervision and is correct to the best of my knowledge and belief. If such work is performed in accordance with the grading and erosion control plan, the work will not become a hazard to life and limb, endanger property, or adversely affect the safety, use, or stability of a public way, drainage channel, or other property.

Michael Hart, P.E.
Registered Professional Engineer
State of Colorado No. 58724

OWNER'S STATEMENT

The owner will comply with the requirements of the Erosion and Stormwater Quality Control Plan including temporary BMP inspection requirements and final stabilization requirements. I acknowledge the responsibility to determine whether the construction activities on these plans require Colorado Discharge Permit System (CDPS) permitting for Stormwater discharges associated with Construction Activity.

Developer/Owner Signature: _____

Name of Developer/Owner: _____ Date: _____

DBA: _____ Phone: _____

Title: _____ Email: _____

Address: _____ Fax: _____

INTRODUCTION

INTRODUCTION AND PURPOSE

This Stormwater Management Report (“SWMP”) Report is provided to support the approval of the Erosion and Sediment Control Plan Construction Drawings through El Paso County (“County”) and the issuance of a CDPS General Permit through Colorado Department of Public Health and Environment (“CDPHE”) for the proposed multifamily project located on Venetucci Boulevard, South of the intersection of Venetucci Boulevard and B Street. This report, in conjunction with the Construction Drawings in **Appendix A**, provide a site and project understanding along with guidelines for implementation and maintenance of erosion, sediment and stormwater quality control measures prior to and during construction of the Project.

The primary goal of pollution prevention efforts during Project construction is to control sediment and pollutants that originate on the site and prevent them from flowing to surface waters. A successful pollution prevention program also relies upon careful inspection and adjustments during the construction process to enhance its effectiveness. It is the intent of this plan to implement stormwater control measures, also referred to as best management practices (BMP) for enhancing the quality of stormwater discharges associated with the construction activity. Control measures designs are based on the criteria set forth by the General Permit and the El Paso County Drainage Criteria Manual Volume II and Engineering Criteria Manual.

This plan must be implemented before construction begins on the site. It primarily addresses the impact of storm rainfall and runoff on areas of the ground surface disturbed during the construction process. In addition, there are recommendations for controlling other sources of pollution that could accompany the major construction activities. Applicability of this plan shall be terminated when disturbed areas are stabilized, temporary erosion controls are removed, construction activities covered herein have ceased and the permit has been inactivated.

PERMIT COVERAGE AND APPLICATIONS

The Grading, Erosion & Sediment Control for this Project shall be approved by El Paso County prior to issuance of construction related permits.

Based upon a Site Disturbance Area of one (1) acre or more, this site requires the issuance of a Colorado Discharge Permit System (CDPS) - Stormwater Discharge Associated with Construction Activities Permit (General Permit) through the Colorado Department of Public Health and Environment (CDPHE). A copy of the CDPS General Permit Application is included in **Appendix B** of this report.

GENERAL LOCATION

PROJECT LOCATION

The Project is located west of Venetucci Blvd. south of B St. and north of South Academy Blvd. in Section 4, Township 15 South, Range 66 West, 6th P.M., County of El Paso, State of Colorado (see Vicinity Map). More specifically, the site is in the South half of Section 4, Township 15 South, Range 66 West of the 6th Principal Meridian in the County of El Paso, State of Colorado (the "Site") and will consist of a new subdivision plat called Venture on Venetucci Filing No. 1 (the "Project").

Parcels adjacent to the site include:

- West – Venetucci Blvd. (Public ROW)
- South – 2 Tracts owned by CFT NV Developments LLC and FRG Properties LLC

VICINITY MAP

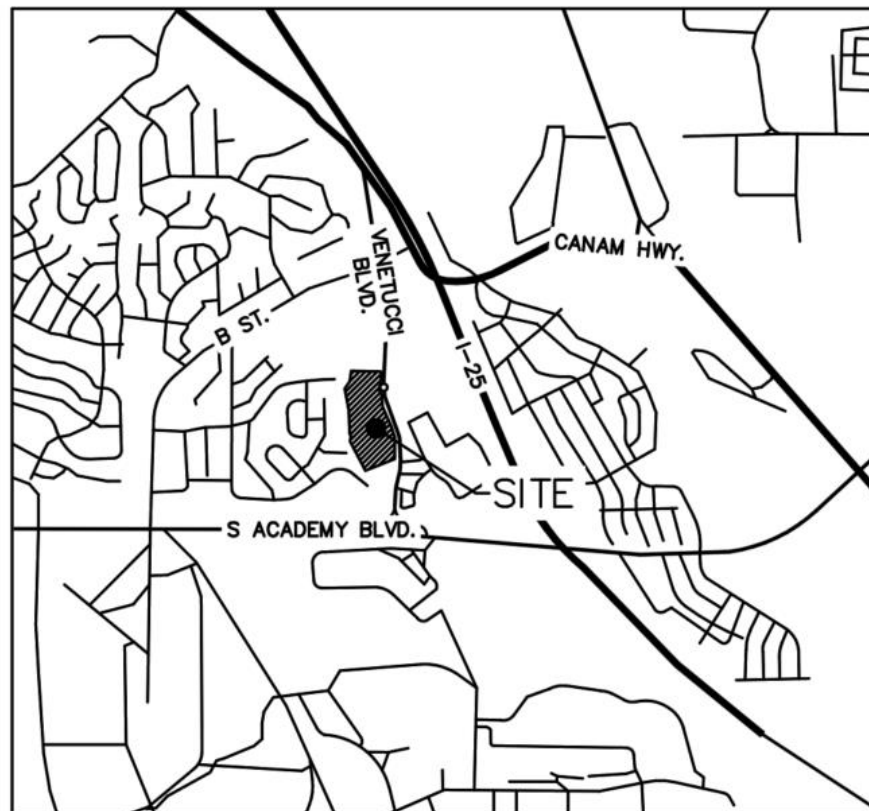

VICINITY MAP

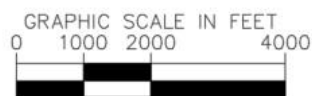

SITE DESCRIPTION

GENERAL PROJECT DESCRIPTION

The site consists of ±16.23 acres of land consisting of vacant land with native vegetation and is classified as “Undeveloped” per Table 6-6 of the City of Colorado Springs Drainage Criteria Manual. The Project consists of the construction of two access points along Venetucci Boulevard, ten multi-family buildings, eight detached garage buildings, a property management building, a clubhouse and leasing amenity space with a pool deck, a dog park, a fitness center, utilities, and adjacent landscape areas. The existing land use is undeveloped vacant land.

An updated Topographic field survey was completed for the Project by WSB Engineering. Dated April 4, 2024 and is the basis for design for the Project improvements.

VEGETATION

The existing site is undeveloped, vacant land. Ground cover consists of short grasses with an approximate density of approximately 100%. Vegetation density was confirmed through a review of photos of the Site.

DRAINAGE CHARACTERISTICS

The existing topography consists of slopes ranging from 8% to 50% and generally slopes from West to East however there is a steep slope on the West edge of the site sloping West toward Fisher’s Canyon Creek. The site is bounded by Venetucci to the West, and the majority of the site currently either overland flows directly to Fisher’s Canyon Creek or flows to an existing sediment basin located in the north central portion of the Site that outlets into Fisher’s Canyon Creek. A Full Spectrum Extended Detention Basin is proposed for the Site which will release flows from the Site into the existing Fisher’s Canyon Creek below historic levels.

The Site improvements are located in Zone X, as determined by the Flood Insurance Rate Map (FIRM) number 08041C0743G effective date, 12/7/2018. The FIRM is provided in **Appendix C**.

There are no major stream crossings located within the construction site boundary or limits of disturbance.

ULTIMATE DISCHARGE

The runoff generated from the roof areas are collected and conveyed via private roof drains and outfall into the proposed private storm sewer system. Other sub-basins include internal areas within the parking lot and adjacent landscape areas. Each sub-basin drains to an inlet within the parking lot and is routed to the private storm sewer system at individual design points indicated on the Proposed Drainage Map. The entirety of the proposed storm sewer system is routed to a Full Spectrum Extended Detention Basin (EDB) at the North side of the Site. The detention system will release flows into Fisher’s Canyon Creek to the West of the EDB via an 18” HDPE pipe with energy dissipation at the outlet. Emergency storm overflows will be conveyed to Fisher’s Canyon Creek via a rip rap channel.

SITE SOILS

A review of the Natural Resource Conservation Service (NRCS) Web Soil Survey determined that soils onsite are generally USCS Types A. The NRSC Soils map is provided in the **Appendix D**. Additionally, the

Correct CDPHE permit for short term dewatering for construction activities is COG080000

Preliminary Geotechnical Exploration by Midwest Testing dated July 6, 2023 states “Existing fill was identified in four of the borings to the west (B-7, -10, -11, -13). The fill generally consists of sandy clay with varying amounts of weathered claystone, which was obtained from the eastern portion of the site.” Additionally, the Geotechnical Report states “An idealized soil profile for this site generally consists of natural, undisturbed cohesive soil overlying sedimentary bedrock. Existing fill was encountered to the west.” The onsite soils were found to have potential for erodibility and the Preliminary Geotechnical Exploration states “the surface soils at this site are susceptible to erosion. Due to the large area, significant relief, and side slopes of the drainage features, the potential for severe siltation exists. Appropriate erosion control measures such as proper site contouring during grading, and siltation fences or straw bales must be used during construction.” The Preliminary Geotechnical Exploration also suggests slopes of 3H:1V or flatter. A Geotechnical Report for the site, which includes soil borings and tests, including the depth of groundwater, if encountered, has also been included in the **Appendix D**.

DEWATERING

Per the Preliminary Geotechnical Exploration by Midwest Testing dated July 6, 2023, “Short-term ground water readings made during the field exploration program indicated the borings to generally be dry during drilling. The true static ground water levels can best be determined in cased holes over long periods of time. Ground water levels will vary based on variations in seasonal precipitation.” If groundwater is encountered during construction and the site must be dewatered, the operator shall file for appropriate dewatering permits (Permit No. **COG070000**) with the CDPHE.

If groundwater is encountered on the project site, a State of Colorado General Permit for Construction Dewater Activities will be required. The state dewatering permit application and associated information can be found at <https://www.colorado.gov/pacific/cdphe/wq-construction-general-permits>. The permit application will need to be filled out 30 days prior to the anticipated discharge. Refer to the UDFCDs detail and fact sheet for additional dewatering operations information.

AREAS AND VOLUMES

The total anticipated project disturbance area is approximately ±16.52 acres. The estimated earthwork quantities are as follows:

Cut: ±106,460 cubic yards

Fill: ±62,605 cubic yards

Net: ±42,855 cubic yards CUT

TIMING AND PHASING SCHEDULE

The operator shall utilize the following general construction practices which are required throughout the project at locations shown on the Erosion and Sediment Control Plan or as dictated by construction activities.

- Materials handling and spill prevention
- Waste management and disposal
- Hazardous material storage and containment area
- Vehicle maintenance fueling and storage
- Solid waste containment facility
- Sanitary waste facility

- Street Sweeping (SS) – performed by the Operator

These practices shall remain active and operational throughout the duration of construction and be identified on the Erosion and Sediment Control Plan. Due to any phasing required for the Project, it is understood that these control measures may be relocated as needed to facilitate construction operations. The Operator shall locate and identify the original and current location of these control measures on the Erosion and Sediment Control Plan, throughout the construction of the Project. An updated copy of the Erosion and Sediment Control Plan shall be kept onsite throughout construction of the Project.

General construction sequencing and activities associated with this project are described below. They are presented in the order (or sequence) they are expected to begin, but each activity will not necessarily be completed before the next begins.

The anticipated construction start date is Fall 2025 and the anticipated construction completion date is Fall 2027. Land disturbance will follow this same timeframe with final stabilization occurring in Fall 2027.

INITIAL PHASE

The initial phase shall consist of applying for and receiving the CDPS General Permit as well as construction/installation of temporary control measures to minimize potential for erosion and sediment transfer while mobilizing and preparing the site for construction activities. The operator shall minimize site disturbance by minimizing the extent of grading and clearing to effectively reduce sediment yield. The operator shall complete the anticipated initial phase sequencing as follows:

1. Prepare and submit the State of Colorado, Colorado Department of Public Health and Environment (CDPHE) Colorado Discharge Permit System (CDPS) General Permit. A copy of the permit shall be provided to the owner upon receipt from the CDPHE.
2. Obtain EPC ESQCP Permit, schedule Kickoff meeting with EPC, and obtain “notice to proceed” from EPC.
3. Install *Vehicle Tracking Control (VTC)* at the proposed southwest site entrance.
4. Install and denote on the plan any of the following areas: trailer, parking, lay down, porta-potty, wheel wash, concrete washout, fuel and material storage containers, solid waste containers, etc.
5. Prepare *Stabilized Staging Area (SSA)* and *Stockpile Protection (SP)*. Contractor to note the actual size and location of this area and shall minimize this area.
6. Install perimeter controls including *Silt Fence (SF)* and *Construction Fence (CF)* as shown on the Grading and Erosion Control Plans. Ensure that the limits of construction are defined as necessary and known by all parties which will be responsible for construction on the site.
7. Install *Diversion Swale (DS)* and *Check Dams (CD)* in the swales as denoted on the Grading and Erosion Control Plans.
8. Install *Inlet Protection (IP)* around all existing inlets as denoted on the Grading and Erosion Control Plans including *Temporary Outlet Protection (TOP)* at each proposed culvert.
9. Install *Rock Socks (RS)* along the curb flowline of the adjacent roadways.
10. Install *Concrete Washout Area (CWA)* prior to construction of concrete improvements.
11. Install *Temporary Sediment Basin (SB)* in the location of the permanent Full Spectrum Extended Detention Basin per the detail as denoted on the Grading and Erosion Control Plans.
12. Upon completion of the initial control measure installation the Operator shall schedule and hold a meeting with the Contractor and Inspector that shall take place prior to the Pre-Construction Meeting.

13. The Operator shall schedule a Pre-Construction Meeting with the County and Owner to confirm control measures installed are adequate prior to proceeding with additional land disturbing activities.
14. Begin clearing and grubbing of the site.

INTERIM PHASE

The interim phase shall consist of site improvements including utility installation, foundation pouring, and vertical construction. The operator shall complete the anticipated interim phase sequencing as follows:

1. Confirm existing control measures from the initial phase which are to be maintained throughout construction, are in working order and compliant with applicable regulations.
2. Repair and/or replace any existing control measures which are deemed inadequate.
3. *Temporarily Seed (TS)*, throughout construction, denuded areas that will be inactive for 14 days or more.
4. Complete installation of utilities.
5. Install *Inlet Protection (IP)* around all constructed and existing inlets as denoted on the Erosion and Sediment Control Plans including *Temporary Outlet Protection (TOP)* at each proposed culvert.
6. Construct permanent Full Spectrum Extended Detention Basin

FINAL PHASE

The final phase shall consist of construction of site improvements, construction of permanent control measures, and final stabilization of the Site. The operator shall complete the anticipated final phase sequencing as follows:

1. Confirm existing control measures from the initial phase which are to be maintained throughout construction, are in working order and compliant with applicable regulations.
2. Repair and/or replace any existing control measures which are deemed inadequate.
3. *Temporarily Seed (TS)*, throughout construction, denuded areas that will be inactive for 14 days or more.
4. Complete installation of curb and gutters.
5. Permanently stabilize areas to be vegetated as they are brought to final grade.
6. Prepare site for paving.
7. Pave site, including gravel roadways, concrete sidewalk, and paved parking lot.
8. Complete grading and installation of final stabilization over all areas in accordance with the approved landscape plans for the Project.
9. Remove remaining control measures once permanent stabilization has been achieved and accepted by the County Inspector. Repair and stabilize areas disturbed through control measure removal.
10. Notify the owner of intent to file the Notice of Inactivation with CDPHE and receive Owner acceptance to proceed with Stormwater Management Close-out.
11. Proceed with filing the Notice of Inactivation with CDPHE.
12. Provide the Owner with a copy of all stormwater documentation (permits, inspection reports, logs, etc.) upon completion of Project Stormwater Notice of Inactivation.

STORMWATER MANAGEMENT PLAN SITE MAP

SITE MAP MINIMUM REQUIREMENTS

The Site Map for this project is included within **Appendix A** of this report and meets the following minimum requirements:

- Construction Site Boundaries
- Flow Arrows Depicting Stormwater Flow Directions
- Identification of Ground Surface Disturbance
- Areas of Storage of Building Materials, Equipment, Soil or Waste
- Location of Dedicated Asphalt or Concrete Batch Plants (As Applicable)
- Location of Structural Control Measures
- Location of Non-Structural Control Measures
- Location of Springs, Streams, Wetlands or other Surface Waters (As Applicable)
- Location of All Stream Crossings Located Within the Construction Site Boundary (As Applicable)

STORMWATER MANAGEMENT CONTROLS

QUALIFIED STORMWATER MANAGER

The Qualified Stormwater Manager is the Operator selected for the project. The Qualified Stormwater Manager is an individual knowledgeable in the principles and practices of erosion and sediment control and pollution prevention, and with the skills to assess the effectiveness of stormwater controls implemented to meet the requirements of the General Permit. **The Qualified Stormwater Manager will be sufficiently qualified for the required duties per the ECM Appendix 1.5.** The Qualified Stormwater Manager is responsible for developing, implementing, maintaining and revising the Grading, Erosion and Sediment Control Plan. The activities and responsibilities of the Qualified Stormwater Manager shall address all aspects of the facility's Grading, Erosion and Sediment Control Plan.

Company: TBD

Contact:

Address:

Phone:

Email:

SITE SPECIFIC POLLUTION SOURCES

Further identification of site-specific pollutants that fall within the categories outlined in the next section may be field noted using the corresponding log included in **Appendix E** of this report. The logs are intended to record site specific pollutants, the date of arrival on the site, the date removed from the site, and the methods of treatment.

IDENTIFICATION OF POLLUTANT SOURCES

Evaluation of general sediment and non-sediment pollution sources associated with site construction activities, as outlined within the General Permit, consist of the following:

- **Disturbed and Stored Soils** – Earth disturbing activities (grading, excavation, etc.) will be necessary for this project; therefore, the potential exists for disturbed site soils to contribute sediment to stormwater discharges.
- **Vehicle Tracking and Sediment** – Construction traffic will be entering and exiting the Site; therefore, the potential exists for vehicle tracking to contribute sediment to stormwater discharges.
- **Management of Contaminated Soils** – Contaminated soils are not anticipated on this Site. If encountered, the Qualified Stormwater Manager shall take appropriate containment and treatment measures.
- **Loading and Unloading Operations** – Loading and unloading operations will be taking place at the Site; therefore, the potential exists for these operations to introduce sediment and non-sediment pollutants to stormwater discharges.
- **Outdoor Storage of Materials** – Limited outdoor storage of materials is anticipated with construction of this site; however, outdoor storage of chemicals, fertilizers, etc. is not anticipated.
- **Vehicle and Equipment Maintenance and Fueling** – Routine maintenance and fueling of vehicles and equipment is anticipated with this Site; therefore, the potential exists for pollutants associated with these activities to contribute pollutants to stormwater discharges.
- **Significant Dust or Particulate Generating Processes** – Earth disturbing activities (grading, excavation, etc.) will be necessary for this project; therefore, the potential exists for windblown site soils to contribute sediment to stormwater discharges.
- **Routine Maintenance** – Routine maintenance involving fertilizers, pesticides, detergents, fuels, solvents, oils, etc., other than those identified within Vehicle and Equipment Maintenance and Fueling are not anticipated with this project. If encountered, the Qualified Stormwater Manager shall take appropriate containment and treatment measures.
- **Onsite Waste Management** – Waste management consisting of solid waste piles, liquid wastes, dumpsters, etc. are anticipated onsite; therefore, the potential exists for these operations to introduce sediment and non-sediment pollutants to stormwater discharges.
- **Concrete Truck / Equipment Washing** – Concrete truck and equipment washing are not anticipated with this project. If encountered, the Qualified Stormwater Manager shall take appropriate containment and treatment measures.
- **Dedicated Asphalt and Concrete Batch Plants** – Dedicated asphalt and/or concrete batch plants are not anticipated with this project. If encountered, the Qualified Stormwater Manager shall take appropriate containment and treatment measures and document as necessary.
- **Non-Industrial Waste Sources** – Non-Industrial waste sources limited to portable sanitary facilities are anticipated with this project.
- **Additional Pollutant Sources** – Additional areas or procedures where potential spills could occur are not anticipated with this project.

Logs for the identification of pollutant sources are included in **Appendix E** for reference and use.

Based on the following, the potential to contribute pollutants to stormwater discharges is not significant for most of the pollutants identified above:

- Relatively Low Frequency of the Activities

Item 10. List should include concrete washout

- The Ability to Schedule Activities During Dry Weather
- Existing Site Topography
- The Ability to Implement Primary and Secondary Containment for Product Storage
- The Ability to Locate Activities Away from Drainage Ways

Potential pollutant sources noted below shall be mitigated by use of Best Management Practices (BMPs) as noted in the following sections:

- Disturbed and Stored Soils
- Vehicle Tracking and Sediment
- Loading and Unloading Operations
- Outdoor Storage
- Vehicle Equipment and Maintenance Fueling
- Significant Dust or Particulate Generating Processes
- Non-Industrial Waste Sources

NON-STORMWATER DISCHARGE COMPONENTS

Only specifically authorized non-stormwater discharges are allowed to enter the storm sewer and all authorized non-stormwater discharges shall be eliminated or reduced to the extent practical. **There are no non-stormwater discharges anticipated at the Site.**

Appropriate control measures shall be used to minimize the discharge of pollutants. Such control measures will be strictly followed to ensure any impacts from non-stormwater discharges are reduced or eliminated.

Appropriate control measures are:

- Emergency Fire Fighting Activities

- Uncontaminated ground water or spring water

If possible, direct uncontaminated ground water or spring water to stabilized points of discharge. If discharged to a disturbed area, assure measures to control erosive velocities and sediment control measures are implemented. Velocity control measures include riprap aprons and other conveyance measures. Sediment control measures might include stone check dams, sediment traps and basins.

If uncontaminated ground water is discharged off-site, a Construction Dewatering Permit will be required. This Permit will not apply if dewatering is not performed or if water is not discharged off-site.

- Landscape Irrigation Return Flows

Volume of water used for irrigation prior to establishment of vegetation shall be controlled to prevent excess runoff and erosion. Temporary sediment control measures shall remain in place until all upstream disturbed areas are stabilized. Sediment loss will be controlled using sediment control measures such as wattles, sediment fence, and vegetative buffers.

Item 14. Per COR400000 Permit section A.1.b.ii, discharges to the ground of concrete or masonry washout water is an allowable non-stormwater discharge. This should be noted here as a CWA is anticipated.

CONTROL MEASURES FOR STORMWATER POLLUTION PREVENTION

There are three general types of control measures that will be utilized for the Project: Erosion Control, Sediment Control, and Site/Material Management control measures. Erosion Control measures are used

Item 18. Temporary outlet protection shown on submitted GEC plan.

to limit the amount and extent of erosion. Sediment Control measures are designed to capture eroded sediments prior to their conveyance offsite. Site/Material Management control measures are related to construction access and staging. Several control measures described below may be categorized into more than one of the types described above. Also, these control measures may be categorized into one or more of the following construction phases which pertain to the phase of development in which they may be implemented. Initial Stage control measures shall be installed on existing grades at the outset of construction. Interim Stage control measures shall be installed on proposed grades and drainage features after initial site grading. Final Stage control measures shall be installed on proposed grades and drainage features after final site grading. Construction of the identified improvements will take place under three phases of construction anticipated as identified within the construction sequencing included within this report.

Refer to the Erosion and Sediment Control Plans for the location and implementation of erosion control measures for the phases of the Project. The following is a brief description of temporary sediment and erosion control measures to be utilized on this Site and the application those control measures are treating.

EROSION CONTROL

Item 18. Diversion ditch/swale is shown on submitted GEC plan.

Protection of steep slopes is not anticipated on this project. Steep slopes are defined as slopes greater than 3:1 that are higher than 5-feet vertically. Temporary slopes during construction that are greater than 3:1 need to be addressed along with any permanent slopes which are greater than 3:1. The Permittee may need to implement the use of diversion ditches to reroute the storm runoff, terrace the grades to break up the flow of incidental runoff down slopes, compost mulch to protect the exposed soil or other control measure as approved by the inspector. Slopes steeper than 3:1 shall be protected with an erosion control blanket. No un-protected final grades shall be allowed greater than 2:1.

Permanent soil erosion control measures for all slopes, channels, ditches, or any disturbed land area shall be completed within fourteen (14) calendar days after final grading or the final earth disturbances has been completed. When it is not possible to permanently stabilize a disturbed area after an earth disturbance has been completed or where significant earth disturbance activity ceases, temporary soil erosion control measures shall be implemented within fourteen (14) calendar days. All temporary soil erosion control measures shall be maintained until permanent soil erosion measures are implemented.

All disturbed areas shall be stabilized as soon as possible. Seeding and Mulching (SM), to provide protection against rain and wind erosion, shall be performed temporarily, as needed, during the pre-construction, initial, and interim phases and maintained until final stabilization is completed. Site Stabilization will be achieved through use of temporary seeding and mulching (TS) and ultimately permanent landscaping (PS). All disturbed areas which are either final graded or will remain inactive for a period of more than 30 days shall be required to be stabilized within 14 days of the completion of the grading activities.

SEDIMENT CONTROL

Silt Fence (SF) is located downstream of disturbed areas and provides a sediment barrier for runoff. SF is installed to help reduce the amount of sediment in surface runoff that will be exiting/entering the Site. SF will be installed along portions of the limits of construction line located throughout the Site as denoted on the Site Map. The SF will be installed during the initial phases of construction activities and maintained throughout construction.

Item 18. Check dams VTC, and rock socks shown on submitted GEC plan.

Per COR400000 Permit stabilization requirements: temporary stabilization must be implemented for earth disturbing activities on any portion of the site where ground disturbing activity has permanently ceased, or temporarily ceased for more than 14 calendar days

Inlet Protection (IP) will be installed at each storm sewer inlet to minimize the sediment and debris entering the storm drainage system. IP will be present offsite during all phases of construction and will be placed on-site immediately following inlet installation.

In addition, a Temporary Sediment Basin (TSB) is located on the Southeast corner of the property to capture and slowly release runoff prior to discharge. The TSB will ensure sediment settles out of the stormwater runoff before discharging into the detention pond to the South of the site.

SITE/MATERIAL MANAGEMENT

One construction entrance with Vehicle Tracking Control (VTC) shall be installed at the southwest entrance of the Site in an effort to reduce off-site sediment tracking. The VTC shall be installed during the initial phase of construction activities.

A Concrete Washout Area (CWA) will be installed near the VTC to help isolate concrete truck washout operations upon departure. A CWA is installed when a site anticipates the generation of concrete wash water. CWAs provide an area for the proper collection and disposal of all liquid concrete waste. The CWA will be installed during the initial phase of construction activities. Three basic approaches are available to the Contractor and include an above-grade storage area, excavation of a pit in the ground, and a prefabricated haul-away concrete washout container. All concrete washout areas shall, as a minimum adhere to the following guidelines:

- Maintain a minimum distance of 400 feet from a stream or water body.
- Maintain a minimum distance of 1,000 feet from any wells or drinking water source.
- Shall not be located in a natural draw or drainage swale.
- Shall not be located in areas of highly permeable soils, i.e., gravels and sands.
- The chosen location shall be sited so that if a failure or overtopping occurs, the flow would be directed to a flat or depressed grassy area away from any water sources.
- The use of solvents, cleaners, or hazardous materials when cleaning or removing concrete is strictly prohibited.
- Backflushing shall not be permitted on site.
- Adequate and proper disposal of contents is required once the CWA has reached ½ capacity and at the end of concrete construction activities.

A stabilized staging area (SSA) to provide an area for construction activities and material storage will be located on the north side of the Site. The SSA provides a designated area for staging of construction materials and equipment, placement of job trailer, contractor parking, etc.

Street Sweeping (SS) is necessary for any site that has track out onto adjacent sites or roadways. Paved and impervious surfaces which are adjacent to construction sites must be swept on a weekly basis or as needed during the week when sediment and other materials are tracked or discharged onto them. Either sweeping by hand or use of street sweepers is acceptable. Street sweepers using water while sweeping is preferred in order to minimize dust. Scraped or swept material shall not be deposited in the storm sewer. Materials collected by the inlet protection shall be removed and shall not be deposited in the storm sewer. Street sweeping is the responsibility of the Operator and will not be performed by the County to meet the requirements of this Plan.

A documented use agreement is required between the applicable construction site owner or operator and the owner or operator of any Control Measures located outside of the construction site boundaries that are used by the applicable construction site for compliance with the GEC Plan, but not under the direct control of the applicable construction site owner or operator. The applicable construction site owner or operator is responsible for ensuring that all Control Measures located outside of the construction site boundaries, that

are being used by the applicable construction site, are properly maintained and in compliance with all terms and conditions of Part I.B.3. However, the need of a use agreement is not anticipated for this project because all control measures are located onsite or in the public right-of-way.

OTHER POTENTIAL POLLUTION CONSIDERATIONS

MATERIALS HANDLING AND SPILL PREVENTION

Any hazardous or potentially hazardous material that is brought onto the construction site shall be handled properly to reduce the potential for stormwater pollution. In an effort to minimize the potential for a spill of petroleum product or hazardous materials to come in contact with stormwater, the following steps shall be implemented:

- Material Safety Data Sheets (MSDS) information shall be kept on site for any and all applicable materials.
- All materials with hazardous properties (such as pesticides, petroleum products, fertilizers, detergents, construction chemicals, acids, paints, paint solvents, additives for soil stabilization, concrete, curing compounds and additives, etc.) shall be stored in a secure location, under cover and in appropriate, tightly sealed containers when not in use.
- The minimum practical quantity of all such materials shall be kept on the job site and scheduled for delivery as close to time of use as practical.
- A spill control and containment kit shall be provided on the construction site and location(s) shown on Site Maps.
- All of the product in a container shall be used before the container is disposed of. All such containers shall be triple rinsed, with water prior to disposal. The rinse water used in these containers shall be disposed of in a manner in compliance with State and Federal regulations and shall not be allowed to mix with stormwater discharges.
- All products shall be stored in and used from the original container with the original product label and used in strict compliance with the instructions on the product label.
- The disposal of excess or used products shall be in strict compliance with instructions on the product label.

Fueling for construction is anticipated to be conducted with a fuel truck that will not be kept permanently on-site. If utilized, temporary onsite fuel tanks for construction vehicles shall meet all state and federal regulations. Tanks shall have approved spill containment with the capacity required by the applicable regulations. From NFPA 30: All tanks shall be provided with secondary containment (i.e. containment external to and separate from primary containment). Secondary containment shall be constructed of materials of sufficient thickness, density and composition so as not to be structurally weakened as a result of contact with the fuel stored and capable of containing discharged fuel for a period of time equal to or longer than the maximum anticipated time sufficient to allow recovery of discharged fuel. Secondary containment may only be required on larger fuel tanks and the qualified stormwater manager should familiarize themselves with and follow local and state requirements.

The tanks shall be in sound condition free of rust or other damage which might compromise containment. Fuel storage areas shall meet all Environmental Protection Agency (EPA), OSHA and other regulatory requirements for signage, fire extinguisher, etc. Hoses, valves, fittings, caps, filler nozzles and associated hardware shall be maintained in proper working condition at all times. The location of fuel tanks shall be

shown on the Site Maps and shall be located to minimize exposure to weather and surface water drainage features.

The Operator shall develop and implement a Materials Handling and Spill Prevention Plan (MHSP) in accordance with the EPA and State of Colorado requirements. In the event of an accidental spill, immediate action shall be undertaken by the Operator to contain and remove the spilled material. All hazardous materials, including contaminated soil, shall be disposed of by the Operator in the manner specified by federal, state and local regulations and by the manufacturer of such products. As soon as possible, the spill shall be reported to the appropriate agencies. As required under the provisions of the Clean Water Act, any spill or discharge entering waters of the United States shall be properly reported. The Operator shall prepare a written record of any spill and associated clean-up activities of petroleum products or hazardous materials in excess of 1 gallon or reportable quantities, whichever is less. A copy of the Spill Report Form is included in **Appendix G** of this report.

Accidental spills shall be handled expeditiously as outlined in CDPHE guidance. Any spills of petroleum products or hazardous materials in excess of Reportable Quantities as defined by EPA or the state or local agency regulations, shall be immediately reported to the Colorado Department of Public Health and Environment spill reporting lines.

- CDPHE Environmental Release and Incident Reporting Line (877) 518-5608.
- National Response Center - (800) 424-8802

VEHICLE TRACKING AND DUST CONTROL

Vehicle Tracking Control measures (structural and non-structural) shall be implemented in order to control potential sediment discharges from vehicle tracking. Practices shall be implemented for all areas of potential vehicle tracking which include but are not limited to reduced site access and utilization of designated haul routes.

Areas of soil that are denuded of vegetation and have little protection from particles being picked up and carried by wind should be protected with a temporary cover or kept under control with water or other soil adhering products to limit wind transported particles exiting the site perimeter.

DEDICATED CONCRETE OR ASPHALT BATCH PLANTS

Dedicated concrete or asphalt batch plants are not anticipated with this project. If encountered, the Qualified Stormwater Manager shall notify EPC immediately and take appropriate containment and treatment measures and document as necessary.

WASTE MANAGEMENT AND DISPOSAL

An effective first step towards preventing pollution in stormwater from work sites involves using a common-sense approach to improve the facility's basic housekeeping methods. Poor housekeeping practices result in increased waste and potential for stormwater contamination.

No solid materials are allowed to be discharged from the site with stormwater. All solid waste, including disposable materials incidental to the construction activities, must be collected and placed in containers. Secure covers for the containers shall be provided if required by state and local requirements. The location of solid waste receptacles shall be identified on the SWMP by the Operator.

Item 13. Discuss inspection procedure for checking waste disposal bins for leaks and overflowing capacity. And discuss frequency that they will be emptied (or at what level of capacity would trigger the need to be emptied).

Per COR400000 Permit stabilization requirements: temporary stabilization must be implemented for earth disturbing activities on any portion of the site where ground disturbing activity has permanently ceased, or temporarily ceased for more than 14 calendar days

Concrete waste is anticipated with this project; and therefore, a dedicated concrete washout is required. The Qualified Stormwater Manager shall take appropriate containment and treatment measures and document as necessary

PORTABLE TOILETS

Portable toilets shall be provided on-site as necessary for construction personnel. Portable toilets shall be located on flat surfaces away from drainage paths. Toilets shall be located a minimum of 10 feet from stormwater inlets and 50 feet from state waters. They will be secured at all four corners to prevent overturning and cleaned on a weekly basis. They will be inspected daily for spills.

STABILIZATION AND STORMWATER MANAGEMENT

TEMPORARY STABILIZATION AND SHORT-TERM STORMWATER MANAGEMENT

The County considers the completion of over-lot grading operations, by definition, to be substantially complete; therefore, all areas that will be dormant for more than 30 days after the completion of the over-lot grading will require temporary seeding within 14 days of establishment. This does not preclude the 7-day requirement for areas fully completed in the future. At a minimum, in ensuring that this requirement is followed, adequate phasing/scheduling will be required.

FINAL STABILIZATION AND LONG-TERM STORMWATER MANAGEMENT

In the natural condition, the site soil is stabilized by means of native vegetation. The final stabilization technique to be used at this project for stabilizing soils shall be to provide a protective cover of landscaping vegetation, pavement and granular stabilization material. Seeding should be conducted after final grade is achieved and soils are prepared to take advantage of soil moisture and seed germination. Long term stabilization of the proposed extended detention basin includes this permanent seeding. Long-term water quality is provided by the EDB and proposed vegetative swales. The EDB provides maintenance access roads to clean sediment and debris from trickle channels and the outlet structure, which should be routinely maintained. The Qualified Stormwater Manager should evaluate the short and long-term forecasts prior to applying permanent seed.

Final site stabilization is achieved when vegetative cover provides permanent stabilization with a density greater than 70 percent of the pre-disturbance levels, or equivalent permanent, physical erosion reduction methods have been employed over the entire area to be stabilized by vegetative cover. This area is exclusive of areas that are covered with rock (crushed granite, gravel, etc.) or landscape mulch, paved or have a building or other permanent structure on them.

INSPECTION AND MAINTENANCE

Inspections shall be the responsibility of the Qualified Stormwater Manager throughout the construction process.

INSPECTION SCHEDULE REQUIREMENTS

Inspection and maintenance of erosion control measures shall comply with the criteria set forth by the General Permit (COR400000), or the following, whichever is more stringent.

Item 22. Regarding final stabilization via vegetative cover, discussion should include the methods used to achieve vegetative cover such as specific seed mix & application rate, application method (e.g. drill seed, hydro seed), soil prep/amendments, selected soil stabilization methods (e.g. crimped straw, hydro mulch, ECB, TRM). Alternatively, reference the document (e.g. the landscape plan) where this information is located. Note that the landscape plan submitted with PPR2444 only discusses the seed mix & application rate and application method.

The Permittee or Contractor shall produce written and signed records every seven (7) days and after within 24 hours after every significant precipitation or snow melt events that causes surface erosion. All necessary maintenance and repair shall be completed immediately. If more frequent inspections are required to ensure that control measures are properly maintained and operated, the inspection schedule shall be modified to meet this need.

When snow cover exists over the entire site for an extended period, inspections are not always feasible. This condition should be documented, including date of snowfall and date of melting conditions to bring awareness of and preparation for areas where melting conditions may pose a risk of surface erosion.

A copy of the SWMP shall be maintained at the site at all times. Any degradation of the control measures described in the SWMP or excessive accumulation of sediments shall be remedied immediately upon discovery. The Contractor shall record all storm events on the Storm Event Log included in **Appendix H**.

INSPECTION PROCEDURES

The inspection shall include observations of:

- The Construction Site Perimeter and Discharge Points;
- All Disturbed Areas;
- Vehicles and Equipment;
- Areas Used for Material / Waste Storage That are Exposed to Precipitation;
- Other Areas Determined to Have a Significant Potential for Stormwater Pollution;
- Erosion and Sediment Control Measures Identified in the SWMP; and
- Any Other Structural Control Measures That May Require Maintenance.

The inspection must determine if there is evidence of, or the potential for, pollutants entering the drainage system. Control measures should be reviewed to determine if they still meet the design intent and operational criteria in the SWMP and if they continue to adequately control pollutants at the site. Any control measures not operating in accordance with the SWMP must be addressed as soon as possible, immediately in most cases, to minimize the discharge of pollutants and the SWMP must be updated and inspections must be documented.

Examples of specific items to evaluate during site inspections are listed below. This list is not intended to be comprehensive. Ultimately, it is the responsibility of the Contractor to assure the adequacy of site pollutant discharge controls. Actual physical site conditions or contractor practices could make it necessary to install more controls than are shown on the plans. Assessing the need for additional controls and implementing them or adjusting existing controls will be an ongoing requirement until the site achieves final stabilization.

1. Vehicle Tracking Control - Locations where vehicles enter and exit the site shall be inspected for evidence of offsite sediment tracking. Exits shall be maintained as necessary to prevent the release of sediment from vehicles leaving the site. Any sediment deposited on the adjacent roadway shall be removed as necessary throughout the day or at the end of every day and disposed of in an appropriate manner. Sediment shall not be washed into storm sewer systems.
2. Erosion Control Devices - Rolled erosion control products (nets, blankets, turf reinforcement mats) and marginally vegetated areas (areas not meeting required vegetative densities for final stabilization) must be inspected frequently. Riling, rutting and other signs of erosion indicate the erosion control device is not functioning properly and additional erosion control devices are warranted.

3. Sediment Control Devices - Sediment barriers (silt fence, sediment control logs, etc.), traps and basins must be inspected, and they must be cleaned out at such time as their original capacity has been reduced by 50 percent. All material excavated from behind sediment barriers or in traps and basins shall be incorporated into onsite soils or spread out on an upland portion of the site and stabilized. To minimize the potential for sediment releases from the Project, site perimeter control devices shall be inspected with consideration given to changing up-gradient conditions.
4. Material Storage Areas - Material storage areas should be located to minimize exposure to weather. Inspections shall evaluate disturbed areas and areas used for storing materials that are exposed to rainfall for evidence of, or the potential for, pollutants entering the drainage system or discharging from the site. If necessary, the materials must be covered, or original covers must be repaired or supplemented. Also, protective berms must be constructed, if needed, in order to contain runoff from material storage areas. All state and local regulations pertaining to material storage areas shall be adhered to.
5. Vegetation - Seed/Sod shall be free of weedy species and appropriate for site soils and regional climate. Seeding, sodding, tacking, and mulching shall be completed, in accordance with the requirements outlined within the Project Manual and locations identified within the plans, immediately after topsoil is applied and final grade is reached. Grassed areas shall be inspected to confirm that a healthy stand of grass is maintained. Rip-rap, mulch, gravel, decomposed granite or other equivalent permanent stabilization measures may be employed in lieu of vegetation based on site-specific conditions and Owner approval.
6. Discharge Points - All discharge points must be inspected to determine whether erosion and sediment control measures are effective in preventing discharge of sediment from the site or impacts to receiving waters.

Based on the inspection results, all necessary maintenance and repair shall be completed immediately and in no cases longer than seventy-two (72) hours after identification. The inspection reports must be completed after each inspection. An important aspect of the inspection report is the description of additional measures that need to be taken to enhance plan effectiveness. The inspection report must identify whether the site was in compliance with the SWMP at the time of inspection and specifically identify all incidents of non-compliance.

The Qualified Stormwater Manager shall ensure that, at a minimum, the following is recorded for each inspection and kept onsite for reference:

- a. The inspector's name and signature (must be a Qualified Stormwater Manager),
- b. The date and type of the inspection (regular inspection vs. post-storm inspection),
- c. Weather conditions at the time of the inspection,
- d. Phase of construction at the time of the inspection,
- e. Estimated acreage of disturbance at the time of inspection,
- f. The minimum frequency of inspections chosen,
- g. Location(s) of discharges of sediment or other pollutants from the site,
- h. Location(s) of control measures needing maintenance,
- i. Location(s) and identification of inadequate control measures
- j. Location(s) and identification of additional control measures are needed that were not in place at the time of inspection, and
- k. Any corrective actions taken.

If repairs are needed to any control measures, they shall be completed immediately. After adequate corrective action(s) and maintenance have been taken, or where a report does not identify any incidents requiring corrective action or maintenance, the report shall contain a statement stating the following:

"I verify that, to the best of my knowledge and belief, all corrective action and maintenance items identified during the inspection are complete, and the site is currently in compliance with the permit."

This statement must be signed by a Qualified Stormwater Manager. If it is infeasible to install or repair of control measure immediately after discovering the deficiency, the following information must be documented and kept on record:

1. Describe why it is infeasible to initiate the installation or repair immediately; and
2. Provide a schedule for installing or repairing the control measure and returning it to an effective operating condition as soon as possible.

The use and maintenance of log books, photographs, field notebooks, drawings or maps should also be included in the SWMP records when appropriate. Copies of the Inspection and Sampling Report Forms have been included in **Appendix I** for reference and use.

CONTROL MEASURE MAINTENANCE / REPLACEMENT AND FAILED CONTROL MEASURES

Site inspection procedures noted above must address maintenance of control measures that are found to no longer function as needed and designed, as well as preventive measures to proactively ensure continued operation.

The Qualified Stormwater Manager shall implement a preventative maintenance program to ensure that control measure breakdowns and failures are handled proactively. Site inspections should uncover any conditions which could result in the discharge of pollutants to storm sewers and surface waters and shall be rectified. For example, sediment shall be removed from silt fences on a regular basis to prevent failure of the control measure. Sediment shall be removed to an appropriate location so that it will not become an additional pollutant source.

The inspection process must also include replacement of control measures when needed or the addition of new control measures in order to adequately manage the pollutant sources at the site.

Any control measure deficiencies, replacement or additional control measures that may be required shall be documented on the Stormwater Management Site Map and on the appropriate Inspection Form. If amendments to the SWMP are required, these amendments shall be documented on the SWMP Amendment Log included in **Appendix J** for reference and use.

DISPOSITION OF TEMPORARY MEASURES

Most temporary erosion and sediment control measures must be removed within 30 days after final site stabilization is achieved. Trapped sediment and disturbed soil areas resulting from the disposal of temporary measures must be returned to final plan grades and permanently stabilized to prevent further soil erosion.

PLAN MODIFICATIONS

Plan revisions made prior to or following a change(s) onsite, including revisions to sections addressing site conditions and control measures, a notation must be included in the plan that identifies:

- Date of site change,
- The control measure removed or modified,
- The location(s) of those control measures, and

- Any changes to the control measure.

This project does not rely on control measures owned or operated by another entity.

The SWMP Report should be viewed as a “living document” that is continuously being reviewed and modified as a part of the overall process of evaluating and managing storm water quality issues at the site. The QSM shall amend the SWMP when there is a change in design, construction, O&M of the site which would require the implementation of new or revised BMPs or if the SWMP proves to be ineffective in achieving the general objectives of controlling pollutants in storm water discharges associated with construction activity of when BMPs are no longer necessary and are removed.

REFERENCES

Colorado Discharge Permit System (CDPS) – Stormwater Discharge Associated with Construction Activities Application - Prepared by Water Quality Control Division, Colorado Department of Public Health and Environment; Revised April 2019.

Colorado Discharge Permit System (CDPS) General Permit – Stormwater Discharges Associated with Construction Activity - Prepared by Water Quality Control Division, Colorado Department of Public Health and Environment; signed and issued on May 31, 2007 and administratively continued effective July 1, 2012.

NRCS Web Soil Survey - Website: <http://websoilsurvey.nrcs.usda.gov>

Stormwater Discharges Associated with Construction Activity – Stormwater Management Plan Preparation Guidance - Prepared by Water Quality Control Division, Colorado Department of Public Health and Environment; Revised April 2011.

Threatened, Endangered, Candidate and Proposed Species by County - Prepared by US Department of the Interior, Fish and Wildlife Services, Ecological Services, Colorado Field Offices; printed March 2019.

Urban Storm Drainage Criteria Manual, Volume 3 – Mile High Flood District, Denver, CO.; November 2015.

APPENDIX A – GRADING AND EROSION CONTROL PLANS

VENTURE ON VENETUCCI GRADING AND EROSION CONTROL PLAN

LOCATED IN THE SOUTH HALF OF SECTION 4,
TOWNSHIP 15 SOUTH, RANGE 66 WEST OF THE 6TH P.M.
COUNTY OF EL PASO, STATE OF COLORADO

LEGAL DESCRIPTION

COMMENCING AT THE SOUTHEAST QUARTER OF SAID SECTION 4, AS MONUMENTED BY A RECOVERED 2-1/2" ALUMINUM CAP, 0.1 FEET ABOVE GRADE, STAMPED "ASC 1999 PLS 28651", WHENCE THE EAST QUARTER CORNER OF SAID SECTION 4, AS MONUMENTED BY A RECOVERED 2-1/2" ALUMINUM CAP IN RANGE BOX, STAMPED "ASC 1999 PLS 28651, BEARS N 01°01'43" W, FOR A DISTANCE OF 2633.35 FEET, SAID LINE FORMING THE BASIS OF BEARINGS FOR THIS DESCRIPTION;

THENCE N 73°56'11" W, A DISTANCE OF 2734.78 FEET TO THE NORTHEAST CORNER OF LOT 1, SOUTH ACADEMY HIGHLANDS FILING NO. 4 AS RECORDED AT RECEPTION NO. 222714970 IN THE RECORDS OF EL PASO COUNTY, SAID POINT BEING THE POINT OF BEGINNING;

THENCE COINCIDENT WITH THE NORTH LINE AND EXTENSION THEREOF OF SAID LOT 1 THE FOLLOWING THREE (3) COURSES:

- 1) S 89°29'47" W, A DISTANCE OF 62.20 FEET;
- 2) ALONG A TANGENT CURVE TO THE LEFT WITH A CENTRAL ANGLE OF 35°30'48", A RADIUS OF 238.00 FEET, AN ARC LENGTH OF 147.52 FEET; AND A CHORD BEARING AND DISTANCE OF S 71°44'24" W, 145.17 FEET;
- 3) S 53°58'59" W, A DISTANCE OF 190.82 FEET;

THENCE N 36°03'36" W, A DISTANCE OF 155.64 FEET;
 THENCE N 21°58'50" W, A DISTANCE OF 272.69 FEET;
 THENCE N 02°31'59" W, A DISTANCE OF 127.26 FEET;
 THENCE N 21°58'47" W, A DISTANCE OF 284.99 FEET;
 THENCE N 08°14'28" W, A DISTANCE OF 450.13 FEET;
 THENCE N 18°57'10" E, A DISTANCE OF 224.76 FEET;
 THENCE N 68°01'13" E, A DISTANCE OF 452.74 FEET TO A POINT ON THE WEST LINE OF TRACT B, SOUTH ACADEMY HIGHLANDS FILING NO. 2 AS RECORDED AT RECEPTION NO. 216713726 IN SAID RECORDS;

THENCE COINCIDENT WITH SAID WEST LINE THE FOLLOWING TWO (2) COURSES:

- 1) S 05°08'13" W, A DISTANCE OF 273.60 FEET;
- 2) ALONG A TANGENT CURVE TO THE LEFT WITH A CENTRAL ANGLE OF 27°13'21", A RADIUS OF 605.00 FEET, AN ARC LENGTH OF 287.45 FEET; AND A CHORD BEARING AND DISTANCE OF S 08°28'27" E, 284.75 FEET TO A POINT ON THE WEST LINE OF TRACT A, SOUTH ACADEMY HIGHLANDS FILING NO. 1 AS RECORDED AT RECEPTION NO. 214713425 IN SAID RECORDS;

THENCE COINCIDENT WITH THE WEST LINE OF SAID TRACT A AND EXTENSION THEREOF S 22°05'08" E, A DISTANCE OF 501.71 FEET TO A POINT ON THE WEST LINE OF VENETUCCI BOULEVARD AS DEDICATED IN SAID SOUTH ACADEMY HIGHLANDS FILING NO. 1;

THENCE COINCIDENT WITH SAID WEST LINE THE FOLLOWING FOUR (4) COURSES:

- 1) ALONG A TANGENT CURVE TO THE RIGHT WITH A CENTRAL ANGLE OF 21°34'55", A RADIUS OF 560.00 FEET, AN ARC LENGTH OF 210.94 FEET; AND A CHORD BEARING AND DISTANCE OF S 11°17'40" E, 209.69 FEET;
- 2) S 00°30'10" E, A DISTANCE OF 51.78 FEET;
- 3) S 89°29'47" W, A DISTANCE OF 17.00 FEET;
- 4) S 00°30'13" E, A DISTANCE OF 162.77 FEET TO THE POINT OF BEGINNING.

CONTAINING A CALCULATED AREA OF 706,978 SQUARE FEET OR 16.2300 ACRES, MORE OR LESS.

AGENCY CONTACTS:

<p>STRATMOOR HILLS FIRE DISTRICT 2160 B ST. COLORADO SPRINGS, CO 80906 PHONE: (719) 576-1200 CONTACT: MARK STANWOOD</p>	<p>STRATMOOR HILLS WATER AND SANITATION DISTRICTS 1811 B ST. COLORADO SPRINGS, CO 80906 PHONE: (719) 210-5295 CONTACT: KIRK MEDINA</p>
<p>PIKES PEAK REGIONAL BUILDING DEPT. 2880 INTERNATIONAL CIRCLE, COLORADO SPRINGS, CO 80910 PHONE: (719) 327-2880</p>	<p>PLANNING AND COMMUNITY DEVELOPMENT 2880 INTERNATIONAL CIRCLE, COLORADO SPRINGS, CO 80910 PHONE: (719) 520-7952 CONTACT: SCOTT WEEKS, P.E.</p>

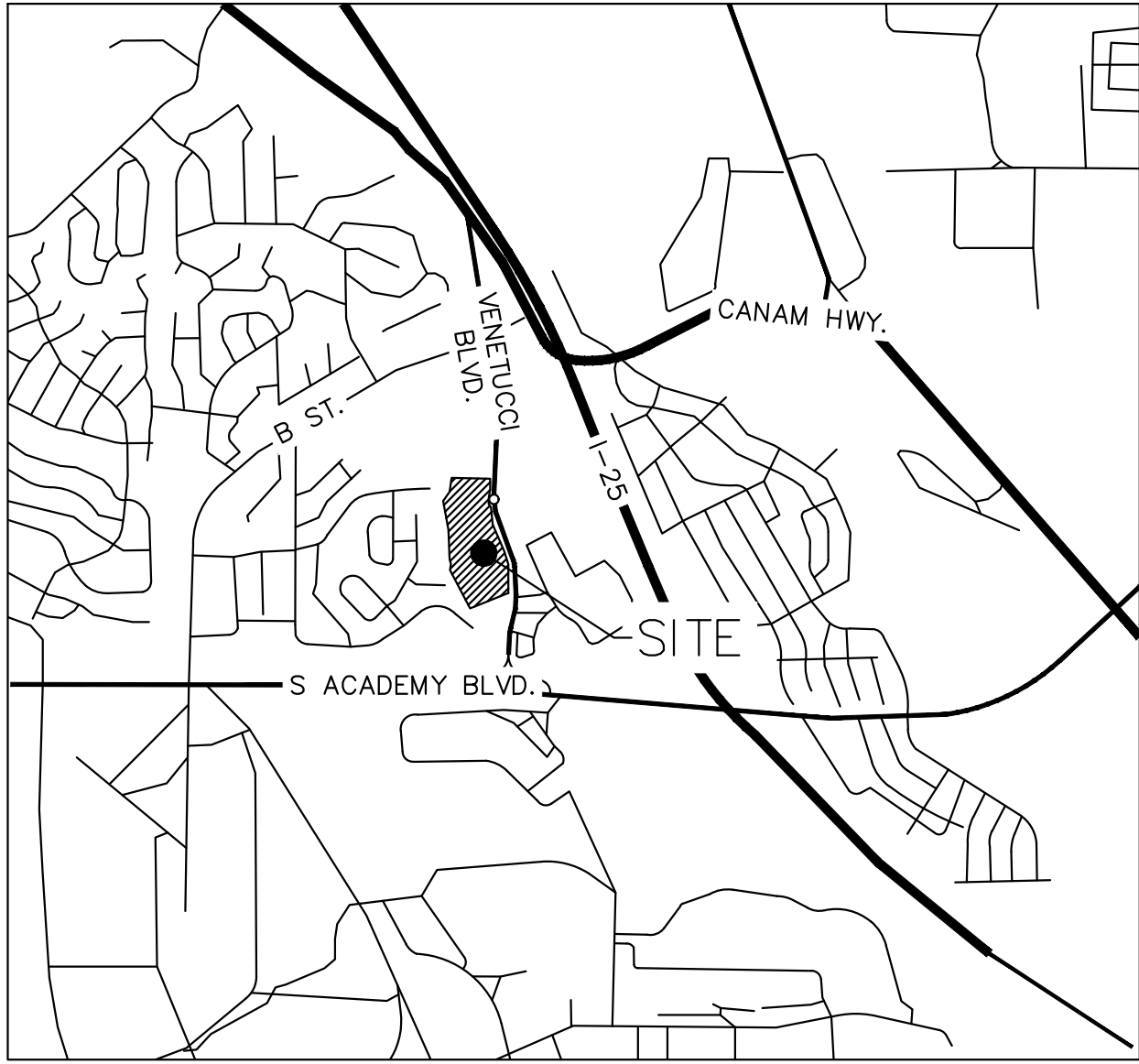

SHEET LIST TABLE	
SHEET NUMBER	SHEET TITLE
C002	GEC COVER SHEET
C300	GEC GENERAL NOTES
C301	GEC INITIAL PLAN
C302	GEC INTERIM PLAN
C303	GEC FINAL PLAN
C304	GEC DETAILS
C305	GEC DETAILS
C306	GEC DETAILS
C307	GEC DETAILS

DESIGN TEAM CONTACTS:

<p>OWNER/DEVELOPER THOMPSON THRIFT DEVELOPMENT, INC. 111 MONUMENT CIRCLE, SUITE 1500, INDIANAPOLIS, IN 46204 TEL: (336) 609-2131 CONTACT: DONALD DUNGU</p>	<p>ARCHITECT STUDIO M 275 VETERANS WAY, SUITE 200 CARMEL, IN 46032 PHONE: (317) 810-1502 CONTACT: NICK ALEXANDER, AIA, LEED AP</p>
<p>CIVIL ENGINEER KIMLEY-HORN AND ASSOCIATES, INC. 6200 SOUTH SYRACUSE WAY, SUITE 300 GREENWOOD VILLAGE, CO 80111 PHONE: (303) 228-2300 CONTACT: MICHAEL HART, P.E.</p>	<p>LANDSCAPE ARCHITECT N.E.S. INC. 619 N. CASCADE AVENUE, SUITE 200 COLORADO SPRINGS, CO 80903 TEL: (719) 471-0073 CONTACT: JORDAN SMITH</p>
<p>SURVEYOR KIMLEY-HORN AND ASSOCIATES, INC. 6200 SOUTH SYRACUSE WAY, SUITE 300 GREENWOOD VILLAGE, CO 80111 PHONE: (303) 228-2300 CONTACT: DARREN WOLTERSTORFF, P.L.S.</p>	

LAND AREA:

TOTAL PROPERTY AREA: ±16.23

BENCHMARK:

ELEVATIONS ARE BASED UPON MONUMENT FH12, A 3-1/4" ALUMINUM CAP IN RANGE BOX IN THE MEDIAN OF THE PARKING LOT AT MARY KYER PARK, COLORADO SPRINGS, COLORADO. (ELEVATION = 6745.47 NAVD 88)

FLOOD ZONE DESIGNATION:

FEDERAL EMERGENCY MANAGEMENT AGENCY, FLOOD INSURANCE RATE MAP, MAP NUMBER 08041C0743G, EFFECTIVE DATE DECEMBER 07, 2018, INDICATES THIS PARCEL OF LAND TO BE LOCATED IN ZONE X (AREAS DETERMINED TO BE OUTSIDE THE 0.2% ANNUAL CHANCE FLOODPLAIN).

SITE INFORMATION:

TIMING:
ANTICIPATED STARTING AND COMPLETION TIME PERIOD OF SITE GRADING:
START: FALL 2025
END: SPRING 2026

EXPECTED DATE ON WHICH THE FINAL STABILIZATION WILL BE COMPLETE:
FALL 2027

AREAS:
TOTAL DISTURBED AREA: 16.44 ACRES

RECEIVING WATERS:
NAME OF RECEIVING WATERS: FISHER'S CANYON CREEK

DESCRIPTION OF EXISTING VEGETATION:
THE EXISTING SITE IS CURRENTLY UNDEVELOPED AND GROUND COVER CONSISTS OF 100% WEEDS, BRUSH, GRASSES, AND VEGETATIVE SWALES.

DESCRIPTION OF PERMANENT BMPs:
FULL SPECTRUM EXTENDED DETENTION BASIN

SOILS INFORMATION:
100% HYDROLOGIC SOIL GROUP A

OWNER'S STATEMENT

I, THE OWNER/DEVELOPER HAVE READ AND WILL COMPLY WITH THE REQUIREMENTS OF THE GRADING AND EROSION CONTROL PLAN.

THOMPSON THRIFT DEVELOPMENT, INC.
OWNER SIGNATURE _____ DATE _____

ENGINEER'S STATEMENT

THIS GRADING AND EROSION CONTROL PLAN WAS PREPARED UNDER MY DIRECTION AND SUPERVISION AND IS CORRECT TO THE BEST OF MY KNOWLEDGE AND BELIEF. SAID PLAN HAS BEEN PREPARED ACCORDING TO THE CRITERIA ESTABLISHED BY THE COUNTY FOR GRADING AND EROSION CONTROL PLANS. I ACCEPT RESPONSIBILITY FOR ANY LIABILITY CAUSED BY ANY NEGLIGENT ACTS, ERRORS OR OMISSIONS ON MY PART IN PREPARING THIS PLAN.

MICHAEL HART, PE - KIMLEY-HORN AND ASSOCIATES, INC. DATE _____

EL PASO COUNTY

COUNTY PLAN REVIEW IS PROVIDED ONLY FOR GENERAL CONFORMANCE WITH COUNTY DESIGN CRITERIA. THE COUNTY IS NOT RESPONSIBLE FOR THE ACCURACY AND ADEQUACY OF THE DESIGN, DIMENSIONS, AND/OR ELEVATIONS WHICH SHALL BE CONFIRMED AT THE JOB SITE. THE COUNTY THROUGH THE APPROVAL OF THIS DOCUMENT ASSUMES NO RESPONSIBILITY FOR COMPLETENESS AND/OR ACCURACY OF THIS DOCUMENT.

FILED IN ACCORDANCE WITH THE REQUIREMENTS OF THE EL PASO COUNTY LAND DEVELOPMENT CODE, DRAINAGE CRITERIA MANUAL VOLUMES 1 AND 2, AND ENGINEERING CRITERIA MANUAL, AS AMENDED.

IN ACCORDANCE WITH ECM SECTION 1.12, THESE CONSTRUCTION DOCUMENTS WILL BE VALID FOR CONSTRUCTION FOR A PERIOD OF 2 YEARS FROM THE DATE SIGNED BY THE EL PASO COUNTY ENGINEER. IF CONSTRUCTION HAS NOT STARTED WITHIN THOSE 2 YEARS, THE PLANS WILL NEED TO BE RESUBMITTED FOR APPROVAL, INCLUDING PAYMENT OF REVIEW FEES AT THE PLANNING AND COMMUNITY DEVELOPMENT DIRECTOR'S DISCRETION.

JENNIFER IRVINE, P.E. _____ DATE _____

NO.	REVISION	BY	DATE	APPR

Kimley»Horn

2024 KIMLEY-HORN AND ASSOCIATES, INC.
6200 South Syracuse Way, Suite 300
Greenwood Village, Colorado 80111 (303) 228-2300

DESIGNED BY: MTH
DRAWN BY: FCR
CHECKED BY: MTH
DATE: 11/12/2024

VENTURE ON VENETUCCI
 EL PASO COUNTY, COLORADO
 GRADING AND EROSION CONTROL PLAN
GEC COVER SHEET

PROJECT NO.
096302017

SHEET
C002



K:\DEN_Civil\096302017_Venetucci\Multi-Family\CADD\PlanSheets\GEC\096302017_GEC-INT.dwg Rankin, Cormac 11/14/2024 11:56 AM

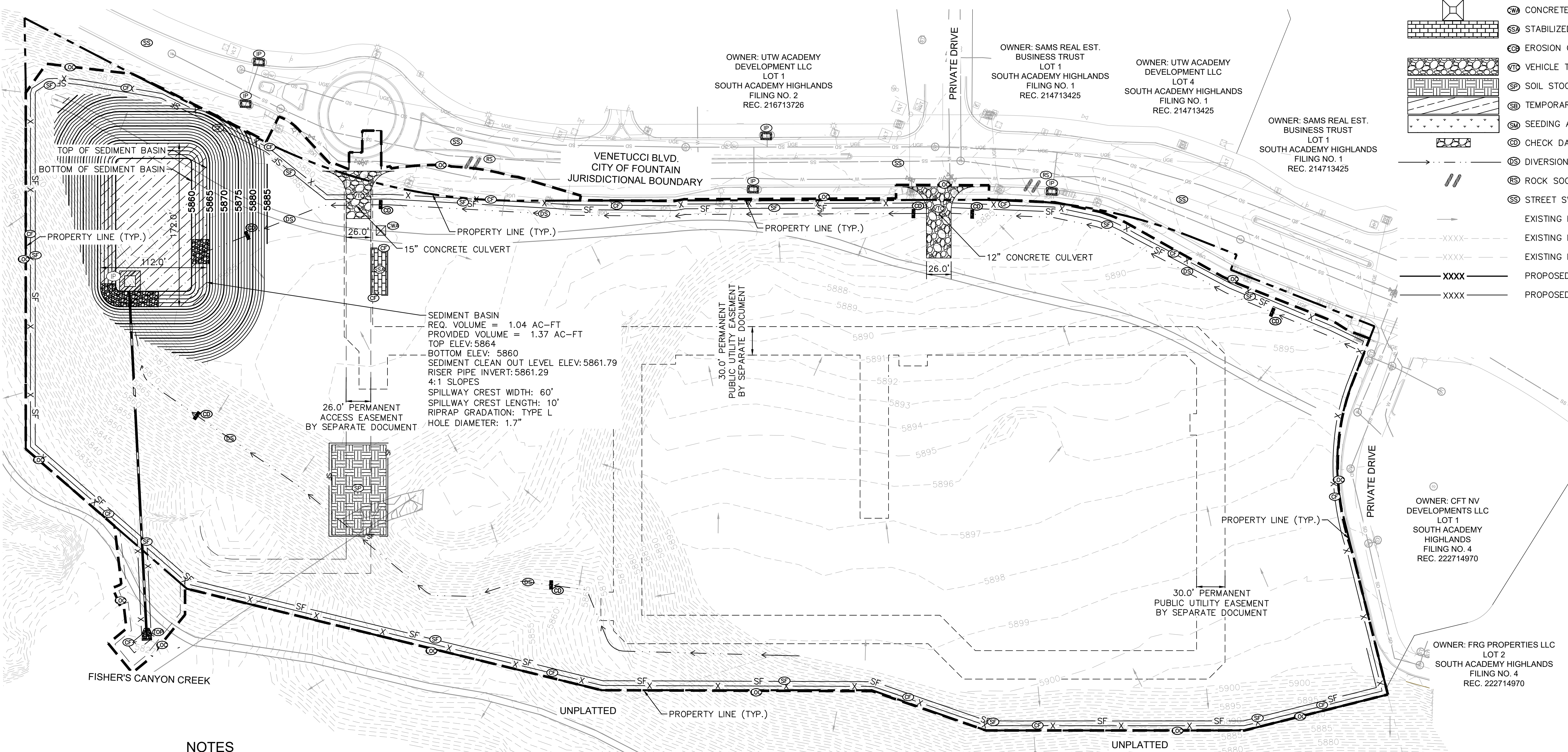

LEGEND	
	PROPERTY LINE
	LIMITS OF CONSTRUCTION/DISTURBANCE
	SILT FENCE
	CONSTRUCTION FENCE
	TEMPORARY OUTLET PROTECTION
	INLET/OUTLET PROTECTION
	CONCRETE WASHOUT AREA
	STABILIZED STAGING AREA
	EROSION CONTROL BLANKET
	VEHICLE TRACKING CONTROL
	SOIL STOCKPILE
	TEMPORARY SEDIMENT BASIN
	SEEDING AND MULCHING
	CHECK DAM
	DIVERSION SWALE
	ROCK SOCKS
	STREET SWEEPING
	EXISTING FLOW ARROW
	EXISTING MINOR CONTOUR
	EXISTING MAJOR CONTOUR
	PROPOSED MAJOR CONTOUR
	PROPOSED MINOR CONTOUR

NOTES

- THE INTENT OF THIS PLAN IS TO IDENTIFY THE EROSION CONTROL PRACTICES RECOMMENDED. THE CONTRACTOR SHALL REFERENCE ADDITIONAL CONSTRUCTION PLANS FOR DEMOLITION OF EXISTING AND CONSTRUCTION OF PROPOSED IMPROVEMENTS.
- ADJACENT STREETS SHALL BE KEPT CLEAN AND FREE OF SEDIMENT AND/OR DEBRIS AT ALL TIMES.
- TEMPORARY STABILIZATION (TS) SHALL BE IMPLEMENTED WITHIN THE DISTURBED PORTIONS OF THE PROJECT SITE NO LATER THAN 14 DAYS FOLLOWING THE CEASE OF CONSTRUCTION ACTIVITIES WITHIN THE DISTURBED AREAS.
- PERMANENT STABILIZATION (PS) MAY BE USED WITHIN AREAS OF TEMPORARY STABILIZATION (TS) AT THE CONTRACTOR'S DISCRETION. STABILIZATION SHALL BE APPLIED IN ACCORDANCE WITH APPLICABLE TEMPORARY STABILIZATION SEQUENCING REQUIREMENTS.
- CONTRACTOR SHALL UTILIZE ROLLED EROSION CONTROL PRODUCTS ON ALL SLOPES 3H:1V OR GREATER TO ACHIEVE REQUIRED STABILIZATION.
- CONTRACTOR SHALL MAINTAIN ACCEPTABLE EROSION CONTROL PRACTICES WITHIN THE ANTICIPATED LIMITS OF CONSTRUCTION IDENTIFIED HEREIN. BEST MANAGEMENT PRACTICES AND STABILIZATION SHALL BE COMPLETED AS IDENTIFIED HEREIN IN ACCORDANCE WITH OWNER REQUIREMENTS.
- ALL WORK IN THE VENETUCCI BLVD. ROW REQUIRES A ROW PERMIT FROM EL PASO COUNTY. CONTRACTOR IS RESPONSIBLE FOR APPLYING FOR AND OBTAINING ALL NECESSARY ROW PERMITS.
- SILT FENCE TO BE INSTALLED PRIOR TO COMMENCEMENT OF ONSITE GRADING AND CONSTRUCTION ACTIVITIES.
- DEMOLITION, REMOVAL, OVEREXCAVATION AND SOIL TREATMENT SHALL BE IN ACCORDANCE WITH THE GEOTECHNICAL ENGINEER RECOMMENDATIONS AS NOTED IN THE APPROVED PROJECT GEOTECHNICAL REPORT.
- SEE THIS SHEET FOR RISER PIPE AND SEDIMENT BASIN DETAILS.
- EXISTING SITE CONSISTS OF NATIVE WEEDS, BRUSH, GRASSES, AND VEGETATIVE SWALES.

BASIN NAME	TRIBUTARY AREA (AC)	REQUIRED VOLUME (AC-FT)	PROVIDED VOLUME (AC-FT)	WATER SURFACE ELEVATION (FT)	BASIN TOP ELEVATION (FT)	BASIN BOTTOM ELEVATION (FT)	SPILLWAY CREST LENGTH (FT)
A	12.58	1.04	1.04	5863.23	5864.00	5860.00	50.00

BASIN NAME	100% STORAGE ELEVATION (RISER TOP) (FT)	50% STORAGE ELEVATION (CENTER OF BOTTOM HOLE) (FT)	HOLE DIAMETER (IN)	NUMBER OF COLUMNS	NUMBER OF ROWS	UPSTREAM INVERT OF PIPE OUTFALL (FT)	DOWNSTREAM INVERT OF PIPE OUTFALL (FT)
A	5863.23	5861.79	1.7	1	3	5861.29	5828.58

LIMITS OF CONSTRUCTION

TOTAL DISTURBANCE	= ±16.23 ACRES
OFFSITE DISTURBANCE	= ±0.21 ACRES
TOTAL	= ±16.44 ACRES

Cut	Fill	Net
107,498 Cu. Yd.	65,192 Cu. Yd.	42,306 Cu. Yd. <Cut>

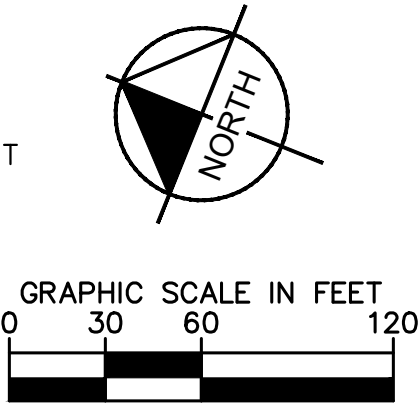
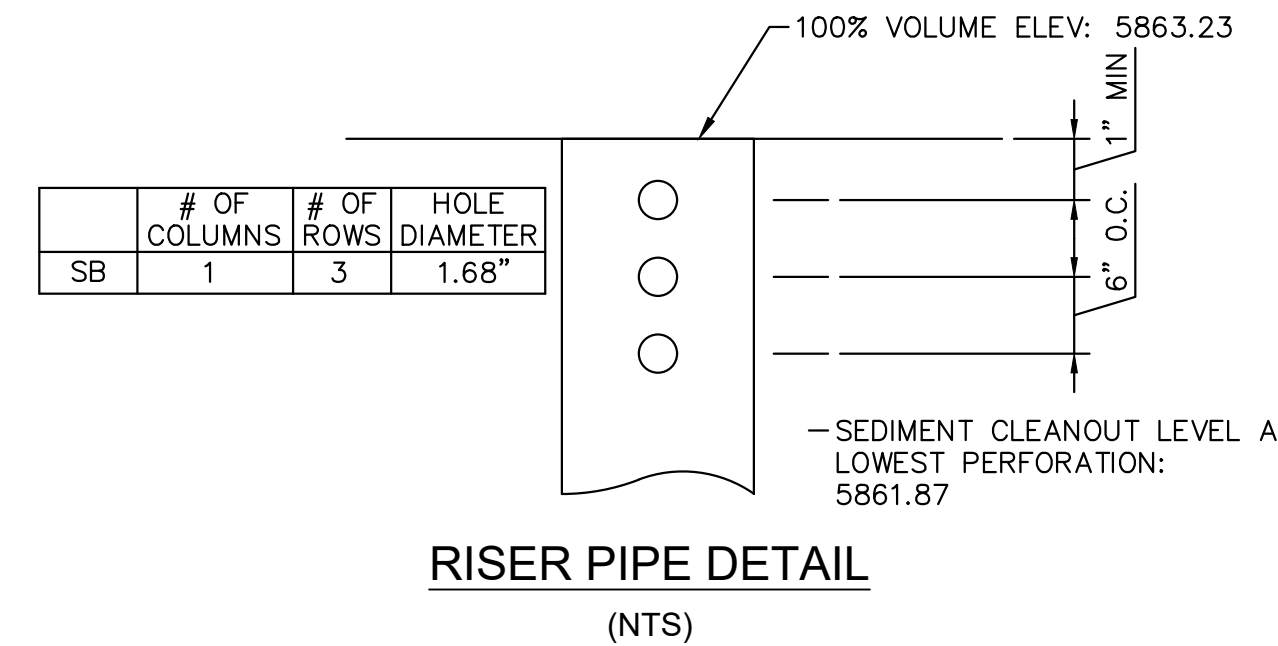

NO.
REVISION
BY
DATE
APPR

2024 KIMLEY-HORN AND ASSOCIATES, INC.
6200 South Syracuse Way, Suite 300
Greenwood Village, Colorado 80111 (303) 228-2300

DESIGNED BY: MTH
DRAWN BY: FCR
CHECKED BY: MTH
DATE: 11/05/2024

VENETUCCI MULTIFAMILY
EL PASO COUNTY, COLORADO
GRADING AND EROSION CONTROL PLANS
GEC INITIAL PLAN

PROJECT NO.
0963020187
SHEET
C301

K:\DEN_Civil\096302017_Venetucci\Multi-Family\CADD\PlanSheets\GEC\096302017_GEC-INTER.dwg Rankin, Cormac 11/14/2024 11:56 AM

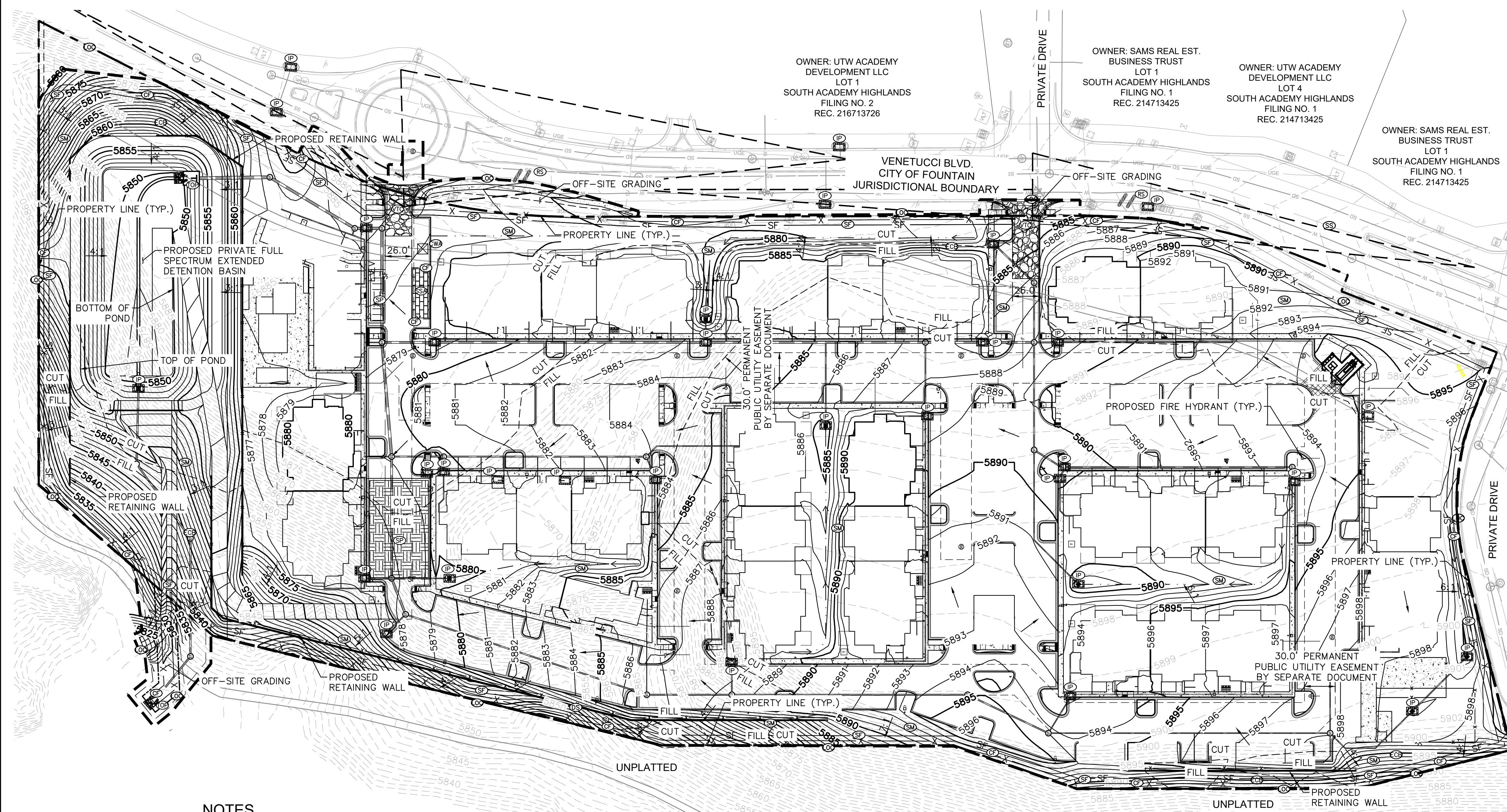

LEGEND

	PROPERTY LINE
	LIMITS OF CONSTRUCTION/DISTURBANCE
	SILT FENCE
	CONSTRUCTION FENCE
	TEMPORARY OUTLET PROTECTION
	INLET/OUTLET PROTECTION
	CONCRETE WASHOUT AREA
	STABILIZED STAGING AREA
	EROSION CONTROL BLANKET
	VEHICLE TRACKING CONTROL
	SOIL STOCKPILE
	SEEDING AND MULCHING
	CHECK DAM
	DIVERSION SWALE
	ROCK SOCKS
	EXISTING FLOW ARROW
	STREET SWEEPING
	EXISTING MINOR CONTOUR
	EXISTING MAJOR CONTOUR
	PROPOSED MAJOR CONTOUR
	PROPOSED MINOR CONTOUR
	CUT/FILL BOUNDARY
	PROPOSED FLOW ARROW
	PROPOSED SLOPE ARROW

NOTES

- THE INTENT OF THIS PLAN IS TO IDENTIFY THE EROSION CONTROL PRACTICES RECOMMENDED. THE CONTRACTOR SHALL REFERENCE ADDITIONAL CONSTRUCTION PLANS FOR DEMOLITION OF EXISTING AND CONSTRUCTION OF PROPOSED IMPROVEMENTS.
- ADJACENT STREETS SHALL BE KEPT CLEAN AND FREE OF SEDIMENT AND/OR DEBRIS AT ALL TIMES.
- TEMPORARY STABILIZATION (TS) SHALL BE IMPLEMENTED WITHIN THE DISTURBED PORTIONS OF THE PROJECT SITE NO LATER THAN 14 DAYS FOLLOWING THE CEASE OF CONSTRUCTION ACTIVITIES WITHIN THE DISTURBED AREAS.
- PERMANENT STABILIZATION (PS) MAY BE USED WITHIN AREAS OF TEMPORARY STABILIZATION (TS) AT THE CONTRACTOR'S DISCRETION. STABILIZATION SHALL BE APPLIED IN ACCORDANCE WITH APPLICABLE TEMPORARY STABILIZATION SEQUENCING REQUIREMENTS.
- CONTRACTOR SHALL UTILIZE ROLLED EROSION CONTROL PRODUCTS ON ALL SLOPES 3H:1V OR GREATER TO ACHIEVE REQUIRED STABILIZATION.
- CONTRACTOR SHALL MAINTAIN ACCEPTABLE EROSION CONTROL PRACTICES WITHIN THE ANTICIPATED LIMITS OF CONSTRUCTION IDENTIFIED HEREIN. BEST MANAGEMENT PRACTICES AND STABILIZATION SHALL BE COMPLETED AS IDENTIFIED HEREIN IN ACCORDANCE WITH OWNER REQUIREMENTS.
- ALL WORK IN THE VENETUCCI BLVD. AND WALMART HTS. ROW REQUIRES A ROW PERMIT FROM EL PASO COUNTY. CONTRACTOR IS RESPONSIBLE FOR APPLYING FOR AND OBTAINING ALL NECESSARY ROW PERMITS.
- SILT FENCE TO BE INSTALLED PRIOR TO COMMENCEMENT OF ONSITE GRADING AND CONSTRUCTION ACTIVITIES.
- DEMOLITION, REMOVAL, OVEREXCAVATION AND SOIL TREATMENT SHALL BE IN ACCORDANCE WITH THE GEOTECHNICAL ENGINEER RECOMMENDATIONS AS NOTED IN THE APPROVED PROJECT GEOTECHNICAL REPORT.
- SEE SHEET C301 FOR RISER PIPE AND SEDIMENT BASIN DETAILS.
- EXISTING SITE CONSISTS OF NATIVE WEEDS, BRUSH, GRASSES, AND VEGETATIVE SWALES.

LIMITS OF CONSTRUCTION

TOTAL DISTURBANCE	= ±16.23 ACRES
OFFSITE DISTURBANCE	= ±0.21 ACRES
TOTAL	= ±16.44 ACRES

Earthwork Summary

Cut	Fill	Net
107,498 Cu. Yd	65,192 Cu. Yd	42,306 Cu. Yd <Cut>

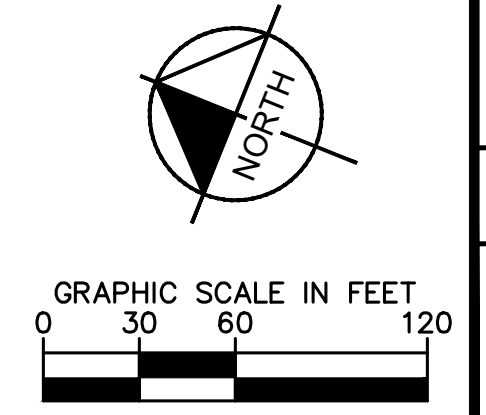

Kimley»Horn
 2024 KIMLEY-HORN AND ASSOCIATES, INC.
 6200 South Syracuse Way, Suite 300
 Greenwood Village, Colorado 80111 (303) 228-2300

DESIGNED BY: MTH
 DRAWN BY: FCR
 CHECKED BY: MTH
 DATE: 11/05/2024

VENETUCCI MULTIFAMILY
 EL PASO COUNTY, COLORADO
 GRADING AND EROSION CONTROL PLANS
GEC INTERIM PLAN

NO.	REVISION	BY	DATE	APPR.

PROJECT NO. 0963020187
 SHEET C302

K:\DEN_Civil\096302017_Venetucci\Multi-Family\CADD\PlanSheets\GEC\096302017_GEC-FINAL.dwg Rankin, Cormac 11/14/2024 11:58 AM

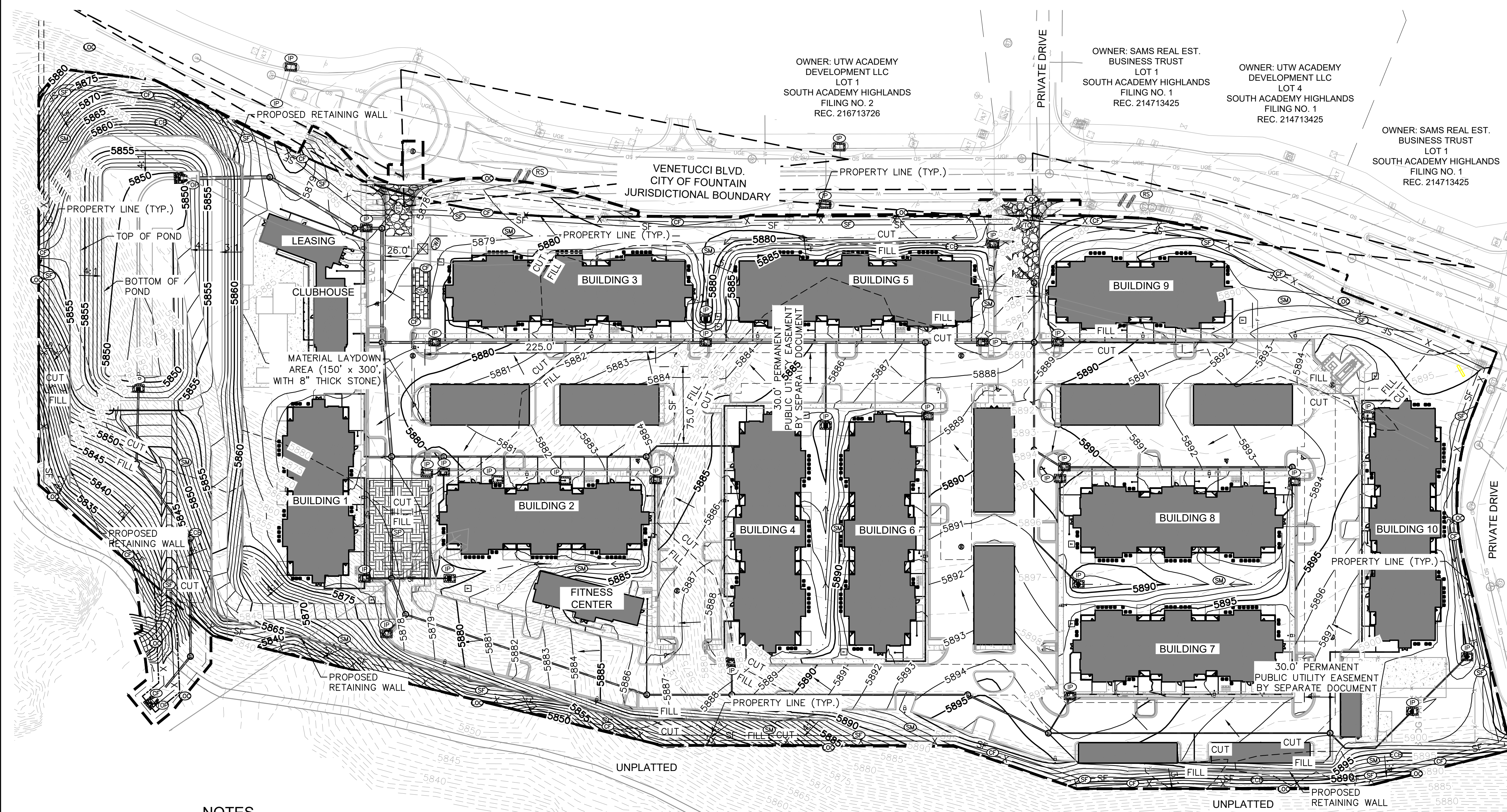

LEGEND

- PROPERTY LINE
- LIMITS OF CONSTRUCTION/DISTURBANCE
- SILT FENCE
- CONSTRUCTION FENCE
- TEMPORARY OUTLET PROTECTION
- CULVERT INLET/OUTLET PROTECTION
- CONCRETE WASHOUT AREA
- STABILIZED STAGING AREA
- EROSION CONTROL BLANKET
- VEHICLE TRACKING CONTROL
- SOIL STOCKPILE
- SEEDING AND MULCHING
- CHECK DAM
- DIVERSION SWALE
- ROCK SOCKS
- EXISTING FLOW ARROW
- EXISTING MINOR CONTOUR
- EXISTING MAJOR CONTOUR
- PROPOSED MAJOR CONTOUR
- PROPOSED MINOR CONTOUR
- CUT/FILL BOUNDARY
- PROPOSED FLOW ARROW
- PROPOSED FLOW ARROW WITH RUN:RISE

NOTES

1. THE INTENT OF THIS PLAN IS TO IDENTIFY THE EROSION CONTROL PRACTICES RECOMMENDED. THE CONTRACTOR SHALL REFERENCE ADDITIONAL CONSTRUCTION PLANS FOR DEMOLITION OF EXISTING AND CONSTRUCTION OF PROPOSED IMPROVEMENTS.
2. ADJACENT STREETS SHALL BE KEPT CLEAN AND FREE OF SEDIMENT AND/OR DEBRIS AT ALL TIMES.
3. TEMPORARY STABILIZATION (TS) SHALL BE IMPLEMENTED WITHIN THE DISTURBED PORTIONS OF THE PROJECT SITE NO LATER THAN 14 DAYS FOLLOWING THE CEASE OF CONSTRUCTION ACTIVITIES WITHIN THE DISTURBED AREAS.
4. PERMANENT STABILIZATION (PS) MAY BE USED WITHIN AREAS OF TEMPORARY STABILIZATION (TS) AT THE CONTRACTOR'S DISCRETION. STABILIZATION SHALL BE APPLIED IN ACCORDANCE WITH APPLICABLE TEMPORARY STABILIZATION SEQUENCING REQUIREMENTS.
5. CONTRACTOR SHALL UTILIZE ROLLED EROSION CONTROL PRODUCTS ON ALL SLOPES 3H:1V OR GREATER TO ACHIEVE REQUIRED STABILIZATION.
6. CONTRACTOR SHALL MAINTAIN ACCEPTABLE EROSION CONTROL PRACTICES WITHIN THE ANTICIPATED LIMITS OF CONSTRUCTION IDENTIFIED HEREIN. BEST MANAGEMENT PRACTICES AND STABILIZATION SHALL BE COMPLETED AS IDENTIFIED HEREIN IN ACCORDANCE WITH OWNER REQUIREMENTS.
7. ALL WORK IN THE VENETUCCI BLVD. AND WALMART HTS. ROW REQUIRES A ROW PERMIT FROM EL PASO COUNTY. CONTRACTOR IS RESPONSIBLE FOR APPLYING FOR AND OBTAINING ALL NECESSARY ROW PERMITS.
8. SILT FENCE TO BE INSTALLED PRIOR TO COMMENCEMENT OF ONSITE GRADING AND CONSTRUCTION ACTIVITIES.
9. DEMOLITION, REMOVAL, OVEREXCAVATION AND SOIL TREATMENT SHALL BE IN ACCORDANCE WITH THE GEOTECHNICAL ENGINEER RECOMMENDATIONS AS NOTED IN THE APPROVED PROJECT GEOTECHNICAL REPORT.
10. SEE SHEET C301 FOR RISER PIPE AND SEDIMENT BASIN DETAILS.
11. EXISTING SITE CONSISTS OF NATIVE WEEDS, BRUSH, GRASSES, AND VEGETATIVE SWALES.

LIMITS OF CONSTRUCTION

TOTAL DISTURBANCE	= ±16.23 ACRES
OFFSITE DISTURBANCE	= ±0.21 ACRES
TOTAL	= ±16.44 ACRES

Earthwork Summary		
Cut	Fill	Net
107,498 Cu. Yd.	65,192 Cu. Yd.	42,306 Cu. Yd. <Cut>

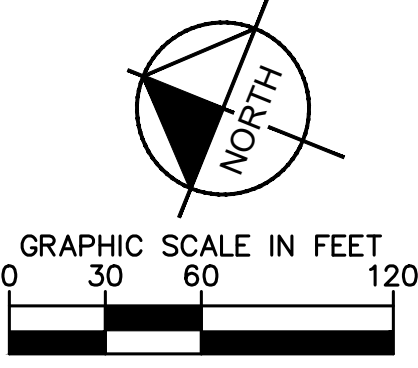

NO. _____ BY _____ DATE _____

REVISION _____

DESIGNED BY: MTH
DRAWN BY: FCR
CHECKED BY: MTH
DATE: 11/05/2024

VENETUCCI MULTIFAMILY
EL PASO COUNTY, COLORADO
GRADING AND EROSION CONTROL PLANS
GEC FINAL PLAN

PROJECT NO.
0963020187

SHEET
C303

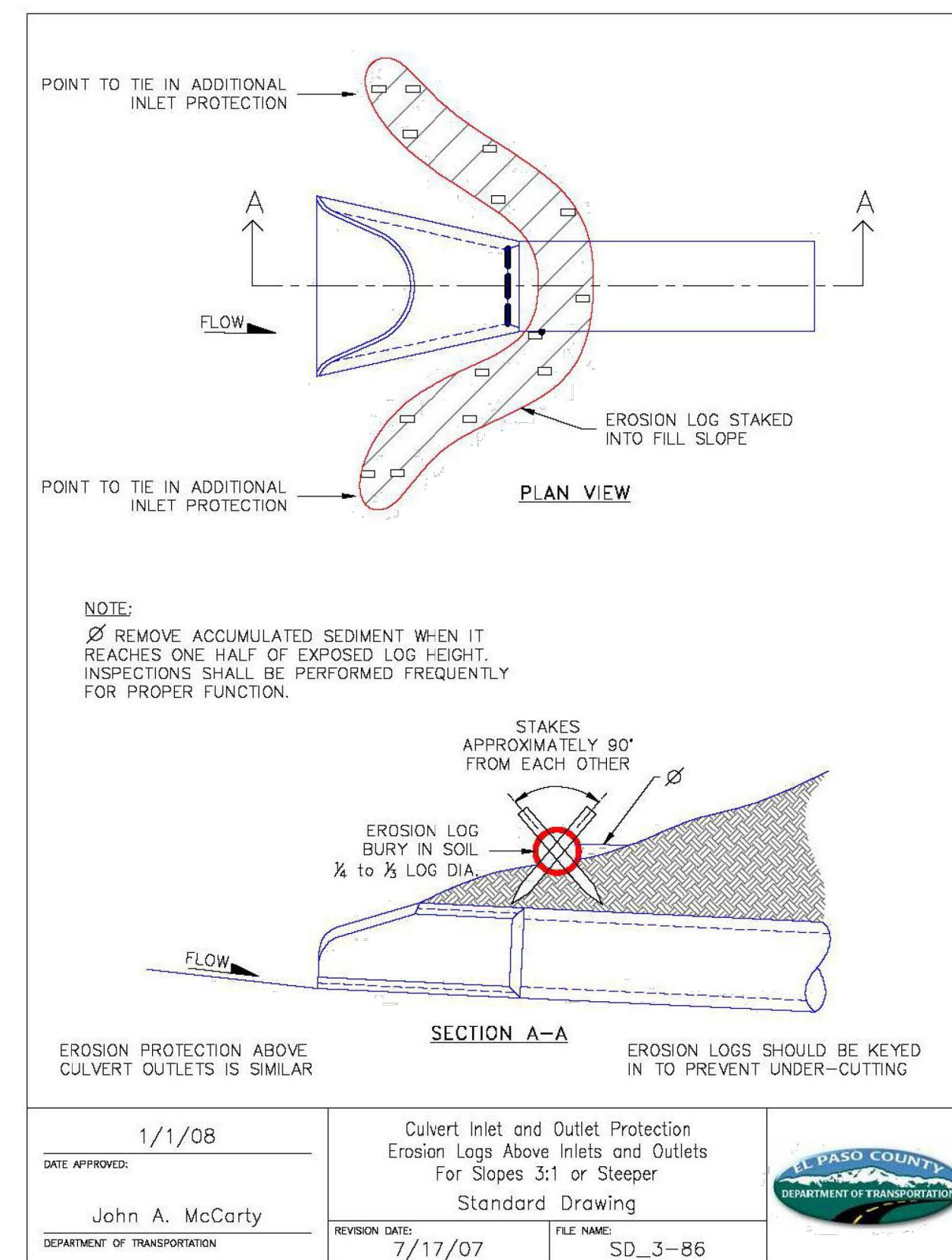
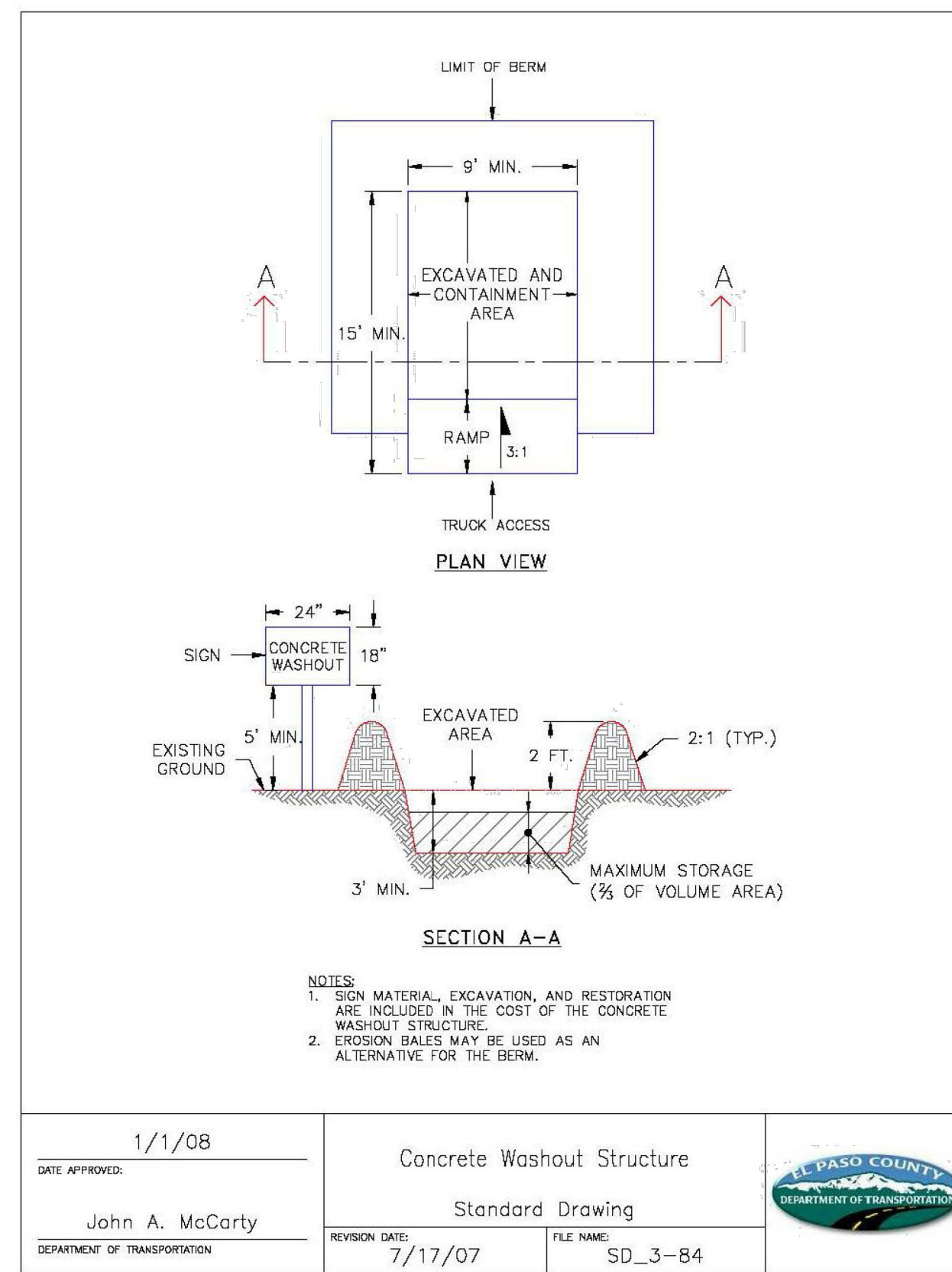

SM-3 Construction Fence (CF)

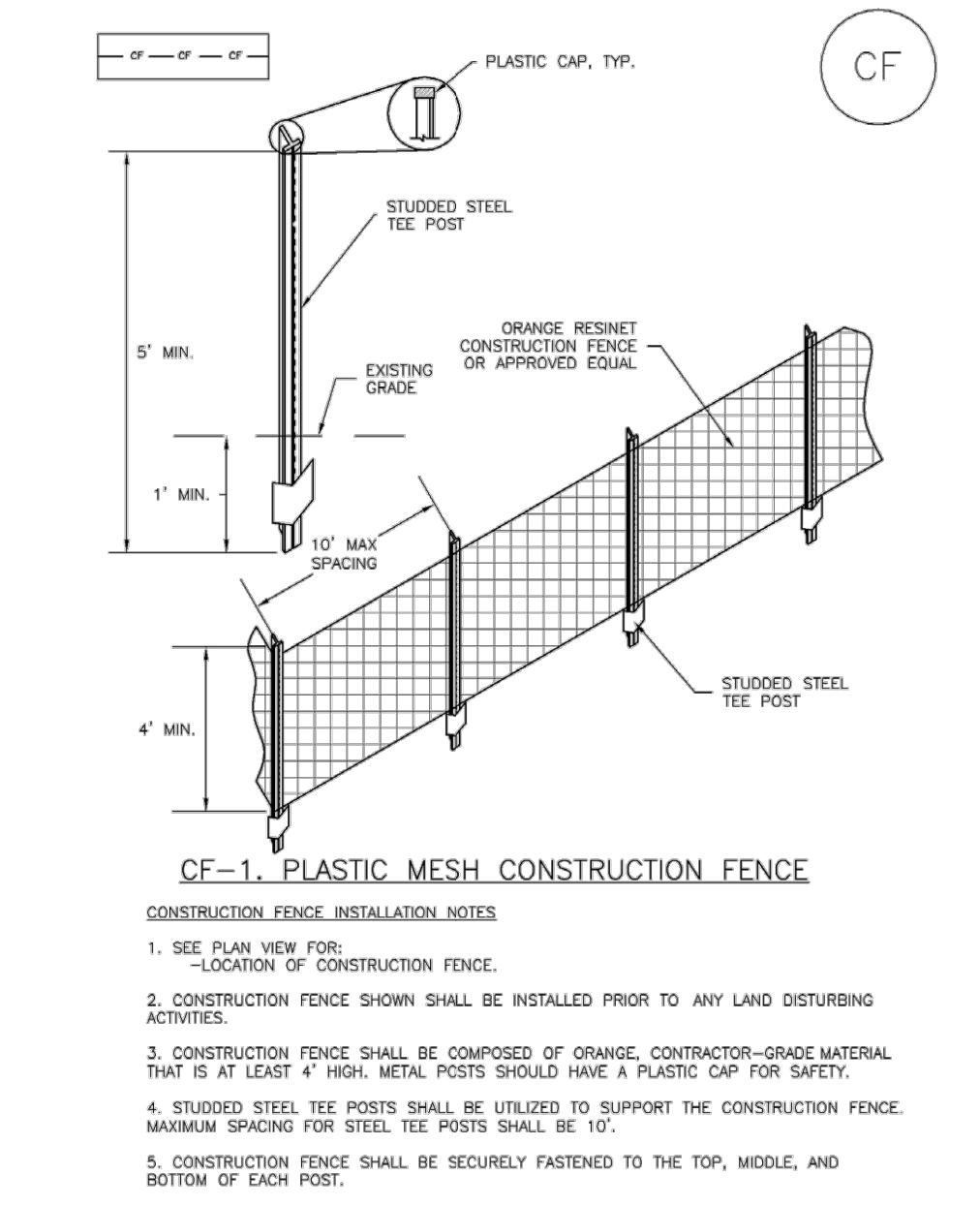

November 2010
 Urban Drainage and Flood Control District
 Urban Storm Drainage Criteria Manual Volume 3

Silt Fence (SF) SC-1

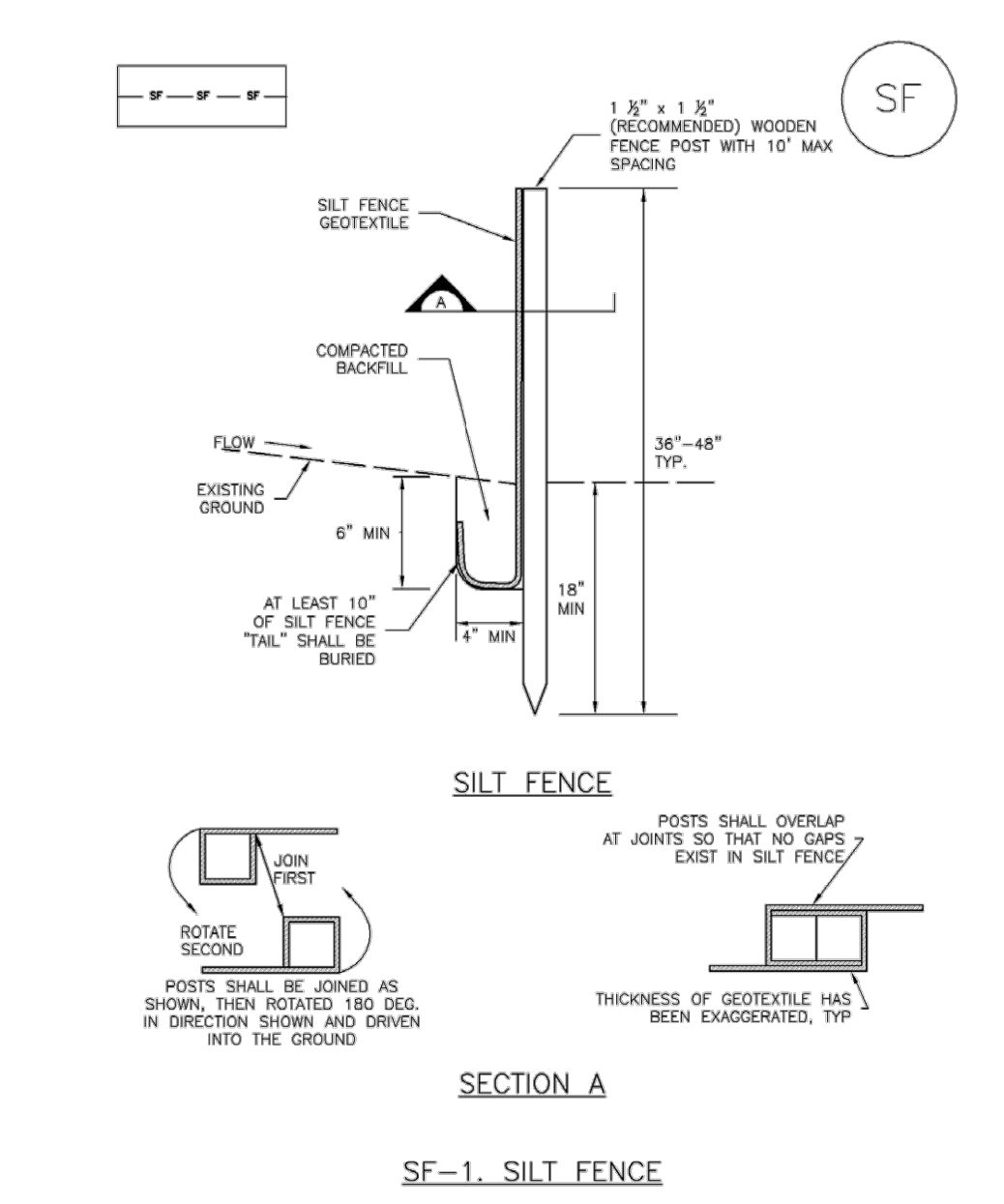

November 2010
 Urban Drainage and Flood Control District
 Urban Storm Drainage Criteria Manual Volume 3

Check Dams (CD) EC-12

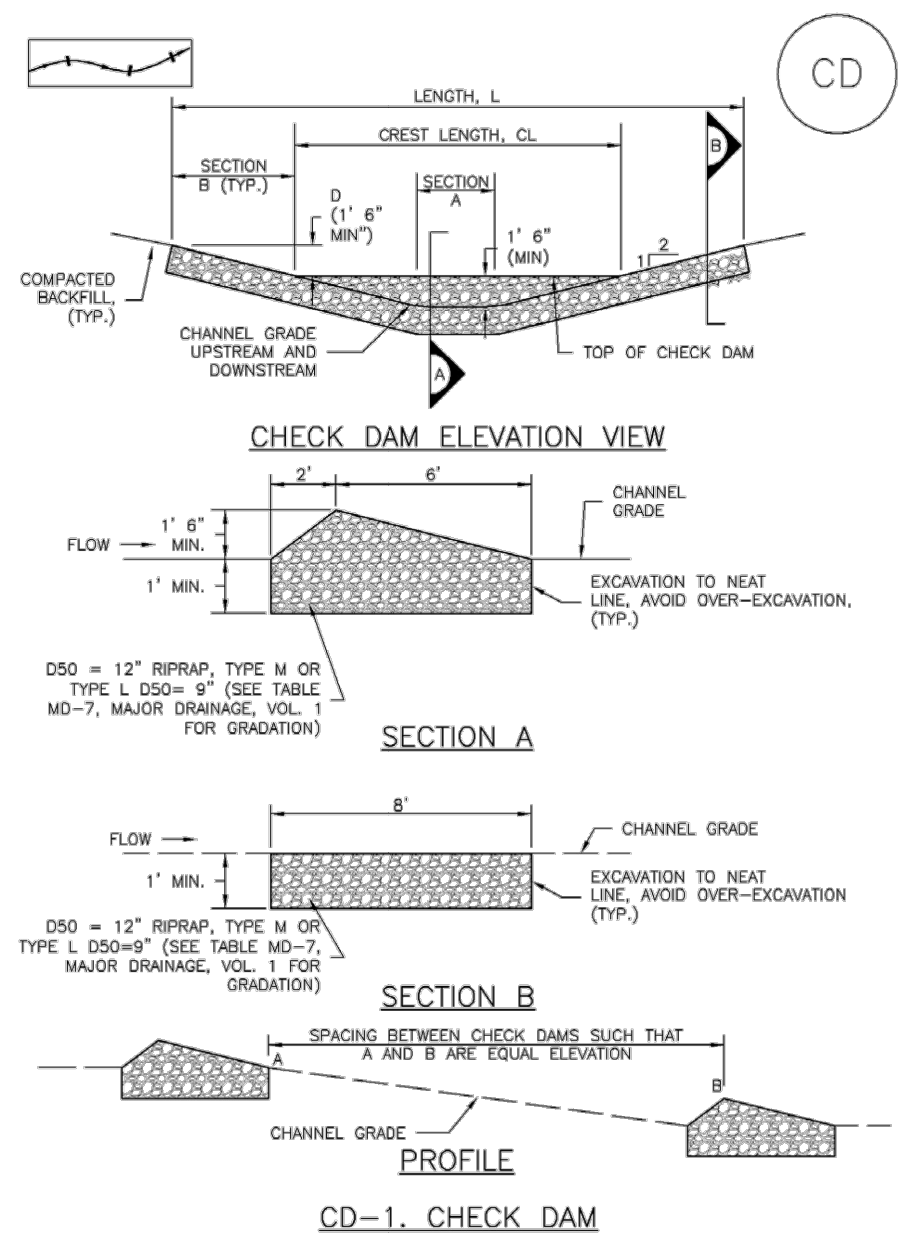

Stabilized Staging Area (SSA) SM-6

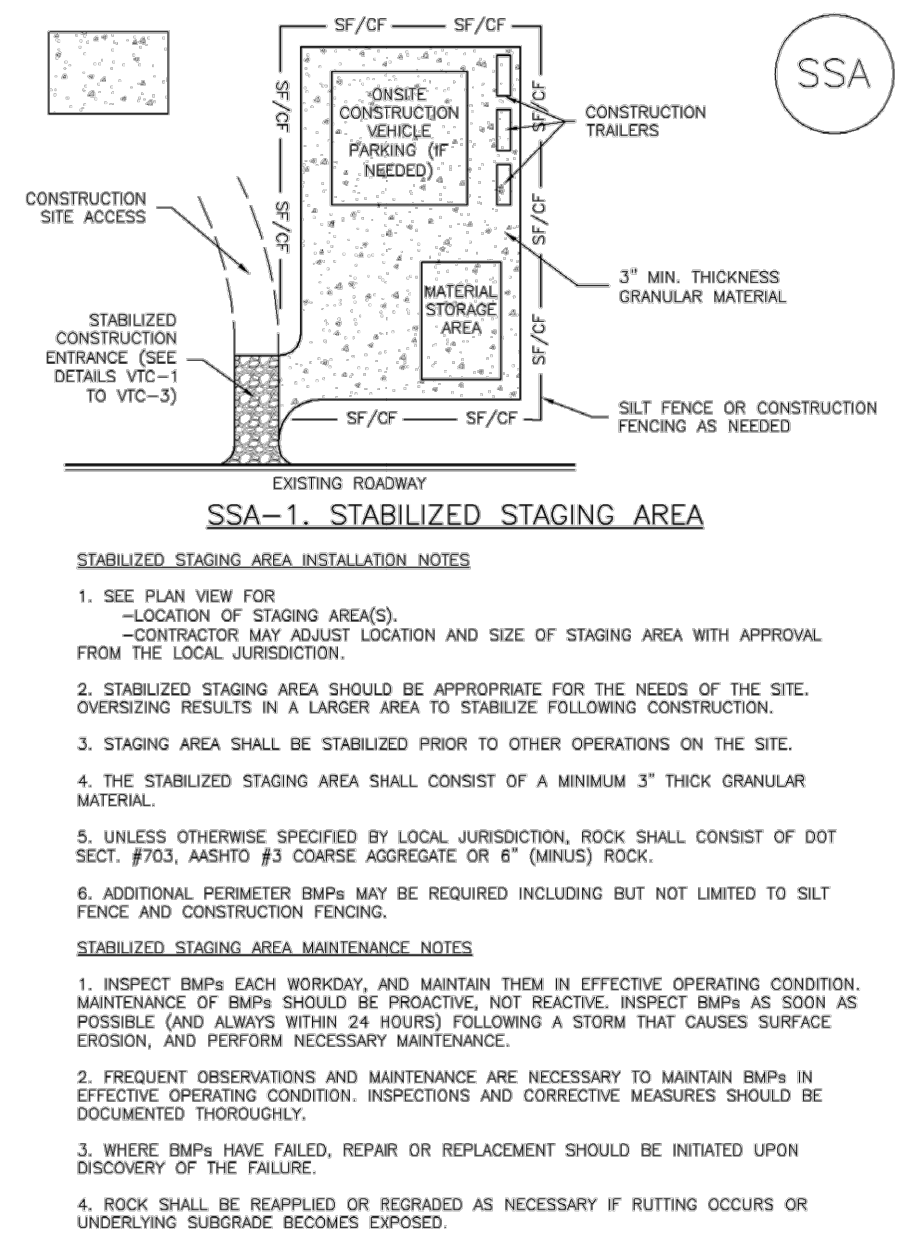

November 2010
 Urban Drainage and Flood Control District
 Urban Storm Drainage Criteria Manual Volume 3

NO.	REVISION	BY	DATE	APPR

Kimley»Horn
 2024 KIMLEY-HORN AND ASSOCIATES, INC.
 6200 South Syracuse Way, Suite 300
 Greenwood Village, Colorado 80111 (303) 228-2300

DESIGNED BY: MTH
 DRAWN BY: FCR
 CHECKED BY: MTH
 DATE: 11/12/2024

VENTURE ON VENETUCCI
 EL PASO COUNTY, COLORADO
 GRADING AND EROSION CONTROL PLAN
 GEC DETAILS

PROJECT NO.
 096302017
 SHEET
C304

K:\DEN_Civil\096302017_Venettucci\Multi-Famil\CADD\PlanSheets\GEC\096302017 - GEC_DT.dwg Rankin, Cormac 11/14/2024 11:58 AM



Temporary Outlet Protection (TOP)

EC-8

Description

Outlet protection helps to reduce erosion immediately downstream of a pipe, culvert, slope drain, rundown or other conveyance with concentrated, high-velocity flows. Typical outlet protection consists of riprap or rock aprons at the conveyance outlet.



Photograph TOP-1. Riprap outlet protection.

Appropriate Uses

Outlet protection should be used when a conveyance discharges onto a disturbed area where there is potential for accelerated erosion due to concentrated flow. Outlet protection should be provided where the velocity at the culvert outlet exceeds the maximum permissible velocity of the material in the receiving channel.

Note: This Fact Sheet and detail are for temporary outlet protection, outlets that are intended to be used for less than 2 years. For permanent, long-term outlet protection, see the *Major Drainage* chapter of Volume 1.

Design and Installation

Design outlet protection to handle runoff from the largest drainage area that may be contributing runoff during construction (the drainage area may change as a result of grading). Key in rock, around the entire perimeter of the apron, to a minimum depth of 6 inches for stability. Extend riprap to the height of the culvert or the normal flow depth of the downstream channel, whichever is less. Additional erosion control measures such as vegetative lining, turf reinforcement mat and/or other channel lining methods may be required downstream of the outlet protection if the channel is susceptible to erosion. See Design Detail OP-1 for additional information.

Maintenance and Removal

Inspect apron for damage and displaced rocks. If rocks are missing or significantly displaced, repair or replace as necessary. If rocks are continuously missing or displaced, consider increasing the size of the riprap or deeper keying of the perimeter.

Remove sediment accumulated at the outlet before the outlet protection becomes buried and ineffective. When sediment accumulation is noted, check that upgradient BMPs, including inlet protection, are in effective operating condition.

Outlet protection may be removed once the pipe is no longer draining an upstream area, or once the downstream area has been sufficiently stabilized. If the drainage pipe is permanent, outlet protection can be left in place; however, permanent outlet protection should be designed and constructed in accordance with the requirements of the *Major Drainage* chapter of Volume 2.

Outlet Protection	
Functions	
Erosion Control	Yes
Sediment Control	Moderate
Site/Material Management	No

November 2010 Urban Drainage and Flood Control District Urban Storm Drainage Criteria Manual Volume 3 TOP-1

EC-8

Temporary Outlet Protection (TOP)

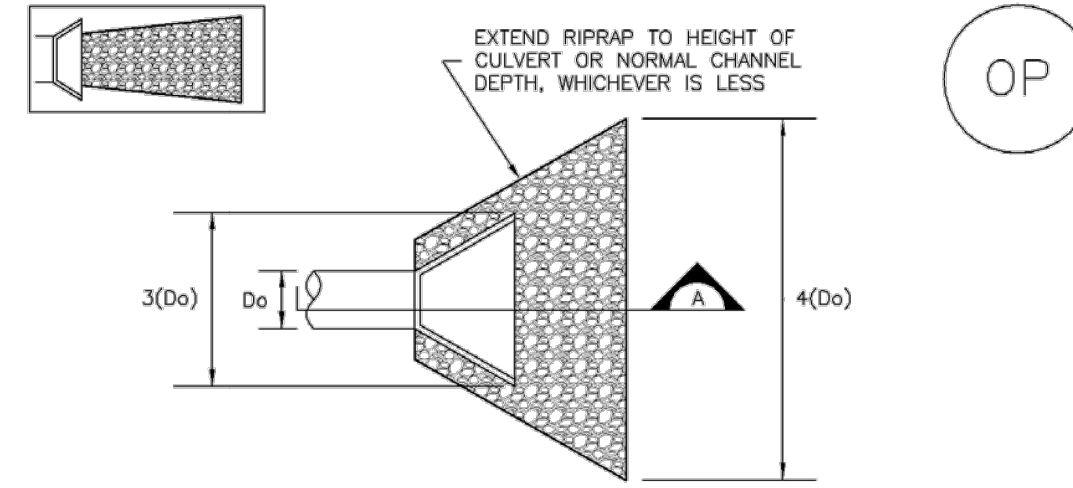

TEMPORARY OUTLET PROTECTION PLAN

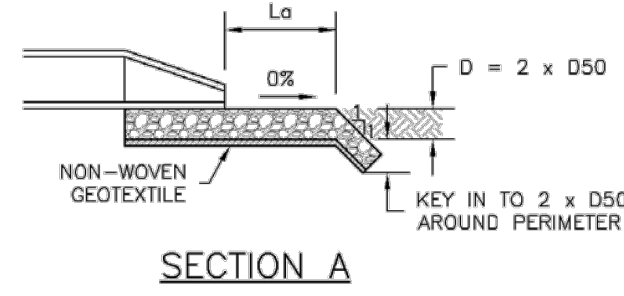

PIPE DIAMETER, D _o (INCHES)	DISCHARGE, Q (CFS)	APRON LENGTH, L _a (FT)	RIPRAP D ₅₀ DIAMETER MIN. (INCHES)
8	2.5	5	4
	5	10	6
12	5	10	4
	10	13	6
	10	10	6
18	20	16	9
	30	23	12
	40	26	16
	30	16	9
24	40	26	9
	50	26	12
	60	30	16
	30	16	9

OP-1. TEMPORARY OUTLET PROTECTION

TOP-2 Urban Drainage and Flood Control District Urban Storm Drainage Criteria Manual Volume 3 November 2010

Temporary Outlet Protection (TOP)

EC-8

TEMPORARY OUTLET PROTECTION INSTALLATION NOTES

- SEE PLAN VIEW FOR:
 - LOCATION OF OUTLET PROTECTION.
 - DIMENSIONS OF OUTLET PROTECTION.
- DETAIL IS INTENDED FOR PIPES WITH SLOPE \leq 10%. ADDITIONAL EVALUATION OF RIPRAP SIZING AND OUTLET PROTECTION DIMENSIONS REQUIRED FOR STEEPER SLOPES.
- TEMPORARY OUTLET PROTECTION INFORMATION IS FOR OUTLETS INTENDED TO BE UTILIZED LESS THAN 2 YEARS.

TEMPORARY OUTLET PROTECTION INSPECTION AND MAINTENANCE NOTES

- INSPECT BMPs EACH WORKDAY, AND MAINTAIN THEM IN EFFECTIVE OPERATING CONDITION. MAINTENANCE OF BMPs SHOULD BE PROACTIVE, NOT REACTIVE. INSPECT BMPs AS SOON AS POSSIBLE (AND ALWAYS WITHIN 24 HOURS) FOLLOWING A STORM THAT CAUSES SURFACE EROSION, AND PERFORM NECESSARY MAINTENANCE.
- FREQUENT OBSERVATIONS AND MAINTENANCE ARE NECESSARY TO MAINTAIN BMPs IN EFFECTIVE OPERATING CONDITION. INSPECTIONS AND CORRECTIVE MEASURES SHOULD BE DOCUMENTED THOROUGHLY.
- WHERE BMPs HAVE FAILED, REPAIR OR REPLACEMENT SHOULD BE INITIATED UPON DISCOVERY OF THE FAILURE.

NOTE: MANY JURISDICTIONS HAVE BMP DETAILS THAT VARY FROM UDFCD STANDARD DETAILS. CONSULT WITH LOCAL JURISDICTIONS AS TO WHICH DETAIL SHOULD BE USED WHEN DIFFERENCES ARE NOTED.

(DETAILS ADAPTED FROM AURORA, COLORADO AND PREVIOUS VERSION OF VOLUME 3, NOT AVAILABLE IN AUTOCAD)

November 2010 Urban Drainage and Flood Control District Urban Storm Drainage Criteria Manual Volume 3 TOP-3

NO.	REVISION	BY	DATE	APPR

Kimley»Horn
 2024 KIMLEY-HORN AND ASSOCIATES, INC.
 6200 South Syracuse Way, Suite 300
 Greenwood Village, Colorado 80111 (303) 228-2300

DESIGNED BY: MTH
 DRAWN BY: FCR
 CHECKED BY: MTH
 DATE: 11/12/2024

VENTURE ON VENETUCCI
 EL PASO COUNTY, COLORADO
 GRADING AND EROSION CONTROL PLAN
GEC DETAILS

PROJECT NO.
 096302017

SHEET

C307



APPENDIX B – CDPHE STORMWATER PERMIT





STATE OF COLORADO

COLORADO DEPARTMENT OF PUBLIC HEALTH AND ENVIRONMENT

Water Quality Control Division

CDPS GENERAL PERMIT
STORMWATER DISCHARGES ASSOCIATED WITH
CONSTRUCTION ACTIVITY
AUTHORIZATION TO DISCHARGE UNDER THE
COLORADO DISCHARGE PERMIT SYSTEM (CDPS)

In compliance with the provisions of the Colorado Water Quality Control Act, (25-8-101 et seq., CRS, 1973 as amended) and the Federal Water Pollution Control Act, as amended (33 U.S.C. 1251 et seq.; the "Act"), this permit authorizes the discharge of stormwater associated with construction activities (and specific allowable non-stormwater discharges in accordance with Part I.A.1. of the permit) certified under this permit, from those locations specified throughout the State of Colorado to specified waters of the State.

Such discharges shall be in accordance with the conditions of this permit. This permit specifically authorizes the facility listed on the certification to discharge in accordance with permit requirements and conditions set forth in Parts I and II hereof. All discharges authorized herein shall be consistent with the terms and conditions of this permit.

This permit becomes effective on April 1, 2019, and shall expire at midnight March 31, 2024.

Issued and signed this 1st day of November 2018.

COLORADO DEPARTMENT OF PUBLIC HEALTH AND ENVIRONMENT

Ellen Howard Kutzer, Permits Section Manager
Water Quality Control Division

Permit History

Originally signed and issued October 31, 2018; effective April 1, 2019.

Table of Contents

Part I	1
A. COVERAGE UNDER THIS PERMIT.....	1
1. Authorized Discharges	1
2. Limitations on Coverage.....	1
3. Permit Certification and Submittal Procedures	2
B. EFFLUENT LIMITATIONS	6
1. Requirements for Control Measures Used to Meet Effluent Limitations	6
2. Discharges to an Impaired Waterbody.....	9
3. General Requirements	10
C. STORMWATER MANAGEMENT PLAN (SWMP) REQUIREMENTS	11
1. SWMP General Requirements	11
2. SWMP Content	11
3. SWMP Review and Revisions	13
4. SWMP Availability.....	14
D. SITE INSPECTIONS.....	14
1. Person Responsible for Conducting Inspections	14
2. Inspection Frequency	14
3. Inspection Frequency for Discharges to Outstanding Waters.....	15
4. Reduced Inspection Frequency	15
5. Inspection Scope.....	16
E. DEFINITIONS	17
F. MONITORING.....	20
G. Oil and Gas Construction	21
Part II: Standard Permit Conditions.....	22
A. DUTY TO COMPLY.....	22
B. DUTY TO REAPPLY	22
C. NEED TO HALT OR REDUCE ACTIVITY NOT A DEFENSE	22
D. DUTY TO MITIGATE	22
E. PROPER OPERATION AND MAINTENANCE	22
F. PERMIT ACTIONS	22
G. PROPERTY RIGHTS	22
H. DUTY TO PROVIDE INFORMATION	23
I. INSPECTION AND ENTRY	23
J. MONITORING AND RECORDS	23
K. SIGNATORY REQUIREMENTS	24

- 1. Authorization to Sign:..... 24
- 2. Electronic Signatures 25
- 3. Change in Authorization to Sign 25
- L. REPORTING REQUIREMENTS 25
 - 1. Planned Changes..... 25
 - 2. Anticipated Non-Compliance 25
 - 3. Transfer of Ownership or Control 25
 - 4. Monitoring reports..... 26
 - 5. Compliance Schedules 26
 - 6. Twenty-four hour reporting..... 26
 - 7. Other non-compliance 27
 - 8. Other information 27
- M. BYPASS 27
 - 1. Bypass not exceeding limitations 27
 - 2. Notice of bypass 27
 - 3. Prohibition of Bypass..... 27
- N. UPSET..... 28
 - 1. Effect of an upset 28
 - 2. Conditions necessary for demonstration of an Upset 28
 - 3. Burden of Proof 28
- O. RETENTION OF RECORDS..... 28
 - 1. Post-Expiration or Termination Retention 28
 - 2. On-site Retention..... 29
- P. REOPENER CLAUSE..... 29
 - 1. Procedures for modification or revocation 29
 - 2. Water quality protection 29
- Q. SEVERABILITY..... 29
- R. NOTIFICATION REQUIREMENTS 29
 - 1. Notification to Parties 29
- S. RESPONSIBILITIES 30
 - 1. Reduction, Loss, or Failure of Treatment Facility 30
- T. Oil and Hazardous Substance Liability..... 30
- U. Emergency Powers..... 30
- V. Confidentiality 30
- W. Fees..... 30

X. Duration of Permit..... 30

Y. Section 307 Toxics..... 30

Part I

Note: At the first mention of terminology that has a specific connotation for the purposes of this permit, the terminology is electronically linked to the definitions section of the permit in Part I.E.

A. COVERAGE UNDER THIS PERMIT**1. Authorized Discharges**

This general permit authorizes [permittee\(s\)](#) to discharge the following to state waters: stormwater associated with [construction activity](#) and specified non-stormwater associated with construction activity. The following types of stormwater and non-stormwater discharges are authorized under this permit:

a. Allowable Stormwater Discharges

- i. Stormwater discharges associated with construction activity.
- ii. Stormwater discharges associated with producing earthen materials, such as soils, sand, and gravel dedicated to providing material to a single contiguous site, or within ¼ mile of a construction site (i.e. borrow or fill areas)
- iii. Stormwater discharges associated with [dedicated asphalt, concrete batch plants and masonry mixing stations](#) (Coverage under this permit is not required if alternative coverage has been obtained.)

b. Allowable Non-Stormwater Discharges

The following non-stormwater discharges are allowable under this permit if the discharges are identified in the stormwater management plan in accordance with Part I.C. and if they have appropriate [control measures](#) in accordance with Part I.B.1.

- i. Discharges from uncontaminated springs that do not originate from an area of land disturbance.
- ii. Discharges to the ground of concrete washout water associated with the washing of concrete tools and concrete mixer chutes. Discharges of concrete washout water must not leave the site as surface runoff or reach [receiving waters](#) as defined by this permit.
- iii. Discharges of landscape irrigation return flow.

c. Emergency Fire Fighting

Discharges resulting from emergency firefighting activities are authorized by this permit.

2. Limitations on Coverage

Discharges not authorized by this permit include, but are not limited to, the discharges and activities listed below. Permittees may seek individual or alternate general permit coverage for the discharges, as appropriate and available.

a. Discharges of Non-Stormwater

Discharges of non-stormwater, except the authorized non-stormwater discharges listed in Part I.A.1.b., are not eligible for coverage under this permit.

- b. Discharges Currently Covered by another Individual or General Permit
 - c. Discharges Currently Covered by a Water Quality Control Division (division) Low Risk Guidance Document
3. Permit Certification and Submittal Procedures
- a. Duty to apply
The following activities shall apply for coverage under this permit:
 - i. Construction sites that will disturb one acre or more; or
 - ii. Construction sites that are part of a [common plan of development or sale](#); or
 - iii. Stormwater discharges that are designated by the division as needing a stormwater permit because the discharge:
 - (a) Contributes to a violation of a water quality standard; or
 - (b) is a significant contributor of pollutants to state waters.
 - b. Application Requirements
To obtain authorization to discharge under this permit, applicants applying for coverage following the effective date of the renewal permit shall meet the following requirements:
 - i. Owners and operators submitting an application for permit coverage will be co-permittees subject to the same benefits, duties, and obligations under this permit.
 - ii. Signature requirements: Both the [owner](#) and [operator](#) (permittee) of the construction site, as defined in Part I.E., must agree to the terms and conditions of the permit and submit a completed application that includes the signature of both the owner and the operator. In cases where the duties of the owner and operator are managed by the owner, both application signatures may be completed by the owner. Both the owner and operator are responsible for ensuring compliance with all terms and conditions of the permit, including implementation of the stormwater management plan.
 - iii. Applicants must use the paper form provided by the division or the electronic form provided on the division's web-based application platform when applying for coverage under this permit.
 - iv. The applicant(s) must develop a stormwater management plan (SWMP) in accordance with the requirements of Part I.C. The applicant(s) must also certify that the SWMP is complete, or will be complete, prior to commencement of any construction activity.

- v. The applicant(s) must submit a complete, accurate, and signed permit application electronically, by mail or hand delivery to the division at least 10 days prior to the commencement of construction activity except that construction activities that are in response to a **public emergency related site** shall apply for coverage no later than 14 days after the commencement of construction activities. The provisions of this part in no way remove a violation of the Colorado Water Quality Control Act if a point source discharge occurs prior to the issuance of a CDPS permit.
 - vi. The application must be signed in accordance with the requirements of Part IA. Applications submitted by mail or hand delivered should be directed to:

Colorado Department of Public Health and Environment
Water Quality Control Division
Permits Section, WQCD-PS-B2
4300 Cherry Creek Drive South
Denver, CO 80246
 - vii. The applicant(s) must receive written notification that the division granted permit coverage prior to conducting construction activities except for construction activities that are in response to a public emergency related site
- c. Division Review of Permit Application
Within 10 days of receipt of the application, and following review of the application, the division may:
- i. Issue a certification of coverage;
 - ii. request additional information necessary to evaluate the discharge;
 - iii. delay the authorization to discharge pending further review;
 - iv. notify the applicant that additional terms and conditions are necessary; or
 - v. deny the authorization to discharge under this general permit.
- d. Alternative Permit Coverage
- i. Division Required Alternate Permit Coverage:
The Division may require an applicant or permittee to apply for an individual permit or an alternative general permit if it determines the discharge does not fall under the scope of this general permit. In this case, the Division will notify the applicant or permittee that an individual permit application is required.
 - ii. Permittee Request for alternate permit coverage:
A permittee authorized to discharge stormwater under this permit may request to be excluded from coverage under this general permit by applying for an individual permit. In this case, the permittee must submit an individual application, with reasons supporting the request, to the Division at least 180 days prior to any discharge. When an individual permit is issued, the permittee's authorization to discharge under this permit is terminated on the effective date of the individual permit.
- e. Submittal Signature Requirements

Documents required for submittal to the division in accordance with this permit, including applications for permit coverage and other documents as requested by the division, must include signatures by both the owner and the operator, except for instances where the duties of the owner and operator are managed by the owner.

Signatures on all documents submitted to the division as required by this permit must meet the Standard Signatory Requirements in Part II.K. of this permit in accordance with 40 C.F.R. 122.41(k).

i. Signature Certification

Any person(s) signing documents required for submittal to the Division must make the following certification:

"I certify under penalty of law that this document and all attachments were prepared under my direction or supervision in accordance with a system designed to assure that qualified personnel properly gather and evaluate the information submitted. Based on my inquiry of the person or persons who manage the system, or those persons directly responsible for gathering the information, the information submitted is, to the best of my knowledge and belief, true, accurate, and complete. I am aware that there are significant penalties for submitting false information, including the possibility of fine and imprisonment for knowing violations."

f. Compliance Document Signature Requirements

Documents which are required for compliance with the permit, but for which submittal to the division is not required unless specifically requested by the division, must be signed by the individual(s) designated as the Qualified Stormwater Manager, as defined in Part I.E.

i. Any person(s) signing inspection documents required for compliance with the permit must make the following statement:

"I verify that, to the best of my knowledge and belief, all corrective action and maintenance items identified during the inspection are complete, and the site is currently in compliance with the permit."

g. Field Wide Permit Coverage for Oil and Gas Construction

At the discretion of the division, a single permit certification may be issued to a single oil and gas permittee to cover construction activity related discharges from an oil and gas field at multiple locations that are not necessarily contiguous.

h. Permit Coverage without Application

Qualifying Local Program: When a small construction site is within the jurisdiction of a qualifying local program, the owner and operator of the construction activity are authorized to discharge stormwater associated with small construction activity under this general permit without the submittal of an application to the division. Sites covered by a qualifying local program are exempt from the following sections of this general permit:

Part I.A.3.a.; Part I.A.3.b.; Part I.A.3.c.; Part I.A.3.d.; Part I.A.3.g.; Part I.A.3.i.; Part I.A.3.j.; Part I.A.3.k.

Sites covered by a qualifying local program are subject to the following requirements:

- i. **Local Agency Authority:** This permit does not pre-empt or supersede the authority of local agencies to prohibit, restrict, or control discharges of stormwater to storm drain systems or other water courses within their jurisdiction.
 - ii. **Permit Coverage Termination:** When a site under a Qualifying Local Program is finally stabilized, coverage under this permit is automatically terminated.
 - iii. **Compliance with Qualifying Local Program:** Qualifying Local Program requirements that are equivalent to the requirements of this permit are incorporated by reference. Permittees authorized to discharge under this permit, must comply with the equivalent requirements of the Qualifying Local Program that has jurisdiction over the site as a condition of this permit.
 - iv. **Compliance with Remaining Permit Conditions.** Requirements of this permit that are in addition to or more stringent than the requirements of the Qualifying Local Program apply in addition to the requirements of the Qualifying Local Program.
 - v. **Written Authorization of Coverage:** The division or local municipality may require any permittee within the jurisdiction of a Qualifying Local Program covered under this permit to apply for, and obtain written authorization of coverage under this permit. The permittee must be notified in writing that an application for written authorization of coverage is required.
- i. **Permittee Initiated Permit Actions**
Permittee initiated permit actions, including but not limited to modifications, contact changes, transfers, reassignments, and terminations, shall be conducted following division guidance and using appropriate division-provided forms.
 - j. **Sale of Residence to Homeowner**
Residential construction sites only: The permittee may remove residential lots from permit coverage once the lot meets the following criteria:
 - i. the residential lot has been sold to the homeowner(s) for private residential use;
 - ii. a certificate of occupancy, or equivalent, is maintained on-site and is available during division inspections;
 - iii. the lot is less than one acre of disturbance;
 - iv. all construction activity conducted on the lot by the permittee is complete;
 - v. the permittee is not responsible for final stabilization of the lot; and
 - vi. the SWMP was modified to indicate the lot is no longer part of the construction activity.

If the residential lot meets the criteria listed above then activities occurring on the lot are no longer considered to be construction activities with a duty to apply and maintain permit coverage. Therefore, the permittee is not required to meet the final stabilization requirements and may terminate permit coverage for the lot.

k. Permit Expiration and Continuation of Permit Coverage

Authorization to discharge under this general permit shall expire at midnight on March 31, 2024. While Regulation 61.4 requires a permittee to submit an application for continuing permit coverage 180 days before the permit expires, the division is requiring that permittees desiring continued coverage under this general permit must reapply at least 90 days in advance of this permit expiration. The Division will determine if the permittee may continue to discharge stormwater under the terms of the general permit. An individual permit may be required for any facility not reauthorized to discharge under the reissued general permit.

If this permit is not reissued or replaced prior to the expiration date, it will be administratively continued and remain in force and effect. For permittees that have applied for continued permit coverage, discharges authorized under this permit prior to the expiration date will automatically remain covered by this permit until the earliest of:

- i. An authorization to discharge under a reissued permit, or a replacement of this permit, following the timely and appropriate submittal of a complete application requesting authorization to discharge under the new permit and compliance with the requirements of the new permit; or
- ii. The issuance and effect of a termination issued by the Division; or
- iii. The issuance or denial of an individual permit for the facility's discharges; or
- iv. A formal permit decision by the Division not to reissue this general permit, at which time the Division will identify a reasonable time period for covered dischargers to seek coverage under an alternative general permit or an individual permit. Coverage under this permit will cease when coverage under another permit is granted/authorized; or
- v. The Division has informed the permittee that discharges previously authorized under this permit are no longer covered under this permit.

B. EFFLUENT LIMITATIONS

1. Requirements for Control Measures Used to Meet Effluent Limitations

The permittee must implement control measures to **minimize** the discharge of pollutants from all potential pollutant sources at the site. Control measures must be installed prior to commencement of activities that may contribute pollutants to stormwater discharges. Control measures must be selected, designed, installed and maintained in accordance with good engineering, hydrologic and pollution control practices. Control measures implemented at the site must be designed to prevent pollution or degradation of state waters.

a. Stormwater Pollution Prevention

The permittee must implement structural and/or nonstructural control measures that effectively minimize erosion, sediment transport, and the release of other pollutants related to construction activity.

i. Control Measures for Erosion and Sediment Control

Control measures for erosion and sediment control may include, but are not limited to, wattles/sediment control logs, silt fences, earthen dikes, drainage swales, sediment traps, subsurface drains, pipe slope drains, inlet protection, outlet protection, gabions, sediment basins, temporary vegetation, permanent vegetation, mulching, geotextiles, sod stabilization, slope roughening, maintaining existing vegetation, protection of trees, and preservation of mature vegetation. Specific non-structural control measures must meet the requirements listed below.

Specific control measures must meet the requirements listed below.

- (a) Vehicle tracking controls shall either be implemented to minimize vehicle tracking of sediment from disturbed areas, or the areas where vehicle tracking occurs shall meet subsection Part I.B.1.a.i(b);
- (b) Stormwater runoff from all disturbed areas and soil storage areas for which permanent or temporary stabilization is not implemented, must flow to at least one control measure to minimize sediment in the discharge. This may be accomplished through filtering, settling, or straining. The control measure must be selected, designed, installed and adequately sized in accordance with good engineering, hydrologic and pollution control practices. The control measure(s) must contain or filter flows in order to prevent the bypass of flows without treatment and must be appropriate for stormwater runoff from disturbed areas and for the expected flow rate, duration, and flow conditions (i.e., sheet or concentrated flow);
- (c) Outlets that withdraw water from or near the surface shall be installed when discharging from basins and impoundments, unless **infeasible**.
- (d) Maintain pre-existing vegetation or equivalent control measures for areas within 50 horizontal feet of receiving waters as defined by this permit, unless **infeasible**.
- (e) Soil compaction must be minimized for areas where infiltration control measures will occur or where **final stabilization** will be achieved through vegetative cover.
- (f) Unless **infeasible**, topsoil shall be preserved for those areas of a site that will utilize vegetative final stabilization.
- (g) Minimize the amount of soil exposed during construction activity, including the disturbance of steep slopes.

ii. Practices for Other Common Pollutants

- (a) Bulk storage, 55 gallons or greater, for petroleum products and other liquid chemicals must have secondary containment, or equivalent protection, in order to contain **spills** and to prevent spilled material from entering state waters.
- (b) Control measures designed for concrete washout waste must be implemented. This includes washout waste discharged to the ground as authorized under this permit and washout waste from concrete trucks and masonry operations contained on site. The permittee must ensure the washing activities do not contribute pollutants to stormwater runoff, or receiving waters in accordance Part I.A.1.b.ii. Discharges that may reach groundwater must flow through soil

that has buffering capacity prior to reaching groundwater, as necessary to meet the effluent limits in this permit, including Part I.B.3.a. The concrete washout location shall not be located in an area where shallow groundwater may be present and would result in buffering capacity not being adequate, such as near natural drainages, springs, or wetlands. This permit authorizes discharges to the ground of concrete washout waste.

iii. Stabilization Requirements

The following requirements must be implemented for each site.

- (a) Temporary stabilization must be implemented for earth disturbing activities on any portion of the site where ground disturbing construction activity has permanently ceased, or temporarily ceased for more than 14 calendar days. Temporary stabilization methods may include, but are not limited to, tarps, soil tackifier, and hydroseed. The permittee may exceed the 14-day schedule when either the function of the specific area of the site requires it to remain disturbed, or, physical characteristics of the terrain and climate prevent stabilization. The SWMP must document the constraints necessitating the alternative schedule, provide the alternate stabilization schedule, and identify all locations where the alternative schedule is applicable on the site map.
- (b) Final stabilization must be implemented for all construction sites. Final stabilization is reached when all ground surface disturbing activities at the construction site are complete; and, for all areas of ground surface disturbing activities, either a uniform vegetative cover with an individual plant density of at least 70 percent of pre-disturbance levels is established, or equivalent permanent alternative stabilization methods are implemented. The division may approve alternative final stabilization criteria for specific operations.
- (c) Final stabilization must be designed and installed as a permanent feature. Final stabilization measures for obtaining a vegetative cover or alternative stabilization methods include, but are not limited to, the following as appropriate:
 - (1) Seed mix selection and application methods;
 - (2) Soil preparation and amendments;
 - (3) Soil stabilization methods (e.g., crimped straw, hydro mulch or rolled erosion control products);
 - (4) Appropriate sediment control measures as needed until final stabilization is achieved;
 - (5) Permanent pavement, hardscape, xeriscape, stabilized driving surfaces;
 - (6) Other alternative stabilization practices as applicable;

(d) The permittee(s) must ensure all temporary control measures are removed from the construction site once final stabilization is achieved, except when the control measure specifications allow the control measure to be left in place (i.e., bio-degradable control measures).

b. Maintenance

The permittee must ensure that all control measures remain in effective operating condition and are protected from activities that would reduce their effectiveness. Control measures must be maintained in accordance with good engineering, hydrologic and pollution control practices. Observations leading to the required maintenance of control measures can be made during a site inspection, or during general observations of site conditions. The necessary repairs or modifications to a [control measure requiring routine maintenance](#), as defined in Part I.E., must be conducted to maintain an effective operating condition. This section is not subject to the requirements in Part I.B.1.c. below.

c. Corrective Actions

The permittee must assess the adequacy of control measures at the site, and the need for changes to those control measures, to ensure continued effective performance. When an [inadequate control measure](#), as defined in Part I.E., is identified (i.e., new or replacement control measures become necessary), the following corrective action requirements apply. The permittee is in noncompliance with the permit until the inadequate control measure is replaced or corrected and returned to effective operating condition in compliance with Part I.B.1. and the general requirements in Part I.B.3. If the inadequate control measure results in noncompliance that meets the conditions of Part II.L., the permittee must also meet the requirements of that section.

i. The permittee must take all necessary steps to minimize or prevent the discharge of pollutants, until a control measure is implemented and made operational and/or an inadequate control measure is replaced or corrected and returned to effective operating condition. If it is infeasible to install or repair of control measure immediately after discovering the deficiency, the following must be documented and kept on record in accordance with the recordkeeping requirements in Part II.

(a) Describe why it is infeasible to initiate the installation or repair immediately; and

(b) Provide a schedule for installing or repairing the control measure and returning it to an effective operating condition as soon as possible.

ii. If applicable, the permittee must remove and properly dispose of any unauthorized release or discharge (e.g., discharge of non-stormwater, spill, or leak not authorized by this permit.) The permittee must also clean up any contaminated surfaces to minimize discharges of the material in subsequent storm events.

2. Discharges to an Impaired Waterbody

a. Total Maximum Daily Load (TMDL)

If the permittee's discharge flows to or could reasonably be expected to flow to any water body for which a TMDL has been approved, and stormwater discharges

associated with construction activity were assigned a pollutant-specific Wasteload Allocation (WLA) under the TMDL, the division may:

- i. ensure the WLA is implemented properly through alternative local requirements, such as by a municipal stormwater permit; or
- ii. notify the permittee of the WLA and amend the permittee's certification to add specific effluent limits and other requirements, as appropriate. The permittee may be required to do the following:
 - (a) under the permittee's SWMP, implement specific control measures based on requirements of the WLA, and evaluate whether the requirements are met through implementation of existing stormwater control measures or if additional control measures are necessary. Document the calculations or other evidence demonstrating that the requirements are expected to be met; and
 - (b) if the evaluation shows that additional or modified control measures are necessary, describe the type and schedule for the control measure additions or modifications.
- iii. Discharge monitoring may also be required. The permittee may maintain coverage under the general permit provided they comply with the applicable requirements outlined above. The division reserves the right to require individual or alternate general permit coverage.

3. General Requirements

- a. Discharges authorized by this permit shall not cause, have the reasonable potential to cause, or measurably contribute to an exceedance of any applicable water quality standard, including narrative standards for water quality.
- b. The division may require sampling and testing, on a case-by-case basis, in the event that there is reason to suspect that the SWMP is not adequately minimizing pollutants in stormwater or in order to measure the effectiveness of the control measures in removing pollutants in the effluent. Such monitoring may include Whole Effluent Toxicity testing.
- c. The permittee must comply with the lawful requirements of federal agencies, municipalities, counties, drainage districts and other local agencies including applicable requirements in Municipal Stormwater Management Programs developed to comply with CDPS permits. The permittee must comply with local stormwater management requirements, policies and guidelines including those for erosion and sediment control.
- d. All construction site wastes must be properly managed to prevent potential pollution of state waters. This permit does not authorize on-site waste disposal.
- e. This permit does not relieve the permittee of the reporting requirements in 40 CFR 110, 40 CFR 117 or 40 CFR 302. Any discharge of hazardous material must be handled in accordance with the division's Noncompliance Notification Requirements (see Part II.L. of the permit).

C. STORMWATER MANAGEMENT PLAN (SWMP) REQUIREMENTS**1. SWMP General Requirements**

- a. A SWMP shall be developed for each construction site covered by this permit. The SWMP must be prepared in accordance with good engineering, hydrologic and pollution control practices.
 - i. For public emergency related sites a SWMP shall be created no later than 14 days after the commencement of construction activities.
- b. The permittee must implement the provisions of the SWMP as written and updated, from commencement of construction activity until final stabilization is complete. The division may review the SWMP.
- c. A copy of the SWMP must be retained onsite or be onsite when construction activities are occurring at the site unless the permittee specifies another location and obtains approval from the division.

2. SWMP Content

- a. The SWMP, at a minimum, must include the following elements.
 - i. Qualified Stormwater Manager. The SWMP must list individual(s) by title and name who are designated as the site's qualified stormwater manager(s) responsible for implementing the SWMP in its entirety. This role may be filled by more than one individual.
 - ii. Spill Prevention and Response Plan. The SWMP must have a spill prevention and response plan. The plan may incorporate by reference any part of a Spill Prevention Control and Countermeasure (SPCC) plan under section 311 of the Clean Water Act (CWA) or a Spill Prevention Plan required by a separate CDPS permit. The relevant sections of any referenced plans must be available as part of the SWMP consistent with Part I.C.4.
 - iii. Materials Handling. The SWMP must describe and locate all control measures implemented at the site to minimize impacts from handling **significant materials** that could contribute pollutants to runoff. These handling procedures can include control measures for pollutants and activities such as, exposed storage of building materials, paints and solvents, landscape materials, fertilizers or chemicals, sanitary waste material, trash and equipment maintenance or fueling procedures.
 - iv. Potential Sources of Pollution. The SWMP must list all potential sources of pollution which may reasonably be expected to affect the quality of stormwater discharges associated with construction activity from the site. This shall include, but is not limited to, the following pollutant sources:
 - (a) disturbed and stored soils;
 - (b) vehicle tracking of sediments;
 - (c) management of contaminated soils;
 - (d) loading and unloading operations;

- (e) outdoor storage activities (erodible building materials, fertilizers, chemicals, etc.);
 - (f) vehicle and equipment maintenance and fueling;
 - (g) significant dust or particulate generating processes (e.g., saw cutting material, including dust);
 - (h) routine maintenance activities involving fertilizers, pesticides, herbicides, detergents, fuels, solvents, oils, etc.;
 - (i) on-site waste management practices (waste piles, liquid wastes, dumpsters);
 - (j) concrete truck/equipment washing, including washing of the concrete truck chute and associated fixtures and equipment;
 - (k) dedicated asphalt, concrete batch plants and masonry mixing stations;
 - (l) non-industrial waste sources such as worker trash and portable toilets.
- v. Implementation of Control Measures. The SWMP must include design specifications that contain information on the implementation of the control measure in accordance with good engineering hydrologic and pollution control practices; including as applicable drawings, dimensions, installation information, materials, implementation processes, control measure-specific inspection expectations, and maintenance requirements.

The SWMP must include a documented use agreement between the permittee and the owner or operator of any control measures located outside of the permitted area, that are utilized by the permittee's construction site for compliance with this permit, but not under the direct control of the permittee. The permittee is responsible for ensuring that all control measures located outside of their permitted area, that are being utilized by the permittee's construction site, are properly maintained and in compliance with all terms and conditions of the permit. The SWMP must include all information required of and relevant to any such control measures located outside the permitted area, including location, installation specifications, design specifications and maintenance requirements.

- vi. Site Description. The SWMP must include a site description which includes, at a minimum, the following:
- (a) the nature of the construction activity at the site;
 - (b) the proposed schedule for the sequence for major construction activities and the planned implementation of control measures for each phase. (e.g.: clearing, grading, utilities, vertical, etc.);
 - (c) estimates of the total acreage of the site, and the acreage expected to be disturbed by clearing, excavation, grading, or any other construction activities;
 - (d) a summary of any existing data used in the development of the construction site plans or SWMP that describe the soil or existing potential for soil erosion;

- (e) a description of the percent of existing vegetative ground cover relative to the entire site and the method for determining the percentage;
 - (f) a description of any allowable non-stormwater discharges at the site, including those being discharged under a division low risk discharge guidance policy;
 - (g) a description of areas receiving discharge from the site. Including a description of the immediate source receiving the discharge. If the stormwater discharge is to a municipal separate storm sewer system, the name of the entity owning that system, the location of the storm sewer discharge, and the ultimate receiving water(s); and
 - (h) a description of all stream crossings located within the construction site boundary.
- vii. Site Map. The SWMP must include a site map which includes, at a minimum, the following:
- (a) construction site boundaries;
 - (b) flow arrows that depict stormwater flow directions on-site and runoff direction;
 - (c) all areas of ground disturbance including areas of borrow and fill;
 - (d) areas used for storage of soil;
 - (e) locations of all waste accumulation areas, including areas for liquid, concrete, masonry, and asphalt;
 - (f) locations of dedicated asphalt, concrete batch plants and masonry mixing stations;
 - (g) locations of all structural control measures;
 - (h) locations of all non-structural control measures;
 - (i) locations of springs, streams, wetlands and other state waters, including areas that require pre-existing vegetation be maintained within 50 feet of a receiving water, where determined feasible in accordance with Part I.B.1.a.i.(d).; and
 - (j) locations of all stream crossings located within the construction site boundary.
- viii. Final Stabilization and Long Term Stormwater Management. The SWMP must describe the practices used to achieve final stabilization of all disturbed areas at the site and any planned practices to control pollutants in stormwater discharges that will occur after construction operations are completed. Including but not limited to, detention/retention ponds, rain gardens, stormwater vaults, etc.
- ix. Inspection Reports. The SWMP must include documented inspection reports in accordance with Part ID.

3. SWMP Review and Revisions

Permittees must keep a record of SWMP changes made that includes the date and identification of the changes. The SWMP must be amended when the following occurs:

- a. a change in design, construction, operation, or maintenance of the site requiring implementation of new or revised control measures;
- b. the SWMP proves ineffective in controlling pollutants in stormwater runoff in compliance with the permit conditions;
- c. control measures identified in the SWMP are no longer necessary and are removed; and
- d. corrective actions are taken onsite that result in a change to the SWMP.

For SWMP revisions made prior to or following a change(s) onsite, including revisions to sections addressing site conditions and control measures, a notation must be included in the SWMP that identifies the date of the site change, the control measure removed, or modified, the location(s) of those control measures, and any changes to the control measure(s). The permittee must ensure the site changes are reflected in the SWMP. The permittee is noncompliant with the permit until the SWMP revisions have been made.

4. SWMP Availability

A copy of the SWMP must be provided upon request to the division, EPA, and any local agency with authority for approving sediment and erosion plans, grading plans or stormwater management plans within the time frame specified in the request. If the SWMP is required to be submitted to any of these entities, the submission must include a signed certification in accordance with Part I.A.3.e., certifying that the SWMP is complete and compliant with all terms and conditions of the permit.

All SWMPs required under this permit are considered reports that must be available to the public under Section 308(b) of the CWA and Section 61.5(4) of the CDPS regulations. The permittee must make plans available to members of the public upon request. However, the permittee may claim any portion of a SWMP as confidential in accordance with 40 CFR Part 2.

D. SITE INSPECTIONS

Site inspections must be conducted in accordance with the following requirements. The required inspection schedules are a minimum frequency and do not affect the permittee's responsibility to implement control measures in effective operating condition as prescribed in the SWMP. Proper maintenance of control measures may require more frequent inspections. Site inspections shall start within 7 calendar days of the commencement of construction activities on site.

1. Person Responsible for Conducting Inspections

The person(s) inspecting the site may be on the permittee's staff or a third party hired to conduct stormwater inspections under the direction of the permittee(s). The permittee is responsible for ensuring that the inspector is a qualified stormwater manager.

2. Inspection Frequency

Permittees must conduct site inspections in accordance with one of the following minimum frequencies, unless the site meets the requirements of Part ID.3

- a. At least one inspection every 7 calendar days. Or
 - b. At least one inspection every 14 calendar days, if post-storm event inspections are conducted within 24 hours after the end of any precipitation or snowmelt event that causes surface erosion. Post-storm inspections may be used to fulfill the 14-day routine inspection requirement.
 - c. When site conditions make the schedule required in this section impractical, the permittee may petition the Division to grant an alternate inspection schedule. The alternative inspection schedule may not be implemented prior to written approval by the division and incorporation into the SWMP.
3. Inspection Frequency for Discharges to Outstanding Waters

Permittees must conduct site inspections at least once every 7 calendar days for sites that discharge to a water body designated as an Outstanding Water by the Water Quality Control Commission.

4. Reduced Inspection Frequency

The permittee may perform site inspections at the following reduced frequencies when one of the following conditions exists:

- a. Post-Storm Inspections at Temporarily Idle Sites
For permittees choosing to combine 14-day inspections and post-storm-event-inspections, if no construction activities will occur following a storm event, post-storm event inspections must be conducted prior to re-commencing construction activities, but no later than 72 hours following the storm event. The delay of any post-storm event inspection must be documented in the inspection record. Routine inspections must still be conducted at least every 14 calendar days.
- b. Inspections at Completed Sites/Areas
When the site, or portions of a site are awaiting establishment of a vegetative ground cover and final stabilization, the permittee must conduct a thorough inspection of the stormwater management system at least once every 30 days. Post-storm event inspections are not required under this schedule. This reduced inspection schedule is allowed if all of the following criteria are met:
 - i. all construction activities resulting in ground disturbance are complete;
 - ii. all activities required for final stabilization, in accordance with the SWMP, have been completed, with the exception of the application of seed that has not occurred due to seasonal conditions or the necessity for additional seed application to augment previous efforts; and
 - iii. the SWMP has been amended to locate those areas to be inspected in accordance with the reduced schedule allowed for in this paragraph.
- c. Winter Conditions Inspections Exclusion

Inspections are not required for sites that meet all of the following conditions: construction activities are temporarily halted, snow cover exists over the entire site for an extended period, and melting conditions posing a risk of surface erosion do not exist. This inspection exception is applicable only during the period where melting conditions do not exist, and applies to the routine 7-day, 14-day and monthly inspections, as well as the post-storm-event inspections. When this inspection exclusion is implemented, the following information must be documented in accordance with the requirements in Part II:

- i. dates when snow cover existed;
- ii. date when construction activities ceased; and
- iii. date melting conditions began.

5. Inspection Scope

a. Areas to be Inspected

When conducting a site inspection the following areas, if applicable, must be inspected for evidence of, or the potential for, pollutants leaving the construction site boundaries, entering the stormwater drainage system, or discharging to state waters:

- i. construction site perimeter;
- ii. all disturbed areas;
- iii. designated haul routes;
- iv. material and waste storage areas exposed to precipitation;
- v. locations where stormwater has the potential to discharge offsite; and
- vi. locations where vehicles exit the site.

b. Inspection Requirements

- i. Visually verify whether all implemented control measures are in effective operational condition and are working as designed in their specifications to minimize pollutant discharges.
- ii. Determine if there are new potential sources of pollutants.
- iii. Assess the adequacy of control measures at the site to identify areas requiring new or modified control measures to minimize pollutant discharges.
- iv. Identify all areas of non-compliance with the permit requirements and, if necessary, implement corrective action in accordance with Part IB.1.c.

c. Inspection Reports

The permittee must keep a record of all inspections conducted for each permitted site. Inspection reports must identify any incidents of noncompliance with the terms and conditions of this permit. Inspection records must be retained in accordance with Part II.O. and signed in accordance with Part I.A.3.f. At a minimum, the inspection report must include:

- i. the inspection date;

- ii. name(s) and title(s) of personnel conducting the inspection;
- iii. weather conditions at the time of inspection;
- iv. phase of construction at the time of inspection;
- v. estimated acreage of disturbance at the time of inspection
- vi. location(s) of discharges of sediment or other pollutants from the site;
- vii. location(s) of control measures needing maintenance;
- viii. location(s) and identification of inadequate control measures;
- ix. location(s) and identification of additional control measures are needed that were not in place at the time of inspection;
- x. description of the minimum inspection frequency (either in accordance with Part I.D.2., I.D.3. or I.D.4.) utilized when conducting each inspection.
- xi. deviations from the minimum inspection schedule as required in Part I.D.2.;
- xii. after adequate corrective action(s) and maintenance have been taken, or where a report does not identify any incidents requiring corrective action or maintenance, the report shall contain a statement as required in Part I.A.3.f.

E. DEFINITIONS

For the purposes of this permit:

- (1) Bypass - the intentional diversion of waste streams from any portion of a treatment facility in accordance with 40 CFR 122.41(m)(1)(i) and Regulation 61.2(12).
- (2) Common Plan of Development or Sale - A contiguous area where multiple separate and distinct construction activities may be taking place at different times on different schedules, but remain related. The Division has determined that "contiguous" means construction activities located in close proximity to each other (within ¼ mile). Construction activities are considered to be "related" if they share the same development plan, builder or contractor, equipment, storage areas, etc. "Common plan of development or sale" includes construction activities that are associated with the construction of field wide oil and gas permits for facilities that are related.
- (3) Construction Activity - Ground surface disturbing and associated activities (land disturbance), which include, but are not limited to, clearing, grading, excavation, demolition, installation of new or improved haul roads and access roads, staging areas, stockpiling of fill materials, and borrow areas. Construction does not include routine maintenance to maintain the original line and grade, hydraulic capacity, or original purpose of the facility. Activities to conduct repairs that are not part of routine maintenance or for replacement are construction activities and are not routine maintenance. Repaving activities where underlying and/or surrounding soil is exposed as part of the repaving operation are considered construction activities. Construction activity is from initial ground breaking to final stabilization regardless of ownership of the construction activities.
- (4) Control Measure - Any best management practice or other method used to prevent or reduce the discharge of pollutants to state waters. Control measures include, but are not limited to, best management practices. Control measures can include other methods such as the installation, operation, and maintenance of structural controls and treatment devices.

- (5) Control Measure Requiring Routine Maintenance - Any control measure that is still operating in accordance with its design and the requirements of this permit, but requires maintenance to prevent a breach of the control measure. See also inadequate control measure.
- (6) Dedicated Asphalt, Concrete Batch Plants and Masonry Mixing Stations - are batch plants or mixing stations located on, or within ¼ mile of, a construction site and that provide materials only to that specific construction site.
- (7) Final Stabilization - The condition reached when all ground surface disturbing activities at the site have been completed, and for all areas of ground surface disturbing activities where a uniform vegetative cover has been established with an individual plant density of at least 70 percent of pre-disturbance levels, or equivalent permanent, physical erosion reduction methods have been employed.
- (8) Good Engineering, Hydrologic and Pollution Control Practices: are methods, procedures, and practices that:
 - a. Are based on basic scientific fact(s).
 - b. Reflect best industry practices and standards.
 - c. Are appropriate for the conditions and pollutant sources.
 - d. Provide appropriate solutions to meet the associated permit requirements, including practice based effluent limits.
- (9) Inadequate Control Measure - Any control measure that is not designed or implemented in accordance with the requirements of the permit and/or any control measure that is not implemented to operate in accordance with its design. See also Control Measure Requiring Routine Maintenance.
- (10) Infeasible - Not technologically possible, or not economically practicable and achievable in light of best industry practices.
- (11) Minimize - reduce or eliminate to the extent achievable using control measures that are technologically available and economically practicable and achievable in light of best industry practice.
- (12) Municipality - A city, town, county, district, association, or other public body created by, or under, State law and having jurisdiction over disposal of sewage, industrial wastes, or other wastes, or a designated and approved management agency under section 208 of CWA (1987).
- (13) Municipal Separate Storm Sewer System (MS4) - A conveyance or system of conveyances (including roads with drainage systems, municipal streets, catch basins, curbs, gutters, ditches, man-made channels, or storm drains):
 - a) owned or operated by a State, city, town, county, district, association, or other public body (created by or pursuant to State law) having jurisdiction over disposal of sewage, industrial wastes, stormwater, or other wastes, including special districts under State law such as a sewer district, flood control district or drainage district, or similar entity, or a designated and approved management agency under section 208 of the CWA that discharges to state waters;
 - i. designed or used for collecting or conveying stormwater;
 - ii. are not a combined sewer; and
 - iii. are not part of a Publicly Owned Treatment Works (POTW). See 5 CCR 1002-61.2(62).
- (14) Municipal Stormwater Management Program - A stormwater program operated by a municipality, typically to meet the requirements of the municipalities MS4 discharge certification.

- (15) Operator - The party that has operational control over day-to-day activities at a project site which are necessary to ensure compliance with the permit. This party is authorized to direct individuals at a site to carry out activities required by the permit. (e.g. the general contractor)
- (16) Owner - The party that has overall control of the activities and that has funded the implementation of the construction plans and specifications. This is the party with ownership of, a long term lease of, or easements on the property on which the construction activity is occurring (e.g., the developer).
- (17) Permittee(s) - The owner and operator named in the discharge certification issued under this permit for the construction site specified in the certification.
- (18) Point Source - Any discernible, confined, and discrete conveyance, including, but not limited to, any pipe, ditch, channel, tunnel, conduit, well, discrete fissure, container, rolling stock, concentrated animal feeding operation, or vessel or other floating craft, from which pollutants are or may be discharged. Point source does not include irrigation return flow. See 5 CCR 102-61.2(75).
- (19) Pollutant - Dredged spoil, dirt, slurry, solid waste, incinerator residue, sewage, sewage sludge, garbage, trash, chemical waste, biological nutrient, biological material, radioactive material, heat, wrecked or discarded equipment, rock, sand, or any industrial, municipal or agricultural waste. See 5 CCR 1002-61.2(76).
- (20) Presentation of credentials - a government issued form of identification, if in person; or (ii) providing name, position and purpose of inspection if request to enter is made via telephone, email or other form of electronic communication. A Permittee's non-response to a request to enter upon presentation of credentials constitutes a denial to such request, and may result in violation of the Permit.
- (21) Process Water - Any water which, during manufacturing or processing, comes into contact with or results from the production of any raw material, intermediate product, finished product, by product or waste product.
- (22) Public Emergency Related Site - a project initiated in response to an unanticipated emergency (e.g., mud slides, earthquake, extreme flooding conditions, disruption in essential public services), for which the related work requires immediate authorization to avoid imminent endangerment to human health or the environment, or to reestablish essential public services.
- (23) Qualified Stormwater Manager - An individual knowledgeable in the principles and practices of erosion and sediment control and pollution prevention, and with the skills to assess conditions at construction sites that could impact stormwater quality and to assess the effectiveness of stormwater controls implemented to meet the requirements of this permit.
- (24) Qualifying Local Program - A municipal program for stormwater discharges associated with small construction activity that was formally approved by the division as a qualifying local program.
- (25) Receiving Water - Any classified or unclassified surface water segment (including tributaries) in the State of Colorado into which stormwater associated with construction activities discharges. This definition includes all water courses, even if they are usually dry, such as borrow ditches, arroyos, and other unnamed waterways.
- (26) Severe Property Damage - substantial physical damage to property, damage to the treatment facilities which causes them to become inoperable, or substantial and permanent loss of natural resources which can reasonably be expected to occur in the absence of a bypass. Severe property damage does not mean economic loss caused by delays in production. See 40 CFR 122.41(m)(1)(ii).

- (27) Significant Materials - Include, but not limited to, raw materials; fuels; materials such as solvents, detergents, and plastic pellets; finished materials such as metallic products; raw materials used in food processing or production; hazardous substances designated under section 101(14) of CERCLA; any chemical the permittee is required to report under section 313 of Title III of the Superfund Amendments and Reauthorization Act (SARA); fertilizers; pesticides; and waste products such as ashes, slag and sludge that have the potential to be released with stormwater discharges.
- (28) Small Construction Activity - The discharge of stormwater from construction activities that result in land disturbance of equal to, or greater than, one acre and less than five acres. Small construction activity also includes the disturbance of less than one acre of total land area that is part of a larger common plan of development or sale, if the larger common plan ultimately disturbs equal to, or greater than, one acre and less than five acres.
- (29) Spill - An unintentional release of solid or liquid material which may pollute state waters.
- (30) State Waters - means any and all surface and subsurface waters which are contained in or flow in or through this state, but does not include waters in sewage systems, waters in treatment works of disposal systems, waters in potable water distribution systems, and all water withdrawn for use until use and treatment have been completed.
- (31) Steep Slopes: where a local government, or industry technical manual (e.g., stormwater BMP manual) has defined what is to be considered a "steep slope", this permit's definition automatically adopts that definition. Where no such definition exists, steep slopes are automatically defined as those that are 3:1 or greater.
- (32) Stormwater - Precipitation runoff, snow melt runoff, and surface runoff and drainage. See 5 CCR 1002-61.2(103).
- (33) Total Maximum Daily Loads (TMDLs) -The sum of the individual wasteload allocations (WLA) for point sources and load allocations (LA) for nonpoint sources and natural background. For the purposes of this permit, a TMDL is a calculation of the maximum amount of a pollutant that a waterbody can receive and still meet water quality standards, and an allocation of that amount to the pollutant's sources. A TMDL includes WLAs, LAs, and must include a margin of safety (MOS), and account for seasonal variations. See section 303(d) of the CWA and 40 C.F.R. 130.2 and 130.7.
- (34) Upset - an exceptional incident in which there is unintentional and temporary noncompliance with permit effluent limitations because of factors beyond the reasonable control of the permittee. An upset does not include noncompliance to the extent caused by operational error, improperly designed treatment facilities, inadequate treatment facilities, lack of preventative maintenance, or careless or improper operation in accordance with 40 CFR 122.41(n) and Regulation 61.2(114).

F. MONITORING

The division may require sampling and testing, on a case-by-case basis. If the division requires sampling and testing, the division will send a notification to the permittee. Reporting procedures for any monitoring data collected will be included in the notification.

If monitoring is required, the following applies:

1. the thirty (30) day average must be determined by the arithmetic mean of all samples collected during a thirty (30) consecutive-day period; and
2. a grab sample, for monitoring requirements, is a single "dip and take" sample.

G. Oil and Gas Construction

Stormwater discharges associated with construction activities directly related to oil and gas exploration, production, processing, and treatment operations or transmission facilities are regulated under the Colorado Discharge Permit System Regulations (5 CCR 1002-61), and require coverage under this permit in accordance with that regulation. However, references in this permit to specific authority under the CWA do not apply to stormwater discharges associated with these oil and gas related construction activities, to the extent that the references are limited by the federal Energy Policy Act of 2005.

Part II: Standard Permit Conditions

A. DUTY TO COMPLY

The permittee must comply with all conditions of this permit. Any permit noncompliance constitutes a violation of the Water Quality Control Act and is grounds for:

- a. enforcement action;
- b. permit termination, revocation and reissuance, or modification; or
- c. denial of a permit renewal application.

B. DUTY TO REAPPLY

If the permittee wishes to continue an activity regulated by this permit after the expiration date of this permit, the permittee must apply for and obtain authorization as required by Part I.A.3.k. of the permit.

C. NEED TO HALT OR REDUCE ACTIVITY NOT A DEFENSE

It shall not be a defense for a permittee in an enforcement action that it would have been necessary to halt or reduce the permitted activity in order to maintain compliance with the conditions of this permit.

D. DUTY TO MITIGATE

A permittee must take all reasonable steps to minimize or prevent any discharge in violation of this permit which has a reasonable likelihood of adversely affecting human health or the environment.

E. PROPER OPERATION AND MAINTENANCE

A permittee must at all times properly operate and maintain all facilities and systems of treatment and control (and related appurtenances) that are installed or used by the permittee to achieve compliance with the conditions of this permit. Proper operation and maintenance also includes adequate laboratory controls and appropriate quality assurance procedures. This provision requires the operation of backup or auxiliary facilities or similar systems which are installed by the permittee only when the operation is necessary to achieve compliance with the conditions of this permit. This requirement can be met by meeting the requirements for Part I.B., I.C., and I.D. above. See also 40 C.F.R. § 122.41(e).

F. PERMIT ACTIONS

This permit may be modified, revoked and reissued, or terminated for cause. The permittee request for a permit modification, revocation and reissuance, or termination, or a notification of planned changes or anticipated noncompliance does not stay any permit condition. Any request for modification, revocation, reissuance, or termination under this permit must comply with all terms and conditions of Regulation 61.8(8).

G. PROPERTY RIGHTS

In accordance with 40 CFR 122.41(g) and 5 CCR 1002-61, 61.8(9):

1. The issuance of a permit does not convey any property or water rights in either real or personal property, or stream flows or any exclusive privilege.

2. The issuance of a permit does not authorize any injury to person or property or any invasion of personal rights, nor does it authorize the infringement of federal, state, or local laws or regulations.
3. Except for any toxic effluent standard or prohibition imposed under Section 307 of the Federal act or any standard for sewage sludge use or disposal under Section 405(d) of the Federal act, compliance with a permit during its term constitutes compliance, for purposes of enforcement, with Sections 301, 302, 306, 318, 403, and 405(a) and (b) of the Federal act. However, a permit may be modified, revoked and reissued, or terminated during its term for cause as set forth in Section 61.8(8) of the Colorado Discharge Permit System Regulations.

H. DUTY TO PROVIDE INFORMATION

The permittee shall furnish to the division, within a reasonable time, any information which the division may request to determine whether cause exists for modifying, revoking and reissuing, or terminating this permit, or to determine compliance with this permit. The permittee shall also furnish to the division, upon request, copies of records required to be kept by this permit in accordance with 40 CFR 122.41(h) and/or Regulation 61.8(3)(q).

I. INSPECTION AND ENTRY

The permittee shall allow the division and the authorized representative, upon the presentation of credentials as required by law, to allow for inspections to be conducted in accordance with 40 CFR 122.41(i), Regulation 61.8(3), and Regulation 61.8(4):

1. to enter upon the permittee's premises where a regulated facility or activity is located or in which any records are required to be kept under the terms and conditions of this permit;
2. at reasonable times to have access to and copy any records required to be kept under the terms and conditions of this permit;
3. at reasonable times, inspect any monitoring equipment or monitoring method required in the permit; and
4. to enter upon the permittee's premises in a reasonable manner and at a reasonable time to inspect or investigate, any actual, suspected, or potential source of water pollution, or any violation of the Colorado Water Quality Control Act. The investigation may include: sampling of any discharges, stormwater or process water, taking of photographs, interviewing site staff on alleged violations and other matters related to the permit, and assessing any and all facilities or areas within the site that may affect discharges, the permit, or an alleged violation.

The permittee shall provide access to the division or other authorized representatives upon presentation of proper credentials. A permittee's non-response to a request to enter upon presentation of credentials constitutes a denial of such request, and may result in a violation of the permit.

J. MONITORING AND RECORDS

1. Samples and measurements taken for the purpose of monitoring must be representative of the volume and nature of the monitored activity.

2. The permittee must retain records of all monitoring information, including all calibration and maintenance records and all original strip chart recordings for continuous monitoring instrumentation, copies of all reports required by this permit, and records of all data used to complete the application for this permit, for a period of at least three years from the date the permit expires or the date the permittee's authorization is terminated. This period may be extended by request of the division at any time.
3. Records of monitoring information must include:
 - a. The date, exact place, and time of sampling or measurements;
 - b. The individual(s) who performed the sampling or measurements;
 - c. The date(s) analyses were performed
 - d. The individual(s) who performed the analyses;
 - e. The analytical techniques or methods used; and
 - f. The results of such analyses.
4. Monitoring must be conducted according to test procedures approved under 40 CFR Part 136, unless other test procedures have been specified in the permit.

K. SIGNATORY REQUIREMENTS

1. Authorization to Sign:

All documents required to be submitted to the division by the permit must be signed in accordance with the following criteria:

- a. For a corporation: By a responsible corporate officer. For the purpose of this subsection, a responsible corporate officer means:
 - i. a president, secretary, treasurer, or vice president of the corporation in charge of a principal business function, or any other person who performs similar policy- or decision-making functions for the corporation, or
 - ii. the manager of one or more manufacturing, production, or operating facilities, provided, the manager is authorized to make management decisions which govern the operation of the regulated facility including having the explicit or implicit duty of making major capital investment recommendations, and initiating and directing other comprehensive measures to assure long term environmental compliance with environmental laws and regulations; the manager can ensure that the necessary systems are established or actions taken to gather complete and accurate information for permit application requirements; and where authority to sign documents has been assigned or delegated to the manager in accordance with corporate procedures.
- b. For a partnership or sole proprietorship: By a general partner or the proprietor, respectively; or
- c. For a municipality, state, federal, or other public agency: By either a principal executive officer or ranking elected official. For purposes of this subsection, a principal executive officer of a federal agency includes
 - i. (i) the chief executive officer of the agency, or

- ii. (ii) a senior executive officer having responsibility for the overall operations of a principal geographic unit of the agency. (e.g., Regional Administrator of EPA)

2. Electronic Signatures

For persons signing applications for coverage under this permit electronically, in addition to meeting other applicable requirements stated above, such signatures must meet the same signature, authentication, and identity-proofing standards set forth at 40 CFR § 3.2000(b) for electronic reports (including robust second-factor authentication). Compliance with this requirement can be achieved by submitting the application using the Colorado Environmental Online Service (CEOS) system.

3. Change in Authorization to Sign

If an authorization is no longer accurate because a different individual or position has responsibility for the overall operation of the facility, a new authorization must be submitted to the division, prior to the re-authorization, or together with any reports, information, or applications to be signed by an authorized representative.

L. REPORTING REQUIREMENTS

1. Planned Changes

The permittee shall give advance notice to the division, in writing, of any planned physical alterations or additions to the permitted facility in accordance with 40 CFR 122.41(l) and Regulation 61.8(5)(a). Notice is required only when:

- a. The alteration or addition to a permitted facility may meet one of the criteria for determining whether a facility is a new source in 40 CFR 122.29(b); or
- b. The alteration or addition could significantly change the nature or increase the quantity of pollutants discharged. This notification applies to pollutants which are subject neither to effluent limitations in the permit, nor to notification requirements under 40 CFR 122.41(a)(1).

2. Anticipated Non-Compliance

The permittee shall give advance notice to the division, in writing, of any planned changes in the permitted facility or activity that may result in noncompliance with permit requirements. The timing of notification requirements differs based on the type of non-compliance as described in subparagraphs 5, 6, 7, and 8 below.

3. Transfer of Ownership or Control

The permittee shall notify the division, in writing, ten (10) calendar days in advance of a proposed transfer of the permit. This permit is not transferable to any person except after notice is given to the division.

- a. Where a facility wants to change the name of the permittee, the original permittee (the first owner or operators) must submit a Notice of Termination.
- b. The new owner or operator must submit an application. See also signature requirements in Part II.K, above.
- c. A permit may be automatically transferred to a new permittee if:
 - i. The current permittee notifies the Division in writing 30 calendar days in advance of the proposed transfer date; and
 - ii. The notice includes a written agreement between the existing and new permittee(s) containing a specific date for transfer of permit responsibility, coverage and liability between them; and
 - iii. The division does not notify the existing permittee and the proposed new permittee of its intent to modify, or revoke and reissue the permit.
 - iv. Fee requirements of the Colorado Discharge Permit System Regulations, Section 61.15, have been met.

4. Monitoring reports

Monitoring results must be reported at the intervals specified in this permit per the requirements of 40 CFR 122.41(l)(4).

5. Compliance Schedules

Reports of compliance or noncompliance with, or any progress reports on, interim and final requirements contained in any compliance schedule in the permit, shall be submitted on the date listed in the compliance schedule section. The fourteen (14) calendar day provision in Regulation 61.8(4)(n)(i) has been incorporated into the due date.

6. Twenty-four hour reporting

In addition to the reports required elsewhere in this permit, the permittee shall report the following circumstances orally within twenty-four (24) hours from the time the permittee becomes aware of the circumstances, and shall mail to the division a written report containing the information requested within five (5) working days after becoming aware of the following circumstances:

- a. Circumstances leading to any noncompliance which may endanger health or the environment regardless of the cause of the incident;
- b. Circumstances leading to any unanticipated bypass which exceeds any effluent limitations in the permit;
- c. Circumstances leading to any upset which causes an exceedance of any effluent limitation in the permit;

- d. Daily maximum violations for any of the pollutants limited by Part I of this permit. This includes any toxic pollutant or hazardous substance or any pollutant specifically identified as the method to control any toxic pollutant or hazardous substance.
- e. The division may waive the written report required under subparagraph 6 of this section if the oral report has been received within 24 hours.

7. Other non-compliance

A permittee must report all instances of noncompliance at the time monitoring reports are due. If no monitoring reports are required, these reports are due at least annually in accordance with Regulation 61.8(4)(p). The annual report must contain all instances of non-compliance required under either subparagraph 5 or subparagraph 6 of this subsection.

8. Other information

Where a permittee becomes aware that it failed to submit any relevant facts in a permit application, or submitted incorrect information in a permit application, or in any report to the Permitting Authority, it has a duty to promptly submit such facts or information.

M. BYPASS

1. Bypass not exceeding limitations

The permittees may allow any bypass to occur which does not cause effluent limitations to be exceeded, but only if it also is for essential maintenance to assure efficient operation. These bypasses are not subject to the provisions of Part II.M.2 of this permit. See 40 CFR 122.41(m)(2).

2. Notice of bypass

- a. Anticipated bypass. If the permittee knows in advance of the need for a bypass, the permittee must submit prior notice, if possible at least ten days before the date of the bypass. See 40 CFR §122.41(m)(3)(i) and/or Regulation 61.9(5)(c).
- b. Unanticipated bypass. The permittee must submit notice of an unanticipated bypass in accordance with Part II.L.6. See 40 CFR §122.41(m)(3)(ii) .

3. Prohibition of Bypass

Bypasses are prohibited and the division may take enforcement action against the permittee for bypass, unless:

- i. the bypass is unavoidable to prevent loss of life, personal injury, or severe property damage;

- ii. There were no feasible alternatives to the bypass, such as the use of auxiliary treatment facilities, retention of untreated wastes, or maintenance during normal periods of equipment downtime. This condition is not satisfied if adequate backup equipment should have been installed in the exercise of reasonable engineering judgment to prevent a bypass which occurred during normal periods of equipment downtime or preventive maintenance; and
- iii. proper notices were submitted to the division.

N. UPSET

1. Effect of an upset

An upset constitutes an affirmative defense to an action brought for noncompliance with permit effluent limitations if the requirements of Part II.N.2. of this permit are met. No determination made during administrative review of claims that noncompliance was caused by upset, and before an action for noncompliance, is final administrative action subject to judicial review in accordance with Regulation 61.8(3)(j).

2. Conditions necessary for demonstration of an Upset

A permittee who wishes to establish the affirmative defense of upset shall demonstrate through properly signed contemporaneous operating logs, or other relevant evidence that

- a. an upset occurred and the permittee can identify the specific cause(s) of the upset;
- b. the permitted facility was at the time being properly operated and maintained; and
- c. the permittee submitted proper notice of the upset as required in Part II.L.6. (24-hour notice); and
- d. the permittee complied with any remedial measure necessary to minimize or prevent any discharge or sludge use or disposal in violation of this permit which has a reasonable likelihood of adversely affecting human health or the environment. In addition to the demonstration required above, a permittee who wishes to establish the affirmative defense of upset for a violation of effluent limitations based upon water quality standards shall also demonstrate through monitoring, modeling or other methods that the relevant standards were achieved in the receiving water.

3. Burden of Proof

In any enforcement proceeding, the permittee seeking to establish the occurrence of an upset has the burden of proof.

O. RETENTION OF RECORDS

1. Post-Expiration or Termination Retention

Copies of documentation required by this permit, including records of all data used to complete the application for permit coverage to be covered by this permit, must be

retained for at least three years from the date that permit coverage expires or is terminated. This period may be extended by request of EPA at any time.

2. On-site Retention

The permittee must retain an electronic version or hardcopy of the SWMP at the construction site from the date of the initiation of construction activities to the date of expiration or inactivation of permit coverage; unless another location, specified by the permittee, is approved by the division.

P. REOPENER CLAUSE

1. Procedures for modification or revocation

Permit modification or revocation of this permit or coverage under this permit will be conducted according to Regulation 61.8(8).

2. Water quality protection

If there is evidence indicating that the stormwater discharges authorized by this permit cause, have the reasonable potential to cause or contribute to an excursion above any applicable water quality standard, the permittee may be required to obtain an individual permit, or the permit may be modified to include different limitations and/or requirements.

Q. SEVERABILITY

The provisions of this permit are severable. If any provisions or the application of any provision of this permit to any circumstances, is held invalid, the application of such provision to other circumstances and the application of the remainder of this permit shall not be affected.

R. NOTIFICATION REQUIREMENTS

1. Notification to Parties

All notification requirements, excluding information submitted using the CEOS portal, shall be directed as follows:

a. Oral Notifications, during normal business hours shall be to:

Clean Water Compliance Section
Water Quality Control Division
Telephone: (303) 692-3500

b. Written notification shall be to:

Clean Water Compliance Section
Water Quality Control Division
Colorado Department of Public Health and Environment
WQCD-WQP-B2
4300 Cherry Creek Drive South
Denver, CO 80246-1530

S. RESPONSIBILITIES**1. Reduction, Loss, or Failure of Treatment Facility**

The permittee has the duty to halt or reduce any activity if necessary to maintain compliance with the effluent limitations of the permit. It shall not be a defense for a permittee in an enforcement action that it would be necessary to halt or reduce the permitted activity in order to maintain compliance with the conditions of this permit.

T. Oil and Hazardous Substance Liability

Nothing in this permit shall be construed to preclude the institution of any legal action or relieve the permittee from any responsibilities, liabilities, or penalties to which the permittee is or may be subject to under Section 311 (Oil and Hazardous Substance Liability) of the CWA.

U. Emergency Powers

Nothing in this permit shall be construed to prevent or limit application of any emergency power of the division.

V. Confidentiality

Any information relating to any secret process, method of manufacture or production, or sales or marketing data which has been declared confidential by the permittee, and which may be acquired, ascertained, or discovered, whether in any sampling investigation, emergency investigation, or otherwise, shall not be publicly disclosed by any member, officer, or employee of the Water Quality Control Commission or the division, but shall be kept confidential. Any person seeking to invoke the protection of of this section shall bear the burden of proving its applicability. This section shall never be interpreted as preventing full disclosure of effluent data.

W. Fees

The permittee is required to submit payment of an annual fee as set forth in the 2016 amendments to the Water Quality Control Act. Section 25-8-502 (1.1) (b), and the Colorado Discharge Permit System Regulations 5 CCR 1002-61, Section 61.15 as amended. Failure to submit the required fee when due and payable is a violation of the permit and will result in enforcement action pursuant to Section 25-8-601 et. seq., C.R.S.1973 as amended.

X. Duration of Permit

The duration of a permit shall be for a fixed term and shall not exceed five (5) years. If the permittee desires to continue to discharge, a permit renewal application shall be submitted at least ninety (90) calendar days before this permit expires. Filing of a timely and complete application shall cause the expired permit to continue in force to the effective date of the new permit. The permit's duration may be extended only through administrative extensions and not through interim modifications. If the permittee anticipates there will be no discharge after the expiration date of this permit, the division should be promptly notified so that it can terminate the permit in accordance with Part I.A.3.i.

Y. Section 307 Toxics

If a toxic effluent standard or prohibition, including any applicable schedule of compliance specified, is established by regulation pursuant to Section 307 of the Federal Act for a toxic pollutant which is present in the permittee's discharge and such standard or prohibition is more stringent than any limitation upon such pollutant in the discharge permit, the division

shall institute proceedings to modify or revoke and reissue the permit to conform to the toxic effluent standard or prohibition

APPENDIX C – FEMA FIRM MAP



National Flood Hazard Layer FIRMMette



104°47'29"W 38°46'27"N



Legend

SEE FIS REPORT FOR DETAILED LEGEND AND INDEX MAP FOR FIRM PANEL LAYOUT

<p>SPECIAL FLOOD HAZARD AREAS</p>	<p>Without Base Flood Elevation (BFE) <i>Zone A, V, A99</i></p> <p>With BFE or Depth <i>Zone AE, AO, AH, VE, AR</i></p> <p>Regulatory Floodway</p>
<p>OTHER AREAS OF FLOOD HAZARD</p>	<p>0.2% Annual Chance Flood Hazard, Areas of 1% annual chance flood with average depth less than one foot or with drainage areas of less than one square mile <i>Zone X</i></p> <p>Future Conditions 1% Annual Chance Flood Hazard <i>Zone X</i></p> <p>Area with Reduced Flood Risk due to Levee. See Notes. <i>Zone X</i></p> <p>Area with Flood Risk due to Levee <i>Zone D</i></p>
<p>OTHER AREAS</p>	<p>NO SCREEN Area of Minimal Flood Hazard <i>Zone X</i></p> <p>Effective LOMRs</p> <p>Area of Undetermined Flood Hazard <i>Zone D</i></p>
<p>GENERAL STRUCTURES</p>	<p>Channel, Culvert, or Storm Sewer</p> <p>Levee, Dike, or Floodwall</p>
<p>OTHER FEATURES</p>	<p>20.2 Cross Sections with 1% Annual Chance Water Surface Elevation</p> <p>17.5 Coastal Transect</p> <p>Base Flood Elevation Line (BFE)</p> <p>Limit of Study</p> <p>Jurisdiction Boundary</p> <p>Coastal Transect Baseline</p> <p>Profile Baseline</p> <p>Hydrographic Feature</p>
<p>MAP PANELS</p>	<p>Digital Data Available</p> <p>No Digital Data Available</p> <p>Unmapped</p>

N

The pin displayed on the map is an approximate point selected by the user and does not represent an authoritative property location.

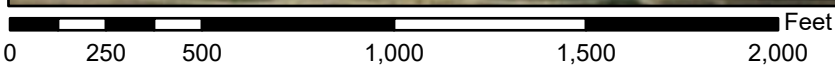

1:6,000

104°46'52"W 38°45'59"N

Basemap Imagery Source: USGS National Map 2023

This map complies with FEMA's standards for the use of digital flood maps if it is not void as described below. The basemap shown complies with FEMA's basemap accuracy standards

The flood hazard information is derived directly from the authoritative NFHL web services provided by FEMA. This map was exported on **10/17/2024 at 9:57 AM** and does not reflect changes or amendments subsequent to this date and time. The NFHL and effective information may change or become superseded by new data over time.

This map image is void if the one or more of the following map elements do not appear: basemap imagery, flood zone labels, legend, scale bar, map creation date, community identifiers, FIRM panel number, and FIRM effective date. Map images for unmapped and unmodernized areas cannot be used for regulatory purposes.

APPENDIX D – SOILS INFORMATION





United States
Department of
Agriculture

NRCS

Natural
Resources
Conservation
Service

A product of the National
Cooperative Soil Survey,
a joint effort of the United
States Department of
Agriculture and other
Federal agencies, State
agencies including the
Agricultural Experiment
Stations, and local
participants

Custom Soil Resource Report for El Paso County Area, Colorado



Preface

Soil surveys contain information that affects land use planning in survey areas. They highlight soil limitations that affect various land uses and provide information about the properties of the soils in the survey areas. Soil surveys are designed for many different users, including farmers, ranchers, foresters, agronomists, urban planners, community officials, engineers, developers, builders, and home buyers. Also, conservationists, teachers, students, and specialists in recreation, waste disposal, and pollution control can use the surveys to help them understand, protect, or enhance the environment.

Various land use regulations of Federal, State, and local governments may impose special restrictions on land use or land treatment. Soil surveys identify soil properties that are used in making various land use or land treatment decisions. The information is intended to help the land users identify and reduce the effects of soil limitations on various land uses. The landowner or user is responsible for identifying and complying with existing laws and regulations.

Although soil survey information can be used for general farm, local, and wider area planning, onsite investigation is needed to supplement this information in some cases. Examples include soil quality assessments (<http://www.nrcs.usda.gov/wps/portal/nrcs/main/soils/health/>) and certain conservation and engineering applications. For more detailed information, contact your local USDA Service Center (<https://offices.sc.egov.usda.gov/locator/app?agency=nrcs>) or your NRCS State Soil Scientist (http://www.nrcs.usda.gov/wps/portal/nrcs/detail/soils/contactus/?cid=nrcs142p2_053951).

Great differences in soil properties can occur within short distances. Some soils are seasonally wet or subject to flooding. Some are too unstable to be used as a foundation for buildings or roads. Clayey or wet soils are poorly suited to use as septic tank absorption fields. A high water table makes a soil poorly suited to basements or underground installations.

The National Cooperative Soil Survey is a joint effort of the United States Department of Agriculture and other Federal agencies, State agencies including the Agricultural Experiment Stations, and local agencies. The Natural Resources Conservation Service (NRCS) has leadership for the Federal part of the National Cooperative Soil Survey.

Information about soils is updated periodically. Updated information is available through the NRCS Web Soil Survey, the site for official soil survey information.

The U.S. Department of Agriculture (USDA) prohibits discrimination in all its programs and activities on the basis of race, color, national origin, age, disability, and where applicable, sex, marital status, familial status, parental status, religion, sexual orientation, genetic information, political beliefs, reprisal, or because all or a part of an individual's income is derived from any public assistance program. (Not all prohibited bases apply to all programs.) Persons with disabilities who require

alternative means for communication of program information (Braille, large print, audiotape, etc.) should contact USDA's TARGET Center at (202) 720-2600 (voice and TDD). To file a complaint of discrimination, write to USDA, Director, Office of Civil Rights, 1400 Independence Avenue, S.W., Washington, D.C. 20250-9410 or call (800) 795-3272 (voice) or (202) 720-6382 (TDD). USDA is an equal opportunity provider and employer.

Contents

Preface	2
How Soil Surveys Are Made	5
Soil Map	8
Soil Map.....	9
Legend.....	10
Map Unit Legend.....	11
Map Unit Descriptions.....	11
El Paso County Area, Colorado.....	13
82—Schamber-Razor complex, 8 to 50 percent slopes.....	13
Soil Information for All Uses	15
Soil Properties and Qualities.....	15
Soil Qualities and Features.....	15
Hydrologic Soil Group.....	15
References	20

How Soil Surveys Are Made

Soil surveys are made to provide information about the soils and miscellaneous areas in a specific area. They include a description of the soils and miscellaneous areas and their location on the landscape and tables that show soil properties and limitations affecting various uses. Soil scientists observed the steepness, length, and shape of the slopes; the general pattern of drainage; the kinds of crops and native plants; and the kinds of bedrock. They observed and described many soil profiles. A soil profile is the sequence of natural layers, or horizons, in a soil. The profile extends from the surface down into the unconsolidated material in which the soil formed or from the surface down to bedrock. The unconsolidated material is devoid of roots and other living organisms and has not been changed by other biological activity.

Currently, soils are mapped according to the boundaries of major land resource areas (MLRAs). MLRAs are geographically associated land resource units that share common characteristics related to physiography, geology, climate, water resources, soils, biological resources, and land uses (USDA, 2006). Soil survey areas typically consist of parts of one or more MLRA.

The soils and miscellaneous areas in a survey area occur in an orderly pattern that is related to the geology, landforms, relief, climate, and natural vegetation of the area. Each kind of soil and miscellaneous area is associated with a particular kind of landform or with a segment of the landform. By observing the soils and miscellaneous areas in the survey area and relating their position to specific segments of the landform, a soil scientist develops a concept, or model, of how they were formed. Thus, during mapping, this model enables the soil scientist to predict with a considerable degree of accuracy the kind of soil or miscellaneous area at a specific location on the landscape.

Commonly, individual soils on the landscape merge into one another as their characteristics gradually change. To construct an accurate soil map, however, soil scientists must determine the boundaries between the soils. They can observe only a limited number of soil profiles. Nevertheless, these observations, supplemented by an understanding of the soil-vegetation-landscape relationship, are sufficient to verify predictions of the kinds of soil in an area and to determine the boundaries.

Soil scientists recorded the characteristics of the soil profiles that they studied. They noted soil color, texture, size and shape of soil aggregates, kind and amount of rock fragments, distribution of plant roots, reaction, and other features that enable them to identify soils. After describing the soils in the survey area and determining their properties, the soil scientists assigned the soils to taxonomic classes (units). Taxonomic classes are concepts. Each taxonomic class has a set of soil characteristics with precisely defined limits. The classes are used as a basis for comparison to classify soils systematically. Soil taxonomy, the system of taxonomic classification used in the United States, is based mainly on the kind and character of soil properties and the arrangement of horizons within the profile. After the soil

Custom Soil Resource Report

scientists classified and named the soils in the survey area, they compared the individual soils with similar soils in the same taxonomic class in other areas so that they could confirm data and assemble additional data based on experience and research.

The objective of soil mapping is not to delineate pure map unit components; the objective is to separate the landscape into landforms or landform segments that have similar use and management requirements. Each map unit is defined by a unique combination of soil components and/or miscellaneous areas in predictable proportions. Some components may be highly contrasting to the other components of the map unit. The presence of minor components in a map unit in no way diminishes the usefulness or accuracy of the data. The delineation of such landforms and landform segments on the map provides sufficient information for the development of resource plans. If intensive use of small areas is planned, onsite investigation is needed to define and locate the soils and miscellaneous areas.

Soil scientists make many field observations in the process of producing a soil map. The frequency of observation is dependent upon several factors, including scale of mapping, intensity of mapping, design of map units, complexity of the landscape, and experience of the soil scientist. Observations are made to test and refine the soil-landscape model and predictions and to verify the classification of the soils at specific locations. Once the soil-landscape model is refined, a significantly smaller number of measurements of individual soil properties are made and recorded. These measurements may include field measurements, such as those for color, depth to bedrock, and texture, and laboratory measurements, such as those for content of sand, silt, clay, salt, and other components. Properties of each soil typically vary from one point to another across the landscape.

Observations for map unit components are aggregated to develop ranges of characteristics for the components. The aggregated values are presented. Direct measurements do not exist for every property presented for every map unit component. Values for some properties are estimated from combinations of other properties.

While a soil survey is in progress, samples of some of the soils in the area generally are collected for laboratory analyses and for engineering tests. Soil scientists interpret the data from these analyses and tests as well as the field-observed characteristics and the soil properties to determine the expected behavior of the soils under different uses. Interpretations for all of the soils are field tested through observation of the soils in different uses and under different levels of management. Some interpretations are modified to fit local conditions, and some new interpretations are developed to meet local needs. Data are assembled from other sources, such as research information, production records, and field experience of specialists. For example, data on crop yields under defined levels of management are assembled from farm records and from field or plot experiments on the same kinds of soil.

Predictions about soil behavior are based not only on soil properties but also on such variables as climate and biological activity. Soil conditions are predictable over long periods of time, but they are not predictable from year to year. For example, soil scientists can predict with a fairly high degree of accuracy that a given soil will have a high water table within certain depths in most years, but they cannot predict that a high water table will always be at a specific level in the soil on a specific date.

After soil scientists located and identified the significant natural bodies of soil in the survey area, they drew the boundaries of these bodies on aerial photographs and

Custom Soil Resource Report

identified each as a specific map unit. Aerial photographs show trees, buildings, fields, roads, and rivers, all of which help in locating boundaries accurately.

Soil Map

The soil map section includes the soil map for the defined area of interest, a list of soil map units on the map and extent of each map unit, and cartographic symbols displayed on the map. Also presented are various metadata about data used to produce the map, and a description of each soil map unit.

Custom Soil Resource Report Soil Map



Map Scale: 1:2,460 if printed on A portrait (8.5" x 11") sheet.



Map projection: Web Mercator Corner coordinates: WGS84 Edge tics: UTM Zone 13N WGS84

MAP LEGEND

Area of Interest (AOI)

 Area of Interest (AOI)

Soils

 Soil Map Unit Polygons

 Soil Map Unit Lines

 Soil Map Unit Points

Special Point Features

-  Blowout
-  Borrow Pit
-  Clay Spot
-  Closed Depression
-  Gravel Pit
-  Gravelly Spot
-  Landfill
-  Lava Flow
-  Marsh or swamp
-  Mine or Quarry
-  Miscellaneous Water
-  Perennial Water
-  Rock Outcrop
-  Saline Spot
-  Sandy Spot
-  Severely Eroded Spot
-  Sinkhole
-  Slide or Slip
-  Sodic Spot

-  Spoil Area
-  Stony Spot
-  Very Stony Spot
-  Wet Spot
-  Other
-  Special Line Features

Water Features

 Streams and Canals

Transportation

-  Rails
-  Interstate Highways
-  US Routes
-  Major Roads
-  Local Roads

Background

 Aerial Photography

MAP INFORMATION

The soil surveys that comprise your AOI were mapped at 1:24,000.

Warning: Soil Map may not be valid at this scale.

Enlargement of maps beyond the scale of mapping can cause misunderstanding of the detail of mapping and accuracy of soil line placement. The maps do not show the small areas of contrasting soils that could have been shown at a more detailed scale.

Please rely on the bar scale on each map sheet for map measurements.

Source of Map: Natural Resources Conservation Service
 Web Soil Survey URL:
 Coordinate System: Web Mercator (EPSG:3857)

Maps from the Web Soil Survey are based on the Web Mercator projection, which preserves direction and shape but distorts distance and area. A projection that preserves area, such as the Albers equal-area conic projection, should be used if more accurate calculations of distance or area are required.

This product is generated from the USDA-NRCS certified data as of the version date(s) listed below.

Soil Survey Area: El Paso County Area, Colorado
 Survey Area Data: Version 21, Aug 24, 2023

Soil map units are labeled (as space allows) for map scales 1:50,000 or larger.

Date(s) aerial images were photographed: Aug 19, 2018—Sep 23, 2018

The orthophoto or other base map on which the soil lines were compiled and digitized probably differs from the background imagery displayed on these maps. As a result, some minor shifting of map unit boundaries may be evident.

Map Unit Legend

Map Unit Symbol	Map Unit Name	Acres in AOI	Percent of AOI
82	Schamber-Razor complex, 8 to 50 percent slopes	18.7	100.0%
Totals for Area of Interest		18.7	100.0%

Map Unit Descriptions

The map units delineated on the detailed soil maps in a soil survey represent the soils or miscellaneous areas in the survey area. The map unit descriptions, along with the maps, can be used to determine the composition and properties of a unit.

A map unit delineation on a soil map represents an area dominated by one or more major kinds of soil or miscellaneous areas. A map unit is identified and named according to the taxonomic classification of the dominant soils. Within a taxonomic class there are precisely defined limits for the properties of the soils. On the landscape, however, the soils are natural phenomena, and they have the characteristic variability of all natural phenomena. Thus, the range of some observed properties may extend beyond the limits defined for a taxonomic class. Areas of soils of a single taxonomic class rarely, if ever, can be mapped without including areas of other taxonomic classes. Consequently, every map unit is made up of the soils or miscellaneous areas for which it is named and some minor components that belong to taxonomic classes other than those of the major soils.

Most minor soils have properties similar to those of the dominant soil or soils in the map unit, and thus they do not affect use and management. These are called noncontrasting, or similar, components. They may or may not be mentioned in a particular map unit description. Other minor components, however, have properties and behavioral characteristics divergent enough to affect use or to require different management. These are called contrasting, or dissimilar, components. They generally are in small areas and could not be mapped separately because of the scale used. Some small areas of strongly contrasting soils or miscellaneous areas are identified by a special symbol on the maps. If included in the database for a given area, the contrasting minor components are identified in the map unit descriptions along with some characteristics of each. A few areas of minor components may not have been observed, and consequently they are not mentioned in the descriptions, especially where the pattern was so complex that it was impractical to make enough observations to identify all the soils and miscellaneous areas on the landscape.

The presence of minor components in a map unit in no way diminishes the usefulness or accuracy of the data. The objective of mapping is not to delineate pure taxonomic classes but rather to separate the landscape into landforms or landform segments that have similar use and management requirements. The delineation of such segments on the map provides sufficient information for the development of resource plans. If intensive use of small areas is planned, however, onsite investigation is needed to define and locate the soils and miscellaneous areas.

Custom Soil Resource Report

An identifying symbol precedes the map unit name in the map unit descriptions. Each description includes general facts about the unit and gives important soil properties and qualities.

Soils that have profiles that are almost alike make up a *soil series*. Except for differences in texture of the surface layer, all the soils of a series have major horizons that are similar in composition, thickness, and arrangement.

Soils of one series can differ in texture of the surface layer, slope, stoniness, salinity, degree of erosion, and other characteristics that affect their use. On the basis of such differences, a soil series is divided into *soil phases*. Most of the areas shown on the detailed soil maps are phases of soil series. The name of a soil phase commonly indicates a feature that affects use or management. For example, Alpha silt loam, 0 to 2 percent slopes, is a phase of the Alpha series.

Some map units are made up of two or more major soils or miscellaneous areas. These map units are complexes, associations, or undifferentiated groups.

A *complex* consists of two or more soils or miscellaneous areas in such an intricate pattern or in such small areas that they cannot be shown separately on the maps. The pattern and proportion of the soils or miscellaneous areas are somewhat similar in all areas. Alpha-Beta complex, 0 to 6 percent slopes, is an example.

An *association* is made up of two or more geographically associated soils or miscellaneous areas that are shown as one unit on the maps. Because of present or anticipated uses of the map units in the survey area, it was not considered practical or necessary to map the soils or miscellaneous areas separately. The pattern and relative proportion of the soils or miscellaneous areas are somewhat similar. Alpha-Beta association, 0 to 2 percent slopes, is an example.

An *undifferentiated group* is made up of two or more soils or miscellaneous areas that could be mapped individually but are mapped as one unit because similar interpretations can be made for use and management. The pattern and proportion of the soils or miscellaneous areas in a mapped area are not uniform. An area can be made up of only one of the major soils or miscellaneous areas, or it can be made up of all of them. Alpha and Beta soils, 0 to 2 percent slopes, is an example.

Some surveys include *miscellaneous areas*. Such areas have little or no soil material and support little or no vegetation. Rock outcrop is an example.

El Paso County Area, Colorado

82—Schamber-Razor complex, 8 to 50 percent slopes

Map Unit Setting

National map unit symbol: 369y
Elevation: 5,500 to 6,500 feet
Mean annual precipitation: 12 to 14 inches
Mean annual air temperature: 48 to 52 degrees F
Frost-free period: 135 to 170 days
Farmland classification: Not prime farmland

Map Unit Composition

Schamber and similar soils: 55 percent
Razor and similar soils: 43 percent
Minor components: 2 percent
Estimates are based on observations, descriptions, and transects of the mapunit.

Description of Schamber

Setting

Landform: Breaks
Down-slope shape: Linear
Across-slope shape: Linear
Parent material: Alluvium derived from granite and/or colluvium derived from granite and/or eolian deposits derived from granite

Typical profile

A - 0 to 5 inches: gravelly loam
AC - 5 to 15 inches: very gravelly loam
C - 15 to 60 inches: very gravelly sand

Properties and qualities

Slope: 8 to 50 percent
Depth to restrictive feature: More than 80 inches
Drainage class: Well drained
Runoff class: Medium
Capacity of the most limiting layer to transmit water (Ksat): High (2.00 to 6.00 in/hr)
Depth to water table: More than 80 inches
Frequency of flooding: None
Frequency of ponding: None
Calcium carbonate, maximum content: 15 percent
Maximum salinity: Nonsaline to very slightly saline (0.0 to 2.0 mmhos/cm)
Available water supply, 0 to 60 inches: Low (about 3.0 inches)

Interpretive groups

Land capability classification (irrigated): None specified
Land capability classification (nonirrigated): 7e
Hydrologic Soil Group: A
Ecological site: R069XY064CO - Gravel Breaks
Hydric soil rating: No

Description of Razor

Setting

Landform: Breaks

Down-slope shape: Linear

Across-slope shape: Linear

Parent material: Clayey slope alluvium over residuum weathered from shale

Typical profile

A - 0 to 3 inches: clay loam

Bw - 3 to 9 inches: clay loam

Bk - 9 to 31 inches: clay

Cr - 31 to 35 inches: weathered bedrock

Properties and qualities

Slope: 8 to 15 percent

Depth to restrictive feature: 20 to 40 inches to paralithic bedrock

Drainage class: Well drained

Runoff class: Medium

Capacity of the most limiting layer to transmit water (Ksat): Moderately low to moderately high (0.06 to 0.20 in/hr)

Depth to water table: More than 80 inches

Frequency of flooding: None

Frequency of ponding: None

Calcium carbonate, maximum content: 15 percent

Gypsum, maximum content: 5 percent

Maximum salinity: Moderately saline to strongly saline (8.0 to 16.0 mmhos/cm)

Sodium adsorption ratio, maximum: 15.0

Available water supply, 0 to 60 inches: Low (about 5.5 inches)

Interpretive groups

Land capability classification (irrigated): 6e

Land capability classification (nonirrigated): 6e

Hydrologic Soil Group: D

Ecological site: R069XY047CO - Alkaline Plains

Other vegetative classification: ALKALINE PLAINS (069AY047CO)

Hydric soil rating: No

Minor Components

Other soils

Percent of map unit: 1 percent

Hydric soil rating: No

Pleasant

Percent of map unit: 1 percent

Landform: Depressions

Hydric soil rating: Yes

Soil Information for All Uses

Soil Properties and Qualities

The Soil Properties and Qualities section includes various soil properties and qualities displayed as thematic maps with a summary table for the soil map units in the selected area of interest. A single value or rating for each map unit is generated by aggregating the interpretive ratings of individual map unit components. This aggregation process is defined for each property or quality.

Soil Qualities and Features

Soil qualities are behavior and performance attributes that are not directly measured, but are inferred from observations of dynamic conditions and from soil properties. Example soil qualities include natural drainage, and frost action. Soil features are attributes that are not directly part of the soil. Example soil features include slope and depth to restrictive layer. These features can greatly impact the use and management of the soil.

Hydrologic Soil Group

Hydrologic soil groups are based on estimates of runoff potential. Soils are assigned to one of four groups according to the rate of water infiltration when the soils are not protected by vegetation, are thoroughly wet, and receive precipitation from long-duration storms.

The soils in the United States are assigned to four groups (A, B, C, and D) and three dual classes (A/D, B/D, and C/D). The groups are defined as follows:

Group A. Soils having a high infiltration rate (low runoff potential) when thoroughly wet. These consist mainly of deep, well drained to excessively drained sands or gravelly sands. These soils have a high rate of water transmission.

Group B. Soils having a moderate infiltration rate when thoroughly wet. These consist chiefly of moderately deep or deep, moderately well drained or well drained soils that have moderately fine texture to moderately coarse texture. These soils have a moderate rate of water transmission.

Custom Soil Resource Report

Group C. Soils having a slow infiltration rate when thoroughly wet. These consist chiefly of soils having a layer that impedes the downward movement of water or soils of moderately fine texture or fine texture. These soils have a slow rate of water transmission.

Group D. Soils having a very slow infiltration rate (high runoff potential) when thoroughly wet. These consist chiefly of clays that have a high shrink-swell potential, soils that have a high water table, soils that have a claypan or clay layer at or near the surface, and soils that are shallow over nearly impervious material. These soils have a very slow rate of water transmission.

If a soil is assigned to a dual hydrologic group (A/D, B/D, or C/D), the first letter is for drained areas and the second is for undrained areas. Only the soils that in their natural condition are in group D are assigned to dual classes.

Custom Soil Resource Report Map—Hydrologic Soil Group

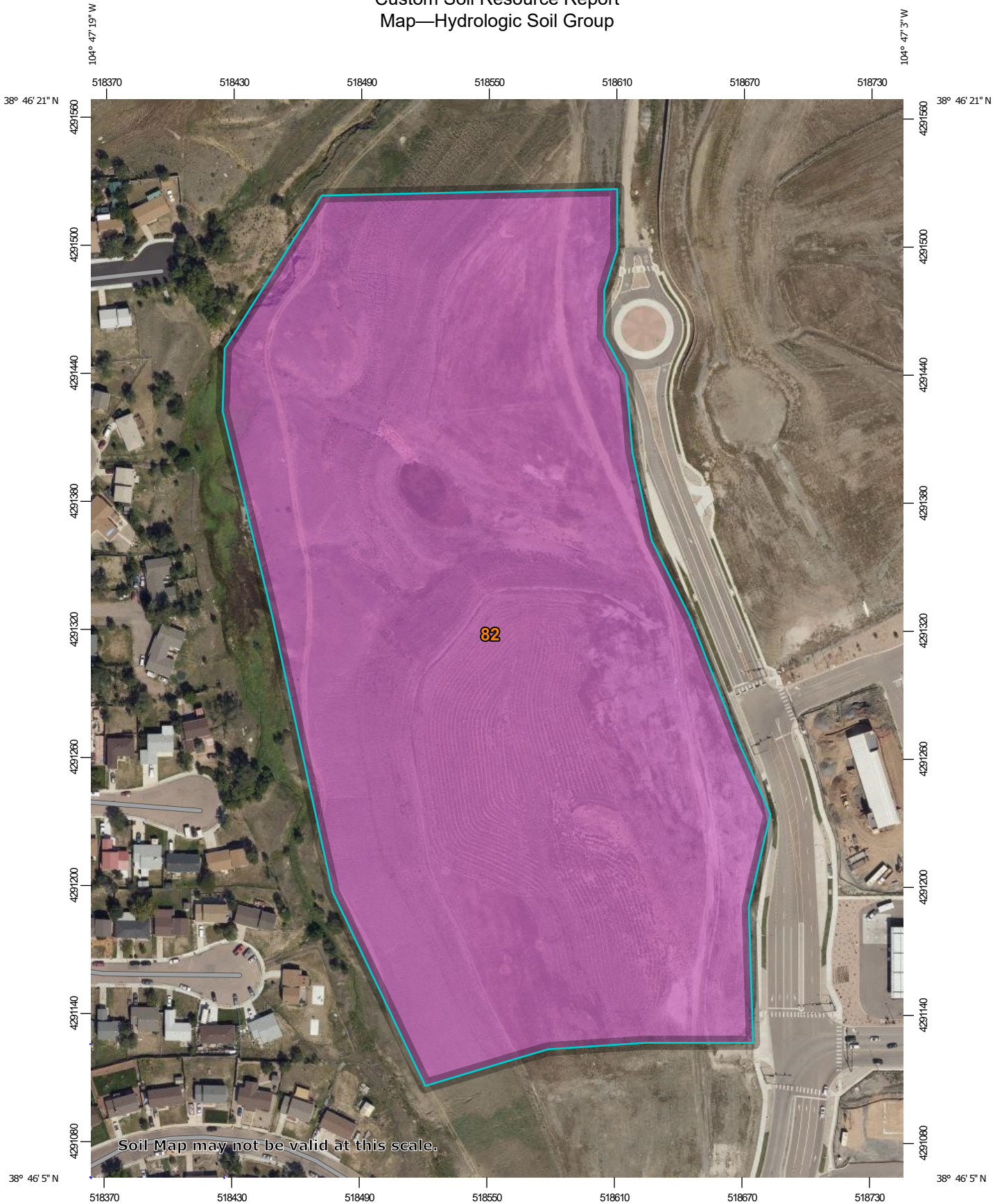

Soil Map may not be valid at this scale.

Map Scale: 1:2,460 if printed on A portrait (8.5" x 11") sheet.



Map projection: Web Mercator Corner coordinates: WGS84 Edge tics: UTM Zone 13N WGS84

MAP LEGEND

Area of Interest (AOI)









 Area of Interest (AOI)

Soils

Soil Rating Polygons





-  A
-  A/D
-  B
-  B/D
-  C
-  C/D
-  D
-  Not rated or not available

Soil Rating Lines

-  A
-  A/D
-  B
-  B/D
-  C
-  C/D
-  D
-  Not rated or not available

Soil Rating Points





-  A
-  A/D
-  B
-  B/D

-  C
-  C/D
-  D
-  Not rated or not available

Water Features

 Streams and Canals

Transportation

-  Rails
-  Interstate Highways
-  US Routes
-  Major Roads
-  Local Roads

Background

 Aerial Photography

MAP INFORMATION

The soil surveys that comprise your AOI were mapped at 1:24,000.

Warning: Soil Map may not be valid at this scale.

Enlargement of maps beyond the scale of mapping can cause misunderstanding of the detail of mapping and accuracy of soil line placement. The maps do not show the small areas of contrasting soils that could have been shown at a more detailed scale.

Please rely on the bar scale on each map sheet for map measurements.

Source of Map: Natural Resources Conservation Service
 Web Soil Survey URL:
 Coordinate System: Web Mercator (EPSG:3857)

Maps from the Web Soil Survey are based on the Web Mercator projection, which preserves direction and shape but distorts distance and area. A projection that preserves area, such as the Albers equal-area conic projection, should be used if more accurate calculations of distance or area are required.

This product is generated from the USDA-NRCS certified data as of the version date(s) listed below.

Soil Survey Area: El Paso County Area, Colorado
 Survey Area Data: Version 21, Aug 24, 2023

Soil map units are labeled (as space allows) for map scales 1:50,000 or larger.

Date(s) aerial images were photographed: Aug 19, 2018—Sep 23, 2018

The orthophoto or other base map on which the soil lines were compiled and digitized probably differs from the background imagery displayed on these maps. As a result, some minor shifting of map unit boundaries may be evident.

Table—Hydrologic Soil Group

Map unit symbol	Map unit name	Rating	Acres in AOI	Percent of AOI
82	Schamber-Razor complex, 8 to 50 percent slopes	A	18.7	100.0%
Totals for Area of Interest			18.7	100.0%

Rating Options—Hydrologic Soil Group

Aggregation Method: Dominant Condition

Component Percent Cutoff: None Specified

Tie-break Rule: Higher

References

- American Association of State Highway and Transportation Officials (AASHTO). 2004. Standard specifications for transportation materials and methods of sampling and testing. 24th edition.
- American Society for Testing and Materials (ASTM). 2005. Standard classification of soils for engineering purposes. ASTM Standard D2487-00.
- Cowardin, L.M., V. Carter, F.C. Golet, and E.T. LaRoe. 1979. Classification of wetlands and deep-water habitats of the United States. U.S. Fish and Wildlife Service FWS/OBS-79/31.
- Federal Register. July 13, 1994. Changes in hydric soils of the United States.
- Federal Register. September 18, 2002. Hydric soils of the United States.
- Hurt, G.W., and L.M. Vasilas, editors. Version 6.0, 2006. Field indicators of hydric soils in the United States.
- National Research Council. 1995. Wetlands: Characteristics and boundaries.
- Soil Survey Division Staff. 1993. Soil survey manual. Soil Conservation Service. U.S. Department of Agriculture Handbook 18. http://www.nrcs.usda.gov/wps/portal/nrcs/detail/national/soils/?cid=nrcs142p2_054262
- Soil Survey Staff. 1999. Soil taxonomy: A basic system of soil classification for making and interpreting soil surveys. 2nd edition. Natural Resources Conservation Service, U.S. Department of Agriculture Handbook 436. http://www.nrcs.usda.gov/wps/portal/nrcs/detail/national/soils/?cid=nrcs142p2_053577
- Soil Survey Staff. 2010. Keys to soil taxonomy. 11th edition. U.S. Department of Agriculture, Natural Resources Conservation Service. http://www.nrcs.usda.gov/wps/portal/nrcs/detail/national/soils/?cid=nrcs142p2_053580
- Tiner, R.W., Jr. 1985. Wetlands of Delaware. U.S. Fish and Wildlife Service and Delaware Department of Natural Resources and Environmental Control, Wetlands Section.
- United States Army Corps of Engineers, Environmental Laboratory. 1987. Corps of Engineers wetlands delineation manual. Waterways Experiment Station Technical Report Y-87-1.
- United States Department of Agriculture, Natural Resources Conservation Service. National forestry manual. http://www.nrcs.usda.gov/wps/portal/nrcs/detail/soils/home/?cid=nrcs142p2_053374
- United States Department of Agriculture, Natural Resources Conservation Service. National range and pasture handbook. <http://www.nrcs.usda.gov/wps/portal/nrcs/detail/national/landuse/rangepasture/?cid=stelprdb1043084>

Custom Soil Resource Report

United States Department of Agriculture, Natural Resources Conservation Service. National soil survey handbook, title 430-VI. http://www.nrcs.usda.gov/wps/portal/nrcs/detail/soils/scientists/?cid=nrcs142p2_054242

United States Department of Agriculture, Natural Resources Conservation Service. 2006. Land resource regions and major land resource areas of the United States, the Caribbean, and the Pacific Basin. U.S. Department of Agriculture Handbook 296. http://www.nrcs.usda.gov/wps/portal/nrcs/detail/national/soils/?cid=nrcs142p2_053624

United States Department of Agriculture, Soil Conservation Service. 1961. Land capability classification. U.S. Department of Agriculture Handbook 210. http://www.nrcs.usda.gov/Internet/FSE_DOCUMENTS/nrcs142p2_052290.pdf

APPENDIX E – IDENTIFICATION OF POLLUTANT SOURCES

APPENDIX F – LAND DISTURBANCE / CONTROL MEASURE /
STABILIZATION LOG



APPENDIX G – SPILL PREVENTION AND RESPONSE PLAN AND REPORTING INFORMATION

Spill Prevention and Response Plan

(Sample Plan – This plan has been produced to assist the General Contractor. This plan shall be revised and updated as needed by the contractor to fit the specific needs of the construction site and may need to be updated to reflect different type of materials and chemicals).

General Spill Control Practices

Any hazardous or potentially hazardous material that is brought onto the construction site shall be handled properly to reduce the potential for stormwater pollution. In an effort to minimize the potential for a spill of petroleum product or hazardous materials to come in contact with stormwater, the following steps shall be implemented:

- Material Safety Data Sheets (MSDS) information shall be kept on site for any and all applicable materials.
- A spill control and containment kit shall be provided on the construction site
- All materials with hazardous properties (such as pesticides, petroleum products, fertilizers, detergents, construction chemicals, acids, paints, paint solvents, additives for soil stabilization, concrete, curing compounds and additives, etc.) shall be stored in a secure location, under cover and in appropriate, tightly sealed containers when not in use.
- The minimum practical quantity of all such materials shall be kept on the job site and scheduled for delivery as close to time of use as practical.
- All products shall be stored in and used from the original container with the original product label and used in strict compliance with the instructions on the product label.
- All of the product in a container shall be used before the container is disposed of. All such containers shall be triple rinsed, with water prior to disposal. The rinse water used in these containers shall be disposed of in a manner in compliance with State and Federal regulations and shall not be allowed to mix with stormwater discharges. The disposal of excess or used products shall be in strict compliance with instructions on the product label.
- If utilized, temporary onsite fuel tanks for construction vehicles shall meet all state and federal regulations. Tanks shall have approved spill containment with the capacity required by the applicable regulations. The tanks shall be in sound condition free of rust or other damage which might compromise containment. All tanks in excess of 50 gallons shall be provided with secondary containment (i.e. containment external to and separate from primary containment). Secondary containment shall be constructed of materials of sufficient thickness, density and composition so as not to be structurally weakened as a result of contact with the fuel stored and capable of containing discharged fuel for a period of time equal to or longer than the maximum anticipated time sufficient to allow recovery of discharged fuel. The operator / qualified stormwater manager should familiarize themselves with and follow local and state requirements.

Spill Response Plan

In the event of an accidental spill, immediate action shall be undertaken by the Operator to contain and remove the spilled material.

- All hazardous materials, including contaminated soil, shall be disposed of by the Operator in the manner specified by federal, state and local regulations and by the manufacturer of such products.
- Spilled materials shall be cleaned-up by following the procedures outlined by the MSDS.
- As soon as possible, the spill shall be reported to the appropriate agencies as required by law. As required under the provisions of the Clean Water Act, any spill or discharge entering waters of the United States shall be properly reported. Any spills of petroleum products or hazardous materials in excess of Reportable Quantities as defined by EPA or the state or local agency regulations, shall be immediately reported to the Colorado Department of Public Health and Environment (CDPHE) spill reporting lines.
 - CDPHE Environmental Release and Incident Reporting Line (877) 518-5608.
 - National Response Center - (800) 424-8802
- The Operator shall prepare a written record of any spill and associated clean-up activities of petroleum products or hazardous materials in excess of 1 gallon or reportable quantities, whichever is less. At a minimum, the following shall be documented: Nature of spill, quantity of spill, date/time spill occurred, agency notification if necessary, clean-up procedures used, daily monitoring (for the following 7 days), photographs, and interview(s) with any witnesses of the event.



Environmental Spill Reporting

*24–Hour Emergency and Incident Reporting Line
Office of Emergency Preparedness & Response*

1-877-518-5608

Updated: June, 2018

Reporting chemical spills and releases in Colorado

General

For all hazardous substance incidents, local emergency response agencies must be notified.

Releases from fixed facilities

The Superfund Amendments and Reauthorization Act (SARA) Title III, requires reporting releases from fixed facilities

Refer to the SARA Title III List of Lists, available from the Environmental Protection Agency (EPA), for the reportable quantity.

The party that owns the spilled material must immediately notify the following agencies or organizations:

- National Response Center (NRC) 1-800-424-8802;
- Colorado Emergency Planning Committee (CEPC), represented by the Colorado Department of Public Health and Environment (CDPHE) 1-877-518-5608; and
- Local Emergency Planning Committee (LEPC) 1-720-852-6600.

In addition to telephone notification, the responsible party must also send written notification describing the release and associated emergency response to both the CEPC (in this case, CDPHE) and the LEPC.

Releases from RCRA facilities

Emergency releases from facilities permitted under the Resource Conservation and Recovery Act (RCRA) are reportable according to the permit requirements.

The permit often requires reporting to CDPHE, even if the amount of the release is less than a reportable quantity under SARA Title III (6 CCR 1007-3 Part 264).

Permitted facilities and generators and transporters of hazardous waste are required to have and implement a contingency plan that describes the actions facility personnel must take in response to fires, explosions or any unplanned sudden or non-sudden release of hazardous waste or hazardous waste constituents to air, soil, surface or ground water at the facility (6 CCR 1007-3 Sections 261, 262, 263, 264 and 265).

Whenever there is an imminent or actual emergency situation, appropriate state or local agencies, with designated response roles as described in the contingency plan, must be notified immediately.

The National Response Center or government official designated as the regional on-scene coordinator must be notified immediately if it is determined that the facility has had a release, fire or explosion that could threaten human health or the environment outside the facility.

CDPHE and local authorities must be notified when the facility is back in compliance and ready to resume operations. In addition, the facility must send a written report to CDPHE within 15 days of any incident that requires implementation of the contingency plan. The contingency plan should include current contact information for notification and submittal of written reports.

Permitted facilities, generators and transporters that store hazardous waste must notify CDPHE within 24 hours of any release to the environment that is greater than one (1) pound and must submit a written report to CDPHE within 30 days of the release (6 CCR 1007-3).

Transportation accidents

Transportation accidents that require reporting:

- Result in a spill or release of a hazardous substance in excess of the reportable quantity (40 CFR Part 302.6)
- Cause injury or death or cause estimated property damage exceeding \$50,000.
- Cause an evacuation of the general public lasting one or more hours.

Those that close or shut down one or more major transportation arteries or facilities or result in fire, breakage, spillage, or suspected contamination from radioactive or infectious substances must immediately be reported to the National Response Center.

Refer to the EPA SARA Title III List of Lists for those substances that have reportable quantities.

In addition to the NRC being notified, the local emergency number (9-1-1) must be called and CDPHE should be notified.

Written notification of any transportation accident involving a release of hazardous materials must be provided to the U.S. Department of Transportation within 30 days (49 CFR Part 171.16)

Since hazardous waste is a subset of hazardous materials, transporters who have discharged hazardous waste must notify the NRC and provide a written report to the US Department of Transportation as noted in the above reporting requirements.

The transporter must give immediate notice to the nearest Colorado State Patrol office (8 CCR 1507-8 HMP 5) and the nearest law enforcement agency if the accident or spill involved a vehicle (42-20-113(3) CRS).

Notification and a written report detailing the ultimate disposition of the discharge of hazardous waste must also be provided to CDPHE (6 CCR 1007-2 Section 263.30). This may be a duplicate copy of the US Department of Transportation report

In the event of a spill or discharge of hazardous waste at a transfer facility, the transporter must notify CDPHE within 24 hours if the spill exceeds 55 gallons or if there is a fire or explosion.

Within 15 days of a reportable incident, the transporter must submit a written report of the incident to CDPHE, including the final disposition of the material (6 CCR 1007-2 Section 263.40).

Releases of hazardous waste at a transfer facility may also require notification to the National Response Center and a written report to the U.S. Department of Transportation.

Releases to water

A release of any chemical, oil, petroleum product, sewage, etc., which may enter waters of the State of Colorado (which include surface water, ground water and dry gullies or storm sewers leading to surface water) must be reported to CDPHE immediately (25-8-601 CRS).

Written notification to CDPHE must follow within five (5) days (5 CCR 1002-61, Section 61.8(5)(d)).

Any accidental discharge to the sanitary sewer system must be reported immediately to the local sewer authority and the affected wastewater treatment plant.

Releases of petroleum products and certain hazardous substances listed under the Federal Clean Water Act (40 CFR Part 116) must be reported to the National Response Center as well as to CDPHE (1-877-518-5608) as required under the Clean Water Act and the Oil Pollution Act.

Releases to air

Any unpredictable failure of air pollution control or process equipment that results in the violation of emission

control regulations should be reported CDPHE by 10 a.m. of the following working day, followed by a written notice explaining the cause of the occurrence and describing action that has been or is being taken to correct the condition causing the violation and to prevent such excess emissions in the future (5 CCR 1001-2 Common Provisions Regulations Section II.E).

If emergency conditions cause excess emissions at a permitted facility, the owner/operator must provide notice to CDPHE no later than noon of the next working day following the emergency, and follow by written notice within one month of the time when emission limitations were exceeded due to the emergency (5 CCR 1001-5, Regulation 3 Part C, Section VII.C.4).

Releases from oil and gas wells

All spills or releases of exploration and production wastes or produced fluids which meet the reporting thresholds of the Colorado Oil and Gas Conservation Commission (COGCC) Rule 906 shall be reported verbally to the COGCC within 24 hours of discovery and on the COGCC Spill/Release Report Form 19 within 72 hours of discovery.

Spills or releases are reportable to the COGCC in the following circumstances:

- 1) the spill or release impacts or threatens to impact any waters of the state, (which include surface water, ground water and dry gullies or storm sewers leading to surface water), a residence or occupied structure, livestock or a public byway;
- 2) a spill or release in which 1 barrel or more is released outside of berms or other secondary containment; or
- 3) any spill or release of 5 barrels or more.

COGCC also requires reportable spills or releases be reported to the surface owner and local government. Whether or not they are reportable, spills or releases of any size must be stopped, cleaned up, and investigated as soon as practicable.

If the spill or release impacts or threatens to impact waters of the state, it must also be reported immediately to CDPHE (25-8-601 CRS).

Releases from storage tanks

Petroleum releases of 25 gallons or more (or any size that causes a sheen on nearby surface waters) from regulated aboveground and underground fuel storage tanks must be reported to the Division of Oil and Public Safety (303-318-8547) within 24 hours. If the report is made after business hours, please leave a message on the technical assistance line for the Division of Oil and Public Safety, and contact the 24 hour CDPHE Emergency and Incident Reporting Line. This includes spills from fuel dispensers.

Spills or releases of hazardous substances from regulated storage tanks in excess of the reportable quantity (40 CFR Part 302.6) must be reported to the National Response Center and the local fire authority immediately, and to the Division of Oil and Public Safety within 24 hours. (8-20.5-208 CRS and 7 CCR 1101-14 Article 4).

Owners/operators of regulated storage tanks must contain and immediately clean up a spill or overfill of less than 25 gallons of petroleum and a spill or overfill of a hazardous substance that is less than the reportable quantity.

If cleanup cannot be accomplished within 24 hours, the Division of Oil and Public Safety must be notified immediately (7 CCR 1101-14 Article 4-4).

CDPHE should also be notified in the case of hazardous substance releases as cleanup activities may be covered by state solid or hazardous waste requirements (6 CCR 1007-2, 6 CCR 1007-3).

Any release that has or may impact waters of the state (which include surface water, ground water and dry

gullies or storm sewers leading to surface water), no matter how small, must be reported immediately to CDPHE (25-8-601 CRS).

Releases from pipelines

Releases of five or more gallons of hazardous liquids or carbon dioxide from a pipeline that result in explosion or fire, cause injury or death or cause estimated property damage (including cost of clean-up and recovery, value of lost product and property damage) exceeding \$50,000 must be reported immediately to the US Department of Transportation Office of Pipeline Safety (49 CFR Part 195 Subpart B) and the National Response Center.

Releases of five or more gallons of hazardous liquids or carbon dioxide from interstate pipelines that do not involve explosion or fire, injury or death or property damage exceeding \$50,000 should be reported to the US Department of Transportation Office of Pipeline Safety within 30 days after the incident.

Releases of natural gas from intrastate pipelines that cause injury or death, property damage in excess of \$50,000 (including the cost of lost product), closure of a public road, or evacuation of 50 or more people must be reported immediately to the Colorado Public Utilities Commission, Pipeline Safety Group (4 CCR 723-11-2).

Releases of natural gas or liquefied natural gas (LNG) from interstate pipelines that cause injury or death, property damage in excess of \$50,000 (including the cost of lost product), or results in an emergency shutdown of the facility must be reported immediately to the National Response Center and the US Dept of Transportation Office of Pipeline Safety.

Releases of oil, petroleum products or other hazardous liquids from interstate and intrastate pipelines that have or may enter waters of the State of Colorado (which include surface water, ground water and dry gullies or storm sewers leading to surface water) must be reported to CDPHE immediately (25-8-601 CRS). CDPHE should also be notified of releases to soil, as cleanup activities may be covered by state solid or hazardous waste requirements (6 CCR 1007-2, 6 CCR 1007-3).

Radiological accidents, incidents, and events

CDPHE must be notified of any condition that has caused or threatens to cause an event, which meets or exceeds the criteria specified in (6 CCR 1007-1) RH 4.51 and RH 4.52 of the State of Colorado *Rules and Regulations Pertaining to Radiation Control*. Reportable events include lost radioactive materials, lost radiation producing machines, over-exposures to persons, contamination events and fires or explosions involving radioactive materials.

Depending upon the severity of the event, notification may be required immediately, within 24 hours, or within 30 days. In most cases, a written follow-up report is also required.

If you are unsure of the proper notification requirement, please contact CDPHE immediately. Telephone event notifications can be made to the CDPHE Radiation Program at any time by calling 1-303-877-9757.

Notification Numbers

Colorado Department of Public Health and Environment toll-free 24-hour environmental emergency and incident reporting line: (877) 518-5608 (24-hour)

National Response Center
(800) 424-8802 (24-hour)

State Oil Inspector (Colorado Division of Oil & Public Safety-Above & Underground Storage Tank Regulators)
(303) 318-8547

APPENDIX H – STORM EVENT LOG



APPENDIX I – INSPECTION AND SAMPLING REPORTS

CONSTRUCTION STORMWATER SITE INSPECTION REPORT

Facility Name		Permittee					
Date of Inspection		Weather Conditions					
Permit Certification #		Disturbed Acreage					
Phase of Construction		Inspector Title					
Inspector Name							
Is the above inspector a qualified stormwater manager? (permittee is responsible for ensuring that the inspector is a qualified stormwater manager)			<table border="1" style="width: 100%; border-collapse: collapse;"> <tr> <td style="width: 50%; text-align: center;">YES</td> <td style="width: 50%; text-align: center;">NO</td> </tr> <tr> <td style="text-align: center;"><input type="checkbox"/></td> <td style="text-align: center;"><input type="checkbox"/></td> </tr> </table>	YES	NO	<input type="checkbox"/>	<input type="checkbox"/>
YES	NO						
<input type="checkbox"/>	<input type="checkbox"/>						

INSPECTION FREQUENCY					
Check the box that describes the minimum inspection frequency utilized when conducting each inspection					
At least one inspection every 7 calendar days	<input type="checkbox"/>				
At least one inspection every 14 calendar days, with post-storm event inspections conducted within 24 hours after the end of any precipitation or snowmelt event that causes surface erosions	<input type="checkbox"/>				
<ul style="list-style-type: none"> • This is this a post-storm event inspection. Event Date: _____ 	<input type="checkbox"/>				
Reduced inspection frequency - Include site conditions that warrant reduced inspection frequency	<input type="checkbox"/>				
<ul style="list-style-type: none"> • Post-storm inspections at temporarily idle sites 	<input type="checkbox"/>				
<ul style="list-style-type: none"> • Inspections at completed sites/area 	<input type="checkbox"/>				
<ul style="list-style-type: none"> • Winter conditions exclusion 	<input type="checkbox"/>				
Have there been any deviations from the minimum inspection schedule? If yes, describe below.	<table border="1" style="width: 100%; border-collapse: collapse;"> <tr> <td style="width: 50%; text-align: center;">YES</td> <td style="width: 50%; text-align: center;">NO</td> </tr> <tr> <td style="text-align: center;"><input type="checkbox"/></td> <td style="text-align: center;"><input type="checkbox"/></td> </tr> </table>	YES	NO	<input type="checkbox"/>	<input type="checkbox"/>
YES	NO				
<input type="checkbox"/>	<input type="checkbox"/>				

INSPECTION REQUIREMENTS*
i. Visually verify all implemented control measures are in effective operational condition and are working as designed in the specifications
ii. Determine if there are new potential sources of pollutants
iii. Assess the adequacy of control measures at the site to identify areas requiring new or modified control measures to minimize pollutant discharges
iv. Identify all areas of non-compliance with the permit requirements, and if necessary, implement corrective action
*Use the attached Control Measures Requiring Routine Maintenance and Inadequate Control Measures Requiring Corrective Action forms to document results of this assessment that trigger either maintenance or corrective actions

AREAS TO BE INSPECTED			
Is there evidence of, or the potential for, pollutants leaving the construction site boundaries, entering the stormwater drainage system or discharging to state waters at the following locations?			
	NO	YES	If "YES" describe discharge or potential for discharge below. Document related maintenance, inadequate control measures and corrective actions Inadequate Control Measures Requiring Corrective Action form
Construction site perimeter	<input type="checkbox"/>	<input type="checkbox"/>	
All disturbed areas	<input type="checkbox"/>	<input type="checkbox"/>	
Designated haul routes	<input type="checkbox"/>	<input type="checkbox"/>	
Material and waste storage areas exposed to precipitation	<input type="checkbox"/>	<input type="checkbox"/>	
Locations where stormwater has the potential to discharge offsite	<input type="checkbox"/>	<input type="checkbox"/>	
Locations where vehicles exit the site	<input type="checkbox"/>	<input type="checkbox"/>	
Other: _____	<input type="checkbox"/>	<input type="checkbox"/>	

REPORTING REQUIREMENTS

The permittee shall report the following circumstances orally within twenty-four (24) hours from the time the permittee becomes aware of the circumstances, and shall mail to the division a written report containing the information requested within five (5) working days after becoming aware of the following circumstances. The division may waive the written report required if the oral report has been received within 24 hours.

All Noncompliance Requiring 24-Hour Notification per Part II.L.6 of the Permit		
a. Endangerment to Health or the Environment Circumstances leading to any noncompliance which may endanger health or the environment regardless of the cause of the incident (See Part II.L.6.a of the Permit) <i>This category would primarily result from the discharge of pollutants in violation of the permit</i>		
b. Numeric Effluent Limit Violations <ul style="list-style-type: none"> o Circumstances leading to any unanticipated bypass which exceeds any effluent limitations (See Part II.L.6.b of the Permit) o Circumstances leading to any upset which causes an exceedance of any effluent limitation (See Part II.L.6.c of the Permit) o Daily maximum violations (See Part II.L.6.d of the Permit) <i>Numeric effluent limits are very uncommon in certifications under the COR400000 general permit. This category of noncompliance only applies if numeric effluent limits are included in a permit certification.</i>		

Has there been an incident of noncompliance requiring 24-hour notification?	NO	YES	
	<input type="checkbox"/>	<input type="checkbox"/>	If "YES" document below

Date and Time of Incident	Location	Description of Noncompliance	Description of Corrective Action	Date and Time of 24 Hour Oral Notification	Date of 5 Day Written Notification *

*Attach copy of 5 day written notification to report. Indicate if written notification was waived, including the name of the division personnel who granted waiver.

After adequate corrective action(s) and maintenance have been taken, or where a report does not identify any incidents requiring corrective action or maintenance, the individual(s) designated as the Qualified Stormwater Manager, shall sign and certify the below statement:

“I verify that, to the best of my knowledge and belief, all corrective action and maintenance items identified during the inspection are complete, and the site is currently in compliance with the permit.”

Name of Qualified Stormwater Manager

Title of Qualified Stormwater Manager

Signature of Qualified Stormwater Manager

Date

Notes/Comments

APPENDIX J – SWMP AMENDMENT LOG / CONTROL MEASURE DETAILS



APPENDIX K – GEOTECH REPORT

DRAFT COPY – FOR REVIEW



Report of Geotechnical Engineering Evaluation

Proposed Multifamily Development
Venetucci Boulevard at South Academy Boulevard
Colorado Springs, Colorado

Prepared for

Thompson Thrift Residential
111 Monument Circle, Suite 1500
Indianapolis, Indiana 46204
ATTN: Mr. Tim Govert

Prepared by

Professional Service Industries, Inc.
1070 West 124th Avenue
Suite 800
Westminster, Colorado 80234

October 11, 2024

PSI Project 05322879



Professional Service Industries, Inc.
1070 West 124th Avenue, Suite 800
Westminster, Colorado 80234
Phone: (303) 424-5578
Fax: (303) 423-5625

Mr. Tim Govert
Thompson Thrift Residential
111 Monument Circle, Suite 1500
Indianapolis, Indiana 46204

**Subject: Report of Geotechnical Engineering Evaluation
Proposed Multi-family Development
Venetucci Boulevard at South Academy Boulevard
Colorado Springs, Colorado**

Dear Mr. Tim Govert:

Professional Service Industries, Inc (PSI), an Intertek Company, is pleased to transmit our Report of Geotechnical Engineering Evaluation for the proposed multifamily development in Colorado Springs, Colorado. This report includes the results of the field exploration and laboratory testing, as well as recommendations for site preparation and foundation design.

If you have questions pertaining to this report, or if we may be of further service, please contact us at your convenience.

PSI thanks you for your business and we look forward to finding ways to grow our partnership, expand our services, and continue Building Better Together.

For Professional Service Industries, Inc.

DRAFT COPY – FOR REVIEW

DRAFT COPY – FOR REVIEW

Joshua W. Edin
Staff Engineer

Hannah C. Tawfik, P.E.
Senior Project Engineer

Reviewed by: Lloyd Lasher, P.E.
Principal Consultant

TABLE OF CONTENTS

1.0 INTRODUCTION	1
2.0 PROJECT INFORMATION	1
3.0 SUBSURFACE INFORMATION	3
3.1 SITE GEOLOGY AND GEOLOGIC HAZARDS	3
3.2 SUBSURFACE CONDITIONS	4
<u>3.2.1 General Subsurface Profile</u>	5
<u>3.2.2 Groundwater Conditions</u>	5
<u>3.2.3 Swell Potential</u>	6
<u>3.2.4 Laboratory Testing</u>	7
4.0 GEOTECHNICAL EVALUATION	8
5.0 SITE GRADING RECOMMENDATIONS	9
6.0 GEOTECHNICAL RECOMMENDATIONS	11
6.1 MONOLITHIC SLAB-ON-GRADE FOUNDATION RECOMMENDATIONS	11
6.2 SEISMIC PARAMETERS	12
6.3 PAVEMENT RECOMMENDATIONS	13
6.4 LATERAL EARTH PRESSURES	15
6.5 POOL RECOMMENDATIONS	18
6.6 SOIL CORROSIVITY	19
6.7 PERCOLATION TEST	19
6.8 DRAINAGE RECOMMENDATIONS	20
7.0 LIMITATIONS	20
ATTACHMENTS	
Site Vicinity Maps (Figures 1a and 1b)	
Boring Location Maps (Figure 2)	
Boring Logs (Figures 3 through 32)	
Key to Symbols	
Appendix A – Laboratory Test Results	



DRAFT COPY – FOR REVIEW

1.0 INTRODUCTION

Professional Service Industries, Inc. (PSI), an Intertek Company, has conducted a geotechnical engineering evaluation for the proposed multifamily development in Colorado Springs, Colorado. The purpose of our study was to characterize the general subsurface strata at the subject site and to develop recommendations for site preparation and provide geotechnical parameters for the pavement and foundation design for the proposed development. Our services on this project were performed in general accordance with PSI Proposal Number 431918 Revision 1 dated August 12, 2024, and authorized by the Agreement for Consulting Services between PSI and Thompson Thrift Residential signed August 20, 2024.

PSI's scope of services for the geotechnical study did not include an assessment of environmental conditions in the soil, bedrock, surface water, groundwater, or air, on or below, or around this site. Any statements in this report or on the boring logs regarding odors, colors, and unusual or suspicious items or conditions are strictly for informational purposes.

The report, which follows, presents a brief review of our understanding of the project, a discussion of the site and subsurface conditions encountered, and our recommendations for design and construction of foundations and pavements.

2.0 PROJECT INFORMATION

PSI understands that Thompson Thrift Residential is planning a multifamily development in Colorado Springs Colorado. The site lies at 38.7699 N latitude and 104.7866 W longitude. The site is bordered by vacant land and a creek to the north, Venetucci Boulevard and a commercial development to the east, undeveloped lots and more vacant land to the south, and a creek, additional vacant land, and a residential development to the west.

Project information was provided in an email by Tim Govert, which included a Geotechnical RFP dated July 30, 2024 and a Site Plan dated July 22, 2024. PSI was also provided a preliminary geotechnical report dated July 6, 2023, and testing documents from earthwork performed at the site in 2013. We understand plans are to develop an approximately 16.23-acre site located west of Venetucci Boulevard and approximately ¼ mile north of South Academy Boulevard in Colorado Springs, Colorado. We anticipate the proposed development will consist of 10, three-story multi-family apartment buildings; three, single to two-story amenity buildings; a detention pond; retaining walls 4 to 30 feet in height; and a swimming pool. The apartment buildings are anticipated to be wood frame with no basements planned. Surface parking is also planned with several carport structures.

The site slopes significantly downward towards the northern and western sides of the site up to approximately 60 feet. Significant site grading (cuts of up to 70 feet and fills of up to 20 feet) reportedly occurred in the early 2010s to support surrounding development.



DRAFT COPY – FOR REVIEW

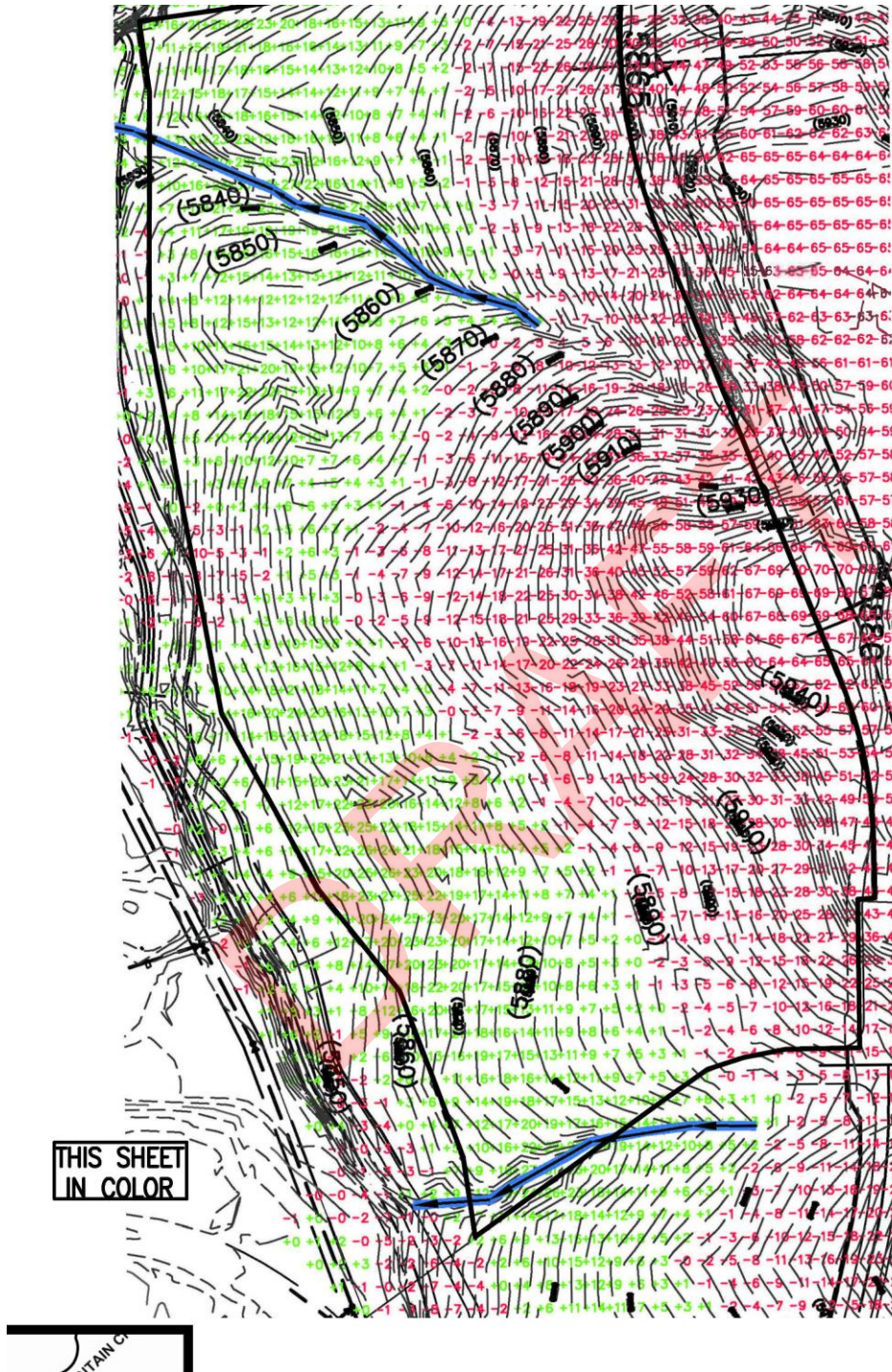

The above map was obtained from the provided preliminary geotechnical report by others, showing the grading that reportedly occurred in the early 2010s.

Descriptions of the site are based upon observations made during our field exploration program.



DRAFT COPY – FOR REVIEW

Proposed grades were provided on the July 22, 2024 grading plan. Based on our current project understanding, we anticipate the proposed development will follow existing grades to the extent possible with maximum cuts and/or fills of 5 feet or less across much of the previously graded site area. Fills of up to 40 feet may be required to achieve planned grades along the western side of the site to expand the development area further west. Cuts of 5 to 35 feet are planned for the proposed detention pond area in the northern portion of the site.

It appears retaining walls are planned around the pond and along the western side of the site, ranging from 4 to 30-feet in height, and appear to be supporting new fill. No information was provided regarding the pond or retaining wall design. PSI has provided recommended soil parameters for typical wall backfill including lateral earth pressures to aid in design of the retaining walls by others. Internal stability is typically performed by the wall manufacturer depending on the proposed wall type. External stability is not included in this scope of services but will need to be performed once the wall type and geometry is established. Global and external wall stability analysis can be performed, if requested, for a separate fee once more design information is known.

Anticipated structural loads were provided in the RFP. Based on this, we anticipate structural loads will be on the order of 75 kips for isolated columns in residential buildings and 3 kips per linear foot for walls. No below grade levels are planned.

Pavements are estimated to have a design traffic load of 2 (standard duty) or 5 (heavy duty) EDLAs for a 20-year pavement life. Please notify PSI of the anticipated loads when available, such that our recommendations may be reviewed and modified as necessary.

The geotechnical recommendations presented in this report are based upon the provided project information and the subsurface materials described in this report. If any of the noted information is incorrect, please inform us so that we may amend the recommendations presented in this report, if needed.

3.0 SUBSURFACE INFORMATION

The following sections provide information relating to subsurface conditions encountered at the boring locations and published geologic information in the general vicinity of the project site. The geology section is based upon the “Geological Map of Colorado” by Ogden Tweto dated 1979 and information relating to subsurface conditions within the property gathered from our current field study.

3.1 Site Geology and Geologic Hazards

Based on the referenced map by Tweto 1979, the site lies in an area mapped as Pierre Shale-Upper unit (Phanerozoic, Mesozoic, Cretaceous) can be described as “Sedimentary, Clastic, Mudstone, Shale”.



DRAFT COPY – FOR REVIEW

The site was apparently undeveloped prior to 1993, however significant site grading (cuts of up to 70 feet and fills of up to 20 feet) reportedly occurred in the early 2010s to support surrounding development. PSI was provided the testing documents for the mass grading that was performed in 2014. Based on the provided information the fill was generally placed in a controlled manner, however; the 2023 report and previous documentation provided indicate substandard on-site soils were utilized during site grading.

The site may be considered as part of the Colorado Springs Geological Hazard Ordinance area, which includes areas west of I-25. A geological hazard report is not included in this scope of services. Due to the current and proposed slopes, the Colorado Geological Survey may require a geological hazards study.

3.2 Subsurface Conditions

As part of PSI's evaluation of this site, thirty (30) exploratory borings were drilled at the approximate locations as indicated on Figure 2, the Boring Location Map, as follows:

- Fifteen (15) borings were drilled in the approximate areas of the multi-family apartment buildings approximately 25 to 35 feet below existing grade;
- Two (2) borings were drilled in the approximate locations of the amenity buildings to a depth of approximately 20 to 25 feet below existing grade;
- One (1) boring was drilled in the approximate area of the 4 foot retaining wall location to depths of approximately 15 feet below existing grade;
- Four (4) borings were drilled in the approximate location of the 11 to 30 feet retaining wall to depths of approximately 20 to 40 feet below existing grade;
- One (1) boring was drilled in the planned location of the detention pond to depths of approximately 45 feet below existing grade. One boring was also drilled to a depth of 5-feet for a percolation test;
- Six (6) borings were drilled in the pavement areas to depths of approximately 10 to 15 feet below existing grade.

The borings were advanced using a CME-75/55 truck-mounted drill rig equipped with 4-inch diameter, solid-stem, continuous-flight augers. Soil samples were recovered at selected depths during drilling with the truck-mounted drill rig using a Modified California Barrel Sampler (with an inside diameter of 2 inches and an outside diameter of 2.4 inches) or split spoon sampler (with a outside diameter of 2 inches) driven by a 140-pound hammer free-falling 30 inches. The total number of blows required to drive the sampler for 12 inches of penetration is designated as the penetration resistance (N-value, blows per foot) which provides an indication of the consistency of cohesive soils and the relative density of granular materials. While the procedure is similar to that employed in the Standard Penetration Test (ASTM D1586), the penetration resistance obtained using the California barrel sampler is generally higher than that obtained using the standard split-spoon sampler. A correction factor of 0.6 for sand and 0.77 for clay is



DRAFT COPY – FOR REVIEW

used for N-Values collected using the Modified California sampler. The N-values on the logs were not corrected for the Modified California sampler or hammer efficiency.

A representative from our office observed the drilling of the borings and logs were prepared of the encountered conditions. Individual logs of the borings are presented on Figures 3 through 32. It should be noted that the subsurface conditions presented on the boring logs are representative of the conditions at the specific locations drilled. Variations may occur and should be expected across the site. The stratification represents the approximate boundary between subsurface materials and the transitions may be gradual and indistinct. Water level information obtained during our field operations is also shown on the boring logs.

3.2.1 General Subsurface Profile

The soil profile generally consisted of documented fill material, low to high plasticity clay, and bedrock. PSI observed the documented fill material from the current ground surface to approximately 14-feet below existing grade in the borings performed along the western portion of the site. However, based on the provided information, we understand deeper fills are likely present on the slopes where PSI was unable to obtain borings. The documented fill material generally consisted of clay with varying amounts of sand, described as dry to moist, brown to dark brown, gray, orange, medium stiff to hard, and medium dense to dense in consistency. Claystone fragments and trace gravel were also observed within the fill. The fill was predominantly encountered along the western side of the site to extend the terrace. It should be noted that the apparent fill can be difficult to discern in the absence of deleterious materials, therefore depths should be considered approximate.

The low to high plasticity clay was observed at surface grade to approximately 3 to 10-feet below existing grade, with the exception of few areas. The clay can be described as having fine to coarse grained sand with trace gravel, dry to moist, brown to dark brown, gray to dark gray, black, and stiff to hard in consistency.

Claystone was encountered at the ground surface generally on the eastern portion of the site where the site was previously cut during grading and varied to up to 29 feet below existing grade. It can be described as containing fine to coarse sand with trace gravel, dry to moist, brown to dark brown, gray to dark gray, black and orange, weathered to hard in consistency. Bedrock depths were variable across the site.

3.2.2 Groundwater Conditions

Groundwater was observed in one boring, B28, as shown in figure 2, approximately 15 feet below existing grade during drilling operations. It should be noted that it is possible for the groundwater to be perched or fluctuate during the year depending upon climatic and rainfall conditions and changes to surface topography and drainage patterns. Discontinuous zones of perched water may also exist, or develop, within the overburden and bedrock materials. The groundwater levels presented in this report are the levels that were observed at the time of our field activities. We recommend the contractor determine water levels at the time of construction.



DRAFT COPY – FOR REVIEW

3.2.3 Swell Potential

PSI has reviewed the “Potentially Swelling Soil and Rock in the Front Range Urban Corridor, Colorado” by Stephen S. Hart, dated 1972. Based on this published map, the subject site lies with an area described as having “Low and Moderate Swell Potential” designation. Low Swell Potential designation is described as “This category includes several bedrock formations and many surficial deposits. The thickness of the surficial deposits may be variable, therefore, bedrock with a higher swell potential may locally be less than 10 feet below the surface.” Moderate Swell Potential designation is described as, “This category includes several bedrock formations and a few surficial deposits of variable thickness. Special foundation designs are generally necessary to prevent damage.”

PSI performed ASTM D4546 Swell Testing on selected samples of the recovered on-site material from the soil borings. The following table summarizes the results of the Denver Swell tests:

Boring	Depth (feet)	Surcharge Pressure (psf)	Moisture Content (%)	Volume Change (%)	Swell Pressure (psf)
B1	2 ½	250	21.2	2.7	2,100
B1	7 ½	750	20.5	2.7	3,900
B2	7 ½	750	15.8	3.5	4,100
B2	10	1000	10.7	3.1	3,800
B3	7 ½	750	15.1	3.9	9,300
B3	10	1000	16.8	2.7	6,300
B4	2 ½	250	22.9	9.2	7,200
B5	5	500	13.6	6.0	7,500
B6	5	250	20.5	6.3	6,300
B6	7 ½	500	15.2	4.4	4,100
B8	7 ½	750	12.7	15.7	5,300
B9	5	500	12.2	17.1	4,300
B10	2 ½	250	18.6	5.5	4,800
B10	5	250	13.0	6.0	1,100
B10	7 ½	500	13.2	13.2	10,000
B11	5	500	9.6	2.8	3,200
B12	5	500	11.6	3.1	3,400
B12	10	1000	13.2	3.1	5,900
B13	15	1000	18.7	5.9	12,400
B14	7 ½	750	21.6	6.9	9,600
B14	10	1000	20.3	7.5	13,700
B16	2 ½	250	20.1	8.5	10,600
B16	5	500	14.2	7.3	11,500
B17	5	500	19.0	5.1	8,800
B18	5	250	15.3	12.3	11,000
B18	10	750	18.9	4.7	12,500
B19	5	250	18.2	7.5	6,300
B19	7 ½	500	20.4	5.3	6,800



DRAFT COPY – FOR REVIEW

B20	7 ½	250	11.6	7.1	4,100
B20	10	500	15.4	4.9	6,100
B20	15	1000	13.6	4.1	6,300
B22	10	500	13.5	5.1	4,300
B23	5	500	14.6	4.8	3,900
B23	10	1000	15.4	3.6	7,600
B24	5	500	15.8	6.0	11,100
B25	5	250	14.3	11.6	11,600
B26	5	500	24.6	4.0	6,200
B26	7 ½	750	21.5	4.7	7,800
B27	7 ½	750	12.5	5.9	4,100
B27	10	1000	11.9	-0.8	NA
B28	2 ½	250	15.1	6.4	4,500
B29	10	1000	19.7	3.1	6,100
B30	5	500	18.1	-0.1	NA
B30	7 1/2	500	19.5	7.7	12,800

The laboratory swell test results are included in Appendix A and on the individual boring logs. The test results indicated swell percentages of -0.8 to 17.1 percent when tested under a surcharge pressure of 250, 500, 750 and 1,000 psf. Once the samples were hydrated under the surcharge pressure and swelling had stopped, additional pressure was applied until the sample was at or below its initial volume.

Based upon the swell test results, the majority of the on-site soils and bedrock materials encountered are classified as having a “very high” potential for swell, therefore; mitigation for swell is required. A Standard Proctor test indicated the remolded clay soils also exhibited a swell percent of 3.9 percent when tested within the range of optimum moisture content. If excessive drying and rewetting of these soils is allowed to occur, the risk of swell will increase. Proper drainage and good maintenance should be followed.

3.2.4 Laboratory Testing

The soil samples obtained during the field exploration were transported to the laboratory and selected soil samples were tested in the laboratory to determine material properties for our evaluation. Laboratory testing was accomplished in general accordance with ASTM and other applicable procedures. Laboratory testing was performed on selected samples to evaluate the classification and other engineering characteristics of the subsurface materials. Laboratory test data along with detailed descriptions of the soils can be found on the logs of borings and in Appendix A. The samples that were not altered by laboratory testing will be retained for 30 days from the date of this report and then will be discarded without further notice.



DRAFT COPY – FOR REVIEW

4.0 GEOTECHNICAL EVALUATION

The primary geotechnical concerns at this site are high swelling and high plastic soils, significant previous and future planned site grading, and variable depths to bedrock.

- The on-site soils and bedrock exhibited very high swell potential. PSI performed a Standard Proctor test on a bulk sample of the high plastic clay soils, which appears to be the majority of the shallow site soils. The majority of the in-place soils were tested to be below optimum moisture content. A remolded sample was tested for swell potential, and exhibited a borderline high result.

Due to the composition of the soils being high plastic, generally 90 percent clay, and having significant concentrations of high swelling claystone bedrock that is difficult to process, it is PSI's opinion that the on-site soils and bedrock should NOT be reused for structural purposes. An imported fill should be used for structural support of the buildings and pavements.

- Significant site grading has previously occurred on the site, including along the western slopes. We have been provided with testing reports of this fill placement. We understand Thompson Thrift will also perform significant site grading in areas. Due to the thickness and extent of the previously placed fill, there is still an inherent risk of poorly compacted or unsuitable materials may exist. We assess the risk of supporting the proposed development on the previously placed fill materials as relatively low given the relatively light anticipated structural loads associated with the proposed development and the assumption that the materials were likely placed with the intention of supporting commercial or retail development based on the adjacent properties. We recommend a contingency be included in the event that unsuitable materials such as organic materials, debris or other unsuitable/unstable materials are encountered and require additional overexcavation or removal.

However, due to the amount of site grading and construction of slopes, the depth of the previously placed fill, and the clay soils, secondary post-construction settlement may occur within the deep fills and clay soils. Therefore, PSI recommends using an imported fill in accordance with Section 5.1 with a higher sand content. This will compact more thoroughly and attempt to limit secondary consolidation in the building areas.

- Depths to bedrock were variable across the site. Due to the low permeability rates of the claystone bedrock, excavations into bedrock may trap water and provide opportunity to activate swelling soils and bedrock. Therefore, we recommend placing dry wells within each excavation and the bottom of the excavation should be sloped to drain to the area of the dry well. Permanent sumps are also an option. We further recommend that excavations into bedrock across the site be positively drained to proper drainage channels so as not to create additional pooling areas. Drainage of the excavations will be imperative to reduce the risk of swell of the on-site soils and bedrock.



DRAFT COPY – FOR REVIEW

Based on these concerns, PSI recommends the soils in the building areas be overexcavated to a depth of no less than 10-feet below bottom of proposed slab elevation and replaced with properly placed imported fill, in accordance with this report. Pavements may bear on no less than 5-feet of properly placed imported fill. New fill soils used to bring the site to final grade may be included in the total amount of amended soil below buildings and pavements, provided they are placed in accordance with this report.

In lieu of an overexcavation, PSI recommends consideration of a drilled pier and structural slab design for proposed buildings. Lime treatment may also be considered for pavement areas to potentially reduce the amount of overexcavation.

The recommended minimum pavement thicknesses for the subject development have been based on imported fill and a subgrade support R-Value of at least 20. All pavement areas should bear on no less than 5-feet of structural fill.

Moisture fluctuation of the onsite soils will increase its swell/settlement potential, therefore maintenance of the structure and pavements, as well as controlling water runoff will be critical to the functionality of the facility. Proper moisture control will be imperative at this site during and following construction, and for the life of the project. The risk of swelling/collapsing soils can be reduced, but not eliminated, by preventing fluctuations in moisture content. Therefore, it is imperative that positive slope away from the building and foundations is maintained, hardscape is constructed around the building perimeter, utilities are prevented from transmitting water via trench bedding or broken lines, and pavements are regularly maintained. Plantings may be placed near the buildings so long as they are xeric in nature and require only drip irrigation. Positive drainage away from the building must be provided and maintained.

The following geotechnical design recommendations have been developed on the basis of the described project characteristics and subsurface conditions encountered. Once final design/grading plans and specifications are available, a general review by PSI is required as a means to check that the recommendations presented in the following sections of this report are properly interpreted and implemented.

5.0 SITE GRADING RECOMMENDATIONS

Prior to site grading or excavation for foundation construction, the site will need to be stripped of all topsoil, vegetation, abandoned utilities, demolition or other debris, etc. We recommend a stripping depth of approximately 3-inches be anticipated for removal of topsoil and vegetation based on the soil boring results. Structures should bear no less than 10-feet of imported structural fill below bottom of slab in the building areas. Pavements should bear at least 5-feet of imported structural fill. Soils should be compacted in accordance with Section 5.2. Excavations should extend no less than 10-feet laterally outside building limits and to one-foot behind back of curb in pavement areas.



DRAFT COPY – FOR REVIEW

Overexcavation into bedrock can create areas where surface water and slowly infiltrating water to collect in the excavation. Therefore, we recommend placing dry wells within each excavation and the bottom of the excavation should be sloped to drain to the area of the dry well. Permanent sumps are also an option. Drainage of the excavations and overall site will be imperative to reduce the risk of swell of the on-site soils and bedrock.

Following rough grading and over-excavation for moisture conditioning and prior to placement of structural fill, a proofroll should be performed. The proofroll should be conducted with a loaded tandem-axle dump truck or similar pneumatic-tired equipment with a minimum weight of 15 tons. Areas that deflect excessively should be further over-excavated, moisture conditioned and recompacted.

Trash and debris, if encountered, should be removed from the site and disposed of in accordance with local and state regulations.

Some areas may be more difficult to process and may require additional stabilization effort. This may include additional overexcavation, rock, and/or geogrid.

The quantity of bedrock requiring excavation will be dependent on proposed grades. Excavations into the sandstone/claystone bedrock are expected to require moderate effort with standard excavation equipment. No blasting, chiseling, etc. is anticipated to be needed, based on the soils at the boring locations.

5.1 Structural Fill

Based on PSI’s field and laboratory data, the on-site overburden and bedrock material is generally unsuitable for re-use as site grading, backfill soils, or for use as structural fill. Therefore, we recommend imported fill as outlined below. Depending on the proposed retaining wall type, stricter backfill specifications may need to be met possibly including permeability and gradation requirements. On-site soils may be used in non-structural areas.

Imported structural fill, if required, should be free of organic or other deleterious materials, have a liquid limit less than 30, a plasticity index less than 10, and meet the following gradation outlined below. This select fill criteria is intended as a general guideline. Select imported fill materials should have a swell potential of less than 1 percent when compacted to 95 percent of maximum dry unit weight (MDUW) and at 2 percent below optimum moisture content (OMC) and tested under a swell test surcharge of 500 psf. The MDUW and OMC should be determined by ASTM D698 (Standard Proctor).

<u>Screen Size</u>	<u>Percent Passing</u>
2 Inch	100
#4	50 – 100
#200	10 – 30



DRAFT COPY – FOR REVIEW

Imported fill material proposed for use on this site that does not meet these criteria should be submitted to the project geotechnical engineer for evaluation and approval. The geotechnical engineer should evaluate the proposed import fill prior to purchase and delivery. Fine-grained soils used for fill require close moisture content control and careful placement by the contractor to achieve the recommended degree of compaction and to address swell potential and settlement issues.

5.2 General Fill Placement and Testing

Unless otherwise specified, imported fill material should be compacted to at least 95 percent of the maximum dry unit weight as determined by the Standard Proctor Test (ASTM D698). **For fill depths in excess of 5 feet, compaction should be 100 percent maximum dry unit weight. Each lift of compacted fill should be tested for density by a representative of the geotechnical engineer prior to placement of subsequent lifts.** Clay fill soils should be moisture conditioned to a range from optimum moisture content to four percent above optimum moisture content. Sand fill soils should be moisture conditioned to between 2 percent below and 2 percent above optimum moisture content. Fill material should be placed in maximum eight-inch loose lifts.

PSI must be retained as the materials testing firm to provide full-time testing and observation services. A sample(s) of the proposed backfill soil(s) should be obtained for moisture density relationship (proctor test) three to four days prior to backfilling operations to expedite compaction and moisture content testing by PSI.

Weather conditions in the site area are typically dry in the summer and early fall. Precipitation in the form of snowfall is common from October through March. While grading can be inhibited for short periods during and following times of precipitation, grading can generally be conducted year-round. The major factor that must be considered during the winter months is ground freezing. During extended periods of sub-freezing weather, it can be difficult to properly moisture condition and compact soils. Grading must be conducted during the warmer parts of the day in freezing weather.

6.0 GEOTECHNICAL RECOMMENDATIONS

The proposed structures may be founded on monolithic slab foundations bearing on moisture conditioned and recompacted structural fill soils.

6.1 Monolithic Slab-on-Grade Foundation Recommendations

Based on the information encountered at the boring locations, the site soils and bedrock exhibit moderate to high swell potential. Based on the recommended imported fill, we anticipate the swell potential will be less than 1 percent, if the recommendations are followed in accordance with this report. Therefore, a BRAB Type II monolithic slab-on-ground foundation bearing on a subgrade prepared as recommended may be utilized to support the proposed apartment buildings. A Type III may be used, if preferred by the owner.



DRAFT COPY – FOR REVIEW

The grade beam width and depth shall be determined by the project Structural Engineer. Grade beams may be thickened and widened at column or load bearing wall locations to support concentrated load areas, if necessary. Foundation elements such as grade beams or turned down portions of the slab can be designed for a maximum allowable soil bearing capacity of 3,000 pounds per square foot (psf). Exterior or perimeter foundation elements should be founded no less than 30-inches below adjacent ground surfaces for frost depth. All grade beams and floor slabs should be adequately reinforced with steel to reduce cracking and support bending moments caused by loading and minor movements of foundation soils.

Where concrete slabs will be covered with tile or other moisture sensitive covering, we recommend the use of a vapor retarder beneath the slabs on grade to reduce vapor transmission through the slab.

Exterior slabs should be isolated from the building. These slabs should be reinforced to function as independent units. Movement of these slabs should not be transmitted to the building foundation or superstructure.

6.2 Seismic Parameters

The project site is located within a municipality that employs the International Building Code, 2018 edition. As part of this code, the design of structures must consider dynamic forces resulting from seismic events. These forces are dependent upon the magnitude of the earthquake event as well as the properties of the soils that underlay the site. As part of the procedure to evaluate seismic forces, the code requires the evaluation of the Seismic Site Class, which categorizes the site based upon the characteristics of the subsurface profile within the upper 100 feet of the ground surface. To define the Site Class for this project, we have interpreted the expected results of soil test borings drilled with the project site and estimated appropriate soil properties below grade to a depth of 100 feet, as permitted by Chapter 20.3-1 of the code. The estimated soil properties were based upon data available in published geologic reports and our experience with subsurface conditions in the general site area.

Based upon our evaluation, it is our opinion that the subsurface conditions within the site are consistent with the characteristics of Site Class C as defined in Chapter 20.3-1 of the ASCE 7-16 code.

The USGS-NEHRP interpolated probabilistic ground motion values near latitude 38.7699° N latitude and 104.7866° W longitude obtained from the USGS geohazards web page are as follows:



DRAFT COPY – FOR REVIEW

Period (seconds)	2% Probability of Event in 50 years (g)	Site Coefficients	Maximum Spectral Acceleration Parameters	Design Spectral Acceleration Parameters	
				S_{D5}	T_0
0.2 (S_s)	0.199	$F_a = 1.3$	$S_{ms} = 0.259$	$S_{D5} = 0.173$	$T_0 = 0.067$
1.0 (S_1)	0.058	$F_v = 1.5$	$S_{m1} = 0.087$	$S_{D1} = 0.058$	$T_s = 0.335$

$$S_{ms} = F_a S_s \quad S_{D5} = \frac{2}{3} * S_{ms} \quad T_0 = 0.2 * S_{D1} / S_{D5}$$

$$S_{m1} = F_v S_1 \quad S_{D1} = \frac{2}{3} * S_{m1} \quad T_s = S_{D1} / S_{D5}$$

The Site Coefficients, F_a and F_v presented in the above table were interpolated from Chapter 20.3-1 as a function of the site classification and mapped spectral response acceleration at the short (S_s) and 1 second (S_1) periods.

6.3 Pavement Recommendations

The following analysis and minimum pavement thickness recommendations are in general accordance with AASHTO and the Colorado Department of Transportation Manual for Road and Bridge Construction based upon our current understanding of the project.

6.3.1 Subgrade Preparation Recommendations

PSI recommends the pavement sections bear on no less than 5-feet of imported structural fill. Lime treatment may be considered to potentially reduce the amount of overexcavation/imported fill. PSI can provide these recommendations if desired.

Once the areas below the parking area have been recompacted, the existing site soils should be proofrolled to identify areas of loose soils. The proofroll should be conducted with a loaded tandem-axle dump truck or similar pneumatic-tired equipment with a minimum weight of 15 tons.

6.3.2 Minimum Pavement Thickness Recommendations

Based on the use of imported soils, PSI has used an R-value of 20 for the support soils of the proposed pavement sections. Pavements will be designed to the minimum asphalt depth for this soil type. Once a source of import is known or if lime treatment is proposed, the pavement recommendations should be reviewed.

PSI has identified two pavement categories based on the proposed development anticipated traffic use and traffic loads:

- 14,600 ESALs (Light-Duty Traffic)
- 36,500 ESALs (Heavy-Duty Traffic)

We have also used the following design criteria; a 20-year design life, a Pavement Serviceability Index (PSI) of 2.5 and a Reliability of 85 percent.



DRAFT COPY – FOR REVIEW

Minimum pavement section options are provided for asphalt over aggregate base course (composite section), and rigid (Portland Cement Concrete) pavement. Based on this information for the subject pavement, the following minimum pavement sections were determined, as presented in the following table.

Pavement Area	Composite Section	Full-Depth Asphalt	Full-Depth Portland Cement Concrete
Light Duty Traffic	4 inches Asphalt over 4 inches Aggregate Base Course	5 inches	5 inches
Heavy Duty Traffic	4 inches Asphalt over 6 inches Aggregate Base Course	5 ½ inches	6 inches

Concrete pavement at least **seven inches thick** is recommended for the **trash dumpster run-ups** due to the heavy wheel and impact loads that this area receives. The run-up should extend far enough away to support all wheels of the sanitation truck while stopped and in the loading position. Concrete pavement is also recommended in areas, which receive continuous repetitive traffic such as product unloading areas and parking lot entrances.

6.3.3 Flexible Pavement

Flexible pavement is not recommended for Dumpster Pad/ Sanitation Truck Run-up areas. For Dumpster Pad/Sanitation Truck Run-up areas, we recommend rigid pavement as discussed in the following *Rigid Pavement Section*. Allowances for proper drainage and proper material selection of base materials are most important for performance of asphaltic pavements. Ruts and birdbaths in asphalt pavement allow for quick deterioration of the pavement primarily due to saturation of the underlying base and subgrade.

Hot bituminous pavement should meet the requirements as detailed for SuperPave Mixtures in Colorado Department of Transportation Standard Specifications for Road and Bridge Construction. Material meeting the Colorado Department of Transportation requirements for Grading S (¾ inch nominal) or Grading SG (1½ inch nominal) is recommended. In addition, the following are presented as general guidelines for properties of asphaltic concrete.

Parking Lot	
Asphalt Cement	PG 64-22
Asphalt Content	As per mix design
Percent Air Voids	3½-5

Asphalt material should be obtained from an approved mix design stating the SuperPave Mixture properties, including optimum asphalt content, job mix formula, and recommended



DRAFT COPY – FOR REVIEW

mixing and placing temperatures. Materials and construction methods should be in accordance with the CDOT Standard Specifications for Road and Bridge Construction Section 403.

6.3.4 Aggregate Base Course

If aggregate base course is used as part of the pavement section, the materials should conform to CDOT requirements for Class 6 aggregate base course per Table 703-2 and construction methods should conform to Section 304 of the Colorado Department of Transportation Standard Specifications for Road and Bridge Construction.

6.3.5 Rigid Pavement

The use of concrete for on-site pavements may be considered by the owner. Should concrete pavement be utilized, the concrete should be properly reinforced and jointed and should be constructed from a concrete mixture, which has a 28-day minimum laboratory compressive strength of 4,000 psi. We recommend a maximum water cement ratio of 0.45 and an air-entrainment specification of 5 percent (± 1.5 percent) be followed. Expansion joints should be sealed with a polyurethane sealant so that moisture infiltration into the subgrade soils and resultant concrete deterioration at the joints is reduced.

6.4 Lateral Earth Pressures

Based on our understanding of the project, retaining walls will be required (approximately 4 to 30-feet in height). We have provided soil parameters for typical wall backfill materials to assist with the design of conventional retaining walls. Additional or different soil parameters may be required for other wall types (mechanically stabilized earth (MSE), sheet pile, tie-back/anchored, etc.). PSI should review retaining wall design once known to verify our parameters are applicable.

Retaining walls should be designed to resist lateral earth pressures. Lateral earth pressure is developed from the soils present within a wedge formed by the vertical retaining wall and an imaginary line extending up and away from the bottom of the wall at an approximate 45° angle. The lateral earth pressures are determined by multiplying the vertical applied pressure by the appropriate lateral earth pressure coefficient K . If the walls are rigidly attached to the structure and not free to rotate or deflect at the top, PSI recommends designing the walls for the “at-rest” lateral earth pressure condition using K_0 . Walls that are permitted to rotate and deflect at the top can be designed for the active lateral earth pressure condition using K_a . Passive pressure can be determined using K_p , with a factor of safety of 2.0. Recommended parameters for use in relatively short above grade walls are as follows:



DRAFT COPY – FOR REVIEW

Recommended Parameters Typical Wall Backfill Materials			
Material Type	Drained Friction Angle (ϕ')		
In-Situ Lean Clay***	24°		
On-Site Clayey Sands/Structural Fill***	30°		
Compacted Dense Graded Crushed Stone	42°		
Total Soil Density (pcf)	110		
Maximum Toe Pressure on Structural Fill (psf)	2,000		
Groundwater Elevation	Approximately 5810 in Boring B28; generally dry in remaining (elevations approximate)		
Parameters specific to soil type	Clays	Structural Fill	Crushed Stone
Friction Factor for Base	0.30	0.38	0.60 *
Coefficient of Active Pressure (K_a) **	0.42	0.33	0.20 *
Coefficient of Passive Pressure (K_p) **	2.37	3.00	5.0 *
Coefficient of At-Rest Pressure (K_0) **	0.59	0.50	0.33 *

* These values may be used for design only if the crushed stone backfill extends back from the wall certain distances. These are a horizontal distance approximately equal to or greater than the total height of the wall at the surface, and at least one-foot beyond the heel of the wall footing.

** Earth pressure coefficients valid for level backfill conditions with no surcharge

*** The on-site high plastic clays and bedrock should **not** be used as wall backfill

The values presented above were calculated based on positive drainage and are provided to prevent the buildup of hydrostatic pressure. If surface loads are placed near the walls, such as traffic loads, they should be designed to resist an additional uniform lateral load of one-half of the vertical surface loads. An “equivalent fluid” pressure can be obtained from the above chart by multiplying the appropriate K-factor times the total unit weight of the soil. This applies to unsaturated conditions only. If a saturated “equivalent fluid” pressure is needed, the effective unit weight (total unit weight minus unit weight of water) should be multiplied times the appropriate K-factor and the unit weight of water added to that resultant. However, PSI does not recommend that earth retaining walls be designed with a hydrostatic load and that drainage should be provided to relieve the pressure.

PSI recommends that retaining wall backfill be provided with positive drainage. In specific design cases where water is allowed to build up on the wall structure, the hydrostatic load correlating to the maximum height of the water build up should be added to the lateral loads acting on the wall.

The designs of retaining walls need to take into account the effects of geometry and loading conditions. The following charts have been included from NAVFAC 7.02 concerning slopes in the grade at the top of below grade wall. Depending on the geometry of the site, the lateral loading on the retaining wall should be modified according to these charts.



DRAFT COPY – FOR REVIEW

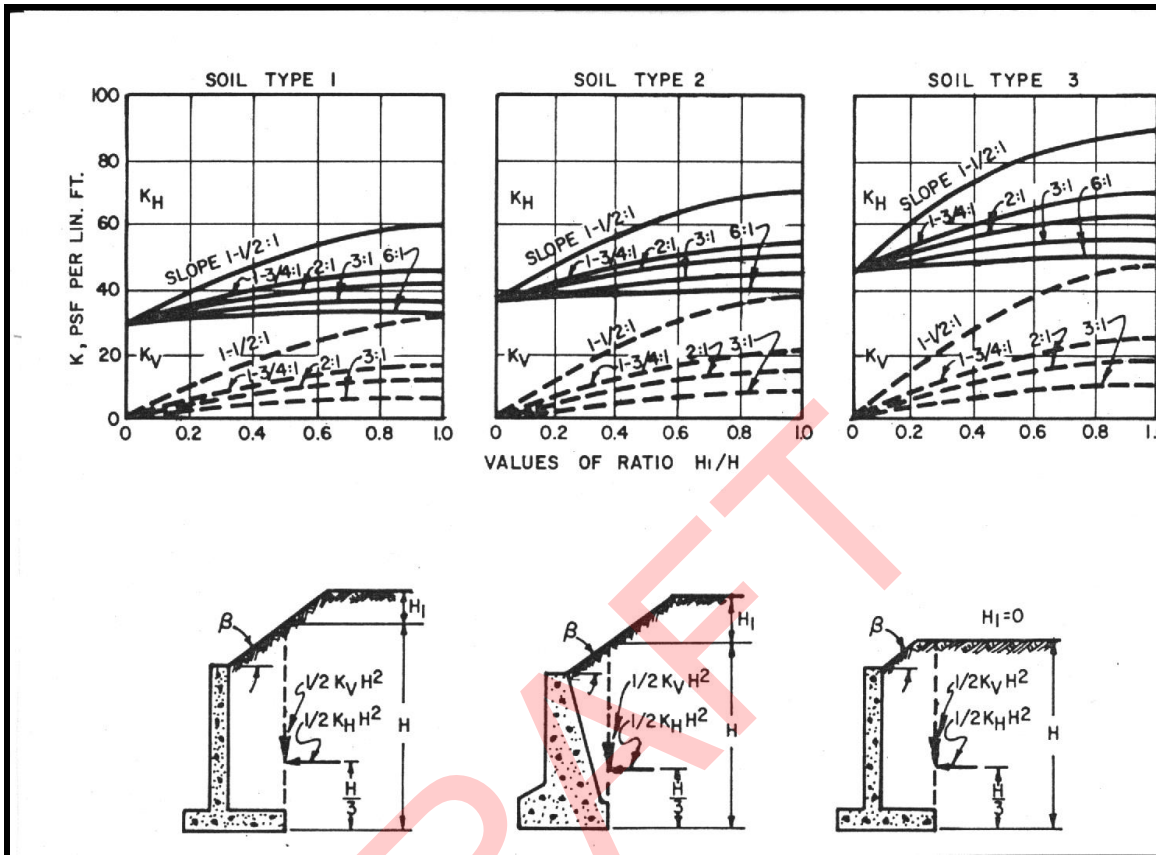

- Soil Type 1 – Clean Sand and Gravel, GW, GP, SW, SP
- Soil Type 2 – Dirty Sand and Gravel of Restricted Permeability, GM, GM-GP, SM-SP, SM
- Soil Type 3 – Stiff Residual Silts and Clays, Silty Fine Sands, Clayey Sands and Gravels: CL, ML, CH, MH, SM, SC, GC

Retaining Wall Backfill and Compaction

Backfill of retaining walls shall consist of low plastic soils or granular materials. The backfill materials should be placed in lifts that do not exceed 8-inches loose. The lift thickness may need to be reduced to thinner lifts immediately behind the walls to achieve the desired amount of compaction without overstressing the wall with the compaction process. The backfill materials should be compacted to at least 90 percent of the standard Proctor maximum dry density. Granular material with less than 10 percent passing the #200 sieve should be placed in uniform lifts. Granular material shall be compacted to a minimum dry density of at least 90 percent standard Proctor or 70 percent relative density. Backfill that is placed within 4-feet or 4-feet plus the height of the wall (minus 4-feet) / 2 for wall over 4 feet high, should be placed in thinner lifts with hand compaction equipment to achieve the specified density. Heavy compactors and grading equipment should not be allowed to operate within these limits during the backfilling of the below grade walls to reduce the developing of excessive temporary or long-term lateral soil pressures from the installation process. PSI recommends that a



DRAFT COPY – FOR REVIEW

representative of the geotechnical engineer be present to monitor the below grade wall excavation, construction and backfilling processes. Care should be exercised during the backfilling operation to prevent overstressing and damaging the walls.

PSI recommends that retaining wall backfill be provided with adequate drainage. The actual wall drainage system is a function of the elevation, height and geometry of the wall system and should be designed by a licensed professional engineer. An example of a typical wall drain is as follows:

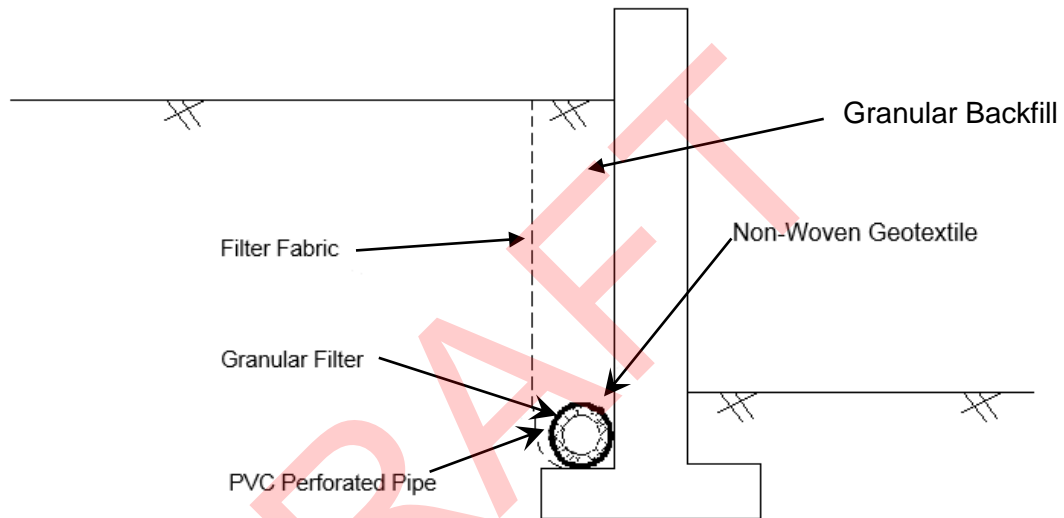

The placement of a limited amount of granular material behind a retaining wall does not appreciably change the coefficient of lateral earth pressure acting on that wall. The lateral earth pressure acting on a retaining structure is a function of the weight of the soil that exist above the theoretical plane projecting up from the base of the wall. The soil above this plane is held in place by two forces, the strength of the soil itself and the lateral resistance of the retaining wall. Therefore, a thin layer of granular material behind the wall is of little consequence on the forces acting on the wall.

6.5 Pool Recommendations

We recommend the pool bottom and walls should be constructed in and atop no less than 5-feet of imported structural fill. Lateral earth pressure values from the previous section may be used to aid in design of the below grade pool walls.

PSI recommends the following with regard to the proposed swimming pool:

- Special care should be given during construction to prevent surface runoff, rain, or other



DRAFT COPY – FOR REVIEW

precipitation from collecting under the pool. If gravity drainage or sumps are not available this water can cause extreme distress to the pool construction and clog the drainage system.

- PSI recommends installing a free draining granular underdrain system below the bottom of the pool and beside the sidewalls of the pool that is gravity drained or has access to an operating sump system.
- In the presence of plastic clays either under the pool or along the sidewalls, care should be taken to reduce the potential for water to pool, collect or otherwise interact with the high plasticity clays for periods of time exceeding a few days. High plasticity clays can swell in the presence of free water and cause heaving of the floor of the pool or distress in the sidewalls resulting in distress in the pool liner. A non-permeable liner placed on the clay with a free draining granular drain between the liner and the pool structure should be considered in these cases.
- Leaks and other sources of water associated with the swimming pool should be prevented from transmitting water to surrounding soils.

6.6 Soil Corrosivity

Samples obtained in the subsurface profile of the upper 5 feet was tested to evaluate the chemical reactivity of the on-site soils and are shown in the following table. Soil pH was performed using method AASHTO T289-91. Water Soluble Sulfate testing was performed using AASHTO T290-91/ASTM D4327.

Summary of Chemical Reactivity Testing

Boring ID	Depth (feet)	Soil pH	Water Soluble Sulfates
B7	5	9.0	0.044%
B26	2 ½	7.8	0.31%

The existing soil has a potential for corrosion issues in the presence of water. Consideration should be given to providing cathodic protection for buried metal surfaces greater than 5-feet.

These results classified the soil in the “S0 to S2” sulfate exposure category according to the American Concrete Institute (ACI) Design Manual Section 318, Chapter 4, 2014 Edition. It is our opinion that concrete in contact with the existing soils may be designed for “S2” sulfate exposure. PSI recommends using Type V Portland Cement. A corrosion engineer should be contacted prior to construction. The source of imported fill should be tested for corrosivity properties.

6.7 Percolation Test

On September 19, 2024, PSI conducted a percolation test near Boring Nos. B28, within the proposed detention pond area. The soil in that area generally consisted of low to high plasticity clay. Based on the percolation test performed, the soil has an estimated percolation rate of 8



DRAFT COPY – FOR REVIEW

inches per hour. The underlying clay soils and bedrock will percolate at a much slower rate. Depending on the grading of the pond area and the imported soils used, a percolation test should be performed at that time. An appropriate factor of safety should be applied. The grading and pond soils should be reviewed prior to design.

6.8 Drainage Recommendations

PSI recommends that surface infiltration be minimized to reduce the potential for surface water to saturate the soils below the foundations. The ground surface, landscaping, and flatwork should be sloped to drain away from the building. Roof down spouts and drains should discharge well beyond the limits of the building or into the sewer collection system. Additionally, drains should be placed behind retaining walls to prevent hydrostatic buildup.

The precautions listed below are considered good construction practice. These recommendations are not required but can be followed to prevent moisture content variation and help reduce potential damage caused by movement of the supporting subgrade.

- Some increase in moisture content is inevitable as a result of development and associated landscaping. However, extreme moisture content increases can be largely controlled by proper and responsible site drainage, building maintenance and irrigation practices. Drought tolerant planting design as well as low-pressure, drip irrigation utilizing a master valve and flow sensor should be used within 5-feet of the building foundations.
- Proper slope away from building (5 to 10 percent) and in parking areas (3 to 5 percent) should be maintained. ADA ramp areas may be designed as needed for accessibility, provided the area is sloped to drain away from the building and foundations. The proper drainage away from the building should extend at least 10-feet outside building limits.
- Swales placed within 10-feet of the building should be designed to prevent water collection next to the building foundations. The positive drainage away from buildings should be properly constructed and maintained. Sedimentation build up or other flow and/or grade changes should be prevented.
- Utility backfill in areas supporting slabs should be moisture conditioned or dried by scarification and compacted. Backfill in all interior and exterior water and sewer line trenches should be uniformly compacted. Care must be taken to prevent water transmission via bedding material.

7.0 LIMITATIONS

The recommendations submitted are based on the subsurface information obtained by PSI and design details provided by Thompson Thrift Residential. If there are revisions to the plans for this project or if deviations from the subsurface conditions noted in this report are encountered during



DRAFT COPY – FOR REVIEW

construction, PSI should be notified immediately to determine if changes in the foundation recommendations are required. If PSI is not retained to perform these functions, PSI will not be responsible for the impact of those conditions on the project.

The geotechnical engineer warrants that the findings, recommendations, specifications, or professional advice contained herein have been made in accordance with generally accepted professional geotechnical engineering practices in the local area. No other warranties are implied or expressed.

After the plans and specifications are more complete, the geotechnical engineer should be retained and provided the opportunity to review the final design plans and specifications to check that our engineering recommendations have been properly incorporated into the design documents. This report has been prepared for the exclusive use of Thompson Thrift Residential and their consultants for the specific application to the proposed multifamily development to be located at Venetucci Boulevard at South Academy Boulevard in Colorado Springs, Colorado.

DRAFT



Taken From Google Earth



TTRes Multifamily Venetucci – Colorado Springs ,CO JOB NO. 05322874

Site Vicinity Map

FIGURE NO. 1a

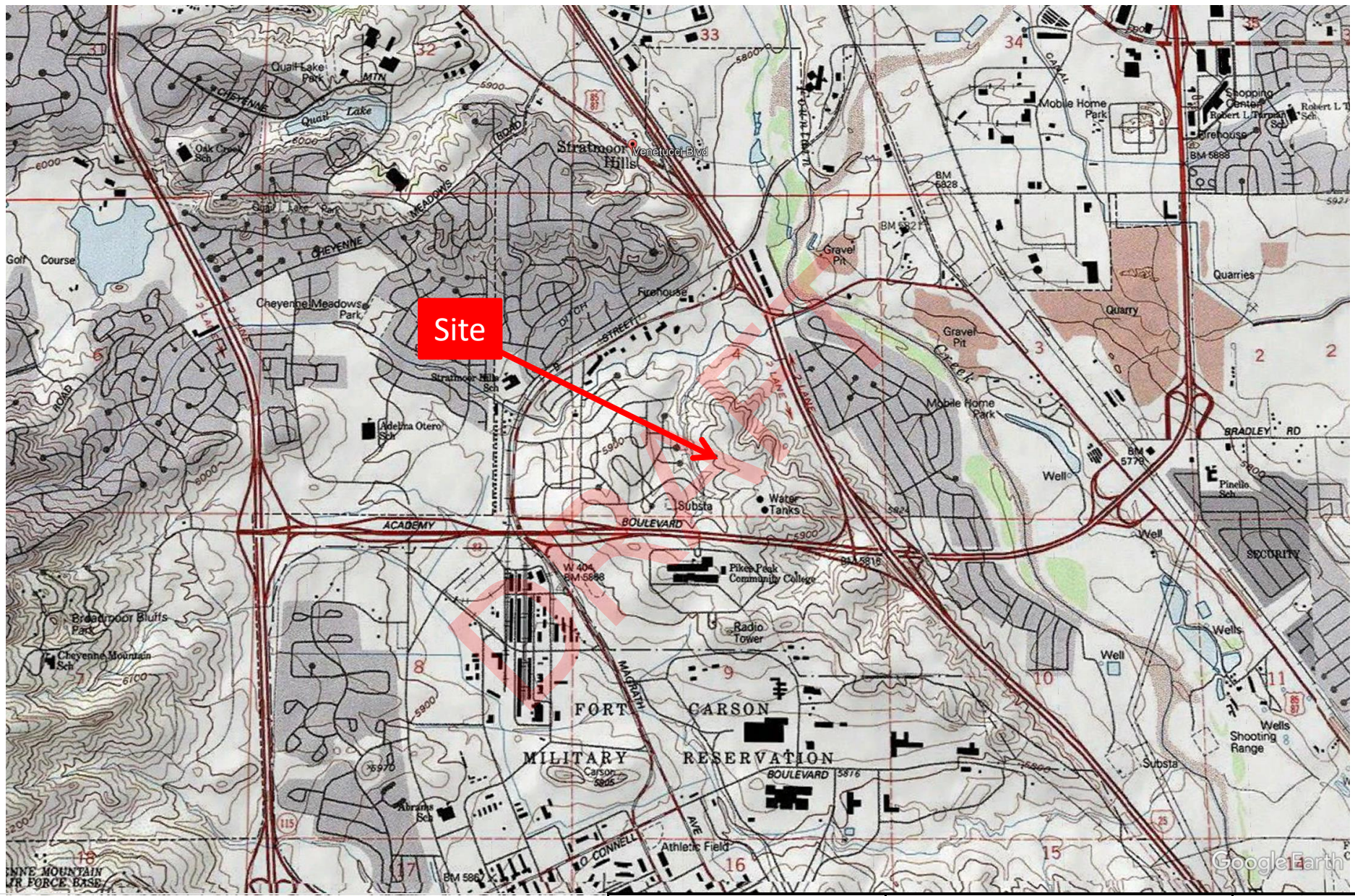

Taken From USGS Map -



TTRes Multifamily Venetucci – Colorado Springs ,CO JOB NO. 05322874

Site Topographical Map FIGURE NO. 1b

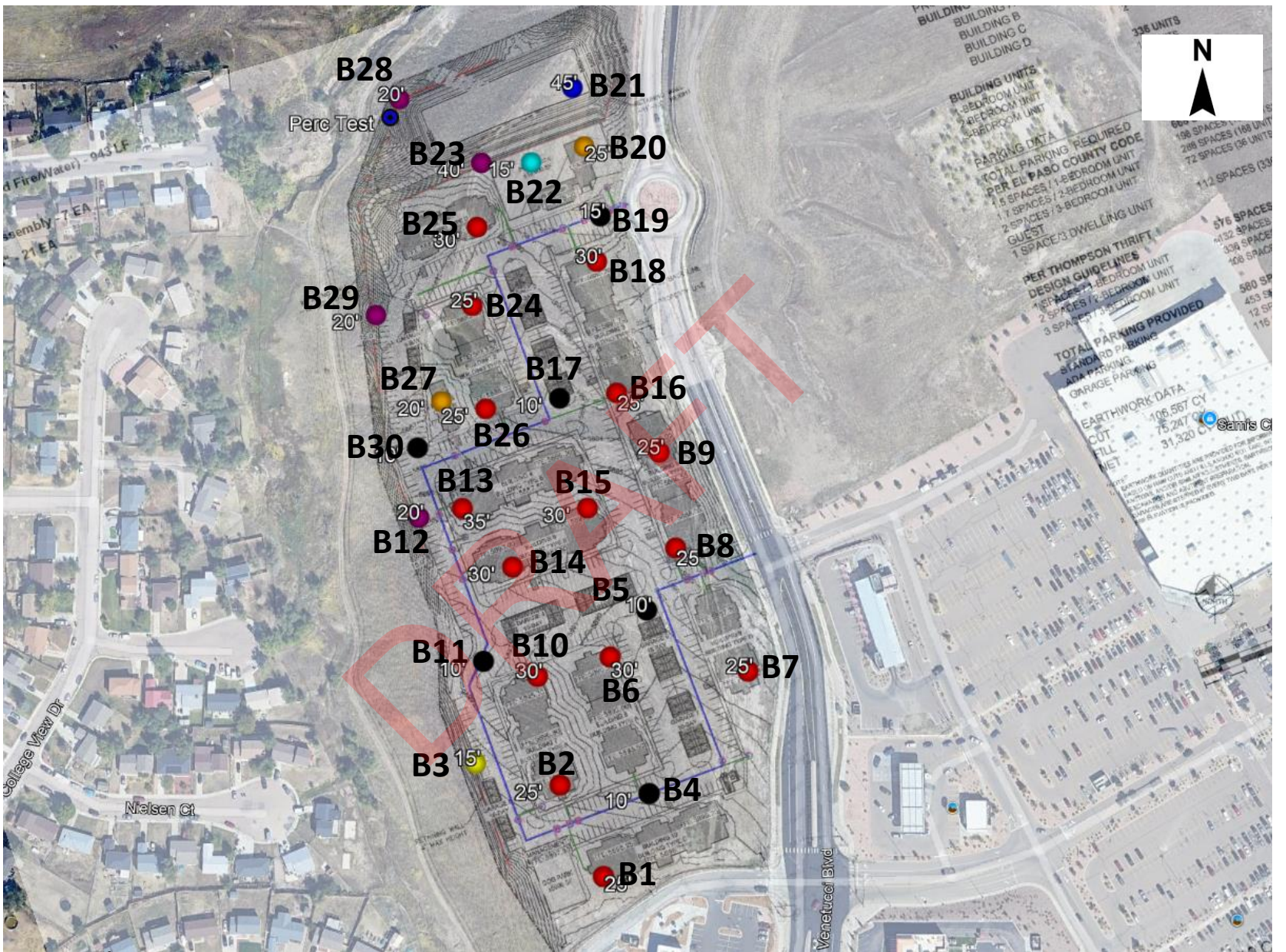

Indicates Approximate Location of Boring

Taken From Google Earth



TTRes Multifamily Venetucci – Colorado Springs ,CO

JOB NO. 05322874

Boring Location Map

FIGURE NO.

2

FIGURE: 3

DATE STARTED: 9/11/24	DRILL COMPANY: Dakota Drilling, Inc.	BORING B 1
DATE COMPLETED: 9/11/24	DRILLER: DER LOGGED BY: DW	
COMPLETION DEPTH: 25.0 ft	DRILL RIG: CME-75	Water ▽ While Drilling Not Observed ▽ Upon Completion Not Observed ▽ Delay N/A
BENCHMARK: N/A	DRILLING METHOD: Solid Stem Auger	BORING LOCATION: Building 10
ELEVATION: 5900 ft	SAMPLING METHOD: Modified California	
LATITUDE: 38.7686°	HAMMER TYPE: Manual	See Figure No. 2
LONGITUDE: -104.7854°	EFFICIENCY: N/A	
STATION: N/A OFFSET: N/A	REVIEWED BY: HT	
REMARKS:		

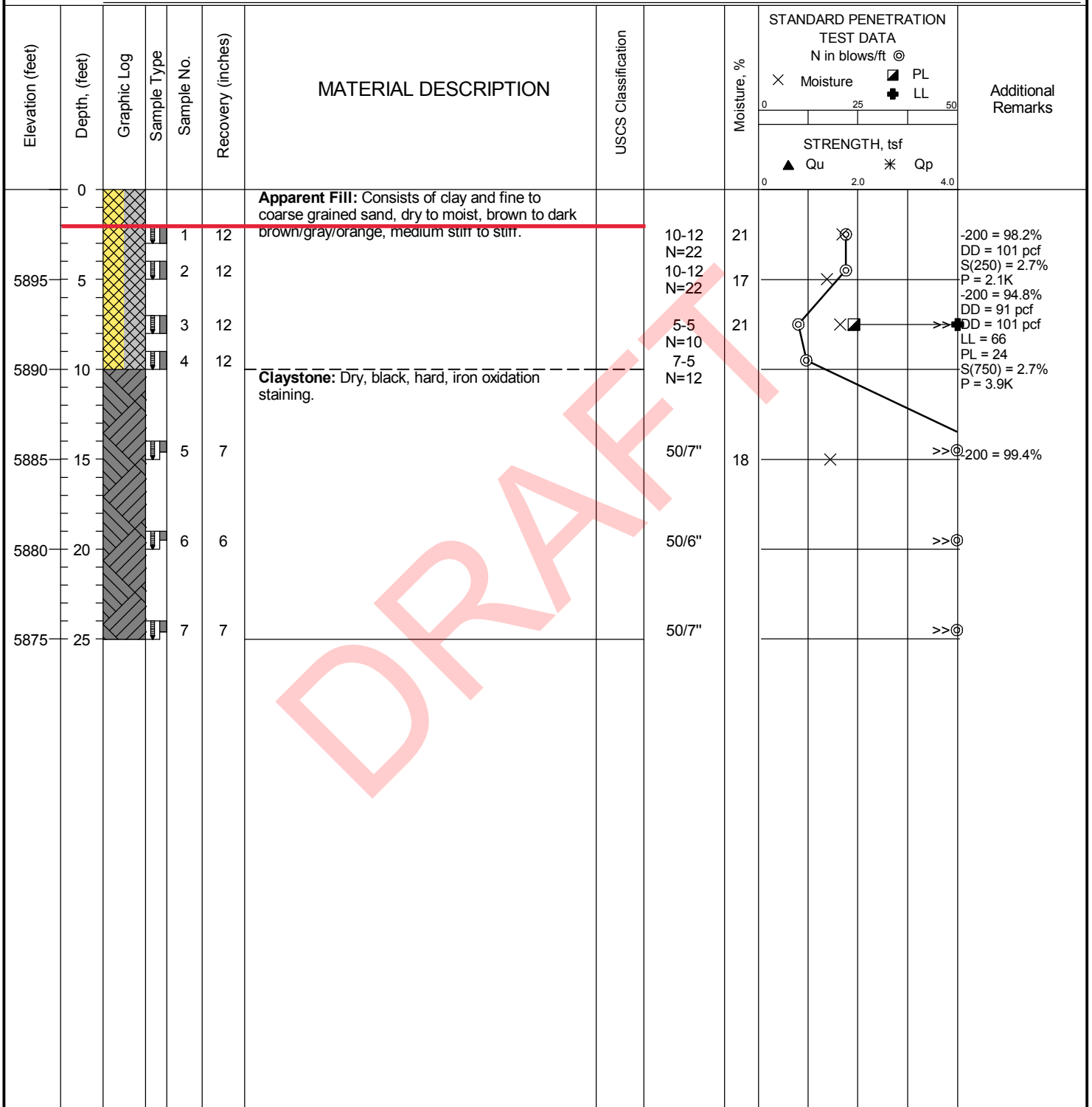

Professional Service Industries, Inc.
 1070 West 124th Avenue, Suite 800
 Westminster, CO 80234
 Telephone: (303) 424-5578

PROJECT NO.: 05322879
PROJECT: TTRes Venetucci Multifamily
LOCATION: Venetucci Blvd at South Academy Blvd
 Colorado Springs, CO

The stratification lines represent approximate boundaries. The transition may be gradual.

FIGURE: 4

DATE STARTED: 9/11/24	DRILL COMPANY: Dakota Drilling, Inc.	BORING B 2
DATE COMPLETED: 9/11/24	DRILLER: DER LOGGED BY: DW	
COMPLETION DEPTH: 25.0 ft	DRILL RIG: CME-75	Water <input type="checkbox"/> While Drilling Not Observed
BENCHMARK: N/A	DRILLING METHOD: Solid Stem Auger	<input type="checkbox"/> Upon Completion Not Observed
ELEVATION: 5899 ft	SAMPLING METHOD: Modified California	<input type="checkbox"/> Delay N/A
LATITUDE: 38.7689°	HAMMER TYPE: Manual	BORING LOCATION:
LONGITUDE: -104.7861°	EFFICIENCY: N/A	Building 7
STATION: N/A OFFSET: N/A	REVIEWED BY: HT	See Figure No. 2
REMARKS:		

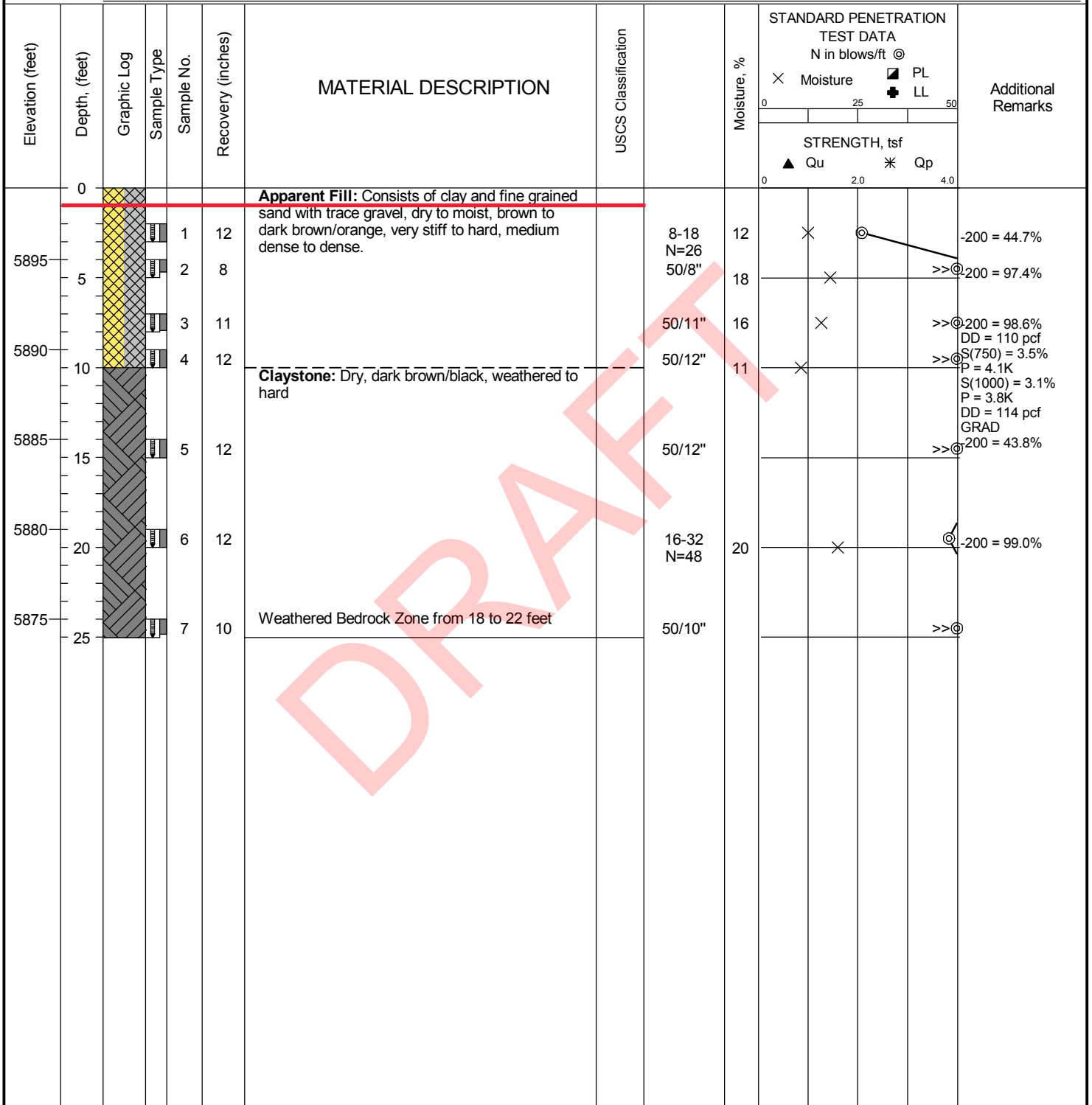

Professional Service Industries, Inc.
1070 West 124th Avenue, Suite 800
Westminster, CO 80234
Telephone: (303) 424-5578

PROJECT NO.: 05322879
PROJECT: TTRes Venetucci Multifamily
LOCATION: Venetucci Blvd at South Academy Blvd
Colorado Springs, CO

FIGURE: 5

DATE STARTED: 9/11/24	DRILL COMPANY: Dakota Drilling, Inc.	BORING B 3
DATE COMPLETED: 9/11/24	DRILLER: DER LOGGED BY: DW	
COMPLETION DEPTH: 15.0 ft	DRILL RIG: CME-75	Water <input type="checkbox"/> While Drilling Not Observed <input type="checkbox"/> Upon Completion Not Observed <input type="checkbox"/> Delay N/A
BENCHMARK: N/A	DRILLING METHOD: Solid Stem Auger	BORING LOCATION: Retaining Wall
ELEVATION: 5898 ft	SAMPLING METHOD: Modified California	
LATITUDE: 38.7688°	HAMMER TYPE: Manual	See Figure No. 2
LONGITUDE: -104.7864°	EFFICIENCY: N/A	
STATION: N/A OFFSET: N/A	REVIEWED BY: HT	
REMARKS:		

Elevation (feet)	Depth (feet)	Graphic Log	Sample Type	Sample No.	Recovery (inches)	MATERIAL DESCRIPTION	USCS Classification	Moisture, %	STANDARD PENETRATION TEST DATA N in blows/ft @	Additional Remarks
								0 25 50 X Moisture PL LL		
								0 2.0 4.0 ▲ Qu * Qp		
5895	0			1	8	Apparent Fill: Consists of clay and poorly graded sand with trace gravel, dry to moist, brown to dark brown, very stiff to hard.	50/8"			>>⊙
	5			2	12		20-22 N=42			⊙
5890				3	7	Claystone: Dry, brown/black, weathered to hard, iron oxidation staining.	50/7"	15	X	>>⊙ GRAD -200 = 59.9%
	10			4	12		20-24 N=44	17	X	>>⊙ DD = 122 pcf S(750) = 3.9% P = 9.3K -200 = 97.0% S(1000) = 2.7% P = 6.3K DD = 112 pcf
5885	15			5	8	Weathered Bedrock Zone from 8 to 12 feet	50/8"			>>⊙

DRAFT

	Professional Service Industries, Inc. 1070 West 124th Avenue, Suite 800 Westminster, CO 80234 Telephone: (303) 424-5578	PROJECT NO.: 05322879
		PROJECT: TTRes Venetucci Multifamily
		LOCATION: Venetucci Blvd at South Academy Blvd Colorado Springs, CO

The stratification lines represent approximate boundaries. The transition may be gradual.

FIGURE: 6

DATE STARTED: 9/11/24	DRILL COMPANY: Dakota Drilling, Inc.	BORING B 4
DATE COMPLETED: 9/11/24	DRILLER: DER LOGGED BY: DW	
COMPLETION DEPTH: 10.0 ft	DRILL RIG: CME-75	Water <input type="checkbox"/> While Drilling Not Observed <input type="checkbox"/> Upon Completion Not Observed <input type="checkbox"/> Delay N/A
BENCHMARK: N/A	DRILLING METHOD: Solid Stem Auger	BORING LOCATION: Pavement
ELEVATION: 5897 ft	SAMPLING METHOD: Modified California	
LATITUDE: 38.7688°	HAMMER TYPE: Manual	See Figure No. 2
LONGITUDE: -104.7855°	EFFICIENCY: N/A	
STATION: N/A OFFSET: N/A	REVIEWED BY: HT	
REMARKS:		

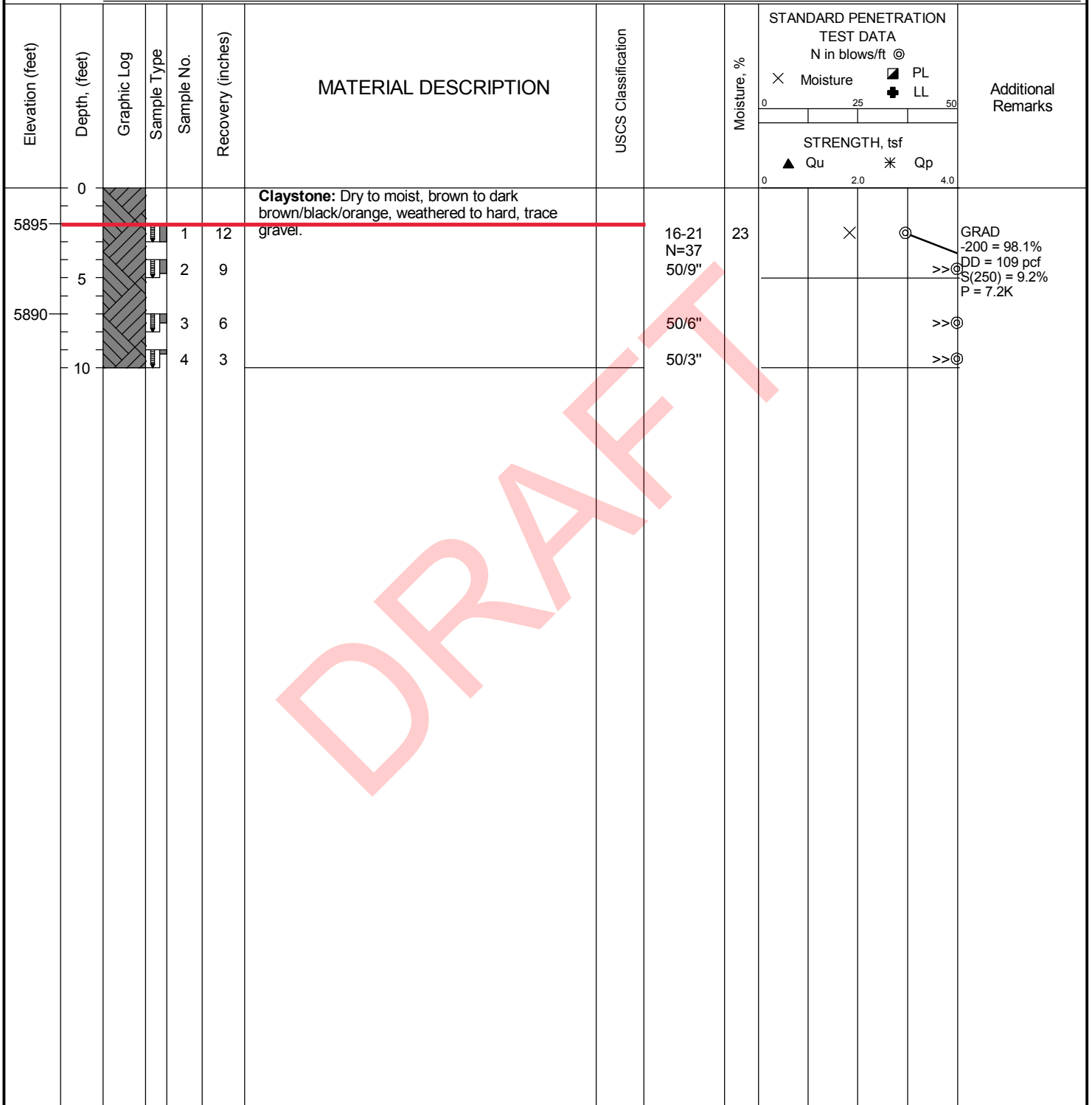

DRAFT

	Professional Service Industries, Inc. 1070 West 124th Avenue, Suite 800 Westminster, CO 80234 Telephone: (303) 424-5578	PROJECT NO.: 05322879
		PROJECT: TTRes Venetucci Multifamily
		LOCATION: Venetucci Blvd at South Academy Blvd Colorado Springs, CO

The stratification lines represent approximate boundaries. The transition may be gradual.

FIGURE: 7

DATE STARTED: 9/11/24	DRILL COMPANY: Dakota Drilling, Inc.	BORING B 5
DATE COMPLETED: 9/11/24	DRILLER: DER LOGGED BY: DW	
COMPLETION DEPTH: 10.0 ft	DRILL RIG: CME-75	Water
BENCHMARK: N/A	DRILLING METHOD: Solid Stem Auger	▽ While Drilling Not Observed
ELEVATION: 5892 ft	SAMPLING METHOD: Modified California	▼ Upon Completion Not Observed
LATITUDE: 38.7697°	HAMMER TYPE: Manual	▽ Delay N/A
LONGITUDE: -104.7852°	EFFICIENCY: N/A	BORING LOCATION:
STATION: N/A OFFSET: N/A	REVIEWED BY: HT	Pavement
REMARKS:		See Figure No. 2

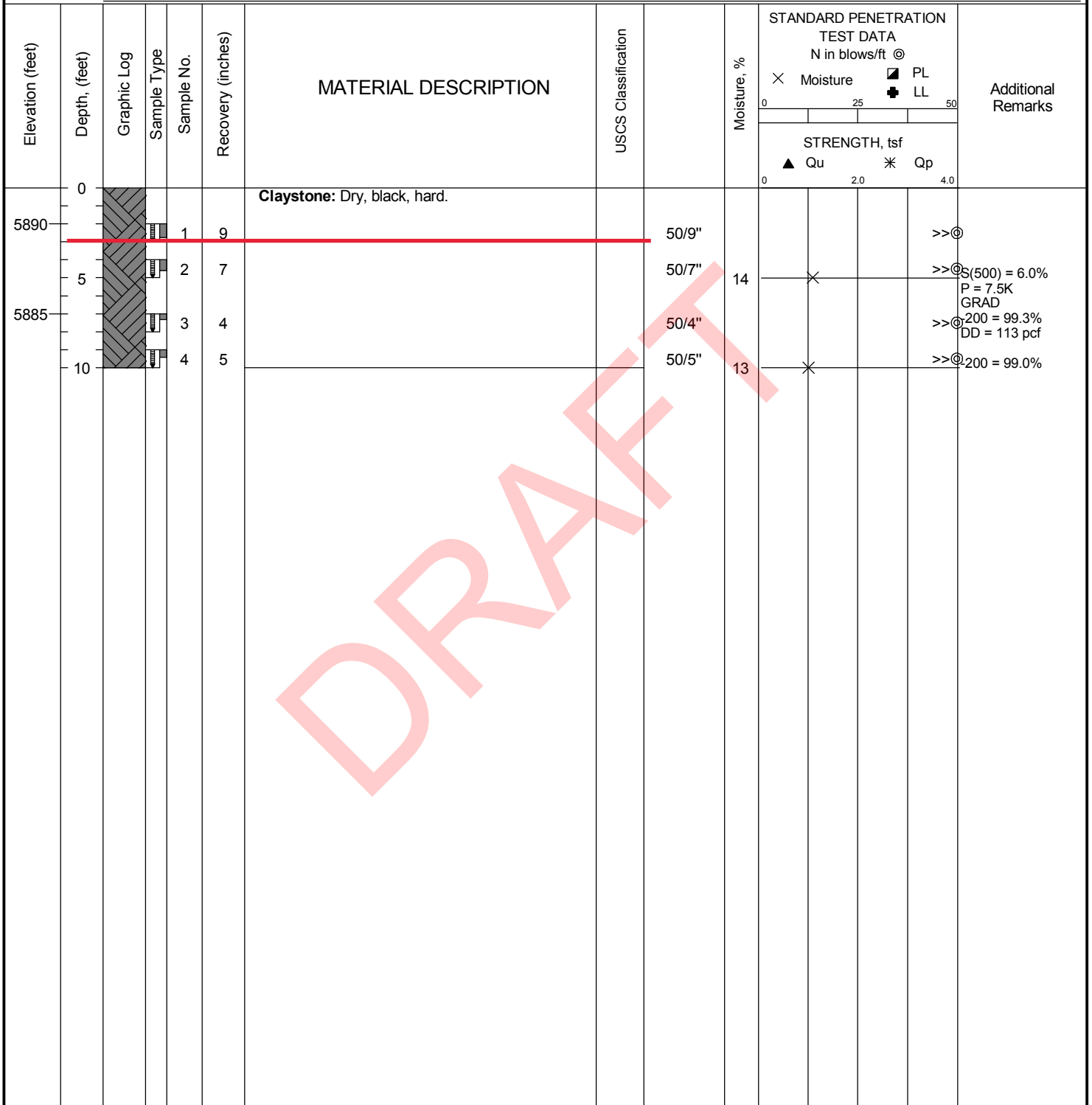

DRAFT

	Professional Service Industries, Inc. 1070 West 124th Avenue, Suite 800 Westminster, CO 80234 Telephone: (303) 424-5578	PROJECT NO.: 05322879
		PROJECT: TTRes Venetucci Multifamily
		LOCATION: Venetucci Blvd at South Academy Blvd Colorado Springs, CO

The stratification lines represent approximate boundaries. The transition may be gradual.

FIGURE: 8

DATE STARTED: 9/11/24	DRILL COMPANY: Dakota Drilling, Inc.	BORING B 6
DATE COMPLETED: 9/11/24	DRILLER: DER LOGGED BY: DW	
COMPLETION DEPTH: 30.0 ft	DRILL RIG: CME-75	Water ▽ ▽ ▽
BENCHMARK: N/A	DRILLING METHOD: Solid Stem Auger	
ELEVATION: 5896 ft	SAMPLING METHOD: Modified California	BORING LOCATION: Building 8
LATITUDE: 38.7694°	HAMMER TYPE: Manual	
LONGITUDE: -104.7856°	EFFICIENCY: N/A	See Figure No. 2
STATION: N/A OFFSET: N/A	REVIEWED BY: HT	
REMARKS:		

Elevation (feet)	Depth (feet)	Graphic Log	Sample Type	Sample No.	Recovery (inches)	MATERIAL DESCRIPTION	USCS Classification	STANDARD PENETRATION TEST DATA				Additional Remarks
								N in blows/ft ⊙				
								Moisture, %		STRENGTH, tsf		
								×	Moisture	■	PL	
										+	LL	
								▲	Qu	*	Qp	
5895	0	[Graphic Log]				Claystone: Dry to moist, brown/dark gray/black, hard	50/9"					>> ⊙
	1		1	9	50/9"						>> ⊙ 200 = 99.0%	
	2		2	9	50/9"		21	×			S(250) = 6.3%	
5890	5		3	3	50/3"		15	×			P = 6.3K	
	3		4	5	50/5"						DD = 104 pcf	
	4		5	5	50/5"						DD = 110 pcf	
5885	10		6	3	50/3"						S(500) = 4.4%	
	5		7	3	50/3"		11	×			P = 4.1K	
5880	15	8	0	50/0"					DD = 108 pcf			
5875	20								>> ⊙			
5870	25								>> ⊙ 200 = 99.7%			
	30								>> ⊙			



Professional Service Industries, Inc.
1070 West 124th Avenue, Suite 800
Westminster, CO 80234
Telephone: (303) 424-5578

PROJECT NO.: 05322879
PROJECT: TTRes Venetucci Multifamily
LOCATION: Venetucci Blvd at South Academy Blvd
Colorado Springs, CO

The stratification lines represent approximate boundaries. The transition may be gradual.

FIGURE: 9

DATE STARTED: 9/12/24	DRILL COMPANY: Dakota Drilling, Inc.	BORING B 7
DATE COMPLETED: 9/12/24	DRILLER: DER LOGGED BY: DW	
COMPLETION DEPTH: 25.0 ft	DRILL RIG: CME-75	Water <input type="checkbox"/> While Drilling Not Observed
BENCHMARK: N/A	DRILLING METHOD: Solid Stem Auger	<input checked="" type="checkbox"/> Upon Completion Not Observed
ELEVATION: 5890 ft	SAMPLING METHOD: Modified California	<input checked="" type="checkbox"/> Delay N/A
LATITUDE: 38.7695°	HAMMER TYPE: Manual	BORING LOCATION:
LONGITUDE: -104.7851°	EFFICIENCY: N/A	Building 9
STATION: N/A OFFSET: N/A	REVIEWED BY: HT	See Figure No. 2
REMARKS:		

Elevation (feet)	Depth (feet)	Graphic Log	Sample Type	Sample No.	Recovery (inches)	MATERIAL DESCRIPTION	USCS Classification	Moisture, %	STRENGTH, tsf	Additional Remarks
0						Claystone: Dry, dark gray/black, hard.				
5885	5			1	7		50/7"	14	X	>>⊙
				2	5		50/5"	14	X ■	>>⊙ PL = 94 >>⊙ PL = 20
				3	5		50/5"	11	X	>>⊙ GRAD -200 = 99.3%
5880	10			4	4		50/4"			>>⊙
5875	15			5	4		50/4"	12	X	>>⊙
5870	20			6	5		50/5"			>>⊙
5865	25			7	6		50/6"			>>⊙

DRAFT

	Professional Service Industries, Inc. 1070 West 124th Avenue, Suite 800 Westminster, CO 80234 Telephone: (303) 424-5578	PROJECT NO.: 05322879
		PROJECT: TTRes Venetucci Multifamily
		LOCATION: Venetucci Blvd at South Academy Blvd Colorado Springs, CO

The stratification lines represent approximate boundaries. The transition may be gradual.

FIGURE: 10

DATE STARTED: 9/12/24	DRILL COMPANY: Dakota Drilling, Inc.	BORING B 8
DATE COMPLETED: 9/12/24	DRILLER: DER LOGGED BY: DW	
COMPLETION DEPTH: 25.0 ft	DRILL RIG: CME-75	Water <input type="checkbox"/> While Drilling Not Observed <input type="checkbox"/> Upon Completion Not Observed <input type="checkbox"/> Delay N/A
BENCHMARK: N/A	DRILLING METHOD: Solid Stem Auger	BORING LOCATION: Building 5
ELEVATION: 5887 ft	SAMPLING METHOD: Modified California	
LATITUDE: 38.7761°	HAMMER TYPE: Manual	See Figure No. 2
LONGITUDE: -104.7853°	EFFICIENCY: N/A	
STATION: N/A OFFSET: N/A	REVIEWED BY: HT	
REMARKS:		

Elevation (feet)	Depth (feet)	Graphic Log	Sample Type	Sample No.	Recovery (inches)	MATERIAL DESCRIPTION	USCS Classification	Moisture, %	STRENGTH, tsf	Additional Remarks	
STANDARD PENETRATION TEST DATA N in blows/ft @ X Moisture PL + LL STRENGTH, tsf ▲ Qu * Qp											
5885	0			1	4	Claystone: Dry, dark gray/black, hard.	50/4"			>>⊙	
5880	5			2	4		50/4"	12	X		>>⊙
5875	10			3	4		50/4"	13	X		>>⊙200 = 96.4% DD = 101 pcf
5870	15			4	3		50/3"	12	X		>>⊙S(750) = 15.7% P = 5.3K
5865	20			5	6		50/6"	12	X		>>⊙ DD = 112 pcf
	25			6	3		50/3"	12	X		>>⊙
	25			7	6		50/6"				>>⊙



Professional Service Industries, Inc.
 1070 West 124th Avenue, Suite 800
 Westminster, CO 80234
 Telephone: (303) 424-5578

PROJECT NO.: 05322879
 PROJECT: TTRes Venetucci Multifamily
 LOCATION: Venetucci Blvd at South Academy Blvd
 Colorado Springs, CO

The stratification lines represent approximate boundaries. The transition may be gradual.

FIGURE: 11

DATE STARTED: 9/12/24	DRILL COMPANY: Dakota Drilling, Inc.	BORING B 9
DATE COMPLETED: 9/12/24	DRILLER: DER LOGGED BY: DW	
COMPLETION DEPTH: 25.0 ft	DRILL RIG: CME-75	Water <input type="checkbox"/> While Drilling Not Observed
BENCHMARK: N/A	DRILLING METHOD: Solid Stem Auger	<input type="checkbox"/> Upon Completion Not Observed
ELEVATION: 5889 ft	SAMPLING METHOD: Modified California	<input type="checkbox"/> Delay N/A
LATITUDE: 38.7704°	HAMMER TYPE: Manual	BORING LOCATION:
LONGITUDE: -104.7854°	EFFICIENCY: N/A	Building 5
STATION: N/A OFFSET: N/A	REVIEWED BY: HT	See Figure No. 2
REMARKS:		

Elevation (feet)	Depth (feet)	Graphic Log	Sample Type	Sample No.	Recovery (inches)	MATERIAL DESCRIPTION	USCS Classification	Moisture, %	STANDARD PENETRATION TEST DATA N in blows/ft @	Additional Remarks
									X Moisture PL + LL STRENGTH, tsf ▲ Qu * Qp	
0						Claystone: Dry, dark gray/black, hard.				
5885				1	7		50/7"	16	X	>> @200 = 99.2%
	5			2	4		50/4"	12	*	>> @5(500) = 17.1% P = 6.5K DD = 97 pcf
				3	4		50/4"			>> @
5880				4	4		50/4"	13	*	>> @
	10									
				5	4		50/4"			>> @
5875										
	15									
				6	4		50/4"			>> @
5870										
	20									
				7	6		50/6"			>> @
5865										
	25									

DRAFT

	Professional Service Industries, Inc. 1070 West 124th Avenue, Suite 800 Westminster, CO 80234 Telephone: (303) 424-5578	PROJECT NO.: 05322879
		PROJECT: TTRes Venetucci Multifamily
		LOCATION: Venetucci Blvd at South Academy Blvd Colorado Springs, CO

The stratification lines represent approximate boundaries. The transition may be gradual.

FIGURE: 12

DATE STARTED: 9/12/24	DRILL COMPANY: Dakota Drilling, Inc.	BORING B10
DATE COMPLETED: 9/12/24	DRILLER: DER LOGGED BY: DW	
COMPLETION DEPTH: 30.0 ft	DRILL RIG: CME-75	Water <input type="checkbox"/> While Drilling Not Observed
BENCHMARK: N/A	DRILLING METHOD: Solid Stem Auger	<input type="checkbox"/> Upon Completion Not Observed
ELEVATION: 5898 ft	SAMPLING METHOD: Modified California	<input type="checkbox"/> Delay N/A
LATITUDE: 38.7684°	HAMMER TYPE: Manual	BORING LOCATION:
LONGITUDE: -104.7863°	EFFICIENCY: N/A	Building 7
STATION: N/A OFFSET: N/A	REVIEWED BY: HT	See Figure No. 2
REMARKS:		

Elevation (feet)	Depth (feet)	Graphic Log	Sample Type	Sample No.	Recovery (inches)	MATERIAL DESCRIPTION	USCS Classification	Moisture, %	STANDARD PENETRATION TEST DATA N in blows/ft @	Additional Remarks
0						Fat Clay: Coarse grained sand, dry, brown to dark brown, very stiff.	CH			
5895	0			1	12	Claystone: Dry, brown/dark gray/black, hard. trace gravel	11-24 N=35 50/11"	19	×	⊙ -200 = 94.3% DD = 109 pcf S(250) = 5.5% P = 4.8K
	5			2	11		50/10"	13	×	>> ⊙ -200 = 96.1% S(250) = 6.0% P = 1.1K
5890				3	10		50/5"	13	×	>> ⊙ DD = 92 pcf DD = 115 pcf S(500) = 13.2% P = 10.0K
	10			4	5			17	×	>> ⊙ -200 = 97.9%
5885				5	11		50/11"			>> ⊙
	15			6	11		50/11"	19	×	>> ⊙
5880				7	6		50/6"			>> ⊙
	20			8	6		50/6"	15	×	>> ⊙
5875										
	25									
5870										
	30									



Professional Service Industries, Inc.
1070 West 124th Avenue, Suite 800
Westminster, CO 80234
Telephone: (303) 424-5578

PROJECT NO.: 05322879
PROJECT: TTRes Venetucci Multifamily
LOCATION: Venetucci Blvd at South Academy Blvd
Colorado Springs, CO

FIGURE: 13

DATE STARTED: 9/12/24	DRILL COMPANY: Dakota Drilling, Inc.	BORING B11
DATE COMPLETED: 9/12/24	DRILLER: DER LOGGED BY: DW	
COMPLETION DEPTH: 10.0 ft	DRILL RIG: CME-75	Water <input type="checkbox"/> While Drilling Not Observed <input type="checkbox"/> Upon Completion Not Observed <input type="checkbox"/> Delay N/A
BENCHMARK: N/A	DRILLING METHOD: Solid Stem Auger	BORING LOCATION: Pavement
ELEVATION: 5899 ft	SAMPLING METHOD: Modified California	
LATITUDE: 38.7694°	HAMMER TYPE: Manual	See Figure No. 2
LONGITUDE: -104.7866°	EFFICIENCY: N/A	
STATION: N/A OFFSET: N/A	REVIEWED BY: HT	
REMARKS:		

Elevation (feet)	Depth (feet)	Graphic Log	Sample Type	Sample No.	Recovery (inches)	MATERIAL DESCRIPTION	USCS Classification	Moisture, %	STANDARD PENETRATION TEST DATA N in blows/ft ⊙	Additional Remarks
0	0			1	7	Apparent Fill: Consists of clay and fine to medium grained sand with gravel, moist, brown to dark brown, hard.	50/7"			>> ⊙
5895	5			2	7	Claystone: Dry, dark gray/black, hard.	50/7"	10	×	>> ⊙ ⊙200 = 42.5% S(500) = 2.8% P = 3.2K DD = 119 pcf
5890	10			3	7		50/7"			>> ⊙
				4	9		50/9"			>> ⊙

DRAFT

	Professional Service Industries, Inc. 1070 West 124th Avenue, Suite 800 Westminster, CO 80234 Telephone: (303) 424-5578	PROJECT NO.: 05322879
		PROJECT: TTRes Venetucci Multifamily
		LOCATION: Venetucci Blvd at South Academy Blvd Colorado Springs, CO

The stratification lines represent approximate boundaries. The transition may be gradual.

FIGURE: 14

DATE STARTED: 9/12/24	DRILL COMPANY: Dakota Drilling, Inc.	BORING B12
DATE COMPLETED: 9/12/24	DRILLER: DER LOGGED BY: DW	
COMPLETION DEPTH: 20.0 ft	DRILL RIG: CME-75	Water <input type="checkbox"/> While Drilling Not Observed <input checked="" type="checkbox"/> Upon Completion Not Observed <input type="checkbox"/> Delay N/A
BENCHMARK: N/A	DRILLING METHOD: Solid Stem Auger	BORING LOCATION: Retaining Wall
ELEVATION: 5895 ft	SAMPLING METHOD: Modified California	
LATITUDE: 38.77°	HAMMER TYPE: Manual	See Figure No. 2
LONGITUDE: -104.7867°	EFFICIENCY: N/A	
STATION: N/A OFFSET: N/A	REVIEWED BY: HT	
REMARKS:		

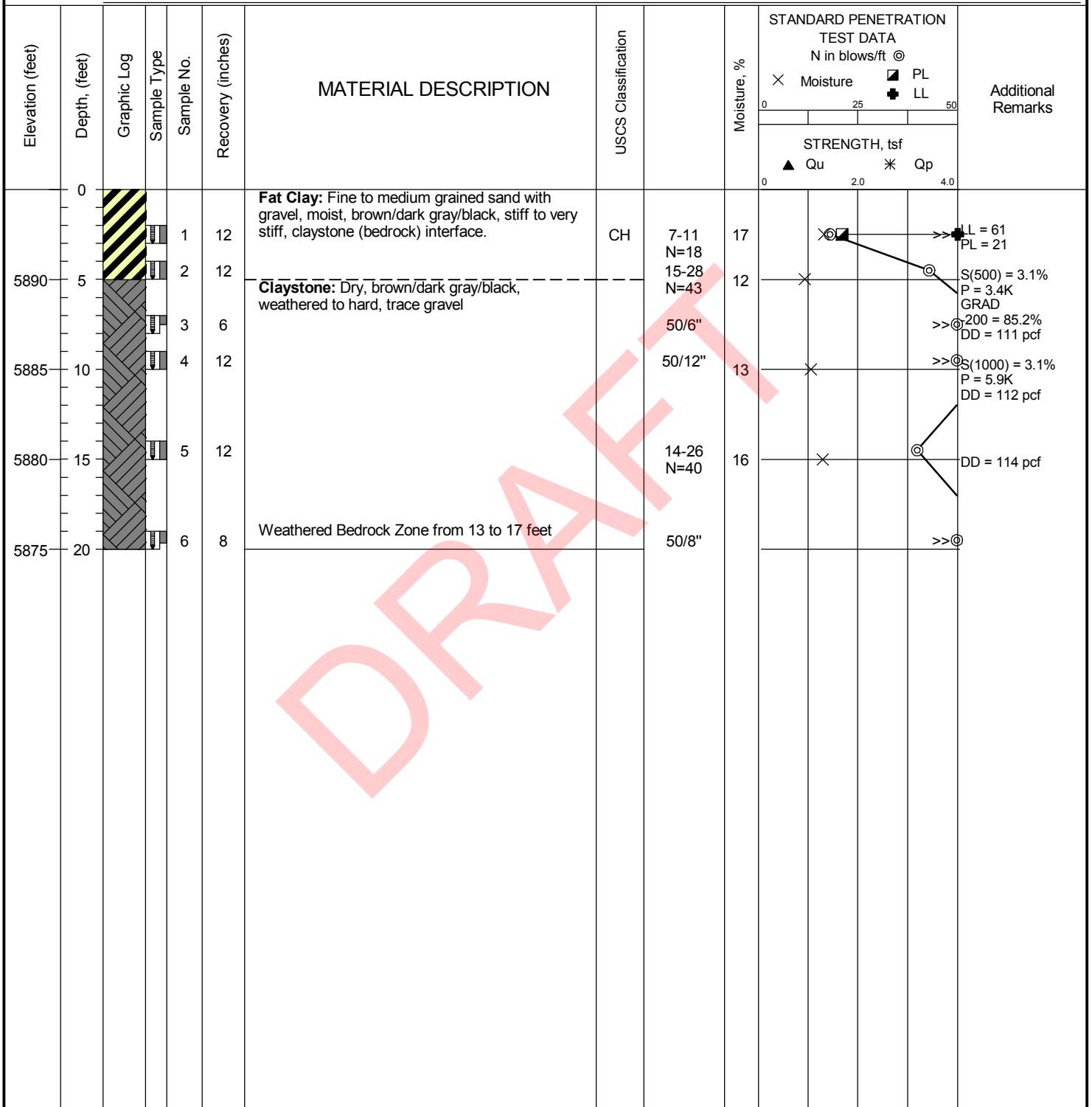

Professional Service Industries, Inc.
 1070 West 124th Avenue, Suite 800
 Westminster, CO 80234
 Telephone: (303) 424-5578

PROJECT NO.: 05322879
PROJECT: TTRes Venetucci Multifamily
LOCATION: Venetucci Blvd at South Academy Blvd
 Colorado Springs, CO

FIGURE: 15

DATE STARTED: 9/12/24	DRILL COMPANY: Dakota Drilling, Inc.	BORING B13
DATE COMPLETED: 9/12/24	DRILLER: DER LOGGED BY: DW	
COMPLETION DEPTH: 35.0 ft	DRILL RIG: CME-75	Water <input type="checkbox"/> While Drilling Not Observed <input type="checkbox"/> Upon Completion Not Observed <input type="checkbox"/> Delay N/A
BENCHMARK: N/A	DRILLING METHOD: Solid Stem Auger	BORING LOCATION: Building 4
ELEVATION: 5898 ft	SAMPLING METHOD: Modified California	
LATITUDE: 38.7701°	HAMMER TYPE: Manual	See Figure No. 2
LONGITUDE: -104.7866°	EFFICIENCY: N/A	
STATION: N/A OFFSET: N/A	REVIEWED BY: HT	
REMARKS:		

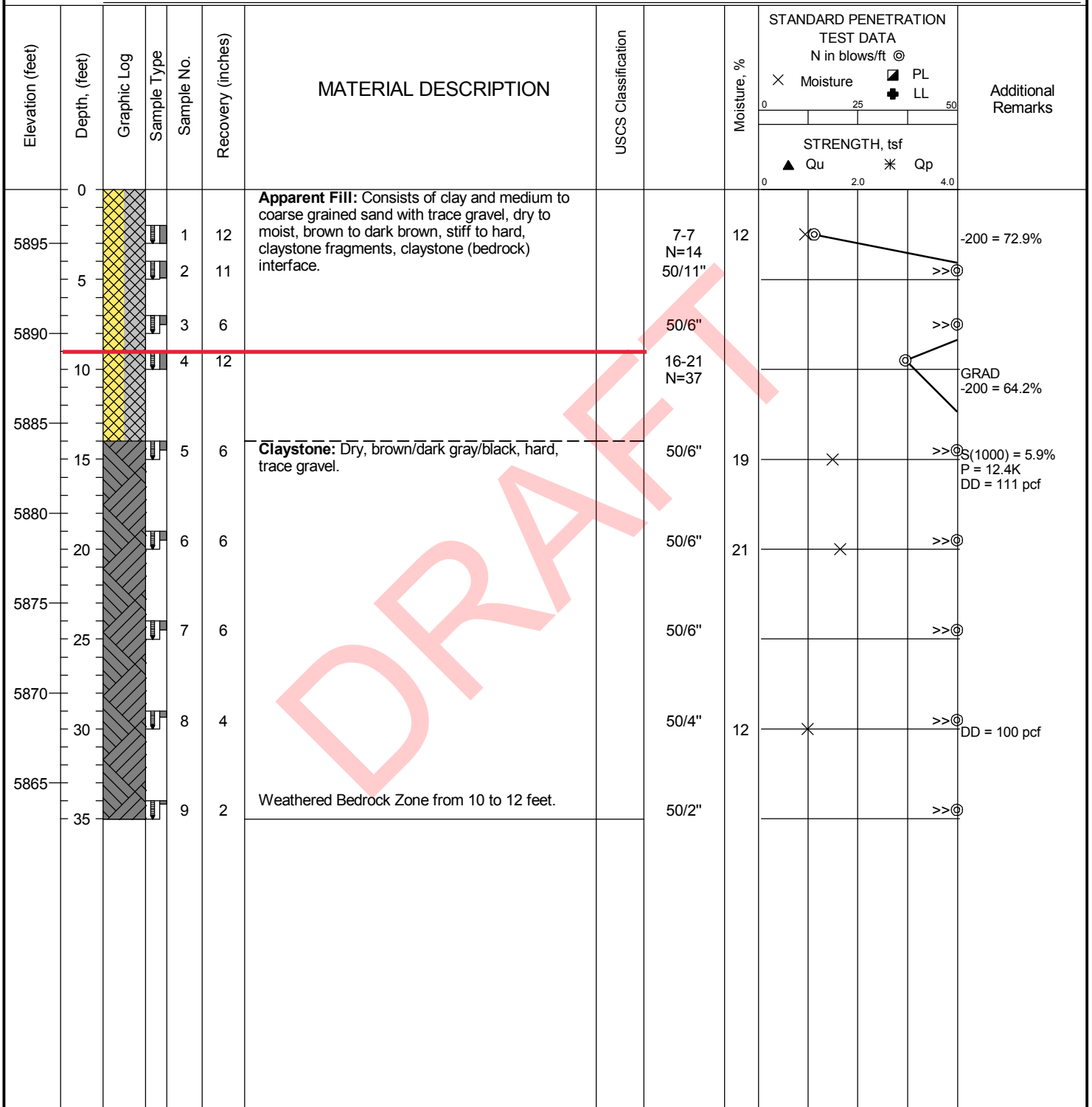

Professional Service Industries, Inc.
 1070 West 124th Avenue, Suite 800
 Westminster, CO 80234
 Telephone: (303) 424-5578

PROJECT NO.: 05322879
 PROJECT: TTRes Venetucci Multifamily
 LOCATION: Venetucci Blvd at South Academy Blvd
 Colorado Springs, CO

The stratification lines represent approximate boundaries. The transition may be gradual.

FIGURE: 16

DATE STARTED: 9/12/24		DRILL COMPANY: Dakota Drilling, Inc.		BORING B14	
DATE COMPLETED: 9/12/24		DRILLER: DER	LOGGED BY: DW		
COMPLETION DEPTH: 30.0 ft		DRILL RIG: CME-75		Water	
BENCHMARK: N/A		DRILLING METHOD: Solid Stem Auger		<input type="checkbox"/> While Drilling Not Observed <input type="checkbox"/> Upon Completion Not Observed <input type="checkbox"/> Delay N/A	
ELEVATION: 5898 ft		SAMPLING METHOD: Modified California		BORING LOCATION:	
LATITUDE: 38.7698°		HAMMER TYPE: Manual		Building 6	
LONGITUDE: -104.7864°		EFFICIENCY: N/A		See Figure No. 2	
STATION: N/A		OFFSET: N/A		REVIEWED BY: HT	
REMARKS:					

Elevation (feet)	Depth (feet)	Graphic Log	Sample Type	Sample No.	Recovery (inches)	MATERIAL DESCRIPTION	USCS Classification	STANDARD PENETRATION TEST DATA		Additional Remarks
								N in blows/ft	Moisture, %	
0	0					Fat Clay: Medium to coarse grained sand with trace gravel, moist, brown to dark brown, hard.				
5895	5			1	12		50/12"	12	X	>>⊙
				2	10		50/10"			>>⊙
5890	10			3	12	Claystone: Dry, brown to dark brown/dark gray/black/orange, weathered to hard, trace gravel.	17-20 N=37	22	■	DD = 109 pcf LL = 74 PL = 21 S(750) = 6.9% P = 9.6K -200 = 99.3% S(1000) = 7.5% P = 13.7K DD = 110 pcf
				4	12		50/12"	20	X	>>⊙
5885	15			5	9		50/9"			>>⊙
5880	20			6	11		50/11"	21	X	>>⊙
5875	25			7	4		50/4"			>>⊙
5870	30			8	6		50/6"			>>⊙



Professional Service Industries, Inc.
 1070 West 124th Avenue, Suite 800
 Westminster, CO 80234
 Telephone: (303) 424-5578

PROJECT NO.: 05322879
PROJECT: TTRes Venetucci Multifamily
LOCATION: Venetucci Blvd at South Academy Blvd
 Colorado Springs, CO

The stratification lines represent approximate boundaries. The transition may be gradual.

FIGURE: 17

DATE STARTED: 9/12/24	DRILL COMPANY: Dakota Drilling, Inc.	BORING B15
DATE COMPLETED: 9/12/24	DRILLER: DER LOGGED BY: DW	
COMPLETION DEPTH: 30.0 ft	DRILL RIG: CME-75	Water <input type="checkbox"/> While Drilling Not Observed <input type="checkbox"/> Upon Completion Not Observed <input type="checkbox"/> Delay N/A
BENCHMARK: N/A	DRILLING METHOD: Solid Stem Auger	BORING LOCATION: Building 6
ELEVATION: 5894 ft	SAMPLING METHOD: Modified California	
LATITUDE: 38.7699°	HAMMER TYPE: Manual	See Figure No. 2
LONGITUDE: -104.7858°	EFFICIENCY: N/A	
STATION: N/A OFFSET: N/A	REVIEWED BY: HT	
REMARKS:		

Elevation (feet)	Depth (feet)	Graphic Log	Sample Type	Sample No.	Recovery (inches)	MATERIAL DESCRIPTION	USCS Classification	Moisture, %	STANDARD PENETRATION TEST DATA N in blows/ft ⊙	Additional Remarks
0						Claystone: Dry, dark gray/black, hard				
5890	5			1	6		50/6"			>>⊙
				2	4		50/4"	12	×	>>⊙
				3	4		50/4"			>>⊙
5885	10			4	4		50/4"	12	×	>>⊙
				5	4		50/4"	6	×	>>⊙ 200 = 99.9%
5880	15			6	3		50/3"			>>⊙
5875	20			7	0		50/3"			>>⊙
5870	25			8	0	50/3"			>>⊙	
5865	30									

	Professional Service Industries, Inc. 1070 West 124th Avenue, Suite 800 Westminster, CO 80234 Telephone: (303) 424-5578	PROJECT NO.: 05322879
		PROJECT: TTRes Venetucci Multifamily
		LOCATION: Venetucci Blvd at South Academy Blvd Colorado Springs, CO

The stratification lines represent approximate boundaries. The transition may be gradual.

FIGURE: 18

DATE STARTED: 9/13/24	DRILL COMPANY: Dakota Drilling, Inc.	BORING B16
DATE COMPLETED: 9/13/24	DRILLER: DER LOGGED BY: DW	
COMPLETION DEPTH: 25.0 ft	DRILL RIG: CME-75	Water <input type="checkbox"/> While Drilling Not Observed
BENCHMARK: N/A	DRILLING METHOD: Solid Stem Auger	<input checked="" type="checkbox"/> Upon Completion Not Observed
ELEVATION: 5880 ft	SAMPLING METHOD: Modified California	<input checked="" type="checkbox"/> Delay N/A
LATITUDE: 38.7708°	HAMMER TYPE: Manual	BORING LOCATION:
LONGITUDE: -104.7857°	EFFICIENCY: N/A	Building 3
STATION: N/A OFFSET: N/A	REVIEWED BY: HT	See Figure No. 2
REMARKS:		

Elevation (feet)	Depth (feet)	Graphic Log	Sample Type	Sample No.	Recovery (inches)	MATERIAL DESCRIPTION	USCS Classification	Moisture, %	STANDARD PENETRATION TEST DATA N in blows/ft @	Additional Remarks
0						Claystone: Dry, dark gray/black, hard				
5875	5			2	4		13-41 N=54 50/4"	20	×	>> @GRAD -200 = 98.5% DD = 109 pcf
5870	10			4	4		50/4"	14	×	>> @S(250) = 8.5% P = 10.6K S(500) = 7.3% >> @P = 11.5K DD = 122 pcf LL = 63 >> @PL = 19
5865	15			5	2		50/2"			>> @
5860	20			6	4		50/4"	12	×	>> @DD = 92 pcf
5855	25			7	4		50/4"			>> @



DRAFT

	Professional Service Industries, Inc. 1070 West 124th Avenue, Suite 800 Westminster, CO 80234 Telephone: (303) 424-5578	PROJECT NO.: 05322879
		PROJECT: TTRes Venetucci Multifamily
		LOCATION: Venetucci Blvd at South Academy Blvd Colorado Springs, CO

The stratification lines represent approximate boundaries. The transition may be gradual.

FIGURE: 19

DATE STARTED: 9/13/24	DRILL COMPANY: Dakota Drilling, Inc.	BORING B17
DATE COMPLETED: 9/13/24	DRILLER: DER LOGGED BY: DW	
COMPLETION DEPTH: 10.0 ft	DRILL RIG: CME-75	Water <input type="checkbox"/> While Drilling Not Observed <input checked="" type="checkbox"/> Upon Completion Not Observed <input checked="" type="checkbox"/> Delay N/A
BENCHMARK: N/A	DRILLING METHOD: Solid Stem Auger	BORING LOCATION: Pavement
ELEVATION: 5885 ft	SAMPLING METHOD: Modified California	
LATITUDE: 38.7708°	HAMMER TYPE: Manual	See Figure No. 2
LONGITUDE: -104.7858°	EFFICIENCY: N/A	
STATION: N/A OFFSET: N/A	REVIEWED BY: HT	
REMARKS:		

Elevation (feet)	Depth (feet)	Graphic Log	Sample Type	Sample No.	Recovery (inches)	MATERIAL DESCRIPTION	USCS Classification	Moisture, %	STANDARD PENETRATION TEST DATA N in blows/ft @	Additional Remarks
0				1	12	Fat Clay: Moist, brown to dark gray/black, very stiff, claystone fragments.	CH			
5880	5			2	9	Claystone: Dry to moist, dark gray/black, hard.		21	15-14 N=29	
				3	4			19	50/9"	-200 = 97.7%
				4	5				50/4"	>> @ 200 = 97.0%
5875	10								50/5"	S(500) = 5.1% P = 8.8K DD = 115 pcf

DRAFT

	Professional Service Industries, Inc. 1070 West 124th Avenue, Suite 800 Westminster, CO 80234 Telephone: (303) 424-5578	PROJECT NO.: 05322879
		PROJECT: TTRes Venetucci Multifamily
		LOCATION: Venetucci Blvd at South Academy Blvd Colorado Springs, CO

The stratification lines represent approximate boundaries. The transition may be gradual.

FIGURE: 20

DATE STARTED: 9/13/24	DRILL COMPANY: Dakota Drilling, Inc.	<h2 style="margin: 0;">BORING B18</h2>
DATE COMPLETED: 9/13/24	DRILLER: DER LOGGED BY: DW	
COMPLETION DEPTH: 30.0 ft	DRILL RIG: CME-75	
BENCHMARK: N/A	DRILLING METHOD: Solid Stem Auger	
ELEVATION: 5883 ft	SAMPLING METHOD: Modified California	
LATITUDE: 38.769°	HAMMER TYPE: Manual	
LONGITUDE: -104.7859°	EFFICIENCY: N/A	
STATION: N/A OFFSET: N/A	REVIEWED BY: HT	

Water	∇ While Drilling Not Observed ▼ Upon Completion Not Observed ▽ Delay N/A	BORING LOCATION: Building 3
REMARKS:		See Figure No. 2

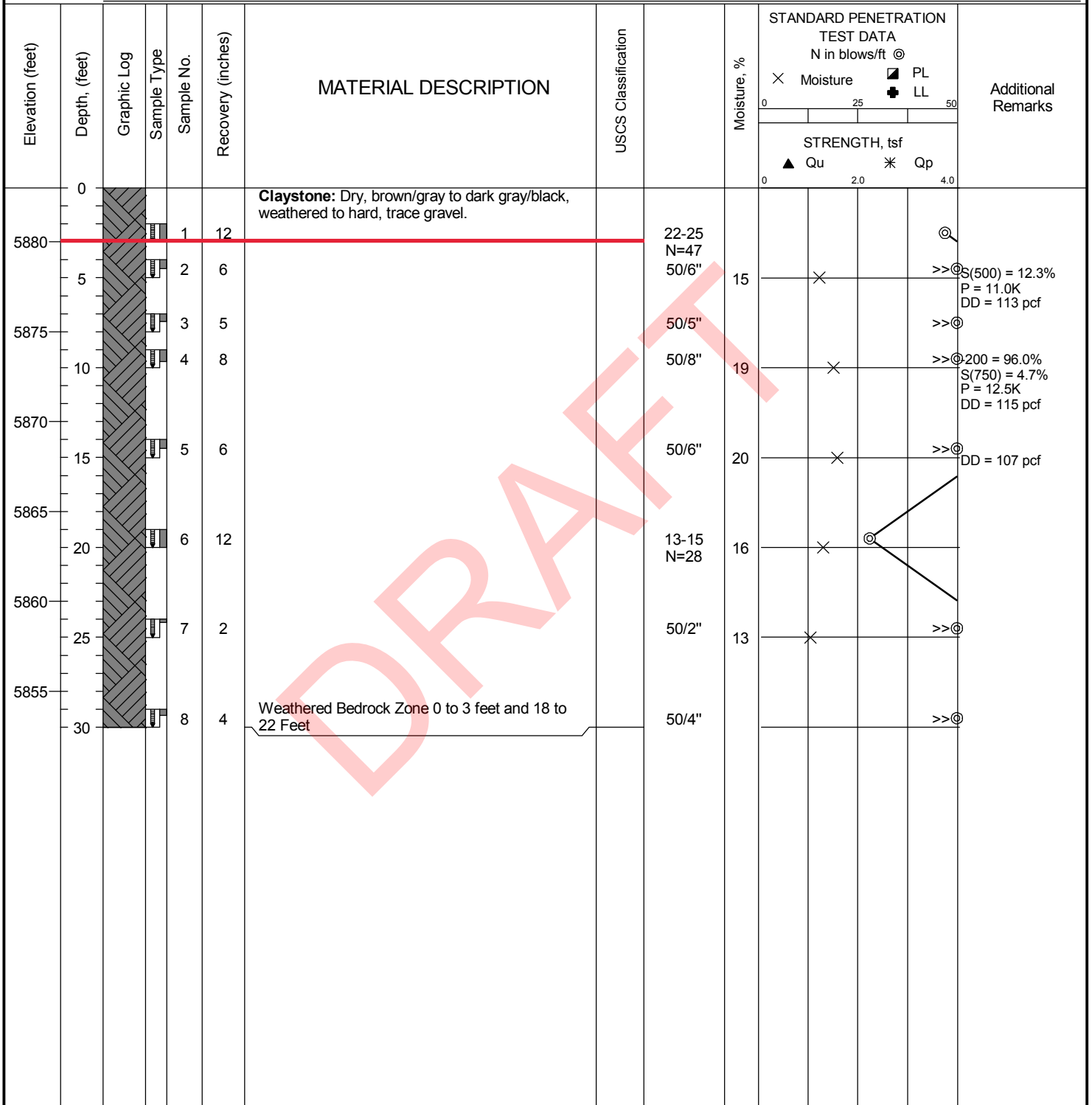

Professional Service Industries, Inc.
 1070 West 124th Avenue, Suite 800
 Westminster, CO 80234
 Telephone: (303) 424-5578

PROJECT NO.: 05322879
PROJECT: TTRes Venetucci Multifamily
LOCATION: Venetucci Blvd at South Academy Blvd
 Colorado Springs, CO

The stratification lines represent approximate boundaries. The transition may be gradual.

FIGURE: 21

DATE STARTED: 9/13/24	DRILL COMPANY: Dakota Drilling, Inc.	BORING B19
DATE COMPLETED: 9/13/24	DRILLER: DER LOGGED BY: DW	
COMPLETION DEPTH: 15.0 ft	DRILL RIG: CME-75	Water <input type="checkbox"/> While Drilling Not Observed
BENCHMARK: N/A	DRILLING METHOD: Solid Stem Auger	<input type="checkbox"/> Upon Completion Not Observed
ELEVATION: 5884 ft	SAMPLING METHOD: Modified California	<input type="checkbox"/> Delay N/A
LATITUDE: 38.7718°	HAMMER TYPE: Manual	BORING LOCATION:
LONGITUDE: -104.7816°	EFFICIENCY: N/A	Pavement
STATION: N/A OFFSET: N/A	REVIEWED BY: HT	See Figure No. 2
REMARKS:		

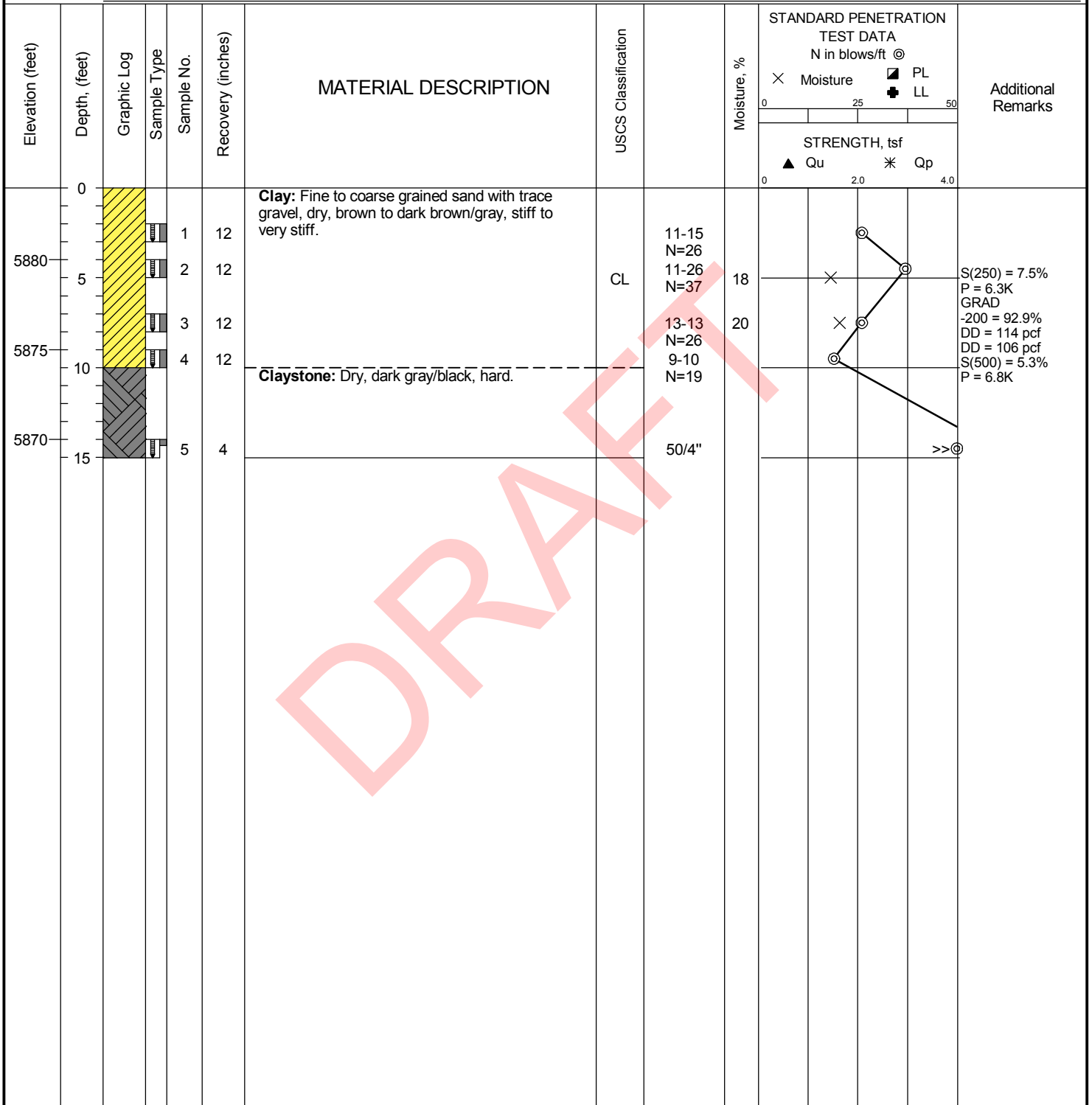

DRAFT



Professional Service Industries, Inc.
 1070 West 124th Avenue, Suite 800
 Westminster, CO 80234
 Telephone: (303) 424-5578

PROJECT NO.: 05322879
 PROJECT: TTRes Venetucci Multifamily
 LOCATION: Venetucci Blvd at South Academy Blvd
 Colorado Springs, CO

FIGURE: 22

DATE STARTED: 9/13/24	DRILL COMPANY: Dakota Drilling, Inc.	BORING B20
DATE COMPLETED: 9/13/24	DRILLER: DER LOGGED BY: DW	
COMPLETION DEPTH: 25.0 ft	DRILL RIG: CME-75	Water <input type="checkbox"/> While Drilling Not Observed
BENCHMARK: N/A	DRILLING METHOD: Solid Stem Auger	<input type="checkbox"/> Upon Completion Not Observed
ELEVATION: 5885 ft	SAMPLING METHOD: Modified California	<input type="checkbox"/> Delay N/A
LATITUDE: 38.7719°	HAMMER TYPE: Manual	BORING LOCATION:
LONGITUDE: -104.7859°	EFFICIENCY: N/A	Amenity Building
STATION: N/A OFFSET: N/A	REVIEWED BY: HT	See Figure No. 2
REMARKS:		

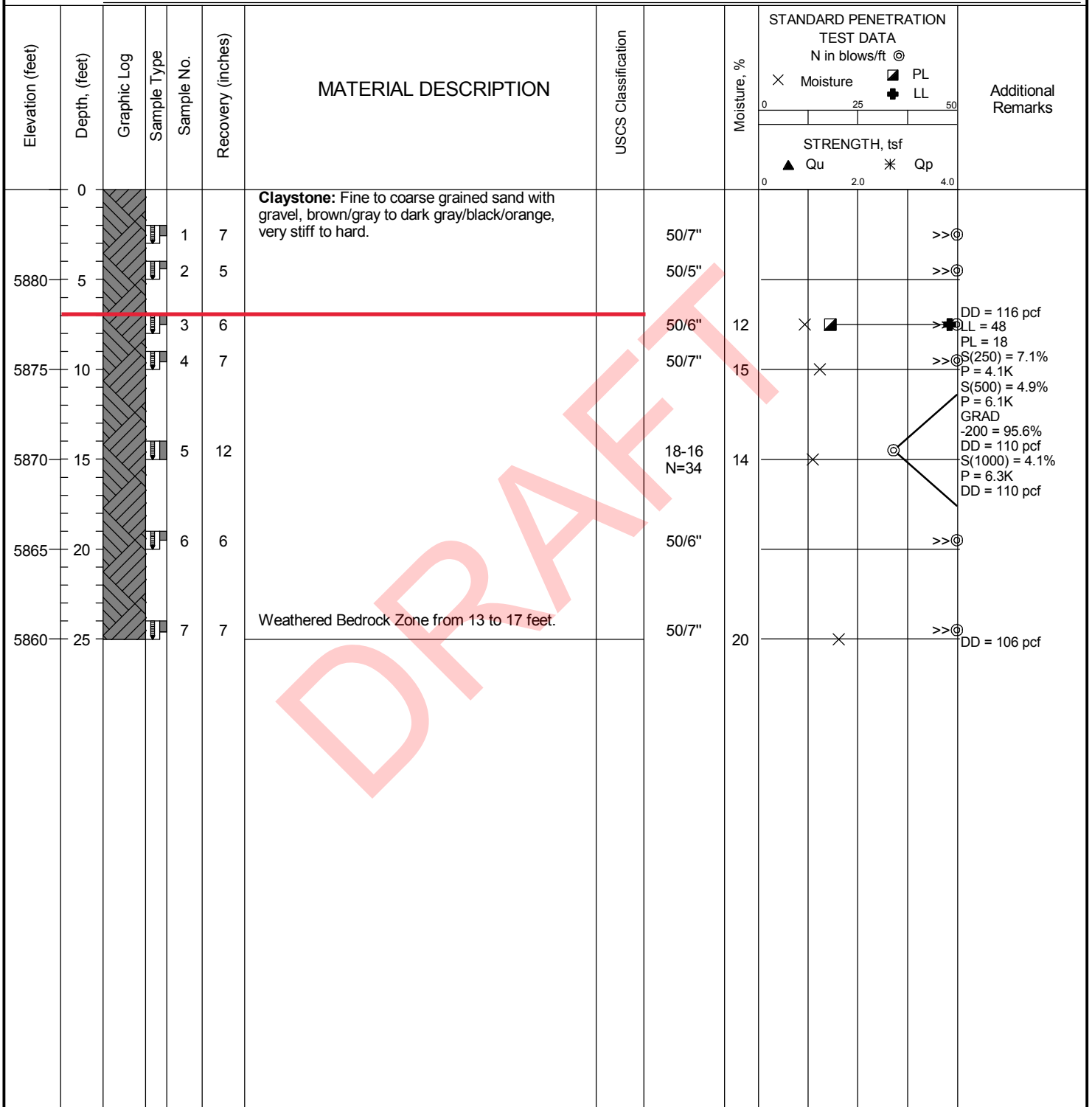

	Professional Service Industries, Inc. 1070 West 124th Avenue, Suite 800 Westminster, CO 80234 Telephone: (303) 424-5578	PROJECT NO.: 05322879
		PROJECT: TTRes Venetucci Multifamily
		LOCATION: Venetucci Blvd at South Academy Blvd Colorado Springs, CO

The stratification lines represent approximate boundaries. The transition may be gradual.

FIGURE: 23

DATE STARTED: 9/13/24	DRILL COMPANY: Dakota Drilling, Inc.	BORING B21
DATE COMPLETED: 9/13/24	DRILLER: DER LOGGED BY: DW	
COMPLETION DEPTH: 45.0 ft	DRILL RIG: CME-75	Water ▽ While Drilling Not Observed ▽ Upon Completion Not Observed ▽ Delay N/A
BENCHMARK: N/A	DRILLING METHOD: Solid Stem Auger	BORING LOCATION: Detention Pond
ELEVATION: 5886 ft	SAMPLING METHOD: Modified California	
LATITUDE: 38.7723°	HAMMER TYPE: Manual	See Figure No. 2
LONGITUDE: -104.7859°	EFFICIENCY: N/A	
STATION: N/A OFFSET: N/A	REVIEWED BY: HT	
REMARKS:		

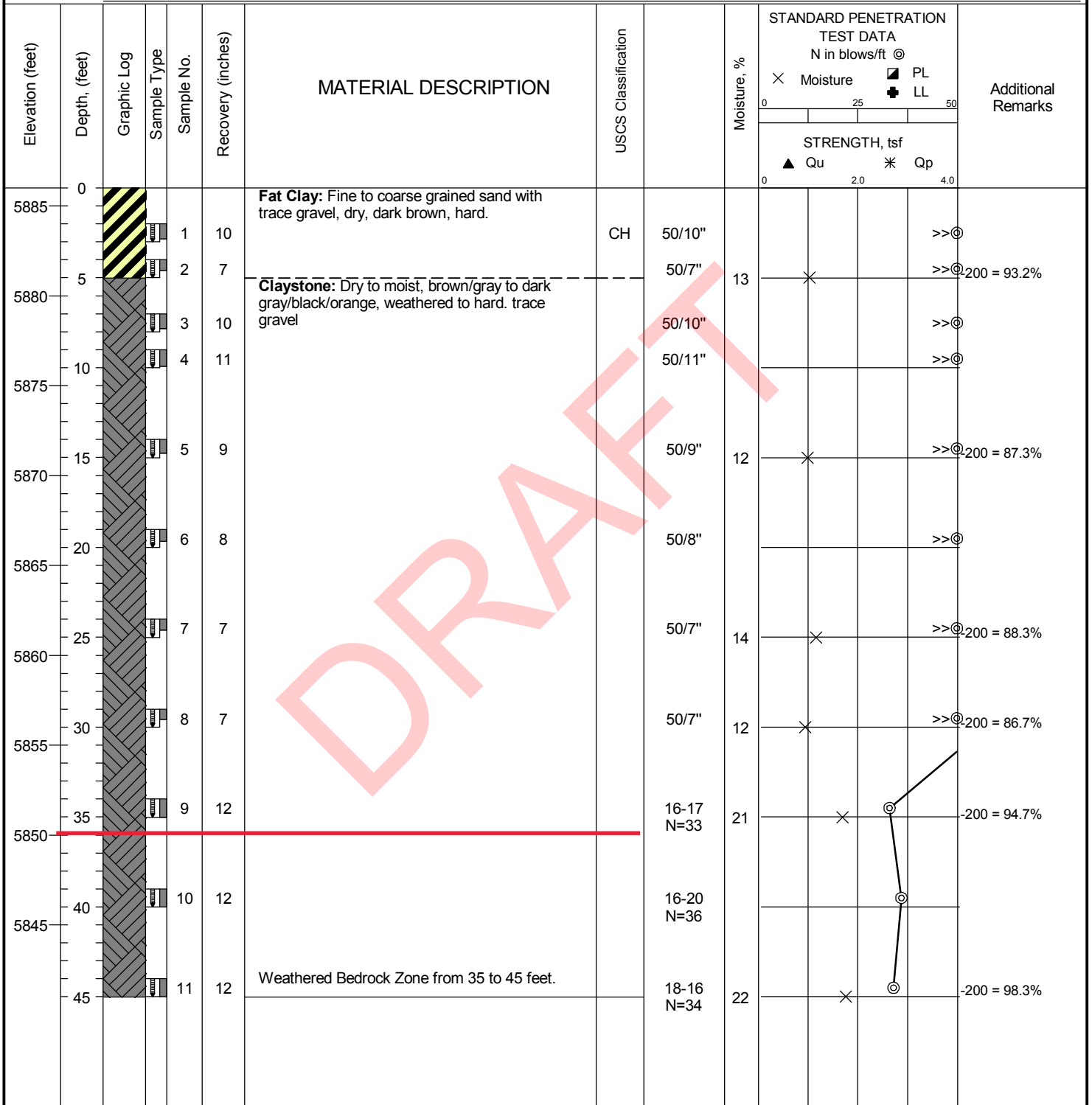

Professional Service Industries, Inc.
 1070 West 124th Avenue, Suite 800
 Westminster, CO 80234
 Telephone: (303) 424-5578

PROJECT NO.: 05322879
PROJECT: TTRes Venetucci Multifamily
LOCATION: Venetucci Blvd at South Academy Blvd
 Colorado Springs, CO

The stratification lines represent approximate boundaries. The transition may be gradual.

FIGURE: 24

DATE STARTED: 9/13/24	DRILL COMPANY: Dakota Drilling, Inc.	BORING B22
DATE COMPLETED: 9/13/24	DRILLER: DER LOGGED BY: DW	
COMPLETION DEPTH: 15.0 ft	DRILL RIG: CME-75	Water <input type="checkbox"/> While Drilling Not Observed <input type="checkbox"/> Upon Completion Not Observed <input type="checkbox"/> Delay N/A
BENCHMARK: N/A	DRILLING METHOD: Solid Stem Auger	BORING LOCATION: Pool
ELEVATION: 5885 ft	SAMPLING METHOD: Modified California	
LATITUDE: 38.7701°	HAMMER TYPE: Manual	See Figure No. 2
LONGITUDE: -104.7863°	EFFICIENCY: N/A	
STATION: N/A OFFSET: N/A	REVIEWED BY: HT	
REMARKS:		

Elevation (feet)	Depth (feet)	Graphic Log	Sample Type	Sample No.	Recovery (inches)	MATERIAL DESCRIPTION	USCS Classification	Moisture, %	STANDARD PENETRATION TEST DATA N in blows/ft @	Additional Remarks
0	0			1	12	Fat Clay: Dry, dark brown/dark gray/black, very stiff to hard, trace gravel, claystone fragments	CH			
5880	5			2	6	Claystone: Dry, brown/dark gray/black, weathered to hard, trace gravel				
5875	10			3	7		50/7"	12	X	>>⊙ 200 = 97.3%
5870	15			4	12		16-24 N=40	14	X	⊙ S(500) = 5.1% P = 4.3K DD = 109 pcf
				5	9	Weathered Bedrock Zone from 8 to 12 feet.	50/9"			>>⊙

DRAFT

	Professional Service Industries, Inc. 1070 West 124th Avenue, Suite 800 Westminster, CO 80234 Telephone: (303) 424-5578	PROJECT NO.: 05322879
		PROJECT: TTRes Venetucci Multifamily
		LOCATION: Venetucci Blvd at South Academy Blvd Colorado Springs, CO

The stratification lines represent approximate boundaries. The transition may be gradual.

FIGURE: 25

DATE STARTED: 9/13/24	DRILL COMPANY: Dakota Drilling, Inc.	BORING B23
DATE COMPLETED: 9/13/24	DRILLER: DER LOGGED BY: DW	
COMPLETION DEPTH: 40.0 ft	DRILL RIG: CME-75	Water <input type="checkbox"/> While Drilling Not Observed
BENCHMARK: N/A	DRILLING METHOD: Solid Stem Auger	<input type="checkbox"/> Upon Completion Not Observed
ELEVATION: 5884 ft	SAMPLING METHOD: Modified California	<input type="checkbox"/> Delay N/A
LATITUDE: 38.7718°	HAMMER TYPE: Manual	BORING LOCATION:
LONGITUDE: -104.7865°	EFFICIENCY: N/A	Retaining Wall
STATION: N/A OFFSET: N/A	REVIEWED BY: HT	See Figure No. 2
REMARKS:		

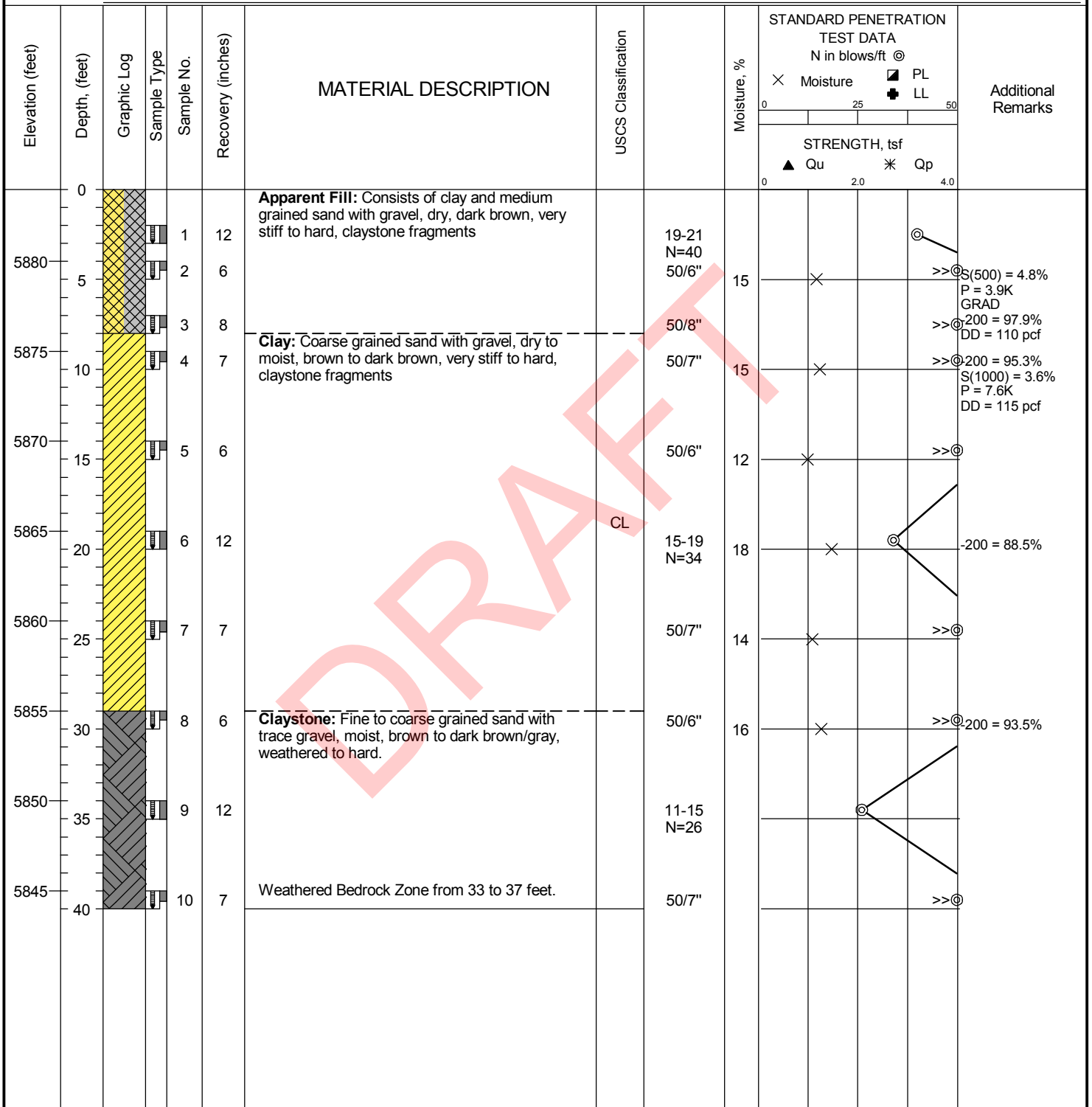

Professional Service Industries, Inc.
1070 West 124th Avenue, Suite 800
Westminster, CO 80234
Telephone: (303) 424-5578

PROJECT NO.: 05322879
PROJECT: TTRes Venetucci Multifamily
LOCATION: Venetucci Blvd at South Academy Blvd
Colorado Springs, CO

The stratification lines represent approximate boundaries. The transition may be gradual.

FIGURE: 26

DATE STARTED: 9/14/24	DRILL COMPANY: Dakota Drilling, Inc.	BORING B24
DATE COMPLETED: 9/14/24	DRILLER: DER LOGGED BY: DW	
COMPLETION DEPTH: 25.0 ft	DRILL RIG: CME-75	
BENCHMARK: N/A	DRILLING METHOD: Solid Stem Auger	
ELEVATION: 5882 ft	SAMPLING METHOD: Modified California	
LATITUDE: 38.7712°	HAMMER TYPE: Manual	
LONGITUDE: -104.7866°	EFFICIENCY: N/A	
STATION: N/A OFFSET: N/A	REVIEWED BY: HT	BORING LOCATION: Building 2
REMARKS:		See Figure No. 2

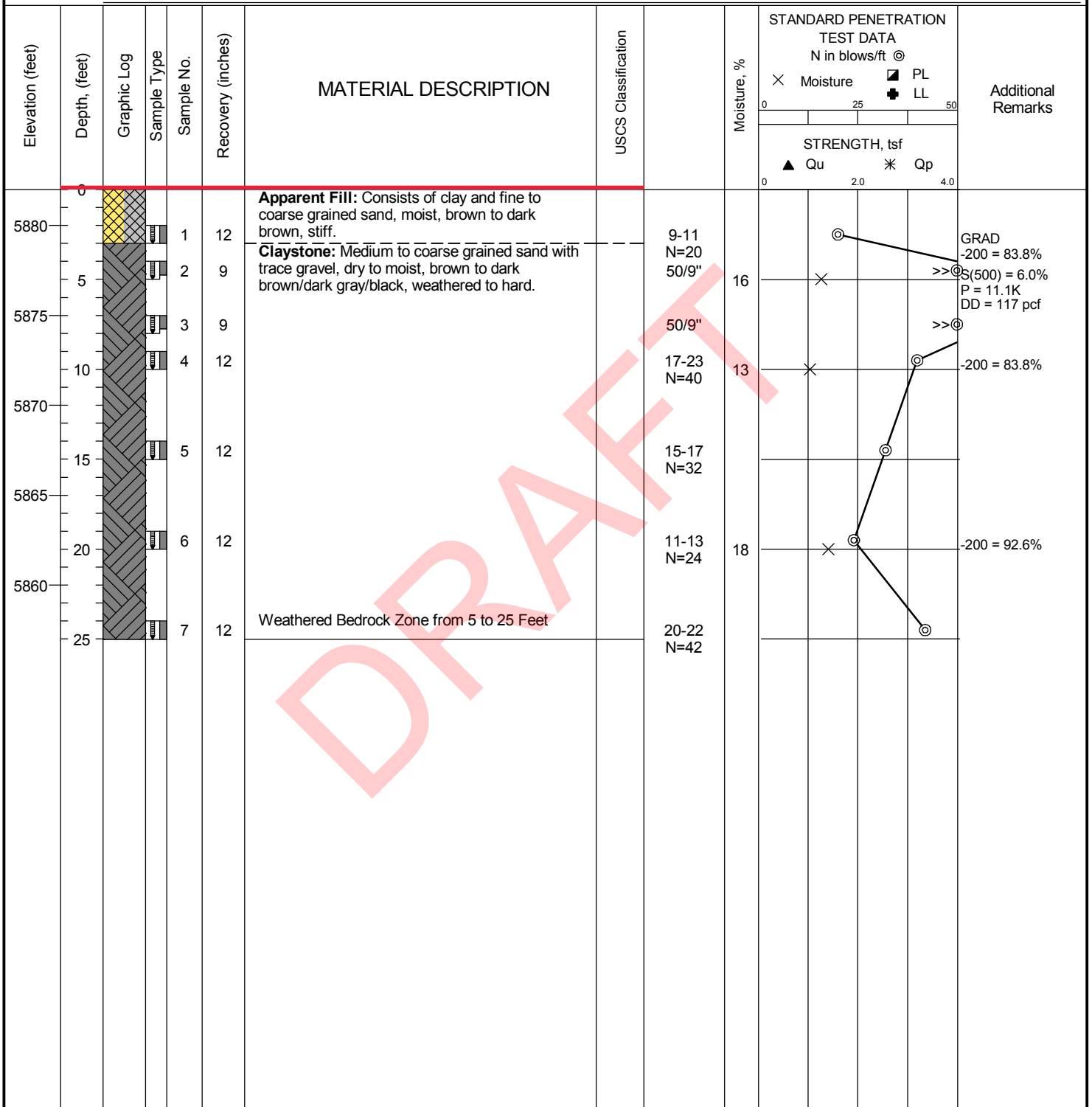

Professional Service Industries, Inc.
1070 West 124th Avenue, Suite 800
Westminster, CO 80234
Telephone: (303) 424-5578

PROJECT NO.: 05322879
PROJECT: TTRes Venetucci Multifamily
LOCATION: Venetucci Blvd at South Academy Blvd
Colorado Springs, CO

The stratification lines represent approximate boundaries. The transition may be gradual.

FIGURE: 27

DATE STARTED: 9/14/24	DRILL COMPANY: Dakota Drilling, Inc.	BORING B25
DATE COMPLETED: 9/14/24	DRILLER: DER LOGGED BY: DW	
COMPLETION DEPTH: 30.0 ft	DRILL RIG: CME-75	Water <input type="checkbox"/> While Drilling Not Observed
BENCHMARK: N/A	DRILLING METHOD: Solid Stem Auger	<input type="checkbox"/> Upon Completion Not Observed
ELEVATION: 5884 ft	SAMPLING METHOD: Modified California	<input type="checkbox"/> Delay N/A
LATITUDE: 38.7714°	HAMMER TYPE: Manual	BORING LOCATION:
LONGITUDE: -104.7866°	EFFICIENCY: N/A	Building 1
STATION: N/A OFFSET: N/A	REVIEWED BY: HT	See Figure No. 2
REMARKS:		

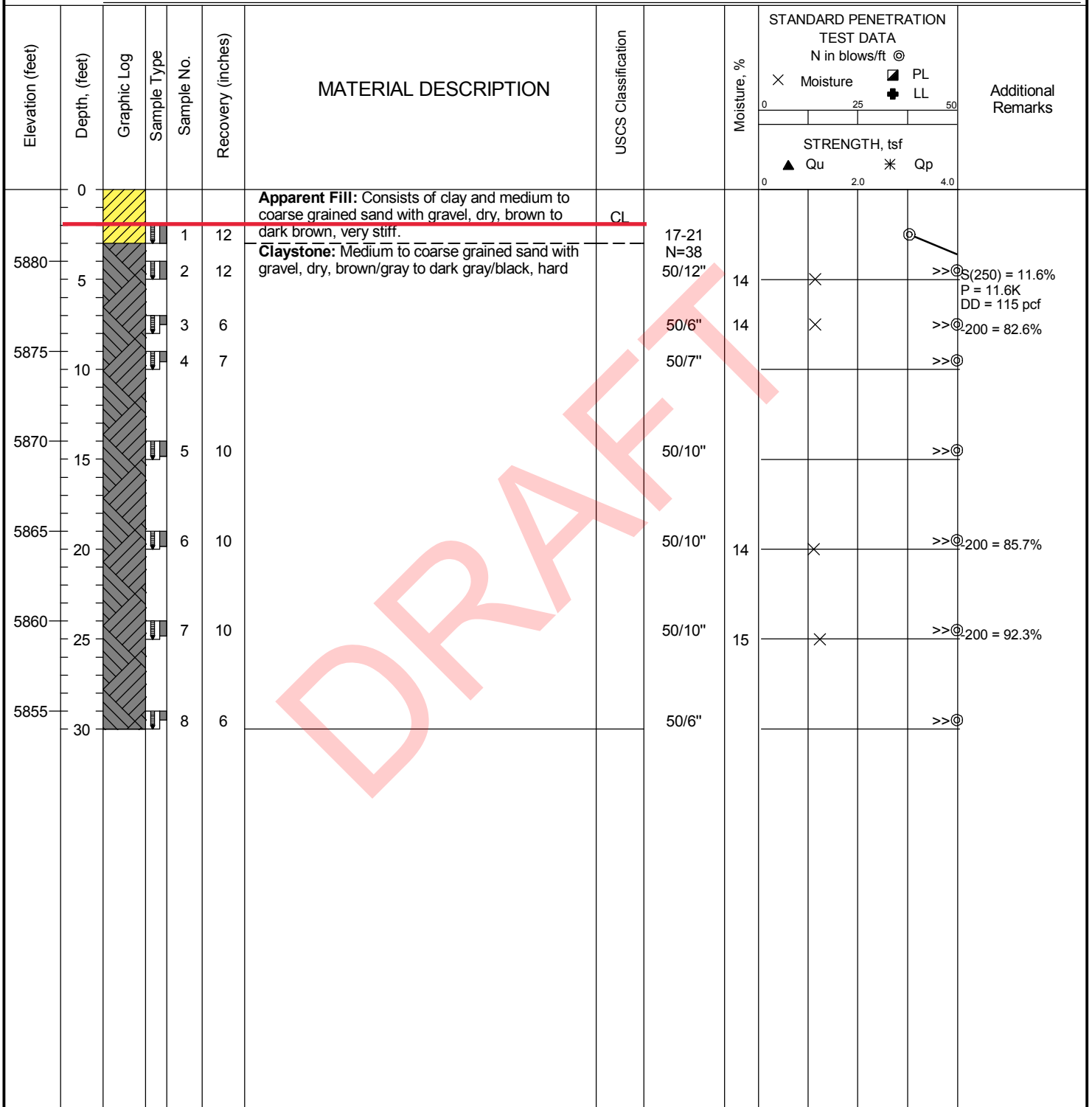

Professional Service Industries, Inc.
1070 West 124th Avenue, Suite 800
Westminster, CO 80234
Telephone: (303) 424-5578

PROJECT NO.: 05322879
PROJECT: TTRes Venetucci Multifamily
LOCATION: Venetucci Blvd at South Academy Blvd
Colorado Springs, CO

The stratification lines represent approximate boundaries. The transition may be gradual.

FIGURE: 28

DATE STARTED: 9/19/24		DRILL COMPANY: Dakota Drilling, Inc.		BORING B26											
DATE COMPLETED: 9/19/24		DRILLER: ERC	LOGGED BY: JW	<table border="1" style="width:100%; border-collapse: collapse;"> <tr> <td rowspan="3" style="text-align: center; vertical-align: middle;">Water</td> <td style="text-align: center;">▽</td> <td>While Drilling</td> <td>Not Observed</td> </tr> <tr> <td style="text-align: center;">▼</td> <td>Upon Completion</td> <td>Not Observed</td> </tr> <tr> <td style="text-align: center;">▽</td> <td>Delay</td> <td>N/A</td> </tr> </table>		Water	▽	While Drilling	Not Observed	▼	Upon Completion	Not Observed	▽	Delay	N/A
Water	▽	While Drilling	Not Observed												
	▼	Upon Completion	Not Observed												
	▽	Delay	N/A												
COMPLETION DEPTH: 25.0 ft		DRILL RIG: CME-55		BORING LOCATION: Building 2											
BENCHMARK: N/A		DRILLING METHOD: Solid Stem Auger													
ELEVATION: 5882 ft		SAMPLING METHOD: Modified California		See Figure No. 2											
LATITUDE: 38.7707°		HAMMER TYPE: Manual													
LONGITUDE: -104.7867°		EFFICIENCY: N/A													
STATION: N/A		OFFSET: N/A													
REMARKS:		REVIEWED BY: HT													

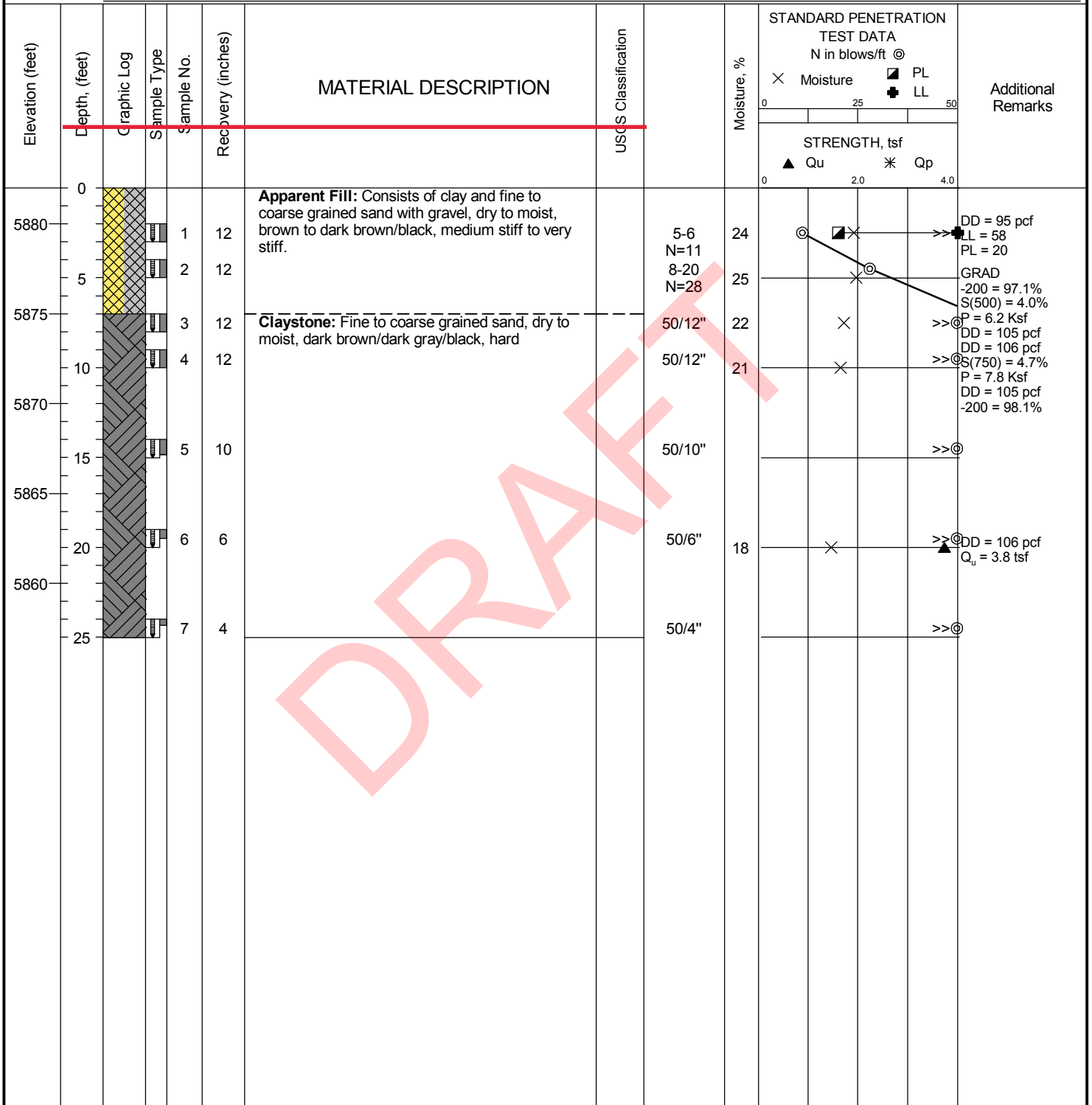

Professional Service Industries, Inc.
 1070 West 124th Avenue, Suite 800
 Westminster, CO 80234
 Telephone: (303) 424-5578

PROJECT NO.: 05322879
PROJECT: TTRes Venetucci Multifamily
LOCATION: Venetucci Blvd at South Academy Blvd
 Colorado Springs, CO

The stratification lines represent approximate boundaries. The transition may be gradual.

FIGURE: 29

DATE STARTED: 9/19/24	DRILL COMPANY: Dakota Drilling, Inc.	BORING B27
DATE COMPLETED: 9/19/24	DRILLER: ERC LOGGED BY: JW	
COMPLETION DEPTH: 20.0 ft	DRILL RIG: CME-55	
BENCHMARK: N/A	DRILLING METHOD: Solid Stem Auger	
ELEVATION: 5882 ft	SAMPLING METHOD: Modified California	
LATITUDE: 38.7708°	HAMMER TYPE: Manual	
LONGITUDE: -104.7868°	EFFICIENCY: N/A	
STATION: N/A OFFSET: N/A	REVIEWED BY: HT	BORING LOCATION: Amenity Building
REMARKS:		See Figure No. 2

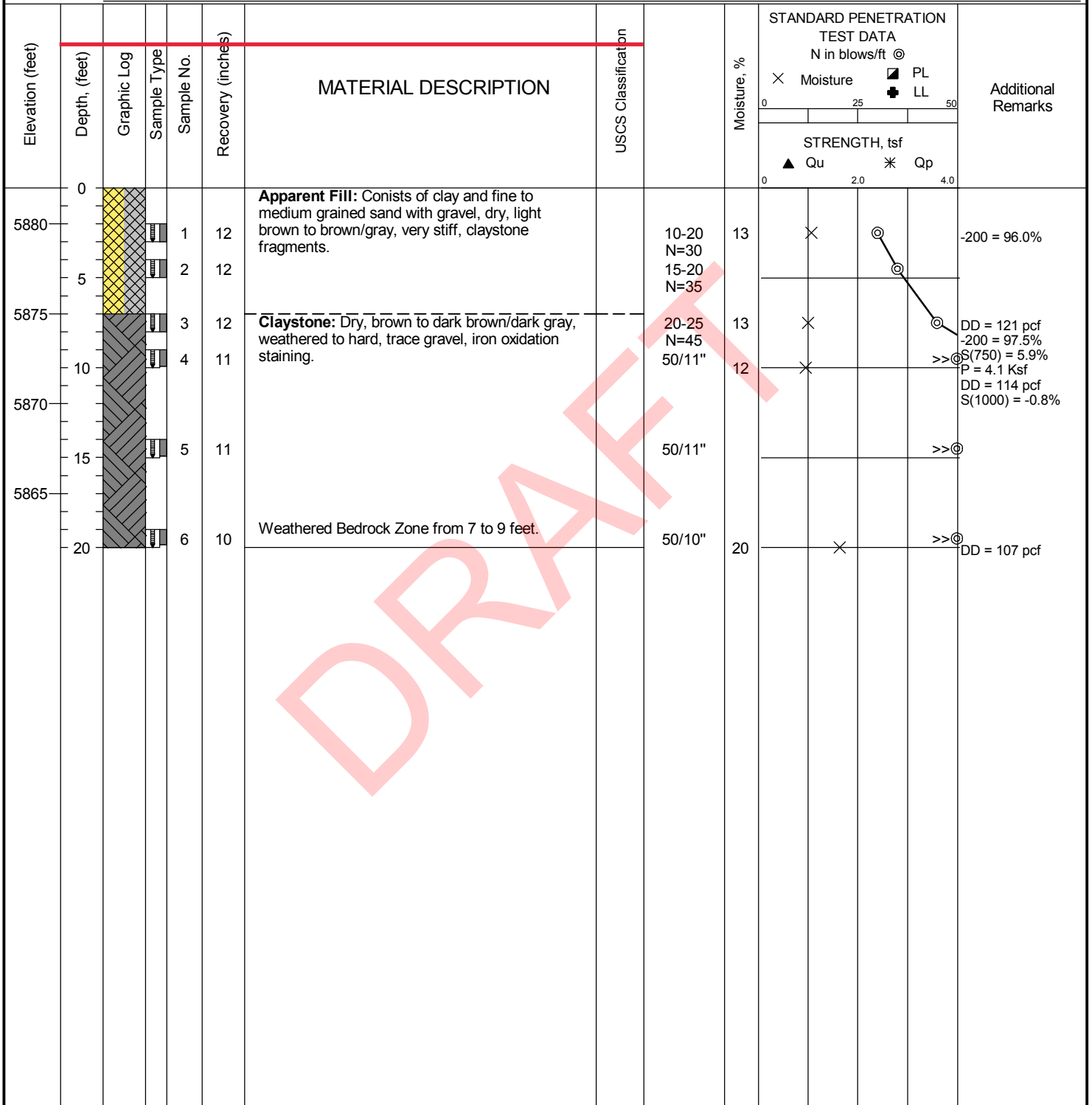

DRAFT

	Professional Service Industries, Inc. 1070 West 124th Avenue, Suite 800 Westminster, CO 80234 Telephone: (303) 424-5578	PROJECT NO.: 05322879
		PROJECT: TTRes Venetucci Multifamily
		LOCATION: Venetucci Blvd at South Academy Blvd Colorado Springs, CO

The stratification lines represent approximate boundaries. The transition may be gradual.

FIGURE: 30

DATE STARTED: 9/19/24	DRILL COMPANY: Dakota Drilling, Inc.	BORING B28
DATE COMPLETED: 9/19/24	DRILLER: ERC LOGGED BY: JW	
COMPLETION DEPTH: 20.0 ft	DRILL RIG: CME-55	Water ▽ While Drilling 15 feet ▼ Upon Completion 15 feet ▽ Delay N/A
BENCHMARK: N/A	DRILLING METHOD: Solid Stem Auger	BORING LOCATION: Retaining Wall
ELEVATION: 5825 ft	SAMPLING METHOD: Modified California	
LATITUDE: 38.7721°	HAMMER TYPE: Manual	See Figure No. 2
LONGITUDE: -104.7872°	EFFICIENCY: N/A	
STATION: N/A OFFSET: N/A	REVIEWED BY: HT	
REMARKS:		

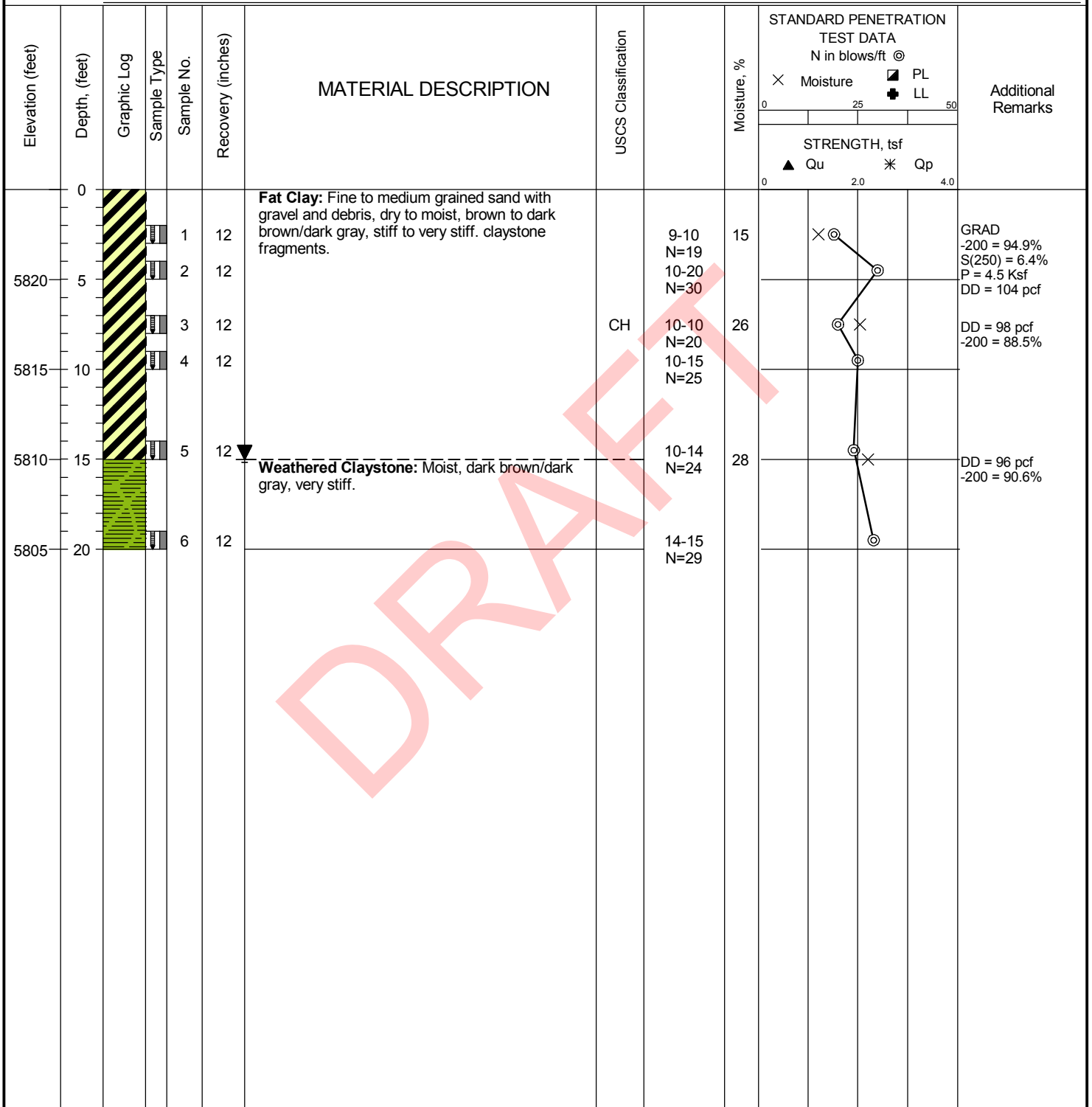

Professional Service Industries, Inc.
 1070 West 124th Avenue, Suite 800
 Westminster, CO 80234
 Telephone: (303) 424-5578

PROJECT NO.: 05322879
PROJECT: TTRes Venetucci Multifamily
LOCATION: Venetucci Blvd at South Academy Blvd
 Colorado Springs, CO

The stratification lines represent approximate boundaries. The transition may be gradual.

FIGURE: 31

DATE STARTED: 9/19/24	DRILL COMPANY: Dakota Drilling, Inc.	BORING B29
DATE COMPLETED: 9/19/24	DRILLER: ERC LOGGED BY: JW	
COMPLETION DEPTH: 20.0 ft	DRILL RIG: CME-55	
BENCHMARK: N/A	DRILLING METHOD: Solid Stem Auger	
ELEVATION: N/A	SAMPLING METHOD: Modified California	
LATITUDE: 38.7713°	HAMMER TYPE: Manual	
LONGITUDE: -104.7873°	EFFICIENCY: N/A	
STATION: N/A OFFSET: N/A	REVIEWED BY: HT	
REMARKS:		BORING LOCATION: Retaining Wall
		See Figure No. 2

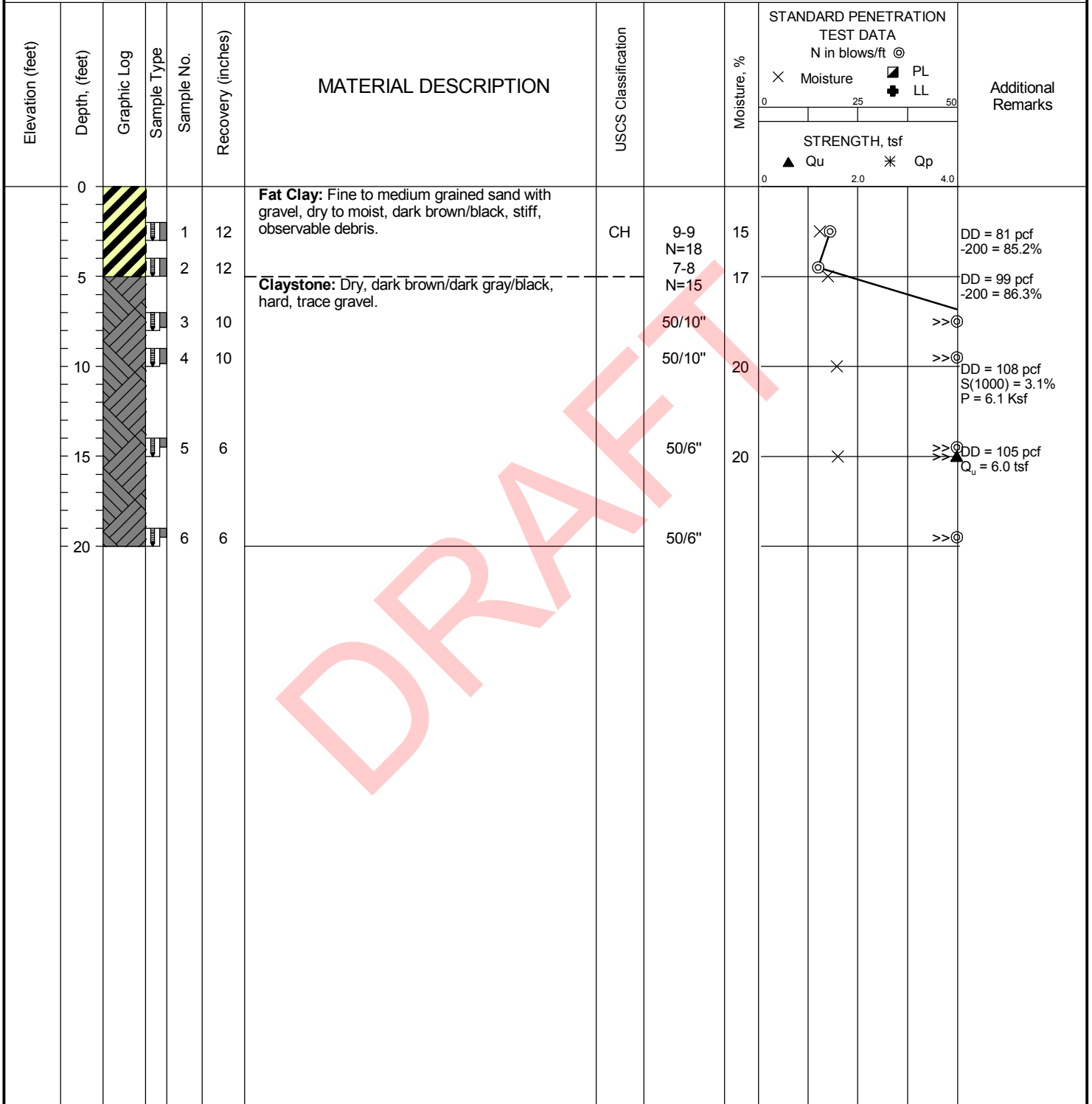

DRAFT



Professional Service Industries, Inc.
1070 West 124th Avenue, Suite 800
Westminster, CO 80234
Telephone: (303) 424-5578

PROJECT NO.: 05322879
PROJECT: TTRes Venetucci Multifamily
LOCATION: Venetucci Blvd at South Academy Blvd
Colorado Springs, CO

FIGURE: 32

DATE STARTED: 9/19/24	DRILL COMPANY: Dakota Drilling, Inc.	BORING B30
DATE COMPLETED: 9/19/24	DRILLER: ERC LOGGED BY: JW	
COMPLETION DEPTH: 10.0 ft	DRILL RIG: CME-55	Water <input type="checkbox"/> While Drilling Not Observed <input type="checkbox"/> Upon Completion Not Observed <input type="checkbox"/> Delay N/A
BENCHMARK: N/A	DRILLING METHOD: Solid Stem Auger	BORING LOCATION: Pavement
ELEVATION: 5875 ft	SAMPLING METHOD: Modified California	
LATITUDE: 38.7707°	HAMMER TYPE: Manual	See Figure No. 2
LONGITUDE: -104.7871°	EFFICIENCY: N/A	
STATION: N/A OFFSET: N/A	REVIEWED BY: HT	
REMARKS:		

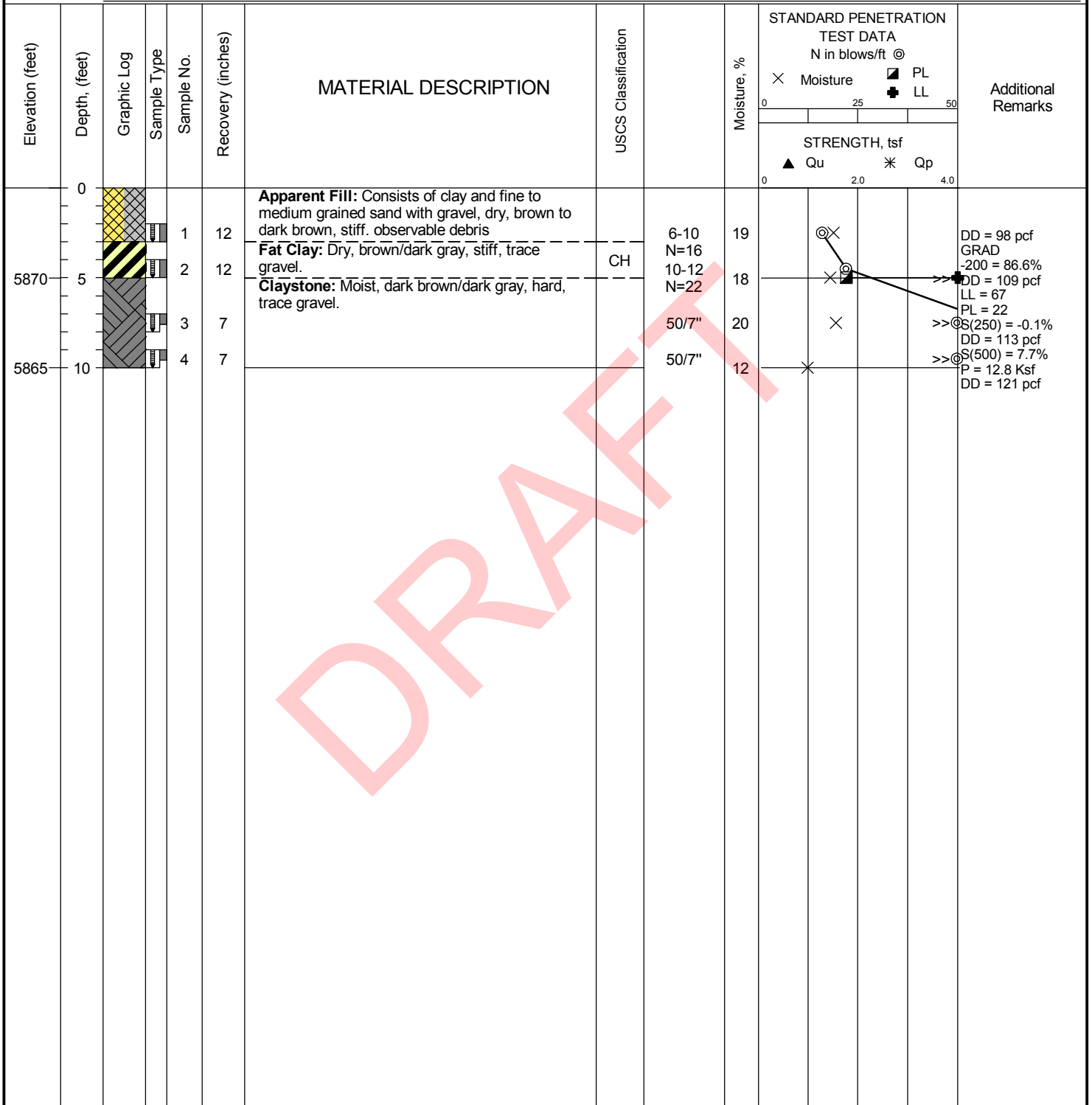

DRAFT



Professional Service Industries, Inc.
 1070 West 124th Avenue, Suite 800
 Westminster, CO 80234
 Telephone: (303) 424-5578

PROJECT NO.: 05322879
PROJECT: TTRes Venetucci Multifamily
LOCATION: Venetucci Blvd at South Academy Blvd
 Colorado Springs, CO

The stratification lines represent approximate boundaries. The transition may be gradual.

KEY TO SYMBOLS



Apparent Fill



USCS High Plasticity Clay



USCS Low Plasticity Clay



Bedrock



Weathered Shale

SSA = Solid Stem Auger

HSA = Hollow Stem Auger

CFA = Continuous Flight Auger

SPT = Standard Penetration Test

MC - Modified California Sampler

SS = Split-spoon Sampler

ST = Shelby Tube Sampler

RC = Rock Core

DD = Dry Density

MC = Moisture Content

LL = Liquid Limit

PL = Plastic Limit

-200 = Percent Passing the
No. 200 Sieve (%)S(250) = Swell under 250 psf
surcharge pressure (%)S(500) = Swell under 500 psf
surcharge pressure (%)S(1000) = Swell under 1000 psf
surcharge pressure (%)Qu = Unconfined Compressive
Strength

RQD = Rock Quality Designation

REC'D = Rock Core Recovery
Percentage

PID = Photo Ionic Detector (ppm)

The borings were advanced into the ground using 4-inch solid stem augers. At regular intervals throughout the boring depths, soil samples were obtained with either a 1.4-inch I.D., 2.0-inch O.D., split-spoon sampler or a 2.0-inch I.D., 2.4-inch O.D. Modified California sampler. The samplers were first seated 6-inches to penetrate any loose cuttings and then driven an additional foot where possible with blows of a 140-pound hammer falling 30-inches. The number of hammer blows required to drive the sampler each 6-inch increment is recorded in the field. The penetration resistance "N-value" is redesignated as the number of hammer blows required to drive the sampler the final foot and, when properly evaluated, is an index to cohesion for clays and relative density for sands. N-values recorded on the boring logs are uncorrected. The split-spoon sampling procedures used during this exploration are in general accordance with ASTM Designation D 1586.



Professional Service Industries, Inc.
1070 West 124th Avenue, Suite 800
Westminster, CO 80234
Telephone: (303) 424-5578
Fax: (303) 423-5625

PSI Job No.: 05322879
Project: TTRes Venetucci Multifamily
Location: Venetucci Blvd at South Academy Blvd
Colorado Springs, CO

Appendix A

Laboratory Test Results

DRAFT

SWELL-CONSOLIDATION TEST

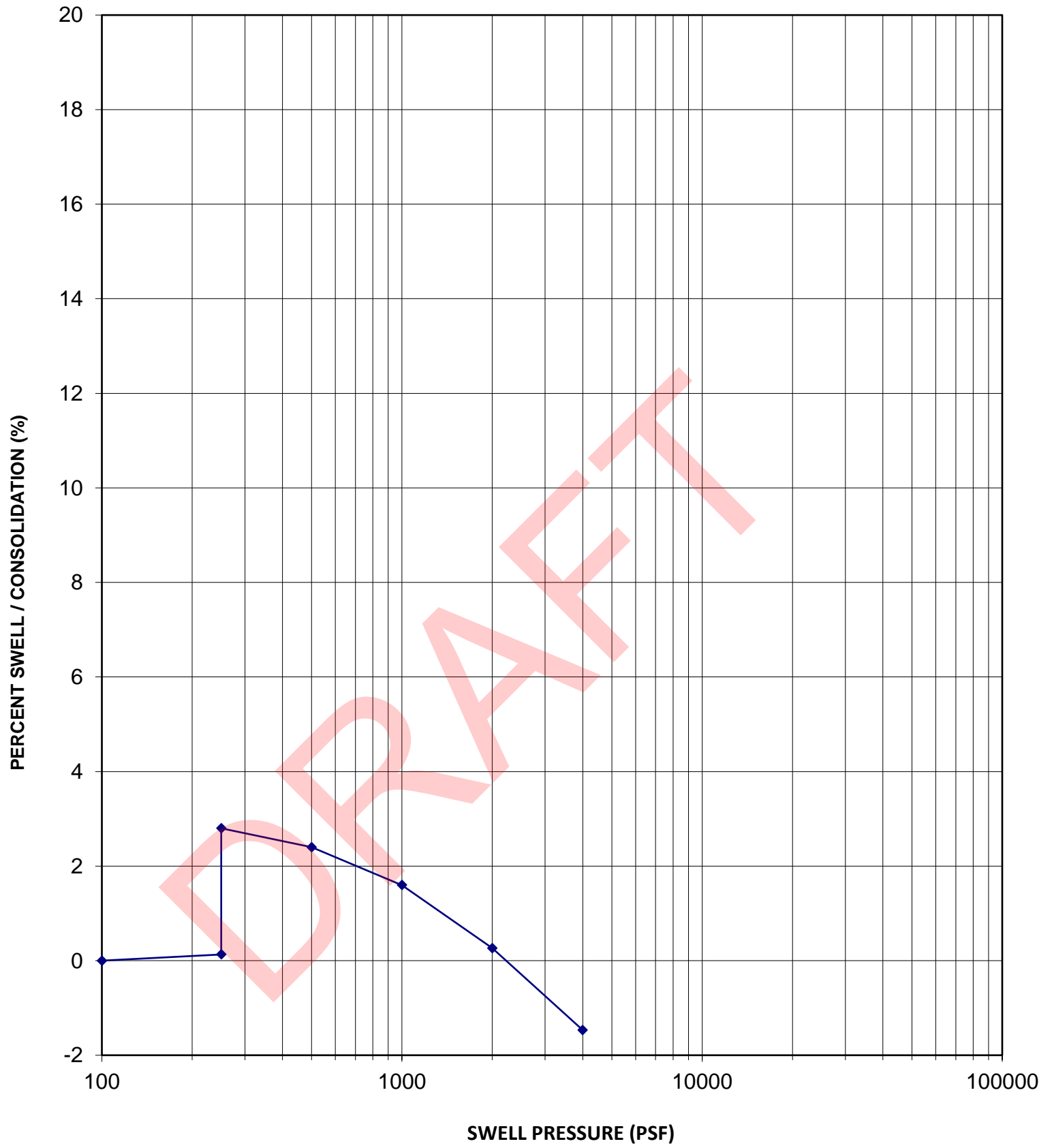

Sample Location	B1
Sample Depth	2.5 feet
Sample Description	Apparent Fill
USCS Classification	

Dry Density	101 pcf
In-Situ Moisture Content	21.2 %
Volume Change	2.7 %
Swell Pressure	2,100 psf



TRes Venetucci Multifamily

JOB NO. 5322879

SWELL - CONSOLIDATION TEST

FIGURE NO. A1

SWELL-CONSOLIDATION TEST

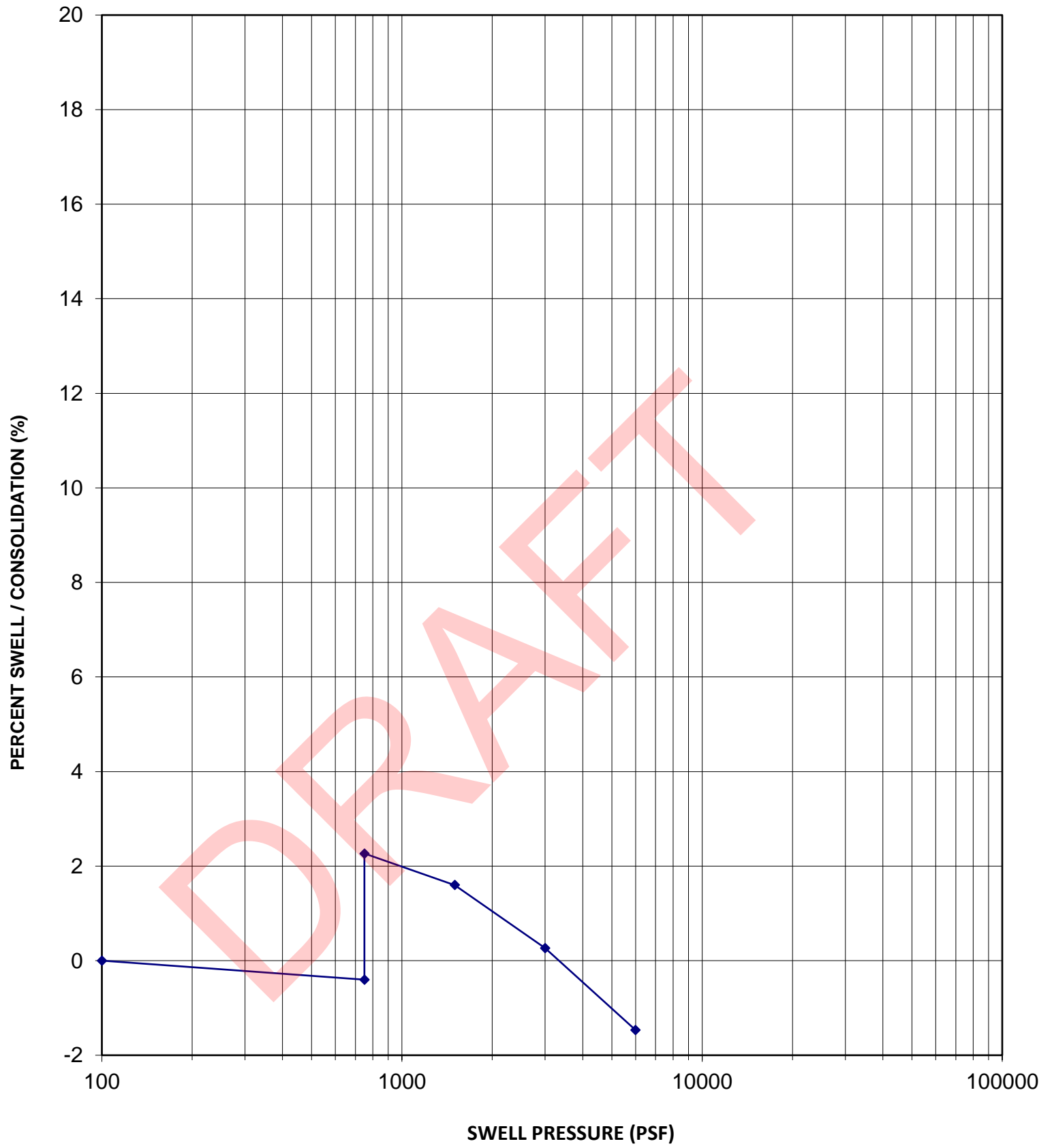

Sample Location	B1
Sample Depth	7.5 feet
Sample Description	Apparent Fill
USCS Classification	

Dry Density	101 pcf
In-Situ Moisture Content	20.5 %
Volume Change	2.7 %
Swell Pressure	3,900 psf



TRes Venetucci Multifamily

JOB NO. 5322879

SWELL - CONSOLIDATION TEST

FIGURE NO. A2

SWELL-CONSOLIDATION TEST

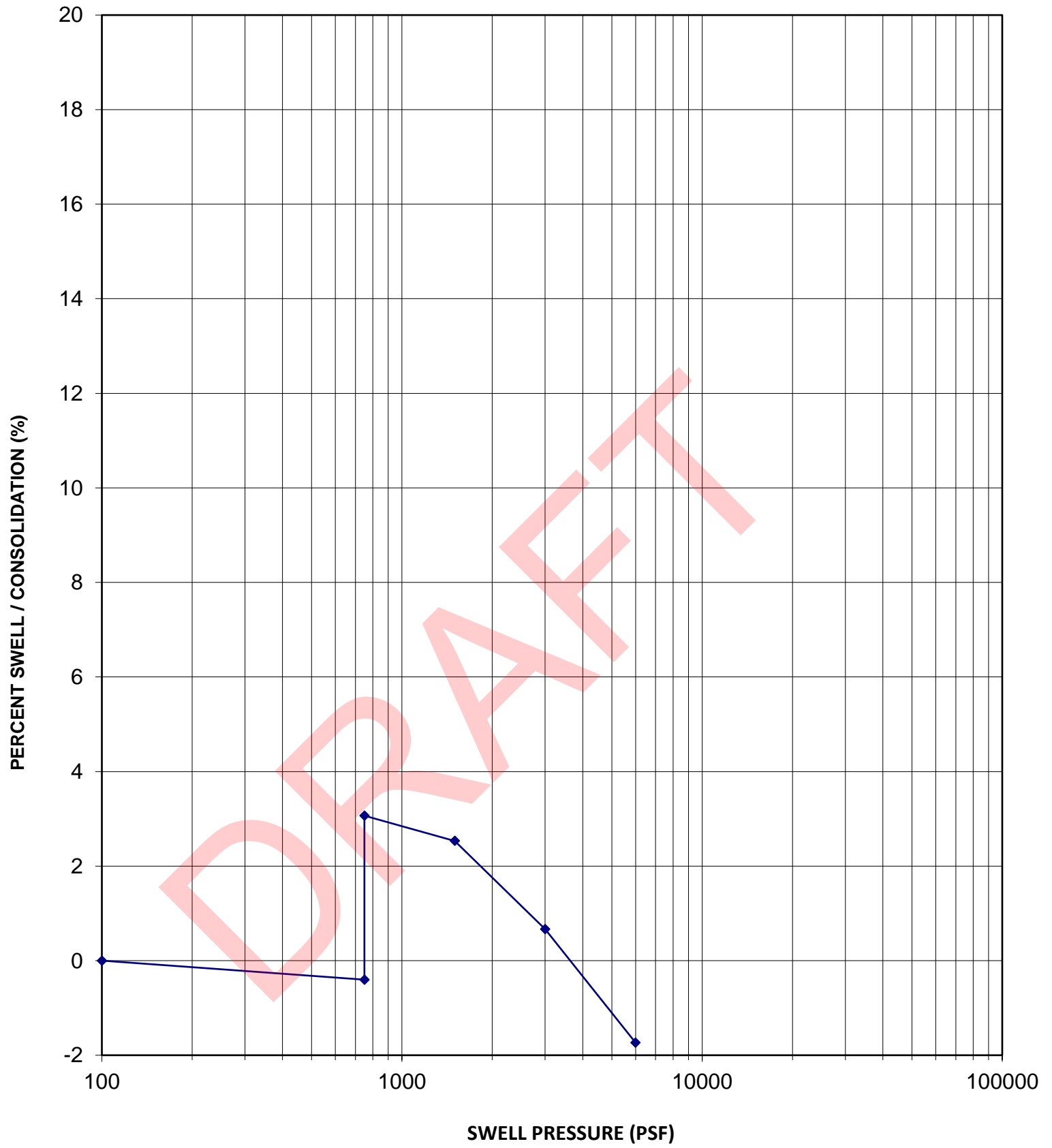

Sample Location	B2
Sample Depth	7.5 feet
Sample Description	Apparent Fill
USCS Classification	

Dry Density	110 pcf
In-Situ Moisture Content	15.8 %
Volume Change	3.5 %
Swell Pressure	4,100 psf



TRes Venetucci Multifamily

JOB NO.

5322879

SWELL - CONSOLIDATION TEST

FIGURE NO.

A3

SWELL-CONSOLIDATION TEST

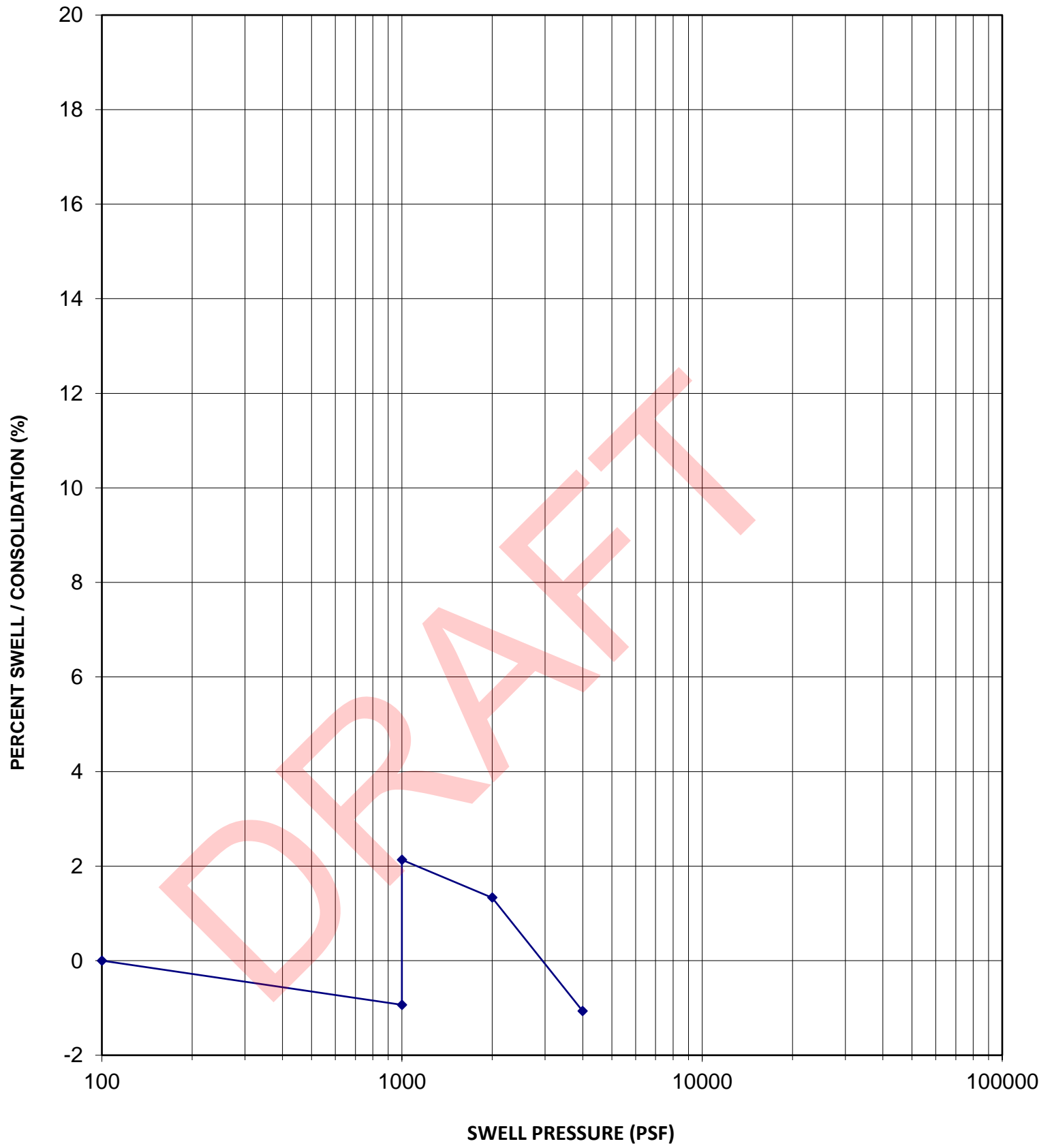

Sample Location	B2
Sample Depth	10 feet
Sample Description	Bedrock
USCS Classification	

Dry Density	114 pcf
In-Situ Moisture Content	10.7 %
Volume Change	3.1 %
Swell Pressure	3,800 psf



TRes Venetucci Multifamily

JOB NO.

5322879

SWELL - CONSOLIDATION TEST

FIGURE NO.

A4

SWELL-CONSOLIDATION TEST

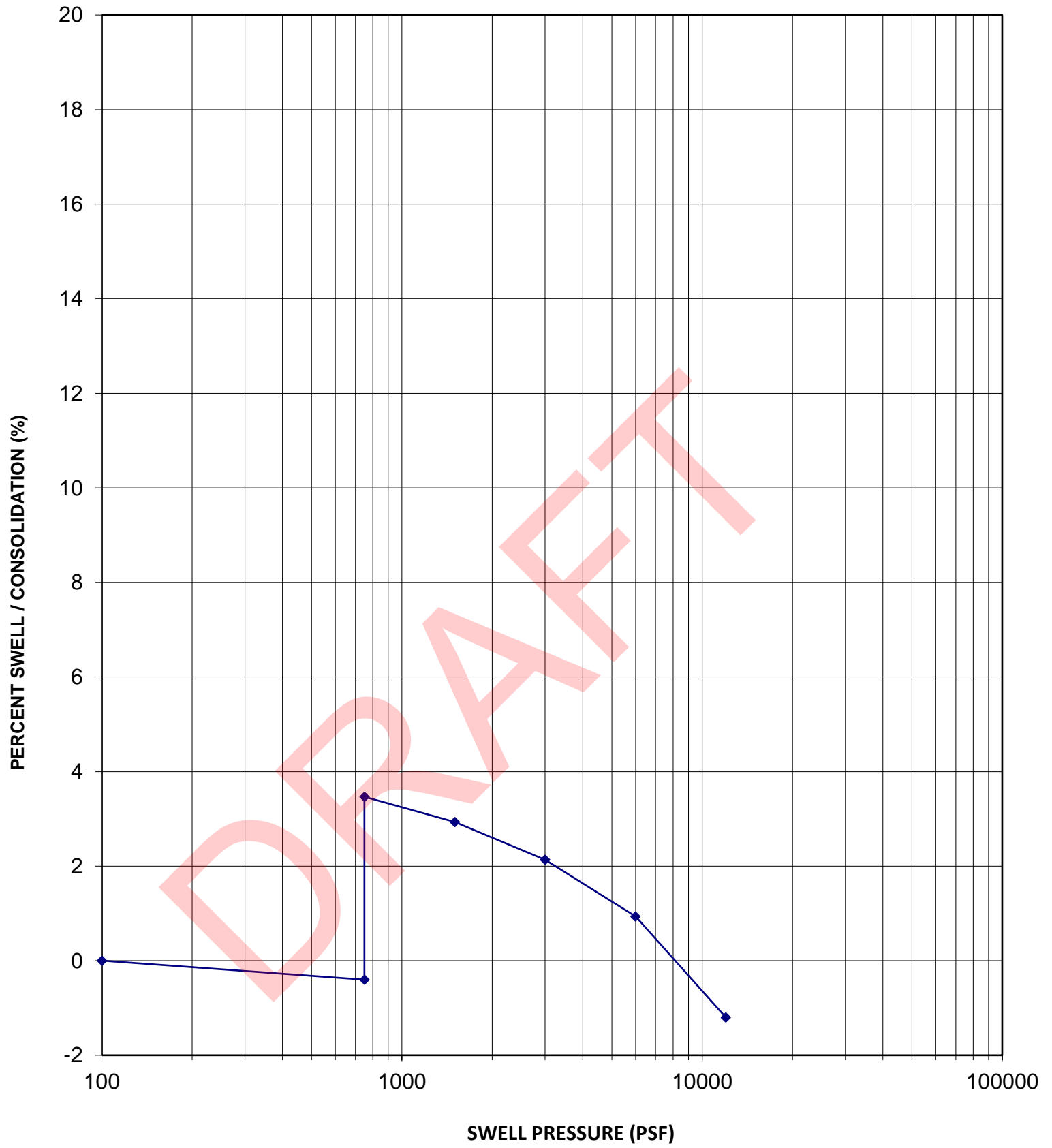

Sample Location	B3
Sample Depth	7.5 feet
Sample Description	Bedrock
USCS Classification	

Dry Density	122 pcf
In-Situ Moisture Content	15.1 %
Volume Change	3.9 %
Swell Pressure	9,300 psf



TRes Venetucci Multifamily

JOB NO. 5322879

SWELL - CONSOLIDATION TEST

FIGURE NO. A5

SWELL-CONSOLIDATION TEST

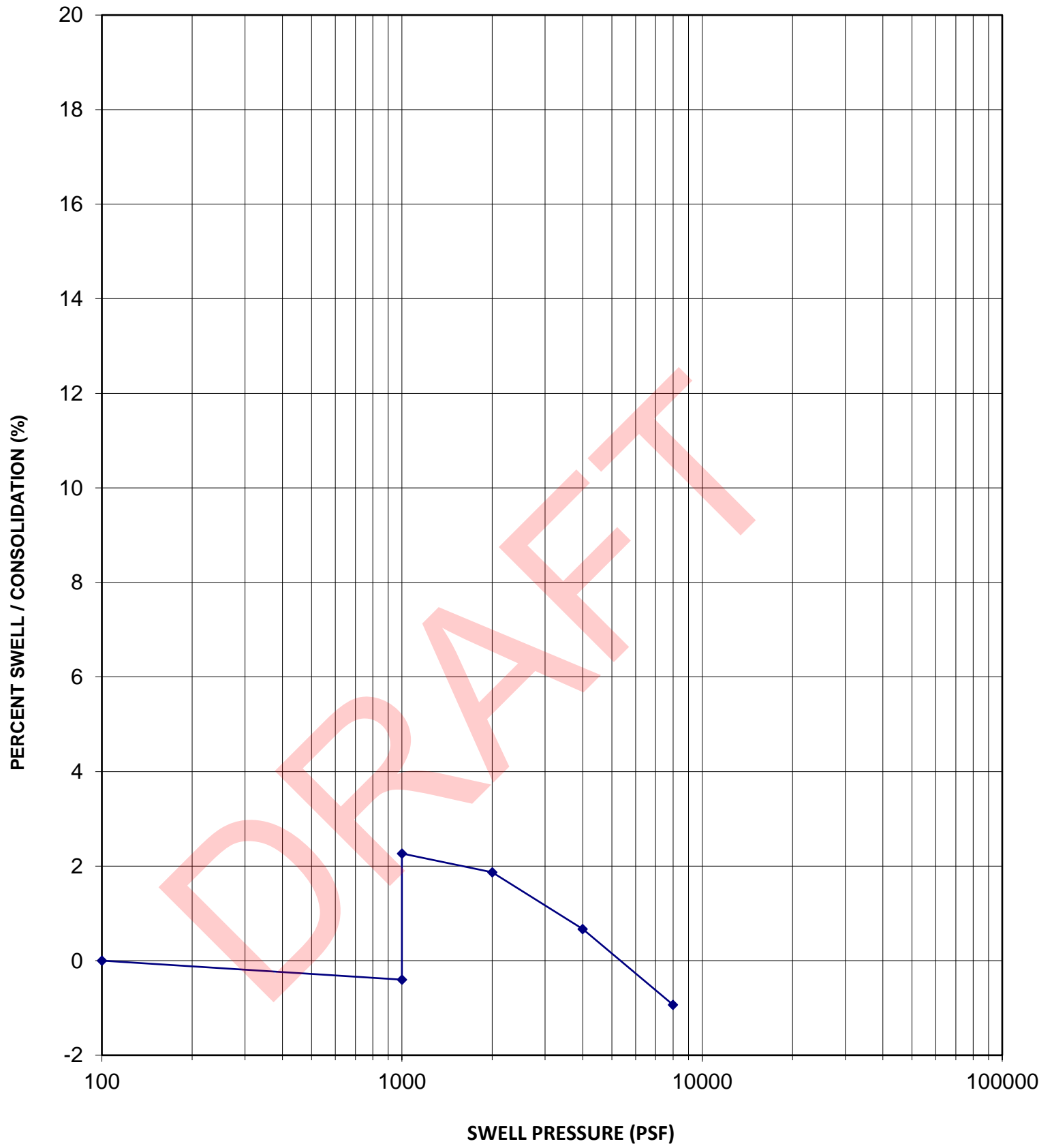

Sample Location	B3
Sample Depth	10 feet
Sample Description	Bedrock
USCS Classification	

Dry Density	112 pcf
In-Situ Moisture Content	16.8 %
Volume Change	2.7 %
Swell Pressure	6,300 psf



TRes Venetucci Multifamily

JOB NO. 5322879

SWELL - CONSOLIDATION TEST

FIGURE NO. A6

SWELL-CONSOLIDATION TEST

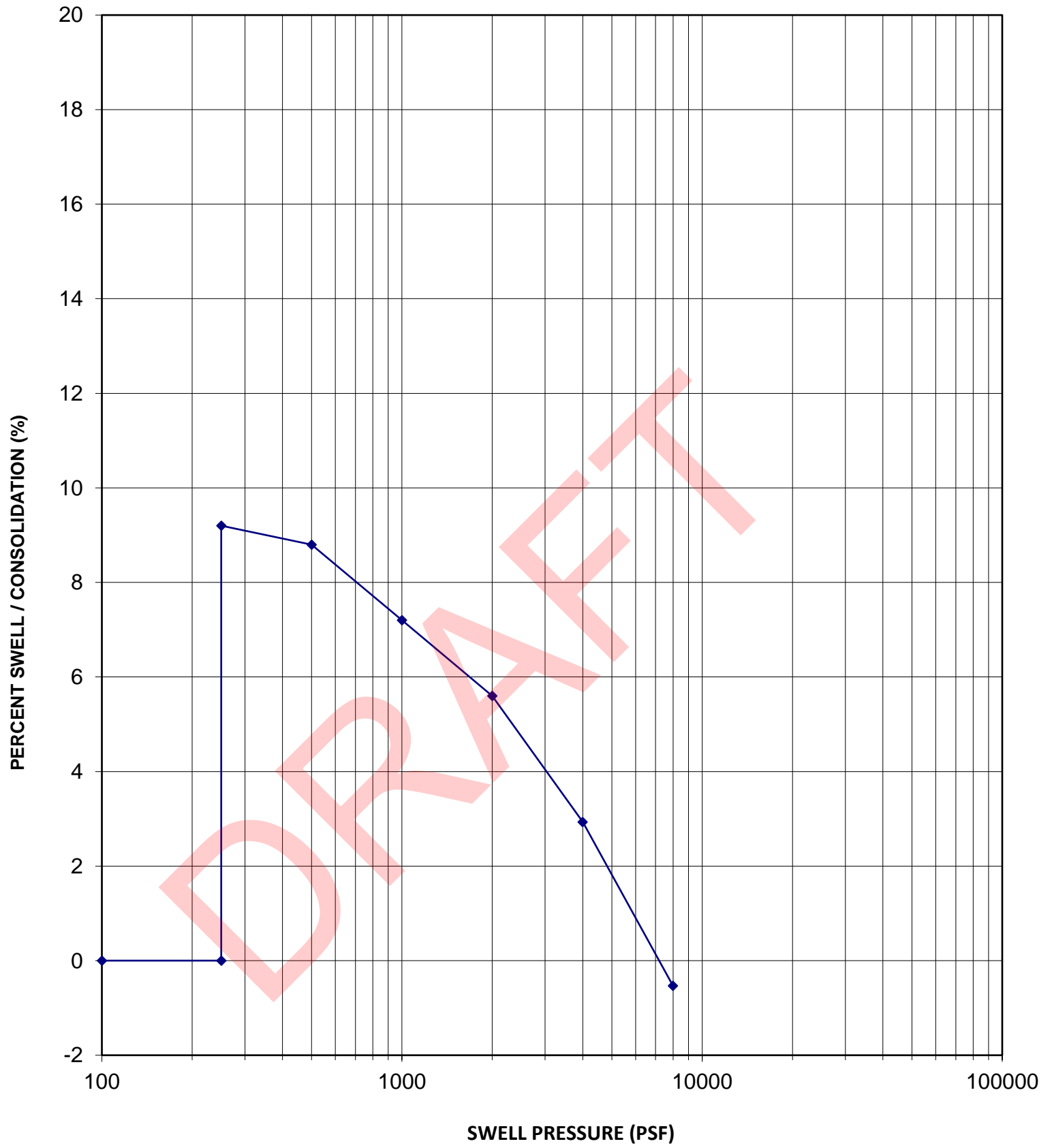

Sample Location	B4
Sample Depth	2.5 feet
Sample Description	Bedrock
USCS Classification	

Dry Density	109 pcf
In-Situ Moisture Content	22.9 %
Volume Change	9.2 %
Swell Pressure	7,200 psf



TRes Venetucci Multifamily

JOB NO.

5322879

SWELL - CONSOLIDATION TEST

FIGURE NO.

A7

SWELL-CONSOLIDATION TEST

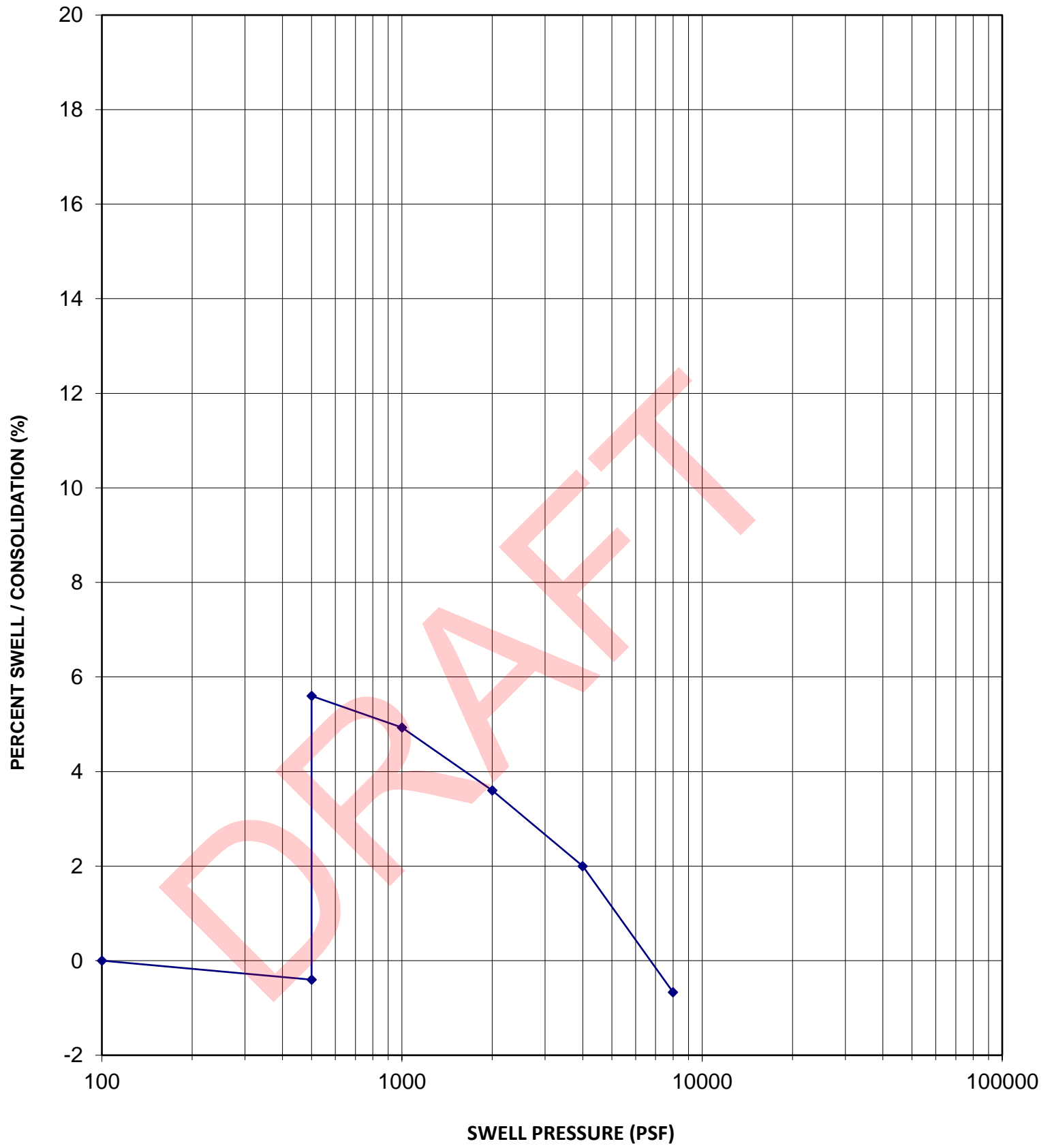

Sample Location	B5
Sample Depth	5 feet
Sample Description	Bedrock
USCS Classification	

Dry Density	113 pcf
In-Situ Moisture Content	13.6 %
Volume Change	6.0 %
Swell Pressure	7,500 psf



TRes Venetucci Multifamily

JOB NO.

5322879

SWELL - CONSOLIDATION TEST

FIGURE NO.

A8

SWELL-CONSOLIDATION TEST

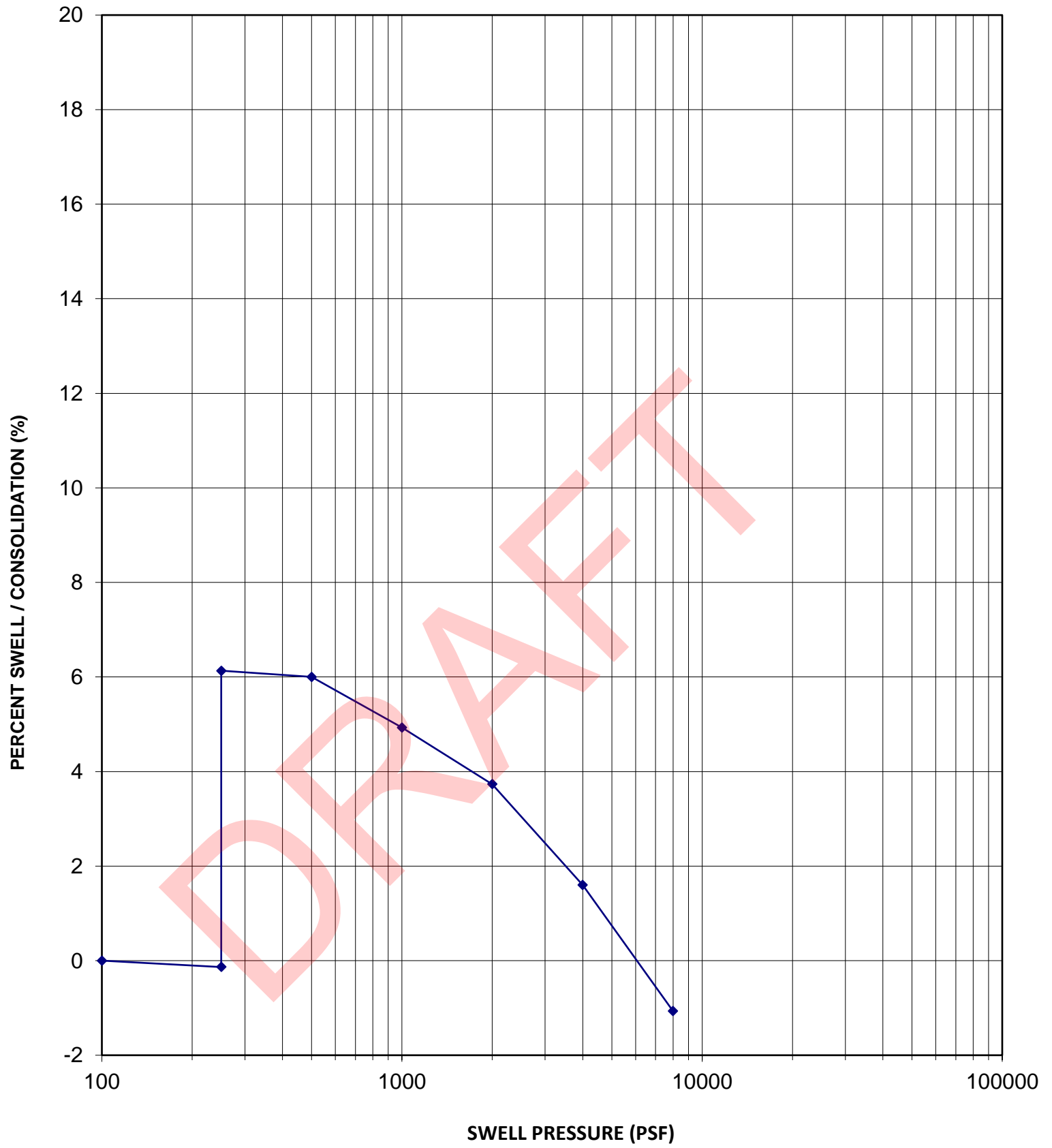

Sample Location	B6
Sample Depth	5 feet
Sample Description	Bedrock
USCS Classification	

Dry Density	104 pcf
In-Situ Moisture Content	20.5 %
Volume Change	6.3 %
Swell Pressure	6,300 psf



TRes Venetucci Multifamily

JOB NO. 5322879

SWELL - CONSOLIDATION TEST

FIGURE NO. A9

SWELL-CONSOLIDATION TEST

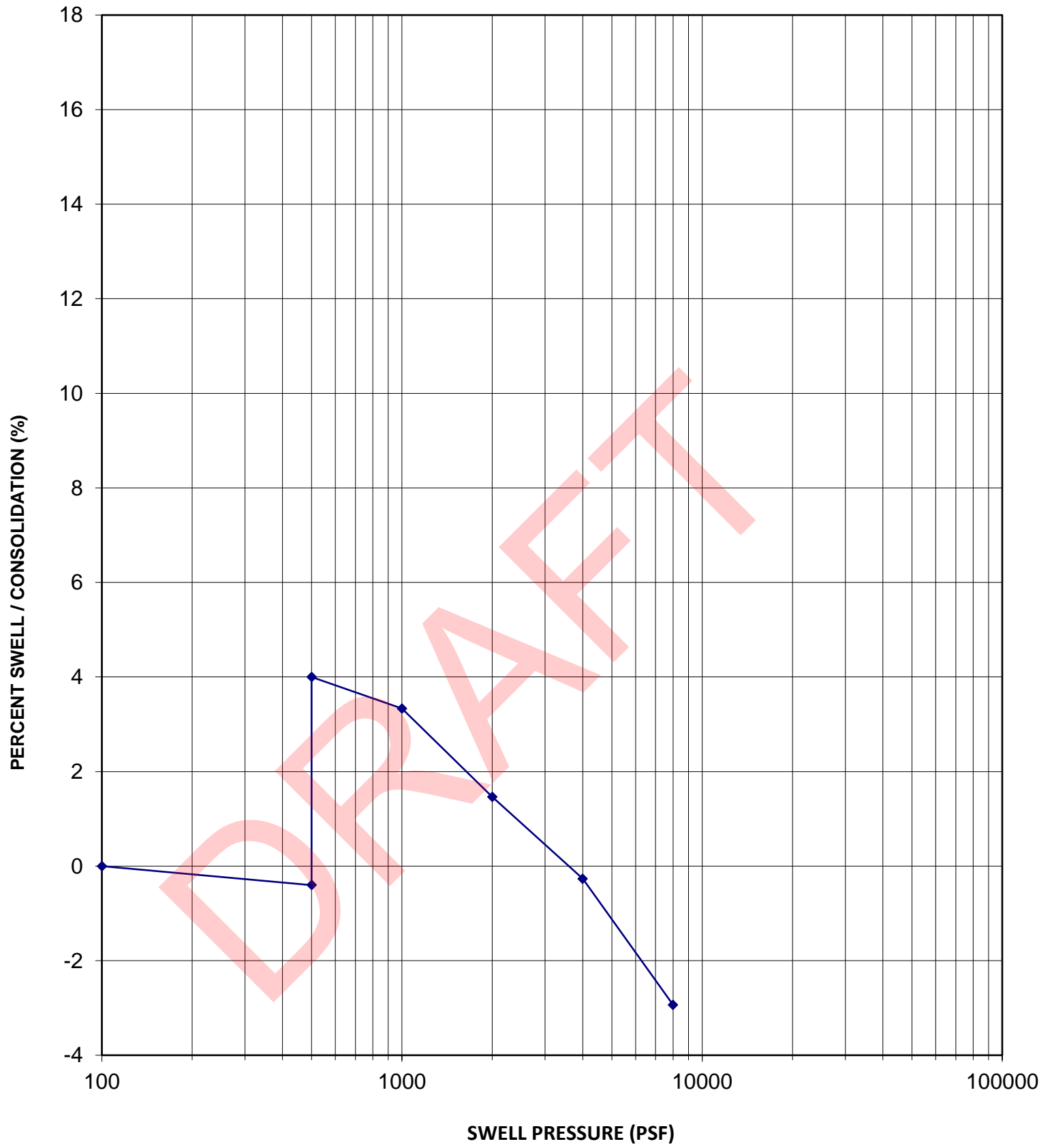

Sample Location	B6
Sample Depth	7.5 feet
Sample Description	Bedrock
USCS Classification	

Dry Density	110 pcf
In-Situ Moisture Content	15.2 %
Volume Change	4.4 %
Swell Pressure	4,100 psf



TRes Venetucci Multifamily

JOB NO.

5322879

SWELL - CONSOLIDATION TEST

FIGURE NO.

A10

SWELL-CONSOLIDATION TEST

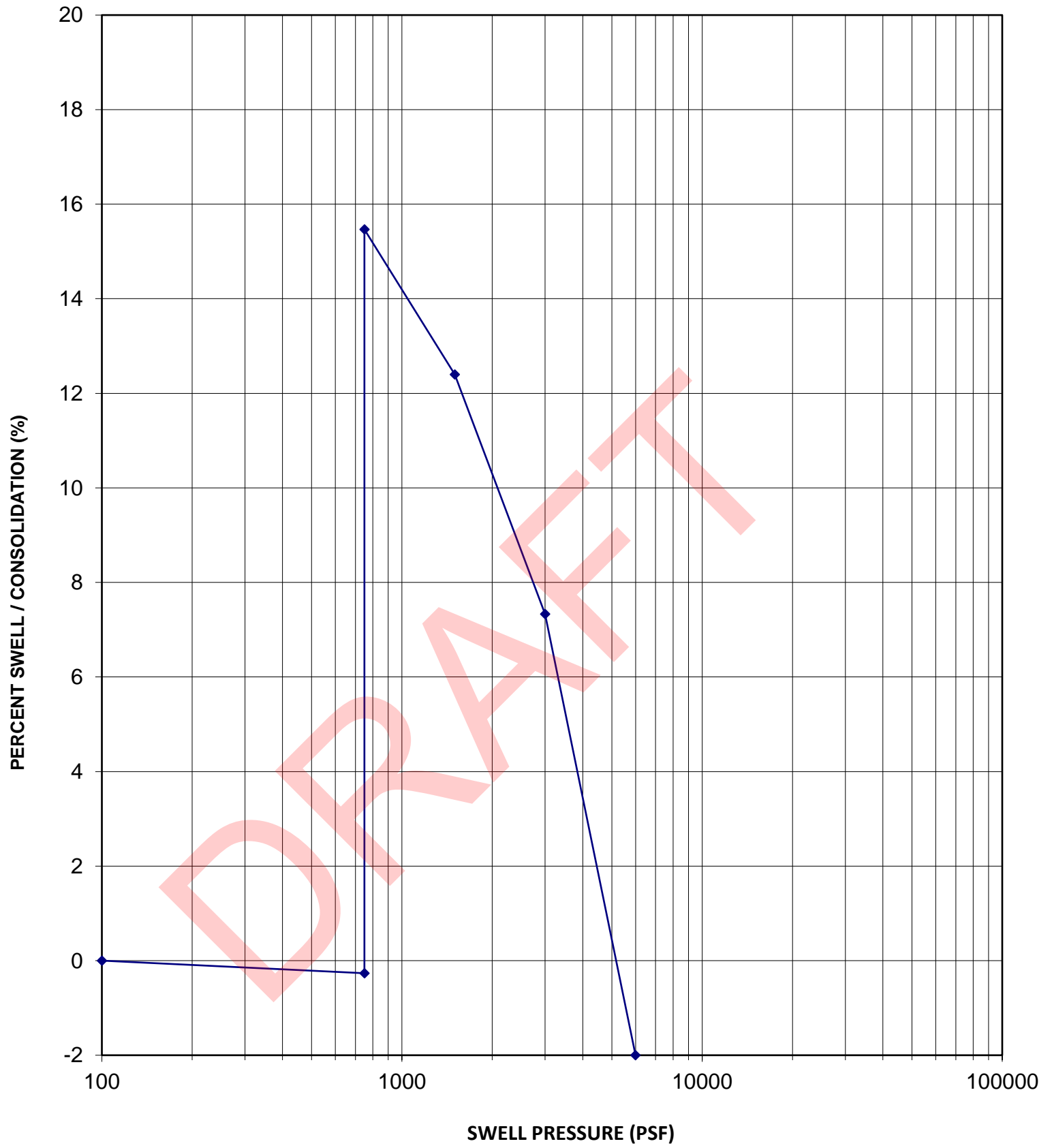

Sample Location	B8
Sample Depth	7.5 feet
Sample Description	Bedrock
USCS Classification	

Dry Density	101 pcf
In-Situ Moisture Content	12.7 %
Volume Change	15.7 %
Swell Pressure	5,300 psf



TRes Venetucci Multifamily

JOB NO. 5322879

SWELL - CONSOLIDATION TEST

FIGURE NO. A11

SWELL-CONSOLIDATION TEST

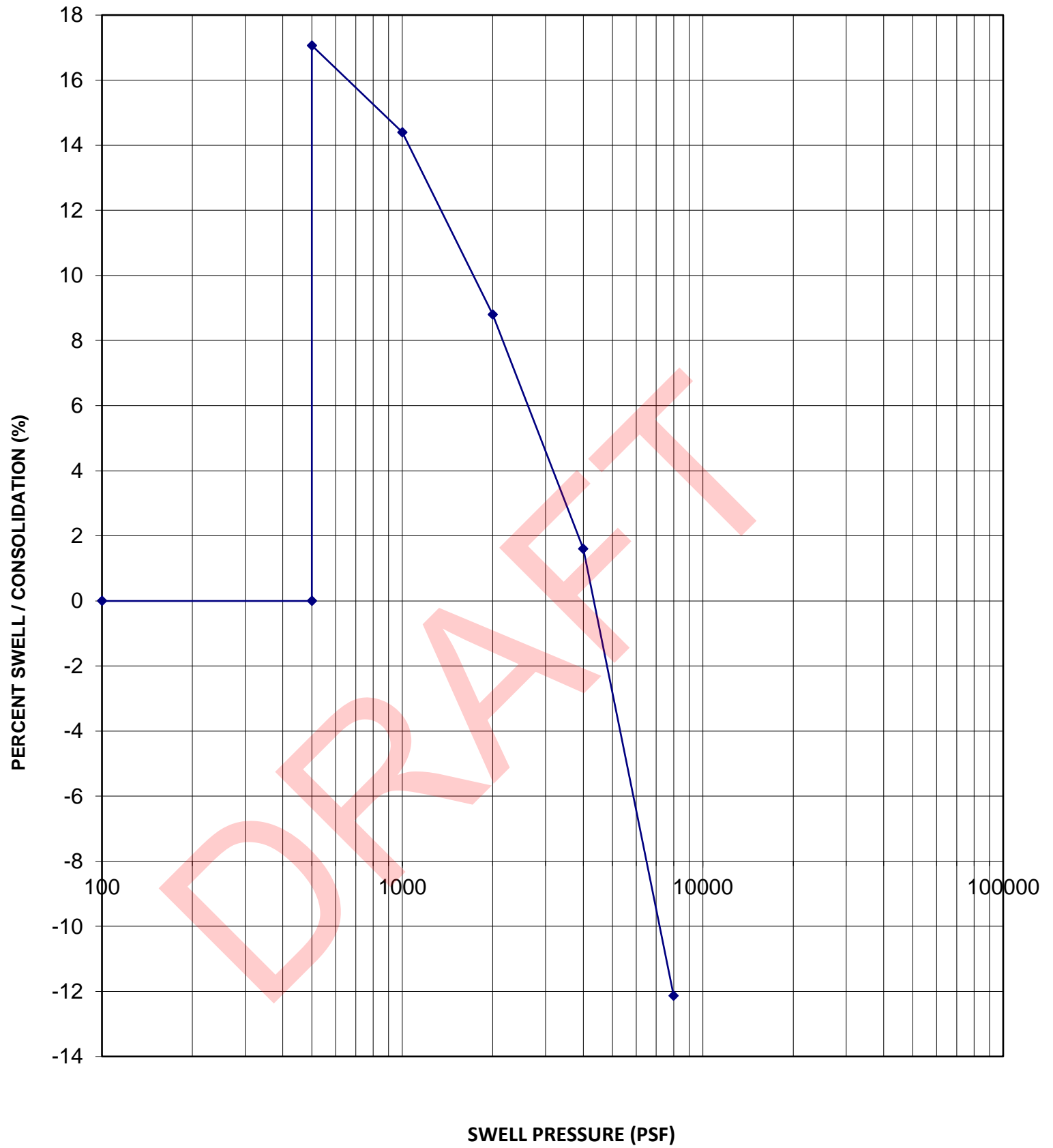

Sample Location	B9
Sample Depth	5 feet
Sample Description	Bedrock
USCS Classification	

Dry Density	97 pcf
In-Situ Moisture Content	12.2 %
Volume Change	17.1 %
Swell Pressure	4,300 psf



TRes Venetucci Multifamily
SWELL - CONSOLIDATION TEST

JOB NO. 5322879
FIGURE NO. A12

SWELL-CONSOLIDATION TEST

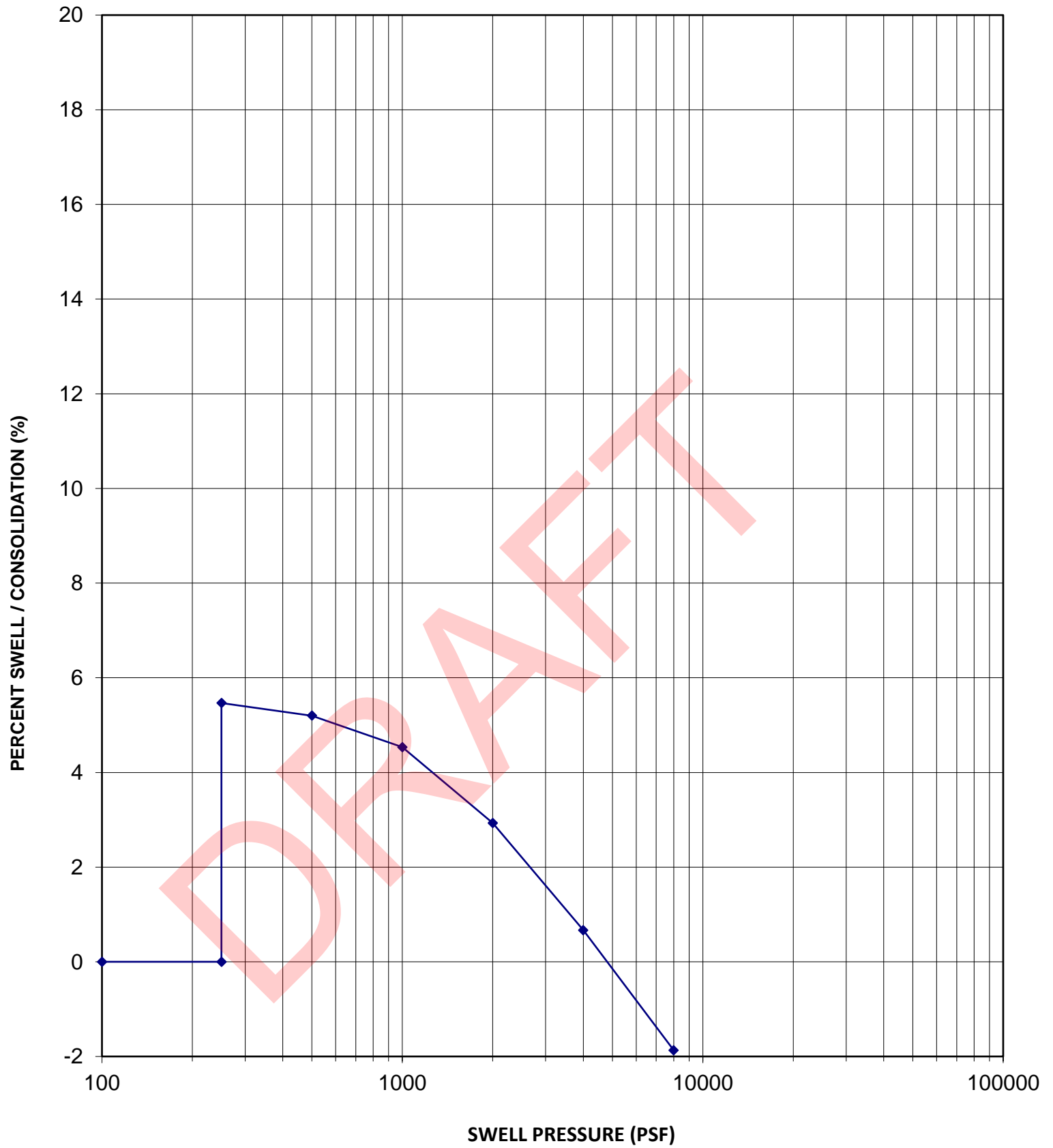

Sample Location	B10
Sample Depth	2.5 feet
Sample Description	Clay
USCS Classification	CH

Dry Density	109 pcf
In-Situ Moisture Content	18.6 %
Volume Change	5.5 %
Swell Pressure	4,800 psf



TRes Venetucci Multifamily

JOB NO. 5322879

SWELL - CONSOLIDATION TEST

FIGURE NO. A13

SWELL-CONSOLIDATION TEST

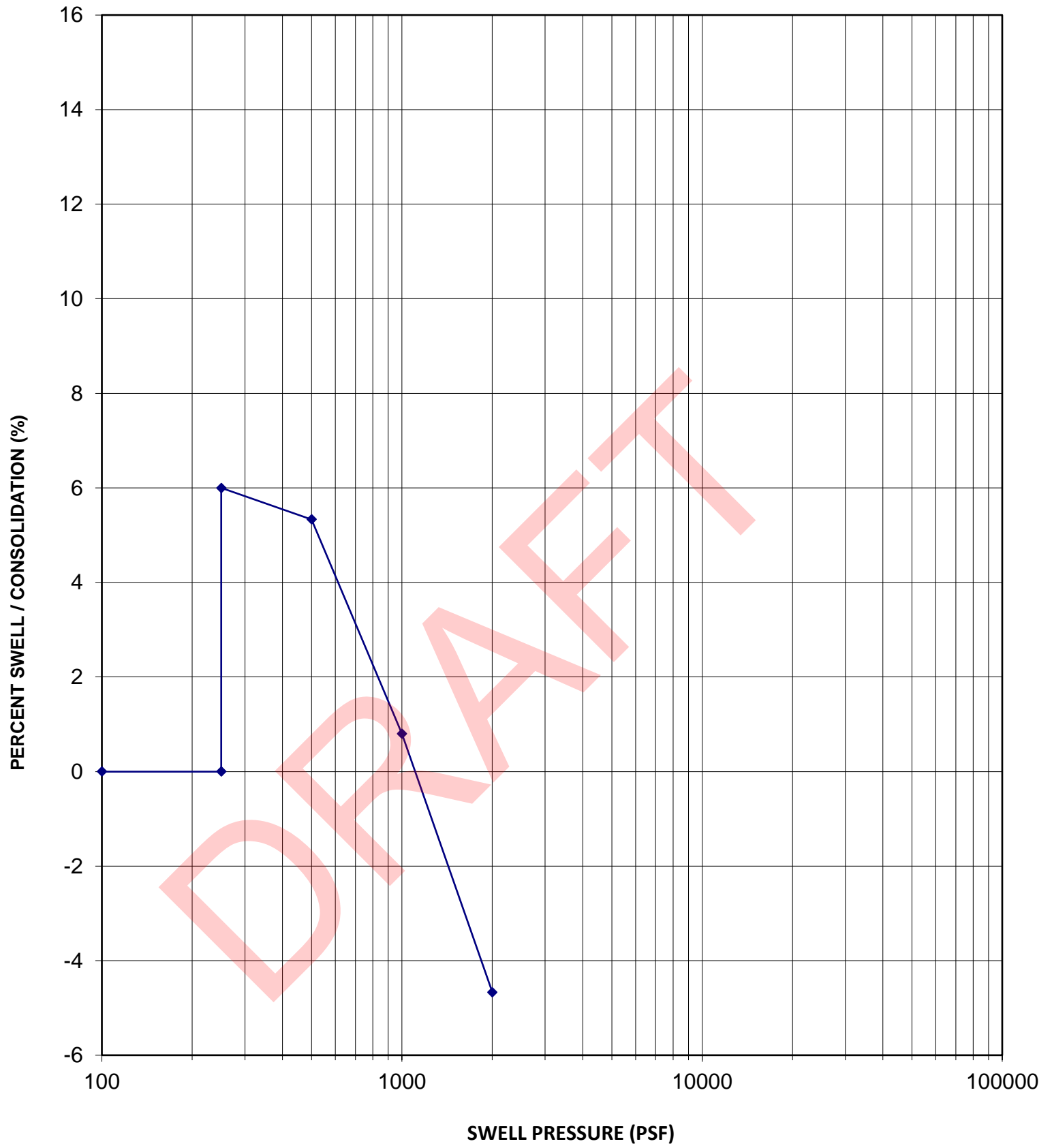

Sample Location	B10
Sample Depth	5 feet
Sample Description	Bedrock
USCS Classification	

Dry Density	92 pcf
In-Situ Moisture Content	13.0 %
Volume Change	6.0 %
Swell Pressure	1,100 psf



TRes Venetucci Multifamily

JOB NO. 5322879

SWELL - CONSOLIDATION TEST

FIGURE NO. A14

SWELL-CONSOLIDATION TEST

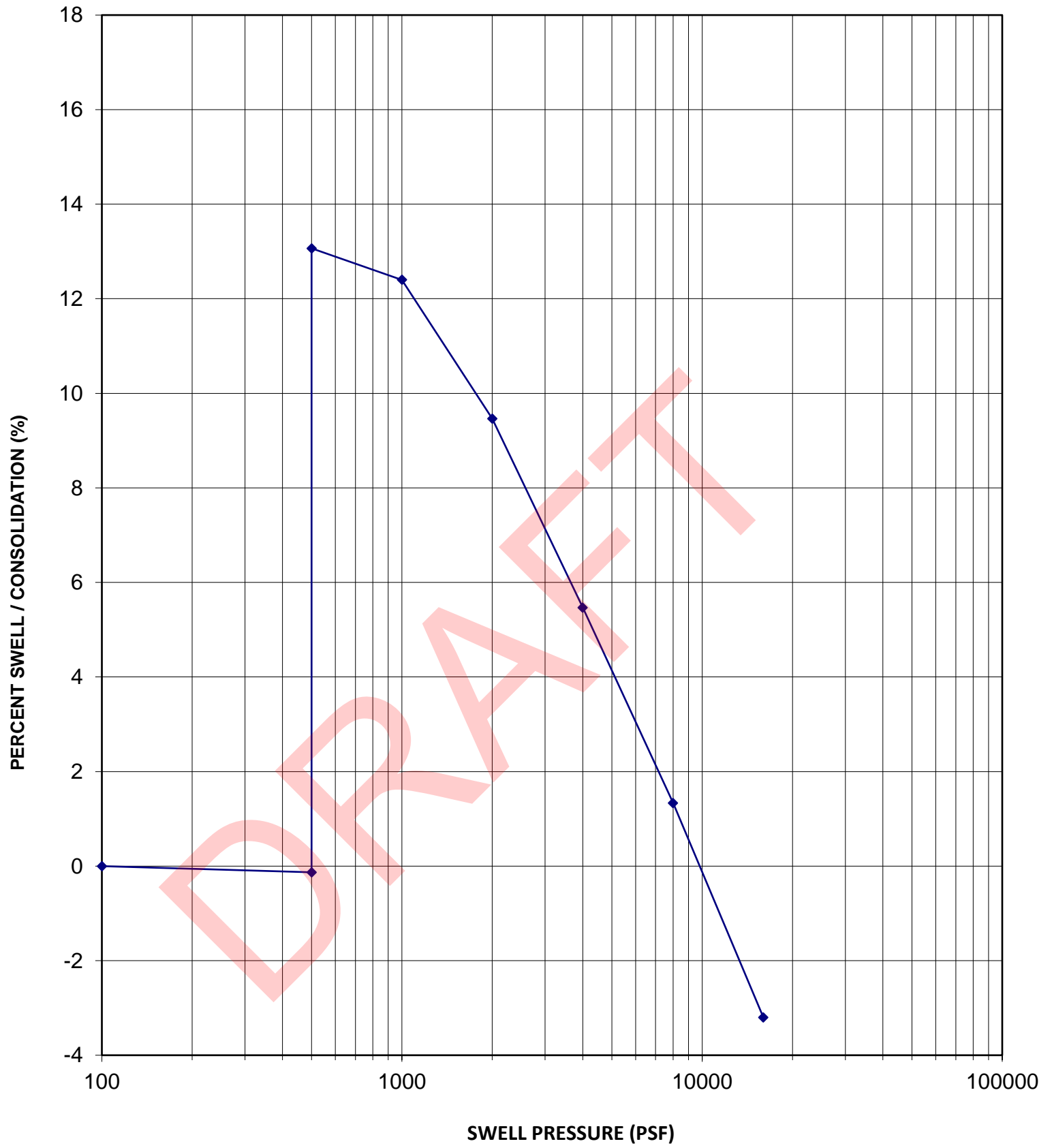

Sample Location	B10
Sample Depth	7.5 feet
Sample Description	Bedrock
USCS Classification	

Dry Density	115 pcf
In-Situ Moisture Content	13.2 %
Volume Change	13.2 %
Swell Pressure	10,000 psf



TRes Venetucci Multifamily

JOB NO. 5322879

SWELL - CONSOLIDATION TEST

FIGURE NO. A15

SWELL-CONSOLIDATION TEST

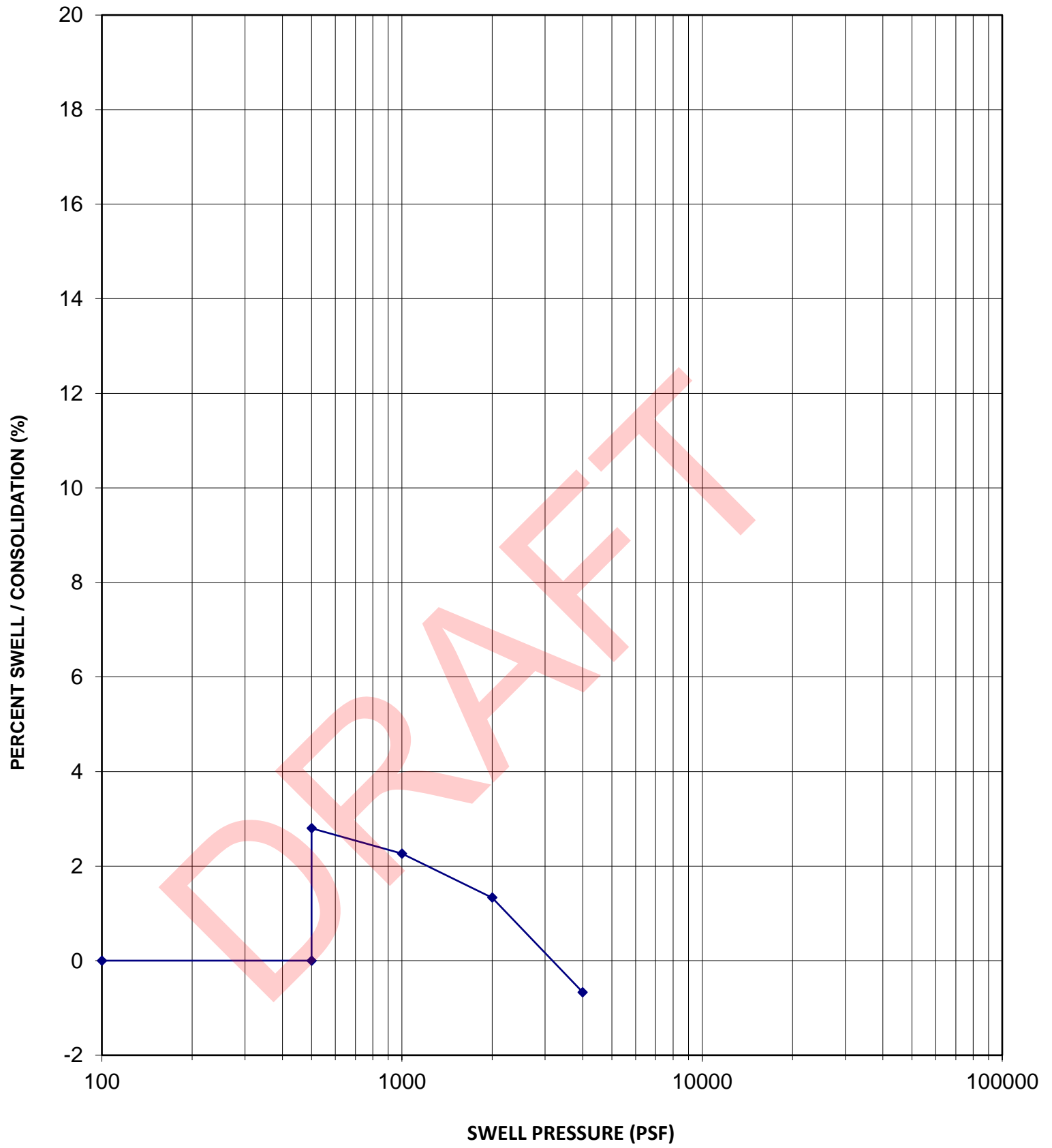

Sample Location	B11
Sample Depth	5 feet
Sample Description	Bedrock
USCS Classification	

Dry Density	119 pcf
In-Situ Moisture Content	9.6 %
Volume Change	2.8 %
Swell Pressure	3,200 psf



TTRes Venetucci Multifamily

JOB NO. 5322879

SWELL - CONSOLIDATION TEST

FIGURE NO. A16

SWELL-CONSOLIDATION TEST

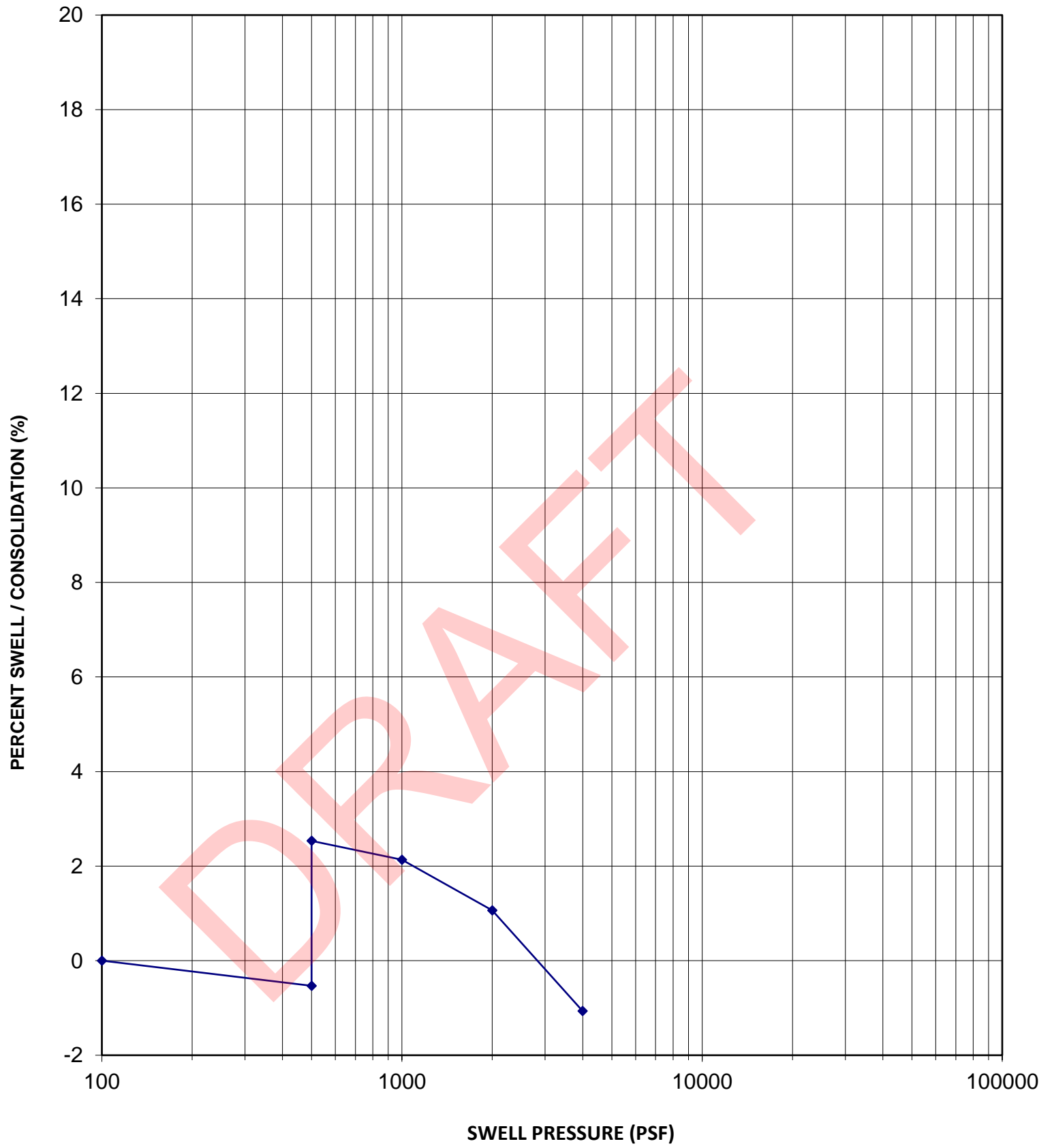

Sample Location	B12
Sample Depth	5 feet
Sample Description	Bedrock
USCS Classification	

Dry Density	111 pcf
In-Situ Moisture Content	11.6 %
Volume Change	3.1 %
Swell Pressure	3,400 psf



TRes Venetucci Multifamily

JOB NO. 5322879

SWELL - CONSOLIDATION TEST

FIGURE NO. A17

SWELL-CONSOLIDATION TEST

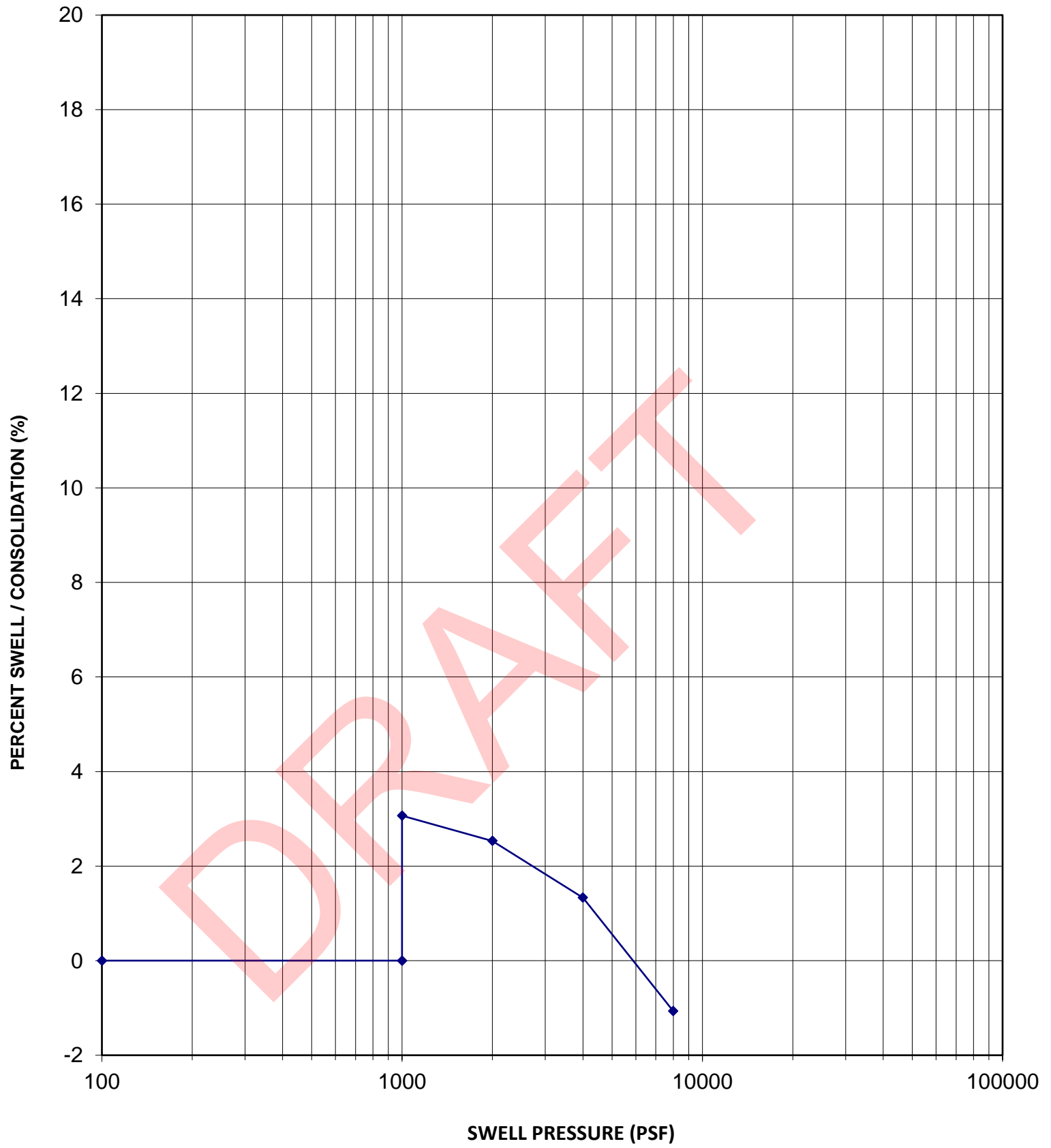

Sample Location	B12
Sample Depth	10 feet
Sample Description	Bedrock
USCS Classification	

Dry Density	112 pcf
In-Situ Moisture Content	13.2 %
Volume Change	3.1 %
Swell Pressure	5,900 psf



TRes Venetucci Multifamily

JOB NO.

5322879

SWELL - CONSOLIDATION TEST

FIGURE NO.

A18

SWELL-CONSOLIDATION TEST

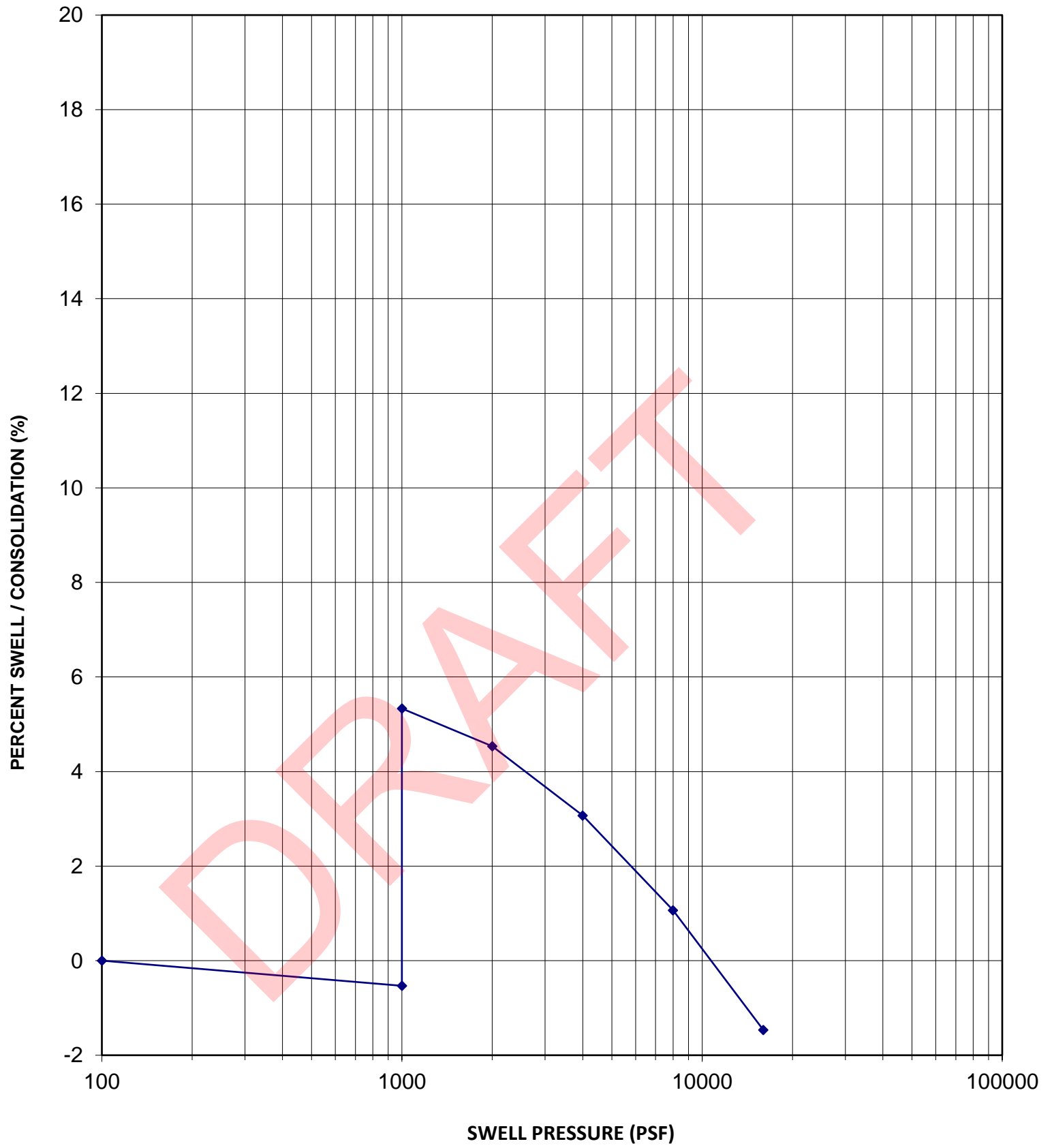

Sample Location	B13
Sample Depth	15 feet
Sample Description	Bedrock
USCS Classification	

Dry Density	111 pcf
In-Situ Moisture Content	18.7 %
Volume Change	5.9 %
Swell Pressure	12,400 psf



TTRes Venetucci Multifamily

JOB NO.

5322879

SWELL - CONSOLIDATION TEST

FIGURE NO.

A19

SWELL-CONSOLIDATION TEST

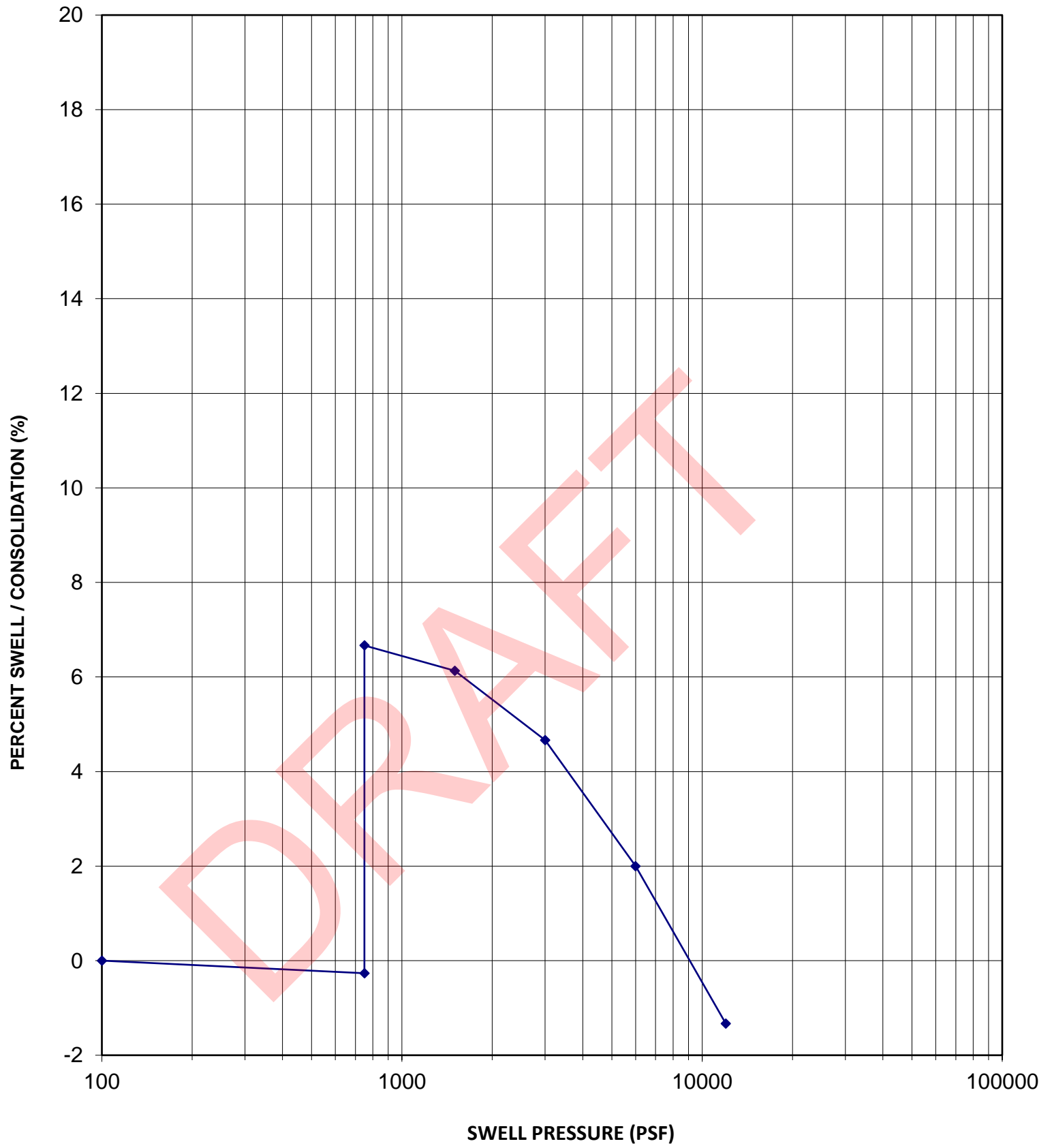

Sample Location	B14
Sample Depth	7.5 feet
Sample Description	Bedrock
USCS Classification	

Dry Density	109 pcf
In-Situ Moisture Content	21.6 %
Volume Change	6.9 %
Swell Pressure	9,600 psf



TRes Venetucci Multifamily

JOB NO.

5322879

SWELL - CONSOLIDATION TEST

FIGURE NO.

A20

SWELL-CONSOLIDATION TEST

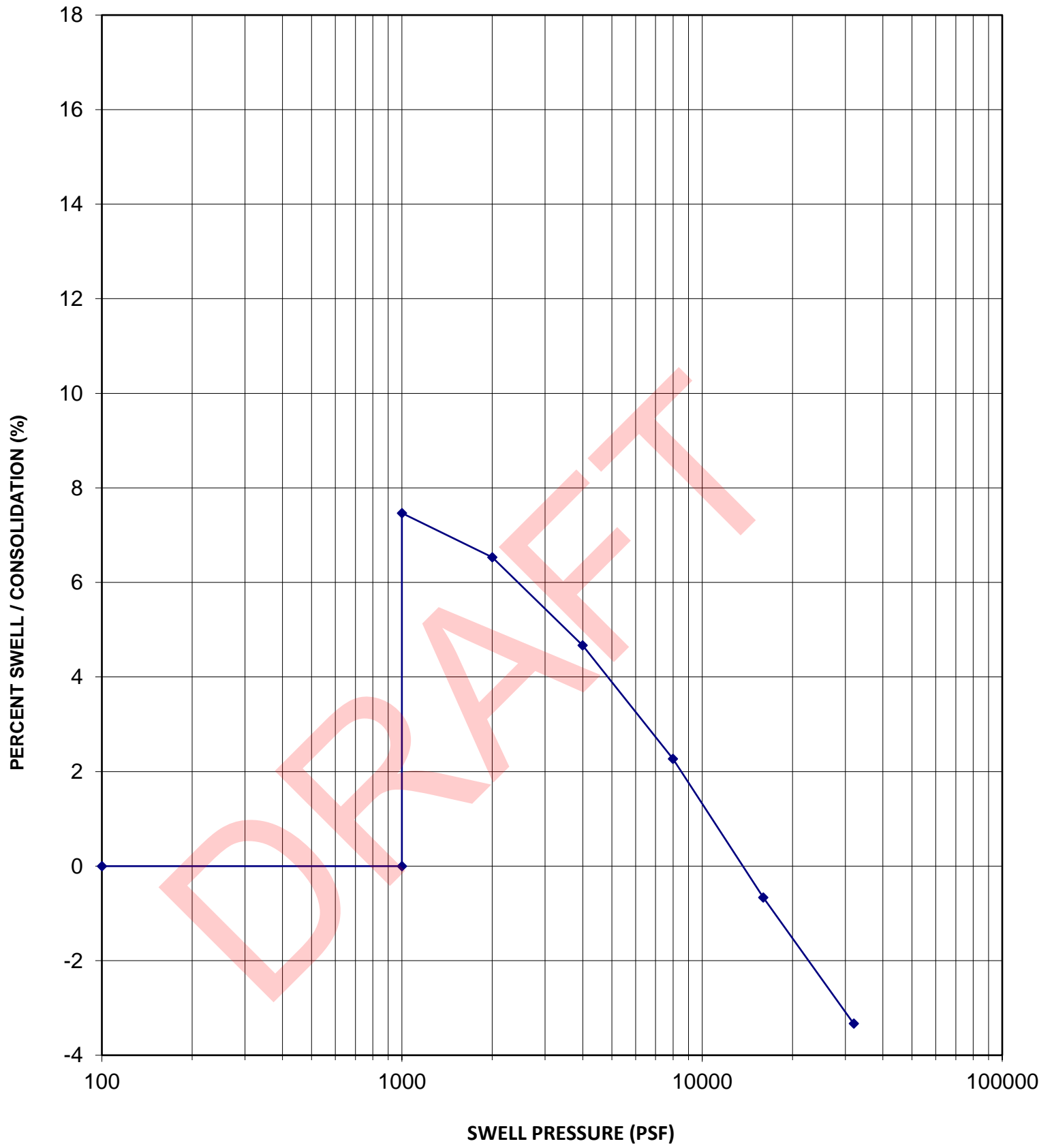

Sample Location	B14
Sample Depth	10 feet
Sample Description	Bedrock
USCS Classification	

Dry Density	110 pcf
In-Situ Moisture Content	20.3 %
Volume Change	7.5 %
Swell Pressure	13,700 psf



TRes Venetucci Multifamily

JOB NO. 5322879

SWELL - CONSOLIDATION TEST

FIGURE NO. A21

SWELL-CONSOLIDATION TEST

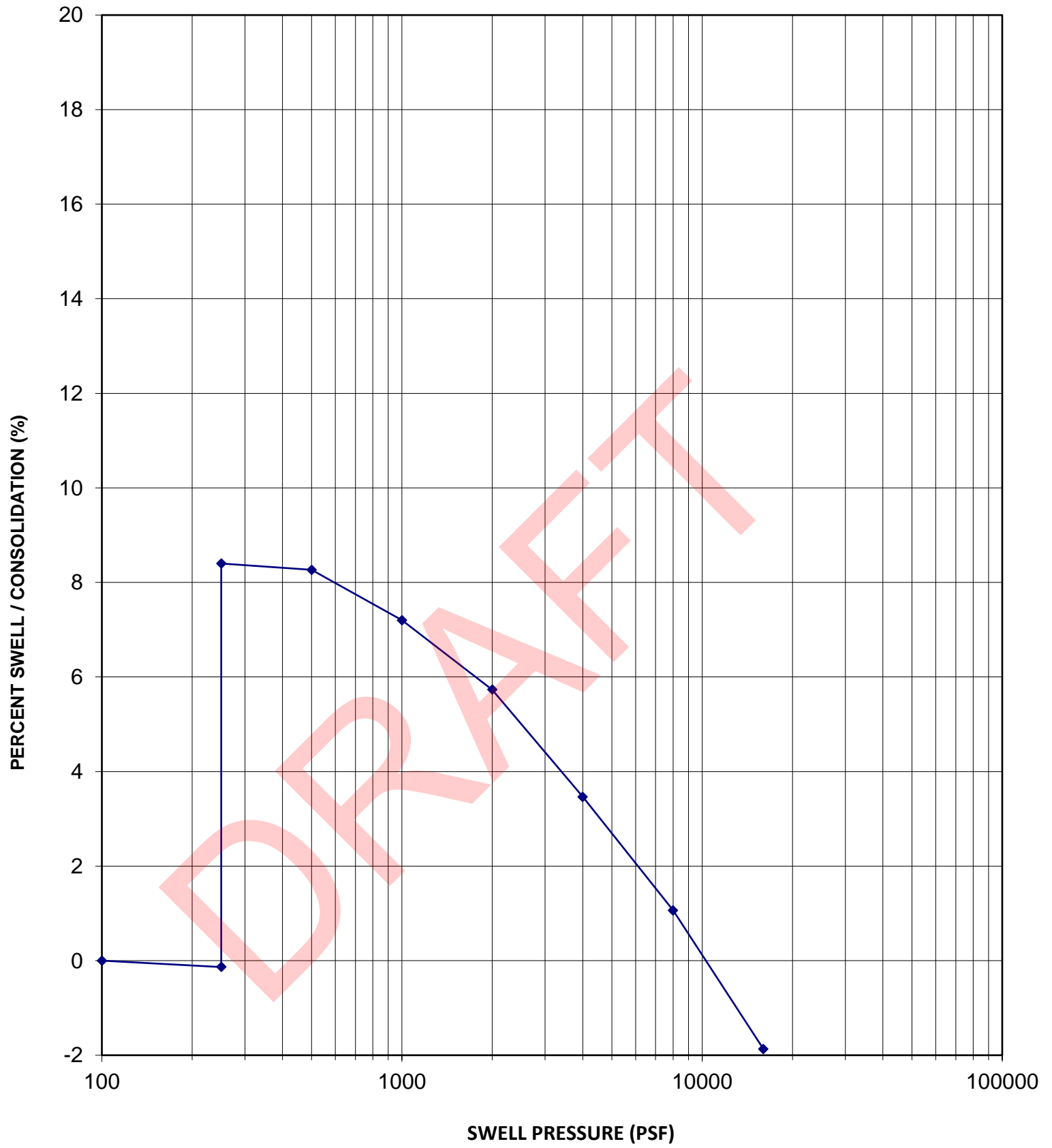

Sample Location	B16
Sample Depth	2.5 feet
Sample Description	Bedrock
USCS Classification	

Dry Density	109 pcf
In-Situ Moisture Content	20.1 %
Volume Change	8.5 %
Swell Pressure	10,600 psf



TRes Venetucci Multifamily

JOB NO. 5322879

SWELL - CONSOLIDATION TEST

FIGURE NO. A22

SWELL-CONSOLIDATION TEST

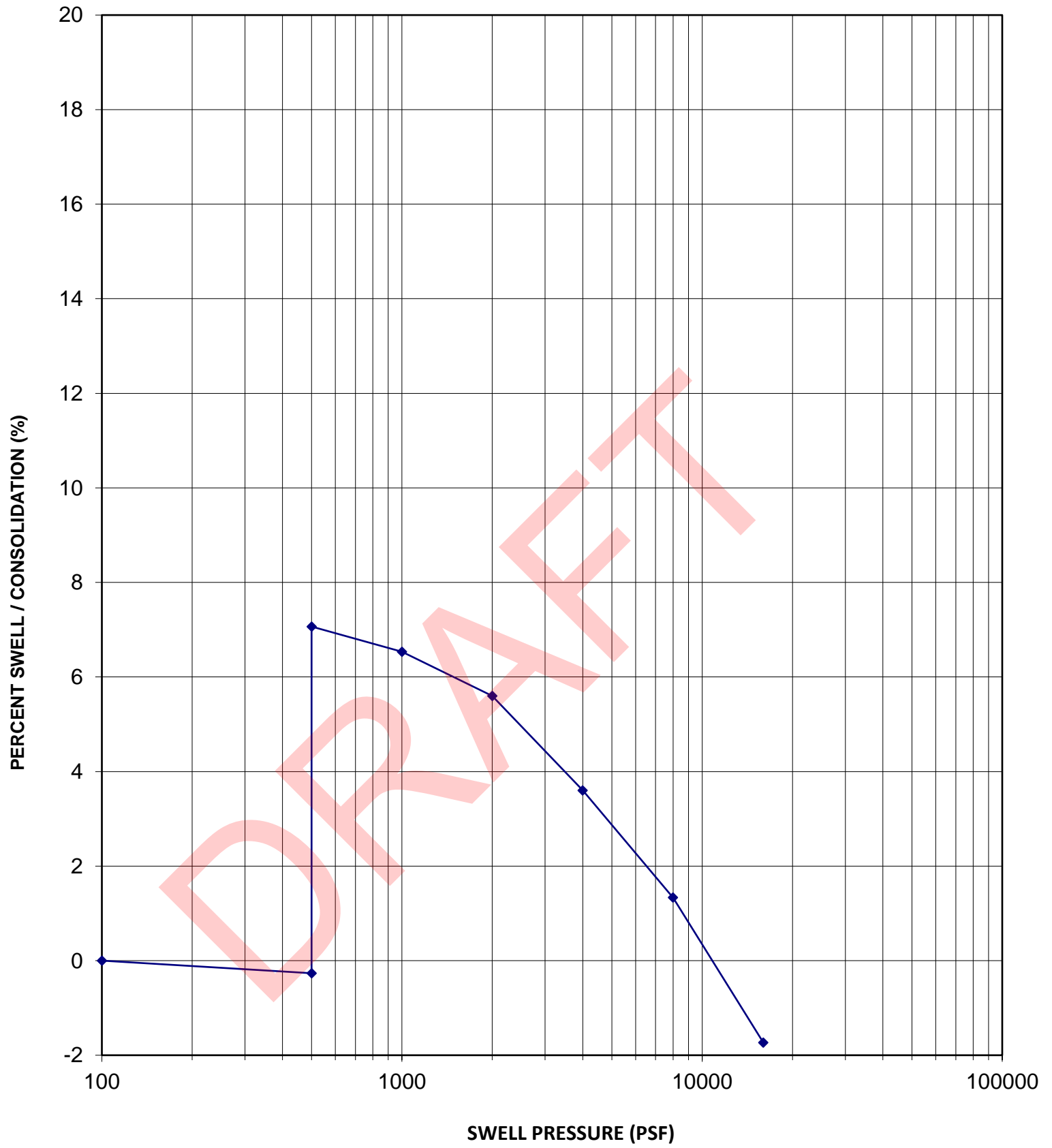

Sample Location	B16
Sample Depth	5 feet
Sample Description	Bedrock
USCS Classification	

Dry Density	122 pcf
In-Situ Moisture Content	14.2 %
Volume Change	7.3 %
Swell Pressure	11,500 psf



TRes Venetucci Multifamily

JOB NO. 5322879

SWELL - CONSOLIDATION TEST

FIGURE NO. A23

SWELL-CONSOLIDATION TEST

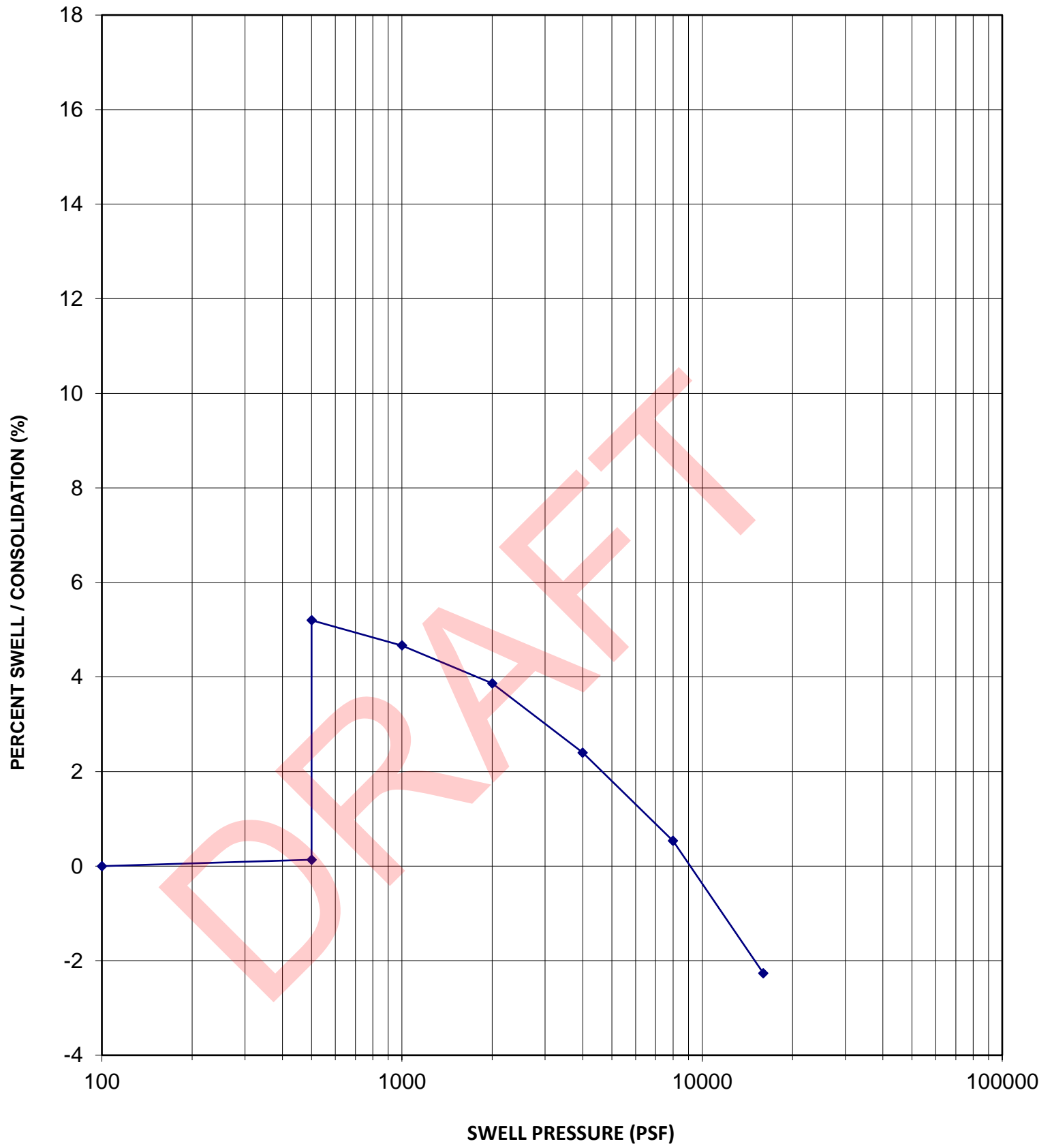

Sample Location	B27
Sample Depth	5 feet
Sample Description	Bedrock
USCS Classification	

Dry Density	115 pcf
In-Situ Moisture Content	19.0 %
Volume Change	5.1 %
Swell Pressure	8,800 psf



TTRes Venetucci Multifamily

JOB NO. 5322879

SWELL - CONSOLIDATION TEST

FIGURE NO. A24

SWELL-CONSOLIDATION TEST

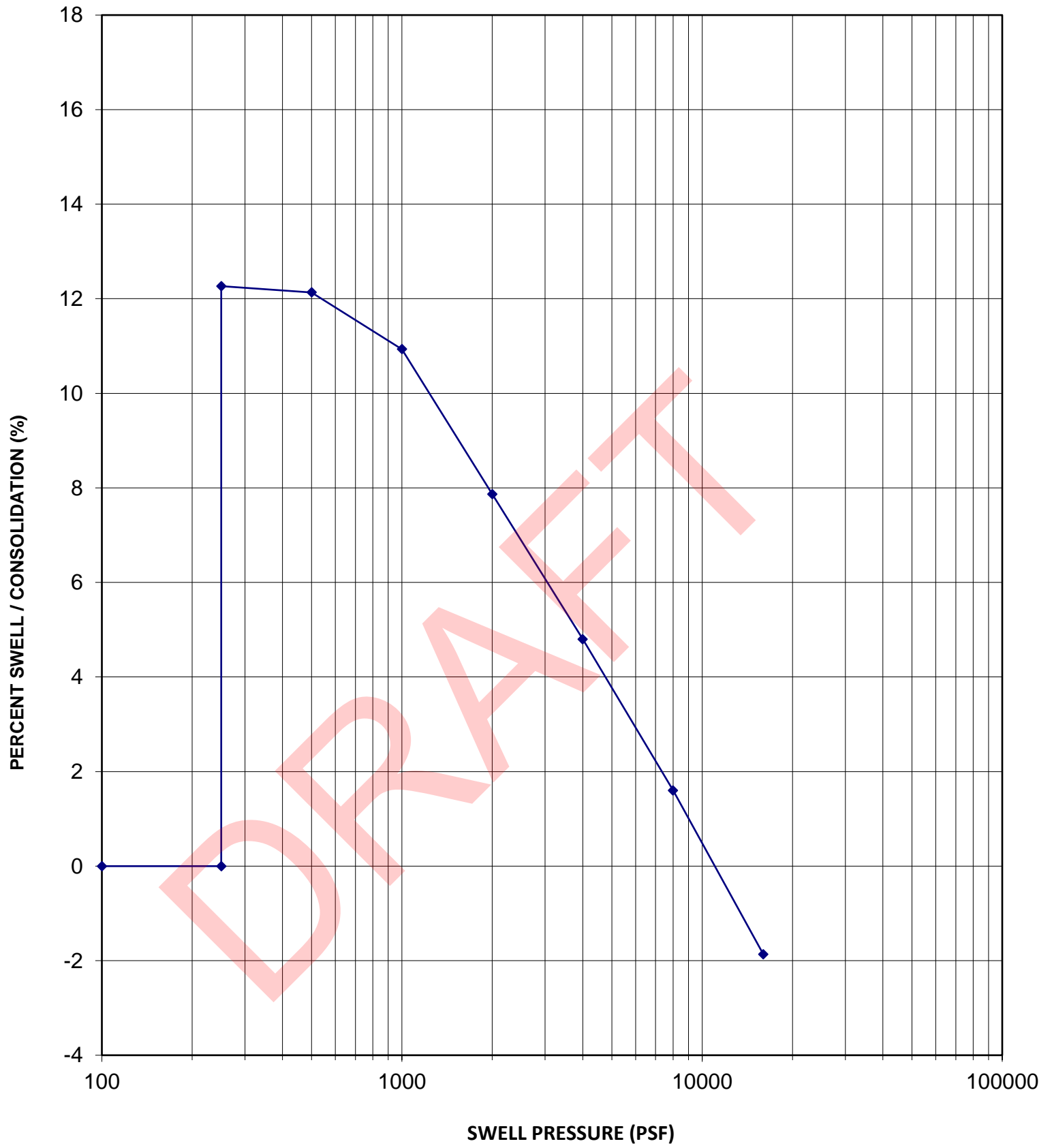

Sample Location	B18
Sample Depth	5 feet
Sample Description	Bedrock
USCS Classification	

Dry Density	113 pcf
In-Situ Moisture Content	15.3 %
Volume Change	12.3 %
Swell Pressure	11,000 psf



TRes Venetucci Multifamily

JOB NO.

5322879

SWELL - CONSOLIDATION TEST

FIGURE NO.

A25

SWELL-CONSOLIDATION TEST

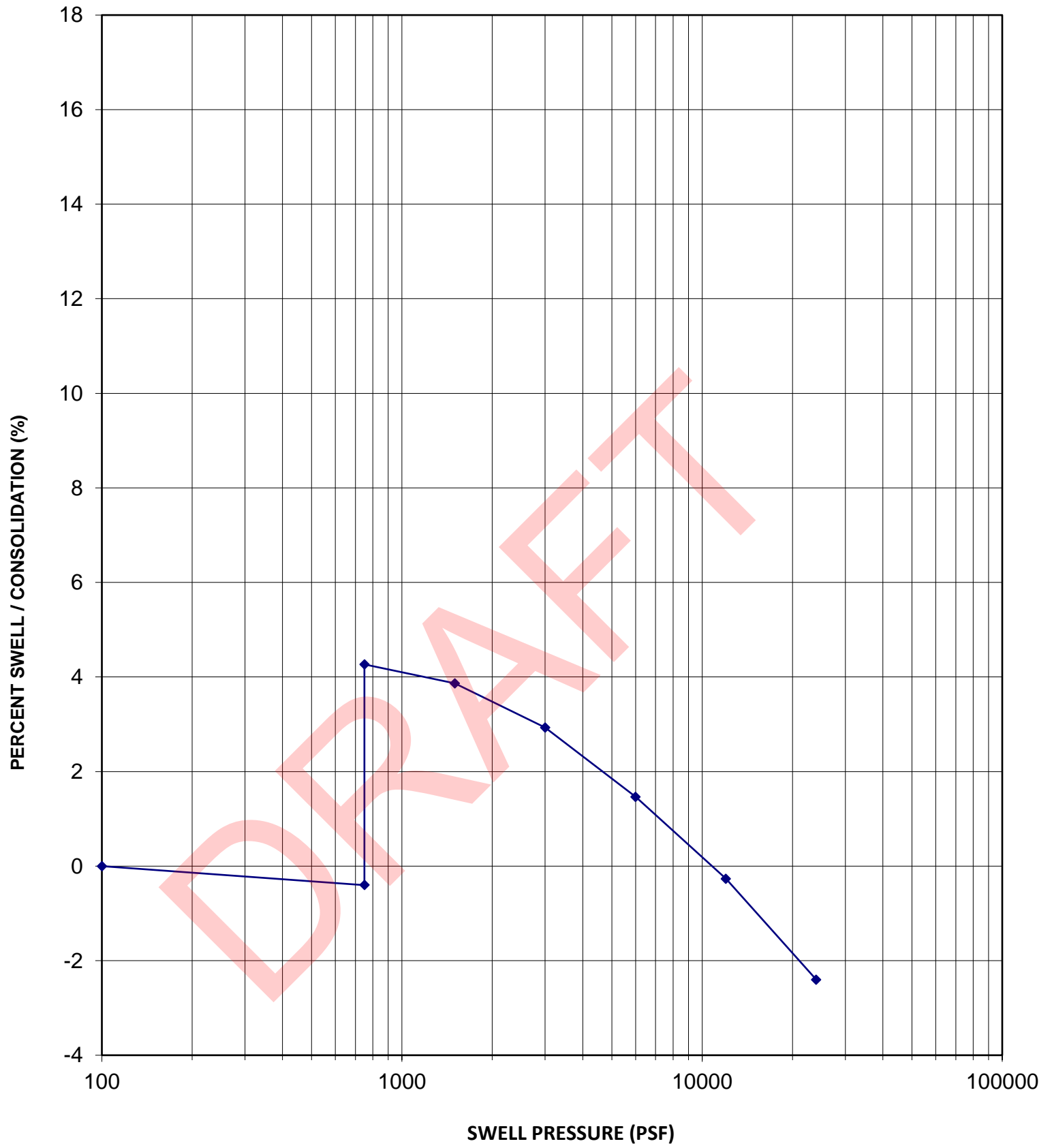

Sample Location	B18
Sample Depth	10 feet
Sample Description	Bedrock
USCS Classification	

Dry Density	115 pcf
In-Situ Moisture Content	18.9 %
Volume Change	4.7 %
Swell Pressure	12,500 psf



TRes Venetucci Multifamily

JOB NO.

5322879

SWELL - CONSOLIDATION TEST

FIGURE NO.

A26

SWELL-CONSOLIDATION TEST

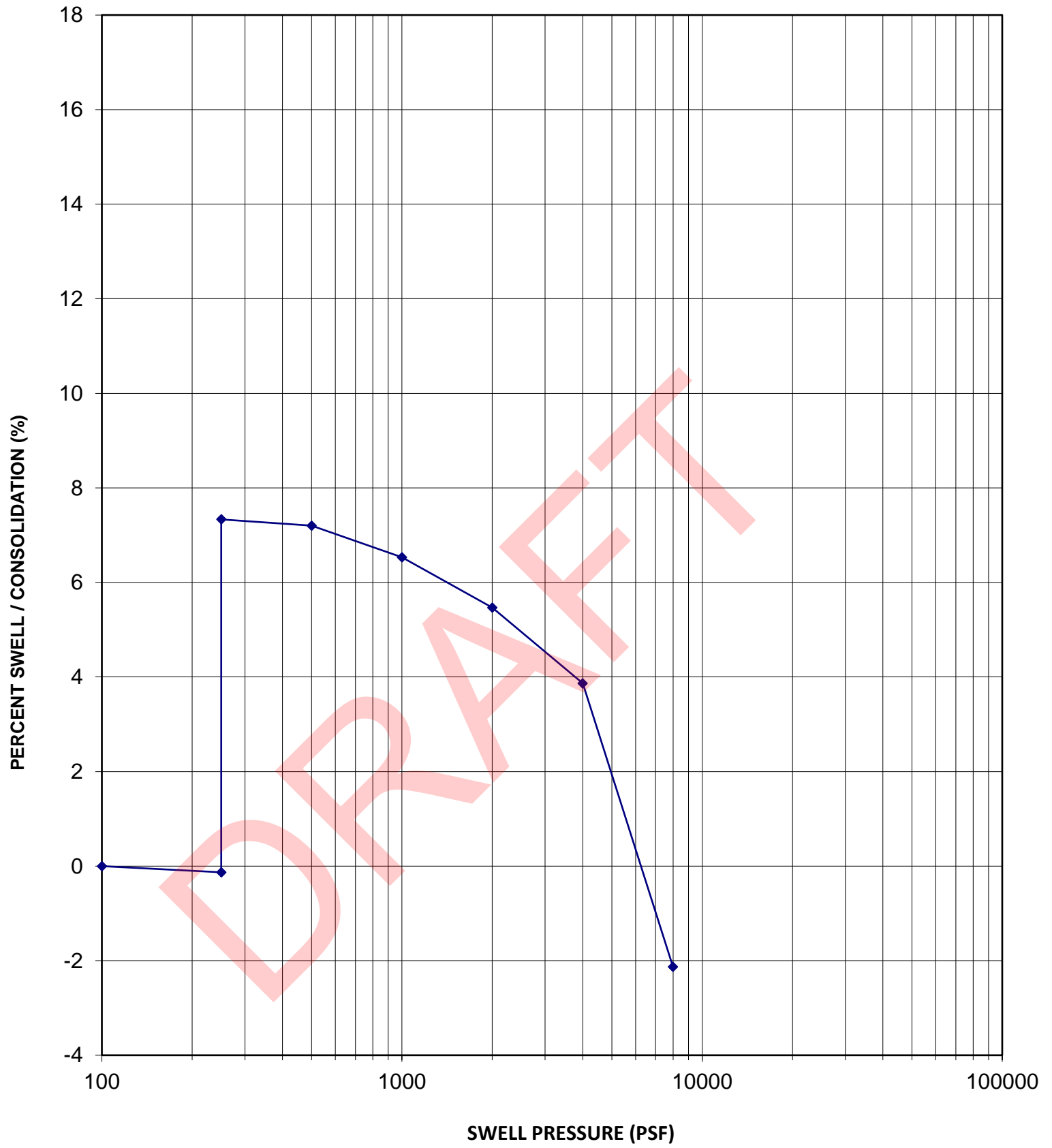

Sample Location	B19
Sample Depth	5 feet
Sample Description	Clay
USCS Classification	CL

Dry Density	114 pcf
In-Situ Moisture Content	18.2 %
Volume Change	7.5 %
Swell Pressure	6,300 psf



TRes Venetucci Multifamily

JOB NO. 5322879

SWELL - CONSOLIDATION TEST

FIGURE NO. A27

SWELL-CONSOLIDATION TEST

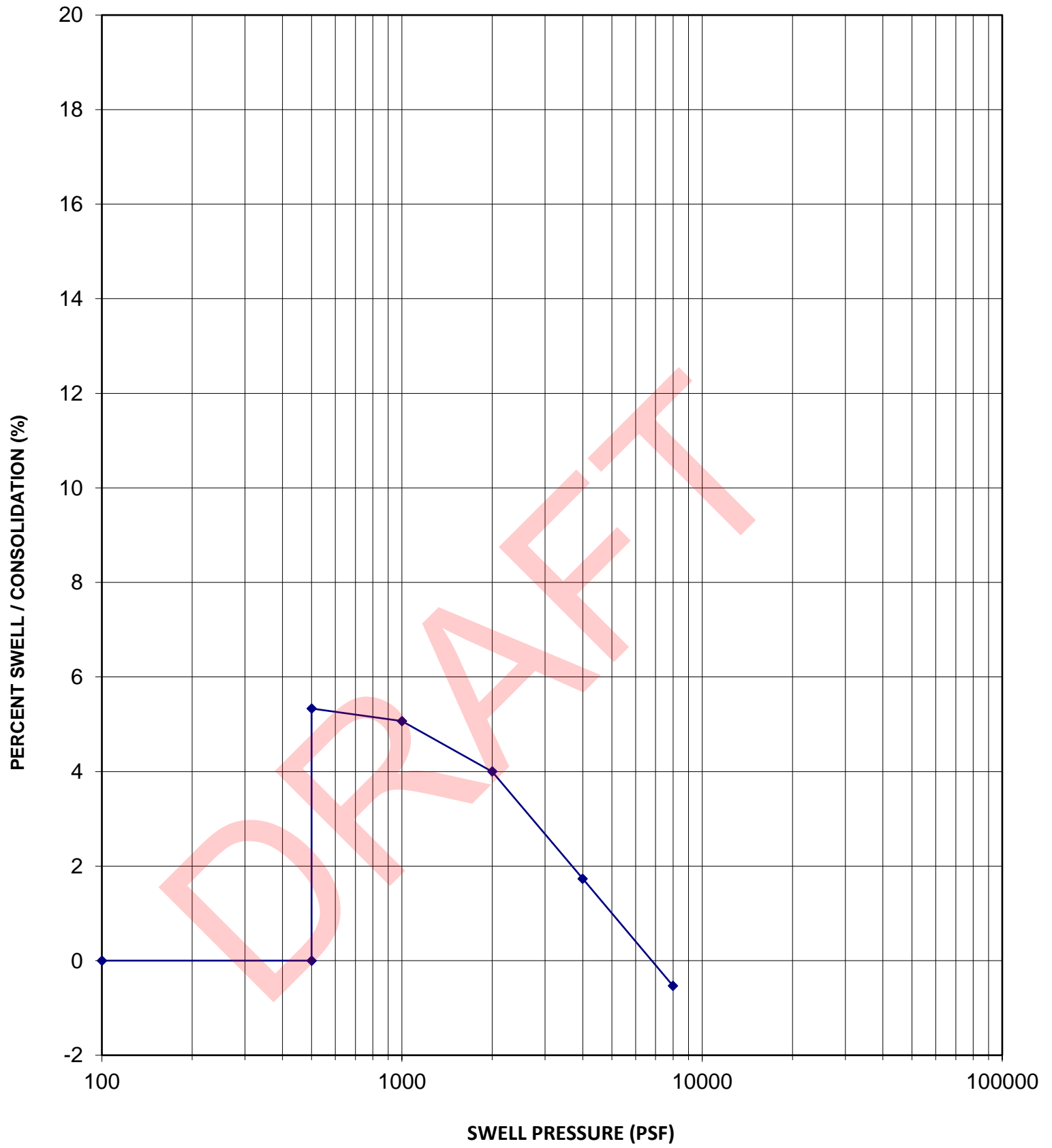

Sample Location	B19
Sample Depth	7.5 feet
Sample Description	Clay
USCS Classification	CL

Dry Density	106 pcf
In-Situ Moisture Content	20.4 %
Volume Change	5.3 %
Swell Pressure	6,800 psf



TRes Venetucci Multifamily

JOB NO. 5322879

SWELL - CONSOLIDATION TEST

FIGURE NO. A28

SWELL-CONSOLIDATION TEST

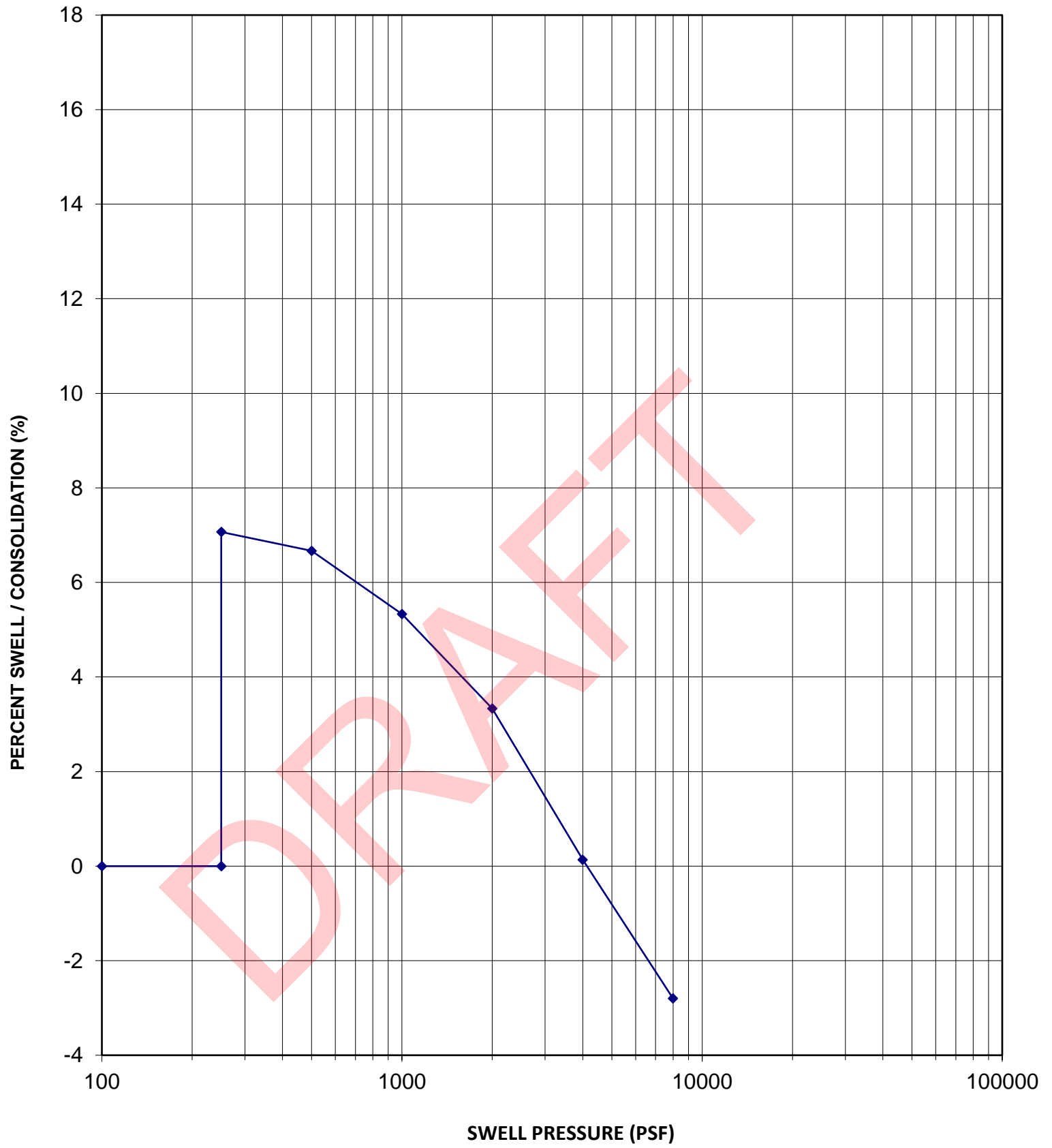

Sample Location	B20
Sample Depth	7.5 feet
Sample Description	Bedrock
USCS Classification	

Dry Density	116 pcf
In-Situ Moisture Content	11.6 %
Volume Change	7.1 %
Swell Pressure	4,100 psf



TRes Venetucci Multifamily

JOB NO. 5322879

SWELL - CONSOLIDATION TEST

FIGURE NO. A29

SWELL-CONSOLIDATION TEST

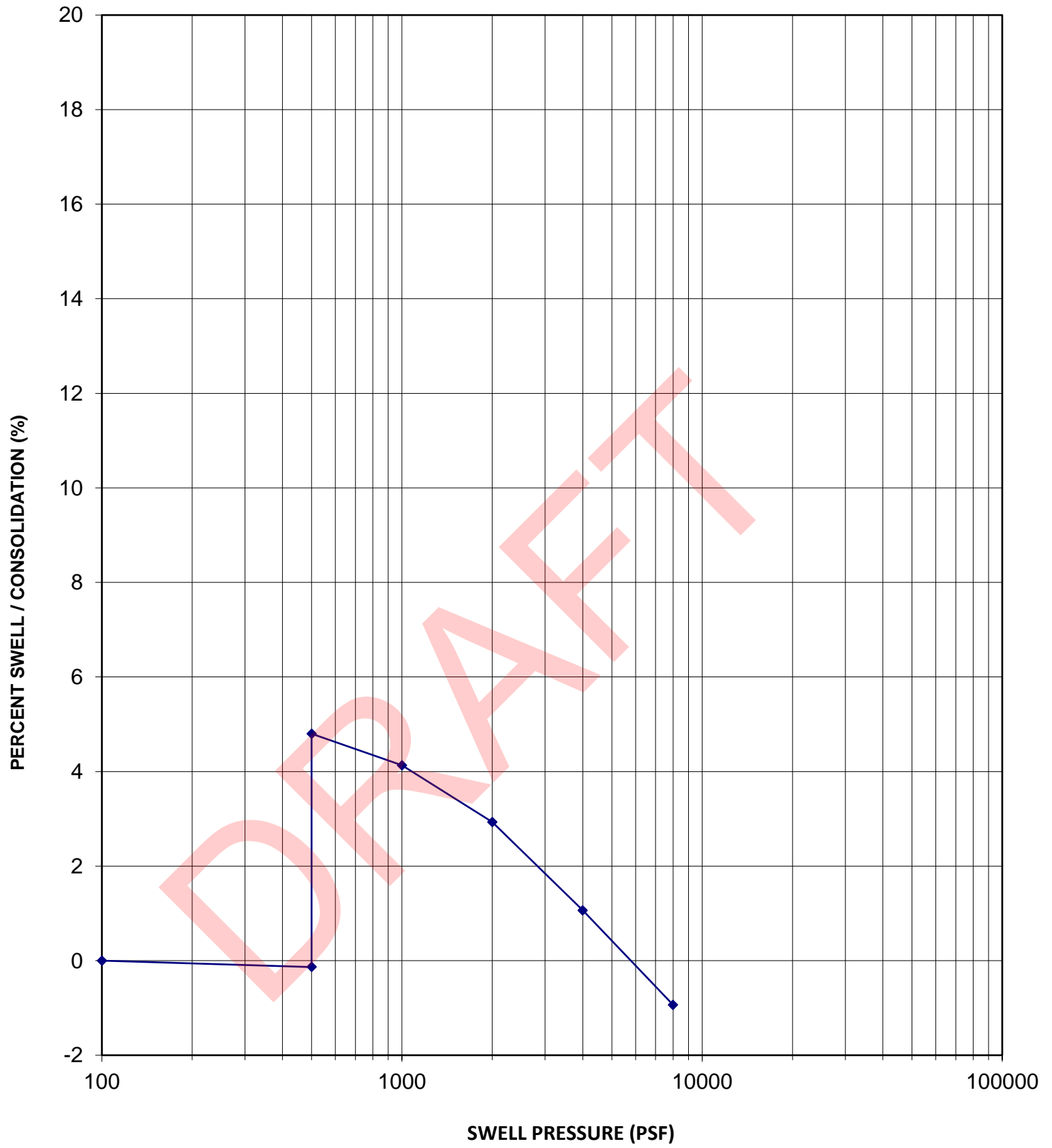

Sample Location	B20
Sample Depth	10 feet
Sample Description	Bedrock
USCS Classification	

Dry Density	110 pcf
In-Situ Moisture Content	15.4 %
Volume Change	4.9 %
Swell Pressure	6,100 psf



TRes Venetucci Multifamily

JOB NO.

5322879

SWELL - CONSOLIDATION TEST

FIGURE NO.

A30

SWELL-CONSOLIDATION TEST

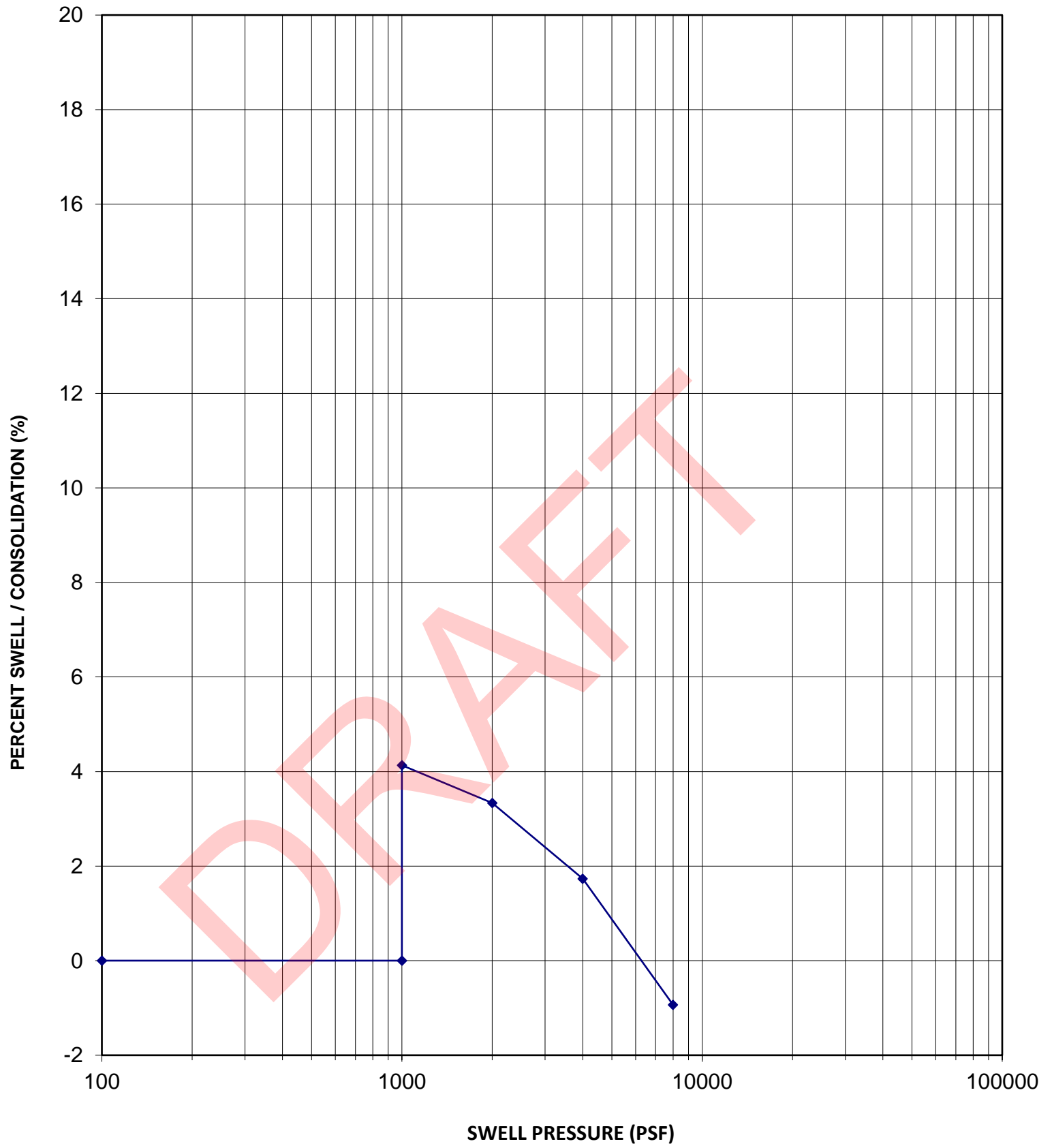

Sample Location	B20
Sample Depth	15 feet
Sample Description	Bedrock
USCS Classification	

Dry Density	110 pcf
In-Situ Moisture Content	13.6 %
Volume Change	4.1 %
Swell Pressure	6,300 psf



TRes Venetucci Multifamily

JOB NO. 5322879

SWELL - CONSOLIDATION TEST

FIGURE NO. A31

SWELL-CONSOLIDATION TEST

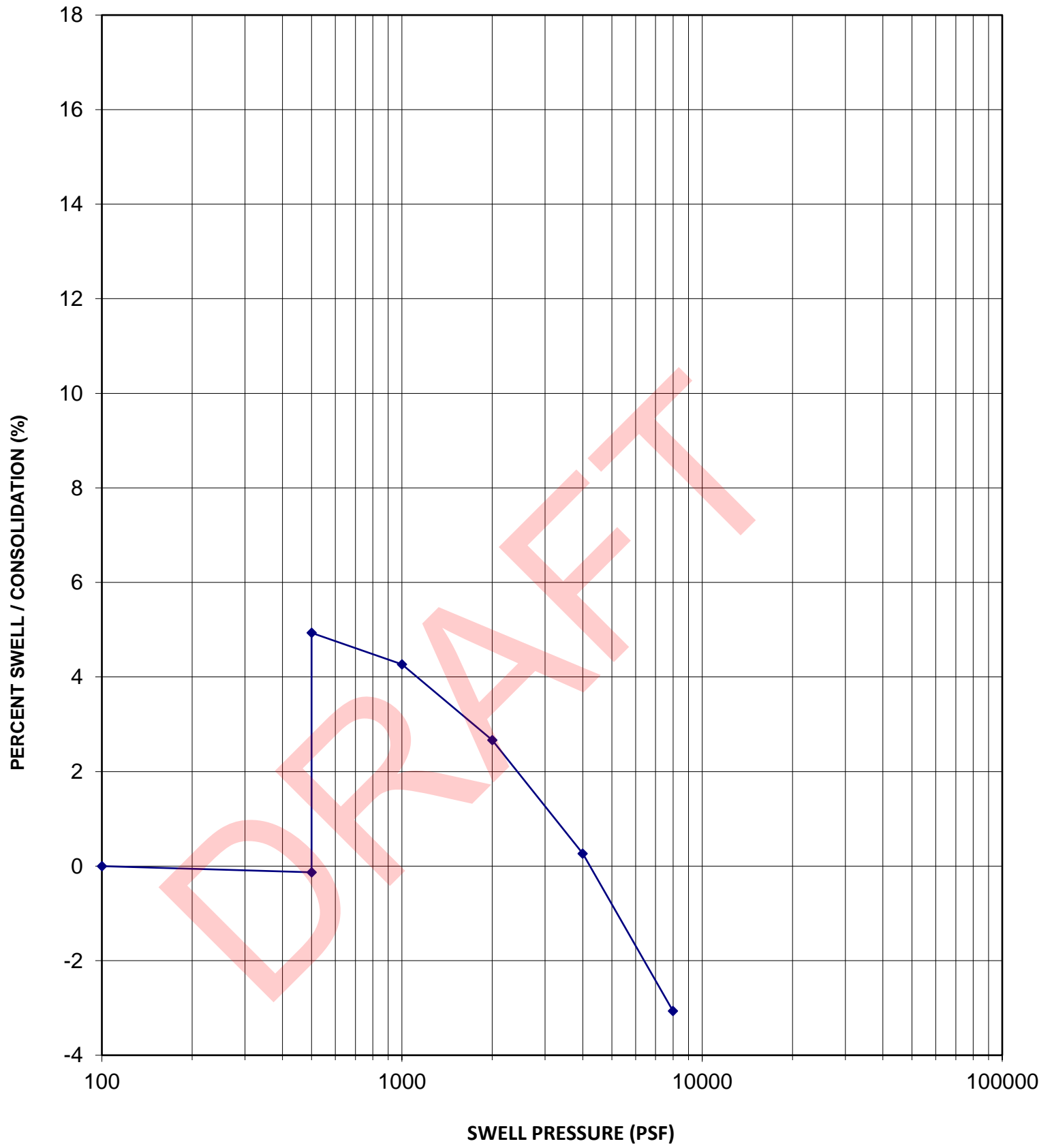

Sample Location	B22
Sample Depth	10 feet
Sample Description	Bedrock
USCS Classification	

Dry Density	109 pcf
In-Situ Moisture Content	13.5 %
Volume Change	5.1 %
Swell Pressure	4,300 psf



TRes Venetucci Multifamily

JOB NO. 5322879

SWELL - CONSOLIDATION TEST

FIGURE NO. A32

SWELL-CONSOLIDATION TEST

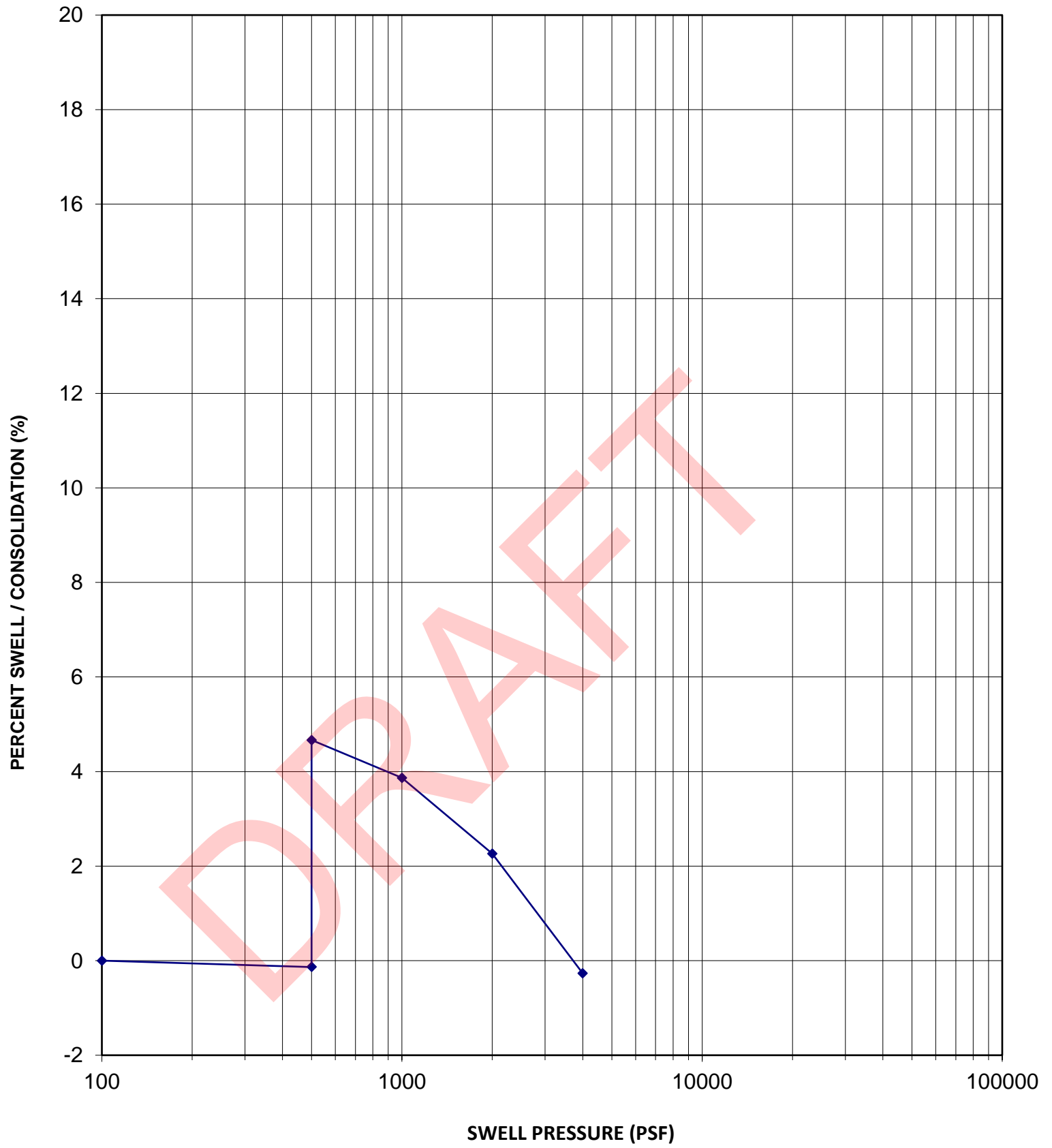

Sample Location	B23
Sample Depth	5 feet
Sample Description	Apparent Fill
USCS Classification	

Dry Density	110 pcf
In-Situ Moisture Content	14.6 %
Volume Change	4.8 %
Swell Pressure	3,900 psf



TRes Venetucci Multifamily

JOB NO. 5322879

SWELL - CONSOLIDATION TEST

FIGURE NO. A33

SWELL-CONSOLIDATION TEST

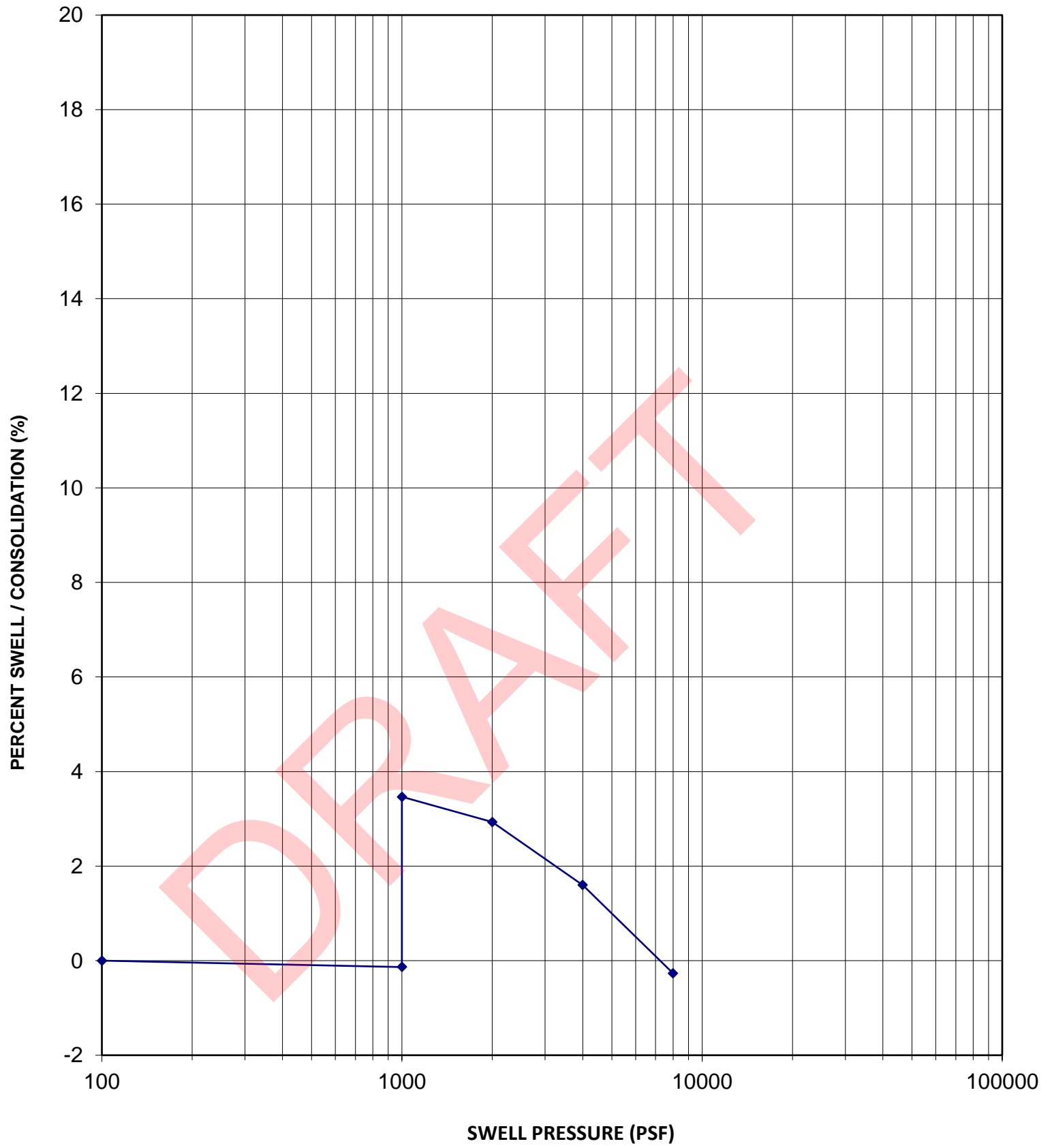

Sample Location	B23
Sample Depth	10 feet
Sample Description	Clay
USCS Classification	CL

Dry Density	115 pcf
In-Situ Moisture Content	15.4 %
Volume Change	3.6 %
Swell Pressure	7,600 psf



TRes Venetucci Multifamily

JOB NO. 5322879

SWELL - CONSOLIDATION TEST

FIGURE NO. A34

SWELL-CONSOLIDATION TEST

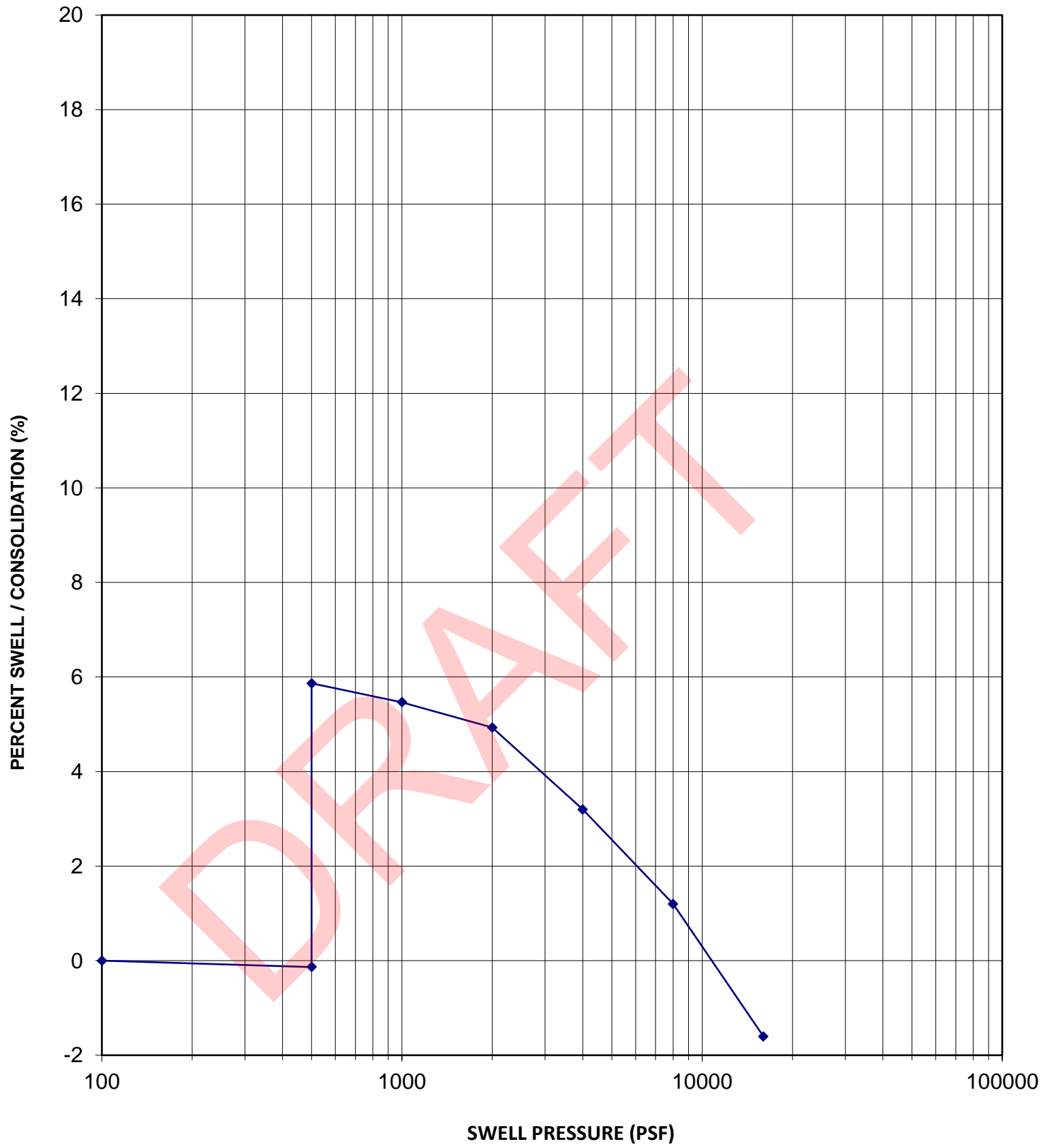

Sample Location	B24
Sample Depth	5 feet
Sample Description	Bedrock
USCS Classification	

Dry Density	117 pcf
In-Situ Moisture Content	15.8 %
Volume Change	6.0 %
Swell Pressure	11,100 psf



TRes Venetucci Multifamily

JOB NO.

5322879

SWELL - CONSOLIDATION TEST

FIGURE NO.

A35

SWELL-CONSOLIDATION TEST

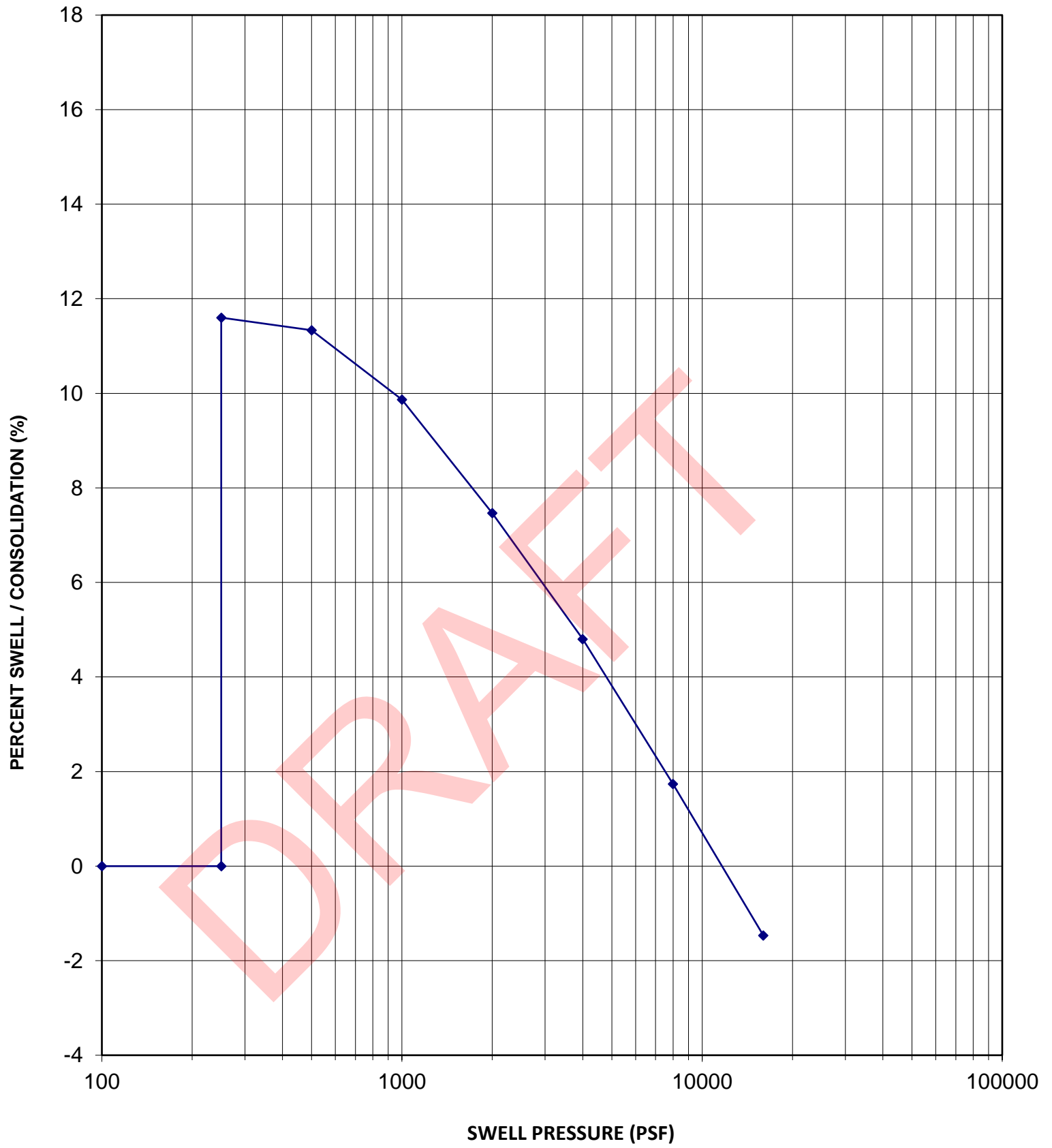

Sample Location	B25
Sample Depth	5 feet
Sample Description	Bedrock
USCS Classification	

Dry Density	115 pcf
In-Situ Moisture Content	14.3 %
Volume Change	11.6 %
Swell Pressure	11,600 psf



TRes Venetucci Multifamily

JOB NO. 5322879

SWELL - CONSOLIDATION TEST

FIGURE NO. A36

SWELL-CONSOLIDATION TEST

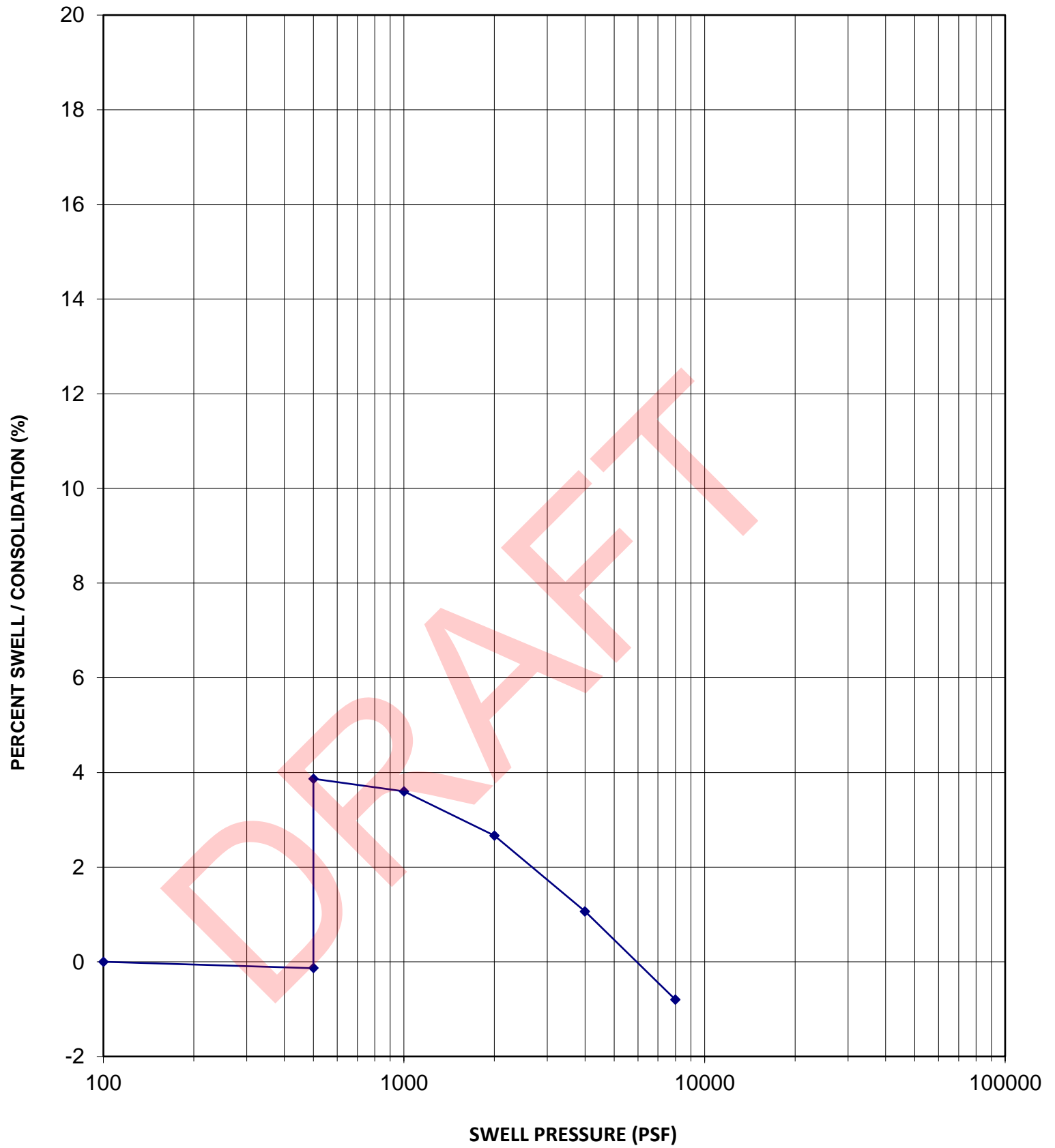

Sample Location	B26
Sample Depth	5 feet
Sample Description	Apparent Fill
USCS Classification	

Dry Density	105 pcf
In-Situ Moisture Content	24.6 %
Volume Change	4.0 %
Swell Pressure	6,200 psf



TRes Venetucci Multifamily

JOB NO.

5322879

SWELL - CONSOLIDATION TEST

FIGURE NO.

A37

SWELL-CONSOLIDATION TEST

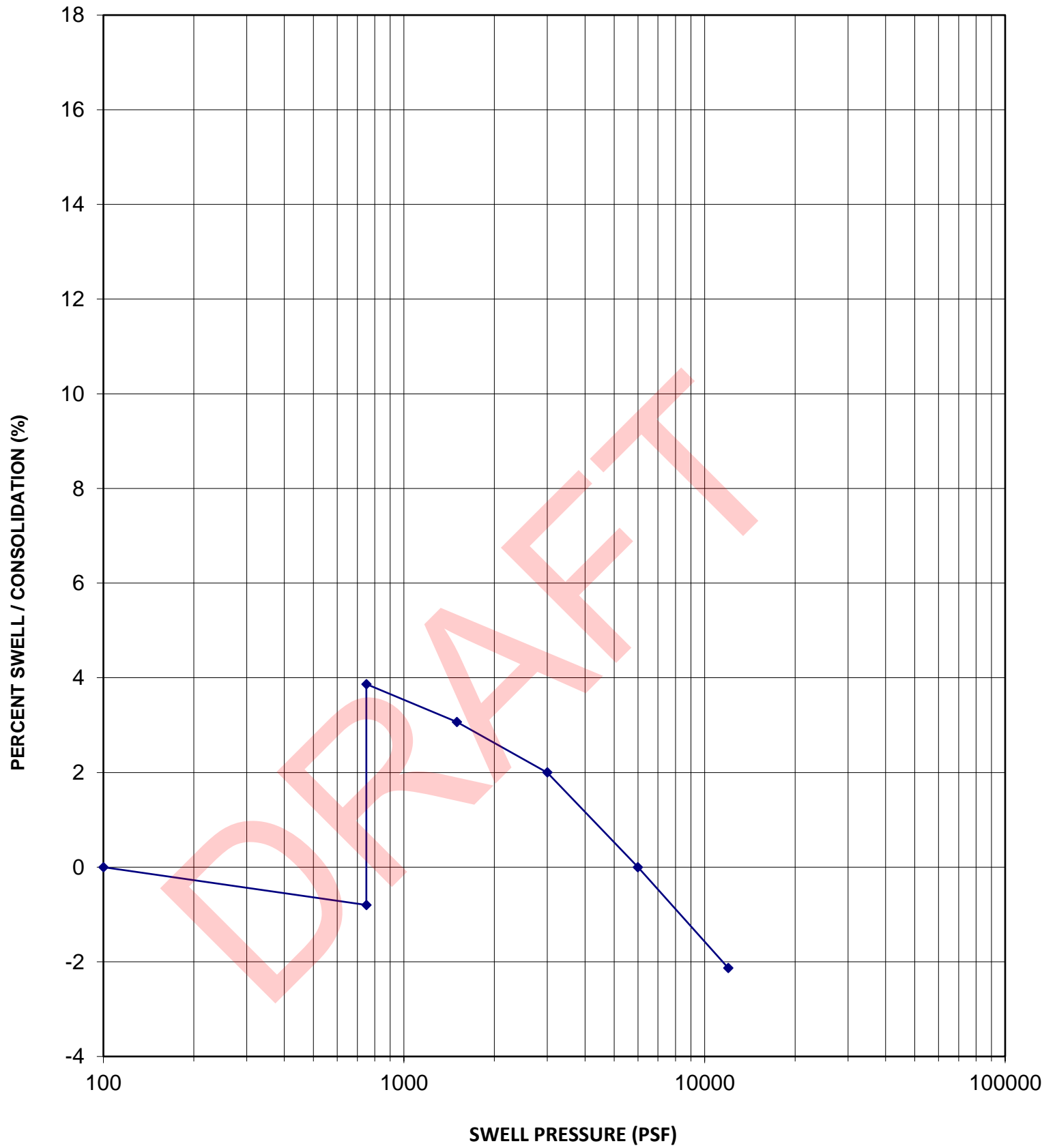

Sample Location	B26
Sample Depth	7.5 feet
Sample Description	Bedrock
USCS Classification	

Dry Density	106 pcf
In-Situ Moisture Content	21.5 %
Volume Change	4.7 %
Swell Pressure	7,800 psf



TRes Venetucci Multifamily

JOB NO. 5322879

SWELL - CONSOLIDATION TEST

FIGURE NO. A38

SWELL-CONSOLIDATION TEST

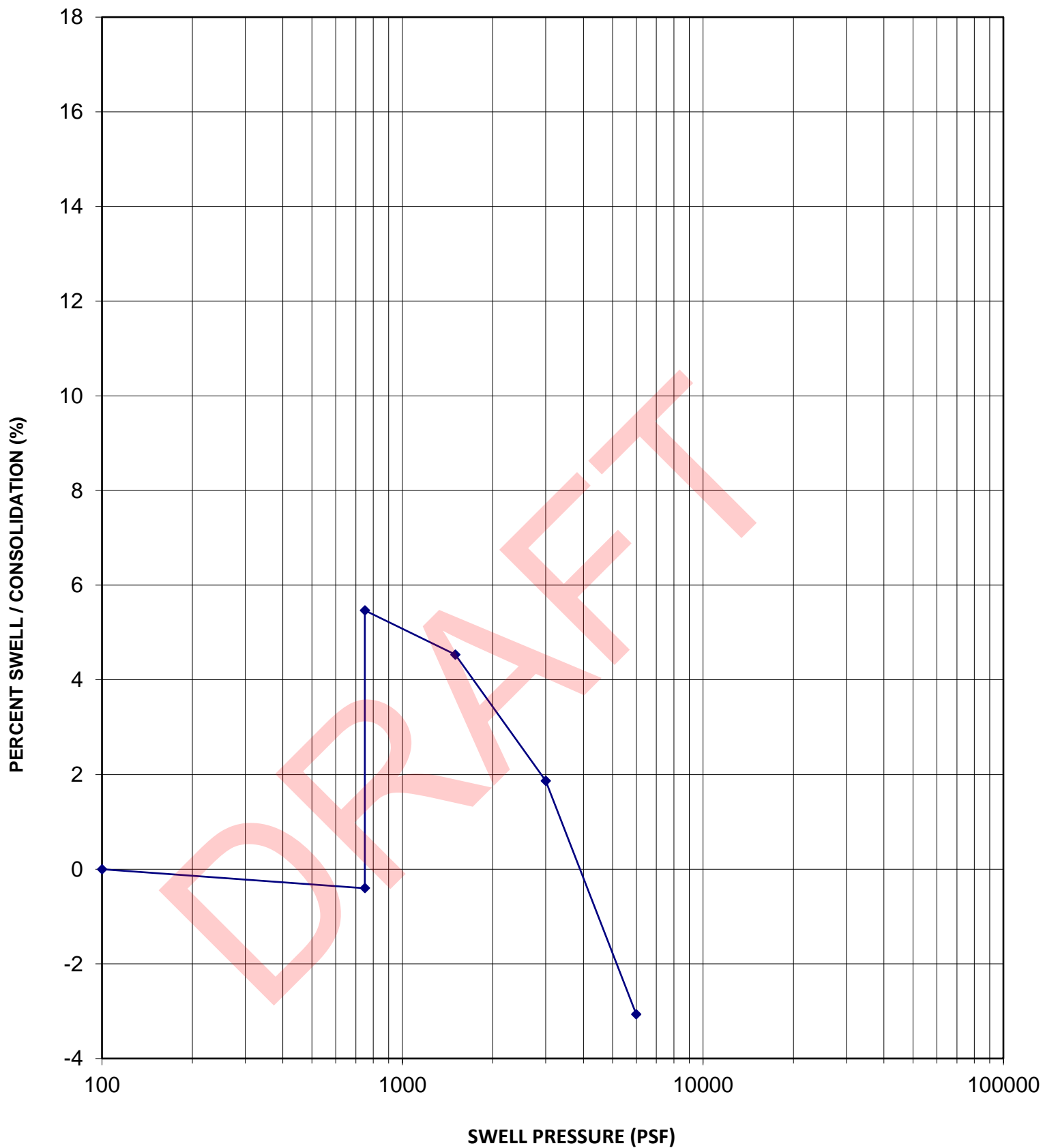

Sample Location	B27
Sample Depth	7.5 feet
Sample Description	Bedrock
USCS Classification	

Dry Density	121 pcf
In-Situ Moisture Content	12.5 %
Volume Change	5.9 %
Swell Pressure	4,100 psf

	TRes Venetucci Multifamily	JOB NO.	5322879
	SWELL - CONSOLIDATION TEST	FIGURE NO.	A39

SWELL-CONSOLIDATION TEST

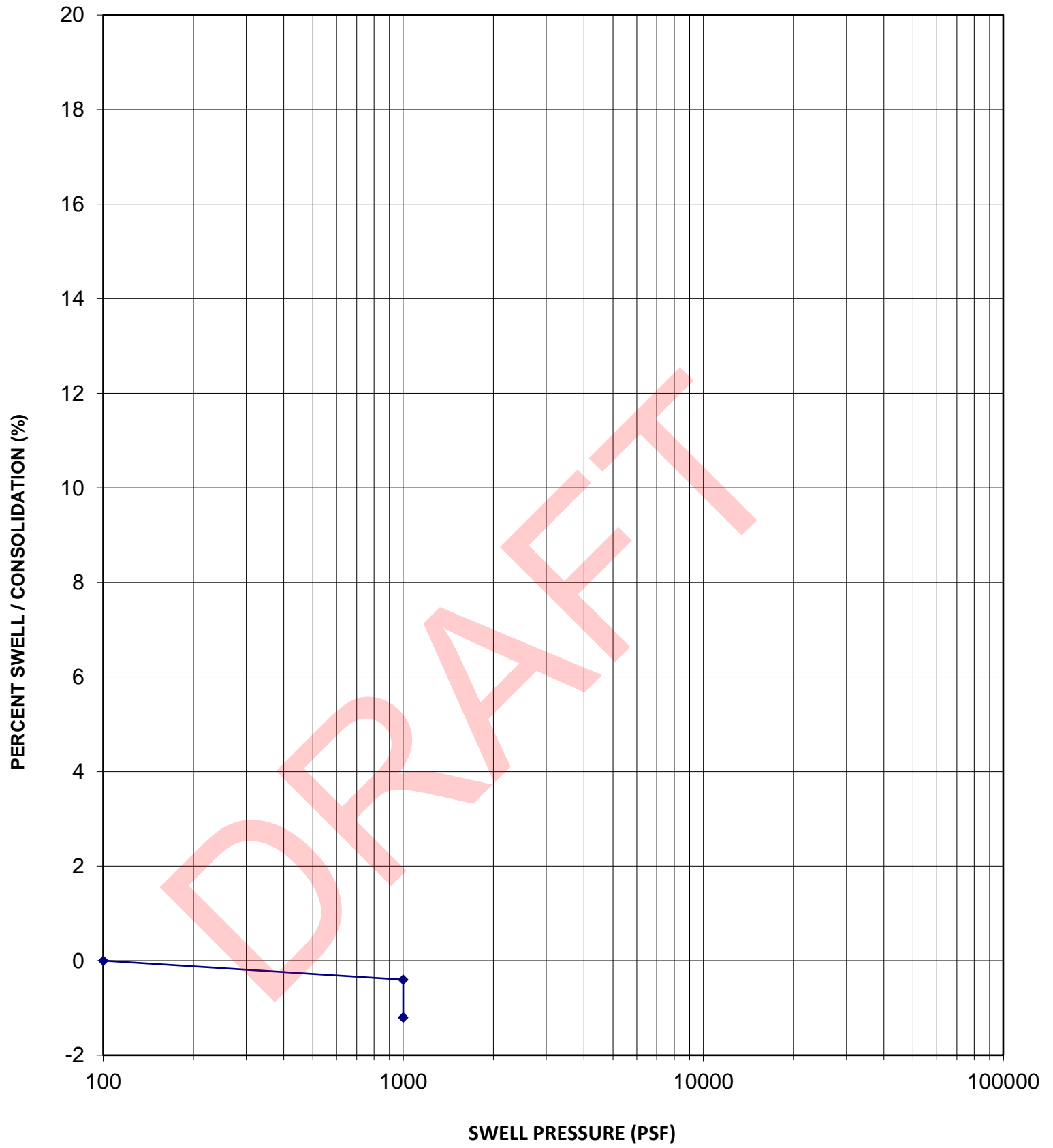

Sample Location	B27
Sample Depth	10 feet
Sample Description	Bedrock
USCS Classification	

Dry Density	114 pcf
In-Situ Moisture Content	11.9 %
Volume Change	-0.8 %
Swell Pressure	psf



TRes Venetucci Multifamily

JOB NO.

5322879

SWELL - CONSOLIDATION TEST

FIGURE NO.

A40

SWELL-CONSOLIDATION TEST

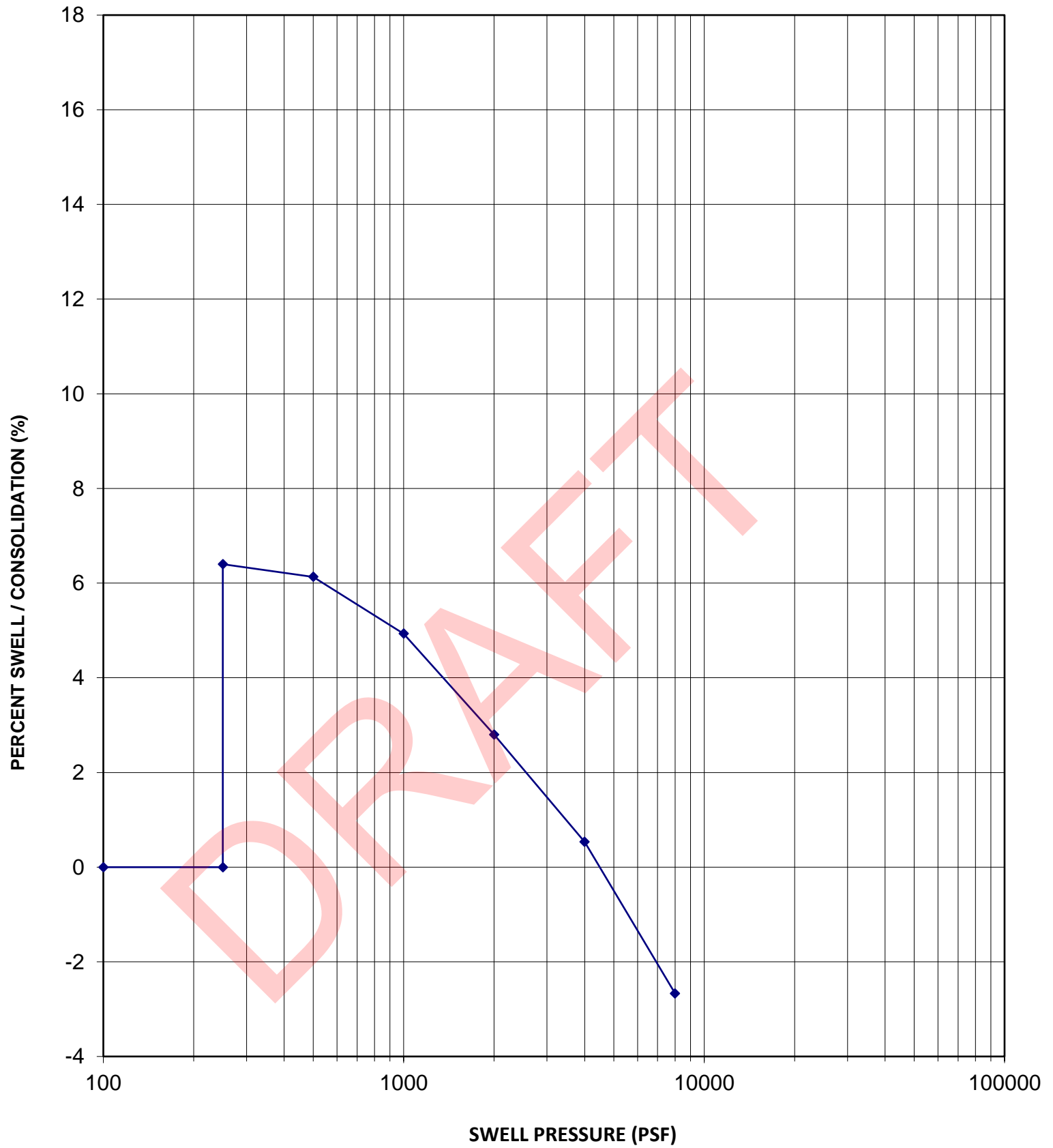

Sample Location	B28
Sample Depth	2.5 feet
Sample Description	Clay
USCS Classification	CH

Dry Density	104 pcf
In-Situ Moisture Content	15.1 %
Volume Change	6.4 %
Swell Pressure	4,500 psf



TRes Venetucci Multifamily

JOB NO. 5322879

SWELL - CONSOLIDATION TEST

FIGURE NO. A41

SWELL-CONSOLIDATION TEST

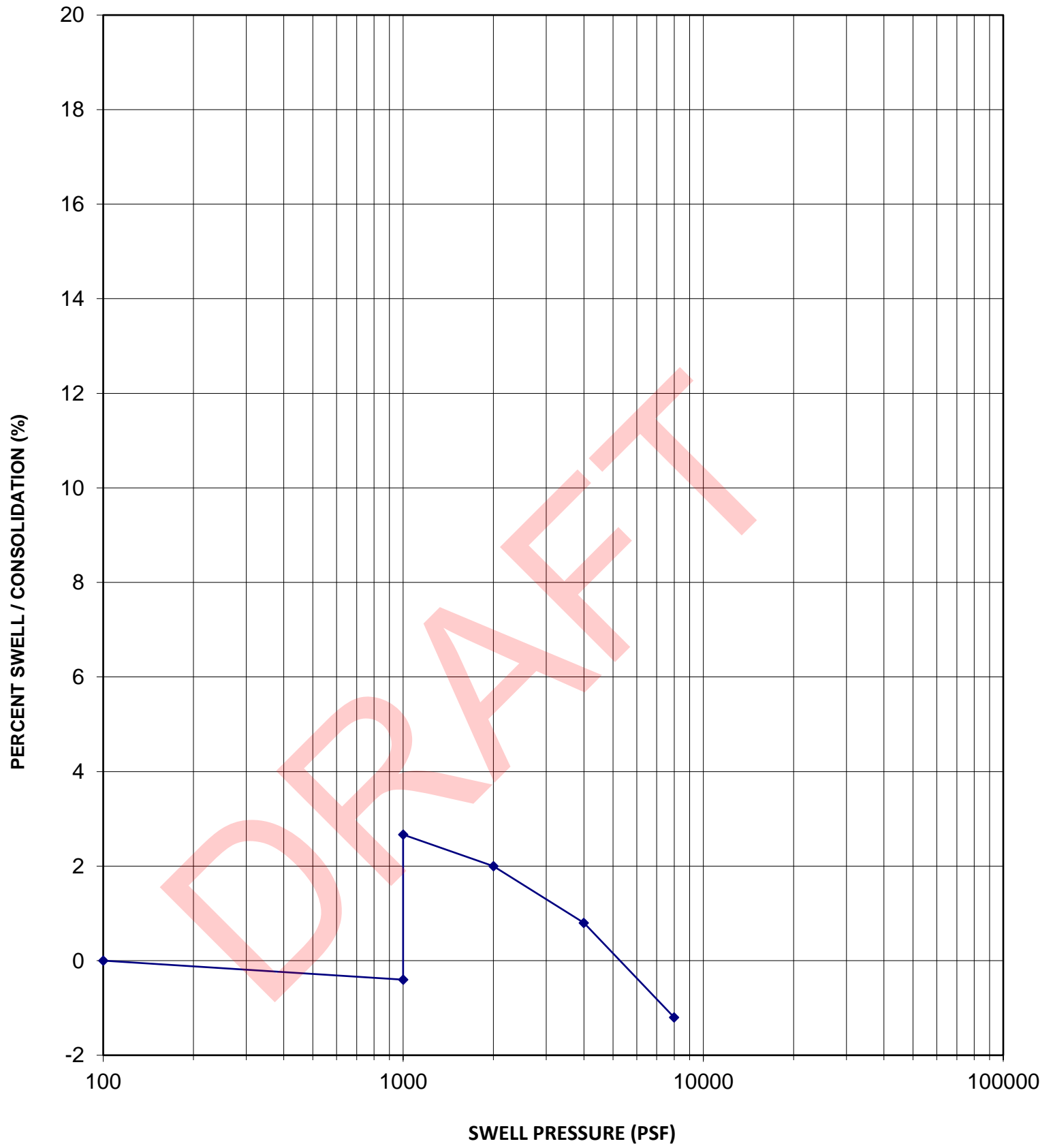

Sample Location	B29
Sample Depth	10 feet
Sample Description	Bedrock
USCS Classification	

Dry Density	108 pcf
In-Situ Moisture Content	19.7 %
Volume Change	3.1 %
Swell Pressure	6,100 psf



TRes Venetucci Multifamily

JOB NO.

5322879

SWELL - CONSOLIDATION TEST

FIGURE NO.

A42

SWELL-CONSOLIDATION TEST

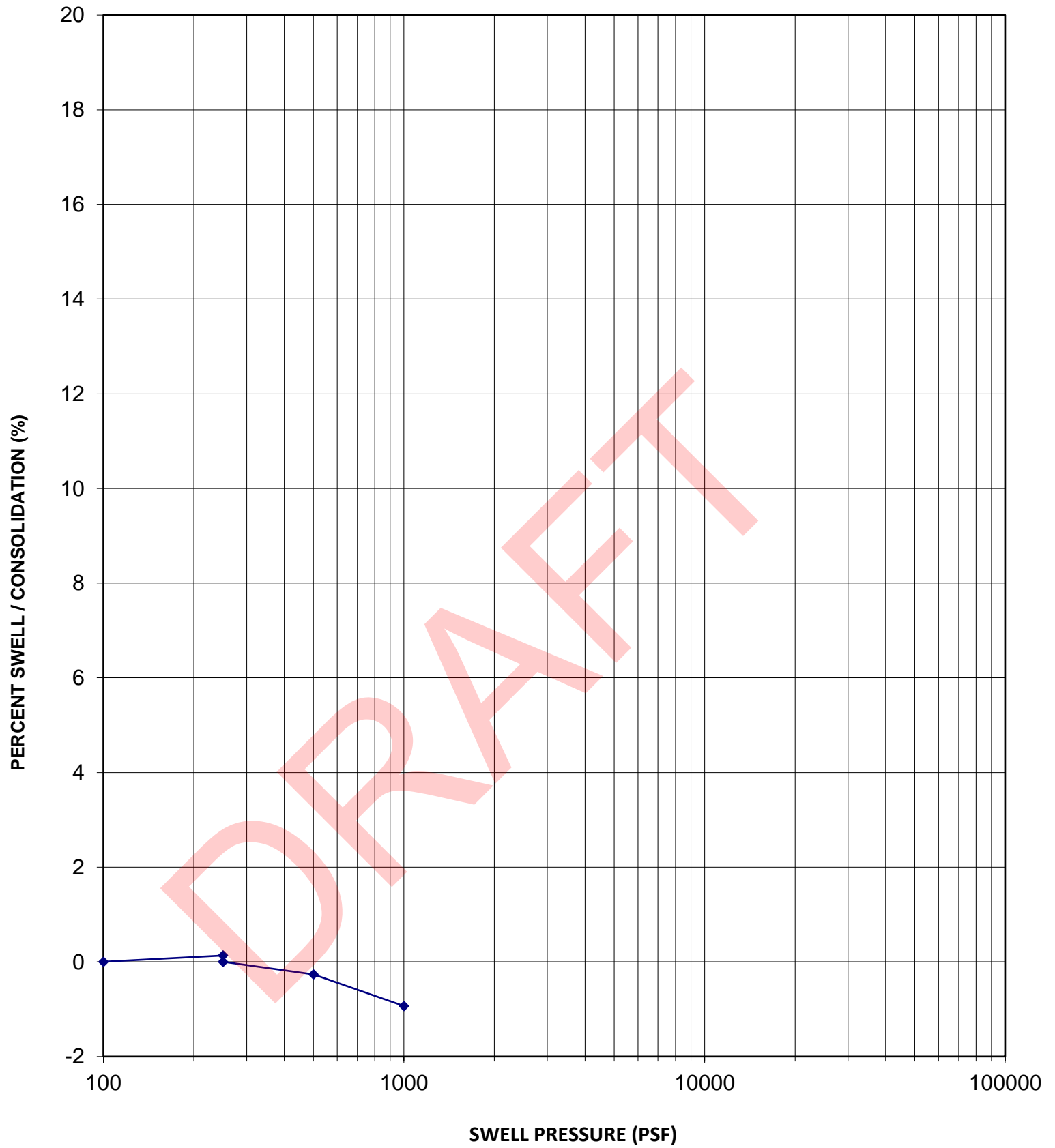

Sample Location	B30
Sample Depth	5 feet
Sample Description	Bedrock
USCS Classification	

Dry Density	109 pcf
In-Situ Moisture Content	18.1 %
Volume Change	-0.1 %
Swell Pressure	psf



TRes Venetucci Multifamily
SWELL - CONSOLIDATION TEST

JOB NO. 5322879
FIGURE NO. A43

SWELL-CONSOLIDATION TEST

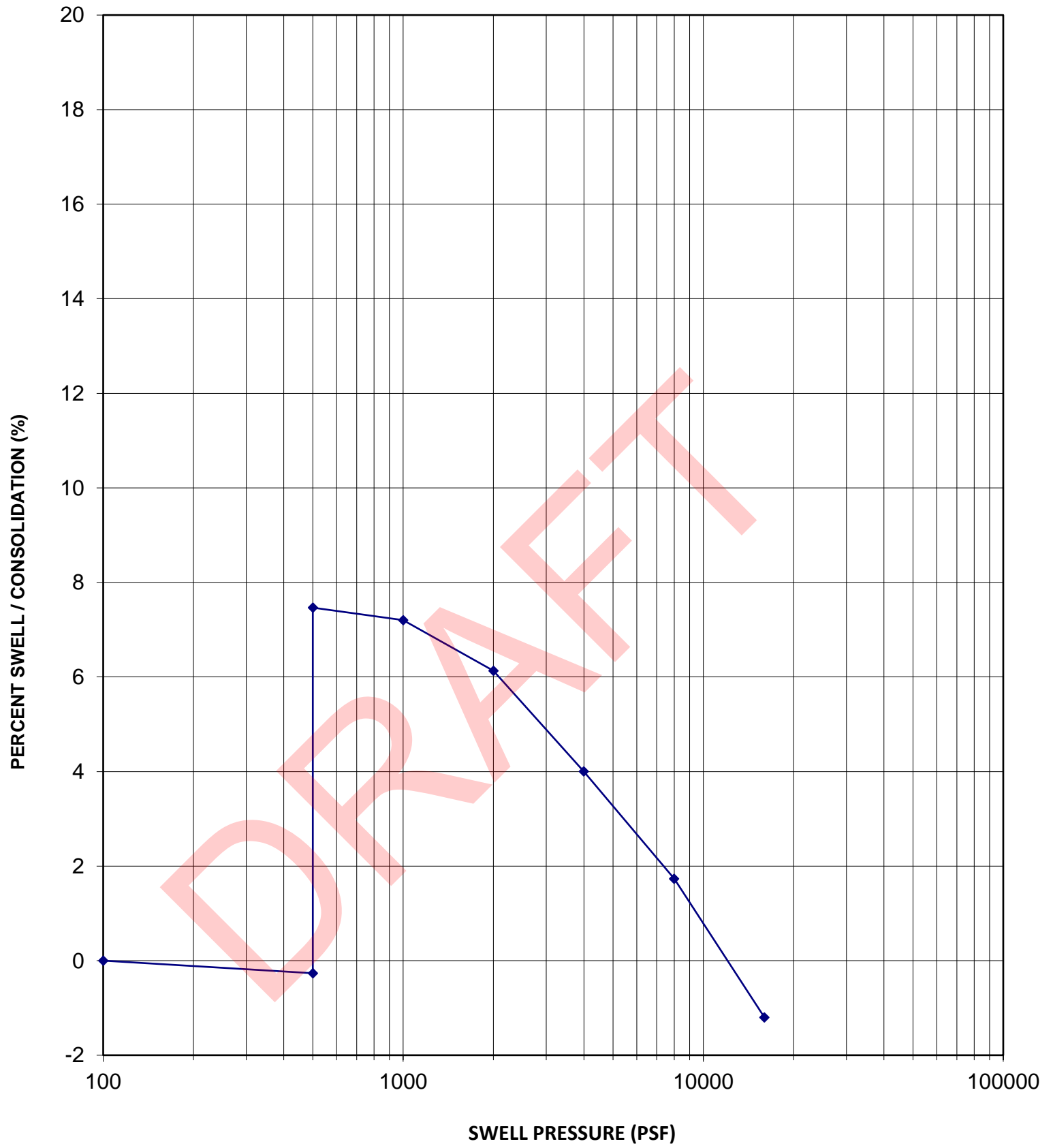

Sample Location	B30
Sample Depth	7.5 feet
Sample Description	Bedrock
USCS Classification	

Dry Density	113 pcf
In-Situ Moisture Content	19.5 %
Volume Change	7.7 %
Swell Pressure	12,800 psf



TRes Venetucci Multifamily

JOB NO.

5322879

SWELL - CONSOLIDATION TEST

FIGURE NO.

A44

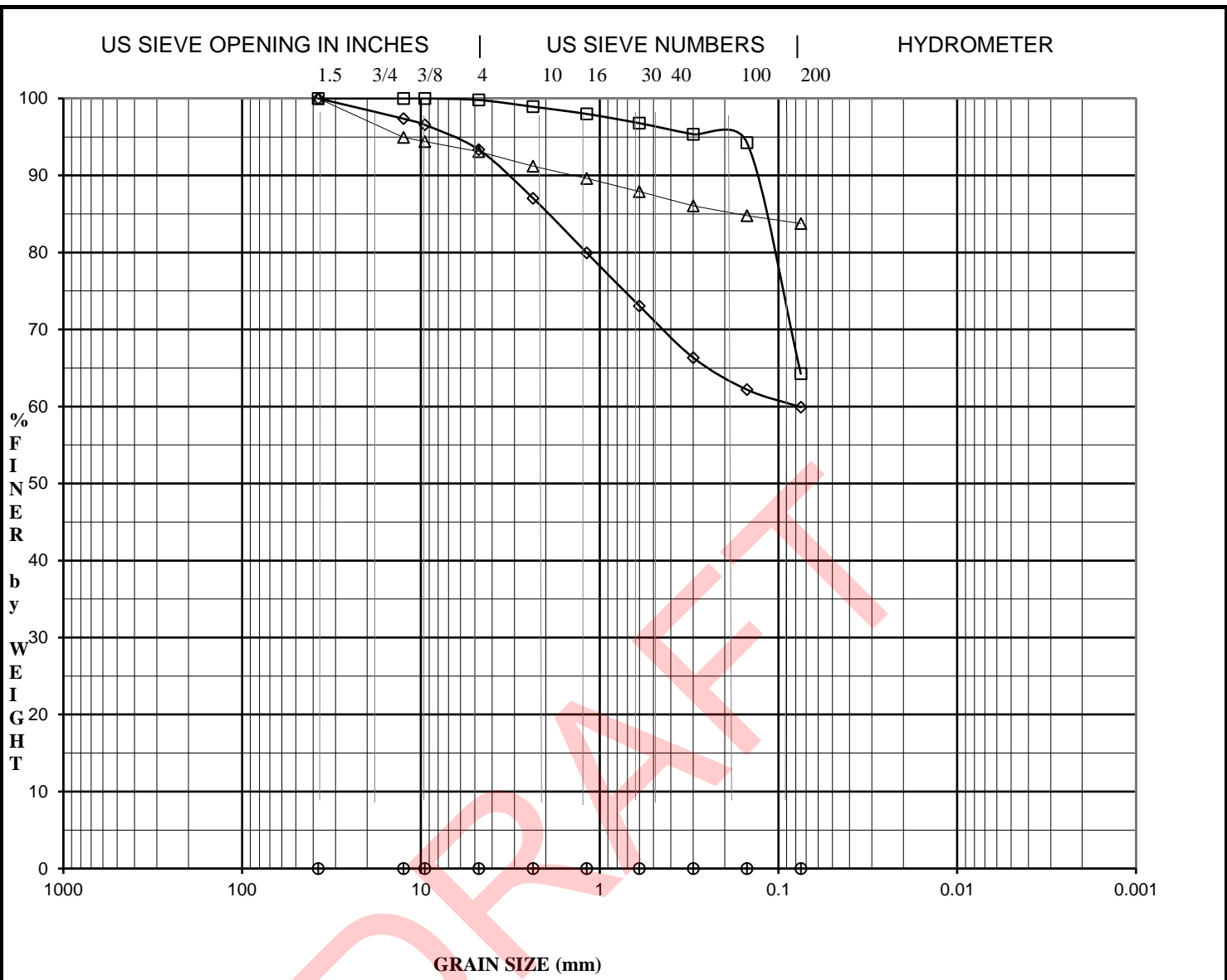

COBBLES	GRAVEL		SAND			SILT OR CLAY
	COARSE	FINE	CRS	MED	FINE	

Specimen I.D.	Description	USCS	AASHTO	Group Index	LL	PI	PL
◇ B3 @ 5 FEET	High Plastic Clay	CH	A-7-6	23	66	42	24
□ B13 @ 10 FEET	High Plastic Clay	CH	A-7-6	32	74	53	21
△ B24 @ 2.5 FEET	High Plastic Clay	CH	A-7-6	33	58	38	20
○							
+							

Specimen I.D.	D100	D60	D30	D10	Cc	Cu	%Gravel	%Sand	%Silt&Clay
◇ B3 @ 5 FEET	37.50	0.08					7	33	60
□ B13 @ 10 FEET	9.50						0	36	64
△ B24 @ 2.5 FEET	37.50						7	9	84
○									
+									

	TTRes Venetucci Multifamily	JOB NO. 5322879
	GRADATION CURVES	FIGURE NO. A45

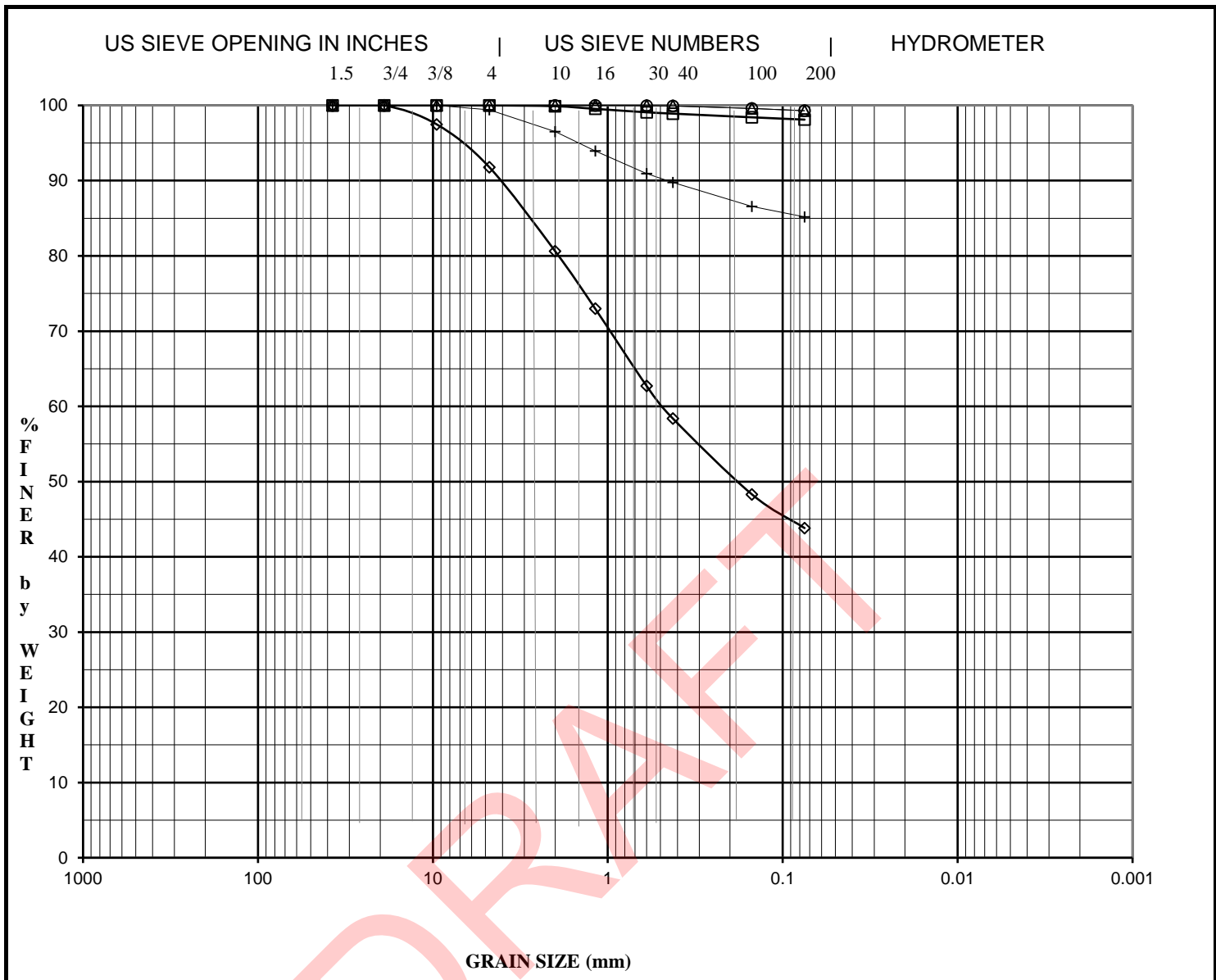

COBBLES	GRAVEL		SAND			SILT OR CLAY
	COARSE	FINE	CRS	MED	FINE	

Specimen I.D.	Description	USCS	AASHTO	Group Index	LL	PI	PL
◇ B2 @ 10 FEET	Clayey Sand	SC	A-7-6	12	66	42	24
□ B4 @ 2.5 FEET	High Plastic Clay	CH	A-7-6	47	66	42	24
△ B5 @ 5 FEET	High Plastic Clay	CH	A-7-6	85	95	75	20
○ B7 @ 2.5 FEET	High Plastic Clay	CH	A-7-6	85	95	75	20
+ B12 @ 5 FEET	High Plastic Clay	CH	A-7-6	49	74	53	21

Specimen I.D.	D100	D60	D30	D10	Cc	Cu	%Gravel	%Sand	%Silt&Clay
◇ B2 @ 10 FEET	19.00	0.49					8	48	44
□ B4 @ 2.5 FEET	4.75						0	2	98
△ B5 @ 5 FEET	2.00						0	1	99
○ B7 @ 2.5 FEET	1.18						0	1	99
+ B12 @ 5 FEET	9.50						1	14	85

	TTRes Venetucci Multifamily	JOB NO.	5322879
	GRADATION CURVES	FIGURE NO.	A46

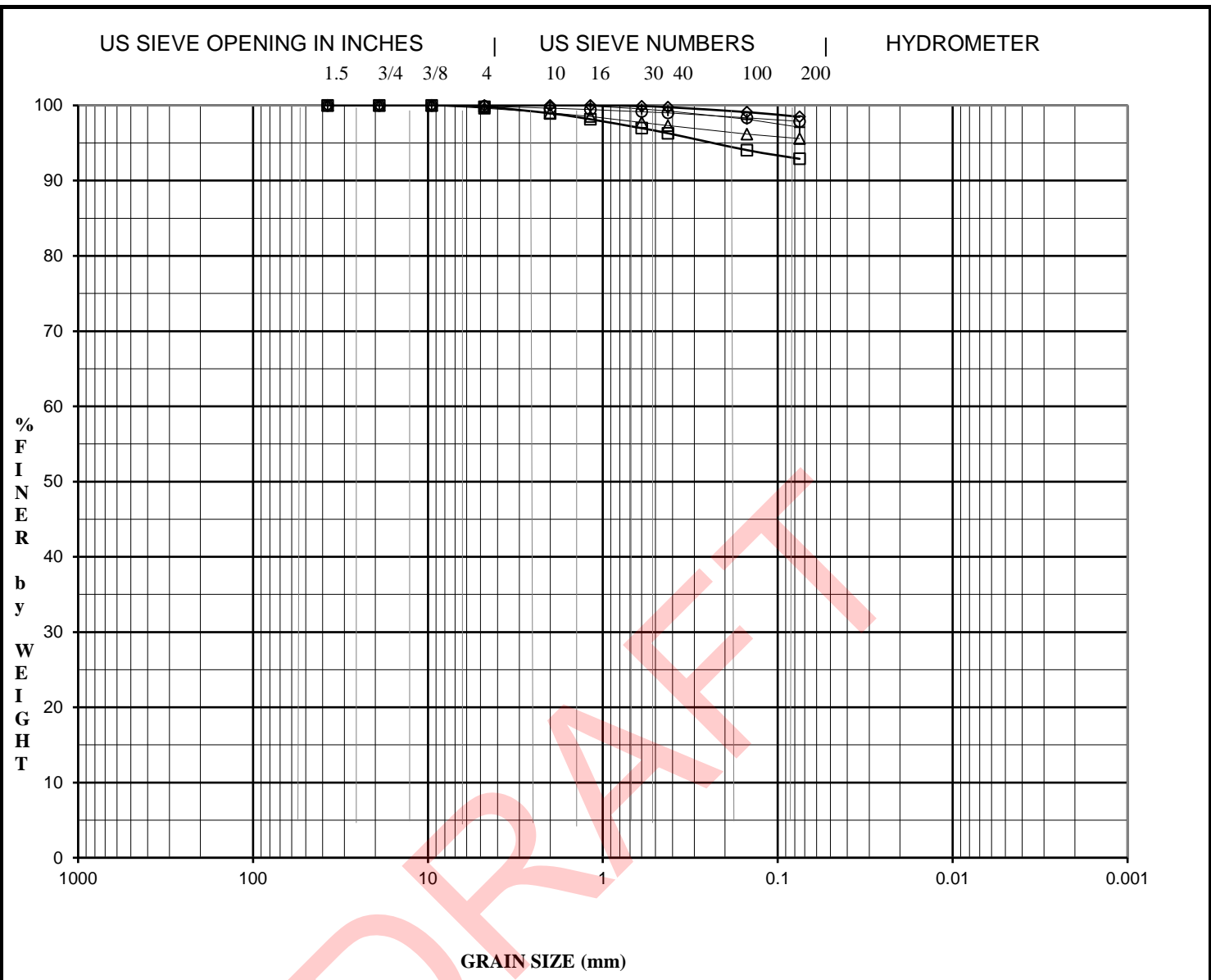

COBBLES	GRAVEL		SAND			SILT OR CLAY
	COARSE	FINE	CRS	MED	FINE	

Specimen I.D.	Description	USCS	AASHTO	Group Index	LL	PI	PL
◇ B16 @ 2.5 FEET	High Plastic Clay	CH	A-7-6	48	63	44	19
□ B19 @ 5 FEET	Low Plastic Clay	CL	A-7-6	29	48	30	18
△ B20 @ 10 FEET	Low Plastic Clay	CL	A-7-6	31	48	30	18
○ B23 @ 5 FEET	Low Plastic Clay	CL	A-7-6	32	48	30	18
+ B26 @ 5 FEET	High Plastic Clay	CH	A-7-6	41	58	38	20

Specimen I.D.	D100	D60	D30	D10	Cc	Cu	%Gravel	%Sand	%Silt&Clay
◇ B16 @ 2.5 FEET	2.00						0	2	98
□ B19 @ 5 FEET	9.50						0	7	93
△ B20 @ 10 FEET	9.50						0	4	96
○ B23 @ 5 FEET	9.50						0	2	98
+ B26 @ 5 FEET	4.75						0	3	97

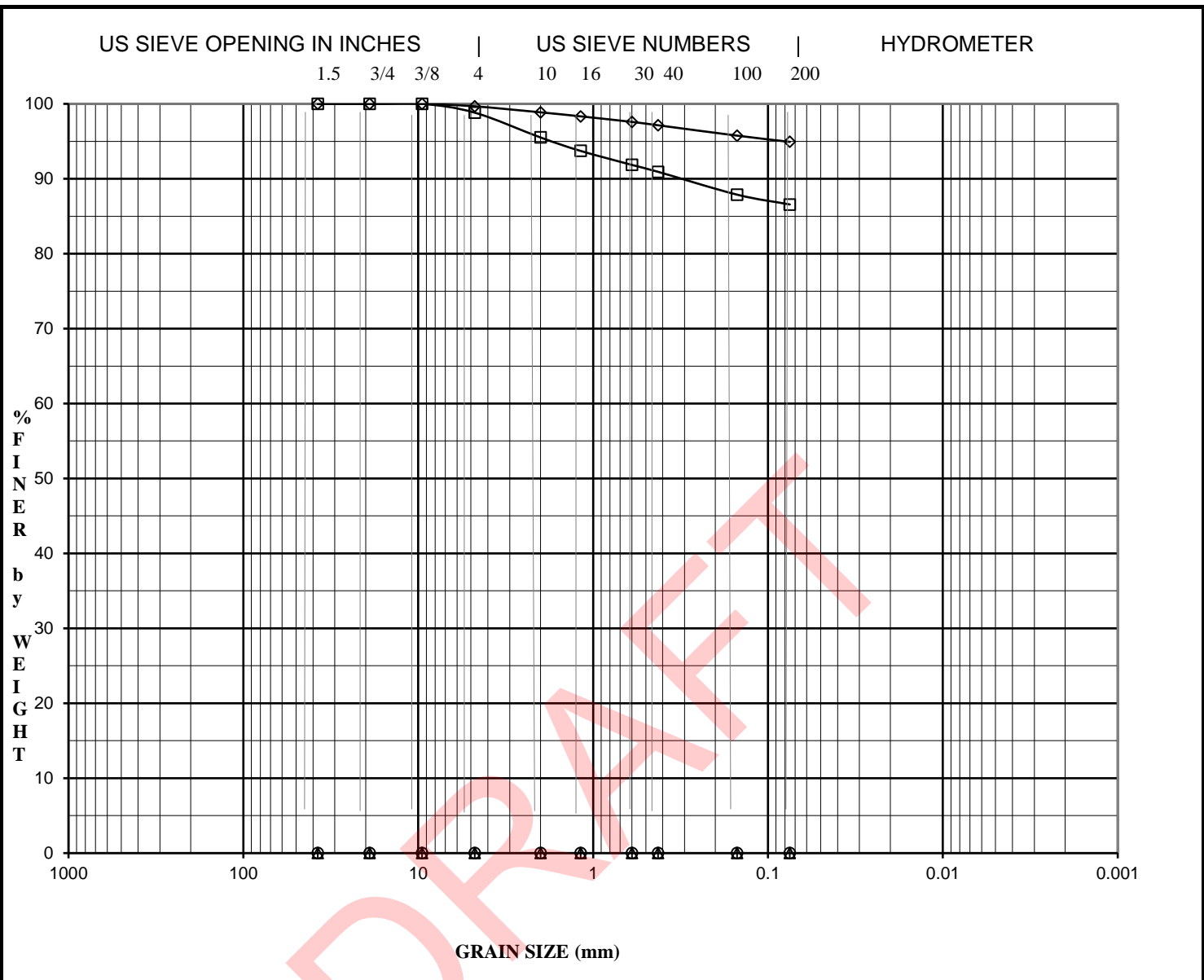

COBBLES	GRAVEL		SAND			SILT OR CLAY
	COARSE	FINE	CRS	MED	FINE	

Specimen I.D.	Description	USCS	AASHTO	Group Index	LL	PI	PL
◇ B28 @ 2.5 FEET	High Plastic Clay	CH	A-7-6	48	67	45	22
□ B30 @ 2.5 FEET	High Plastic Clay	CH	A-7-6	42	67	45	22
△							
○							
+							

Specimen I.D.	D100	D60	D30	D10	Cc	Cu	%Gravel	%Sand	%Silt&Clay
◇ B28 @ 2.5 FEET	9.50						0	5	95
□ B30 @ 2.5 FEET	9.50						1	12	87
△									
○									
+									

	TTRes Venetucci Multifamily	JOB NO. 5322879
	GRADATION CURVES	FIGURE NO. A48

UNCONFINED COMPRESSION REPORT

Tested For: Thompson Thrift Residential
 111 Monument Circle, Suite 1500
 Indianapolis, Indiana 46204

Project Name: Proposed Multi-Family
 Development
 Sample Date: September 14, 2024
 Project No. 05322879
 Sample No. B26
 Depth 20

UNCONFINED COMPRESSION TEST: ASTM D2166

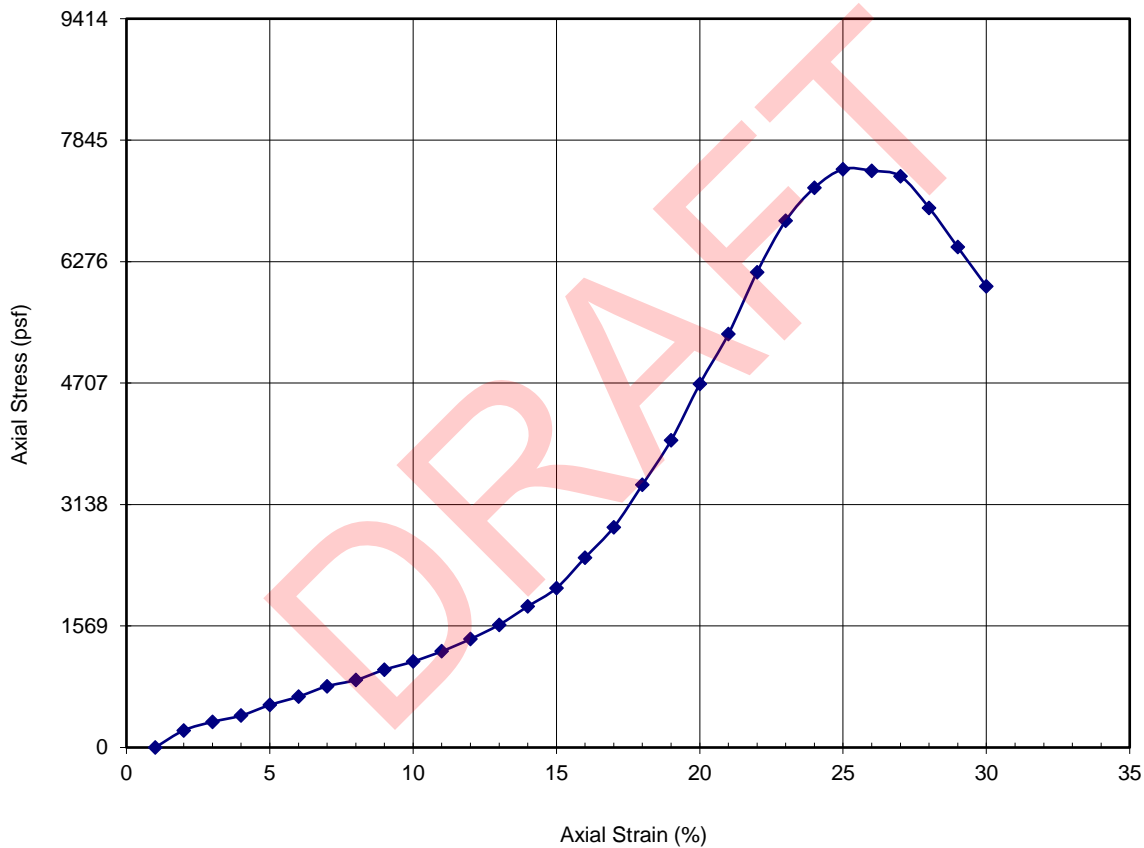

Wet Density (pcf)	125.0	Initial Height (in)	3.96
Dry Density (pcf)	105.6	Initial Diameter (in)	1.92
Moisture Content (%)	18.3	Relative Compaction (%)	N/A
Compressive Strength (psf)	7,500	Deviation From OMC (%)	N/A

Remarks:

Respectfully Submitted,
Professional Service Industries, Inc.

UNCONFINED COMPRESSION REPORT

Tested For: Thompson Thrift Residential
 111 Monument Circle, Suite 1500
 Indianapolis, Indiana 46204

Project Name: Proposed Multi-Family
 Development
 Sample Date: September 14, 2024
 Project No. 05322879
 Sample No. B29
 Depth 15

UNCONFINED COMPRESSION TEST: ASTM D2166

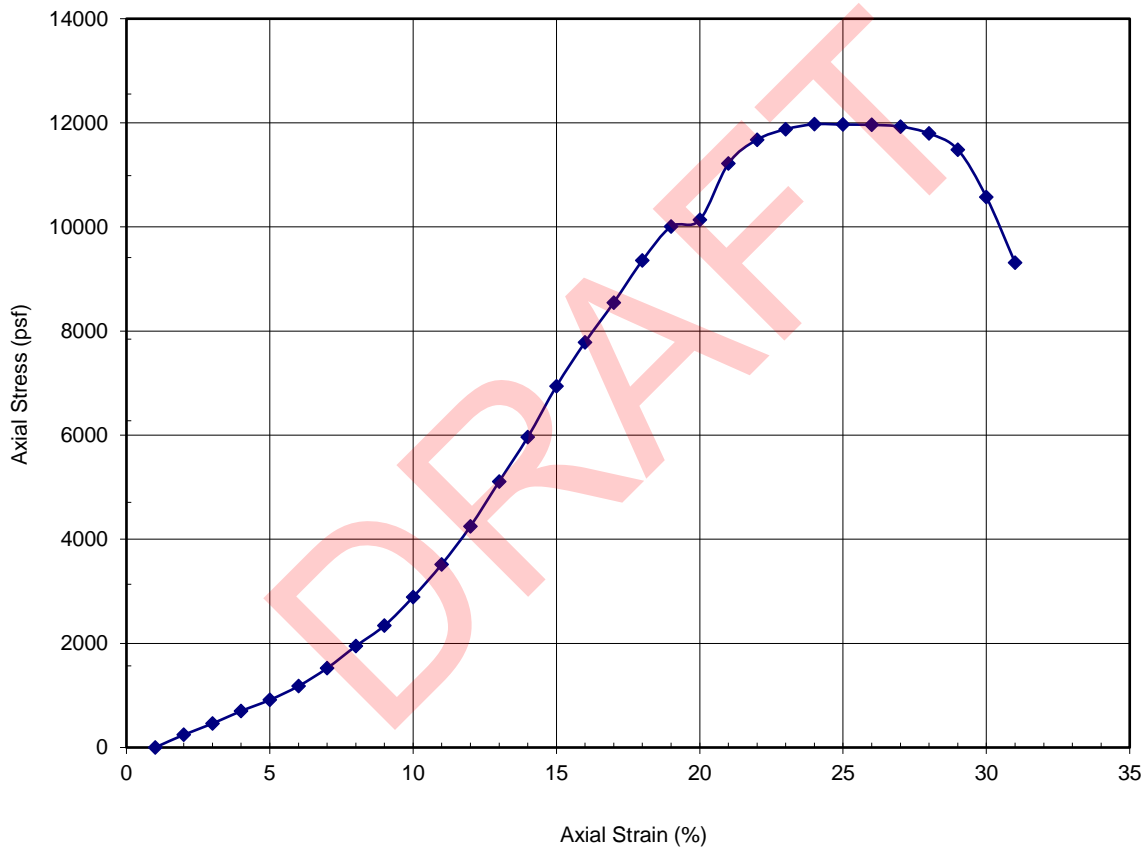

Wet Density (pcf)	126.2	Initial Height (in)	4.01
Dry Density (pcf)	105.2	Initial Diameter (in)	1.94
Moisture Content (%)	20.0	Relative Compaction (%)	N/A
Compressive Strength (psf)	12,000	Deviation From OMC (%)	N/A

Remarks:

Respectfully Submitted,
Professional Service Industries, Inc.

REPORT OF MOISTURE DENSITY RELATIONSHIP OF SOIL

Tested For: Thompson Thrift Residential

Project Name: TTRes Venetucci Blvd

Sample Date: September 11, 2024

Project No. 05322879-1

Report No. 1

Sample No. 1

Sample Source:

Sample Classification: A-7-6 (51) CH fat clay

General Description:

Test Method: ASTM D698 Method A

Rammer: Manual

Method of Preparation: Moist

Atterberg Limits (AASHTO T-89/T-90)

LL: 67.8 PL: 20.06 PI: 47.7

Specific Gravity: 2.60 Estimate

Maximum Dry Density (pcf): 95.6

Optimum Moisture Content (%): 22.2

Grain Size Analysis

(ASTM C136 and/ or C117)

Sieve Size	Percent Passing
3"	100
3"	100
1 1/2"	100
3/4"	100
1/2"	100
3/8"	100
No. 4	99
No. 8	99
No. 10	98
No. 16	98
No. 30	97
No. 40	97
No. 50	97
No. 100	96
No. 200	95

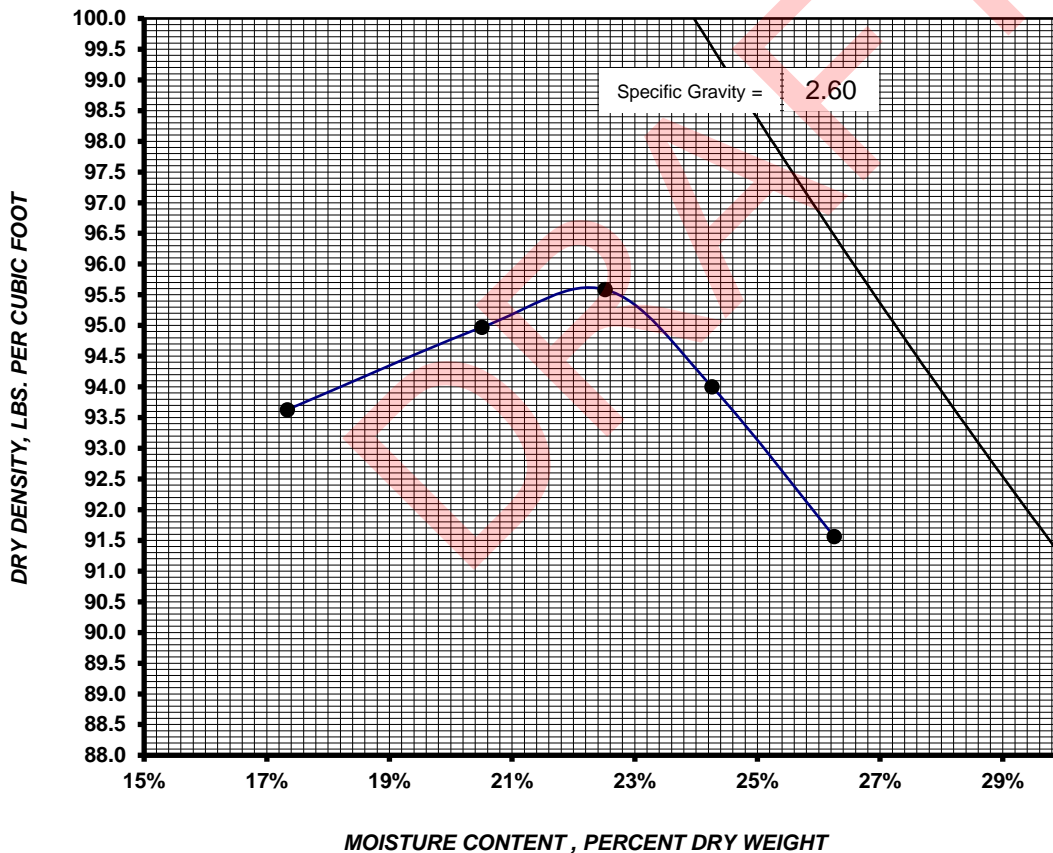

Respectfully Submitted,
Professional Service Industries, Inc.

Remarks:

Lab Tech: TH

REPORTS MAY NOT BE REPRODUCED, EXCEPT IN FULL, WITHOUT WRITTEN PERMISSION BY PROFESSIONAL SERVICE INDUSTRIES, INC.

SWELL-CONSOLIDATION TEST

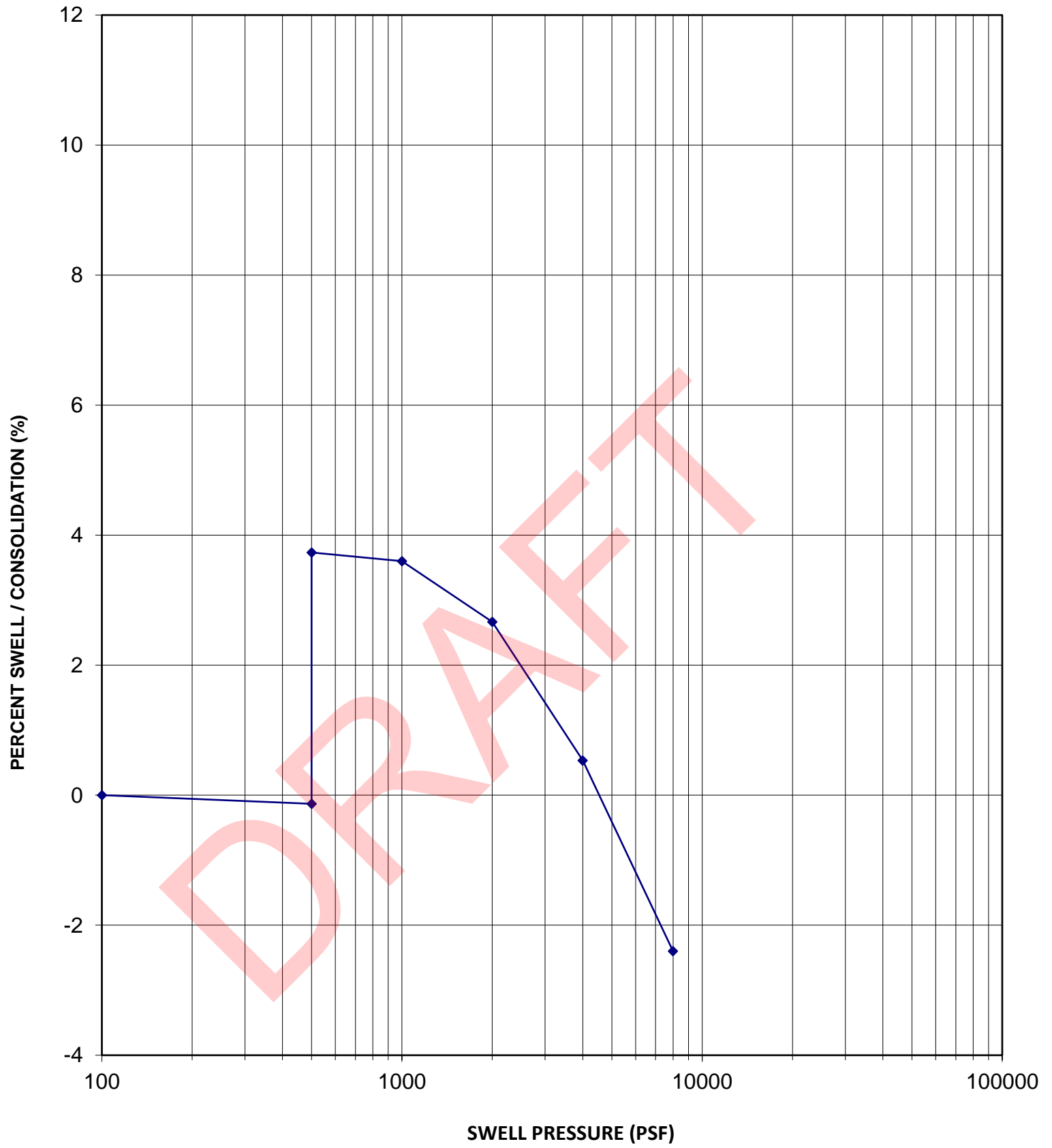

Sample Location	Remolded
Sample Depth	0 feet
Sample Description	Fat Clay
USCS Classification	CH

Dry Density	102 pcf
In-Situ Moisture Content	24.5 %
Volume Change	3.9 %
Swell Pressure	4,700 psf



TRes Venetucci Multifamily

JOB NO. 5322879

SWELL - CONSOLIDATION TEST

FIGURE NO. 0