



**MVE, INC.**  
ENGINEERS SURVEYORS

1903 kalaray street, suite 200  
colorado springs, co 80909  
719.635.5736

# Final Drainage Report

## **Townhomes at Western**

**Lot 1, Cimarron Southeast Filing  
No. 2C**

**Project No. 61203**

**July 11, 2024**

PCD File No. PPR-24-15

# Final Drainage Report

for

**Townhomes at Western  
Lot 1, Cimarron Southeast Filing No. 2C  
Project No. 61203**

**July 11, 2024**

prepared for

**J Elliott Homes, Inc.**  
13761 Bandanero Drive  
Peyton, CO 80831  
719.499.8214

prepared by

**MVE, Inc.**  
1903 Lelaray Street, Suite 200  
Colorado Springs, CO 80909  
719.635.5736

Copyright © MVE, Inc., 2024  
61203-Townhomes at Western Drainage Report.odt

# Statements and Acknowledgments

## Engineer's Statement

The attached drainage plan and report were prepared under my direction and supervision and are correct to the best of my knowledge and belief. Said drainage report has been prepared according to the criteria established by the County for drainage reports and said report is in conformity with the applicable master plan of the drainage basin. I accept responsibility for any liability caused by any negligent acts, errors or omissions or omissions occurring during this report.

David R. Gorman, P.E.  
Colorado No. 31672  
For and on Behalf of MVE, Inc.

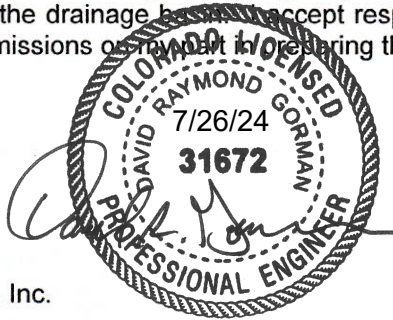

## Developer's Statement

I, the owner/developer have read and will comply with all of the requirements specified in this drainage report and plan.

  
\_\_\_\_\_  
J Elliott Homes, Inc.  
13761 Bandanero Drive  
Peyton, CO 80831

6/14/24  
Date

## El Paso County

Filed in accordance with the requirements of the Drainage Criteria Manual, Volumes 1 and 2, El Paso County Engineering Criteria Manual and Land Development Code as amended.

\_\_\_\_\_  
Joshua Palmer, P.E.,  
County Engineer / ECM Administrator

7/30/2024  
Date

# Contents

Statements and Acknowledgments.....	iii
Contents.....	v
Final Drainage Report.....	1
<b>1 General Location and Description.....</b>	<b>1</b>
1.1 Location.....	1
1.2 Description of Property.....	1
1.3 Soils.....	1
1.4 Floodplain .....	2
<b>2 Drainage Basins and Sub-Basins.....</b>	<b>2</b>
2.1 Major Basin Descriptions.....	2
2.2 Other Drainage Reports.....	2
2.3 Sub-Basin Description.....	2
<b>3 Drainage Design Criteria.....</b>	<b>3</b>
3.1 Development Criteria Reference.....	3
3.2 Hydrologic Criteria.....	3
<b>4 Drainage Facility Design.....</b>	<b>3</b>
4.1 General Concept.....	3
4.2 Specific Details.....	3
4.3 Drainage Facilities.....	8
4.4 Erosion Control.....	8
4.5 Water Quality Enhancement Best Management Practices.....	9
<b>5 Opinion of Probable Cost for Drainage Facilities.....</b>	<b>9</b>

<b>6 Drainage and Bridge Fees</b> .....	10
<b>7 Conclusion</b> .....	10
References.....	11
Appendices.....	13
<b>1 General Maps and Supporting Data</b> .....	13
<b>2 Hydrologic Calculations</b> .....	14
<b>3 Hydraulic Calculations</b> .....	31
<b>4 Drainage Maps</b> .....	41

# Final Drainage Report

The purpose of this Final Drainage Report is to identify drainage patterns and quantities within and affecting the proposed Townhomes at Western site. The report will discuss the recommended drainage improvements to the site and identify drainage requirements relative to the existing conditions and proposed project. This report has been prepared and submitted in accordance with the requirements of the El Paso County development approval process. An Appendix is included with this report with pertinent calculations and graphs used in the drainage analyses and design.

## 1 General Location and Description

### 1.1 Location

The proposed Townhomes at Western site is located within the southeast quarter of Section 7, Township 14 South, Range 65 west of the 6th principal meridian in El Paso County, Colorado. The site is platted as Lot 1, Cimarron Southeast Filing No. 2C. The site is situated east of Hathaway Drive and on the south side of Western Drive. The EPC Assessor's Schedule Number for the site is 5407401016 with the address of 721 Western Drive. Commercial properties and multifamily are located to the west and north and golf course to the east. US Highway 24 is to the south. A **Vicinity Map** is included in the **Appendix**.

### 1.2 Description of Property

The Townhomes at Western site is 7.118± acres and zoned RM-30 (residential multi-dwelling). This site is currently vacant except for some concrete pavement in the south access drive.

Ground cover in most of the Lot is undisturbed pasture/meadow conditions with fair to good ground cover featuring native grasses with a few dirt / gravel vehicle drive areas.

The site slopes from northwest to southeast grades averaging 10%. The East Fork of Sand Creek flows adjacent to the site along the east edge and no significant drainage improvements or drainage facilities currently exist on the site.

### 1.3 Soils

According to the National Resource Conservation Service, there is one (1) soil type identified in the Townhomes at Western site. The primary soil is Blakeland loamy sand, 1 to 9 percent slopes (map unit 8).

Blakeland loamy sand (map unit 8) is deep and somewhat excessively drained. Permeability is rapid, surface runoff is slow, the hazard of erosion is moderate. Blakeland loamy sand is classified as being part of Hydrologic Soil Group A.

A portion of the Soil Map and data tables from the National Cooperative Soil Survey and relevant Official Soil Series Descriptions (OSD) are included in the **Appendix**.<sup>1 2</sup>

---

1 WSS  
2 OSD

## 1.4 Floodplain

The current Flood Insurance Study of the region includes Flood Insurance Rate Maps (FIRM), effective on December 7, 2018.<sup>3</sup> The proposed development is included in Community Panel Numbered 08041C0754 G of the Flood Insurance Rate Maps for the El Paso County. A portion of the site is shown to be included in Special Flood Hazard Area Zone AE as determined by FEMA. The Floodplain line as shown on the FIRM Panel lies above the base flood elevation listed when compared to the field survey. A Letter Of Map Amendment (LOMA) has been filed with FEMA. No structures shall be constructed within the designated floodplain until a LOMA has been approved. A portion of the current FEMA Flood Insurance Rate Maps with the site delineated is included in the **Appendix**.

## 2 Drainage Basins and Sub-Basins

### 2.1 Major Basin Descriptions

The Townhomes at Western site is located in the Sand Creek Drainage Basin (FOFO4000) of the Fountain Creek Major Drainage Basin (FO). This basin drains to the adjacent East Fork Sand Creek east of the site. The Sand Creek Drainage Basin encompasses a portion of El Paso County and Colorado Springs east of Colorado Springs extending from Shoup Road south to Hancock Expressway and generally drains southwesterly into Fountain Creek.

### 2.2 Other Drainage Reports

The Drainage Letter for “Cimarron Southeast Filing No. 2C” prepared by G. L. Williams & Partners, LTD dated August 17, 1978 (No Project Number). was written for this one lot which contains the Townhomes at Western site. A copy of this letter is included in the **Appendix**.

### 2.3 Sub-Basin Description

The existing drainage patterns of the Townhomes at Western are described by three off-site and six on-site drainage basins. These basins are previously disturbed or developed to a degree as described below. All existing basin delineations and data are depicted on the attached **Existing Drainage Map**.

#### 2.3.1 Existing Drainage Patterns (Off-Site)

There are three offsite sub-basins that drain into this site from the north and west consisting of a portion of Western Drive (Sub-Basin OS-A1), the rear of the apartment complex to the west (Sub-Basin OS-B1) and the commercial building and paved area to the southwest (Sub-Basin OS-B2).

#### 2.3.2 Existing Drainage Patterns (On-Site)

Existing Sub-Basin EX-A2 represents the majority of the existing site. This sub-basin slopes approximately 10% from northwest to southeast. The flows concentrate at a point along the eastern edge of the property very close to the elevation of the Base Flood Elevation (BFE) of Sand Creek.

Existing Sub-Basin EX-A3 represents the central portion of the existing site. This sub-basin slopes approximately 10% from northwest to southeast. The flows sheet across the property and drain directly into the adjacent East Fork Sand Creek along a portion of the east edge.

Existing Sub-Basin EX-A4 represents the northern portion of the existing site. This sub-basin slopes approximately 10% from northwest to southeast. The flows sheet across the property and drain directly into the adjacent East Fork Sand Creek along a portion of the east edge.

Existing Sub-Basin EX-B3 is a small portion of the western side of the site receiving flows from the apartments adjacent to the west and then flowing back off-site into OS-B2.

Existing Sub-Basin EX-B4 represents the south paved drive/parking. This sub-basin features very mild slopes eventually draining to the east edge of the site and drain directly into the adjacent East Fork Sand Creek at a point of erosion identified in the existing Drainage Letter.

---

3 FIRM

Existing sub-basin EX-C1 represents the side slope of the East Fork Sand Creek channel that lies on the property.

The Drainage Letter for “Cimarron Southeast Filing No. 2C” identified the site as sub-basins 2 & 3 with about 15.9 cfs in the 100 year storm generally in sub-basin EX-A2 and 14.3 cfs in sub-basin EX-B4.

### 3 Drainage Design Criteria

#### 3.1 Development Criteria Reference

This Final Drainage Report for Townhomes at Western has been prepared according to the report guidelines presented in the latest edition of *El Paso County Drainage Criteria Manual (DCM)*<sup>4</sup>. The County has also adopted portions of the City of Colorado Springs Drainage Criteria Manual Volumes 1 and 2, especially concerning the calculation of rainfall runoff flow rates.<sup>5 6</sup> The hydrologic analysis is based on a collection of data from the DCM, the NRCS Web Soil Survey<sup>7</sup>, and existing topographic data by Polaris Surveying.

#### 3.2 Hydrologic Criteria

For this Final Drainage Report, the Rational Method as described in the *Drainage Criteria Manual* has been used for all Storm Runoff calculations, as the development and all sub-basins are less than 130 acres in area. “Colorado Springs Rainfall Intensity Duration Frequency” curves, Figure 6-5 in the DCM, was used to obtain the design rainfall values; a copy is included in the **Appendix**. The “Overland (Initial) Flow Equation” (Eq. 6-8) in the DCM, and Manning's equation with estimated depths were used in time of concentration calculations. “Runoff Coefficients for Rational Method”, Table 6-6 in the DCM, was utilized as a guide in estimating runoff coefficient and Percent Impervious values; a copy is included in the **Appendix**. Peak runoff discharges were calculated for each drainage sub-basin for both the 5-year storm event and the 100-year storm event with the Rational Method formula, (Eq. 6-5) in the DCM.<sup>8</sup>

The Full Spectrum Extended Detention Basin (FS EDB) was sized and designed according to the procedures and tools presented by the Mile High Flood District's Urban Storm Drainage Criteria Manuals Volume 2 and Volume 3 as adopted by City of Colorado Springs.<sup>9 10</sup> Private storm drain inlets were also sized and analyzed using Mile High Flood District's design worksheets.

### 4 Drainage Facility Design

#### 4.1 General Concept

The intent of the drainage concept presented in this Final Drainage Report is to maintain the existing drainage patterns on the site Major and minor storm flows will continue to be safely conveyed through the site and downstream.

The existing and proposed drainage hydrologic conditions are described in more detail below. Input data and results for all calculations are included in the **Appendix**. Drainage maps for the hydrology are also included in the **Appendix**.

#### 4.2 Specific Details

##### 4.2.1 Off-Site Hydrologic Conditions

Sub-Basin **OS-A1** (0.31± acres) represents the south half of a portion of Western Drive and a portion of the off-site slope west of the site. This sub-basin drains from north to south at with slopes ranging from 6% to 25%. Existing runoff discharges for this sub-basin are  $Q_5 = 0.5$  cfs and  $Q_{100} = 1.5$  cfs (existing flows). This flow enters the site along the northwest edge and into sub-basin **EX-A2**.

4 DCM Section 4.3 and Section 4.4

5 CS DCM Vol 1

6 CS DCM Vol 2

7 WSS

8 DCM

9 UDFCD V2

10 UDFCD V3



Sub-Basin **OS-B1** (0.54± acres) represents the eastern portion of the adjacent apartment building site containing gravel and grass open space areas. This sub-basin drains from west to east at with slopes ranging from 1% to 25%. Existing runoff discharges for this sub-basin are  $Q_5 = 1.1$  cfs and  $Q_{100} = 2.7$  cfs (existing flows). This flow enters the site along the northwest edge and primarily into sub-basin **EX-B3**.

Sub-Basin **OS-B2** (1.63± acres) represents the south commercial site lying west of the southern access drive of the site and consist or mostly paved parking area and building. This sub-basin drains from west to east at with slopes of approximately 1%. Existing runoff discharges for this sub-basin are  $Q_5 = 5.8$  cfs and  $Q_{100} = 11.3$  cfs (existing flows). This flow enters the site along the west edge and into sub-basin **EX-B4**.

#### 4.2.2 Existing Hydrologic Conditions

Existing Sub-Basin **EX-B3** (0.27± acres) represents the a small portion of the site lying between off-site sub-basin OS-B1 and OS-B2. This sub-basin is undeveloped pasture/meadow and drains into off-site sub-basin OS-B2. Existing runoff discharges for this sub-basin are  $Q_5 = 0.5$  cfs and  $Q_{100} = 1.3$  cfs (existing flows).

Existing Sub-Basin **EX-A2** (3.47± acres) represents the bulk of the central portion of the site. This sub-basin slopes approximately 10% from north to south with areas near 25%. The flows concentrate at a point along the eastern edge of the site very close to the elevation of the Base Flood Elevation (BFE) of the East Fork Sand Creek. The sub-basin is undeveloped and consist of mostly pasture/meadow. Existing runoff discharges for this sub-basin are  $Q_5 = 1.2$  cfs and  $Q_{100} = 8.3$  cfs (existing flows). This runoff combines with additional flows from off-site sub-basin OS-A1 before existing the property along the southeast side at **Design Point 2 (EX-DP2)**. The combined existing runoff discharges for this design point are  $Q_5 = 1.6$  cfs and  $Q_{100} = 9.4$  cfs (existing flows).

Existing Sub-Basin **EX-A3** (0.59± acres) represents a portion of the central portion of the site. This sub-basin slopes approximately 10% from north to south with areas near 25%. The flows sheet off of the site into the west edge of the East Fork Sand Creek. The sub-basin is undeveloped and consist of mostly pasture/meadow. Existing runoff discharges for this sub-basin are  $Q_5 = 0.9$  cfs and  $Q_{100} = 2.4$  cfs (existing flows).

Existing Sub-Basin **EX-A4** (1.52± acres) represents the northern portion of the site. This sub-basin slopes approximately 10% from north to south with areas near 25%. The flows sheet off of the site into the west edge of the East Fork Sand Creek. The sub-basin is undeveloped and consist of mostly pasture/meadow. Existing runoff discharges for this sub-basin are  $Q_5 = 0.6$  cfs and  $Q_{100} = 4.2$  cfs (existing flows).

Existing Sub-Basin **EX-B3** (0.27± acres) represents the a small portion of the site lying between off-site sub-basin OS-B1 and OS-B2. This sub-basin is undeveloped pasture/meadow and drains into off-site sub-basin OS-B2. Existing runoff discharges for this sub-basin are  $Q_5 = 0.5$  cfs and  $Q_{100} = 1.3$  cfs (existing flows).

Existing Sub-Basin **EX-B4** (0.66± acres) represents the drive/parking area of the adjacent commercial property that lies on the site. This sub-basin is entirely paved and drains primarily via an existing curb & gutter to a concentrated point of discharge at the southeast of the sub-basin. This point was identified in the previous drainage letter as a point needing filled and protected. Existing runoff discharges for this sub-basin are  $Q_5 = 3.1$  cfs and  $Q_{100} = 5.5$  cfs (existing flows).

Existing Sub-Basin **EX-C1** (0.60± acres) represents the side slope of the East Fork Sand Creek channel that lies on the site. The eastern portion of the sub-basin is heavily wooded and the southern is existing pasture/meadow. Existing runoff discharges for this sub-basin are  $Q_5 = 0.2$  cfs and  $Q_{100} = 1.8$  cfs (existing flows). This runoff combines with additional flows from off-site sub-basins OS-B1, OS-B2 and on-site sub-basins EX-B3 and EX-B4 before existing the property along the southeast side at **Design Point 1 (EX-DP1)**. The combined existing runoff discharges for this design point are  $Q_5 = 10.7$  cfs and  $Q_{100} = 22.5$  cfs (existing flows).

The **Existing Drainage Map** depicts the existing topographic mapping, drainage basin delineations, drainage patterns, existing drives, drainage facilities, and runoff quantities with a data table including drainage areas and flow rates.

#### 4.2.3 Proposed Hydrologic Conditions

Proposed Sub-Basin **A2** (0.14± acres) represents a portion of the northern part of the site along Western Drive being landscape area between the northern buildings and the property line. This sub-basin slopes approximately 2% from south to north and into Western Drive. Proposed runoff discharges for this sub-basin are  $Q_5 = 0.1$  cfs and  $Q_{100} = 0.4$  cfs. Sub-Basin A2 is not routed to the proposed pond and contains no proposed improvements except landscape. Sub-Basin A2 can not be reasonably directed to a water quality facility and is excluded from water quality treatment per ECM App I.7.1.C.1. Sub-Basin A2 is 0.14 acres and comprises 1.9% of the site.

Developed Sub-Basin **A3** (0.59± acres) is located in the eastern portion of the site. The sub-basin will contain paved drive, buildings, sidewalks and landscaped areas draining to the southeast. Sub-basin A3 does not accept off-site flows from Western Drive adjacent on the north. Sub-basin A3 produces peak discharges of  $Q_5 = 1.5$  cfs and  $Q_{100} = 3.3$  cfs. These storm water flows travel overland through the landscaped areas and to the paved drives. Then they flow across the paved area and via curb & gutter to the southeast corner of the site to Inlet A3. A proposed private single Denver Type 16 Combination sump inlet at the end of the drive will collect these flows and they will flow via a private 12" HDPE pipe to Inlet A10. The inlet will collect the flows with no bypass. Emergency overflow from this inlet will overtop the curb and flow southeast directly to the East Fork Sand Creek channel.

Developed Sub-Basin **A4** (0.36± acres) is located in the northern central portion of the site. The sub-basin will contain paved drive, buildings, sidewalks and landscaped areas draining to the southwest. Sub-basin A4 produces peak discharges of  $Q_5 = 1.3$  cfs and  $Q_{100} = 2.5$  cfs. These storm water flows travel overland through the landscaped areas and to the paved drives. Then they flow across the paved area and via curb & gutter to the southwest to Inlet A4. A proposed private triple Denver Type 16 Combination inlet on grade will collect these flows and they will flow via a private 12" HDPE pipe to Inlet A5. The inlet will collect flows the flows with no bypass. Per the MHFD Inlet Worksheet, the storm sewer was sized with the interception capacity of Inlet A4 being  $Q_5 = 1.4$  cfs and  $Q_{100} = 2.4$  cfs. Emergency overflow from this inlet will continue along the proposed curb & gutter to Inlet A5.

Developed Sub-Basin **A5** (0.30± acres) is located in the northern central portion of the site. The sub-basin will contain paved drive, buildings, sidewalks and landscaped areas draining to the southwest. Sub-basin A5 produces peak discharges of  $Q_5 = 1.0$  cfs and  $Q_{100} = 2.0$  cfs. These storm water flows travel overland through the landscaped areas and to the paved drives. Then they flow across the paved area and via curb & gutter to the southwest to Inlet A5. A proposed private triple Denver Type 16 Combination inlet on grade will collect these flows and they will flow via a private 12" HDPE pipe to Inlet A6. The inlet will collect flows the flows with no bypass. Per the MHFD Inlet Worksheet, the storm sewer was sized with the interception capacity of Inlet A5 being  $Q_5 = 1.0$  cfs and  $Q_{100} = 2.1$  cfs. Bypass flows  $Q_5 = 0.0$  cfs and  $Q_{100} = 0.1$  cfs continue southwest to Inlet A6. Emergency overflow from this inlet will continue along the proposed curb & gutter to Inlet A6.

Developed Sub-Basin **A6** (0.29± acres) is located in the northern central portion of the site. The sub-basin will contain paved drive, buildings, sidewalks and landscaped areas draining to the southwest. Sub-basin A5 produces peak discharges of  $Q_5 = 1.1$  cfs and  $Q_{100} = 2.1$  cfs. These storm water flows travel overland through the landscaped areas and to the paved drives. Then they flow across the paved area and via curb & gutter to the southwest to Inlet A6. A proposed private triple Denver Type 16 Combination inlet on grade will collect these flows and they will flow via a private 18" HDPE pipe south to Inlet A11. The inlet will collect the flows with no bypass. Per the MHFD Inlet Worksheet, the storm sewer was sized with the interception capacity of Inlet A6 being  $Q_5 = 1.1$  cfs and  $Q_{100} = 2.1$  cfs. Emergency overflow from this inlet will continue along the proposed curb & gutter to Inlet A7.

Developed Sub-Basin **A7** (1.14± acres) is located in the northwestern and western portion of the site. The sub-basin will contain paved drive, buildings, sidewalks and landscaped areas draining to the south. Sub-basin A7 produces peak discharges of  $Q_5 = 3.5$  cfs and  $Q_{100} = 7.1$  cfs. These storm

water flows travel overland through the landscaped areas and to the paved drives. Then they flow across the paved area and via curb & gutter to the southwest, south and east to Inlet A7. A proposed private triple Denver Type 16 Combination inlet on grade will collect these flows and they will flow via a private 18" HDPE pipe north to Inlet A8. The inlet will bypass flows of  $Q_5 = 0.2$  cfs and  $Q_{100} = 1.4$  cfs east to Inlet A9. Per the MHFD Inlet Worksheet, the storm sewer was sized with the interception capacity of Inlet A7 being  $Q_5 = 3.3$  cfs and  $Q_{100} = 5.7$  cfs. Emergency overflow from this inlet will continue along the proposed curb & gutter to Inlet A9.

Developed Sub-Basin **A8** (0.18± acres) is located in the west central portion of the site. The sub-basin will contain paved drive, buildings, sidewalks and landscaped areas draining to the east. Sub-basin A8 produces peak discharges of  $Q_5 = 0.6$  cfs and  $Q_{100} = 1.2$  cfs. These storm water flows travel overland through the landscaped areas and to the paved drives. Then they flow across the paved area and via curb & gutter to the southeast to Inlet A8. A proposed private triple Denver Type 16 Combination inlet on grade will collect these flows and they will flow via a private 18" HDPE pipe east to the pond. The inlet will collect the flows with no bypass. Per the MHFD Inlet Worksheet, the storm sewer was sized with the interception capacity of Inlet A8 being  $Q_5 = 0.6$  cfs and  $Q_{100} = 1.2$  cfs. Emergency overflow from this inlet will continue along the proposed curb & gutter to Inlet A9.

Developed Sub-Basin **A9** (0.84± acres) is located in the central portion of the site. The sub-basin will contain paved drive, buildings, sidewalks and landscaped areas draining to the east. Sub-basin A9 produces peak discharges of  $Q_5 = 2.7$  cfs and  $Q_{100} = 5.5$  cfs. These storm water flows travel overland through the landscaped areas and to the paved drives. Then they flow across the paved area and via curb & gutter to the central area of the site to Inlet A9. A proposed private triple Denver Type 16 Combination sump inlet at the low point of the drive will collect these flows and they will flow via a private 24" HDPE pipe to the pond. The inlet will collect the flows with no bypass. Emergency overflow from this inlet will overtop the curb and flow east and down the slope to the East Fork Sand Creek channel.

Developed Sub-Basin **A10** (0.42± acres) is located in the east central portion of the site. The sub-basin will contain paved drive, buildings, sidewalks and landscaped areas draining to the southwest. Sub-basin A10 produces peak discharges of  $Q_5 = 1.5$  cfs and  $Q_{100} = 2.9$  cfs. These storm water flows travel overland through the landscaped areas and to the paved drives. Then they flow across the paved area and via curb & gutter to the southwest to Inlet A10. A proposed private triple Denver Type 16 Combination inlet on grade will collect these flows and they will flow via a private 18" HDPE pipe southwest to Inlet A11. The inlet will bypass flows of  $Q_5 = 0.0$  cfs and  $Q_{100} = 0.2$  cfs southwest to Inlet A11. Per the MHFD Inlet Worksheet, the storm sewer was sized with the interception capacity of Inlet A10 being  $Q_5 = 1.5$  cfs and  $Q_{100} = 2.5$  cfs. Emergency overflow from this inlet will continue along the proposed curb & gutter to Inlet A11.

Developed Sub-Basin **A11** (0.22± acres) is located in the central portion of the site. The sub-basin will contain paved drive, buildings, sidewalks and landscaped areas draining to the southwest. Sub-basin A11 produces peak discharges of  $Q_5 = 0.8$  cfs and  $Q_{100} = 1.6$  cfs. These storm water flows travel overland through the landscaped areas and to the paved drives. Then they flow across the paved area and via curb & gutter to the southwest to Inlet A11. A proposed private triple Denver Type 16 Combination inlet on grade will collect these flows and they will flow via a private 18" HDPE pipe south into the pond. The inlet will collect the flows with no bypass. Per the MHFD Inlet Worksheet, the storm sewer was sized with the interception capacity of Inlet A11 being  $Q_5 = 0.8$  cfs and  $Q_{100} = 1.8$  cfs. Emergency overflow from this inlet will continue along the proposed curb & gutter to Inlet A9.

Proposed Sub-Basin **A12** (0.43± acres) represents the Full Spectrum Extended Detention Basin (FS-EDB) Pond 1. Sub-Basin A12 will consist of native grasses, gravel access drive and paved inlet and outlet works of the FS-EDB. Proposed runoff discharges for this sub-basin are  $Q_5 = 0.3$  cfs and  $Q_{100} = 1.5$  cfs. The FS-EDB receives flows from sub-basin OS-A1, A2, A7, A8 & A9 into a forebay at the south side of the FS-EDB and from sub-basins A3, A4, A5, A6, A10 & A11 into a forebay at the north side of the FS-EDB. The combined flows from all sources entering the FS-EDB are  $Q_5 = 15.0$  cfs and  $Q_{100} = 31.6$  cfs. These flows are treated and detained by the facility and released directly into the East Fork Sand Creek channel. The FS-EDB is discussed in more detail in the next section.

Proposed Sub-Basin **B3** (0.16± acres) represents the a small portion of the site lying between off-site sub-basin OS-B1 and OS-B2. This sub-basin is will contain landscape and drain east to sub-basin B4. Sub-Basin B3 produces peak discharges of  $Q_5 = 0.1$  cfs and  $Q_{100} = 0.4$  cfs. Sub-Basin B3 is existing undeveloped land that will receive disturbance and remain primary undeveloped and is excluded from water quality treatment per ECM App I.7.1.B.7.

Proposed Sub-Basin **B4** (0.67± acres) converts the existing drive/parking area of the adjacent commercial property into an access drive and landscape buffer. The existing curb & gutter shall be removed from the edge of the drive and flows shall sheet off to the southeast. Sub-Basin B4 produces peak discharges of  $Q_5 = 2.2$  cfs and  $Q_{100} = 4.3$  cfs. Sub-Basin B4 can not be reasonably directed to a water quality facility and is excluded from water quality treatment per ECM App I.7.1.C.1. Sub-Basin B4 is 0.67 acres and comprises 9.4% of the site.

Proposed Sub-Basin **C1** (0.66± acres) represents the side slope of the East Fork Sand Creek channel that lies on the site. The eastern portion of the sub-basin is heavily wooded and the southern is existing pasture/meadow. Sub-basin C1 produces peak discharges of  $Q_5 = 0.3$  cfs and  $Q_{100} = 2.0$  cfs. This runoff combines with additional flows from off-site sub-basins OS-B1, OS-B2 and on-site sub-basins B3 and B4 before exiting the property along the southeast side at **Design Point 1 (DP1)**. The combined developed runoff discharges for this design point are  $Q_5 = 9.4$  cfs and  $Q_{100} = 20.8$  cfs. Sub-Basin C1 is existing undeveloped land that will receive disturbance and remain primary undeveloped and is excluded from water quality treatment per ECM App I.7.1.B.7.

Proposed Sub-Basins B3 & B4 which comprise 11.6% of the property (6.5% of that is paved) can not physically be directed to the FS-EDB and no practical means of treatment can be provided. The existing percent imperviousness for Sub-Basins B3 & B4 is 82.6%. The developed conditions remove a large amount of pavement and replaces it with landscape for a resulting 56.8% imperviousness, a reduction of 25.8%. The resulting flows existing the site at DP1 are decreased  $Q_5 = 1.3$  cfs and  $Q_{100} = 1.7$  cfs. The reduction of exiting imperviousness and flows adequately offsets the treatment requirement.

Proposed Sub-Basin **C2** (0.34± acres) is located along the eastern edge of the site. Sub-Basin C2 will contain reseeded graded slopes with no proposed improvements. Flows from sub-basin C2 drain east directly in the East Fork Sand Creek channel. Sub-basin C2 produces peak discharges of  $Q_5 = 0.2$  cfs and  $Q_{100} = 0.9$  cfs. Sub-Basin C2 is existing undeveloped land that will receive disturbance and remain primary undeveloped and is excluded from water quality treatment per ECM App I.7.1.B.7.

**Design Point 2 (DP2)** represents the location and the flows released from Pond 1. The developed runoff discharges for this design point are  $Q_5 = 0.2$  cfs and  $Q_{100} = 6.5$  cfs (developed flows). These flows combine with the flows from sub-basin C2. For a combined  $Q_5 = 0.4$  cfs and  $Q_{100} = 7.4$  cfs. The developed flows leaving the site at DP2 are 1.2 cfs lower in the 5 yr and 2.0 cfs lower in the 100 yr events.

Proposed Sub-Basin **C3** (0.36± acres) is located along the eastern edge of the site. Sub-Basin C3 will contain reseeded graded slopes with no proposed improvements. Flows from sub-basin C3 drain east directly in the East Fork Sand Creek channel. Sub-basin C3 produces peak discharges of  $Q_5 = 0.2$  cfs and  $Q_{100} = 0.9$  cfs. Sub-Basin C3 is existing undeveloped land that will receive disturbance and remain primary undeveloped and is excluded from water quality treatment per ECM App I.7.1.B.7.

The **Proposed Drainage Map** depicts the existing topographic mapping, proposed grading, proposed building, proposed pavement, drainage basin delineations, drainage patterns, and runoff quantities with a data table including drainage areas and flow rates.

The existing total flows from on-site and off-site that enter Sand Creek along the east of the site have peak discharges of  $Q_5 = 14.5$  cfs and  $Q_{100} = 41.9$  cfs. In the developed conditions, the combined total flows from the site entering directly into Sand Creek or through the FS-EDB Pond 1 have peak discharges of  $Q_5 = 10.0$  cfs and  $Q_{100} = 29.6$  cfs. The peak runoff entering Sand Creek from this project site are being reduced by  $Q_5 = 4.5$  cfs and  $Q_{100} = 12.3$  cfs. The peak runoff that sheet flows from DP1 into Sand Creek from this project site are being reduced by  $Q_5 = 1.3$  cfs and  $Q_{100} = 1.7$  cfs.

The concentrated peak runoff that at DP2 that enters Sand Creek from this project site are being reduced by  $Q_5 = 1.2$  cfs and  $Q_{100} = 2.0$  cfs. At all points, the flows entering the East Fork Sand Creek are reduced or maintained as described above.

### 4.3 Drainage Facilities

The proposed interior grading, landscaping, paved drives, storm drain inlets and storm drain pipes will direct the developed drainage runoff flows resulting from the proposed developed Lot 1 and to the proposed private FS-EDB. The private FS-EDB will be a private facility, owned and maintained by the property owner. Calculations for the drainage facilities are included in the **Appendix** of this report.

The storm drain inlets as described above will be Denver Type 16 Combination Inlets with steel grate and inlet throat on concrete boxes. The inlets were sized using the MHFCD Inlet worksheets containing the characteristics of the chosen inlet type. Inlet sizing calculations are included in the **Appendix**. The pipes leading from the inlets, through the site and to the FS-EDB forebay will be 12" to 24" diameter HDPE Pipe. Hydraulic Grade Line calculations for the storm drain pipes in the 5-year and 100-year scenarios were performed using MHFCD UD-Sewer and used the 5-year and 100-year maximum ponding depths in the FS-EDB to determine the tailwater elevations. The pipes were sized to contain the 5-year site flows with no surcharged segments. The calculations for the storm drain piping is included in the **Appendix** of this report.

The Full Spectrum Extended Detention Basin (FS-EDB) in sub-basin A12 will be constructed in accordance with El Paso Counties drainage criteria. The FS-EDB has been designed utilizing the MHFD – Detention, Version 4.06 (July 2022). The calculations for the FS-EDB are included in the **Appendix**. The contributed watershed area is 5.22 acres with the watershed imperviousness of 60.40% as determined in the runoff worksheet which is included in the **Appendix**. The total required detention volume was calculated to be 0.562 acre-feet as calculated with the Detention Basin Stage-Storage Table Builder. The total detention volume provided meets/exceeds said required volume. The outlet will be a concrete outlet box with close-mesh grate, concrete enclosed micro-pool with protective metal grate, also including the initial surcharge volume, 3' wide concrete trickle channel, concrete forebay and 18 inch HDPE outlet pipe. The Excess Urban Runoff Volume (EURV) will drain through the box by way of an orifice plate with three orifice holes. The 100-year outflows will drain through the grate top and will be limited by a restrictor plate at the 18 inch outlet pipe. Pipe outflows will drain to the adjacent West Fork Sub-Tributary as described above and shall be dissipated through type VL rip rap pad at the bottom of a 6" deep rip rap stilling basin with concrete level spreader. Calculations for rip rap pad are included in the **Appendix**. Any flows greater than the 500-year event will overflow the pond embankment at a 20 foot wide rip rap overflow spillway with concrete crest wall to the adjacent East Fork Sand Creek channel. The emergency overflow rip rap shall extend to the toe of the pond slope and be incorporated in the stilling basin. This point of outfall discharges less than the existing flows at this location, discharging only 7.4 cfs (when combined with sub-basin C2) in the 100 year event. The flow path between the level spreader and the bank of the East Fork Sand Creek consist of native vegetation and sandy soils. This outfall has been analyzed and velocities have been calculated to be 2.7 ft/s at the level spreader rip rap and 2 ft/s or less along the entire flow path to the creek. These are non-erosive velocities for the loamy sand soil type present at the site and for any type of vegetation. The riprap and level spreader disperses the pipe outflows across the width of the existing existing gently depressed flow path. The resulting peak flow rate and flow depth are less than the existing flows at this location. Therefore, this is a suitable outfall for the pond outflows entering the adjacent property and flowing to the creek. An exhibit map and channel calculations for several points downstream of the site along this flow path are included in the **Appendix**. Detailed design of this drainage facility and outfall will be provided with Construction Documents for the site

### 4.4 Erosion Control

During future construction, control measures (CM's) for erosion control will be employed based on the previously referenced City of Colorado Springs Drainage Criteria Manual Volume 2 and the Erosion Control Plan for the site. During Construction, silt fencing, sediment control logs, vehicle

tracking control, concrete washout area will be in place to minimize erosion from the site. Silt Fencing will be placed along the south and east portions of the disturbed areas. This will inhibit suspended sediment from leaving the site during construction. Silt fencing is to remain in place until the proposed berms are stabilized and vegetation is reestablished in the other disturbed areas which are to be reseeded. Vehicle tracking control will be placed at the access point in Western Drive. CM's will be utilized as deemed necessary by the contractor, engineer, owner, or County inspector and are not limited to the measures described above.

#### 4.5 Water Quality Enhancement Best Management Practices

The Extended Detention Basin described above will provide storage for the Water Quality Capture Volume (WQCV) for the site. A Grading and Erosion Control Plan for the construction of the site has been prepared in accordance with the provisions of the DCM. Placement of construction stormwater CM's will as required by the plan will limit soil erosion and deposition by stormwater flowing over the site.

The El Paso County Engineering Criteria Manual (Appendix I, Section 1.7.2 ) requires the consideration of a "Four Step Process for receiving water protection that focuses on reducing runoff volumes, treating the water quality capture volume (WQCV), stabilizing drainageways, and implementing long term source controls". The Four Step Process is incorporated in this project and the elements are discussed below.

- 1) Runoff Reduction Practices are employed in this project. Impervious surfaces have been reduced as much as practically possible.
- 2) All drainage paths on the site are stabilized with appropriate landscape treatment. The EDB is intended to intercept flows from the developed areas. Additionally, the pond outfall will drain to the adjacent West Fork Sub-Tributary as described above and shall be dissipated through type VL rip rap pad at the bottom of a 6" deep rip rap stilling basin with concrete level spreader.
- 3) The project contains no potentially hazardous uses. All developed areas drain into a proposed a WQCV CM except for Sub-Basins A2, B3, B4, C1, C2 and C3 which are excluded from water quality treatment as described above.
- 4) The site contains no storage of potentially harmful substances or use of potentially harmful substances. No Site Specific or Other Source Control CM's are required.

An exhibit map and table identifying each Sub-Basin and its respective method of Water Quality Treatment is included in the **Appendix**.

## 5 Opinion of Probable Cost for Drainage Facilities

The following cost opinion is for the construction of the required private storm water appurtenances which are non reimbursable. There are no public storm water facilities required.

### Opinion of Costs – On-Site Private Permanent CM Facilities – Non Reimbursable

• 2,500 CY Earthwork @ \$6/CY	= \$15,000
• Outlet Structure, Trickle Channel, & Forebays	= \$10,500
• 66 LF 18" HDPE Drain Pipe @ \$35/LF	= \$ 2,310
• 1 HDPE Flared End-section @ \$210/EA	= \$ 210
• 120 tons of VL Riprap @ \$104/Ton	= <u>\$12,480</u>
Sub – Total =	\$40,500
10% Engineering Contingency =	\$ 4,050
GRAND TOTAL =	\$44,550

### Opinion of Costs – On-Site Private Storm Water Facilities – Non Reimbursable

• 1 Inlet Denver Type 16 Combination (single) @ \$7210/EA	= \$ 7,210
• 8 Inlet Denver Type 16 Combination (triple) @ \$9925/EA	= \$79,400
• 1 Type II Manhole @ \$8,320/EA	= \$ 8,320
• 2 Nyloplast Drain Basin @ 4,600/EA	= \$ 9,200
• 722 LF 12" HDPE Drain Pipe @ \$35/LF	= \$25,270
• 418 LF 18" HDPE Drain Pipe @ \$45/LF	= \$18,810
• 56 LF 24" HDPE Drain Pipe @ \$55/LF	= \$ 3,080
Sub – Total =	\$151,290
10% Engineering Contingency =	\$ 15,129
GRAND TOTAL =	\$166,419

## 6 Drainage and Bridge Fees

The site is located within the Sand Creek Drainage Basin of Fountain Creek, El Paso Basin Number FOMO4000, which was last studied in 1996. Fees associated with this basin are Drainage Fees of \$25,632 per impervious acre and Bridge Fees of \$10,484 per impervious acre. The Lot was previously platted and replatted and originally zones M (Industrial). The percent Imperiousness of the Industrial site is 85% in accordance with El Paso County Engineering Criteria Manual Appendix L Table 3-1. The actual predeveloped percent imperiousness of the site is 14.0% and a developed percent imperviousness of 50.2%. Lot 1, Cimarron Southeast Filing No. 2C site contains 7.118 acres.

Since this Lot was previously platted in a zone with a higher assumed percent imperviousness, no Drainage or Bridge Fees are due.

## 7 Conclusion

This Final Drainage Report presents existing and proposed drainage conditions for the proposed Townhomes at Western project. The development will have negligible and inconsequential effects on the existing site drainage and drainage conditions downstream. The proposed project will not, with respect to stormwater runoff, negatively impact the adjacent properties and downstream properties.

# References

*NRCS Web Soil Survey.* United States Department of Agriculture, Natural Resources Conservation Service ("<http://websoilsurvey.nrcs.usda.gov/app/WebSoilSurvey.aspx>", accessed March, 2018).

*NRCS Official Soil Series Descriptions.* United States Department of Agriculture, Natural Resources Conservation Service ("<http://soils.usda.gov/technical/classification/osd/index.html>", accessed March, 2018).

*Flood Insurance Rate Map.* Federal Emergency Management Agency, National Flood Insurance Program (Washington D.C.: FEMA, March 17, 1997).

*NCSS Web Soil Survey.* United States Department of Agriculture, Natural Resources Conservation Service ("<http://websoilsurvey.nrcs.usda.gov/app/WebSoilSurvey.aspx>", accessed May, 2017).

*Drainage Criteria Manual Volume 2, Stormwater Quality Policies, Procedures and Best Management Practices (BMPs).* City of Colorado Spring Engineering Division (Colorado Springs: , May 2014).

*City of Colorado Springs Drainage Criteria Manual, Volume 1.* City of Colorado Springs Engineering Division Staff, Matrix Design Group/Wright Water Engineers (Colorado Springs: , May 2014).

*City of Colorado Springs/El Paso County Drainage Criteria Manual.* City of Colorado Springs, Department of Public Works, Engineering Division; HDR Infrastructure, Inc.; El Paso County, Department of Public Works, Engineering Division (Colorado Springs: City of Colorado Springs, Revised November 1991).

*City of Colorado Springs Drainage Criteria Manual Volume 1.* City of Colorado Springs Engineering Division with Matrix Design Group and Wright Water Engineers (Colorado Springs, Colorado: , May 2014).

*Urban Drainage Criteria Manual: Volume 3, Best Management Practices.* Urban Drainage and Flood Control District (Denver, Colorado: , November 2010).

*Urban Storm Drainage Criteria Manual: Volume 2, Structures, Storage, and Recreation.* Urban Drainage and Flood Control District (Denver, Colorado : , January 2016).

*Engineering Criteria Manual. County of El Paso, Colorado* (El Paso County, 2018)

*Drainage Letter for "Cimarron Southeast Filing No. 2C,* G. L. Williams & Partners, LTD, No Project Number, (El Paso County, August 17, 1978)



# | Appendices

## **1 General Maps and Supporting Data**

Vicinity Map  
Portion of Flood Insurance Rate Map  
Soil Type map and Tables  
Official Soil Series Descriptions  
Hydrologic Soil Group Map and Tables  
Previous Drainage letter

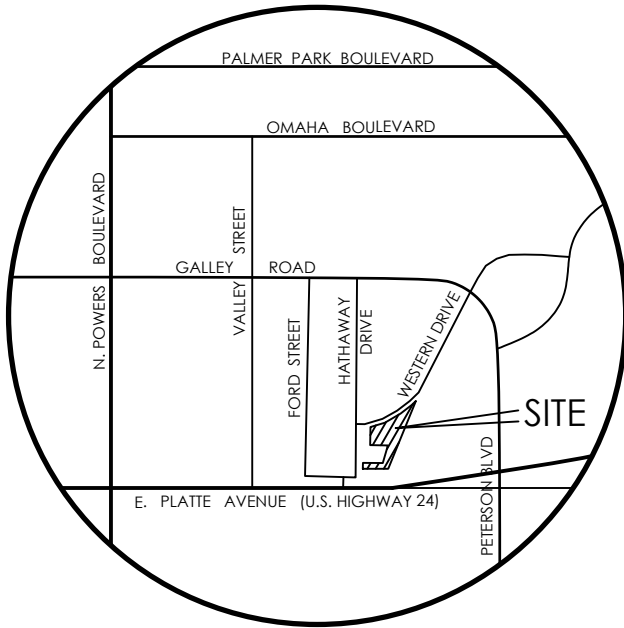

VICINITY MAP

---

NOT TO SCALE



# National Flood Hazard Layer FIRMMette



104°42'46"W 38°50'42"N

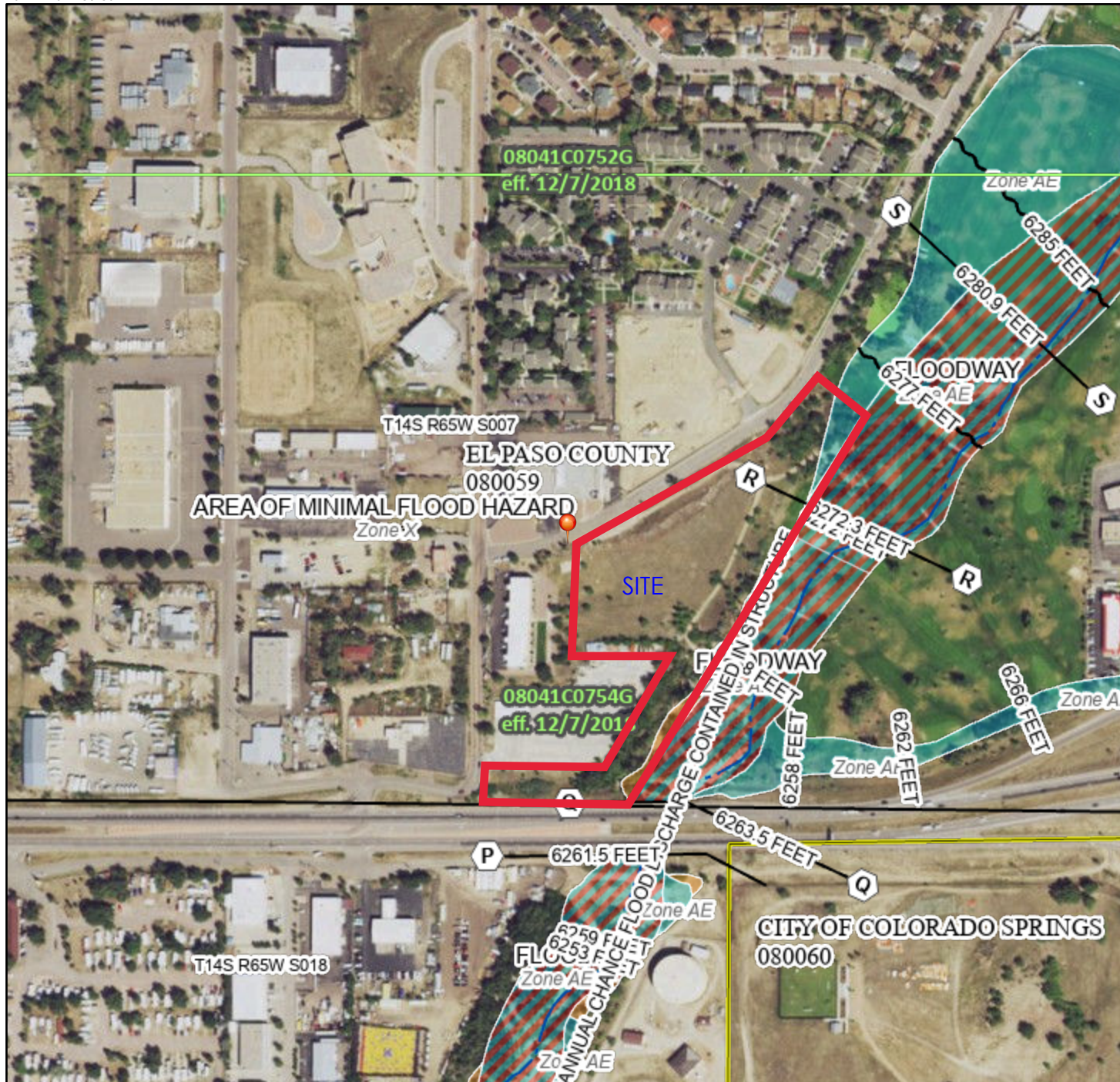

## Legend

SEE FIS REPORT FOR DETAILED LEGEND AND INDEX MAP FOR FIRM PANEL LAYOUT

- |                                    |  |   |
|------------------------------------|--|---|
| <b>SPECIAL FLOOD HAZARD AREAS</b>  |  | Without Base Flood Elevation (BFE)<br>Zone A, V, A99  |
|                                    |  | With BFE or Depth Zone AE, AO, AH, VE, AR   |
|                                    |  | Regulatory Floodway   |
| <b>OTHER AREAS OF FLOOD HAZARD</b> |  | 0.2% Annual Chance Flood Hazard, Areas of 1% annual chance flood with average depth less than one foot or with drainage areas of less than one square mile Zone X |
|                                    |  | Future Conditions 1% Annual Chance Flood Hazard Zone X  |
|                                    |  | Area with Reduced Flood Risk due to Levee. See Notes. Zone X  |
|                                    |  | Area with Flood Risk due to Levee Zone D  |
| <b>OTHER AREAS</b>                 |  | NO SCREEN Area of Minimal Flood Hazard Zone X   |
|                                    |  | Effective LOMRs   |
|                                    |  | Area of Undetermined Flood Hazard Zone D  |
| <b>GENERAL STRUCTURES</b>          |  | Channel, Culvert, or Storm Sewer  |
|                                    |  | Levee, Dike, or Floodwall   |
| <b>OTHER FEATURES</b>              |  | 20.2 Cross Sections with 1% Annual Chance Water Surface Elevation   |
|                                    |  | 17.5 Water Surface Elevation  |
|                                    |  | Coastal Transect  |
|                                    |  | Base Flood Elevation Line (BFE)   |
|                                    |  | Limit of Study  |
|                                    |  | Jurisdiction Boundary   |
|                                    |  | Coastal Transect Baseline   |
|                                    |  | Profile Baseline  |
|                                    |  | Hydrographic Feature  |
| <b>MAP PANELS</b>                  |  | Digital Data Available  |
|                                    |  | No Digital Data Available   |
|                                    |  | Unmapped  |



The pin displayed on the map is an approximate point selected by the user and does not represent an authoritative property location.

This map complies with FEMA's standards for the use of digital flood maps if it is not void as described below. The basemap shown complies with FEMA's basemap accuracy standards

The flood hazard information is derived directly from the authoritative NFHL web services provided by FEMA. This map was exported on 8/18/2023 at 4:22 PM and does not reflect changes or amendments subsequent to this date and time. The NFHL and effective information may change or become superseded by new data over time.

This map image is void if the one or more of the following map elements do not appear: basemap imagery, flood zone labels, legend, scale bar, map creation date, community identifiers, FIRM panel number, and FIRM effective date. Map images for unmapped and unmodernized areas cannot be used for regulatory purposes.

0 250 500 1,000 1,500 2,000 Feet 1:6,000

104°42'8"W 38°50'14"N

Basemap Imagery Source: USGS National Map 2023

# Custom Soil Resource Report for El Paso County Area, Colorado

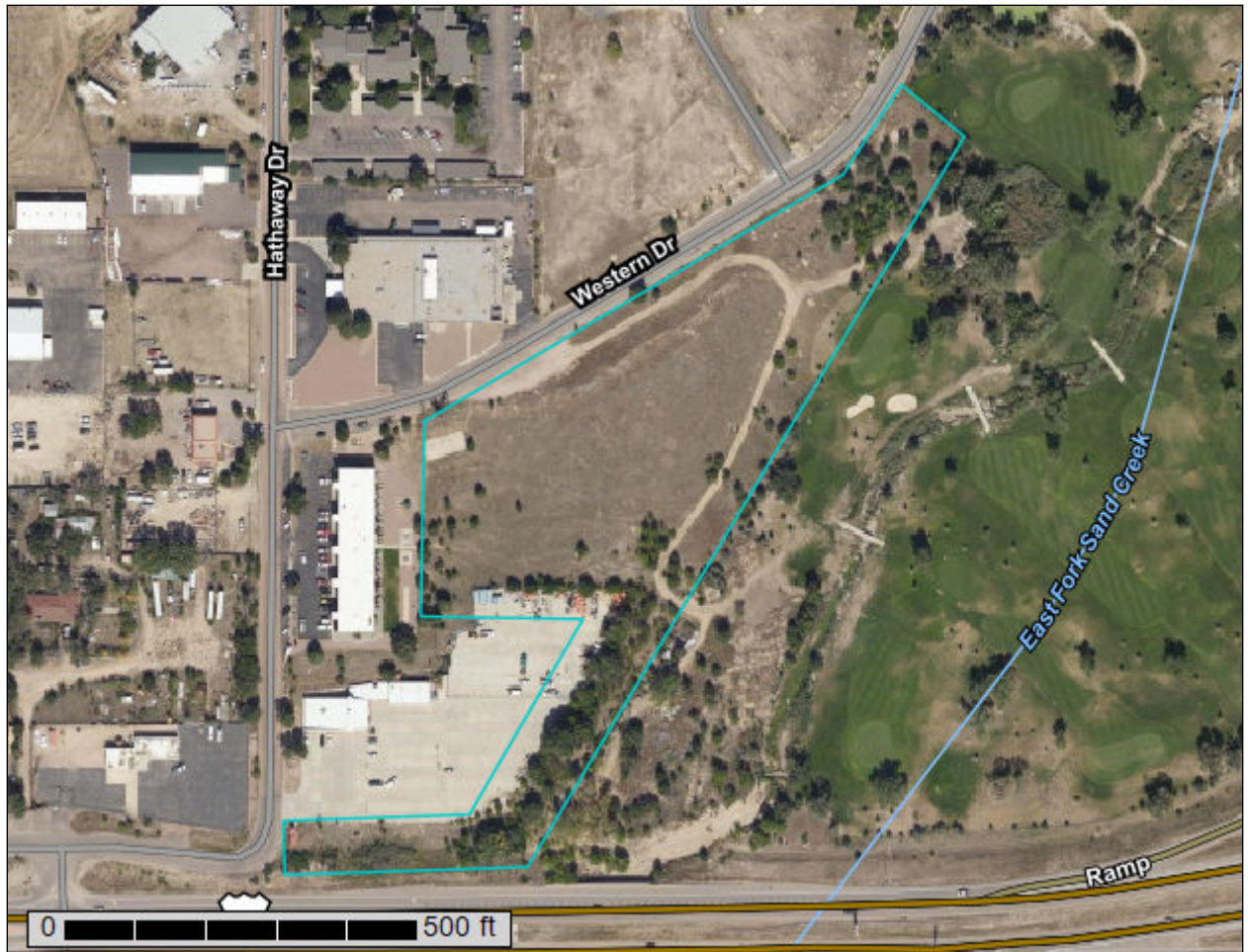

# Preface

---

Soil surveys contain information that affects land use planning in survey areas. They highlight soil limitations that affect various land uses and provide information about the properties of the soils in the survey areas. Soil surveys are designed for many different users, including farmers, ranchers, foresters, agronomists, urban planners, community officials, engineers, developers, builders, and home buyers. Also, conservationists, teachers, students, and specialists in recreation, waste disposal, and pollution control can use the surveys to help them understand, protect, or enhance the environment.

Various land use regulations of Federal, State, and local governments may impose special restrictions on land use or land treatment. Soil surveys identify soil properties that are used in making various land use or land treatment decisions. The information is intended to help the land users identify and reduce the effects of soil limitations on various land uses. The landowner or user is responsible for identifying and complying with existing laws and regulations.

Although soil survey information can be used for general farm, local, and wider area planning, onsite investigation is needed to supplement this information in some cases. Examples include soil quality assessments (<http://www.nrcs.usda.gov/wps/portal/nrcs/main/soils/health/>) and certain conservation and engineering applications. For more detailed information, contact your local USDA Service Center (<https://offices.sc.egov.usda.gov/locator/app?agency=nrcs>) or your NRCS State Soil Scientist ([http://www.nrcs.usda.gov/wps/portal/nrcs/detail/soils/contactus/?cid=nrcs142p2\\_053951](http://www.nrcs.usda.gov/wps/portal/nrcs/detail/soils/contactus/?cid=nrcs142p2_053951)).

Great differences in soil properties can occur within short distances. Some soils are seasonally wet or subject to flooding. Some are too unstable to be used as a foundation for buildings or roads. Clayey or wet soils are poorly suited to use as septic tank absorption fields. A high water table makes a soil poorly suited to basements or underground installations.

The National Cooperative Soil Survey is a joint effort of the United States Department of Agriculture and other Federal agencies, State agencies including the Agricultural Experiment Stations, and local agencies. The Natural Resources Conservation Service (NRCS) has leadership for the Federal part of the National Cooperative Soil Survey.

Information about soils is updated periodically. Updated information is available through the NRCS Web Soil Survey, the site for official soil survey information.

The U.S. Department of Agriculture (USDA) prohibits discrimination in all its programs and activities on the basis of race, color, national origin, age, disability, and where applicable, sex, marital status, familial status, parental status, religion, sexual orientation, genetic information, political beliefs, reprisal, or because all or a part of an individual's income is derived from any public assistance program. (Not all prohibited bases apply to all programs.) Persons with disabilities who require

alternative means for communication of program information (Braille, large print, audiotape, etc.) should contact USDA's TARGET Center at (202) 720-2600 (voice and TDD). To file a complaint of discrimination, write to USDA, Director, Office of Civil Rights, 1400 Independence Avenue, S.W., Washington, D.C. 20250-9410 or call (800) 795-3272 (voice) or (202) 720-6382 (TDD). USDA is an equal opportunity provider and employer.

# Contents

---

<b>Preface</b> .....	2
<b>How Soil Surveys Are Made</b> .....	5
<b>Soil Map</b> .....	8
Soil Map (SOIL MAP ).....	9
Legend.....	10
Map Unit Legend (SOIL MAP ).....	11
Map Unit Descriptions (SOIL MAP ).....	11
El Paso County Area, Colorado.....	13
8—Blakeland loamy sand, 1 to 9 percent slopes.....	13
28—Ellicott loamy coarse sand, 0 to 5 percent slopes.....	14
<b>References</b> .....	16

# How Soil Surveys Are Made

---

Soil surveys are made to provide information about the soils and miscellaneous areas in a specific area. They include a description of the soils and miscellaneous areas and their location on the landscape and tables that show soil properties and limitations affecting various uses. Soil scientists observed the steepness, length, and shape of the slopes; the general pattern of drainage; the kinds of crops and native plants; and the kinds of bedrock. They observed and described many soil profiles. A soil profile is the sequence of natural layers, or horizons, in a soil. The profile extends from the surface down into the unconsolidated material in which the soil formed or from the surface down to bedrock. The unconsolidated material is devoid of roots and other living organisms and has not been changed by other biological activity.

Currently, soils are mapped according to the boundaries of major land resource areas (MLRAs). MLRAs are geographically associated land resource units that share common characteristics related to physiography, geology, climate, water resources, soils, biological resources, and land uses (USDA, 2006). Soil survey areas typically consist of parts of one or more MLRA.

The soils and miscellaneous areas in a survey area occur in an orderly pattern that is related to the geology, landforms, relief, climate, and natural vegetation of the area. Each kind of soil and miscellaneous area is associated with a particular kind of landform or with a segment of the landform. By observing the soils and miscellaneous areas in the survey area and relating their position to specific segments of the landform, a soil scientist develops a concept, or model, of how they were formed. Thus, during mapping, this model enables the soil scientist to predict with a considerable degree of accuracy the kind of soil or miscellaneous area at a specific location on the landscape.

Commonly, individual soils on the landscape merge into one another as their characteristics gradually change. To construct an accurate soil map, however, soil scientists must determine the boundaries between the soils. They can observe only a limited number of soil profiles. Nevertheless, these observations, supplemented by an understanding of the soil-vegetation-landscape relationship, are sufficient to verify predictions of the kinds of soil in an area and to determine the boundaries.

Soil scientists recorded the characteristics of the soil profiles that they studied. They noted soil color, texture, size and shape of soil aggregates, kind and amount of rock fragments, distribution of plant roots, reaction, and other features that enable them to identify soils. After describing the soils in the survey area and determining their properties, the soil scientists assigned the soils to taxonomic classes (units). Taxonomic classes are concepts. Each taxonomic class has a set of soil characteristics with precisely defined limits. The classes are used as a basis for comparison to classify soils systematically. Soil taxonomy, the system of taxonomic classification used in the United States, is based mainly on the kind and character of soil properties and the arrangement of horizons within the profile. After the soil



## Custom Soil Resource Report

scientists classified and named the soils in the survey area, they compared the individual soils with similar soils in the same taxonomic class in other areas so that they could confirm data and assemble additional data based on experience and research.

The objective of soil mapping is not to delineate pure map unit components; the objective is to separate the landscape into landforms or landform segments that have similar use and management requirements. Each map unit is defined by a unique combination of soil components and/or miscellaneous areas in predictable proportions. Some components may be highly contrasting to the other components of the map unit. The presence of minor components in a map unit in no way diminishes the usefulness or accuracy of the data. The delineation of such landforms and landform segments on the map provides sufficient information for the development of resource plans. If intensive use of small areas is planned, onsite investigation is needed to define and locate the soils and miscellaneous areas.

Soil scientists make many field observations in the process of producing a soil map. The frequency of observation is dependent upon several factors, including scale of mapping, intensity of mapping, design of map units, complexity of the landscape, and experience of the soil scientist. Observations are made to test and refine the soil-landscape model and predictions and to verify the classification of the soils at specific locations. Once the soil-landscape model is refined, a significantly smaller number of measurements of individual soil properties are made and recorded. These measurements may include field measurements, such as those for color, depth to bedrock, and texture, and laboratory measurements, such as those for content of sand, silt, clay, salt, and other components. Properties of each soil typically vary from one point to another across the landscape.

Observations for map unit components are aggregated to develop ranges of characteristics for the components. The aggregated values are presented. Direct measurements do not exist for every property presented for every map unit component. Values for some properties are estimated from combinations of other properties.

While a soil survey is in progress, samples of some of the soils in the area generally are collected for laboratory analyses and for engineering tests. Soil scientists interpret the data from these analyses and tests as well as the field-observed characteristics and the soil properties to determine the expected behavior of the soils under different uses. Interpretations for all of the soils are field tested through observation of the soils in different uses and under different levels of management. Some interpretations are modified to fit local conditions, and some new interpretations are developed to meet local needs. Data are assembled from other sources, such as research information, production records, and field experience of specialists. For example, data on crop yields under defined levels of management are assembled from farm records and from field or plot experiments on the same kinds of soil.

Predictions about soil behavior are based not only on soil properties but also on such variables as climate and biological activity. Soil conditions are predictable over long periods of time, but they are not predictable from year to year. For example, soil scientists can predict with a fairly high degree of accuracy that a given soil will have a high water table within certain depths in most years, but they cannot predict that a high water table will always be at a specific level in the soil on a specific date.

After soil scientists located and identified the significant natural bodies of soil in the survey area, they drew the boundaries of these bodies on aerial photographs and

## Custom Soil Resource Report

identified each as a specific map unit. Aerial photographs show trees, buildings, fields, roads, and rivers, all of which help in locating boundaries accurately.

# Soil Map

---

The soil map section includes the soil map for the defined area of interest, a list of soil map units on the map and extent of each map unit, and cartographic symbols displayed on the map. Also presented are various metadata about data used to produce the map, and a description of each soil map unit.

# Custom Soil Resource Report Soil Map (SOIL MAP)

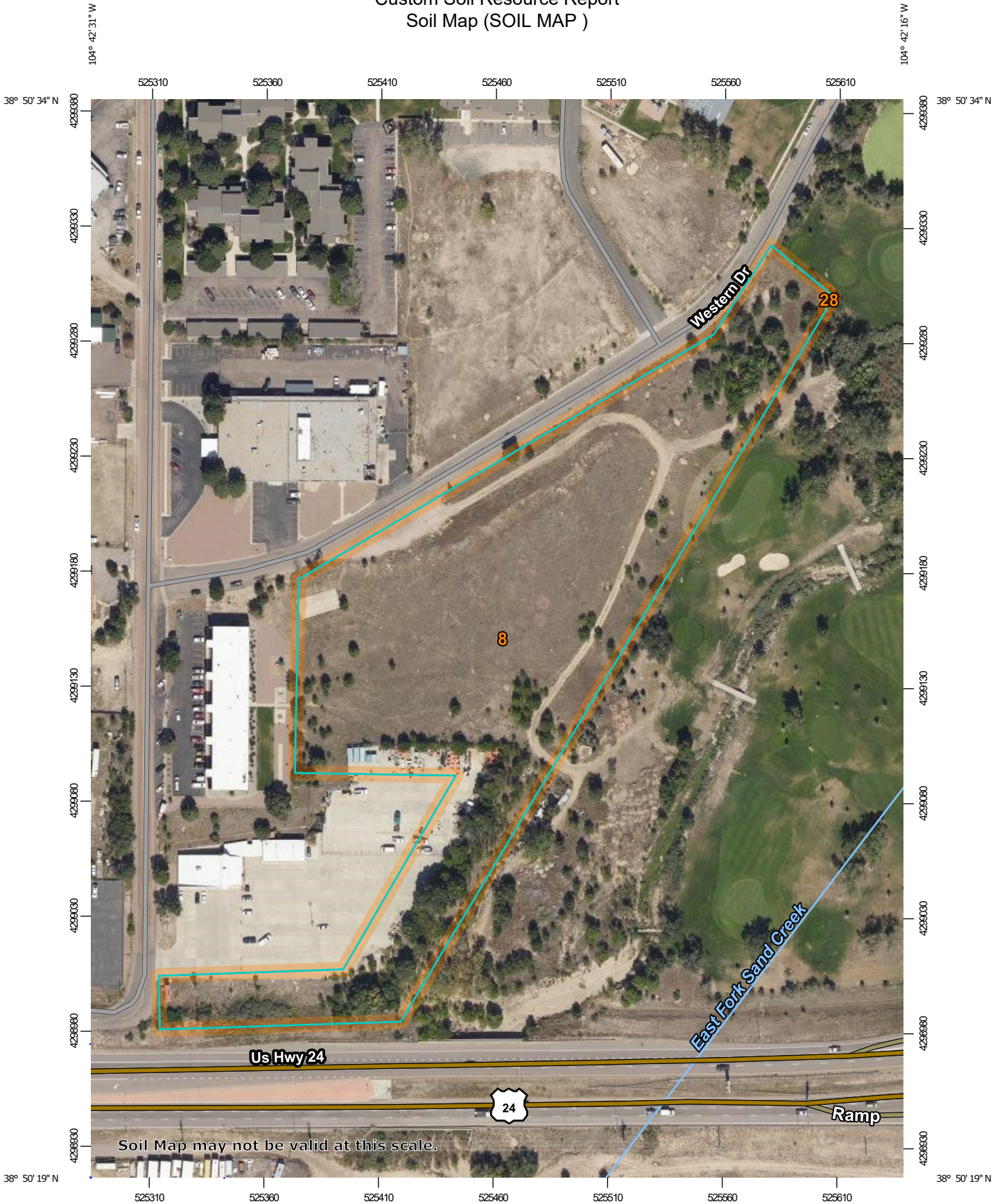

Soil Map may not be valid at this scale.

Map Scale: 1:2,280 if printed on A portrait (8.5" x 11") sheet.

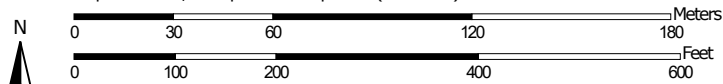

Map projection: Web Mercator Corner coordinates: WGS84 Edge tics: UTM Zone 13N WGS84

### MAP LEGEND

**Area of Interest (AOI)**

 Area of Interest (AOI)

**Soils**

 Soil Map Unit Polygons

 Soil Map Unit Lines

 Soil Map Unit Points

**Special Point Features**





-  Blowout
-  Borrow Pit
-  Clay Spot
-  Closed Depression
-  Gravel Pit
-  Gravelly Spot
-  Landfill
-  Lava Flow
-  Marsh or swamp
-  Mine or Quarry
-  Miscellaneous Water
-  Perennial Water
-  Rock Outcrop
-  Saline Spot
-  Sandy Spot
-  Severely Eroded Spot
-  Sinkhole
-  Slide or Slip
-  Sodic Spot

-  Spoil Area
-  Stony Spot
-  Very Stony Spot
-  Wet Spot
-  Other
-  Special Line Features

**Water Features**

 Streams and Canals

**Transportation**

-  Rails
-  Interstate Highways
-  US Routes
-  Major Roads
-  Local Roads

**Background**

 Aerial Photography

### MAP INFORMATION

The soil surveys that comprise your AOI were mapped at 1:24,000.

Warning: Soil Map may not be valid at this scale.

Enlargement of maps beyond the scale of mapping can cause misunderstanding of the detail of mapping and accuracy of soil line placement. The maps do not show the small areas of contrasting soils that could have been shown at a more detailed scale.

Please rely on the bar scale on each map sheet for map measurements.

Source of Map: Natural Resources Conservation Service  
 Web Soil Survey URL:  
 Coordinate System: Web Mercator (EPSG:3857)

Maps from the Web Soil Survey are based on the Web Mercator projection, which preserves direction and shape but distorts distance and area. A projection that preserves area, such as the Albers equal-area conic projection, should be used if more accurate calculations of distance or area are required.

This product is generated from the USDA-NRCS certified data as of the version date(s) listed below.

Soil Survey Area: El Paso County Area, Colorado  
 Survey Area Data: Version 21, Aug 24, 2023

Soil map units are labeled (as space allows) for map scales 1:50,000 or larger.

Date(s) aerial images were photographed: Aug 19, 2018—Sep 23, 2018

The orthophoto or other base map on which the soil lines were compiled and digitized probably differs from the background imagery displayed on these maps. As a result, some minor shifting of map unit boundaries may be evident.

## Map Unit Legend (SOIL MAP )

Map Unit Symbol	Map Unit Name	Acres in AOI	Percent of AOI
8	Blakeland loamy sand, 1 to 9 percent slopes	7.3	100.0%
28	Ellicott loamy coarse sand, 0 to 5 percent slopes	0.0	0.0%
<b>Totals for Area of Interest</b>		<b>7.3</b>	<b>100.0%</b>

## Map Unit Descriptions (SOIL MAP )

The map units delineated on the detailed soil maps in a soil survey represent the soils or miscellaneous areas in the survey area. The map unit descriptions, along with the maps, can be used to determine the composition and properties of a unit.

A map unit delineation on a soil map represents an area dominated by one or more major kinds of soil or miscellaneous areas. A map unit is identified and named according to the taxonomic classification of the dominant soils. Within a taxonomic class there are precisely defined limits for the properties of the soils. On the landscape, however, the soils are natural phenomena, and they have the characteristic variability of all natural phenomena. Thus, the range of some observed properties may extend beyond the limits defined for a taxonomic class. Areas of soils of a single taxonomic class rarely, if ever, can be mapped without including areas of other taxonomic classes. Consequently, every map unit is made up of the soils or miscellaneous areas for which it is named and some minor components that belong to taxonomic classes other than those of the major soils.

Most minor soils have properties similar to those of the dominant soil or soils in the map unit, and thus they do not affect use and management. These are called noncontrasting, or similar, components. They may or may not be mentioned in a particular map unit description. Other minor components, however, have properties and behavioral characteristics divergent enough to affect use or to require different management. These are called contrasting, or dissimilar, components. They generally are in small areas and could not be mapped separately because of the scale used. Some small areas of strongly contrasting soils or miscellaneous areas are identified by a special symbol on the maps. If included in the database for a given area, the contrasting minor components are identified in the map unit descriptions along with some characteristics of each. A few areas of minor components may not have been observed, and consequently they are not mentioned in the descriptions, especially where the pattern was so complex that it was impractical to make enough observations to identify all the soils and miscellaneous areas on the landscape.

The presence of minor components in a map unit in no way diminishes the usefulness or accuracy of the data. The objective of mapping is not to delineate pure taxonomic classes but rather to separate the landscape into landforms or landform segments that have similar use and management requirements. The delineation of such segments on the map provides sufficient information for the development of resource plans. If intensive use of small areas is planned, however,

## Custom Soil Resource Report

onsite investigation is needed to define and locate the soils and miscellaneous areas.

An identifying symbol precedes the map unit name in the map unit descriptions. Each description includes general facts about the unit and gives important soil properties and qualities.

Soils that have profiles that are almost alike make up a *soil series*. Except for differences in texture of the surface layer, all the soils of a series have major horizons that are similar in composition, thickness, and arrangement.

Soils of one series can differ in texture of the surface layer, slope, stoniness, salinity, degree of erosion, and other characteristics that affect their use. On the basis of such differences, a soil series is divided into *soil phases*. Most of the areas shown on the detailed soil maps are phases of soil series. The name of a soil phase commonly indicates a feature that affects use or management. For example, Alpha silt loam, 0 to 2 percent slopes, is a phase of the Alpha series.

Some map units are made up of two or more major soils or miscellaneous areas. These map units are complexes, associations, or undifferentiated groups.

A *complex* consists of two or more soils or miscellaneous areas in such an intricate pattern or in such small areas that they cannot be shown separately on the maps. The pattern and proportion of the soils or miscellaneous areas are somewhat similar in all areas. Alpha-Beta complex, 0 to 6 percent slopes, is an example.

An *association* is made up of two or more geographically associated soils or miscellaneous areas that are shown as one unit on the maps. Because of present or anticipated uses of the map units in the survey area, it was not considered practical or necessary to map the soils or miscellaneous areas separately. The pattern and relative proportion of the soils or miscellaneous areas are somewhat similar. Alpha-Beta association, 0 to 2 percent slopes, is an example.

An *undifferentiated group* is made up of two or more soils or miscellaneous areas that could be mapped individually but are mapped as one unit because similar interpretations can be made for use and management. The pattern and proportion of the soils or miscellaneous areas in a mapped area are not uniform. An area can be made up of only one of the major soils or miscellaneous areas, or it can be made up of all of them. Alpha and Beta soils, 0 to 2 percent slopes, is an example.

Some surveys include *miscellaneous areas*. Such areas have little or no soil material and support little or no vegetation. Rock outcrop is an example.

## El Paso County Area, Colorado

### 8—Blakeland loamy sand, 1 to 9 percent slopes

#### Map Unit Setting

*National map unit symbol:* 369v  
*Elevation:* 4,600 to 5,800 feet  
*Mean annual precipitation:* 14 to 16 inches  
*Mean annual air temperature:* 46 to 48 degrees F  
*Frost-free period:* 125 to 145 days  
*Farmland classification:* Not prime farmland

#### Map Unit Composition

*Blakeland and similar soils:* 98 percent  
*Minor components:* 2 percent  
*Estimates are based on observations, descriptions, and transects of the mapunit.*

#### Description of Blakeland

##### Setting

*Landform:* Hills, flats  
*Landform position (three-dimensional):* Side slope, talf  
*Down-slope shape:* Linear  
*Across-slope shape:* Linear  
*Parent material:* Alluvium derived from sedimentary rock and/or eolian deposits derived from sedimentary rock

##### Typical profile

*A - 0 to 11 inches:* loamy sand  
*AC - 11 to 27 inches:* loamy sand  
*C - 27 to 60 inches:* sand

##### Properties and qualities

*Slope:* 1 to 9 percent  
*Depth to restrictive feature:* More than 80 inches  
*Drainage class:* Somewhat excessively drained  
*Runoff class:* Low  
*Capacity of the most limiting layer to transmit water (Ksat):* High to very high (5.95 to 19.98 in/hr)  
*Depth to water table:* More than 80 inches  
*Frequency of flooding:* None  
*Frequency of ponding:* None  
*Calcium carbonate, maximum content:* 5 percent  
*Available water supply, 0 to 60 inches:* Low (about 4.5 inches)

##### Interpretive groups

*Land capability classification (irrigated):* 3e  
*Land capability classification (nonirrigated):* 6e  
*Hydrologic Soil Group:* A  
*Ecological site:* R049XB210CO - Sandy Foothill  
*Hydric soil rating:* No

#### Minor Components

##### Other soils

*Percent of map unit:* 1 percent



## Custom Soil Resource Report

*Hydric soil rating:* No

### **Pleasant**

*Percent of map unit:* 1 percent

*Landform:* Depressions

*Hydric soil rating:* Yes

## **28—Ellicott loamy coarse sand, 0 to 5 percent slopes**

### **Map Unit Setting**

*National map unit symbol:* 3680

*Elevation:* 5,500 to 6,500 feet

*Mean annual precipitation:* 13 to 15 inches

*Mean annual air temperature:* 47 to 50 degrees F

*Frost-free period:* 125 to 145 days

*Farmland classification:* Not prime farmland

### **Map Unit Composition**

*Ellicott and similar soils:* 97 percent

*Minor components:* 3 percent

*Estimates are based on observations, descriptions, and transects of the mapunit.*

### **Description of Ellicott**

#### **Setting**

*Landform:* Flood plains, stream terraces

*Landform position (three-dimensional):* Tread

*Down-slope shape:* Linear

*Across-slope shape:* Linear

*Parent material:* Sandy alluvium

#### **Typical profile**

*A - 0 to 4 inches:* loamy coarse sand

*C - 4 to 60 inches:* stratified coarse sand to sandy loam

#### **Properties and qualities**

*Slope:* 0 to 5 percent

*Depth to restrictive feature:* More than 80 inches

*Drainage class:* Somewhat excessively drained

*Runoff class:* Very low

*Capacity of the most limiting layer to transmit water (Ksat):* High to very high (5.95 to 19.98 in/hr)

*Depth to water table:* More than 80 inches

*Frequency of flooding:* Frequent

*Frequency of ponding:* None

*Available water supply, 0 to 60 inches:* Low (about 4.1 inches)

#### **Interpretive groups**

*Land capability classification (irrigated):* None specified

*Land capability classification (nonirrigated):* 7w

*Hydrologic Soil Group:* A

## Custom Soil Resource Report

*Ecological site:* R069XY031CO - Sandy Bottomland

*Other vegetative classification:* SANDY BOTTOMLAND (069AY031CO)

*Hydric soil rating:* No

### **Minor Components**

#### **Fluvaquentic haplaquoll**

*Percent of map unit:* 1 percent

*Landform:* Swales

*Hydric soil rating:* Yes

#### **Other soils**

*Percent of map unit:* 1 percent

*Hydric soil rating:* No

#### **Pleasant**

*Percent of map unit:* 1 percent

*Landform:* Depressions

*Hydric soil rating:* Yes

# References

---

- American Association of State Highway and Transportation Officials (AASHTO). 2004. Standard specifications for transportation materials and methods of sampling and testing. 24th edition.
- American Society for Testing and Materials (ASTM). 2005. Standard classification of soils for engineering purposes. ASTM Standard D2487-00.
- Cowardin, L.M., V. Carter, F.C. Golet, and E.T. LaRoe. 1979. Classification of wetlands and deep-water habitats of the United States. U.S. Fish and Wildlife Service FWS/OBS-79/31.
- Federal Register. July 13, 1994. Changes in hydric soils of the United States.
- Federal Register. September 18, 2002. Hydric soils of the United States.
- Hurt, G.W., and L.M. Vasilas, editors. Version 6.0, 2006. Field indicators of hydric soils in the United States.
- National Research Council. 1995. Wetlands: Characteristics and boundaries.
- Soil Survey Division Staff. 1993. Soil survey manual. Soil Conservation Service. U.S. Department of Agriculture Handbook 18. [http://www.nrcs.usda.gov/wps/portal/nrcs/detail/national/soils/?cid=nrcs142p2\\_054262](http://www.nrcs.usda.gov/wps/portal/nrcs/detail/national/soils/?cid=nrcs142p2_054262)
- Soil Survey Staff. 1999. Soil taxonomy: A basic system of soil classification for making and interpreting soil surveys. 2nd edition. Natural Resources Conservation Service, U.S. Department of Agriculture Handbook 436. [http://www.nrcs.usda.gov/wps/portal/nrcs/detail/national/soils/?cid=nrcs142p2\\_053577](http://www.nrcs.usda.gov/wps/portal/nrcs/detail/national/soils/?cid=nrcs142p2_053577)
- Soil Survey Staff. 2010. Keys to soil taxonomy. 11th edition. U.S. Department of Agriculture, Natural Resources Conservation Service. [http://www.nrcs.usda.gov/wps/portal/nrcs/detail/national/soils/?cid=nrcs142p2\\_053580](http://www.nrcs.usda.gov/wps/portal/nrcs/detail/national/soils/?cid=nrcs142p2_053580)
- Tiner, R.W., Jr. 1985. Wetlands of Delaware. U.S. Fish and Wildlife Service and Delaware Department of Natural Resources and Environmental Control, Wetlands Section.
- United States Army Corps of Engineers, Environmental Laboratory. 1987. Corps of Engineers wetlands delineation manual. Waterways Experiment Station Technical Report Y-87-1.
- United States Department of Agriculture, Natural Resources Conservation Service. National forestry manual. [http://www.nrcs.usda.gov/wps/portal/nrcs/detail/soils/home/?cid=nrcs142p2\\_053374](http://www.nrcs.usda.gov/wps/portal/nrcs/detail/soils/home/?cid=nrcs142p2_053374)
- United States Department of Agriculture, Natural Resources Conservation Service. National range and pasture handbook. <http://www.nrcs.usda.gov/wps/portal/nrcs/detail/national/landuse/rangepasture/?cid=stelprdb1043084>

## Custom Soil Resource Report

United States Department of Agriculture, Natural Resources Conservation Service. National soil survey handbook, title 430-VI. [http://www.nrcs.usda.gov/wps/portal/nrcs/detail/soils/scientists/?cid=nrcs142p2\\_054242](http://www.nrcs.usda.gov/wps/portal/nrcs/detail/soils/scientists/?cid=nrcs142p2_054242)

United States Department of Agriculture, Natural Resources Conservation Service. 2006. Land resource regions and major land resource areas of the United States, the Caribbean, and the Pacific Basin. U.S. Department of Agriculture Handbook 296. [http://www.nrcs.usda.gov/wps/portal/nrcs/detail/national/soils/?cid=nrcs142p2\\_053624](http://www.nrcs.usda.gov/wps/portal/nrcs/detail/national/soils/?cid=nrcs142p2_053624)

United States Department of Agriculture, Soil Conservation Service. 1961. Land capability classification. U.S. Department of Agriculture Handbook 210. [http://www.nrcs.usda.gov/Internet/FSE\\_DOCUMENTS/nrcs142p2\\_052290.pdf](http://www.nrcs.usda.gov/Internet/FSE_DOCUMENTS/nrcs142p2_052290.pdf)

is severely eroded and blowouts have developed, the new seeding should be fertilized.

Windbreaks and environmental plantings are generally suited to this soil. Soil blowing is the main limitation for the establishment of trees and shrubs. This limitation can be overcome by cultivating only in the tree rows and leaving a strip of vegetation between the rows. Supplemental irrigation may be necessary when planting and during dry periods. Trees that are best suited and have good survival are Rocky Mountain juniper, eastern redcedar, ponderosa pine, Siberian elm, Russian-olive, and hackberry. Shrubs that are best suited are skunkbush sumac, lilac, and Siberian peashrub.

This soil is suited to wildlife habitat. It is best suited to habitat for openland and rangeland wildlife. In cropland areas, habitat favorable for ring-necked pheasant, mourning dove, and many nongame species can be developed by establishing areas for nesting and escape cover. For pheasant, the provision of undisturbed nesting cover is vital and should be included in plans for habitat development. Rangeland wildlife, such as pronghorn antelope, can be encouraged by developing livestock watering facilities, properly managing livestock grazing, and reseeding range where needed.

This soil has good potential for use as homesites. Shallow excavation is severely limited because cut banks cave in. This sandy soil requires special management practices to reduce water erosion and soil blowing. Capability subclasses IIIe, irrigated, and IVe, nonirrigated.

**7—Bijou sandy loam, 3 to 8 percent slopes.** This deep, well drained soil is on flood plains, terraces, and uplands. It formed in sandy alluvium and eolian material derived from arkose deposits. Elevation ranges from 5,400 to 6,200 feet. The average annual precipitation is about 13 inches, the average annual air temperature is about 49 degrees F, and the average frost-free period is about 145 days.

Typically, the surface layer is brown sandy loam about 4 inches thick. The subsoil is brown or grayish brown sandy loam about 24 inches thick. The substratum is pale brown loamy coarse sand.

Included with this soil in mapping are small areas of Olney sandy loam, 3 to 5 percent slopes; Valent sand, 1 to 9 percent slopes; Vona sandy loam, 3 to 9 percent slopes; and Wigton loamy sand, 1 to 8 percent slopes.

Permeability of this Bijou soil is rapid. Effective rooting depth is 60 inches or more. Available water capacity is moderate. Organic matter content of the surface layer is low. Surface runoff is slow, and the hazards of erosion and soil blowing are moderate.

Almost all areas of this soil are used for range.

This soil is suited to the production of native vegetation suitable for grazing. Because of the hazards of water erosion and soil blowing, the soil is not suited to nonirrigated crops.

Native vegetation is dominantly blue grama, sand dropseed, needleandthread, side-oats grama, and buckwheat.

Seeding is a suitable practice if the range has deteriorated. Seeding the native grasses is a good practice. If the range is severely eroded and blowouts have developed, the new seeding should be fertilized. Brush control and grazing management may be needed to improve the depleted range. Grazing should be managed so that enough forage is left standing to protect the soil from blowing, to increase infiltration of water, and to catch and hold snow.

Windbreaks and environmental plantings are generally suited to this soil. Soil blowing is the main limitation for the establishment of trees and shrubs. This limitation can be overcome by cultivating only in the tree rows and leaving a strip of vegetation between the rows. Supplemental irrigation may be needed when planting and during dry periods. Trees that are best suited and have good survival are Rocky Mountain juniper, eastern redcedar, ponderosa pine, Siberian elm, Russian-olive, and hackberry. Shrubs that are best suited are skunkbush sumac, lilac, and Siberian peashrub.

This soil is suited to wildlife habitat. It is best suited to habitat for openland and rangeland wildlife. Rangeland wildlife, such as pronghorn antelope, can be encouraged by developing livestock watering facilities, by properly managing livestock grazing, and by reseeding range where needed.

This soil has good potential for use as homesites. Shallow excavation is severely limited because cut banks cave in. This soil requires special management practices to reduce water erosion and soil blowing. Capability subclass VIe.

**8—Blakeland loamy sand, 1 to 9 percent slopes.** This deep, somewhat excessively drained soil formed in alluvial and eolian material derived from arkosic sedimentary rock on uplands. The average annual precipitation is about 15 inches, the average annual air temperature is about 47 degrees F, and the average frost-free period is about 135 days.

Typically, the surface layer is dark grayish brown loamy sand about 11 inches thick. The substratum, to a depth of 27 inches, is brown loamy sand; it grades to pale brown sand that extends to a depth of 60 inches.

Included with this soil in mapping are small areas of Bresser sandy loam, 0 to 3 percent slopes; Bresser sandy loam, 3 to 5 percent slopes; Truckton sandy loam, 0 to 3 percent slopes; Truckton sandy loam, 3 to 9 percent slopes; and Stapleton sandy loam, 3 to 8 percent slopes. In some areas, mainly north of Colorado Springs in the Cottonwood Creek area, arkosic beds of sandstone and shale are at a depth of 0 to 40 inches.

Permeability of this Blakeland soil is rapid. Effective rooting depth is 60 inches or more. Available water capacity is low to moderate. Organic matter content of the surface layer is medium. Surface runoff is slow, the hazard of erosion is moderate, and the hazard of soil blowing is severe.

Most areas of this soil are used for range, homesites, and wildlife habitat.

Native vegetation is dominantly western wheatgrass, side-oats grama, and needleandthread. This soil is best suited to deep-rooted grasses.

Proper range management is necessary to prevent excessive removal of plant cover from the soil. Interseeding improves the existing vegetation. Deferment of grazing in spring increases plant vigor and soil stability. Proper location of livestock watering facilities helps to control grazing.

Windbreaks and environmental plantings are fairly well suited to this soil. Blowing sand and low available water capacity are the main limitations for the establishment of trees and shrubs. The soil is so loose that trees need to be planted in shallow furrows and plant cover needs to be maintained between the rows. Supplemental irrigation may be needed to insure survival. Trees that are best suited and have good survival are Rocky Mountain juniper, eastern redcedar, ponderosa pine, and Siberian elm. Shrubs that are best suited are skunkbush sumac, lilac, and Siberian peashrub.

This soil is suited to wildlife habitat. It is best suited to habitat for openland and rangeland wildlife. Rangeland wildlife, such as pronghorn antelope, can be encouraged by developing livestock watering facilities, properly managing livestock grazing, and reseeding range where needed.

This soil has good potential for urban development. Soil blowing is a hazard if protective vegetation is removed. Special erosion control practices must be provided to minimize soil losses. Capability subclass VIe.

**9—Blakeland complex, 1 to 9 percent slopes.** This complex is on uplands, mostly in the Falcon area. The average annual precipitation is about 15 inches, the average annual air temperature is about 47 degrees F, and the frost-free period is about 135 days.

This complex is about 60 percent Blakeland loamy sand, about 30 percent Fluvaquentic Haplaquolls, and 10 percent other soils.

Included with these soils in mapping are areas of Columbine gravelly sandy loam, 0 to 3 percent slopes, Ellicott loamy coarse sand, 0 to 5 percent slopes, and Ustic Torrifluvents, loamy.

The Blakeland soil is in the more sloping areas. It is deep and somewhat excessively drained. It formed in sandy alluvium and eolian material derived from arkosic sedimentary rock. Typically, the surface layer is dark grayish brown loamy sand about 11 inches thick. The substratum, to a depth of 27 inches, is brown loamy sand; it grades to pale brown sand that extends to a depth of 60 inches or more.

Permeability of the Blakeland soil is rapid. The effective rooting depth is more than 60 inches. The available water capacity is moderate to low. Surface runoff is slow, and the hazard of erosion is moderate.

The Fluvaquentic Haplaquolls are in swale areas. They are deep, poorly drained soils. They formed in alluvium derived from arkosic sedimentary rock. Typically, the surface layer is brown. The texture is variable throughout. The water table is at a depth of 0 to 3 feet.

The Blakeland soil is well suited to deep-rooted grasses. Native vegetation is dominantly western wheatgrass, side-oats grama, and needleandthread. Rangeland vegetation on the Fluvaquentic Haplaquolls is dominantly tall grasses, including sand bluestem, switchgrass, prairie cordgrass, little bluestem, and sand reedgrass. Cattails and bulrushes are common in the swampy areas.

Proper range management is needed to prevent excess removal of plant cover from these soils. It is also needed to maintain the productive grasses. Interseeding improves the existing vegetation. Deferment of grazing during the growing season increases plant vigor and soil stability, and it helps to maintain and improve range condition. Proper location of livestock watering facilities helps to control grazing of animals.

Windbreaks and environmental plantings are fairly well suited to these soils. Blowing sand and low available water capacity are the main limitations to the establishment of trees and shrubs. The soils are so loose that trees need to be planted in shallow furrows and plant cover needs to be maintained between the rows. Supplemental irrigation may be needed to insure survival. Trees that are best suited and have good survival are Rocky Mountain juniper, eastern redcedar, ponderosa pine, and Siberian elm. Shrubs that are best suited are skunkbush sumac, lilac, and Siberian peashrub.

The Blakeland soil is well suited to wildlife habitat. It is best suited to habitat for openland and rangeland wildlife. Rangeland wildlife, such as pronghorn antelope, can be encouraged by developing livestock watering facilities, properly managing livestock grazing, and reseeding range where needed. Wetland wildlife can be attracted to the Fluvaquentic Haplaquolls and the wetland habitat can be enhanced by several means. Shallow water developments can be created by digging or by blasting potholes to create open-water areas. Fencing to control livestock grazing is beneficial, and it allows wetland plants such as cattails, reed canarygrass, and rushes to grow. Control of unplanned burning and prevention of drainage that would remove water from the wetlands are good practices. Openland wildlife use the vegetation on these soils for nesting and escape cover. These shallow marsh areas are especially important for winter cover if natural vegetation is allowed to grow.

The Blakeland soil has good potential for homesites, roads, and streets. It needs to be protected from erosion when vegetation has been removed from building sites. The Fluvaquentic Haplaquolls have poor potential for homesites. Their main limitations for this use are the high water table and the hazard of flooding. Capability subclass VIe.

**10—Blendon sandy loam, 0 to 3 percent slopes.** This deep, well drained soil formed in sandy arkosic alluvium on alluvial fans and terraces. The average annual precipitation is about 15 inches, the mean annual air temperature is about 47 degrees F, and the average frost-free period is about 135 days.

G. L. WILLIAMS & PARTNERS, LTD.  
SURVEYING — PLANNING — ENGINEERING  
WATER RESOURCES

17 EAST LAS VEGAS ST.  
COLORADO SPRINGS, COLO. 80903  
(303) 633-1773



August 17, 1978

El Paso County Land Use Dept.  
27 East Vermijo  
Colorado Springs, CO 80903

Gentlemen:

The intent of this letter is to serve as a report on drainage and erosion conditions for Cimarron Southeast Filing No. 2C, a one lot subdivision intended for use as a parking lot.

As shown on the attached sketch map the drainage basin for this 7.12 acre subdivision also includes the south half of Western Drive, the former Hathaway Apartment tract, and the former Red Barn tract which is presently in use for Mobile Home sales, and totals 11.16 acres.

Sub-basin 1 is about 0.55 acre and develops a runoff of about 1.38 cfs in a 100 year storm along the channel.

Sub-basin 2 is about 6.37 acres and develops a runoff of about 15.9 cfs in a 100 year storm, conveyed mostly by sheet flow to the indicated erosion leading to the channel. This erosion should be filled during the parking lot grading, and passage of the runoff to the channel formalized and protected by rip-rap. A swale should also be cut along the edge of the new channel bank to eliminate minor erosion there.

Sub-basin 3 is about 4.24 acres and develops a runoff of about 16.9 cfs in a 100 year storm. About 2.6 cfs is presently picked up by a drop inlet and conveyed to the channel by a 12" CMP. The remainder goes on along the existing curb to the eroded area and will be conveyed to the channel via the rip-rap swale recommended for Sub-basin 2.

Runoff determinations, using the Rational Formula, postulated a 5" rainfall intensity, a runoff coefficient of 0.5 for sub-basins 1 and 2 and 0.8 for the occupied sub-basin 3. The results should be conservative.

Respectfully submitted,

*George L. Williams*

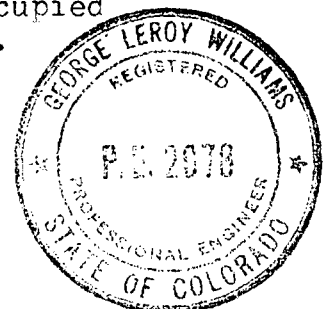





## **2 Hydrologic Calculations**

City of Colorado Springs DCM Runoff Coefficients – Table 6-6

Colorado Springs DCM Rainfall Intensity Duration Frequency – Figure 6-5

Sub-Basin Time of Concentration – Form SF-1

5-yr Sub-Basin and Combined Flows – Form SF-2

100-yr Sub-Basin and Combined Flows – Form SF-2

Sub-Basin Calculations

**Table 6-6. Runoff Coefficients for Rational Method**  
(Source: UDFCD 2001)

Land Use or Surface Characteristics	Percent Impervious	Runoff Coefficients											
		2-year		5-year		10-year		25-year		50-year		100-year	
		HSG A&B	HSG C&D	HSG A&B	HSG C&D	HSG A&B	HSG C&D	HSG A&B	HSG C&D	HSG A&B	HSG C&D	HSG A&B	HSG C&D
<b>Business</b>													
Commercial Areas	95	0.79	0.80	0.81	0.82	0.83	0.84	0.85	0.87	0.87	0.88	0.88	0.89
Neighborhood Areas	70	0.45	0.49	0.49	0.53	0.53	0.57	0.58	0.62	0.60	0.65	0.62	0.68
<b>Residential</b>													
1/8 Acre or less	65	0.41	0.45	0.45	0.49	0.49	0.54	0.54	0.59	0.57	0.62	0.59	0.65
1/4 Acre	40	0.23	0.28	0.30	0.35	0.36	0.42	0.42	0.50	0.46	0.54	0.50	0.58
1/3 Acre	30	0.18	0.22	0.25	0.30	0.32	0.38	0.39	0.47	0.43	0.52	0.47	0.57
1/2 Acre	25	0.15	0.20	0.22	0.28	0.30	0.36	0.37	0.46	0.41	0.51	0.46	0.56
1 Acre	20	0.12	0.17	0.20	0.26	0.27	0.34	0.35	0.44	0.40	0.50	0.44	0.55
<b>Industrial</b>													
Light Areas	80	0.57	0.60	0.59	0.63	0.63	0.66	0.66	0.70	0.68	0.72	0.70	0.74
Heavy Areas	90	0.71	0.73	0.73	0.75	0.75	0.77	0.78	0.80	0.80	0.82	0.81	0.83
<b>Parks and Cemeteries</b>													
Parks and Cemeteries	7	0.05	0.09	0.12	0.19	0.20	0.29	0.30	0.40	0.34	0.46	0.39	0.52
Playgrounds	13	0.07	0.13	0.16	0.23	0.24	0.31	0.32	0.42	0.37	0.48	0.41	0.54
Railroad Yard Areas	40	0.23	0.28	0.30	0.35	0.36	0.42	0.42	0.50	0.46	0.54	0.50	0.58
<b>Undeveloped Areas</b>													
Historic Flow Analysis-- Greenbelts, Agriculture	2	0.03	0.05	0.09	0.16	0.17	0.26	0.26	0.38	0.31	0.45	0.36	0.51
Pasture/Meadow	0	0.02	0.04	0.08	0.15	0.15	0.25	0.25	0.37	0.30	0.44	0.35	0.50
Forest	0	0.02	0.04	0.08	0.15	0.15	0.25	0.25	0.37	0.30	0.44	0.35	0.50
Exposed Rock	100	0.89	0.89	0.90	0.90	0.92	0.92	0.94	0.94	0.95	0.95	0.96	0.96
Offsite Flow Analysis (when landuse is undefined)	45	0.26	0.31	0.32	0.37	0.38	0.44	0.44	0.51	0.48	0.55	0.51	0.59
<b>Streets</b>													
Paved	100	0.89	0.89	0.90	0.90	0.92	0.92	0.94	0.94	0.95	0.95	0.96	0.96
Gravel	80	0.57	0.60	0.59	0.63	0.63	0.66	0.66	0.70	0.68	0.72	0.70	0.74
<b>Drive and Walks</b>													
Drive and Walks	100	0.89	0.89	0.90	0.90	0.92	0.92	0.94	0.94	0.95	0.95	0.96	0.96
<b>Roofs</b>													
Roofs	90	0.71	0.73	0.73	0.75	0.75	0.77	0.78	0.80	0.80	0.82	0.81	0.83
<b>Lawns</b>													
Lawns	0	0.02	0.04	0.08	0.15	0.15	0.25	0.25	0.37	0.30	0.44	0.35	0.50

Figure 6-5. Colorado Springs Rainfall Intensity Duration Frequency

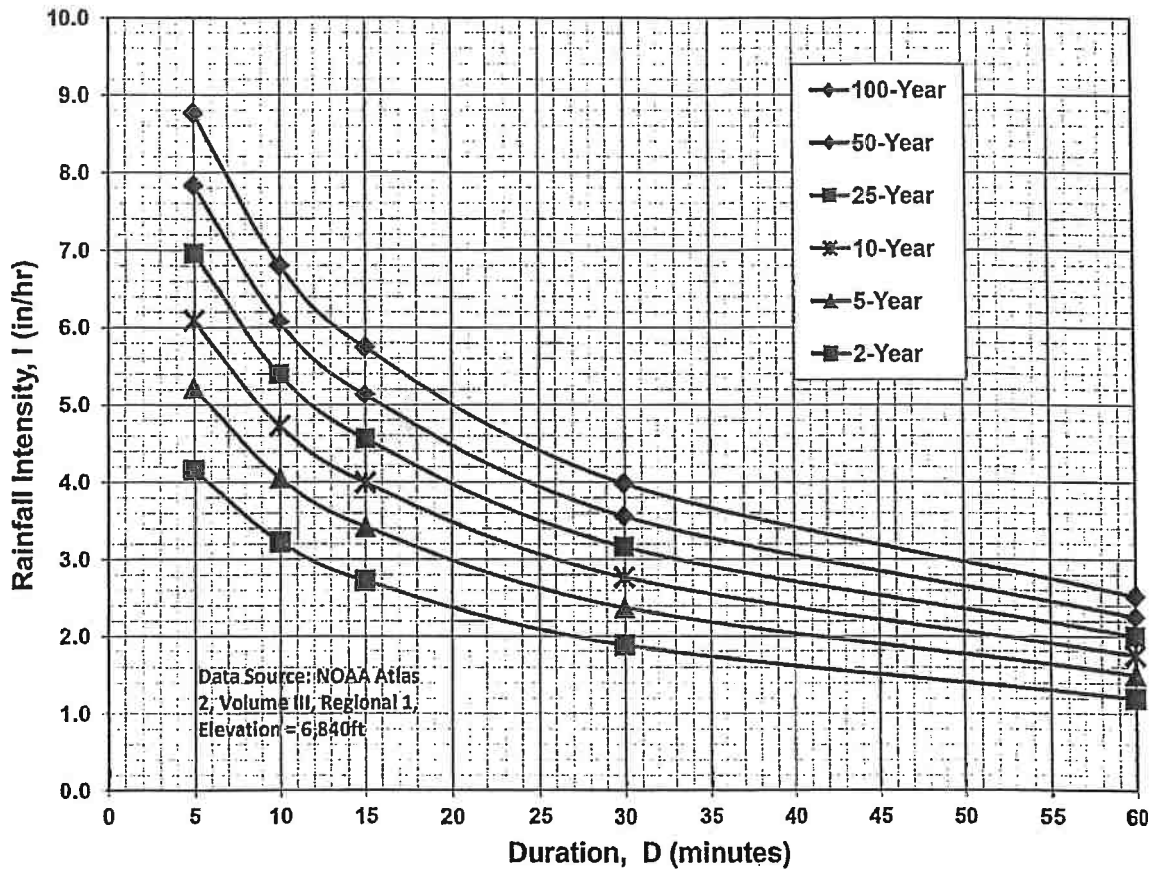

**IDF Equations**

$$I_{100} = -2.52 \ln(D) + 12.735$$

$$I_{50} = -2.25 \ln(D) + 11.375$$

$$I_{25} = -2.00 \ln(D) + 10.111$$

$$I_{10} = -1.75 \ln(D) + 8.847$$

$$I_5 = -1.50 \ln(D) + 7.583$$

$$I_2 = -1.19 \ln(D) + 6.035$$

Note: Values calculated by equations may not precisely duplicate values read from figure.





## Sub-Basin OS-A1 Runoff Calculations

Job No.: 61203  
 Project: Townhomes at Western  
 Jurisdiction: DCM  
 Runoff Coefficient: Surface Type

Date: 7/11/2024 9:35  
 Calcs by: TJW  
 Checked by: \_\_\_\_\_  
 Soil Type: B  
 Urbanization: Urban

### Basin Land Use Characteristics

Surface	Area		Runoff Coefficient						% Imperv.
	(SF)	(Acres)	C2	C5	C10	C25	C50	C100	
Pasture/Meadow	9,024	0.21	0.02	0.08	0.15	0.25	0.3	0.35	0%
Paved	4,324	0.10	0.89	0.9	0.92	0.94	0.95	0.96	100%
Roofs			0.71	0.73	0.75	0.78	0.8	0.81	90%
<b>Combined</b>	<b>13,348</b>	<b>0.31</b>	<b>0.30</b>	<b>0.35</b>	<b>0.40</b>	<b>0.47</b>	<b>0.51</b>	<b>0.55</b>	<b>32.4%</b>

13348

### Basin Travel Time

	Shallow Channel	Ground Cover	Short Pasture/Lawns				
$L_{max,Overland}$	100	ft	$C_v$	7			
$L$ (ft)	$\Delta Z_0$ (ft)	$S_0$ (ft/ft)	$v$ (ft/s)	$t$ (min)	$t_{Alt}$ (min)		
Total	145	16	-	-	-		
Initial Time	31	9	0.290	-	2.5	10.8 DCM Eq. 6-8	
Shallow Channel	114	7	0.061	1.7	1.1	- DCM Eq. 6-9	
Channelized			0.000	0.0	0.0	- V-Ditch	
				$t_c$	5.0 min.		

### Rainfall Intensity & Runoff

	2-Yr	5-Yr	10-Yr	25-Yr	50-Yr	100-Yr
Intensity (in/hr)	4.12	5.17	6.03	6.89	7.75	8.68
Runoff (cfs)	0.4	0.5	0.7	1.0	1.2	1.5
Release Rates (cfs/ac)	-	-	-	-	-	-
Allowed Release (cfs)	0.4	0.5	0.7	1.0	1.2	1.5

DCM:  $I = C1 * \ln(tc) + C2$

C1      1.19      1.5      1.75      2      2.25      2.52  
 C2      6.035      7.583      8.847      10.111      11.375      12.735

### Notes

## Sub-Basin OS-B1 Runoff Calculations

Job No.: 61203  
 Project: Townhomes at Western  
 Jurisdiction: DCM  
 Runoff Coefficient: Surface Type

Date: 7/11/2024 9:35  
 Calcs by: TJW  
 Checked by: \_\_\_\_\_  
 Soil Type: B  
 Urbanization: Urban

### Basin Land Use Characteristics

Surface	Area		Runoff Coefficient						% Imperv.
	(SF)	(Acres)	C2	C5	C10	C25	C50	C100	
Pasture/Meadow	10,166	0.23	0.02	0.08	0.15	0.25	0.3	0.35	0%
Paved	1,547	0.04	0.89	0.9	0.92	0.94	0.95	0.96	100%
Gravel	12,017	0.28	0.57	0.59	0.63	0.66	0.68	0.7	80%
<b>Combined</b>	<b>23,730</b>	<b>0.54</b>	<b>0.36</b>	<b>0.39</b>	<b>0.44</b>	<b>0.50</b>	<b>0.53</b>	<b>0.57</b>	<b>47.0%</b>

23730

### Basin Travel Time

	Shallow Channel	Ground Cover	Short Pasture/Lawns				
$L_{max,Overland}$	100	ft	$C_v$	7			
$L$ (ft)	$\Delta Z_0$ (ft)	$S_0$ (ft/ft)	$v$ (ft/s)	$t$ (min)	$t_{Alt}$ (min)		
Total	190	20	-	-	-		
Initial Time	65	11	0.169	-	4.1	11.1 DCM Eq. 6-8	
Shallow Channel	125	9	0.072	1.9	1.1	- DCM Eq. 6-9	
Channelized			0.000	0.0	0.0	- V-Ditch	
				$t_c$	5.2 min.		

### Rainfall Intensity & Runoff

	2-Yr	5-Yr	10-Yr	25-Yr	50-Yr	100-Yr
Intensity (in/hr)	4.08	5.12	5.97	6.83	7.68	8.60
Runoff (cfs)	0.8	1.1	1.4	1.9	2.2	2.7
Release Rates (cfs/ac)	-	-	-	-	-	-
Allowed Release (cfs)	0.8	1.1	1.4	1.9	2.2	2.7

DCM:  $I = C1 * \ln(tc) + C2$

C1      1.19      1.5      1.75      2      2.25      2.52  
 C2      6.035      7.583      8.847      10.111      11.375      12.735

### Notes

## Sub-Basin OS-B2 Runoff Calculations

Job No.: 61203  
 Project: Townhomes at Western  
 Jurisdiction: DCM  
 Runoff Coefficient: Surface Type

Date: 7/11/2024 9:35  
 Calcs by: TJW  
 Checked by: \_\_\_\_\_  
 Soil Type: B  
 Urbanization: Urban

### Basin Land Use Characteristics

Surface	Area		Runoff Coefficient						% Imperv.
	(SF)	(Acres)	C2	C5	C10	C25	C50	C100	
Pasture/Meadow	17,020	0.39	0.02	0.08	0.15	0.25	0.3	0.35	0%
Paved	47,177	1.08	0.89	0.9	0.92	0.94	0.95	0.96	100%
Roofs	6,867	0.16	0.71	0.73	0.75	0.78	0.8	0.81	90%
<b>Combined</b>	<b>71,064</b>	<b>1.63</b>	<b>0.66</b>	<b>0.69</b>	<b>0.72</b>	<b>0.76</b>	<b>0.78</b>	<b>0.80</b>	<b>75.1%</b>

71064

### Basin Travel Time

	Shallow Channel Ground Cover		Paved areas/shallow paved swales				
	$L_{max,Overland}$	ft	$C_v$				
	L (ft)	$\Delta Z_0$ (ft)	$S_0$ (ft/ft)	v (ft/s)	t (min)	$t_{Alt}$ (min)	
Total	192	18	-	-	-	-	
Initial Time	40	14	0.350	-	1.5	11.1	DCM Eq. 6-8
Shallow Channel	152	4	0.023	3.0	0.8	-	DCM Eq. 6-9
Channelized			0.000	0.0	0.0	-	V-Ditch
				$t_c$	<b>5.0 min.</b>		

### Rainfall Intensity & Runoff

	2-Yr	5-Yr	10-Yr	25-Yr	50-Yr	100-Yr
<b>Intensity (in/hr)</b>	4.12	5.17	6.03	6.89	7.75	8.68
<b>Runoff (cfs)</b>	4.5	<b>5.8</b>	7.1	8.5	9.9	<b>11.3</b>
<b>Release Rates (cfs/ac)</b>	-	-	-	-	-	-
<b>Allowed Release (cfs)</b>	4.5	<b>5.8</b>	7.1	8.5	9.9	<b>11.3</b>

DCM:  $I = C1 * \ln(tc) + C2$

C1      1.19      1.5      1.75      2      2.25      2.52  
 C2      6.035      7.583      8.847      10.111      11.375      12.735

### Notes



## Sub-Basin Ex-A2 Runoff Calculations

Job No.: 61203  
 Project: Townhomes at Western  
 Jurisdiction: DCM  
 Runoff Coefficient: Surface Type

Date: 7/11/2024 9:35  
 Calcs by: TJW  
 Checked by: \_\_\_\_\_  
 Soil Type: B  
 Urbanization: Urban

### Basin Land Use Characteristics

Surface	Area		Runoff Coefficient						% Imperv.
	(SF)	(Acres)	C2	C5	C10	C25	C50	C100	
Pasture/Meadow	149,760	3.44	0.02	0.08	0.15	0.25	0.3	0.35	0%
Paved	1,301	0.03	0.89	0.9	0.92	0.94	0.95	0.96	100%
Roofs			0.71	0.73	0.75	0.78	0.8	0.81	90%
<b>Combined</b>	<b>151,061</b>	<b>3.47</b>	<b>0.03</b>	<b>0.09</b>	<b>0.16</b>	<b>0.26</b>	<b>0.31</b>	<b>0.36</b>	<b>0.9%</b>

151061

### Basin Travel Time

	Shallow Channel	Ground Cover	Short Pasture/Lawns				
$L_{max,Overland}$	100	ft	$C_v$	7			
$L$ (ft)	$\Delta Z_0$ (ft)	$S_0$ (ft/ft)	$v$ (ft/s)	$t$ (min)	$t_{Alt}$ (min)		
Total	487	39	-	-	-		
Initial Time	82	10	0.122	-	7.3	12.7 DCM Eq. 6-8	
Shallow Channel	405	29	0.072	1.9	3.6	- DCM Eq. 6-9	
Channelized			0.000	0.0	0.0	- V-Ditch	
				$t_c$	<b>10.9 min.</b>		

### Rainfall Intensity & Runoff

	2-Yr	5-Yr	10-Yr	25-Yr	50-Yr	100-Yr
<b>Intensity (in/hr)</b>	3.20	4.01	4.67	5.34	6.01	6.72
<b>Runoff (cfs)</b>	0.3	1.2	2.5	4.7	6.4	8.3
<b>Release Rates (cfs/ac)</b>	-	-	-	-	-	-
<b>Allowed Release (cfs)</b>	0.3	1.2	2.5	4.7	6.4	8.3

DCM:  $I = C1 * \ln(tc) + C2$

C1      1.19      1.5      1.75      2      2.25      2.52  
 C2      6.035      7.583      8.847      10.111      11.375      12.735

### Notes

## Sub-Basin Ex-A3 Runoff Calculations

Job No.: 61203  
 Project: Townhomes at Western  
 Jurisdiction: DCM  
 Runoff Coefficient: Surface Type

Date: 7/11/2024 9:35  
 Calcs by: TJW  
 Checked by: \_\_\_\_\_  
 Soil Type: B  
 Urbanization: Urban

### Basin Land Use Characteristics

Surface	Area		Runoff Coefficient						% Imperv.
	(SF)	(Acres)	C2	C5	C10	C25	C50	C100	
Pasture/Meadow	17,280	0.40	0.02	0.08	0.15	0.25	0.3	0.35	0%
Paved	8,494	0.19	0.89	0.9	0.92	0.94	0.95	0.96	100%
Roofs			0.71	0.73	0.75	0.78	0.8	0.81	90%
<b>Combined</b>	<b>25,774</b>	<b>0.59</b>	<b>0.31</b>	<b>0.35</b>	<b>0.40</b>	<b>0.48</b>	<b>0.51</b>	<b>0.55</b>	<b>33.0%</b>

25774

### Basin Travel Time

	Shallow Channel	Ground Cover	Short Pasture/Lawns				
$L_{max,Overland}$	100	ft	$C_v$	7			
$L$ (ft)	$\Delta Z_0$ (ft)	$S_0$ (ft/ft)	$v$ (ft/s)	$t$ (min)	$t_{Alt}$ (min)		
Total	300	19	-	-	-		
Initial Time	95	10	0.105	-	6.1	11.7	DCM Eq. 6-8
Shallow Channel	205	9	0.044	1.5	2.3	-	DCM Eq. 6-9
Channelized			0.000	0.0	0.0	-	V-Ditch
				$t_c$	<b>8.4 min.</b>		

### Rainfall Intensity & Runoff

	2-Yr	5-Yr	10-Yr	25-Yr	50-Yr	100-Yr
Intensity (in/hr)	3.50	4.39	5.12	5.86	6.59	7.37
Runoff (cfs)	0.6	<b>0.9</b>	1.2	1.7	2.0	<b>2.4</b>
Release Rates (cfs/ac)	-	-	-	-	-	-
Allowed Release (cfs)	0.6	<b>0.9</b>	1.2	1.7	2.0	<b>2.4</b>

DCM:  $I = C1 * \ln(tc) + C2$

C1      1.19      1.5      1.75      2      2.25      2.52  
 C2      6.035      7.583      8.847      10.111      11.375      12.735

### Notes

## Sub-Basin Ex-A4 Runoff Calculations

Job No.: 61203  
 Project: Townhomes at Western  
 Jurisdiction: DCM  
 Runoff Coefficient: Surface Type

Date: 7/11/2024 9:35  
 Calcs by: TJW  
 Checked by: \_\_\_\_\_  
 Soil Type: B  
 Urbanization: Urban

### Basin Land Use Characteristics

Surface	Area		Runoff Coefficient						% Imperv.
	(SF)	(Acres)	C2	C5	C10	C25	C50	C100	
Pasture/Meadow	66,217	1.52	0.02	0.08	0.15	0.25	0.3	0.35	0%
Paved			0.89	0.9	0.92	0.94	0.95	0.96	100%
Roofs			0.71	0.73	0.75	0.78	0.8	0.81	90%
<b>Combined</b>	<b>66,217</b>	<b>1.52</b>	<b>0.02</b>	<b>0.08</b>	<b>0.15</b>	<b>0.25</b>	<b>0.30</b>	<b>0.35</b>	<b>0.0%</b>

66217

### Basin Travel Time

	Shallow Channel	Ground Cover	Short Pasture/Lawns				
$L_{max,Overland}$	100	ft	$C_v$	7			
$L$ (ft)	$\Delta Z_0$ (ft)	$S_0$ (ft/ft)	$v$ (ft/s)	$t$ (min)	$t_{Alt}$ (min)		
Total	179	27	-	-	-		
Initial Time	65	10	0.154	-	6.0	11.0	DCM Eq. 6-8
Shallow Channel	114	17	0.149	2.7	0.7	-	DCM Eq. 6-9
Channelized			0.000	0.0	0.0	-	V-Ditch
				$t_c$	6.7 min.		

### Rainfall Intensity & Runoff

	2-Yr	5-Yr	10-Yr	25-Yr	50-Yr	100-Yr
Intensity (in/hr)	3.77	4.72	5.51	6.30	7.09	7.93
Runoff (cfs)	0.1	0.6	1.3	2.4	3.2	4.2
Release Rates (cfs/ac)	-	-	-	-	-	-
Allowed Release (cfs)	0.1	0.6	1.3	2.4	3.2	4.2

DCM:  $I = C1 * \ln(tc) + C2$

C1      1.19      1.5      1.75      2      2.25      2.52  
 C2      6.035      7.583      8.847      10.111      11.375      12.735

### Notes

## Sub-Basin Ex-B3 Runoff Calculations

Job No.: 61203  
 Project: Townhomes at Western  
 Jurisdiction: DCM  
 Runoff Coefficient: Surface Type

Date: 7/11/2024 9:35  
 Calcs by: TJW  
 Checked by: \_\_\_\_\_  
 Soil Type: B  
 Urbanization: Urban

### Basin Land Use Characteristics

Surface	Area		Runoff Coefficient						% Imperv.
	(SF)	(Acres)	C2	C5	C10	C25	C50	C100	
Pasture/Meadow	7,067	0.16	0.02	0.08	0.15	0.25	0.3	0.35	0%
Paved	4,665	0.11	0.89	0.9	0.92	0.94	0.95	0.96	100%
Roofs			0.71	0.73	0.75	0.78	0.8	0.81	90%
<b>Combined</b>	<b>11,732</b>	<b>0.27</b>	<b>0.37</b>	<b>0.41</b>	<b>0.46</b>	<b>0.52</b>	<b>0.56</b>	<b>0.59</b>	<b>39.8%</b>

11732

### Basin Travel Time

	Shallow Channel	Ground Cover	Short Pasture/Lawns				
$L_{max,Overland}$	100	ft	$C_v$	7			
$L$ (ft)	$\Delta Z_0$ (ft)	$S_0$ (ft/ft)	$v$ (ft/s)	$t$ (min)	$t_{Alt}$ (min)		
Total	227	15	-	-	-		
Initial Time	83	9	0.108	-	5.2	11.3 DCM Eq. 6-8	
Shallow Channel	144	6	0.042	1.4	1.7	- DCM Eq. 6-9	
Channelized			0.000	0.0	0.0	- V-Ditch	
				$t_c$	<b>6.9 min.</b>		

### Rainfall Intensity & Runoff

	2-Yr	5-Yr	10-Yr	25-Yr	50-Yr	100-Yr
Intensity (in/hr)	3.74	4.69	5.47	6.25	7.04	7.88
Runoff (cfs)	0.4	<b>0.5</b>	0.7	0.9	1.1	<b>1.3</b>
Release Rates (cfs/ac)	-	-	-	-	-	-
Allowed Release (cfs)	0.4	<b>0.5</b>	0.7	0.9	1.1	<b>1.3</b>

DCM:  $I = C1 * \ln(tc) + C2$

C1      1.19      1.5      1.75      2      2.25      2.52  
 C2      6.035      7.583      8.847      10.111      11.375      12.735

### Notes

## Sub-Basin Ex-B4 Runoff Calculations

Job No.: 61203  
 Project: Townhomes at Western  
 Jurisdiction: DCM  
 Runoff Coefficient: Surface Type

Date: 7/11/2024 9:35  
 Calcs by: TJW  
 Checked by: \_\_\_\_\_  
 Soil Type: B  
 Urbanization: Urban

### Basin Land Use Characteristics

Surface	Area		Runoff Coefficient						% Imperv.
	(SF)	(Acres)	C2	C5	C10	C25	C50	C100	
Pasture/Meadow	28,941	0.66	0.02	0.08	0.15	0.25	0.3	0.35	0%
Paved			0.89	0.9	0.92	0.94	0.95	0.96	100%
Roofs			0.71	0.73	0.75	0.78	0.8	0.81	90%
<b>Combined</b>	<b>28,941</b>	<b>0.66</b>	<b>0.89</b>	<b>0.90</b>	<b>0.92</b>	<b>0.94</b>	<b>0.95</b>	<b>0.96</b>	<b>100.0%</b>

28941

### Basin Travel Time

	Shallow Channel	Ground Cover	Short Pasture/Lawns				
$L_{max,Overland}$	100	ft	$C_v$	7			
$L$ (ft)	$\Delta Z_0$ (ft)	$S_0$ (ft/ft)	$v$ (ft/s)	$t$ (min)	$t_{Alt}$ (min)		
Total	50	1	-	-	-		
Initial Time	50	1	0.010	-	2.6	10.3 DCM Eq. 6-8	
Shallow Channel			0.000	0.0	0.0	- DCM Eq. 6-9	
Channelized			0.000	0.0	0.0	- V-Ditch	
				$t_c$	5.0 min.		

### Rainfall Intensity & Runoff

	2-Yr	5-Yr	10-Yr	25-Yr	50-Yr	100-Yr
Intensity (in/hr)	4.12	5.17	6.03	6.89	7.75	8.68
Runoff (cfs)	2.4	3.1	3.7	4.3	4.9	5.5
Release Rates (cfs/ac)	-	-	-	-	-	-
Allowed Release (cfs)	2.4	3.1	3.7	4.3	4.9	5.5

DCM:  $I = C1 * \ln(tc) + C2$

C1      1.19      1.5      1.75      2      2.25      2.52  
 C2      6.035      7.583      8.847      10.111      11.375      12.735

### Notes

## Sub-Basin Ex-C1 Runoff Calculations

Job No.: 61203  
 Project: Townhomes at Western  
 Jurisdiction: DCM  
 Runoff Coefficient: Surface Type

Date: 7/11/2024 9:35  
 Calcs by: TJW  
 Checked by: \_\_\_\_\_  
 Soil Type: B  
 Urbanization: Urban

### Basin Land Use Characteristics

Surface	Area		Runoff Coefficient						% Imperv.
	(SF)	(Acres)	C2	C5	C10	C25	C50	C100	
Pasture/Meadow	26,060	0.60	0.02	0.08	0.15	0.25	0.3	0.35	0%
Paved			0.89	0.9	0.92	0.94	0.95	0.96	100%
Roofs			0.71	0.73	0.75	0.78	0.8	0.81	90%
<b>Combined</b>	<b>26,060</b>	<b>0.60</b>	<b>0.02</b>	<b>0.08</b>	<b>0.15</b>	<b>0.25</b>	<b>0.30</b>	<b>0.35</b>	<b>0.0%</b>

26060

### Basin Travel Time

	Shallow Channel	Ground Cover	Short Pasture/Lawns				
$L_{max,Overland}$	100	ft	$C_v$	7			
$L$ (ft)	$\Delta Z_0$ (ft)	$S_0$ (ft/ft)	$v$ (ft/s)	$t$ (min)	$t_{Alt}$ (min)		
Total	49	9	-	-	-		
Initial Time	49	9	0.184	-	4.9	10.3 DCM Eq. 6-8	
Shallow Channel			0.000	0.0	0.0	- DCM Eq. 6-9	
Channelized			0.000	0.0	0.0	- V-Ditch	
				$t_c$	5.0 min.		

### Rainfall Intensity & Runoff

	2-Yr	5-Yr	10-Yr	25-Yr	50-Yr	100-Yr
Intensity (in/hr)	4.12	5.17	6.03	6.89	7.75	8.68
Runoff (cfs)	0.0	0.2	0.5	1.0	1.4	1.8
Release Rates (cfs/ac)	-	-	-	-	-	-
Allowed Release (cfs)	0.0	0.2	0.5	1.0	1.4	1.8

DCM:  $I = C1 * \ln(tc) + C2$

C1      1.19      1.5      1.75      2      2.25      2.52  
 C2      6.035      7.583      8.847      10.111      11.375      12.735

### Notes

## Combined Sub-Basin Runoff Calculations (EX-DP1)

Includes Basins OS-B1 OS-B2 EX-B3 EX-B4 EX-C1

Job No.:	<b>61203</b>	Date:	<b>7/11/2024 9:35</b>
Project:	<b>Townhomes at Western</b>	Calcs by:	<b>TJW</b>
Jurisdiction	<b>DCM</b>	Checked by:	
Runoff Coefficient	<b>Surface Type</b>	Soil Type	<b>B</b>
		Urbanization	<b>Urban</b>

### Basin Land Use Characteristics

Surface	Area		Runoff Coefficient						% Imperv.
	(SF)	(Acres)	C2	C5	C10	C25	C50	C100	
Pasture/Meadow	60,313	1.38	0.02	0.08	0.15	0.25	0.3	0.35	0%
Gravel	12,017	0.28	0.57	0.59	0.63	0.66	0.68	0.7	80%
Paved	82,330	1.89	0.89	0.9	0.92	0.94	0.95	0.96	100%
Roofs	6,867	0.16	0.71	0.73	0.75	0.78	0.8	0.81	90%
<b>Combined</b>	<b>161,527</b>	<b>3.71</b>	<b>0.53</b>	<b>0.56</b>	<b>0.60</b>	<b>0.65</b>	<b>0.68</b>	<b>0.71</b>	<b>60.7%</b>

### Basin Travel Time

	Sub-basin or Channel Type	Material Type	L (ft)	Elev. ΔZ <sub>0</sub> (ft)	Q <sub>i</sub> (cfs)	Base or Dia (ft)	Sides z:1 (ft/ft)	v (ft/s)	t (min)
Furthest Reach	OS-B1	-	190	20	-	-	-	-	5.2
Channelized-1									
Channelized-2									
Channelized-3									
Total			190	20					
								<b>t<sub>c</sub> (min)</b>	<b>5.2</b>

### Contributing Offsite Flows (Added to Runoff and Allowed Release, below.)

Contributing Basins/Areas: [Redacted]

Q<sub>Minor</sub>: [Redacted] (cfs) - 5-year Storm

Q<sub>Major</sub>: [Redacted] (cfs) - 100-year Storm

### Rainfall Intensity & Runoff

	2-Yr	5-Yr	10-Yr	25-Yr	50-Yr	100-Yr
<b>Intensity (in/hr)</b>	4.08	5.12	5.97	6.83	7.68	8.60
<b>Site Runoff (cfs)</b>	8.08	<b>10.70</b>	13.37	16.58	19.39	<b>22.53</b>
<b>OffSite Runoff (cfs)</b>	-	<b>0.00</b>	-	-	-	<b>0.00</b>
<b>Release Rates (cfs/ac)</b>	-	-	-	-	-	-
<b>Allowed Release (cfs)</b>	-	<b>10.7</b>	-	-	-	<b>22.5</b>

DCM:  $I = C1 * \ln(tc) + C2$

C1	1.19	1.5	1.75	2	2.25	2.52
C2	6.035	7.583	8.847	10.111	11.375	12.735

### Notes

Runoff from Offsite basins have been assumed constant, despite additional times of concentration.

## Combined Sub-Basin Runoff Calculations (EX-DP2)

Includes Basins OS-A1 EX-A2

Job No.:	<b>61203</b>	Date:	<b>7/11/2024 9:35</b>
Project:	<b>Townhomes at Western</b>	Calcs by:	<b>TJW</b>
Jurisdiction	<b>DCM</b>	Checked by:	
Runoff Coefficient	<b>Surface Type</b>	Soil Type	<b>B</b>
		Urbanization	<b>Urban</b>

### Basin Land Use Characteristics

Surface	Area		Runoff Coefficient						% Imperv.
	(SF)	(Acres)	C2	C5	C10	C25	C50	C100	
Pasture/Meadow	158,784	3.65	0.02	0.08	0.15	0.25	0.3	0.35	0%
Gravel	-	0.00	0.57	0.59	0.63	0.66	0.68	0.7	80%
Paved	5,625	0.13	0.89	0.9	0.92	0.94	0.95	0.96	100%
Roofs	-	0.00	0.71	0.73	0.75	0.78	0.8	0.81	90%
<b>Combined</b>	<b>164,409</b>	<b>3.77</b>	<b>0.05</b>	<b>0.11</b>	<b>0.18</b>	<b>0.27</b>	<b>0.32</b>	<b>0.37</b>	<b>3.4%</b>

### Basin Travel Time

	Sub-basin or Channel Type	Material Type	L (ft)	Elev. ΔZ <sub>0</sub> (ft)	Q <sub>i</sub> (cfs)	Base or Dia (ft)	Sides z:1 (ft/ft)	v (ft/s)	t (min)
Furthest Reach	EX-A2	-	487	39	-	-	-	-	10.9
Channelized-1									
Channelized-2									
Channelized-3									
Total			487	39					
								<b>t<sub>c</sub> (min)</b>	<b>10.9</b>

### Contributing Offsite Flows (Added to Runoff and Allowed Release, below.)

Contributing Basins/Areas: [Redacted]

Q<sub>Minor</sub>: [Redacted] (cfs) - 5-year Storm

Q<sub>Major</sub>: [Redacted] (cfs) - 100-year Storm

### Rainfall Intensity & Runoff

	2-Yr	5-Yr	10-Yr	25-Yr	50-Yr	100-Yr
<b>Intensity (in/hr)</b>	3.20	4.01	4.67	5.34	6.01	6.72
<b>Site Runoff (cfs)</b>	0.60	<b>1.63</b>	3.11	5.52	7.31	<b>9.41</b>
<b>OffSite Runoff (cfs)</b>	-	<b>0.00</b>	-	-	-	<b>0.00</b>
<b>Release Rates (cfs/ac)</b>	-	-	-	-	-	-
<b>Allowed Release (cfs)</b>	-	<b>1.6</b>	-	-	-	<b>9.4</b>

DCM:  $I = C1 * \ln(tc) + C2$

C1	1.19	1.5	1.75	2	2.25	2.52
C2	6.035	7.583	8.847	10.111	11.375	12.735

### Notes

Runoff from Offsite basins have been assumed constant, despite additional times of concentration.



## Combined Sub-Basin Runoff Calculations (EX-DP1)

Includes Basins OS-B1 OS-B2 EX-B3 EX-B4 EX-C1 OS-A1 EX-A2

Job No.:	<b>61203</b>	Date:	<b>7/11/2024 9:35</b>
Project:	<b>Townhomes at Western</b>	Calcs by:	<b>TJW</b>
Jurisdiction	<b>DCM</b>	Checked by:	
Runoff Coefficient	<b>Surface Type</b>	Soil Type	<b>B</b>
		Urbanization	<b>Urban</b>

### Basin Land Use Characteristics

Surface	Area		Runoff Coefficient						% Imperv.
	(SF)	(Acres)	C2	C5	C10	C25	C50	C100	
Pasture/Meadow	219,097	5.03	0.02	0.08	0.15	0.25	0.3	0.35	0%
Gravel	12,017	0.28	0.57	0.59	0.63	0.66	0.68	0.7	80%
Paved	87,955	2.02	0.89	0.9	0.92	0.94	0.95	0.96	100%
Roofs	6,867	0.16	0.71	0.73	0.75	0.78	0.8	0.81	90%
<b>Combined</b>	<b>325,936</b>	<b>7.48</b>	<b>0.29</b>	<b>0.33</b>	<b>0.39</b>	<b>0.46</b>	<b>0.50</b>	<b>0.54</b>	<b>31.8%</b>

### Basin Travel Time

	Sub-basin or Channel Type	Material Type	L (ft)	Elev. ΔZ <sub>0</sub> (ft)	Q <sub>i</sub> (cfs)	Base or Dia (ft)	Sides z:1 (ft/ft)	v (ft/s)	t (min)
Furthest Reach	OS-B1	-	190	20	-	-	-	-	5.2
Channelized-1									
Channelized-2									
Channelized-3									
Total			190	20					
								<b>t<sub>c</sub> (min)</b>	<b>5.2</b>

### Contributing Offsite Flows (Added to Runoff and Allowed Release, below.)

Contributing Basins/Areas: [Redacted]

Q<sub>Minor</sub>: [Redacted] (cfs) - 5-year Storm

Q<sub>Major</sub>: [Redacted] (cfs) - 100-year Storm

### Rainfall Intensity & Runoff

	2-Yr	5-Yr	10-Yr	25-Yr	50-Yr	100-Yr
<b>Intensity (in/hr)</b>	4.08	5.12	5.97	6.83	7.68	8.60
<b>Site Runoff (cfs)</b>	8.84	<b>12.79</b>	17.35	23.63	28.74	<b>34.56</b>
<b>OffSite Runoff (cfs)</b>	-	<b>0.00</b>	-	-	-	<b>0.00</b>
<b>Release Rates (cfs/ac)</b>	-	-	-	-	-	-
<b>Allowed Release (cfs)</b>	-	<b>12.8</b>	-	-	-	<b>34.6</b>

DCM:  $I = C1 * \ln(tc) + C2$

C1	1.19	1.5	1.75	2	2.25	2.52
C2	6.035	7.583	8.847	10.111	11.375	12.735

### Notes

Runoff from Offsite basins have been assumed constant, despite additional times of concentration.

## Sub-Basin A2 Runoff Calculations

Job No.: 61203  
 Project: Townhomes at Western  
 Jurisdiction: DCM  
 Runoff Coefficient: Surface Type

Date: 7/11/2024 9:35  
 Calcs by: TJW  
 Checked by: \_\_\_\_\_  
 Soil Type: B  
 Urbanization: Urban

### Basin Land Use Characteristics

Surface	Area		Runoff Coefficient						% Imperv.
	(SF)	(Acres)	C2	C5	C10	C25	C50	C100	
Pasture/Meadow	6,257	0.14	0.02	0.08	0.15	0.25	0.3	0.35	0%
Landscaping			0.03	0.09	0.17	0.26	0.31	0.36	2%
Paved			0.89	0.9	0.92	0.94	0.95	0.96	100%
Roofs			0.71	0.73	0.75	0.78	0.8	0.81	90%
<b>Combined</b>	<b>6,257</b>	<b>0.14</b>	<b>0.03</b>	<b>0.09</b>	<b>0.17</b>	<b>0.26</b>	<b>0.31</b>	<b>0.36</b>	<b>2.0%</b>

6257

### Basin Travel Time

	Shallow Channel	Ground Cover	Paved areas/shallow paved swales			
	$L_{max,Overland}$	100 ft			$C_v$	20
	L (ft)	$\Delta Z_0$ (ft)	$S_0$ (ft/ft)	v (ft/s)	t (min)	$t_{Alt}$ (min)
Total	18	1	-	-	-	-
Initial Time	18	1	0.028	-	5.5	10.1 DCM Eq. 6-8
Shallow Channel			0.000	0.0	0.0	- DCM Eq. 6-9
Channelized			0.000	0.0	0.0	- C&G
				$t_c$	<b>5.5 min.</b>	

### Rainfall Intensity & Runoff

	2-Yr	5-Yr	10-Yr	25-Yr	50-Yr	100-Yr
<b>Intensity (in/hr)</b>	4.00	5.02	5.86	6.69	7.53	8.43
<b>Runoff (cfs)</b>	0.0	0.1	0.1	0.2	0.3	0.4
<b>Release Rates (cfs/ac)</b>	-	-	-	-	-	-
<b>Allowed Release (cfs)</b>	0.0	0.1	0.1	0.2	0.3	0.4

DCM:  $I = C1 * \ln(tc) + C2$

C1	1.19	1.5	1.75	2	2.25	2.52
C2	6.035	7.583	8.847	10.111	11.375	12.735

### Notes

## Sub-Basin A3 Runoff Calculations

Job No.: 61203  
 Project: Townhomes at Western  
 Jurisdiction: DCM  
 Runoff Coefficient: Surface Type

Date: 7/11/2024 9:35  
 Calcs by: TJW  
 Checked by: \_\_\_\_\_  
 Soil Type: B  
 Urbanization: Urban

### Basin Land Use Characteristics

Surface	Area		Runoff Coefficient						% Imperv.
	(SF)	(Acres)	C2	C5	C10	C25	C50	C100	
Pasture/Meadow			0.02	0.08	0.15	0.25	0.3	0.35	0%
Landscaping	10,570	0.24	0.03	0.09	0.17	0.26	0.31	0.36	2%
Paved	9,425	0.22	0.89	0.9	0.92	0.94	0.95	0.96	100%
Roofs	5,796	0.13	0.71	0.73	0.75	0.78	0.8	0.81	90%
<b>Combined</b>	<b>25,791</b>	<b>0.59</b>	<b>0.50</b>	<b>0.53</b>	<b>0.57</b>	<b>0.63</b>	<b>0.65</b>	<b>0.68</b>	<b>57.6%</b>

25791

### Basin Travel Time

	Shallow Channel Ground Cover		Paved areas/shallow paved swales			
	$L_{max,Overland}$	ft	$S_0$ (ft/ft)	$v$ (ft/s)	$t$ (min)	$t_{Alt}$ (min)
Total	320	19	-	-	-	-
Initial Time	86	6	0.070	-	5.0	11.8 DCM Eq. 6-8
Shallow Channel			0.000	0.0	0.0	- DCM Eq. 6-9
Channelized	234	13	0.056	4.4	0.9	- C&G
				$t_c$	<b>5.9 min.</b>	

### Rainfall Intensity & Runoff

	2-Yr	5-Yr	10-Yr	25-Yr	50-Yr	100-Yr
<b>Intensity (in/hr)</b>	3.92	4.92	5.74	6.56	7.38	8.26
<b>Runoff (cfs)</b>	1.2	1.5	2.0	2.4	2.9	3.3
<b>Release Rates (cfs/ac)</b>	-	-	-	-	-	-
<b>Allowed Release (cfs)</b>	1.2	1.5	2.0	2.4	2.9	3.3

DCM:  $I = C1 * \ln(tc) + C2$

C1	1.19	1.5	1.75	2	2.25	2.52
C2	6.035	7.583	8.847	10.111	11.375	12.735

### Notes

## Sub-Basin A4 Runoff Calculations

Job No.: 61203  
 Project: Townhomes at Western  
 Jurisdiction: DCM  
 Runoff Coefficient: Surface Type

Date: 7/11/2024 9:35  
 Calcs by: TJW  
 Checked by: \_\_\_\_\_  
 Soil Type: B  
 Urbanization: Urban

### Basin Land Use Characteristics

Surface	Area		Runoff Coefficient						% Imperv.
	(SF)	(Acres)	C2	C5	C10	C25	C50	C100	
Pasture/Meadow			0.02	0.08	0.15	0.25	0.3	0.35	0%
Landscaping	3,623	0.08	0.03	0.09	0.17	0.26	0.31	0.36	2%
Paved	8,261	0.19	0.89	0.9	0.92	0.94	0.95	0.96	100%
Roofs	3,864	0.09	0.71	0.73	0.75	0.78	0.8	0.81	90%
<b>Combined</b>	<b>15,748</b>	<b>0.36</b>	<b>0.65</b>	<b>0.67</b>	<b>0.71</b>	<b>0.74</b>	<b>0.77</b>	<b>0.79</b>	<b>75.0%</b>

15748

### Basin Travel Time

	Shallow Channel	Ground Cover	Paved areas/shallow paved swales			
	$L_{max,Overland}$	100 ft			$C_v$	20
	L (ft)	$\Delta Z_0$ (ft)	$S_0$ (ft/ft)	v (ft/s)	t (min)	$t_{Alt}$ (min)
Total	219	14	-	-	-	-
Initial Time	86	11	0.128	-	3.1	11.2 DCM Eq. 6-8
Shallow Channel	36	1	0.028	3.3	0.2	- DCM Eq. 6-9
Channelized	97	2	0.015	2.6	0.6	- C&G
				$t_c$	5.0 min.	

### Rainfall Intensity & Runoff

	2-Yr	5-Yr	10-Yr	25-Yr	50-Yr	100-Yr
Intensity (in/hr)	4.12	5.17	6.03	6.89	7.75	8.68
Runoff (cfs)	1.0	1.3	1.5	1.9	2.1	2.5
Release Rates (cfs/ac)	-	-	-	-	-	-
Allowed Release (cfs)	1.0	1.3	1.5	1.9	2.1	2.5

DCM:  $I = C1 * \ln(tc) + C2$

C1	1.19	1.5	1.75	2	2.25	2.52
C2	6.035	7.583	8.847	10.111	11.375	12.735

### Notes

## Sub-Basin A5 Runoff Calculations

Job No.: 61203  
 Project: Townhomes at Western  
 Jurisdiction: DCM  
 Runoff Coefficient: Surface Type

Date: 7/11/2024 9:35  
 Calcs by: TJW  
 Checked by: \_\_\_\_\_  
 Soil Type: B  
 Urbanization: Urban

### Basin Land Use Characteristics

Surface	Area		Runoff Coefficient						% Imperv.
	(SF)	(Acres)	C2	C5	C10	C25	C50	C100	
Pasture/Meadow			0.02	0.08	0.15	0.25	0.3	0.35	0%
Landscaping	3,235	0.07	0.03	0.09	0.17	0.26	0.31	0.36	2%
Paved	5,831	0.13	0.89	0.9	0.92	0.94	0.95	0.96	100%
Roofs	3,864	0.09	0.71	0.73	0.75	0.78	0.8	0.81	90%
<b>Combined</b>	<b>12,930</b>	<b>0.30</b>	<b>0.62</b>	<b>0.65</b>	<b>0.68</b>	<b>0.72</b>	<b>0.75</b>	<b>0.77</b>	<b>72.5%</b>

12930

### Basin Travel Time

	Shallow Channel Ground Cover		Paved areas/shallow paved swales			
	$L_{max,Overland}$ (ft)	100 ft	$S_0$ (ft/ft)	$v$ (ft/s)	$t$ (min)	$t_{Alt}$ (min)
Total	233	15	-	-	-	-
Initial Time	90	12	0.133	-	3.3	11.3 DCM Eq. 6-8
Shallow Channel	39	1	0.026	3.2	0.2	- DCM Eq. 6-9
Channelized	104	2	0.019	2.6	0.7	- C&G
				$t_c$	<b>5.0 min.</b>	

### Rainfall Intensity & Runoff

	2-Yr	5-Yr	10-Yr	25-Yr	50-Yr	100-Yr
Intensity (in/hr)	4.12	5.17	6.03	6.89	7.75	8.68
Runoff (cfs)	0.8	1.0	1.2	1.5	1.7	2.0
Release Rates (cfs/ac)	-	-	-	-	-	-
Allowed Release (cfs)	0.8	1.0	1.2	1.5	1.7	2.0

DCM:  $I = C1 * \ln(tc) + C2$

C1	1.19	1.5	1.75	2	2.25	2.52
C2	6.035	7.583	8.847	10.111	11.375	12.735

### Notes

## Sub-Basin A6 Runoff Calculations

Job No.: 61203  
 Project: Townhomes at Western  
 Jurisdiction: DCM  
 Runoff Coefficient: Surface Type

Date: 7/11/2024 9:35  
 Calcs by: TJW  
 Checked by: \_\_\_\_\_  
 Soil Type: B  
 Urbanization: Urban

### Basin Land Use Characteristics

Surface	Area		Runoff Coefficient						% Imperv.
	(SF)	(Acres)	C2	C5	C10	C25	C50	C100	
Pasture/Meadow			0.02	0.08	0.15	0.25	0.3	0.35	0%
Landscaping	1,957	0.04	0.03	0.09	0.17	0.26	0.31	0.36	2%
Paved	6,904	0.16	0.89	0.9	0.92	0.94	0.95	0.96	100%
Roofs	3,864	0.09	0.71	0.73	0.75	0.78	0.8	0.81	90%
<b>Combined</b>	<b>12,725</b>	<b>0.29</b>	<b>0.70</b>	<b>0.72</b>	<b>0.75</b>	<b>0.79</b>	<b>0.81</b>	<b>0.82</b>	<b>81.9%</b>

12725

### Basin Travel Time

	Shallow Channel Ground Cover		Paved areas/shallow paved swales				
	$L_{max,Overland}$	100 ft	$S_0$ (ft/ft)	$v$ (ft/s)	$t$ (min)	$t_{Alt}$ (min)	$C_v$ 20
Total	205	14	-	-	-	-	-
Initial Time	55	11	0.200	-	1.9	11.1	DCM Eq. 6-8
Shallow Channel	54	1	0.019	2.7	0.3	-	DCM Eq. 6-9
Channelized	96	2	0.016	2.7	0.6	-	C&G
				$t_c$	5.0 min.		

### Rainfall Intensity & Runoff

	2-Yr	5-Yr	10-Yr	25-Yr	50-Yr	100-Yr
Intensity (in/hr)	4.12	5.17	6.03	6.89	7.75	8.68
Runoff (cfs)	0.8	1.1	1.3	1.6	1.8	2.1
Release Rates (cfs/ac)	-	-	-	-	-	-
Allowed Release (cfs)	0.8	1.1	1.3	1.6	1.8	2.1

DCM:  $I = C1 * \ln(tc) + C2$

C1      1.19      1.5      1.75      2      2.25      2.52  
 C2      6.035      7.583      8.847      10.111      11.375      12.735

### Notes

## Sub-Basin A7 Runoff Calculations

Job No.: 61203  
 Project: Townhomes at Western  
 Jurisdiction: DCM  
 Runoff Coefficient: Surface Type

Date: 7/11/2024 9:35  
 Calcs by: TJW  
 Checked by: \_\_\_\_\_  
 Soil Type: B  
 Urbanization: Urban

### Basin Land Use Characteristics

Surface	Area		Runoff Coefficient						% Imperv.
	(SF)	(Acres)	C2	C5	C10	C25	C50	C100	
Pasture/Meadow			0.02	0.08	0.15	0.25	0.3	0.35	0%
Landscaping	15,849	0.36	0.03	0.09	0.17	0.26	0.31	0.36	2%
Paved	22,197	0.51	0.89	0.9	0.92	0.94	0.95	0.96	100%
Roofs	11,592	0.27	0.71	0.73	0.75	0.78	0.8	0.81	90%
<b>Combined</b>	<b>49,638</b>	<b>1.14</b>	<b>0.57</b>	<b>0.60</b>	<b>0.64</b>	<b>0.69</b>	<b>0.71</b>	<b>0.73</b>	<b>66.4%</b>

49638

### Basin Travel Time

	Shallow Channel	Ground Cover	Paved areas/shallow paved swales			
	$L_{max,Overland}$	100 ft			$C_v$	20
	L (ft)	$\Delta Z_0$ (ft)	$S_0$ (ft/ft)	v (ft/s)	t (min)	$t_{Alt}$ (min)
Total	556	27	-	-	-	-
Initial Time	74	10	0.135	-	3.3	13.1 DCM Eq. 6-8
Shallow Channel	170	3	0.018	2.7	1.1	- DCM Eq. 6-9
Channelized	312	14	0.045	4.9	1.1	- C&G
				$t_c$	<b>5.4 min.</b>	

### Rainfall Intensity & Runoff

	2-Yr	5-Yr	10-Yr	25-Yr	50-Yr	100-Yr
<b>Intensity (in/hr)</b>	4.03	5.05	5.90	6.74	7.58	8.48
<b>Runoff (cfs)</b>	2.6	<b>3.5</b>	4.3	5.3	6.1	<b>7.1</b>
<b>Release Rates (cfs/ac)</b>	-	-	-	-	-	-
<b>Allowed Release (cfs)</b>	2.6	<b>3.5</b>	4.3	5.3	6.1	<b>7.1</b>

DCM:  $I = C1 * \ln(tc) + C2$

C1	1.19	1.5	1.75	2	2.25	2.52
C2	6.035	7.583	8.847	10.111	11.375	12.735

### Notes

## Sub-Basin A8 Runoff Calculations

Job No.: 61203  
 Project: Townhomes at Western  
 Jurisdiction: DCM  
 Runoff Coefficient: Surface Type

Date: 7/11/2024 9:35  
 Calcs by: TJW  
 Checked by: \_\_\_\_\_  
 Soil Type: B  
 Urbanization: Urban

### Basin Land Use Characteristics

Surface	Area		Runoff Coefficient						% Imperv.
	(SF)	(Acres)	C2	C5	C10	C25	C50	C100	
Pasture/Meadow			0.02	0.08	0.15	0.25	0.3	0.35	0%
Landscaping		0.03	0.03	0.09	0.17	0.26	0.31	0.36	2%
Paved	3,502	0.08	0.89	0.9	0.92	0.94	0.95	0.96	100%
Roofs	2,898	0.07	0.71	0.73	0.75	0.78	0.8	0.81	90%
<b>Combined</b>	<b>7,893</b>	<b>0.18</b>	<b>0.66</b>	<b>0.68</b>	<b>0.72</b>	<b>0.75</b>	<b>0.77</b>	<b>0.79</b>	<b>77.8%</b>

7893

### Basin Travel Time

	Shallow Channel Ground Cover		Paved areas/shallow paved swales			
	$L_{max,Overland}$	100 ft			$C_v$	20
	L (ft)	$\Delta Z_0$ (ft)	$S_0$ (ft/ft)	v (ft/s)	t (min)	$t_{Alt}$ (min)
Total	160	13	-	-	-	-
Initial Time	52	11	0.212	-	2.0	10.9 DCM Eq. 6-8
Shallow Channel	33	1	0.030	3.5	0.2	- DCM Eq. 6-9
Channelized	75	1	0.013	2.0	0.6	- C&G
				$t_c$	5.0 min.	

### Rainfall Intensity & Runoff

	2-Yr	5-Yr	10-Yr	25-Yr	50-Yr	100-Yr
Intensity (in/hr)	4.12	5.17	6.03	6.89	7.75	8.68
Runoff (cfs)	0.5	0.6	0.8	0.9	1.1	1.2
Release Rates (cfs/ac)	-	-	-	-	-	-
Allowed Release (cfs)	0.5	0.6	0.8	0.9	1.1	1.2

DCM:  $I = C1 * \ln(tc) + C2$

C1      1.19      1.5      1.75      2      2.25      2.52  
 C2      6.035      7.583      8.847      10.111      11.375      12.735

### Notes



## Sub-Basin A9 Runoff Calculations

Job No.: 61203  
 Project: Townhomes at Western  
 Jurisdiction: DCM  
 Runoff Coefficient: Surface Type

Date: 7/11/2024 9:35  
 Calcs by: TJW  
 Checked by: \_\_\_\_\_  
 Soil Type: B  
 Urbanization: Urban

### Basin Land Use Characteristics

Surface	Area		Runoff Coefficient						% Imperv.
	(SF)	(Acres)	C2	C5	C10	C25	C50	C100	
Pasture/Meadow			0.02	0.08	0.15	0.25	0.3	0.35	0%
Landscaping	10,259	0.24	0.03	0.09	0.17	0.26	0.31	0.36	2%
Paved	17,482	0.40	0.89	0.9	0.92	0.94	0.95	0.96	100%
Roofs	8,694	0.20	0.71	0.73	0.75	0.78	0.8	0.81	90%
<b>Combined</b>	<b>36,435</b>	<b>0.84</b>	<b>0.60</b>	<b>0.63</b>	<b>0.67</b>	<b>0.71</b>	<b>0.73</b>	<b>0.76</b>	<b>70.0%</b>

36435

### Basin Travel Time

	Shallow Channel	Ground Cover	Paved areas/shallow paved swales			
	$L_{max,Overland}$	100 ft			$C_v$	20
	$L$ (ft)	$\Delta Z_0$ (ft)	$S_0$ (ft/ft)	$v$ (ft/s)	$t$ (min)	$t_{Alt}$ (min)
Total	215	15	-	-	-	-
Initial Time	72	12	0.167	-	2.8	11.2 DCM Eq. 6-8
Shallow Channel	37	1	0.027	3.3	0.2	- DCM Eq. 6-9
Channelized	106	2	0.019	3.3	0.5	- C&G
				$t_c$	5.0 min.	

### Rainfall Intensity & Runoff

	2-Yr	5-Yr	10-Yr	25-Yr	50-Yr	100-Yr
Intensity (in/hr)	4.12	5.17	6.03	6.89	7.75	8.68
Runoff (cfs)	2.1	2.7	3.4	4.1	4.8	5.5
Release Rates (cfs/ac)	-	-	-	-	-	-
Allowed Release (cfs)	2.1	2.7	3.4	4.1	4.8	5.5

DCM:  $I = C1 * \ln(tc) + C2$

C1	1.19	1.5	1.75	2	2.25	2.52
C2	6.035	7.583	8.847	10.111	11.375	12.735

### Notes

## Sub-Basin A10 Runoff Calculations

Job No.: 61203  
 Project: Townhomes at Western  
 Jurisdiction: DCM  
 Runoff Coefficient: Surface Type

Date: 7/11/2024 9:35  
 Calcs by: TJW  
 Checked by: \_\_\_\_\_  
 Soil Type: B  
 Urbanization: Urban

### Basin Land Use Characteristics

Surface	Area		Runoff Coefficient						% Imperv.
	(SF)	(Acres)	C2	C5	C10	C25	C50	C100	
Pasture/Meadow			0.02	0.08	0.15	0.25	0.3	0.35	0%
Landscaping	3,638	0.08	0.03	0.09	0.17	0.26	0.31	0.36	2%
Paved	8,706	0.20	0.89	0.9	0.92	0.94	0.95	0.96	100%
Roofs	5,796	0.13	0.71	0.73	0.75	0.78	0.8	0.81	90%
<b>Combined</b>	<b>18,140</b>	<b>0.42</b>	<b>0.66</b>	<b>0.68</b>	<b>0.72</b>	<b>0.75</b>	<b>0.77</b>	<b>0.79</b>	<b>77.2%</b>

18140

### Basin Travel Time

	Shallow Channel	Ground Cover	Paved areas/shallow paved swales			
	$L_{max,Overland}$	100 ft			$C_v$	20
	L (ft)	$\Delta Z_0$ (ft)	$S_0$ (ft/ft)	v (ft/s)	t (min)	$t_{Alt}$ (min)
Total	254	14	-	-	-	-
Initial Time	76	11	0.145	-	2.7	11.4 DCM Eq. 6-8
Shallow Channel	36	1	0.028	3.3	0.2	- DCM Eq. 6-9
Channelized	142	2	0.014	2.6	0.9	- C&G
				$t_c$	5.0 min.	

### Rainfall Intensity & Runoff

	2-Yr	5-Yr	10-Yr	25-Yr	50-Yr	100-Yr
Intensity (in/hr)	4.12	5.17	6.03	6.89	7.75	8.68
Runoff (cfs)	1.1	1.5	1.8	2.2	2.5	2.9
Release Rates (cfs/ac)	-	-	-	-	-	-
Allowed Release (cfs)	1.1	1.5	1.8	2.2	2.5	2.9

DCM:  $I = C1 * \ln(tc) + C2$

C1	1.19	1.5	1.75	2	2.25	2.52
C2	6.035	7.583	8.847	10.111	11.375	12.735

### Notes

## Sub-Basin A11 Runoff Calculations

Job No.: 61203  
 Project: Townhomes at Western  
 Jurisdiction: DCM  
 Runoff Coefficient: Surface Type

Date: 7/11/2024 9:35  
 Calcs by: TJW  
 Checked by: \_\_\_\_\_  
 Soil Type: B  
 Urbanization: Urban

### Basin Land Use Characteristics

Surface	Area		Runoff Coefficient						% Imperv.
	(SF)	(Acres)	C2	C5	C10	C25	C50	C100	
Pasture/Meadow			0.02	0.08	0.15	0.25	0.3	0.35	0%
Landscaping	1,228	0.03	0.03	0.09	0.17	0.26	0.31	0.36	2%
Paved	4,529	0.10	0.89	0.9	0.92	0.94	0.95	0.96	100%
Roofs	3,864	0.09	0.71	0.73	0.75	0.78	0.8	0.81	90%
<b>Combined</b>	<b>9,621</b>	<b>0.22</b>	<b>0.71</b>	<b>0.73</b>	<b>0.76</b>	<b>0.79</b>	<b>0.81</b>	<b>0.82</b>	<b>83.5%</b>

9621

### Basin Travel Time

	Shallow Channel Ground Cover		Paved areas/shallow paved swales				
	$L_{max,Overland}$	ft	$C_v$				
	L (ft)	$\Delta Z_0$ (ft)	$S_0$ (ft/ft)	v (ft/s)	t (min)	$t_{Alt}$ (min)	
Total	177	14	-	-	-	-	
Initial Time	73	12	0.164	-	2.3	11.0	DCM Eq. 6-8
Shallow Channel	33	1	0.030	3.5	0.2	-	DCM Eq. 6-9
Channelized	71	1	0.014	2.2	0.5	-	C&G
				$t_c$	<b>5.0 min.</b>		

### Rainfall Intensity & Runoff

	2-Yr	5-Yr	10-Yr	25-Yr	50-Yr	100-Yr
<b>Intensity (in/hr)</b>	4.12	5.17	6.03	6.89	7.75	8.68
<b>Runoff (cfs)</b>	0.6	<b>0.8</b>	1.0	1.2	1.4	<b>1.6</b>
<b>Release Rates (cfs/ac)</b>	-	-	-	-	-	-
<b>Allowed Release (cfs)</b>	0.6	<b>0.8</b>	1.0	1.2	1.4	<b>1.6</b>

DCM:  $I = C1 * \ln(tc) + C2$

C1      1.19      1.5      1.75      2      2.25      2.52  
 C2      6.035      7.583      8.847      10.111      11.375      12.735

### Notes

## Sub-Basin A12 Runoff Calculations

Job No.: 61203  
 Project: Townhomes at Western  
 Jurisdiction: DCM  
 Runoff Coefficient: Surface Type

Date: 7/11/2024 9:35  
 Calcs by: TJW  
 Checked by: \_\_\_\_\_  
 Soil Type: B  
 Urbanization: Urban

### Basin Land Use Characteristics

Surface	Area		Runoff Coefficient						% Imperv.
	(SF)	(Acres)	C2	C5	C10	C25	C50	C100	
Pasture/Meadow			0.02	0.08	0.15	0.25	0.3	0.35	0%
Landscaping	16,775	0.39	0.03	0.09	0.17	0.26	0.31	0.36	2%
Paved	601	0.01	0.89	0.9	0.92	0.94	0.95	0.96	100%
Roofs			0.71	0.73	0.75	0.78	0.8	0.81	90%
Gravel	1,429	0.03	0.57	0.59	0.63	0.66	0.68	0.7	80%
<b>Combined</b>	<b>18,805</b>	<b>0.43</b>	<b>0.10</b>	<b>0.15</b>	<b>0.23</b>	<b>0.31</b>	<b>0.36</b>	<b>0.41</b>	<b>11.1%</b>

18805

### Basin Travel Time

	Shallow Channel	Ground Cover	Paved areas/shallow paved swales			
	$L_{max,Overland}$	100 ft			$C_v$	20
	L (ft)	$\Delta Z_0$ (ft)	$S_0$ (ft/ft)	v (ft/s)	t (min)	$t_{Alt}$ (min)
Total	0	0	-	-	-	-
Initial Time			0.000	-	0.0	10.0 DCM Eq. 6-8
Shallow Channel			0.000	0.0	0.0	- DCM Eq. 6-9
Channelized			0.000	0.0	0.0	- C&G
				$t_c$	<b>5.0 min.</b>	

### Rainfall Intensity & Runoff

	2-Yr	5-Yr	10-Yr	25-Yr	50-Yr	100-Yr
<b>Intensity (in/hr)</b>	4.12	5.17	6.03	6.89	7.75	8.68
<b>Runoff (cfs)</b>	0.2	<b>0.3</b>	0.6	0.9	1.2	<b>1.5</b>
<b>Release Rates (cfs/ac)</b>	-	-	-	-	-	-
<b>Allowed Release (cfs)</b>	0.2	<b>0.3</b>	0.6	0.9	1.2	<b>1.5</b>

DCM:  $I = C1 * \ln(tc) + C2$

C1      1.19      1.5      1.75      2      2.25      2.52  
 C2      6.035      7.583      8.847      10.111      11.375      12.735

### Notes

## Sub-Basin B3 Runoff Calculations

Job No.: 61203  
 Project: Townhomes at Western  
 Jurisdiction: DCM  
 Runoff Coefficient: Surface Type

Date: 7/11/2024 9:35  
 Calcs by: TJW  
 Checked by: \_\_\_\_\_  
 Soil Type: B  
 Urbanization: Urban

### Basin Land Use Characteristics

Surface	Area		Runoff Coefficient						% Imperv.
	(SF)	(Acres)	C2	C5	C10	C25	C50	C100	
Pasture/Meadow	7,154	0.16	0.02	0.08	0.15	0.25	0.3	0.35	0%
Landscaping			0.03	0.09	0.17	0.26	0.31	0.36	2%
Paved			0.89	0.9	0.92	0.94	0.95	0.96	100%
Roofs			0.71	0.73	0.75	0.78	0.8	0.81	90%
<b>Combined</b>	<b>7,154</b>	<b>0.16</b>	<b>0.03</b>	<b>0.09</b>	<b>0.17</b>	<b>0.26</b>	<b>0.31</b>	<b>0.36</b>	<b>2.0%</b>

7154

### Basin Travel Time

	Shallow Channel Ground Cover		Short Pasture/Lawns				
	$L_{max,Overland}$	100 ft			$C_v$	7	
	L (ft)	$\Delta Z_0$ (ft)	$S_0$ (ft/ft)	v (ft/s)	t (min)	$t_{Alt}$ (min)	
Total	263	11	-	-	-	-	
Initial Time	61	7	0.115	-	6.4	11.5	DCM Eq. 6-8
Shallow Channel	202	4	0.017	0.9	3.7	-	DCM Eq. 6-9
Channelized			0.000	0.0	0.0	-	C&G
				$t_c$	<b>10.0 min.</b>		

### Rainfall Intensity & Runoff

	2-Yr	5-Yr	10-Yr	25-Yr	50-Yr	100-Yr
<b>Intensity (in/hr)</b>	3.29	4.13	4.81	5.50	6.19	6.93
<b>Runoff (cfs)</b>	0.0	0.1	0.1	0.2	0.3	0.4
<b>Release Rates (cfs/ac)</b>	-	-	-	-	-	-
<b>Allowed Release (cfs)</b>	0.0	0.1	0.1	0.2	0.3	0.4

DCM:  $I = C1 * \ln(tc) + C2$

C1      1.19      1.5      1.75      2      2.25      2.52  
 C2      6.035      7.583      8.847      10.111      11.375      12.735

### Notes

## Sub-Basin B4 Runoff Calculations

Job No.: 61203  
 Project: Townhomes at Western  
 Jurisdiction: DCM  
 Runoff Coefficient: Surface Type

Date: 7/11/2024 9:35  
 Calcs by: TJW  
 Checked by: \_\_\_\_\_  
 Soil Type: B  
 Urbanization: Urban

### Basin Land Use Characteristics

Surface	Area		Runoff Coefficient						% Imperv.
	(SF)	(Acres)	C2	C5	C10	C25	C50	C100	
Pasture/Meadow			0.02	0.08	0.15	0.25	0.3	0.35	0%
Landscaping	8,800	0.20	0.03	0.09	0.17	0.26	0.31	0.36	2%
Paved	20,209	0.46	0.89	0.9	0.92	0.94	0.95	0.96	100%
Roofs			0.71	0.73	0.75	0.78	0.8	0.81	90%
<b>Combined</b>	<b>29,009</b>	<b>0.67</b>	<b>0.63</b>	<b>0.65</b>	<b>0.69</b>	<b>0.73</b>	<b>0.76</b>	<b>0.78</b>	<b>70.3%</b>

29009

### Basin Travel Time

	Shallow Channel	Ground Cover	Paved areas/shallow paved swales			
	$L_{max,Overland}$	100 ft			$C_v$	20
	L (ft)	$\Delta Z_0$ (ft)	$S_0$ (ft/ft)	v (ft/s)	t (min)	$t_{Alt}$ (min)
Total	51	1	-	-	-	-
Initial Time	51	1	0.010	-	5.8	10.3 DCM Eq. 6-8
Shallow Channel			0.000	0.0	0.0	- DCM Eq. 6-9
Channelized			0.000	0.0	0.0	- C&G
				$t_c$	<b>5.8 min.</b>	

### Rainfall Intensity & Runoff

	2-Yr	5-Yr	10-Yr	25-Yr	50-Yr	100-Yr
<b>Intensity (in/hr)</b>	3.95	4.95	5.78	6.60	7.43	8.31
<b>Runoff (cfs)</b>	1.7	<b>2.2</b>	2.7	3.2	3.7	<b>4.3</b>
<b>Release Rates (cfs/ac)</b>	-	-	-	-	-	-
<b>Allowed Release (cfs)</b>	1.7	<b>2.2</b>	2.7	3.2	3.7	<b>4.3</b>

DCM:  $I = C1 * \ln(tc) + C2$

C1	1.19	1.5	1.75	2	2.25	2.52
C2	6.035	7.583	8.847	10.111	11.375	12.735

### Notes

## Sub-Basin C1 Runoff Calculations

Job No.: 61203  
 Project: Townhomes at Western  
 Jurisdiction: DCM  
 Runoff Coefficient: Surface Type

Date: 7/11/2024 9:35  
 Calcs by: TJW  
 Checked by: \_\_\_\_\_  
 Soil Type: B  
 Urbanization: Urban

### Basin Land Use Characteristics

Surface	Area		Runoff Coefficient						% Imperv.
	(SF)	(Acres)	C2	C5	C10	C25	C50	C100	
Pasture/Meadow	28,901	0.66	0.02	0.08	0.15	0.25	0.3	0.35	0%
Landscaping			0.03	0.09	0.17	0.26	0.31	0.36	2%
Paved			0.89	0.9	0.92	0.94	0.95	0.96	100%
Roofs			0.71	0.73	0.75	0.78	0.8	0.81	90%
<b>Combined</b>	<b>28,901</b>	<b>0.66</b>	<b>0.02</b>	<b>0.08</b>	<b>0.15</b>	<b>0.25</b>	<b>0.30</b>	<b>0.35</b>	<b>0.0%</b>

28901

### Basin Travel Time

	Shallow Channel	Ground Cover	Paved areas/shallow paved swales			
	$L_{max,Overland}$	100 ft	$S_0$ (ft/ft)	$v$ (ft/s)	$t$ (min)	$t_{Alt}$ (min)
Total	49	9	-	-	-	-
Initial Time	49	9	0.184	-	4.9	10.3 DCM Eq. 6-8
Shallow Channel			0.000	0.0	0.0	- DCM Eq. 6-9
Channelized			0.000	0.0	0.0	- C&G
				$t_c$	<b>5.0 min.</b>	

### Rainfall Intensity & Runoff

	2-Yr	5-Yr	10-Yr	25-Yr	50-Yr	100-Yr
<b>Intensity (in/hr)</b>	4.12	5.17	6.03	6.89	7.75	8.68
<b>Runoff (cfs)</b>	0.1	<b>0.3</b>	0.6	1.1	1.5	<b>2.0</b>
<b>Release Rates (cfs/ac)</b>	-	-	-	-	-	-
<b>Allowed Release (cfs)</b>	0.1	<b>0.3</b>	0.6	1.1	1.5	<b>2.0</b>

DCM:  $I = C1 * \ln(tc) + C2$

C1	1.19	1.5	1.75	2	2.25	2.52
C2	6.035	7.583	8.847	10.111	11.375	12.735

### Notes

## Sub-Basin C2 Runoff Calculations

Job No.: 61203  
 Project: Townhomes at Western  
 Jurisdiction: DCM  
 Runoff Coefficient: Surface Type

Date: 7/11/2024 9:35  
 Calcs by: TJW  
 Checked by: \_\_\_\_\_  
 Soil Type: B  
 Urbanization: Urban

### Basin Land Use Characteristics

Surface	Area		Runoff Coefficient						% Imperv.
	(SF)	(Acres)	C2	C5	C10	C25	C50	C100	
Pasture/Meadow	13,488	0.31	0.02	0.08	0.15	0.25	0.3	0.35	0%
Landscaping			0.03	0.09	0.17	0.26	0.31	0.36	2%
Paved			0.89	0.9	0.92	0.94	0.95	0.96	100%
Roofs			0.71	0.73	0.75	0.78	0.8	0.81	90%
Gravel	1,318	0.03	0.57	0.59	0.63	0.66	0.68	0.7	80%
<b>Combined</b>	<b>14,806</b>	<b>0.34</b>	<b>0.07</b>	<b>0.13</b>	<b>0.19</b>	<b>0.29</b>	<b>0.33</b>	<b>0.38</b>	<b>7.1%</b>

14806

### Basin Travel Time

	Shallow Channel Ground Cover		Paved areas/shallow paved swales			
	$L_{max,Overland}$ (ft)	$\Delta Z_0$ (ft)	$S_0$ (ft/ft)	$v$ (ft/s)	$t$ (min)	$t_{Alt}$ (min)
Total	320	19	-	-	-	-
Initial Time	86	6	0.070	-	8.6	11.8 DCM Eq. 6-8
Shallow Channel			0.000	0.0	0.0	- DCM Eq. 6-9
Channelized	234	13	0.056	4.4	0.9	- C&G
				$t_c$	<b>9.5 min.</b>	

### Rainfall Intensity & Runoff

	2-Yr	5-Yr	10-Yr	25-Yr	50-Yr	100-Yr
<b>Intensity (in/hr)</b>	3.36	4.21	4.91	5.61	6.32	7.07
<b>Runoff (cfs)</b>	0.1	<b>0.2</b>	0.3	0.5	0.7	<b>0.9</b>
<b>Release Rates (cfs/ac)</b>	-	-	-	-	-	-
<b>Allowed Release (cfs)</b>	0.1	<b>0.2</b>	0.3	0.5	0.7	<b>0.9</b>

DCM:  $I = C1 * \ln(tc) + C2$

C1	1.19	1.5	1.75	2	2.25	2.52
C2	6.035	7.583	8.847	10.111	11.375	12.735

### Notes



## Sub-Basin C3 Runoff Calculations

Job No.: 61203  
 Project: Townhomes at Western  
 Jurisdiction: DCM  
 Runoff Coefficient: Surface Type

Date: 7/11/2024 9:35  
 Calcs by: TJW  
 Checked by: \_\_\_\_\_  
 Soil Type: B  
 Urbanization: Urban

### Basin Land Use Characteristics

Surface	Area		Runoff Coefficient						% Imperv.
	(SF)	(Acres)	C2	C5	C10	C25	C50	C100	
Pasture/Meadow	14,891	0.34	0.02	0.08	0.15	0.25	0.3	0.35	0%
Landscaping			0.03	0.09	0.17	0.26	0.31	0.36	2%
Paved			0.89	0.9	0.92	0.94	0.95	0.96	100%
Roofs			0.71	0.73	0.75	0.78	0.8	0.81	90%
Gravel	724	0.02	0.57	0.59	0.63	0.66	0.68	0.7	80%
<b>Combined</b>	<b>15,615</b>	<b>0.36</b>	<b>0.05</b>	<b>0.10</b>	<b>0.17</b>	<b>0.27</b>	<b>0.32</b>	<b>0.37</b>	<b>3.7%</b>

15615

### Basin Travel Time

	Shallow Channel Ground Cover		Paved areas/shallow paved swales			
	$L_{max,Overland}$	ft	$S_0$ (ft/ft)	$v$ (ft/s)	$t$ (min)	$t_{Alt}$ (min)
Total	320	19	-	-	-	-
Initial Time	86	6	0.070	-	8.8	11.8 DCM Eq. 6-8
Shallow Channel			0.000	0.0	0.0	- DCM Eq. 6-9
Channelized	234	13	0.056	4.4	0.9	- C&G
				$t_c$	<b>9.7 min.</b>	

### Rainfall Intensity & Runoff

	2-Yr	5-Yr	10-Yr	25-Yr	50-Yr	100-Yr
<b>Intensity (in/hr)</b>	3.34	4.18	4.88	5.57	6.27	7.02
<b>Runoff (cfs)</b>	0.1	<b>0.2</b>	0.3	0.5	0.7	<b>0.9</b>
<b>Release Rates (cfs/ac)</b>	-	-	-	-	-	-
<b>Allowed Release (cfs)</b>	0.1	<b>0.2</b>	0.3	0.5	0.7	<b>0.9</b>

DCM:  $I = C1 * \ln(tc) + C2$

C1	1.19	1.5	1.75	2	2.25	2.52
C2	6.035	7.583	8.847	10.111	11.375	12.735

### Notes

## Combined Sub-Basin Runoff Calculations (DP1)

Includes Basins OS-B1 OS-B2 B3 B4 C1

Job No.:	<b>61203</b>	Date:	<b>7/11/2024 9:35</b>
Project:	<b>Townhomes at Western</b>	Calcs by:	<b>TJW</b>
Jurisdiction	<b>DCM</b>	Checked by:	
Runoff Coefficient	<b>Surface Type</b>	Soil Type	<b>B</b>
		Urbanization	<b>Urban</b>

### Basin Land Use Characteristics

Surface	Area		Runoff Coefficient						% Imperv.
	(SF)	(Acres)	C2	C5	C10	C25	C50	C100	
Pasture/Meadow	56,087	1.29	0.02	0.08	0.15	0.25	0.3	0.35	0%
Landscaping	15,954	0.37	0.03	0.09	0.17	0.26	0.31	0.36	2%
Gravel	12,017	0.28	0.57	0.59	0.63	0.66	0.68	0.7	80%
Paved	68,933	1.58	0.89	0.9	0.92	0.94	0.95	0.96	100%
Roofs	6,867	0.16	0.71	0.73	0.75	0.78	0.8	0.81	90%
<b>Combined</b>	<b>159,858</b>	<b>3.67</b>	<b>0.47</b>	<b>0.50</b>	<b>0.55</b>	<b>0.60</b>	<b>0.63</b>	<b>0.66</b>	<b>53.2%</b>

### Basin Travel Time

	Sub-basin or Channel Type	Material Type	L (ft)	Elev. $\Delta Z_0$ (ft)	$Q_i$ (cfs)	Base or Dia (ft)	Sides z:1 (ft/ft)	v (ft/s)	t (min)
Furthest Reach	OS-B1	-	190	20	-	-	-	-	5.2
Channelized-1									
Channelized-2									
Channelized-3									
Total			190	20					
							$t_c$ (min)		<b>5.2</b>

### Contributing Offsite Flows (Added to Runoff and Allowed Release, below.)

Contributing Basins/Areas: [Redacted]

$Q_{Minor}$  (cfs) - 5-year Storm [Redacted]

$Q_{Major}$  (cfs) - 100-year Storm [Redacted]

### Rainfall Intensity & Runoff

	2-Yr	5-Yr	10-Yr	25-Yr	50-Yr	100-Yr
<b>Intensity (in/hr)</b>	4.08	5.12	5.97	6.83	7.68	8.60
<b>Site Runoff (cfs)</b>	7.00	<b>9.41</b>	11.97	15.09	17.80	<b>20.83</b>
<b>OffSite Runoff (cfs)</b>	-	<b>0.00</b>	-	-	-	<b>0.00</b>
<b>Release Rates (cfs/ac)</b>	-	-	-	-	-	-
<b>Allowed Release (cfs)</b>	-	<b>9.4</b>	-	-	-	<b>20.8</b>

DCM:  $I = C1 * \ln(tc) + C2$

C1	1.19	1.5	1.75	2	2.25	2.52
C2	6.035	7.583	8.847	10.111	11.375	12.735

### Notes

Runoff from Offsite basins have been assumed constant, despite additional times of concentration.

## Combined Sub-Basin Runoff Calculations (DP2)

Includes Basins C2

Job No.:	<b>61203</b>	Date:	<b>7/11/2024 9:35</b>
Project:	<b>Townhomes at Western</b>	Calcs by:	<b>TJW</b>
Jurisdiction	<b>DCM</b>	Checked by:	
Runoff Coefficient	<b>Surface Type</b>	Soil Type	<b>B</b>
		Urbanization	<b>Urban</b>

### Basin Land Use Characteristics

Surface	Area		Runoff Coefficient						% Imperv.
	(SF)	(Acres)	C2	C5	C10	C25	C50	C100	
Pasture/Meadow	13,488	0.31	0.02	0.08	0.15	0.25	0.3	0.35	0%
Landscaping	-	0.00	0.03	0.09	0.17	0.26	0.31	0.36	2%
Gravel	1,318	0.03	0.57	0.59	0.63	0.66	0.68	0.7	80%
Paved	-	0.00	0.89	0.9	0.92	0.94	0.95	0.96	100%
Roofs	-	0.00	0.71	0.73	0.75	0.78	0.8	0.81	90%
<b>Combined</b>	<b>14,806</b>	<b>0.34</b>	<b>0.07</b>	<b>0.13</b>	<b>0.19</b>	<b>0.29</b>	<b>0.33</b>	<b>0.38</b>	<b>7.1%</b>

### Basin Travel Time

	Sub-basin or Channel Type	Material Type	L (ft)	Elev. ΔZ <sub>0</sub> (ft)	Q <sub>i</sub> (cfs)	Base or Dia (ft)	Sides z:1 (ft/ft)	v (ft/s)	t (min)
Furthest Reach	C2	-	320	19	-	-	-	-	9.5
Channelized-1									
Channelized-2									
Channelized-3									
Total			320	19					
								<b>t<sub>c</sub> (min)</b>	<b>9.5</b>

### Contributing Offsite Flows (Added to Runoff and Allowed Release, below.)

Contributing Basins/Areas	Pond Outfall
Q <sub>Minor</sub>	0.2 (cfs) - 5-year Storm
Q <sub>Major</sub>	6.5 (cfs) - 100-year Storm

### Rainfall Intensity & Runoff

	2-Yr	5-Yr	10-Yr	25-Yr	50-Yr	100-Yr
<b>Intensity (in/hr)</b>	3.36	4.21	4.91	5.61	6.32	7.07
<b>Site Runoff (cfs)</b>	0.08	<b>0.18</b>	0.32	0.55	0.72	<b>0.92</b>
<b>OffSite Runoff (cfs)</b>	-	<b>0.20</b>	-	-	-	<b>6.50</b>
<b>Release Rates (cfs/ac)</b>	-	-	-	-	-	-
<b>Allowed Release (cfs)</b>	-	<b>0.4</b>	-	-	-	<b>7.4</b>

DCM:  $I = C1 * \ln(tc) + C2$

C1	1.19	1.5	1.75	2	2.25	2.52
C2	6.035	7.583	8.847	10.111	11.375	12.735

### Notes

Runoff from Offsite basins have been assumed constant, despite additional times of concentration.

## Combined Sub-Basin Runoff Calculations (Inlet A9)

Includes Basins OS-A1 A2 A7 A8 A9

Job No.:	<b>61203</b>	Date:	<b>7/11/2024 9:35</b>
Project:	<b>Townhomes at Western</b>	Calcs by:	<b>TJW</b>
Jurisdiction	<b>DCM</b>	Checked by:	
Runoff Coefficient	<b>Surface Type</b>	Soil Type	<b>B</b>
		Urbanization	<b>Urban</b>

### Basin Land Use Characteristics

Surface	Area		Runoff Coefficient						% Imperv.
	(SF)	(Acres)	C2	C5	C10	C25	C50	C100	
Pasture/Meadow	9,024	0.21	0.02	0.08	0.15	0.25	0.3	0.35	0%
Landscaping	33,858	0.78	0.03	0.09	0.17	0.26	0.31	0.36	2%
Gravel	-	0.00	0.57	0.59	0.63	0.66	0.68	0.7	80%
Paved	47,505	1.09	0.89	0.9	0.92	0.94	0.95	0.96	100%
Roofs	23,184	0.53	0.71	0.73	0.75	0.78	0.8	0.81	90%
<b>Combined</b>	<b>113,571</b>	<b>2.61</b>	<b>0.53</b>	<b>0.56</b>	<b>0.60</b>	<b>0.65</b>	<b>0.68</b>	<b>0.70</b>	<b>60.8%</b>

### Basin Travel Time

	Sub-basin or Channel Type	Material Type	L (ft)	Elev. ΔZ <sub>0</sub> (ft)	Q <sub>i</sub> (cfs)	Base or Dia (ft)	Sides z:1 (ft/ft)	v (ft/s)	t (min)
Furthest Reach	OS-B1	-	190	20	-	-	-	-	5.2
Channelized-1									
Channelized-2									
Channelized-3									
Total			190	20					
								<b>t<sub>c</sub> (min)</b>	<b>5.2</b>

### Contributing Offsite Flows (Added to Runoff and Allowed Release, below.)

Contributing Basins/Areas: [Redacted]

Q<sub>Minor</sub>: [Redacted] (cfs) - 5-year Storm

Q<sub>Major</sub>: [Redacted] (cfs) - 100-year Storm

### Rainfall Intensity & Runoff

	2-Yr	5-Yr	10-Yr	25-Yr	50-Yr	100-Yr
<b>Intensity (in/hr)</b>	4.08	5.12	5.97	6.83	7.68	8.60
<b>Site Runoff (cfs)</b>	5.62	<b>7.46</b>	9.35	11.57	13.56	<b>15.74</b>
<b>OffSite Runoff (cfs)</b>	-	<b>0.00</b>	-	-	-	<b>0.00</b>
<b>Release Rates (cfs/ac)</b>	-	-	-	-	-	-
<b>Allowed Release (cfs)</b>	-	<b>7.5</b>	-	-	-	<b>15.7</b>

DCM:  $I = C1 * \ln(tc) + C2$

C1	1.19	1.5	1.75	2	2.25	2.52
C2	6.035	7.583	8.847	10.111	11.375	12.735

### Notes

Runoff from Offsite basins have been assumed constant, despite additional times of concentration.

## Combined Sub-Basin Runoff Calculations (Inlet A11)

Includes Basins A3 A4 A5 A6 A10 A11

Job No.:	<b>61203</b>	Date:	<b>7/11/2024 9:35</b>
Project:	<b>Townhomes at Western</b>	Calcs by:	<b>TJW</b>
Jurisdiction	<b>DCM</b>	Checked by:	
Runoff Coefficient	<b>Surface Type</b>	Soil Type	<b>B</b>
		Urbanization	<b>Urban</b>

### Basin Land Use Characteristics

Surface	Area		Runoff Coefficient						% Imperv.
	(SF)	(Acres)	C2	C5	C10	C25	C50	C100	
Pasture/Meadow	-	0.00	0.02	0.08	0.15	0.25	0.3	0.35	0%
Landscaping	24,251	0.56	0.03	0.09	0.17	0.26	0.31	0.36	2%
Gravel	-	0.00	0.57	0.59	0.63	0.66	0.68	0.7	80%
Paved	43,656	1.00	0.89	0.9	0.92	0.94	0.95	0.96	100%
Roofs	27,048	0.62	0.71	0.73	0.75	0.78	0.8	0.81	90%
<b>Combined</b>	<b>94,955</b>	<b>2.18</b>	<b>0.62</b>	<b>0.64</b>	<b>0.68</b>	<b>0.72</b>	<b>0.74</b>	<b>0.76</b>	<b>72.1%</b>

### Basin Travel Time

	Sub-basin or Channel Type	Material Type	L (ft)	Elev. ΔZ <sub>0</sub> (ft)	Q <sub>i</sub> (cfs)	Base or Dia (ft)	Sides z:1 (ft/ft)	v (ft/s)	t (min)
Furthest Reach	OS-B1	-	190	20	-	-	-	-	5.2
Channelized-1									
Channelized-2									
Channelized-3									
Total			190	20					
								<b>t<sub>c</sub> (min)</b>	<b>5.2</b>

### Contributing Offsite Flows (Added to Runoff and Allowed Release, below.)

Contributing Basins/Areas: [Redacted]

Q<sub>Minor</sub>: [Redacted] (cfs) - 5-year Storm

Q<sub>Major</sub>: [Redacted] (cfs) - 100-year Storm

### Rainfall Intensity & Runoff

	2-Yr	5-Yr	10-Yr	25-Yr	50-Yr	100-Yr
<b>Intensity (in/hr)</b>	4.08	5.12	5.97	6.83	7.68	8.60
<b>Site Runoff (cfs)</b>	5.51	<b>7.20</b>	8.86	10.73	12.46	<b>14.32</b>
<b>OffSite Runoff (cfs)</b>	-	<b>0.00</b>	-	-	-	<b>0.00</b>
<b>Release Rates (cfs/ac)</b>	-	-	-	-	-	-
<b>Allowed Release (cfs)</b>	-	<b>7.2</b>	-	-	-	<b>14.3</b>

DCM:  $I = C1 * \ln(tc) + C2$

C1	1.19	1.5	1.75	2	2.25	2.52
C2	6.035	7.583	8.847	10.111	11.375	12.735

### Notes

Runoff from Offsite basins have been assumed constant, despite additional times of concentration.

## Combined Sub-Basin Runoff Calculations (Pond 1)

Includes Basins Inlet A9 Inlet A11 A12

Job No.:	<b>61203</b>	Date:	<b>7/11/2024 9:35</b>
Project:	<b>Townhomes at Western</b>	Calcs by:	<b>TJW</b>
Jurisdiction	<b>DCM</b>	Checked by:	
Runoff Coefficient	<b>Surface Type</b>	Soil Type	<b>B</b>
		Urbanization	<b>Urban</b>

### Basin Land Use Characteristics

Surface	Area		Runoff Coefficient						% Imperv.
	(SF)	(Acres)	C2	C5	C10	C25	C50	C100	
Pasture/Meadow	9,024	0.21	0.02	0.08	0.15	0.25	0.3	0.35	0%
Landscaping	74,884	1.72	0.03	0.09	0.17	0.26	0.31	0.36	2%
Gravel	1,429	0.03	0.57	0.59	0.63	0.66	0.68	0.7	80%
Paved	91,762	2.11	0.89	0.9	0.92	0.94	0.95	0.96	100%
Roofs	50,232	1.15	0.71	0.73	0.75	0.78	0.8	0.81	90%
<b>Combined</b>	<b>227,331</b>	<b>5.22</b>	<b>0.53</b>	<b>0.56</b>	<b>0.60</b>	<b>0.65</b>	<b>0.68</b>	<b>0.70</b>	<b>61.4%</b>

### Basin Travel Time

	Sub-basin or Channel Type	Material Type	L (ft)	Elev. ΔZ <sub>0</sub> (ft)	Q <sub>i</sub> (cfs)	Base or Dia (ft)	Sides z:1 (ft/ft)	v (ft/s)	t (min)
Furthest Reach	OS-B1	-	190	20	-	-	-	-	5.2
Channelized-1									
Channelized-2									
Channelized-3									
Total			190	20					
							<b>t<sub>c</sub></b>		<b>5.2</b>
							<b>(min)</b>		

### Contributing Offsite Flows (Added to Runoff and Allowed Release, below.)

Contributing Basins/Areas: [Redacted]

Q<sub>Minor</sub>: [Redacted] (cfs) - 5-year Storm

Q<sub>Major</sub>: [Redacted] (cfs) - 100-year Storm

### Rainfall Intensity & Runoff

	2-Yr	5-Yr	10-Yr	25-Yr	50-Yr	100-Yr
<b>Intensity (in/hr)</b>	4.08	5.12	5.97	6.83	7.68	8.60
<b>Site Runoff (cfs)</b>	11.30	<b>15.00</b>	18.80	23.22	27.20	<b>31.56</b>
<b>OffSite Runoff (cfs)</b>	-	<b>0.00</b>	-	-	-	<b>0.00</b>
<b>Release Rates (cfs/ac)</b>	-	-	-	-	-	-
<b>Allowed Release (cfs)</b>	-	<b>15.0</b>	-	-	-	<b>31.6</b>

DCM:  $I = C1 * \ln(tc) + C2$

C1	1.19	1.5	1.75	2	2.25	2.52
C2	6.035	7.583	8.847	10.111	11.375	12.735

### Notes

Runoff from Offsite basins have been assumed constant, despite additional times of concentration.

### **3 Hydraulic Calculations**

#### FS- EDB Calculations

- FS EDB design calculations (UD-BMP)
- FS EDB design calculations (MHFD-Detention)
- Spillway Riprap Sizing

#### Riprap Sizing Calculations

#### Street Capacity Calculations

#### Storm Inlet Calculations

#### Storm Pipe Calculations

# INLET MANAGEMENT

Worksheet Protected

INLET NAME	Inlet A3	Inlet A4	Inlet A5
Site Type (Urban or Rural)	URBAN	URBAN	URBAN
Inlet Application (Street or Area)	STREET	STREET	STREET
Hydraulic Condition	In Sump	On Grade	On Grade
Inlet Type	Denver No. 16 Combination	Denver No. 16 Combination	Denver No. 16 Combination

## USER-DEFINED INPUT

### User-Defined Design Flows

Minor $Q_{Known}$ (cfs)	1.5	1.3	1.0
Major $Q_{Known}$ (cfs)	3.3	2.5	2.0

### Bypass (Carry-Over) Flow from Upstream Inlets must be organized from upstream (left) to downstream (right) in order for bypass flows to be linked.

Receive Bypass Flow from:	No Bypass Flow Received	No Bypass Flow Received	User-Defined
Minor Bypass Flow Received, $Q_b$ (cfs)	0.0	0.0	0.0
Major Bypass Flow Received, $Q_b$ (cfs)	0.0	0.0	0.1

### Watershed Characteristics

Subcatchment Area (acres)			
Percent Impervious			
NRCS Soil Type			

### Watershed Profile

Overland Slope (ft/ft)			
Overland Length (ft)			
Channel Slope (ft/ft)			
Channel Length (ft)			

### Minor Storm Rainfall Input

Design Storm Return Period, $T_r$ (years)			
One-Hour Precipitation, $P_1$ (inches)			

### Major Storm Rainfall Input

Design Storm Return Period, $T_r$ (years)			
One-Hour Precipitation, $P_1$ (inches)			

## CALCULATED OUTPUT

<b>Minor Total Design Peak Flow, <math>Q</math> (cfs)</b>	<b>1.5</b>	<b>1.3</b>	<b>1.0</b>
<b>Major Total Design Peak Flow, <math>Q</math> (cfs)</b>	<b>3.3</b>	<b>2.5</b>	<b>2.1</b>
Minor Flow Bypassed Downstream, $Q_b$ (cfs)	N/A	-0.1	-0.1
Major Flow Bypassed Downstream, $Q_b$ (cfs)	N/A	0.1	0.0



# INLET MANAGEMENT

Worksheet Protected

INLET NAME	<a href="#">Inlet A6</a>	<a href="#">Inlet A7</a>	<a href="#">Inlet A8</a>
Site Type (Urban or Rural)	URBAN	URBAN	URBAN
Inlet Application (Street or Area)	STREET	STREET	STREET
Hydraulic Condition	On Grade	On Grade	On Grade
Inlet Type	Denver No. 16 Combination	Denver No. 16 Combination	Denver No. 16 Combination

## USER-DEFINED INPUT

### User-Defined Design Flows

Minor $Q_{Known}$ (cfs)	1.1	3.5	0.6
Major $Q_{Known}$ (cfs)	2.1	7.1	1.2

### Bypass (Carry-Over) Flow from Upstream

Receive Bypass Flow from:	User-Defined	User-Defined	No Bypass Flow Received
Minor Bypass Flow Received, $Q_b$ (cfs)	0.0	0.0	0.0
Major Bypass Flow Received, $Q_b$ (cfs)	0.0	0.0	0.0

### Watershed Characteristics

Subcatchment Area (acres)			
Percent Impervious			
NRCS Soil Type			

### Watershed Profile

Overland Slope (ft/ft)			
Overland Length (ft)			
Channel Slope (ft/ft)			
Channel Length (ft)			

### Minor Storm Rainfall Input

Design Storm Return Period, $T_r$ (years)			
One-Hour Precipitation, $P_1$ (inches)			

### Major Storm Rainfall Input

Design Storm Return Period, $T_r$ (years)			
One-Hour Precipitation, $P_1$ (inches)			

## CALCULATED OUTPUT

<b>Minor Total Design Peak Flow, <math>Q</math> (cfs)</b>	<b>1.1</b>	<b>3.5</b>	<b>0.6</b>
<b>Major Total Design Peak Flow, <math>Q</math> (cfs)</b>	<b>2.1</b>	<b>7.1</b>	<b>1.2</b>
Minor Flow Bypassed Downstream, $Q_b$ (cfs)	-0.1	0.2	-0.1
Major Flow Bypassed Downstream, $Q_b$ (cfs)	0.0	1.4	-0.1

# INLET MANAGEMENT

Worksheet Protected

<b>INLET NAME</b>	<a href="#">Inlet A10</a>	<a href="#">Inlet A11</a>	<a href="#">Inlet A9</a>
Site Type (Urban or Rural)	URBAN	URBAN	URBAN
Inlet Application (Street or Area)	STREET	STREET	STREET
Hydraulic Condition	On Grade	On Grade	In Sump
Inlet Type	Denver No. 16 Combination	Denver No. 16 Combination	Denver No. 16 Combination

## USER-DEFINED INPUT

<b>User-Defined Design Flows</b>			
Minor $Q_{Known}$ (cfs)	1.5	0.8	2.7
Major $Q_{Known}$ (cfs)	2.9	1.6	5.5
<b>Bypass (Carry-Over) Flow from Upstream</b>			
Receive Bypass Flow from:	No Bypass Flow Received	User-Defined	User-Defined
Minor Bypass Flow Received, $Q_b$ (cfs)	0.0	0.0	0.2
Major Bypass Flow Received, $Q_b$ (cfs)	0.0	0.2	1.4
<b>Watershed Characteristics</b>			
Subcatchment Area (acres)			
Percent Impervious			
NRCS Soil Type			
<b>Watershed Profile</b>			
Overland Slope (ft/ft)			
Overland Length (ft)			
Channel Slope (ft/ft)			
Channel Length (ft)			
<b>Minor Storm Rainfall Input</b>			
Design Storm Return Period, $T_r$ (years)			
One-Hour Precipitation, $P_1$ (inches)			
<b>Major Storm Rainfall Input</b>			
Design Storm Return Period, $T_r$ (years)			
One-Hour Precipitation, $P_1$ (inches)			

## CALCULATED OUTPUT

<b>Minor Total Design Peak Flow, <math>Q</math> (cfs)</b>	<b>1.5</b>	<b>0.8</b>	<b>2.9</b>
<b>Major Total Design Peak Flow, <math>Q</math> (cfs)</b>	<b>2.9</b>	<b>1.8</b>	<b>6.9</b>
Minor Flow Bypassed Downstream, $Q_b$ (cfs)	-0.1	-0.1	N/A
Major Flow Bypassed Downstream, $Q_b$ (cfs)	0.2	0.0	N/A

**ALLOWABLE CAPACITY FOR ONE-HALF OF STREET (Minor & Major Storm)**  
 (Based on Regulated Criteria for Maximum Allowable Flow Depth and Spread)

Project:  
 Inlet ID: **Inlet A3**

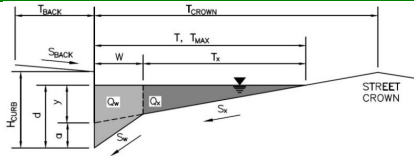

<b>Gutter Geometry:</b>									
Maximum Allowable Width for Spread Behind Curb	$T_{BACK} = 0.0$ ft								
Side Slope Behind Curb (leave blank for no conveyance credit behind curb)	$S_{BACK} =$ ft/ft								
Manning's Roughness Behind Curb (typically between 0.012 and 0.020)	$n_{BACK} = 0.015$								
Height of Curb at Gutter Flow Line	$H_{CURB} = 6.00$ inches								
Distance from Curb Face to Street Crown	$T_{CROWN} = 24.0$ ft								
Gutter Width	$W = 2.00$ ft								
Street Transverse Slope	$S_x = 0.020$ ft/ft								
Gutter Cross Slope (typically 2 inches over 24 inches or 0.083 ft/ft)	$S_w = 0.083$ ft/ft								
Street Longitudinal Slope - Enter 0 for sump condition	$S_o = 0.000$ ft/ft								
Manning's Roughness for Street Section (typically between 0.012 and 0.020)	$n_{STREET} = 0.015$								
Max. Allowable Spread for Minor & Major Storm	<table border="1"> <tr> <td></td> <td>Minor Storm</td> <td>Major Storm</td> <td>ft</td> </tr> <tr> <td><math>T_{MAX} =</math></td> <td>12.0</td> <td>24.0</td> <td></td> </tr> </table>		Minor Storm	Major Storm	ft	$T_{MAX} =$	12.0	24.0	
	Minor Storm	Major Storm	ft						
$T_{MAX} =$	12.0	24.0							
Max. Allowable Depth at Gutter Flowline for Minor & Major Storm	<table border="1"> <tr> <td></td> <td>Minor Storm</td> <td>Major Storm</td> <td>inches</td> </tr> <tr> <td><math>d_{MAX} =</math></td> <td>6.0</td> <td>6.0</td> <td></td> </tr> </table>		Minor Storm	Major Storm	inches	$d_{MAX} =$	6.0	6.0	
	Minor Storm	Major Storm	inches						
$d_{MAX} =$	6.0	6.0							
Check boxes are not applicable in SUMP conditions	<input type="checkbox"/> <input type="checkbox"/>								
MINOR STORM Allowable Capacity is not applicable to Sump Condition									
MAJOR STORM Allowable Capacity is not applicable to Sump Condition									
	<table border="1"> <tr> <td></td> <td>Minor Storm</td> <td>Major Storm</td> <td>cfs</td> </tr> <tr> <td><math>Q_{allow} =</math></td> <td><b>SUMP</b></td> <td><b>SUMP</b></td> <td></td> </tr> </table>		Minor Storm	Major Storm	cfs	$Q_{allow} =$	<b>SUMP</b>	<b>SUMP</b>	
	Minor Storm	Major Storm	cfs						
$Q_{allow} =$	<b>SUMP</b>	<b>SUMP</b>							

# INLET IN A SUMP OR SAG LOCATION

MHFD-Inlet, Version 5.02 (August 2022)

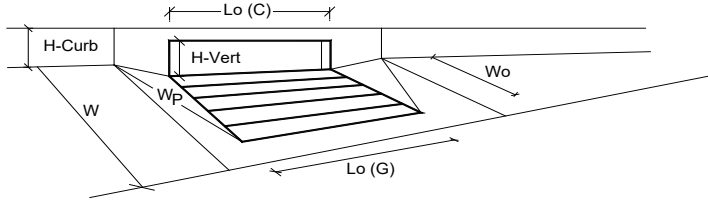

Design Information (Input)	MINOR	MAJOR	
Type of Inlet	Denver No. 16 Combination		
Local Depression (additional to continuous gutter depression 'a' from above)	2.00	2.00	inches
Number of Unit Inlets (Grate or Curb Opening)	1	1	
Water Depth at Flowline (outside of local depression)	4.4	6.0	inches
<b>Grate Information</b>			
Length of a Unit Grate	3.00	3.00	feet
Width of a Unit Grate	1.73	1.73	feet
Open Area Ratio for a Grate (typical values 0.15-0.90)	0.31	0.31	
Clogging Factor for a Single Grate (typical value 0.50 - 0.70)	0.50	0.50	
Grate Weir Coefficient (typical value 2.15 - 3.60)	3.60	3.60	
Grate Orifice Coefficient (typical value 0.60 - 0.80)	0.60	0.60	
<b>Curb Opening Information</b>			
Length of a Unit Curb Opening	3.00	3.00	feet
Height of Vertical Curb Opening in Inches	6.50	6.50	inches
Height of Curb Orifice Throat in Inches	5.25	5.25	inches
Angle of Throat (see USDCM Figure ST-5)	0.00	0.00	degrees
Side Width for Depression Pan (typically the gutter width of 2 feet)	2.00	2.00	feet
Clogging Factor for a Single Curb Opening (typical value 0.10)	0.10	0.10	
Curb Opening Weir Coefficient (typical value 2.3-3.7)	3.70	3.70	
Curb Opening Orifice Coefficient (typical value 0.60 - 0.70)	0.66	0.66	
<b>Low Head Performance Reduction (Calculated)</b>			
Depth for Grate Midwidth	0.39	0.52	ft
Depth for Curb Opening Weir Equation	0.20	0.33	ft
Grated Inlet Performance Reduction Factor for Long Inlets	0.69	0.94	
Curb Opening Performance Reduction Factor for Long Inlets	N/A	N/A	
Combination Inlet Performance Reduction Factor for Long Inlets	0.69	0.94	
<b>Total Inlet Interception Capacity (assumes clogged condition)</b>			
<b>Inlet Capacity IS GOOD for Minor and Major Storms (&gt;Q Peak)</b>	<b>2.4</b>	<b>5.6</b>	<b>cfs</b>
Q <sub>PEAK REQUIRED</sub>	1.5	3.3	cfs

**ALLOWABLE CAPACITY FOR ONE-HALF OF STREET (Minor & Major Storm)**  
 (Based on Regulated Criteria for Maximum Allowable Flow Depth and Spread)

Project:  
 Inlet ID: **Inlet A4**

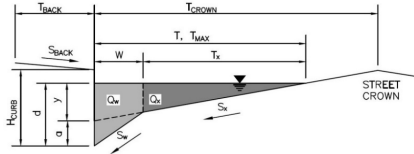

<b>Gutter Geometry:</b>					
Maximum Allowable Width for Spread Behind Curb	$T_{BACK} = 0.0$ ft				
Side Slope Behind Curb (leave blank for no conveyance credit behind curb)	$S_{BACK} =$ ft/ft				
Manning's Roughness Behind Curb (typically between 0.012 and 0.020)	$n_{BACK} = 0.015$				
Height of Curb at Gutter Flow Line	$H_{CURB} = 6.00$ inches				
Distance from Curb Face to Street Crown	$T_{CROWN} = 24.0$ ft				
Gutter Width	$W = 2.00$ ft				
Street Transverse Slope	$S_x = 0.020$ ft/ft				
Gutter Cross Slope (typically 2 inches over 24 inches or 0.083 ft/ft)	$S_w = 0.083$ ft/ft				
Street Longitudinal Slope - Enter 0 for sump condition	$S_o = 0.015$ ft/ft				
Manning's Roughness for Street Section (typically between 0.012 and 0.020)	$n_{STREET} = 0.015$				
Max. Allowable Spread for Minor & Major Storm	$T_{MAX} =$ <table border="1"><tr><td>Minor Storm</td><td>Major Storm</td></tr><tr><td>24.0</td><td>24.0</td></tr></table> ft	Minor Storm	Major Storm	24.0	24.0
Minor Storm	Major Storm				
24.0	24.0				
Max. Allowable Depth at Gutter Flowline for Minor & Major Storm	$d_{MAX} =$ <table border="1"><tr><td>Minor Storm</td><td>Major Storm</td></tr><tr><td>6.0</td><td>6.0</td></tr></table> inches	Minor Storm	Major Storm	6.0	6.0
Minor Storm	Major Storm				
6.0	6.0				
Allow Flow Depth at Street Crown (check box for yes, leave blank for no)	<input type="checkbox"/> <input type="checkbox"/>				
<a href="#">MINOR STORM Allowable Capacity is based on Depth Criterion</a>					
<a href="#">MAJOR STORM Allowable Capacity is based on Depth Criterion</a>					
<b>Minor storm max. allowable capacity GOOD - greater than the design peak flow of 1.30 cfs on sheet 'Inlet Management'</b>					
<b>Major storm max. allowable capacity GOOD - greater than the design peak flow of 2.50 cfs on sheet 'Inlet Management'</b>					
$Q_{allow} =$	<table border="1"><tr><td>Minor Storm</td><td>Major Storm</td></tr><tr><td>18.0</td><td>18.0</td></tr></table> cfs	Minor Storm	Major Storm	18.0	18.0
Minor Storm	Major Storm				
18.0	18.0				

# INLET ON A CONTINUOUS GRADE

MHFD-Inlet, Version 5.02 (August 2022)

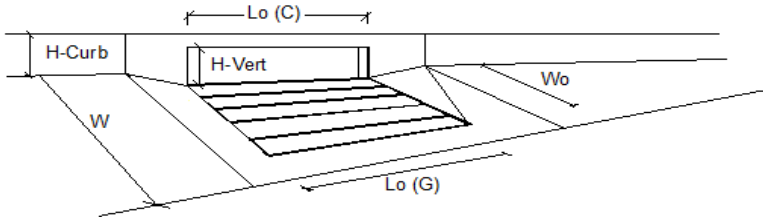

<b>Design Information (Input)</b>		<table border="1" style="display: inline-table; border-collapse: collapse;"> <thead> <tr> <th style="width: 50%;"></th> <th style="width: 50%;"></th> </tr> </thead> <tbody> <tr> <td style="text-align: center;">MINOR</td> <td style="text-align: center;">MAJOR</td> </tr> <tr> <td colspan="2" style="text-align: center;">Denver No. 16 Combination</td> </tr> <tr> <td>Type =</td> <td style="text-align: center;">Denver No. 16 Combination</td> </tr> <tr> <td>a<sub>LOCAL</sub> =</td> <td style="text-align: center;">2.0</td> </tr> <tr> <td>No =</td> <td style="text-align: center;">3</td> </tr> <tr> <td>L<sub>o</sub> =</td> <td style="text-align: center;">3.00</td> </tr> <tr> <td>W<sub>o</sub> =</td> <td style="text-align: center;">1.73</td> </tr> <tr> <td>C<sub>f</sub> (G) =</td> <td style="text-align: center;">0.50</td> </tr> <tr> <td>C<sub>f</sub> (C) =</td> <td style="text-align: center;">0.10</td> </tr> </tbody> </table>			MINOR	MAJOR	Denver No. 16 Combination		Type =	Denver No. 16 Combination	a <sub>LOCAL</sub> =	2.0	No =	3	L <sub>o</sub> =	3.00	W <sub>o</sub> =	1.73	C <sub>f</sub> (G) =	0.50	C <sub>f</sub> (C) =	0.10
MINOR	MAJOR																					
Denver No. 16 Combination																						
Type =	Denver No. 16 Combination																					
a <sub>LOCAL</sub> =	2.0																					
No =	3																					
L <sub>o</sub> =	3.00																					
W <sub>o</sub> =	1.73																					
C <sub>f</sub> (G) =	0.50																					
C <sub>f</sub> (C) =	0.10																					
Type of Inlet	Denver No. 16 Combination																					
Local Depression (additional to continuous gutter depression 'a')		inches																				
Total Number of Units in the Inlet (Grate or Curb Opening)																						
Length of a Single Unit Inlet (Grate or Curb Opening)		ft																				
Width of a Unit Grate (cannot be greater than W, Gutter Width)		ft																				
Clogging Factor for a Single Unit Grate (typical min. value = 0.5)																						
Clogging Factor for a Single Unit Curb Opening (typical min. value = 0.1)																						
Street Hydraulics: OK - Q < Allowable Street Capacity																						
Total Inlet Interception Capacity	<table border="1" style="display: inline-table; border-collapse: collapse;"> <thead> <tr> <th style="width: 50%;"></th> <th style="width: 50%;"></th> </tr> </thead> <tbody> <tr> <td style="text-align: center;">MINOR</td> <td style="text-align: center;">MAJOR</td> </tr> <tr> <td>Q =</td> <td style="text-align: center;">1.4</td> </tr> <tr> <td>Q<sub>b</sub> =</td> <td style="text-align: center;">-0.1</td> </tr> <tr> <td>C% =</td> <td style="text-align: center;">107</td> </tr> </tbody> </table>			MINOR	MAJOR	Q =	1.4	Q <sub>b</sub> =	-0.1	C% =	107	cfs										
MINOR	MAJOR																					
Q =	1.4																					
Q <sub>b</sub> =	-0.1																					
C% =	107																					
Total Inlet Carry-Over Flow (flow bypassing inlet)		cfs																				
Capture Percentage = Q <sub>i</sub> /Q <sub>s</sub>		%																				

NEGATIVE BYPASS  
 FLOWS  
 CALCULATED BY  
 WORKSHEET  
 IGNORED AND NOT  
 APPLIED TO  
 DOWNSTREAM  
 INLET.

BYPASS FLOWS TO  
 INLET A5

**ALLOWABLE CAPACITY FOR ONE-HALF OF STREET (Minor & Major Storm)**  
 (Based on Regulated Criteria for Maximum Allowable Flow Depth and Spread)

Project:  
 Inlet ID: **Inlet A5**

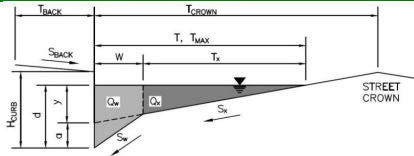

<b>Gutter Geometry:</b>					
Maximum Allowable Width for Spread Behind Curb	$T_{BACK} = 0.0$ ft				
Side Slope Behind Curb (leave blank for no conveyance credit behind curb)	$S_{BACK} =$ ft/ft				
Manning's Roughness Behind Curb (typically between 0.012 and 0.020)	$n_{BACK} = 0.015$				
Height of Curb at Gutter Flow Line	$H_{CURB} = 6.00$ inches				
Distance from Curb Face to Street Crown	$T_{CROWN} = 24.0$ ft				
Gutter Width	$W = 2.00$ ft				
Street Transverse Slope	$S_x = 0.020$ ft/ft				
Gutter Cross Slope (typically 2 inches over 24 inches or 0.083 ft/ft)	$S_w = 0.083$ ft/ft				
Street Longitudinal Slope - Enter 0 for sump condition	$S_o = 0.015$ ft/ft				
Manning's Roughness for Street Section (typically between 0.012 and 0.020)	$n_{STREET} = 0.015$				
Max. Allowable Spread for Minor & Major Storm	$T_{MAX} =$ <table border="1"><tr><th>Minor Storm</th><th>Major Storm</th></tr><tr><td>24.0</td><td>24.0</td></tr></table> ft	Minor Storm	Major Storm	24.0	24.0
Minor Storm	Major Storm				
24.0	24.0				
Max. Allowable Depth at Gutter Flowline for Minor & Major Storm	$d_{MAX} =$ <table border="1"><tr><th>Minor Storm</th><th>Major Storm</th></tr><tr><td>6.0</td><td>6.0</td></tr></table> inches	Minor Storm	Major Storm	6.0	6.0
Minor Storm	Major Storm				
6.0	6.0				
Allow Flow Depth at Street Crown (check box for yes, leave blank for no)	<input type="checkbox"/> <input type="checkbox"/>				
<a href="#">MINOR STORM Allowable Capacity is based on Depth Criterion</a>					
<a href="#">MAJOR STORM Allowable Capacity is based on Depth Criterion</a>					
<b>Minor storm max. allowable capacity GOOD - greater than the design peak flow of 1.00 cfs on sheet 'Inlet Management'</b>					
<b>Major storm max. allowable capacity GOOD - greater than the design peak flow of 2.11 cfs on sheet 'Inlet Management'</b>					
$Q_{allow} =$	<table border="1"><tr><th>Minor Storm</th><th>Major Storm</th></tr><tr><td>18.0</td><td>18.0</td></tr></table> cfs	Minor Storm	Major Storm	18.0	18.0
Minor Storm	Major Storm				
18.0	18.0				

# INLET ON A CONTINUOUS GRADE

MHFD-Inlet, Version 5.02 (August 2022)

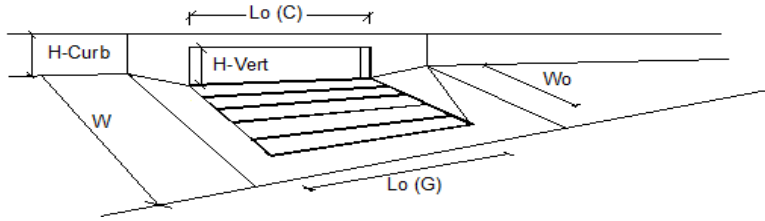

<b>Design Information (Input)</b>		MINOR	MAJOR	
Type of Inlet	Denver No. 16 Combination	Denver No. 16 Combination		
Local Depression (additional to continuous gutter depression 'a')		2.0	2.0	inches
Total Number of Units in the Inlet (Grate or Curb Opening)		3	3	
Length of a Single Unit Inlet (Grate or Curb Opening)		3.00	3.00	ft
Width of a Unit Grate (cannot be greater than W, Gutter Width)		1.73	1.73	ft
Clogging Factor for a Single Unit Grate (typical min. value = 0.5)		0.50	0.50	
Clogging Factor for a Single Unit Curb Opening (typical min. value = 0.1)		0.10	0.10	
Street Hydraulics: OK - Q < Allowable Street Capacity				
Total Inlet Interception Capacity		1.1	2.1	cfs
Total Inlet Carry-Over Flow (flow bypassing inlet)		-0.1	0.0	cfs
Capture Percentage = $Q_i/Q_o$		111	99	%

NEGATIVE BYPASS  
FLOWS  
CALCULATED BY  
WORKSHEET  
IGNORED AND NOT  
APPLIED TO  
DOWNSTREAM  
INLET.





**ALLOWABLE CAPACITY FOR ONE-HALF OF STREET (Minor & Major Storm)**  
 (Based on Regulated Criteria for Maximum Allowable Flow Depth and Spread)

Project:  
 Inlet ID: **Inlet A6**

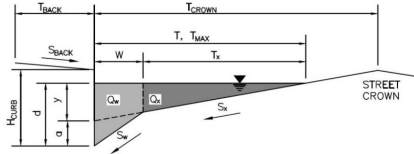

<b>Gutter Geometry:</b>					
Maximum Allowable Width for Spread Behind Curb	$T_{BACK} = 0.0$ ft				
Side Slope Behind Curb (leave blank for no conveyance credit behind curb)	$S_{BACK} =$ ft/ft				
Manning's Roughness Behind Curb (typically between 0.012 and 0.020)	$n_{BACK} = 0.015$				
Height of Curb at Gutter Flow Line	$H_{CURB} = 6.00$ inches				
Distance from Curb Face to Street Crown	$T_{CROWN} = 24.0$ ft				
Gutter Width	$W = 2.00$ ft				
Street Transverse Slope	$S_x = 0.020$ ft/ft				
Gutter Cross Slope (typically 2 inches over 24 inches or 0.083 ft/ft)	$S_w = 0.083$ ft/ft				
Street Longitudinal Slope - Enter 0 for sump condition	$S_o = 0.015$ ft/ft				
Manning's Roughness for Street Section (typically between 0.012 and 0.020)	$n_{STREET} = 0.015$				
Max. Allowable Spread for Minor & Major Storm	$T_{MAX} =$ <table border="1"><tr><th>Minor Storm</th><th>Major Storm</th></tr><tr><td>24.0</td><td>24.0</td></tr></table> ft	Minor Storm	Major Storm	24.0	24.0
Minor Storm	Major Storm				
24.0	24.0				
Max. Allowable Depth at Gutter Flowline for Minor & Major Storm	$d_{MAX} =$ <table border="1"><tr><th>Minor Storm</th><th>Major Storm</th></tr><tr><td>6.0</td><td>6.0</td></tr></table> inches	Minor Storm	Major Storm	6.0	6.0
Minor Storm	Major Storm				
6.0	6.0				
Allow Flow Depth at Street Crown (check box for yes, leave blank for no)	<input type="checkbox"/> <input type="checkbox"/>				
<a href="#">MINOR STORM Allowable Capacity is based on Depth Criterion</a>					
<a href="#">MAJOR STORM Allowable Capacity is based on Depth Criterion</a>					
<b>Minor storm max. allowable capacity GOOD - greater than the design peak flow of 1.10 cfs on sheet 'Inlet Management'</b>					
<b>Major storm max. allowable capacity GOOD - greater than the design peak flow of 2.13 cfs on sheet 'Inlet Management'</b>					
$Q_{allow} =$	<table border="1"><tr><th>Minor Storm</th><th>Major Storm</th></tr><tr><td>18.0</td><td>18.0</td></tr></table> cfs	Minor Storm	Major Storm	18.0	18.0
Minor Storm	Major Storm				
18.0	18.0				

# INLET ON A CONTINUOUS GRADE

MHFD-Inlet, Version 5.02 (August 2022)

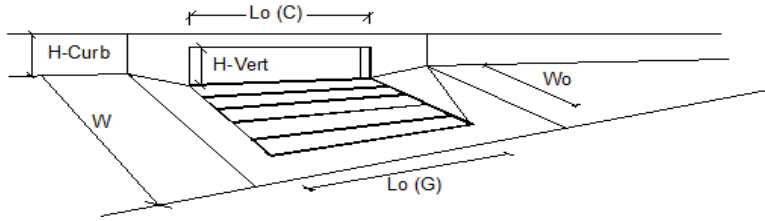

<b>Design Information (Input)</b>		<table border="1" style="display: inline-table; border-collapse: collapse;"> <thead> <tr> <th style="width: 50%;"></th> <th style="width: 25%;">MINOR</th> <th style="width: 25%;">MAJOR</th> </tr> </thead> <tbody> <tr> <td>Type =</td> <td colspan="2" style="text-align: center;">Denver No. 16 Combination</td> </tr> <tr> <td><math>a_{LOCAL}</math> =</td> <td style="text-align: center;">2.0</td> <td style="text-align: center;">2.0</td> </tr> <tr> <td>No =</td> <td style="text-align: center;">3</td> <td style="text-align: center;">3</td> </tr> <tr> <td><math>L_o</math> =</td> <td style="text-align: center;">3.00</td> <td style="text-align: center;">3.00</td> </tr> <tr> <td><math>W_o</math> =</td> <td style="text-align: center;">1.73</td> <td style="text-align: center;">1.73</td> </tr> <tr> <td><math>C_f</math> (G) =</td> <td style="text-align: center;">0.50</td> <td style="text-align: center;">0.50</td> </tr> <tr> <td><math>C_f</math> (C) =</td> <td style="text-align: center;">0.10</td> <td style="text-align: center;">0.10</td> </tr> </tbody> </table>		MINOR	MAJOR	Type =	Denver No. 16 Combination		$a_{LOCAL}$ =	2.0	2.0	No =	3	3	$L_o$ =	3.00	3.00	$W_o$ =	1.73	1.73	$C_f$ (G) =	0.50	0.50	$C_f$ (C) =	0.10	0.10
	MINOR	MAJOR																								
Type =	Denver No. 16 Combination																									
$a_{LOCAL}$ =	2.0	2.0																								
No =	3	3																								
$L_o$ =	3.00	3.00																								
$W_o$ =	1.73	1.73																								
$C_f$ (G) =	0.50	0.50																								
$C_f$ (C) =	0.10	0.10																								
Type of Inlet: <span style="border: 1px solid black; padding: 2px;">Denver No. 16 Combination</span> Local Depression (additional to continuous gutter depression 'a') Total Number of Units in the Inlet (Grate or Curb Opening) Length of a Single Unit Inlet (Grate or Curb Opening) Width of a Unit Grate (cannot be greater than W, Gutter Width) Clogging Factor for a Single Unit Grate (typical min. value = 0.5) Clogging Factor for a Single Unit Curb Opening (typical min. value = 0.1)																										
Street Hydraulics: OK - $Q <$ Allowable Street Capacity																										
Total Inlet Interception Capacity Total Inlet Carry-Over Flow (flow bypassing inlet) Capture Percentage = $Q_i/Q_o$		<table border="1" style="display: inline-table; border-collapse: collapse;"> <thead> <tr> <th style="width: 50%;"></th> <th style="width: 25%;">MINOR</th> <th style="width: 25%;">MAJOR</th> <th style="width: 25%;"></th> </tr> </thead> <tbody> <tr> <td><math>Q</math> =</td> <td style="text-align: center;">1.2</td> <td style="text-align: center;">2.1</td> <td style="text-align: center;">cfs</td> </tr> <tr> <td><math>Q_b</math> =</td> <td style="text-align: center;">-0.1</td> <td style="text-align: center;">0.0</td> <td style="text-align: center;">cfs</td> </tr> <tr> <td><math>C\%</math> =</td> <td style="text-align: center;">110</td> <td style="text-align: center;">99</td> <td style="text-align: center;">%</td> </tr> </tbody> </table>		MINOR	MAJOR		$Q$ =	1.2	2.1	cfs	$Q_b$ =	-0.1	0.0	cfs	$C\%$ =	110	99	%								
	MINOR	MAJOR																								
$Q$ =	1.2	2.1	cfs																							
$Q_b$ =	-0.1	0.0	cfs																							
$C\%$ =	110	99	%																							

NEGATIVE BYPASS  
FLOWS  
CALCULATED BY  
WORKSHEET  
IGNORED AND NOT  
APPLIED TO  
DOWNSTREAM  
INLET.

**ALLOWABLE CAPACITY FOR ONE-HALF OF STREET (Minor & Major Storm)**  
 (Based on Regulated Criteria for Maximum Allowable Flow Depth and Spread)

Project:  
 Inlet ID: **Inlet A7**

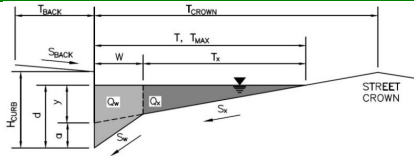

<b>Gutter Geometry:</b>	
Maximum Allowable Width for Spread Behind Curb	$T_{BACK} = 5.0$ ft
Side Slope Behind Curb (leave blank for no conveyance credit behind curb)	$S_{BACK} = 0.020$ ft/ft
Manning's Roughness Behind Curb (typically between 0.012 and 0.020)	$n_{BACK} = 0.015$
Height of Curb at Gutter Flow Line	$H_{CURB} = 6.00$ inches
Distance from Curb Face to Street Crown	$T_{CROWN} = 28.0$ ft
Gutter Width	$W = 2.00$ ft
Street Transverse Slope	$S_x = 0.020$ ft/ft
Gutter Cross Slope (typically 2 inches over 24 inches or 0.083 ft/ft)	$S_w = 0.083$ ft/ft
Street Longitudinal Slope - Enter 0 for sump condition	$S_o = 0.010$ ft/ft
Manning's Roughness for Street Section (typically between 0.012 and 0.020)	$n_{STREET} = 0.015$
Max. Allowable Spread for Minor & Major Storm	$T_{MAX} = \begin{matrix} \text{Minor Storm} & \text{Major Storm} \\ 28.0 & 28.0 \end{matrix}$ ft
Max. Allowable Depth at Gutter Flowline for Minor & Major Storm	$d_{MAX} = \begin{matrix} \text{Minor Storm} & \text{Major Storm} \\ 6.0 & 6.0 \end{matrix}$ inches
Allow Flow Depth at Street Crown (check box for yes, leave blank for no)	<input type="checkbox"/> <input type="checkbox"/>
<a href="#">MINOR STORM Allowable Capacity is based on Depth Criterion</a>	
<a href="#">MAJOR STORM Allowable Capacity is based on Depth Criterion</a>	
<b>Minor storm max. allowable capacity GOOD - greater than the design peak flow of 3.50 cfs on sheet 'Inlet Management'</b>	$Q_{allow} = \begin{matrix} \text{Minor Storm} & \text{Major Storm} \\ 14.7 & 14.7 \end{matrix}$ cfs
<b>Major storm max. allowable capacity GOOD - greater than the design peak flow of 7.13 cfs on sheet 'Inlet Management'</b>	

# INLET ON A CONTINUOUS GRADE

MHFD-Inlet, Version 5.02 (August 2022)

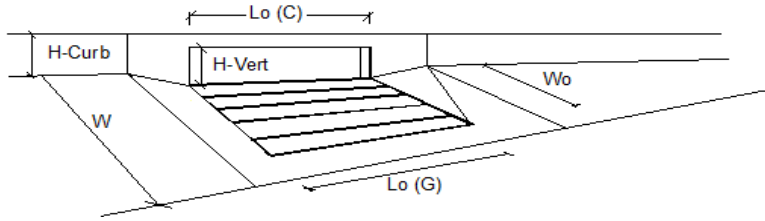

Design Information (Input)	MINOR	MAJOR	
Type of Inlet	Denver No. 16 Combination		
Local Depression (additional to continuous gutter depression 'a')	2.0	2.0	inches
Total Number of Units in the Inlet (Grate or Curb Opening)	3	3	
Length of a Single Unit Inlet (Grate or Curb Opening)	3.00	3.00	ft
Width of a Unit Grate (cannot be greater than W, Gutter Width)	1.73	1.73	ft
Clogging Factor for a Single Unit Grate (typical min. value = 0.5)	0.50	0.50	
Clogging Factor for a Single Unit Curb Opening (typical min. value = 0.1)	0.10	0.10	
Street Hydraulics: OK - Q < Allowable Street Capacity			
Total Inlet Interception Capacity	3.3	5.7	cfs
Total Inlet Carry-Over Flow (flow bypassing inlet)	0.2	1.4	cfs
Capture Percentage = $Q_i/Q_o$	94	80	%

BYPASS FLOWS TO  
INLET A9



**ALLOWABLE CAPACITY FOR ONE-HALF OF STREET (Minor & Major Storm)**  
 (Based on Regulated Criteria for Maximum Allowable Flow Depth and Spread)

Project:  
 Inlet ID: **Inlet A8**

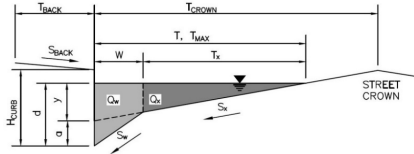

<b>Gutter Geometry:</b>	
Maximum Allowable Width for Spread Behind Curb	$T_{BACK} = 5.0$ ft
Side Slope Behind Curb (leave blank for no conveyance credit behind curb)	$S_{BACK} = 0.020$ ft/ft
Manning's Roughness Behind Curb (typically between 0.012 and 0.020)	$n_{BACK} = 0.015$
Height of Curb at Gutter Flow Line	$H_{CURB} = 6.00$ inches
Distance from Curb Face to Street Crown	$T_{CROWN} = 24.0$ ft
Gutter Width	$W = 2.00$ ft
Street Transverse Slope	$S_x = 0.020$ ft/ft
Gutter Cross Slope (typically 2 inches over 24 inches or 0.083 ft/ft)	$S_w = 0.083$ ft/ft
Street Longitudinal Slope - Enter 0 for sump condition	$S_o = 0.015$ ft/ft
Manning's Roughness for Street Section (typically between 0.012 and 0.020)	$n_{STREET} = 0.015$
Max. Allowable Spread for Minor & Major Storm	$T_{MAX} = \begin{matrix} \text{Minor Storm} & \text{Major Storm} \\ 24.0 & 24.0 \end{matrix}$ ft
Max. Allowable Depth at Gutter Flowline for Minor & Major Storm	$d_{MAX} = \begin{matrix} \text{Minor Storm} & \text{Major Storm} \\ 6.0 & 6.0 \end{matrix}$ inches
Allow Flow Depth at Street Crown (check box for yes, leave blank for no)	<input type="checkbox"/> <input type="checkbox"/>
<a href="#">MINOR STORM Allowable Capacity is based on Depth Criterion</a>	
<a href="#">MAJOR STORM Allowable Capacity is based on Depth Criterion</a>	
<b>Minor storm max. allowable capacity GOOD - greater than the design peak flow of 0.60 cfs on sheet 'Inlet Management'</b>	
<b>Major storm max. allowable capacity GOOD - greater than the design peak flow of 1.20 cfs on sheet 'Inlet Management'</b>	
$Q_{allow} =$	$\begin{matrix} \text{Minor Storm} & \text{Major Storm} \\ 18.0 & 18.0 \end{matrix}$ cfs

# INLET ON A CONTINUOUS GRADE

MHFD-Inlet, Version 5.02 (August 2022)

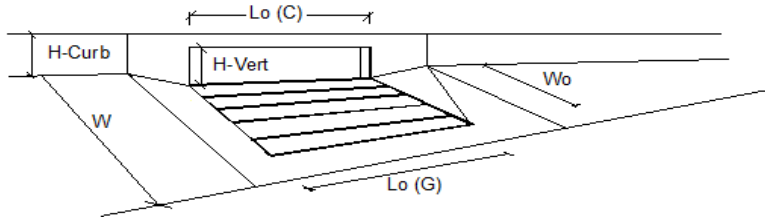

Design Information (Input)		<table border="1" style="display: inline-table; border-collapse: collapse;"> <tr> <td style="padding: 2px;">Denver No. 16 Combination</td> </tr> </table>	Denver No. 16 Combination		
Denver No. 16 Combination					
Type of Inlet	Type = <b>Denver No. 16 Combination</b>				
Local Depression (additional to continuous gutter depression 'a')	a <sub>LOCAL</sub> =	<table border="1" style="display: inline-table; border-collapse: collapse;"> <tr> <td style="padding: 2px;">2.0</td> <td style="padding: 2px;">2.0</td> <td style="padding: 2px;">inches</td> </tr> </table>	2.0	2.0	inches
2.0	2.0	inches			
Total Number of Units in the Inlet (Grate or Curb Opening)	No =	<table border="1" style="display: inline-table; border-collapse: collapse;"> <tr> <td style="padding: 2px;">3</td> <td style="padding: 2px;">3</td> <td></td> </tr> </table>	3	3	
3	3				
Length of a Single Unit Inlet (Grate or Curb Opening)	L <sub>o</sub> =	<table border="1" style="display: inline-table; border-collapse: collapse;"> <tr> <td style="padding: 2px;">3.00</td> <td style="padding: 2px;">3.00</td> <td style="padding: 2px;">ft</td> </tr> </table>	3.00	3.00	ft
3.00	3.00	ft			
Width of a Unit Grate (cannot be greater than W, Gutter Width)	W <sub>o</sub> =	<table border="1" style="display: inline-table; border-collapse: collapse;"> <tr> <td style="padding: 2px;">1.73</td> <td style="padding: 2px;">1.73</td> <td style="padding: 2px;">ft</td> </tr> </table>	1.73	1.73	ft
1.73	1.73	ft			
Clogging Factor for a Single Unit Grate (typical min. value = 0.5)	C <sub>f</sub> (G) =	<table border="1" style="display: inline-table; border-collapse: collapse;"> <tr> <td style="padding: 2px;">0.50</td> <td style="padding: 2px;">0.50</td> <td></td> </tr> </table>	0.50	0.50	
0.50	0.50				
Clogging Factor for a Single Unit Curb Opening (typical min. value = 0.1)	C <sub>f</sub> (C) =	<table border="1" style="display: inline-table; border-collapse: collapse;"> <tr> <td style="padding: 2px;">0.10</td> <td style="padding: 2px;">0.10</td> <td></td> </tr> </table>	0.10	0.10	
0.10	0.10				
Street Hydraulics: OK - Q < Allowable Street Capacity					
Total Inlet Interception Capacity	Q =	<table border="1" style="display: inline-table; border-collapse: collapse;"> <tr> <td style="padding: 2px;">0.7</td> <td style="padding: 2px;">1.3</td> <td style="padding: 2px;">cfs</td> </tr> </table>	0.7	1.3	cfs
0.7	1.3	cfs			
Total Inlet Carry-Over Flow (flow bypassing inlet)	Q <sub>b</sub> =	<table border="1" style="display: inline-table; border-collapse: collapse;"> <tr> <td style="padding: 2px;">-0.1</td> <td style="padding: 2px;">-0.1</td> <td style="padding: 2px;">cfs</td> </tr> </table>	-0.1	-0.1	cfs
-0.1	-0.1	cfs			
Capture Percentage = Q <sub>i</sub> /Q <sub>o</sub>	C% =	<table border="1" style="display: inline-table; border-collapse: collapse;"> <tr> <td style="padding: 2px;">112</td> <td style="padding: 2px;">109</td> <td style="padding: 2px;">%</td> </tr> </table>	112	109	%
112	109	%			

NEGATIVE BYPASS  
FLOWS  
CALCULATED BY  
WORKSHEET  
IGNORED AND NOT  
APPLIED TO  
DOWNSTREAM  
INLET.



**ALLOWABLE CAPACITY FOR ONE-HALF OF STREET (Minor & Major Storm)**  
 (Based on Regulated Criteria for Maximum Allowable Flow Depth and Spread)

Project:  
 Inlet ID: **Inlet A10**

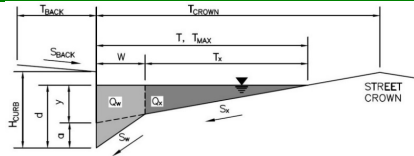

<b>Gutter Geometry:</b>													
Maximum Allowable Width for Spread Behind Curb	$T_{BACK} = 5.0$ ft												
Side Slope Behind Curb (leave blank for no conveyance credit behind curb)	$S_{BACK} = 0.020$ ft/ft												
Manning's Roughness Behind Curb (typically between 0.012 and 0.020)	$n_{BACK} = 0.015$												
Height of Curb at Gutter Flow Line	$H_{CURB} = 6.00$ inches												
Distance from Curb Face to Street Crown	$T_{CROWN} = 24.0$ ft												
Gutter Width	$W = 2.00$ ft												
Street Transverse Slope	$S_x = 0.020$ ft/ft												
Gutter Cross Slope (typically 2 inches over 24 inches or 0.083 ft/ft)	$S_w = 0.083$ ft/ft												
Street Longitudinal Slope - Enter 0 for sump condition	$S_o = 0.015$ ft/ft												
Manning's Roughness for Street Section (typically between 0.012 and 0.020)	$n_{STREET} = 0.015$												
Max. Allowable Spread for Minor & Major Storm	<table border="1"> <tr> <th></th> <th>Minor Storm</th> <th>Major Storm</th> <th></th> </tr> <tr> <td><math>T_{MAX}</math></td> <td>24.0</td> <td>24.0</td> <td>ft</td> </tr> <tr> <td><math>d_{MAX}</math></td> <td>6.0</td> <td>6.0</td> <td>inches</td> </tr> </table>		Minor Storm	Major Storm		$T_{MAX}$	24.0	24.0	ft	$d_{MAX}$	6.0	6.0	inches
	Minor Storm	Major Storm											
$T_{MAX}$	24.0	24.0	ft										
$d_{MAX}$	6.0	6.0	inches										
Max. Allowable Depth at Gutter Flowline for Minor & Major Storm													
Allow Flow Depth at Street Crown (check box for yes, leave blank for no)	<input type="checkbox"/> <input type="checkbox"/>												
<a href="#">MINOR STORM Allowable Capacity is based on Depth Criterion</a> <a href="#">MAJOR STORM Allowable Capacity is based on Depth Criterion</a>	<table border="1"> <tr> <th></th> <th>Minor Storm</th> <th>Major Storm</th> <th></th> </tr> <tr> <td><math>Q_{allow}</math></td> <td>18.0</td> <td>18.0</td> <td>cfs</td> </tr> </table>		Minor Storm	Major Storm		$Q_{allow}$	18.0	18.0	cfs				
	Minor Storm	Major Storm											
$Q_{allow}$	18.0	18.0	cfs										
<p><b>Minor storm max. allowable capacity GOOD - greater than the design peak flow of 1.50 cfs on sheet 'Inlet Management'</b>  <b>Major storm max. allowable capacity GOOD - greater than the design peak flow of 2.90 cfs on sheet 'Inlet Management'</b></p>													

# INLET ON A CONTINUOUS GRADE

MHFD-Inlet, Version 5.02 (August 2022)

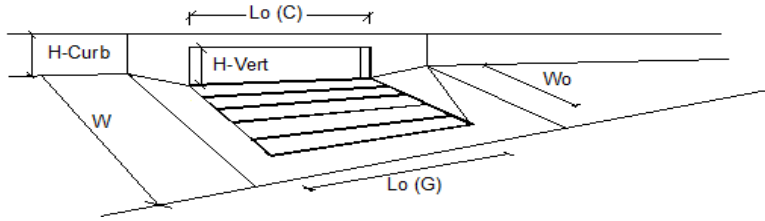

<b>Design Information (Input)</b>		<table border="1" style="display: inline-table; border-collapse: collapse;"> <thead> <tr> <th style="width: 50%;"></th> <th style="width: 25%;">MINOR</th> <th style="width: 25%;">MAJOR</th> </tr> </thead> <tbody> <tr> <td>Type =</td> <td colspan="2" style="text-align: center;">Denver No. 16 Combination</td> </tr> <tr> <td><math>a_{LOCAL}</math> =</td> <td style="text-align: center;">2.0</td> <td style="text-align: center;">2.0</td> </tr> <tr> <td>No =</td> <td style="text-align: center;">3</td> <td style="text-align: center;">3</td> </tr> <tr> <td><math>L_o</math> =</td> <td style="text-align: center;">3.00</td> <td style="text-align: center;">3.00</td> </tr> <tr> <td><math>W_o</math> =</td> <td style="text-align: center;">1.73</td> <td style="text-align: center;">1.73</td> </tr> <tr> <td><math>C_f (G)</math> =</td> <td style="text-align: center;">0.50</td> <td style="text-align: center;">0.50</td> </tr> <tr> <td><math>C_f (C)</math> =</td> <td style="text-align: center;">0.10</td> <td style="text-align: center;">0.10</td> </tr> </tbody> </table>		MINOR	MAJOR	Type =	Denver No. 16 Combination		$a_{LOCAL}$ =	2.0	2.0	No =	3	3	$L_o$ =	3.00	3.00	$W_o$ =	1.73	1.73	$C_f (G)$ =	0.50	0.50	$C_f (C)$ =	0.10	0.10
	MINOR	MAJOR																								
Type =	Denver No. 16 Combination																									
$a_{LOCAL}$ =	2.0	2.0																								
No =	3	3																								
$L_o$ =	3.00	3.00																								
$W_o$ =	1.73	1.73																								
$C_f (G)$ =	0.50	0.50																								
$C_f (C)$ =	0.10	0.10																								
Type of Inlet: <span style="border: 1px solid black; padding: 2px;">Denver No. 16 Combination</span> Local Depression (additional to continuous gutter depression 'a') Total Number of Units in the Inlet (Grate or Curb Opening) Length of a Single Unit Inlet (Grate or Curb Opening) Width of a Unit Grate (cannot be greater than W, Gutter Width) Clogging Factor for a Single Unit Grate (typical min. value = 0.5) Clogging Factor for a Single Unit Curb Opening (typical min. value = 0.1)																										
Street Hydraulics: OK - $Q <$ Allowable Street Capacity																										
Total Inlet Interception Capacity Total Inlet Carry-Over Flow (flow bypassing inlet) Capture Percentage = $Q_i/Q_o$		<table border="1" style="display: inline-table; border-collapse: collapse;"> <thead> <tr> <th style="width: 50%;"></th> <th style="width: 25%;">MINOR</th> <th style="width: 25%;">MAJOR</th> <th style="width: 25%;"></th> </tr> </thead> <tbody> <tr> <td><math>Q</math> =</td> <td style="text-align: center;">1.6</td> <td style="text-align: center;">2.7</td> <td style="text-align: center;">cfs</td> </tr> <tr> <td><math>Q_b</math> =</td> <td style="text-align: center;">-0.1</td> <td style="text-align: center;">0.2</td> <td style="text-align: center;">cfs</td> </tr> <tr> <td><math>C\%</math> =</td> <td style="text-align: center;">105</td> <td style="text-align: center;">93</td> <td style="text-align: center;">%</td> </tr> </tbody> </table>		MINOR	MAJOR		$Q$ =	1.6	2.7	cfs	$Q_b$ =	-0.1	0.2	cfs	$C\%$ =	105	93	%								
	MINOR	MAJOR																								
$Q$ =	1.6	2.7	cfs																							
$Q_b$ =	-0.1	0.2	cfs																							
$C\%$ =	105	93	%																							

NEGATIVE BYPASS  
 FLOWS  
 CALCULATED BY  
 WORKSHEET  
 IGNORED AND NOT  
 APPLIED TO  
 DOWNSTREAM  
 INLET.

BYPASS FLOWS TO  
 INLET A11



**ALLOWABLE CAPACITY FOR ONE-HALF OF STREET (Minor & Major Storm)**  
 (Based on Regulated Criteria for Maximum Allowable Flow Depth and Spread)

Project:  
 Inlet ID: **Inlet A11**

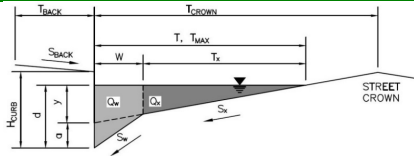

<b>Gutter Geometry:</b>	
Maximum Allowable Width for Spread Behind Curb	$T_{BACK} = 5.0$ ft
Side Slope Behind Curb (leave blank for no conveyance credit behind curb)	$S_{BACK} = 0.020$ ft/ft
Manning's Roughness Behind Curb (typically between 0.012 and 0.020)	$n_{BACK} = 0.015$
Height of Curb at Gutter Flow Line	$H_{CURB} = 6.00$ inches
Distance from Curb Face to Street Crown	$T_{CROWN} = 24.0$ ft
Gutter Width	$W = 2.00$ ft
Street Transverse Slope	$S_x = 0.020$ ft/ft
Gutter Cross Slope (typically 2 inches over 24 inches or 0.083 ft/ft)	$S_w = 0.083$ ft/ft
Street Longitudinal Slope - Enter 0 for sump condition	$S_o = 0.015$ ft/ft
Manning's Roughness for Street Section (typically between 0.012 and 0.020)	$n_{STREET} = 0.015$
Max. Allowable Spread for Minor & Major Storm	$T_{MAX} = \begin{matrix} \text{Minor Storm} & \text{Major Storm} \\ 24.0 & 24.0 \end{matrix}$ ft
Max. Allowable Depth at Gutter Flowline for Minor & Major Storm	$d_{MAX} = \begin{matrix} \text{Minor Storm} & \text{Major Storm} \\ 6.0 & 6.0 \end{matrix}$ inches
Allow Flow Depth at Street Crown (check box for yes, leave blank for no)	<input type="checkbox"/> <input type="checkbox"/>
<a href="#">MINOR STORM Allowable Capacity is based on Depth Criterion</a>	
<a href="#">MAJOR STORM Allowable Capacity is based on Depth Criterion</a>	
<b>Minor storm max. allowable capacity GOOD - greater than the design peak flow of 0.80 cfs on sheet 'Inlet Management'</b>	
<b>Major storm max. allowable capacity GOOD - greater than the design peak flow of 1.80 cfs on sheet 'Inlet Management'</b>	
$Q_{allow} =$	$\begin{matrix} \text{Minor Storm} & \text{Major Storm} \\ 18.0 & 18.0 \end{matrix}$ cfs

# INLET ON A CONTINUOUS GRADE

MHFD-Inlet, Version 5.02 (August 2022)

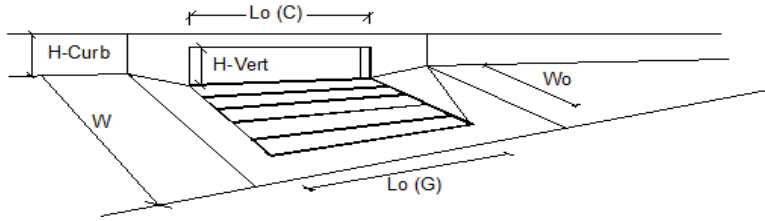

Design Information (Input)	MINOR	MAJOR	
Type of Inlet	Denver No. 16 Combination		
Local Depression (additional to continuous gutter depression 'a')	2.0	2.0	inches
Total Number of Units in the Inlet (Grate or Curb Opening)	3	3	
Length of a Single Unit Inlet (Grate or Curb Opening)	3.00	3.00	ft
Width of a Unit Grate (cannot be greater than W, Gutter Width)	1.73	1.73	ft
Clogging Factor for a Single Unit Grate (typical min. value = 0.5)	0.50	0.50	
Clogging Factor for a Single Unit Curb Opening (typical min. value = 0.1)	0.10	0.10	
Street Hydraulics: OK - Q < Allowable Street Capacity			
Total Inlet Interception Capacity	Q = 0.9	1.8	cfs
Total Inlet Carry-Over Flow (flow bypassing inlet)	Q <sub>b</sub> = -0.1	0.0	cfs
Capture Percentage = Q <sub>i</sub> /Q <sub>s</sub>	C% = 114	102	%

NEGATIVE BYPASS  
FLOWS  
CALCULATED BY  
WORKSHEET  
IGNORED AND NOT  
APPLIED TO  
DOWNSTREAM  
INLET.

**ALLOWABLE CAPACITY FOR ONE-HALF OF STREET (Minor & Major Storm)**  
 (Based on Regulated Criteria for Maximum Allowable Flow Depth and Spread)

Project:  
 Inlet ID: **Inlet A9**

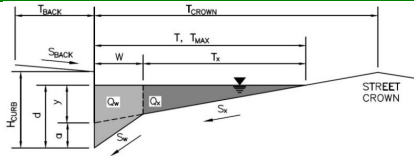

<b>Gutter Geometry:</b>					
Maximum Allowable Width for Spread Behind Curb	$T_{BACK} = 0.0$ ft				
Side Slope Behind Curb (leave blank for no conveyance credit behind curb)	$S_{BACK} =$ ft/ft				
Manning's Roughness Behind Curb (typically between 0.012 and 0.020)	$n_{BACK} = 0.015$				
Height of Curb at Gutter Flow Line	$H_{CURB} = 6.00$ inches				
Distance from Curb Face to Street Crown	$T_{CROWN} = 28.0$ ft				
Gutter Width	$W = 2.00$ ft				
Street Transverse Slope	$S_X = 0.020$ ft/ft				
Gutter Cross Slope (typically 2 inches over 24 inches or 0.083 ft/ft)	$S_Y = 0.083$ ft/ft				
Street Longitudinal Slope - Enter 0 for sump condition	$S_0 = 0.000$ ft/ft				
Manning's Roughness for Street Section (typically between 0.012 and 0.020)	$n_{STREET} = 0.015$				
Max. Allowable Spread for Minor & Major Storm	$T_{MAX} =$ <table border="1"><tr><td>Minor Storm</td><td>Major Storm</td></tr><tr><td>28.0</td><td>28.0</td></tr></table> ft	Minor Storm	Major Storm	28.0	28.0
Minor Storm	Major Storm				
28.0	28.0				
Max. Allowable Depth at Gutter Flowline for Minor & Major Storm	$d_{MAX} =$ <table border="1"><tr><td>Minor Storm</td><td>Major Storm</td></tr><tr><td>6.0</td><td>6.0</td></tr></table> inches	Minor Storm	Major Storm	6.0	6.0
Minor Storm	Major Storm				
6.0	6.0				
Check boxes are not applicable in SUMP conditions	<input type="checkbox"/> <input type="checkbox"/>				
MINOR STORM Allowable Capacity is not applicable to Sump Condition					
MAJOR STORM Allowable Capacity is not applicable to Sump Condition					
	$Q_{allow} =$ <table border="1"><tr><td>Minor Storm</td><td>Major Storm</td></tr><tr><td>SUMP</td><td>SUMP</td></tr></table> cfs	Minor Storm	Major Storm	SUMP	SUMP
Minor Storm	Major Storm				
SUMP	SUMP				

# INLET IN A SUMP OR SAG LOCATION

MHFD-Inlet, Version 5.02 (August 2022)

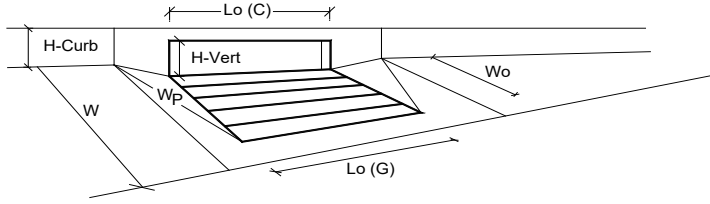

Design Information (Input)	MINOR	MAJOR	
Type of Inlet	Denver No. 16 Combination		
Local Depression (additional to continuous gutter depression 'a' from above)	2.00	2.00	inches
Number of Unit Inlets (Grate or Curb Opening)	3	3	
Water Depth at Flowline (outside of local depression)	6.0	6.0	inches
<b>Grate Information</b>			
Length of a Unit Grate	3.00	3.00	feet
Width of a Unit Grate	1.73	1.73	feet
Open Area Ratio for a Grate (typical values 0.15-0.90)	0.31	0.31	
Clogging Factor for a Single Grate (typical value 0.50 - 0.70)	0.50	0.50	
Grate Weir Coefficient (typical value 2.15 - 3.60)	3.60	3.60	
Grate Orifice Coefficient (typical value 0.60 - 0.80)	0.60	0.60	
<b>Curb Opening Information</b>			
Length of a Unit Curb Opening	3.00	3.00	feet
Height of Vertical Curb Opening in Inches	6.50	6.50	inches
Height of Curb Orifice Throat in Inches	5.25	5.25	inches
Angle of Throat (see USDCM Figure ST-5)	0.00	0.00	degrees
Side Width for Depression Pan (typically the gutter width of 2 feet)	2.00	2.00	feet
Clogging Factor for a Single Curb Opening (typical value 0.10)	0.10	0.10	
Curb Opening Weir Coefficient (typical value 2.3-3.7)	3.70	3.70	
Curb Opening Orifice Coefficient (typical value 0.60 - 0.70)	0.66	0.66	
<b>Low Head Performance Reduction (Calculated)</b>			
Depth for Grate Midwidth	0.52	0.52	ft
Depth for Curb Opening Weir Equation	0.33	0.33	ft
Grated Inlet Performance Reduction Factor for Long Inlets	0.57	0.57	
Curb Opening Performance Reduction Factor for Long Inlets	N/A	N/A	
Combination Inlet Performance Reduction Factor for Long Inlets	0.57	0.57	
<b>Total Inlet Interception Capacity (assumes clogged condition)</b>			
<b>Inlet Capacity IS GOOD for Minor and Major Storms (&gt;Q Peak)</b>	<b>8.7</b>	<b>8.7</b>	<b>cfs</b>
Q <sub>PEAK REQUIRED</sub>	2.9	6.9	cfs

LINES 1 & 2

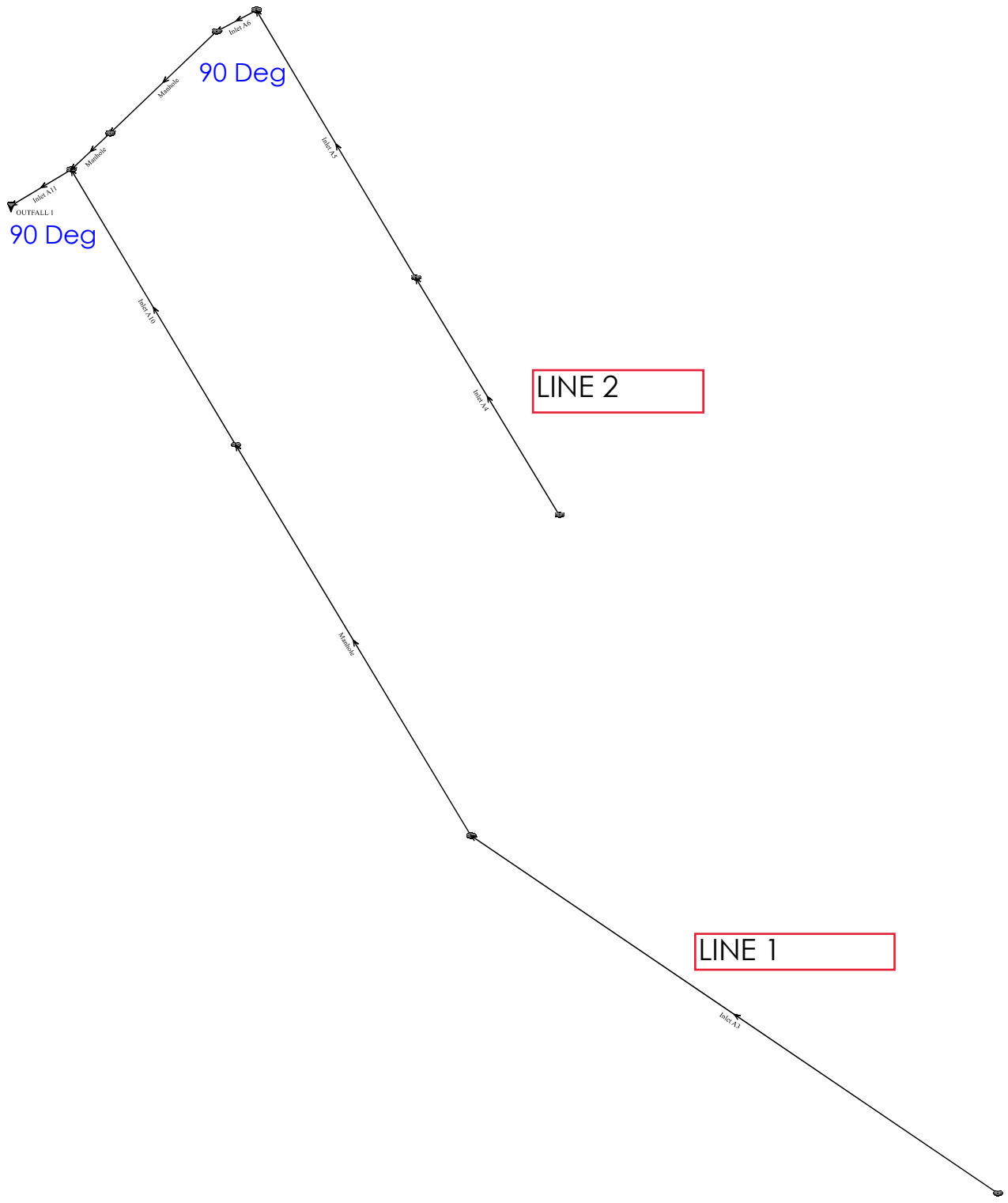

<b>Program:</b> UDSEWER Math Model Interface 2.1.1.4 <b>Run Date:</b> 5/23/2024 10:52:47 AM	<b>UDSewer Results Summary</b>  <b>Project Title:</b> Townhomes at Western <b>Project Description:</b> Storm Line 1 & 2 - 5yr
---	--

## System Input Summary

### Rainfall Parameters

**Rainfall Return Period:** 5  
**Rainfall Calculation Method:** Formula

**One Hour Depth (in):**  
**Rainfall Constant "A":** 28.5  
**Rainfall Constant "B":** 10  
**Rainfall Constant "C":** 0.786

### Rational Method Constraints

**Minimum Urban Runoff Coeff.:** 0.20  
**Maximum Rural Overland Len. (ft):** 500  
**Maximum Urban Overland Len. (ft):** 300  
**Used UDFCD Tc. Maximum:** Yes

### Sizer Constraints

**Minimum Sewer Size (in):** 18.00  
**Maximum Depth to Rise Ratio:** 0.90  
**Maximum Flow Velocity (fps):** 18.0  
**Minimum Flow Velocity (fps):** 2.0

### Backwater Calculations:

**Tailwater Elevation (ft):** 6272.00      ELEVATION CALCULATED FROM MAX PONDING DEPTH SHOWN IN DETENTION WORKSHEET



Inlet A6	0.00	0.00	0.00	0.00	1.10	0.00	0.00	0.00	3.50	
Inlet A5	0.00	0.00	0.00	0.00	1.00	0.00	0.00	0.00	2.40	
Inlet A4	0.00	0.00	0.00	0.00	1.40	0.00	0.00	0.00	1.40	

## Sewer Input Summary:

		Elevation			Loss Coefficients			Given Dimensions		
Element Name	Sewer Length (ft)	Downstream Invert (ft)	Slope (%)	Upstream Invert (ft)	Mannings n	Bend Loss	Lateral Loss	Cross Section	Rise (ft or in)	Span (ft or in)
Inlet A11	20.59	6268.64	6.6	6270.00	0.012	0.00	0.00	CIRCULAR	18.00 in	18.00 in
Inlet A10	107.49	6271.01	1.9	6273.05	0.012	0.05	0.25	CIRCULAR	18.00 in	18.00 in
Manhole	168.90	6273.66	0.5	6274.50	0.012	0.05	0.00	CIRCULAR	12.00 in	12.00 in
Inlet A3	263.81	6274.82	3.1	6283.00	0.012	0.12	0.00	CIRCULAR	12.00 in	12.00 in
Manhole	31.38	6271.00	8.6	6273.70	0.012	0.05	0.00	CIRCULAR	18.00 in	18.00 in
Manhole	48.20	6274.01	14.5	6281.00	0.012	0.05	0.00	CIRCULAR	18.00 in	18.00 in
Inlet A6	18.35	6281.29	10.4	6283.20	0.012	1.99	0.00	CIRCULAR	18.00 in	18.00 in
Inlet A5	106.46	6284.21	5.1	6289.64	0.012	0.05	0.00	CIRCULAR	12.00 in	12.00 in
Inlet A4	106.46	6290.19	1.3	6291.57	0.012	0.05	0.00	CIRCULAR	12.00 in	12.00 in

## Sewer Flow Summary:

		Full Flow Capacity		Critical Flow		Normal Flow					
Element Name	Flow (cfs)	Velocity (fps)	Depth (in)	Velocity (fps)	Depth (in)	Velocity (fps)	Froude Number	Flow Condition	Flow (cfs)	Surcharged Length (ft)	Comment
Inlet A11	29.31	16.59	12.56	5.55	6.12	13.77	3.97	Pressurized	7.30	20.59	
Inlet A10	15.73	8.90	7.90	4.02	5.33	6.86	2.14	Supercritical Jump	3.00	2.89	
Manhole	2.74	3.48	6.23	3.64	6.34	3.56	0.97	Subcritical	1.50	0.00	
Inlet A3	6.81	8.68	6.23	3.64	3.83	6.96	2.55	Supercritical	1.50	0.00	





Inlet A5	2.40	CIRCULAR	12.00 in	12.00 in	18.00 in	18.00 in	12.00 in	12.00 in	0.79	Height is too small. Width is too small. Existing height is smaller than the suggested height. Existing width is smaller than the suggested width.
Inlet A4	1.40	CIRCULAR	12.00 in	12.00 in	18.00 in	18.00 in	12.00 in	12.00 in	0.79	Height is too small. Width is too small. Existing height is smaller than the suggested height. Existing width is smaller than the suggested width.

- Calculated diameter was determined by sewer hydraulic capacity rounded up to the nearest commercially available size.
- Sewer sizes should not decrease downstream.
- All hydraulics were calculated using the 'Used' parameters.

## Grade Line Summary:

Tailwater Elevation (ft): 6272.00

Element Name	Invert Elev.		Downstream Manhole Losses		HGL		EGL		
	Downstream (ft)	Upstream (ft)	Bend Loss (ft)	Lateral Loss (ft)	Downstream (ft)	Upstream (ft)	Downstream (ft)	Friction Loss (ft)	Upstream (ft)
Inlet A11	6268.64	6270.00	0.00	0.00	6272.00	6272.08	6272.26	0.08	6272.35
Inlet A10	6271.01	6273.05	0.00	0.25	6272.56	6273.71	6272.61	1.35	6273.96
Manhole	6273.66	6274.50	0.00	0.00	6274.17	6275.04	6274.38	0.85	6275.23
Inlet A3	6274.82	6283.00	0.01	0.00	6275.14	6283.52	6275.89	7.83	6283.73
Manhole	6271.00	6273.70	0.00	0.00	6272.09	6274.41	6273.67	1.02	6274.69
Manhole	6274.01	6281.00	0.00	0.00	6274.42	6281.71	6277.68	4.31	6281.99
Inlet A6	6281.29	6283.20	0.12	0.00	6281.83	6284.14	6284.28	0.00	6284.28
Inlet A5	6284.21	6289.64	0.01	0.00	6284.57	6290.30	6285.97	4.63	6290.60
Inlet A4	6290.19	6291.57	0.00	0.00	6290.57	6292.07	6290.96	1.31	6292.27

- Bend and Lateral losses only apply when there is an outgoing sewer. The system outfall, sewer #0, is not considered a sewer.
- Bend loss = Bend K \* V<sub>fi</sub> ^ 2/(2\*g)
- Lateral loss = V<sub>fo</sub> ^ 2/(2\*g)- Junction Loss K \* V<sub>fi</sub> ^ 2/(2\*g).
- Friction loss is always Upstream EGL - Downstream EGL.

## Excavation Estimate:

The trench side slope is 1.0 ft/ft  
 The minimum trench width is 2.00 ft

Element Name	Length (ft)	Wall (in)	Bedding (in)	Bottom Width (ft)	Downstream			Upstream			Volume (cu. yd)	Comment
					Top Width (ft)	Trench Depth (ft)	Cover (ft)	Top Width (ft)	Trench Depth (ft)	Cover (ft)		
Inlet A11	20.59	2.50	4.00	4.92	0.00	0.54	0.00	14.58	8.08	5.83	25.07	Sewer Too Shallow
Inlet A10	107.49	2.50	4.00	4.92	12.56	7.07	4.82	12.04	6.81	4.56	190.26	
Manhole	168.90	2.00	4.00	4.33	11.33	6.16	4.50	12.00	6.50	4.83	255.88	
Inlet A3	263.81	2.00	4.00	4.33	11.36	6.18	4.51	15.04	8.02	6.35	500.82	
Manhole	31.38	2.50	4.00	4.92	12.58	7.08	4.83	9.10	5.34	3.09	46.56	
Manhole	48.20	2.50	4.00	4.92	8.48	5.03	2.78	13.90	7.74	5.49	76.89	
Inlet A6	18.35	2.50	4.00	4.92	13.32	7.45	5.20	19.50	10.54	8.29	54.12	
Inlet A5	106.46	2.00	4.00	4.33	17.98	9.49	7.82	10.52	5.76	4.09	240.92	
Inlet A4	106.46	2.00	4.00	4.33	9.43	5.21	3.55	10.06	5.53	3.86	120.74	

**Total earth volume for sewer trenches = 1511 cubic yards.**

- The trench was estimated to have a bottom width equal to the outer pipe diameter plus 36 inches.
- If the calculated width of the trench bottom is less than the minimum acceptable width, the minimum acceptable width was used.
- The sewer wall thickness is equal to: (equivalent diameter in inches/12)+1 inches
- The sewer bedding thickness is equal to:
  - Four inches for pipes less than 33 inches.
  - Six inches for pipes less than 60 inches.
  - Eight inches for all larger sizes.

# Line 1

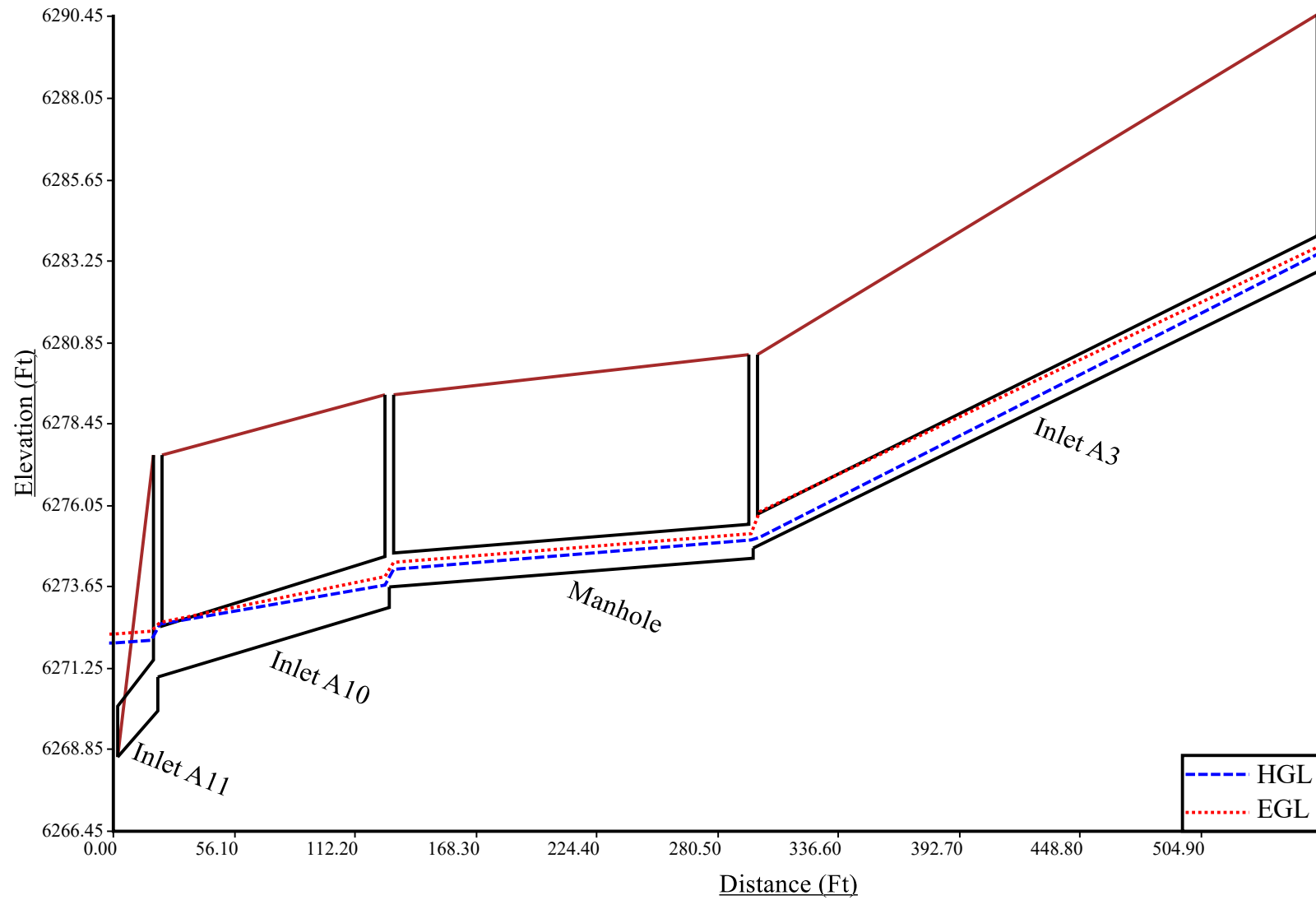

# Line 2

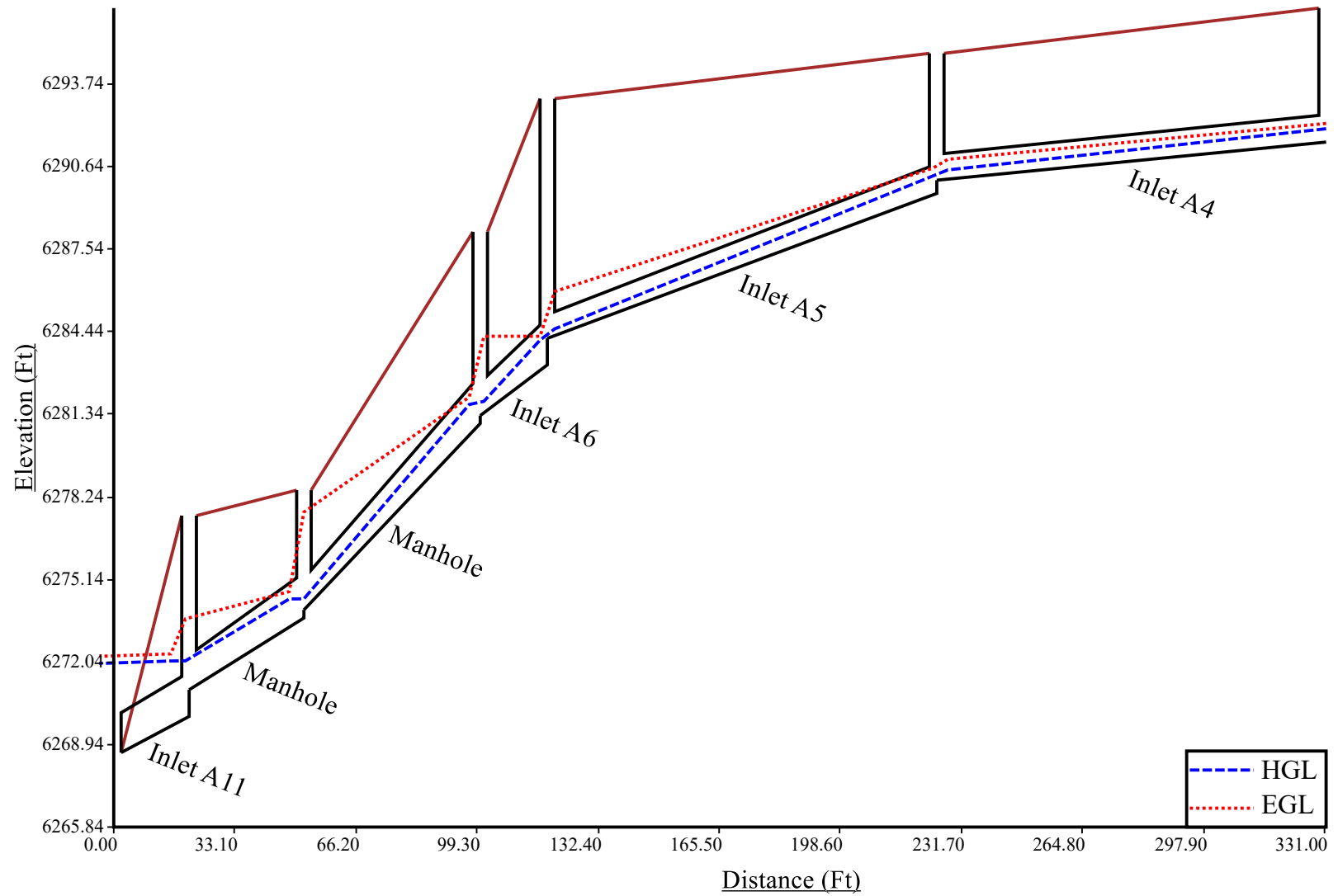

<b>Program:</b> UDSEWER Math Model Interface 2.1.1.4 <b>Run Date:</b> 5/23/2024 10:25:08 AM	<b>UDSewer Results Summary</b>  <b>Project Title:</b> Townhomes at Western <b>Project Description:</b> Storm Line 1 & 2 - 100yr
---	--

## System Input Summary

### Rainfall Parameters

**Rainfall Return Period:** 100  
**Rainfall Calculation Method:** Formula

**One Hour Depth (in):**  
**Rainfall Constant "A":** 28.5  
**Rainfall Constant "B":** 10  
**Rainfall Constant "C":** 0.786

### Rational Method Constraints

**Minimum Urban Runoff Coeff.:** 0.20  
**Maximum Rural Overland Len. (ft):** 500  
**Maximum Urban Overland Len. (ft):** 300  
**Used UDFCD Tc. Maximum:** Yes

### Sizer Constraints

**Minimum Sewer Size (in):** 18.00  
**Maximum Depth to Rise Ratio:** 0.90  
**Maximum Flow Velocity (fps):** 18.0  
**Minimum Flow Velocity (fps):** 2.0

### Backwater Calculations:

**Tailwater Elevation (ft):** 6272.61      ELEVATION CALCULATED FROM MAX PONDING DEPTH SHOWN IN DETENTION WORKSHEET



Inlet A6	0.00	0.00	0.00	0.00	2.10	0.00	0.00	0.00	6.60	
Inlet A5	0.00	0.00	0.00	0.00	2.10	0.00	0.00	0.00	4.50	
Inlet A4	0.00	0.00	0.00	0.00	2.40	0.00	0.00	0.00	2.40	

## Sewer Input Summary:

		Elevation			Loss Coefficients			Given Dimensions		
Element Name	Sewer Length (ft)	Downstream Invert (ft)	Slope (%)	Upstream Invert (ft)	Mannings n	Bend Loss	Lateral Loss	Cross Section	Rise (ft or in)	Span (ft or in)
Inlet A11	20.59	6268.64	6.6	6270.00	0.012	0.00	0.00	CIRCULAR	18.00 in	18.00 in
Inlet A10	107.49	6271.01	1.9	6273.05	0.012	0.05	0.25	CIRCULAR	18.00 in	18.00 in
Manhole	168.90	6273.66	0.5	6274.50	0.012	0.05	0.00	CIRCULAR	12.00 in	12.00 in
Inlet A3	263.81	6274.82	3.1	6283.00	0.012	0.12	0.00	CIRCULAR	12.00 in	12.00 in
Manhole	31.38	6271.00	8.6	6273.70	0.012	0.05	0.00	CIRCULAR	18.00 in	18.00 in
Manhole	48.20	6274.01	14.5	6281.00	0.012	0.05	0.00	CIRCULAR	18.00 in	18.00 in
Inlet A6	18.35	6281.29	10.4	6283.20	0.012	1.99	0.00	CIRCULAR	18.00 in	18.00 in
Inlet A5	106.46	6284.21	5.1	6289.64	0.012	0.05	0.00	CIRCULAR	12.00 in	12.00 in
Inlet A4	106.46	6290.19	1.3	6291.57	0.012	0.05	0.00	CIRCULAR	12.00 in	12.00 in

## Sewer Flow Summary:

		Full Flow Capacity		Critical Flow		Normal Flow					
Element Name	Flow (cfs)	Velocity (fps)	Depth (in)	Velocity (fps)	Depth (in)	Velocity (fps)	Froude Number	Flow Condition	Flow (cfs)	Surcharged Length (ft)	Comment
Inlet A11	29.31	16.59	16.64	8.32	8.83	16.46	3.82	Pressurized	14.20	20.59	
Inlet A10	15.73	8.90	11.15	5.04	7.57	8.23	2.10	Pressurized	5.80	107.49	
Manhole	2.74	3.48	12.00	4.20	12.00	4.20	0.00	Pressurized	3.30	168.90	
Inlet A3	6.81	8.68	9.33	5.04	5.89	8.61	2.45	Supercritical Jump	3.30	19.55	





Inlet A6	6.60	CIRCULAR	18.00 in	18.00 in	18.00 in	18.00 in	18.00 in	18.00 in	1.77	
Inlet A5	4.50	CIRCULAR	12.00 in	12.00 in	18.00 in	18.00 in	12.00 in	12.00 in	0.79	Height is too small. Width is too small. Existing height is smaller than the suggested height. Existing width is smaller than the suggested width.
Inlet A4	2.40	CIRCULAR	12.00 in	12.00 in	18.00 in	18.00 in	12.00 in	12.00 in	0.79	Height is too small. Width is too small. Existing height is smaller than the suggested height. Existing width is smaller than the suggested width.

- Calculated diameter was determined by sewer hydraulic capacity rounded up to the nearest commercially available size.
- Sewer sizes should not decrease downstream.
- All hydraulics were calculated using the 'Used' parameters.

## Grade Line Summary:

Tailwater Elevation (ft): 6272.61

Element Name	Invert Elev.		Downstream Manhole Losses		HGL		EGL		
	Downstream (ft)	Upstream (ft)	Bend Loss (ft)	Lateral Loss (ft)	Downstream (ft)	Upstream (ft)	Downstream (ft)	Friction Loss (ft)	Upstream (ft)
Inlet A11	6268.64	6270.00	0.00	0.00	6272.61	6272.93	6273.61	0.32	6273.93
Inlet A10	6271.01	6273.05	0.01	0.96	6274.73	6275.01	6274.90	0.28	6275.18
Manhole	6273.66	6274.50	0.01	0.00	6275.02	6276.25	6275.30	1.23	6276.53
Inlet A3	6274.82	6283.00	0.03	0.00	6276.29	6283.78	6276.56	7.61	6284.17
Manhole	6271.00	6273.70	0.01	0.00	6273.73	6274.69	6273.94	1.19	6275.13
Manhole	6274.01	6281.00	0.01	0.00	6274.70	6281.99	6279.30	3.13	6282.43
Inlet A6	6281.29	6283.20	0.43	0.00	6282.42	6285.36	6285.58	0.00	6285.58
Inlet A5	6284.21	6289.64	0.03	0.00	6285.39	6290.53	6285.72	5.39	6291.11

Inlet A4	6290.19	6291.57	0.01	0.00	6290.71	6292.23	6291.22	1.30	6292.53
----------	---------	---------	------	------	---------	---------	---------	------	---------

- Bend and Lateral losses only apply when there is an outgoing sewer. The system outfall, sewer #0, is not considered a sewer.
- Bend loss = Bend K \* V<sub>fi</sub> ^ 2/(2\*g)
- Lateral loss = V<sub>fo</sub> ^ 2/(2\*g)- Junction Loss K \* V<sub>fi</sub> ^ 2/(2\*g).
- Friction loss is always Upstream EGL - Downstream EGL.

## Excavation Estimate:

The trench side slope is 1.0 ft/ft  
The minimum trench width is 2.00 ft

Element Name	Length (ft)	Wall (in)	Bedding (in)	Bottom Width (ft)	Downstream			Upstream			Volume (cu. yd)	Comment
					Top Width (ft)	Trench Depth (ft)	Cover (ft)	Top Width (ft)	Trench Depth (ft)	Cover (ft)		
Inlet A11	20.59	2.50	4.00	4.92	0.00	0.54	0.00	14.58	8.08	5.83	25.07	Sewer Too Shallow
Inlet A10	107.49	2.50	4.00	4.92	12.56	7.07	4.82	12.04	6.81	4.56	190.26	
Manhole	168.90	2.00	4.00	4.33	11.33	6.16	4.50	12.00	6.50	4.83	255.88	
Inlet A3	263.81	2.00	4.00	4.33	11.36	6.18	4.51	15.04	8.02	6.35	500.82	
Manhole	31.38	2.50	4.00	4.92	12.58	7.08	4.83	9.10	5.34	3.09	46.56	
Manhole	48.20	2.50	4.00	4.92	8.48	5.03	2.78	13.90	7.74	5.49	76.89	
Inlet A6	18.35	2.50	4.00	4.92	13.32	7.45	5.20	19.50	10.54	8.29	54.12	
Inlet A5	106.46	2.00	4.00	4.33	17.98	9.49	7.82	10.52	5.76	4.09	240.92	
Inlet A4	106.46	2.00	4.00	4.33	9.43	5.21	3.55	10.06	5.53	3.86	120.74	

**Total earth volume for sewer trenches = 1511 cubic yards.**

- The trench was estimated to have a bottom width equal to the outer pipe diameter plus 36 inches.
- If the calculated width of the trench bottom is less than the minimum acceptable width, the minimum acceptable width was used.
- The sewer wall thickness is equal to: (equivalent diameter in inches/12)+1 inches
- The sewer bedding thickness is equal to:
  - Four inches for pipes less than 33 inches.
  - Six inches for pipes less than 60 inches.
  - Eight inches for all larger sizes.

# Line 1

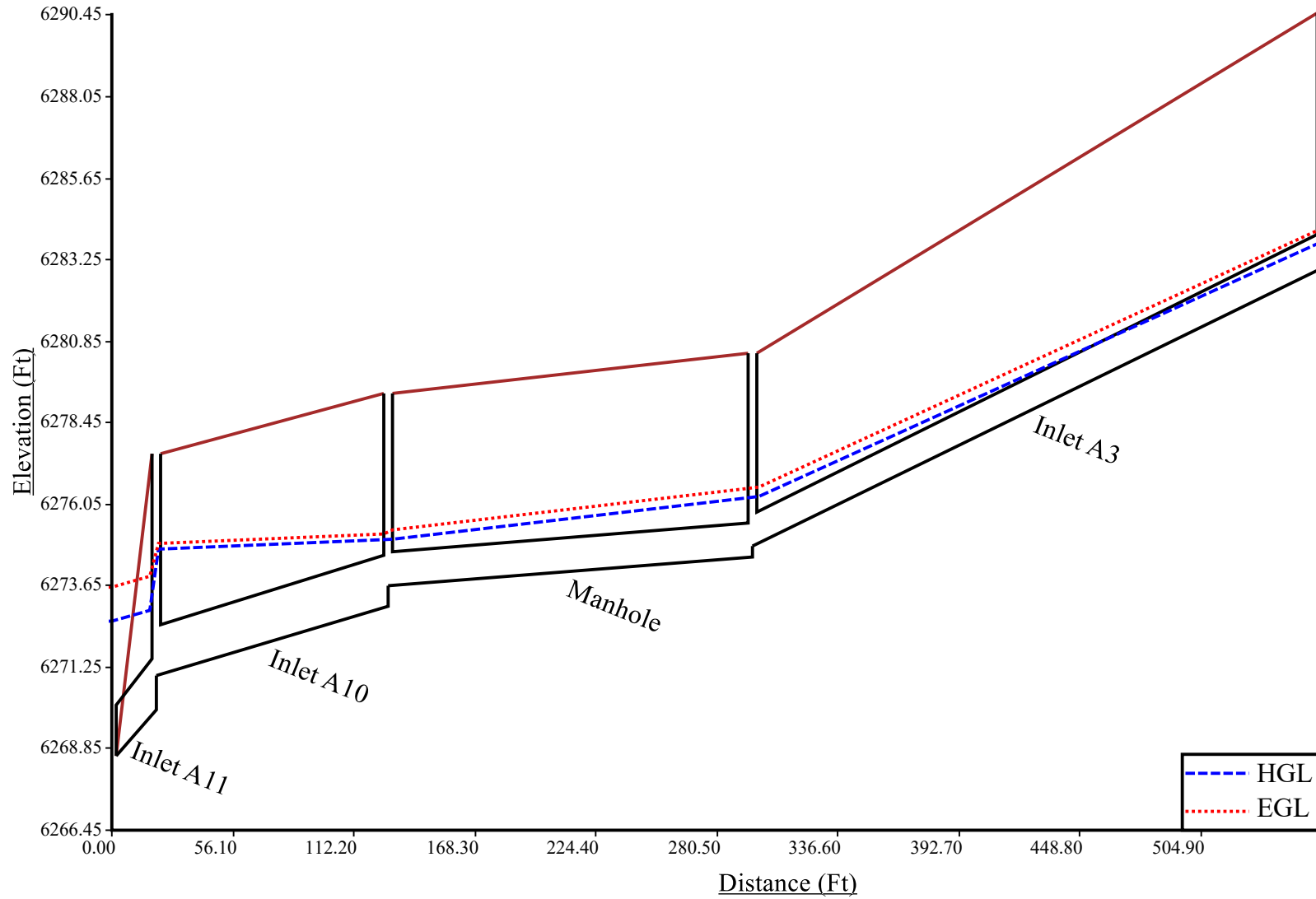

# Line 2

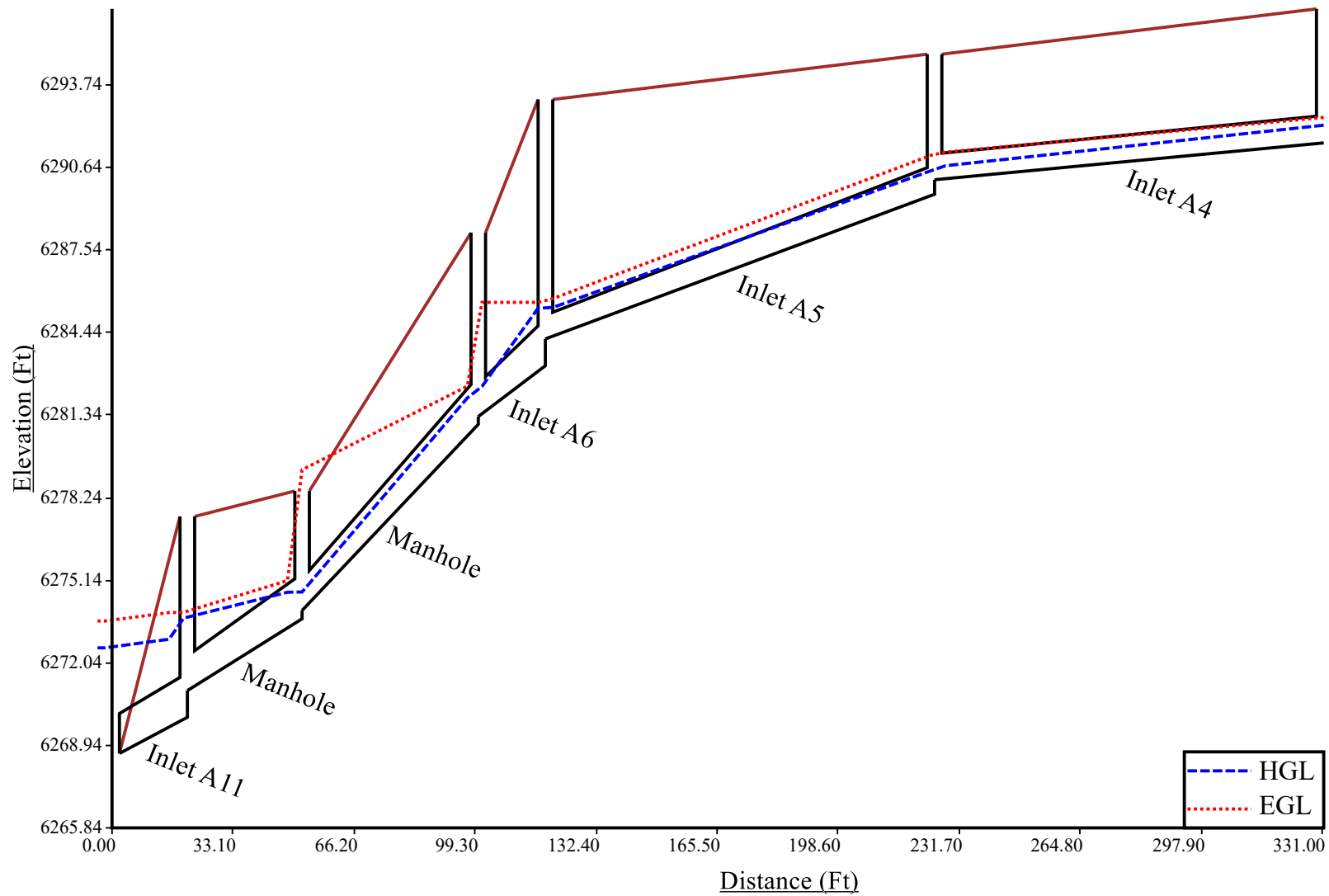

LINE 3

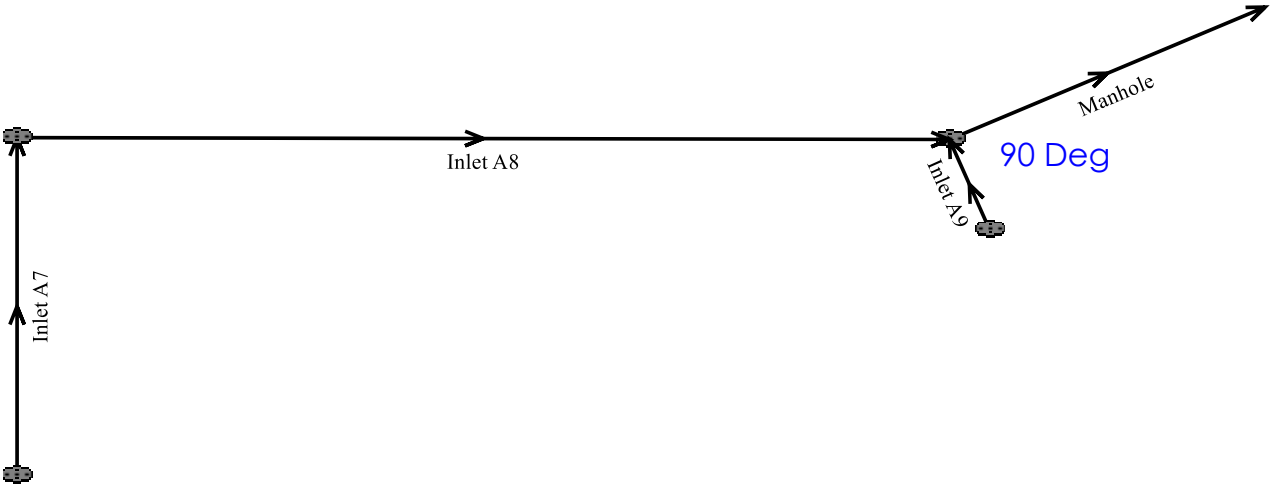

<b>Program:</b> UDSEWER Math Model Interface 2.1.1.4 <b>Run Date:</b> 5/23/2024 10:39:27 AM	<b>UDSewer Results Summary</b>  <b>Project Title:</b> Townhomes at Western <b>Project Description:</b> Storm Line 3 - 5yr
---	--

## System Input Summary

### Rainfall Parameters

**Rainfall Return Period:** 5  
**Rainfall Calculation Method:** Formula

**One Hour Depth (in):**  
**Rainfall Constant "A":** 28.5  
**Rainfall Constant "B":** 10  
**Rainfall Constant "C":** 0.786

### Rational Method Constraints

**Minimum Urban Runoff Coeff.:** 0.20  
**Maximum Rural Overland Len. (ft):** 500  
**Maximum Urban Overland Len. (ft):** 300  
**Used UDFCD Tc. Maximum:** Yes

### Sizer Constraints

**Minimum Sewer Size (in):** 18.00  
**Maximum Depth to Rise Ratio:** 0.90  
**Maximum Flow Velocity (fps):** 18.0  
**Minimum Flow Velocity (fps):** 2.0

### Backwater Calculations:

**Tailwater Elevation (ft):** 6272.00      ELEVATION CALCULATED FROM MAX PONDING DEPTH SHOWN IN DETENTION WORKSHEET

## Manhole Input Summary:

		Given Flow		Sub Basin Information						
Element Name	Ground Elevation (ft)	Total Known Flow (cfs)	Local Contribution (cfs)	Drainage Area (Ac.)	Runoff Coefficient	5yr Coefficient	Overland Length (ft)	Overland Slope (%)	Gutter Length (ft)	Gutter Velocity (fps)
OUTFALL 1	6268.38	0.00	0.00	0.00	0.00	0.00	0.00	0.00	0.00	0.00
Manhole	6275.20	6.80	0.00	0.00	0.00	0.00	0.00	0.00	0.00	0.00
Inlet A8	6278.29	3.90	0.60	0.00	0.00	0.00	0.00	0.00	0.00	0.00
Inlet A7	6276.67	3.30	3.30	0.00	0.00	0.00	0.00	0.00	0.00	0.00
Inlet A9	6274.84	2.90	2.90	0.00	0.00	0.00	0.00	0.00	0.00	0.00

## Manhole Output Summary:

		Local Contribution				Total Design Flow				
Element Name	Overland Time (min)	Gutter Time (min)	Basin Tc (min)	Intensity (in/hr)	Local Contrib (cfs)	Coeff. Area	Intensity (in/hr)	Manhole Tc (min)	Peak Flow (cfs)	Comment
OUTFALL 1	0.00	0.00	0.00	0.00	0.00	0.00	0.00	0.00	0.00	Surface Water Present (Upstream)
Manhole	0.00	0.00	0.00	0.00	0.00	0.00	0.00	0.00	6.80	Surface Water Present (Downstream)
Inlet A8	0.00	0.00	0.00	0.00	0.60	0.00	0.00	0.00	3.90	
Inlet A7	0.00	0.00	0.00	0.00	3.30	0.00	0.00	0.00	3.30	
Inlet A9	0.00	0.00	0.00	0.00	2.90	0.00	0.00	0.00	2.90	

## Sewer Input Summary:

		Elevation			Loss Coefficients			Given Dimensions		
Element Name	Sewer Length (ft)	Downstream Invert (ft)	Slope (%)	Upstream Invert (ft)	Mannings n	Bend Loss	Lateral Loss	Cross Section	Rise (ft or in)	Span (ft or in)





Inlet A9	2.90	CIRCULAR	12.00 in	12.00 in	18.00 in	18.00 in	12.00 in	12.00 in	0.79	Height is too small. Width is too small. Existing height is smaller than the suggested height. Existing width is smaller than the suggested width.
----------	------	----------	----------	----------	----------	----------	----------	----------	------	---

- Calculated diameter was determined by sewer hydraulic capacity rounded up to the nearest commercially available size.
- Sewer sizes should not decrease downstream.
- All hydraulics were calculated using the 'Used' parameters.

## Grade Line Summary:

Tailwater Elevation (ft): 6272.00

Element Name	Invert Elev.		Downstream Manhole Losses		HGL		EGL		
	Downstream (ft)	Upstream (ft)	Bend Loss (ft)	Lateral Loss (ft)	Downstream (ft)	Upstream (ft)	Downstream (ft)	Friction Loss (ft)	Upstream (ft)
Manhole	6268.87	6270.00	0.00	0.00	6272.00	6272.04	6272.07	0.04	6272.12
Inlet A8	6270.51	6272.18	0.01	0.00	6272.05	6272.94	6272.13	1.10	6273.23
Inlet A7	6272.49	6273.00	0.07	0.00	6273.07	6273.69	6273.49	0.47	6273.96
Inlet A9	6271.01	6271.34	0.01	0.02	6272.07	6272.07	6272.22	0.20	6272.42

- Bend and Lateral losses only apply when there is an outgoing sewer. The system outfall, sewer #0, is not considered a sewer.
- Bend loss = Bend K \* V<sub>fi</sub> ^ 2 / (2 \* g)
- Lateral loss = V<sub>fo</sub> ^ 2 / (2 \* g) - Junction Loss K \* V<sub>fi</sub> ^ 2 / (2 \* g).
- Friction loss is always Upstream EGL - Downstream EGL.

## Excavation Estimate:

The trench side slope is 1.0 ft/ft  
The minimum trench width is 2.00 ft

					Downstream			Upstream				
Element Name	Length (ft)	Wall (in)	Bedding (in)	Bottom Width (ft)	Top Width (ft)	Trench Depth (ft)	Cover (ft)	Top Width (ft)	Trench Depth (ft)	Cover (ft)	Volume (cu. yd)	Comment
Manhole	56.41	3.00	4.00	5.50	0.00	0.09	0.00	9.40	5.78	2.95	37.73	Sewer Too Shallow
Inlet A8	111.47	2.50	4.00	4.92	8.88	5.23	2.98	11.72	6.65	4.40	152.64	
Inlet A7	64.00	2.50	4.00	4.92	11.10	6.34	4.09	6.84	4.21	1.96	73.95	Sewer Too Shallow
Inlet A9	16.65	2.00	4.00	4.33	8.39	4.69	3.03	7.00	4.00	2.33	13.43	

**Total earth volume for sewer trenches = 278 cubic yards.**

- The trench was estimated to have a bottom width equal to the outer pipe diameter plus 36 inches.
- If the calculated width of the trench bottom is less than the minimum acceptable width, the minimum acceptable width was used.
- The sewer wall thickness is equal to: (equivalent diameter in inches/12)+1 inches
- The sewer bedding thickness is equal to:
  - Four inches for pipes less than 33 inches.
  - Six inches for pipes less than 60 inches.
  - Eight inches for all larger sizes.

# Line 3

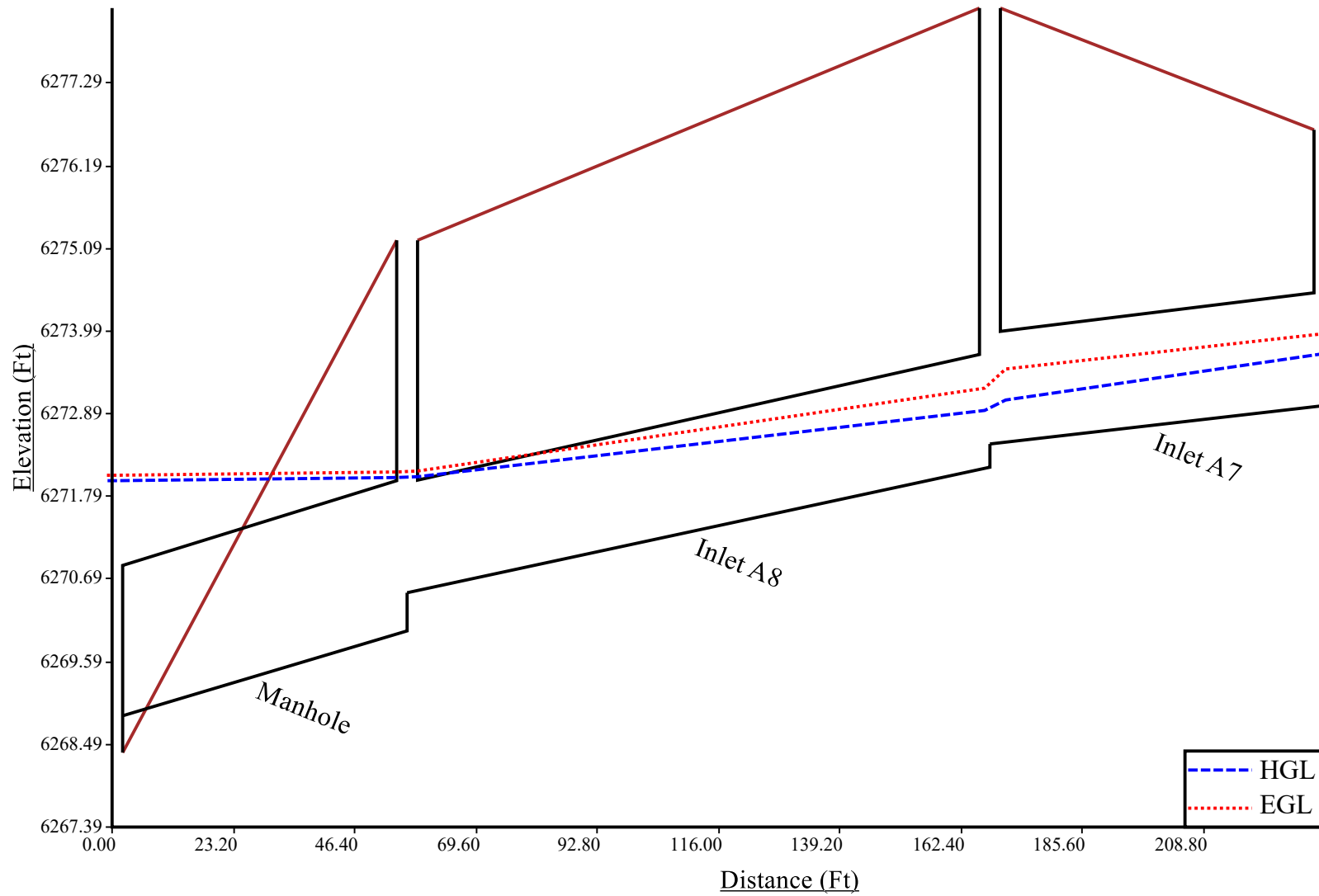

# Line 3A

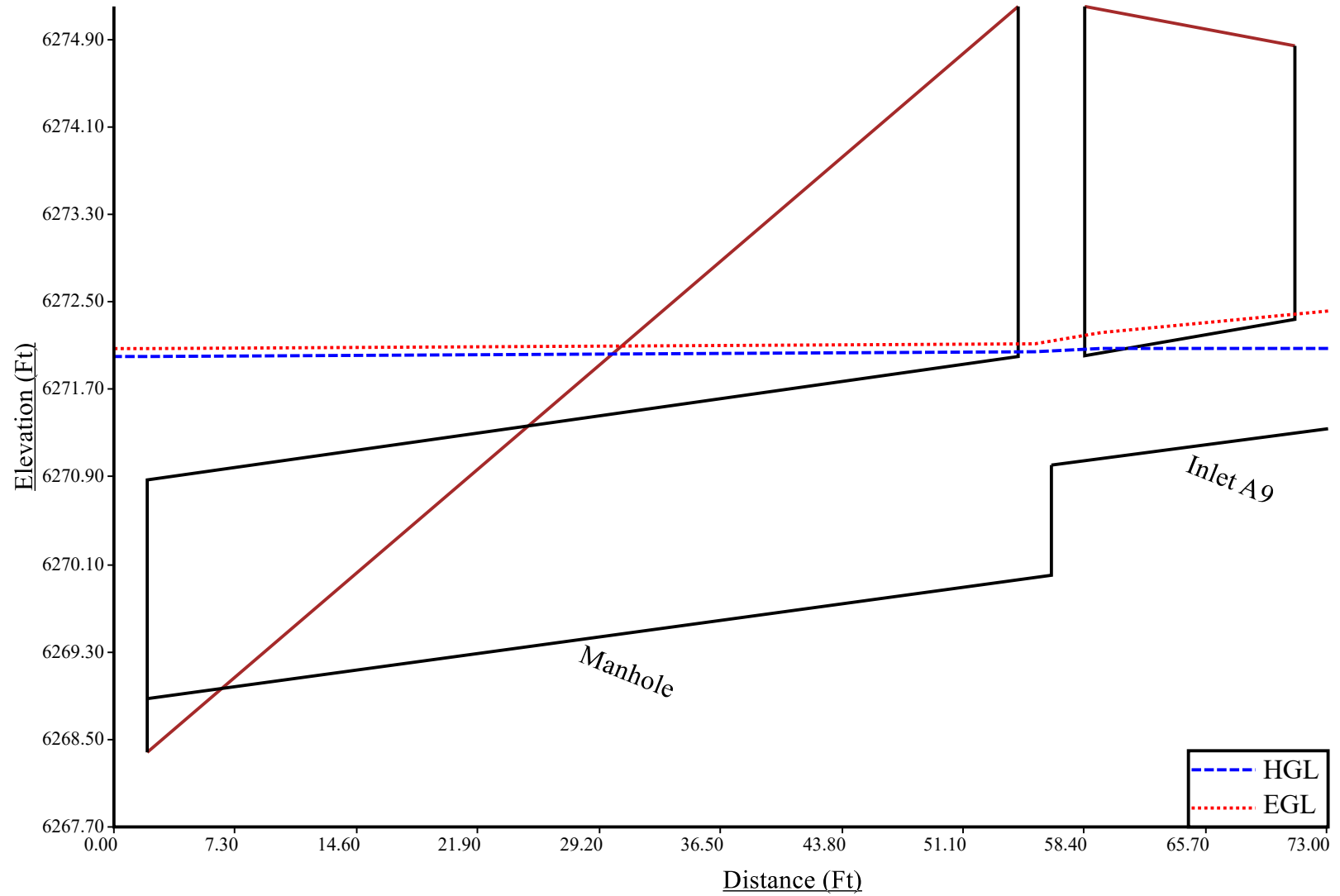

<b>Program:</b> UDSEWER Math Model Interface 2.1.1.4 <b>Run Date:</b> 5/28/2024 2:35:08 PM	<b>UDSewer Results Summary</b>  <b>Project Title:</b> Townhomes at Western <b>Project Description:</b> Storm Line 3 - 100yr
--	--

## System Input Summary

### Rainfall Parameters

**Rainfall Return Period:** 100

**Rainfall Calculation Method:** Formula

**One Hour Depth (in):**

**Rainfall Constant "A":** 28.5

**Rainfall Constant "B":** 10

**Rainfall Constant "C":** 0.786

### Rational Method Constraints

**Minimum Urban Runoff Coeff.:** 0.20

**Maximum Rural Overland Len. (ft):** 500

**Maximum Urban Overland Len. (ft):** 300

**Used UDFCD Tc. Maximum:** Yes

### Sizer Constraints

**Minimum Sewer Size (in):** 18.00

**Maximum Depth to Rise Ratio:** 0.90

**Maximum Flow Velocity (fps):** 18.0

**Minimum Flow Velocity (fps):** 2.0

### Backwater Calculations:

**Tailwater Elevation (ft):** 6272.61

ELEVATION CALCULATED FROM MAX PONDING DEPTH SHOWN IN DETENTION WORKSHEET

## Manhole Input Summary:

		Given Flow		Sub Basin Information						
Element Name	Ground Elevation (ft)	Total Known Flow (cfs)	Local Contribution (cfs)	Drainage Area (Ac.)	Runoff Coefficient	5yr Coefficient	Overland Length (ft)	Overland Slope (%)	Gutter Length (ft)	Gutter Velocity (fps)
OUTFALL 1	6268.38	0.00	0.00	0.00	0.00	0.00	0.00	0.00	0.00	0.00
Manhole	6275.20	13.80	0.00	0.00	0.00	0.00	0.00	0.00	0.00	0.00
Inlet A8	6278.29	6.90	1.20	0.00	0.00	0.00	0.00	0.00	0.00	0.00
Inlet A7	6276.67	5.70	5.70	0.00	0.00	0.00	0.00	0.00	0.00	0.00
Inlet A9	6274.84	6.90	6.90	0.00	0.00	0.00	0.00	0.00	0.00	0.00

## Manhole Output Summary:

		Local Contribution				Total Design Flow				
Element Name	Overland Time (min)	Gutter Time (min)	Basin Tc (min)	Intensity (in/hr)	Local Contrib (cfs)	Coeff. Area	Intensity (in/hr)	Manhole Tc (min)	Peak Flow (cfs)	Comment
OUTFALL 1	0.00	0.00	0.00	0.00	0.00	0.00	0.00	0.00	0.00	Surface Water Present (Upstream)
Manhole	0.00	0.00	0.00	0.00	0.00	0.00	0.00	0.00	13.80	Surface Water Present (Downstream)
Inlet A8	0.00	0.00	0.00	0.00	1.20	0.00	0.00	0.00	6.90	
Inlet A7	0.00	0.00	0.00	0.00	5.70	0.00	0.00	0.00	5.70	
Inlet A9	0.00	0.00	0.00	0.00	6.90	0.00	0.00	0.00	6.90	

## Sewer Input Summary:

		Elevation			Loss Coefficients			Given Dimensions		
Element Name	Sewer Length (ft)	Downstream Invert (ft)	Slope (%)	Upstream Invert (ft)	Mannings n	Bend Loss	Lateral Loss	Cross Section	Rise (ft or in)	Span (ft or in)

Manhole	56.41	6268.38	2.9	6270.00	0.012	0.00	0.00	CIRCULAR	24.00 in	24.00 in
Inlet A8	111.47	6270.51	1.5	6272.18	0.012	0.13	0.00	CIRCULAR	18.00 in	18.00 in
Inlet A7	64.00	6272.49	0.8	6273.00	0.012	1.32	0.00	CIRCULAR	18.00 in	18.00 in
Inlet A9	16.65	6271.01	2.0	6271.34	0.012	0.05	0.25	CIRCULAR	12.00 in	12.00 in

## Sewer Flow Summary:

Element Name	Full Flow Capacity		Critical Flow		Normal Flow				Flow (cfs)	Surcharged Length (ft)	Comment
	Flow (cfs)	Velocity (fps)	Depth (in)	Velocity (fps)	Depth (in)	Velocity (fps)	Froude Number	Flow Condition			
Manhole	41.65	13.26	16.05	6.18	9.51	11.91	2.73	Pressurized	13.80	56.41	
Inlet A8	13.97	7.91	12.20	5.41	8.93	7.88	1.82	Supercritical Jump	6.90	77.02	
Inlet A7	10.21	5.78	11.05	5.01	9.62	5.93	1.31	Supercritical	5.70	0.00	
Inlet A9	5.47	6.97	12.00	8.79	12.00	8.79	0.00	Pressurized	6.90	16.65	

- A Froude number of 0 indicates that pressured flow occurs (adverse slope or undersized pipe).
- If the sewer is not pressurized, full flow represents the maximum gravity flow in the sewer.
- If the sewer is pressurized, full flow represents the pressurized flow conditions.

## Sewer Sizing Summary:

Element Name	Peak Flow (cfs)	Cross Section	Existing		Calculated		Used			Comment
			Rise	Span	Rise	Span	Rise	Span	Area (ft <sup>2</sup> )	
Manhole	13.80	CIRCULAR	24.00 in	24.00 in	18.00 in	18.00 in	24.00 in	24.00 in	3.14	
Inlet A8	6.90	CIRCULAR	18.00 in	18.00 in	18.00 in	18.00 in	18.00 in	18.00 in	1.77	
Inlet A7	5.70	CIRCULAR	18.00 in	18.00 in	18.00 in	18.00 in	18.00 in	18.00 in	1.77	
Inlet A9	6.90	CIRCULAR	12.00 in	12.00 in	18.00 in	18.00 in	12.00 in	12.00 in	0.79	Height is too small. Width is too small.



Existing height is smaller than the suggested height.  
Existing width is smaller than the suggested width.  
Exceeds max. Depth/Rise

- Calculated diameter was determined by sewer hydraulic capacity rounded up to the nearest commercially available size.
- Sewer sizes should not decrease downstream.
- All hydraulics were calculated using the 'Used' parameters.

## Grade Line Summary:

Tailwater Elevation (ft): 6272.61

Element Name	Invert Elev.		Downstream Manhole Losses		HGL		EGL		
	Downstream (ft)	Upstream (ft)	Bend Loss (ft)	Lateral Loss (ft)	Downstream (ft)	Upstream (ft)	Downstream (ft)	Friction Loss (ft)	Upstream (ft)
Manhole	6268.38	6270.00	0.00	0.00	6272.61	6272.79	6272.91	0.18	6273.09
Inlet A8	6270.51	6272.18	0.03	0.00	6272.88	6273.20	6273.12	0.53	6273.65
Inlet A7	6272.49	6273.00	0.21	0.00	6273.62	6273.92	6273.86	0.45	6274.31
Inlet A9	6271.01	6271.34	0.06	0.00	6272.85	6272.85	6273.21	0.84	6274.05

- Bend and Lateral losses only apply when there is an outgoing sewer. The system outfall, sewer #0, is not considered a sewer.
- Bend loss =  $Bend\ K * V_{fi}^2 / (2 * g)$
- Lateral loss =  $V_{fo}^2 / (2 * g) - Junction\ Loss\ K * V_{fi}^2 / (2 * g)$ .
- Friction loss is always Upstream EGL - Downstream EGL.

## Excavation Estimate:

The trench side slope is 1.0 ft/ft  
The minimum trench width is 2.00 ft

	Downstream	Upstream	
--	------------	----------	--

Element Name	Length (ft)	Wall (in)	Bedding (in)	Bottom Width (ft)	Top Width (ft)	Trench Depth (ft)	Cover (ft)	Top Width (ft)	Trench Depth (ft)	Cover (ft)	Volume (cu. yd)	Comment
Manhole	56.41	3.00	4.00	5.50	0.00	0.58	0.00	9.40	5.78	2.95	40.55	Sewer Too Shallow
Inlet A8	111.47	2.50	4.00	4.92	8.88	5.23	2.98	11.72	6.65	4.40	152.64	
Inlet A7	64.00	2.50	4.00	4.92	11.10	6.34	4.09	6.84	4.21	1.96	73.95	Sewer Too Shallow
Inlet A9	16.65	2.00	4.00	4.33	8.39	4.69	3.03	7.00	4.00	2.33	13.43	

**Total earth volume for sewer trenches = 281 cubic yards.**

- The trench was estimated to have a bottom width equal to the outer pipe diameter plus 36 inches.
- If the calculated width of the trench bottom is less than the minimum acceptable width, the minimum acceptable width was used.
- The sewer wall thickness is equal to:  $(\text{equivalent diameter in inches}/12)+1$  inches
- The sewer bedding thickness is equal to:
  - Four inches for pipes less than 33 inches.
  - Six inches for pipes less than 60 inches.
  - Eight inches for all larger sizes.

# Line 3

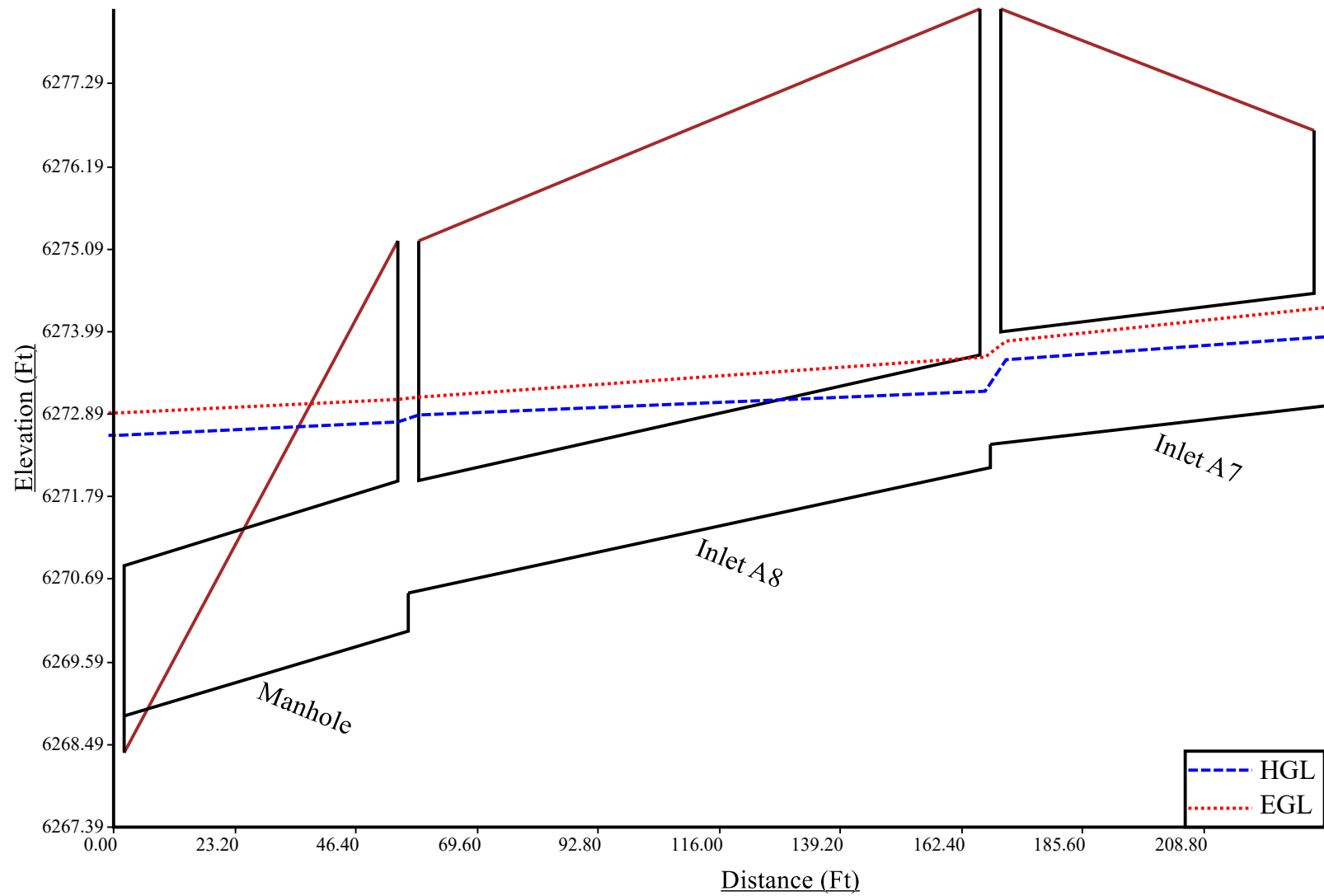

# Line 3A

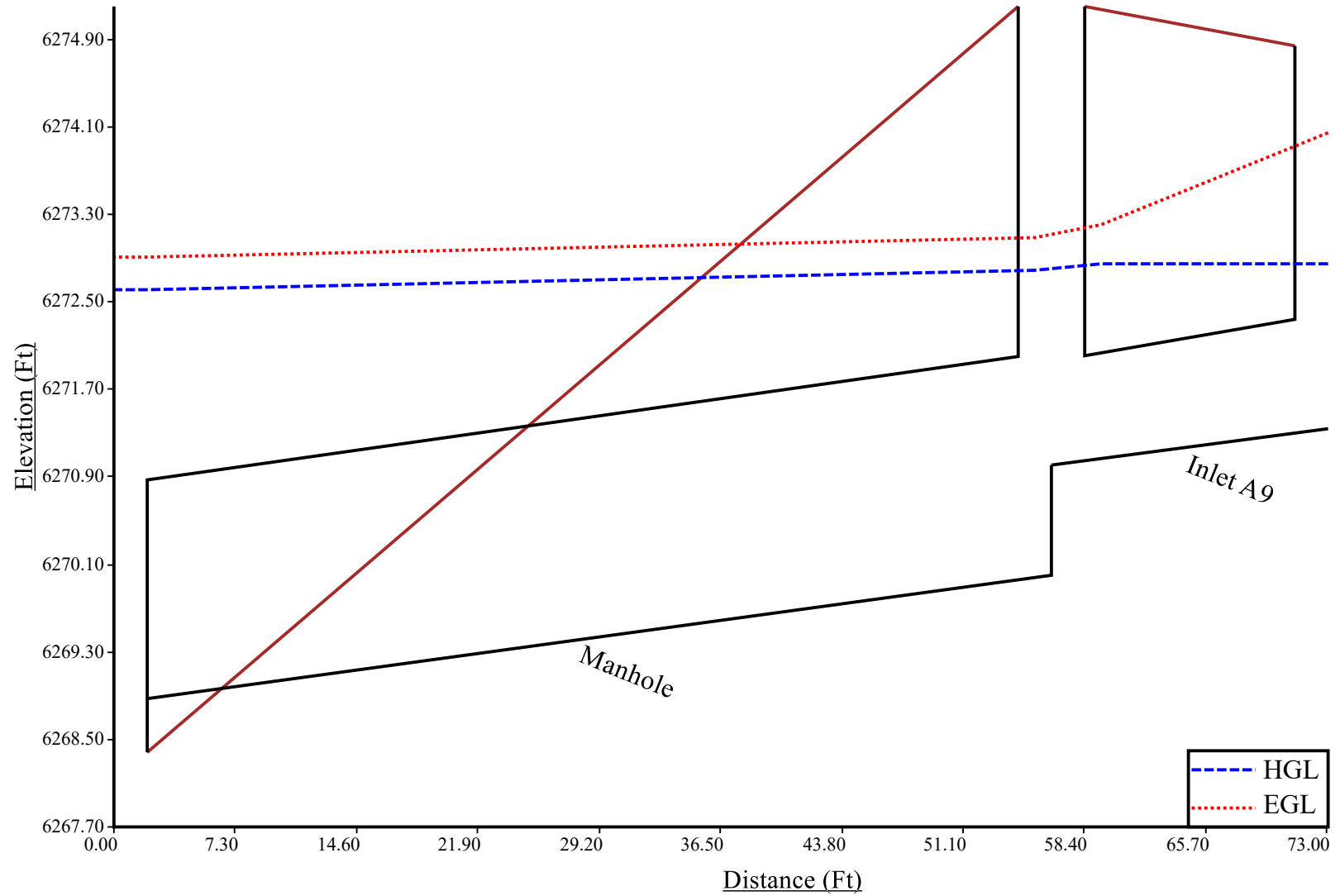

**Design Procedure Form: Extended Detention Basin (EDB)**

UD-BMP (Version 3.07, March 2018)

Sheet 1 of 3

**Designer:** TJW  
**Company:** M.V.E., Inc.  
**Date:** May 23, 2024  
**Project:** Townhomes at Western  
**Location:** FS-EDB Pond 1

<p>1. Basin Storage Volume</p> <p>A) Effective Imperviousness of Tributary Area, <math>I_a</math></p> <p>B) Tributary Area's Imperviousness Ratio (<math>i = I_a / 100</math>)</p> <p>C) Contributing Watershed Area</p> <p>D) For Watersheds Outside of the Denver Region, Depth of Average Runoff Producing Storm</p> <p>E) Design Concept (Select EURV when also designing for flood control)</p> <p>F) Design Volume (WQCV) Based on 40-hour Drain Time (<math>V_{DESIGN} = (1.0 * (0.91 * i^3 - 1.19 * i^2 + 0.78 * i) / 12 * Area)</math>)</p> <p>G) For Watersheds Outside of the Denver Region, Water Quality Capture Volume (WQCV) Design Volume (<math>V_{WQCV\ OTHER} = (d_6 * (V_{DESIGN} / 0.43))</math>)</p> <p>H) User Input of Water Quality Capture Volume (WQCV) Design Volume (Only if a different WQCV Design Volume is desired)</p> <p>I) NRCS Hydrologic Soil Groups of Tributary Watershed              i) Percentage of Watershed consisting of Type A Soils              ii) Percentage of Watershed consisting of Type B Soils              iii) Percentage of Watershed consisting of Type C/D Soils</p> <p>J) Excess Urban Runoff Volume (EURV) Design Volume              For HSG A: <math>EURV_A = 1.68 * i^{1.28}</math>              For HSG B: <math>EURV_B = 1.36 * i^{1.08}</math>              For HSG C/D: <math>EURV_{C/D} = 1.20 * i^{1.08}</math></p> <p>K) User Input of Excess Urban Runoff Volume (EURV) Design Volume (Only if a different EURV Design Volume is desired)</p>	<p><math>I_a =</math> <input type="text" value="61.4"/> %</p> <p><math>i =</math> <input type="text" value="0.614"/></p> <p>Area = <input type="text" value="5.220"/> ac</p> <p><math>d_6 =</math> <input type="text" value="0.42"/> in</p> <div style="border: 1px solid black; padding: 5px; margin: 5px 0;"> <p>Choose One</p> <p><input type="radio"/> Water Quality Capture Volume (WQCV)</p> <p><input checked="" type="radio"/> Excess Urban Runoff Volume (EURV)</p> </div> <p><math>V_{DESIGN} =</math> <input type="text"/> ac-ft</p> <p><math>V_{DESIGN\ OTHER} =</math> <input type="text" value="0.102"/> ac-ft</p> <p><math>V_{DESIGN\ USER} =</math> <input type="text"/> ac-ft</p> <p>HSG <sub>A</sub> = <input type="text" value="0"/> %              HSG <sub>B</sub> = <input type="text" value="100"/> %              HSG <sub>C/D</sub> = <input type="text" value="0"/> %</p> <p>EURV<sub>DESIGN</sub> = <input type="text" value="0.349"/> ac-ft</p> <p>EURV<sub>DESIGN\ USER</sub> = <input type="text"/> ac-ft</p>
<p>2. Basin Shape: Length to Width Ratio (A basin length to width ratio of at least 2:1 will improve TSS reduction.)</p>	<p>L : W = <input type="text" value="3.0"/> : 1</p>
<p>3. Basin Side Slopes</p> <p>A) Basin Maximum Side Slopes (Horizontal distance per unit vertical, 4:1 or flatter preferred)</p>	<p>Z = <input type="text" value="3.00"/> ft / ft</p> <p align="center"><b>DIFFICULT TO MAINTAIN, INCREASE WHERE POSSIBLE</b></p>
<p>4. Inlet</p> <p>A) Describe means of providing energy dissipation at concentrated inflow locations:</p>	<p>Forebays with Baffles</p> <hr/> <hr/> <hr/> <hr/>
<p>5. Forebay</p> <p>A) Minimum Forebay Volume (<math>V_{MIN} =</math> <input type="text" value="2"/> % of the WQCV)</p> <p>B) Actual Forebay Volume</p> <p>C) Forebay Depth (<math>D_F =</math> <input type="text" value="18"/> inch maximum)</p> <p>D) Forebay Discharge              i) Undetained 100-year Peak Discharge              ii) Forebay Discharge Design Flow (<math>Q_F = 0.02 * Q_{100}</math>)</p> <p>E) Forebay Discharge Design</p> <p>F) Discharge Pipe Size (minimum 8-inches)</p> <p>G) Rectangular Notch Width</p>	<p><math>V_{FMIN} =</math> <input type="text" value="0.002"/> ac-ft</p> <p><math>V_F =</math> <input type="text" value="0.003"/> ac-ft</p> <p><math>D_F =</math> <input type="text" value="6.0"/> in</p> <p><math>Q_{100} =</math> <input type="text" value="15.90"/> cfs</p> <p><math>Q_F =</math> <input type="text" value="0.32"/> cfs</p> <div style="border: 1px solid black; padding: 5px; margin: 5px 0;"> <p>Choose One</p> <p><input type="radio"/> Berm With Pipe</p> <p><input checked="" type="radio"/> Wall with Rect. Notch</p> <p><input type="radio"/> Wall with V-Notch Weir</p> </div> <p>Calculated <math>D_p =</math> <input type="text"/> in</p> <p>Calculated <math>W_N =</math> <input type="text" value="4.4"/> in</p> <p align="right" style="color: blue;"><i>Flow too small for berm w/ pipe</i></p>

**Design Procedure Form: Extended Detention Basin (EDB)**

**Designer:** TJW  
**Company:** M.V.E., Inc.  
**Date:** May 23, 2024  
**Project:** Townhomes at Western  
**Location:** FS-EDB Pond 1

<p>6. Trickle Channel</p> <p>A) Type of Trickle Channel</p> <p>F) Slope of Trickle Channel</p>	<div style="border: 1px solid black; padding: 5px; margin-bottom: 10px;"> <p>Choose One</p> <p><input checked="" type="radio"/> Concrete</p> <p><input type="radio"/> Soft Bottom</p> </div> <p>S = <input type="text" value="0.0050"/> ft / ft</p>
<p>7. Micropool and Outlet Structure</p> <p>A) Depth of Micropool (2.5-foot minimum)</p> <p>B) Surface Area of Micropool (10 ft<sup>2</sup> minimum)</p> <p>C) Outlet Type</p> <p>D) Smallest Dimension of Orifice Opening Based on Hydrograph Routing (Use UD-Detention)</p> <p>E) Total Outlet Area</p>	<p>D<sub>M</sub> = <input type="text" value="2.5"/> ft</p> <p>A<sub>M</sub> = <input type="text" value="10"/> sq ft</p> <div style="border: 1px solid black; padding: 5px; margin-bottom: 10px;"> <p>Choose One</p> <p><input checked="" type="radio"/> Orifice Plate</p> <p><input type="radio"/> Other (Describe):</p> </div> <hr/> <hr/> <p>D<sub>orifice</sub> = <input type="text" value="0.50"/> inches</p> <p>A<sub>ot</sub> = <input type="text" value="3.07"/> square inches</p>
<p>8. Initial Surcharge Volume</p> <p>A) Depth of Initial Surcharge Volume (Minimum recommended depth is 4 inches)</p> <p>B) Minimum Initial Surcharge Volume (Minimum volume of 0.3% of the WQCV)</p> <p>C) Initial Surcharge Provided Above Micropool</p>	<p>D<sub>IS</sub> = <input type="text" value="4"/> in</p> <p>V<sub>IS</sub> = <input type="text"/> cu ft</p> <p>V<sub>s</sub> = <input type="text" value="3.3"/> cu ft</p>
<p>9. Trash Rack</p> <p>A) Water Quality Screen Open Area: <math>A_t = A_{ot} * 38.5 * (e^{-0.095D})</math></p> <p>B) Type of Screen (If specifying an alternative to the materials recommended in the USDCM, indicate "other" and enter the ratio of the total open area to the total screen area for the material specified.)</p> <p style="margin-left: 40px;">Other (Y/N): <input type="text" value="N"/></p> <p>C) Ratio of Total Open Area to Total Area (only for type 'Other')</p> <p>D) Total Water Quality Screen Area (based on screen type)</p> <p>E) Depth of Design Volume (EURV or WQCV) (Based on design concept chosen under 1E)</p> <p>F) Height of Water Quality Screen (H<sub>TR</sub>)</p> <p>G) Width of Water Quality Screen Opening (W<sub>opening</sub>) (Minimum of 12 inches is recommended)</p>	<p>A<sub>t</sub> = <input type="text" value="113"/> square inches</p> <div style="border: 1px solid black; padding: 2px; margin-bottom: 10px; width: fit-content;"> <p>S.S. Well Screen with 60% Open Area</p> </div> <hr/> <hr/> <p>User Ratio = <input type="text"/></p> <p>A<sub>total</sub> = <input type="text" value="188"/> sq. in.</p> <p>H = <input type="text" value="3.75"/> feet</p> <p>H<sub>TR</sub> = <input type="text" value="73"/> inches</p> <p>W<sub>opening</sub> = <input type="text" value="12.0"/> inches <span style="color: red; font-weight: bold;">VALUE LESS THAN RECOMMENDED MIN. WIDTH. WIDTH HAS BEEN SET TO 12 INCHES.</span></p>

Design Procedure Form: Extended Detention Basin (EDB)

Designer: TJW  
Company: M.V.E., Inc.  
Date: May 23, 2024  
Project: Townhomes at Western  
Location: FS-EDB Pond 1

<p>10. Overflow Embankment</p> <p>A) Describe embankment protection for 100-year and greater overtopping:</p> <p>B) Slope of Overflow Embankment (Horizontal distance per unit vertical, 4:1 or flatter preferred)</p>	<p><u>Riprap lined Spillway</u></p> <p>Ze = <input type="text" value="4.00"/> ft / ft</p>
<p>11. Vegetation</p>	<p>Choose One</p> <p><input type="radio"/> Irrigated</p> <p><input checked="" type="radio"/> Not Irrigated</p>
<p>12. Access</p> <p>A) Describe Sediment Removal Procedures</p>	<p><u>Vehicle access from maintenance access road or street south of the pond.</u></p>
<p>Notes: _____</p> <p>_____</p> <p>_____</p>	

**Design Procedure Form: Extended Detention Basin (EDB)**

UD-BMP (Version 3.07, March 2018)

Sheet 1 of 3

**Designer:** TJW  
**Company:** M.V.E., Inc.  
**Date:** May 23, 2024  
**Project:** Townhomes at Western  
**Location:** FS-EDB Pond 1 - North Forebay

<p>1. Basin Storage Volume</p> <p>A) Effective Imperviousness of Tributary Area, <math>I_a</math></p> <p>B) Tributary Area's Imperviousness Ratio (<math>i = I_a / 100</math>)</p> <p>C) Contributing Watershed Area</p> <p>D) For Watersheds Outside of the Denver Region, Depth of Average Runoff Producing Storm</p> <p>E) Design Concept (Select EURV when also designing for flood control)</p> <p>F) Design Volume (WQCV) Based on 40-hour Drain Time (<math>V_{DESIGN} = (1.0 * (0.91 * i^2 - 1.19 * i^2 + 0.78 * i) / 12 * Area)</math>)</p> <p>G) For Watersheds Outside of the Denver Region, Water Quality Capture Volume (WQCV) Design Volume (<math>V_{WQCV\ OTHER} = (d_6 * (V_{DESIGN} / 0.43))</math>)</p> <p>H) User Input of Water Quality Capture Volume (WQCV) Design Volume (Only if a different WQCV Design Volume is desired)</p> <p>I) NRCS Hydrologic Soil Groups of Tributary Watershed              i) Percentage of Watershed consisting of Type A Soils              ii) Percentage of Watershed consisting of Type B Soils              iii) Percentage of Watershed consisting of Type C/D Soils</p> <p>J) Excess Urban Runoff Volume (EURV) Design Volume              For HSG A: <math>EURV_A = 1.68 * i^{1.26}</math>              For HSG B: <math>EURV_B = 1.36 * i^{1.08}</math>              For HSG C/D: <math>EURV_{C/D} = 1.20 * i^{1.08}</math></p> <p>K) User Input of Excess Urban Runoff Volume (EURV) Design Volume (Only if a different EURV Design Volume is desired)</p>	<p><math>I_a = </math> <input type="text" value="72.1"/> %</p> <p><math>i = </math> <input type="text" value="0.721"/></p> <p>Area = <input type="text" value="2.180"/> ac</p> <p><math>d_6 = </math> <input type="text" value="0.42"/> in</p> <div style="border: 1px solid black; padding: 5px; margin-bottom: 10px;"> <p>Choose One</p> <p><input type="radio"/> Water Quality Capture Volume (WQCV)</p> <p><input checked="" type="radio"/> Excess Urban Runoff Volume (EURV)</p> </div> <p><math>V_{DESIGN} = </math> <input type="text"/> ac-ft</p> <p><math>V_{DESIGN\ OTHER} = </math> <input type="text" value="0.051"/> ac-ft</p> <p><math>V_{DESIGN\ USER} = </math> <input type="text"/> ac-ft</p> <p>HSG A = <input type="text" value="0"/> %              HSG B = <input type="text" value="100"/> %              HSG C/D = <input type="text" value="0"/> %</p> <p>EURV<sub>DESIGN</sub> = <input type="text" value="0.174"/> ac-ft</p> <p>EURV<sub>DESIGN\ USER</sub> = <input type="text"/> ac-ft</p>
<p>2. Basin Shape: Length to Width Ratio (A basin length to width ratio of at least 2:1 will improve TSS reduction.)</p>	<p>L : W = <input type="text" value="3.0"/> : 1</p>
<p>3. Basin Side Slopes</p> <p>A) Basin Maximum Side Slopes (Horizontal distance per unit vertical, 4:1 or flatter preferred)</p>	<p>Z = <input type="text" value="3.00"/> ft / ft</p> <p style="color: red; font-weight: bold;">DIFFICULT TO MAINTAIN, INCREASE WHERE POSSIBLE</p>
<p>4. Inlet</p> <p>A) Describe means of providing energy dissipation at concentrated inflow locations:</p>	<p><u>Forebays with Baffles</u></p> <hr/> <hr/> <hr/>
<p>5. Forebay</p> <p>A) Minimum Forebay Volume (<math>V_{MIN} = </math> <input type="text" value="1"/> % of the WQCV)</p> <p>B) Actual Forebay Volume</p> <p>C) Forebay Depth (<math>D_F = </math> <input type="text" value="12"/> inch maximum)</p> <p>D) Forebay Discharge</p> <p>i) Undetained 100-year Peak Discharge</p> <p>ii) Forebay Discharge Design Flow (<math>Q_F = 0.02 * Q_{100}</math>)</p> <p>E) Forebay Discharge Design</p> <p>F) Discharge Pipe Size (minimum 8-inches)</p> <p>G) Rectangular Notch Width</p>	<p><math>V_{MIN} = </math> <input type="text" value="0.001"/> ac-ft</p> <p><math>V_F = </math> <input type="text" value="0.001"/> ac-ft</p> <p><math>D_F = </math> <input type="text" value="6.0"/> in</p> <p><math>Q_{100} = </math> <input type="text" value="14.30"/> cfs</p> <p><math>Q_F = </math> <input type="text" value="0.29"/> cfs</p> <div style="border: 1px solid black; padding: 5px; margin-bottom: 10px;"> <p>Choose One</p> <p><input type="radio"/> Berm With Pipe</p> <p><input checked="" type="radio"/> Wall with Rect. Notch</p> <p><input type="radio"/> Wall with V-Notch Weir</p> </div> <p style="color: blue; font-weight: bold;">Flow too small for berm w/ pipe</p> <p>Calculated <math>D_P = </math> <input type="text"/> in</p> <p>Calculated <math>W_N = </math> <input type="text" value="4.1"/> in</p>



**Design Procedure Form: Extended Detention Basin (EDB)**

UD-BMP (Version 3.07, March 2018)

Sheet 1 of 3

**Designer:** TJW  
**Company:** M.V.E., Inc.  
**Date:** May 23, 2024  
**Project:** Townhomes at Western  
**Location:** FS-EDB Pond 1 - South Forebay

<p>1. Basin Storage Volume</p> <p>A) Effective Imperviousness of Tributary Area, <math>I_a</math></p> <p>B) Tributary Area's Imperviousness Ratio (<math>i = I_a / 100</math>)</p> <p>C) Contributing Watershed Area</p> <p>D) For Watersheds Outside of the Denver Region, Depth of Average Runoff Producing Storm</p> <p>E) Design Concept (Select EURV when also designing for flood control)</p> <p>F) Design Volume (WQCV) Based on 40-hour Drain Time (<math>V_{DESIGN} = (1.0 * (0.91 * i^2 - 1.19 * i^2 + 0.78 * i) / 12 * Area)</math>)</p> <p>G) For Watersheds Outside of the Denver Region, Water Quality Capture Volume (WQCV) Design Volume (<math>V_{WQCV\ OTHER} = (d_6 * (V_{DESIGN} / 0.43))</math>)</p> <p>H) User Input of Water Quality Capture Volume (WQCV) Design Volume (Only if a different WQCV Design Volume is desired)</p> <p>I) NRCS Hydrologic Soil Groups of Tributary Watershed              i) Percentage of Watershed consisting of Type A Soils              ii) Percentage of Watershed consisting of Type B Soils              iii) Percentage of Watershed consisting of Type C/D Soils</p> <p>J) Excess Urban Runoff Volume (EURV) Design Volume              For HSG A: <math>EURV_A = 1.68 * i^{1.26}</math>              For HSG B: <math>EURV_B = 1.36 * i^{1.08}</math>              For HSG C/D: <math>EURV_{CD} = 1.20 * i^{1.08}</math></p> <p>K) User Input of Excess Urban Runoff Volume (EURV) Design Volume (Only if a different EURV Design Volume is desired)</p>	<p><math>I_a = </math> <input type="text" value="60.8"/> %</p> <p><math>i = </math> <input type="text" value="0.608"/></p> <p>Area = <input type="text" value="2.610"/> ac</p> <p><math>d_6 = </math> <input type="text" value="0.42"/> in</p> <div style="border: 1px solid black; padding: 5px; margin-bottom: 10px;"> <p>Choose One</p> <p><input type="radio"/> Water Quality Capture Volume (WQCV)</p> <p><input checked="" type="radio"/> Excess Urban Runoff Volume (EURV)</p> </div> <p><math>V_{DESIGN} = </math> <input type="text"/> ac-ft</p> <p><math>V_{DESIGN\ OTHER} = </math> <input type="text" value="0.051"/> ac-ft</p> <p><math>V_{DESIGN\ USER} = </math> <input type="text"/> ac-ft</p> <p>HSG A = <input type="text" value="0"/> %              HSG B = <input type="text" value="100"/> %              HSG C/D = <input type="text" value="0"/> %</p> <p>EURV<sub>DESIGN</sub> = <input type="text" value="0.173"/> ac-ft</p> <p>EURV<sub>DESIGN\ USER</sub> = <input type="text"/> ac-ft</p>
<p>2. Basin Shape: Length to Width Ratio (A basin length to width ratio of at least 2:1 will improve TSS reduction.)</p>	<p>L : W = <input type="text" value="3.0"/> : 1</p>
<p>3. Basin Side Slopes</p> <p>A) Basin Maximum Side Slopes (Horizontal distance per unit vertical, 4:1 or flatter preferred)</p>	<p>Z = <input type="text" value="3.00"/> ft / ft</p> <p style="color: red; font-weight: bold;">DIFFICULT TO MAINTAIN, INCREASE WHERE POSSIBLE</p>
<p>4. Inlet</p> <p>A) Describe means of providing energy dissipation at concentrated inflow locations:</p>	<p><u>Forebays with Baffles</u></p> <hr/> <hr/> <hr/>
<p>5. Forebay</p> <p>A) Minimum Forebay Volume (<math>V_{MIN} = </math> <input type="text" value="1"/> % of the WQCV)</p> <p>B) Actual Forebay Volume</p> <p>C) Forebay Depth (<math>D_F = </math> <input type="text" value="12"/> inch maximum)</p> <p>D) Forebay Discharge</p> <p>i) Undetained 100-year Peak Discharge</p> <p>ii) Forebay Discharge Design Flow (<math>Q_F = 0.02 * Q_{100}</math>)</p> <p>E) Forebay Discharge Design</p> <p>F) Discharge Pipe Size (minimum 8-inches)</p> <p>G) Rectangular Notch Width</p>	<p><math>V_{MIN} = </math> <input type="text" value="0.001"/> ac-ft</p> <p><math>V_F = </math> <input type="text" value="0.001"/> ac-ft</p> <p><math>D_F = </math> <input type="text" value="6.0"/> in</p> <p><math>Q_{100} = </math> <input type="text" value="15.70"/> cfs</p> <p><math>Q_F = </math> <input type="text" value="0.31"/> cfs</p> <div style="border: 1px solid black; padding: 5px; margin-bottom: 10px;"> <p>Choose One</p> <p><input type="radio"/> Berm With Pipe</p> <p><input checked="" type="radio"/> Wall with Rect. Notch</p> <p><input type="radio"/> Wall with V-Notch Weir</p> </div> <p style="color: blue; font-weight: bold;">Flow too small for berm w/ pipe</p> <p>Calculated <math>D_P = </math> <input type="text"/> in</p> <p>Calculated <math>W_N = </math> <input type="text" value="4.4"/> in</p>

Figure 13-12c. Emergency Spillway Protection

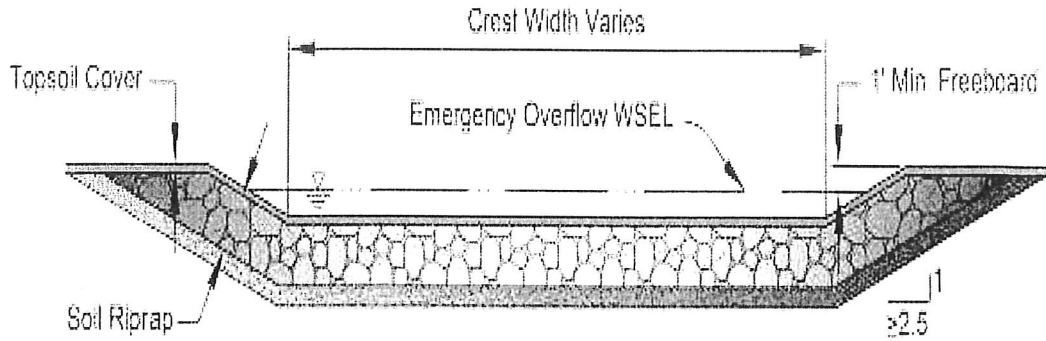
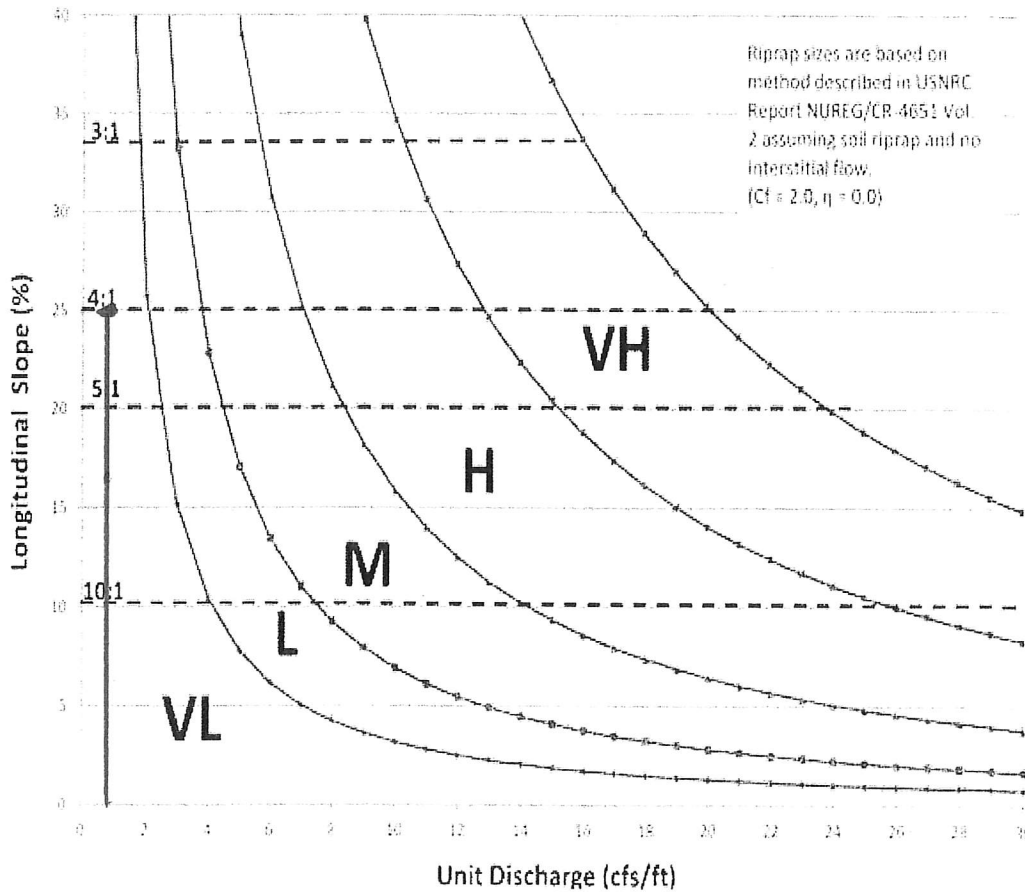

Figure 13-12d. Riprap Types for Emergency Spillway Protection



100 yr PEAK INFLOW  
= 15.9 cfs

SPILLWAY WIDTH  
= 20'

SCOPE = 4:1

UNIT DISCHARGE  
=  $\frac{15.9 \text{ cfs}}{20 \text{ ft}}$   
= 0.8 cfs/ft.

USE TYPE VL



# DETENTION BASIN OUTLET STRUCTURE DESIGN

*MHFD-Detention, Version 4.06 (July 2022)*

**Project: Townhomes at Western**

**Basin ID: FS-EDB Pond 1**

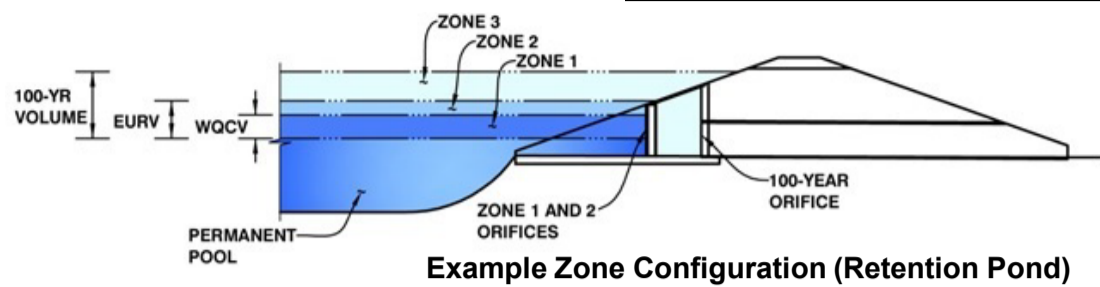

	Estimated Stage (ft)	Estimated Volume (ac-ft)	Outlet Type
Zone 1 (WQCV)	2.39	0.105	Orifice Plate
Zone 2 (EURV)	3.75	0.244	Orifice Plate
Zone 3 (100-year)	4.76	0.221	Weir&Pipe (Restrict)
Total (all zones)		0.569	

User Input: Orifice at Underdrain Outlet (typically used to drain WQCV in a Filtration BMP)

Underdrain Orifice Invert Depth =  ft (distance below the filtration media surface)  
 Underdrain Orifice Diameter =  inches

Calculated Parameters for Underdrain

Underdrain Orifice Area =  ft<sup>2</sup>  
 Underdrain Orifice Centroid =  feet

User Input: Orifice Plate with one or more orifices or Elliptical Slot Weir (typically used to drain WQCV and/or EURV in a sedimentation BMP)

Centroid of Lowest Orifice =  ft (relative to basin bottom at Stage = 0 ft)  
 Depth at top of Zone using Orifice Plate =  ft (relative to basin bottom at Stage = 0 ft)  
 Orifice Plate: Orifice Vertical Spacing =  inches  
 Orifice Plate: Orifice Area per Row =  sq. inches

Calculated Parameters for Plate

WQ Orifice Area per Row =  ft<sup>2</sup>  
 Elliptical Half-Width =  feet  
 Elliptical Slot Centroid =  feet  
 Elliptical Slot Area =  ft<sup>2</sup>

User Input: Stage and Total Area of Each Orifice Row (numbered from lowest to highest)

	Row 1 (required)	Row 2 (optional)	Row 3 (optional)	Row 4 (optional)	Row 5 (optional)	Row 6 (optional)	Row 7 (optional)	Row 8 (optional)
Stage of Orifice Centroid (ft)	0.00	1.25	2.50					
Orifice Area (sq. inches)	0.50	0.50	2.07					

	Row 9 (optional)	Row 10 (optional)	Row 11 (optional)	Row 12 (optional)	Row 13 (optional)	Row 14 (optional)	Row 15 (optional)	Row 16 (optional)
Stage of Orifice Centroid (ft)								
Orifice Area (sq. inches)								

User Input: Vertical Orifice (Circular or Rectangular)

Invert of Vertical Orifice =  ft (relative to basin bottom at Stage = 0 ft)  
 Depth at top of Zone using Vertical Orifice =  ft (relative to basin bottom at Stage = 0 ft)  
 Vertical Orifice Diameter =  inches

Calculated Parameters for Vertical Orifice

Vertical Orifice Area =  ft<sup>2</sup>  
 Vertical Orifice Centroid =  feet

User Input: Overflow Weir (Dropbox with Flat or Sloped Grate and Outlet Pipe OR Rectangular/Trapezoidal Weir and No Outlet Pipe)

Overflow Weir Front Edge Height, H<sub>o</sub> =  ft (relative to basin bottom at Stage = 0 ft)  
 Overflow Weir Front Edge Length =  feet  
 Overflow Weir Grate Slope =  H:V  
 Horiz. Length of Weir Sides =  feet  
 Overflow Grate Type =   
 Debris Clogging % =  %

Calculated Parameters for Overflow Weir

Height of Grate Upper Edge, H<sub>t</sub> =  feet  
 Overflow Weir Slope Length =  feet  
 Grate Open Area / 100-yr Orifice Area =   
 Overflow Grate Open Area w/o Debris =  ft<sup>2</sup>  
 Overflow Grate Open Area w/ Debris =  ft<sup>2</sup>

User Input: Outlet Pipe w/ Flow Restriction Plate (Circular Orifice, Restrictor Plate, or Rectangular Orifice)

Depth to Invert of Outlet Pipe =  ft (distance below basin bottom at Stage = 0 ft)  
 Outlet Pipe Diameter =  inches  
 Restrictor Plate Height Above Pipe Invert =  inches

Calculated Parameters for Outlet Pipe w/ Flow Restriction Plate

Outlet Orifice Area =  ft<sup>2</sup>  
 Outlet Orifice Centroid =  feet  
 Half-Central Angle of Restrictor Plate on Pipe =  radians

User Input: Emergency Spillway (Rectangular or Trapezoidal)

Spillway Invert Stage =  ft (relative to basin bottom at Stage = 0 ft)  
 Spillway Crest Length =  feet  
 Spillway End Slopes =  H:V  
 Freeboard above Max Water Surface =  feet

Calculated Parameters for Spillway

Spillway Design Flow Depth =  feet  
 Stage at Top of Freeboard =  feet  
 Basin Area at Top of Freeboard =  acres  
 Basin Volume at Top of Freeboard =  acre-ft

## Routed Hydrograph Results

*The user can override the default CUHP hydrographs and runoff volumes by entering new values in the Inflow Hydrographs table (Columns W through AF).*

	WQCV	EURV	2 Year	5 Year	10 Year	25 Year	50 Year	100 Year	500 Year
Design Storm Return Period =									
One-Hour Rainfall Depth (in) =	N/A	N/A	1.19	1.50	1.75	2.00	2.25	2.52	3.25
CUHP Runoff Volume (acre-ft) =	0.105	0.348	0.308	0.424	0.523	0.647	0.753	0.883	1.201
Inflow Hydrograph Volume (acre-ft) =	N/A	N/A	0.308	0.424	0.523	0.647	0.753	0.883	1.201
CUHP Predevelopment Peak Q (cfs) =	N/A	N/A	0.6	1.7	2.6	4.6	5.7	7.1	10.5
OPTIONAL Override Predevelopment Peak Q (cfs) =	N/A	N/A							
Predevelopment Unit Peak Flow, q (cfs/acre) =	N/A	N/A	0.12	0.33	0.49	0.87	1.09	1.37	2.01
Peak Inflow Q (cfs) =	N/A	N/A	5.6	7.7	9.2	11.6	13.5	16.1	21.6
Peak Outflow Q (cfs) =	0.0	0.1	0.1	0.2	1.3	3.6	5.4	6.5	7.0
Ratio Peak Outflow to Predevelopment Q =	N/A	N/A	N/A	0.1	0.5	0.8	0.9	0.9	0.7
Structure Controlling Flow =	Plate	Plate	Plate	Overflow Weir 1	Overflow Weir 1	Overflow Weir 1	Overflow Weir 1	Outlet Plate 1	Outlet Plate 1
Max Velocity through Grate 1 (fps) =	N/A	N/A	N/A	0.0	0.2	0.5	0.7	0.9	1.0
Max Velocity through Grate 2 (fps) =	N/A	N/A	N/A	N/A	N/A	N/A	N/A	N/A	N/A
Time to Drain 97% of Inflow Volume (hours) =	38	65	62	70	69	67	66	64	61
Time to Drain 99% of Inflow Volume (hours) =	40	69	67	76	76	75	74	73	71
Maximum Ponding Depth (ft) =	2.40	3.75	3.46	4.00	4.14	4.30	4.40	4.61	5.35
Area at Maximum Ponding Depth (acres) =	0.13	0.21	0.20	0.21	0.22	0.22	0.23	0.23	0.26
Maximum Volume Stored (acre-ft) =	0.106	0.349	0.288	0.401	0.431	0.466	0.486	0.534	0.717

## Determination of Culvert Headwater and Outlet Protection

Project: **61203 - Townhomes at Western**

Basin ID: **100yr Pond 1 Outfall**

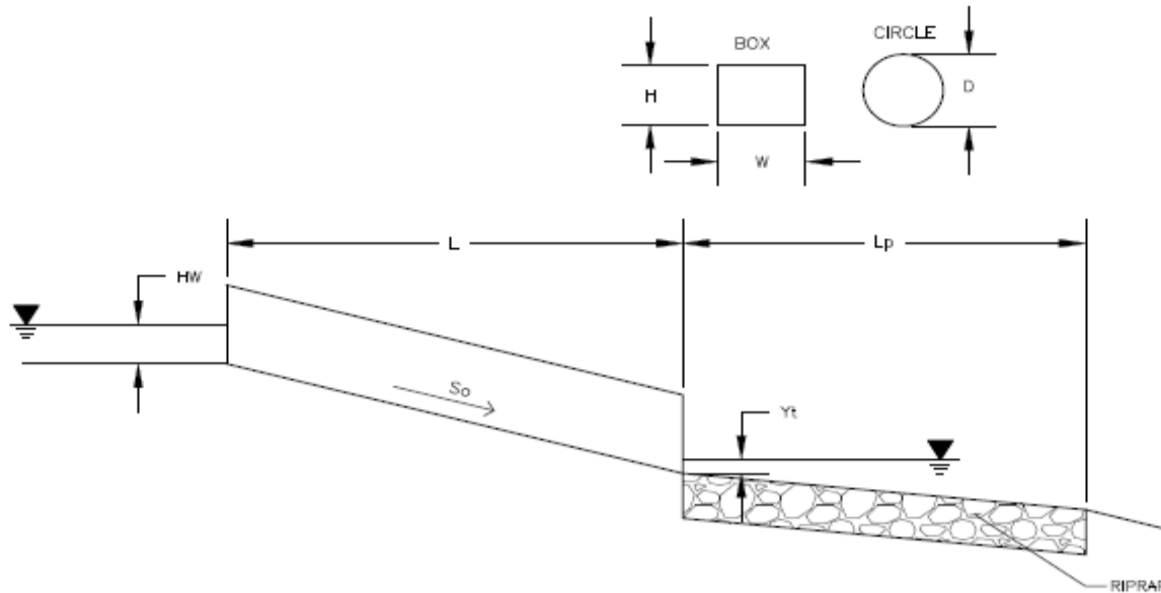

Soil Type:

Choose One:

Sandy

Non-Sandy

**Supercritical Flow! Using  $D_a$  to calculate protection type.**

<b>Design Information (Input):</b>	
Design Discharge	Q = <input style="width: 50px;" type="text" value="6.5"/> cfs
<b>Circular Culvert:</b>	
Barrel Diameter in Inches	D = <input style="width: 50px;" type="text" value="18"/> inches
Inlet Edge Type (Choose from pull-down list)	Grooved End Projection <input style="width: 50px;" type="text" value="Grooved End Projection"/>
<b>OR</b>	
<b>Box Culvert:</b>	
Barrel Height (Rise) in Feet	Height (Rise) = <input style="width: 50px;" type="text"/>
Barrel Width (Span) in Feet	Width (Span) = <input style="width: 50px;" type="text"/>
Inlet Edge Type (Choose from pull-down list)	<input style="width: 50px;" type="text"/>
Number of Barrels	No = <input style="width: 50px;" type="text" value="1"/>
Inlet Elevation	Elev IN = <input style="width: 50px;" type="text" value="6267"/> ft
Outlet Elevation <b>OR</b> Slope	So = <input style="width: 50px;" type="text" value="0.01"/> ft/ft
Culvert Length	L = <input style="width: 50px;" type="text" value="67"/> ft
Manning's Roughness	n = <input style="width: 50px;" type="text" value="0.012"/>
Bend Loss Coefficient	$k_b$ = <input style="width: 50px;" type="text" value="0"/>
Exit Loss Coefficient	$k_x$ = <input style="width: 50px;" type="text" value="1"/>
Tailwater Surface Elevation	Elev $Y_t$ = <input style="width: 50px;" type="text"/>
Max Allowable Channel Velocity	V = <input style="width: 50px;" type="text" value="5"/> ft/s

<b>Required Protection (Output):</b>	
Tailwater Surface Height	$Y_t$ = <input style="width: 50px;" type="text" value="0.60"/> ft
Flow Area at Max Channel Velocity	$A_t$ = <input style="width: 50px;" type="text" value="1.30"/> ft <sup>2</sup>
Culvert Cross Sectional Area Available	A = <input style="width: 50px;" type="text" value="1.77"/> ft <sup>2</sup>
Entrance Loss Coefficient	$k_e$ = <input style="width: 50px;" type="text" value="0.20"/>
Friction Loss Coefficient	$k_f$ = <input style="width: 50px;" type="text" value="1.03"/>
Sum of All Losses Coefficients	$k_s$ = <input style="width: 50px;" type="text" value="2.23"/> ft
Culvert Normal Depth	$Y_n$ = <input style="width: 50px;" type="text" value="0.81"/> ft
Culvert Critical Depth	$Y_c$ = <input style="width: 50px;" type="text" value="0.99"/> ft
Tailwater Depth for Design	d = <input style="width: 50px;" type="text" value="1.24"/> ft
Adjusted Diameter <b>OR</b> Adjusted Rise	$D_a$ = <input style="width: 50px;" type="text" value="1.16"/> ft
Expansion Factor	$1/(2*\tan(\Theta))$ = <input style="width: 50px;" type="text" value="6.46"/>
Flow/Diameter <sup>2.5</sup> <b>OR</b> Flow/(Span * Rise <sup>1.5</sup> )	$Q/D^{2.5}$ = <input style="width: 50px;" type="text" value="2.36"/> ft <sup>0.5</sup> /s
Froude Number	Fr = <input style="width: 50px;" type="text" value="1.45"/> <span style="color: red; font-weight: bold;">Supercritical!</span>
Tailwater/Adjusted Diameter <b>OR</b> Tailwater/Adjusted Rise	$Y_t/D$ = <input style="width: 50px;" type="text" value="0.52"/>
Inlet Control Headwater	HW <sub>I</sub> = <input style="width: 50px;" type="text" value="1.45"/> ft
Outlet Control Headwater	HW <sub>O</sub> = <input style="width: 50px;" type="text" value="1.04"/> ft
<b>Design Headwater Elevation</b>	<b>HW</b> = <input style="width: 50px;" type="text" value="6,268.45"/> ft
<b>Headwater/Diameter <u>OR</u> Headwater/Rise Ratio</b>	<b>HW/D</b> = <input style="width: 50px;" type="text" value="0.97"/>
Minimum Theoretical Riprap Size	$d_{50}$ = <input style="width: 50px;" type="text" value="3"/> in
Nominal Riprap Size	$d_{50}$ = <input style="width: 50px;" type="text" value="6"/> in
<b>UDFCD Riprap Type</b>	<b>Type</b> = <input style="width: 50px;" type="text" value="VL"/>
<b>Length of Protection</b>	$L_p$ = <input style="width: 50px;" type="text" value="5"/> ft
<b>Width of Protection</b>	T = <input style="width: 50px;" type="text" value="3"/> ft

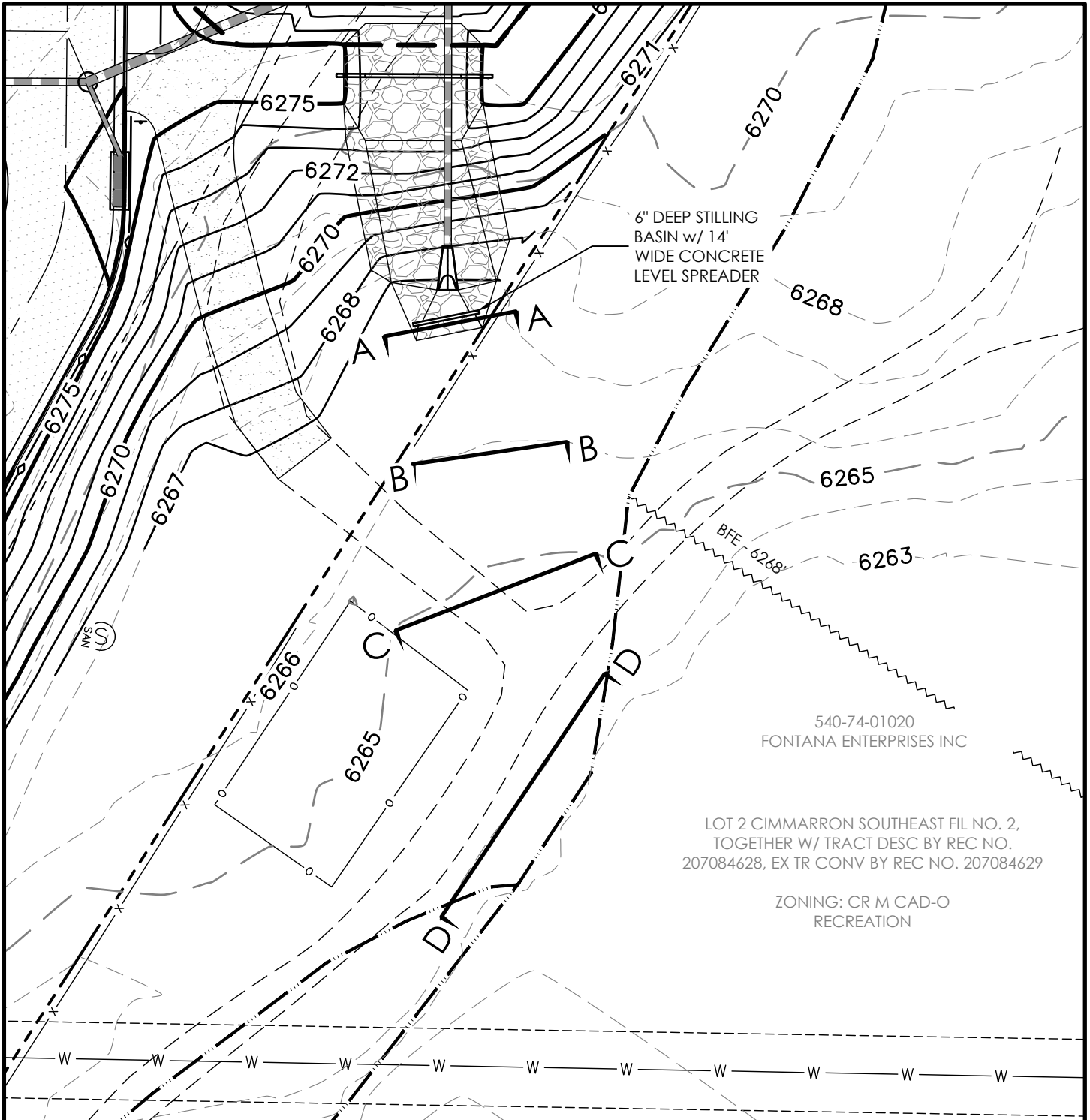

540-74-01020  
 FONTANA ENTERPRISES INC

LOT 2 CIMMARRON SOUTHEAST FIL NO. 2,  
 TOGETHER W/ TRACT DESC BY REC NO.  
 207084628, EX TR CONV BY REC NO. 207084629

ZONING: CR M CAD-O  
 RECREATION

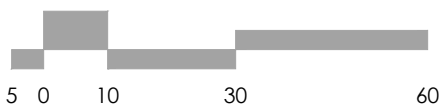

1" = 30' 1:360

NOTES:

SEE CHANNEL REPORTS FOR  
 CALCULATED VELOCITIES.

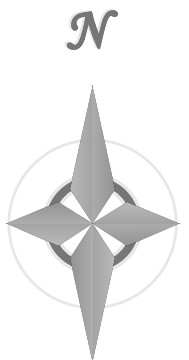

POND 1 OUTFALL  
 EXHIBIT

# Channel Report

## 61203-Sand Creek Outfall Section AA (6.5 cfs - 100yr)

### Trapezoidal

Bottom Width (ft) = 12.00  
Side Slopes (z:1) = 4.00, 4.00  
Total Depth (ft) = 0.25  
Invert Elev (ft) = 6367.00  
Slope (%) = 4.00  
N-Value = 0.034

### Highlighted

Depth (ft) = 0.19  
Q (cfs) = 6.500  
Area (sqft) = 2.42  
Velocity (ft/s) = 2.68  
Wetted Perim (ft) = 13.57  
Crit Depth, Yc (ft) = 0.21  
Top Width (ft) = 13.52  
EGL (ft) = 0.30

### Calculations

Compute by: Known Q  
Known Q (cfs) = 6.50

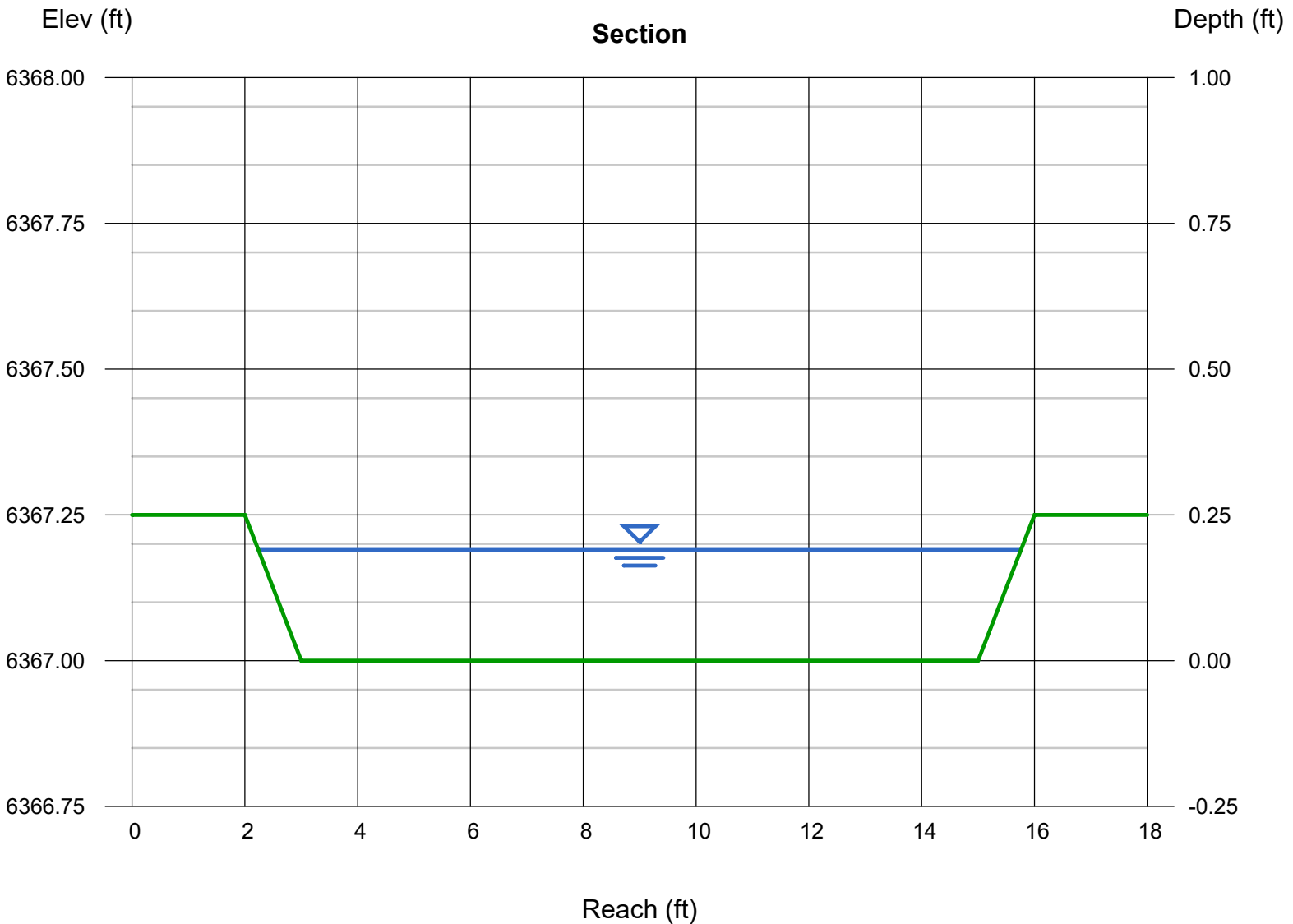

# Channel Report

## 61203-Sand Creek Outfall Section BB (7.4 cfs - 100yr)

### Trapezoidal

Bottom Width (ft) = 33.00  
Side Slopes (z:1) = 20.00, 20.00  
Total Depth (ft) = 0.20  
Invert Elev (ft) = 6367.00  
Slope (%) = 4.00  
N-Value = 0.034

### Highlighted

Depth (ft) = 0.11  
Q (cfs) = 7.400  
Area (sqft) = 3.87  
Velocity (ft/s) = 1.91  
Wetted Perim (ft) = 37.41  
Crit Depth, Yc (ft) = 0.12  
Top Width (ft) = 37.40  
EGL (ft) = 0.17

### Calculations

Compute by: Known Q  
Known Q (cfs) = 7.40

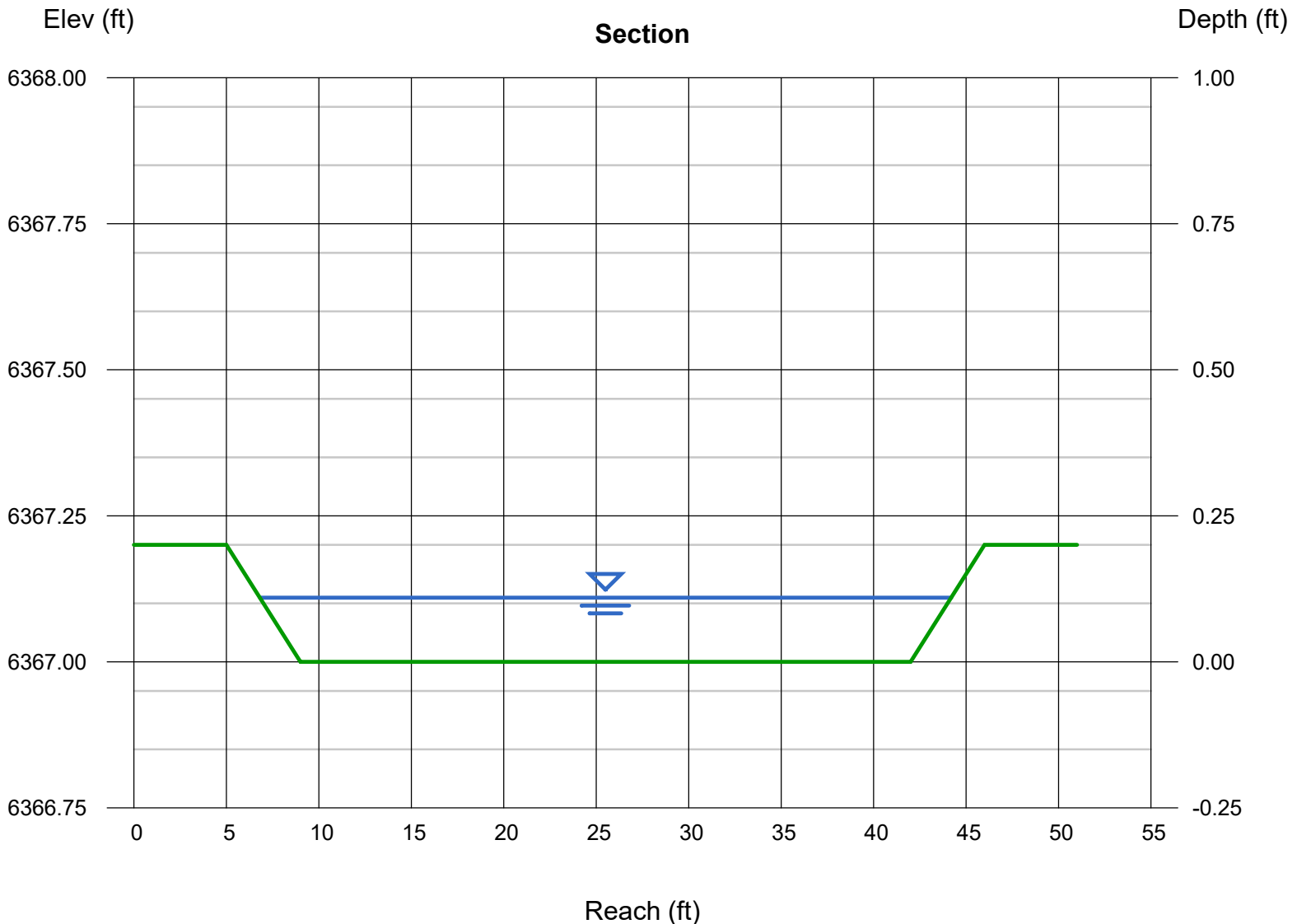



# Channel Report

## 61203-Sand Creek Outfall Section CC (7.4 cfs - 100yr)

### Trapezoidal

Bottom Width (ft) = 44.00  
Side Slopes (z:1) = 20.00, 20.00  
Total Depth (ft) = 0.20  
Invert Elev (ft) = 6367.00  
Slope (%) = 4.00  
N-Value = 0.034

### Highlighted

Depth (ft) = 0.10  
Q (cfs) = 7.400  
Area (sqft) = 4.60  
Velocity (ft/s) = 1.61  
Wetted Perim (ft) = 48.01  
Crit Depth, Yc (ft) = 0.10  
Top Width (ft) = 48.00  
EGL (ft) = 0.14

### Calculations

Compute by: Known Q  
Known Q (cfs) = 7.40

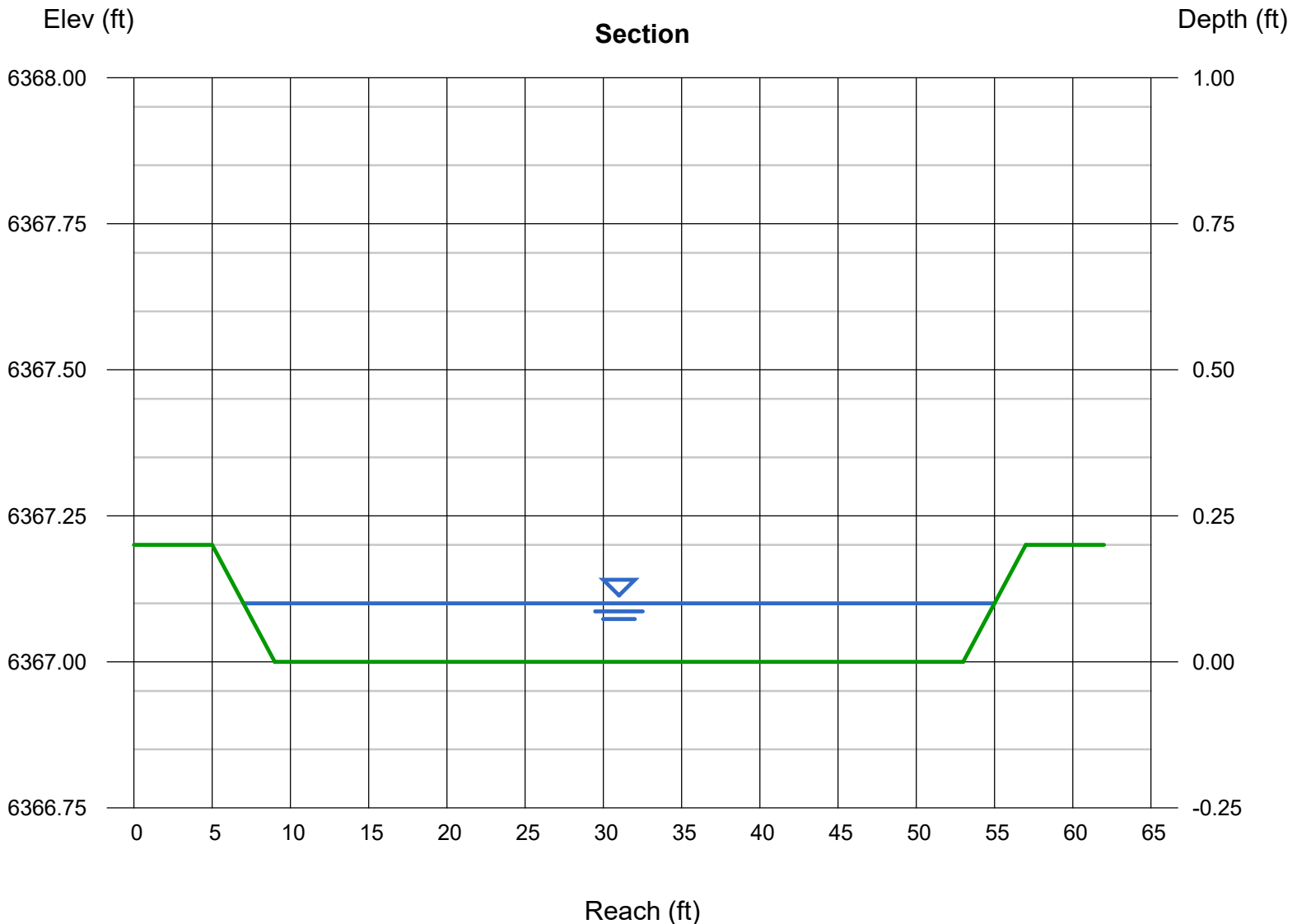

# Channel Report

## 61203-Sand Creek Outfall Section DD (7.4 cfs - 100yr)

### Trapezoidal

Bottom Width (ft) = 60.00  
Side Slopes (z:1) = 10.00, 10.00  
Total Depth (ft) = 0.20  
Invert Elev (ft) = 6367.00  
Slope (%) = 10.00  
N-Value = 0.034

### Highlighted

Depth (ft) = 0.06  
Q (cfs) = 7.400  
Area (sqft) = 3.64  
Velocity (ft/s) = 2.04  
Wetted Perim (ft) = 61.21  
Crit Depth, Yc (ft) = 0.08  
Top Width (ft) = 61.20  
EGL (ft) = 0.12

### Calculations

Compute by: Known Q  
Known Q (cfs) = 7.40

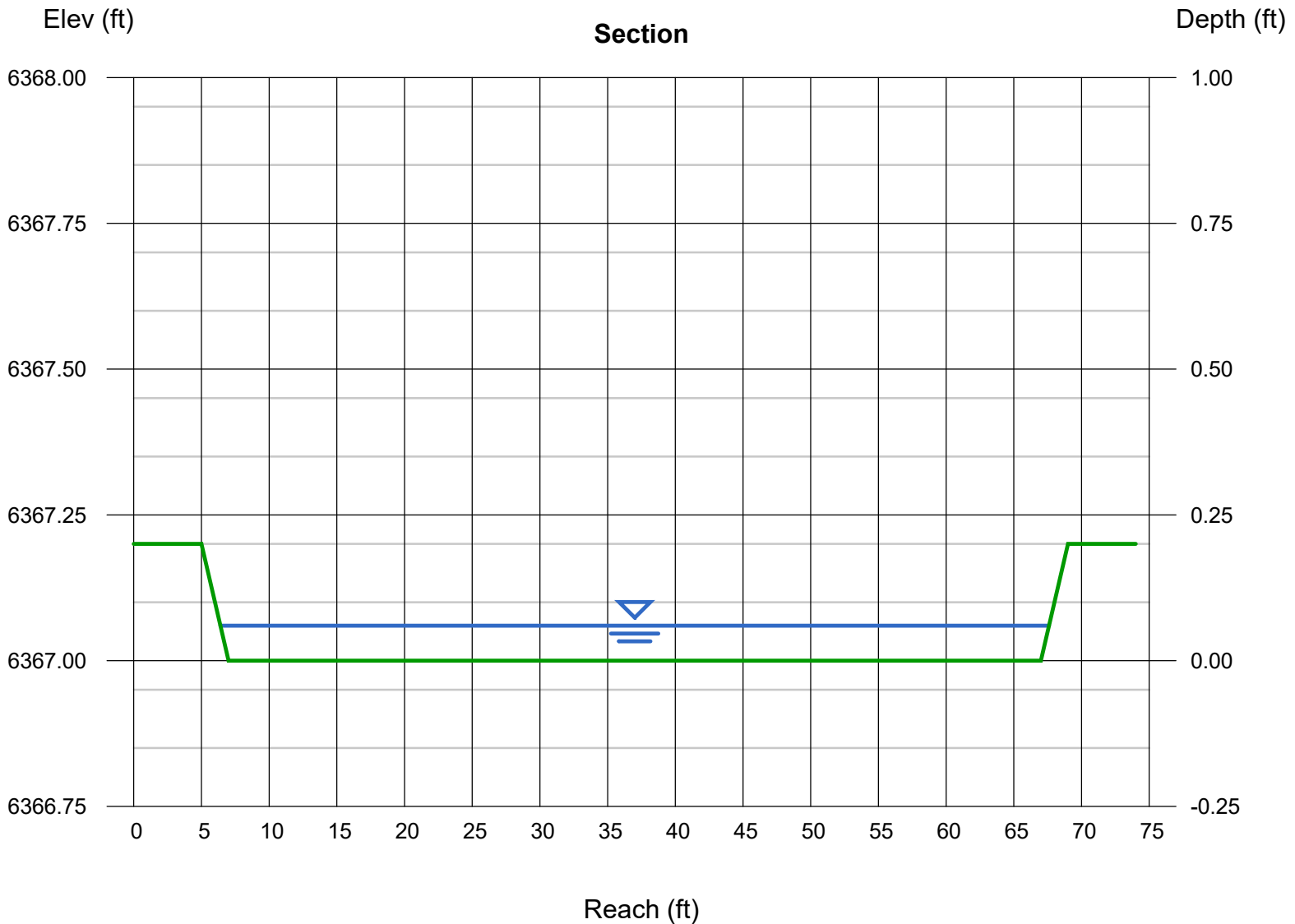



**LEGEND**

- PROPERTY LINE
- EASEMENT LINE
- LOT LINE

**EXISTING**

- 5985- INDEX CONTOUR
- 84- INTERMEDIATE CONTOUR

**PROPOSED**

- 5985- INDEX CONTOUR
- 84- INTERMEDIATE CONTOUR
- BASIN BOUNDARY
- GENERAL FLOW/DIRECTION
- SLOPE DIRECTION AND GRADE
- BASIN LABEL  
AREA IN ACRES  
PERCENT IMPERVIOUS
- DESIGN POINT

- AREA TRIBUTARY TO POND 1 RECEIVING WQ TREATMENT
- AREA EXCLUDED FROM TREATMENT PER ECM App I.7.1.B.7
- AREA EXCLUDED FROM TREATMENT PER ECM App I.7.1.C.1

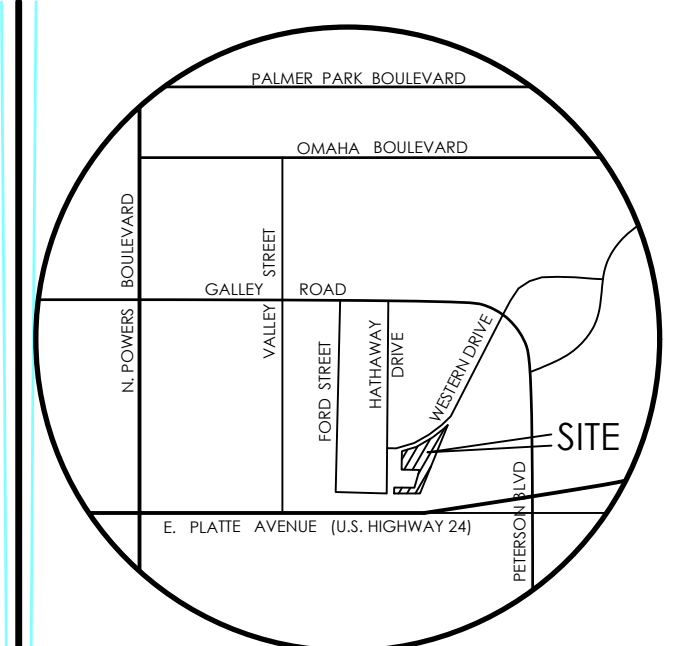

**VICINITY MAP**  
NOT TO SCALE

BENCHMARK

1" = 50' 1:600

**WATER QUALITY TREATMENT SUMMARY TABLE**

BASIN ID	AREA(AC.)	TREATMENT/EXCLUSION
A2	0.14	EXCLUDED PER ECM App I.7.1.B.7
A3	0.59	TRIBUTARY TO POND 1
A4	0.36	TRIBUTARY TO POND 1
A5	0.30	TRIBUTARY TO POND 1
A6	0.29	TRIBUTARY TO POND 1
A7	1.14	TRIBUTARY TO POND 1
A8	0.18	TRIBUTARY TO POND 1
A9	0.84	TRIBUTARY TO POND 1
A10	0.42	TRIBUTARY TO POND 1
A11	0.22	TRIBUTARY TO POND 1
A12	0.43	TRIBUTARY TO POND 1
B3	0.16	EXCLUDED PER ECM App I.7.1.C.1
B4	0.67	EXCLUDED PER ECM App I.7.1.B.7
C1	0.66	EXCLUDED PER ECM App I.7.1.C.1
C2	0.34	EXCLUDED PER ECM App I.7.1.C.1
C3	0.36	EXCLUDED PER ECM App I.7.1.C.1
<b>TOTAL SITE AREA 7.1 ACRES</b>		
BASIN ID	AREA(AC.)	TREATMENT/EXCLUSION
A2, B4	0.81	(11.4%) EXCLUDED PER ECM App I.7.1.C.1
B3, C1, C2, C3	1.52	(21.4%) EXCLUDED PER ECM App I.7.1.B.7
A3 - A12	4.77	TRIBUTARY TO POND 1

**MVE, INC.**  
ENGINEERS / SURVEYORS

1903 Leary Street, Suite 200 Colorado Springs CO 80909 719.635.5736

DESIGNED BY \_\_\_\_\_  
 DRAWN BY \_\_\_\_\_  
 CHECKED BY \_\_\_\_\_  
 AS-BUILTS BY \_\_\_\_\_  
 CHECKED BY \_\_\_\_\_

**TOWNHOMES AT WESTERN**  
 LOT I, CIMARRON SOUTHEAST  
 FILLING NO - 2C

**FINAL DRAINAGE REPORT**  
**WQ TREATMENT TABLE**

MVE PROJECT 61203  
 MVE DRAWN BY \_\_\_\_\_  
**DRAIN-AREA**

**JUNE 7, 2024**  
**SHEET 1 OF 1**

## **4 Drainage Maps**

Existing Conditions Drainage Map  
Proposed Conditions Drainage Map

(Map Pocket)  
(Map Pocket)

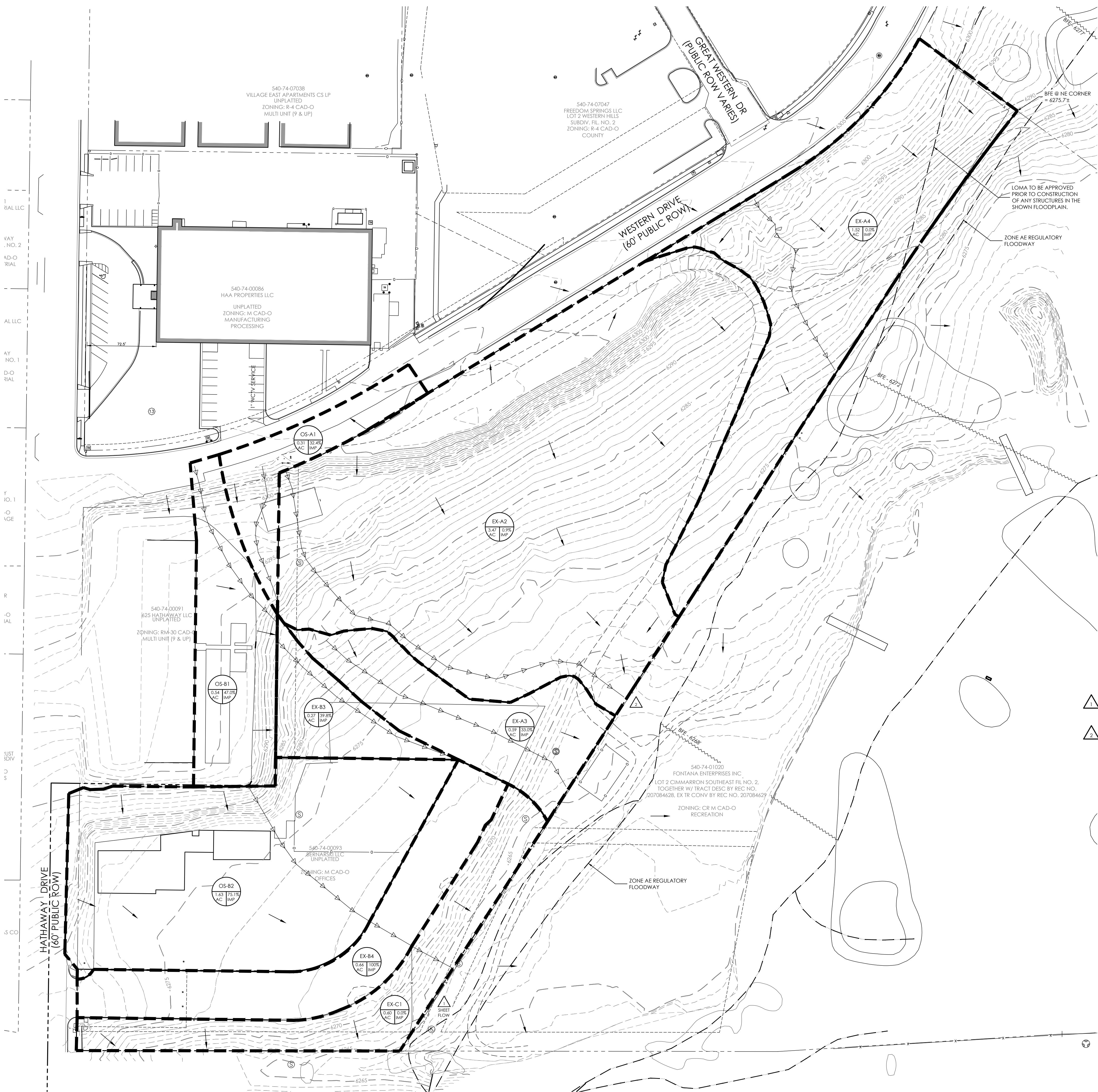

**LEGEND**

- PROPERTY LINE
- EASEMENT LINE
- LOT LINE

**EXISTING**

- INDEX CONTOUR
- INTERMEDIATE CONTOUR

$Q = 19.0$  cfs  
 $Q_{100} = 60.0$  cfs

BASIN BOUNDARY  
 GENERAL FLOW/DIRECTION  
 SLOPE DIRECTION AND GRADE  
 BASIN LABEL  
 AREA IN ACRES  
 PERCENT IMPERVIOUS  
 DESIGN POINT

**FLOODPLAIN STATEMENT**

A PORTION OF THE SUBJECT PROPERTY IS LOCATED WITHIN FEMA DESIGNATED SPECIAL FLOOD HAZARD AREA (SFHA'S) ZONE AE AS INDICATED ON THE FLOOD INSURANCE RATE MAP (FIRM) FOR EL PASO COUNTY, COLORADO AND INCORPORATED AREAS - MAP NUMBER 08041C0754 G, EFFECTIVE DECEMBER 7, 2018.

**EXISTING DRAINAGE SUMMARY TABLE**

DESIGN POINTS	INCLUDED BASINS	AREA (AC)	Tc (MIN.)	RUNOFF		METHOD
				Q5 (CFS)	Q100 (CFS)	
	OS-A1	0.31	5.0	0.5	1.5	RATIONAL
	OS-B1	0.54	5.2	1.1	2.7	RATIONAL
	OS-B2	1.63	5.0	5.8	11.3	RATIONAL
	EX-A2	3.47	10.9	1.2	8.3	RATIONAL
	EX-A3	0.59	8.4	0.9	2.4	RATIONAL
	EX-A4	1.52	6.7	0.6	4.2	RATIONAL
	EX-B3	0.27	6.9	0.5	1.3	RATIONAL
	EX-B4	0.66	5.0	3.1	5.5	RATIONAL
	EX-C1	0.60	5.0	0.2	1.8	RATIONAL
EX-DP1	OS-B1, OSB2, EX-B3, EX-B4, EX-C1	3.71	5.2	10.7	22.5	RATIONAL
EX-DP2	OS-A1, EX-A2	3.77	10.9	1.6	9.4	RATIONAL

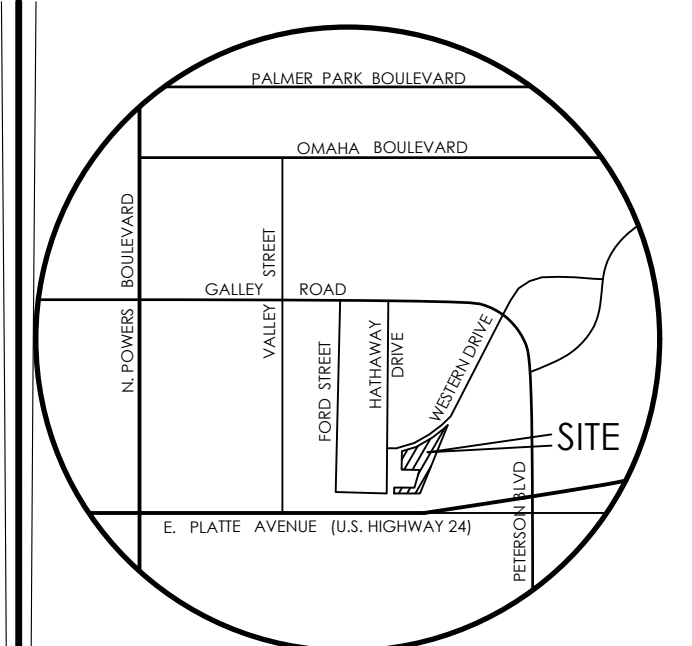

**VICINITY MAP**  
NOT TO SCALE

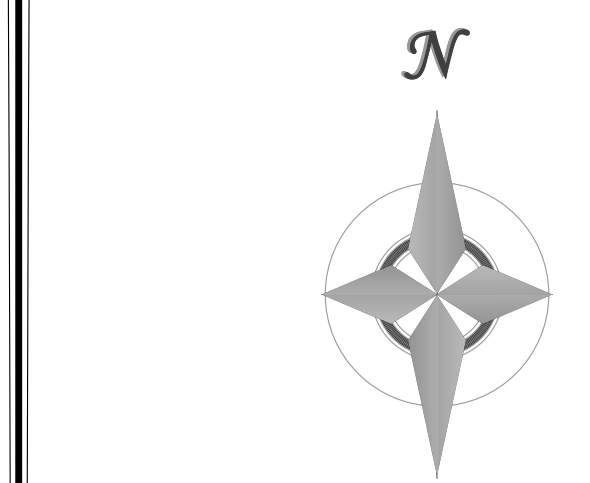

1" = 50' 1:600

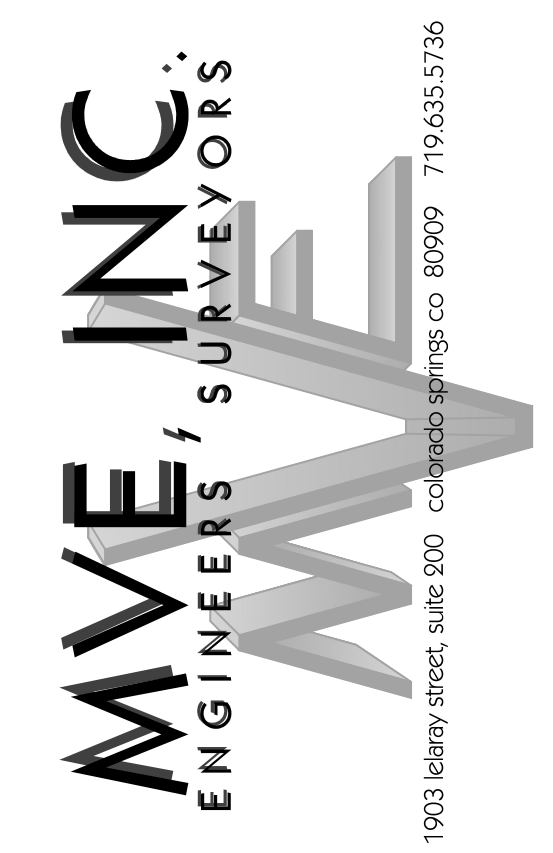

REVISIONS

DESIGNED BY \_\_\_\_\_  
 DRAWN BY \_\_\_\_\_  
 CHECKED BY \_\_\_\_\_  
 AS-BUILT BY \_\_\_\_\_  
 CHECKED BY \_\_\_\_\_

**TOWNHOMES AT WESTERN**  
 LOT I, CIMARRON SOUTHEAST  
 FILLING NO - 2C

**FINAL DRAINAGE REPORT**  
 EXISTING CONDITIONS

MVE PROJECT 61203  
 MVE DRAWING DRAIN-EX

JULY 11, 2024  
 SHEET 1 OF 1

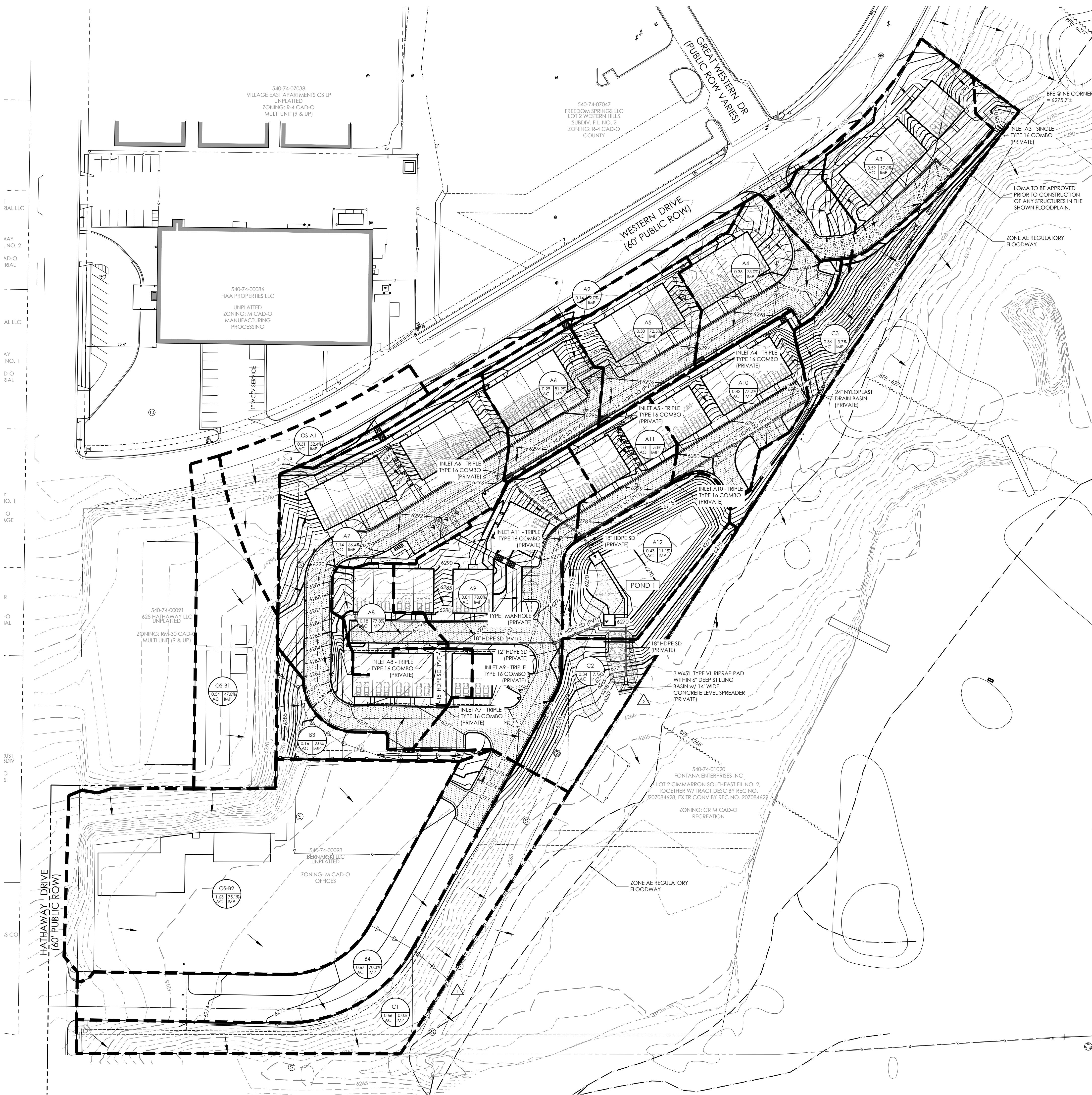

**LEGEND**

- PROPERTY LINE
- EASEMENT LINE
- LOT LINE

**EXISTING**

- 5985- INDEX CONTOUR
- 84- INTERMEDIATE CONTOUR

**PROPOSED**

- 5985- INDEX CONTOUR
- 84- INTERMEDIATE CONTOUR
- BASIN BOUNDARY
- GENERAL FLOW/DIRECTION
- SLOPE DIRECTION AND GRADE
- BASIN LABEL  
AREA IN ACRES  
PERCENT IMPERVIOUS
- DESIGN POINT

$Q = 19.0$  cfs  
 $Q_{50} = 60.0$  cfs

A1  
 1.0 AC  
 50% IMP

1  
 DESIGN POINT

**FLOODPLAIN STATEMENT**

A PORTION OF THE SUBJECT PROPERTY IS LOCATED WITHIN FEMA DESIGNATED SPECIAL FLOOD HAZARD AREA (SFHA) ZONE AE AS INDICATED ON THE FLOOD INSURANCE RATE MAP (FIRM) FOR EL PASO COUNTY, COLORADO AND INCORPORATED AREAS - MAP NUMBER 08041C0754 G, EFFECTIVE DECEMBER 7, 2018.

**EASEMENTS:**

TRACT A (THE ENTIRETY OF THE PROPERTY EXCEPT UNIT FOOTPRINTS) IS PLATTED FOR PRIVATE DRAINAGE.

TRACT A IS DESCRIBED AS THE EASEMENT AREA FOR THE BMP MAINTENANCE AREA.

**DEVELOPED DRAINAGE SUMMARY TABLE**

DESIGN POINTS	INCLUDED BASINS	AREA (AC)	Tc (MIN.)	Q5 (CFS)	RUNOFF Q100 (CFS)	METHOD
	OS-A1	0.31	5.0	0.5	1.5	RATIONAL
	OS-B1	0.54	5.2	1.1	2.7	RATIONAL
	OS-B2	1.63	5.0	5.8	11.3	RATIONAL
	A2	0.14	5.5	0.1	0.4	RATIONAL
	A3	0.59	5.9	1.5	3.3	RATIONAL
	A4	0.36	5.0	1.3	2.5	RATIONAL
	A5	0.30	5.0	1.0	2.0	RATIONAL
	A6	0.29	5.0	1.1	2.1	RATIONAL
	A7	1.14	5.4	3.5	7.1	RATIONAL
	A8	0.18	5.0	0.6	1.2	RATIONAL
	A9	0.84	5.0	2.7	5.5	RATIONAL
	A10	0.42	5.0	1.5	2.9	RATIONAL
	A11	0.22	5.0	0.8	1.6	RATIONAL
	A12	0.43	5.0	0.3	1.5	RATIONAL
	B3	0.16	10.0	0.1	0.4	RATIONAL
	B4	0.67	5.8	2.2	4.3	RATIONAL
	C1	0.66	5.0	0.3	2.0	RATIONAL
DP1	OS-B1, OSB2, B3, B4, C1	3.67	5.2	9.4	20.8	RATIONAL
	C2	0.34	9.5	0.2	0.9	RATIONAL
	C3	0.36	9.7	0.2	0.9	RATIONAL
DP2	C2, POND OUTFALL	5.56	9.5	0.4	7.4	RATIONAL

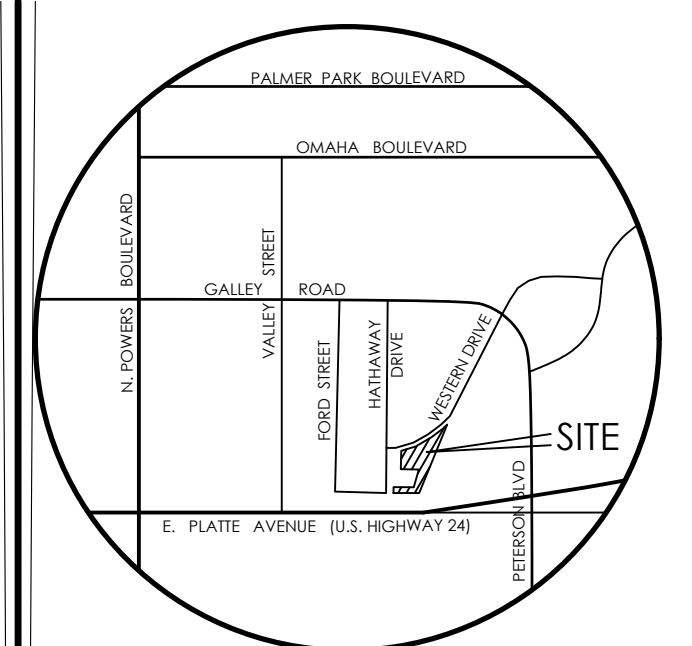

**VICINITY MAP**  
NOT TO SCALE

BENCHMARK

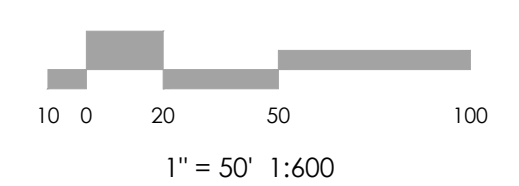
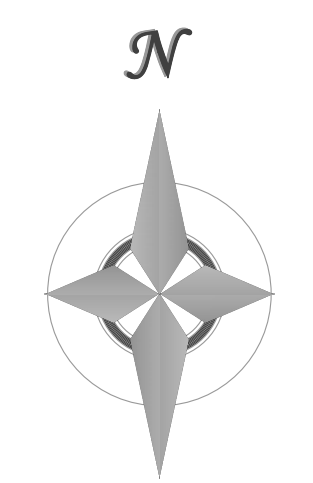

**MVE, INC.**  
ENGINEERS / SURVEYORS

1903 Leary street, suite 200 Colorado springs, CO 80909 719.635.5736

REVISIONS

DESIGNED BY  
DRAWN BY  
CHECKED BY  
AS-BUILT BY  
CHECKED BY

**TOWNHOMES AT WESTERN**  
LOT I, CIMARRON SOUTHEAST  
FILLING NO - 2C

**FINAL DRAINAGE REPORT**  
PROPOSED CONDITIONS

MVE PROJECT 61203  
MVE DRAWING DRAIN-PP

JULY 11, 2024  
SHEET 1 OF 1