

SITE PLAN 1" = 200'

NORTH

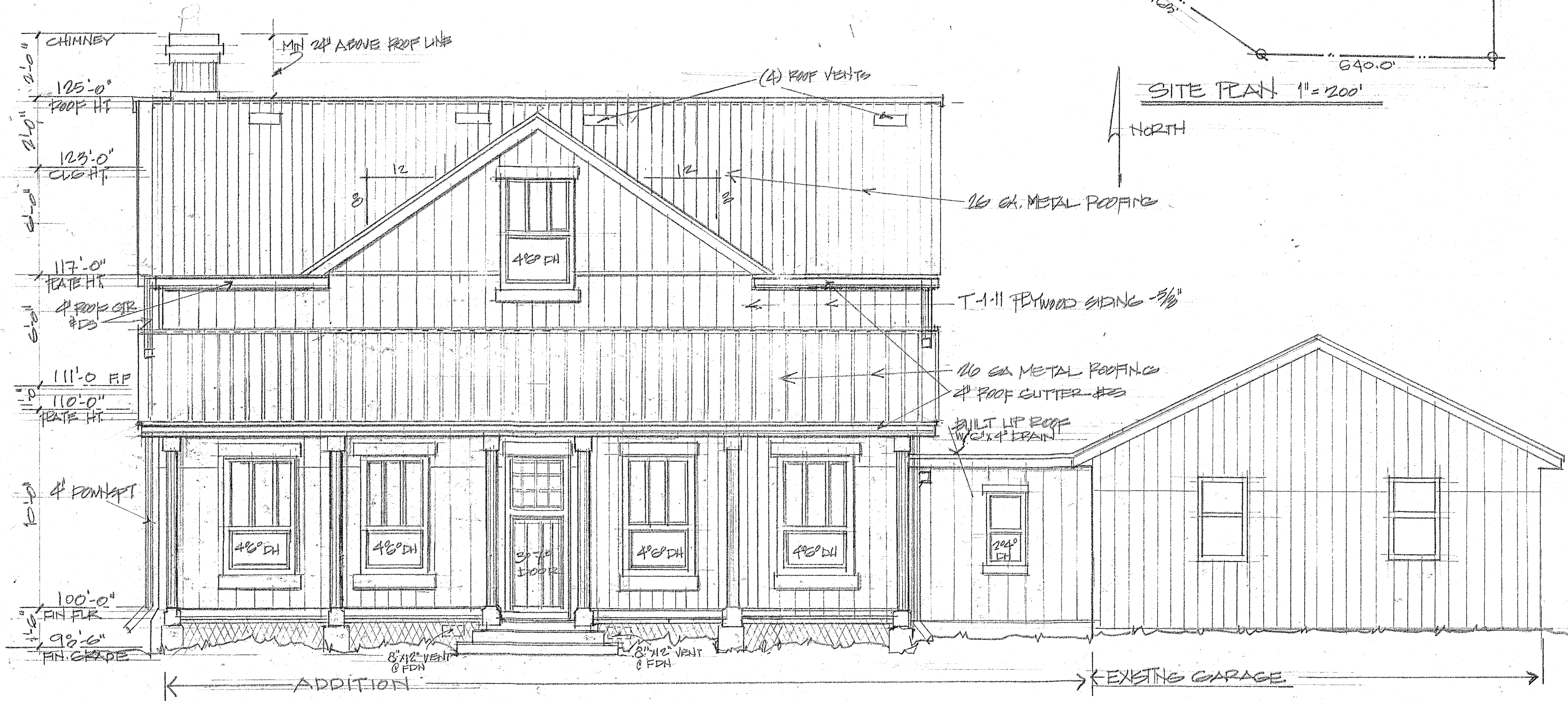

NORTH FRONT ELEVATION 1/4" = 1'-0"

RESIDENTIAL ADDITION for GUY & SUZANNAH MARTIN  
10275 EAGLE NEST DRIVE, COLORADO SPRINGS, CO. 80930

A-1 1/20/2019







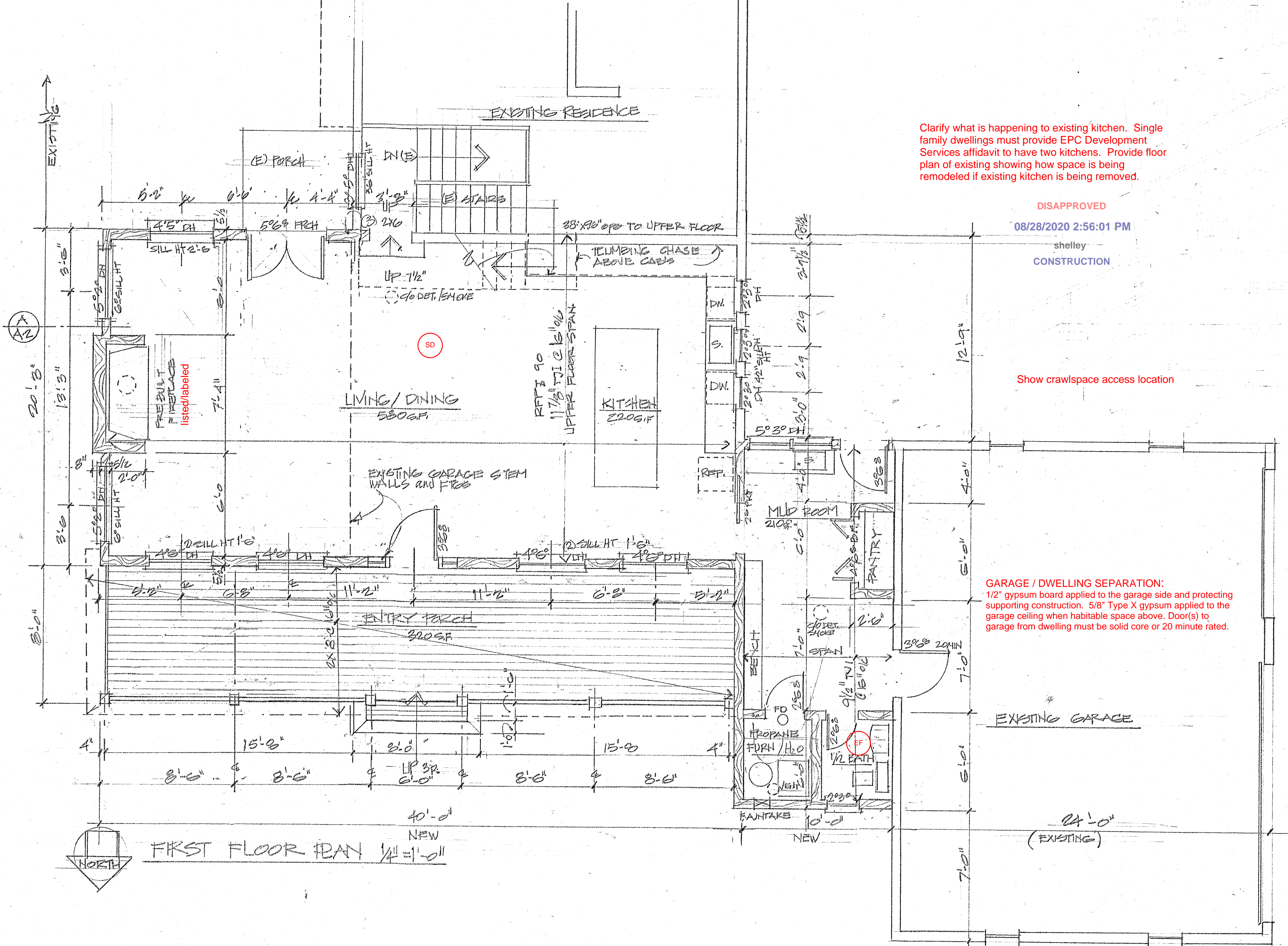

Clarify what is happening to existing kitchen. Single family dwellings must provide EPC Development Services affidavit to have two kitchens. Provide floor plan of existing showing how space is being remodeled if existing kitchen is being removed.

DISAPPROVED  
 08/28/2020 2:56:01 PM  
 shelley  
 CONSTRUCTION

Show crawspace access location

GARAGE / DWELLING SEPARATION:  
 1/2" gypsum board applied to the garage side and protecting supporting construction. 5/8" Type X gypsum applied to the garage ceiling when habitable space above. Door(s) to garage from dwelling must be solid core or 20 minute rated.

FIRST FLOOR PLAN 1/4" = 1'-0"

RESIDENTIAL ADDITION for GUY & SUZANNAH MARTIN  
 16275 EDGEMONT DRIVE, COLORADO SPRINGS, CO. 80905

A.3 H20/2019





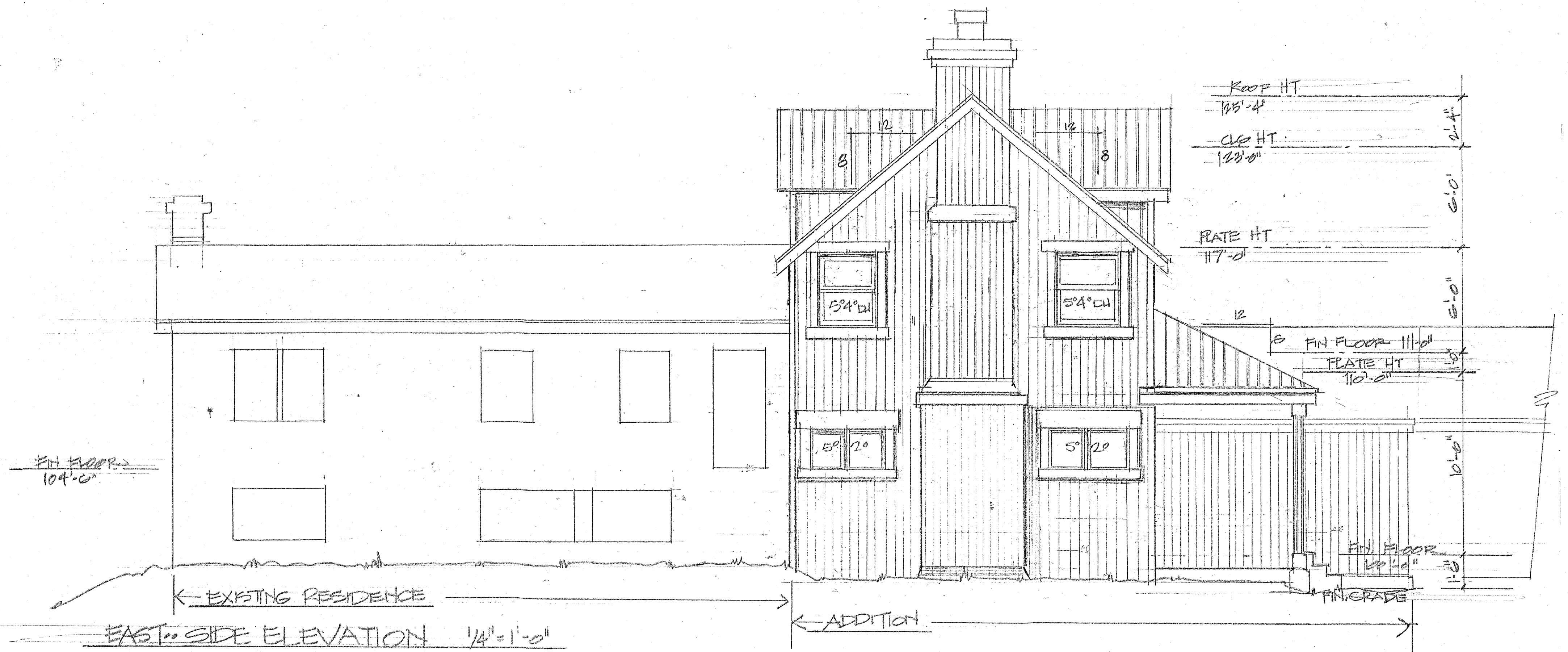

RESIDENTIAL ADDITION for GUY & SUZANNAH MARTIN  
 10175 EAGLENEST DRIVE, COLORADO SPRINGS, CO 80930

A5 11/30/2019





SOUTH - REAR ELEVATION 1/4" = 1'-0"

RESIDENTIAL ADDITION for GUY & SUZANNAH MARTIN  
 16275 EAGLE NEST DRIVE, COLORADO SPRINGS, CO 80930

A-6 1/30/19

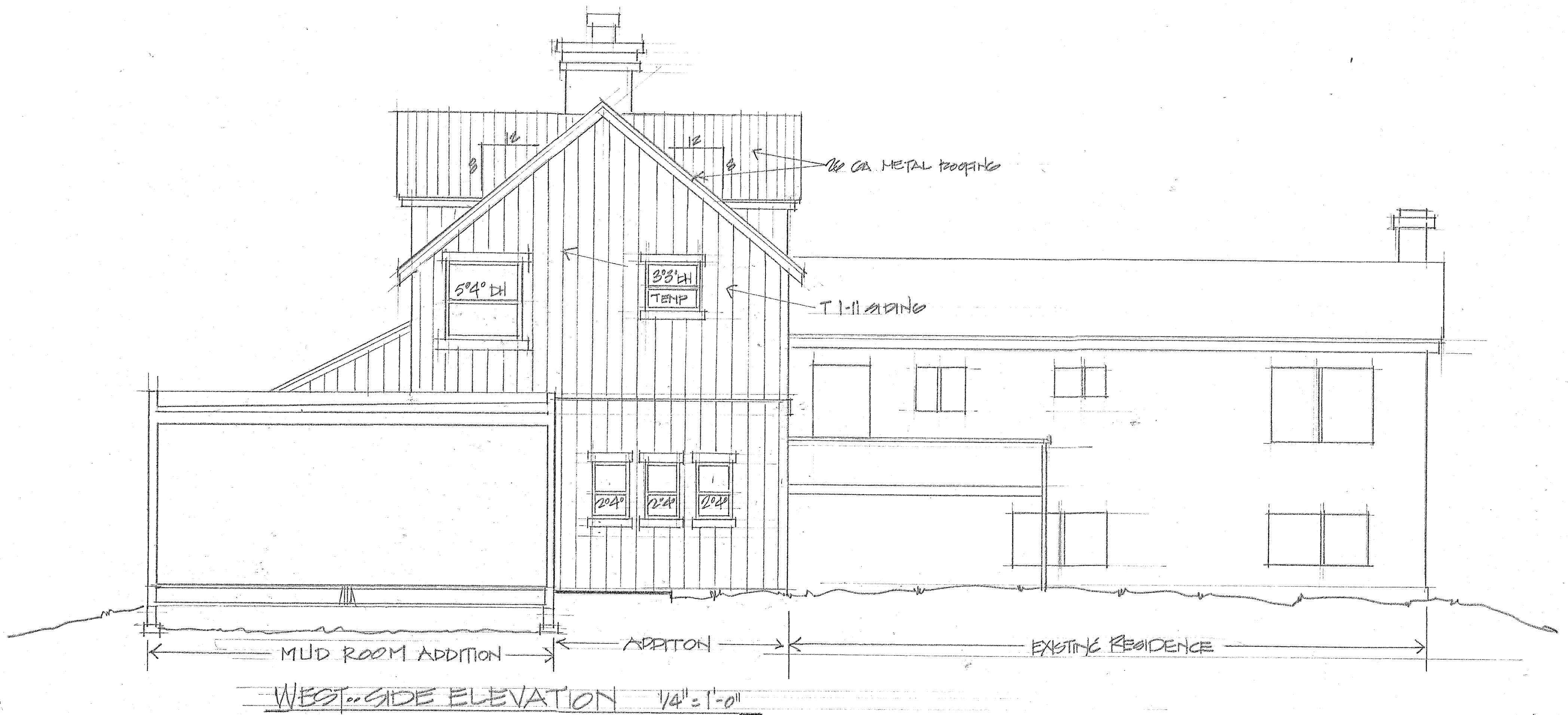

RESIDENTIAL ADDITION for GUY & SUZANNAH MARTIN  
 6275 EAGLENEST DRIVE, COLORADO SPRINGS, COLO 80930

A.7 1/30/2019



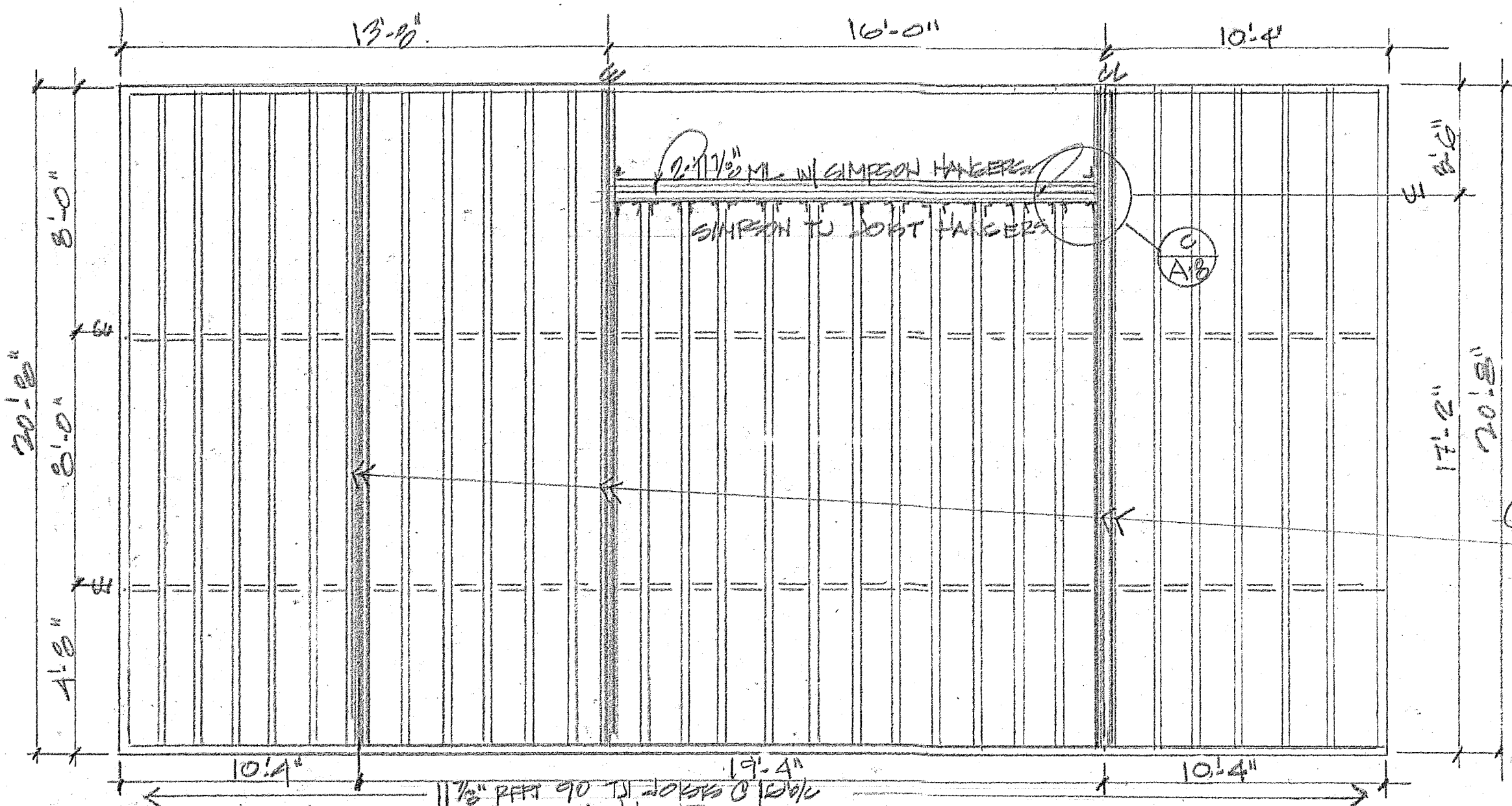

DISAPPROVED  
08/28/2020 3:08:16 PM  
shelley  
CONSTRUCTION

**DOOR/WINDOW HEADER REQ'N'S**

SPAN	# KING STUDS	# TRIMMER STUD	HEADER DEPTH/#
0'-0" - 0'	1 PER SIDE	1 PER SIDE	2-2x8
2'-0" - 4'-0"	2 "	2 "	2-2x10
4'-0" - 6'-0"	2 "	2 "	2-2x12

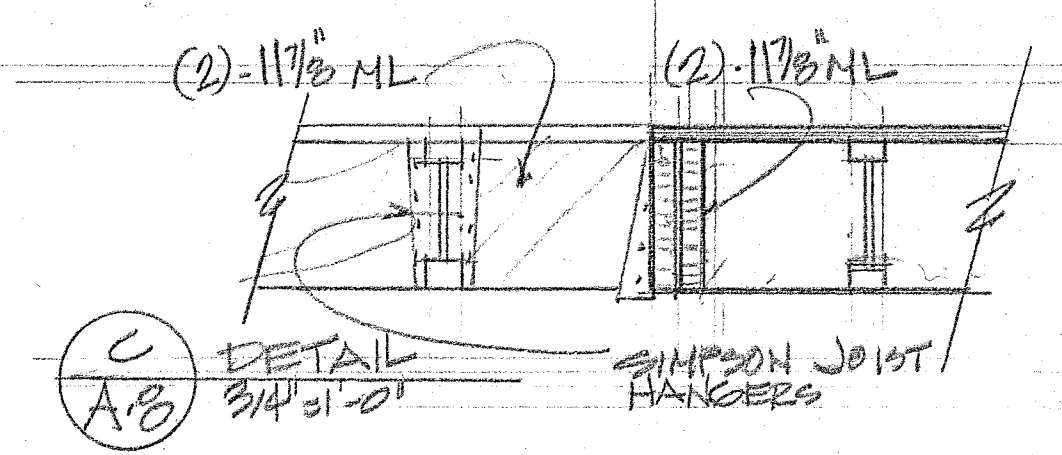

Show crawlspace access framing  
Show and specify all headers, kings, and trimmers

LIMITED STRUCTURAL REVIEW

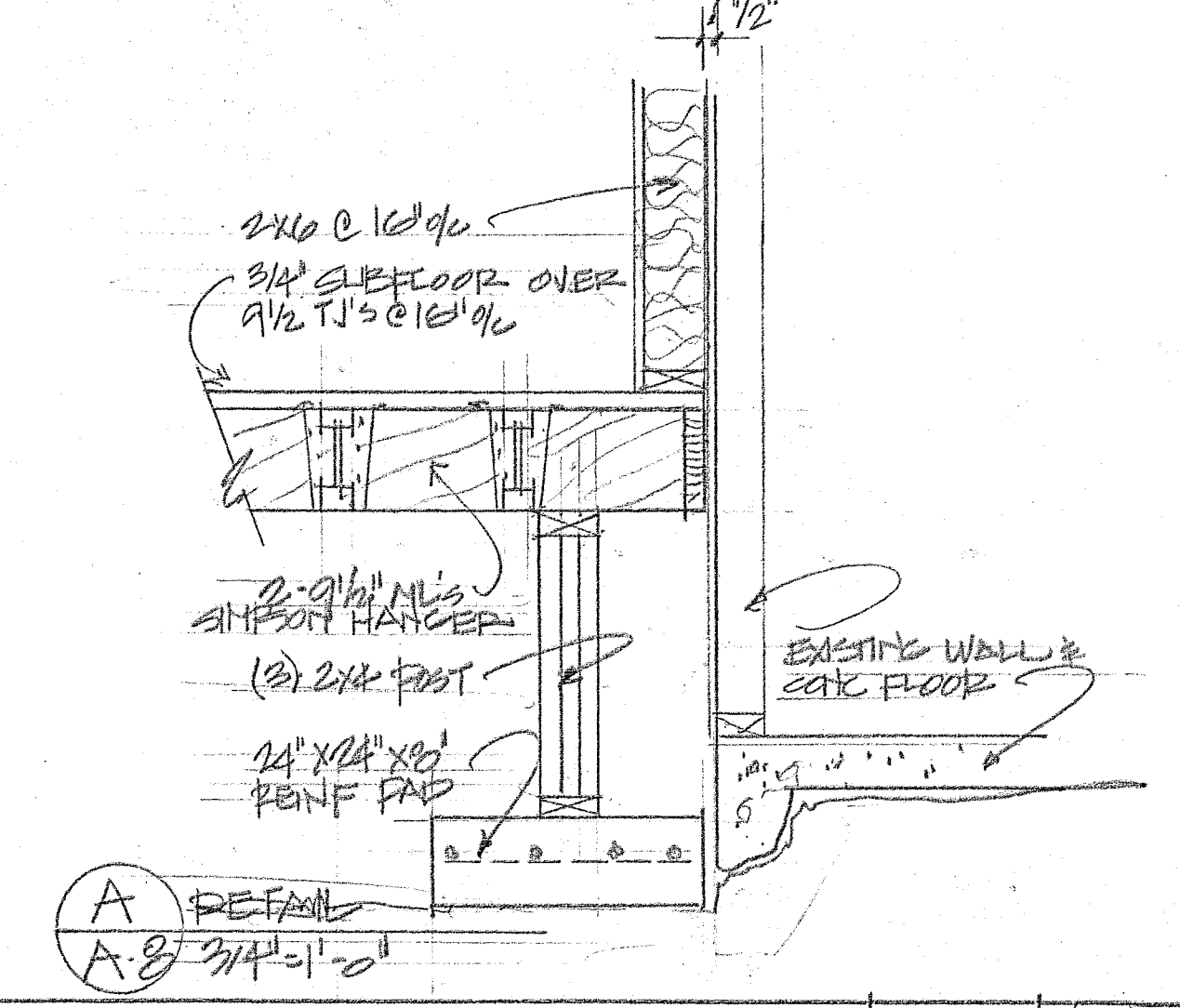
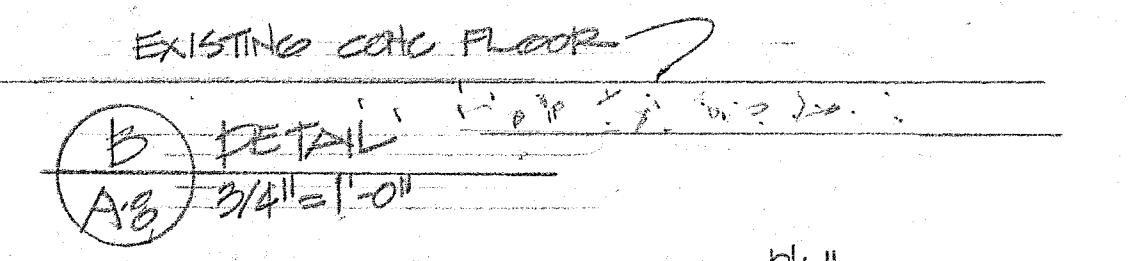
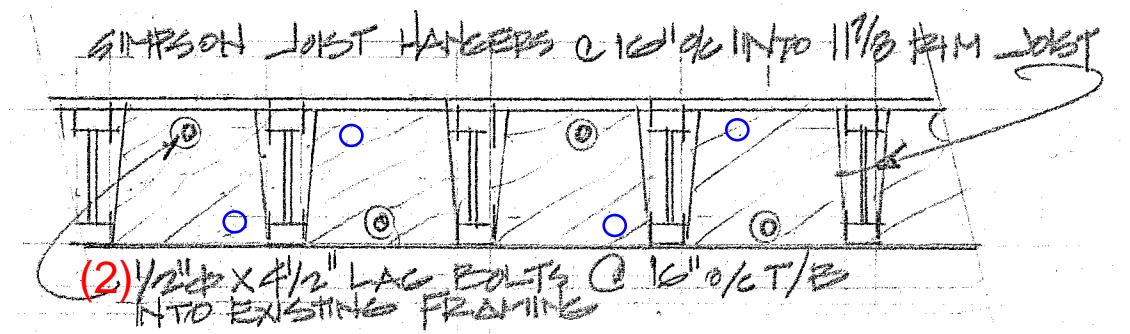
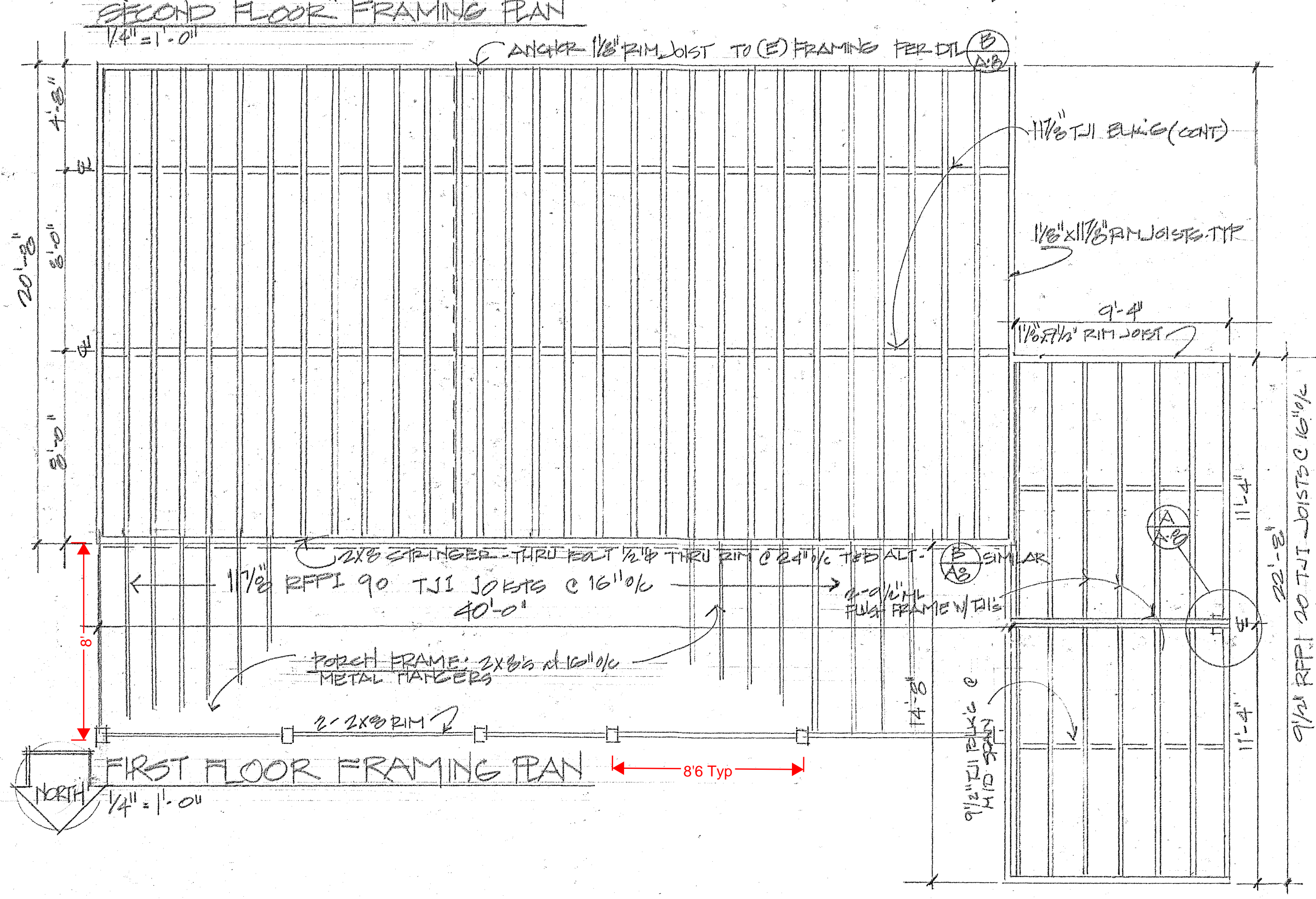

RESIDENTIAL ADDITION for GUY & SUZANNAH MARTIN  
16275 EAGLENEST DRIVE, COLORADO SPRINGS, COLO 80920

A-8 1/30/2019



Show and specify all headers, kings and trimmers  
 Label truss locations on roof framing plan, manufacturers layout cannot be used in lieu of labeled plan

DISAPPROVED  
 08/28/2020 3:08:11 PM  
 shelley  
 CONSTRUCTION

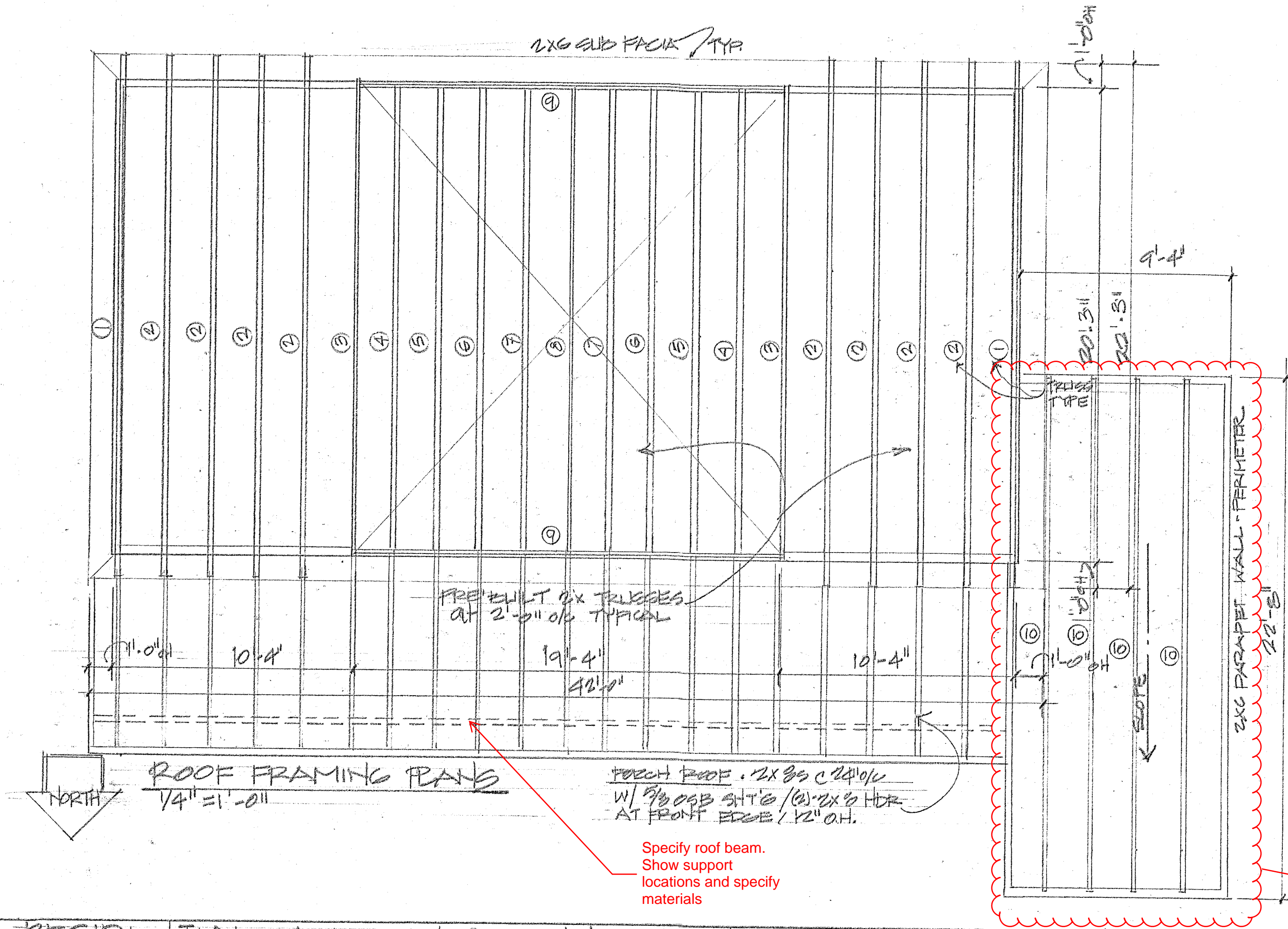

TRUSS TYPES

TRUSS TYPE	SPAN	QTY	SLOPE
①	20'-3"	8	8/12
②	20'-3"	2	8/12
③	19'-6"	2	8/12
④	19'-6"	2	8/12
⑤	19'-6"	2	8/12
⑥	19'-6"	2	8/12
⑦	19'-6"	2	8/12
⑧	19'-0"	1	
⑨	20'-3"		8/12
⑩	22'-5 1/2"		A 1/4' FT SLOPE

Specify roof beam.  
 Show support locations and specify materials

Per truss manufacturers layout, there aren't trusses here, clarify

RESIDENTIAL ADDITION for GUY & SUZANNAH MARTIN  
 16215 EAGLENEST DRIVE, COLORADO SPRINGS CO. 80930

A9 1/30/2019