



# FINAL DRAINAGE REPORT

## **FALCON MEADOWS AT BENT GRASS FILING NO. 4**

El Paso County, Colorado

---

PREPARED FOR:  
**Challenger Communities**  
**8605 Explorer Dr., Suite 250**  
**Colorado Springs, CO 80920**

PREPARED BY:  
**Galloway & Company, Inc.**  
**1155 Kelly Johnson Blvd., Suite 305**  
**Colorado Springs, CO 80920**

DATE:  
**Prepared: July 1, 2022**  
**Revised: October 10, 2022**  
**Revised: March 22, 2024**

*PCD Filing No.: SF-22-023*



**ENGINEER'S STATEMENT**

*The attached drainage plan and report were prepared under my direction and supervision and are correct to the best of my knowledge and belief. Said drainage report has been prepared according to the criteria established by the County for drainage reports and said report is in conformity with the applicable master plan of the drainage basin. I accept responsibility for any liability caused by any negligent acts, errors or omissions on my part in preparing this report.*

\_\_\_\_\_  
Brady A. Shyrock, PE 38164  
For and on behalf of Galloway & Company, Inc.

\_\_\_\_\_  
Date

**DEVELOPER'S CERTIFICATION**

*I, The developer, have read and will comply with all of the requirements specified in this drainage report and plan.*

By: \_\_\_\_\_

\_\_\_\_\_  
Date

Address: Challenger Communities, LLC  
8605 Explorer Dr., Suite 250  
Colorado Springs, CO 80920

**EL PASO COUNTY CERTIFICATION**

*Filed in accordance with the requirements of the Drainage Criteria Manual, Volumes 1 and 2, El Paso County Engineering Criteria Manual and Land Development Code as amended.*

\_\_\_\_\_  
Joshua Palmer, P.E.  
County Engineer/ECM Administrator

\_\_\_\_\_  
Date

Conditions:

## TABLE OF CONTENTS

I.	Purpose.....	1
II.	General Description.....	1
III.	Previous Reports .....	1
IV.	Drainage Criteria.....	2
V.	Historic Drainage Conditions .....	3
VI.	Existing Drainage Conditions .....	3
VII.	Four Step Process .....	5
	1.    Employ Runoff Reduction Practices.....	5
	2.    Stabilize Drainageways.....	5
	3.    Provide Water Quality Capture Volume (WQCV) .....	6
	4.    Consider Need for Industrial and Commercial BMPs .....	6
VIII.	Proposed Drainage Conditions.....	6
IX.	Storm Sewer System.....	9
X.	Proposed Water Quality Detention Ponds.....	9
XI.	Channel and Swales.....	10
	Swales.....	10
	Channel.....	10
XII.	Maintenance .....	10
XIII.	Wetlands Mitigation .....	10
XIV.	Floodplain Statement.....	10
XV.	Drainage/Bridge Fees and Credits/Reimbursements.....	10
XVI.	Conclusion .....	12
XVII.	References .....	12

Appendices:

- A. Exhibits and Figures
- B. Excerpts from Previous Reports
- C. Hydrologic Computations
- D. Hydraulic Computations
- E. Pond Analysis
- F. Drainage Maps

## I. Purpose

The purpose of this Final Drainage Report is to identify on and offsite drainage patterns, locate and identify tributary or downstream drainage features and facilities that impact the site, and to identify which types of drainage facilities will be needed and where they will be located. This report will remain in compliance with the MDDP for the site, prepared by Galloway & Company, September 2021.

## II. General Description

The Falcon Meadows at Bent Grass Filing No. 4 is approximately 10.42 acres within the Bent Grass development. It is located along the northern boundary line of the overall Bent Grass development and is bisected by the existing West Tributary of the Falcon Basin. The project is a single-family residential development of 39 lots, located in the Falcon area of El Paso County, Colorado. The site is located in the Northwest  $\frac{1}{4}$  and Southwest  $\frac{1}{4}$  of Section 1, Township 13S, Range 65W, of the Sixth Principal Meridian, County of El Paso, State of Colorado. The subject property is located on either side of the existing West Tributary of the Falcon Basin with the majority of the site located to the north of Bent Grass Meadows Drive, sandwiched between Bent Grass Residential Filing No. 2 (to the east) and Falcon Meadows at Bent Grass Filing Nos. 1 through 3 (to the west). 11 lots are located to the south of Bent Grass Meadows Drive and are situated to the west of the existing West Tributary of the Falcon Basin immediately adjacent to Falcon Meadows at Bent Grass Filing No. 1. A Vicinity Map is included in Appendix A.

Construction of the Falcon Meadows at Bent Grass Drainage Channel (SF-21-014) and FEMA LOMR must be completed prior to the recording of the Falcon Meadows at Bent Grass Filing No. 4 Subdivision Plat.

A Planned Unit Development Plan Amendment was approved for the site, PUD-14-002 in July 2014. An additional amendment to this PUD has also been approved (PUD-SP-205). The overall Bent Grass site consists of approximately 103.4 acres and included 309 dwelling units.

The existing soil types within the proposed site as determined by the NRCS Web Soil Survey for El Paso County Area consist of Columbine gravelly sandy loam and Blakeland loamy sand. All soils are defined as having hydrologic soil group A. See the soils map included in Appendix A.

## III. Previous Reports

The proposed site has been included in multiple drainage studies in the past. The following is a composite list of the existing reports pertaining to this site analysis.

1. *Falcon Drainage Basin Planning Study*, by Matrix Design Group, September 2015.
2. *Master Development Drainage Plan – Bent Grass Residential Subdivision*, by Galloway & Company, September 2021.
3. *Master Development Drainage Plan and Preliminary Drainage Plan – Bent Grass Subdivision*, by Kiowa Engineering Corporation, December 2006.
4. *Final Drainage Report for Bent Grass Residential (Filing No. 1)*, by Classic Consulting Engineers & Surveyors, LLC, August 2014.
5. *Final Drainage Report Addendum for Bent Grass Residential (Filing No. 1)*, by Classic Consulting Engineers & Surveyors, LLC, August 2015.
6. *Master Development Drainage Plan for The Ranch*, by Classic Consulting Engineers & Surveyors, LLC, November 2018.

7. *Falcon Highlands Master Development Drainage Plan & Preliminary Drainage Report & Final Drainage Report for Filing 1*, by URS, January 2005.
8. *Final Drainage Report and Erosion Control Plan – Latigo Business Center Filing No. 1 A Re-subdivision of a Portion of Latigo Business and Research Center Filing No. 1*, by Kiowa Engineering Corporation, November 2004.
9. *Final Drainage Letter Report for Lot 1, Latigo Business Center Filing No. 1*, by Colorado Design Concepts, April 2005.
10. *Final Drainage and Erosion Control for The Meadows Filing Three Subdivision*, by LADD Engineering, July 2000.
11. *Final Drainage Report Bent Grass Residential Subdivision, Filing No. 2*, Galloway & Company, March 2020.
12. *Preliminary Drainage Report Falcon Meadows at Bent Grass*, by Galloway & Company, February 2021.
13. *Final Drainage Report for Falcon Meadows at Bent Grass Filing No. 1*, by Galloway & Company, September 2021.
14. *Final Drainage Report for Falcon Meadows at Bent Grass Filing No. 2*, by Galloway & Company, April, 2022.
15. *Final Drainage Report for Falcon Meadows at Bent Grass Filing No. 3*, by Galloway & Company, August, 2022.

#### IV. Drainage Criteria

Hydrology calculations were performed using the City of Colorado Springs/El Paso County Drainage Criteria Manual, as revised in November 1991 and October 1994 with County adopted Chapter 6 and Section 3.2.1 of Chapter 13 of the City of Colorado Springs/El Paso County Drainage Criteria Manual as revised in May 2014 and the El Paso County Engineering Criteria Manual (ECM) as revised in July 2019.

The drainage calculations were based on the criteria manual Figure 6-5 and IDF equations to determine the intensity and are listed in Table 1 below.

**Table 1 - Precipitation Data**

Return Period	One Hour Depth (in).	Intensity (in/hr)
5-year	1.50	5.17
100-year	2.52	8.68

The rational method was used to calculate peak flows as the tributary areas are less than 100 acres. The rational method has been proven to be accurate for basins of this size and is based on the following formula:

$$Q = CIA$$

Where:

- Q = Peak Discharge (cfs)
- C = Runoff Coefficient
- I = Runoff intensity (inches/hour)
- A = Drainage area (acres)

The runoff coefficients are calculated based on land use, percent imperviousness, and design storm for each basin, as shown in the drainage criteria manual (Table 6-6). Composite percent impervious and C values were calculated using the residential, streets, roofs, and lawns coefficients found in Table 6-6 of the manual.

The 100-year event was used as the major storm event for pipes and inlets. The 5-year event was used as the minor event.

The UD-Detention spreadsheet was utilized for to check the existing the water quality ponds still function with the revised tributary areas and impervious values. This spreadsheet was also utilized for the original design of the on-site water quality ponds, Pond (North) and Pond (South).

UD-Inlet was utilized to calculate both the street capacities and the inlet capacities.

StormCAD was utilized to size the storm sewer systems.

## **V. Historic Drainage Conditions**

The site is contained fully within the Falcon Drainage Basin, more specifically the West Falcon Tributary. The site generally drains from north to south with an average slope of 2%. The rational method was used to analyze the individual basins within the site as the proposed drainage basins are less than 100 acres. The project site was studied in the Falcon Basin Drainage Basin Planning Study (DBPS) and in the Master Development and Drainage Plan (MDDP) for Bent Grass.

Per the Falcon DBPS by Matrix, the site lies within the basins, WT200, WT210, and WT220. These basins connect to channel reaches RWT202, RWT204, and RWT210. Both the RWT204 and RWT210 sections of channel currently exist and appear as a drainageway when visiting the site. Reach RWT202 appears to be a shallow overland flow through the project site. It is nearly unrecognizable through the site from a visual standpoint.

A historic basin map has been prepared for this site to analyze the historic basins as well as the offsite basins contributing to the site. Historic basins have been discussed in the Bent Grass Residential Filing No. 2 Final Drainage Report, El Paso County Project # SF-19-014. Copies of the hydrology calculations have been included in Appendix B and a copy of the historic map is included in Appendix B. Efforts have been made to comply with the recommendations set forth in the approved DBPS and MDDP.

## **VI. Existing Drainage Conditions**

With respect to the existing/current conditions, developed conditions maps from previous studies are being utilized for Falcon Meadows at Bent Grass Filing No. 4 and will be the existing condition as Filing No. 4 begins construction. Under this scenario, it is assumed that Bent Grass Residential Filing No. 2 and Falcon Meadows at Bent Grass Filing Nos. 1, 2 and 3 are developed. The Falcon Meadows at Bent Grass Filing No. 3 proposed drainage maps are included in Appendix B and the basins are described below.

Below is a description of the basins which were developed as part of Falcon Meadows at Bent Grass Filing No. 3:

**Basin EX-1** (1.19 AC,  $Q_5 = 0.4$  cfs,  $Q_{100} = 2.5$  cfs): is associated with the northwestern portion of the Bent Grass Residential Filing No. 2 site east of the existing channel (now the northeast portion of Falcon Meadows at Bent Grass Filing No. 4). The basin is currently undeveloped. Runoff from the basin generally flows to the southwest, into Basins EX-2 and B-1.

**Basin EX-2** (1.60 AC,  $Q_5 = 0.5$  cfs,  $Q_{100} = 3.8$  cfs): is along the western boundary portion of the Bent Grass Residential Filing No. 2 site and is south of Basin EX-1, east of the existing channel (now the eastern portion of Falcon Meadows at Bent Grass Filing No. 4). The basin is currently undeveloped and receives flows from Basins OS-4 & OS-5. Runoff from the basin generally flows to the southeast into Basin EX-3 at **DP 5** combined with flows from **DP 1, & 2**.

**Basin EX-3** (0.66 AC,  $Q_5 = 0.2$  cfs,  $Q_{100} = 1.6$  cfs): is along the western boundary portion of the Bent Grass Residential Filing No. 2 site south of Basin EX-2 and east of the existing channel (now southeast portion of Falcon Meadows at Bent Grass Filing No. 4). The basin currently contains an existing WQCV pond created as part of Bent Grass Residential Filing No. 2 (North Pond). This basin receives flows from **DP 5** and **DP 3**.

**Basin C-1e** (0.49 AC,  $Q_5 = 2.3$  cfs,  $Q_{100} = 4.1$  cfs): a basin that will include the east half of Henzlee Place. Runoff will flow from the R.O.W. into the existing mountable curb and gutter where it will be conveyed to **DP 12**. Flows will then enter an existing 15' at grade CDOT Type R inlet, part of Storm System B, where it will be piped to the existing north WQCV pond at **DP 13**. Bypass flows from the inlet at **DP 12** will travel to the south, then east in Bent Grass Meadows Drive to **DP 8**, an existing 20' CDOT sump Type R inlet, which releases into the existing WQCV pond in Bent Grass Residential Filing No. 2.

**Basin C-5** (0.60 AC,  $Q_5 = 0.3$  cfs,  $Q_{100} = 1.9$  cfs): Is a basin which will encompass the existing north WQCV pond area. The stormwater within the existing north WQCV pond will be released at a controlled rate, via an outlet structure with orifice holes, into the existing channel RWT204.

**Basin B-1** (6.59 AC,  $Q_5 = 1.8$  cfs,  $Q_{100} = 11.8$  cfs): a basin that is along the north boundary of the site and through the center of the site, encompassing the existing rerouted channel RWT202 and channel RWT204. Flows will continue south in the existing channel where they will then be conveyed through the existing twin 16' x 6' RCBC's to **DP AA**.

**Basin D-4c** (1.21 AC,  $Q_5 = 2.4$  cfs,  $Q_{100} = 5.0$  cfs): a basin that is east of Henzlee Place and south of Bent Grass Meadows Drive. It encompasses single-family residential lots, & portions of Nico Way, Jayla Trail, and Henzlee Place. Runoff will flow from each lot onto the existing public R.O.W. where existing mountable curb and gutter will convey flows to **DP 17c**, the north side of **DP 17**. Flows at **DP 17** (combined flows from **DP 17b** & **DP 17c** with bypass from **DP 18**) will then enter an existing sump CDOT Type R inlet, part of Storm System A, where it will then be piped and ultimately outfall in the existing south WQCV pond at **DP 31**. Overflow from this inlet would be to overtop the curb and then continue via an existing swale, following the same path as the existing pipe, to the east until flows are released into the existing south water quality pond.

**Basin D-7** (7.65 AC,  $Q_5 = 4.3$  cfs,  $Q_{100} = 18.2$  cfs): a basin that is in the south end of the site, east of Bent Grass Meadows Drive & west of the existing channel. It encompasses the back half of several single-family residential lots as well as the existing south WQCV pond and an existing drainage ditch (Swale F). Runoff will flow, via sheet flow, until it enters the existing swale and is conveyed to the existing south WQCV pond or will directly flow into the existing south WQCV pond at **DP 30**.

**Basin D-8** (1.69 AC, Q5 = 2.6 cfs, Q100 = 6.0 cfs): a basin that is west of the existing channel & south of Bent Grass Meadows Drive. It encompasses the back half of single-family residential lots. Runoff will flow from each lot and discharge into an existing drainage swale (Swale C). The swale will convey flows to the south, ultimately discharging into the existing south WQCV pond at **DP 32**.

**Basin OS-4** (4.46 AC, Q5 = 5.6 cfs, Q100 = 14.0 cfs) is associated with The Bent Grass Residential Filing No. 2, lots 152-160, lots 163-168, Tract D, and portions of Thedford Court & Willmore Drive. Runoff from this basin flows via curb & gutter south on Thedford Court then continues flowing west along the northern curb & gutter along Willmore Drive before discharging into Basin EX-2 at **DP 1**. This basin remains unchanged.

**Basin OS-5** (0.46 AC, Q5 = 1.1 cfs, Q100 = 2.3 cfs): is associated with The Bent Grass Residential Filing No. 2, lots 161 & 162 along with a portion of Silky Thread Road. Runoff from this basin generally flows to the west via curb & gutter along Silky Thread Road before discharging into Basin EX-2 at **DP 2**. This basin remains unchanged.

**Basin OS-6** (1.17 AC, Q5 = 2.0 cfs, Q100 = 4.3 cfs): is associated with The Bent Grass Residential Filing No. 2, the northern halves of Lots 170-178 and a portion of the southern side of Willmore Drive. Runoff from this basin generally flows to the west via curb & gutter along Willmore Drive before discharging into Basin EX-2 at **DP 3**. This basin remains unchanged.

**Basin RWT204** (38.4 AC, Q5 = 7 cfs, Q100 = 43 cfs) represents one of the larger offsite basins to the north of the proposed project. This area was studied as part of the Falcon Basin DBPS prepared by Matrix and were also part of the Bent Grass MDDP, approved September 21, 2021. There have been no changes to this basin as it is offsite and existing.

**Design Point AA** is the location in channel reach RWT204, where flows cross Bent Grass Meadows Drive within the existing twin 16' x 6' RCBC. The minor flows are 335.9 cfs and the major flows are 1450 cfs.

**Design Point CC** is the location in channel reach RWT210, where flows exit the Falcon Meadows development, including the offsite flows from RWT202, RWT204 and WT200. The minor flows are 335.9 cfs and the major flows are 1450 cfs.

## VII. Four Step Process

The Four Step Process is used to minimize the adverse impacts of urbanization and is a vital component of developing a balanced, sustainable project. Below identifies the approach to the four-step process:

### 1. Employ Runoff Reduction Practices

The proposed development uses Low Impact Development (LID) practices to reduce runoff at the source. Rather than creating point discharges that are directly connected to impervious areas, runoff is routed through pervious areas to promote infiltration and minimize directly connected impervious areas (MDCIA). Grass buffers and swales are used where practical.

### 2. Stabilize Drainageways

This step implements stabilization to channels to accommodate developed flows while protecting infrastructure and controlling sediment loading from erosion in the drainageways. Erosion protection



in the form of riprap pads at all outfall points to the channel to prevent scouring of the channel from point discharges. This will be further discussed later in this report, see Section XI Channels and Swales.

### **3. Provide Water Quality Capture Volume (WQCV)**

This step utilizes formalized water quality capture volume to slow the release of runoff from the site. The WQCV will release in no less than 40 hours. On-site water quality control volume detention ponds will provide water quality treatment prior to the runoff being released into the channel.

### **4. Consider Need for Industrial and Commercial BMPs**

Industrial and Commercial BMP's are not applicable to this proposed site. Source control BMPs for homeowners include the use of garages as the primary area where pollutants can be stored. The single-family detached homes provide garages which can act as storage areas. The proposed development does not include outdoor storage or the potential for introduction of contaminants to the Counties' MS4, thus no targeted source control BMPs are necessary. The biggest source control BMP is public education which can be found on the El Paso County website and discuss topics such as: pet waste, car washing, lawn care, fall leaves, and snow melt and deicer.

## **VIII. Proposed Drainage Conditions**

Three existing WQCV Detention Ponds will provide water quality treatment for the site prior to discharging the runoff directly into the West Tributary channel RWT204/RWT210.

1. Existing Pond 1 was designed and constructed with Bent Grass Residential Filing No. 2 (SF-19-014).
2. Existing Pond (South) was designed and constructed with Bent Grass Residential Filing No. 2 (SF-21-020).
3. Existing Pond (North) was designed and constructed with Falcon Meadows at Bent Grass Filing No. 2. (SF-21-034).

The project site is Single Family Residential. Runoff from the residential lots will either sheet flow or concentrate in side-yard swales and spill onto the proposed roadway. Curb and gutter will convey these flows to storm drain infrastructure and routed to existing WQCV Detention Ponds before outfalling directly into the West Tributary Channel.

**The following basins are offsite basins that impact the Filing 4 site.**

**Basin OS-4** (4.48 AC, Q5 = 7.8 cfs, Q100 = 16.1 cfs) is associated with Bent Grass Residential Filing No. 2. Runoff from this basin sheet flows to the frontage of the residential lots to Thedford Court and then flows, via existing curb and gutter, to a proposed 5' sump CDOT Type R inlet on Willmore Drive at **DP 2**. Runoff continues to route to the south to proposed Lemon Grass Road (Flg No. 4), which will direct runoff to a proposed 15' at-grade CDOT Type R inlet at **DP 4**. Runoff is conveyed downstream via proposed 24" RCP through a proposed 5' manhole at **DP 4b**, to Design Point 5 where flows are combined with runoff generated in sub-basin A-3. Bypass flows are routed via curb & gutter to an existing 20' CDOT Type R sump inlet at DP 8. Emergency overflows will overtop the curb & gutter and be directed to Existing Pond 1.

**Basin OS-5** (0.46 AC, Q5 = 1.2 cfs, Q100 = 2.5 cfs) is associated with Bent Grass Residential Filing No. 2. Runoff from this basin sheet flows to the frontage of the residential lots to Willmore Drive and then flows, via existing curb and gutter, to proposed Lemon Grass Road at **DP 1**. Runoff continues to route to

the south within proposed Lemon Grass Road (Flg No. 4), which will direct runoff to a proposed 15' at-grade CDOT Type R inlet at **DP 4**. Runoff is conveyed downstream via proposed 24" RCP through a proposed 5' manhole at **DP 4b**, to Design Point 5 where flows are combined with runoff generated in sub-basin A-3. Bypass flows are routed via curb & gutter to an existing 20' CDOT Type R sump inlet at DP 8. Emergency overflows will overtop the curb & gutter and be directed to Existing Pond 1.

**Basin OS-6** (1.17 AC, Q5 = 2.2 cfs, Q100 = 4.6 cfs) is associated with Bent Grass Residential Filing No. 2. Runoff from this basin sheet flows to the frontage of the residential lots to Silky Thread Road and then flows, via existing curb and gutter, to proposed Lemon Grass Road at **DP 3**. Runoff continues to route to the south within proposed Lemon Grass Road (Flg No. 4), which will direct runoff to a proposed 15' at-grade CDOT Type R inlet at **DP 4**. Runoff is conveyed downstream via proposed 24" RCP through a proposed 5' manhole at **DP 4b**, to Design Point 5 where flows are combined with runoff generated in sub-basin A-3. Bypass flows are routed via curb & gutter to an existing 20' CDOT Type R sump inlet at DP 8. Emergency overflows will overtop the curb & gutter and be directed to Existing Pond 1.

Below is a description of the basins that encompass Falcon Meadows at Bent Grass Filing No. 4.

**Basin A-1** (2.18 AC, Q5 = 4.5 cfs, Q100 = 9.3 cfs): a basin that includes residential lots and the east half of Lemon Grass Road. Runoff will flow from each lot onto the proposed public R.O.W. where proposed mountable curb and gutter will convey flows to a proposed 15' at-grade CDOT Type R inlet at **DP 4**. Runoff is conveyed downstream via proposed 24" RCP through a proposed 5' manhole at **DP 4b**, to Design Point 5 where flows are combined with runoff generated in sub-basin A-3. Bypass flows are routed via curb & gutter to an existing 20' CDOT Type R sump inlet at DP 8. Emergency overflows will overtop the curb & gutter and be directed to Existing Pond 1.

**Basin A-2** (0.92 AC, Q5 = 2.1 cfs, Q100 = 4.4 cfs): a basin that includes the rear portion of residential lots along proposed Lemon Grass Road. Runoff from this basin will sheet flow directly to the West Tributary channel RWT204/RWT210. All roof drains (for lots 13-21) within this sub-basin will be directed toward Lemon Grass Road, no impervious surfaces will be allowed within the rear lot setbacks and runoff reduction will be implemented within this sub-basin. Additionally, the existing riprap lined swale will be removed and relocated. The associated lots must be reseeded and stabilized to help mitigate any unnecessary sediment spilling into the channel.

**Basin A-3** (1.13 AC, Q5 = 2.1 cfs, Q100 = 4.4 cfs): a basin that includes residential lots and the west half of Lemon Grass Road. Runoff will flow from each lot onto the proposed public R.O.W. where proposed mountable curb and gutter will convey flows to a proposed 15' at-grade CDOT Type R inlet at **DP 5**. Runoff is conveyed downstream via proposed 24" RCP to Design Point 6 where flows are combined within Existing Pond 1. Bypass flows are routed via curb & gutter to an existing 20' CDOT Type R sump inlet at DP 8. Emergency overflows will overtop the curb & gutter and be directed to Existing Pond 1.

**Basin A-4** (0.54 AC, Q5 = 0.0 cfs, Q100 = 0.6 cfs): a basin that includes undeveloped land and Existing Pond 1. Runoff will sheet flow directly to Existing Pond 1 at **DP 6**. This basin receives flows from **DP 5** and **DP 8**.

**Basin B-1** (4.33 AC, Q5 = 0.1 cfs, Q100 = 2.8 cfs): a basin that is along the north boundary of the site and through the center of the site, encompassing the existing rerouted channel RWT202 and channel RWT204. This basin has been reduced in size from the existing condition with the development of areas immediately adjacent to the channel. Flows will continue south in the existing channel where they will then be conveyed through the existing twin 16' x 6' RCBC's to **DP AA**.

**Basin C-1e** (0.49 AC, Q5 = 2.2 cfs, Q100 = 3.8 cfs): a basin that includes the east half of Henzlee Place. Runoff will flow from each lot onto the proposed public R.O.W. where proposed mountable curb and gutter will convey flows to an existing 15' CDOT Type R sump inlet at **DP 12**. Runoff is conveyed downstream via existing 42" RCP to **DP 13** where flows are combined within Existing Pond North. Emergency overflows will overtop the curb & gutter and be directed to Existing Pond North. This basin remains unchanged from the existing condition.

**Basin C-1g** (0.87 AC, Q5 = 2.1 cfs, Q100 = 4.3 cfs): a basin that includes the front half of lots along Henzlee Place. Runoff will flow from each lot onto the proposed public R.O.W. where proposed mountable curb and gutter will convey flows to an existing 15' CDOT Type R sump inlet at **DP 12**. Runoff is conveyed downstream via existing 42" RCP to **DP 13** where flows are combined within Existing Pond North. Emergency overflows will overtop the curb & gutter and be directed to Existing Pond North.

**Basin C-1h** (1.12 AC, Q5 = 1.7 cfs, Q100 = 4.0 cfs): a basin that includes the rear half of lots along Henzlee Place. Runoff will flow from each lot into proposed swale A and conveyed to a proposed CDOT-Type C Inlet at **DP 19**. Flows are conveyed downstream via an existing 18" RCP to **DP 13** where flows are combined within Existing Pond North. Emergency overflows will overtop the adjacent maintenance road and be directed to Existing Pond North. Swale A is located within a tract and maintained by Bent Grass Metropolitan District.

**Basin C-5** (0.51 AC, Q5 = 0.0 cfs, Q100 = 0.6 cfs): a basin that encompasses Existing Pond North. Runoff will sheet flow directly to Existing Pond North at **DP 13**. This basin receives flows from **DP 12** and **DP 19**.

**Basin D-4c** (3.00 AC, Q5 = 5.4 cfs, Q100 = 11.2 cfs): a basin that includes residential lots and the east half of Jayla Trail and Henzlee Place. Runoff will flow from each lot onto the proposed public R.O.W. where existing mountable curb and gutter will convey flows to an existing 15' CDOT Type R sump inlet at **DP 17**. Runoff is conveyed downstream via existing 24" RCP to **DP31** where flows outfall into existing Pond South. Emergency overflows will overtop the curb & gutter and be directed to Existing Pond South via an existing emergency overflow swale.

**Basin D-7** (8.01 AC, Q5 = 1.7 cfs, Q100 = 10.0 cfs): a basin that includes the rear portion of residential lots along Linley Way and Jayla Trail, respectively. The portion of this basin impacted by proposed design for Falcon Meadows at Bent Grass Filing No. 4 will sheet flow to the rear property line, then onward directly to Existing Pond South.

**Basin D-8** (1.46 AC, Q5 = 0.6 cfs, Q100 = 2.3 cfs): a basin that includes the rear portion of residential lots along Jayla Trail & Henzlee Place. Runoff will sheet flow towards the rear property line to proposed Swale C, where runoff is directed to Existing Pond South at **DP 32**. Swale C is located within a tract and will be maintained by Bent Grass Metropolitan District.

**Design Point AA** is the location in channel reach RWT204, where flows are conveyed under Bent Grass Meadows Drive within an existing twin 16' x 6' RCBC. The minor flows are 335.9 cfs and the major flows are 1450 cfs. The MDDP Amendment, from the HEC-HMS model, has flows of 191.8 cfs and 1075.3 cfs for the 5- and 100-year flows under proposed/future conditions analysis. The FEMA FIS report has a total flow of 1400 cfs in channel reach RWT210. Falcon Meadows at Bent Grass Filing No. 4 will not increase these flows.

**Design Point 8** is the location of the existing 20' CDOT Type R curb inlet where by-pass flows are received from **DP 5a** and **DP 4a**. As shown in existing excerpts (Appendix B) the current flows at DP 8 is 10.0 cfs in the minor storm, and 22.2 cfs in the major storm. The proposed condition adds 2.8 cfs in the major storm, and 13.1 cfs in the minor storm, totaling to 12.8 cfs in the minor storm, and 35.3 cfs in the major storm. The capacity of the existing inlet is 14.4 cfs in the minor storm, and 52.7 in the major storm. Therefore, the inlet has sufficient capacity with the added bypass flow.

## IX. Storm Sewer System

All development is anticipated to be urban and will include storm sewer & street inlets. Storm sewers collect storm water runoff and convey the water to existing water quality facilities prior to discharging. Storm sewer systems will be designed to the 100-year storm and checked with the 5-year storm. Inlets will be placed at sump areas and intersections where street flow is larger than street capacity. The UDFCD Inlet spreadsheet is used to determine the size of all at-grade and sump inlets. There will be 1 proposed storm system and three existing systems within the site.

The proposed storm system (Storm System A), collects flows northeast of Bent Grass Meadows Drive, over to Existing Pond 1 just west from Lemon Grass Road. These flows are routed directly to Existing Pond 1, constructed as part of Bent Grass Residential Filing No. 2. The design of the proposed system has been included in the appendix. Flows not intercepted from this area, reach the existing sump inlet at DP 8, which releases into the existing WQCV pond in Bent Grass Residential Filing No. 2. All design calculations (StormCAD, inlet design & street capacity spreadsheets, etc.) have been included in Appendix D for this system.

The inlets located within Bent Grass Meadows Drive (DP-8), Henzlee Place (DP-12), and Jayla Trail (DP-17) were all designed under the FDRs for Bent Grass Residential Filing No. 2, Falcon Meadows at Bent Grass Filing No. 3, and Falcon Meadows at Bent Grass Filing No. 2, respectively. The inlets were "rechecked" based on updated flows reaching each of these design points. The analysis of these inlets is included in Appendix D. Analysis of the existing inlets, have also been included in Appendix D, to ensure inlets still perform adequately.

The proposed inlets located within Lemon Grass Drive (DP-4 & DP-5) are 15' & 10' at-grade CDOT Type R inlets were sized appropriately to intercept flows so that the existing 20' CDOT Type R sump inlet at DP 8 has sufficient capacity for the added bypass flows. The analysis of these inlets is included in Appendix D.

## X. Proposed Water Quality Detention Ponds

There are 3 facilities which provide water quality for this site. One facility was constructed under the Bent Grass Residential Filing No. 2 project and is located north of Bent Grass Meadows Drive (*Existing Pond 1*). An existing inlet at DP 8 and proposed inlets at DP 4 and DP 5 releases collected runoff into this facility. The second WQCV (*Existing Pond South*) was constructed as part of the Falcon Meadows at Bent Grass Filing No. 1 project and is situated north of the southern property line and west of the existing channel. Design Points 30, 31 and 32 are the ultimate outfalls releasing into this facility. The final WQCV facility (*Existing Pond North*) was constructed as part of Falcon Meadows at Bent Grass Filing No. 2 and is located north of Bent Grass Meadows Drive and west of the existing facility built with Bent Grass Residential Filing No. 2. Ultimate release points into this facility are DP 19 and 12. An analysis of the existing pond facilities (*Existing Pond 1, Existing Pond South, and Existing Pond North*) is included in

Appendix E to ensure they function adequately with minor revisions made to hydrology routing with this filing.

All three facilities release treated waters to the existing channel at RWT204 (north of Bent Grass Meadows Drive) or RWT210 (south of Bent Grass Meadows Drive).

Basin B-1 represents the improvements that is to be constructed as a part of CDR-21-014. Falcon Meadows at Bent Grass Drainage Channel (CDR-21-014) is a standalone stream stabilization project, and therefore falls under the Water Quality I.7.1.B.7 exclusion. These improvements will be completed prior to the recording of the Falcon Meadows at Bent Grass Filing No. 4 Final Plat. Therefore, it does not “count” towards the allowable 1 acre of area to be untreated from the site.

Basin A-2 will outfall directly into RWT204 untreated. The total area of this basin is 0.71 acres, less than the allowable 1 acre. All roof drains (for lots 13-21) within Basin A-2 will be directed toward Lemon Grass Road.

## **XI. Channel and Swales**

### **Swales**

Swale A and Swale C were designed for this Filing within the Falcon Meadows at Bent Grass development. Analysis has been provided in Appendix D of this report.

### **Channel**

No channel improvements are proposed in this project. Please refer to Falcon Meadows at Bent Grass Drainage Channel (CDR-21-014) for the associated adjacent channel improvements. The channel construction as shown in (CDR-21-014) must be completed prior to the recording of Falcon Meadows at Bent Grass Filing No. 4 Final Plat.

## **XII. Maintenance**

After completion of construction and upon the Board of County Commissioners acceptance, all public drainage facilities within easements and public Right-of-Way will be owned and maintained by El Paso County. All private drainage facilities shown on this project will be owned and maintained by Bent Grass Metropolitan District.

## **XIII. Wetlands Mitigation**

No wetlands are located on site.

## **XIV. Floodplain Statement**

A portion of the project site lies within Zone AE Special Flood Hazard Area as defined by the FIRM Map number 08041C0553G effective December 7, 2018. A copy of the FIRM Panel is included in Appendix A.

## **XV. Drainage/Bridge Fees and Credits/Reimbursements**

The site lies within the Falcon Drainage Basin. The DBPS was approved in 2013 and has drainage and bridge fees associated with the basin.

The project site has a total area of 10.42 acres. The tracts account for a total of 4.05 acres, 39 residential lots are 5.73 acres and 1.04 acres of right-of-way. The following calculations for the imperviousness of this development have been computed as follows:

$$\text{Average Residential lot size: } 5.73 \text{ acres} / 39 \text{ lots} = 6,398 \text{ sf/lot}$$

$$\text{Average lot imperviousness} = 6,398 \text{ sf} \times 43\% = 2,751 \text{ sf}$$

$$\text{Average Residential imperviousness: } 2,751/6,398 = 43.0\%$$

ROW area is 100% impervious

Open Space is 0% impervious

Average imperviousness for developed area:

$$(0.43 \times 5.73) + (1.0 \times 1.04) + (0 \times 4.05) / 10.42 = 0.3363$$

$$10.42 \text{ acres} \times 33.63\% = 3.5039 \text{ Impervious Acres}$$

The following calculations are based on the 2022 Falcon Basin drainage/bridge fees:

**Drainage Fees**

$$\$34,117 \times 3.5039 \text{ Imp. Acres} = \underline{\$119,542.56}$$

**Bridge Fees**

$$\$4,687 \times 3.5039 \text{ Imp. Acres} = \underline{\$16,422.78}$$

Per discussions with El Paso County the fees will be offset by drainage improvements. The tables on the next page provide a tabular summary of previous fees and offsets for the overall Bent Grass development.

**(SF-19-014) Bent Grass Residential Filing No. 2 - Final Drainage Report**  
**FALCON DRAINAGE BASIN**  
**2019 Original Drainage and Bridge Fees**

	Impervious Area (acres) *	Fee Per Impervious Acre	=	Total Fee	- (	Total Collateral from FAE	+	Remaining Fee Offset from Previous Filings	) =	Remaining Fee Offset	OR	Fee Due at Platting
Drainage Fee	23.45	\$ 29,622.00	=	\$ 694,635.90	- (	\$ 1,270,481.00	+	\$ -	) =	\$ 575,845.10		
Bridge Fee	23.45	\$ 4,069.00	=	\$ 95,418.05	- (	\$ 480,000.00	+	\$ -	) =	\$ 384,581.95		

**(SF-21-020) Falcon Meadows at Bent Grass Filing No. 1 - Final Drainage Report**  
**FALCON DRAINAGE BASIN**  
**2021 Original Drainage and Bridge Fees**

	Impervious Area (acres) *	Fee Per Impervious Acre	=	Total Fee	- (	Total Collateral from FAE	+	Remaining Fee Offset from Previous Filings	) =	Remaining Fee Offset	OR	Fee Due at Platting
Drainage Fee	5.73	\$ 31,885.00	=	\$ 182,701.05	- (	\$ -	+	\$ 575,845.10	) =	\$ 393,144.05		
Bridge Fee	5.73	\$ 4,380.00	=	\$ 25,097.40	- (	\$ -	+	\$ 384,581.95	) =	\$ 359,484.55		

**(SF-21-034) Falcon Meadows at Bent Grass Filing No. 2 - Final Drainage Report**  
**FALCON DRAINAGE BASIN**  
**2021 Original Drainage and Bridge Fees**

	Impervious Area (acres) *	Fee Per Impervious Acre	=	Total Fee	- (	Total Collateral from FAE	+	Remaining Fee Offset from Previous Filings	) =	Remaining Fee Offset	OR	Fee Due at Platting
Drainage Fee	9.6	\$ 31,885.00	=	\$ 306,096.00	- (	\$ -	+	\$ 393,144.05	) =	\$ 87,048.05		
Bridge Fee	9.6	\$ 4,380.00	=	\$ 42,048.00	- (	\$ -	+	\$ 359,484.55	) =	\$ 317,436.55		

**(SF-22-016) Falcon Meadows at Bent Grass Filing No. 3 - Final Drainage Report**  
**FALCON DRAINAGE BASIN**  
**2022 Original Drainage and Bridge Fees**

	Impervious Area (acres) *	Fee Per Impervious Acre	=	Total Fee	- (	Total Collateral from FAE	+	Remaining Fee Offset from Previous Filings	) =	Remaining Fee Offset	OR	Fee Due at Platting
Drainage Fee	6.665	\$ 34,117.00	=	\$ 227,389.81	- (	\$ -	+	\$ 87,048.05	) =			\$ (140,341.76)
Bridge Fee	6.665	\$ 4,687.00	=	\$ 31,238.86	- (	\$ -	+	\$ 317,436.55	) =	\$ 286,197.70		

**(SF-22-023) Falcon Meadows at Bent Grass Filing No. 4 - Final Drainage Report**  
**FALCON DRAINAGE BASIN**  
**2022 Original Drainage and Bridge Fees**

	Impervious Area (acres) *	Fee Per Impervious Acre	=	Total Fee	- (	Total Collateral from FAE	+	Remaining Fee Offset from Previous Filings	) =	Remaining Fee Offset	OR	Fee Due at Platting
Drainage Fee	3.504	\$ 34,117.00	=	\$ 119,542.56	- (	\$ -	+	\$ -	) =			\$ (119,542.56)
Bridge Fee	3.504	\$ 4,687.00	=	\$ 16,422.78	- (	\$ -	+	\$ 317,436.55	) =	\$ 301,013.77		

Below is a cost estimate for the improvements proposed with this filing.

Item	Quantity	Unit	Unit Cost	Cost
<b>Storm Drain Improvements</b>				
5' CDOT Type R Inlet (Public)	1	EA	\$ 7,212.00	\$ 7,212.00
10' CDOT Type R Inlet (Public)	1	EA	\$ 9,925.00	\$ 9,925.00
15' CDOT Type R Inlet (Public)	1	EA	\$ 12,907.00	\$ 12,907.00
CDOT Type C Inlet (Private)	1	EA	\$ 6,037.00	\$ 6,037.00
15" RCP Storm Drain (Public)	195	LF	\$ 60.00	\$ 2,340.00
24" RCP Storm Drain (Public)	35	LF	\$ 98.00	\$ 3,430.00
<b>Total</b>				<b>\$ 41,851.00</b>
Contingency			10%	\$ 4,185.00
<b>Grand Total</b>				<b>\$ 46,036.00</b>
<b>Existing Pond 1 Improvements (Private)</b>				
24" RCP Storm Drain (Private)	53	LF	\$ 98.00	\$ 5,194.00
Trickle Channel	75	LF	\$ 15.00	\$ 1,125.00
Fence (Forebay)	46	LF	\$ 3.00	\$ 138.00
Forebay	1	EA	\$ 10,000.00	\$ 98.00
<b>Total</b>				<b>\$ 6,555.00</b>
Contingency			10%	\$ 655.00
<b>Grand Total</b>				<b>\$ 7,210.00</b>

## XVI. Conclusion

The Falcon Meadows at Bent Grass Filing No. 4 Subdivision lies within the West Tributary of the Falcon Basin Area Watershed. Detention for the site is provided from three existing WQCV ponds to provide water quality for the entire tributary area. The proposed development will not have any adverse impacts to downstream developments or existing drainageways.

## XVII. References

1. *City of Colorado Springs/County of El Paso Drainage Criteria Manual*, October 1991.
2. *Drainage Criteria Manual, Volume 2*, City of Colorado Springs, November 2002.
3. *Urban Storm Drainage Criteria Manual*, Urban Drainage and Flood Control District, January 2016 (with current revisions).
4. *Falcon Drainage Basin Planning Study*, by Matrix Design Group, September 2015.
5. *Master Development Drainage Plan and Preliminary Drainage Plan – Bent Grass Subdivision*, by Kiowa Engineering Corporation, December 2006.
6. *Final Drainage Report for Bent Grass Residential (Filing No. 1)*, by Classic Consulting Engineers & Surveyors, LLC, August 2014.
7. *Final Drainage Report Addendum for Bent Grass Residential (Filing No. 1)*, by Classic Consulting Engineers & Surveyors, LLC, August 2015.
8. *Master Development Drainage Plan for The Ranch*, by Classic Consulting Engineers & Surveyors, LLC, November 2018.



9. *Falcon Highlands Master Development Drainage Plan & Preliminary Drainage Report & Final Drainage Report for Filing 1*, by URS, January 2005.
10. *Final Drainage Report and Erosion Control Plan – Latigo Business Center Filing No. 1 A Re-subdivision of a Portion of Latigo Business and Research Center Filing No. 1*, by Kiowa Engineering Corporation, November 2004.
11. *Final Drainage Report for Bent Grass Residential (Filing No. 2)*, by Galloway & Company, May 2020.
12. *Preliminary Drainage Report-Falcon Meadows at Bent Grass*, by Galloway & Company, February 2021.
13. *Final Drainage Report for Falcon Meadows at Bent Grass Filing No. 1*, by Galloway & Company, September 2021.
14. *Final Drainage Report for Falcon Meadows at Bent Grass Filing No. 2*, by Galloway & Company, April, 2022.
15. *Final Drainage Report for Falcon Meadows at Bent Grass Filing No. 3*, by Galloway & Company, August, 2022.

**APPENDIX A**  
**Exhibits and Figures**



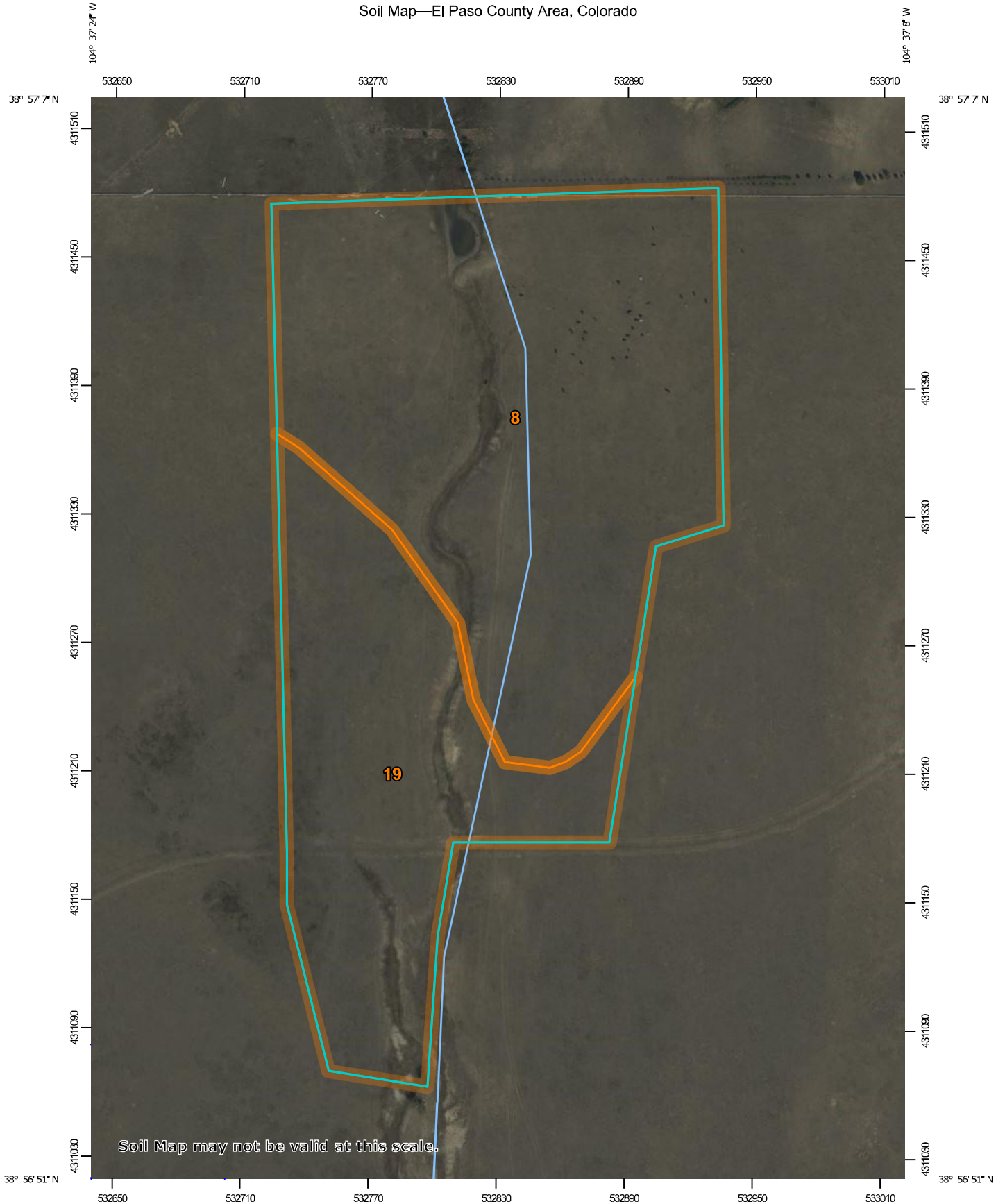



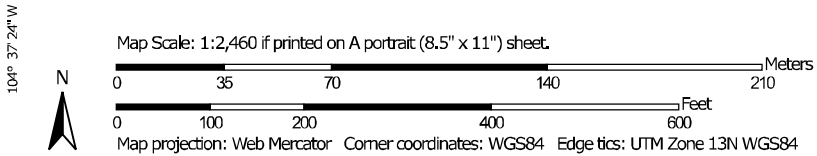





























Soil Map—El Paso County Area, Colorado



Soil Map may not be valid at this scale.



## MAP LEGEND

-  **Area of Interest (AOI)**
-  Area of Interest (AOI)
- Soils**
-  Soil Map Unit Polygons
-  Soil Map Unit Lines
-  Soil Map Unit Points
- Special Point Features**
-  Blowout
-  Borrow Pit
-  Clay Spot
-  Closed Depression
-  Gravel Pit
-  Gravelly Spot
-  Landfill
-  Lava Flow
-  Marsh or swamp
-  Mine or Quarry
-  Miscellaneous Water
-  Perennial Water
-  Rock Outcrop
-  Saline Spot
-  Sandy Spot
-  Severely Eroded Spot
-  Sinkhole
-  Slide or Slip
-  Sodic Spot
-  Spoil Area
-  Stony Spot
-  Very Stony Spot
-  Wet Spot
-  Other
-  Special Line Features
- Water Features**
-  Streams and Canals
- Transportation**
-  Rails
-  Interstate Highways
-  US Routes
-  Major Roads
-  Local Roads
- Background**
-  Aerial Photography

## MAP INFORMATION

The soil surveys that comprise your AOI were mapped at 1:24,000.

Warning: Soil Map may not be valid at this scale.

Enlargement of maps beyond the scale of mapping can cause misunderstanding of the detail of mapping and accuracy of soil line placement. The maps do not show the small areas of contrasting soils that could have been shown at a more detailed scale.

Please rely on the bar scale on each map sheet for map measurements.

Source of Map: Natural Resources Conservation Service  
 Web Soil Survey URL:  
 Coordinate System: Web Mercator (EPSG:3857)

Maps from the Web Soil Survey are based on the Web Mercator projection, which preserves direction and shape but distorts distance and area. A projection that preserves area, such as the Albers equal-area conic projection, should be used if more accurate calculations of distance or area are required.

This product is generated from the USDA-NRCS certified data as of the version date(s) listed below.

Soil Survey Area: El Paso County Area, Colorado  
 Survey Area Data: Version 19, Aug 31, 2021

Soil map units are labeled (as space allows) for map scales 1:50,000 or larger.

Date(s) aerial images were photographed: Sep 11, 2018—Oct 20, 2018

The orthophoto or other base map on which the soil lines were compiled and digitized probably differs from the background imagery displayed on these maps. As a result, some minor shifting of map unit boundaries may be evident.

## Map Unit Legend

Map Unit Symbol	Map Unit Name	Acres in AOI	Percent of AOI
8	Blakeland loamy sand, 1 to 9 percent slopes	10.0	63.4%
19	Columbine gravelly sandy loam, 0 to 3 percent slopes	5.8	36.6%
<b>Totals for Area of Interest</b>		<b>15.8</b>	<b>100.0%</b>

## El Paso County Area, Colorado

### 8—Blakeland loamy sand, 1 to 9 percent slopes

#### Map Unit Setting

*National map unit symbol:* 369v  
*Elevation:* 4,600 to 5,800 feet  
*Mean annual precipitation:* 14 to 16 inches  
*Mean annual air temperature:* 46 to 48 degrees F  
*Frost-free period:* 125 to 145 days  
*Farmland classification:* Not prime farmland

#### Map Unit Composition

*Blakeland and similar soils:* 98 percent  
*Minor components:* 2 percent  
*Estimates are based on observations, descriptions, and transects of the mapunit.*

#### Description of Blakeland

##### Setting

*Landform:* Hills, flats  
*Landform position (three-dimensional):* Side slope, talf  
*Down-slope shape:* Linear  
*Across-slope shape:* Linear  
*Parent material:* Alluvium derived from sedimentary rock and/or eolian deposits derived from sedimentary rock

##### Typical profile

*A - 0 to 11 inches:* loamy sand  
*AC - 11 to 27 inches:* loamy sand  
*C - 27 to 60 inches:* sand

##### Properties and qualities

*Slope:* 1 to 9 percent  
*Depth to restrictive feature:* More than 80 inches  
*Drainage class:* Somewhat excessively drained  
*Runoff class:* Low  
*Capacity of the most limiting layer to transmit water (Ksat):* High to very high (5.95 to 19.98 in/hr)  
*Depth to water table:* More than 80 inches  
*Frequency of flooding:* None  
*Frequency of ponding:* None  
*Calcium carbonate, maximum content:* 5 percent  
*Available water supply, 0 to 60 inches:* Low (about 4.5 inches)

##### Interpretive groups

*Land capability classification (irrigated):* 3e  
*Land capability classification (nonirrigated):* 6e  
*Hydrologic Soil Group:* A  
*Ecological site:* R049XB210CO - Sandy Foothill  
*Hydric soil rating:* No

### **Minor Components**

#### **Other soils**

*Percent of map unit:* 1 percent

*Hydric soil rating:* No

#### **Pleasant**

*Percent of map unit:* 1 percent

*Landform:* Depressions

*Hydric soil rating:* Yes

## **Data Source Information**

Soil Survey Area: El Paso County Area, Colorado

Survey Area Data: Version 19, Aug 31, 2021

## El Paso County Area, Colorado

### 19—Columbine gravelly sandy loam, 0 to 3 percent slopes

#### Map Unit Setting

*National map unit symbol:* 367p  
*Elevation:* 6,500 to 7,300 feet  
*Mean annual precipitation:* 14 to 16 inches  
*Mean annual air temperature:* 46 to 50 degrees F  
*Frost-free period:* 125 to 145 days  
*Farmland classification:* Not prime farmland

#### Map Unit Composition

*Columbine and similar soils:* 97 percent  
*Minor components:* 3 percent  
*Estimates are based on observations, descriptions, and transects of the mapunit.*

#### Description of Columbine

##### Setting

*Landform:* Flood plains, fan terraces, fans  
*Down-slope shape:* Linear  
*Across-slope shape:* Linear  
*Parent material:* Alluvium

##### Typical profile

*A - 0 to 14 inches:* gravelly sandy loam  
*C - 14 to 60 inches:* very gravelly loamy sand

##### Properties and qualities

*Slope:* 0 to 3 percent  
*Depth to restrictive feature:* More than 80 inches  
*Drainage class:* Well drained  
*Runoff class:* Very low  
*Capacity of the most limiting layer to transmit water (Ksat):* High to very high (5.95 to 19.98 in/hr)  
*Depth to water table:* More than 80 inches  
*Frequency of flooding:* None  
*Frequency of ponding:* None  
*Available water supply, 0 to 60 inches:* Very low (about 2.5 inches)

##### Interpretive groups

*Land capability classification (irrigated):* 4e  
*Land capability classification (nonirrigated):* 6e  
*Hydrologic Soil Group:* A  
*Ecological site:* R049XY214CO - Gravelly Foothill  
*Hydric soil rating:* No

#### Minor Components

##### Fluvaquentic haplaquolls

*Percent of map unit:* 1 percent



*Landform: Swales*  
*Hydric soil rating: Yes*

**Other soils**

*Percent of map unit: 1 percent*  
*Hydric soil rating: No*

**Pleasant**

*Percent of map unit: 1 percent*  
*Landform: Depressions*  
*Hydric soil rating: Yes*

## Data Source Information

Soil Survey Area: El Paso County Area, Colorado  
Survey Area Data: Version 19, Aug 31, 2021

**NOTES TO USERS**

This map is for use in administering the National Flood Insurance Program. It does not necessarily identify all areas subject to flooding, particularly from local drainage sources of small size. The community map repository should be consulted for possible updated or additional flood hazard information.

To obtain more detailed information in areas where **Base Flood Elevations (BFEs)** and/or **floodways** have been determined, users are encouraged to consult the Flood Profiles and Floodway Data and/or Summary of Stillwater Elevations tables contained within the Flood Insurance Study (FIS) report that accompanies this FIRM. Users should be aware that BFEs shown on the FIRM represent rounded whole-foot elevations. These BFEs are intended for flood insurance rating purposes only and should not be used as the sole source of flood elevation information. Accordingly, flood elevation data presented in the FIS report should be utilized in conjunction with the FIRM for purposes of construction and/or floodplain management.

**Coastal Base Flood Elevations** shown on this map apply only landward of 0.0' North American Vertical Datum of 1988 (NAVD88). Users of this FIRM should be aware that coastal flood elevations are also provided in the Summary of Stillwater Elevations table in the Flood Insurance Study report for this jurisdiction. Elevations shown in the Summary of Stillwater Elevations table should be used for construction and/or floodplain management purposes when they are higher than the elevations shown on this FIRM.

Boundaries of the **floodways** were computed at cross sections and interpolated between cross sections. The floodways were based on hydraulic considerations with regard to requirements of the National Flood Insurance Program. Floodway widths and other pertinent floodway data are provided in the Flood Insurance Study report for this jurisdiction.

Certain areas not in Special Flood Hazard Areas may be protected by **flood control structures**. Refer to section 2.4 "Flood Protection Measures" of the Flood Insurance Study report for information on flood control structures for this jurisdiction.

The **projection** used in the preparation of this map was Universal Transverse Mercator (UTM) zone 13. The **horizontal datum** was NAD83, GRS80 spheroid. Differences in datum, spheroid, projection or UTM zones used in the production of FIRMs for adjacent jurisdictions may result in slight positional differences in map features across jurisdiction boundaries. These differences do not affect the accuracy of this FIRM.

Flood elevations on this map are referenced to the **North American Vertical Datum of 1988 (NAVD88)**. These flood elevations must be compared to structure and ground elevations referenced to the same vertical datum. For information regarding conversion between the National Geodetic Vertical Datum of 1929 and the North American Vertical Datum of 1988, visit the National Geodetic Survey website at <http://www.ngs.noaa.gov/> or contact the National Geodetic Survey at the following address:

NGS Information Services  
NOAA, NINGS12  
National Geodetic Survey  
SSMC-3, #9202  
1315 East-West Highway  
Silver Spring, MD 20910-3282

To obtain current elevation, description, and/or location information for **bench marks** shown on this map, please contact the Information Services Branch of the National Geodetic Survey at (301) 713-3242 or visit its website at <http://www.ngs.noaa.gov/>.

**Base Map** information shown on this FIRM was provided in digital format by El Paso County, Colorado Springs Utilities, City of Fountain, Bureau of Land Management, National Oceanic and Atmospheric Administration, United States Geological Survey, and Anderson Consulting Engineers, Inc. These data are current as of 2006.

This map reflects more detailed and up-to-date **stream channel configurations and floodplain delineations** than those shown on the previous FIRM for this jurisdiction. The floodplains and floodways that were transferred from the previous FIRM may have been adjusted to conform to these new stream channel configurations. As a result, the Flood Profiles and Floodway Data tables in the Flood Insurance Study Report (which contains authoritative hydraulic data) may reflect stream channel distances that differ from what is shown on this map. The profile baselines depicted on this map represent the hydraulic modeling baselines that match the flood profiles and Floodway Data Tables if applicable, in the FIS report. As a result, the profile baselines may deviate significantly from the new base map channel representation and may appear outside of the floodplain.

**Corporate limits** shown on this map are based on the best data available at the time of publication. Because changes due to annexations or de-annexations may have occurred after this map was published, map users should contact appropriate community officials to verify current corporate limit locations.

Please refer to the separately printed **Map Index** for an overview map of the county showing the layout of map panels; community map repository addresses; and a Listing of Communities table containing National Flood Insurance Program dates for each community as well as a listing of the panels on which each community is located.

Contact **FEMA Map Service Center (MSC)** via the FEMA Map Information eXchange (FMIX) 1-877-336-2627 for information on available products associated with this FIRM. Available products may include previously issued Letters of Map Change, a Flood Insurance Study Report, and/or digital versions of this map. The MSC may also be reached by Fax at 1-800-358-9820 and its website at <http://www.msc.fema.gov/>.

If you have **questions about this map** or **questions concerning the National Flood Insurance Program** in general, please call **1-877-FEMA MAP (1-877-336-2627)** or visit the FEMA website at <http://www.fema.gov/business/nfp>.

El Paso County Vertical Datum Offset Table	
Flooding Source	Vertical Datum Offset (ft)
REFER TO SECTION 3.3 OF THE EL PASO COUNTY FLOOD INSURANCE STUDY FOR STREAM BY STREAM VERTICAL DATUM CONVERSION INFORMATION	

**Panel Location Map**

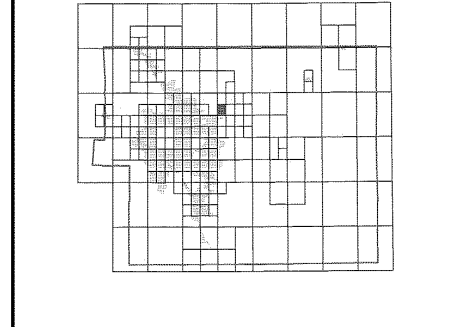

This Digital Flood Insurance Rate Map (DFIRM) was produced through a Cooperating Technical Partner (CTP) agreement between the State of Colorado Water Conservation Board (CWCB) and the Federal Emergency Management Agency (FEMA).

Additional Flood Hazard information and resources are available from local communities and the Colorado Water Conservation Board.

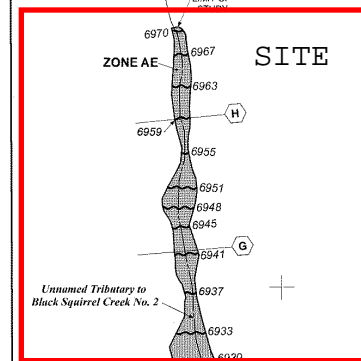
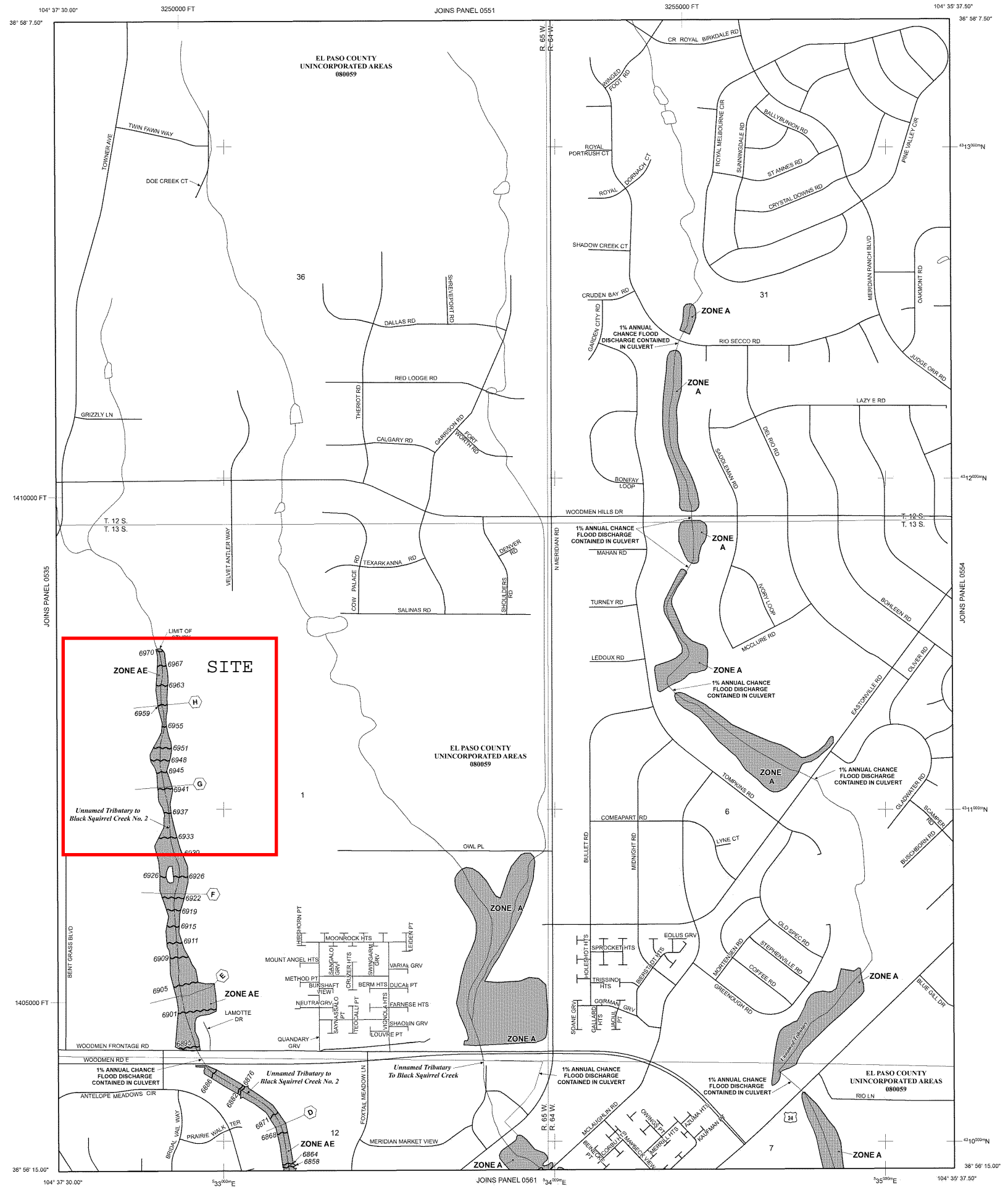

**LEGEND**

- SPECIAL FLOOD HAZARD AREAS (SFHAS) SUBJECT TO INUNDATION BY THE 1% ANNUAL CHANCE FLOOD**
  - ZONE A** No Base Flood Elevations determined.
  - ZONE AE** Base Flood Elevations determined.
  - ZONE AH** Flood depths of 1 to 3 feet (usually areas of ponding); Base Flood Elevations determined.
  - ZONE AO** Flood depths of 1 to 3 feet (usually sheet flow on sloping terrain); average depths determined. For areas of alluvial fan flooding, velocities also determined.
  - ZONE AR** Special Flood Hazard Area Formerly protected from the 1% annual chance flood by a flood control system that was subsequently decertified. Zone AR indicates that the former flood control system is being restored to provide protection from the 1% annual chance or greater flood.
  - ZONE A99** Area to be protected from 1% annual chance flood by a Federal flood protection system under construction; no Base Flood Elevations determined.
  - ZONE V** Coastal flood zone with velocity hazard (wave action); no Base Flood Elevations determined.
  - ZONE VE** Coastal flood zone with velocity hazard (wave action); Base Flood Elevations determined.
- FLOODWAY AREAS IN ZONE AE**
  - The floodway is the channel of a stream plus any adjacent floodplain areas that must be kept free of encroachment so that the 1% annual chance flood can be carried without substantial increases in flood heights.
- OTHER FLOOD AREAS**
  - ZONE X** Areas of 0.2% annual chance flood; areas of 1% annual chance flood with average depths of less than 1 foot or with drainage areas less than 1 square mile; and areas protected by levees from 1% annual chance flood.
- OTHER AREAS**
  - ZONE X** Areas determined to be outside the 0.2% annual chance floodplain.
  - ZONE D** Areas in which flood hazards are undetermined, but possible.
- COASTAL BARRIER RESOURCES SYSTEM (CBRS) AREAS**
- OTHERWISE PROTECTED AREAS (OPAs)**
  - CBRS areas and OPAs are normally located within or adjacent to Special Flood Hazard Areas.
- Boundaries**
  - Floodplain boundary
  - Floodway boundary
  - Zone D Boundary
  - CBRS and OPA boundary
- Boundary dividing Special Flood Hazard Areas of different Base Flood Elevations, flood depths or flood velocities**
- Base Flood Elevation line and value; elevation in feet\***
- Base Flood Elevation value where uniform within zone; elevation in feet\***

\* Referenced to the North American Vertical Datum of 1988 (NAVD 88)

- A-A** Cross section line
- 23-23** Transect line
- 97° 07' 30.00" 32° 22' 30.00"** Geographic coordinates referenced to the North American Datum of 1983 (NAD 83)
- 4750000N** 1000-meter Universal Transverse Mercator grid ticks, zone 13
- 6000000 FT** 5000-foot grid ticks: Colorado State Plane coordinate system, central zone (FIPSZONE 0502), Lambert Conformal Conic Projection
- DX5510** Bench mark (see explanation in Notes to Users section of this FIRM panel)
- M1.5** River Mile

**MAP REPOSITORIES**  
Refer to Map Repositories list on Map Index

**EFFECTIVE DATE OF COUNTYWIDE FLOOD INSURANCE RATE MAP**  
MARCH 17, 1997

**EFFECTIVE DATE(S) OF REVISION(S) TO THIS PANEL**  
DECEMBER 7, 2018 - to update corporate limits, to change Base Flood Elevations and Special Flood Hazard Areas, to update map format, to add roads and road names, and to incorporate previously issued Letters of Map Revision.

For community map revision history prior to countywide mapping, refer to the Community Map History Table located in the Flood Insurance Study report for this jurisdiction.

To determine if flood insurance is available in this community, contact your insurance agent or call the National Flood Insurance Program at 1-800-638-6620.

**MAP SCALE 1" = 500'**

**NFP**

**PANEL 0553G**

**FIRM**  
FLOOD INSURANCE RATE MAP  
EL PASO COUNTY,  
COLORADO  
AND INCORPORATED AREAS

**PANEL 553 OF 1300**  
(SEE MAP INDEX FOR FIRM PANEL LAYOUT)

CONTAINS:  
COMMUNITY NUMBER PANEL SUFFIX  
EL PASO COUNTY 08059 0553 G

Noted to User: The Map Number shown below should be used when placing map orders. The Community Number shown above should be used on insurance applications for the subject community.

**MAP NUMBER**  
08041C0553G

**MAP REVISED**  
DECEMBER 7, 2018

Federal Emergency Management Agency

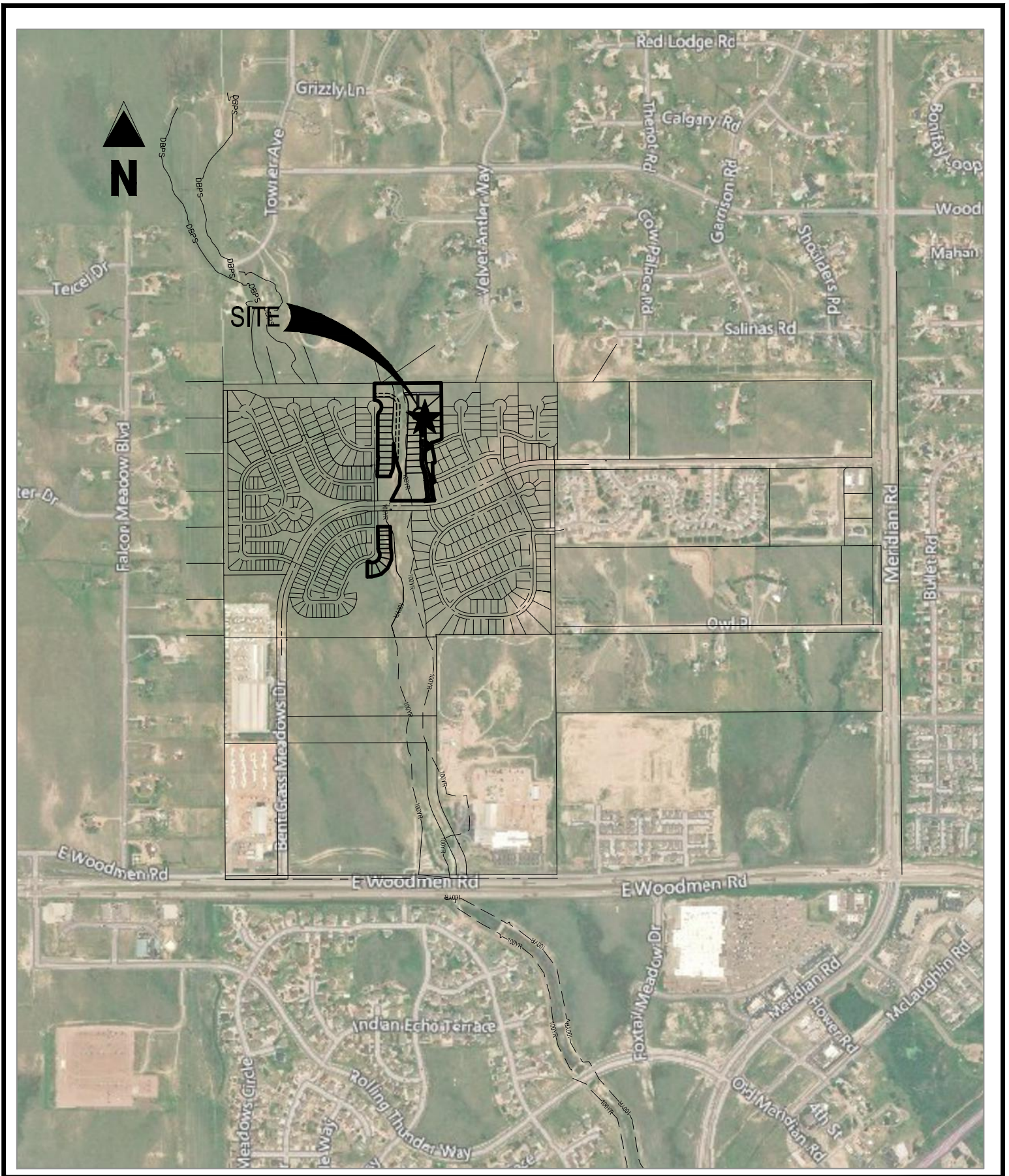

FALCON MEADOWS AT BENT GRASS  
 FILING NO. 4  
 BENT GRASS MEADOWS DRIVE  
 SCALE: 1"=1,000'  
 VICINITY MAP

Project No:	CLH000021.20
Drawn By:	TJE
Checked By:	CMD
Date:	07/08/2021

**Galloway**  
 1155 Kelly Johnson Blvd., Suite 305  
 Colorado Springs, CO 80920  
 719.900.7220 • GallowayUS.com

**APPENDIX B**  
**Excerpts From Previous Reports**

## Historic Computations

### COMPOSITE % IMPERVIOUS CALCULATIONS (EXISTING/HISTORIC CONDITIONS)

**Subdivision:** Falcon Meadows

Falcon Meadows at Bent Grass Filing No. 3

**Location:** CO, Colorado Springs

CLH020.20

TJE

CMD

12/2/20

Basin ID	Total Area (ac)	Paved Roads			Lawns			Roofs			Basins Total Weighted % Imp.
		% Imp.	Area (ac)	Weighted % Imp.	% Imp.	Area (ac)	Weighted % Imp.	% Imp.	Area (ac)	Weighted % Imp.	
<b>OFFSITE BASINS</b>											
WT200	192.00										10.0
OS-25	14.13	100	0.17	1.2	2	13.71	1.9	90	0.22	1.4	4.5
OS-26	5.81	100	0.00	0.0	2	5.81	2.0	90	0.00	0.0	2.0
OS-1	13.06	100	0.84	6.4	2	11.65	1.8	90	0.57	3.9	12.1
OS-2	17.81	100	2.00	11.2	2	15.18	1.7	90	0.63	3.2	16.1
OS-4	30.69	100	1.42	4.6	2	28.41	1.9	90	0.86	2.5	9.0
<b>BENT GRASS FILING NO. 2 &amp; BENT GRASS WEST BASINS</b>											
A-1	5.42	100	0.16	3.0	2	5.26	1.9	90	0.00	0.0	4.9
A-2	18.00	100	0.00	0.0	2	18.00	2.0	90	0.00	0.0	2.0
A-3	19.59	100	0.00	0.0	2	19.59	2.0	90	0.00	0.0	2.0
A-4	23.81	100	0.57	2.4	2	23.12	1.9	90	0.12	0.5	4.8
B-1	32.53	100	0.00	0.0	2	32.53	2.0	90	0.00	0.0	2.0
B-2	4.51	100	0.00	0.0	2	4.51	2.0	90	0.00	0.0	2.0
B-3	16.18	100	1.00	6.2	2	15.18	1.9	90	0.00	0.0	8.1

### COMPOSITE RUNOFF COEFFICIENT CALCULATIONS (EXISTING/HISTORIC CONDITIONS)

Subdivision: Falcon Meadows Falcon Meadows at Bent Grass Filing No. 3  
 Location: CO, Colorado Springs CLH020.20  
 TJE  
 CMD  
 12/2/20

Basin ID	Total Area (ac)	Hydrologic Soils Group	Paved Roads			Lawns			Roofs			Composite C <sub>5</sub>	Composite C <sub>100</sub>	
			C <sub>5</sub>	C <sub>100</sub>	Area (ac)	C <sub>5</sub>	C <sub>100</sub>	Area (ac)	C <sub>5</sub>	C <sub>100</sub>	Area (ac)			
<b>OFFSITE BASINS</b>														
WT200	192.00											0.20	0.44	
OS-25	14.13	A	0.90	0.96	0.17	0.09	0.36	13.71	0.73	0.81	0.22	0.11	0.37	
OS-26	5.81	A	0.90	0.96	0.00	0.09	0.36	5.81	0.73	0.81	0.00	0.09	0.36	
OS-1	13.06	A	0.90	0.96	0.84	0.09	0.36	11.65	0.73	0.81	0.57	0.17	0.42	
OS-2	17.81	A	0.90	0.96	2.00	0.09	0.36	15.18	0.73	0.81	0.63	0.20	0.44	
OS-4	30.69	A	0.90	0.96	1.42	0.09	0.36	28.41	0.73	0.81	0.86	0.15	0.40	
<b>BENT GRASS FILING NO. 2 &amp; BENT GRASS WEST BASINS</b>														
A-1	5.42	A	0.90	0.96	0.16	0.09	0.36	5.26	0.73	0.81	0.00	0.11	0.38	
A-2	18.00	A	0.90	0.96	0.00	0.09	0.36	18.00	0.73	0.81	0.00	0.09	0.36	
A-3	19.59	A	0.90	0.96	0.00	0.09	0.36	19.59	0.73	0.81	0.00	0.09	0.36	
A-4	23.81	A	0.90	0.96	0.57	0.09	0.36	23.12	0.73	0.81	0.12	0.11	0.38	
B-1	32.53	A	0.90	0.96	0.00	0.09	0.36	32.53	0.73	0.81	0.00	0.09	0.36	
B-2	4.51	A	0.90	0.96	0.00	0.09	0.36	4.51	0.73	0.81	0.00	0.09	0.36	
B-3	16.18	A	0.90	0.96	1.00	0.09	0.36	15.18	0.73	0.81	0.00	0.14	0.40	

**STANDARD FORM SF-2  
TIME OF CONCENTRATION  
EXISTING/HISTORIC CONDITIONS**

Subdivision: Falcon Meadows \_\_\_\_\_  
Location: CO, Colorado Springs \_\_\_\_\_

Project Name: Falcon Meadows at Bent Grass Filing No. 3 \_\_\_\_\_  
Project No.: CLH020.20 \_\_\_\_\_  
Calculated By: TJE \_\_\_\_\_  
Checked By: CMD \_\_\_\_\_  
Date: 12/2/20 \_\_\_\_\_

SUB-BASIN						INITIAL/OVERLAND			TRAVEL TIME					T <sub>c</sub> CHECK			FINAL T <sub>c</sub> (MIN)
DATA						(T <sub>i</sub> )			(T <sub>t</sub> )					(URBANIZED BASINS)			
BASIN ID	D.A. (AC)	Hydrologic Soils Group	Impervious (%)	C5	C <sub>100</sub>	L (FT)	S (%)	T <sub>i</sub> (MIN)	L (FT)	S (%)	C <sub>v</sub>	VEL. (FPS)	T <sub>t</sub> (MIN)	COMP. T <sub>c</sub> (MIN)	TOTAL LENGTH (FT)	Urbanized T <sub>c</sub> (MIN)	
<b>OFFSITE BASINS</b>																	
WT200	192.00	A	10.00	0.20	0.44	300	2.0	22.7	2060	2.0	15.0	2.1	16.2	38.8	2360.0	23.1	23.1
OS-25	14.13	A	4.50	0.11	0.37	300	2.5	23.1	1400	3.0	15.0	2.6	9.0	32.1	1700.0	19.4	19.4
OS-26	5.81	A	2.00	0.09	0.36	300	2.0	25.4	400	2.0	15.0	2.1	3.1	28.6	700.0	13.9	13.9
OS-1	13.06	A	12.10	0.17	0.42	300	2.5	21.7	1420	2.5	15.0	2.4	10.0	31.7	1720.0	19.6	19.6
OS-2	17.81	A	16.10	0.20	0.44	300	2.3	21.6	1370	2.3	15.0	2.3	10.0	31.7	1670.0	19.3	19.3
OS-4	30.69	A	9.00	0.15	0.40	300	2.3	22.8	2600	2.3	15.0	2.3	19.0	41.9	2900.0	26.1	26.1
<b>BENT GRASS FILING NO. 2 &amp; BENT GRASS WEST BASINS</b>																	
A-1	5.42	A	4.90	0.11	0.38	300	2.5	23.0	466	2.5	15.0	2.4	3.3	26.3	766.0	14.3	14.3
A-2	18.00	A	2.00	0.09	0.36	300	2.4	23.9	1130	2.0	15.0	2.1	8.9	32.8	1430.0	17.9	17.9
A-3	19.59	A	2.00	0.09	0.36	300	2.7	23.0	760	2.7	15.0	2.5	5.1	28.1	1060.0	15.9	15.9
A-4	23.81	A	4.80	0.11	0.38	300	2.0	24.9	1500	2.0	15.0	2.1	11.8	36.7	1800.0	20.0	20.0
B-1	32.53	A	2.00	0.09	0.36	300	2.6	23.3	1100	2.6	15.0	2.4	7.6	30.9	1400.0	17.8	17.8
B-2	4.51	A	2.00	0.09	0.36	300	3.0	22.2	323	5.0	15.0	3.4	1.6	23.8	623.0	13.5	13.5
B-3	16.18	A	8.10	0.14	0.40	300	2.9	21.4	780	2.9	15.0	2.6	5.1	26.4	1080.0	16.0	16.0

**NOTES:**

$T_i = (0.395 * (1.1 - C_5) * (L)^{0.5}) / ((S)^{0.33})$ , S in ft/ft

$T_t = L / 60V$

Velocity  $V = C_v * S^{0.5}$ , S in ft/ft

$T_c \text{ Check} = 10 + L / 180$

For Urbanized basins a minimum  $T_c$  of 5.0 minutes is required.

For non-urbanized basins a minimum  $T_c$  of 10.0 minutes is required

Type of Land Surface	C <sub>v</sub>
Heavy Meadow	2.5
Tillage/field	5
Short pasture and lawns	7
Nearly bare ground	10
Grassed waterway	15
Paved areas and shallow paved swales	20



**STANDARD FORM SF-3**  
**STORM DRAINAGE SYSTEM DESIGN (EXISTING/HISTORIC CONDITIONS)**  
(RATIONAL METHOD PROCEDURE)

Subdivision: Falcon Meadows  
Location: CO, Colorado Springs  
Design Storm: 5-Year

Project Name: Falcon Meadows at Bent Grass Filing No. 3  
Project No.: CLH020.20  
Calculated By: TJE  
Checked By: CMD  
Date: 12/2/20

STREET	Design Point	DIRECT RUNOFF							TOTAL RUNOFF				STREET		PIPE			TRAVEL TIME			REMARKS
		Basin ID	Area (Ac)	Runoff Coeff.	Tc (min)	C*A (Ac)	I (in/hr)	Q (cfs)	Tc (min)	C*A (Ac)	I (in/hr)	Q (cfs)	Slope (%)	Street Flow (cfs)	Design Flow (cfs)	Slope (%)	Pipe Size (inches)	Length (ft)	Velocity (fps)	Tt (min)	
		RWT202	1574.40					46.6	7.69	1.82	14.0										From Falcon DBPS by Matrix (Existing Flows)
		RWT204	38.40					11.4	1.78	3.94	7.0										From Falcon DBPS by Matrix (Existing Flows)
		WT200	192.00					37.8	11.74	2.13	25.0										From Falcon DBPS by Matrix (Existing Flows)
		OS-25	14.13	0.11	19.4	1.55	3.13	4.9													
		OS-26	5.81	0.09	13.9	0.52	3.64	1.9													
		OS-1	13.06	0.17	19.6	2.22	3.12	6.9													
		OS-2	17.81	0.20	19.3	3.56	3.14	11.2													
		OS-4	30.69	0.15	26.1	4.60	2.69	12.4													
<b>BENT GRASS FILING NO. 2 &amp; BENT GRASS WEST BASINS</b>																					
		A-1	5.42	0.11	14.3	0.60	3.60	2.2													
		A-2	18.00	0.09	17.9	1.62	3.25	5.3													
		A-3	19.59	0.09	15.9	1.76	3.43	6.0													
		A-4	23.81	0.11	20.0	2.62	3.09	8.1													
		B-1	32.53	0.09	17.8	2.93	3.27	9.6													
		B-2	4.51	0.09	13.5	0.41	3.68	1.5													
		B-3	16.18	0.14	16.0	2.27	3.42	7.8													

**STANDARD FORM SF-3**  
**STORM DRAINAGE SYSTEM DESIGN**  
(RATIONAL METHOD PROCEDURE)

Subdivision: Falcon Meadows  
Location: CO, Colorado Springs  
Design Storm: 100-Year

Project Name: Falcon Meadows at Bent Grass Filing No. 3  
Project No.: CLH020.20  
Calculated By: TJE  
Checked By: CMD  
Date: 12/2/20

STREET	Design Point	DIRECT RUNOFF							TOTAL RUNOFF				STREET		PIPE			TRAVEL TIME			REMARKS
		Basin ID	Area (Ac)	Runoff Coeff.	Tc (min)	C*A (Ac)	I (in/hr)	Q (cfs)	Tc (min)	C*A (Ac)	I (in/hr)	Q (cfs)	Slope (%)	Street Flow (cfs)	Design Flow (cfs)	Slope (%)	Pipe Size (inches)	Length (ft)	Velocity (fps)	Tt (min)	
		RWT202	1574.40					46.6	252.46	3.05	770.0										From Falcon DBPS by Matrix (Existing Flows)
		RWT204	38.40					11.4	6.51	6.61	43.0										From Falcon DBPS by Matrix (Existing Flows)
		WT200	192.00					37.8	30.73	3.58	110.0										From Falcon DBPS by Matrix (Existing Flows)
		OS-25	14.13	0.37	19.4	5.23	5.26	27.5													
		OS-26	5.81	0.36	13.9	2.09	6.10	12.7													
		OS-1	13.06	0.42	19.6	5.49	5.24	28.8													
		OS-2	17.81	0.44	19.3	7.84	5.28	41.4													
		OS-4	30.69	0.40	26.1	12.28	4.51	55.4													
<b>BENT GRASS FILING NO. 2 &amp; BENT GRASS WEST BASINS</b>																					
		A-1	5.42	0.38	14.3	2.06	6.04	12.4													
		A-2	18.00	0.36	17.9	6.48	5.46	35.4													
		A-3	19.59	0.36	15.9	7.05	5.77	40.7													
		A-4	23.81	0.38	20.0	9.05	5.19	47.0													
		B-1	32.53	0.36	17.8	11.71	5.48	64.2													
		B-2	4.51	0.36	13.5	1.62	6.18	10.0													
		B-3	16.18	0.40	16.0	6.47	5.75	37.2													

## Proposed Computations

## COMPOSITE % IMPERVIOUS CALCULATIONS: PROPOSED

Subdivision: Falcon Meadows  
 Location: CO, Colorado Springs

Project Name: Falcon Meadows at Bent Grass Filing No. 3  
 Project No.: CLH000020  
 Calculated By: CMV  
 Checked By: SMB  
 Date: 12/6/21

Basin ID	Total Area (ac)	Paved/Gravel Roads			Lawns/Undeveloped			Residential - 1/8 Acre			Residential - 1/4 Acre			Residential - 1/3 Acre			Residential - 1/2 Acre			Residential - 1 Acre			Basins Total Weighted % Imp.
		% Imp.	Area (ac)	Weighted % Imp.	% Imp.	Area (ac)	Weighted % Imp.	% Imp.	Area (ac)	Weighted % Imp.	% Imp.	Area (ac)	Weighted % Imp.	% Imp.	Area (ac)	Weighted % Imp.	% Imp.	Area (ac)	Weighted % Imp.	% Imp.	Area (ac)	Weighted % Imp.	
<b>OFFSITE</b>																							
OS-1	32.28	100	2.15	6.7	2	29.25	1.8	65.0	0.00	0.0	40	0.00	0.0	30	0.00	0.0	25	0.00	0.0	20	0.00	0.0	11.0
OS-2	20.07	80	0.90	3.6	2	18.62	1.9	65.0	0.00	0.0	40	0.00	0.0	30	0.00	0.0	25	0.00	0.0	20	0.00	0.0	8.0
OS-3	10.61	80	0.48	3.6	2	9.84	1.9	65.0	0.00	0.0	40	0.00	0.0	30	0.00	0.0	25	0.00	0.0	20	0.00	0.0	8.0
<b>BENT GRASS FILING NO. 2 &amp; FALCON MEADOWS AT BENT GRASS FILING NO. 1</b>																							
EX-1	1.19	100	0.00	0.0	2	1.19	2.0	65.0	0.00	0.0	40	0.00	0.0	30	0.00	0.0	25	0.00	0.0	20	0.00	0.0	2.0
EX-2	1.60	100	0.00	0.0	2	1.60	2.0	65.0	0.00	0.0	40	0.00	0.0	30	0.00	0.0	25	0.00	0.0	20	0.00	0.0	2.0
EX-3	0.66	100	0.00	0.0	2	0.66	2.0	65.0	0.00	0.0	40	0.00	0.0	30	0.00	0.0	25	0.00	0.0	20	0.00	0.0	2.0
B-1	6.59	100	0.00	0.0	2	6.59	2.0	65.0	0.00	0.0	40	0.00	0.0	30	0.00	0.0	25	0.00	0.0	20	0.00	0.0	2.0
B-2	4.16	100	0.00	0.0	2	4.16	2.0	65.0	0.00	0.0	40	0.00	0.0	30	0.00	0.0	25	0.00	0.0	20	0.00	0.0	2.0
D-4a	0.98	100	0.21	21.4	2	0.00	0.0	65.0	0.77	51.1	40	0.00	0.0	30	0.00	0.0	25	0.00	0.0	20	0.00	0.0	72.5
D-4b	0.95	100	0.43	45.3	2	0.00	0.0	65.0	0.52	35.6	40	0.00	0.0	30	0.00	0.0	25	0.00	0.0	20	0.00	0.0	80.9
D-4c	1.22	100	0.43	35.2	2	0.24	0.4	65.0	0.55	29.3	40	0.00	0.0	30	0.00	0.0	25	0.00	0.0	20	0.00	0.0	64.9
D-5	1.08	100	0.22	20.4	2	0.11	0.2	65.0	0.75	45.1	40	0.00	0.0	30	0.00	0.0	25	0.00	0.0	20	0.00	0.0	65.7
D-6a	1.33	100	0.44	33.1	2	0.00	0.0	65.0	0.89	43.5	40	0.00	0.0	30	0.00	0.0	25	0.00	0.0	20	0.00	0.0	76.6
D-6b	2.69	100	0.59	21.9	2	0.00	0.0	65.0	2.10	50.7	40	0.00	0.0	30	0.00	0.0	25	0.00	0.0	20	0.00	0.0	72.6
D-7	7.65	100	0.00	0.0	2	6.22	1.6	65.0	1.43	12.2	40	0.00	0.0	30	0.00	0.0	25	0.00	0.0	20	0.00	0.0	13.8
D-8	1.69	100	0.00	0.0	2	0.11	0.1	65.0	1.58	60.8	40	0.00	0.0	30	0.00	0.0	25	0.00	0.0	20	0.00	0.0	60.9
E-1	1.71	100	0.78	45.6	2	0.23	0.3	65.0	0.00	0.0	40	0.70	16.4	30	0.00	0.0	25	0.00	0.0	20	0.00	0.0	62.3
E-2	0.68	100	0.56	82.4	2	0.12	0.4	65.0	0.00	0.0	40	0.00	0.0	30	0.00	0.0	25	0.00	0.0	20	0.00	0.0	82.8
E-3	0.78	100	0.69	88.5	2	0.09	0.2	65.0	0.00	0.0	40	0.00	0.0	30	0.00	0.0	25	0.00	0.0	20	0.00	0.0	88.7
E-4	0.91	100	0.73	80.2	2	0.18	0.4	65.0	0.00	0.0	40	0.00	0.0	30	0.00	0.0	25	0.00	0.0	20	0.00	0.0	80.6
E-5	0.89	100	0.79	88.8	2	0.10	0.2	65.0	0.00	0.0	40	0.00	0.0	30	0.00	0.0	25	0.00	0.0	20	0.00	0.0	89.0
OS-4	4.46	100	0.00	0.0	2	0.00	0.0	65.0	2.28	33.2	40	1.46	13.1	30	0.00	0.0	25	0.00	0.0	20	0.72	3.2	49.5
OS-5	0.46	100	0.00	0.0	2	0.00	0.0	65.0	0.46	65.0	40	0.00	0.0	30	0.00	0.0	25	0.00	0.0	20	0.00	0.0	65.0
OS-6	1.17	100	0.00	0.0	2	0.00	0.0	65.0	1.17	65.0	40	0.00	0.0	30	0.00	0.0	25	0.00	0.0	20	0.00	0.0	65.0
<b>FALCON MEADOWS AT BENT GRASS FILING NO. 2</b>																							
C-1a	0.27	100	0.15	55.6	2	0.00	0.0	65.0	0.12	28.9	40	0.00	0.0	30	0.00	0.0	25	0.00	0.0	20	0.00	0.0	84.5
C-1d	1.97	100	0.40	20.3	2	0.00	0.0	65.0	1.57	51.8	40	0.00	0.0	30	0.00	0.0	25	0.00	0.0	20	0.00	0.0	72.1
C-1e	0.49	100	0.49	100.0	2	0.00	0.0	65.0	0.00	0.0	40	0.00	0.0	30	0.00	0.0	25	0.00	0.0	20	0.00	0.0	100.0
C-3	0.18	100	0.14	77.8	2	0.02	0.3	65.0	0.02	7.6	40	0.00	0.0	30	0.00	0.0	25	0.00	0.0	20	0.00	0.0	85.7
C-4	2.67	100	0.41	15.4	2	0.84	0.6	65.0	1.41	34.3	40	0.00	0.0	30	0.00	0.0	25	0.00	0.0	20	0.00	0.0	50.3
C-5	0.60	100	0.00	0.0	2	0.60	2.0	65.0	0.00	0.0	40	0.00	0.0	30	0.00	0.0	25	0.00	0.0	20	0.00	0.0	2.0
C-6	0.94	100	0.00	0.0	2	0.65	1.4	65.0	0.29	20.1	40	0.00	0.0	30	0.00	0.0	25	0.00	0.0	20	0.00	0.0	21.5
C-7	0.52	100	0.15	29.4	2	0.00	0.0	65.0	0.37	46.3	40	0.00	0.0	30	0.00	0.0	25	0.00	0.0	20	0.00	0.0	75.7
D-9	0.72	100	0.00	0.0	2	0.46	1.3	65.0	0.26	23.5	40	0.00	0.0	30	0.00	0.0	25	0.00	0.0	20	0.00	0.0	24.8
D-1c	3.95	100	0.33	8.4	2	0.00	0.0	65.0	2.67	43.9	40	0.95	9.6	30	0.00	0.0	25	0.00	0.0	20	0.00	0.0	61.9
D-2a	0.50	100	0.33	66.0	2	0.00	0.0	65.0	0.17	22.7	40	0.00	0.0	30	0.00	0.0	25	0.00	0.0	20	0.00	0.0	88.7
D-2b	0.74	100	0.18	24.3	2	0.14	0.4	65.0	0.42	37.1	40	0.00	0.0	30	0.00	0.0	25	0.00	0.0	20	0.00	0.0	61.8
D-2c	0.31	100	0.15	50.0	2	0.00	0.0	65.0	0.16	33.5	40	0.00	0.0	30	0.00	0.0	25	0.00	0.0	20	0.00	0.0	83.5
D-2d	0.24	100	0.10	43.4	2	0.00	0.0	65.0	0.14	37.9	40	0.00	0.0	30	0.00	0.0	25	0.00	0.0	20	0.00	0.0	81.3
D-2e	1.41	100	0.41	29.3	2	0.00	0.0	65.0	1.00	46.1	40	0.00	0.0	30	0.00	0.0	25	0.00	0.0	20	0.00	0.0	75.4
D-2f	2.43	100	0.70	28.8	2	0.07	0.1	65.0	1.67	44.7	40	0.00	0.0	30	0.00	0.0	25	0.00	0.0	20	0.00	0.0	73.6
D-2g	1.81	100	0.48	26.5	2	0.57	0.6	65.0	0.76	27.3	40	0.00	0.0	30	0.00	0.0	25	0.00	0.0	20	0.00	0.0	54.4
D-2h	0.23	100	0.00	0.0	2	0.00	0.0	65.0	0.23	65.0	40	0.00	0.0	30	0.00	0.0	25	0.00	0.0	20	0.00	0.0	65.0
D-3	2.26	100	0.00	0.0	2	0.28	0.2	65.0	1.74	50.0	40	0.13	2.3	30	0.11	1.5	25	0.00	0.0	20	0.00	0.0	54.0
<b>FALCON MEADOWS AT BENT GRASS FILING NO. 3</b>																							
C-1b	1.77	100	0.38	21.5	2	0.10	0.1	65.0	0.75	27.5	40	0.54	12.2	30	0.00	0.0	25	0.00	0.0	20	0.00	0.0	61.3
C-1c	1.19	100	0.26	21.8	2	0.00	0.0	65.0	0.72	39.3	40	0.21	7.1	30	0.00	0.0	25	0.00	0.0	20	0.00	0.0	68.2
C-1f	0.14	100	0.09	64.3	2	0.00	0.0	65.0	0.05	23.2	40	0.00	0.0	30	0.00	0.0	25	0.00	0.0	20	0.00	0.0	87.5
C-2	1.00	100	0.27	27.0	2	0.04	0.1	65.0	0.69	44.9	40	0.00	0.0	30	0.00	0.0	25	0.00	0.0	20	0.00	0.0	72.0
D-1a	1.83	100	0.35	19.1	2	0.15	0.2	65.0	0.75	26.6	40	0.25	5.5	30	0.33	5.4	25	0.00	0.0	20	0.00	0.0	56.8
D-1b	1.19	100	0.29	24.4	2	0.00	0.0	65.0	0.39	21.3	40	0.39	13.1	30	0.12	3.0	25	0.00	0.0	20	0.00	0.0	61.8
D-1f	0.67	100	0.16	23.9	2	0.00	0.0	65.0	0.51	49.5	40	0.00	0.0	30	0.00	0.0	25	0.00	0.0	20	0.00	0.0	73.4
D-1g	0.78	100	0.13	16.7	2	0.20	0.5	65.0	0.34	28.3	40	0.00											

## COMPOSITE RUNOFF COEFFICIENT CALCULATIONS: PROPOSED

Subdivision: Falcon Meadows  
 Location: CO, Colorado Springs

Project Name: Falcon Meadows at Bent Grass Filing No. 3  
 Project No.: CLH000020  
 Calculated By: CMV  
 Checked By: SMB  
 Date: 12/6/21

Basin ID	Total Area (ac)	Paved/Gravel Roads			Lawns/Undeveloped			Residential - 1/8 Acre			Residential - 1/4 Acre			Residential - 1/3 Acre			Residential - 1/2 Acre			Residential - 1 Acre			Composite C <sub>5</sub>	Composite C <sub>100</sub>
		C <sub>5</sub>	C <sub>100</sub>	Area (ac)	C <sub>5</sub>	C <sub>100</sub>	Area (ac)	C <sub>5</sub>	C <sub>100</sub>	Area (ac)	C <sub>5</sub>	C <sub>100</sub>	Area (ac)	C <sub>5</sub>	C <sub>100</sub>	Area (ac)	C <sub>5</sub>	C <sub>100</sub>	Area (ac)	C <sub>5</sub>	C <sub>100</sub>	Area (ac)		
<b>OFFSITE</b>																								
OS-1	32.28	0.90	0.96	2.15	0.09	0.36	29.25	0.45	0.59	0.00	0.30	0.50	0.00	0.25	0.47	0.00	0.22	0.46	0.00	0.20	0.44	0.00	0.16	0.41
OS-2	20.07	0.90	0.96	0.90	0.09	0.36	18.62	0.45	0.59	0.00	0.30	0.50	0.00	0.25	0.47	0.00	0.22	0.46	0.00	0.20	0.44	0.00	0.14	0.40
OS-3	10.61	0.90	0.96	0.48	0.09	0.36	9.84	0.45	0.59	0.00	0.30	0.50	0.00	0.25	0.47	0.00	0.22	0.46	0.00	0.20	0.44	0.00	0.14	0.40
<b>BENT GRASS FILING NO. 2 &amp; FALCON MEADOWS AT BENT GRASS FILING NO. 1</b>																								
EX-1	1.19	0.90	0.96	0.00	0.09	0.36	1.19	0.45	0.59	0.00	0.30	0.50	0.00	0.25	0.47	0.00	0.22	0.46	0.00	0.20	0.44	0.00	0.09	0.36
EX-2	1.60	0.90	0.96	0.00	0.09	0.36	1.60	0.45	0.59	0.00	0.30	0.50	0.00	0.25	0.47	0.00	0.22	0.46	0.00	0.20	0.44	0.00	0.09	0.36
EX-3	0.66	0.90	0.96	0.00	0.09	0.36	0.66	0.45	0.59	0.00	0.30	0.50	0.00	0.25	0.47	0.00	0.22	0.46	0.00	0.20	0.44	0.00	0.09	0.36
B-1	6.59	0.90	0.96	0.00	0.09	0.36	6.59	0.45	0.59	0.00	0.30	0.50	0.00	0.25	0.47	0.00	0.22	0.46	0.00	0.20	0.44	0.00	0.09	0.36
B-2	4.16	0.90	0.96	0.00	0.09	0.36	4.16	0.45	0.59	0.00	0.30	0.50	0.00	0.25	0.47	0.00	0.22	0.46	0.00	0.20	0.44	0.00	0.09	0.36
D-4a	0.98	0.90	0.96	0.21	0.09	0.36	0.00	0.45	0.59	0.77	0.30	0.50	0.00	0.25	0.47	0.00	0.22	0.46	0.00	0.20	0.44	0.00	0.55	0.67
D-4b	0.95	0.90	0.96	0.43	0.09	0.36	0.00	0.45	0.59	0.52	0.30	0.50	0.00	0.25	0.47	0.00	0.22	0.46	0.00	0.20	0.44	0.00	0.65	0.76
D-4c	1.22	0.90	0.96	0.43	0.09	0.36	0.24	0.45	0.59	0.55	0.30	0.50	0.00	0.25	0.47	0.00	0.22	0.46	0.00	0.20	0.44	0.00	0.54	0.68
D-5	1.08	0.90	0.96	0.22	0.09	0.36	0.11	0.45	0.59	0.75	0.30	0.50	0.00	0.25	0.47	0.00	0.22	0.46	0.00	0.20	0.44	0.00	0.51	0.64
D-6a	1.33	0.90	0.96	0.44	0.09	0.36	0.00	0.45	0.59	0.89	0.30	0.50	0.00	0.25	0.47	0.00	0.22	0.46	0.00	0.20	0.44	0.00	0.60	0.71
D-6b	2.69	0.90	0.96	0.59	0.09	0.36	0.00	0.45	0.59	2.10	0.30	0.50	0.00	0.25	0.47	0.00	0.22	0.46	0.00	0.20	0.44	0.00	0.55	0.67
D-7	7.65	0.90	0.96	0.00	0.09	0.36	6.22	0.45	0.59	1.43	0.30	0.50	0.00	0.25	0.47	0.00	0.22	0.46	0.00	0.20	0.44	0.00	0.16	0.40
D-8	1.69	0.90	0.96	0.00	0.09	0.36	0.11	0.45	0.59	1.58	0.30	0.50	0.00	0.25	0.47	0.00	0.22	0.46	0.00	0.20	0.44	0.00	0.43	0.58
E-1	1.71	0.90	0.96	0.78	0.09	0.36	0.23	0.45	0.59	0.00	0.30	0.50	0.70	0.25	0.47	0.00	0.22	0.46	0.00	0.20	0.44	0.00	0.55	0.69
E-2	0.68	0.90	0.96	0.56	0.09	0.36	0.12	0.45	0.59	0.00	0.30	0.50	0.00	0.25	0.47	0.00	0.22	0.46	0.00	0.20	0.44	0.00	0.76	0.85
E-3	0.78	0.90	0.96	0.69	0.09	0.36	0.09	0.45	0.59	0.00	0.30	0.50	0.00	0.25	0.47	0.00	0.22	0.46	0.00	0.20	0.44	0.00	0.81	0.89
E-4	0.91	0.90	0.96	0.73	0.09	0.36	0.18	0.45	0.59	0.00	0.30	0.50	0.00	0.25	0.47	0.00	0.22	0.46	0.00	0.20	0.44	0.00	0.74	0.84
E-5	0.89	0.90	0.96	0.79	0.09	0.36	0.10	0.45	0.59	0.00	0.30	0.50	0.00	0.25	0.47	0.00	0.22	0.46	0.00	0.20	0.44	0.00	0.81	0.89
OS-4	4.46	0.90	0.96	0.00	0.09	0.36	0.00	0.45	0.59	2.28	0.30	0.50	1.46	0.25	0.47	0.00	0.22	0.46	0.00	0.20	0.44	0.72	0.36	0.54
OS-5	0.46	0.90	0.96	0.00	0.09	0.36	0.00	0.45	0.59	0.46	0.30	0.50	0.00	0.25	0.47	0.00	0.22	0.46	0.00	0.20	0.44	0.00	0.45	0.59
OS-6	1.17	0.90	0.96	0.00	0.09	0.36	0.00	0.45	0.59	1.17	0.30	0.50	0.00	0.25	0.47	0.00	0.22	0.46	0.00	0.20	0.44	0.00	0.45	0.59
<b>FALCON MEADOWS FILING NO. 2</b>																								
C-1a	0.27	0.90	0.96	0.15	0.09	0.36	0.00	0.45	0.59	0.12	0.30	0.50	0.00	0.25	0.47	0.00	0.22	0.46	0.00	0.20	0.44	0.00	0.70	0.80
C-1d	1.97	0.90	0.96	0.40	0.09	0.36	0.00	0.45	0.59	1.57	0.30	0.50	0.00	0.25	0.47	0.00	0.22	0.46	0.00	0.20	0.44	0.00	0.54	0.67
C-1e	0.49	0.90	0.96	0.49	0.09	0.36	0.00	0.45	0.59	0.00	0.30	0.50	0.00	0.25	0.47	0.00	0.22	0.46	0.00	0.20	0.44	0.00	0.90	0.96
C-3	0.18	0.90	0.96	0.14	0.09	0.36	0.02	0.45	0.59	0.02	0.30	0.50	0.00	0.25	0.47	0.00	0.22	0.46	0.00	0.20	0.44	0.00	0.76	0.86
C-4	2.67	0.90	0.96	0.41	0.09	0.36	0.84	0.45	0.59	1.41	0.30	0.50	0.00	0.25	0.47	0.00	0.22	0.46	0.00	0.20	0.44	0.00	0.41	0.57
C-5	0.60	0.90	0.96	0.00	0.09	0.36	0.60	0.45	0.59	0.00	0.30	0.50	0.00	0.25	0.47	0.00	0.22	0.46	0.00	0.20	0.44	0.00	0.09	0.36
C-6	0.94	0.90	0.96	0.00	0.09	0.36	0.65	0.45	0.59	0.29	0.30	0.50	0.00	0.25	0.47	0.00	0.22	0.46	0.00	0.20	0.44	0.00	0.20	0.43
C-7	0.52	0.90	0.96	0.15	0.09	0.36	0.00	0.45	0.59	0.37	0.30	0.50	0.00	0.25	0.47	0.00	0.22	0.46	0.00	0.20	0.44	0.00	0.58	0.70
D-9	0.72	0.90	0.96	0.00	0.09	0.36	0.46	0.45	0.59	0.26	0.30	0.50	0.00	0.25	0.47	0.00	0.22	0.46	0.00	0.20	0.44	0.00	0.22	0.44
D-1c	3.95	0.90	0.96	0.33	0.09	0.36	0.00	0.45	0.59	2.67	0.30	0.50	0.95	0.25	0.47	0.00	0.22	0.46	0.00	0.20	0.44	0.00	0.45	0.60
D-2a	0.50	0.90	0.96	0.33	0.09	0.36	0.00	0.45	0.59	0.17	0.30	0.50	0.00	0.25	0.47	0.00	0.22	0.46	0.00	0.20	0.44	0.00	0.75	0.84
D-2b	0.74	0.90	0.96	0.18	0.09	0.36	0.14	0.45	0.59	0.42	0.30	0.50	0.00	0.25	0.47	0.00	0.22	0.46	0.00	0.20	0.44	0.00	0.49	0.64
D-2c	0.31	0.90	0.96	0.15	0.09	0.36	0.00	0.45	0.59	0.16	0.30	0.50	0.00	0.25	0.47	0.00	0.22	0.46	0.00	0.20	0.44	0.00	0.68	0.78
D-2d	0.24	0.90	0.96	0.10	0.09	0.36	0.00	0.45	0.59	0.14	0.30	0.50	0.00	0.25	0.47	0.00	0.22	0.46	0.00	0.20	0.44	0.00	0.65	0.76
D-2e	1.41	0.90	0.96	0.41	0.09	0.36	0.00	0.45	0.59	1.00	0.30	0.50	0.00	0.25	0.47	0.00	0.22	0.46	0.00	0.20	0.44	0.00	0.58	0.70
D-2f	2.43	0.90	0.96	0.70	0.09	0.36	0.07	0.45	0.59	1.67	0.30	0.50	0.00	0.25	0.47	0.00	0.22	0.46	0.00	0.20	0.44	0.00	0.57	0.69
D-2g	1.81	0.90	0.96	0.48	0.09	0.36	0.57	0.45	0.59	0.76	0.30	0.50	0.00	0.25	0.47	0.00	0.22	0.46	0.00	0.20	0.44	0.00	0.46	0.62
D-2h	0.23	0.90	0.96	0.00	0.09	0.36	0.00	0.45	0.59	0.23	0.30	0.50	0.00	0.25	0.47	0.00	0.22	0.46	0.00	0.20	0.44	0.00	0.45	0.59
D-3	2.26	0.90	0.96	0.00	0.09	0.36	0.28	0.45	0.59	1.74	0.30	0.50	0.13	0.25	0.47	0.11	0.22	0.46	0.00	0.20	0.44	0.00	0.39	0.55
<b>FALCON MEADOWS FILING NO. 3</b>																								
C-1b	1.77	0.90	0.96	0.38	0.09	0.36	0.10	0.45	0.59	0.75	0.30	0.50	0.54	0.25	0.47	0.00	0.22	0.46	0.00	0.20	0.44	0.00	0.48	0.63
C-1c	1.19	0.90	0.96	0.26	0.09	0.36	0.00	0.45	0.59	0.72	0.30	0.50	0.21	0.25	0.47	0.00	0.22	0.46	0.00	0.20	0.44	0.00	0.52	0.65
C-1f	0.14	0.90	0.96	0.09	0.09	0.36	0.00	0.45	0.59	0.05	0.30	0.50	0.00	0.25	0.47	0.00	0.22	0.46	0.00	0.20	0.44	0.00	0.74	0.83

Basin ID	Total Area (ac)	Paved/Gravel Roads			Lawns/Undeveloped			Residential - 1/8 Acre			Residential - 1/4 Acre			Residential - 1/3 Acre			Residential - 1/2 Acre			Residential - 1 Acre			Composite C <sub>5</sub>	Composite C <sub>100</sub>
		C <sub>5</sub>	C <sub>100</sub>	Area (ac)	C <sub>5</sub>	C <sub>100</sub>	Area (ac)	C <sub>5</sub>	C <sub>100</sub>	Area (ac)	C <sub>5</sub>	C <sub>100</sub>	Area (ac)	C <sub>5</sub>	C <sub>100</sub>	Area (ac)	C <sub>5</sub>	C <sub>100</sub>	Area (ac)	C <sub>5</sub>	C <sub>100</sub>	Area (ac)		
C-2	1.00	0.90	0.96	0.27	0.09	0.36	0.04	0.45	0.59	0.69	0.30	0.50	0.00	0.25	0.47	0.00	0.22	0.46	0.00	0.20	0.44	0.00	0.56	0.68
D-1a	1.83	0.90	0.96	0.35	0.09	0.36	0.15	0.45	0.59	0.75	0.30	0.50	0.25	0.25	0.47	0.33	0.22	0.46	0.00	0.20	0.44	0.00	0.45	0.61
D-1b	1.19	0.90	0.96	0.29	0.09	0.36	0.00	0.45	0.59	0.39	0.30	0.50	0.39	0.25	0.47	0.12	0.22	0.46	0.00	0.20	0.44	0.00	0.49	0.64
D-1f	0.67	0.90	0.96	0.16	0.09	0.36	0.00	0.45	0.59	0.51	0.30	0.50	0.00	0.25	0.47	0.00	0.22	0.46	0.00	0.20	0.44	0.00	0.56	0.68
D-1g	0.78	0.90	0.96	0.13	0.09	0.36	0.20	0.45	0.59	0.34	0.30	0.50	0.00	0.25	0.47	0.00	0.22	0.46	0.00	0.20	0.44	0.00	0.37	0.51
D-1h	1.57	0.90	0.96	0.23	0.09	0.36	0.31	0.45	0.59	0.58	0.30	0.50	0.19	0.25	0.47	0.26	0.22	0.46	0.00	0.20	0.44	0.00	0.39	0.57
D-1j	0.95	0.90	0.96	0.23	0.09	0.36	0.09	0.45	0.59	0.38	0.30	0.50	0.22	0.25	0.47	0.03	0.22	0.46	0.00	0.20	0.44	0.00	0.48	0.63
D-1k	0.80	0.90	0.96	0.18	0.09	0.36	0.10	0.45	0.59	0.19	0.30	0.50	0.00	0.25	0.47	0.33	0.22	0.46	0.00	0.20	0.44	0.00	0.42	0.60
<b>FUTURE FILINGS</b>																								
C-1g	1.02	0.90	0.96	0.00	0.09	0.36	0.00	0.45	0.59	1.02	0.30	0.50	0.00	0.25	0.47	0.00	0.22	0.46	0.00	0.20	0.44	0.00	0.45	0.59

Lot Type Identification:	
Lot Size (SF)	Lot Size (Acre)
0 - 8,167	<= 1/8 Acre
8,168 - 12,704	1/4 Acre
12,705 - 18,149	1/3 Acre
18,150 - 32,670	1/2 Acre
32,671 - 43,560	1 Acre

**NOTES:**

*C values are taken directly from Table 6-6 in the Colorado Springs DCM Vol. 1. CH. 6 (Referencing UDFCD 2001)*

*Coefficients use HSG A&B soils - Refer to "Appendix A: Exhibits and Figures" for soil map*

## STANDARD FORM SF-2: PROPOSED TIME OF CONCENTRATION

**Subdivision:** Falcon Meadows  
**Location:** CO, Colorado Springs

**Project Name:** Falcon Meadows at Bent Grass Filing No. 3  
**Project No.:** CLH000020  
**Calculated By:** CMV  
**Checked By:** SMB  
**Date:** 12/6/21

SUB-BASIN					INITIAL/OVERLAND			TRAVEL TIME					T <sub>c</sub> CHECK			FINAL
DATA					(T <sub>i</sub> )			(T <sub>t</sub> )					(URBANIZED BASINS)			
BASIN ID	D.A. (AC)	Impervious (%)	C <sub>5</sub>	C <sub>100</sub>	L (FT)	S (%)	T <sub>i</sub> (MIN)	L (FT)	S (%)	C <sub>v</sub>	VEL. (FPS)	T <sub>t</sub> (MIN)	COMP. T <sub>c</sub> (MIN)	TOTAL LENGTH(FT)	Urbanized T <sub>c</sub> (MIN)	
<b>OFFSITE</b>																
OS-1	32.28	11.0	0.16	0.41	100	2.4	12.9	2100	2.2	15	2.2	15.7	28.6	2200.0	22.2	22.2
OS-2	20.07	8.0	0.14	0.40	100	2.3	13.3	1400	2.3	15	2.3	10.3	23.6	1500.0	18.3	18.3
OS-3	10.61	8.0	0.14	0.40	100	2.0	14.0	1500	2.0	15	2.1	11.8	25.7	1600.0	18.9	18.9
<b>BENT GRASS FILING NO. 2 &amp; FALCON MEADOWS AT BENT GRASS FILING NO. 1</b>																
EX-1	1.19	2.0	0.09	0.36	300	2.7	23.0	690	2.7	15	2.5	4.7	27.7	990.0	15.5	15.5
EX-2	1.60	2.0	0.09	0.36	200	2.7	18.8	100	2.7	15	2.5	0.7	19.5	300.0	11.7	11.7
EX-3	0.66	2.0	0.09	0.36	100	5.0	10.8	30	2.7	15	2.5	0.2	11.0	130.0	10.7	10.7
B-1	6.59	2.0	0.09	0.36	90	6.4	9.5	2000	1.7	15	2.0	17.0	26.5	2090.0	21.6	21.6
B-2	4.16	2.0	0.09	0.36	160	11.0	10.5	920	1.6	15	1.9	8.1	18.6	1080.0	16.0	16.0
D-4a	0.98	72.5	0.55	0.67	100	2.3	7.6	420	1.0	20	2.0	3.5	11.1	520.0	12.9	11.1
D-4b	0.95	80.9	0.65	0.76	75	1.5	6.2	480	1.0	20	2.0	4.0	10.2	555.0	13.1	10.2
D-4c	1.22	64.9	0.54	0.68	70	0.5	10.8	690	1.0	20	2.0	5.8	16.6	760.0	14.2	14.2
D-5	1.08	65.7	0.51	0.64	10	2.0	2.7	300	1.1	20	2.1	2.4	5.1	310.0	11.7	5.1
D-6a	1.33	76.6	0.60	0.71	20	2.0	3.2	385	1.0	20	2.0	3.2	6.5	405.0	12.3	6.5
D-6b	2.69	72.6	0.55	0.67	45	2.0	5.4	870	1.0	20	2.0	7.3	12.6	915.0	15.1	12.6
D-7	7.65	13.8	0.16	0.40	200	7.5	12.4	665	1.0	15	1.5	7.4	19.8	865.0	14.8	14.8
D-8	1.69	60.9	0.43	0.58	125	3.7	8.9	600	1.0	15	1.5	6.7	15.5	725.0	14.0	14.0
E-1	1.71	62.3	0.55	0.69	25	2.0	4.0	940	1.0	20	2.0	7.8	11.8	965.0	15.4	11.8
E-2	0.68	82.8	0.76	0.85	25	2.0	2.5	665	1.6	20	2.5	4.4	6.9	690.0	13.8	6.9
E-3	0.78	88.7	0.81	0.89	25	2.0	2.1	632	1.0	20	2.0	5.3	7.4	657.0	13.7	7.4
E-4	0.91	80.6	0.74	0.84	25	2.0	2.6	913	2.0	20	2.8	5.4	8.0	938.0	15.2	8.0
E-5	0.89	89.0	0.81	0.89	25	2.0	2.1	903	2.1	20	2.9	5.2	7.3	928.0	15.2	7.3
OS-4	4.46	49.5	0.36	0.54	100	2.0	10.8	910	1.2	20	2.2	6.9	17.7	1010.0	15.6	15.6
OS-5	0.46	65.0	0.45	0.59	15	2.0	3.7	190	1.0	20	2.0	1.6	5.2	205.0	11.1	5.2
OS-6	1.17	65.0	0.45	0.59	85	0.2	18.7	430	0.9	20	1.9	3.8	22.5	515.0	12.9	12.9
<b>FALCON MEADOWS FILING NO. 2</b>																
C-1a	0.27	84.5	0.70	0.80	10	2.0	1.8	230	1.0	20	2.0	1.9	3.8	240.0	11.3	5.0
C-1d	1.97	72.1	0.54	0.67	100	3.8	6.6	505	0.8	20	1.8	4.6	11.2	605.0	13.4	11.2
C-1e	0.49	100.0	0.90	0.96	10	2.0	0.9	68	3.4	20	3.7	0.3	1.2	78.0	10.4	5.0
C-3	0.18	85.7	0.76	0.86	10	2.0	1.6	580	1.0	20	2.0	4.8	6.4	590.0	13.3	6.4
C-4	2.67	50.3	0.41	0.57	100	3.0	8.8	600	2.0	20	2.8	3.5	12.3	700.0	13.9	12.3
C-5	0.60	2.0	0.09	0.36	5	2.0	3.3		1.0	15	1.5	0.0	3.3	5.0	10.0	5.0
C-6	0.94	21.5	0.20	0.43	20	3.3	5.0	90	5.0	15	3.4	0.4	5.4	110.0	10.6	5.4
C-7	0.52	75.7	0.58	0.70	100	6.8	5.0	165	1.3	15	1.7	1.6	6.7	265.0	11.5	6.7

SUB-BASIN					INITIAL/OVERLAND			TRAVEL TIME					Tc CHECK			FINAL
DATA					(T <sub>i</sub> )			(T <sub>i</sub> )					(URBANIZED BASINS)			T <sub>c</sub>
BASIN ID	D.A. (AC)	Impervious (%)	C <sub>5</sub>	C <sub>100</sub>	L (FT)	S (%)	T <sub>i</sub> (MIN)	L (FT)	S (%)	C <sub>v</sub>	VEL. (FPS)	T <sub>i</sub> (MIN)	COMP. T <sub>c</sub> (MIN)	TOTAL LENGTH(FT)	Urbanized T <sub>c</sub> (MIN)	T <sub>c</sub> (MIN)
D-9	0.72	24.8	0.22	0.44	10	2.0	4.0	250	3.6	15	2.8	1.5	5.5	260.0	11.4	5.5
D-1c	3.95	61.9	0.45	0.60	100	2.6	8.7	1900	1.3	20	2.3	13.9	22.5	2000.0	21.1	21.1
D-2a	0.50	88.7	0.75	0.84	10	2.0	1.6	495	1.3	20	2.3	3.6	5.2	505.0	12.8	5.2
D-2b	0.74	61.8	0.49	0.64	100	1.7	9.4	189	1.0	20	2.0	1.6	10.9	289.0	11.6	10.9
D-2c	0.31	83.5	0.68	0.78	5	2.0	1.4	275	1.0	20	2.0	2.3	3.7	280.0	11.6	5.0
D-2d	0.24	81.3	0.65	0.76	5	2.0	1.5	200	1.3	20	2.3	1.5	2.9	205.0	11.1	5.0
D-2e	1.41	75.4	0.58	0.70	100	1.9	7.7	340	0.8	20	1.8	3.2	10.9	440.0	12.4	10.9
D-2f	2.43	73.6	0.57	0.69	75	2.0	6.7	175	0.5	20	1.4	2.1	8.7	250.0	11.4	8.7
D-2g	1.81	54.4	0.46	0.62	35	2.0	5.5	1355	1.3	20	2.3	9.9	15.4	1390.0	17.7	15.4
D-2h	0.23	65.0	0.45	0.59	35	2.0	5.6	1355	1.3	20	2.3	9.9	15.5	1390.0	17.7	15.5
D-3	2.26	54.0	0.39	0.55	25	8.0	3.3	1960	1.0	15	1.5	21.8	25.0	1985.0	21.0	21.0
<b>FALCON MEADOWS FILING NO. 3</b>																
C-1b	1.77	61.3	0.48	0.63	50	12.0	3.5	570	1.7	20	2.6	3.7	7.2	620.0	13.4	7.2
C-1c	1.19	68.2	0.52	0.65	10	2.0	2.7	440	1.7	20	2.6	2.9	5.5	450.0	12.5	5.5
C-1f	0.14	87.5	0.74	0.83	60	7.0	2.7	90	1.8	20	2.7	0.6	3.2	150.0	10.8	5.0
C-2	1.00	72.0	0.56	0.68	80	2.4	6.6	360	3.4	20	3.7	1.6	8.2	440.0	12.4	8.2
D-1a	1.83	56.8	0.45	0.61	100	3.6	7.8	550	2.2	20	3.0	3.1	10.9	650.0	13.6	10.9
D-1b	1.19	61.8	0.49	0.64	100	3.9	7.1	520	2.2	20	3.0	2.9	10.0	620.0	13.4	10.0
D-1f	0.67	73.4	0.56	0.68	20	2.0	3.5	225	1.0	20	2.0	1.9	5.4	245.0	11.4	5.4
D-1g	0.78	45.5	0.37	0.51	100	2.3	10.1	395	1.0	20	2.0	3.3	13.4	495.0	12.8	12.8
D-1h	1.57	48.8	0.39	0.57	100	2.3	9.8	380	2.9	20	3.4	1.9	11.7	480.0	12.7	11.7
D-1j	0.95	60.6	0.48	0.63	75	4.4	6.0	320	2.9	20	3.4	1.6	7.6	395.0	12.2	7.6
D-1k	0.80	50.6	0.42	0.60	100	3.8	8.0	300	1.7	20	2.6	1.9	9.9	400.0	12.2	9.9
<b>FUTURE FILINGS</b>																
C-1g	1.02	65.0	0.45	0.59	100	6.1	6.5	375	2.4	20	3.1	2.0	8.5	475.0	12.6	8.5

**NOTES:**

$$T_i = (0.395 * (1.1 - C_5) * L^{0.5}) / ((S)^{0.33}), \text{ S in ft/ft}$$

$$T_i = L / 60V \text{ (Velocity From Fig. 501)}$$

$$\text{Velocity } V = C_v * S^{0.5}, \text{ S in ft/ft}$$

$$T_c \text{ Check} = 10 + L / 180$$

For Urbanized basins a minimum T<sub>c</sub> of 5.0 minutes is required.

For non-urbanized basins a minimum T<sub>c</sub> of 10.0 minutes is required

Type of Land Surface	C <sub>v</sub>
Heavy Meadow	2.5
Tillage/field	5
Short pasture and lawns	7
Nearly bare ground	10
Grassed waterway	15
Paved areas and shallow paved swale	20



**STANDARD FORM SF-3: PROPOSED  
STORM DRAINAGE SYSTEM DESIGN  
(RATIONAL METHOD PROCEDURE)**

Subdivision: Falcon Meadows  
 Location: CO, Colorado Springs  
 Design Storm: 5-Year

Project Name: Falcon Meadows at Bent Grass Filing No. 3  
 Project No.: CLH000020  
 Calculated By: CMV  
 Checked By: SMB  
 Date: 12/6/21

STREET	Design Point	DIRECT RUNOFF							TOTAL RUNOFF				STREET		PIPE			TRAVEL TIME			REMARKS
		Basin ID	Area (Ac)	Runoff Coeff.	Tc (min)	C* <sub>A</sub> (Ac)	I (in/hr)	Q (cfs)	Tc (min)	C* <sub>A</sub> (Ac)	I (in/hr)	Q (cfs)	Slope (%)	Street Flow (cfs)	Design Flow (cfs)	Slope (%)	Pipe Size (inches)	Length (ft)	Velocity (fps)	Tt (min)	
		RWT202	1574.40						46.6	120.88	1.82	220.0									From Falcon DBPS by Matrix
		RWT204	38.40						11.37	1.78	3.94	7.0									From Falcon DBPS by Matrix
		WT200	192.00						37.8	24.41	2.13	52.0									From Falcon DBPS by Matrix
	21	OS-1	32.28	0.16	22.2	5.16	2.93	15.1	46.6	152.23	1.82	277.1									Flows obtained from Bent Grass Filing No. 2 FDR. Q=65.1 CFS Cumulation of northern off-site flows entering Basin B-1
	1	OS-4	4.46	0.36	15.6	1.61	3.46	5.6					1.2	5.6			910	2.2	6.9		Flows from Basin B-1 of Bent Grass Filing No. 2 FDR into Basin EX-2
	2	OS-5	0.46	0.45	5.2	0.21	5.10	1.1					1	1.1			190	2.0	1.6		Flows from Basin B-2 of Bent Grass Filing No. 2 FDR into Basin EX-2
	3	OS-6	1.17	0.45	12.9	0.53	3.75	2.0					0.9	2.0			430	1.9	3.8		Flows from Basin B-3 of Bent Grass Filing No. 2 FDR into Basin EX-2
		EX-1	1.19	0.09	15.5	0.11	3.47	0.4													Flows to Basin EX-2
	5	EX-2	1.60	0.09	11.7	0.14	3.90	0.5	22.5	2.60	2.91	7.6									Flows to Basin EX-3
	7	E-3	0.78	0.81	7.4	0.63	4.59	2.9													
		C-6	0.94	0.20	5.4	0.19	5.05	1.0					1	1.0			216	2.0	1.8		
	45	C-7	0.52	0.58	6.7	0.30	4.74	1.4					1	1.4			216	2.0	1.8		
		E-2	0.68	0.76	6.9	0.52	4.70	2.4	8.5	1.01	4.38	4.4									Combination of C-6, C-7, E-2
	8	E-1	1.71	0.55	11.8	0.94	3.88	3.6	11.8	2.58	3.88	10.0									Ex Basin from Filing No. 2(East side of BGMD) Combination of C-7, E-1, E-2, E-3. Flows to Basin EX-3
	6	EX-3	0.66	0.09	10.7	0.06	4.02	0.2	22.5	5.24	2.91	15.2									Flows to Basin B-1
	15a	D-1g	0.78	0.37	12.8	0.29	3.76	1.1					1	1.1			57	2.0	0.5		
		D-1h	1.57	0.39	11.7	0.61	3.89	2.4													
	51	D-1j	0.95	0.48	7.6	0.46	4.55	2.1	13.2	1.36	3.71	5.0	0.9	0.0	5.0		225	1.9	2.0		Flows to existing on-grade inlet at DP51
		D-1f	0.67	0.56	5.4	0.38	5.06	1.9													
	52	D-1k	0.80	0.42	9.9	0.34	4.14	1.4	9.9	0.72	4.14	3.0									
	53	C-1a	0.27	0.70	5.0	0.19	5.17	1.0	15.2	0.92	3.50	3.2	1.1	0.0	3.2		430	2.1	3.4		Flows to proposed on-grade inlet at DP53
	53								15.1	2.26	3.51	7.9			7.9						Total pipe flow at DP 53
		C-1b	1.77	0.48	7.2	0.85	4.62	3.9													
	54	C-2	1.00	0.56	8.2	0.56	4.42	2.5	8.2	1.41	4.42	6.2	1	6.2			130	1.6	1.4		
	41	C-1c	1.19	0.52	5.5	0.62	5.02	3.1	9.6	2.03	4.19	8.5		0.3	8.2	1.3	30	180	2.2	1.3	On-grade inlet
									15.1	4.22	3.51	14.8			14.8						Total pipe flow at DP 41
	42	C-1f	0.14	0.74	5.0	0.10	5.17	0.5	10.9	0.17	4.00	0.7	1	0.7			185	2.0	1.5		Gutter flow to DP15
		C-3	0.18	0.76	6.4	0.14	4.80	0.7					1	0.7			660	2.0	5.5		Gutter flow through C-4 to DP44
	44	C-4	2.67	0.41	12.3	1.09	3.82	4.2	12.3	1.23	3.82	4.7	1	0.0	4.7	1.3	24	70	2.2	0.5	Flow into on-grade inlet at DP44
	43	C-1d	1.97	0.54	11.2	1.06	3.96	4.2	12.5	1.23	3.80	4.7									Flow into inlet at DP15
	15								12.5	1.23	3.80	4.7									Flow into inlet at DP15

**STANDARD FORM SF-3: PROPOSED  
STORM DRAINAGE SYSTEM DESIGN  
(RATIONAL METHOD PROCEDURE)**

**Subdivision:** Falcon Meadows  
**Location:** CO, Colorado Springs  
**Design Storm:** 5-Year

**Project Name:** Falcon Meadows at Bent Grass Filing No. 3  
**Project No.:** CLH000020  
**Calculated By:** CMV  
**Checked By:** SMB  
**Date:** 12/6/21

STREET	Design Point	DIRECT RUNOFF							TOTAL RUNOFF				STREET		PIPE			TRAVEL TIME			REMARKS
		Basin ID	Area (Ac)	Runoff Coeff.	Tc (min)	C*A (Ac)	I (in/hr)	Q (cfs)	Tc (min)	C*A (Ac)	I (in/hr)	Q (cfs)	Slope (%)	Street Flow (cfs)	Design Flow (cfs)	Slope (%)	Pipe Size (inches)	Length (ft)	Velocity (fps)	Tt (min)	
	15																				Total pipe flow at DP15
	12	C-1e	0.49	0.90	5.0	0.44	5.17	2.3	15.1	6.68	3.51	23.5									Flow into inlet at DP12
	19	C-1g	1.02	0.45	8.5	0.46	4.37	2.0	15.1	7.12	3.51	25.0		25.0							Total pipe flow at DP12
																					Flow into Pond North
	13	C-5	0.60	0.09	5.0	0.05	5.17	0.3	15.1	7.63	3.51	26.8									North Pond
		B-1	6.59	0.09	21.6	0.59	2.97	1.8	46.6	165.69	1.82	301.6									Total flow to Pond North. Outfalls to Basin B-1
	AA																				Total flow under BGMD into Basin B-2
		D-2b	0.74	0.49	10.9	0.36	4.00	1.4													
		D-2a	0.50	0.75	5.2	0.38	5.10	1.9													
	14a	D-2c	0.31	0.68	5.0	0.21	5.17	1.1	10.9	0.95	4.00	3.8	1.3	3.8			230	2.3	1.7		Gutter flow through D-2d to DP14b
	14b	D-2d	0.24	0.65	5.0	0.16	5.17	0.8	12.6	1.11	3.78	4.2	1.3	4.2			625	2.3	4.6		Gutter flow through D-2d to DP14b
		D-2g	1.81	0.46	15.4	0.83	3.48	2.9	17.2	1.94	3.32	6.4	2.5	0.9	5.5		625	3.2	3.3		Flow into existing inlet at DP14
	9	OS-2	20.07	0.14	18.3	2.81	3.22	9.0													Overland flow into Basin D-3. Flow obtained from Bent Grass Filing No. 2 FDR
	10	OS-3	10.61	0.14	18.9	1.49	3.18	4.7													Offsite flow into Basin D-3. Flow obtained from Bent Grass Filing No. 2 FDR
	11	D-3	2.26	0.39	21.0	0.88	3.01	2.6	21.0	5.18	3.01	15.6		15.6	1.0	42	100	2.0	0.8		Flows conveyed via existing ditch into proposed area inlet.
	14e	D-2f	2.43	0.57	8.7	1.39	4.33	6.0													Flows to existing inlet at DP14e
	14d	D-2e	1.41	0.58	10.9	0.82	4.01	3.3	10.9	2.21	4.01	8.9		8.9	1.0	42	100	2.0	0.8		Flows to existing inlet at DP14d
		D-1a	1.83	0.45	10.9	0.82	4.01	3.3													Flows conveyed storm sewer to DP16
	16a	D-1b	1.19	0.49	10.0	0.58	4.13	2.4	10.9	1.40	4.01	5.6	1.3	5.6			1300	2.3	9.5		Gutter flow through Basin D-1c to DP16
		D-1c	3.95	0.45	21.1	1.78	3.01	5.4	21.1	3.18	3.01	9.6	2.5	2.7	6.9		625	3.2	3.3		Flows to existing inlet at DP16
	16								21.9	11.34	2.96	33.6			33.6	2.0	48	835	2.8	4.9	Combination of flows to existing inlets at DP14 and DP16. Flows to DP 17
		D-5	1.08	0.51	5.1	0.55	5.14	2.8					1	2.8			600	2.0	5.0		Gutter flow through Basin D-6b to DP18
		D-6b	2.69	0.55	12.6	1.48	3.78	5.6													
	18	D-6a	1.33	0.60	6.5	0.80	4.79	3.8	12.6	2.83	3.78	10.7		10.7	2.0	24	38	2.8	0.2		Flow to existing inlet. Flow out of inlet to DP17c
	17a	D-4a	0.98	0.55	11.1	0.54	3.97	2.1					1	2.1			700	2.0	5.8		Gutter flow through Basin D-4b to DP17b
		D-4b	0.95	0.65	10.2	0.62	4.09	2.5	17.0	1.16	3.34	3.9									Gutter flow to DP17c
	17b								17.0	1.82	3.34	6.1			6.1	2.0	24	8	2.8	0.0	Flows from Basin B-3 of Bent Grass Filing No. 2 FDR.
	17c	D-4c	1.22	0.54	14.2	0.66	3.60	2.4													Flows to existing inlet at DP17c
									17.0	4.65	3.34	15.5									Total pipe flow at DP17c to DP17
	17								26.8	15.99	2.65	42.4									Storm system entering existing pond at Basin D-7
		D-9	0.72	0.22	5.5	0.16	5.02	0.8					1.5	0.8			625	2.4	4.3		Gutter flow through Basin E-4 to DP24
		D-2h	0.23	0.45	15.5	0.10	3.47	0.3					1.5	0.3			550	2.4	3.7		Gutter flow through Basin E-4 to DP24
	24	E-4	0.91	0.74	8.0	0.67	4.46	3.0	24.4	2.10	2.79	5.9									Flow to existing inlet at DP24

**STANDARD FORM SF-3: PROPOSED  
STORM DRAINAGE SYSTEM DESIGN  
(RATIONAL METHOD PROCEDURE)**

Subdivision: Falcon Meadows  
 Location: CO, Colorado Springs  
 Design Storm: 5-Year

Project Name: Falcon Meadows at Bent Grass Filing No. 3  
 Project No.: CLH000020  
 Calculated By: CMV  
 Checked By: SMB  
 Date: 12/6/21

STREET	Design Point	DIRECT RUNOFF							TOTAL RUNOFF				STREET		PIPE			TRAVEL TIME			REMARKS
		Basin ID	Area (Ac)	Runoff Coeff.	Tc (min)	C*A (Ac)	I (in/hr)	Q (cfs)	Tc (min)	C*A (Ac)	I (in/hr)	Q (cfs)	Slope (%)	Street Flow (cfs)	Design Flow (cfs)	Slope (%)	Pipe Size (inches)	Length (ft)	Velocity (fps)	Tt (min)	
	25	E-5	0.89	0.81	7.3	0.72	4.60	3.3													Flow to existing inlet at DP25
	26								24.4	2.82	2.79	7.9									Flow into existing pond via Swale F at DP26
	32	D-8	1.69	0.43	14.0	0.73	3.62	2.6													Flow in Swale C (Basin D-8) into existing pond
	30	D-7	7.65	0.16	14.8	1.22	3.54	4.3													Existing Water quality pond
		B-2	4.16	0.09	16.0	0.37	3.42	1.3	26.8	20.76	2.65	55.0									Outlet to existing channel Basin B-2
	CC								46.6	186.82	1.82	340.0									

**STANDARD FORM SF-3: PROPOSED**  
**STORM DRAINAGE SYSTEM DESIGN**  
(RATIONAL METHOD PROCEDURE)

Subdivision: Falcon Meadows  
Location: CO, Colorado Springs  
Design Storm: 100-Year

Project Name: Falcon Meadows at Bent Grass Filing No. 3  
Project No.: CLH000020  
Calculated By: CMV  
Checked By: SMB  
Date: 12/6/21

STREET	Design Point	DIRECT RUNOFF							TOTAL RUNOFF				STREET		PIPE			TRAVEL TIME			REMARKS
		Basin ID	Area (Ac)	Runoff Coeff.	Tc (min)	C*A (Ac)	I (in/hr)	Q (cfs)	Tc (min)	C*A (Ac)	I (in/hr)	Q (cfs)	Slope (%)	Street Flow (cfs)	Design Flow (cfs)	Slope (%)	Pipe Size (inches)	Length (ft)	Velocity (fps)	Tt (min)	
		RWT202	1574.40						46.6	327.87	3.05	1000.0									From Falcon DBPS by Matrix
		RWT204	38.40						11.4	6.52	6.60	43.0									From Falcon DBPS by Matrix
		WT200	192.00						37.8	53.07	3.58	190.0									From Falcon DBPS by Matrix
	21	OS-1	32.28	0.41	22.2	13.23	4.92	65.1	46.6	400.69	3.05	1222.1									Flows obtained from Bent Grass Filing No. 2 FDR, Q=65.1 CFS Cumulation of northern off-site flows entering Basin B-1
	1	OS-4	4.46	0.54	15.6	2.41	5.81	14.0					1.2	14.0				910	2.2	6.9	Flows from Basin B-1 of Bent Grass Filing No. 2 FDR into Basin EX-2
	2	OS-5	0.46	0.59	5.2	0.27	8.56	2.3					1	2.3				190	2.0	1.6	Flows from Basin B-2 of Bent Grass Filing No. 2 FDR into Basin EX-2
	3	OS-6	1.17	0.59	12.9	0.69	6.30	4.3					0.9	4.3				430	1.9	3.8	Flows from Basin B-3 of Bent Grass Filing No. 2 FDR into Basin EX-2
		EX-1	1.19	0.36	15.5	0.43	5.83	2.5													Flows to Basin EX-2
	5	EX-2	1.60	0.36	11.7	0.58	6.54	3.8													Flows to Basin EX-3
	7	E-3	0.78	0.89	7.4	0.69	7.70	5.3													
		C-6	0.94	0.43	5.4	0.40	8.49	3.4					1	3.4				216	2.0	1.8	
		C-7	0.52	0.70	6.7	0.36	7.95	2.9					1	2.9				216	2.0	1.8	
	45	E-2	0.68	0.85	6.9	0.58	7.89	4.6	16.7	1.28	5.64	7.2									
		E-1	1.71	0.69	11.8	1.18	6.51	7.7	18.5	2.26	5.38	12.2									Combination of C-6, C-7, E-2 Ex Basin from Filing No. 2(East side of BGMD)
	8	EX-3	0.66	0.36	10.7	0.24	6.76	1.6	18.5	4.13	5.38	22.2									Combination of C-6, C-7, E-1, E-2, E-3. Flows to Basin EX-3
	6	D-1g	0.78	0.51	12.8	0.40	6.32	2.5					1	2.5				57	2.0	0.5	Flows to Basin B-1
	15a	D-1h	1.57	0.57	11.7	0.89	6.53	5.8													
		D-1j	0.95	0.63	7.6	0.60	7.63	4.6	13.2	1.89	6.23	11.8	0.9	1.6	10.2			225	1.9	2.0	Flows to existing on-grade inlet at DP51
		D-1f	0.67	0.68	5.4	0.46	8.49	3.9													
		D-1k	0.80	0.60	9.9	0.48	6.95	3.3													
	52	C-1a	0.27	0.80	5.0	0.22	8.68	1.9	9.9	1.19	6.95	8.3									
	53								9.9	1.41	6.95	9.8	1.1	0.8	9.0			430	2.1	3.4	Flows to proposed on-grade inlet at DP53
	53								13.2	2.93	6.23	18.3			18.3						Total pipe flow at DP 53
		C-1b	1.77	0.63	7.2	1.12	7.76	8.7													
		C-2	1.00	0.68	8.2	0.68	7.42	5.0	8.2	1.80	7.42	13.4	1	13.4				130	1.6	1.4	
	54	C-1c	1.19	0.65	5.5	0.77	8.43	6.5	13.3	2.69	6.21	16.7		4.1	12.6	1.3	30	180	2.2	1.3	Flow into existing on-grade inlet at DP41
	41								13.3	4.96	6.21	30.8			30.8						Total pipe flow at DP41
	42	C-1f	0.14	0.83	5.0	0.12	8.68	1.0	14.7	0.78	5.96	4.6	1	4.6				185	2.0	1.5	Gutter flow to DP15
		C-3	0.18	0.86	6.4	0.15	8.06	1.2					1	1.2				660	2.0	5.5	Gutter flow through C-4 to DP44
	44	C-4	2.67	0.57	12.3	1.52	6.41	9.7	12.3	1.67	6.41	10.7	1	1.1	9.6	1.3	24	70	2.2	0.5	Flow into existing on-grade inlet at DP44
	43	C-1d	1.97	0.67	11.2	1.32	6.64	8.8													Flow into inlet at DP15
	15								16.2	2.27	5.71	13.0	2	2.1	10.9			85	2.8	0.5	

**STANDARD FORM SF-3: PROPOSED**  
**STORM DRAINAGE SYSTEM DESIGN**  
(RATIONAL METHOD PROCEDURE)

Subdivision: Falcon Meadows  
Location: CO, Colorado Springs  
Design Storm: 100-Year

Project Name: Falcon Meadows at Bent Grass Filing No. 3  
Project No.: CLH000020  
Calculated By: CMV  
Checked By: SMB  
Date: 12/6/21

STREET	Design Point	DIRECT RUNOFF							TOTAL RUNOFF				STREET		PIPE			TRAVEL TIME			REMARKS	
		Basin ID	Area (Ac)	Runoff Coeff.	Tc (min)	C*A (Ac)	I (in/hr)	Q (cfs)	Tc (min)	C*A (Ac)	I (in/hr)	Q (cfs)	Slope (%)	Street Flow (cfs)	Design Flow (cfs)	Slope (%)	Pipe Size (inches)	Length (ft)	Velocity (fps)	Tt (min)		
	15																				Total pipe flow at DP15	
	12	C-1e	0.49	0.96	5.0	0.47	8.68	4.1	16.2	8.37	5.71	47.8	2	0.1	4.0			85	2.8	0.5	Flow into inlet at DP12 Total pipe flow at DP12	
	19	C-1g	1.02	0.59	8.5	0.60	7.33	4.4													Flow into Pond North	
	13	C-5	0.60	0.36	5.0	0.22	8.68	1.9	16.2	9.65	5.71	55.1									North Pond Total flow to Pond North. Outfalls to Basin B-1	
	AA	B-1	6.59	0.36	21.6	2.37	4.99	11.8	46.6	421.46	3.05	1285.4									Total flow under BGMD into Basin B-2	
		D-2b	0.74	0.64	10.9	0.47	6.71	3.2														
		D-2a	0.50	0.84	5.2	0.42	8.57	3.6														
	14a	D-2c	0.31	0.78	5.0	0.24	8.68	2.1	10.9	1.13	6.71	7.6	1.3	7.6				230	2.3	1.7	Gutter flow through D-2d to DP14b	
	14b	D-2d	0.24	0.76	5.0	0.18	8.68	1.6	12.6	1.31	6.35	8.3	1.3	8.3				625	2.3	4.6	Gutter flow through D-2d to DP14b	
	14	D-2g	1.81	0.62	15.4	1.12	5.84	6.5	17.2	2.43	5.57	13.5	2.5	5.3	8.2			625	3.2	3.3	Flow into existing inlet at DP14	
	9	OS-2	20.07	0.40	18.3	8.03	5.41	43.4													Overland flow into Basin D-3. Flow obtained from Bent Grass Filing No. 2 FDR	
	10	OS-3	10.61	0.40	18.9	4.24	5.33	22.6													Offsite flow into Basin D-3. Flow obtained from Bent Grass Filing No. 2 FDR	
	11	D-3	2.26	0.55	21.0	1.24	5.06	6.3	21.0	13.51	5.06	68.4			68.4	1.0	42	100	2.0	0.8	Flows conveyed via existing ditch into proposed area inlet.	
	14e	D-2f	2.43	0.69	8.7	1.68	7.27	12.2													Flows to existing inlet at DP14e	
	14d	D-2e	1.41	0.70	10.9	0.99	6.73	6.7	10.9	2.67	6.73	18.0			18.0	1.0	42	100	2.0	0.8	Flows to existing inlet at DP14d Flows conveyed storm sewer to DP16	
		D-1a	1.83	0.61	10.9	1.12	6.73	7.5														
	16a	D-1b	1.19	0.64	10.0	0.76	6.93	5.3	10.9	1.88	6.73	12.7	1.3	12.7				1300	2.3	9.5	Gutter flow through Basin D-1c to DP16	
		D-1c	3.95	0.60	21.1	2.37	5.05	12.0	21.1	4.25	5.05	21.5	2.5	11.3	10.2			625	3.2	3.3	Flows to existing inlet at DP16	
	16								21.9	19.67	4.96	97.6			97.6	2.0	48	835	2.8	4.9	Combination of flows to existing inlets at DP14 and DP16. Flows to DP 17	
		D-5	1.08	0.64	5.1	0.69	8.63	6.0					1	6.0				600	2.0	5.0	Gutter flow through Basin D-6b to DP18	
		D-6b	2.69	0.67	12.6	1.80	6.35	11.4														
	18	D-6a	1.33	0.71	6.5	0.94	8.03	7.5	12.6	3.43	6.35	21.8			21.8	2.0	24	38	2.8	0.2	Flow to existing inlet. Flow out of inlet to DP17c	
	17a	D-4a	0.98	0.67	11.1	0.66	6.66	4.4					1	4.4				700	2.0	5.8	Gutter flow through Basin D-4b to DP17b	
		D-4b	0.95	0.76	10.2	0.72	6.87	4.9	17.0	1.38	5.60	7.7									Gutter flow to DP17c	
	17b	D-4c	1.22	0.68	14.2	0.83	6.04	5.0	17.0	2.21	5.60	12.4			12.4	2.0	24	8	2.8	0.0	Flows from Basin B-3 of Bent Grass Filing No. 2 FDR. Flows to existing inlet at DP17c	
	17c								17.0	5.64	5.60	31.6										Total pipe flow at DP17c to DP17
	17								26.8	25.31	4.45	112.6										Storm system entering existing pond at Basin D-7
		D-9	0.72	0.44	5.5	0.32	8.44	2.7					1.5	2.7				625	2.4	4.3	Gutter flow through Basin E-4 to DP24	
		D-2h	0.23	0.59	15.5	0.14	5.83	0.8					1.5	0.8				550	2.4	3.7	Gutter flow through Basin E-4 to DP24	
	24	E-4	0.91	0.84	8.0	0.76	7.50	5.7	24.4	4.41	4.68	20.6										Flow to existing inlet at DP24

**STANDARD FORM SF-3: PROPOSED  
STORM DRAINAGE SYSTEM DESIGN  
(RATIONAL METHOD PROCEDURE)**

**Subdivision:** Falcon Meadows  
**Location:** CO, Colorado Springs  
**Design Storm:** 100-Year

**Project Name:** Falcon Meadows at Bent Grass Filing No. 3  
**Project No.:** CLH000020  
**Calculated By:** CMV  
**Checked By:** SMB  
**Date:** 12/6/21

STREET	Design Point	DIRECT RUNOFF							TOTAL RUNOFF				STREET		PIPE			TRAVEL TIME			REMARKS
		Basin ID	Area (Ac)	Runoff Coeff.	Tc (min)	C*A (Ac)	I (in/hr)	Q (cfs)	Tc (min)	C*A (Ac)	I (in/hr)	Q (cfs)	Slope (%)	Street Flow (cfs)	Design Flow (cfs)	Slope (%)	Pipe Size (inches)	Length (ft)	Velocity (fps)	Tt (min)	
	25	E-5	0.89	0.89	7.3	0.79	7.73	6.1													Flow to existing inlet at DP25
	26								24.4	5.20	4.68	24.3									Flow into existing pond via Swale F at DP26
	32	D-8	1.69	0.58	14.0	0.98	6.08	6.0													Flow in Swale C (Basin D-8) into existing pond
	30	D-7	7.65	0.40	14.8	3.06	5.94	18.2													Existing Water quality pond
	CC	B-2	4.16	0.36	16.0	1.50	5.75	8.6	26.8	34.55	4.45	153.7									Outlet to existing channel Basin B-2
									46.6	457.51	3.05	1395.4									



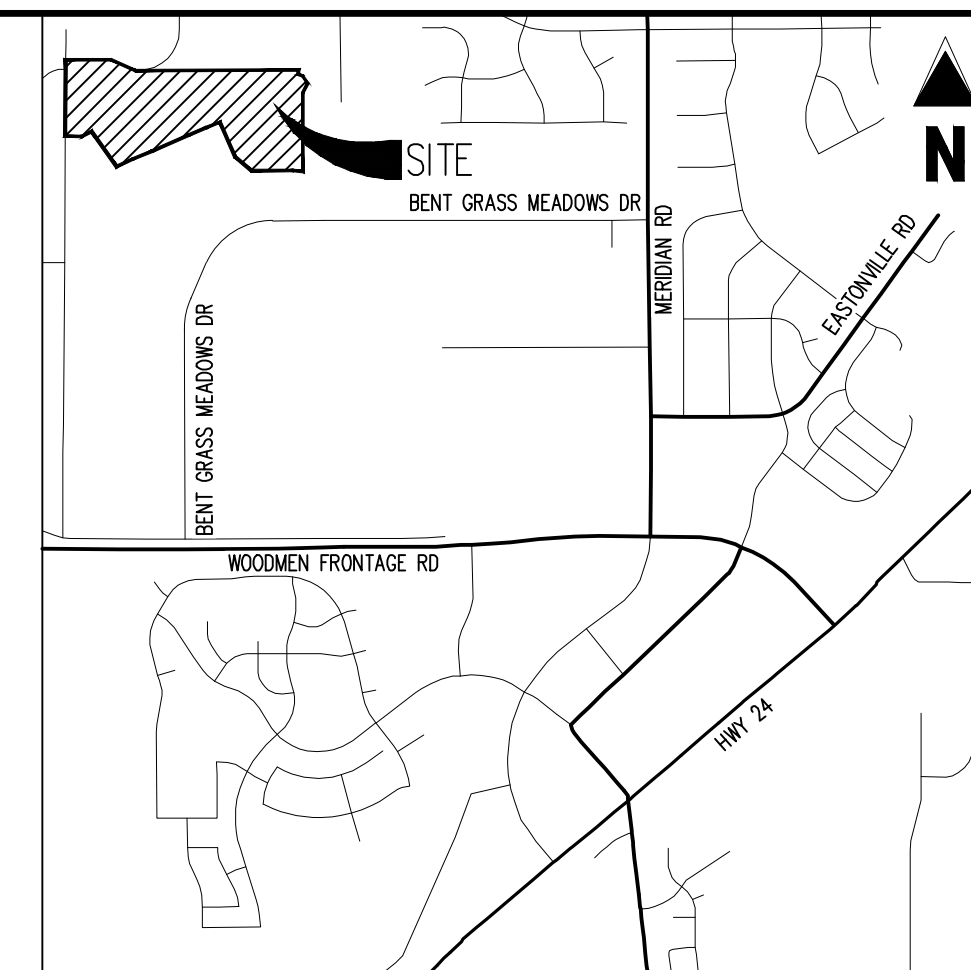
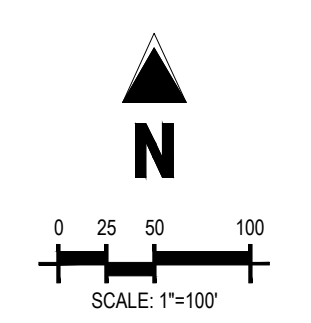
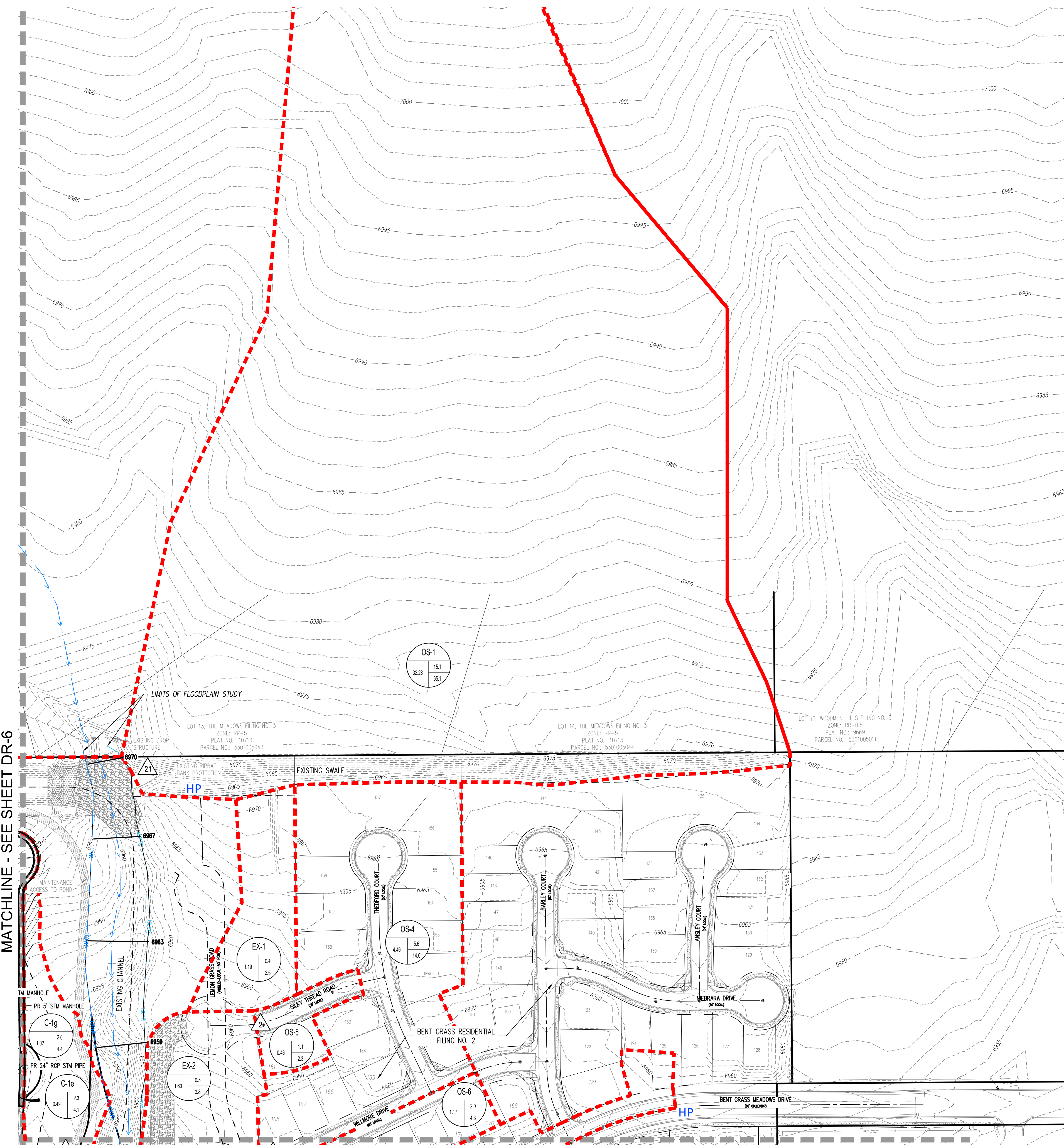

### DRAINAGE LEGEND

- PROPERTY LINE
- EXISTING MAJOR CONTOUR
- EXISTING MINOR CONTOUR
- PROPOSED MAJOR CONTOUR
- PROPOSED MINOR CONTOUR
- BASIN BOUNDARY LINE
- DRAINAGE TRAVEL PATH
- FEMA EFFECTIVE 100-YR FLOODPLAIN
- 100-YR FLOODPLAIN PER MATRIX DBPS
- CENTERLINE OF STREAM
- EXISTING RIPRAP
- EXISTING ACCESS
- PROPOSED RIPRAP
- PROPOSED ACCESS
- BASIN DESIGNATION
- 5-YEAR RUNOFF IN CUBIC FEET PER SECOND
- 100-YEAR RUNOFF IN CUBIC FEET PER SECOND
- BASIN AREA IN ACRES
- DESIGN POINT
- DIRECTION OF RUNOFF

#### RUNOFF SUMMARY TABLE

Basin ID	Area (acres)	Q <sub>p</sub> (cfs)	Q <sub>100</sub> (cfs)
RRF200	192.40	290.0	1020.0
RRF204	38.49	7.0	43.0
W1200	160.00	50.0	190.0
D-1	1.19	0.4	2.9
EX-2	1.60	0.5	3.8
EX-3	0.66	0.2	1.6
B-2	4.56	1.3	8.6
C-1a	0.27	1.0	1.9
C-1b	1.77	3.9	8.7
C-1c	1.19	3.1	6.5
C-1d	1.57	4.2	8.8
C-1e	0.49	2.3	4.1
C-1f	0.34	0.6	1.0
C-1g	1.50	2.5	4.4
C-2	1.00	2.5	5.0
C-3	0.38	0.7	1.2
C-4	2.57	4.2	5.7
C-5	0.60	0.3	1.9
C-6	0.84	1.0	3.4
C-7	0.52	1.4	2.9
D-1a	1.83	3.3	7.5
D-1b	1.19	2.4	5.3
D-1c	3.95	5.4	12.0
D-1d	0.87	1.9	3.9
D-1e	0.76	1.1	2.5
D-1f	1.57	2.4	5.8
D-1g	0.86	2.1	4.8
D-1h	0.86	1.4	3.3
D-2a	0.50	1.9	3.6
D-2b	0.34	1.4	3.2
D-2c	0.31	1.1	2.1
D-2d	0.24	0.8	1.6
D-2e	1.41	3.3	6.7
D-2f	2.43	6.0	12.2
D-2g	1.81	2.5	6.3
D-2h	0.25	0.3	0.8
D-3	2.26	2.6	6.3
D-4a	0.38	2.1	4.4
D-4b	0.58	2.5	4.9
D-4c	1.22	2.4	5.0
D-4d	1.08	2.3	6.0
D-4e	1.33	3.8	7.5
D-4f	2.69	5.0	11.4
D-4g	7.65	4.3	18.2
D-4h	1.69	2.6	6.0
D-4i	0.72	0.8	2.7
OS-1	32.28	15.1	85.1
OS-2	20.07	9.0	43.4
OS-3	10.41	4.7	23.6
OS-4	4.46	5.6	14.1
OS-5	0.48	1.1	2.3
OS-6	1.17	2.0	4.3
E-1	1.71	3.8	7.7
E-2	0.58	2.4	4.6
E-3	0.76	2.9	5.3
E-4	0.91	3.0	5.7
E-5	0.89	3.3	6.1

#### DESIGN POINT SUMMARY TABLE

Design Point	Q <sub>p</sub> (cfs)	Q <sub>100</sub> (cfs)
D-1	5.6	14.0
D-2	1.1	2.3
D-3	2.0	4.3
D-4	7.6	21.4
D-5	0.2	1.6
D-6	5.0	11.8
D-7	10.2	26.6
D-8	7.9	18.3
D-9	8.2	13.4
D-10	14.8	30.8
D-11	0.7	4.6
D-12	4.2	8.8
D-13	4.7	9.7
D-14	2.0	4.4
D-15	20.5	47.8
D-16	25.0	50.4
D-17	1.4	7.2
D-18	26.8	56.1
D-19	7.9	5.3
D-20	10.9	22.2
D-21	30.6	139.4
D-22	9.0	43.4
D-23	4.7	22.6
D-24	15.9	38.4
D-25	3.8	7.6
D-26	6.8	16.6
D-27	5.0	12.2
D-28	4.2	8.3
D-29	6.4	15.5
D-30	5.6	12.7
D-31	16.0	37.6
D-32	10.7	21.8
D-33	2.1	4.4
D-34	2.1	7.7
D-35	2.5	31.6
D-36	47.4	112.6
D-37	2.9	20.6
D-38	3.3	6.1
D-39	7.9	26.3
D-40	60.0	163.7
D-41	2.6	6.0
D-42	340.0	1395.4

COPYRIGHT  
 THESE PLANS ARE AN INSTRUMENT OF SERVICE AND ARE THE PROPERTY OF GALLOWAY, AND MAY NOT BE DUPLICATED, DISCLOSED, OR REPRODUCED WITHOUT THE WRITTEN CONSENT OF GALLOWAY. COPYRIGHTS AND INFRINGEMENTS WILL BE ENFORCED AND PROSECUTED.



MATCHLINE - SEE SHEET DR-6

MATCHLINE - SEE SHEET DR-9

#	Date	Issue / Description	Init.

Project No: CLH000017  
 Drawn By: CMWJ  
 Checked By: RGJ  
 Date: 08/05/2020

PROPOSED DRAINAGE  
 MAP



MATCHLINE - SEE SHEET DR-6

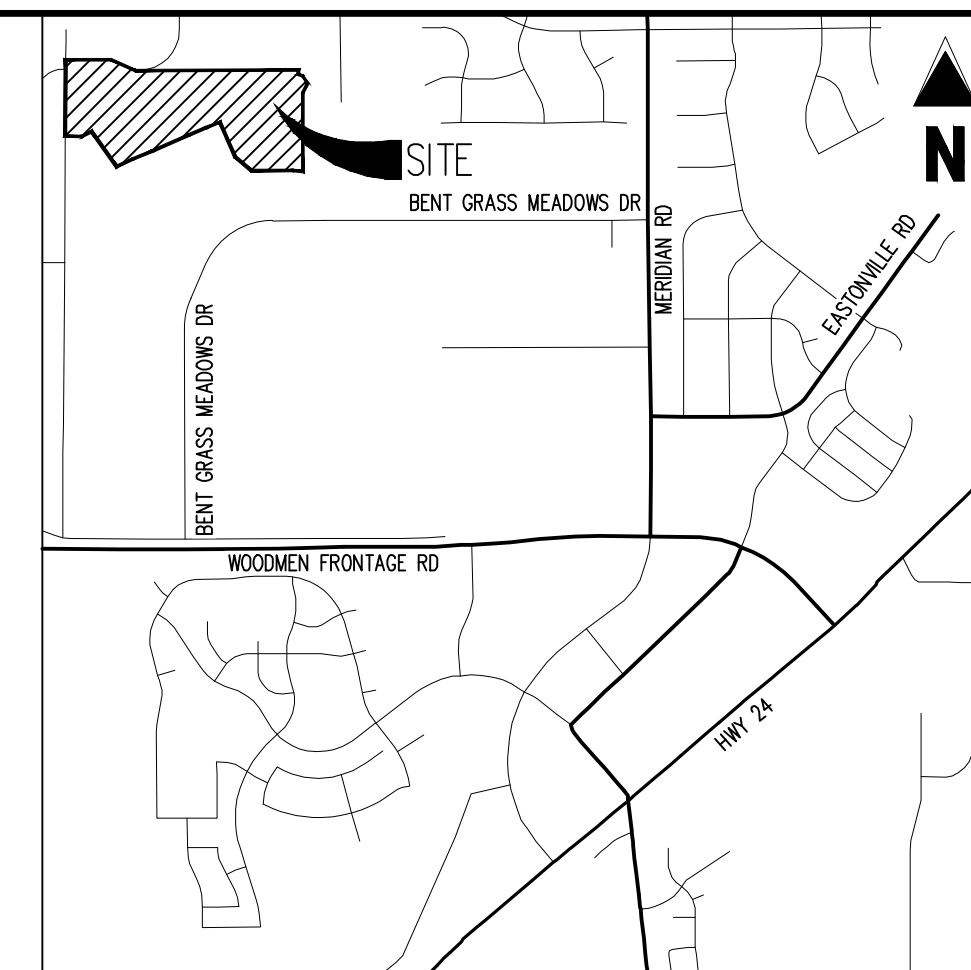
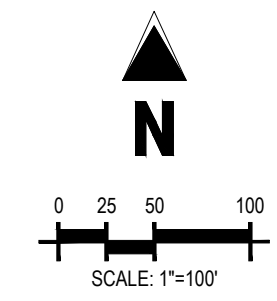

**PRELIMINARY**  
 NOT FOR BIDDING  
 NOT FOR CONSTRUCTION

COPYRIGHT  
 THESE PLANS ARE AN INSTRUMENT OF SERVICE AND ARE THE PROPERTY OF GALLOWAY, AND MAY NOT BE DUPLICATED, DISCLOSED, OR REPRODUCED WITHOUT THE WRITTEN CONSENT OF GALLOWAY. COPYRIGHTS AND INFRINGEMENTS WILL BE ENFORCED AND PROSECUTED.

**CHALLENGER HOMES**

FINAL DRAINAGE REPORT  
 FALCON MEADOWS AT BENT GRASS FILING NO. 3  
 FOR  
 CHALLENGER COMMUNITIES, LLC  
 BENT GRASS MEADOWS DRIVE  
 FALCON, CO 80831 - EL PASO COUNTY

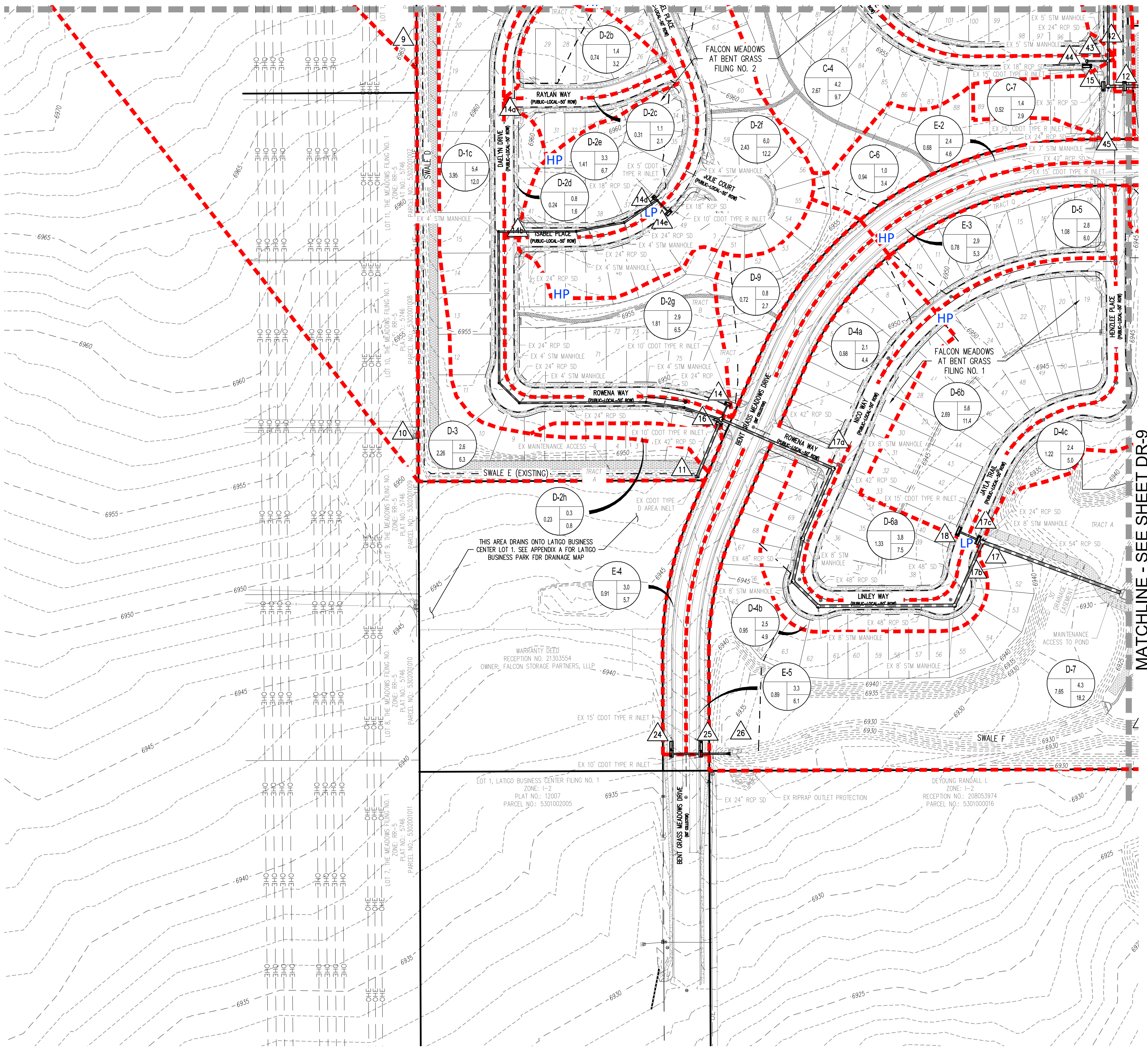

**DRAINAGE LEGEND**

- PROPERTY LINE
- - - - EXISTING MAJOR CONTOUR
- - - - EXISTING MINOR CONTOUR
- PROPOSED MAJOR CONTOUR
- - - - PROPOSED MINOR CONTOUR
- - - - BASIN BOUNDARY LINE
- - - - DRAINAGE TRAVEL PATH
- FEMA EFFECTIVE 100-YR FLOODPLAIN
- 100-YR FLOODPLAIN PER MATRIX DBPS
- CENTERLINE OF STREAM
- EXISTING RIPRAP
- EXISTING ACCESS
- PROPOSED RIPRAP
- PROPOSED ACCESS
- BASIN DESIGNATION
- 5-YEAR RUNOFF IN CUBIC FEET PER SECOND
- 100-YEAR RUNOFF IN CUBIC FEET PER SECOND
- BASIN AREA IN ACRES
- DESIGN POINT
- DIRECTION OF RUNOFF

**RUNOFF SUMMARY TABLE**

Basin ID	Area (acres)	Q <sub>5</sub> (cfs)	Q <sub>100</sub> (cfs)
RM200	151.40	207.0	1009.0
RM201	39.40	72.0	450.0
WF200	192.00	32.0	190.0
E-1	1.19	0.4	2.3
E-2	1.60	0.5	3.8
E-3	0.66	0.2	1.6
B-1	0.98	1.8	11.8
B-2	4.18	1.3	8.8
C-1a	0.27	1.0	1.9
C-1b	1.77	3.9	8.7
C-1c	1.19	3.1	6.5
C-1d	1.59	4.2	8.8
C-1e	0.49	2.3	4.1
C-1f	0.14	0.5	1.0
C-2a	1.00	2.5	4.4
C-2	1.00	2.5	4.4
C-3	0.18	0.7	1.2
C-4	2.87	4.2	9.7
C-5	0.60	0.3	1.9
C-6	0.94	1.0	3.4
C-7	0.95	1.4	2.9
D-1a	1.83	3.3	7.5
D-1b	1.19	2.4	5.3
D-1c	3.95	5.4	12.0
D-1d	0.67	1.9	3.9
D-1e	0.78	1.1	2.5
D-1f	1.57	2.4	5.8
D-1g	0.95	2.1	4.6
D-1h	0.80	1.4	3.3
D-2a	0.50	1.9	3.8
D-2b	0.14	1.4	3.0
D-2c	0.31	1.1	2.4
D-2d	0.24	0.8	1.8
D-2e	1.41	3.3	8.1
D-2f	1.41	3.3	8.1
D-2g	1.81	2.9	6.5
D-2h	0.23	0.3	0.8
D-3	2.28	2.6	6.3
D-4a	0.88	2.1	4.4
D-4b	0.95	2.5	4.9
D-4c	1.22	2.4	5.0
D-4d	1.08	2.8	6.0
D-4e	1.33	3.8	7.5
D-4f	1.09	2.5	5.8
D-4g	1.33	3.8	7.5
D-4h	2.89	5.5	11.4
D-4i	1.09	2.5	5.8
D-4j	0.72	0.8	2.7
D-5	0.89	3.3	6.1
D-6	1.08	2.8	6.0
D-7	7.85	4.3	18.2

**DESIGN POINT SUMMARY TABLE**

Design Point	Q <sub>5</sub> (cfs)	Q <sub>100</sub> (cfs)
1	277.1	1221.1
2	1.1	2.3
3	2.0	4.3
4	7.6	21.4
5	0.2	1.6
6	15.2	69.8
7	5.0	11.8
8	3.0	8.3
9	7.9	18.3
10	6.2	13.4
11	14.8	28.8
12	0.7	1.6
13	4.2	8.8
14	4.7	10.7
15	2.0	4.4
16	29.5	47.8
17	25.0	50.4
18	1.4	7.2
19	26.8	55.1
20	2.9	5.3
21	19.0	22.2
22	20.6	126.4
23	5.0	43.4
24	4.7	22.5
25	15.6	28.4
26	3.8	7.6
27	8.9	18.0
28	6.0	12.2
29	4.2	8.3
30	6.4	13.9
31	5.6	12.7
32	33.6	97.6
33	10.7	21.8
34	2.1	4.4
35	3.9	7.7
36	15.5	31.6
37	42.4	112.6
38	5.9	20.8
39	3.3	5.1
40	7.9	24.3
41	59.0	153.7
42	2.6	5.9
CC	340.0	1394.4

#	Date	Issue / Description	Init.

Project No: CLH000017  
 Drawn By: CMWJ  
 Checked By: RGD  
 Date: 08/05/2020

PROPOSED DRAINAGE MAP

11/20/2020 11:58:00 AM C:\Users\cmw\OneDrive\Documents\Projects\Falco\DR8\DR8.dwg (Sheet) - Sheet: DR-8 (1 of 2)



**PRELIMINARY**  
 NOT FOR BIDDING  
 NOT FOR CONSTRUCTION

**COPYRIGHT**  
 THESE PLANS ARE AN INSTRUMENT OF SERVICE AND ARE THE PROPERTY OF GALLOWAY, AND MAY NOT BE DUPLICATED, DISCLOSED, OR REPRODUCED WITHOUT THE WRITTEN CONSENT OF GALLOWAY. COPYRIGHTS AND INFRINGEMENTS WILL BE ENFORCED AND PROSECUTED.

**CHALLENGER HOMES**

**FINAL DRAINAGE REPORT  
 FALCON MEADOWS AT BENT GRASS FILING NO. 3  
 FOR  
 CHALLENGER COMMUNITIES, LLC**

**BENT GRASS MEADOWS DRIVE  
 FALCON, CO 80831 - EL PASO COUNTY**

#	Date	Issue / Description	Init.

Project No: CLH000014.20  
 Drawn By: CMWJ  
 Checked By: SMB  
 Date: OCTOBER 2019

HISTORIC CONDITIONS DRAINAGE MAP

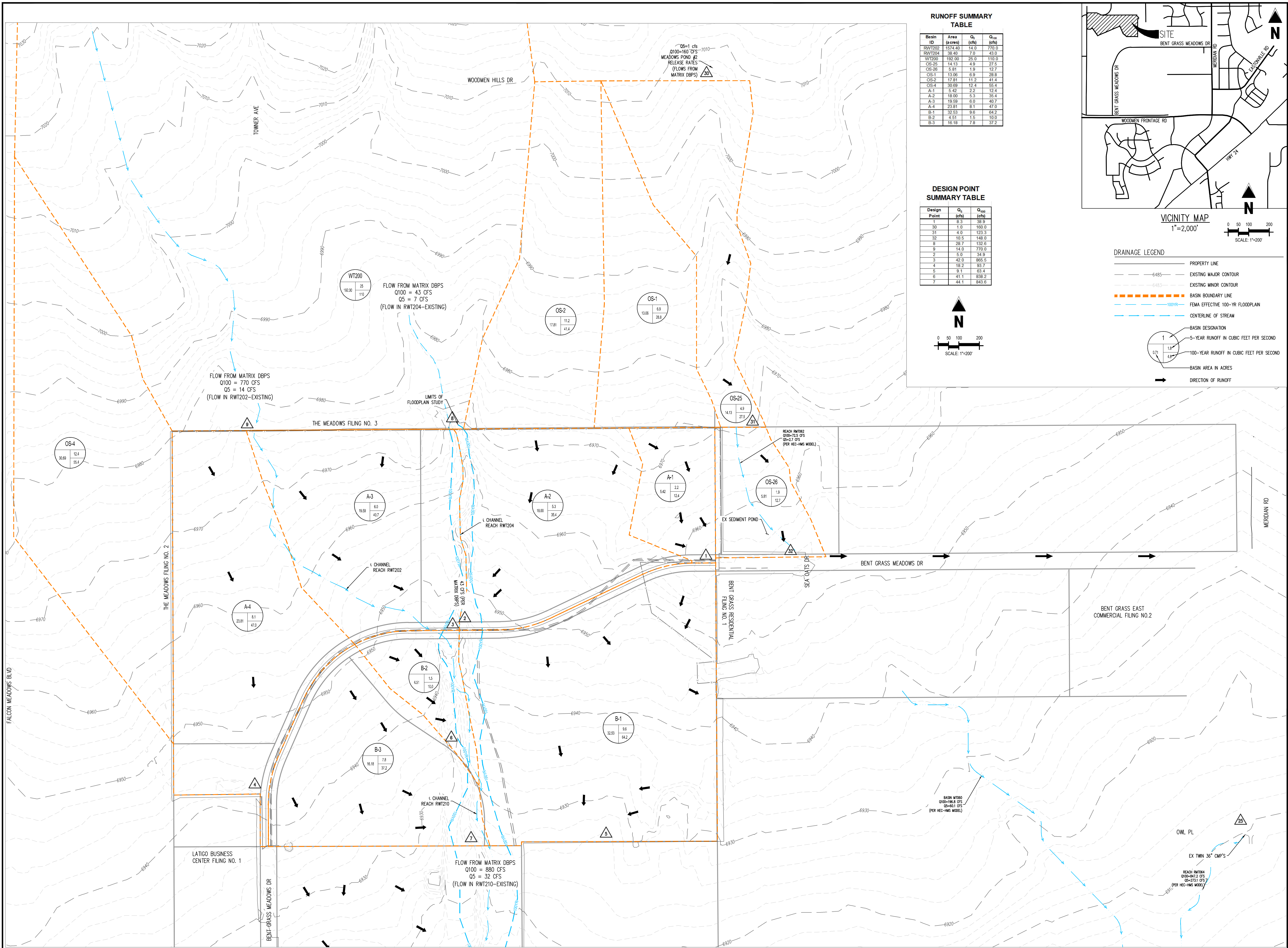

**RUNOFF SUMMARY TABLE**

Basin ID	Area (Acres)	$Q_1$ (cfs)	$Q_{100}$ (cfs)
RWT202	1574.40	14.0	770.0
RWT204	38.40	7.0	43.0
WT200	192.00	25.0	110.0
OS-25	14.13	4.9	27.5
OS-26	5.81	1.9	12.7
OS-1	13.06	6.9	28.8
OS-2	17.81	11.2	41.4
OS-4	30.69	12.4	55.4
A-1	5.42	2.2	12.4
A-2	18.00	5.3	35.4
A-3	19.59	6.0	40.7
A-4	23.81	8.1	47.0
B-1	32.53	9.6	64.2
B-2	4.51	1.5	10.0
B-3	16.18	7.8	37.2

**DESIGN POINT SUMMARY TABLE**

Design Point	$Q_1$ (cfs)	$Q_{100}$ (cfs)
1	8.3	38.9
30	1.9	160.0
31	4.0	123.3
32	10.5	148.0
8	28.7	132.8
9	14.0	770.0
2	5.0	34.6
3	42.0	885.5
4	18.2	93.7
5	9.1	63.4
6	41.1	838.2
7	44.1	843.6

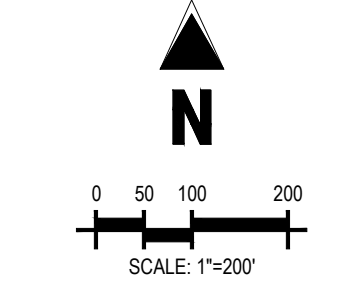
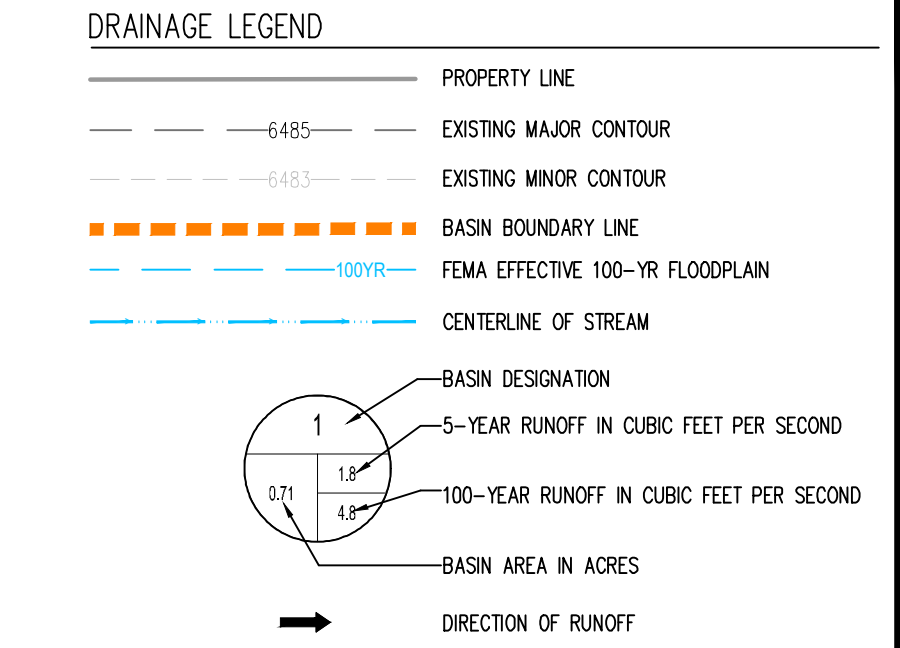

**Approved Construction Drawings**  
**(Falcon Meadows at Bent Grass Drainage Channel)**

# FALCON MEADOWS AT BENT GRASS DRAINAGE CHANNEL

A PARCEL OF LAND, BEING A PORTION OF THE WEST HALF OF SECTION 1, TOWNSHIP 13 SOUTH, RANGE 65 WEST, OF THE 6TH PRINCIPAL MERIDIAN  
 COLORADO SPRINGS, EL PASO COUNTY, STATE OF COLORADO  
 BENT GRASS MEADOWS DRIVE & EAST WOODMEN ROAD

## CONSTRUCTION DRAWINGS (PLAN & PROFILE)

CDR-21-014

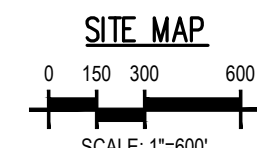
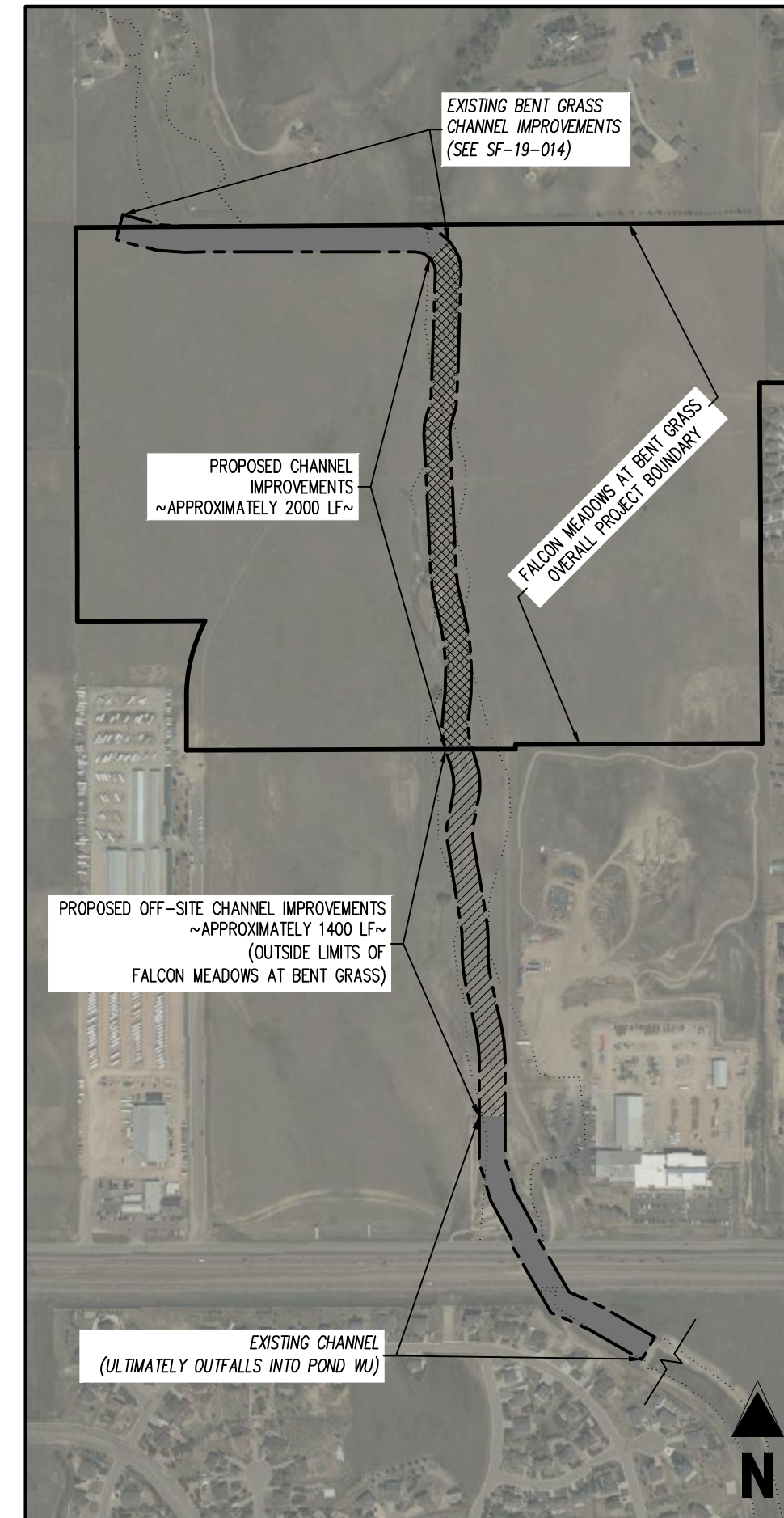
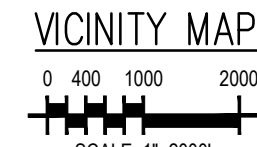
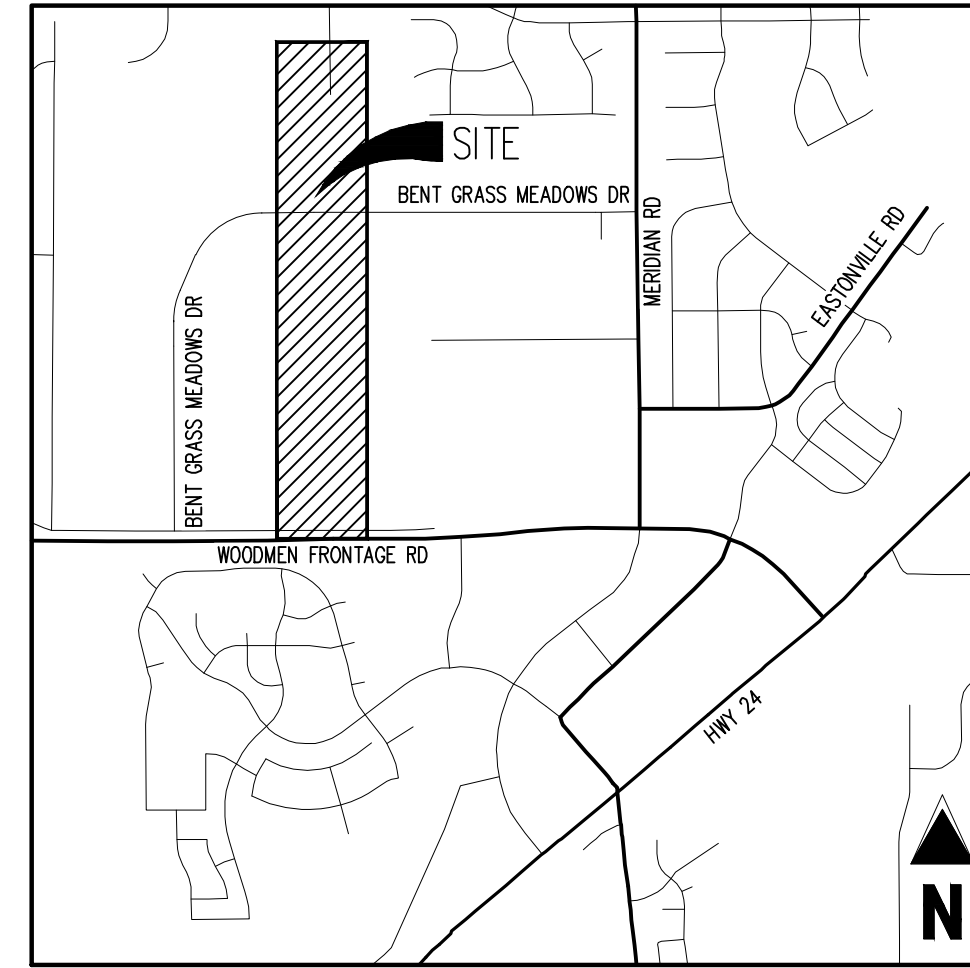

### PROJECT CONTACTS

**PROPERTY OWNER – DEVELOPER**  
 CHALLENGER COMMUNITIES, LLC  
 8605 EXPLORER DR., SUITE 250  
 COLORADO SPRINGS, CO 80920  
 TELE: (719) 598-5192  
 ATTN: JIM BYERS  
 EMAIL: JIMBYERS@CHALLENGERHOMES.COM

**APPLICANT**  
 GALLOWAY & CO., INC.  
 1155 KELLY JOHNSON BLVD., SUITE 305  
 COLORADO SPRINGS, CO 80920  
 TELE: (719) 900-7220  
 ATTN: GRANT DENNIS, P.E.  
 EMAIL: GRANTDENNIS@GALLOWAYUS.COM

**CIVIL ENGINEER**  
 GALLOWAY & CO., INC.  
 1155 KELLY JOHNSON BLVD., SUITE 305  
 COLORADO SPRINGS, CO 80920  
 TELE: (719) 337-1282  
 ATTN: BRIAN DENNIS  
 EMAIL: BRIANDENNIS@GALLOWAYUS.COM

**SURVEYOR**  
 GALLOWAY & CO., INC.  
 1155 KELLY JOHNSON BLVD., SUITE 305  
 COLORADO SPRINGS, CO 80920  
 TELE: (719) 337-1282  
 ATTN: BRIAN DENNIS  
 EMAIL: BRIANDENNIS@GALLOWAYUS.COM

**TRAFFIC ENGINEER**  
 LSC TRANSPORTATION CONSULTANTS, INC.  
 545 EAST PINES PEAK AVENUE, SUITE 210  
 COLORADO SPRINGS, CO 80903  
 TELE: (719) 633-2888  
 ATTN: JEFFREY C. HUDSON, P.E.  
 EMAIL: JEFFHUDSON@LSC.COM

**GEOTECHNICAL ENGINEER**  
 ROCKY MOUNTAIN GROUP  
 2910 JUSTIN BLUFFS PKWY  
 COLORADO SPRINGS, CO 80916  
 TELE: (719) 394-3072  
 ATTN: TONY MUNKER, P.E.  
 EMAIL: TMUNKER@RMG-ENGINEERS.COM

### EL PASO COUNTY & UTILITY CONTACTS

**EL PASO COUNTY – PLANNING REVIEW**  
 PLANNING AND DEVELOPMENT  
 2880 INTERNATIONAL CIRCLE, SUITE 110  
 COLORADO SPRINGS, CO 80910  
 TEL: (719) 520-6300  
 CONTACT: –  
 EMAIL: –

**EL PASO COUNTY – ENGINEERING REVIEW**  
 PLANNING AND DEVELOPMENT  
 2880 INTERNATIONAL CIRCLE, SUITE 110  
 COLORADO SPRINGS, CO 80910  
 TEL: (719) 520-6300  
 CONTACT: –  
 EMAIL: –

**WATER & WASTEWATER**  
 WOODMEN HILLS METRO DISTRICT  
 8046 EASTONVILLE ROAD  
 FALCON, CO 80831  
 TELE: (719) 495-2500  
 ATTN: JERRY JACOBSON  
 EMAIL: JERRY@WMD.ORG

**ELECTRIC**  
 MOUNTAIN VIEW ELECTRIC  
 1140 E WOODMEN RD  
 FALCON, CO 80831  
 TELE: (719) 495-2283  
 CATHY HANSEN-LEE  
 EMAIL: CATHY@HMVEA.COOP

**NATURAL GAS**  
 COLORADO SPRINGS UTILITIES (CSU)  
 7710 DURANT DRIVE, P.O. BOX 1103, MAIL CODE 2150  
 COLORADO SPRINGS, CO 80947-2150  
 TELE: (719) 668-5573  
 ATTN: AARON CASSIO  
 EMAIL: ACASSIO@CSU.ORG

**FIRE DEPARTMENT**  
 FALCON FIRE PROTECTION DISTRICT  
 7030 OLD MERIDIAN ROAD  
 PEYTON, CO 80831  
 TELE: (719) 495-4050  
 EMAIL: FALCONFIRE@FALCONFIREPO.ORG

### LIST OF ABBREVIATIONS

SHT – SHEET  
 Δ – DEFLECTION ANGLE  
 L – LENGTH  
 R – RADIUS  
 CB – CHORD BEARING  
 C – CHORD LENGTH  
 N – NORTH/NORTHING  
 W – WEST  
 E – EAST/EASTING  
 S – SOUTH  
 DET – DETAIL  
 EX – EXISTING  
 W/ – WITH  
 PC – POINT OF CURVATURE/PORTLAND CEMENT  
 HWF – MELTED WIRE FABRIC  
 VERT – VERTICAL  
 OC – ON CENTER  
 FDC – FIRE DEPARTMENT CONNECTION  
 CT – COURT  
 DR – DRIVE  
 TYP – TYPICAL  
 REC – RECEPTION NUMBER  
 Ø, DIA – DIAMETER  
 PT – POINT OF TANGENCY  
 MIN – MINIMUM  
 MAX – MAXIMUM  
 HDPE – HIGH DENSITY POLYETHYLENE

### SHEET INDEX

SHEET NUMBER	SHEET DESCRIPTION	SHEET TITLE
1	C0.0	COVER SHEET
2	C0.1	NOTES & TYPICAL SECTIONS
3	C1.1	PROJECT COST RESPONSIBILITY EXHIBIT
4	C2.1	EXISTING CONDITIONS
5	C3.1	HORIZONTAL CONTROL
6	C4.0	CHANNEL KEY MAP
7	C4.1	CHANNEL NORTH – PLAN & PROFILE
8	C4.2	CHANNEL SOUTH – PLAN & PROFILE
9	C4.3	CHANNEL SOUTH – PLAN & PROFILE
10	C4.4	CHANNEL SOUTH – PLAN & PROFILE
11	C5.0	DROP STRUCTURE KEY MAP
12	C5.1	DROP STRUCTURE DETAILS (
13	C5.2	DROP STRUCTURE DETAILS (
14	C5.3	DROP STRUCTURE DETAILS (
15	C5.4	DROP STRUCTURE DETAILS (
16	C5.5	DROP STRUCTURE DETAILS (
17	C5.6	DROP STRUCTURE GENERAL DETAILS
18	C6.0	CHANNEL SECTIONS KEY MAP
19	C6.1	NORTH CHANNEL SECTIONS
20	C6.2	SOUTH CHANNEL SECTIONS
21	C6.3	SOUTH CHANNEL SECTIONS
22	C6.4	SOUTH CHANNEL SECTIONS

### BENCHMARK

ELEVATIONS ARE BASED ON THE SOUTHWEST CORNER OF LOT, WOODMEN HILLS FILING NO. 4, MONUMENTED BY NO. 4 REBAR WITH A YELLOW PLASTIC CAP, STAMPED L# 24954. ELEVATION = 6947.67

### BASIS OF BEARING

ALL BEARINGS ARE GRID BEARINGS OF THE COLORADO STATE PLANE COORDINATE SYSTEM, CENTRAL ZONE, NORTH AMERICAN DATUM 1983. THE BEARING OF THE LINE BETWEEN THE SOUTHWEST CORNER OF SECTION 1, T13S, R65W AND THE WEST QUARTER CORNER SECTION 1, T13S, R65W IS N001°3'46"W AND MONUMENT AS SHOWN.

NOTE: CONTRACTOR SHALL PROTECT ALL EXISTING SURVEY MONUMENTATION. CONTRACTOR SHALL HAVE LICENSED SURVEYOR REPLACE ANY DAMAGED OR DISTURBED MONUMENTATION AT THEIR COST.

SURVEYOR TO OBTAIN AUTOCAD FILE FROM ENGINEER AND VERIFY ALL HORIZONTAL CONTROL DIMENSIONING PRIOR TO CONSTRUCTION STAKING. SURVEYOR MUST VERIFY ALL BENCHMARK, BASIS OF BEARING AND DATUM INFORMATION TO ENSURE IMPROVEMENTS WILL BE AT THE SAME HORIZONTAL AND VERTICAL LOCATIONS SHOWN ON THE DESIGN CONSTRUCTION DRAWINGS. PRIOR TO CONSTRUCTION STAKING ANY DISCREPANCY MUST BE REPORTED TO OWNER AND ENGINEER PRIOR TO CONTINUATION OF ANY FURTHER STAKING OR CONSTRUCTION WORK.

### CAUTION – NOTICE TO CONTRACTOR

- ALL UTILITY LOCATIONS SHOWN ARE BASED ON MAPS PROVIDED BY THE APPROPRIATE UTILITY COMPANY AND FIELD SURFACE EVIDENCE AT THE TIME OF SURVEY AND IS TO BE CONSIDERED AN APPROXIMATE LOCATION ONLY. IT IS THE CONTRACTOR'S RESPONSIBILITY TO FIELD VERIFY THE LOCATION OF ALL UTILITIES, PUBLIC OR PRIVATE, WHETHER SHOWN ON THE PLANS OR NOT, PRIOR TO CONSTRUCTION. REPORT ANY DISCREPANCIES TO THE ENGINEER PRIOR TO CONSTRUCTION.
- WHERE A PROPOSED UTILITY CROSSES AN EXISTING UTILITY, IT IS THE CONTRACTOR'S RESPONSIBILITY TO FIELD VERIFY THE HORIZONTAL AND VERTICAL LOCATION OF SUCH EXISTING UTILITY, EITHER THROUGH POT-HOLING OR ALTERNATIVE METHOD. REPORT INFORMATION TO THE ENGINEER PRIOR TO CONSTRUCTION.



### ENGINEER'S STATEMENT

THESE DETAILED PLANS AND SPECIFICATIONS WERE PREPARED UNDER MY DIRECTION AND SUPERVISION. SAID PLANS AND SPECIFICATIONS HAVE BEEN PREPARED ACCORDING TO THE CRITERIA ESTABLISHED BY THE COUNTY FOR DETAILED ROADWAY, DRAINAGE, GRADING AND EROSION CONTROL, PLANS AND SPECIFICATIONS, AND SAID PLANS AND SPECIFICATIONS ARE IN CONFORMITY WITH APPLICABLE MASTER DRAINAGE PLANS AND MASTER TRANSPORTATION PLANS. SAID PLANS AND SPECIFICATIONS MEET THE PURPOSES FOR WHICH THE PARTICULAR ROADWAY AND DRAINAGE FACILITIES ARE DESIGNED AND ARE CORRECT TO THE BEST OF MY KNOWLEDGE AND BELIEF. I ACCEPT RESPONSIBILITY FOR ANY LIABILITY CAUSED BY ANY NEGLIGENT ACTS, ERRORS OR OMISSIONS ON MY PART IN PREPARATION OF THESE DETAILED PLANS AND SPECIFICATIONS.

SCOTT M. BROWN, COLORADO P.E. 45900  
 08/22/2022

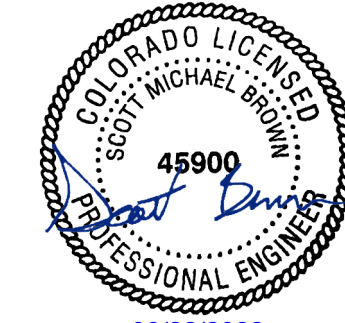

### OWNER'S STATEMENT

I, THE OWNER/DEVELOPER HAVE READ AND WILL COMPLY WITH THE REQUIREMENTS OF THE GRADING AND EROSION CONTROL PLAN AND ALL OF THE REQUIREMENTS SPECIFIED IN THESE DETAILED PLANS AND SPECIFICATIONS.

JIM BYERS  
 CHALLENGER COMMUNITIES, LLC  
 8/22/2022  
 DATE

### EL PASO COUNTY

COUNTY PLAN REVIEW IS PROVIDED ONLY FOR GENERAL CONFORMANCE WITH COUNTY DESIGN CRITERIA. THE COUNTY IS NOT RESPONSIBLE FOR THE ACCURACY AND ADEQUACY OF THE DESIGN, DIMENSIONS, AND/ OR ELEVATIONS WHICH SHALL BE CONFIRMED AT THE JOB SITE. THE COUNTY THROUGH THE APPROVAL OF THIS DOCUMENT ASSUMES NO RESPONSIBILITY FOR COMPLETENESS AND/ OR ACCURACY OF THIS DOCUMENT, FILED IN ACCORDANCE WITH THE REQUIREMENTS OF THE EL PASO COUNTY LAND DEVELOPMENT CODE, DRAINAGE CRITERIA MANUAL, VOLUMES 1 AND 2, AND ENGINEERING CRITERIA MANUAL AS AMENDED.

JOSHUA PALMER, P.E.  
 COUNTY ENGINEER / EOM ADMINISTRATOR  
 APPROVED  
 Engineering Review  
 Date: 8/22/2022

Condition: No construction is permitted on offsite parcels (Case and DeYoung) unless the necessary easements and Woodmen Hills Metropolitan District approvals have been obtained. The permanent channel maintenance agreement shall be provided prior to preliminary acceptance.



**COPYRIGHT**  
 THESE PLANS ARE AN INSTRUMENT OF SERVICE AND ARE THE PROPERTY OF GALLOWAY, AND MAY NOT BE DUPLICATED, DISCLOSED, OR REPRODUCED WITHOUT THE WRITTEN CONSENT OF GALLOWAY. COPYRIGHTS AND INFRAINGEMENTS WILL BE ENFORCED AND PROSECUTED.



CONSTRUCTION DOCUMENTS  
 FALCON MEADOWS AT BENT GRASS  
 FOR  
 CHALLENGER COMMUNITIES, LLC  
 BENT GRASS MEADOWS DRIVE & MERIDIAN ROAD  
 FALCON, CO 80831 - EL PASO COUNTY

#	Date	Issue / Description	Init.

Cover Sheet

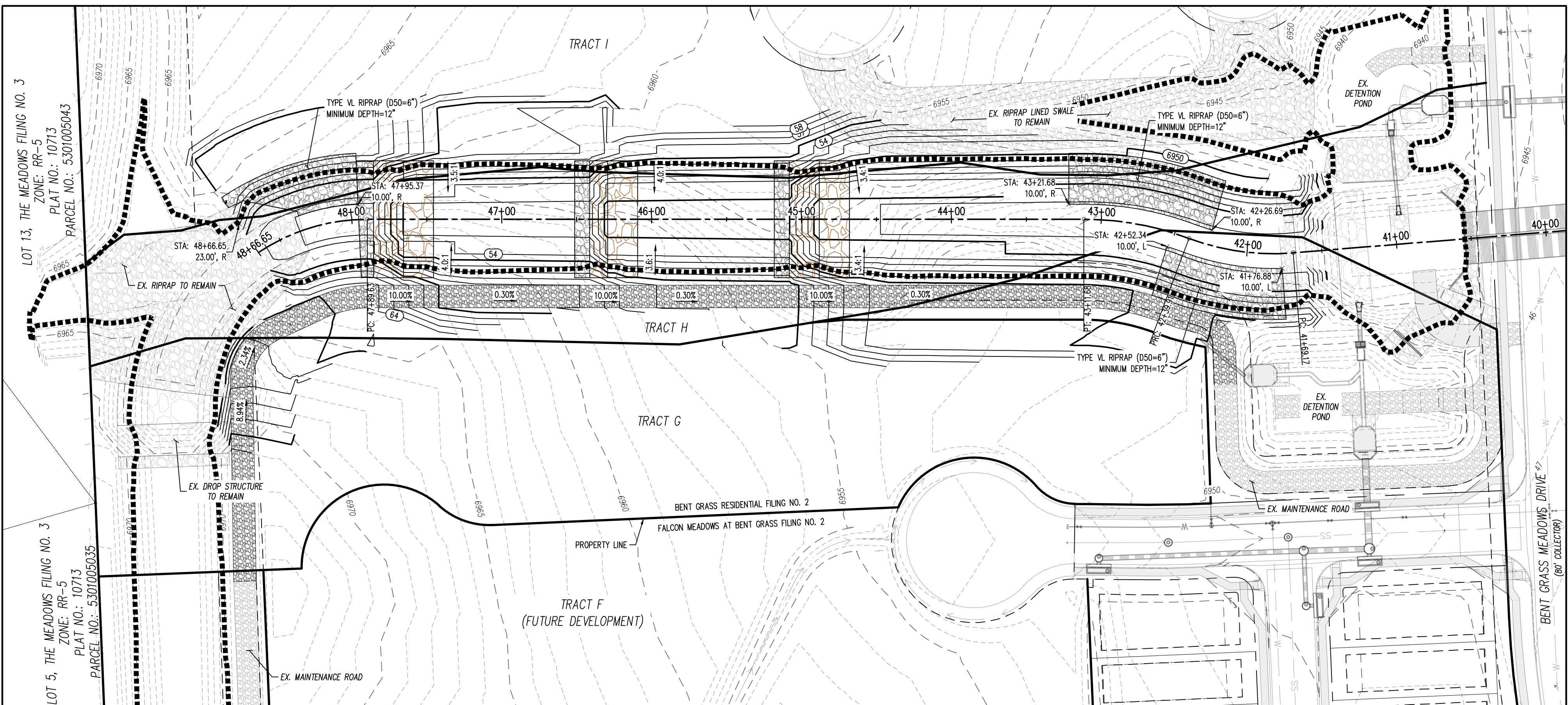
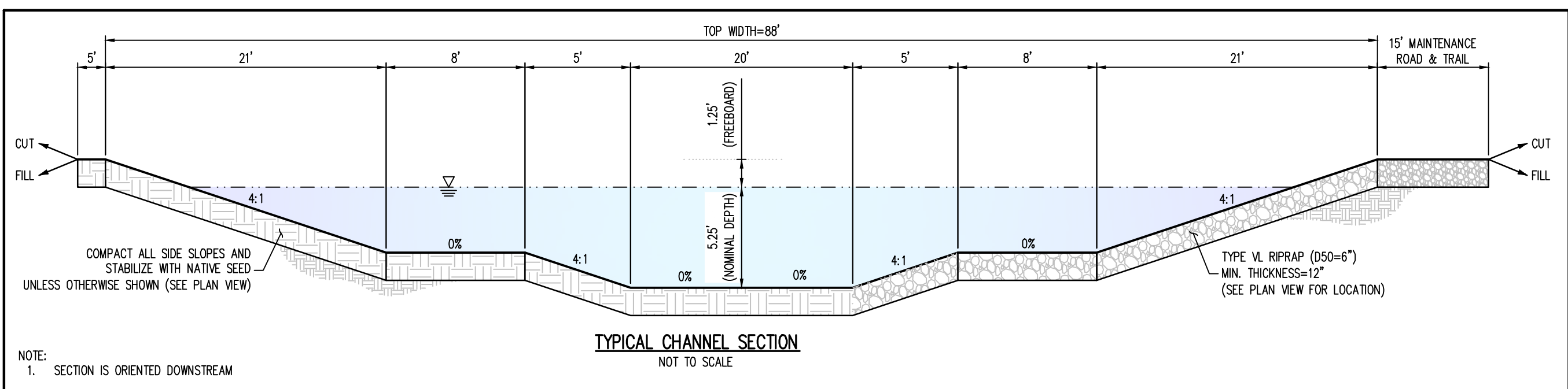

PLAN VIEW - NORTH CHANNEL (STA: 40+00 - 48+66.65)

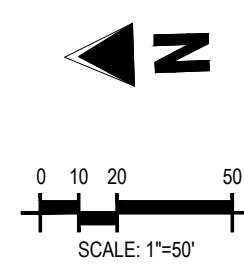

**GRADING LEGEND**

- 5460 --- EXISTING MAJOR CONTOUR
- 52 --- EXISTING MINOR CONTOUR
- 5485 --- PROPOSED MAJOR CONTOUR
- 66 --- PROPOSED MINOR CONTOUR
- 2.00% --- EXISTING SLOPE - PERCENT
- 4:1 --- EXISTING SLOPE - RISE/RUN
- 2.00% --- PROPOSED SLOPE - PERCENT
- 4:1 --- PROPOSED SLOPE - RISE/RUN
- 55.00 FG --- PROPOSED SPOT ELEVATION - FINISHED GROUND
- 55.00 CL --- PROPOSED SPOT ELEVATION - CENTER LINE
- 55.00 TOB --- PROPOSED SPOT ELEVATION - TOP OF BANK

**UTILITY LEGEND**

- W --- EXISTING WATER LINE
- W --- PROPOSED WATER LINE
- SS --- EXISTING SANITARY SEWER
- FO --- EXISTING FIBER OPTIC LINE
- G --- EXISTING GAS LINE
- UT --- EXISTING UNDERGROUND TELEPHONE
- UE --- EXISTING UNDERGROUND ELECTRICAL
- OH-T --- EXISTING OVERHEAD TELEPHONE
- OH-E --- EXISTING OVERHEAD ELECTRICAL
- S --- EXISTING STORM SEWER
- S --- EXISTING ELECTRICAL BOX
- T --- EXISTING PAD MOUNTED TRANSFORMER
- P --- EXISTING TRAFFIC POLE
- L --- PROPOSED SITE LIGHTING
- S --- EXISTING SANITARY SEWER MANHOLE
- S --- EXISTING STORM SEWER MANHOLE
- M --- EXISTING WATER METER
- V --- EXISTING WATER VALVE
- F --- EXISTING FIRE HYDRANT
- F --- PROPOSED FIRE HYDRANT

**SITE LEGEND**

- P --- PROPERTY BOUNDARY LINE
- R --- RIGHT OF WAY BOUNDARY LINE
- E --- EXISTING EASEMENT LINE
- 100 --- PROPOSED 100-YEAR FLOODPLAIN
- C --- EXISTING CURB AND GUTTER
- G --- EXISTING CONCRETE
- G --- EXISTING CDOT CLASS 6 GRAVEL
- R --- EXISTING RIPRAP
- B --- EXISTING BouldERS
- G --- PROPOSED CDOT CLASS 6 GRAVEL
- R --- PROPOSED RIPRAP
- B --- PROPOSED BouldERS
- X --- EXISTING SIGN
- C --- REFERENCE TO DETAIL AND SHEET NUMBER

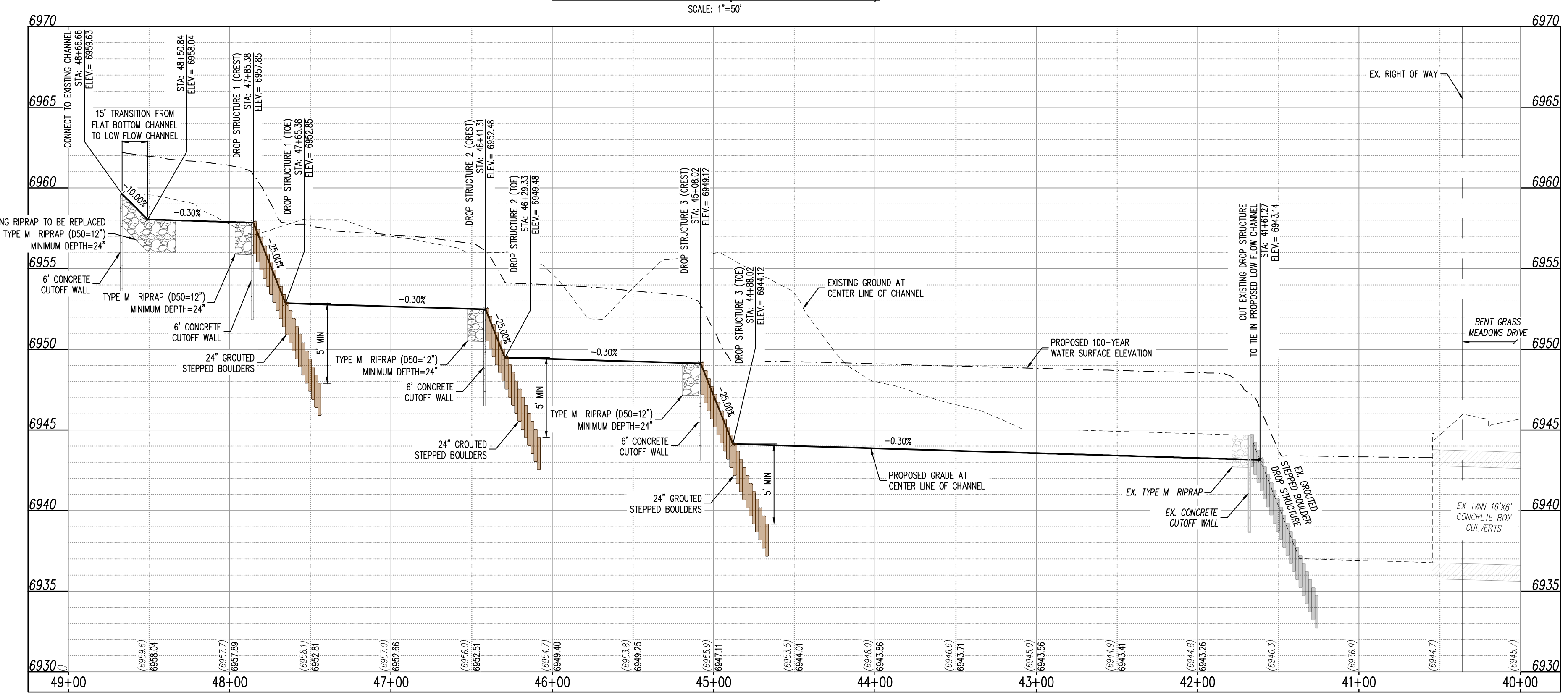

PROFILE VIEW - NORTH CHANNEL (STA: 40+00 - 48+66.65)

NOTE: CONTRACTOR SHALL PROTECT ALL EXISTING SURVEY MONUMENTATION. CONTRACTOR SHALL HAVE LICENSED SURVEYOR REPLACE ANY DAMAGED OR DISTURBED MONUMENTATION AT THEIRS COST.

SURVEYOR TO OBTAIN AUTOCAD FILE FROM ENGINEER AND VERIFY ALL HORIZONTAL CONTROL DIMENSIONING PRIOR TO CONSTRUCTION STAKING. SURVEYOR MUST VERIFY ALL BENCHMARK, BASIS OF BEARING AND DATUM INFORMATION TO ENSURE IMPROVEMENTS WILL BE AT THE SAME HORIZONTAL AND VERTICAL LOCATIONS SHOWN ON THE DESIGN CONSTRUCTION DRAWINGS. PRIOR TO CONSTRUCTION STAKING ANY DISCREPANCY MUST BE REPORTED TO OWNER AND ENGINEER PRIOR TO CONTINUATION OF ANY FURTHER STAKING OR CONSTRUCTION WORK.

**BENCHMARK**

ELEVATIONS ARE BASED ON THE SOUTHWEST CORNER OF LOT 1, WOODMEN HILLS FILING NO. 4, MONUMENTED BY A NO. 4 REBAR WITH A YELLOW PLASTIC CAP, STAMPED L5# 24954. ELEVATION = 6947.67.

**CAUTION - NOTICE TO CONTRACTOR**

1. ALL UTILITY LOCATIONS SHOWN ARE BASED ON MAPS PROVIDED BY THE APPROPRIATE UTILITY COMPANY AND FIELD SURFACE EVIDENCE AT THE TIME OF SURVEY AND IS TO BE CONSIDERED AN APPROXIMATE LOCATION ONLY. IT IS THE CONTRACTOR'S RESPONSIBILITY TO FIELD VERIFY THE LOCATION OF ALL UTILITIES, PUBLIC OR PRIVATE, WHETHER SHOWN ON THE PLANS OR NOT, PRIOR TO CONSTRUCTION. REPORT ANY DISCREPANCIES TO THE ENGINEER PRIOR TO CONSTRUCTION.



2. WHERE A PROPOSED UTILITY CROSSES AN EXISTING UTILITY, IT IS THE CONTRACTOR'S RESPONSIBILITY TO FIELD VERIFY THE HORIZONTAL AND VERTICAL LOCATION OF SUCH EXISTING UTILITY, EITHER THROUGH POTHOLES OR ALTERNATIVE METHOD. REPORT INFORMATION TO THE ENGINEER PRIOR TO CONSTRUCTION.

**Galloway**

1155 Kelly Johnson Blvd., Suite 305  
 Colorado Springs, CO 80920  
 719.900.7220  
 GallowayUS.com

**COPYRIGHT**

THESE PLANS ARE AN INSTRUMENT OF SERVICE AND ARE THE PROPERTY OF GALLOWAY, AND MAY NOT BE DUPLICATED, DISCLOSED OR REPRODUCED WITHOUT THE WRITTEN CONSENT OF GALLOWAY. COPYRIGHTS AND INFRINGEMENTS WILL BE ENFORCED AND PROSECUTED.

**CHALLENGER HOMES**

CONSTRUCTION DOCUMENTS  
 FALCON MEADOWS AT BENT GRASS  
 FOR  
 CHALLENGER COMMUNITIES, LLC

BENT GRASS MEADOWS DRIVE & MERIDAN ROAD  
 FALCON, CO 80831 - EL PASO COUNTY

#	Date	Issue / Description	Init.

Project No: CLH000023  
 Drawn By: CMVJJ  
 Checked By: RGD  
 Date: 8/19/2022

CHANNEL NORTH - PLAN & PROFILE

**C4.1**  
 Sheet 7 of 23

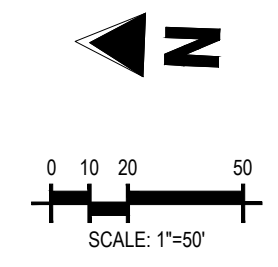
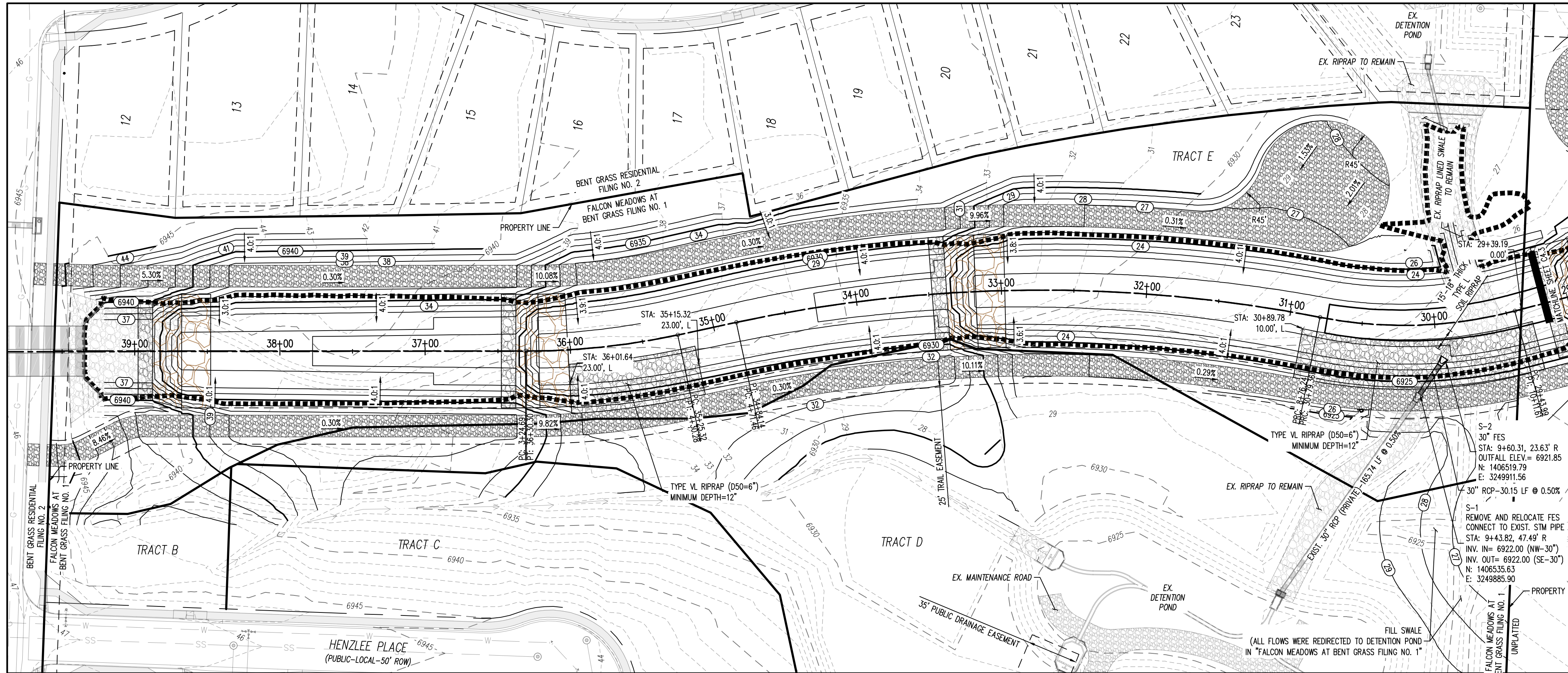
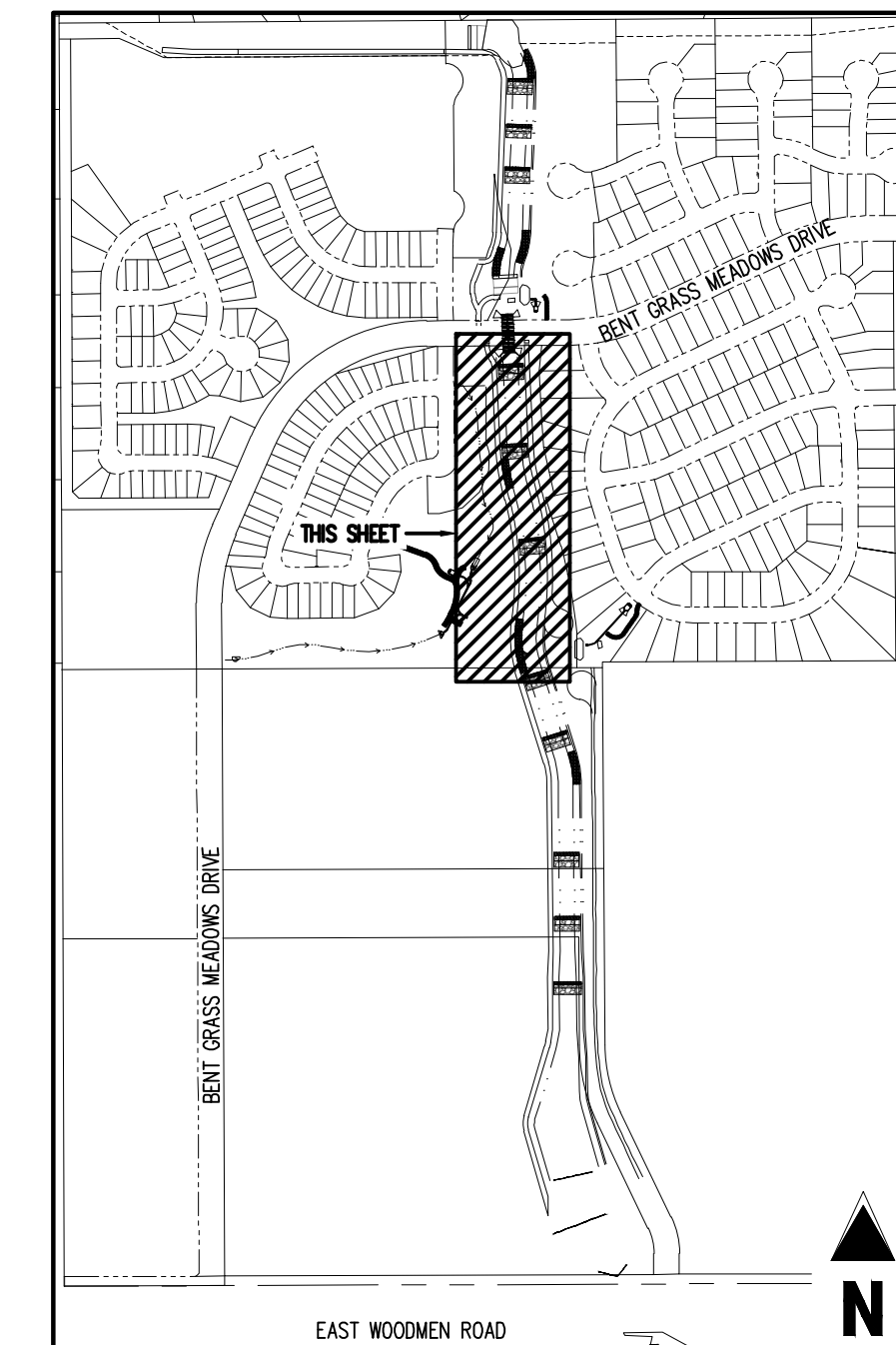
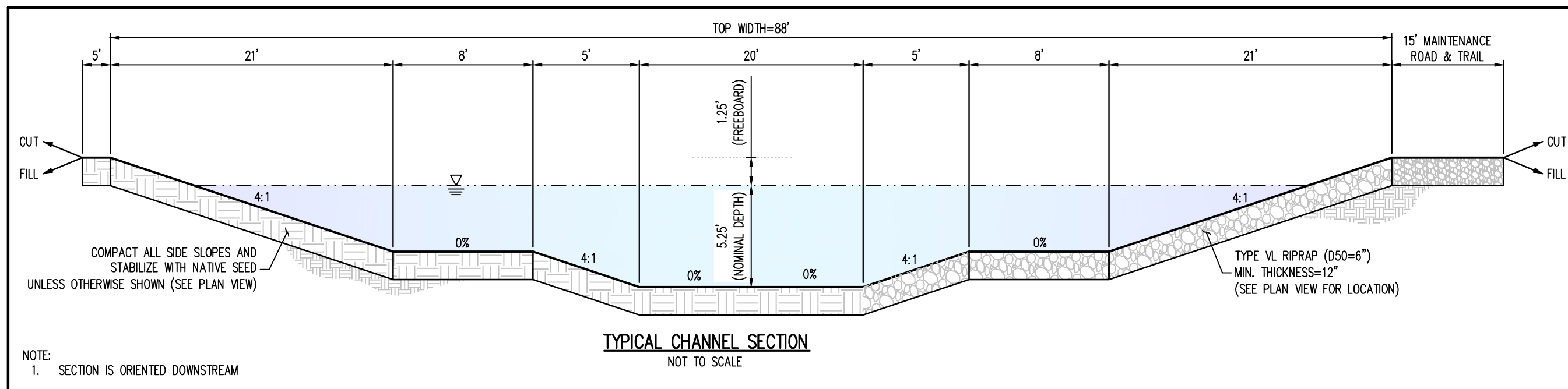

- | GRADING LEGEND |   |
|----------------|---|
| — 5460 —       | EXISTING MAJOR CONTOUR                    |
| — 52 —         | EXISTING MINOR CONTOUR                    |
| — 5485 —       | PROPOSED MAJOR CONTOUR                    |
| — 66 —         | PROPOSED MINOR CONTOUR                    |
| — 2.00% —      | EXISTING SLOPE - PERCENT                  |
| 4:1            | EXISTING SLOPE - RISE/RUN                 |
| 2.00%          | PROPOSED SLOPE - PERCENT                  |
| 4:1            | PROPOSED SLOPE - RISE/RUN                 |
| [Symbol]       | PROPOSED SPOT ELEVATION - FINISHED GROUND |
| [Symbol]       | PROPOSED SPOT ELEVATION - CENTER LINE     |
| [Symbol]       | PROPOSED SPOT ELEVATION - TOP OF BANK     |

- | SITE LEGEND |                                      |
|-------------|--------------------------------------|
| — —         | PROPERTY BOUNDARY LINE               |
| — — —       | RIGHT OF WAY BOUNDARY LINE           |
| - - -       | EXISTING EASEMENT LINE               |
| [Symbol]    | PROPOSED 100-YEAR FLOODPLAIN         |
| [Symbol]    | EXISTING CURB AND GUTTER             |
| [Symbol]    | EXISTING CONCRETE                    |
| [Symbol]    | EXISTING CDOT CLASS 6 GRAVEL         |
| [Symbol]    | EXISTING RIRRAP                      |
| [Symbol]    | EXISTING BOULDERS                    |
| [Symbol]    | PROPOSED CDOT CLASS 6 GRAVEL         |
| [Symbol]    | PROPOSED RIRRAP                      |
| [Symbol]    | PROPOSED BOULDERS                    |
| [Symbol]    | EXISTING SIGN                        |
| [Symbol]    | REFERENCE TO DETAIL AND SHEET NUMBER |

- | UTILITY LEGEND |                                  |
|----------------|----------------------------------|
| — W —          | EXISTING WATER LINE              |
| — W —          | PROPOSED WATER LINE              |
| — SS —         | EXISTING SANITARY SEWER          |
| — FO —         | EXISTING FIBER OPTIC LINE        |
| — G —          | EXISTING GAS LINE                |
| — UT —         | EXISTING UNDERGROUND TELEPHONE   |
| — UE —         | EXISTING UNDERGROUND ELECTRICAL  |
| — OHT —        | EXISTING OVERHEAD TELEPHONE      |
| — OHE —        | EXISTING OVERHEAD ELECTRICAL     |
| [Symbol]       | EXISTING STORM SEWER             |
| [Symbol]       | EXISTING ELECTRICAL BOX          |
| [Symbol]       | EXISTING PAD MOUNTED TRANSFORMER |
| [Symbol]       | EXISTING TRAFFIC POLE            |
| [Symbol]       | PROPOSED SITE LIGHTING           |
| [Symbol]       | EXISTING SANITARY SEWER MANHOLE  |
| [Symbol]       | EXISTING STORM SEWER MANHOLE     |
| [Symbol]       | EXISTING WATER METER             |
| [Symbol]       | EXISTING WATER VALVE             |
| [Symbol]       | EXISTING FIRE HYDRANT            |
| [Symbol]       | PROPOSED FIRE HYDRANT            |

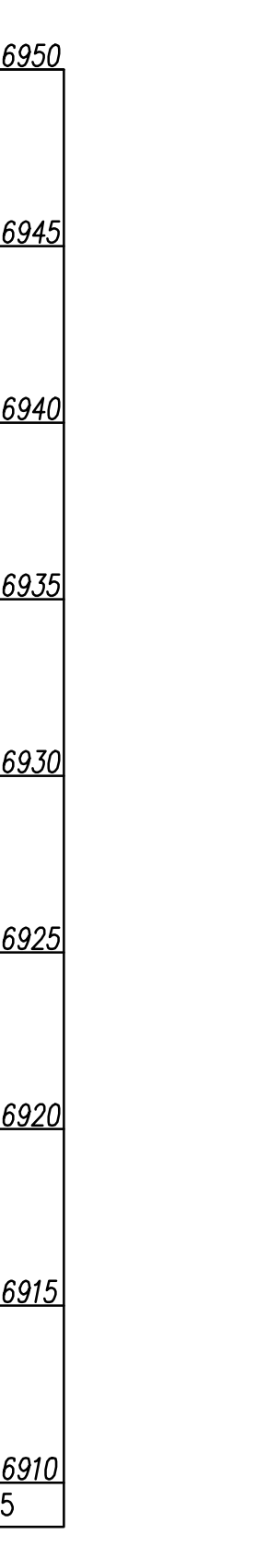
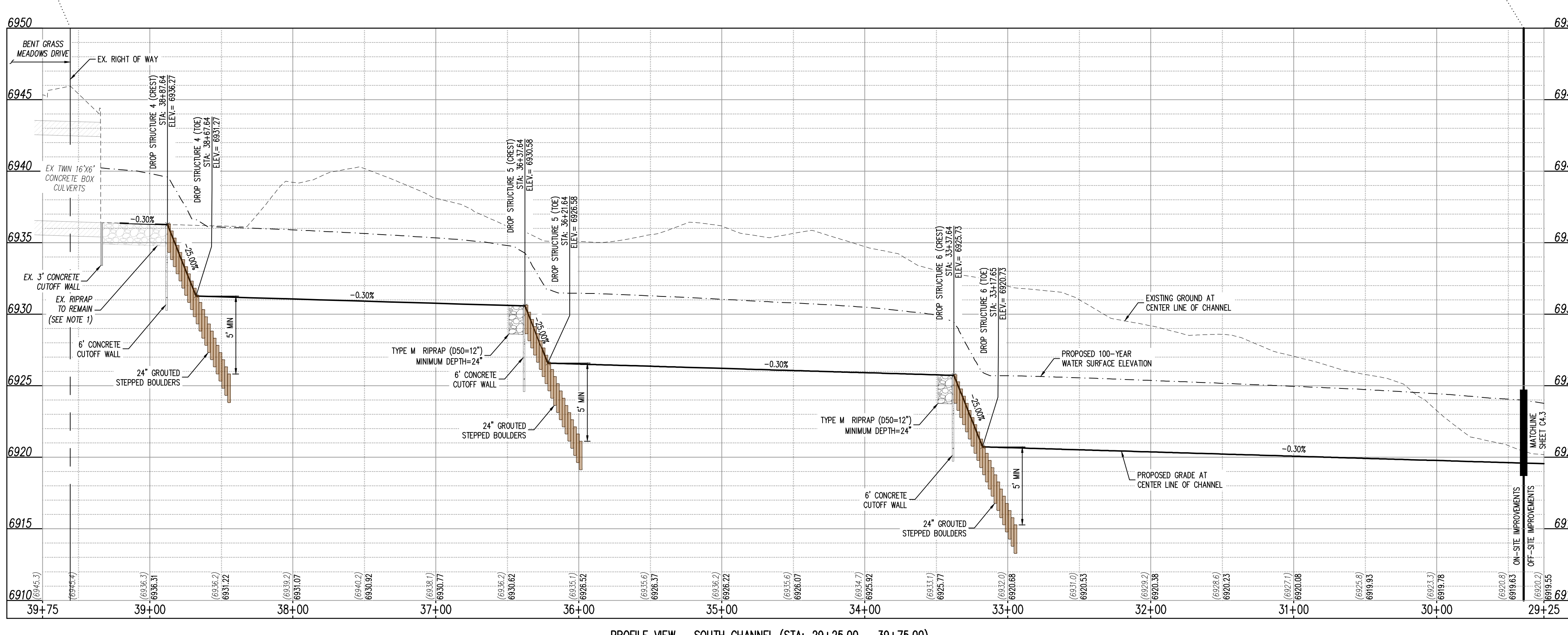

**NOTES:**

- Maintain flat bottom channel after the existing 16"x6" concrete box culverts and immediately before drop structure #4. Transition channel from flat bottom to low flow within drop structure #4.

NOTE: CONTRACTOR SHALL PROTECT ALL EXISTING SURVEY MONUMENTATION. CONTRACTOR SHALL HAVE LICENSED SURVEYOR REPLACE ANY DAMAGED OR DISTURBED MONUMENTATION AT THEIR COST.

SURVEYOR TO OBTAIN AUTOCAD FILE FROM ENGINEER AND VERIFY ALL HORIZONTAL CONTROL DIMENSIONS PRIOR TO CONSTRUCTION STAKING. SURVEYOR MUST VERIFY ALL BENCHMARK, BASIS OF BEARING AND DATUM INFORMATION TO ENSURE IMPROVEMENTS WILL BE AT THE SAME HORIZONTAL AND VERTICAL LOCATIONS SHOWN ON THE DESIGN CONSTRUCTION DRAWINGS. PRIOR TO CONSTRUCTION STAKING ANY DISCREPANCY MUST BE REPORTED TO OWNER AND ENGINEER PRIOR TO CONTINUATION OF ANY FURTHER STAKING OR CONSTRUCTION WORK.

**BENCHMARK**  
ELEVATIONS ARE BASED ON THE SOUTHWEST CORNER OF LOT 1, WOODMEN HILLS FILING NO. 4, MONUMENTED BY A NO. 4 REBAR WITH A YELLOW PLASTIC CAP, STAMPED L5# 24954. ELEVATION = 6948.87

**CAUTION - NOTICE TO CONTRACTOR**

- All utility locations shown are based on maps provided by the appropriate utility company and field surface evidence at the time of survey and is to be considered an approximate location only. It is the contractor's responsibility to field verify the location of all utilities, public or private, whether shown on the plans or not, prior to construction. Report any discrepancy to the engineer prior to construction.
- Where a proposed utility crosses an existing utility, it is the contractor's responsibility to field verify the horizontal and vertical location of such existing utility, either through pot-holing or alternative method. Report information to the engineer prior to construction.

811 Know what's below. Call before you dig.

**COPYRIGHT**  
THESE PLANS ARE AN INSTRUMENT OF SERVICE AND ARE THE PROPERTY OF GALLOWAY, AND MAY NOT BE DUPLICATED, DISCLOSED, OR REPRODUCED WITHOUT THE WRITTEN CONSENT OF GALLOWAY. COPYRIGHTS AND INFRINGEMENTS WILL BE ENFORCED AND PROSECUTED.

CONSTRUCTION DOCUMENTS  
FALCON MEADOWS AT BENT GRASS  
FOR  
CHALLENGER COMMUNITIES, LLC  
BENT GRASS MEADOWS DRIVE & MERIDAN ROAD  
FALCON, CO 80831 - EL PASO COUNTY

#	Date	Issue / Description	Init.
1	8/19/2022	Sheet 8 of 23	

Project No: CLH000023  
Drawn By: CMWJ  
Checked By: RGD  
Date: 8/19/2022

CHANNEL SOUTH - PLAN & PROFILE

Sheet 8 of 23

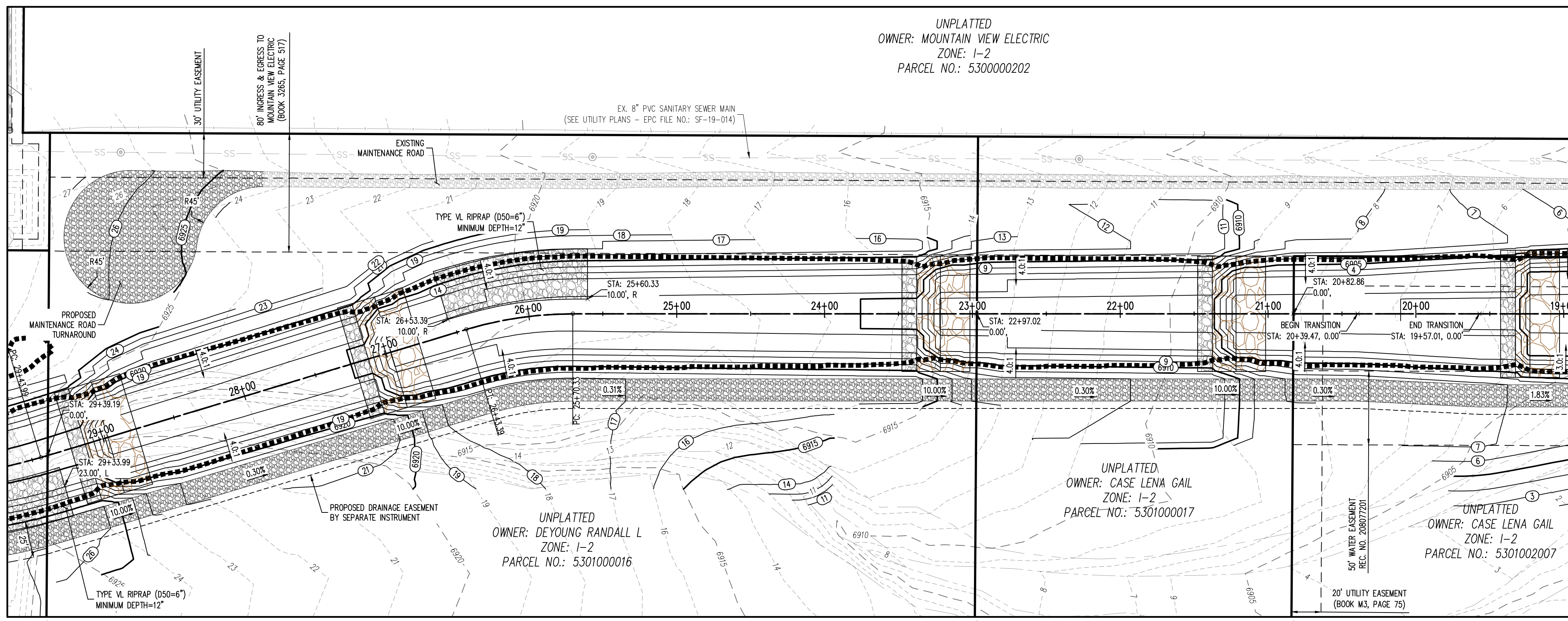
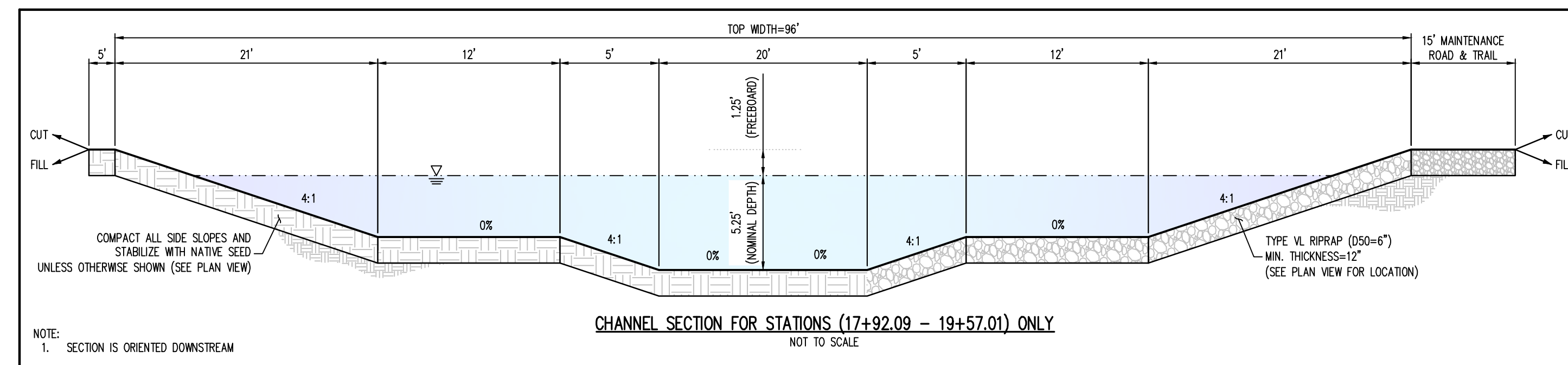
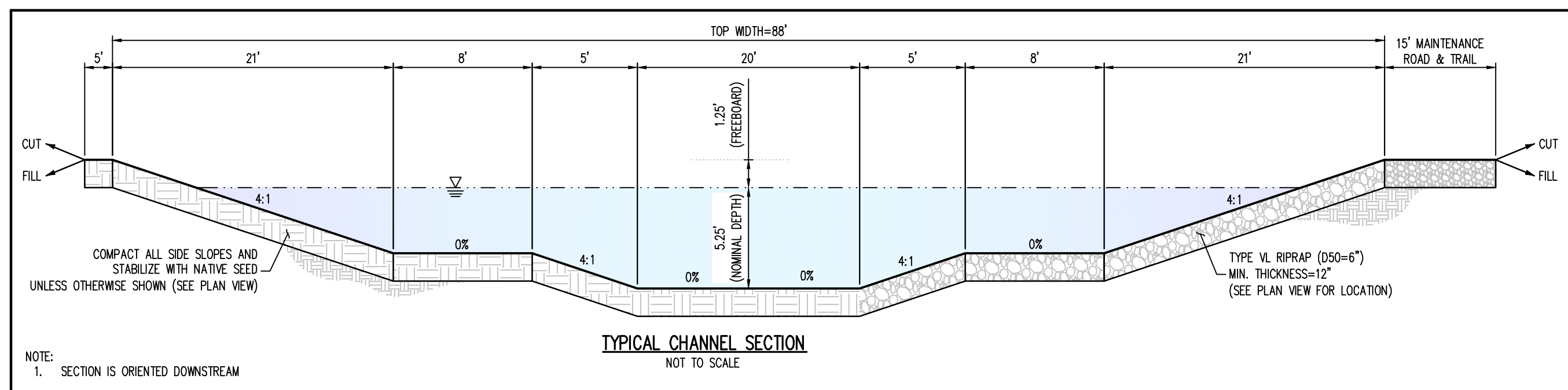

**GRADING LEGEND**

- 5460 - EXISTING MAJOR CONTOUR
- 52 - EXISTING MINOR CONTOUR
- 5485 - PROPOSED MAJOR CONTOUR
- 66 - PROPOSED MINOR CONTOUR
- 2.00% - EXISTING SLOPE - PERCENT
- 4:1 - EXISTING SLOPE - RISE/RUN
- 2.00% - PROPOSED SLOPE - PERCENT
- 4:1 - PROPOSED SLOPE - RISE/RUN
- 55.00 FG - PROPOSED SPOT ELEVATION - FINISHED GROUND
- 55.00 CL - PROPOSED SPOT ELEVATION - CENTER LINE
- 55.00 TOB - PROPOSED SPOT ELEVATION - TOP OF BANK

**UTILITY LEGEND**

- - - - - EXISTING WATER LINE
- - - - - PROPOSED WATER LINE
- - - - - EXISTING SANITARY SEWER
- - - - - EXISTING FIBER OPTIC LINE
- - - - - EXISTING GAS LINE
- - - - - EXISTING STORM SEWER
- - - - - EXISTING ELECTRICAL BOX
- - - - - EXISTING PAD MOUNTED TRANSFORMER
- - - - - EXISTING TRAFFIC POLE
- - - - - PROPOSED SITE LIGHTING
- - - - - EXISTING SANITARY SEWER MANHOLE
- - - - - EXISTING STORM SEWER MANHOLE
- - - - - EXISTING WATER METER
- - - - - EXISTING FIRE HYDRANT
- - - - - PROPOSED FIRE HYDRANT

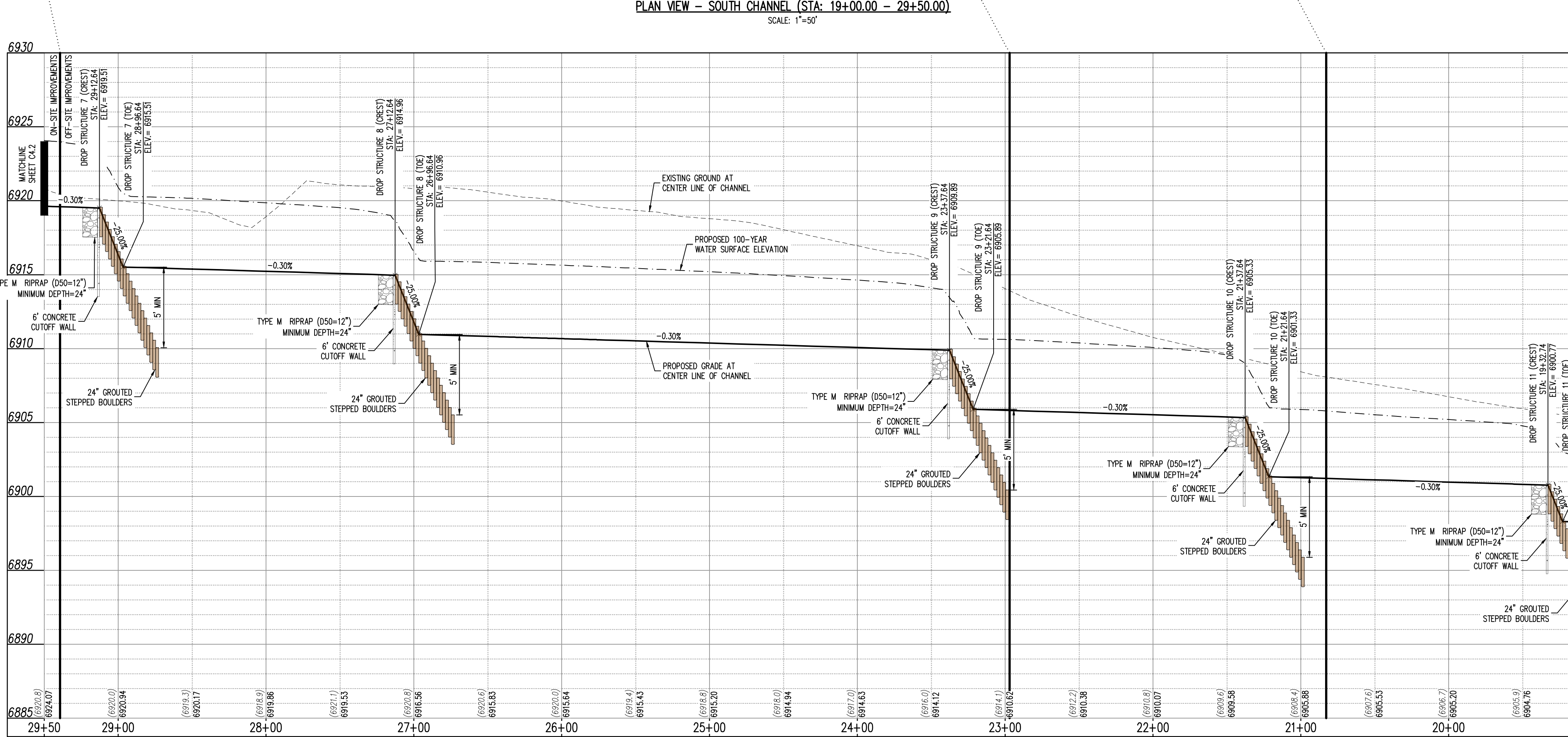
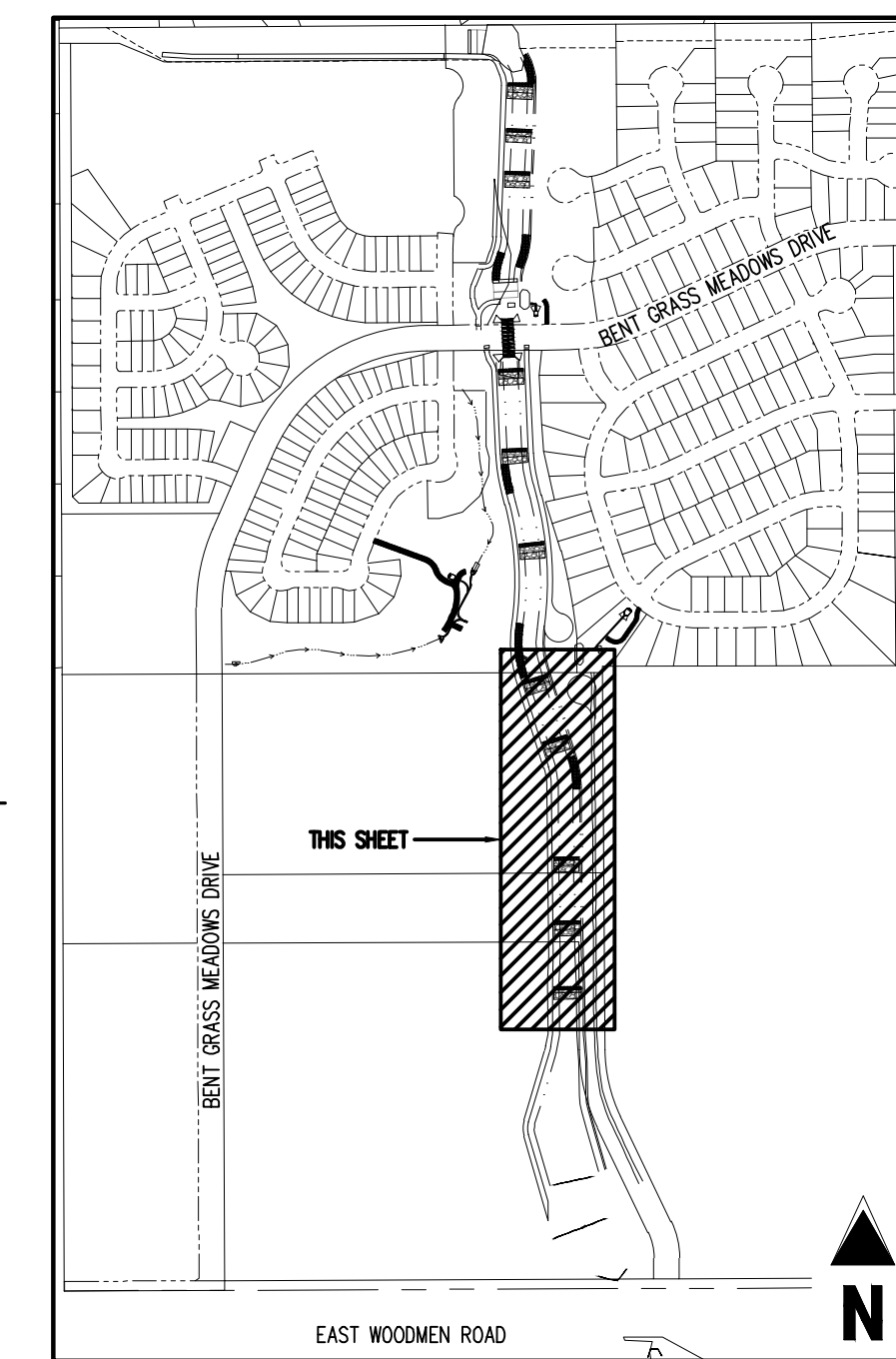

**SITE LEGEND**

- - - - - PROPERTY BOUNDARY LINE
- - - - - RIGHT OF WAY BOUNDARY LINE
- - - - - EXISTING EASEMENT LINE
- - - - - PROPOSED 100-YEAR FLOODPLAIN
- - - - - EXISTING CURB AND GUTTER
- - - - - EXISTING CONCRETE
- - - - - EXISTING CDOT CLASS 6 GRAVEL
- - - - - EXISTING RIPRAP
- - - - - EXISTING BOULDERS
- - - - - PROPOSED CDOT CLASS 6 GRAVEL
- - - - - PROPOSED RIPRAP
- - - - - PROPOSED BOULDERS
- - - - - EXISTING SIGN
- - - - - REFERENCE TO DETAIL AND SHEET NUMBER

**NOTE:** CONTRACTOR SHALL PROTECT ALL EXISTING SURVEY MONUMENTATION. CONTRACTOR SHALL HAVE LICENSED SURVEYOR REPLACE ANY DAMAGED OR DISTURBED MONUMENTATION AT THEIR COST.

**SURVEYOR TO OBTAIN AUTOCAD FILE FROM ENGINEER AND VERIFY ALL HORIZONTAL CONTROL, DIMENSIONING PRIOR TO CONSTRUCTION STAKING. SURVEYOR MUST VERIFY ALL BENCHMARK, BASIS OF BEARING AND DATUM INFORMATION TO ENSURE IMPROVEMENTS WILL BE AT THE SAME HORIZONTAL AND VERTICAL LOCATIONS SHOWN ON THE DESIGN CONSTRUCTION DRAWINGS. PRIOR TO CONSTRUCTION STAKING ANY DISCREPANCY MUST BE REPORTED TO OWNER AND ENGINEER PRIOR TO CONTINUATION OF ANY FURTHER STAKING OR CONSTRUCTION WORK.**

**BENCHMARK**

ELEVATIONS ARE BASED ON THE SOUTHWEST CORNER OF LOT 1, WOODMEN HILLS FILING NO. 4, MONUMENTED BY N. 4 REBAR WITH A YELLOW PLASTIC CAP, STAMPED L5# 24954. ELEVATION = 6947.67

**CAUTION - NOTICE TO CONTRACTOR**

1. ALL UTILITY LOCATIONS SHOWN ARE BASED ON MAPS PROVIDED BY THE APPROPRIATE UTILITY COMPANY AND FIELD SURFACE EVIDENCE AT THE TIME OF SURVEY AND IS TO BE CONSIDERED AN APPROXIMATE LOCATION ONLY. IT IS THE CONTRACTOR'S RESPONSIBILITY TO FIELD VERIFY THE LOCATION OF ALL UTILITIES, PUBLIC OR PRIVATE, WHETHER SHOWN ON THE PLANS OR NOT, PRIOR TO CONSTRUCTION. REPORT ANY DISCREPANCIES TO THE ENGINEER PRIOR TO CONSTRUCTION.

**811**  
Know what's below. Call before you dig.

2. WHERE A PROPOSED UTILITY CROSSES AN EXISTING UTILITY, IT IS THE CONTRACTOR'S RESPONSIBILITY TO FIELD VERIFY THE HORIZONTAL AND VERTICAL LOCATION OF SUCH EXISTING UTILITY, EITHER THROUGH POT-HOLING OR ALTERNATIVE METHOD. REPORT INFORMATION TO THE ENGINEER PRIOR TO CONSTRUCTION.

**Galloway**

1155 Kelly Johnson Blvd., Suite 305  
Colorado Springs, CO 80920  
719.900.7220  
gallowayus.com

PROFESSIONAL ENGINEER  
45900  
08/22/2022

**COPYRIGHT**  
THESE PLANS ARE AN INSTRUMENT OF SERVICE AND ARE THE PROPERTY OF GALLOWAY, AND MAY NOT BE DUPLICATED, DISCLOSED, OR REPRODUCED WITHOUT THE WRITTEN CONSENT OF GALLOWAY. COPYRIGHTS AND INFRINGEMENTS WILL BE ENFORCED AND PROSECUTED.

**CHALLENGER HOMES**

CONSTRUCTION DOCUMENTS  
FALCON MEADOWS AT BENT GRASS  
FOR  
CHALLENGER COMMUNITIES, LLC

BENT GRASS MEADOWS DRIVE & MERIDAN ROAD  
FALCON, CO 80831 - EL PASO COUNTY

#	Date	Issue / Description	Init.

Project No: CLH000023  
Drawn By: CMVJ  
Checked By: SMB  
Date: 8/19/2022

CHANNEL SOUTH - PLAN & PROFILE





**APPENDIX C**  
**Hydrologic Computations**

**APPENDIX D**  
**Hydraulic Computations**

# Channel Report

## Swale A (Basin C-6)

### Triangular

Side Slopes (z:1) = 3.00, 3.00  
Total Depth (ft) = 1.50

Invert Elev (ft) = 1.00  
Slope (%) = 2.00  
N-Value = 0.020

### Calculations

Compute by: Known Q  
Known Q (cfs) = 4.00

### Highlighted

Depth (ft) = 0.56  
Q (cfs) = 4.000  
Area (sqft) = 0.94  
Velocity (ft/s) = 4.25  
Wetted Perim (ft) = 3.54  
Crit Depth, Yc (ft) = 0.65  
Top Width (ft) = 3.36  
EGL (ft) = 0.84

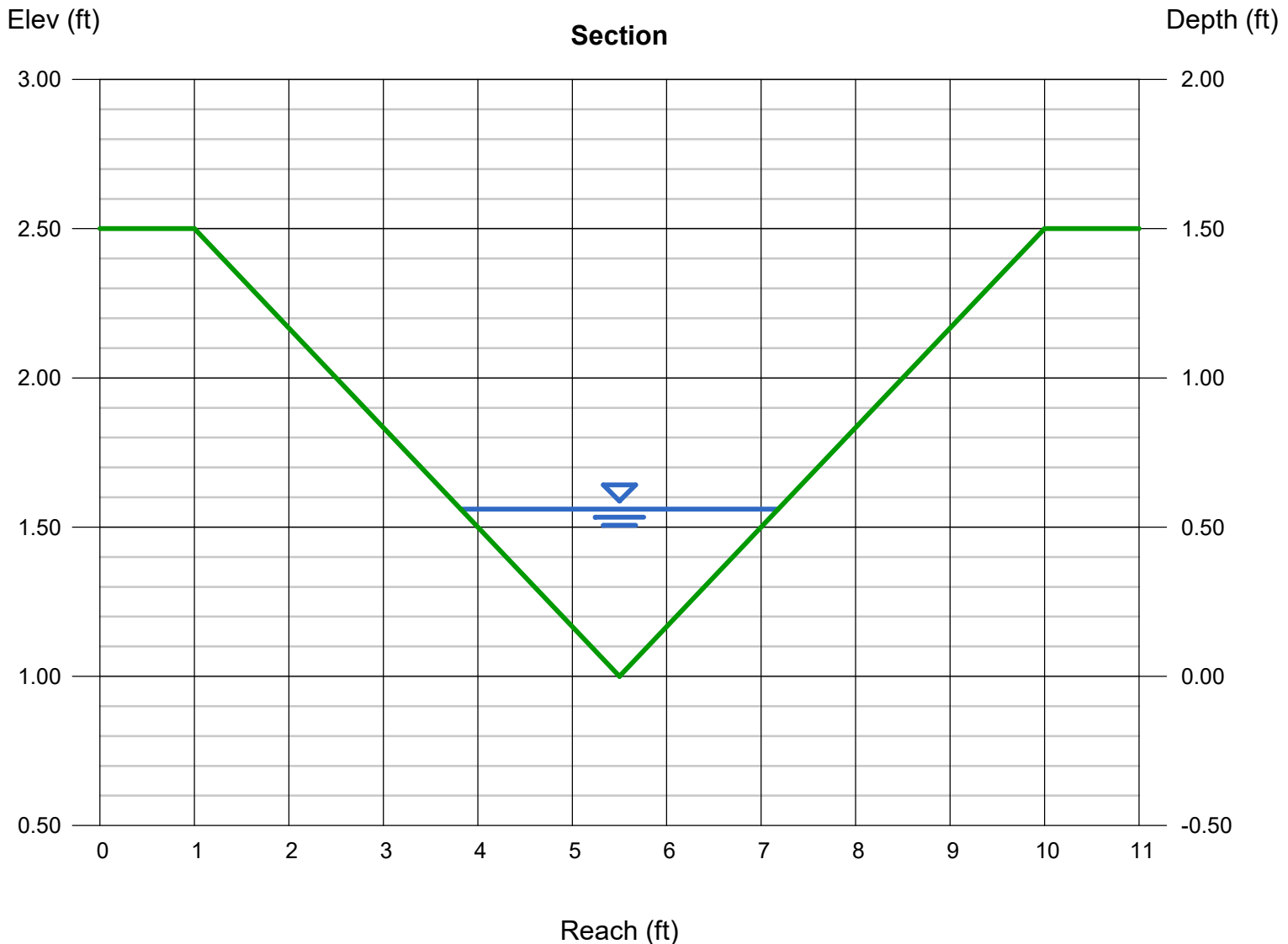

# Channel Report

## Swale C (Basin D-8)

### Trapezoidal

Bottom Width (ft)	= 1.00
Side Slopes (z:1)	= 3.00, 3.00
Total Depth (ft)	= 1.25
Invert Elev (ft)	= 1.00
Slope (%)	= 2.00
N-Value	= 0.020

### Highlighted

Depth (ft)	= 0.32
Q (cfs)	= 2.300
Area (sqft)	= 0.63
Velocity (ft/s)	= 3.67
Wetted Perim (ft)	= 3.02
Crit Depth, Yc (ft)	= 0.39
Top Width (ft)	= 2.92
EGL (ft)	= 0.53

### Calculations

Compute by:	Known Q
Known Q (cfs)	= 2.30

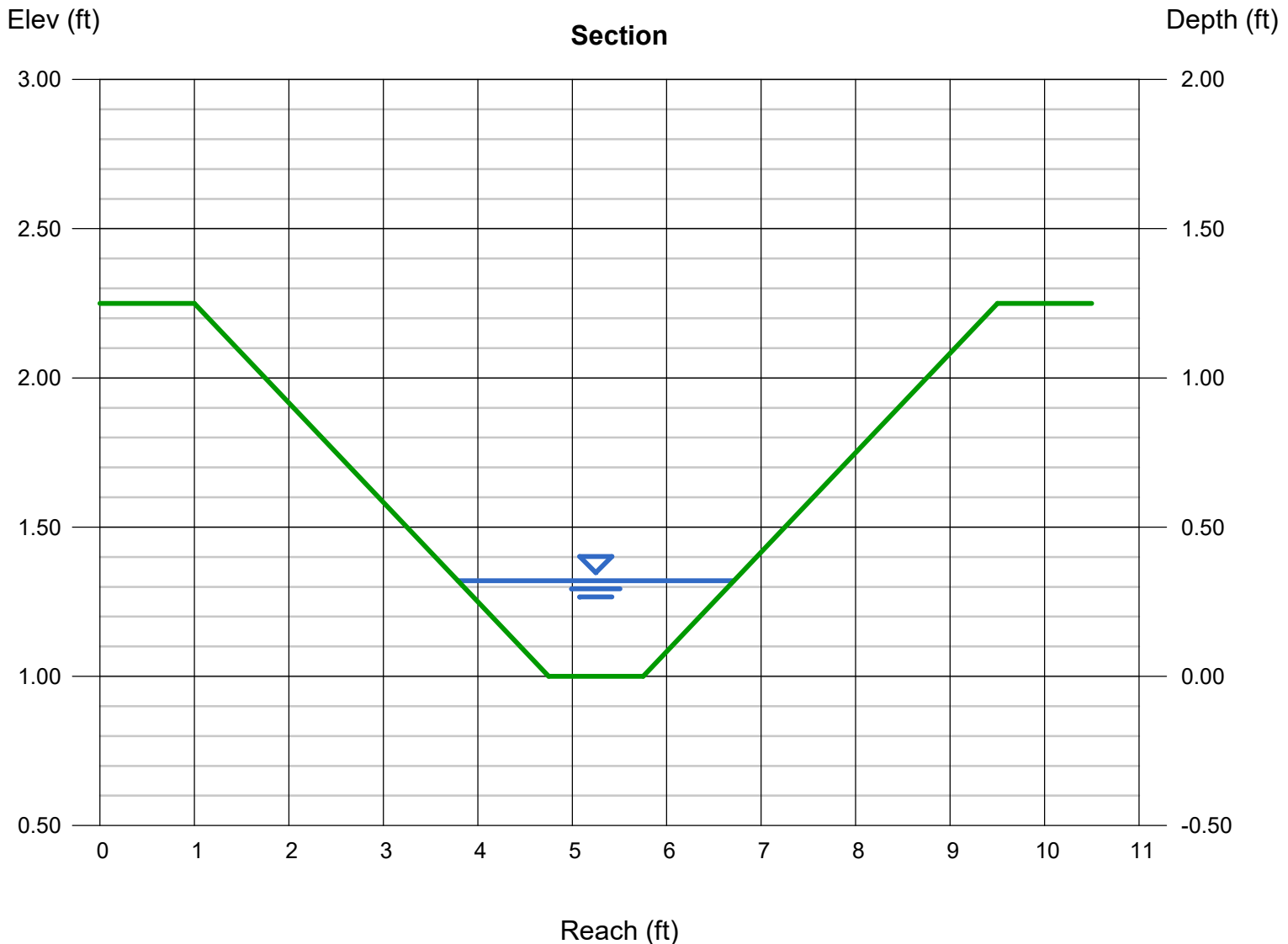

## **Inlets – Proposed Design**

# INLET MANAGEMENT

Worksheet Protected

<b>INLET NAME</b>	<a href="#">Basin A-1 (DP 4)</a>	<a href="#">Basin A-3 (DP 5)</a>	<a href="#">Ex Inlet BGM Drive(DP 8)</a>
Site Type (Urban or Rural)	URBAN	URBAN	URBAN
Inlet Application (Street or Area)	STREET	STREET	STREET
Hydraulic Condition	On Grade	On Grade	In Sump
Inlet Type	CDOT Type R Curb Opening	CDOT Type R Curb Opening	CDOT Type R Curb Opening

## USER-DEFINED INPUT

<b>User-Defined Design Flows</b>			
Minor $Q_{Known}$ (cfs)	10.5	2.2	0.9
Major $Q_{Known}$ (cfs)	24.2	4.4	9.1
<b>Bypass (Carry-Over) Flow from Upstream</b>			
Receive Bypass Flow from:	No Bypass Flow Received	No Bypass Flow Received	User-Defined
Minor Bypass Flow Received, $Q_b$ (cfs)	0.0	0.0	0.9
Major Bypass Flow Received, $Q_b$ (cfs)	0.0	0.0	9.1
<b>Watershed Characteristics</b>			
Subcatchment Area (acres)			
Percent Impervious			
NRCS Soil Type			
<b>Watershed Profile</b>			
Overland Slope (ft/ft)			
Overland Length (ft)			
Channel Slope (ft/ft)			
Channel Length (ft)			
<b>Minor Storm Rainfall Input</b>			
Design Storm Return Period, $T_r$ (years)			
One-Hour Precipitation, $P_1$ (inches)			
<b>Major Storm Rainfall Input</b>			
Design Storm Return Period, $T_r$ (years)			
One-Hour Precipitation, $P_1$ (inches)			

## CALCULATED OUTPUT

<b>Minor Total Design Peak Flow, <math>Q</math> (cfs)</b>	<b>10.5</b>	<b>2.2</b>	<b>1.8</b>
<b>Major Total Design Peak Flow, <math>Q</math> (cfs)</b>	<b>24.2</b>	<b>4.4</b>	<b>18.2</b>
Minor Flow Bypassed Downstream, $Q_b$ (cfs)	0.9	0.0	N/A
Major Flow Bypassed Downstream, $Q_b$ (cfs)	8.9	0.1	N/A

# INLET MANAGEMENT

Worksheet Protected

INLET NAME	<a href="#">Ex Inlet BasinC-1e(DP12)</a>	<a href="#">ExInletBasinD-4c(DP 17)</a>	<a href="#">Basin A-1A (DP 2)</a>
Site Type (Urban or Rural)	URBAN	URBAN	URBAN
Inlet Application (Street or Area)	STREET	STREET	STREET
Hydraulic Condition	On Grade	In Sump	On Grade
Inlet Type	CDOT Type R Curb Opening	CDOT Type R Curb Opening	CDOT Type R Curb Opening

## USER-DEFINED INPUT

User-Defined Design Flows			
Minor $Q_{Known}$ (cfs)	4.1	5.4	7.8
Major $Q_{Known}$ (cfs)	7.8	11.2	16.2
Bypass (Carry-Over) Flow from Upstream			
Receive Bypass Flow from:	No Bypass Flow Received	No Bypass Flow Received	No Bypass Flow Received
Minor Bypass Flow Received, $Q_b$ (cfs)	0.0	0.0	
Major Bypass Flow Received, $Q_b$ (cfs)	0.0	0.0	
Watershed Characteristics			
Subcatchment Area (acres)			
Percent Impervious			
NRCS Soil Type			
Watershed Profile			
Overland Slope (ft/ft)			
Overland Length (ft)			
Channel Slope (ft/ft)			
Channel Length (ft)			
Minor Storm Rainfall Input			
Design Storm Return Period, $T_r$ (years)			
One-Hour Precipitation, $P_1$ (inches)			
Major Storm Rainfall Input			
Design Storm Return Period, $T_r$ (years)			
One-Hour Precipitation, $P_1$ (inches)			

## CALCULATED OUTPUT

Minor Total Design Peak Flow, $Q$ (cfs)	4.1	5.4	7.8
Major Total Design Peak Flow, $Q$ (cfs)	7.8	11.2	16.2
Minor Flow Bypassed Downstream, $Q_b$ (cfs)	0.0	N/A	4.4
Major Flow Bypassed Downstream, $Q_b$ (cfs)	0.1	N/A	11.6



**ALLOWABLE CAPACITY FOR ONE-HALF OF STREET (Minor & Major Storm)**

(Based on Regulated Criteria for Maximum Allowable Flow Depth and Spread)

Project: Falcon Meadows at Bent Grass Filing No. 4  
 Inlet ID: Basin A-1 (DP 4)

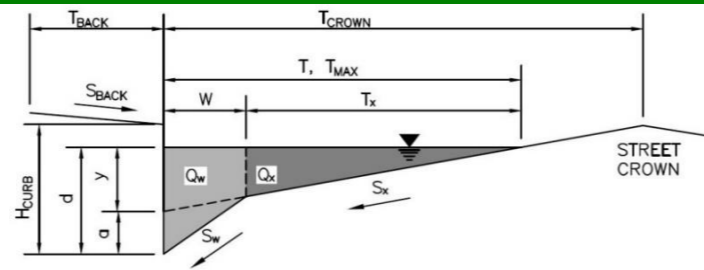

<b>Gutter Geometry:</b>									
Maximum Allowable Width for Spread Behind Curb	$T_{BACK} = 8.0$ ft								
Side Slope Behind Curb (leave blank for no conveyance credit behind curb)	$S_{BACK} = 0.020$ ft/ft								
Manning's Roughness Behind Curb (typically between 0.012 and 0.020)	$n_{BACK} = 0.013$								
Height of Curb at Gutter Flow Line	$H_{CURB} = 6.00$ inches								
Distance from Curb Face to Street Crown	$T_{CROWN} = 17.0$ ft								
Gutter Width	$W = 2.00$ ft								
Street Transverse Slope	$S_x = 0.020$ ft/ft								
Gutter Cross Slope (typically 2 inches over 24 inches or 0.083 ft/ft)	$S_w = 0.083$ ft/ft								
Street Longitudinal Slope - Enter 0 for sump condition	$S_o = 0.025$ ft/ft								
Manning's Roughness for Street Section (typically between 0.012 and 0.020)	$n_{STREET} = 0.016$								
Max. Allowable Spread for Minor & Major Storm	<table border="1"> <tr> <td></td> <td>Minor Storm</td> <td>Major Storm</td> <td></td> </tr> <tr> <td><math>T_{MAX} =</math></td> <td>17.0</td> <td>17.0</td> <td>ft</td> </tr> </table>		Minor Storm	Major Storm		$T_{MAX} =$	17.0	17.0	ft
	Minor Storm	Major Storm							
$T_{MAX} =$	17.0	17.0	ft						
Max. Allowable Depth at Gutter Flowline for Minor & Major Storm	<table border="1"> <tr> <td></td> <td>Minor Storm</td> <td>Major Storm</td> <td></td> </tr> <tr> <td><math>d_{MAX} =</math></td> <td>6.0</td> <td>8.0</td> <td>inches</td> </tr> </table>		Minor Storm	Major Storm		$d_{MAX} =$	6.0	8.0	inches
	Minor Storm	Major Storm							
$d_{MAX} =$	6.0	8.0	inches						
Allow Flow Depth at Street Crown (check box for yes, leave blank for no)	<table border="1"> <tr> <td></td> <td>Minor Storm</td> <td>Major Storm</td> <td></td> </tr> <tr> <td></td> <td><input type="checkbox"/></td> <td><input checked="" type="checkbox"/></td> <td></td> </tr> </table>		Minor Storm	Major Storm			<input type="checkbox"/>	<input checked="" type="checkbox"/>	
	Minor Storm	Major Storm							
	<input type="checkbox"/>	<input checked="" type="checkbox"/>							
MINOR STORM Allowable Capacity is based on Spread Criterion									
MAJOR STORM Allowable Capacity is based on Depth Criterion									
<b>Minor storm max. allowable capacity GOOD - greater than the design flow given on sheet 'Inlet Management'</b>									
<b>Major storm max. allowable capacity GOOD - greater than the design flow given on sheet 'Inlet Management'</b>									
$Q_{allow} =$	<table border="1"> <tr> <td></td> <td>Minor Storm</td> <td>Major Storm</td> <td></td> </tr> <tr> <td></td> <td>17.2</td> <td>38.3</td> <td>cfs</td> </tr> </table>		Minor Storm	Major Storm			17.2	38.3	cfs
	Minor Storm	Major Storm							
	17.2	38.3	cfs						

# INLET ON A CONTINUOUS GRADE

*MHFD-Inlet, Version 5.01 (April 2021)*

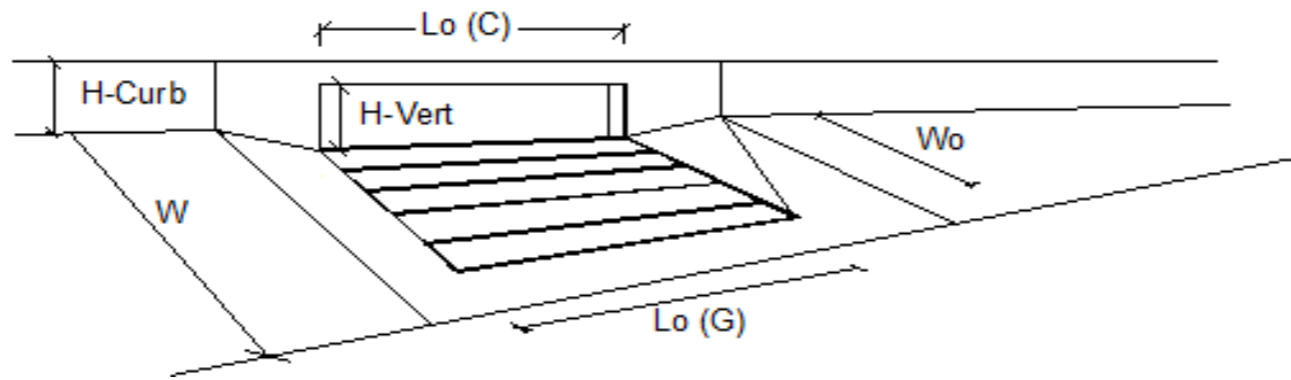

Design Information (Input)	MINOR	MAJOR	
Type of Inlet	CDOT Type R Curb Opening		
Local Depression (additional to continuous gutter depression 'a')	3.0	3.0	inches
Total Number of Units in the Inlet (Grate or Curb Opening)	1	1	
Length of a Single Unit Inlet (Grate or Curb Opening)	15.00	15.00	ft
Width of a Unit Grate (cannot be greater than W, Gutter Width)	N/A	N/A	ft
Clogging Factor for a Single Unit Grate (typical min. value = 0.5)	N/A	N/A	
Clogging Factor for a Single Unit Curb Opening (typical min. value = 0.1)	0.10	0.10	
<b>Street Hydraulics: OK - Q &lt; Allowable Street Capacity'</b>			
Total Inlet Interception Capacity	<b>Q = 9.6</b>	<b>15.3</b>	<b>cfs</b>
Total Inlet Carry-Over Flow (flow bypassing inlet)	<b>Q<sub>b</sub> = 0.9</b>	<b>8.9</b>	<b>cfs</b>
Capture Percentage = $Q_a/Q_o =$	<b>C% = 91</b>	<b>63</b>	<b>%</b>

## **Inlets – Existing Analysis**

**ALLOWABLE CAPACITY FOR ONE-HALF OF STREET (Minor & Major Storm)**

(Based on Regulated Criteria for Maximum Allowable Flow Depth and Spread)

Project: Falcon Meadows at Bent Grass Filing No. 4  
 Inlet ID: Basin A-1A (DP 2)

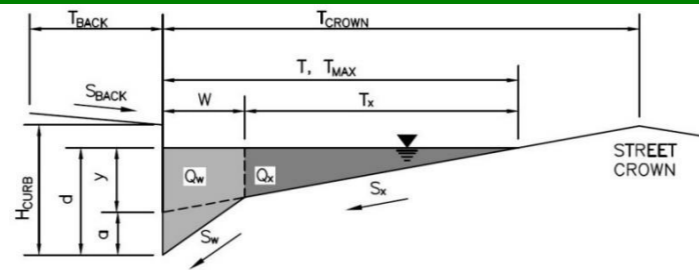

<b>Gutter Geometry:</b>	
Maximum Allowable Width for Spread Behind Curb	$T_{BACK} = 8.0$ ft
Side Slope Behind Curb (leave blank for no conveyance credit behind curb)	$S_{BACK} = 0.020$ ft/ft
Manning's Roughness Behind Curb (typically between 0.012 and 0.020)	$n_{BACK} = 0.013$
Height of Curb at Gutter Flow Line	$H_{CURB} = 6.00$ inches
Distance from Curb Face to Street Crown	$T_{CROWN} = 17.0$ ft
Gutter Width	$W = 2.00$ ft
Street Transverse Slope	$S_X = 0.020$ ft/ft
Gutter Cross Slope (typically 2 inches over 24 inches or 0.083 ft/ft)	$S_W = 0.083$ ft/ft
Street Longitudinal Slope - Enter 0 for sump condition	$S_O = 0.009$ ft/ft
Manning's Roughness for Street Section (typically between 0.012 and 0.020)	$n_{STREET} = 0.016$
Max. Allowable Spread for Minor & Major Storm	$T_{MAX} = \begin{matrix} \text{Minor Storm} & \text{Major Storm} \\ 17.0 & 17.0 \end{matrix}$ ft
Max. Allowable Depth at Gutter Flowline for Minor & Major Storm	$d_{MAX} = \begin{matrix} \text{Minor Storm} & \text{Major Storm} \\ 6.0 & 8.0 \end{matrix}$ inches
Allow Flow Depth at Street Crown (check box for yes, leave blank for no)	<input type="checkbox"/> <input type="checkbox"/>
MINOR STORM Allowable Capacity is based on Spread Criterion	
MAJOR STORM Allowable Capacity is based on Spread Criterion	
<b>Minor storm max. allowable capacity GOOD - greater than the design flow given on sheet 'Inlet Management'</b>	
<b>WARNING: MAJOR STORM max. allowable capacity is less than the design flow given on sheet 'Inlet Management'</b>	
	$Q_{allow} = \begin{matrix} \text{Minor Storm} & \text{Major Storm} \\ 10.1 & 10.1 \end{matrix}$ cfs

# INLET ON A CONTINUOUS GRADE

MHFD-Inlet, Version 5.01 (April 2021)

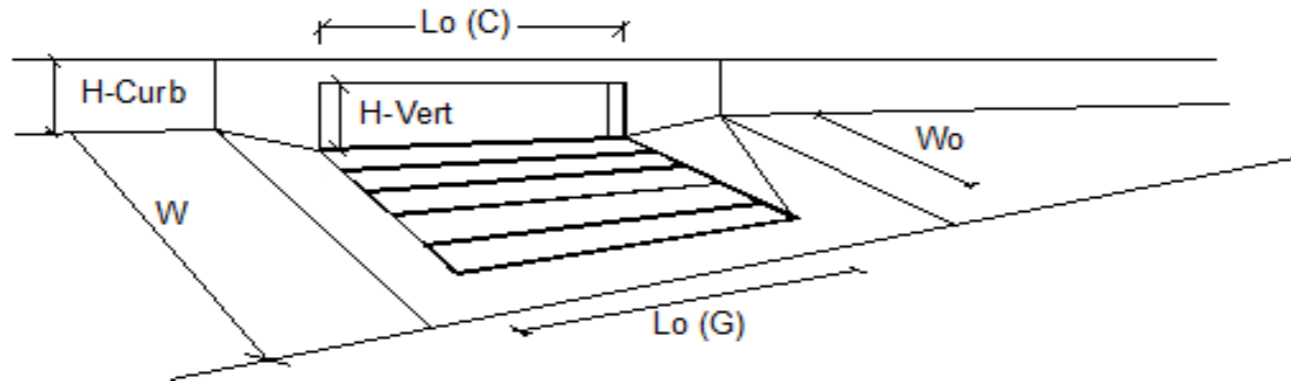

Design Information (Input)	MINOR	MAJOR	
Type of Inlet	CDOT Type R Curb Opening		
Local Depression (additional to continuous gutter depression 'a')	3.0	3.0	inches
Total Number of Units in the Inlet (Grate or Curb Opening)	1	1	
Length of a Single Unit Inlet (Grate or Curb Opening)	5.00	5.00	ft
Width of a Unit Grate (cannot be greater than W, Gutter Width)	N/A	N/A	ft
Clogging Factor for a Single Unit Grate (typical min. value = 0.5)	N/A	N/A	
Clogging Factor for a Single Unit Curb Opening (typical min. value = 0.1)	0.10	0.10	
<b>Street Hydraulics: WARNING: Q &gt; ALLOWABLE Q FOR MAJOR STORM</b>			
Total Inlet Interception Capacity	3.4	4.6	cfs
Total Inlet Carry-Over Flow (flow bypassing inlet)	4.4	11.6	cfs
Capture Percentage = $Q_a/Q_o =$	44	29	%

## ALLOWABLE CAPACITY FOR ONE-HALF OF STREET (Minor & Major Storm)

(Based on Regulated Criteria for Maximum Allowable Flow Depth and Spread)

**Project:** Falcon Meadows at Bent Grass Filing No. 4

**Inlet ID:** Basin A-3 (DP 5)

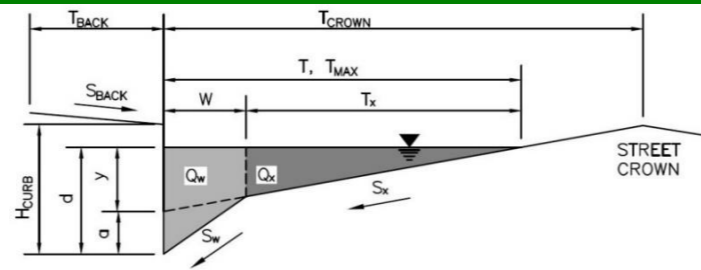

**Gutter Geometry:**

Maximum Allowable Width for Spread Behind Curb  
 Side Slope Behind Curb (leave blank for no conveyance credit behind curb)  
 Manning's Roughness Behind Curb (typically between 0.012 and 0.020)

$T_{BACK} = 8.0$  ft  
 $S_{BACK} = 0.020$  ft/ft  
 $n_{BACK} = 0.013$

Height of Curb at Gutter Flow Line  
 Distance from Curb Face to Street Crown  
 Gutter Width  
 Street Transverse Slope  
 Gutter Cross Slope (typically 2 inches over 24 inches or 0.083 ft/ft)  
 Street Longitudinal Slope - Enter 0 for sump condition  
 Manning's Roughness for Street Section (typically between 0.012 and 0.020)

$H_{CURB} = 6.00$  inches  
 $T_{CROWN} = 17.0$  ft  
 $W = 2.00$  ft  
 $S_x = 0.020$  ft/ft  
 $S_w = 0.083$  ft/ft  
 $S_o = 0.025$  ft/ft  
 $n_{STREET} = 0.016$

Max. Allowable Spread for Minor & Major Storm  
 Max. Allowable Depth at Gutter Flowline for Minor & Major Storm  
 Allow Flow Depth at Street Crown (check box for yes, leave blank for no)

	Minor Storm	Major Storm	
$T_{MAX} =$	17.0	17.0	ft
$d_{MAX} =$	6.0	8.0	inches
	<input type="checkbox"/>	<input checked="" type="checkbox"/>	

MINOR STORM Allowable Capacity is based on Spread Criterion  
 MAJOR STORM Allowable Capacity is based on Depth Criterion

	Minor Storm	Major Storm	
$Q_{allow} =$	17.2	38.3	cfs

**Minor storm max. allowable capacity GOOD - greater than the design flow given on sheet 'Inlet Management'**  
**Major storm max. allowable capacity GOOD - greater than the design flow given on sheet 'Inlet Management'**

# INLET ON A CONTINUOUS GRADE

*MHFD-Inlet, Version 5.01 (April 2021)*

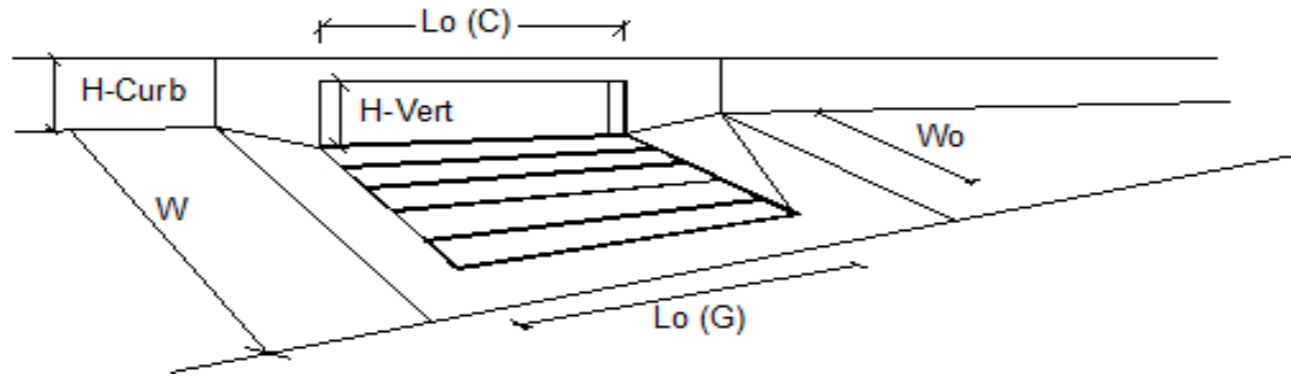

Design Information (Input)	MINOR	MAJOR	
Type of Inlet	CDOT Type R Curb Opening		
Local Depression (additional to continuous gutter depression 'a')	3.0	3.0	inches
Total Number of Units in the Inlet (Grate or Curb Opening)	1	1	
Length of a Single Unit Inlet (Grate or Curb Opening)	10.00	10.00	ft
Width of a Unit Grate (cannot be greater than W, Gutter Width)	N/A	N/A	ft
Clogging Factor for a Single Unit Grate (typical min. value = 0.5)	N/A	N/A	
Clogging Factor for a Single Unit Curb Opening (typical min. value = 0.1)	0.10	0.10	
<b>Street Hydraulics: OK - Q &lt; Allowable Street Capacity'</b>			
Total Inlet Interception Capacity	2.2	4.3	cfs
Total Inlet Carry-Over Flow (flow bypassing inlet)	0.0	0.1	cfs
Capture Percentage = $Q_a/Q_o =$	100	97	%

## ALLOWABLE CAPACITY FOR ONE-HALF OF STREET (Minor & Major Storm)

(Based on Regulated Criteria for Maximum Allowable Flow Depth and Spread)

**Project:** Falcon Meadows at Bent Grass Filing No. 4

**Inlet ID:** Ex Inlet BGM Drive(DP 8)

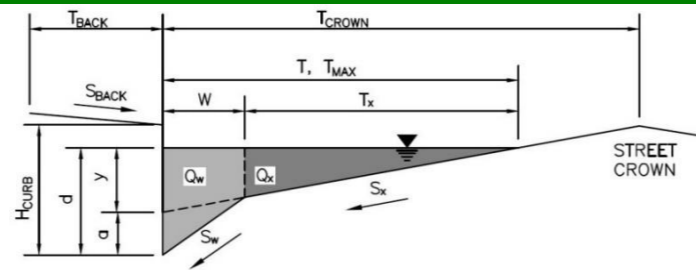

**Gutter Geometry:**

Maximum Allowable Width for Spread Behind Curb  
 Side Slope Behind Curb (leave blank for no conveyance credit behind curb)  
 Manning's Roughness Behind Curb (typically between 0.012 and 0.020)

$T_{BACK} = 14.0$  ft  
 $S_{BACK} = 0.020$  ft/ft  
 $n_{BACK} = 0.013$

Height of Curb at Gutter Flow Line  
 Distance from Curb Face to Street Crown  
 Gutter Width  
 Street Transverse Slope  
 Gutter Cross Slope (typically 2 inches over 24 inches or 0.083 ft/ft)  
 Street Longitudinal Slope - Enter 0 for sump condition  
 Manning's Roughness for Street Section (typically between 0.012 and 0.020)

$H_{CURB} = 6.00$  inches  
 $T_{CROWN} = 26.0$  ft  
 $W = 2.00$  ft  
 $S_X = 0.020$  ft/ft  
 $S_W = 0.083$  ft/ft  
 $S_O = 0.000$  ft/ft  
 $n_{STREET} = 0.016$

Max. Allowable Spread for Minor & Major Storm  
 Max. Allowable Depth at Gutter Flowline for Minor & Major Storm  
 Check boxes are not applicable in SUMP conditions

	Minor Storm	Major Storm	
$T_{MAX} =$	26.0	26.0	ft
$d_{MAX} =$	6.0	12.0	inches
	<input type="checkbox"/>	<input type="checkbox"/>	

MINOR STORM Allowable Capacity is based on Depth Criterion  
 MAJOR STORM Allowable Capacity is based on Depth Criterion

$Q_{allow} =$ 

Minor Storm	Major Storm
<b>SUMP</b>	<b>SUMP</b>

 cfs



# INLET IN A SUMP OR SAG LOCATION

MHFD-Inlet, Version 5.01 (April 2021)

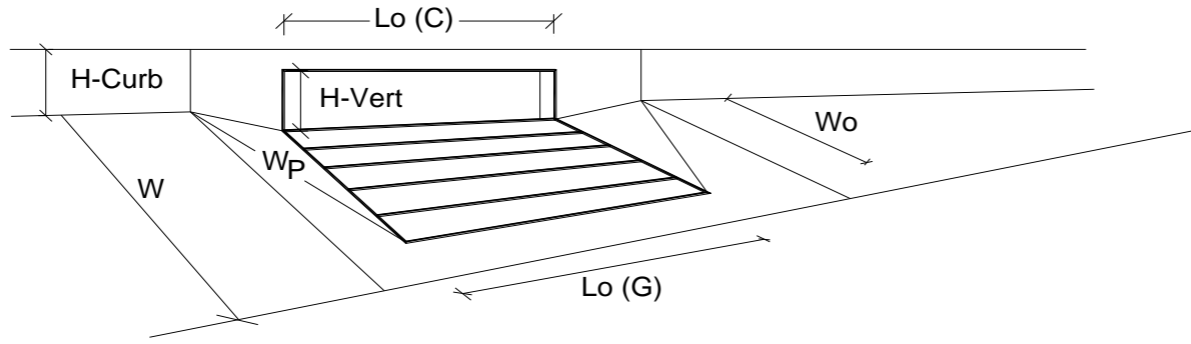

Design Information (Input)	MINOR	MAJOR	
Type of Inlet	CDOT Type R Curb Opening		
Local Depression (additional to continuous gutter depression 'a' from above)	3.00	3.00	inches
Number of Unit Inlets (Grate or Curb Opening)	2	2	
Water Depth at Flowline (outside of local depression)	6.0	12.0	inches
<b>Grate Information</b>			
Length of a Unit Grate	N/A	N/A	feet
Width of a Unit Grate	N/A	N/A	feet
Area Opening Ratio for a Grate (typical values 0.15-0.90)	N/A	N/A	
Clogging Factor for a Single Grate (typical value 0.50 - 0.70)	N/A	N/A	
Grate Weir Coefficient (typical value 2.15 - 3.60)	N/A	N/A	
Grate Orifice Coefficient (typical value 0.60 - 0.80)	N/A	N/A	
<b>Curb Opening Information</b>			
Length of a Unit Curb Opening	10.00	10.00	feet
Height of Vertical Curb Opening in Inches	6.00	6.00	inches
Height of Curb Orifice Throat in Inches	6.00	6.00	inches
Angle of Throat (see USDCM Figure ST-5)	63.40	63.40	degrees
Side Width for Depression Pan (typically the gutter width of 2 feet)	2.00	2.00	feet
Clogging Factor for a Single Curb Opening (typical value 0.10)	0.10	0.10	
Curb Opening Weir Coefficient (typical value 2.3-3.7)	3.60	3.60	
Curb Opening Orifice Coefficient (typical value 0.60 - 0.70)	0.67	0.67	
<b>Low Head Performance Reduction (Calculated)</b>			
Depth for Grate Midwidth	N/A	N/A	ft
Depth for Curb Opening Weir Equation	0.33	0.83	ft
Combination Inlet Performance Reduction Factor for Long Inlets	0.57	1.00	
Curb Opening Performance Reduction Factor for Long Inlets	0.79	1.00	
Grated Inlet Performance Reduction Factor for Long Inlets	N/A	N/A	
<b>Total Inlet Interception Capacity (assumes clogged condition)</b>			
<b>Q<sub>a</sub></b>	<b>14.4</b>	<b>52.7</b>	<b>cfs</b>
<b>Q<sub>PEAK REQUIRED</sub></b>	<b>1.8</b>	<b>18.2</b>	<b>cfs</b>

Inlet Capacity IS GOOD for Minor and Major Storms(>Q PEAK)

## ALLOWABLE CAPACITY FOR ONE-HALF OF STREET (Minor & Major Storm)

(Based on Regulated Criteria for Maximum Allowable Flow Depth and Spread)

**Project:** Falcon Meadows at Bent Grass Filing No. 4

**Inlet ID:** Ex Inlet BasinC-1e(DP12)

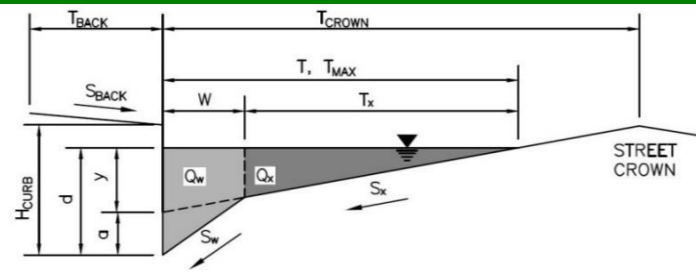

**Gutter Geometry:**

Maximum Allowable Width for Spread Behind Curb  
 Side Slope Behind Curb (leave blank for no conveyance credit behind curb)  
 Manning's Roughness Behind Curb (typically between 0.012 and 0.020)

$T_{BACK}$	=	8.0	ft
$S_{BACK}$	=	0.020	ft/ft
$n_{BACK}$	=	0.013	

Height of Curb at Gutter Flow Line  
 Distance from Curb Face to Street Crown  
 Gutter Width  
 Street Transverse Slope  
 Gutter Cross Slope (typically 2 inches over 24 inches or 0.083 ft/ft)  
 Street Longitudinal Slope - Enter 0 for sump condition  
 Manning's Roughness for Street Section (typically between 0.012 and 0.020)

$H_{CURB}$	=	6.00	inches
$T_{CROWN}$	=	17.0	ft
$W$	=	2.00	ft
$S_x$	=	0.020	ft/ft
$S_w$	=	0.083	ft/ft
$S_o$	=	0.030	ft/ft
$n_{STREET}$	=	0.016	

Max. Allowable Spread for Minor & Major Storm  
 Max. Allowable Depth at Gutter Flowline for Minor & Major Storm  
 Allow Flow Depth at Street Crown (check box for yes, leave blank for no)

	Minor Storm	Major Storm	
$T_{MAX}$	= 17.0	= 17.0	ft
$d_{MAX}$	= 6.0	= 12.0	inches
	<input type="checkbox"/>	<input type="checkbox"/>	

MINOR STORM Allowable Capacity is based on Depth Criterion  
 MAJOR STORM Allowable Capacity is based on Spread Criterion

	Minor Storm	Major Storm	
$Q_{allow}$	= 17.7	= 18.8	cfs

**Minor storm max. allowable capacity GOOD - greater than the design flow given on sheet 'Inlet Management'**  
**Major storm max. allowable capacity GOOD - greater than the design flow given on sheet 'Inlet Management'**

# INLET ON A CONTINUOUS GRADE

MHFD-Inlet, Version 5.01 (April 2021)

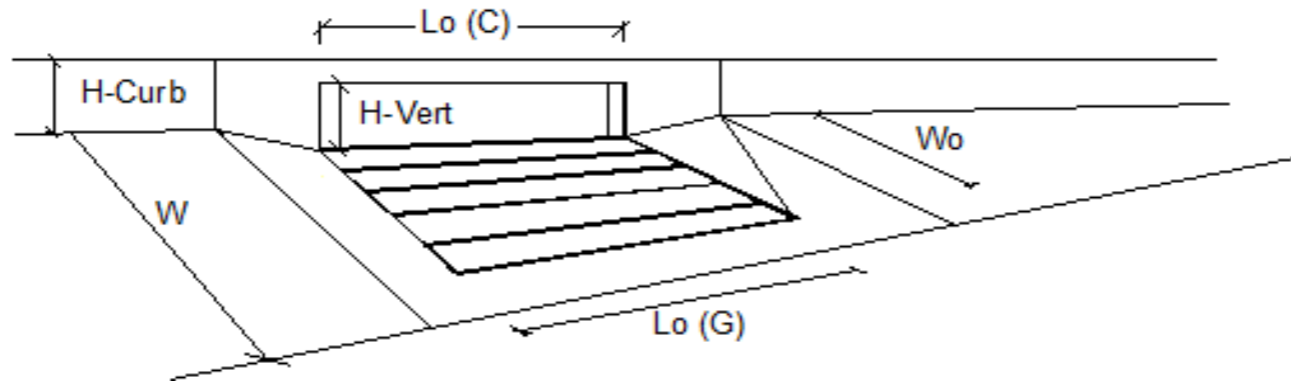

Design Information (Input)	MINOR	MAJOR	
Type of Inlet	CDOT Type R Curb Opening		
Local Depression (additional to continuous gutter depression 'a')	3.0	3.0	inches
Total Number of Units in the Inlet (Grate or Curb Opening)	1	1	
Length of a Single Unit Inlet (Grate or Curb Opening)	15.00	15.00	ft
Width of a Unit Grate (cannot be greater than W, Gutter Width)	N/A	N/A	ft
Clogging Factor for a Single Unit Grate (typical min. value = 0.5)	N/A	N/A	
Clogging Factor for a Single Unit Curb Opening (typical min. value = 0.1)	0.10	0.10	
<b>Street Hydraulics: OK - Q &lt; Allowable Street Capacity'</b>			
Total Inlet Interception Capacity	4.1	7.7	cfs
Total Inlet Carry-Over Flow (flow bypassing inlet)	0.0	0.1	cfs
Capture Percentage = $Q_a/Q_o =$	100	98	%

## ALLOWABLE CAPACITY FOR ONE-HALF OF STREET (Minor & Major Storm)

(Based on Regulated Criteria for Maximum Allowable Flow Depth and Spread)

**Project:** Falcon Meadows at Bent Grass Filing No. 4

**Inlet ID:** ExInletBasinD-4c(DP 17)

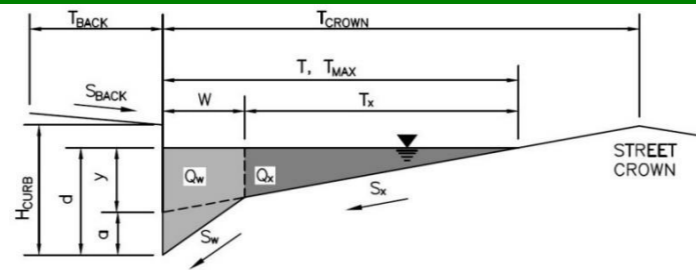

**Gutter Geometry:**

Maximum Allowable Width for Spread Behind Curb  
 Side Slope Behind Curb (leave blank for no conveyance credit behind curb)  
 Manning's Roughness Behind Curb (typically between 0.012 and 0.020)

$T_{BACK} = 8.0$  ft  
 $S_{BACK} = 0.020$  ft/ft  
 $n_{BACK} = 0.013$

Height of Curb at Gutter Flow Line  
 Distance from Curb Face to Street Crown  
 Gutter Width  
 Street Transverse Slope  
 Gutter Cross Slope (typically 2 inches over 24 inches or 0.083 ft/ft)  
 Street Longitudinal Slope - Enter 0 for sump condition  
 Manning's Roughness for Street Section (typically between 0.012 and 0.020)

$H_{CURB} = 6.00$  inches  
 $T_{CROWN} = 17.0$  ft  
 $W = 2.00$  ft  
 $S_X = 0.020$  ft/ft  
 $S_W = 0.083$  ft/ft  
 $S_O = 0.000$  ft/ft  
 $n_{STREET} = 0.016$

Max. Allowable Spread for Minor & Major Storm  
 Max. Allowable Depth at Gutter Flowline for Minor & Major Storm  
 Check boxes are not applicable in SUMP conditions

	Minor Storm	Major Storm	
$T_{MAX} =$	17.0	17.0	ft
$d_{MAX} =$	6.0	12.0	inches
	<input type="checkbox"/>	<input type="checkbox"/>	

MINOR STORM Allowable Capacity is based on Depth Criterion  
 MAJOR STORM Allowable Capacity is based on Depth Criterion

$Q_{allow} =$ 

Minor Storm	Major Storm
<b>SUMP</b>	<b>SUMP</b>

 cfs

# INLET IN A SUMP OR SAG LOCATION

MHFD-Inlet, Version 5.01 (April 2021)

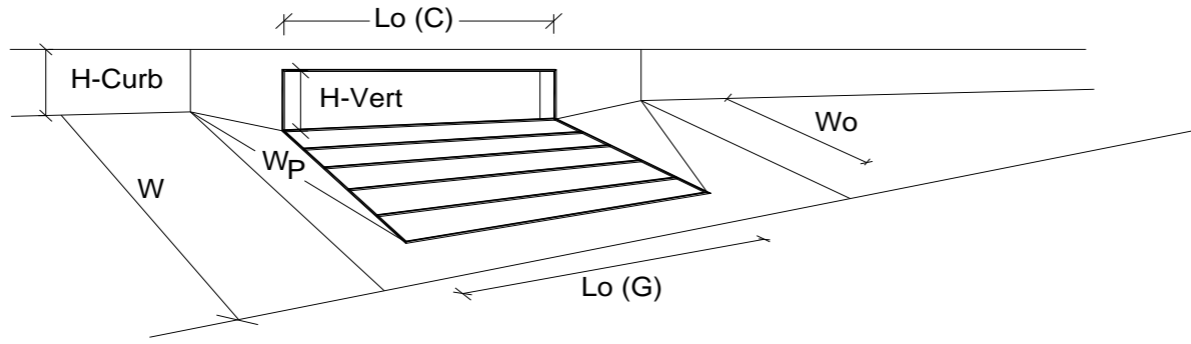

Design Information (Input)	MINOR	MAJOR	
Type of Inlet	CDOT Type R Curb Opening		
Local Depression (additional to continuous gutter depression 'a' from above)	3.00	3.00	inches
Number of Unit Inlets (Grate or Curb Opening)	1	1	
Water Depth at Flowline (outside of local depression)	5.6	12.0	inches
<b>Grate Information</b>			
Length of a Unit Grate	N/A	N/A	feet
Width of a Unit Grate	N/A	N/A	feet
Area Opening Ratio for a Grate (typical values 0.15-0.90)	N/A	N/A	
Clogging Factor for a Single Grate (typical value 0.50 - 0.70)	N/A	N/A	
Grate Weir Coefficient (typical value 2.15 - 3.60)	N/A	N/A	
Grate Orifice Coefficient (typical value 0.60 - 0.80)	N/A	N/A	
<b>Curb Opening Information</b>			
Length of a Unit Curb Opening	15.00	15.00	feet
Height of Vertical Curb Opening in Inches	6.00	6.00	inches
Height of Curb Orifice Throat in Inches	6.00	6.00	inches
Angle of Throat (see USDCM Figure ST-5)	63.40	63.40	degrees
Side Width for Depression Pan (typically the gutter width of 2 feet)	2.00	2.00	feet
Clogging Factor for a Single Curb Opening (typical value 0.10)	0.10	0.10	
Curb Opening Weir Coefficient (typical value 2.3-3.7)	3.60	3.60	
Curb Opening Orifice Coefficient (typical value 0.60 - 0.70)	0.67	0.67	
<b>Low Head Performance Reduction (Calculated)</b>			
Depth for Grate Midwidth	N/A	N/A	ft
Depth for Curb Opening Weir Equation	0.30	0.83	ft
Combination Inlet Performance Reduction Factor for Long Inlets	0.53	1.00	
Curb Opening Performance Reduction Factor for Long Inlets	0.76	1.00	
Grated Inlet Performance Reduction Factor for Long Inlets	N/A	N/A	
<b>Total Inlet Interception Capacity (assumes clogged condition)</b>			
	<b>8.0</b>	<b>39.1</b>	<b>cfs</b>
<b>Inlet Capacity IS GOOD for Minor and Major Storms(&gt;Q PEAK)</b>	5.4	11.2	cfs

**StormCAD**

# Falcon Meadows at Bent Grass Filing No. 4

## StormCAD Schematic

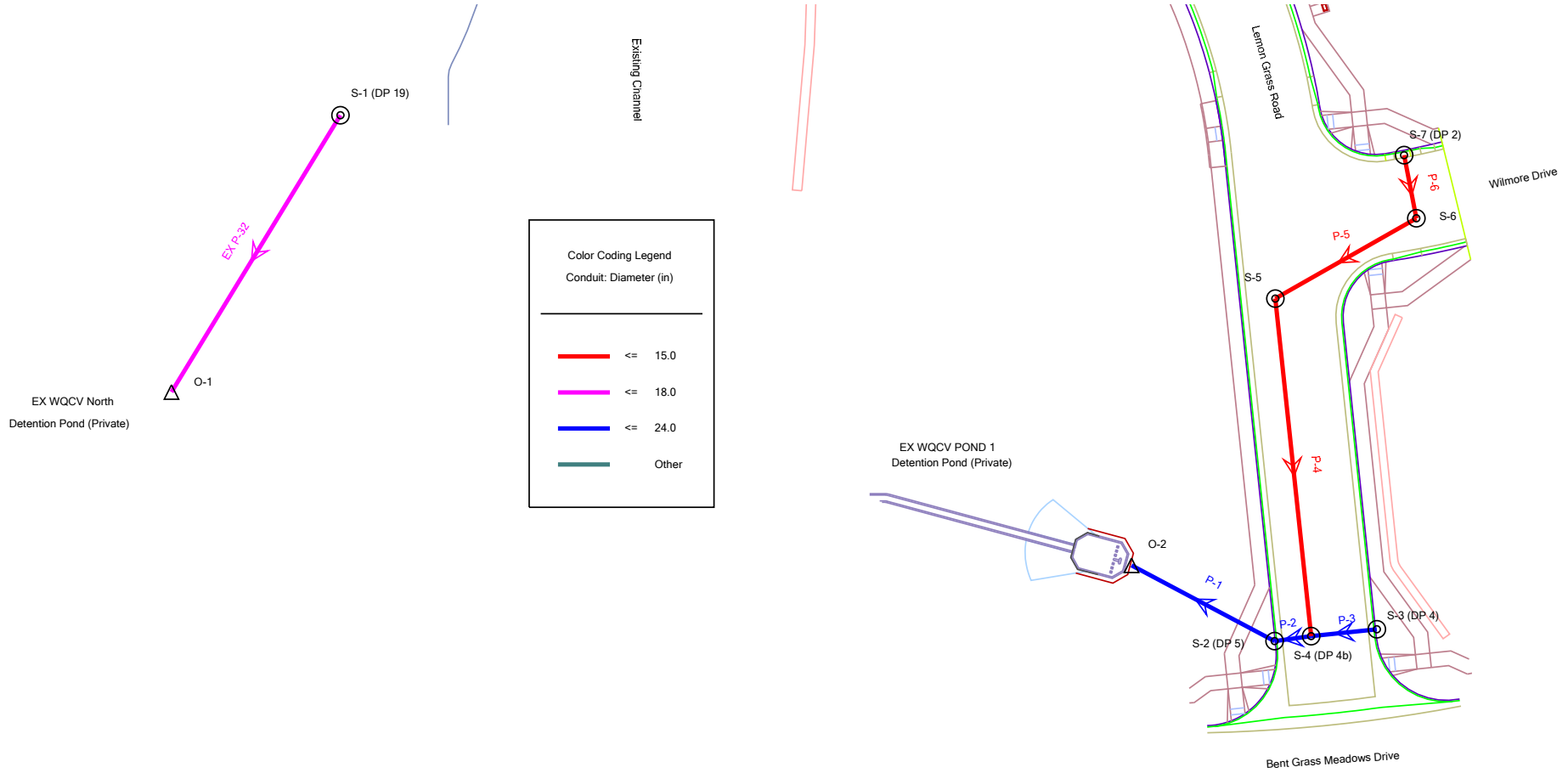

## FlexTable: Conduit Table

### Active Scenario: 5 YR

Label	Start Node	Stop Node	Invert (Start) (ft)	Invert (Stop) (ft)	Length (User Defined) (ft)	Slope (Calculated) (ft/ft)	Section Type	Diameter (in)	Manning's n	Material	Flow (cfs)	Velocity (ft/s)	Capacity (Full Flow) (cfs)	Hydraulic Grade Line (In) (ft)	Hydraulic Grade Line (Out) (ft)	Energy Grade Line (In) (ft)	Energy Grade Line (Out) (ft)
EX P-32	S-1 (DP 19)	O-1	6,943.93	6,942.30	38.6	0.042	Circle	18.0	0.013	Concrete	1.70	7.28	21.58	6,945.14	6,945.13	6,945.15	6,945.14
P-1	S-2 (DP 5)	O-2	6,942.26	6,940.00	53.0	0.043	Circle	24.0	0.013	Concrete	14.70	13.17	46.73	6,943.64	6,942.00	6,944.27	6,942.34
P-3	S-3 (DP 4)	S-4 (DP 4b)	6,943.34	6,942.71	27.5	0.023	Circle	24.0	0.013	Concrete	9.60	9.35	34.24	6,944.45	6,944.64	6,944.90	6,944.79
P-2	S-4 (DP 4b)	S-2 (DP 5)	6,942.61	6,942.46	7.5	0.020	Circle	24.0	0.013	Concrete	12.90	9.64	31.99	6,943.90	6,943.54	6,944.46	6,944.40
P-6	S-7 (DP 2)	S-6	6,951.76	6,950.80	24.0	0.040	Circle	15.0	0.013	Concrete	3.40	8.88	12.93	6,952.50	6,951.27	6,952.81	6,952.29
P-5	S-6	S-5	6,950.50	6,948.05	61.2	0.040	Circle	15.0	0.013	Concrete	3.40	8.88	12.93	6,951.24	6,948.49	6,951.55	6,949.71
P-4	S-5	S-4 (DP 4b)	6,947.75	6,943.46	110.2	0.039	Circle	15.0	0.013	Concrete	3.40	8.79	12.74	6,948.49	6,944.64	6,948.80	6,944.77



## FlexTable: Manhole Table

### Active Scenario: 5 YR

Label	Elevation (Rim) (ft)	Elevation (Invert) (ft)	Flow (Total Out) (cfs)	Headloss Coefficient (Standard)	Hydraulic Grade Line (In) (ft)	Hydraulic Grade Line (Out) (ft)
S-1 (DP 19)	6,949.32	6,943.93	1.70	0.640	6,945.15	6,945.14
S-2 (DP 5)	6,947.36	6,942.26	14.70	0.100	6,943.70	6,943.64
S-3 (DP 4)	6,947.34	6,943.34	9.60	0.050	6,944.47	6,944.45
S-4 (DP 4b)	6,947.07	6,942.61	12.90	1.320	6,944.64	6,943.90
S-5	6,953.58	6,947.75	3.40	0.640	6,948.69	6,948.49
S-6	6,955.52	6,950.50	3.40	0.640	6,951.44	6,951.24
S-7 (DP 2)	6,955.76	6,951.76	3.40	0.000	6,952.50	6,952.50

## FlexTable: Outfall Table

### Active Scenario: 5 YR

Label	Elevation (Ground) (ft)	Elevation (Invert) (ft)	Boundary Condition Type	Elevation (User Defined Tailwater) (ft)	Hydraulic Grade (ft)	Flow (Total Out) (cfs)
O-1	6,944.51	6,942.30	User Defined Tailwater	6,945.13	6,945.13	1.70
O-2	6,942.93	6,940.00	User Defined Tailwater	6,942.00	6,942.00	14.70

**Falcon Meadows at Bent Grass Filing No. 4**  
**Profile Report**  
**Engineering Profile - DP 19 - O-1 (FM Filing 4 System.stsw)**  
**Active Scenario: 5 YR**

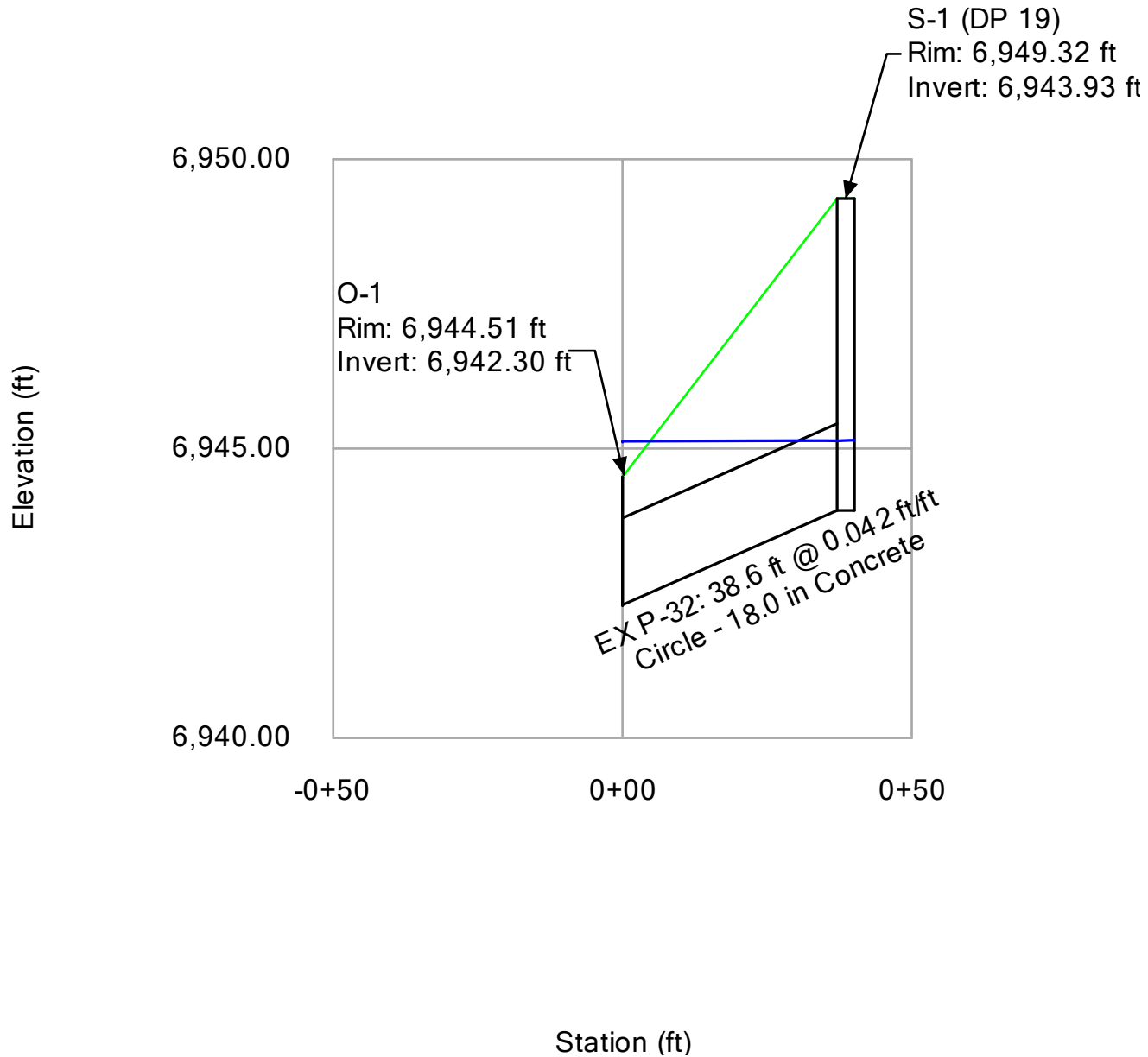

**Falcon Meadows at Bent Grass Filing No. 4**  
**Profile Report**  
**Engineering Profile - DP 4 - O-2 (FM Filing 4 System.stsw)**  
**Active Scenario: 5 YR**

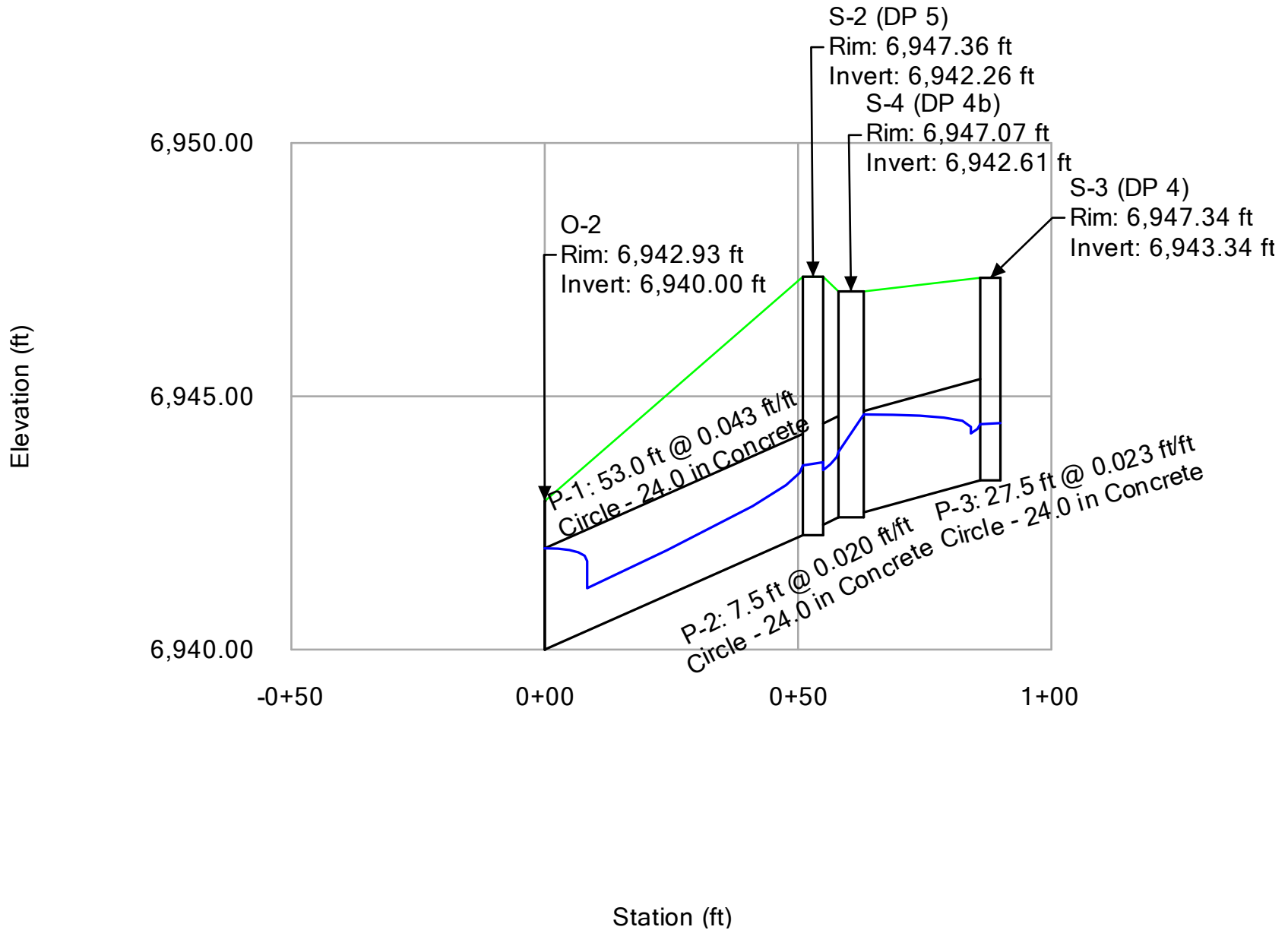

**Falcon Meadows at Bent Grass Filing No. 4**  
**Profile Report**  
**Engineering Profile - DP4b - DP 2 (5 Year) (FM Filing 4 System.stsw)**  
**Active Scenario: 5 YR**

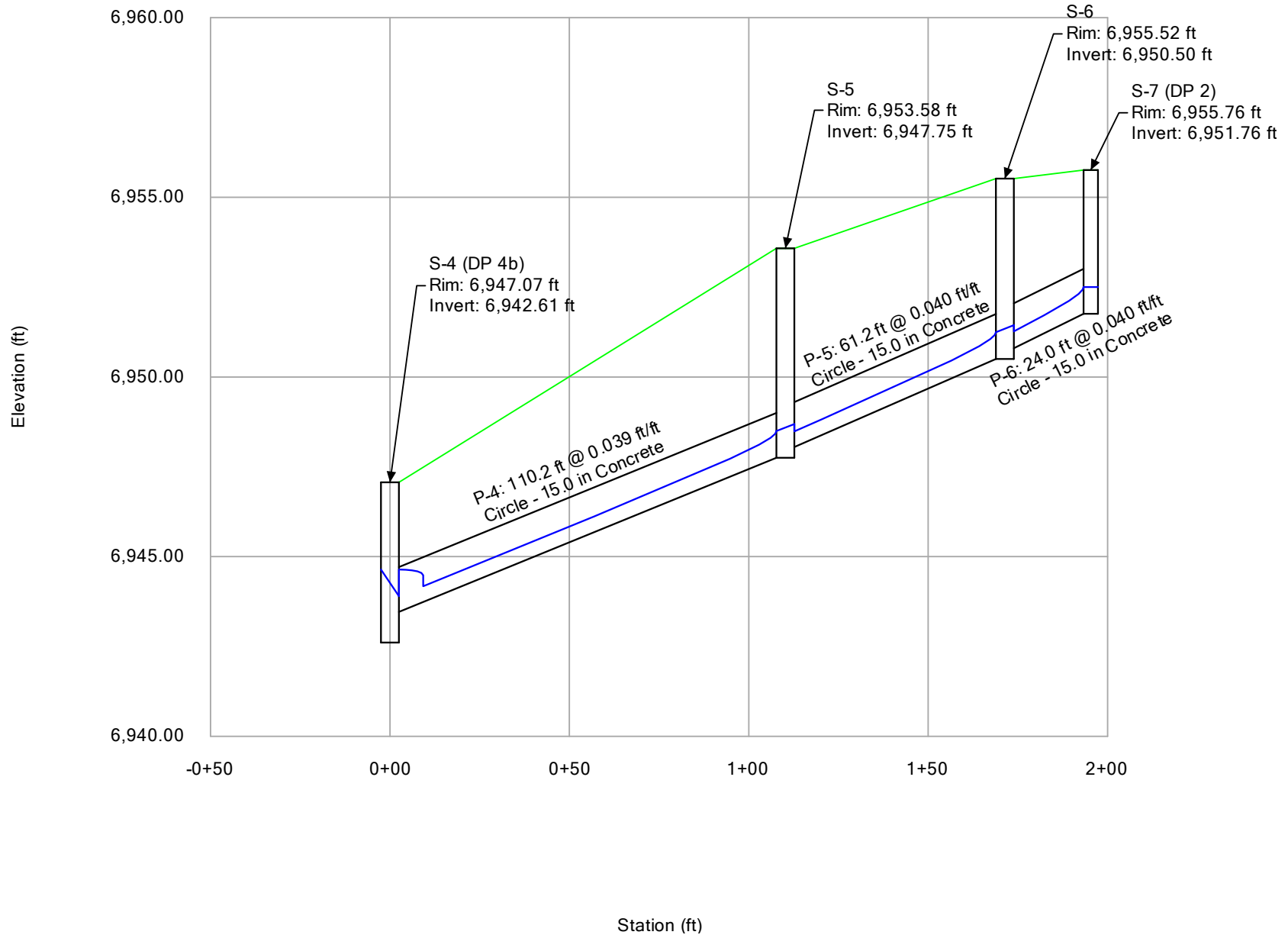

## FlexTable: Conduit Table

### Active Scenario: 100 YR

Label	Start Node	Stop Node	Invert (Start) (ft)	Invert (Stop) (ft)	Length (User Defined) (ft)	Slope (Calculated) (ft/ft)	Section Type	Diameter (in)	Manning's n	Material	Flow (cfs)	Velocity (ft/s)	Capacity (Full Flow) (cfs)	Hydraulic Grade Line (In) (ft)	Hydraulic Grade Line (Out) (ft)	Energy Grade Line (In) (ft)	Energy Grade Line (Out) (ft)
EX P-32	S-1 (DP 19)	O-1	6,943.93	6,942.30	38.6	0.042	Circle	18.0	0.013	Concrete	4.00	2.26	21.58	6,945.56	6,945.50	6,945.64	6,945.58
P-1	S-2 (DP 5)	O-2	6,942.26	6,940.00	53.0	0.043	Circle	24.0	0.013	Concrete	23.60	14.92	46.73	6,943.98	6,942.00	6,945.03	6,942.88
P-3	S-3 (DP 4)	S-4 (DP 4b)	6,943.34	6,942.71	27.5	0.023	Circle	24.0	0.013	Concrete	15.30	4.87	34.24	6,945.43	6,945.31	6,945.80	6,945.68
P-2	S-4 (DP 4b)	S-2 (DP 5)	6,942.61	6,942.46	7.5	0.020	Circle	24.0	0.013	Concrete	19.70	10.71	31.99	6,944.21	6,944.09	6,945.04	6,944.89
P-6	S-7 (DP 2)	S-6	6,951.76	6,950.80	24.0	0.040	Circle	15.0	0.013	Concrete	4.60	9.64	12.93	6,952.63	6,951.36	6,953.03	6,952.52
P-5	S-6	S-5	6,950.50	6,948.05	61.2	0.040	Circle	15.0	0.013	Concrete	4.60	9.64	12.93	6,951.37	6,948.57	6,951.77	6,950.00
P-4	S-5	S-4 (DP 4b)	6,947.75	6,943.46	110.2	0.039	Circle	15.0	0.013	Concrete	4.60	9.55	12.74	6,948.62	6,945.31	6,949.02	6,945.53

## FlexTable: Manhole Table

### Active Scenario: 100 YR

Label	Elevation (Rim) (ft)	Elevation (Invert) (ft)	Flow (Total Out) (cfs)	Headloss Coefficient (Standard)	Hydraulic Grade Line (In) (ft)	Hydraulic Grade Line (Out) (ft)
S-1 (DP 19)	6,949.32	6,943.93	4.00	0.640	6,945.61	6,945.56
S-2 (DP 5)	6,947.36	6,942.26	23.60	0.100	6,944.09	6,943.98
S-3 (DP 4)	6,947.34	6,943.34	15.30	0.050	6,945.45	6,945.43
S-4 (DP 4b)	6,947.07	6,942.61	19.70	1.320	6,945.31	6,944.21
S-5	6,953.58	6,947.75	4.60	0.640	6,948.87	6,948.62
S-6	6,955.52	6,950.50	4.60	0.640	6,951.62	6,951.37
S-7 (DP 2)	6,955.76	6,951.76	4.60	0.000	6,952.63	6,952.63

## FlexTable: Outfall Table

### Active Scenario: 100 YR

Label	Elevation (Ground) (ft)	Elevation (Invert) (ft)	Boundary Condition Type	Elevation (User Defined Tailwater) (ft)	Hydraulic Grade (ft)	Flow (Total Out) (cfs)
O-1	6,944.51	6,942.30	User Defined Tailwater	6,945.50	6,945.50	4.00
O-2	6,942.93	6,940.00	User Defined Tailwater	6,942.00	6,942.00	23.60



**Falcon Meadows at Bent Grass Filing No. 4**  
**Profile Report**  
**Engineering Profile - DP 19 - O-1 (FM Filing 4 System.stsw)**  
**Active Scenario: 100 YR**

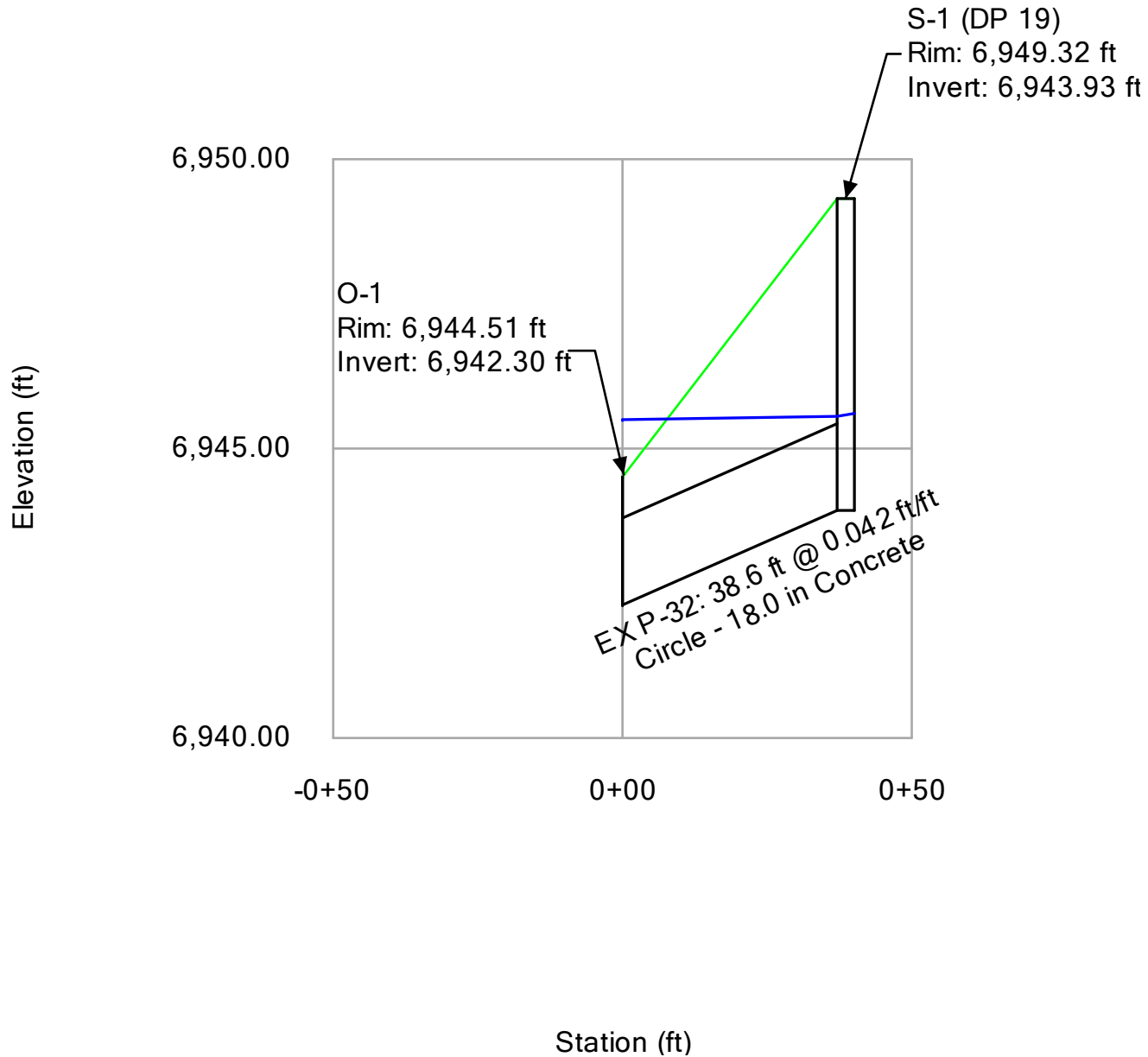

**Falcon Meadows at Bent Grass Filing No. 4**  
**Profile Report**  
**Engineering Profile - DP 4 - O-2 (FM Filing 4 System.stsw)**  
**Active Scenario: 100 YR**

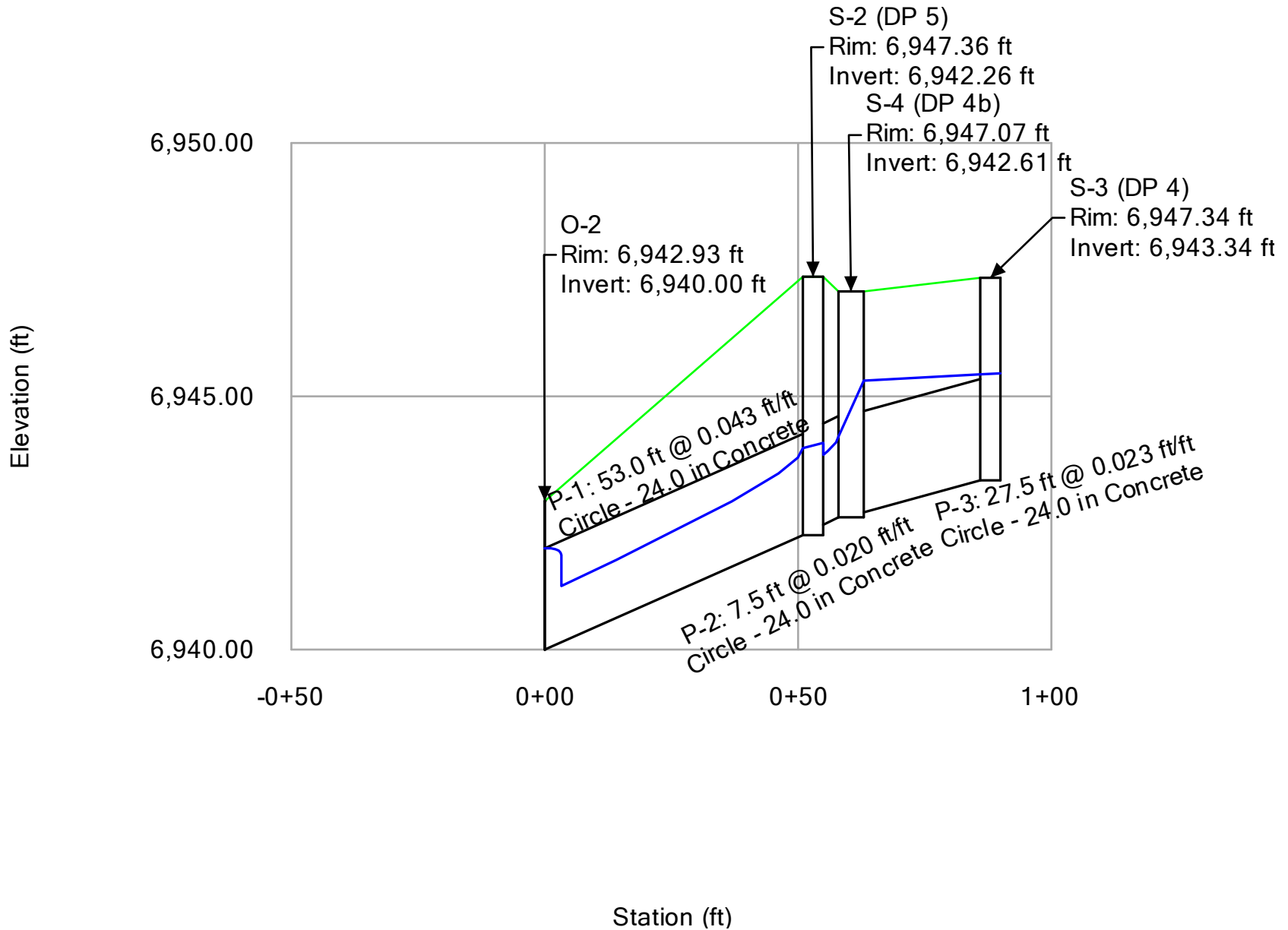

**Falcon Meadows at Bent Grass Filing No. 4**  
**Profile Report**  
**Engineering Profile - DP4b - DP 2 (FM Filing 4 System.stsw)**  
**Active Scenario: 100 YR**

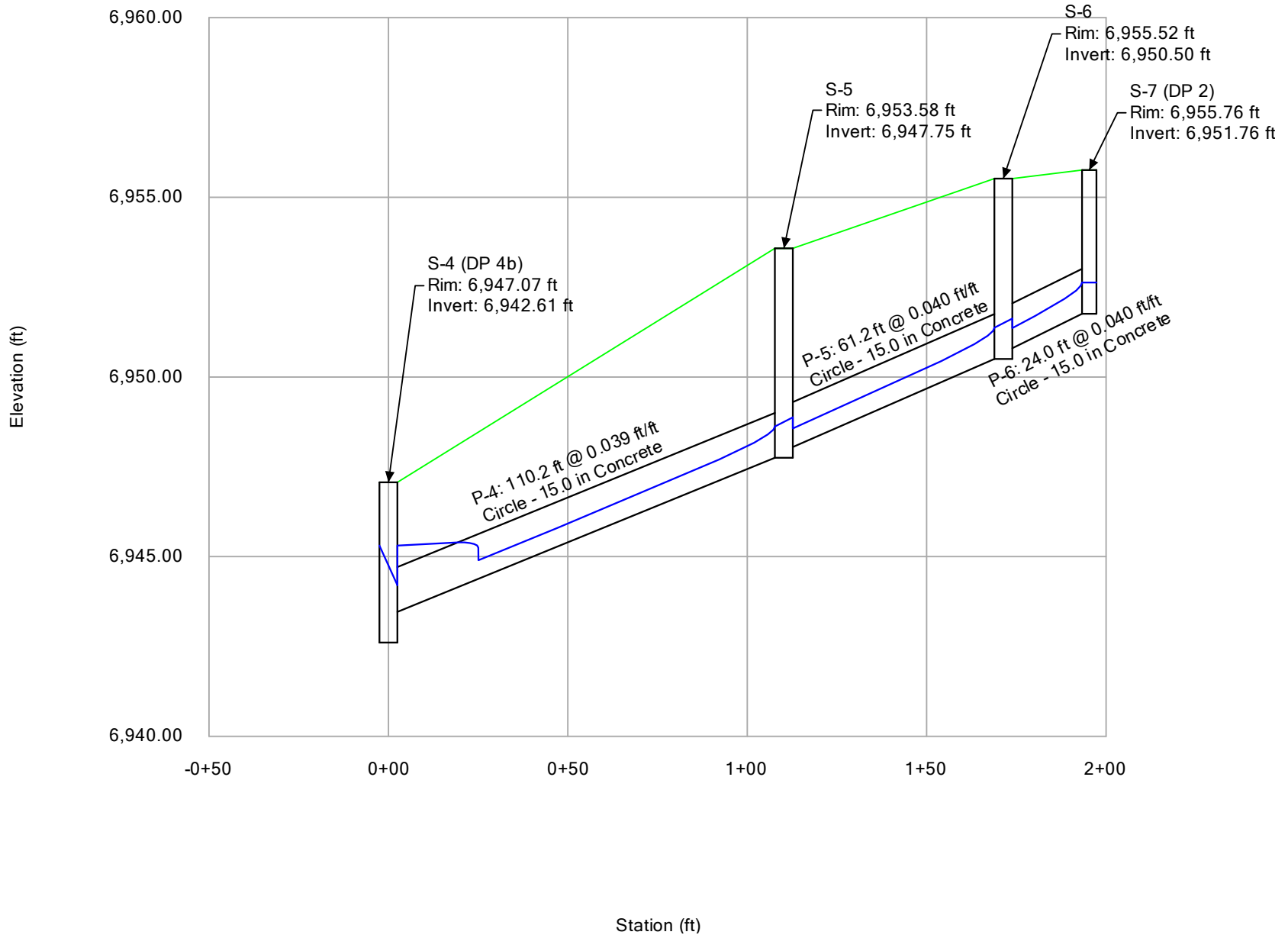

**APPENDIX E**  
**Existing Pond Analysis**

**DETENTION POND TRIBUTARY AREAS**

**Subdivision:** Falcon Meadows  
**Location:** CO, Colorado Springs

**Project Name:** Falcon Meadows at Bent Grass Filing No. 4  
**Project No.:** CLH021  
**Calculated By:** TJE  
**Checked By:** BAS  
**Date:** 6/29/22

**Pond North (Existing)**

Basin	Area	% Imp	
C-1a	0.27	84.5	(Obtained from Falcon Meadows Filing No. 3)
C-1b	1.77	61.3	(Obtained from Falcon Meadows Filing No. 3)
C-1c	1.19	68.2	(Obtained from Falcon Meadows Filing No. 3)
C-1d	1.97	72.1	(Obtained from Falcon Meadows Filing No. 3)
C-1e	0.49	100	(Obtained from Falcon Meadows Filing No. 3)
C-1f	0.14	87.5	(Obtained from Falcon Meadows Filing No. 3)
C-1g	0.87	65	
C-1h	1.12	49.3	
C-2	1	72	(Obtained from Falcon Meadows Filing No. 3)
C-3	0.18	85.7	(Obtained from Falcon Meadows Filing No. 3)
C-4	2.67	50.3	(Obtained from Falcon Meadows Filing No. 3)
C-5	0.6	2	(Obtained from Falcon Meadows Filing No. 3)
D-1f	0.67	73.4	(Obtained from Falcon Meadows Filing No. 3)
D-1g	0.78	45.5	(Obtained from Falcon Meadows Filing No. 3)
D-1h	1.57	48.8	(Obtained from Falcon Meadows Filing No. 3)
D-1j	0.95	60.6	(Obtained from Falcon Meadows Filing No. 3)
D-1k	0.8	50.6	(Obtained from Falcon Meadows Filing No. 3)
<b>Total</b>	<b>17.04</b>	<b>59.3</b>	

**Pond South (Existing)**

Basin	Area	% Imp	
D-1a	1.83	56.8	(Obtained from Falcon Meadows Filing No. 3)
D-1b	1.19	61.8	(Obtained from Falcon Meadows Filing No. 3)
D-1c	3.95	61.9	(Obtained from Falcon Meadows Filing No. 3)
D-2a	0.5	88.7	(Obtained from Falcon Meadows Filing No. 3)
D-2b	0.74	61.8	(Obtained from Falcon Meadows Filing No. 3)
D-2c	0.31	83.5	(Obtained from Falcon Meadows Filing No. 3)
D-2d	0.24	81.3	(Obtained from Falcon Meadows Filing No. 3)
D-2e	1.41	75.4	(Obtained from Falcon Meadows Filing No. 3)
D-2f	2.43	73.6	(Obtained from Falcon Meadows Filing No. 3)
D-2g	1.81	54.4	(Obtained from Falcon Meadows Filing No. 3)
D-2h	0.23	65	(Obtained from Falcon Meadows Filing No. 3)
D-3	2.26	54	(Obtained from Falcon Meadows Filing No. 3)
D-4a	0.98	72.5	(Obtained from Falcon Meadows Filing No. 3)
D-4b	0.95	80.9	(Obtained from Falcon Meadows Filing No. 3)
D-4c	3	65	
D-5	1.08	65.7	(Obtained from Falcon Meadows Filing No. 3)
D-6a	1.33	76.6	(Obtained from Falcon Meadows Filing No. 3)
D-6b	2.69	72.6	(Obtained from Falcon Meadows Filing No. 3)
D-7	8.01	13.2	
D-8	1.46	19.7	
D-9	0.72	24.8	(Obtained from Falcon Meadows Filing No. 3)
E-4	0.91	80.6	(Obtained from Falcon Meadows Filing No. 3)
E-5	0.89	89	(Obtained from Falcon Meadows Filing No. 3)
OS-2	20.07	8	(Obtained from Falcon Meadows Filing No. 3)
OS-3	10.61	8	(Obtained from Falcon Meadows Filing No. 3)
<b>Total</b>	<b>69.6</b>	<b>33.6</b>	

**DETENTION POND TRIBUTARY AREAS**

**Subdivision:** Falcon Meadows  
**Location:** CO, Colorado Springs

**Project Name:** Falcon Meadows at Bent Grass Filing No. 4  
**Project No.:** CLH021  
**Calculated By:** TJE  
**Checked By:** BAS  
**Date:** 6/29/22

**Existing Pond - Bent Grass Residential Filing No. 1**

Basin	Area	% Imp
E-1	1.71	62.3
E-2	0.68	82.8
E-3	0.78	88.7
A-1 Thru A-4	7.7	46
OS-4	4.46	65
OS-5	0.46	65
OS-6	1.17	65
A-1	2.19	65
A-3	1.08	65
A-4	0.81	2
<b>Total</b>	<b>21.04</b>	<b>56.9</b>

(Obtained from Bent Grass Residential Subdivision Filing 2)  
(Obtained from Bent Grass Residential Subdivision Filing 2)  
(Obtained from Bent Grass Residential Subdivision Filing 2)  
(Obtained from Bent Grass Residential Subdivision Filing 2)



# DETENTION BASIN STAGE-STORAGE TABLE BUILDER

*MHFD-Detention, Version 4.03 (May 2020)*

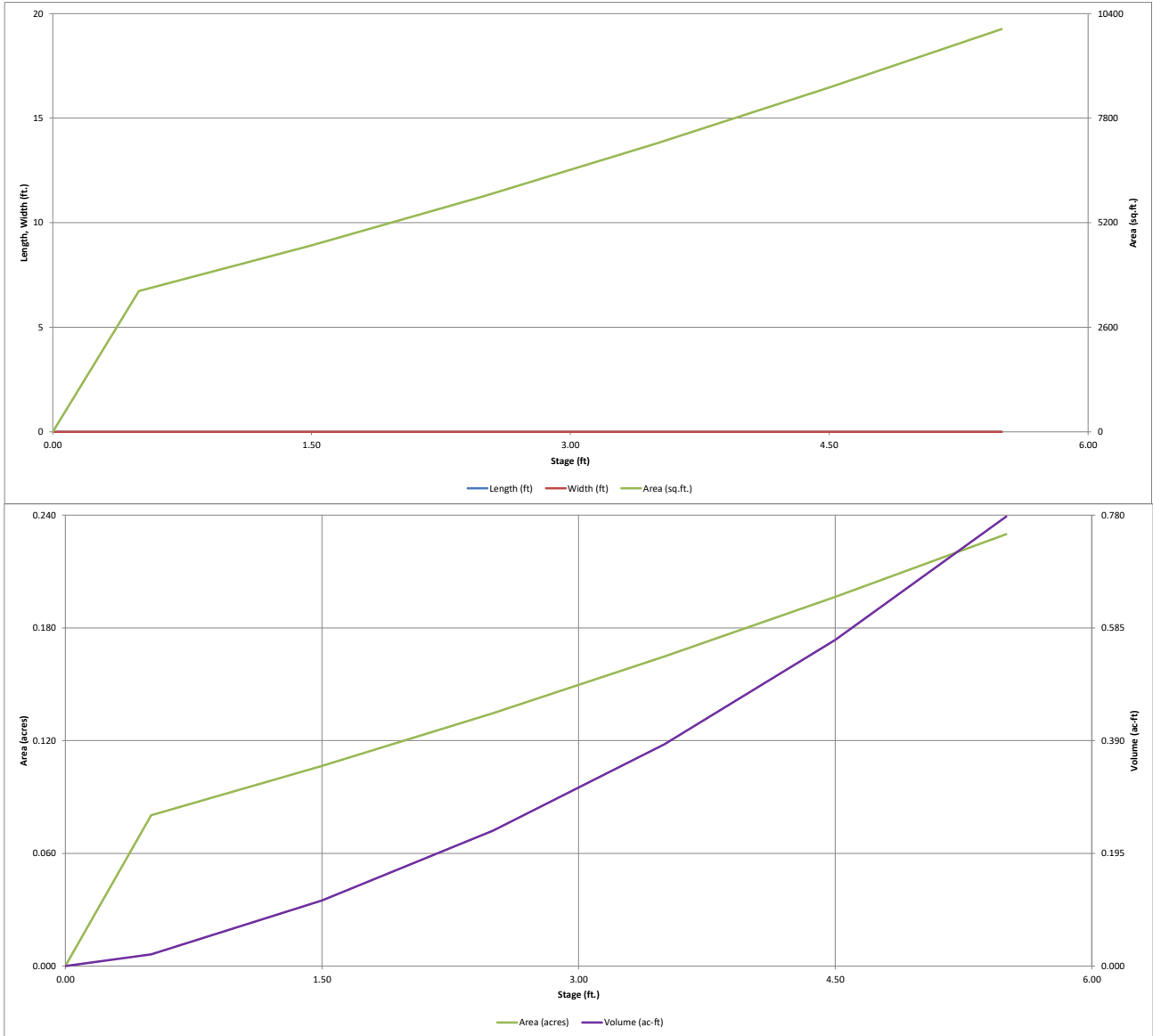



# DETENTION BASIN OUTLET STRUCTURE DESIGN

MHFD-*Detention, Version 4.03 (May 2020)*

**Project:** Bent Grass Residential Filing No. 2  
**Basin ID:** Ex WQCV Pond - North

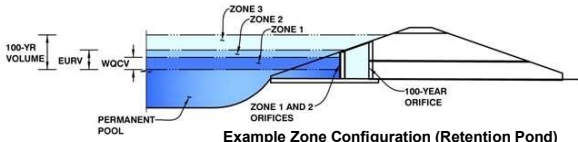

	Estimated Stage (ft)	Estimated Volume (ac-ft)	Outlet Type
Zone 1 (WQCV)	3.66	0.410	Orifice Plate
Zone 2			
Zone 3			
<b>Total (all zones)</b>		0.410	

**User Input:** Orifice at Underdrain Outlet (typically used to drain WQCV in a Filtration BMP)

Underdrain Orifice Invert Depth = <input type="text"/> ft (distance below the filtration media surface)	Underdrain Orifice Area = <input type="text"/> ft <sup>2</sup>
Underdrain Orifice Diameter = <input type="text"/> inches	Underdrain Orifice Centroid = <input type="text"/> feet

**User Input:** Orifice Plate with one or more orifices or Elliptical Slot Weir (typically used to drain WQCV and/or EURV in a sedimentation BMP)

Invert of Lowest Orifice = <input type="text"/> 0.00 ft (relative to basin bottom at Stage = 0 ft)	WQ Orifice Area per Row = <input type="text"/> 1.153E-02 ft <sup>2</sup>
Depth at top of Zone using Orifice Plate = <input type="text"/> 3.10 ft (relative to basin bottom at Stage = 0 ft)	Elliptical Half-Width = <input type="text"/> N/A feet
Orifice Plate: Orifice Vertical Spacing = <input type="text"/> 12.00 inches	Elliptical Slot Centroid = <input type="text"/> N/A feet
Orifice Plate: Orifice Area per Row = <input type="text"/> 1.66 sq. inches (diameter = 1-7/16 inches)	Elliptical Slot Area = <input type="text"/> N/A ft <sup>2</sup>

**User Input:** Stage and Total Area of Each Orifice Row (numbered from lowest to highest)

	Row 1 (required)	Row 2 (optional)	Row 3 (optional)	Row 4 (optional)	Row 5 (optional)	Row 6 (optional)	Row 7 (optional)	Row 8 (optional)
Stage of Orifice Centroid (ft)	0.00	1.00	2.00	3.00				
Orifice Area (sq. inches)	1.66	1.66	1.66					

	Row 9 (optional)	Row 10 (optional)	Row 11 (optional)	Row 12 (optional)	Row 13 (optional)	Row 14 (optional)	Row 15 (optional)	Row 16 (optional)
Stage of Orifice Centroid (ft)								
Orifice Area (sq. inches)								

**User Input:** Vertical Orifice (Circular or Rectangular)

Invert of Vertical Orifice = <input type="text"/> Not Selected <input type="text"/> Not Selected ft (relative to basin bottom at Stage = 0 ft)	Vertical Orifice Area = <input type="text"/> Not Selected <input type="text"/> Not Selected ft <sup>2</sup>
Depth at top of Zone using Vertical Orifice = <input type="text"/> ft (relative to basin bottom at Stage = 0 ft)	Vertical Orifice Centroid = <input type="text"/> feet
Vertical Orifice Diameter = <input type="text"/> inches	

**User Input:** Overflow Weir (Dropbox with Flat or Sloped Gate and Outlet Pipe OR Rectangular/Trapezoidal Weir (and No Outlet Pipe))

Overflow Weir Front Edge Height, Ho = <input type="text"/> Not Selected <input type="text"/> Not Selected ft (relative to basin bottom at Stage = 0 ft)	Height of Gate Upper Edge, H <sub>1</sub> = <input type="text"/> Not Selected <input type="text"/> Not Selected feet
Overflow Weir Front Edge Length = <input type="text"/> feet	Overflow Weir Slope Length = <input type="text"/> feet
Overflow Weir Gate Slope = <input type="text"/> H:V	Gate Open Area / 100-yr Orifice Area = <input type="text"/>
Horiz. Length of Weir Sides = <input type="text"/> feet	Overflow Gate Open Area w/o Debris = <input type="text"/> ft <sup>2</sup>
Overflow Gate Open Area % = <input type="text"/> %	Overflow Gate Open Area w/ Debris = <input type="text"/> ft <sup>2</sup>
Debris Clogging % = <input type="text"/> %	

**User Input:** Outlet Pipe w/ Flow Restriction Plate (Circular Orifice, Restrictor Plate, or Rectangular Orifice)

Depth to Invert of Outlet Pipe = <input type="text"/> Not Selected <input type="text"/> Not Selected ft (distance below basin bottom at Stage = 0 ft)	Outlet Orifice Area = <input type="text"/> Not Selected <input type="text"/> Not Selected ft <sup>2</sup>
Circular Orifice Diameter = <input type="text"/> inches	Outlet Orifice Centroid = <input type="text"/> feet
	Half-Central Angle of Restrictor Plate on Pipe = <input type="text"/> N/A <input type="text"/> N/A radians

**User Input:** Emergency Spillway (Rectangular or Trapezoidal)

Spillway Invert Stage = <input type="text"/> 3.25 ft (relative to basin bottom at Stage = 0 ft)	Spillway Design Flow Depth = <input type="text"/> 0.45 feet
Spillway Crest Length = <input type="text"/> 40.00 feet	Stage at Top of Freeboard = <input type="text"/> 4.70 feet
Spillway End Slopes = <input type="text"/> 4.00 H:V	Basin Area at Top of Freeboard = <input type="text"/> 0.20 acres
Freeboard above Max Water Surface = <input type="text"/> 1.00 feet	Basin Volume at Top of Freeboard = <input type="text"/> 0.60 acre-ft

**Routed Hydrograph Results**

The user can override the default CUHP hydrographs and runoff volumes by entering new values in the Inflow Hydrographs table (Columns W through AF).

	WQCV	EURV	2 Year	5 Year	10 Year	25 Year	50 Year	100 Year	500 Year
Design Storm Return Period =									
One-Hour Rainfall Depth (in) =	N/A	N/A	1.19	1.50	1.75	2.00	2.25	2.52	3.68
CUHP Runoff Volume (acre-ft) =	0.410	1.509	1.123	1.481	1.767	2.162	2.551	3.031	5.036
Inflow Hydrograph Volume (acre-ft) =	N/A	N/A	1.123	1.481	1.767	2.162	2.551	3.031	5.036
CUHP Predevelopment Peak Q (cfs) =	N/A	N/A	0.1	0.2	0.3	2.9	5.8	9.7	25.4
OPTIONAL Override Predevelopment Peak Q (cfs) =	N/A	N/A							
Predevelopment Unit Peak Flow, q (cfs/acre) =	N/A	N/A	0.01	0.01	0.02	0.14	0.28	0.46	1.21
Peak Inflow Q (cfs) =	N/A	N/A	14.5	19.1	22.7	29.6	35.7	43.1	72.1
Peak Outflow Q (cfs) =	10.4	257.5	14.0	20.8	21.4	36.4	39.5	44.9	84.6
Ratio Peak Outflow to Predevelopment Q =	N/A	N/A	N/A	90.7	66.7	12.5	6.8	4.6	3.3
Structure Controlling Flow =	Spillway	Plate	Spillway	Spillway	Spillway	Spillway	Spillway	Spillway	Spillway
Max Velocity through Gate 1 (fps) =	N/A	N/A	N/A	N/A	N/A	N/A	N/A	N/A	N/A
Max Velocity through Gate 2 (fps) =	N/A	N/A	N/A	N/A	N/A	N/A	N/A	N/A	N/A
Time to Drain 97% of Inflow Volume (hours) =	37	>120	33	31	29	26	24	22	15
Time to Drain 99% of Inflow Volume (hours) =	40	>120	40	39	38	37	36	34	29
Maximum Ponding Depth (ft) =	3.66	0.00	3.48	3.55	3.56	3.69	3.71	3.75	4.01
Area at Maximum Ponding Depth (acres) =	0.17	0.00	0.16	0.17	0.17	0.17	0.17	0.17	0.18
Maximum Volume Stored (acre-ft) =	0.410	0.000	0.380	0.392	0.392	0.414	0.419	0.426	0.470

# DETENTION BASIN OUTLET STRUCTURE DESIGN

*MHFD-Detention, Version 4.00 (December 2019)*

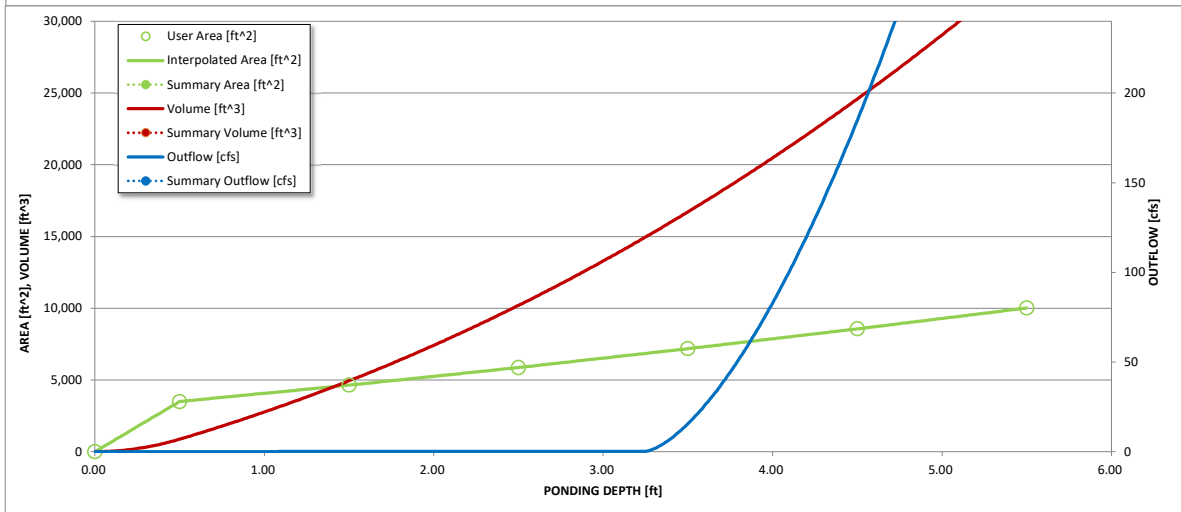
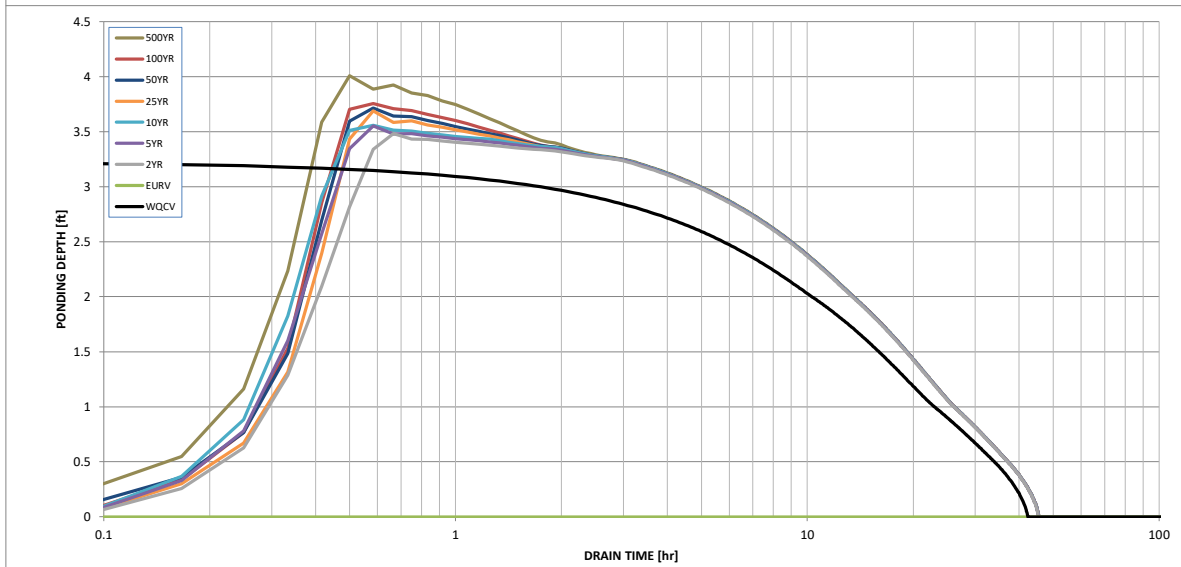
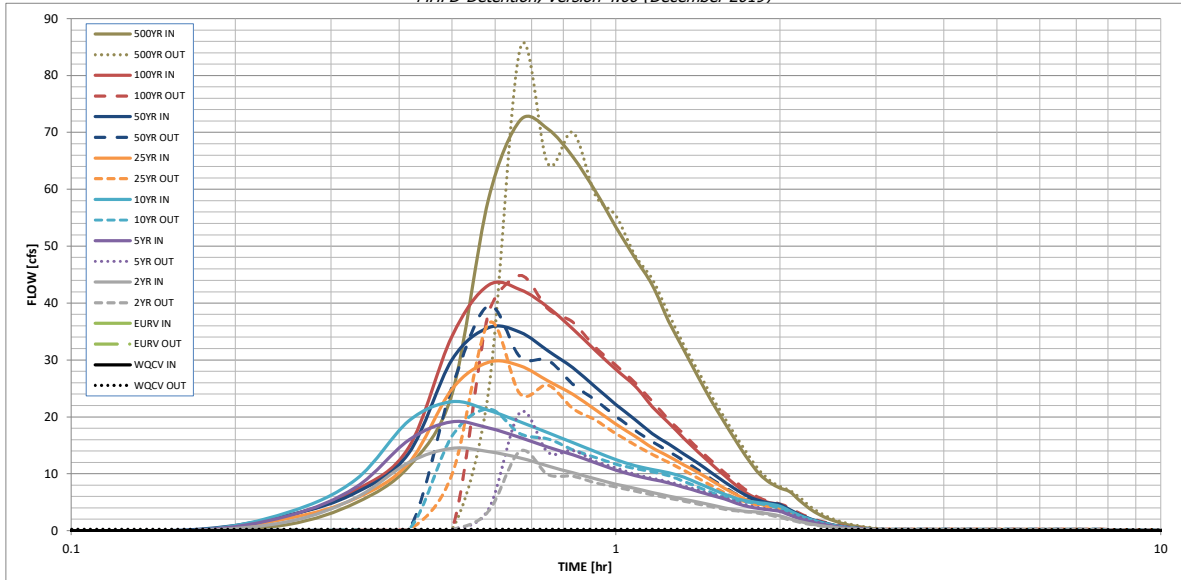

S-A-V-D Chart Axis Override	X-axis	Left Y-Axis	Right Y-Axis
minimum bound			
maximum bound			

# DETENTION BASIN OUTLET STRUCTURE DESIGN

Outflow Hydrograph Workbook Filename: \_\_\_\_\_

## Inflow Hydrographs

The user can override the calculated inflow hydrographs from this workbook with inflow hydrographs developed in a separate program.

Time Interval	SOURCE	CUHP	CUHP	CUHP	CUHP	CUHP	CUHP	CUHP	CUHP	CUHP
	TIME	WQCV [cfs]	EURV [cfs]	2 Year [cfs]	5 Year [cfs]	10 Year [cfs]	25 Year [cfs]	50 Year [cfs]	100 Year [cfs]	500 Year [cfs]
5.00 min	0:00:00	0.00	0.00	0.00	0.00	0.00	0.00	0.00	0.00	0.00
	0:05:00	0.00	0.00	0.00	0.00	0.00	0.00	0.00	0.00	0.00
	0:10:00	0.00	0.00	0.00	0.00	0.00	0.00	0.18	0.02	1.07
	0:15:00	0.00	0.00	1.59	2.58	3.20	2.16	2.71	2.64	4.89
	0:20:00	0.00	0.00	5.79	7.64	9.00	5.70	6.67	7.12	11.25
	0:25:00	0.00	0.00	11.99	15.90	19.26	11.89	13.60	14.62	23.96
	0:30:00	0.00	0.00	14.48	19.14	22.66	24.84	30.02	34.16	58.20
	0:35:00	0.00	0.00	13.87	18.05	21.15	29.59	35.68	43.15	72.13
	0:40:00	0.00	0.00	12.78	16.35	19.11	28.97	34.88	42.37	70.59
	0:45:00	0.00	0.00	11.37	14.69	17.22	26.34	31.61	39.27	65.71
	0:50:00	0.00	0.00	10.16	13.33	15.48	23.96	28.62	35.45	59.67
	0:55:00	0.00	0.00	9.10	11.93	13.89	21.24	25.27	31.64	53.40
	1:00:00	0.00	0.00	8.16	10.65	12.48	18.74	22.18	28.33	47.91
	1:05:00	0.00	0.00	7.45	9.67	11.42	16.59	19.53	25.43	43.13
	1:10:00	0.00	0.00	6.71	9.03	10.75	14.54	17.04	21.79	36.78
	1:15:00	0.00	0.00	6.08	8.36	10.20	13.04	15.23	18.93	31.73
	1:20:00	0.00	0.00	5.52	7.60	9.38	11.56	13.45	16.22	26.96
	1:25:00	0.00	0.00	5.00	6.88	8.32	10.20	11.82	13.79	22.69
	1:30:00	0.00	0.00	4.49	6.19	7.30	8.77	10.13	11.63	18.95
	1:35:00	0.00	0.00	4.00	5.55	6.39	7.45	8.56	9.65	15.53
	1:40:00	0.00	0.00	3.60	4.79	5.65	6.27	7.16	7.88	12.47
	1:45:00	0.00	0.00	3.36	4.22	5.18	5.30	5.99	6.40	9.93
	1:50:00	0.00	0.00	3.23	3.88	4.91	4.68	5.27	5.47	8.42
	1:55:00	0.00	0.00	2.90	3.64	4.65	4.31	4.85	4.92	7.50
	2:00:00	0.00	0.00	2.60	3.39	4.30	4.08	4.59	4.56	6.86
	2:05:00	0.00	0.00	2.10	2.74	3.48	3.28	3.69	3.62	5.40
	2:10:00	0.00	0.00	1.65	2.15	2.74	2.56	2.87	2.77	4.10
	2:15:00	0.00	0.00	1.30	1.69	2.14	2.00	2.24	2.12	3.11
	2:20:00	0.00	0.00	1.01	1.32	1.66	1.54	1.73	1.62	2.34
	2:25:00	0.00	0.00	0.78	1.02	1.28	1.19	1.33	1.24	1.80
	2:30:00	0.00	0.00	0.60	0.77	0.97	0.90	1.01	0.95	1.37
	2:35:00	0.00	0.00	0.46	0.58	0.73	0.68	0.76	0.72	1.03
	2:40:00	0.00	0.00	0.34	0.43	0.55	0.51	0.57	0.55	0.78
	2:45:00	0.00	0.00	0.25	0.32	0.41	0.39	0.43	0.41	0.59
	2:50:00	0.00	0.00	0.18	0.23	0.30	0.28	0.31	0.30	0.42
	2:55:00	0.00	0.00	0.11	0.15	0.20	0.19	0.21	0.20	0.29
	3:00:00	0.00	0.00	0.07	0.10	0.12	0.12	0.13	0.12	0.17
	3:05:00	0.00	0.00	0.03	0.05	0.06	0.06	0.07	0.07	0.09
	3:10:00	0.00	0.00	0.01	0.02	0.02	0.03	0.03	0.03	0.03
	3:15:00	0.00	0.00	0.00	0.00	0.00	0.00	0.00	0.00	0.00
	3:20:00	0.00	0.00	0.00	0.00	0.00	0.00	0.00	0.00	0.00
	3:25:00	0.00	0.00	0.00	0.00	0.00	0.00	0.00	0.00	0.00
	3:30:00	0.00	0.00	0.00	0.00	0.00	0.00	0.00	0.00	0.00
	3:35:00	0.00	0.00	0.00	0.00	0.00	0.00	0.00	0.00	0.00
	3:40:00	0.00	0.00	0.00	0.00	0.00	0.00	0.00	0.00	0.00
	3:45:00	0.00	0.00	0.00	0.00	0.00	0.00	0.00	0.00	0.00
	3:50:00	0.00	0.00	0.00	0.00	0.00	0.00	0.00	0.00	0.00
	3:55:00	0.00	0.00	0.00	0.00	0.00	0.00	0.00	0.00	0.00
	4:00:00	0.00	0.00	0.00	0.00	0.00	0.00	0.00	0.00	0.00
	4:05:00	0.00	0.00	0.00	0.00	0.00	0.00	0.00	0.00	0.00
	4:10:00	0.00	0.00	0.00	0.00	0.00	0.00	0.00	0.00	0.00
	4:15:00	0.00	0.00	0.00	0.00	0.00	0.00	0.00	0.00	0.00
	4:20:00	0.00	0.00	0.00	0.00	0.00	0.00	0.00	0.00	0.00
	4:25:00	0.00	0.00	0.00	0.00	0.00	0.00	0.00	0.00	0.00
	4:30:00	0.00	0.00	0.00	0.00	0.00	0.00	0.00	0.00	0.00
	4:35:00	0.00	0.00	0.00	0.00	0.00	0.00	0.00	0.00	0.00
	4:40:00	0.00	0.00	0.00	0.00	0.00	0.00	0.00	0.00	0.00
	4:45:00	0.00	0.00	0.00	0.00	0.00	0.00	0.00	0.00	0.00
	4:50:00	0.00	0.00	0.00	0.00	0.00	0.00	0.00	0.00	0.00
	4:55:00	0.00	0.00	0.00	0.00	0.00	0.00	0.00	0.00	0.00
	5:00:00	0.00	0.00	0.00	0.00	0.00	0.00	0.00	0.00	0.00
	5:05:00	0.00	0.00	0.00	0.00	0.00	0.00	0.00	0.00	0.00
	5:10:00	0.00	0.00	0.00	0.00	0.00	0.00	0.00	0.00	0.00
	5:15:00	0.00	0.00	0.00	0.00	0.00	0.00	0.00	0.00	0.00
	5:20:00	0.00	0.00	0.00	0.00	0.00	0.00	0.00	0.00	0.00
	5:25:00	0.00	0.00	0.00	0.00	0.00	0.00	0.00	0.00	0.00
	5:30:00	0.00	0.00	0.00	0.00	0.00	0.00	0.00	0.00	0.00
	5:35:00	0.00	0.00	0.00	0.00	0.00	0.00	0.00	0.00	0.00
	5:40:00	0.00	0.00	0.00	0.00	0.00	0.00	0.00	0.00	0.00
	5:45:00	0.00	0.00	0.00	0.00	0.00	0.00	0.00	0.00	0.00
	5:50:00	0.00	0.00	0.00	0.00	0.00	0.00	0.00	0.00	0.00
	5:55:00	0.00	0.00	0.00	0.00	0.00	0.00	0.00	0.00	0.00
	6:00:00	0.00	0.00	0.00	0.00	0.00	0.00	0.00	0.00	0.00



DETENTION BASIN STAGE-STORAGE TABLE BUILDER

MHFD-Detention, Version 4.03 (May 2020)

Project: Falcon Meadows at Bent Grass Filing No. 2

Basin ID: Existing WQCV Pond - North (Analysis)

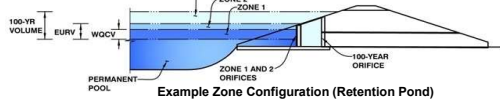

Example Zone Configuration (Retention Pond)

Watershed Information

Table with watershed parameters: Selected BMP Type (EDB), Watershed Area (17.04 acres), Watershed Length (1,275 ft), Watershed Length to Centroid (750 ft), Watershed Slope (0.030 ft/ft), Watershed Imperviousness (59.30%), etc.

After providing required inputs above including 1-hour rainfall depths, click 'Run CUHP' to generate runoff hydrographs using the embedded Colorado Urban Hydrograph Procedure.

Table of runoff volumes and detention volumes: Water Quality Capture Volume (0.332 acre-feet), Excess Urban Runoff Volume (1.222 acre-feet), 2-yr Runoff Volume (0.900 acre-feet), etc.

Optional User Overrides

Table for optional user overrides: 1.19 inches, 1.50 inches, 1.75 inches, 2.00 inches, 2.25 inches, 2.52 inches, 3.68 inches.

Define Zones and Basin Geometry

Table for basin geometry: Zone 1 Volume (0.332 acre-feet), Select Zone 2 Storage Volume (Optional), Select Zone 3 Storage Volume (Optional), Total Detention Basin Volume, etc.

Total detention volume is less than 100-year volume.

Table for basin geometry: Initial Surcharge Area (A\_ISV), Surcharge Volume Length (L\_ISV), Surcharge Volume Width (W\_ISV), Depth of Basin Floor (H\_FLOOR), etc.

Main stage-storage table with columns: Stage - Storage Description, Stage (ft), Optional Override Stage (ft), Length (ft), Width (ft), Area (ft^2), Optional Override Area (ft^2), Area (acre), Volume (ft^3), Volume (ac-ft). Rows include Top of Micropool, Trickle Channel Inv, and Top of Bank.

# DETENTION BASIN STAGE-STORAGE TABLE BUILDER

*MHFD-Detention, Version 4.03 (May 2020)*

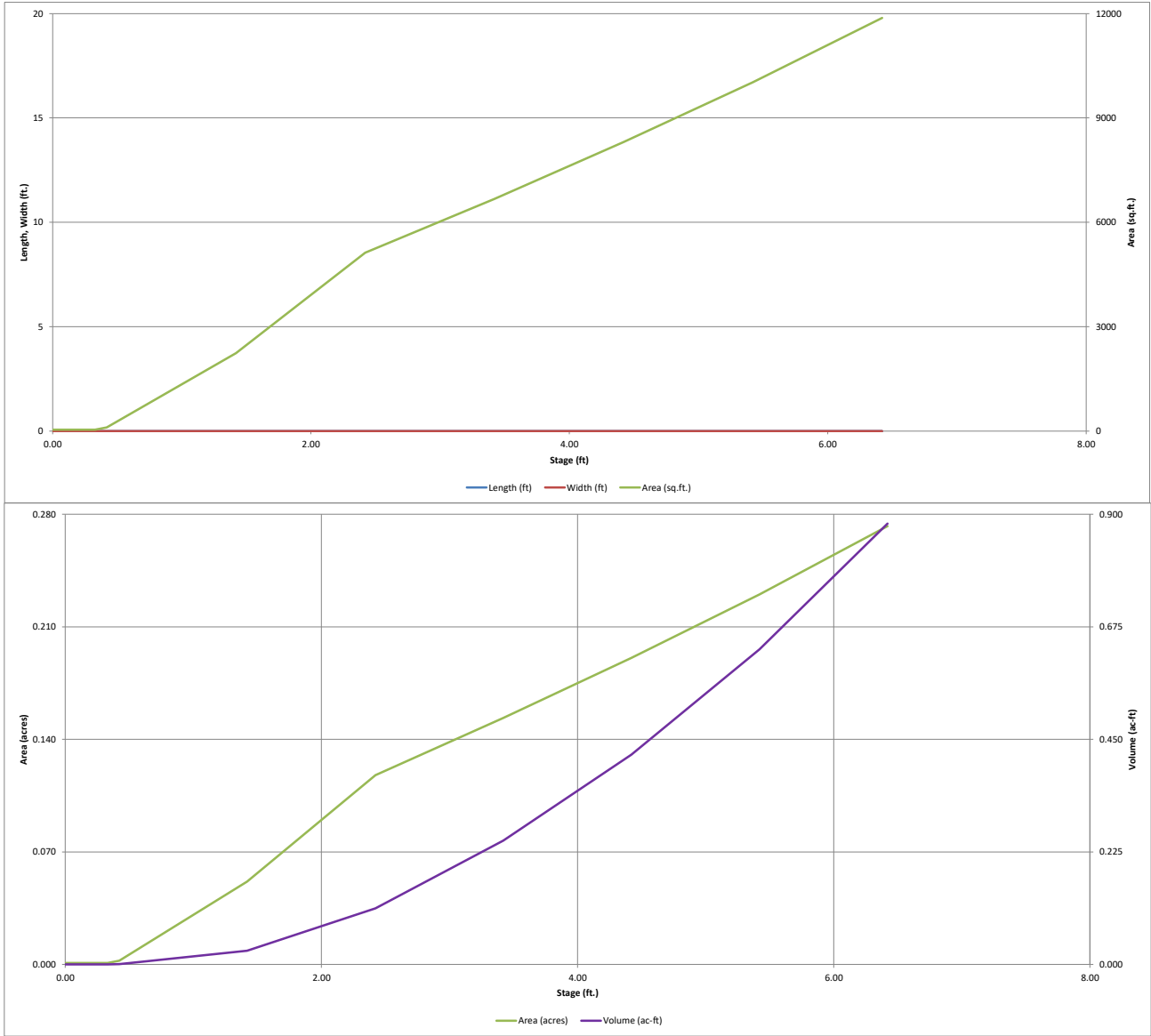

# DETENTION BASIN OUTLET STRUCTURE DESIGN

*MHFD-Detention, Version 4.03 (May 2020)*

**Project:** Falcon Meadows at Bent Grass Filing No. 2  
**Basin ID:** Existing WQCV Pond - North (Analysis)

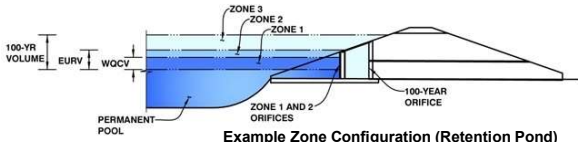

	Estimated Stage (ft)	Estimated Volume (ac-ft)	Outlet Type
Zone 1 (WQCV)	3.94	0.332	Orifice Plate
Zone 2			
Zone 3			
<b>Total (all zones)</b>		<b>0.332</b>	

**User Input:** Orifice at Underdrain Outlet (typically used to drain WQCV in a Filtration BMP)

Underdrain Orifice Invert Depth =  ft (distance below the filtration media surface)  
 Underdrain Orifice Diameter =  inches

**Calculated Parameters for Underdrain**

Underdrain Orifice Area =  ft<sup>2</sup>  
 Underdrain Orifice Centroid =  feet

**User Input:** Orifice Plate with one or more orifices or Elliptical Slot Weir (typically used to drain WQCV and/or EURV in a sedimentation BMP)

Invert of Lowest Orifice =  0.00 ft (relative to basin bottom at Stage = 0 ft)  
 Depth at top of Zone using Orifice Plate =  4.07 ft (relative to basin bottom at Stage = 0 ft)  
 Orifice Plate: Orifice Vertical Spacing =  N/A inches  
 Orifice Plate: Orifice Area per Row =  1.01 sq. inches (diameter = 1-1/8 inches)

**Calculated Parameters for Plate**

WQ Orifice Area per Row =  7.014E-03 ft<sup>2</sup>  
 Elliptical Half-Width =  N/A feet  
 Elliptical Slot Centroid =  N/A feet  
 Elliptical Slot Area =  N/A ft<sup>2</sup>

**User Input:** Stage and Total Area of Each Orifice Row (numbered from lowest to highest)

	Row 1 (required)	Row 2 (optional)	Row 3 (optional)	Row 4 (optional)	Row 5 (optional)	Row 6 (optional)	Row 7 (optional)	Row 8 (optional)
Stage of Orifice Centroid (ft)	0.00	1.10	2.20					
Orifice Area (sq. inches)	1.01	1.01	1.01					

	Row 9 (optional)	Row 10 (optional)	Row 11 (optional)	Row 12 (optional)	Row 13 (optional)	Row 14 (optional)	Row 15 (optional)	Row 16 (optional)
Stage of Orifice Centroid (ft)								
Orifice Area (sq. inches)								

**User Input:** Vertical Orifice (Circular or Rectangular)

Invert of Vertical Orifice =  Not Selected  Not Selected ft (relative to basin bottom at Stage = 0 ft)  
 Depth at top of Zone using Vertical Orifice =  ft (relative to basin bottom at Stage = 0 ft)  
 Vertical Orifice Diameter =  inches

**Calculated Parameters for Vertical Orifice**

Vertical Orifice Area =  Not Selected  Not Selected ft<sup>2</sup>  
 Vertical Orifice Centroid =  feet

**User Input:** Overflow Weir (Dropbox with Flat or Sloped Gate and Outlet Pipe OR Rectangular/Trapezoidal Weir (and No Outlet Pipe)

Overflow Weir Front Edge Height, Ho =  Not Selected  Not Selected ft (relative to basin bottom at Stage = 0 ft)  
 Overflow Weir Front Edge Length =  6.00 feet  
 Overflow Weir Gate Slope =  0.00 H:V  
 Horiz. Length of Weir Sides =  3.00 feet  
 Overflow Gate Open Area % =  70% %, gate open area/total area  
 Debris Clogging % =  50% %

**Calculated Parameters for Overflow Weir**

Height of Gate Upper Edge, H<sub>1</sub> =  Not Selected  Not Selected feet  
 Overflow Weir Slope Length =  3.00 feet  
 Gate Open Area / 100-yr Orifice Area =  4.01  
 Overflow Gate Open Area w/o Debris =  12.60 ft<sup>2</sup>  
 Overflow Gate Open Area w/ Debris =  6.30 ft<sup>2</sup>

**User Input:** Outlet Pipe w/ Flow Restriction Plate (Circular Orifice, Restrictor Plate, or Rectangular Orifice)

Depth to Invert of Outlet Pipe =  Not Selected  Not Selected ft (distance below basin bottom at Stage = 0 ft)  
 Circular Orifice Diameter =  24.00 inches

**Calculated Parameters for Outlet Pipe w/ Flow Restriction Plate**

Outlet Orifice Area =  Not Selected  Not Selected ft<sup>2</sup>  
 Outlet Orifice Centroid =  1.00 feet  
 Half-Central Angle of Restrictor Plate on Pipe =  N/A  N/A radians

**User Input:** Emergency Spillway (Rectangular or Trapezoidal)

Spillway Invert Stage =  4.92 ft (relative to basin bottom at Stage = 0 ft)  
 Spillway Crest Length =  25.00 feet  
 Spillway End Slopes =  4.00 H:V  
 Freeboard above Max Water Surface =  0.00 feet

**Calculated Parameters for Spillway**

Spillway Design Flow Depth =  0.66 feet  
 Stage at Top of Freeboard =  5.58 feet  
 Basin Area at Top of Freeboard =  0.24 acres  
 Basin Volume at Top of Freeboard =  0.67 acre-ft

**Routed Hydrograph Results**

*The user can override the default CUHP hydrographs and runoff volumes by entering new values in the Inflow Hydrographs table (Columns W through AF).*

	WQCV	EURV	2 Year	5 Year	10 Year	25 Year	50 Year	100 Year	500 Year
Design Storm Return Period =									
One-Hour Rainfall Depth (in) =	N/A	N/A	1.19	1.50	1.75	2.00	2.25	2.52	3.68
CUHP Runoff Volume (acre-ft) =	0.332	1.222	0.900	1.186	1.414	1.730	2.041	2.425	4.027
Inflow Hydrograph Volume (acre-ft) =	N/A	N/A	0.900	1.186	1.414	1.730	2.041	2.425	4.027
CUHP Predevelopment Peak Q (cfs) =	N/A	N/A	0.1	0.2	0.3	3.1	6.1	10.0	25.6
OPTIONAL Override Predevelopment Peak Q (cfs) =	N/A	N/A							
Predevelopment Unit Peak Flow, q (cfs/acre) =	N/A	N/A	0.01	0.01	0.02	0.18	0.36	0.59	1.50
Peak Inflow Q (cfs) =	N/A	N/A	14.0	18.5	21.8	28.5	34.3	41.9	69.7
Peak Outflow Q (cfs) =	0.2	130.9	7.9	12.6	15.8	24.5	29.8	37.7	67.9
Ratio Peak Outflow to Predevelopment Q =	N/A	N/A	N/A	53.3	47.4	8.0	4.9	3.8	2.7
Structure Controlling Flow =	Plate	Plate	Overflow Weir 1	Overflow Weir 1	Overflow Weir 1	Overflow Weir 1	Spillway	Spillway	Spillway
Max Velocity through Gate 1 (fps) =	N/A	N/A	0.60	1.0	1.2	1.9	2.3	2.5	2.6
Max Velocity through Gate 2 (fps) =	N/A	N/A	N/A	N/A	N/A	N/A	N/A	N/A	N/A
Time to Drain 97% of Inflow Volume (hours) =	36	32	37	35	34	32	31	29	23
Time to Drain 99% of Inflow Volume (hours) =	39	36	41	40	40	39	38	37	34
Maximum Ponding Depth (ft) =	3.94	3.87	4.42	4.55	4.63	4.81	4.96	5.11	5.49
Area at Maximum Ponding Depth (acres) =	0.17	0.17	0.19	0.20	0.20	0.21	0.21	0.22	0.23
Maximum Volume Stored (acre-ft) =	0.332	0.319	0.420	0.445	0.458	0.497	0.526	0.558	0.646

# DETENTION BASIN OUTLET STRUCTURE DESIGN

*MHFD-Detention, Version 4.00 (December 2019)*

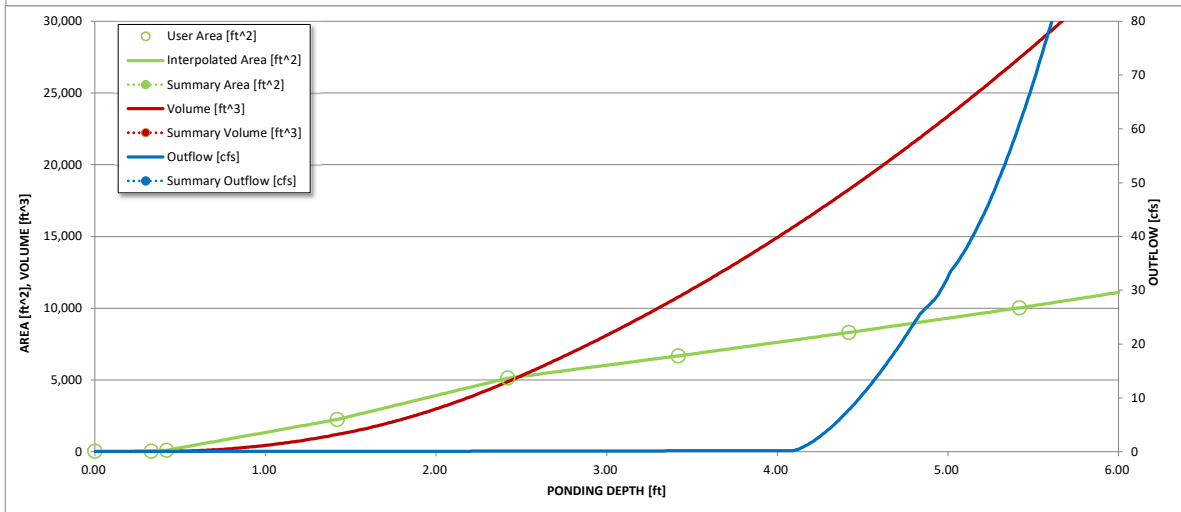
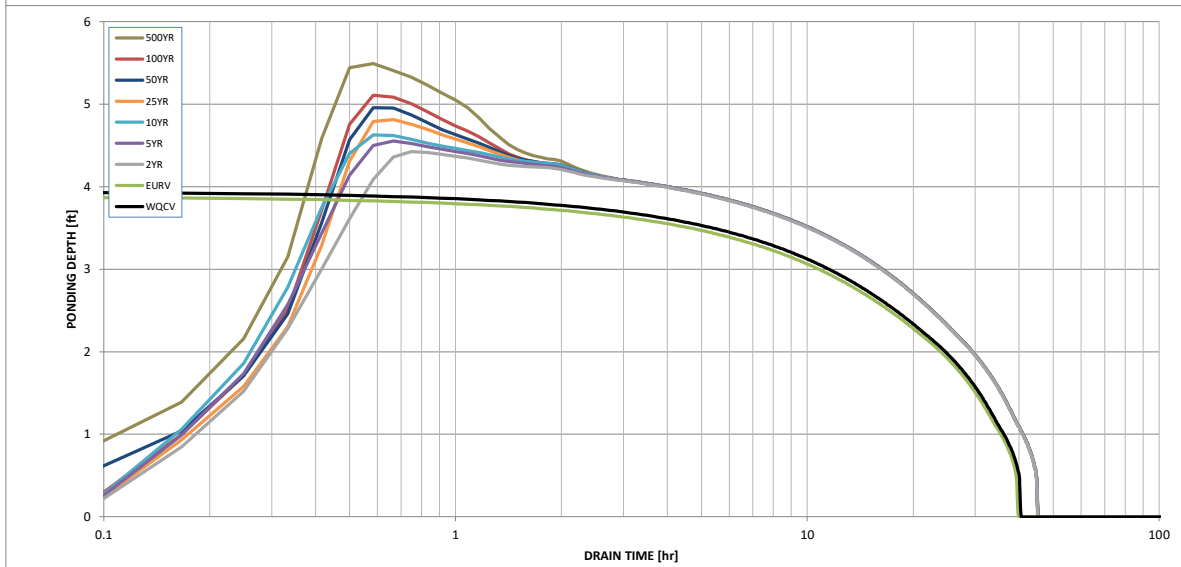
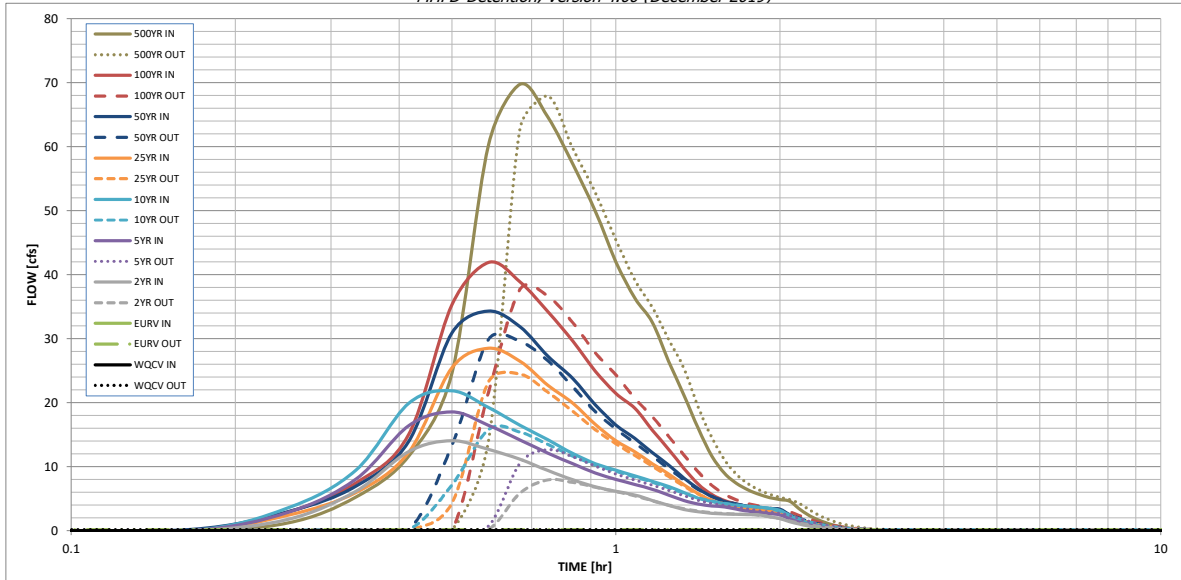

S-A-V-D Chart Axis Override	X-axis	Left Y-Axis	Right Y-Axis
minimum bound			
maximum bound			



# DETENTION BASIN OUTLET STRUCTURE DESIGN

Outflow Hydrograph Workbook Filename: \_\_\_\_\_

**Inflow Hydrographs**

The user can override the calculated inflow hydrographs from this workbook with inflow hydrographs developed in a separate program.

Time Interval	SOURCE	CUHP	CUHP	CUHP	CUHP	CUHP	CUHP	CUHP	CUHP	CUHP
	TIME	WQCV [cfs]	EURV [cfs]	2 Year [cfs]	5 Year [cfs]	10 Year [cfs]	25 Year [cfs]	50 Year [cfs]	100 Year [cfs]	500 Year [cfs]
5.00 min	0:00:00	0.00	0.00	0.00	0.00	0.00	0.00	0.00	0.00	0.00
	0:05:00	0.00	0.00	0.00	0.00	0.00	0.00	0.00	0.00	0.00
	0:10:00	0.00	0.00	0.00	0.00	0.00	0.00	0.00	0.02	0.02
	0:15:00	0.00	0.00	1.76	2.86	3.55	2.39	2.97	2.91	5.24
	0:20:00	0.00	0.00	6.17	8.06	9.47	5.97	6.95	7.46	11.66
	0:25:00	0.00	0.00	12.37	16.41	19.89	12.25	13.97	15.03	24.62
	0:30:00	0.00	0.00	14.04	18.53	21.84	25.47	30.88	35.29	60.20
	0:35:00	0.00	0.00	12.69	16.46	19.23	28.47	34.31	41.88	69.73
	0:40:00	0.00	0.00	11.15	14.15	16.47	26.45	31.84	38.85	64.58
	0:45:00	0.00	0.00	9.39	12.11	14.18	22.72	27.24	34.22	57.27
	0:50:00	0.00	0.00	7.93	10.45	12.05	19.91	23.76	29.59	49.88
	0:55:00	0.00	0.00	6.87	9.01	10.46	16.59	19.65	24.92	42.01
	1:00:00	0.00	0.00	6.16	8.02	9.43	14.04	16.52	21.43	36.28
	1:05:00	0.00	0.00	5.57	7.22	8.56	12.29	14.38	19.10	32.54
	1:10:00	0.00	0.00	4.72	6.46	7.70	10.46	12.18	15.69	26.45
	1:15:00	0.00	0.00	3.94	5.55	6.89	8.84	10.23	12.72	21.15
	1:20:00	0.00	0.00	3.32	4.70	5.94	7.15	8.22	9.72	15.93
	1:25:00	0.00	0.00	2.93	4.15	5.07	5.77	6.56	7.25	11.64
	1:30:00	0.00	0.00	2.72	3.87	4.55	4.70	5.31	5.63	8.94
	1:35:00	0.00	0.00	2.61	3.70	4.21	4.06	4.57	4.71	7.36
	1:40:00	0.00	0.00	2.55	3.33	3.97	3.65	4.11	4.13	6.34
	1:45:00	0.00	0.00	2.51	3.04	3.79	3.38	3.80	3.74	5.65
	1:50:00	0.00	0.00	2.47	2.83	3.67	3.20	3.59	3.48	5.17
	1:55:00	0.00	0.00	2.16	2.67	3.49	3.07	3.45	3.29	4.83
	2:00:00	0.00	0.00	1.90	2.47	3.17	2.98	3.35	3.16	4.62
	2:05:00	0.00	0.00	1.42	1.85	2.36	2.23	2.50	2.36	3.43
	2:10:00	0.00	0.00	1.03	1.34	1.70	1.61	1.81	1.70	2.48
	2:15:00	0.00	0.00	0.75	0.97	1.23	1.16	1.31	1.24	1.80
	2:20:00	0.00	0.00	0.53	0.69	0.88	0.83	0.93	0.89	1.29
	2:25:00	0.00	0.00	0.37	0.47	0.61	0.58	0.65	0.62	0.90
	2:30:00	0.00	0.00	0.25	0.32	0.42	0.41	0.45	0.43	0.62
	2:35:00	0.00	0.00	0.16	0.22	0.28	0.28	0.31	0.29	0.42
	2:40:00	0.00	0.00	0.10	0.14	0.17	0.17	0.19	0.18	0.26
	2:45:00	0.00	0.00	0.05	0.07	0.09	0.09	0.10	0.10	0.14
	2:50:00	0.00	0.00	0.02	0.03	0.04	0.04	0.04	0.04	0.05
	2:55:00	0.00	0.00	0.00	0.01	0.01	0.01	0.01	0.01	0.01
	3:00:00	0.00	0.00	0.00	0.00	0.00	0.00	0.00	0.00	0.00
	3:05:00	0.00	0.00	0.00	0.00	0.00	0.00	0.00	0.00	0.00
	3:10:00	0.00	0.00	0.00	0.00	0.00	0.00	0.00	0.00	0.00
	3:15:00	0.00	0.00	0.00	0.00	0.00	0.00	0.00	0.00	0.00
	3:20:00	0.00	0.00	0.00	0.00	0.00	0.00	0.00	0.00	0.00
	3:25:00	0.00	0.00	0.00	0.00	0.00	0.00	0.00	0.00	0.00
	3:30:00	0.00	0.00	0.00	0.00	0.00	0.00	0.00	0.00	0.00
	3:35:00	0.00	0.00	0.00	0.00	0.00	0.00	0.00	0.00	0.00
	3:40:00	0.00	0.00	0.00	0.00	0.00	0.00	0.00	0.00	0.00
	3:45:00	0.00	0.00	0.00	0.00	0.00	0.00	0.00	0.00	0.00
	3:50:00	0.00	0.00	0.00	0.00	0.00	0.00	0.00	0.00	0.00
	3:55:00	0.00	0.00	0.00	0.00	0.00	0.00	0.00	0.00	0.00
	4:00:00	0.00	0.00	0.00	0.00	0.00	0.00	0.00	0.00	0.00
	4:05:00	0.00	0.00	0.00	0.00	0.00	0.00	0.00	0.00	0.00
	4:10:00	0.00	0.00	0.00	0.00	0.00	0.00	0.00	0.00	0.00
	4:15:00	0.00	0.00	0.00	0.00	0.00	0.00	0.00	0.00	0.00
	4:20:00	0.00	0.00	0.00	0.00	0.00	0.00	0.00	0.00	0.00
	4:25:00	0.00	0.00	0.00	0.00	0.00	0.00	0.00	0.00	0.00
	4:30:00	0.00	0.00	0.00	0.00	0.00	0.00	0.00	0.00	0.00
	4:35:00	0.00	0.00	0.00	0.00	0.00	0.00	0.00	0.00	0.00
	4:40:00	0.00	0.00	0.00	0.00	0.00	0.00	0.00	0.00	0.00
	4:45:00	0.00	0.00	0.00	0.00	0.00	0.00	0.00	0.00	0.00
	4:50:00	0.00	0.00	0.00	0.00	0.00	0.00	0.00	0.00	0.00
	4:55:00	0.00	0.00	0.00	0.00	0.00	0.00	0.00	0.00	0.00
5:00:00	0.00	0.00	0.00	0.00	0.00	0.00	0.00	0.00	0.00	
5:05:00	0.00	0.00	0.00	0.00	0.00	0.00	0.00	0.00	0.00	
5:10:00	0.00	0.00	0.00	0.00	0.00	0.00	0.00	0.00	0.00	
5:15:00	0.00	0.00	0.00	0.00	0.00	0.00	0.00	0.00	0.00	
5:20:00	0.00	0.00	0.00	0.00	0.00	0.00	0.00	0.00	0.00	
5:25:00	0.00	0.00	0.00	0.00	0.00	0.00	0.00	0.00	0.00	
5:30:00	0.00	0.00	0.00	0.00	0.00	0.00	0.00	0.00	0.00	
5:35:00	0.00	0.00	0.00	0.00	0.00	0.00	0.00	0.00	0.00	
5:40:00	0.00	0.00	0.00	0.00	0.00	0.00	0.00	0.00	0.00	
5:45:00	0.00	0.00	0.00	0.00	0.00	0.00	0.00	0.00	0.00	
5:50:00	0.00	0.00	0.00	0.00	0.00	0.00	0.00	0.00	0.00	
5:55:00	0.00	0.00	0.00	0.00	0.00	0.00	0.00	0.00	0.00	
6:00:00	0.00	0.00	0.00	0.00	0.00	0.00	0.00	0.00	0.00	

# DETENTION BASIN OUTLET STRUCTURE DESIGN

MHFD-Detention, Version 4.03 (May 2020)

**Summary Stage-Area-Volume-Discharge Relationships**

The user can create a summary S-A-V-D by entering the desired stage increments and the remainder of the table will populate automatically.

The user should graphically compare the summary S-A-V-D table to the full S-A-V-D table in the chart to confirm it captures all key transition points.

Stage - Storage Description	Stage [ft]	Area [ft <sup>2</sup> ]	Area [acres]	Volume [ft <sup>3</sup> ]	Volume [ac-ft]	Total Outflow [cfs]

For best results, include the stages of all grade slope changes (e.g. ISV and Floor) from the S-A-V table on Sheet 'Basin'.

Also include the inverts of all outlets (e.g. vertical orifice, overflow grate, and spillway, where applicable).



# DETENTION BASIN STAGE-STORAGE TABLE BUILDER

*MHFD-Detention, Version 4.03 (May 2020)*

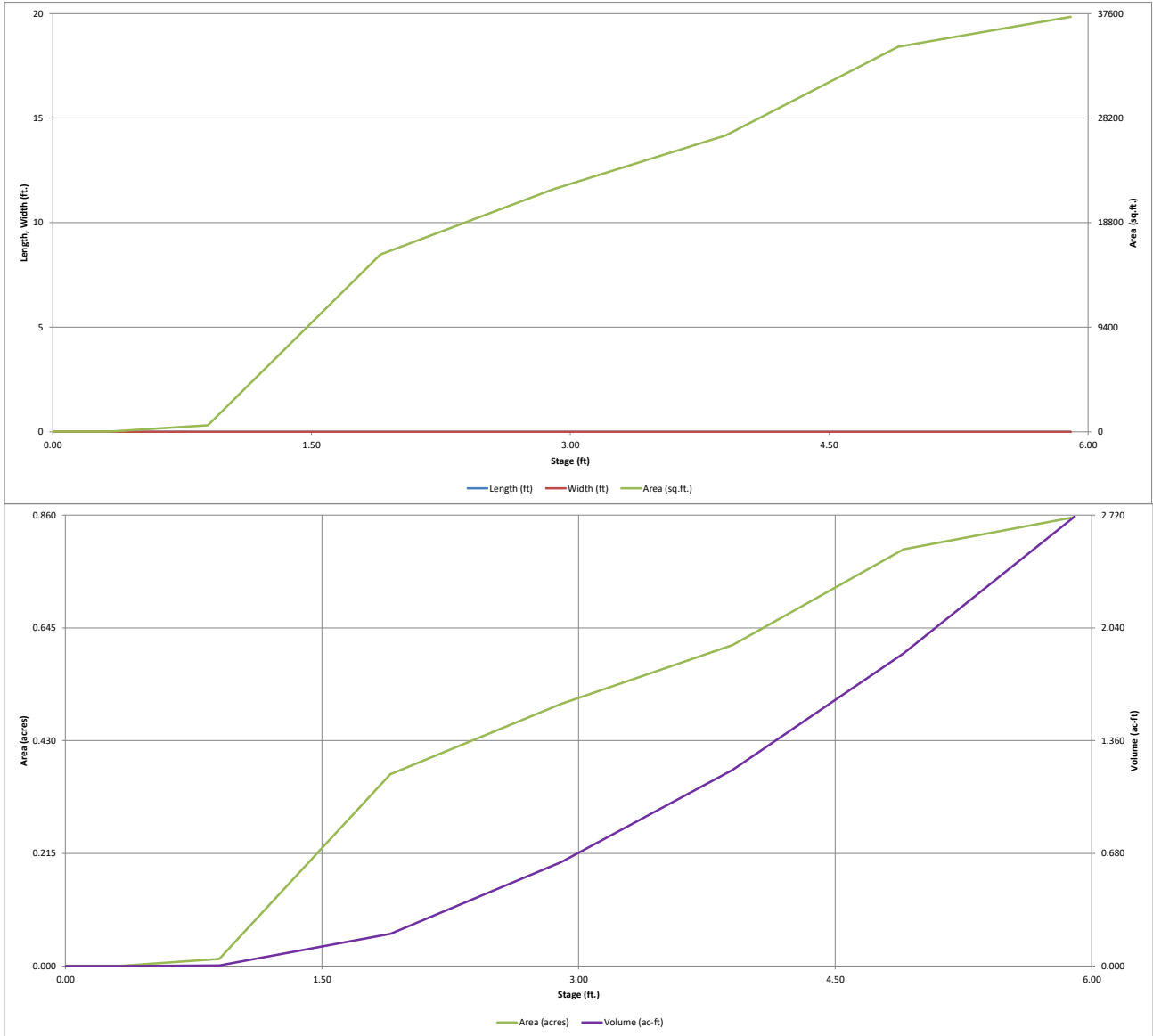

# DETENTION BASIN OUTLET STRUCTURE DESIGN

MHFD-Detention, Version 4.03 (May 2020)

**Project:** Falcon Meadows at Bent Grass Filing No. 2

**Basin ID:** Existing WQCV Pond - South (Analysis)

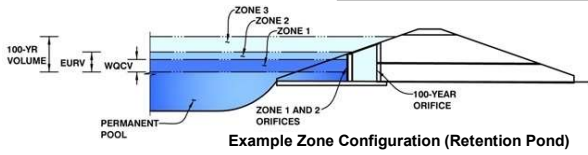

	Estimated Stage (ft)	Estimated Volume (ac-ft)	Outlet Type
Zone 1 (WQCV)	3.49	0.941	Orifice Plate
Zone 2			
Zone 3			
<b>Total (all zones)</b>		<b>0.941</b>	

**User Input: Orifice at Underdrain Outlet** (typically used to drain WQCV in a Filtration BMP)

**Calculated Parameters for Underdrain**

Underdrain Orifice Invert Depth = <input type="text" value=""/>	ft (distance below the filtration media surface)	Underdrain Orifice Area = <input type="text" value=""/>	ft <sup>2</sup>
Underdrain Orifice Diameter = <input type="text" value=""/>	inches	Underdrain Orifice Centroid = <input type="text" value=""/>	feet

**User Input: Orifice Plate with one or more orifices or Elliptical Slot Weir** (typically used to drain WQCV and/or EURV in a sedimentation BMP)

**Calculated Parameters for Plate**

Invert of Lowest Orifice = <input type="text" value="0.00"/>	ft (relative to basin bottom at Stage = 0 ft)	WQ Orifice Area per Row = <input type="text" value="1.670E-02"/>	ft <sup>2</sup>
Depth at top of Zone using Orifice Plate = <input type="text" value="3.41"/>	ft (relative to basin bottom at Stage = 0 ft)	Elliptical Half-Width = <input type="text" value="N/A"/>	feet
Orifice Plate: Orifice Vertical Spacing = <input type="text" value="N/A"/>	inches	Elliptical Slot Centroid = <input type="text" value="N/A"/>	feet
Orifice Plate: Orifice Area per Row = <input type="text" value="2.41"/>	sq. inches (diameter = 1-3/4 inches)	Elliptical Slot Area = <input type="text" value="N/A"/>	ft <sup>2</sup>

**User Input: Stage and Total Area of Each Orifice Row** (numbered from lowest to highest)

	Row 1 (required)	Row 2 (optional)	Row 3 (optional)	Row 4 (optional)	Row 5 (optional)	Row 6 (optional)	Row 7 (optional)	Row 8 (optional)
Stage of Orifice Centroid (ft)	0.00	1.14	2.27					
Orifice Area (sq. inches)	2.41	2.41	2.41					

	Row 9 (optional)	Row 10 (optional)	Row 11 (optional)	Row 12 (optional)	Row 13 (optional)	Row 14 (optional)	Row 15 (optional)	Row 16 (optional)
Stage of Orifice Centroid (ft)								
Orifice Area (sq. inches)								

**User Input: Vertical Orifice (Circular or Rectangular)**

**Calculated Parameters for Vertical Orifice**

Invert of Vertical Orifice = <input type="text" value="Not Selected"/>	<input type="text" value="Not Selected"/>	ft (relative to basin bottom at Stage = 0 ft)	Vertical Orifice Area = <input type="text" value="Not Selected"/>	ft <sup>2</sup>
Depth at top of Zone using Vertical Orifice = <input type="text" value="Not Selected"/>	<input type="text" value="Not Selected"/>	ft (relative to basin bottom at Stage = 0 ft)	Vertical Orifice Centroid = <input type="text" value="Not Selected"/>	feet
Vertical Orifice Diameter = <input type="text" value="Not Selected"/>	<input type="text" value="Not Selected"/>	inches		

**User Input: Overflow Weir (Dropbox with Flat or Sloped Grate and Outlet Pipe OR Rectangular/Trapezoidal Weir (and No Outlet Pipe))**

**Calculated Parameters for Overflow Weir**

Overflow Weir Front Edge Height, H <sub>o</sub> = <input type="text" value="3.50"/>	ft (relative to basin bottom at Stage = 0 ft)	Height of Grate Upper Edge, H <sub>t</sub> = <input type="text" value="3.50"/>	feet
Overflow Weir Front Edge Length = <input type="text" value="6.00"/>	feet	Overflow Weir Slope Length = <input type="text" value="6.00"/>	feet
Overflow Weir Grate Slope = <input type="text" value="0.00"/>	H:V	Grate Open Area / 100-yr Orifice Area = <input type="text" value="5.87"/>	
Horiz. Length of Weir Sides = <input type="text" value="6.00"/>	feet	Overflow Grate Open Area w/o Debris = <input type="text" value="28.80"/>	ft <sup>2</sup>
Overflow Grate Open Area % = <input type="text" value="80%"/>	%, grate open area/total area	Overflow Grate Open Area w/ Debris = <input type="text" value="14.40"/>	ft <sup>2</sup>
Debris Clogging % = <input type="text" value="50%"/>	%		

**User Input: Outlet Pipe w/ Flow Restriction Plate (Circular Orifice, Restrictor Plate, or Rectangular Orifice)**

**Calculated Parameters for Outlet Pipe w/ Flow Restriction Plate**

Depth to Invert of Outlet Pipe = <input type="text" value="2.50"/>	ft (distance below basin bottom at Stage = 0 ft)	Outlet Orifice Area = <input type="text" value="4.91"/>	ft <sup>2</sup>
Circular Orifice Diameter = <input type="text" value="30.00"/>	inches	Outlet Orifice Centroid = <input type="text" value="1.25"/>	feet
		Half-Central Angle of Restrictor Plate on Pipe = <input type="text" value="N/A"/>	radians

**User Input: Emergency Spillway (Rectangular or Trapezoidal)**

**Calculated Parameters for Spillway**

Spillway Invert Stage = <input type="text" value="4.90"/>	ft (relative to basin bottom at Stage = 0 ft)	Spillway Design Flow Depth = <input type="text" value="0.93"/>	feet
Spillway Crest Length = <input type="text" value="24.00"/>	feet	Stage at Top of Freeboard = <input type="text" value="5.83"/>	feet
Spillway End Slopes = <input type="text" value="4.00"/>	H:V	Basin Area at Top of Freeboard = <input type="text" value="0.85"/>	acres
Freeboard above Max Water Surface = <input type="text" value="0.00"/>	feet	Basin Volume at Top of Freeboard = <input type="text" value="2.65"/>	acre-ft

**Routed Hydrograph Results**

*The user can override the default CUHP hydrographs and runoff volumes by entering new values in the Inflow Hydrographs table (Columns W through AF).*

	WQCV	EURV	2 Year	5 Year	10 Year	25 Year	50 Year	100 Year	500 Year
Design Storm Return Period =									
One-Hour Rainfall Depth (in) =	N/A	N/A	1.19	1.50	1.75	2.00	2.25	2.52	3.68
CUHP Runoff Volume (acre-ft) =	0.941	2.412	1.746	2.380	2.898	4.083	5.199	6.686	12.916
Inflow Hydrograph Volume (acre-ft) =	N/A	N/A	1.746	2.380	2.898	4.083	5.199	6.686	12.916
CUHP Predevelopment Peak Q (cfs) =	N/A	N/A	0.4	0.8	1.1	10.5	21.0	35.0	91.0
OPTIONAL Override Predevelopment Peak Q (cfs) =	N/A	N/A							
Predevelopment Unit Peak Flow, q (cfs/acre) =	N/A	N/A	0.01	0.01	0.02	0.15	0.30	0.50	1.31
Peak Inflow Q (cfs) =	N/A	N/A	17.5	24.1	29.6	47.0	61.9	80.6	155.3
Peak Outflow Q (cfs) =	0.4	74.6	7.7	14.0	18.8	35.4	49.6	58.2	138.4
Ratio Peak Outflow to Predevelopment Q =	N/A	N/A	N/A	17.2	16.5	3.4	2.4	1.7	1.5
Structure Controlling Flow =	Plate	Spillway	Overflow Weir 1	Overflow Weir 1	Overflow Weir 1	Overflow Weir 1	Overflow Weir 1	Outlet Plate 1	Spillway
Max Velocity through Grate 1 (fps) =	N/A	2.12	0.26	0.5	0.6	1.2	1.7	2.0	2.2
Max Velocity through Grate 2 (fps) =	N/A	N/A	N/A	N/A	N/A	N/A	N/A	N/A	N/A
Time to Drain 97% of Inflow Volume (hours) =	46	45	48	47	45	43	40	37	26
Time to Drain 99% of Inflow Volume (hours) =	49	49	52	51	51	49	48	47	42
Maximum Ponding Depth (ft) =	3.49	5.55	3.75	3.88	3.96	4.20	4.38	4.82	5.85
Area at Maximum Ponding Depth (acres) =	0.57	0.83	0.59	0.61	0.62	0.67	0.70	0.78	0.85
Maximum Volume Stored (acre-ft) =	0.942	2.417	1.087	1.165	1.215	1.376	1.499	1.816	2.670

# DETENTION BASIN OUTLET STRUCTURE DESIGN

*MHFD-Detention, Version 4.00 (December 2019)*

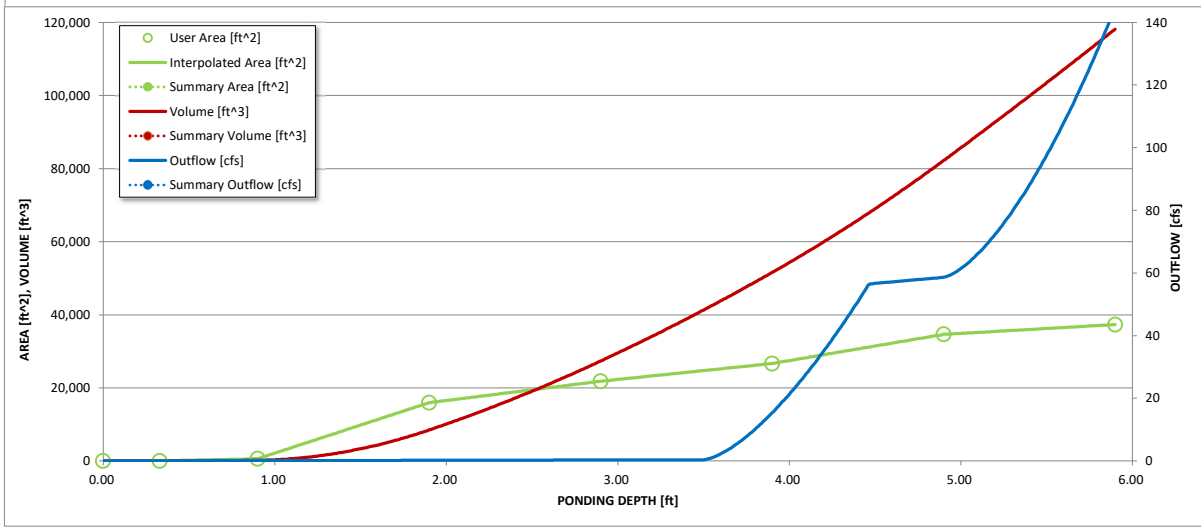
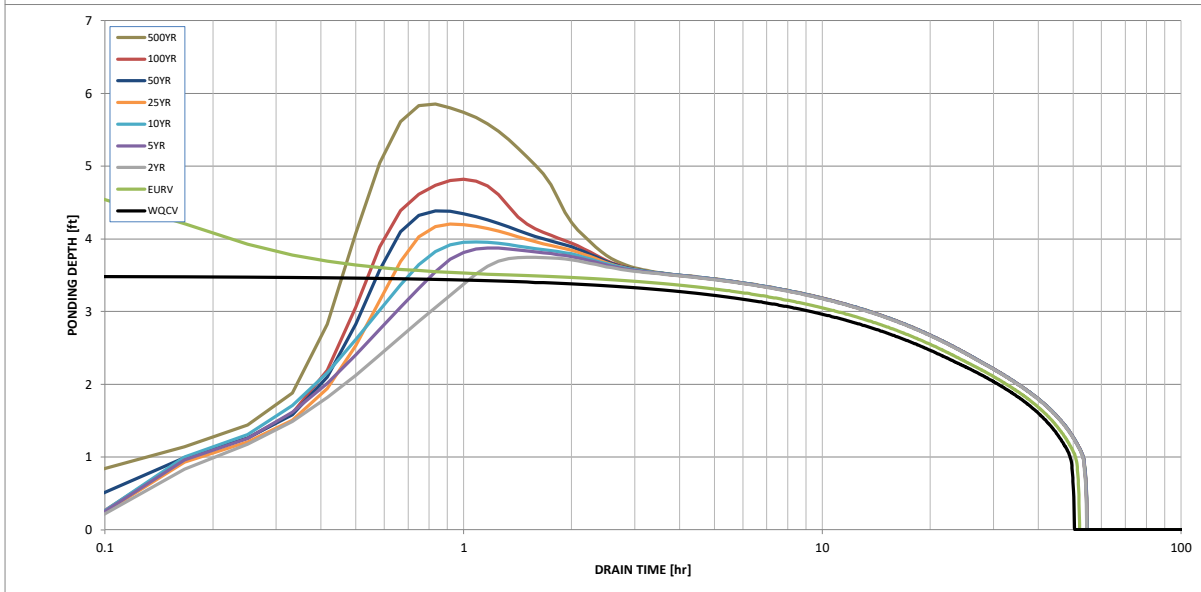
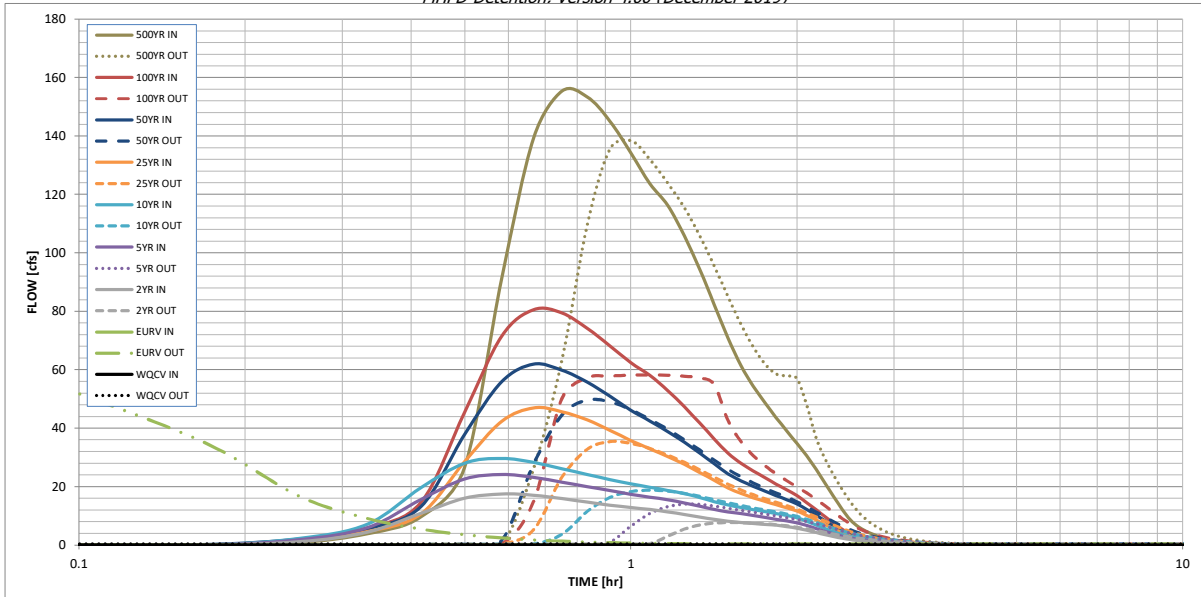

S-A-V-D Chart Axis Override	X-axis	Left Y-Axis	Right Y-Axis
minimum bound			
maximum bound			

# DETENTION BASIN OUTLET STRUCTURE DESIGN

Outflow Hydrograph Workbook Filename: \_\_\_\_\_

## Inflow Hydrographs

The user can override the calculated inflow hydrographs from this workbook with inflow hydrographs developed in a separate program.

Time Interval	SOURCE	CUHP	CUHP	CUHP	CUHP	CUHP	CUHP	CUHP	CUHP	CUHP
	TIME	WQCV [cfs]	EURV [cfs]	2 Year [cfs]	5 Year [cfs]	10 Year [cfs]	25 Year [cfs]	50 Year [cfs]	100 Year [cfs]	500 Year [cfs]
5.00 min	0:00:00	0.00	0.00	0.00	0.00	0.00	0.00	0.00	0.00	0.00
	0:05:00	0.00	0.00	0.00	0.00	0.00	0.00	0.00	0.00	0.00
	0:10:00	0.00	0.00	0.00	0.00	0.00	0.00	0.13	0.01	0.79
	0:15:00	0.00	0.00	1.10	1.78	2.24	1.53	1.98	1.90	3.87
	0:20:00	0.00	0.00	4.41	5.94	7.13	4.60	5.49	5.81	9.65
	0:25:00	0.00	0.00	10.85	15.61	19.66	10.61	13.20	14.60	26.52
	0:30:00	0.00	0.00	16.03	22.62	28.01	28.50	37.86	45.41	91.19
	0:35:00	0.00	0.00	17.45	24.13	29.62	42.31	55.85	71.47	139.37
	0:40:00	0.00	0.00	17.06	23.18	28.26	46.96	61.90	80.57	155.33
	0:45:00	0.00	0.00	15.88	21.50	26.13	45.64	59.83	79.44	153.41
	0:50:00	0.00	0.00	14.69	20.01	24.16	42.82	55.75	74.22	145.10
	0:55:00	0.00	0.00	13.67	18.61	22.38	39.29	50.94	68.18	134.29
	1:00:00	0.00	0.00	12.82	17.39	20.95	35.78	46.19	62.46	123.69
	1:05:00	0.00	0.00	12.15	16.40	19.79	32.95	42.45	58.03	116.21
	1:10:00	0.00	0.00	11.34	15.47	18.69	30.24	38.78	52.87	105.87
	1:15:00	0.00	0.00	10.44	14.41	17.59	27.59	35.17	47.37	94.37
	1:20:00	0.00	0.00	9.56	13.24	16.28	24.82	31.43	41.72	82.34
	1:25:00	0.00	0.00	8.77	12.14	14.83	22.13	27.81	36.28	70.90
	1:30:00	0.00	0.00	8.16	11.30	13.70	19.55	24.40	31.46	61.34
	1:35:00	0.00	0.00	7.73	10.73	12.86	17.64	21.98	27.98	54.33
	1:40:00	0.00	0.00	7.40	10.11	12.13	16.19	20.10	25.35	48.70
	1:45:00	0.00	0.00	7.08	9.45	11.45	14.94	18.47	23.02	43.67
	1:50:00	0.00	0.00	6.78	8.82	10.81	13.78	16.94	20.89	39.06
	1:55:00	0.00	0.00	6.29	8.21	10.13	12.70	15.50	18.86	34.70
	2:00:00	0.00	0.00	5.74	7.59	9.33	11.64	14.10	16.90	30.54
	2:05:00	0.00	0.00	5.02	6.67	8.14	10.16	12.21	14.52	25.86
	2:10:00	0.00	0.00	4.26	5.66	6.85	8.55	10.19	12.05	21.10
	2:15:00	0.00	0.00	3.54	4.68	5.61	6.98	8.23	9.64	16.49
	2:20:00	0.00	0.00	2.88	3.79	4.51	5.53	6.41	7.39	12.19
	2:25:00	0.00	0.00	2.30	3.02	3.58	4.23	4.78	5.35	8.56
	2:30:00	0.00	0.00	1.85	2.41	2.93	3.15	3.54	3.87	6.31
	2:35:00	0.00	0.00	1.52	2.00	2.46	2.46	2.76	2.94	4.79
	2:40:00	0.00	0.00	1.27	1.68	2.06	1.97	2.21	2.29	3.64
	2:45:00	0.00	0.00	1.06	1.40	1.72	1.60	1.78	1.79	2.75
	2:50:00	0.00	0.00	0.88	1.17	1.42	1.29	1.43	1.39	2.07
	2:55:00	0.00	0.00	0.73	0.96	1.17	1.05	1.15	1.08	1.54
	3:00:00	0.00	0.00	0.61	0.79	0.96	0.84	0.93	0.85	1.17
	3:05:00	0.00	0.00	0.50	0.65	0.79	0.69	0.76	0.69	0.95
	3:10:00	0.00	0.00	0.42	0.53	0.64	0.56	0.61	0.56	0.76
	3:15:00	0.00	0.00	0.34	0.43	0.51	0.45	0.49	0.45	0.61
	3:20:00	0.00	0.00	0.27	0.34	0.40	0.35	0.38	0.35	0.47
	3:25:00	0.00	0.00	0.21	0.26	0.31	0.27	0.29	0.27	0.35
	3:30:00	0.00	0.00	0.15	0.19	0.23	0.20	0.21	0.20	0.25
	3:35:00	0.00	0.00	0.11	0.14	0.16	0.14	0.15	0.13	0.16
	3:40:00	0.00	0.00	0.07	0.09	0.11	0.09	0.10	0.08	0.10
	3:45:00	0.00	0.00	0.04	0.06	0.06	0.05	0.05	0.05	0.05
	3:50:00	0.00	0.00	0.02	0.03	0.03	0.03	0.02	0.02	0.01
	3:55:00	0.00	0.00	0.01	0.01	0.01	0.01	0.01	0.00	0.00
	4:00:00	0.00	0.00	0.00	0.00	0.00	0.00	0.00	0.00	0.00
	4:05:00	0.00	0.00	0.00	0.00	0.00	0.00	0.00	0.00	0.00
	4:10:00	0.00	0.00	0.00	0.00	0.00	0.00	0.00	0.00	0.00
	4:15:00	0.00	0.00	0.00	0.00	0.00	0.00	0.00	0.00	0.00
	4:20:00	0.00	0.00	0.00	0.00	0.00	0.00	0.00	0.00	0.00
	4:25:00	0.00	0.00	0.00	0.00	0.00	0.00	0.00	0.00	0.00
	4:30:00	0.00	0.00	0.00	0.00	0.00	0.00	0.00	0.00	0.00
	4:35:00	0.00	0.00	0.00	0.00	0.00	0.00	0.00	0.00	0.00
	4:40:00	0.00	0.00	0.00	0.00	0.00	0.00	0.00	0.00	0.00
	4:45:00	0.00	0.00	0.00	0.00	0.00	0.00	0.00	0.00	0.00
	4:50:00	0.00	0.00	0.00	0.00	0.00	0.00	0.00	0.00	0.00
	4:55:00	0.00	0.00	0.00	0.00	0.00	0.00	0.00	0.00	0.00
	5:00:00	0.00	0.00	0.00	0.00	0.00	0.00	0.00	0.00	0.00
	5:05:00	0.00	0.00	0.00	0.00	0.00	0.00	0.00	0.00	0.00
	5:10:00	0.00	0.00	0.00	0.00	0.00	0.00	0.00	0.00	0.00
	5:15:00	0.00	0.00	0.00	0.00	0.00	0.00	0.00	0.00	0.00
	5:20:00	0.00	0.00	0.00	0.00	0.00	0.00	0.00	0.00	0.00
	5:25:00	0.00	0.00	0.00	0.00	0.00	0.00	0.00	0.00	0.00
	5:30:00	0.00	0.00	0.00	0.00	0.00	0.00	0.00	0.00	0.00
	5:35:00	0.00	0.00	0.00	0.00	0.00	0.00	0.00	0.00	0.00
	5:40:00	0.00	0.00	0.00	0.00	0.00	0.00	0.00	0.00	0.00
	5:45:00	0.00	0.00	0.00	0.00	0.00	0.00	0.00	0.00	0.00
	5:50:00	0.00	0.00	0.00	0.00	0.00	0.00	0.00	0.00	0.00
	5:55:00	0.00	0.00	0.00	0.00	0.00	0.00	0.00	0.00	0.00
	6:00:00	0.00	0.00	0.00	0.00	0.00	0.00	0.00	0.00	0.00





## Site-Level Low Impact Development (LID) Design Effective Impervious Calculator

### LID Credit by Impervious Reduction Factor (IRF) Method

UD-BMP (Version 3.06, November 2016)

User Input			
Calculated cells			
***Design Storm: 1-Hour Rain Depth	WQCV Event	0.60	inches
***Minor Storm: 1-Hour Rain Depth	5-Year Event	1.50	inches
***Major Storm: 1-Hour Rain Depth	100-Year Event	2.52	inches
Optional User Defined Storm	CUHP		
(CUHP) NOAA 1 Hour Rainfall Depth and Frequency for User Defined Storm	100-Year Event		
Max Intensity for Optional User Defined Storm		0	

**Designer:** TJE  
**Company:** Galloway & Company  
**Date:** June 29, 2022  
**Project:** Falcon Meadows at Bent Grass Filing No. 4  
**Location:** Falcon, CO

**SITE INFORMATION (USER-INPUT)**

<b>Sub-basin Identifier</b>	A-2												
Receiving Pervious Area Soil Type	Loamy Sand												
Total Area (ac., Sum of DCIA, UIA, RPA, & SPA)	0.710												
Directly Connected Impervious Area (DCIA, acres)	0.000												
Unconnected Impervious Area (UIA, acres)	0.090												
Receiving Pervious Area (RPA, acres)	0.620												
Separate Pervious Area (SPA, acres)	0.000												
RPA Treatment Type: Conveyance (C), Volume (V), or Permeable Pavement (PP)	C												

**CALCULATED RESULTS (OUTPUT)**

Total Calculated Area (ac, check against input)	0.710												
Directly Connected Impervious Area (DCIA, %)	0.0%												
Unconnected Impervious Area (UIA, %)	12.7%												
Receiving Pervious Area (RPA, %)	87.3%												
Separate Pervious Area (SPA, %)	0.0%												
$A_p$ (RPA / UIA)	6.889												
$I_p$ Check	0.130												
$f / I$ for WQCV Event:	3.2												
$f / I$ for 5-Year Event:	0.5												
$f / I$ for 100-Year Event:	0.4												
<b><math>f / I</math> for Optional User Defined Storm CUHP:</b>													
IRF for WQCV Event:	0.28												
IRF for 5-Year Event:	0.54												
IRF for 100-Year Event:	0.56												
<b>IRF for Optional User Defined Storm CUHP:</b>													
Total Site Imperviousness: $I_{total}$	12.7%												
Effective Imperviousness for WQCV Event:	3.6%												
Effective Imperviousness for 5-Year Event:	6.9%												
Effective Imperviousness for 100-Year Event:	7.1%												
<b>Effective Imperviousness for Optional User Defined Storm CUHP:</b>													

**LID / EFFECTIVE IMPERVIOUSNESS CREDITS**

WQCV Event CREDIT: Reduce Detention By:	67.8%	N/A	N/A	N/A	N/A	N/A	N/A	N/A	N/A	N/A	N/A	N/A	N/A	N/A	N/A
This line only for 10-Year Event	N/A	N/A	N/A	N/A	N/A	N/A	N/A	N/A	N/A	N/A	N/A	N/A	N/A	N/A	N/A
100-Year Event CREDIT**:	51.7%	N/A	N/A	N/A	N/A	N/A	N/A	N/A	N/A	N/A	N/A	N/A	N/A	N/A	N/A
<b>User Defined CUHP CREDIT: Reduce Detention By:</b>															

<b>Total Site Imperviousness:</b>	<b>12.7%</b>
<b>Total Site Effective Imperviousness for WQCV Event:</b>	<b>3.6%</b>
<b>Total Site Effective Imperviousness for 5-Year Event:</b>	<b>6.9%</b>
<b>Total Site Effective Imperviousness for 100-Year Event:</b>	<b>7.1%</b>
<b>Total Site Effective Imperviousness for Optional User Defined Storm CUHP:</b>	

Notes:

- \* Use Green-Ampt average infiltration rate values from Table 3-3.
- \*\* Flood control detention volume credits based on empirical equations from Storage Chapter of USDCM.
- \*\*\* Method assumes that 1-hour rainfall depth is equivalent to 1-hour intensity for calculation purposes

## **APPENDIX F**

**Drainage Maps (Refer to Appendix B for Existing Drainage Maps)**



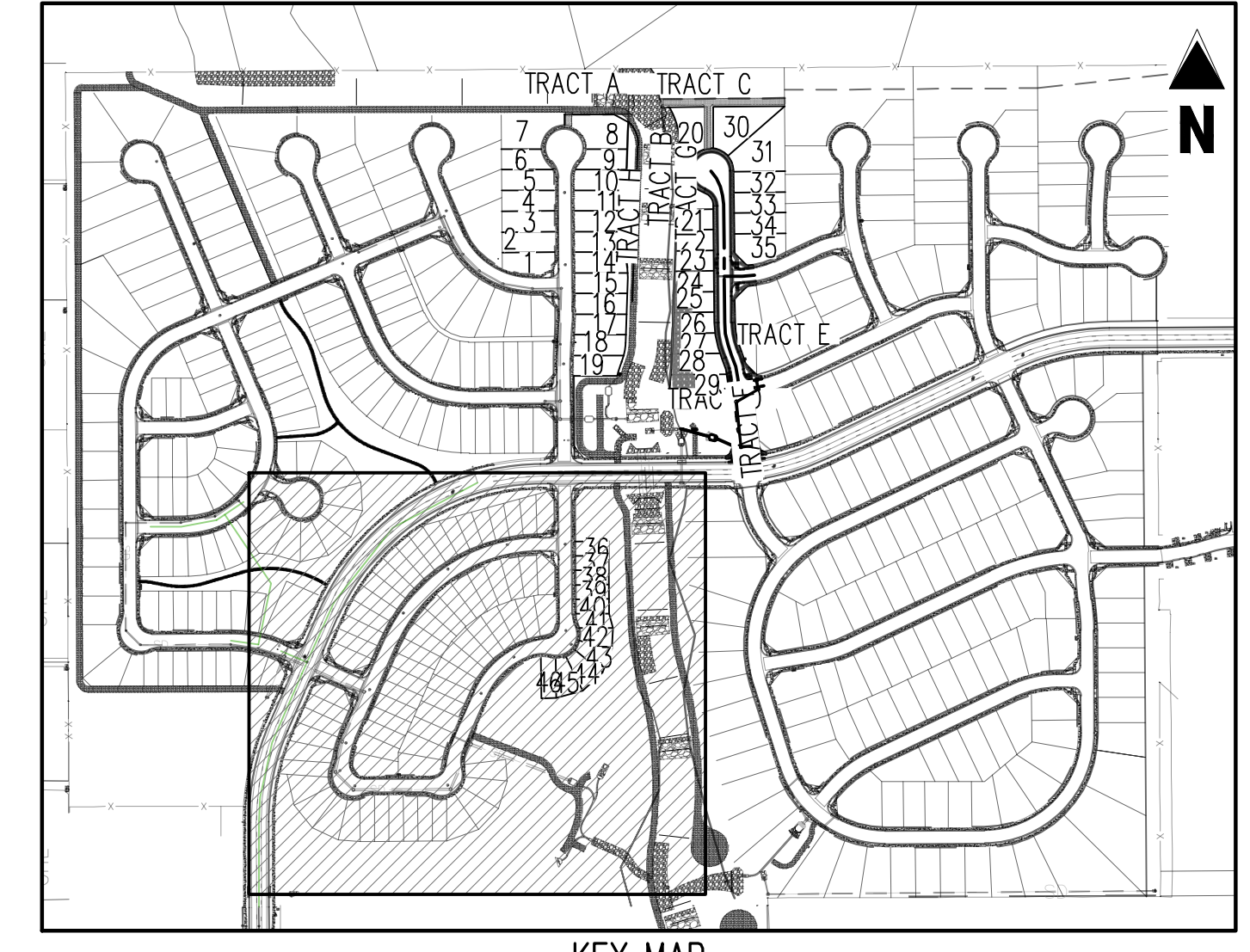
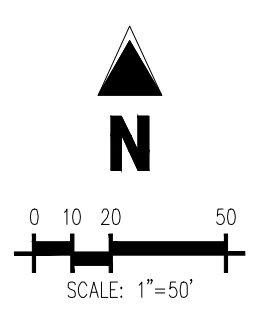
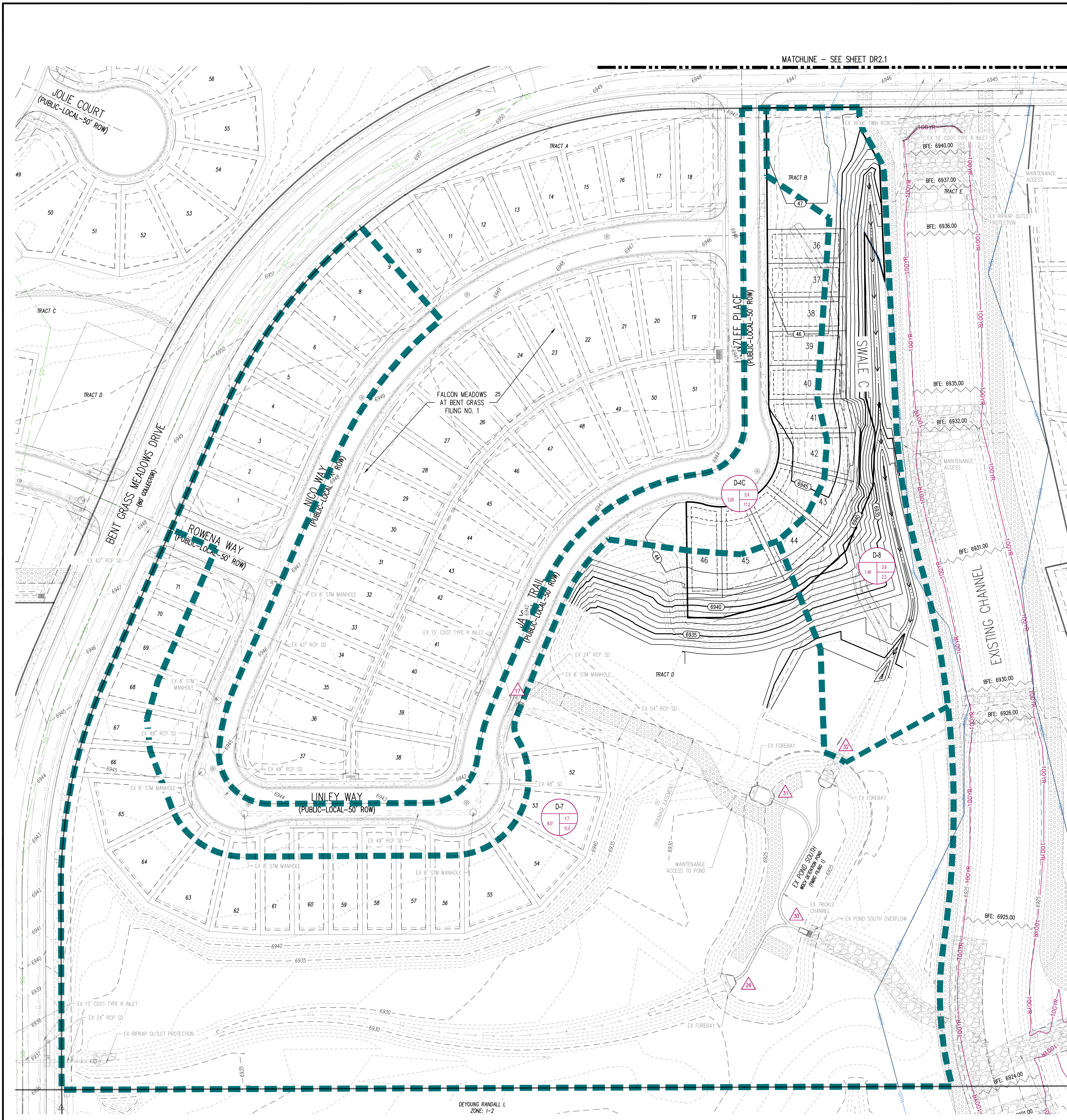

**DRAINAGE LEGEND**

- PROPERTY LINE
- - - - - EXISTING MAJOR CONTOUR
- - - - - EXISTING MINOR CONTOUR
- PROPOSED MAJOR CONTOUR
- - - - - PROPOSED MINOR CONTOUR
- BASIN BOUNDARY LINE
- FEMA EFFECTIVE 100-YR FLOODPLAIN
- 100-YR FLOODPLAIN PER MATRIX DBPS
- CENTERLINE OF STREAM
- EXISTING RIPRAP
- EXISTING ACCESS
- PROPOSED RIPRAP
- PROPOSED ACCESS
- BASIN DESIGNATION
- 5-YEAR RUNOFF IN CUBIC FEET PER SECOND
- 100-YEAR RUNOFF IN CUBIC FEET PER SECOND
- BASIN AREA IN ACRES
- DESIGN POINT

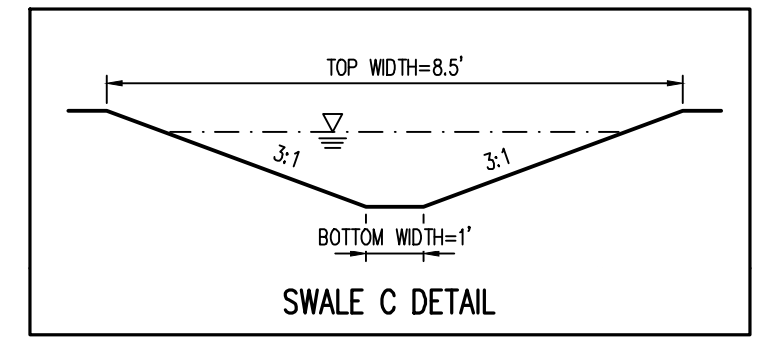

**DESIGN POINT TABLE**

Design Point	Q <sub>s</sub> (cfs)	Q <sub>100</sub> (cfs)
1	1.2	2.5
2	7.8	16.2
3	2.2	4.6
4	10.5	24.2
4a	0.9	8.9
4b	12.9	19.7
5 (inlet)	2.2	4.4
5 (Pipe)	14.7	23.6
5a	0.0	0.1
6	14.8	32.4
8	0.9	9.0
12	4.1	7.8
13	5.4	11.5
17	5.4	11.2
19	1.7	4.0
30	52.6	149.2
31	42.4	112.6
32	0.6	2.3
AA	191.8	1075.3

**BASIN SUMMARY TABLE**

Tributary Sub-basin	Area (acres)	C <sub>s</sub>	C <sub>100</sub>	t <sub>c</sub> (min)	Q <sub>s</sub> (cfs)	Q <sub>100</sub> (cfs)
OS-4	4.48	0.50	0.62	15.61	7.8	16.1
OS-5	0.46	0.50	0.62	5.00	1.2	2.5
OS-6	1.17	0.50	0.62	12.86	2.2	4.6
A-1	2.18	0.50	0.62	10.22	4.5	9.3
A-2	0.92	0.50	0.62	7.24	2.1	4.4
A-3	1.13	0.50	0.62	12.59	2.1	4.4
A-4	0.54	0.01	0.13	5.00	0.0	0.6
B-1	4.33	0.01	0.13	21.61	0.1	2.8
C-1E	0.49	0.86	0.89	5.00	2.2	3.8
C-1G	0.87	0.50	0.62	6.75	2.1	4.3
C-5	0.51	0.01	0.13	5.00	0.0	0.6
C-1H	1.12	0.35	0.49	8.94	1.7	4.0
D-4C	3.00	0.50	0.62	14.22	5.4	11.2
D-7	8.01	0.05	0.21	14.81	1.7	10.0
D-8	1.46	0.11	0.26	14.03	0.6	2.3

#	Date	Issue / Description	Init.

Project No: CLH021  
Drawn By: TJE  
Checked By: BAS  
Date: JULY 1, 2022

**PROPOSED DRAINAGE MAP**

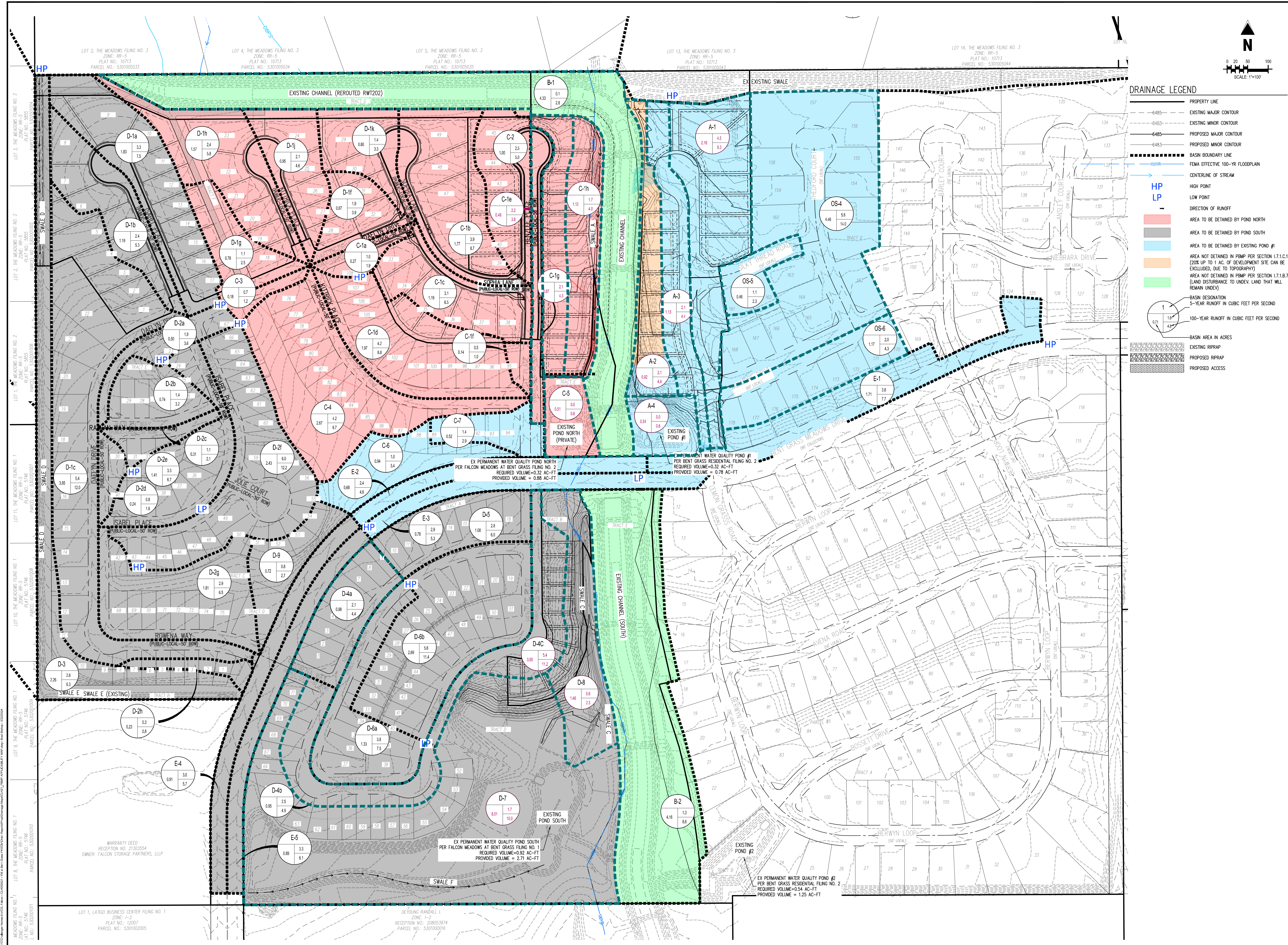

**DRAINAGE LEGEND**

- PROPERTY LINE
- - - 6485 EXISTING MAJOR CONTOUR
- - - 6483 EXISTING MINOR CONTOUR
- - - 6485 PROPOSED MAJOR CONTOUR
- - - 6483 PROPOSED MINOR CONTOUR
- - - BASIN BOUNDARY LINE
- FEMA EFFECTIVE 100-YR FLOODPLAIN
- CENTERLINE OF STREAM
- HP HIGH POINT
- LP LOW POINT
- DIRECTION OF RUNOFF
- AREA TO BE DETAINED BY POND NORTH
- AREA TO BE DETAINED BY POND SOUTH
- AREA TO BE DETAINED BY EXISTING POND #1
- AREA NOT DETAINED IN PMP PER SECTION 17.1.1, C.1 (20% UP TO 1 AC. OF DEVELOPMENT SITE CAN BE EXCLUDED, DUE TO TOPOGRAPHY)
- AREA NOT DETAINED IN PMP PER SECTION 17.1.1, B.7 (LAND DISTURBANCE TO UNDEV. LAND THAT WILL REMAIN UNDER)
- BASIN DESIGNATION
- 5-YEAR RUNOFF IN CUBIC FEET PER SECOND
- 100-YEAR RUNOFF IN CUBIC FEET PER SECOND
- BASIN AREA IN ACRES
- ▨ EXISTING RIPRAP
- ▨ PROPOSED RIPRAP
- ▨ PROPOSED ACCESS

#	Date	Issue / Description	Init.

Project No: CLH00021  
 Drawn By: BAS  
 Checked By: RGD  
 Date: 07/01/2022  
**WQ PLAN**