

**DRAINAGE LEGEND**

- PROPERTY LINE
- - - - - EXISTING MAJOR CONTOUR
- - - - - EXISTING MINOR CONTOUR
- — — — PROPOSED MAJOR CONTOUR
- - - - - PROPOSED MINOR CONTOUR
- — — — BASIN BOUNDARY LINE
- FEMA EFFECTIVE 100-YR FLOODPLAIN
- 100-YR FLOODPLAIN PER MATRIX DBPS
- CENTERLINE OF STREAM
- EXISTING RIPRAP
- EXISTING ACCESS
- PROPOSED RIPRAP
- PROPOSED ACCESS
- BASIN DESIGNATION
- 5-YEAR RUNOFF IN CUBIC FEET PER SECOND
- 100-YEAR RUNOFF IN CUBIC FEET PER SECOND
- BASIN AREA IN ACRES
- DESIGN POINT

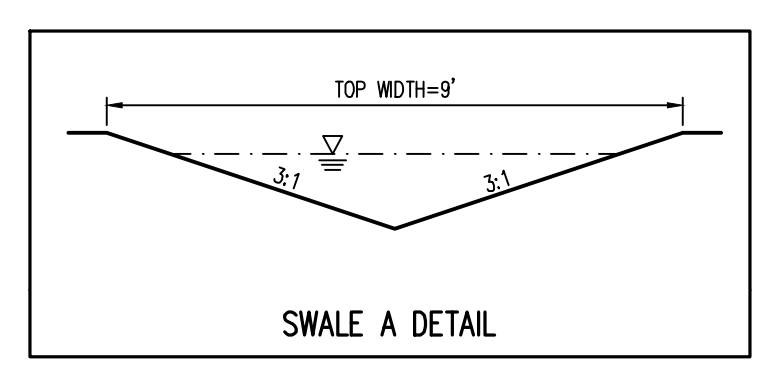

DESIGN POINT TABLE		
Design Point	Q <sub>s</sub> (cfs)	Q <sub>100</sub> (cfs)
1	7.7	16.1
2	1.2	2.5
3	2.2	4.6
4	14.4	29.9
4a	2.8	12.9
5	2.2	4.5
5a	-0.0	0.2
6	16.3	34.5
8	2.8	13.1
12	4.1	7.8
13	5.4	11.5
17	5.4	11.2
19	1.7	4.0
26	7.9	24.3
30	52.6	149.2
31	42.4	112.6
32	0.6	2.3
AA	191.8	1075.3

BASIN SUMMARY TABLE						
Tributary Sub-basin	Area (acres)	C <sub>s</sub>	C <sub>100</sub>	t <sub>c</sub> (min)	Q <sub>s</sub> (cfs)	Q <sub>100</sub> (cfs)
OS-4	4.46	0.50	0.62	15.61	7.7	16.1
OS-5	0.46	0.50	0.62	5.00	1.2	2.5
OS-6	1.17	0.50	0.62	12.86	2.2	4.6
A-1	2.19	0.50	0.62	10.95	4.4	9.1
A-2	0.71	0.50	0.62	5.00	1.8	3.8
A-3	1.08	0.50	0.62	10.63	2.2	4.5
A-4	0.81	0.01	0.13	5.00	0.0	0.9
B-1	4.32	0.01	0.13	21.61	0.1	2.8
C-1E	0.49	0.86	0.89	5.00	2.2	3.8
C-1G	0.87	0.50	0.62	6.75	2.1	4.3
C-5	0.51	0.01	0.13	5.00	0.0	0.6
C-1H	1.12	0.35	0.49	8.94	1.7	4.0
D-4C	3.00	0.50	0.62	14.22	5.4	11.2
D-7	8.01	0.06	0.21	14.81	1.7	10.0
D-8	1.46	0.11	0.26	14.03	0.6	2.3

**COPYRIGHT**  
 THESE PLANS ARE AN INSTRUMENT OF SERVICE AND ARE THE PROPERTY OF GALLOWAY, AND MAY NOT BE DUPLICATED, DISCLOSED, OR REPRODUCED WITHOUT THE WRITTEN CONSENT OF GALLOWAY. COPYRIGHTS AND INFRINGEMENTS WILL BE ENFORCED AND PROSECUTED.

**FINAL DRAINAGE REPORT  
 FALCON MEADOWS AT BENT GRASS FILING NO. 4  
 FOR  
 CHALLENGER COMMUNITIES, LLC  
 BENT GRASS MEADOWS DRIVE  
 FALCON, CO 80831 - EL PASO COUNTY**

#	Date	Issue / Description	Init.

Project No: CLH021  
 Drawn By: TJE  
 Checked By: BAS  
 Date: JULY 1, 2022

**PROPOSED DRAINAGE MAP**