

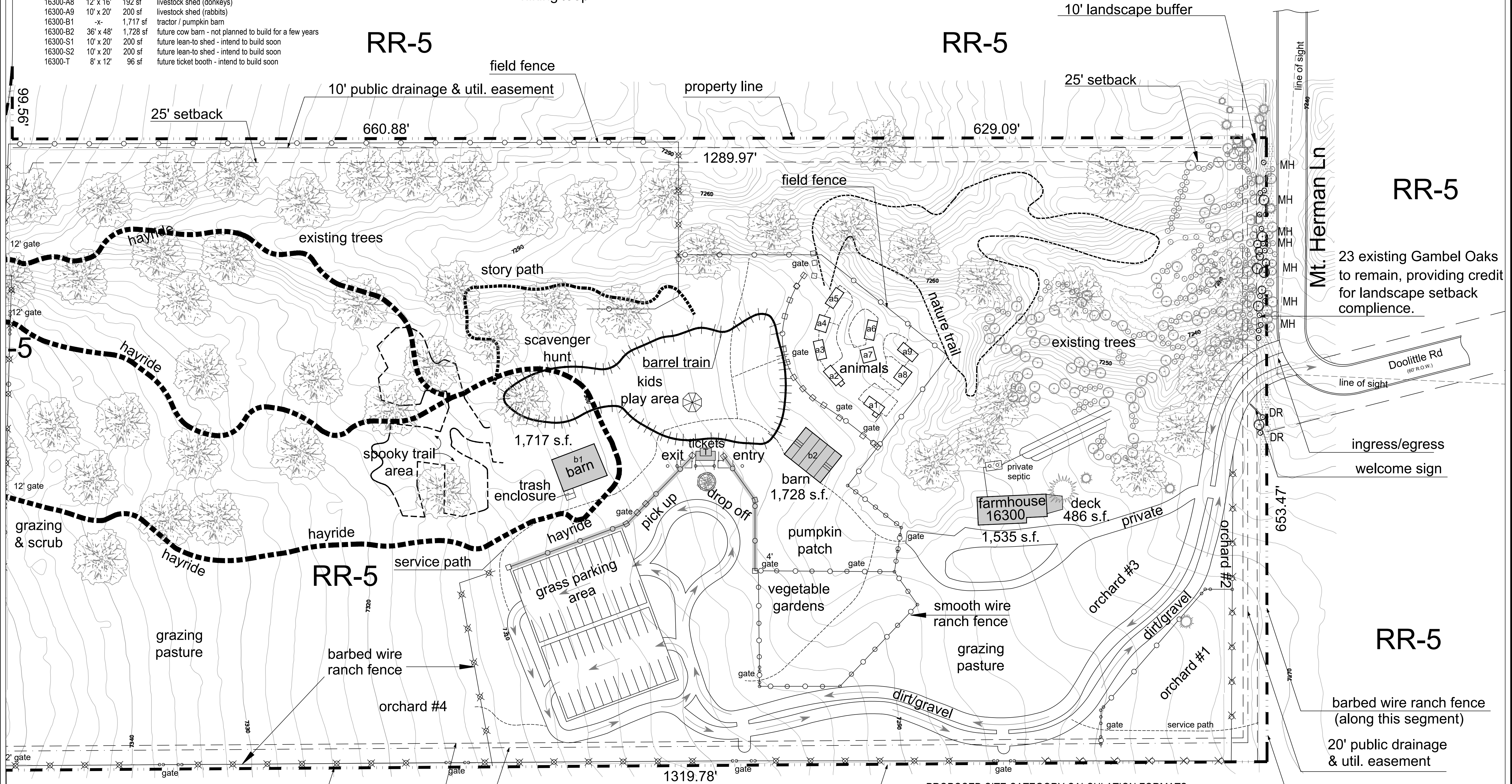

BUILDING	SIZE	AREA	DESCRIPTION
16300	30' x 51'	1,535 sf	farmhouse
16300-A1	10' x 20'	200 sf	livestock shed / pigs
16300-A2	10' x 20'	200 sf	livestock shed / hay storage
16300-A3	10' x 20'	200 sf	livestock shed (goats)
16300-A4	12' x 16'	192 sf	livestock shed (sheep)
16300-A5	10' x 20'	200 sf	livestock shed (mini cows)
16300-A6	10' x 20'	200 sf	livestock shed (tortoise/reptile)
16300-A7	14' x 14'	196 sf	livestock shed / calving shed / vet/prep
16300-A8	12' x 16'	192 sf	livestock shed (donkeys)
16300-A9	10' x 20'	200 sf	livestock shed (rabbits)
16300-B1	-	1,717 sf	tractor / pumpkin barn
16300-B2	36' x 48'	1,728 sf	future cow barn - not planned to build for a few years
16300-S1	10' x 20'	200 sf	future lean-to shed - intend to build soon
16300-S2	10' x 20'	200 sf	future lean-to shed - intend to build soon
16300-T	8' x 12'	96 sf	future ticket booth - intend to build soon

# LEGEND

- hayride
- barrel train
- hiking loop
- story path
- nature trail
- spooky trail
- setback
- property line
- easement line
- service path
- barbed wire ranch fence
- field fence
- boxed field fence
- semi-opaque wind fence
- smooth wire ranch fence



RR-5  
 23 existing Gambel Oaks to remain, providing credit for landscape setback compliance.

**William Guman & Associates, Ltd.**  
 LANDSCAPE ARCHITECTURE  
 731 North Weber Street  
 Colorado Springs, CO 80903  
 (719) 633-9700  
 www.gumanltd.com  
 bill@gumanltd.com

THIS DRAWING IS AN INSTRUMENT OF SERVICE AND AS SUCH REMAINS THE EXCLUSIVE PROPERTY OF WILLIAM GUMAN & ASSOCIATES, LTD. ANY REPRODUCTION OR UNAUTHORIZED USE OF THIS DRAWING WITHOUT PRIOR WRITTEN PERMISSION IS PROHIBITED. FIELD CHANGES MADE WITHOUT PRIOR APPROVAL BY REVIEWING AGENCY OF THE RECORD DRAWING WILL RESULT IN DELAY OF FINAL ACCEPTANCE AND/OR ISSUANCE OF CERTIFICATE OF OCCUPANCY WHERE APPLICABLE.

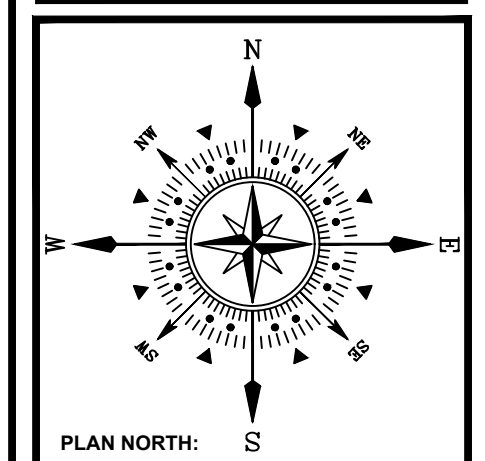

**FALL MOUNTAIN FARM**  
**16300 MOUNT HERMAN LANE**  
**MONUMENT, CO 80132**  
 PRELIMINARY LANDSCAPE PLAN

DATE: 07/29/2022  
 DESIGNED: GEM  
 CHECKED: WFG

REVISIONS:	DATE:	BY:	DESCRIPTION:
R1	11/18/2022	GEM	RESPOND TO INITIAL COMMENTS

NOTES:

PLAN SCALE: 1" = 50' (OR AS NOTED ON PLAN)

SHEET TITLE:  
**LANDSCAPE PLAN**

SHEET NO.  
**2**  
 2 OF 3 SHEETS

FILE NO.  
 PCD FILE# PPR 2246

### PROPOSED SITE CATEGORY CALCULATION FORMATS

LANDSCAPE SETBACKS (or Double Frontage Lot Streetscapes)

Street Name or Zone Boundary (elev.)	Street Classification	Width (in ft.) Req./Prov.	Linear Footage	Tree/Foot Required	No. of Trees Req./Prov.
Mount Herman Lane	Non Arterial	10' / 10'	209'	1 / 30'	7 / 7'
Doolittle Road	Non Arterial	10' / 10'	39'	1 / 30'	2 / 2'

\* Credit is sought for the existing trees along the east perimeter of the site. The existing Gambel Oaks within the setback exceed trees required.

Shrub Substitutes Req./Prov.	Ornamental Grass Substitutes Req./Prov.	Setback Plant Abbr. Denoted on Plan	Percent Ground Plane Veg. Req./Prov.
n/a	n/a	MH	75% / 75%
n/a	n/a	DR	75% / 75%

Street Name or Property Line	Width (in ft.) Req./Prov.	Linear Footage	Buffer Trees (120') Required / Provided	Evergreen Trees Req. (50%) / Provided
n/a	n/a	n/a	n/a	n/a

**NOTE: DUE TO LIMITED WATER AVAILABLE ON SITE, ANY PROPOSED LANDSCAPE MATERIAL WILL BE ESTABLISHED VIA HAND WATERING.**

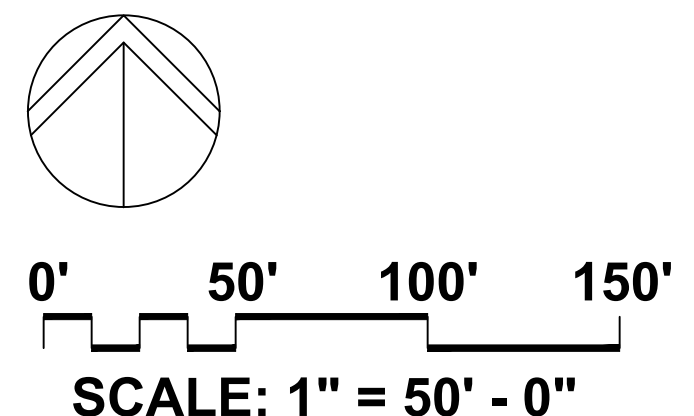

**LANDSCAPE SCHEDULE (Outlying Areas):**  
Planting Schedule:

QTY.	SYM.	KEY	DROUGHT (TOLERANT / DEER RESISTANT)	BOTANICAL/COMMON NAME	MATURE HT./WD.	PLANTING SIZE	NOTES

Percent Signature Trees\*\* (60% minimum - Policy 311.3.K) Signature Trees: 9 Total No. of Trees: 9 = 100% Signature Trees

QTY.	SYM.	KEY	DROUGHT (TOLERANT / DEER RESISTANT)	BOTANICAL/COMMON NAME	MATURE HT./WD.	PLANTING SIZE	NOTES

Percent Signature Shrubs\*\* (60% minimum - Policy 311.3.K) Signature Shrubs: 468 Total No. of Shrubs: 585 = 80% Signature Shrubs

QTY.	SYM.	KEY	DROUGHT (TOLERANT / DEER RESISTANT)	BOTANICAL/COMMON NAME	MATURE HT./WD.	PLANTING SIZE	NOTES

Percent Signature Grasses\*\* (60% minimum - Policy 311.3.K) Signature Grasses: 468 Total No. of Grasses: 585 = 80% Signature Grasses

SYMBOL	DESCRIPTION/REMARKS
	STEEL MAINTENANCE EDGE; 3/16" x 4" ROLL TOP STEEL, GREEN COLOR
	IDaho CEDAR WOOD MULCH: UNIFORMLY PLACED TO A 4" DEPTH AROUND ALL TREE ROOT BALLS IN TURF AREAS ONLY [Equal to that supplied by Pioneer Sand and Gravel, Colorado Springs, CO] Area: 255 square feet.
	SEEDED TURF (El Paso County All Purpose Low Grow Mix for Upland and Transition Areas): [25% BUFFALOGRASS, 20% BLUE GRAMA, 29% SIDEOATS GRAMA, 5% GREEN NEEDLEGRASS, 20% WESTERN WHEATGRASS, 1% SAND DROPSSEED] Seed rate (lbs PLS/acre) : 42 irrigated broadcast or irrigated hydroseeded. Area: 3,116 square feet.
	SEEDED TURF (El Paso County Conservation District All Purpose Mix for Upland, Transition and Permanent Control Measure Areas): [20% BIG BLUESTEM, 10% BLUE GRAMA, 10% GREEN NEEDLEGRASS, 20% WESTERN WHEATGRASS, 10% SIDEOATS GRAMA, 10% SWITCHGRASS, 10% PRAIRIE SAND REED, 10% YELLOW INDIAN GRASS] Seed rate (lbs PLS/acre) : 19.3 irrigated broadcast or irrigated hydroseeded.
	ORGANIC MULCH TYPE 'A': 'DECO SHRED' BARK MULCH, PLACED TO A UNIFORM 3" DEPTH ON FABRIC UNDERLAYMENT [Equal to that supplied by Pioneer Sand and Gravel, Colorado Springs, CO]
	NEW SOD: FESCUE/HTN KENTUCKY BLUEGRASS 4-WAY BLEND ON PREPARED SOIL.
	AGGREGATE 'A': 1-1/2" SIZE WHOLE WASHED WHITE RIVER ROCK PLACED TO A UNIFORM DEPTH OF 3" ON FABRIC UNDERLAYMENT. [Equal to that supplied by Pioneer Sand and Gravel, Colorado Springs, CO]
	AGGREGATE 'B': 1-1/2" SIZE WHOLE WASHED WHITE RIVER ROCK PLACED TO A UNIFORM DEPTH OF 3" ON FABRIC UNDERLAYMENT. [Equal to that supplied by Pioneer Sand and Gravel, Colorado Springs, CO]
	LOW CEDAR PEDESTRIAN SAFETY FENCE (Per Detail)

\*PLANTED\* BOULDERS: Equal to Sileam quarried boulders (Canon City, CO), avg. 3' width, set in grade w/ 18-24" ht. exposed above grade (Per Detail).

**LANDSCAPE NOTES:**

- REFER TO SPECIFICATION SECTION 32-94-00: LANDSCAPE ACCESSORIES FOR REQUIRED INSTALLATION AND WORKMANSHIP STANDARDS FOR NEW LANDSCAPING. IN THE EVENT OF A CONFLICT WITH THE MOST STRINGENT INTERPRETATION WILL PREVAIL.
- DRAWINGS ARE DIAGRAMMATIC; PRECISE PLACEMENT OF LANDSCAPE ACCESSORIES MAY NOT BE POSSIBLE AS INDICATED. CONSULT PROJECT LANDSCAPE ARCHITECT PRIOR TO MAKING RANDOM FIELD CHANGES WHICH MAY ALTER DESIGN INTENT.
- QUANTITIES ARE PROVIDED FOR REFERENCE ONLY. VERIFY ALL QUANTITIES PRIOR TO SUBMITTING COST PROPOSAL. IN THE EVENT OF A CONFLICT BETWEEN SCHEDULED, IMPLIED OR EXPRESSED QUANTITIES, QUANTITIES WHICH CAN BE DETERMINED GRAPHICALLY FROM THE DRAWINGS WILL PREVAIL IN ANY CASE.
- THE CONTRACTOR IS RESPONSIBLE FOR INSPECTION AND VERIFICATION OF ALL FIELD CONDITIONS AND RESOLVING CONFLICTS PERTAINING TO DIMENSIONS, LAYOUT, ETC., WHICH MAY AFFECT THE LANDSCAPE INSTALLATION. MOBILIZING SHALL BE CONSTRUED AS ACCEPTANCE OF CONDITIONS.
- COORDINATE ALL WORK INDICATED ON THESE DRAWINGS WITH WORK OF OTHER TRADES.
- THE PROJECT LANDSCAPE ARCHITECT RESERVES THE RIGHT TO CONSIDER AND APPROVE ALTERNATE INSTALLATIONS AT ANY TIME WHICH IN THE LANDSCAPE ARCHITECT'S OPINION MAXIMIZES THE CONSTRUCTION BUDGET AND MAINTAINS DESIGN INTENT.
- PROVIDE A 3 FOOT CLEAR SPACE AROUND THE CIRCUMFERENCE AROUND ALL FIRE HYDRANTS AND LIGHTING STANDARDS.
- CONTRACTOR TO UTILIZE STOCKPILED TOPSOIL FROM GRADING OPERATION AS MAY BE AVAILABLE. IF THE AMOUNT OF TOPSOIL NEEDED TO COMPLETE FINAL GRADING IS NOT AVAILABLE, THE CONTRACTOR SHALL IMPORT THE AMOUNT OF SOIL NEEDED.
- CONTRACTOR SHALL ENSURE THAT PROPER IRRIGATION VIA THE IRRIGATION SYSTEM IS CAPABLE OF EXTENDING AMOUNT OF WATER REQUIRED TO ESTABLISH AND SUSTAIN PLANT GROWTH AT THE TIME OF INSTALLATION.
- ALL LANDSCAPE AND IRRIGATION MAINTENANCE SHALL BE COMMENCED BY THE OWNER UPON COMPLETION AND FINAL ACCEPTANCE OF ALL LANDSCAPE AND IRRIGATION SYSTEM INSTALLATIONS.
- SOIL AMENDMENT AND FINAL GRADING FOR ALL SOD AND SEEDED TURF AREAS TO BE PROVIDED IN ACCORDANCE WITH SPECIFICATIONS.
- AN AUTOMATIC UNDERGROUND IRRIGATION SYSTEM IS TO BE PROVIDED AND INSTALLED IN ACCORDANCE WITH THE IRRIGATION SYSTEM DRAWING AND SPECIFICATIONS:
  - IN LANDSCAPE SETBACK AREAS ALONG ROAD FRONTAGES; IN-LINE DRIP EMITTER RINGS FOR ALL TREES
  - NEW SODDED TURF INTERIOR LANDSCAPE AREAS; 20' ROTOR SPRINKLERS AND POP-UP SPRAY SPRINKLERS
  - NEW SEEDED TURF AREAS; 30' ROTOR SPRINKLERS AND POP-UP SPRAY SPRINKLERS SHRUBS AND TREES; IN-LINE DRIP EMITTER RINGS FOR ALL TREES, EMITTERS FOR ALL SHRUBS
- 4"x14 GAUGE GALVANIZED STEEL MAINTENANCE EDGING TO BE INSTALLED TO SEPARATE ALL ORGANIC AND AGGREGATE MULCHES FROM ADJACENT SOD AND SEEDED TURF AREAS. PIN EDGING WITH 12" STEEL EDGING PINS AT 24" SPACING.
- ALL PLANT MATERIAL TO BE INSTALLED PER DETAILS AND SPECIFICATIONS. GUY AND STAKE ALL DECIDUOUS AND EVERGREEN TREES PER DETAILS. PROVIDE SHREDDED MULCH RINGS IN RETENTION BASINS AROUND ALL TREES PLANTED IN SOD AND SEEDED AREAS (MULCH RINGS ARE NOT REQUIRED FOR TREES PLANTED IN AGGREGATE MULCH AREAS).
- PLANT QUANTITIES AND SIZES INDICATED ARE THE MINIMUM TO SATISFY LANDSCAPE CODE REQUIREMENTS; NO SUBSTITUTIONS ARE PERMITTED WITHOUT PRIOR APPROVAL OF THE MUNICIPAL REVIEWING AGENCY.

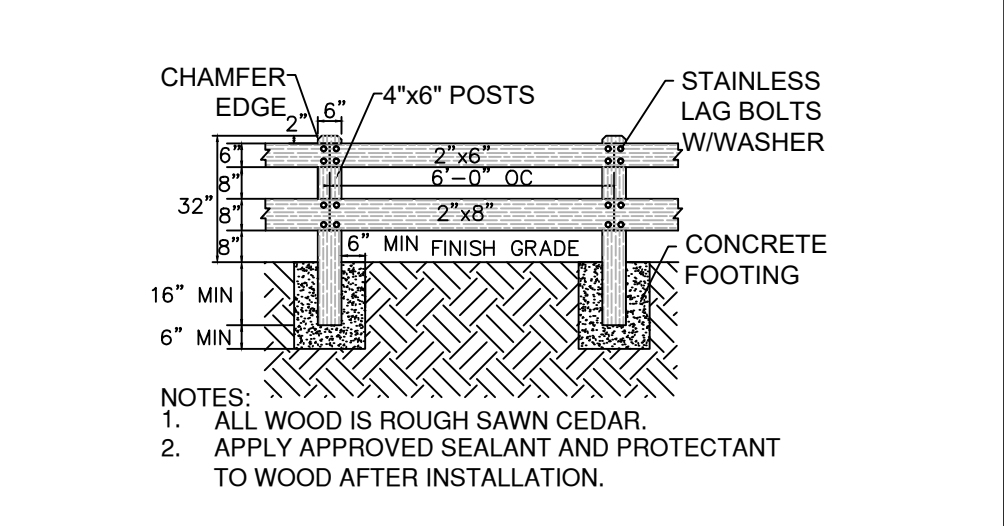

**A LOW CEDAR PEDESTRIAN FENCE**  
NOT TO SCALE

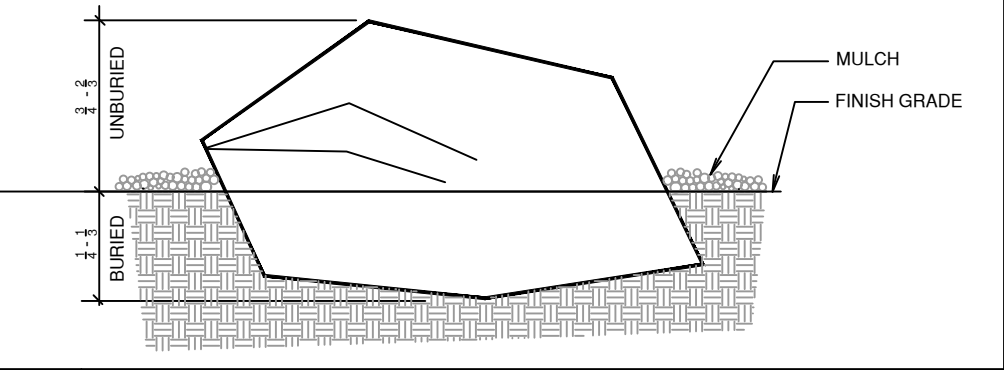

**B PLANTED BOULDER**  
NOT TO SCALE

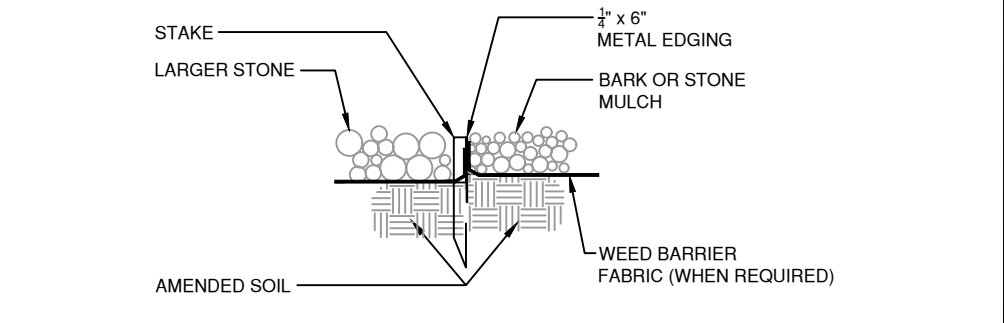

**C STEEL MAINTENANCE EDGE**  
NOT TO SCALE



**G SMOOTH WIRE RANCH FENCE (6'-7' HEIGHT)**  
NOT TO SCALE



**H BARBED WIRE FENCE**  
NOT TO SCALE

**J TRASH ENCLOSURE PLAN**  
NOT TO SCALE

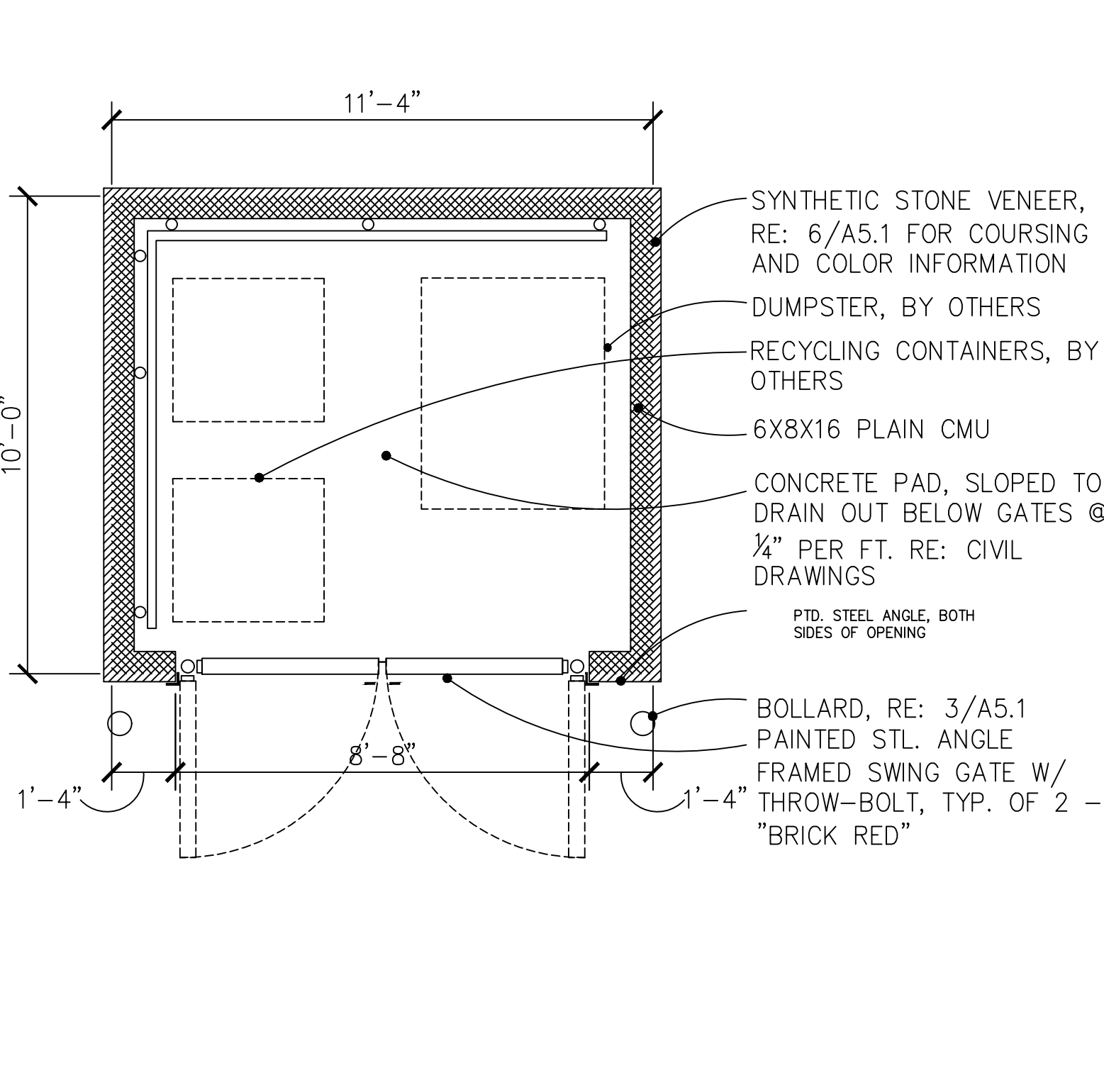

**J TRASH ENCLOSURE PLAN**  
NOT TO SCALE

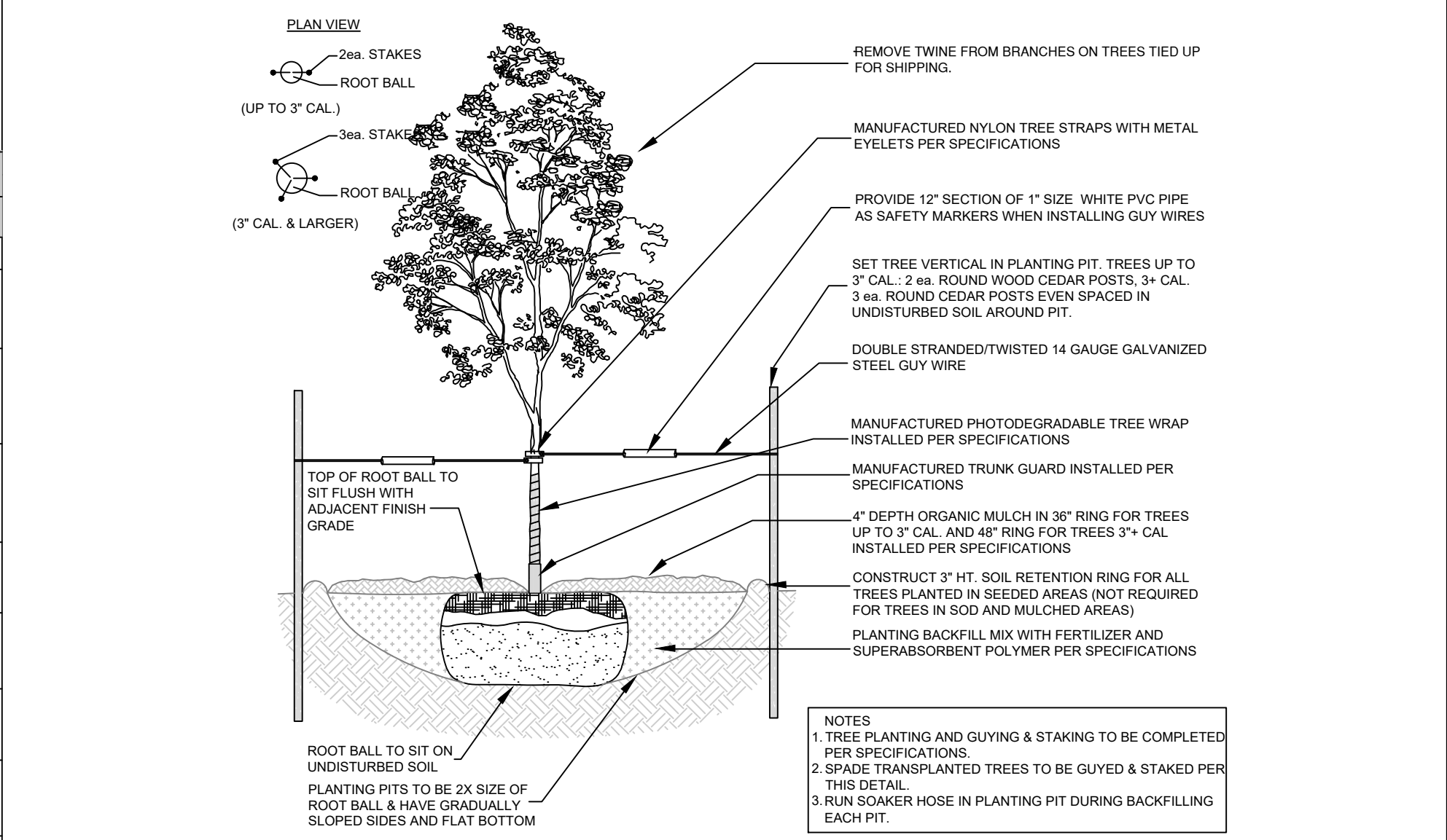

**D DECIDUOUS TREE PLANTING DETAIL**  
NOT TO SCALE



**I SEMI-OPAQUE WIND FENCE**  
NOT TO SCALE

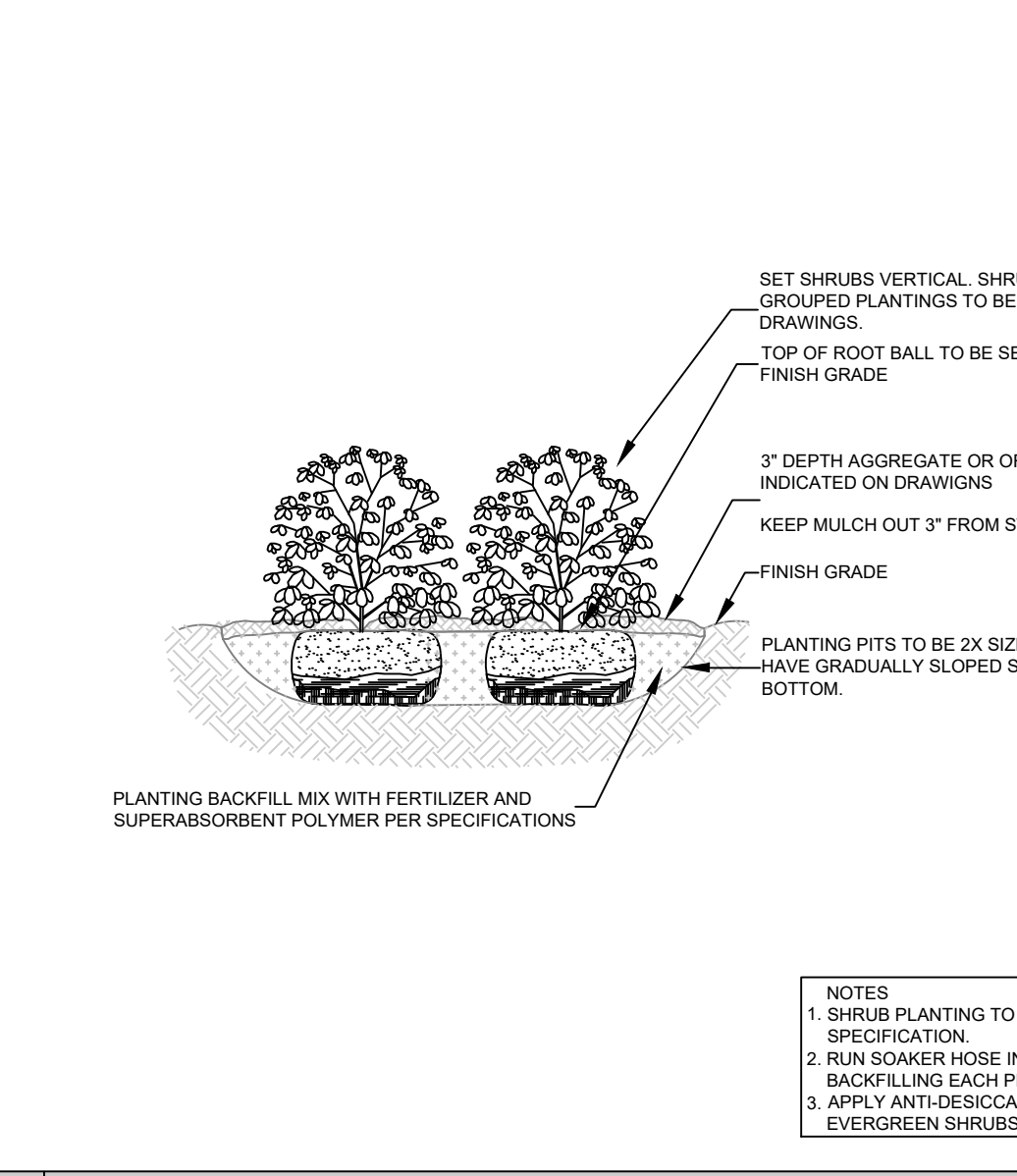

**E SHRUB PLANTING DETAIL**  
NOT TO SCALE

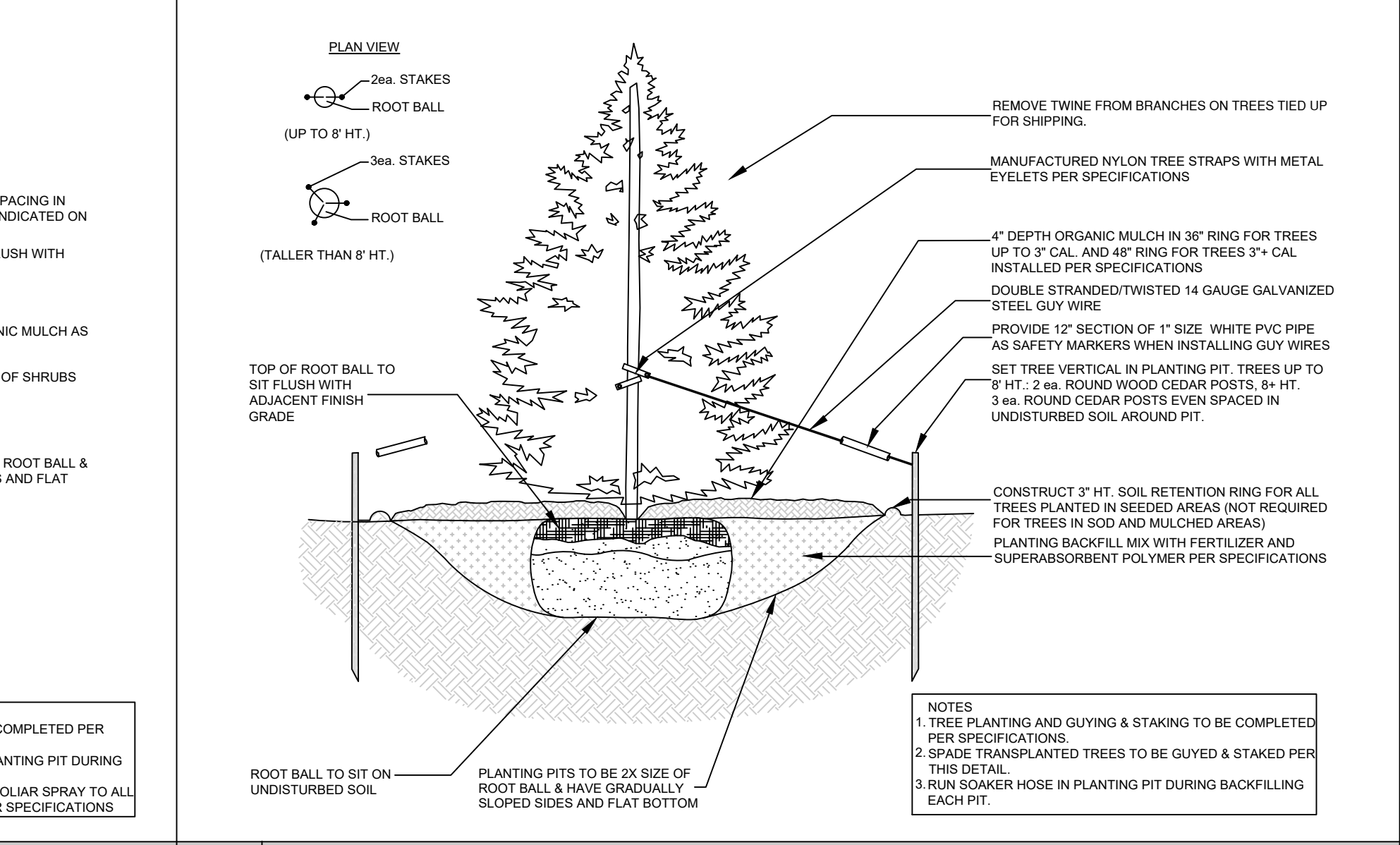

**F EVERGREEN TREE PLANTING DETAIL**  
NOT TO SCALE



**J FIELD FENCE**  
NOT TO SCALE

THIS DRAWING IS AN INSTRUMENT OF SERVICE AND AS SUCH REMAINS THE EXCLUSIVE PROPERTY OF WILLIAM GUMAN & ASSOCIATES, LTD. ANY REPRODUCTION OR UNAUTHORIZED USE OF THIS DRAWING WITHOUT PRIOR WRITTEN PERMISSION IS PROHIBITED. ANY REPRODUCTION OR UNAUTHORIZED USE OF THIS DRAWING WITHOUT PRIOR WRITTEN PERMISSION IS PROHIBITED.

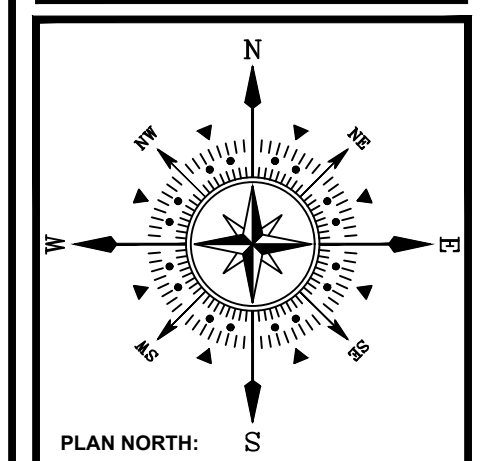

**FALL MOUNTAIN FARM**  
**16300 MOUNT HERMAN LANE**  
**MONUMENT, CO 80132**  
LANDSCAPE DETAILS

DATE:	07/29/2022
DESIGNED:	GEM
CHECKED:	WFG

REVISIONS:	DATE:	BY:	DESCRIPTION:
R1	11/18/2022	GEM	RESPOND TO INITIAL COMMENTS

PLAN SCALE: 1" = 50' (OR AS NOTED ON PLAN)

SHEET TITLE:  
**LANDSCAPE DETAILS**

SHEET NO.  
**3**  
3 OF 3 SHEETS

FILE NO.  
PCD FILE# PPR 2246