

**STORMWATER MANAGEMENT PLAN (SWMP)
FOR
MAYBERRY, COLORADO SPRINGS – FILING NO. 2**

Prepared for:

Colorado Springs Mayberry, LLC
32823 Temecula Parkway
Temecula, CA 92592

**ACCEPTED for FILE
Engineering Review**

*11/05/2020 6:15:35 PM
dsdnijkamp*

**EPC Planning & Community
Development Department**

March 27, 2019
Revised January 30, 2020

Prepared by:

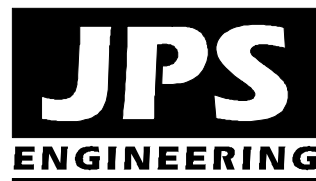

**19 East Willamette Avenue
Colorado Springs, CO 80903
(719)-477-9429
www.jpsegr.com**

**JPS Project No. 030502
EPC Project No. SF-1910**

MAYBERRY, COLORADO SPRINGS - FILING NO. 2
STORMWATER MANAGEMENT PLAN (SWMP)
TABLE OF CONTENTS

	<u>PAGE</u>
1. APPLICANT / CONTACT INFORMATION.....	1
2. SITE DESCRIPTION	1
3. SITE MAP.....	2
4. BMP'S FOR STORMWATER POLLUTION PREVENTION	2
5. FINAL STABILIZATION AND LONG-TERM STORMWATER MANAGEMENT	5
6. OTHER CONTROLS.....	6
7. INSPECTION AND MAINTENANCE	6

FIGURES

Sheet C1.03	Vicinity Map
Sheet C1.04	Site Grading & Erosion Control Plan
	Erosion Control Notes & Details

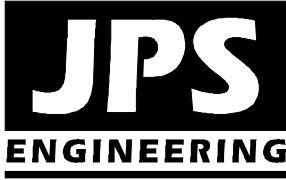

MAYBERRY, COLORADO SPRINGS – FILING NO. 2 STORMWATER MANAGEMENT PLAN (SWMP)

PCD File No. SF-1910

January, 2020

1. Applicant / Contact Information

Developer: Colorado Springs Mayberry, LLC
32823 Temecula Parkway
Temecula, CA 92592
Attn: Rick Scott (619)-218 8348
rick@cormanleigh.com

Engineer: JPS Engineering, Inc.
19 E. Willamette Avenue
Colorado Springs, CO 80903
Attn: John P. Schwab, P.E. (719)-477-9429
john@jpsengr.com

Contractor: TBD

2. Site Description

- a. Ellicott Town Center is a proposed subdivision located west of Ellicott, Colorado in El Paso County. The development is located on the south side of State Highway 94, approximately 1-1/2 miles west of Ellicott Highway. The approved Ellicott Town Center PUD includes a total of 1,048 single-family dwelling units and 32 acres of commercial space. Colorado Springs Mayberry, LLC is moving forward with development of Ellicott Town Center Filing No. 1, consisting of 98 single-family residential lots near the north boundary of the project. Filing No. 1 was approved by the Board of County Commissioners on April 12, 2007 (Resolution No. 07-132) and is currently pending recording. Ellicott Town Center Filing No. 2 consists of a replat of Tract L and Tract Q of Ellicott Town Center Filing No. 1, creating 3 commercial lots along the extension of Cattlemen Run on the west side of Springs Road.
- b. There are no stream crossings in the project area.

- c. The proposed development consists of subdivision development to create new commercial building lots. Site development activities will include site grading, utilities, roadways, parking areas, and related site improvements.
- d. Proposed sequence of major activities:
 - Mobilization / implementation of BMP's
 - Clearing and grubbing
 - Rough grading
 - Roadway grading / paving
 - Final grading of building sites and parking areas
- e. Total site area = 85.8 acres; Projected disturbed area = 3.8 acres (approx.)
- f. Historic runoff coefficient, C = 0.35;
Developed runoff coefficient, C = 0.545
- g. Existing vegetation on site: existing gravel parking areas; native meadow grasses (approx. 10% coverage)
- h. Potential pollution sources: vehicle fueling on-site
- i. Non-stormwater components of discharge: none anticipated
- j. Receiving water: Surface drainage from this site will flow southeasterly to existing natural drainage swales flowing to the West Fork of Black Squirrel Creek located east of this parcel between the site and Ellicott Highway. Black Squirrel Creek ultimately outfalls into the Arkansas River.
- k. Soil erosion potential and potential impacts upon discharge: According to the Soil Survey of El Paso County prepared by the Soil Conservation Service, on-site soils are comprised primarily of "Blakeland series (type 8). The Blakeland soils are characterized as well-drained loamy sand with rapid permeability, slow surface runoff rates, and moderate hazard of erosion. These soils are classified as hydrologic soils group "A" for drainage analysis purposes (low runoff potential; high infiltration rate; slight to moderate hazard of erosion). Uncontrolled soil erosion may adversely impact downstream drainageways; on-site BMP's will be provided and maintained to mitigate adverse impacts.

3. Site Map (see Filing No. 1 GEC Plans – Sheet C1.03)

4. BMP's for Stormwater Pollution Prevention (See Sh. C1.03-C1.04):

<u>Phase</u>	<u>BMP</u>
Clearing and Grubbing necessary for perimeter controls	VTC's
Initiation of perimeter controls	Silt Fence
Remaining clearing and grubbing	
Site Grading	IP / SF
Extended detention basin (sediment pond during construction)	EDB / SB
Stabilization	SM
Removal of erosion control measures	

- a. Erosion and Sediment Controls
 - 1) Structural Practices:
 - Vehicle Tracking Control (VTC) pad at construction entry
 - Silt fence at toe of slope along downstream limits of disturbed areas
 - Inlet protection (IP) at storm inlets
 - Extended Detention Basin (EDB) within Tract B south of Commercial Lots 1-3 (constructed with Filing No. 1)
 - 2) Non-Structural Practices:
 - Preserve existing vegetation beyond limits of work
 - Temporary seeding of areas to remain disturbed for significant periods of time
 - Permanent seeding/mulching (SM) upon completion of rough grading
- b. Materials Handling and Spill Prevention
 - General Materials Handling Practices:
 - Potential pollutants shall be stored and used in a manner consistent with the manufacturer's instructions in a secure location. To the extent practical, material storage areas should not be located near storm drain inlets and should be equipped with covers, roofs, or secondary containment as required to prevent storm water from contacting stored materials. Chemicals that are not compatible shall be stored and segregated areas so that spilled materials cannot combine and react.
 - Disposal of materials shall be in accordance with the manufacturer's instructions and applicable local, state, and federal regulations.
 - Materials no longer required for construction shall be removed from the site as soon as possible.
 - Adequate garbage, construction waste, and sanitary waste handling and disposal facilities shall be provided as necessary to keep the site clear of obstruction and BMPs clear and functional.
 - Specific Materials Handling Practices:
 - All pollutants, including waste materials and demolition debris, that occur on-site during construction shall be handled in a way that does not contaminate storm water.
 - All chemicals including liquid products, petroleum products, water treatment chemicals, and wastes stored on site shall be covered and contained and protected from vandalism.
 - Maintenance and repair of all equipment and vehicles involving oil changes, hydraulic system drain down, degreasing operations, fuel tank drain down and removal, and other activities which may result in the accidental release of contaminants, shall be conducted under cover during wet weather and on an impervious surface to prevent release of contaminants onto the ground. Materials spilled during

maintenance operations shall be cleaned up immediately and properly disposed of.

- Wheel wash water shall be settled and discharged on site by infiltration. Wheel wash water shall not be discharged to the storm water system.
- Application of agricultural chemicals, including fertilizers and pesticides, shall be conducted in a manner and at application rates that will not result in loss of chemical to storm water runoff. Follow manufacturer's recommendations for application rates and procedures.
- pH-modifying sources shall be managed to prevent contamination of runoff and storm water collected on site. The most common sources of pH-modifying materials are bulk cement, cement kiln dust (CKD), fly ash, new concrete washing and curing waters, waste streams generated from concrete grinding and sawing, exposed aggregate processes, and concrete pumping and mixer washout waters.
- Equipment maintenance and fueling: Contractor shall implement appropriate spill prevention and response procedures
- Spill Prevention and Response Procedures:
 - The primary objective in responding to a spill is to quickly contain the material(s) and prevent or minimize their migration into storm water runoff and conveyance systems. If the release has impacted on-site storm water, it is critical to contain the released materials on site and prevent their release into receiving waters.
 - Spill Response Procedures:
 - Notify site superintendent immediately when a spill, or the threat of a spill, is observed. The superintendent shall assess the situation and determine the appropriate response.
 - If spills represent an imminent threat of escaping on-site facilities and entering the receiving waters, site personnel shall respond immediately to contain the release and notify the superintendent after the situation has stabilized.
 - The site superintendent, or his designee, shall be responsible for completing a spill reporting form and for reporting the spill to the appropriate agency.
 - Spill response equipment shall be inspected and maintained as necessary to replace any materials used in spill response activities.
 - Spill kits shall be on-hand at all fueling sites. Spill kit location(s) shall be reported to the SWMP Administrator.

- Absorbent materials shall be on-hand at all fueling areas for use in containing inadvertent spills. Containers shall be on-hand at all fueling sites for disposal of used absorbents.
- Recommended components of spill kits include the following:
 - Oil absorbent pads (one bale)
 - Oil absorbent booms (40 feet)
 - 55-gallon drums (2)
 - 9-mil plastic bags (10)
 - Personal protective equipment including gloves and goggles
- Concrete Wash Water: Unless confined in a pre-defined, bermed containment area, the cleaning of concrete truck delivery chutes is prohibited at the job site. The discharge of water containing waste cement to the storm drainage system is prohibited.
- Concrete Batch Plant: This project will not have an on-site dedicated batch plant.
- Notification Procedures:
 - In the event of an accident or spill, the SWMP Administrator shall be notified as a minimum.
 - Depending on the nature of the spill material involved, the Colorado Department of Public Health and Environment (24-hour spill reporting line: 877-518-5608), downstream water users, or other agencies may also need to be notified.
 - Any spill of oil which 1) violates water quality standards, 2) produces a “sheen” on a surface water, or 3) causes a sludge or emulsion, or any hazardous substance release, or hazardous waste release which exceeds the reportable quantity, must be reported immediately by telephone to the National Response Center Hotline at (800)-424-8802.

5. Final Stabilization and Long-term Stormwater Management

- Permanent seeding will be provided to achieve long-term stabilization of the site.
- Seed Mix: “Foothills Mix” or approved equal:
- Seeding Application Rate: Drill seed 0.25” to 0.5” into the soil. In small areas not accessible to a drill, hand broadcast at double the rate and rake 0.25” to 0.5” into the soil. Apply seed at the following rates:
 - Dryland: 20-25 lbs/acre
 - Irrigated: 40 lbs/acre
- Soil Stabilization Practices:
 - Mulching Application: Apply 1-1/2 tons of certified weed free hay per acre mechanically crimped into the soil in combination with an organic mulch tackifier. On slopes and ditches requiring a blanket, the blanket shall be placed in lieu of much and mulch tackifier.

- Soil Conditioning and Fertilizer Requirements:
 - Soil conditioner, organic amendment shall be applied to all seeded areas at 3 CY / 1000 SF.
 - Fertilizer shall consist of 90% fungal biomass (mycelium) and 10% potassium-magnesia with a grade of 6-1-3 or approved equal. Fertilizer shall be applied as recommended by seed supplier.
- Final stabilization is reached when all soil-disturbing activities at the site have been completed, and uniform vegetative cover has been established with an individual plant density of at least 70 percent of pre-disturbance levels, or equivalent permanent, physical erosion reduction methods have been employed.

6. Other Controls

- Contractor shall dispose of all waste materials at a permitted off-site disposal site.
- Vehicle tracking pads will be installed at all access points to limit off-site soil tracking.

7. Inspection and Maintenance

a. Inspection Schedules:

- Contractor shall inspect BMPs bi-weekly as a minimum, and immediately (within 24 hours) after any precipitation or snowmelt event that causes surface erosion (i.e. that results in stormwater running across the ground), to ensure that BMPs are maintained in effective operating condition.

b. Inspection Procedures:

1) Site Inspection / Observation Items:

- Construction site perimeter and discharge points (including discharges into a storm sewer system)
- All disturbed areas
- Areas used for material / waste storage that are exposed to precipitation
- Other areas having a significant potential for stormwater pollution, such as demolition areas or concrete washout locations, or locations where vehicles enter or leave the site
- Erosion and sediment control measures identified in the SWMP
- Any other structural BMPs that may require maintenance, such as secondary containment around fuel tanks, or the condition of spill response kits.

2) Inspection Requirements:

- Determine if there is any evidence of, or potential for, pollutants entering the drainage system.

- Review BMPs to determine if they still meet design and operational criteria in the SWMP, and if they continue to adequately control pollutants at the site.
 - Upgrade and/or revise any BMPs not operating in accordance with the SWMP and update the SWMP to reflect any revisions.
- c. BMP Maintenance / Replacement and Failed BMPs:
- Contractor shall remove sediment that has been collected by perimeter controls, such as silt fence and inlet protection, on a regular basis to prevent failure of BMPs, and remove potential of sediment from being discharged from the site in the event of BMP failure.
 - Removed sediment must be moved to an appropriate location where it will not become an additional pollutant source, and should never be placed in ditches or streams.
 - Contractor shall update Erosion Control Plans as required with any new BMPs added during the construction period.
 - Contractor shall address BMPs that have failed, or have the potential to fail without maintenance or modifications, as soon as possible, immediately in most cases, to prevent discharge of pollutants.
- d. Record Keeping and Documenting Inspections:
- Contractor shall maintain records of all inspection reports, including signed inspection logs, at the project site.
 - Permittee shall document inspection results and maintain a record of the results for a period of 3 years following expiration or inactivation of permit coverage.
 - Site inspection records shall include the following:
 - Inspection date
 - Name and title of personnel making the inspection
 - Location of discharges of sediment or other pollutants from the site
 - Location(s) of BMPs that need to be maintained
 - Location(s) of BMPs that failed to operate as designed or proved inadequate for a particular location
 - Location(s) where additional BMPs are needed that were not in place at the time of inspection
 - Deviations from the minimum inspection schedule

Z:\090001.EllcottTC\dwg\Civil\A1.dwg Jan 30, 2020 - 3:02pm

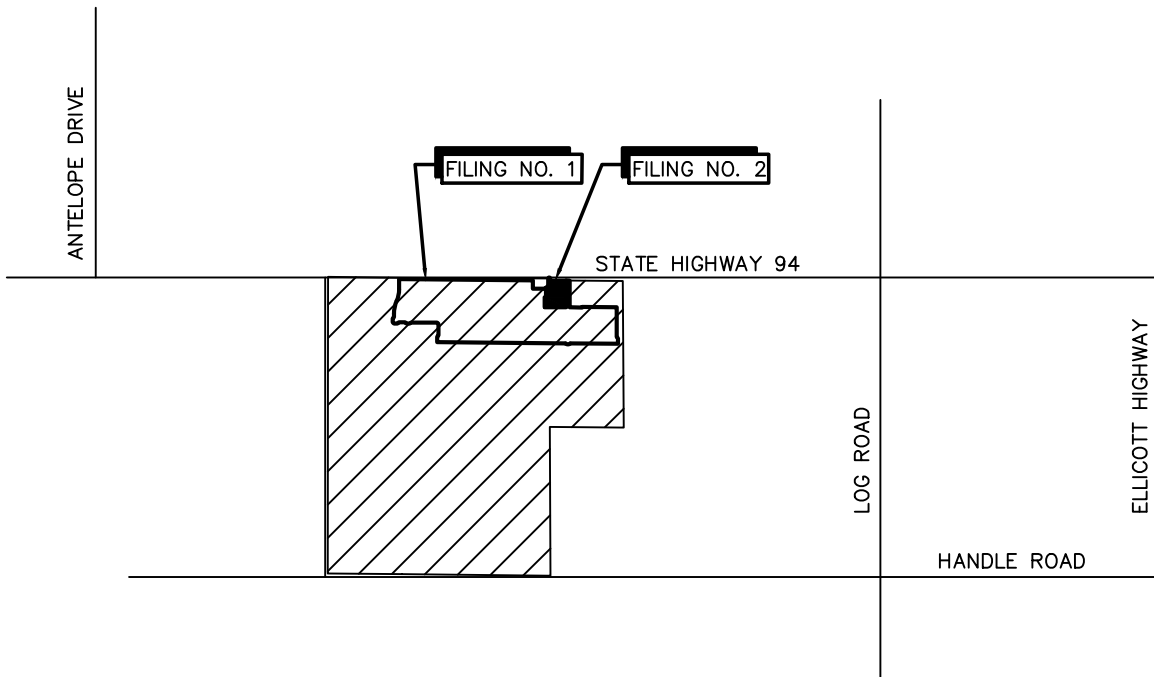

VICINITY MAP

NTS



**VICINITY
MAP**

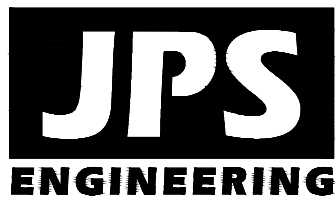

**MAYBERRY
COLORADO SPRINGS**

FIGURE A1
JPS PROJ NO. 090001

Z:\090001.Elliptic\TTC.dwg_Civil\F2-COMMA\C1.03-F2.DWG Jan 31, 2020 - 8:52am

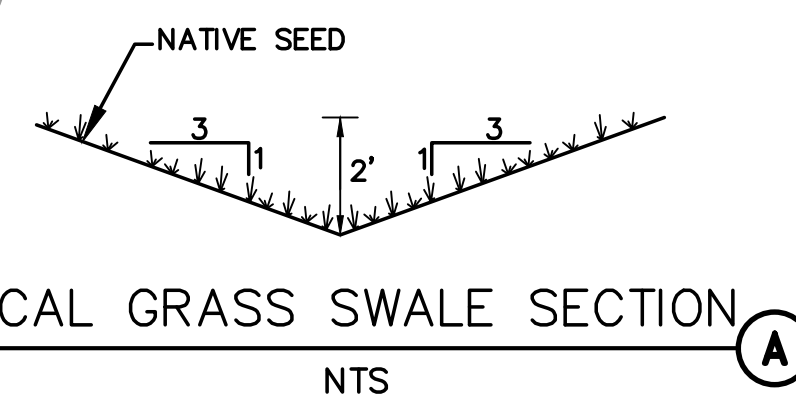
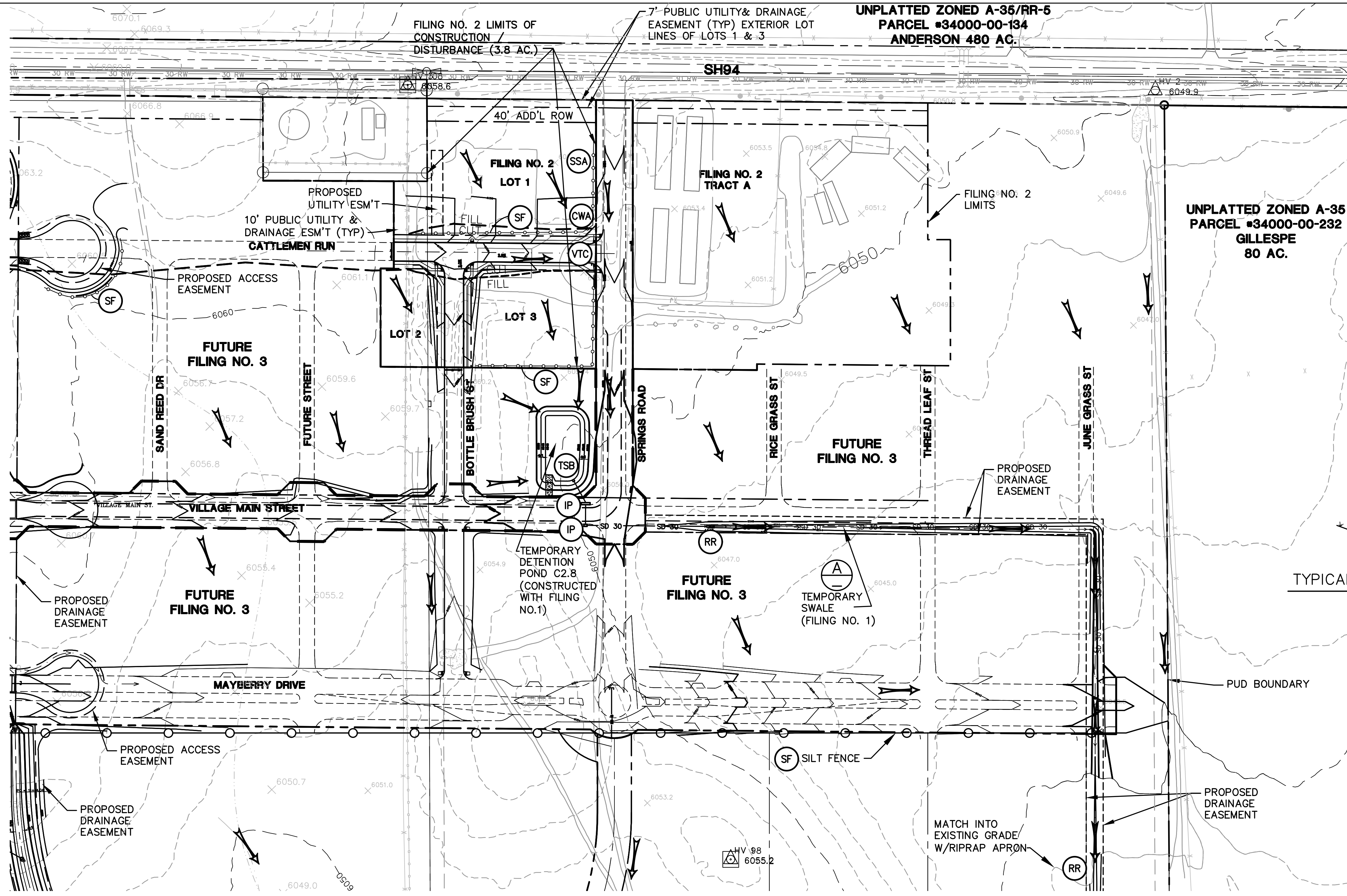

LEGEND:

- BOUNDARY LINES
- 6490 EXISTING CONTOURS
- 6490 PROPOSED CONTOURS
- x 99.00 PROPOSED SPOT ELEVATION (FLOWLINE)
- PROPOSED STREET PROFILE GRADE
- - - CUT-FILL DEMARCATION LINES
- FLOW DIRECTION ARROWS

EROSION CONTROL LEGEND:

- IP INLET PROTECTION (GRAVEL FILTER)
- SF SILT FENCE
- VTC VEHICLE TRACKING CONTROL PAD (PER EPC STD. DETAIL)
- TM TEMPORARY SEED AND MULCH ON DISTURBED SLOPES
- STB STRAW BALE BARRIER
- TSB TEMPORARY SEDIMENT BASIN
- RR RIPRAP
- CWA CONCRETE WASHOUT AREA
- SSA STABILIZED STAGING AREA

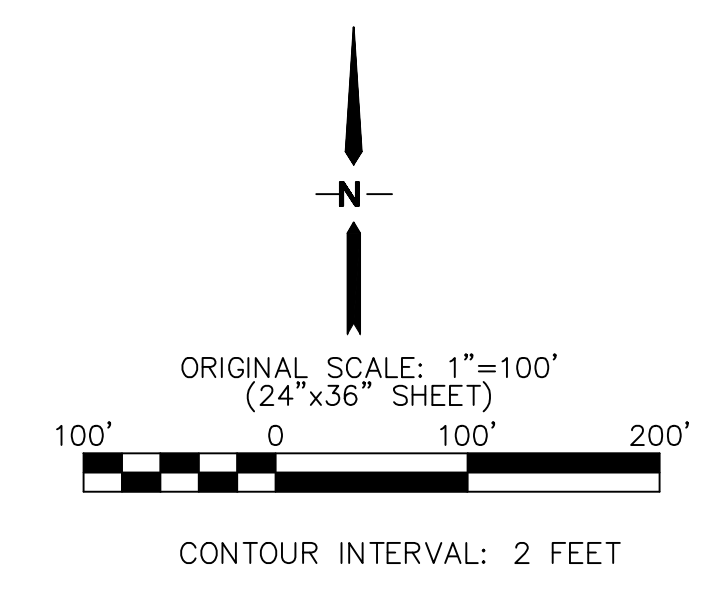

MAYBERRY, COLORADO SPRINGS - FILING NO. 2

SITE GRADING & EROSION CONTROL PLAN

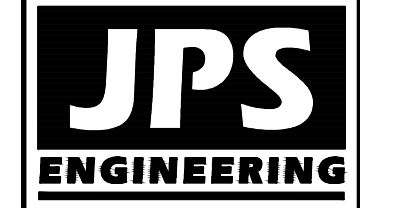

19 E. Willamette Ave.
Colorado Springs, CO
80903
PH: 719-477-9429
FAX: 719-471-0766



CALL UTILITY NOTIFICATION CENTER OF COLORADO
1-800-922-1987
CALL BEFORE YOU DIG. IN AN UNPLATTED AREA BEFORE YOU GRADE, OR EXCAVATE FOR THE MARKING OF UNDERGROUND MEMBER UTILITIES.

NO.	REVISION	DATE	BY
1	EPC COMMENTS	7/18/19	JPS
2	EPC COMMENTS	11/30/20	JPS

HORZ. SCALE: 1"=100'	DRAWN: RMD
VERT. SCALE: N/A	DESIGNED: JPS
SURVEYED: UP&E	CHECKED: JPS
CREATED: 12/03/00	LAST MODIFIED: 11/30/20
PROJECT NO: 090001	MODIFIED BY: BJJ

SHEET: **C1.03-F2**

REVISED 7/02/19

- STORMWATER DISCHARGES FROM CONSTRUCTION SITES SHALL NOT CAUSE OR THREATEN TO CAUSE POLLUTION, CONTAMINATION, OR DEGRADATION OF STATE WATERS. ALL WORK AND EARTH DISTURBANCE SHALL BE DONE IN A MANNER THAT MINIMIZES POLLUTION OF ANY ON-SITE OR OFF-SITE WATERS, INCLUDING WETLANDS.
- NOTWITHSTANDING ANYTHING DEPICTED IN THESE PLANS IN WORDS OR GRAPHIC REPRESENTATION, ALL DESIGN AND CONSTRUCTION RELATED TO ROADS, STORM DRAINAGE AND EROSION CONTROL SHALL CONFORM TO THE STANDARDS AND REQUIREMENTS OF THE MOST RECENT VERSION OF THE RELEVANT ADOPTED EL PASO COUNTY STANDARDS, INCLUDING THE LAND DEVELOPMENT CODE, THE ENGINEERING CRITERIA MANUAL, THE DRAINAGE CRITERIA MANUAL, AND THE DRAINAGE CRITERIA MANUAL VOLUME 2. ANY DEVIATIONS FROM REGULATIONS AND STANDARDS MUST BE REQUESTED, AND APPROVED, IN WRITING.
- A SEPARATE STORMWATER MANAGEMENT PLAN (SMWP) FOR THIS PROJECT SHALL BE COMPLETED AND AN EROSION AND STORMWATER QUALITY CONTROL PERMIT (ESQCP) ISSUED PRIOR TO COMMENCING CONSTRUCTION. MANAGEMENT OF THE SWMP DURING CONSTRUCTION IS THE RESPONSIBILITY OF THE DESIGNATED QUALIFIED STORMWATER MANAGER OR CERTIFIED EROSION CONTROL INSPECTOR. THE SWMP SHALL BE LOCATED ON SITE AT ALL TIMES DURING CONSTRUCTION AND SHALL BE KEPT UP TO DATE WITH WORK PROGRESS AND CHANGES IN THE FIELD.
- ONCE THE ESQCP IS APPROVED AND A "NOTICE TO PROCEED" HAS BEEN ISSUED, THE CONTRACTOR MAY INSTALL THE INITIAL STAGE EROSION AND SEDIMENT CONTROL MEASURES AS INDICATED ON THE APPROVED GEC. A PRECONSTRUCTION MEETING BETWEEN THE CONTRACTOR, ENGINEER, AND EL PASO COUNTY WILL BE HELD PRIOR TO ANY CONSTRUCTION. IT IS THE RESPONSIBILITY OF THE APPLICANT TO COORDINATE THE MEETING TIME AND PLACE WITH COUNTY STAFF.
- CONTROL MEASURES MUST BE INSTALLED PRIOR TO COMMENCEMENT OF ACTIVITIES THAT COULD CONTRIBUTE POLLUTANTS TO STORMWATER. CONTROL MEASURES FOR ALL SLOPES, CHANNELS, DITCHES, AND DISTURBED LAND AREAS SHALL BE INSTALLED IMMEDIATELY UPON COMPLETION OF THE DISTURBANCE.
- ALL TEMPORARY SEDIMENT AND EROSION CONTROL MEASURES SHALL BE MAINTAINED AND REMAIN IN EFFECTIVE OPERATING CONDITION UNTIL PERMANENT SOIL EROSION CONTROL MEASURES ARE IMPLEMENTED AND FINAL STABILIZATION IS ESTABLISHED. ALL PERSONS ENGAGED IN LAND DISTURBANCE ACTIVITIES SHALL ASSESS THE ADEQUACY OF CONTROL MEASURES AT THE SITE AND IDENTIFY IF CHANGES TO THOSE CONTROL MEASURES ARE NEEDED TO ENSURE THE CONTINUED EFFECTIVE PERFORMANCE OF THE CONTROL MEASURES. ALL CHANGES TO TEMPORARY SEDIMENT AND EROSION CONTROL MEASURES MUST BE INCORPORATED INTO THE STORMWATER MANAGEMENT PLAN.
- TEMPORARY STABILIZATION SHALL BE IMPLEMENTED ON DISTURBED AREAS AND STOCKPILES WHERE GROUND DISTURBING CONSTRUCTION ACTIVITY HAS PERMANENTLY CEASED OR TEMPORARILY CEASED FOR LONGER THAN 14 DAYS.
- FINAL STABILIZATION MUST BE IMPLEMENTED AT ALL APPLICABLE CONSTRUCTION SITES. FINAL STABILIZATION IS ACHIEVED WHEN ALL GROUND DISTURBING ACTIVITIES ARE COMPLETE AND ALL DISTURBED AREAS EITHER HAVE A UNIFORM VEGETATIVE COVER WITH INDIVIDUAL PLANT DENSITY OF 70 PERCENT OF PRE-DISTURBANCE LEVELS ESTABLISHED OR EQUIVALENT PERMANENT ALTERNATIVE STABILIZATION METHOD IS IMPLEMENTED. ALL TEMPORARY SEDIMENT AND EROSION CONTROL MEASURES SHALL BE REMOVED UPON FINAL STABILIZATION AND BEFORE PERMIT CLOSURE.
- ALL PERMANENT STORMWATER MANAGEMENT FACILITIES SHALL BE INSTALLED AS DESIGNED IN THE APPROVED PLANS. ANY PROPOSED CHANGES THAT AFFECT THE DESIGN OR FUNCTION OF PERMANENT STORMWATER MANAGEMENT STRUCTURES MUST BE APPROVED BY THE ECM ADMINISTRATOR PRIOR TO IMPLEMENTATION.
- EARTH DISTURBANCES SHALL BE CONDUCTED IN SUCH A MANNER SO AS TO EFFECTIVELY MINIMIZE ACCELERATED SOIL EROSION AND RESULTING SEDIMENTATION. ALL DISTURBANCES SHALL BE DESIGNED, CONSTRUCTED, AND COMPLETED SO THAT THE EXPOSED AREA OF ANY DISTURBED LAND SHALL BE LIMITED TO THE SHORTEST PRACTICAL PERIOD OF TIME. PRE-EXISTING VEGETATION SHALL BE PROTECTED AND MAINTAINED WITHIN 50 HORIZONTAL FEET OF A WATERS OF THE STATE UNLESS SHOWN TO BE INFEASIBLE AND SPECIFICALLY REQUESTED AND APPROVED.
- COMPACTION OF SOIL MUST BE PREVENTED IN AREAS DESIGNATED FOR INFILTRATION CONTROL MEASURES OR WHERE FINAL STABILIZATION WILL BE ACHIEVED BY VEGETATIVE COVER. AREAS DESIGNATED FOR INFILTRATION CONTROL MEASURES SHALL ALSO BE PROTECTED FROM SEDIMENTATION DURING CONSTRUCTION UNTIL FINAL STABILIZATION IS ACHIEVED. IF COMPACTION PREVENTION IS NOT FEASIBLE DUE TO SITE CONSTRAINTS, ALL AREAS DESIGNATED FOR INFILTRATION AND VEGETATION CONTROL MEASURES MUST BE LOOSENEED PRIOR TO INSTALLATION OF THE CONTROL MEASURE(S).
- ANY TEMPORARY OR PERMANENT FACILITY DESIGNED AND CONSTRUCTED FOR THE CONVEYANCE OF STORMWATER AROUND, THROUGH, OR FROM THE EARTH DISTURBANCE AREA SHALL BE A STABILIZED CONVEYANCE DESIGNED TO MINIMIZE EROSION AND THE DISCHARGE OF SEDIMENT OFF SITE.
- CONCRETE WASH WATER SHALL BE CONTAINED AND DISPOSED OF IN ACCORDANCE WITH THE SWMP. NO WASH WATER SHALL BE DISCHARGED TO OR ALLOWED TO ENTER STATE WATERS, INCLUDING ANY SURFACE OR SUBSURFACE STORM DRAINAGE SYSTEM OR FACILITIES. CONCRETE WASHOUTS SHALL NOT BE LOCATED IN AN AREA WHERE SHALLOW GROUNDWATER MAY BE PRESENT, OR WITHIN 50 FEET OF A SURFACE WATER BODY, CREEK OR STREAM.
- DURING DEWATERING OPERATIONS OF UNCONTAMINATED GROUND WATER MAY BE DISCHARGED ON SITE, BUT SHALL NOT LEAVE THE SITE IN THE FORM OF SURFACE RUNOFF UNLESS AN APPROVED STATE DEWATERING PERMIT IS IN PLACE.
- EROSION CONTROL BLANKETING OR OTHER PROTECTIVE COVERING SHALL BE USED ON SLOPES STEEPER THAN 3:1.
- CONTRACTOR SHALL BE RESPONSIBLE FOR THE REMOVAL OF ALL WASTES FROM THE CONSTRUCTION SITE FOR DISPOSAL IN ACCORDANCE WITH LOCAL AND STATE REGULATORY REQUIREMENTS. NO CONSTRUCTION DEBRIS, TREE SLASH, BUILDING MATERIAL WASTES OR UNUSED BUILDING MATERIALS SHALL BE BURIED, DUMPED, OR DISCHARGED AT THE SITE.
- WASTE MATERIALS SHALL NOT BE TEMPORARILY PLACED OR STORED IN THE STREET, ALLEY, OR OTHER PUBLIC WAY, UNLESS IN ACCORDANCE WITH AN APPROVED TRAFFIC CONTROL PLAN. CONTROL MEASURES MAY BE REQUIRED BY EL PASO COUNTY ENGINEERING IF DEEMED NECESSARY, BASED ON SPECIFIC CONDITIONS AND CIRCUMSTANCES.
- TRACKING OF SOILS AND CONSTRUCTION DEBRIS OFF-SITE SHALL BE MINIMIZED. MATERIALS TRACKED OFF-SITE SHALL BE CLEANED UP AND PROPERLY DISPOSED OF IMMEDIATELY.
- THE OWNER/DEVELOPER SHALL BE RESPONSIBLE FOR THE REMOVAL OF ALL CONSTRUCTION DEBRIS, DIRT, TRASH, ROCK, SEDIMENT, SOIL, AND SAND THAT MAY ACCUMULATE IN ROADS, STORM DRAINS AND OTHER DRAINAGE CONVEYANCE SYSTEMS AND STORMWATER APPURTENANCES AS A RESULT OF SITE DEVELOPMENT.
- THE QUANTITY OF MATERIALS STORED ON THE PROJECT SITE SHALL BE LIMITED, AS MUCH AS PRACTICAL, TO THAT QUANTITY REQUIRED TO PERFORM THE WORK IN AN ORDERLY SEQUENCE. ALL MATERIALS STORED ON-SITE SHALL BE STORED IN A NEAT, ORDERLY MANNER, IN THEIR ORIGINAL CONTAINERS, WITH ORIGINAL MANUFACTURER'S LABELS.
- NO CHEMICAL(S) HAVING THE POTENTIAL TO BE RELEASED IN STORMWATER ARE TO BE STORED OR USED ONSITE UNLESS PERMISSION FOR THE USE OF SUCH CHEMICAL(S) IS GRANTED IN WRITING BY THE ECM ADMINISTRATOR. IN GRANTING APPROVAL FOR THE USE OF SUCH CHEMICAL(S), SPECIAL CONDITIONS AND MONITORING MAY BE REQUIRED.
- BULK STORAGE OF ALLOWED PETROLEUM PRODUCTS OR OTHER ALLOWED LIQUID CHEMICALS IN EXCESS OF 55 GALLONS SHALL REQUIRE ADEQUATE SECONDARY CONTAINMENT PROTECTION TO CONTAIN ALL SPILLS ONSITE AND TO PREVENT ANY SPILLED MATERIALS FROM ENTERING STATE WATERS, ANY SURFACE OR SUBSURFACE STORM DRAINAGE SYSTEM OR OTHER FACILITIES.
- NO PERSON SHALL CAUSE THE IMPEDIMENT OF STORMWATER FLOW IN THE CURB AND GUTTER OR DITCH EXCEPT WITH APPROVED SEDIMENT CONTROL MEASURES.
- OWNER/DEVELOPER AND THEIR AGENTS SHALL COMPLY WITH THE "COLORADO WATER QUALITY CONTROL ACT" (TITLE 25, ARTICLE 8, CRS), AND THE "CLEAN WATER ACT" (33 USC 1344), IN ADDITION TO THE REQUIREMENTS OF THE LAND DEVELOPMENT CODE, DCM VOLUME II AND THE ECM APPENDIX I. ALL APPROPRIATE PERMITS MUST BE OBTAINED BY THE CONTRACTOR PRIOR TO CONSTRUCTION (1041, NPDES, FLOODPLAIN, 404, FUGITIVE DUST, ETC.). IN THE EVENT OF CONFLICTS BETWEEN THESE REQUIREMENTS AND OTHER LAWS, RULES, OR REGULATIONS OF OTHER FEDERAL, STATE, LOCAL, OR COUNTY AGENCIES, THE MOST RESTRICTIVE LAWS, RULES, OR REGULATIONS SHALL APPLY.
- ALL CONSTRUCTION TRAFFIC MUST ENTER/EXIT THE SITE ONLY AT APPROVED CONSTRUCTION ACCESS POINTS.
- PRIOR TO CONSTRUCTION THE PERMITTEE SHALL VERIFY THE LOCATION OF EXISTING UTILITIES.
- A WATER SOURCE SHALL BE AVAILABLE ON SITE DURING EARTHWORK OPERATIONS AND SHALL BE UTILIZED AS REQUIRED TO MINIMIZE DUST FROM EARTHWORK EQUIPMENT AND WIND.
- THE SOILS REPORT FOR THIS SITE HAS BEEN PREPARED BY CTL THOMPSON, DATED JULY 13, 2006 AND SHALL BE CONSIDERED A PART OF THESE PLANS.
- AT LEAST TEN (10) DAYS PRIOR TO THE ANTICIPATED START OF CONSTRUCTION, FOR PROJECTS THAT WILL DISTURB ONE (1) ACRE OR MORE, THE OWNER OR OPERATOR OF CONSTRUCTION ACTIVITY SHALL SUBMIT A PERMIT APPLICATION FOR STORMWATER DISCHARGE TO THE COLORADO DEPARTMENT OF PUBLIC HEALTH AND ENVIRONMENT, WATER QUALITY DIVISION. THE APPLICATION CONTAINS CERTIFICATION OF COMPLETION OF A STORMWATER MANAGEMENT PLAN (SWMP), OF WHICH THIS GRADING AND EROSION CONTROL PLAN MAY BE A PART. FOR INFORMATION OR APPLICATION MATERIALS CONTACT:
 COLORADO DEPARTMENT OF PUBLIC HEALTH AND ENVIRONMENT
 WATER QUALITY CONTROL DIVISION
 WQCD - PERMITS
 4300 CHERRY CREEK DRIVE SOUTH
 DENVER, CO 80246-1530
 ATTN: PERMITS UNIT

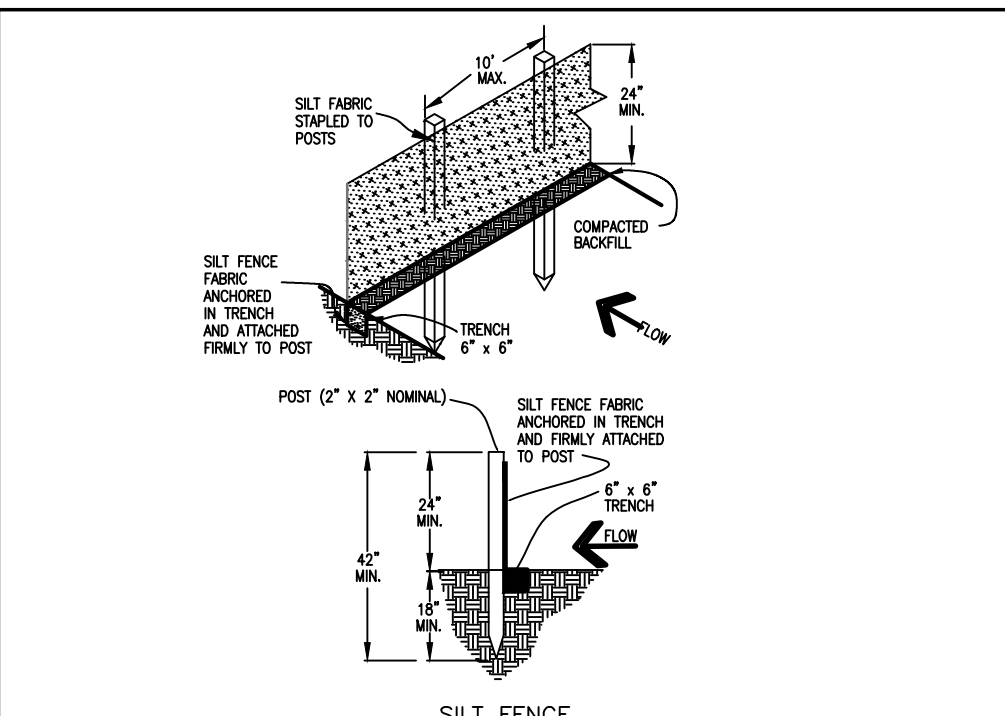

SILT FENCE NOTES

INSTALLATION REQUIREMENTS

- SILT FENCES SHALL BE INSTALLED PRIOR TO ANY LAND DISTURBING ACTIVITIES.
- WHEN JOINTS ARE NECESSARY, SILT FENCE GEOTEXTILE SHALL BE SPUN TOGETHER ONLY AT SUPPORT POST AND SECURELY SEALED.
- METAL POSTS SHALL BE "STUDDED TIE" OR "I" TYPE WITH MINIMUM HEIGHT OF 1.33 FEET PER LINEAR FOOT. WOOD POSTS SHALL HAVE A MINIMUM DIAMETER OR CROSS SECTION DIMENSION OF 2 INCHES.
- THE FILTER MATERIAL SHALL BE FASTENED SECURELY TO METAL OR WOOD POSTS USING WIRE TIE OR TO WOOD POSTS WITH 3/4" LONG #8 HEAVY-DUTY STAPLES. THE SILT FENCE GEOTEXTILE SHALL NOT BE STAPLED TO DRIVING TREES.
- WHERE NOT REQUIRED, WIRE MESH FENCE MAY BE USED TO SUPPORT THE GEOTEXTILE. WIRE FENCE SHALL BE FASTENED SECURELY TO THE UPSLOPE SIDE OF THE POSTS USING HEAVY-DUTY WIRE STAPLES AT LEAST 3/4" LONG. THE WIRE SHALL EXTEND INTO THE TRENCH A MINIMUM OF 6" AND SHALL NOT EXCEED MORE THAN 7" ABOVE THE ORIGINAL GROUND SURFACE.
- ALONG THE TOE OF FILLS, INSTALL THE SILT FENCE ALONG A LEVEL CONTOUR AND PROVIDE AN AREA BEHIND THE FENCE FOR RUNOFF TO POND AND SEDIMENT TO SETTLE A MINIMUM DISTANCE OF 5 FEET FROM THE TOE OF THE FILL IS RECOMMENDED.
- THE HEIGHT OF THE SILT FENCE FROM THE GROUND SURFACE SHALL BE MINIMUM OF 24 INCHES AND SHALL NOT EXCEED 36 INCHES. HIGHER FENCES MAY IMPROVE VOLUMES OF WATER SUFFICIENT TO CAUSE FAILURE OF THE STRUCTURE.

MAINTENANCE REQUIREMENTS

- CONTRACTOR SHALL INSPECT SILT FENCES IMMEDIATELY AFTER EACH RAINFALL, AT LEAST DAILY DURING PROLONGED RAINFALL, AND WEEKLY DURING PERIODS OF NO RAINFALL. DAMAGED, COLLAPSED, UNINTENDED, OR INEFFECTIVE SILT FENCES SHALL BE PROMPTLY REPAIRED OR REPLACED.
- SEDIMENT SHALL BE REMOVED FROM BEHIND SILT FENCE WHEN IT ACCUMULATES TO APPROXIMATELY 1/2 THE HEIGHT OF THE EXPOSED GEOTEXTILE HEIGHT.
- SILT FENCES SHALL BE REMOVED WHEN ADEQUATE VEGETATIVE COVER IS ATTAINED AS APPROVED BY THE CITY.

City of Colorado Springs Stormwater Quality Figure SF-2 Silt Fence Construction Detail and Maintenance Requirements

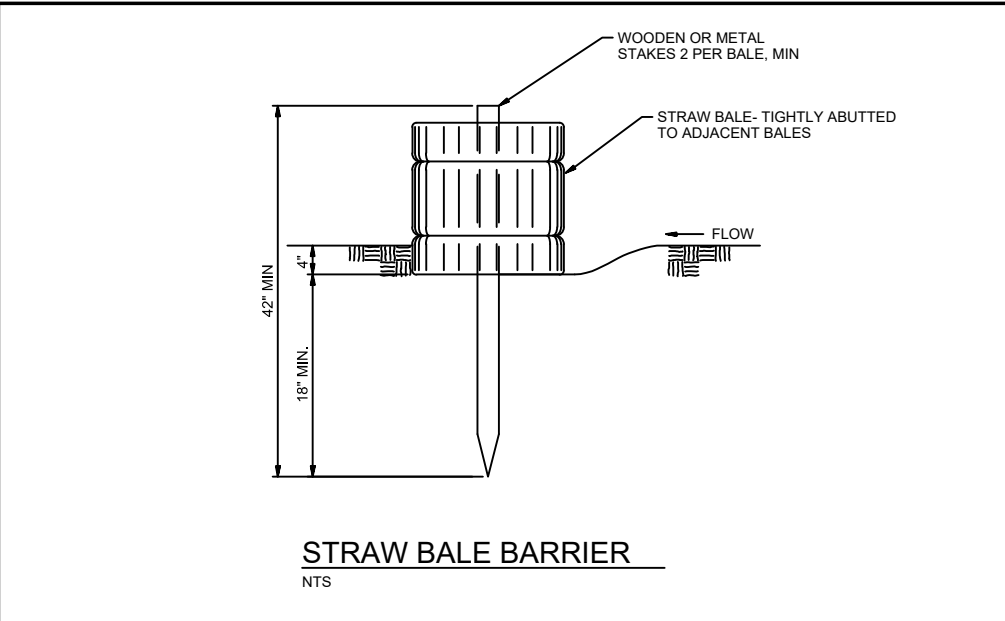

INSTALLATION REQUIREMENTS

- STRAW BALE BARRIERS SHALL BE INSTALLED PRIOR TO ANY LAND DISTURBING ACTIVITIES.
- BALES SHALL CONSIST OF APPROXIMATELY 5 CUBIC FEET OF SORTED WHEAT FREE WAYS OR STRAW AND WEIGH NOT LESS THAN 35 POUNDS.
- BALES ARE TO BE PLACED IN A SINGLE ROW WITH THE END OF THE BALES TIGHTLY ABUTTING ONE ANOTHER.
- EACH BALE IS TO BE SECURELY ANCHORED WITH AT LEAST TWO STAKES AND THE FIRST STAKE IS TO BE COVERED TOWARD THE PREVIOUSLY Laid BALE TO FORCE THE BALES TOGETHER.
- STAKES ARE TO BE A MINIMUM OF 42 INCHES LONG. METAL STAKES SHALL BE STANDING UP OF PER LINEAR FOOT. WOOD STAKES SHALL HAVE A MINIMUM DIAMETER OR CROSS SECTION DIMENSION OF 2 INCHES.
- BALES ARE TO BE BOUND WITH EITHER WIRE OR STRING AND ORIENTED SUCH THAT THE ENDINGS ARE AROUND THE SIDES AND NOT ALONG THE TOPS AND BOTTOMS OF THE BALE.
- GAPS BETWEEN BALES ARE TO BE CHINKED (FILLED BY WEAVING) WITH STRAW OR THE SAME MATERIAL OF THE BALE.
- END BALES ARE TO EXTEND UPLOPE SO THE TRAPPED RUNOFF CANNOT FLOW AROUND THE ENDS OF THE BARRIER.

MAINTENANCE REQUIREMENTS

- CONTRACTOR SHALL INSPECT STRAW BALE BARRIERS IMMEDIATELY AFTER EACH RAINFALL, AT LEAST DAILY DURING PROLONGED RAINFALL, AND WEEKLY DURING PERIODS OF NO RAINFALL.
- DAMAGED OR INEFFECTIVE BARRIERS SHALL PROMPTLY BE REPAIRED. REPAIRING BALES IS NECESSARY, AND UNINTENDED BALES NEED TO BE REPAIRED WITH COMPACTED BACKFILL MATERIAL.
- SEDIMENT SHALL BE REMOVED FROM BEHIND STRAW BALE BARRIERS WHEN IT ACCUMULATES TO APPROXIMATELY 1/2 THE HEIGHT OF THE BARRIER.
- STRAW BALE BARRIERS SHALL BE REMOVED WHEN ADEQUATE VEGETATIVE COVER IS ATTAINED AS APPROVED BY THE CITY.

City of Colorado Springs Stormwater Quality Figure SBB-2 Straw Bale Barrier Construction Detail and Maintenance Requirements

SEEDING MIX:

GRASS	VARIETY	AMOUNT IN PLS LBS. PER ACRE
CRESTED WHEAT GRASS	EPHRAIM	4.0 LBS.
PERENNIAL RYE	LINN	2.0 LBS.
WESTERN WHEATGRASS	SARTON	3.0 LBS.
SMOOTH BROME GRASS	LINCOLN OR MANCHAR	5.0 LBS.
SIDEOATS GRAMA	EPHRAIM	2.5 LBS.
TOTAL:		16.5 LBS.

SEEDING & FERTILIZER APPLICATION: DRILL SEED OR HYDRO-SEED PER CDOT SPEC. SECTION 212.

MULCHING APPLICATION: CONFORM TO CDOT SPEC-SECTION 213.

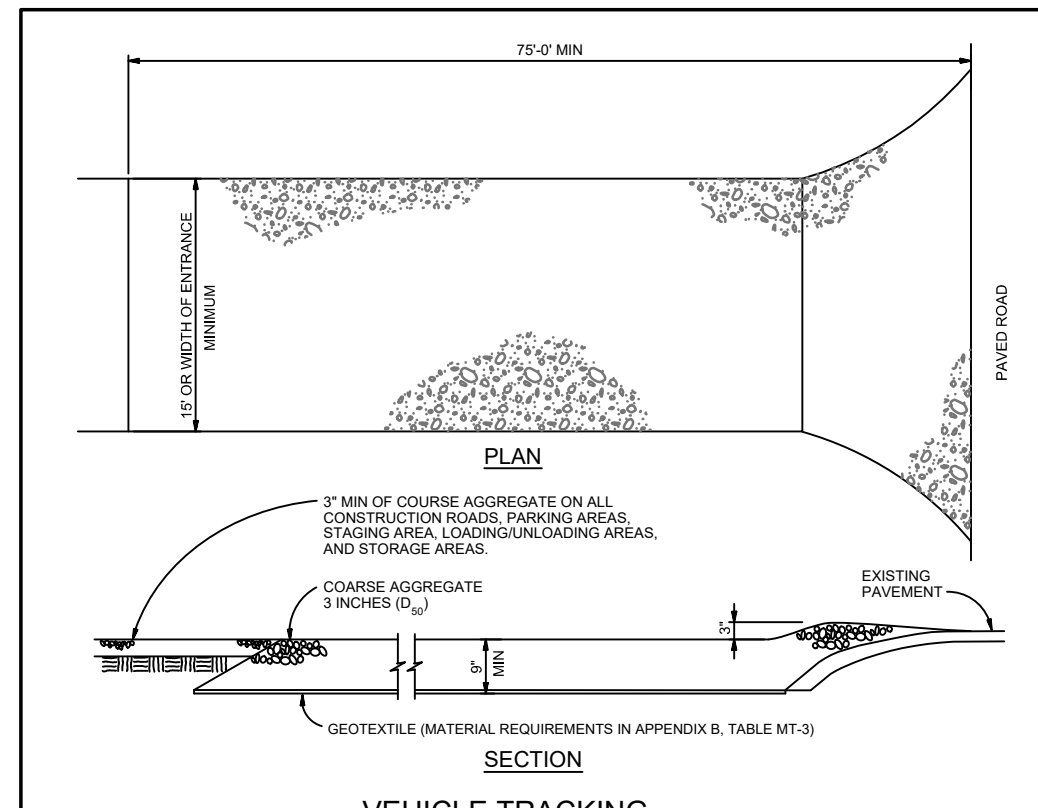

VEHICLE TRACKING

INSTALLATION REQUIREMENTS

- ALL ENTRANCES TO THE CONSTRUCTION SITE ARE TO BE STABILIZED PRIOR TO CONSTRUCTION BEGINNING.
- CONSTRUCTION ENTRANCES ARE TO BE BUILT WITH AN IMPROVEMENT TO ALLOW FOR TURNING TRAFFIC, BUT SHOULD NOT BE BUILT OVER EXISTING PAVEMENT EXCEPT FOR A SLIGHT OVERLAP.
- AREAS TO BE STABILIZED ARE TO BE PROPERLY GRADED AND COMPACTED PRIOR TO LAYING DOWN GEOTEXTILE AND STONE.
- CONSTRUCTION ROADS, PARKING AREAS, LOADING/UNLOADING ZONES, STORAGE AREAS, AND STAGING AREAS ARE TO BE STABILIZED.
- CONSTRUCTION ROADS ARE TO BE BUILT TO CONFORM TO SITE GRADES, BUT SHOULD NOT HAVE SIDE SLOPES OR ROAD GRADES THAT ARE EXCESSIVELY STEEP.

MAINTENANCE REQUIREMENTS

- REGULAR INSPECTIONS ARE TO BE MADE OF ALL STABILIZED AREAS, ESPECIALLY AFTER STORM EVENTS.
- STONES ARE TO BE REPLACED PERIODICALLY AND WHEN REPAIR IS NECESSARY.
- SEMI-TRUCK TRACKED ONTO PAVED ROADS IS TO BE REMOVED ONLY BY SHOULDER OR SHOULDER. SEDIMENT IS NOT TO BE WASHED DOWN STORM DRAINAGE SYSTEMS.
- STORM SEWER INLET PROTECTION IS TO BE IN PLACE, INSPECTED, AND CLEANED IF NECESSARY.
- OTHER ASSOCIATED SEDIMENT CONTROL MEASURES ARE TO BE INSPECTED TO ENSURE GOOD WORKING CONDITION.

City of Colorado Springs Stormwater Quality Figure VT-2 Vehicle Tracking Application Examples

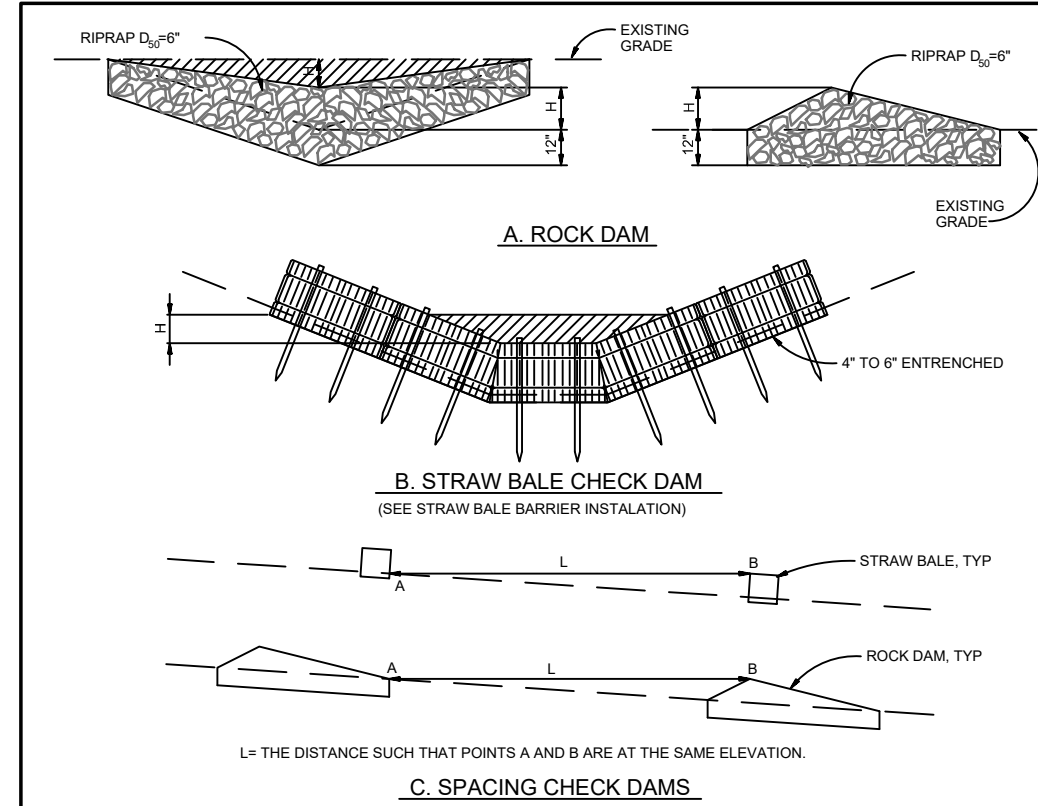

INSTALLATION REQUIREMENTS

- STRAW BALES USED AS CHECK DAMS ARE TO MEET THE REQUIREMENTS STATED IN FIGURE SBB-2.
- THE 1/4" DIMENSION SHALL BE SELECTED TO PROVIDE WEIR FLOW CAPACITY FOR 2-YEAR FLOW OR GREATER.
- ACCUMULATED SEDIMENT AND DEBRIS IS TO BE REMOVED FROM BEHIND THE DAMS AFTER EACH STORM OR WHEN 1/2 OF THE ORIGINAL HEIGHT OF THE DAM IS REACHED.
- CHECK DAMS ARE TO REMAIN IN PLACE AND OPERATIONAL UNTIL THE DRAINAGE AREA AND CHANNEL ARE PERMANENTLY STABILIZED.
- WHEN CHECK DAMS ARE REMOVED THE CHANNEL LINING OR VEGETATION IS TO BE RESTORED.

MAINTENANCE REQUIREMENTS

- REGULAR INSPECTIONS ARE TO BE MADE OF ALL CHECK DAMS, ESPECIALLY AFTER STORM EVENTS.
- REPLACE STONE AS NECESSARY TO MAINTAIN THE CORRECT HEIGHT OF THE DAM.
- ACCUMULATED SEDIMENT AND DEBRIS IS TO BE REMOVED FROM BEHIND THE DAMS AFTER EACH STORM OR WHEN 1/2 OF THE ORIGINAL HEIGHT OF THE DAM IS REACHED.
- WHEN CHECK DAMS ARE REMOVED THE CHANNEL LINING OR VEGETATION IS TO BE RESTORED.

City of Colorado Springs Stormwater Quality Figure CD-1 Check Dam Construction Detail and Maintenance Requirements

EROSION CONTROL NOTES:

AT LEAST TEN DAYS PRIOR TO THE ANTICIPATED START OF CONSTRUCTION, FOR PROJECTS THAT WILL DISTURB 1 ACRE OR MORE, THE OWNER OR OPERATOR OF THE CONSTRUCTION ACTIVITY SHALL SUBMIT A PERMIT APPLICATION FOR STORMWATER DISCHARGE TO THE COLORADO DEPARTMENT OF PUBLIC HEALTH AND ENVIRONMENT, WATER QUALITY CONTROL DIVISION. THE APPLICATION CONTAINS CERTIFICATION OF COMPLETION OF A STORMWATER MANAGEMENT PLAN (SWMP), OF WHICH THIS GRADING AND EROSION CONTROL PLAN MAY BE A PART. FOR INFORMATION OR APPLICATION MATERIALS CONTACT:
 COLORADO DEPARTMENT OF PUBLIC HEALTH AND ENVIRONMENT
 WATER QUALITY CONTROL DIVISION
 WQCD-PERMITS
 4300 CHERRY CREEK DRIVE SOUTH
 DENVER, COLORADO 80246-1530
 ATTN: PERMITS UNIT

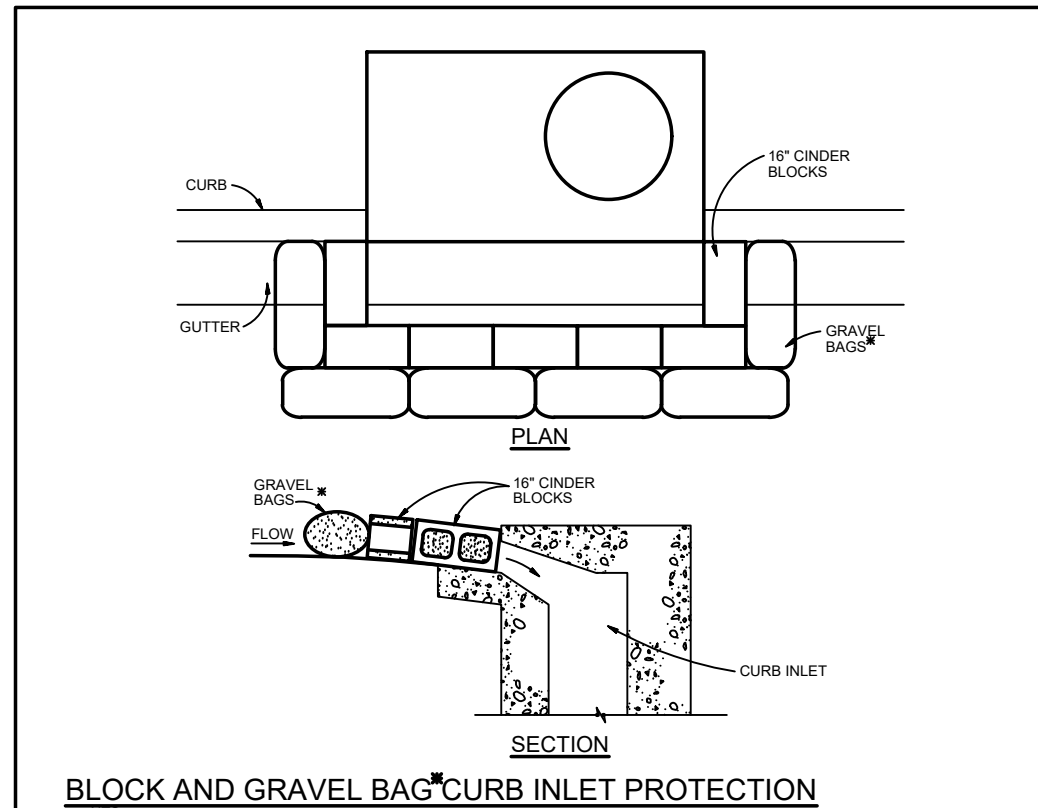

BLOCK AND GRAVEL BAG CURB INLET PROTECTION

INSTALLATION REQUIREMENTS

- INLET PROTECTION SHALL BE INSTALLED IMMEDIATELY AFTER CONSTRUCTION OF INLET.
- CONCRETE BLOCKS ARE TO BE LAID AROUND THE INLET IN A SINGLE ROW ON THEIR SIDES ABUTTING ONE ANOTHER WITH THE OPEN ENDS OF THE BLOCK FACING OUTWARD.
- GRAVEL BAGS ARE TO BE PLACED AROUND THE CONCRETE BLOCKS, ABUTTING ONE ANOTHER SO THERE ARE NO GAPS.
- GRAVEL BAGS ARE TO CONTAIN WASHED SAND OR GRAVEL APPROXIMATELY 3/4 INCH IN DIAMETER.
- BAGS ARE TO BE MADE OF 1/4" INCH WIRE MESH (USED WITH GRAVEL ONLY) OR GEOTEXTILE.

MAINTENANCE REQUIREMENTS

- CONTRACTOR SHALL INSPECT INLET PROTECTION IMMEDIATELY AFTER EACH RAINFALL, AT LEAST DAILY DURING PROLONGED RAINFALL, AND WEEKLY DURING PERIODS OF NO RAINFALL.
- DAMAGED OR INEFFECTIVE INLET PROTECTION SHALL PROMPTLY BE REPAIRED OR REPLACED.
- SEDIMENT SHALL BE REMOVED WHEN SEDIMENT HAS ACCUMULATED TO APPROXIMATELY 1/2 THE DESIGN DEPTH OF THE POND.
- INLET PROTECTION SHALL BE REMOVED WHEN ADEQUATE VEGETATIVE COVER IS ATTAINED WITHIN THE DRAINAGE AREA AS APPROVED BY THE CITY.

WIRE MESH: 1/4" TO 1/2" WIRE FILTER OVER A WIRE SCREEN MAY BE USED IN PLACE OF GRAVEL BAGS. THE WIRE MESH SHALL EXTEND ABOVE THE TOP OF THE CONCRETE BLOCKS AND THE GRAVEL PLACED OVER THE WIRE SCREEN TO THE TOP OF THE CONCRETE BLOCKS.

City of Colorado Springs Stormwater Quality Figure IP-3 Block & Gravel Bag Curb Inlet Protection Construction Detail and Maintenance Requirements

ESTIMATED TIME SCHEDULE:

ACTIVITY	DATE
INSTALL BMP'S	APRIL, 2020
GRADING START	APRIL, 2020
GRADING COMPLETION	AUGUST, 2020
SEEDING & MULCHING	AUGUST, 2020
STABILIZATION	AUGUST, 2021

SEDIMENT CONTROL MAINTENANCE PROGRAM:
 FREQUENCY 1
 BI-WEEKLY
 RE-VEGETATION OF EXPOSED SOILS WITHIN 21 DAYS OF GRADING
 SEDIMENT REMOVAL FROM BMP'S MONTHLY
 REMOVAL OF BMP'S AFTER STABILIZATION ACHIEVED

1 AND AFTER ANY PRECIPITATION OR SNOW MELT EVENT THAT CAUSES SURFACE EROSION.

2 ACCUMULATED SEDIMENT AND DEBRIS SHALL BE REMOVED WHEN THE SEDIMENT LEVEL REACHES ONE HALF THE HEIGHT OF THE BMP OR AT ANY TIME THAT SEDIMENT OR DEBRIS ADVERSELY IMPACTS THE FUNCTION OF THE BMP.

MAYBERRY, COLORADO SPRINGS - FILING NO. 2

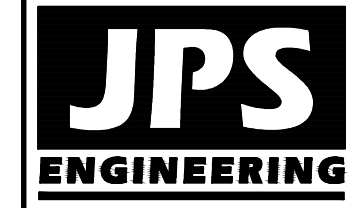

19 E. Willamette Ave.
 Colorado Springs, CO
 80903
 PH: 719-477-9429
 FAX: 719-471-0766
 www.jsengr.com



CALL UTILITY NOTIFICATION CENTER OF COLORADO
 1-800-922-1987
 TO LOCATE UTILITIES BEFORE YOU DIG OR EXCAVATE FOR THE MARKING OF UNDERGROUND MEMBER UTILITIES.

NO.	REVISION	DATE
1	EPC COMMENTS	7/18/19
2	EPC COMMENTS	11/30/20

EROSION CONTROL NOTES & DETAILS

HORIZ. SCALE:	VERT. SCALE:	DATE:	DRAWN:
NTS	N/A	7/18/19	RMD
SURVEYED:	CHECKED:		JPS
CREATED:	LAST MODIFIED:	3/24/06	JPS
PROJECT NO:	MODIFIED BY:	090001	BJJ

SHEET: **C1.04**