

Forsgren Associates, LLC
56 Inverness Drive East, Suite 112
Englewood, CO 80128
(720) 214-5884

August 20, 2019
El Paso County Development Services
Attn: Len Kendall
2880 International Circle, Ste 110
Colorado Springs, CO 80910

**SUBJECT: The Sod Guy
Sales Lot
Drainage Letter – Lot 1 in Appaloosa Highway 24 Subdivision Filing No 1A**

Dear Mr.Kendall,

This letter is being presented to discuss existing and future drainage features of the site at Lot 1 in Appaloosa Highway 24 Subdivision Filing No 1A and to provide a description of the proposed work. Justification will be provided showing there will be no negative impact to existing drainage features or downstream conditions.

Revise statement. the FDR was approved on 3/11/2019.

This project is located in the southwest 1/4 of Section 7, Township 14 South, and Range 65 West of the 6th Principal Meridian. The legal description of the property is Lot 1 in Appaloosa Highway 24 Subdivision. It has a tax ID number of 54073-17-012 and is zoned I-2. The streets that border the project area are US Highway-24 (Platte Avenue) to the South, Amelia St. to the West and Terminal Ave. to the North. Lot 1 in Appaloosa Highway 24 Subdivision is a vacant plot of land with no previous use. A 50-foot drainage easement borders the property to the east and contains a large concrete channel. An existing one-story building is located to the northwest at 5975 Terminal Avenue. A Final Drainage Report for Appaloosa Highway 24 Subdivision Filing No. 2, Lots 1, 2 & 3 has been previously submitted for approval. This site shall be in conformance with all applicable information provided in said Final Drainage Report.

Move the signature blocks to the front after the intro paragraph.

Description of Property

Lot 1 has an area of 0.98 acres and is currently vacant. Runoff from the site flows, generally, to the southwest to an existing swale which delivers the water to an existing storm inlet. The soil type for Lot 1 consists of Truckton sandy loam at slopes of 0-3%. Truckton sandy loams are of the hydrologic soil group A. See Appendix for the Custom Soils Resource Report for the site obtained from the National Cooperative Soil Survey (<https://websoilsurvey.sc.egov.usda.gov/App/HomePage.htm>).

Major Basin Description

The site is located within the Sand Creek Drainage Basin. The site was previously studied as part of the previously approved drainage letter by HY-Power Company, approved December 1, 2000.

Add page numbers

Floodplain Statement

The proposed improvements are not within a 100-year floodplain, FIRM #08041C0754F; revision date May 23, 2007. See Appendix for FEMA FIRM Floodplain maps.

Update to the latest FIRM Map (Dec 2018)

Subbasin Description

The entire site lies within the Sand Creek Drainage Basin. Stormwater runoff collected on site shall generally be detained in a proposed Extended Detention Basin (EDB) on the southwest corner of the site. In addition to the EDB being installed by others, a proposed Type C inlet shall be installed at the southwest corner of Lot 1 to convey flows to Lot 2. Flows will travel along the frontage of Amelia St. to the south along a grass lined swale to a second Type C inlet where the flows will be conveyed through a 18-inch HDPE storm sewer to the EDB. The EDB shall be installed on the east side of Lot 3 in Appaloosa Highway 24 Subdivision.

Revise narrative. Identifying >5% of lot shall be grassed area is not sufficient in describing how the design employed runoff reduction practices. See ECM I.7.2 for reduction practices.

Four Step Process to Minimize Adverse Impacts of

El Paso County requires the UDFCD Four Step Process. The goal of the Four Step Process is to reduce runoff volumes, stabilize drainageways, and implement long-term source controls. With development projects with construction activities disturbing 1 acre or more, the Four Step Process must be implemented. Below is a description of all steps of the Four Step Process and how they were utilized in design.

Step 1: Employ Runoff Reduction Practices

In order to reduce the runoff to Sand Creek Drainage Basin, LID strategies were implemented. LID techniques investigated and/or utilized include conserving existing features and minimizing impact to the overall site. Greater than 5% of the total square footage of the lot shall be grassed area with landscaping.

Step 2: Implement BMPs that Provide a Water Quality Capture Volume with Slow Release

It has been determined that full-spectrum detention is required and will be provided on site. A full-spectrum, EDB will be installed with an outlet structure with three stages to release the water quality capture volume (WQCV) over 40-hours, excess urban runoff volume (EURV) over 72-hours, and the 100-year storm volume.

Update narrative. No on-site EDB is proposed.

Step 3: Stabilize Drainageways

Runoff flows directly offsite via underground storm piping to the southwest. The overall 100-year storm runoff of 5.3 cfs will not impact downstream drainageways. No streams or drainageways are present on, or adjacent to, the site.

Step 4: Implement Site Specific and Other Source Control BMPs

Sites with specific needs, such as material storage or other site operations, require specific, source control BMPs be implemented on site, post-construction. For this site, contaminants from site activities are not anticipated. In addition, no hazardous materials or other outdoor storage will be done on-site. No site specific or other source control BMPs are proposed for this site.

Revise the 4 step process to match ECM I.7.2
Step 1: Employ Runoff Reduction Practices
Step 2: Stabilized Drainageways
Step 3: Provide WQCV
Step 4: Consider Need for Industrial and Commercial BMPs

Proposed Conditions

The Sod Guy proposes the construction of a new sales lot and outdoor storage area. The majority of the surfacing will be gravel, with the entrance and parking being asphalt or concrete pavement. Currently, the site is covered in pervious, grass surface. A final drainage report shall be completed and submitted by others that takes into account all additional impervious surface added per this site work. An extended detention basin shall be installed to provide 100-year detention for Lots 1, 2 & 3 and shall release runoff at historic rates. The Owner of Lot 3 in Appaloosa Highway 24 Subdivision shall be responsible for maintaining this drainage facility. All drainage features shall be approved prior to construction in order to adequately convey and detain stormwater runoff.

It is the professional opinion of the engineer that the proposed improvements will not have any negative impacts on the existing site conditions or the storm drainage system’s ability to convey flows from the site and will not adversely affect the downstream and surrounding developments.

Please let me know if you have any questions.

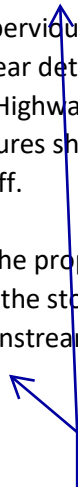

Since the highlighted sentence must be revised. The Appaloosa Hwy 24 FDR (PCD File No. VR-18-013) was approved on 03/11/2019. This drainage letter needs to show that the Lot 1 design is in conformance with the Appaloosa FDR. If it does not conform then provide a design that mitigates the additional impact.
Conner Burba, P.E.
Project Engineer
Example: The narrative on Step 3 (pg 2) noted 100yr runoff of 5.3 cfs which is higher than the Appaloosa FDR which calculated Q100=4.5 cfs

Design Engineer’s Statement:

The attached drainage plan and report were prepared under my direction and supervision and are correct to the best of my knowledge and belief. Said drainage report has been prepared according to the criteria established by the County for drainage reports and said report is in conformity with the applicable master plan of the drainage basin. I accept responsibility for any liability caused by any negligent acts, errors or omissions on my part in preparing this report.

Conner Burba, P.E. #51257

Date

Provide existing and proposed drainage map for Lot 1.
Provide computation of the Lot 1 percent impervious, c-values and Q5/Q100 to show it's in conformance with the approved Appaloosa Hwy 24 subdivision FDR.
Provide a vicinity map

Add a section regarding drainage fees. State whether or not fees are due with this application.

Owner/Developer's Statement:

I, the owner/developer have read and will comply with all of the requirements specified in this drainage report and plan.

Ed Apodaca

Date

The Sod Guy

42600 Summit View Ct, Parker, CO 80138

El Paso County:

Filed in accordance with the requirements of the Drainage Criteria Manual, Volumes 1 and 2, El Paso County Engineering Criteria Manual and Land Development Code as amended.

Jennifer Irvine, P.E.

Date

County Engineer / ECM Administrator

Conditions:

THE SOD GUY - SALES LOT

SITE DEVELOPMENT PLANS

LOT 1, APPALOOSA HIGHWAY 24 SUBDIVISION FILING NO 1A

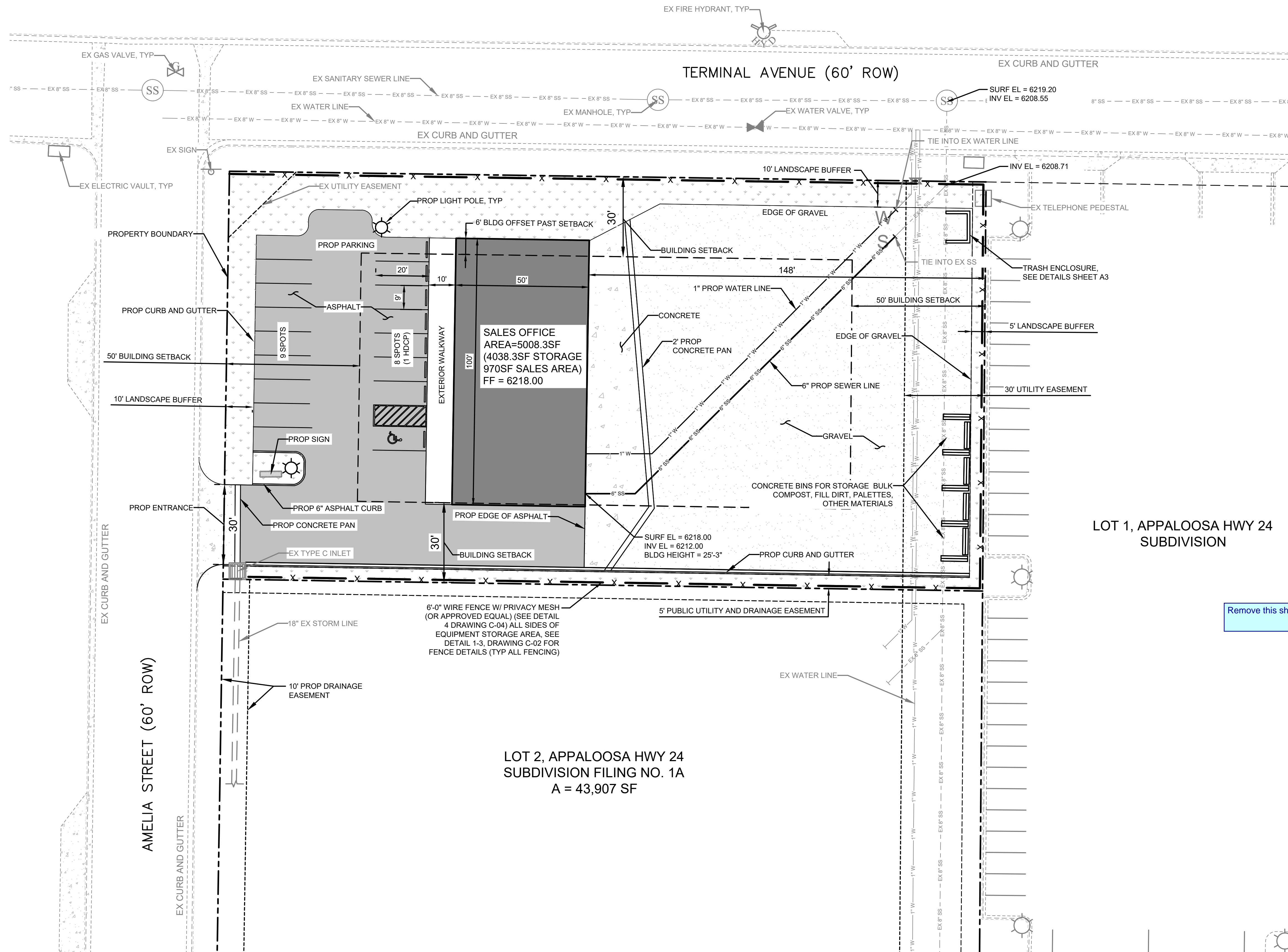

THE PARTIES RESPONSIBLE FOR THIS PLAN HAVE FAMILIARIZED THEMSELVES WITH ALL CURRENT ACCESSIBILITY CRITERIA AND SPECIFICATIONS AND THE PROPOSED PLAN REFLECTS ALL SITE ELEMENTS REQUIRED BY THE APPLICABLE ADA DESIGN STANDARDS AND GUIDELINES AS PUBLISHED BY THE UNITED STATES DEPARTMENT OF JUSTICE. APPROVAL OF THIS PLAN BY EL PASO COUNTY DOES NOT ASSURE COMPLIANCE WITH THE ADA OR ANY REGULATIONS OR GUIDELINES ENACTED OR PROMULGATED UNDER OR WITH RESPECT TO SUCH LAWS.

- LEGEND:**
- PROPOSED GRAVEL
 - PROPOSED ASPHALT
 - PROPOSED FENCE
 - PROPOSED LANDSCAPING

- GENERAL CONSTRUCTION NOTES:**
- PARKING DIMENSIONS ARE TO FACE OF CURB.
 - CONTRACTOR SHALL PROTECT EXISTING APPURTENANCES AND POWER POLES
 - SIDE LOT BUILDING SETBACK = 25'-0". FRONT LOT BUILDING SETBACK = 50'-0"
 - CONTRACTOR SHALL ADHERE TO ALL APPLICABLE ADA REQUIREMENTS.
 - LANDSCAPING AND 6-FOOT FENCING SURROUNDING NORTH, SOUTH AND EAST EDGES OF SITE SHALL BE PROVIDED FOR SCREENING FOR OUTDOOR STORAGE AREA
 - EQUIPMENT AND SOD SHALL BE STORED WITHIN THE BUILDING. OUTDOOR STORAGE SHALL ONLY CONSIST OF WHAT IS BEING STORED WITHIN THE CONCRETE STORAGE BINS.
 - PROPOSED FREESTANDING SIGN SHALL BE LOCATED APPROXIMATELY 13 FEET FROM THE WESTERLY PROPERTY LINE (MINIMUM REQUIRED OF 3 FEET). THE HEIGHT OF THE LOW PROFILE SIGN SHALL NOT EXCEED 12 FEET.

PARKING COUNT CALCULATIONS:
 RETAIL BUILDING FOR SOD SALES = 5008 SQ FT
 RETAIL PARKING REQUIREMENT = 1 SPACE / 600 SQ FT
 TOTAL MINIMUM PARKING COUNT = 5008 / 600
 TOTAL MINIMUM PARKING COUNT = 9 SPACES (1 HANDICAP)

EL PASO COUNTY CODE	REQUIRED	PROVIDED
PARKING SPACES	8	16
HANDICAP PARKING	1	1
TOTAL PARKING	9	17

LOT 1, APPALOOSA HWY 24 SUBDIVISION

Remove this sheet from the drainage letter

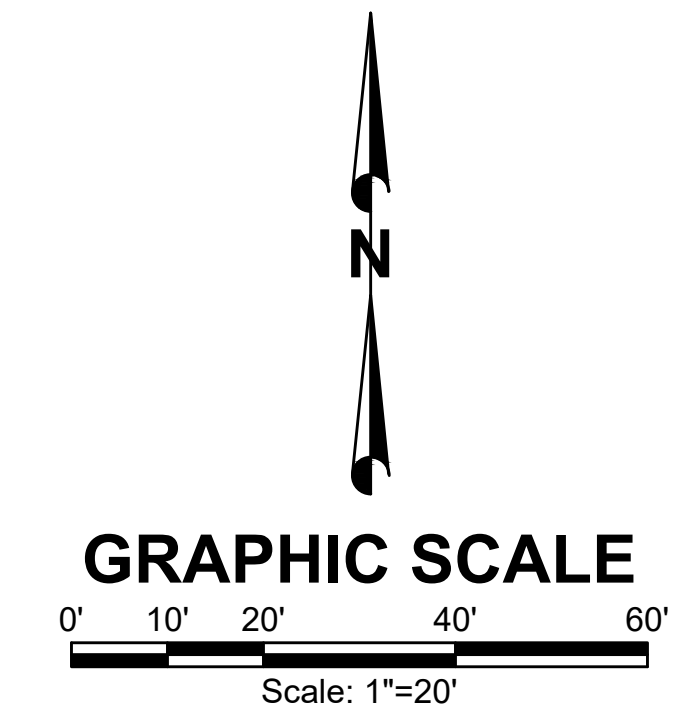

NO.	REVISIONS	BY	DATE

FORSGREN Associates, Inc.
 56 Inverness Drive East, Suite 112, Englewood, CO 80112
 PH: 720.214.5884 FAX: 720.000.0000

PROJECT NO.	04-18-2XXX
DRAWN	C. BURBA
DESIGNED	C. BURBA
APPROVED	C. BURBA
QA/QC	J. MOORE

OWNER
 THE SOD GUY
 COLORADO SPRINGS, CO

THE SOD GUY - SALES LOT
SITE PLAN

SHEET NO:
C-01
 DATE:
 09/10/19
 PAGE NO:
 1 OF 2

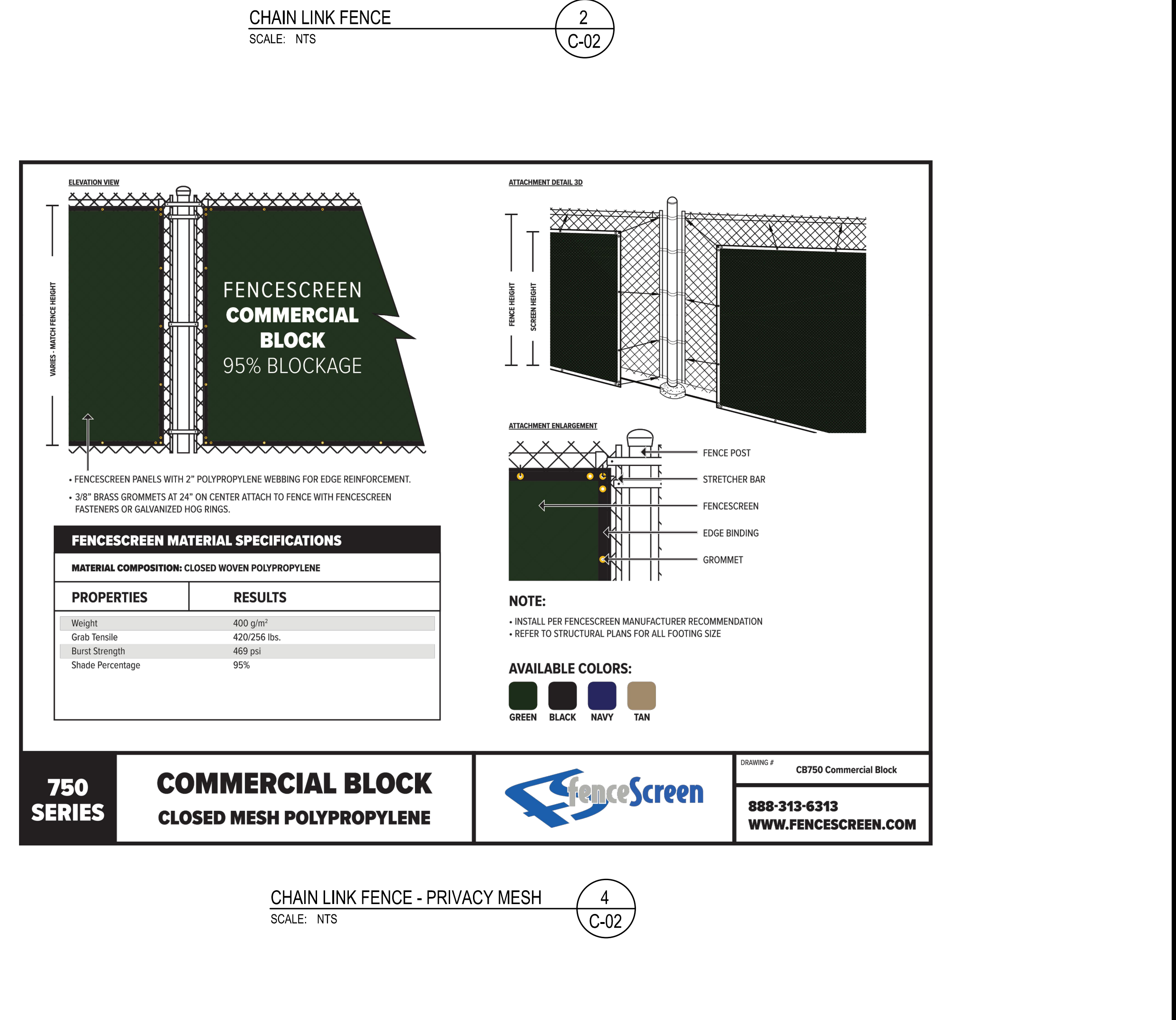
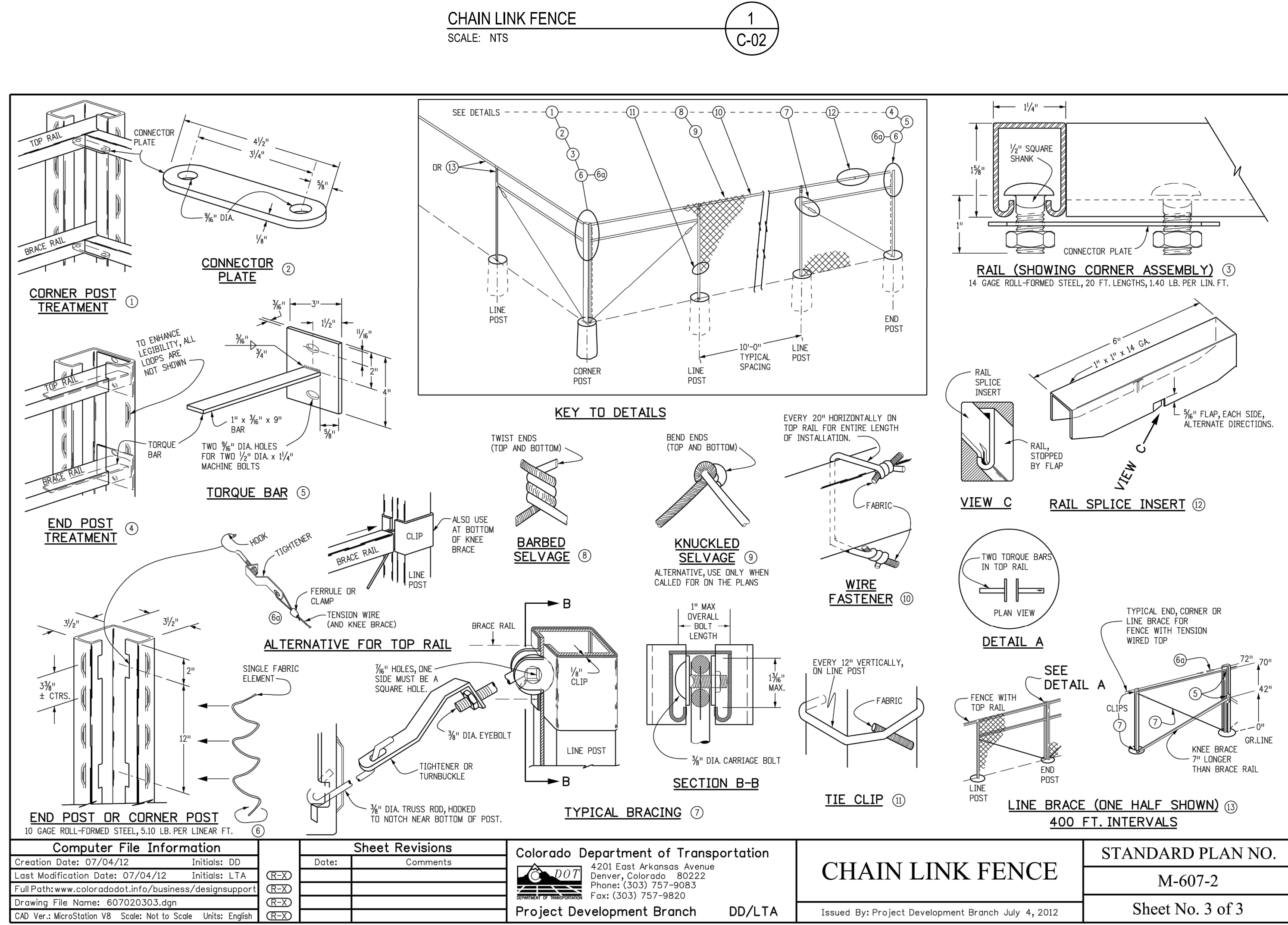
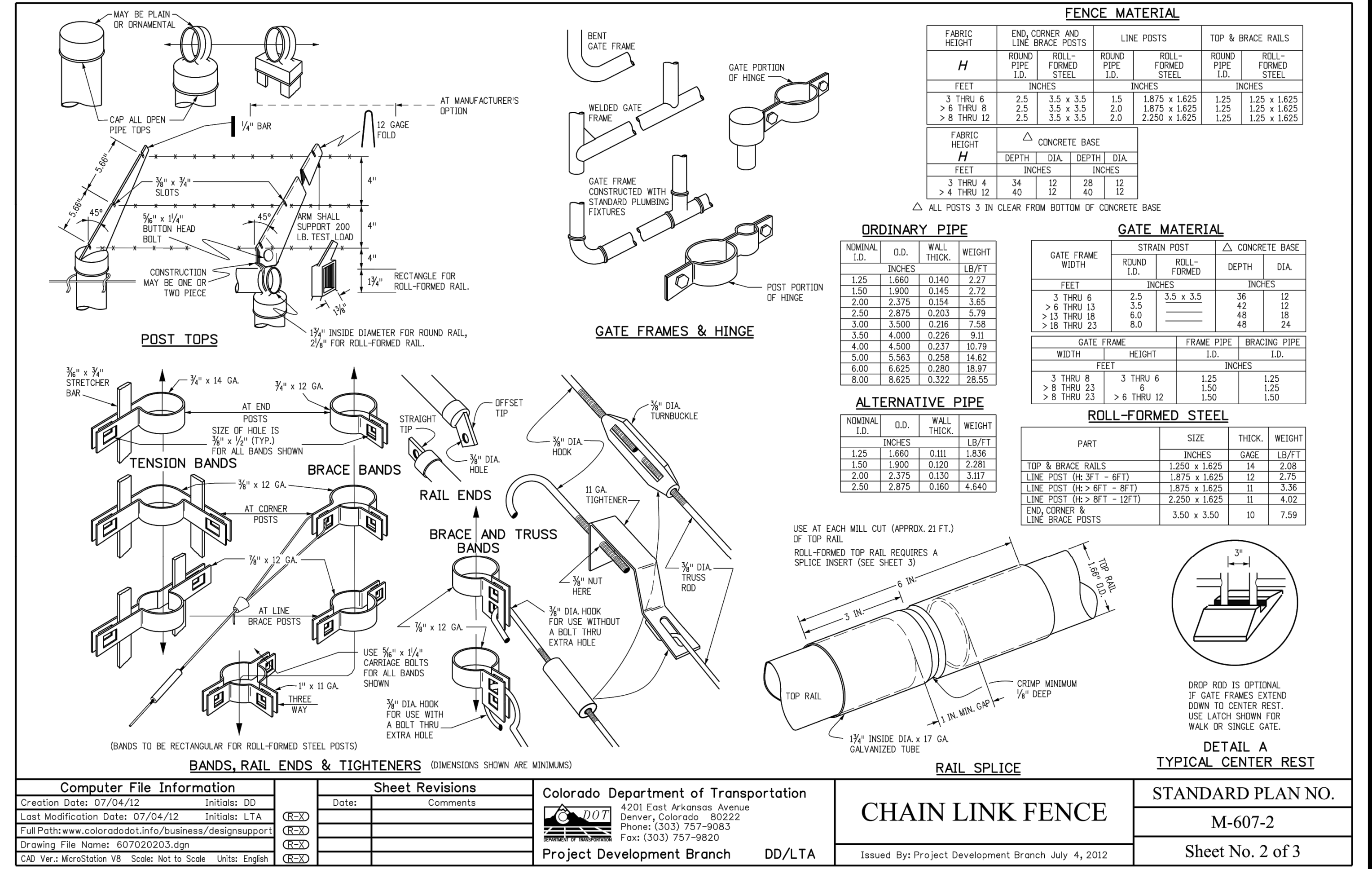
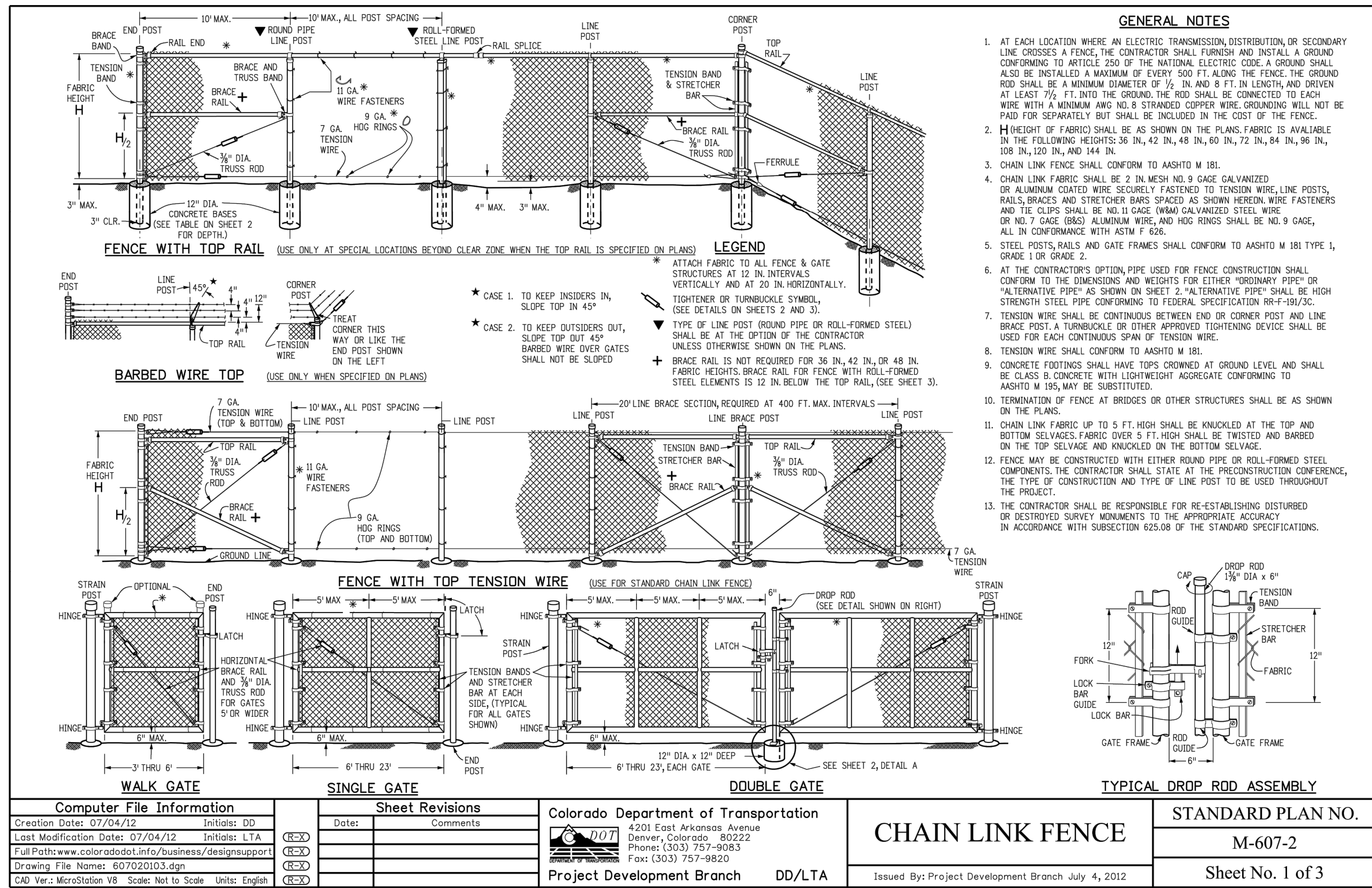

P:\Clients\The Sod Guy\CAD\Development\Plan\Fence Details.dwg --- 9/11/2019 12:07 PM

FORSGREN Associates, Inc.
 56 Inverness Drive East, Suite 112, Englewood, CO 80112
 PH: 720.214.5884 FAX: 720.000.0000

PROJECT NO. 04-18-2XXX
 DRAWN: #####
 DESIGNED: #####
 APPROVED: #####
 QA/QC: #####

OWNER
 THE SOD GUY
 COLORADO SPRINGS, CO

SALES LOT
 THE SOD GUY - SALES LOT

FENCE DETAILS

SHEET NO: C-02
 DATE: 09/10/19
 PAGE NO: 2 OF 2

Remove this sheet from the drainage letter

PCD FILE NO. PPR1925

DATE	ISSUED AS
----	ZD APPROVAL
----	CD PRELIMINARY / REVIEW
----	BID SETS
----	PERMIT SUBMITTED

DATE	REVISIONS
----	----
----	----
----	----
----	----
----	----
----	----
----	----
----	----
----	----
----	----

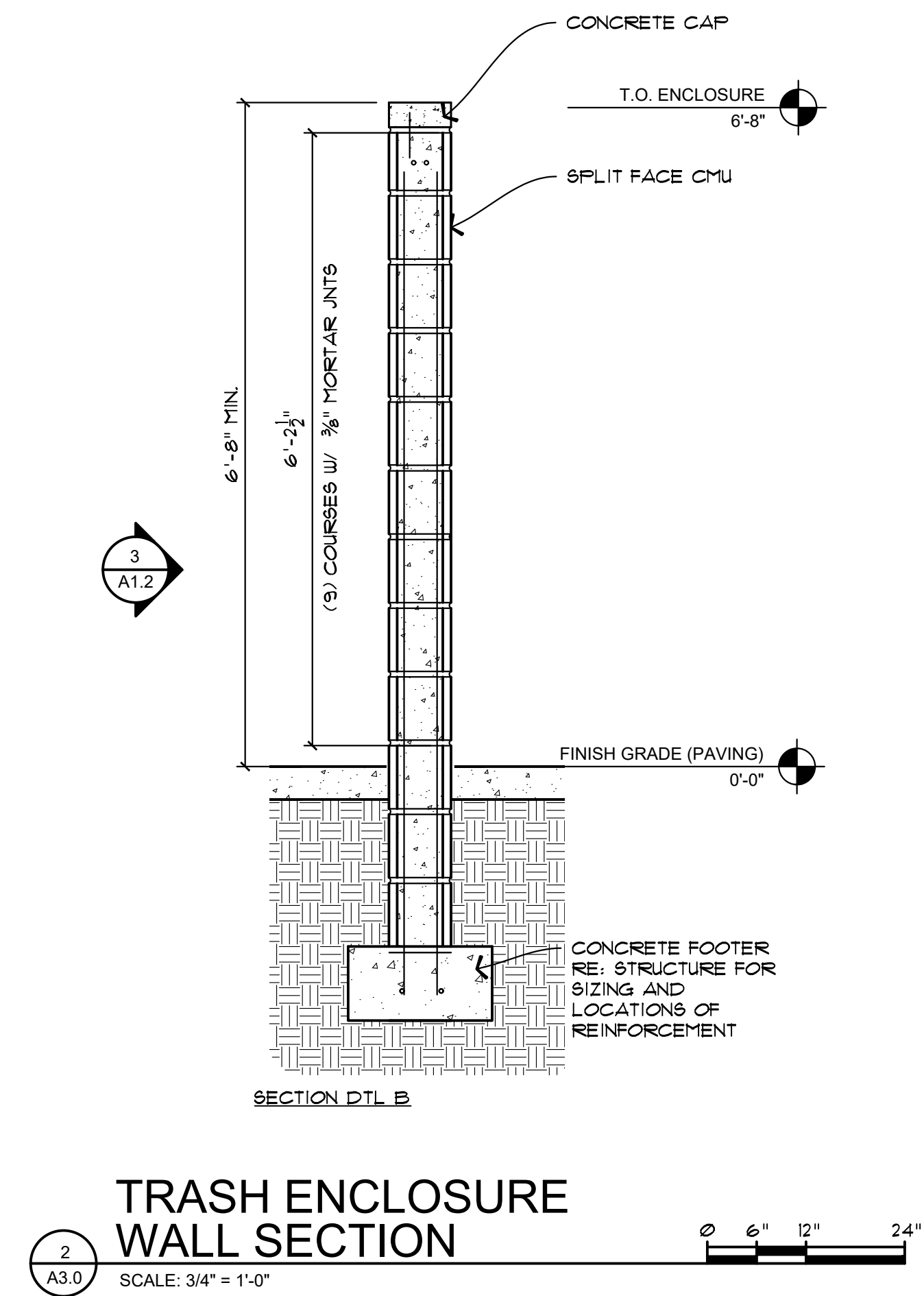

TRASH ENCLOSURE WALL SECTION
 SCALE: 3/4" = 1'-0"
 0" 6" 12" 24"

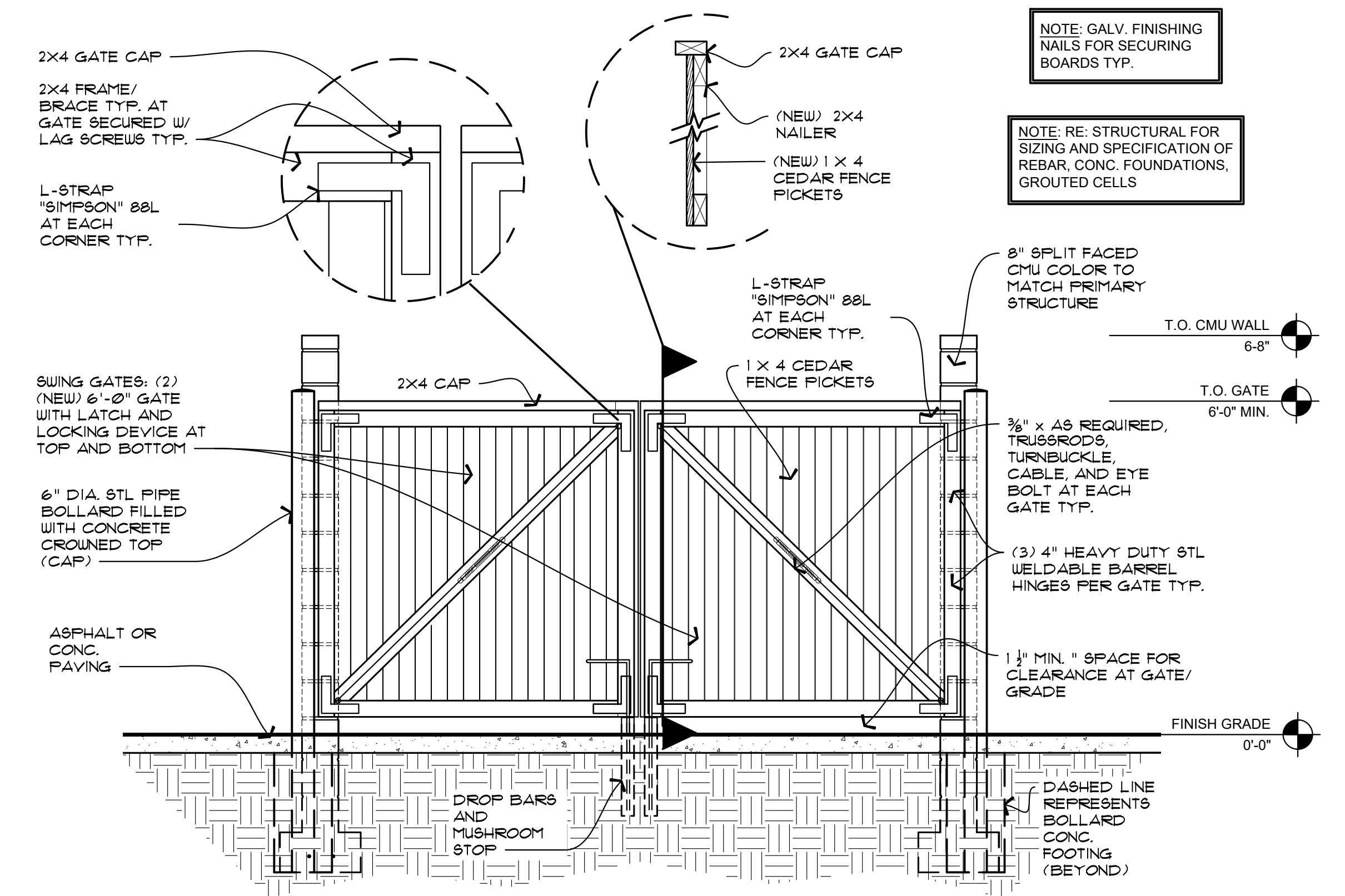

TRASH ENCLOSURE ELEVATION
 SCALE: 1/2" = 1'-0"
 0" 1" 2" 4"

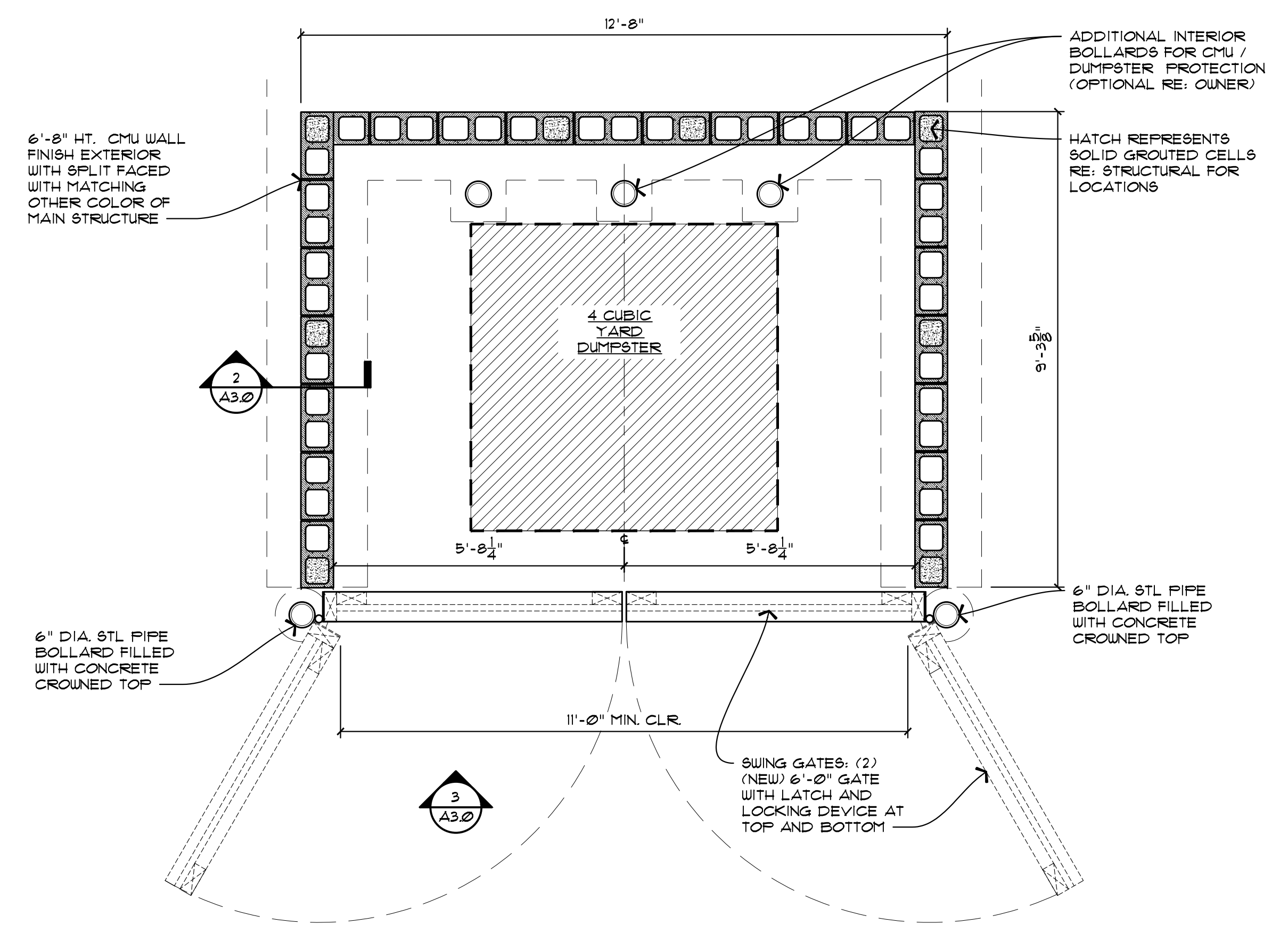

TRASH ENCLOSURE ELEVATION
 SCALE: 1/2" = 1'-0"
 0" 1" 2" 4"
 LOCATE TRASH ENCLOSURE W/ 30' OF APPROACH CLEARANCE OR JURISDICTIONAL REQUIREMENT

Remove this sheet from the drainage letter



Federal Emergency Management Agency

Washington, D.C. 20472

JAN 3 0 2007

CERTIFIED MAIL
RETURN RECEIPT REQUESTED

The Honorable Lionel Rivera
Mayor, City of Colorado Springs
P.O. Box 1575
Colorado Springs, CO 80901

IN REPLY REFER TO:

Case No.: 05-08-0368P
Community Name: City of Colorado Springs, CO
Community No.: 080060
Effective Date of **MAY 23 2007**
This Revision:

Dear Mayor Rivera:

The Flood Insurance Study report and Flood Insurance Rate Map for your community have been revised by this Letter of Map Revision (LOMR). Please use the enclosed annotated map panel(s) revised by this LOMR for floodplain management purposes and for all flood insurance policies and renewals issued in your community.

Additional documents are enclosed which provide information regarding this LOMR. Please see the List of Enclosures below to determine which documents are included. Other attachments specific to this request may be included as referenced in the Determination Document. If you have any questions regarding floodplain management regulations for your community or the National Flood Insurance Program (NFIP) in general, please contact the Consultation Coordination Officer for your community. If you have any technical questions regarding this LOMR, please contact the Director, Federal Insurance and Mitigation Division of the Department of Homeland Security's Federal Emergency Management Agency (FEMA) in Denver, Colorado, at (303) 235-4830, or the FEMA Map Assistance Center toll free at 1-877-336-2627 (1-877-FEMA MAP). Additional information about the NFIP is available on our website at <http://www.fema.gov/nfip>.

Sincerely,

Patrick, F. Sacibit, P.E., CFM, Project Engineer .
Engineering Management Section
Mitigation Division

For: William R. Blanton Jr., CFM, Chief
Engineering Management Section
Mitigation Division

List of Enclosures:

Letter of Map Revision Determination Document
Annotated Flood Insurance Rate Map
Annotated Flood Insurance Study Report

cc: The Honorable Sallie Clark
Chair, El Paso County
Board of Commissioners

Regional Floodplain Administrator
Pikes Peak Regional Building Department

J. F. Sato and Associates, Inc.

Engineering and Surveying, Inc.

Remove the LOMR and replace with the latest FIRMette (pg 8 to pg 22 of this pdf)



Federal Emergency Management Agency
Washington, D.C. 20472

**LETTER OF MAP REVISION
DETERMINATION DOCUMENT**

COMMUNITY AND REVISION INFORMATION		PROJECT DESCRIPTION	BASIS OF REQUEST
COMMUNITY	City of Colorado Springs El Paso County Colorado	CHANNELIZATION CULVERT	FLOODWAY HYDRAULIC ANALYSIS NEW TOPOGRAPHIC DATA BASEMAP CHANGES
	COMMUNITY NO.: 080060		
IDENTIFIER	Sand Creek Center Tributary and East Fork LOMR	APPROXIMATE LATITUDE & LONGITUDE: 38.830, -104.720 SOURCE: USGS QUADRANGLE DATUM: NAD 27	
ANNOTATED MAPPING ENCLOSURES		ANNOTATED STUDY ENCLOSURES	
TYPE: FIRM* NO.: 08041C0753 F DATE: March 17, 1997 TYPE: FIRM NO.: 08041C0754 F DATE: March 17, 1997		DATE OF EFFECTIVE FLOOD INSURANCE STUDY: August 23, 1999 PROFILE(S): 205P, 206P, 209P, and 210P FLOODWAY DATA TABLE: 5	

Enclosures reflect changes to flooding sources affected by this revision.

* FIRM - Flood Insurance Rate Map; ** FBFM - Flood Boundary and Floodway Map; *** FHBM - Flood Hazard Boundary Map

FLOODING SOURCE(S) & REVISED REACH(ES)

See Page 2 for Additional Flooding Sources

Sand Creek Center Tributary – from just upstream of Airport Road to approximately 1,350 feet upstream of East Frontage Road

SUMMARY OF REVISIONS

Flooding Source	Effective Flooding	Revised Flooding	Increases	Decreases
Sand Creek Center Tributary	Zone AE	Zone AE	YES	YES
	Floodway	Floodway	YES	YES
	BFEs*	BFEs	YES	YES
	Zone X (shaded)	Zone X (shaded)	YES	YES

* BFEs - Base Flood Elevations

DETERMINATION

This document provides the determination from the Department of Homeland Security's Federal Emergency Management Agency (FEMA) regarding a request for a Letter of Map Revision (LOMR) for the area described above. Using the information submitted, we have determined that a revision to the flood hazards depicted in the Flood Insurance Study (FIS) report and/or National Flood Insurance Program (NFIP) map is warranted. This document revises the effective NFIP map, as indicated in the attached documentation. Please use the enclosed annotated map panels revised by this LOMR for floodplain management purposes and for all flood insurance policies and renewals in your community.

This determination is based on the flood data presently available. The enclosed documents provide additional information regarding this determination. If you have any questions about this document, please contact the FEMA Map Assistance Center toll free at 1-877-336-2627 (1-877-FEMA MAP) or by letter addressed to the LOMR Depot, 3601 Eisenhower Avenue, Alexandria, VA 22304. Additional Information about the NFIP is available on our website at <http://www.fema.gov/nfip>.

Patrick F. Sacbbit, P.E., CFM, Project Engineer
Engineering Management Section
Mitigation Division



Federal Emergency Management Agency
Washington, D.C. 20472

**LETTER OF MAP REVISION
DETERMINATION DOCUMENT (CONTINUED)**

OTHER FLOODING SOURCES AFFECTED BY THIS REVISION

FLOODING SOURCE(S) & REVISED REACH(ES)

Sand Creek East Fork – from approximately 970 feet downstream of Powers Boulevard to just downstream of Stewart Avenue

SUMMARY OF REVISIONS

Flooding Source	Effective Flooding	Revised Flooding	Increases	Decreases
Sand Creek East Fork	Zone AE	Zone AE	YES	YES
	Floodway	Floodway	YES	YES
	BFEs*	BFEs	YES	YES
	Zone X (shaded)	Zone X (shaded)	YES	YES

* BFEs - Base Flood Elevations

This determination is based on the flood data presently available. The enclosed documents provide additional information regarding this determination. If you have any questions about this document, please contact the FEMA Map Assistance Center toll free at 1-877-336-2627 (1-877-FEMA MAP) or by letter addressed to the LOMR Depot, 3601 Eisenhower Avenue, Alexandria, VA 22304. Additional information about the NFIP is available on our website at <http://www.fema.gov/nfip>.

Patrick F. Sacbbit, P.E., CFM, Project Engineer
Engineering Management Section
Mitigation Division



Federal Emergency Management Agency
Washington, D.C. 20472

**LETTER OF MAP REVISION
DETERMINATION DOCUMENT (CONTINUED)**

OTHER COMMUNITIES AFFECTED BY THIS REVISION

CID Number: 080059 **Name:** El Paso County, Colorado

AFFECTED MAP PANELS

TYPE: FIRM	NO.: 08041C0752 F	DATE: March 17, 1997
TYPE: FIRM	NO.: 08041C0753 F	DATE: March 17, 1997
TYPE: FIRM	NO.: 08041C0754 F	DATE: March 17, 1997

AFFECTED PORTIONS OF THE FLOOD INSURANCE STUDY REPORT

DATE OF EFFECTIVE FLOOD INSURANCE STUDY: August 23, 1999
PROFILE(S): 206P
FLOODWAY DATA TABLE: 5

This determination is based on the flood data presently available. The enclosed documents provide additional information regarding this determination. If you have any questions about this document, please contact the FEMA Map Assistance Center toll free at 1-877-336-2627 (1-877-FEMA MAP) or by letter addressed to the LOMR Depot, 3601 Eisenhower Avenue, Alexandria, VA 22304. Additional Information about the NFIP is available on our website at <http://www.fema.gov/nfip>.

Patrick F. Sacbibit, P.E., CFM, Project Engineer
Engineering Management Section
Mitigation Division



Federal Emergency Management Agency

Washington, D.C. 20472

LETTER OF MAP REVISION DETERMINATION DOCUMENT (CONTINUED)

COMMUNITY INFORMATION

APPLICABLE NFIP REGULATIONS/COMMUNITY OBLIGATION

We have made this determination pursuant to Section 206 of the Flood Disaster Protection Act of 1973 (P.L. 93-234) and in accordance with the National Flood Insurance Act of 1968, as amended (Title XIII of the Housing and Urban Development Act of 1968, P.L. 90-448), 42 U.S.C. 4001-4128, and 44 CFR Part 65. Pursuant to Section 1361 of the National Flood Insurance Act of 1968, as amended, communities participating in the NFIP are required to adopt and enforce floodplain management regulations that meet or exceed NFIP criteria. These criteria, including adoption of the FIS report and FIRM, and the modifications made by this LOMR, are the minimum requirements for continued NFIP participation and do not supersede more stringent State/Commonwealth or local requirements to which the regulations apply.

We provide the floodway designation to your community as a tool to regulate floodplain development. Therefore, the floodway revision we have described in this letter, while acceptable to us, must also be acceptable to your community and adopted by appropriate community action, as specified in Paragraph 60.3(d) of the NFIP regulations.

NFIP regulations Subparagraph 60.3(b)(7) requires communities to ensure that the flood-carrying capacity within the altered or relocated portion of any watercourse is maintained. This provision is incorporated into your community's existing floodplain management ordinances; therefore, responsibility for maintenance of the altered or relocated watercourse, including any related appurtenances such as bridges, culverts, and other drainage structures, rests with your community. We may request that your community submit a description and schedule of maintenance activities necessary to ensure this requirement.

COMMUNITY REMINDERS

We based this determination on the 1-percent-annual-chance flood discharges computed in the FIS for your community without considering subsequent changes in watershed characteristics that could increase flood discharges. Future development of projects upstream could cause increased flood discharges, which could cause increased flood hazards. A comprehensive restudy of your community's flood hazards would consider the cumulative effects of development on flood discharges subsequent to the publication of the FIS report for your community and could, therefore, establish greater flood hazards in this area.

Your community must regulate all proposed floodplain development and ensure that permits required by Federal and/or State/Commonwealth law have been obtained. State/Commonwealth or community officials, based on knowledge of local conditions and in the interest of safety, may set higher standards for construction or may limit development in floodplain areas. If your State/Commonwealth or community has adopted more restrictive or comprehensive floodplain management criteria, those criteria take precedence over the minimum NFIP requirements.

We will not print and distribute this LOMR to primary users, such as local insurance agents or mortgage lenders; instead, the community will serve as a repository for the new data. We encourage you to disseminate the information in this LOMR by preparing a news release for publication in your community's newspaper that describes the revision and explains how your community will provide the data and help interpret the NFIP maps. In that way, interested persons, such as property owners, insurance agents, and mortgage lenders, can benefit from the information.

This determination is based on the flood data presently available. The enclosed documents provide additional information regarding this determination. If you have any questions about this document, please contact the FEMA Map Assistance Center toll free at 1-877-336-2627 (1-877-FEMA MAP) or by letter addressed to the LOMR Depot, 3601 Eisenhower Avenue, Alexandria, VA 22304. Additional information about the NFIP is available on our website at <http://www.fema.gov/nfip>.

A handwritten signature in black ink, appearing to read "P. Sacbibit".

Patrick F. Sacbibit, P.E., CFM, Project Engineer
Engineering Management Section
Mitigation Division



Federal Emergency Management Agency
Washington, D.C. 20472

**LETTER OF MAP REVISION
DETERMINATION DOCUMENT (CONTINUED)**

We have designated a Consultation Coordination Officer (CCO) to assist your community. The CCO will be the primary liaison between your community and FEMA. For information regarding your CCO, please contact:

Ms. Jeanine D. Petterson
Director, Federal Insurance and Mitigation Division
Federal Emergency Management Agency, Region VIII
Denver Federal Center, Building 710
P.O. Box 25267
Denver, CO 80225-0267
(303) 235-4830

STATUS OF THE COMMUNITY NFIP MAPS

We will not physically revise and republish the FIRM and FIS report for your community to reflect the modifications made by this LOMR at this time. When changes to the previously cited FIRM panel(s) and FIS report warrant physical revision and republication in the future, we will incorporate the modifications made by this LOMR at that time.

This determination is based on the flood data presently available. The enclosed documents provide additional information regarding this determination. If you have any questions about this document, please contact the FEMA Map Assistance Center toll free at 1-877-336-2627 (1-877-FEMA MAP) or by letter addressed to the LOMR Depot, 3601 Eisenhower Avenue, Alexandria, VA 22304. Additional Information about the NFIP is available on our website at <http://www.fema.gov/nfip>.

A handwritten signature in black ink, appearing to read "P. Sacbibit".

Patrick F. Sacbibit, P.E., CFM, Project Engineer
Engineering Management Section
Mitigation Division



Federal Emergency Management Agency

Washington, D.C. 20472

LETTER OF MAP REVISION DETERMINATION DOCUMENT (CONTINUED)

PUBLIC NOTIFICATION OF REVISION

PUBLIC NOTIFICATION

FLOODING SOURCE	LOCATION OF REFERENCED ELEVATION	BFE (FEET NGVD 29)		MAP PANEL NUMBER(S)
		EFFECTIVE	REVISED	
Sand Creek Center Tributary	Approximately 150 feet upstream of Airport Road	6,109	6,108	08041C0753 F
	Approximately 1,250 feet upstream of East Frontage Road	6,168	6,164	08041C0753 F
Sand Creek East Fork	Approximately 810 feet downstream of Powers Boulevard	6,099	6,096	08041C0753 F
	Approximately 140 feet downstream of Stewart Avenue	6,206	6,205	08041C0754 F

Within 90 days of the second publication in the local newspaper, a citizen may request that we reconsider this determination. Any request for reconsideration must be based on scientific or technical data. Therefore, this letter will be effective only after the 90-day appeal period has elapsed and we have resolved any appeals that we receive during this appeal period. Until this LOMR is effective, the revised BFEs presented in this LOMR may be changed.

A notice of changes will be published in the *Federal Register*. This information also will be published in your local newspaper on or about the dates listed below.

LOCAL NEWSPAPER Name: *El Paso County News*
 Dates: 02/14/2007 02/21/2007

This determination is based on the flood data presently available. The enclosed documents provide additional information regarding this determination. If you have any questions about this document, please contact the FEMA Map Assistance Center toll free at 1-877-336-2627 (1-877-FEMA MAP) or by letter addressed to the LOMR Depot, 3601 Eisenhower Avenue, Alexandria, VA 22304. Additional information about the NFIP is available on our website at <http://www.fema.gov/nfip>.

Patrick F. Sacbibit, P.E., CFM, Project Engineer
Engineering Management Section
Mitigation Division

FLOODING SOURCE		FLOODWAY			BASE FLOOD WATER SURFACE ELEVATION			INCREASE
CROSS SECTION	DISTANCE ¹	WIDTH (FEET)	SECTION AREA (SQ. FEET)	MEAN VELOCITY (FEET PER SECOND)	REGULATORY	WITHOUT FLOODWAY	WITH FLOODWAY	
					FEET (NGVD)	FEET (NGVD)		
Sand Creek East Fork								
A	1,100	100	455	11.9	6,038.7	6,038.7	0.0	
B	2,400	100	446	12.2	6,054.3	6,054.3	0.0	
C	3,330	100	450	12.0	6,069.9	6,069.9	0.0	
D	4,240	100	449	12.1	6,085.1	6,085.1	0.0	
E	4,870	102	446	12.0	6,095.1	6,095.1	0.0	
F	6,188	70	489	10.9	6,118.5	6,118.5	0.0	
G	7,403	71	396	13.5	6,136.0	6,136.0	0.0	
H	7,931	148	507	10.5	6,158.8	6,158.8	0.0	
I	8,943	98	444	12.0	6,169.0	6,169.0	0.0	
J	9,666	86	423	12.6	6,177.0	6,177.0	0.0	
K	10,721	81	415	12.8	6,193.3	6,193.3	0.0	
L	11,347	166	526	10.1	6,207.3	6,207.3	0.0	
M	11,375	173	632	8.4	6,207.9	6,207.9	0.0	
N	12,610	367	699	7.6	6,228.8	6,228.9	0.1	
O	13,720	188	570	10.0	6,241.7	6,241.7	0.0	
P	14,805	125	479	11.1	6,257.9	6,257.9	0.0	
Q	14,885	125	601	8.9	6,259.9	6,259.9	1.0	
R	15,850	228	582	9.2	6,268.7	6,268.7	0.0	
S	16,325	300	678	7.9	6,277.3	6,277.5	0.2	
T	16,995	321	690	7.7	6,291.4	6,292.0	0.6	
U	17,065	326	667	8.0	6,291.4	6,292.1	0.7	
V	17,915	388	1,598	3.3	6,293.4	6,294.0	0.6	
W	18,995	367	683	7.8	6,307.2	6,307.6	0.4	
X	20,525	413	706	7.5	6,326.4	6,327.1	0.7	
Y	22,125	255	620	8.6	6,348.7	6,348.8	0.1	
Z	23,105	397	706	7.6	6,359.9	6,359.9	0.0	
AA	24,835	431	705	7.4	6,383.7	6,383.7	0.0	
AB	26,505	353	667	7.8	6,401.0	6,401.5	0.5	

Revised Data

Revised by LOMR dated OCT 07 2004

¹ Feet above confluence with Sand Creek

FLOODWAY DATA

FEDERAL EMERGENCY MANAGEMENT AGENCY
EL PASO COUNTY, CO
 AND INCORPORATED AREAS

SAND CREEK EAST FORK

MAY 29 2007

TABLE 5

FLOODING SOURCE		FLOODWAY			BASE FLOOD WATER SURFACE ELEVATION			INCREASE
CROSS SECTION	DISTANCE ¹	WIDTH (FEET)	SECTION AREA (SQ. FEET)	MEAN VELOCITY (FEET PER SECOND)	REGULATORY	WITHOUT FLOODWAY	WITH FLOODWAY	
Sand Creek Center Tributary	940	40	92	Revised Data 8.6	6,106.5	6,106.5	6,106.5	0.0
A	990	40	118	6.7	6,107.2	6,107.2	6,107.2	0.0
B	2,238	91	120	6.6	6,120.2	6,120.2	6,120.2	0.0
C	3,948	46	95	8.0	6,138.3	6,138.3	6,138.3	0.0
D	4,547	170	159	4.8	6,147.4	6,147.4	6,147.4	0.0
E	5,539	52	97	7.8	6,156.8	6,156.8	6,156.8	0.0
F	7,191	63	104	7.3	6,176.2	6,176.2	6,176.2	0.0
G	7,940	52	98	7.8	6,189.6	6,189.6	6,189.6	0.0
H	8,527	40	67	5.7	6,197.6	6,197.6	6,197.6	0.0
I	9,366	17	42	9.0	6,213.4	6,213.4	6,213.4	0.0
J	10,055	232	278	4.0	6,221.9	6,221.9	6,221.9	0.0
K	10,627	539	469	2.4	6,230.6	6,230.6	6,230.6	0.0
L	11,321	31	79	9.1	6,241.1	6,241.1	6,241.1	0.0
M	11,648	60	99	7.3	6,244.6	6,244.6	6,244.6	0.8
N	12,840	29	85	9.6	6,253.8	6,253.8	6,253.8	0.0
O	13,730	27	83	9.9	6,273.6	6,273.6	6,273.6	0.0
P	14,592	26	68	9.3	6,299.7	6,299.7	6,299.7	0.0
Q	14,670	40	61	6.9	6,304.2	6,304.2	6,305.2	1.0
R	15,050	20	63	10.1	6,307.6	6,307.6	6,308.1	0.5
S	15,460	25	68	9.5	6,310.8	6,310.8	6,311.4	0.6
T	15,750	20	41	7.8	6,319.6	6,319.6	6,319.6	0.0
U	16,670	20	39	8.1	6,346.0	6,346.0	6,346.0	0.0
V								

¹ Feet Above confluence with Sand Creek East Fork

FEDERAL EMERGENCY MANAGEMENT AGENCY
EL PASO COUNTY, CO
 AND INCORPORATED AREAS

FLOODWAY DATA

MAY 23 2007

Sand Creek Center Tributary

TABLE 5

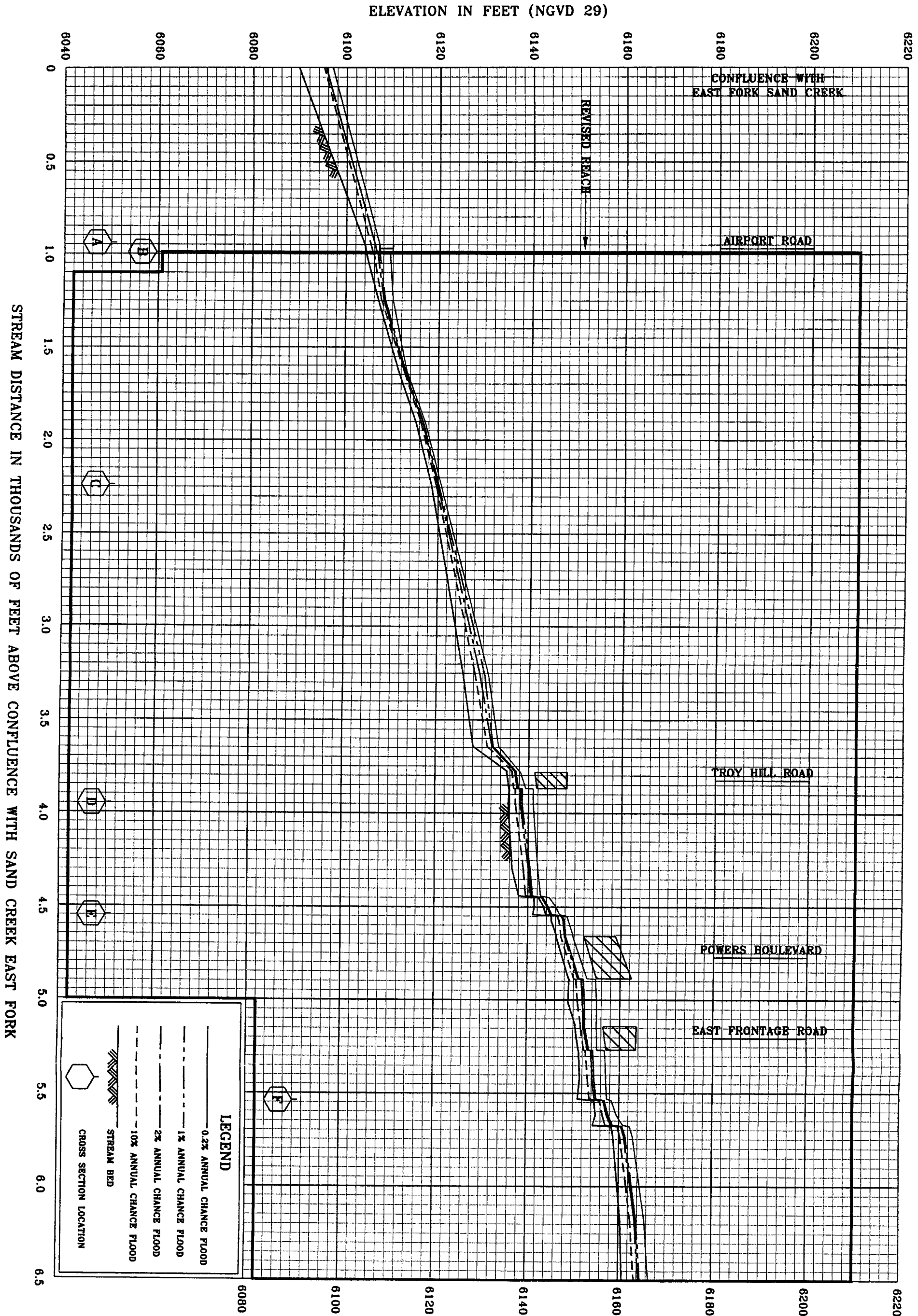

ELEVATION IN FEET (NGVD 29)

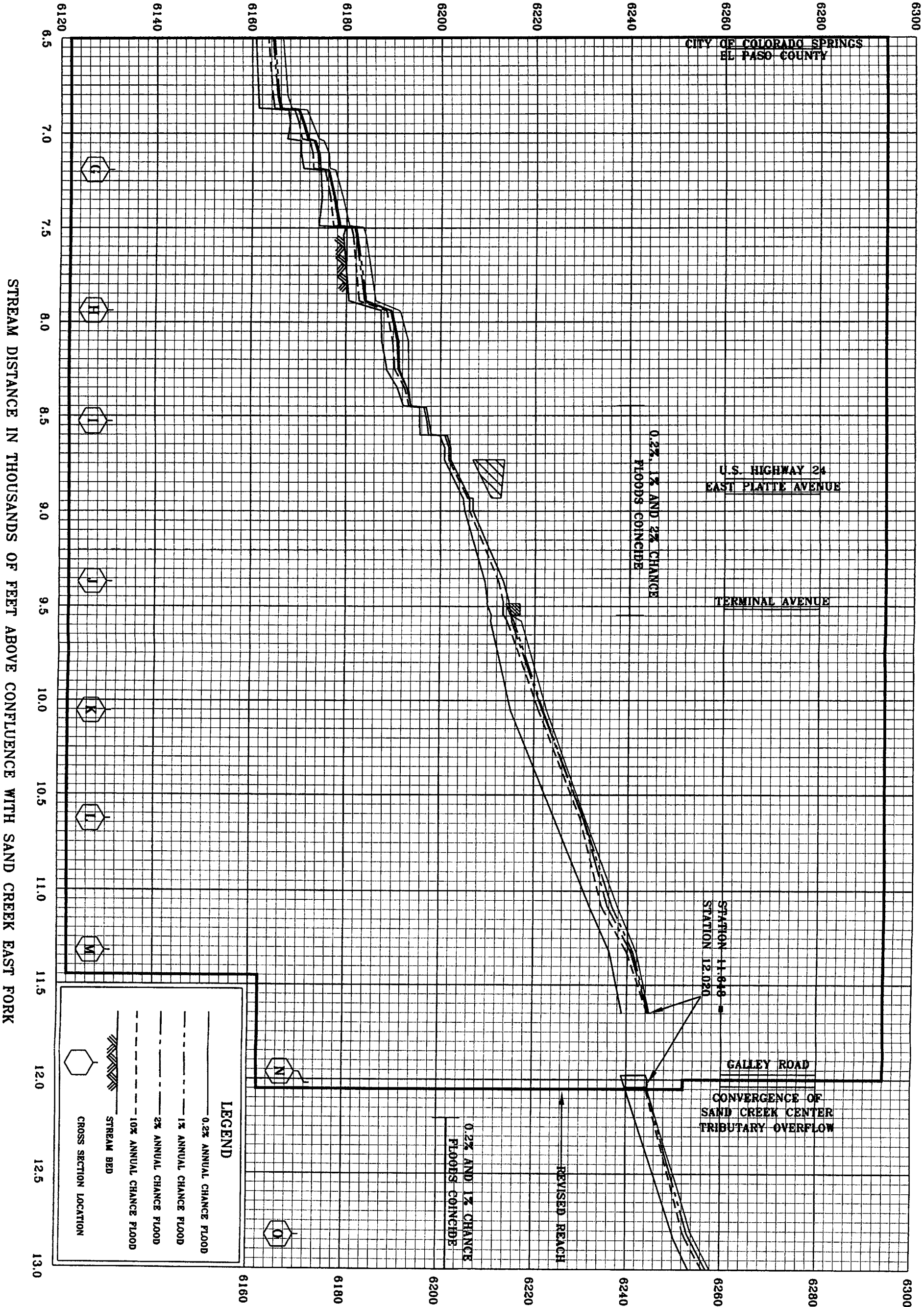

FEDERAL EMERGENCY MANAGEMENT AGENCY

EL PASO COUNTY, CO
AND INCORPORATED AREAS

FLOOD PROFILES

SAND CREEK CENTER TRIBUTARY

206P

10/10/83

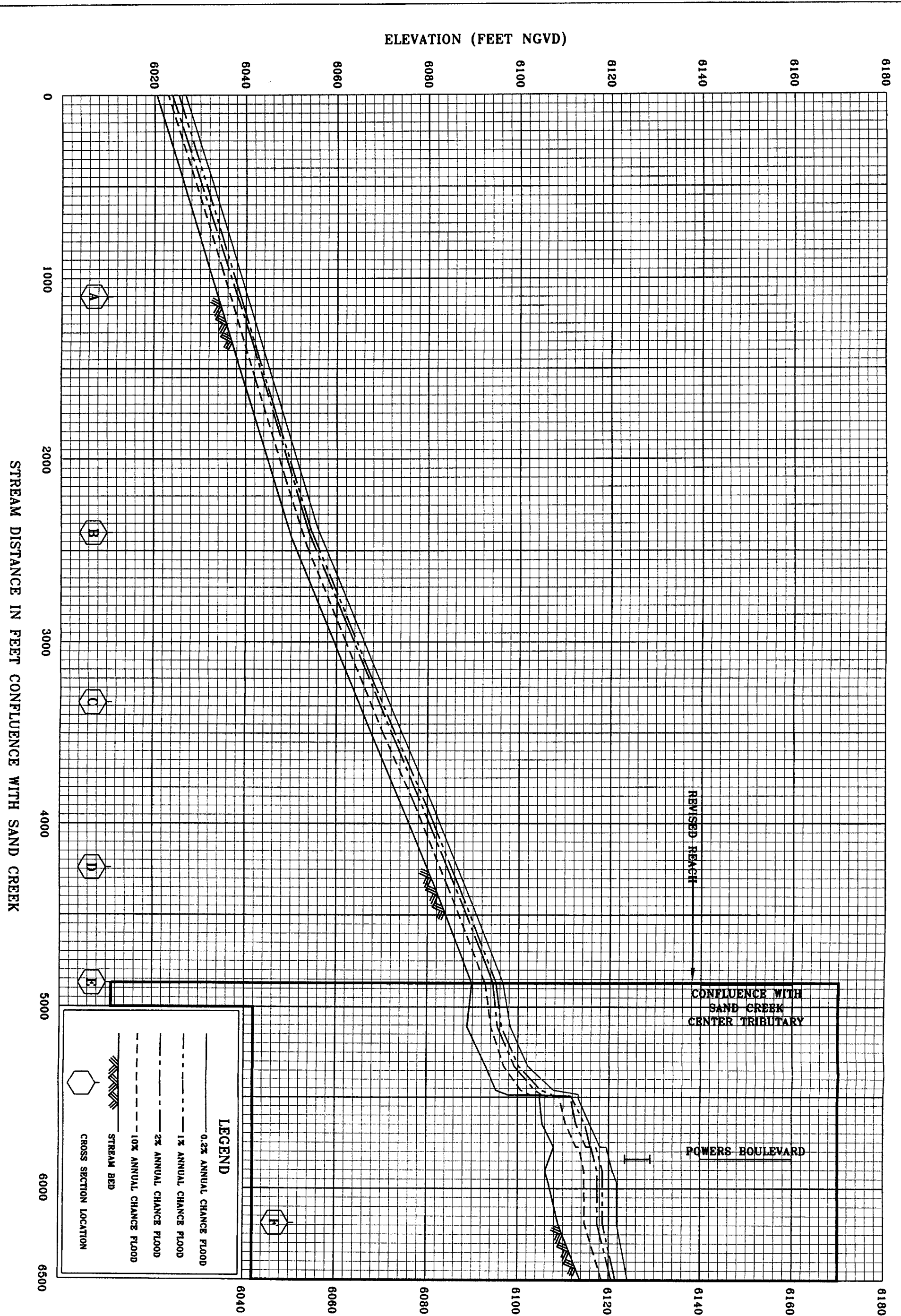

ELEVATION (FEET NGVD)

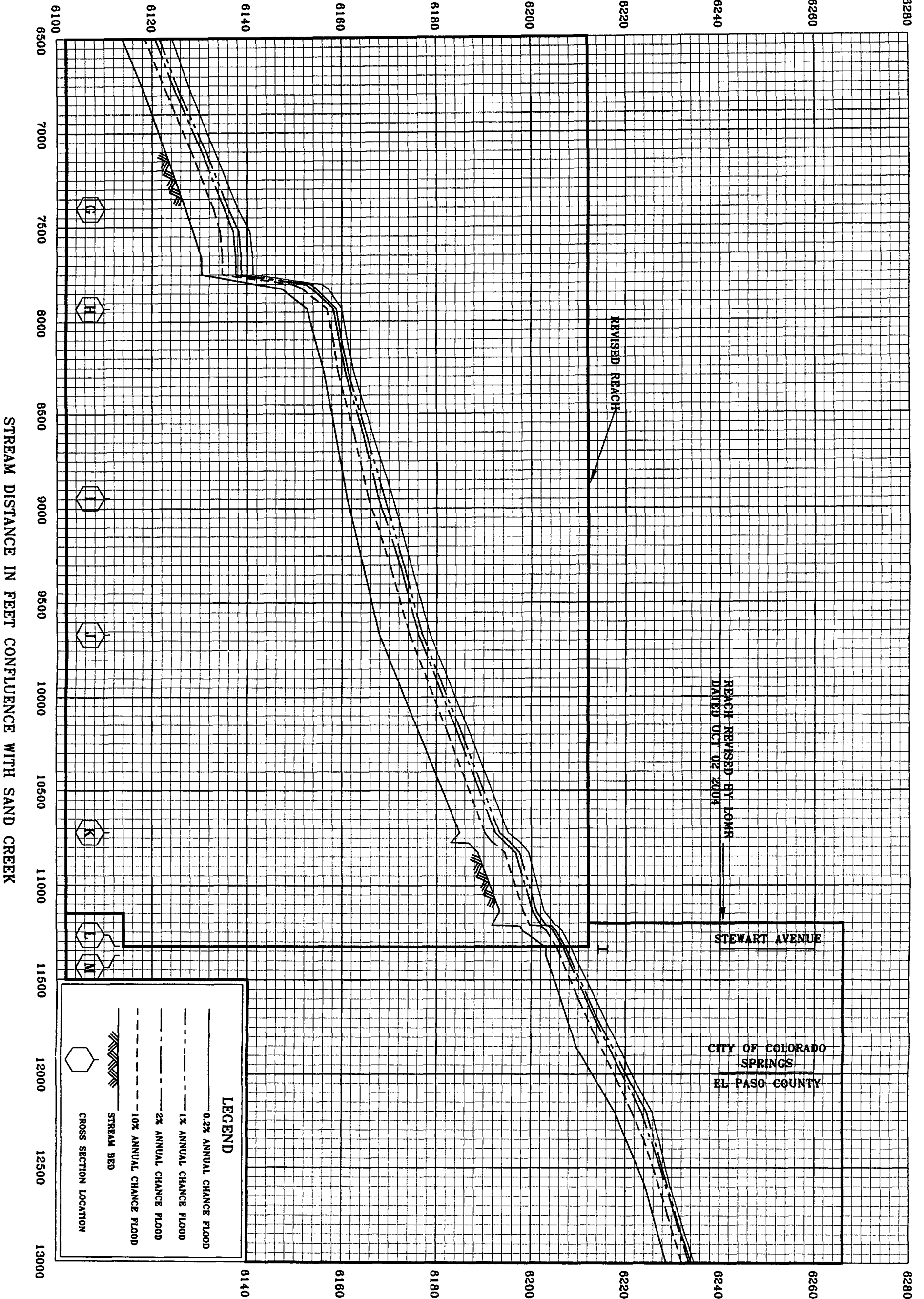

FEDERAL EMERGENCY MANAGEMENT AGENCY



EL PASO COUNTY, CO
AND INCORPORATED AREAS

FLOOD PROFILES

SAND CREEK EAST FORK

210P

EL PASO COUNTY
UNINCORPORATED AREAS
080059

- Legend
-  1% annual chance (100-Year) Floodplain
 -  1% annual chance (100-Year) Floodway
 -  0.2% annual chance (500-Year) Floodplain



APPROXIMATE SCALE IN FEET

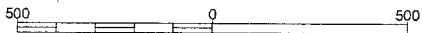

NATIONAL FLOOD INSURANCE PROGRAM

FIRM
FLOOD INSURANCE RATE MAP

EL PASO COUNTY,
COLORADO
AND INCORPORATED AREAS

PANEL 753 OF 1300
(SEE MAP INDEX FOR PANELS NOT PRINTED)

CONTAINS:
COMMUNITY NUMBER PANEL SUFFIX

COLORADO SPRINGS, CITY OF	080060	0753	F
EL PASO COUNTY, UNINCORPORATED AREAS	080059	0753	F

MAP NUMBER
08041C0753 F

EFFECTIVE DATE:
MARCH 17, 1997



Federal Emergency Management Agency

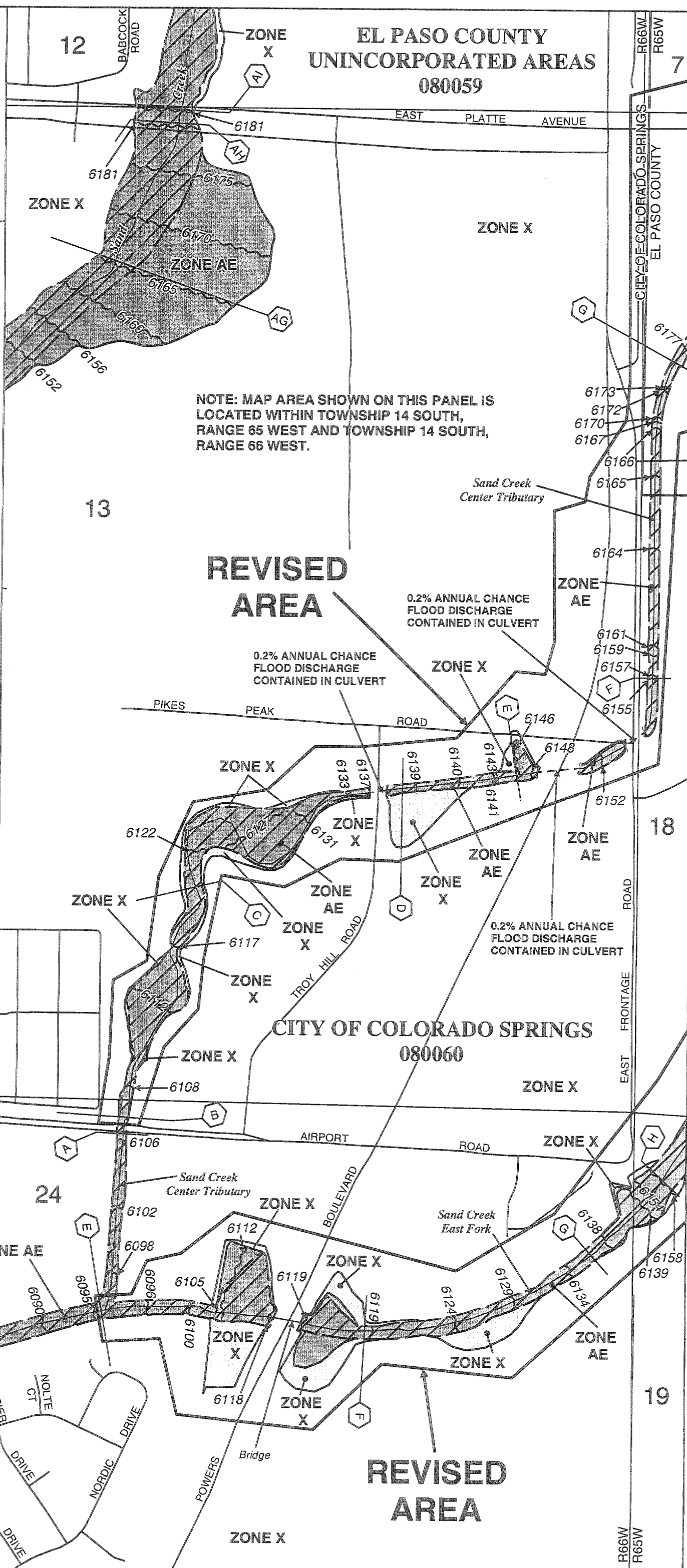

NOTE: MAP AREA SHOWN ON THIS PANEL IS
LOCATED WITHIN TOWNSHIP 14 SOUTH,
RANGE 65 WEST AND TOWNSHIP 14 SOUTH,
RANGE 66 WEST.

**REVISED
AREA**

0.2% ANNUAL CHANCE
FLOOD DISCHARGE
CONTAINED IN CULVERT

0.2% ANNUAL CHANCE
FLOOD DISCHARGE
CONTAINED IN CULVERT

0.2% ANNUAL CHANCE
FLOOD DISCHARGE
CONTAINED IN CULVERT

CITY OF COLORADO SPRINGS
080060

**REVISED
AREA**



JOINS PANEL 0754

R66W
R65W

104°43'07"
38°50'37"

JOINS PANEL 0752

EL PASO COUNTY UNINCORPORATED AREAS 080059

- Legend**
-  1% annual chance (100-Year) Floodplain
 -  1% annual chance (100-Year) Floodway
 -  0.2% annual chance (500-Year) Floodplain



APPROXIMATE SCALE IN FEET

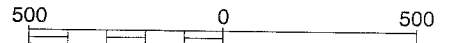

NATIONAL FLOOD INSURANCE PROGRAM

FIRM FLOOD INSURANCE RATE MAP

EL PASO COUNTY,
COLORADO
AND INCORPORATED AREAS

PANEL 754 OF 1300
(SEE MAP INDEX FOR PANELS NOT PRINTED)

CONTAINS:

COMMUNITY	NUMBER	PANEL SUFFIX
COLORADO SPRINGS, CITY OF	080060	0754 F
EL PASO COUNTY, UNINCORPORATED AREAS	080059	0754 F

MAY 23 2007

MAP NUMBER
08041C0754 F
EFFECTIVE DATE:
MARCH 17, 1997



Federal Emergency Management Agency

JOINS PANEL 0753

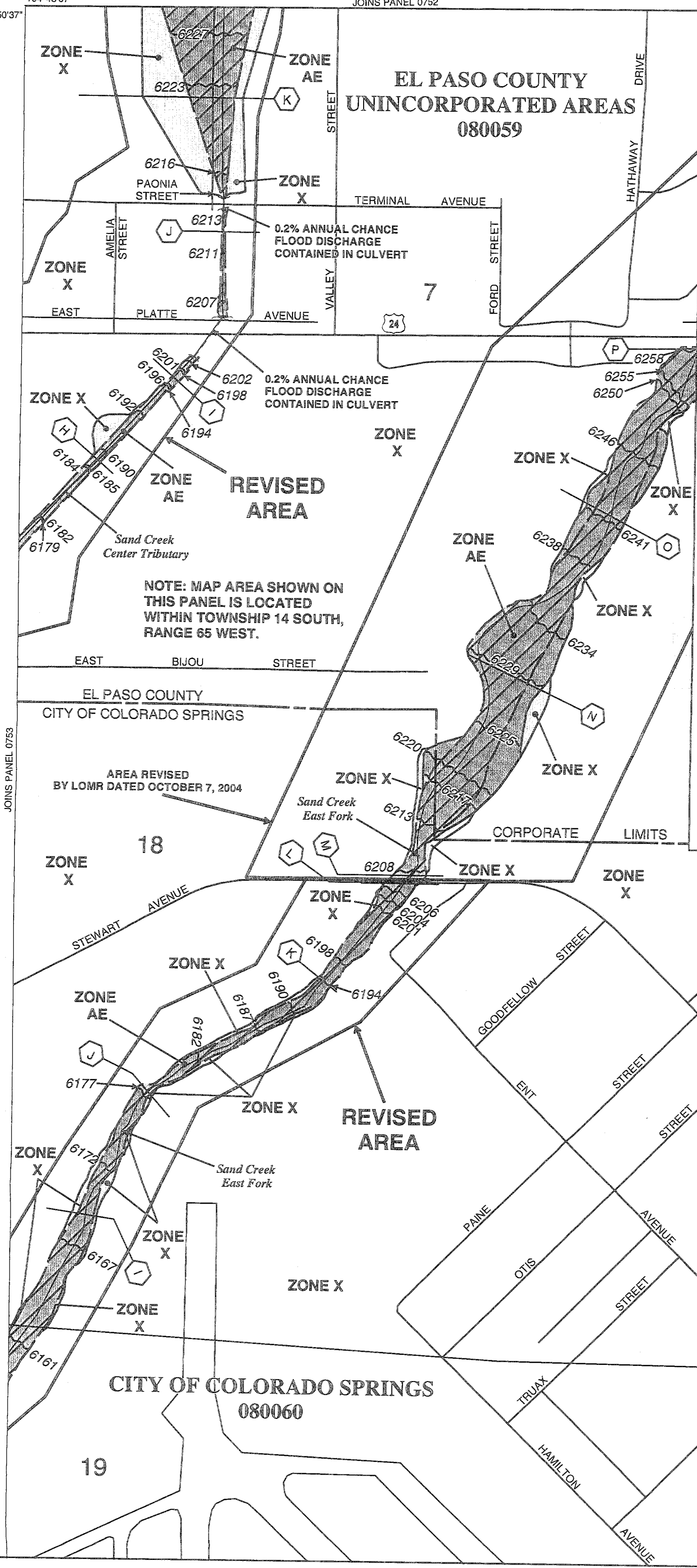

NOTE: MAP AREA SHOWN ON
THIS PANEL IS LOCATED
WITHIN TOWNSHIP 14 SOUTH,
RANGE 65 WEST.

AREA REVISED
BY LOMR DATED OCTOBER 7, 2004

CITY OF COLORADO SPRINGS
080060

2580

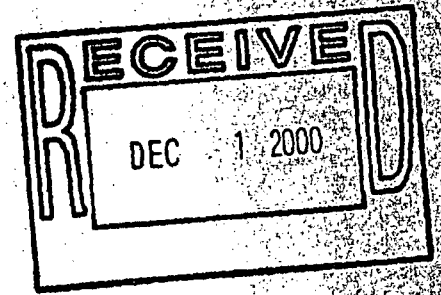

**FINAL
DRAINAGE PLAN AND REPORT**

LOT 1, APPALOOSA HWY 24 SUB.

October 20, 2000

Revised
October 26, 2000

Revised
November 15, 2000

Revised
November 30, 2000

prepared for

HY-POWER COMPANY

Oliver E. Watts
Consulting Engineer
Colorado Springs

Remove this FDR

OLIVER E. WATTS, PE-LS
CONSULTING ENGINEER, INC.
614 ELKTON DRIVE
COLORADO SPRINGS, COLORADO 80907
719-593-0173
olliewatts@aol.com

November 30, 2000

El Paso County D.O.T.
3460 Marksheffel Road
Colorado Springs, CO 80922

ATTN: Andre Bracken

SUBJECT: Final Drainage Plan and Report
Lot 1, Appaloosa Hwy 24 Sub.

Gentlemen

Transmitted herewith for your review and approval is the final drainage plan and report for Lot 1 of the Appaloosa Hwy 24 Subdivision. This report has been revised in accordance with your verbal comments of October 25, 2000 and November 30, 2000.

Please contact me if I may provide any further information.

Sincerely

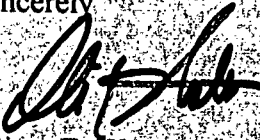

Oliver E. Watts
Consulting Engineer

Encl:

Drainage Report 3 pages
Computations 2 pages
FEMA Panel No. 08041C0754 F
SCS Soils Map and Interpretation Sheets
Backup Information, 4 sheets
Sheet CT-5 Sand Creek Master Plan
Final Drainage Plan, Dwg 00-3039-06

1. ENGINEER'S STATEMENT:

The attached drainage plan and report were prepared under my direction and supervision and are correct to the best of my knowledge and belief. Said drainage report has been prepared according to the criteria established by the County for drainage reports and said report is in conformity with the master plan of the drainage basin. I accept responsibility for any liability caused by any negligent acts, errors or omissions on my part in preparing this report.



Oliver E. Watts

Colo. PE-LS No. 9853

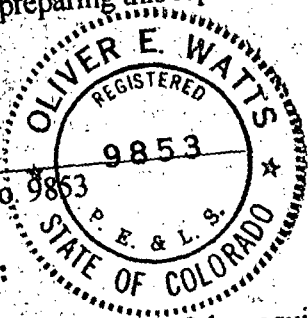

2. DEVELOPER'S STATEMENT:

The developer has read and will comply with all of the requirements specified in this drainage plan and report.

Hy-Power Company

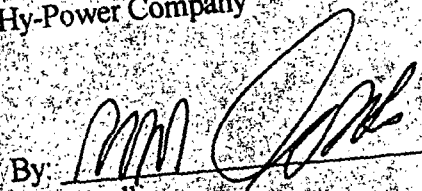

By: Matt Redlin
Hammers Construction, inc.
3460 Capital Drive
Colorado Springs, CO 80915-9731

3. EL PASO COUNTY:

Filed in accordance with Section 51.1 OF THE El Paso Land Development Code, as amended.

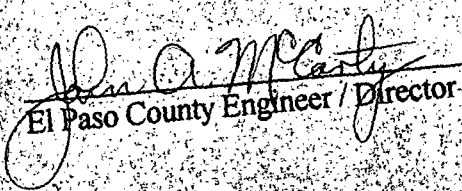

El Paso County Engineer / Director

12-7-00
Date

Conditions:

4. LOCATION AND DESCRIPTION:

The Appaloosa Hwy 24 LLC Subdivision is a replat of lots 1 and 2 and Vacated Paonia Street, Kay Tee Subdivision No. 3, located at the southeast corner of Terminal Avenue and Amelia Street on the North Side of U.S. Highway 24 in El Paso County, Colorado. It occupies 6.57 acres in the Sand Creek Drainage Basin. Lot 1 comprises 1.587 acres in the Northwest corner of the subdivision.

5. FLOOD PLAIN STATEMENT:

This subdivision is partially within the limits of a flood plain or flood hazard area, according to FEMA map panel number 08041C0754 F, dated March 17, 1997, a copy of which is enclosed for reference. The limits of the flood plain are shown on the enclosed drainage plan. The finish floor elevations of the proposed buildings will be elevated to well above the flood protection elevation, and the entire building site is outside the limits of the flood plain, as shown on the enclosed plan.

6. METHOD AND CRITERIA:

The method used for all computations is that specified in the City-County Drainage Criteria Manual, using the rational method for areas of the size of the subdivision. All computations are enclosed for reference and review.

The soils in the subdivision have been mapped by the local USDA/SCS office, and a soils map and interpretation sheet are enclosed for reference. All soils in this area are of hydrologic group "A".

7. DESCRIPTION OF RUNOFF:

The historic runoff from this subdivision is 0.9 / 2.4 cfs (5-year / 100-year runoffs), as shown on the enclosed plan, outfalling near the southwest property corner.

Lot 1 will be graded with a one percent cross slope as shown on the enclosed drainage plan so that the finish floor elevation is more than one foot over the flood elevation, and so that the lot will drain to the Southeast corner. A small portion will drain by overland flow to the drainage channel in the northerly portion of the east boundary. The runoff for this basin "A1" will total 1.3 cfs / 2.2 cfs (5-year / 100-year runoffs) and will be concentrated into a four foot drain inlet at a depth of 0.32' as shown on the computations. A detail of this inlet is shown on the enclosed drainage plan a drainage swale is continued from the end of this outlet to the concrete drainage channel across the drainage easement. This swale is designed to allow traffic crossing. The remainder of the lot (Basin A2) will drain by overland flow to the southeast corner of the parking lot, where another curb outlet will be provided, flowing to a depth of 0.69' as shown on the computations. The runoff for this basin is 4.7 cfs / 8.2 cfs.

These runoffs are well within the anticipated runoff from this property, according to the Master Drainage Study for the drainage basin, and existing drainage facilities have adequate capacity to accommodate the developed runoff.

8. COST ESTIMATE: Two minor structures are proposed as described above, which are considered private and estimated to cost as follows:

Item No.	Description	Quantity	Unit Cost	Cost
----------	-------------	----------	-----------	------

1	4' concrete drainage inlet	2 ea	\$ 600.00	\$ 1200.00
2	8" concrete swale	432 sf	4.00	1728.00
Subtotal Construction Cost				\$ 2928.00
Engineering				292.80
Total Estimated Cost				\$ 3220.80

9. FEES:

Drainage fees are not due on this lot, and described in the final drainage plan for the subdivision.

MAJOR BASIN	SUB BASIN	AREA		BASIN		T _c MIN.	I		SOIL GRP	DEV. TYPE	C		FLOW		RETURN PERIOD	
		PLANIM. READ	ACRES	LENGTH	HEIGHT							qp	qp			
SAND CREEK	A1	COGO	0.29	165	1.6	5	5.3	9.0	A	85%	0.84	0.86	1.3	2.2	5	100
	A2	COGO	1.29	340	3.4	9	4.3	7.4	A	85%	0.84	0.86	4.7	8.2	5	100
	HISTORIC	COGO	1.58	390	5	29	2.4	4.3	A	R/L F	0.25	0.35	0.9	2.4	5	100

HYDROLOGIC COMPUTATION - BASIC DATA
 PROJ: LOT 1 APPALOOSA HWY 24 SUB BY: O.E. WATTS
 RATIONAL METHOD DATE: 10-20-00 10-26-00

Oliver E. Watts
 CONSULTING ENGINEER

Page 1
 Of
 2

STREET AND STORM SEWER CALCULATIONS

STREET	LOCATION	DIST.	ELEVATION & SLOPE	TOTAL RUNOFF	STREET FLOW /CAPACITY	PIPE FLOW	TYPE PIPE, CATCH BASIN & SLOPE %
CHANNEL	BASIN A1			1.3/2.2		2.2	DOWNDRAIN, W=4', D=0.32'
						2.2	8' SWALE, SEE ENCLOSED SHEET
	BASIN A2			4.7/8.2		8.2	DOWNDRAIN, W=4', D=0.69'
						8.2	8' SWALE, SEE ENCLOSED SHEET, D=0.48'

STREET AND STORM SEWER CALCULATIONS
 PROJ: LOT 1 APPALOOSA HWY 24 SUB BY: O.E. WATTS
 DATE: 10-20-00

OLIVER E. WATTS

Page: 1
 Of
 Pages: 2

LEGEND

SPECIAL FLOOD HAZARD AREAS INUNDATED BY 100-YEAR FLOOD

- ZONE A** No base flood elevations determined.
- ZONE AE** Base flood elevations determined.
- ZONE AH** Flood depths of 1 to 3 feet (usually areas of ponding); base flood elevations determined.
- ZONE AO** Flood depths of 1 to 3 feet (usually sheet flow on sloping terrain); average depths determined. For areas of alluvial fan flooding, velocities also determined.
- ZONE A99** To be protected from 100-year flood by Federal flood protection system under construction; no base elevations determined.
- ZONE V** Coastal flood with velocity hazard (wave action); no base flood elevations determined.
- ZONE VE** Coastal flood with velocity hazard (wave action); base flood elevations determined.

FLOODWAY AREAS IN ZONE AE

OTHER FLOOD AREAS

- ZONE X** Areas of 500-year flood; areas of 100-year flood with average depths of less than 1 foot or with drainage areas less than 1 square mile; and areas protected by levees from 100-year flood.

OTHER AREAS

- ZONE X** Areas determined to be outside 500-year floodplain.
- ZONE D** Areas in which flood hazards are undetermined.

UNDEVELOPED COASTAL BARRIERS



Coastal barrier areas are normally located within or adjacent to Special Flood Hazard Areas.

- Flood Boundary
- Floodway Boundary
- Zone D Boundary
- Boundary Dividing Special Flood Hazard Zones and Boundary Dividing Areas of Different Coastal Base Flood Elevations Within Special Flood Hazard Zones.
- Base Flood Elevation Line; Elevation in Feet. See Map Index for Elevation Datum.
- Cross Section Line
- Base Flood Elevation in Feet Where Uniform Within Zone. See Map Index for Elevation Datum.
- Elevation Reference Mark
- River Mile
- Horizontal Coordinates Based on North American Datum of 1927 (NAD 27) Projection.

NOTES

This map is for use in administering the National Flood Insurance Program; it does not necessarily identify all areas subject to flooding, particularly from drainage sources of small size, or all planimetric features outside Special Flood Hazard Areas.

Base flood elevations apply only landward of 0.0 NGVD, and include effects of wave action; these elevations may also differ significantly from those developed by the National Weather Service for hurricane storm planning.

Refer to the FLOOD INSURANCE RATE MAP EFFECTIVE DATE shown on this map to determine when actuarial rates apply to structures in areas where elevations or depths have been established.

To determine if flood insurance is available, contact an insurance agent or the National Flood Insurance Program at (800) 638-6620.



APPROXIMATE SCALE IN FEET

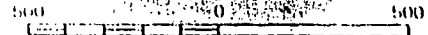

NATIONAL FLOOD INSURANCE PROGRAM

FIRM FLOOD INSURANCE RATE MAP

EL PASO COUNTY COLORADO AND INCORPORATED AREAS

PANEL 754 OF 1300

(SEE MAP INDEX FOR PANELS NOT PRINTED)

CONTAINS
COMMUNITY

NUMBER PANEL ASSET

COLORADO SPRINGS, CITY OF
EL PASO COUNTY,
UNINCORPORATED AREAS

000000 0754
000000 0754

MAP NUMBER
08041C0754 F

EFFECTIVE DATE:
MARCH 17, 1997



Federal Emergency Management Agency

104°43'07"
50'37"

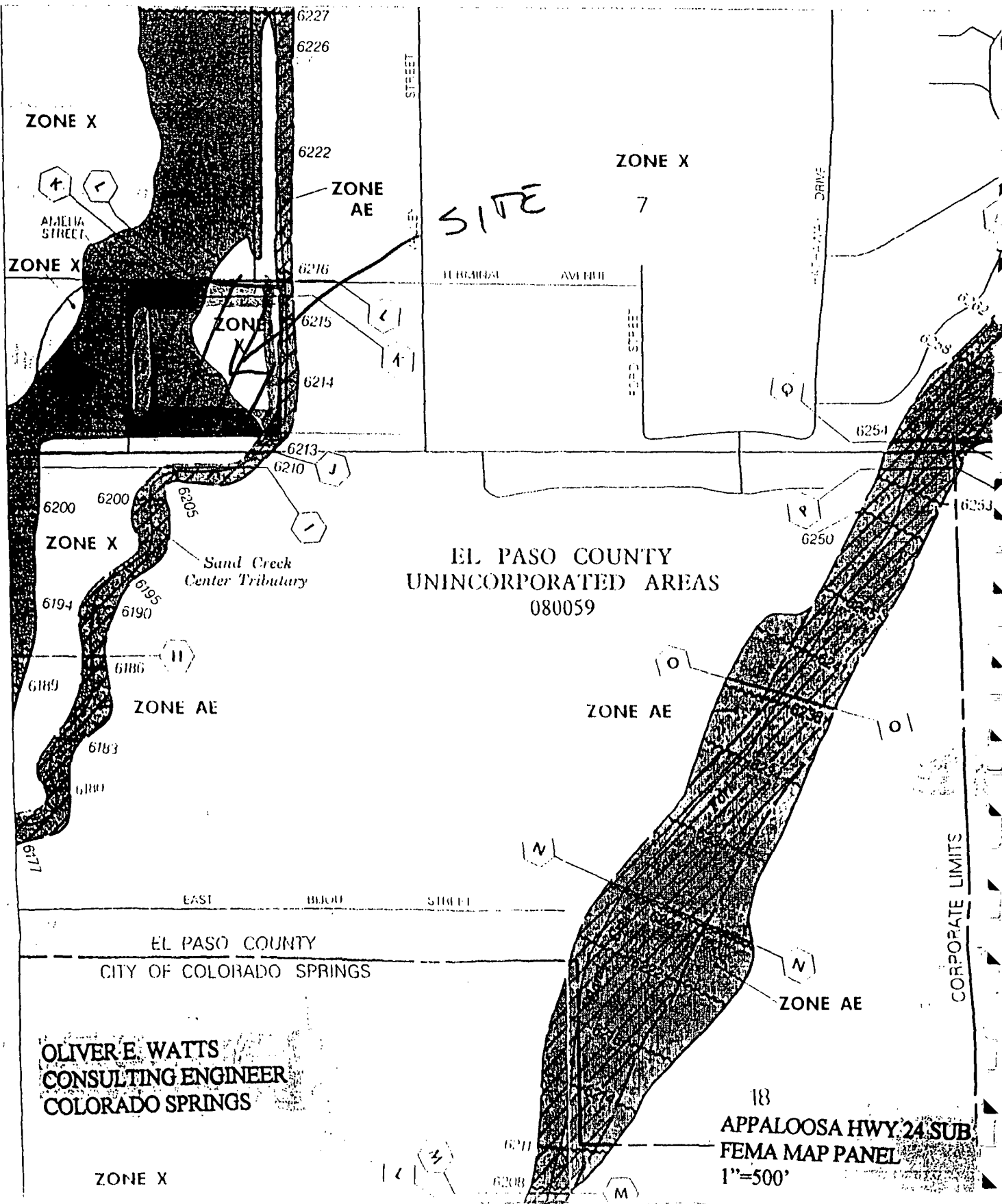

EL PASO COUNTY
UNINCORPORATED AREAS
080059

OLIVER E. WATTS
CONSULTING ENGINEER
COLORADO SPRINGS

18
APPALOOSA HWY. 24 SUB
FEMA MAP PANEL
1"=500'

ZONE X

ZONE X

ZONE AE

ZONE AE

ZONE AE

CORPORATE LIMITS

SITE 7

EAST BIJOU STREET

EL PASO AVENUE

AIJELIA STREET

ZONE X

ZONE X

Sand Creek Center Tributary

ZONE X

ZONE AE

6177

6200

6200

6205

6194

6195

6190

6189

6186

6183

6180

6213

6210

6210

6214

6215

6216

6222

6226

6227

6254

6250

6253

6189

6186

6177

6211

6208

6208

4

5

6

7

8

9

10

11

12

13

14

15

16

17

18



OLIVER E. WATTS
CONSULTING ENGINEER
COLORADO SPRINGS

APPALOOSA HWY 24 SUB
SCS SOILS MAP
1"=2000'

SOIL SURVEY

TABLE 16.--SOIL AND WATER FEATURES--Continued

Soil name and map symbol	Hydro-logic group	Flooding			Bedrock		Potential frost action
		Frequency	Duration	Months	Depth	Hardness	
Elbeth: Pring part-----	B	None-----	---	---	In >60	---	Moderate.
Ellicott: 28-----	A	Frequent-----	Brief-----	Mar-Jun	>60	---	Low.
Fluvaquentic Haplaquolls: 29-----	B/D	Frequent-----	Brief-----	Mar-Jul	>60	---	High.
Fort Collins: 30, 31-----	B	None to rare	---	---	>60	---	Moderate.
Fortwingate: 132: Fortwingate part-----	C	None-----	---	---	20-40	Hard	Low.
Rock outcrop part-----	D	---	---	---	---	---	---
Heldt: 33-----	C	None-----	---	---	>60	---	Moderate.
Holderness: 34, 35, 36-----	C	None-----	---	---	>60	---	Moderate.
Jarre: 37-----	B	None-----	---	---	>60	---	Moderate.
138: Jarre part-----	B	None-----	---	---	>60	---	Moderate.
Tecolote part--	B	None-----	---	---	>60	---	Moderate.
Keith: 39-----	B	None-----	---	---	>60	---	High.
Kettle: 40, 41-----	B	None-----	---	---	>60	---	Moderate.
142: Kettle part-----	B	None-----	---	---	>60	---	Moderate.
Rock outcrop part-----	D	---	---	---	---	---	---
Kim: 43-----	B	None-----	---	---	>60	---	Moderate.
Kutch: 44, 45-----	C	None-----	---	---	20-40	Rippable	Moderate.
Kutler: 146: Kutler part-----	C	None-----	---	---	20-40	Rippable	Low.
Broadmoor part--	C	None-----	---	---	20-40	Rippable	Low.
Rock outcrop part-----	D	---	---	---	---	---	---
Limon: 47-----	C	Occasional-----	Brief-----	May-Sep	>60	---	Moderate.
Louviers: 48-----	D	None-----	---	---	10-20	Rippable	Moderate.
49-----	D	None-----	---	---	10-20	Rippable	Low.

See footnote at end of table.

TABLE 16.--SOIL AND WATER FEATURES--Continued

Soil name and map symbol	Hydro-logic group	Flooding			Bedrock		Potential frost action
		Frequency	Duration	Months	Depth	Hardness	
Tomah: 192, 193:					In		
Tomah part-----	B	None-----	---	---	>60	---	Moderate.
Crowfoot part--	B	None-----	---	---	>60	---	Moderate.
Travessilla: 194:							
Travessilla part-----	D	None-----	---	---	6-20	Hard	Low.
Rock outcrop part-----	D	---	---	---	---	---	---
Truckton: 95, 96, 97-----	B	None-----	---	---	>60	---	Moderate.
198:							
Truckton part--	B	None-----	---	---	>60	---	Moderate.
Blakeland part-	A	None-----	---	---	>60	---	Low.
199, 1100:							
Truckton part--	B	None-----	---	---	>60	---	Moderate.
Bresser part---	B	None-----	---	---	>60	---	Low.
Ustic Torrifluvents: 101-----	B	Occasional-----	Very brief-----	Mar-Aug	>60	---	Moderate.
Valent: 102, 103-----	A	None-----	---	---	>60	---	Low.
Vona: 104, 105-----	B	None-----	---	---	>60	---	Moderate.
Wigton: 106-----	A	None-----	---	---	>60	---	Low.
Wiley: 107, 108-----	B	None-----	---	---	>60	---	Low.
Yoder: 109, 110-----	B	None-----	---	---	>60	---	Low.

¹This map unit is made up of two or more dominant kinds of soil. See map unit description for the composition and behavior characteristics of the map unit.

TABLE 5-1

RECOMMENDED AVERAGE RUNOFF COEFFICIENTS AND PERCENT IMPERVIOUS

LAND USE OR SURFACE CHARACTERISTICS	PERCENT IMPERVIOUS	"C" FREQUENCY			
		10		100	
		A&B*	C&D*	A&B*	C&D*
Business					
Commercial Areas	95	0.90	0.90	0.90	0.90
Neighborhood Areas	70	0.75	0.75	0.80	0.80
Residential					
1/8 Acre or less	65	0.60	0.70	0.70	0.80
1/4 Acre	40	0.50	0.60	0.60	0.70
1/3 Acre	30	0.40	0.50	0.55	0.60
1/2 Acre	25	0.35	0.45	0.45	0.55
1 Acre	20	0.30	0.40	0.40	0.50
Industrial					
Light Areas	80	0.70	0.70	0.80	0.80
Heavy Areas	90	0.80	0.80	0.90	0.90
Parks and Cemeteries	7	0.30	0.35	0.55	0.60
Playgrounds	13	0.30	0.35	0.60	0.65
Railroad Yard Areas	40	0.50	0.55	0.60	0.65
Undeveloped Areas					
Historic Flow Analysis- Greenbelts, Agricultural	2	0.15	0.25	0.20	0.30
Pasture/Meadow	0	0.25	0.30	0.35	0.45
Forest	0	0.10	0.15	0.15	0.20
Exposed Rock	100	0.90	0.90	0.95	0.95
Offsite Flow Analysis (when land use not defined)	45	0.55	0.60	0.65	0.70
Streets					
Paved	100	0.90	0.90	0.95	0.95
Gravel	80	0.80	0.80	0.85	0.85
Drive and Walks	100	0.90	0.90	0.95	0.95
Roofs	90	0.90	0.90	0.95	0.95
Lawns	0	0.25	0.30	0.35	0.45

* Hydrologic Soil Group

9/30/90

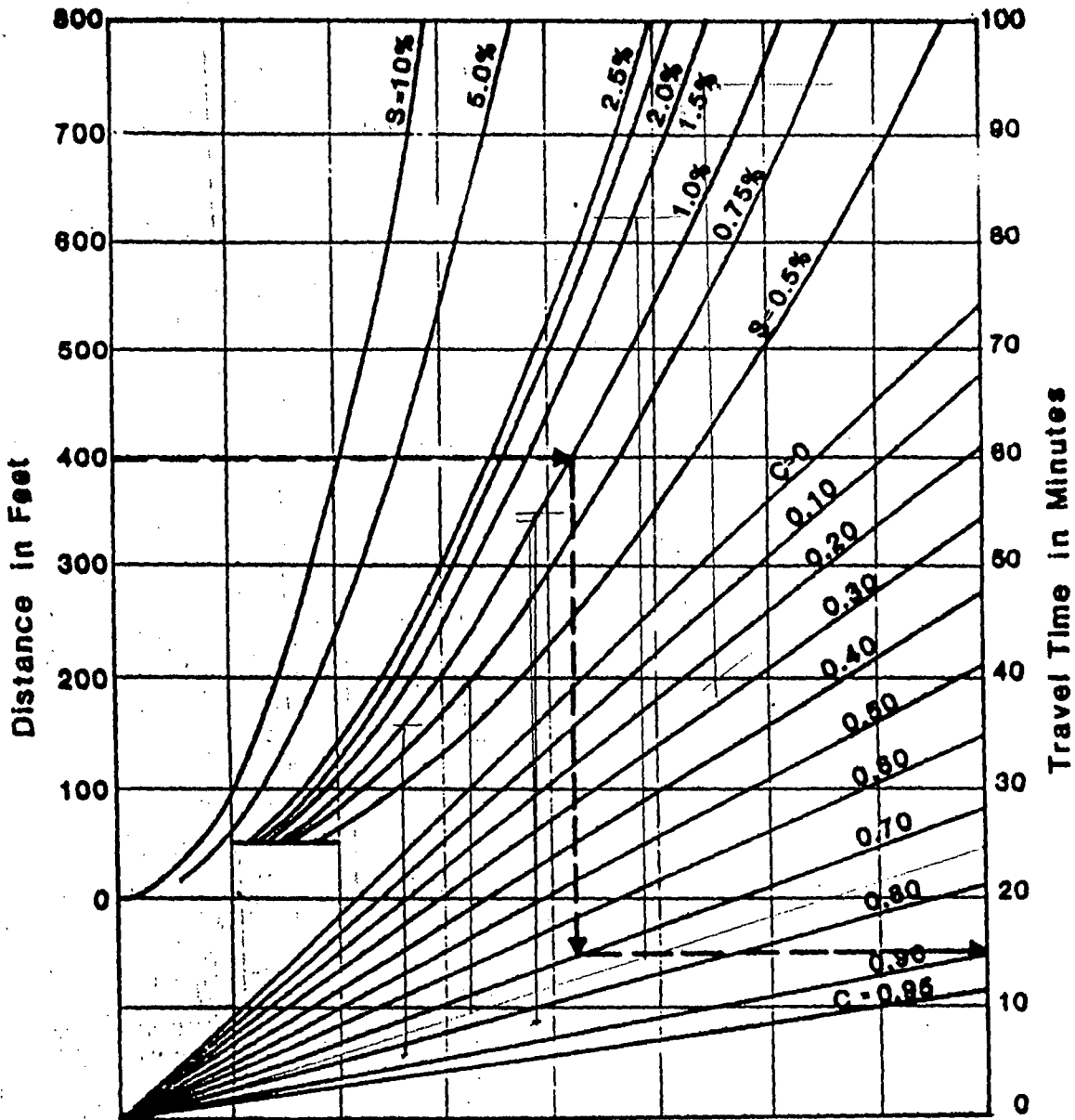

REFERENCE : Wright - McLaughlin Engineers, Urban Storm Drainage Criteria Manual, Vol. 1,
 Denver Regional Council of Governments, Denver, Co. 1977



HDR Infrastructure, Inc.
 A Centerra Company

The City of Colorado Springs / El Paso County
 Drainage Criteria Manual

Overland Flow Curves

Date

OCT. 1987

Figure

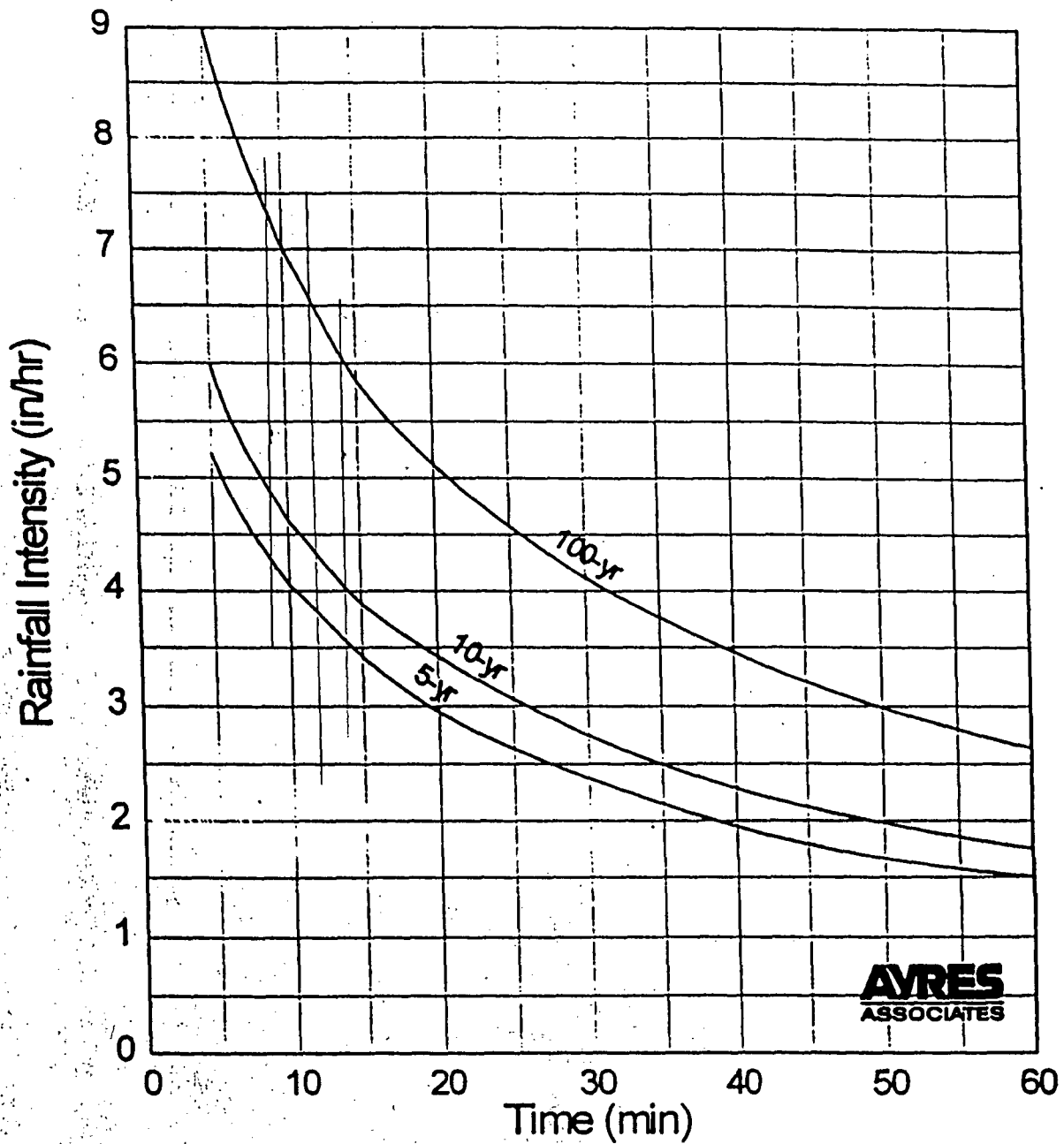

Interim Release October 12, 1994 , Rainfall Intensity Curves
 City Of Colorado Springs Drainage Criteria Manual

INTERCEPTED FLOW - CUBIC FEET PER SECOND

1.00	100
90	90
80	80
70	70
60	60
50	50
40	40
30	30
25	25
20	20
15	15
10	10
5	5
4	4
3	3
2.5	2.5
2	2
1.5	1.5
1	1

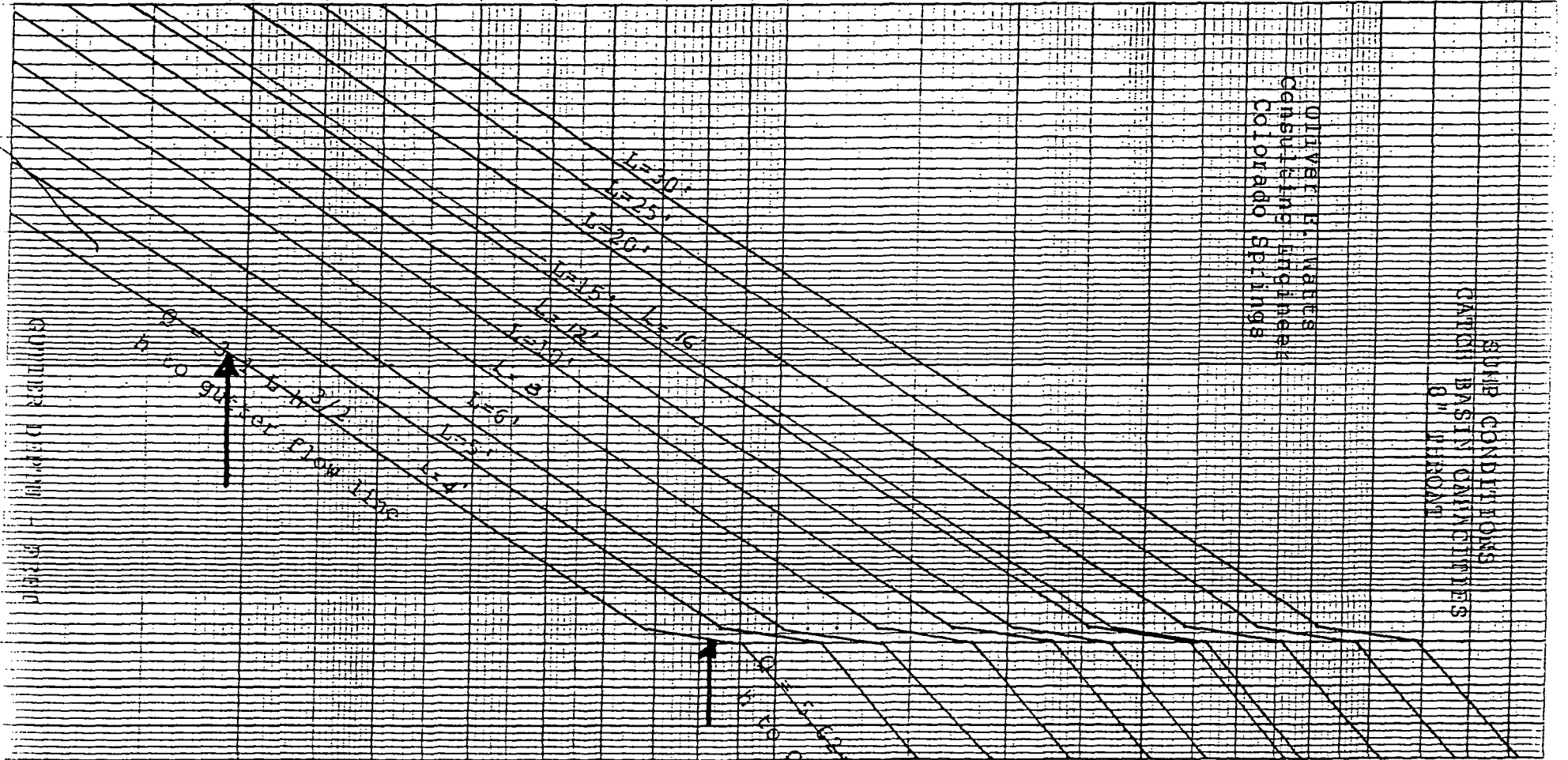

QUANTITY DRAWN FROM

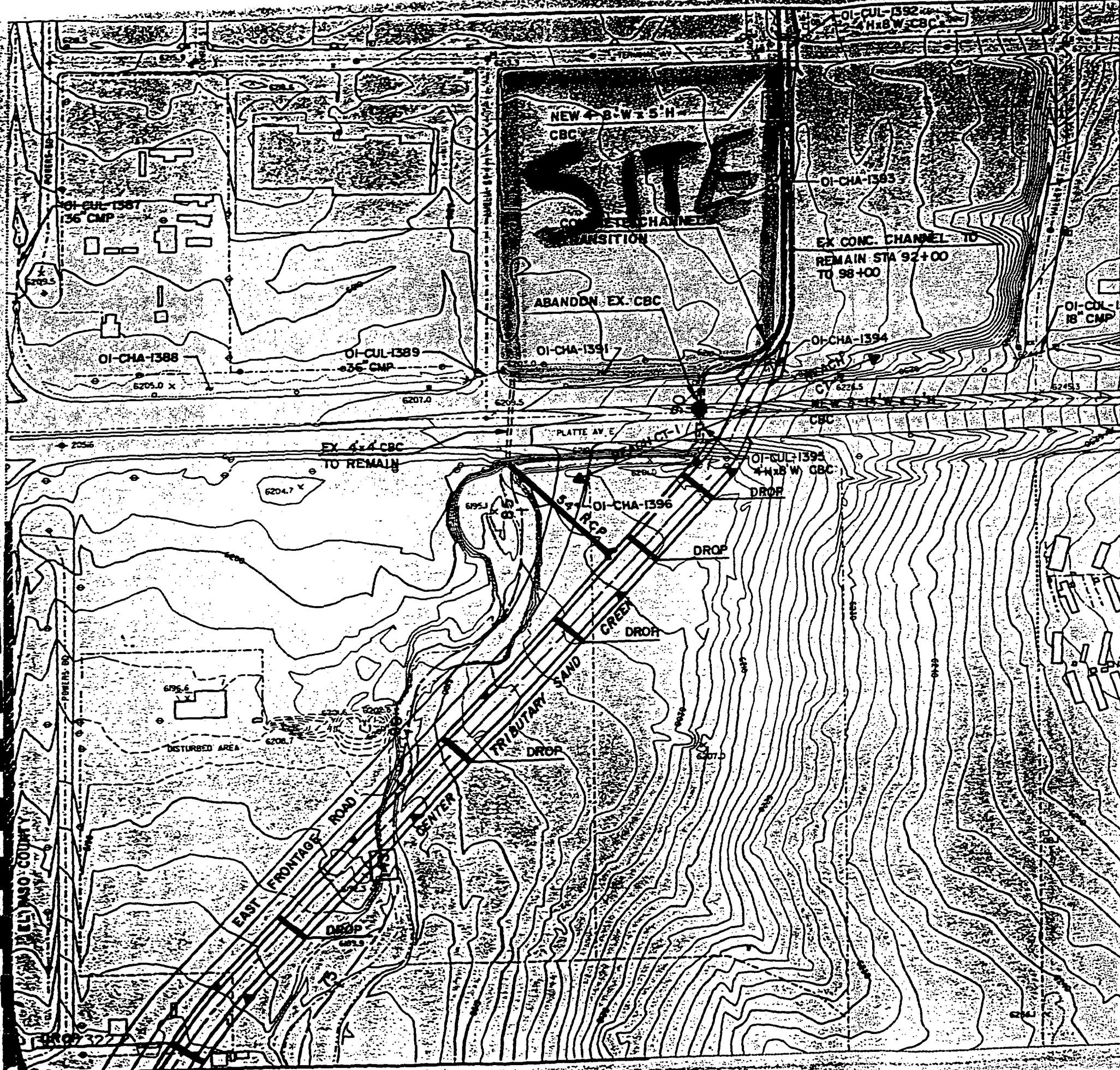

REPRESENTING PRELIMINARY AND CONCEPTUAL ENGINEERING. IT SHOULD NOT BE USED FOR CONSTRUCTION PURPOSES.

CHANNEL IMPROVEMENTS

142	40	100-YEAR RIPRAP CHANNEL
143	40	DEPTH
144	N/A	EXISTING TO REMAIN

FOR PROFILE SEE SHEET CTR-2

OI-CHA-1399
OI-CHA-1400

FOR PROFILE INFORMATION BETWEEN STATIONS 39+00 TO 92+00, SEE US 24 BYPASS PHASE II PROJECT DESIGN PLANS, PROJECT NO. STA(CX)-CY 024-3(41), PREPARED BY THE COLORADO DEPARTMENT OF TRANSPORTATION, JUNE 1992.

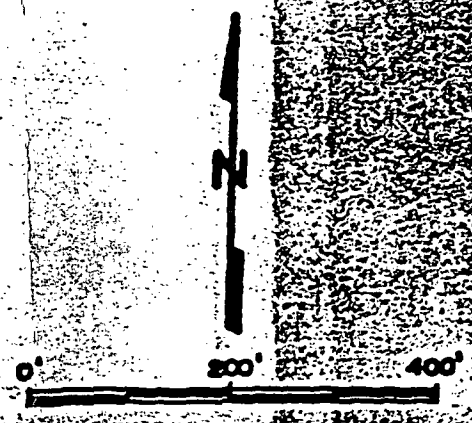

Klows Engineering Corporation
418 W. Bligh Street
Colorado Springs, Colorado
80905-1308

SAND CREEK DRAINAGE BASIN PLANNING STUDY
PRELIMINARY DESIGN PLANS

DATE	04-92
BY	SEA
CHECKED	SEA
APPROVED	SEA

CT-5

MATCH STA 73+50 SHT CT-4

CITY OF COLORADO & EL PASO COUNTY



United States
Department of
Agriculture

NRCS

Natural
Resources
Conservation
Service

A product of the National
Cooperative Soil Survey,
a joint effort of the United
States Department of
Agriculture and other
Federal agencies, State
agencies including the
Agricultural Experiment
Stations, and local
participants

Custom Soil Resource Report for El Paso County Area, Colorado



Preface

Soil surveys contain information that affects land use planning in survey areas. They highlight soil limitations that affect various land uses and provide information about the properties of the soils in the survey areas. Soil surveys are designed for many different users, including farmers, ranchers, foresters, agronomists, urban planners, community officials, engineers, developers, builders, and home buyers. Also, conservationists, teachers, students, and specialists in recreation, waste disposal, and pollution control can use the surveys to help them understand, protect, or enhance the environment.

Various land use regulations of Federal, State, and local governments may impose special restrictions on land use or land treatment. Soil surveys identify soil properties that are used in making various land use or land treatment decisions. The information is intended to help the land users identify and reduce the effects of soil limitations on various land uses. The landowner or user is responsible for identifying and complying with existing laws and regulations.

Although soil survey information can be used for general farm, local, and wider area planning, onsite investigation is needed to supplement this information in some cases. Examples include soil quality assessments (<http://www.nrcs.usda.gov/wps/portal/nrcs/main/soils/health/>) and certain conservation and engineering applications. For more detailed information, contact your local USDA Service Center (<https://offices.sc.egov.usda.gov/locator/app?agency=nrcs>) or your NRCS State Soil Scientist (http://www.nrcs.usda.gov/wps/portal/nrcs/detail/soils/contactus/?cid=nrcs142p2_053951).

Great differences in soil properties can occur within short distances. Some soils are seasonally wet or subject to flooding. Some are too unstable to be used as a foundation for buildings or roads. Clayey or wet soils are poorly suited to use as septic tank absorption fields. A high water table makes a soil poorly suited to basements or underground installations.

The National Cooperative Soil Survey is a joint effort of the United States Department of Agriculture and other Federal agencies, State agencies including the Agricultural Experiment Stations, and local agencies. The Natural Resources Conservation Service (NRCS) has leadership for the Federal part of the National Cooperative Soil Survey.

Information about soils is updated periodically. Updated information is available through the NRCS Web Soil Survey, the site for official soil survey information.

The U.S. Department of Agriculture (USDA) prohibits discrimination in all its programs and activities on the basis of race, color, national origin, age, disability, and where applicable, sex, marital status, familial status, parental status, religion, sexual orientation, genetic information, political beliefs, reprisal, or because all or a part of an individual's income is derived from any public assistance program. (Not all prohibited bases apply to all programs.) Persons with disabilities who require

alternative means for communication of program information (Braille, large print, audiotape, etc.) should contact USDA's TARGET Center at (202) 720-2600 (voice and TDD). To file a complaint of discrimination, write to USDA, Director, Office of Civil Rights, 1400 Independence Avenue, S.W., Washington, D.C. 20250-9410 or call (800) 795-3272 (voice) or (202) 720-6382 (TDD). USDA is an equal opportunity provider and employer.

Contents

Preface	2
How Soil Surveys Are Made	5
Soil Map	8
Soil Map (Lot 3 in Appaloosa Highway 24 Subdivision).....	9
Legend.....	10
Map Unit Legend (Lot 3 in Appaloosa Highway 24 Subdivision).....	11
Map Unit Descriptions (Lot 3 in Appaloosa Highway 24 Subdivision).....	11
El Paso County Area, Colorado.....	13
8—Blakeland loamy sand, 1 to 9 percent slopes.....	13
10—Blendon sandy loam, 0 to 3 percent slopes.....	14
96—Truckton sandy loam, 0 to 3 percent slopes.....	15
Soil Information for All Uses	17
Soil Reports.....	17
Soil Physical Properties.....	17
Engineering Properties (Lot 3 in Appaloosa Highway 24 Subdivision).....	17
References	22

How Soil Surveys Are Made

Soil surveys are made to provide information about the soils and miscellaneous areas in a specific area. They include a description of the soils and miscellaneous areas and their location on the landscape and tables that show soil properties and limitations affecting various uses. Soil scientists observed the steepness, length, and shape of the slopes; the general pattern of drainage; the kinds of crops and native plants; and the kinds of bedrock. They observed and described many soil profiles. A soil profile is the sequence of natural layers, or horizons, in a soil. The profile extends from the surface down into the unconsolidated material in which the soil formed or from the surface down to bedrock. The unconsolidated material is devoid of roots and other living organisms and has not been changed by other biological activity.

Currently, soils are mapped according to the boundaries of major land resource areas (MLRAs). MLRAs are geographically associated land resource units that share common characteristics related to physiography, geology, climate, water resources, soils, biological resources, and land uses (USDA, 2006). Soil survey areas typically consist of parts of one or more MLRA.

The soils and miscellaneous areas in a survey area occur in an orderly pattern that is related to the geology, landforms, relief, climate, and natural vegetation of the area. Each kind of soil and miscellaneous area is associated with a particular kind of landform or with a segment of the landform. By observing the soils and miscellaneous areas in the survey area and relating their position to specific segments of the landform, a soil scientist develops a concept, or model, of how they were formed. Thus, during mapping, this model enables the soil scientist to predict with a considerable degree of accuracy the kind of soil or miscellaneous area at a specific location on the landscape.

Commonly, individual soils on the landscape merge into one another as their characteristics gradually change. To construct an accurate soil map, however, soil scientists must determine the boundaries between the soils. They can observe only a limited number of soil profiles. Nevertheless, these observations, supplemented by an understanding of the soil-vegetation-landscape relationship, are sufficient to verify predictions of the kinds of soil in an area and to determine the boundaries.

Soil scientists recorded the characteristics of the soil profiles that they studied. They noted soil color, texture, size and shape of soil aggregates, kind and amount of rock fragments, distribution of plant roots, reaction, and other features that enable them to identify soils. After describing the soils in the survey area and determining their properties, the soil scientists assigned the soils to taxonomic classes (units). Taxonomic classes are concepts. Each taxonomic class has a set of soil characteristics with precisely defined limits. The classes are used as a basis for comparison to classify soils systematically. Soil taxonomy, the system of taxonomic classification used in the United States, is based mainly on the kind and character of soil properties and the arrangement of horizons within the profile. After the soil

Custom Soil Resource Report

scientists classified and named the soils in the survey area, they compared the individual soils with similar soils in the same taxonomic class in other areas so that they could confirm data and assemble additional data based on experience and research.

The objective of soil mapping is not to delineate pure map unit components; the objective is to separate the landscape into landforms or landform segments that have similar use and management requirements. Each map unit is defined by a unique combination of soil components and/or miscellaneous areas in predictable proportions. Some components may be highly contrasting to the other components of the map unit. The presence of minor components in a map unit in no way diminishes the usefulness or accuracy of the data. The delineation of such landforms and landform segments on the map provides sufficient information for the development of resource plans. If intensive use of small areas is planned, onsite investigation is needed to define and locate the soils and miscellaneous areas.

Soil scientists make many field observations in the process of producing a soil map. The frequency of observation is dependent upon several factors, including scale of mapping, intensity of mapping, design of map units, complexity of the landscape, and experience of the soil scientist. Observations are made to test and refine the soil-landscape model and predictions and to verify the classification of the soils at specific locations. Once the soil-landscape model is refined, a significantly smaller number of measurements of individual soil properties are made and recorded. These measurements may include field measurements, such as those for color, depth to bedrock, and texture, and laboratory measurements, such as those for content of sand, silt, clay, salt, and other components. Properties of each soil typically vary from one point to another across the landscape.

Observations for map unit components are aggregated to develop ranges of characteristics for the components. The aggregated values are presented. Direct measurements do not exist for every property presented for every map unit component. Values for some properties are estimated from combinations of other properties.

While a soil survey is in progress, samples of some of the soils in the area generally are collected for laboratory analyses and for engineering tests. Soil scientists interpret the data from these analyses and tests as well as the field-observed characteristics and the soil properties to determine the expected behavior of the soils under different uses. Interpretations for all of the soils are field tested through observation of the soils in different uses and under different levels of management. Some interpretations are modified to fit local conditions, and some new interpretations are developed to meet local needs. Data are assembled from other sources, such as research information, production records, and field experience of specialists. For example, data on crop yields under defined levels of management are assembled from farm records and from field or plot experiments on the same kinds of soil.

Predictions about soil behavior are based not only on soil properties but also on such variables as climate and biological activity. Soil conditions are predictable over long periods of time, but they are not predictable from year to year. For example, soil scientists can predict with a fairly high degree of accuracy that a given soil will have a high water table within certain depths in most years, but they cannot predict that a high water table will always be at a specific level in the soil on a specific date.

After soil scientists located and identified the significant natural bodies of soil in the survey area, they drew the boundaries of these bodies on aerial photographs and

Custom Soil Resource Report

identified each as a specific map unit. Aerial photographs show trees, buildings, fields, roads, and rivers, all of which help in locating boundaries accurately.

Soil Map

The soil map section includes the soil map for the defined area of interest, a list of soil map units on the map and extent of each map unit, and cartographic symbols displayed on the map. Also presented are various metadata about data used to produce the map, and a description of each soil map unit.

Custom Soil Resource Report

Soil Map (Lot 3 in Appaloosa Highway 24 Subdivision)

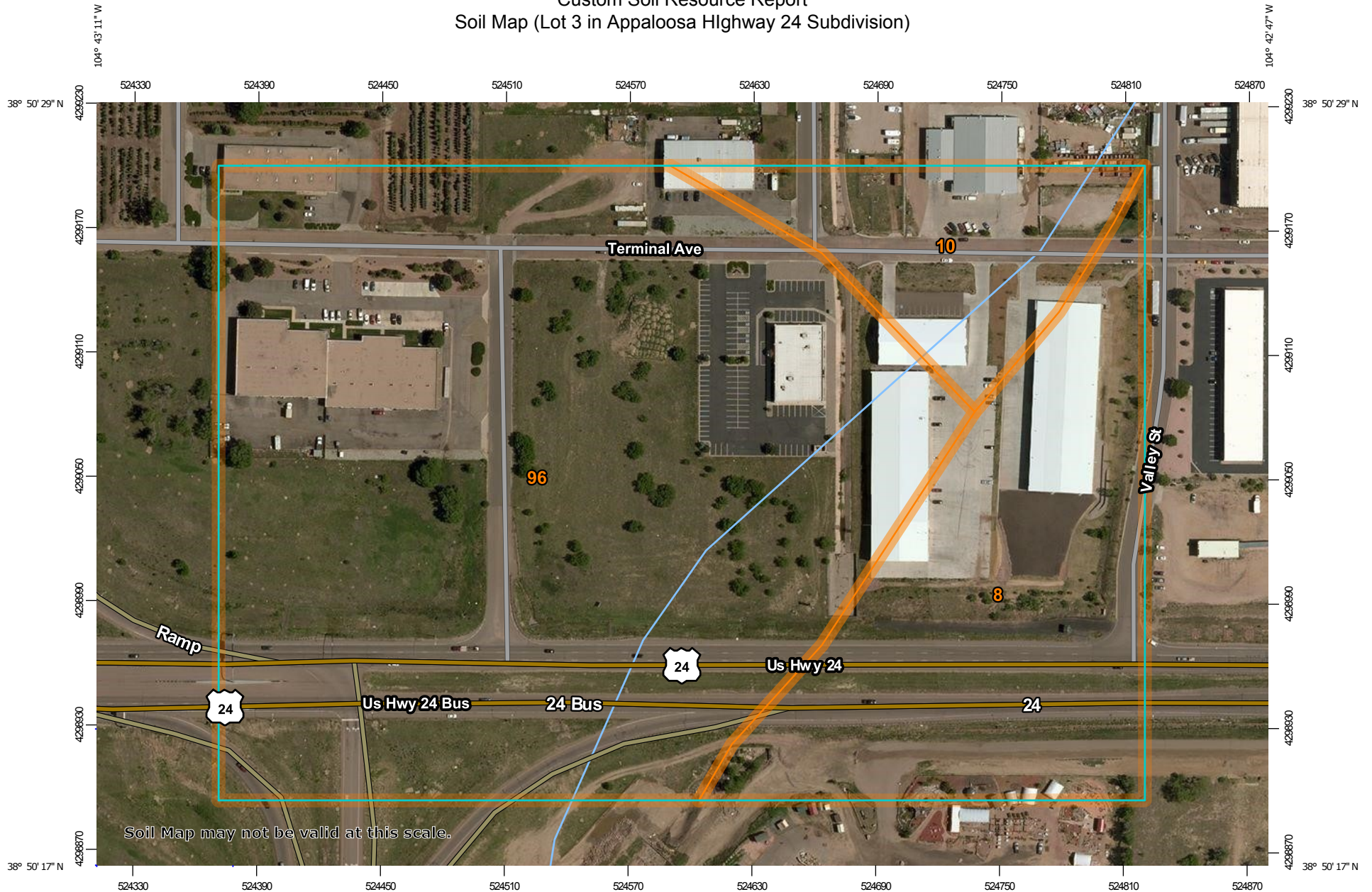

Soil Map may not be valid at this scale.

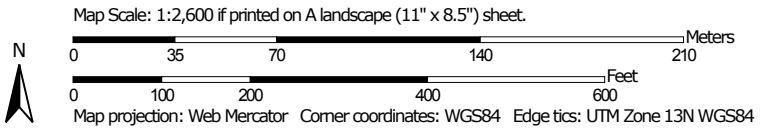

MAP LEGEND

Area of Interest (AOI)

 Area of Interest (AOI)



















Soils







 Soil Map Unit Polygons

 Soil Map Unit Lines

 Soil Map Unit Points

Special Point Features





-  Blowout
-  Borrow Pit
-  Clay Spot
-  Closed Depression
-  Gravel Pit
-  Gravelly Spot
-  Landfill
-  Lava Flow
-  Marsh or swamp
-  Mine or Quarry
-  Miscellaneous Water
-  Perennial Water
-  Rock Outcrop
-  Saline Spot
-  Sandy Spot
-  Severely Eroded Spot
-  Sinkhole
-  Slide or Slip
-  Sodic Spot

-  Spoil Area
-  Stony Spot
-  Very Stony Spot
-  Wet Spot
-  Other
-  Special Line Features

Water Features

 Streams and Canals

Transportation

-  Rails
-  Interstate Highways
-  US Routes
-  Major Roads
-  Local Roads

Background

 Aerial Photography

MAP INFORMATION

The soil surveys that comprise your AOI were mapped at 1:24,000.

Warning: Soil Map may not be valid at this scale.

Enlargement of maps beyond the scale of mapping can cause misunderstanding of the detail of mapping and accuracy of soil line placement. The maps do not show the small areas of contrasting soils that could have been shown at a more detailed scale.

Please rely on the bar scale on each map sheet for map measurements.

Source of Map: Natural Resources Conservation Service
 Web Soil Survey URL:
 Coordinate System: Web Mercator (EPSG:3857)

Maps from the Web Soil Survey are based on the Web Mercator projection, which preserves direction and shape but distorts distance and area. A projection that preserves area, such as the Albers equal-area conic projection, should be used if more accurate calculations of distance or area are required.

This product is generated from the USDA-NRCS certified data as of the version date(s) listed below.

Soil Survey Area: El Paso County Area, Colorado
 Survey Area Data: Version 15, Oct 10, 2017

Soil map units are labeled (as space allows) for map scales 1:50,000 or larger.

Date(s) aerial images were photographed: Jun 3, 2014—Jun 17, 2014

The orthophoto or other base map on which the soil lines were compiled and digitized probably differs from the background imagery displayed on these maps. As a result, some minor shifting of map unit boundaries may be evident.

Map Unit Legend (Lot 3 in Appaloosa Highway 24 Subdivision)

Map Unit Symbol	Map Unit Name	Acres in AOI	Percent of AOI
8	Blakeland loamy sand, 1 to 9 percent slopes	8.0	23.3%
10	Blendon sandy loam, 0 to 3 percent slopes	3.2	9.4%
96	Truckton sandy loam, 0 to 3 percent slopes	23.0	67.3%
Totals for Area of Interest		34.1	100.0%

Map Unit Descriptions (Lot 3 in Appaloosa Highway 24 Subdivision)

The map units delineated on the detailed soil maps in a soil survey represent the soils or miscellaneous areas in the survey area. The map unit descriptions, along with the maps, can be used to determine the composition and properties of a unit.

A map unit delineation on a soil map represents an area dominated by one or more major kinds of soil or miscellaneous areas. A map unit is identified and named according to the taxonomic classification of the dominant soils. Within a taxonomic class there are precisely defined limits for the properties of the soils. On the landscape, however, the soils are natural phenomena, and they have the characteristic variability of all natural phenomena. Thus, the range of some observed properties may extend beyond the limits defined for a taxonomic class. Areas of soils of a single taxonomic class rarely, if ever, can be mapped without including areas of other taxonomic classes. Consequently, every map unit is made up of the soils or miscellaneous areas for which it is named and some minor components that belong to taxonomic classes other than those of the major soils.

Most minor soils have properties similar to those of the dominant soil or soils in the map unit, and thus they do not affect use and management. These are called noncontrasting, or similar, components. They may or may not be mentioned in a particular map unit description. Other minor components, however, have properties and behavioral characteristics divergent enough to affect use or to require different management. These are called contrasting, or dissimilar, components. They generally are in small areas and could not be mapped separately because of the scale used. Some small areas of strongly contrasting soils or miscellaneous areas are identified by a special symbol on the maps. If included in the database for a given area, the contrasting minor components are identified in the map unit descriptions along with some characteristics of each. A few areas of minor components may not have been observed, and consequently they are not mentioned in the descriptions, especially where the pattern was so complex that it was impractical to make enough observations to identify all the soils and miscellaneous areas on the landscape.

Custom Soil Resource Report

The presence of minor components in a map unit in no way diminishes the usefulness or accuracy of the data. The objective of mapping is not to delineate pure taxonomic classes but rather to separate the landscape into landforms or landform segments that have similar use and management requirements. The delineation of such segments on the map provides sufficient information for the development of resource plans. If intensive use of small areas is planned, however, onsite investigation is needed to define and locate the soils and miscellaneous areas.

An identifying symbol precedes the map unit name in the map unit descriptions. Each description includes general facts about the unit and gives important soil properties and qualities.

Soils that have profiles that are almost alike make up a *soil series*. Except for differences in texture of the surface layer, all the soils of a series have major horizons that are similar in composition, thickness, and arrangement.

Soils of one series can differ in texture of the surface layer, slope, stoniness, salinity, degree of erosion, and other characteristics that affect their use. On the basis of such differences, a soil series is divided into *soil phases*. Most of the areas shown on the detailed soil maps are phases of soil series. The name of a soil phase commonly indicates a feature that affects use or management. For example, Alpha silt loam, 0 to 2 percent slopes, is a phase of the Alpha series.

Some map units are made up of two or more major soils or miscellaneous areas. These map units are complexes, associations, or undifferentiated groups.

A *complex* consists of two or more soils or miscellaneous areas in such an intricate pattern or in such small areas that they cannot be shown separately on the maps. The pattern and proportion of the soils or miscellaneous areas are somewhat similar in all areas. Alpha-Beta complex, 0 to 6 percent slopes, is an example.

An *association* is made up of two or more geographically associated soils or miscellaneous areas that are shown as one unit on the maps. Because of present or anticipated uses of the map units in the survey area, it was not considered practical or necessary to map the soils or miscellaneous areas separately. The pattern and relative proportion of the soils or miscellaneous areas are somewhat similar. Alpha-Beta association, 0 to 2 percent slopes, is an example.

An *undifferentiated group* is made up of two or more soils or miscellaneous areas that could be mapped individually but are mapped as one unit because similar interpretations can be made for use and management. The pattern and proportion of the soils or miscellaneous areas in a mapped area are not uniform. An area can be made up of only one of the major soils or miscellaneous areas, or it can be made up of all of them. Alpha and Beta soils, 0 to 2 percent slopes, is an example.

Some surveys include *miscellaneous areas*. Such areas have little or no soil material and support little or no vegetation. Rock outcrop is an example.

El Paso County Area, Colorado

8—Blakeland loamy sand, 1 to 9 percent slopes

Map Unit Setting

National map unit symbol: 369v
Elevation: 4,600 to 5,800 feet
Mean annual precipitation: 14 to 16 inches
Mean annual air temperature: 46 to 48 degrees F
Frost-free period: 125 to 145 days
Farmland classification: Not prime farmland

Map Unit Composition

Blakeland and similar soils: 85 percent
Estimates are based on observations, descriptions, and transects of the mapunit.

Description of Blakeland

Setting

Landform: Flats, hills
Landform position (three-dimensional): Side slope, talf
Down-slope shape: Linear
Across-slope shape: Linear
Parent material: Alluvium derived from sedimentary rock and/or eolian deposits derived from sedimentary rock

Typical profile

A - 0 to 11 inches: loamy sand
AC - 11 to 27 inches: loamy sand
C - 27 to 60 inches: sand

Properties and qualities

Slope: 1 to 9 percent
Depth to restrictive feature: More than 80 inches
Natural drainage class: Somewhat excessively drained
Runoff class: Low
Capacity of the most limiting layer to transmit water (Ksat): High to very high (5.95 to 19.98 in/hr)
Depth to water table: More than 80 inches
Frequency of flooding: None
Frequency of ponding: None
Calcium carbonate, maximum in profile: 5 percent
Available water storage in profile: Low (about 4.5 inches)

Interpretive groups

Land capability classification (irrigated): 3e
Land capability classification (nonirrigated): 6e
Hydrologic Soil Group: A
Ecological site: Sandy Foothill (R049BY210CO)
Hydric soil rating: No

Minor Components

Other soils

Percent of map unit:
Hydric soil rating: No

Pleasant

Percent of map unit:

Landform: Depressions

Hydric soil rating: Yes

10—Blendon sandy loam, 0 to 3 percent slopes

Map Unit Setting

National map unit symbol: 3671

Elevation: 6,000 to 6,800 feet

Mean annual precipitation: 14 to 16 inches

Mean annual air temperature: 46 to 48 degrees F

Frost-free period: 125 to 145 days

Farmland classification: Not prime farmland

Map Unit Composition

Blendon and similar soils: 85 percent

Estimates are based on observations, descriptions, and transects of the mapunit.

Description of Blendon

Setting

Landform: Alluvial fans, terraces

Down-slope shape: Linear

Across-slope shape: Linear

Parent material: Sandy alluvium derived from arkose

Typical profile

A - 0 to 10 inches: sandy loam

Bw - 10 to 36 inches: sandy loam

C - 36 to 60 inches: gravelly sandy loam

Properties and qualities

Slope: 0 to 3 percent

Depth to restrictive feature: More than 80 inches

Natural drainage class: Well drained

Runoff class: Low

Capacity of the most limiting layer to transmit water (Ksat): Moderately high to high (0.60 to 2.00 in/hr)

Depth to water table: More than 80 inches

Frequency of flooding: None

Frequency of ponding: None

Calcium carbonate, maximum in profile: 2 percent

Available water storage in profile: Moderate (about 6.2 inches)

Interpretive groups

Land capability classification (irrigated): None specified

Land capability classification (nonirrigated): 3e

Hydrologic Soil Group: B

Ecological site: Sandy Foothill (R049BY210CO)

Custom Soil Resource Report

Hydric soil rating: No

Minor Components

Other soils

Percent of map unit:

Hydric soil rating: No

Pleasant

Percent of map unit:

Landform: Depressions

Hydric soil rating: Yes

96—Truckton sandy loam, 0 to 3 percent slopes

Map Unit Setting

National map unit symbol: 36bf

Elevation: 6,000 to 7,000 feet

Mean annual precipitation: 14 to 15 inches

Mean annual air temperature: 46 to 50 degrees F

Frost-free period: 125 to 145 days

Farmland classification: Prime farmland if irrigated and the product of I (soil erodibility) x C (climate factor) does not exceed 60

Map Unit Composition

Truckton and similar soils: 85 percent

Estimates are based on observations, descriptions, and transects of the mapunit.

Description of Truckton

Setting

Landform: Flats

Landform position (three-dimensional): Talf

Down-slope shape: Linear

Across-slope shape: Linear

Parent material: Arkosic alluvium derived from sedimentary rock and/or arkosic residuum weathered from sedimentary rock

Typical profile

A - 0 to 8 inches: sandy loam

Bt - 8 to 24 inches: sandy loam

C - 24 to 60 inches: coarse sandy loam

Properties and qualities

Slope: 0 to 3 percent

Depth to restrictive feature: More than 80 inches

Natural drainage class: Well drained

Runoff class: Very low

Capacity of the most limiting layer to transmit water (Ksat): High (1.98 to 6.00 in/hr)

Depth to water table: More than 80 inches

Custom Soil Resource Report

Frequency of flooding: None

Frequency of ponding: None

Available water storage in profile: Low (about 5.7 inches)

Interpretive groups

Land capability classification (irrigated): 2e

Land capability classification (nonirrigated): 3e

Hydrologic Soil Group: A

Ecological site: Sandy Foothill (R049BY210CO)

Hydric soil rating: No

Minor Components

Other soils

Percent of map unit:

Hydric soil rating: No

Pleasant

Percent of map unit:

Landform: Depressions

Hydric soil rating: Yes

Soil Information for All Uses

Soil Reports

The Soil Reports section includes various formatted tabular and narrative reports (tables) containing data for each selected soil map unit and each component of each unit. No aggregation of data has occurred as is done in reports in the Soil Properties and Qualities and Suitabilities and Limitations sections.

The reports contain soil interpretive information as well as basic soil properties and qualities. A description of each report (table) is included.

Soil Physical Properties

This folder contains a collection of tabular reports that present soil physical properties. The reports (tables) include all selected map units and components for each map unit. Soil physical properties are measured or inferred from direct observations in the field or laboratory. Examples of soil physical properties include percent clay, organic matter, saturated hydraulic conductivity, available water capacity, and bulk density.

Engineering Properties (Lot 3 in Appaloosa Highway 24 Subdivision)

This table gives the engineering classifications and the range of engineering properties for the layers of each soil in the survey area.

Hydrologic soil group is a group of soils having similar runoff potential under similar storm and cover conditions. The criteria for determining Hydrologic soil group is found in the National Engineering Handbook, Chapter 7 issued May 2007(<http://directives.sc.egov.usda.gov/OpenNonWebContent.aspx?content=17757.wba>). Listing HSGs by soil map unit component and not by soil series is a new concept for the engineers. Past engineering references contained lists of HSGs by soil series. Soil series are continually being defined and redefined, and the list of soil series names changes so frequently as to make the task of maintaining a single national list virtually impossible. Therefore, the criteria is now used to calculate the HSG using the component soil properties and no such national series lists will be maintained. All such references are obsolete and their use should be discontinued. Soil properties that influence runoff potential are those that influence the minimum rate of infiltration for a bare soil after prolonged wetting and when not frozen. These

Custom Soil Resource Report

properties are depth to a seasonal high water table, saturated hydraulic conductivity after prolonged wetting, and depth to a layer with a very slow water transmission rate. Changes in soil properties caused by land management or climate changes also cause the hydrologic soil group to change. The influence of ground cover is treated independently. There are four hydrologic soil groups, A, B, C, and D, and three dual groups, A/D, B/D, and C/D. In the dual groups, the first letter is for drained areas and the second letter is for undrained areas.

The four hydrologic soil groups are described in the following paragraphs:

Group A. Soils having a high infiltration rate (low runoff potential) when thoroughly wet. These consist mainly of deep, well drained to excessively drained sands or gravelly sands. These soils have a high rate of water transmission.

Group B. Soils having a moderate infiltration rate when thoroughly wet. These consist chiefly of moderately deep or deep, moderately well drained or well drained soils that have moderately fine texture to moderately coarse texture. These soils have a moderate rate of water transmission.

Group C. Soils having a slow infiltration rate when thoroughly wet. These consist chiefly of soils having a layer that impedes the downward movement of water or soils of moderately fine texture or fine texture. These soils have a slow rate of water transmission.

Group D. Soils having a very slow infiltration rate (high runoff potential) when thoroughly wet. These consist chiefly of clays that have a high shrink-swell potential, soils that have a high water table, soils that have a claypan or clay layer at or near the surface, and soils that are shallow over nearly impervious material. These soils have a very slow rate of water transmission.

Depth to the upper and lower boundaries of each layer is indicated.

Texture is given in the standard terms used by the U.S. Department of Agriculture. These terms are defined according to percentages of sand, silt, and clay in the fraction of the soil that is less than 2 millimeters in diameter. "Loam," for example, is soil that is 7 to 27 percent clay, 28 to 50 percent silt, and less than 52 percent sand. If the content of particles coarser than sand is 15 percent or more, an appropriate modifier is added, for example, "gravelly."

Classification of the soils is determined according to the Unified soil classification system (ASTM, 2005) and the system adopted by the American Association of State Highway and Transportation Officials (AASHTO, 2004).

The Unified system classifies soils according to properties that affect their use as construction material. Soils are classified according to particle-size distribution of the fraction less than 3 inches in diameter and according to plasticity index, liquid limit, and organic matter content. Sandy and gravelly soils are identified as GW, GP, GM, GC, SW, SP, SM, and SC; silty and clayey soils as ML, CL, OL, MH, CH, and OH; and highly organic soils as PT. Soils exhibiting engineering properties of two groups can have a dual classification, for example, CL-ML.

The AASHTO system classifies soils according to those properties that affect roadway construction and maintenance. In this system, the fraction of a mineral soil that is less than 3 inches in diameter is classified in one of seven groups from A-1 through A-7 on the basis of particle-size distribution, liquid limit, and plasticity index. Soils in group A-1 are coarse grained and low in content of fines (silt and clay). At the other extreme, soils in group A-7 are fine grained. Highly organic soils are classified in group A-8 on the basis of visual inspection.

Custom Soil Resource Report

If laboratory data are available, the A-1, A-2, and A-7 groups are further classified as A-1-a, A-1-b, A-2-4, A-2-5, A-2-6, A-2-7, A-7-5, or A-7-6. As an additional refinement, the suitability of a soil as subgrade material can be indicated by a group index number. Group index numbers range from 0 for the best subgrade material to 20 or higher for the poorest.

Percentage of rock fragments larger than 10 inches in diameter and 3 to 10 inches in diameter are indicated as a percentage of the total soil on a dry-weight basis. The percentages are estimates determined mainly by converting volume percentage in the field to weight percentage. Three values are provided to identify the expected Low (L), Representative Value (R), and High (H).

Percentage (of soil particles) passing designated sieves is the percentage of the soil fraction less than 3 inches in diameter based on an oven-dry weight. The sieves, numbers 4, 10, 40, and 200 (USA Standard Series), have openings of 4.76, 2.00, 0.420, and 0.074 millimeters, respectively. Estimates are based on laboratory tests of soils sampled in the survey area and in nearby areas and on estimates made in the field. Three values are provided to identify the expected Low (L), Representative Value (R), and High (H).

Liquid limit and plasticity index (Atterberg limits) indicate the plasticity characteristics of a soil. The estimates are based on test data from the survey area or from nearby areas and on field examination. Three values are provided to identify the expected Low (L), Representative Value (R), and High (H).

References:

- American Association of State Highway and Transportation Officials (AASHTO). 2004. Standard specifications for transportation materials and methods of sampling and testing. 24th edition.
- American Society for Testing and Materials (ASTM). 2005. Standard classification of soils for engineering purposes. ASTM Standard D2487-00.

Custom Soil Resource Report

Absence of an entry indicates that the data were not estimated. The asterisk '*' denotes the representative texture; other possible textures follow the dash. The criteria for determining the hydrologic soil group for individual soil components is found in the National Engineering Handbook, Chapter 7 issued May 2007(<http://directives.sc.egov.usda.gov/OpenNonWebContent.aspx?content=17757.wba>). Three values are provided to identify the expected Low (L), Representative Value (R), and High (H).

Engineering Properties—El Paso County Area, Colorado														
Map unit symbol and soil name	Pct. of map unit	Hydrologic group	Depth	USDA texture	Classification		Pct Fragments		Percentage passing sieve number—				Liquid limit	Plasticity index
					Unified	AASHTO	>10 inches	3-10 inches	4	10	40	200		
			<i>In</i>				<i>L-R-H</i>	<i>L-R-H</i>	<i>L-R-H</i>	<i>L-R-H</i>	<i>L-R-H</i>	<i>L-R-H</i>	<i>L-R-H</i>	<i>L-R-H</i>
8—Blakeland loamy sand, 1 to 9 percent slopes														
Blakeland	85	A	0-11	Loamy sand	SM	A-1, A-2	0- 0- 0	0- 0- 0	95-98-100	90-95-100	40-50-60	15-23-30	—	NP
			11-27	Loamy sand	SM	A-1, A-2	0- 0- 0	0- 0- 0	95-98-100	90-95-100	40-50-60	15-23-30	—	NP
			27-60	Loamy sand, loamy coarse sand, sand	SM, SP-SM, SW-SM	A-1, A-2, A-3	0- 0- 0	0- 0- 0	95-98-100	80-90-100	35-48-60	5-15- 25	—	NP
10—Blendon sandy loam, 0 to 3 percent slopes														
Blendon	85	B	0-10	Sandy loam	SC, SC-SM	A-2-4, A-4	0- 0- 0	0- 0- 0	100-100-100	90-95-100	60-65-70	30-35-40	25-28-30	5-8 -10
			10-36	Sandy loam, fine sandy loam	CL, CL-ML, SC, SC-SM	A-2-4, A-4	0- 0- 0	0- 0- 0	85-93-100	80-90-100	50-68-85	25-40-55	25-28-30	5-8 -10
			36-60	Gravelly sandy loam	GM, SC-SM, SM	A-1-b, A-2	0- 0- 0	0- 0- 0	60-70-80	55-65-75	35-43-50	20-25-30	20-23-25	NP-3 -5

Custom Soil Resource Report

Engineering Properties—El Paso County Area, Colorado														
Map unit symbol and soil name	Pct. of map unit	Hydrologic group	Depth	USDA texture	Classification		Pct Fragments		Percentage passing sieve number—				Liquid limit	Plasticity index
					Unified	AASHTO	>10 inches	3-10 inches	4	10	40	200		
			<i>In</i>				<i>L-R-H</i>	<i>L-R-H</i>	<i>L-R-H</i>	<i>L-R-H</i>	<i>L-R-H</i>	<i>L-R-H</i>	<i>L-R-H</i>	<i>L-R-H</i>
96—Truckton sandy loam, 0 to 3 percent slopes														
Truckton	85	A	0-8	Sandy loam	SC-SM, SM	A-2-4, A-4	0- 0- 0	0- 0- 0	95-98-100	95-98-100	60-65-70	30-35-40	20-23-25	NP-3 -5
			8-24	Sandy loam	SC-SM, SM	A-2-4, A-4	0- 0- 0	0- 0- 0	95-98-100	95-98-100	60-65-70	30-35-40	20-23-25	NP-3 -5
			24-60	Coarse sandy loam, loamy coarse sand	SM, SP-SM, SC-SM	A-2-4, A-1	0- 0- 0	0- 0- 0	85-93-100	80-90-100	35-53-70	10-20-30	20-23-25	NP-3 -5

References

- American Association of State Highway and Transportation Officials (AASHTO). 2004. Standard specifications for transportation materials and methods of sampling and testing. 24th edition.
- American Society for Testing and Materials (ASTM). 2005. Standard classification of soils for engineering purposes. ASTM Standard D2487-00.
- Cowardin, L.M., V. Carter, F.C. Golet, and E.T. LaRoe. 1979. Classification of wetlands and deep-water habitats of the United States. U.S. Fish and Wildlife Service FWS/OBS-79/31.
- Federal Register. July 13, 1994. Changes in hydric soils of the United States.
- Federal Register. September 18, 2002. Hydric soils of the United States.
- Hurt, G.W., and L.M. Vasilas, editors. Version 6.0, 2006. Field indicators of hydric soils in the United States.
- National Research Council. 1995. Wetlands: Characteristics and boundaries.
- Soil Survey Division Staff. 1993. Soil survey manual. Soil Conservation Service. U.S. Department of Agriculture Handbook 18. http://www.nrcs.usda.gov/wps/portal/nrcs/detail/national/soils/?cid=nrcs142p2_054262
- Soil Survey Staff. 1999. Soil taxonomy: A basic system of soil classification for making and interpreting soil surveys. 2nd edition. Natural Resources Conservation Service, U.S. Department of Agriculture Handbook 436. http://www.nrcs.usda.gov/wps/portal/nrcs/detail/national/soils/?cid=nrcs142p2_053577
- Soil Survey Staff. 2010. Keys to soil taxonomy. 11th edition. U.S. Department of Agriculture, Natural Resources Conservation Service. http://www.nrcs.usda.gov/wps/portal/nrcs/detail/national/soils/?cid=nrcs142p2_053580
- Tiner, R.W., Jr. 1985. Wetlands of Delaware. U.S. Fish and Wildlife Service and Delaware Department of Natural Resources and Environmental Control, Wetlands Section.
- United States Army Corps of Engineers, Environmental Laboratory. 1987. Corps of Engineers wetlands delineation manual. Waterways Experiment Station Technical Report Y-87-1.
- United States Department of Agriculture, Natural Resources Conservation Service. National forestry manual. http://www.nrcs.usda.gov/wps/portal/nrcs/detail/soils/home/?cid=nrcs142p2_053374
- United States Department of Agriculture, Natural Resources Conservation Service. National range and pasture handbook. <http://www.nrcs.usda.gov/wps/portal/nrcs/detail/national/landuse/rangepasture/?cid=stelprdb1043084>

Custom Soil Resource Report

United States Department of Agriculture, Natural Resources Conservation Service. National soil survey handbook, title 430-VI. http://www.nrcs.usda.gov/wps/portal/nrcs/detail/soils/scientists/?cid=nrcs142p2_054242

United States Department of Agriculture, Natural Resources Conservation Service. 2006. Land resource regions and major land resource areas of the United States, the Caribbean, and the Pacific Basin. U.S. Department of Agriculture Handbook 296. http://www.nrcs.usda.gov/wps/portal/nrcs/detail/national/soils/?cid=nrcs142p2_053624

United States Department of Agriculture, Soil Conservation Service. 1961. Land capability classification. U.S. Department of Agriculture Handbook 210. http://www.nrcs.usda.gov/Internet/FSE_DOCUMENTS/nrcs142p2_052290.pdf