

STORMWATER MANAGEMENT PLAN (SWMP) STORMWATER BEST MANAGEMENT PRACTICES

NORTHERN DELIVERY SYSTEM BOOSTER PUMP STATION

Prepared for:
Triview Metropolitan District
16055 Old Forest Point STE 300
Monument, CO 80132

Prepared by:
RESPEC
121 S Tejon St, Suite 1110
Colorado Springs, CO 80903
Contact: Richard Gallegos, P.E., C.F.M.

QSM/GEC Administrator:
RESPEC
121 S. Tejon St., Suite 1110
Colorado Springs, CO 80903
Richard Gallegos

Date:
November 2022
EPC: PPR2262



Owner/Preparer Information

Owner: Triview Metropolitan District
16055 Old Forest Point STE 300
Monument, CO 80132

Engineer: RESPEC
Mr. Richard Gallegos, P.E., C.F.M., Project Manager
121 S Tejon St, Suite 1110
Colorado Springs, CO 80903
719-266-5212

Contractor: *To be Determined*

Table of Contents

Owner/Preparer Information	1
Site Description	2
Proposed Construction Narrative	2
Construction Phasing	2
Soils.....	2
Soil Boring/Tests and Groundwater	2
Self-Inspection	2
GEC Administrator Certification	3
Colorado Department of Public Health & Environment.....	3
Final Stabilization and Long-Term Stormwater Management.....	8

Appendix A – Vicinity Map

Appendix B – Grading & Erosion Control Plans

Appendix C – Soils

Appendix D – GEC Administrator Certification

Appendix E – Spill Prevention Plan

Appendix F – Temporary Control Measure Details

Site Description

The site is currently developed with an existing water tank zoned as RR-5. This site is located along Highway-83, Colorado Springs in central El Paso County, see vicinity map in the appendix below for reference. It is further described as the Southwest One-Quarter of the Northwest One-Quarter of Section 3, Township 12 South, Range 66 West of the 6th P.M. This 9.75-acre site is located within the Black Squirrel Creek – FOM03600 basin. The tax schedule number for this site is 6203000002. A vicinity map is provided in *Appendix A*.

Proposed Construction Narrative

Work will include the construction of a 1500 square foot pump station and asphalt driveway. With an area of disturbance less than 1 acre, detention will not be required for the site per El Paso County Engineering Criteria Manual (ECM) Appendix 1.7, 1.B. No portion of the site is located within a FEMA designated 100-year floodplain per map no.: 08041C0295G that is effective on December 7th, 2018.

Construction Phasing

This project will be constructed in a single phase. Once construction begins, it will continue until the project is complete; therefore, construction phasing will not be necessary. Out of the 9.75 acres, there is only 0.88-acre area of land disturbance.

confirm on GEC Plan

Soils

According to the El Paso County Area Soils Survey, the soil on the site is classified as follows:

SOIL #	SOIL TYPE	HYDROLOGIC CLASSIFICATION	PERCENT OF SITE
41	Kettle Gravelly Loamy Sand, 8 to 40 Percent Slopes	B	10.8%
69	Peyton-Pring Complex, 8 to 15 Percent Slopes	B	0.0%
71	Pring Coarse Sandy Loam, 3 to 8 Percent Slopes	B	89.2%

The Kettle Gravelly soil can be described as having high permeability, low surface runoff, and slight hazard of erosion. The Pring Coarse Sandy soils is described, similarly, as having high permeability and low surface runoff. The hydrologic soil classification used for this study is 'B'. See soil maps in the Appendix for reference.

Soil Boring/Tests and Groundwater

There are no soil borings/ tests or available groundwater data for this site.

Self-Inspection

The GEC Administrator is required to conduct self-inspections. The purpose of these inspections to ensure that all Erosion Control measures are installed according to the approved plans, appropriate as to the intended use, operating effectively, and properly maintained.

The GEC Administrator shall, at a minimum, make a thorough inspection at least once every 14 calendar days. Also, post-storm event inspection must be conducted within 24 hours following

the end of any precipitation or snowmelt event that causes surface erosion. Providing the timing is appropriate, the post-storm inspections may be used to fulfill the 14-day routine inspection requirement. Alternately, the GEC Administrator may choose to perform self-inspections every 7 calendar days and forego post-storm event inspections. The self-inspection schedule must be identified in the GEC Administrator's most recent self-inspection. A more frequent inspection schedule than the minimum described may be necessary to ensure that Control Measures continue to operate as needed to comply with the GEC Plan. Site conditions such as steep grades and proximity to state water are reasons for increasing the frequency of self-inspections.

Completed self-inspection forms must be submitted electronically within 5 business days of the self-inspection. The self-inspections must also be always available either physically or electronically at the construction site throughout the duration of the project. GEC Inspectors will review self-inspections during compliance inspections. The use of a third-party inspection program does not remove this requirement. Additionally, the use of a third-party inspection program does not relieve the Permittee of the requirement to comply with all compliance inspections.

For sites or portions of sites where construction activities have been completed and final stabilization measures installed but final stabilization has not yet been achieved, the GEC Administrator shall make a thorough inspection of their Control Measures at least every month. Post-storm event inspections must be conducted within 72 hours following the end of any precipitation or snowmelt event that causes surface erosion. The GEC Plan must be amended to indicate those areas where construction activities have been completed but final stabilization has yet been achieved that will be inspected once a month.

When site conditions make the schedule required in this section impractical, permittee petition the county to grant an alternate inspection schedule. The alternative inspection schedule may not be implemented prior to written approval by the county and incorporation into the SWMP.

The permittee is responsible to confirm that the frequency of inspection is sufficient to ensure that Control Measures always remain in good working condition.

GEC Administrator Certification

The project GEC Administrator Certificate is included in *Appendix D*.

Colorado Department of Public Health & Environment

- a. A Qualified Stormwater Manager will be Richard Gallegos, Certification #63, 719-266-5212.
- b. The Spill Prevention and Response Plan will be as follows:
See *Appendix E* for contractor's spill prevention plan.
- c. A Materials Handling Plan will be as follows:
 - All site material will be contained within the stage storage area. Paints, solvents, chemicals, and fertilizer's will be stored in a closed metal container within the staged storage area.

- Sediment control logs provided around the exterior of the site and the perimeter of the stage storage area are to prevent any erosion leaving the site from material movement.
- A concrete washout area will be provided for concrete foundation placement.
- Equipment fueling and maintenance will take place within the stage storage area.
- The site is laid out for drainage to be contained within the site limits. As a secondary precaution, sediment control logs and check dams are placed around site in specifically determined areas. Inlet protection is provided for all drainage structures.
- Design specifications that contain information on the implementation of the Control Measure in accordance with good engineering hydrologic/ hydraulic and pollution control practices, including as applicable drawings, dimensions, installation information, materials, implementation processes, Control Measure-specific inspection expectations, and maintenance requirements are referenced in *Appendix F*.

d. Potential Sources of Pollution (Table 1):

TABLE 1: POTENTIAL POLLUTION SOURCES

Potential Pollution Sources	Possible Site Contributions of Pollutants to Stormwater Discharges
All disturbed and stored soils	Stockpiles of fill and topsoil.
Vehicle tracking of sediments	See plan for vehicle tracking control for vehicle entrance and exits.
Management of contaminated soils	No contaminated soils are expected to be encountered.
Loading and unloading operations	Unloading of materials.
Outdoor storage activities (building material, fertilizers, chemicals, etc.)	Soil stockpiles and equipment storage areas (no fertilizers, petroleum or chemical products will be stored on-site).
Vehicle and equipment maintenance and fueling	Fueling will occur on-site using mobile equipment (will not be stored on-site). Equipment maintenance will occur off-site.
Significant dust or particulate-generating processes	Vehicle tracking, stockpiles, fill placement.
Routine maintenance activities involving fertilizers, pesticides, detergents, fuels, solvents, oils, etc.	All equipment maintenance will occur off-site. No fertilizers, pesticides, detergents, and/or solvents will be used or stored on-site.
On-site waste management practices (waste piles, liquid wastes, dumpsters, etc.)	All waste will be removed from site as soon as possible.
Concrete truck/equipment washing, including the concrete truck chute and associated fixtures and equipment	Concrete wash areas delineated on-site.
Dedicated asphalt and concrete batch plants	No dedicated asphalt and concrete batch plants are on-site.
Non-industrial waste sources such as worker trash and portable toilets	Worker trash will be removed from the site as soon as possible. Portable toilets will be provided on-site.
Other areas or procedures where potential spills can occur	Petroleum releases from equipment are possible.

e. Implementation of Control Measures are as follows:

Clearing & Grubbing Operations

The proposed perimeter control measures will be installed prior to the start of construction operations. These perimeter controls will include sediment control logs.

Earthwork

The major work to be completed for this project will involve grading the upper portion of the lot to construct the proposed parking lot and office building. Erosion control for the site will be placed prior to the work commencing. This will include the placement of sedimentary control logs along the proposed disturbed area.

All the disturbed areas on the site are shown on the GEC plans in *Appendix B*.

Erosion and Sediment Control Measures

Erosion control and sediment prevention measures describe a wide range of management procedures, schedules of activities, prohibitions on practices, and other best management practices (BMP). BMPs also include operating procedures, treatment requirements and practices to control site runoff, drainage from materials storage, spills, or leaks. Structural practices for this site include sediment control logs, inlet protection, and vehicular tracking control. Erosion matting may be required on unstable slopes, if directed by the engineer. General descriptions of the BMPs to be used during the construction of this project are listed below. See the Erosion Control Plans for the specific type and location of each erosion and sediment control device required for this project. Stockpiles and staging areas will be protected by erosion control logs to minimize impacts from handling significant materials that could contribute pollutants to runoff.

Initial Stage

These BMPs shall be installed at the outset of construction, prior to the initial pre-construction meeting and any other land-disturbing activities. Initial controls are to be placed on existing grades but shall be based in part on proposed grading operations. The initial stage includes clearing, grubbing, over lot grading, and utility and other construction prior to paving operations.

Temporary Stabilization

Disturbed areas will be temporarily stabilized as soon as construction activities are completed. Seeding will be applied to completed areas within 14 days of completion.

Sediment Control Logs

Prior to the start of construction sediment control logs will be installed along the perimeter of all disturbed areas that are within the project site. Sediment control logs shall be placed as indicated on the plan drawing. Sediment shall be removed when depth exceeds one-half the height of the sediment control logs. The engineer may require additional sediment control logs as necessary to retard sediment transport on or off the project site.

Upon completion of the grading, temporary seeding and mulching will be applied to all disturbed areas on and adjacent to the site. All seeding, fertilizers, and mulching shall conform to *El Paso Drainage Criteria Manual*.

include interim and final stages unresolved.

discuss all non-structural BMPs including seeding/mulching unresolved.

Non-Structural Practices

f. A Use Agreement does not apply to this project. We have full control of the project boundary, and the owner is responsible for the control measures.

g. Proposed Sequence for Major Activities.

Discuss all temporary control measures in detail.
unresolved.

i. The site will be graded to resemble existing flow patterns of the existing conditions. Grading and erosion control will be contained within the site the removal of temporary BMPs will happen once final stabilization is established. The general sequence for major construction activities will be as follows:

1. Establish limits of disturbance – install construction fence around proposed site
2. Implement initial CCMs such as vehicle tracking, silt fencing, sediment control logs and check dams as specified in the GEC plans for this site.
3. Clear and grub the site
4. Excavation and Stockpiling – staging area and stockpile storage should be CCMs implemented in accordance with the GEC plans for this site
5. Installation of proposed infrastructure such as buildings and roads
6. Redistributing of existing soils – add seeding and mulching per GEC plans for this site
7. Install permanent landscaping and irrigation
8. Remove CCMs specified on the GEC plans for this site once final stabilizations occurs

To be fully effective, erosion and sediment control measures must be installed and phased with the construction activities. The vehicular tracking control device shall be installed at the entrance prior to the mobilization of construction equipment on-site. Prior to the clearing and grubbing of the entire construction area, localized clearing shall be performed for the placement of perimeter erosion control measures. Site clearing shall commence only after the perimeter erosion control measures are in place. Erosion control devices must be in place to reduce the potential of eroded excavated material entering the storm drainage system. Protection devices shall be placed during grading activities, in the appropriate areas, as indicated on the GEC drawings that is in the *Appendix B*.

Anticipated starting and completion date: March 1, 2023 to August 1, 2024

Expected date on which the final stabilization will be completed: September, 2024

The seedbed shall be well settled and firm, but friable enough that seed can be placed at the seeding depth specified. The seedbed shall be reasonably free of weeds. Soils that have been over-compacted by traffic or equipment, especially when wet, shall be tilled to break up rooting restrictive layers and then harrowed, rolled, or packed to prepare the required firm seedbed. Mulch shall be applied at a rate of two and one-half (2 ½) tons per acre and shall be spread uniformly, in a continuous blanket, after seeding is complete. Mulch shall be clean, weed and seed free, long-stemmed grass or hay, or long-stemmed straw of oats, wheat, or rye. At least 50 percent of mulch, by weight, shall be ten inches or longer. Mulch shall be spread by hand or blower-type mulch spreader. Mulching shall be started on the windward side of relatively flat areas or on the upper part of steep slope and continued uniformly until the area is covered. The mulch shall not be bunched. Immediately following spreading, the mulch shall be anchored to the soil by a v-type wheel land packer or scalloped-disk land packer designed to force mulch into the soil surface a minimum of three inches. All seeded

areas shall be mulched after seeding on the same day as the seeding. The type of seed mix used for permanent vegetation shall utilize perennial grasses as delineated on the plans.

All temporary and permanent erosion and sediment control practices shall be maintained and repaired as needed by the contractor throughout the duration of construction to assure that each BMP will function as intended. As required by the stormwater discharge permit, a weekly inspection of these items will be performed. In addition, all facilities must be inspected by the owner or the owner's representative following each heavy precipitation or snowmelt event that results in runoff, with maintenance occurring immediately after discovering a need.

Sediment control logs may require periodic replacement. All sediment accumulated behind the sediment control logs must be removed and disposed of properly when depth exceeds one-half the height of the sediment control logs. On-site construction traffic will be monitored to minimize the transport of sediment onto the proposed on-site streets, as well as onto adjacent streets. The Owner, Site Developer, Contractor, and/or their authorized agents shall prevent loss of cut and fill material being transported to and from the site by taking appropriate measures. All mud and sediment tracked onto public streets shall be cleaned immediately. Road cleaning includes shoveling and sweeping activities. Inlet/outlet protection shall be inspected to ensure proper operation. Excess debris or sediment must be removed prior to final acceptance of the project.

- ii. The total estimated acreage of the site is 9.75 acres, and the acreage expected to be disturbed by clearing, excavation, grading, or any other construction activities is approximately 0.88 acres.
- iii. Based on the soil description from the NRCS, the Pring Sandy soils is described as having a high permeability rate and low surface runoff. The hydrologic soil classification used for this study is 'B'.
- iv. The total land disturbance for this development is 0.88 acres. According to the El Paso County Engineering Criteria Manual (ECM), "The following types of sites and associated land disturbances are excluded from the requirements of this Section 1.7". furthermore, in El Paso County ECM Appendix 1.7, 1.B, a "County Growth Areas" are excluded from the requirements defined in Section 1.7. Since this site will be considered a "Commercial or Industrial development site or land disturbance of less than or equal to 10 acres, the site can be excluded from water quality control measure requirements.
- v. No non-stormwater Discharges will be allowed at the site.
- vi. All site flows are directly tributary to Black Squirrel Drainage Basin
- vii. No stream crossings exist within the project work limits.
- viii. Noxious weeds do not contribute to the 70% pre-disturbance vegetation cover.

please remove this paragraph (see LOI for additional information). unresolved.

Final Stabilization and Long-Term Stormwater Management

Disturbed areas shall be permanently stabilized as soon as construction activities are completed. Viable vegetative cover shall be established no later than one year from disturbance. Areas to be revegetated shall be treated with soil amendments to provide an adequate grown medium to sustain vegetation and shall match the existing percent pre-disturbed vegetation cover.

- a) See Grading and Erosion Control Plans for proposed control measures in *Appendix B*.

Item Numbers refer to SWMP Checklist:

Item 9. Include method used to determine ground cover (i.e., visual, aerial inspection)

Item 12. Note that this project does not anticipate utilizing onsite batch plants in the SWMP text

Item 13. Discuss inspection procedure for checking waste disposal bins for leaks and overflowing capacity. And discuss frequency that they will be emptied (or at what level of capacity would trigger the need to be emptied).

Toilets: Portable toilets will be located a minimum of 10ft from stormwater inlets and 50ft from state waters. They will be secured at all four corners to prevent overturning and cleaned on a weekly basis. They will be inspected daily for spills.

Item 18: Include a description of all structural control measures to be used.

Item 19: Include a description of all non-structural control measures to be used.

Item 21. Add text stating that the SWMP should be viewed as a "living document" that is continuously being reviewed and modified as a part of the overall process of evaluating and managing SW quality issues at the site. The QSM shall amend the SWMP when there is a change in design, construction, O&M of the site which would require the implementation of new or revised BMPs or if the SWMP proves to be ineffective in achieving the general objectives of controlling pollutants in SW discharges associated with construction activity or when BMPs are no longer necessary and are removed.

Item 26. Add a note stating that this project does not rely on control measures owned or operated by another entity.

Unresolved.

APPENDIX A

VICINITY MAP

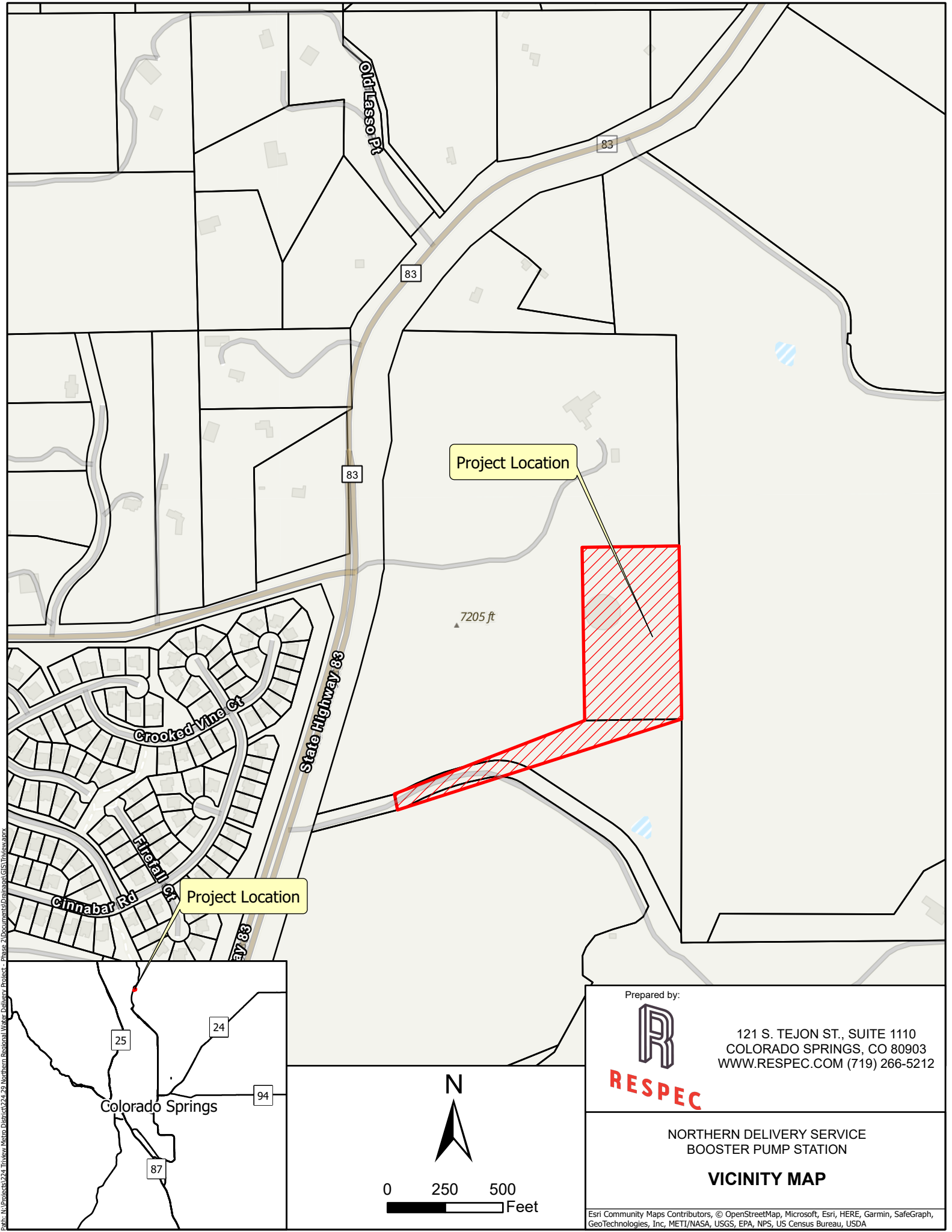

Project Location

Project Location

7205 ft

Path: N:\Projects\244 Tiview Metro District\244_23 Northern Regional Water Delivery Project - Phase 2\Documents\Drawings\GIS\Tiview\main

Prepared by:



121 S. TEJON ST., SUITE 1110
COLORADO SPRINGS, CO 80903
WWW.RESPEC.COM (719) 266-5212

RESPEC

NORTHERN DELIVERY SERVICE
BOOSTER PUMP STATION

VICINITY MAP



0 250 500
Feet

Esri Community Maps Contributors, © OpenStreetMap, Microsoft, Esri, HERE, Garmin, SafeGraph, GeoTechnologies, Inc, METI/NASA, USGS, EPA, NPS, US Census Bureau, USDA

APPENDIX B

GRADING & EROSION CONTROL PLANS

$$H_s = \frac{(H + Y_s)}{2}$$

Equation 9-19

Where the maximum value of H_s shall not exceed H_s and:

- D_o = parameter to use in place of D in Figure 9-38 when flow is supercritical (ft)
- D_c = diameter of circular culvert (ft)
- H_s = parameter to use in place of H in Figure 9-39 when flow is supercritical (ft)
- H = height of rectangular culvert (ft)
- Y_s = normal depth of supercritical flow in the culvert (ft)

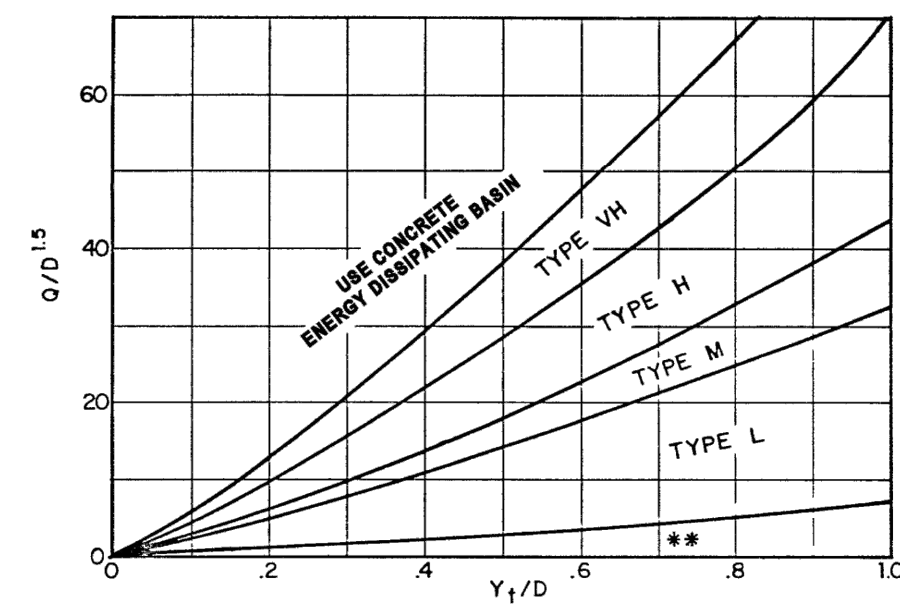

Figure 9-38. Riprap erosion protection at circular conduit outlet (valid for Q/D2.5 ≤ 6.0)

9-74 Urban Drainage and Flood Control District
Urban Storm Drainage Criteria Manual Volume 2 September 2017

NOT TO SCALE

TIMING, CONSTRUCTION STAGING, AND SEQUENCING:

EXPECTED START DATE: JAN 2023
INSTALL TEMPORARY EROSION CONTROL - 2 DAYS
- PERIMETER SILT FENCING
- VEHICLE TRACKING CONTROL PAD

ROUGH GRADING - 5 DAYS
INSTALL FINAL SITE IMPROVEMENTS - 10 MONTHS
REMOVE TEMPORARY EROSION CONTROL - 5 DAYS

MINIMUM BEST MANAGEMENT PRACTICES ELEMENTS:

- STEP 1- EROSION AND SEDIMENT CONTROL
INSTALL SEDIMENT TRAPPING DEVICES (PERIMETER CONTROLS) PRIOR TO THE START OF CONSTRUCTION.
- STEP 2- SPILL PREVENTION AND RESPONSE
- STEP 3- MATERIAL MANAGEMENT
MATERIAL AND EQUIPMENT STORAGE AREAS SHALL BE SECURE AND CONTAINED TO PREVENT DISCHARGE OF ANY MATERIAL IN RUNOFF. WASTE SHALL BE CONTAINED AND DISPOSED OF PROPERLY. MAINTAIN BMP'S DURING BUILDING AND UTILITY CONSTRUCTION.
- STEP 4- INSPECTION AND MAINTENANCE (SEE EROSION CONTROL NOTES).
- STEP 5- INSTALL FINAL STABILIZATION - BASE COURSE, LANDSCAPING, EROSION CONTROL BLANKETS, AND SEEDING.
- STEP 6- REMOVE TEMPORARY CONTROLS - SILT FENCING AFTER PERMANENT FEATURES ARE INSTALLED.

FINAL STABILIZATION AND LONG-TERM STORMWATER MANAGEMENT:

FINAL STABILIZATION MEASURES INCLUDE BASE COURSE, PARTIAL LANDSCAPE, AND REVEGETATION

EARTHWORK SUMMARY:

PROPOSED SITE:
CUT - 93 CY
FILL - 186 (*1.15) = 214 CY
NET - 122 CY CUT

ACCESS DRIVE & PUMP STATION SITE DISTURBED AREA - 34,124 SF, 0.78 AC
SECONDARY ACCESS DRIVE DISTURBED AREA - 4,260, 0.10 AC
SEED MIX AREA - 38,384 SF, 0.88 AC

EROSION CONTROL FACILITIES:

SECONDARY ACCESS DRIVE	PUMP STATION ACCESS DRIVE	PUMP STATION SITE
SILT FENCE (SF) - 372 LF	SILT FENCE (SF) - 1,597 LF	SILT FENCE (SF) - 478 LF
VEHICLE TRACKING PAD (VT) - 0	VEHICLE TRACKING PAD (VT) - 1	VEHICLE TRACKING PAD (VT) - 1
INLET PROTECTIONS - 0	INLET PROTECTIONS - 0	INLET PROTECTIONS - 1
CHECK DAMS - 0	CHECK DAMS - 0	CHECK DAMS - 2
STABILIZED STAGING AREA - 0	STABILIZED STAGING AREA - 0	STABILIZED STAGING AREA - 1
STOCKPILE PROTECTION - 0	STOCKPILE PROTECTION - 0	STOCKPILE PROTECTION - 1
PORTABLE TOILET - 0	PORTABLE TOILET - 0	PORTABLE TOILET - 1

EROSION CONTROL NOTES:

1. STORMWATER DISCHARGES FROM CONSTRUCTION SITES SHALL NOT CAUSE OR THREATEN TO CAUSE POLLUTION, CONTAMINATION, OR DEGRADATION OF STATE WATERS. ALL WORK AND EARTH DISTURBANCE SHALL BE DONE IN A MANNER THAT MINIMIZES POLLUTION OF ANY ON-SITE OR OFF-SITE WATERS, INCLUDING WETLANDS AND SENSITIVE ENVIRONMENTAL AREAS.
2. NOTWITHSTANDING ANYTHING DEPICTED IN THESE PLANS IN WORDS OR GRAPHIC REPRESENTATION, ALL DESIGN AND CONSTRUCTION RELATED TO ROADS, STORM DRAINAGE, AND EROSION CONTROL SHALL CONFORM TO THE STANDARDS AND REQUIREMENTS OF THE MOST RECENT VERSION OF THE RELEVANT ADOPTED EL PASO COUNTY STANDARDS, INCLUDING THE LAND DEVELOPMENT CODE, THE ENGINEERING CRITERIA MANUAL, THE DRAINAGE CRITERIA MANUAL, AND THE DRAINAGE CRITERIA MANUAL VOLUME 2. ANY DEVIATIONS FROM REGULATIONS AND STANDARDS MUST BE REQUESTED, AND APPROVED, IN WRITING.
3. MANAGEMENT OF THE STORMWATER MANAGEMENT PLAN (SWMP) DURING CONSTRUCTION IS THE RESPONSIBILITY OF THE DESIGNATED QUALIFIED STORMWATER MANAGER OR CERTIFIED EROSION CONTROL MANAGER (ECM). THE SWMP SHALL BE LOCATED ON SITE AT ALL TIMES DURING CONSTRUCTION AND SHALL BE KEPT UP TO DATE WITH WORK PROGRESS AND CHANGES IN THE FIELD.
4. ONCE THE EROSION AND STORMWATER QUALITY CONTROL PERMIT (ESQCP) IS APPROVED AND A "NOTICE TO PROCEED" HAS BEEN ISSUED, THE CONTRACTOR MAY INSTALL THE INITIAL STAGE EROSION AND SEDIMENT CONTROL MEASURES AS INDICATED ON THE APPROVED DEC. A PRECONSTRUCTION MEETING BETWEEN THE CONTRACTOR, ENGINEER, AND EL PASO COUNTY WILL BE HELD PRIOR TO ANY CONSTRUCTION. IT IS THE RESPONSIBILITY OF THE APPLICANT TO COORDINATE THE MEETING TIME AND PLACE WITH COUNTY STAFF.
5. CONTROL MEASURES MUST BE INSTALLED PRIOR TO COMMENCEMENT OF ACTIVITIES THAT COULD CONTRIBUTE POLLUTANTS TO STORMWATER. CONTROL MEASURES FOR ALL SLOPES, CHANNELS, DITCHES, AND DISTURBED LAND AREAS SHALL BE INSTALLED IMMEDIATELY UPON COMPLETION OF THE DISTURBANCE.
6. ALL TEMPORARY SEDIMENT AND EROSION CONTROL MEASURES SHALL BE MAINTAINED AND REMAIN IN EFFECTIVE OPERATING CONDITION UNTIL PERMANENT SOIL EROSION CONTROL MEASURES ARE IMPLEMENTED AND FINAL STABILIZATION IS ESTABLISHED. ALL PERSONS ENGAGED IN LAND DISTURBANCE ACTIVITIES SHALL ASSESS THE ADEQUACY OF CONTROL MEASURES AT THE SITE AND IDENTIFY IF CHANGES TO THOSE CONTROL MEASURES ARE NEEDED TO ENSURE THE CONTINUED EFFECTIVE PERFORMANCE OF THE CONTROL MEASURES. ALL CHANGES TO TEMPORARY SEDIMENT AND EROSION CONTROL MEASURES MUST BE INCORPORATED INTO THE STORMWATER MANAGEMENT PLAN.
7. TEMPORARY STABILIZATION SHALL BE IMPLEMENTED ON DISTURBED AREAS AND STOCKPILES WHERE GROUND-DISTURBING CONSTRUCTION ACTIVITY HAS PERMANENTLY CEASED OR TEMPORARILY CEASED FOR LONGER THAN 14 DAYS.
8. FINAL STABILIZATION MUST BE IMPLEMENTED AT ALL APPLICABLE CONSTRUCTION SITES. FINAL STABILIZATION IS ACHIEVED WHEN ALL GROUND-DISTURBING ACTIVITIES ARE COMPLETE AND ALL DISTURBED AREAS EITHER HAVE A UNIFORM VEGETATIVE COVER WITH INDIVIDUAL PLANT DENSITY OF 70 PERCENT OF PRE-DISTURBANCE LEVELS ESTABLISHED OR EQUIVALENT PERMANENT ALTERNATIVE STABILIZATION METHOD IS IMPLEMENTED. ALL TEMPORARY SEDIMENT AND EROSION CONTROL MEASURES SHALL BE REMOVED UPON FINAL STABILIZATION AND BEFORE PERMIT CLOSURE.
9. ALL PERMANENT STORMWATER MANAGEMENT FACILITIES SHALL BE INSTALLED AS DESIGNATED IN THE APPROVED PLANS. ANY PROPOSED CHANGES THAT AFFECT THE DESIGN OR FUNCTION OF PERMANENT STORMWATER MANAGEMENT STRUCTURES MUST BE APPROVED BY THE ECM ADMINISTRATOR PRIOR TO IMPLEMENTATION.
10. EARTH DISTURBANCES SHALL BE CONDUCTED IN SUCH A MANNER SO AS TO EFFECTIVELY MINIMIZE ACCELERATED SOIL EROSION AND RESULTING SEDIMENTATION. ALL DISTURBANCES SHALL BE DESIGNED, CONSTRUCTED, AND COMPLETED SO THAT THE EXPOSED AREA OF ANY DISTURBED LAND SHALL BE LIMITED TO THE SHORTEST PRACTICAL PERIOD OF TIME. PRE-EXISTING VEGETATION SHALL BE PROTECTED AND MAINTAINED WITHIN 50 HORIZONTAL FEET OF A WATERS OF THE STATE UNLESS SHOWN TO BE INFEASIBLE AND SPECIFICALLY REQUESTED AND APPROVED.
11. COMPACTION OF SOIL MUST BE PREVENTED IN AREAS DESIGNATED FOR INFILTRATION CONTROL MEASURES OR WHERE FINAL STABILIZATION WILL BE ACHIEVED BY VEGETATIVE COVER. AREAS DESIGNATED FOR INFILTRATION CONTROL MEASURES SHALL ALSO BE PROTECTED FROM SEDIMENTATION DURING CONSTRUCTION UNTIL FINAL STABILIZATION IS ACHIEVED. IF COMPACTION PREVENTION IS NOT FEASIBLE DUE TO SITE CONSTRAINTS, ALL AREAS DESIGNATED FOR INFILTRATION AND VEGETATION CONTROL MEASURES MUST BE LOOSENED PRIOR TO INSTALLATION OF THE CONTROL MEASURE(S).
12. ANY TEMPORARY OR PERMANENT FACILITY DESIGNED AND CONSTRUCTED FOR THE CONVEYANCE OF STORMWATER AROUND, THROUGH, OR FROM THE EARTH DISTURBANCE AREA SHALL BE A STABILIZED CONVEYANCE DESIGNED TO MINIMIZE EROSION AND THE DISCHARGE OF SEDIMENT OFF SITE.
13. CONCRETE WASH WATER SHALL BE CONTAINED AND DISPOSED OF IN ACCORDANCE WITH THE SWMP. NO WASH WATER SHALL BE DISCHARGE TO OR ALLOWED TO ENTER STATE WATERS, INCLUDING ANY SURFACE OR SUBSURFACE STORM DRAINAGE SYSTEM OR FACILITIES. CONCRETE WASHOUTS SHALL OCCUR AS SHOWN WITHIN THE PLANS.
14. DURING DEWATERING OPERATIONS OF UNCONTAMINATED GROUND WATER MAY BE DISCHARGED ON SITE, BUT SHALL NOT LEAVE THE SITE IN THE FORM OF SURFACE RUNOFF UNLESS AN APPROVED STATE DEWATERING PERMIT IS IN PLACE.
15. EROSION CONTROL BLANKETING OR OTHER PROTECTIVE COVERING SHALL BE USED ON SLOPES STEEPER THAN 3:1.
16. CONTRACTOR SHALL BE RESPONSIBLE FOR THE REMOVAL OF ALL WASTES FROM THE CONSTRUCTION SITE FOR DISPOSAL IN ACCORDANCE WITH LOCAL AND STATE REGULATORY REQUIREMENTS. NO CONSTRUCTION DEBRIS, ORGANIC MATERIAL, BUILDING MATERIAL WASTES, OR UNUSED BUILDING MATERIALS SHALL BE BURIED, DUMPED, OR DISCHARGED AT THE SITE.
17. WASTE MATERIALS SHALL NOT BE TEMPORARILY PLACED OR STORED IN THE STREET, ALLEY, OR OTHER PUBLIC WAY, UNLESS IN ACCORDANCE WITH AN APPROVED TRAFFIC CONTROL PLAN. CONTROL MEASURES MAY BE REQUIRED BY EL PASO COUNTY ENGINEERING IF DEEMED NECESSARY, BASED ON SPECIFIC CONDITIONS AND CIRCUMSTANCES.
18. TRACKING OF SOILS AND CONSTRUCTION DEBRIS OFF SITE SHALL BE MINIMIZED. MATERIALS TRACKED OFF SITE SHALL BE CLEANED UP AND PROPERLY DISPOSED OF IMMEDIATELY.
19. THE OWNER/DEVELOPER SHALL BE RESPONSIBLE FOR THE REMOVAL OF ALL CONSTRUCTION DEBRIS, DIRT, TRASH, ROCK, SEDIMENT, SOIL, AND SAND THAT MAY ACCUMULATE IN ROADS, STORM DRAINS, AND OTHER DRAINAGE CONVEYANCE SYSTEMS AND STORMWATER APPURTENANCES AS A RESULT OF SITE DEVELOPMENT.
20. THE QUANTITY OF MATERIALS STORED ON THE PROJECT SITE SHALL BE LIMITED, AS MUCH AS PRACTICAL, TO THAT QUANTITY REQUIRED TO PERFORM THE WORK IN AN ORDERLY SEQUENCE. ALL MATERIALS STORED ON SITE SHALL BE STORED IN A NEAT, ORDERLY MANNER, IN THEIR ORIGINAL CONTAINERS, AND WITH ORIGINAL MANUFACTURER'S LABELS.
21. NO CHEMICAL(S) HAVING THE POTENTIAL TO BE RELEASED IN STORMWATER ARE TO BE STORED OR USED ON SITE UNLESS PERMISSION FOR THE USE OF SUCH CHEMICAL(S) IS GRANTED IN WRITING BY THE ECM ADMINISTRATOR. IN GRANTING APPROVAL FOR THE USE OF SUCH CHEMICAL(S), SPECIAL CONDITIONS AND MONITORING MAY BE REQUIRED.
22. BULK STORAGE OF ALLOWED PETROLEUM PRODUCTS OR OTHER ALLOWED LIQUID CHEMICALS IN EXCESS OF 55 GALLONS SHALL REQUIRE ADEQUATE SECONDARY CONTAINMENT PROTECTION TO CONTAIN ALL SPILLS ON SITE AND TO PREVENT ANY SPILLED MATERIALS FROM ENTERING STATE WATERS, ANY SURFACE OR SUBSURFACE STORM DRAINAGE SYSTEM, OR OTHER FACILITIES.
23. OWNER/DEVELOPER AND THEIR AGENTS SHALL COMPLY WITH THE "COLORADO WATER QUALITY CONTROL ACT" (TITLE 25, ARTICLE 8, CRS) AND THE "CLEAN WATER ACT" (33 USC 1344), IN ADDITION TO THE REQUIREMENTS OF THE LAND DEVELOPMENT CODE, DCM VOLUME II AND THE ECM APPENDIX I. ALL APPROPRIATE PERMITS MUST BE OBTAINED BY THE CONTRACTOR PRIOR TO CONSTRUCTION (1041, NPDES, FLOODPLAIN, 404, FUGITIVE DUST, ETC.). IN THE EVENT OF CONFLICTS BETWEEN THESE REQUIREMENTS AND OTHER LAWS, RULES, OR REGULATIONS OF OTHER FEDERAL, STATE, LOCAL, OR COUNTY AGENCIES, THE MOST RESTRICTIVE LAWS, RULES, OR REGULATIONS SHALL APPLY.
24. ALL CONSTRUCTION TRAFFIC MUST ENTER/EXIT THE SITE ONLY AT APPROVED CONSTRUCTION ACCESS POINTS.
25. PRIOR TO CONSTRUCTION, THE PERMITTEE SHALL VERIFY THE LOCATION OF EXISTING UTILITIES.
26. A WATER SOURCE SHALL BE AVAILABLE ON SITE DURING EARTHWORK OPERATIONS AND SHALL BE UTILIZED AS REQUIRED TO MINIMIZE DUST FROM EARTHWORK EQUIPMENT AND WIND.
27. THE SOILS REPORT FOR THIS SITE WAS PREPARED BY ENTECH ENGINEERING, INC. (DATED 02/26/2021) AND SHALL BE CONSIDERED A PART OF THESE PLANS
28. CONTRACTOR SHALL BE RESPONSIBLE FOR ANY RE-EXCAVATION OF SEDIMENT AND DEBRIS THAT COLLECTS IN THE DOWNSTREAM SEDIMENT BASIN DEPRESSION REQUIRED TO ENSURE THAT THE BASIN MEETS THE DESIGN GRADES FOLLOWING CONSTRUCTION. THE ROADSIDE DITCHES CONVEYING SITE RUNOFF TO THE BASIN SHALL ALSO BE CLEANED AND FREE OF SEDIMENT ONCE THE SITE BECOMES STABILIZED.
29. AT LEAST TEN (10) DAYS PRIOR TO THE ANTICIPATED START OF CONSTRUCTION, FOR PROJECTS THAT WILL DISTURB ONE (1) ACRE OR MORE, THE OWNER OR OPERATOR OF CONSTRUCTION ACTIVITY SHALL SUBMIT A PERMIT APPLICATION FOR STORMWATER DISCHARGE TO THE COLORADO DEPARTMENT OF PUBLIC HEALTH AND ENVIRONMENT, WATER QUALITY DIVISION. THE APPLICATION CONTAINS CERTIFICATION OF COMPLETION OF A STORMWATER MANAGEMENT PLAN (SWMP), OF WHICH THIS GRADING AND EROSION CONTROL PLAN MAY BE A PART. FOR INFORMATION OR APPLICATIONS MATERIALS, CONTACT:

COLORADO DEPARTMENT OF PUBLIC HEALTH AND ENVIRONMENT
WATER QUALITY CONTROL DIVISION
WOOD - PERMITS
4300 CHERRY CREEK DRIVE SOUTH
DENVER, CO 80246-1530
ATTN: PERMITS UNIT
30. BASED ON THE DESIGN SHOWN THE DISTURBANCE IS LESS THAN ONE (1) ACRE.
31. EXISTING VEGETATION IS NOT NOTABLE, ONLY GRASSES/WEEDS ARE WITHIN THE LIMITS OF CONSTRUCTION.
32. THERE ARE NO BATCH PLANTS/ASPHALT PLANTS EXISTING OR PROPOSED FOR THIS SITE.
33. RECEIVING WATERS: TRIBUTARY OF BLACK SQUIRREL CREEK
34. THERE ARE NO SPRINGS, STREAMS, WETLANDS, OR OTHER SURFACE WATERS, INCLUDING AREAS THAT REQUIRE MAINTENANCE OF PRE-EXISTING VEGETATION WITHIN 50 FEET OF A RECEIVING WATER.

NAME: N:\Projects\224 Triview Metro District\224-28 Northern Regional Water Delivery Project - Phase 2\Drawings\Working\Segment A - Pump Station\02_Civil\Sheets\2 GENERAL GRADING NOTES.dwg PLOT DATE: Oct 26, 2022 1:23pm

DESIGNED _____ DRAWN _____ CHECKED _____ DATE 10.26.2022	REVISION _____ _____ _____
RESPEC COMMUNITY DESIGN SOLUTIONS 127 SOUTH TEJAS STREET SUITE 1100 DENVER, CO 80202 WWW.RESPEC.COM PHONE: (719) 966-5212	
STAMP	
PRELIMINARY NOT FOR CONSTRUCTION 10/2022 THIS DRAWING IS INCOMPLETE AND NOT TO BE USED FOR CONSTRUCTION UNLESS IT IS STAMPED, SIGNED AND DATED	
Know what's below. Call before you dig.	
PROJECT NAME: NORTHERN DELIVERY SERVICE BOOSTER PUMP STATION	
SHEET TITLE: GENERAL GRADING NOTES	
SUBMITTED FOR: TRIVIEW METROPOLITAN DISTRICT	
SHEET NUMBER: SHEET 2 OF 7	

NAME: N:\Projects\224 Triview Metro District\224_29 Northern Regional Water Delivery Project - Phase 2\Drawings\Working\Segment A - Pump Station\02_Civil\Sheets\3 OVERALL SITE PLAN.dwg PLOT DATE: Oct 26, 2022 1:24pm

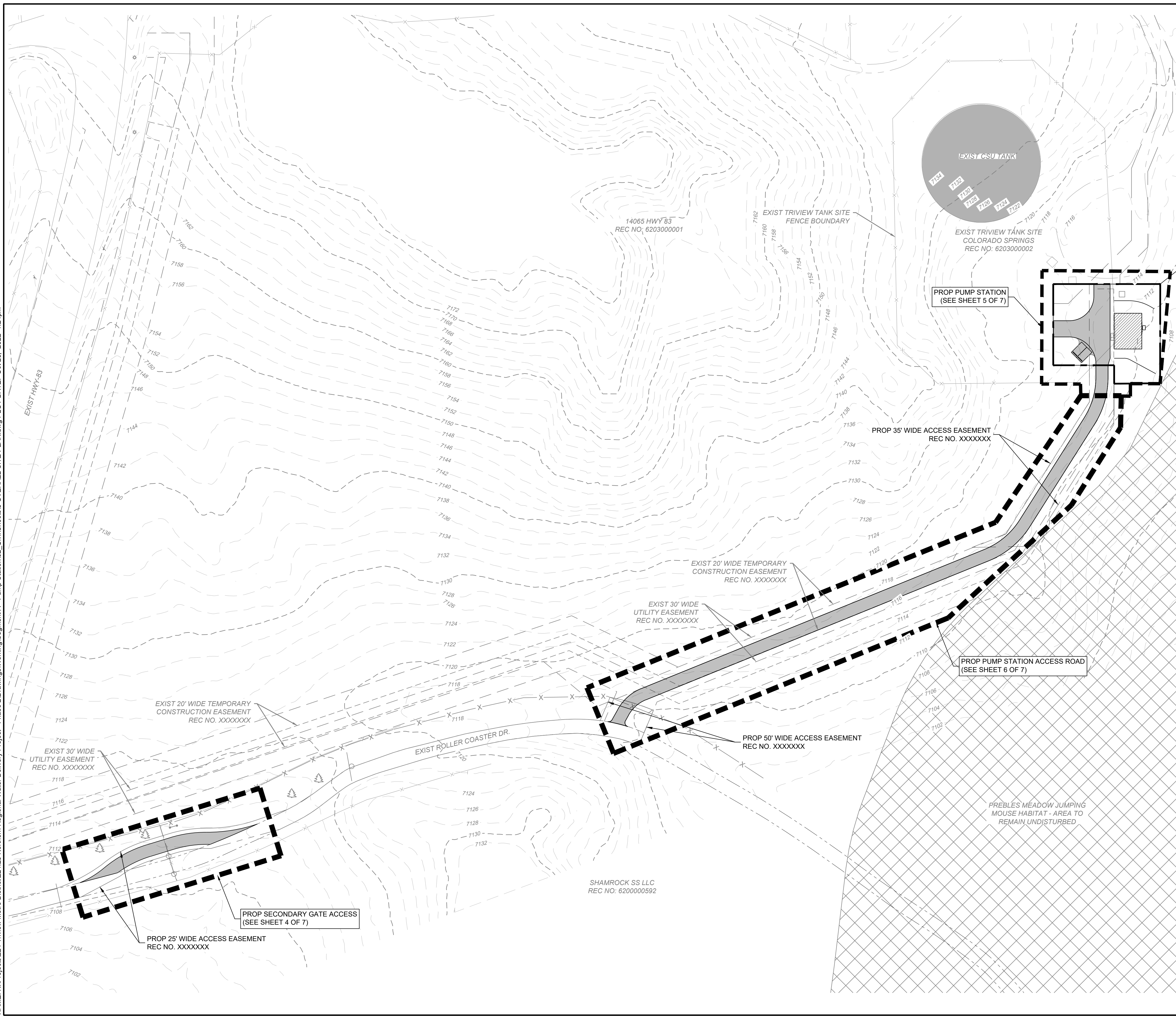

VICINITY MAP TRIVIEW METRO DISTRICT NTS

BENCHMARK
 TOPOGRAPHY SURVEY CENTENNIAL LAND SURVEYING, LLC. SEE SURVEY FOR ESTABLISHED CONTROL. THE FOLLOWING COORDINATE SYSTEM AND DATUM RECORD IS AS FOLLOWS:

HORIZONTAL DATUM: HORIZONTAL COORDINATES ARE MODIFIED COLORADO STATE PLANE CENTRAL BASED UPON THE FOLLOWING: COORDINATES ARE SCALED FROM CONTROL POINT 5052 BEING A 2-INCH ALUMINUM CAP STAMPED AZTEC CP 52 SET AT THE TOP OF A DIRT BANK ALONG THE EAST SIDE OF GLEN EAGLE DR. APPROXIMATELY 380+ FEET NORTHERLY OF ST. LAWRENCE WAY. VALUES ARE BASED UPON A STATIC SURVEY SESSION WITH THE FOLLOWING RESULTS:
 LATITUDE: 39-04-05916N;
 LONGITUDE: 104-49-24.82486 W
 STATE PLANE NORTHING: 1,450,401.759;
 STATE PLANE EASTING: 3,192,049.712
 SCALE FACTOR: 1.0004063250
 TRUNCATE NORTHING: 1,000,000.00;
 TRUNCATE EASTING: 3,000,000.00
 PROJECT NORTHING: 450,401.759;
 PROJECT EASTING: 192,049.712

VERTICAL DATUM: NAVD 88 WITH GEOID G18US;
 BENCHMARK: CP 5052 EL: 7213.70
 BENCHMARK: NGS CS110/DM9842 EL: 6843.25; BENCHMARK: NGS S294/KK0272 EL: 7116.72

LEGEND

— 7290 —	PROPOSED MAJOR CONTOUR
— 7291 —	PROPOSED MINOR CONTOUR
- - - 7290 - - -	EXISTING MAJOR CONTOUR
- - - 7291 - - -	EXISTING MINOR CONTOUR
▬▬▬	PROPOSED PROJECT AREAS
— — — — —	PROPERTY LINE
— — — — —	LIMITS OF CONSTRUCTION
- - - - -	LIMITS OF DISTURBANCE
— SCL —	PROPOSED SEDIMENT CONTROL LOG
▬▬▬	PROPOSED ASPHALT PAVEMENT
- - - - -	EXISTING EDGE OF ASPHALT
x x x x x	EXISTING FENCE LINE
- - - - -	EXISTING EASEMENT

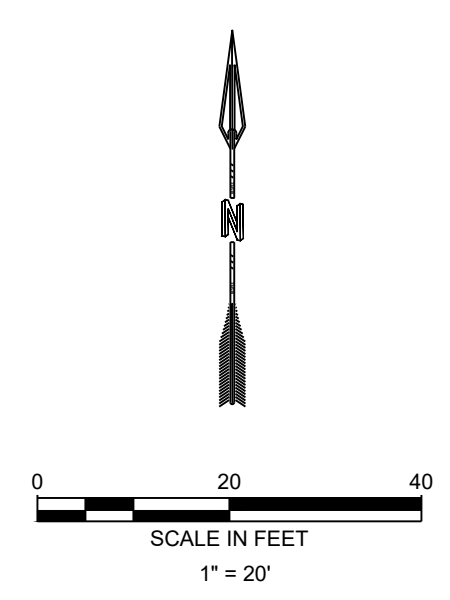

DESIGNED	DRAWN	CHECKED	DATE
			10.26.2022

RESPEC
 COMMUNITY DESIGN SOLUTIONS
 121 SOUTH GLEN STREET SUITE 110
 DENVER, CO 80202
 WWW.RESPEC.COM PHONE: (719) 966-8212

STAMP

PRELIMINARY
 NOT FOR CONSTRUCTION
 10/2022

THIS DRAWING IS INCOMPLETE AND NOT TO BE USED FOR CONSTRUCTION UNLESS IT IS STAMPED, SIGNED AND DATED

81
 Know what's below.
 Call before you dig.

PROJECT NAME:
**NORTHERN DELIVERY SERVICE
 BOOSTER PUMP STATION**

SHEET TITLE:
OVERALL SITE PLAN

SUBMITTED FOR:
TRIVIEW METROPOLITAN DISTRICT

SHEET NUMBER:
SHEET 3 OF 7

NAME: N:\Projects\224 Triview Metro District\224-29 Northern Regional Water Delivery Project - Phase 2\Drawings\Working\Segment A - Pump Station\02_Civil\Sheets\4 SECONDARY GATE ACCESS GRADING PLAN.dwg PLOT DATE: Oct 26, 2022 1:24pm

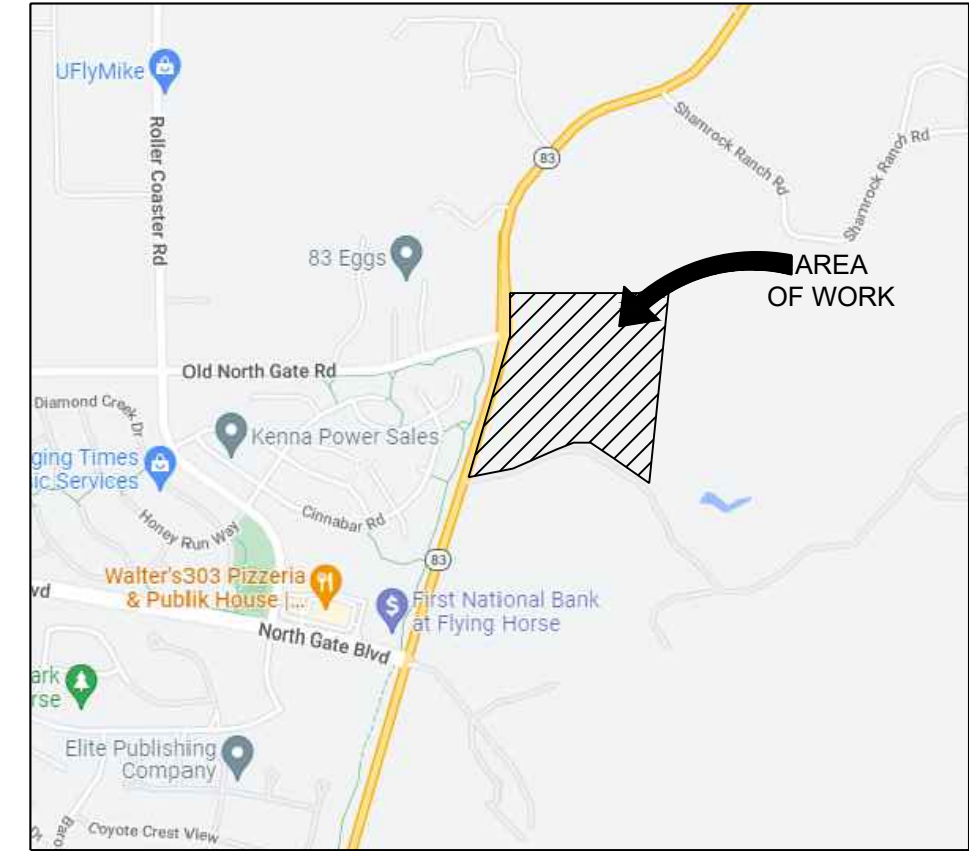
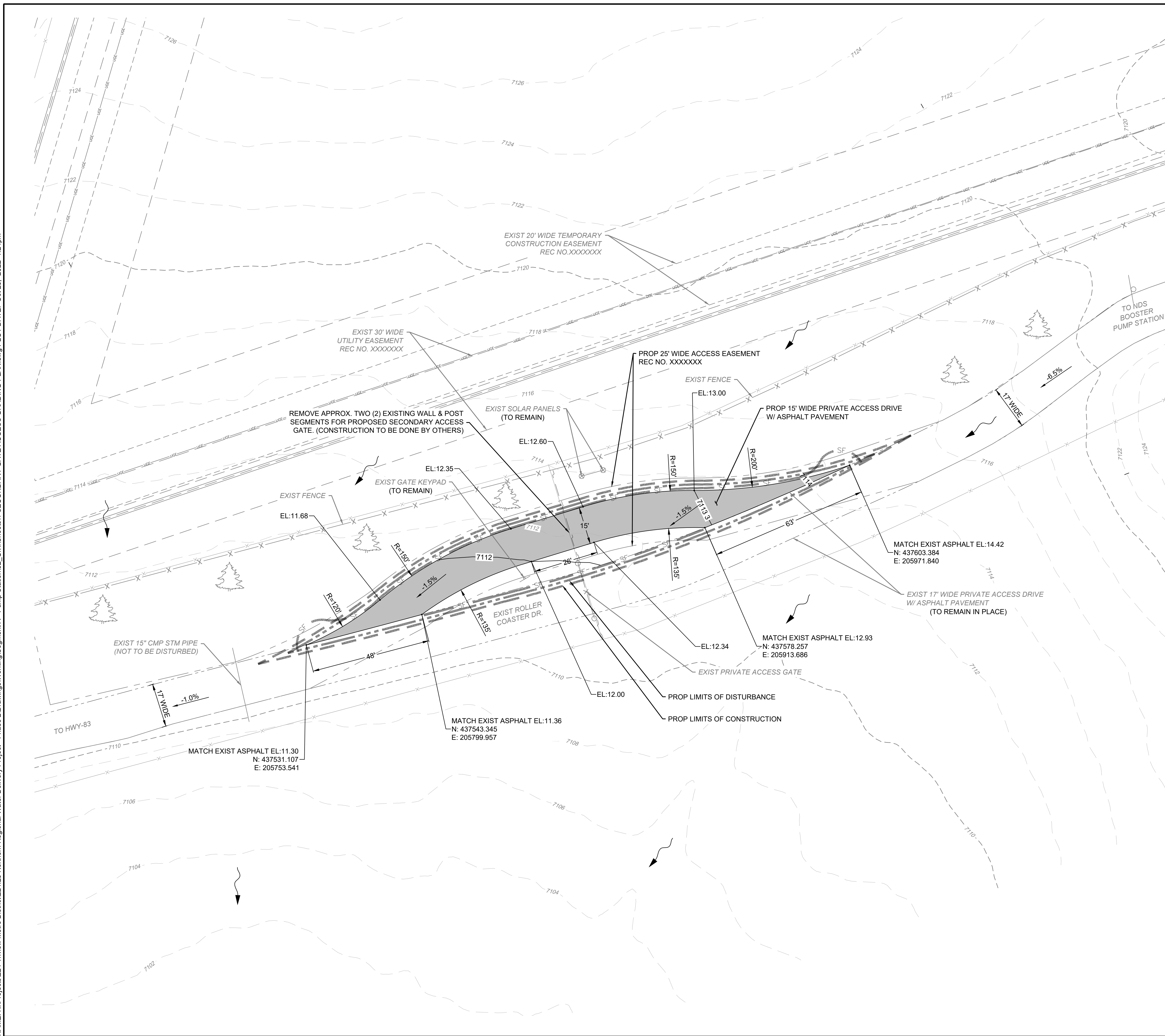

VICINITY MAP TRIVIEW METRO DISTRICT
NTS

BENCHMARK

TOPOGRAPHY SURVEY CENTENNIAL LAND SURVEYING, LLC. SEE SURVEY FOR ESTABLISHED CONTROL. THE FOLLOWING COORDINATE SYSTEM AND DATUM RECORD IS AS FOLLOWS:

HORIZONTAL DATUM: HORIZONTAL COORDINATES ARE MODIFIED COLORADO STATE PLANE CENTRAL BASED UPON THE FOLLOWING: COORDINATES ARE SCALED FROM CONTROL POINT 5052 BEING A 2-INCH ALUMINUM CAP STAMPED AZTEC CP 52 SET AT THE TOP OF A DIRT BANK ALONG THE EAST SIDE OF GLEN EAGLE DR. APPROXIMATELY 380+ FEET NORTHERLY OF ST. LAWRENCE WAY. VALUES ARE BASED UPON A STATIC SURVEY SESSION WITH THE FOLLOWING RESULTS:

LONGITUDE: 104-49-24.82486 W
 STATE PLANE EASTING: 3,192,049.712
 SCALE FACTOR: 1.0004063250
 TRUNCATE NORTHING: 1,000,000.00;
 TRUNCATE EASTING: 3,000,000.00
 PROJECT NORTHING: 450,401.759;
 PROJECT EASTING: 192,049.712

VERTICAL DATUM: NAVD 88 WITH GEOID G18US;
 BENCHMARK: CP 5052 EL: 7213.70
 BENCHMARK: NGS CS110/DM9842 EL: 6843.25; BENCHMARK: NGS S294/KK0272 EL: 7116.72

LEGEND

- 7290 ——— PROPOSED MAJOR CONTOUR
- 7291 ——— PROPOSED MINOR CONTOUR
- 7290 - - - EXISTING MAJOR CONTOUR
- 7291 - - - EXISTING MINOR CONTOUR
- PROPERTY LINE
- - - - - LIMITS OF CONSTRUCTION
- - - - - LIMITS OF DISTURBANCE
- SCL — PROPOSED SEDIMENT CONTROL LOG
- PROPOSED ASPHALT PAVEMENT
- - - - - EXISTING EDGE OF ASPHALT
- X - X - EXISTING FENCE LINE
- - - - - EXISTING EASEMENT
- - - - - EXISTING STORM SEWER
- - - - - EXISTING UNDERGROUND ELECTRIC
- — — — — EXISTING WATER LINE

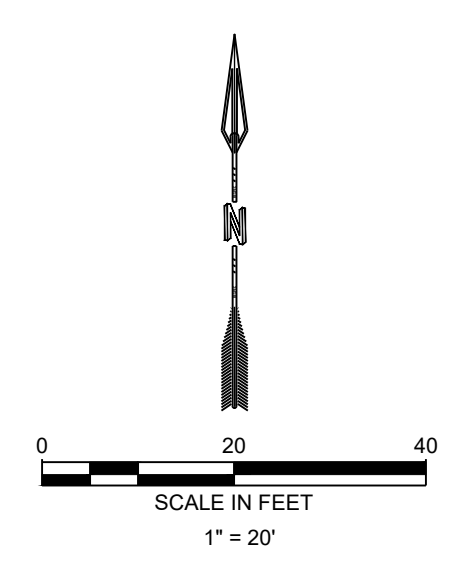

DESIGNED		DRAWN		CHECKED		DATE	
							10.26.2022

RESPEC
 COMMUNITY DESIGN SOLUTIONS
 121 SOUTH ELMO STREET SUITE 110
 DENVER, CO 80202
 WWW.RESPEC.COM PHONE: (719) 966-5212

STAMP

PRELIMINARY
 NOT FOR CONSTRUCTION
 10/2022

THIS DRAWING IS INCOMPLETE AND NOT TO BE USED FOR CONSTRUCTION UNLESS IT IS STAMPED, SIGNED AND DATED



Know what's below.
 Call before you dig.

PROJECT NAME:
**NORTHERN DELIVERY SERVICE
 BOOSTER PUMP STATION**

SHEET TITLE:
**SECONDARY GATE
 ACCESS GRADING PLAN**

SUBMITTED FOR:
**TRIVIEW
 METROPOLITAN
 DISTRICT**

SHEET NUMBER:
SHEET 4 OF 7

NAME: N:\Projects\24 Triview Metro District\24-29 Northern Regional Water Delivery Project - Phase 2\Drawings\Working\Segment A - Pump Station\02_Civil\Sheets\5 Pump Station Grading Plan.dwg PLOT DATE: Oct 26, 2022 1:25pm

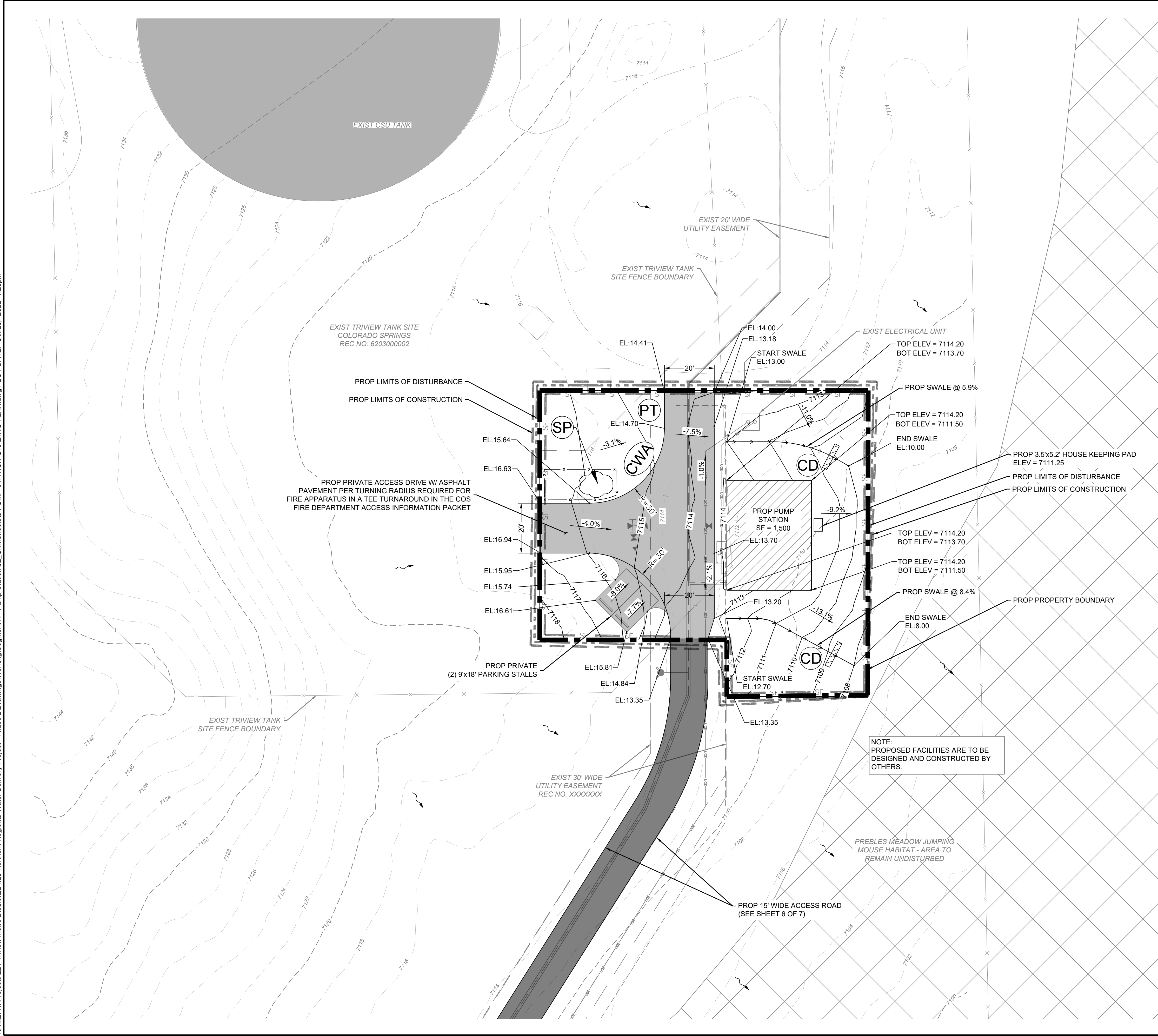

BENCHMARK

TOPOGRAPHY SURVEY CENTENNIAL LAND SURVEYING, LLC. SEE SURVEY FOR ESTABLISHED CONTROL. THE FOLLOWING COORDINATE SYSTEM AND DATUM RECORD IS AS FOLLOWS:

HORIZONTAL DATUM: HORIZONTAL COORDINATES ARE MODIFIED COLORADO STATE PLANE CENTRAL BASED UPON THE FOLLOWING: COORDINATES ARE SCALED FROM CONTROL POINT 5052 BEING A 2-INCH ALUMINUM CAP STAMPED AZTEC CP 52 SET AT THE TOP OF A DIRT BANK ALONG THE EAST SIDE OF GLEN EAGLE DR. APPROXIMATELY 380+ FEET NORTHERLY OF ST. LAWRENCE WAY. VALUES ARE BASED UPON A STATIC SURVEY SESSION WITH THE FOLLOWING RESULTS:

LATITUDE: 39-04-05916N;
LONGITUDE: 104-49-24.82486 W
STATE PLANE NORTHING: 1,450,401.759;
STATE PLANE EASTING: 3,192,049.712
SCALE FACTOR: 1.0004063250
TRUNCATE EASTING: 3,000,000.00
PROJECT NORTHING: 450,401.759;
PROJECT EASTING: 192,049.712

VERTICAL DATUM: NAVD 88 WITH GEOID G18US;
BENCHMARK: CP 5052 EL: 7213.70
BENCHMARK: NGS CS110/DM9842 EL: 6843.25; BENCHMARK: NGS S294/KK0272 EL: 7116.72

LEGEND

- 7290 — PROPOSED MAJOR CONTOUR
- 7291 — PROPOSED MINOR CONTOUR
- - - 7290 - - - EXISTING MAJOR CONTOUR
- - - 7291 - - - EXISTING MINOR CONTOUR
- — — — — PROPERTY LINE
- - - - - LIMITS OF CONSTRUCTION
- - - - - LIMITS OF DISTURBANCE
- SCL — PROPOSED SEDIMENT CONTROL LOG
- → → → → PROPOSED SWALE FLOW LINE
- ▬ PROPOSED ASPHALT PAVEMENT
- - - - - EXISTING EDGE OF ASPHALT
- X X X X X EXISTING FENCE LINE
- - - - - EXISTING EASEMENT
- — — — — EXISTING WATER LINE
- — — — — EXISTING UNDERGROUND ELECTRIC
- VTC ○ PROPOSED VEHICLE TRACKING CONTROL
- CWA □ PROPOSED CONCRETE WASHOUT AREA
- SSA □ PROPOSED STABILIZED STAGING AREA
- SP ○ PROPOSED STOCKPILE PROTECTION
- PT ○ PROPOSED PORTABLE TOILET
- CD ○ PROPOSED CHECK DAM

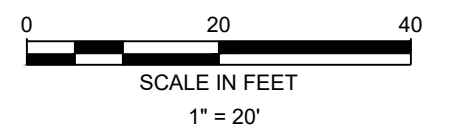

DESIGNED	REVISION
DRAWN	
CHECKED	
DATE	10.26.2022
<p>RESPEC COMMUNITY DESIGN SOLUTIONS 131 SOUTH ELAN STREET SUITE 1110 DENVER, CO 80202 WWW.RESPEC.COM PHONE: (719) 966-5212</p>	
<p>STAMP</p>	
<p>PRELIMINARY NOT FOR CONSTRUCTION 10/2022</p> <p>THIS DRAWING IS INCOMPLETE AND NOT TO BE USED FOR CONSTRUCTION UNLESS IT IS STAMPED, SIGNED AND DATED RESULTS:</p> <p>Know what's below. Call before you dig.</p>	
<p>PROJECT NAME: NORTHERN DELIVERY SERVICE BOOSTER PUMP STATION</p>	
<p>SHEET TITLE: PUMP STATION GRADING PLAN</p>	
<p>SUBMITTED FOR: TRIVIEW METROPOLITAN DISTRICT</p>	
<p>SHEET NUMBER: SHEET 5 OF 7</p>	

NAME: N:\Projects\224 Triview Metro District\224-29 Northern Regional Water Delivery Project - Phase 2\Drawings\Working\Segment A - Pump Station\02_Civil\Sheets\7 GRADING DETAILS.dwg PLOT DATE: Oct 26, 2022 1:26pm

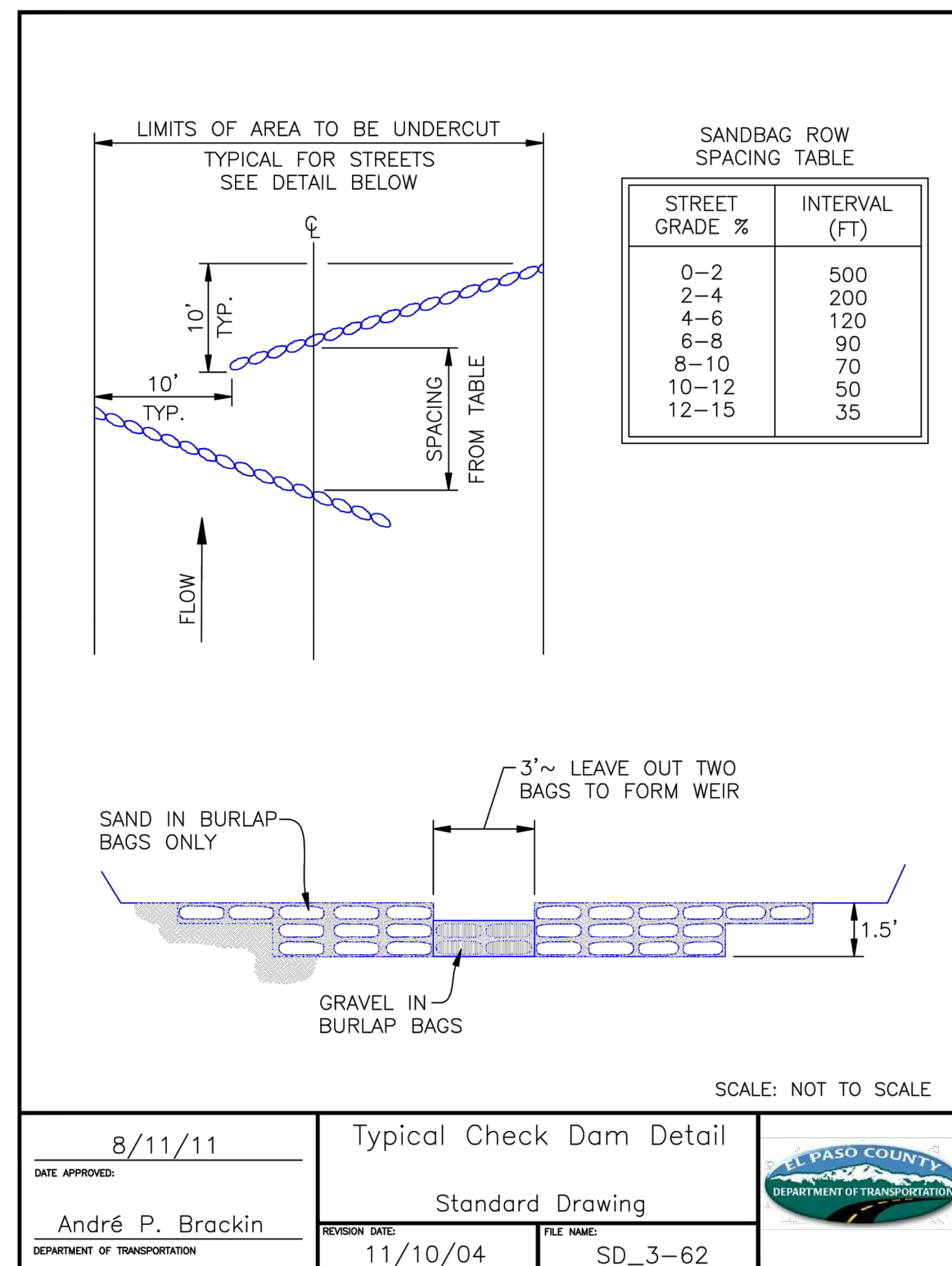

NOT TO SCALE

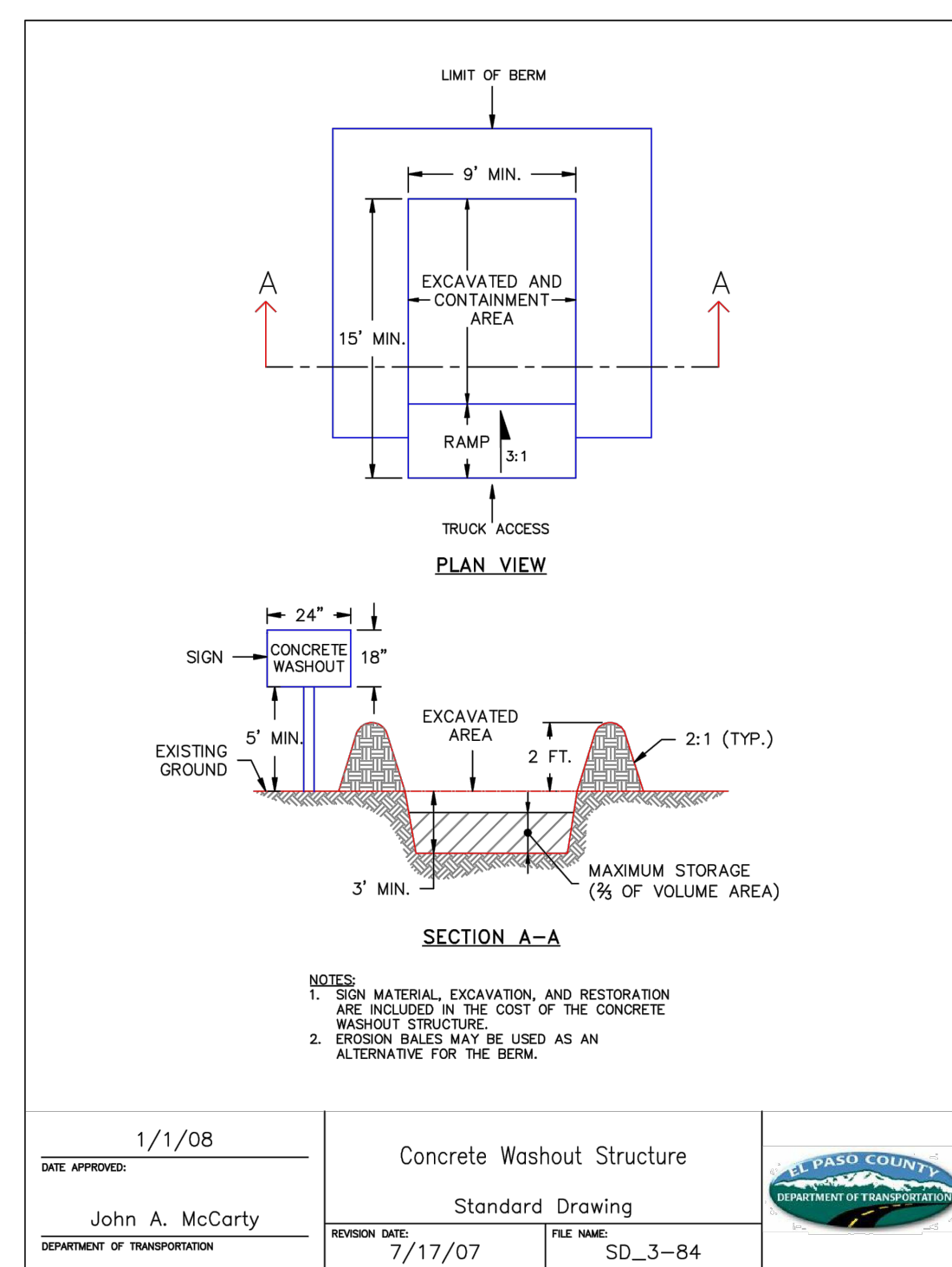

NOT TO SCALE

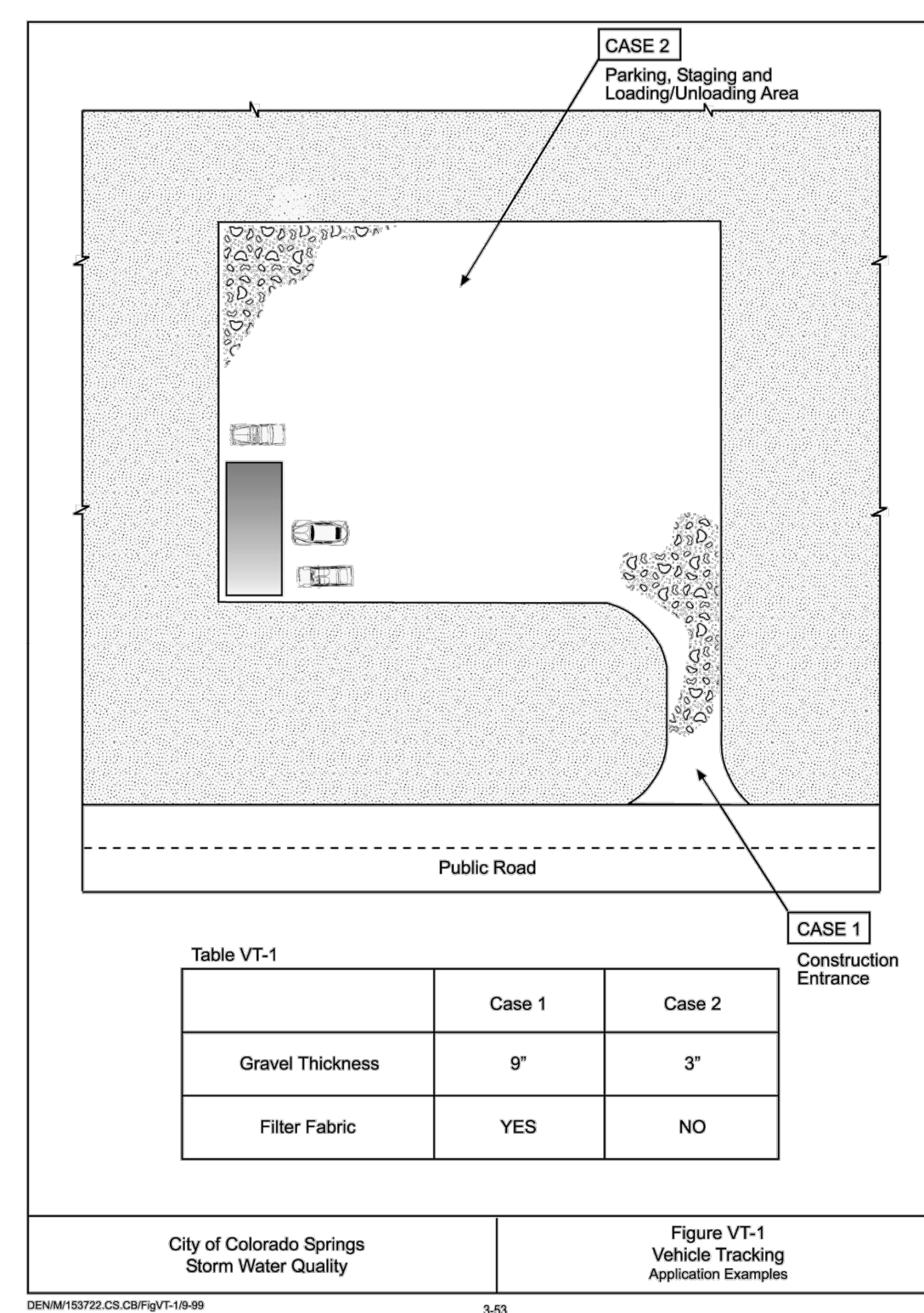

NOT TO SCALE

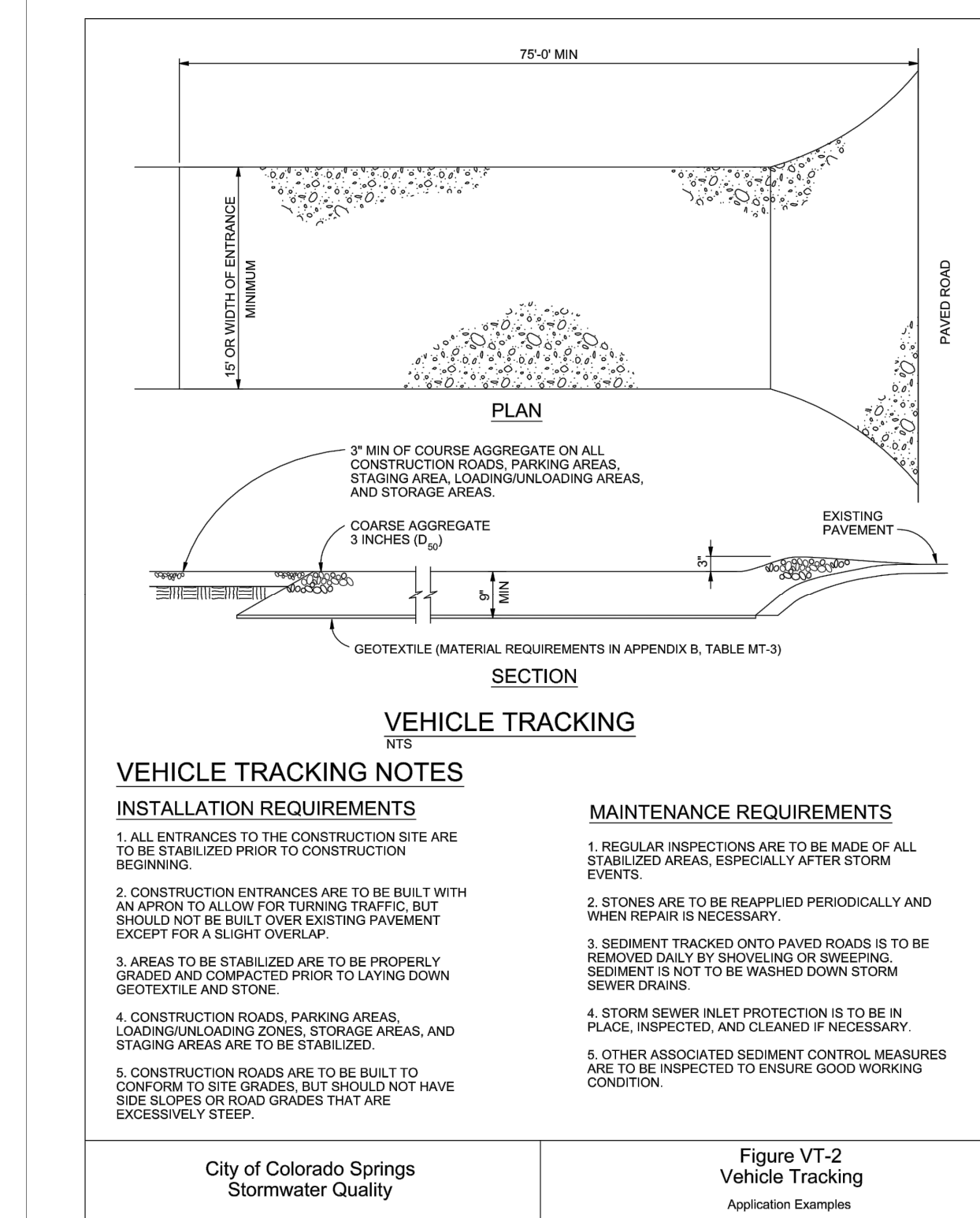

NOT TO SCALE

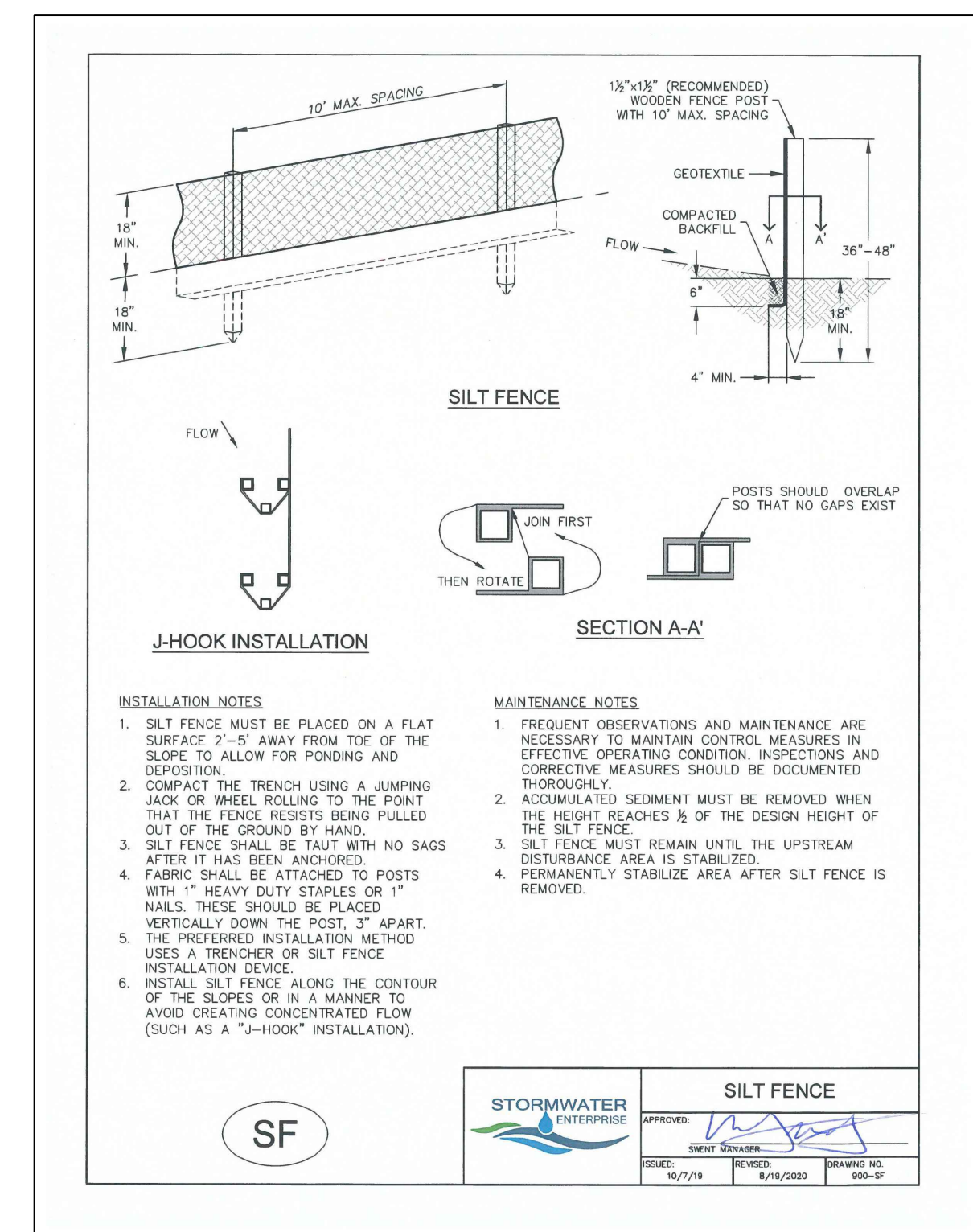

NOT TO SCALE

El Paso County Conservation District Shotgun Mix

Common Name (All Native)	Recommended Variety	Percent of Seed Mix	Non Irrigated PLS Rate Per Acre (Drilled)
Bluestem, Big	Kaw, Bison, Champ	20.0%	1.08
Grama, Blue	Lovington, Hachita, Alma	10.0%	0.12
Green Needlegrass	Lodorn	10.0%	0.48
Wheatgrass, Western	Arriba, Barton	20.0%	1.60
Grama, Sideoats	Vaughn, Butte, El Reno, Niner	10.0%	0.46
Switchgrass	Glackwell, Greenville	10.0%	0.20
Prairie Sandreed	Goshen, Pronghorn	10.0%	0.32
Yellow Indiangrass	Cheyenne, Holt, Llano	10.0%	0.51

Note: The above listed PLS rate per acre is for drilled application. If seeding is completed using broadcasting methods, the PLS rate shall be doubled.

NOT TO SCALE

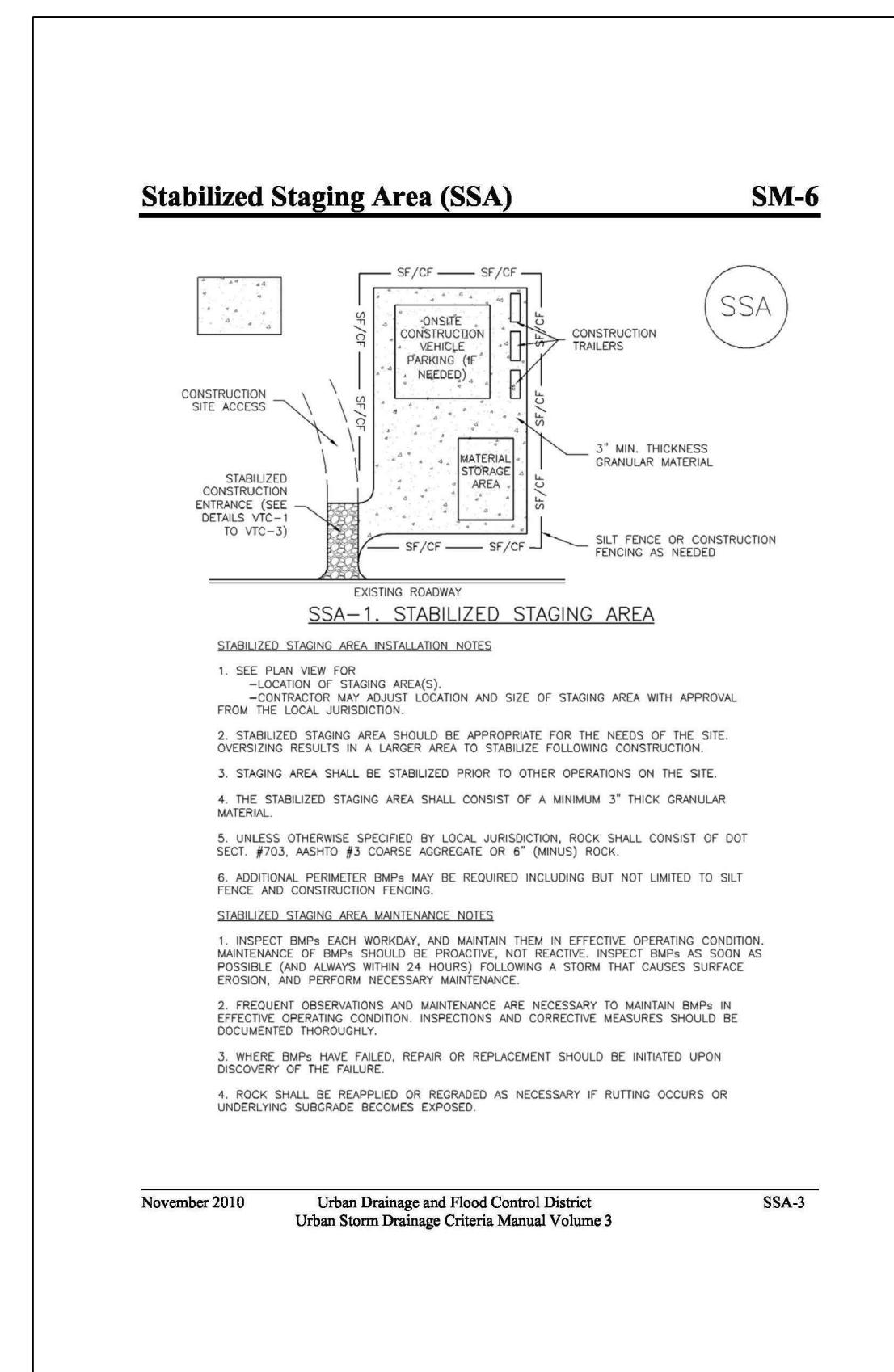

NOT TO SCALE

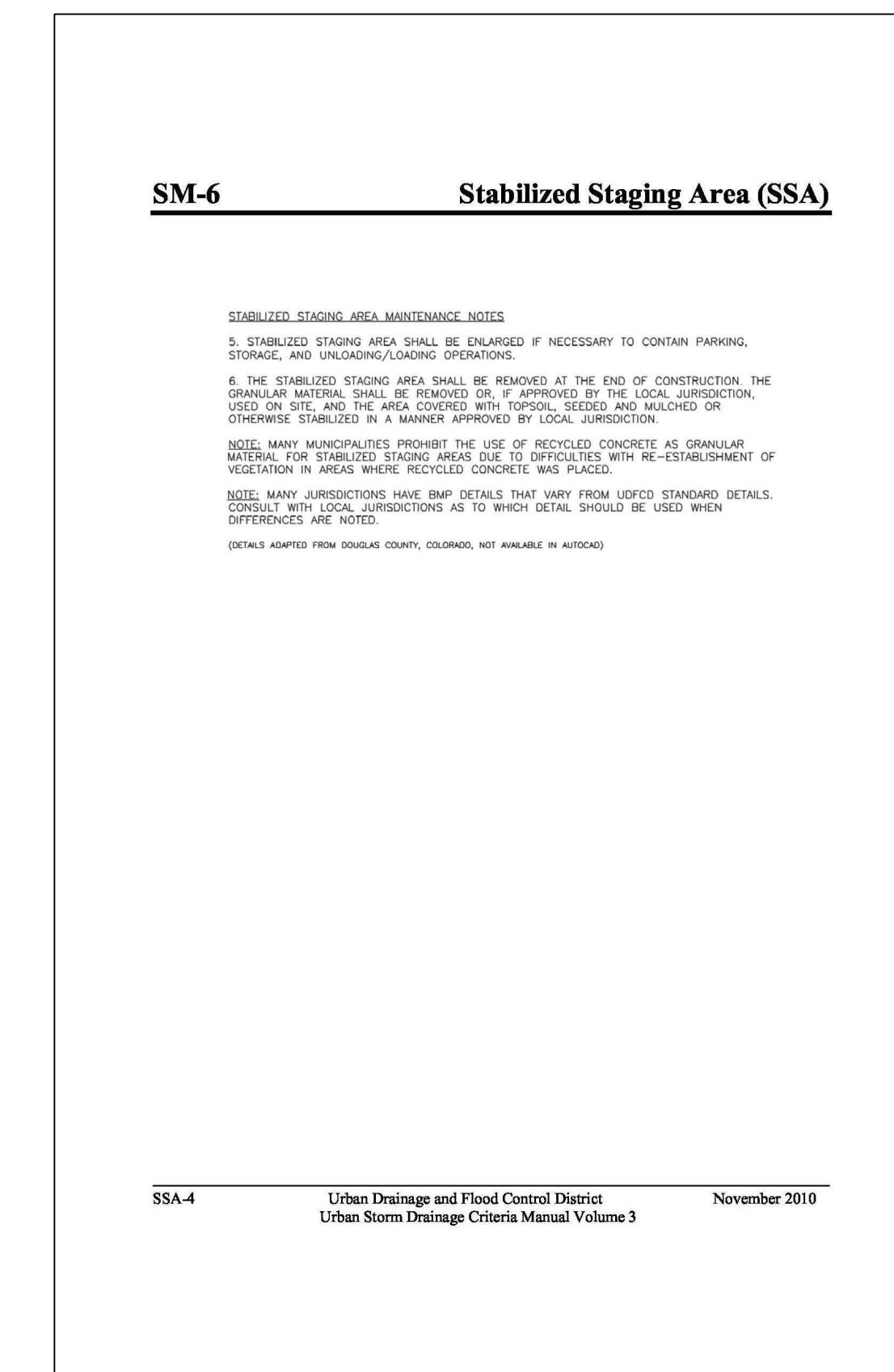

NOT TO SCALE

DESIGNED: _____
 DRAWN: _____
 CHECKED: _____
 DATE: 10.26.2022

REVISION

RESPEC COMMUNITY DESIGN SOLUTIONS
 1372 SOUTH HIGHLAND STREET SUITE 1110
 WWW.RESPEC.COM PHONE (719) 986-5212

STAMP

PRELIMINARY
 NOT FOR CONSTRUCTION
 10/2022

THIS DRAWING IS INCOMPLETE AND NOT TO BE USED FOR CONSTRUCTION UNLESS IT IS STAMPED, SIGNED AND DATED

811
 Know what's below.
 Call before you dig.

PROJECT NAME:
 NORTHERN DELIVERY SERVICE
 BOOSTER PUMP STATION

SHEET TITLE:
 GRADING DETAILS

SUBMITTED FOR:
 TRIVIEW METROPOLITAN DISTRICT

SHEET NUMBER:
 SHEET 7 OF 7

APPENDIX C

SOILS

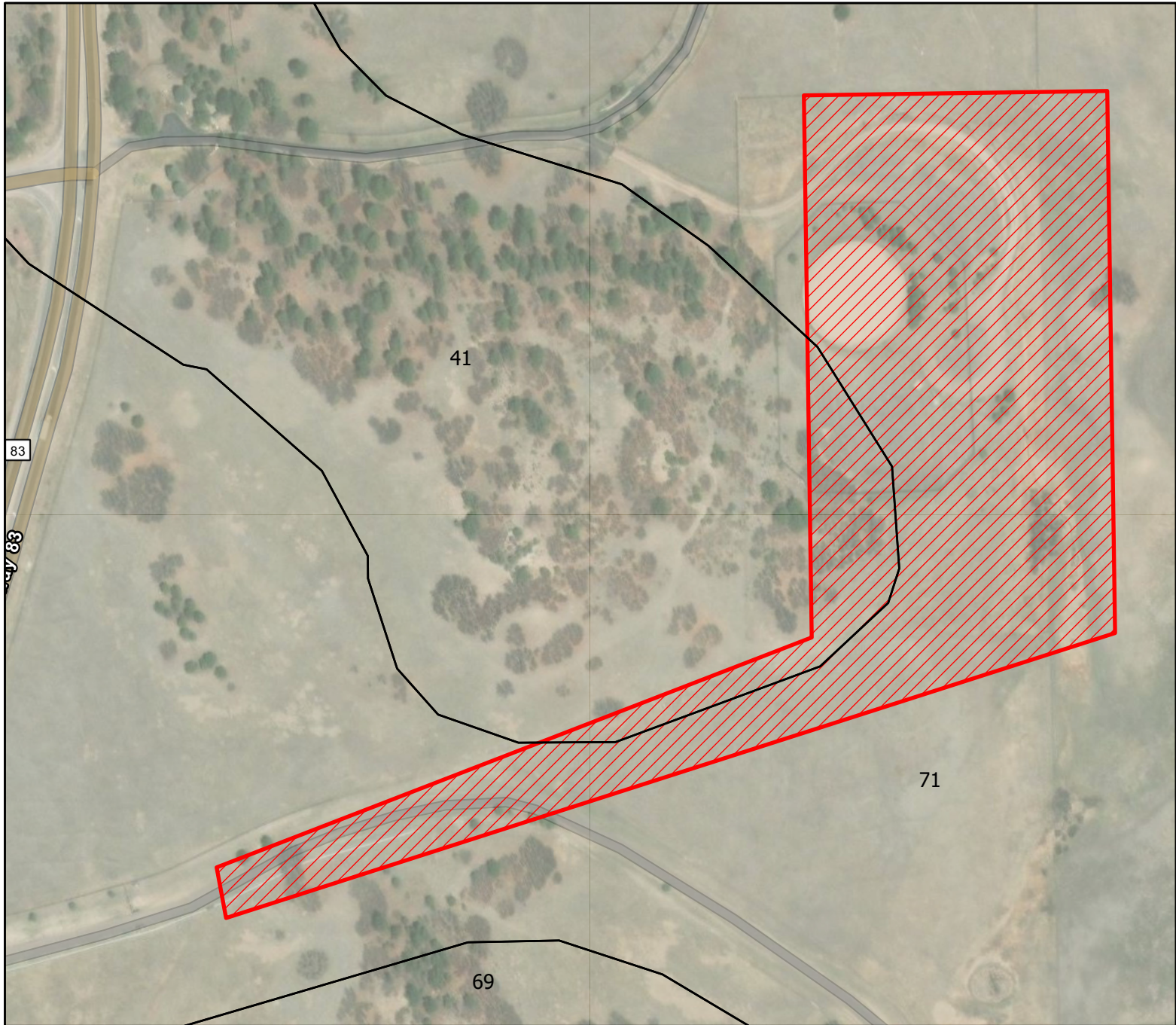

Map Unit Symbol	Map Unit Name	Rating	Percent of Site, %
41	Kettle gravelly loamy sand, 8 to 40 percent slopes	B	10.8
69	Peyton-Pring complex, 8 to 15 percent slopes	B	0.0
71	Pring coarse sandy loam, 3 to 8 percent slopes	B	89.2

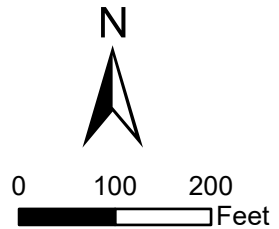

Prepared by:



121 S. TEJON ST., SUITE 1110
 COLORADO SPRINGS, CO 80903
 WWW.RESPEC.COM (719) 266-5212

NORTHERN DELIVERY SERVICE
 BOOSTER PUMP STATION
SOILS MAP

APPENDIX D

GEC ADMINISTRATOR CERTIFICATION

Altitude Training Associates

Awards this Certificate of Completion to

Richard Gallegos

Who on June 15, 2021 Successfully Completed
The Following Training Class:

Stormwater Management and Erosion Control During Construction - GEC Administrator

Certificate Number: 63



Instructor
Altitude Training Associates



APPENDIX E

SPILL PREVENTION PLAN

Introduction

RESPEC in conjunction with **CONTRACTOR** have developed this spill prevention plan to establish standard operation procedures and the necessary employee training to minimize the likelihood of accidental releases of pollutants that can contaminate stormwater runoff.

CONTRACTOR personnel are aware of the following spill control procedures:

- Spill Prevention
- Containment, vessel, tank and piping inspection and maintenance
- Spill response, containment and clean-up
- Company polices on reporting and responding to spills

Environmental Sensitive Areas

There are no environmental sensitive areas within the proposed area of disturbance or construction.

Identification of the Spill Prevention Coordinators

CONTRACTOR

ADDRESS

Colorado Springs, CO ZIP

XXX-XXX-XXXX

Locations of Spill Prevention Kits

The site supervisor will inspect daily to ensure proper use and disposal of materials on-site including building materials, paints, solvents, fertilizers, chemicals, waste materials and equipment maintenance or fueling procedures. All materials stored on-site will be stored in a neat and orderly manner in the original containers with the original manufacturer's label. Before disposing of the container, the product will be used up whenever possible and manufacture's recommendations for proper disposal will be followed according to state and local regulations.

All fueling and maintenance operations will be closely monitored to prevent the spilling of contaminants. In the event of an accidental spill, material and equipment necessary for spill cleanup will be kept on-site. Manufacturer's recommendations for spill cleanup will be available and site personnel will be made aware of the procedures along with the location of the information and cleanup supplies.

Label Systems for Chemical and Material Safety Data Sheets for Products

Any products/ chemicals that are located or stored onsite shall be properly labeled as to the contents of the material. The Material Safety Datasheets for all products/ chemicals utilized onsite can be found in a notebook at the project trailer.

Notification and Cleanup Procedures to be Implemented in the Event of a Spill

Should a spill occur, the contractor supervisor onsite will notify the Colorado Springs Environmental group to assess the severity of the spill and the appropriate action necessary to address the spill.

The Colorado Springs Illicit Discharge Non-Emergency Spill Hot line information is stated below:

1. Stormwater Enterprise: 719-385-5980
2. Spill Hot line: 719-491-6096

For more information visit:

<https://coloradosprings.gov/stormwater-enterprise/page/illicit-discharge?mlid=6331>

APPENDIX F

TEMPORARY CONTROL MEASURES

Description

A silt fence is a woven geotextile fabric attached to wooden posts and trenched into the ground. It is designed as a sediment barrier to intercept sheet flow runoff from disturbed areas.

Appropriate Uses

A silt fence can be used where runoff is conveyed from a disturbed area as sheet flow. Silt fence is not designed to receive concentrated flow or to be used as a filter fabric. Typical uses include:

- Down slope of a disturbed area to accept sheet flow.
- Along the perimeter of a receiving water such as a stream, pond or wetland.
- At the perimeter of a construction site.



Photograph SF-1. Silt fence creates a sediment barrier, forcing sheet flow runoff to evaporate or infiltrate.

Design and Installation

Silt fence should be installed along the contour of slopes so that it intercepts sheet flow. The maximum recommended tributary drainage area per 100 lineal feet of silt fence, installed along the contour, is approximately 0.25 acres with a disturbed slope length of up to 150 feet and a tributary slope gradient no steeper than 3:1. Longer and steeper slopes require additional measures. This recommendation only applies to silt fence installed along the contour. Silt fence installed for other uses, such as perimeter control, should be installed in a way that will not produce concentrated flows. For example, a "J-hook" installation may be appropriate to force runoff to pond and evaporate or infiltrate in multiple areas rather than concentrate and cause erosive conditions parallel to the silt fence.

See Detail SF-1 for proper silt fence installation, which involves proper trenching, staking, securing the fabric to the stakes, and backfilling the silt fence. Properly installed silt fence should not be easily pulled out by hand and there should be no gaps between the ground and the fabric.

Silt fence must meet the minimum allowable strength requirements, depth of installation requirement, and other specifications in the design details. Improper installation of silt fence is a common reason for silt fence failure; however, when properly installed and used for the appropriate purposes, it can be highly effective.

Silt Fence	
Functions	
Erosion Control	No
Sediment Control	Yes
Site/Material Management	No

SILT FENCE INSTALLATION NOTES

1. SILT FENCE MUST BE PLACED AWAY FROM THE TOE OF THE SLOPE TO ALLOW FOR WATER PONDING. SILT FENCE AT THE TOE OF A SLOPE SHOULD BE INSTALLED IN A FLAT LOCATION AT LEAST SEVERAL FEET (2-5 FT) FROM THE TOE OF THE SLOPE TO ALLOW ROOM FOR PONDING AND DEPOSITION.
2. A UNIFORM 6" X 4" ANCHOR TRENCH SHALL BE EXCAVATED USING TRENCHER OR SILT FENCE INSTALLATION DEVICE. NO ROAD GRADERS, BACKHOES, OR SIMILAR EQUIPMENT SHALL BE USED.
3. COMPACT ANCHOR TRENCH BY HAND WITH A "JUMPING JACK" OR BY WHEEL ROLLING. COMPACTION SHALL BE SUCH THAT SILT FENCE RESISTS BEING PULLED OUT OF ANCHOR TRENCH BY HAND.
4. SILT FENCE SHALL BE PULLED TIGHT AS IT IS ANCHORED TO THE STAKES. THERE SHOULD BE NO NOTICEABLE SAG BETWEEN STAKES AFTER IT HAS BEEN ANCHORED TO THE STAKES.
5. SILT FENCE FABRIC SHALL BE ANCHORED TO THE STAKES USING 1" HEAVY DUTY STAPLES OR NAILS WITH 1" HEADS. STAPLES AND NAILS SHOULD BE PLACED 3" ALONG THE FABRIC DOWN THE STAKE.
6. AT THE END OF A RUN OF SILT FENCE ALONG A CONTOUR, THE SILT FENCE SHOULD BE TURNED PERPENDICULAR TO THE CONTOUR TO CREATE A "J-HOOK." THE "J-HOOK" EXTENDING PERPENDICULAR TO THE CONTOUR SHOULD BE OF SUFFICIENT LENGTH TO KEEP RUNOFF FROM FLOWING AROUND THE END OF THE SILT FENCE (TYPICALLY 10' - 20').
7. SILT FENCE SHALL BE INSTALLED PRIOR TO ANY LAND DISTURBING ACTIVITIES.

SILT FENCE MAINTENANCE NOTES

1. INSPECT BMPs EACH WORKDAY, AND MAINTAIN THEM IN EFFECTIVE OPERATING CONDITION. MAINTENANCE OF BMPs SHOULD BE PROACTIVE, NOT REACTIVE. INSPECT BMPs AS SOON AS POSSIBLE (AND ALWAYS WITHIN 24 HOURS) FOLLOWING A STORM THAT CAUSES SURFACE EROSION, AND PERFORM NECESSARY MAINTENANCE.
2. FREQUENT OBSERVATIONS AND MAINTENANCE ARE NECESSARY TO MAINTAIN BMPs IN EFFECTIVE OPERATING CONDITION. INSPECTIONS AND CORRECTIVE MEASURES SHOULD BE DOCUMENTED THOROUGHLY.
3. WHERE BMPs HAVE FAILED, REPAIR OR REPLACEMENT SHOULD BE INITIATED UPON DISCOVERY OF THE FAILURE.
4. SEDIMENT ACCUMULATED UPSTREAM OF THE SILT FENCE SHALL BE REMOVED AS NEEDED TO MAINTAIN THE FUNCTIONALITY OF THE BMP, TYPICALLY WHEN DEPTH OF ACCUMULATED SEDIMENTS IS APPROXIMATELY 6".
5. REPAIR OR REPLACE SILT FENCE WHEN THERE ARE SIGNS OF WEAR, SUCH AS SAGGING, TEARING, OR COLLAPSE.
6. SILT FENCE IS TO REMAIN IN PLACE UNTIL THE UPSTREAM DISTURBED AREA IS STABILIZED AND APPROVED BY THE LOCAL JURISDICTION, OR IS REPLACED BY AN EQUIVALENT PERIMETER SEDIMENT CONTROL BMP.
7. WHEN SILT FENCE IS REMOVED, ALL DISTURBED AREAS SHALL BE COVERED WITH TOPSOIL, SEEDED AND MULCHED OR OTHERWISE STABILIZED AS APPROVED BY LOCAL JURISDICTION.

(DETAIL ADAPTED FROM TOWN OF PARKER, COLORADO AND CITY OF AURORA, NOT AVAILABLE IN AUTOCAD)

NOTE: MANY JURISDICTIONS HAVE BMP DETAILS THAT VARY FROM UDFCD STANDARD DETAILS. CONSULT WITH LOCAL JURISDICTIONS AS TO WHICH DETAIL SHOULD BE USED WHEN DIFFERENCES ARE NOTED.

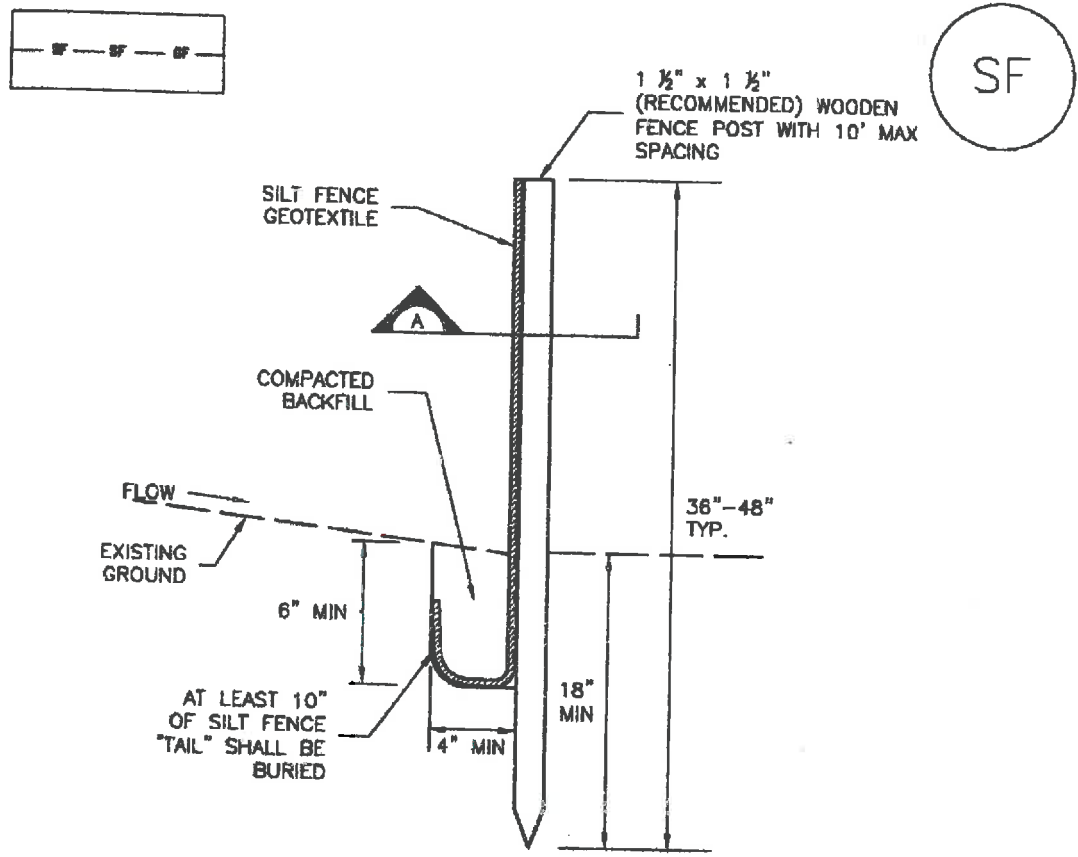

SILT FENCE

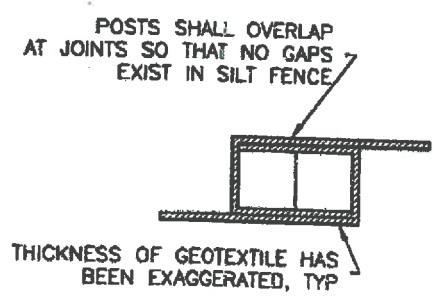
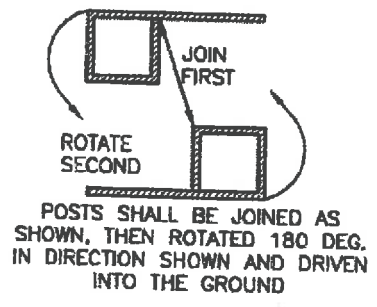

SECTION A

SF-1. SILT FENCE

Maintenance and Removal

Inspection of silt fence includes observing the material for tears or holes and checking for stumping fence and undercut areas bypassing flows. Repair of silt fence typically involves replacing the damaged section with a new section. Sediment accumulated behind silt fence should be removed, as needed to maintain BMP effectiveness, typically before it reaches a depth of 6 inches.

Silt fence may be removed when the upstream area has reached final stabilization.



Photograph SF-2. When silt fence is not installed along the contour, a "J-hook" installation may be appropriate to ensure that the BMP does not create concentrated flow parallel to the silt fence. Photo courtesy of Tom Gore.

Description

Vehicle tracking controls provide stabilized construction site access where vehicles exit the site onto paved public roads. An effective vehicle tracking control helps remove sediment (mud or dirt) from vehicles, reducing tracking onto the paved surface.



Photograph VTC-1. A vehicle tracking control pad constructed with properly sized rock reduces off-site sediment tracking.

Appropriate Uses

Implement a stabilized construction entrance or vehicle tracking control where frequent heavy vehicle traffic exits the construction site onto a paved roadway. An effective vehicle tracking control is particularly important during the following conditions:

- Wet weather periods when mud is easily tracked off site.
- During dry weather periods where dust is a concern.
- When poorly drained, clayey soils are present on site.

Although wheel washes are not required in designs of vehicle tracking controls, they may be needed at particularly muddy sites.

Design and Installation

Construct the vehicle tracking control on a level surface. Where feasible, grade the tracking control towards the construction site to reduce off-site runoff. Place signage, as needed, to direct construction vehicles to the designated exit through the vehicle tracking control. There are several different types of stabilized construction entrances including:

VTC-1. Aggregate Vehicle Tracking Control. This is a coarse-aggregate surfaced pad underlain by a geotextile. This is the most common vehicle tracking control, and when properly maintained can be effective at removing sediment from vehicle tires.

VTC-2. Vehicle Tracking Control with Construction Mat or Turf Reinforcement Mat. This type of control may be appropriate for site access at very small construction sites with low traffic volume over vegetated areas. Although this application does not typically remove sediment from vehicles, it helps protect existing vegetation and provides a stabilized entrance.

Vehicle Tracking Control	
Functions	
Erosion Control	Moderate
Sediment Control	Yes
Site/Material Management	Yes

VTC-3. Stabilized Construction Entrance/Exit with Wheel Wash. This is an aggregate pad, similar to VTC-1, but includes equipment for tire washing. The wheel wash equipment may be as simple as hand-held power washing equipment to more advance proprietary systems. When a wheel wash is provided, it is important to direct wash water to a sediment trap prior to discharge from the site.

Vehicle tracking controls are sometimes installed in combination with a sediment trap to treat runoff.

Maintenance and Removal

Inspect the area for degradation and replace aggregate or material used for a stabilized entrance/exit as needed. If the area becomes clogged and ponds water, remove and dispose of excess sediment or replace material with a fresh layer of aggregate as necessary.

With aggregate vehicle tracking controls, ensure rock and debris from this area do not enter the public right-of-way.

Remove sediment that is tracked onto the public right of way daily or more frequently as needed. Excess sediment in the roadway indicates that the stabilized construction entrance needs maintenance.

Ensure that drainage ditches at the entrance/exit area remain clear.

A stabilized entrance should be removed only when there is no longer the potential for vehicle tracking to occur. This is typically after the site has been stabilized.

When wheel wash equipment is used, be sure that the wash water is discharged to a sediment trap prior to discharge. Also inspect channels conveying the water from the wash area to the sediment trap and stabilize areas that may be eroding.

When a construction entrance/exit is removed, excess sediment from the aggregate should be removed and disposed of appropriately. The entrance should be promptly stabilized with a permanent surface following removal, typically by paving.



Photograph VTC-2. A vehicle tracking control pad with wheel wash facility. Photo courtesy of Tom Gore.

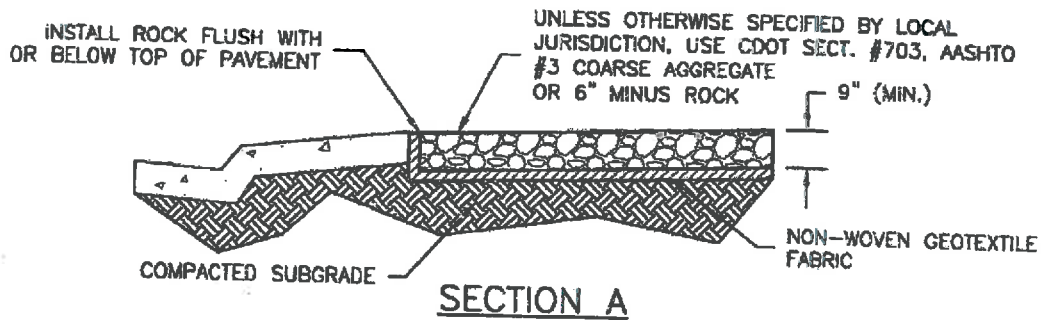
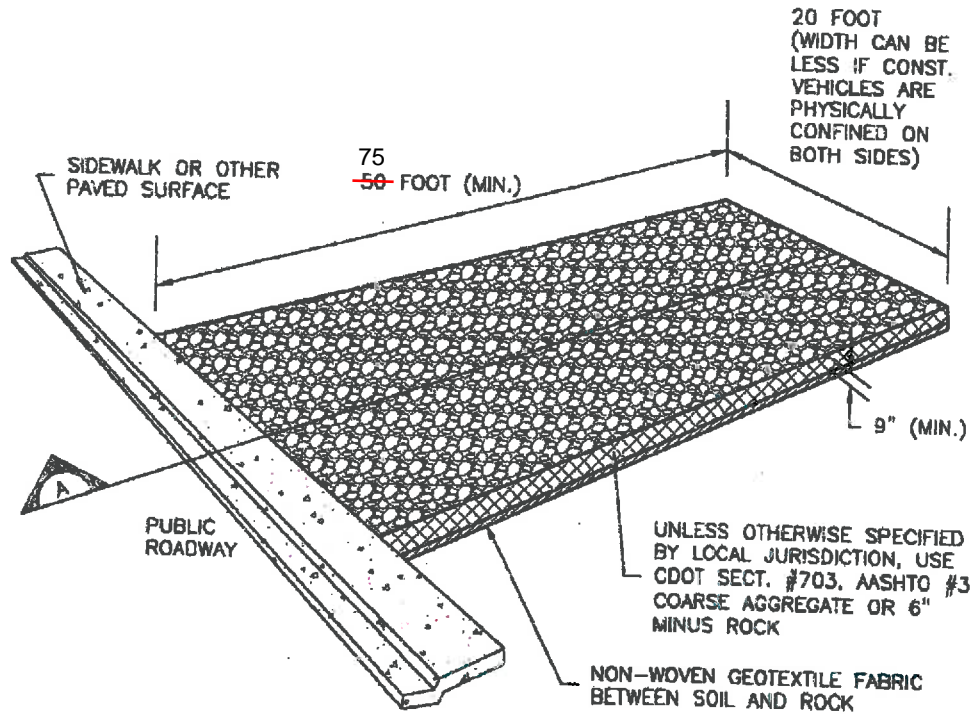
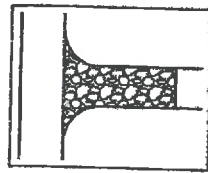

VTC-1. AGGREGATE VEHICLE TRACKING CONTROL

STABILIZED CONSTRUCTION ENTRANCE/EXIT INSTALLATION NOTES

1. SEE PLAN VIEW FOR
 - LOCATION OF CONSTRUCTION ENTRANCE(S)/EXIT(S).
 - TYPE OF CONSTRUCTION ENTRANCE(S)/EXITS(S) (WITH/WITHOUT WHEEL WASH, CONSTRUCTION MAT OR TRM).
2. CONSTRUCTION MAT OR TRM STABILIZED CONSTRUCTION ENTRANCES ARE ONLY TO BE USED ON SHORT DURATION PROJECTS (TYPICALLY RANGING FROM A WEEK TO A MONTH) WHERE THERE WILL BE LIMITED VEHICULAR ACCESS.
3. A STABILIZED CONSTRUCTION ENTRANCE/EXIT SHALL BE LOCATED AT ALL ACCESS POINTS WHERE VEHICLES ACCESS THE CONSTRUCTION SITE FROM PAVED RIGHT-OF-WAYS.
4. STABILIZED CONSTRUCTION ENTRANCE/EXIT SHALL BE INSTALLED PRIOR TO ANY LAND DISTURBING ACTIVITIES.
5. A NON-WOVEN GEOTEXTILE FABRIC SHALL BE PLACED UNDER THE STABILIZED CONSTRUCTION ENTRANCE/EXIT PRIOR TO THE PLACEMENT OF ROCK.
6. UNLESS OTHERWISE SPECIFIED BY LOCAL JURISDICTION, ROCK SHALL CONSIST OF DOT SECT. #703, AASHTO #3 COARSE AGGREGATE OR 6" (MINUS) ROCK.

STABILIZED CONSTRUCTION ENTRANCE/EXIT MAINTENANCE NOTES

1. INSPECT BMPs EACH WORKDAY, AND MAINTAIN THEM IN EFFECTIVE OPERATING CONDITION. MAINTENANCE OF BMPs SHOULD BE PROACTIVE, NOT REACTIVE. INSPECT BMPs AS SOON AS POSSIBLE (AND ALWAYS WITHIN 24 HOURS) FOLLOWING A STORM THAT CAUSES SURFACE EROSION, AND PERFORM NECESSARY MAINTENANCE.
2. FREQUENT OBSERVATIONS AND MAINTENANCE ARE NECESSARY TO MAINTAIN BMPs IN EFFECTIVE OPERATING CONDITION. INSPECTIONS AND CORRECTIVE MEASURES SHOULD BE DOCUMENTED THOROUGHLY.
3. WHERE BMPs HAVE FAILED, REPAIR OR REPLACEMENT SHOULD BE INITIATED UPON DISCOVERY OF THE FAILURE.
4. ROCK SHALL BE REAPPLIED OR REGRADED AS NECESSARY TO THE STABILIZED ENTRANCE/EXIT TO MAINTAIN A CONSISTENT DEPTH.
5. SEDIMENT TRACKED ONTO PAVED ROADS IS TO BE REMOVED THROUGHOUT THE DAY AND AT THE END OF THE DAY BY SHOVELING OR SWEEPING. SEDIMENT MAY NOT BE WASHED DOWN STORM SEWER DRAINS.

NOTE: MANY JURISDICTIONS HAVE BMP DETAILS THAT VARY FROM UDFCD STANDARD DETAILS. CONSULT WITH LOCAL JURISDICTIONS AS TO WHICH DETAIL SHOULD BE USED WHEN DIFFERENCES ARE NOTED.

(DETAILS ADAPTED FROM CITY OF BROOMFIELD, COLORADO, NOT AVAILABLE IN AUTOCAD)

Description

Concrete waste management involves designating and properly managing a specific area of the construction site as a concrete washout area. A concrete washout area can be created using one of several approaches designed to receive wash water from washing of tools and concrete mixer chutes, liquid concrete waste from dump trucks, mobile batch mixers, or pump trucks. Three basic approaches are available: excavation of a pit in the ground, use of an above ground storage area, or use of prefabricated haul-away concrete washout containers. Surface discharges of concrete washout water from construction sites are prohibited.



Photograph CWA-1. Example of concrete washout area. Note gravel tracking pad for access and sign.

Appropriate Uses

Concrete washout areas must be designated on all sites that will generate concrete wash water or liquid concrete waste from onsite concrete mixing or concrete delivery.

Because pH is a pollutant of concern for washout activities, when unlined pits are used for concrete washout, the soil must have adequate buffering capacity to result in protection of state groundwater standards; otherwise, a liner/containment must be used. The following management practices are recommended to prevent an impact from unlined pits to groundwater:

- The use of the washout site should be temporary (less than 1 year), and
- The washout site should be not be located in an area where shallow groundwater may be present, such as near natural drainages, springs, or wetlands.

Design and Installation

Concrete washout activities must be conducted in a manner that does not contribute pollutants to surface waters or stormwater runoff. Concrete washout areas may be lined or unlined excavated pits in the ground, commercially manufactured prefabricated washout containers, or aboveground holding areas constructed of berms, sandbags or straw bales with a plastic liner.

Although unlined washout areas may be used, lined pits may be required to protect groundwater under certain conditions.

Do not locate an unlined washout area within 400 feet of any natural drainage pathway or waterbody or within 1,000 feet of any wells or drinking water sources. Even for lined concrete washouts, it is advisable to locate the facility away from waterbodies and drainage paths. If site constraints make these

Concrete Washout Area	
Functions	
Erosion Control	No
Sediment Control	No
Site/Material Management	Yes

setbacks infeasible or if highly permeable soils exist in the area, then the pit must be installed with an impermeable liner (16 mil minimum thickness) or surface storage alternatives using prefabricated concrete washout devices or a lined aboveground storage area should be used.

Design details with notes are provided in Detail CWA-1 for pits and CWA-2 for aboveground storage areas. Pre-fabricated concrete washout container information can be obtained from vendors.

Maintenance and Removal

A key consideration for concrete washout areas is to ensure that adequate signage is in place identifying the location of the washout area. Part of inspecting and maintaining washout areas is ensuring that adequate signage is provided and in good repair and that the washout area is being used, as opposed to washout in non-designated areas of the site.

Remove concrete waste in the washout area, as needed to maintain BMP function (typically when filled to about two-thirds of its capacity). Collect concrete waste and deliver offsite to a designated disposal location.

Upon termination of use of the washout site, accumulated solid waste, including concrete waste and any contaminated soils, must be removed from the site to prevent on-site disposal of solid waste. If the wash water is allowed to evaporate and the concrete hardens, it may be recycled.



Photograph CWA-2. Prefabricated concrete washout. Photo courtesy of CDOT.



Photograph CWA-3. Earthen concrete washout. Photo courtesy of CDOT.

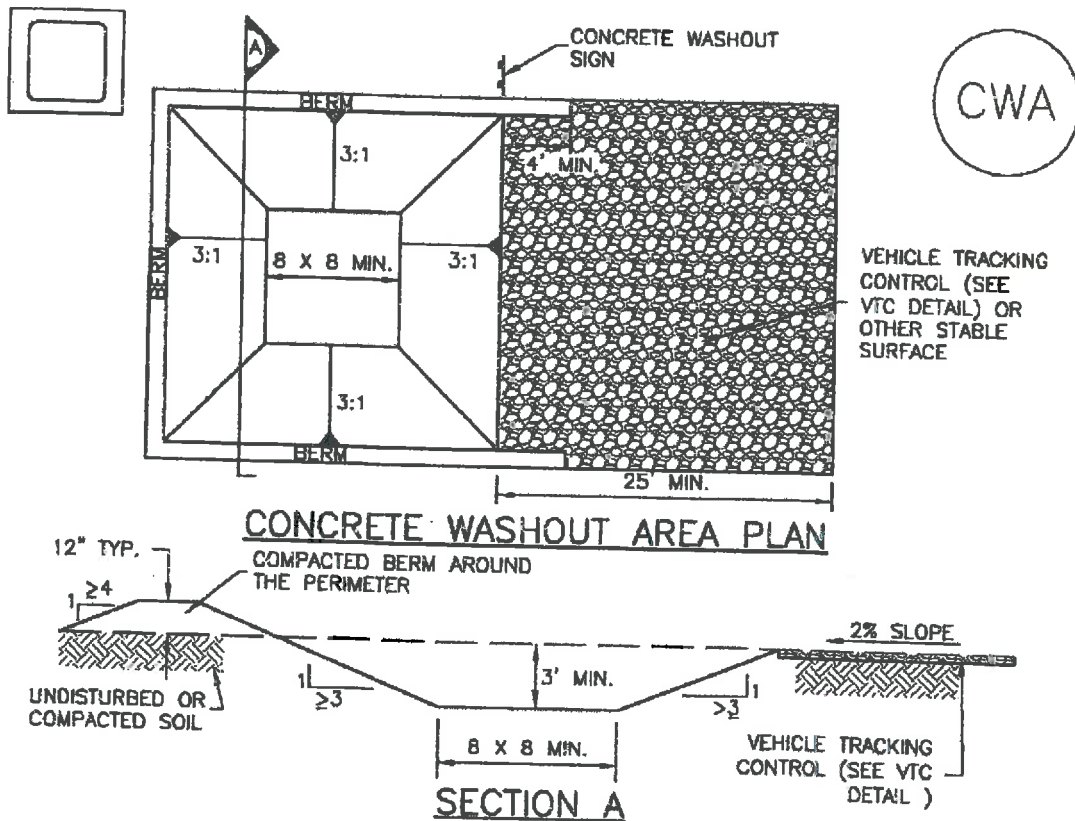

CWA-1. CONCRETE WASHOUT AREA

CWA INSTALLATION NOTES

1. SEE PLAN VIEW FOR:
-CWA INSTALLATION LOCATION.
2. DO NOT LOCATE AN UNLINED CWA WITHIN 400' OF ANY NATURAL DRAINAGE PATHWAY OR WATERBODY. DO NOT LOCATE WITHIN 1,000' OF ANY WELLS OR DRINKING WATER SOURCES. IF SITE CONSTRAINTS MAKE THIS INFEASIBLE, OR IF HIGHLY PERMEABLE SOILS EXIST ON SITE, THE CWA MUST BE INSTALLED WITH AN IMPERMEABLE LINER (16 MIL MIN. THICKNESS) OR SURFACE STORAGE ALTERNATIVES USING PREFABRICATED CONCRETE WASHOUT DEVICES OR A LINED ABOVE GROUND STORAGE ARE SHOULD BE USED.
3. THE CWA SHALL BE INSTALLED PRIOR TO CONCRETE PLACEMENT ON SITE.
4. CWA SHALL INCLUDE A FLAT SUBSURFACE PIT THAT IS AT LEAST 8' BY 8' SLOPES LEADING OUT OF THE SUBSURFACE PIT SHALL BE 3:1 OR FLATTER. THE PIT SHALL BE AT LEAST 3' DEEP.
5. BERM SURROUNDING SIDES AND BACK OF THE CWA SHALL HAVE MINIMUM HEIGHT OF 1'.
6. VEHICLE TRACKING PAD SHALL BE SLOPED 2% TOWARDS THE CWA.
7. SIGNS SHALL BE PLACED AT THE CONSTRUCTION ENTRANCE, AT THE CWA, AND ELSEWHERE AS NECESSARY TO CLEARLY INDICATE THE LOCATION OF THE CWA TO OPERATORS OF CONCRETE TRUCKS AND PUMP RIGS.
8. USE EXCAVATED MATERIAL FOR PERIMETER BERM CONSTRUCTION.

CWA MAINTENANCE NOTES

1. INSPECT BMPs EACH WORKDAY, AND MAINTAIN THEM IN EFFECTIVE OPERATING CONDITION. MAINTENANCE OF BMPs SHOULD BE PROACTIVE, NOT REACTIVE. INSPECT BMPs AS SOON AS POSSIBLE (AND ALWAYS WITHIN 24 HOURS) FOLLOWING A STORM THAT CAUSES SURFACE EROSION, AND PERFORM NECESSARY MAINTENANCE.
2. FREQUENT OBSERVATIONS AND MAINTENANCE ARE NECESSARY TO MAINTAIN BMPs IN EFFECTIVE OPERATING CONDITION. INSPECTIONS AND CORRECTIVE MEASURES SHOULD BE DOCUMENTED THOROUGHLY.
3. WHERE BMPs HAVE FAILED, REPAIR OR REPLACEMENT SHOULD BE INITIATED UPON DISCOVERY OF THE FAILURE.
4. THE CWA SHALL BE REPAIRED, CLEANED, OR ENLARGED AS NECESSARY TO MAINTAIN CAPACITY FOR CONCRETE WASTE. CONCRETE MATERIALS, ACCUMULATED IN PIT, SHALL BE REMOVED ONCE THE MATERIALS HAVE REACHED A DEPTH OF 2'.
5. CONCRETE WASHOUT WATER, WASTED PIECES OF CONCRETE AND ALL OTHER DEBRIS IN THE SUBSURFACE PIT SHALL BE TRANSPORTED FROM THE JOB SITE IN A WATER-TIGHT CONTAINER AND DISPOSED OF PROPERLY.
6. THE CWA SHALL REMAIN IN PLACE UNTIL ALL CONCRETE FOR THE PROJECT IS PLACED.
7. WHEN THE CWA IS REMOVED, COVER THE DISTURBED AREA WITH TOP SOIL, SEED AND MULCH OR OTHERWISE STABILIZED IN A MANNER APPROVED BY THE LOCAL JURISDICTION.

(DETAIL ADAPTED FROM DOUGLAS COUNTY, COLORADO AND THE CITY OF PARKER, COLORADO, NOT AVAILABLE IN AUTOCAD).

NOTE: MANY JURISDICTIONS HAVE BMP DETAILS THAT VARY FROM UDFCD STANDARD DETAILS. CONSULT WITH LOCAL JURISDICTIONS AS TO WHICH DETAIL SHOULD BE USED WHEN DIFFERENCES ARE NOTED.

Description

Temporary seeding can be used to stabilize disturbed areas that will be inactive for an extended period. Permanent seeding should be used to stabilize areas at final grade that will not be otherwise stabilized. Effective seeding includes preparation of a seedbed, selection of an appropriate seed mixture, proper planting techniques, and protection of the seeded area with mulch, geotextiles, or other appropriate measures.

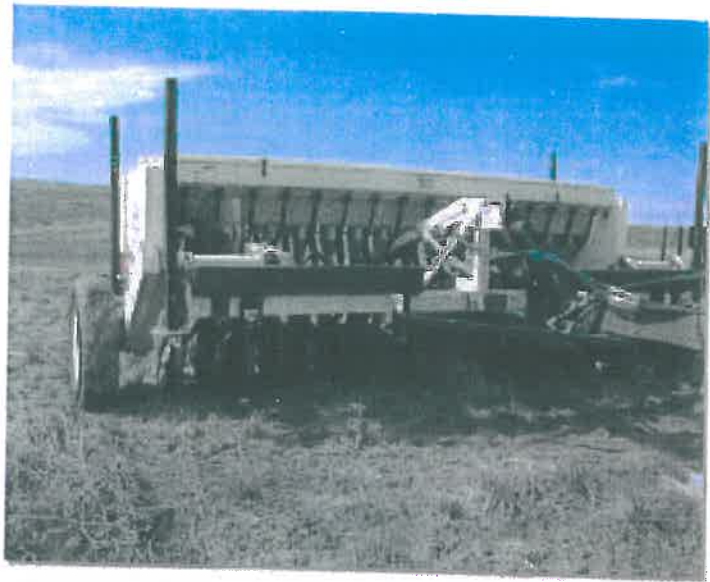

Photograph TS/PS -1. Equipment used to drill seed. Photo courtesy of Douglas County.

Appropriate Uses

When the soil surface is disturbed and will remain inactive for an extended period (typically 30 days or longer), proactive stabilization measures should be implemented. If the inactive period is short-lived (on the order of two weeks), techniques such as surface roughening may be appropriate. For longer periods of inactivity, temporary seeding and mulching can provide effective erosion control. Permanent seeding should be used on finished areas that have not been otherwise stabilized.

Typically, local governments have their own seed mixes and timelines for seeding. Check jurisdictional requirements for seeding and temporary stabilization.

Design and Installation

Effective seeding requires proper seedbed preparation, selection of an appropriate seed mixture, use of appropriate seeding equipment to ensure proper coverage and density, and protection with mulch or fabric until plants are established.

The USDCM Volume 2 *Revegetation* Chapter contains detailed seed mix, soil preparations, and seeding and mulching recommendations that may be referenced to supplement this Fact Sheet.

Drill seeding is the preferred seeding method. Hydroseeding is not recommended except in areas where steep slopes prevent use of drill seeding equipment, and even in these instances it is preferable to hand seed and mulch. Some jurisdictions do not allow hydroseeding or hydromulching.

Seedbed Preparation

Prior to seeding, ensure that areas to be revegetated have soil conditions capable of supporting vegetation. Overlot grading can result in loss of topsoil, resulting in poor quality subsoils at the ground surface that have low nutrient value, little organic matter content, few soil microorganisms, rooting restrictions, and conditions less conducive to infiltration of precipitation. As a result, it is typically necessary to provide stockpiled topsoil, compost, or other

Temporary and Permanent Seeding	
Functions	
Erosion Control	Yes
Sediment Control	No
Site/Material Management	No

EC-2 Temporary and Permanent Seeding (TS/PS)

soil amendments and rototill them into the soil to a depth of 6 inches or more.

Topsoil should be salvaged during grading operations for use and spread on areas to be revegetated later. Topsoil should be viewed as an important resource to be utilized for vegetation establishment, due to its water-holding capacity, structure, texture, organic matter content, biological activity, and nutrient content. The rooting depth of most native grasses in the semi-arid Denver metropolitan area is 6 to 18 inches. At a minimum, the upper 6 inches of topsoil should be stripped, stockpiled, and ultimately respread across areas that will be revegetated.

Where topsoil is not available, subsoils should be amended to provide an appropriate plant-growth medium. Organic matter, such as well digested compost, can be added to improve soil characteristics conducive to plant growth. Other treatments can be used to adjust soil pH conditions when needed. Soil testing, which is typically inexpensive, should be completed to determine and optimize the types and amounts of amendments that are required.

If the disturbed ground surface is compacted, rip or rototill the surface prior to placing topsoil. If adding compost to the existing soil surface, rototilling is necessary. Surface roughening will assist in placement of a stable topsoil layer on steeper slopes, and allow infiltration and root penetration to greater depth.

Prior to seeding, the soil surface should be rough and the seedbed should be firm, but neither too loose nor compacted. The upper layer of soil should be in a condition suitable for seeding at the proper depth and conducive to plant growth. Seed-to-soil contact is the key to good germination.

Seed Mix for Temporary Vegetation

To provide temporary vegetative cover on disturbed areas which will not be paved, built upon, or fully landscaped or worked for an extended period (typically 30 days or more), plant an annual grass appropriate for the time of planting and mulch the planted areas. Annual grasses suitable for the Denver metropolitan area are listed in Table TS/PS-1. These are to be considered only as general recommendations when specific design guidance for a particular site is not available. Local governments typically specify seed mixes appropriate for their jurisdiction.

Seed Mix for Permanent Revegetation

To provide vegetative cover on disturbed areas that have reached final grade, a perennial grass mix should be established. Permanent seeding should be performed promptly (typically within 14 days) after reaching final grade. Each site will have different characteristics and a landscape professional or the local jurisdiction should be contacted to determine the most suitable seed mix for a specific site. In lieu of a specific recommendation, one of the perennial grass mixes appropriate for site conditions and growth season listed in Table TS/PS-2 can be used. The pure live seed (PLS) rates of application recommended in these tables are considered to be absolute minimum rates for seed applied using proper drill-seeding equipment.

If desired for wildlife habitat or landscape diversity, shrubs such as rubber rabbitbrush (*Chrysothamnus nauseosus*), fourwing saltbush (*Atriplex canescens*) and skunkbrush sumac (*Rhus trilobata*) could be added to the upland seedmixes at 0.25, 0.5 and 1 pound PLS/acre, respectively. In riparian zones, planting root stock of such species as American plum (*Prunus americana*), woods rose (*Rosa woodsii*), plains cottonwood (*Populus sargentii*), and willow (*Populus spp.*) may be considered. On non-topsoiled upland sites, a legume such as Ladak alfalfa at 1 pound PLS/acre can be included as a source of nitrogen for perennial grasses.

Seeding dates for the highest success probability of perennial species along the Front Range are generally in the spring from April through early May and in the fall after the first of September until the ground freezes. If the area is irrigated, seeding may occur in summer months, as well. See Table TS/PS-3 for appropriate seeding dates.

Table TS/PS-1. Minimum Drill Seeding Rates for Various Temporary Annual Grasses

Species ^a (Common name)	Growth Season ^b	Pounds of Pure Live Seed (PLS)/acre ^c	Planting Depth (inches)
1. Oats	Cool	35 - 50	1 - 2
2. Spring wheat	Cool	25 - 35	1 - 2
3. Spring barley	Cool	25 - 35	1 - 2
4. Annual ryegrass	Cool	10 - 15	½
5. Millet	Warm	3 - 15	½ - ¾
6. Sudangrass	Warm	5-10	½ - ¾
7. Sorghum	Warm	5-10	½ - ¾
8. Winter wheat	Cool	20-35	1 - 2
9. Winter barley	Cool	20-35	1 - 2
10. Winter rye	Cool	20-35	1 - 2
11. Triticale	Cool	25-40	1 - 2

^a Successful seeding of annual grass resulting in adequate plant growth will usually produce enough dead-plant residue to provide protection from wind and water erosion for an additional year. This assumes that the cover is not disturbed or mowed closer than 8 inches.

Hydraulic seeding may be substituted for drilling only where slopes are steeper than 3:1 or where access limitations exist. When hydraulic seeding is used, hydraulic mulching should be applied as a separate operation, when practical, to prevent the seeds from being encapsulated in the mulch.

^b See Table TS/PS-3 for seeding dates. Irrigation, if consistently applied, may extend the use of cool season species during the summer months.

^c Seeding rates should be doubled if seed is broadcast, or increased by 50 percent if done using a Brillion Drill or by hydraulic seeding.

EC-2 Temporary and Permanent Seeding (TS/PS)

Table TS/PS-2. Minimum Drill Seeding Rates for Perennial Grasses

Common ^a Name	Botanical Name	Growth Season ^b	Growth Form	Seeds/ Pound	Pounds of PLS/acre
Alakali Soil Seed Mix					
Alkali sacaton	<i>Sporobolus airoides</i>	Cool	Bunch	1,750,000	0.25
Basin wildrye	<i>Elymus cinereus</i>	Cool	Bunch	165,000	2.5
Sodar streambank wheatgrass	<i>Agropyron riparium 'Sodar'</i>	Cool	Sod	170,000	2.5
Jose tall wheatgrass	<i>Agropyron elongatum 'Jose'</i>	Cool	Bunch	79,000	7.0
Arriba western wheatgrass	<i>Agropyron smithii 'Arriba'</i>	Cool	Sod	110,000	5.5
Total					17.75
Fertile Loamy Soil Seed Mix					
Ephriam crested wheatgrass	<i>Agropyron cristatum 'Ephriam'</i>	Cool	Sod	175,000	2.0
Dural hard fescue	<i>Festuca ovina 'duriuscula'</i>	Cool	Bunch	565,000	1.0
Lincoln smooth brome	<i>Bromus inermis leyss 'Lincoln'</i>	Cool	Sod	130,000	3.0
Sodar streambank wheatgrass	<i>Agropyron riparium 'Sodar'</i>	Cool	Sod	170,000	2.5
Arriba western wheatgrass	<i>Agropyron smithii 'Arriba'</i>	Cool	Sod	110,000	7.0
Total					15.5
High Water Table Soil Seed Mix					
Meadow foxtail	<i>Alopecurus pratensis</i>	Cool	Sod	900,000	0.5
Redtop	<i>Agrostis alba</i>	Warm	Open sod	5,000,000	0.25
Reed canarygrass	<i>Phalaris arundinacea</i>	Cool	Sod	68,000	0.5
Lincoln smooth brome	<i>Bromus inermis leyss 'Lincoln'</i>	Cool	Sod	130,000	3.0
Pathfinder switchgrass	<i>Panicum virgatum 'Pathfinder'</i>	Warm	Sod	389,000	1.0
Alkar tall wheatgrass	<i>Agropyron elongatum 'Alkar'</i>	Cool	Bunch	79,000	5.5
Total					10.75
Transition Turf Seed Mix^c					
Ruebens Canadian bluegrass	<i>Poa compressa 'Ruebens'</i>	Cool	Sod	2,500,000	0.5
Dural hard fescue	<i>Festuca ovina 'duriuscula'</i>	Cool	Bunch	565,000	1.0
Citation perennial ryegrass	<i>Lolium perenne 'Citation'</i>	Cool	Sod	247,000	3.0
Lincoln smooth brome	<i>Bromus inermis leyss 'Lincoln'</i>	Cool	Sod	130,000	3.0
Total					7.5

Table TS/PS-2. Minimum Drill Seeding Rates for Perennial Grasses (cont.)

Common Name	Botanical Name	Growth Season ^b	Growth Form	Seeds/Pound	Pounds of PLS/acre
Sandy Soil Seed Mix					
Blue grama	<i>Bouteloua gracilis</i>	Warm	Sod-forming bunchgrass	825,000	0.5
Camper little bluestem	<i>Schizachyrium scoparium</i> 'Camper'	Warm	Bunch	240,000	1.0
Prairie sandreed	<i>Calamovilfa longifolia</i>	Warm	Open sod	274,000	1.0
Sand dropseed	<i>Sporobolus cryptandrus</i>	Cool	Bunch	5,298,000	0.25
Vaughn sideoats grama	<i>Bouteloua curtipendula</i> 'Vaughn'	Warm	Sod	191,000	2.0
Arriba western wheatgrass	<i>Agropyron smithii</i> 'Arriba'	Cool	Sod	110,000	5.5
Total					10.25
Heavy Clay, Rocky Foothill Seed Mix					
Ephriam crested wheatgrass ^d	<i>Agropyron cristatum</i> 'Ephriam'	Cool	Sod	175,000	1.5
Oahe Intermediate wheatgrass	<i>Agropyron intermedium</i> 'Oahe'	Cool	Sod	115,000	5.5
Vaughn sideoats grama ^c	<i>Bouteloua curtipendula</i> 'Vaughn'	Warm	Sod	191,000	2.0
Lincoln smooth brome	<i>Bromus inermis leys</i> 'Lincoln'	Cool	Sod	130,000	3.0
Arriba western wheatgrass	<i>Agropyron smithii</i> 'Arriba'	Cool	Sod	110,000	5.5
Total					17.5
<p>^a All of the above seeding mixes and rates are based on drill seeding followed by crimped straw mulch. These rates should be doubled if seed is broadcast and should be increased by 50 percent if the seeding is done using a Brillion Drill or is applied through hydraulic seeding. Hydraulic seeding may be substituted for drilling only where slopes are steeper than 3:1. If hydraulic seeding is used, hydraulic mulching should be done as a separate operation.</p> <p>^b See Table TS/PS-3 for seeding dates.</p> <p>^c If site is to be irrigated, the transition turf seed rates should be doubled.</p> <p>^d Crested wheatgrass should not be used on slopes steeper than 6H to 1V.</p> <p>^e Can substitute 0.5 lbs PLS of blue grama for the 2.0 lbs PLS of Vaughn sideoats grama.</p>					

EC-2 Temporary and Permanent Seeding (TS/PS)

Table TS/PS-3. Seeding Dates for Annual and Perennial Grasses

Seeding Dates	Annual Grasses (Numbers in table reference species in Table TS/PS-1)		Perennial Grasses	
	Warm	Cool	Warm	Cool
January 1–March 15			✓	✓
March 16–April 30	4	1,2,3	✓	✓
May 1–May 15	4		✓	
May 16–June 30	4,5,6,7			
July 1–July 15	5,6,7			
July 16–August 31				
September 1–September 30		8,9,10,11		
October 1–December 31			✓	✓

Mulch

Cover seeded areas with mulch or an appropriate rolled erosion control product to promote establishment of vegetation. Anchor mulch by crimping, netting or use of a non-toxic tackifier. See the Mulching BMP Fact Sheet for additional guidance.

Maintenance and Removal

Monitor and observe seeded areas to identify areas of poor growth or areas that fail to germinate. Reseed and mulch these areas, as needed.

An area that has been permanently seeded should have a good stand of vegetation within one growing season if irrigated and within three growing seasons without irrigation in Colorado. Reseed portions of the site that fail to germinate or remain bare after the first growing season.

Seeded areas may require irrigation, particularly during extended dry periods. Targeted weed control may also be necessary.

Protect seeded areas from construction equipment and vehicle access.

Description

A stabilized staging area is a clearly designated area where construction equipment and vehicles, stockpiles, waste bins, and other construction-related materials are stored. The contractor office trailer may also be located in this area. Depending on the size of the construction site, more than one staging area may be necessary.



Photograph SSA-1. Example of a staging area with a gravel surface to prevent mud tracking and reduce runoff. Photo courtesy of Douglas County.

Appropriate Uses

Most construction sites will require a staging area, which should be clearly designated in SWMP drawings. The layout of the staging area may vary depending on the type of construction activity. Staging areas located in roadways due to space constraints require special measures to avoid materials being washed into storm inlets.

Design and Installation

Stabilized staging areas should be completed prior to other construction activities beginning on the site. Major components of a stabilized staging area include:

- Appropriate space to contain storage and provide for loading/unloading operations, as well as parking if necessary.
- A stabilized surface, either paved or covered, with 3-inch diameter aggregate or larger.
- Perimeter controls such as silt fence, sediment control logs, or other measures.
- Construction fencing to prevent unauthorized access to construction materials.
- Provisions for Good Housekeeping practices related to materials storage and disposal, as described in the Good Housekeeping BMP Fact Sheet.
- A stabilized construction entrance/exit, as described in the Vehicle Tracking Control BMP Fact Sheet, to accommodate traffic associated with material delivery and waste disposal vehicles.

Over-sizing the stabilized staging area may result in disturbance of existing vegetation in excess of that required for the project. This increases costs, as well as requirements for long-term stabilization following the construction period. When designing the stabilized staging area, minimize the area of disturbance to the extent practical.

Stabilized Staging Area	
Functions	
Erosion Control	Yes
Sediment Control	Moderate
Site/Material	Yes

Minimizing Long-Term Stabilization Requirements

- Utilize off-site parking and restrict vehicle access to the site.
- Use construction mats in lieu of rock when staging is provided in an area that will not be disturbed otherwise.
- Consider use of a bermed contained area for materials and equipment that do not require a stabilized surface.
- Consider phasing of staging areas to avoid disturbance in an area that will not be otherwise disturbed.

See Detail SSA-1 for a typical stabilized staging area and SSA-2 for a stabilized staging area when materials staging in roadways is required.

Maintenance and Removal

Maintenance of stabilized staging areas includes maintaining a stable surface cover of gravel, repairing perimeter controls, and following good housekeeping practices.

When construction is complete, debris, unused stockpiles and materials should be recycled or properly disposed. In some cases, this will require disposal of contaminated soil from equipment leaks in an appropriate landfill. Staging areas should then be permanently stabilized with vegetation or other surface cover planned for the development.

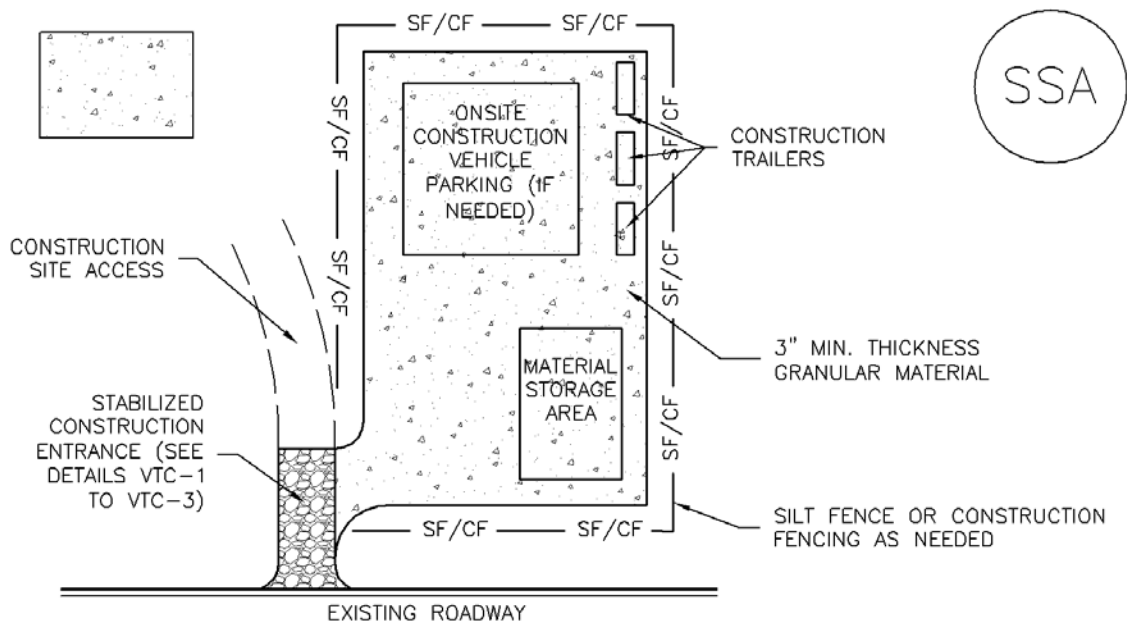

SSA-1. STABILIZED STAGING AREA

STABILIZED STAGING AREA INSTALLATION NOTES

1. SEE PLAN VIEW FOR
 - LOCATION OF STAGING AREA(S).
 - CONTRACTOR MAY ADJUST LOCATION AND SIZE OF STAGING AREA WITH APPROVAL FROM THE LOCAL JURISDICTION.
2. STABILIZED STAGING AREA SHOULD BE APPROPRIATE FOR THE NEEDS OF THE SITE. OVERSIZING RESULTS IN A LARGER AREA TO STABILIZE FOLLOWING CONSTRUCTION.
3. STAGING AREA SHALL BE STABILIZED PRIOR TO OTHER OPERATIONS ON THE SITE.
4. THE STABILIZED STAGING AREA SHALL CONSIST OF A MINIMUM 3" THICK GRANULAR MATERIAL.
5. UNLESS OTHERWISE SPECIFIED BY LOCAL JURISDICTION, ROCK SHALL CONSIST OF DOT SECT. #703, AASHTO #3 COARSE AGGREGATE OR 6" (MINUS) ROCK.
6. ADDITIONAL PERIMETER BMPs MAY BE REQUIRED INCLUDING BUT NOT LIMITED TO SILT FENCE AND CONSTRUCTION FENCING.

STABILIZED STAGING AREA MAINTENANCE NOTES

1. INSPECT BMPs EACH WORKDAY, AND MAINTAIN THEM IN EFFECTIVE OPERATING CONDITION. MAINTENANCE OF BMPs SHOULD BE PROACTIVE, NOT REACTIVE. INSPECT BMPs AS SOON AS POSSIBLE (AND ALWAYS WITHIN 24 HOURS) FOLLOWING A STORM THAT CAUSES SURFACE EROSION, AND PERFORM NECESSARY MAINTENANCE.
2. FREQUENT OBSERVATIONS AND MAINTENANCE ARE NECESSARY TO MAINTAIN BMPs IN EFFECTIVE OPERATING CONDITION. INSPECTIONS AND CORRECTIVE MEASURES SHOULD BE DOCUMENTED THOROUGHLY.
3. WHERE BMPs HAVE FAILED, REPAIR OR REPLACEMENT SHOULD BE INITIATED UPON DISCOVERY OF THE FAILURE.
4. ROCK SHALL BE REAPPLIED OR REGRADED AS NECESSARY IF RUTTING OCCURS OR UNDERLYING SUBGRADE BECOMES EXPOSED.

STABILIZED STAGING AREA MAINTENANCE NOTES

5. STABILIZED STAGING AREA SHALL BE ENLARGED IF NECESSARY TO CONTAIN PARKING, STORAGE, AND UNLOADING/LOADING OPERATIONS.

6. THE STABILIZED STAGING AREA SHALL BE REMOVED AT THE END OF CONSTRUCTION. THE GRANULAR MATERIAL SHALL BE REMOVED OR, IF APPROVED BY THE LOCAL JURISDICTION, USED ON SITE, AND THE AREA COVERED WITH TOPSOIL, SEEDED AND MULCHED OR OTHERWISE STABILIZED IN A MANNER APPROVED BY LOCAL JURISDICTION.

NOTE: MANY MUNICIPALITIES PROHIBIT THE USE OF RECYCLED CONCRETE AS GRANULAR MATERIAL FOR STABILIZED STAGING AREAS DUE TO DIFFICULTIES WITH RE-ESTABLISHMENT OF VEGETATION IN AREAS WHERE RECYCLED CONCRETE WAS PLACED.

NOTE: MANY JURISDICTIONS HAVE BMP DETAILS THAT VARY FROM UDFCD STANDARD DETAILS. CONSULT WITH LOCAL JURISDICTIONS AS TO WHICH DETAIL SHOULD BE USED WHEN DIFFERENCES ARE NOTED.

(DETAILS ADAPTED FROM DOUGLAS COUNTY, COLORADO, NOT AVAILABLE IN AUTOCAD)

Description

Check dams are temporary grade control structures placed in drainage channels to limit the erosivity of stormwater by reducing flow velocity. Check dams are typically constructed from rock, gravel bags, sand bags, or sometimes, proprietary devices. Reinforced check dams are typically constructed from rock and wire gabion. Although the primary function of check dams is to reduce the velocity of concentrated flows, a secondary benefit is sediment trapping upstream of the structure.



Photograph CD-1. Rock check dams in a roadside ditch. Photo courtesy of WWE.

Appropriate Uses

Use as a grade control for temporary drainage ditches or swales until final soil stabilization measures are established upstream and downstream. Check dams can be used on mild or moderately steep slopes. Check dams may be used under the following conditions:

- As temporary grade control facilities along waterways until final stabilization is established.
- Along permanent swales that need protection prior to installation of a non-erodible lining.
- Along temporary channels, ditches or swales that need protection where construction of a non-erodible lining is not practicable.
- Reinforced check dams should be used in areas subject to high flow velocities.

Design and Installation

Place check dams at regularly spaced intervals along the drainage swale or ditch. Check dams heights should allow for pools to develop upstream of each check dam, extending to the downstream toe of the check dam immediately upstream.

When rock is used for the check dam, place rock mechanically or by hand. Do not dump rocks into the drainage channel. Where multiple check dams are used, the top of the lower dam should be at the same elevation as the toe of the upper dam.

When reinforced check dams are used, install erosion control fabric under and around the check dam to prevent erosion on the upstream and downstream sides. Each section of the dam should be keyed in to reduce the potential for washout or undermining. A rock apron upstream and downstream of the dam may be necessary to further control erosion.

Check Dams	
Functions	
Erosion Control	Yes
Sediment Control	Moderate
Site/Material Management	No

Design details with notes are provided for the following types of check dams:

- Rock Check Dams (CD-1)
- Reinforced Check Dams (CD-2)

Sediment control logs may also be used as check dams; however, silt fence is not appropriate for use as a check dam. Many jurisdictions also prohibit or discourage use of straw bales for this purpose.

Maintenance and Removal

Replace missing rocks causing voids in the check dam. If gravel bags or sandbags are used, replace or repair torn or displaced bags.

Remove accumulated sediment, as needed to maintain BMP effectiveness, typically before the sediment depth upstream of the check dam is within ½ of the crest height. Remove accumulated sediment prior to mulching, seeding, or chemical soil stabilization. Removed sediment can be incorporated into the earthwork with approval from the Project Engineer, or disposed of at an alternate location in accordance with the standard specifications.

Check dams constructed in permanent swales should be removed when perennial grasses have become established, or immediately prior to installation of a non-erodible lining. All of the rock and accumulated sediment should be removed, and the area seeded and mulched, or otherwise stabilized.

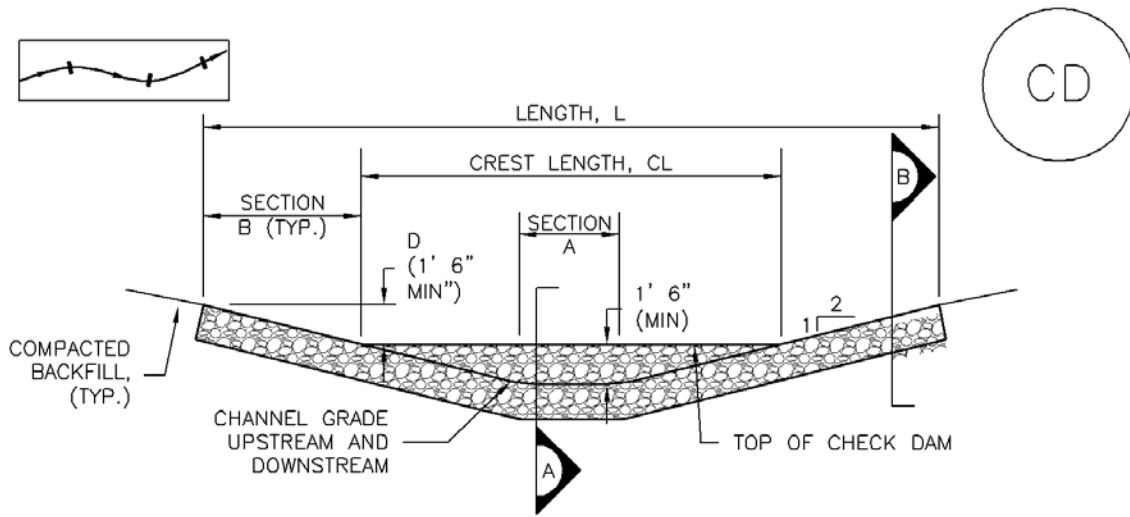

CHECK DAM ELEVATION VIEW

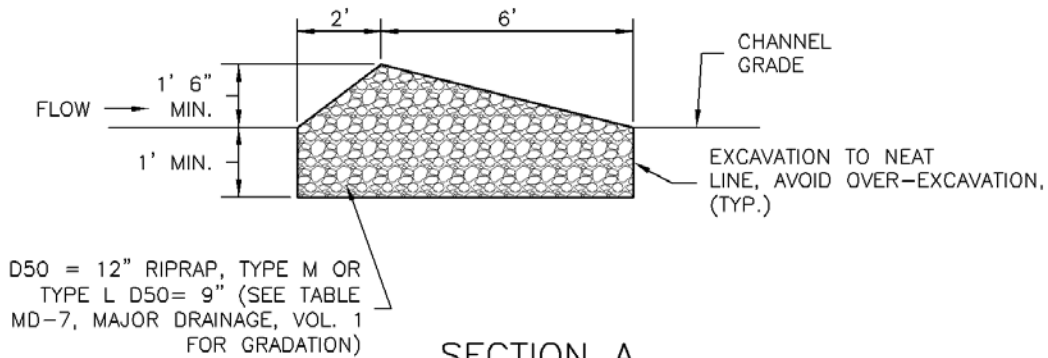

SECTION A

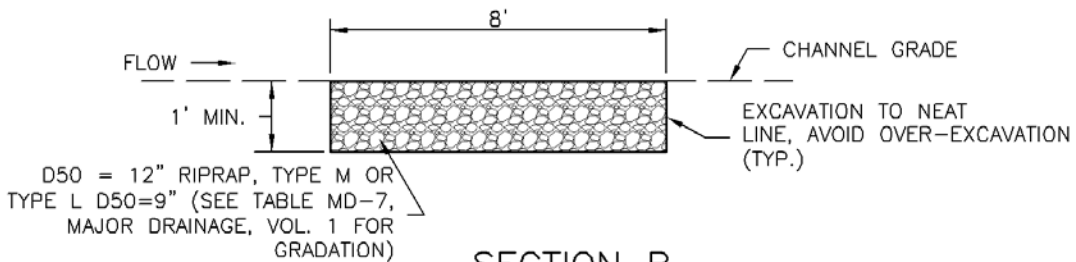

SECTION B

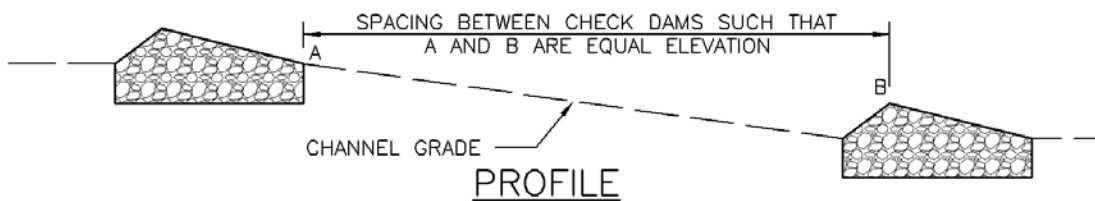

PROFILE

CD-1. CHECK DAM

CHECK DAM INSTALLATION NOTES

1. SEE PLAN VIEW FOR:
 - LOCATION OF CHECK DAMS.
 - CHECK DAM TYPE (CHECK DAM OR REINFORCED CHECK DAM).
 - LENGTH (L), CREST LENGTH (CL), AND DEPTH (D).
2. CHECK DAMS INDICATED ON INITIAL SWMP SHALL BE INSTALLED AFTER CONSTRUCTION FENCE, BUT PRIOR TO ANY UPSTREAM LAND DISTURBING ACTIVITIES.
3. RIPRAP UTILIZED FOR CHECK DAMS SHOULD BE OF APPROPRIATE SIZE FOR THE APPLICATION. TYPICAL TYPES OF RIPRAP USED FOR CHECK DAMS ARE TYPE M (D50 12") OR TYPE L (D50 9").
4. RIPRAP PAD SHALL BE TRENCHED INTO THE GROUND A MINIMUM OF 1'.
5. THE ENDS OF THE CHECK DAM SHALL BE A MINIMUM OF 1' 6" HIGHER THAN THE CENTER OF THE CHECK DAM.

CHECK DAM MAINTENANCE NOTES

1. INSPECT BMPs EACH WORKDAY, AND MAINTAIN THEM IN EFFECTIVE OPERATING CONDITION. MAINTENANCE OF BMPs SHOULD BE PROACTIVE, NOT REACTIVE. INSPECT BMPs AS SOON AS POSSIBLE (AND ALWAYS WITHIN 24 HOURS) FOLLOWING A STORM THAT CAUSES SURFACE EROSION, AND PERFORM NECESSARY MAINTENANCE.
2. FREQUENT OBSERVATIONS AND MAINTENANCE ARE NECESSARY TO MAINTAIN BMPs IN EFFECTIVE OPERATING CONDITION. INSPECTIONS AND CORRECTIVE MEASURES SHOULD BE DOCUMENTED THOROUGHLY.
3. WHERE BMPs HAVE FAILED, REPAIR OR REPLACEMENT SHOULD BE INITIATED UPON DISCOVERY OF THE FAILURE.
4. SEDIMENT ACCUMULATED UPSTREAM OF THE CHECK DAMS SHALL BE REMOVED WHEN THE SEDIMENT DEPTH IS WITHIN $\frac{1}{2}$ OF THE HEIGHT OF THE CREST.
5. CHECK DAMS ARE TO REMAIN IN PLACE UNTIL THE UPSTREAM DISTURBED AREA IS STABILIZED AND APPROVED BY THE LOCAL JURISDICTION.
6. WHEN CHECK DAMS ARE REMOVED, EXCAVATIONS SHALL BE FILLED WITH SUITABLE COMPACTED BACKFILL. DISTURBED AREA SHALL BE SEEDED AND MULCHED AND COVERED WITH GEOTEXTILE OR OTHERWISE STABILIZED IN A MANNER APPROVED BY THE LOCAL JURISDICTION.

(DETAILS ADAPTED FROM DOUGLAS COUNTY, COLORADO, NOT AVAILABLE IN AUTOCAD)

NOTE: MANY JURISDICTIONS HAVE BMP DETAILS THAT VARY FROM UDFCD STANDARD DETAILS. CONSULT WITH LOCAL JURISDICTIONS AS TO WHICH DETAIL SHOULD BE USED WHEN DIFFERENCES ARE NOTED.

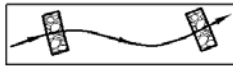

ALTERNATIVE TO STEPS ON BANKS ABOVE CREST:
DEFORM GABIONS AS NECESSARY TO ALIGN TOP OF GABIONS
WITH GROUND SURFACE: AVOID GAPS BETWEEN GABIONS

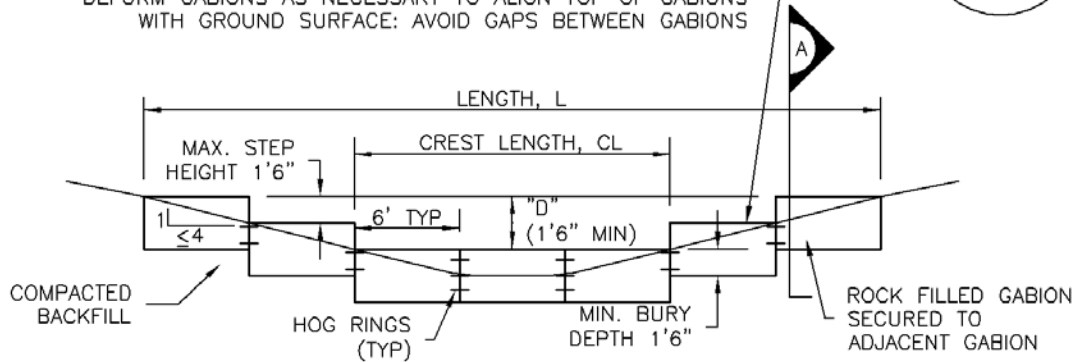

REINFORCED CHECK DAM ELEVATION VIEW

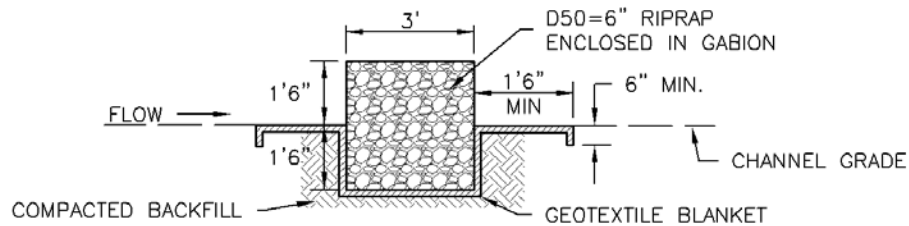

SECTION A

REINFORCED CHECK DAM INSTALLATION NOTES

1. SEE PLAN VIEW FOR:
 - LOCATIONS OF CHECK DAMS.
 - CHECK DAM TYPE (CHECK DAM OR REINFORCED CHECK DAM).
 - LENGTH (L), CREST LENGTH (CL), AND DEPTH (D).
2. CHECK DAMS INDICATED ON THE SWMP SHALL BE INSTALLED PRIOR TO AN UPSTREAM LAND-DISTURBING ACTIVITIES.
3. REINFORCED CHECK DAMS, GABIONS SHALL HAVE GALVANIZED TWISTED WIRE NETTING WITH A MAXIMUM OPENING DIMENSION OF 4½" AND A MINIMUM WIRE THICKNESS OF 0.10". WIRE "HOG RINGS" AT 4" SPACING OR OTHER APPROVED MEANS SHALL BE USED AT ALL GABION SEAMS AND TO SECURE THE GABION TO THE ADJACENT SECTION.
4. THE CHECK DAM SHALL BE TRENCHED INTO THE GROUND A MINIMUM OF 1' 6".
5. GEOTEXTILE BLANKET SHALL BE PLACED IN THE REINFORCED CHECK DAM TRENCH EXTENDING A MINIMUM OF 1' 6" ON BOTH THE UPSTREAM AND DOWNSTREAM SIDES OF THE REINFORCED CHECK DAM.

CD-2. REINFORCED CHECK DAM

REINFORCED CHECK DAM MAINTENANCE NOTES

1. INSPECT BMPs EACH WORKDAY, AND MAINTAIN THEM IN EFFECTIVE OPERATING CONDITION. MAINTENANCE OF BMPs SHOULD BE PROACTIVE, NOT REACTIVE. INSPECT BMPs AS SOON AS POSSIBLE (AND ALWAYS WITHIN 24 HOURS) FOLLOWING A STORM THAT CAUSES SURFACE EROSION, AND PERFORM NECESSARY MAINTENANCE.
2. FREQUENT OBSERVATIONS AND MAINTENANCE ARE NECESSARY TO MAINTAIN BMPs IN EFFECTIVE OPERATING CONDITION. INSPECTIONS AND CORRECTIVE MEASURES SHOULD BE DOCUMENTED THOROUGHLY.
3. WHERE BMPs HAVE FAILED, REPAIR OR REPLACEMENT SHOULD BE INITIATED UPON DISCOVERY OF THE FAILURE.
4. SEDIMENT ACCUMULATED UPSTREAM OF REINFORCED CHECK DAMS SHALL BE REMOVED AS NEEDED TO MAINTAIN THE EFFECTIVENESS OF BMP, TYPICALLY WHEN THE UPSTREAM SEDIMENT DEPTH IS WITHIN ½ THE HEIGHT OF THE CREST.
5. REPAIR OR REPLACE REINFORCED CHECK DAMS WHEN THERE ARE SIGNS OF DAMAGE SUCH AS HOLES IN THE GABION OR UNDERCUTTING.
6. REINFORCED CHECK DAMS ARE TO REMAIN IN PLACE UNTIL THE UPSTREAM DISTURBED AREA IS STABILIZED AND APPROVED BY THE LOCAL JURISDICTION.
7. WHEN REINFORCED CHECK DAMS ARE REMOVED, ALL DISTURBED AREAS SHALL BE COVERED WITH TOPSOIL, SEEDED AND MULCHED, AND COVERED WITH A GEOTEXTILE BLANKET, OR OTHERWISE STABILIZED AS APPROVED BY LOCAL JURISDICTION.

(DETAIL ADAPTED FROM DOUGLAS COUNTY, COLORADO AND CITY OF AURORA, COLORADO, NOT AVAILABLE IN AUTOCAD)

NOTE: MANY JURISDICTIONS HAVE BMP DETAILS THAT VARY FROM UDFCD STANDARD DETAILS. CONSULT WITH LOCAL JURISDICTIONS AS TO WHICH DETAIL SHOULD BE USED WHEN DIFFERENCES ARE NOTED.

Description

Rolled Erosion Control Products (RECPs) include a variety of temporary or permanently installed manufactured products designed to control erosion and enhance vegetation establishment and survivability, particularly on slopes and in channels. For applications where natural vegetation alone will provide sufficient permanent erosion protection, temporary products such as netting, open weave textiles and a variety of erosion control blankets (ECBs) made of biodegradable natural materials (e.g., straw, coconut fiber) can be used. For applications where natural vegetation alone will not be sustainable under expected flow conditions, permanent rolled erosion control products such as turf reinforcement mats (TRMs) can be used. In particular, turf reinforcement mats are designed for discharges that exert velocities and shear stresses that exceed the typical limits of mature natural vegetation.



Photograph RECP-1. Erosion control blanket protecting the slope from erosion and providing favorable conditions for revegetation.

Appropriate Uses

RECPs can be used to control erosion in conjunction with revegetation efforts, providing seedbed protection from wind and water erosion. These products are often used on disturbed areas on steep slopes, in areas with highly erosive soils, or as part of drainageway stabilization. In order to select the appropriate RECP for site conditions, it is important to have a general understanding of the general types of these products, their expected longevity, and general characteristics.

The Erosion Control Technology Council (ECTC 2005) characterizes rolled erosion control products according to these categories:

- **Mulch control netting:** A planar woven natural fiber or extruded geosynthetic mesh used as a temporary degradable rolled erosion control product to anchor loose fiber mulches.
- **Open weave textile:** A temporary degradable rolled erosion control product composed of processed natural or polymer yarns woven into a matrix, used to provide erosion control and facilitate vegetation establishment.
- **Erosion control blanket (ECB):** A temporary degradable rolled erosion control product composed of processed natural or polymer fibers which are mechanically, structurally or chemically bound together to form a continuous matrix to provide erosion control and facilitate vegetation establishment. ECBs can be further differentiated into rapidly degrading single-net and double-net types or slowly degrading types.

Rolled Erosion Control Products	
Functions	
Erosion Control	Yes
Sediment Control	No
Site/Material Management	No

EC-6 Rolled Erosion Control Products (RECP)

- **Turf Reinforcement Mat (TRM):** A rolled erosion control product composed of non-degradable synthetic fibers, filaments, nets, wire mesh, and/or other elements, processed into a permanent, three-dimensional matrix of sufficient thickness. TRMs, which may be supplemented with degradable components, are designed to impart immediate erosion protection, enhance vegetation establishment and provide long-term functionality by permanently reinforcing vegetation during and after maturation. Note: TRMs are typically used in hydraulic applications, such as high flow ditches and channels, steep slopes, stream banks, and shorelines, where erosive forces may exceed the limits of natural, unreinforced vegetation or in areas where limited vegetation establishment is anticipated.

Tables RECP-1 and RECP-2 provide guidelines for selecting rolled erosion control products appropriate to site conditions and desired longevity. Table RECP-1 is for conditions where natural vegetation alone will provide permanent erosion control, whereas Table RECP-2 is for conditions where vegetation alone will not be adequately stable to provide long-term erosion protection due to flow or other conditions.

Table RECP-1. ECTC Standard Specification for Temporary Rolled Erosion Control Products
(Adapted from Erosion Control Technology Council 2005)

Product Description	Slope Applications*		Channel Applications*	Minimum Tensile Strength ¹	Expected Longevity
	Maximum Gradient	C Factor ^{2,5}			
Mulch Control Nets	5:1 (H:V)	≤0.10 @ 5:1	0.25 lbs/ft ² (12 Pa)	5 lbs/ft (0.073 kN/m)	Up to 12 months
Netless Rolled Erosion Control Blankets	4:1 (H:V)	≤0.10 @ 4:1	0.5 lbs/ft ² (24 Pa)	5 lbs/ft (0.073 kN/m)	
Single-net Erosion Control Blankets & Open Weave Textiles	3:1 (H:V)	≤0.15 @ 3:1	1.5 lbs/ft ² (72 Pa)	50 lbs/ft (0.73 kN/m)	
Double-net Erosion Control Blankets	2:1 (H:V)	≤0.20 @ 2:1	1.75 lbs/ft ² (84 Pa)	75 lbs/ft (1.09 kN/m)	
Mulch Control Nets	5:1 (H:V)	≤0.10 @ 5:1	0.25 lbs/ft ² (12 Pa)	25 lbs/ft (0.36 kN/m)	24 months
Erosion Control Blankets & Open Weave Textiles (slowly degrading)	1.5:1 (H:V)	≤0.25 @ 1.5:1	2.00 lbs/ft ² (96 Pa)	100 lbs/ft (1.45 kN/m)	24 months
Erosion Control Blankets & Open Weave Textiles	1:1 (H:V)	≤0.25 @ 1:1	2.25 lbs/ft ² (108 Pa)	125 lbs/ft (1.82 kN/m)	36 months

* C Factor and shear stress for mulch control nettings must be obtained with netting used in conjunction with pre-applied mulch material. (See Section 5.3 of Chapter 7 Construction BMPs for more information on the C Factor.)

¹ Minimum Average Roll Values, Machine direction using ECTC Mod. ASTM D 5035.

² C Factor calculated as ratio of soil loss from RECP protected slope (tested at specified or greater gradient, H:V) to ratio of soil loss from unprotected (control) plot in large-scale testing.

³ Required minimum shear stress RECP (unvegetated) can sustain without physical damage or excess erosion (> 12.7 mm (0.5 in) soil loss) during a 30-minute flow event in large-scale testing.

⁴ The permissible shear stress levels established for each performance category are based on historical experience with products characterized by Manning's roughness coefficients in the range of 0.01 - 0.05.

⁵ Acceptable large-scale test methods may include ASTM D 6459, or other independent testing deemed acceptable by the engineer.

⁶ Per the engineer's discretion. Recommended acceptable large-scale testing protocol may include ASTM D 6460, or other independent testing deemed acceptable by the engineer.

Table RECP-2. ECTC Standard Specification for Permanent¹ Rolled Erosion Control Products
 (Adapted from: Erosion Control Technology Council 2005)

Product Type	Slope Applications	Channel Applications	
TRMs with a minimum thickness of 0.25 inches (6.35 mm) per ASTM D 6525 and UV stability of 80% per ASTM D 4355 (500 hours exposure).	Maximum Gradient	Maximum Shear Stress ^{4,5}	Minimum Tensile Strength ^{2,3}
	0.5:1 (H:V)	6.0 lbs/ft ² (288 Pa)	125 lbs/ft (1.82 kN/m)
	0.5:1 (H:V)	8.0 lbs/ft ² (384 Pa)	150 lbs/ft (2.19 kN/m)
	0.5:1 (H:V)	10.0 lbs/ft ² (480 Pa)	175 lbs/ft (2.55 kN/m)

¹ For TRMs containing degradable components, all property values must be obtained on the non-degradable portion of the matting alone.

² Minimum Average Roll Values, machine direction only for tensile strength determination using [ASTM D 6818](#) (Supersedes Mod. [ASTM D 5035](#) for RECPs)

³ Field conditions with high loading and/or high survivability requirements may warrant the use of a TRM with a tensile strength of 44 kN/m (3,000 lb/ft) or greater.

⁴ Required minimum shear stress TRM (fully vegetated) can sustain without physical damage or excess erosion (> 12.7 mm (0.5 in.) soil loss) during a 30-minute flow event in large scale testing.

⁵ Acceptable large-scale testing protocols may include [ASTM D 6460](#), or other independent testing deemed acceptable by the engineer.

Design and Installation

RECPs should be installed according to manufacturer’s specifications and guidelines. Regardless of the type of product used, it is important to ensure no gaps or voids exist under the material and that all corners of the material are secured using stakes and trenching. Continuous contact between the product and the soil is necessary to avoid failure. Never use metal stakes to secure temporary erosion control products. Often wooden stakes are used to anchor RECPs; however, wood stakes may present installation and maintenance challenges and generally take a long time to biodegrade. Some local jurisdictions have had favorable experiences using biodegradable stakes.

This BMP Fact Sheet provides design details for several commonly used ECB applications, including:

ECB-1 Pipe Outlet to Drainageway

ECB-2 Small Ditch or Drainageway

ECB-3 Outside of Drainageway

Staking patterns are also provided in the design details according to these factors:

- ECB type
- Slope or channel type

For other types of RECPs including TRMs, these design details are intended to serve as general guidelines for design and installation; however, engineers should adhere to manufacturer's installation recommendations.

Maintenance and Removal

Inspection of erosion control blankets and other RECPs includes:

- Check for general signs of erosion, including voids beneath the mat. If voids are apparent, fill the void with suitable soil and replace the erosion control blanket, following the appropriate staking pattern.
- Check for damaged or loose stakes and secure loose portions of the blanket.

Erosion control blankets and other RECPs that are biodegradable typically do not need to be removed after construction. If they must be removed, then an alternate soil stabilization method should be installed promptly following removal.

Turf reinforcement mats, although generally resistant to biodegradation, are typically left in place as a dense vegetated cover grows in through the mat matrix. The turf reinforcement mat provides long-term stability and helps the established vegetation resist erosive forces.

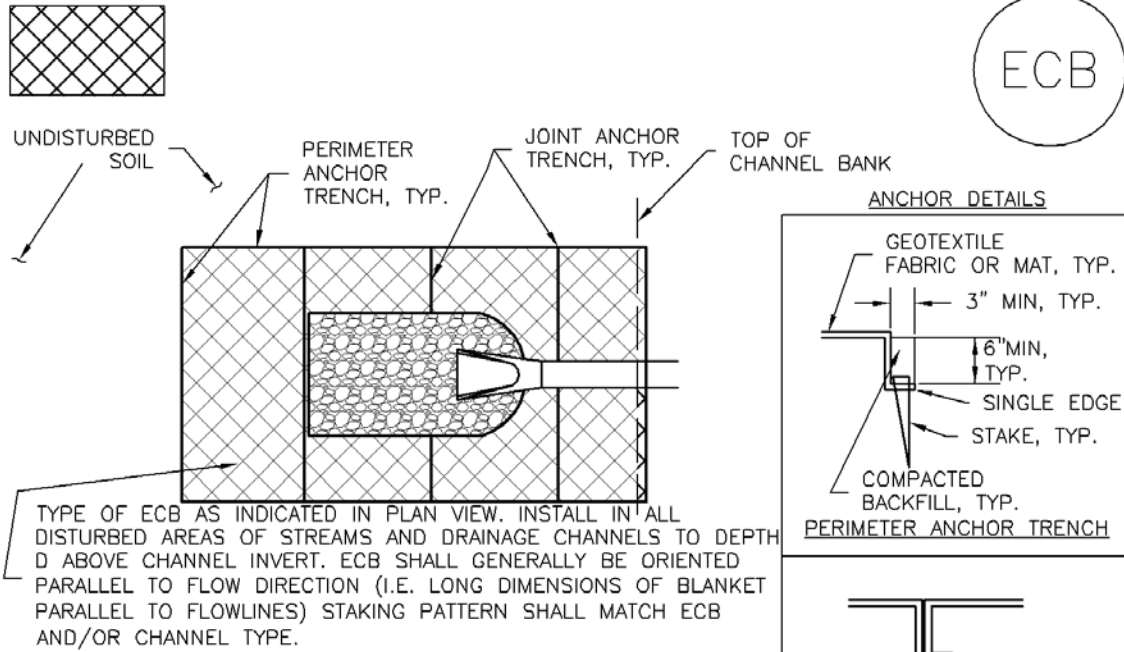

ECB-1. PIPE OUTLET TO DRAINAGEWAY

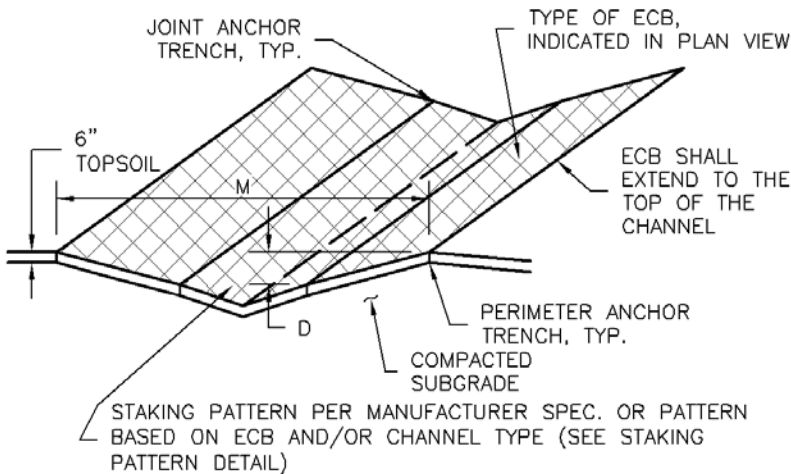

ECB-2. SMALL DITCH OR DRAINAGEWAY

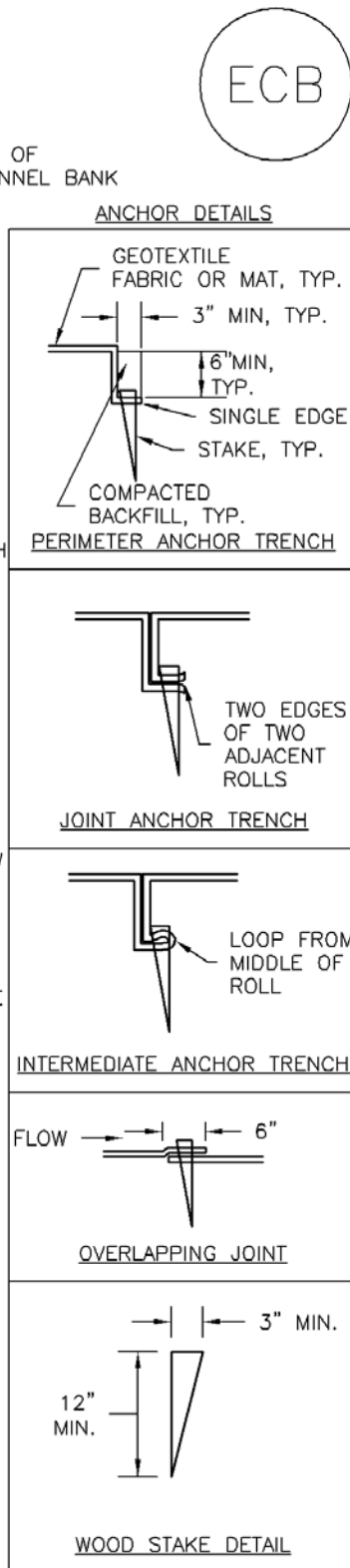

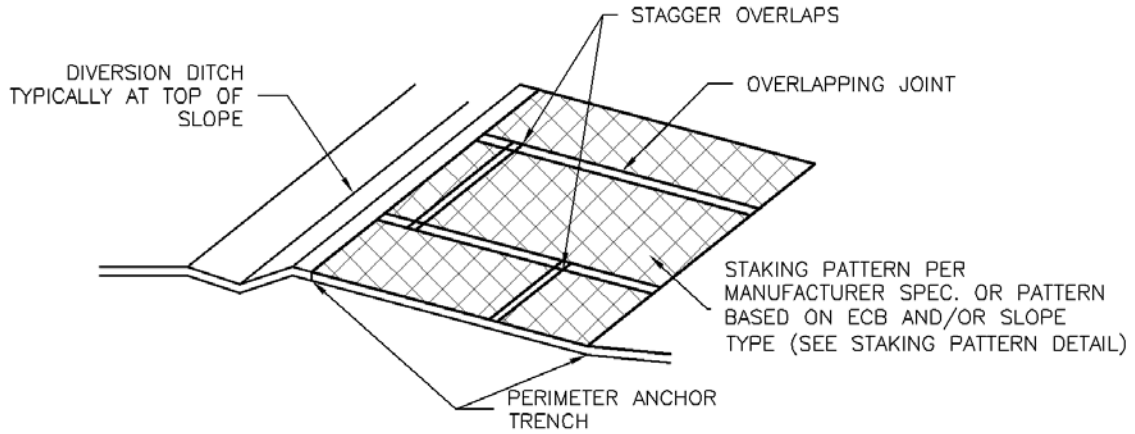

ECB-3. OUTSIDE OF DRAINAGEWAY

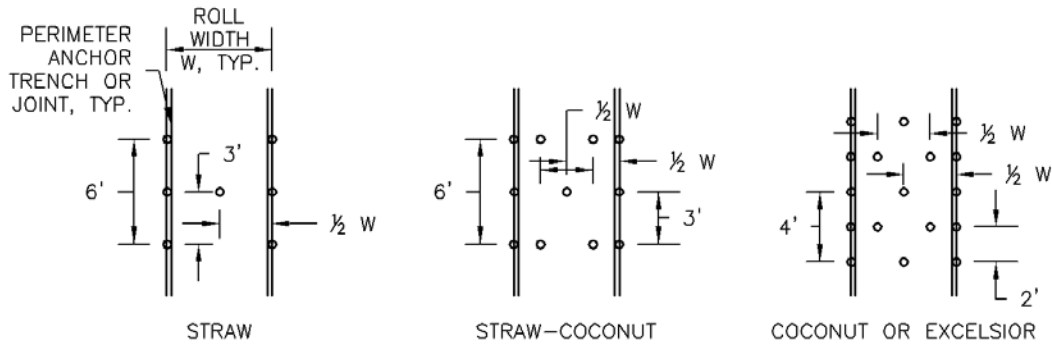

STAKING PATTERNS BY ECB TYPE

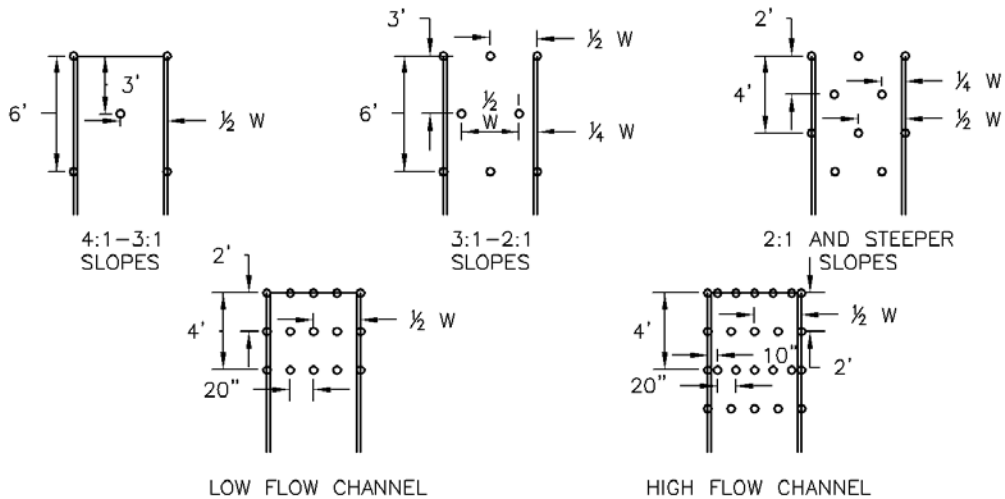

STAKING PATTERNS BY SLOPE OR CHANNEL TYPE

EROSION CONTROL BLANKET INSTALLATION NOTES

1. SEE PLAN VIEW FOR:
 - LOCATION OF ECB.
 - TYPE OF ECB (STRAW, STRAW-COCONUT, COCONUT, OR EXCELSIOR).
 - AREA, A, IN SQUARE YARDS OF EACH TYPE OF ECB.
2. 100% NATURAL AND BIODEGRADABLE MATERIALS ARE PREFERRED FOR RECPs, ALTHOUGH SOME JURISDICTIONS MAY ALLOW OTHER MATERIALS IN SOME APPLICATIONS.
3. IN AREAS WHERE ECBs ARE SHOWN ON THE PLANS, THE PERMITTEE SHALL PLACE TOPSOIL AND PERFORM FINAL GRADING, SURFACE PREPARATION, AND SEEDING AND MULCHING. SUBGRADE SHALL BE SMOOTH AND MOIST PRIOR TO ECB INSTALLATION AND THE ECB SHALL BE IN FULL CONTACT WITH SUBGRADE. NO GAPS OR VOIDS SHALL EXIST UNDER THE BLANKET.
4. PERIMETER ANCHOR TRENCH SHALL BE USED ALONG THE OUTSIDE PERIMETER OF ALL BLANKET AREAS.
5. JOINT ANCHOR TRENCH SHALL BE USED TO JOIN ROLLS OF ECBs TOGETHER (LONGITUDINALLY AND TRANSVERSELY) FOR ALL ECBs EXCEPT STRAW WHICH MAY USE AN OVERLAPPING JOINT.
6. INTERMEDIATE ANCHOR TRENCH SHALL BE USED AT SPACING OF ONE-HALF ROLL LENGTH FOR COCONUT AND EXCELSIOR ECBs.
7. OVERLAPPING JOINT DETAIL SHALL BE USED TO JOIN ROLLS OF ECBs TOGETHER FOR ECBs ON SLOPES.
8. MATERIAL SPECIFICATIONS OF ECBs SHALL CONFORM TO TABLE ECB-1.
9. ANY AREAS OF SEEDING AND MULCHING DISTURBED IN THE PROCESS OF INSTALLING ECBs SHALL BE RESEEDED AND MULCHED.
10. DETAILS ON DESIGN PLANS FOR MAJOR DRAINAGEWAY STABILIZATION WILL GOVERN IF DIFFERENT FROM THOSE SHOWN HERE.

TABLE ECB-1. ECB MATERIAL SPECIFICATIONS				
TYPE	COCONUT CONTENT	STRAW CONTENT	EXCELSIOR CONTENT	RECOMMENDED NETTING**
STRAW*	-	100%	-	DOUBLE/NATURAL
STRAW-COCONUT	30% MIN	70% MAX	-	DOUBLE/NATURAL
COCONUT	100%	-	-	DOUBLE/NATURAL
EXCELSIOR	-	-	100%	DOUBLE/NATURAL

*STRAW ECBs MAY ONLY BE USED OUTSIDE OF STREAMS AND DRAINAGE CHANNEL.
 **ALTERNATE NETTING MAY BE ACCEPTABLE IN SOME JURISDICTIONS

EROSION CONTROL BLANKET MAINTENANCE NOTES

1. INSPECT BMPs EACH WORKDAY, AND MAINTAIN THEM IN EFFECTIVE OPERATING CONDITION. MAINTENANCE OF BMPs SHOULD BE PROACTIVE, NOT REACTIVE. INSPECT BMPs AS SOON AS POSSIBLE (AND ALWAYS WITHIN 24 HOURS) FOLLOWING A STORM THAT CAUSES SURFACE EROSION, AND PERFORM NECESSARY MAINTENANCE.
2. FREQUENT OBSERVATIONS AND MAINTENANCE ARE NECESSARY TO MAINTAIN BMPs IN EFFECTIVE OPERATING CONDITION. INSPECTIONS AND CORRECTIVE MEASURES SHOULD BE DOCUMENTED THOROUGHLY.
3. WHERE BMPs HAVE FAILED, REPAIR OR REPLACEMENT SHOULD BE INITIATED UPON DISCOVERY OF THE FAILURE.
4. ECBs SHALL BE LEFT IN PLACE TO EVENTUALLY BIODEGRADE, UNLESS REQUESTED TO BE REMOVED BY THE LOCAL JURISDICTION.
5. ANY ECB PULLED OUT, TORN, OR OTHERWISE DAMAGED SHALL BE REPAIRED OR REINSTALLED. ANY SUBGRADE AREAS BELOW THE GEOTEXTILE THAT HAVE ERODED TO CREATED A VOID UNDER THE BLANKET, OR THAT REMAIN DEVOID OF GRASS SHALL BE REPAIRED, RESEDED AND MULCHED AND THE ECB REINSTALLED.

NOTE: MANY JURISDICTIONS HAVE BMP DETAILS THAT VARY FROM UDFCD STANDARD DETAILS. CONSULT WITH LOCAL JURISDICTIONS AS TO WHICH DETAIL SHOULD BE USED WHEN DIFFERENCES ARE NOTED.

(DETAILS ADAPTED FROM DOUGLAS COUNTY, COLORADO AND TOWN OF PARKER COLORADO, NOT AVAILABLE IN AUTOCAD)

Description

Mulching consists of evenly applying straw, hay, shredded wood mulch, rock, bark or compost to disturbed soils and securing the mulch by crimping, tackifiers, netting or other measures. Mulching helps reduce erosion by protecting bare soil from rainfall impact, increasing infiltration, and reducing runoff. Although often applied in conjunction with temporary or permanent seeding, it can also be used for temporary stabilization of areas that cannot be reseeded due to seasonal constraints.

Mulch can be applied either using standard mechanical dry application methods or using hydromulching equipment that hydraulically applies a slurry of water, wood fiber mulch, and often a tackifier.



Photograph MU-1. An area that was recently seeded, mulched, and crimped.

Appropriate Uses

Use mulch in conjunction with seeding to help protect the seedbed and stabilize the soil. Mulch can also be used as a temporary cover on low to mild slopes to help temporarily stabilize disturbed areas where growing season constraints prevent effective reseeded. Disturbed areas should be properly mulched and tacked, or seeded, mulched and tacked promptly after final grade is reached (typically within no longer than 14 days) on portions of the site not otherwise permanently stabilized.

Standard dry mulching is encouraged in most jurisdictions; however, hydromulching may not be allowed in certain jurisdictions or may not be allowed near waterways.

Do not apply mulch during windy conditions.

Design and Installation

Prior to mulching, surface-roughen areas by rolling with a crimping or punching type roller or by track walking. Track walking should only be used where other methods are impractical because track walking with heavy equipment typically compacts the soil.

A variety of mulches can be used effectively at construction sites. Consider the following:

Mulch	
Functions	
Erosion Control	Yes
Sediment Control	Moderate
Site/Material Management	No

- Clean, weed-free and seed-free cereal grain straw should be applied evenly at a rate of 2 tons per acre and must be tacked or fastened by a method suitable for the condition of the site. Straw mulch must be anchored (and not merely placed) on the surface. This can be accomplished mechanically by crimping or with the aid of tackifiers or nets. Anchoring with a crimping implement is preferred, and is the recommended method for areas flatter than 3:1. Mechanical crimpers must be capable of tucking the long mulch fibers into the soil to a depth of 3 inches without cutting them. An agricultural disk, while not an ideal substitute, may work if the disk blades are dull or blunted and set vertically; however, the frame may have to be weighted to afford proper soil penetration.
- Grass hay may be used in place of straw; however, because hay is comprised of the entire plant including seed, mulching with hay may seed the site with non-native grass species which might in turn out-compete the native seed. Alternatively, native species of grass hay may be purchased, but can be difficult to find and are more expensive than straw. Purchasing and utilizing a certified weed-free straw is an easier and less costly mulching method. When using grass hay, follow the same guidelines as for straw (provided above).
- On small areas sheltered from the wind and heavy runoff, spraying a tackifier on the mulch is satisfactory for holding it in place. For steep slopes and special situations where greater control is needed, erosion control blankets anchored with stakes should be used instead of mulch.
- Hydraulic mulching consists of wood cellulose fibers mixed with water and a tackifying agent and should be applied at a rate of no less than 1,500 pounds per acre (1,425 lbs of fibers mixed with at least 75 lbs of tackifier) with a hydraulic mulcher. For steeper slopes, up to 2000 pounds per acre may be required for effective hydroseeding. Hydromulch typically requires up to 24 hours to dry; therefore, it should not be applied immediately prior to inclement weather. Application to roads, waterways and existing vegetation should be avoided.
- Erosion control mats, blankets, or nets are recommended to help stabilize steep slopes (generally 3:1 and steeper) and waterways. Depending on the product, these may be used alone or in conjunction with grass or straw mulch. Normally, use of these products will be restricted to relatively small areas. Biodegradable mats made of straw and jute, straw-coconut, coconut fiber, or excelsior can be used instead of mulch. (See the ECM/TRM BMP for more information.)
- Some tackifiers or binders may be used to anchor mulch. Check with the local jurisdiction for allowed tackifiers. Manufacturer's recommendations should be followed at all times. (See the Soil Binder BMP for more information on general types of tackifiers.)
- Rock can also be used as mulch. It provides protection of exposed soils to wind and water erosion and allows infiltration of precipitation. An aggregate base course can be spread on disturbed areas for temporary or permanent stabilization. The rock mulch layer should be thick enough to provide full coverage of exposed soil on the area it is applied.

Maintenance and Removal

After mulching, the bare ground surface should not be more than 10 percent exposed. Reapply mulch, as needed, to cover bare areas.

Description

Stockpile management includes measures to minimize erosion and sediment transport from soil stockpiles.

Appropriate Uses

Stockpile management should be used when soils or other erodible materials are stored at the construction site. Special attention should be given to stockpiles in close proximity to natural or manmade storm systems.



Photograph SP-1. A topsoil stockpile that has been partially revegetated and is protected by silt fence perimeter control.

Design and Installation

Locate stockpiles away from all drainage system components including storm sewer inlets. Where practical, choose stockpile locations that that will remain undisturbed for the longest period of time as the phases of construction progress. Place sediment control BMPs around the perimeter of the stockpile, such as sediment control logs, rock socks, silt fence, straw bales and sand bags. See Detail SP-1 for guidance on proper establishment of perimeter controls around a stockpile. For stockpiles in active use, provide a stabilized designated access point on the upgradient side of the stockpile.

Stabilize the stockpile surface with surface roughening, temporary seeding and mulching, erosion control blankets, or soil binders. Soils stockpiled for an extended period (typically for more than 60 days) should be seeded and mulched with a temporary grass cover once the stockpile is placed (typically within 14 days). Use of mulch only or a soil binder is acceptable if the stockpile will be in place for a more limited time period (typically 30-60 days). Timeframes for stabilization of stockpiles noted in this fact sheet are "typical" guidelines. Check permit requirements for specific federal, state, and/or local requirements that may be more prescriptive.

Stockpiles should not be placed in streets or paved areas unless no other practical alternative exists. See the Stabilized Staging Area Fact Sheet for guidance when staging in roadways is unavoidable due to space or right-of-way constraints. For paved areas, rock socks must be used for perimeter control and all inlets with the potential to receive sediment from the stockpile (even from vehicle tracking) must be protected.

Maintenance and Removal

Inspect perimeter controls and inlet protection in accordance with their respective BMP Fact Sheets. Where seeding, mulch and/or soil binders are used, reseeding or reapplication of soil binder may be necessary.

When temporary removal of a perimeter BMP is necessary to access a stockpile, ensure BMPs are reinstalled in accordance with their respective design detail section.

Stockpile Management	
Functions	
Erosion Control	Yes
Sediment Control	Yes
Site/Material Management	Yes

When the stockpile is no longer needed, properly dispose of excess materials and revegetate or otherwise stabilize the ground surface where the stockpile was located.

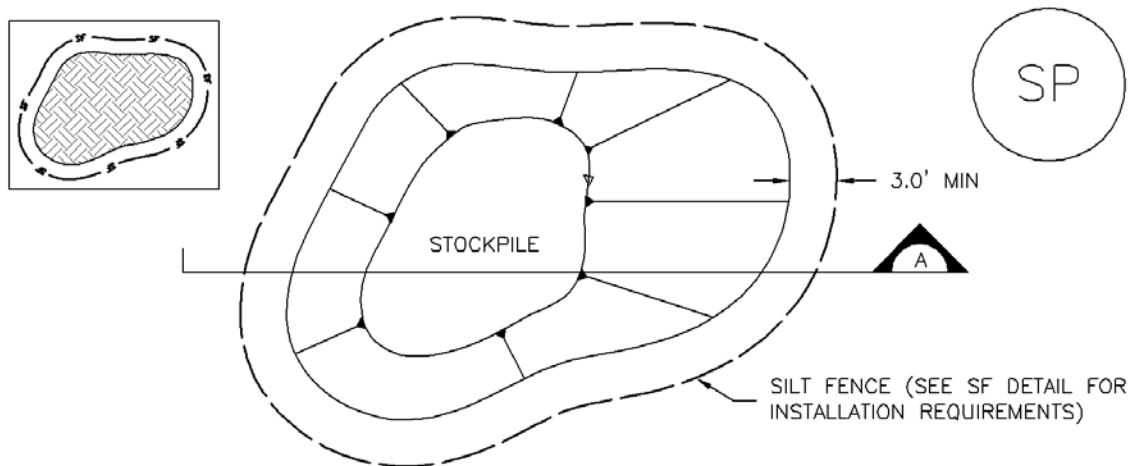

STOCKPILE PROTECTION PLAN

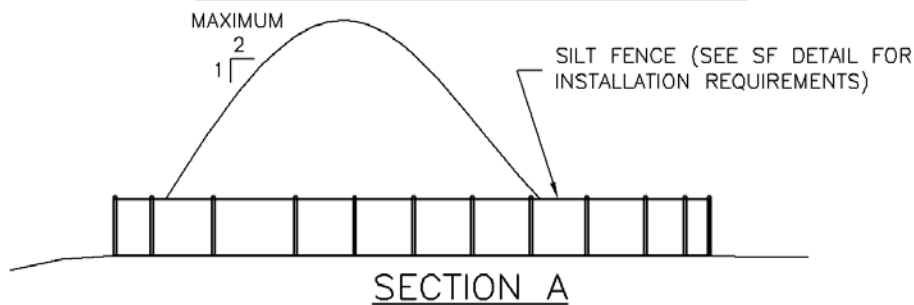

SP-1. STOCKPILE PROTECTION

STOCKPILE PROTECTION INSTALLATION NOTES

1. SEE PLAN VIEW FOR:
 - LOCATION OF STOCKPILES.
 - TYPE OF STOCKPILE PROTECTION.

2. INSTALL PERIMETER CONTROLS IN ACCORDANCE WITH THEIR RESPECTIVE DESIGN DETAILS. SILT FENCE IS SHOWN IN THE STOCKPILE PROTECTION DETAILS; HOWEVER, OTHER TYPES OF PERIMETER CONTROLS INCLUDING SEDIMENT CONTROL LOGS OR ROCK SOCKS MAY BE SUITABLE IN SOME CIRCUMSTANCES. CONSIDERATIONS FOR DETERMINING THE APPROPRIATE TYPE OF PERIMETER CONTROL FOR A STOCKPILE INCLUDE WHETHER THE STOCKPILE IS LOCATED ON A PERVIOUS OR IMPERVIOUS SURFACE, THE RELATIVE HEIGHTS OF THE PERIMETER CONTROL AND STOCKPILE, THE ABILITY OF THE PERIMETER CONTROL TO CONTAIN THE STOCKPILE WITHOUT FAILING IN THE EVENT THAT MATERIAL FROM THE STOCKPILE SHIFTS OR SLUMPS AGAINST THE PERIMETER, AND OTHER FACTORS.

3. STABILIZE THE STOCKPILE SURFACE WITH SURFACE ROUGHENING, TEMPORARY SEEDING AND MULCHING, EROSION CONTROL BLANKETS, OR SOIL BINDERS. SOILS STOCKPILED FOR AN EXTENDED PERIOD (TYPICALLY FOR MORE THAN 60 DAYS) SHOULD BE SEEDING AND MULCHED WITH A TEMPORARY GRASS COVER ONCE THE STOCKPILE IS PLACED (TYPICALLY WITHIN 14 DAYS). USE OF MULCH ONLY OR A SOIL BINDER IS ACCEPTABLE IF THE STOCKPILE WILL BE IN PLACE FOR A MORE LIMITED TIME PERIOD (TYPICALLY 30-60 DAYS).

4. FOR TEMPORARY STOCKPILES ON THE INTERIOR PORTION OF A CONSTRUCTION SITE, WHERE OTHER DOWNGRADIENT CONTROLS, INCLUDING PERIMETER CONTROL, ARE IN PLACE, STOCKPILE PERIMETER CONTROLS MAY NOT BE REQUIRED.

STOCKPILE PROTECTION MAINTENANCE NOTES

1. INSPECT BMPs EACH WORKDAY, AND MAINTAIN THEM IN EFFECTIVE OPERATING CONDITION. MAINTENANCE OF BMPs SHOULD BE PROACTIVE, NOT REACTIVE. INSPECT BMPs AS SOON AS POSSIBLE (AND ALWAYS WITHIN 24 HOURS) FOLLOWING A STORM THAT CAUSES SURFACE EROSION, AND PERFORM NECESSARY MAINTENANCE.

2. FREQUENT OBSERVATIONS AND MAINTENANCE ARE NECESSARY TO MAINTAIN BMPs IN EFFECTIVE OPERATING CONDITION. INSPECTIONS AND CORRECTIVE MEASURES SHOULD BE DOCUMENTED THOROUGHLY.

3. WHERE BMPs HAVE FAILED, REPAIR OR REPLACEMENT SHOULD BE INITIATED UPON DISCOVERY OF THE FAILURE.

STOCKPILE PROTECTION MAINTENANCE NOTES

4. IF PERIMETER PROTECTION MUST BE MOVED TO ACCESS SOIL STOCKPILE, REPLACE PERIMETER CONTROLS BY THE END OF THE WORKDAY.

5. STOCKPILE PERIMETER CONTROLS CAN BE REMOVED ONCE ALL THE MATERIAL FROM THE STOCKPILE HAS BEEN USED.

(DETAILS ADAPTED FROM PARKER, COLORADO, NOT AVAILABLE IN AUTOCAD)

NOTE: MANY JURISDICTIONS HAVE BMP DETAILS THAT VARY FROM UDFCD STANDARD DETAILS. CONSULT WITH LOCAL JURISDICTIONS AS TO WHICH DETAIL SHOULD BE USED WHEN DIFFERENCES ARE NOTED.

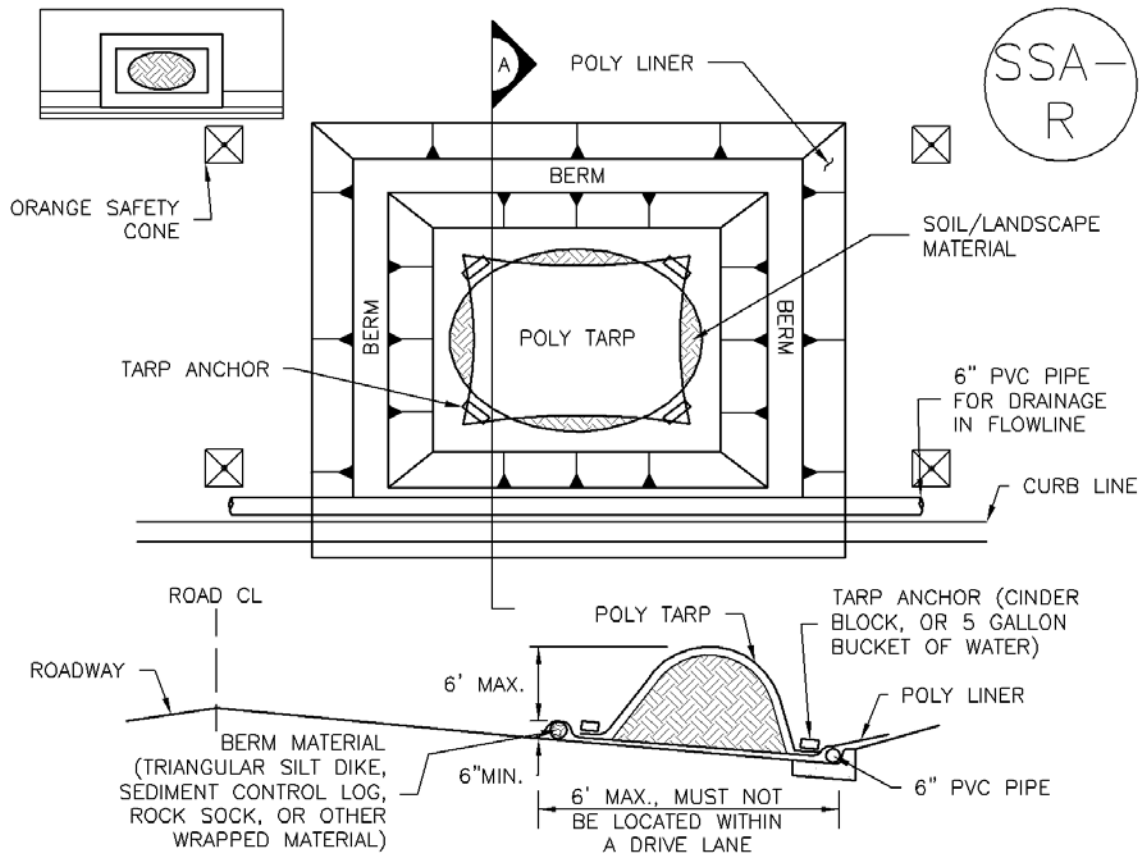

SP-2. MATERIALS STAGING IN ROADWAY

MATERIALS STAGING IN ROADWAYS INSTALLATION NOTES

1. SEE PLAN VIEW FOR
 - LOCATION OF MATERIAL STAGING AREA(S).
 - CONTRACTOR MAY ADJUST LOCATION AND SIZE OF STAGING AREA WITH APPROVAL FROM THE LOCAL JURISDICTION.
2. FEATURE MUST BE INSTALLED PRIOR TO EXCAVATION, EARTHWORK OR DELIVERY OF MATERIALS.
3. MATERIALS MUST BE STATIONED ON THE POLY LINER. ANY INCIDENTAL MATERIALS DEPOSITED ON PAVED SECTION OR ALONG CURB LINE MUST BE CLEANED UP PROMPTLY.
4. POLY LINER AND TARP COVER SHOULD BE OF SIGNIFICANT THICKNESS TO PREVENT DAMAGE OR LOSS OF INTEGRITY.
5. SAND BAGS MAY BE SUBSTITUTED TO ANCHOR THE COVER TARP OR PROVIDE BERMING UNDER THE BASE LINER.
6. FEATURE IS NOT INTENDED FOR USE WITH WET MATERIAL THAT WILL BE DRAINING AND/OR SPREADING OUT ON THE POLY LINER OR FOR DEMOLITION MATERIALS.
7. THIS FEATURE CAN BE USED FOR:
 - UTILITY REPAIRS.
 - WHEN OTHER STAGING LOCATIONS AND OPTIONS ARE LIMITED.
 - OTHER LIMITED APPLICATION AND SHORT DURATION STAGING.

MATERIALS STAGING IN ROADWAY MAINTENANCE NOTES

1. INSPECT BMPs EACH WORKDAY, AND MAINTAIN THEM IN EFFECTIVE OPERATING CONDITION. MAINTENANCE OF BMPs SHOULD BE PROACTIVE, NOT REACTIVE. INSPECT BMPs AS SOON AS POSSIBLE (AND ALWAYS WITHIN 24 HOURS) FOLLOWING A STORM THAT CAUSES SURFACE EROSION, AND PERFORM NECESSARY MAINTENANCE.
2. FREQUENT OBSERVATIONS AND MAINTENANCE ARE NECESSARY TO MAINTAIN BMPs IN EFFECTIVE OPERATING CONDITION. INSPECTIONS AND CORRECTIVE MEASURES SHOULD BE DOCUMENTED THOROUGHLY.
3. WHERE BMPs HAVE FAILED, REPAIR OR REPLACEMENT SHOULD BE INITIATED UPON DISCOVERY OF THE FAILURE.
4. INSPECT PVC PIPE ALONG CURB LINE FOR CLOGGING AND DEBRIS. REMOVE OBSTRUCTIONS PROMPTLY.
5. CLEAN MATERIAL FROM PAVED SURFACES BY SWEEPING OR VACUUMING.

NOTE: MANY JURISDICTIONS HAVE BMP DETAILS THAT VARY FROM UDFCD STANDARD DETAILS. CONSULT WITH LOCAL JURISDICTIONS AS TO WHICH DETAIL SHOULD BE USED WHEN DIFFERENCES ARE NOTED.

(DETAILS ADAPTED FROM AURORA, COLORADO)

SWMP_V2.pdf Markup Summary 5-22-2023

dotprete (8)

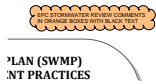

Subject: Stormwater Comments Color
Page Label: 1
Author: dotprete
Date: 5/17/2023 2:11:36 PM
Status:
Color: ■
Layer:
Space:

constructed in a site
complete; therefore,
only 0.88-acre area o

Subject: Highlight
Page Label: 3
Author: dotprete
Date: 5/17/2023 2:12:51 PM
Status:
Color: ■
Layer:
Space:

constructed in a single phase. O
mplete; therefore, construction
by 0.88-acre area of land disturb
confirm on GEC Plan

Subject: Text Box
Page Label: 3
Author: dotprete
Date: 5/17/2023 2:13:05 PM
Status:
Color: ■
Layer:
Space:

confirm on GEC Plan

include interim and final
stages
unresolved.

that
Init
The
com
on e
incl

Subject: Engineer
Page Label: 6
Author: dotprete
Date: 5/17/2023 1:56:03 PM
Status:
Color: ■
Layer:
Space:

include interim and final stages
unresolved.



Subject: Text Box
Page Label: 7
Author: dotprete
Date: 5/17/2023 1:44:37 PM
Status:
Color: ■
Layer:
Space:

Discuss all temporary control measures in detail.
unresolved.

discuss all
non-structural BMPs
including
seeding/mulching
unresolved.

f.
g.

Subject: Text Box
Page Label: 7
Author: dotprete
Date: 5/17/2023 1:45:06 PM
Status:
Color: ■
Layer:
Space:

discuss all non-structural BMPs including
seeding/mulching
unresolved.

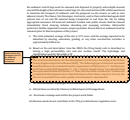

Subject: Cloud+
Page Label: 8
Author: dotprete
Date: 5/17/2023 1:45:51 PM
Status:
Color: ■
Layer:
Space:

please remove this paragraph (see LOI for additional information). unresolved.



Subject: Text Box
Page Label: 9
Author: dotprete
Date: 5/17/2023 1:56:28 PM
Status:
Color: ■
Layer:
Space:

Item Numbers refer to SWMP Checklist:

Item 9. Include method used to determine ground cover (i.e., visual, aerial inspection)

Item 12. Note that this project does not anticipate utilizing onsite batch plants in the SWMP text

Item 13. Discuss inspection procedure for checking waste disposal bins for leaks and overflowing capacity. And discuss frequency that they will be emptied (or at what level of capacity would trigger the need to be emptied).

Toilets: Portable toilets will be located a minimum of 10ft from stormwater inlets and 50ft from state waters. They will be secured at all four corners to prevent overturning and cleaned on a weekly basis. They will be inspected daily for spills.

Item 18: Include a description of all structural control measures to be used.

Item 19: Include a description of all non-structural control measures to be used.

Item 21. Add text stating that the SWMP should be viewed as a "living document" that is continuously being reviewed and modified as a part of the overall process of evaluating and managing SW quality issues at the site. The QSM shall amend the SWMP when there is a change in design, construction, O&M of the site which would require the implementation of new or revised BMPs or if the SWMP proves to be ineffective in achieving the general objectives of controlling pollutants in SW discharges associated with construction activity or when BMPs are no longer necessary and are removed.

Item 26. Add a note stating that this project does not rely on control measures owned or operated by another entity.

Unresolved.