



**Planning and Community
Development Department**
2880 International Circle
Colorado Springs, Colorado 80910
Phone: 719.520.6300
Fax: 719.520.6695
Website www.elpasoco.com

DEVIATION REQUEST AND DECISION FORM

Updated: 6/26/2019

PROJECT INFORMATION

Project Name :	Retreat at TimberRidge Filing No. 3
Schedule No.(s) :	52214-00-001, 52280-00-039, 52272-00-007, 52272-00-008, 52220-00-026, portion of 52220-00-023
Legal Description :	See attached

APPLICANT INFORMATION

Company :	Classic Companies	
Name :	Loren Moreland	
	<input checked="" type="checkbox"/> Owner <input type="checkbox"/> Consultant <input type="checkbox"/> Contractor	
Mailing Address :	2138 Flying Horse Club Dr. Colorado Springs, CO 80921	
Phone Number :	719-592-9333	
FAX Number :	N/A	
Email Address :	Lmoreland@classichomes.com	

ENGINEER INFORMATION

Company :	Classic Consulting	Colorado P.E. Number :	37155
Name :	Marc A. Whorton, P.E.		
Mailing Address :	619 N. Cascade Ave., Suite 200 Colorado Springs, CO 80903		
Phone Number :	719-785-2802		
FAX Number :	N/A		
Email Address :	Mwhorton@classicconsulting.net		

OWNER, APPLICANT, AND ENGINEER DECLARATION

To the best of my knowledge, the information on this application and all additional or supplemental documentation is true, factual and complete. I am fully aware that any misrepresentation of any information on this application may be grounds for denial. I have familiarized myself with the rules, regulations and procedures with respect to preparing and filing this application. I also understand that an incorrect submittal will be cause to have the project removed from the agenda of the Planning Commission, Board of County Commissioners and/or Board of Adjustment or delay review until corrections are made, and that any approval of this application is based on the representations made in the application and may be revoked on any breach of representation or condition(s) of approval.

[Signature]

Signature of owner (or authorized representative)

4/22/2024

Date

Engineer's Seal, Signature
And Date of Signature

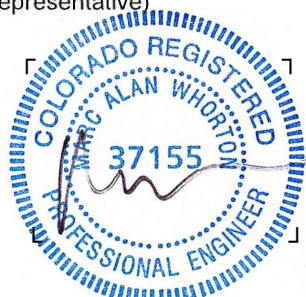

5/15/2024

DEVIATION REQUEST (Attach diagrams, figures, and other documentation to clarify request)

A deviation from the standards of or in Section **Chapter 6 6.4.1 and Table 6-4** of the Drainage Criteria Manual (DCM) is requested.

Identify the specific DCM standard which a deviation is requested:

Rural Minor Collector – Arroya Lane
Allowable culvert overtopping – major drainage system maximum depth of 12”

State the reason for the requested deviation:

The adjacent property owner directly north of Arroya Lane currently has a private driveway with access onto Arroya Lane 125’ east of the culvert crossing of Sand Creek. The current roadway and culvert crossing design required several temporary construction and permanent drainage easements from this property owner. After many discussions and meetings, this neighbor is unwilling to grant any easements for work on his property.

Thus, we have revised the roadway and culvert crossing design to accommodate no disturbance on the adjacent property. In order to make this design work by keeping his current private driveway location in tact yet still provide an adequate 100-yr. culvert crossing of Sand Creek, overtopping depth of a small portion of this roadway will exceed the max. 12” ponding for the Sand Creek DBPS and FEMA 100-yr. flows. (2170 cfs and 2600 cfs, respectively)

Incidentally, the more recent Sterling Ranch MDDP 100-yr. flows are 1468 cfs, which meet current overtopping criteria.

Explain the proposed alternative and compare to the DCM standards (May provide applicable regional or national standards used as basis):

Alternatively, we suggest that the SR MDDP 100-yr. flows are the most recently approved drainage study for this reach of Sand Creek and thus, meet current overtopping criteria of 12” max. for Arroya Lane. (Max. depth = 0.83’)

However, the deviation being requested is for the Sand Creek DBPS and FEMA flows having an overtopping depth that exceed the current criteria of 12” for this type of roadway.

More specifically: SC DBPS 100-yr. flow of 2170 cfs will have a max. depth at the low-point in Arroya Lane. of 1.70’
FEMA 100-yr. flow of 2600 cfs will have a max. depth at the low-point in Arroya Lane of 2.09’

The previous culvert design proposed in 2019 planned a triple cell (6’x12’). However, that design was proposed prior to the above mentioned adjacent property owner unwillingness to provide required easements for construction and no evidence of any embankment erosion or current roadway condition overtopping. Also, the recent draft of the Colorado Water Conservation Board (CWCB) presented floodplain values in this portion of Sand Creek much lower than those contained in the previous Sand Creek DBPS and FEMA 100-yr. flows. Thus, the two-cell culvert design proposed seems to be the appropriate alternative.

LIMITS OF CONSIDERATION

(At least one of the conditions listed below must be met for this deviation request to be considered.)

- The DCM standard is inapplicable to the particular situation.
- Topography, right-of-way, or other geographical conditions or impediments impose an undue hardship and an equivalent alternative that can accomplish the same design objective is available and does not compromise public safety or accessibility.
- A change to a standard is required to address a specific design or construction problem, and if not modified, the standard will impose an undue hardship on the applicant with little or no material benefit to the public.

Provide justification:

In this specific situation, the natural topography adjacent to the Sand Creek channel along with the geographic location of the adjacent properties private driveway make the required Arroya roadway and drainage improvements undue hardships without the ability of gaining off-site easements from the adjacent property owner.

As mentioned previously, the previous culvert design proposed in 2019 planned a triple cell (6’x12’). However, with the draft CWCB floodplain values showing the previous Sand Creek DBPS and FEMA 100-yr. flows being excessive, hydrologically the two-cell culvert design is the appropriate alternative. This design would also involve less maintenance costs. Also, the SR MDDP 100-yr. flows of 1468 cfs are the most recently approved drainage study for this reach of Sand Creek and do indeed meet current overtopping criteria.

CRITERIA FOR APPROVAL

Per ECM section 5.8.7 the request for a deviation may be considered if the request is **not based exclusively on financial considerations**. The deviation must not be detrimental to public safety or surrounding property. The applicant must include supporting information demonstrating compliance with **all of the following criteria**:

The deviation will achieve the intended result with a comparable or superior design and quality of improvement.

This deviation is not based on financial considerations as we were prepared to construct a larger culvert design but could not acquire the off-site easements. We even offered \$ for these easements but the adjacent owner would not even put a value on the easements.

The proposed deviation, with additional warning signage and buried rip-rap embankment protection for this roadway overtopping will result in a comparable design for the roadway.

The deviation will not adversely affect safety or operations.

With the additional warning signage and buried rip-rap embankment protection proposed, this deviation will not affect safety or operations. Also, the draft CWCB floodplain values show the previous Sand Creek DBPS and FEMA 100-yr. flows being excessive.

The deviation will not adversely affect maintenance and its associated cost.

The proposed two-cell culvert will have less maintenance costs versus the previously planned triple cell design. Also, other than the two additional signs and buried rip-rap protection, the roadway design remains the same.

The deviation will not adversely affect aesthetic appearance.

The proposed two-cell culvert design will aesthetically appear smaller to the adjacent and surrounding properties than the previous triple-cell design. The roadway design visually remains the same and does not affect the aesthetic appearance.

The deviation meets the design intent and purpose of the DCM standards.

This deviation seems to meet the design intent and purpose of the DCM as we are proposing to use slightly higher overtopping depth for a short stretch of roadway.

Also, as mentioned earlier, the SR MDDP 100-yr. flows of 1468 cfs are the most recently approved drainage study for this reach of Sand Creek and do indeed meet current overtopping criteria of 12" max. with a ponding depth of 0.83'.

The deviation meets the control measure requirements of Part I.E.3 and Part I.E.4 of the County's MS4 permit, as applicable.

This deviation has no affect on the County's MS4 permit as the collected runoff from this stretch of roadway will still be routed directly into a proposed SWQ facility.

REVIEW AND RECOMMENDATION:

Approved by the ECM Administrator

This request has been determined to have met the criteria for approval. A deviation from Section _____ of the ECM is hereby granted based on the justification provided.

Γ

Γ

L

J

Denied by the ECM Administrator

This request has been determined not to have met criteria for approval. A deviation from Section _____ of the ECM is hereby denied.

Γ

Γ

L

J

ECM ADMINISTRATOR COMMENTS/CONDITIONS:

1.1. PURPOSE

The purpose of this resource is to provide a form for documenting the findings and decision by the ECM Administrator concerning a deviation request. The form is used to document the review and decision concerning a requested deviation. The request and decision concerning each deviation from a specific section of the ECM shall be recorded on a separate form.

1.2. BACKGROUND

A deviation is a critical aspect of the review process and needs to be documented to ensure that the deviations granted are applied to a specific development application in conformance with the criteria for approval and that the action is documented as such requests can point to potential needed revisions to the ECM.

1.3. APPLICABLE STATUTES AND REGULATIONS

Section 5.8 of the ECM establishes a mechanism whereby an engineering design standard can be modified when if strictly adhered to, would cause unnecessary hardship or unsafe design because of topographical or other conditions particular to the site, and that a departure may be made without destroying the intent of such provision.

1.4. APPLICABILITY

All provisions of the ECM are subject to deviation by the ECM Administrator provided that one of the following conditions is met:

- The ECM standard is inapplicable to a particular situation.
- Topography, right-of-way, or other geographical conditions or impediments impose an undue hardship on the applicant, and an equivalent alternative that can accomplish the same design objective is available and does not compromise public safety or accessibility.
- A change to a standard is required to address a specific design or construction problem, and if not modified, the standard will impose an undue hardship on the applicant with little or no material benefit to the public.

1.5. TECHNICAL GUIDANCE

The review shall ensure all criteria for approval are adequately considered and that justification for the deviation is properly documented.

1.6. LIMITS OF APPROVAL

Whether a request for deviation is approved as proposed or with conditions, the approval is for project-specific use and shall not constitute a precedent or general deviation from these Standards.

1.7. REVIEW FEES

A Deviation Review Fee shall be paid in full at the time of submission of a request for deviation. The fee for Deviation Review shall be as determined by resolution of the BoCC.

ARROYA LANE CULVERT CALCULATIONS

HY-8 Culvert Analysis Report

Crossing Discharge Data

Discharge Selection Method: User Defined

Table 1 - Summary of Culvert Flows at Crossing: Arroya Lane

Headwater Elevation (ft)	Discharge Names	Total Discharge (cfs)	Box Culverts Discharge (cfs)	Roadway Discharge (cfs)	Iterations
7235.87	SR MDDP 10 yr.	581.00	581.00	0.00	1
7236.11	DBPS 10 yr.	630.00	630.00	0.00	1
7239.67	SR MDDP 100 yr.	1468.00	1300.34	167.37	8
7240.54	SC DBPS 100 yr.	2170.00	1438.87	730.27	3
7240.93	FEMA	2600.00	1496.86	1102.71	4
7238.84	Overtopping	1159.20	1159.20	0.00	Overtopping

Culvert Data: Box Culverts

Site Data - Box Culverts

Site Data Option: Culvert Invert Data

Inlet Station: 100.00 ft

Inlet Elevation: 7231.50 ft

Outlet Station: 165.00 ft

Outlet Elevation: 7230.70 ft

Number of Barrels: 2

Culvert Data Summary - Box Culverts

Barrel Shape: Concrete Box

Barrel Span: 12.00 ft

Barrel Rise: 6.00 ft

Barrel Material: Concrete

Embedment: 0.00 in

Barrel Manning's n: 0.0130

Culvert Type: Straight

Inlet Configuration: Square Edge (0° flare) Wingwall (Ke=0.7)

Inlet Depression: None

Roadway Data for Crossing: Arroya Lane

Roadway Profile Shape: Irregular Roadway Shape (coordinates)

Irregular Roadway Cross-Section

Coord No.	Station (ft)	Elevation (ft)
0	1000.00	7240.44
1	1025.00	7239.69
2	1050.00	7239.17
3	1075.00	7238.89
4	1091.73	7238.84
5	1100.00	7238.85
6	1125.00	7239.05
7	1150.00	7239.49
8	1175.00	7240.16
9	1200.00	7241.07

Roadway Surface: Paved

Roadway Top Width: 45.00 ft

HY-8 Culvert Analysis Report

Rating Curve Plot for Crossing: Arroya Lane

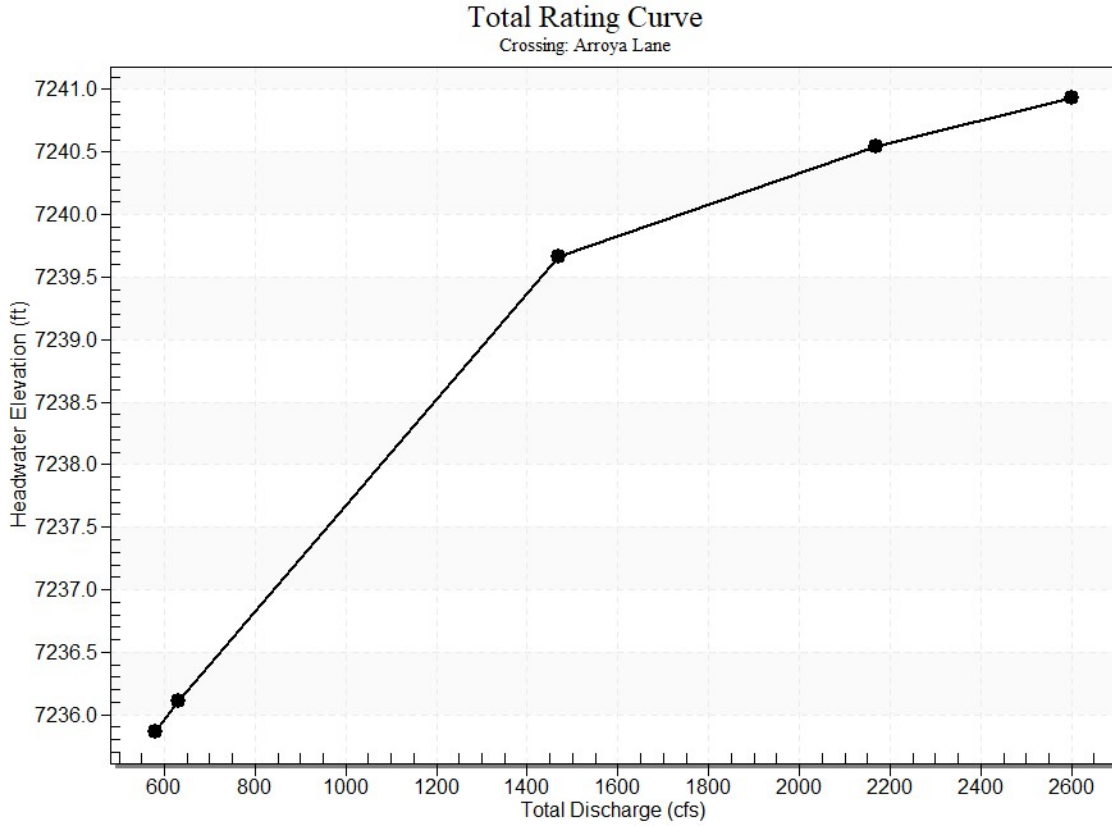

Crossing - Arroya Lane, Design Discharge - 1468.0 cfs (SR MDDP 100 YR.)

Culvert - Box Culverts, Culvert Discharge - 1300.4 cfs

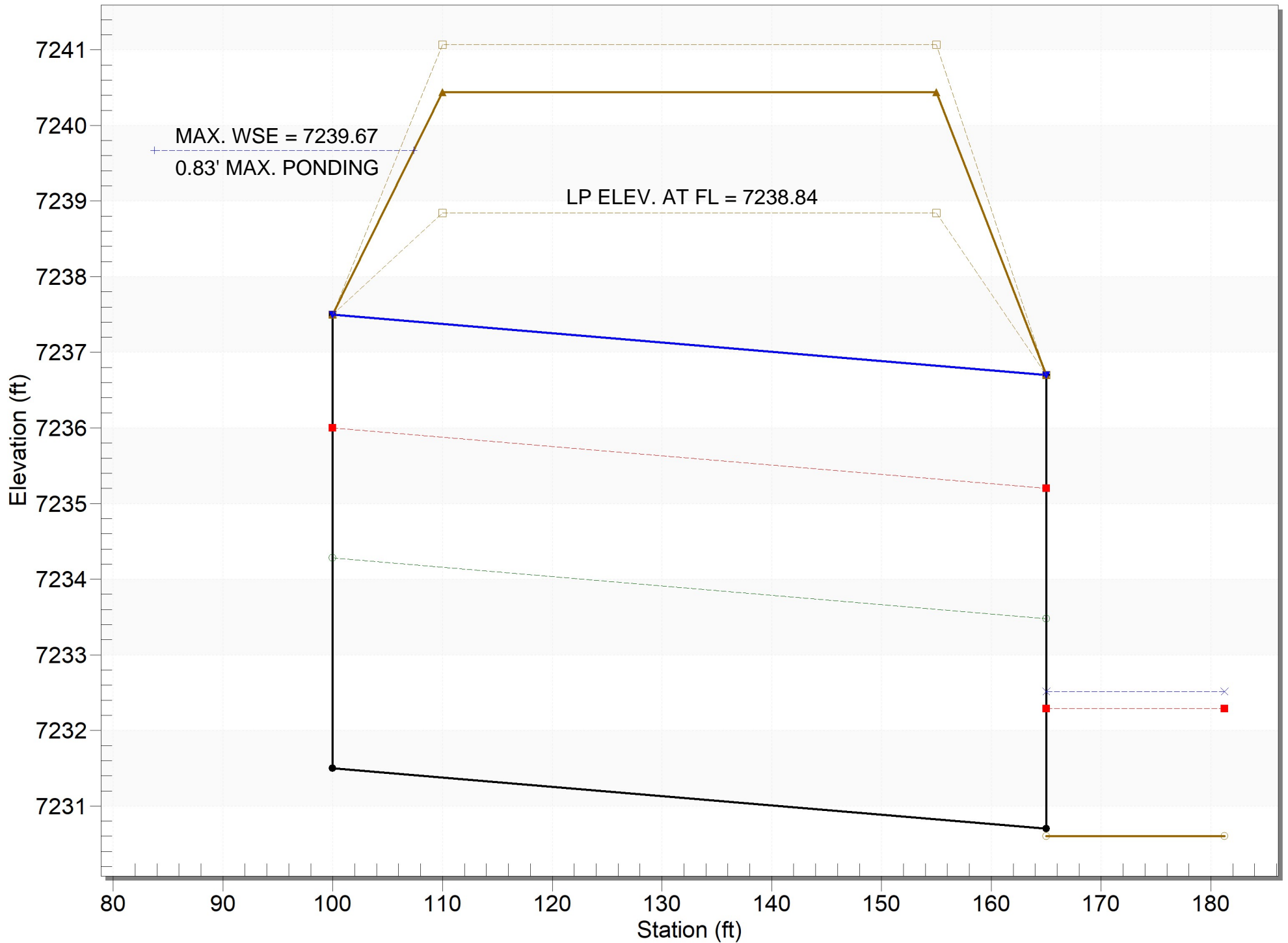

Crossing - Arroya Lane, Design Discharge - 2170.0 cfs (SC DBPS 100 YR.)

Culvert - Box Culverts, Culvert Discharge - 1438.9 cfs

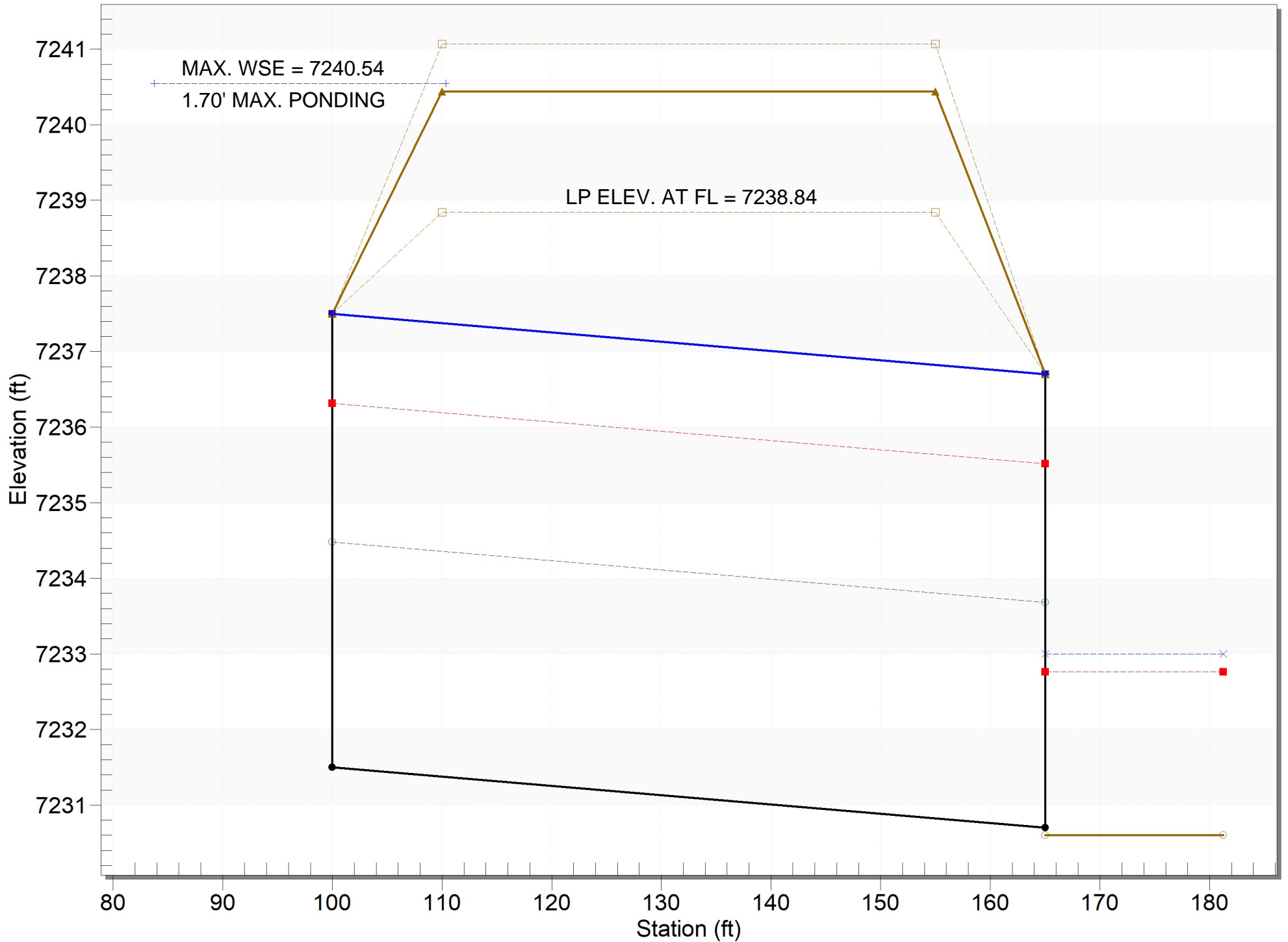

Crossing - Arroya Lane, Design Discharge - 2600.0 cfs (FEMA 100 YR.)

Culvert - Box Culverts, Culvert Discharge - 1496.8 cfs

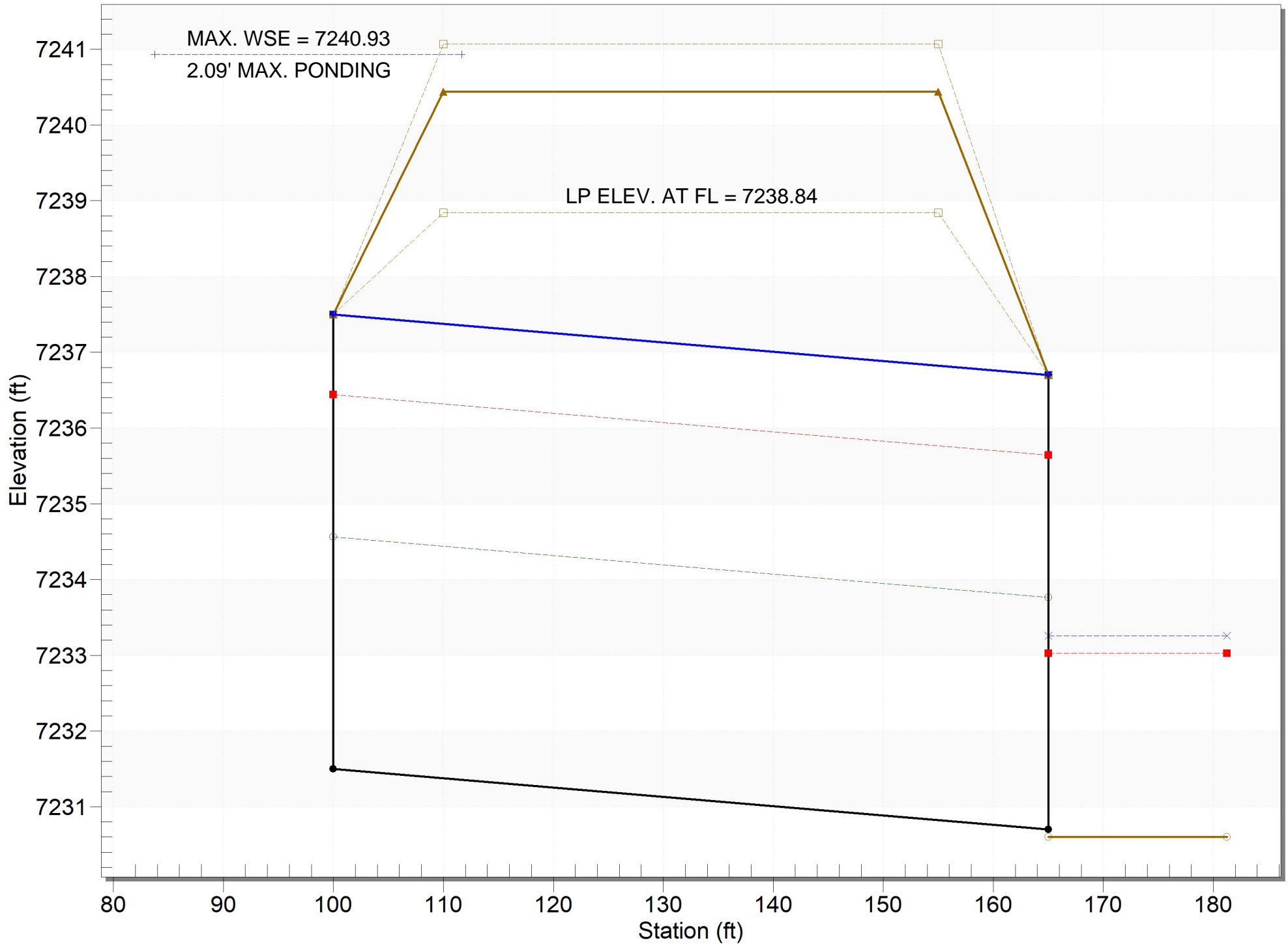

ARROYA LANE OVERTOPPING PROTECTION CALCULATIONS

Figure 13-12c. Emergency Spillway Protection

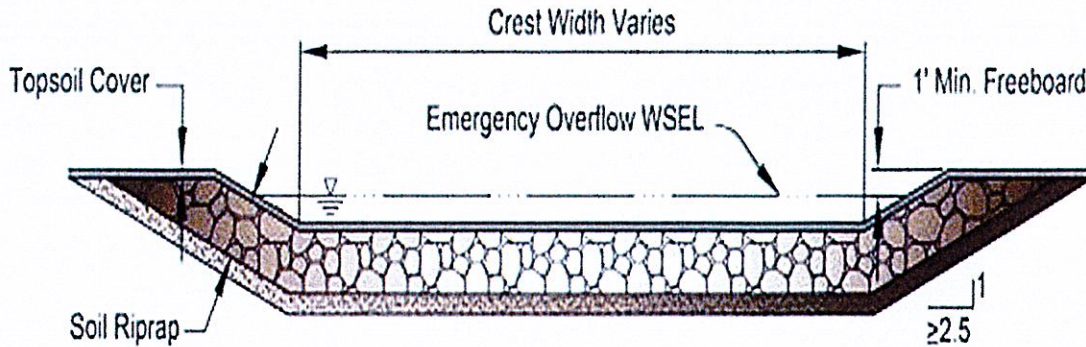
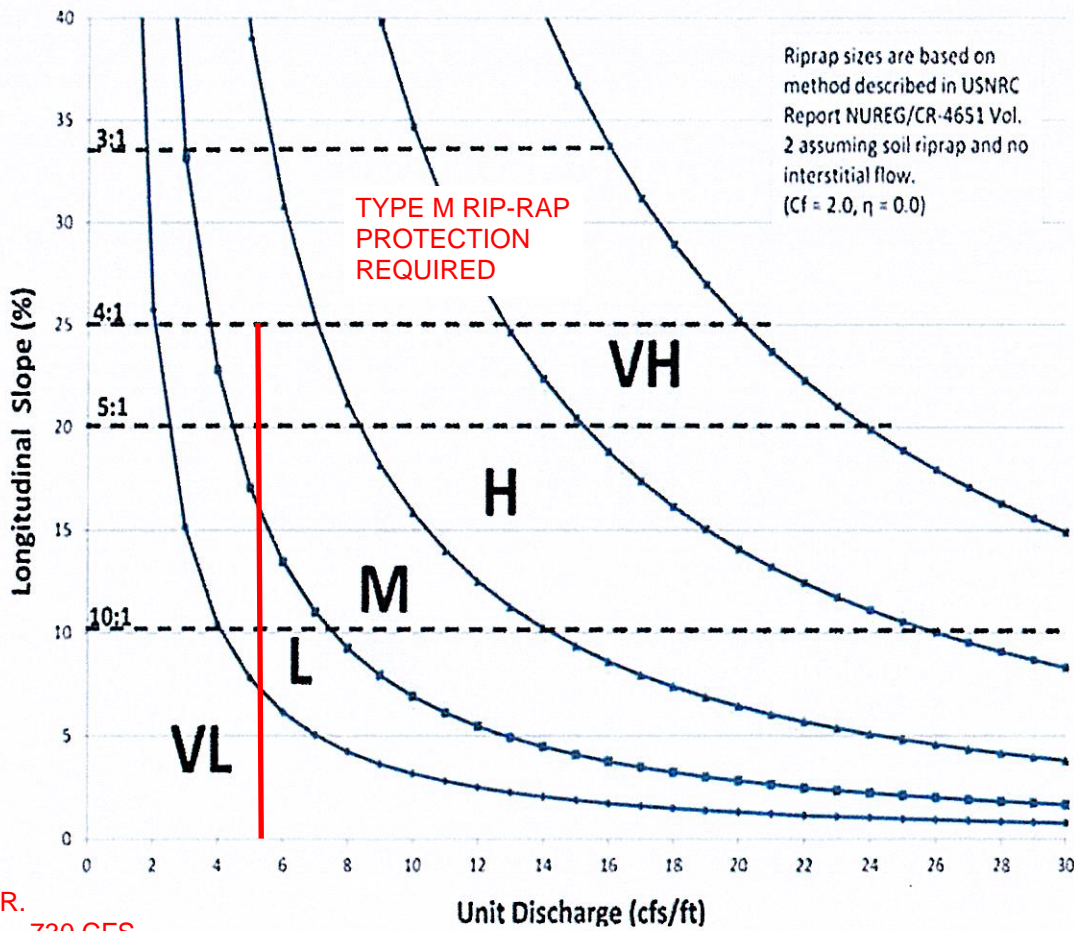

Figure 13-12d. Riprap Types for Emergency Spillway Protection



SC DBPS 100-YR.
OVERTOPPING = 730 CFS

FEMA 100-YR.
OVERTOPPING = 1,103 CFS

ROADWAY DISCHARGE
WIDTH = 200'

ROADWAY UNIT DISCHARGE
MAX. = 5.5 CFS/FT.

DETERMINATION OF CULVERT HEADWATER AND OUTLET PROTECTION

MHFD-Culvert, Version 4.00 (May 2020)

Project: RETREAT AT TIMBERRIDGE FILING NO. 3

ID: DUAL 6'X12' CBC'S

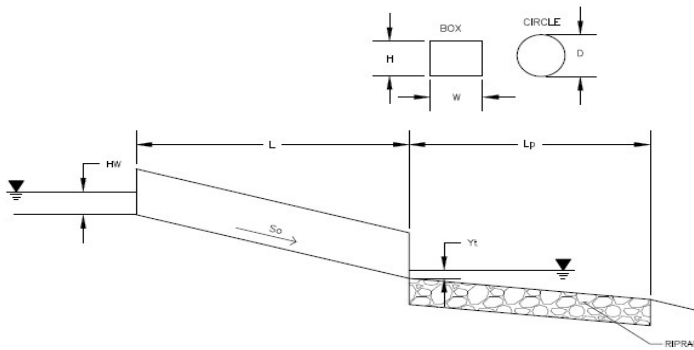

Soil Type:

Choose One:

- Sandy
 Non-Sandy

Supercritical Flow! Using Adjusted Rise to calculate protection type.

Design Information:	
Design Discharge	Q = <input style="width: 100px;" type="text" value="1486"/> cfs
Circular Culvert:	
Barrel Diameter in Inches	D = <input style="width: 100px;" type="text"/>
Inlet Edge Type (Choose from pull-down list)	
OR:	
Box Culvert:	
Barrel Height (Rise) in Feet	H (Rise) = <input style="width: 100px;" type="text" value="6"/> ft
Barrel Width (Span) in Feet	W (Span) = <input style="width: 100px;" type="text" value="12"/> ft
Inlet Edge Type (Choose from pull-down list)	Square Edge w/ 90 deg. Headwall & 15 deg. Flared Wingwall
Number of Barrels	# Barrels = <input style="width: 100px;" type="text" value="2"/>
Inlet Elevation	Elev IN = <input style="width: 100px;" type="text" value="7231.5"/> ft
Outlet Elevation OR Slope	Elev OUT = <input style="width: 100px;" type="text" value="7230.7"/> ft
Culvert Length	L = <input style="width: 100px;" type="text" value="65"/> ft
Manning's Roughness	n = <input style="width: 100px;" type="text" value="0.013"/>
Bend Loss Coefficient	k _b = <input style="width: 100px;" type="text" value="0"/>
Exit Loss Coefficient	k _x = <input style="width: 100px;" type="text" value="1"/>
Tailwater Surface Elevation	Y _t Elevation = <input style="width: 100px;" type="text"/>
Max Allowable Channel Velocity	V = <input style="width: 100px;" type="text" value="5"/> ft/s
Calculated Results:	
Culvert Cross Sectional Area Available	A = <input style="width: 100px;" type="text" value="72.00"/> ft ²
Culvert Normal Depth	Y _n = <input style="width: 100px;" type="text" value="3.05"/> ft
Culvert Critical Depth	Y _c = <input style="width: 100px;" type="text" value="4.92"/> ft
Froude Number	Fr = <input style="width: 100px;" type="text" value="2.05"/> Supercritical!
Entrance Loss Coefficient	k _e = <input style="width: 100px;" type="text" value="0.20"/>
Friction Loss Coefficient	k _f = <input style="width: 100px;" type="text" value="0.13"/>
Sum of All Loss Coefficients	k _s = <input style="width: 100px;" type="text" value="1.33"/> ft
Headwater:	
Inlet Control Headwater	HW _I = <input style="width: 100px;" type="text" value="8.92"/> ft
Outlet Control Headwater	HW _O = <input style="width: 100px;" type="text" value="6.85"/> ft
Design Headwater Elevation	HW = <input style="width: 100px;" type="text" value="7240.42"/> ft
Headwater/Diameter OR Headwater/Rise Ratio	HW/H = <input style="width: 100px;" type="text" value="1.49"/>
Outlet Protection:	
Flow/(Span * Rise ^{1.5})	Q/WH ^{1.5} = <input style="width: 100px;" type="text" value="4.21"/> ft ^{0.5} /s
Tailwater Surface Height	Y _t = <input style="width: 100px;" type="text" value="2.40"/> ft
Tailwater/Rise	Y _t /H = <input style="width: 100px;" type="text" value="0.40"/>
Expansion Factor	1/(2*tan(Θ)) = <input style="width: 100px;" type="text" value="2.12"/>
Flow Area at Max Channel Velocity	A _t = <input style="width: 100px;" type="text" value="297.20"/> ft ²
Width of Equivalent Conduit for Multiple Barrels	W _{eq} = <input style="width: 100px;" type="text" value="24.00"/> ft
Length of Riprap Protection	L_p = <input style="width: 100px;" type="text" value="60"/> ft
Width of Riprap Protection at Downstream End	T = <input style="width: 100px;" type="text" value="53"/> ft
Adjusted Rise for Supercritical Flow	
Minimum Theoretical Riprap Size	Ha = <input style="width: 100px;" type="text" value="4.52"/> ft
Nominal Riprap Size	d ₅₀ min = <input style="width: 100px;" type="text" value="9"/> in
MHFD Riprap Type	d ₅₀ nominal = <input style="width: 100px;" type="text" value="12"/> in
	Type = <input style="width: 100px;" type="text" value="M"/>

CURVE	LENGTH	RADIUS	DELTA
C1	62.81'	40.00'	89°58'07"
C2	62.85'	40.00'	90°01'53"
C3	47.12'	30.00'	89°59'37"
C4	46.59'	30.00'	89°59'54"
C5	47.13'	30.00'	90°01'05"
C6	47.11'	30.00'	89°58'55"

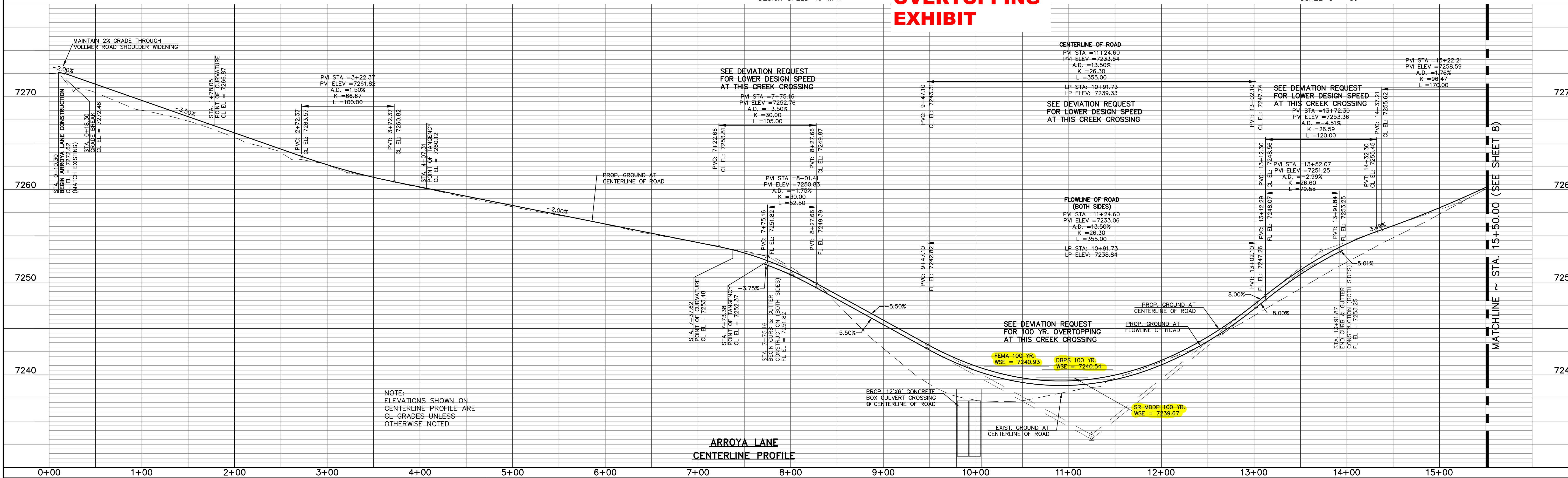
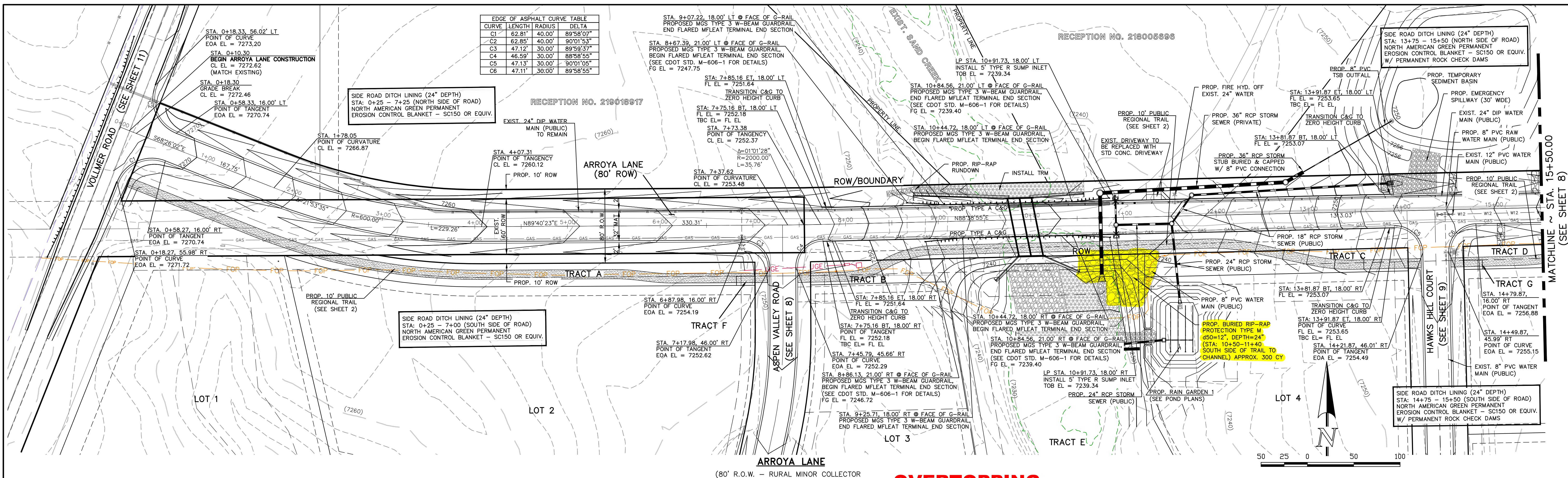

48 HOURS BEFORE YOU DIG,
CALL UTILITY LOCATORS
811
UTILITY NOTIFICATION CENTER OF COLORADO
IT'S THE LAW

THE LOCATIONS OF EXISTING UNDERGROUND UTILITIES ARE SHOWN IN AN APPROXIMATE WAY ONLY. THE CONTRACTOR SHALL DETERMINE THE EXACT LOCATION OF ALL EXISTING UTILITIES BEFORE COMMENCING WORK. THE CONTRACTOR SHALL BE FULLY RESPONSIBLE FOR ANY AND ALL DAMAGES WHICH MIGHT BE CAUSED BY HIS FAILURE TO EXACTLY LOCATE AND PRESERVE ANY AND ALL UNDERGROUND UTILITIES.

NO.	REVISION	DATE
1	REVISED PER EPC COMMENTS	3-07-23
2	REVISED PER COUNTY PARKS COMMENTS	12-6-23
3	REVISED ROAD GRADE PER CULVERT REVISION	1-30-24
4	REVISED PER COUNTY COMMENTS	3-14-24
5	REVISED PER COUNTY COMMENTS	4-18-24

REVIEW:
PREPARED UNDER MY DIRECT SUPERVISION FOR AND ON BEHALF OF CLASSIC CONSULTING AND SURVEYORS, LLC

MARC A. WHORTON
REGISTERED PROFESSIONAL ENGINEER
#37155

5/15/2024
DATE



RETREAT AT TIMBERIDGE FILING NO. 3
CONSTRUCTION PLANS
STREET IMPROVEMENT PLANS
ARROYA LANE

DESIGNED BY: PRA SCALE: DATE: 11-22-2022
DRAWN BY: PRA (H) 1" = 50' SHEET 7 OF 27
CHECKED BY: (V) 1" = 5' JOB NO. 1185.30

V:\118530\UPDRAWINGS\CONSTRUCT\DRAW07-118530-9-01.dwg, 5/15/2024, 2:01:47 PM, 1:1