



ENTECH
ENGINEERING, INC.

505 ELKTON DRIVE
COLORADO SPRINGS, CO 80907
PHONE (719) 531-5599

**SOILS AND GEOLOGY STUDY
FLYING HORSE NORTH, FILING NO. 5
EL PASO COUNTY, COLORADO**

Prepared for:

Flying Horse North, LLC
2138 Flying Horse Club Drive
Colorado Springs, Colorado 80921

Attn: Drew Balsick

October 2, 2024

Respectfully Submitted,

ENTECH ENGINEERING, INC.

Logan L. Langford, P.G.
Sr. Geologist

Reviewed by:



Joseph C. Goode Jr., P.E.
President

LLL

PCD No.

Table of Contents

1 SUMMARY..... 1

2 GENERAL SITE CONDITIONS AND PROJECT DESCRIPTION 2

3 SCOPE OF THE REPORT 2

4 FIELD INVESTIGATION 2

5 SOIL, GEOLOGY, AND ENGINEERING GEOLOGY..... 3

 5.1 General Geology 3

 5.2 Soil Conservation Survey 4

 5.3 Site Stratigraphy 4

 5.4 Soil Conditions 5

 5.5 Groundwater 6

6 ENGINEERING GEOLOGY – IDENTIFICATION AND MITIGATION OF GEOLOGIC HAZARDS..... 6

 6.1 Relevance of Geologic Conditions to Land Use Planning 10

7 ECONOMIC MINERAL RESOURCES 11

8 EROSION CONTROL 12

9 ROADWAY AND EMBANKMENT CONSTRUCTION RECOMMENDATIONS..... 13

10 CLOSURE..... 14

11 REFERENCES..... 15

FIGURES

- Figure 1: Vicinity Map
- Figure 2: USGS Map
- Figure 3: Development Plan/Test Boring Location Map
- Figure 4: Soil Survey Map
- Figure 5: Black Forest Quadrangle Geology Map
- Figure 6: Geology Map/Engineering Geology
- Figure 7: Floodplain Map
- Figure 8: Typical Perimeter Drain Details
- Figure 9: Underslab Drainage Layer (Capillary Break)
- Figure 10: Interceptor Drain Detail
- Figure 11: Overexcavation Drain

- APPENDIX A: Site Photographs
- APPENDIX B: Test Boring and Test Pit Logs
- APPENDIX C: Laboratory Test Results
- APPENDIX D: EEI Laboratory Testing Summary and Test Boring Logs Job No. 220404
- APPENDIX E: Soil Survey Descriptions

1 SUMMARY

Project Location

The site consists of portions of the NW¼ of Section 31, Township 11 South, Range 65 West of the 6th Principal Meridian in El Paso County, Colorado. The site is located approximately 3½ miles northeast of Colorado Springs, Colorado.

Project Description

Flying Horse North Filing No. 5 Subdivision is approximately 110 acres with twenty-one (21) lots and other associated site improvements proposed for the filing. The proposed development is to consist of approximately 2.5 to 5-acre single-family residential lots. The development will be serviced by individual water wells and on-site wastewater systems (OWTS).

Scope of Report

This report presents the results of our geologic evaluation and treatment of engineering geologic hazard study.

Land Use and Engineering Geology

This site was found to be suitable for the proposed development. Areas were encountered where the geologic conditions will impose some minor constraints on development and land use. These include areas of seasonal and potentially seasonal shallow groundwater areas, artificial fill, expansive soils, and potential for elevated radon levels. Based on the proposed development plan, it appears that these areas will have some impact on the development. These conditions will be discussed in greater detail in the report.

It is our opinion that the development can be achieved if the observed geologic conditions on site are either avoided or properly mitigated. All recommendations are subject to the limitations discussed in the report.

2 GENERAL SITE CONDITIONS AND PROJECT DESCRIPTION

The site consists of portions of the NW¼ of Section 31, Township 11 South, Range 65 West of the 6th Principal Meridian in El Paso County, Colorado. The site is located approximately 3½ miles northeast of Colorado Springs, Colorado, at the Stagecoach Road and west of Flying Horse North Country Club. The location of the site is as shown on the Vicinity Map, Figure 1.

The topography of the site varies from gently to moderately sloping generally to the east and north with some steeper slopes along the drainages in portions of the site. Palmer Divide is located to the west of Filing No. 5. The drainages on site generally flow in a northerly direction through the site. Water was not observed in any of the drainages within Filing No. 5 at the time of our site investigation. The existing retention pond is located along the northwest side of Filing No. 5. The site contains primarily field grasses and weeds in with areas of scattered ponderosa pine trees in the northern portion of the site along Old Stagecoach Road. Site photographs are included in Appendix A. The locations and directions of the photographs are indicated in Figure 3.

Flying Horse North Filing No. 5 Subdivision is approximately 110 acres with twenty-one (21) lots proposed for the filing and other associated site improvements. The proposed development is to consist of approximately 2.5 to 5-acre single-family residential lots. Grading is expected to be primarily associated with the construction of roads. The Site and Exploration Plan is presented in Figure 3.

3 SCOPE OF THE REPORT

The scope of the report will include a general geologic analysis utilizing published geologic data. Detailed site-specific mapping will be conducted to obtain general information in respect to major geographic and geologic features, geologic descriptions and their effects on the development of the property.

4 FIELD INVESTIGATION

Our field investigation consisted of the preparation of a geologic map of any bedrock features and significant surficial deposits. The Natural Resource Conservation Service (NRCS), previously the Soil Conservation Service (SCS) survey was also reviewed to evaluate the site. The position of mappable units within the subject property are shown on the Geologic Map. Our mapping procedures involved both field reconnaissance and measurements and air photo reconnaissance and interpretation. The same mapping procedures have also been utilized to produce the

Engineering Geology Map which identified pertinent geologic conditions affecting development. The field mapping was initially performed by personnel of Entech Engineering, Inc. (Entech) on November 21 and December 2, 2014. Field mapping was updated by Entech on October 31 and November 3, 2017 (References 1 and 2). The previously completed Sketch Plan for Flying Horse North and Flying Horse North Filing No. 4 were also used in the preparation of this report (References 3 and 4). The site was revisited and additional mapping completed in September of 2024. Recent site photographs are included in Appendix A.

Five (5) test borings were drilled and four (4) test pits excavated across the site as part of this study to determine the soils classification and engineering characteristics. The borings were drilled to depths of 20 feet using a truck-mounted, continuous flight auger drilling rig supplied and operated by Entech, and the test pits were excavated to depths ranging from 4.5 to 8 feet.

Four (4) test borings (TB-18, TB-20, TB-22, and TB-25) from previous Flying Horse North investigations were used in the in preparing this report (Reference 3). The location of the previous Test Borings indicated on the Site and Exploration Plan, Figure 3.

Laboratory testing was performed on some of the soils to classify and determine the soils engineering characteristics. Laboratory tests included moisture content testing, ASTM D-2216, tests included grain-size analysis ASTM D-422, Atterberg Limits ASTM D-4318, volume change testing using Swell/Consolidation test. Sulfate testing was performed on select samples to evaluate potential for below grade concrete degradation due to sulfate attack. Results of the laboratory testing are included in Appendix C. A Summary of Laboratory Test Results is presented in Table C-1. Previous Laboratory Testing Summary and Test Boring are included in Appendix D.

5 SOIL, GEOLOGY, AND ENGINEERING GEOLOGY

5.1 General Geology

Physiographically, the site lies in the western portion of the Great Plains Physiographic Province. Approximately 10 miles to the west is a major structural feature known as the Rampart Range Fault. This fault marks the boundary between the Great Plains Physiographic Province and the Southern Rocky Mountain Province. The site exists within the southeastern edge of a large structural feature known as the Denver Basin. Bedrock in the area tends to be very gently dipping in a northerly direction (Reference 5). The rocks in the area of the site are sedimentary in nature, and typically Tertiary to Cretaceous in age. The bedrock underlying the site consists of the

Dawson Arkose Formation. Overlying this formation are unconsolidated deposits of residual, colluvial, man-made, and alluvial soils of the Quaternary Age. The residual soils are produced by the in-situ action of weathering of the bedrock on site. Some colluvial soils exist which are deposited by gravity and sheetwash. The alluvial soils were deposited by water in the drainages on site. Man-made soils exist as earthen dams and erosion berms. The site's stratigraphy will be discussed in more detail in Section 5.3.

5.2 Soil Conservation Survey

The Natural Resource Conservation Service (Reference 6), previously the Soil Conservation Service (Reference 7) has mapped one soil type within Filing No. 5 (Figure 4). In general, the soils classify as sandy loam and sandy clay loam. The soils are described as follows:

Type	Description
68	Peyton-Pring complex, 3 to 8% slopes

Complete description of the soil type is presented in Appendix E. The soils have generally been described to have moderate to rapid permeabilities. Limitations on development include limited ability to support a load, shrink swell potential, slopes and frost action potential. Possible hazards with soil erosion are present on the site. The erosion potential can be controlled with vegetation. The majority of the soils have been described to have moderate erosion hazards.

5.3 Site Stratigraphy

The Black Forest Quadrangle Geology Map showing the site is presented in Figure 5 (Reference 8). The Geology Map prepared for the site is presented in Figure 6. Three mappable units were identified on this site which are described as follows:

Qaf Artificial Fill of Holocene Age: These are man placed fill deposits associated with erosion berms, earthen dams on-site, and stockpiles of fill. Additionally, temporary stockpiles were observed on the site. Other areas of fill may exist on the site other than those mapped due to on-going construction.

Qal Recent Alluvium of Quaternary Age: These are recent stream deposits associated with the drainages on-site. These materials generally consist of silty to clayey sands and may contain clay lenses. Highly organic soils may be encountered in some of these areas.

Tkd Dawson Formation of Tertiary to Cretaceous Age: The Dawson formation typically consists of arkosic sandstone with interbedded fine-grained sandstone, siltstone and claystone. Overlying this formation is a variable layer of residual soil. The residual soils were derived from the in-situ weathering of the bedrock materials on-site. These soils consisted of silty to clayey sands and sandy clays. Areas of colluvial soils may exist on some of the slopes on site. These materials are derived from the bedrock materials and have been re-deposited by the action of sheetwash and gravity.

The bedrock underlying the site consists of the Dawson Formation of Tertiary to Cretaceous Age. The Dawson Formation typically consists of arkosic sandstone with interbedded fine-grained sandstone, siltstone and claystone. Overlying this formation are variable layers of man placed fill deposits, alluvial deposits, and residual soil. The residual soils were derived from the in-situ weathering of the bedrock materials on-site. These soils consisted of silty to clayey sands and sandy clays.

The soils listed above were mapped from site-specific mapping, the *Geologic Map of the Black Forest Quadrangle* distributed by the Colorado Geological Survey in 2003 (References 8), the *Geologic Map of the Colorado Springs-Castle Rock Area*, distributed by the US Geological Survey in 1979 (Reference 9), and the *Geologic Map of the Denver 1⁰ x 2⁰ Quadrangle*, distributed by the US Geological Survey in 1981 (Reference 10). The Test Borings and Test Pit Logs used in evaluating the site and are included in Appendix B. The Geology Map prepared for the site is presented in Figure 6.

5.4 Soil Conditions

The soils encountered in the Test Borings can be grouped into four general soil and rock types. The soils were classified using the Unified Soil Classification System (USCS).

Soil Type 1 classified as clayey sand fill (SC). The sand fill was encountered in TB-1 at the surface and extended to approximately 5 feet bgs. The sand was encountered at medium dense states and moist conditions.

Soil Type 2 classified as silty sand, sand with silt, and clayey sand (SW-SM, SW, SC). The sand was encountered in all of the test borings at depths ranging from the ground surface to 6 feet bgs and extending to depths ranging from 7 to 20 feet bgs. The sand was encountered at medium dense to dense states and moist conditions.

Soil Type 3 classified as slightly sandy clay (CL) The clay was encountered in TB-5 at the existing surface extending to approximately 6 feet bgs. The clay was encountered at very stiff consistencies and moist conditions.

Soil Type 4 classified as silty sandstone (SM), or as a silty sand when classified as a soil. The claystone was encountered in TB-4 at 18 feet bgs, and extended to the termination of the test boring (20 feet). The claystone was encountered at hard consistencies. The claystone is typically expansive.

The Test Boring Logs are presented in Appendix B, and the depth to bedrock and groundwater are presented on Table B-1. Laboratory Test Results are presented in Appendix C, and a Summary of Laboratory Test Results is presented in Table C-1.

5.5 Groundwater

Groundwater was not encountered in any of the test borings within Filing No. 5 which were drilled to 20 feet. Areas potentially seasonal shallow groundwater have been mapped in the drainages and low-lying areas on the site. These areas are discussed in the following section. Fluctuation in groundwater conditions may occur due to variations in rainfall and other factors not readily apparent at this time. It should be noted that in the sandy materials on-site, some groundwater conditions might be encountered due to the variability in the soil profile. Isolated sand and gravel layers within the soils, sometimes only a few feet in thickness and width, can carry water in the subsurface. Groundwater may also flow on top of the underlying bedrock. Builders and planners should be cognizant of the potential for the occurrence of such subsurface water features during construction on-site and deal with each individual problem as necessary at the time of construction.

6 ENGINEERING GEOLOGY – IDENTIFICATION AND MITIGATION OF GEOLOGIC HAZARDS

Detailed mapping has been performed on this site to produce an Engineering Geology Map Figure 6. This map shows the location of various geologic conditions of which the developers should be cognizant during the planning, design and construction stages of the project. These hazards and the recommended mitigation techniques are as follows:

Artificial Fill – Constraint

These are areas of man-placed fill associated with minor fill piles in the future road areas, and erosion berms on the site.

Mitigation: The fill piles in the areas of future roadways and erosion berms will be mitigated with the proposed roadway site grading. The erosion berms can either be avoided or removed from building areas on each. The fill on this site is considered uncontrolled for construction purposes. Any uncontrolled fill encountered beneath foundations or drainage structures will require removal and recompaction at a minimum of 95% of its maximum Modified Proctor Dry Density, ASTM D-1557.

Areas of Erosion – Constraint

These are areas that are undergoing erosion by water and sheetwash producing gullies and rill erosion and primarily located along portions of the drainages in the southeastern and northern portions of the site.

Mitigation: Due to the nature of the soils on this site, virtually all the soils are subject to erosion by wind and water. Other minor areas of erosion were observed on site other than those mapped, particularly where some rill erosion has occurred. Areas of erosion can occur across the entire site, particularly if the soils are disturbed during construction. Vegetation reduces the potential for erosion. The areas identified where erosion is actually taking place may require check dams, regrading and revegetation using channel lining mats to anchor vegetation. Further recommendations for erosion control are discussed under Section 9.0 "Erosion Control" of this report. Recommendations pertaining to revegetation may require input from a qualified landscape architect and/or the Natural Resource Conservation Service (previously Soil Conservation Service)

Expansive Soils – Constraint

The site is classified in an area of low to moderate swell potential according to *the Map of Potentially Swelling Soil and Rock in the Front Range Urban Corridor, Colorado* by Hart, 1974 (Reference 11). Potentially expansive soils were encountered in some of the test borings drilled on the site as a part of the entire Flying Horse North Subdivision (References 1 – 3). These occurrences are typically sporadic; therefore, none have been indicated on the maps. These clays or claystone, if encountered beneath foundations, can cause differential movement in the structure foundation. These occurrences should be identified and dealt with on an individual basis.

Mitigation Should expansive soils be encountered beneath the foundation; mitigation will be necessary. Mitigation of expansive soils will require special foundation design. Overexcavation and replacement with non-expansive soils at a minimum of 95% of its maximum Modified Proctor Dry Density, ASTM D-1557 is a suitable mitigation, which is common in the area. Another alternative in areas of highly expansive soils is the use of drilled pier foundation systems. Typical minimum pier depths are on the order of 25 feet or more and require penetration into the bedrock material a minimum of 4 to 6 feet, depending upon building loads. Floor slabs on expansive soils should be expected to experience movement. Overexcavation and replacement has been successful in minimizing slab movements. The use of structural floors should be considered for basement construction on highly expansive clays. Final recommendations should be determined after additional investigation of each building site.

Groundwater and Drainage Areas – Constraint

Drainages are located in the southeast and northern portions of Filing No. 4, and several minor drainages are located across the site that generally flow in northerly directions. None of the drainages on the site have been mapped within floodplain zones according to the FEMA Map No. 08041CO315G, (Figure 7, Reference 12). Areas where potentially seasonal shallow groundwater have been indicated on the site geology/engineering geology map, Figure 6. Lots adjacent to the drainages may experience higher groundwater levels during peak flows. Finished floor levels must be a minimum of one floor above any floodplain level. **Exact floodplain locations and drainage studies are beyond the scope of this report.**

Groundwater was not encountered in any of the test borings within Filing No. 5 which were drilled to 20 feet. Areas of potential seasonally shallow groundwater were observed on the site and are further discussed below. Buildings should maintain a minimum separation of 3 feet between the lowest foundation grade and the maximum anticipated groundwater level. Subsurface perimeter drains are recommended for structures with useable below grade space, and additional drains may be required in building areas close drainages to help prevent the intrusion of water into areas below grade. Shallow groundwater areas can be mitigated with the installation of drains. Typical drain options/details are presented in Figures 8 through 11. These areas are discussed as follows:

Potential Seasonally Shallow Groundwater – Constraint

In these areas, we would anticipate periodic high subsurface moisture conditions and frost heave potential on a seasonal basis. Additional, highly organic soils could be encountered in these areas. These areas lie within defined drainages and it is anticipated they will be avoided by development. Minor drainage swales in building areas should be properly diverted away from the

structures. Any structures in or adjacent to these areas should follow the mitigation discussed below.

Mitigation: In these locations, foundations subject to severe frost heave potential should penetrate sufficient depth so as to discourage the formation of ice lenses beneath foundations. At this location and elevation, foundation depth for frost protection is 30 inches. In areas where high subsurface moisture conditions are anticipated periodically, a subsurface perimeter drain will be necessary to help prevent the intrusion of water into areas located below grade. Subsurface perimeter drains may be necessary to prevent the intrusion of water into areas below grade. Typical drain details are presented in Figure 8. Where shallow groundwater is encountered, underslab drains or interceptor drains may be necessary Figures 9 and 10. Specific recommendations should be made after additional investigation has been completed and building locations have been identified on a lot by lot basis. Swales should be created to intercept surface runoff and carry it safely around and away from structures.

Landslide Hazard and Slope Stability – Hazard

The topography of the site varies from gently to moderately sloping generally to the east and north with some steeper slopes along the drainages in portions of the site. No signs of unstable or potentially unstable slopes were observed within Filing No. 5.

Shallow Bedrock – Constraint

Bedrock was encountered in ten of the test borings and one test pit located within Filing No. 5 at depths ranging from the 7 to 16 feet in the borings. A Summary of the Depth to Bedrock is included in Table B-1. Shallow bedrock will be encountered across the portions of the site. Where shallow bedrock is encountered, excavation/grading may be difficult requiring track-mounted excavators with ripper attachments. Bedrock will likely be encountered in cuts for utility excavations.

Radon – Hazard

Radon levels for the area have been reported by the Colorado Geologic Survey in the open file, Report No. 91-4 (Reference 14). Average Radon levels for the 80908-zip code is 3.40 pCi/l. The following is a table of radon levels in this area:

Average Radon Levels for the 80908 Zip Code	
0 < 4 pCi/L	50.00%
4 < 10 pCi/L	50.00%
10 < 20 pCi/L	0.00%
> 20 pCi/L	0.00%

Mitigation:

The potential for high radon levels is present for the site. Build-up of radon gas can usually be mitigated by providing increased ventilation of basement and crawlspace and sealing joints.

Specific requirements for mitigation should be based on site specific testing.

6.1 Relevance of Geologic Conditions to Land Use Planning

The development will be single-family rural residential utilizing individual water wells and OWTS. It is our opinion that the existing geologic and engineering geologic conditions will impose some constraints on the proposed development and construction. The most significant problems affecting development will be those associated with the drainages on site that can be avoided. Other hazards on site may be satisfactorily mitigated through proper engineering design and construction practices.

The upper residual soils are typically at medium to very dense states. The granular soils encountered in the upper soil profiles of the test borings should provide good support for foundations. Expansive soils were encountered on portions of the site that will require mitigation. Foundations anticipated for the site are standard spread footings possibly in conjunction with overexcavation in areas of expansive soils. Areas containing arkosic sandstone will have high allowable bearing conditions. Difficult excavation should be anticipated in areas of shallow bedrock. Expansive layers may also be encountered in the soil and bedrock on this site. Areas of expansive soils encountered on site are sporadic; therefore, none have been indicated on the maps. Expansive soils, if encountered, will require special foundation design and/or overexcavation. These soils will not prohibit development.

Areas potentially seasonal high groundwater areas were encountered on the site. Due to the size of the lots and the proposed development, these areas can be avoided by construction or properly mitigated. Absorption fields are not recommended in these areas. Structures should not block drainages. Drains may be necessary for structures adjacent to these areas to help prevent the intrusion of water into areas below grade. Buildings should maintain a minimum separation of 3 feet between the lowest foundation grade and the maximum anticipated groundwater level. Shallow groundwater areas can be mitigated with the installation of drains. Typical drain options/details are presented in Figures 8 through 11. The site is not mapped within any floodplain zones according to FEMA Map No. 08041CO315G, dated December 7, 2018 (Figure 7, Reference 12). Exact locations of floodplain and specific drainage studies are beyond the scope of this report.

Areas of fill were observed on site associated with erosion berms, embankments, and areas of man-placed fill piles. It is anticipated the fill piles/erosion berms will be mitigated during site grading. Any uncontrolled fill encountered beneath foundations should be removed and recompacted at a minimum of 95% of its maximum Modified Proctor Dry Density, ASTM D-1557.

Areas of erosion and gulying may require the construction of check dams and revegetation if construction encroaches on these areas. General recommendations for erosion control are discussed under Section 8 "Erosion Control".

In summary, development of the site can be achieved if the items mentioned above are mitigated. These items can be mitigated through proper design and construction or through avoidance. Investigation on each lot is also recommended prior to construction.

7 ECONOMIC MINERAL RESOURCES

Some of the sandy materials on-site could be considered a low grade sand resource. According to the *El Paso County Aggregate Resource Evaluation Map* (Reference 15), portions of the area are mapped as stream terrace and floodplain deposits. According to the *Atlas of Sand, Gravel and Quarry Aggregate Resources, Colorado Front Range Counties* distributed by the Colorado Geological Survey (Reference 16), areas of the site are not mapped with any resources. According to the *Evaluation of Mineral and Mineral Fuel Potential* (Reference 17), the area of the site has been mapped as "Little or No Potential" for industrial minerals. It is possible sand materials on site could be an aggregate resource. However, considering the silty to clayey nature of much of these materials and abundance of similar materials through the region and the close proximity to developed land, they would be considered to have little significance as an economic resource.

According to *the Evaluation of Mineral and Mineral Fuel Potential of El Paso County State Mineral Lands* (Reference 17), the site is mapped within the Denver Basin Coal Region. However, the area of the site has been mapped as "Poor" for coal resources. No active or inactive mines have been mapped in the area of the site. No metallic mineral resources have been mapped on the site (Reference 17).

The site has been mapped as "Fair" for oil and gas resources (Reference 16). No oil or gas fields have been discovered in the area of the site. The sedimentary rocks in the area may lack the geologic structure for trapping oil or gas; therefore, it may not be considered a significant resource. Hydraulic fracturing is a new method that is being used to extract oil and gas from rocks. It utilizes

pressurized fluid to extract oil and gas from rocks that would not normally be productive. The area of the site has not been explored to determine if the rocks underlying the site would be commercially viable utilizing hydraulic fracturing. The practice of hydraulic fracturing has come under review due to concerns about environmental impacts, health and safety.

8 EROSION CONTROL

The soil types observed on the site are mildly to highly susceptible to wind erosion, and moderately to highly susceptible to water erosion. A minor wind erosion and dust problem may be created for a short time during and immediately after construction. Should the problem be considered severe enough during this time, watering of the cut areas or the use of chemical palliative may be required to control dust. However, once construction has been completed and vegetation re-established, the potential for wind erosion should be considerably reduced.

With regard to water erosion, loosely compacted soils will be the most susceptible to water erosion, residually weathered soils and weathered bedrock materials become increasingly less susceptible to water erosion. For the typical soils observed on site, allowable velocities on unvegetated and unlined earth channels would be on the order of 3 to 4 feet/second, depending upon the sediment load carried by the water. Permissible velocities may be increased through the use of vegetation to something on the order of 4 to 7 feet/second, depending upon the type of vegetation established. Should the anticipated velocities exceed these values, some form of channel lining material may be required to reduce erosion potential. These might consist of some of the synthetic channel lining materials on the market or conventional riprap. In cases where ditch-lining materials are still insufficient to control erosion, small check dams or sediment traps may be required. The check dams will serve to reduce flow velocities, as well as provide small traps for containing sediment. The determination of the amount, location and placement of ditch linings, check dams and of the special erosion control features should be performed by or in conjunction with the drainage engineer who is more familiar with the flow quantities and velocities.

Cut and fill slope areas will be subjected primarily to sheetwash and rill erosion. Unchecked rill erosion can eventually lead to concentrated flows of water and gully erosion. The best means to combat this type of erosion is, where possible, the adequate re-vegetation of cut and fill slopes. Cut and fill slopes having gradients more than three (3) horizontal to one (1) vertical become increasingly more difficult to revegetate successfully. Therefore, recommendations pertaining to

the vegetation of the cut and fill slopes may require input from a qualified landscape architect and/or the Soil Conservation Service.

9 ROADWAY, EMBANKMENT, and STORM WATER FACILITY CONSTRUCTION RECOMMENDATIONS

In general, the site soils are suitable for the proposed roadways and embankments. Groundwater is not anticipated to affect roadway or pond construction. If road or embankment excavations encroach on the groundwater level unstable soil conditions may be encountered. Unstable soils are not anticipated in areas of shallow bedrock. Excavation of saturated soils will be difficult with rubber-tired equipment. Stabilization using shot rock or geogrids may be necessary.

Any areas to receive fill should have all topsoil, organic material or debris removed. Prior to fill placement Entech should observe the subgrade. Fill must be properly benched and compacted to minimize potentially unstable conditions in slope areas. Fill slopes should be 3:1. The subgrade should be scarified and moisture conditioned to within 2% of optimum moisture content and compacted to a minimum of 95% of its maximum Modified Proctor Dry Density, ASTM D-1557, prior to placing new fill. Areas receiving fill may require stabilization with rock or fabric if shallow groundwater conditions are encountered.

New fill should be placed in thin lifts not to exceed 6 inches after compaction while maintaining at least 95% of its maximum Modified Proctor Dry Density, ASTM D-1557. These materials should be placed at a moisture content conducive to compaction, usually 0 to $\pm 2\%$ of Proctor optimum moisture content. The placement and compaction of fill should be observed and tested by Entech during construction. Entech should approve any import materials prior to placing or hauling them to the site. Additional investigation will be required for pavement designs once roadway grading is completed and utilities are installed.

10 CLOSURE

It is our opinion that the existing geologic engineering and geologic conditions will impose some constraints on development and construction of the site. The majority of these conditions can be mitigated through proper engineering design and construction practices. The proposed development and use are consistent with anticipated geologic and engineering geologic conditions.

It should be pointed out that because of the nature of data obtained by random sampling of such variable and non-homogeneous materials as soil and rock, it is important that we be informed of any differences observed between surface and subsurface conditions encountered in construction and those assumed in the body of this report. Individual investigations for building sites will be required prior to construction. Construction and design personnel should be made familiar with the contents of this report. Reporting such discrepancies to Entech Engineering, Inc. soon after they are discovered would be greatly appreciated and could possibly help avoid construction and development problems.

This report has been prepared for Flying Horse North, LLC for application to the proposed project in accordance with generally accepted geologic soil and engineering practices. No other warranty expressed or implied is made.

We trust that this report has provided you with all the information that you required. Should you require additional information, please do not hesitate to contact Entech Engineering, Inc.

11 REFERENCES

1. Entech Engineering, Inc., February 26, 2015. *Soil, Geology, Geologic Hazard, and Wastewater Study, Shamrock Ranch, El Paso County, Colorado*. Entech Job No. 141588
2. Entech Engineering, Inc., February 22, 2016. *Soil, Geology, Geologic Hazard, and Wastewater Study, Flying Horse North, PUD Submittal, El Paso County, Colorado*. Entech Job No. 160118.
3. Entech Engineering, Inc., revised date April 11, 2024. *Soil, Geology, Geologic Hazard, and Wastewater Study, Flying Horse North, Sketch Plan, El Paso County, Colorado*. Entech Job No. 220404.
4. Entech Engineering, Inc., date September 11, 2024. *Soils and Geology Study, Flying Horse North Filing No. 4, El Paso County, Colorado*. Entech Job No. 241421.
5. Bryant, Bruce; McGrew, Laura W. and Wobus, Reinhard A. 1981. *Geologic Structure Map of the Denver 1° x 2° Quadrangle, North-Central Colorado*. U.S. Geologic Survey. Map 1-1163.
6. Natural Resource Conservation Service, June 20, 2007. *Web Soil Survey*. United States Department Agriculture, <http://web soil survey.nrcs.usda.gov>.
7. United States Department of Agriculture Soil Conservation Service. June 1981. *Soil Survey of El Paso County Area, Colorado*.
8. Thorson, Jon P. 2003. *Geologic Map of the Black Forest Quadrangle, El Paso County, Colorado*. Colorado Geological Survey. Open-File Report 03-6.
9. Trimble, Donald E. and Machette, Michael N. 1979. *Geologic Map of the Colorado Springs-Castle Rock Area, Front Range Urban Corridor, Colorado*. USGS, Map I-857-F.
10. Bryant, Bruce; McGrew, Laura W. and Wobus, Reinhard A. 1981. *Geologic Map of the Denver 1° x 2° Quadrangle, North-Central Colorado*. U.S. Geologic Survey. Map 1-1163.
11. Hart, Stephen S. 1974. *Potentially Swelling Soil and Rock in the Front Range Urban Corridor, Colorado*. Colorado Springs-Castle Rock Map. Colorado Geological Survey. Environmental Geology 7.
12. Federal Emergency Management Agency. December 7, 2018. *Flood Insurance Rate Maps for the City of Colorado Springs, Colorado*. Map Number 08041CO315G.
13. U.S. Fish & Wildlife Service. *National Wetlands Inventory*. Department of the Interior, fws.gov/wetlands/data/Mapper.html.
14. Colorado Geological Survey. 1991. *Results of the 1987-88 EPA Supported Radon Study in Colorado*. Open-file Report 91-4.
15. El Paso County Planning Development. December 1995. *El Paso County Aggregate Resource Evaluation Maps*.
16. Schwochow, S.D.; Shroba, R.R. and Wicklein, P.C. 1974. *Atlas of Sand, Gravel, and Quarry Aggregate Resources, Colorado Front Range Counties*. Colorado Geological Survey. Special Publication 5-B.
17. Keller, John W.; TerBest, Harry and Garrison, Rachel E. 2003. *Evaluation of Mineral and Mineral Fuel Potential of El Paso County State Mineral Lands Administered by the Colorado State Land Board*. Colorado Geological Survey. Open-File Report 03-07.

FIGURES

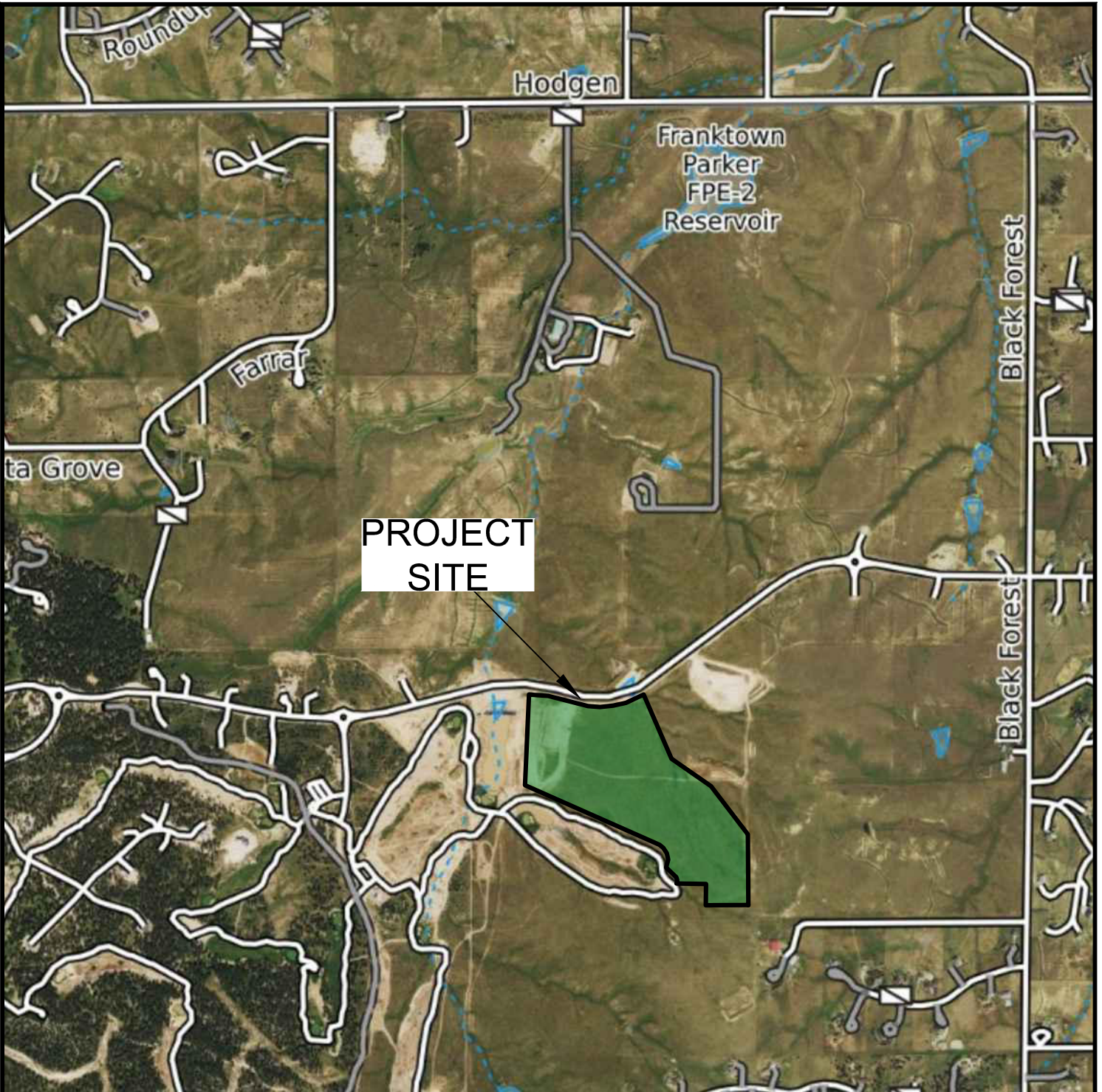

VICINITY MAP

FLYING HORSE NORTH, FILING NO. 5
FLYING HORSE NORTH, LLC

JOB NO.
241421

FIG. 1

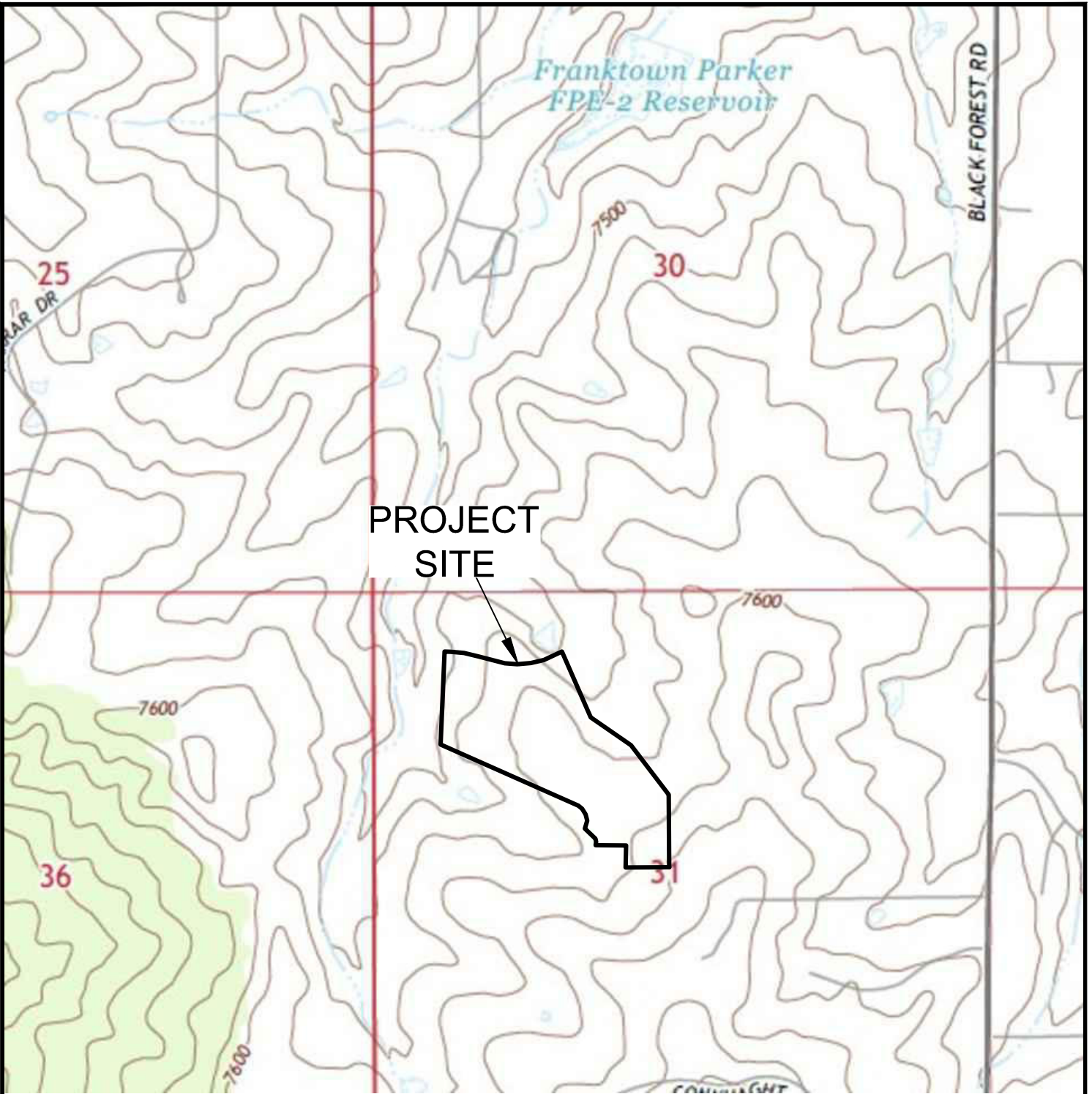

USGS TOPOGRAPHY MAP

FLYING HORSE NORTH, FILING NO. 5
FLYING HORSE NORTH, LLC

JOB NO.
241421

FIG. 2

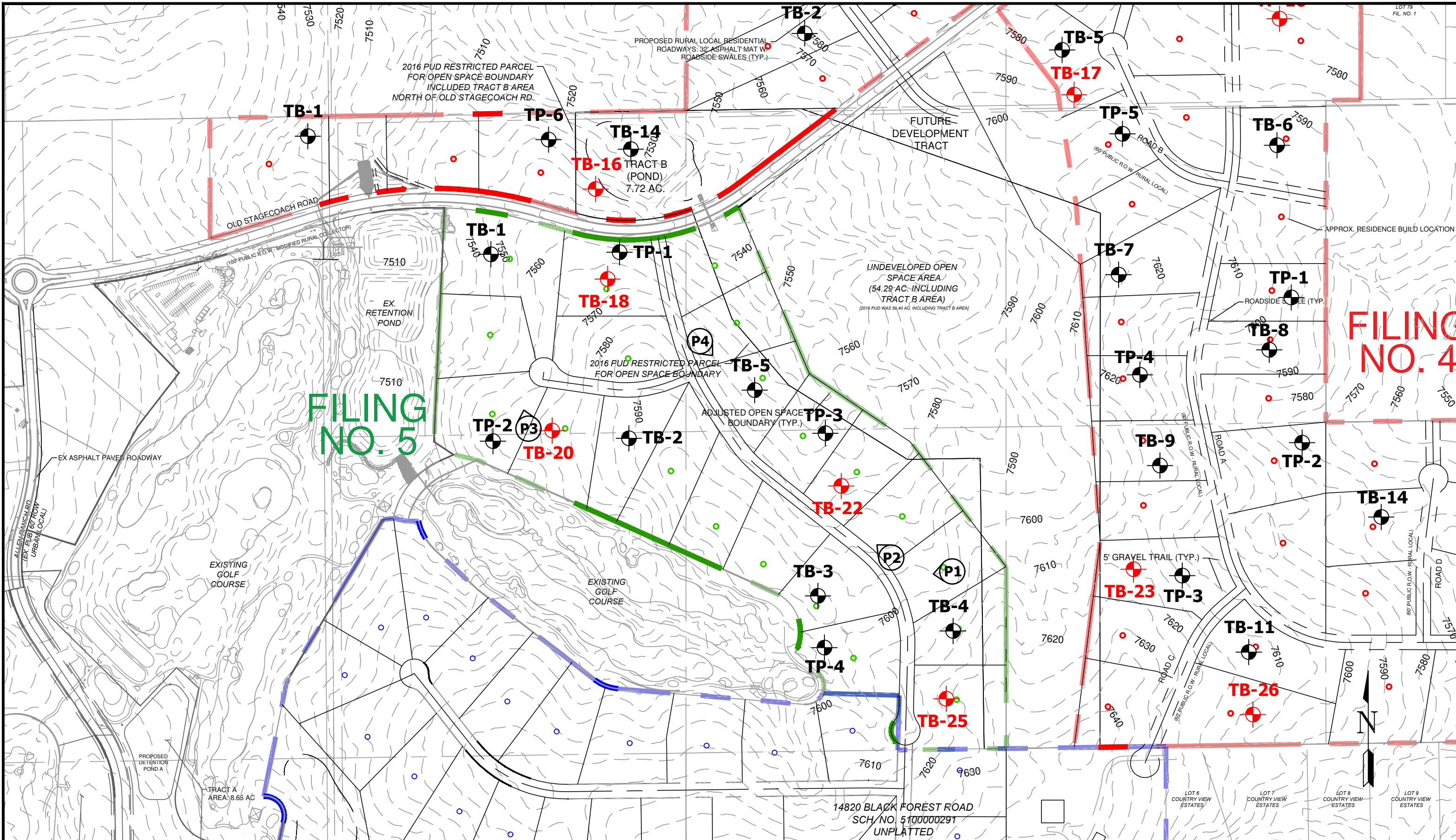

- TB- APPROXIMATE TEST BORING LOCATION AND NUMBER
- TP- APPROXIMATE TEST PIT LOCATION AND NUMBER
- TB- APPROXIMATE TEST BORING LOCATION AND NUMBER (EEI JOB NO. 220404)
- APPROXIMATE PHOTOGRAPH LOCATION AND NUMBER

SITE AND EXPLORATION PLAN
 FLYING HORSE NORTH, FILING NO. 5
 FLYING HORSE NORTH, LLC

JOB NO.
241421
FIG. 3

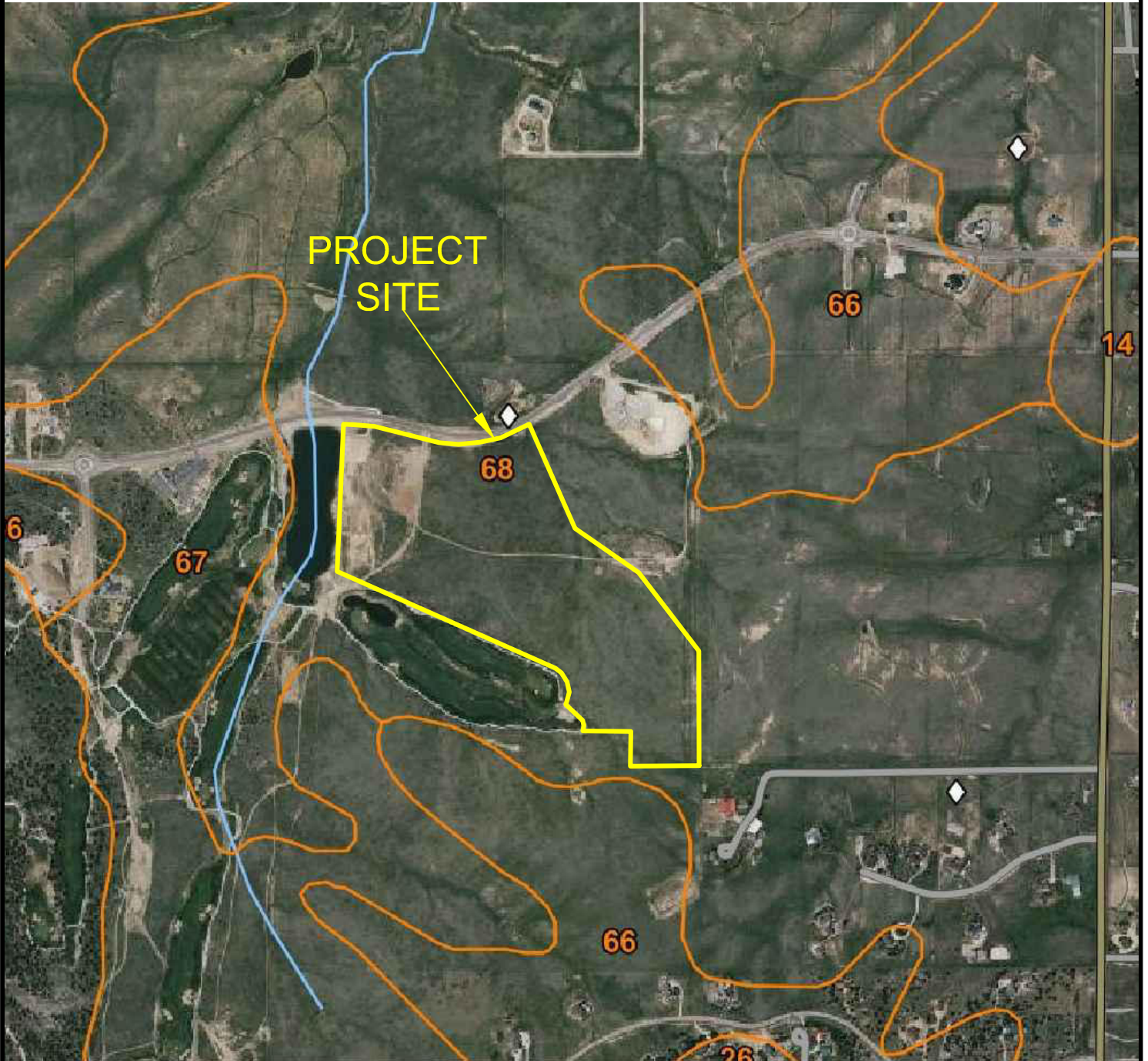

SOIL SURVEY MAP

FLYING HORSE NORTH, FILING NO. 5
FLYING HORSE NORTH, LLC

JOB NO.
241421

FIG. 4

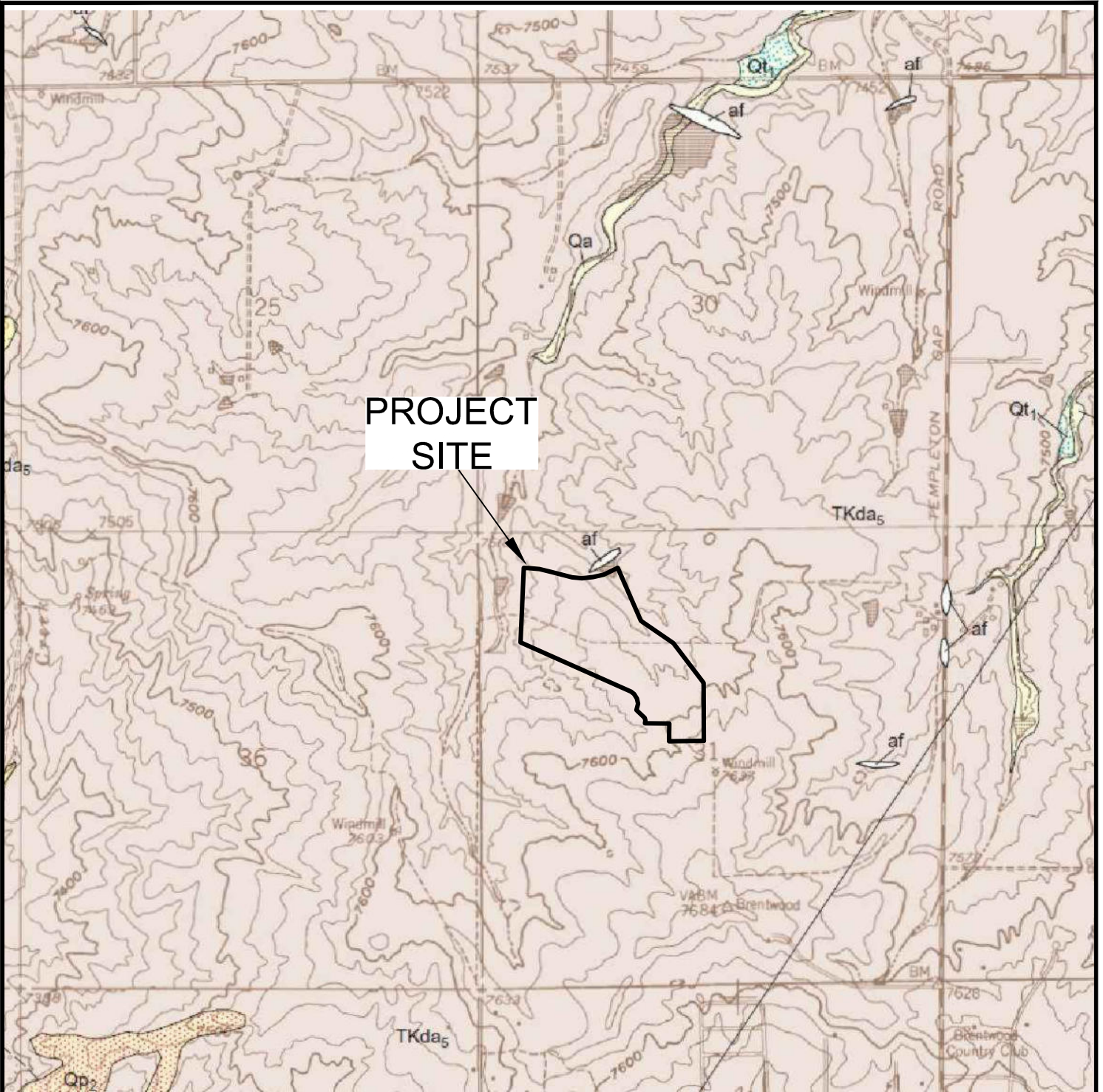

**GEOLOGIC MAP OF THE
BLACK FOREST QUADRANGLE**
FLYING HORSE NORTH, FILING NO. 5
FLYING HORSE NORTH, LLC

JOB NO.
241421

FIG. 5

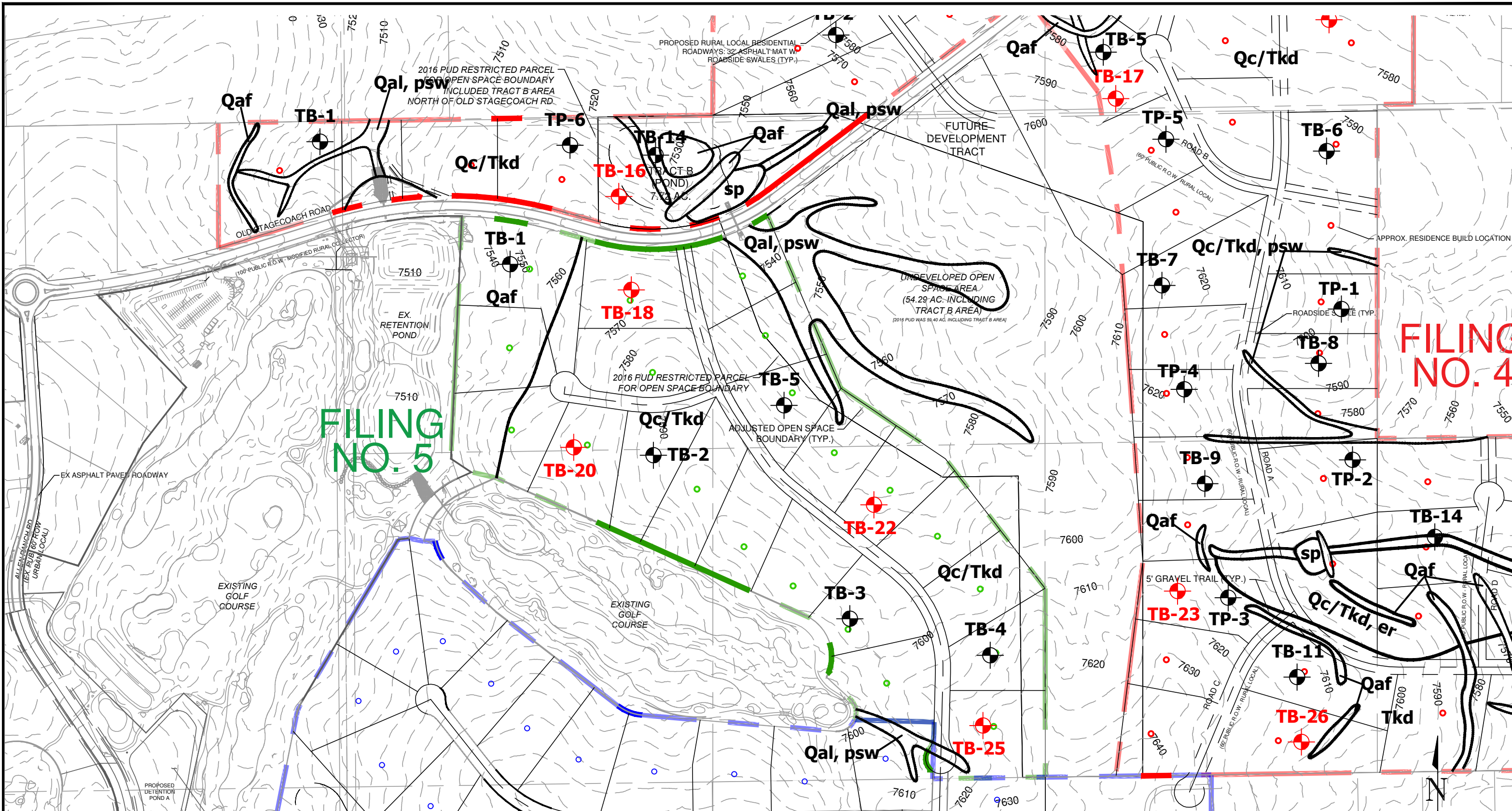

Legend:

- Qaf - Artificial Fill of Holocene Age: man-place fill deposits associated
- Qal - Alluvium of Holocene Age: recent water deposited sediments along drainages
- Qc/Tkd - Colluvium of Quaternary Age overlying the Dawson Formation of Tertiary to Cretaceous Age: Sheetwash and residual soil deposits overlying arkosic sandstone with interbedded claystone and siltstone
- er - erosion
- psw - potential seasonally shallow groundwater area
- sp - seasonally area of ponded water

14820 BLACK FOREST ROAD
SCH. NO. 5100000291
UNPLATTED
ZONING DISTRICT

	<p>GEOLOGY / ENGINEERING MAP</p> <p>FLYING HORSE NORTH, FILING NO. 5 FLYING HORSE NORTH, LLC</p>	<p>JOB NO. 241421</p> <p>FIG. 6</p>
---	---	--

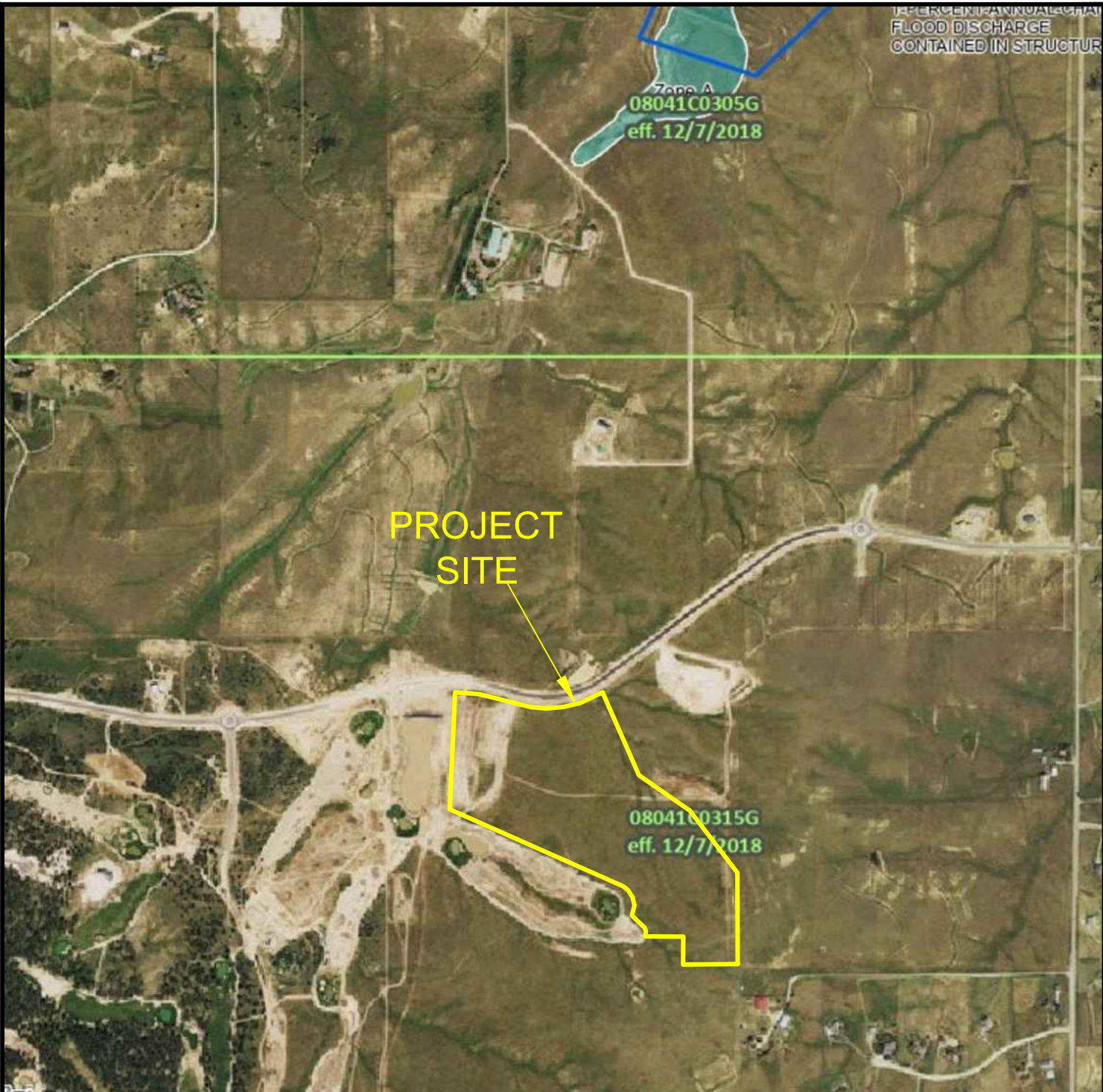

FEMA FLOODPLAIN MAP

FLYING HORSE NORTH, FILING NO. 5
FLYING HORSE NORTH, LLC

JOB NO.
241421

FIG. 7

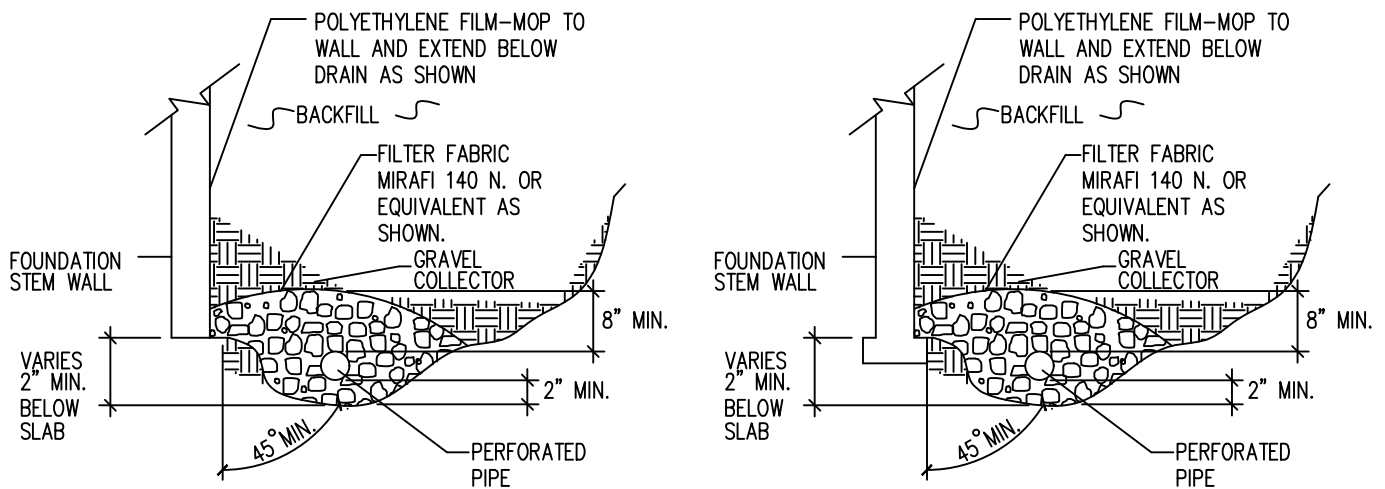

NOTES:

-GRAVEL SIZE IS RELATED TO DIAMETER OF PIPE PERFORATIONS-85% GRAVEL GREATER THAN 2x PERFORATION DIAMETER.

-PIPE DIAMETER DEPENDS UPON EXPECTED SEEPAGE. 4-INCH DIAMETER IS MOST OFTEN USED.

-ALL PIPE SHALL BE PERFORATED PLASTIC. THE DISCHARGE PORTION OF THE PIPE SHOULD BE NON-PERFORATED PIPE.

-FLEXIBLE PIPE MAY BE USED UP TO 8 FEET IN DEPTH, IF SUCH PIPE IS DESIGNED TO WITHSTAND THE PRESSURES. RIGID PLASTIC PIPE WOULD OTHERWISE BE REQUIRED.

-MINIMUM GRADE FOR DRAIN PIPE TO BE 1% OR 3 INCHES OF FALL IN 25 FEET.

-DRAIN TO BE PROVIDED WITH A FREE GRAVITY OUTFALL, IF POSSIBLE. A SUMP AND PUMP MAY BE USED IF GRAVITY OUT FALL IS NOT AVAILABLE.



PERIMETER DRAIN DETAIL

FLYING HORSE NORTH, FILING NO. 5
FLYING HORSE NORTH, LLC

JOB NO.
241421

FIG. 8

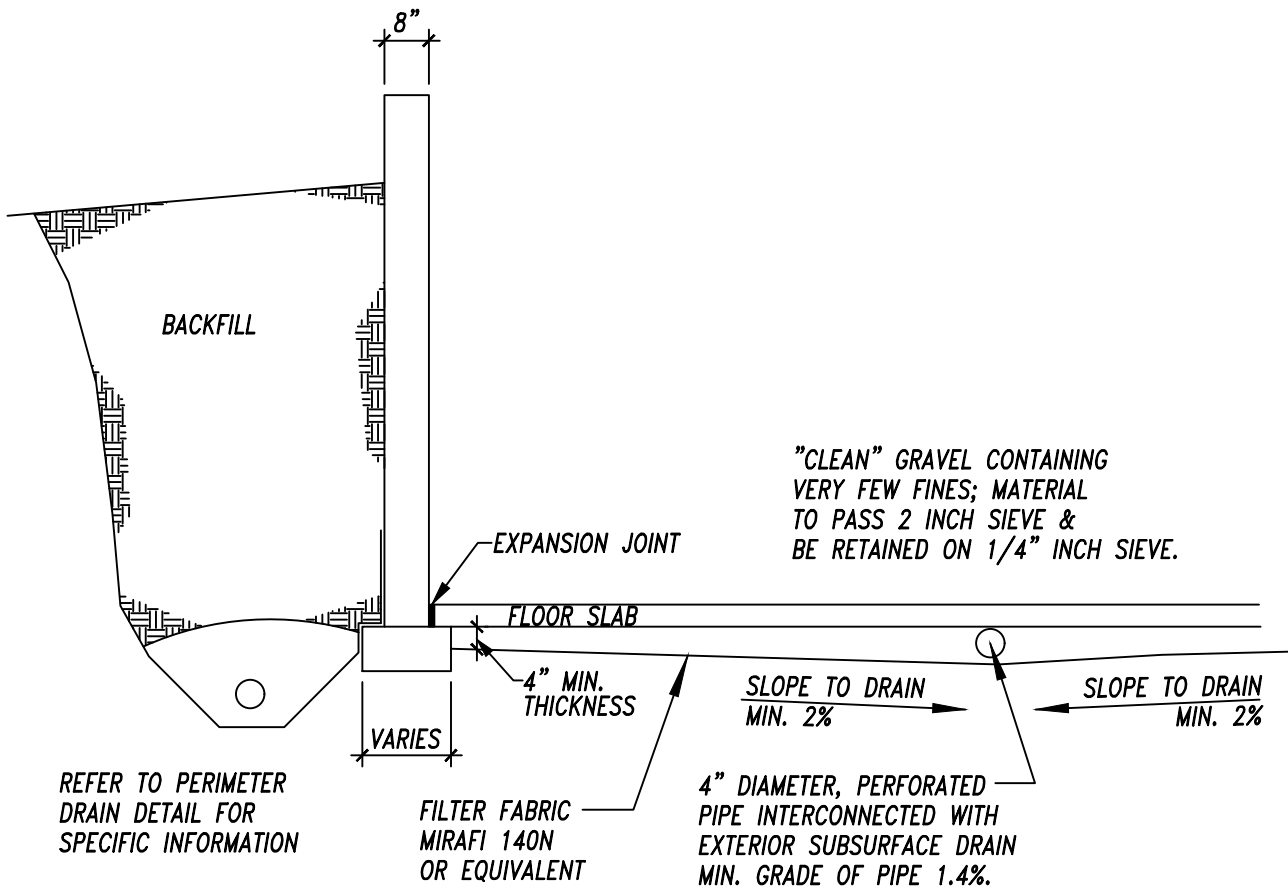

**TYP. UNDERSLAB DRAINAGE LAYER
(CAPILLARY BREAK)**
FLYING HORSE NORTH, FILING NO. 5
FLYING HORSE NORTH, LLC

JOB NO.
241421

FIG. 9

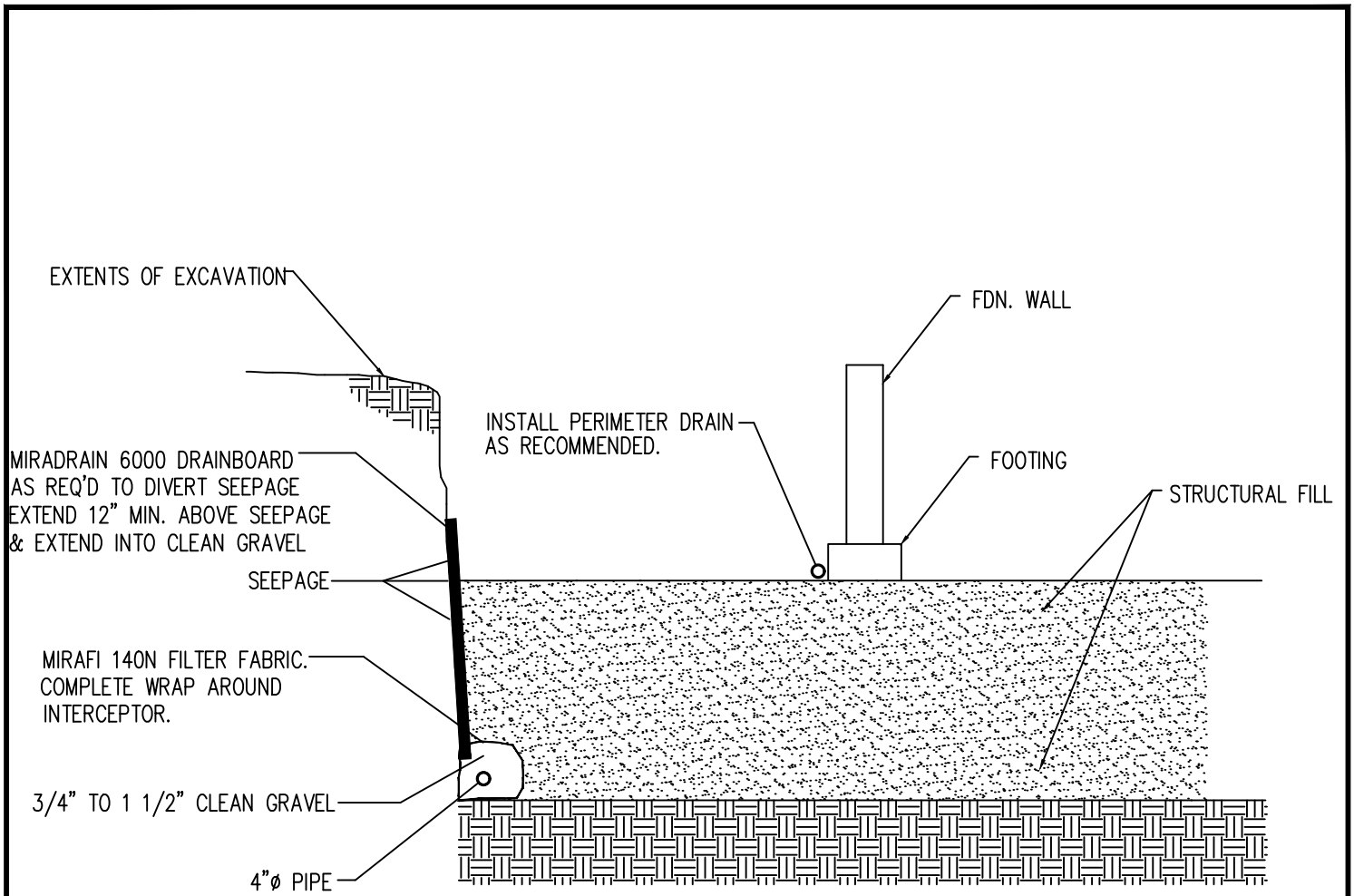

NOTE:
 EXTEND INTERCEPTOR DRAIN TO UNDERDRAIN OR TO SUMP.
 BENCH DRAIN INTO NATIVE SOILS 12 INCHES MINIMUM.

INTERCEPTOR DRAIN DETAIL

N.T.S.



INTERCEPTOR DRAIN DETAIL

FLYING HORSE NORTH, FILING NO. 5
 FLYING HORSE NORTH, LLC

JOB NO.
 241421

FIG. 10

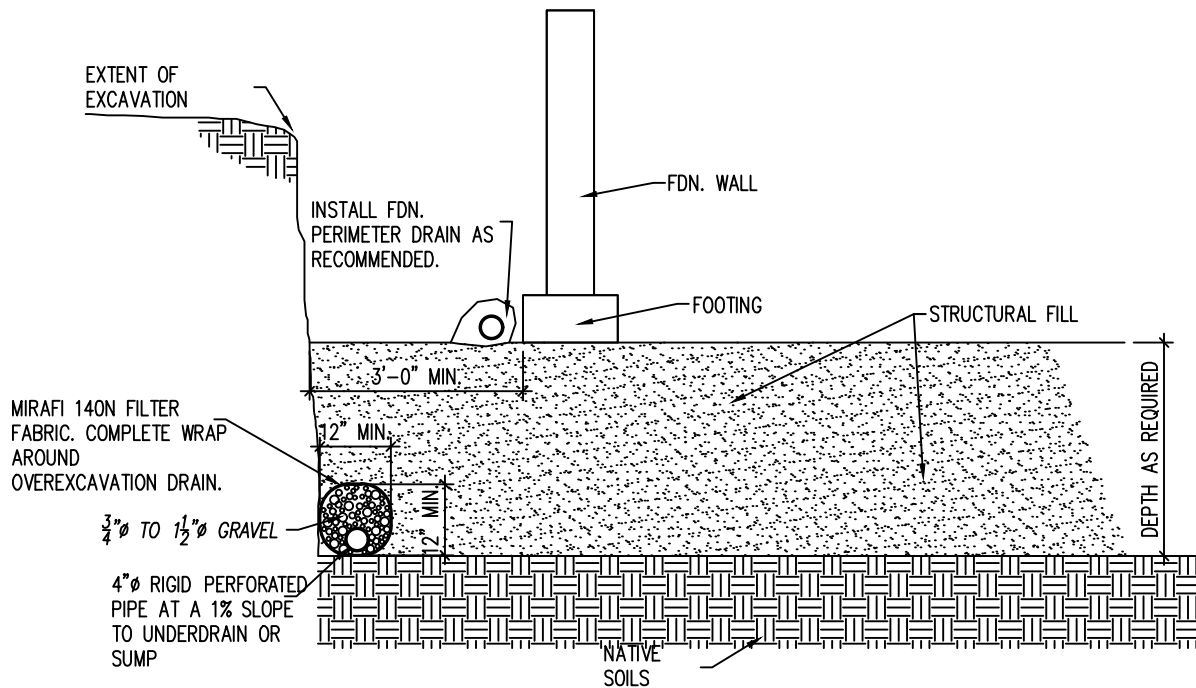

OVEREXCAVATION DRAIN DETAIL

N.T.S.

NOTE:
EXTEND DRAIN TO SUMP AS REQ'D.



OVEREXCAVATION DRAIN

FLYING HORSE NORTH, FILING NO. 5
FLYING HORSE NORTH, LLC

JOB NO.
241421

FIG. 11

APPENDIX A: Site Photographs

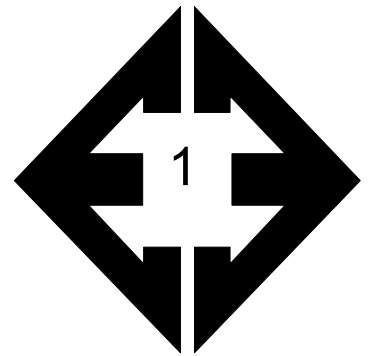

Looking west from the southeastern portion of the site.

September 19, 2024

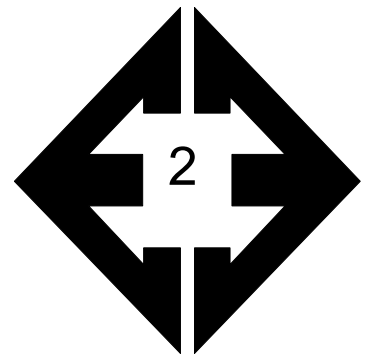

Looking northwest from the southeastern portion of the site.

September 19, 2024

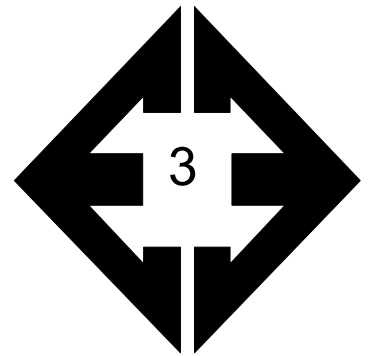

Looking north from the western portion of the site.

September 19, 2024

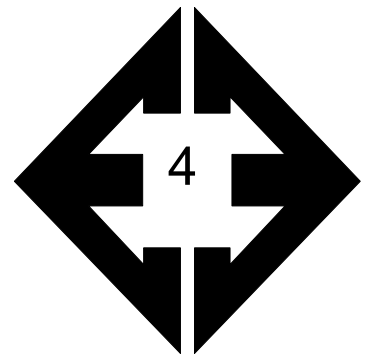

Looking southeast from the northeastern portion of the site.

September 19, 2024



APPENDIX B: Test Boring and Test Pit Logs

TABLE B-1
DEPTH TO GROUNDWATER, BEDROCK, & FILL

TEST BORING	DEPTH TO GROUNDWATER (ft.)	DEPTH TO BEDROCK (ft.)	DEPTH TO FILL (ft.)
1	>20	>20	4
2	>20	16	0
3	>20	>20	0
4	>20	7	0
5	>20	>20	0

TEST BORING 1
DATE DRILLED 9/18/2024

TEST BORING 2
DATE DRILLED 9/18/2024

REMARKS

REMARKS

DRY TO 20', 9/19/24

DRY TO 20', 9/19/24

FILL 0-4', SAND, CLAYEY, BROWN, MEDIUM DENSE, MOIST

SAND, SILTY, LIGHT BROWN to TAN, MEDIUM DENSE to DENSE, MOIST to DRY

SAND, SILTY, BROWN to TAN, MEDIUM DENSE to DENSE, MOIST

SANDSTONE, EXTREMELY WEAK, TAN, WEATHERED (SAND, SILTY, VERY DENSE, MOIST)

Depth (ft)	Symbol	Samples	Blows per foot	Watercontent %	Soil Type	Depth (ft)	Symbol	Samples	Blows per foot	Watercontent %	Soil Type
0-4						0-4					
5			11	5.5	1	5			14	7.5	2
5			14	3.5	2	5			20	7.7	2
10			17	3.6	2	10			13	5.0	2
15			12	4.7	2	15			39	2.6	2
20			30	17.4	2	20			50 10"	4.1	4



TEST BORING LOGS
FLYING HORSE NORTH, FILING NO. 5
FLYING HORSE NORTH, LLC

JOB NO.
241421

FIG. B-1

TEST BORING 3
 DATE DRILLED 9/18/2024

TEST BORING 4
 DATE DRILLED 9/18/2024

REMARKS

REMARKS

DRY TO 20', 9/19/24

DRY TO 20', 9/19/24

SAND, SILTY, LIGHT BROWN to
 TAN, MEDIUM DENSE to DENSE,
 MOIST

SAND, SILTY, LIGHT BROWN,
 MEDIUM DENSE, MOIST

Depth (ft)	Symbol	Samples	Blows per foot	Watercontent %	Soil Type
			29	4.2	2
5			38	6.7	2
10			16	6.9	2
15			18	10.8	2
20			37	11.8	2

SANDSTONE, VERY WEAK, TAN,
 MODERATELY WEATHERED
 (SAND, SILTY, VERY DENSE,
 MOIST)

Depth (ft)	Symbol	Samples	Blows per foot	Watercontent %	Soil Type
				6.7	2
5				11.0	2
10			<u>50</u> 4"	6.0	4
15			<u>50</u> 9"	7.7	4
20			<u>50</u> 9"	9.3	4



TEST BORING LOGS
 FLYING HORSE NORTH, FILING NO. 5
 FLYING HORSE NORTH, LLC

JOB NO.
 241421

FIG. B-2



TEST BORING 5
 DATE DRILLED 9/18/2024

REMARKS

DRY TO 20', 9/19/24

CLAY, SLIGHTLY SANDY, BROWN
 to TAN, VERY STIFF, MOIST

SAND, SILTY, TAN, MEDIUM
 DENSE, MOIST

Depth (ft)	Symbol	Samples	Blows per foot	Watercontent %	Soil Type
5			16	6.1	3
			15	6.5	3
10			21	3.6	2
15			16	4.2	2
20			36	7.5	2



TEST BORING LOGS
 FLYING HORSE NORTH, FILING NO. 5
 FLYING HORSE NORTH, LLC

JOB NO.
 241421

FIG. B-3

TEST PIT 1
 DATE EXCAVATED 9/20/2024

TEST PIT 2
 DATE EXCAVATED 9/20/2024

REMARKS

REMARKS

REMARKS	Depth (ft.)	Symbol	Samples	Soil Structure Shape	Soil Structure Grade	Soil Type	REMARKS	Depth (ft.)	Symbol	Samples	Soil Structure Shape	Soil Structure Grade	Soil Type
topsoil, sandy clay loam, brown, moist	1						topsoil, sandy clay loam, brown, moist	1					
sandy clay, fine to medium grained, brown, moist	2			bl	m	4	sandy clay, fine to medium grained, brown, moist	2			ma	sl	4A
	3						sandy clay loam, fine to medium grained, brown, moist,	3			ma	sl	3
	4							4					
sandy clay, fine to medium grained, brown, moist	5			ma	sl	4A		5					
	6							6					
	7							7					
	8							8					
	9							9					
	10							10					

Soil Structure Shape

- granular - gr
- platy - pl
- blocky - bl
- prismatic - pr
- single grain - sg
- massive - ma

Soil Structure Grade

- weak - w
- moderate - m
- strong - s
- loose - l
- structureless - sl



TEST PIT LOGS

FLYING HORSE NORTH FILING NO. 5
 FLYING HORSE DEVELOPMENT

JOB NO.
 241421

FIG. B-4

TEST PIT 3
 DATE EXCAVATED 9/20/2024

TEST PIT 4
 DATE EXCAVATED 9/20/2024

REMARKS	Depth (ft.)	Symbol	Samples	Soil Structure Shape	Soil Structure Grade	Soil Type	REMARKS	Depth (ft.)	Symbol	Samples	Soil Structure Shape	Soil Structure Grade	Soil Type
topsoil, sandy clay loam, brown, moist	1						topsoil, sandy clay loam, brown, moist	1					
sandy clay, fine to medium grained, dark brown, moist	2			bl	m	4	sandy clay, fine to medium grained, brown, moist	2			bl	m	4
	3							3					
	4						sandy clay, fine to medium grained, brown, moist, R1	4			ma	sl	4
sandy clay, fine to medium grained, brown, moist	5			bl	s	4A		5					
	6							6					
	7							7					
	8							8					
	9							9					
	10							10					

Soil Structure Shape

granular - gr
 platy - pl
 blocky - bl
 prismatic - pr
 single grain - sg
 massive - ma

Soil Structure Grade

weak - w
 moderate - m
 strong - s
 loose - l
 structureless - sl



TEST PIT LOGS

FLYING HORSE NORTH FILING NO. 5
 FLYING HORSE DEVELOPMENT

JOB NO.
 241421

FIG. B-5

APPENDIX C: Laboratory Testing Results

**TABLE C-1
SUMMARY OF LABORATORY TEST RESULTS**

SOIL TYPE	TEST BORING NO.	DEPTH (FT)	PASSING NO. 200 SIEVE (%)	LIQUID LIMIT	PLASTIC LIMIT	PLASTIC INDEX	SULFATE (WT %)	USCS	SOIL DESCRIPTION
1	1	5	44.8				#DIV/0!	SC	SAND, CLAYEY
2	3	5	19.5					SM	SAND, SILTY
3	5	2-3	99.1				#DIV/0!	CL	CLAY, SLIGHTLY SANDY
4	2	20	14.9	NV	NP	NP	#DIV/0!	SM	SANDSTONE (SAND, SILTY)
4	4	10	41.2					SM	SANDSTONE (SAND, SILTY)

TEST BORING 1
 DEPTH (FT) 5

SOIL DESCRIPTION SAND, CLAYEY
 SOIL TYPE 1

**Sieve Analysis
 Grain Size Distribution**

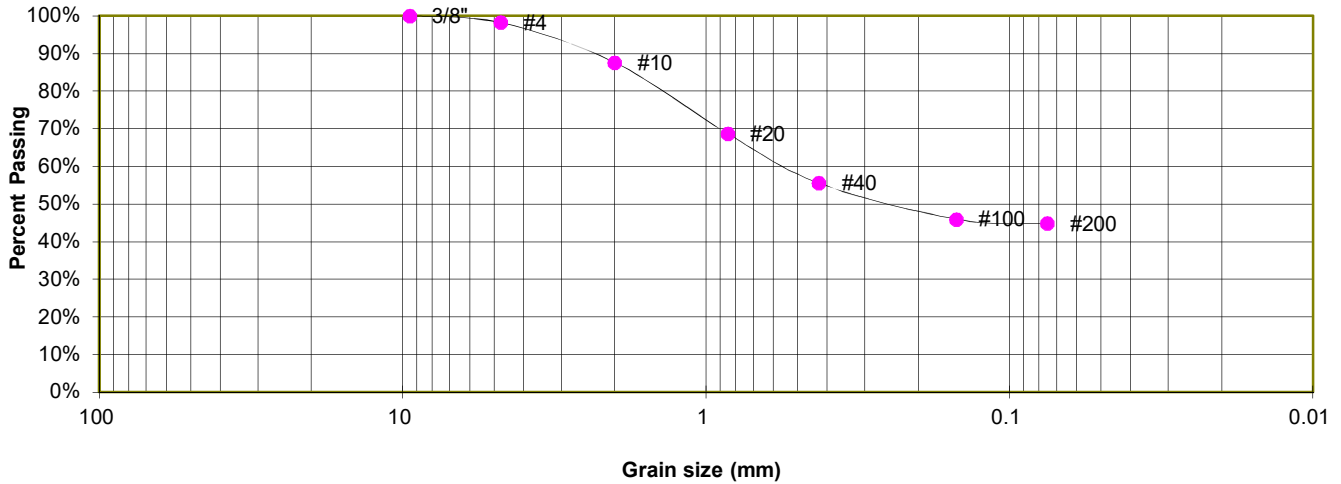

GRAIN SIZE ANALYSIS

U.S. Sieve #	Percent Finer
3"	
1 1/2"	
3/4"	
1/2"	
3/8"	100.0%
4	98.2%
10	87.6%
20	68.7%
40	55.6%
100	46.0%
200	44.8%

SOIL CLASSIFICATION

USCS CLASSIFICATION: SC



LABORATORY TEST RESULTS

FLYING HORSE NORTH, FILING NO. 5
 FLYING HORSE NORTH, LLC

JOB NO.
 241421

FIG. C-1

TEST BORING 3
 DEPTH (FT) 5

SOIL DESCRIPTION SAND, SILTY
 SOIL TYPE 2

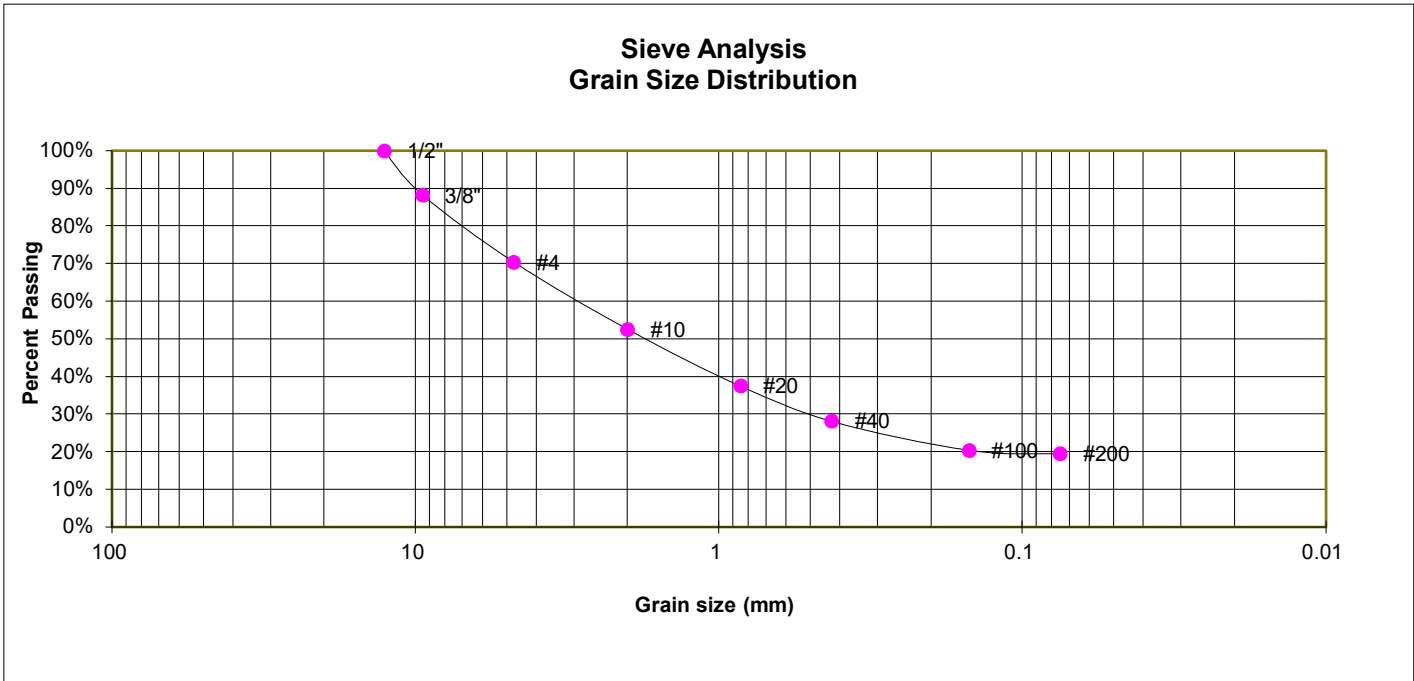

GRAIN SIZE ANALYSIS

U.S. Sieve #	Percent Finer
3"	
1 1/2"	
3/4"	
1/2"	100.0%
3/8"	88.3%
4	70.4%
10	52.5%
20	37.5%
40	28.1%
100	20.4%
200	19.5%

SOIL CLASSIFICATION

USCS CLASSIFICATION: SM



LABORATORY TEST RESULTS

FLYING HORSE NORTH, FILING NO. 5
 FLYING HORSE NORTH, LLC

JOB NO.
 241421

FIG. C-2

TEST BORING 5
 DEPTH (FT) 2-3

SOIL DESCRIPTION CLAY, SLIGHTLY SANDY
 SOIL TYPE 3

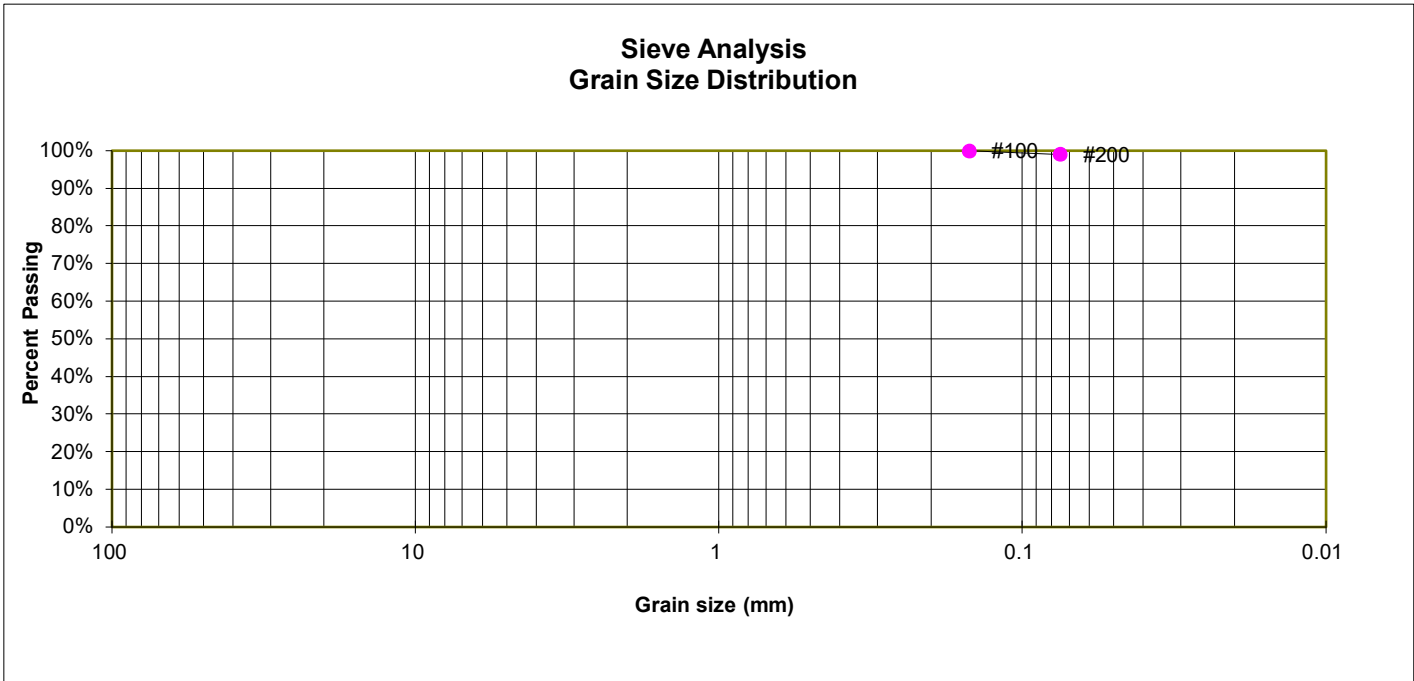

GRAIN SIZE ANALYSIS

U.S. Sieve #	Percent Finer
3"	
1 1/2"	
3/4"	
1/2"	
3/8"	
4	
10	
20	
40	
100	100.0%
200	99.1%

SOIL CLASSIFICATION

USCS CLASSIFICATION: CL



LABORATORY TEST RESULTS

FLYING HORSE NORTH, FILING NO. 5
 FLYING HORSE NORTH, LLC

JOB NO.
 241421

FIG. C-3

TEST BORING 2
 DEPTH (FT) 20

SOIL DESCRIPTION SANDSTONE (SAND, SILTY)
 SOIL TYPE 4

**Sieve Analysis
 Grain Size Distribution**

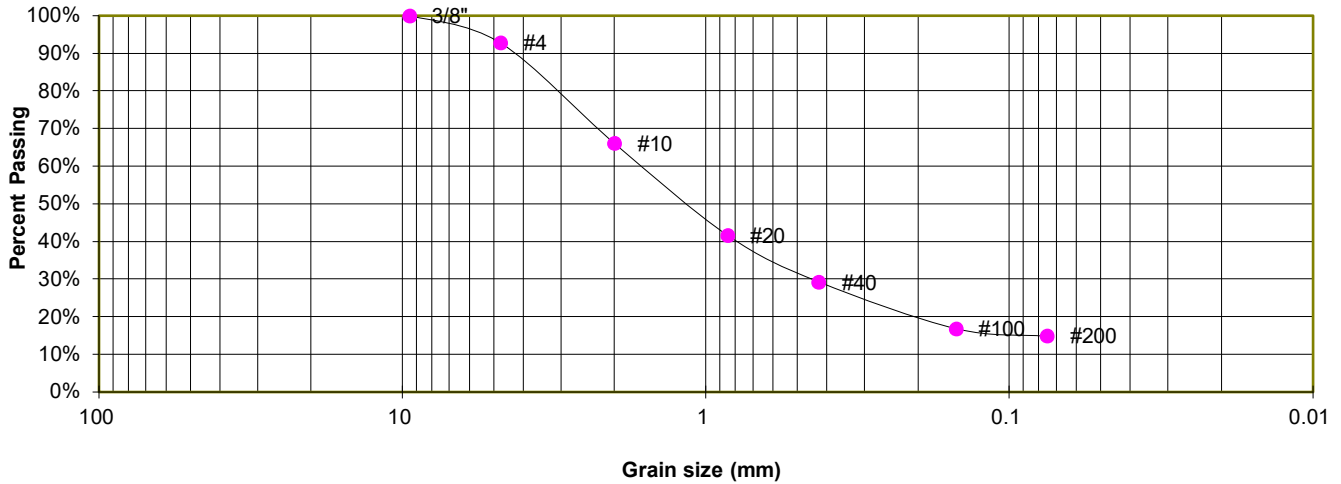

GRAIN SIZE ANALYSIS

U.S. Sieve #	Percent Finer
3"	
1 1/2"	
3/4"	
1/2"	
3/8"	100.0%
4	92.8%
10	66.1%
20	41.7%
40	29.3%
100	16.8%
200	14.9%

ATTERBERG LIMITS

Plastic Limit	NP
Liquid Limit	NV
Plastic Index	NP

SOIL CLASSIFICATION

USCS CLASSIFICATION: SM



LABORATORY TEST RESULTS

FLYING HORSE NORTH, FILING NO. 5
 FLYING HORSE NORTH, LLC

JOB NO.
 241421

FIG. C-4

TEST BORING 4
DEPTH (FT) 10

SOIL DESCRIPTION SANDSTONE (SAND, SILTY)
SOIL TYPE 4

**Sieve Analysis
Grain Size Distribution**

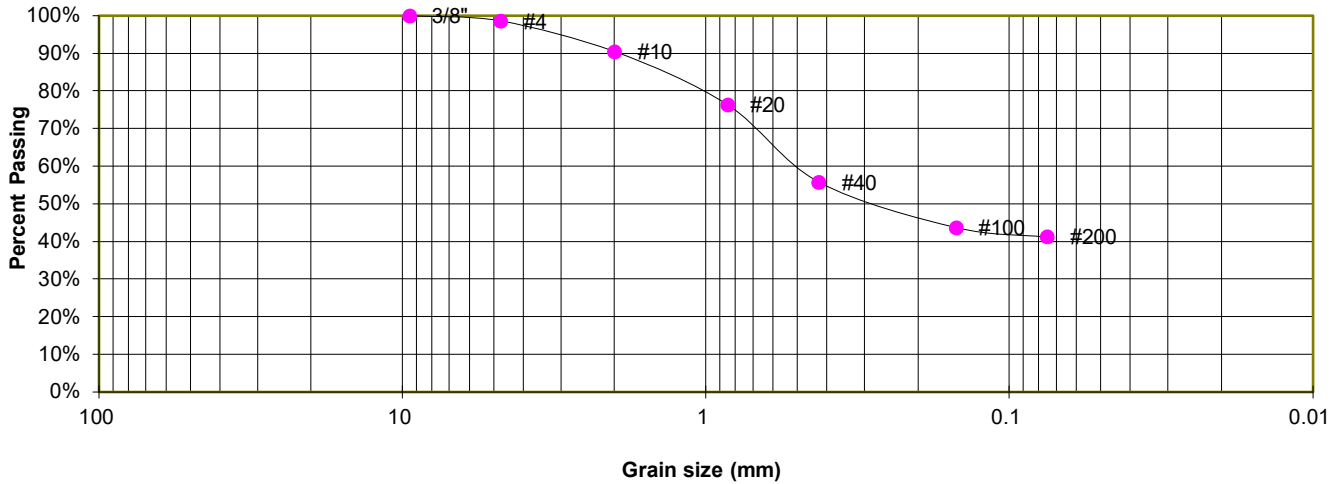

GRAIN SIZE ANALYSIS

U.S. Sieve #	Percent Finer
3"	
1 1/2"	
3/4"	
1/2"	
3/8"	100.0%
4	98.6%
10	90.5%
20	76.4%
40	55.8%
100	43.8%
200	41.2%

SOIL CLASSIFICATION

USCS CLASSIFICATION: SM



LABORATORY TEST RESULTS

FLYING HORSE NORTH, FILING NO. 5
FLYING HORSE NORTH, LLC

JOB NO.
241421

FIG. C-5

TEST BORING TP-1
DEPTH (FT) 2

SOIL DESCRIPTION CLAY, SANDY

**Sieve Analysis
Grain Size Distribution**

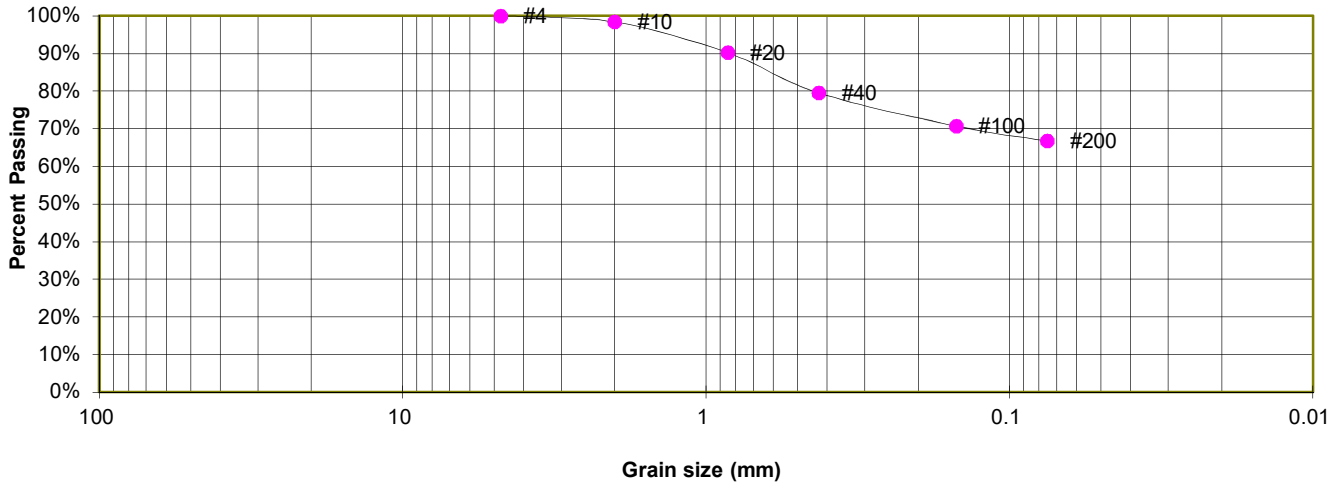

GRAIN SIZE ANALYSIS

U.S. Sieve #	Percent Finer
3"	
1 1/2"	
3/4"	
1/2"	
3/8"	
4	100.0%
10	98.4%
20	90.2%
40	79.5%
100	70.7%
200	66.7%

SOIL CLASSIFICATION

USCS CLASSIFICATION: CL



LABORATORY TEST RESULTS

FLYING HORSE NORTH, FILING NO. 5
FLYING HORSE NORTH, LLC

JOB NO.
241421

FIG. C-6

TEST BORING TP-2
DEPTH (FT) 2

SOIL DESCRIPTION CLAY, SANDY

Sieve Analysis Grain Size Distribution

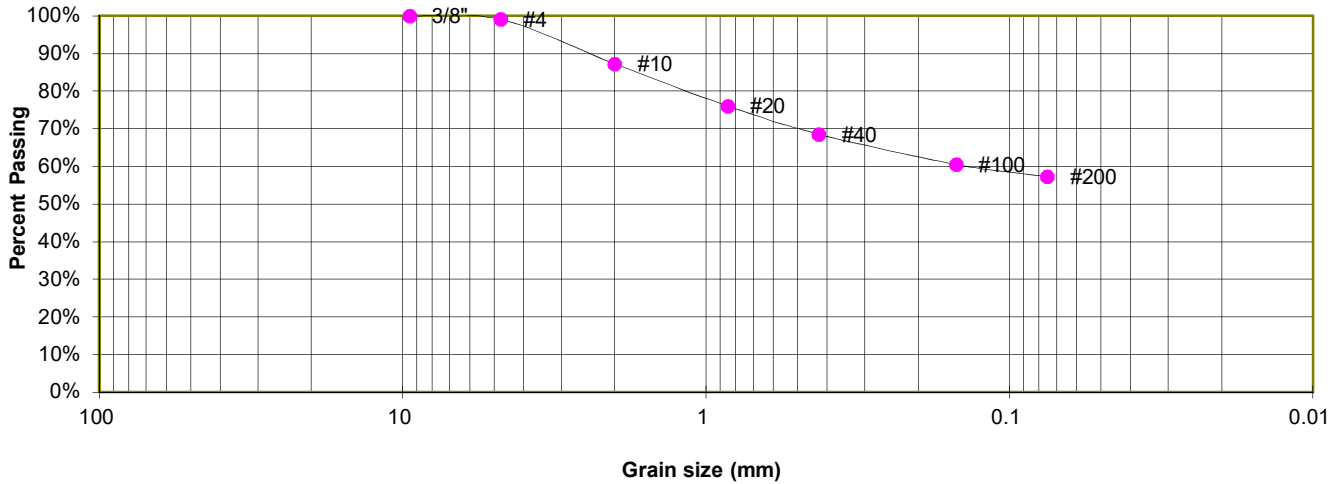

GRAIN SIZE ANALYSIS

U.S. Sieve #	Percent Finer
3"	
1 1/2"	
3/4"	
1/2"	
3/8"	100.0%
4	99.1%
10	87.2%
20	76.1%
40	68.6%
100	60.5%
200	57.3%

SOIL CLASSIFICATION

USCS CLASSIFICATION: CL



LABORATORY TEST RESULTS

FLYING HORSE NORTH, FILING NO. 5
FLYING HORSE NORTH, LLC

JOB NO.
241421

FIG. C-7

TEST BORING TP-2
DEPTH (FT) 3.5

SOIL DESCRIPTION SAND, CLAYEY

Sieve Analysis Grain Size Distribution

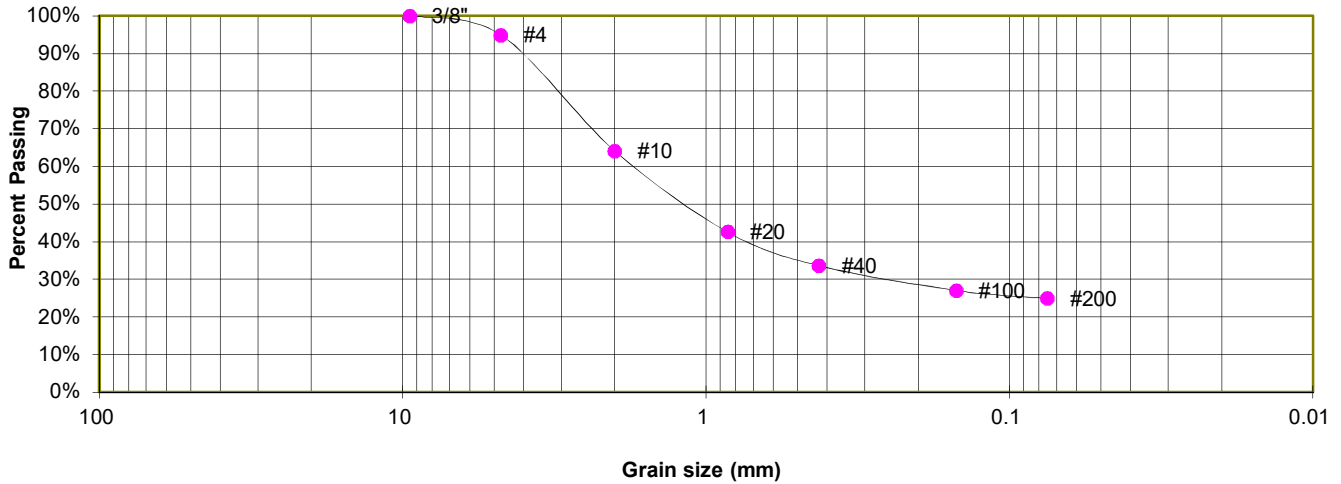

GRAIN SIZE ANALYSIS

U.S. Sieve #	Percent Finer
3"	
1 1/2"	
3/4"	
1/2"	
3/8"	100.0%
4	95.0%
10	64.1%
20	42.6%
40	33.7%
100	27.0%
200	25.0%

SOIL CLASSIFICATION

USCS CLASSIFICATION: SC



LABORATORY TEST RESULTS

FLYING HORSE NORTH, FILING NO. 5
FLYING HORSE NORTH, LLC

JOB NO.
241421

FIG. C-7

TEST BORING TP-4
 DEPTH (FT) 4

SOIL DESCRIPTION SAND, SILTY

**Sieve Analysis
 Grain Size Distribution**

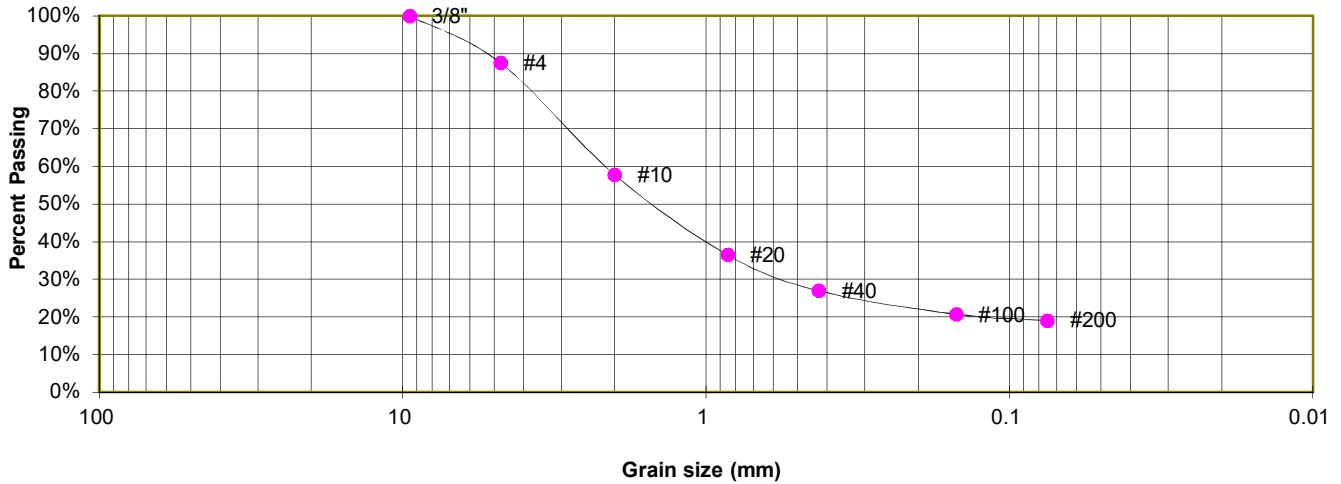

GRAIN SIZE ANALYSIS

U.S. Sieve #	Percent Finer
3"	
1 1/2"	
3/4"	
1/2"	
3/8"	100.0%
4	87.5%
10	57.8%
20	36.5%
40	26.9%
100	20.7%
200	19.1%

SOIL CLASSIFICATION

USCS CLASSIFICATION: SM



LABORATORY TEST RESULTS

FLYING HORSE NORTH, FILING NO. 5
 FLYING HORSE NORTH, LLC

JOB NO.
 241421

FIG. C-8



**APPENDIX D: EEI Laboratory Testing Summary and
Test Boring Logs Job No. 220404**

TEST BORING 17
DATE DRILLED 12/28/2023

TEST BORING 18
DATE DRILLED 1/3/2024

REMARKS

REMARKS

DRY TO 20', 12/28/23

DRY TO 20', 1/3/24

REMARKS	Depth (ft)	Symbol	Samples	Blows per foot	Watercontent %	Soil Type
6" TOPSOIL						
CLAY, SANDY, BROWN, VERY STIFF, MOIST				19	8.0	2
SILT, SANDY, BROWN, MEDIUM STIFF, MOIST	5			5	8.6	2
CLAY, SANDY, BROWN, VERY STIFF, MOIST				22	3.8	2
SAND, SILTY, TAN, DENSE, MOIST				44	3.9	1
SANDSTONE, VERY WEAK, OLIVE, HIGHLY WEATHERED (SAND, SILTY, VERY DENSE, MOIST)	20			50	4.4	4
				10"		

REMARKS	Depth (ft)	Symbol	Samples	Blows per foot	Watercontent %	Soil Type
SAND, SILTY, TAN, MEDIUM DENSE, MOIST				23	6.5	1
	5			17	13.8	1
				27	12.5	1
SAND, SILTY, TAN, DENSE, MOIST (SANDSTONE, WEAK, RESIDUAL SOIL)	15			47	8.9	1
	20			49	11.1	1



TEST BORING LOGS
FLYING HORSE NORTH SKETCH PLAN
FLYING HORSE DEVELOPMENT

JOB NO.
220404

FIG. B-9

TEST BORING 19
 DATE DRILLED 1/3/2024

TEST BORING 20
 DATE DRILLED 1/3/2024

REMARKS

REMARKS

DRY TO 20', 1/3/24

DRY TO 20', 1/3/24

SAND, SILTY, TAN, MEDIUM
 DENSE, MOIST

CLAY, SANDY, TAN, STIFF, MOIST

CLAY, SANDY, TAN, STIFF, MOIST

SAND, SILTY, BROWN, MEDIUM
 DENSE to DENSE, MOIST

SAND, SILTY, TAN, DENSE to
 DENSE, MOIST (SANDSTONE,
 WEAK, RESIDUAL SOIL)

Depth (ft)	Symbol	Samples	Blows per foot	Watercontent %	Soil Type
0-5	(Dotted pattern)		20	6.7	1
5-10	(Dotted pattern)		26	8.6	1
10-15	(Diagonal hatching)		15	13.6	2
15-20	(Dotted pattern)		45	7.5	1
20	(Dotted pattern)		50	8.1	1

Depth (ft)	Symbol	Samples	Blows per foot	Watercontent %	Soil Type
0-5	(Diagonal hatching)		7	9.7	2
5-10	(Diagonal hatching)		9	14.7	2
10-15	(Dotted pattern)		16	5.3	1
15-20	(Dotted pattern)		34	4.3	1
20	(Dotted pattern)		15	11.7	1



TEST BORING LOGS
 FLYING HORSE NORTH SKETCH PLAN
 FLYING HORSE DEVELOPMENT

JOB NO.
 220404

FIG. B-10

TEST BORING 21
DATE DRILLED 1/9/2024

TEST BORING 22
DATE DRILLED 1/9/2024

REMARKS

REMARKS

DRY TO 20', 1/9/24

DRY TO 20', 1/9/24

SAND, SILTY, BROWN to TAN,
MEDIUM DENSE to DENSE,
MOIST

SAND, CLAYEY, LIGHT BROWN,
LOOSE, MOIST

Depth (ft)	Symbol	Samples	Blows per foot	Watercontent %	Soil Type
5			11	6.7	1
5			27	4.4	1
10			11	7.8	1
15			36	11.5	1
20			50	8.9	3
			11"		

Depth (ft)	Symbol	Samples	Blows per foot	Watercontent %	Soil Type
5			8	9.4	1
5			10	14.2	2
10			11	10.3	2
15			44	4.7	1
20			50	3.2	4
			9"		

SANDSTONE, VERY WEAK, OLIVE,
HIGHLY WEATHERED (SAND,
SILTY, VERY DENSE, MOIST)

SAND, SILTY, TAN, DENSE, MOIST

SANDSTONE, VERY WEAK, OLIVE,
HIGHLY WEATHERED (SAND,
SILTY, VERY DENSE, MOIST)



TEST BORING LOGS
FLYING HORSE NORTH SKETCH PLAN
FLYING HORSE DEVELOPMENT

JOB NO.
220404

FIG. B-11

TEST BORING 25
 DATE DRILLED 1/9/2024

TEST BORING 26
 DATE DRILLED 1/9/2024

REMARKS

REMARKS

DRY TO 20', 1/9/24

DRY TO 20', 1/9/24

6" TOPSOIL
 CLAY, WITH SAND, BROWN to
 OLIVE, VERY STIFF, MOIST

SAND, CLAYEY, BROWN, MEDIUM
 DENSE, MOIST

SANDSTONE, VERY WEAK, TAN to
 OLIVE, HIGHLY WEATHERED
 (SAND, CLAYEY, VERY DENSE,
 MOIST)

SAND, SILTY, BROWN to TAN,
 MEDIUM DENSE, MOIST

SAND, SILTY, TAN, DENSE to VERY
 DENSE, MOIST (SANDSTONE,
 WEAK, RESIDUAL SOIL)

Depth (ft)	Symbol	Samples	Blows per foot	Watercontent %	Soil Type	Depth (ft)	Symbol	Samples	Blows per foot	Watercontent %	Soil Type
0-6"	Diagonal lines		21	6.2	2	0-6"	Diagonal lines		12	13.0	1
5-10"	Diagonal lines		19	16.4	2	5-10"	Diagonal lines		12	6.2	1
10-15"	Dotted pattern		<u>50</u> 8"	8.1	3	10-15"	Dotted pattern		23	7.7	1
15-20"	Dotted pattern		<u>50</u> 9"	10.0	3	15-20"	Dotted pattern		<u>50</u> 11"	6.8	1
20-24"	Dotted pattern		<u>50</u> 10"	8.9	3	20-24"	Dotted pattern		41	12.6	1



TEST BORING LOGS
 FLYING HORSE NORTH SKETCH PLAN
 FLYING HORSE DEVELOPMENT

JOB NO.
 220404

FIG. B-13

**TABLE C-1
SUMMARY OF LABORATORY TEST RESULTS**

SOIL TYPE	TEST BORING NO.	DEPTH (FT)	WATER (%)	DRY DENSITY (PCF)	PASSING NO. 200 SIEVE (%)	LIQUID LIMIT	PLASTIC LIMIT	PLASTIC INDEX	SULFATE (WT %)	FHA SWELL (PSF)	SWELL/ CONSOL (%)	USCS	SOIL DESCRIPTION
1	18	15			14.8					270		SM	SAND, SILTY
2	20	2-3			64.6							CL	CLAY, SANDY
2	22	5			77.2							CL	CLAY, WITH SAND
2	25	5	16.8	111.3	71.2						-0.3	CL	CLAY, WITH SAND



APPENDIX E: Soil Survey Descriptions

El Paso County Area, Colorado

68—Peyton-Pring complex, 3 to 8 percent slopes

Map Unit Setting

National map unit symbol: 369f

Elevation: 6,800 to 7,600 feet

Farmland classification: Not prime farmland

Map Unit Composition

Peyton and similar soils: 40 percent

Pring and similar soils: 30 percent

Estimates are based on observations, descriptions, and transects of the mapunit.

Description of Peyton

Setting

Landform: Hills

Landform position (three-dimensional): Side slope

Down-slope shape: Linear

Across-slope shape: Linear

Parent material: Arkosic alluvium derived from sedimentary rock and/or arkosic residuum weathered from sedimentary rock

Typical profile

A - 0 to 12 inches: sandy loam

Bt - 12 to 25 inches: sandy clay loam

BC - 25 to 35 inches: sandy loam

C - 35 to 60 inches: sandy loam

Properties and qualities

Slope: 3 to 5 percent

Depth to restrictive feature: More than 80 inches

Drainage class: Well drained

Runoff class: Low

Capacity of the most limiting layer to transmit water

(Ksat): Moderately high (0.20 to 0.60 in/hr)

Depth to water table: More than 80 inches

Frequency of flooding: None

Frequency of ponding: None

Available water supply, 0 to 60 inches: Moderate (about 7.3 inches)

Interpretive groups

Land capability classification (irrigated): None specified

Land capability classification (nonirrigated): 4c

Hydrologic Soil Group: B

Ecological site: R049XY216CO - Sandy Divide

Hydric soil rating: No

Description of Pring

Setting

Landform: Hills

Landform position (three-dimensional): Side slope

Down-slope shape: Linear

Across-slope shape: Linear

Parent material: Arkosic alluvium derived from sedimentary rock

Typical profile

A - 0 to 14 inches: coarse sandy loam

C - 14 to 60 inches: gravelly sandy loam

Properties and qualities

Slope: 3 to 8 percent

Depth to restrictive feature: More than 80 inches

Drainage class: Well drained

Runoff class: Low

Capacity of the most limiting layer to transmit water (Ksat): High
(2.00 to 6.00 in/hr)

Depth to water table: More than 80 inches

Frequency of flooding: None

Frequency of ponding: None

Available water supply, 0 to 60 inches: Low (about 6.0 inches)

Interpretive groups

Land capability classification (irrigated): None specified

Land capability classification (nonirrigated): 3e

Hydrologic Soil Group: B

Ecological site: R048AY222CO - Loamy Park

Hydric soil rating: No

Minor Components

Other soils

Percent of map unit:

Hydric soil rating: No

Pleasant

Percent of map unit:

Landform: Depressions

Hydric soil rating: Yes

Data Source Information

Soil Survey Area: El Paso County Area, Colorado

Survey Area Data: Version 21, Aug 24, 2023