

PRELIMINARY/FINAL DRAINAGE REPORT FOR HIGH PLAINS FILING NO. 1

July 2018

Prepared for:

Savage Development, Inc.
835 Diamond Rim Drive
Colorado Springs, CO 80921

Prepared By:



321 W. Henrietta Ave, Suite A
Woodland Park, CO 80863
719-426-2124

PCD FILE NO's: SP-18-003
SF-18-024

PRELIMINARY/FINAL DRAINAGE REPORT
HIGH PLAINS FILING NO. 1

Engineer's Statement:

The attached drainage plan and report were prepared under my direction and supervision and are correct to the best of my knowledge and belief. Said drainage report has been prepared according the criteria established for drainage reports and said report is in conformity with the master plan of the drainage basin. I accept responsibility for any liability caused by any negligent acts, errors, or omissions on my part in preparing this report.

Certification Statement:

This report and plan for the preliminary and final drainage design for the HIGH PLAINS FILING NO. 1 was prepared by me (or under my direct supervision) in accordance with the provisions of City of Colorado Springs/El Paso County Drainage Criteria Manual Volumes 1 and 2 Drainage Design and Technical Criteria for the owners thereof. I understand that El Paso County does not and will not assume liability for drainage facilities designed by others.

David L. Mijares, Colorado PE #40510
For and on behalf of Catamount Engineering

Date

Developer's Statement:

I, the developer have read and will comply with all of the requirements specified in this drainage report and plan.

Savage Development, Inc. hereby certifies that the drainage facilities for HIGH PLAINS FILING NO. 1 shall be constructed according to the design presented in this report. I understand that El Paso County does not and will not assume liability for the drainage facilities designed and or certified by my engineer and that the El Paso County reviews drainage plans pursuant to Colorado Revised Statutes, Title 30, Article 28; but cannot, on behalf of HIGH PLAINS FILING NO. 1, guarantee that final drainage design review will absolve Savage Development, Inc. and/or their successors and/or assigns of future liability for improper design. I further understand that approval of the final plat does not imply approval of my engineer's drainage design.

Savage Development, Inc.
Business Name

By: Jordan Savage

Title: President

Address: 835 Diamond Rim Drive

Colorado Springs, CO 80921

El Paso County:

Filed in accordance with the requirements of the El Paso County land Development Code and the Drainage Criteria manual Volumes 1 and 2, and the El Paso County Engineering Criteria Manual, latest revision.

Jennifer Irvine, PE
County Engineer/ECM Administrator

Date

Conditions:

PRELIMINARY/FINAL DRAINAGE REPORT for HIGH PLAINS FILING NO. 1

PURPOSE

The purpose of this drainage report is to identify existing drainage patterns, quantify developed storm water runoff, and establish outfall scenarios from the proposed development.

GENERAL LOCATION AND DESCRIPTION

The subject 38.49 acres consists of unplatted land to be developed into 7 rural residential lots (RR-5 zoning) located within the SE ¼ of Section 19, Township 11 South, Range 65 West of the 6th principal meridian in unincorporated El Paso County. The parcel is bounded to the north by unplatted land zoned RR-5, to the east and west by platted RR-5 residential lots, and to the south by Hodgen Road.

The parcel contains an unnamed tributary of the east fork of East Cherry Creek that flows from a dual culvert crossing of Hodgen Road at the southern limits of the parcel to the northeast and exits the parcel along the easterly property line. The site drains directly to the reach of Cherry Creek at slopes between 4% and 25%.

Existing soils on the site consist of Peyton sandy loam, hydrologic soil group B (51%), and Peyton -Pring complex, hydrologic soil group B (49%) as determined by the Natural Resources Conservation Service Web Soil Survey. The site is located within the East Cherry Creek Basin.

The site is sparsely vegetated with native grasses. Some volunteer shrubs and trees are evident within the existing drainage. A swale along the south edge of the project running from west to east and outfalls to the unnamed tributary of East Cherry Creek. The site lies within the East Cherry Creek Basin.

Existing soils on the site consist of Peyton sandy loam, hydrologic soil group B (51%), and Peyton -Pring complex, hydrologic soil group B (49%) as determined by the Natural Resources Conservation Service Web Soil Survey. Hydrologic Group B soils were used in analysis.

A portion of the site lies within an F.E.M.A. designated zone 'A' (unstudied) floodplain per FIRM 08041C0325 F, effective March 17, 1997. A LOMR is in process to develop base flood elevations for the reach and has been included in the appendix. Analysis of the floodplain indicates significant reduction in effective zone 'A' (unstudied) floodplain. The area currently identified as Zone 'A' (unstudied) has been included in a no build easement to be dedicated to El Paso County with plat recordation.

EXISTING DRAINAGE CONDITIONS

No existing studies on the site or overall basin have been identified. The parcel contains two unnamed tributaries to the Cherry Creek Basin. The westerly reach identified as design point SS3 ($Q_{100}=153$ cfs) enters the westerly boundary of the property within an unimproved swale and conveys flows to a confluence with the southerly unnamed tributary within the property. The southerly reach identified as design point SS2 ($Q_{100}=295$ cfs) enters the property through a dual 48" crossing of Hodgen Road installed by El Paso County. No hydrologic or hydraulic analysis was available for the crossing information. Combined flows are conveyed through the property northeasterly to the easterly property boundary (design point SS1, $Q_{100}=357$ cfs). USGS Streamstats modeling developed for the LOMR submittal was utilized in obtaining approximate flows within the reaches.

Basin E1 (22.00 Acres, $Q_2=0.8$ cfs, $Q_5=2.8$ cfs, $Q_{10}=6.2$ cfs, $Q_{25}=10.9$ cfs, $Q_{50}=14.6$ cfs, and $Q_{100}=18.9$ cfs) consists of that portion tributary to the westerly lot line of the parcel and sheetflow directly to the unnamed reach of East Cherry Creek within the parcel.

Basin E2 (5.46 Acres, $Q_2=0.3$ cfs, $Q_5=1.3$ cfs, $Q_{10}=2.8$ cfs, $Q_{25}=4.8$ cfs, $Q_{50}=6.5$ cfs, and $Q_{100}=8.4$ cfs) consists of that portion tributary to the northerly lot line of the parcel and sheetflow directly to the unnamed reach of East Cherry Creek within the parcel.

Basin E3 (1.62 Acres, $Q_2=1.0$ cfs, $Q_5=1.5$ cfs, $Q_{10}=2.2$ cfs, $Q_{25}=3.1$ cfs, $Q_{50}=3.8$ cfs, and $Q_{100}=4.6$ cfs) consists of that portion tributary to the southerly lot line of the parcel west of the channel and sheetflow directly to the unnamed reach of East Cherry Creek within the parcel.

Basin E4 (3.53 Acres, $Q_2=0.9$ cfs, $Q_5=1.6$ cfs, $Q_{10}=2.8$ cfs, $Q_{25}=4.3$ cfs, $Q_{50}=5.5$ cfs, and $Q_{100}=6.9$ cfs) consists of that portion tributary to the southerly lot line of the parcel east of the channel and sheetflow directly to the unnamed reach of East Cherry Creek within the parcel.

Basin E5 (38.49 Acres, $Q_2=2.4$ cfs, $Q_5=9.1$ cfs, $Q_{10}=20.0$ cfs, $Q_{25}=34.9$ cfs, $Q_{50}=46.8$ cfs, and $Q_{100}=60.8$ cfs) consists of the majority of the development parcel which sheetflow directly to the reach of East Cherry Creek within the parcel.

DEVELOPED DRAINAGE BASINS

The majority of the area within basins was modeled as 1-acre residential. Areas identified as no-build were modeled as agricultural land. Roadways and shoulders were modeled as pavement and gravel roadways where proposed.

Basin A1 (5.91 Acres, $Q_2=2.9$ cfs, $Q_5=5.1$ cfs, $Q_{10}=7.3$ cfs, $Q_{25}=10.3$ cfs, $Q_{50}=12.9$ cfs, and $Q_{100}=15.6$ cfs) represents the northwesterly portion of proposed residential lots and the central cul-de-sac. Runoff generated within the basin will sheet flow to the roadside ditch adjacent to the proposed cul-de-sac and be conveyed to a lowpoint at a common lot line within the cul-de-sac bulb at Design Point 3. Flows from Design Point 3 will be conveyed in a 1' deep type 'M' riprap lined swale with swale with 5:1 side slopes and a maximum longitudinal slope of 8.0% directly to the reach of East Cherry Creek.

Basin A2 (0.88 Acres, $Q_2=2.5$ cfs, $Q_5=3.1$ cfs, $Q_{10}=3.7$ cfs, $Q_{25}=4.3$ cfs, $Q_{50}=4.9$ cfs, and $Q_{100}=5.6$ cfs) consists of the westerly half of the proposed north-south roadway. The roadway was modeled assuming ultimate construction to the northerly property line rather than the interim condition of termination at connection with the cul-de-sac connection to allow for appropriate southerly culvert analysis. Sheet flow from the roadway is conveyed south to the proposed culvert triple 30" culvert crossing at Design Point 1. Design point 1 ($Q_{100}=173.9$ cfs) represents the confluence of Basins A2, Basin E1, and Stream Stats Design Point SS3. Flows are conveyed in a 3.5' deep, 5' bottom width channel with a 1% longitudinal slope to the reach of East Cherry Creek.

Basin A3 (3.48 Acres, $Q_2=0.7$ cfs, $Q_5=1.5$ cfs, $Q_{10}=2.6$ cfs, $Q_{25}=4.0$ cfs, $Q_{50}=5.2$ cfs, and $Q_{100}=6.5$ cfs) consists of the southeasterly portion of the residential lots directly tributary to the existing Hodgen Roadside ditch. Combined flows from Basin A-3 and existing Basin E3 are conveyed within the existing roadside ditch directly to the Reach of the East Fork of Cherry Creek at Design Point 2 ($Q_2=2.5$ cfs, $Q_5=3.4$ cfs, $Q_{10}=4.3$ cfs, $Q_{25}=5.5$ cfs, $Q_{50}=6.4$ cfs, and $Q_{100}=7.5$ cfs).

Basin A4 (28.21 Acres, $Q_2=6.8$ cfs, $Q_5=15.0$ cfs, $Q_{10}=24.9$ cfs, $Q_{25}=38.0$ cfs, $Q_{50}=49.3$ cfs, and $Q_{100}=61.4$ cfs) consists of residential, no-build, and roadway areas in the center of the property directly tributary to the Reach of the East Fork of Cherry Creek.

The rational methodology was utilized in analyzing on-site basins for development of on-site improvements not tributary to large off-site basins utilized in channel analysis. The minor increase in impervious area due to roadway and homesite development within the 38.49 acre subdivision would not substantially impact overall channel flows within the 3 square miles contributing to design point SS1. The impact on flow rate at design point SS1 would also be mitigated by substantial increase in time of concentration for runoff calculations within the channel. The rational analysis estimated peak is 60 minutes while the unit hydrograph exhibits a 3.6 hour time of concentration.

Detention is not typically pursued in rural development scenarios unless undetained upstream development would negatively affect the development. A significant portion of runoff generated within typical rural development does not flow directly into County stormwater systems, but leaves improved areas as sheetflow into undeveloped and vegetated portions of lots and infiltrates into the ground. A large pond exists upstream of the development on the main branch of east Cherry Creek further negating the need for on-site detention.

See Appendix for Calculations.

Update narrative. Calculation provided is no longer for a triple culvert. Additionally provide justification that it meets the multiple pipe crossing criteria in ECM 2.6.9G and chapter 9 of CDOT DCM.

Multiple Barrels

Multiple-barrel culverts shall fit within the natural dominant channel with minor widening of the channel to avoid conveyance loss through sediment deposition in some of the barrels. They are to be avoided where:

- The approach flow is high velocity, particularly if supercritical. (these sites require either a single barrel or special inlet treatment to avoid adverse hydraulic jump effects.);
- Irrigation canals or ditches are present unless approved by the canal or ditch owner;
- Fish passage is required unless special treatment is provided to ensure adequate low flows (commonly one barrel is lowered);
- A high potential exists for debris problems (clogging of culvert inlet); or
- A meander bend is present immediately upstream.

PRUDENT LINE ESTABLISHMENT

As mentioned prior, the owner proposes to leave the channel in a natural state to preserve the channel and vegetation as site amenities. In addition, from an runoff and channel stability standpoint it is preferable to keep existing vegetation within the channel and the accompanying natural ecosystems preserved to the maximum extent possible. In order to accomplish this goal, the "Prudent Line" approach is proposed in lieu of constructed channel stabilization techniques being used (e.g. - riprap lining, reconstruction of the channel, drop structure placement). This approach is applicable because large lot development will not greatly impact the hydrology within the reach and the existing upstream detention pond upstream of Hodgen road. No DBPS improvements have been recommended for the East Cherry Creek drainage.

Per the Prudent Line Addendum (PLA), the channel must meet certain criteria for use of the concept (refer to Table 1 in the PLA).

Applicability

1. Does basin have a DBPS?

No, No DBPS has been developed for the East Cherry Creek Basin. Therefore, discussions with the County must be conducted to determine if the prudent line approach is acceptable.

2. Has a County discussion taken place with regards to PLA applicability?

Yes, County staff has determined that prudent line application is applicable for the reach within the development.

3. Is the development density greater than 1 unit per acre? (If yes, a PLA is not applicable)

No, existing and proposed land use density in the watershed is less than 1 unit per acre.

4. Is the channel capacity greater than or equal to the 10 yr storm flow? (If no, a PLA is not applicable)

Yes, the channel has adequate capacity for the 100 yr storm.

5. Is the watershed imperviousness value in less than 15%? (If no, a PLA must be discussed with County engineering staff regarding transition issues)

The existing and future contributing basin imperviousness value is less than 15%. The ECM estimates impervious values for 5-acre lots at 7%.

Transition Issues

Case 1 - Transition between an improved channel reach and a prudent line reach, or vice versa.

This case is not applicable for this site as there is no proposed improved channel reaches upstream or downstream of the limits of this study. If at such a time in the future upstream development requires improvements along their reach; consideration shall be given that this project is being developed with the prudent line concept.

Case 2 - Transition that is necessary at road crossings on a prudent line reach.

As stated in the PLA, considerations must be given to situations where road crossings occur. The existing County installed crossing of Hodgen Road was incorporated in the analysis. Upstream

deposition will be minimized due to presence of existing Franktown parker FPE-2 Reservoir directly upstream of the crossing.

Defining the Prudent Line

The prudent line for the High Plains development was defined considering the 100 yr floodplain boundary, the erosion during a 100 yr event, and the long-term anticipated erosion over a 30 year period.

Maintenance Line

A maintenance line is a way of monitoring the amount of lateral migration from erosion a streambed has incurred. If a channel begins to encroach on the maintenance line from significant hydrologic events or from long-term erosion, corrective measures should be evaluated to ensure the prudent line as proposed in this study is still valid. Such measures include riprap, regarding, revegetation, or other channel stability remedial approaches. The prudent line addendum does not provide a basis for establishing a maintenance line with regards to the prudent line setback. However, it is the recommendation of this study that the line be located at the top of bank where the main channel is basically defined.

Maintenance Access

The PLA requires that maintenance access be provided at each lot line. 20' width easements exist along each property line within the development providing adequate access.

Calculating the Prudent Line

The prudent line calculations performed as a part of this analysis was based on the "Sandy Soil" methodology. A prudent line was developed from the calculations found in the appendix of this report and is shown on the drainage map. In typical scenarios the prudent line is defined as either from the top of the bank of the low flow channel or the 10-YR water surface. Conservatively, the easterly prudent line setback was established from the toe of the channel bank from station 3+50 to station 10+00 where areas of significant slope defined the channel, providing additional buffer.

See Appendix for Prudent Line Calculations.

WATER QUALITY/4-STEP PROCESS

Provide the header of each step as listed in appendix I of ECM

The development addresses Low Impact Development strategies primarily through the utilization of large impervious areas and utilization of landscape swales receiving runoff generated within impervious roadways.

Step 1-

Impervious areas generated within the development will flow across pervious disconnected areas prior to offsite discharge. Runoff generated within roadway improvements will be directed to grassed roadside ditches and conveyed to grassed channels no curb or storm sewer improvements are proposed with the development.

Step2-

Proposed channel improvements are designed at sizes and grades allowing development as grass lined swales rather than hard-sided improvements. The reach of East Cherry Creek that runs through the project is proposed as prudent line setback per the requirements of Appendix J of the El Paso County Engineering Criteria Manual.

Step3-

Permanent water quality facility is not proposed for development of 5 acre lots per the requirements of El Paso County Engineering Criteria Manual section I.7.1B.

Step4-

A Grading, Erosion Control, and Stormwater Quality Plan and narrative have been submitted concurrently for the development and will be subject to county approval prior to any soil disturbance. The erosion control plan included specific source control BMP's as well defined overall site management practices for the construction period.

COST ESTIMATE

Public Improvements Non-reimbursable

30" RCP	247 LF	@\$	75/LF	\$ 18,525
30" FES	8 EA	@\$	350/EA	\$ 2,800
24" RCP	52 LF	@\$	60/LF	\$ 3,120
24" FES	2 EA	@\$	300/EA	\$ 600
Rip Rap Outfall	4 EA	@\$	500/EA	\$ 2,000
Rip Rap Swale	278 LF	@\$	30/LF	\$ 8,340
SUBTOTAL				\$ 35,385
<i>15% CONTINGENCY</i>				<i>\$ 5,308</i>
TOTAL				\$ 40,693

DRAINAGE FEE CALCULATION

The development proposes to plat 38.49 acres within El Paso County, all contained within the East Cherry Creek Drainage Basin. The East Cherry Creek Drainage Basin has not been studied and no drainage or bridge fees have been adopted.

DRAINAGE METHODOLOGY

This drainage report was prepared in accordance to the criteria established in the City of Colorado Springs/El Paso County Drainage Criteria Manual Volumes 1 and 2, as revised May 2014.

The rational method for drainage basin study areas of less than 100 acres was utilized in the on-site analysis. For the Rational Method, flows were calculated for the 2, 5, 10, 25, 50, and 100-year recurrence intervals. The average runoff coefficients, 'C' values, are taken from Table 6-6 and the Intensity-Duration-Frequency curves are taken from Figure 6-5 of the City Drainage Criteria Manual. Time of concentration for overland flow and storm drain or gutter flow are calculated per Section 3.2 of the City Drainage Criteria Manual. Calculations for the Rational Method are shown in the Appendix of this report.

StreamStats version 4 (USGS) was utilized in development of hydrology for off-site basins in floodplain development for FEMA submittal. HEC-RAS version 5.0.1 was utilized in channel and existing culvert modeling developing base flood elevations refining the existing Zone 'A' unstudied floodplain within the development.

SUMMARY

The High Plains Filing No. 1 project consists of large lot development with minor increases in impervious areas consistent with surrounding rural development. The development proposes no development and a setback approach in regards to the reach of the East Cherry Creek drainage within the parcel. A no-build easement has been established outside of the limits of the existing jurisdictional zone 'A' unstudied 100-YR floodplain. A LOMR is in process developing base flood elevations through the reach. Development of the parcel is in conformance of current El Paso County criteria and will not adversely affect downstream properties or facilities.

REFERENCES:

City of Colorado Springs Engineering Division Drainage Criteria Manual Volumes 1 and 2, revised May 2014

“Drainage Study Rockin’ Four-ESE Subdivision El Paso County, Colorado”, prepared by E.L.B. & Asso. Inc., dated April 24, 1980.

“LOMR Case # 18-08-072”, prepared by Catamount Engineering, DRAFT

Flood Insurance rate map 08041C0325 F

Natural Resources Conservation Service Web Soil Survey

APPENDIX

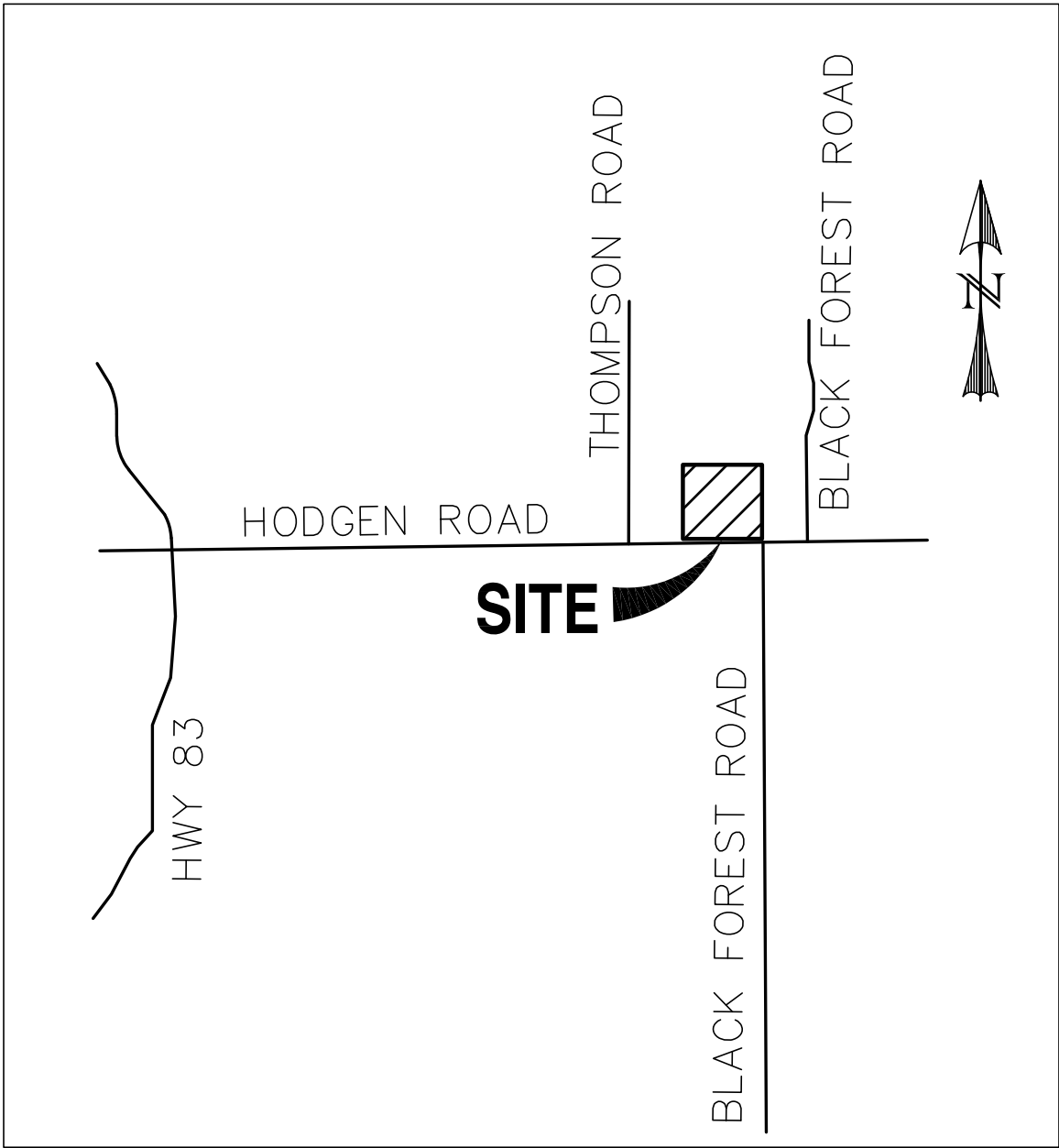

VICINITY MAP

SCALE: N.T.S.

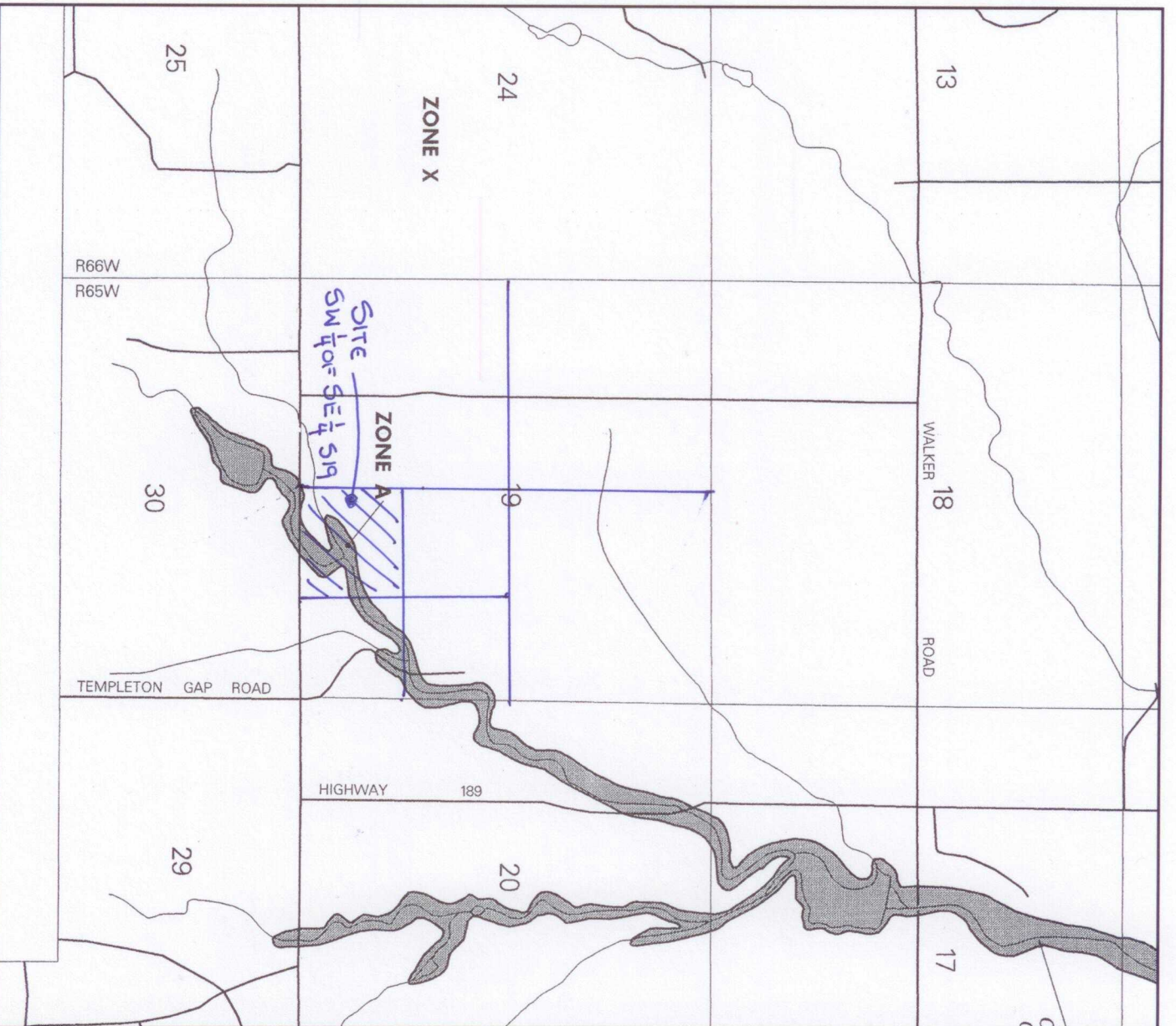

APPROXIMATE SCALE IN FEET
 2000 0 2000

NATIONAL FLOOD INSURANCE PROGRAM

FIRM
FLOOD INSURANCE RATE MAP
 EL PASO COUNTY,
 COLORADO AND
 INCORPORATED AREAS

PANEL 325 OF 1300
 (SEE MAP INDEX FOR PANELS NOT PRINTED)

CONTAINS:
 COMMUNITY NUMBER PANEL SUFFIX
 EL PASO COUNTY 08041C0325 F
 UNINCORPORATED AREAS 080299 0293 F



Federal Emergency Management Agency

MAP NUMBER
 08041C0325 F
 EFFECTIVE DATE:
 MARCH 17, 1997

This is an official copy of a portion of the above referenced flood map. It was extracted using F-MIT On-Line. This map does not reflect changes or amendments which may have been made subsequent to the date on the title block. For the latest product information about National Flood Insurance Program flood maps check the FEMA Flood Map Store at www.nsc.fema.gov

Hydrologic Soil Group—El Paso County Area, Colorado
(HIGH PLAINS FILING NO. 1)

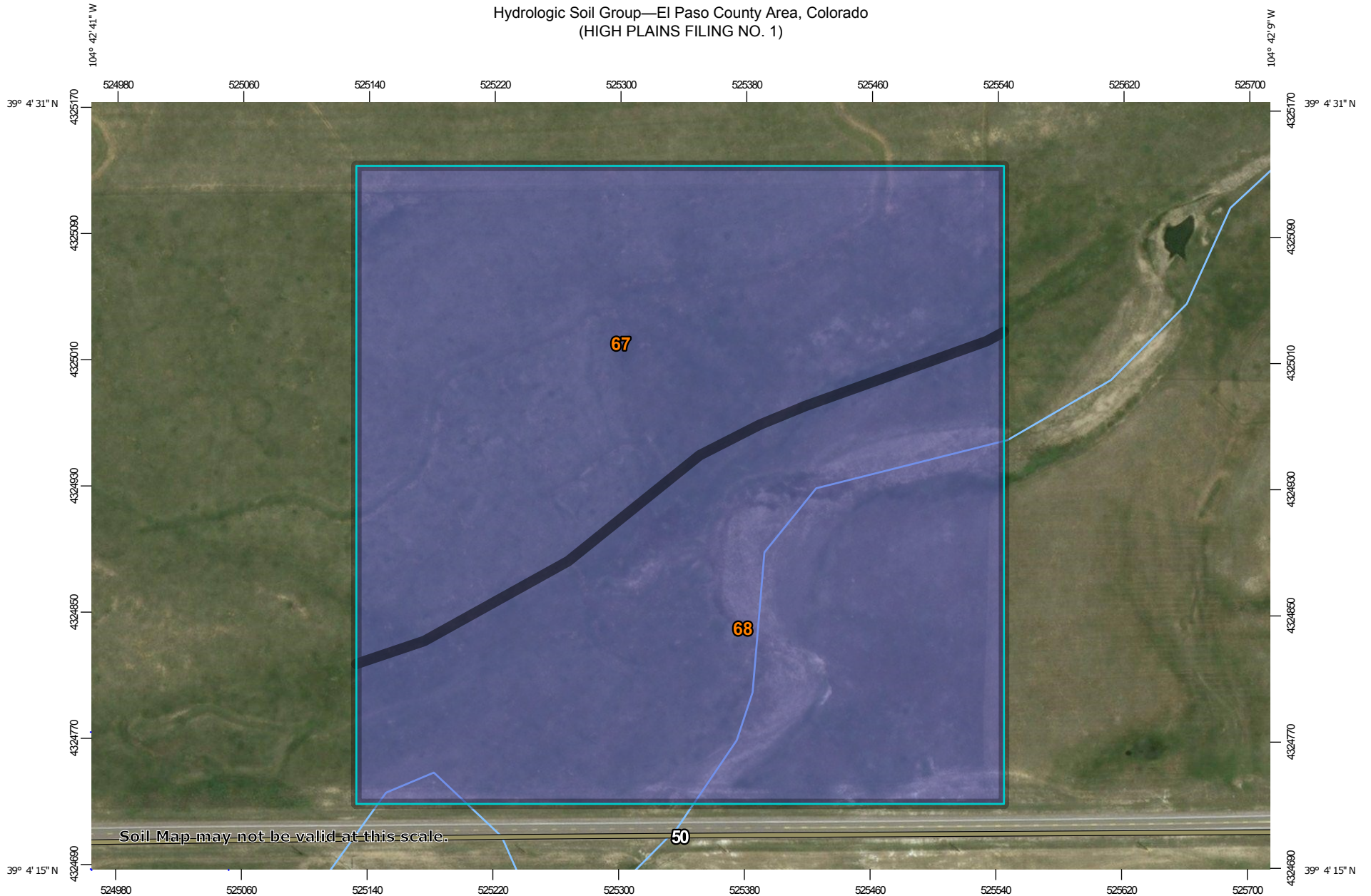

Soil Map may not be valid at this scale.

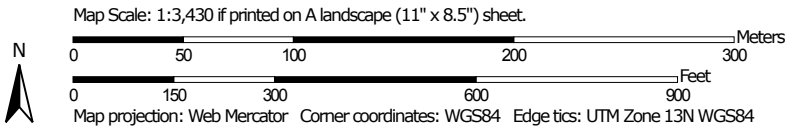

MAP LEGEND

Area of Interest (AOI)









 Area of Interest (AOI)

Soils

Soil Rating Polygons





 A
 A/D
 B
 B/D
 C
 C/D
 D
 Not rated or not available

Soil Rating Lines

 A
 A/D
 B
 B/D
 C
 C/D
 D
 Not rated or not available

Soil Rating Points





 A
 A/D
 B
 B/D

 C
 C/D
 D
 Not rated or not available

Water Features

 Streams and Canals

Transportation

 Rails
 Interstate Highways
 US Routes
 Major Roads
 Local Roads

Background

 Aerial Photography

MAP INFORMATION

The soil surveys that comprise your AOI were mapped at 1:24,000.

Warning: Soil Map may not be valid at this scale.

Enlargement of maps beyond the scale of mapping can cause misunderstanding of the detail of mapping and accuracy of soil line placement. The maps do not show the small areas of contrasting soils that could have been shown at a more detailed scale.

Please rely on the bar scale on each map sheet for map measurements.

Source of Map: Natural Resources Conservation Service
 Web Soil Survey URL:
 Coordinate System: Web Mercator (EPSG:3857)

Maps from the Web Soil Survey are based on the Web Mercator projection, which preserves direction and shape but distorts distance and area. A projection that preserves area, such as the Albers equal-area conic projection, should be used if more accurate calculations of distance or area are required.

This product is generated from the USDA-NRCS certified data as of the version date(s) listed below.

Soil Survey Area: El Paso County Area, Colorado
 Survey Area Data: Version 15, Oct 10, 2017

Soil map units are labeled (as space allows) for map scales 1:50,000 or larger.

Date(s) aerial images were photographed: May 22, 2016—Mar 9, 2017

The orthophoto or other base map on which the soil lines were compiled and digitized probably differs from the background imagery displayed on these maps. As a result, some minor shifting of map unit boundaries may be evident.

Hydrologic Soil Group

Map unit symbol	Map unit name	Rating	Acres in AOI	Percent of AOI
67	Peyton sandy loam, 5 to 9 percent slopes	B	20.9	50.6%
68	Peyton-Pring complex, 3 to 8 percent slopes	B	20.4	49.4%
Totals for Area of Interest			41.4	100.0%

Description

Hydrologic soil groups are based on estimates of runoff potential. Soils are assigned to one of four groups according to the rate of water infiltration when the soils are not protected by vegetation, are thoroughly wet, and receive precipitation from long-duration storms.

The soils in the United States are assigned to four groups (A, B, C, and D) and three dual classes (A/D, B/D, and C/D). The groups are defined as follows:

Group A. Soils having a high infiltration rate (low runoff potential) when thoroughly wet. These consist mainly of deep, well drained to excessively drained sands or gravelly sands. These soils have a high rate of water transmission.

Group B. Soils having a moderate infiltration rate when thoroughly wet. These consist chiefly of moderately deep or deep, moderately well drained or well drained soils that have moderately fine texture to moderately coarse texture. These soils have a moderate rate of water transmission.

Group C. Soils having a slow infiltration rate when thoroughly wet. These consist chiefly of soils having a layer that impedes the downward movement of water or soils of moderately fine texture or fine texture. These soils have a slow rate of water transmission.

Group D. Soils having a very slow infiltration rate (high runoff potential) when thoroughly wet. These consist chiefly of clays that have a high shrink-swell potential, soils that have a high water table, soils that have a claypan or clay layer at or near the surface, and soils that are shallow over nearly impervious material. These soils have a very slow rate of water transmission.

If a soil is assigned to a dual hydrologic group (A/D, B/D, or C/D), the first letter is for drained areas and the second is for undrained areas. Only the soils that in their natural condition are in group D are assigned to dual classes.

Rating Options

Aggregation Method: Dominant Condition

Component Percent Cutoff: None Specified

Tie-break Rule: Higher

EXISTING HYDROLOGY

BASIN	AREA TOTAL (Acres)	CONVEYANCE TC									TT		INTENSITY						TOTAL FLOWS										
		C ₂	C ₅	C ₁₀	C ₂₅	C ₅₀	C ₁₀₀	Length (ft)	Height (ft)	TI (min)	Length (ft)	Height (ft)	C _v	Slope (%)	Velocity (fps)	TC (min)	TOTAL (min)	I ₂ (in/hr)	I ₅ (in/hr)	I ₁₀ (in/hr)	I ₂₅ (in/hr)	I ₅₀ (in/hr)	I ₁₀₀ (in/hr)	Q ₂ (c.f.s.)	Q ₅ (c.f.s.)	Q ₁₀ (c.f.s.)	Q ₂₅ (c.f.s.)	Q ₅₀ (c.f.s.)	Q ₁₀₀ (c.f.s.)
E1 <i>AGRICULTURE</i>	22.00	0.03	0.09	0.17	0.26	0.31	0.36	200	8	17.3	1597	24	5	1.5%	0.6	43.4	60.7	1.1	1.4	1.7	1.9	2.1	2.4	0.8	2.8	6.2	10.9	14.6	18.9
E2 <i>AGRICULTURE</i>	5.46	0.03	0.09	0.17	0.26	0.31	0.36	200	12	15.1	834	35	5	4.2%	1.0	13.6	28.7	2.0	2.5	3.0	3.4	3.8	4.3	0.3	1.3	2.8	4.8	6.5	8.4
E3 <i>AGRICULTURE</i> <i>ROADWAY</i>	1.62 1.25 0.37	0.23 0.03 0.89	0.28 0.09 0.90	0.34 0.17 0.92	0.42 0.26 0.94	0.46 0.31 0.95	0.50 0.36 0.96	100	3	11.0	186	3	5	1.6%	0.6	4.9	15.9	2.7	3.4	4.0	4.6	5.2	5.8	1.0	1.5	2.2	3.1	3.8	4.6
E4 <i>AGRICULTURE</i> <i>ROADWAY</i>	3.53 3.20 0.33	0.11 0.03 0.89	0.17 0.09 0.90	0.24 0.17 0.92	0.32 0.26 0.94	0.37 0.31 0.95	0.42 0.36 0.96	200	7	16.7	610	43	5	7.0%	1.3	7.7	24.4	2.2	2.8	3.3	3.7	4.2	4.7	0.9	1.6	2.8	4.3	5.5	6.9
E5 <i>AGRICULTURE</i>	38.49	0.03	0.09	0.17	0.26	0.31	0.36	200	9	16.6	790	47	5	5.9%	1.2	10.8	27.4	2.1	2.6	3.1	3.5	3.9	4.4	2.4	9.1	20.0	34.9	46.8	60.8

Calculated by: DLM
Date: 7/16/2018

PROPOSED HYDROLOGY

BASIN	AREA TOTAL (Acres)	CONVEYANCE TC							CONVEYANCE TC							TT TOTAL (min)	INTENSITY						TOTAL FLOWS							
		C ₂	C ₅	C ₁₀	C ₂₅	C ₅₀	C ₁₀₀	Length (ft)	Height (ft)	TI (min)	Length (ft)	Height (ft)	C _v	Slope (%)	Velocity (fps)		TC (min)	I ₂ (in/hr)	I ₅ (in/hr)	I ₁₀ (in/hr)	I ₂₅ (in/hr)	I ₅₀ (in/hr)	I ₁₀₀ (in/hr)	Q ₂ (c.f.s.)	Q ₅ (c.f.s.)	Q ₁₀ (c.f.s.)	Q ₂₅ (c.f.s.)	Q ₅₀ (c.f.s.)	Q ₁₀₀ (c.f.s.)	
E1 AGRICULTURE	22.00	0.03	0.09	0.17	0.26	0.31	0.36	200	8	17.3	1597	24	5	1.5%	0.6	43.4	60.7	1.1	1.4	1.7	1.9	2.1	2.4	0.8	2.8	6.2	10.9	14.6	18.9	
E2 AGRICULTURE	5.46	0.03	0.09	0.17	0.26	0.31	0.36	200	12	15.1	834	35	5	4.2%	1.0	13.6	28.7	2.0	2.5	3.0	3.4	3.8	4.3	0.3	1.3	2.8	4.8	6.5	8.4	
E3 AGRICULTURE ROADWAY	1.62 1.25 0.37	0.23 0.03 0.89	0.28 0.09 0.90	0.34 0.17 0.92	0.42 0.26 0.94	0.46 0.31 0.95	0.50 0.36 0.96	100	3	11.0	186	3	5	1.6%	0.6	4.9	15.9	2.7	3.4	4.0	4.6	5.2	5.8	1.0	1.5	2.2	3.1	3.8	4.6	
E4 AGRICULTURE ROADWAY	3.53 3.20 0.33	0.11 0.03 0.89	0.17 0.09 0.90	0.24 0.17 0.92	0.32 0.26 0.94	0.37 0.31 0.95	0.42 0.36 0.96	200	7	16.7	610	43	5	7.0%	1.3	7.7	24.4	2.2	2.8	3.3	3.7	4.2	4.7	0.9	1.6	2.8	4.3	5.5	6.9	
A1 RESIDENTIAL ROADWAY	5.91 5.35 0.56	0.19 0.12 0.89	0.27 0.20 0.90	0.33 0.27 0.92	0.41 0.35 0.94	0.45 0.40 0.95	0.49 0.44 0.96	100	4	10.4	740	35	7	4.7%	1.5	8.1	18.5	2.6	3.2	3.7	4.3	4.8	5.4	2.9	5.1	7.3	10.3	12.9	15.6	
A2 ROADWAY	0.88	0.89	0.90	0.92	0.94	0.95	0.96	40	0.7	2.0	1053	36	10	3.4%	1.8	9.5	11.5	3.1	3.9	4.6	5.2	5.9	6.6	2.5	3.1	3.7	4.3	4.9	5.6	
A3 RESIDENTIAL NO BUILD	3.48 2.16 1.32	0.09 0.12 0.03	0.16 0.20 0.09	0.23 0.27 0.17	0.32 0.35 0.26	0.37 0.40 0.31	0.41 0.44 0.36	100	3	12.7	509	9	5	1.8%	0.7	12.8	25.5	2.2	2.7	3.2	3.6	4.1	4.6	0.7	1.5	2.6	4.0	5.2	6.5	
A4 RESIDENTIAL NO BUILD ROADWAY	28.21 20.92 7.02 0.27	0.10 0.12 0.03 0.89	0.17 0.20 0.09 0.90	0.24 0.27 0.17 0.92	0.32 0.35 0.26 0.94	0.37 0.40 0.31 0.95	0.42 0.44 0.36 0.96	100	6	10.0	693	40	5	5.8%	1.2	9.6	19.6	2.5	3.1	3.6	4.2	4.7	5.2	6.8	15.0	24.9	38.0	49.3	61.4	

Calculated by: DLM
Date: 7/16/2018

DESIGN POINT	AREA TOTAL (Acres)	WEIGHTED						TT	INTENSITY						TOTAL FLOWS						
		C ₂	C ₅	C ₁₀	C ₂₅	C ₅₀	C ₁₀₀	TOTAL (min)	I ₂ (in/hr)	I ₅ (in/hr)	I ₁₀ (in/hr)	I ₂₅ (in/hr)	I ₅₀ (in/hr)	I ₁₀₀ (in/hr)	Q ₂ (c.f.s.)	Q ₅ (c.f.s.)	Q ₁₀ (c.f.s.)	Q ₂₅ (c.f.s.)	Q ₅₀ (c.f.s.)	Q ₁₀₀ (c.f.s.)	
DP-1	22.88	0.06	0.12	0.20	0.29	0.33	0.38	140.0	0.2	0.2	0.2	0.2	0.3	0.3							155.5
BASIN E1	22.00	0.03	0.09	0.17	0.26	0.31	0.36														
BASIN A2	0.88	0.89	0.90	0.92	0.94	0.95	0.96														
DP-SS3	448.00																				153
DP-2	2.50	0.46	0.50	0.55	0.60	0.63	0.66	25.5	2.2	2.7	3.2	3.6	4.1	4.6	2.5	3.4	4.3	5.5	6.4	7.5	
BASIN E3	1.62	0.23	0.28	0.34	0.42	0.46	0.50														
BASIN A3	0.88	0.89	0.90	0.92	0.94	0.95	0.96														
DP-3	5.91	0.19	0.27	0.33	0.41	0.45	0.49	18.5	2.6	3.2	3.7	4.3	4.8	5.4	2.9	5.1	7.3	10.3	12.9	15.6	
BASIN A1	5.91	0.19	0.27	0.33	0.41	0.45	0.49														
SS1	1894.00							216.0													357.0

Calculated by: DLM
Date: 7/16/2018



Federal Emergency Management Agency

Washington, D.C. 20472

November 16, 2018

CERTIFIED MAIL
RETURN RECEIPT REQUESTED

The Honorable Darryl Glenn
President, El Paso County Board of Commissioners
200 South Cascade Avenue, Suite 100
Colorado Springs, CO 80903

IN REPLY REFER TO:

Case No.: 18-08-0702P
Community Name: El Paso County, CO
Community No.: 080059
Effective Date of
This Revision: April 4, 2019

Dear Mr. Glenn:

The Flood Insurance Study report and Flood Insurance Rate Map for your community have been revised by this Letter of Map Revision (LOMR). Please use the enclosed annotated map panel revised by this LOMR for floodplain management purposes and for all flood insurance policies and renewals issued in your community.

Additional documents are enclosed that provide information regarding this LOMR. Please see the List of Enclosures below to determine which documents are included. Other enclosures specific to this request may be included as referenced in the Determination Document. If you have any questions regarding floodplain management regulations for your community or the National Flood Insurance Program (NFIP) in general, please contact the Consultation Coordination Officer for your community. If you have any technical questions regarding this LOMR, please contact the Director, Mitigation Division of the Department of Homeland Security's Federal Emergency Management Agency (FEMA) in Denver, Colorado, at (303) 235-4830, or the FEMA Map Information eXchange (FMIX) toll free at 1-877-336-2627 (1-877-FEMA MAP). Additional information about the NFIP is available on our website at <https://www.fema.gov/national-flood-insurance-program>.

Sincerely,

Patrick "Rick" F. Sacbibit, P.E., Branch Chief
Engineering Services Branch
Federal Insurance and Mitigation Administration

List of Enclosures:

Letter of Map Revision Determination Document
Annotated Flood Insurance Rate Map
Annotated Flood Insurance Study Report

cc: Mr. Keith Curtis, P.E., CFM
Floodplain Administrator
El Paso County

Mr. Jordan Savage, CPA, CMA, CFE
President
Savage Development, Inc.

Mr. David Mijares, P.E.
President
Catamount Engineering



Federal Emergency Management Agency

Washington, D.C. 20472

LETTER OF MAP REVISION DETERMINATION DOCUMENT

COMMUNITY AND REVISION INFORMATION		PROJECT DESCRIPTION	BASIS OF REQUEST
COMMUNITY	El Paso County Colorado (Unincorporated Areas)	NO PROJECT	HYDRAULIC ANALYSIS HYDROLOGIC ANALYSIS UPDATED TOPOGRAPHIC DATA
	COMMUNITY NO.: 080059		
IDENTIFIER	Savage Subdivision	APPROXIMATE LATITUDE AND LONGITUDE: 39.072, -104.707 SOURCE: USGS QUADRANGLE DATUM: NAD 83	
ANNOTATED MAPPING ENCLOSURES		ANNOTATED STUDY ENCLOSURES	
TYPE: FIRM*	NO.: 08041C0305G DATE: December 7, 2018	DATE OF EFFECTIVE FLOOD INSURANCE STUDY: December 7, 2018 PROFILE: 450P SUMMARY OF DISCHARGES TABLE: 4	

Enclosures reflect changes to flooding sources affected by this revision.

* FIRM - Flood Insurance Rate Map

FLOODING SOURCE AND REVISED REACH

Unnamed Tributary to East Cherry Creek - From approximately 2,330 feet downstream of Hodgen Road to approximately 1,630 feet upstream of Hodgen Road

SUMMARY OF REVISIONS

Flooding Source	Effective Flooding	Revised Flooding	Increases	Decreases
Unnamed Tributary to East Cherry Creek	Zone A	Zone A	NONE	YES
	No BFEs*	BFEs	YES	NONE
	Zone A	Zone AE	YES	YES

* BFEs - Base Flood Elevations

DETERMINATION

This document provides the determination from the Department of Homeland Security's Federal Emergency Management Agency (FEMA) regarding a request for a Letter of Map Revision (LOMR) for the area described above. Using the information submitted, we have determined that a revision to the flood hazards depicted in the Flood Insurance Study (FIS) report and/or National Flood Insurance Program (NFIP) map is warranted. This document revises the effective NFIP map, as indicated in the attached documentation. Please use the enclosed annotated map panels revised by this LOMR for floodplain management purposes and for all flood insurance policies and renewals in your community.

This determination is based on the flood data presently available. The enclosed documents provide additional information regarding this determination. If you have any questions about this document, please contact the FEMA Map Information eXchange toll free at 1-877-336-2627 (1-877-FEMA MAP) or by letter addressed to the LOMC Clearinghouse, 3601 Eisenhower Avenue, Suite 500, Alexandria, VA 22304-6426. Additional Information about the NFIP is available on our website at <https://www.fema.gov/national-flood-insurance-program>.

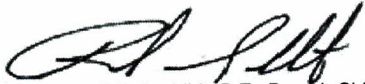
 Patrick "Rick" F. Sacbbit, P.E., Branch Chief
 Engineering Services Branch
 Federal Insurance and Mitigation Administration



Federal Emergency Management Agency

Washington, D.C. 20472

LETTER OF MAP REVISION DETERMINATION DOCUMENT (CONTINUED)

COMMUNITY INFORMATION

APPLICABLE NFIP REGULATIONS/COMMUNITY OBLIGATION

We have made this determination pursuant to Section 206 of the Flood Disaster Protection Act of 1973 (P.L. 93-234) and in accordance with the National Flood Insurance Act of 1968, as amended (Title XIII of the Housing and Urban Development Act of 1968, P.L. 90-448), 42 U.S.C. 4001-4128, and 44 CFR Part 65. Pursuant to Section 1361 of the National Flood Insurance Act of 1968, as amended, communities participating in the NFIP are required to adopt and enforce floodplain management regulations that meet or exceed NFIP criteria. These criteria, including adoption of the FIS report and FIRM, and the modifications made by this LOMR, are the minimum requirements for continued NFIP participation and do not supersede more stringent State/Commonwealth or local requirements to which the regulations apply.

COMMUNITY REMINDERS

We based this determination on the 1-percent-annual-chance discharges computed in the submitted hydrologic model. Future development of projects upstream could cause increased discharges, which could cause increased flood hazards. A comprehensive restudy of your community's flood hazards would consider the cumulative effects of development on discharges and could, therefore, indicate that greater flood hazards exist in this area.

Your community must regulate all proposed floodplain development and ensure that permits required by Federal and/or State/Commonwealth law have been obtained. State/Commonwealth or community officials, based on knowledge of local conditions and in the interest of safety, may set higher standards for construction or may limit development in floodplain areas. If your State/Commonwealth or community has adopted more restrictive or comprehensive floodplain management criteria, those criteria take precedence over the minimum NFIP requirements.

We will not print and distribute this LOMR to primary users, such as local insurance agents or mortgage lenders; instead, the community will serve as a repository for the new data. We encourage you to disseminate the information in this LOMR by preparing a news release for publication in your community's newspaper that describes the revision and explains how your community will provide the data and help interpret the NFIP maps. In that way, interested persons, such as property owners, insurance agents, and mortgage lenders, can benefit from the information.

This determination is based on the flood data presently available. The enclosed documents provide additional information regarding this determination. If you have any questions about this document, please contact the FEMA Map Information eXchange toll free at 1-877-336-2627 (1-877-FEMA MAP) or by letter addressed to the LOMC Clearinghouse, 3601 Eisenhower Avenue, Suite 500, Alexandria, VA 22304-6426. Additional Information about the NFIP is available on our website at <https://www.fema.gov/national-flood-insurance-program>.

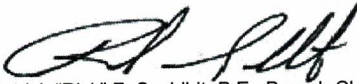
Patrick "Rick" F. Sacibit, P.E., Branch Chief
Engineering Services Branch
Federal Insurance and Mitigation Administration



Federal Emergency Management Agency
Washington, D.C. 20472

**LETTER OF MAP REVISION
DETERMINATION DOCUMENT (CONTINUED)**

We have designated a Consultation Coordination Officer (CCO) to assist your community. The CCO will be the primary liaison between your community and FEMA. For information regarding your CCO, please contact:

Ms. Jeanine D. Petterson
Director, Mitigation Division
Federal Emergency Management Agency, Region VIII
Denver Federal Center, Building 710
P.O. Box 25267
Denver, CO 80225-0267
(303) 235-4830

STATUS OF THE COMMUNITY NFIP MAPS

We will not physically revise and republish the FIRM and FIS report for your community to reflect the modifications made by this LOMR at this time. When changes to the previously cited FIRM panel and FIS report warrant physical revision and republication in the future, we will incorporate the modifications made by this LOMR at that time.

This determination is based on the flood data presently available. The enclosed documents provide additional information regarding this determination. If you have any questions about this document, please contact the FEMA Map Information eXchange toll free at 1-877-336-2627 (1-877-FEMA MAP) or by letter addressed to the LOMC Clearinghouse, 3601 Eisenhower Avenue, Suite 500, Alexandria, VA 22304-6426. Additional information about the NFIP is available on our website at <https://www.fema.gov/national-flood-insurance-program>.

Patrick "Rick" F. Sacbbit, P.E., Branch Chief
Engineering Services Branch
Federal Insurance and Mitigation Administration



Federal Emergency Management Agency

Washington, D.C. 20472

LETTER OF MAP REVISION DETERMINATION DOCUMENT (CONTINUED)

PUBLIC NOTIFICATION OF REVISION

A notice of changes will be published in the *Federal Register*. This information also will be published in your local newspaper on or about the dates listed below, and through FEMA's Flood Hazard Mapping website at https://www.floodmaps.fema.gov/fhm/bfe_status/bfe_main.asp

LOCAL NEWSPAPER

Name: *Colorado Springs Gazette*

Dates: November 28, 2018 and December 5, 2018

Within 90 days of the second publication in the local newspaper, any interested party may request that we reconsider this determination. Any request for reconsideration must be based on scientific or technical data. Therefore, this letter will be effective only after the 90-day appeal period has elapsed and we have resolved any appeals that we receive during this appeal period. Until this LOMR is effective, the revised flood hazard determination presented in this LOMR may be changed.

This determination is based on the flood data presently available. The enclosed documents provide additional information regarding this determination. If you have any questions about this document, please contact the FEMA Map Information eXchange toll free at 1-877-336-2627 (1-877-FEMA MAP) or by letter addressed to the LOMC Clearinghouse, 3601 Eisenhower Avenue, Suite 500, Alexandria, VA 22304-6426. Additional Information about the NFIP is available on our website at <https://www.fema.gov/national-flood-insurance-program>.

A handwritten signature in black ink, appearing to read "Rick F. Sacbibit".

Patrick "Rick" F. Sacbibit, P.E., Branch Chief
Engineering Services Branch
Federal Insurance and Mitigation Administration

Table 4. Summary of Discharges (cont.)

<u>Flooding Source and Location</u>	<u>Drainage Area (Square Miles)</u>	Peak Discharges (Cubic Feet Per Second)			
		<u>10-Year</u>	<u>50-Year</u>	<u>100-Year</u>	<u>500-Year</u>
Unnamed Tributary to Black Squirrel Creek No. 2 At US Highway 24	3.66	-- ¹	-- ¹	1,225	-- ¹
At Rolling Thunder Way	3.60	-- ¹	-- ¹	1,717	-- ¹
At Woodmen Road	3.23	-- ¹	-- ¹	1,482	-- ¹
Upper East Tributary to Chico Creek At Barbwire Road	4.6	-- ¹	-- ¹	705	-- ¹
Upper Fountain Creek (see Fountain Creek)					
West Fork Black Squirrel Creek – Solberg Ranch East Tributary At confluence with West Fork Black Squirrel Creek – Solberg Ranch Tributary	1.63	-- ¹	-- ¹	784	-- ¹
West Fork Black Squirrel Creek – Solberg Ranch Tributary Above Slocum Road	7.22	-- ¹	-- ¹	2,184	-- ¹
At confluence with West Fork Black Squirrel Creek – Solberg Ranch East Tributary	5.59	-- ¹	-- ¹	1,847	-- ¹
West Fork Squirrel Creek – Solberg Ranch – West Unnamed Tributary	1.5	-- ¹	-- ¹	1,935	-- ¹
West Tributary to Black Squirrel Creek At confluence with Black Squirrel Creek	0.59	-- ¹	-- ¹	55	-- ¹
Widefield Creek At confluence with Fountain Creek	15.1	4,600	7,700	10,000	24,000
Williams Canyon At confluence with Fountain Creek	2.68	1,930	3,640	4,710	8,940
Unnamed Tributary to East Cherry Creek Above confluence with Unnamed Tributary At Hodgen Road	2.95	-- ¹	-- ¹	357	-- ¹
	2.07	-- ¹	-- ¹	287	-- ¹

REVISED
REACH →

¹Data not available

REVISED TO
REFLECT LOMR
EFFECTIVE: April 4, 2019

FLOOD PROFILES

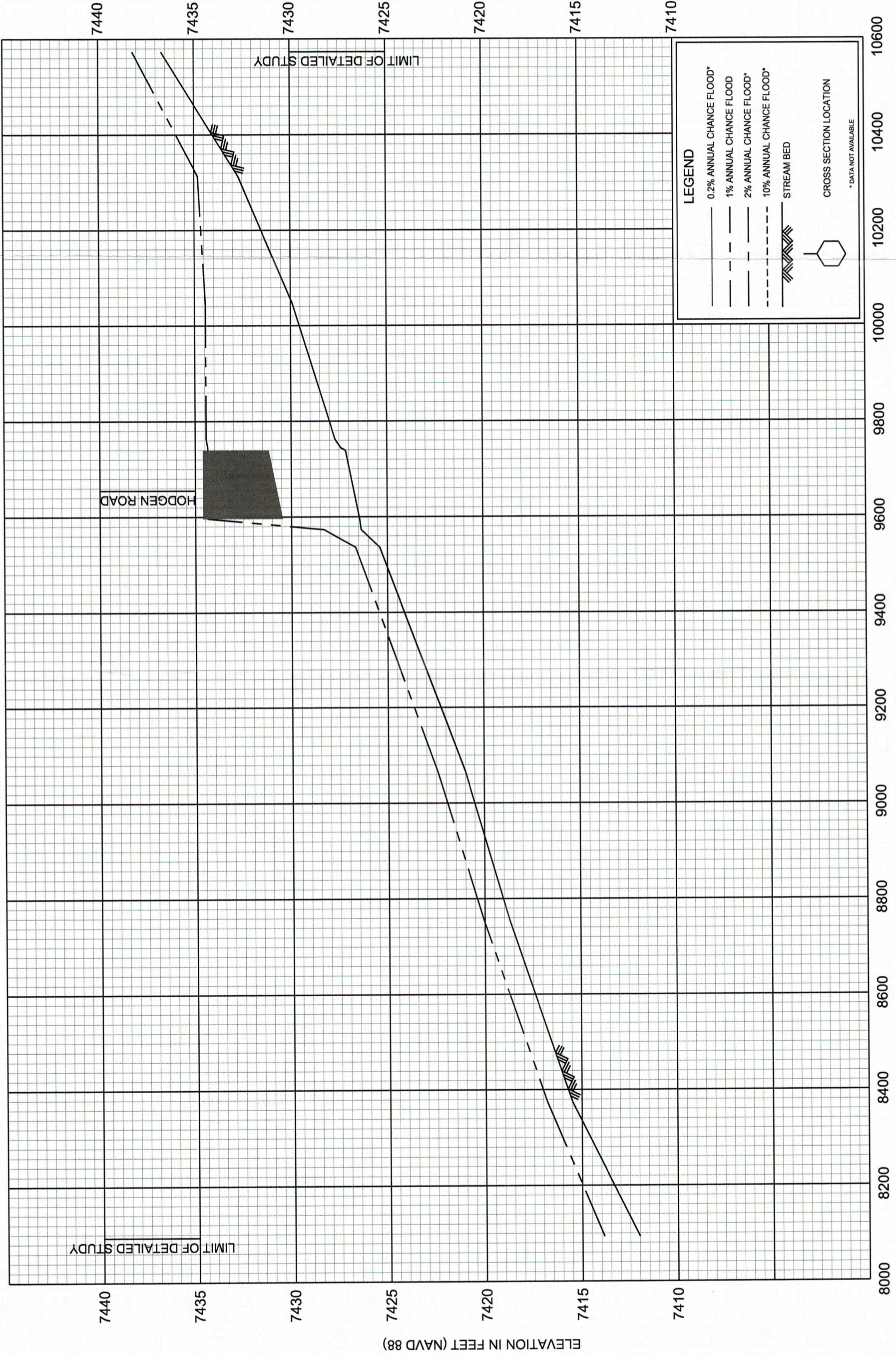

STREAM DISTANCE IN FEET ABOVE CONFLUENCE WITH EAST CHERRY CREEK

ELEVATION IN FEET (NAVD 88)

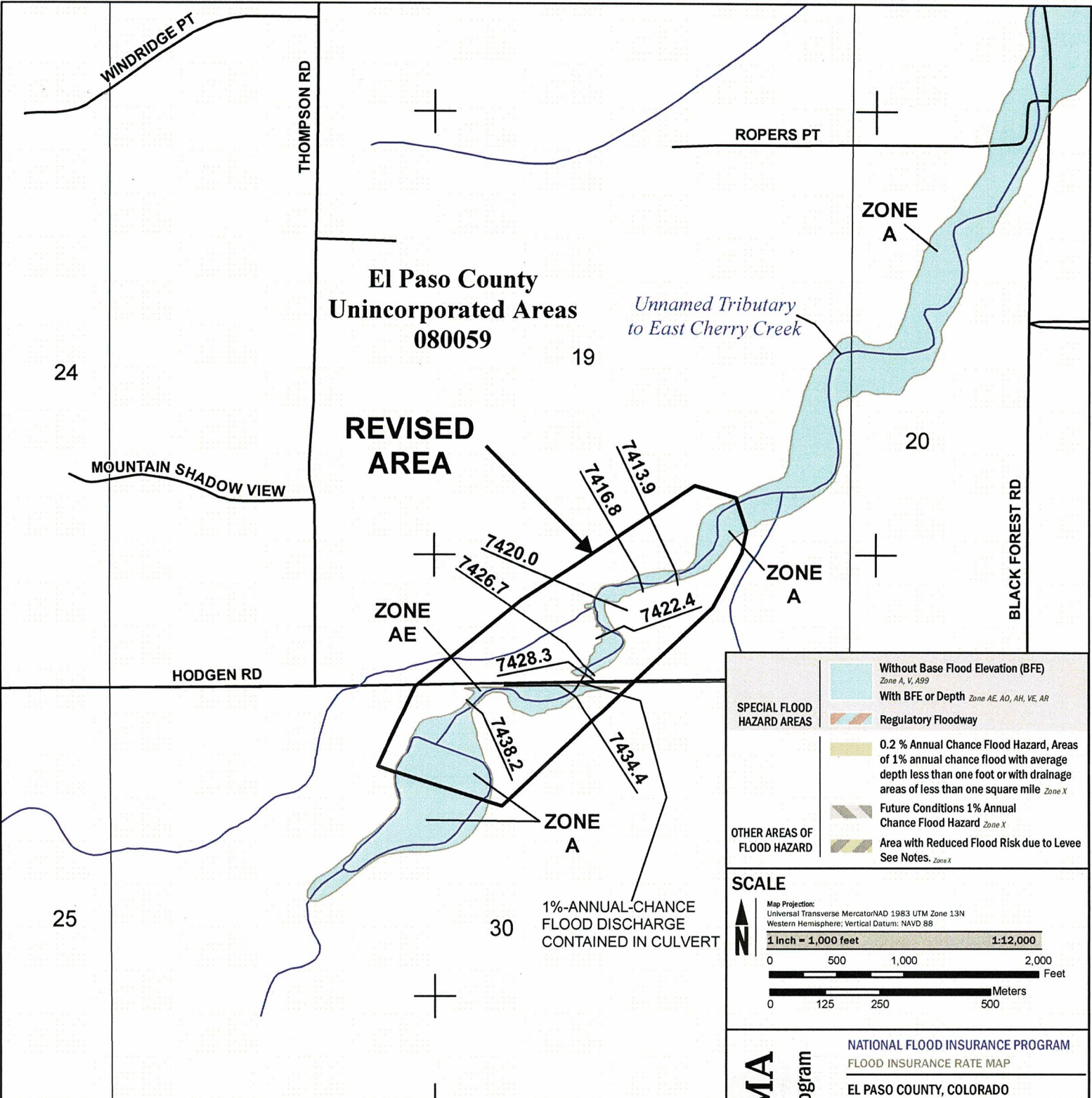

SPECIAL FLOOD HAZARD AREAS

- Without Base Flood Elevation (BFE)
Zone A, V, A99
- With BFE or Depth *Zone AE, AO, AH, VE, AR*
- Regulatory Floodway
- 0.2% Annual Chance Flood Hazard, Areas of 1% annual chance flood with average depth less than one foot or with drainage areas of less than one square mile *Zone X*
- Future Conditions 1% Annual Chance Flood Hazard *Zone X*
- Area with Reduced Flood Risk due to Levee See Notes. *Zone X*

OTHER AREAS OF FLOOD HAZARD

SCALE

Map Projection:
Universal Transverse Mercator NAD 1983 UTM Zone 13N
Western Hemisphere; Vertical Datum: NAVD 88

1 inch = 1,000 feet 1:12,000

0 500 1,000 2,000 Feet

0 125 250 500 Meters

FEMA
National Flood Insurance Program

NATIONAL FLOOD INSURANCE PROGRAM
FLOOD INSURANCE RATE MAP

EL PASO COUNTY, COLORADO
and Incorporated Areas

PANEL 305 OF 1300

Panel Contains:

COMMUNITY	NUMBER	PANEL	SUFFIX
EL PASO COUNTY	080059	0305	G

REVISED TO REFLECT LOMR EFFECTIVE: April 4, 2019

VERSION NUMBER
1.1.1.0

MAP NUMBER
08041C0305G

MAP REVISED
DECEMBER 7, 2018

JOINS PANEL 0315

525'000m E

NOTE: MAP AREA SHOWN ON THIS PANEL IS LOCATED WITHIN TOWNSHIP 11 SOUTH, RANGE 65 WEST, AND TOWNSHIP 11 SOUTH, RANGE 66 WEST.

SAVAGE PROJECT - StreamStats Report 1

Region ID: CO
 Workspace ID: CO20180218171329262000
 Clicked Point (Latitude, Longitude): 39.07488, -104.70275
 Time: 2018-02-18 10:13:45 -0700

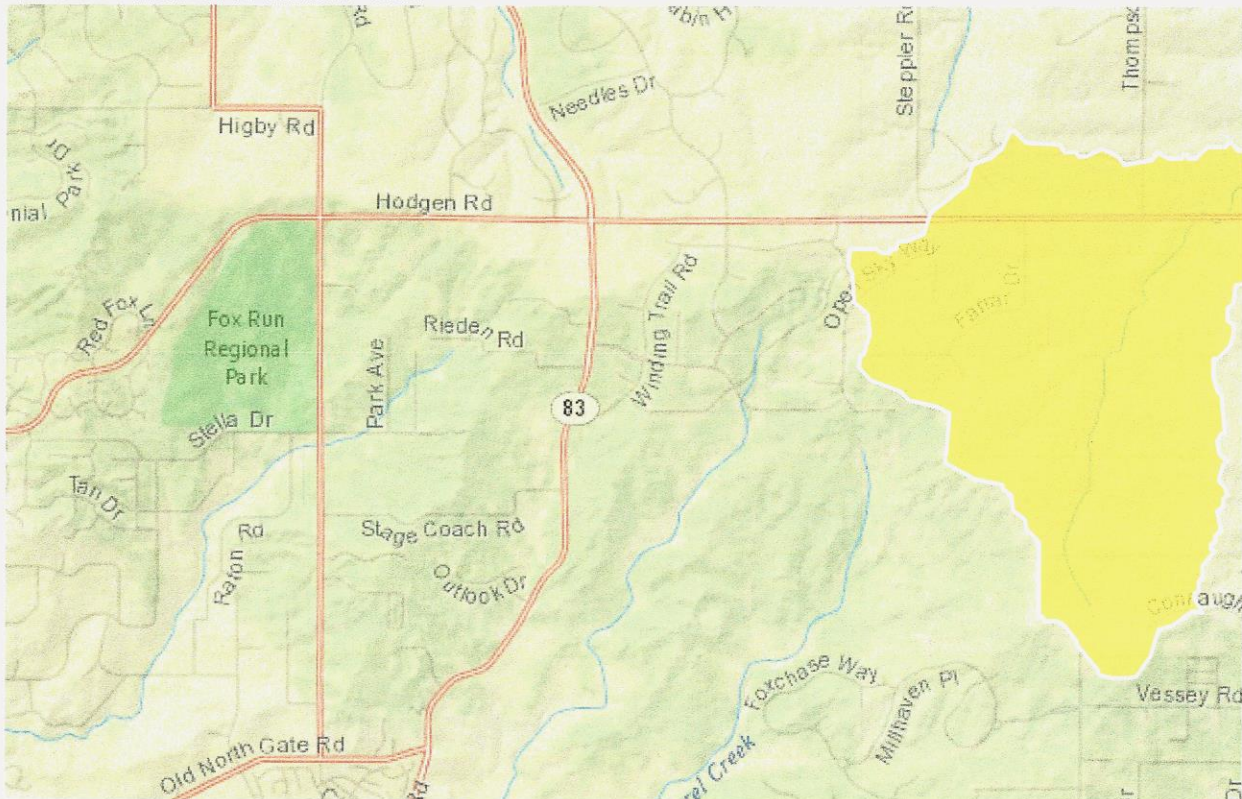

Design Point Above Minor Trib TGap

Basin Characteristics

Parameter Code	Parameter Description	Value	Unit
DRNAREA	Area that drains to a point on a stream	2.96	square miles
16H100Y	6-hour precipitation that is expected to occur on average once in 100 years	3.84	inches
STATSCLAY	Percentage of clay soils from STATSGO	16.3	percent
OUTLETELEV	Elevation of the stream outlet in thousands of feet above NAVD88.	7416	feet
124H100Y	Maximum 24-hour precipitation that occurs on average once in 100 years	4.99	inches

Parameter Code	Parameter Description	Value	Unit
RCN	Runoff-curve number as defined by NRCS (http://policy.nrcs.usda.gov/OpenNonWebContent.aspx?content=17758.wba)	60.68	
TOC	Time of concentration in hours	3.6	
RUNCO_CO	Soil runoff coefficient as defined by Verdin and Gross (2017)	0.25	
LFPLENGTH	Length of longest flow path	3.41	miles
BSLDEM10M	Mean basin slope computed from 10 m DEM	6.42	percent
CSL1085LFP	Change in elevation divided by length between points 10 and 85 percent of distance along the longest flow path to the basin divide, LFP from 2D grid	68	feet per mi
EL7500	Percent of area above 7500 ft	83	percent
ELEV	Mean Basin Elevation	7557	feet
ELEVMAX	Maximum basin elevation	7690	feet
I24H2Y	Maximum 24-hour precipitation that occurs on average once in 2 years - Equivalent to precipitation intensity index	1.92	inches
I6H2Y	Maximum 6-hour precipitation that occurs on average once in 2 years	1.38	
LAT_OUT	Latitude of Basin Outlet	4325125	degrees
LC11BARE	Percentage of barren from NLCD 2011 class 31	0	
LC11CRPHAY	Percentage of cultivated crops and hay, classes 81 and 82, from NLCD 2011	0	percent
LC11DEV	Percentage of developed (urban) land from NLCD 2011 classes 21-24	3.1	percent
LC11FOREST	Percentage of forest from NLCD 2011 classes 41-43	2.1	percent
LC11GRASS	Percent of area covered by grassland/herbaceous using 2011 NLCD	76.1	
LC11IMP	Average percentage of impervious area determined from NLCD 2011 impervious dataset	3.1	percent
LC11SHRUB	Percent of area covered by shrubland using 2011 NLCD	18.7	
LC11SNOIC	Percent snow and ice from NLCD 2011 class 12	0	
LC11WATER	Percent of open water, class 11, from NLCD 2011	0	
LC11WETLND	Percentage of wetlands, classes 90 and 95, from NLCD 2011	0	
LONG_OUT	Longitude of Basin Outlet	525705	degrees
MINBELEV	Minimum basin elevation	7410	feet
PRECIP	Mean Annual Precipitation	20.83	inches
SSURGOA	Percentage of area of Hydrologic Soil Type A from SSURGO	0	percent
SSURGOB	Percentage of area of Hydrologic Soil Type B from SSURGO	91.2	percent
SSURGOC	Percentage of area of Hydrologic Soil Type C from SSURGO	7.1	percent
SSURGOD	Percentage of area of Hydrologic Soil Type D from SSURGO	1.65	percent
STORNHD	Percent storage (wetlands and waterbodies) determined from 1:24K NHD	0.9	percent

General Disclaimers

Upstream regulation was checked for this watershed.

Peak-Flow Statistics Parameters [Foothills Region Peak Flow 2016 5099]

Parameter Code	Parameter Name	Value	Units	Min Limit	Max Limit
DRNAREA	Drainage Area	2.96	square miles	0.6	2850
16H100Y	6 Hour 100 Year Precipitation	3.84	inches	2.38	4.89
STATSCLAY	STATSGO Percentage of Clay Soils	16.3	percent	9.87	37.5
OUTLETELEV	Elevation of Gage	7416	feet	4290	8270

Peak-Flow Statistics Flow Report [Foothills Region Peak Flow 2016 5099]

PII: Prediction Interval-Lower, PIu: Prediction Interval-Upper, SEp: Standard Error of Prediction, SE: Standard Error (other -- see report)

Statistic	Value	Unit	SEp
2 Year Peak Flood	22	ft ³ /s	117
5 Year Peak Flood	61.8	ft ³ /s	87
10 Year Peak Flood	104	ft ³ /s	80
25 Year Peak Flood	181	ft ³ /s	80
50 Year Peak Flood	257	ft ³ /s	83
100 Year Peak Flood	357	ft ³ /s	88
200 Year Peak Flood	474	ft ³ /s	94
500 Year Peak Flood	661	ft ³ /s	104

Peak-Flow Statistics Citations

Kohn, M.S., Stevens, M.R., Harden, T.M., Godaire, J.E., Klinger, R.E., and Mommandi, A., 2016, Paleoflood investigations to improve peak-streamflow regional-regression equations for natural streamflow in eastern Colorado, 2015: U.S. Geological Survey Scientific Investigations Report 2016-5099, 58 p. (<http://dx.doi.org/10.3133/sir20165099>)

High Plains Subdivision Filing No. 1

Region ID: CO

Workspace ID: CO20181017225213162000

Clicked Point (Latitude, Longitude): 39.07165, -104.70965

Time: 2018-10-17 16:52:24 -0600

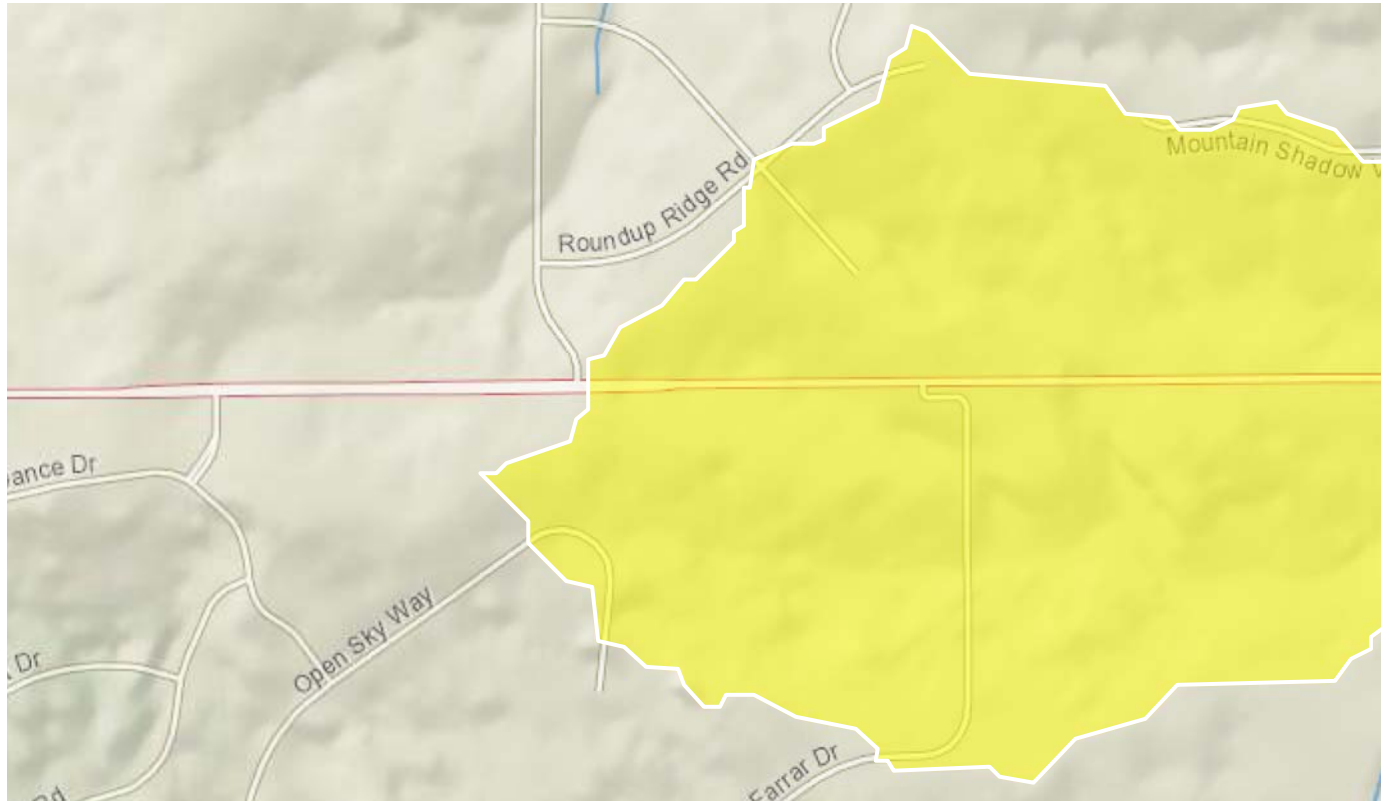

Design Point SS3

Basin Characteristics

Parameter Code	Parameter Description	Value	Unit
DRNAREA	Area that drains to a point on a stream	0.7	square miles
I6H100Y	6-hour precipitation that is expected to occur on average once in 100 years	3.83	inches
STATSCLAY	Percentage of clay soils from STATSGO	16.3	percent
OUTLETELEV	Elevation of the stream outlet in thousands of feet above NAVD88.	7441	feet

Peak-Flow Statistics Parameters [Foothills Region Peak Flow 2016 5099]

Parameter Code	Parameter Name	Value	Units	Min Limit	Max Limit
DRNAREA	Drainage Area	0.7	square miles	0.6	2850
I6H100Y	6 Hour 100 Year Precipitation	3.83	inches	2.38	4.89
STATSCLAY	STATSGO Percentage of Clay Soils	16.3	percent	9.87	37.5
OUTLETELEV	Elevation of Gage	7441	feet	4290	8270

Peak-Flow Statistics Flow Report [Foothills Region Peak Flow 2016 5099]

PI: Prediction Interval-Lower, PIu: Prediction Interval-Upper, SEp: Standard Error of Prediction, SE: Standard Error (other -- see report)

Statistic	Value	Unit	SEp
2 Year Peak Flood	8.82	ft ³ /s	117
5 Year Peak Flood	25.8	ft ³ /s	87
10 Year Peak Flood	44.2	ft ³ /s	80
25 Year Peak Flood	77.3	ft ³ /s	80
50 Year Peak Flood	110	ft ³ /s	83
100 Year Peak Flood	153	ft ³ /s	88
200 Year Peak Flood	204	ft ³ /s	94
500 Year Peak Flood	286	ft ³ /s	104

Peak-Flow Statistics Citations

Kohn, M.S., Stevens, M.R., Harden, T.M., Godaire, J.E., Klinger, R.E., and Mommandi, A., 2016, Paleoflood investigations to improve peak-streamflow regional-regression equations for natural streamflow in eastern Colorado, 2015: U.S. Geological Survey Scientific Investigations Report 2016–5099, 58 p. (<http://dx.doi.org/10.3133/sir20165099>)

USGS Data Disclaimer: Unless otherwise stated, all data, metadata and related materials are considered to satisfy the quality standards relative to the purpose for which the data were collected. Although these data and associated metadata have been reviewed for accuracy and completeness and approved for

release by the U.S. Geological Survey (USGS), no warranty expressed or implied is made regarding the display or utility of the data for other purposes, nor on all computer systems, nor shall the act of distribution constitute any such warranty.

USGS Software Disclaimer: This software has been approved for release by the U.S. Geological Survey (USGS). Although the software has been subjected to rigorous review, the USGS reserves the right to update the software as needed pursuant to further analysis and review. No warranty, expressed or implied, is made by the USGS or the U.S. Government as to the functionality of the software and related material nor shall the fact of release constitute any such warranty. Furthermore, the software is released on condition that neither the USGS nor the U.S. Government shall be held liable for any damages resulting from its authorized or unauthorized use.

USGS Product Names Disclaimer: Any use of trade, firm, or product names is for descriptive purposes only and does not imply endorsement by the U.S. Government.

Application Version: 4.2.1

SAVAGE PROJECT - StreamStats Report3

Region ID: CO
 Workspace ID: CO20180218175120980000
 Clicked Point (Latitude, Longitude): 39.07058, -104.71005
 Time: 2018-02-18 10:51:39 -0700

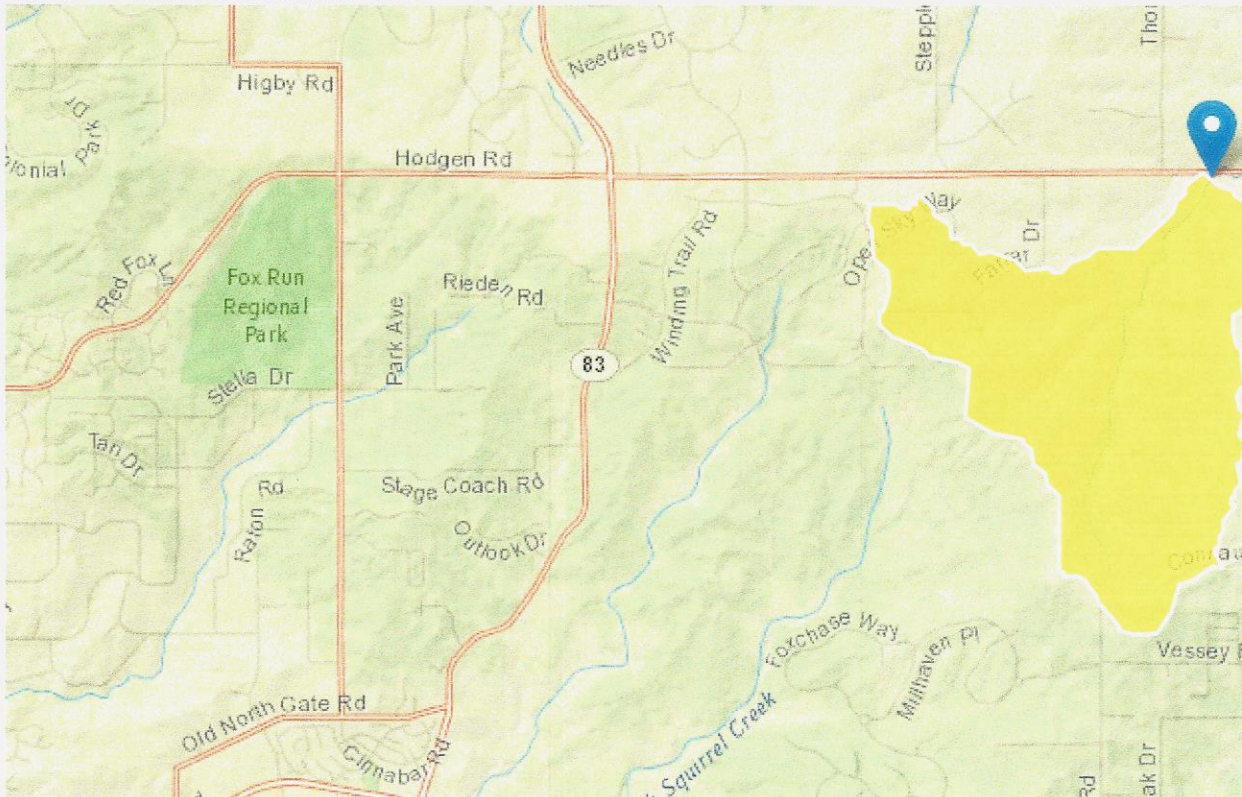

Design Point Above Hodgen

Basin Characteristics			
Parameter Code	Parameter Description	Value	Unit
DRNAREA	Area that drains to a point on a stream	2.07	square miles
16H100Y	6-hour precipitation that is expected to occur on average once in 100 years	3.84	inches
STATSCLAY	Percentage of clay soils from STATSGO	16.3	percent
OUTLETELEV	Elevation of the stream outlet in thousands of feet above NAVD88.	7445	feet
BSLDEM10M	Mean basin slope computed from 10 m DEM	6.52	percent

Parameter Code	Parameter Description	Value	Unit
CSL1085LFP	Change in elevation divided by length between points 10 and 85 percent of distance along the longest flow path to the basin divide, LFP from 2D grid	73.1	feet per mi
EL7500	Percent of area above 7500 ft	90	percent
ELEV	Mean Basin Elevation	7568	feet
ELEVMAX	Maximum basin elevation	7690	feet
I24H100Y	Maximum 24-hour precipitation that occurs on average once in 100 years	5	inches
I24H2Y	Maximum 24-hour precipitation that occurs on average once in 2 years - Equivalent to precipitation intensity index	1.92	inches
I6H2Y	Maximum 6-hour precipitation that occurs on average once in 2 years	1.38	
LAT_OUT	Latitude of Basin Outlet	4324655	degrees
LC11BARE	Percentage of barren from NLCD 2011 class 31	0	
LC11CRPHAY	Percentage of cultivated crops and hay, classes 81 and 82, from NLCD 2011	0	percent
LC11DEV	Percentage of developed (urban) land from NLCD 2011 classes 21-24	1.1	percent
LC11FOREST	Percentage of forest from NLCD 2011 classes 41-43	3.1	percent
LC11GRASS	Percent of area covered by grassland/herbaceous using 2011 NLCD	74	
LC11IMP	Average percentage of impervious area determined from NLCD 2011 impervious dataset	1.2	percent
LC11SHRUB	Percent of area covered by shrubland using 2011 NLCD	21.7	
LC11SNOIC	Percent snow and ice from NLCD 2011 class 12	0	
LC11WATER	Percent of open water, class 11, from NLCD 2011	0	
LC11WETLND	Percentage of wetlands, classes 90 and 95, from NLCD 2011	0	
LFPLENGTH	Length of longest flow path	2.79	miles
LONG_OUT	Longitude of Basin Outlet	525085	degrees
MINBELEV	Minimum basin elevation	7440	feet
PRECIP	Mean Annual Precipitation	20.73	inches
RCN	Runoff-curve number as defined by NRCS (http://policy.nrcs.usda.gov/OpenNonWebContent.aspx?content=17758.wba)	61.04	
RUNCO_CO	Soil runoff coefficient as defined by Verdin and Gross (2017)	0.25	
SSURGOA	Percentage of area of Hydrologic Soil Type A from SSURGO	0	percent
SSURGOB	Percentage of area of Hydrologic Soil Type B from SSURGO	92.2	percent
SSURGOC	Percentage of area of Hydrologic Soil Type C from SSURGO	6.25	percent
SSURGOD	Percentage of area of Hydrologic Soil Type D from SSURGO	1.5	percent
STORNHD	Percent storage (wetlands and waterbodies) determined from 1:24K NHD	1.2	percent

Parameter Code	Parameter Description	Value	Unit
TOC	Time of concentration in hours	3.01	

Peak-Flow Statistics Parameters [Foothills Region Peak Flow 2016 5099]

Parameter Code	Parameter Name	Value	Units	Min Limit	Max Limit
DRNAREA	Drainage Area	2.07	square miles	0.6	2850
I6H100Y	6 Hour 100 Year Precipitation	3.84	inches	2.38	4.89
STATSCLAY	STATSGO Percentage of Clay Soils	16.3	percent	9.87	37.5
OUTLETELEV	Elevation of Gage	7445	feet	4290	8270

Peak-Flow Statistics Flow Report [Foothills Region Peak Flow 2016 5099]

PIl: Prediction Interval-Lower, Plu: Prediction Interval-Upper, SEp: Standard Error of Prediction, SE: Standard Error (other -- see report)

Statistic	Value	Unit	SEp
2 Year Peak Flood	17.4	ft ³ /s	117
5 Year Peak Flood	49.4	ft ³ /s	87
10 Year Peak Flood	83.6	ft ³ /s	80
25 Year Peak Flood	145	ft ³ /s	80
50 Year Peak Flood	207	ft ³ /s	83
100 Year Peak Flood	287	ft ³ /s	88
200 Year Peak Flood	381	ft ³ /s	94
500 Year Peak Flood	532	ft ³ /s	104

Peak-Flow Statistics Citations

Kohn, M.S., Stevens, M.R., Harden, T.M., Godaire, J.E., Klinger, R.E., and Mommandi, A., 2016, Paleoflood investigations to improve peak-streamflow regional-regression equations for natural streamflow in eastern Colorado, 2015: U.S. Geological Survey Scientific Investigations Report 2016-5099, 58 p. (<http://dx.doi.org/10.3133/sir20165099>)

North
1" = 800'

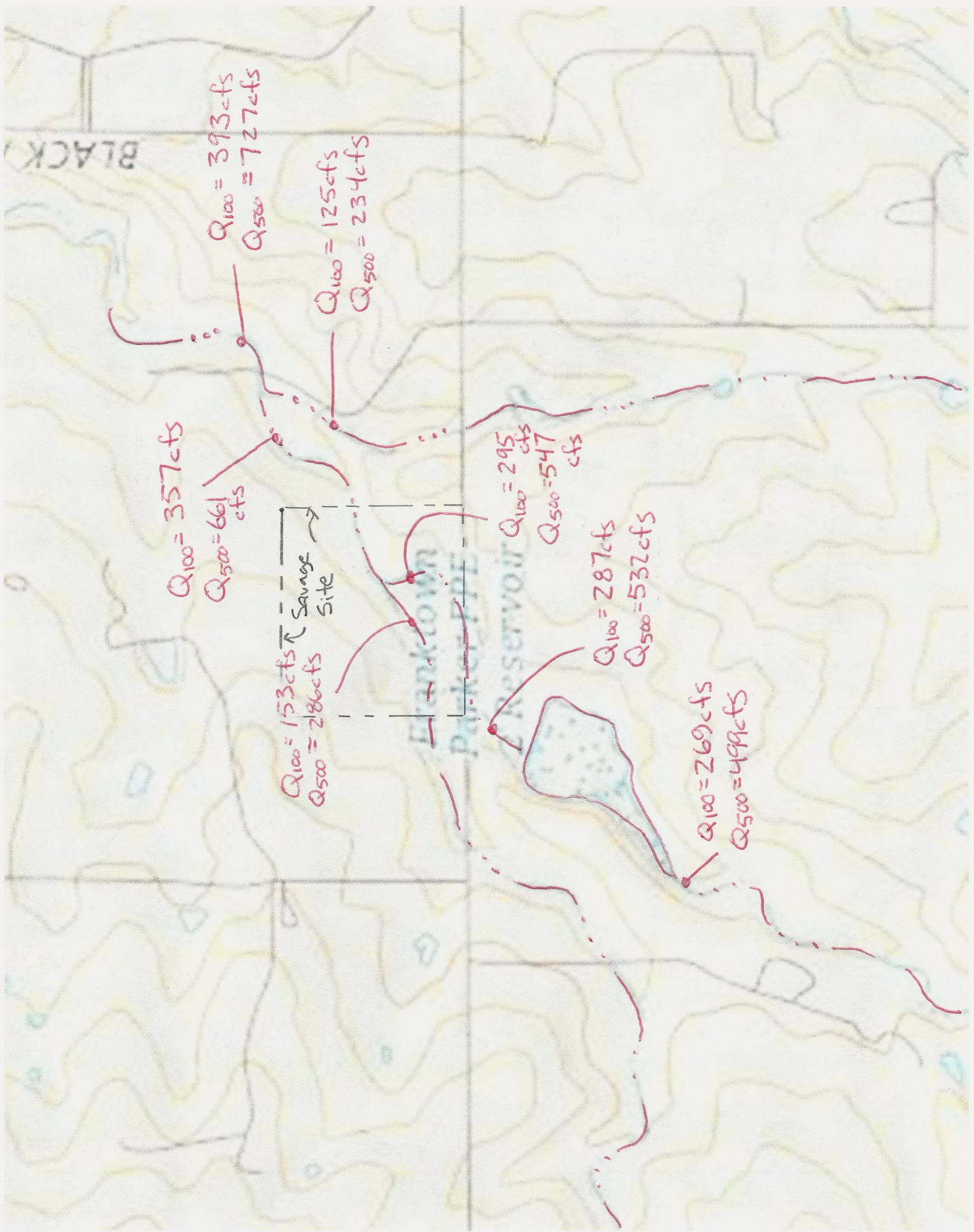

HYDRAULIC CALCULATIONS

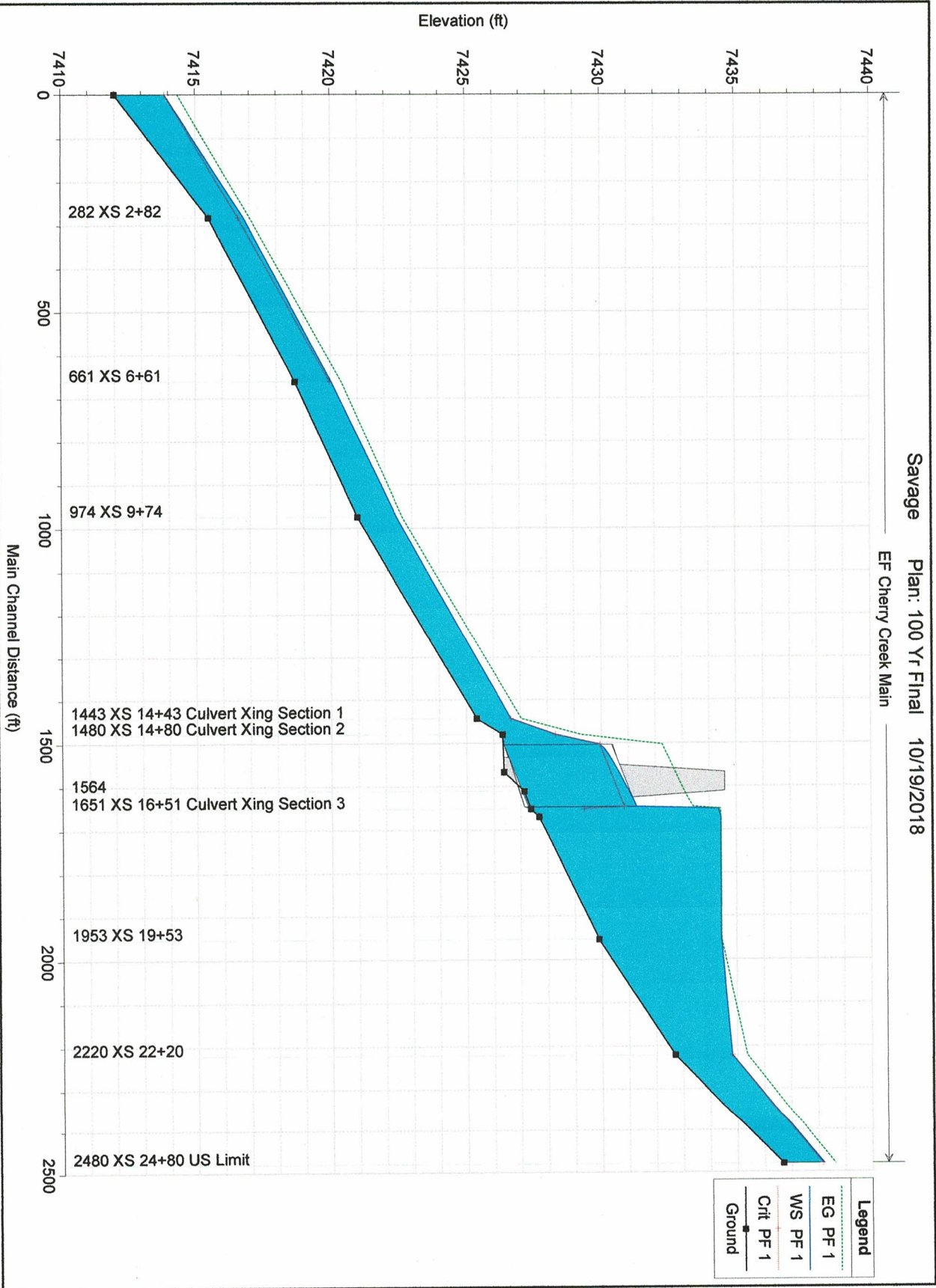

HEC-RAS Plan: 100 Yr Final River: EF Cherry Creek Reach: Main Profile: PF 1

Reach	River Sta	Profile	Q Total (cfs)	Min Ch El (ft)	W/S Elev (ft)	Crit W/S (ft)	E.G. Elev (ft)	E.G. Slope (ft/ft)	Vel Chnl (ft/s)	Flow Area (sq ft)	Top Width (ft)	Froude # Chl
Main	2480	PF 1	287.00	7436.70	7438.21	7438.15	7438.61	0.011838	5.12	56.07	60.44	0.94
Main	2220	PF 1	287.00	7432.70	7434.81	7434.81	7435.37	0.013054	6.01	47.72	43.29	1.01
Main	1953	PF 1	287.00	7429.90	7434.44		7434.45	0.000051	0.86	483.92	299.10	0.08
Main	1869	PF 1	287.00	7427.70	7434.43		7434.44	0.000025	0.68	495.95	133.03	0.05
Main	1651	PF 1	287.00	7427.40	7434.35	7429.35	7434.42	0.000137	2.09	137.08	133.33	0.14
Main	1564		Culvert									
Main	1480	PF 1	287.00	7426.36	7428.30	7428.30	7429.22	0.010459	7.68	37.36	102.86	0.99
Main	1443	PF 1	295.00	7425.40	7426.65	7426.65	7427.05	0.014381	5.04	58.52	74.74	1.00
Main	974	PF 1	295.00	7421.00	7422.44		7422.65	0.004485	3.71	82.43	83.40	0.60
Main	661	PF 1	357.00	7418.70	7420.04	7419.98	7420.41	0.011572	4.89	73.04	82.83	0.92
Main	282	PF 1	357.00	7415.50	7416.80	7416.59	7417.03	0.006957	3.80	93.85	106.04	0.71
Main	0	PF 1	357.00	7412.00	7413.86	7413.86	7414.34	0.013549	5.59	64.34	68.74	1.01

Plan: 100 Yr Final EF Cherry Creek Main RS: 2480 Profile: PF 1

E.G. Elev (ft)	7438.61	Element		Left OB	Channel	Right OB
Vel Head (ft)	0.41	Wt. n-Val.			0.030	
W.S. Elev (ft)	7438.21	Reach Len. (ft)		305.00	260.00	132.00
Crit W.S. (ft)	7438.15	Flow Area (sq ft)			56.07	
E.G. Slope (ft/ft)	0.011838	Area (sq ft)			56.07	
Q Total (cfs)	287.00	Flow (cfs)			287.00	
Top Width (ft)	60.44	Top Width (ft)			60.44	
Vel Total (ft/s)	5.12	Avg. Vel. (ft/s)			5.12	
Max Chl Dpth (ft)	1.50	Hydr. Depth (ft)			0.93	
Conv. Total (cfs)	2637.8	Conv. (cfs)			2637.8	
Length Wtd. (ft)	260.00	Wetted Per. (ft)			60.57	
Min Ch EI (ft)	7436.70	Shear (lb/sq ft)			0.68	
Alpha	1.00	Stream Power (lb/ft s)			3.50	
Frcn Loss (ft)	3.23	Cum Volume (acre-ft)		1.32	6.10	0.51
C & E Loss (ft)	0.02	Cum SA (acres)		1.23	4.13	0.65

Plan: 100 Yr Final EF Cherry Creek Main RS: 2220 Profile: PF 1

E.G. Elev (ft)	7435.37	Element		Left OB	Channel	Right OB
Vel Head (ft)	0.56	Wt. n-Val.			0.030	
W.S. Elev (ft)	7434.81	Reach Len. (ft)		231.00	267.00	245.00
Crit W.S. (ft)	7434.81	Flow Area (sq ft)			47.72	
E.G. Slope (ft/ft)	0.013054	Area (sq ft)			47.72	
Q Total (cfs)	287.00	Flow (cfs)			287.00	
Top Width (ft)	43.29	Top Width (ft)			43.29	
Vel Total (ft/s)	6.01	Avg. Vel. (ft/s)			6.01	
Max Chl Dpth (ft)	2.11	Hydr. Depth (ft)			1.10	
Conv. Total (cfs)	2512.0	Conv. (cfs)			2512.0	

Plan: 100 Yr Final EF Cherry Creek Main RS: 2220 Profile: PF 1 (Continued)

Length Wtd. (ft)	262.14	Wetted Per. (ft)		43.56
Min Ch EI (ft)	7432.70	Shear (lb/sq ft)		0.89
Alpha	1.00	Stream Power (lb/ft s)		5.37
Frcdn Loss (ft)	0.05	Cum Volume (acre-ft)	1.32	5.79
C & E Loss (ft)	0.17	Cum SA (acres)	1.23	3.82
				0.65

Plan: 100 Yr Final EF Cherry Creek Main RS: 1953 Profile: PF 1

	Element	Left OB	Channel	Right OB
E.G. Elev (ft)	7434.45			
Vel Head (ft)	0.01	0.044	0.030	0.045
W.S. Elev (ft)	7434.44	Reach Len. (ft)	245.00	284.00
Crit W.S. (ft)		Flow Area (sq ft)	188.29	239.37
E.G. Slope (ft/ft)	0.000051	Area (sq ft)	188.29	239.37
Q Total (cfs)	287.00	Flow (cfs)	70.44	204.99
Top Width (ft)	299.10	Top Width (ft)	166.58	63.40
Vel Total (ft/s)	0.59	Avg. Vel. (ft/s)	0.37	0.86
Max Chl Dpth (ft)	4.54	Hydr. Depth (ft)	1.13	3.78
Conv. Total (cfs)	40142.9	Conv. (cfs)	9852.1	28672.5
Length Wtd. (ft)	278.40	Wetted Per. (ft)	166.82	63.65
Min Ch EI (ft)	7429.90	Shear (lb/sq ft)	0.00	0.01
Alpha	1.59	Stream Power (lb/ft s)	0.00	0.01
Frcdn Loss (ft)	0.01	Cum Volume (acre-ft)	0.82	4.91
C & E Loss (ft)	0.00	Cum SA (acres)	0.78	3.49
				0.45

Plan: 100 Yr Final EF Cherry Creek Main RS: 1669 Profile: PF 1

E.G. Elev (ft)	7434.44	Element	Left OB	Channel	Right OB
Vel Head (ft)	0.01	Wt. n-Val.	0.045	0.032	0.045
W.S. Elev (ft)	7434.43	Reach Len. (ft)	18.00	18.00	18.00
Crit W.S. (ft)		Flow Area (sq ft)	83.73	376.96	35.26
E.G. Slope (ft/ft)	0.000025	Area (sq ft)	83.73	376.96	35.26
Q Total (cfs)	287.00	Flow (cfs)	22.59	256.20	8.21
Top Width (ft)	133.03	Top Width (ft)	39.46	73.00	20.57
Vel Total (ft/s)	0.58	Avg. Vel. (ft/s)	0.27	0.68	0.23
Max Chl Dpth (ft)	6.73	Hydr. Depth (ft)	2.12	5.16	1.71
Conv. Total (cfs)	57748.8	Conv. (cfs)	4545.8	51550.7	1652.3
Length Wtd. (ft)	18.00	Wetted Per. (ft)	39.72	73.63	20.85
Min Ch El (ft)	7427.70	Shear (lb/sq ft)	0.00	0.01	0.00
Alpha	1.25	Stream Power (lb/ft s)	0.00	0.01	0.00
Frctn Loss (ft)	0.00	Cum Volume (acre-ft)	0.06	2.90	0.03
C & E Loss (ft)	0.02	Cum SA (acres)	0.20	3.05	0.14

Plan: 100 Yr Final EF Cherry Creek Main RS: 1651 Profile: PF 1

E.G. Elev (ft)	7434.42	Element	Left OB	Channel	Right OB
Vel Head (ft)	0.07	Wt. n-Val.		0.030	
W.S. Elev (ft)	7434.35	Reach Len. (ft)	164.00	171.00	167.00
Crit W.S. (ft)	7429.35	Flow Area (sq ft)		137.08	
E.G. Slope (ft/ft)	0.000137	Area (sq ft)	115.33	382.98	25.12
Q Total (cfs)	287.00	Flow (cfs)		287.00	
Top Width (ft)	133.33	Top Width (ft)	48.45	65.00	19.88
Vel Total (ft/s)	2.09	Avg. Vel. (ft/s)		2.09	
Max Chl Dpth (ft)	6.95	Hydr. Depth (ft)		6.85	
Conv. Total (cfs)	24493.6	Conv. (cfs)		24493.6	

Plan: 100 Yr Final EF Cherry Creek Main RS: 1651 Profile: PF 1 (Continued)

Length Wtd. (ft)	171.00	Wetted Per. (ft)	20.00	
Min Ch El (ft)	7427.40	Shear (lb/sq ft)	0.06	
Alpha	1.00	Stream Power (lb/ft s)	0.12	
Frctn Loss (ft)		Cum Volume (acre-ft)	0.02	0.02
C & E Loss (ft)		Cum SA (acres)	0.19	3.02
				0.13

Plan: 100 Yr Final EF Cherry Creek Main RS: 1480 Profile: PF 1

E.G. Elev (ft)	7429.22	Element	Left OB	Channel	Right OB
Vel Head (ft)	0.92	Wt. n-Val.		0.030	
W.S. Elev (ft)	7428.30	Reach Len. (ft)	53.00	37.00	40.00
Crit W.S. (ft)	7428.30	Flow Area (sq ft)		37.36	
E.G. Slope (ft/ft)	0.010459	Area (sq ft)	14.62	124.41	0.64
Q Total (cfs)	287.00	Flow (cfs)		287.00	
Top Width (ft)	102.86	Top Width (ft)	22.46	77.50	2.91
Vel Total (ft/s)	7.68	Avg. Vel. (ft/s)		7.68	
Max Chl Dpth (ft)	1.94	Hydr. Depth (ft)		1.87	
Conv. Total (cfs)	2806.3	Conv. (cfs)		2806.3	
Length Wtd. (ft)	37.00	Wetted Per. (ft)		20.00	
Min Ch El (ft)	7426.36	Shear (lb/sq ft)		1.22	
Alpha	1.00	Stream Power (lb/ft s)		9.37	
Frctn Loss (ft)	0.45	Cum Volume (acre-ft)	0.02	2.60	0.02
C & E Loss (ft)	0.26	Cum SA (acres)	0.05	2.74	0.09

Plan: 100 Yr Final EF Cherry Creek Main RS: 1443 Profile: PF 1

E.G. Elev (ft)	7427.05	Element	Left OB	Channel	Right OB
Vel Head (ft)	0.39	Wt. n-Val.		0.030	
W.S. Elev (ft)	7426.65	Reach Len. (ft)	268.00	469.00	453.00
Crit W.S. (ft)	7426.65	Flow Area (sq ft)		58.52	
E.G. Slope (ft/ft)	0.014381	Area (sq ft)		58.52	
Q Total (cfs)	295.00	Flow (cfs)		295.00	
Top Width (ft)	74.74	Top Width (ft)		74.74	
Vel Total (ft/s)	5.04	Avg. Vel. (ft/s)		5.04	
Max Chl Dpth (ft)	1.25	Hydr. Depth (ft)		0.78	
Conv. Total (cfs)	2459.9	Conv. (cfs)		2459.9	
Length Wtd. (ft)	468.64	Wetted Per. (ft)		74.84	
Min Ch EI (ft)	7425.40	Shear (lb/sq ft)		0.70	
Alpha	1.00	Stream Power (lb/ft s)		3.54	
Froth Loss (ft)	3.46	Cum Volume (acre-ft)	0.01	2.52	0.02
C & E Loss (ft)	0.05	Cum SA (acres)	0.04	2.68	0.08

Plan: 100 Yr Final EF Cherry Creek Main RS: 974 Profile: PF 1

E.G. Elev (ft)	7422.65	Element	Left OB	Channel	Right OB
Vel Head (ft)	0.21	Wt. n-Val.	0.045	0.030	0.045
W.S. Elev (ft)	7422.44	Reach Len. (ft)	278.00	313.00	173.00
Crit W.S. (ft)		Flow Area (sq ft)	1.13	78.71	2.59
E.G. Slope (ft/ft)	0.004485	Area (sq ft)	1.13	78.71	2.59
Q Total (cfs)	295.00	Flow (cfs)	0.90	292.01	2.09
Top Width (ft)	83.40	Top Width (ft)	5.13	66.47	11.81
Vel Total (ft/s)	3.58	Avg. Vel. (ft/s)	0.80	3.71	0.80
Max Chl Dpth (ft)	1.44	Hydr. Depth (ft)	0.22	1.18	0.22
Conv. Total (cfs)	4405.2	Conv. (cfs)	13.5	4360.5	31.2

Plan: 100 Yr Final EF Cherry Creek Main RS: 974 Profile: PF 1 (Continued)

Length Wtd. (ft)	312.50	Wetted Per. (ft)	5.15	66.53	11.82
Min Ch EI (ft)	7421.00	Shear (lb/sq ft)	0.06	0.33	0.06
Alpha	1.06	Stream Power (lb/ft s)	0.05	1.23	0.05
Frcn Loss (ft)	2.23	Cum Volume (acre-ft)	0.01	1.78	0.01
C & E Loss (ft)	0.02	Cum SA (acres)	0.02	1.92	0.02

Plan: 100 Yr Final EF Cherry Creek Main RS: 661 Profile: PF 1

E.G. Elev (ft)	7420.41	Element	Left OB	Channel	Right OB
Vel Head (ft)	0.37	Wt. n-Val.		0.030	
W.S. Elev (ft)	7420.04	Reach Len. (ft)	390.00	379.00	189.00
Crit W.S. (ft)	7419.98	Flow Area (sq ft)		73.04	
E.G. Slope (ft/ft)	0.011572	Area (sq ft)		73.04	
Q Total (cfs)	357.00	Flow (cfs)		357.00	
Top Width (ft)	82.83	Top Width (ft)		82.83	
Vel Total (ft/s)	4.89	Avg. Vel. (ft/s)		4.89	
Max Chl Dpth (ft)	1.34	Hydr. Depth (ft)		0.88	
Conv. Total (cfs)	3318.7	Conv. (cfs)		3318.7	
Length Wtd. (ft)	379.00	Wetted Per. (ft)		83.12	
Min Ch EI (ft)	7418.70	Shear (lb/sq ft)		0.63	
Alpha	1.00	Stream Power (lb/ft s)		3.10	
Frcn Loss (ft)	3.35	Cum Volume (acre-ft)	0.00	1.24	
C & E Loss (ft)	0.04	Cum SA (acres)	0.01	1.38	

Plan: 100 Yr Final EF Cherry Creek Main RS: 282 Profile: PF 1

	Element	Left OB	Channel	Right OB
E.G. Elev (ft)	7417.03		0.030	
Vel Head (ft)	0.22			
W.S. Elev (ft)	7416.80	294.00	282.00	256.00
Crit W.S. (ft)	7416.59		93.85	
E.G. Slope (ft/ft)	0.006957	0.00	93.85	
Q Total (cfs)	357.00		357.00	
Top Width (ft)	106.04		106.04	
Vel Total (ft/s)	3.80		3.80	
Max Chl Dpth (ft)	1.30		0.89	
Conv. Total (cfs)	4280.2		4280.2	
Length Wtd. (ft)	282.02		106.21	
Min Ch El (ft)	7415.50		0.38	
Alpha	1.00		1.46	
Frcn Loss (ft)	2.66	0.00	0.51	
C & E Loss (ft)	0.03	0.01	0.56	

Plan: 100 Yr Final EF Cherry Creek Main RS: 0 Profile: PF 1

	Element	Left OB	Channel	Right OB
E.G. Elev (ft)	7414.34			
Vel Head (ft)	0.48	0.045	0.030	
W.S. Elev (ft)	7413.86			
Crit W.S. (ft)	7413.86	0.72	63.63	
E.G. Slope (ft/ft)	0.013549	0.72	63.63	
Q Total (cfs)	357.00	1.28	355.72	
Top Width (ft)	68.74	2.19	66.55	
Vel Total (ft/s)	5.55	1.78	5.59	
Max Chl Dpth (ft)	1.86	0.33	0.96	
Conv. Total (cfs)	3067.0	11.0	3056.1	

Plan: 100 Yr Final EF Cherry Creek Main RS: 0 Profile: PF 1 (Continued)

Length W/d. (ft)		Wetted Per. (ft)	2.28	66.62	
Min Ch EI (ft)	7412.00	Shear (lb/sq ft)	0.27	0.81	
Alpha	1.01	Stream Power (lb/ft s)	0.47	4.52	
Frcn Loss (ft)		Cum Volume (acre-ft)			
C & E Loss (ft)		Cum SA (acres)			

Savage Plan: 100 Yr Final 10/19/2018
 River = EF Cherry Creek Reach = Main RS = 2480 XS 24+80 US Limit

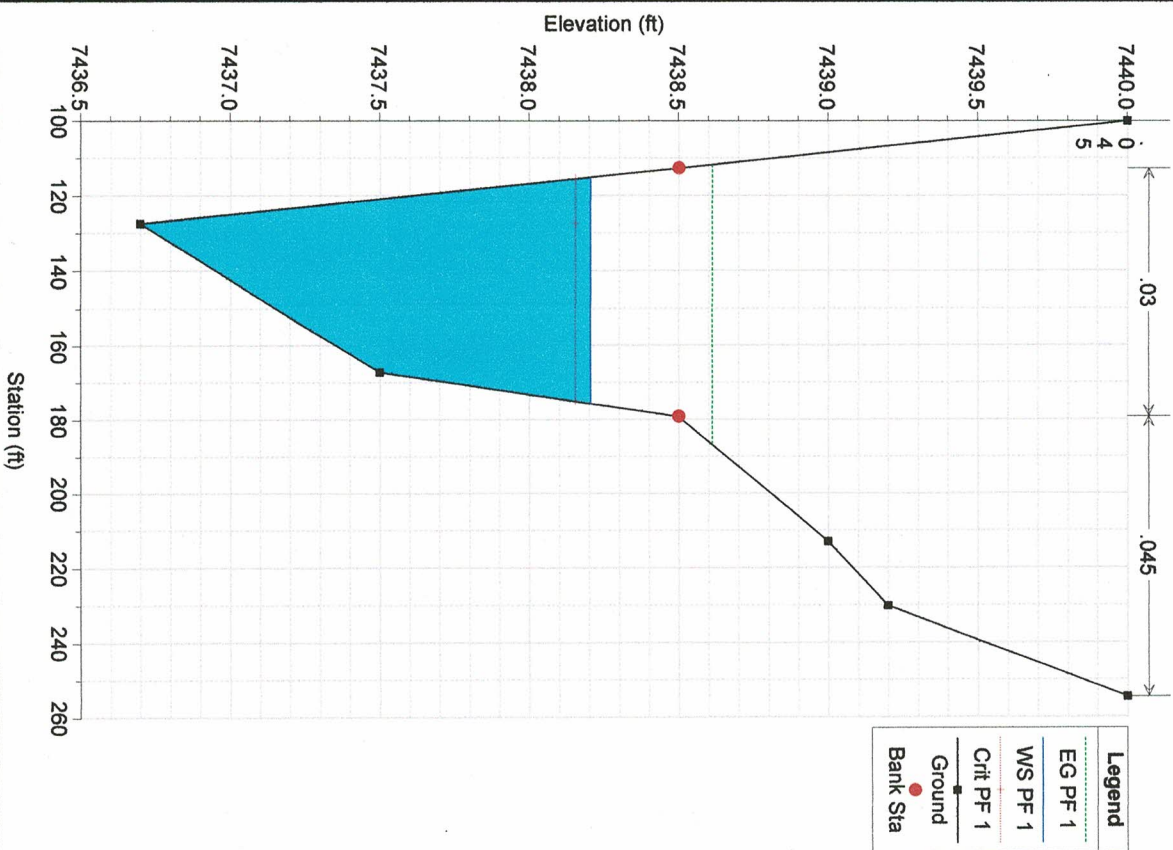

Savage Plan: 100 Yr Final 10/19/2018
 River = EF Cherry Creek Reach = Main RS = 2220 XS 22+20

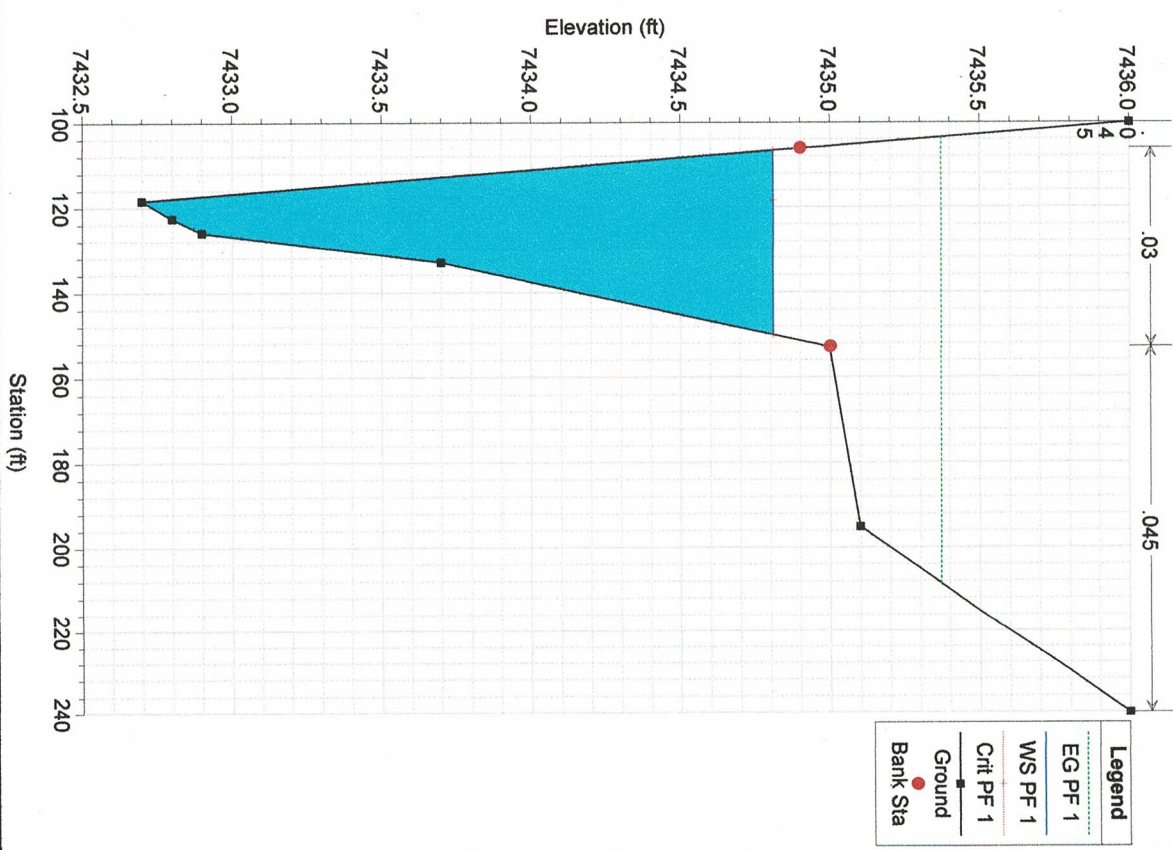

Savage Plan: 100 Yr Final 10/19/2018
 River = EF Cherry Creek Reach = Main RS = 1953 XS 19+53

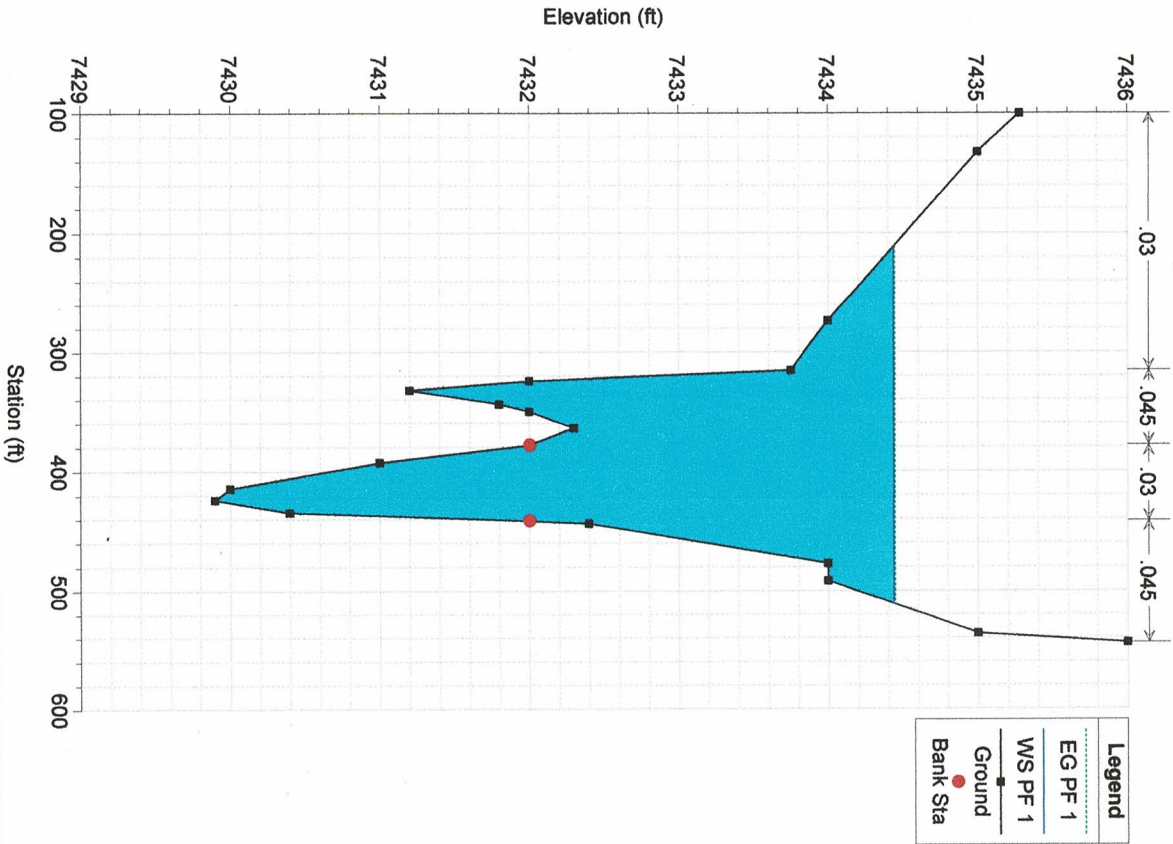

Savage Plan: 100 Yr Final 10/19/2018
 River = EF Cherry Creek Reach = Main RS = 1869 XS 18+69 Culvert Xing Section 4

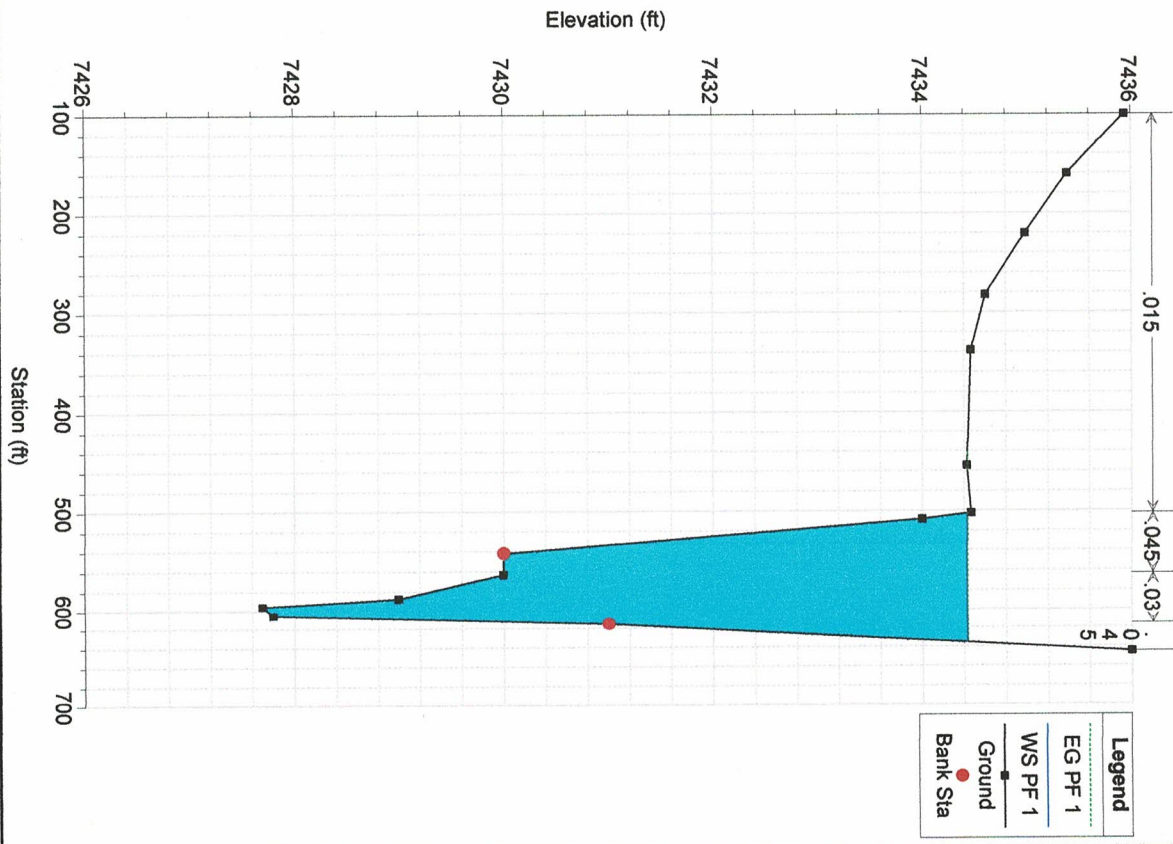

Savage Plan: 100 Yr Final 10/19/2018
 River = EF Cherry Creek Reach = Main RS = 1651 XS 16+51 Culvert King Section 3

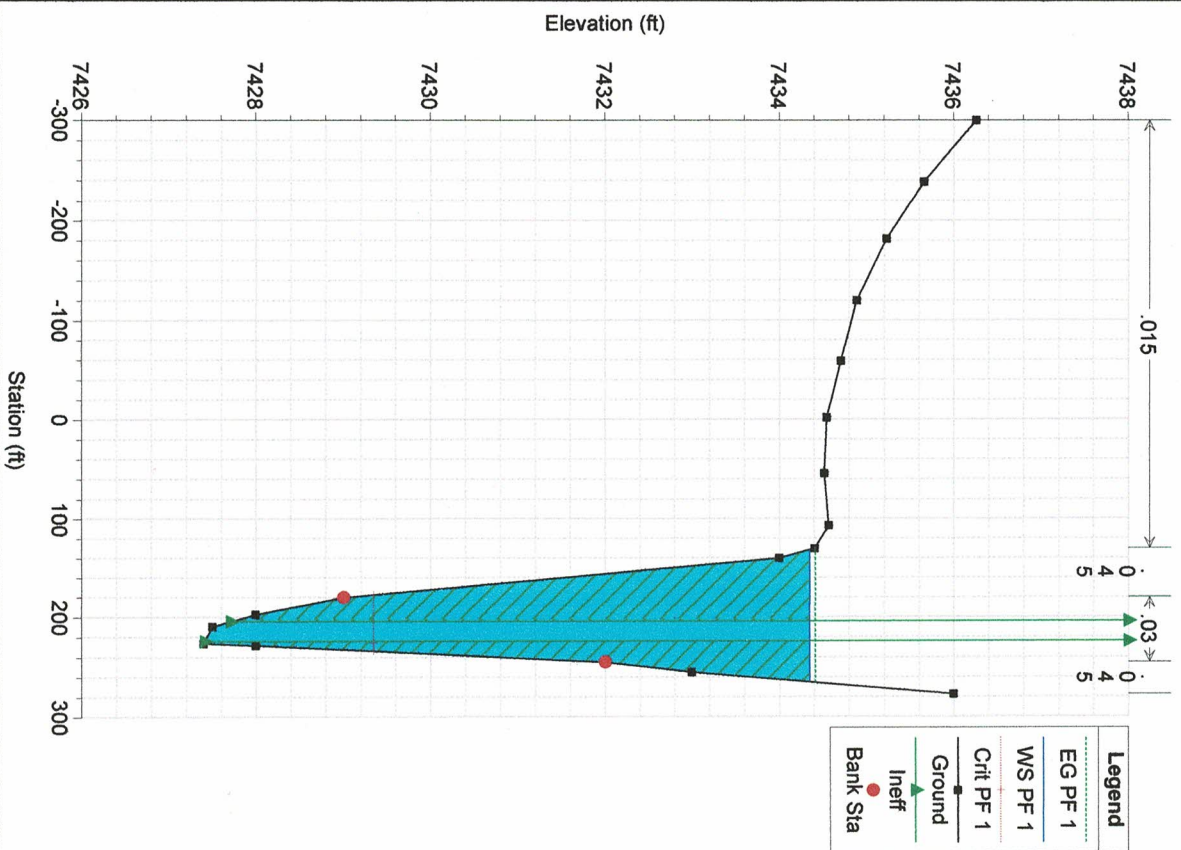

Savage Plan: 100 Yr Final 10/19/2018
 River = EF Cherry Creek Reach = Main RS = 1564 Culiv

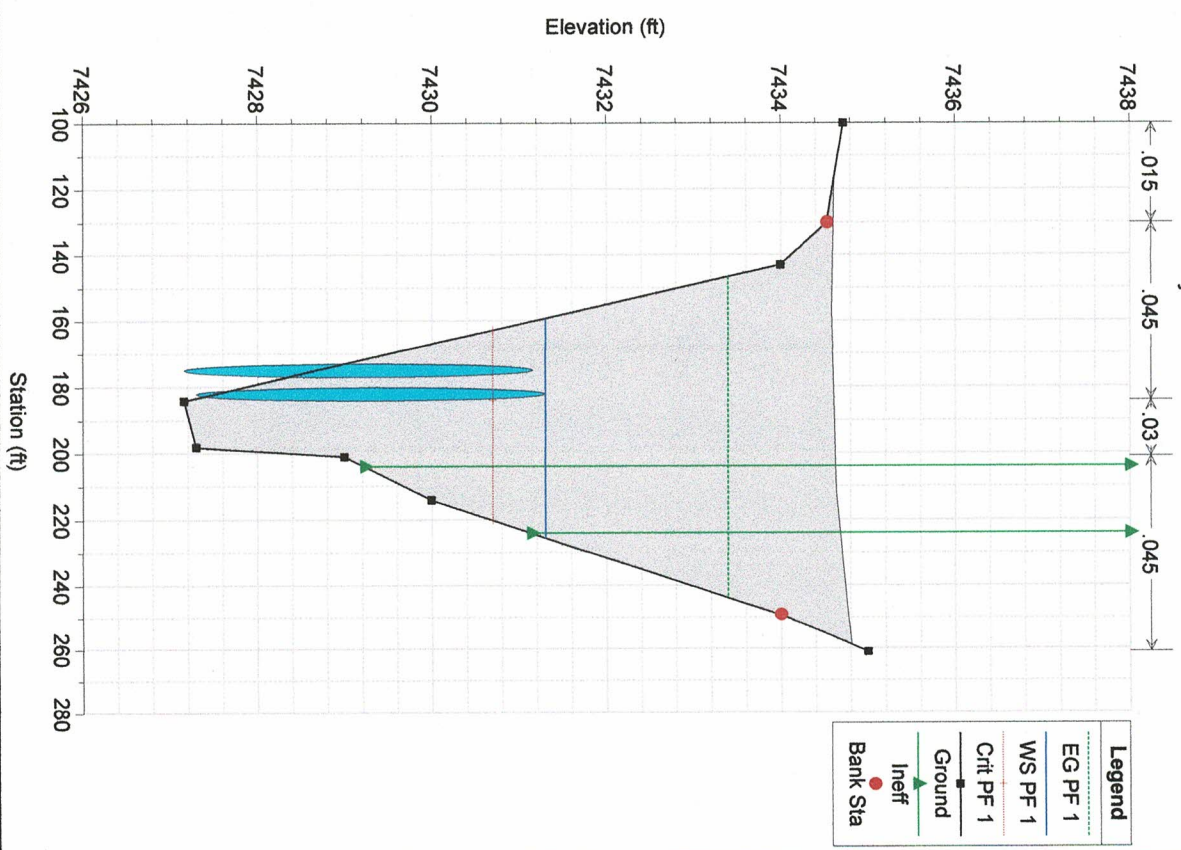

Savage Plan: 100 Yr Final 10/19/2018
 River = EF Cherry Creek Reach = Main RS = 1564 Culiv

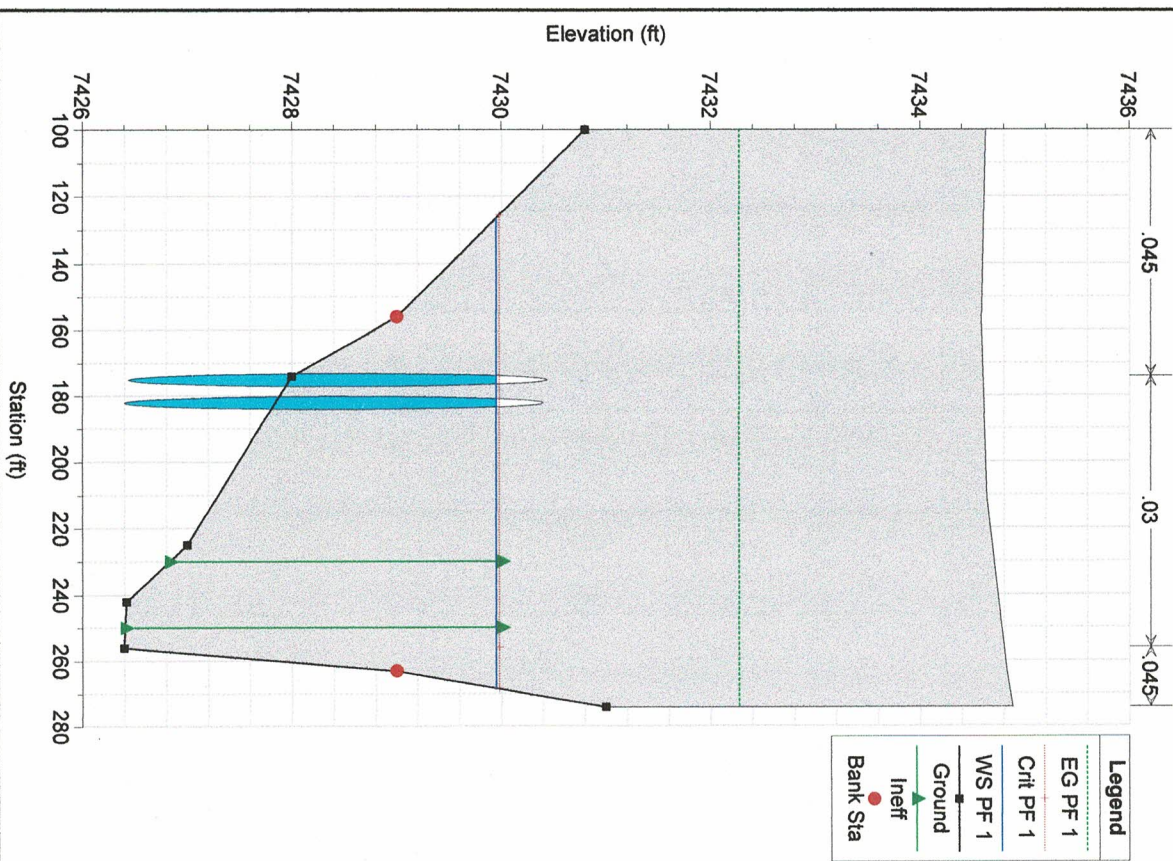

Savage Plan: 100 Yr Final 10/19/2018
 River = EF Cherry Creek Reach = Main RS = 1480 XS 14+80 Culvert Xing Section 2

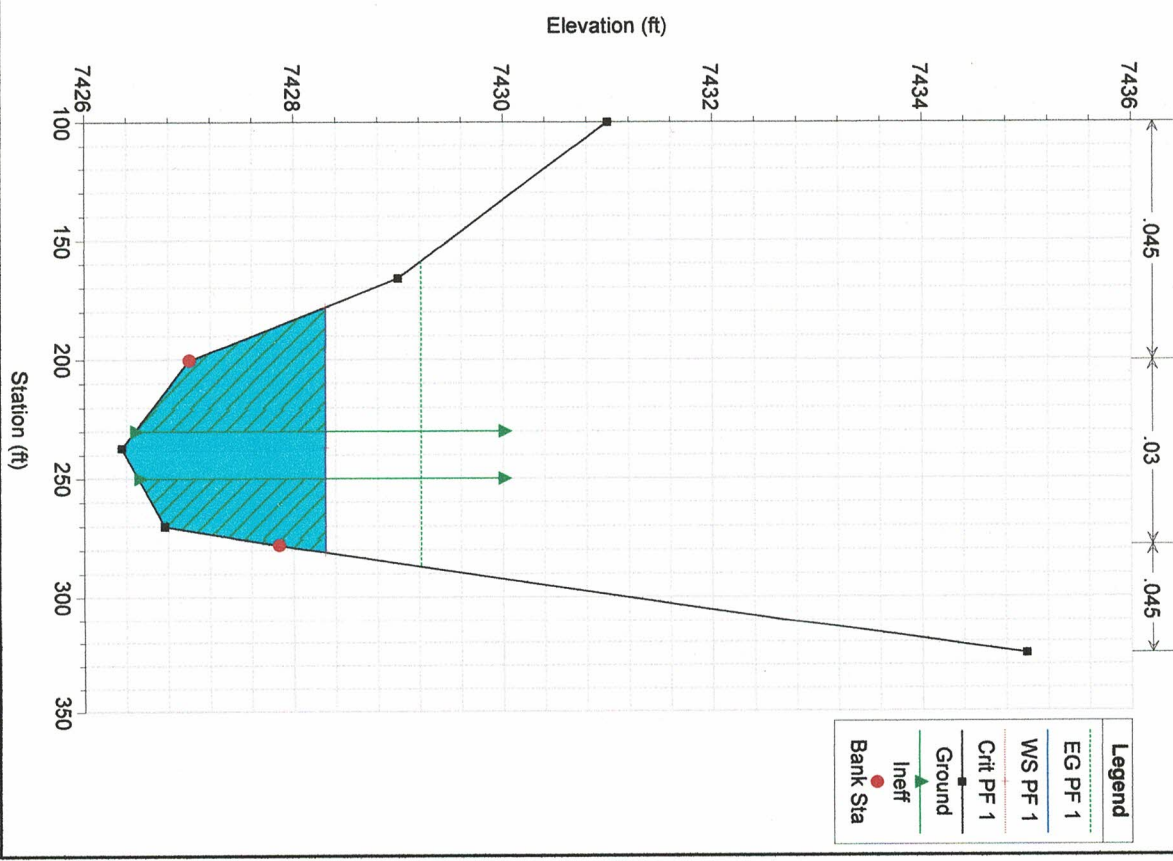

Savage Plan: 100 Yr Final 10/19/2018
 River = EF Cherry Creek Reach = Main RS = 1443 XS 14+43 Culvert Xing Section 1

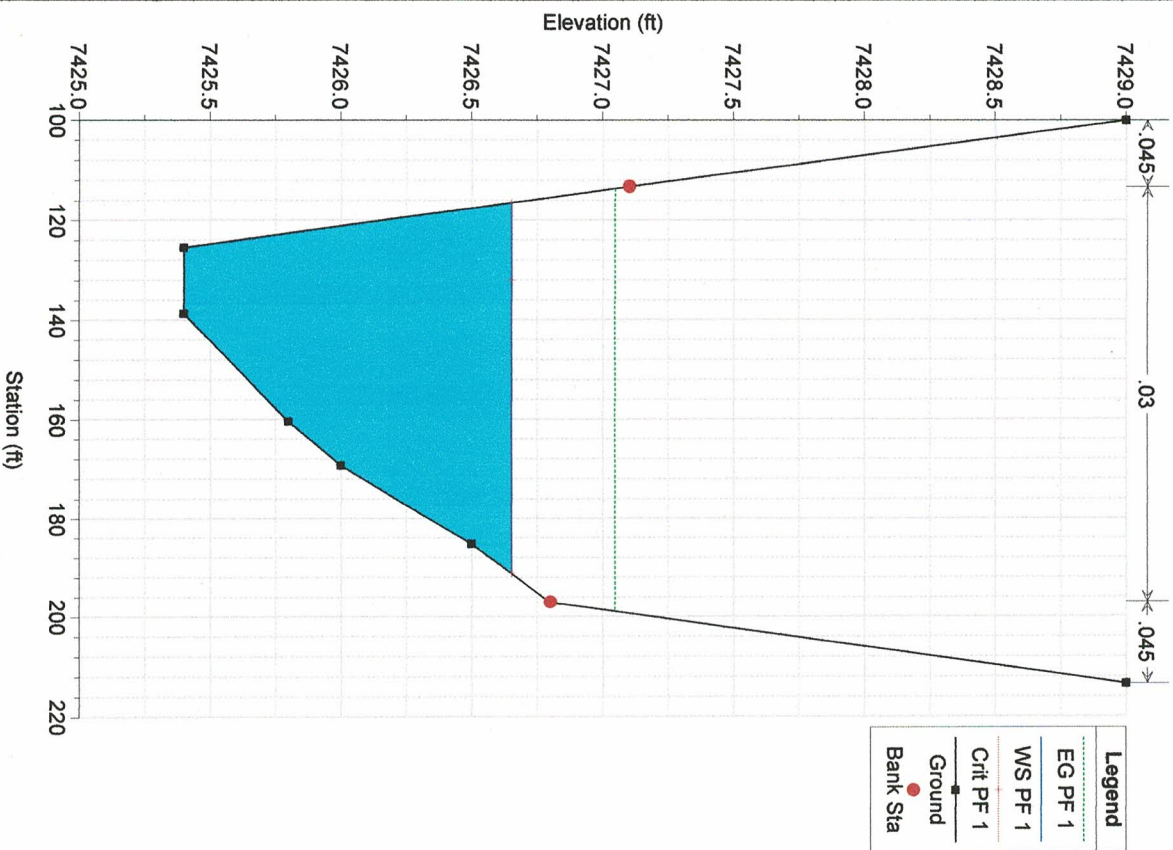

Savage Plan: 100 Yr Final 10/19/2018
 River = EF Cherry Creek Reach = Main RS = 974 XS 9+74

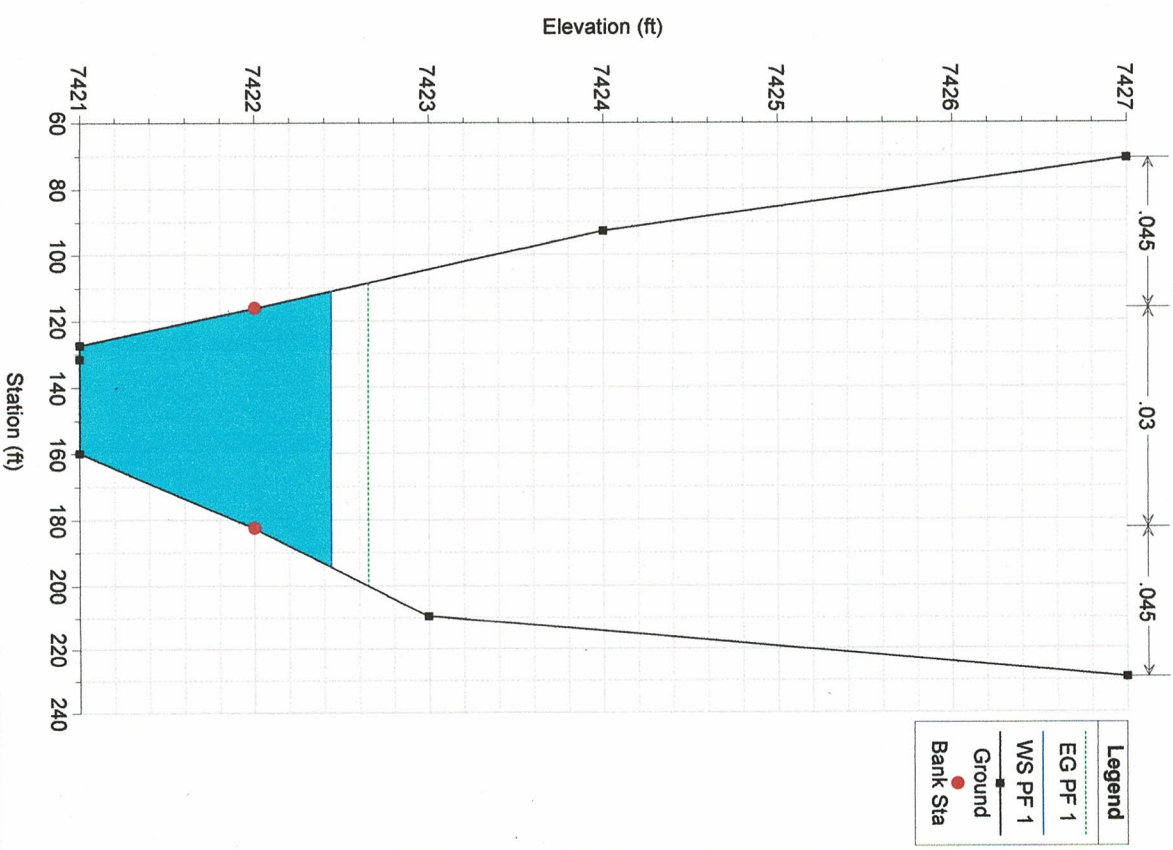

Savage Plan: 100 Yr Final 10/19/2018
 River = EF Cherry Creek Reach = Main RS = 661 XS 6+61

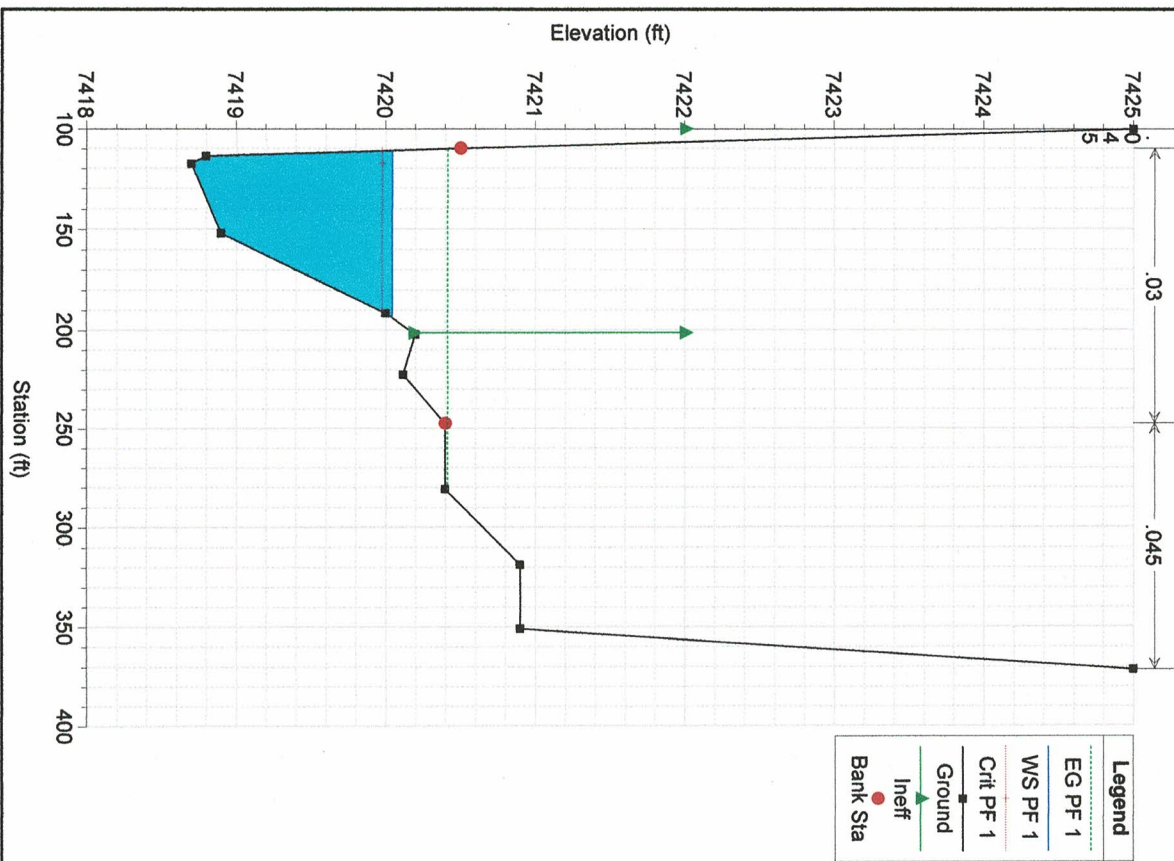

Savage Plan: 100 Yr Final 10/19/2018
 River = EF Cherry Creek Reach = Main RS = 282 XS 2+82

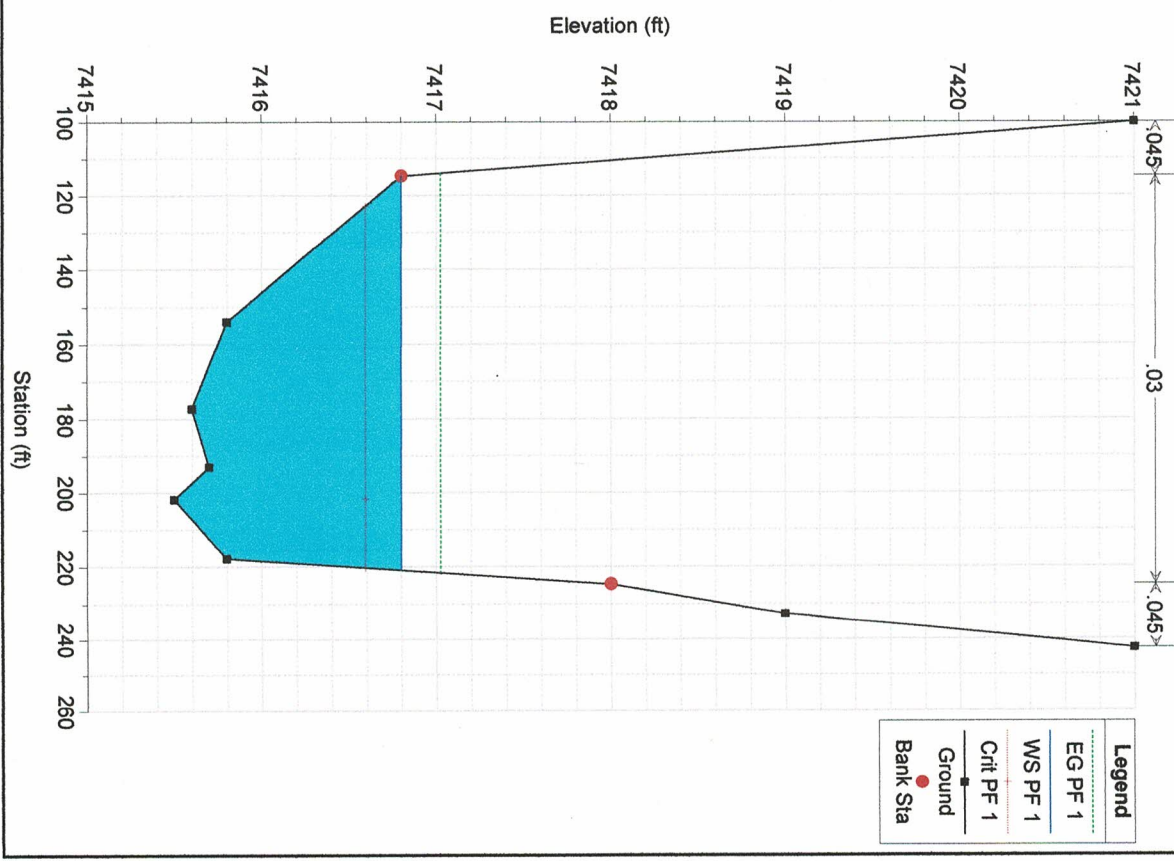

Savage Plan: 100 Yr Final 10/19/2018
 River = EF Cherry Creek Reach = Main RS = 0 XS 0+00 DS Limits

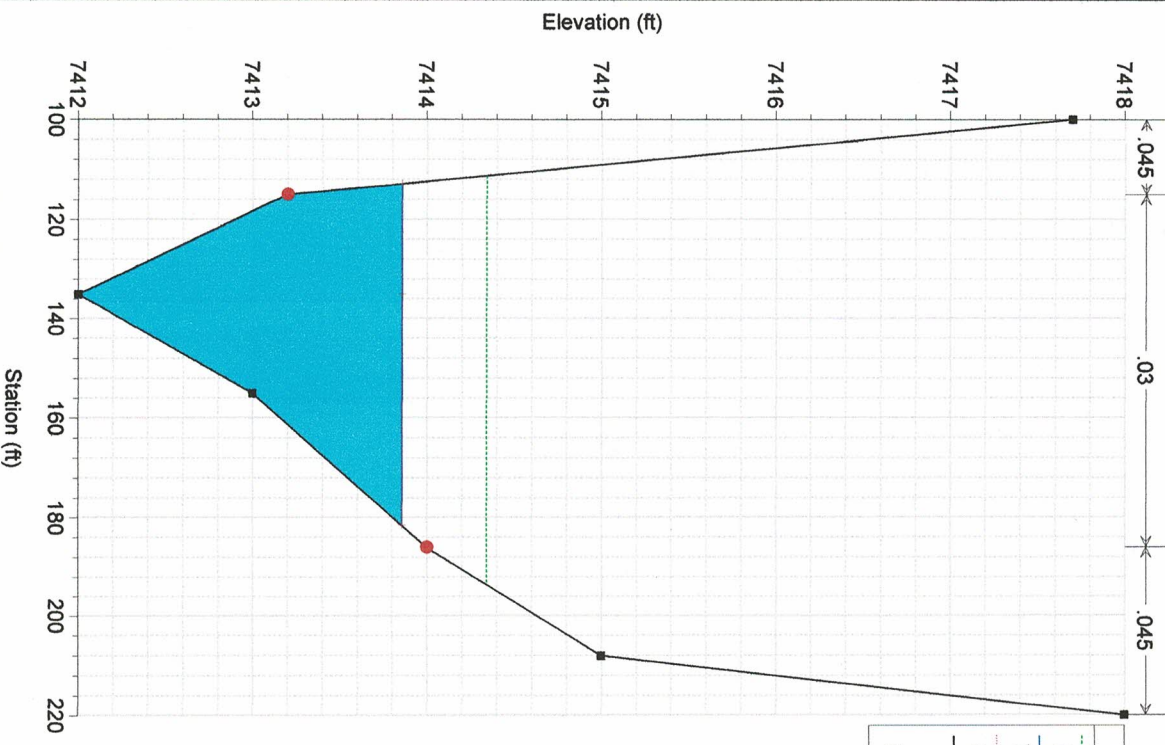

Legend	
.....	EG PF 1
-----	WS PF 1
-----	Crit PF 1
-----	Ground
●	Bank Sta

CULVERT STAGE-DISCHARGE SIZING (INLET vs. OUTLET CONTROL WITH TAILWATER EFFECTS)

Project: **HIGH PLAINS SUBDIVISION FILING NO. 1**
 Basin ID: **BASIN E-3**
 Status: _____

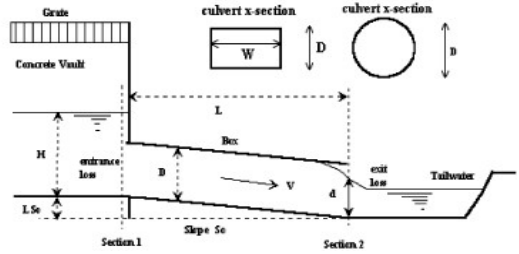

Design Information (Input):

Circular Culvert: Barrel Diameter in Inches D = inches
 Inlet Edge Type (choose from pull-down list)

OR:
Box Culvert: Barrel Height (Rise) in Feet Height (Rise) =
 Barrel Width (Span) in Feet Width (Span) =
 Inlet Edge Type (choose from pull-down list)

Number of Barrels No =
 Inlet Elevation at Culvert Invert Inlet Elev = ft. elev.
 Outlet Elevation at Culvert Invert OR Slope of Culvert (ft v./ft h.) Outlet Elev = ft. elev.
 Culvert Length in Feet L = ft.
 Manning's Roughness n =
 Bend Loss Coefficient K_b =
 Exit Loss Coefficient K_x =

Design Information (calculated):

Entrance Loss Coefficient K_e =
 Friction Loss Coefficient K_f =
 Sum of All Loss Coefficients K_s =
 Orifice Inlet Condition Coefficient C_d =
 Minimum Energy Condition Coefficient KE_{low} =

Calculations of Culvert Capacity (output):

Water Surface Elevation (ft., linked)	Tailwater Surface Elevation ft	Culvert Inlet-Control Flowrate cfs	Culvert Outlet-Control Flowrate cfs	Controlling Culvert Flowrate cfs (output)	Inlet Equation Used:	Flow Control Used
7431.87		0.00	0.00	0.00	No Flow (WS < inlet)	N/A
7431.97		0.10	2.78	0.10	Min. Energy Eqn.	INLET
7432.07		0.20	3.56	0.20	Min. Energy Eqn.	INLET
7432.17		0.40	4.25	0.40	Min. Energy Eqn.	INLET
7432.27		0.80	5.03	0.80	Min. Energy Eqn.	INLET
7432.37		1.30	5.73	1.30	Min. Energy Eqn.	INLET
7432.47		1.80	6.42	1.80	Min. Energy Eqn.	INLET
7432.57		2.40	7.11	2.40	Min. Energy Eqn.	INLET
7432.67		3.00	7.81	3.00	Min. Energy Eqn.	INLET
7432.77		3.70	7.98	3.70	Min. Energy Eqn.	INLET
7432.87		4.60	7.98	4.60	Min. Energy Eqn.	INLET
7432.97		5.20	8.07	5.20	Regression Eqn.	INLET
7433.07		6.00	8.24	6.00	Regression Eqn.	INLET
7433.17		6.80	8.42	6.80	Regression Eqn.	INLET
7433.27		7.70	8.59	7.70	Regression Eqn.	INLET
7433.37		8.70	8.85	8.70	Regression Eqn.	INLET
7433.47		9.70	9.20	9.20	Regression Eqn.	OUTLET
7433.57		10.80	9.54	9.54	Regression Eqn.	OUTLET
7433.67		11.90	9.98	9.98	Regression Eqn.	OUTLET
7433.77		13.00	10.24	10.24	Regression Eqn.	OUTLET
7433.87		14.10	10.24	10.24	Regression Eqn.	OUTLET
7433.97		15.10	11.45	11.45	Regression Eqn.	OUTLET
7434.07		16.20	13.01	13.01	Regression Eqn.	OUTLET
7434.17		17.20	14.32	14.32	Regression Eqn.	OUTLET
7434.27		18.10	15.53	15.53	Regression Eqn.	OUTLET
7434.37		19.10	16.66	16.66	Regression Eqn.	OUTLET
7434.47		20.00	17.70	17.70	Regression Eqn.	OUTLET
7434.57		20.90	18.74	18.74	Regression Eqn.	OUTLET
7434.67		21.70	19.70	19.70	Regression Eqn.	OUTLET
7434.77		22.50	20.56	20.56	Regression Eqn.	OUTLET

Processing Time: 00.92 Seconds

CULVERT STAGE-DISCHARGE SIZING (INLET vs. OUTLET CONTROL WITH TAILWATER EFFECTS)

Project: HIGH PLAINS SUBDIVISION FILING NO. 1
Basin ID: BASIN E-3

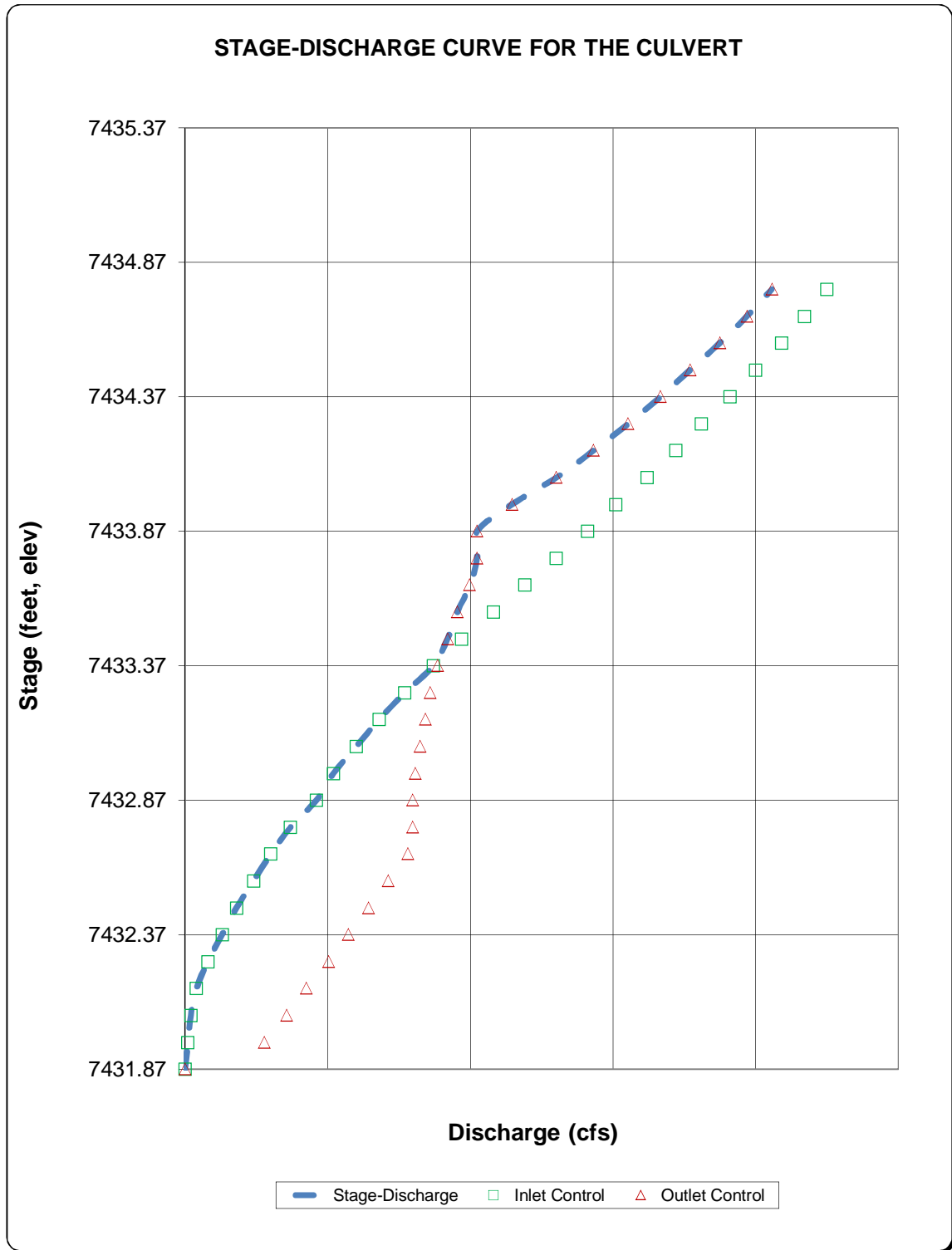

Determination of Culvert Headwater and Outlet Protection

Project: **Blue cells are for user data entry**

Basin ID: **Green cells are calculated values**

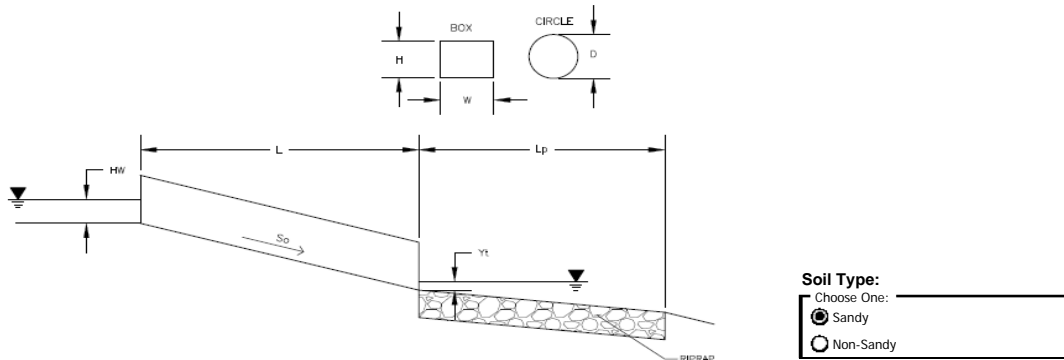

Supercritical Flow! Using Da to calculate protection type.

Design Information (Input):	
Design Discharge	Q = <input style="width: 50px;" type="text" value="4.6"/> cfs
Circular Culvert:	
Barrel Diameter in Inches	D = <input style="width: 50px;" type="text" value="24"/> inches
Inlet Edge Type (Choose from pull-down list)	<input type="text" value="1.5 : 1 Beveled Edge"/> OR
Box Culvert:	
Barrel Height (Rise) in Feet	Height (Rise) = <input style="width: 50px;" type="text"/>
Barrel Width (Span) in Feet	Width (Span) = <input style="width: 50px;" type="text"/>
Inlet Edge Type (Choose from pull-down list)	<input type="text"/>
Number of Barrels	No = <input style="width: 50px;" type="text" value="1"/>
Inlet Elevation	Elev IN = <input style="width: 50px;" type="text" value="7431.87"/> ft
Outlet Elevation OR Slope	Elev OUT = <input style="width: 50px;" type="text" value="7431.61"/> ft
Culvert Length	L = <input style="width: 50px;" type="text" value="51.86"/> ft
Manning's Roughness	n = <input style="width: 50px;" type="text" value="0.012"/>
Bend Loss Coefficient	k_b = <input style="width: 50px;" type="text" value="0"/>
Exit Loss Coefficient	k_x = <input style="width: 50px;" type="text" value="1"/>
Tailwater Surface Elevation	Elev Y_t = <input style="width: 50px;" type="text"/>
Max Allowable Channel Velocity	V = <input style="width: 50px;" type="text" value="5"/> ft/s
Required Protection (Output):	
Tailwater Surface Height	Y_t = <input style="width: 50px;" type="text" value="0.80"/> ft
Flow Area at Max Channel Velocity	A_f = <input style="width: 50px;" type="text" value="0.92"/> ft ²
Culvert Cross Sectional Area Available	A = <input style="width: 50px;" type="text" value="3.14"/> ft ²
Entrance Loss Coefficient	k_e = <input style="width: 50px;" type="text" value="0.20"/>
Friction Loss Coefficient	k_f = <input style="width: 50px;" type="text" value="0.55"/>
Sum of All Losses Coefficients	k_s = <input style="width: 50px;" type="text" value="1.75"/> ft
Culvert Normal Depth	Y_n = <input style="width: 50px;" type="text" value="0.70"/> ft
Culvert Critical Depth	Y_c = <input style="width: 50px;" type="text" value="0.75"/> ft
Tailwater Depth for Design	d = <input style="width: 50px;" type="text" value="1.38"/> ft
Adjusted Diameter OR Adjusted Rise	D_a = <input style="width: 50px;" type="text" value="1.35"/> ft
Expansion Factor	$1/(2*\tan(\theta))$ = <input style="width: 50px;" type="text" value="6.70"/>
Flow/Diameter ^{2.5} OR Flow/(Span * Rise ^{1.5})	$Q/D^{2.5}$ = <input style="width: 50px;" type="text" value="0.81"/> ft ^{0.5} /s
Froude Number	Fr = <input style="width: 50px;" type="text" value="1.15"/> Supercritical!
Tailwater/Adjusted Diameter OR Tailwater/Adjusted Rise	Y_t/D = <input style="width: 50px;" type="text" value="0.59"/>
Inlet Control Headwater	HW_i = <input style="width: 50px;" type="text" value="1.02"/> ft
Outlet Control Headwater	HW_o = <input style="width: 50px;" type="text" value="1.18"/> ft
Design Headwater Elevation	HW = <input style="width: 50px;" type="text" value="7,433.05"/> ft
Headwater/Diameter OR Headwater/Rise Ratio	HW/D = <input style="width: 50px;" type="text" value="0.59"/>
Minimum Theoretical Riprap Size	d_{50} = <input style="width: 50px;" type="text" value="2"/> in
Nominal Riprap Size	d_{50} = <input style="width: 50px;" type="text" value="6"/> in
UDFCD Riprap Type	Type = <input style="width: 50px;" type="text" value="VL"/>
Length of Protection	L_p = <input style="width: 50px;" type="text" value="6"/> ft
Width of Protection	T = <input style="width: 50px;" type="text" value="3"/> ft

CULVERT STAGE-DISCHARGE SIZING (INLET vs. OUTLET CONTROL WITH TAILWATER EFFECTS)

Project: **High Plains Filing no. 1**
 Basin ID: **Design Point 1**
 Status: _____

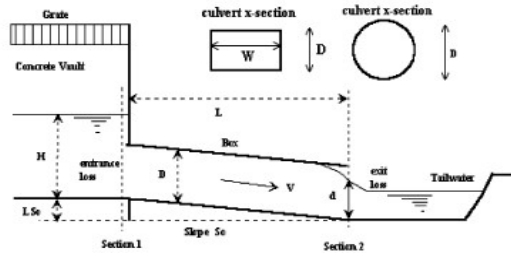

Design Information (Input):

Circular Culvert: Barrel Diameter in Inches D = inches
 Inlet Edge Type (choose from pull-down list)

OR:
Box Culvert: Barrel Height (Rise) in Feet Height (Rise) =
 Barrel Width (Span) in Feet Width (Span) =
 Inlet Edge Type (choose from pull-down list)

Number of Barrels No =
 Inlet Elevation at Culvert Invert Inlet Elev = ft. elev.
 Outlet Elevation at Culvert Invert OR Slope of Culvert (ft v./ft h.) Outlet Elev = ft. elev.
 Culvert Length in Feet L = ft.
 Manning's Roughness n =
 Bend Loss Coefficient K_b =
 Exit Loss Coefficient K_x =

Design Information (calculated):

Entrance Loss Coefficient K_e =
 Friction Loss Coefficient K_f =
 Sum of All Loss Coefficients K_s =
 Orifice Inlet Condition Coefficient C_d =
 Minimum Energy Condition Coefficient KE_{low} =

Calculations of Culvert Capacity (output):

Water Surface Elevation (ft., linked)	Tailwater Surface Elevation ft	Culvert Inlet-Control Flowrate cfs	Culvert Outlet-Control Flowrate cfs	Controlling Culvert Flowrate cfs (output)	Inlet Equation Used:	Flow Control Used
7432.00		0.80	180.38	0.80	Min. Energy Eqn.	INLET
7432.25		4.00	185.36	4.00	Min. Energy Eqn.	INLET
7432.50		11.20	190.35	11.20	Min. Energy Eqn.	INLET
7432.75		20.00	195.13	20.00	Min. Energy Eqn.	INLET
7433.00		30.80	199.70	30.80	Min. Energy Eqn.	INLET
7433.25		42.00	204.27	42.00	Regression Eqn.	INLET
7433.50		54.00	208.84	54.00	Regression Eqn.	INLET
7433.75		68.00	213.21	68.00	Regression Eqn.	INLET
7434.00		82.80	217.57	82.80	Regression Eqn.	INLET
7434.25		98.00	221.73	98.00	Regression Eqn.	INLET
7434.50		112.80	229.00	112.80	Regression Eqn.	INLET
7434.75		126.80	236.90	126.80	Regression Eqn.	INLET
7435.00		139.60	244.59	139.60	Regression Eqn.	INLET
7435.25		151.60	252.07	151.60	Regression Eqn.	INLET
7435.50		162.80	259.13	162.80	Regression Eqn.	INLET
7435.75		173.60	266.20	173.60	Regression Eqn.	INLET
7436.00		183.60	273.06	183.60	Regression Eqn.	INLET
7436.25		193.60	279.91	193.60	Regression Eqn.	INLET
7436.50		202.80	286.36	202.80	Regression Eqn.	INLET
7436.75		211.60	292.80	211.60	Regression Eqn.	INLET
7437.00		220.40	299.03	220.40	Regression Eqn.	INLET
7437.25		228.80	305.06	228.80	Regression Eqn.	INLET
7437.50		237.20	311.08	237.20	Regression Eqn.	INLET
7437.75		244.80	316.90	244.80	Regression Eqn.	INLET
7438.00		252.40	322.72	252.40	Regression Eqn.	INLET
7438.25		260.00	328.54	260.00	Regression Eqn.	INLET
7438.50		267.20	333.94	267.20	Regression Eqn.	INLET
7438.75		274.00	339.55	274.00	Regression Eqn.	INLET
7439.00		280.40	344.96	280.40	Regression Eqn.	INLET
7439.25		286.80	350.36	286.80	Regression Eqn.	INLET

Processing Time: 01.02 Seconds

CULVERT STAGE-DISCHARGE SIZING (INLET vs. OUTLET CONTROL WITH TAILWATER EFFECTS)

Project: High Plains Filing no. 1
Basin ID: Design Point 1

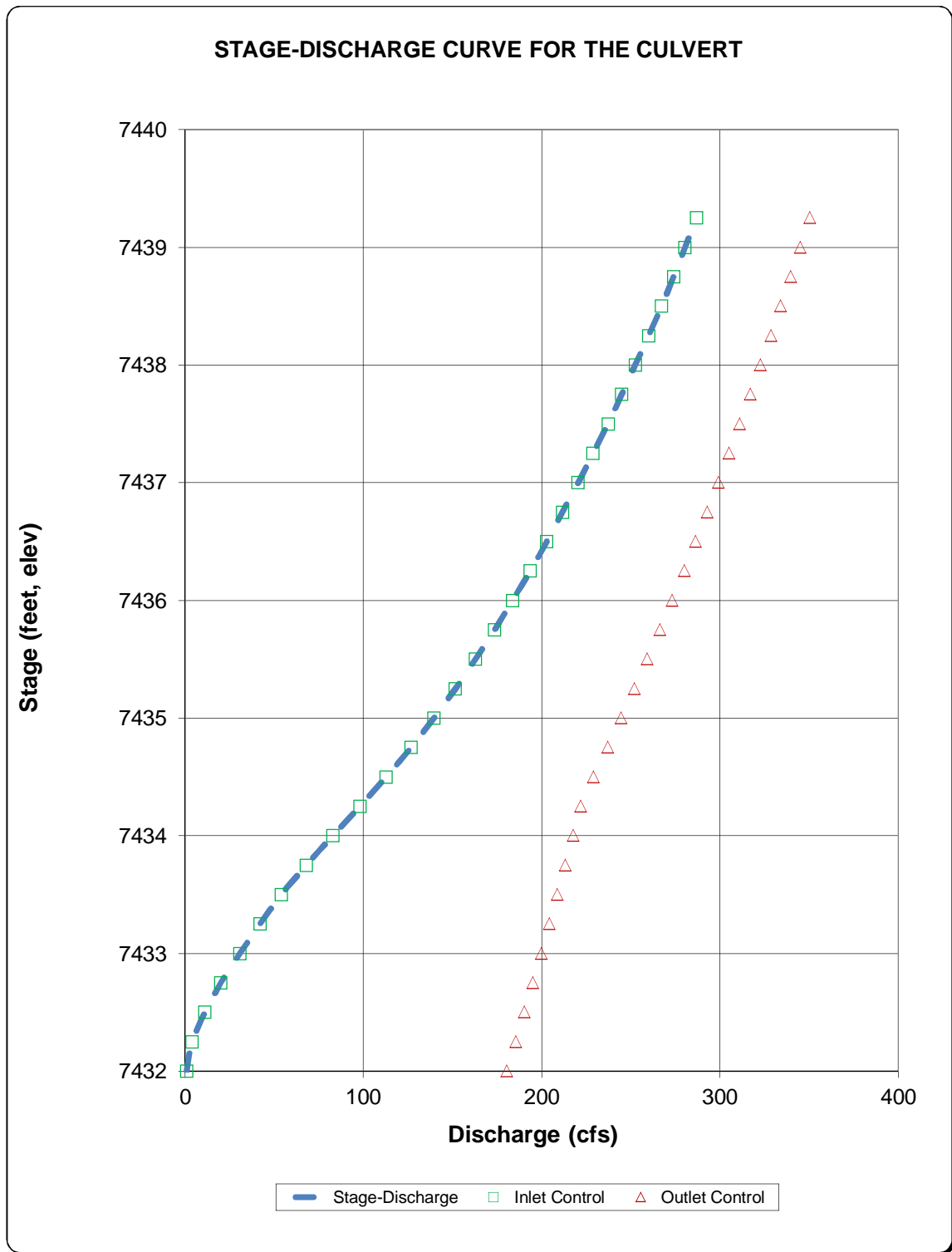

Determination of Culvert Headwater and Outlet Protection

Project: **Blue cells are for user data entry**

Basin ID: **Green cells are calculated values**

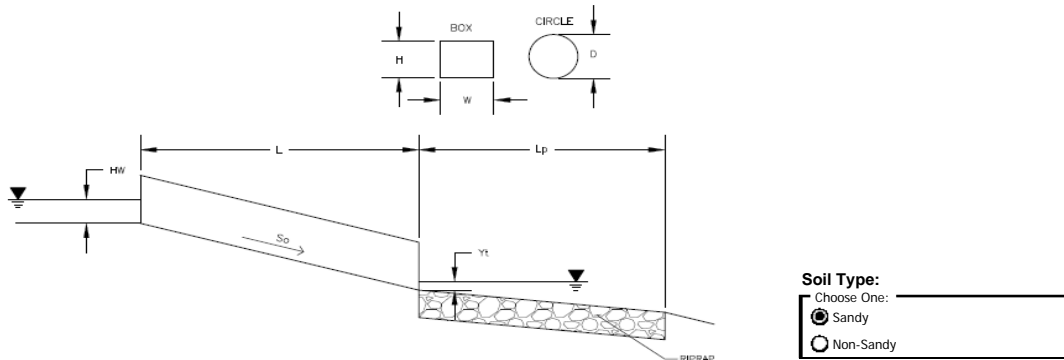

Soil Type:
 Choose One: Sandy Non-Sandy

Supercritical Flow! Using D_a to calculate protection type.

Design Information (Input):	
Design Discharge	Q = <input style="width: 100px;" type="text" value="155.6"/> cfs
Circular Culvert:	
Barrel Diameter in Inches	D = <input style="width: 100px;" type="text" value="30"/> inches
Inlet Edge Type (Choose from pull-down list)	<input type="text" value="1.5 : 1 Beveled Edge"/> OR
Box Culvert:	
Barrel Height (Rise) in Feet	Height (Rise) = <input style="width: 100px;" type="text"/>
Barrel Width (Span) in Feet	Width (Span) = <input style="width: 100px;" type="text"/>
Inlet Edge Type (Choose from pull-down list)	<input type="text"/>
Number of Barrels	No = <input style="width: 100px;" type="text" value="4"/>
Inlet Elevation	Elev IN = <input style="width: 100px;" type="text" value="7431.81"/> ft
Outlet Elevation OR Slope	Elev OUT = <input style="width: 100px;" type="text" value="7428.46"/> ft
Culvert Length	L = <input style="width: 100px;" type="text" value="61.72"/> ft
Manning's Roughness	n = <input style="width: 100px;" type="text" value="0.012"/>
Bend Loss Coefficient	k_b = <input style="width: 100px;" type="text" value="0"/>
Exit Loss Coefficient	k_x = <input style="width: 100px;" type="text" value="1"/>
Tailwater Surface Elevation	Elev Y_t = <input style="width: 100px;" type="text"/>
Max Allowable Channel Velocity	V = <input style="width: 100px;" type="text" value="5"/> ft/s
Required Protection (Output):	
Tailwater Surface Height	Y_t = <input style="width: 100px;" type="text" value="1.00"/> ft
Flow Area at Max Channel Velocity	A_f = <input style="width: 100px;" type="text" value="7.78"/> ft ²
Culvert Cross Sectional Area Available	A = <input style="width: 100px;" type="text" value="4.91"/> ft ²
Entrance Loss Coefficient	k_e = <input style="width: 100px;" type="text" value="0.20"/>
Friction Loss Coefficient	k_f = <input style="width: 100px;" type="text" value="0.48"/>
Sum of All Losses Coefficients	k_s = <input style="width: 100px;" type="text" value="1.68"/> ft
Culvert Normal Depth	Y_n = <input style="width: 100px;" type="text" value="1.06"/> ft
Culvert Critical Depth	Y_c = <input style="width: 100px;" type="text" value="2.10"/> ft
Tailwater Depth for Design	d = <input style="width: 100px;" type="text" value="2.30"/> ft
Adjusted Diameter OR Adjusted Rise	D_a = <input style="width: 100px;" type="text" value="1.78"/> ft
Expansion Factor	$1/(2*\tan(\theta))$ = <input style="width: 100px;" type="text" value="5.67"/>
Flow/Diameter ^{2.5} OR Flow/(Span * Rise ^{1.5})	$Q/D^{2.5}$ = <input style="width: 100px;" type="text" value="3.94"/> ft ^{0.5} /s
Froude Number	Fr = <input style="width: 100px;" type="text" value="3.86"/> Supercritical!
Tailwater/Adjusted Diameter OR Tailwater/Adjusted Rise	Y_t/D = <input style="width: 100px;" type="text" value="0.56"/>
Inlet Control Headwater	HW_i = <input style="width: 100px;" type="text" value="3.53"/> ft
Outlet Control Headwater	HW_o = <input style="width: 100px;" type="text" value="0.59"/> ft
Design Headwater Elevation	HW = <input style="width: 100px;" type="text" value="7,435.34"/> ft
Headwater/Diameter OR Headwater/Rise Ratio	HW/D = <input style="width: 100px;" type="text" value="1.41"/>
Minimum Theoretical Riprap Size	d_{50} = <input style="width: 100px;" type="text" value="9"/> in
Nominal Riprap Size	d_{50} = <input style="width: 100px;" type="text" value="9"/> in
UDFCD Riprap Type	Type = <input style="width: 100px;" type="text" value="M"/>
Length of Protection	L_p = <input style="width: 100px;" type="text" value="25"/> ft
Width of Protection	T = <input style="width: 100px;" type="text" value="7"/> ft

$Q_{100} = 15.6 \text{ CFS}$

MAX SLOPE = 8.0%

AVE SLOPE = 4.1%

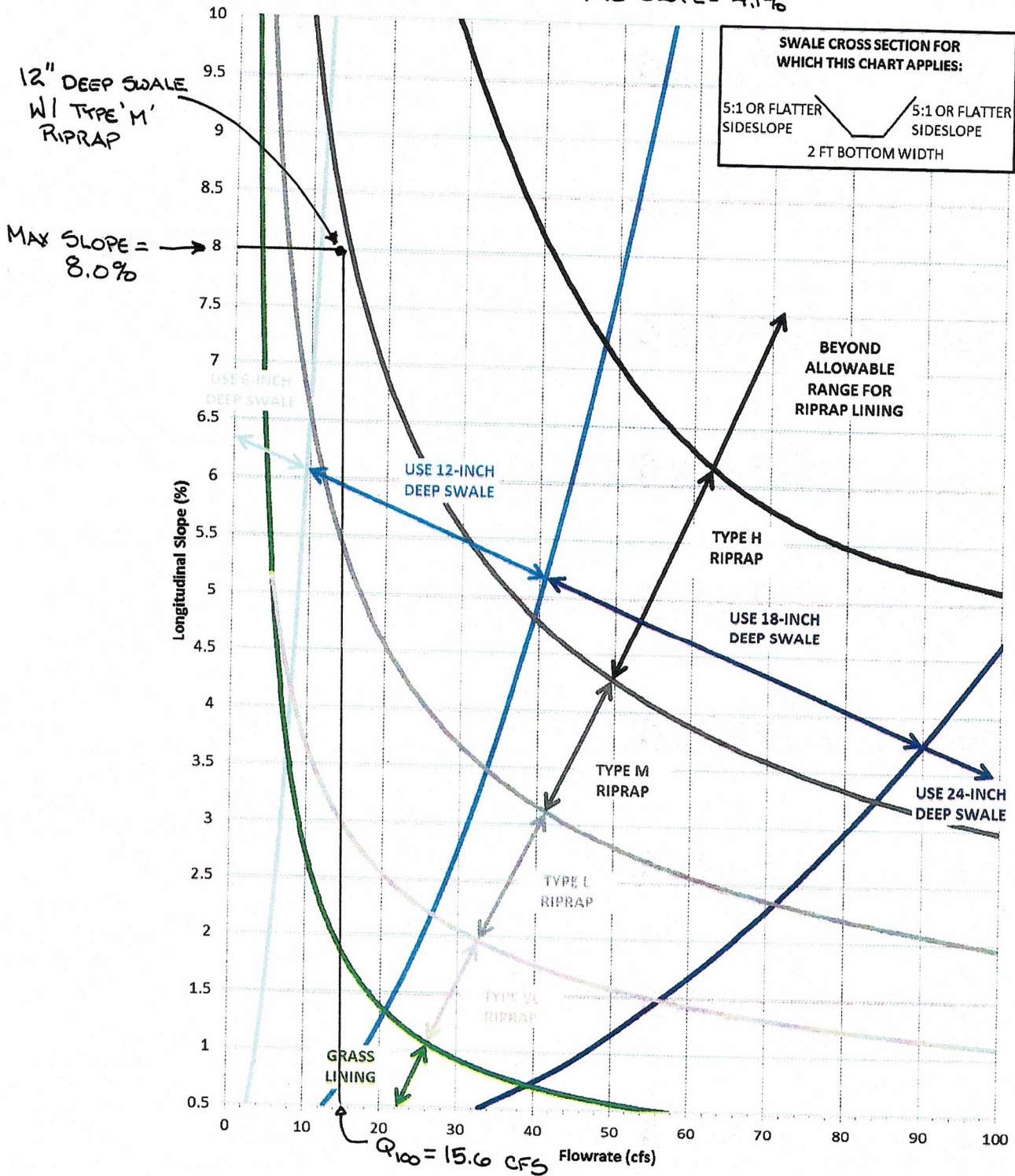

Figure 8-22. Swale stability chart; 2- to 4-foot bottom width and side slopes between 5:1 and 10:1 (Note: Riprap classifications refer to gradation for riprap used in soil riprap or void-filled riprap. See Figure 8-34 for gradations.) (Source: Muller Engineering Company)

PRUDENT LINE CALCULATIONS FOR SANDY SOILS

West Bank Calculations

1. Calculate the sediment transport capacity for different return period events:

$$VOLi = 6 * Qp * d$$

Return Period	Qp(cfs)	d(hr)	Voli(cf)
100	356	24	51264
50	256	24	36864
25	181	24	26064
10	104	24	14976
5	62	24	8928
2	22	24	3168

2. Calculate the potential sediment deficit in any given reach of the study area:

$$Yi = 0.25 * VOLi$$

Return Period	Voli(cf)	Yi(cf)
100	51264	12816
50	36864	9216
25	26064	6516
10	14976	3744
5	8928	2232
2	3168	792

3. Calculate the average annual sediment deficit:

$$Ym = 0.015 * Y100 + 0.015 * Y50 + 0.04 * Y25 + 0.08 * Y10 + 0.2 * Y5 + 0.4 * Y2$$

$$Ym = 1653.84 \text{ cf}$$

4. Convert the calculated sediment deficit to a long-term lateral migration distance along a 500' reach:

a. Average Annual Deficit (assume BF=1.67)

$$Y_m * 1.67 = 2762 \text{ cf}$$

b. Estimate the potential lateral migration with variable length reaches

Station	Side (looking US)	US Reach(ft)	Bank Ht(ft)	Setback Dist (ft) ²
0+00	RT	282	4	1.4
2+82	RT	379	4.5	1.2
6+61	RT	313	6	0.9
9+74	RT	469	8.5	0.6
14+43	RT	37	3.5	1.6
14+80	RT	53	3.5	1.6

c. Calculate setback distance over a 30yr period

Station	Setback Dist (ft)	HECRAS Sect. 10Yr WS Sta	Prudent Line Sta.
0+00	41	113	72
2+82	37	137	100
6+61	28	112	84
9+74	19	165	146
14+43	47	120	73
14+80	47	192	145

5. Calculate the short-term lateral migration distance along a 150' reach:

a. 100 yr erosion deficit times the bulking factor (assume BF=1.67)

$$Y_i(\text{cf}) \quad \text{Erosion Deficit}(\text{cf})$$

$$12816 \quad 21403$$

b. Estimate the potential lateral migration assuming a right triangle w/variable length legs

Station	Side	Bank Ht(ft)	Setback Dist (ft) ³
0+00	RT	4	71
2+82	RT	4.5	63
6+61	RT	6	48
9+74	RT	8.5	34
14+43	RT	3.5	82
14+80	RT	3.5	82

6. Prudent line establishment (larger of setback distances, 50' or 100 yr floodplain)

Station	100 Yr F.Plain(ft) ¹	Long-term S.Back(ft)	Shrt-term S.Back(ft)	50'(ft)	S. Back Selected	W. Bank 100yr Sta	W. Bank 10yr Sta
0+00	-4	41	71	50	71	109	113
2+82	-21	37	63	50	63	116	137
6+61	0	28	48	50	50	112	112
9+74	-8	19	34	50	50	157	165
14+43	-4	47	82	50	82	116	120
14+80	-12	47	82	50	82	180	192

NOTE:

1. 100 yr floodplain setbacks that are negative because confined within TOB.
2. Long Term Setback Distance = Average Annual Deficit / (Bank Ht) X 500 ft reach
3. Short Term Setback Distance = E100-YR Erosion Deficit / (Bank Ht) X (150 ft reach) X (1/2)

HECRAS Station	S. Back Selected	W. Bank 10yr Sta	Prudent Line H. RAS Sta
0+00	71	113	-58
2+82	63	137	-26
6+61	50	112	-38
9+74	50	165	15
14+43	82	120	-62
14+80	82	192	130

*

* Denotes adjustment made on drawing, 50' further west to be conservative.

PRUDENT LINE CALCULATIONS FOR SANDY SOILS

East Bank Calculations

1. Calculate the sediment transport capacity for different return period events:

$$VOLi = 6 * Qp * d$$

Return Period	Qp(cfs)	d(hr)	Voli(cf)
100	356	24	51264
50	256	24	36864
25	181	24	26064
10	104	24	14976
5	62	24	8928
2	22	24	3168

2. Calculate the potential sediment deficit in any given reach of the study area:

$$Yi = 0.25 * VOLi$$

Return Period	Voli(cf)	Yi(cf)
100	51264	12816
50	36864	9216
25	26064	6516
10	14976	3744
5	8928	2232
2	3168	792

3. Calculate the average annual sediment deficit:

$$Ym = 0.015 * Y100 + 0.015 * Y50 + 0.04 * Y25 + 0.08 * Y10 + 0.2 * Y5 + 0.4 * Y2$$

$$Ym = 1653.84 \text{ cf}$$

4. Convert the calculated sediment deficit to a long-term lateral migration distance along a 500' reach:

a. Average Annual Deficit (assume BF=1.67)

$$Y_m * 1.67 = 2762 \text{ cf}$$

b. Estimate the potential lateral migration with variable length reaches

Station	Side (looking US)	US Reach(ft)	Bank Ht(ft)	Setback Dist (ft) ²
0+00	LT	282	9	0.6
2+82	LT	379	7	0.8
6+61	LT	313	6	0.9
9+74	LT	469	8.5	0.6
14+43	LT	37	9	0.6
14+80	LT	53	7	0.8

c. Calculate setback distance over a 30yr period

Station	Setback Dist (ft)	HECRAS Sect. 10Yr WS Sta	Prudent Line Sta.
0+00	18	181	199
2+82	24	216	240
6+61	28	188	216
9+74	19	236	255
14+43	18	191	209
14+80	24	270	294

5. Calculate the short-term lateral migration distance along a 150' reach:

a. 100 yr erosion deficit times the bulking factor (assume BF=1.67)

$$Y_i(\text{cf}) \quad \text{Erosion Deficit}(\text{cf})$$

$$12816 \quad 21403$$

b. Estimate the potential lateral migration assuming a right triangle w/variable length legs

Station	Side	Bank Ht(ft)	Setback Dist (ft) ³
0+00	LT	9	32
2+82	LT	7	41
6+61	LT	6	48
9+74	LT	8.5	34
14+43	LT	9	32
14+80	LT	7	41

6. Prudent line establishment (larger of setback distances, 50' or 100 yr floodplain)

Station	100 Yr F.Plain(ft) ¹	Long-term S.Back(ft)	Shrt-term S.Back(ft)	50'(ft)	S. Back Selected	E. Bank 100yr Sta	E. Bank 10yr Sta
0+00	7	18	32	50	50	188	181
2+82	4	24	41	50	50	220	216
6+61	2	28	48	50	50	190	188
9+74	-1	19	34	50	50	235	236
14+43	4	18	32	50	50	195	191
14+80	10	24	41	50	50	280	270

NOTE:

- 100 yr floodplain setbacks that are negative because confined within TOB.
- Long Term Setback Distance = Average Annual Deficit / (Bank Ht) X 500 ft reach
- Short Term Setback Distance = E100-YR Erosion Deficit / (Bank Ht) X (150 ft reach) X (1/2)

HECRAS Station	S. Back Selected	E. Bank 10yr Sta	Prudent Line H. RAS Sta
0+00	50	181	231
2+82	50	216	266
6+61	50	188	238
9+74	50	236	286
14+43	50	191	241
14+80	50	270	320

DRAINAGE MAPS

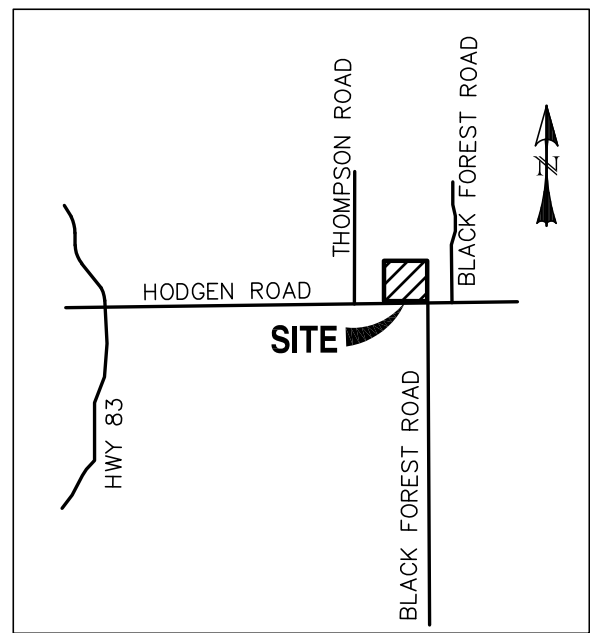

VICINITY MAP
SCALE: N.T.S.

EXISTING DRAINAGE BASINS							
BASIN	AREA (ACRES)	Q2 (CFS)	Q5 (CFS)	Q10 (CFS)	Q25 (CFS)	Q50 (CFS)	Q100 (CFS)
E1	22.00	0.8	2.8	6.2	10.9	14.6	18.9
E2	5.46	0.3	1.3	2.8	4.8	6.5	8.4
E3	1.62	1.0	1.5	2.2	3.1	3.8	4.6
E4	3.53	0.9	1.6	2.8	4.3	5.5	6.9
E5	38.49	2.4	9.1	20.0	34.9	46.8	60.8

EXISTING DESIGN POINTS		
DESIGN POINT	Q100 (CFS)	Q500 (CFS)
SS1	357	661.0
SS2	295.0	547.0
SS3	153.0	286.0

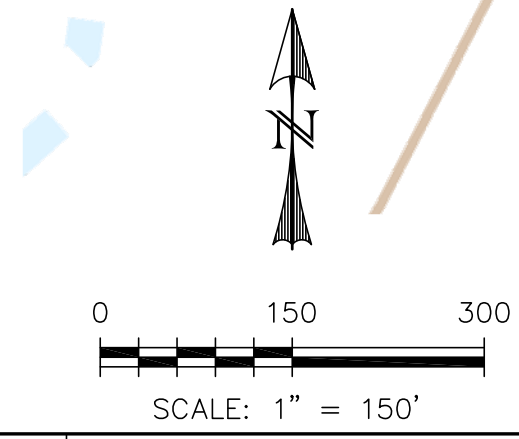
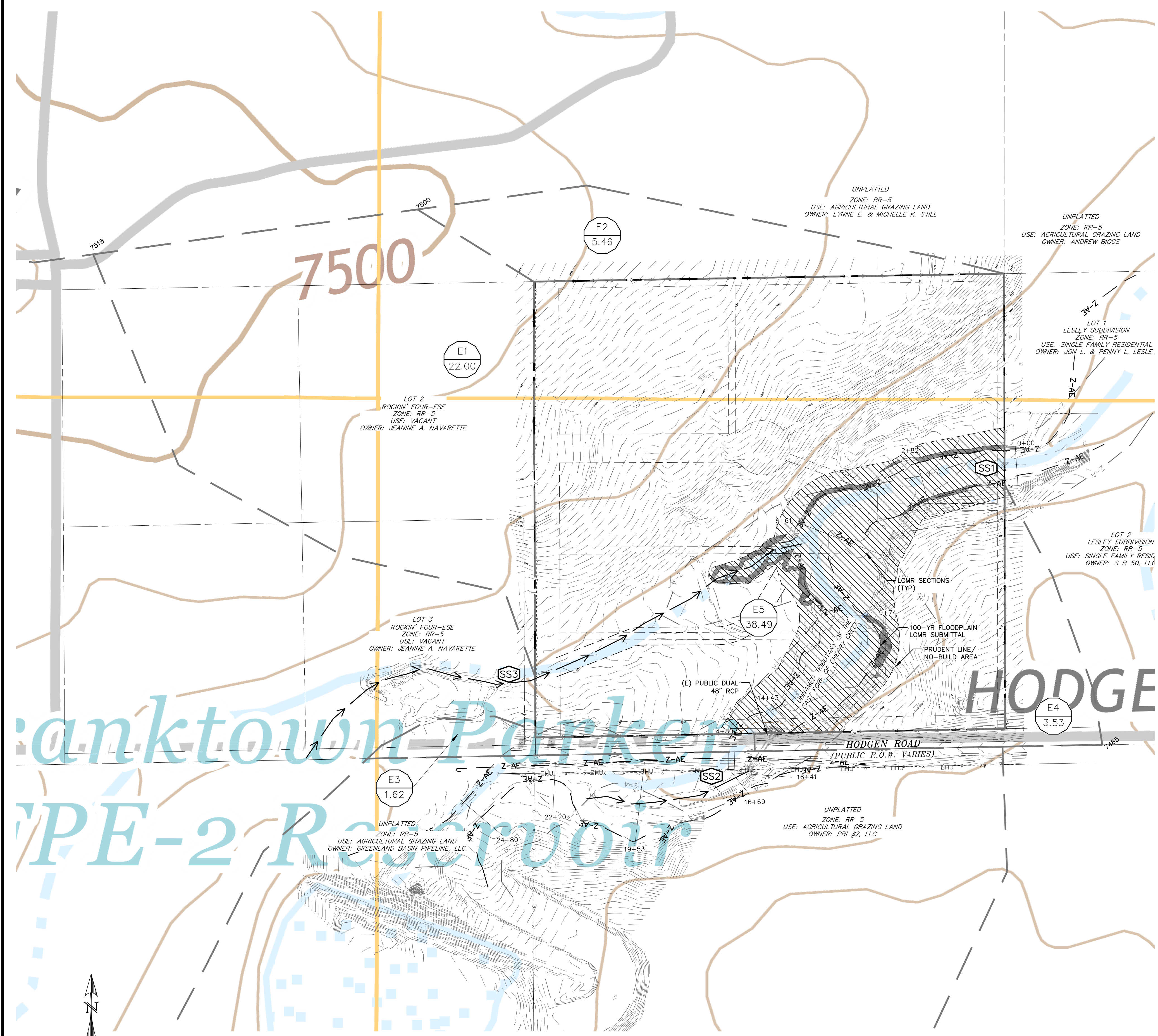

LEGEND

EXISTING	(E)
PROPOSED	(P)
BOUNDARY	---
RIGHT-OF-WAY	----
LOT LINE	-----
EASEMENT	-----
(E) CONTOUR, INDEX	-----
(E) CONTOUR	-----
(P) CONTOUR, INDEX	-----
(P) CONTOUR	-----

REV.	DESCRIPTION	DATE

811 Know what's below.
Call 72 hours before you dig.
For more details visit:
www.call811.com

PREPARED FOR:
SAVAGE DEVELOPMENT INC
1125 DIAMOND RIM DR.
COLORADO SPRINGS, CO 80921



HIGH PLAINS FILING NO. 1

EXISTING CONDITIONS

DESIGNED BY: DLM	DRAWN BY:
SCALE: 1"=150'	DATE: 07/09/18
JOB NUMBER: 17-135	SHEET: 1 OF 1

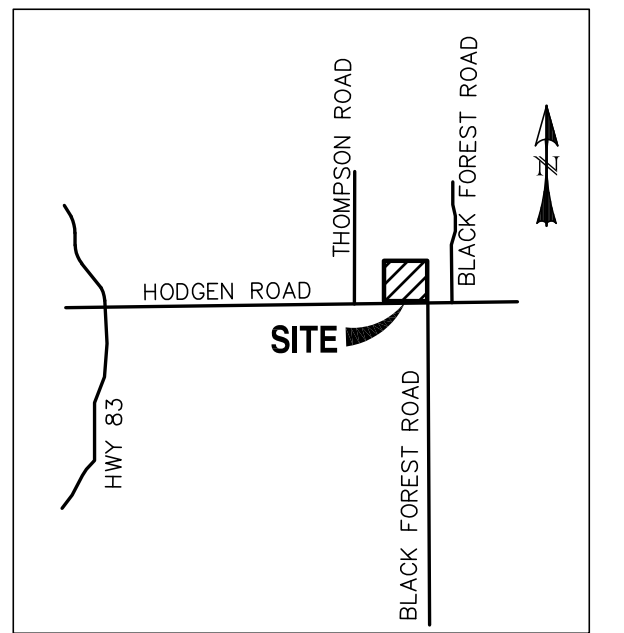
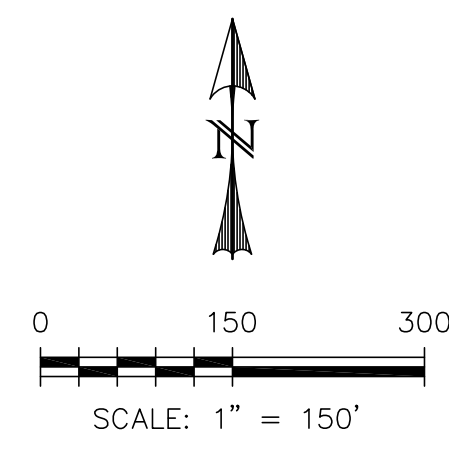

VICINITY MAP
SCALE: N.T.S.

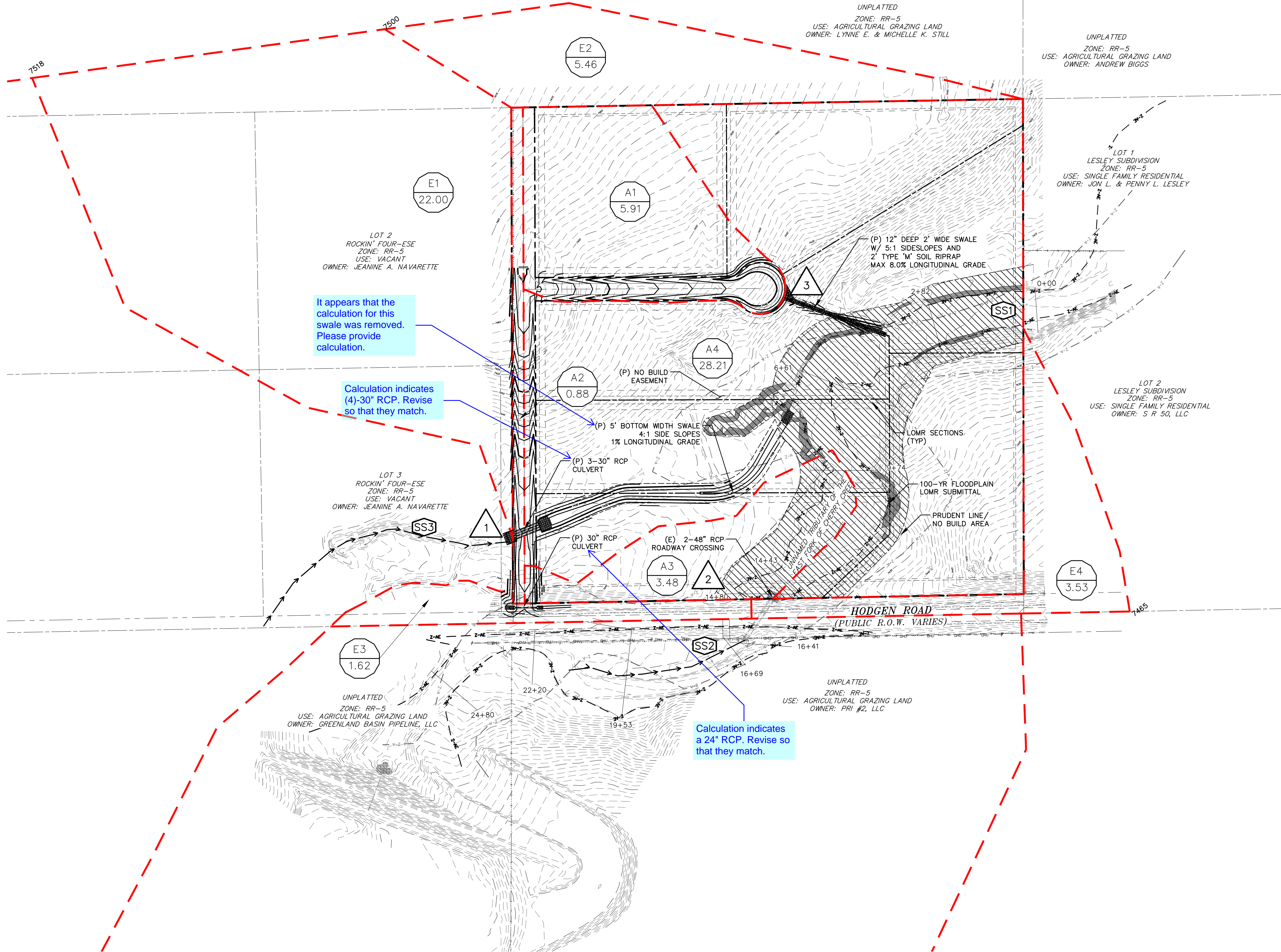

It appears that the calculation for this swale was removed. Please provide calculation.

Calculation indicates (4)-30" RCP. Revise so that they match.

Calculation indicates a 24" RCP. Revise so that they match.

PROPOSED DRAINAGE BASINS							
BASIN	AREA (ACRES)	Q2 (CFS)	Q5 (CFS)	Q10 (CFS)	Q25 (CFS)	Q50 (CFS)	Q100 (CFS)
E1	22.00	0.8	2.8	6.2	10.9	14.6	18.9
E2	5.46	0.3	1.3	2.8	4.8	6.5	8.4
E3	1.62	1.0	1.5	2.2	3.1	3.8	4.6
E4	3.53	0.9	1.6	2.8	4.3	5.5	6.9
A1	5.91	2.9	5.1	7.3	10.3	12.9	15.6
A2	0.88	2.5	3.1	3.7	4.3	4.9	5.6
A3	3.48	0.7	1.5	2.6	4.0	5.2	6.5
A4	28.21	6.8	15.0	24.9	38.0	49.3	61.4

PROPOSED DESIGN POINTS							
DESIGN POINT	Q2 (CFS)	Q5 (CFS)	Q10 (CFS)	Q25 (CFS)	Q50 (CFS)	Q100 (CFS)	Q500 (CFS)
SS1						357.0	661.0
SS2						295.0	547.0
SS3						153.0	286.0
1						155.6	
2	2.5	3.4	4.3	5.5	6.4	7.5	
3	2.9	5.1	7.3	10.3	12.9	15.6	

LEGEND

EXISTING	(E)
PROPOSED	(P)
BOUNDARY	---
RIGHT-OF-WAY	----
LOT LINE	-----
EASEMENT	-----
(E) CONTOUR, INDEX	-----
(E) CONTOUR	-----
(P) CONTOUR, INDEX	-----
(P) CONTOUR	-----

REV.	DESCRIPTION	DATE



PREPARED FOR:
SAVAGE DEVELOPMENT INC
1125 DIAMOND RIM DR.
COLORADO SPRINGS, CO 80921



HIGH PLAINS FILING NO. 1

PROPOSED CONDITIONS

DESIGNED BY: DLM	DRAWN BY:
SCALE: 1"=150'	DATE: 07/09/18
JOB NUMBER: 17-135	SHEET: 1 OF 1