

LORSON RANCH

Carriage Meadows South PUD Development & Preliminary Plan Minor Amendment

A TRACT OF LAND LOCATED IN A PORTION OF THE NORTHEAST ONE-QUARTER (NE 1/4) OF SECTION 22 AND A PORTION OF THE NORTHWEST ONE-QUARTER (NW 1/4) OF SECTION 23, ALL IN TOWNSHIP 15 SOUTH, RANGE 65 WEST OF THE 6TH P.M., EL PASO COUNTY, COLORADO

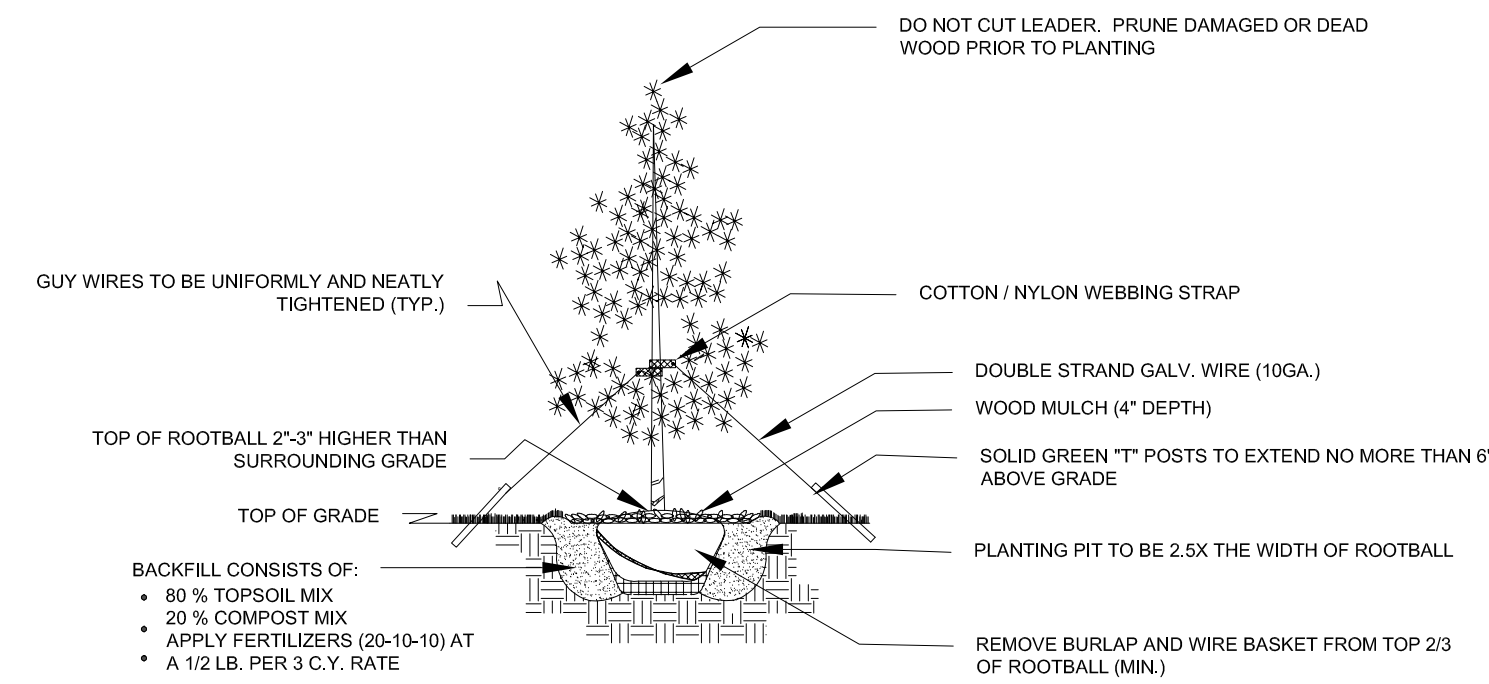

EVERGREEN TREE PLANTING DETAIL

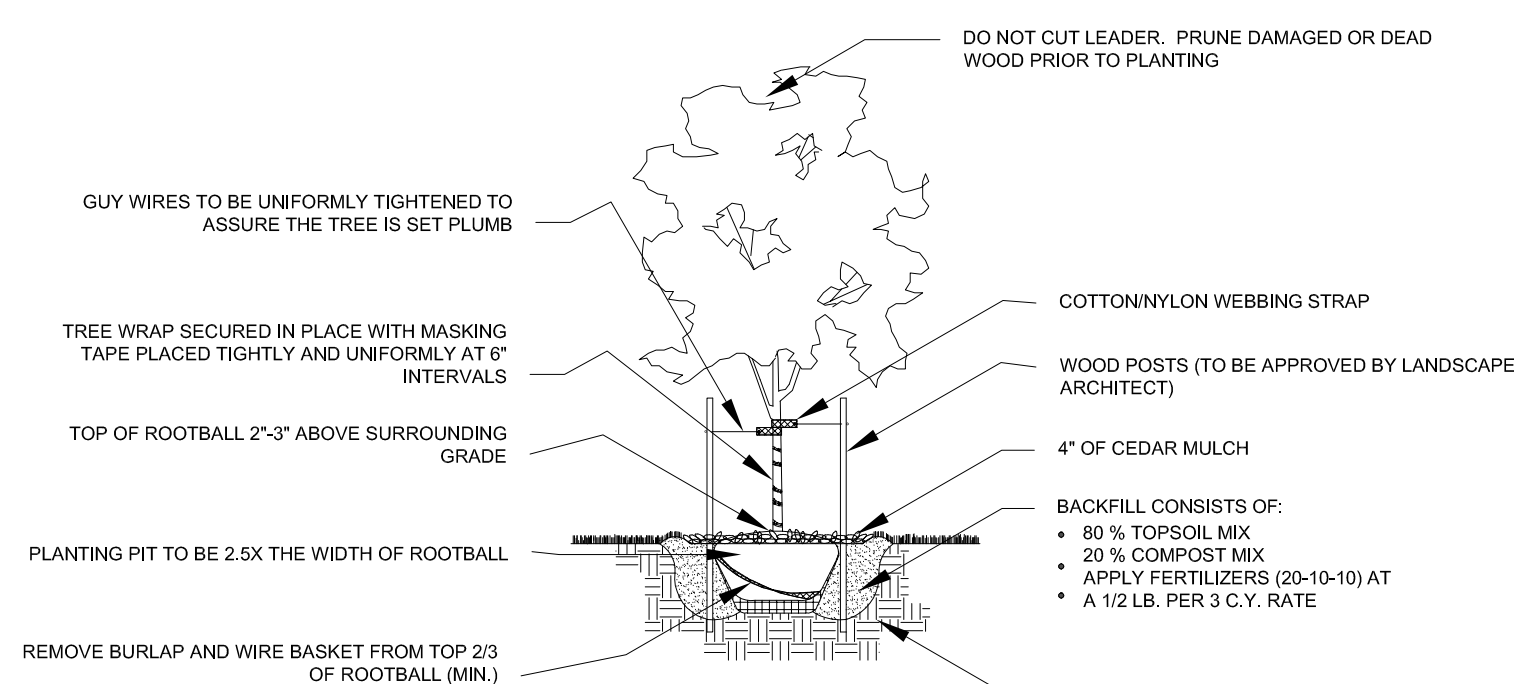

DECIDUOUS TREE PLANTING DETAIL

PUD LANDSCAPE STREETSCAPES:

STREET NAME OR ZONE BOUNDARY:	MARKSHEFFEL RD.	LORSON RANCH BLVD. (NORTH SIDE)	LORSON RANCH BLVD. (SOUTH SIDE)
ROADWAY CLASSIFICATION:	PRINCIPAL ARTERIAL	COLLECTOR	COLLECTOR
SETBACK DEPTH REQUIRED/PROVIDED:	25' / 25'	10' / 10'	10' / 10'
LINEAR FOOTAGE:	1,394'	2,163'	2,163'
TREES/FEET REQUIRED:	1 / 30'	1 / 50'	1 / 50'
NUMBER OF TREES REQUIRED/PROVIDED:	46 / 46	43 / 43	43 / 43
NUMBER OF EVERGREEN TREES REQ / PROV:	N/A	N/A	N/A
% GROUND PLANE VEG. REQUIRED/PROVIDED:	75 / 75	75 / 75	75 / 75
EVERGREEN TREE SYMBOLS:			
DECIDUOUS TREE SYMBOLS:			

GENERAL PLANTING NOTES:

- COMMON OPEN SPACE AREAS SHALL BE XERISCAPED WITH NATIVE SEED PER THE EROSION CONTROL PLANS. ANY URBAN PARK IMPROVEMENTS WILL BE COORDINATED AT A LATER DATE WITH EL PASO COUNTY PARKS VIA PARK LAND AGREEMENTS.
- THE PROPOSED GRAVEL PATHS TO MATCH THE EXISTING PATHS WITHIN LORSON RANCH.
- ALL UTILITY LOCATIONS MUST BE OBTAINED BY THE LANDSCAPE CONTRACTOR PRIOR TO DIGGING.
- ALL AREAS DISTURBED DUE TO CONSTRUCTION SHALL BE REVEGETATED AS PART OF THE BASE BID UNLESS OTHERWISE SHOWN.
- ALL TREE LOCATIONS SHALL BE STAKED PRIOR TO PLANTING FOR APPROVAL BY THE OWNER'S REPRESENTATIVE. ALL SHRUBS SHALL BE PLACED AND THEIR LOCATION APPROVED BY THE OWNER'S REPRESENTATIVE PRIOR TO PLANTING.
- CONTRACTOR IS RESPONSIBLE FOR EROSION CONTROL PRACTICES AS REQUIRED.
- TURF AREAS ARE TO BE IRRIGATED VIA AN AUTOMATED SYSTEM OF GEAR DRIVEN ROTORS AND POP-UP SPRAYS. ALL SHRUBS AND TREES (EXCEPT THOSE IN TURF AREAS) SHALL BE DRIP IRRIGATED. AN AUTOMATIC IRRIGATION CONTROLLER AND RAIN SENSOR WILL BE INCLUDED IN THE IRRIGATION SYSTEM DESIGN.
- SEEDING SHALL OCCUR AFTER SPRING THAW AND BEFORE APRIL 15 OR AFTER SEPTEMBER 1 AND BEFORE CONSISTENT GROUND FREEZE.
- FOR PROPOSED SITE GRADING, HEIGHT AND SLOPE OF BERMS, SEE GRADING PLAN.
- LANDSCAPING AREAS, TRAILS, COMMON OPEN SPACE AND BUFFERS SHALL BE MAINTAINED BY THE LORSON RANCH METROPOLITAN DISTRICT.
- TRAILS TO BE SOFT SURFACE TO MATCH EXISTING TRAILS FOUND WITHIN LORSON RANCH.
- ANY FUTURE TRAILS SHALL BE PUBLIC. FINAL TRAIL ALIGNMENT TO BE DETERMINED IN THE FIELD BASED ON GRADE, VEGETATION, AND OTHER EXISTING SITE FEATURES.

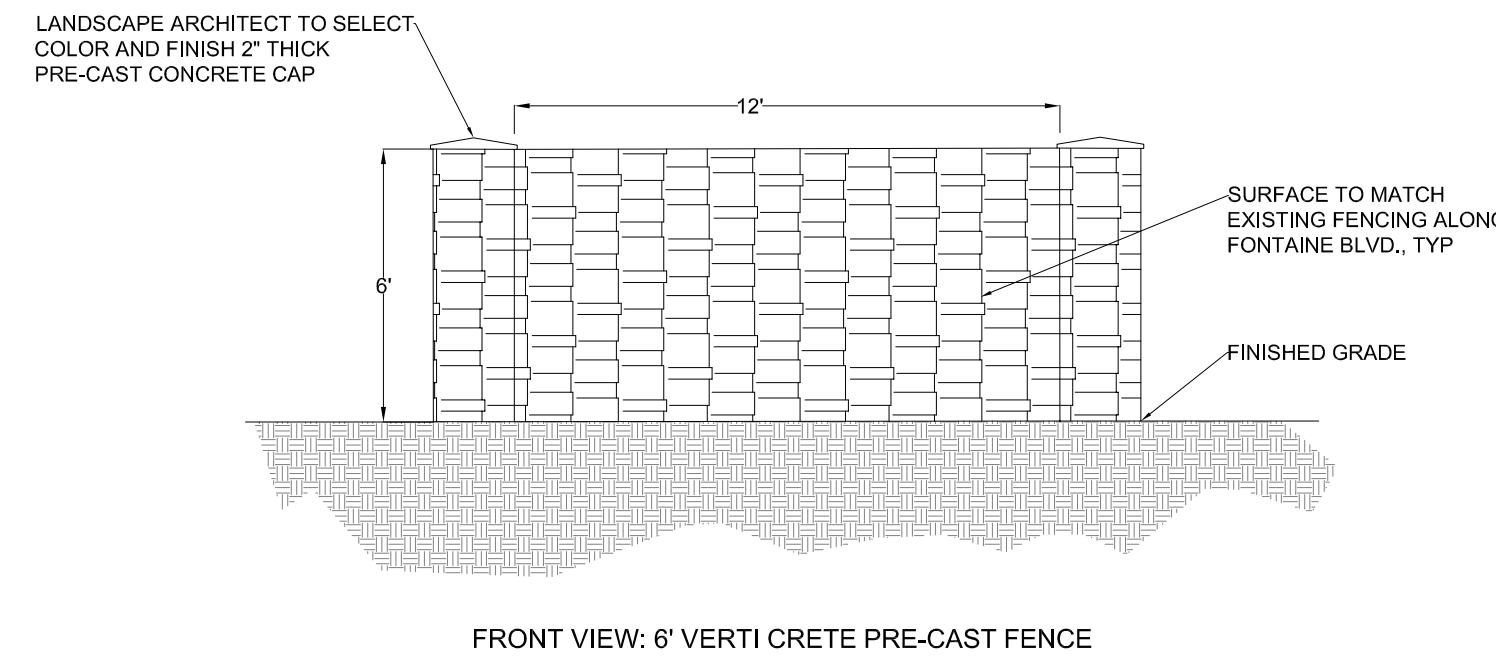
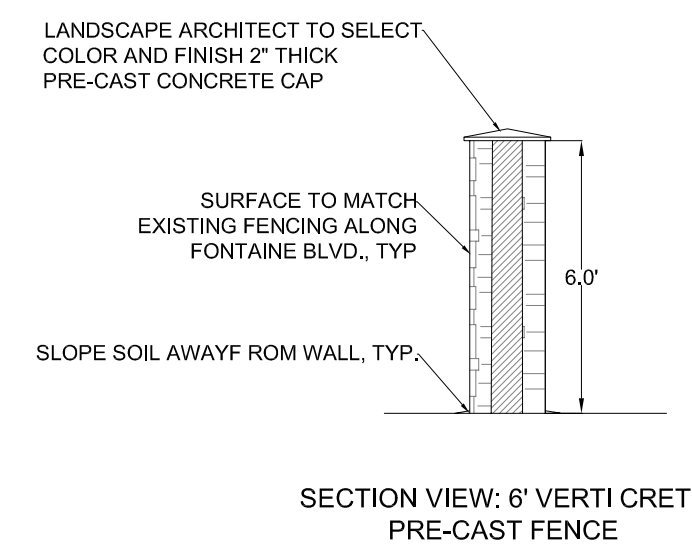
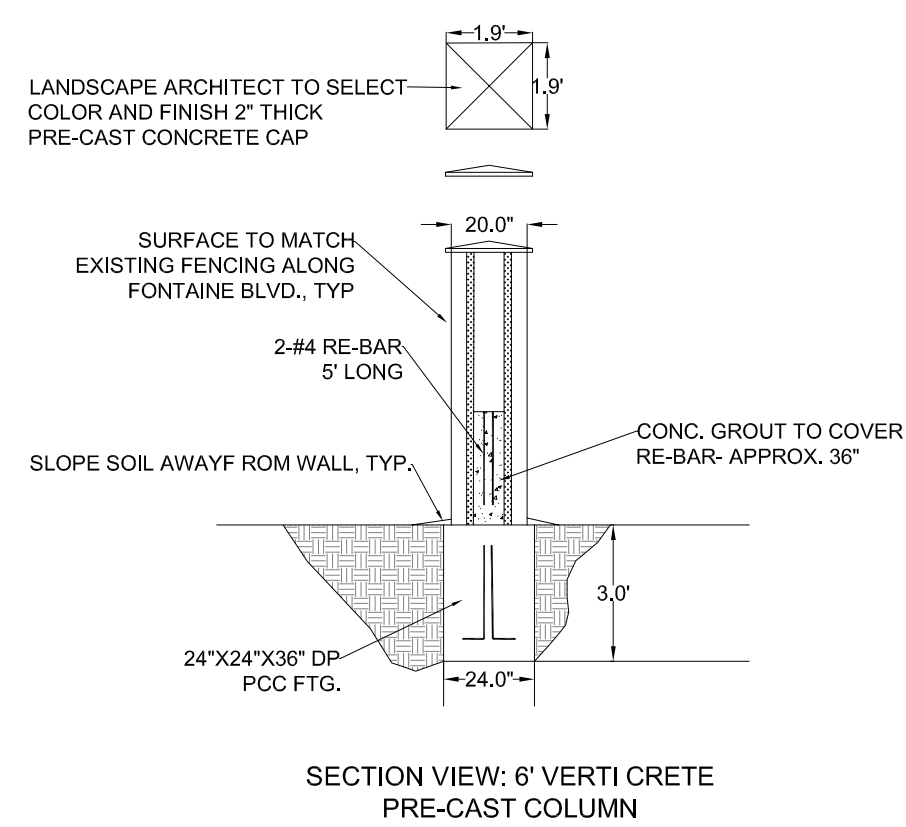

- NOTE:
- FENCING, COLUMNS, CAP, ETC. TO MATCH EXISTING FOUND WITHIN LORSON RANCH, TYP.
 - FENCE AND COLUMN COLOR, TEXTURE, PATTERN, ETC. TO MATCH EXISTING FOUND WITHIN LORSON RANCH, TYP.
 - COLUMNS, WALL, STEEL FENCING PER MANUFACTURERS SPECIFICATIONS.
 - SUBMIT CUT SHEETS AND SAMPLE PRIOR TO INSTALLATION.

CONCRETE FENCE DETAIL

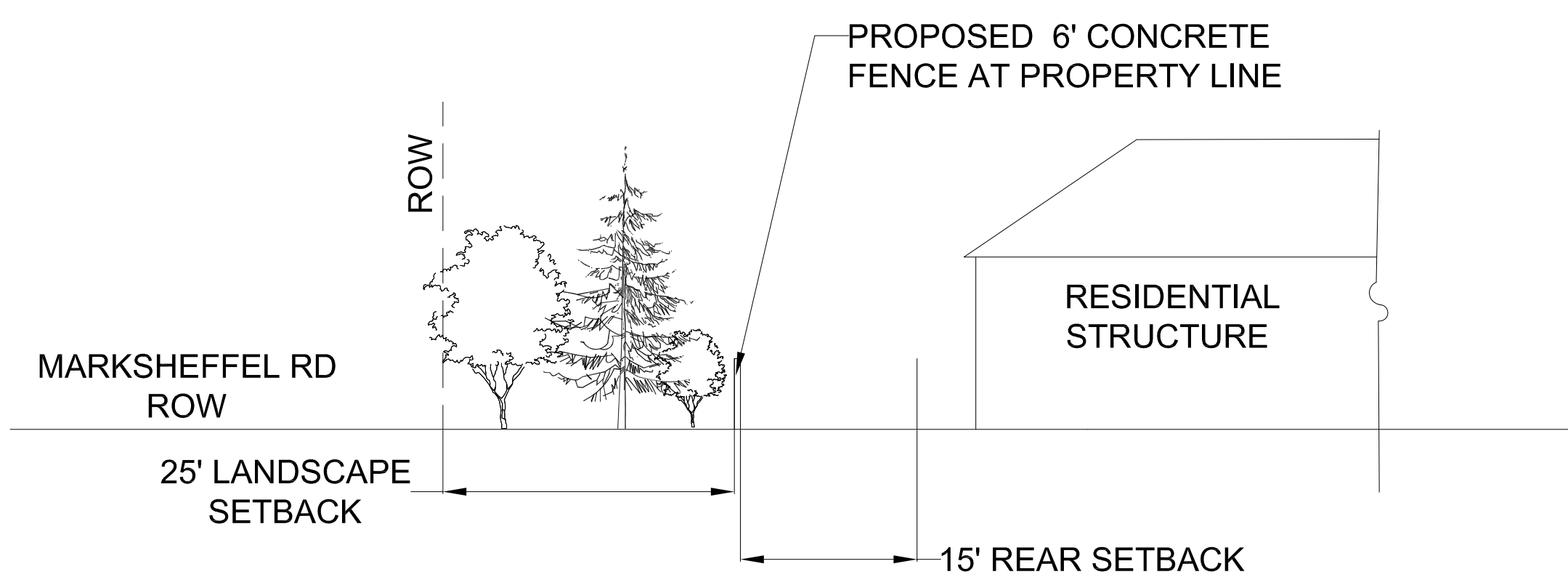

CONCRETE FENCE SECTION ALONG MARKSHEFFEL RD.

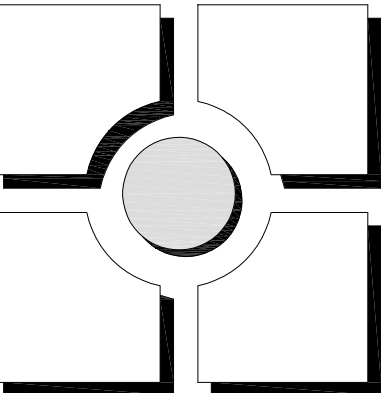
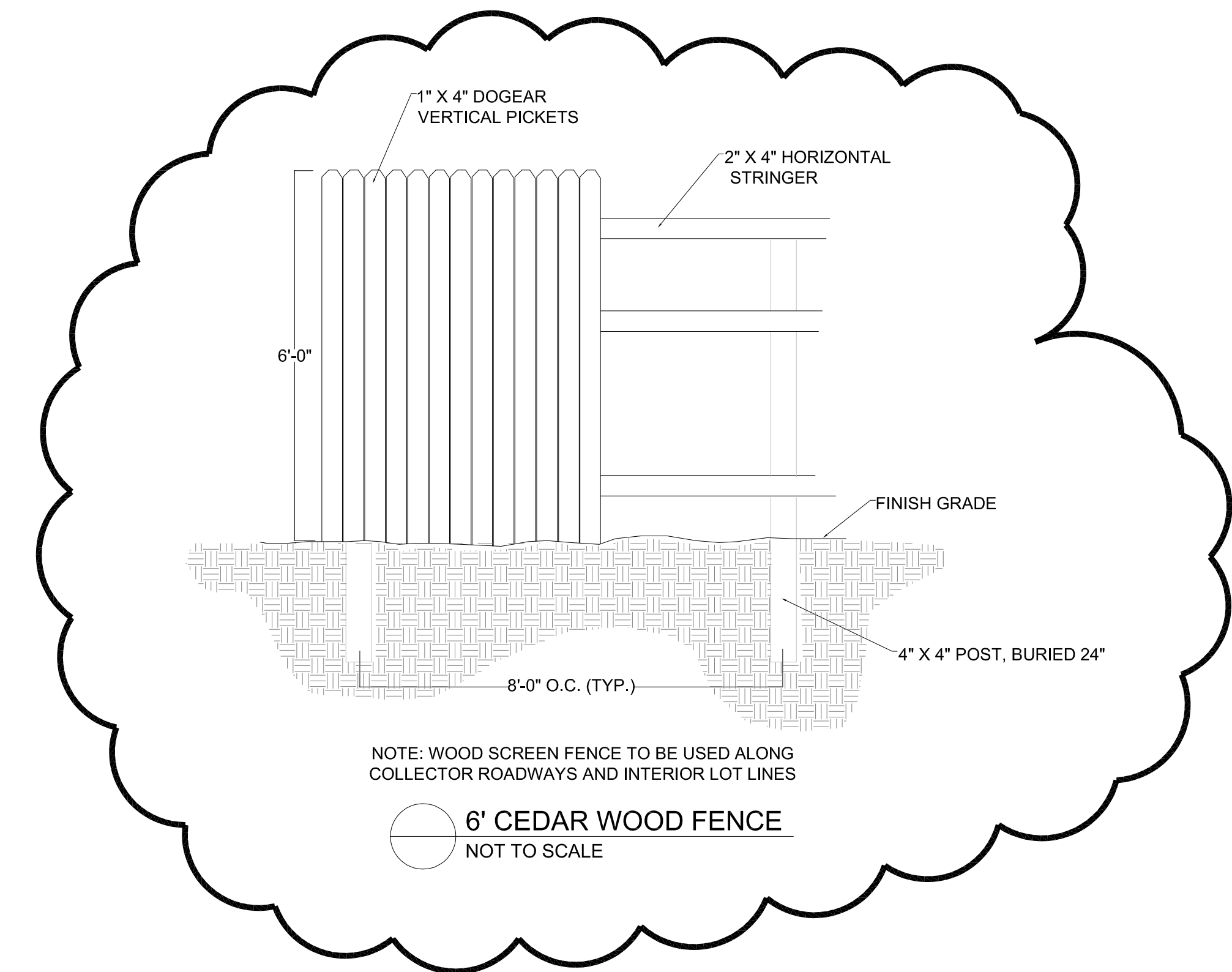

THOMAS THOMAS
 Planning
 Urban Design
 Landscape Architecture
 702 North Tejon
 Springs, Colorado 80903
 (719) 576-6777

REV #	REVISIONS	DATE	DRAWN	CHECKED	APPROVED
1					
2					
3					
4					
5					
6					

DESIGNED	JRA	05.21.18
DRAWN	JRA	05.21.18
CHECKED	LMT	05.21.18
PROJECT NUMBER:		2816.11
SCALE:		AS NOTED

Lorson Ranch
 Carriage Meadows South
 Colorado Springs, CO

MINOR AMENDMENT
 PUD & PRELIMINARY PLAN

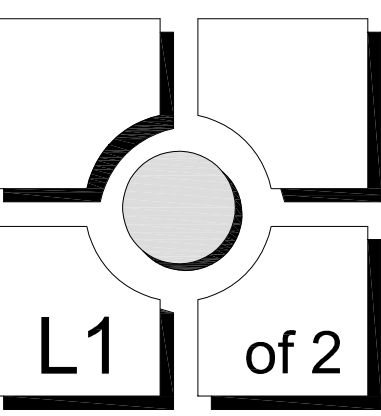

LORSON RANCH

Carriage Meadows South PUD Development & Preliminary Plan Minor Amendment

A TRACT OF LAND LOCATED IN A PORTION OF THE NORTHEAST ONE-QUARTER (NE 1/4) OF SECTION 22 AND A PORTION OF THE NORTHWEST ONE-QUARTER (NW 1/4) OF SECTION 23, ALL IN TOWNSHIP 15 SOUTH, RANGE 65 WEST OF THE 6TH P.M., EL PASO COUNTY, COLORADO

County Zoning: RR-0.5
Existing Land Use: Residential



THOMAS THOMAS
Planning
Urban Design
Landscape Architecture
702 North Tejon
Colorado Springs, Colorado 80903
(719) 576-6777

REV #	REVISIONS	DATE	DRAWN	CHECKED	APPROVED
1					
2					
3					
4					
5					
6					

DESIGNED	JRA	05.21.18
DRAWN	JRA	05.21.18
CHECKED	LIMIT	05.21.18
PROJECT NUMBER:		2816.11
SCALE:		AS NOTED

Lorson Ranch
Carriage Meadows South
Colorado Springs, CO
MINOR AMENDMENT
PUD & PRELIMINARY PLAN

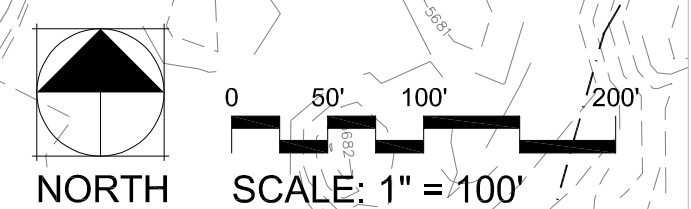

DSD FILE NO.: PUDSP-16-002