

North
Scale: 1" = 200'

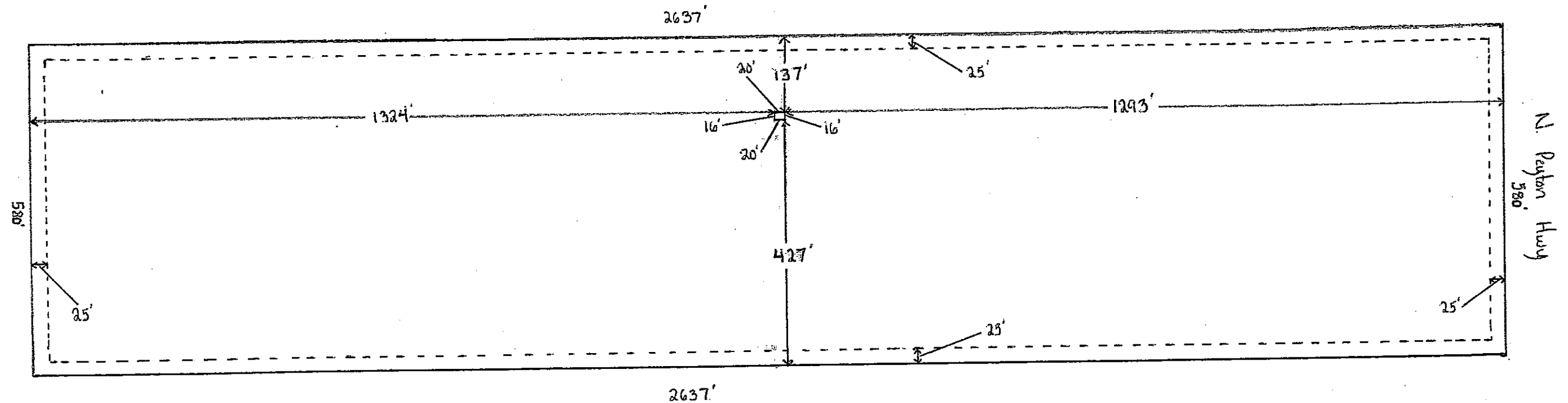

OWNER: WILLIAMS CHARLIE
 ADDRESS: 1412 N PEYTON HWY
 CALHAN, CO 80808
 SCHEDULE: 3400000372
 ZONING: RR-5
 PLAT No: -

LEGAL DESCRIPTION: THAT PT
 NE4 SEC 8-14-63 DESC AS FOLS;
 COM AT NE4NE4 SD SEC,
 TH S00<38'19" E 328.50 FT TO POB;
 TH CONT S00<38'19" E 579.35 FT;
 S89<34'37" W 2634.95 FT TO A PT
 ON THE W LN SD NE4, THN00<34'06"
 W 578.33 FT, N89<33'17" E 2634.23
 FT TO POB

PROPOSED ACCESSORY STRUCTURE:
 16x20', 320 SF
 PROPOSED ACCESSORY STRUCTURE
 HEIGHT: 18'2 1/2"
 LOT COVERAGE: 0.02%

Drafted by Adam A
 Tuff Shed Inc.
 12/23/2020