

# JUDGE ORR ROAD RV PARK & STORAGE DEVELOPMENT

## GRADING, EROSION CONTROL AND STORMWATER QUALITY REPORT (SWMP)

Prepared For:  
McDonald Paving & Chip Sealing (Owner & Contractor)  
3507 El Paso St.  
Colorado Springs, CO 80907  
719-590-1680

Prepared By:  
Associated Design Professionals, Inc.  
121 S. Tejon St., Suite 1110  
Colorado Springs, CO 80903  
719.266.5212

Qualified Stormwater Manager  
Richard Gallegos, PE  
Respec  
121 S. Tejon St., Suite 1110  
Colorado Springs, CO 80903

ADP Project No. 160301  
July 21, 2022

PCD Project #PPR-16-040

# Table of Contents

TABLE OF CONTENTS	i
VICINITY MAP	ii
PROJECT DESCRIPTION	1
General Location	1
SITE DESCRIPTION	1
Soils	1
EROSION AND SEDIMENT CONTROL CRITERIA	1
Areas and Volumes	1
Erosion and Sediment Control Measures	2
Initial Stage	2
Temporary Stabilization	2
Vehicle Tracking Control	2
Silt Fence	2
Outlet Protection	2
Non-Structural Practices	2
Construction Timing	2
Permanent Stabilization	3
Stormwater Management	4
Maintenance	4
Cost	4
STORMWATER MANAGEMENT	5
Stormwater Management	5
Potential Pollution Sources	5
CONCLUSION	6
Compliance with Standards	7
REFERENCES	7
APPENDIX A	
Grading and Erosion Control Plans	
APPENDIX C	
Inspection Checklist	

# PROJECT DESCRIPTION

## General Location

The Judge Orr Road RV Park & Storage project consists of 39.9 acres located along Judge Orr Road just east of US 24 and approximately two miles northeast of Falcon, Colorado. The project is located within the previously approved Meadowlake Commons Master Plan area. The site is further described as being located in central El Paso County within the Southwest Quarter of Section 33, Township 12 South, Range 64 West of the 6<sup>th</sup> Principal Meridian, El Paso County, Colorado.

The proposed development lies within the Haegler Ranch Drainage Basin Planning Study area, prepared by URS Corporation in 2007. It is also included in the Meadowlake Commons MDDP, prepared by Springs Engineering in 2008. For this report, the existing flows for this project utilize the findings of the Meadowlake Commons MDDP and flows into the Middle Fork of Black Squirrel Creek. No streams are located or cross the project area.

# SITE DESCRIPTION

## Existing Site Conditions

The existing site is mostly undeveloped with a residence and a barn. The remainder of the site is vacant and covered with rangeland grasses with about 90% coverage determined by visual inspection. The existing impervious value is approximately 1.4%. The site does not contain any springs or irrigation systems.

## Soils

The Soil Conservation Service (NRCS) soil survey for El Paso County has identified the soil type in this study area as follows:

Map Symbol No.	Soil Name	Hydrologic Soil Group
19	Columbine Gravelly Sandy Loam	A

The soil erosion potential of this soil is slight to moderate.

# EROSION AND SEDIMENT CONTROL CRITERIA

## Areas and Volumes

The proposed site development shall require the construction of approximately 7,150 lineal feet of private roadways, 120 RV pads, gravel RV storage area and associated utilities. The site will be overlotted graded with two (2) connections to Judge Orr Road. This will increase the estimated imperviousness to 44.0% from 1.4%, in addition the runoff coefficients for the 100-year storm will increase from 0.36 to 0.57.

Improvements shall include the construction of a detention/water quality basin on the property to account for the areas of the most disturbances. The total area of disturbance shall be about 30 acres. Construction activities shall consist of clearing, grubbing and grading for the new development. Approximately 60,000 cubic yards of cut and fill shall be moved. Disturbed and exposed areas of the site shall be seeded and mulched if construction activities cease for more than 30 consecutive days. The site shall also require the sedimentation basins listed below to handle the potential erosion.

## **Erosion and Sediment Control Measures**

Erosion control and sediment prevention measures describe a wide range of management procedures, schedules of activities, prohibitions on practices, and other best management practices (BMP). BMPs also include operating procedures, treatment requirements and practices to control site runoff, drainage from materials storage, spills or leaks. Structural practices for this site include silt fences, straw bales, inlet protection, and vehicular tracking control. Erosion matting may be required on unstable slopes, if directed by the engineer. General descriptions of the BMPs to be used during the construction of this project are listed below. See the Erosion Control Plans for the specific type and location of each erosion and sediment control device required for this project.

### **Initial Stage**

These BMPs shall be installed at the outset of construction, prior to the initial pre-construction meeting and any other land-disturbing activities. Initial controls are to be placed on existing grades but shall be based in part on proposed grading operations. The initial stage includes clearing, grubbing, overlot grading, and utility and other construction prior to paving operations.

### **Temporary Stabilization**

Disturbed areas will be temporarily stabilized as soon as construction activities are completed. Seeding will be applied to completed areas within 14 days of completion.

### **Vehicle Tracking Control**

A vehicle tracking control device will be installed at the construction entrance where the construction entrance intersects an existing paved private roadway.

### **Silt Fence**

Prior to the start of construction, silt fence will be installed along the perimeter of all disturbed areas that are within the project site. Silt fence shall be placed as indicated on the plan drawing. Sediment shall be removed when depth exceeds one-fourth the height of the silt fence. The engineer may require additional silt fence as necessary to retard sediment transport on or off the project site.

### **Outlet Protection**

Outlet protection at the water quality basin on the site will be provided to prevent erosion and scour of the water quality basin area by the concentrated flows gathered by the storm sewer system both during and after construction.

### **Non-Structural Practices**

Upon completion of the grading, temporary seeding and mulching will be applied to all disturbed areas on and adjacent to the site. All seeding, fertilizers, and mulching shall conform to *El Paso County Engineering Criteria Manual*.

## **SPILL PREVENTION AND RESPONSE PLAN**

- a. A Qualified Stormwater Manager will be Richard Gallegos, Certification #63, 713-492-8296.
- b. The Spill Prevention and Response Plan will be as follows:
  - Fueling will occur on-site using mobile equipment (will not be stored on-site).
  - Equipment maintenance will occur off-site.
  - All equipment maintenance will occur off-site. No fertilizers, pesticides, detergents, and/or solvents will be used or stored on-site.

- c. A Materials Handling Plan will be as follows:  
Construction Material will mostly include gravel and recycled asphalt. Only a small amount of asphalt will be placed on the site.  
Storage containers will be transported to the site and placed on a gravel base with no buildings being constructed on-site.
- d. Potential Sources of Pollution

**TABLE 1: POTENTIAL POLLUTION SOURCES**

<b>Potential Pollution Sources</b>	<b>Possible Site Contributions of Pollutants to Stormwater Discharges</b>
All disturbed and stored soils	Stockpiles of fill and topsoil.
Vehicle tracking of sediments	See plan for vehicle tracking control for vehicle entrance and exits.
Management of contaminated soils	No contaminated soils are expected to be encountered.
Loading and unloading operations	Unloading of materials.
Outdoor storage activities (building material, fertilizers, chemicals, etc.)	Soil stockpiles and equipment storage areas (no fertilizers, petroleum or chemical products will be stored on-site).
Vehicle and equipment maintenance and fueling	Fueling will occur on-site using mobile equipment (will not be stored on-site). Equipment maintenance will occur off-site.
Significant dust or particulate-generating processes	Vehicle tracking, stockpiles, fill placement.
Routine maintenance activities involving fertilizers, pesticides, detergents, fuels, solvents, oils, etc.	All equipment maintenance will occur off-site. No fertilizers, pesticides, detergents, and/or solvents will be used or stored on-site.
On-site waste management practices (waste piles, liquid wastes, dumpsters, etc.)	All waste will be removed from site as soon as possible.
Concrete truck/equipment washing, including the concrete truck chute and associated fixtures and equipment	Concrete wash areas delineated on-site.
Dedicated asphalt and concrete batch plants	No dedicated asphalt and concrete batch plants are on-site.
Non-industrial waste sources such as worker trash and portable toilets	Worker trash will be removed from the site as soon as possible. Portable toilets will be provided on-site.
Other areas or procedures where potential spills can occur	Petroleum releases from equipment are possible.

- e. Should a spill occur, the construction supervisor onsite will notify the El Paso County Environmental group to assess the severity of the spill and the appropriate action necessary to address the spill.

f. Implementation of Control Measures

**Construction Timing**

The site will be graded to accommodate the proposed redevelopment items delineated previously. This project will be constructed in a single phase. Once construction begins, it will continue until the project is complete; therefore, construction phasing will not be necessary. The construction process will consist of grading (excavation and fill) activities, installation of utilities, paving,

concrete placement, landscaping, and building construction. The general sequence for major construction activities will be as follows:

- Establish limits of disturbance
- Install vehicle tracking control (VTC)
- Install silt fence
- Install Building Materials Storage area (located within Phase I Area)
- Install Soils/Waste Storage area (located within Phase I Area)
- Install temporary sedimentation basin
- Clear and grub the site
- Excavation and fill placement
- Install underground utilities
- Install inlet and outlet protection BMPs
- RV pad construction
- Paving
- Install permanent landscaping and irrigation
- Remove temporary sediment pond and reshape for water quality/detention basin
- Remove BMPs

To be fully effective, erosion and sediment control measures must be installed and phased with the construction activities. The vehicular tracking control device shall be installed at the entrance prior to the mobilization of construction equipment on-site. Prior to the clearing and grubbing of the entire construction area, localized clearing shall be performed for the placement of perimeter erosion control measures. Site clearing shall commence only after the perimeter erosion control measures are in place. Erosion control devices must be in place to reduce the potential of eroded excavated material entering the storm drainage system. Protection devices shall be placed during grading activities, in the appropriate areas, as indicated on the plan drawing that is located in the Appendix.

Should conditions change during construction the Engineer shall modify the SWMP accordingly.

Anticipated starting and completion date: June 1, 2022 to October 1, 2022

**Expected date on which the final stabilization will be completed: October 1, 2022**

### **Permanent Stabilization**

Disturbed areas shall be permanently stabilized as soon as construction activities are completed. Viable vegetative cover shall be established no later than one year from disturbance. Areas to be revegetated shall be treated with soil amendments to provide an adequate grown medium to sustain vegetation and shall match the existing 70 percent pre-disturbed vegetation cover.

The seedbed shall be well settled and firm, but friable enough that seed can be placed at the seeding depth specified. The seedbed shall be reasonably free of weeds. Soils that have been over-compacted by traffic or equipment, especially when wet, shall be tilled to break up rooting restrictive layers and then harrowed, rolled, or packed to prepare the required firm seedbed. Mulch shall be applied at a rate of two and one-half (2 ½) tons per acre and shall be spread uniformly, in a continuous blanket, after seeding is complete. Mulch shall be clean, weed and seed free, long-stemmed grass or hay, or long-stemmed straw of oats, wheat, or rye. At least 50 percent of mulch, by weight, shall be ten inches or longer. Mulch shall be spread by hand or

blower-type mulch spreader. Mulching shall be started on the windward side of relatively flat areas or on the upper part of steep slope and continued uniformly until the area is covered. The mulch shall not be bunched. Immediately following spreading, the mulch shall be anchored to the soil by a v-type wheel land packer or scalloped-disk land packer designed to force mulch into the soil surface a minimum of three inches. All seeded areas shall be mulched after seeding on the same day as the seeding. The type of seed mix used for permanent vegetation shall utilize perennial grasses as delineated on the plans.

## Stormwater Management

All developed stormwater will be routed through the EDB facilities to provide stormwater quality as delineated on the drawings.

## Maintenance

All temporary and permanent erosion and sediment control practices shall be maintained and repaired as needed by the contractor throughout the duration of construction to assure that each BMP will function as intended. As required by the stormwater discharge permit, a weekly inspection of these items will be performed. In addition, all facilities must be inspected by the owner or the owner's representative following each heavy precipitation or snowmelt event that results in runoff, with maintenance occurring immediately after discovering a need.

Silt fence may require periodic replacement. All sediment accumulated behind the silt fence must be removed and disposed of properly when depth exceeds one-fourth the height of the silt fence. On-site construction traffic will be monitored to minimize the transport of sediment onto the proposed on-site streets, as well as onto adjacent city streets. The Owner, Site Developer, Contractor, and/or their authorized agents shall prevent loss of cut and fill material being transported to and from the site by taking appropriate measures. All mud and sediment tracked onto public streets shall be cleaned immediately. Road cleaning includes shoveling and sweeping activities.

Diversion ditches shall be kept clean and functional during construction. They shall be routinely checked on a weekly basis and cleaned if the height of sedimentation exceeds one-half its depth.

Inlet/outlet protection shall be inspected to ensure proper operation. Excess debris or sediment must be removed prior to final acceptance of the project.

The temporary sedimentation pond shall remain in place until such time as the major grading operations in the area are completed and the ground stabilized by either temporary or permanent measures. The ponds will be cleaned out periodically with depth of sediment at no time allowed to accumulate more than one-half the depth of the facility.

## Cost

An engineer's cost estimate for the anticipated erosion and sediment control items for the entire site are listed below:

Section 1 – Grading & Erosion Control BMPs	Quantity	Units	Price	Total
Earthwork*	60000	CY	\$5	\$300,000
Permanent Seeding*	5.0	AC	\$582	\$ 2,910
Mulching*	5.0	AC	\$507	\$ 2,535
Erosion Bales	22	EA	\$21	\$ 462

Inlet Protection	6	EA	\$153	\$ 918
Vehicle Tracking Control	1	EA	\$1,625	\$ 1,625
Sedimentation Basin	1	EA	\$1,625	\$ 1,625
Silt Fence	3725	LF	\$4	\$14,900
Concrete Washout Basin	1	EA	\$776	\$776
<b>TOTAL EROSION &amp; SEDIMENT CONTROL COST</b>				<b>\$325,751</b>

*\*Private*

This project does not rely on control measures owned or operated by another entity.

## STORMWATER MANAGEMENT

### Stormwater Management

Stormwater quality shall be protected and preserved throughout the life of this development. During mass grading and construction, measures such as sediment fences, straw bales, and vehicle tracking control shall be used to minimize erosion and sedimentation on site. During construction, the proposed extended detention basin shall function as a temporary sediment basin to reduce the potential for sediment leaving this development. Temporary diversion dikes shall be constructed to transport runoff that may contain sediment to the temporary sediment basin located on site until a stormwater system is installed. After various stages of the construction, when applicable, temporary or permanent erosion control stabilization shall be installed and maintained (landscaping, seeding, mulching, etc.).

### Potential Pollution Sources

Materials are sometimes used at the construction site that present a potential for contamination of stormwater runoff. These include sediment, equipment/vehicle washing, vehicle maintenance and fueling, petroleum products, paint, solvents, treated wood products, asphalt (bituminous) paving, concrete, concrete-curing compounds, metal, waste storage and disposal and other liquid chemicals such as fertilizers, herbicides, and pesticides. Practices that can be used to prevent or minimize toxic materials in runoff from a construction site are described in this section.

Areas at the construction site that are used for storage of toxic materials and petroleum products shall be designed with an enclosure, container, or dike located around the perimeter of the storage area to prevent discharge of these materials in runoff from the construction site. These barriers shall also function to contain spilled materials from contact with surface runoff. Proposed locations for storage of toxic materials have not been determined at the time of this report. Locations shall depend upon construction phasing.

Measures to prevent spills or leaks of fuel, gear oil, lubricants, antifreeze, and other fluids from construction vehicles and heavy equipment shall be considered to protect groundwater and runoff quality. All equipment maintenance shall be performed in designated areas and shall use spill control measures, such as drip pans, to contain petroleum products. Spills of construction-related materials, such as paints, solvents, or other fluids and chemicals, shall be cleaned up immediately and disposed of properly. **No batch plants will be located on this site.**

Trash receptacles shall be provided and kept clean as required to keep the site clean of trash. In addition, portable toilets shall be provided for all workers on the site during construction. All portable toilet facilities shall be located at least three feet from curb flow lines and paved surfaces. The facilities shall be stationed on ground and secured down to prevent tipping.



Potable water is anticipated as a non-stormwater discharge. Potable water shall be used for grading, dust control, and irrigation of erosion control and permanent landscaping. An effort shall be made to use only the amount of potable water required for these operations.

### **Owner Inspection and Maintenance of Constructed BMPs**

All inspection logs will include signatures on the logs and be kept on site along with other SWWP records. The SWMP should be viewed as a "living document" that is continuously being reviewed and modified as a part of the overall process of evaluating and managing SW quality issues at the site. The QSM shall amend the SWMP when there is a change in design, construction, O&M of the site which would require the implementation of new or revised BMP's or if the SWMP proves to be ineffective in achieving the general objectives of the controlling pollutants in SW discharge associated with the construction activity or when BMP's are no longer necessary and are removed.

1. **Minimum Inspection Schedule.** The permittee shall, at a minimum, make a thorough inspection at least once every 14 calendar days. Also, post-storm event inspections shall be conducted within 24 hours after the end of any precipitation or snowmelt event that causes surface erosion. Provided the timing is appropriate, the post-storm inspections shall be used to fulfill the 14-day routine inspection requirement. A more frequent inspection schedule than the minimum inspections described may be necessary to ensure that BMPs continue to operate as needed to comply with the permit. Existing BMP's will be evaluated during inspections and revised as necessary to achieve site compliance. Revisions shall be annotated on the plan and initialed and dated by the Stormwater and El Paso County inspector.

1.1. **Post-Storm Event Inspections at Temporarily Idle Sites.** If no construction activities will occur following a storm event, post-storm event inspections shall be conducted prior to re-commencing construction activities, but no later than 72 hours following the storm event. The occurrence of any such delayed inspection must be documented in the inspection record. Routine inspections still must be conducted at least every 14 calendar days.

1.2. **Inspections at Completed Sites/Areas.** For sites, or portions of sites, that meet the following criteria; but final stabilization has not been achieved due to a vegetative cover that has not become established, the permittee shall make a thorough inspection of their stormwater management system at least once every month. Post-storm event inspections are not required. This reduced inspection schedule is only allowed if:

1.2.1.all construction activities that will result in surface ground disturbance are completed;

1.2.2.all activities required for final stabilization in accordance with the Grading and Erosion Control/Stormwater Quality Plan have been completed, with the exception of the application of seed that has not occurred due to seasonal conditions or the necessity for additional seed application to augment previous efforts; and

1.2.3.the Grading and Erosion Control/Stormwater Quality Plan has been amended to indicate those areas that will be inspected in accordance with the reduced schedule allowed for in this section.

1.3. **Winter Conditions Inspections Exclusion.** No changes are expected for winter work.

## CONCLUSION

This SWMP Report and the Best Management Practices (BMPs) specified on the Erosion Control Plans have been designed to reduce any adverse impacts the construction of this project might have on the surrounding properties. If properly installed and maintained, the design shall protect the quality of the stormwater runoff that is released from this development.

All temporary erosion and sediment control measures shall be removed and disposed of within thirty (30) days after final site stabilization is achieved, or after temporary measures are no longer needed, whichever occurs earliest, or as authorized by the local governing jurisdiction.

Temporary erosion control measures may be removed only after streets and drives are paved, and all disturbed areas have been stabilized. Trapped sediment and disturbed soil areas resulting from the disposal of temporary measures must be returned to final plan grades and permanently stabilized to prevent additional soil erosion.

Final stabilization is reached when all soil disturbing activities at the site have been completed, and uniform vegetative cover has been established with a density of at least 70 percent of pre-disturbance levels; or equivalent permanent, physical erosion reduction methods have been employed.

### Compliance with Standards

This report was prepared in accordance with the procedures and concepts outlined in the *El Paso County Engineering Criteria Manual*.

## REFERENCES

- *City of Colorado Springs Drainage Criteria Manual*, Volume 2, including Addendums I and II.
- *El Paso County Engineering Criteria Manual*.

## **APPENDIX A**

### **Grading and Erosion Control Plans**

# GRADING AND EROSION CONTROL PLAN

## JUDGE ORR ROAD RV PARK AND STORAGE EL PASO COUNTY, COLORADO

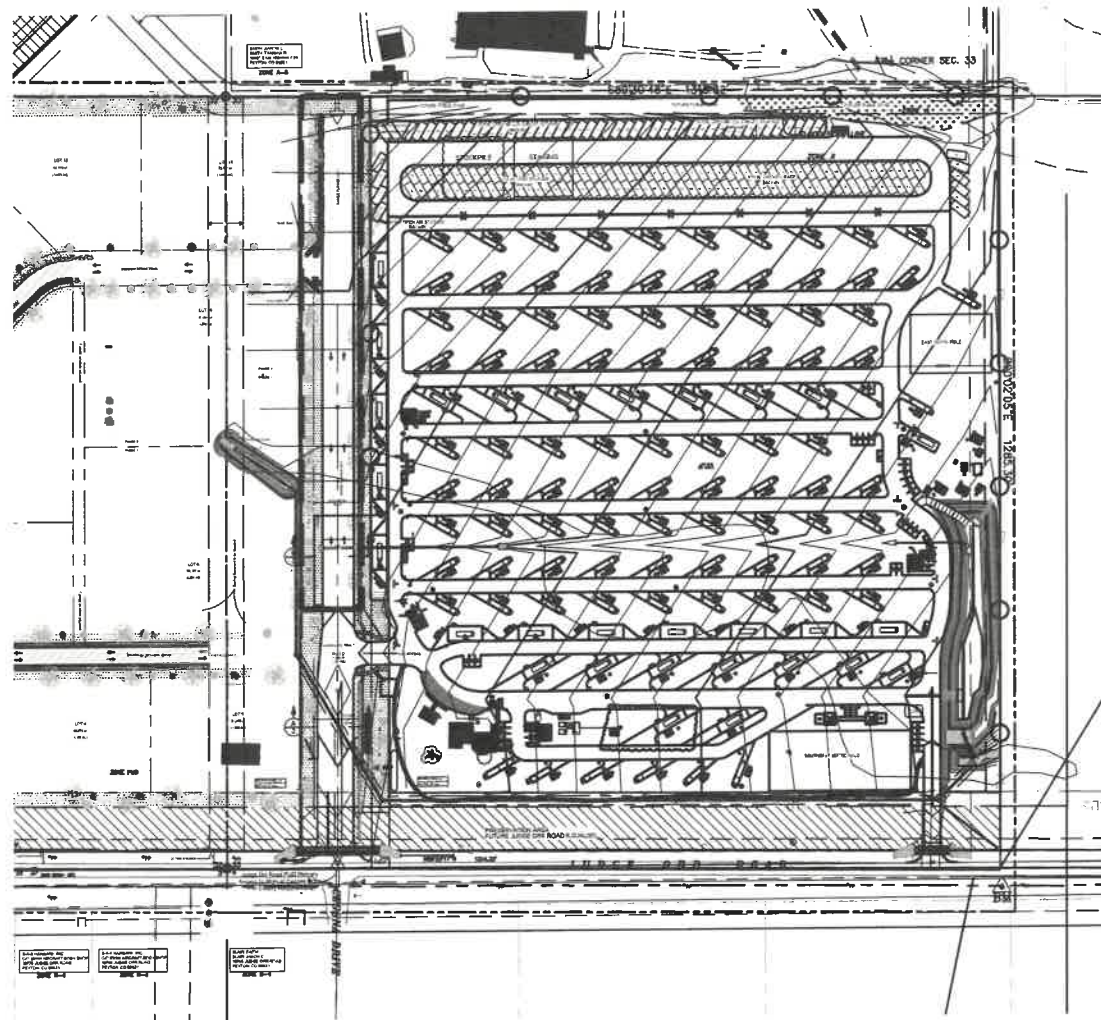

**SITE MAP**

**BENCHMARK**  
CONTROL POINT SET ON FENCE LINE, SOUTH SIDE OF JUDGE ORR ROAD FT DUE SOUTH OF EAST PROPERTY LINE. ELEV = 6841.90 (HV100)

**BASIS OF BEARING**  
WEST LINE SW 1/4 OF THE SW 1/4 SECTION 33 N00°04' 00"W

**VICINITY MAP:**



NORTH

**OWNER'S STATEMENT:**

THE OWNER WILL COMPLY WITH THE REQUIREMENTS OF THE GRADING AND EROSION CONTROL PLAN.

\_\_\_\_\_  
PRAIRIE STONE, LLC DATE  
ANDREA MINNICH, MANAGER

**ENGINEER'S STATEMENT:**

This Grading and Erosion Control Plan was prepared under my direction and supervision and is correct to the best of my knowledge and belief. Said Plan has been prepared according to the criteria established by the County for Grading and Erosion Control Plans. I accept responsibility for any liability caused by any negligent acts, errors or omissions on my part in preparing this plan.

\_\_\_\_\_  
Michael A. Bartusek, P.E. #23329

**DEVELOPER'S STATEMENT:**

I, the Developer, have read and will comply with all of the requirements specified on this plan.

By: TEDDY MCDONALD  
Title: MANAGER  
Address: MCDONALD PAVING & CHIP SEALING  
3507 EL PASO ST  
COLORADO SPRINGS, CO 80907

Filed in accordance with the El Paso County Land Development Code, Drainage Criteria Manual Volumes 1 and 2, and the Engineering Criteria Manual, as amended.

\_\_\_\_\_  
Teddy McDonald, Manager Date

**ENGINEER'S STATEMENT:**

THIS GRADING AND EROSION CONTROL PLAN WAS PREPARED UNDER MY DIRECTION AND SUPERVISION AND IS CORRECT TO THE BEST OF MY KNOWLEDGE AND BELIEF. SAID PLAN HAS BEEN PREPARED ACCORDING TO THE CRITERIA ESTABLISHED BY THE COUNTY FOR GRADING AND EROSION CONTROL PLANS. I ACCEPT RESPONSIBILITY FOR ANY LIABILITY CAUSED BY ANY NEGLIGENT ACTS, ERRORS OR OMISSIONS ON MY PART IN PREPARING THIS PLAN.

\_\_\_\_\_  
MICHAEL BARTUSEK, COLORADO P.E. # 23329 DATE  
ASSOCIATED DESIGN PROFESSIONALS, INC.

**EL PASO COUNTY:**

COUNTY PLAN REVIEW IS PROVIDED ONLY FOR GENERAL CONFORMANCE WITH COUNTY DESIGN CRITERIA. THE COUNTY IS NOT RESPONSIBLE FOR THE ACCURACY AND ADEQUACY OF THE DESIGN, DIMENSIONS, AND/OR ELEVATIONS WHICH SHALL BE CONFIRMED AT THE JOB SITE. THE COUNTY THROUGH THE APPROVAL OF THIS DOCUMENT ASSUMES NO RESPONSIBILITY FOR COMPLETENESS AND/OR ACCURACY OF THIS DOCUMENT.

FILED IN ACCORDANCE WITH THE REQUIREMENTS OF THE EL PASO COUNTY LAND DEVELOPMENT CODE, DRAINAGE CRITERIA MANUAL, VOLUMES 1 AND 2, AND ENGINEERING CRITERIA MANUAL AS AMENDED.

IN ACCORDANCE WITH ECM SECTION 1.12, THESE CONSTRUCTION DOCUMENTS WILL BE VALID FOR CONSTRUCTION FOR A PERIOD OF 2 YEARS FROM THE DATE SIGNED BY EL PASO COUNTY ENGINEER. IF CONSTRUCTION HAS NOT STARTED WITHIN THOSE 2 YEARS, THE PLANS WILL NEED TO BE RESUBMITTED FOR APPROVAL, INCLUDING PAYMENT OF REVIEW FEES AT THE PLANNING AND COMMUNITY DEVELOPMENT DIRECTOR'S DISCRETION.

\_\_\_\_\_  
JENIFER IRVINE, P.E. DATE  
COUNTY ENGINEER/ECM ADMINISTRATOR

**LEGEND:**

- PROPOSED MAJOR CONTOUR
- PROPOSED MINOR CONTOUR
- EXISTING MAJOR CONTOUR
- EXISTING MINOR CONTOUR
- U/G PIPE (MATERIAL AND SIZE AS NOTED)
- ⊙ SF — SF SILT FENCE
- LIMITS OF CONSTRUCTION
- PHASE 2 PROJECT LIMITS
- CW CONCRETE WASHOUT
- VTC VEHICLE TRACKING CONTROL
- SBB STRAW BALE BARRIER
- IP INLET PROTECTION
- TRAFFIC FLOW ARROWS

**DRAWING INDEX**

ABBR.	NAME	SHEET #/5
DPC	GRADING AND EROSION CONTROL COVER	1 OF 7
DPC	DRAINAGE, GRADING & EROSION CONTROL PLAN	2 OF 7
DPC	DRAINAGE, GRADING & EROSION CONTROL DETAIL	3 OF 7
DPC	DRAINAGE, GRADING & EROSION CONTROL DETAIL	4 OF 7
DPC	EROSION CONTROL DETAILS	5 OF 7
DPC	STANDARD NOTES	6 OF 7
DPC	STORM SEWER PROFILES	7 OF 7

PCD PROJECT NO. CDR222

DESIGNED BY MAB PROJECT ENGINEER MAB PROJECT MANAGER MAB CAD FILE NO. 180001 18001-8888 DRAWN BY MAB SCALE: 1" = 60' VERT. 1" = 10'	DATE: 07/09/19 JOB NO: 180001 CAD FILE NO.: 18001-8888 DRAWN BY: MAB SCALE: 1" = 60' VERT. 1" = 10'	PREPARED BY:	3520 Austin Bluffs Parkway Suite 102 Colorado Springs, CO 80918 (719) 266-5212 fax (719) 266-5341
NO. DATE REVISION BY		JUDGE ORR ROAD RV PARK & STORAGE COLORADO SPRINGS, COLORADO DRAINAGE, GRADING & EROSION CONTROL COVER	
<b>SHEET</b>		<b>1 of 7</b>	

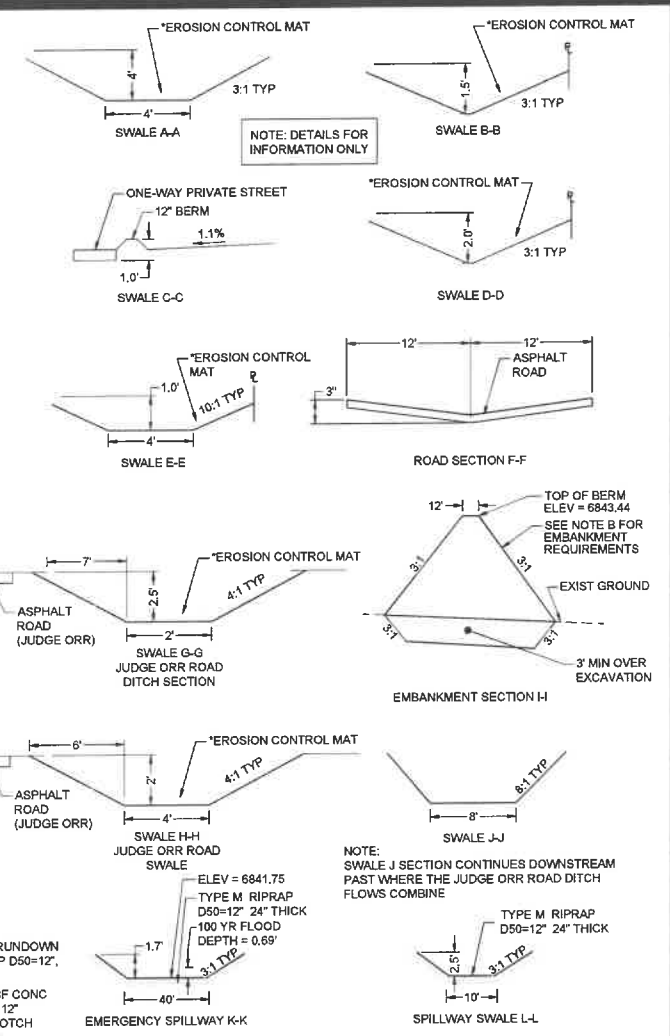
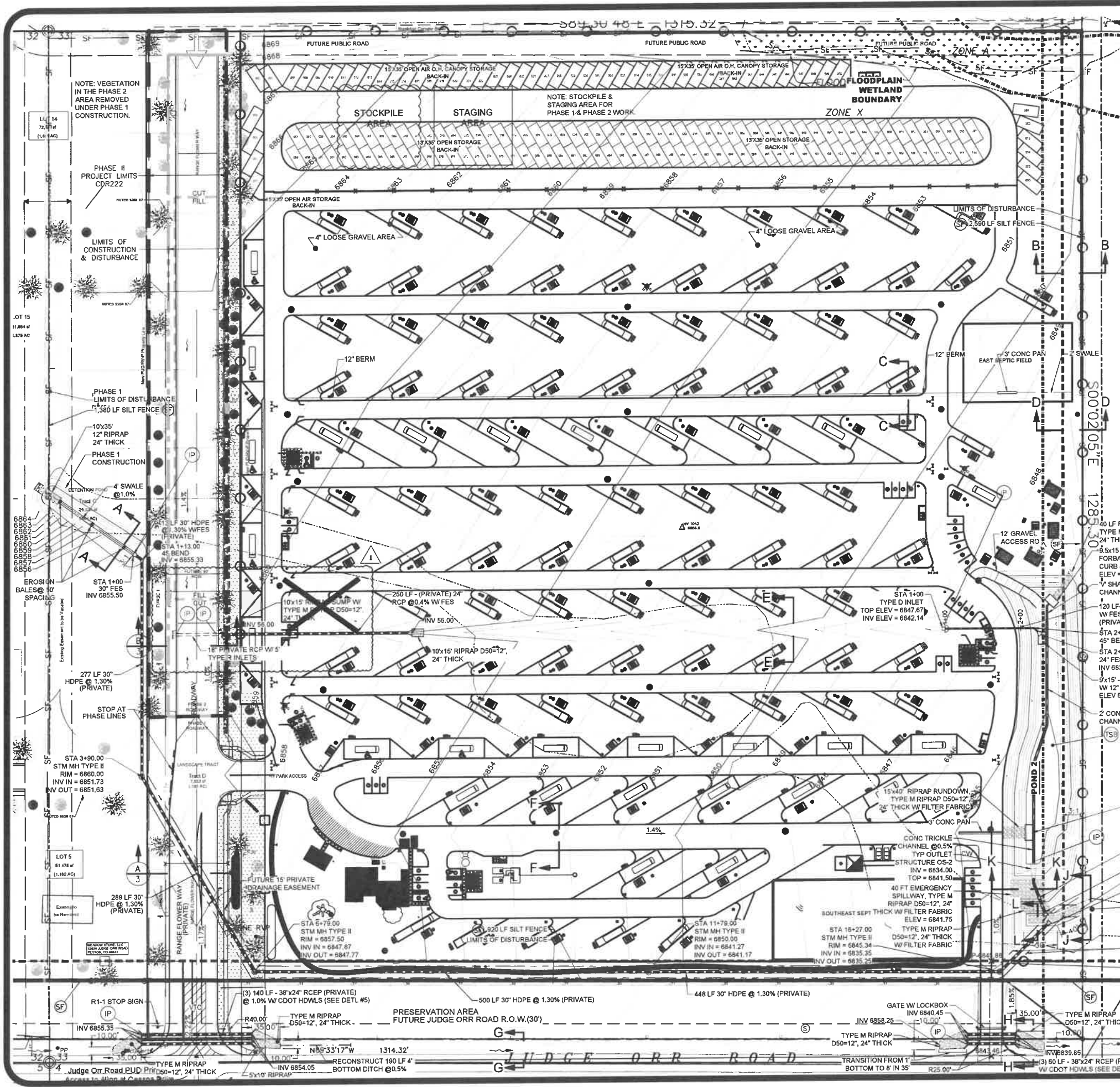

**NOTES:**

A. DETENTION POND AREA TO BE UTILIZED AS A SEDIMENTATION BASIN UNTIL EARTH MOVING IS COMPLETED AND THE GROUND STABILIZED AT WHICH TIME IT WILL BE CLEANED OUT. THE SEDIMENT BASIN OUTLET PIPE REMOVED AND THE DETENTION POND STRUCTURE COMPAS ADDED. SEE SEDIMENT BASIN DETAIL SB ON SHEET 5 OF 7.

B. EMBANKMENT COMPACTION SHALL FOLLOW THE REQUIREMENTS OF THE GEOTECHNICAL LETTER FROM ENTECH ENGINEERING, INC. LOCATED IN APPENDIX C OF THE DRAINAGE REPORT.

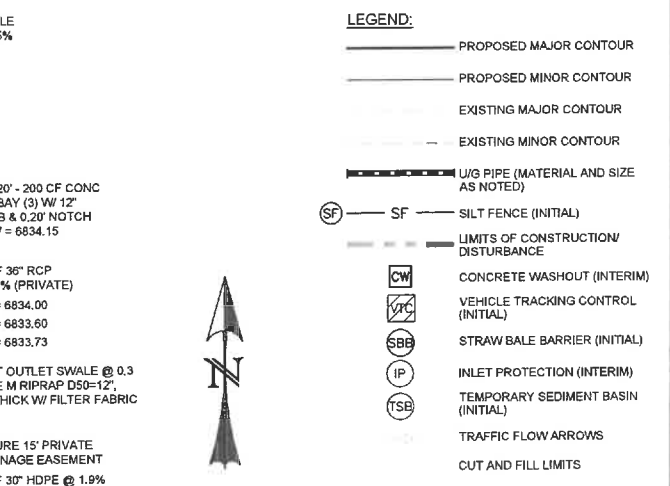

**NOTE:** JUDGE ORR ROAD DITCH FLOWS COMBINE WITH OUTLET SWALE FLOWS APPROX 300' EAST OF THE PROPERTY

PCD PROJECT NO. CDR222  
PCD PROJECT NO. PPR-16-040

DESIGNED BY: MAB  
PROJECT ENGINEER: MAB  
PROJECT MANAGER: MAB  
DATE: 02/26/19  
JOB NO.: 160301  
CAD FILE NO.: 160301.dwg  
DRAWN BY: HAK  
SCALE: 1" = 60'  
HORIZ.: N/A  
VERT.: N/A

PREPARED BY:

3520 Austin Bluffs Parkway Suite 102  
Colorado Springs, CO 80918  
(719) 266-5212  
fax (719) 266-5341

NO.	DATE	REVISION	BY
1	03/29/20	ACCESS ROAD REVISIONS	MAB

**JUDGE ORR ROAD RV PARK & STORAGE**  
**COLORADO SPRINGS, COLORADO**  
**DRAINAGE, GRADING & EROSION CONTROL PLAN**

- ALL CONSTRUCTION AND MATERIALS SHALL BE IN ACCORDANCE WITH THE EL PASO COUNTY ENGINEERING SPECIFICATIONS.
- THE CONTRACTOR SHALL NOTIFY COLORADO STATE UTILITIES CENTRAL LOCATING (1-800-822-1987 AT LEAST 48 HOURS PRIOR TO ANY EXCAVATION SO THAT THEY MAY LOCATE THEIR FACILITIES. THE LOCATION OF FACILITIES SHOWN ON THE DRAWINGS IS FROM AVAILABLE RECORDS AND IS APPROXIMATE.
- ALL EXISTING UTILITY LOCATIONS SHOWN ON THE DRAWINGS REFLECT THE AVAILABLE INFORMATION AND DO NOT NECESSARILY INDICATE THE ACTUAL LOCATIONS. PRIOR TO ANY CONSTRUCTION THE CONTRACTOR SHALL VERIFY THE HORIZONTAL AND VERTICAL LOCATIONS OF ALL UTILITIES THAT MAY CONFLICT WITH OR OBSTRUCT THE NEW CONSTRUCTION. ANY REQUIRED RELOCATIONS THAT ARE NOT SPECIFICALLY SHOWN ON THE DRAWINGS SHALL BE COORDINATED WITH AND HAVE PRIOR APPROVAL OF EL PASO COUNTY UTILITIES.
- ALL DIMENSIONS ARE TO FACE OF CURB, EDGE OF ASPHALT & FLOWLINE OF PAN.
- ALL ELEVATIONS ARE TO TOP/ASPHALT & FLOWLINE/CURE UNLESS OTHERWISE NOTED.

ALL STORM SEWER PIPE AND SANITARY SEWER PIPE LENGTHS AND SLOPES ARE SHOWN FROM CENTER OF STRUCTURE TO CENTER OF STRUCTURE

**Note:**  
Details for information only

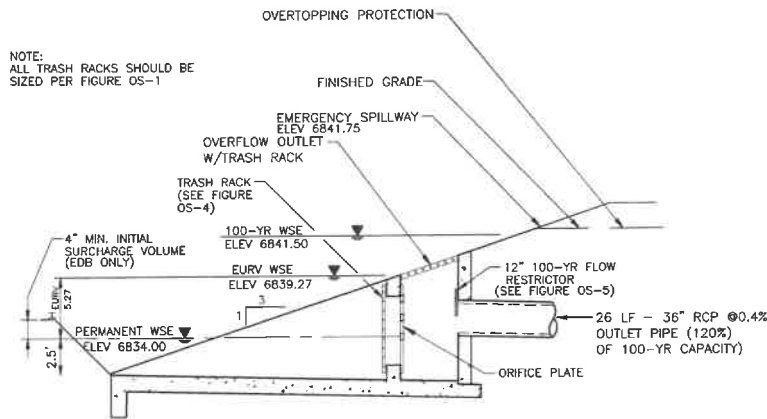
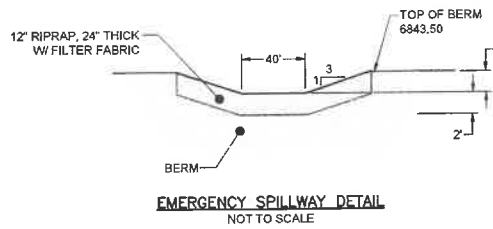
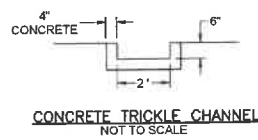
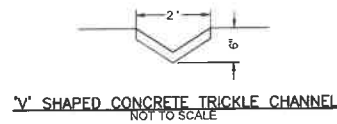
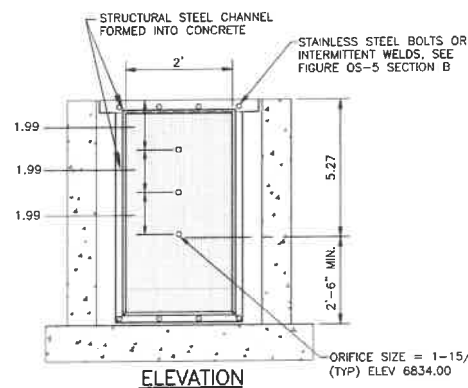

FIGURE OS-2 TYPICAL OUTLET STRUCTURE FOR FULL SPECTRUM DETENTION  
OUTLET STRUCTURE DETAIL  
NOT TO SCALE



**ORIFICE PLATE NOTES:**

- PROVIDE CONTINUOUS NEOPRENE GASKET MATERIAL BETWEEN THE ORIFICE PLATE AND CONCRETE.
- BOLT PLATE TO CONCRETE 12" MAX. ON CENTER. PLATE THICKNESS = 1/4".

**EURV AND WOCV TRASH RACKS:**

- WELL-SCREEN TRASH RACKS SHALL BE STAINLESS STEEL AND SHALL BE ATTACHED BY INTERMITTENT WELDS ALONG THE EDGE OF THE MOUNTING FRAME.
- BAR GATE TRASH RACKS SHALL BE ALUMINUM AND SHALL BE BOLTED USING STAINLESS STEEL HARDWARE.
- TRASH RACK OPEN AREAS ARE FOR SPECIFIED TRASH RACK MATERIALS. TOTAL TRASH RACK SIZE MAY NEED TO BE ADJUSTED FOR MATERIALS HAVING DIFFERENT OPEN AREA/GROSS AREA RATIO (R VALUE).
- STRUCTURAL DESIGN OF TRASH RACKS SHALL BE BASED ON FULL HYDROSTATIC HEAD WITH ZERO HEAD DOWNSTREAM OF THE RACK.

**OVERFLOW SAFETY GRATES:**

- ALL SAFETY GRATES SHALL BE MOUNTED USING STAINLESS STEEL HARDWARE AND PROVIDED WITH HINGED AND LOCKABLE OR BOLTABLE ACCESS PANELS.
- SAFETY GRATES SHALL BE STAINLESS STEEL, ALUMINUM, OR STEEL. STEEL GRATES SHALL BE HOT DIP GALVANIZED AND MAY BE HOT POWDER COATED AFTER GALVANIZING.
- SAFETY GRATES SHALL BE DESIGNED SUCH THAT THE DIAGONAL DIMENSION OF EACH OPENING IS SMALLER THAN THE DIAMETER OF THE OUTLET PIPE.
- STRUCTURAL DESIGN OF SAFETY GRATES SHALL BE BASED ON FULL HYDROSTATIC HEAD WITH ZERO HEAD DOWNSTREAM OF THE RACK.

**FIGURE OS-4 ORIFICE PLATE AND TRASH RACK DETAILS AND NOTES**  
NTS

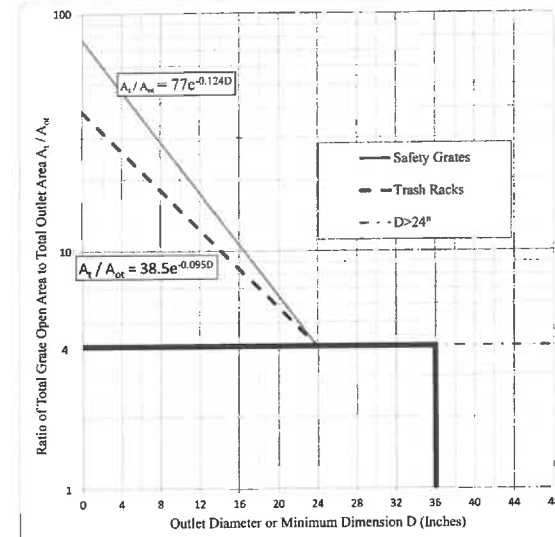
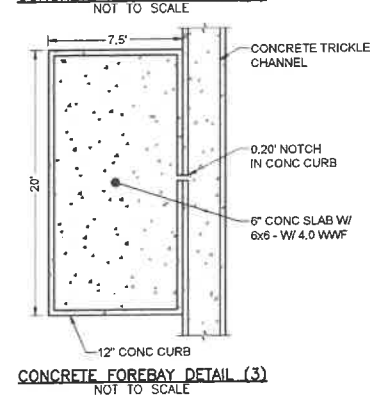
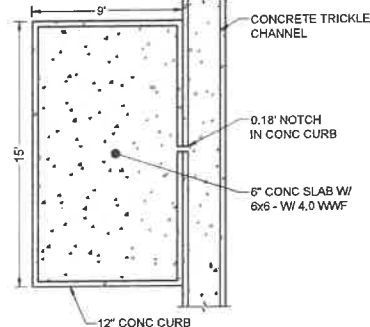
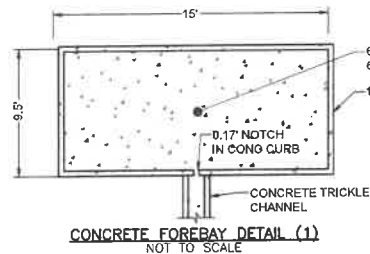
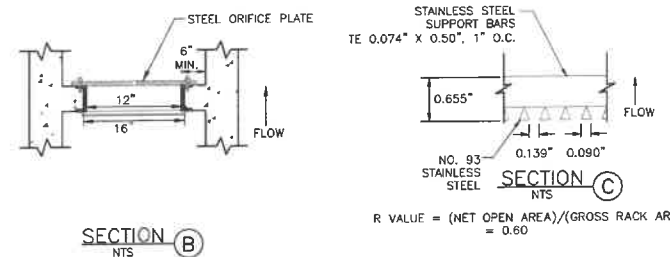
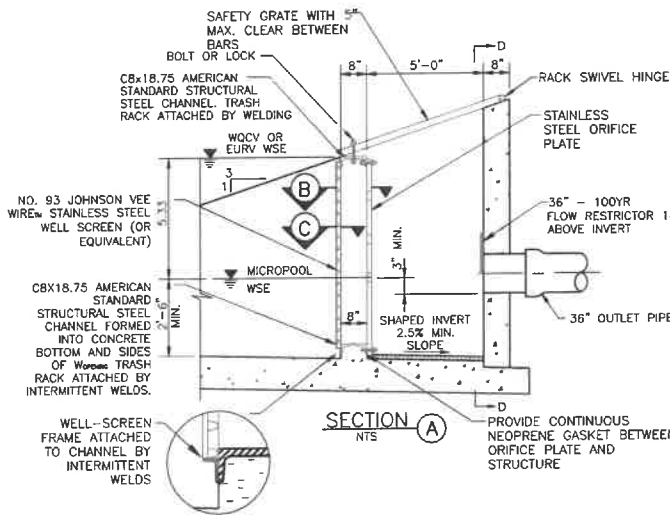
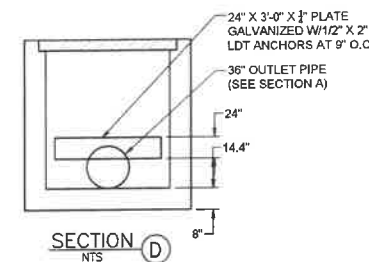

Figure OS-1. Trash Rack Sizing



**FIGURE OS-5 TYPICAL OUTLET STRUCTURE WITH WELL SCREEN TRASH RACK**

**STANDARD NOTES FOR EL PASO COUNTY GRADING AND EROSION CONTROL PLANS**

- STORMWATER DISCHARGES FROM CONSTRUCTION SITES SHALL NOT CAUSE OR THREATEN TO CAUSE POLLUTION, CONTAMINATION, OR DEGRADATION OF STATE WATERS. ALL WORK AND EARTH DISTURBANCE SHALL BE DONE IN A MANNER THAT MINIMIZES POLLUTION OF ANY ON-SITE OR OFF-SITE WATERS, INCLUDING WETLANDS.
- NOTWITHSTANDING ANYTHING DEPICTED IN THESE PLANS IN WORDS OR GRAPHIC REPRESENTATION, ALL DESIGN AND CONSTRUCTION RELATED TO ROADS, STORM DRAINAGE AND EROSION CONTROL SHALL CONFORM TO THE STANDARDS AND REQUIREMENTS OF THE MOST RECENT VERSION OF THE RELEVANT ADOPTED EL PASO COUNTY STANDARDS, INCLUDING THE LAND DEVELOPMENT CODE, THE ENGINEERING CRITERIA MANUAL, THE DRAINAGE CRITERIA MANUAL, AND THE DRAINAGE CRITERIA MANUAL VOLUME 2. ANY DEVIATIONS TO REGULATIONS AND STANDARDS MUST BE REQUESTED, AND APPROVED, IN WRITING.
- A SEPARATE STORMWATER MANAGEMENT PLAN (SMWP) FOR THIS PROJECT SHALL BE COMPLETED AND AN EROSION AND STORMWATER QUALITY CONTROL PERMIT (ESQCP) ISSUED PRIOR TO COMMENCING CONSTRUCTION. MANAGEMENT OF THE SWMP DURING CONSTRUCTION IS THE RESPONSIBILITY OF THE DESIGNATED QUALIFIED STORM WATER MANAGER OR CERTIFIED EROSION CONTROL INSPECTOR. THE SWMP SHALL BE LOCATED ON-SITE AT ALL TIMES DURING CONSTRUCTION AND SHALL BE KEPT UP TO DATE WITH WORK PROGRESS AND CHANGES IN THE FIELD.
- ONCE THE ESQCP IS APPROVED AND A "NOTICE TO PROCEED" HAS BEEN ISSUED, THE CONTRACTOR MAY INSTALL THE INITIAL STAGE EROSION AND SEDIMENT CONTROL BMPs AS INDICATED ON THE DEC. A PRE-CONSTRUCTION MEETING BETWEEN THE CONTRACTOR, ENGINEER, AND EL PASO COUNTY WILL BE HELD PRIOR TO ANY CONSTRUCTION. IT IS THE RESPONSIBILITY OF THE APPLICANT TO COORDINATE THE MEETING TIME AND PLACE WITH COUNTY STAFF.
- CONTROL MEASURES MUST BE INSTALLED PRIOR TO COMMENCEMENT OF ACTIVITIES THAT COULD CONTRIBUTE POLLUTANTS TO STORMWATER. CONTROL MEASURES FOR ALL SLOPES, CHANNELS, DITCHES, OR ANY DISTURBED LAND AREA SHALL BE COMPLETED UPON COMPLETION OF THE DISTURBANCE.
- ALL TEMPORARY SOIL EROSION CONTROL MEASURES SHALL BE MAINTAINED AND REMAIN IN EFFECTIVE OPERATING CONDITION UNTIL PERMANENT SOIL CONTROL MEASURES ARE IMPLEMENTED AND FINAL STABILIZATION IS ESTABLISHED. ALL PERSONS ENGAGED IN LAND DISTURBANCE ACTIVITIES SHALL ASSESS THE ADEQUACY OF CONTROL MEASURES AT THE SITE AND IDENTIFY IF CHANGES TO THOSE CONTROL MEASURES ARE NEEDED TO ENSURE THE CONTINUED EFFECTIVE PERFORMANCE OF THE CONTROL MEASURES. ALL CHANGES TO TEMPORARY SEDIMENT AND EROSION CONTROL MEASURES MUST BE INCORPORATED INTO THE STORMWATER MASTER PLAN.
- TEMPORARY STABILIZATION SHALL BE IMPLEMENTED ON DISTURBED AREAS AND STOCKPILES WHERE GROUND DISTURBING CONSTRUCTION ACTIVITY HAS PERMANENTLY CEASED OR TEMPORARILY CEASED FOR LONGER THAN 14 DAYS.
- FINAL STABILIZATION MUST BE IMPLEMENTED AT ALL APPLICABLE CONSTRUCTION SITES. FINAL STABILIZATION IS ACHIEVED WHEN ALL GROUND DISTURBING ACTIVITIES ARE COMPLETE AND ALL DISTURBED AREAS EITHER HAVE A UNIFORM VEGETATIVE COVER WITH INDIVIDUAL PLANT DENSITY OF 70 PERCENT OF PRE-DISTURBANCE LEVELS ESTABLISHED OR EQUIVALENT PERMANENT ALTERNATIVE STABILIZATION METHODS IS IMPLEMENTED. ALL TEMPORARY SEDIMENT AND EROSION CONTROL MEASURES SHALL BE REMOVED UPON FINAL STABILIZATION AND BEFORE PERMIT CLOSURE.
- ALL PERMANENT STORMWATER MANAGEMENT FACILITIES SHALL BE INSTALLED AS DESIGNED IN THE APPROVED PLANS. ANY PROPOSED CHANGES THAT EFFECT THE DESIGN OR FUNCTION OF THE PERMANENT STORMWATER MANAGEMENT STRUCTURES MUST BE APPROVED BY THE EGM ADMINISTRATOR PRIOR TO IMPLEMENTATION.
- EARTH DISTURBANCE SHALL BE CONDUCTED IN SUCH A MANNER SO AS TO EFFECTIVELY MINIMIZE SOIL EROSION AND RESULTING SEDIMENTATION. ALL DISTURBANCES SHALL BE DESIGNED, CONSTRUCTED, AND COMPLETED SO THAT THE EXPOSED AREA OF ANY DISTURBED LAND SHALL BE LIMITED TO THE SHORTEST PRACTICAL PERIOD OF TIME. PRE-EXISTING VEGETATION SHALL BE PROTECTED AND MAINTAINED WITHIN 50 HORIZONTAL FEET OF A WATER OF THE STATE UNLESS SHOWN TO BE INFEASIBLE AND SPECIFICALLY REQUESTED AND APPROVED.
- COMPACTION OF SOIL MUST BE PREVENTED IN AREAS DESIGNATED FOR INFILTRATION CONTROL MEASURES OR WHERE FINAL STABILIZATION WILL BE ACHIEVED BY VEGETATIVE COVER. AREAS DESIGNATED FOR INFILTRATION CONTROL MEASURES SHALL ALSO BE PROTECTED FROM SEDIMENTATION DURING CONSTRUCTION UNTIL FINAL STABILIZATION IS ACHIEVED. IF COMPACTION PREVENTION IS NOT FEASIBLE DUE TO SITE CONSTRAINTS, ALL AREAS DESIGNATED FOR INFILTRATION AND VEGETATION CONTROL MEASURES MUST BE LOOSENEED PRIOR TO INSTALLATION OF THE CONTROL MEASURE(S).
- ANY TEMPORARY OR PERMANENT FACILITY DESIGNED AND CONSTRUCTED FOR THE CONVEYANCE OF STORMWATER AROUND, THROUGH, OR FROM THE EARTH DISTURBANCE AREA SHALL BE A STABILIZED CONVEYANCE DESIGNED TO MINIMIZE EROSION AND THE DISCHARGE OF SEDIMENT OFF-SITE.
- CONCRETE WASH WATER SHALL BE CONTAINED AND DISPOSED OF IN ACCORDANCE WITH THE SWMP. NO WASH WATER SHALL BE DISCHARGED TO OR ALLOWED TO RUNOFF TO STATE WATERS, INCLUDING ANY SURFACE OR SUBSURFACE STORM DRAINAGE SYSTEM OR FACILITIES. CONCRETE WASHOUTS SHALL NOT BE LOCATED IN AN AREA WHERE SHALLOW GROUNDWATER MAY BE PRESENT, OR WITHIN 50 FEET OF A SURFACE WATER BODY, CREEK OR STREAM.
- DURING DEWATERING OPERATIONS, UNCONTAMINATED GROUND WATER MAY BE DISCHARGED ON-SITE, BUT SHALL NOT LEAVE THE SITE IN THE FORM OF SURFACE RUNOFF UNLESS AN APPROVED STATE DEWATERING PERMIT IS IN PLACE.
- EROSION CONTROL BLANKETING OR OTHER PROTECTIVE COVERING SHALL TO BE USED ON SLOPES STEEPER THAN 3:1.
- CONTRACTOR SHALL BE RESPONSIBLE FOR THE REMOVAL OF ALL WASTES FROM THE CONSTRUCTION SITE FOR DISPOSAL IN ACCORDANCE WITH LOCAL AND STATE REGULATORY REQUIREMENTS. NO CONSTRUCTION DEBRIS, TREE SLASH, BUILDING MATERIAL WASTES OR UNUSED BUILDING MATERIALS SHALL BE BURIED, DUMPED, OR DISCHARGED AT THE SITE.
- WASTE MATERIALS SHALL NOT BE TEMPORARILY PLACED OR STORED IN THE STREET, ALLEY, OR OTHER PUBLIC WAY, UNLESS IN ACCORDANCE WITH AN APPROVED TRAFFIC CONTROL PLAN. CONTROL MEASURES MAY BE REQUIRED BY EL PASO COUNTY ENGINEERING IF DEEMED NECESSARY, BASED ON SPECIFIC CONDITIONS AND CIRCUMSTANCES.
- TRACKING OF SOILS AND CONSTRUCTION DEBRIS OFF-SITE SHALL BE MINIMIZED. MATERIALS TRACKED OFF-SITE SHALL BE CLEANED UP AND PROPERLY DISPOSED IMMEDIATELY.
- THE OWNER/DEVELOPER SHALL BE RESPONSIBLE FOR THE REMOVAL OF ALL CONSTRUCTION DEBRIS, DIRT, TRASH, ROCK, SEDIMENT, SOIL AND SAND THAT MAY ACCUMULATE IN ROADS, STORM DRAINS AND OR OTHER DRAINAGE CONVEYANCE SYSTEM AND STORMWATER APPURTENANCES AS A RESULT OF SITE DEVELOPMENT.
- THE QUANTITY OF MATERIALS STORED ON THE PROJECT SITE SHALL BE LIMITED, AS MUCH AS PRACTICAL, TO THAT QUANTITY REQUIRED TO PERFORM THE WORK IN AN ORDERLY SEQUENCE. ALL MATERIALS STORED ON-SITE SHALL BE STORED IN A NEAT, ORDERLY MANNER, IN THEIR ORIGINAL CONTAINERS, WITH ORIGINAL MANUFACTURER'S LABELS.
- NO CHEMICAL(S) HAVING THE POTENTIAL TO BE RELEASED IN STORMWATER ARE TO BE STORED OR USED ON-SITE UNLESS PERMISSION FOR THE USE OF SUCH CHEMICAL(S) IS GRANTED IN WRITING BY THE EGM ADMINISTRATOR. IN GRANTING THE USE OF SUCH CHEMICALS, SPECIAL CONDITIONS AND MONITORING MAY BE REQUIRED.
- BULK STORAGE OF ALLOWED PETROLEUM PRODUCTS OR OTHER ALLOWED LIQUID CHEMICALS IN EXCESS OF 55 GALLONS SHALL REQUIRE ADEQUATE SECONDARY CONTAINMENT PROTECTION TO CONTAIN ALL SPILLS ON-SITE AND TO PREVENT ANY SPILLED MATERIAL FROM ENTERING STATE WATERS, ANY SURFACE OR SUBSURFACE STORM DRAINAGE SYSTEM OR FACILITIES.
- NO PERSON SHALL CAUSE THE IMPEDIMENT OF STORMWATER FLOW IN THE CURB AND GUTTER OR IN THE DITCH-LINE EXCEPT APPROVED SEDIMENT CONTROL MEASURES.
- OWNER/DEVELOPER AND THEIR AGENTS SHALL COMPLY WITH THE "COLORADO WATER QUALITY CONTROL ACT" (TITLE 25, ARTICLE 8, CRS), AND THE "CLEAN WATER ACT" (33 USC 1341), IN ADDITION TO THE REQUIREMENTS INCLUDED IN THE DCM VOLUME II AND THE EGM APPENDIX I. ALL APPROPRIATE PERMITS MUST BE OBTAINED BY THE CONTRACTOR PRIOR TO CONSTRUCTION (1041, NPDES, FLOODPLAIN, 404, FUGITIVE DUST, ETC.) IN THE EVENT OF CONFLICTS BETWEEN THESE REQUIREMENTS AND LAWS, RULES, OR REGULATIONS OF OTHER FEDERAL, STATE, OR COUNTY AGENCIES, THE MORE RESTRICTIVE LAWS, RULES, OR REGULATIONS SHALL APPLY.
- ALL CONSTRUCTION TRAFFIC MUST ENTER/EXIT THE SITE AT APPROVED CONSTRUCTION ACCESS POINTS.
- PRIOR TO ACTUAL CONSTRUCTION THE PERMITEE SHALL VERIFY THE LOCATION OF EXISTING UTILITIES.
- A WATER SOURCE SHALL BE AVAILABLE ON SITE DURING EARTHWORK OPERATIONS AND UTILIZED AS REQUIRED TO MINIMIZE DUST FROM EARTHWORK EQUIPMENT AND WIND.
- THE SOILS REPORT FOR THIS SITE HAS BEEN PREPARED BY RMG INC AND SHALL BE CONSIDERED A PART OF THESE PLANS.
- AT LEAST TEN (10) DAYS PRIOR TO THE ANTICIPATED START OF CONSTRUCTION, FOR PROJECTS THAT WILL DISTURB 1 ACRE OR MORE, THE OWNER OR OPERATOR OF CONSTRUCTION ACTIVITY SHALL SUBMIT A PERMIT APPLICATION FOR STORMWATER DISCHARGE TO THE COLORADO DEPARTMENT OF PUBLIC HEALTH AND ENVIRONMENT, WATER QUALITY DIVISION. THE APPLICATION CONTAINS CERTIFICATION OF COMPLETION OF A STORMWATER MANAGEMENT PLAN (SMWP), OF WHICH THIS GRADING AND EROSION CONTROL PLAN MAY BE A PART. FOR INFORMATION OR APPLICATION MATERIALS CONTACT: COLORADO DEPARTMENT OF PUBLIC HEALTH AND ENVIRONMENT, WATER QUALITY CONTROL DIVISION, WQCD - PERMITS, 4300 CHERRY CREEK DR. S., DENVER, CO 80246-1530, ATTN: PERMITS UNIT



Know what's below.  
Call before you dig.

DESIGNED BY DATE	PROJECT ENGINEER JOB NO. DATE	PROJECT MANAGER JOB NO. DATE	SCALE: H/A V/A N/A	PREPARED BY:	3520 Austin Bluffs Parkway Suite 100 Colorado Springs, CO 80918 (719) 266-8212 Fax: (719) 266-8241
					BY
<b>JUDGE ORR ROAD RV PARK &amp; STORAGE</b>					<b>COLORADO SPRINGS, COLORADO</b> <b>DRAINAGE, GRADING &amp; EROSION CONTROL DETAIL</b>
<b>SHEET</b>					
3 of 7					

Silt Fence (SF)

SC-1

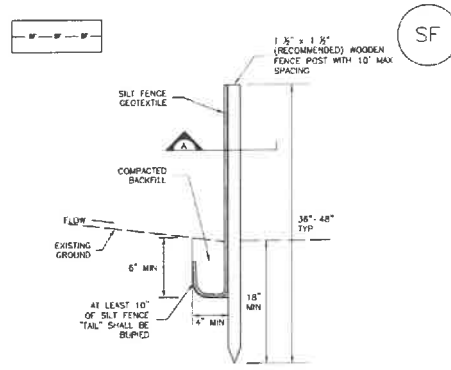

**SILT FENCE INSTALLATION NOTES**

- SILT FENCE MUST BE PLACED AWAY FROM THE TOE OF THE SLOPE TO ALLOW FOR WATER PONDING. SILT FENCE AT THE TOE OF A SLOPE SHOULD BE INSTALLED IN A FLAT LOCATION AT LEAST SEVERAL FEET (2-3 FT) FROM THE TOE OF THE SLOPE TO ALLOW ROOM FOR PONDING AND SEDIMENTATION.
- A UNIFORM 6\"/>

**SILT FENCE MAINTENANCE NOTES**

- INSPECT BMPs EACH WORKDAY, AND MAINTAIN THEM IN EFFECTIVE OPERATING CONDITION. MAINTENANCE OF BMPs SHOULD BE PROACTIVE, NOT REACTIVE. INSPECT BMPs AS SOON AS POSSIBLE (AND ALWAYS WITHIN 24 HOURS) FOLLOWING A STORM THAT CAUSES SURFACE EROSION, AND PERFORM NECESSARY MAINTENANCE.
- FREQUENT OBSERVATIONS AND MAINTENANCE ARE NECESSARY TO MAINTAIN BMPs IN EFFECTIVE OPERATING CONDITION. INSPECTIONS AND CORRECTIVE MEASURES SHOULD BE DOCUMENTED THOROUGHLY.
- WHERE BMPs HAVE FAILED, REPAIR OR REPLACEMENT SHOULD BE INITIATED UPON DISCOVERY OF THE FAILURE.
- SEDIMENT ACCUMULATED UPSTREAM OF THE SILT FENCE SHALL BE REMOVED AS NEEDED TO MAINTAIN THE FUNCTIONALITY OF THE BMP. TYPICALLY WHEN DEPTH OF ACCUMULATED SEDIMENT IS APPROXIMATELY 6\"/>

(DETAILS ADAPTED FROM TOWN OF PARKER, COLORADO AND CITY OF AURORA, NOT AVAILABLE IN AUTOCAD)

**NOTE:** MANY JURISDICTIONS HAVE BMP DETAILS THAT VARY FROM LISTED STANDARD DETAILS. CONSULT WITH LOCAL JURISDICTIONS AS TO WHICH DETAIL SHOULD BE USED WHEN DIFFERENCES ARE NOTED.

November 2010 Urban Drainage and Flood Control District Urban Storm Drainage Criteria Manual Volume 3 SF-3

Silt Fence (SF)

SC-4

November 2010 Urban Drainage and Flood Control District Urban Storm Drainage Criteria Manual Volume 3 SF-4

Straw Bale Barrier (SBB)

SC-3

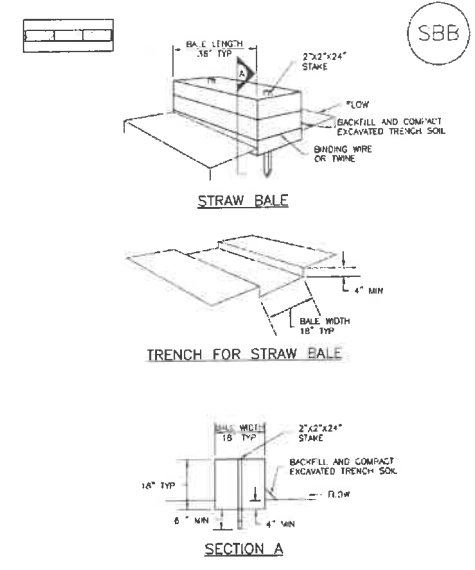

November 2010 Urban Drainage and Flood Control District Urban Storm Drainage Criteria Manual Volume 3 SBB-2

Straw Bale Barrier (SBB)

SC-3

**STRAW BALE INSTALLATION NOTES**

- SEE PLAN VIEW FOR -LOCATION(S) OF STRAW BALES
- STRAW BALES SHALL CONSIST OF CERTIFIED WOOD FREE STRAW OR MAY LOAN JURISDICTIONS MAY REQUIRE PROOF THAT BALES ARE WOOD FREE.
- STRAW BALES SHALL CONSIST OF APPROXIMATELY 5 CUBIC FEET OF STRAW OR MAY AND WEIGH NOT LESS THAN 35 POUNDS.
- WHEN STRAW BALES ARE USED IN SERIES AS A BARRIER, THE END OF EACH BALE SHALL BE TIGHTLY ADJUTING ONE ANOTHER.
- STRAW BALE DIMENSIONS SHALL BE APPROXIMATELY 36\"/>

**STRAW BALE MAINTENANCE NOTES**

- INSPECT BMPs EACH WORKDAY, AND MAINTAIN THEM IN EFFECTIVE OPERATING CONDITION. MAINTENANCE OF BMPs SHOULD BE PROACTIVE, NOT REACTIVE. INSPECT BMPs AS SOON AS POSSIBLE (AND ALWAYS WITHIN 24 HOURS) FOLLOWING A STORM THAT CAUSES SURFACE EROSION, AND PERFORM NECESSARY MAINTENANCE.
- FREQUENT OBSERVATIONS AND MAINTENANCE ARE NECESSARY TO MAINTAIN BMPs IN EFFECTIVE OPERATING CONDITION. INSPECTIONS AND CORRECTIVE MEASURES SHOULD BE DOCUMENTED THOROUGHLY.
- WHERE BMPs HAVE FAILED, REPAIR OR REPLACEMENT SHOULD BE INITIATED UPON DISCOVERY OF THE FAILURE.
- STRAW BALES SHALL BE REPLACED IF THEY BECOME HEAVILY SOILED, ROTTEN, OR DAMAGED BEYOND REPAIR.
- SEDIMENT ACCUMULATED UPSTREAM OF STRAW BALE BARRIER SHALL BE REMOVED AS NEEDED TO MAINTAIN FUNCTIONALITY OF THE BMP. TYPICALLY WHEN DEPTH OF ACCUMULATED SEDIMENT IS APPROXIMATELY 6\"/>

(DETAILS ADAPTED FROM TOWN OF PARKER, COLORADO, NOT AVAILABLE IN AUTOCAD)

**NOTE:** MANY JURISDICTIONS HAVE BMP DETAILS THAT VARY FROM LISTED STANDARD DETAILS. CONSULT WITH LOCAL JURISDICTIONS AS TO WHICH DETAIL SHOULD BE USED WHEN DIFFERENCES ARE NOTED.

November 2010 Urban Drainage and Flood Control District Urban Storm Drainage Criteria Manual Volume 3 SBB-3

Sediment Basin (SB)

SC-7

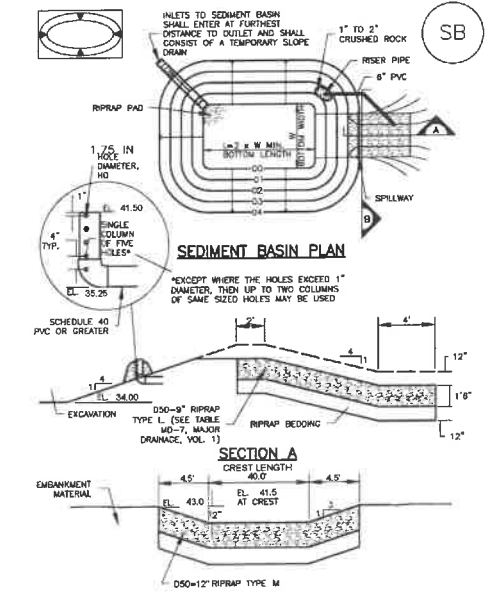

**TABLE SB-1. SIZING INFORMATION FOR STANDARD SEDIMENT BASIN**

Upstream Drainage Area (rounded to nearest acre), (ac.)	Basin Bottom Width (ft.)	Spillway Crest Length (ft.), (ft.)	Basin Diameter (ft.) (ft.)
1	12.5	2	7 1/2
2	21	3	14
3	28	6	14
4	33.5	8	14
5	38	8	14
6	41	9	14
8	47.5	12	14
9	51	12	14
10	55	13	14
11	58.5	15	14
12	64	18	14
13	67.5	19	14
14	70.5	21	14
15	73.5	22	14

**SEDIMENT BASIN INSTALLATION NOTES**

- SEE PLAN VIEW FOR -LOCATION OF SEDIMENT BASIN -TYPE OF BASIN (STANDARD BASIN OR NONSTANDARD BASIN) -FOR STANDARD BASIN, BOTTOM WIDTH W, CREST LENGTH CL, AND HOLE DIAMETER, HD -FOR NONSTANDARD BASIN, SEE CONSTRUCTION DRAWINGS FOR DESIGN OF BASIN INCLUDING RISER HEIGHT H, NUMBER OF COLUMNS M, HOLE DIAMETER HD AND PIPE DIAMETER D
- FOR STANDARD BASIN, BOTTOM DIMENSION MAY BE MODIFIED AS LONG AS BOTTOM AREA IS NOT REDUCED.
- SEDIMENT BASINS SHALL BE INSTALLED PRIOR TO ANY OTHER LAND-DISTURBING ACTIVITY THAT RELIES ON THE BASINS AS A STORMWATER CONTROL.
- EMBANKMENT MATERIAL SHALL CONSIST OF SOIL FREE OF DEBRIS, ORGANIC MATERIAL, AND ROCKS OR CONCRETE GREATER THAN 3 INCHES AND SHALL HAVE A MINIMUM OF 15 PERCENT BY WEIGHT PASSING THE NO. 200 SIEVE.
- EMBANKMENT MATERIAL SHALL BE COMPACTED TO AT LEAST 95 PERCENT OF MAXIMUM DENSITY IN ACCORDANCE WITH ASTM D698.
- PIPE SCH 40 OR GREATER SHALL BE USED.

**7. THE DETAILS SHOWN ON THESE SHEETS PERTAIN TO STANDARD SEDIMENT BASIN(S) FOR DRAINAGE AREAS LESS THAN 15 ACRES. SEE CONSTRUCTION DRAWINGS FOR EMBANKMENT, STORAGE VOLUME, SPILLWAY, OUTLET, AND OUTLET PROTECTION DETAILS FOR ANY SEDIMENT BASIN(S) THAT HAVE BEEN INDIVIDUALLY DESIGNED FOR DRAINAGE AREAS LARGER THAN 15 ACRES.**

August 2013 Urban Drainage and Flood Control District Urban Storm Drainage Criteria Manual Volume 3 SB-5

Sediment Basin (SB)

SC-7

August 2013 Urban Drainage and Flood Control District Urban Storm Drainage Criteria Manual Volume 3 SB-6

Sediment Basin (SB)

SC-7

August 2013 Urban Drainage and Flood Control District Urban Storm Drainage Criteria Manual Volume 3 SB-7

NOTE: PROPOSED 2.5 AC. FT EDB TO BE USED AS SEDIMENT BASIN

DESIGNED BY: MAB  
 PROJECT ENGINEER: MAB  
 PROJECT MANAGER: MAB  
 CAD FILE NO.: 18050-HB-MAB  
 DRAWN BY: MAB  
 SCALE: HORIZ. N/A  
 VERT. N/A

PREPARED BY:

NO.	DATE	REVISION

**HEADWALLS FOR PIPES**

**GENERAL NOTES**

- CONCRETE SHALL BE CLASS B.
- HEADWALL SHALL BE PERPENDICULAR TO THE PIPE UNLESS OTHERWISE SHOWN ON THE PLANS. VARIATED DIMENSIONS AND QUANTITIES MUST BE ADJUSTED FOR SLOPED INSTALLATIONS.
- FOR WINGWALL DETAILS, SEE STANDARD PLAN M-601-20.
- VOLUME OCCUPIED BY PIPE HAS BEEN DEDUCTED FROM STEEL AND CONCRETE QUANTITIES.
- EXPOSED CONCRETE CORNERS SHALL BE CHAMFERED 1/4" IN.
- ALL REINFORCING BARS SHALL HAVE A 2" MINIMUM CLEARANCE.
- WHEN TWO OR MORE PIPES ARE LAD SIDE BY SIDE, THEY SHALL BE PLACED SO THAT THE ADJACENT PIPES WILL BE 1/2" INSIDE DIAMETER APART OR 1/2" INSIDE SPAN APART, OR 3" FT. APART (INCLUDING WALL THICKNESS, WHICHEVER IS LESS).
- ADD CURB + (X OR X1) (O.B.) WHEN APRON IS REQUIRED.

**HEADWALL FOR SINGLE PIPE**

**HEADWALL FOR DOUBLE PIPE**

**TYPICAL BAR LAYOUT FOR CONCRETE HEADWALLS**

**HEADWALL FOR RIGID ROUND PIPE**

**HEADWALL FOR FLEXIBLE ROUND PIPE**

**HEADWALL FOR STRUCTURAL PLATE ARCH**

**HEADWALL FOR WINGWALL CONNECTION**

**FRONT VIEW**

**TOP VIEW**

**WINGWALL CONNECTION**

**INLET** **OUTLET** **ENDS OF FLEXIBLE PIPE**

**APRON** **WHEN APRON IS REQUIRED**

**SKIN FACTOR TABLE**

SKIN #	90	85	80	75	70	65	60	55	50	45	40	35	30
1.000	1.004	1.015	1.035	1.064	1.103	1.150	1.221	1.305	1.414	1.556	1.743	2.000	

**Computer File Information**

Creation Date: 07/04/06 Initials: SJR  
 Last Modification Date: 07/04/06 Initials: LTA  
 Full Path: www.dot.state.co.us/Desktop/Support/  
 Drawing File Name: 60100010.dwg  
 CAD Ver: MicroStation V8 Scan: Not to Scale Units: English

**Sheet Revisions**

Date:	Comments:

**Colorado Department of Transportation**

4201 East Arkansas Avenue  
 Denver, Colorado 80222  
 Phone: (303) 757-9000  
 Fax: (303) 757-9820

Project Development Branch SRJ/LTA

**HEADWALLS FOR PIPES**

**STANDARD PLAN NO. M-601-10**

Issued By: Project Development Branch on July 04, 2006

Sheet No. 1 of 1

NOTE:  
 WINGWALLS FOR RANGE FLOWER WAY AND  
 FIRE ACCESS DRIVE CULVERTS TO BE 45'  
 AND 8' LONG.

**MM-1 Concrete Washout Area (CWA)**

**CONCRETE WASHOUT AREA PLAN**

**SECTION A**

**CWA-1 CONCRETE WASHOUT AREA**

**CWA INSTALLATION NOTES**

- SEE PLAN VIEW FOR CWA INSTALLATION LOCATION.
- DO NOT LOCATE AN UNLINED CWA WITHIN 400' OF ANY NATURAL DRAINAGE PATHWAY OR WATERBODY. DO NOT LOCATE WITHIN 1,000' OF ANY WELLS OR DRINKING WATER SOURCES IF SUCH CONSTRAINTS MAKE THIS UNDESIRABLE, OR IF HIGHLY PERMEABLE SOILS EXIST ON SITE. THE CWA MUST BE INSTALLED WITH AN IMPERMEABLE LINER (16 MIL THICKNESS) OR SURFACE STORAGE ALTERNATIVES USING PREFABRICATED CONCRETE WASHOUT DEVICES OR A LINED ABOVE GROUND STORAGE ARE SHOULD BE USED.
- THE CWA SHALL BE INSTALLED PRIOR TO CONCRETE PLACEMENT ON SITE.
- CWA SHALL INCLUDE A FLAT SURFACE WITH A FINISH THAT IS AT LEAST 8" BY 8" SLOPES LEADING OUT OF THE SURFACE. IT SHALL BE 3:1 OR FLATTER. THE PIT SHALL BE AT LEAST 3' DEEP.
- BERM SURROUNDING SIDES AND BACK OF THE CWA SHALL HAVE MINIMUM HEIGHT OF 1'.
- VEHICLE TRACKING PAD SHALL BE SLOPED 2% TOWARDS THE CWA.
- SDS SHALL BE PLACED AT THE CONSTRUCTION ENTRANCE, AT THE CWA AND ELSEWHERE AS NECESSARY TO CLEARLY INDICATE THE LOCATION OF THE CWA TO OPERATORS OF CONCRETE TRUCKS AND PUMP TRUCKS.
- USE EXCAVATED MATERIAL FOR PERIMETER BERM CONSTRUCTION.

**GENERAL NOTES**

- Do not prepare or seed frozen soils.
- Do not seed when wind exceeds 5 mph.
- Perform seeding only after preceding work affecting ground surface is completed.
- Do not mulch over seeded areas when wind exceeds 15 mph.
- Seed all disturbed areas.
- Seed to be a blend of native prairie grasses.
- Watering shall be provided in the form of watering trucks and spray bars.

**MULCH MATERIALS**

- HAY OR STRAW MULCH
  - Chopped of oats, wheat or rye grass hay.
  - Free from noxious weed seeds.
  - Rotted, brittle or moldy hay is not acceptable.
  - 50% by weight greater than 10" inch length.
- FIBER
  - Short wood fiber.
  - "Conwed", "Silver Fiber" or equivalent.

**BED PREPARATION**

- Prepare to a minimum depth of 4" with disc harrows or chiseling tools.
- Uproot all competitive vegetation.
- Work soil uniformly to a smooth surface free of clods, stones over 2" in any dimension or any material which will interfere seeding equipment.
- Till across slopes.
- Do not till when soil moisture is unsuitable.
  - Soil texture after tillage shall be uniform, free of wet compressed or dry lumps.
- Do not prepare seed bed more than twenty four hours in advance of seeding.
  - Fertilizer into soil a minimum of two (2) inches.

SPECIES	LBS/ACRE DRILLED
Western Wheat Grass	Paspalum smithii 3.0
Sideoats Grama	Bouteloua curtipendula 2.0
Slender Wheat Grass	Schizochyrium scoparium 2.0
Little Bluestem	Bouteloua gracilis 0.5
Switch Grass	Panicum virgatum 2.0
Sand Dropseed	Sporobolus cryptandrus

**EROSION CONTROL PLAN NOTES**

- All disturbed areas are to be reseeded.
- Schedule of Grading - approximate time frame of one month to complete grading and installation of erosion control measures.
- Temporary Sediment Barriers shall be kept in place and maintained until the vegetation has been reestablished. Removal of sediment is required once it reaches half the height of the sediment control log.

DESIGNED BY: MAB  
 PROJECT ENGINEER: MAB  
 PROJECT MANAGER: MAB  
 CAD FILE NO.: 180001-180001  
 DRAWN BY: MAB  
 SCALE: N/A  
 VERT.:

PREPARED BY:

3520 Austin Bluffs Parkway  
 Suite 102  
 Colorado Springs, CO 80918  
 (719) 266-5212  
 Fax: (719) 266-5341

NO.	DATE	REVISION

JUDGE ORR ROAD RV PARK & STORAGE

COLORADO SPRINGS, COLORADO

EROSION CONTROL DETAILS

SHEET

5 of 7



**Standard Notes for El Paso County Construction Plans**

ALL DRAINAGE AND ROADWAY CONSTRUCTION SHALL MEET THE STANDARDS AND SPECIFICATIONS OF THE CITY OF COLORADO SPRINGS/EL PASO COUNTY DRAINAGE CRITERIA MANUAL, VOLUMES 1 AND 2, AND THE EL PASO COUNTY ENGINEERING CRITERIA MANUAL.

1. CONTRACTOR SHALL BE RESPONSIBLE FOR THE NOTIFICATION AND FIELD NOTIFICATION OF ALL EXISTING UTILITIES, WHETHER SHOWN ON THE PLANS OR NOT, BEFORE BEGINNING CONSTRUCTION. LOCATION OF EXISTING UTILITIES SHALL BE VERIFIED BY THE CONTRACTOR PRIOR TO CONSTRUCTION. CALL 811 TO CONTACT THE UTILITY NOTIFICATION CENTER OF COLORADO (UNCC).
2. CONTRACTOR SHALL KEEP A COPY OF THESE APPROVED PLANS, THE GRADING AND EROSION CONTROL PLAN, THE STORMWATER MANAGEMENT PLAN (SWMP), THE SOILS AND GEOTECHNICAL REPORT, AND THE APPROPRIATE DESIGN AND CONSTRUCTION STANDARDS AND SPECIFICATIONS AT THE JOB SITE AT ALL TIMES, INCLUDING THE FOLLOWING:
  - a. EL PASO COUNTY ENGINEERING CRITERIA MANUAL (ECM)
  - b. CITY OF COLORADO SPRINGS/EL PASO COUNTY DRAINAGE CRITERIA MANUAL, VOLUMES 1 AND 2
  - c. COLORADO DEPARTMENT OF TRANSPORTATION (CDOT) STANDARD SPECIFICATIONS FOR ROAD AND BRIDGE CONSTRUCTION
  - d. CDOT M & S STANDARDS
4. NOTWITHSTANDING ANYTHING DEPICTED IN THESE PLANS IN WORDS OR GRAPHIC REPRESENTATION, ALL DESIGN AND CONSTRUCTION RELATED TO ROADS, STORM DRAINAGE, AND EROSION CONTROL SHALL CONFORM TO THE STANDARDS AND REQUIREMENTS OF THE MOST RECENT VERSION OF THE RELEVANT ADOPTED EL PASO COUNTY STANDARDS, INCLUDING THE LAND DEVELOPMENT CODE, THE ENGINEERING CRITERIA MANUAL, THE DRAINAGE CRITERIA MANUAL, AND THE DRAINAGE CRITERIA MANUAL VOLUME 2. ANY DEVIATIONS FROM REGULATIONS AND STANDARDS MUST BE REQUESTED, AND APPROVED, IN WRITING. ANY MODIFICATIONS NECESSARY TO MEET CRITERIA AFTER-THE-FACT WILL BE ENTIRELY THE DEVELOPER'S RESPONSIBILITY TO RECTIFY.
5. IT IS THE DESIGN ENGINEER'S RESPONSIBILITY TO ACCURATELY SHOW EXISTING CONDITIONS, BOTH ONSITE AND OFFSITE, ON THE CONSTRUCTION PLANS. ANY MODIFICATIONS NECESSARY DUE TO CONFLICTS, OMISSIONS, OR CHANGED CONDITIONS WILL BE ENTIRELY THE DEVELOPER'S RESPONSIBILITY TO RECTIFY.
6. CONTRACTOR SHALL SCHEDULE A PRE-CONSTRUCTION MEETING WITH EL PASO COUNTY PLANNING AND COMMUNITY DEVELOPEMENT (PCD) - INSPECTIONS, PRIOR TO STARTING CONSTRUCTION.
7. IT IS THE CONTRACTOR'S RESPONSIBILITY TO UNDERSTAND THE REQUIREMENTS OF ALL JURISDICTIONAL AGENCIES AND TO OBTAIN ALL REQUIRED PERMITS, INCLUDING BUT NOT LIMITED TO EL PASO COUNTY EROSION AND STORMWATER QUALITY CONTROL PERMIT (ESQCP), REGIONAL BUILDING FLOODPLAIN DEVELOPMENT PERMIT, U.S. ARMY CORPS OF ENGINEERS-ISSUED 401 AND/OR 404 PERMITS, AND COUNTY AND STATE FUGITIVE DUST PERMITS.
8. CONTRACTOR SHALL NOT DEVIATE FROM THE PLANS WITHOUT FIRST OBTAINING WRITTEN APPROVAL FROM THE DESIGN ENGINEER AND PCD. CONTRACTOR SHALL NOTIFY THE DESIGN ENGINEER IMMEDIATELY UPON DISCOVERY OF ANY ERRORS OR INCONSISTENCIES.
9. ALL STORM DRAIN PIPE SHALL BE CLASS III RCP UNLESS OTHERWISE NOTED AND APPROVED BY PCD.
10. CONTRACTOR SHALL COORDINATE GEOTECHNICAL TESTING PER ECM STANDARDS. PAVEMENT DESIGN SHALL BE APPROVED BY EL PASO COUNTY PCD PRIOR TO PLACEMENT OF CURB AND GUTTER AND PAVEMENT.
11. ALL CONSTRUCTION TRAFFIC MUST ENTER/EXIT THE SITE AT APPROVED CONSTRUCTION ACCESS POINTS.
12. SIGHT VISIBILITY TRIANGLES AS IDENTIFIED IN THE PLANS SHALL BE PROVIDED AT ALL INTERSECTIONS. OBSTRUCTIONS GREATER THAN 18 INCHES ABOVE FLOWLINE ARE NOT ALLOWED WITHIN SIGHT TRIANGLES.
13. SIGNING AND STRIPING SHALL COMPLY WITH EL PASO COUNTY DOT AND MUTCD CRITERIA. [IF APPLICABLE, ADDITIONAL SIGNING AND STRIPING NOTES WILL BE PROVIDED.]
14. CONTRACTOR SHALL OBTAIN ANY PERMITS REQUIRED BY EL PASO COUNTY DOT, INCLUDING WORK WITHIN THE RIGHT-OF-WAY AND SPECIAL TRANSPORT PERMITS.
15. THE LIMITS OF DISTURBANCE SHALL REMAIN WITHIN THE PROPERTY LINE UNLESS OTHERWISE NOTED. THE OWNER/DEVELOPER SHALL OBTAIN WRITTEN PERMISSION AND EASEMENTS, WHERE REQUIRED, FROM ADJOINING PROPERTY OWNER(S) PRIOR TO ANY OFF-SITE DISTURBANCE, GRADING, OR CONSTRUCTION.

**NOTES:**

1. CONTRACTOR SHALL VERIFY LOCATION OF UTILITIES PRIOR TO ANY CONSTRUCTION.
2. CONTRACTOR SHALL NOTIFY EL PASO COUNTY DEPARTMENT OF TRANSPORTATION FOR A PRE-CONSTRUCTION CONFERENCE PRIOR TO COMMENCEMENT OF CONSTRUCTION.
3. CONTRACTOR SHALL OBTAIN NECESSARY CONSTRUCTION PERMITS PRIOR TO CONSTRUCTION.
4. ALL ROAD AND DRAINAGE CONSTRUCTION SHALL CONFORM TO EL PASO COUNTY STANDARD SPECIFICATIONS.

**NOTE:**

AT LEAST 10 DAYS PRIOR TO THE ANTICIPATED START OF CONSTRUCTION, FOR PROJECTS THAT WILL DISTURB ONE ACRE OR MORE, THE OWNER OR OPERATOR OF THE CONSTRUCTION ACTIVITY SHALL SUBMIT A PERMIT APPLICATION FOR STORMWATER DISCHARGE TO THE COLORADO DEPARTMENT OF PUBLIC HEALTH AND ENVIRONMENT, WATER QUALITY CONTROL DIVISION. THE APPLICATION CONTAINS CERTIFICATION OF COMPLETION OF A STORMWATER MANAGEMENT PLAN (SWMP), OF WHICH THIS GRADING AND EROSION CONTROL PLAN MAY BE A PART.

**SIGNING AND STRIPING NOTES:**

1. ALL SIGNS AND PAVEMENT MARKINGS SHALL BE IN COMPLIANCE WITH THE CURRENT MANUAL ON UNIFORM TRAFFIC CONTROL DEVICES (MUTCD).
2. REMOVAL OF EXISTING PAVEMENT MARKINGS SHALL BE ACCOMPLISHED BY A METHOD THAT DOES NOT MATERIALLY DAMAGE THE PAVEMENT. THE PAVEMENT MARKINGS SHALL BE REMOVED TO THE EXTENT THAT THEY WILL NOT BE VISIBLE UNDER DAY OR NIGHT CONDITIONS. AT NO TIME WILL IT BE ACCEPTABLE TO PAINT OVER EXISTING PAVEMENT MARKINGS.
3. ANY DEVIATION FROM THE STRIPING AND SIGNING PLAN SHALL BE APPROVED BY EL PASO COUNTY PLANNING AND COMMUNITY DEVELOPEMENT.
4. ALL SIGNS SHOWN ON THE SIGNING AND STRIPING PLAN SHALL BE NEW SIGNS. EXISTING SIGNS MAY REMAIN OR BE REUSED IF THEY MEET CURRENT EL PASO COUNTY AND MUTCD STANDARDS.
5. STREET NAME AND REGULATORY STOP SIGNS SHALL BE ON THE SAME POST AT INTERSECTIONS.
6. ALL REMOVED SIGNS SHALL BE DISPOSED OF IN A PROPER MANNER BY THE CONTRACTOR.
7. ALL STREET NAME SIGNS SHALL HAVE "D" SERIES LETTERS, WITH LOCAL ROADWAY SIGNS BEING 4" UPPER-LOWER CASE LETTERING ON 8" BLANK AND NON-LOCAL ROADWAY SIGNS BEING 6" LETTERING, UPPER-LOWER CASE ON 12" BLANK, WITH A WHITE BORDER THAT IS NOT RECESSED. MULTI-LANE ROADWAYS WITH SPEED LIMITS OF 40 MPH OR HIGHER SHALL HAVE 8" UPPER-LOWER CASE LETTERING ON 18" BLANK WITH A WHITE BORDER THAT IS NOT RECESSED. THE WIDTH OF THE NON-RECESSED WHITE BORDERS SHALL MATCH PAGE 255 OF THE 2012 MUTCD "STANDARD HIGHWAY SIGNS".
8. ALL TRAFFIC SIGNS SHALL HAVE A MINIMUM HIGH INTENSITY PRISMATIC GRADE SHEETING.
9. ALL LOCAL RESIDENTIAL STREET SIGNS SHALL BE MOUNTED ON A 1.75' X 1.75' SQUARE TUBE SIGN POST AND STUB POST BASE. FOR OTHER APPLICATIONS, REFER TO THE CDOT STANDARD S-614-B REGARDING USE OF THE P2 TUBULAR STEEL POST SLIPBASE DESIGN.
10. ALL SIGNS SHALL BE SINGLE SHEET ALUMINUM WITH 0.100" MINIMUM THICKNESS.
11. ALL LIMIT LINES/STOP LINES, CROSSWALK LINES, PAVEMENT LEGENDS, AND ARROWS SHALL BE A MINIMUM 125 MIL THICKNESS PREFORMED THERMOPLASTIC PAVEMENT MARKINGS WITH TAPERED LEADING EDGES PER CDOT STANDARD S-627-1. WORD AND SYMBOL MARKINGS SHALL BE THE NARROW TYPE. STOP BARS SHALL BE 24" IN WIDTH. CROSSWALKS LINES SHALL BE 12" WIDE AND 8' LONG PER CDOT S-627-1.
12. ALL LONGITUDINAL LINES SHALL BE A MINIMUM 15MIL THICKNESS EPOXY PAINT. ALL NON-LOCAL RESIDENTIAL ROADWAYS SHALL INCLUDE BOTH RIGHT AND LEFT EDGE LINE STRIPING AND ANY ADDITIONAL STRIPING AS REQUIRED BY CDOT S-627-1.
13. THE CONTRACTOR SHALL NOTIFY EL PASO COUNTY PLANNING AND COMMUNITY DEVELOPEMENT (719) 520-6819 PRIOR TO AND UPON COMPLETION OF SIGNING AND STRIPING.
14. THE CONTRACTOR SHALL OBTAIN A WORK IN THE RIGHT OF WAY PERMIT FROM THE EL PASO COUNTY DEPARTMENT OF PUBLIC WORKS (DPW) PRIOR TO ANY SIGNAGE OR STRIPING WORK WITHIN AN EXISTING EL PASO COUNTY ROADWAY.

DESIGNED BY RHS	PROJECT ENGINEER RHS	PROJECT MANAGER MOB	SCALE: HORIZ.: VERT.: N/A
DATE 02/29/19	JOB NO. 18031	CAD FILE NO. 18031-000	DRAWN BY HUS

PREPARED BY:

3520 Austin Blvd's Parkway  
Suite 102  
Colorado Springs, CO 80918  
(719) 256-6212  
fax: (719) 265-5341

BY	
REVISION	
NO.	DATE

**JUDGE ORR ROAD RV PARK & STORAGE**  
**COLORADO SPRINGS, COLORADO**  
**STANDARD NOTES**

SHEET

6 of 7

Note:  
Details for information only

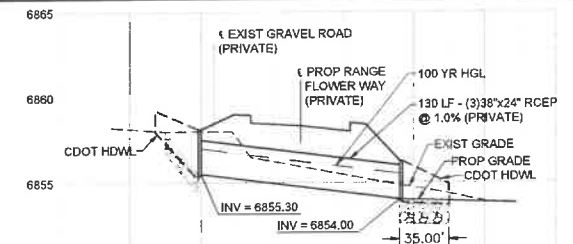
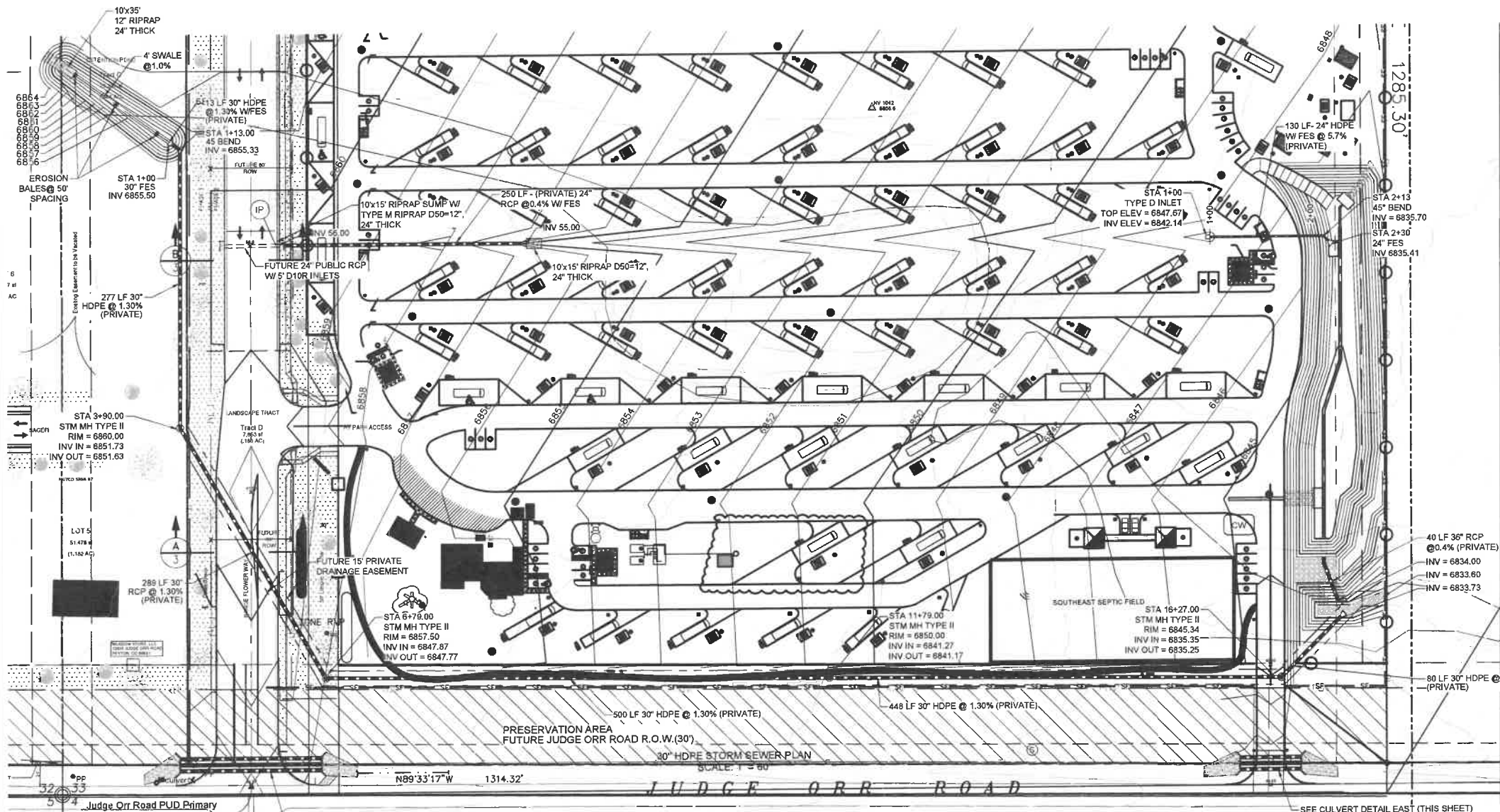

38"x24" (PRIVATE) RCEP STORM CULVERT WEST PROFILE  
RANGE FLOWER WAY  
SCALES HORIZONTAL 1"=60' VERTICAL 1"=5'

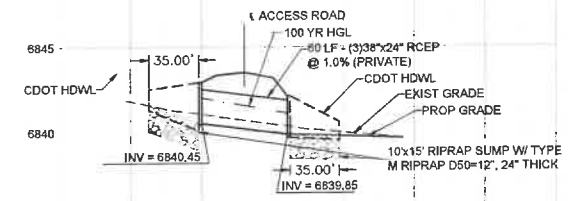

38"x24" (PRIVATE) RCEP STORM CULVERT EAST PROFILE  
S. FIRE ACCESS RD  
SCALES HORIZONTAL 1"=60' VERTICAL 1"=5'

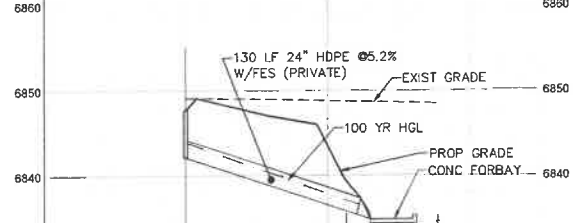

24" HDPE STORM SEWER PROFILE  
SCALES HORIZONTAL 1"=60' VERTICAL 1"=10'

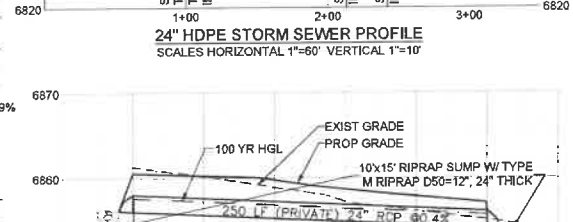

24" RCP STORM SEWER PROFILE  
SCALES HORIZONTAL 1"=60' VERTICAL 1"=10'

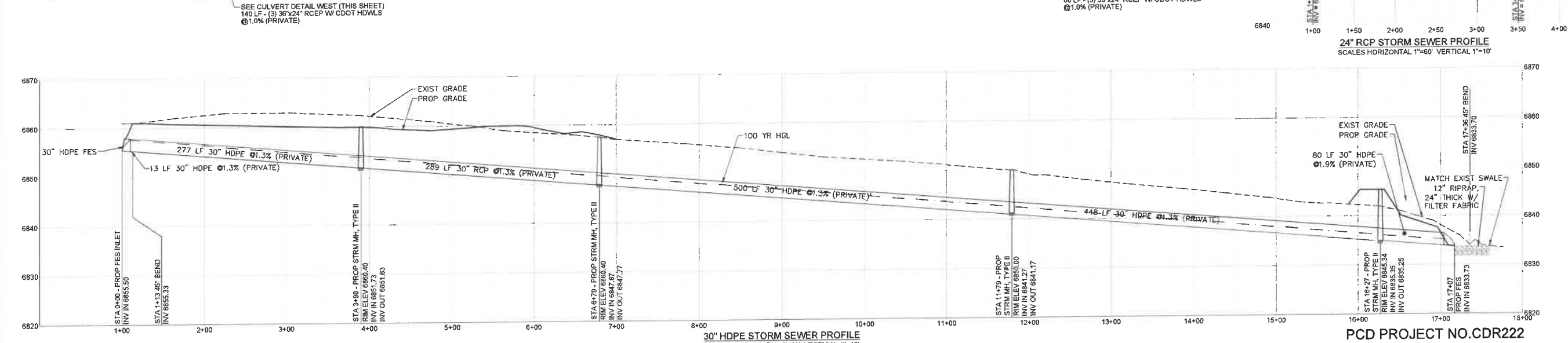

30" HDPE STORM SEWER PROFILE  
SCALES HORIZONTAL 1"=60' VERTICAL 1"=10'

PCD PROJECT NO. CDR222

DESIGNED BY: MAB  
PROJECT ENGINEER: MAB  
PROJECT MANAGER: MAB  
DATE: 02/25/19  
JOB NO.: 180001  
CAD FILE NO.: 18001-888  
DRAWN BY: MAB  
SCALE: HORIZ.: N/A  
VERT.: 1"=10'

PREPARED BY:

3520 Austin Bluffs Parkway  
Suite 102  
Colorado Springs, CO 80918  
(719) 266-5212  
fax (719) 266-5341

NO.	DATE	REVISION	BY

**JUDGE ORR ROAD RV PARK & STORAGE**  
**COLORADO SPRINGS, COLORADO**  
**STORM SEWER PROFILES**

SHEET

7 of 7

**APPENDIX C**  
Inspection Checklist

## EXTENDED DETENTION BASIN (EDB) MAINTENANCE FORM

Subdivision/Business Name: \_\_\_\_\_ Completion Date: \_\_\_\_\_  
 Subdivision/Business Address: \_\_\_\_\_ Contact Name: \_\_\_\_\_

**Maintenance Category:**                      Routine                      Restoration                      Rehabilitation  
 (Circle All That Apply)

### MAINTENANCE ACTIVITIES PERFORMED

#### ROUTINE WORK

- \_\_\_ MOWING
- \_\_\_ TRASH/DEBRIS REMOVAL
- \_\_\_ OUTLET WORKS CLEANING (TRASH RACK/WELL SCREEN)
- \_\_\_ WEED CONTROL (HERBICIDE APPLICATION)
- \_\_\_ MOSQUITO TREATMENT
- \_\_\_ ALGAE TREATMENT

#### RESTORATION WORK

- \_\_\_ SEDIMENT REMOVAL
  - \_\_\_ FOREBAY
  - \_\_\_ TRICKLE CHANNEL
  - \_\_\_ INFLOW
- \_\_\_ EROSION REPAIR
  - \_\_\_ INFLOW POINT
  - \_\_\_ TRICKLE CHANNEL
- \_\_\_ VEGETATION REMOVAL/TREE THINNING
  - \_\_\_ INFLOW(S)
  - \_\_\_ TRICKLE CHANNEL
  - \_\_\_ UPPER STAGE
  - \_\_\_ BOTTOM STAGE
- \_\_\_ REVEGETATION
- \_\_\_ JET-VAC/CLEARING DRAINS
  - \_\_\_ FOREBAY
  - \_\_\_ OUTLET WORKS
  - \_\_\_ INFLOWS

#### REHABILITATION WORK

- \_\_\_ SEDIMENT REMOVAL (DREDGING)
  - \_\_\_ BOTTOM STAGE
  - \_\_\_ UPPER STAGE
- \_\_\_ EROSION REPAIR
  - \_\_\_ OUTLET WORKS
  - \_\_\_ UPPER STAGE
  - \_\_\_ BOTTOM STAGE
  - \_\_\_ SPILLWAY
- \_\_\_ STRUCTURAL REPAIR
  - \_\_\_ INFLOW
  - \_\_\_ OUTLET WORKS
  - \_\_\_ FOREBAY
  - \_\_\_ TRICKLE CHANNEL

OTHER \_\_\_\_\_  
 \_\_\_\_\_  
 \_\_\_\_\_

ESTIMATED TOTAL MANHOURS: \_\_\_\_\_

COSTS INCURRED (include description of costs): \_\_\_\_\_

EQUIPMENT/MATERIAL USED (include hours of equipment usage and quantity of material used):  
 \_\_\_\_\_  
 \_\_\_\_\_

COMMENTS/ADDITIONAL INFO:  
 \_\_\_\_\_  
 \_\_\_\_\_

This Maintenance Activity Form shall be kept a minimum of 5 years and made available to the City of Colorado Springs upon request.