



April 11, 2022

Mr. Gilbert LaForce
El Paso County
2880 International Cir., Suite 110
Colorado Springs, CO 80910

Dear Gilbert:

DRAINAGE LETTER – JUDGE ORR ROAD RV PARK & STORAGE

THIS DRAINAGE LETTER is to Certify that the Approved Final Drainage Report for the Judge Orr Road RV Park & Storage Development prepared by Associated Design Professionals, Inc. included the area involved in the extension of Range Flower Way. The area included in the Range Flower Way drainage area was delineated as Sub-basin A2A and contained 2.58 acres. The flows from this basin produced 5.7 cfs for the 5-year storm and 12.0 cfs for the 100-year storm. These flows will be intercepted by two 5' D10R inlets which connect to the 24" RCP which flows east to the approved detention basin.

I hereby Certify that there are no changes to these flows from the date of the approved report to the development of the roadway improvement plans.

Please call me if you have questions.

Sincerely,

Michael A. Bartusek, PE
Project Engineer

W3925.-Judge Orr Rd RV Park & Storage

121 S. TEJON ST.
SUITE 1110
COLORADO SPRINGS, CO 80903
719.283-7671



ENGINEER'S STATEMENT:

The attached drainage plan and report were prepared under my direction and supervision and are correct to the best of my knowledge and belief. Said drainage report has been prepared according to the criteria established by the County for drainage reports, and said report is in conformity with the master plan of the drainage basin. I accept responsibility for any liability caused by any negligent acts, errors or omissions on my part in preparing this report.



Michael A. Bartusek, P.E. #23329

DEVELOPER'S STATEMENT:

I, the Developer, have read and will comply with all of the requirements specified in this drainage report and plan.

By: _____

Edward "Teddy" McDonald 

Title: Owner

Address: McDonald Paving & Chip Sealing
3507 N. El Paso St.
Colorado Springs, CO 80907

Filed in accordance the El Paso County Land Development Code, Drainage Criteria Manual Volumes 1 and 2, and the Engineering Criteria Manual, as amended.

Jennifer Irvine, County Engineer/ECM Administrator

Date

Conditions:

Developed Conditions								
AREA	TOTAL AREA	SURFACE CONDITION AREAS				CALCULATED C		
		GRASSED SURFACE	LOOSE GRAVEL	GRAVEL RV PARKING	PAVED ROADS	5 YR	100 YR	
DESIG.	(acre)							
A1	8.30	0.61	7.69	0.00	0.00	0.55	0.67	
A2A	2.58	0.86	0.00	0.00	1.72	0.63	0.76	
A3	6.85	3.88	0.00	1.15	1.82	0.38	0.57	
A4	11.92	9.18	0.00	1.49	1.25	0.23	0.46	
Total @Pond	29.65	14.53	7.69	2.64	4.79	0.39	0.57	
A2B	0.70	0.16	0.00	0.00	0.54	0.71	0.82	
A5	1.80	1.72	0.00	0.00	0.08	0.08	0.38	
% Impervious		0%	80%	80%	100%			
Imp x A		0	6.15	2.11	4.79			
Total I x A	13.05							
Total Imp	13.05/29.65 = 44.0%							
B	0.87	0.87	0.00	0.00	0.00	0.08	0.35	
OS1	7.81	7.19	0.00	0.00	0.62	0.15	0.40	
OS2	42.70	19.20	0.00	0.00	23.50	0.53	0.69	
OS3	27.21	From Heagler DBPS					0.30	0.60
OS4	4.18	2.82	0.00	0.00	1.36	0.35	0.55	
OS5	0.70	0.42	0.00	0.00	0.28	0.41	0.59	
Pond 1								
% Impervious								
	TOTAL AREA	GRASSED SURFACE	NEIGHBORHOOD COMMERCIAL					
OS1	7.81	7.81						
OS2	42.70	1.65	41.05					
	50.51	9.46	41.05					
% Impervious		0%	70%					
Imp x A		0	28.74					
Total I x A	28.74							
Total Imp	28.74/50.51 = 56.9%							

JUDGE ORR ROAD RV PARK & STORAGE DEVELOPMENT

PROJ. #160301
 DRAINAGE CALCULATION SHEET
 file:judge orr rvl dr
 07/17/19

AREA DESIG.	AREA (acre)	C5 (5 yr)	C100 (100 yr)	C5 X A	C100 X A	Initial Tci			Travel Time			TC (min)	I5 (in/hr)	I100 (in/hr)	Q5 (cfs)	Q100 (cfs)	Length L (feet)	vel. V (fps)	t (min)	AREA DSSIG.
						Slope (%)	ti (min)	L (ft)	Slope (%)	V (fps)	Tt (min)									
EXISTING CONDITIONS																				
A1	11.75	0.08	0.35	0.94	4.11	200	2.00	21.46	1150	1.90	2.10	9.13	30.59	2.29	4.00	2.15	16.47		A1	
OS1	7.81	0.15	0.40	1.17	3.12	150	2.00	17.31	600	1.18	2.35	4.26	21.56	2.80	4.89	3.28	15.27	450	4.50	OS1
OS2	22.10	0.09	0.36	1.99	7.96	150	2.00	18.40	1400	1.20	1.20	19.44	37.85	2.01	3.52	4.00	27.97		OS2	
DP1	29.91			3.16	11.08								37.85	2.01	3.52	6.36	38.95	1250	2.10	DP1
A2	17.47	0.08	0.35	1.40	6.11	250	3.20	20.55	1400	1.90	2.10	11.11	31.66	2.25	3.92	3.14	23.98		A2	
DP2	47.38			4.56	17.19								47.77	1.73	3.03	7.91	52.10		DP2	
OS3	27.21	0.30	0.60	8.16	16.33	250	2.00	18.82	1570	2.90	1.80	14.54	33.35	2.18	3.80	17.76	62.04	1800	4.00	OS3
OS4	25.14	0.16	0.41	4.02	10.31	250	2.00	22.11	1800	1.00	2.00	15.00	37.11	2.04	3.56	8.20	36.68		OS4	
DP3	52.35			12.19	26.63								37.11	2.04	3.56	24.83	94.79	1050	2.25	DP3
A3	2.80	0.14	0.39	0.39	1.09	100	2.00	14.28	1050	1.23	2.25	7.78	22.06	2.76	4.83	1.08	5.27		A3	
OS5	0.82	0.41	0.60	0.34	0.49	10	2.00	3.25	1050	1.23	2.25	7.78	11.02	3.89	6.79	1.31	3.34		OS5	
DP4	55.97			12.91	28.22								44.89	1.81	3.15	23.32	89.02		DP4	
DP5	115.10			18.41	49.52								44.89	1.81	3.15	33.25	156.23		DP5	
B	0.87	0.08	0.35	0.07	0.30	80	2.00	13.57	650	1.30	2.30	4.71	18.28	3.05	5.34	0.21	1.62		B	
DEVELOPED CONDITIONS																				
OS1	7.81	0.15	0.40	1.17	3.12	150	2.00	17.31	600	1.18	2.35	4.26	21.56	2.80	4.89	3.28	15.27	450	4.50	OS1
OS2	22.10	0.09	0.36	1.99	7.96	150	2.00	18.40	1400	1.20	1.20	19.44	37.85	2.01	3.52	4.00	27.97		OS2	
DP1	29.91			3.16	11.08								37.85	2.01	3.52	6.36	38.95	1594	10.00	DP1
A1	8.30	0.56	0.68	4.65	5.64	100	2.00	8.03	1150	1.50	1.20	15.97	24.01	2.64	4.61	12.26	26.00	650	1.20	A1
A2A	2.58	0.63	0.76	1.63	1.96	35	2.00	4.14	700	1.50	1.20	9.72	13.86	3.50	6.12	5.69	12.00	675	1.20	A2A
A3	6.85	0.38	0.57	2.60	3.90	100	2.00	10.71	950	1.50	1.20	13.19	23.91	2.64	4.62	6.88	18.03	230	1.20	A3
DP2	9.43			4.23	5.87								23.91	2.64	4.62	11.18	27.08		DP2	
A4	11.92	0.39	0.57	4.65	6.79	100	2.00	10.56	1100	1.50	1.20	15.28	25.84	2.53	4.42	11.76	30.02		A4	
DP3	29.65			13.53	18.30								33.03	2.19	3.82	29.60	69.97	150	5.00	DP3
DPD2	29.65			0.23	8.93								33.03	2.19	3.82	0.50	33.70		DPD2	
DP4	59.56			3.39	20.01								40.50	1.93	3.37	6.54	67.41		DP4	
OS3	27.21	0.30	0.60	8.16	16.33	250	2.00	18.82	1570	2.90	1.80	14.54	33.35	2.18	3.80	17.76	62.04	1800	4.00	OS3
OS4	25.14	0.16	0.41	4.02	10.31	250	2.00	22.11	1800	1.00	2.00	15.00	37.11	2.04	3.56	8.20	36.68		OS4	

*Adjusted C Factor for Detention Basin

ALLOWABLE CAPACITY FOR ONE-HALF OF STREET (Minor & Major Storm)

(Based on Regulated Criteria for Maximum Allowable Flow Depth and Spread)

Project: Judge Orr Rd RV & Storage
 Inlet ID: Inlet 1

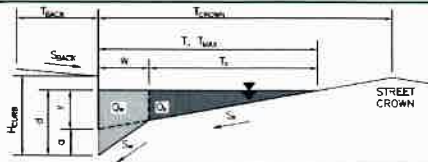

Gutter Geometry (Enter data in the blue cells)

Maximum Allowable Width for Spread Behind Curb
 Side Slope Behind Curb (leave blank for no conveyance credit behind curb)
 Manning's Roughness Behind Curb (typically between 0.012 and 0.020)

Height of Curb at Gutter Flow Line
 Distance from Curb Face to Street Crown
 Gutter Width
 Street Transverse Slope
 Gutter Cross Slope (typically 2 inches over 24 inches or 0.083 ft/ft)
 Street Longitudinal Slope - Enter 0 for sump condition
 Manning's Roughness for Street Section (typically between 0.012 and 0.020)

Max. Allowable Spread for Minor & Major Storm
 Max. Allowable Depth at Gutter Flowline for Minor & Major Storm
 Check boxes are not applicable in SUMP conditions

T _{BACK} =	5.0	ft.
S _{BACK} =	0.020	ft/ft
n _{BACK} =	0.015	
H _{CURB} =	6.00	inches
T _{CROWN} =	40.0	ft
W =	2.00	ft
S _x =	0.020	ft/ft
S _w =	0.100	ft/ft
S _o =	0.000	ft/ft
n _{STREET} =	0.015	

	Minor Storm	Major Storm	
T _{MAX} =	18.0	18.0	ft
d _{MAX} =	12.0	12.0	inches

Warning 02

Maximum Capacity for 1/2 Street based on Allowable Spread

Water Depth without Gutter Depression (Eq. ST-2)
 Vertical Depth between Gutter Lip and Gutter Flowline (usually 2")
 Gutter Depression (d_c - (W * S_x * 12))
 Water Depth at Gutter Flowline
 Allowable Spread for Discharge outside the Gutter Section W (T - W)
 Gutter Flow to Design Flow Ratio by FHWA HEC-22 method (Eq. ST-7)
 Discharge outside the Gutter Section W, carried in Section T_x
 Discharge within the Gutter Section W (Q_T - Q_x)
 Discharge Behind the Curb (e.g., sidewalk, driveways, & lawns)
Maximum Flow Based on Allowable Spread
 Flow Velocity within the Gutter Section
 V*d Product: Flow Velocity times Gutter Flowline Depth

	Minor Storm	Major Storm	
y =	4.32	4.32	inches
d _c =	2.4	2.4	inches
a =	1.92	1.92	inches
d =	6.24	6.24	inches
T _x =	16.0	16.0	ft
E _o =	0.346	0.346	
Q _x =	0.0	0.0	cfs
Q _w =	0.0	0.0	cfs
Q _{BACK} =	0.0	0.0	cfs
Q _T =	SUMP	SUMP	cfs
V =	0.0	0.0	fps
V*d =	0.0	0.0	

Maximum Capacity for 1/2 Street based on Allowable Depth

Theoretical Water Spread
 Theoretical Spread for Discharge outside the Gutter Section W (T - W)
 Gutter Flow to Design Flow Ratio by FHWA HEC-22 method (Eq. ST-7)
 Theoretical Discharge outside the Gutter Section W, carried in Section T_{xTH}
 Actual Discharge outside the Gutter Section W, (limited by distance T_{CROWN})
 Discharge within the Gutter Section W (Q_d - Q_x)
 Discharge Behind the Curb (e.g., sidewalk, driveways, & lawns)
 Total Discharge for Major & Minor Storm (Pre-Safety Factor)
 Average Flow Velocity Within the Gutter Section
 V*d Product: Flow Velocity Times Gutter Flowline Depth
 Slope-Based Depth Safety Reduction Factor for Major & Minor (d ≥ 6") Storm
Max Flow Based on Allowable Depth (Safety Factor Applied)
 Resultant Flow Depth at Gutter Flowline (Safety Factor Applied)
 Resultant Flow Depth at Street Crown (Safety Factor Applied)

	Minor Storm	Major Storm	
T _{TH} =	42.0	42.0	ft
T _{xTH} =	40.0	40.0	ft
E _o =	0.140	0.140	
Q _{xTH} =	0.0	0.0	cfs
Q _x =	0.0	0.0	cfs
Q _w =	0.0	0.0	cfs
Q _{BACK} =	0.0	0.0	cfs
Q =	0.0	0.0	cfs
V =	0.0	0.0	fps
V*d =	0.0	0.0	
R =	SUMP	SUMP	
Q _d =	SUMP	SUMP	cfs
d =			inches
d _{CROWN} =			inches

	Minor Storm	Major Storm	
Q _{allow} =	SUMP	SUMP	cfs

MINOR STORM Allowable Capacity is based on Depth Criterion
 MAJOR STORM Allowable Capacity is based on Depth Criterion

INLET IN A SUMP OR SAG LOCATION

Version 4.05 Released March 2017

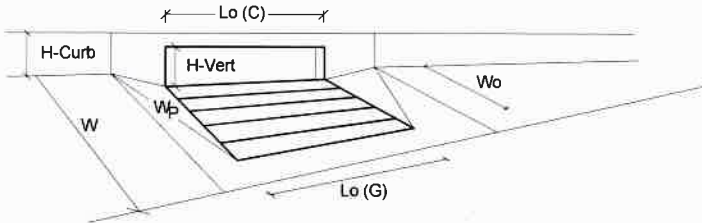

Design Information (Input)	Colorado Springs D-10-R	
Type of Inlet	MINOR MAJOR Colorado Springs D-10-R	
Local Depression (additional to continuous gutter depression 'a' from above)	$a_{local} = 4.00$	4.00 inches
Number of Unit Inlets (Grate or Curb Opening)	No = 1	1
Water Depth at Flowline (outside of local depression)	Ponding Depth = 8.0	8.0 inches
Grate Information	<input checked="" type="checkbox"/> Override Depths	
Length of a Unit Grate	$L_o (G) = N/A$	N/A feet
Width of a Unit Grate	$W_p = N/A$	N/A feet
Area Opening Ratio for a Grate (typical values 0.15 - 0.90)	$A_{ratio} = N/A$	N/A
Clogging Factor for a Single Grate (typical value 0.50 - 0.70)	$C_r (G) = N/A$	N/A
Grate Weir Coefficient (typical value 2.15 - 3.60)	$C_w (G) = N/A$	N/A
Grate Orifice Coefficient (typical value 0.60 - 0.80)	$C_o (G) = N/A$	N/A
Curb Opening Information	MINOR MAJOR	
Length of a Unit Curb Opening	$L_o (C) = 5.00$	5.00 feet
Height of Vertical Curb Opening in Inches	$H_{vert} = 8.00$	8.00 inches
Height of Curb Orifice Throat in Inches	$H_{throat} = 8.00$	8.00 inches
Angle of Throat (see USDCM Figure ST-5)	Theta = 81.00	81.00 degrees
Side Width for Depression Pan (typically the gutter width of 2 feet)	$W_p = 0.83$	0.83 feet
Clogging Factor for a Single Curb Opening (typical value 0.10)	$C_r (C) = 0.10$	0.10
Curb Opening Weir Coefficient (typical value 2.3 - 3.7)	$C_w (C) = 3.60$	3.60
Curb Opening Orifice Coefficient (typical value 0.60 - 0.70)	$C_o (C) = 0.67$	0.67
Grate Flow Analysis (Calculated)	MINOR MAJOR	
Clogging Coefficient for Multiple Units	Coef = N/A	N/A
Clogging Factor for Multiple Units	Clog = N/A	N/A
Grate Capacity as a Weir (based on Modified HEC22 Method)	MINOR MAJOR	
Interception without Clogging	$Q_{w0} = N/A$	N/A cfs
Interception with Clogging	$Q_{wC} = N/A$	N/A cfs
Grate Capacity as an Orifice (based on Modified HEC22 Method)	MINOR MAJOR	
Interception without Clogging	$Q_{o0} = N/A$	N/A cfs
Interception with Clogging	$Q_{oC} = N/A$	N/A cfs
Grate Capacity as Mixed Flow	MINOR MAJOR	
Interception without Clogging	$Q_{m0} = N/A$	N/A cfs
Interception with Clogging	$Q_{mC} = N/A$	N/A cfs
Resulting Grate Capacity (assumes clogged condition)	$Q_{grate} = N/A$	N/A cfs
Curb Opening Flow Analysis (Calculated)	MINOR MAJOR	
Clogging Coefficient for Multiple Units	Coef = 1.00	1.00
Clogging Factor for Multiple Units	Clog = 0.10	0.10
Curb Opening as a Weir (based on Modified HEC22 Method)	MINOR MAJOR	
Interception without Clogging	$Q_{w0} = 9.9$	9.9 cfs
Interception with Clogging	$Q_{wC} = 8.9$	8.9 cfs
Curb Opening as an Orifice (based on Modified HEC22 Method)	MINOR MAJOR	
Interception without Clogging	$Q_{o0} = 14.7$	14.7 cfs
Interception with Clogging	$Q_{oC} = 13.2$	13.2 cfs
Curb Opening Capacity as Mixed Flow	MINOR MAJOR	
Interception without Clogging	$Q_{m0} = 11.2$	11.2 cfs
Interception with Clogging	$Q_{mC} = 10.1$	10.1 cfs
Resulting Curb Opening Capacity (assumes clogged condition)	$Q_{curb} = 8.9$	8.9 cfs
Resultant Street Conditions	MINOR MAJOR	
Total Inlet Length	L = 5.00	5.00 feet
Resultant Street Flow Spread (based on street geometry from above)	T = 25.3	25.3 ft
Resultant Flow Depth at Street Crown	$d_{crown} = 0.0$	0.0 inches
Low Head Performance Reduction (Calculated)	MINOR MAJOR	
Depth for Grate Midwidth	$d_{grate} = N/A$	N/A ft
Depth for Curb Opening Weir Equation	$d_{curb} = 0.47$	0.47 ft
Combination Inlet Performance Reduction Factor for Long Inlets	$RF_{combination} = 1.00$	1.00
Curb Opening Performance Reduction Factor for Long Inlets	$RF_{curb} = 1.00$	1.00
Grated Inlet Performance Reduction Factor for Long Inlets	$RF_{grate} = N/A$	N/A
Total Inlet Interception Capacity (assumes clogged condition)	$Q_a = 8.9$	8.9 cfs
Inlet Capacity IS GOOD for Minor and Major Storms(>Q PEAK)	$Q_{PEAK REQUIRED} = 2.9$	6.0 cfs

Warning 1

Warning 1: Dimension entered is not a typical dimension for inlet type specified.

ALLOWABLE CAPACITY FOR ONE-HALF OF STREET (Minor & Major Storm)

(Based on Regulated Criteria for Maximum Allowable Flow Depth and Spread)

Project: **Judge Orr Rd RV & Storage**
 Inlet ID: **Inlet 2**

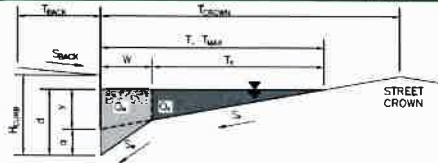

Gutter Geometry (Enter data in the blue cells)					
Maximum Allowable Width for Spread Behind Curb	$T_{BACK} = 18.0$ ft				
Side Slope Behind Curb (leave blank for no conveyance credit behind curb)	$S_{BACK} = 0.020$ ft/ft				
Manning's Roughness Behind Curb (typically between 0.012 and 0.020)	$n_{BACK} = 0.035$				
Height of Curb at Gutter Flow Line	$H_{CURB} = 6.00$ inches				
Distance from Curb Face to Street Crown	$T_{CROWN} = 18.0$ ft				
Gutter Width	$W = 2.00$ ft				
Street Transverse Slope	$S_x = 0.020$ ft/ft				
Gutter Cross Slope (typically 2 inches over 24 inches or 0.083 ft/ft)	$S_w = 0.083$ ft/ft				
Street Longitudinal Slope - Enter 0 for sump condition	$S_{LO} = 0.000$ ft/ft				
Manning's Roughness for Street Section (typically between 0.012 and 0.020)	$n_{STREET} = 0.015$				
Max. Allowable Spread for Minor & Major Storm	<table border="1"> <tr> <th>Minor Storm</th> <th>Major Storm</th> </tr> <tr> <td>$T_{MAX} = 18.0$</td> <td>18.0</td> </tr> </table> ft	Minor Storm	Major Storm	$T_{MAX} = 18.0$	18.0
Minor Storm	Major Storm				
$T_{MAX} = 18.0$	18.0				
Max. Allowable Depth at Gutter Flowline for Minor & Major Storm	<table border="1"> <tr> <th>Minor Storm</th> <th>Major Storm</th> </tr> <tr> <td>$Q_{MAX} = 12.0$</td> <td>12.0</td> </tr> </table> inches	Minor Storm	Major Storm	$Q_{MAX} = 12.0$	12.0
Minor Storm	Major Storm				
$Q_{MAX} = 12.0$	12.0				
Check boxes are not applicable in SUMP conditions:					
MINOR STORM Allowable Capacity is based on Depth Criterion					
MAJOR STORM Allowable Capacity is based on Depth Criterion					
Q _{allow}	<table border="1"> <tr> <th>Minor Storm</th> <th>Major Storm</th> </tr> <tr> <td>SUMP</td> <td>SUMP</td> </tr> </table> cfs	Minor Storm	Major Storm	SUMP	SUMP
Minor Storm	Major Storm				
SUMP	SUMP				

Warning 01

Warning 02

Warning 01: Manning's n-value does not meet the USDCM recommended design range.

INLET IN A SUMP OR SAG LOCATION

Version 4.05 Released March 2017

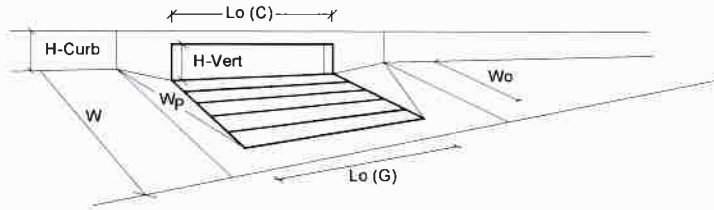

Design Information (Input)	MINOR		MAJOR		
Type of Inlet	Colorado Springs D-10-R				
Local Depression (additional to continuous gutter depression 'a' from above)					
Number of Unit Inlets (Grate or Curb Opening)	1		1		
Water Depth at Flowline (outside of local depression)	8.0		8.0		inches
Grate Information	MINOR		MAJOR		<input checked="" type="checkbox"/> Override Depths
Length of a Unit Grate	N/A		N/A		feet
Width of a Unit Grate	N/A		N/A		feet
Area Opening Ratio for a Grate (typical values 0.15 - 0.90)	N/A		N/A		
Clogging Factor for a Single Grate (typical value 0.50 - 0.70)	N/A		N/A		
Grate Weir Coefficient (typical value 2.15 - 3.60)	N/A		N/A		
Grate Orifice Coefficient (typical value 0.60 - 0.80)	N/A		N/A		
Curb Opening Information	MINOR		MAJOR		
Length of a Unit Curb Opening	5.00		5.00		feet
Height of Vertical Curb Opening in Inches	8.00		8.00		inches
Height of Curb Orifice Throat in Inches	8.00		8.00		inches
Angle of Throat (see USDCM Figure ST-5)	81.00		81.00		degrees
Side Width for Depression Pan (typically the gutter width of 2 feet)	2.00		2.00		feet
Clogging Factor for a Single Curb Opening (typical value 0.10)	0.10		0.10		
Curb Opening Weir Coefficient (typical value 2.3 - 3.7)	3.60		3.60		
Curb Opening Orifice Coefficient (typical value 0.60 - 0.70)	0.67		0.67		
Low Head Performance Reduction (Calculated)	MINOR		MAJOR		
Depth for Grate Midwidth	N/A		N/A		ft
Depth for Curb Opening Weir Equation	0.50		0.50		ft
Combination Inlet Performance Reduction Factor for Long Inlets	1.00		1.00		
Curb Opening Performance Reduction Factor for Long Inlets	1.00		1.00		
Grated Inlet Performance Reduction Factor for Long Inlets	N/A		N/A		
Total Inlet Interception Capacity (assumes clogged condition)	MINOR		MAJOR		
Inlet Capacity IS GOOD for Minor and Major Storms(>Q PEAK)	9.9		9.9		cfs
Q PEAK REQUIRED =	2.9		6.0		cfs

M:\LAND PROJECTS\2016\160101-Judge Dr. Road RV Park\160101-Developed Conditions.dwg Mike Berkbeck, Thu, 07/18/13 5:52 AM

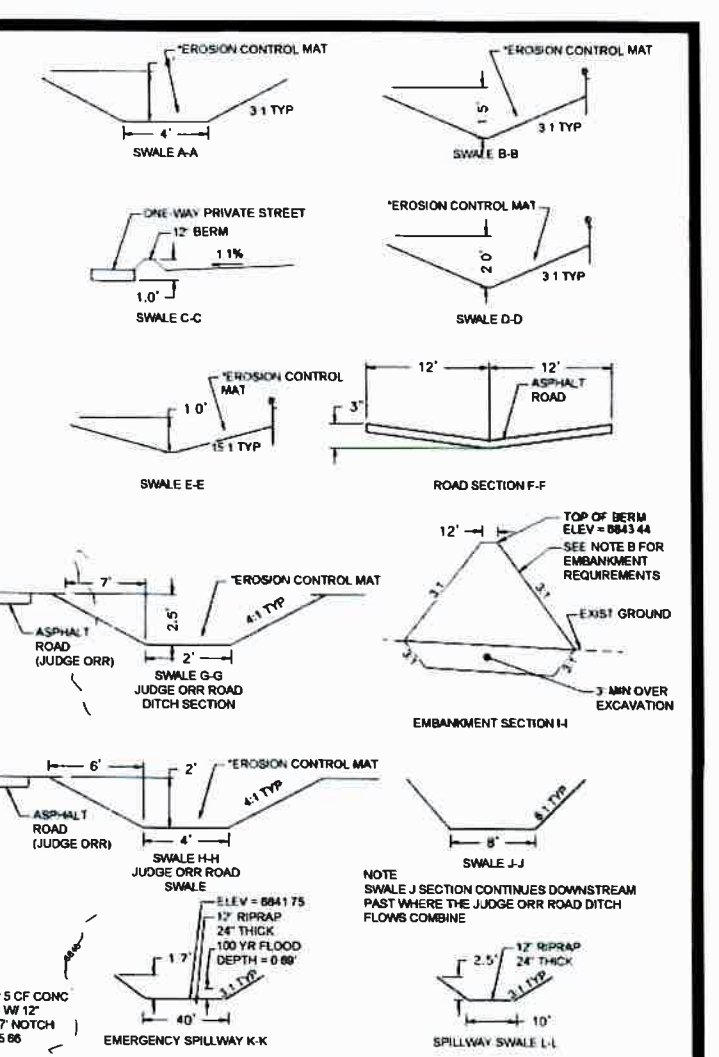
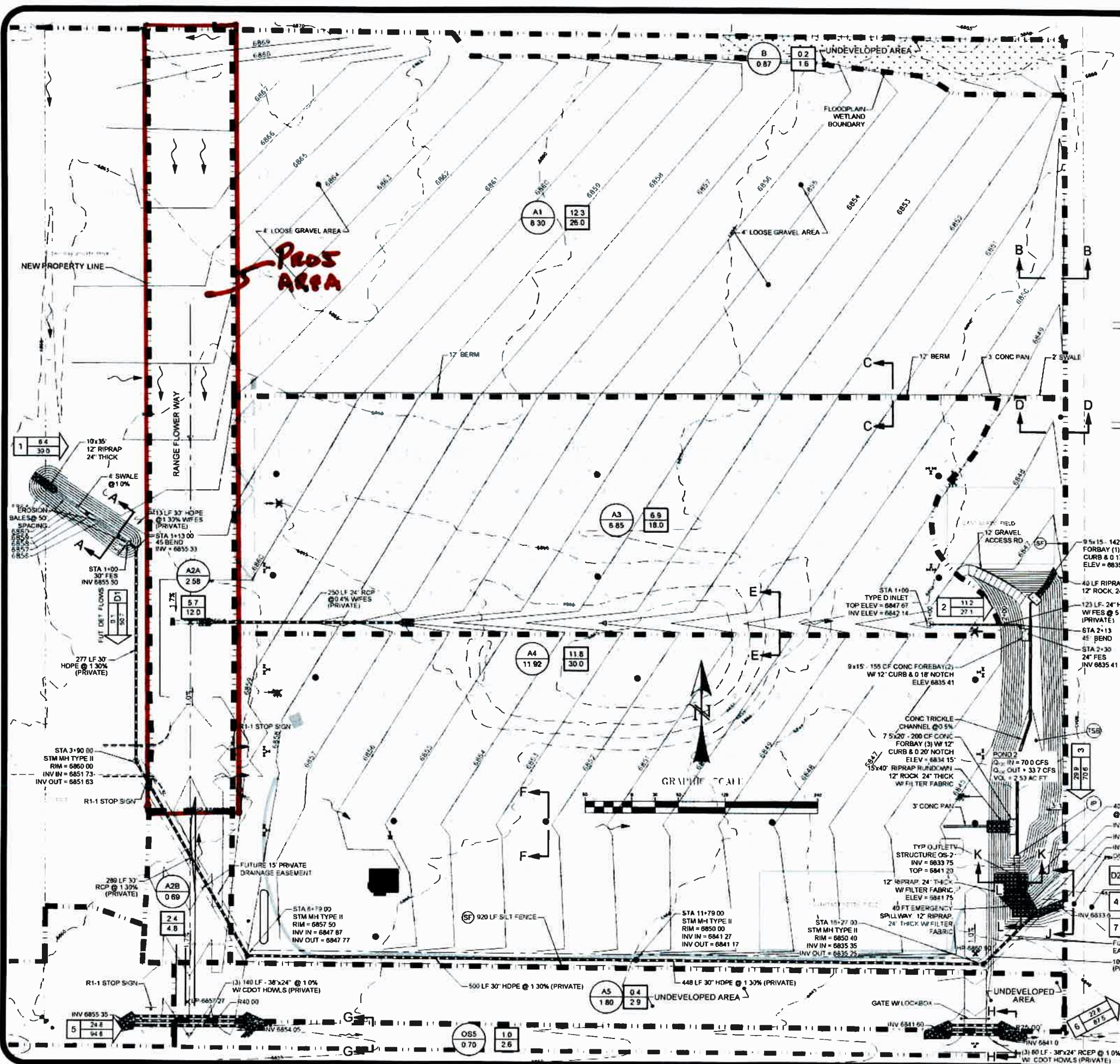

LEGEND

- A1A BASIN DESIGNATION
- XX BASIN AREA, ACRES
- XX 5 YEAR STORM, CFS
- XX 100 YEAR STORM, CFS
- XX XX 5 YEAR ACCUMULATED FLOW, CFS
- XX XX 100 YEAR ACCUMULATED FLOW, CFS
- SUB-BASIN BOUNDARY
- DIRECTION OF DRAINAGE FLOW

- NOTES**
- A DETENTION POND AREA TO BE UTILIZED AS A SEDIMENTATION BASIN UNTIL EARTH MOVING IS COMPLETED AND THE GROUND STABILIZED AT WHICH TIME IT WILL BE CLEANED OUT, THE SEDIMENT BASIN OUTLET PIPE REMOVED AND THE DETENTION POND STRUCTURE OS2 ADDED. SEE SEDIMENT BASIN DETAIL SB ON SHEET 5 OF 7
 - B EMBANKMENT COMPACTION SHALL FOLLOW THE REQUIREMENTS OF THE GEOTECHNICAL LETTER FROM ENTECH ENGINEERING, INC. LOCATED IN APPENDIX C OF THE DRAINAGE REPORT

NO TOPOGRAPHY AVAILABLE BEYOND THIS AREA (SEE OFFSITE DRAINAGE MAP FOR CONTINUATION)

NOTE: JUDGE ORR ROAD DITCH FLOWS COMBINE WITH OUTLET SWALE FLOWS APPROX 300' EAST OF THE PROPERTY

DESIGNED BY MAB	PROJECT ENGINEER MAB	PROJECT MANAGER MAB	SCALE HORIZ 1" = 87' VERT 1" = 87'
DATE 08/01/13	JOB NO 160101	CAD FILE NO 160101-Dev Cond	DRAWN BY MAB
PREPARED BY:			
BY			
REVISION			
NO			
JUDGE ORR ROAD RV PARK & STORAGE COLORADO SPRINGS, COLORADO DRAINAGE - DEVELOPED CONDITIONS			
SHEET 3 of 3			