



LSC TRANSPORTATION CONSULTANTS, INC.
2504 East Pikes Peak Avenue, Suite 304
Colorado Springs, CO 80909
(719) 633-2868
E-mail: lsc@lsctrans.com
Website: <http://www.lsctrans.com>

April 16, 2020

Mr. Jeff Chamberlain
National Heritage Academies, Inc
3850 Broadmoor SE
Grand Rapids, MI 49512

RE: Mountain View Academy
El Paso County, Colorado
Traffic Impact Study
LSC #204140

Dear Mr. Chamberlain:

LSC Transportation Consultants, Inc. has prepared this traffic impact study for the proposed development to be located in Claremont Ranch, southwest of Meadowbrook Parkway and Pinyon Jay Drive in El Paso County, Colorado. The site location is shown in Figure 1.

REPORT CONTENTS

The report contains the following:

- Recent/current street and traffic conditions in the vicinity of the site for identification of existing and planned street widths, lane geometries, traffic controls, posted speed limits, street classification, etc.
- Existing traffic volumes at the key intersections in the vicinity of the site and estimates of short-term and 2040 background traffic volumes
- The projected average weekday and peak-hour vehicle trips to be generated by the proposed development
- The assignment of the projected trips to the existing and planned street system
- The resulting short-term and 2040 total traffic volumes on the street system
- The resulting traffic impacts at the study intersections
- Recommendations for traffic controls and auxiliary turn lanes

RECENT TRAFFIC STUDIES

The following traffic studies have been completed in the past few years in the vicinity of the site:

- The Sand Industrial, LSC, November 5, 2019
- Claremont Commercial Filing No. 2, LSC, April 15, 2020

- Meadowbrook Parkway, LSC, June 8, 2017
- Meadowbrook Crossing, LSC, May 5, 2017
- The Sands, LSC, May 17, 2016

All of these studies were considered when developing background traffic projections. Additionally, LSC is currently working on updating the traffic study for the Villas at Claremont, which was also included in the background traffic.

SITE DEVELOPMENT, LAND USE, AND ACCESS

The site is located south of Meadowbrook Parkway and west of Pinyon Drive in the Claremont Ranch development. Access into the site is proposed off of Pinyon Jay Drive approximately 200 feet north of the intersection with Hames Drive. The site exit is proposed to be the fourth leg of the existing Hames Drive/Lattern Court intersection. The site plan is shown in Figure 2.

Short-Term Land Use and Access

The short-term development is planned to include a charter school with the potential to ultimately serve up to 772 students. The school is expected to open in the fall of 2020 with 520 students in Kindergarten through 5th grade. The school will then add one grade per year until it reaches its max capacity in 2023. Faculty and staff are expected to total about 65. This school is not anticipated to have any buses providing transportation.

Site Circulation

Figure 3 shows the site circulation for the proposed school. As shown, all vehicles will enter off of Pinyon Jay Drive. After entering, a vehicle can turn right or left. A right turn will allow the vehicle to drive directly through the drop-off/pick-up loop in front of the school. A left turn winds the vehicle through the parking lot prior to entering the drop-off/pick-up loop.

School Internal Queuing Estimates – Parent Pick up and Drop Off

quantify the queue length provided by the proposed design.

The NC MSTA-calculated requirement for “high traffic demand” queue distance is 4,269 feet. The dual lanes that wind through the parking lot prior to entering the drop-off/pick-up loop in front of the school provide enough distance to allow for this length of queue.

Pedestrian and Bicycle Plan Facilities/Multi-Modal & TDM Opportunities

The developed properties through Claremont Ranch have existing detached sidewalks. Detached sidewalks will be constructed on Meadowbrook Parkway, Pinyon Jay Drive, and Hames Drive adjacent to the property. Figure 4 shows the existing and proposed sidewalk in the vicinity of the school.

The MTCP Multimodal Improvements plan shows a future bicycle route along Marksheffel Road extending north from US Highway 24 and along Constitution from Springside Drive east across US Highway 24 to the south side and future connecting trails.

In the future, connections to the Rock Island Regional Trail (future section) west and north of Claremont Ranch will likely be in place.

The US Highway 24 PEL Study shows a proposed multi-use path along the north side of the highway. Mountain Metro Transit does not currently provide service to the Claremont Ranch area. Transit service may expand to the east as growth continues to the east.

Sight Distance

The available sight distance at the site access on Hames Drive has been measured to exceed the required stopping sight distance criteria contained in Table 2-17 of the ECM. Based on a posted speed limit of 25 miles per hour (mph), 155 feet are required. The required driveway intersection sight distance is 250 feet for the site exit. There is currently a tree adjacent to the roadway to the north of the intersection that limits the sight distance to approximately 170 feet. With the removal of the tree, the intersection sight distance would meet the required 250 feet in both directions. Figure 5 shows the required stopping sight distance, as well as the intersection sight distance.

ROADWAY AND TRAFFIC CONDITIONS

Area Roadways

Figure 1 shows the roadways in the vicinity of the site. The major roadways are identified below followed by a brief description of each.

- **US Highway 24** (US Hwy 24) extends from Colorado Springs at State Highway (SH) 21 to Limon. Near the site, US Hwy 24 is classified as an Expressway (E-X). At this location, US Hwy 24 is a four-lane urban highway with a depressed median and a speed limit of 65 mph. The intersections with Marksheffel Road and Constitution Avenue are signalized.
- **Marksheffel Road** is a Principal Arterial that extends north from the City of Fountain to Woodmen Road. It is currently a four-lane roadway with a posted speed limit of 50 mph adjacent to the study area. The intersection with Meadowbrook Parkway was recently signalized. Marksheffel Road is shown as a six-lane expressway in the *2016 Major Transportation Corridors Plan Update* (MTCP) for 2060 corridor preservation.
- **Constitution Avenue** is a Principal Arterial that extends west from US Hwy 24 to Paseo Road. It is currently a four-lane roadway adjacent to the site. The intersection with Meadowbrook Parkway was recently signalized. The speed limit is 50 mph adjacent to the study area.
- **Meadowbrook Parkway** is a Major Collector that extends from SH 94 Road to Constitution Avenue, running approximately parallel to US Hwy 24.

Add Hames Dr and Pinyon Jay Dr

Revise to Urban Residential Collector. Identify the posted speed.

Access Management Plans

The 2006 US Highway 24 Access Control Plan indicates that the RI/RO at US Highway 24/Brookings Drive may be closed when Constitution/Banning Lewis Parkway/US Highway 24 interchange is constructed. The recent *US Highway 24 PEL study* recommended revisions indicate the access “*may be closed with highway and/or Constitution or Marksheffel intersection improvements.*”

The date of a possible future closure of this access is not known, but a future closure would have an effect on the local jurisdiction intersections - most notably, the intersection of Marksheffel/Meadowbrook. The analysis scenario in this report representing potential long-term future closure indicates the possible need for an additional westbound-to-southbound left-turn lane. This report includes two scenarios for the Meadowbrook/Marksheffel intersection in the long-term - 1) the access remaining open and 2) assuming future closure.

Planned CDOT and County Projects

Based on the US Hwy 24 PEL study, US Hwy 24 is planned to be widened to a six-lane roadway in the future. The timings of these improvements are not known. Both improvements have been included in the long-term analysis.

Existing Traffic Volumes

Study intersections identified by the County to be included in the study area include:

- US Hwy 24/Marksheffel Road
- US Hwy 24/Brookings Drive
- US Hwy 24/Constitution Avenue
- Constitution Avenue/Springside Drive
- Meadowbrook Parkway/Marksheffel Road
- Meadowbrook Parkway/Riverwalk Parkway
- Meadowbrook Parkway/Hames Drive
- Meadowbrook Parkway/Springside Drive
- Meadowbrook Parkway/Pinyon Jay Drive
- Meadowbrook Parkway/Constitution Avenue
- Hames Drive/Lattern Court
- Hames Drive/Pinyon Jay Drive

Traffic counts were conducted in January 2020 at the study intersections during the anticipated school start time (7 am to 9 am) and school dismissal time (2 pm to 4 pm). The afternoon count does not coincide with the evening peak hour of traffic on the adjacent roadway, but was chosen because it coincides with the school’s afternoon peak hour.

Figure 6 shows the traffic volumes at study intersections. The traffic count reports are attached.

Existing Levels of Service

Level of service (LOS) is a quantitative measure of the level of congestion or delay at an intersection. Level of service is indicated on a scale from “A” to “F.” LOS A represents control delay of less than 10 seconds for unsignalized and signalized intersections. LOS F represents control delay of more than 50 seconds for unsignalized intersections and more than 80 seconds for signalized intersections. Table 1 shows the level of service delay ranges.

Table 1: Intersection Levels of Service Delay Ranges

Level of Service	Signalized Intersections	Unsignalized Intersections
	Average Control Delay (seconds per vehicle)	Average Control Delay (seconds per vehicle) ⁽¹⁾
A	10.0 sec or less	10.0 sec or less
B	10.1-20.0 sec	10.1-15.0 sec
C	20.1-35.0 sec	15.1-25.0 sec
D	35.1-55.0 sec	25.1-35.0 sec
E	55.1-80.0 sec	35.1-50.0 sec
F	80.1 sec or more	50.1 sec or more

(1) For unsignalized intersections if V/C ratio is greater than 1.0 the level of service is LOS F regardless of the projected average control

The study intersections were analyzed to determine the existing levels of service using Synchro. The peak-hour factors used for each approach are based on the peak fifteen minutes for that approach. Figure 7 shows the existing lane geometry, traffic control, and level of service analysis results. As shown in the figure, all movements at these intersections are level of service D or better during the peak hours with the following exceptions:

- US Hwy 24/Marksheffel Road – The eastbound, northbound, and southbound left movements all currently operate at LOS E during both peak hours. The southbound through movement operates at LOS E during the AM peak hour and the northbound through operates at LOS E during the afternoon peak hour.
- US Hwy 24/Constitution Avenue – The southbound left turn operates at LOS E during both peak hours.

The level of service (LOS) reports are attached.

Crash History

Three years of crash data were collected at the study intersections. The intersection of Meadowbrook Parkway/Marksheffel Road experienced nine crashes with two resulting in injuries. Of the nine crashes, 5 were broadside type crashes between an eastbound left-turning vehicle and a southbound through vehicle. All of these crashes occurred prior to the signal

installation. With the signal, the number of broadside crashes at this intersection should be reduced.

The intersection of US Hwy 24/Constitution Avenue had 16 crashes during the three-year study period, with one resulting in an injury. Eight of the crashes were rear-end type crashes. There were no correctable crash patterns detected at the intersection.

The intersection of US Hwy 24/Marksheffel Road had 43 crashes recorded during the study period with 13 crashes resulting in injuries. Of the 43 crashes, 12 were approach turn crashes between a westbound left-turning vehicle and an eastbound through vehicle. Six of these crashes resulted in injuries. All but one of the westbound left approach turn crashes occurred in the afternoon evening period when there is a high volume of westbound left turning vehicles against a high volume of eastbound through vehicles. Due to the projected increase in traffic volumes at this intersection, it is anticipated that these crashes will continue to occur if no countermeasures are taken. It is recommended that the westbound left-turn be converted to protected-only to reduce the approach turn crashes.

The intersection of US Hwy 24/Marksheffel Road also had eight broadside crashes with no patterns and 13 rear-end crashes with no crash patterns.

No crashes were reported at the remaining study intersections during the study period.

BACKGROUND TRAFFIC

Background traffic is the traffic estimated to be on the adjacent roadways and at adjacent intersections without the proposed development's trip generation of site-generated traffic volumes. Background traffic includes the through traffic and the traffic generated by nearby developments but assumes zero traffic generated by the site.

Short Term Traffic Volumes

Figure 8 shows the short-term (year 2023) background traffic volumes. The background volumes are estimates by LSC, based on the existing traffic volumes shown in Figure 9, with a yearly growth rate of two percent per year. In addition, planned developments that are anticipated to be constructed in the near future have been included in the background traffic, including Villas at Claremont and Claremont Business Park.

Long Term Traffic Volumes

Figure 10 shows the projected 2040 background traffic volumes. The 2040 background traffic volumes are estimates by LSC, based on the Colorado Department of Transportation (CDOT) twenty-year growth factor (about one and a half percent per year) on US Hwy 24 adjacent to the site. The Pikes Peak Area Council of Governments (PPACCG) travel demand model was also used

in projecting traffic volumes. Additionally, traffic generated by planned adjacent developments has been included.

The 2040 background traffic volumes assume that the right-in/right-out intersection of US Hwy 24/Brookings Drive has been closed. The traffic turning at the intersection was rerouted through the development.

TRIP GENERATION

New trips expected to be generated by the proposed school were estimated based on North Carolina Department of Transportation's (NCDOT) Municipal School Transportation Assistance (MSTA) *School Traffic Calculator*, which provides morning arrival and afternoon dismissal trips, based on the number of students as well as staff size. We have found that the trip generation at National Heritage Academies schools are very similar to the MSTA calculator. It was assumed that all trips to and from this proposed school would be from personal vehicles. The school will not have busing. No factor for pedestrian trips or bicycle trips were estimated for this analysis.

In order to validate the expected trip generation for the school, the trip generation estimates provided by the NCDOT MSTA school calculator were compared to trip generation estimates, based on information and procedures contained in the Institute of Transportation Engineer's (ITE) report *Trip Generation, Tenth Edition, 2017*. ITE Land Use Code 537 – Charter Elementary School was used for the estimates. The ITE *Trip Generation* method has been widely used for many years by traffic engineering professionals and has become an accepted forecasting practice. The ITE methodology was used to generate morning arrival and afternoon dismissal trips at full build out of 772 students.

Table 2 provides the trip generation comparison between the MSTA school calculator and the ITE methodology. This data provides indication that the number of projected trips based on NCDOT MSTA school calculator provides a similar, but conservative, estimate of the number of expected trips for the new school during the morning arrival peak hour and afternoon dismissal peak hour. The NCDOT MSTA school traffic calculator estimates are proposed to be used as the estimates for the traffic impact study. The average daily trips expected to be generated by the proposed school at 772 students is 1,600 vehicles per day, based on the MSTA school traffic calculator.

Table 2: Trip Generation Summary

	AM PEAK HOUR			PM PEAK HOUR		
	TOTAL TRIPS	INBOUND	OUTBOUND	TOTAL TRIPS	INBOUND	OUTBOUND
NCDOT MSTASCHOOL TRAFFIC CALCULATOR	929	497	432	671	303	368
ITE TRIP GENERATION	876	464	412	501	230	271

Traffic for the proposed school is assumed to consist solely of new trips, whose only purpose is to visit the school. New Trips are those that are new to the study area and consist of motorists whose primary destination is the proposed school. Pass-by trips are typically associated with retail uses, as well as gas stations and restaurants. Pass-by trips are comprised of vehicles already travelling on the adjacent roads, which divert from their original path of travel to visit a use. The ultimate destination of a pass-by trip is directed elsewhere. Pass-by trips will not be accounted for in this study, as the proposed institutional use is typically not associated with pass-by trip making. However, it is likely that parents on the adjacent street network may very well drop-off and pick-up their child on their way to/from work, which would be considered pass-by traffic. However, in order to remain conservative, the potential pass-by traffic was not considered.

TRIP DISTRIBUTION AND ASSIGNMENT

The directional distribution of the site-generated traffic volumes on the street and roadway system serving the site is one of the most important factors in determining the site’s traffic impacts. Trip distribution for the school was determined, based on census data within a twenty-two-minute drive time from the school site which is NHA’s expected trade area to draw students. A drivetime analysis was completed to determine the drivetime boundary around the proposed school site. Once the drivetime boundary was formed, available travel routes to/from the school site within the boundary area were determined. Population data for ages 5-14 years were obtained from the U.S. Census Bureau and were reviewed to determine the percentage of this age population within the boundary area and the available travel routes to/from the site. The drivetime analysis and census data for the available travel routes to/from the school site are attached. Figure 12 shows the directional distribution estimates for site-generated traffic volumes.

When the distribution percentages (from Figure 12) were applied to the trip generation estimates (from Table 2), the site-generated traffic volumes on the area roadways were determined. Figure 13 and Figure 14 show the short-term and long-term site-generated traffic volumes. Both short-term and long-term site-generated traffic volumes assume school is at maximum capacity. The long-term traffic assignment assumes the intersection of US Hwy 24/Brookings Drive is closed.

PROJECTED TOTAL TRAFFIC

Short Term (2023)

Figure 15 shows the short-term total traffic volumes at all of the study area intersections. These volumes are the sum of the short-term background traffic volumes (from Figure 8) plus the short-term site-generated traffic volumes (from Figure 13).

Long Term (2040)

Figure 17 shows the 2040 total traffic volumes. These volumes are the sum of the 2040 background traffic volumes (from Figure 10) plus the long-term site-generated traffic volumes (from Figure 14). These volumes assume the closure of the US Hwy 24/Brookings Drive intersection.

PROJECTED TOTAL TRAFFIC LEVELS OF SERVICE

The study intersections have been analyzed to determine the projected levels of service for the short-term and 2040 background and total traffic volumes, based on the signalized method of analysis from Synchro and the unsignalized method of analysis procedures outlined in the *Highway Capacity Manual, 6th Edition* by the Transportation Research Board. The level of service reports are attached.

The peak-hour factor for school traffic was assumed to be 0.50 in the total traffic scenarios. Therefore, when the majority of traffic for a turning movement was site-generated traffic, the peak-hour factor for the movement was changed to 0.50. For all other movements, the peak-hour factor was calculated by assuming the school 15-minute peak coincided with the current movement's 15-minute peak.

It was assumed that the roadway network was unchanged in the short-term scenario. In the long-term scenario, the traffic volumes reflect an assumption of closure of the US Hwy 24/Brookings Drive intersection. However, for the intersection of Meadowbrook/Marksheffel, projected intersection volumes assuming US Hwy 24/Brookings Drive still open has also been included for comparison. It was also assumed that US Hwy 24 was widened to a six-lane roadway, based on improvements in the US Hwy 24 EA.

Figure 9 and Figure 11 show the lane geometry, traffic control, and level of service analysis results for the short-term and long-term background volumes, respectively. Figure 16 and Figure 18 show the results for the short-term and long-term total traffic volumes, respectively. All turning movements and overall intersection levels of service are LOS D or better for the studied peak hours, with the exception discussed below.

Neighborhood Intersections

In the background conditions, all movements at this intersection operate at acceptable levels of service at all the intersections within the Claremont Ranch Neighborhood. With the addition of the site generated traffic, several intersections are anticipated to have LOS E or F for select movements.

Table 4 provides the delay, level of service, V/C ratio, and queue for the movements at the neighborhood intersections anticipated to operate at LOS E or F in the total traffic scenarios. As shown, with the exception of the westbound approach to the Hames Drive/Pinyon Jay Drive intersection, the movements are projected to have a V/C ratio at or below 1.0, indicating these movements are at or below capacity despite the level of service.

It is recommended that an eastbound right-turn lane be constructed at the intersection of Meadowbrook Parkway/Pinyon Jay Drive due to the projected volume of turning vehicles.

Constitution Avenue/Springside Drive

Quantify the proportional traffic impact generated by the school at these major intersections with LOS E or lower.

The northbound approach at this intersection is anticipated to operate at LOS E during both peak hours in the long-term background scenario. In the long-term total traffic scenario, this approach is projected to operate at LOS F due to the increase in traffic. These poor levels of service are due to the high volume of traffic on Constitution Avenue in the long-term future. The northbound approach is forecasted to have a V/C ratio at or below 1.0.

Constitution Avenue/Meadowbrook Parkway

The turning movements at the intersection of Constitution Avenue/Meadowbrook Parkway are anticipated to operate at acceptable levels of service in the short-term total traffic scenario. Due to the background increase in traffic on Constitution Avenue in the long-term future, the northbound left is projected to operate at LOS E in the afternoon peak hour in the background scenario. With the addition of site-generated traffic in the long-term future, this intersection is expected to fail. It is recommended that the intersection be monitored for signalization. With a traffic signal, the overall intersection is expected to operate at LOS A during both peak hours.

Meadowbrook Parkway/Marksheffel Road

In the short-term future, all movements are expected to operate at LOS D or better, both with and without the site-generated traffic. In the long-term future many of the through and left-turning movements are projected to operate at LOS E or F due to the high volume of projected traffic on Marksheffel Road. With the addition of the site-generated traffic and future background traffic, a westbound dual left-turn may be required if the intersection of US Hwy 24/Brookings Drive is closed. As mentioned previously, the timing of this potential closure is unknown and closure would result in a traffic volume shift to the Meadowbrook

Parkway/Marksheffel Road intersection. A second scenario was run in which the intersection of US Hwy 24/Brookings Drive is not closed. The scenario analysis results project acceptable operations with a single westbound left-turn lane (current condition). The overall intersection is projected to continue to operate at LOS D or better during both peak hours in both scenarios.

The scenario, in which the US Hwy 24/Brookings Drive remains open, has lower delay for several of the movements and none of the movements are above capacity. With US Hwy 24/Brookings Drive closed, the average delay would be higher and a few movements are above capacity, even with dual westbound left-turn lanes. This is partly due to the analysis assumption of protected-only left-turn phasing for both eastbound and west bound approaches with dual left-turn lanes on both eastbound and westbound approaches.

US Hwy 24/Marksheffel Road

The intersection of US Hwy 24/Marksheffel Road is expected to operate at LOS F during both peak hours in the long-term future, without the addition of the site-generated traffic. This is expected to occur even with US Hwy 24 widened to 6-lanes. The volume of traffic at the intersections is very close to the available capacity in existing conditions. Traffic volume growth on US Hwy 24 and Marksheffel Road will cause the volumes to exceed capacity in the near future. These poor levels of service are expected to occur with or without the site-generated traffic.

US Hwy 24/Constitution Avenue

The southbound left-turning movement is anticipated to operate at LOS E during the peak hours in the short-term background and total traffic scenarios. In the long-term, the widening of US Hwy 24 to 6-lanes improves the southbound left-turning movement. In the long-term background and total traffic scenarios, this movement is projected to operate at LOS D during the peak hours.

PHASING OF TRAFFIC CONTROL

US Hwy 24/Brookings Drive

In the US 24 Access Control Plan and US Highway 24 PEL study, the intersection of US Hwy 24/Brookings was recommended for closure. The timing of a planned future closure of this access is not known, but if/when the closure does occur, it will have an effect on the local jurisdiction intersections. The analysis scenario in this report representing potential long-term future closure indicates the possible need for an additional westbound-to-southbound left-turn lane at the intersection of Marksheffel/Meadowbrook .

Constituti

The inter
signalizati
intersectio

Meadowb

In the lon
traffic, a
Parkway/I
closed.

For clarity, include an exhibit identifying the midblocks proposed to be removed. Staff only sees midblock ramps that are required at T-intersections.

The only mid-block crossing staff sees is on Pinyon Jar Dr between Hames Dr and Meadowbrook. Update narrative to include a recommendation for this midblock crossing.

Applicant must submit a deviation request to remove midblock crossings if said removal results in non-compliance with ECM Section 2.5.2.C.4 which notes access ramps on local roadways shall be spaced no greater than 600 feet apart, where spacing is greater than 600 feet, mid-block access ramps shall be provided.

SIGNING AND STRIPING

Figure 19 provides a conceptual school-related signing plan. School speed limit signs (20 mph) with programmable flashing beacons would be the best option if a significant number of students from the neighborhood attend this school and walk/bike to school. Alternatively, LSC recommends a supplemental sign plate under the speed limit sign with the expected time periods when children would be walking to/from school. El Paso County also uses a supplemental sign plate reading "When Children are Present" in other applications.

There are currently mid-block ramps located on Hames Drive and Meadowbrook Parkway. These ramps should be removed and crossings should be limited to intersections. Crossings at the school exit and Hames Drive will require fluorescent yellow-green school pedestrian warning signs (S1-1) with a supplemental diagonal arrow (W16-7P) on each approach. It is not anticipated that there will be as many students walking, by comparison to a traditional, neighborhood public school. However, this should be monitored and, if necessary, the school should provide crossing guards during arrival and dismissal periods.

It is unlikely that the two intersections of Meadowbrook/Pinyon Jay and Hames/Lattern with recommendations for pedestrian crossing signs and markings would meet MUTCD all-way, stop sign-control (AWSC) warrants. Therefore, these have been shown to remain two-way, stop sign-controlled (TWSC). However, this would result in students crossing "uncontrolled" approaches (i.e. no stop signs for traffic on the "major street"). Depending on the number of children expected to walk to school from the neighborhood and other factors, consideration could be given to potentially changing to AWSC. If these remain TWSC, measures should be taken to ensure the safety of children crossing. These measures may include (but are not limited to) posting trained crossing guards, posting supplemental MUTCD standard pedestrian signs within the street during peak times or as permanent signs, staff/parent supervision, chokers/curb extensions, raised median islands with pedestrian refuge, elimination of the requirement for separate eastbound right-turn lane on Meadowbrook (required by ECM based on turning volume), and other potential measures.

edit

COUNTY ROAD IMPACT FEE PROGRAM

Transportation Impact Fees

Per ECM Appendix B: *State what the current applicable Transportation Impact Fees are and what option the developer will be selecting for payment.*

The fee schedule indicates a full fee amount of \$3,372 per 1,000 square feet of building floor area. The upfront fee with the 5 mil PID option would be \$1,645 per 1,000 square feet of floor area.

<<<< opt out of the PID options and will pay the full fee amount at the time of building permit. The current "full-fee" single family residential housing rate is \$3,372 per 1,000 square feet of building floor area. The total fee amount for the ____ square foot school building is \$____.>>>>

Or

<<<join the 5 mil PID and pay the associated upfront fee amount at a rate of \$1,645 per 1,000 square feet. The total upfront fee under this option would be ____ based on a planned ____ square foot school building.>>>>

Reimbursable Improvements

There are no apparent reimbursable improvements programmed in the general vicinity of this site.

CONCLUSIONS AND RECOMMENDATIONS

Trip Generation

- During the morning peak hour, the site is projected to have approximately 497 vehicles entering and 432 vehicles exiting the site. During the afternoon peak hour of the school approximately 303 vehicles would enter and 368 vehicles would exit the site.

Projected Levels of Service

- Please refer to the level of service section above for analysis results. Table 4 provides details on the internal neighborhood street intersections with results showing levels of service LOS E or F with the addition of the school.

Add a section listing the deviation request the applicant has submitted and was approved by the Engineering Review Manager. include in the appendix.



Traffic Circulation

remove speed reduction on Meadowbrook Parkway. There is no driveway access into the school from Meadowbrook Parkway

- Figure 2 shows the circulation plan for the proposed school, based on 772 students. The site circulation plan allows for the projected 4,269 feet of high demand queueing.

Recommendations

revise to signage not flashers.

Table 3: Recommended Improvements

Item #	Location	Improvement	Timing
1	Pinyon Jay Drive	Crosswalk striping and signing	With the construction of the school
2	Hames Drive	Crosswalk striping and signing	1With the construction of the school
3	Meadowbrook Parkway Hames Drive Pinyon Jay Drive	School zone speed reduction signs with flashers	With the construction of the school
4	Meadowbrook Parkway/Pinyon Jay Drive	EB right-turn lane	With the construction of the school
5	Constitution Avenue/Meadowbrook Parkway	Signalize	Should be monitored to identify when needed
6	Meadowbrook Parkway/Marksheffel Road	Westbound dual left-turn lanes	With the construction of the Villas at Claremont

Source: LSC Transportation Consultants, Inc.

- The intersection of Meadowbrook Parkway/Pinyon Jay Drive will require an eastbound right-turn lane with the development of the school, based on ECM criteria. However, please refer to the Signing and Striping section above for discussion regarding the option of potentially **not** adding this turn lane to this intersection in the interest of pedestrian safety.
- The intersection of Constitution Avenue/Meadowbrook Parkway should be monitored to determine when signalization is required.
- In the long-term future, the intersection of Meadowbrook Parkway/Marksheffel Road may require westbound dual left-turn lanes if/when US Hwy 24/Brookings Drive access/intersection is closed. The timing of a potential closure is currently unknown.
- Appropriate school signs, per the discussion above, are recommended. Please refer to the section above and Figure 19.

* * * * *

Staff will be informing DPW/County Engineer regarding the TIS analysis. Additional comments from DPW or County Engineer may be forthcoming. (This space left blank intentionally.)

Please contact me if you have any questions regarding this report.

Respectfully Submitted,

LSC TRANSPORTATION CONSULTANTS, INC.

By: Jeffrey C. Hodsdon, P.E.
Principal

CRG:jas

Enclosures: Table 4
Figure 1-19
Counts
Level of Service Reports

Add a school route plan map similar to the exhibit shown below.
The construction plans appears to require additional crosswalks in the vicinity of the school specifically the west side of Lantern/Hames intersection and north side of Hames/Pinyon Jay intersection.



Tables and Figures



Table 4: Neighborhood Intersections - LOS E and F Movements

Intersection/Movement	Level of Service				Delay (sec)				V/C				Queue Length (ft)			
	Short-Term		Long-Term		Short-Term		Long-Term		Short-Term		Long-Term		Short-Term		Long-Term	
	AM	PM	AM	PM	AM	PM	AM	PM	AM	PM	AM	PM	AM	PM	AM	PM
Meadowbrook Pkwy/Riverwalk Pkwy																
Northbound Approach	C	C	F	D	23.9	16.6	103.5	29.7	0.3	0.2	1.0	0.6	50	25	250	100
Southbound Approach	F	C	F	C	53.7	19.7	95.4	23.8	0.8	0.4	1.0	0.4	150	50	200	75
Meadowbrook Pkwy/Hames Dr																
Northbound Approach	F	C	D	C	62.3	16.4	29.2	18.7	1.0	0.6	0.8	0.7	400	125	200	125
Westbound Approach	F	C	F	E	67.6	20.3	113.9	35.9	1.0	0.7	1.2	0.9	425	175	650	300
Meadowbrook Pkwy/Pinyon Jay Dr																
Northbound Approach	E	B	E	F	36.8	13.1	36.8	106	0.4	0.1	0.4	0.9	50	25	50	175
Southbound Approach	F	C	F	B	78.2	20.8	78.2	14.6	0.9	0.4	1.0	0.0	200	50	200	25

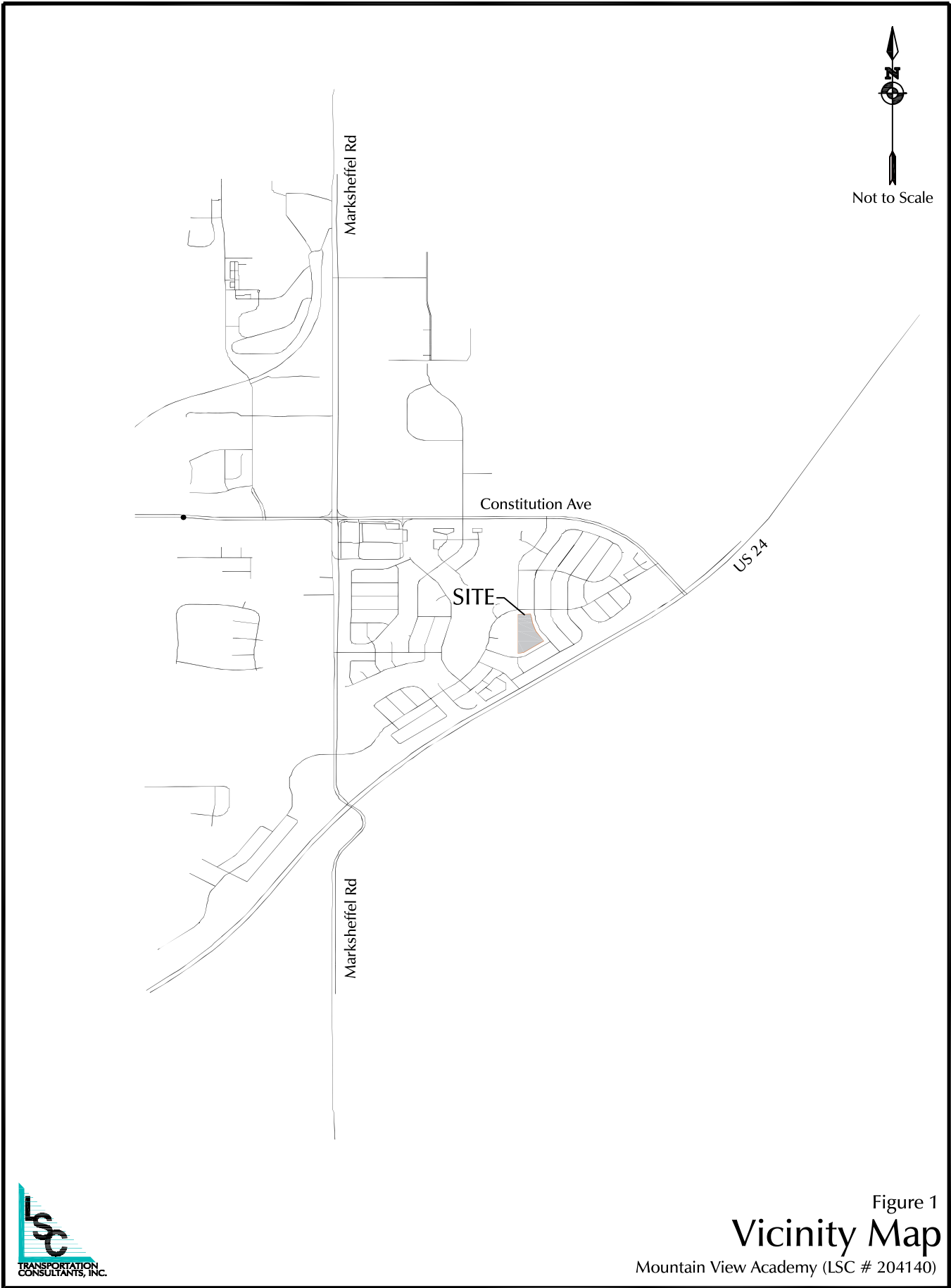
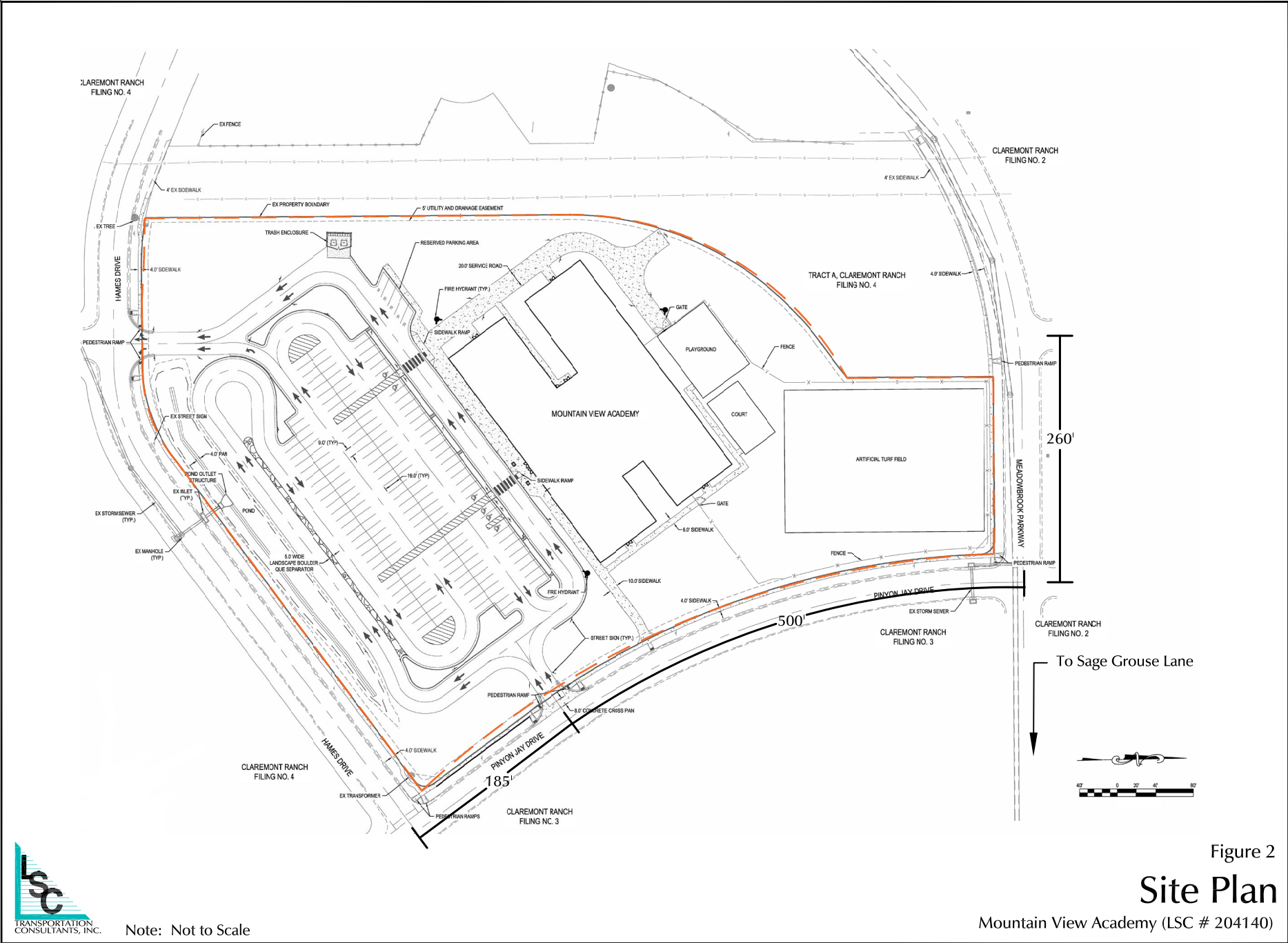


Figure 1
Vicinity Map

Mountain View Academy (LSC # 204140)





Note: Not to Scale

Figure 2
Site Plan
 Mountain View Academy (LSC # 204140)

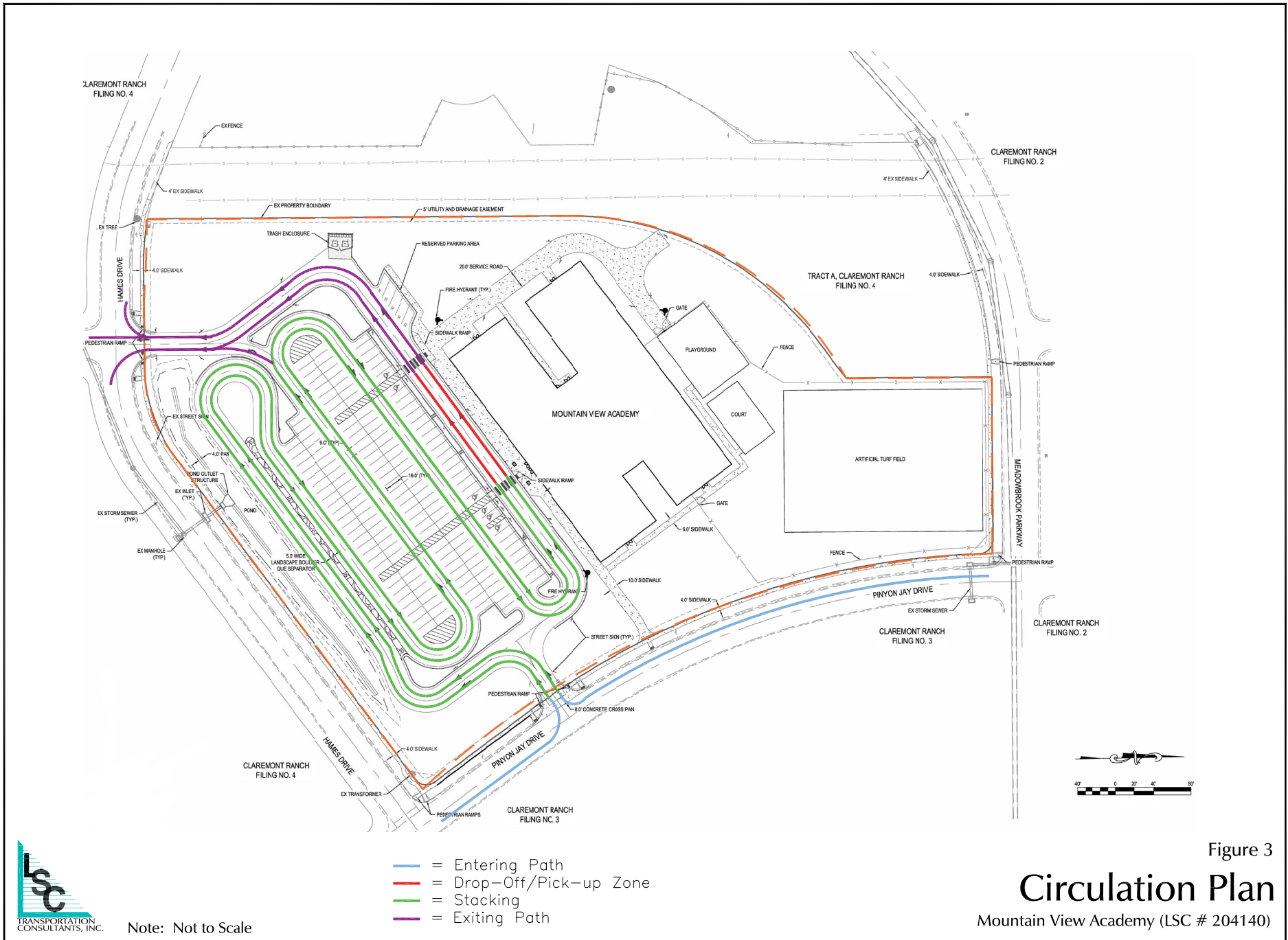
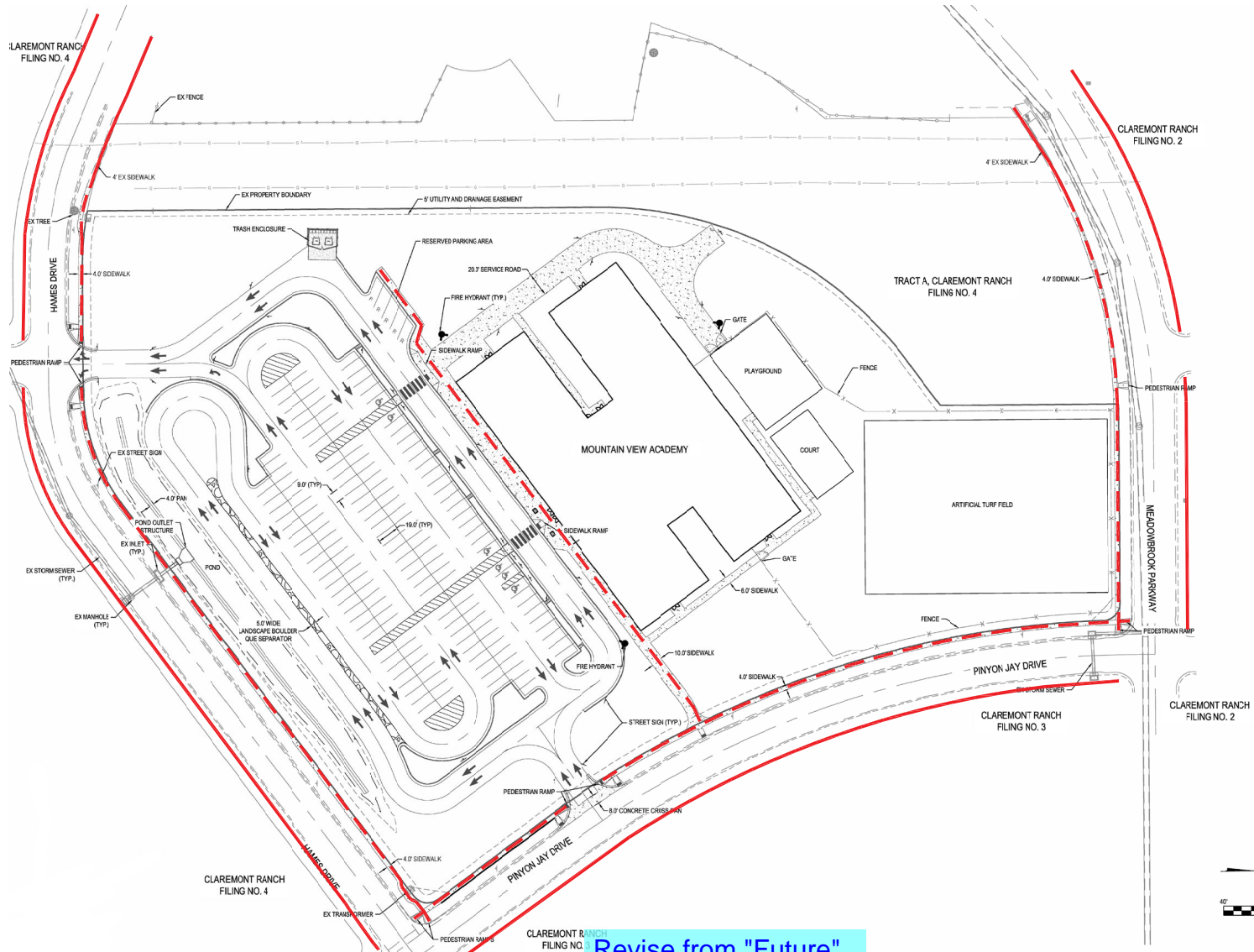


Figure 3
Circulation Plan
 Mountain View Academy (LSC # 204140)



Revise from "Future" to "proposed"

- - - = Future Sidewalk
- = Existing Sidewalk

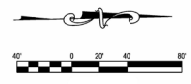
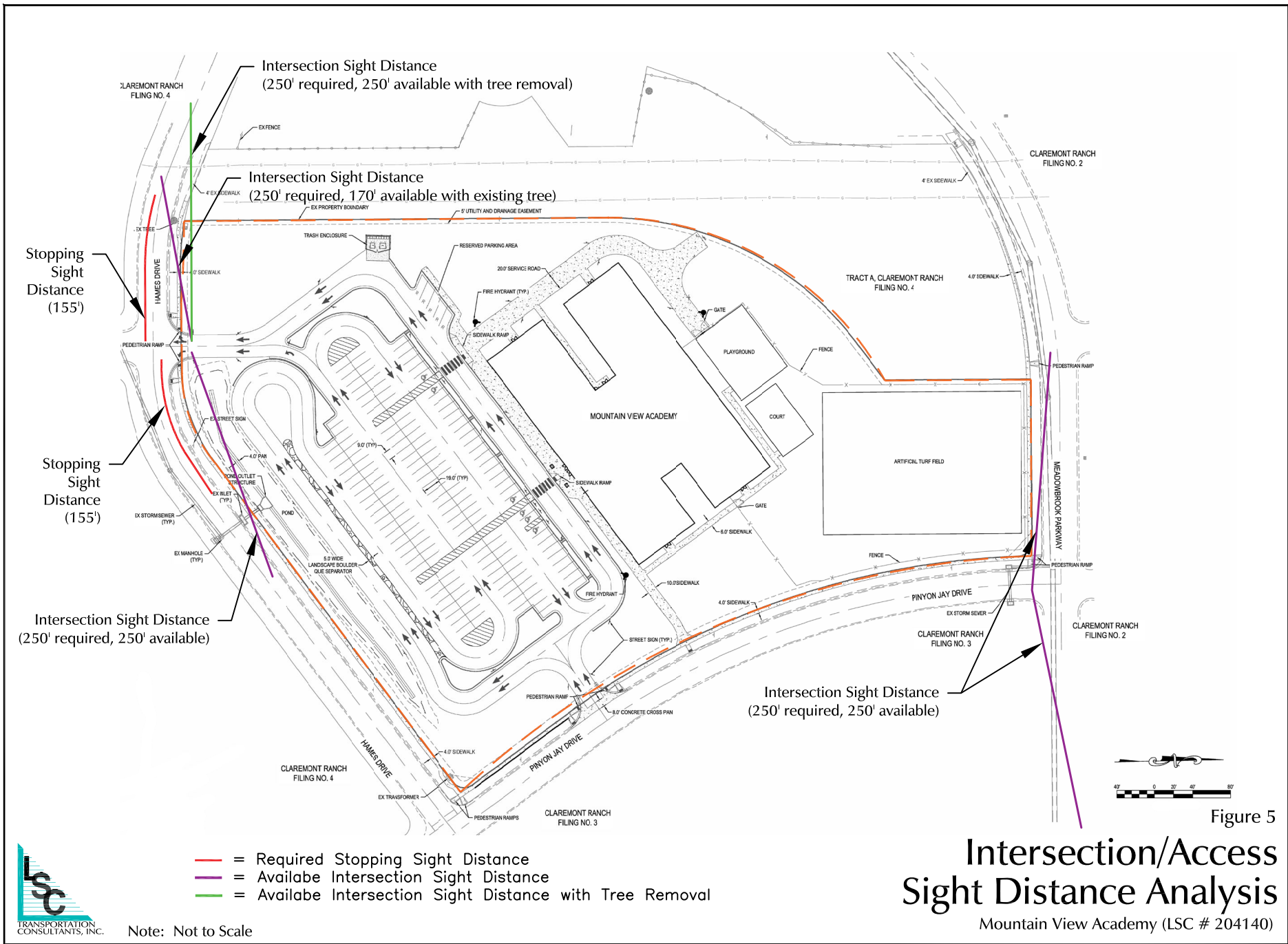
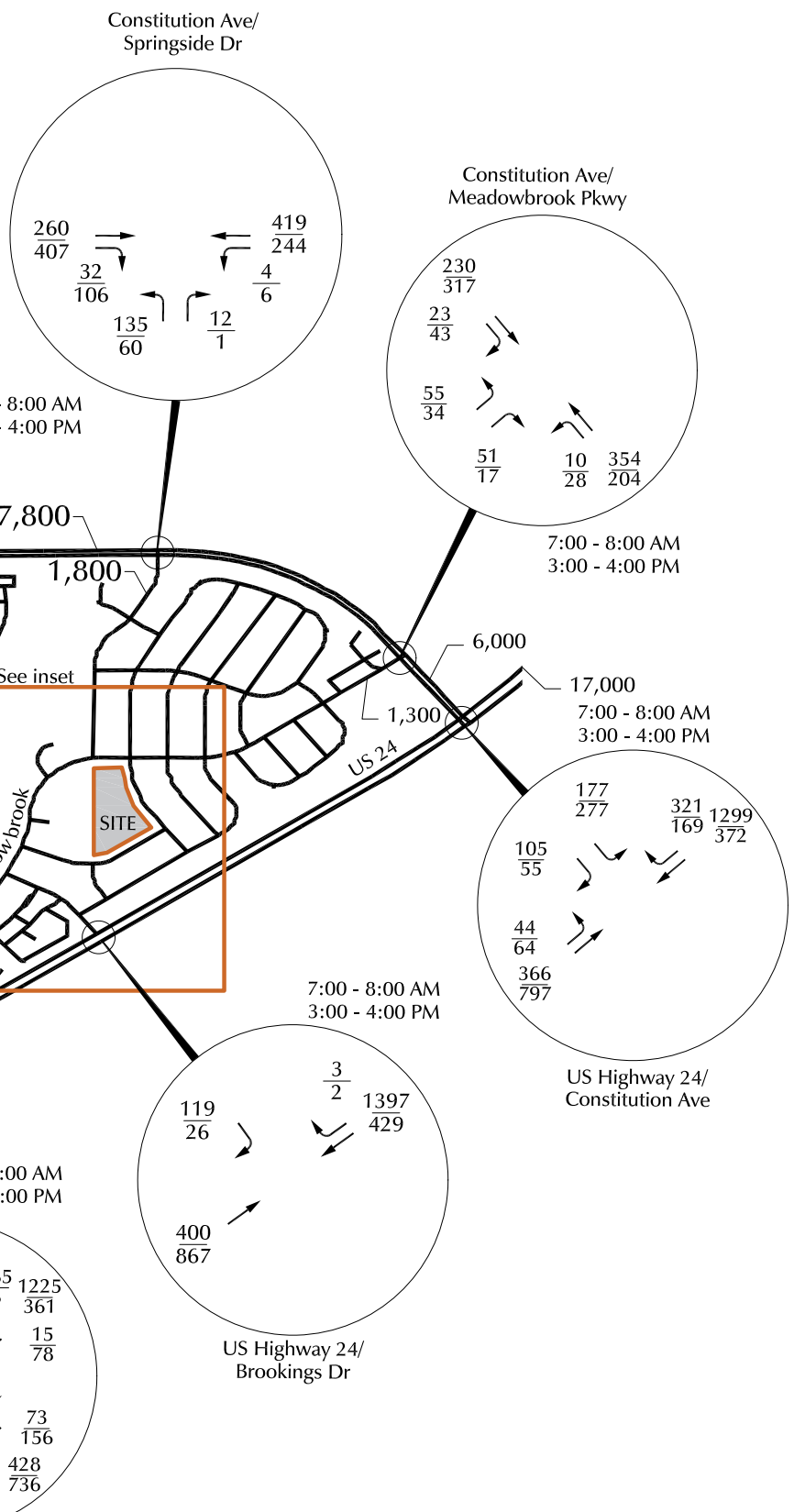
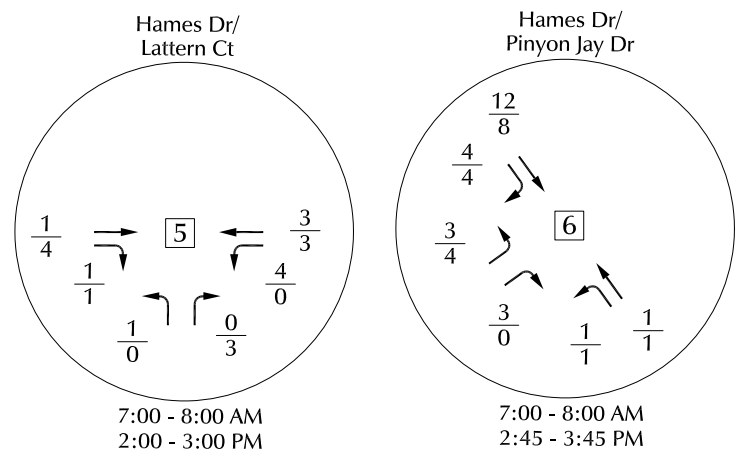
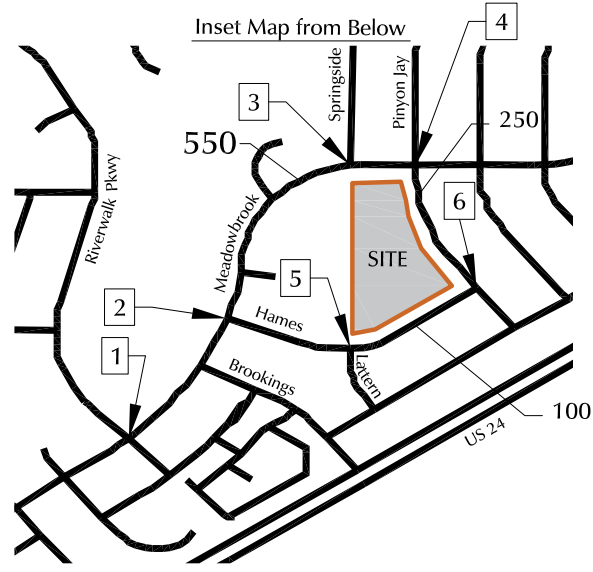
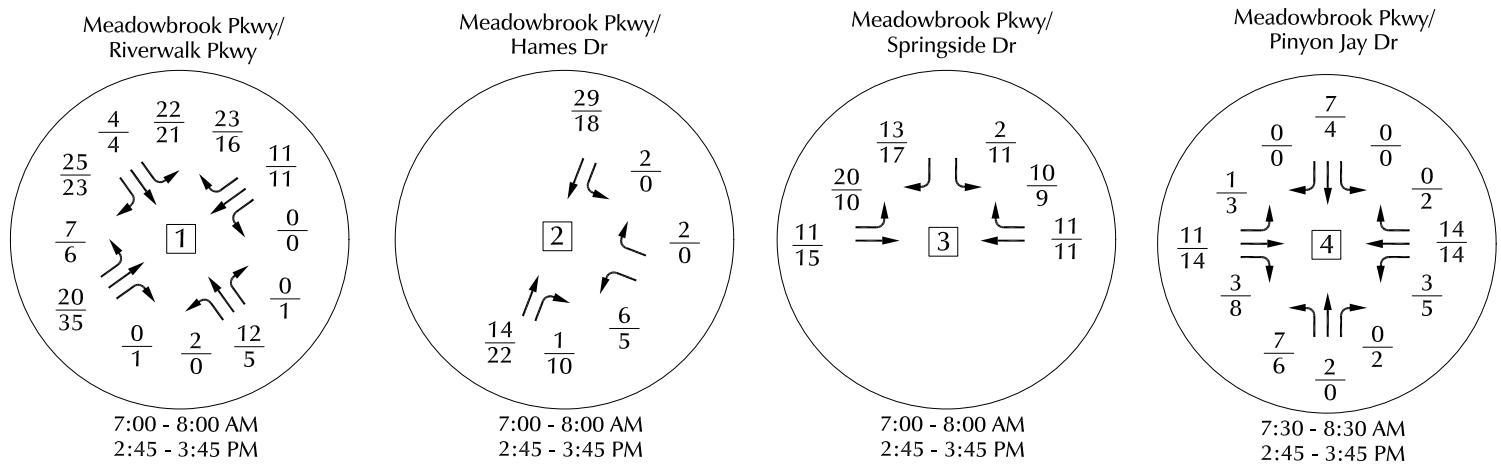


Figure 4
Pedestrian and Bicycle Plan
 Mountain View Academy (LSC # 204140)



Note: Not to Scale





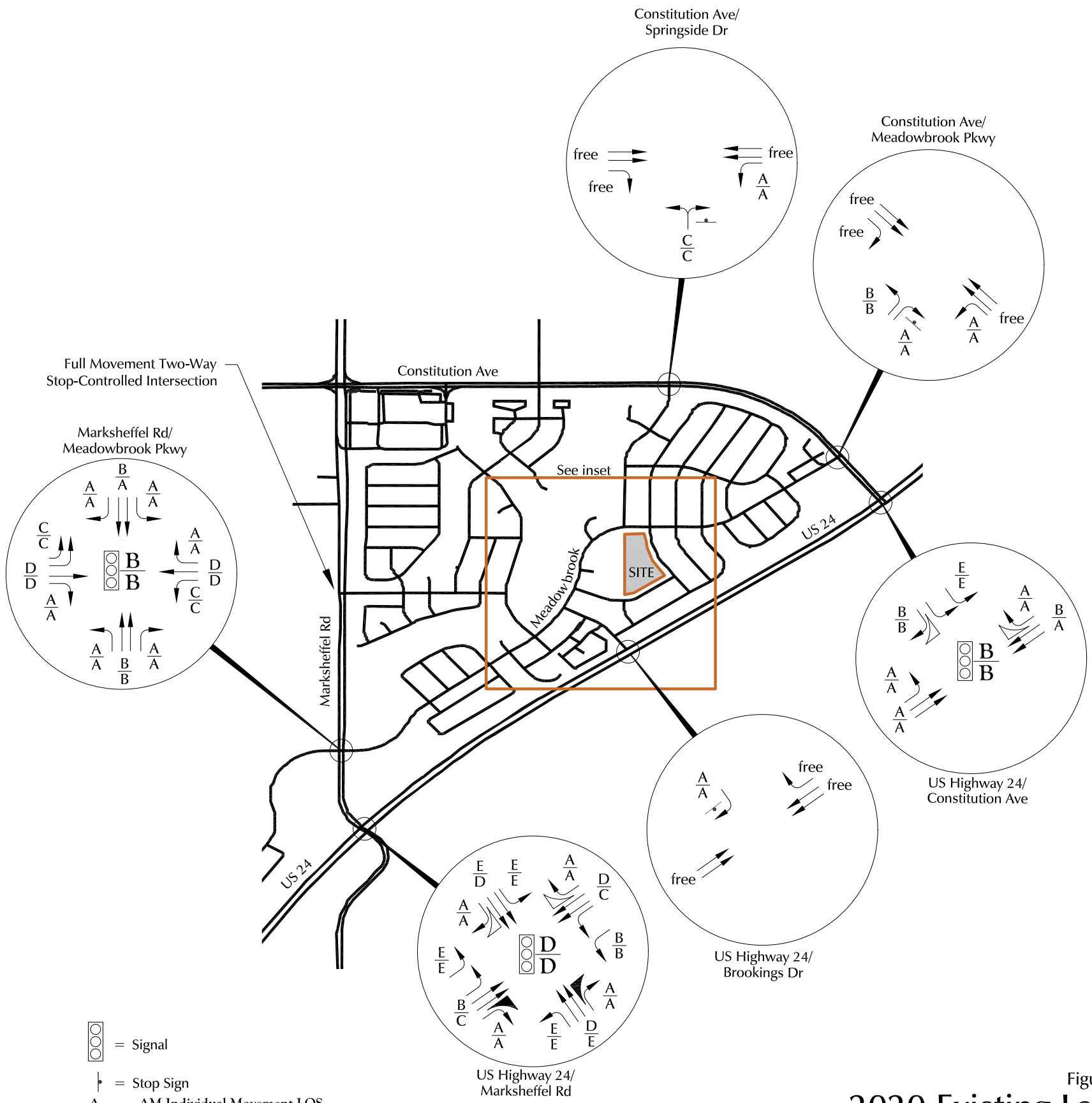
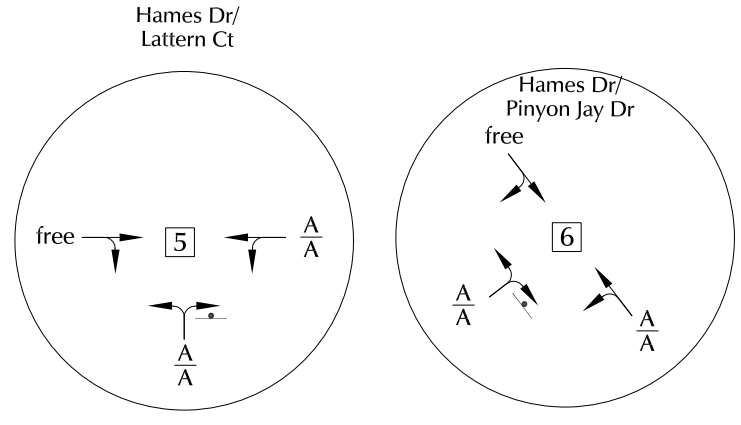
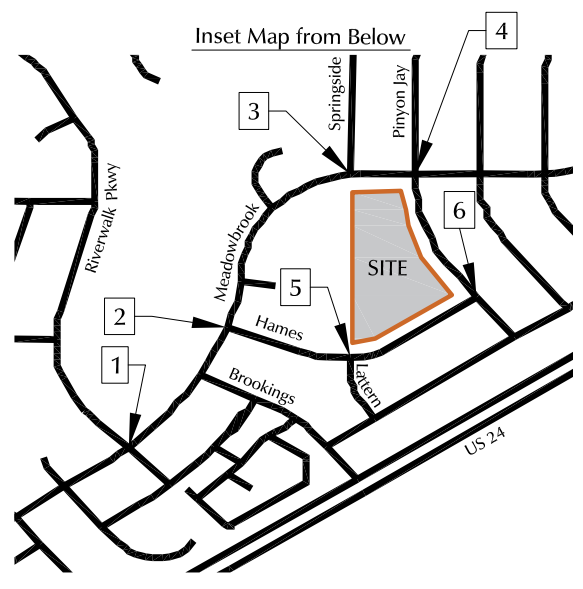
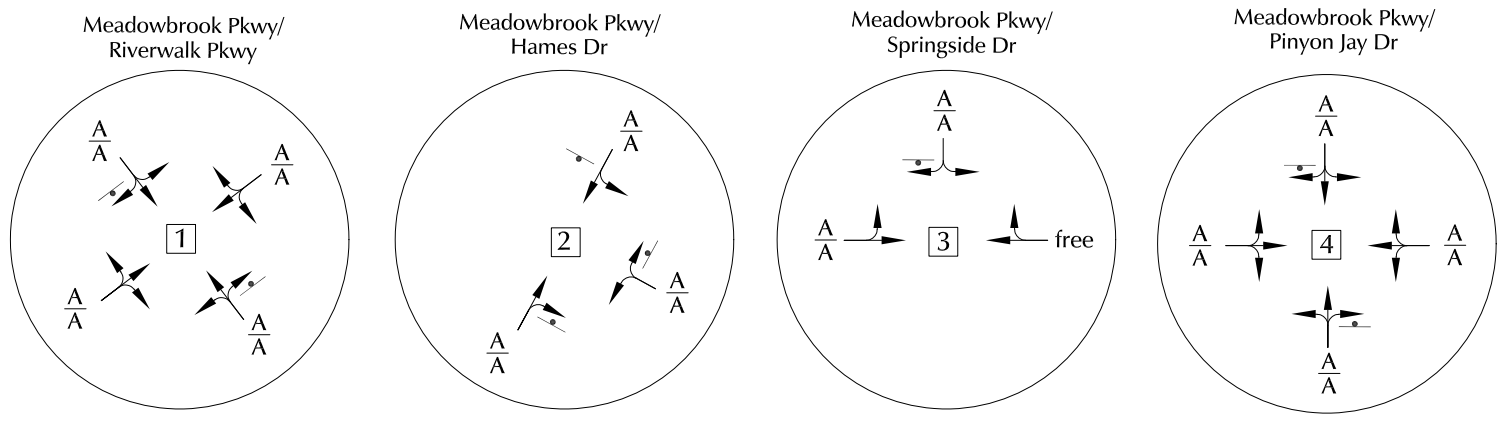
XX = AM Weekday Peak-Hour Traffic (veh/hr)
XX = PM School Weekday Peak-Hour Traffic (veh/hr)
XX,XXX = Average Daily Traffic Volumes (ADTs)

US Highway 24/
Marksheffel Rd

Based on counts by January 2020
Peak hour times noted for each intersection

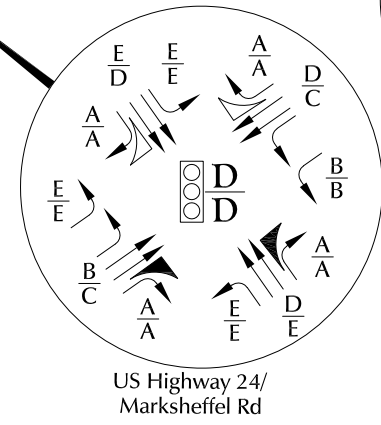
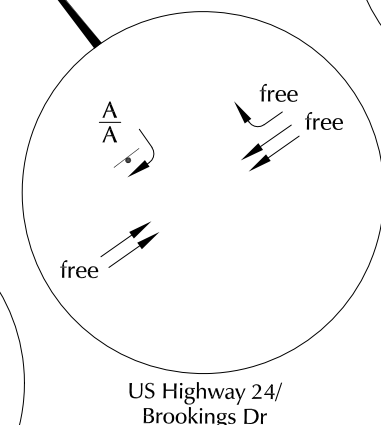
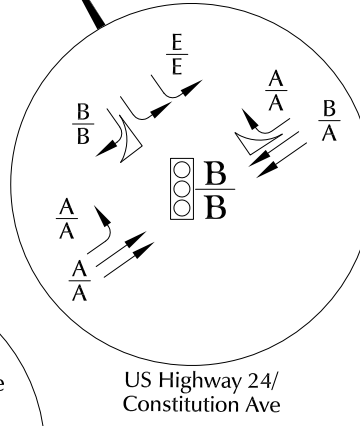
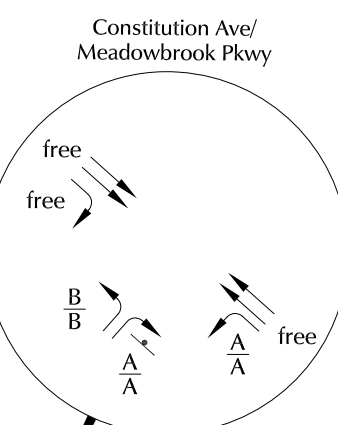
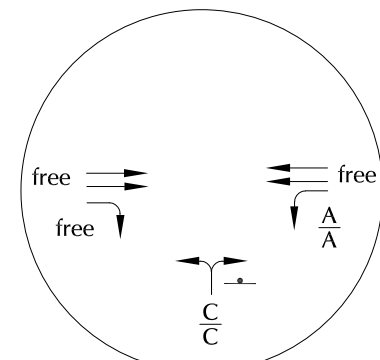
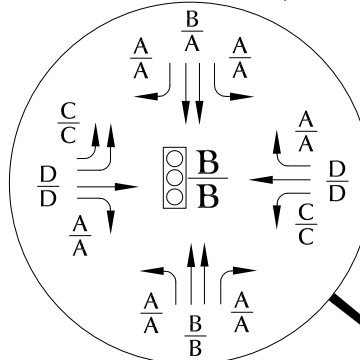


Figure 6
Existing Volume
Mountain View Academy (LSC # 204140)



Full Movement Two-Way Stop-Controlled Intersection

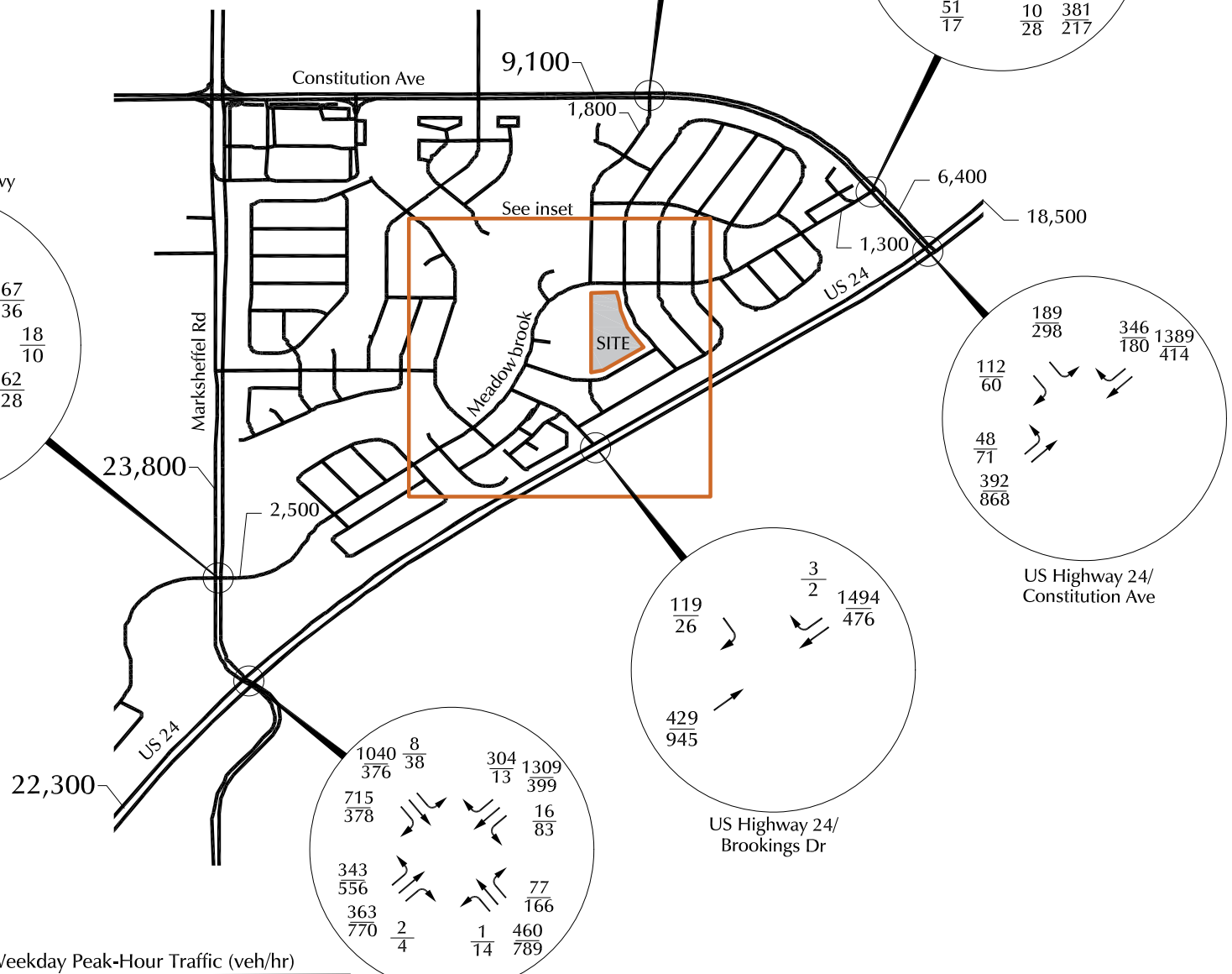
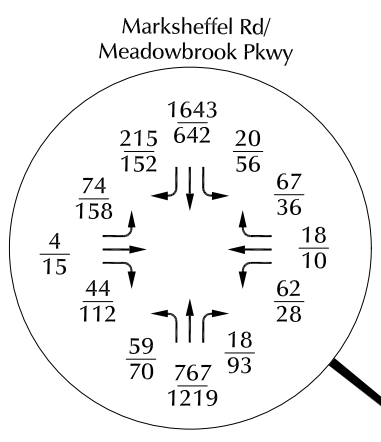
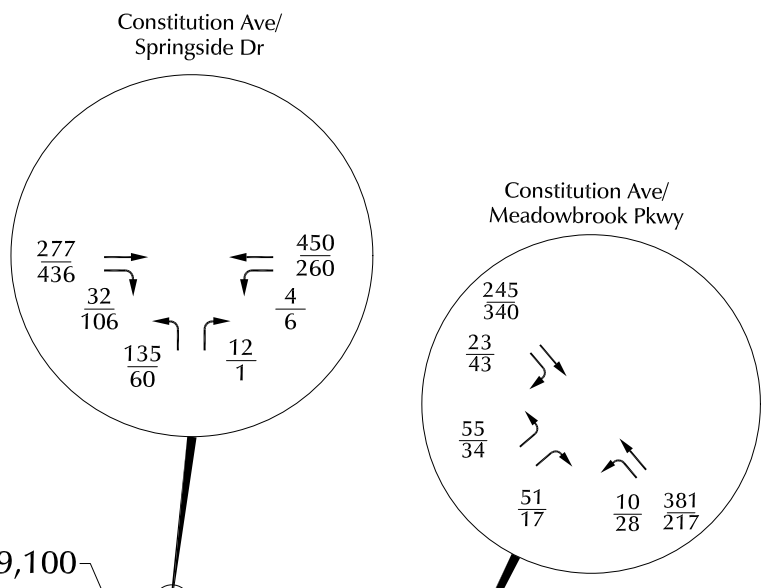
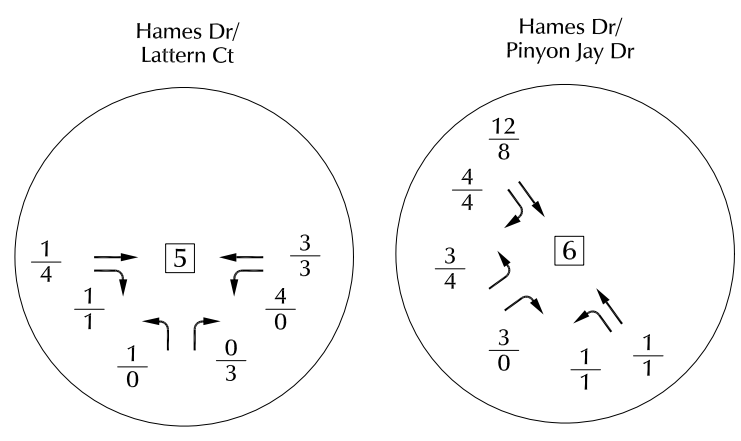
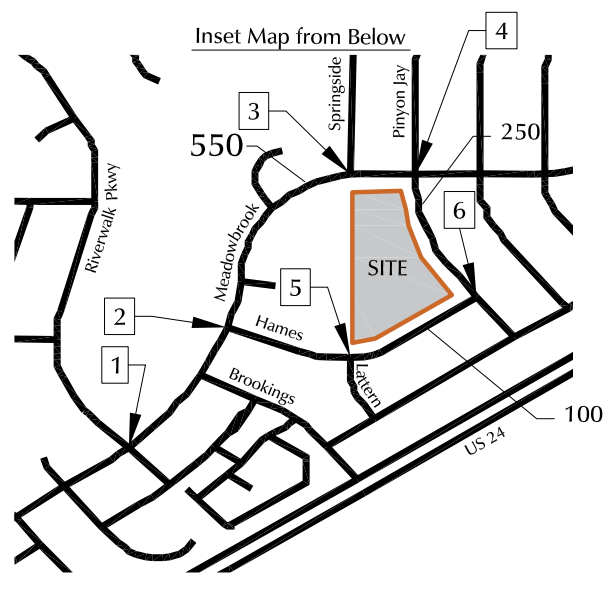
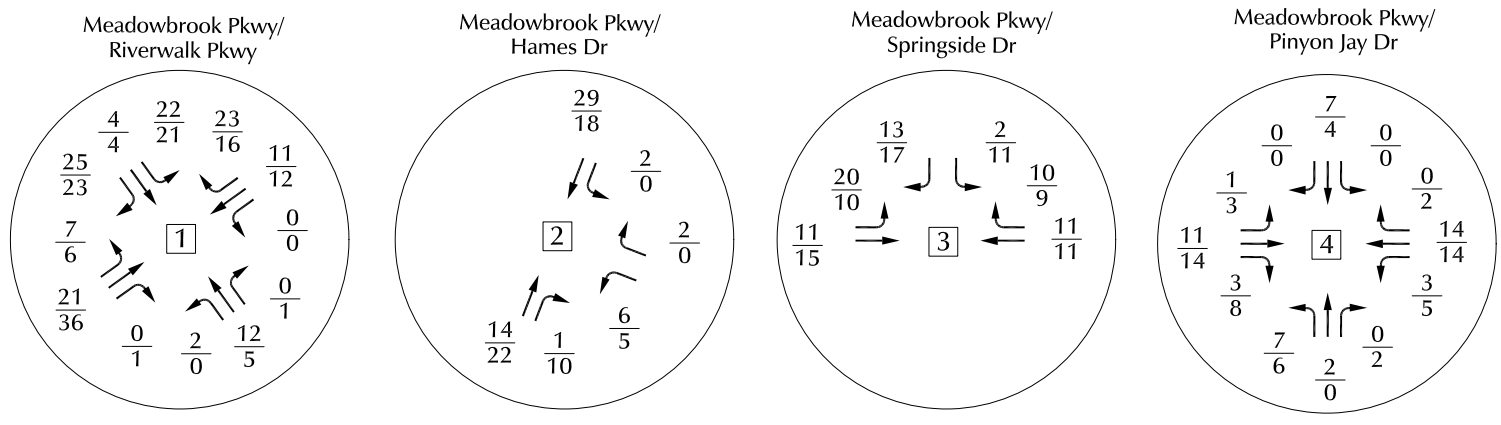
Marksheffel Rd/
Meadowbrook Pkwy



- = Signal
- = Stop Sign
- A = AM Individual Movement LOS
- A = PM Individual Movement LOS
- B = AM Intersection LOS
- C = PM Intersection LOS



Figure 7
**2020 Existing Lane
 Geometry, Traffic Control, and LOS**
 Mountain View Academy (LSC # 204140)



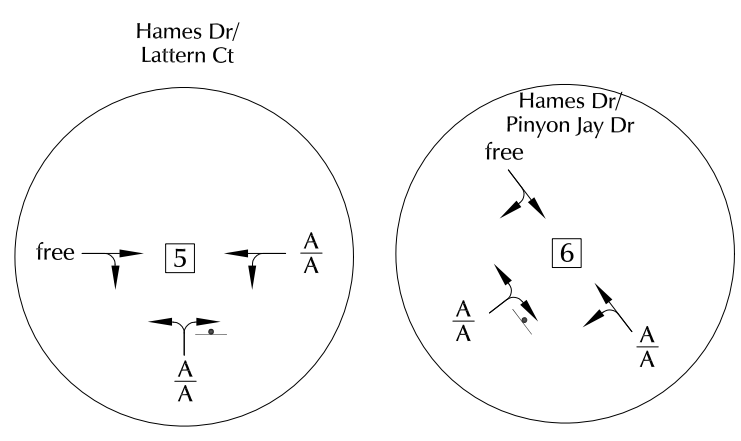
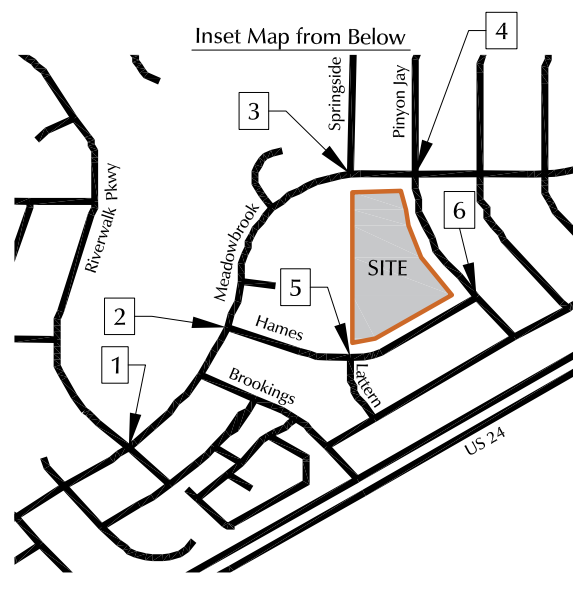
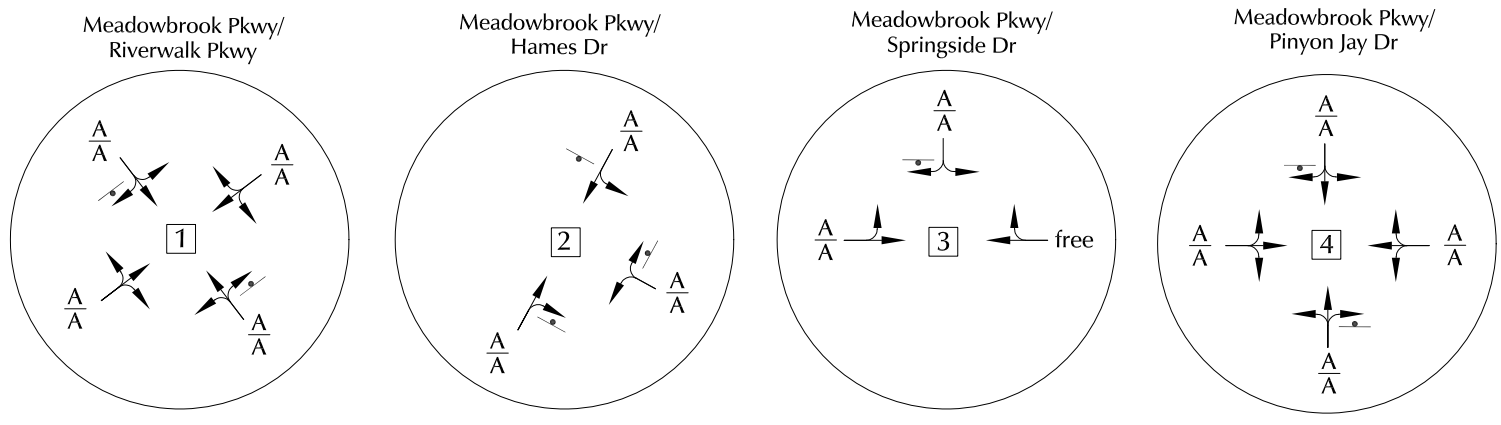
XX = AM Weekday Peak-Hour Traffic (veh/hr)
 XX = PM School Weekday Peak-Hour Traffic (veh/hr)
 XX,XXX = Average Daily Traffic Volumes (ADTs)

US Highway 24/
 Marksheffel Rd

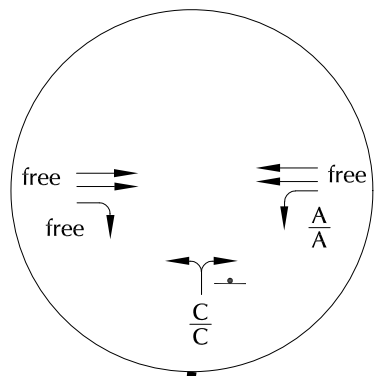


Figure 8
 Short-Term Background Volumes

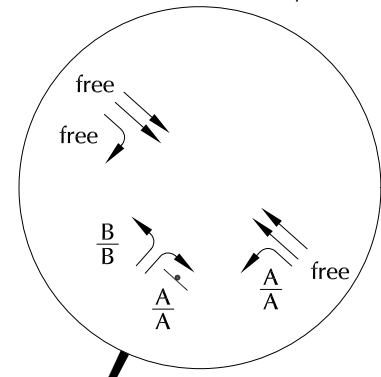
Mountain View Academy (LSC # 204140)



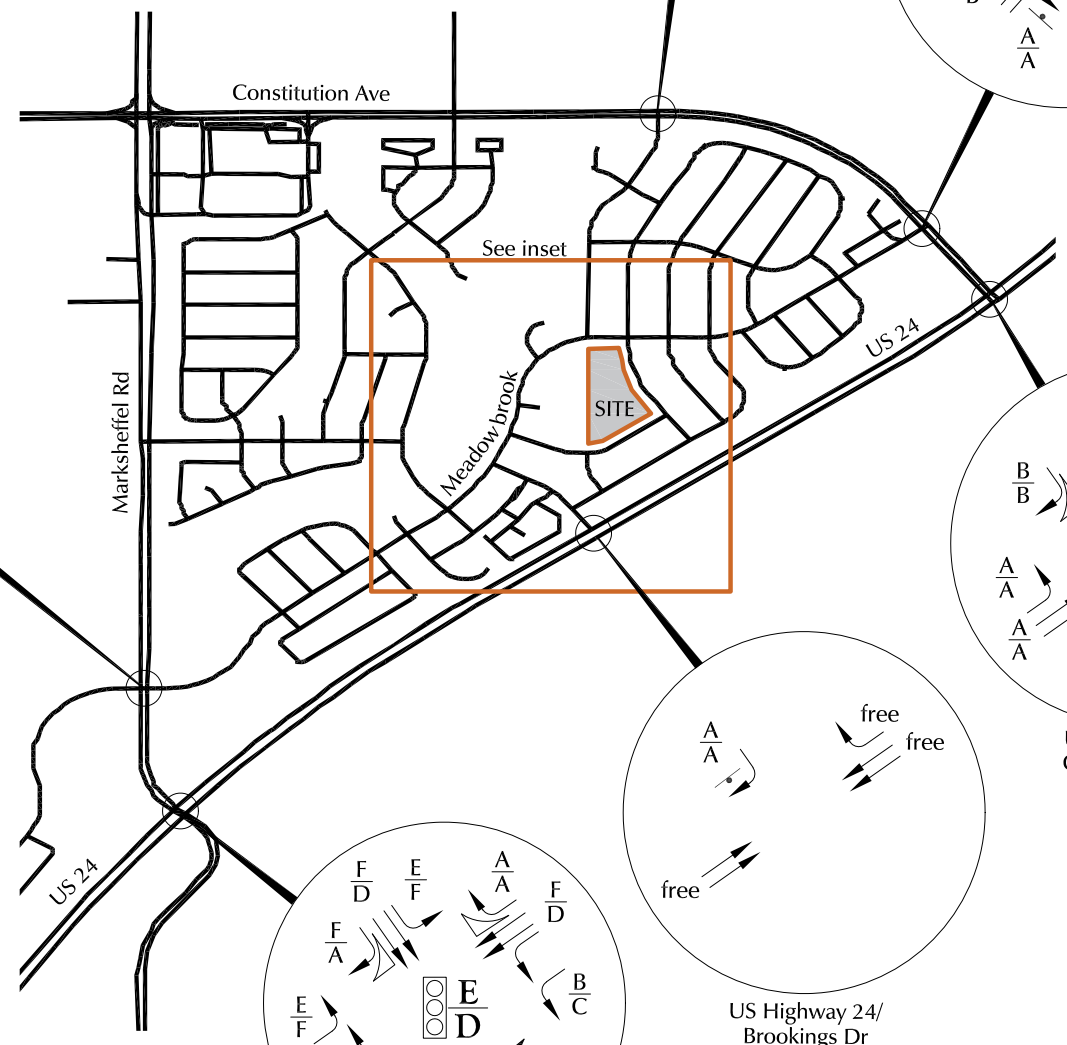
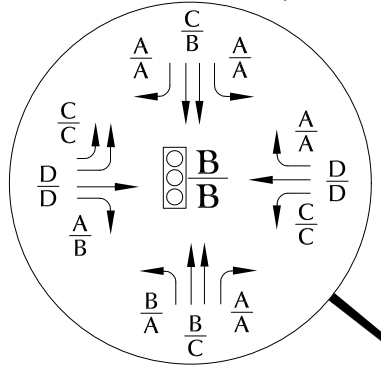
Constitution Ave/
Springside Dr



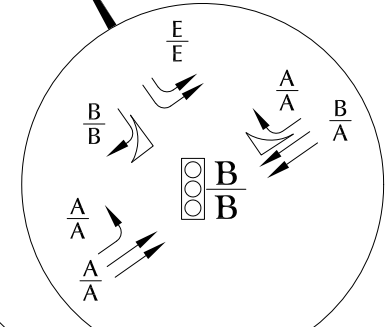
Constitution Ave/
Meadowbrook Pkwy



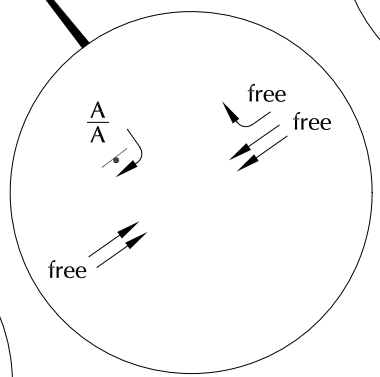
Marksheffel Rd/
Meadowbrook Pkwy



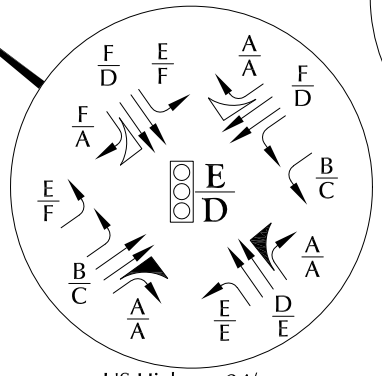
US Highway 24/
Constitution Ave



US Highway 24/
Brookings Dr



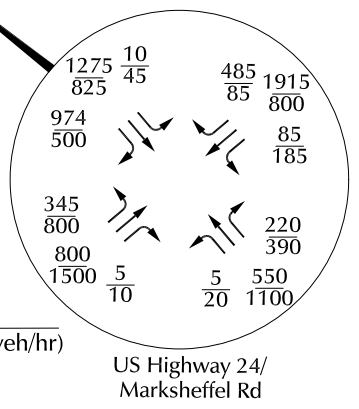
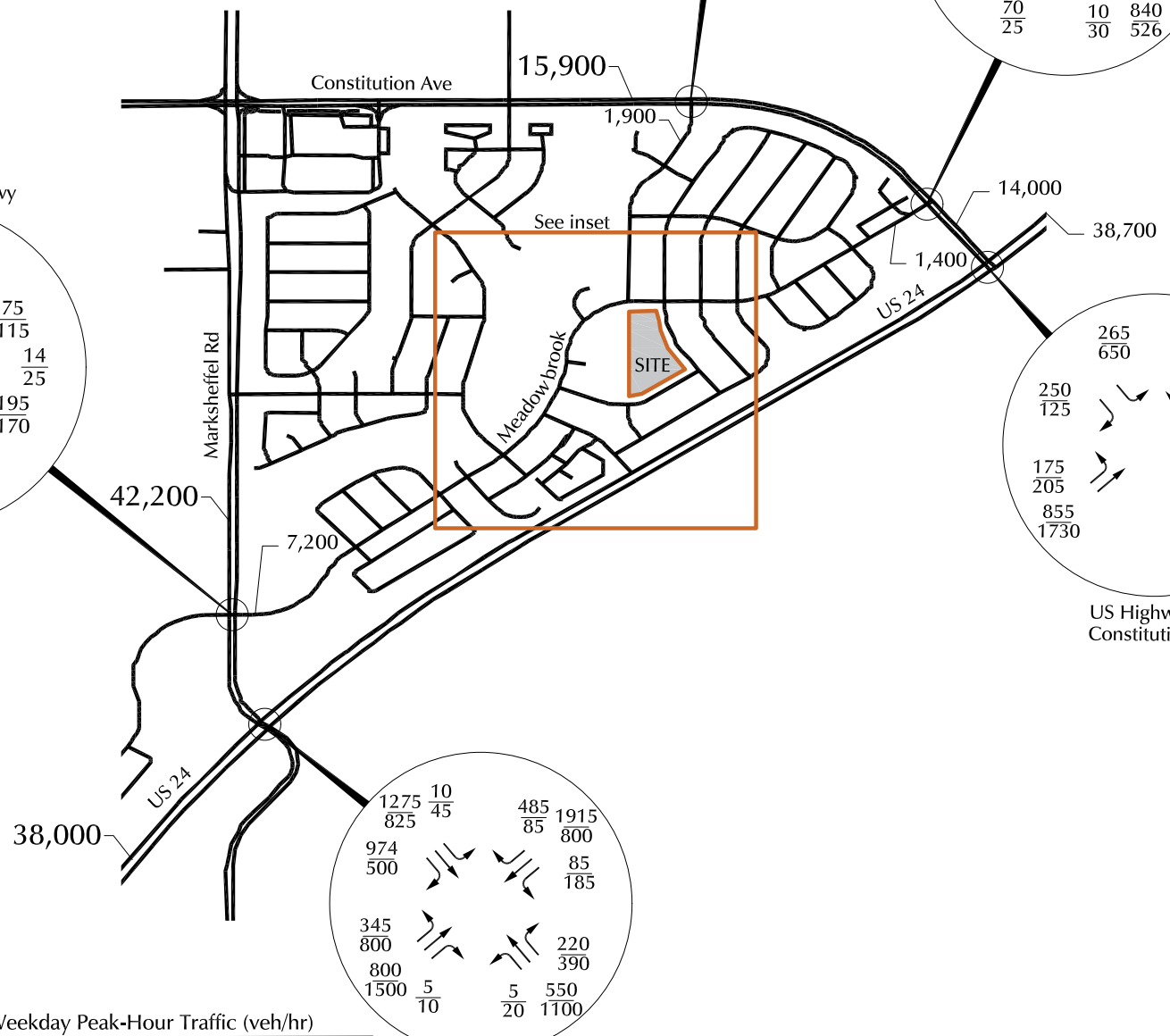
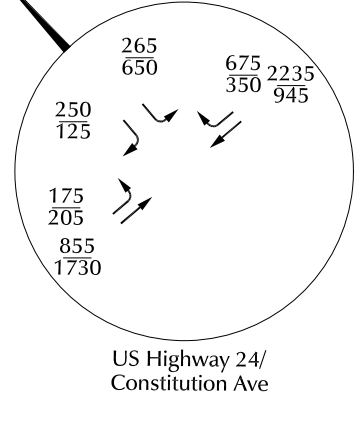
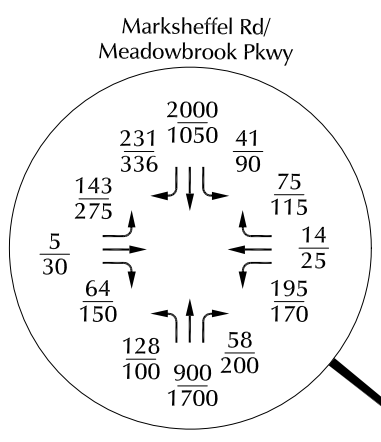
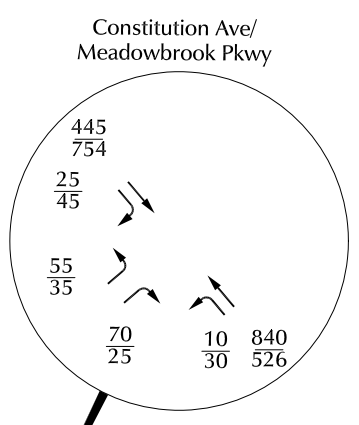
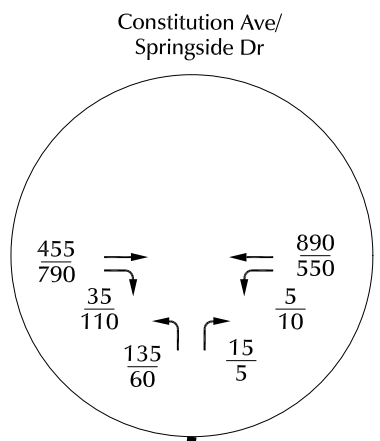
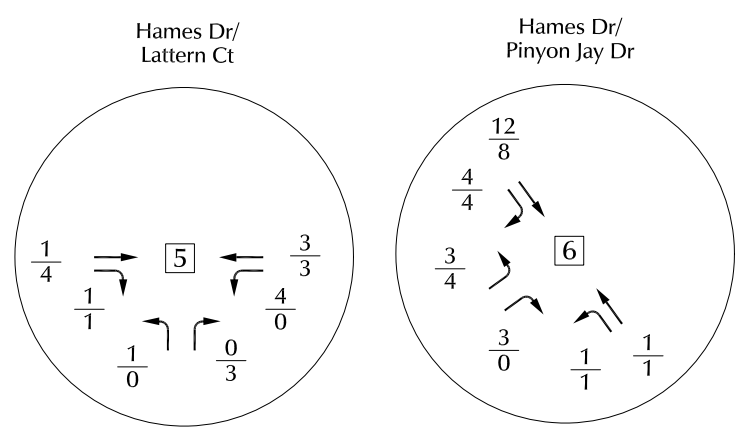
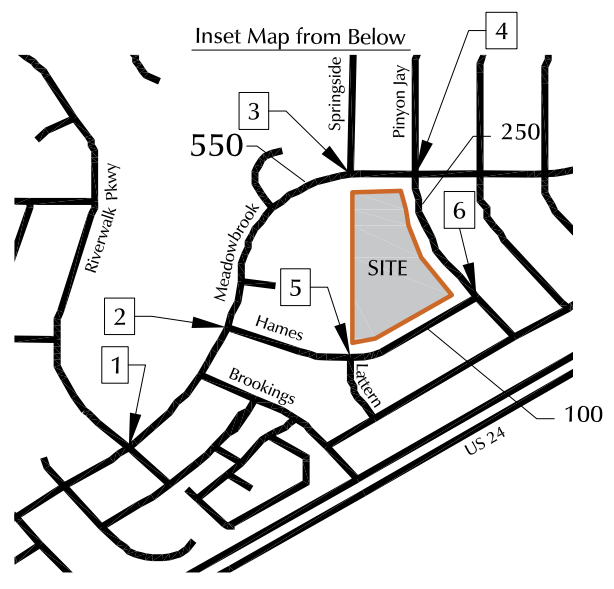
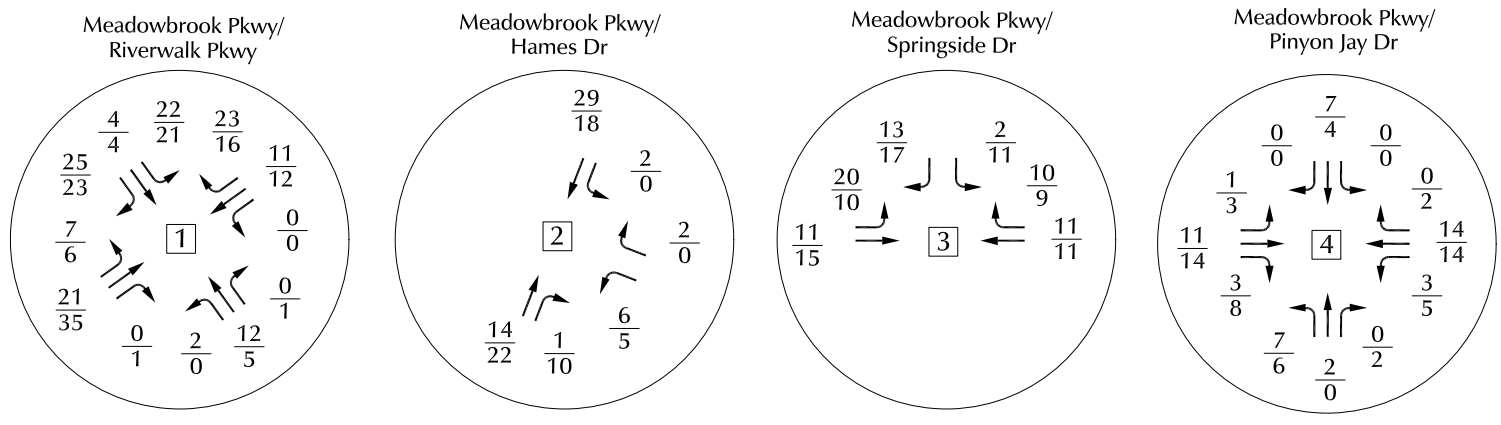
US Highway 24/
Marksheffel Rd



- = Signal
- = Stop Sign
- $\frac{A}{A}$ = AM Individual Movement LOS
- $\frac{A}{A}$ = PM Individual Movement LOS
- $\frac{B}{B}$ = AM Intersection LOS
- $\frac{C}{C}$ = PM Intersection LOS



Figure 9
**Short-Term Background Lane
Geometry, Traffic Control, and LOS**
Mountain View Academy (LSC # 204140)

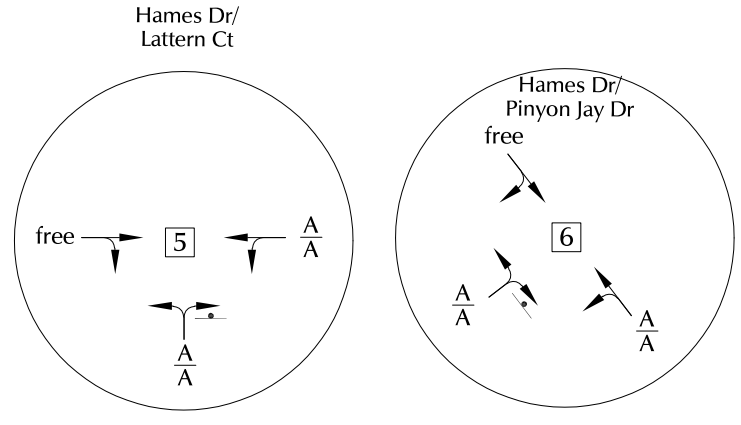
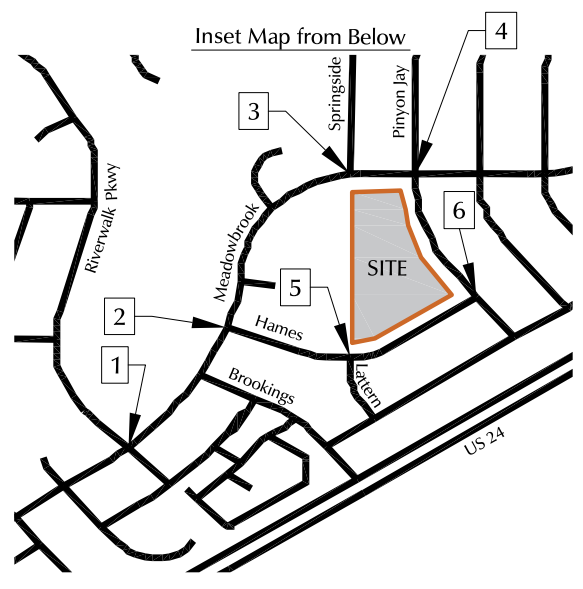
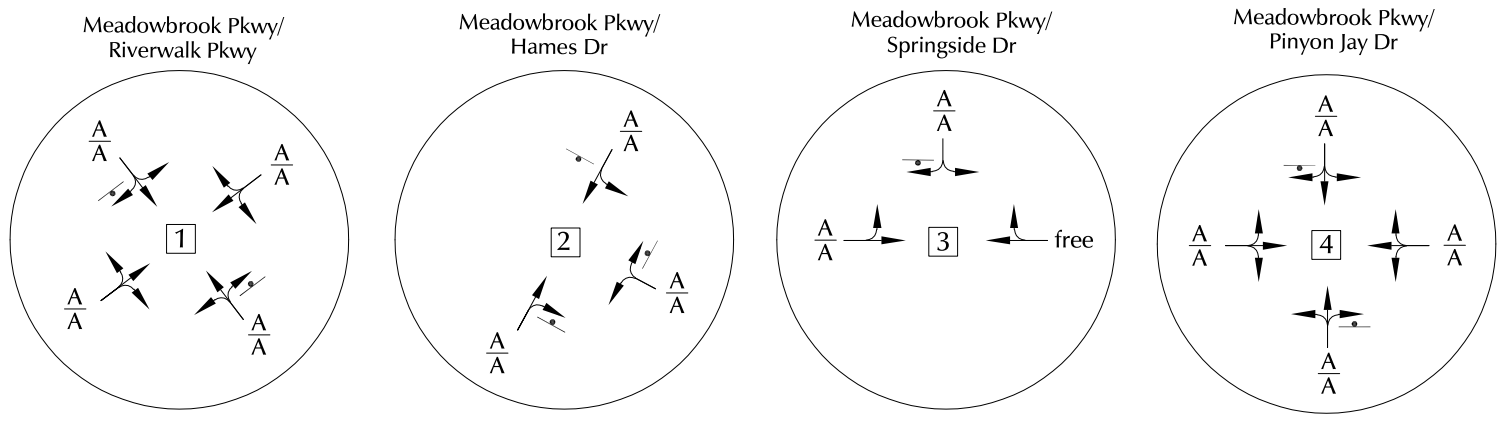


XX = AM Weekday Peak-Hour Traffic (veh/hr)
 XX = PM School Weekday Peak-Hour Traffic (veh/hr)
 XX,XXX = Average Daily Traffic Volumes (ADTs)

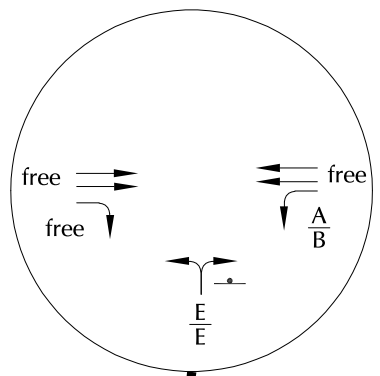
US Highway 24/
Marksheffel Rd



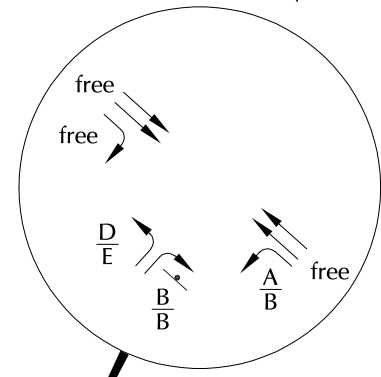
Figure 10
Long-Term Background Volumes
 Mountain View Academy (LSC # 204140)



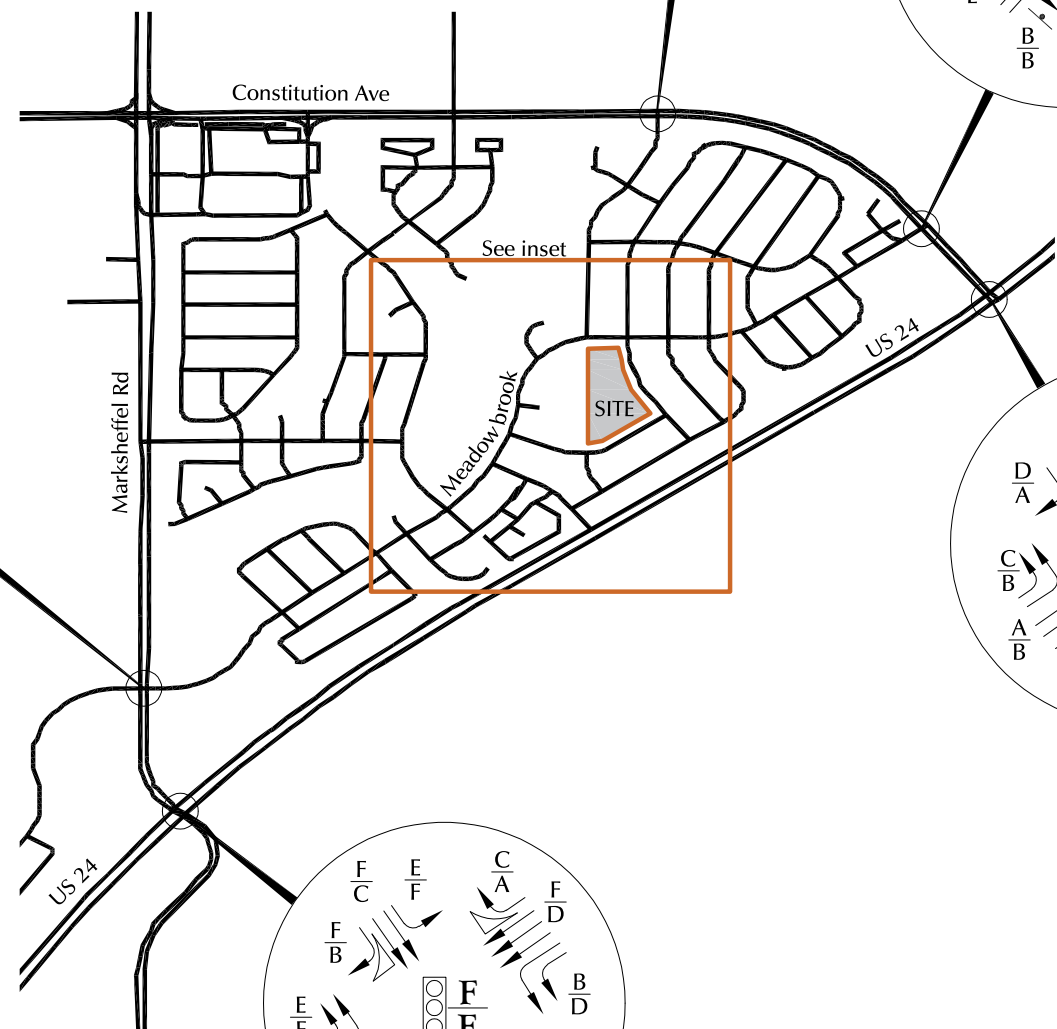
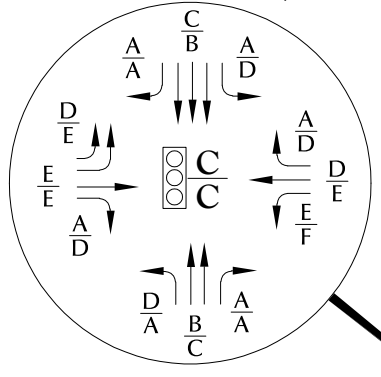
Constitution Ave/
Springside Dr



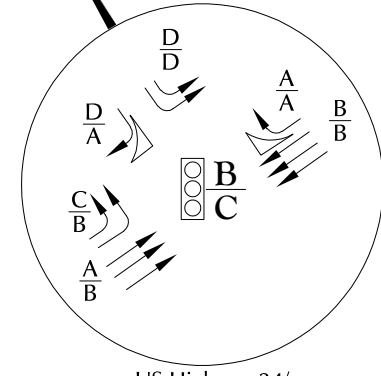
Constitution Ave/
Meadowbrook Pkwy



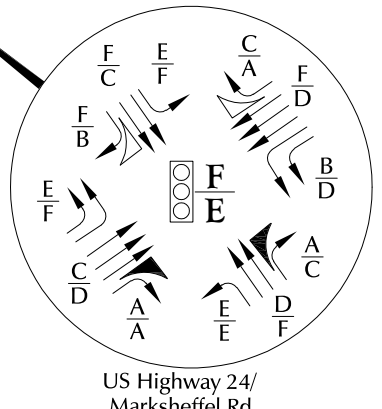
Marksheffel Rd/
Meadowbrook Pkwy



US Highway 24/
Constitution Ave



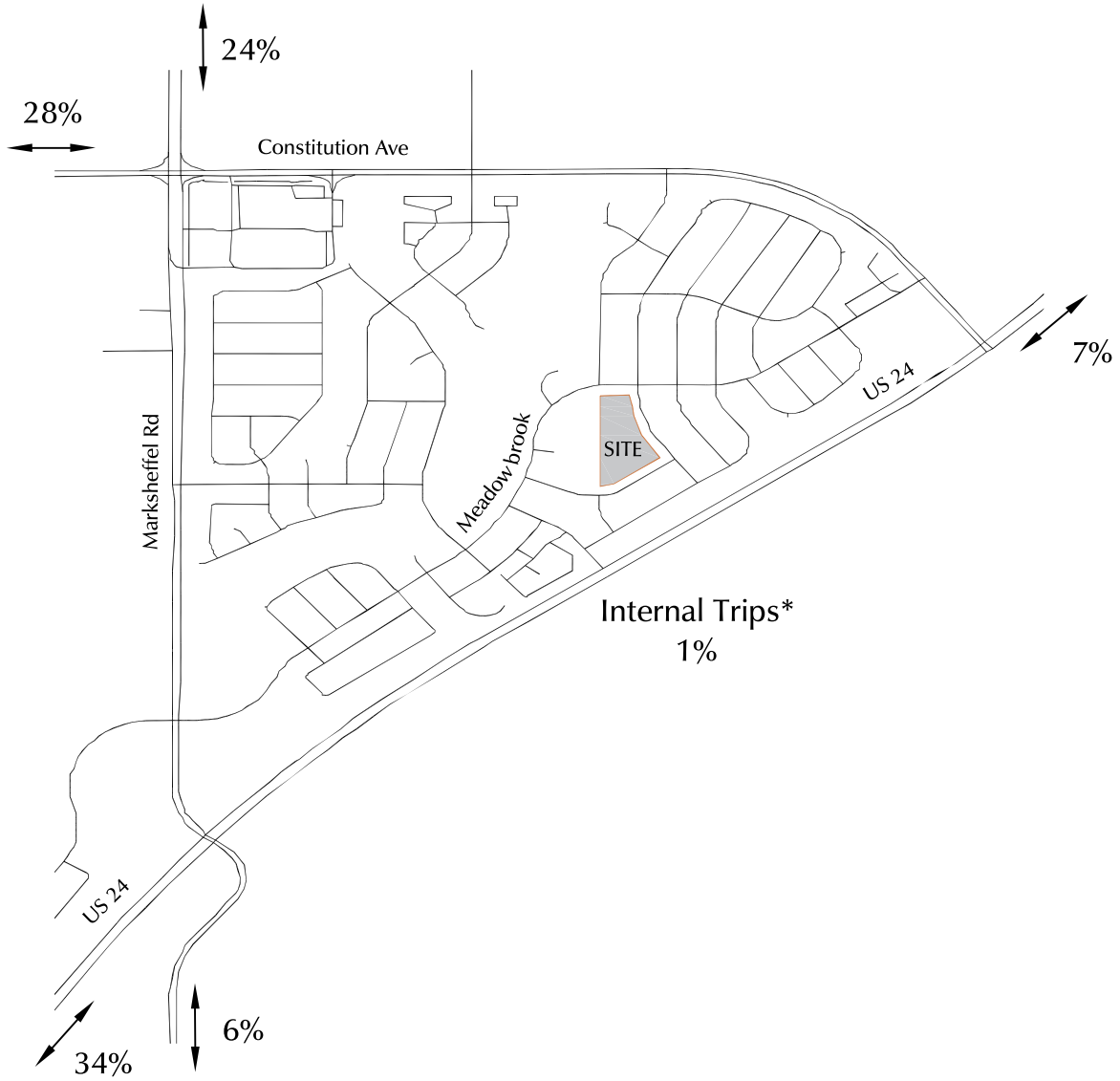
US Highway 24/
Marksheffel Rd



- = Signal
- = Stop Sign
- A = AM Individual Movement LOS
- A = PM Individual Movement LOS
- B = AM Intersection LOS
- C = PM Intersection LOS



Figure 11
**Long-Term Background Lane
Geometry, Traffic Control, and LOS**
Mountain View Academy (LSC # 204140)

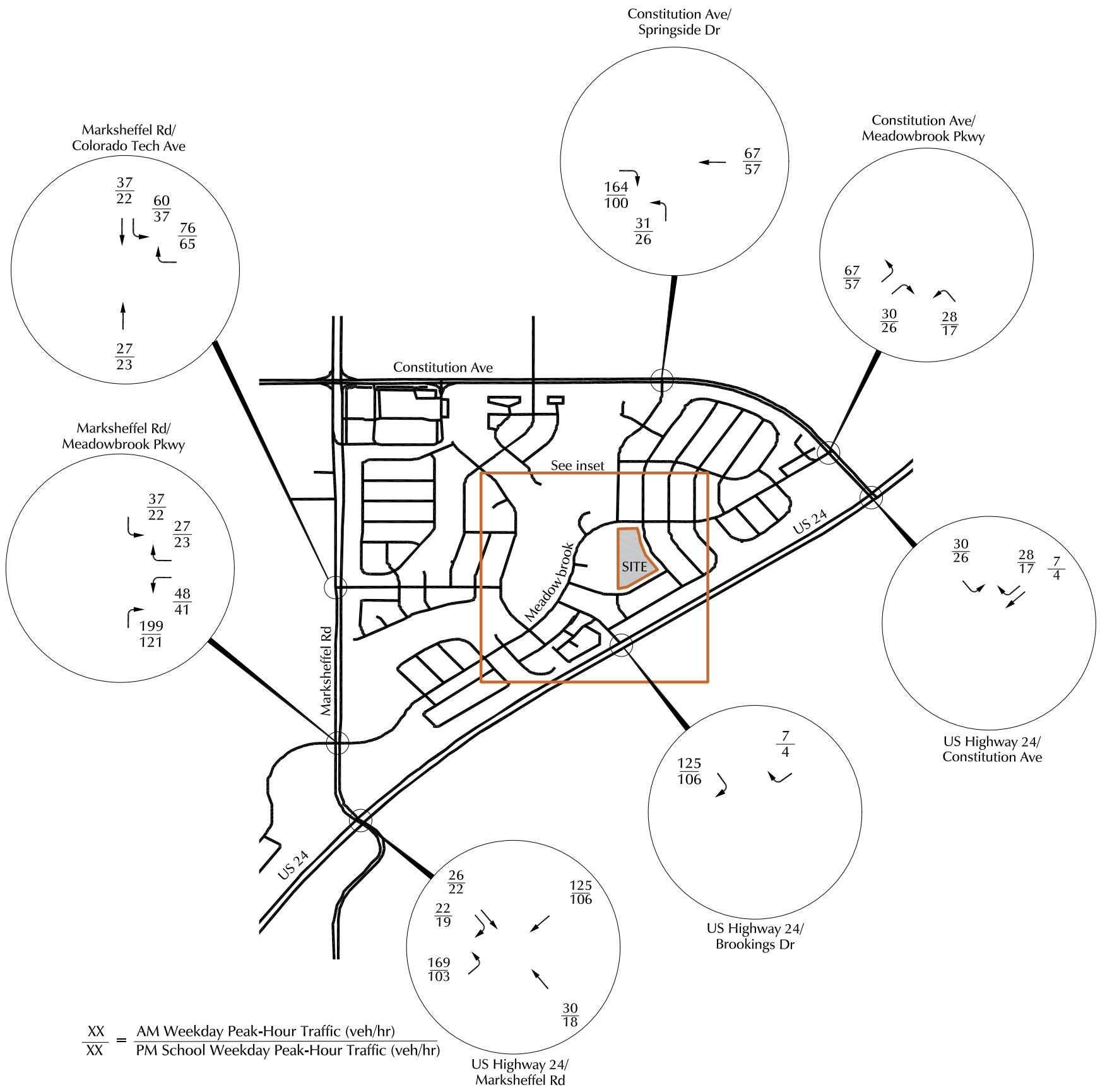
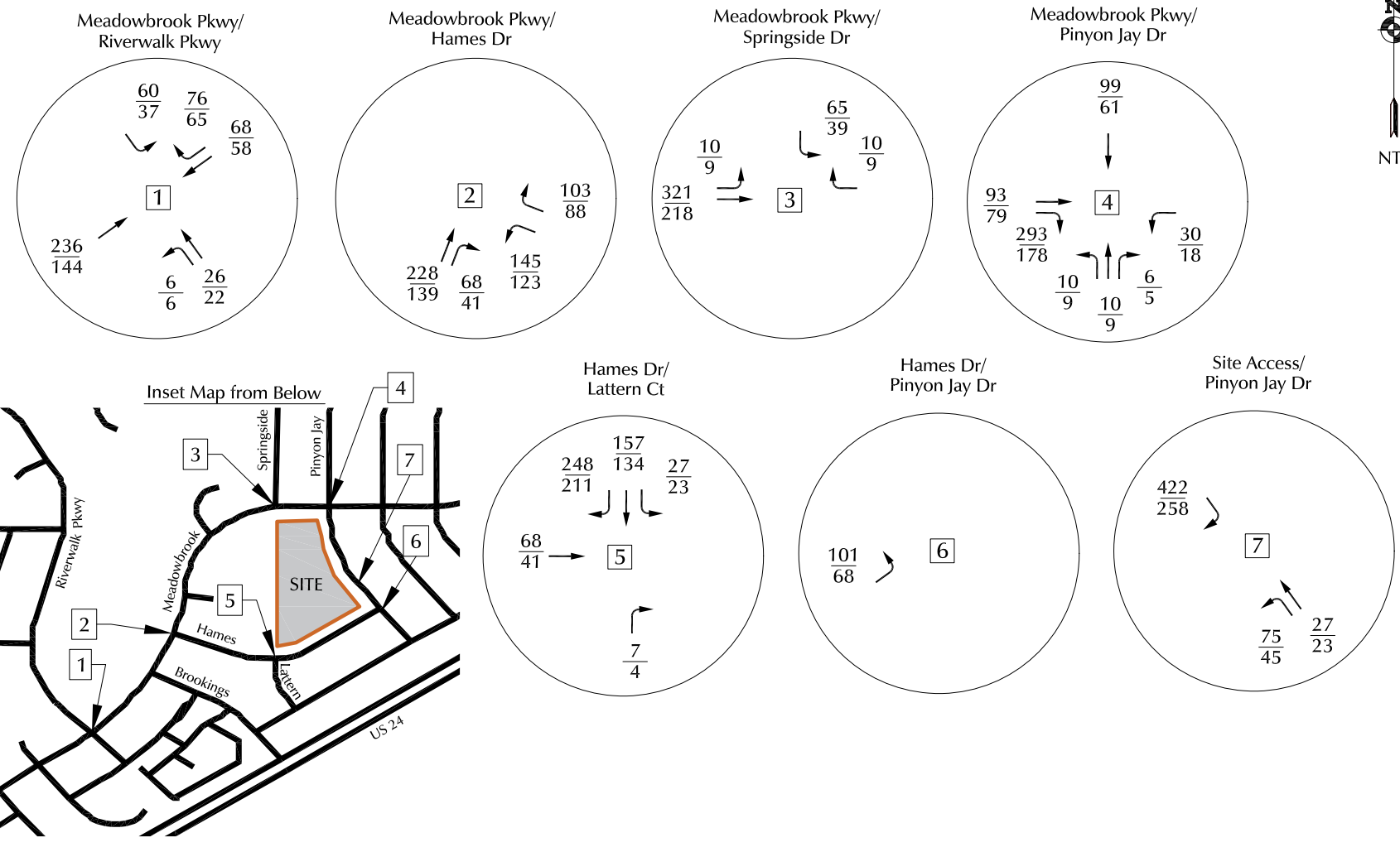


*Internal to the
Claremont Ranch
Neighborhood



XX% = Percent Directional Distribution

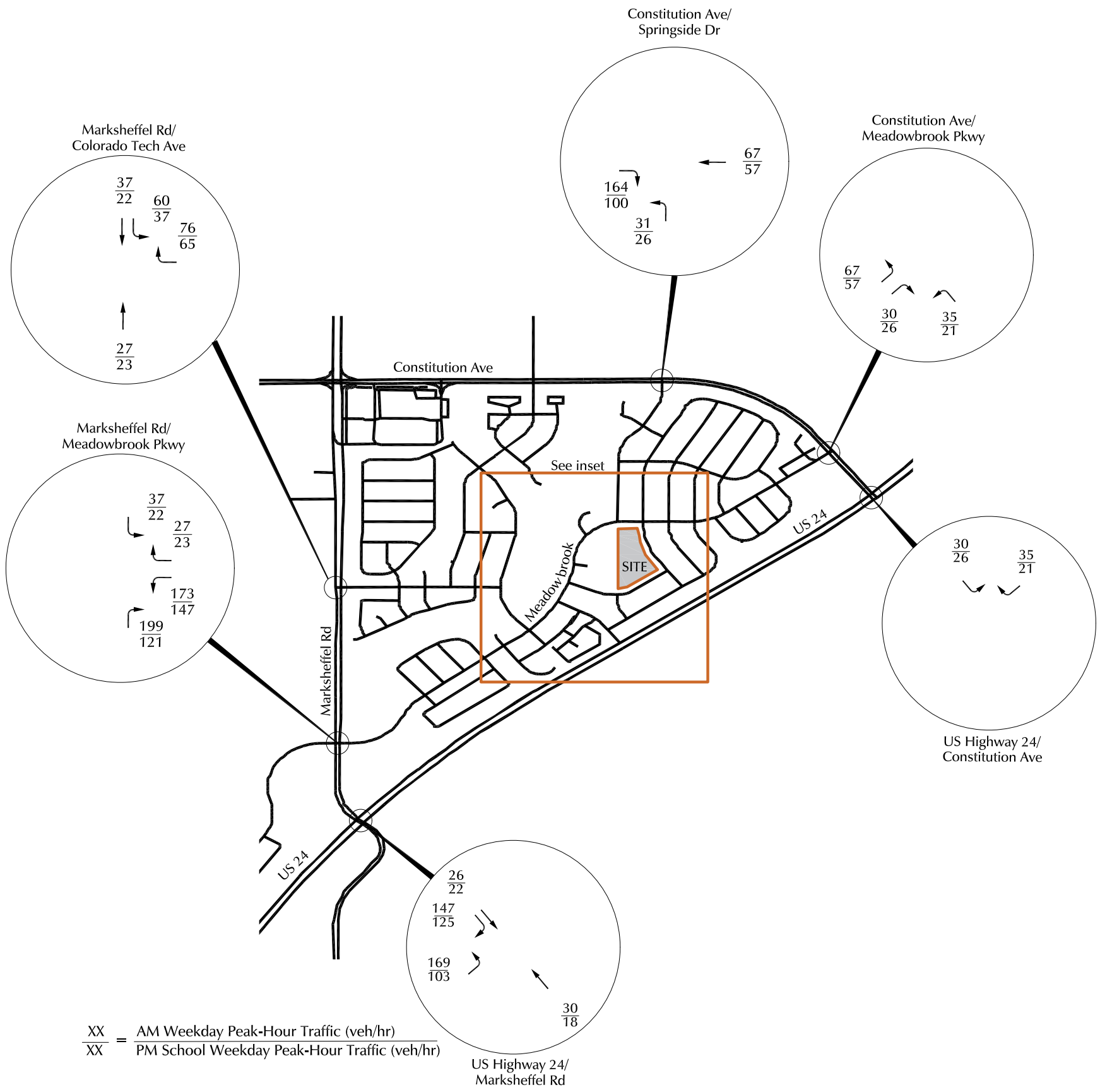
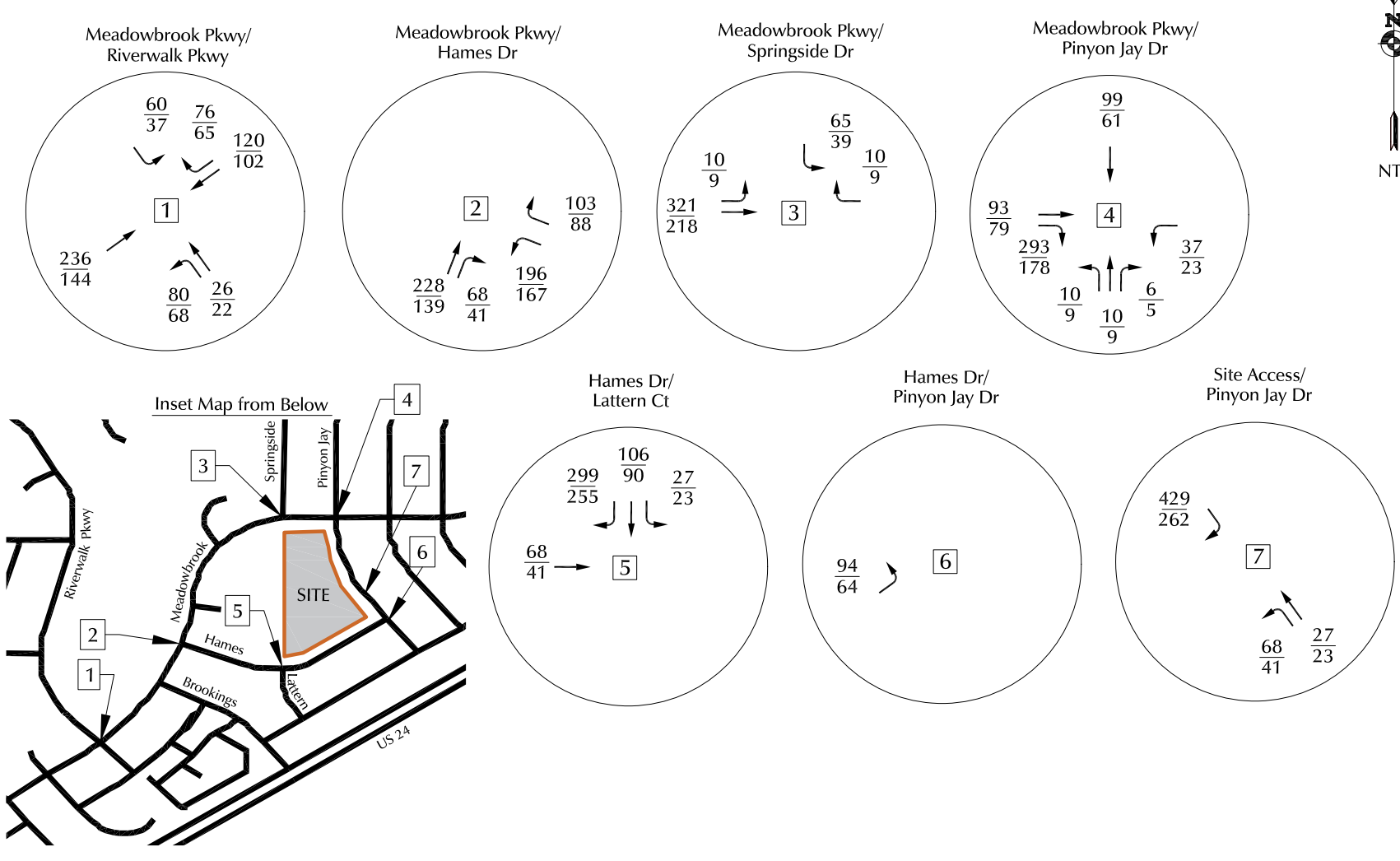
Figure 12
Directional Distribution
Mountain View Academy (LSC # 204140)



XX = AM Weekday Peak-Hour Traffic (veh/hr)
 XX = PM School Weekday Peak-Hour Traffic (veh/hr)



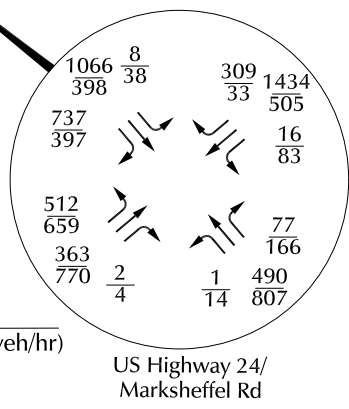
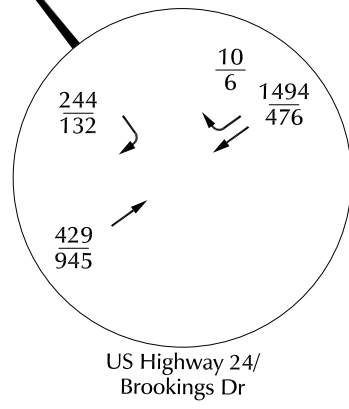
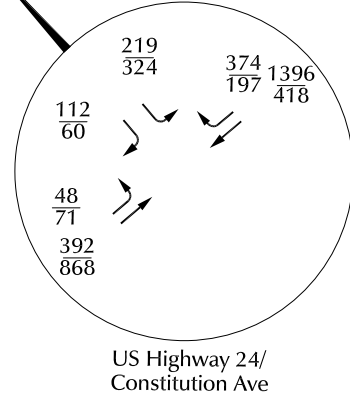
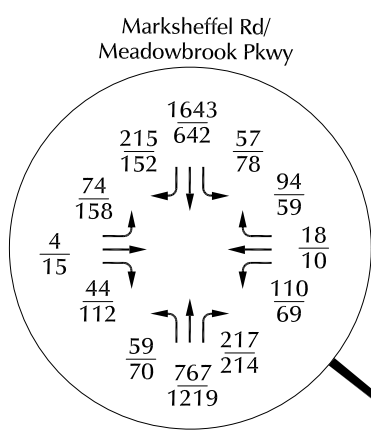
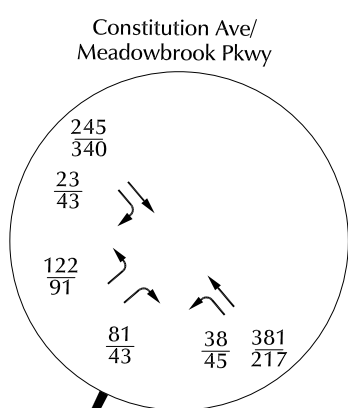
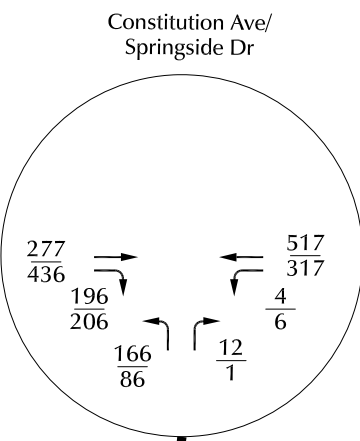
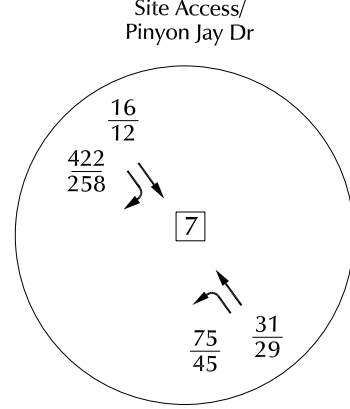
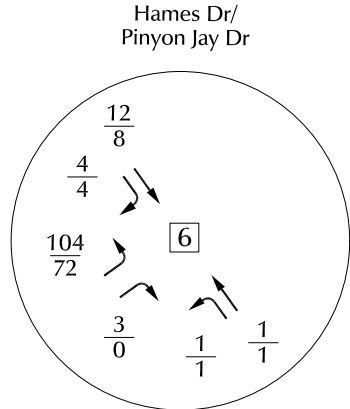
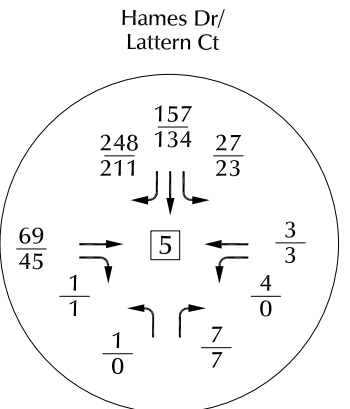
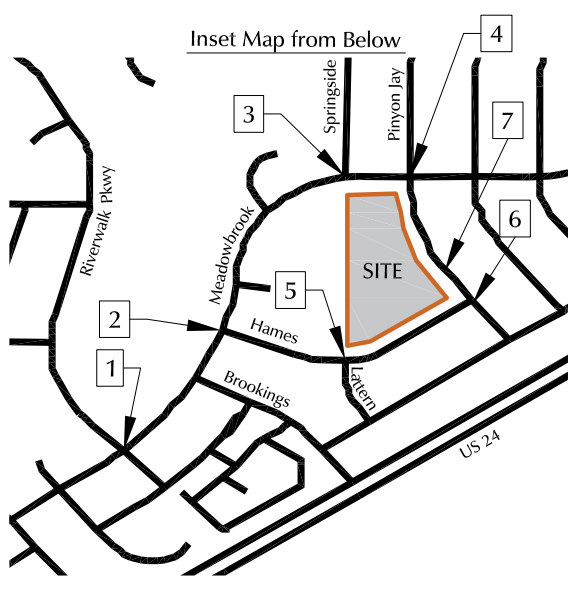
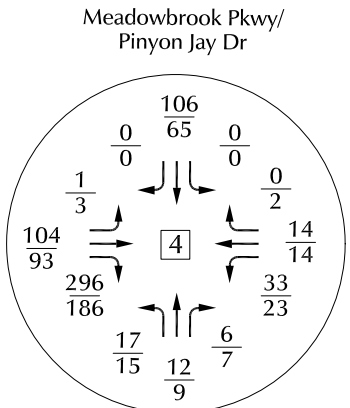
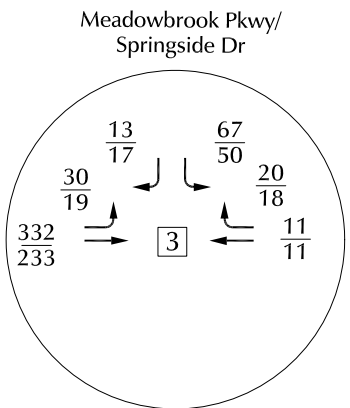
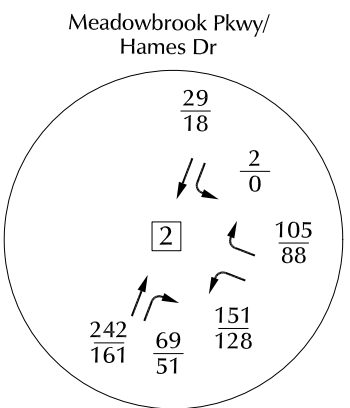
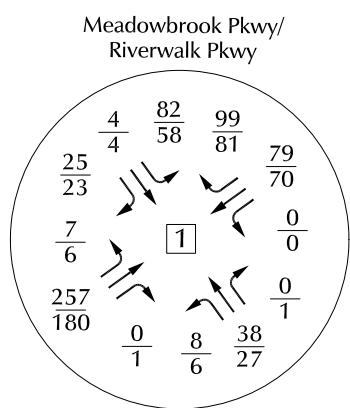
Figure 13
Short-Term Site Generated
 Mountain View Academy (LSC # 204140)



XX = AM Weekday Peak-Hour Traffic (veh/hr)
 XX = PM School Weekday Peak-Hour Traffic (veh/hr)



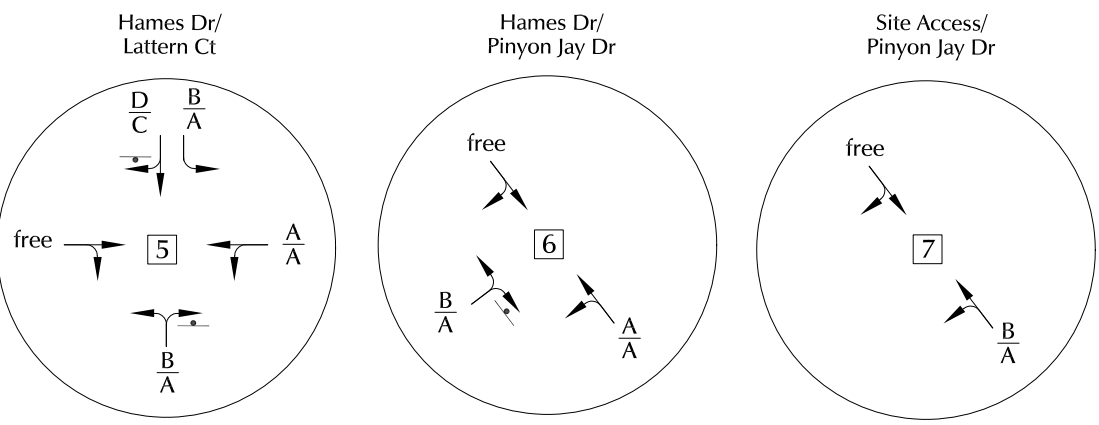
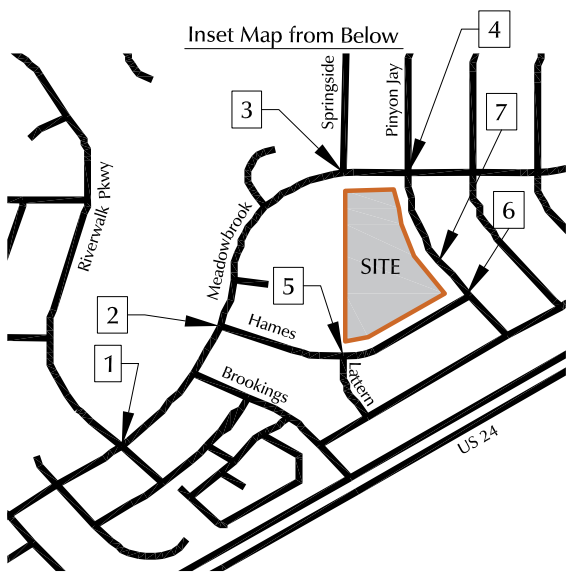
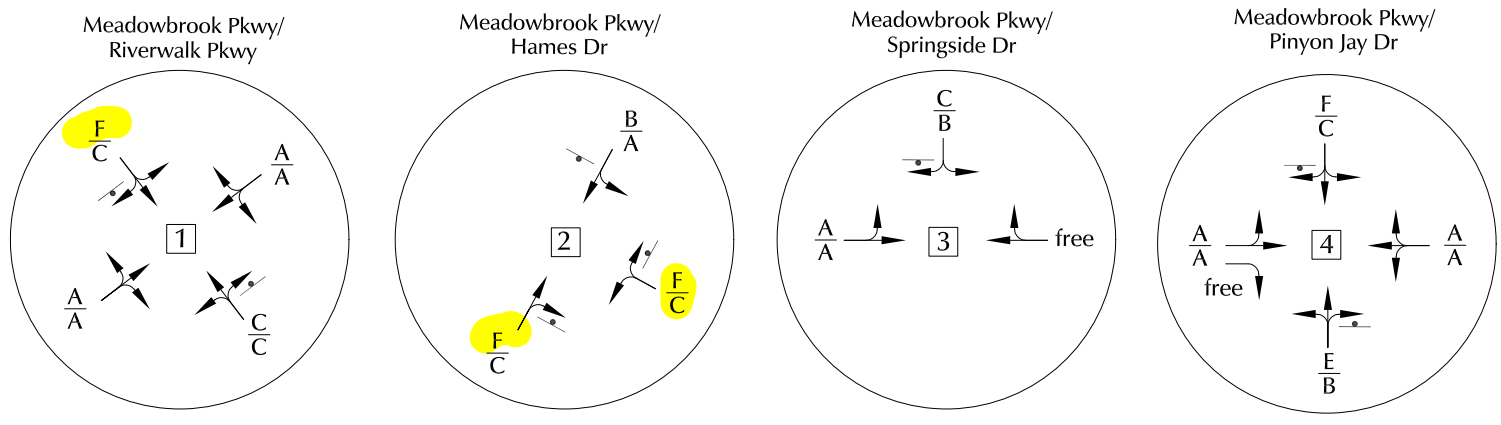
Figure 14
Long-Term Site Generated
 Mountain View Academy (LSC # 204140)



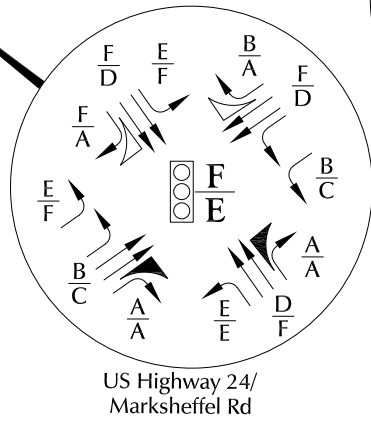
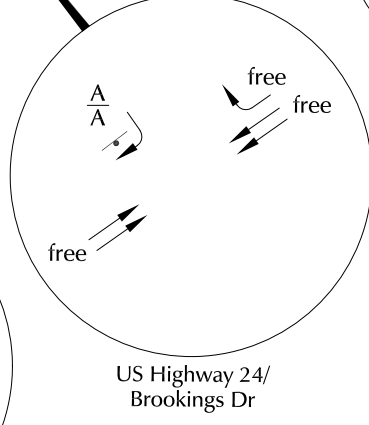
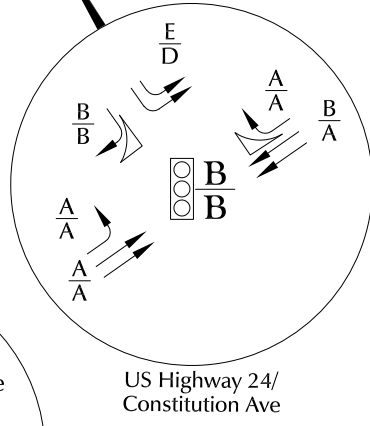
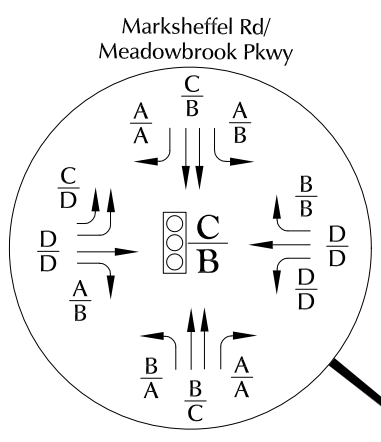
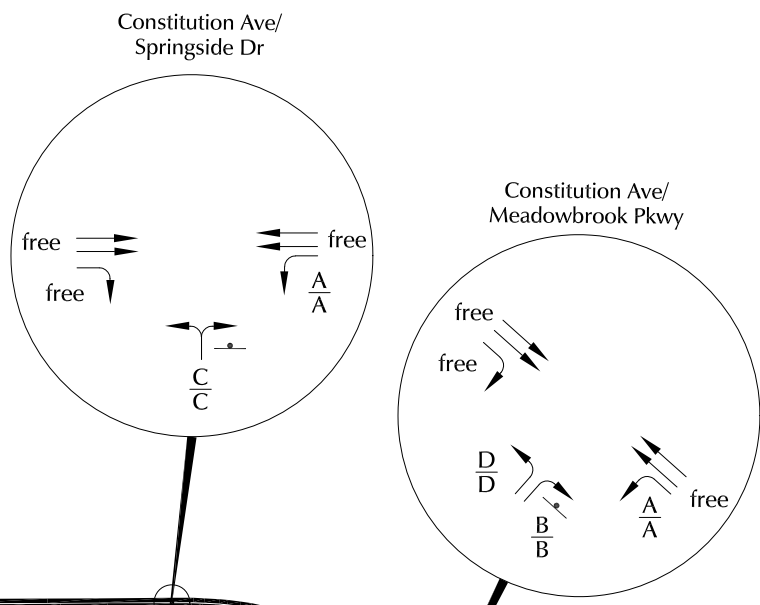
XX = AM Weekday Peak-Hour Traffic (veh/hr)
XX = PM School Weekday Peak-Hour Traffic (veh/hr)



Figure 15
Short-Term Total Volumes
Mountain View Academy (LSC # 204140)



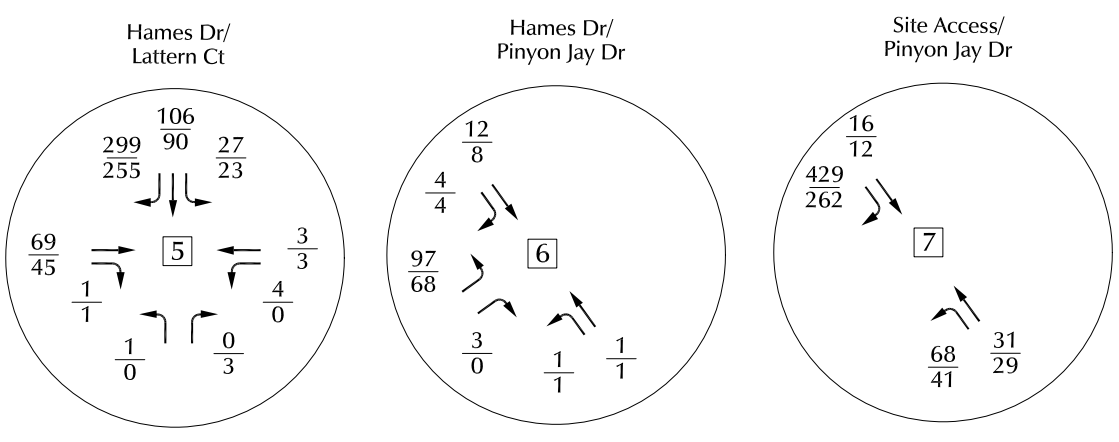
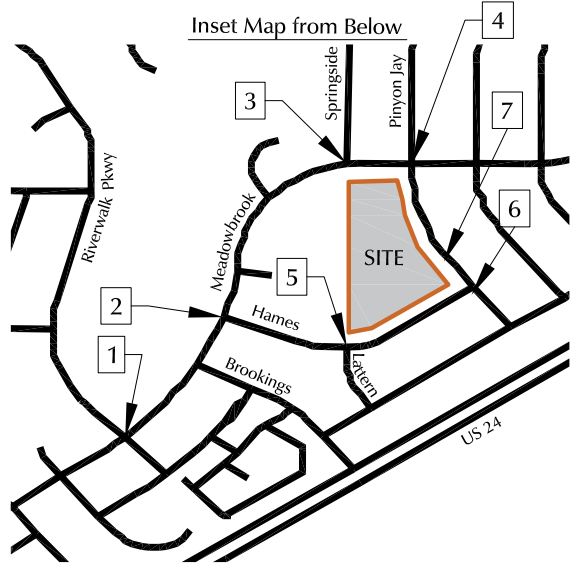
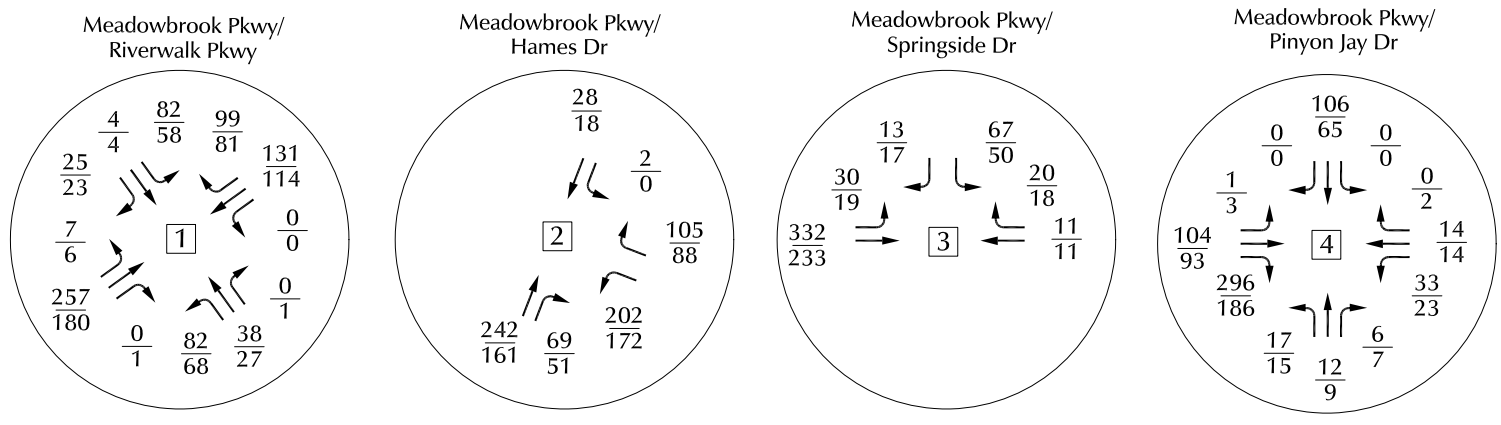
Include a narrative under the Neighborhood Intersections on Pg 10 for Meadowbrook/Riverwalk and Meadowbrook/Hames intersection with recommendations to address the resulting LOS F due to the project.



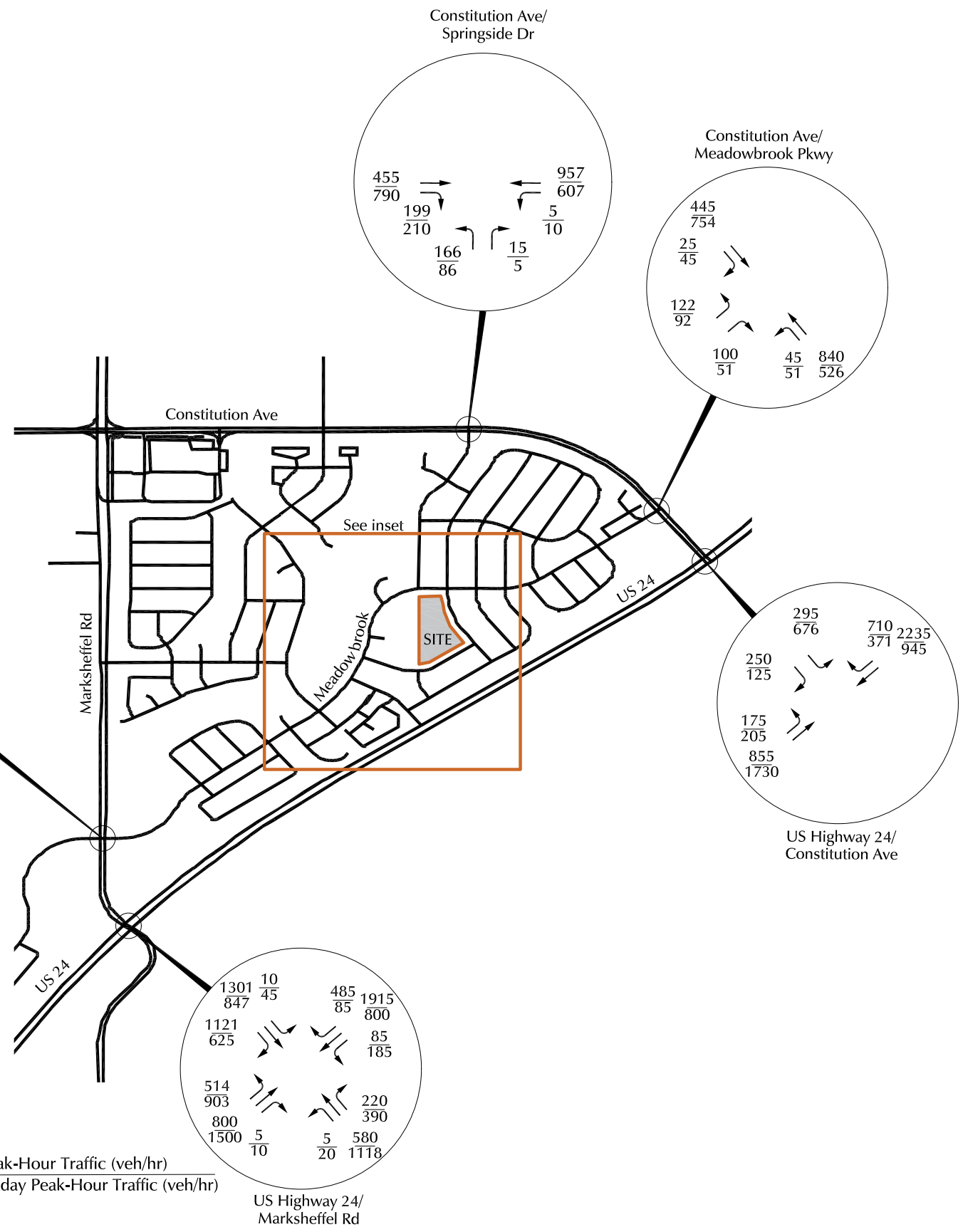
- = Signal
- = Stop Sign
- A = AM Individual Movement LOS
- A = PM Individual Movement LOS
- B = AM Intersection LOS
- C = PM Intersection LOS



Figure 16
Short-Term Total Lane Geometry, Traffic Control, and LOS
 Mountain View Academy (LSC # 204140)



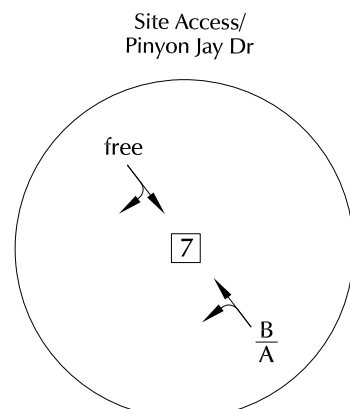
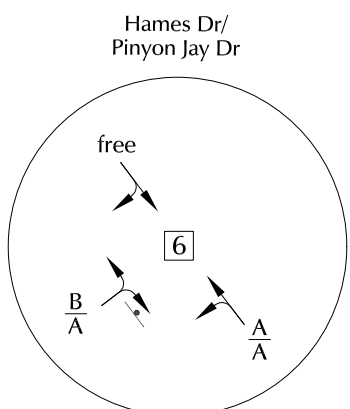
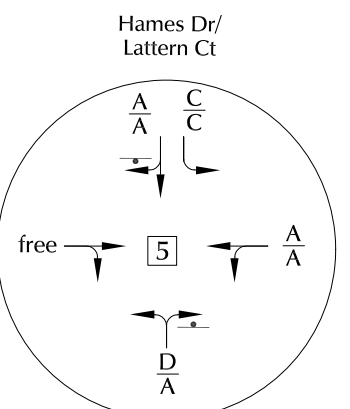
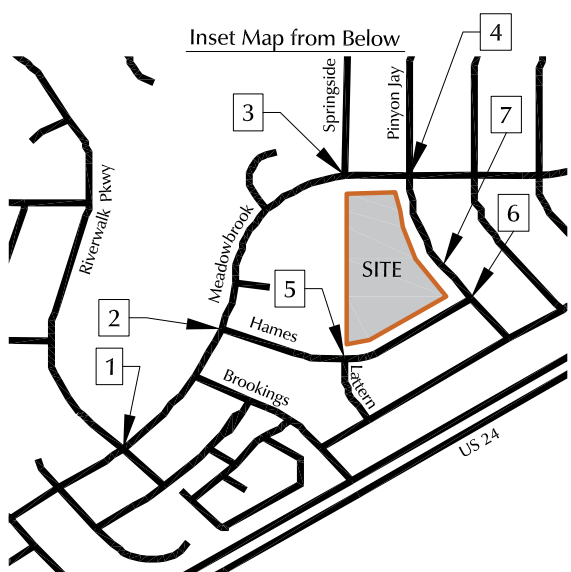
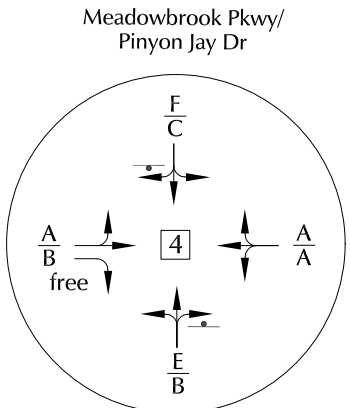
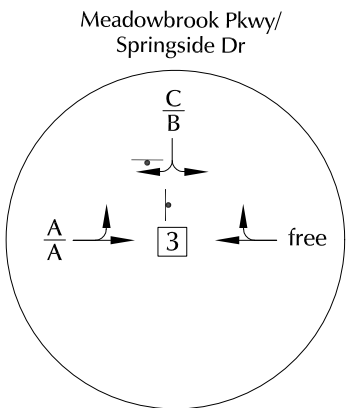
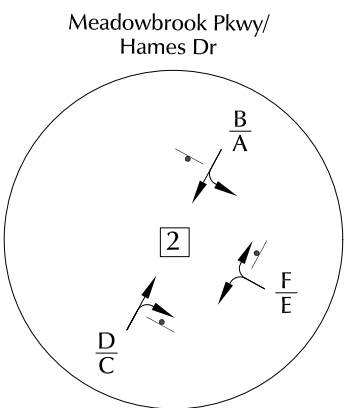
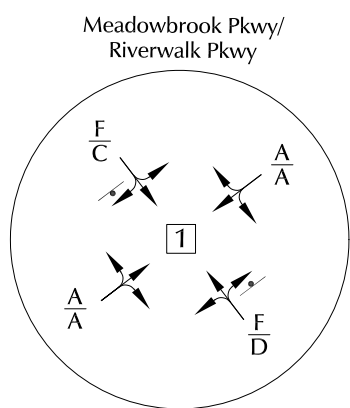
Note: All volumes assume the closure of the US 24/Brookings Avenue intersection



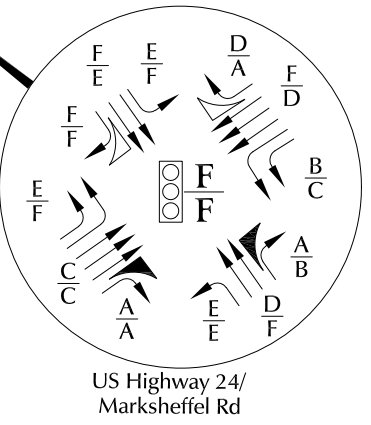
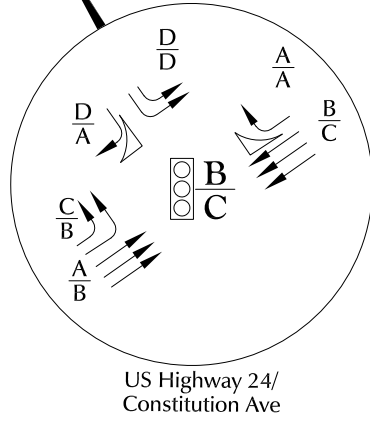
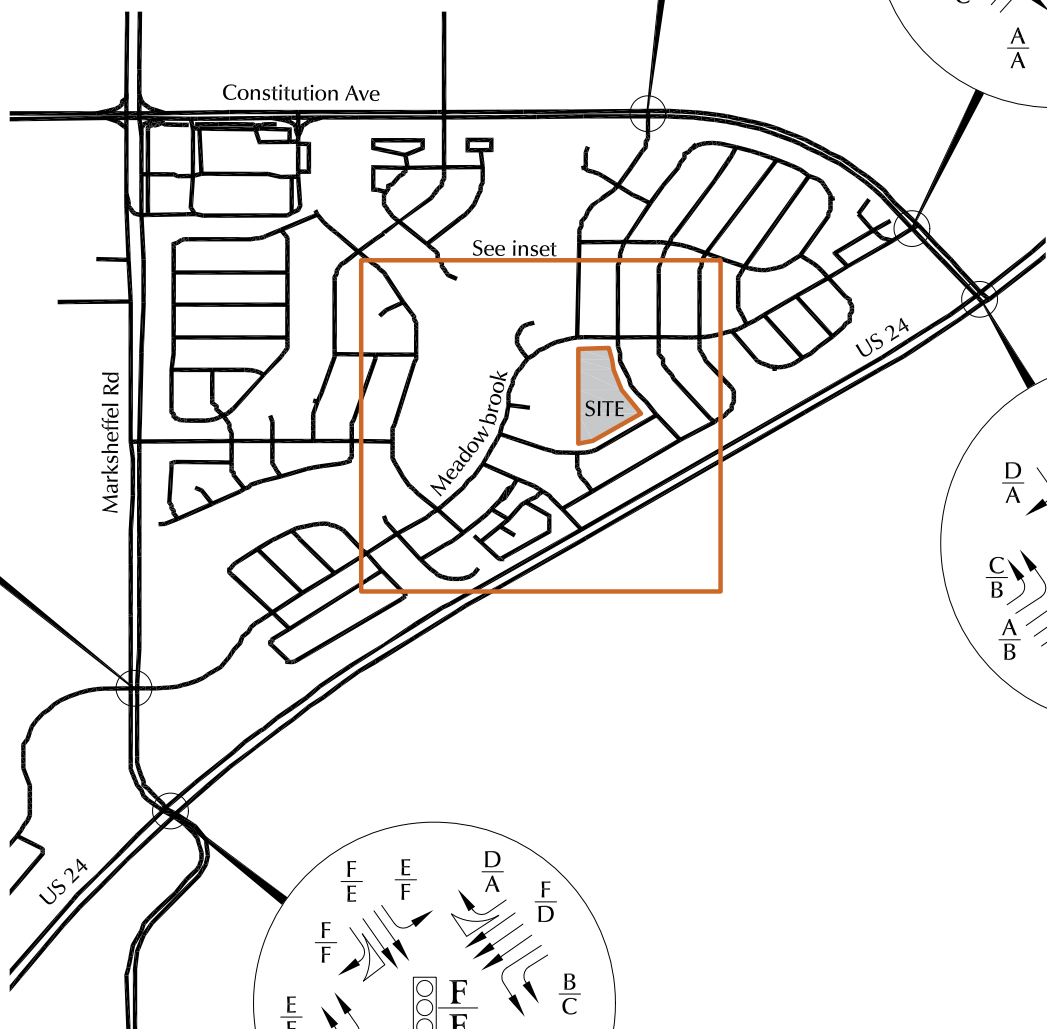
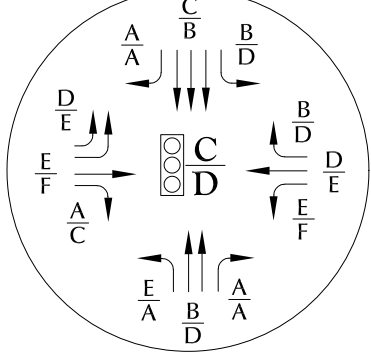
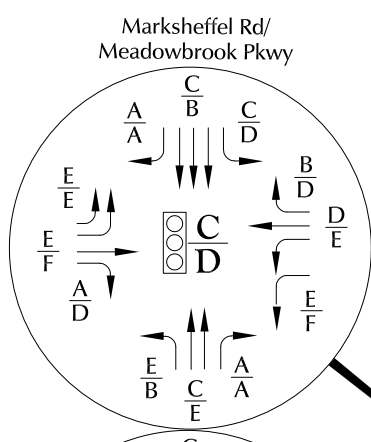
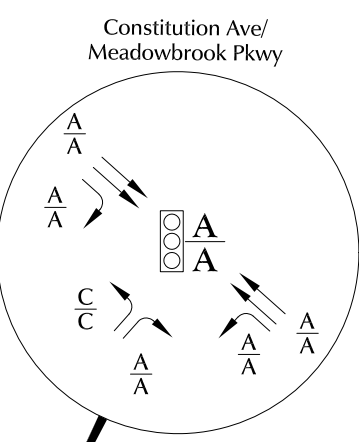
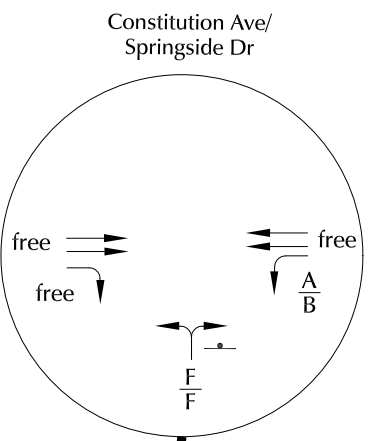
XX = AM Weekday Peak-Hour Traffic (veh/hr)
 XX = PM School Weekday Peak-Hour Traffic (veh/hr)



Figure 17
Long-Term Total Volumes
 Mountain View Academy (LSC # 204140)



Note: All levels of service assume the closure of the US 24/Brookings Avenue intersection except where indicated

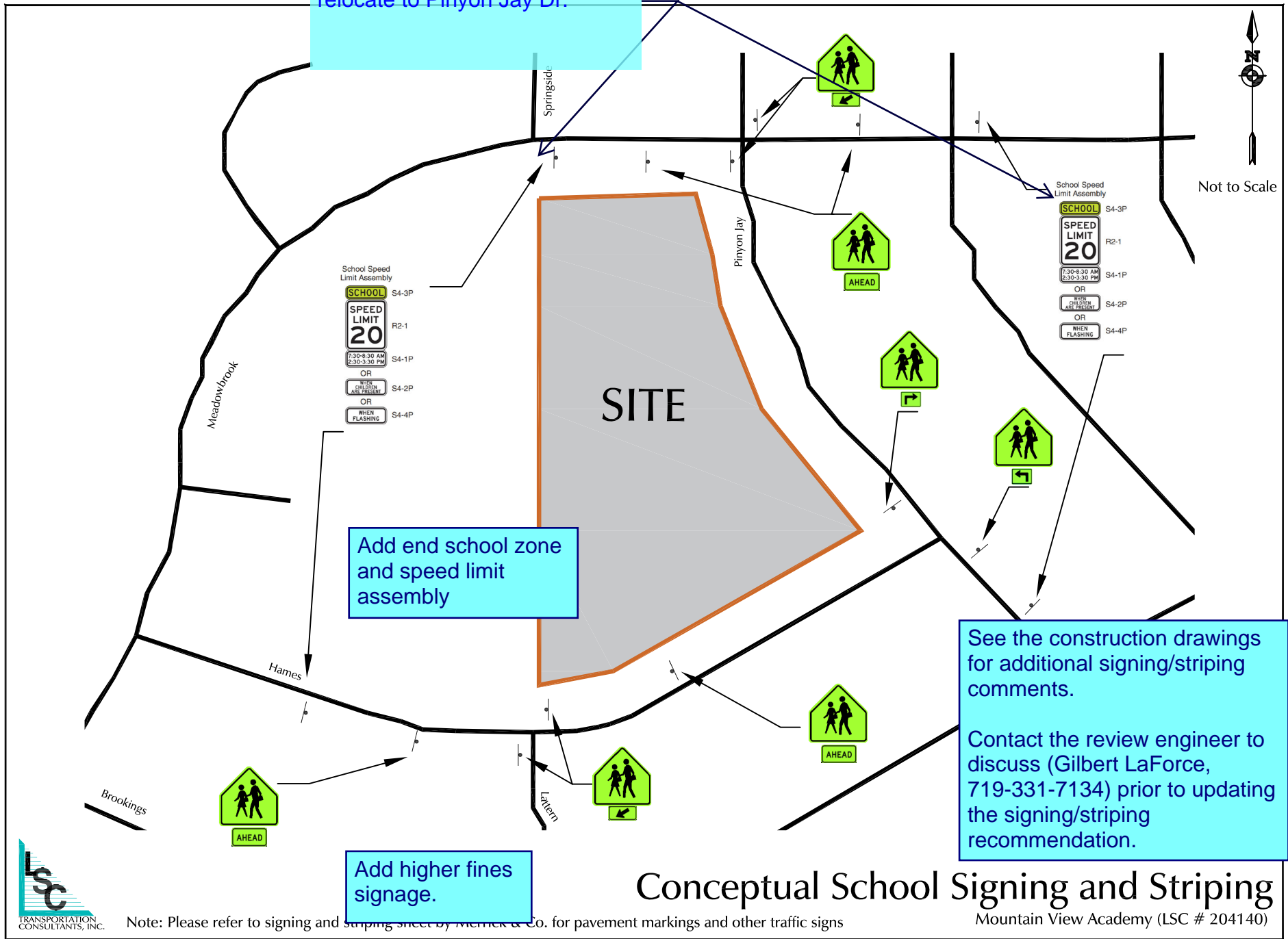


- = Signal
- = Stop Sign
- A = AM Individual Movement LOS
- A = PM Individual Movement LOS
- B = AM Intersection LOS
- C = PM Intersection LOS



Figure 18
**Long-Term Total Lane
 Geometry, Traffic Control, and LOS**
 Mountain View Academy (LSC # 204140)

Remove speed limit assembly along Meadowbrook Pkwy. and relocate to Pinyon Jay Dr.



Add end school zone and speed limit assembly

Add higher fines signage.

See the construction drawings for additional signing/striping comments.

Contact the review engineer to discuss (Gilbert LaForce, 719-331-7134) prior to updating the signing/striping recommendation.

Conceptual School Signing and Striping

Note: Please refer to signing and striping sheet by Mattern & Co. for pavement markings and other traffic signs

Mountain View Academy (LSC # 204140)



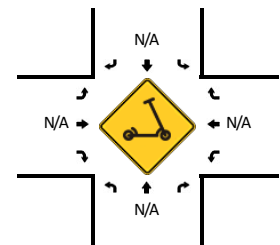
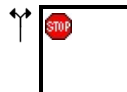
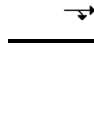
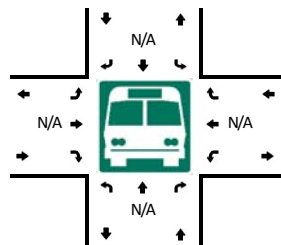
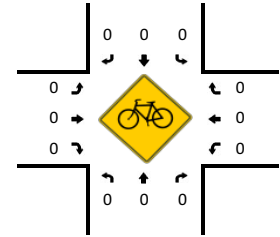
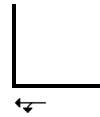
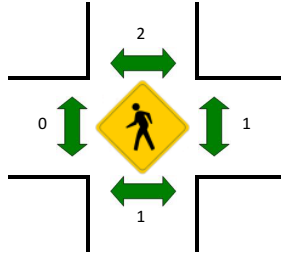
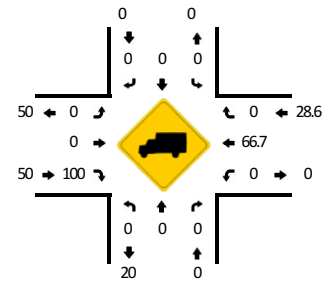
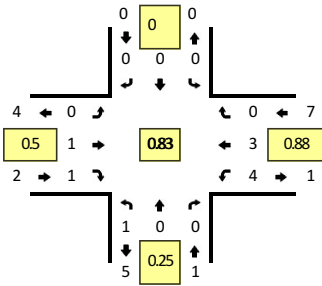
Traffic Counts



LOCATION: Latern Ct -- Hames Dr
CITY/STATE: El Paso, CO

QC JOB #: 15171501
DATE: Tue, Jan 28 2020

Peak-Hour: 7:00 AM -- 8:00 AM
 Peak 15-Min: 7:30 AM -- 7:45 AM



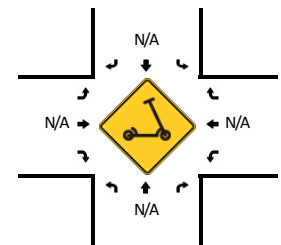
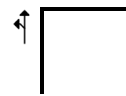
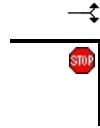
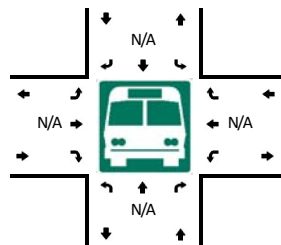
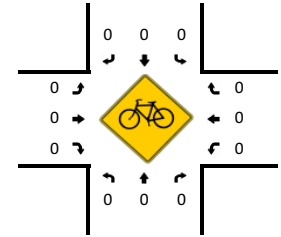
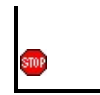
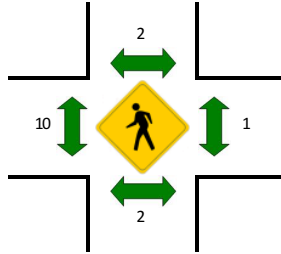
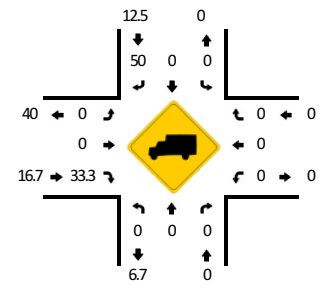
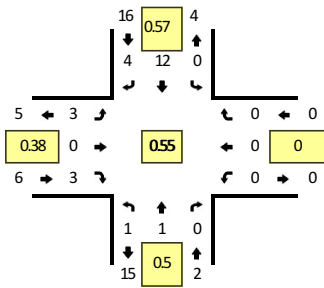
15-Min Count Period Beginning At	Latern Ct (Northbound)				Latern Ct (Southbound)				Hames Dr (Eastbound)				Hames Dr (Westbound)				Total	Hourly Totals	
	Left	Thru	Right	U	Left	Thru	Right	U	Left	Thru	Right	U	Left	Thru	Right	U			
7:00 AM	1	0	0	0	0	0	0	0	0	0	0	0	0	1	0	0	0	2	
7:15 AM	0	0	0	0	0	0	0	0	0	0	0	0	1	1	0	0	0	2	
7:30 AM	0	0	0	0	0	0	0	0	0	1	0	0	2	0	0	0	0	3	
7:45 AM	0	0	0	0	0	0	0	0	0	0	1	0	1	1	0	0	0	3	10
8:00 AM	0	0	0	0	0	0	0	0	0	1	1	0	0	0	0	0	0	2	10
8:15 AM	0	0	0	0	0	0	0	0	0	0	0	0	0	0	0	0	0	0	8
8:30 AM	0	0	0	0	0	0	0	0	0	1	1	0	1	0	0	0	0	3	8
8:45 AM	0	0	0	0	0	0	0	0	0	0	0	0	0	0	0	0	0	0	5
Peak 15-Min Flowrates	Northbound				Southbound				Eastbound				Westbound				Total		
	Left	Thru	Right	U	Left	Thru	Right	U	Left	Thru	Right	U	Left	Thru	Right	U			
All Vehicles	0	0	0	0	0	0	0	0	0	4	0	0	8	0	0	0	0	12	
Heavy Trucks	0	0	0	0	0	0	0	0	0	0	0	0	0	0	0	0	0	0	
Buses																			
Pedestrians		0				0				0				0				0	
Bicycles	0	0	0		0	0	0		0	0	0		0	0	0			0	
Scoters																			

Comments:

LOCATION: Pinyon Jay Dr -- Hames Dr
CITY/STATE: El Paso, CO

QC JOB #: 15171503
DATE: Tue, Jan 28 2020

Peak-Hour: 7:00 AM -- 8:00 AM
 Peak 15-Min: 7:30 AM -- 7:45 AM

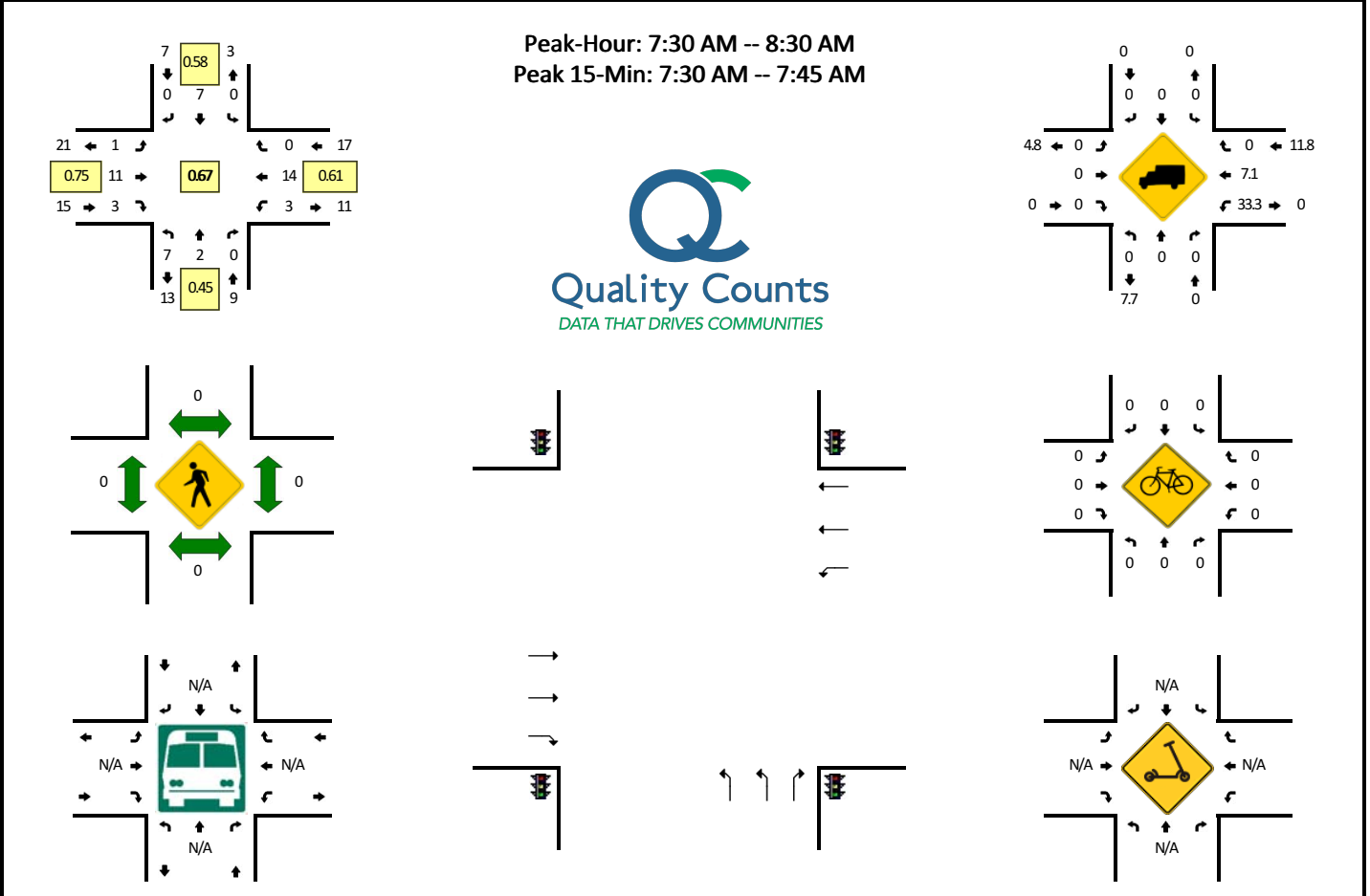


15-Min Count Period Beginning At	Pinyon Jay Dr (Northbound)				Pinyon Jay Dr (Southbound)				Hames Dr (Eastbound)				Hames Dr (Westbound)				Total	Hourly Totals
	Left	Thru	Right	U	Left	Thru	Right	U	Left	Thru	Right	U	Left	Thru	Right	U		
7:00 AM	1	0	0	0	0	1	0	0	0	0	1	0	0	0	0	0	3	
7:15 AM	0	1	0	0	0	2	1	0	0	0	0	0	0	0	0	0	4	
7:30 AM	0	0	0	0	0	5	2	0	3	0	1	0	0	0	0	0	11	
7:45 AM	0	0	0	0	0	4	1	0	0	0	1	0	0	0	0	0	6	24
8:00 AM	0	1	0	0	0	1	0	0	0	0	0	0	0	0	0	0	2	23
8:15 AM	0	1	0	0	0	2	0	0	1	0	0	0	0	0	0	0	4	23
8:30 AM	0	0	0	0	0	0	0	0	0	0	0	0	0	0	0	0	0	12
8:45 AM	0	0	0	0	0	2	0	0	1	0	0	0	0	0	0	0	3	9
Peak 15-Min Flowrates	Northbound				Southbound				Eastbound				Westbound				Total	
	Left	Thru	Right	U	Left	Thru	Right	U	Left	Thru	Right	U	Left	Thru	Right	U		
All Vehicles	0	0	0	0	0	20	8	0	12	0	4	0	0	0	0	0	44	
Heavy Trucks	0	0	0	0	0	0	0	0	0	0	4	0	0	0	0	0	4	
Buses																		
Pedestrians		0				0				0				0			0	
Bicycles	0	0	0		0	0	0		0	0	0		0	0	0		0	
Scoters																		

Comments:

LOCATION: Pinyon Jay Dr -- Meadowbrook Pkwy
CITY/STATE: El Paso, CO

QC JOB #: 15171505
DATE: Tue, Jan 28 2020



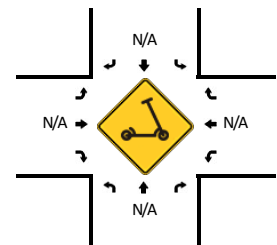
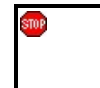
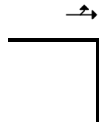
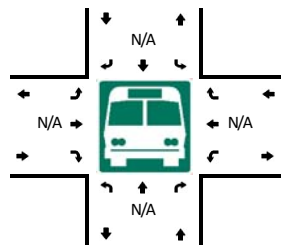
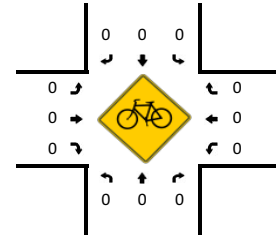
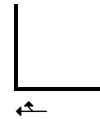
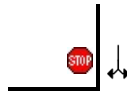
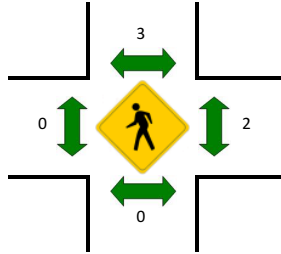
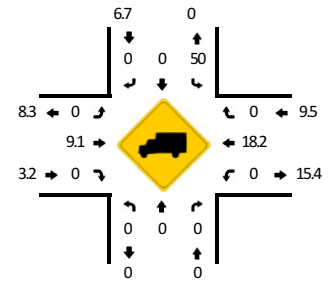
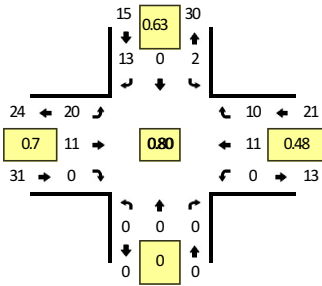
15-Min Count Period Beginning At	Pinyon Jay Dr (Northbound)				Pinyon Jay Dr (Southbound)				Meadowbrook Pkwy (Eastbound)				Meadowbrook Pkwy (Westbound)				Total	Hourly Totals
	Left	Thru	Right	U	Left	Thru	Right	U	Left	Thru	Right	U	Left	Thru	Right	U		
7:00 AM	0	0	0	0	0	1	0	0	0	3	0	0	0	4	0	0	8	
7:15 AM	1	0	1	0	1	2	0	0	0	0	1	0	0	1	0	0	7	
7:30 AM	5	0	0	0	0	3	0	0	0	3	0	0	1	6	0	0	18	
7:45 AM	0	1	0	0	0	3	0	0	0	4	1	0	1	4	0	0	14	47
8:00 AM	1	1	0	0	0	1	0	0	0	1	1	0	0	2	0	0	7	46
8:15 AM	1	0	0	0	0	0	0	0	1	3	1	0	1	2	0	0	9	48
8:30 AM	1	0	0	0	0	0	1	0	0	1	0	0	0	2	0	0	5	35
8:45 AM	2	0	0	0	0	1	0	0	0	2	0	0	1	2	0	0	8	29
Peak 15-Min Flowrates	Northbound				Southbound				Eastbound				Westbound				Total	
	Left	Thru	Right	U	Left	Thru	Right	U	Left	Thru	Right	U	Left	Thru	Right	U		
All Vehicles	20	0	0	0	0	12	0	0	0	12	0	0	4	24	0	0	72	
Heavy Trucks	0	0	0	0	0	0	0	0	0	0	0	0	0	0	0	0	0	
Buses																	0	
Pedestrians		0				0				0				0			0	
Bicycles	0	0	0		0	0	0		0	0	0		0	0	0		0	
Scoters																	0	

Comments:

LOCATION: Springside Dr -- Meadowbrook Pkwy
CITY/STATE: El Paso, CO

QC JOB #: 15171507
DATE: Tue, Jan 28 2020

Peak-Hour: 7:00 AM -- 8:00 AM
 Peak 15-Min: 7:30 AM -- 7:45 AM



15-Min Count Period Beginning At	Springside Dr (Northbound)				Springside Dr (Southbound)				Meadowbrook Pkwy (Eastbound)				Meadowbrook Pkwy (Westbound)				Total	Hourly Totals
	Left	Thru	Right	U	Left	Thru	Right	U	Left	Thru	Right	U	Left	Thru	Right	U		
7:00 AM	0	0	0	0	0	0	2	0	7	3	0	0	0	2	2	0	16	
7:15 AM	0	0	0	0	1	0	5	0	3	0	0	0	0	2	0	0	11	
7:30 AM	0	0	0	0	0	0	3	0	4	3	0	0	0	4	7	0	21	
7:45 AM	0	0	0	0	1	0	3	0	6	5	0	0	0	3	1	0	19	67
8:00 AM	0	0	0	0	1	0	3	0	2	0	0	0	0	2	1	0	9	60
8:15 AM	0	0	0	0	2	0	2	0	1	3	0	0	0	0	3	0	11	60
8:30 AM	0	0	0	0	0	0	2	0	0	1	0	0	0	2	2	0	7	46
8:45 AM	0	0	0	0	0	0	2	0	2	2	0	0	0	1	3	0	10	37

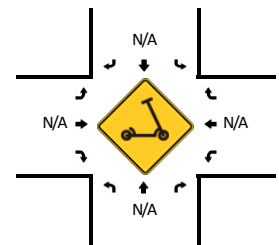
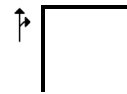
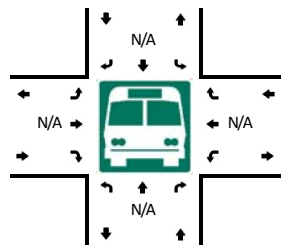
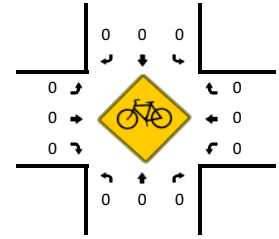
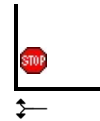
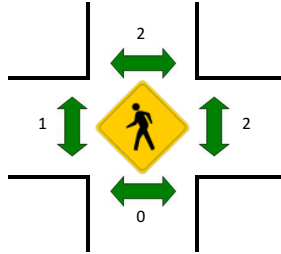
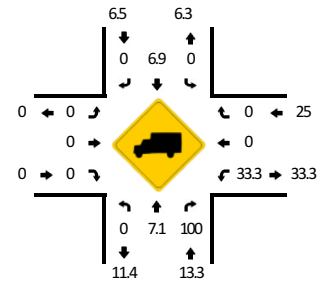
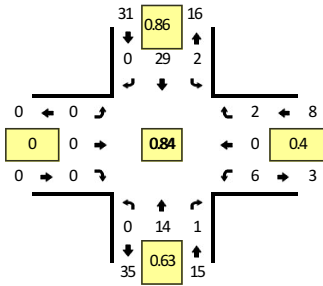
Peak 15-Min Flowrates	Northbound				Southbound				Eastbound				Westbound				Total
	Left	Thru	Right	U	Left	Thru	Right	U	Left	Thru	Right	U	Left	Thru	Right	U	
All Vehicles	0	0	0	0	0	0	12	0	16	12	0	0	0	16	28	0	84
Heavy Trucks	0	0	0	0	0	0	0	0	0	0	0	0	0	0	0	0	0
Buses																	
Pedestrians		0				0				0				0			0
Bicycles	0	0	0		0	0	0		0	0	0		0	0	0		0
Scoters																	

Comments:

LOCATION: Meadowbrook Pkwy -- Hames Dr
CITY/STATE: El Paso, CO

QC JOB #: 15171509
DATE: Tue, Jan 28 2020

Peak-Hour: 7:00 AM -- 8:00 AM
 Peak 15-Min: 7:00 AM -- 7:15 AM



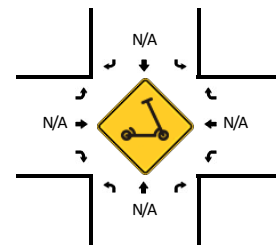
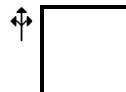
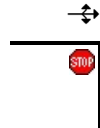
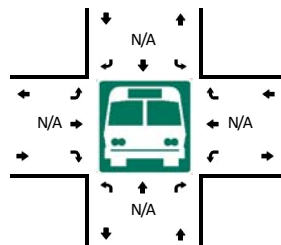
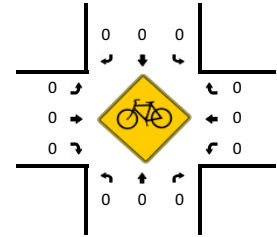
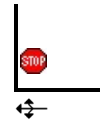
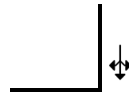
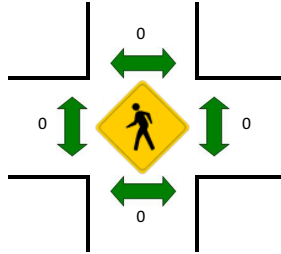
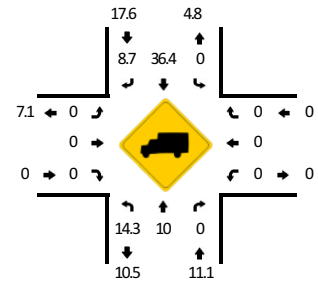
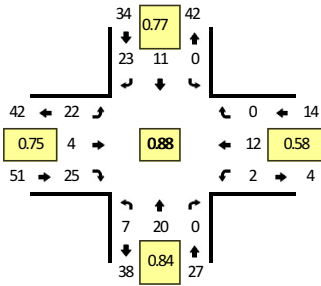
15-Min Count Period Beginning At	Meadowbrook Pkwy (Northbound)				Meadowbrook Pkwy (Southbound)				Hames Dr (Eastbound)				Hames Dr (Westbound)				Total	Hourly Totals
	Left	Thru	Right	U	Left	Thru	Right	U	Left	Thru	Right	U	Left	Thru	Right	U		
7:00 AM	0	4	0	0	0	7	0	0	0	0	0	0	4	0	1	0	16	
7:15 AM	0	2	0	0	0	7	0	0	0	0	0	0	1	0	1	0	11	
7:30 AM	0	3	0	0	1	8	0	0	0	0	0	0	0	0	0	0	12	
7:45 AM	0	5	1	0	1	7	0	0	0	0	0	0	1	0	0	0	15	54
8:00 AM	0	0	1	0	0	4	0	0	0	0	0	0	0	0	2	0	7	45
8:15 AM	0	4	0	0	1	0	0	0	0	0	0	0	0	0	0	0	5	39
8:30 AM	0	1	1	0	0	4	0	0	0	0	0	0	1	0	0	0	7	34
8:45 AM	0	3	0	0	0	2	0	0	0	0	0	0	0	0	0	0	5	24
Peak 15-Min Flowrates	Northbound				Southbound				Eastbound				Westbound				Total	
	Left	Thru	Right	U	Left	Thru	Right	U	Left	Thru	Right	U	Left	Thru	Right	U		
All Vehicles	0	16	0	0	0	28	0	0	0	0	0	0	16	0	4	0	64	
Heavy Trucks	0	4	0	0	0	0	0	0	0	0	0	0	0	0	0	0	4	
Buses																	0	
Pedestrians		0				0				0				0			0	
Bicycles	0	0	0		0	0	0		0	0	0		0	0	0		0	
Scoters																	0	

Comments:

LOCATION: Meadowbrook Pkwy -- Riverwalk Pkwy
CITY/STATE: El Paso, CO

QC JOB #: 15171511
DATE: Tue, Jan 28 2020

Peak-Hour: 7:00 AM -- 8:00 AM
 Peak 15-Min: 7:00 AM -- 7:15 AM



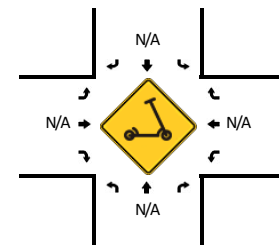
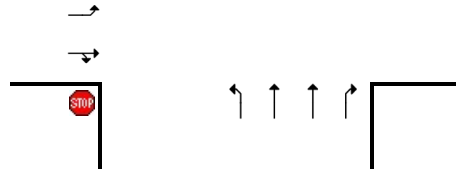
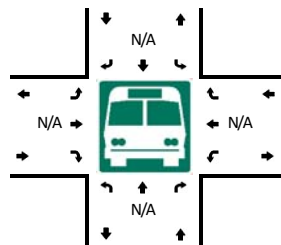
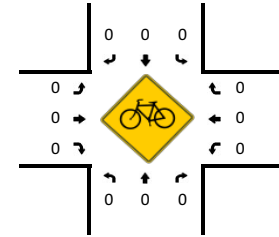
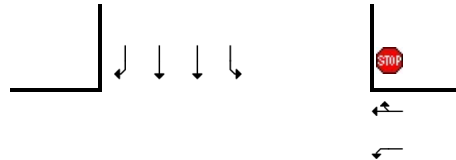
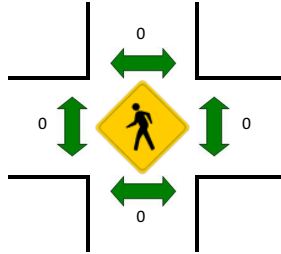
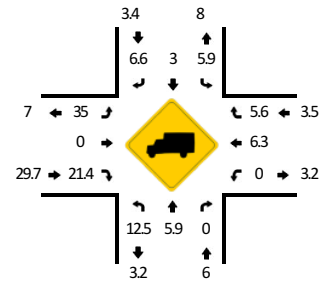
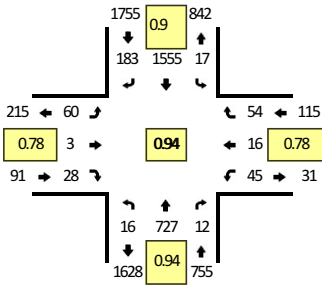
15-Min Count Period Beginning At	Meadowbrook Pkwy (Northbound)				Meadowbrook Pkwy (Southbound)				Riverwalk Pkwy (Eastbound)				Riverwalk Pkwy (Westbound)				Total	Hourly Totals
	Left	Thru	Right	U	Left	Thru	Right	U	Left	Thru	Right	U	Left	Thru	Right	U		
7:00 AM	1	4	0	0	0	3	8	0	7	2	8	0	0	3	0	0	36	
7:15 AM	1	5	0	0	0	2	6	0	3	1	4	0	0	5	0	0	27	
7:30 AM	2	6	0	0	0	2	2	0	7	1	8	0	0	0	0	0	28	
7:45 AM	3	5	0	0	0	4	7	0	5	0	5	0	2	4	0	0	35	126
8:00 AM	2	4	0	0	0	1	1	0	5	1	2	0	0	1	0	0	17	107
8:15 AM	1	2	1	0	0	0	1	0	2	3	1	0	0	2	0	0	13	93
8:30 AM	2	5	0	0	0	1	1	0	0	2	2	0	0	2	0	0	15	80
8:45 AM	1	4	0	0	0	1	1	0	1	1	0	0	0	1	0	0	10	55
Peak 15-Min Flowrates	Northbound				Southbound				Eastbound				Westbound				Total	
	Left	Thru	Right	U	Left	Thru	Right	U	Left	Thru	Right	U	Left	Thru	Right	U		
All Vehicles	4	16	0	0	0	12	32	0	28	8	32	0	0	12	0	0	144	
Heavy Trucks	0	4	0	0	0	4	0	0	0	0	0	0	0	0	0	0	8	
Buses																	0	
Pedestrians		0				0				0				0			0	
Bicycles	0	0	0		0	0	0		0	0	0		0	0	0		0	
Scoters																	0	

Comments:

LOCATION: Marksheffel Rd -- Meadowbrook Pkwy
CITY/STATE: Cimarron Hills, CO

QC JOB #: 15171513
DATE: Tue, Jan 28 2020

Peak-Hour: 7:00 AM -- 8:00 AM
 Peak 15-Min: 7:15 AM -- 7:30 AM



15-Min Count Period Beginning At	Marksheffel Rd (Northbound)				Marksheffel Rd (Southbound)				Meadowbrook Pkwy (Eastbound)				Meadowbrook Pkwy (Westbound)				Total	Hourly Totals
	Left	Thru	Right	U	Left	Thru	Right	U	Left	Thru	Right	U	Left	Thru	Right	U		
7:00 AM	5	172	0	0	4	435	34	0	19	0	8	0	16	2	16	0	711	
7:15 AM	3	194	4	0	5	438	43	0	11	0	3	0	10	1	8	0	720	
7:30 AM	3	191	4	0	1	375	57	1	10	2	9	0	8	9	20	0	690	
7:45 AM	5	170	4	0	6	307	49	0	20	1	8	0	11	4	10	0	595	2716
8:00 AM	6	121	4	0	4	299	19	0	18	2	3	0	4	0	10	0	490	2495
8:15 AM	4	113	3	0	7	247	16	0	13	1	3	0	7	0	10	0	424	2199
8:30 AM	1	133	3	0	3	238	27	0	24	1	3	0	5	0	9	0	447	1956
8:45 AM	5	94	2	0	1	176	27	0	12	1	2	0	3	1	10	0	334	1695

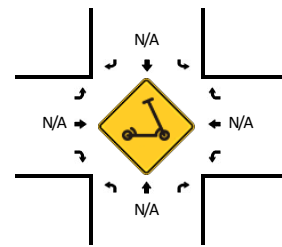
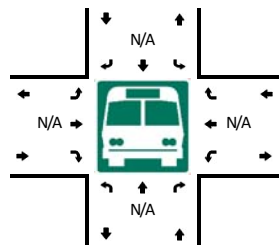
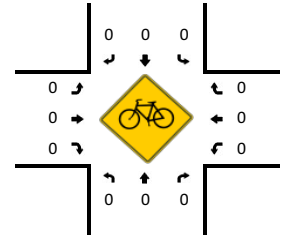
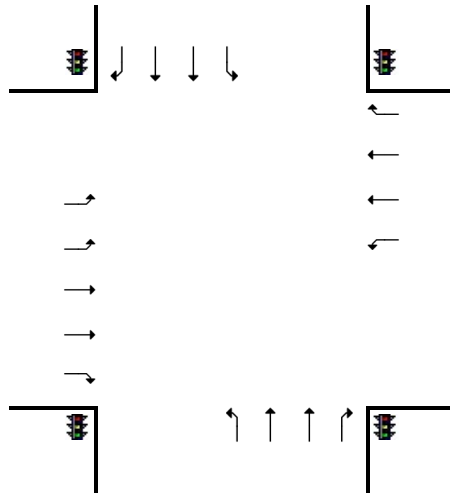
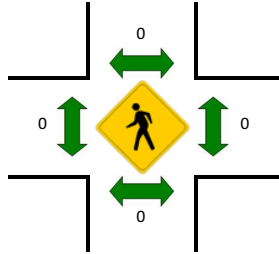
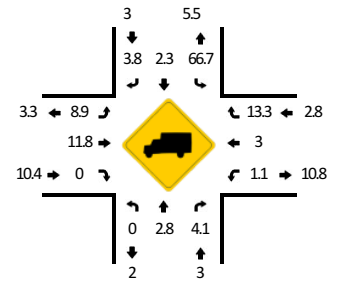
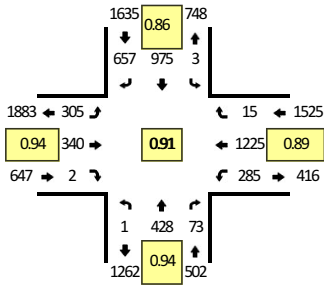
Peak 15-Min Flowrates	Northbound				Southbound				Eastbound				Westbound				Total
	Left	Thru	Right	U	Left	Thru	Right	U	Left	Thru	Right	U	Left	Thru	Right	U	
All Vehicles	12	776	16	0	20	1752	172	0	44	0	12	0	40	4	32	0	2880
Heavy Trucks	0	28	0		0	60	12		16	0	4		0	0	8		128
Buses																	0
Pedestrians		0				0				0				0			0
Bicycles	0	0	0		0	0	0		0	0	0		0	0	0		0
Scoters																	0

Comments:

LOCATION: Marksheffel Rd -- Hwy 24
CITY/STATE: Colorado Springs, CO

QC JOB #: 15171515
DATE: Tue, Jan 28 2020

Peak-Hour: 7:00 AM -- 8:00 AM
 Peak 15-Min: 7:15 AM -- 7:30 AM



15-Min Count Period Beginning At	Marksheffel Rd (Northbound)				Marksheffel Rd (Southbound)				Hwy 24 (Eastbound)				Hwy 24 (Westbound)				Total	Hourly Totals
	Left	Thru	Right	U	Left	Thru	Right	U	Left	Thru	Right	U	Left	Thru	Right	U		
7:00 AM	1	103	19	0	1	286	190	0	75	96	0	0	87	312	4	0	1174	
7:15 AM	0	111	23	0	0	255	187	0	81	90	1	0	73	355	2	0	1178	
7:30 AM	0	111	14	0	1	240	151	0	78	77	0	0	58	281	5	0	1016	
7:45 AM	0	103	17	0	1	194	129	0	71	77	1	0	67	277	4	0	941	4309
8:00 AM	0	70	6	0	0	162	165	0	57	94	1	0	57	222	3	1	838	3973
8:15 AM	2	75	12	0	2	135	130	0	43	75	0	0	32	193	2	1	702	3497
8:30 AM	0	80	11	0	0	100	130	0	51	83	1	0	30	191	4	0	681	3162
8:45 AM	3	47	7	0	1	104	91	0	50	64	2	0	17	144	4	0	534	2755

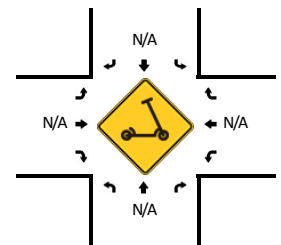
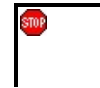
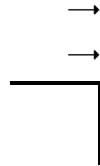
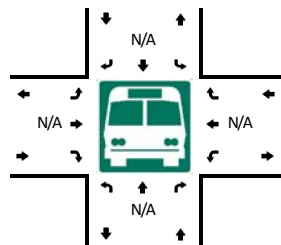
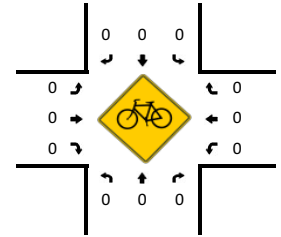
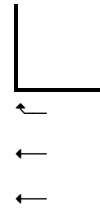
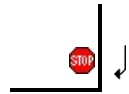
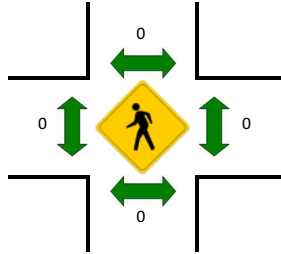
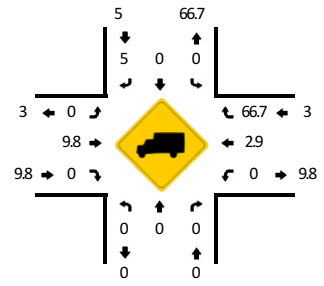
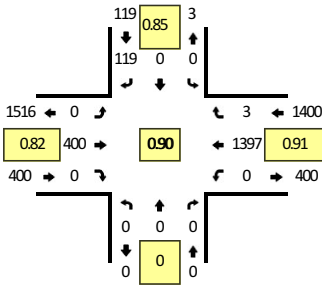
Peak 15-Min Flowrates	Northbound				Southbound				Eastbound				Westbound				Total
	Left	Thru	Right	U	Left	Thru	Right	U	Left	Thru	Right	U	Left	Thru	Right	U	
All Vehicles	0	444	92	0	0	1020	748	0	324	360	4	0	292	1420	8	0	4712
Heavy Trucks	0	8	0		0	24	36		20	40	0		8	24	0		160
Buses																	
Pedestrians		0				0				0				0			0
Bicycles	0	0	0		0	0	0		0	0	0		0	0	0		0
Scoters																	

Comments:

LOCATION: Brookings Dr -- Hwy 24
CITY/STATE: El Paso, CO

QC JOB #: 15171517
DATE: Tue, Jan 28 2020

Peak-Hour: 7:00 AM -- 8:00 AM
 Peak 15-Min: 7:15 AM -- 7:30 AM



15-Min Count Period Beginning At	Brookings Dr (Northbound)				Brookings Dr (Southbound)				Hwy 24 (Eastbound)				Hwy 24 (Westbound)				Total	Hourly Totals
	Left	Thru	Right	U	Left	Thru	Right	U	Left	Thru	Right	U	Left	Thru	Right	U		
7:00 AM	0	0	0	0	0	0	35	0	0	95	0	0	0	377	1	0	508	
7:15 AM	0	0	0	0	0	0	28	0	0	122	0	0	0	385	0	0	535	
7:30 AM	0	0	0	0	0	0	30	0	0	90	0	0	0	337	0	0	457	
7:45 AM	0	0	0	0	0	0	26	0	0	93	0	0	0	298	2	0	419	1919
8:00 AM	0	0	0	0	0	0	23	0	0	104	0	0	0	248	1	0	376	1787
8:15 AM	0	0	0	0	0	0	5	0	0	90	0	0	0	227	0	0	322	1574
8:30 AM	0	0	0	0	0	0	16	0	0	93	0	0	0	206	1	0	316	1433
8:45 AM	0	0	0	0	0	0	6	0	0	72	0	0	0	162	2	0	242	1256

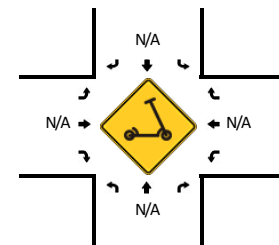
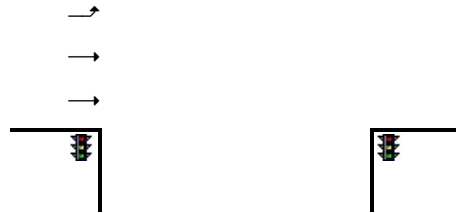
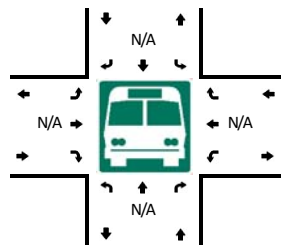
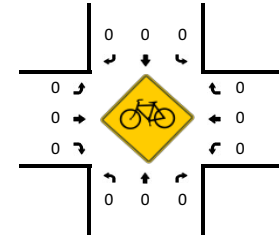
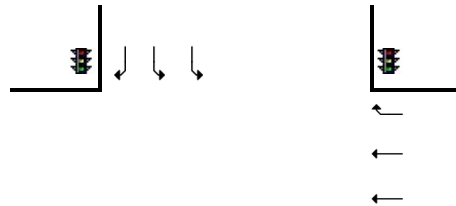
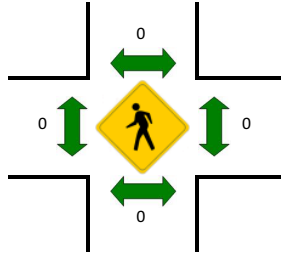
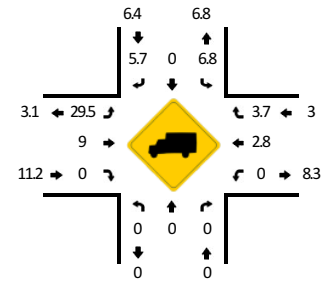
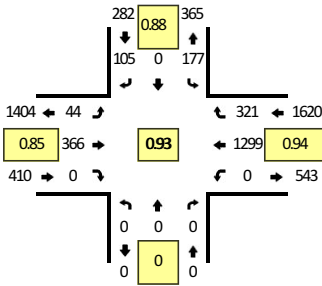
Peak 15-Min Flowrates	Northbound				Southbound				Eastbound				Westbound				Total
	Left	Thru	Right	U	Left	Thru	Right	U	Left	Thru	Right	U	Left	Thru	Right	U	
All Vehicles	0	0	0	0	0	0	112	0	0	488	0	0	0	1540	0	0	2140
Heavy Trucks	0	0	0	0	0	0	0	0	0	48	0	0	0	24	0	0	72
Buses																	
Pedestrians		0				0				0				0			0
Bicycles	0	0	0		0	0	0			0	0	0		0	0		0
Scoters																	

Comments:

LOCATION: Constitution Ave -- Hwy 24
CITY/STATE: Colorado Springs, CO

QC JOB #: 15171519
DATE: Tue, Jan 28 2020

Peak-Hour: 7:00 AM -- 8:00 AM
 Peak 15-Min: 7:15 AM -- 7:30 AM



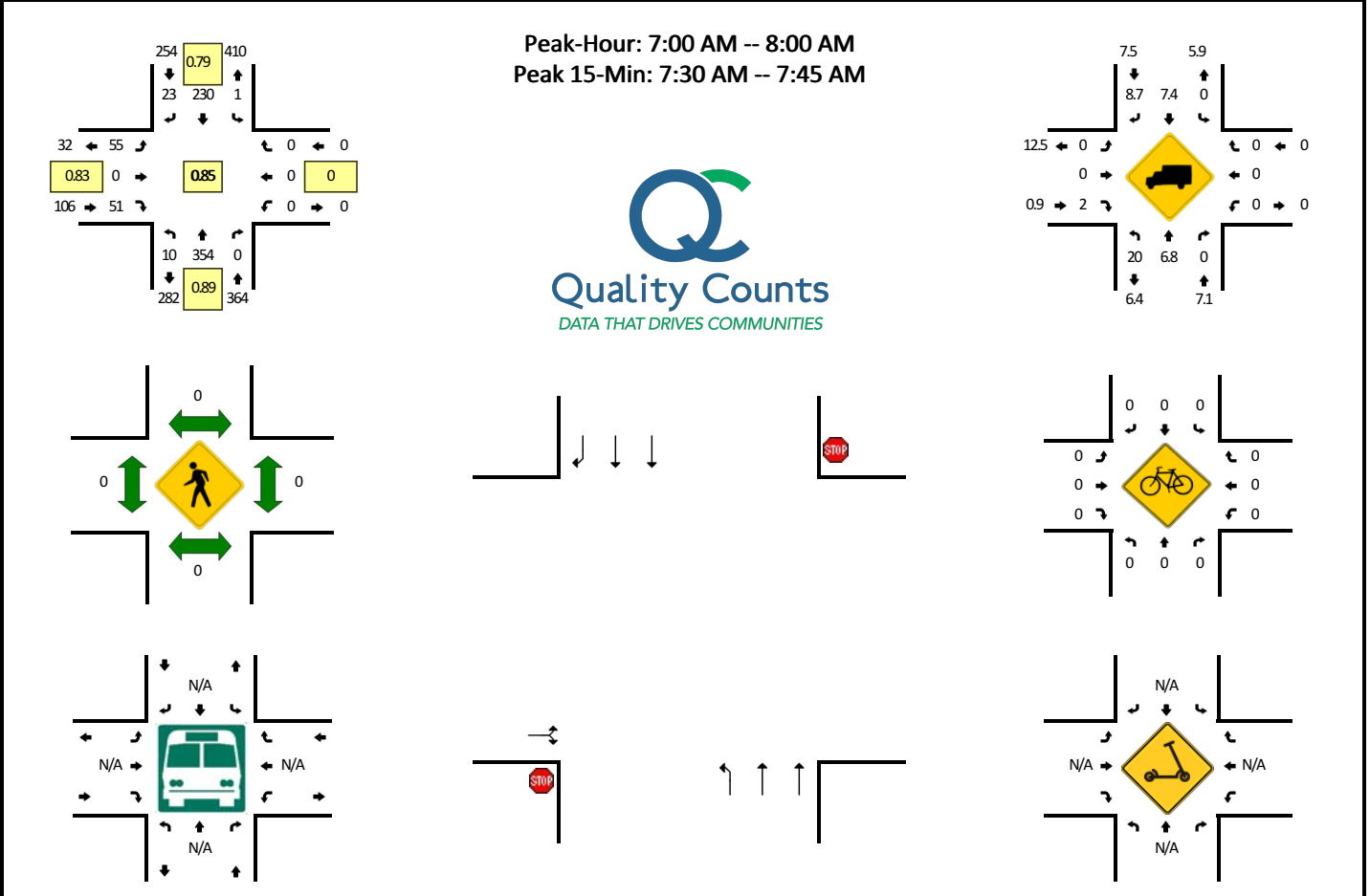
15-Min Count Period Beginning At	Constitution Ave (Northbound)				Constitution Ave (Southbound)				Hwy 24 (Eastbound)				Hwy 24 (Westbound)				Total	Hourly Totals
	Left	Thru	Right	U	Left	Thru	Right	U	Left	Thru	Right	U	Left	Thru	Right	U		
7:00 AM	0	0	0	0	43	0	34	0	12	85	0	0	0	349	69	0	592	
7:15 AM	0	0	0	0	39	0	31	0	11	110	0	0	0	350	80	0	621	
7:30 AM	0	0	0	0	59	0	21	0	10	97	0	0	0	304	93	0	584	
7:45 AM	0	0	0	0	36	0	19	0	11	74	0	0	0	296	79	0	515	2312
8:00 AM	0	0	0	0	37	0	18	0	15	91	0	0	0	232	66	0	459	2179
8:15 AM	0	0	0	0	31	0	16	0	9	79	0	1	0	211	62	0	409	1967
8:30 AM	0	0	0	0	27	0	22	0	8	92	0	0	0	175	52	0	376	1759
8:45 AM	0	0	0	0	26	0	14	0	11	59	0	0	0	149	67	0	326	1570

Peak 15-Min Flowrates	Northbound				Southbound				Eastbound				Westbound				Total
	Left	Thru	Right	U	Left	Thru	Right	U	Left	Thru	Right	U	Left	Thru	Right	U	
All Vehicles	0	0	0	0	156	0	124	0	44	440	0	0	0	1400	320	0	2484
Heavy Trucks	0	0	0	0	16	0	8	0	20	32	0	0	0	20	4	0	100
Buses																	
Pedestrians		0				0				0				0			0
Bicycles	0	0	0		0	0	0		0	0	0		0	0	0		0
Scoters																	

Comments:

LOCATION: Constitution Ave -- Meadowbrook Pkwy
CITY/STATE: El Paso, CO

QC JOB #: 15171521
DATE: Tue, Jan 28 2020



15-Min Count Period Beginning At	Constitution Ave (Northbound)				Constitution Ave (Southbound)				Meadowbrook Pkwy (Eastbound)				Meadowbrook Pkwy (Westbound)				Total	Hourly Totals
	Left	Thru	Right	U	Left	Thru	Right	U	Left	Thru	Right	U	Left	Thru	Right	U		
7:00 AM	2	77	0	1	0	57	3	0	14	0	16	0	0	0	0	0	170	
7:15 AM	3	87	0	0	0	56	7	0	12	0	14	0	0	0	0	0	179	
7:30 AM	2	100	0	0	0	71	9	0	21	0	11	0	0	0	0	0	214	
7:45 AM	2	90	0	0	0	46	4	1	8	0	10	0	0	0	0	0	161	724
8:00 AM	3	77	0	0	0	52	7	0	7	0	7	0	0	0	0	0	153	707
8:15 AM	4	70	0	0	0	42	5	0	13	0	1	0	0	0	0	0	135	663
8:30 AM	5	55	0	0	0	45	1	0	4	0	3	0	0	0	0	0	113	562
8:45 AM	1	75	0	1	0	43	4	0	9	0	1	0	0	0	0	0	134	535
Peak 15-Min Flowrates	Northbound				Southbound				Eastbound				Westbound				Total	
	Left	Thru	Right	U	Left	Thru	Right	U	Left	Thru	Right	U	Left	Thru	Right	U		
All Vehicles	8	400	0	0	0	284	36	0	84	0	44	0	0	0	0	0	856	
Heavy Trucks	0	16	0	0	0	12	4	0	0	0	0	0	0	0	0	0	32	
Buses																		
Pedestrians		0				0				0				0			0	
Bicycles	0	0	0		0	0	0		0	0	0		0	0	0		0	
Scoters																		

Comments:

LSC Transportation Consultants, Inc.

545 E Pikes Peak Ave, Suite 210
 Colorado Springs, CO 80905
 719-633-2868

File Name : Springside Dr - Constitution Ave AM
 Site Code : 00204140
 Start Date : 2/26/2020
 Page No : 1

Groups Printed- Unshifted

Start Time	Southbound					Constitution Ave Westbound					Springside Dr Northbound					Constitution Ave Eastbound					Int. Total
	L	T	R	U	App. Total	L	T	R	U	App. Total	L	T	R	U	App. Total	L	T	R	U	App. Total	
07:00 AM	0	0	0	0	0	0	102	0	0	102	34	0	5	0	39	0	77	5	1	83	224
07:15 AM	0	0	0	0	0	1	91	0	0	92	33	0	3	0	36	0	57	12	0	69	197
07:30 AM	0	0	0	0	0	2	111	0	0	113	37	0	1	0	38	0	61	7	0	68	219
07:45 AM	0	0	0	0	0	1	115	0	0	116	31	0	3	0	34	0	65	8	0	73	223
Total	0	0	0	0	0	4	419	0	0	423	135	0	12	0	147	0	260	32	1	293	863
08:00 AM	0	0	0	0	0	1	72	0	0	73	14	0	0	0	14	0	42	17	0	59	146
08:15 AM	0	0	0	0	0	0	67	0	0	67	13	0	1	0	14	0	48	15	0	63	144
08:30 AM	0	0	0	0	0	0	86	0	0	86	10	0	2	0	12	0	47	7	0	54	152
08:45 AM	0	0	0	0	0	0	61	0	0	61	14	0	1	0	15	0	45	7	0	52	128
Total	0	0	0	0	0	1	286	0	0	287	51	0	4	0	55	0	182	46	0	228	570
Grand Total	0	0	0	0	0	5	705	0	0	710	186	0	16	0	202	0	442	78	1	521	1433
Apprch %	0	0	0	0	0	0.7	99.3	0	0		92.1	0	7.9	0		0	84.8	15	0.2		
Total %	0	0	0	0	0	0.3	49.2	0	0	49.5	13	0	1.1	0	14.1	0	30.8	5.4	0.1	36.4	

LSC Transportation Consultants, Inc.

545 E Pikes Peak Ave, Suite 210
 Colorado Springs, CO 80905
 719-633-2868

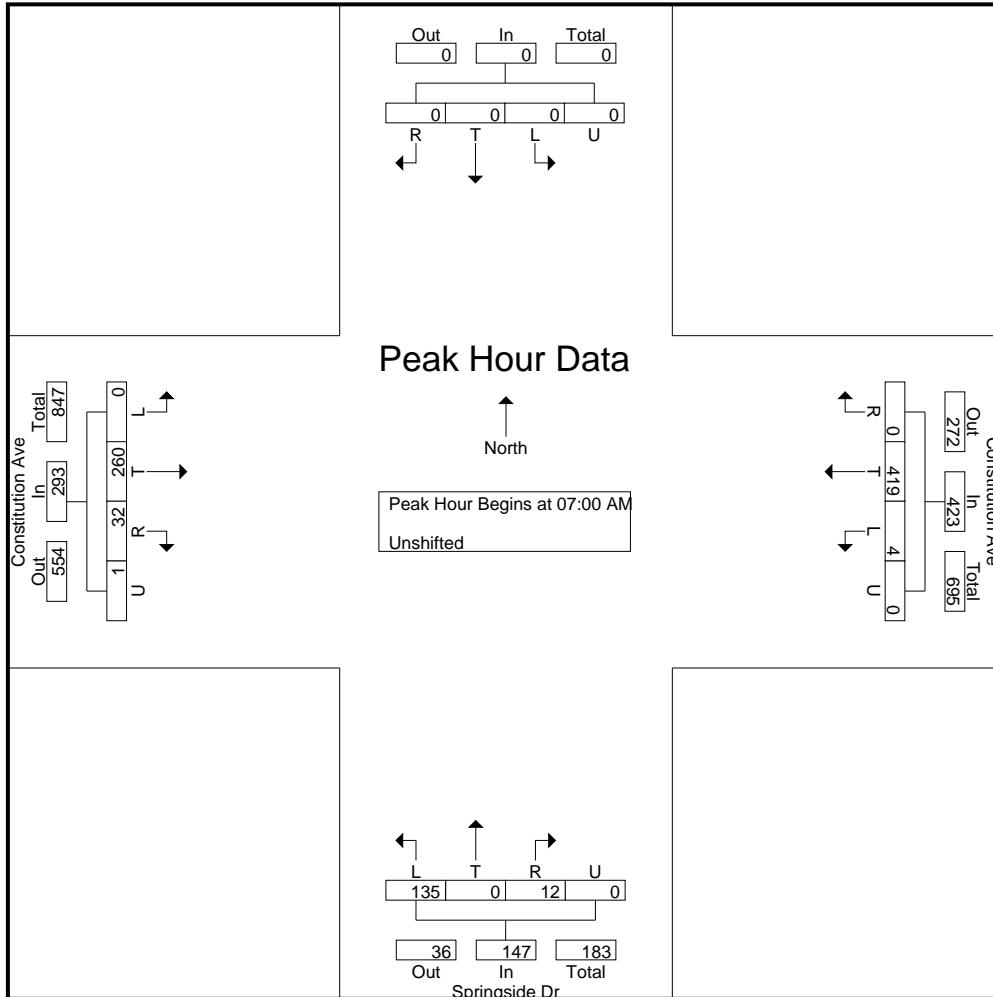
File Name : Springside Dr - Constitution Ave AM
 Site Code : 00204140
 Start Date : 2/26/2020
 Page No : 2

Start Time	Southbound					Constitution Ave Westbound					Springside Dr Northbound					Constitution Ave Eastbound					Int. Total
	L	T	R	U	App. Total	L	T	R	U	App. Total	L	T	R	U	App. Total	L	T	R	U	App. Total	
Peak Hour Analysis From 7:00:00 AM to 8:45:00 AM - Peak 1 of 1																					
Peak Hour for Entire Intersection Begins at 7:00:00 AM																					
7:00:00 AM	0	0	0	0	0	0	102	0	0	102	34	0	5	0	39	0	77	5	1	83	224
7:15:00 AM	0	0	0	0	0	1	91	0	0	92	33	0	3	0	36	0	57	12	0	69	197
7:30:00 AM	0	0	0	0	0	2	111	0	0	113	37	0	1	0	38	0	61	7	0	68	219
7:45:00 AM	0	0	0	0	0	1	115	0	0	116	31	0	3	0	34	0	65	8	0	73	223
Total Volume	0	0	0	0	0	4	419	0	0	423	135	0	12	0	147	0	260	32	1	293	863
% App. Total	0	0	0	0	0	0.9	99.1	0	0		91.8	0	8.2	0		0	88.7	10.9	0.3		
PHF	.000	.000	.000	.000	.000	.500	.911	.000	.000	.912	.912	.000	.600	.000	.942	.000	.844	.667	.250	.883	.963

LSC Transportation Consultants, Inc.

545 E Pikes Peak Ave, Suite 210
 Colorado Springs, CO 80905
 719-633-2868

File Name : Springside Dr - Constitution Ave AM
 Site Code : 00204140
 Start Date : 2/26/2020
 Page No : 3



LSC Transportation Consultants, Inc.

545 E Pikes Peak Ave, Suite 210
 Colorado Springs, CO 80905
 719-633-2868

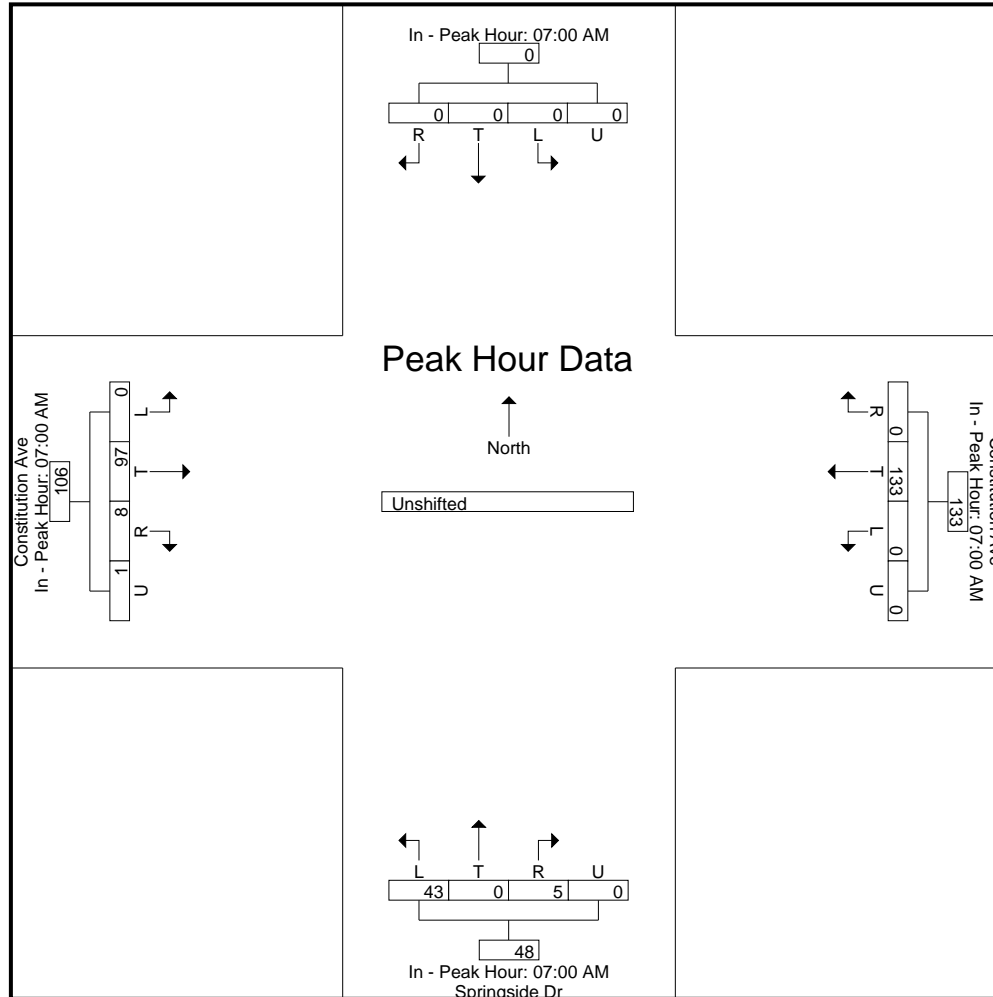
File Name : Springside Dr - Constitution Ave AM
 Site Code : 00204140
 Start Date : 2/26/2020
 Page No : 4

Start Time	Southbound					Constitution Ave Westbound					Springside Dr Northbound					Constitution Ave Eastbound					Int. Total
	L	T	R	U	App. Total	L	T	R	U	App. Total	L	T	R	U	App. Total	L	T	R	U	App. Total	
Peak Hour Analysis From 7:00:00 AM to 8:45:00 AM - Peak 1 of 1																					
Peak Hour for Each Approach Begins at:																					
	7:00:00 AM					7:00:00 AM					7:00:00 AM					7:00:00 AM					
+0 mins.	0	0	0	0	0	0	102	0	0	102	34	0	5	0	39	0	77	5	1	83	
+5 mins.	0	0	0	0	0	1	91	0	0	92	33	0	3	0	36	0	57	12	0	69	
+10 mins.	0	0	0	0	0	2	111	0	0	113	37	0	1	0	38	0	61	7	0	68	
+15 mins.	0	0	0	0	0	1	115	0	0	116	31	0	3	0	34	0	65	8	0	73	
Total Volume	0	0	0	0	0	4	419	0	0	423	135	0	12	0	147	0	260	32	1	293	
% App. Total	0	0	0	0	0	0.9	99.1	0	0		91.8	0	8.2	0		0	88.7	10.9	0.3		
PHF	.000	.000	.000	.000	.000	.500	.911	.000	.000	.912	.912	.000	.600	.000	.942	.000	.844	.667	.250	.883	

LSC Transportation Consultants, Inc.

545 E Pikes Peak Ave, Suite 210
 Colorado Springs, CO 80905
 719-633-2868

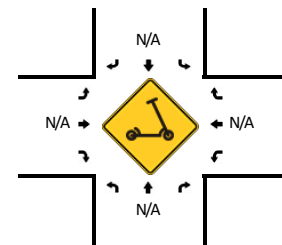
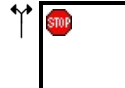
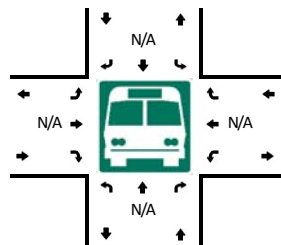
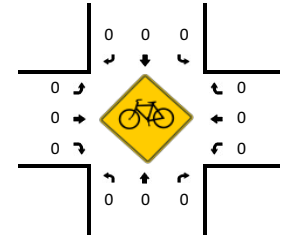
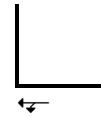
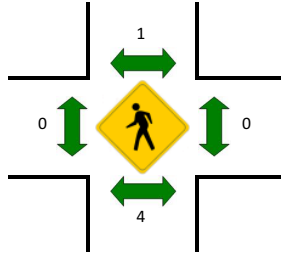
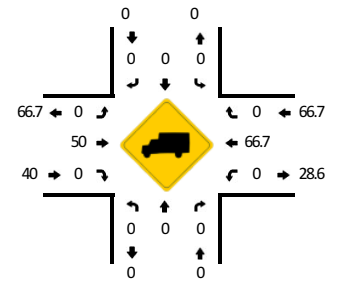
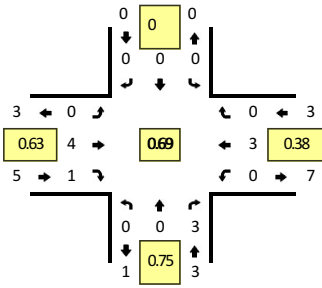
File Name : Springside Dr - Constitution Ave AM
 Site Code : 00204140
 Start Date : 2/26/2020
 Page No : 5



LOCATION: Latern Ct -- Hames Dr
CITY/STATE: El Paso, CO

QC JOB #: 15171502
DATE: Tue, Jan 28 2020

Peak-Hour: 2:00 PM -- 3:00 PM
 Peak 15-Min: 2:15 PM -- 2:30 PM



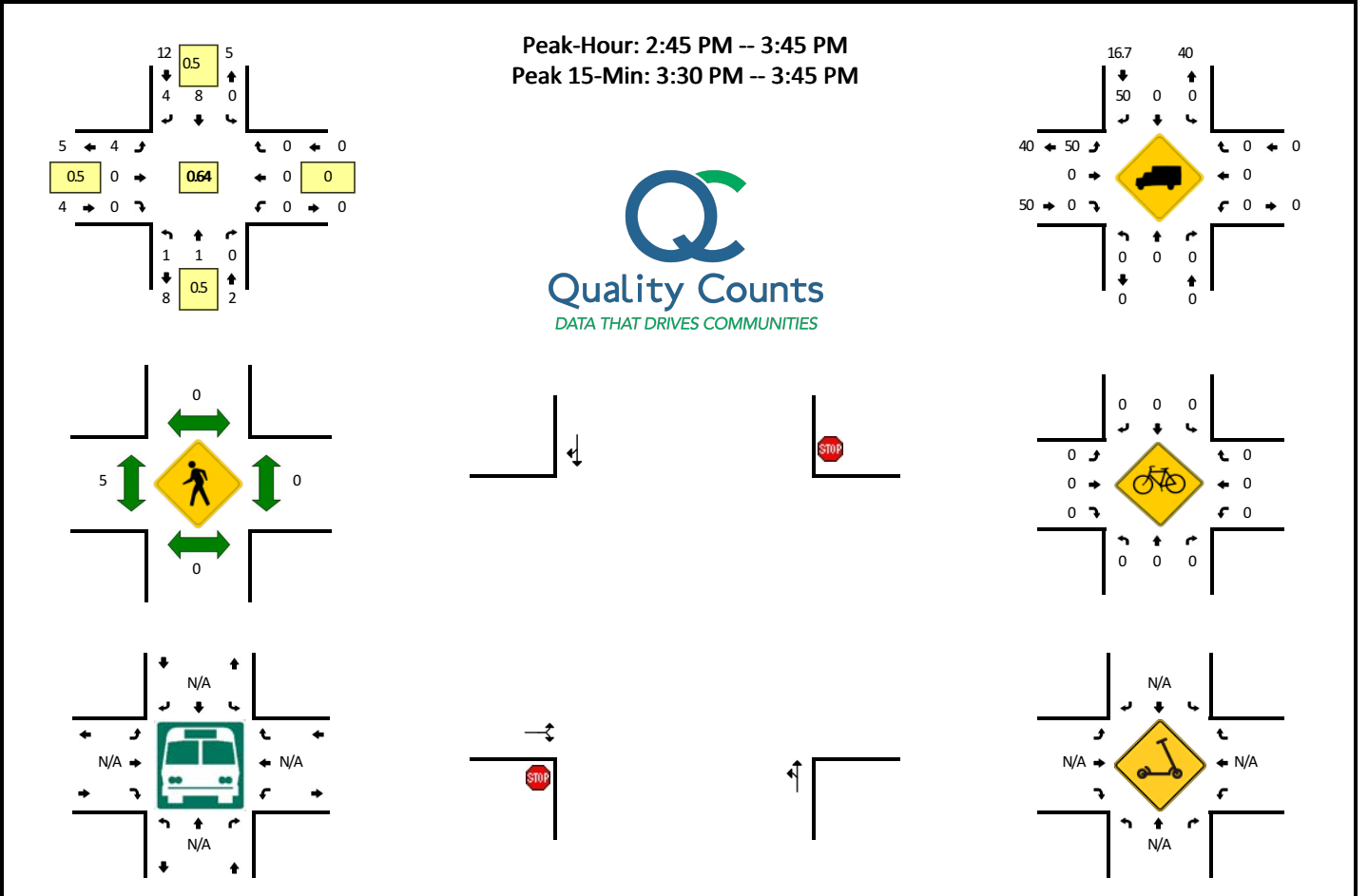
15-Min Count Period Beginning At	Latern Ct (Northbound)				Latern Ct (Southbound)				Hames Dr (Eastbound)				Hames Dr (Westbound)				Total	Hourly Totals
	Left	Thru	Right	U	Left	Thru	Right	U	Left	Thru	Right	U	Left	Thru	Right	U		
2:00 PM	0	0	1	0	0	0	0	0	0	0	1	0	0	0	0	0	2	
2:15 PM	0	0	1	0	0	0	0	0	0	2	0	0	0	1	0	0	4	
2:30 PM	0	0	0	0	0	0	0	0	0	1	0	0	0	0	0	0	1	
2:45 PM	0	0	1	0	0	0	0	0	0	1	0	0	0	2	0	0	4	11
3:00 PM	1	0	0	0	0	0	0	0	0	0	0	0	0	0	0	0	1	10
3:15 PM	0	0	1	0	0	0	0	0	0	0	1	0	0	0	0	0	2	8
3:30 PM	0	0	0	0	0	0	0	0	0	1	1	0	0	1	0	0	3	10
3:45 PM	0	0	1	0	0	0	0	0	0	1	1	0	1	0	0	0	4	10

Peak 15-Min Flowrates	Northbound				Southbound				Eastbound				Westbound				Total
	Left	Thru	Right	U	Left	Thru	Right	U	Left	Thru	Right	U	Left	Thru	Right	U	
All Vehicles	0	0	4	0	0	0	0	0	0	8	0	0	0	4	0	0	16
Heavy Trucks	0	0	0		0	0	0		0	4	0		0	4	0		8
Buses																	0
Pedestrians		0				0				0				0			0
Bicycles	0	0	0		0	0	0		0	0	0		0	0	0		0
Scoters																	0

Comments:

LOCATION: Pinyon Jay Dr -- Hames Dr
CITY/STATE: El Paso, CO

QC JOB #: 15171504
DATE: Tue, Jan 28 2020

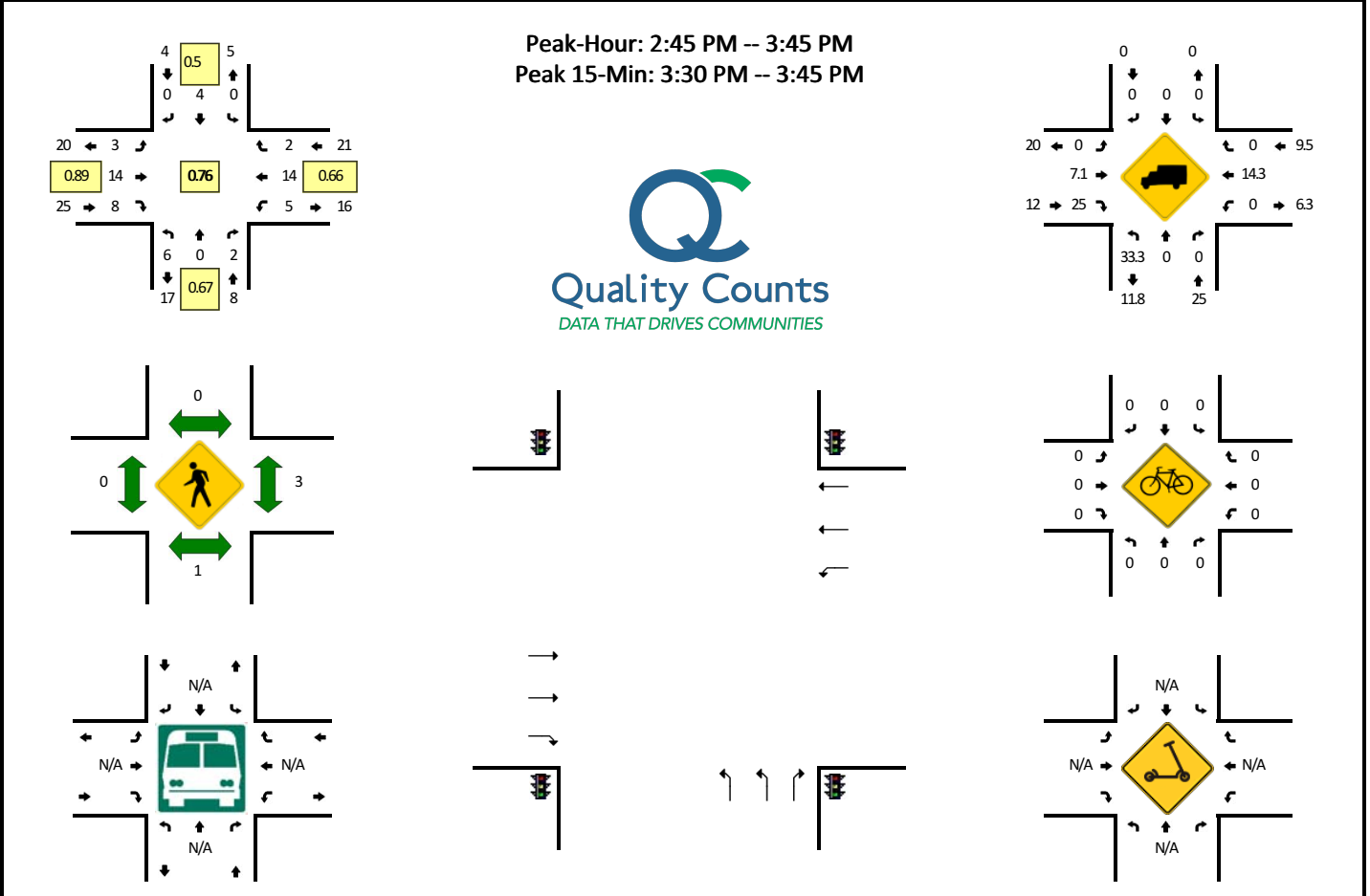


15-Min Count Period Beginning At	Pinyon Jay Dr (Northbound)				Pinyon Jay Dr (Southbound)				Hames Dr (Eastbound)				Hames Dr (Westbound)				Total	Hourly Totals
	Left	Thru	Right	U	Left	Thru	Right	U	Left	Thru	Right	U	Left	Thru	Right	U		
2:00 PM	0	1	0	0	0	3	0	0	0	0	0	0	0	0	0	0	4	
2:15 PM	0	0	0	0	0	2	0	0	1	0	0	0	0	0	0	0	3	
2:30 PM	0	0	0	0	0	0	0	0	0	0	0	0	0	0	0	0	0	
2:45 PM	1	0	0	0	0	1	2	0	2	0	0	0	0	0	0	0	6	13
3:00 PM	0	0	0	0	0	1	0	0	0	0	0	0	0	0	0	0	1	10
3:15 PM	0	1	0	0	0	2	0	0	1	0	0	0	0	0	0	0	4	11
3:30 PM	0	0	0	0	0	4	2	0	1	0	0	0	0	0	0	0	7	18
3:45 PM	1	0	0	0	0	2	0	0	1	0	1	0	0	0	0	0	5	17
Peak 15-Min Flowrates	Northbound				Southbound				Eastbound				Westbound				Total	
	Left	Thru	Right	U	Left	Thru	Right	U	Left	Thru	Right	U	Left	Thru	Right	U		
All Vehicles	0	0	0	0	0	16	8	0	4	0	0	0	0	0	0	0	28	
Heavy Trucks	0	0	0	0	0	0	4	0	0	0	0	0	0	0	0	0	4	
Buses																		
Pedestrians		0				0				4				0			4	
Bicycles	0	0	0		0	0	0		0	0	0		0	0	0		0	
Scooters																		

Comments:

LOCATION: Pinyon Jay Dr -- Meadowbrook Pkwy
CITY/STATE: El Paso, CO

QC JOB #: 15171506
DATE: Tue, Jan 28 2020



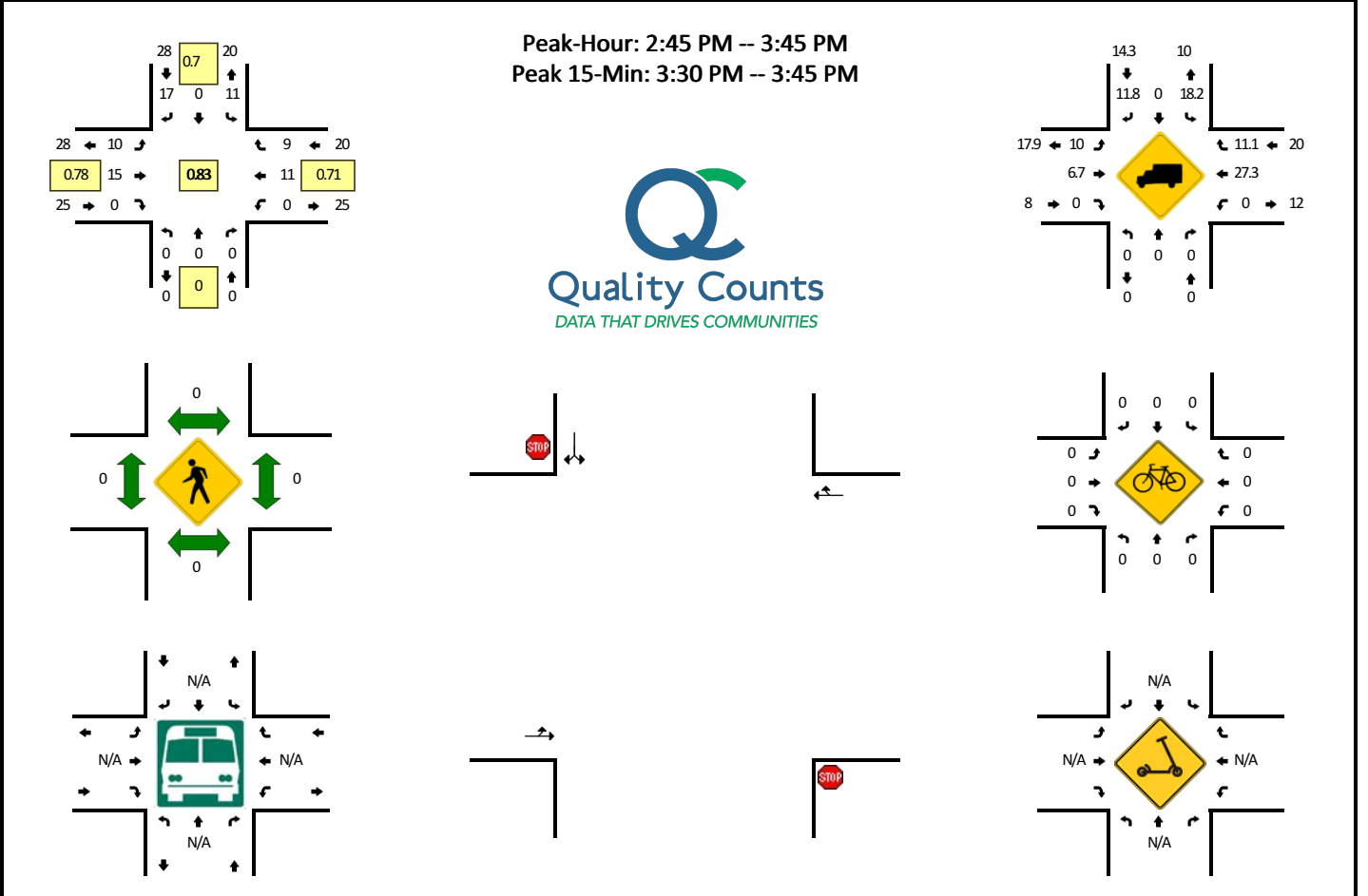
15-Min Count Period Beginning At	Pinyon Jay Dr (Northbound)				Pinyon Jay Dr (Southbound)				Meadowbrook Pkwy (Eastbound)				Meadowbrook Pkwy (Westbound)				Total	Hourly Totals
	Left	Thru	Right	U	Left	Thru	Right	U	Left	Thru	Right	U	Left	Thru	Right	U		
2:00 PM	3	0	0	0	0	1	1	0	1	0	2	0	1	2	0	0	11	
2:15 PM	0	0	0	0	0	0	0	0	0	1	0	0	2	3	0	0	6	
2:30 PM	1	0	0	0	0	0	0	1	0	3	0	0	0	1	0	0	6	
2:45 PM	2	0	1	0	0	0	0	0	1	3	3	0	1	3	1	0	15	38
3:00 PM	1	0	0	0	0	1	0	0	1	2	1	0	0	6	1	0	13	40
3:15 PM	1	0	1	0	0	1	0	0	1	5	1	0	0	1	0	0	11	45
3:30 PM	2	0	0	0	0	2	0	0	0	4	3	0	4	4	0	0	19	58
3:45 PM	1	1	0	0	0	1	0	0	0	5	2	0	0	3	0	0	13	56

Peak 15-Min Flowrates	Northbound				Southbound				Eastbound				Westbound				Total
	Left	Thru	Right	U	Left	Thru	Right	U	Left	Thru	Right	U	Left	Thru	Right	U	
All Vehicles	8	0	0	0	0	8	0	0	0	16	12	0	16	16	0	0	76
Heavy Trucks	0	0	0	0	0	0	0	0	0	0	4	0	0	0	0	0	4
Buses																	
Pedestrians		4				0				0				0			4
Bicycles	0	0	0		0	0	0		0	0	0		0	0	0		0
Scooters																	

Comments:

LOCATION: Springside Dr -- Meadowbrook Pkwy
CITY/STATE: El Paso, CO

QC JOB #: 15171508
DATE: Tue, Jan 28 2020



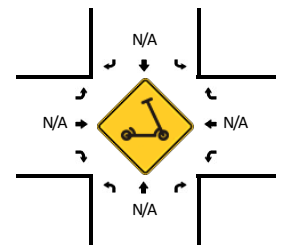
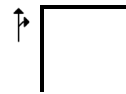
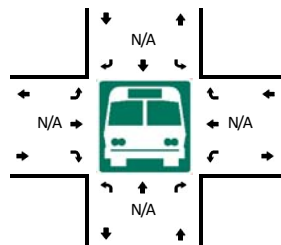
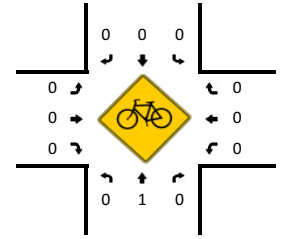
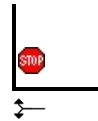
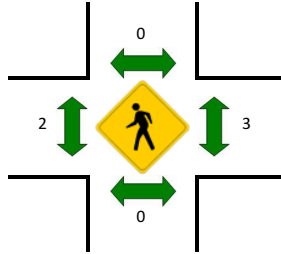
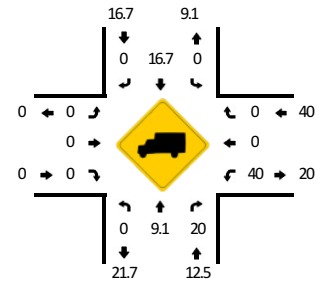
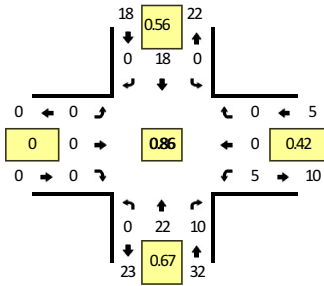
15-Min Count Period Beginning At	Springside Dr (Northbound)				Springside Dr (Southbound)				Meadowbrook Pkwy (Eastbound)				Meadowbrook Pkwy (Westbound)				Total	Hourly Totals
	Left	Thru	Right	U	Left	Thru	Right	U	Left	Thru	Right	U	Left	Thru	Right	U		
2:00 PM	0	0	0	0	3	0	4	0	0	0	0	0	0	1	5	0	13	
2:15 PM	0	0	0	0	0	0	1	0	1	1	0	0	0	0	3	0	6	
2:30 PM	0	0	0	0	0	0	0	0	5	3	0	0	0	1	1	0	10	
2:45 PM	0	0	0	0	2	0	5	0	3	5	0	0	0	2	3	0	20	49
3:00 PM	0	0	0	0	2	0	5	0	2	2	0	0	0	3	4	0	18	54
3:15 PM	0	0	0	0	1	0	3	0	1	6	0	0	0	2	0	0	13	61
3:30 PM	0	0	0	0	5	0	4	1	4	2	0	0	0	4	2	0	22	73
3:45 PM	0	0	0	0	2	0	6	1	1	5	0	0	0	2	2	0	19	72
Peak 15-Min Flowrates	Northbound				Southbound				Eastbound				Westbound				Total	
	Left	Thru	Right	U	Left	Thru	Right	U	Left	Thru	Right	U	Left	Thru	Right	U		
All Vehicles	0	0	0	0	20	0	16	4	16	8	0	0	0	16	8	0	88	
Heavy Trucks	0	0	0	0	4	0	4	0	0	0	0	0	0	0	0	0	8	
Buses																		
Pedestrians		0				0				0				0			0	
Bicycles	0	0	0		0	0	0		0	0	0		0	0	0		0	
Scooters																		

Comments:

LOCATION: Meadowbrook Pkwy -- Hames Dr
CITY/STATE: El Paso, CO

QC JOB #: 15171510
DATE: Tue, Jan 28 2020

Peak-Hour: 2:45 PM -- 3:45 PM
 Peak 15-Min: 3:15 PM -- 3:30 PM



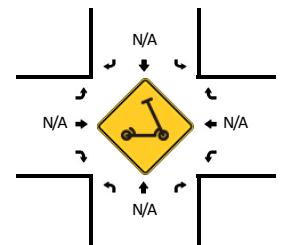
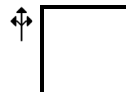
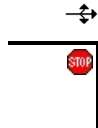
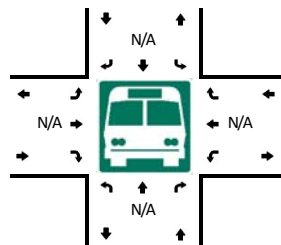
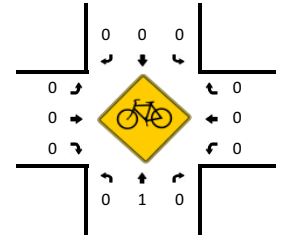
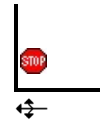
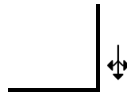
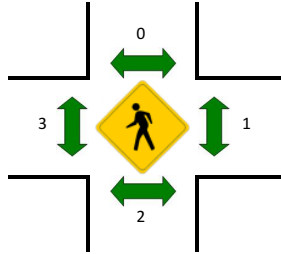
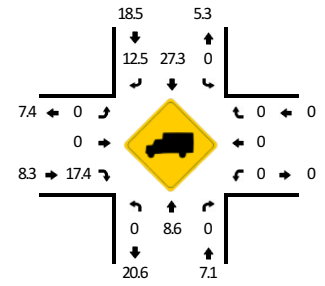
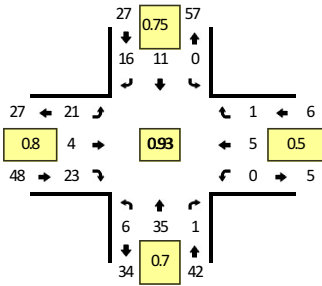
15-Min Count Period Beginning At	Meadowbrook Pkwy (Northbound)				Meadowbrook Pkwy (Southbound)				Hames Dr (Eastbound)				Hames Dr (Westbound)				Total	Hourly Totals
	Left	Thru	Right	U	Left	Thru	Right	U	Left	Thru	Right	U	Left	Thru	Right	U		
2:00 PM	0	0	1	0	0	4	0	0	0	0	0	0	1	0	0	0	6	
2:15 PM	0	3	2	0	1	0	0	0	0	0	0	0	1	0	0	0	7	
2:30 PM	0	5	1	1	0	4	0	0	0	0	0	0	0	0	0	0	11	
2:45 PM	0	3	3	0	0	3	0	0	0	0	0	0	3	0	0	0	12	36
3:00 PM	0	4	0	0	0	8	0	0	0	0	0	0	0	0	0	0	12	42
3:15 PM	0	10	2	0	0	4	0	0	0	0	0	0	0	0	0	0	16	51
3:30 PM	0	5	5	0	0	3	0	0	0	0	0	0	2	0	0	0	15	55
3:45 PM	0	6	1	0	1	3	0	0	0	0	0	0	0	0	0	0	11	54
Peak 15-Min Flowrates	Northbound				Southbound				Eastbound				Westbound				Total	
	Left	Thru	Right	U	Left	Thru	Right	U	Left	Thru	Right	U	Left	Thru	Right	U		
All Vehicles	0	40	8	0	0	16	0	0	0	0	0	0	0	0	0	0	64	
Heavy Trucks	0	0	0		0	4	0		0	0	0		0	0	0		4	
Buses																		
Pedestrians		0				0				4				0			4	
Bicycles	0	0	0		0	0	0		0	0	0		0	0	0		0	
Scoters																		

Comments:

LOCATION: Meadowbrook Pkwy -- Riverwalk Pkwy
CITY/STATE: El Paso, CO

QC JOB #: 15171512
DATE: Tue, Jan 28 2020

Peak-Hour: 2:45 PM -- 3:45 PM
 Peak 15-Min: 3:00 PM -- 3:15 PM



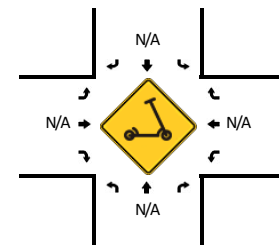
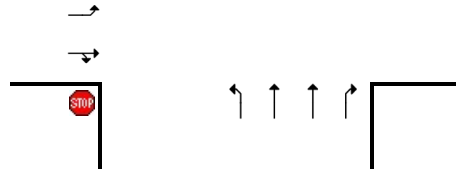
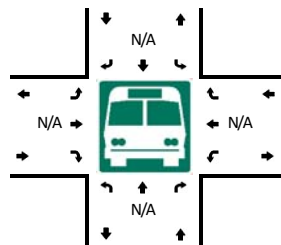
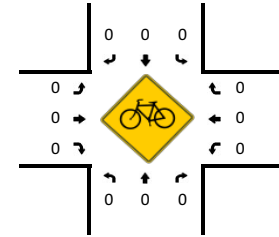
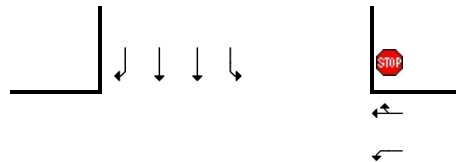
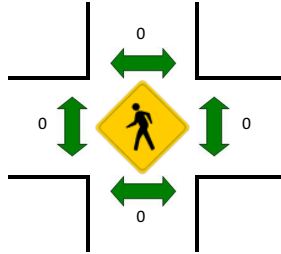
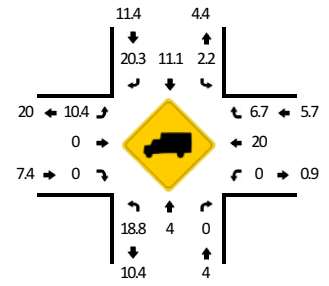
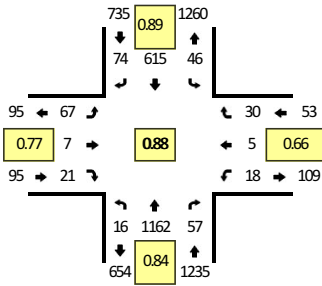
15-Min Count Period Beginning At	Meadowbrook Pkwy (Northbound)				Meadowbrook Pkwy (Southbound)				Riverwalk Pkwy (Eastbound)				Riverwalk Pkwy (Westbound)				Total	Hourly Totals
	Left	Thru	Right	U	Left	Thru	Right	U	Left	Thru	Right	U	Left	Thru	Right	U		
2:00 PM	2	5	1	0	0	3	2	0	2	1	2	0	0	0	0	0	18	
2:15 PM	1	4	0	0	0	2	2	0	0	1	2	0	0	0	0	0	12	
2:30 PM	1	2	1	0	0	2	3	0	3	2	2	0	0	1	0	0	17	
2:45 PM	3	5	1	0	0	2	3	0	8	1	4	0	0	2	0	0	29	76
3:00 PM	2	4	0	0	0	4	5	0	5	2	8	0	0	2	1	0	33	91
3:15 PM	1	14	0	0	0	2	3	0	3	1	8	0	0	1	0	0	33	112
3:30 PM	0	12	0	0	0	3	5	0	5	0	3	0	0	0	0	0	28	123
3:45 PM	0	11	2	0	0	0	2	0	2	2	5	0	0	0	0	0	24	118
Peak 15-Min Flowrates	Northbound				Southbound				Eastbound				Westbound				Total	
	Left	Thru	Right	U	Left	Thru	Right	U	Left	Thru	Right	U	Left	Thru	Right	U		
All Vehicles	8	16	0	0	0	16	20	0	20	8	32	0	0	8	4	0	132	
Heavy Trucks	0	0	0	0	0	0	4	0	0	0	4	0	0	0	0	0	8	
Buses																		
Pedestrians		0				0				8				4			12	
Bicycles	0	0	0		0	0	0		0	0	0		0	0	0		0	
Scoters																		

Comments:

LOCATION: Marksheffel Rd -- Meadowbrook Pkwy
CITY/STATE: Cimarron Hills, CO

QC JOB #: 15171514
DATE: Tue, Jan 28 2020

Peak-Hour: 3:00 PM -- 4:00 PM
Peak 15-Min: 3:45 PM -- 4:00 PM



15-Min Count Period Beginning At	Marksheffel Rd (Northbound)				Marksheffel Rd (Southbound)				Meadowbrook Pkwy (Eastbound)				Meadowbrook Pkwy (Westbound)				Total	Hourly Totals
	Left	Thru	Right	U	Left	Thru	Right	U	Left	Thru	Right	U	Left	Thru	Right	U		
2:00 PM	3	108	3	0	4	96	12	0	17	1	10	0	5	2	4	0	265	
2:15 PM	3	164	9	0	0	121	20	0	14	0	6	0	2	0	7	0	346	
2:30 PM	4	180	1	0	3	136	19	0	14	4	6	0	5	2	12	0	386	
2:45 PM	3	198	11	0	6	133	23	0	10	2	3	0	2	0	6	0	397	1394
3:00 PM	1	234	6	0	10	148	23	0	12	1	2	0	4	0	14	0	455	1584
3:15 PM	6	276	19	0	9	135	15	0	17	1	5	0	2	3	5	0	493	1731
3:30 PM	5	307	15	0	10	160	17	1	21	1	9	0	9	2	9	0	566	1911
3:45 PM	4	345	17	0	16	172	19	0	17	4	5	0	3	0	2	0	604	2118

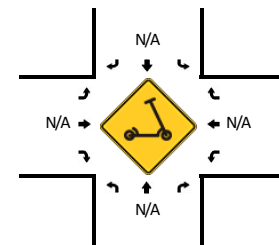
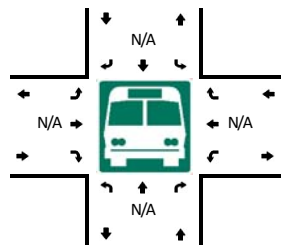
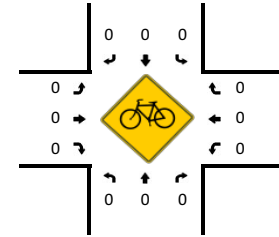
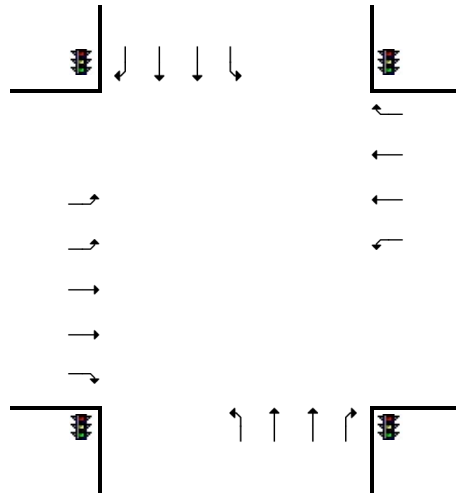
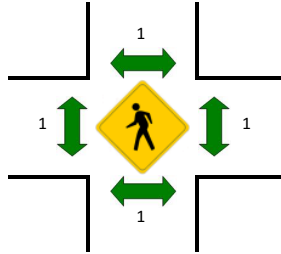
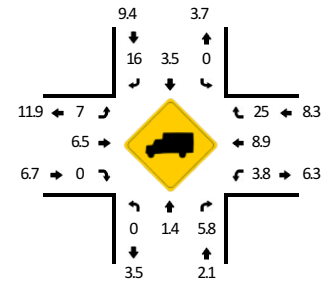
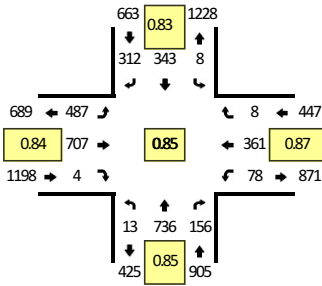
Peak 15-Min Flowrates	Northbound				Southbound				Eastbound				Westbound				Total	
	Left	Thru	Right	U	Left	Thru	Right	U	Left	Thru	Right	U	Left	Thru	Right	U		
All Vehicles	16	1380	68	0	64	688	76	0	68	16	20	0	12	0	8	0	2416	
Heavy Trucks	0	48	0		4	84	20		0	0	0		0	0	0		156	
Buses																		
Pedestrians		0				0				0				0				0
Bicycles	0	0	0		0	0	0		0	0	0		0	0	0			0
Scooters																		

Comments:

LOCATION: Marksheffel Rd -- Hwy 24
CITY/STATE: Colorado Springs, CO

QC JOB #: 15171516
DATE: Tue, Jan 28 2020

Peak-Hour: 3:00 PM -- 4:00 PM
Peak 15-Min: 3:45 PM -- 4:00 PM



15-Min Count Period Beginning At	Marksheffel Rd (Northbound)				Marksheffel Rd (Southbound)				Hwy 24 (Eastbound)				Hwy 24 (Westbound)				Total	Hourly Totals
	Left	Thru	Right	U	Left	Thru	Right	U	Left	Thru	Right	U	Left	Thru	Right	U		
2:00 PM	1	59	18	0	1	54	45	0	53	117	0	0	18	77	4	0	447	
2:15 PM	1	118	22	0	3	66	73	0	76	111	0	0	25	87	3	0	585	
2:30 PM	1	98	25	0	1	65	68	0	65	124	0	0	15	83	1	0	546	
2:45 PM	1	119	18	0	0	74	76	0	92	147	2	0	19	89	2	0	639	2217
3:00 PM	1	128	31	0	1	71	73	0	111	155	1	3	18	77	2	0	672	2442
3:15 PM	2	177	38	0	3	81	73	0	120	160	1	0	17	97	2	0	771	2628
3:30 PM	5	215	43	0	2	92	68	0	105	186	1	0	22	81	3	0	823	2905
3:45 PM	5	216	44	0	2	99	98	0	148	206	1	0	21	106	1	0	947	3213

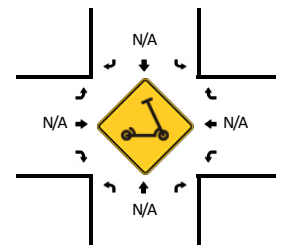
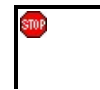
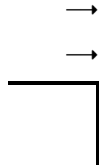
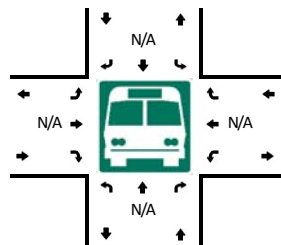
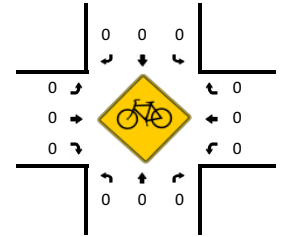
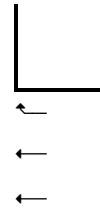
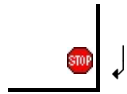
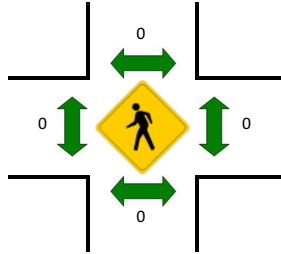
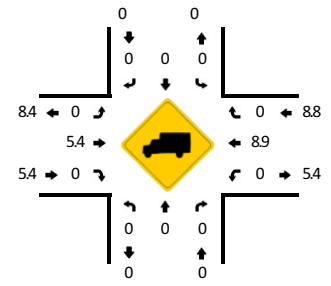
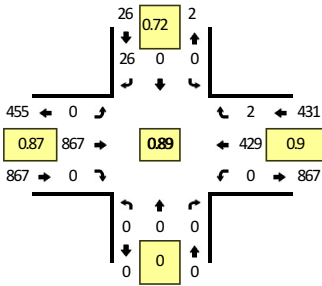
Peak 15-Min Flowrates	Northbound				Southbound				Eastbound				Westbound				Total
	Left	Thru	Right	U	Left	Thru	Right	U	Left	Thru	Right	U	Left	Thru	Right	U	
All Vehicles	20	864	176	0	8	396	392	0	592	824	4	0	84	424	4	0	3788
Heavy Trucks	0	12	12		0	20	68		32	32	0		0	52	0		228
Buses																	
Pedestrians		4				4				4				4			16
Bicycles	0	0	0		0	0	0		0	0	0		0	0	0		0
Scooters																	

Comments:

LOCATION: Brookings Dr -- Hwy 24
CITY/STATE: El Paso, CO

QC JOB #: 15171518
DATE: Tue, Jan 28 2020

Peak-Hour: 3:00 PM -- 4:00 PM
 Peak 15-Min: 3:45 PM -- 4:00 PM



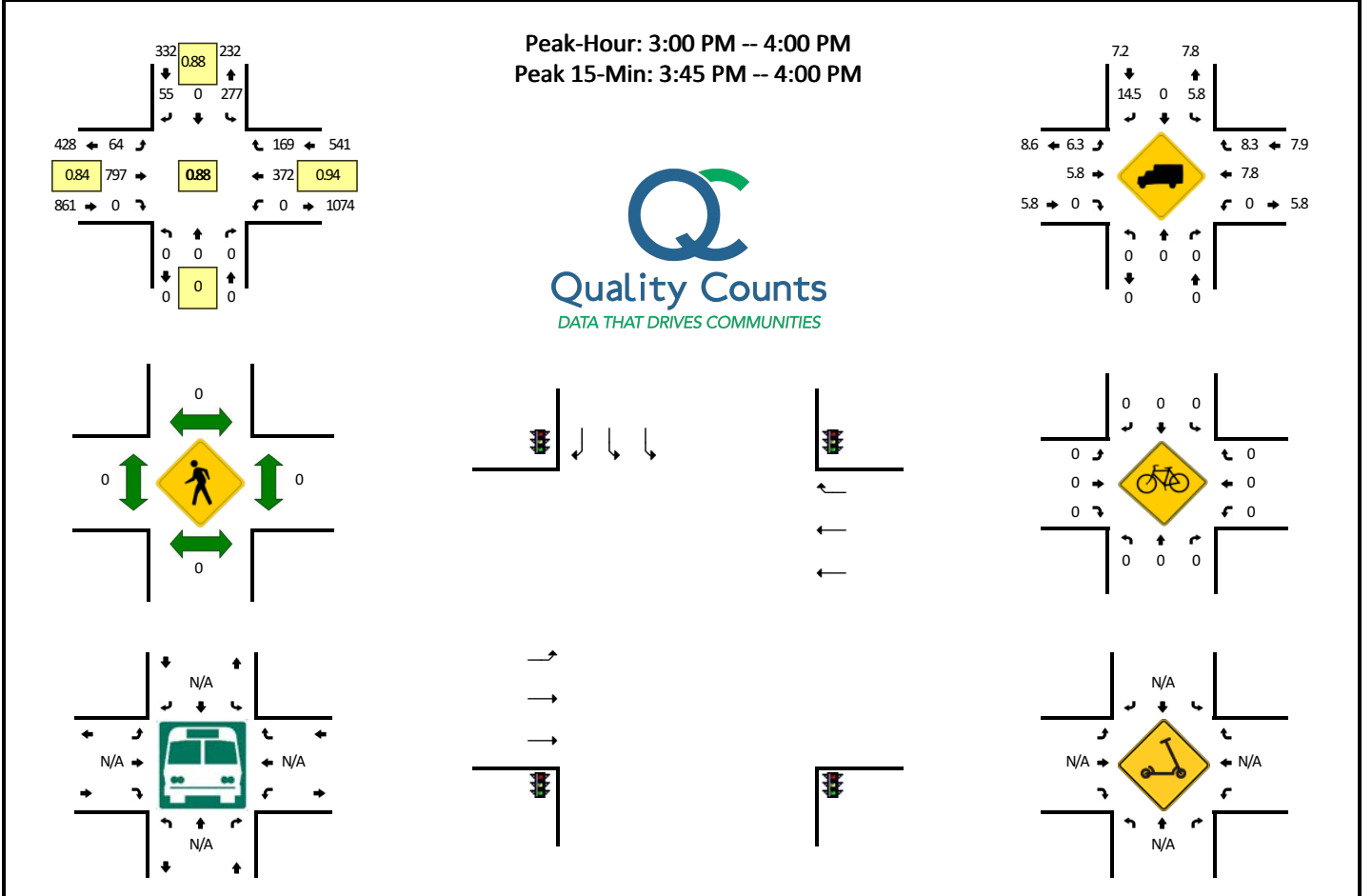
15-Min Count Period Beginning At	Brookings Dr (Northbound)				Brookings Dr (Southbound)				Hwy 24 (Eastbound)				Hwy 24 (Westbound)				Total	Hourly Totals
	Left	Thru	Right	U	Left	Thru	Right	U	Left	Thru	Right	U	Left	Thru	Right	U		
2:00 PM	0	0	0	0	0	0	8	0	0	139	0	0	0	98	0	0	245	
2:15 PM	0	0	0	0	0	0	4	0	0	136	0	0	0	118	0	0	258	
2:30 PM	0	0	0	0	0	0	8	0	0	136	0	0	0	85	1	0	230	
2:45 PM	0	0	0	0	0	0	4	0	0	159	0	0	0	101	0	0	264	997
3:00 PM	0	0	0	0	0	0	7	0	0	201	0	0	0	95	0	0	303	1055
3:15 PM	0	0	0	0	0	0	9	0	0	186	0	0	0	113	1	0	309	1106
3:30 PM	0	0	0	0	0	0	6	0	0	232	0	0	0	102	0	0	340	1216
3:45 PM	0	0	0	0	0	0	4	0	0	248	0	0	0	119	1	0	372	1324

Peak 15-Min Flowrates	Northbound				Southbound				Eastbound				Westbound				Total
	Left	Thru	Right	U	Left	Thru	Right	U	Left	Thru	Right	U	Left	Thru	Right	U	
All Vehicles	0	0	0	0	0	0	16	0	0	992	0	0	0	476	4	0	1488
Heavy Trucks	0	0	0	0	0	0	0	0	0	36	0	0	0	48	0	0	84
Buses																	
Pedestrians		0				0				0				0			0
Bicycles	0	0	0		0	0	0		0	0	0		0	0	0		0
Scooters																	

Comments:

LOCATION: Constitution Ave -- Hwy 24
CITY/STATE: Colorado Springs, CO

QC JOB #: 15171520
DATE: Tue, Jan 28 2020



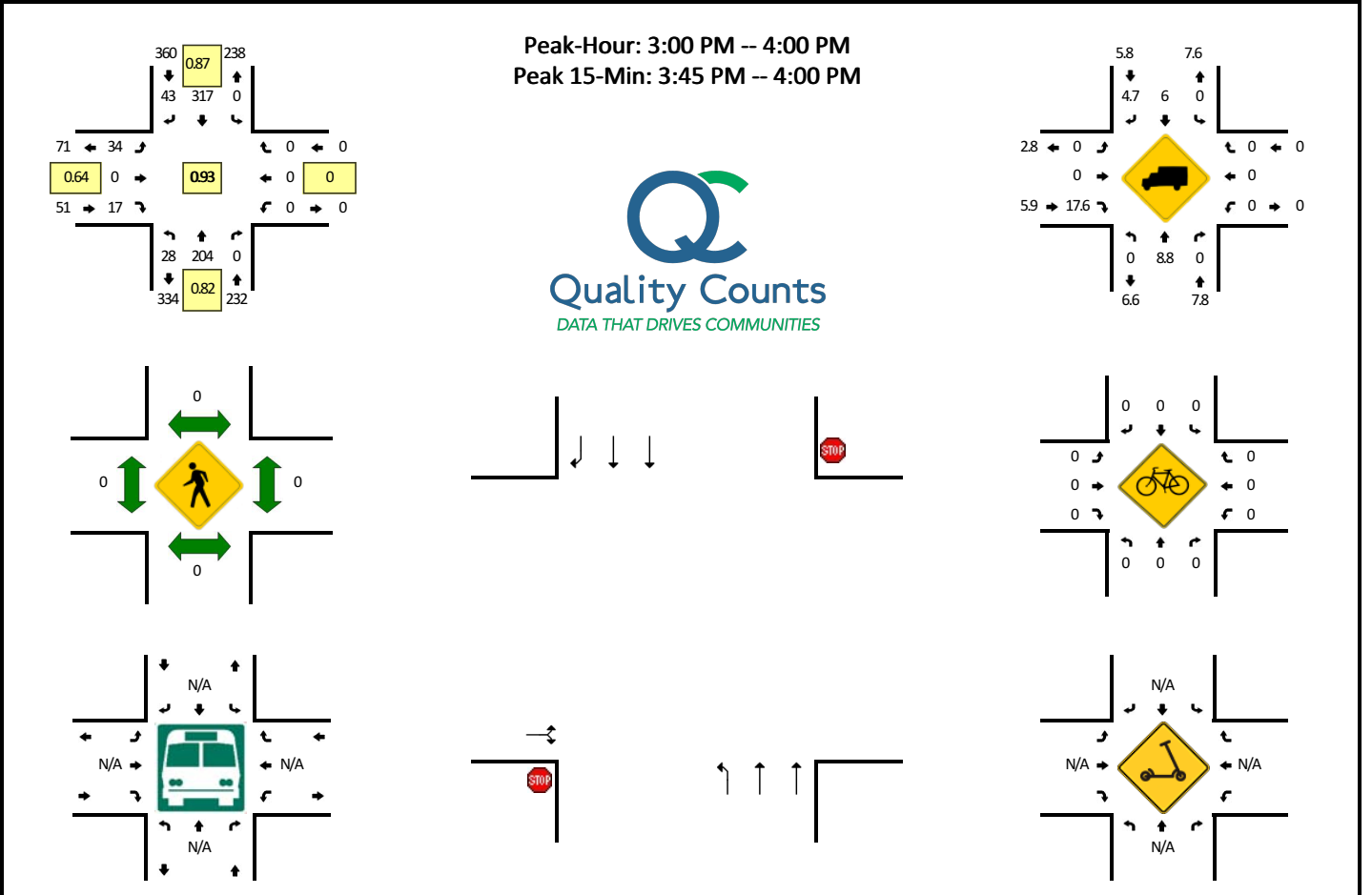
15-Min Count Period Beginning At	Constitution Ave (Northbound)				Constitution Ave (Southbound)				Hwy 24 (Eastbound)				Hwy 24 (Westbound)				Total	Hourly Totals
	Left	Thru	Right	U	Left	Thru	Right	U	Left	Thru	Right	U	Left	Thru	Right	U		
2:00 PM	0	0	0	0	53	0	14	0	16	109	0	1	0	93	34	0	320	
2:15 PM	0	0	0	0	38	0	18	0	13	134	0	4	0	87	41	0	335	
2:30 PM	0	0	0	0	53	0	12	0	13	120	0	0	0	75	31	0	304	
2:45 PM	0	0	0	0	65	0	11	0	21	145	0	1	0	83	41	0	367	1326
3:00 PM	0	0	0	0	67	0	11	0	9	172	0	0	0	86	44	0	389	1395
3:15 PM	0	0	0	0	72	0	16	0	18	180	0	0	0	93	32	0	411	1471
3:30 PM	0	0	0	0	63	0	9	0	22	204	0	1	0	94	50	0	443	1610
3:45 PM	0	0	0	0	75	0	19	0	14	241	0	0	0	99	43	0	491	1734

Peak 15-Min Flowrates	Northbound				Southbound				Eastbound				Westbound				Total
	Left	Thru	Right	U	Left	Thru	Right	U	Left	Thru	Right	U	Left	Thru	Right	U	
All Vehicles	0	0	0	0	300	0	76	0	56	964	0	0	0	396	172	0	1964
Heavy Trucks	0	0	0	0	24	0	20	0	0	48	0	0	0	28	20	0	140
Buses																	
Pedestrians		0				0				0				0			0
Bicycles	0	0	0		0	0	0		0	0	0		0	0	0		0
Scoters																	

Comments:

LOCATION: Constitution Ave -- Meadowbrook Pkwy
CITY/STATE: El Paso, CO

QC JOB #: 15171522
DATE: Tue, Jan 28 2020



15-Min Count Period Beginning At	Constitution Ave (Northbound)				Constitution Ave (Southbound)				Meadowbrook Pkwy (Eastbound)				Meadowbrook Pkwy (Westbound)				Total	Hourly Totals
	Left	Thru	Right	U	Left	Thru	Right	U	Left	Thru	Right	U	Left	Thru	Right	U		
2:00 PM	4	48	0	0	0	68	9	0	1	0	2	0	0	0	0	0	132	
2:15 PM	4	50	0	1	0	56	5	1	5	0	1	0	0	0	0	0	123	
2:30 PM	6	38	0	0	0	58	3	0	4	0	3	0	0	0	0	0	112	
2:45 PM	8	54	0	0	0	75	13	0	3	0	2	0	0	0	0	0	155	522
3:00 PM	4	47	0	0	0	72	9	0	13	0	7	0	0	0	0	0	152	542
3:15 PM	6	46	0	0	0	83	11	0	7	0	4	0	0	0	0	0	157	576
3:30 PM	7	64	0	0	0	71	11	0	7	0	1	0	0	0	0	0	161	625
3:45 PM	11	47	0	0	0	91	12	0	7	0	5	0	0	0	0	0	173	643
Peak 15-Min Flowrates	Northbound				Southbound				Eastbound				Westbound				Total	
	Left	Thru	Right	U	Left	Thru	Right	U	Left	Thru	Right	U	Left	Thru	Right	U		
All Vehicles	44	188	0	0	0	364	48	0	28	0	20	0	0	0	0	0	692	
Heavy Trucks	0	20	0	0	0	32	4	0	0	0	8	0	0	0	0	0	64	
Buses																		
Pedestrians		0				0				0				0			0	
Bicycles	0	0	0		0	0	0		0	0	0		0	0	0		0	
Scoters																		

Comments:

LSC Transportation Consultants, Inc.

545 E Pikes Peak Ave, Suite 210
 Colorado Springs, CO 80905
 719-633-2868

File Name : Springside Dr - Constitution Ave PM
 Site Code : 00204140
 Start Date : 2/26/2020
 Page No : 1

Groups Printed- Unshifted

Start Time	Southbound					Constitution Ave Westbound					Springside Dr Northbound					Constitution Ave Eastbound					Int. Total
	L	T	R	U	App. Total	L	T	R	U	App. Total	L	T	R	U	App. Total	L	T	R	U	App. Total	
02:00 PM	0	0	0	0	0	2	41	0	0	43	11	0	0	0	11	0	85	8	0	93	147
02:15 PM	0	0	0	0	0	0	59	0	0	59	11	0	0	0	11	0	62	9	0	71	141
02:30 PM	0	0	0	0	0	0	54	0	0	54	18	0	1	0	19	0	93	15	0	108	181
02:45 PM	0	0	0	0	0	2	49	0	0	51	16	0	0	0	16	0	85	18	0	103	170
Total	0	0	0	0	0	4	203	0	0	207	56	0	1	0	57	0	325	50	0	375	639
03:00 PM	0	0	0	0	0	0	56	0	0	56	15	0	0	0	15	0	98	26	1	125	196
03:15 PM	0	0	0	0	0	4	51	0	0	55	14	0	0	0	14	0	90	15	0	105	174
03:30 PM	0	0	0	0	0	1	68	0	0	69	13	0	0	0	13	0	115	38	0	153	235
03:45 PM	0	0	0	0	0	1	69	0	0	70	18	0	1	0	19	0	104	27	0	131	220
Total	0	0	0	0	0	6	244	0	0	250	60	0	1	0	61	0	407	106	1	514	825
Grand Total	0	0	0	0	0	10	447	0	0	457	116	0	2	0	118	0	732	156	1	889	1464
Apprch %	0	0	0	0	0	2.2	97.8	0	0		98.3	0	1.7	0		0	82.3	17.5	0.1		
Total %	0	0	0	0	0	0.7	30.5	0	0	31.2	7.9	0	0.1	0	8.1	0	50	10.7	0.1	60.7	

LSC Transportation Consultants, Inc.

545 E Pikes Peak Ave, Suite 210
 Colorado Springs, CO 80905
 719-633-2868

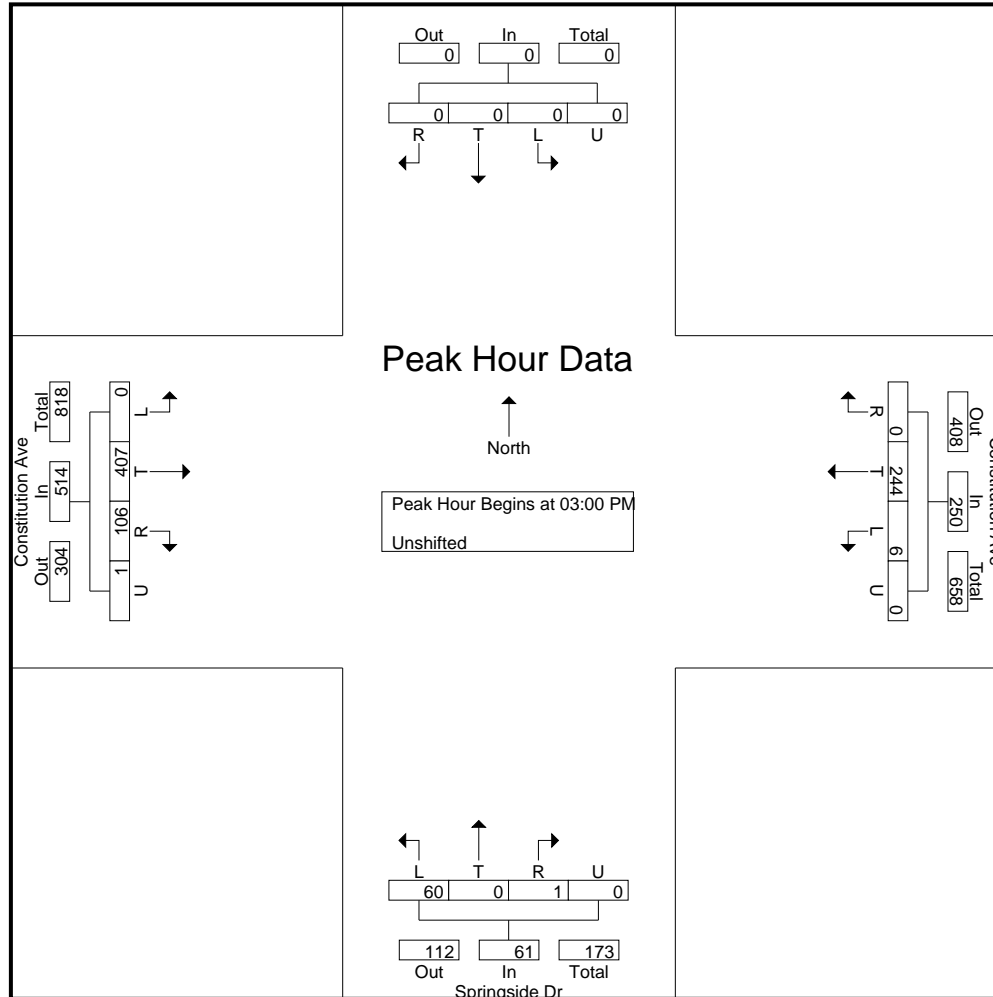
File Name : Springside Dr - Constitution Ave PM
 Site Code : 00204140
 Start Date : 2/26/2020
 Page No : 2

Start Time	Southbound					Constitution Ave Westbound					Springside Dr Northbound					Constitution Ave Eastbound					Int. Total
	L	T	R	U	App. Total	L	T	R	U	App. Total	L	T	R	U	App. Total	L	T	R	U	App. Total	
Peak Hour Analysis From 2:00:00 PM to 3:45:00 PM - Peak 1 of 1																					
Peak Hour for Entire Intersection Begins at 3:00:00 PM																					
3:00:00 PM	0	0	0	0	0	0	56	0	0	56	15	0	0	0	15	0	98	26	1	125	196
3:15:00 PM	0	0	0	0	0	4	51	0	0	55	14	0	0	0	14	0	90	15	0	105	174
3:30:00 PM	0	0	0	0	0	1	68	0	0	69	13	0	0	0	13	0	115	38	0	153	235
3:45:00 PM	0	0	0	0	0	1	69	0	0	70	18	0	1	0	19	0	104	27	0	131	220
Total Volume	0	0	0	0	0	6	244	0	0	250	60	0	1	0	61	0	407	106	1	514	825
% App. Total	0	0	0	0	0	2.4	97.6	0	0		98.4	0	1.6	0		0	79.2	20.6	0.2		
PHF	.000	.000	.000	.000	.000	.375	.884	.000	.000	.893	.833	.000	.250	.000	.803	.000	.885	.697	.250	.840	.878

LSC Transportation Consultants, Inc.

545 E Pikes Peak Ave, Suite 210
 Colorado Springs, CO 80905
 719-633-2868

File Name : Springside Dr - Constitution Ave PM
 Site Code : 00204140
 Start Date : 2/26/2020
 Page No : 3



LSC Transportation Consultants, Inc.

545 E Pikes Peak Ave, Suite 210
 Colorado Springs, CO 80905
 719-633-2868

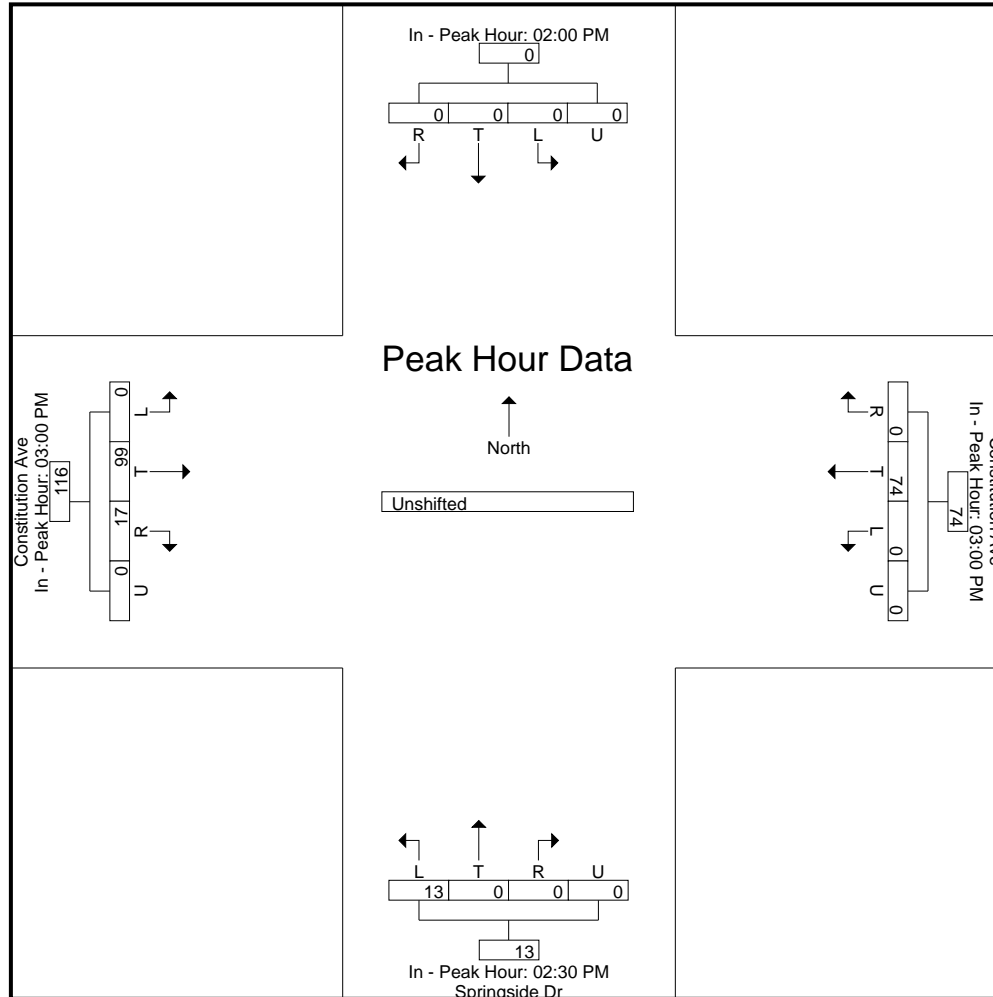
File Name : Springside Dr - Constitution Ave PM
 Site Code : 00204140
 Start Date : 2/26/2020
 Page No : 4

Start Time	Southbound					Constitution Ave Westbound					Springside Dr Northbound					Constitution Ave Eastbound					Int. Total
	L	T	R	U	App. Total	L	T	R	U	App. Total	L	T	R	U	App. Total	L	T	R	U	App. Total	
Peak Hour Analysis From 2:00:00 PM to 3:45:00 PM - Peak 1 of 1																					
Peak Hour for Each Approach Begins at:																					
	2:00:00 PM					3:00:00 PM					2:30:00 PM					3:00:00 PM					
+0 mins.	0	0	0	0	0	0	56	0	0	56	18	0	1	0	19	0	98	26	1	125	
+5 mins.	0	0	0	0	0	4	51	0	0	55	16	0	0	0	16	0	90	15	0	105	
+10 mins.	0	0	0	0	0	1	68	0	0	69	15	0	0	0	15	0	115	38	0	153	
+15 mins.	0	0	0	0	0	1	69	0	0	70	14	0	0	0	14	0	104	27	0	131	
Total Volume	0	0	0	0	0	6	244	0	0	250	63	0	1	0	64	0	407	106	1	514	
% App. Total	0	0	0	0	0	2.4	97.6	0	0		98.4	0	1.6	0		0	79.2	20.6	0.2		
PHF	.000	.000	.000	.000	.000	.375	.884	.000	.000	.893	.875	.000	.250	.000	.842	.000	.885	.697	.250	.840	

LSC Transportation Consultants, Inc.

545 E Pikes Peak Ave, Suite 210
 Colorado Springs, CO 80905
 719-633-2868

File Name : Springside Dr - Constitution Ave PM
 Site Code : 00204140
 Start Date : 2/26/2020
 Page No : 5



Levels of Service



HCM 6th TWSC
1: Meadowbrook Pkwy

Existing
AM Peak Hour

Intersection												
Int Delay, s/veh	5.7											
Movement	EBL	EBT	EBR	WBL	WBT	WBR	NBL	NBT	NBR	SBL	SBT	SBR
Lane Configurations		↕			↕			↕			↕	
Traffic Vol, veh/h	22	4	25	2	12	0	7	20	0	0	11	23
Future Vol, veh/h	22	4	25	2	12	0	7	20	0	0	11	23
Conflicting Peds, #/hr	0	0	0	0	0	0	0	0	0	0	0	0
Sign Control	Free	Free	Free	Free	Free	Free	Stop	Stop	Stop	Stop	Stop	Stop
RT Channelized	-	-	None	-	-	None	-	-	None	-	-	None
Storage Length	-	-	-	-	-	-	-	-	-	-	-	-
Veh in Median Storage, #	-	0	-	-	0	-	-	0	-	-	0	-
Grade, %	-	0	-	-	0	-	-	0	-	-	0	-
Peak Hour Factor	75	75	75	58	58	58	84	84	84	77	77	77
Heavy Vehicles, %	2	2	2	2	2	2	2	2	2	2	2	2
Mvmt Flow	29	5	33	3	21	0	8	24	0	0	14	30

Major/Minor	Major1		Major2		Minor1		Minor2					
Conflicting Flow All	21	0	0	38	0	0	129	107	22	119	123	21
Stage 1	-	-	-	-	-	-	80	80	-	27	27	-
Stage 2	-	-	-	-	-	-	49	27	-	92	96	-
Critical Hdwy	4.12	-	-	4.12	-	-	7.12	6.52	6.22	7.12	6.52	6.22
Critical Hdwy Stg 1	-	-	-	-	-	-	6.12	5.52	-	6.12	5.52	-
Critical Hdwy Stg 2	-	-	-	-	-	-	6.12	5.52	-	6.12	5.52	-
Follow-up Hdwy	2.218	-	-	2.218	-	-	3.518	4.018	3.318	3.518	4.018	3.318
Pot Cap-1 Maneuver	1595	-	-	1572	-	-	844	783	1055	857	767	1056
Stage 1	-	-	-	-	-	-	929	828	-	990	873	-
Stage 2	-	-	-	-	-	-	964	873	-	915	815	-
Platoon blocked, %		-	-		-	-						
Mov Cap-1 Maneuver	1595	-	-	1572	-	-	795	767	1055	824	751	1056
Mov Cap-2 Maneuver	-	-	-	-	-	-	795	767	-	824	751	-
Stage 1	-	-	-	-	-	-	911	812	-	971	871	-
Stage 2	-	-	-	-	-	-	920	871	-	871	800	-

Approach	EB	WB	NB	SB
HCM Control Delay, s	3.1	1	9.9	9.1
HCM LOS			A	A

Minor Lane/Major Mvmt	NBLn1	EBL	EBT	EBR	WBL	WBT	WBR	SBLn1
Capacity (veh/h)	774	1595	-	-	1572	-	-	933
HCM Lane V/C Ratio	0.042	0.018	-	-	0.002	-	-	0.047
HCM Control Delay (s)	9.9	7.3	0	-	7.3	0	-	9.1
HCM Lane LOS	A	A	A	-	A	A	-	A
HCM 95th %tile Q(veh)	0.1	0.1	-	-	0	-	-	0.1

Intersection	
Intersection Delay, s/veh	7.2
Intersection LOS	A

Movement	WBL	WBR	NBT	NBR	SBL	SBT
Lane Configurations	Y		T			T
Traffic Vol, veh/h	6	2	14	1	2	29
Future Vol, veh/h	6	2	14	1	2	29
Peak Hour Factor	0.40	0.40	0.63	0.63	0.86	0.86
Heavy Vehicles, %	2	2	2	2	2	2
Mvmt Flow	15	5	22	2	2	34
Number of Lanes	1	0	1	0	0	1

Approach	WB	NB	SB
Opposing Approach		SB	NB
Opposing Lanes	0	1	1
Conflicting Approach Left	NB		WB
Conflicting Lanes Left	1	0	1
Conflicting Approach Right	SB	WB	
Conflicting Lanes Right	1	1	0
HCM Control Delay	7.2	7.1	7.2
HCM LOS	A	A	A

Lane	NBLn1	WBLn1	SBLn1
Vol Left, %	0%	75%	6%
Vol Thru, %	93%	0%	94%
Vol Right, %	7%	25%	0%
Sign Control	Stop	Stop	Stop
Traffic Vol by Lane	15	8	31
LT Vol	0	6	2
Through Vol	14	0	29
RT Vol	1	2	0
Lane Flow Rate	24	20	36
Geometry Grp	1	1	1
Degree of Util (X)	0.026	0.022	0.04
Departure Headway (Hd)	3.956	4.037	4
Convergence, Y/N	Yes	Yes	Yes
Cap	907	887	898
Service Time	1.971	2.062	2.012
HCM Lane V/C Ratio	0.026	0.023	0.04
HCM Control Delay	7.1	7.2	7.2
HCM Lane LOS	A	A	A
HCM 95th-tile Q	0.1	0.1	0.1

HCM 6th TWSC
3: Meadowbrook Pkwy & Springside Dr

Existing
AM Peak Hour

Intersection						
Int Delay, s/veh	3.7					
Movement	EBL	EBT	WBT	WBR	SBL	SBR
Lane Configurations		↔	↔		↔	
Traffic Vol, veh/h	20	11	11	10	2	13
Future Vol, veh/h	20	11	11	10	2	13
Conflicting Peds, #/hr	0	0	0	0	0	0
Sign Control	Free	Free	Free	Free	Stop	Stop
RT Channelized	-	None	-	None	-	None
Storage Length	-	-	-	-	0	-
Veh in Median Storage, #	-	0	0	-	0	-
Grade, %	-	0	0	-	0	-
Peak Hour Factor	70	70	48	48	63	63
Heavy Vehicles, %	2	2	2	2	2	2
Mvmt Flow	29	16	23	21	3	21

Major/Minor	Major1	Major2	Minor2		
Conflicting Flow All	44	0	-	0	108 34
Stage 1	-	-	-	-	34 -
Stage 2	-	-	-	-	74 -
Critical Hdwy	4.12	-	-	-	6.42 6.22
Critical Hdwy Stg 1	-	-	-	-	5.42 -
Critical Hdwy Stg 2	-	-	-	-	5.42 -
Follow-up Hdwy	2.218	-	-	-	3.518 3.318
Pot Cap-1 Maneuver	1564	-	-	-	889 1039
Stage 1	-	-	-	-	988 -
Stage 2	-	-	-	-	949 -
Platoon blocked, %		-	-	-	
Mov Cap-1 Maneuver	1564	-	-	-	872 1039
Mov Cap-2 Maneuver	-	-	-	-	872 -
Stage 1	-	-	-	-	969 -
Stage 2	-	-	-	-	949 -

Approach	EB	WB	SB
HCM Control Delay, s	4.7	0	8.6
HCM LOS			A

Minor Lane/Major Mvmt	EBL	EBT	WBT	WBR	SBLn1
Capacity (veh/h)	1564	-	-	-	1013
HCM Lane V/C Ratio	0.018	-	-	-	0.024
HCM Control Delay (s)	7.3	0	-	-	8.6
HCM Lane LOS	A	A	-	-	A
HCM 95th %tile Q(veh)	0.1	-	-	-	0.1

HCM 6th TWSC
4: Pinyon Jay Dr & Meadowbrook Pkwy

Existing
AM Peak Hour

Intersection												
Int Delay, s/veh	4.3											
Movement	EBL	EBT	EBR	WBL	WBT	WBR	NBL	NBT	NBR	SBL	SBT	SBR
Lane Configurations		↕			↕			↕			↕	
Traffic Vol, veh/h	1	11	3	3	14	0	7	2	0	0	7	0
Future Vol, veh/h	1	11	3	3	14	0	7	2	0	0	7	0
Conflicting Peds, #/hr	0	0	0	0	0	0	0	0	0	0	0	0
Sign Control	Free	Free	Free	Free	Free	Free	Stop	Stop	Stop	Stop	Stop	Stop
RT Channelized	-	-	None	-	-	None	-	-	None	-	-	None
Storage Length	-	-	-	-	-	-	-	-	-	-	-	-
Veh in Median Storage, #	-	0	-	-	0	-	-	0	-	-	0	-
Grade, %	-	0	-	-	0	-	-	0	-	-	0	-
Peak Hour Factor	75	75	75	61	61	61	45	45	45	58	58	58
Heavy Vehicles, %	2	2	2	2	2	2	2	2	2	2	2	2
Mvmt Flow	1	15	4	5	23	0	16	4	0	0	12	0

Major/Minor	Major1		Major2		Minor1			Minor2				
Conflicting Flow All	23	0	0	19	0	0	58	52	17	54	54	23
Stage 1	-	-	-	-	-	-	19	19	-	33	33	-
Stage 2	-	-	-	-	-	-	39	33	-	21	21	-
Critical Hdwy	4.12	-	-	4.12	-	-	7.12	6.52	6.22	7.12	6.52	6.22
Critical Hdwy Stg 1	-	-	-	-	-	-	6.12	5.52	-	6.12	5.52	-
Critical Hdwy Stg 2	-	-	-	-	-	-	6.12	5.52	-	6.12	5.52	-
Follow-up Hdwy	2.218	-	-	2.218	-	-	3.518	4.018	3.318	3.518	4.018	3.318
Pot Cap-1 Maneuver	1592	-	-	1597	-	-	939	839	1062	944	837	1054
Stage 1	-	-	-	-	-	-	1000	880	-	983	868	-
Stage 2	-	-	-	-	-	-	976	868	-	998	878	-
Platoon blocked, %	-	-	-	-	-	-	-	-	-	-	-	-
Mov Cap-1 Maneuver	1592	-	-	1597	-	-	926	836	1062	937	834	1054
Mov Cap-2 Maneuver	-	-	-	-	-	-	926	836	-	937	834	-
Stage 1	-	-	-	-	-	-	999	879	-	982	865	-
Stage 2	-	-	-	-	-	-	959	865	-	992	877	-

Approach	EB		WB		NB		SB	
HCM Control Delay, s	0.5		1.3		9.1		9.4	
HCM LOS					A		A	

Minor Lane/Major Mvmt	NBLn1	EBL	EBT	EBR	WBL	WBT	WBR	SBLn1
Capacity (veh/h)	904	1592	-	-	1597	-	-	834
HCM Lane V/C Ratio	0.022	0.001	-	-	0.003	-	-	0.014
HCM Control Delay (s)	9.1	7.3	0	-	7.3	0	-	9.4
HCM Lane LOS	A	A	A	-	A	A	-	A
HCM 95th %tile Q(veh)	0.1	0	-	-	0	-	-	0

Intersection						
Int Delay, s/veh	4.2					
Movement	EBT	EBR	WBL	WBT	NBL	NBR
Lane Configurations	↔			↔	↔	
Traffic Vol, veh/h	1	1	4	3	1	0
Future Vol, veh/h	1	1	4	3	1	0
Conflicting Peds, #/hr	0	0	0	0	0	0
Sign Control	Free	Free	Free	Free	Stop	Stop
RT Channelized	-	None	-	None	-	None
Storage Length	-	-	-	-	0	-
Veh in Median Storage, #	0	-	-	0	0	-
Grade, %	0	-	-	0	0	-
Peak Hour Factor	50	50	88	88	25	25
Heavy Vehicles, %	2	2	2	2	2	2
Mvmt Flow	2	2	5	3	4	0

Major/Minor	Major1	Major2	Minor1		
Conflicting Flow All	0	0	4	0	16
Stage 1	-	-	-	-	3
Stage 2	-	-	-	-	13
Critical Hdwy	-	-	4.12	-	6.42
Critical Hdwy Stg 1	-	-	-	-	5.42
Critical Hdwy Stg 2	-	-	-	-	5.42
Follow-up Hdwy	-	-	2.218	-	3.518
Pot Cap-1 Maneuver	-	-	1618	-	1002
Stage 1	-	-	-	-	1020
Stage 2	-	-	-	-	1010
Platoon blocked, %	-	-	-	-	-
Mov Cap-1 Maneuver	-	-	1618	-	999
Mov Cap-2 Maneuver	-	-	-	-	999
Stage 1	-	-	-	-	1020
Stage 2	-	-	-	-	1007

Approach	EB	WB	NB
HCM Control Delay, s	0	4.1	8.6
HCM LOS			A

Minor Lane/Major Mvmt	NBLn1	EBT	EBR	WBL	WBT
Capacity (veh/h)	999	-	-	1618	-
HCM Lane V/C Ratio	0.004	-	-	0.003	-
HCM Control Delay (s)	8.6	-	-	7.2	0
HCM Lane LOS	A	-	-	A	A
HCM 95th %tile Q(veh)	0	-	-	0	-

Intersection						
Int Delay, s/veh	3.1					
Movement	EBL	EBR	NBL	NBT	SBT	SBR
Lane Configurations	TT			TT	TT	
Traffic Vol, veh/h	3	3	1	1	12	4
Future Vol, veh/h	3	3	1	1	12	4
Conflicting Peds, #/hr	0	0	0	0	0	0
Sign Control	Stop	Stop	Free	Free	Free	Free
RT Channelized	-	None	-	None	-	None
Storage Length	0	-	-	-	-	-
Veh in Median Storage, #	0	-	-	0	0	-
Grade, %	0	-	-	0	0	-
Peak Hour Factor	38	38	50	50	57	57
Heavy Vehicles, %	2	2	2	2	2	2
Mvmt Flow	8	8	2	2	21	7

Major/Minor	Minor2	Major1		Major2	
Conflicting Flow All	31	25	28	0	0
Stage 1	25	-	-	-	-
Stage 2	6	-	-	-	-
Critical Hdwy	6.42	6.22	4.12	-	-
Critical Hdwy Stg 1	5.42	-	-	-	-
Critical Hdwy Stg 2	5.42	-	-	-	-
Follow-up Hdwy	3.518	3.318	2.218	-	-
Pot Cap-1 Maneuver	983	1051	1585	-	-
Stage 1	998	-	-	-	-
Stage 2	1017	-	-	-	-
Platoon blocked, %				-	-
Mov Cap-1 Maneuver	982	1051	1585	-	-
Mov Cap-2 Maneuver	982	-	-	-	-
Stage 1	997	-	-	-	-
Stage 2	1017	-	-	-	-

Approach	EB	NB	SB
HCM Control Delay, s	8.6	3.6	0
HCM LOS	A		

Minor Lane/Major Mvmt	NBL	NBT	EBLn1	SBT	SBR
Capacity (veh/h)	1585	-	1015	-	-
HCM Lane V/C Ratio	0.001	-	0.016	-	-
HCM Control Delay (s)	7.3	0	8.6	-	-
HCM Lane LOS	A	A	A	-	-
HCM 95th %tile Q(veh)	0	-	0	-	-

Intersection						
Int Delay, s/veh	2.7					
Movement	EBT	EBR	WBL	WBT	NBL	NBR
Lane Configurations	↑↑	↗	↘	↑↑	↘	
Traffic Vol, veh/h	260	32	4	419	135	12
Future Vol, veh/h	260	32	4	419	135	12
Conflicting Peds, #/hr	0	0	0	0	0	0
Sign Control	Free	Free	Free	Free	Stop	Stop
RT Channelized	-	None	-	None	-	None
Storage Length	-	300	450	-	0	-
Veh in Median Storage, #	0	-	-	0	0	-
Grade, %	0	-	-	0	0	-
Peak Hour Factor	88	88	91	91	92	92
Heavy Vehicles, %	2	2	2	2	2	2
Mvmt Flow	295	36	4	460	147	13

Major/Minor	Major1	Major2	Minor1		
Conflicting Flow All	0	0	331	0	533 148
Stage 1	-	-	-	-	295 -
Stage 2	-	-	-	-	238 -
Critical Hdwy	-	-	4.14	-	6.84 6.94
Critical Hdwy Stg 1	-	-	-	-	5.84 -
Critical Hdwy Stg 2	-	-	-	-	5.84 -
Follow-up Hdwy	-	-	2.22	-	3.52 3.32
Pot Cap-1 Maneuver	-	-	1225	-	477 872
Stage 1	-	-	-	-	730 -
Stage 2	-	-	-	-	779 -
Platoon blocked, %	-	-	-	-	-
Mov Cap-1 Maneuver	-	-	1225	-	476 872
Mov Cap-2 Maneuver	-	-	-	-	476 -
Stage 1	-	-	-	-	730 -
Stage 2	-	-	-	-	777 -

Approach	EB	WB	NB
HCM Control Delay, s	0	0.1	15.7
HCM LOS			C

Minor Lane/Major Mvmt	NBLn1	EBT	EBR	WBL	WBT
Capacity (veh/h)	494	-	-	1225	-
HCM Lane V/C Ratio	0.323	-	-	0.004	-
HCM Control Delay (s)	15.7	-	-	7.9	-
HCM Lane LOS	C	-	-	A	-
HCM 95th %tile Q(veh)	1.4	-	-	0	-

HCM 6th TWSC
8: Constitution Ave & Meadowbrook Pkwy

Existing
AM Peak Hour

Intersection						
Int Delay, s/veh	1.8					
Movement	EBL	EBR	NBL	NBT	SBT	SBR
Lane Configurations	↵	↶	↵	↕	↕	↶
Traffic Vol, veh/h	55	51	10	354	230	23
Future Vol, veh/h	55	51	10	354	230	23
Conflicting Peds, #/hr	0	0	0	0	0	0
Sign Control	Stop	Stop	Free	Free	Free	Free
RT Channelized	-	None	-	None	-	None
Storage Length	0	50	325	-	-	250
Veh in Median Storage, #	0	-	-	0	0	-
Grade, %	0	-	-	0	0	-
Peak Hour Factor	83	83	89	89	79	79
Heavy Vehicles, %	2	2	2	2	2	2
Mvmt Flow	66	61	11	398	291	29

Major/Minor	Minor2	Major1	Major2			
Conflicting Flow All	512	146	320	0	-	0
Stage 1	291	-	-	-	-	-
Stage 2	221	-	-	-	-	-
Critical Hdwy	6.84	6.94	4.14	-	-	-
Critical Hdwy Stg 1	5.84	-	-	-	-	-
Critical Hdwy Stg 2	5.84	-	-	-	-	-
Follow-up Hdwy	3.52	3.32	2.22	-	-	-
Pot Cap-1 Maneuver	491	875	1237	-	-	-
Stage 1	733	-	-	-	-	-
Stage 2	795	-	-	-	-	-
Platoon blocked, %				-	-	-
Mov Cap-1 Maneuver	487	875	1237	-	-	-
Mov Cap-2 Maneuver	487	-	-	-	-	-
Stage 1	726	-	-	-	-	-
Stage 2	795	-	-	-	-	-

Approach	EB	NB	SB
HCM Control Delay, s	11.6	0.2	0
HCM LOS	B		

Minor Lane/Major Mvmt	NBL	NBT	EBLn1	EBLn2	SBT	SBR
Capacity (veh/h)	1237	-	487	875	-	-
HCM Lane V/C Ratio	0.009	-	0.136	0.07	-	-
HCM Control Delay (s)	7.9	-	13.6	9.4	-	-
HCM Lane LOS	A	-	B	A	-	-
HCM 95th %tile Q(veh)	0	-	0.5	0.2	-	-

Intersection						
Int Delay, s/veh	0					
Movement	EBL	EBT	WBT	WBR	SBL	SBR
Lane Configurations		↑↑	↑↑	↗		↗
Traffic Vol, veh/h	0	400	1397	3	0	119
Future Vol, veh/h	0	400	1397	3	0	119
Conflicting Peds, #/hr	0	0	0	0	0	0
Sign Control	Free	Free	Free	Free	Stop	Stop
RT Channelized	-	None	-	None	-	Free
Storage Length	-	-	-	800	-	0
Veh in Median Storage, #	-	0	0	-	0	-
Grade, %	-	0	0	-	0	-
Peak Hour Factor	82	82	91	91	85	85
Heavy Vehicles, %	2	2	2	2	2	2
Mvmt Flow	0	488	1535	3	0	140

Major/Minor	Major1	Major2	Minor2
Conflicting Flow All	-	0	-
Stage 1	-	-	-
Stage 2	-	-	-
Critical Hdwy	-	-	-
Critical Hdwy Stg 1	-	-	-
Critical Hdwy Stg 2	-	-	-
Follow-up Hdwy	-	-	-
Pot Cap-1 Maneuver	0	-	-
Stage 1	0	-	-
Stage 2	0	-	-
Platoon blocked, %	-	-	-
Mov Cap-1 Maneuver	-	-	-
Mov Cap-2 Maneuver	-	-	-
Stage 1	-	-	-
Stage 2	-	-	-

Approach	EB	WB	SB
HCM Control Delay, s	0	0	0
HCM LOS			A

Minor Lane/Major Mvmt	EBT	WBT	WBR	SBLn1
Capacity (veh/h)	-	-	-	-
HCM Lane V/C Ratio	-	-	-	-
HCM Control Delay (s)	-	-	-	0
HCM Lane LOS	-	-	-	A
HCM 95th %tile Q(veh)	-	-	-	-

Lanes, Volumes, Timings
 9: Marksheffel Rd & Meadowbrook Pkwy

Existing
 AM Peak Hour

Lane Group	EBL	EBT	EBR	WBL	WBT	WBR	NBL	NBT	NBR	SBL	SBT	SBR
Lane Configurations												
Traffic Volume (vph)	60	3	28	45	16	54	16	727	12	17	1555	183
Future Volume (vph)	60	3	28	45	16	54	16	727	12	17	1555	183
Satd. Flow (prot)	3433	1863	1583	1770	1863	1583	1770	3539	1583	1770	3539	1583
Flt Permitted	0.669			0.755			0.074			0.326		
Satd. Flow (perm)	2418	1863	1583	1406	1863	1583	138	3539	1583	607	3539	1583
Satd. Flow (RTOR)			120			120			112			136
Peak Hour Factor	0.78	0.78	0.78	0.78	0.78	0.78	0.92	0.92	0.92	0.90	0.90	0.90
Shared Lane Traffic (%)												
Lane Group Flow (vph)	77	4	36	58	21	69	17	790	13	19	1728	203
Turn Type	pm+pt	NA	Perm	pm+pt	NA	Perm	pm+pt	NA	Perm	pm+pt	NA	Perm
Protected Phases	7	4		3	8		5	2		1	6	
Permitted Phases	4		4	8		8	2		2	6		6
Detector Phase	7	4	4	3	8	8	5	2	2	1	6	6
Switch Phase												
Minimum Initial (s)	4.0	4.0	4.0	4.0	4.0	4.0	4.0	4.0	4.0	4.0	4.0	4.0
Minimum Split (s)	9.0	10.0	10.0	9.0	10.0	10.0	9.0	11.0	11.0	9.0	11.0	11.0
Total Split (s)	17.0	36.0	36.0	17.0	36.0	36.0	17.0	57.0	57.0	17.0	57.0	57.0
Total Split (%)	13.4%	28.3%	28.3%	13.4%	28.3%	28.3%	13.4%	44.9%	44.9%	13.4%	44.9%	44.9%
Yellow Time (s)	3.0	4.0	4.0	3.0	4.0	4.0	3.0	5.0	5.0	3.0	5.0	5.0
All-Red Time (s)	2.0	2.0	2.0	2.0	2.0	2.0	2.0	2.0	2.0	2.0	2.0	2.0
Lost Time Adjust (s)	0.0	0.0	0.0	0.0	0.0	0.0	0.0	0.0	0.0	0.0	0.0	0.0
Total Lost Time (s)	5.0	6.0	6.0	5.0	6.0	6.0	5.0	7.0	7.0	5.0	7.0	7.0
Lead/Lag	Lead	Lag	Lag	Lead	Lag	Lag	Lead	Lag	Lag	Lead	Lag	Lag
Lead-Lag Optimize?	Yes	Yes	Yes	Yes	Yes	Yes	Yes	Yes	Yes	Yes	Yes	Yes
Recall Mode	None	None	None	None	None	None	None	Max	Max	None	Max	Max
Act Effct Green (s)	13.5	8.3	8.3	13.8	6.6	6.6	58.3	55.7	55.7	58.4	55.8	55.8
Actuated g/C Ratio	0.16	0.10	0.10	0.16	0.08	0.08	0.69	0.66	0.66	0.69	0.66	0.66
v/c Ratio	0.16	0.02	0.14	0.22	0.15	0.30	0.08	0.34	0.01	0.04	0.74	0.19
Control Delay	28.6	41.3	1.1	30.2	41.9	4.9	6.4	10.3	0.0	5.7	17.5	4.4
Queue Delay	0.0	0.0	0.0	0.0	0.0	0.0	0.0	0.0	0.0	0.0	0.0	0.0
Total Delay	28.6	41.3	1.1	30.2	41.9	4.9	6.4	10.3	0.0	5.7	17.5	4.4
LOS	C	D	A	C	D	A	A	B	A	A	B	A
Approach Delay		20.5			20.1			10.0			16.1	
Approach LOS		C			C			B			B	

Intersection Summary

Cycle Length: 127
 Actuated Cycle Length: 84.7
 Natural Cycle: 70
 Control Type: Actuated-Uncoordinated
 Maximum v/c Ratio: 0.74
 Intersection Signal Delay: 14.8
 Intersection Capacity Utilization 64.7%
 Analysis Period (min) 15
 Intersection LOS: B
 ICU Level of Service C

Splits and Phases: 9: Marksheffel Rd & Meadowbrook Pkwy



Lanes, Volumes, Timings
10: Marksheffel Rd & US 24

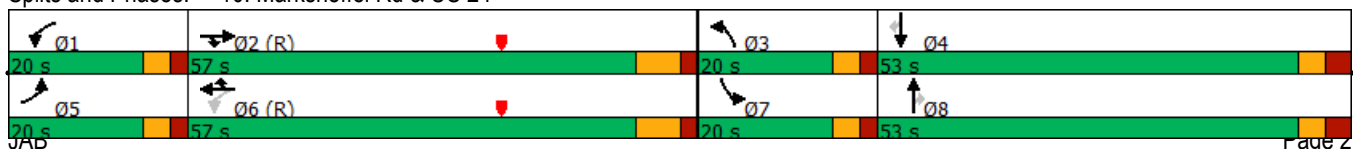
Existing
AM Peak Hour

Lane Group	EBL	EBT	EBR	WBL	WBT	WBR	NBL	NBT	NBR	SBL	SBT	SBR
Lane Configurations												
Traffic Volume (vph)	305	340	2	15	1225	285	1	428	73	3	975	657
Future Volume (vph)	305	340	2	15	1225	285	1	428	73	3	975	657
Satd. Flow (prot)	3433	3539	1583	1770	3539	1583	1770	3539	1583	1770	3539	1583
Flt Permitted	0.950			0.532			0.950			0.950		
Satd. Flow (perm)	3433	3539	1583	991	3539	1583	1770	3539	1583	1770	3539	1583
Satd. Flow (RTOR)			95			313			102			409
Peak Hour Factor	0.92	0.92	0.92	0.89	0.89	0.89	0.92	0.92	0.92	0.86	0.86	0.86
Shared Lane Traffic (%)												
Lane Group Flow (vph)	332	370	2	17	1376	320	1	465	79	3	1134	764
Turn Type	Prot	NA	Prot	pm+pt	NA	Prot	Prot	NA	Perm	Prot	NA	Perm
Protected Phases	5	2	2	1	6	6	3	8		7	4	
Permitted Phases				6					8			4
Detector Phase	5			1			3	8	8	7	4	4
Switch Phase												
Minimum Initial (s)	6.0	23.0	23.0	6.0	23.0	23.0	6.0	6.0	6.0	6.0	6.0	6.0
Minimum Split (s)	15.0	35.0	35.0	15.0	35.0	35.0	15.0	16.0	16.0	15.0	16.0	16.0
Total Split (s)	20.0	57.0	57.0	20.0	57.0	57.0	20.0	53.0	53.0	20.0	53.0	53.0
Total Split (%)	13.3%	38.0%	38.0%	13.3%	38.0%	38.0%	13.3%	35.3%	35.3%	13.3%	35.3%	35.3%
Yellow Time (s)	3.0	5.0	5.0	3.0	5.0	5.0	3.0	3.0	3.0	3.0	3.0	3.0
All-Red Time (s)	2.0	2.0	2.0	2.0	2.0	2.0	2.0	3.0	3.0	2.0	3.0	3.0
Lost Time Adjust (s)	0.0	-2.0	-2.0	0.0	-2.0	-2.0	0.0	-1.0	1.0	0.0	-1.0	1.0
Total Lost Time (s)	5.0	5.0	5.0	5.0	5.0	5.0	5.0	5.0	7.0	5.0	5.0	7.0
Lead/Lag	Lead	Lag	Lag	Lead	Lag	Lag	Lead	Lag	Lag	Lead	Lag	Lag
Lead-Lag Optimize?												
Recall Mode	None	C-Max	C-Max	None	C-Max	C-Max	None	None	None	None	None	None
Act Effct Green (s)	21.5	85.0	85.0	69.8	63.3	63.3	6.0	47.9	45.9	6.1	48.0	46.0
Actuated g/C Ratio	0.14	0.57	0.57	0.47	0.42	0.42	0.04	0.32	0.31	0.04	0.32	0.31
v/c Ratio	0.68	0.18	0.00	0.03	0.92	0.38	0.01	0.41	0.14	0.04	1.00	0.99
Control Delay	68.2	17.4	0.0	15.3	51.9	4.9	70.0	41.4	3.7	70.3	77.6	54.8
Queue Delay	0.0	0.0	0.0	0.0	0.0	0.0	0.0	0.0	0.0	0.0	0.0	0.0
Total Delay	68.2	17.4	0.0	15.3	51.9	4.9	70.0	41.4	3.7	70.3	77.6	54.8
LOS	E	B	A	B	D	A	E	D	A	E	E	D
Approach Delay		41.3			42.7			36.0			68.4	
Approach LOS		D			D			D			E	

Intersection Summary

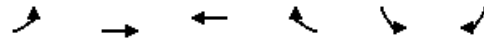
Cycle Length: 150
 Actuated Cycle Length: 150
 Offset: 50 (33%), Referenced to phase 2:EBT and 6:WBTL, Start of FDW or yellow
 Natural Cycle: 145
 Control Type: Actuated-Coordinated
 Maximum v/c Ratio: 1.00
 Intersection Signal Delay: 51.8
 Intersection LOS: D
 Intersection Capacity Utilization 93.7%
 ICU Level of Service F
 Analysis Period (min) 15

Splits and Phases: 10: Marksheffel Rd & US 24



Lanes, Volumes, Timings
12: US 24 & Constitution Ave

Existing
AM Peak Hour



Lane Group	EBL	EBT	WBT	WBR	SBL	SBR
Lane Configurations	↵	↕↕	↕↕	↕	↵↵	↕
Traffic Volume (vph)	44	366	1299	321	177	105
Future Volume (vph)	44	366	1299	321	177	105
Satd. Flow (prot)	1770	3539	3539	1583	3433	1583
Flt Permitted	0.147				0.950	
Satd. Flow (perm)	274	3539	3539	1583	3433	1583
Satd. Flow (RTOR)				341		119
Peak Hour Factor	0.85	0.85	0.94	0.94	0.88	0.88
Shared Lane Traffic (%)						
Lane Group Flow (vph)	52	431	1382	341	201	119
Turn Type	pm+pt	NA	NA	Perm	Prot	Perm
Protected Phases	5	2	6		4	
Permitted Phases	2			6		4
Detector Phase	5	2	6	6	4	4
Switch Phase						
Minimum Initial (s)	6.0	24.0	24.0	24.0	6.0	6.0
Minimum Split (s)	11.0	31.0	31.0	31.0	23.0	23.0
Total Split (s)	13.0	82.0	69.0	69.0	38.0	38.0
Total Split (%)	10.8%	68.3%	57.5%	57.5%	31.7%	31.7%
Yellow Time (s)	3.0	5.0	5.0	5.0	3.0	3.0
All-Red Time (s)	2.0	2.0	2.0	2.0	2.0	2.0
Lost Time Adjust (s)	0.0	0.0	0.0	0.0	0.0	0.0
Total Lost Time (s)	5.0	7.0	7.0	7.0	5.0	5.0
Lead/Lag	Lead		Lag	Lag		
Lead-Lag Optimize?	Yes		Yes	Yes		
Recall Mode	Min	C-Min	C-Min	C-Min	Min	Min
Act Effct Green (s)	97.6	95.6	84.3	84.3	12.4	12.4
Actuated g/C Ratio	0.81	0.80	0.70	0.70	0.10	0.10
v/c Ratio	0.17	0.15	0.56	0.28	0.57	0.44
Control Delay	3.8	3.1	10.1	1.3	57.3	13.8
Queue Delay	0.0	0.0	0.0	0.0	0.0	0.0
Total Delay	3.8	3.1	10.1	1.3	57.3	13.8
LOS	A	A	B	A	E	B
Approach Delay		3.2	8.4		41.1	
Approach LOS		A	A		D	

Intersection Summary

Cycle Length: 120
 Actuated Cycle Length: 120
 Offset: 20 (17%), Referenced to phase 2:EBTL and 6:WBT, Start of Green
 Natural Cycle: 70
 Control Type: Actuated-Coordinated
 Maximum v/c Ratio: 0.57
 Intersection Signal Delay: 11.5
 Intersection Capacity Utilization 52.4%
 Analysis Period (min) 15
 Intersection LOS: B
 ICU Level of Service A

Splits and Phases: 12: US 24 & Constitution Ave



HCM 6th TWSC
1: Meadowbrook Pkwy

Existing
PM Peak Hour

Intersection													
Int Delay, s/veh	6.6												
Movement	EBL	EBT	EBR	WBL	WBT	WBR	NBL	NBT	NBR	SBL	SBT	SBR	
Lane Configurations		↕			↕			↕			↕		
Traffic Vol, veh/h	21	4	23	0	5	1	6	35	1	0	11	16	
Future Vol, veh/h	21	4	23	0	5	1	6	35	1	0	11	16	
Conflicting Peds, #/hr	0	0	0	0	0	0	0	0	0	0	0	0	
Sign Control	Free	Free	Free	Free	Free	Free	Stop	Stop	Stop	Stop	Stop	Stop	
RT Channelized	-	-	None	-	-	None	-	-	None	-	-	None	
Storage Length	-	-	-	-	-	-	-	-	-	-	-	-	
Veh in Median Storage, #	-	0	-	-	0	-	-	0	-	-	0	-	
Grade, %	-	0	-	-	0	-	-	0	-	-	0	-	
Peak Hour Factor	80	80	80	50	50	50	70	70	70	75	75	75	
Heavy Vehicles, %	2	2	2	2	2	2	2	2	2	2	2	2	
Mvmt Flow	26	5	29	0	10	2	9	50	1	0	15	21	

Major/Minor	Major1			Major2			Minor1			Minor2		
Conflicting Flow All	12	0	0	34	0	0	101	84	20	108	97	11
Stage 1	-	-	-	-	-	-	72	72	-	11	11	-
Stage 2	-	-	-	-	-	-	29	12	-	97	86	-
Critical Hdwy	4.12	-	-	4.12	-	-	7.12	6.52	6.22	7.12	6.52	6.22
Critical Hdwy Stg 1	-	-	-	-	-	-	6.12	5.52	-	6.12	5.52	-
Critical Hdwy Stg 2	-	-	-	-	-	-	6.12	5.52	-	6.12	5.52	-
Follow-up Hdwy	2.218	-	-	2.218	-	-	3.518	4.018	3.318	3.518	4.018	3.318
Pot Cap-1 Maneuver	1607	-	-	1578	-	-	880	806	1058	871	793	1070
Stage 1	-	-	-	-	-	-	938	835	-	1010	886	-
Stage 2	-	-	-	-	-	-	988	886	-	910	824	-
Platoon blocked, %		-	-		-	-						
Mov Cap-1 Maneuver	1607	-	-	1578	-	-	840	792	1058	817	780	1070
Mov Cap-2 Maneuver	-	-	-	-	-	-	840	792	-	817	780	-
Stage 1	-	-	-	-	-	-	922	821	-	993	886	-
Stage 2	-	-	-	-	-	-	952	886	-	839	810	-

Approach	EB	WB	NB	SB
HCM Control Delay, s	3.2	0	9.8	9
HCM LOS			A	A

Minor Lane/Major Mvmt	NBLn1	EBL	EBT	EBR	WBL	WBT	WBR	SBLn1
Capacity (veh/h)	803	1607	-	-	1578	-	-	929
HCM Lane V/C Ratio	0.075	0.016	-	-	-	-	-	0.039
HCM Control Delay (s)	9.8	7.3	0	-	0	-	-	9
HCM Lane LOS	A	A	A	-	A	-	-	A
HCM 95th %tile Q(veh)	0.2	0.1	-	-	0	-	-	0.1

Intersection	
Intersection Delay, s/veh	7.1
Intersection LOS	A

Movement	WBL	WBR	NBT	NBR	SBL	SBT
Lane Configurations	Y		T			T
Traffic Vol, veh/h	5	0	22	10	0	18
Future Vol, veh/h	5	0	22	10	0	18
Peak Hour Factor	0.42	0.42	0.67	0.67	0.56	0.56
Heavy Vehicles, %	2	2	2	2	2	2
Mvmt Flow	12	0	33	15	0	32
Number of Lanes	1	0	1	0	0	1

Approach	WB	NB	SB
Opposing Approach		SB	NB
Opposing Lanes	0	1	1
Conflicting Approach Left	NB		WB
Conflicting Lanes Left	1	0	1
Conflicting Approach Right	SB	WB	
Conflicting Lanes Right	1	1	0
HCM Control Delay	7.4	7	7.2
HCM LOS	A	A	A

Lane	NBLn1	WBLn1	SBLn1
Vol Left, %	0%	100%	0%
Vol Thru, %	69%	0%	100%
Vol Right, %	31%	0%	0%
Sign Control	Stop	Stop	Stop
Traffic Vol by Lane	32	5	18
LT Vol	0	5	0
Through Vol	22	0	18
RT Vol	10	0	0
Lane Flow Rate	48	12	32
Geometry Grp	1	1	1
Degree of Util (X)	0.05	0.014	0.036
Departure Headway (Hd)	3.792	4.272	3.991
Convergence, Y/N	Yes	Yes	Yes
Cap	947	837	900
Service Time	1.804	2.301	2.004
HCM Lane V/C Ratio	0.051	0.014	0.036
HCM Control Delay	7	7.4	7.2
HCM Lane LOS	A	A	A
HCM 95th-tile Q	0.2	0	0.1

HCM 6th TWSC
3: Meadowbrook Pkwy & Springside Dr

Existing
PM Peak Hour

Intersection						
Int Delay, s/veh	4.4					
Movement	EBL	EBT	WBT	WBR	SBL	SBR
Lane Configurations		↔	↔		↔	
Traffic Vol, veh/h	10	15	11	9	11	17
Future Vol, veh/h	10	15	11	9	11	17
Conflicting Peds, #/hr	0	0	0	0	0	0
Sign Control	Free	Free	Free	Free	Stop	Stop
RT Channelized	-	None	-	None	-	None
Storage Length	-	-	-	-	0	-
Veh in Median Storage, #	-	0	0	-	0	-
Grade, %	-	0	0	-	0	-
Peak Hour Factor	78	78	71	71	70	70
Heavy Vehicles, %	2	2	2	2	2	2
Mvmt Flow	13	19	15	13	16	24

Major/Minor	Major1	Major2	Minor2		
Conflicting Flow All	28	0	-	0	67 22
Stage 1	-	-	-	-	22 -
Stage 2	-	-	-	-	45 -
Critical Hdwy	4.12	-	-	-	6.42 6.22
Critical Hdwy Stg 1	-	-	-	-	5.42 -
Critical Hdwy Stg 2	-	-	-	-	5.42 -
Follow-up Hdwy	2.218	-	-	-	3.518 3.318
Pot Cap-1 Maneuver	1585	-	-	-	938 1055
Stage 1	-	-	-	-	1001 -
Stage 2	-	-	-	-	977 -
Platoon blocked, %		-	-	-	
Mov Cap-1 Maneuver	1585	-	-	-	930 1055
Mov Cap-2 Maneuver	-	-	-	-	930 -
Stage 1	-	-	-	-	993 -
Stage 2	-	-	-	-	977 -

Approach	EB	WB	SB
HCM Control Delay, s	2.9	0	8.7
HCM LOS			A

Minor Lane/Major Mvmt	EBL	EBT	WBT	WBR	SBLn1
Capacity (veh/h)	1585	-	-	-	1002
HCM Lane V/C Ratio	0.008	-	-	-	0.04
HCM Control Delay (s)	7.3	0	-	-	8.7
HCM Lane LOS	A	A	-	-	A
HCM 95th %tile Q(veh)	0	-	-	-	0.1

HCM 6th TWSC
4: Pinyon Jay Dr & Meadowbrook Pkwy

Existing
PM Peak Hour

Intersection

Int Delay, s/veh 3.3

Movement	EBL	EBT	EBR	WBL	WBT	WBR	NBL	NBT	NBR	SBL	SBT	SBR
Lane Configurations		↕			↕			↕			↕	
Traffic Vol, veh/h	3	14	8	5	14	2	6	0	2	0	4	0
Future Vol, veh/h	3	14	8	5	14	2	6	0	2	0	4	0
Conflicting Peds, #/hr	0	0	0	0	0	0	0	0	0	0	0	0
Sign Control	Free	Free	Free	Free	Free	Free	Stop	Stop	Stop	Stop	Stop	Stop
RT Channelized	-	-	None	-	-	None	-	-	None	-	-	None
Storage Length	-	-	-	-	-	-	-	-	-	-	-	-
Veh in Median Storage, #	-	0	-	-	0	-	-	0	-	-	0	-
Grade, %	-	0	-	-	0	-	-	0	-	-	0	-
Peak Hour Factor	89	89	89	66	66	66	67	67	67	50	50	50
Heavy Vehicles, %	2	2	2	2	2	2	2	2	2	2	2	2
Mvmt Flow	3	16	9	8	21	3	9	0	3	0	8	0

Major/Minor	Major1		Major2		Minor1		Minor2					
Conflicting Flow All	24	0	0	25	0	0	70	67	21	67	70	23
Stage 1	-	-	-	-	-	-	27	27	-	39	39	-
Stage 2	-	-	-	-	-	-	43	40	-	28	31	-
Critical Hdwy	4.12	-	-	4.12	-	-	7.12	6.52	6.22	7.12	6.52	6.22
Critical Hdwy Stg 1	-	-	-	-	-	-	6.12	5.52	-	6.12	5.52	-
Critical Hdwy Stg 2	-	-	-	-	-	-	6.12	5.52	-	6.12	5.52	-
Follow-up Hdwy	2.218	-	-	2.218	-	-	3.518	4.018	3.318	3.518	4.018	3.318
Pot Cap-1 Maneuver	1591	-	-	1589	-	-	922	824	1056	926	821	1054
Stage 1	-	-	-	-	-	-	990	873	-	976	862	-
Stage 2	-	-	-	-	-	-	971	862	-	989	869	-
Platoon blocked, %		-	-		-	-						
Mov Cap-1 Maneuver	1591	-	-	1589	-	-	910	818	1056	919	815	1054
Mov Cap-2 Maneuver	-	-	-	-	-	-	910	818	-	919	815	-
Stage 1	-	-	-	-	-	-	988	871	-	974	858	-
Stage 2	-	-	-	-	-	-	957	858	-	984	867	-

Approach	EB	WB	NB	SB
HCM Control Delay, s	0.9	1.7	8.9	9.5
HCM LOS			A	A

Minor Lane/Major Mvmt	NBLn1	EBL	EBT	EBR	WBL	WBT	WBR	SBLn1
Capacity (veh/h)	943	1591	-	-	1589	-	-	815
HCM Lane V/C Ratio	0.013	0.002	-	-	0.005	-	-	0.01
HCM Control Delay (s)	8.9	7.3	0	-	7.3	0	-	9.5
HCM Lane LOS	A	A	A	-	A	A	-	A
HCM 95th %tile Q(veh)	0	0	-	-	0	-	-	0

Intersection						
Int Delay, s/veh	1.7					
Movement	EBT	EBR	WBL	WBT	NBL	NBR
Lane Configurations	↔			↔	↔	
Traffic Vol, veh/h	4	1	0	3	0	3
Future Vol, veh/h	4	1	0	3	0	3
Conflicting Peds, #/hr	0	0	0	0	0	0
Sign Control	Free	Free	Free	Free	Stop	Stop
RT Channelized	-	None	-	None	-	None
Storage Length	-	-	-	-	0	-
Veh in Median Storage, #	0	-	-	0	0	-
Grade, %	0	-	-	0	0	-
Peak Hour Factor	63	63	38	38	75	75
Heavy Vehicles, %	2	2	2	2	2	2
Mvmt Flow	6	2	0	8	0	4

Major/Minor	Major1	Major2	Minor1	Minor2	Minor3
Conflicting Flow All	0	0	8	0	15
Stage 1	-	-	-	-	7
Stage 2	-	-	-	-	8
Critical Hdwy	-	-	4.12	-	6.42
Critical Hdwy Stg 1	-	-	-	-	5.42
Critical Hdwy Stg 2	-	-	-	-	5.42
Follow-up Hdwy	-	-	2.218	-	3.518
Pot Cap-1 Maneuver	-	-	1612	-	1004
Stage 1	-	-	-	-	1016
Stage 2	-	-	-	-	1015
Platoon blocked, %	-	-	-	-	-
Mov Cap-1 Maneuver	-	-	1612	-	1004
Mov Cap-2 Maneuver	-	-	-	-	1004
Stage 1	-	-	-	-	1016
Stage 2	-	-	-	-	1015

Approach	EB	WB	NB
HCM Control Delay, s	0	0	8.4
HCM LOS			A

Minor Lane/Major Mvmt	NBLn1	EBT	EBR	WBL	WBT
Capacity (veh/h)	1075	-	-	1612	-
HCM Lane V/C Ratio	0.004	-	-	-	-
HCM Control Delay (s)	8.4	-	-	0	-
HCM Lane LOS	A	-	-	A	-
HCM 95th %tile Q(veh)	0	-	-	0	-

Intersection						
Int Delay, s/veh	2.3					
Movement	EBL	EBR	NBL	NBT	SBT	SBR
Lane Configurations	↔			↔	↔	
Traffic Vol, veh/h	4	0	1	1	8	4
Future Vol, veh/h	4	0	1	1	8	4
Conflicting Peds, #/hr	0	0	0	0	0	0
Sign Control	Stop	Stop	Free	Free	Free	Free
RT Channelized	-	None	-	None	-	None
Storage Length	0	-	-	-	-	-
Veh in Median Storage, #	0	-	-	0	0	-
Grade, %	0	-	-	0	0	-
Peak Hour Factor	50	50	50	50	50	50
Heavy Vehicles, %	2	2	2	2	2	2
Mvmt Flow	8	0	2	2	16	8

Major/Minor	Minor2	Major1		Major2	
Conflicting Flow All	26	20	24	0	0
Stage 1	20	-	-	-	-
Stage 2	6	-	-	-	-
Critical Hdwy	6.42	6.22	4.12	-	-
Critical Hdwy Stg 1	5.42	-	-	-	-
Critical Hdwy Stg 2	5.42	-	-	-	-
Follow-up Hdwy	3.518	3.318	2.218	-	-
Pot Cap-1 Maneuver	989	1058	1591	-	-
Stage 1	1003	-	-	-	-
Stage 2	1017	-	-	-	-
Platoon blocked, %				-	-
Mov Cap-1 Maneuver	988	1058	1591	-	-
Mov Cap-2 Maneuver	988	-	-	-	-
Stage 1	1002	-	-	-	-
Stage 2	1017	-	-	-	-

Approach	EB	NB	SB
HCM Control Delay, s	8.7	3.6	0
HCM LOS	A		

Minor Lane/Major Mvmt	NBL	NBT	EBLn1	SBT	SBR
Capacity (veh/h)	1591	-	988	-	-
HCM Lane V/C Ratio	0.001	-	0.008	-	-
HCM Control Delay (s)	7.3	0	8.7	-	-
HCM Lane LOS	A	A	A	-	-
HCM 95th %tile Q(veh)	0	-	0	-	-

Intersection						
Int Delay, s/veh	1.3					
Movement	EBT	EBR	WBL	WBT	NBL	NBR
Lane Configurations	↑↑	↗	↘	↑↑	↘	
Traffic Vol, veh/h	407	106	6	244	60	1
Future Vol, veh/h	407	106	6	244	60	1
Conflicting Peds, #/hr	0	0	0	0	0	0
Sign Control	Free	Free	Free	Free	Stop	Stop
RT Channelized	-	None	-	None	-	None
Storage Length	-	300	450	-	0	-
Veh in Median Storage, #	0	-	-	0	0	-
Grade, %	0	-	-	0	0	-
Peak Hour Factor	84	84	89	89	80	80
Heavy Vehicles, %	2	2	2	2	2	2
Mvmt Flow	485	126	7	274	75	1

Major/Minor	Major1	Major2	Minor1			
Conflicting Flow All	0	0	611	0	636	243
Stage 1	-	-	-	-	485	-
Stage 2	-	-	-	-	151	-
Critical Hdwy	-	-	4.14	-	6.84	6.94
Critical Hdwy Stg 1	-	-	-	-	5.84	-
Critical Hdwy Stg 2	-	-	-	-	5.84	-
Follow-up Hdwy	-	-	2.22	-	3.52	3.32
Pot Cap-1 Maneuver	-	-	964	-	410	758
Stage 1	-	-	-	-	585	-
Stage 2	-	-	-	-	861	-
Platoon blocked, %	-	-	-	-	-	-
Mov Cap-1 Maneuver	-	-	964	-	407	758
Mov Cap-2 Maneuver	-	-	-	-	407	-
Stage 1	-	-	-	-	585	-
Stage 2	-	-	-	-	855	-

Approach	EB	WB	NB
HCM Control Delay, s	0	0.2	15.8
HCM LOS			C

Minor Lane/Major Mvmt	NBLn1	EBT	EBR	WBL	WBT
Capacity (veh/h)	410	-	-	964	-
HCM Lane V/C Ratio	0.186	-	-	0.007	-
HCM Control Delay (s)	15.8	-	-	8.8	-
HCM Lane LOS	C	-	-	A	-
HCM 95th %tile Q(veh)	0.7	-	-	0	-

HCM 6th TWSC
8: Constitution Ave & Meadowbrook Pkwy

Existing
PM Peak Hour

Intersection						
Int Delay, s/veh	1.7					
Movement	EBL	EBR	NBL	NBT	SBT	SBR
Lane Configurations	↘	↗	↘	↕	↕	↗
Traffic Vol, veh/h	34	17	28	204	317	43
Future Vol, veh/h	34	17	28	204	317	43
Conflicting Peds, #/hr	0	0	0	0	0	0
Sign Control	Stop	Stop	Free	Free	Free	Free
RT Channelized	-	None	-	None	-	None
Storage Length	0	50	325	-	-	250
Veh in Median Storage, #	0	-	-	0	0	-
Grade, %	0	-	-	0	0	-
Peak Hour Factor	64	64	82	82	87	87
Heavy Vehicles, %	2	2	2	2	2	2
Mvmt Flow	53	27	34	249	364	49

Major/Minor	Minor2	Major1	Major2			
Conflicting Flow All	557	182	413	0	-	0
Stage 1	364	-	-	-	-	-
Stage 2	193	-	-	-	-	-
Critical Hdwy	6.84	6.94	4.14	-	-	-
Critical Hdwy Stg 1	5.84	-	-	-	-	-
Critical Hdwy Stg 2	5.84	-	-	-	-	-
Follow-up Hdwy	3.52	3.32	2.22	-	-	-
Pot Cap-1 Maneuver	460	829	1142	-	-	-
Stage 1	673	-	-	-	-	-
Stage 2	821	-	-	-	-	-
Platoon blocked, %				-	-	-
Mov Cap-1 Maneuver	446	829	1142	-	-	-
Mov Cap-2 Maneuver	446	-	-	-	-	-
Stage 1	653	-	-	-	-	-
Stage 2	821	-	-	-	-	-

Approach	EB	NB	SB
HCM Control Delay, s	12.6	1	0
HCM LOS	B		

Minor Lane/Major Mvmt	NBL	NBT	EBLn1	EBLn2	SBT	SBR
Capacity (veh/h)	1142	-	446	829	-	-
HCM Lane V/C Ratio	0.03	-	0.119	0.032	-	-
HCM Control Delay (s)	8.2	-	14.2	9.5	-	-
HCM Lane LOS	A	-	B	A	-	-
HCM 95th %tile Q(veh)	0.1	-	0.4	0.1	-	-

Intersection						
Int Delay, s/veh	0					
Movement	EBL	EBT	WBT	WBR	SBL	SBR
Lane Configurations		↑↑	↑↑	↗		↗
Traffic Vol, veh/h	0	867	429	2	0	26
Future Vol, veh/h	0	867	429	2	0	26
Conflicting Peds, #/hr	0	0	0	0	0	0
Sign Control	Free	Free	Free	Free	Stop	Stop
RT Channelized	-	None	-	None	-	Free
Storage Length	-	-	-	800	-	0
Veh in Median Storage, #	-	0	0	-	0	-
Grade, %	-	0	0	-	0	-
Peak Hour Factor	87	87	90	90	72	72
Heavy Vehicles, %	2	2	2	2	2	2
Mvmt Flow	0	997	477	2	0	36

Major/Minor	Major1	Major2	Minor2		
Conflicting Flow All	-	0	-	0	-
Stage 1	-	-	-	-	-
Stage 2	-	-	-	-	-
Critical Hdwy	-	-	-	-	-
Critical Hdwy Stg 1	-	-	-	-	-
Critical Hdwy Stg 2	-	-	-	-	-
Follow-up Hdwy	-	-	-	-	-
Pot Cap-1 Maneuver	0	-	-	-	0
Stage 1	0	-	-	-	0
Stage 2	0	-	-	-	0
Platoon blocked, %	-	-	-	-	-
Mov Cap-1 Maneuver	-	-	-	-	-
Mov Cap-2 Maneuver	-	-	-	-	-
Stage 1	-	-	-	-	-
Stage 2	-	-	-	-	-

Approach	EB	WB	SB
HCM Control Delay, s	0	0	0
HCM LOS			A

Minor Lane/Major Mvmt	EBT	WBT	WBR	SBLn1
Capacity (veh/h)	-	-	-	-
HCM Lane V/C Ratio	-	-	-	-
HCM Control Delay (s)	-	-	-	0
HCM Lane LOS	-	-	-	A
HCM 95th %tile Q(veh)	-	-	-	-

Lanes, Volumes, Timings
 9: Marksheffel Rd & Meadowbrook Pkwy

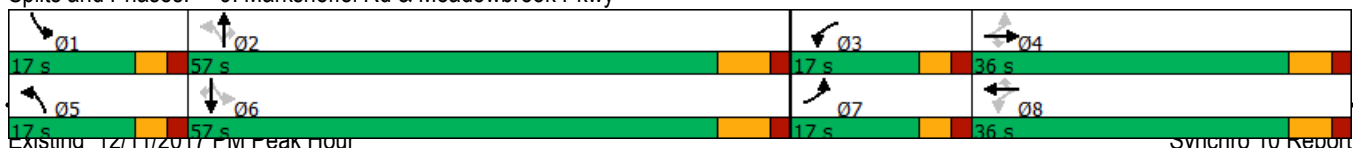
Existing
 PM Peak Hour

Lane Group	EBL	EBT	EBR	WBL	WBT	WBR	NBL	NBT	NBR	SBL	SBT	SBR
Lane Configurations												
Traffic Volume (vph)	67	7	21	18	5	30	16	1162	57	46	615	74
Future Volume (vph)	67	7	21	18	5	30	16	1162	57	46	615	74
Satd. Flow (prot)	3433	1863	1583	1770	1863	1583	1770	3539	1583	1770	3539	1583
Flt Permitted	0.541			0.976			0.389			0.123		
Satd. Flow (perm)	1955	1863	1583	1818	1863	1583	725	3539	1583	229	3539	1583
Satd. Flow (RTOR)			120			120			112			112
Peak Hour Factor	0.77	0.77	0.77	0.66	0.66	0.66	0.84	0.84	0.84	0.89	0.89	0.89
Shared Lane Traffic (%)												
Lane Group Flow (vph)	87	9	27	27	8	45	19	1383	68	52	691	83
Turn Type	pm+pt	NA	Perm	pm+pt	NA	Perm	pm+pt	NA	Perm	pm+pt	NA	Perm
Protected Phases	7	4		3	8		5	2		1	6	
Permitted Phases	4		4	8		8	2		2	6		6
Detector Phase	7	4	4	3	8	8	5	2	2	1	6	6
Switch Phase												
Minimum Initial (s)	4.0	4.0	4.0	4.0	4.0	4.0	4.0	4.0	4.0	4.0	4.0	4.0
Minimum Split (s)	9.0	10.0	10.0	9.0	10.0	10.0	9.0	11.0	11.0	9.0	11.0	11.0
Total Split (s)	17.0	36.0	36.0	17.0	36.0	36.0	17.0	57.0	57.0	17.0	57.0	57.0
Total Split (%)	13.4%	28.3%	28.3%	13.4%	28.3%	28.3%	13.4%	44.9%	44.9%	13.4%	44.9%	44.9%
Yellow Time (s)	3.0	4.0	4.0	3.0	4.0	4.0	3.0	5.0	5.0	3.0	5.0	5.0
All-Red Time (s)	2.0	2.0	2.0	2.0	2.0	2.0	2.0	2.0	2.0	2.0	2.0	2.0
Lost Time Adjust (s)	0.0	0.0	0.0	0.0	0.0	0.0	0.0	0.0	0.0	0.0	0.0	0.0
Total Lost Time (s)	5.0	6.0	6.0	5.0	6.0	6.0	5.0	7.0	7.0	5.0	7.0	7.0
Lead/Lag	Lead	Lag	Lag	Lead	Lag	Lag	Lead	Lag	Lag	Lead	Lag	Lag
Lead-Lag Optimize?	Yes	Yes	Yes	Yes	Yes	Yes	Yes	Yes	Yes	Yes	Yes	Yes
Recall Mode	None	None	None	None	None	None	None	Max	Max	None	Max	Max
Act Effct Green (s)	12.8	8.8	8.8	10.7	6.0	6.0	60.9	56.0	56.0	63.7	60.8	60.8
Actuated g/C Ratio	0.15	0.10	0.10	0.12	0.07	0.07	0.70	0.64	0.64	0.73	0.70	0.70
v/c Ratio	0.21	0.05	0.10	0.12	0.06	0.20	0.03	0.61	0.06	0.19	0.28	0.07
Control Delay	31.7	40.0	0.8	31.3	42.6	2.1	5.3	15.1	0.8	6.5	8.7	1.3
Queue Delay	0.0	0.0	0.0	0.0	0.0	0.0	0.0	0.0	0.0	0.0	0.0	0.0
Total Delay	31.7	40.0	0.8	31.3	42.6	2.1	5.3	15.1	0.8	6.5	8.7	1.3
LOS	C	D	A	C	D	A	A	B	A	A	A	A
Approach Delay		25.5			16.0			14.3			7.8	
Approach LOS		C			B			B			A	

Intersection Summary

Cycle Length: 127
 Actuated Cycle Length: 87
 Natural Cycle: 60
 Control Type: Actuated-Uncoordinated
 Maximum v/c Ratio: 0.61
 Intersection Signal Delay: 12.8
 Intersection Capacity Utilization 57.6%
 Analysis Period (min) 15
 Intersection LOS: B
 ICU Level of Service B

Splits and Phases: 9: Marksheffel Rd & Meadowbrook Pkwy



Lanes, Volumes, Timings
10: Marksheffel Rd & US 24

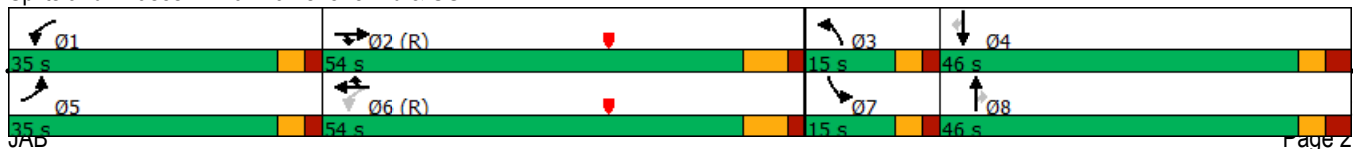
Existing
PM Peak Hour

Lane Group	EBL	EBT	EBR	WBL	WBT	WBR	NBL	NBT	NBR	SBL	SBT	SBR
Lane Configurations												
Traffic Volume (vph)	487	707	4	78	361	8	13	736	156	8	343	312
Future Volume (vph)	487	707	4	78	361	8	13	736	156	8	343	312
Satd. Flow (prot)	3433	3539	1583	1770	3539	1583	1770	3539	1583	1770	3539	1583
Flt Permitted	0.950			0.335			0.950			0.950		
Satd. Flow (perm)	3433	3539	1583	624	3539	1583	1770	3539	1583	1770	3539	1583
Satd. Flow (RTOR)			95			95			184			376
Peak Hour Factor	0.84	0.84	0.84	0.87	0.87	0.87	0.85	0.85	0.85	0.83	0.83	0.83
Shared Lane Traffic (%)												
Lane Group Flow (vph)	580	842	5	90	415	9	15	866	184	10	413	376
Turn Type	Prot	NA	Prot	pm+pt	NA	Prot	Prot	NA	Perm	Prot	NA	Perm
Protected Phases	5	2	2	1	6	6	3	8		7	4	
Permitted Phases				6					8			4
Detector Phase	5			1			3	8	8	7	4	4
Switch Phase												
Minimum Initial (s)	6.0	23.0	23.0	6.0	23.0	23.0	6.0	6.0	6.0	6.0	6.0	6.0
Minimum Split (s)	15.0	35.0	35.0	15.0	35.0	35.0	15.0	16.0	16.0	15.0	16.0	16.0
Total Split (s)	35.0	54.0	54.0	35.0	54.0	54.0	15.0	46.0	46.0	15.0	46.0	46.0
Total Split (%)	23.3%	36.0%	36.0%	23.3%	36.0%	36.0%	10.0%	30.7%	30.7%	10.0%	30.7%	30.7%
Yellow Time (s)	3.0	5.0	5.0	3.0	5.0	5.0	3.0	3.0	3.0	3.0	3.0	3.0
All-Red Time (s)	2.0	2.0	2.0	2.0	2.0	2.0	2.0	3.0	3.0	2.0	3.0	3.0
Lost Time Adjust (s)	0.0	-2.0	-2.0	0.0	-2.0	-2.0	0.0	-1.0	1.0	0.0	-1.0	1.0
Total Lost Time (s)	5.0	5.0	5.0	5.0	5.0	5.0	5.0	5.0	7.0	5.0	5.0	7.0
Lead/Lag	Lead	Lag	Lag	Lead	Lag	Lag	Lead	Lag	Lag	Lead	Lag	Lag
Lead-Lag Optimize?												
Recall Mode	None	C-Max	C-Max	None	C-Max	C-Max	None	None	None	None	None	None
Act Effct Green (s)	29.8	80.9	80.9	68.7	59.9	59.9	7.0	40.3	38.3	6.6	40.0	38.0
Actuated g/C Ratio	0.20	0.54	0.54	0.46	0.40	0.40	0.05	0.27	0.26	0.04	0.27	0.25
v/c Ratio	0.85	0.44	0.01	0.25	0.29	0.01	0.18	0.91	0.34	0.13	0.44	0.55
Control Delay	70.5	23.1	0.0	16.8	33.2	0.0	73.3	67.3	7.3	72.1	47.3	7.4
Queue Delay	0.0	0.0	0.0	0.0	0.0	0.0	0.0	0.0	0.0	0.0	0.0	0.0
Total Delay	70.5	23.1	0.0	16.8	33.2	0.0	73.3	67.3	7.3	72.1	47.3	7.4
LOS	E	C	A	B	C	A	E	E	A	E	D	A
Approach Delay		42.3			29.7			57.0			28.8	
Approach LOS		D			C			E			C	

Intersection Summary

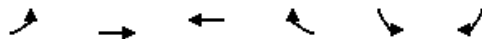
Cycle Length: 150
 Actuated Cycle Length: 150
 Offset: 70 (47%), Referenced to phase 2:EBT and 6:WBTL, Start of FDW or yellow
 Natural Cycle: 95
 Control Type: Actuated-Coordinated
 Maximum v/c Ratio: 0.91
 Intersection Signal Delay: 41.9
 Intersection LOS: D
 Intersection Capacity Utilization 65.9%
 ICU Level of Service C
 Analysis Period (min) 15

Splits and Phases: 10: Marksheffel Rd & US 24



Lanes, Volumes, Timings
12: US 24 & Constitution Ave

Existing
PM Peak Hour

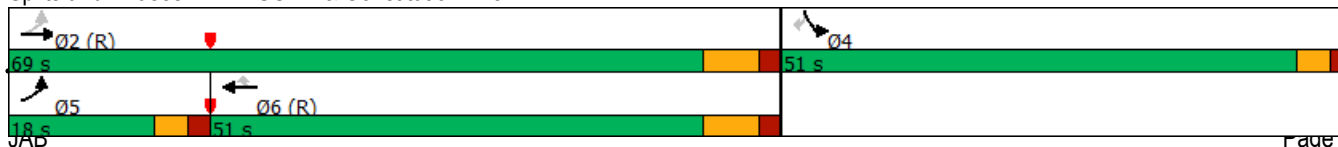


Lane Group	EBL	EBT	WBT	WBR	SBL	SBR
Lane Configurations	↖	↕	↕	↗	↖	↗
Traffic Volume (vph)	64	797	372	169	277	55
Future Volume (vph)	64	797	372	169	277	55
Satd. Flow (prot)	1770	3539	3539	1583	3433	1583
Flt Permitted	0.484				0.950	
Satd. Flow (perm)	902	3539	3539	1583	3433	1583
Satd. Flow (RTOR)				184		63
Peak Hour Factor	0.84	0.84	0.92	0.92	0.88	0.88
Shared Lane Traffic (%)						
Lane Group Flow (vph)	76	949	404	184	315	63
Turn Type	pm+pt	NA	NA	Perm	Prot	Perm
Protected Phases	5	2	6		4	
Permitted Phases	2			6		4
Detector Phase	5	2	6	6	4	4
Switch Phase						
Minimum Initial (s)	6.0	24.0	24.0	24.0	6.0	6.0
Minimum Split (s)	11.0	31.0	31.0	31.0	23.0	23.0
Total Split (s)	18.0	69.0	51.0	51.0	51.0	51.0
Total Split (%)	15.0%	57.5%	42.5%	42.5%	42.5%	42.5%
Yellow Time (s)	3.0	5.0	5.0	5.0	3.0	3.0
All-Red Time (s)	2.0	2.0	2.0	2.0	2.0	2.0
Lost Time Adjust (s)	0.0	0.0	0.0	0.0	0.0	0.0
Total Lost Time (s)	5.0	7.0	7.0	7.0	5.0	5.0
Lead/Lag	Lead		Lag	Lag		
Lead-Lag Optimize?	Yes		Yes	Yes		
Recall Mode	Min	C-Min	C-Min	C-Min	Min	Min
Act Effct Green (s)	93.5	91.5	79.7	79.7	16.5	16.5
Actuated g/C Ratio	0.78	0.76	0.66	0.66	0.14	0.14
v/c Ratio	0.10	0.35	0.17	0.17	0.67	0.23
Control Delay	3.8	5.3	8.3	1.6	56.0	12.7
Queue Delay	0.0	0.0	0.0	0.0	0.0	0.0
Total Delay	3.8	5.3	8.3	1.6	56.0	12.7
LOS	A	A	A	A	E	B
Approach Delay		5.2	6.2		48.8	
Approach LOS		A	A		D	

Intersection Summary

Cycle Length: 120
 Actuated Cycle Length: 120
 Offset: 112 (93%), Referenced to phase 2:EBTL and 6:WBT, Start of Green
 Natural Cycle: 65
 Control Type: Actuated-Coordinated
 Maximum v/c Ratio: 0.67
 Intersection Signal Delay: 13.8
 Intersection Capacity Utilization 47.1%
 Analysis Period (min) 15
 Intersection LOS: B
 ICU Level of Service A

Splits and Phases: 12: US 24 & Constitution Ave



Intersection												
Int Delay, s/veh	5.4											
Movement	EBL	EBT	EBR	WBL	WBT	WBR	NBL	NBT	NBR	SBL	SBT	SBR
Lane Configurations		↕			↕			↕			↕	
Traffic Vol, veh/h	7	21	0	0	11	23	2	12	0	22	4	25
Future Vol, veh/h	7	21	0	0	11	23	2	12	0	22	4	25
Conflicting Peds, #/hr	0	0	0	0	0	0	0	0	0	0	0	0
Sign Control	Free	Free	Free	Free	Free	Free	Stop	Stop	Stop	Stop	Stop	Stop
RT Channelized	-	-	None	-	-	None	-	-	None	-	-	None
Storage Length	-	-	-	-	-	-	-	-	-	-	-	-
Veh in Median Storage, #	-	0	-	-	0	-	-	0	-	-	0	-
Grade, %	-	0	-	-	0	-	-	0	-	-	0	-
Peak Hour Factor	84	84	84	77	77	77	58	58	58	75	75	75
Heavy Vehicles, %	2	2	2	2	2	2	2	2	2	2	2	2
Mvmt Flow	8	25	0	0	14	30	3	21	0	29	5	33

Major/Minor	Major1			Major2			Minor1			Minor2		
Conflicting Flow All	44	0	0	25	0	0	89	85	25	81	70	29
Stage 1	-	-	-	-	-	-	41	41	-	29	29	-
Stage 2	-	-	-	-	-	-	48	44	-	52	41	-
Critical Hdwy	4.12	-	-	4.12	-	-	7.12	6.52	6.22	7.12	6.52	6.22
Critical Hdwy Stg 1	-	-	-	-	-	-	6.12	5.52	-	6.12	5.52	-
Critical Hdwy Stg 2	-	-	-	-	-	-	6.12	5.52	-	6.12	5.52	-
Follow-up Hdwy	2.218	-	-	2.218	-	-	3.518	4.018	3.318	3.518	4.018	3.318
Pot Cap-1 Maneuver	1564	-	-	1589	-	-	896	805	1051	907	821	1046
Stage 1	-	-	-	-	-	-	974	861	-	988	871	-
Stage 2	-	-	-	-	-	-	965	858	-	961	861	-
Platoon blocked, %		-	-		-	-						
Mov Cap-1 Maneuver	1564	-	-	1589	-	-	860	801	1051	886	817	1046
Mov Cap-2 Maneuver	-	-	-	-	-	-	860	801	-	886	817	-
Stage 1	-	-	-	-	-	-	969	857	-	983	871	-
Stage 2	-	-	-	-	-	-	929	858	-	933	857	-

Approach	EB			WB			NB			SB		
HCM Control Delay, s	1.8			0			9.6			9.1		
HCM LOS							A			A		

Minor Lane/Major Mvmt	NBLn1	EBL	EBT	EBR	WBL	WBT	WBR	SBLn1
Capacity (veh/h)	809	1564	-	-	1589	-	-	951
HCM Lane V/C Ratio	0.03	0.005	-	-	-	-	-	0.072
HCM Control Delay (s)	9.6	7.3	0	-	0	-	-	9.1
HCM Lane LOS	A	A	A	-	A	-	-	A
HCM 95th %tile Q(veh)	0.1	0	-	-	0	-	-	0.2

Intersection	
Intersection Delay, s/veh	7.2
Intersection LOS	A

Movement	WBL	WBR	NBT	NBR	SBL	SBT
Lane Configurations	↔		↔			↔
Traffic Vol, veh/h	6	2	14	1	2	29
Future Vol, veh/h	6	2	14	1	2	29
Peak Hour Factor	0.40	0.40	0.63	0.63	0.86	0.86
Heavy Vehicles, %	2	2	2	2	2	2
Mvmt Flow	15	5	22	2	2	34
Number of Lanes	1	0	1	0	0	1

Approach	WB	NB	SB
Opposing Approach		SB	NB
Opposing Lanes	0	1	1
Conflicting Approach Left	NB		WB
Conflicting Lanes Left	1	0	1
Conflicting Approach Right	SB	WB	
Conflicting Lanes Right	1	1	0
HCM Control Delay	7.2	7.1	7.2
HCM LOS	A	A	A

Lane	NBLn1	WBLn1	SBLn1
Vol Left, %	0%	75%	6%
Vol Thru, %	93%	0%	94%
Vol Right, %	7%	25%	0%
Sign Control	Stop	Stop	Stop
Traffic Vol by Lane	15	8	31
LT Vol	0	6	2
Through Vol	14	0	29
RT Vol	1	2	0
Lane Flow Rate	24	20	36
Geometry Grp	1	1	1
Degree of Util (X)	0.026	0.022	0.04
Departure Headway (Hd)	3.956	4.037	4
Convergence, Y/N	Yes	Yes	Yes
Cap	907	887	898
Service Time	1.971	2.062	2.012
HCM Lane V/C Ratio	0.026	0.023	0.04
HCM Control Delay	7.1	7.2	7.2
HCM Lane LOS	A	A	A
HCM 95th-tile Q	0.1	0.1	0.1

Intersection						
Int Delay, s/veh	3.7					
Movement	EBL	EBT	WBT	WBR	SBL	SBR
Lane Configurations		↔	↔		↔	
Traffic Vol, veh/h	20	11	11	10	2	13
Future Vol, veh/h	20	11	11	10	2	13
Conflicting Peds, #/hr	0	0	0	0	0	0
Sign Control	Free	Free	Free	Free	Stop	Stop
RT Channelized	-	None	-	None	-	None
Storage Length	-	-	-	-	0	-
Veh in Median Storage, #	-	0	0	-	0	-
Grade, %	-	0	0	-	0	-
Peak Hour Factor	70	70	48	48	63	63
Heavy Vehicles, %	2	2	2	2	2	2
Mvmt Flow	29	16	23	21	3	21

Major/Minor	Major1	Major2	Minor2		
Conflicting Flow All	44	0	-	0	108 34
Stage 1	-	-	-	-	34 -
Stage 2	-	-	-	-	74 -
Critical Hdwy	4.12	-	-	-	6.42 6.22
Critical Hdwy Stg 1	-	-	-	-	5.42 -
Critical Hdwy Stg 2	-	-	-	-	5.42 -
Follow-up Hdwy	2.218	-	-	-	3.518 3.318
Pot Cap-1 Maneuver	1564	-	-	-	889 1039
Stage 1	-	-	-	-	988 -
Stage 2	-	-	-	-	949 -
Platoon blocked, %		-	-	-	
Mov Cap-1 Maneuver	1564	-	-	-	872 1039
Mov Cap-2 Maneuver	-	-	-	-	872 -
Stage 1	-	-	-	-	969 -
Stage 2	-	-	-	-	949 -

Approach	EB	WB	SB
HCM Control Delay, s	4.7	0	8.6
HCM LOS			A

Minor Lane/Major Mvmt	EBL	EBT	WBT	WBR	SBLn1
Capacity (veh/h)	1564	-	-	-	1013
HCM Lane V/C Ratio	0.018	-	-	-	0.024
HCM Control Delay (s)	7.3	0	-	-	8.6
HCM Lane LOS	A	A	-	-	A
HCM 95th %tile Q(veh)	0.1	-	-	-	0.1

Intersection												
Int Delay, s/veh	4.3											
Movement	EBL	EBT	EBR	WBL	WBT	WBR	NBL	NBT	NBR	SBL	SBT	SBR
Lane Configurations		↕			↕			↕			↕	
Traffic Vol, veh/h	1	11	3	3	14	0	7	2	0	0	7	0
Future Vol, veh/h	1	11	3	3	14	0	7	2	0	0	7	0
Conflicting Peds, #/hr	0	0	0	0	0	0	0	0	0	0	0	0
Sign Control	Free	Free	Free	Free	Free	Free	Stop	Stop	Stop	Stop	Stop	Stop
RT Channelized	-	-	None	-	-	None	-	-	None	-	-	None
Storage Length	-	-	-	-	-	-	-	-	-	-	-	-
Veh in Median Storage, #	-	0	-	-	0	-	-	0	-	-	0	-
Grade, %	-	0	-	-	0	-	-	0	-	-	0	-
Peak Hour Factor	75	75	75	61	61	61	45	45	45	58	58	58
Heavy Vehicles, %	2	2	2	2	2	2	2	2	2	2	2	2
Mvmt Flow	1	15	4	5	23	0	16	4	0	0	12	0

Major/Minor	Major1		Major2		Minor1		Minor2					
Conflicting Flow All	23	0	0	19	0	0	58	52	17	54	54	23
Stage 1	-	-	-	-	-	-	19	19	-	33	33	-
Stage 2	-	-	-	-	-	-	39	33	-	21	21	-
Critical Hdwy	4.12	-	-	4.12	-	-	7.12	6.52	6.22	7.12	6.52	6.22
Critical Hdwy Stg 1	-	-	-	-	-	-	6.12	5.52	-	6.12	5.52	-
Critical Hdwy Stg 2	-	-	-	-	-	-	6.12	5.52	-	6.12	5.52	-
Follow-up Hdwy	2.218	-	-	2.218	-	-	3.518	4.018	3.318	3.518	4.018	3.318
Pot Cap-1 Maneuver	1592	-	-	1597	-	-	939	839	1062	944	837	1054
Stage 1	-	-	-	-	-	-	1000	880	-	983	868	-
Stage 2	-	-	-	-	-	-	976	868	-	998	878	-
Platoon blocked, %		-	-	-	-	-						
Mov Cap-1 Maneuver	1592	-	-	1597	-	-	926	836	1062	937	834	1054
Mov Cap-2 Maneuver	-	-	-	-	-	-	926	836	-	937	834	-
Stage 1	-	-	-	-	-	-	999	879	-	982	865	-
Stage 2	-	-	-	-	-	-	959	865	-	992	877	-

Approach	EB		WB		NB		SB	
HCM Control Delay, s	0.5		1.3		9.1		9.4	
HCM LOS					A		A	

Minor Lane/Major Mvmt	NBLn1	EBL	EBT	EBR	WBL	WBT	WBR	SBLn1
Capacity (veh/h)	904	1592	-	-	1597	-	-	834
HCM Lane V/C Ratio	0.022	0.001	-	-	0.003	-	-	0.014
HCM Control Delay (s)	9.1	7.3	0	-	7.3	0	-	9.4
HCM Lane LOS	A	A	A	-	A	A	-	A
HCM 95th %tile Q(veh)	0.1	0	-	-	0	-	-	0

Intersection						
Int Delay, s/veh	4.2					
Movement	EBT	EBR	WBL	WBT	NBL	NBR
Lane Configurations	↔			↔	↔	
Traffic Vol, veh/h	1	1	4	3	1	0
Future Vol, veh/h	1	1	4	3	1	0
Conflicting Peds, #/hr	0	0	0	0	0	0
Sign Control	Free	Free	Free	Free	Stop	Stop
RT Channelized	-	None	-	None	-	None
Storage Length	-	-	-	-	0	-
Veh in Median Storage, #	0	-	-	0	0	-
Grade, %	0	-	-	0	0	-
Peak Hour Factor	50	50	88	88	25	25
Heavy Vehicles, %	2	2	2	2	2	2
Mvmt Flow	2	2	5	3	4	0

Major/Minor	Major1	Major2	Minor1		
Conflicting Flow All	0	0	4	0	16 3
Stage 1	-	-	-	-	3 -
Stage 2	-	-	-	-	13 -
Critical Hdwy	-	-	4.12	-	6.42 6.22
Critical Hdwy Stg 1	-	-	-	-	5.42 -
Critical Hdwy Stg 2	-	-	-	-	5.42 -
Follow-up Hdwy	-	-	2.218	-	3.518 3.318
Pot Cap-1 Maneuver	-	-	1618	-	1002 1081
Stage 1	-	-	-	-	1020 -
Stage 2	-	-	-	-	1010 -
Platoon blocked, %	-	-	-	-	-
Mov Cap-1 Maneuver	-	-	1618	-	999 1081
Mov Cap-2 Maneuver	-	-	-	-	999 -
Stage 1	-	-	-	-	1020 -
Stage 2	-	-	-	-	1007 -

Approach	EB	WB	NB
HCM Control Delay, s	0	4.1	8.6
HCM LOS			A

Minor Lane/Major Mvmt	NBLn1	EBT	EBR	WBL	WBT
Capacity (veh/h)	999	-	-	1618	-
HCM Lane V/C Ratio	0.004	-	-	0.003	-
HCM Control Delay (s)	8.6	-	-	7.2	0
HCM Lane LOS	A	-	-	A	A
HCM 95th %tile Q(veh)	0	-	-	0	-

Intersection						
Int Delay, s/veh	3.1					
Movement	EBL	EBR	NBL	NBT	SBT	SBR
Lane Configurations	↔			↔	↔	
Traffic Vol, veh/h	3	3	1	1	12	4
Future Vol, veh/h	3	3	1	1	12	4
Conflicting Peds, #/hr	0	0	0	0	0	0
Sign Control	Stop	Stop	Free	Free	Free	Free
RT Channelized	-	None	-	None	-	None
Storage Length	0	-	-	-	-	-
Veh in Median Storage, #	0	-	-	0	0	-
Grade, %	0	-	-	0	0	-
Peak Hour Factor	38	38	50	50	57	57
Heavy Vehicles, %	2	2	2	2	2	2
Mvmt Flow	8	8	2	2	21	7

Major/Minor	Minor2	Major1		Major2	
Conflicting Flow All	31	25	28	0	0
Stage 1	25	-	-	-	-
Stage 2	6	-	-	-	-
Critical Hdwy	6.42	6.22	4.12	-	-
Critical Hdwy Stg 1	5.42	-	-	-	-
Critical Hdwy Stg 2	5.42	-	-	-	-
Follow-up Hdwy	3.518	3.318	2.218	-	-
Pot Cap-1 Maneuver	983	1051	1585	-	-
Stage 1	998	-	-	-	-
Stage 2	1017	-	-	-	-
Platoon blocked, %				-	-
Mov Cap-1 Maneuver	982	1051	1585	-	-
Mov Cap-2 Maneuver	982	-	-	-	-
Stage 1	997	-	-	-	-
Stage 2	1017	-	-	-	-

Approach	EB	NB	SB
HCM Control Delay, s	8.6	3.6	0
HCM LOS	A		

Minor Lane/Major Mvmt	NBL	NBT	EBLn1	SBT	SBR
Capacity (veh/h)	1585	-	1015	-	-
HCM Lane V/C Ratio	0.001	-	0.016	-	-
HCM Control Delay (s)	7.3	0	8.6	-	-
HCM Lane LOS	A	A	A	-	-
HCM 95th %tile Q(veh)	0	-	0	-	-

Intersection						
Int Delay, s/veh	2.7					
Movement	EBT	EBR	WBL	WBT	NBL	NBR
Lane Configurations	↑↑	↗	↘	↑↑	↘	
Traffic Vol, veh/h	277	32	4	450	135	12
Future Vol, veh/h	277	32	4	450	135	12
Conflicting Peds, #/hr	0	0	0	0	0	0
Sign Control	Free	Free	Free	Free	Stop	Stop
RT Channelized	-	None	-	None	-	None
Storage Length	-	300	450	-	0	-
Veh in Median Storage, #	0	-	-	0	0	-
Grade, %	0	-	-	0	0	-
Peak Hour Factor	88	88	91	91	92	92
Heavy Vehicles, %	2	2	2	2	2	2
Mvmt Flow	315	36	4	495	147	13

Major/Minor	Major1	Major2	Minor1		
Conflicting Flow All	0	0	351	0	571 158
Stage 1	-	-	-	-	315 -
Stage 2	-	-	-	-	256 -
Critical Hdwy	-	-	4.14	-	6.84 6.94
Critical Hdwy Stg 1	-	-	-	-	5.84 -
Critical Hdwy Stg 2	-	-	-	-	5.84 -
Follow-up Hdwy	-	-	2.22	-	3.52 3.32
Pot Cap-1 Maneuver	-	-	1204	-	451 859
Stage 1	-	-	-	-	713 -
Stage 2	-	-	-	-	763 -
Platoon blocked, %	-	-	-	-	-
Mov Cap-1 Maneuver	-	-	1204	-	450 859
Mov Cap-2 Maneuver	-	-	-	-	450 -
Stage 1	-	-	-	-	713 -
Stage 2	-	-	-	-	761 -

Approach	EB	WB	NB
HCM Control Delay, s	0	0.1	16.6
HCM LOS			C

Minor Lane/Major Mvmt	NBLn1	EBT	EBR	WBL	WBT
Capacity (veh/h)	468	-	-	1204	-
HCM Lane V/C Ratio	0.341	-	-	0.004	-
HCM Control Delay (s)	16.6	-	-	8	-
HCM Lane LOS	C	-	-	A	-
HCM 95th %tile Q(veh)	1.5	-	-	0	-

Intersection						
Int Delay, s/veh	1.8					
Movement	EBL	EBR	NBL	NBT	SBT	SBR
Lane Configurations	↘	↗	↘	↕	↕	↗
Traffic Vol, veh/h	55	51	10	381	245	23
Future Vol, veh/h	55	51	10	381	245	23
Conflicting Peds, #/hr	0	0	0	0	0	0
Sign Control	Stop	Stop	Free	Free	Free	Free
RT Channelized	-	None	-	None	-	None
Storage Length	0	50	325	-	-	250
Veh in Median Storage, #	0	-	-	0	0	-
Grade, %	0	-	-	0	0	-
Peak Hour Factor	83	83	89	89	79	79
Heavy Vehicles, %	2	2	2	2	2	2
Mvmt Flow	66	61	11	428	310	29

Major/Minor	Minor2	Major1	Major2			
Conflicting Flow All	546	155	339	0	-	0
Stage 1	310	-	-	-	-	-
Stage 2	236	-	-	-	-	-
Critical Hdwy	6.84	6.94	4.14	-	-	-
Critical Hdwy Stg 1	5.84	-	-	-	-	-
Critical Hdwy Stg 2	5.84	-	-	-	-	-
Follow-up Hdwy	3.52	3.32	2.22	-	-	-
Pot Cap-1 Maneuver	468	863	1217	-	-	-
Stage 1	717	-	-	-	-	-
Stage 2	781	-	-	-	-	-
Platoon blocked, %				-	-	-
Mov Cap-1 Maneuver	464	863	1217	-	-	-
Mov Cap-2 Maneuver	464	-	-	-	-	-
Stage 1	711	-	-	-	-	-
Stage 2	781	-	-	-	-	-

Approach	EB	NB	SB
HCM Control Delay, s	11.8	0.2	0
HCM LOS	B		

Minor Lane/Major Mvmt	NBL	NBT	EBLn1	EBLn2	SBT	SBR
Capacity (veh/h)	1217	-	464	863	-	-
HCM Lane V/C Ratio	0.009	-	0.143	0.071	-	-
HCM Control Delay (s)	8	-	14	9.5	-	-
HCM Lane LOS	A	-	B	A	-	-
HCM 95th %tile Q(veh)	0	-	0.5	0.2	-	-

Intersection						
Int Delay, s/veh	0					
Movement	EBL	EBT	WBT	WBR	SBL	SBR
Lane Configurations		↑↑	↑↑	↗		↗
Traffic Vol, veh/h	0	429	1494	3	0	119
Future Vol, veh/h	0	429	1494	3	0	119
Conflicting Peds, #/hr	0	0	0	0	0	0
Sign Control	Free	Free	Free	Free	Stop	Stop
RT Channelized	-	None	-	None	-	Free
Storage Length	-	-	-	800	-	0
Veh in Median Storage, #	-	0	0	-	0	-
Grade, %	-	0	0	-	0	-
Peak Hour Factor	82	82	91	91	85	85
Heavy Vehicles, %	2	2	2	2	2	2
Mvmt Flow	0	523	1642	3	0	140

Major/Minor	Major1	Major2	Minor2
Conflicting Flow All	-	0	-
Stage 1	-	-	-
Stage 2	-	-	-
Critical Hdwy	-	-	-
Critical Hdwy Stg 1	-	-	-
Critical Hdwy Stg 2	-	-	-
Follow-up Hdwy	-	-	-
Pot Cap-1 Maneuver	0	-	-
Stage 1	0	-	-
Stage 2	0	-	-
Platoon blocked, %	-	-	-
Mov Cap-1 Maneuver	-	-	-
Mov Cap-2 Maneuver	-	-	-
Stage 1	-	-	-
Stage 2	-	-	-

Approach	EB	WB	SB
HCM Control Delay, s	0	0	0
HCM LOS			A

Minor Lane/Major Mvmt	EBT	WBT	WBR	SBLn1
Capacity (veh/h)	-	-	-	-
HCM Lane V/C Ratio	-	-	-	-
HCM Control Delay (s)	-	-	-	0
HCM Lane LOS	-	-	-	A
HCM 95th %tile Q(veh)	-	-	-	-

Lanes, Volumes, Timings
9: Marksheffel Rd & Meadowbrook Pkwy

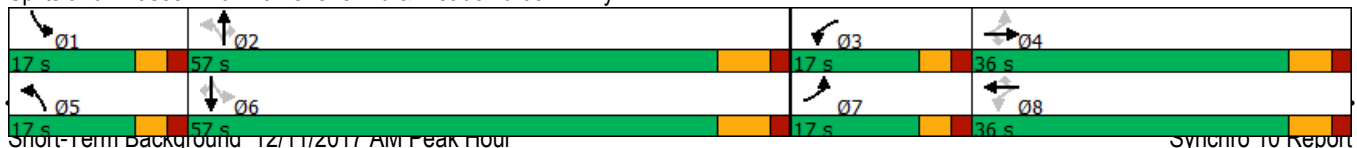
Short-Term Background
AM Peak Hour

Lane Group	EBL	EBT	EBR	WBL	WBT	WBR	NBL	NBT	NBR	SBL	SBT	SBR
Lane Configurations												
Traffic Volume (vph)	74	4	44	62	18	67	59	767	18	20	1643	215
Future Volume (vph)	74	4	44	62	18	67	59	767	18	20	1643	215
Satd. Flow (prot)	3433	1863	1583	1770	1863	1583	1770	3539	1583	1770	3539	1583
Flt Permitted	0.870			0.690			0.067			0.327		
Satd. Flow (perm)	3144	1863	1583	1285	1863	1583	125	3539	1583	609	3539	1583
Satd. Flow (RTOR)			120			120			112			151
Peak Hour Factor	0.78	0.78	0.78	0.78	0.78	0.78	0.92	0.92	0.92	0.90	0.90	0.90
Shared Lane Traffic (%)												
Lane Group Flow (vph)	95	5	56	79	23	86	64	834	20	22	1826	239
Turn Type	pm+pt	NA	Perm	pm+pt	NA	Perm	pm+pt	NA	Perm	pm+pt	NA	Perm
Protected Phases	7	4		3	8		5	2		1	6	
Permitted Phases	4		4	8		8	2		2	6		6
Detector Phase	7	4	4	3	8	8	5	2	2	1	6	6
Switch Phase												
Minimum Initial (s)	4.0	4.0	4.0	4.0	4.0	4.0	4.0	4.0	4.0	4.0	4.0	4.0
Minimum Split (s)	9.0	10.0	10.0	9.0	10.0	10.0	9.0	11.0	11.0	9.0	11.0	11.0
Total Split (s)	17.0	36.0	36.0	17.0	36.0	36.0	17.0	57.0	57.0	17.0	57.0	57.0
Total Split (%)	13.4%	28.3%	28.3%	13.4%	28.3%	28.3%	13.4%	44.9%	44.9%	13.4%	44.9%	44.9%
Yellow Time (s)	3.0	4.0	4.0	3.0	4.0	4.0	3.0	5.0	5.0	3.0	5.0	5.0
All-Red Time (s)	2.0	2.0	2.0	2.0	2.0	2.0	2.0	2.0	2.0	2.0	2.0	2.0
Lost Time Adjust (s)	0.0	0.0	0.0	0.0	0.0	0.0	0.0	0.0	0.0	0.0	0.0	0.0
Total Lost Time (s)	5.0	6.0	6.0	5.0	6.0	6.0	5.0	7.0	7.0	5.0	7.0	7.0
Lead/Lag	Lead	Lag	Lag	Lead	Lag	Lag	Lead	Lag	Lag	Lead	Lag	Lag
Lead-Lag Optimize?	Yes	Yes	Yes	Yes	Yes	Yes	Yes	Yes	Yes	Yes	Yes	Yes
Recall Mode	None	None	None	None	None	None	None	Max	Max	None	Max	Max
Act Effct Green (s)	12.9	5.9	5.9	15.5	7.2	7.2	64.5	61.4	61.4	61.1	56.3	56.3
Actuated g/C Ratio	0.14	0.06	0.06	0.17	0.08	0.08	0.71	0.67	0.67	0.67	0.62	0.62
v/c Ratio	0.20	0.04	0.26	0.30	0.16	0.37	0.30	0.35	0.02	0.05	0.84	0.23
Control Delay	31.0	44.0	3.0	33.5	44.1	8.1	10.7	10.5	0.1	6.0	24.7	5.7
Queue Delay	0.0	0.0	0.0	0.0	0.0	0.0	0.0	0.0	0.0	0.0	0.0	0.0
Total Delay	31.0	44.0	3.0	33.5	44.1	8.1	10.7	10.5	0.1	6.0	24.7	5.7
LOS	C	D	A	C	D	A	B	B	A	A	C	A
Approach Delay		21.3			23.2			10.3			22.4	
Approach LOS		C			C			B			C	

Intersection Summary

Cycle Length: 127
 Actuated Cycle Length: 91.1
 Natural Cycle: 75
 Control Type: Actuated-Uncoordinated
 Maximum v/c Ratio: 0.84
 Intersection Signal Delay: 19.0
 Intersection Capacity Utilization 70.0%
 Analysis Period (min) 15
 Intersection LOS: B
 ICU Level of Service C

Splits and Phases: 9: Marksheffel Rd & Meadowbrook Pkwy



Lanes, Volumes, Timings
10: Marksheffel Rd & US 24

Short-Term Background
AM Peak Hour

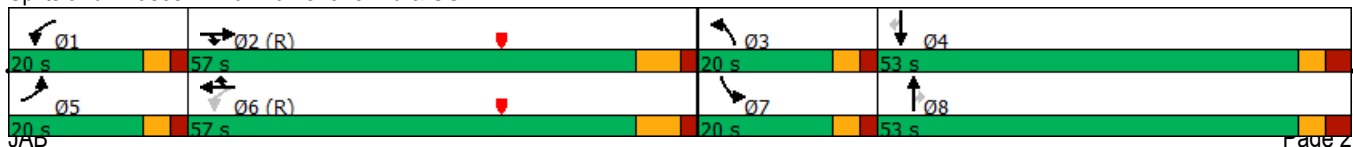
Lane Group	EBL	EBT	EBR	WBL	WBT	WBR	NBL	NBT	NBR	SBL	SBT	SBR
Lane Configurations												
Traffic Volume (vph)	343	363	2	16	1309	316	1	460	77	8	1040	715
Future Volume (vph)	343	363	2	16	1309	316	1	460	77	8	1040	715
Satd. Flow (prot)	3433	3539	1583	1770	3539	1583	1770	3539	1583	1770	3539	1583
Flt Permitted	0.950			0.519			0.950			0.950		
Satd. Flow (perm)	3433	3539	1583	967	3539	1583	1770	3539	1583	1770	3539	1583
Satd. Flow (RTOR)			95			299			102			408
Peak Hour Factor	0.92	0.92	0.92	0.89	0.89	0.89	0.92	0.92	0.92	0.86	0.86	0.86
Shared Lane Traffic (%)												
Lane Group Flow (vph)	373	395	2	18	1471	355	1	500	84	9	1209	831
Turn Type	Prot	NA	Prot	pm+pt	NA	Prot	Prot	NA	Perm	Prot	NA	Perm
Protected Phases	5	2	2	1	6	6	3	8		7	4	
Permitted Phases				6					8			4
Detector Phase	5			1			3	8	8	7	4	4
Switch Phase												
Minimum Initial (s)	6.0	23.0	23.0	6.0	23.0	23.0	6.0	6.0	6.0	6.0	6.0	6.0
Minimum Split (s)	15.0	35.0	35.0	15.0	35.0	35.0	15.0	16.0	16.0	15.0	16.0	16.0
Total Split (s)	20.0	57.0	57.0	20.0	57.0	57.0	20.0	53.0	53.0	20.0	53.0	53.0
Total Split (%)	13.3%	38.0%	38.0%	13.3%	38.0%	38.0%	13.3%	35.3%	35.3%	13.3%	35.3%	35.3%
Yellow Time (s)	3.0	5.0	5.0	3.0	5.0	5.0	3.0	3.0	3.0	3.0	3.0	3.0
All-Red Time (s)	2.0	2.0	2.0	2.0	2.0	2.0	2.0	3.0	3.0	2.0	3.0	3.0
Lost Time Adjust (s)	0.0	-2.0	-2.0	0.0	-2.0	-2.0	0.0	-1.0	1.0	0.0	-1.0	1.0
Total Lost Time (s)	5.0	5.0	5.0	5.0	5.0	5.0	5.0	5.0	7.0	5.0	5.0	7.0
Lead/Lag	Lead	Lag	Lag	Lead	Lag	Lag	Lead	Lag	Lag	Lead	Lag	Lag
Lead-Lag Optimize?												
Recall Mode	None	C-Max	C-Max	None	C-Max	C-Max	None	None	None	None	None	None
Act Effct Green (s)	25.2	82.7	82.7	66.1	59.6	59.6	6.0	47.6	45.6	6.6	48.0	46.0
Actuated g/C Ratio	0.17	0.55	0.55	0.44	0.40	0.40	0.04	0.32	0.30	0.04	0.32	0.31
v/c Ratio	0.65	0.20	0.00	0.04	1.05	0.44	0.01	0.44	0.15	0.12	1.07	1.08
Control Delay	64.3	18.6	0.0	15.5	80.5	8.0	70.0	42.3	4.8	71.8	94.9	81.8
Queue Delay	0.0	0.0	0.0	0.0	0.0	0.0	0.0	0.0	0.0	0.0	0.0	0.0
Total Delay	64.3	18.6	0.0	15.5	80.5	8.0	70.0	42.3	4.8	71.8	94.9	81.8
LOS	E	B	A	B	F	A	E	D	A	E	F	F
Approach Delay		40.7			65.9			37.0			89.5	
Approach LOS		D			E			D			F	

Intersection Summary

Cycle Length: 150
 Actuated Cycle Length: 150
 Offset: 50 (33%), Referenced to phase 2:EBT and 6:WBTL, Start of FDW or yellow
 Natural Cycle: 145
 Control Type: Actuated-Coordinated
 Maximum v/c Ratio: 1.08
 Intersection Signal Delay: 68.2
 Intersection Capacity Utilization 99.6%
 Analysis Period (min) 15

Intersection LOS: E
 ICU Level of Service F

Splits and Phases: 10: Marksheffel Rd & US 24



Lanes, Volumes, Timings
12: US 24 & Constitution Ave

Short-Term Background
AM Peak Hour

Lane Group	EBL	EBT	WBT	WBR	SBL	SBR
Lane Configurations						
Traffic Volume (vph)	48	392	1389	346	189	112
Future Volume (vph)	48	392	1389	346	189	112
Satd. Flow (prot)	1770	3539	3539	1583	3433	1583
Flt Permitted	0.126				0.950	
Satd. Flow (perm)	235	3539	3539	1583	3433	1583
Satd. Flow (RTOR)				368		127
Peak Hour Factor	0.85	0.85	0.94	0.94	0.88	0.88
Shared Lane Traffic (%)						
Lane Group Flow (vph)	56	461	1478	368	215	127
Turn Type	pm+pt	NA	NA	Perm	Prot	Perm
Protected Phases	5	2	6		4	
Permitted Phases	2			6		4
Detector Phase	5	2	6	6	4	4
Switch Phase						
Minimum Initial (s)	6.0	24.0	24.0	24.0	6.0	6.0
Minimum Split (s)	11.0	31.0	31.0	31.0	23.0	23.0
Total Split (s)	13.0	82.0	69.0	69.0	38.0	38.0
Total Split (%)	10.8%	68.3%	57.5%	57.5%	31.7%	31.7%
Yellow Time (s)	3.0	5.0	5.0	5.0	3.0	3.0
All-Red Time (s)	2.0	2.0	2.0	2.0	2.0	2.0
Lost Time Adjust (s)	0.0	0.0	0.0	0.0	0.0	0.0
Total Lost Time (s)	5.0	7.0	7.0	7.0	5.0	5.0
Lead/Lag	Lead		Lag	Lag		
Lead-Lag Optimize?	Yes		Yes	Yes		
Recall Mode	Min	C-Min	C-Min	C-Min	Min	Min
Act Effct Green (s)	97.1	95.1	83.7	83.7	12.9	12.9
Actuated g/C Ratio	0.81	0.79	0.70	0.70	0.11	0.11
v/c Ratio	0.21	0.16	0.60	0.30	0.58	0.45
Control Delay	4.4	3.3	11.1	1.4	57.2	13.3
Queue Delay	0.0	0.0	0.0	0.0	0.0	0.0
Total Delay	4.4	3.3	11.1	1.4	57.2	13.3
LOS	A	A	B	A	E	B
Approach Delay		3.4	9.1		40.9	
Approach LOS		A	A		D	

Intersection Summary

Cycle Length: 120
 Actuated Cycle Length: 120
 Offset: 20 (17%), Referenced to phase 2:EBTL and 6:WBT, Start of Green
 Natural Cycle: 70
 Control Type: Actuated-Coordinated
 Maximum v/c Ratio: 0.60
 Intersection Signal Delay: 12.1
 Intersection Capacity Utilization 55.3%
 Analysis Period (min) 15
 Intersection LOS: B
 ICU Level of Service B

Splits and Phases: 12: US 24 & Constitution Ave



Intersection												
Int Delay, s/veh	4.2											
Movement	EBL	EBT	EBR	WBL	WBT	WBR	NBL	NBT	NBR	SBL	SBT	SBR
Lane Configurations		↕			↕			↕			↕	
Traffic Vol, veh/h	6	36	1	0	12	16	0	5	1	21	4	23
Future Vol, veh/h	6	36	1	0	12	16	0	5	1	21	4	23
Conflicting Peds, #/hr	0	0	0	0	0	0	0	0	0	0	0	0
Sign Control	Free	Free	Free	Free	Free	Free	Stop	Stop	Stop	Stop	Stop	Stop
RT Channelized	-	-	None	-	-	None	-	-	None	-	-	None
Storage Length	-	-	-	-	-	-	-	-	-	-	-	-
Veh in Median Storage, #	-	0	-	-	0	-	-	0	-	-	0	-
Grade, %	-	0	-	-	0	-	-	0	-	-	0	-
Peak Hour Factor	70	70	70	75	75	75	50	50	50	80	80	80
Heavy Vehicles, %	2	2	2	2	2	2	2	2	2	2	2	2
Mvmt Flow	9	51	1	0	16	21	0	10	2	26	5	29

Major/Minor	Major1			Major2			Minor1			Minor2		
Conflicting Flow All	37	0	0	52	0	0	114	107	52	103	97	27
Stage 1	-	-	-	-	-	-	70	70	-	27	27	-
Stage 2	-	-	-	-	-	-	44	37	-	76	70	-
Critical Hdwy	4.12	-	-	4.12	-	-	7.12	6.52	6.22	7.12	6.52	6.22
Critical Hdwy Stg 1	-	-	-	-	-	-	6.12	5.52	-	6.12	5.52	-
Critical Hdwy Stg 2	-	-	-	-	-	-	6.12	5.52	-	6.12	5.52	-
Follow-up Hdwy	2.218	-	-	2.218	-	-	3.518	4.018	3.318	3.518	4.018	3.318
Pot Cap-1 Maneuver	1574	-	-	1554	-	-	863	783	1016	877	793	1048
Stage 1	-	-	-	-	-	-	940	837	-	990	873	-
Stage 2	-	-	-	-	-	-	970	864	-	933	837	-
Platoon blocked, %	-	-	-	-	-	-	-	-	-	-	-	-
Mov Cap-1 Maneuver	1574	-	-	1554	-	-	831	778	1016	863	788	1048
Mov Cap-2 Maneuver	-	-	-	-	-	-	831	778	-	863	788	-
Stage 1	-	-	-	-	-	-	934	832	-	984	873	-
Stage 2	-	-	-	-	-	-	938	864	-	914	832	-

Approach	EB	WB	NB	SB
HCM Control Delay, s	1	0	9.5	9.1
HCM LOS			A	A

Minor Lane/Major Mvmt	NBLn1	EBL	EBT	EBR	WBL	WBT	WBR	SBLn1
Capacity (veh/h)	810	1574	-	-	1554	-	-	935
HCM Lane V/C Ratio	0.015	0.005	-	-	-	-	-	0.064
HCM Control Delay (s)	9.5	7.3	0	-	0	-	-	9.1
HCM Lane LOS	A	A	A	-	A	-	-	A
HCM 95th %tile Q(veh)	0	0	-	-	0	-	-	0.2

Intersection	
Intersection Delay, s/veh	7.1
Intersection LOS	A

Movement	WBL	WBR	NBT	NBR	SBL	SBT
Lane Configurations	↔		↔			↔
Traffic Vol, veh/h	5	0	22	10	0	18
Future Vol, veh/h	5	0	22	10	0	18
Peak Hour Factor	0.42	0.42	0.67	0.67	0.56	0.56
Heavy Vehicles, %	2	2	2	2	2	2
Mvmt Flow	12	0	33	15	0	32
Number of Lanes	1	0	1	0	0	1

Approach	WB	NB	SB
Opposing Approach		SB	NB
Opposing Lanes	0	1	1
Conflicting Approach Left	NB		WB
Conflicting Lanes Left	1	0	1
Conflicting Approach Right	SB	WB	
Conflicting Lanes Right	1	1	0
HCM Control Delay	7.4	7	7.2
HCM LOS	A	A	A

Lane	NBLn1	WBLn1	SBLn1
Vol Left, %	0%	100%	0%
Vol Thru, %	69%	0%	100%
Vol Right, %	31%	0%	0%
Sign Control	Stop	Stop	Stop
Traffic Vol by Lane	32	5	18
LT Vol	0	5	0
Through Vol	22	0	18
RT Vol	10	0	0
Lane Flow Rate	48	12	32
Geometry Grp	1	1	1
Degree of Util (X)	0.05	0.014	0.036
Departure Headway (Hd)	3.792	4.272	3.991
Convergence, Y/N	Yes	Yes	Yes
Cap	947	837	900
Service Time	1.804	2.301	2.004
HCM Lane V/C Ratio	0.051	0.014	0.036
HCM Control Delay	7	7.4	7.2
HCM Lane LOS	A	A	A
HCM 95th-tile Q	0.2	0	0.1

Intersection						
Int Delay, s/veh	4.4					
Movement	EBL	EBT	WBT	WBR	SBL	SBR
Lane Configurations		↔	↔		↔	
Traffic Vol, veh/h	10	15	11	9	11	17
Future Vol, veh/h	10	15	11	9	11	17
Conflicting Peds, #/hr	0	0	0	0	0	0
Sign Control	Free	Free	Free	Free	Stop	Stop
RT Channelized	-	None	-	None	-	None
Storage Length	-	-	-	-	0	-
Veh in Median Storage, #	-	0	0	-	0	-
Grade, %	-	0	0	-	0	-
Peak Hour Factor	78	78	71	71	70	70
Heavy Vehicles, %	2	2	2	2	2	2
Mvmt Flow	13	19	15	13	16	24

Major/Minor	Major1	Major2	Minor2		
Conflicting Flow All	28	0	-	0	67 22
Stage 1	-	-	-	-	22 -
Stage 2	-	-	-	-	45 -
Critical Hdwy	4.12	-	-	-	6.42 6.22
Critical Hdwy Stg 1	-	-	-	-	5.42 -
Critical Hdwy Stg 2	-	-	-	-	5.42 -
Follow-up Hdwy	2.218	-	-	-	3.518 3.318
Pot Cap-1 Maneuver	1585	-	-	-	938 1055
Stage 1	-	-	-	-	1001 -
Stage 2	-	-	-	-	977 -
Platoon blocked, %		-	-	-	
Mov Cap-1 Maneuver	1585	-	-	-	930 1055
Mov Cap-2 Maneuver	-	-	-	-	930 -
Stage 1	-	-	-	-	993 -
Stage 2	-	-	-	-	977 -

Approach	EB	WB	SB
HCM Control Delay, s	2.9	0	8.7
HCM LOS			A

Minor Lane/Major Mvmt	EBL	EBT	WBT	WBR	SBLn1
Capacity (veh/h)	1585	-	-	-	1002
HCM Lane V/C Ratio	0.008	-	-	-	0.04
HCM Control Delay (s)	7.3	0	-	-	8.7
HCM Lane LOS	A	A	-	-	A
HCM 95th %tile Q(veh)	0	-	-	-	0.1

Intersection												
Int Delay, s/veh	3.3											
Movement	EBL	EBT	EBR	WBL	WBT	WBR	NBL	NBT	NBR	SBL	SBT	SBR
Lane Configurations		↕			↕			↕			↕	
Traffic Vol, veh/h	3	14	8	5	14	2	6	0	2	0	4	0
Future Vol, veh/h	3	14	8	5	14	2	6	0	2	0	4	0
Conflicting Peds, #/hr	0	0	0	0	0	0	0	0	0	0	0	0
Sign Control	Free	Free	Free	Free	Free	Free	Stop	Stop	Stop	Stop	Stop	Stop
RT Channelized	-	-	None	-	-	None	-	-	None	-	-	None
Storage Length	-	-	-	-	-	-	-	-	-	-	-	-
Veh in Median Storage, #	-	0	-	-	0	-	-	0	-	-	0	-
Grade, %	-	0	-	-	0	-	-	0	-	-	0	-
Peak Hour Factor	89	89	89	66	66	66	67	67	67	50	50	50
Heavy Vehicles, %	2	2	2	2	2	2	2	2	2	2	2	2
Mvmt Flow	3	16	9	8	21	3	9	0	3	0	8	0

Major/Minor	Major1		Major2		Minor1			Minor2				
Conflicting Flow All	24	0	0	25	0	0	70	67	21	67	70	23
Stage 1	-	-	-	-	-	-	27	27	-	39	39	-
Stage 2	-	-	-	-	-	-	43	40	-	28	31	-
Critical Hdwy	4.12	-	-	4.12	-	-	7.12	6.52	6.22	7.12	6.52	6.22
Critical Hdwy Stg 1	-	-	-	-	-	-	6.12	5.52	-	6.12	5.52	-
Critical Hdwy Stg 2	-	-	-	-	-	-	6.12	5.52	-	6.12	5.52	-
Follow-up Hdwy	2.218	-	-	2.218	-	-	3.518	4.018	3.318	3.518	4.018	3.318
Pot Cap-1 Maneuver	1591	-	-	1589	-	-	922	824	1056	926	821	1054
Stage 1	-	-	-	-	-	-	990	873	-	976	862	-
Stage 2	-	-	-	-	-	-	971	862	-	989	869	-
Platoon blocked, %	-	-	-	-	-	-	-	-	-	-	-	-
Mov Cap-1 Maneuver	1591	-	-	1589	-	-	910	818	1056	919	815	1054
Mov Cap-2 Maneuver	-	-	-	-	-	-	910	818	-	919	815	-
Stage 1	-	-	-	-	-	-	988	871	-	974	858	-
Stage 2	-	-	-	-	-	-	957	858	-	984	867	-

Approach	EB		WB		NB		SB	
HCM Control Delay, s	0.9		1.7		8.9		9.5	
HCM LOS					A		A	

Minor Lane/Major Mvmt	NBLn1	EBL	EBT	EBR	WBL	WBT	WBR	SBLn1
Capacity (veh/h)	943	1591	-	-	1589	-	-	815
HCM Lane V/C Ratio	0.013	0.002	-	-	0.005	-	-	0.01
HCM Control Delay (s)	8.9	7.3	0	-	7.3	0	-	9.5
HCM Lane LOS	A	A	A	-	A	A	-	A
HCM 95th %tile Q(veh)	0	0	-	-	0	-	-	0

Intersection						
Int Delay, s/veh	1.7					
Movement	EBT	EBR	WBL	WBT	NBL	NBR
Lane Configurations	↔			↔	↔	
Traffic Vol, veh/h	4	1	0	3	0	3
Future Vol, veh/h	4	1	0	3	0	3
Conflicting Peds, #/hr	0	0	0	0	0	0
Sign Control	Free	Free	Free	Free	Stop	Stop
RT Channelized	-	None	-	None	-	None
Storage Length	-	-	-	-	0	-
Veh in Median Storage, #	0	-	-	0	0	-
Grade, %	0	-	-	0	0	-
Peak Hour Factor	63	63	38	38	75	75
Heavy Vehicles, %	2	2	2	2	2	2
Mvmt Flow	6	2	0	8	0	4

Major/Minor	Major1	Major2	Minor1	Minor2	Minor3
Conflicting Flow All	0	0	8	0	15
Stage 1	-	-	-	-	7
Stage 2	-	-	-	-	8
Critical Hdwy	-	-	4.12	-	6.42
Critical Hdwy Stg 1	-	-	-	-	5.42
Critical Hdwy Stg 2	-	-	-	-	5.42
Follow-up Hdwy	-	-	2.218	-	3.518
Pot Cap-1 Maneuver	-	-	1612	-	1004
Stage 1	-	-	-	-	1016
Stage 2	-	-	-	-	1015
Platoon blocked, %	-	-	-	-	-
Mov Cap-1 Maneuver	-	-	1612	-	1004
Mov Cap-2 Maneuver	-	-	-	-	1004
Stage 1	-	-	-	-	1016
Stage 2	-	-	-	-	1015

Approach	EB	WB	NB
HCM Control Delay, s	0	0	8.4
HCM LOS			A

Minor Lane/Major Mvmt	NBLn1	EBT	EBR	WBL	WBT
Capacity (veh/h)	1075	-	-	1612	-
HCM Lane V/C Ratio	0.004	-	-	-	-
HCM Control Delay (s)	8.4	-	-	0	-
HCM Lane LOS	A	-	-	A	-
HCM 95th %tile Q(veh)	0	-	-	0	-

Intersection						
Int Delay, s/veh	2.3					
Movement	EBL	EBR	NBL	NBT	SBT	SBR
Lane Configurations	T			T		T
Traffic Vol, veh/h	4	0	1	1	8	4
Future Vol, veh/h	4	0	1	1	8	4
Conflicting Peds, #/hr	0	0	0	0	0	0
Sign Control	Stop	Stop	Free	Free	Free	Free
RT Channelized	-	None	-	None	-	None
Storage Length	0	-	-	-	-	-
Veh in Median Storage, #	0	-	-	0	0	-
Grade, %	0	-	-	0	0	-
Peak Hour Factor	50	50	50	50	50	50
Heavy Vehicles, %	2	2	2	2	2	2
Mvmt Flow	8	0	2	2	16	8

Major/Minor	Minor2	Major1		Major2	
Conflicting Flow All	26	20	24	0	0
Stage 1	20	-	-	-	-
Stage 2	6	-	-	-	-
Critical Hdwy	6.42	6.22	4.12	-	-
Critical Hdwy Stg 1	5.42	-	-	-	-
Critical Hdwy Stg 2	5.42	-	-	-	-
Follow-up Hdwy	3.518	3.318	2.218	-	-
Pot Cap-1 Maneuver	989	1058	1591	-	-
Stage 1	1003	-	-	-	-
Stage 2	1017	-	-	-	-
Platoon blocked, %				-	-
Mov Cap-1 Maneuver	988	1058	1591	-	-
Mov Cap-2 Maneuver	988	-	-	-	-
Stage 1	1002	-	-	-	-
Stage 2	1017	-	-	-	-

Approach	EB	NB	SB
HCM Control Delay, s	8.7	3.6	0
HCM LOS	A		

Minor Lane/Major Mvmt	NBL	NBT	EBLn1	SBT	SBR
Capacity (veh/h)	1591	-	988	-	-
HCM Lane V/C Ratio	0.001	-	0.008	-	-
HCM Control Delay (s)	7.3	0	8.7	-	-
HCM Lane LOS	A	A	A	-	-
HCM 95th %tile Q(veh)	0	-	0	-	-

Intersection						
Int Delay, s/veh	1.3					
Movement	EBT	EBR	WBL	WBT	NBL	NBR
Lane Configurations	↑↑	↗	↘	↑↑	↘	
Traffic Vol, veh/h	436	106	6	260	60	1
Future Vol, veh/h	436	106	6	260	60	1
Conflicting Peds, #/hr	0	0	0	0	0	0
Sign Control	Free	Free	Free	Free	Stop	Stop
RT Channelized	-	None	-	None	-	None
Storage Length	-	300	450	-	0	-
Veh in Median Storage, #	0	-	-	0	0	-
Grade, %	0	-	-	0	0	-
Peak Hour Factor	84	84	89	89	80	80
Heavy Vehicles, %	2	2	2	2	2	2
Mvmt Flow	519	126	7	292	75	1

Major/Minor	Major1	Major2	Minor1		
Conflicting Flow All	0	0	645	0	679 260
Stage 1	-	-	-	-	519 -
Stage 2	-	-	-	-	160 -
Critical Hdwy	-	-	4.14	-	6.84 6.94
Critical Hdwy Stg 1	-	-	-	-	5.84 -
Critical Hdwy Stg 2	-	-	-	-	5.84 -
Follow-up Hdwy	-	-	2.22	-	3.52 3.32
Pot Cap-1 Maneuver	-	-	936	-	385 739
Stage 1	-	-	-	-	562 -
Stage 2	-	-	-	-	852 -
Platoon blocked, %	-	-	-	-	-
Mov Cap-1 Maneuver	-	-	936	-	382 739
Mov Cap-2 Maneuver	-	-	-	-	382 -
Stage 1	-	-	-	-	562 -
Stage 2	-	-	-	-	846 -

Approach	EB	WB	NB
HCM Control Delay, s	0	0.2	16.6
HCM LOS			C

Minor Lane/Major Mvmt	NBLn1	EBT	EBR	WBL	WBT
Capacity (veh/h)	385	-	-	936	-
HCM Lane V/C Ratio	0.198	-	-	0.007	-
HCM Control Delay (s)	16.6	-	-	8.9	-
HCM Lane LOS	C	-	-	A	-
HCM 95th %tile Q(veh)	0.7	-	-	0	-

Intersection						
Int Delay, s/veh	1.6					
Movement	EBL	EBR	NBL	NBT	SBT	SBR
Lane Configurations	↵	↶	↵	↕	↕	↶
Traffic Vol, veh/h	34	17	28	217	340	43
Future Vol, veh/h	34	17	28	217	340	43
Conflicting Peds, #/hr	0	0	0	0	0	0
Sign Control	Stop	Stop	Free	Free	Free	Free
RT Channelized	-	None	-	None	-	None
Storage Length	0	50	325	-	-	250
Veh in Median Storage, #	0	-	-	0	0	-
Grade, %	0	-	-	0	0	-
Peak Hour Factor	64	64	82	82	87	87
Heavy Vehicles, %	2	2	2	2	2	2
Mvmt Flow	53	27	34	265	391	49

Major/Minor	Minor2	Major1	Major2			
Conflicting Flow All	592	196	440	0	-	0
Stage 1	391	-	-	-	-	-
Stage 2	201	-	-	-	-	-
Critical Hdwy	6.84	6.94	4.14	-	-	-
Critical Hdwy Stg 1	5.84	-	-	-	-	-
Critical Hdwy Stg 2	5.84	-	-	-	-	-
Follow-up Hdwy	3.52	3.32	2.22	-	-	-
Pot Cap-1 Maneuver	437	812	1116	-	-	-
Stage 1	653	-	-	-	-	-
Stage 2	813	-	-	-	-	-
Platoon blocked, %				-	-	-
Mov Cap-1 Maneuver	424	812	1116	-	-	-
Mov Cap-2 Maneuver	424	-	-	-	-	-
Stage 1	633	-	-	-	-	-
Stage 2	813	-	-	-	-	-

Approach	EB	NB	SB
HCM Control Delay, s	13	1	0
HCM LOS	B		

Minor Lane/Major Mvmt	NBL	NBT	EBLn1	EBLn2	SBT	SBR
Capacity (veh/h)	1116	-	424	812	-	-
HCM Lane V/C Ratio	0.031	-	0.125	0.033	-	-
HCM Control Delay (s)	8.3	-	14.7	9.6	-	-
HCM Lane LOS	A	-	B	A	-	-
HCM 95th %tile Q(veh)	0.1	-	0.4	0.1	-	-

Intersection						
Int Delay, s/veh	0					
Movement	EBL	EBT	WBT	WBR	SBL	SBR
Lane Configurations		↑↑	↑↑	↗		↗
Traffic Vol, veh/h	0	945	476	2	0	26
Future Vol, veh/h	0	945	476	2	0	26
Conflicting Peds, #/hr	0	0	0	0	0	0
Sign Control	Free	Free	Free	Free	Stop	Stop
RT Channelized	-	None	-	None	-	Free
Storage Length	-	-	-	800	-	0
Veh in Median Storage, #	-	0	0	-	0	-
Grade, %	-	0	0	-	0	-
Peak Hour Factor	87	87	90	90	72	72
Heavy Vehicles, %	2	2	2	2	2	2
Mvmt Flow	0	1086	529	2	0	36

Major/Minor	Major1	Major2	Minor2
Conflicting Flow All	-	0	-
Stage 1	-	-	-
Stage 2	-	-	-
Critical Hdwy	-	-	-
Critical Hdwy Stg 1	-	-	-
Critical Hdwy Stg 2	-	-	-
Follow-up Hdwy	-	-	-
Pot Cap-1 Maneuver	0	-	-
Stage 1	0	-	-
Stage 2	0	-	-
Platoon blocked, %	-	-	-
Mov Cap-1 Maneuver	-	-	-
Mov Cap-2 Maneuver	-	-	-
Stage 1	-	-	-
Stage 2	-	-	-

Approach	EB	WB	SB
HCM Control Delay, s	0	0	0
HCM LOS			A

Minor Lane/Major Mvmt	EBT	WBT	WBR	SBLn1
Capacity (veh/h)	-	-	-	-
HCM Lane V/C Ratio	-	-	-	-
HCM Control Delay (s)	-	-	-	0
HCM Lane LOS	-	-	-	A
HCM 95th %tile Q(veh)	-	-	-	-

Lanes, Volumes, Timings
9: Marksheffel Rd & Meadowbrook Pkwy

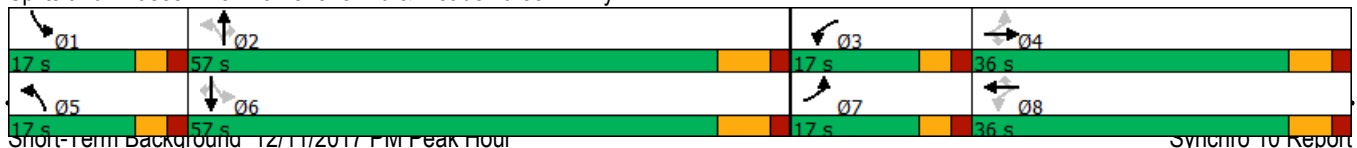
Short-Term Background
PM Peak Hour

Lane Group	EBL	EBT	EBR	WBL	WBT	WBR	NBL	NBT	NBR	SBL	SBT	SBR
Lane Configurations												
Traffic Volume (vph)	158	15	112	28	10	36	70	1219	93	56	642	152
Future Volume (vph)	158	15	112	28	10	36	70	1219	93	56	642	152
Satd. Flow (prot)	3433	1863	1583	1770	1863	1583	1770	3539	1583	1770	3539	1583
Flt Permitted	0.402			0.745			0.338			0.092		
Satd. Flow (perm)	1453	1863	1583	1388	1863	1583	630	3539	1583	171	3539	1583
Satd. Flow (RTOR)			145			120			112			171
Peak Hour Factor	0.77	0.77	0.77	0.66	0.66	0.66	0.84	0.84	0.84	0.89	0.89	0.89
Shared Lane Traffic (%)												
Lane Group Flow (vph)	205	19	145	42	15	55	83	1451	111	63	721	171
Turn Type	pm+pt	NA	Perm	pm+pt	NA	Perm	pm+pt	NA	Perm	pm+pt	NA	Perm
Protected Phases	7	4		3	8		5	2		1	6	
Permitted Phases	4		4	8		8	2		2	6		6
Detector Phase	7	4	4	3	8	8	5	2	2	1	6	6
Switch Phase												
Minimum Initial (s)	4.0	4.0	4.0	4.0	4.0	4.0	4.0	4.0	4.0	4.0	4.0	4.0
Minimum Split (s)	9.0	10.0	10.0	9.0	10.0	10.0	9.0	11.0	11.0	9.0	11.0	11.0
Total Split (s)	17.0	36.0	36.0	17.0	36.0	36.0	17.0	57.0	57.0	17.0	57.0	57.0
Total Split (%)	13.4%	28.3%	28.3%	13.4%	28.3%	28.3%	13.4%	44.9%	44.9%	13.4%	44.9%	44.9%
Yellow Time (s)	3.0	4.0	4.0	3.0	4.0	4.0	3.0	5.0	5.0	3.0	5.0	5.0
All-Red Time (s)	2.0	2.0	2.0	2.0	2.0	2.0	2.0	2.0	2.0	2.0	2.0	2.0
Lost Time Adjust (s)	0.0	0.0	0.0	0.0	0.0	0.0	0.0	0.0	0.0	0.0	0.0	0.0
Total Lost Time (s)	5.0	6.0	6.0	5.0	6.0	6.0	5.0	7.0	7.0	5.0	7.0	7.0
Lead/Lag	Lead	Lag	Lag	Lead	Lag	Lag	Lead	Lag	Lag	Lead	Lag	Lag
Lead-Lag Optimize?	Yes	Yes	Yes	Yes	Yes	Yes	Yes	Yes	Yes	Yes	Yes	Yes
Recall Mode	None	None	None	None	None	None	None	Max	Max	None	Max	Max
Act Effct Green (s)	18.8	11.4	11.4	13.2	6.5	6.5	59.2	51.5	51.5	58.4	51.0	51.0
Actuated g/C Ratio	0.20	0.12	0.12	0.14	0.07	0.07	0.64	0.56	0.56	0.63	0.55	0.55
v/c Ratio	0.40	0.08	0.45	0.19	0.11	0.25	0.17	0.74	0.12	0.28	0.37	0.18
Control Delay	32.6	41.3	12.3	31.5	45.4	2.6	7.2	20.9	3.0	9.8	14.4	2.8
Queue Delay	0.0	0.0	0.0	0.0	0.0	0.0	0.0	0.0	0.0	0.0	0.0	0.0
Total Delay	32.6	41.3	12.3	31.5	45.4	2.6	7.2	20.9	3.0	9.8	14.4	2.8
LOS	C	D	B	C	D	A	A	C	A	A	B	A
Approach Delay		25.1			19.2			19.0			12.0	
Approach LOS		C			B			B			B	

Intersection Summary

Cycle Length: 127
 Actuated Cycle Length: 92.6
 Natural Cycle: 60
 Control Type: Actuated-Uncoordinated
 Maximum v/c Ratio: 0.74
 Intersection Signal Delay: 17.6
 Intersection Capacity Utilization 63.2%
 Analysis Period (min) 15
 Intersection LOS: B
 ICU Level of Service B

Splits and Phases: 9: Marksheffel Rd & Meadowbrook Pkwy



Lanes, Volumes, Timings
10: Marksheffel Rd & US 24

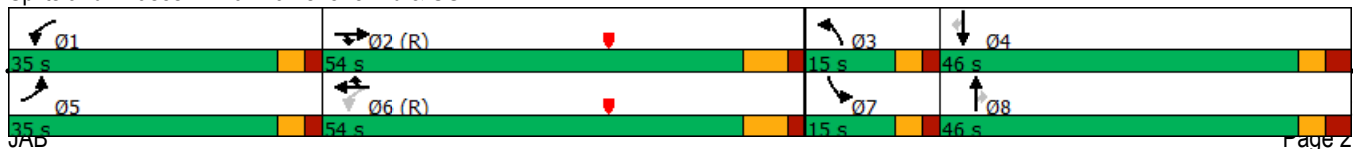
Short-Term Background
PM Peak Hour

Lane Group	EBL	EBT	EBR	WBL	WBT	WBR	NBL	NBT	NBR	SBL	SBT	SBR
Lane Configurations												
Traffic Volume (vph)	556	770	4	83	399	28	14	789	166	38	376	378
Future Volume (vph)	556	770	4	83	399	28	14	789	166	38	376	378
Satd. Flow (prot)	3433	3539	1583	1770	3539	1583	1770	3539	1583	1770	3539	1583
Flt Permitted	0.950			0.288			0.950			0.950		
Satd. Flow (perm)	3433	3539	1583	536	3539	1583	1770	3539	1583	1770	3539	1583
Satd. Flow (RTOR)			95			95			195			455
Peak Hour Factor	0.84	0.84	0.84	0.87	0.87	0.87	0.85	0.85	0.85	0.83	0.83	0.83
Shared Lane Traffic (%)												
Lane Group Flow (vph)	662	917	5	95	459	32	16	928	195	46	453	455
Turn Type	Prot	NA	Prot	pm+pt	NA	Prot	Prot	NA	Perm	Prot	NA	Perm
Protected Phases	5	2	2	1	6	6	3	8		7	4	
Permitted Phases				6					8			4
Detector Phase	5			1			3	8	8	7	4	4
Switch Phase												
Minimum Initial (s)	6.0	23.0	23.0	6.0	23.0	23.0	6.0	6.0	6.0	6.0	6.0	6.0
Minimum Split (s)	15.0	35.0	35.0	15.0	35.0	35.0	15.0	16.0	16.0	15.0	16.0	16.0
Total Split (s)	35.0	54.0	54.0	35.0	54.0	54.0	15.0	46.0	46.0	15.0	46.0	46.0
Total Split (%)	23.3%	36.0%	36.0%	23.3%	36.0%	36.0%	10.0%	30.7%	30.7%	10.0%	30.7%	30.7%
Yellow Time (s)	3.0	5.0	5.0	3.0	5.0	5.0	3.0	3.0	3.0	3.0	3.0	3.0
All-Red Time (s)	2.0	2.0	2.0	2.0	2.0	2.0	2.0	3.0	3.0	2.0	3.0	3.0
Lost Time Adjust (s)	0.0	-2.0	-2.0	0.0	-2.0	-2.0	0.0	-1.0	1.0	0.0	-1.0	1.0
Total Lost Time (s)	5.0	5.0	5.0	5.0	5.0	5.0	5.0	5.0	7.0	5.0	5.0	7.0
Lead/Lag	Lead	Lag	Lag	Lead	Lag	Lag	Lead	Lag	Lag	Lead	Lag	Lag
Lead-Lag Optimize?												
Recall Mode	None	C-Max	C-Max	None	C-Max	C-Max	None	None	None	None	None	None
Act Effct Green (s)	30.6	72.9	72.9	61.6	51.9	51.9	7.1	41.0	39.0	8.6	47.1	45.1
Actuated g/C Ratio	0.20	0.49	0.49	0.41	0.35	0.35	0.05	0.27	0.26	0.06	0.31	0.30
v/c Ratio	0.94	0.53	0.01	0.32	0.37	0.05	0.19	0.96	0.35	0.45	0.41	0.57
Control Delay	81.3	29.3	0.0	20.2	38.8	0.2	73.6	74.1	7.3	82.1	42.1	6.7
Queue Delay	0.0	0.0	0.0	0.0	0.0	0.0	0.0	0.0	0.0	0.0	0.0	0.0
Total Delay	81.3	29.3	0.0	20.2	38.8	0.2	73.6	74.1	7.3	82.1	42.1	6.7
LOS	F	C	A	C	D	A	E	E	A	F	D	A
Approach Delay		51.0			33.7			62.6			27.2	
Approach LOS		D			C			E			C	

Intersection Summary

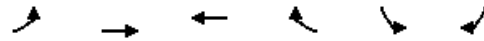
Cycle Length: 150
 Actuated Cycle Length: 150
 Offset: 70 (47%), Referenced to phase 2:EBT and 6:WBTL, Start of FDW or yellow
 Natural Cycle: 105
 Control Type: Actuated-Coordinated
 Maximum v/c Ratio: 0.96
 Intersection Signal Delay: 46.4
 Intersection LOS: D
 Intersection Capacity Utilization 78.5%
 ICU Level of Service D
 Analysis Period (min) 15

Splits and Phases: 10: Marksheffel Rd & US 24



Lanes, Volumes, Timings
12: US 24 & Constitution Ave

Short-Term Background
PM Peak Hour



Lane Group	EBL	EBT	WBT	WBR	SBL	SBR
Lane Configurations	↶	↷	↷	↷	↶	↷
Traffic Volume (vph)	71	868	414	180	298	60
Future Volume (vph)	71	868	414	180	298	60
Satd. Flow (prot)	1770	3539	3539	1583	3433	1583
Flt Permitted	0.463				0.950	
Satd. Flow (perm)	862	3539	3539	1583	3433	1583
Satd. Flow (RTOR)				196		68
Peak Hour Factor	0.84	0.84	0.92	0.92	0.88	0.88
Shared Lane Traffic (%)						
Lane Group Flow (vph)	85	1033	450	196	339	68
Turn Type	pm+pt	NA	NA	Perm	Prot	Perm
Protected Phases	5	2	6		4	
Permitted Phases	2			6		4
Detector Phase	5	2	6	6	4	4
Switch Phase						
Minimum Initial (s)	6.0	24.0	24.0	24.0	6.0	6.0
Minimum Split (s)	11.0	31.0	31.0	31.0	23.0	23.0
Total Split (s)	18.0	69.0	51.0	51.0	51.0	51.0
Total Split (%)	15.0%	57.5%	42.5%	42.5%	42.5%	42.5%
Yellow Time (s)	3.0	5.0	5.0	5.0	3.0	3.0
All-Red Time (s)	2.0	2.0	2.0	2.0	2.0	2.0
Lost Time Adjust (s)	0.0	0.0	0.0	0.0	0.0	0.0
Total Lost Time (s)	5.0	7.0	7.0	7.0	5.0	5.0
Lead/Lag	Lead		Lag	Lag		
Lead-Lag Optimize?	Yes		Yes	Yes		
Recall Mode	Min	C-Min	C-Min	C-Min	Min	Min
Act Effct Green (s)	92.6	90.6	78.6	78.6	17.4	17.4
Actuated g/C Ratio	0.77	0.76	0.66	0.66	0.14	0.14
v/c Ratio	0.12	0.39	0.19	0.18	0.68	0.24
Control Delay	4.1	5.9	8.9	1.7	55.6	12.1
Queue Delay	0.0	0.0	0.0	0.0	0.0	0.0
Total Delay	4.1	5.9	8.9	1.7	55.6	12.1
LOS	A	A	A	A	E	B
Approach Delay		5.7	6.7		48.3	
Approach LOS		A	A		D	

Intersection Summary

Cycle Length: 120
 Actuated Cycle Length: 120
 Offset: 112 (93%), Referenced to phase 2:EBTL and 6:WBT, Start of Green
 Natural Cycle: 65
 Control Type: Actuated-Coordinated
 Maximum v/c Ratio: 0.68
 Intersection Signal Delay: 14.0
 Intersection Capacity Utilization 47.7%
 Analysis Period (min) 15
 Intersection LOS: B
 ICU Level of Service A

Splits and Phases: 12: US 24 & Constitution Ave



Intersection												
Int Delay, s/veh	5.4											
Movement	EBL	EBT	EBR	WBL	WBT	WBR	NBL	NBT	NBR	SBL	SBT	SBR
Lane Configurations		↕			↕			↕			↕	
Traffic Vol, veh/h	7	21	0	0	11	23	2	12	0	22	4	25
Future Vol, veh/h	7	21	0	0	11	23	2	12	0	22	4	25
Conflicting Peds, #/hr	0	0	0	0	0	0	0	0	0	0	0	0
Sign Control	Free	Free	Free	Free	Free	Free	Stop	Stop	Stop	Stop	Stop	Stop
RT Channelized	-	-	None	-	-	None	-	-	None	-	-	None
Storage Length	-	-	-	-	-	-	-	-	-	-	-	-
Veh in Median Storage, #	-	0	-	-	0	-	-	0	-	-	0	-
Grade, %	-	0	-	-	0	-	-	0	-	-	0	-
Peak Hour Factor	84	84	84	77	77	77	58	58	58	75	75	75
Heavy Vehicles, %	2	2	2	2	2	2	2	2	2	2	2	2
Mvmt Flow	8	25	0	0	14	30	3	21	0	29	5	33

Major/Minor	Major1			Major2			Minor1			Minor2		
Conflicting Flow All	44	0	0	25	0	0	89	85	25	81	70	29
Stage 1	-	-	-	-	-	-	41	41	-	29	29	-
Stage 2	-	-	-	-	-	-	48	44	-	52	41	-
Critical Hdwy	4.12	-	-	4.12	-	-	7.12	6.52	6.22	7.12	6.52	6.22
Critical Hdwy Stg 1	-	-	-	-	-	-	6.12	5.52	-	6.12	5.52	-
Critical Hdwy Stg 2	-	-	-	-	-	-	6.12	5.52	-	6.12	5.52	-
Follow-up Hdwy	2.218	-	-	2.218	-	-	3.518	4.018	3.318	3.518	4.018	3.318
Pot Cap-1 Maneuver	1564	-	-	1589	-	-	896	805	1051	907	821	1046
Stage 1	-	-	-	-	-	-	974	861	-	988	871	-
Stage 2	-	-	-	-	-	-	965	858	-	961	861	-
Platoon blocked, %		-	-		-	-						
Mov Cap-1 Maneuver	1564	-	-	1589	-	-	860	801	1051	886	817	1046
Mov Cap-2 Maneuver	-	-	-	-	-	-	860	801	-	886	817	-
Stage 1	-	-	-	-	-	-	969	857	-	983	871	-
Stage 2	-	-	-	-	-	-	929	858	-	933	857	-

Approach	EB	WB	NB	SB
HCM Control Delay, s	1.8	0	9.6	9.1
HCM LOS			A	A

Minor Lane/Major Mvmt	NBLn1	EBL	EBT	EBR	WBL	WBT	WBR	SBLn1
Capacity (veh/h)	809	1564	-	-	1589	-	-	951
HCM Lane V/C Ratio	0.03	0.005	-	-	-	-	-	0.072
HCM Control Delay (s)	9.6	7.3	0	-	0	-	-	9.1
HCM Lane LOS	A	A	A	-	A	-	-	A
HCM 95th %tile Q(veh)	0.1	0	-	-	0	-	-	0.2

Intersection	
Intersection Delay, s/veh	7.2
Intersection LOS	A

Movement	WBL	WBR	NBT	NBR	SBL	SBT
Lane Configurations	↔		↔			↔
Traffic Vol, veh/h	6	2	14	1	2	29
Future Vol, veh/h	6	2	14	1	2	29
Peak Hour Factor	0.40	0.40	0.63	0.63	0.86	0.86
Heavy Vehicles, %	2	2	2	2	2	2
Mvmt Flow	15	5	22	2	2	34
Number of Lanes	1	0	1	0	0	1

Approach	WB	NB	SB
Opposing Approach		SB	NB
Opposing Lanes	0	1	1
Conflicting Approach Left	NB		WB
Conflicting Lanes Left	1	0	1
Conflicting Approach Right	SB	WB	
Conflicting Lanes Right	1	1	0
HCM Control Delay	7.2	7.1	7.2
HCM LOS	A	A	A

Lane	NBLn1	WBLn1	SBLn1
Vol Left, %	0%	75%	6%
Vol Thru, %	93%	0%	94%
Vol Right, %	7%	25%	0%
Sign Control	Stop	Stop	Stop
Traffic Vol by Lane	15	8	31
LT Vol	0	6	2
Through Vol	14	0	29
RT Vol	1	2	0
Lane Flow Rate	24	20	36
Geometry Grp	1	1	1
Degree of Util (X)	0.026	0.022	0.04
Departure Headway (Hd)	3.956	4.037	4
Convergence, Y/N	Yes	Yes	Yes
Cap	907	887	898
Service Time	1.971	2.062	2.012
HCM Lane V/C Ratio	0.026	0.023	0.04
HCM Control Delay	7.1	7.2	7.2
HCM Lane LOS	A	A	A
HCM 95th-tile Q	0.1	0.1	0.1

Intersection						
Int Delay, s/veh	3.7					
Movement	EBL	EBT	WBT	WBR	SBL	SBR
Lane Configurations		↔	↔		↔	
Traffic Vol, veh/h	20	11	11	10	2	13
Future Vol, veh/h	20	11	11	10	2	13
Conflicting Peds, #/hr	0	0	0	0	0	0
Sign Control	Free	Free	Free	Free	Stop	Stop
RT Channelized	-	None	-	None	-	None
Storage Length	-	-	-	-	0	-
Veh in Median Storage, #	-	0	0	-	0	-
Grade, %	-	0	0	-	0	-
Peak Hour Factor	70	70	48	48	63	63
Heavy Vehicles, %	2	2	2	2	2	2
Mvmt Flow	29	16	23	21	3	21

Major/Minor	Major1	Major2	Minor2		
Conflicting Flow All	44	0	-	0	108 34
Stage 1	-	-	-	-	34 -
Stage 2	-	-	-	-	74 -
Critical Hdwy	4.12	-	-	-	6.42 6.22
Critical Hdwy Stg 1	-	-	-	-	5.42 -
Critical Hdwy Stg 2	-	-	-	-	5.42 -
Follow-up Hdwy	2.218	-	-	-	3.518 3.318
Pot Cap-1 Maneuver	1564	-	-	-	889 1039
Stage 1	-	-	-	-	988 -
Stage 2	-	-	-	-	949 -
Platoon blocked, %		-	-	-	
Mov Cap-1 Maneuver	1564	-	-	-	872 1039
Mov Cap-2 Maneuver	-	-	-	-	872 -
Stage 1	-	-	-	-	969 -
Stage 2	-	-	-	-	949 -

Approach	EB	WB	SB
HCM Control Delay, s	4.7	0	8.6
HCM LOS			A

Minor Lane/Major Mvmt	EBL	EBT	WBT	WBR	SBLn1
Capacity (veh/h)	1564	-	-	-	1013
HCM Lane V/C Ratio	0.018	-	-	-	0.024
HCM Control Delay (s)	7.3	0	-	-	8.6
HCM Lane LOS	A	A	-	-	A
HCM 95th %tile Q(veh)	0.1	-	-	-	0.1

Intersection												
Int Delay, s/veh	4.3											
Movement	EBL	EBT	EBR	WBL	WBT	WBR	NBL	NBT	NBR	SBL	SBT	SBR
Lane Configurations		↕			↕			↕			↕	
Traffic Vol, veh/h	1	11	3	3	14	0	7	2	0	0	7	0
Future Vol, veh/h	1	11	3	3	14	0	7	2	0	0	7	0
Conflicting Peds, #/hr	0	0	0	0	0	0	0	0	0	0	0	0
Sign Control	Free	Free	Free	Free	Free	Free	Stop	Stop	Stop	Stop	Stop	Stop
RT Channelized	-	-	None	-	-	None	-	-	None	-	-	None
Storage Length	-	-	-	-	-	-	-	-	-	-	-	-
Veh in Median Storage, #	-	0	-	-	0	-	-	0	-	-	0	-
Grade, %	-	0	-	-	0	-	-	0	-	-	0	-
Peak Hour Factor	75	75	75	61	61	61	45	45	45	58	58	58
Heavy Vehicles, %	2	2	2	2	2	2	2	2	2	2	2	2
Mvmt Flow	1	15	4	5	23	0	16	4	0	0	12	0

Major/Minor	Major1		Major2			Minor1			Minor2			
Conflicting Flow All	23	0	0	19	0	0	58	52	17	54	54	23
Stage 1	-	-	-	-	-	-	19	19	-	33	33	-
Stage 2	-	-	-	-	-	-	39	33	-	21	21	-
Critical Hdwy	4.12	-	-	4.12	-	-	7.12	6.52	6.22	7.12	6.52	6.22
Critical Hdwy Stg 1	-	-	-	-	-	-	6.12	5.52	-	6.12	5.52	-
Critical Hdwy Stg 2	-	-	-	-	-	-	6.12	5.52	-	6.12	5.52	-
Follow-up Hdwy	2.218	-	-	2.218	-	-	3.518	4.018	3.318	3.518	4.018	3.318
Pot Cap-1 Maneuver	1592	-	-	1597	-	-	939	839	1062	944	837	1054
Stage 1	-	-	-	-	-	-	1000	880	-	983	868	-
Stage 2	-	-	-	-	-	-	976	868	-	998	878	-
Platoon blocked, %	-	-	-	-	-	-	-	-	-	-	-	-
Mov Cap-1 Maneuver	1592	-	-	1597	-	-	926	836	1062	937	834	1054
Mov Cap-2 Maneuver	-	-	-	-	-	-	926	836	-	937	834	-
Stage 1	-	-	-	-	-	-	999	879	-	982	865	-
Stage 2	-	-	-	-	-	-	959	865	-	992	877	-

Approach	EB		WB			NB			SB		
HCM Control Delay, s	0.5		1.3			9.1			9.4		
HCM LOS						A			A		

Minor Lane/Major Mvmt	NBLn1	EBL	EBT	EBR	WBL	WBT	WBR	SBLn1
Capacity (veh/h)	904	1592	-	-	1597	-	-	834
HCM Lane V/C Ratio	0.022	0.001	-	-	0.003	-	-	0.014
HCM Control Delay (s)	9.1	7.3	0	-	7.3	0	-	9.4
HCM Lane LOS	A	A	A	-	A	A	-	A
HCM 95th %tile Q(veh)	0.1	0	-	-	0	-	-	0

Intersection						
Int Delay, s/veh	4.2					
Movement	EBT	EBR	WBL	WBT	NBL	NBR
Lane Configurations	↔			↔	↔	
Traffic Vol, veh/h	1	1	4	3	1	0
Future Vol, veh/h	1	1	4	3	1	0
Conflicting Peds, #/hr	0	0	0	0	0	0
Sign Control	Free	Free	Free	Free	Stop	Stop
RT Channelized	-	None	-	None	-	None
Storage Length	-	-	-	-	0	-
Veh in Median Storage, #	0	-	-	0	0	-
Grade, %	0	-	-	0	0	-
Peak Hour Factor	50	50	88	88	25	25
Heavy Vehicles, %	2	2	2	2	2	2
Mvmt Flow	2	2	5	3	4	0

Major/Minor	Major1	Major2	Minor1		
Conflicting Flow All	0	0	4	0	16
Stage 1	-	-	-	-	3
Stage 2	-	-	-	-	13
Critical Hdwy	-	-	4.12	-	6.42
Critical Hdwy Stg 1	-	-	-	-	5.42
Critical Hdwy Stg 2	-	-	-	-	5.42
Follow-up Hdwy	-	-	2.218	-	3.518
Pot Cap-1 Maneuver	-	-	1618	-	1002
Stage 1	-	-	-	-	1020
Stage 2	-	-	-	-	1010
Platoon blocked, %	-	-	-	-	-
Mov Cap-1 Maneuver	-	-	1618	-	999
Mov Cap-2 Maneuver	-	-	-	-	999
Stage 1	-	-	-	-	1020
Stage 2	-	-	-	-	1007

Approach	EB	WB	NB
HCM Control Delay, s	0	4.1	8.6
HCM LOS			A

Minor Lane/Major Mvmt	NBLn1	EBT	EBR	WBL	WBT
Capacity (veh/h)	999	-	-	1618	-
HCM Lane V/C Ratio	0.004	-	-	0.003	-
HCM Control Delay (s)	8.6	-	-	7.2	0
HCM Lane LOS	A	-	-	A	A
HCM 95th %tile Q(veh)	0	-	-	0	-

Intersection						
Int Delay, s/veh	3.1					
Movement	EBL	EBR	NBL	NBT	SBT	SBR
Lane Configurations	TT			TT	TT	
Traffic Vol, veh/h	3	3	1	1	12	4
Future Vol, veh/h	3	3	1	1	12	4
Conflicting Peds, #/hr	0	0	0	0	0	0
Sign Control	Stop	Stop	Free	Free	Free	Free
RT Channelized	-	None	-	None	-	None
Storage Length	0	-	-	-	-	-
Veh in Median Storage, #	0	-	-	0	0	-
Grade, %	0	-	-	0	0	-
Peak Hour Factor	38	38	50	50	57	57
Heavy Vehicles, %	2	2	2	2	2	2
Mvmt Flow	8	8	2	2	21	7

Major/Minor	Minor2	Major1		Major2	
Conflicting Flow All	31	25	28	0	0
Stage 1	25	-	-	-	-
Stage 2	6	-	-	-	-
Critical Hdwy	6.42	6.22	4.12	-	-
Critical Hdwy Stg 1	5.42	-	-	-	-
Critical Hdwy Stg 2	5.42	-	-	-	-
Follow-up Hdwy	3.518	3.318	2.218	-	-
Pot Cap-1 Maneuver	983	1051	1585	-	-
Stage 1	998	-	-	-	-
Stage 2	1017	-	-	-	-
Platoon blocked, %				-	-
Mov Cap-1 Maneuver	982	1051	1585	-	-
Mov Cap-2 Maneuver	982	-	-	-	-
Stage 1	997	-	-	-	-
Stage 2	1017	-	-	-	-

Approach	EB	NB	SB
HCM Control Delay, s	8.6	3.6	0
HCM LOS	A		

Minor Lane/Major Mvmt	NBL	NBT	EBLn1	SBT	SBR
Capacity (veh/h)	1585	-	1015	-	-
HCM Lane V/C Ratio	0.001	-	0.016	-	-
HCM Control Delay (s)	7.3	0	8.6	-	-
HCM Lane LOS	A	A	A	-	-
HCM 95th %tile Q(veh)	0	-	0	-	-

Intersection						
Int Delay, s/veh	4.1					
Movement	EBT	EBR	WBL	WBT	NBL	NBR
Lane Configurations	↑↑	↗	↘	↑↑	↘	
Traffic Vol, veh/h	455	35	5	890	135	15
Future Vol, veh/h	455	35	5	890	135	15
Conflicting Peds, #/hr	0	0	0	0	0	0
Sign Control	Free	Free	Free	Free	Stop	Stop
RT Channelized	-	None	-	None	-	None
Storage Length	-	300	450	-	0	-
Veh in Median Storage, #	0	-	-	0	0	-
Grade, %	0	-	-	0	0	-
Peak Hour Factor	88	88	91	91	92	92
Heavy Vehicles, %	2	2	2	2	2	2
Mvmt Flow	517	40	5	978	147	16

Major/Minor	Major1	Major2	Minor1		
Conflicting Flow All	0	0	557	0	1016 259
Stage 1	-	-	-	-	517 -
Stage 2	-	-	-	-	499 -
Critical Hdwy	-	-	4.14	-	6.84 6.94
Critical Hdwy Stg 1	-	-	-	-	5.84 -
Critical Hdwy Stg 2	-	-	-	-	5.84 -
Follow-up Hdwy	-	-	2.22	-	3.52 3.32
Pot Cap-1 Maneuver	-	-	1010	-	234 740
Stage 1	-	-	-	-	563 -
Stage 2	-	-	-	-	575 -
Platoon blocked, %	-	-	-	-	-
Mov Cap-1 Maneuver	-	-	1010	-	233 740
Mov Cap-2 Maneuver	-	-	-	-	233 -
Stage 1	-	-	-	-	563 -
Stage 2	-	-	-	-	572 -

Approach	EB	WB	NB
HCM Control Delay, s	0	0	42.9
HCM LOS			E

Minor Lane/Major Mvmt	NBLn1	EBT	EBR	WBL	WBT
Capacity (veh/h)	250	-	-	1010	-
HCM Lane V/C Ratio	0.652	-	-	0.005	-
HCM Control Delay (s)	42.9	-	-	8.6	-
HCM Lane LOS	E	-	-	A	-
HCM 95th %tile Q(veh)	4.1	-	-	0	-

Intersection						
Int Delay, s/veh	1.7					
Movement	EBL	EBR	NBL	NBT	SBT	SBR
Lane Configurations	↖	↗	↖	↕	↕	↗
Traffic Vol, veh/h	55	70	10	840	445	25
Future Vol, veh/h	55	70	10	840	445	25
Conflicting Peds, #/hr	0	0	0	0	0	0
Sign Control	Stop	Stop	Free	Free	Free	Free
RT Channelized	-	None	-	None	-	None
Storage Length	0	50	-	-	-	250
Veh in Median Storage, #	0	-	-	0	0	-
Grade, %	0	-	-	0	0	-
Peak Hour Factor	83	83	89	89	79	79
Heavy Vehicles, %	2	2	2	2	2	2
Mvmt Flow	66	84	11	944	563	32

Major/Minor	Minor2	Major1	Major2			
Conflicting Flow All	1057	282	595	0	-	0
Stage 1	563	-	-	-	-	-
Stage 2	494	-	-	-	-	-
Critical Hdwy	6.84	6.94	4.14	-	-	-
Critical Hdwy Stg 1	5.84	-	-	-	-	-
Critical Hdwy Stg 2	5.84	-	-	-	-	-
Follow-up Hdwy	3.52	3.32	2.22	-	-	-
Pot Cap-1 Maneuver	220	715	977	-	-	-
Stage 1	534	-	-	-	-	-
Stage 2	579	-	-	-	-	-
Platoon blocked, %				-	-	-
Mov Cap-1 Maneuver	218	715	977	-	-	-
Mov Cap-2 Maneuver	218	-	-	-	-	-
Stage 1	528	-	-	-	-	-
Stage 2	579	-	-	-	-	-

Approach	EB	NB	SB
HCM Control Delay, s	18.6	0.1	0
HCM LOS	C		

Minor Lane/Major Mvmt	NBL	NBT	EBLn1	EBLn2	SBT	SBR
Capacity (veh/h)	977	-	218	715	-	-
HCM Lane V/C Ratio	0.012	-	0.304	0.118	-	-
HCM Control Delay (s)	8.7	-	28.6	10.7	-	-
HCM Lane LOS	A	-	D	B	-	-
HCM 95th %tile Q(veh)	0	-	1.2	0.4	-	-

Lanes, Volumes, Timings
9: Marksheffel Rd & Meadowbrook Pkwy

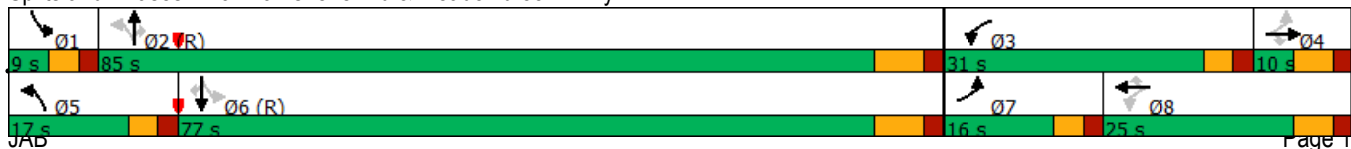
Long-Term Background - Brookings Closed
AM Peak Hour

Lane Group	EBL	EBT	EBR	WBL	WBT	WBR	NBL	NBT	NBR	SBL	SBT	SBR
Lane Configurations												
Traffic Volume (vph)	143	5	64	195	14	75	128	900	58	41	2000	231
Future Volume (vph)	143	5	64	195	14	75	128	900	58	41	2000	231
Satd. Flow (prot)	3433	1863	1583	1770	1863	1583	1770	3539	1583	1770	5085	1583
Flt Permitted	0.769			0.392			0.050			0.261		
Satd. Flow (perm)	2779	1863	1583	730	1863	1583	93	3539	1583	486	5085	1583
Satd. Flow (RTOR)			194			154			145			227
Peak Hour Factor	0.78	0.78	0.78	0.78	0.78	0.78	0.92	0.92	0.92	0.90	0.90	0.90
Shared Lane Traffic (%)												
Lane Group Flow (vph)	183	6	82	250	18	96	139	978	63	46	2222	257
Turn Type	pm+pt	NA	Perm	pm+pt	NA	Perm	pm+pt	NA	Perm	pm+pt	NA	Perm
Protected Phases	7	4		3	8		5	2		1	6	
Permitted Phases	4		4	8		8	2		2	6		6
Detector Phase	7	4	4	3	8	8	5	2	2	1	6	6
Switch Phase												
Minimum Initial (s)	4.0	4.0	4.0	4.0	4.0	4.0	4.0	4.0	4.0	4.0	4.0	4.0
Minimum Split (s)	9.0	10.0	10.0	9.0	10.0	10.0	9.0	11.0	11.0	9.0	11.0	11.0
Total Split (s)	16.0	10.0	10.0	31.0	25.0	25.0	17.0	85.0	85.0	9.0	77.0	77.0
Total Split (%)	11.9%	7.4%	7.4%	23.0%	18.5%	18.5%	12.6%	63.0%	63.0%	6.7%	57.0%	57.0%
Yellow Time (s)	3.0	4.0	4.0	3.0	4.0	4.0	3.0	5.0	5.0	3.0	5.0	5.0
All-Red Time (s)	2.0	2.0	2.0	2.0	2.0	2.0	2.0	2.0	2.0	2.0	2.0	2.0
Lost Time Adjust (s)	0.0	0.0	0.0	0.0	0.0	0.0	0.0	0.0	0.0	0.0	0.0	0.0
Total Lost Time (s)	5.0	6.0	6.0	5.0	6.0	6.0	5.0	7.0	7.0	5.0	7.0	7.0
Lead/Lag	Lead	Lag	Lag	Lead	Lag	Lag	Lead	Lag	Lag	Lead	Lag	Lag
Lead-Lag Optimize?	Yes	Yes	Yes	Yes	Yes	Yes	Yes	Yes	Yes	Yes	Yes	Yes
Recall Mode	None	None	None	None	None	None	None	C-Max	C-Max	None	C-Max	C-Max
Act Effct Green (s)	16.5	5.2	5.2	32.7	16.4	16.4	91.9	82.3	82.3	82.2	75.1	75.1
Actuated g/C Ratio	0.12	0.04	0.04	0.24	0.12	0.12	0.68	0.61	0.61	0.61	0.56	0.56
v/c Ratio	0.47	0.08	0.33	0.73	0.08	0.29	0.73	0.45	0.06	0.13	0.79	0.26
Control Delay	45.6	66.0	3.6	57.8	51.9	3.0	50.0	15.9	0.1	9.2	27.1	3.8
Queue Delay	0.0	0.0	0.0	0.0	0.0	0.0	0.0	0.0	0.0	0.0	0.0	0.0
Total Delay	45.6	66.0	3.6	57.8	51.9	3.0	50.0	15.9	0.1	9.2	27.1	3.8
LOS	D	E	A	E	D	A	D	B	A	A	C	A
Approach Delay		33.3			43.0			19.1			24.4	
Approach LOS		C			D			B			C	

Intersection Summary

Cycle Length: 135
 Actuated Cycle Length: 135
 Offset: 0 (0%), Referenced to phase 2:NBT and 6:SBTL, Start of Green
 Natural Cycle: 70
 Control Type: Actuated-Coordinated
 Maximum v/c Ratio: 0.79
 Intersection Signal Delay: 25.1
 Intersection Capacity Utilization 78.2%
 Analysis Period (min) 15
 Intersection LOS: C
 ICU Level of Service D

Splits and Phases: 9: Marksheffel Rd & Meadowbrook Pkwy



Lanes, Volumes, Timings
10: Marksheffel Rd & US 24

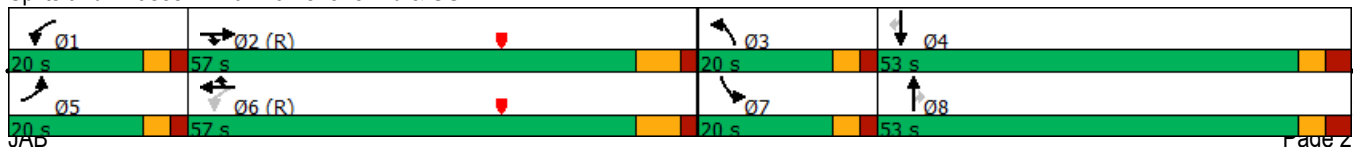
Long-Term Background - Brookings Closed
AM Peak Hour

Lane Group	EBL	EBT	EBR	WBL	WBT	WBR	NBL	NBT	NBR	SBL	SBT	SBR
Lane Configurations												
Traffic Volume (vph)	345	800	5	85	1915	485	5	550	220	10	1275	974
Future Volume (vph)	345	800	5	85	1915	485	5	550	220	10	1275	974
Satd. Flow (prot)	3433	5085	1583	3433	5085	1583	1770	3539	1583	1770	3539	1583
Flt Permitted	0.950			0.314			0.950			0.950		
Satd. Flow (perm)	3433	5085	1583	1135	5085	1583	1770	3539	1583	1770	3539	1583
Satd. Flow (RTOR)			95			269			239			397
Peak Hour Factor	0.92	0.92	0.92	0.89	0.89	0.89	0.92	0.92	0.92	0.86	0.86	0.86
Shared Lane Traffic (%)												
Lane Group Flow (vph)	375	870	5	96	2152	545	5	598	239	12	1483	1133
Turn Type	Prot	NA	Prot	pm+pt	NA	Prot	Prot	NA	Perm	Prot	NA	Perm
Protected Phases	5	2	2	1	6	6	3	8		7	4	
Permitted Phases				6					8			4
Detector Phase	5			1			3	8	8	7	4	4
Switch Phase												
Minimum Initial (s)	6.0	23.0	23.0	6.0	23.0	23.0	6.0	6.0	6.0	6.0	6.0	6.0
Minimum Split (s)	15.0	35.0	35.0	15.0	35.0	35.0	15.0	16.0	16.0	15.0	16.0	16.0
Total Split (s)	20.0	57.0	57.0	20.0	57.0	57.0	20.0	53.0	53.0	20.0	53.0	53.0
Total Split (%)	13.3%	38.0%	38.0%	13.3%	38.0%	38.0%	13.3%	35.3%	35.3%	13.3%	35.3%	35.3%
Yellow Time (s)	3.0	5.0	5.0	3.0	5.0	5.0	3.0	3.0	3.0	3.0	3.0	3.0
All-Red Time (s)	2.0	2.0	2.0	2.0	2.0	2.0	2.0	3.0	3.0	2.0	3.0	3.0
Lost Time Adjust (s)	0.0	-2.0	-2.0	0.0	-2.0	-2.0	0.0	-1.0	1.0	0.0	-1.0	1.0
Total Lost Time (s)	5.0	5.0	5.0	5.0	5.0	5.0	5.0	5.0	7.0	5.0	5.0	7.0
Lead/Lag	Lead	Lag	Lag	Lead	Lag	Lag	Lead	Lag	Lag	Lead	Lag	Lag
Lead-Lag Optimize?												
Recall Mode	None	C-Max	C-Max	None	C-Max	C-Max	None	None	None	None	None	None
Act Effct Green (s)	25.2	77.0	77.0	66.7	59.2	59.2	6.3	45.5	43.5	6.8	48.2	46.2
Actuated g/C Ratio	0.17	0.51	0.51	0.44	0.39	0.39	0.04	0.30	0.29	0.05	0.32	0.31
v/c Ratio	0.65	0.33	0.01	0.16	1.07	0.69	0.07	0.56	0.38	0.15	1.31	1.49
Control Delay	64.6	22.5	0.0	15.7	85.4	23.9	70.8	46.6	6.5	72.6	184.4	251.0
Queue Delay	0.0	0.0	0.0	0.0	0.0	0.0	0.0	0.0	0.0	0.0	0.0	0.0
Total Delay	64.6	22.5	0.0	15.7	85.4	23.9	70.8	46.6	6.5	72.6	184.4	251.0
LOS	E	C	A	B	F	C	E	D	A	E	F	F
Approach Delay		35.0			71.0			35.4			212.6	
Approach LOS		D			E			D			F	

Intersection Summary

Cycle Length: 150
 Actuated Cycle Length: 150
 Offset: 50 (33%), Referenced to phase 2:EBT and 6:WBTL, Start of FDW or yellow
 Natural Cycle: 145
 Control Type: Actuated-Coordinated
 Maximum v/c Ratio: 1.49
 Intersection Signal Delay: 110.6
 Intersection Capacity Utilization 116.5%
 Analysis Period (min) 15
 Intersection LOS: F
 ICU Level of Service H

Splits and Phases: 10: Marksheffel Rd & US 24



Lane Group	EBL	EBT	WBT	WBR	SBL	SBR
Lane Configurations						
Traffic Volume (vph)	175	855	2235	675	265	250
Future Volume (vph)	175	855	2235	675	265	250
Satd. Flow (prot)	3433	5085	5085	1583	3433	1583
Flt Permitted	0.049				0.950	
Satd. Flow (perm)	177	5085	5085	1583	3433	1583
Satd. Flow (RTOR)				718		126
Peak Hour Factor	0.85	0.85	0.94	0.94	0.88	0.88
Shared Lane Traffic (%)						
Lane Group Flow (vph)	206	1006	2378	718	301	284
Turn Type	pm+pt	NA	NA	Perm	Prot	Perm
Protected Phases	5	2	6		4	
Permitted Phases	2			6		4
Detector Phase	5	2	6	6	4	4
Switch Phase						
Minimum Initial (s)	6.0	24.0	24.0	24.0	6.0	6.0
Minimum Split (s)	11.0	31.0	31.0	31.0	23.0	23.0
Total Split (s)	13.0	82.0	69.0	69.0	38.0	38.0
Total Split (%)	10.8%	68.3%	57.5%	57.5%	31.7%	31.7%
Yellow Time (s)	3.0	5.0	5.0	5.0	3.0	3.0
All-Red Time (s)	2.0	2.0	2.0	2.0	2.0	2.0
Lost Time Adjust (s)	0.0	0.0	0.0	0.0	0.0	0.0
Total Lost Time (s)	5.0	7.0	7.0	7.0	5.0	5.0
Lead/Lag	Lead		Lag	Lag		
Lead-Lag Optimize?	Yes		Yes	Yes		
Recall Mode	Min	C-Min	C-Min	C-Min	Min	Min
Act Effct Green (s)	90.9	88.9	75.9	75.9	19.1	19.1
Actuated g/C Ratio	0.76	0.74	0.63	0.63	0.16	0.16
v/c Ratio	0.59	0.27	0.74	0.57	0.55	0.80
Control Delay	22.1	5.8	18.6	3.0	49.4	42.3
Queue Delay	0.0	0.0	0.0	0.0	0.0	0.0
Total Delay	22.1	5.8	18.6	3.0	49.4	42.3
LOS	C	A	B	A	D	D
Approach Delay		8.6	14.9		46.0	
Approach LOS		A	B		D	

Intersection Summary

Cycle Length: 120
 Actuated Cycle Length: 120
 Offset: 20 (17%), Referenced to phase 2:EBTL and 6:WBT, Start of Green
 Natural Cycle: 80
 Control Type: Actuated-Coordinated
 Maximum v/c Ratio: 0.80
 Intersection Signal Delay: 17.1
 Intersection Capacity Utilization 69.9%
 Analysis Period (min) 15
 Intersection LOS: B
 ICU Level of Service C

Splits and Phases: 12: US 24 & Constitution Ave






Intersection												
Int Delay, s/veh	4.2											
Movement	EBL	EBT	EBR	WBL	WBT	WBR	NBL	NBT	NBR	SBL	SBT	SBR
Lane Configurations		↕			↕			↕			↕	
Traffic Vol, veh/h	6	36	1	0	12	16	0	5	1	21	4	23
Future Vol, veh/h	6	36	1	0	12	16	0	5	1	21	4	23
Conflicting Peds, #/hr	0	0	0	0	0	0	0	0	0	0	0	0
Sign Control	Free	Free	Free	Free	Free	Free	Stop	Stop	Stop	Stop	Stop	Stop
RT Channelized	-	-	None	-	-	None	-	-	None	-	-	None
Storage Length	-	-	-	-	-	-	-	-	-	-	-	-
Veh in Median Storage, #	-	0	-	-	0	-	-	0	-	-	0	-
Grade, %	-	0	-	-	0	-	-	0	-	-	0	-
Peak Hour Factor	70	70	70	75	75	75	50	50	50	80	80	80
Heavy Vehicles, %	2	2	2	2	2	2	2	2	2	2	2	2
Mvmt Flow	9	51	1	0	16	21	0	10	2	26	5	29

Major/Minor	Major1			Major2			Minor1			Minor2		
Conflicting Flow All	37	0	0	52	0	0	114	107	52	103	97	27
Stage 1	-	-	-	-	-	-	70	70	-	27	27	-
Stage 2	-	-	-	-	-	-	44	37	-	76	70	-
Critical Hdwy	4.12	-	-	4.12	-	-	7.12	6.52	6.22	7.12	6.52	6.22
Critical Hdwy Stg 1	-	-	-	-	-	-	6.12	5.52	-	6.12	5.52	-
Critical Hdwy Stg 2	-	-	-	-	-	-	6.12	5.52	-	6.12	5.52	-
Follow-up Hdwy	2.218	-	-	2.218	-	-	3.518	4.018	3.318	3.518	4.018	3.318
Pot Cap-1 Maneuver	1574	-	-	1554	-	-	863	783	1016	877	793	1048
Stage 1	-	-	-	-	-	-	940	837	-	990	873	-
Stage 2	-	-	-	-	-	-	970	864	-	933	837	-
Platoon blocked, %	-	-	-	-	-	-	-	-	-	-	-	-
Mov Cap-1 Maneuver	1574	-	-	1554	-	-	831	778	1016	863	788	1048
Mov Cap-2 Maneuver	-	-	-	-	-	-	831	778	-	863	788	-
Stage 1	-	-	-	-	-	-	934	832	-	984	873	-
Stage 2	-	-	-	-	-	-	938	864	-	914	832	-

Approach	EB			WB			NB			SB		
HCM Control Delay, s	1			0			9.5			9.1		
HCM LOS							A			A		

Minor Lane/Major Mvmt	NBLn1	EBL	EBT	EBR	WBL	WBT	WBR	SBLn1
Capacity (veh/h)	810	1574	-	-	1554	-	-	935
HCM Lane V/C Ratio	0.015	0.005	-	-	-	-	-	0.064
HCM Control Delay (s)	9.5	7.3	0	-	0	-	-	9.1
HCM Lane LOS	A	A	A	-	A	-	-	A
HCM 95th %tile Q(veh)	0	0	-	-	0	-	-	0.2

Intersection	
Intersection Delay, s/veh	7.1
Intersection LOS	A

Movement	WBL	WBR	NBT	NBR	SBL	SBT
Lane Configurations						
Traffic Vol, veh/h	5	0	22	10	0	18
Future Vol, veh/h	5	0	22	10	0	18
Peak Hour Factor	0.42	0.42	0.67	0.67	0.56	0.56
Heavy Vehicles, %	2	2	2	2	2	2
Mvmt Flow	12	0	33	15	0	32
Number of Lanes	1	0	1	0	0	1

Approach	WB	NB	SB
Opposing Approach		SB	NB
Opposing Lanes	0	1	1
Conflicting Approach Left	NB		WB
Conflicting Lanes Left	1	0	1
Conflicting Approach Right	SB	WB	
Conflicting Lanes Right	1	1	0
HCM Control Delay	7.4	7	7.2
HCM LOS	A	A	A

Lane	NBLn1	WBLn1	SBLn1
Vol Left, %	0%	100%	0%
Vol Thru, %	69%	0%	100%
Vol Right, %	31%	0%	0%
Sign Control	Stop	Stop	Stop
Traffic Vol by Lane	32	5	18
LT Vol	0	5	0
Through Vol	22	0	18
RT Vol	10	0	0
Lane Flow Rate	48	12	32
Geometry Grp	1	1	1
Degree of Util (X)	0.05	0.014	0.036
Departure Headway (Hd)	3.792	4.272	3.991
Convergence, Y/N	Yes	Yes	Yes
Cap	947	837	900
Service Time	1.804	2.301	2.004
HCM Lane V/C Ratio	0.051	0.014	0.036
HCM Control Delay	7	7.4	7.2
HCM Lane LOS	A	A	A
HCM 95th-tile Q	0.2	0	0.1

Intersection						
Int Delay, s/veh	4.4					
Movement	EBL	EBT	WBT	WBR	SBL	SBR
Lane Configurations		↔	↔		↔	
Traffic Vol, veh/h	10	15	11	9	11	17
Future Vol, veh/h	10	15	11	9	11	17
Conflicting Peds, #/hr	0	0	0	0	0	0
Sign Control	Free	Free	Free	Free	Stop	Stop
RT Channelized	-	None	-	None	-	None
Storage Length	-	-	-	-	0	-
Veh in Median Storage, #	-	0	0	-	0	-
Grade, %	-	0	0	-	0	-
Peak Hour Factor	78	78	71	71	70	70
Heavy Vehicles, %	2	2	2	2	2	2
Mvmt Flow	13	19	15	13	16	24

Major/Minor	Major1	Major2	Minor2		
Conflicting Flow All	28	0	-	0	67 22
Stage 1	-	-	-	-	22 -
Stage 2	-	-	-	-	45 -
Critical Hdwy	4.12	-	-	-	6.42 6.22
Critical Hdwy Stg 1	-	-	-	-	5.42 -
Critical Hdwy Stg 2	-	-	-	-	5.42 -
Follow-up Hdwy	2.218	-	-	-	3.518 3.318
Pot Cap-1 Maneuver	1585	-	-	-	938 1055
Stage 1	-	-	-	-	1001 -
Stage 2	-	-	-	-	977 -
Platoon blocked, %		-	-	-	
Mov Cap-1 Maneuver	1585	-	-	-	930 1055
Mov Cap-2 Maneuver	-	-	-	-	930 -
Stage 1	-	-	-	-	993 -
Stage 2	-	-	-	-	977 -

Approach	EB	WB	SB
HCM Control Delay, s	2.9	0	8.7
HCM LOS			A

Minor Lane/Major Mvmt	EBL	EBT	WBT	WBR	SBLn1
Capacity (veh/h)	1585	-	-	-	1002
HCM Lane V/C Ratio	0.008	-	-	-	0.04
HCM Control Delay (s)	7.3	0	-	-	8.7
HCM Lane LOS	A	A	-	-	A
HCM 95th %tile Q(veh)	0	-	-	-	0.1

Intersection												
Int Delay, s/veh	3.3											
Movement	EBL	EBT	EBR	WBL	WBT	WBR	NBL	NBT	NBR	SBL	SBT	SBR
Lane Configurations		↕			↕			↕			↕	
Traffic Vol, veh/h	3	14	8	5	14	2	6	0	2	0	4	0
Future Vol, veh/h	3	14	8	5	14	2	6	0	2	0	4	0
Conflicting Peds, #/hr	0	0	0	0	0	0	0	0	0	0	0	0
Sign Control	Free	Free	Free	Free	Free	Free	Stop	Stop	Stop	Stop	Stop	Stop
RT Channelized	-	-	None	-	-	None	-	-	None	-	-	None
Storage Length	-	-	-	-	-	-	-	-	-	-	-	-
Veh in Median Storage, #	-	0	-	-	0	-	-	0	-	-	0	-
Grade, %	-	0	-	-	0	-	-	0	-	-	0	-
Peak Hour Factor	89	89	89	66	66	66	67	67	67	50	50	50
Heavy Vehicles, %	2	2	2	2	2	2	2	2	2	2	2	2
Mvmt Flow	3	16	9	8	21	3	9	0	3	0	8	0

Major/Minor	Major1		Major2		Minor1			Minor2				
Conflicting Flow All	24	0	0	25	0	0	70	67	21	67	70	23
Stage 1	-	-	-	-	-	-	27	27	-	39	39	-
Stage 2	-	-	-	-	-	-	43	40	-	28	31	-
Critical Hdwy	4.12	-	-	4.12	-	-	7.12	6.52	6.22	7.12	6.52	6.22
Critical Hdwy Stg 1	-	-	-	-	-	-	6.12	5.52	-	6.12	5.52	-
Critical Hdwy Stg 2	-	-	-	-	-	-	6.12	5.52	-	6.12	5.52	-
Follow-up Hdwy	2.218	-	-	2.218	-	-	3.518	4.018	3.318	3.518	4.018	3.318
Pot Cap-1 Maneuver	1591	-	-	1589	-	-	922	824	1056	926	821	1054
Stage 1	-	-	-	-	-	-	990	873	-	976	862	-
Stage 2	-	-	-	-	-	-	971	862	-	989	869	-
Platoon blocked, %		-	-		-	-						
Mov Cap-1 Maneuver	1591	-	-	1589	-	-	910	818	1056	919	815	1054
Mov Cap-2 Maneuver	-	-	-	-	-	-	910	818	-	919	815	-
Stage 1	-	-	-	-	-	-	988	871	-	974	858	-
Stage 2	-	-	-	-	-	-	957	858	-	984	867	-

Approach	EB	WB	NB	SB
HCM Control Delay, s	0.9	1.7	8.9	9.5
HCM LOS			A	A

Minor Lane/Major Mvmt	NBLn1	EBL	EBT	EBR	WBL	WBT	WBR	SBLn1
Capacity (veh/h)	943	1591	-	-	1589	-	-	815
HCM Lane V/C Ratio	0.013	0.002	-	-	0.005	-	-	0.01
HCM Control Delay (s)	8.9	7.3	0	-	7.3	0	-	9.5
HCM Lane LOS	A	A	A	-	A	A	-	A
HCM 95th %tile Q(veh)	0	0	-	-	0	-	-	0

Intersection						
Int Delay, s/veh	1.7					
Movement	EBT	EBR	WBL	WBT	NBL	NBR
Lane Configurations	↔			↔	↔	
Traffic Vol, veh/h	4	1	0	3	0	3
Future Vol, veh/h	4	1	0	3	0	3
Conflicting Peds, #/hr	0	0	0	0	0	0
Sign Control	Free	Free	Free	Free	Stop	Stop
RT Channelized	-	None	-	None	-	None
Storage Length	-	-	-	-	0	-
Veh in Median Storage, #	0	-	-	0	0	-
Grade, %	0	-	-	0	0	-
Peak Hour Factor	63	63	38	38	75	75
Heavy Vehicles, %	2	2	2	2	2	2
Mvmt Flow	6	2	0	8	0	4

Major/Minor	Major1	Major2	Minor1	Minor2	Minor3
Conflicting Flow All	0	0	8	0	15
Stage 1	-	-	-	-	7
Stage 2	-	-	-	-	8
Critical Hdwy	-	-	4.12	-	6.42
Critical Hdwy Stg 1	-	-	-	-	5.42
Critical Hdwy Stg 2	-	-	-	-	5.42
Follow-up Hdwy	-	-	2.218	-	3.518
Pot Cap-1 Maneuver	-	-	1612	-	1004
Stage 1	-	-	-	-	1016
Stage 2	-	-	-	-	1015
Platoon blocked, %	-	-	-	-	-
Mov Cap-1 Maneuver	-	-	1612	-	1004
Mov Cap-2 Maneuver	-	-	-	-	1004
Stage 1	-	-	-	-	1016
Stage 2	-	-	-	-	1015

Approach	EB	WB	NB
HCM Control Delay, s	0	0	8.4
HCM LOS			A

Minor Lane/Major Mvmt	NBLn1	EBT	EBR	WBL	WBT
Capacity (veh/h)	1075	-	-	1612	-
HCM Lane V/C Ratio	0.004	-	-	-	-
HCM Control Delay (s)	8.4	-	-	0	-
HCM Lane LOS	A	-	-	A	-
HCM 95th %tile Q(veh)	0	-	-	0	-

Intersection						
Int Delay, s/veh	2.3					
Movement	EBL	EBR	NBL	NBT	SBT	SBR
Lane Configurations	↔			↔	↔	
Traffic Vol, veh/h	4	0	1	1	8	4
Future Vol, veh/h	4	0	1	1	8	4
Conflicting Peds, #/hr	0	0	0	0	0	0
Sign Control	Stop	Stop	Free	Free	Free	Free
RT Channelized	-	None	-	None	-	None
Storage Length	0	-	-	-	-	-
Veh in Median Storage, #	0	-	-	0	0	-
Grade, %	0	-	-	0	0	-
Peak Hour Factor	50	50	50	50	50	50
Heavy Vehicles, %	2	2	2	2	2	2
Mvmt Flow	8	0	2	2	16	8

Major/Minor	Minor2	Major1		Major2	
Conflicting Flow All	26	20	24	0	0
Stage 1	20	-	-	-	-
Stage 2	6	-	-	-	-
Critical Hdwy	6.42	6.22	4.12	-	-
Critical Hdwy Stg 1	5.42	-	-	-	-
Critical Hdwy Stg 2	5.42	-	-	-	-
Follow-up Hdwy	3.518	3.318	2.218	-	-
Pot Cap-1 Maneuver	989	1058	1591	-	-
Stage 1	1003	-	-	-	-
Stage 2	1017	-	-	-	-
Platoon blocked, %				-	-
Mov Cap-1 Maneuver	988	1058	1591	-	-
Mov Cap-2 Maneuver	988	-	-	-	-
Stage 1	1002	-	-	-	-
Stage 2	1017	-	-	-	-

Approach	EB	NB	SB
HCM Control Delay, s	8.7	3.6	0
HCM LOS	A		

Minor Lane/Major Mvmt	NBL	NBT	EBLn1	SBT	SBR
Capacity (veh/h)	1591	-	988	-	-
HCM Lane V/C Ratio	0.001	-	0.008	-	-
HCM Control Delay (s)	7.3	0	8.7	-	-
HCM Lane LOS	A	A	A	-	-
HCM 95th %tile Q(veh)	0	-	0	-	-

Intersection						
Int Delay, s/veh	2.2					
Movement	EBT	EBR	WBL	WBT	NBL	NBR
Lane Configurations	↑↑	↗	↘	↑↑	↘	
Traffic Vol, veh/h	790	110	10	550	60	5
Future Vol, veh/h	790	110	10	550	60	5
Conflicting Peds, #/hr	0	0	0	0	0	0
Sign Control	Free	Free	Free	Free	Stop	Stop
RT Channelized	-	None	-	None	-	None
Storage Length	-	300	450	-	0	-
Veh in Median Storage, #	0	-	-	0	0	-
Grade, %	0	-	-	0	0	-
Peak Hour Factor	84	84	91	91	80	80
Heavy Vehicles, %	2	2	2	2	2	2
Mvmt Flow	940	131	11	604	75	6

Major/Minor	Major1	Major2	Minor1		
Conflicting Flow All	0	0	1071	0	1264 470
Stage 1	-	-	-	-	940 -
Stage 2	-	-	-	-	324 -
Critical Hdwy	-	-	4.14	-	6.84 6.94
Critical Hdwy Stg 1	-	-	-	-	5.84 -
Critical Hdwy Stg 2	-	-	-	-	5.84 -
Follow-up Hdwy	-	-	2.22	-	3.52 3.32
Pot Cap-1 Maneuver	-	-	647	-	161 540
Stage 1	-	-	-	-	340 -
Stage 2	-	-	-	-	705 -
Platoon blocked, %	-	-	-	-	-
Mov Cap-1 Maneuver	-	-	647	-	158 540
Mov Cap-2 Maneuver	-	-	-	-	158 -
Stage 1	-	-	-	-	340 -
Stage 2	-	-	-	-	693 -

Approach	EB	WB	NB
HCM Control Delay, s	0	0.2	45.4
HCM LOS			E

Minor Lane/Major Mvmt	NBLn1	EBT	EBR	WBL	WBT
Capacity (veh/h)	167	-	-	647	-
HCM Lane V/C Ratio	0.487	-	-	0.017	-
HCM Control Delay (s)	45.4	-	-	10.7	-
HCM Lane LOS	E	-	-	B	-
HCM 95th %tile Q(veh)	2.3	-	-	0.1	-

Intersection						
Int Delay, s/veh	1.8					
Movement	EBL	EBR	NBL	NBT	SBT	SBR
Lane Configurations	↵	↶	↵	↕	↕	↶
Traffic Vol, veh/h	35	25	30	526	754	45
Future Vol, veh/h	35	25	30	526	754	45
Conflicting Peds, #/hr	0	0	0	0	0	0
Sign Control	Stop	Stop	Free	Free	Free	Free
RT Channelized	-	None	-	None	-	None
Storage Length	0	50	-	-	-	250
Veh in Median Storage, #	0	-	-	0	0	-
Grade, %	0	-	-	0	0	-
Peak Hour Factor	64	64	82	82	87	87
Heavy Vehicles, %	2	2	2	2	2	2
Mvmt Flow	55	39	37	641	867	52

Major/Minor	Minor2	Major1	Major2			
Conflicting Flow All	1262	434	919	0	-	0
Stage 1	867	-	-	-	-	-
Stage 2	395	-	-	-	-	-
Critical Hdwy	6.84	6.94	4.14	-	-	-
Critical Hdwy Stg 1	5.84	-	-	-	-	-
Critical Hdwy Stg 2	5.84	-	-	-	-	-
Follow-up Hdwy	3.52	3.32	2.22	-	-	-
Pot Cap-1 Maneuver	162	570	738	-	-	-
Stage 1	372	-	-	-	-	-
Stage 2	650	-	-	-	-	-
Platoon blocked, %				-	-	-
Mov Cap-1 Maneuver	154	570	738	-	-	-
Mov Cap-2 Maneuver	154	-	-	-	-	-
Stage 1	353	-	-	-	-	-
Stage 2	650	-	-	-	-	-

Approach	EB	NB	SB
HCM Control Delay, s	28.7	0.5	0
HCM LOS	D		

Minor Lane/Major Mvmt	NBL	NBT	EBLn1	EBLn2	SBT	SBR
Capacity (veh/h)	738	-	154	570	-	-
HCM Lane V/C Ratio	0.05	-	0.355	0.069	-	-
HCM Control Delay (s)	10.1	-	40.7	11.8	-	-
HCM Lane LOS	B	-	E	B	-	-
HCM 95th %tile Q(veh)	0.2	-	1.5	0.2	-	-

Lanes, Volumes, Timings
 9: Marksheffel Rd & Meadowbrook Pkwy

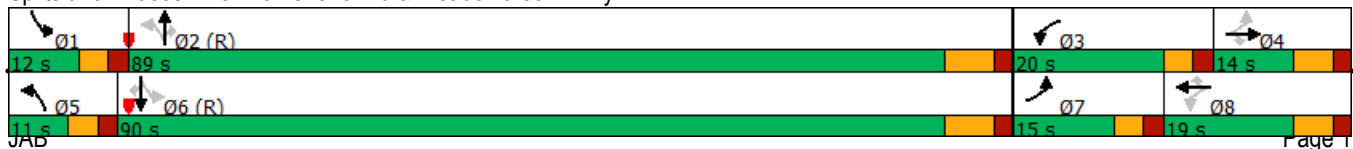
Long-Term Background - Brookings Closed
 PM Peak Hour

Lane Group	EBL	EBT	EBR	WBL	WBT	WBR	NBL	NBT	NBR	SBL	SBT	SBR
Lane Configurations												
Traffic Volume (vph)	275	30	150	170	25	115	100	1700	200	90	1050	336
Future Volume (vph)	275	30	150	170	25	115	100	1700	200	90	1050	336
Satd. Flow (prot)	3433	1863	1583	1770	1863	1583	1770	3539	1583	1770	5085	1583
Flt Permitted	0.732			0.444			0.204			0.048		
Satd. Flow (perm)	2645	1863	1583	827	1863	1583	380	3539	1583	89	5085	1583
Satd. Flow (RTOR)			151			113			167			378
Peak Hour Factor	0.77	0.77	0.77	0.66	0.66	0.66	0.84	0.84	0.84	0.89	0.89	0.89
Shared Lane Traffic (%)												
Lane Group Flow (vph)	357	39	195	258	38	174	119	2024	238	101	1180	378
Turn Type	pm+pt	NA	Perm	pm+pt	NA	Perm	pm+pt	NA	Perm	pm+pt	NA	Perm
Protected Phases	7	4		3	8		5	2		1	6	
Permitted Phases	4		4	8		8	2		2	6		6
Detector Phase	7	4	4	3	8	8	5	2	2	1	6	6
Switch Phase												
Minimum Initial (s)	4.0	4.0	4.0	4.0	4.0	4.0	4.0	4.0	4.0	4.0	4.0	4.0
Minimum Split (s)	9.0	10.0	10.0	9.0	10.0	10.0	9.0	11.0	11.0	9.0	11.0	11.0
Total Split (s)	15.0	14.0	14.0	20.0	19.0	19.0	11.0	89.0	89.0	12.0	90.0	90.0
Total Split (%)	11.1%	10.4%	10.4%	14.8%	14.1%	14.1%	8.1%	65.9%	65.9%	8.9%	66.7%	66.7%
Yellow Time (s)	3.0	4.0	4.0	3.0	4.0	4.0	3.0	5.0	5.0	3.0	5.0	5.0
All-Red Time (s)	2.0	2.0	2.0	2.0	2.0	2.0	2.0	2.0	2.0	2.0	2.0	2.0
Lost Time Adjust (s)	0.0	0.0	0.0	0.0	0.0	0.0	0.0	0.0	0.0	0.0	0.0	0.0
Total Lost Time (s)	5.0	6.0	6.0	5.0	6.0	6.0	5.0	7.0	7.0	5.0	7.0	7.0
Lead/Lag	Lead	Lag	Lag	Lead	Lag	Lag	Lead	Lag	Lag	Lead	Lag	Lag
Lead-Lag Optimize?	Yes	Yes	Yes	Yes	Yes	Yes	Yes	Yes	Yes	Yes	Yes	Yes
Recall Mode	None	None	None	None	None	None	None	C-Max	C-Max	None	C-Max	C-Max
Act Effct Green (s)	18.7	7.7	7.7	28.7	12.7	12.7	90.5	82.3	82.3	92.1	83.1	83.1
Actuated g/C Ratio	0.14	0.06	0.06	0.21	0.09	0.09	0.67	0.61	0.61	0.68	0.62	0.62
v/c Ratio	0.84	0.37	0.84	0.92	0.22	0.69	0.37	0.94	0.23	0.69	0.38	0.34
Control Delay	67.3	71.3	46.1	86.7	59.8	37.2	9.6	34.1	4.2	45.8	13.4	1.9
Queue Delay	0.0	0.0	0.0	0.0	0.0	0.0	0.0	0.1	0.0	0.0	0.0	0.0
Total Delay	67.3	71.3	46.1	86.7	59.8	37.2	9.6	34.3	4.2	45.8	13.4	1.9
LOS	E	E	D	F	E	D	A	C	A	D	B	A
Approach Delay		60.6			66.2			30.0			12.8	
Approach LOS		E			E			C			B	

Intersection Summary

Cycle Length: 135
 Actuated Cycle Length: 135
 Offset: 0 (0%), Referenced to phase 2:NBT and 6:SBTL, Start of Green
 Natural Cycle: 90
 Control Type: Actuated-Coordinated
 Maximum v/c Ratio: 0.94
 Intersection Signal Delay: 31.3
 Intersection Capacity Utilization 83.1%
 Analysis Period (min) 15
 Intersection LOS: C
 ICU Level of Service E

Splits and Phases: 9: Marksheffel Rd & Meadowbrook Pkwy



Lanes, Volumes, Timings
10: Marksheffel Rd & US 24

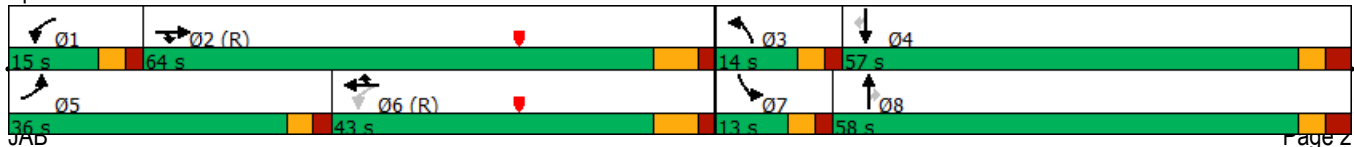
Long-Term Background - Brookings Closed
PM Peak Hour

Lane Group	EBL	EBT	EBR	WBL	WBT	WBR	NBL	NBT	NBR	SBL	SBT	SBR
Lane Configurations												
Traffic Volume (vph)	800	1500	10	185	800	85	20	1100	390	45	825	500
Future Volume (vph)	800	1500	10	185	800	85	20	1100	390	45	825	500
Satd. Flow (prot)	3433	5085	1583	3433	5085	1583	1770	3539	1583	1770	3539	1583
Flt Permitted	0.950			0.118			0.950			0.950		
Satd. Flow (perm)	3433	5085	1583	426	5085	1583	1770	3539	1583	1770	3539	1583
Satd. Flow (RTOR)			95			131			190			456
Peak Hour Factor	0.84	0.84	0.84	0.87	0.87	0.87	0.85	0.85	0.85	0.83	0.83	0.83
Shared Lane Traffic (%)												
Lane Group Flow (vph)	952	1786	12	213	920	98	24	1294	459	54	994	602
Turn Type	Prot	NA	Prot	pm+pt	NA	Prot	Prot	NA	Perm	Prot	NA	Perm
Protected Phases	5	2	2	1	6	6	3	8		7	4	
Permitted Phases				6					8			4
Detector Phase	5			1			3	8	8	7	4	4
Switch Phase												
Minimum Initial (s)	6.0	23.0	23.0	6.0	23.0	23.0	6.0	6.0	6.0	6.0	6.0	6.0
Minimum Split (s)	15.0	35.0	35.0	15.0	35.0	35.0	15.0	16.0	16.0	15.0	16.0	16.0
Total Split (s)	36.0	64.0	64.0	15.0	43.0	43.0	14.0	58.0	58.0	13.0	57.0	57.0
Total Split (%)	24.0%	42.7%	42.7%	10.0%	28.7%	28.7%	9.3%	38.7%	38.7%	8.7%	38.0%	38.0%
Yellow Time (s)	3.0	5.0	5.0	3.0	5.0	5.0	3.0	3.0	3.0	3.0	3.0	3.0
All-Red Time (s)	2.0	2.0	2.0	2.0	2.0	2.0	2.0	3.0	3.0	2.0	3.0	3.0
Lost Time Adjust (s)	0.0	-2.0	-2.0	0.0	-2.0	-2.0	0.0	-1.0	1.0	0.0	-1.0	1.0
Total Lost Time (s)	5.0	5.0	5.0	5.0	5.0	5.0	5.0	5.0	7.0	5.0	5.0	7.0
Lead/Lag	Lead	Lag	Lag	Lead	Lag	Lag	Lead	Lag	Lag	Lead	Lag	Lag
Lead-Lag Optimize?												
Recall Mode	None	C-Max	C-Max	None	C-Max	C-Max	None	None	None	None	None	None
Act Effct Green (s)	33.6	62.1	62.1	47.5	38.0	38.0	7.5	53.0	51.0	7.6	55.4	53.4
Actuated g/C Ratio	0.22	0.41	0.41	0.32	0.25	0.25	0.05	0.35	0.34	0.05	0.37	0.36
v/c Ratio	1.24	0.85	0.02	0.65	0.71	0.20	0.27	1.04	0.69	0.60	0.76	0.70
Control Delay	165.0	45.2	0.0	37.2	54.7	3.4	76.0	81.9	30.4	96.2	46.5	14.7
Queue Delay	0.0	0.0	0.0	0.0	0.0	0.0	0.0	0.0	0.0	0.0	0.0	0.0
Total Delay	165.0	45.2	0.0	37.2	54.7	3.4	76.0	81.9	30.4	96.2	46.5	14.7
LOS	F	D	A	D	D	A	E	F	C	F	D	B
Approach Delay		86.5			47.6			68.5			36.5	
Approach LOS		F			D			E			D	

Intersection Summary

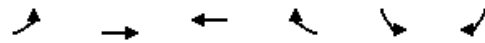
Cycle Length: 150
 Actuated Cycle Length: 150
 Offset: 46 (31%), Referenced to phase 2:EBT and 6:WBTL, Start of FDW or yellow
 Natural Cycle: 145
 Control Type: Actuated-Coordinated
 Maximum v/c Ratio: 1.24
 Intersection Signal Delay: 64.6
 Intersection LOS: E
 Intersection Capacity Utilization 91.9%
 ICU Level of Service F
 Analysis Period (min) 15

Splits and Phases: 10: Marksheffel Rd & US 24



Lanes, Volumes, Timings
12: US 24 & Constitution Ave

Long-Term Background - Brookings Closed
PM Peak Hour

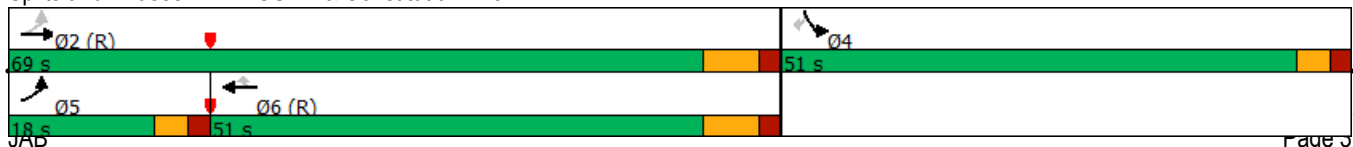


Lane Group	EBL	EBT	WBT	WBR	SBL	SBR
Lane Configurations	↖↗	↕↕↕	↕↕↕	↖	↘↘	↘
Traffic Volume (vph)	205	1730	945	350	650	125
Future Volume (vph)	205	1730	945	350	650	125
Satd. Flow (prot)	3433	5085	5085	1583	3433	1583
Flt Permitted	0.213				0.950	
Satd. Flow (perm)	770	5085	5085	1583	3433	1583
Satd. Flow (RTOR)				380		142
Peak Hour Factor	0.84	0.84	0.92	0.92	0.88	0.88
Shared Lane Traffic (%)						
Lane Group Flow (vph)	244	2060	1027	380	739	142
Turn Type	pm+pt	NA	NA	Perm	Prot	Perm
Protected Phases	5	2	6		4	
Permitted Phases	2			6		4
Detector Phase	5	2	6	6	4	4
Switch Phase						
Minimum Initial (s)	6.0	24.0	24.0	24.0	6.0	6.0
Minimum Split (s)	11.0	31.0	31.0	31.0	23.0	23.0
Total Split (s)	18.0	69.0	51.0	51.0	51.0	51.0
Total Split (%)	15.0%	57.5%	42.5%	42.5%	42.5%	42.5%
Yellow Time (s)	3.0	5.0	5.0	5.0	3.0	3.0
All-Red Time (s)	2.0	2.0	2.0	2.0	2.0	2.0
Lost Time Adjust (s)	0.0	0.0	0.0	0.0	0.0	0.0
Total Lost Time (s)	5.0	7.0	7.0	7.0	5.0	5.0
Lead/Lag	Lead		Lag	Lag		
Lead-Lag Optimize?	Yes		Yes	Yes		
Recall Mode	Min	C-Min	C-Min	C-Min	Min	Min
Act Effct Green (s)	77.5	75.5	61.6	61.6	32.5	32.5
Actuated g/C Ratio	0.65	0.63	0.51	0.51	0.27	0.27
v/c Ratio	0.35	0.64	0.39	0.38	0.79	0.27
Control Delay	10.3	15.8	19.4	3.2	47.1	6.0
Queue Delay	0.0	0.0	0.0	0.0	0.0	0.0
Total Delay	10.3	15.8	19.4	3.2	47.1	6.0
LOS	B	B	B	A	D	A
Approach Delay		15.2	15.0		40.5	
Approach LOS		B	B		D	

Intersection Summary

Cycle Length: 120
 Actuated Cycle Length: 120
 Offset: 112 (93%), Referenced to phase 2:EBTL and 6:WBT, Start of Green
 Natural Cycle: 65
 Control Type: Actuated-Coordinated
 Maximum v/c Ratio: 0.79
 Intersection Signal Delay: 20.0
 Intersection Capacity Utilization 62.0%
 Analysis Period (min) 15
 Intersection LOS: C
 ICU Level of Service B

Splits and Phases: 12: US 24 & Constitution Ave



HCM 2010 TWSC
1: Meadowbrook Pkwy

Short-Term Total
AM Peak Hour




Intersection												
Int Delay, s/veh	11.2											
Movement	EBL	EBT	EBR	WBL	WBT	WBR	NBL	NBT	NBR	SBL	SBT	SBR
Lane Configurations		↕			↕			↕			↕	
Traffic Vol, veh/h	7	257	0	0	79	99	8	38	0	82	4	25
Future Vol, veh/h	7	257	0	0	79	99	8	38	0	82	4	25
Conflicting Peds, #/hr	0	0	0	0	0	0	0	0	0	0	0	0
Sign Control	Free	Free	Free	Free	Free	Free	Stop	Stop	Stop	Stop	Stop	Stop
RT Channelized	-	-	None	-	-	None	-	-	None	-	-	None
Storage Length	-	-	-	-	-	-	-	-	-	-	-	-
Veh in Median Storage, #	-	0	-	-	0	-	-	0	-	-	0	-
Grade, %	-	0	-	-	0	-	-	0	-	-	0	-
Peak Hour Factor	84	50	84	77	50	50	50	50	58	50	75	75
Heavy Vehicles, %	2	2	2	2	2	2	2	2	2	2	2	2
Mvmt Flow	8	514	0	0	158	198	16	76	0	164	5	33

Major/Minor	Major1			Major2			Minor1			Minor2		
Conflicting Flow All	356	0	0	514	0	0	806	886	514	825	787	257
Stage 1	-	-	-	-	-	-	530	530	-	257	257	-
Stage 2	-	-	-	-	-	-	276	356	-	568	530	-
Critical Hdwy	4.12	-	-	4.12	-	-	7.12	6.52	6.22	7.12	6.52	6.22
Critical Hdwy Stg 1	-	-	-	-	-	-	6.12	5.52	-	6.12	5.52	-
Critical Hdwy Stg 2	-	-	-	-	-	-	6.12	5.52	-	6.12	5.52	-
Follow-up Hdwy	2.218	-	-	2.218	-	-	3.518	4.018	3.318	3.518	4.018	3.318
Pot Cap-1 Maneuver	1203	-	-	1052	-	-	300	284	560	292	324	782
Stage 1	-	-	-	-	-	-	533	527	-	748	695	-
Stage 2	-	-	-	-	-	-	730	629	-	508	527	-
Platoon blocked, %		-	-		-	-						
Mov Cap-1 Maneuver	1203	-	-	1052	-	-	282	281	560	230	321	782
Mov Cap-2 Maneuver	-	-	-	-	-	-	282	281	-	230	321	-
Stage 1	-	-	-	-	-	-	528	522	-	741	695	-
Stage 2	-	-	-	-	-	-	694	629	-	430	522	-

Approach	EB	WB	NB	SB
HCM Control Delay, s	0.1	0	23.9	53.7
HCM LOS			C	F

Minor Lane/Major Mvmt	NBLn1	EBL	EBT	EBR	WBL	WBT	WBR	SBLn1
Capacity (veh/h)	281	1203	-	-	1052	-	-	262
HCM Lane V/C Ratio	0.327	0.007	-	-	-	-	-	0.774
HCM Control Delay (s)	23.9	8	0	-	0	-	-	53.7
HCM Lane LOS	C	A	A	-	A	-	-	F
HCM 95th %tile Q(veh)	1.4	0	-	-	0	-	-	5.8

Intersection	
Intersection Delay, s/veh	63.5
Intersection LOS	F

Movement	WBL	WBR	NBT	NBR	SBL	SBT
Lane Configurations						
Traffic Vol, veh/h	151	105	242	69	2	29
Future Vol, veh/h	151	105	242	69	2	29
Peak Hour Factor	0.40	0.40	0.50	0.50	0.86	0.86
Heavy Vehicles, %	2	2	2	2	2	2
Mvmt Flow	378	263	484	138	2	34
Number of Lanes	1	0	1	0	0	1

Approach	WB	NB	SB
Opposing Approach		SB	NB
Opposing Lanes	0	1	1
Conflicting Approach Left	NB		WB
Conflicting Lanes Left	1	0	1
Conflicting Approach Right	SB	WB	
Conflicting Lanes Right	1	1	0
HCM Control Delay	67.6	62.3	10.8
HCM LOS	F	F	B

Lane	NBLn1	WBLn1	SBLn1
Vol Left, %	0%	59%	6%
Vol Thru, %	78%	0%	94%
Vol Right, %	22%	41%	0%
Sign Control	Stop	Stop	Stop
Traffic Vol by Lane	311	256	31
LT Vol	0	151	2
Through Vol	242	0	29
RT Vol	69	105	0
Lane Flow Rate	622	640	36
Geometry Grp	1	1	1
Degree of Util (X)	1.007	1.028	0.071
Departure Headway (Hd)	5.83	5.78	7.256
Convergence, Y/N	Yes	Yes	Yes
Cap	616	621	497
Service Time	3.917	3.861	5.256
HCM Lane V/C Ratio	1.01	1.031	0.072
HCM Control Delay	62.3	67.6	10.8
HCM Lane LOS	F	F	B
HCM 95th-tile Q	15.4	16.5	0.2

Intersection						
Int Delay, s/veh	4.2					
Movement	EBL	EBT	WBT	WBR	SBL	SBR
Lane Configurations		↕	↕		↕	
Traffic Vol, veh/h	30	332	11	20	67	13
Future Vol, veh/h	30	332	11	20	67	13
Conflicting Peds, #/hr	0	0	0	0	0	0
Sign Control	Free	Free	Free	Free	Stop	Stop
RT Channelized	-	None	-	None	-	None
Storage Length	-	-	-	-	0	-
Veh in Median Storage, #	-	0	0	-	0	-
Grade, %	-	0	0	-	0	-
Peak Hour Factor	50	50	48	48	50	63
Heavy Vehicles, %	2	2	2	2	2	2
Mvmt Flow	60	664	23	42	134	21

Major/Minor	Major1	Major2	Minor2		
Conflicting Flow All	65	0	-	0	828 44
Stage 1	-	-	-	-	44 -
Stage 2	-	-	-	-	784 -
Critical Hdwy	4.12	-	-	-	6.42 6.22
Critical Hdwy Stg 1	-	-	-	-	5.42 -
Critical Hdwy Stg 2	-	-	-	-	5.42 -
Follow-up Hdwy	2.218	-	-	-	3.518 3.318
Pot Cap-1 Maneuver	1537	-	-	-	341 1026
Stage 1	-	-	-	-	978 -
Stage 2	-	-	-	-	450 -
Platoon blocked, %		-	-	-	
Mov Cap-1 Maneuver	1537	-	-	-	320 1026
Mov Cap-2 Maneuver	-	-	-	-	320 -
Stage 1	-	-	-	-	917 -
Stage 2	-	-	-	-	450 -

Approach	EB	WB	SB
HCM Control Delay, s	0.6	0	23
HCM LOS			C

Minor Lane/Major Mvmt	EBL	EBT	WBT	WBR	SBLn1
Capacity (veh/h)	1537	-	-	-	352
HCM Lane V/C Ratio	0.039	-	-	-	0.439
HCM Control Delay (s)	7.4	0	-	-	23
HCM Lane LOS	A	A	-	-	C
HCM 95th %tile Q(veh)	0.1	-	-	-	2.2

Intersection												
Int Delay, s/veh	17											
Movement	EBL	EBT	EBR	WBL	WBT	WBR	NBL	NBT	NBR	SBL	SBT	SBR
Lane Configurations		↕	↕		↕			↕			↕	
Traffic Vol, veh/h	1	104	296	33	14	0	17	12	6	0	106	0
Future Vol, veh/h	1	104	296	33	14	0	17	12	6	0	106	0
Conflicting Peds, #/hr	0	0	0	0	0	0	0	0	0	0	0	0
Sign Control	Free	Free	Free	Free	Free	Free	Stop	Stop	Stop	Stop	Stop	Stop
RT Channelized	-	-	None	-	-	None	-	-	None	-	-	None
Storage Length	-	-	50	-	-	-	-	-	-	-	-	-
Veh in Median Storage, #	-	0	-	-	0	-	-	0	-	-	0	-
Grade, %	-	0	-	-	0	-	-	0	-	-	0	-
Peak Hour Factor	75	50	50	50	61	61	45	45	45	58	50	58
Heavy Vehicles, %	2	2	2	2	2	2	2	2	2	2	2	2
Mvmt Flow	1	208	592	66	23	0	38	27	13	0	212	0

Major/Minor	Major1			Major2			Minor1			Minor2		
Conflicting Flow All	23	0	0	800	0	0	471	365	208	681	957	23
Stage 1	-	-	-	-	-	-	210	210	-	155	155	-
Stage 2	-	-	-	-	-	-	261	155	-	526	802	-
Critical Hdwy	4.12	-	-	4.12	-	-	7.12	6.52	6.22	7.12	6.52	6.22
Critical Hdwy Stg 1	-	-	-	-	-	-	6.12	5.52	-	6.12	5.52	-
Critical Hdwy Stg 2	-	-	-	-	-	-	6.12	5.52	-	6.12	5.52	-
Follow-up Hdwy	2.218	-	-	2.218	-	-	3.518	4.018	3.318	3.518	4.018	3.318
Pot Cap-1 Maneuver	1592	-	-	823	-	-	503	563	832	364	258	1054
Stage 1	-	-	-	-	-	-	792	728	-	847	769	-
Stage 2	-	-	-	-	-	-	744	769	-	535	396	-
Platoon blocked, %	-	-	-	-	-	-	-	-	-	-	-	-
Mov Cap-1 Maneuver	1592	-	-	823	-	-	110	517	832	323	237	1054
Mov Cap-2 Maneuver	-	-	-	-	-	-	110	517	-	323	237	-
Stage 1	-	-	-	-	-	-	791	727	-	846	707	-
Stage 2	-	-	-	-	-	-	479	707	-	507	396	-

Approach	EB			WB			NB			SB		
HCM Control Delay, s	0			7.2			36.8			78.2		
HCM LOS							E			F		

Minor Lane/Major Mvmt	NBLn1	EBL	EBT	EBR	WBL	WBT	WBR	SBLn1
Capacity (veh/h)	189	1592	-	-	823	-	-	237
HCM Lane V/C Ratio	0.412	0.001	-	-	0.08	-	-	0.895
HCM Control Delay (s)	36.8	7.3	0	-	9.8	0	-	78.2
HCM Lane LOS	E	A	A	-	A	A	-	F
HCM 95th %tile Q(veh)	1.9	0	-	-	0.3	-	-	7.5

Intersection												
Int Delay, s/veh	24.5											
Movement	EBL	EBT	EBR	WBL	WBT	WBR	NBL	NBT	NBR	SBL	SBT	SBR
Lane Configurations		↻			↻			↻		↻	↻	
Traffic Vol, veh/h	0	69	1	4	3	0	1	0	7	27	157	248
Future Vol, veh/h	0	69	1	4	3	0	1	0	7	27	157	248
Conflicting Peds, #/hr	0	0	0	0	0	0	0	0	0	0	0	0
Sign Control	Free	Free	Free	Free	Free	Free	Stop	Stop	Stop	Stop	Stop	Stop
RT Channelized	-	-	None	-	-	None	-	-	None	-	-	None
Storage Length	-	-	-	-	-	-	-	-	-	0	-	-
Veh in Median Storage, #	-	0	-	-	0	-	-	0	-	-	0	-
Grade, %	-	0	-	-	0	-	-	0	-	-	0	-
Peak Hour Factor	50	50	50	88	88	88	25	25	25	50	50	50
Heavy Vehicles, %	2	2	2	2	2	2	2	2	2	2	2	2
Mvmt Flow	0	138	2	5	3	0	4	0	28	54	314	496

Major/Minor	Major1			Major2			Minor1			Minor2		
Conflicting Flow All	-	0	0	140	0	0	557	152	139	166	153	3
Stage 1	-	-	-	-	-	-	139	139	-	13	13	-
Stage 2	-	-	-	-	-	-	418	13	-	153	140	-
Critical Hdwy	-	-	-	4.12	-	-	7.12	6.52	6.22	7.12	6.52	6.22
Critical Hdwy Stg 1	-	-	-	-	-	-	6.12	5.52	-	6.12	5.52	-
Critical Hdwy Stg 2	-	-	-	-	-	-	6.12	5.52	-	6.12	5.52	-
Follow-up Hdwy	-	-	-	2.218	-	-	3.518	4.018	3.318	3.518	4.018	3.318
Pot Cap-1 Maneuver	0	-	-	1443	-	0	441	740	909	798	739	1081
Stage 1	0	-	-	-	-	0	864	782	-	1007	885	-
Stage 2	0	-	-	-	-	0	612	885	-	849	781	-
Platoon blocked, %	-	-	-	-	-	-	-	-	-	-	-	-
Mov Cap-1 Maneuver	-	-	-	1443	-	-	159	738	909	772	737	1081
Mov Cap-2 Maneuver	-	-	-	-	-	-	159	738	-	772	737	-
Stage 1	-	-	-	-	-	-	864	782	-	1007	882	-
Stage 2	-	-	-	-	-	-	213	882	-	823	781	-

Approach	EB	WB	NB	SB
HCM Control Delay, s	0	4.3	11.7	29.1
HCM LOS			B	D

Minor Lane/Major Mvmt	NBLn1	EBT	EBR	WBL	WBT	SBLn1	SBLn2
Capacity (veh/h)	572	-	-	1443	-	772	915
HCM Lane V/C Ratio	0.056	-	-	0.003	-	0.07	0.885
HCM Control Delay (s)	11.7	-	-	7.5	0	10	30.4
HCM Lane LOS	B	-	-	A	A	B	D
HCM 95th %tile Q(veh)	0.2	-	-	0	-	0.2	12.1

Intersection						
Int Delay, s/veh	9.1					
Movement	EBL	EBR	NBL	NBT	SBT	SBR
Lane Configurations	T			T		T
Traffic Vol, veh/h	104	3	1	1	12	4
Future Vol, veh/h	104	3	1	1	12	4
Conflicting Peds, #/hr	0	0	0	0	0	0
Sign Control	Stop	Stop	Free	Free	Free	Free
RT Channelized	-	None	-	None	-	None
Storage Length	0	-	-	-	-	-
Veh in Median Storage, #	0	-	-	0	0	-
Grade, %	0	-	-	0	0	-
Peak Hour Factor	38	38	50	50	57	57
Heavy Vehicles, %	2	2	2	2	2	2
Mvmt Flow	274	8	2	2	21	7

Major/Minor	Minor2	Major1		Major2	
Conflicting Flow All	31	25	28	0	0
Stage 1	25	-	-	-	-
Stage 2	6	-	-	-	-
Critical Hdwy	6.42	6.22	4.12	-	-
Critical Hdwy Stg 1	5.42	-	-	-	-
Critical Hdwy Stg 2	5.42	-	-	-	-
Follow-up Hdwy	3.518	3.318	2.218	-	-
Pot Cap-1 Maneuver	983	1051	1585	-	-
Stage 1	998	-	-	-	-
Stage 2	1017	-	-	-	-
Platoon blocked, %				-	-
Mov Cap-1 Maneuver	982	1051	1585	-	-
Mov Cap-2 Maneuver	982	-	-	-	-
Stage 1	997	-	-	-	-
Stage 2	1017	-	-	-	-

Approach	EB	NB	SB
HCM Control Delay, s	10.1	3.6	0
HCM LOS	B		

Minor Lane/Major Mvmt	NBL	NBT	EBLn1	SBT	SBR
Capacity (veh/h)	1585	-	984	-	-
HCM Lane V/C Ratio	0.001	-	0.286	-	-
HCM Control Delay (s)	7.3	0	10.1	-	-
HCM Lane LOS	A	A	B	-	-
HCM 95th %tile Q(veh)	0	-	1.2	-	-

Intersection						
Int Delay, s/veh	3.2					
Movement	EBT	EBR	WBL	WBT	NBL	NBR
Lane Configurations	↑↑	↑	↑	↑↑	↑	↑
Traffic Vol, veh/h	277	196	4	517	166	12
Future Vol, veh/h	277	196	4	517	166	12
Conflicting Peds, #/hr	0	0	0	0	0	0
Sign Control	Free	Free	Free	Free	Stop	Stop
RT Channelized	-	None	-	None	-	None
Storage Length	-	300	450	-	0	-
Veh in Median Storage, #	0	-	-	0	0	-
Grade, %	0	-	-	0	0	-
Peak Hour Factor	88	50	91	82	80	92
Heavy Vehicles, %	2	2	2	2	2	2
Mvmt Flow	315	392	4	630	208	13

Major/Minor	Major1	Major2	Minor1		
Conflicting Flow All	0	0	707	0	638 158
Stage 1	-	-	-	-	315 -
Stage 2	-	-	-	-	323 -
Critical Hdwy	-	-	4.14	-	6.84 6.94
Critical Hdwy Stg 1	-	-	-	-	5.84 -
Critical Hdwy Stg 2	-	-	-	-	5.84 -
Follow-up Hdwy	-	-	2.22	-	3.52 3.32
Pot Cap-1 Maneuver	-	-	887	-	409 859
Stage 1	-	-	-	-	713 -
Stage 2	-	-	-	-	706 -
Platoon blocked, %	-	-	-	-	-
Mov Cap-1 Maneuver	-	-	887	-	407 859
Mov Cap-2 Maneuver	-	-	-	-	407 -
Stage 1	-	-	-	-	713 -
Stage 2	-	-	-	-	702 -

Approach	EB	WB	NB
HCM Control Delay, s	0	0.1	22.7
HCM LOS			C

Minor Lane/Major Mvmt	NBLn1	EBT	EBR	WBL	WBT
Capacity (veh/h)	420	-	-	887	-
HCM Lane V/C Ratio	0.525	-	-	0.005	-
HCM Control Delay (s)	22.7	-	-	9.1	-
HCM Lane LOS	C	-	-	A	-
HCM 95th %tile Q(veh)	3	-	-	0	-

Intersection						
Int Delay, s/veh	8.3					
Movement	EBL	EBR	NBL	NBT	SBT	SBR
Lane Configurations	↖	↗	↖	↕↕	↕↕	↗
Traffic Vol, veh/h	122	81	38	381	245	23
Future Vol, veh/h	122	81	38	381	245	23
Conflicting Peds, #/hr	0	0	0	0	0	0
Sign Control	Stop	Stop	Free	Free	Free	Free
RT Channelized	-	None	-	None	-	None
Storage Length	0	50	325	-	-	250
Veh in Median Storage, #	0	-	-	0	0	-
Grade, %	0	-	-	0	0	-
Peak Hour Factor	50	50	50	89	79	79
Heavy Vehicles, %	2	2	2	2	2	2
Mvmt Flow	244	162	76	428	310	29

Major/Minor	Minor2	Major1	Major2			
Conflicting Flow All	676	155	339	0	-	0
Stage 1	310	-	-	-	-	-
Stage 2	366	-	-	-	-	-
Critical Hdwy	6.84	6.94	4.14	-	-	-
Critical Hdwy Stg 1	5.84	-	-	-	-	-
Critical Hdwy Stg 2	5.84	-	-	-	-	-
Follow-up Hdwy	3.52	3.32	2.22	-	-	-
Pot Cap-1 Maneuver	387	863	1217	-	-	-
Stage 1	717	-	-	-	-	-
Stage 2	672	-	-	-	-	-
Platoon blocked, %				-	-	-
Mov Cap-1 Maneuver	363	863	1217	-	-	-
Mov Cap-2 Maneuver	363	-	-	-	-	-
Stage 1	673	-	-	-	-	-
Stage 2	672	-	-	-	-	-

Approach	EB	NB	SB
HCM Control Delay, s	23.9	1.2	0
HCM LOS	C		

Minor Lane/Major Mvmt	NBL	NBT	EBLn1	EBLn2	SBT	SBR
Capacity (veh/h)	1217	-	363	863	-	-
HCM Lane V/C Ratio	0.062	-	0.672	0.188	-	-
HCM Control Delay (s)	8.2	-	33	10.1	-	-
HCM Lane LOS	A	-	D	B	-	-
HCM 95th %tile Q(veh)	0.2	-	4.7	0.7	-	-

Intersection						
Int Delay, s/veh	0					
Movement	EBL	EBT	WBT	WBR	SBL	SBR
Lane Configurations		↑↑	↑↑	↑		↑
Traffic Vol, veh/h	0	429	1494	10	0	244
Future Vol, veh/h	0	429	1494	10	0	244
Conflicting Peds, #/hr	0	0	0	0	0	0
Sign Control	Free	Free	Free	Free	Stop	Stop
RT Channelized	-	None	-	None	-	Free
Storage Length	-	-	-	800	-	0
Veh in Median Storage, #	-	0	0	-	0	-
Grade, %	-	0	0	-	0	-
Peak Hour Factor	82	82	91	50	85	50
Heavy Vehicles, %	2	2	2	2	2	2
Mvmt Flow	0	523	1642	20	0	488

Major/Minor	Major1	Major2	Minor2
Conflicting Flow All	-	0	-
Stage 1	-	-	-
Stage 2	-	-	-
Critical Hdwy	-	-	-
Critical Hdwy Stg 1	-	-	-
Critical Hdwy Stg 2	-	-	-
Follow-up Hdwy	-	-	-
Pot Cap-1 Maneuver	0	-	-
Stage 1	0	-	-
Stage 2	0	-	-
Platoon blocked, %	-	-	-
Mov Cap-1 Maneuver	-	-	-
Mov Cap-2 Maneuver	-	-	-
Stage 1	-	-	-
Stage 2	-	-	-

Approach	EB	WB	SB
HCM Control Delay, s	0	0	0
HCM LOS			A

Minor Lane/Major Mvmt	EBT	WBT	WBR	SBLn1
Capacity (veh/h)	-	-	-	-
HCM Lane V/C Ratio	-	-	-	-
HCM Control Delay (s)	-	-	-	0
HCM Lane LOS	-	-	-	A
HCM 95th %tile Q(veh)	-	-	-	-

Intersection						
Int Delay, s/veh	1.5					
Movement	EBL	EBR	NBL	NBT	SBT	SBR
Lane Configurations	T			T		T
Traffic Vol, veh/h	0	0	75	31	16	422
Future Vol, veh/h	0	0	75	31	16	422
Conflicting Peds, #/hr	0	0	0	0	0	0
Sign Control	Stop	Stop	Free	Free	Free	Free
RT Channelized	-	None	-	None	-	None
Storage Length	0	-	-	-	-	-
Veh in Median Storage, #	0	-	-	0	0	-
Grade, %	0	-	-	0	0	-
Peak Hour Factor	92	25	50	50	50	50
Heavy Vehicles, %	2	2	2	2	2	2
Mvmt Flow	0	0	150	62	32	844

Major/Minor	Minor2	Major1	Major2			
Conflicting Flow All	816	454	876	0	-	0
Stage 1	454	-	-	-	-	-
Stage 2	362	-	-	-	-	-
Critical Hdwy	6.42	6.22	4.12	-	-	-
Critical Hdwy Stg 1	5.42	-	-	-	-	-
Critical Hdwy Stg 2	5.42	-	-	-	-	-
Follow-up Hdwy	3.518	3.318	2.218	-	-	-
Pot Cap-1 Maneuver	347	606	771	-	-	-
Stage 1	640	-	-	-	-	-
Stage 2	704	-	-	-	-	-
Platoon blocked, %				-	-	-
Mov Cap-1 Maneuver	277	606	771	-	-	-
Mov Cap-2 Maneuver	277	-	-	-	-	-
Stage 1	511	-	-	-	-	-
Stage 2	704	-	-	-	-	-

Approach	EB	NB	SB
HCM Control Delay, s	0	7.6	0
HCM LOS	A		

Minor Lane/Major Mvmt	NBL	NBT	EBLn1	SBT	SBR
Capacity (veh/h)	771	-	-	-	-
HCM Lane V/C Ratio	0.195	-	-	-	-
HCM Control Delay (s)	10.8	0	0	-	-
HCM Lane LOS	B	A	A	-	-
HCM 95th %tile Q(veh)	0.7	-	-	-	-

Lanes, Volumes, Timings
 9: Marksheffel Rd & Meadowbrook Pkwy

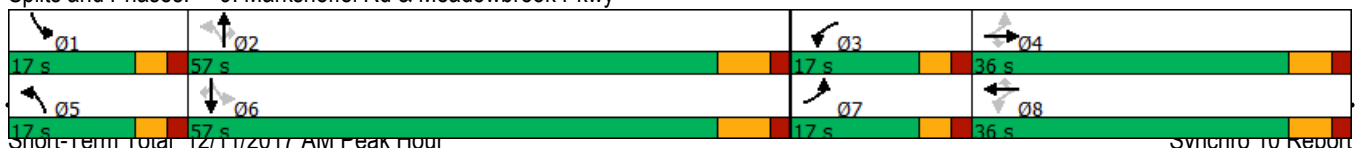
Short-Term Total
 AM Peak Hour

Lane Group	EBL	EBT	EBR	WBL	WBT	WBR	NBL	NBT	NBR	SBL	SBT	SBR
Lane Configurations												
Traffic Volume (vph)	74	4	44	110	18	94	59	767	217	57	1643	215
Future Volume (vph)	74	4	44	110	18	94	59	767	217	57	1643	215
Satd. Flow (prot)	3433	1863	1583	1770	1863	1583	1770	3539	1583	1770	3539	1583
Flt Permitted	0.800			0.400			0.078			0.271		
Satd. Flow (perm)	2891	1863	1583	745	1863	1583	145	3539	1583	505	3539	1583
Satd. Flow (RTOR)			120			140			434			151
Peak Hour Factor	0.78	0.78	0.78	0.50	0.78	0.67	0.92	0.92	0.50	0.50	0.90	0.90
Shared Lane Traffic (%)												
Lane Group Flow (vph)	95	5	56	220	23	140	64	834	434	114	1826	239
Turn Type	pm+pt	NA	Perm	pm+pt	NA	Perm	pm+pt	NA	Perm	pm+pt	NA	Perm
Protected Phases	7	4		3	8		5	2		1	6	
Permitted Phases	4		4	8		8	2		2	6		6
Detector Phase	7	4	4	3	8	8	5	2	2	1	6	6
Switch Phase												
Minimum Initial (s)	4.0	4.0	4.0	4.0	4.0	4.0	4.0	4.0	4.0	4.0	4.0	4.0
Minimum Split (s)	9.0	10.0	10.0	9.0	10.0	10.0	9.0	11.0	11.0	9.0	11.0	11.0
Total Split (s)	17.0	36.0	36.0	17.0	36.0	36.0	17.0	57.0	57.0	17.0	57.0	57.0
Total Split (%)	13.4%	28.3%	28.3%	13.4%	28.3%	28.3%	13.4%	44.9%	44.9%	13.4%	44.9%	44.9%
Yellow Time (s)	3.0	4.0	4.0	3.0	4.0	4.0	3.0	5.0	5.0	3.0	5.0	5.0
All-Red Time (s)	2.0	2.0	2.0	2.0	2.0	2.0	2.0	2.0	2.0	2.0	2.0	2.0
Lost Time Adjust (s)	0.0	0.0	0.0	0.0	0.0	0.0	0.0	0.0	0.0	0.0	0.0	0.0
Total Lost Time (s)	5.0	6.0	6.0	5.0	6.0	6.0	5.0	7.0	7.0	5.0	7.0	7.0
Lead/Lag	Lead	Lag	Lag	Lead	Lag	Lag	Lead	Lag	Lag	Lead	Lag	Lag
Lead-Lag Optimize?	Yes	Yes	Yes	Yes	Yes	Yes	Yes	Yes	Yes	Yes	Yes	Yes
Recall Mode	None	None	None	None	None	None	None	Max	Max	None	Max	Max
Act Effct Green (s)	13.5	6.3	6.3	20.6	10.3	10.3	59.1	50.3	50.3	62.1	53.7	53.7
Actuated g/C Ratio	0.14	0.07	0.07	0.21	0.11	0.11	0.61	0.52	0.52	0.64	0.56	0.56
v/c Ratio	0.21	0.04	0.26	0.78	0.12	0.48	0.32	0.45	0.42	0.27	0.93	0.25
Control Delay	31.2	44.8	2.9	53.2	42.7	13.4	11.2	16.5	2.8	8.1	32.2	6.1
Queue Delay	0.0	0.0	0.0	0.0	0.0	0.0	0.0	0.0	0.0	0.0	0.0	0.0
Total Delay	31.2	44.8	2.9	53.2	42.7	13.4	11.2	16.5	2.8	8.1	32.2	6.1
LOS	C	D	A	D	D	B	B	B	A	A	C	A
Approach Delay		21.5			38.0			11.8			28.0	
Approach LOS		C			D			B			C	

Intersection Summary

Cycle Length: 127
 Actuated Cycle Length: 96.6
 Natural Cycle: 90
 Control Type: Actuated-Uncoordinated
 Maximum v/c Ratio: 0.93
 Intersection Signal Delay: 23.4
 Intersection Capacity Utilization 72.6%
 Analysis Period (min) 15
 Intersection LOS: C
 ICU Level of Service C

Splits and Phases: 9: Marksheffel Rd & Meadowbrook Pkwy



Short-term Total 12/11/2017 AM Peak Hour

Synchronizing to Report

Lanes, Volumes, Timings
12: US 24 & Constitution Ave

Short-Term Total
AM Peak Hour

Lane Group	EBL	EBT	WBT	WBR	SBL	SBR
Lane Configurations						
Traffic Volume (vph)	48	392	1396	374	219	112
Future Volume (vph)	48	392	1396	374	219	112
Satd. Flow (prot)	1770	3539	3539	1583	3433	1583
Flt Permitted	0.120				0.950	
Satd. Flow (perm)	224	3539	3539	1583	3433	1583
Satd. Flow (RTOR)				425		127
Peak Hour Factor	0.85	0.85	0.94	0.88	0.80	0.88
Shared Lane Traffic (%)						
Lane Group Flow (vph)	56	461	1485	425	274	127
Turn Type	pm+pt	NA	NA	Perm	Prot	Perm
Protected Phases	5	2	6		4	
Permitted Phases	2			6		4
Detector Phase	5	2	6	6	4	4
Switch Phase						
Minimum Initial (s)	6.0	24.0	24.0	24.0	6.0	6.0
Minimum Split (s)	11.0	31.0	31.0	31.0	23.0	23.0
Total Split (s)	13.0	79.0	66.0	66.0	41.0	41.0
Total Split (%)	10.8%	65.8%	55.0%	55.0%	34.2%	34.2%
Yellow Time (s)	3.0	5.0	5.0	5.0	3.0	3.0
All-Red Time (s)	2.0	2.0	2.0	2.0	2.0	2.0
Lost Time Adjust (s)	0.0	0.0	0.0	0.0	0.0	0.0
Total Lost Time (s)	5.0	7.0	7.0	7.0	5.0	5.0
Lead/Lag	Lead		Lag	Lag		
Lead-Lag Optimize?	Yes		Yes	Yes		
Recall Mode	Min	C-Min	C-Min	C-Min	Min	Min
Act Effct Green (s)	95.1	93.1	81.6	81.6	14.9	14.9
Actuated g/C Ratio	0.79	0.78	0.68	0.68	0.12	0.12
v/c Ratio	0.22	0.17	0.62	0.35	0.64	0.41
Control Delay	5.0	3.9	12.5	1.6	56.8	11.9
Queue Delay	0.0	0.0	0.0	0.0	0.0	0.0
Total Delay	5.0	3.9	12.5	1.6	56.8	11.9
LOS	A	A	B	A	E	B
Approach Delay		4.0	10.1		42.6	
Approach LOS		A	B		D	

Intersection Summary

Cycle Length: 120
 Actuated Cycle Length: 120
 Offset: 0 (0%), Referenced to phase 2:EBTL and 6:WBT, Start of Green
 Natural Cycle: 75
 Control Type: Actuated-Coordinated
 Maximum v/c Ratio: 0.64
 Intersection Signal Delay: 13.6
 Intersection Capacity Utilization 56.1%
 Analysis Period (min) 15
 Intersection LOS: B
 ICU Level of Service B

Splits and Phases: 12: US 24 & Constitution Ave



HCM 6th TWSC
1: Meadowbrook Pkwy

Short-Term Total
PM Peak Hour




Intersection												
Int Delay, s/veh	4.7											
Movement	EBL	EBT	EBR	WBL	WBT	WBR	NBL	NBT	NBR	SBL	SBT	SBR
Lane Configurations		↕			↕			↕			↕	
Traffic Vol, veh/h	6	180	1	0	70	81	6	27	1	58	4	23
Future Vol, veh/h	6	180	1	0	70	81	6	27	1	58	4	23
Conflicting Peds, #/hr	0	0	0	0	0	0	0	0	0	0	0	0
Sign Control	Free	Free	Free	Free	Free	Free	Stop	Stop	Stop	Stop	Stop	Stop
RT Channelized	-	-	None	-	-	None	-	-	None	-	-	None
Storage Length	-	-	-	-	-	-	-	-	-	-	-	-
Veh in Median Storage, #	-	0	-	-	0	-	-	0	-	-	0	-
Grade, %	-	0	-	-	0	-	-	0	-	-	0	-
Peak Hour Factor	70	50	70	75	50	50	50	50	50	50	80	80
Heavy Vehicles, %	2	2	2	2	2	2	2	2	2	2	2	2
Mvmt Flow	9	360	1	0	140	162	12	54	2	116	5	29

Major/Minor	Major1			Major2			Minor1			Minor2		
Conflicting Flow All	302	0	0	361	0	0	617	681	361	628	600	221
Stage 1	-	-	-	-	-	-	379	379	-	221	221	-
Stage 2	-	-	-	-	-	-	238	302	-	407	379	-
Critical Hdwy	4.12	-	-	4.12	-	-	7.12	6.52	6.22	7.12	6.52	6.22
Critical Hdwy Stg 1	-	-	-	-	-	-	6.12	5.52	-	6.12	5.52	-
Critical Hdwy Stg 2	-	-	-	-	-	-	6.12	5.52	-	6.12	5.52	-
Follow-up Hdwy	2.218	-	-	2.218	-	-	3.518	4.018	3.318	3.518	4.018	3.318
Pot Cap-1 Maneuver	1259	-	-	1198	-	-	402	373	684	395	415	819
Stage 1	-	-	-	-	-	-	643	615	-	781	720	-
Stage 2	-	-	-	-	-	-	765	664	-	621	615	-
Platoon blocked, %	-	-	-	-	-	-	-	-	-	-	-	-
Mov Cap-1 Maneuver	1259	-	-	1198	-	-	381	370	684	348	411	819
Mov Cap-2 Maneuver	-	-	-	-	-	-	381	370	-	348	411	-
Stage 1	-	-	-	-	-	-	637	609	-	774	720	-
Stage 2	-	-	-	-	-	-	733	664	-	559	609	-

Approach	EB	WB	NB	SB
HCM Control Delay, s	0.2	0	16.6	19.7
HCM LOS			C	C

Minor Lane/Major Mvmt	NBLn1	EBL	EBT	EBR	WBL	WBT	WBR	SBLn1
Capacity (veh/h)	377	1259	-	-	1198	-	-	393
HCM Lane V/C Ratio	0.18	0.007	-	-	-	-	-	0.381
HCM Control Delay (s)	16.6	7.9	0	-	0	-	-	19.7
HCM Lane LOS	C	A	A	-	A	-	-	C
HCM 95th %tile Q(veh)	0.6	0	-	-	0	-	-	1.7

Intersection	
Intersection Delay, s/veh	18.2
Intersection LOS	C

Movement	WBL	WBR	NBT	NBR	SBL	SBT
Lane Configurations						
Traffic Vol, veh/h	128	88	161	51	0	18
Future Vol, veh/h	128	88	161	51	0	18
Peak Hour Factor	0.42	0.42	0.50	0.50	0.56	0.56
Heavy Vehicles, %	2	2	2	2	2	2
Mvmt Flow	305	210	322	102	0	32
Number of Lanes	1	0	1	0	0	1

Approach	WB	NB	SB
Opposing Approach		SB	NB
Opposing Lanes	0	1	1
Conflicting Approach Left	NB		WB
Conflicting Lanes Left	1	0	1
Conflicting Approach Right	SB	WB	
Conflicting Lanes Right	1	1	0
HCM Control Delay	20.3	16.4	9.4
HCM LOS	C	C	A

Lane	NBLn1	WBLn1	SBLn1
Vol Left, %	0%	59%	0%
Vol Thru, %	76%	0%	100%
Vol Right, %	24%	41%	0%
Sign Control	Stop	Stop	Stop
Traffic Vol by Lane	212	216	18
LT Vol	0	128	0
Through Vol	161	0	18
RT Vol	51	88	0
Lane Flow Rate	424	514	32
Geometry Grp	1	1	1
Degree of Util (X)	0.618	0.724	0.054
Departure Headway (Hd)	5.247	5.069	6.022
Convergence, Y/N	Yes	Yes	Yes
Cap	687	715	594
Service Time	3.278	3.097	4.068
HCM Lane V/C Ratio	0.617	0.719	0.054
HCM Control Delay	16.4	20.3	9.4
HCM Lane LOS	C	C	A
HCM 95th-tile Q	4.3	6.3	0.2

HCM 6th TWSC
 3: Meadowbrook Pkwy & Springside Dr

Short-Term Total
 PM Peak Hour

Intersection						
Int Delay, s/veh	3					
Movement	EBL	EBT	WBT	WBR	SBL	SBR
Lane Configurations		↕	↕		↕	
Traffic Vol, veh/h	19	233	11	18	50	17
Future Vol, veh/h	19	233	11	18	50	17
Conflicting Peds, #/hr	0	0	0	0	0	0
Sign Control	Free	Free	Free	Free	Stop	Stop
RT Channelized	-	None	-	None	-	None
Storage Length	-	-	-	-	0	-
Veh in Median Storage, #	-	0	0	-	0	-
Grade, %	-	0	0	-	0	-
Peak Hour Factor	50	50	71	50	50	70
Heavy Vehicles, %	2	2	2	2	2	2
Mvmt Flow	38	466	15	36	100	24

Major/Minor	Major1	Major2	Minor2		
Conflicting Flow All	51	0	-	0	575 33
Stage 1	-	-	-	-	33 -
Stage 2	-	-	-	-	542 -
Critical Hdwy	4.12	-	-	-	6.42 6.22
Critical Hdwy Stg 1	-	-	-	-	5.42 -
Critical Hdwy Stg 2	-	-	-	-	5.42 -
Follow-up Hdwy	2.218	-	-	-	3.518 3.318
Pot Cap-1 Maneuver	1555	-	-	-	480 1041
Stage 1	-	-	-	-	989 -
Stage 2	-	-	-	-	583 -
Platoon blocked, %		-	-	-	
Mov Cap-1 Maneuver	1555	-	-	-	464 1041
Mov Cap-2 Maneuver	-	-	-	-	464 -
Stage 1	-	-	-	-	956 -
Stage 2	-	-	-	-	583 -

Approach	EB	WB	SB
HCM Control Delay, s	0.6	0	14.1
HCM LOS			B

Minor Lane/Major Mvmt	EBL	EBT	WBT	WBR	SBLn1
Capacity (veh/h)	1555	-	-	-	520
HCM Lane V/C Ratio	0.024	-	-	-	0.239
HCM Control Delay (s)	7.4	0	-	-	14.1
HCM Lane LOS	A	A	-	-	B
HCM 95th %tile Q(veh)	0.1	-	-	-	0.9

HCM 6th TWSC
4: Pinyon Jay Dr & Meadowbrook Pkwy

Short-Term Total
PM Peak Hour

Intersection												
Int Delay, s/veh	4.8											
Movement	EBL	EBT	EBR	WBL	WBT	WBR	NBL	NBT	NBR	SBL	SBT	SBR
Lane Configurations		↕	↗		↕			↕			↕	
Traffic Vol, veh/h	3	93	186	23	14	2	15	9	7	0	65	0
Future Vol, veh/h	3	93	186	23	14	2	15	9	7	0	65	0
Conflicting Peds, #/hr	0	0	0	0	0	0	0	0	0	0	0	0
Sign Control	Free	Free	Free	Free	Free	Free	Stop	Stop	Stop	Stop	Stop	Stop
RT Channelized	-	-	None	-	-	None	-	-	None	-	-	None
Storage Length	-	-	50	-	-	-	-	-	-	-	-	-
Veh in Median Storage, #	-	0	-	-	0	-	-	0	-	-	0	-
Grade, %	-	0	-	-	0	-	-	0	-	-	0	-
Peak Hour Factor	89	50	50	50	66	66	50	50	50	50	50	50
Heavy Vehicles, %	2	2	2	2	2	2	2	2	2	2	2	2
Mvmt Flow	3	186	372	46	21	3	30	18	14	0	130	0

Major/Minor	Major1			Major2			Minor1			Minor2		
Conflicting Flow All	24	0	0	558	0	0	372	308	186	509	679	23
Stage 1	-	-	-	-	-	-	192	192	-	115	115	-
Stage 2	-	-	-	-	-	-	180	116	-	394	564	-
Critical Hdwy	4.12	-	-	4.12	-	-	7.12	6.52	6.22	7.12	6.52	6.22
Critical Hdwy Stg 1	-	-	-	-	-	-	6.12	5.52	-	6.12	5.52	-
Critical Hdwy Stg 2	-	-	-	-	-	-	6.12	5.52	-	6.12	5.52	-
Follow-up Hdwy	2.218	-	-	2.218	-	-	3.518	4.018	3.318	3.518	4.018	3.318
Pot Cap-1 Maneuver	1591	-	-	1013	-	-	585	606	856	475	374	1054
Stage 1	-	-	-	-	-	-	810	742	-	890	800	-
Stage 2	-	-	-	-	-	-	822	800	-	631	508	-
Platoon blocked, %	-	-	-	-	-	-	-	-	-	-	-	-
Mov Cap-1 Maneuver	1591	-	-	1013	-	-	404	576	856	439	356	1054
Mov Cap-2 Maneuver	-	-	-	-	-	-	404	576	-	439	356	-
Stage 1	-	-	-	-	-	-	808	740	-	887	763	-
Stage 2	-	-	-	-	-	-	651	763	-	604	506	-

Approach	EB			WB			NB			SB		
HCM Control Delay, s	0			5.7			13.1			20.8		
HCM LOS							B			C		

Minor Lane/Major Mvmt	NBLn1	EBL	EBT	EBR	WBL	WBT	WBR	SBLn1
Capacity (veh/h)	509	1591	-	-	1013	-	-	356
HCM Lane V/C Ratio	0.122	0.002	-	-	0.045	-	-	0.365
HCM Control Delay (s)	13.1	7.3	0	-	8.7	0	-	20.8
HCM Lane LOS	B	A	A	-	A	A	-	C
HCM 95th %tile Q(veh)	0.4	0	-	-	0.1	-	-	1.6

Intersection												
Int Delay, s/veh	15.7											
Movement	EBL	EBT	EBR	WBL	WBT	WBR	NBL	NBT	NBR	SBL	SBT	SBR
Lane Configurations		↔			↔			↔		↔	↔	
Traffic Vol, veh/h	0	45	1	0	3	0	0	0	7	23	134	211
Future Vol, veh/h	0	45	1	0	3	0	0	0	7	23	134	211
Conflicting Peds, #/hr	0	0	0	0	0	0	0	0	0	0	0	0
Sign Control	Free	Free	Free	Free	Free	Free	Stop	Stop	Stop	Stop	Stop	Stop
RT Channelized	-	-	None	-	-	None	-	-	None	-	-	None
Storage Length	-	-	-	-	-	-	-	-	-	0	-	-
Veh in Median Storage, #	-	0	-	-	0	-	-	0	-	-	0	-
Grade, %	-	0	-	-	0	-	-	0	-	-	0	-
Peak Hour Factor	63	50	63	38	38	38	75	75	50	50	50	50
Heavy Vehicles, %	2	2	2	2	2	2	2	2	2	2	2	2
Mvmt Flow	0	90	2	0	8	0	0	0	14	46	268	422

Major/Minor	Major1			Major2			Minor1			Minor2		
Conflicting Flow All	-	0	0	92	0	0	444	99	91	106	100	8
Stage 1	-	-	-	-	-	-	91	91	-	8	8	-
Stage 2	-	-	-	-	-	-	353	8	-	98	92	-
Critical Hdwy	-	-	-	4.12	-	-	7.12	6.52	6.22	7.12	6.52	6.22
Critical Hdwy Stg 1	-	-	-	-	-	-	6.12	5.52	-	6.12	5.52	-
Critical Hdwy Stg 2	-	-	-	-	-	-	6.12	5.52	-	6.12	5.52	-
Follow-up Hdwy	-	-	-	2.218	-	-	3.518	4.018	3.318	3.518	4.018	3.318
Pot Cap-1 Maneuver	0	-	-	1503	-	0	524	791	967	873	790	1074
Stage 1	0	-	-	-	-	0	916	820	-	1013	889	-
Stage 2	0	-	-	-	-	0	664	889	-	908	819	-
Platoon blocked, %	-	-	-	-	-	-	-	-	-	-	-	-
Mov Cap-1 Maneuver	-	-	-	1503	-	-	234	791	967	861	790	1074
Mov Cap-2 Maneuver	-	-	-	-	-	-	234	791	-	861	790	-
Stage 1	-	-	-	-	-	-	916	820	-	1013	889	-
Stage 2	-	-	-	-	-	-	282	889	-	895	819	-

Approach	EB			WB			NB			SB		
HCM Control Delay, s	0			0			8.8			17.9		
HCM LOS							A			C		

Minor Lane/Major Mvmt	NBLn1	EBT	EBR	WBL	WBT	SBLn1	SBLn2
Capacity (veh/h)	967	-	-	1503	-	861	942
HCM Lane V/C Ratio	0.014	-	-	-	-	0.053	0.732
HCM Control Delay (s)	8.8	-	-	0	-	9.4	18.5
HCM Lane LOS	A	-	-	A	-	A	C
HCM 95th %tile Q(veh)	0	-	-	0	-	0.2	6.8

Intersection						
Int Delay, s/veh	7.9					
Movement	EBL	EBR	NBL	NBT	SBT	SBR
Lane Configurations						
Traffic Vol, veh/h	72	0	1	1	8	4
Future Vol, veh/h	72	0	1	1	8	4
Conflicting Peds, #/hr	0	0	0	0	0	0
Sign Control	Stop	Stop	Free	Free	Free	Free
RT Channelized	-	None	-	None	-	None
Storage Length	0	-	-	-	-	-
Veh in Median Storage, #	0	-	-	0	0	-
Grade, %	0	-	-	0	0	-
Peak Hour Factor	50	50	50	50	50	50
Heavy Vehicles, %	2	2	2	2	2	2
Mvmt Flow	144	0	2	2	16	8

Major/Minor	Minor2	Major1		Major2	
Conflicting Flow All	26	20	24	0	0
Stage 1	20	-	-	-	-
Stage 2	6	-	-	-	-
Critical Hdwy	6.42	6.22	4.12	-	-
Critical Hdwy Stg 1	5.42	-	-	-	-
Critical Hdwy Stg 2	5.42	-	-	-	-
Follow-up Hdwy	3.518	3.318	2.218	-	-
Pot Cap-1 Maneuver	989	1058	1591	-	-
Stage 1	1003	-	-	-	-
Stage 2	1017	-	-	-	-
Platoon blocked, %				-	-
Mov Cap-1 Maneuver	988	1058	1591	-	-
Mov Cap-2 Maneuver	988	-	-	-	-
Stage 1	1002	-	-	-	-
Stage 2	1017	-	-	-	-

Approach	EB	NB	SB
HCM Control Delay, s	9.3	3.6	0
HCM LOS	A		

Minor Lane/Major Mvmt	NBL	NBT	EBLn1	SBT	SBR
Capacity (veh/h)	1591	-	988	-	-
HCM Lane V/C Ratio	0.001	-	0.146	-	-
HCM Control Delay (s)	7.3	0	9.3	-	-
HCM Lane LOS	A	A	A	-	-
HCM 95th %tile Q(veh)	0	-	0.5	-	-

Intersection						
Int Delay, s/veh	1.9					
Movement	EBT	EBR	WBL	WBT	NBL	NBR
Lane Configurations	↑↑	↑	↑	↑↑	↑	
Traffic Vol, veh/h	436	206	6	317	86	1
Future Vol, veh/h	436	206	6	317	86	1
Conflicting Peds, #/hr	0	0	0	0	0	0
Sign Control	Free	Free	Free	Free	Stop	Stop
RT Channelized	-	None	-	None	-	None
Storage Length	-	300	450	-	0	-
Veh in Median Storage, #	0	-	-	0	0	-
Grade, %	0	-	-	0	0	-
Peak Hour Factor	84	50	89	78	68	80
Heavy Vehicles, %	2	2	2	2	2	2
Mvmt Flow	519	412	7	406	126	1

Major/Minor	Major1	Major2	Minor1			
Conflicting Flow All	0	0	931	0	736	260
Stage 1	-	-	-	-	519	-
Stage 2	-	-	-	-	217	-
Critical Hdwy	-	-	4.14	-	6.84	6.94
Critical Hdwy Stg 1	-	-	-	-	5.84	-
Critical Hdwy Stg 2	-	-	-	-	5.84	-
Follow-up Hdwy	-	-	2.22	-	3.52	3.32
Pot Cap-1 Maneuver	-	-	731	-	354	739
Stage 1	-	-	-	-	562	-
Stage 2	-	-	-	-	798	-
Platoon blocked, %	-	-	-	-	-	-
Mov Cap-1 Maneuver	-	-	731	-	350	739
Mov Cap-2 Maneuver	-	-	-	-	350	-
Stage 1	-	-	-	-	562	-
Stage 2	-	-	-	-	790	-

Approach	EB	WB	NB
HCM Control Delay, s	0	0.2	20.9
HCM LOS			C

Minor Lane/Major Mvmt	NBLn1	EBT	EBR	WBL	WBT
Capacity (veh/h)	352	-	-	731	-
HCM Lane V/C Ratio	0.363	-	-	0.009	-
HCM Control Delay (s)	20.9	-	-	10	-
HCM Lane LOS	C	-	-	A	-
HCM 95th %tile Q(veh)	1.6	-	-	0	-

HCM 6th TWSC
8: Constitution Ave & Meadowbrook Pkwy

Short-Term Total
PM Peak Hour

Intersection						
Int Delay, s/veh	6.2					
Movement	EBL	EBR	NBL	NBT	SBT	SBR
Lane Configurations	↙	↗	↙	↕↕	↕↕	↗
Traffic Vol, veh/h	91	43	45	217	340	43
Future Vol, veh/h	91	43	45	217	340	43
Conflicting Peds, #/hr	0	0	0	0	0	0
Sign Control	Stop	Stop	Free	Free	Free	Free
RT Channelized	-	None	-	None	-	None
Storage Length	0	50	325	-	-	250
Veh in Median Storage, #	0	-	-	0	0	-
Grade, %	0	-	-	0	0	-
Peak Hour Factor	50	50	50	82	87	87
Heavy Vehicles, %	2	2	2	2	2	2
Mvmt Flow	182	86	90	265	391	49

Major/Minor	Minor2	Major1		Major2	
Conflicting Flow All	704	196	440	0	0
Stage 1	391	-	-	-	-
Stage 2	313	-	-	-	-
Critical Hdwy	6.84	6.94	4.14	-	-
Critical Hdwy Stg 1	5.84	-	-	-	-
Critical Hdwy Stg 2	5.84	-	-	-	-
Follow-up Hdwy	3.52	3.32	2.22	-	-
Pot Cap-1 Maneuver	371	812	1116	-	-
Stage 1	653	-	-	-	-
Stage 2	715	-	-	-	-
Platoon blocked, %				-	-
Mov Cap-1 Maneuver	341	812	1116	-	-
Mov Cap-2 Maneuver	341	-	-	-	-
Stage 1	600	-	-	-	-
Stage 2	715	-	-	-	-

Approach	EB	NB	SB
HCM Control Delay, s	21.5	2.2	0
HCM LOS	C		

Minor Lane/Major Mvmt	NBL	NBT	EBLn1	EBLn2	SBT	SBR
Capacity (veh/h)	1116	-	341	812	-	-
HCM Lane V/C Ratio	0.081	-	0.534	0.106	-	-
HCM Control Delay (s)	8.5	-	27	10	-	-
HCM Lane LOS	A	-	D	B	-	-
HCM 95th %tile Q(veh)	0.3	-	3	0.4	-	-

Intersection						
Int Delay, s/veh	0					
Movement	EBL	EBT	WBT	WBR	SBL	SBR
Lane Configurations		↑↑	↑↑	↑		↑
Traffic Vol, veh/h	0	945	476	6	0	132
Future Vol, veh/h	0	945	476	6	0	132
Conflicting Peds, #/hr	0	0	0	0	0	0
Sign Control	Free	Free	Free	Free	Stop	Stop
RT Channelized	-	None	-	None	-	Free
Storage Length	-	-	-	800	-	0
Veh in Median Storage, #	-	0	0	-	0	-
Grade, %	-	0	0	-	0	-
Peak Hour Factor	87	87	90	50	72	50
Heavy Vehicles, %	2	2	2	2	2	2
Mvmt Flow	0	1086	529	12	0	264

Major/Minor	Major1	Major2	Minor2
Conflicting Flow All	-	0	-
Stage 1	-	-	-
Stage 2	-	-	-
Critical Hdwy	-	-	-
Critical Hdwy Stg 1	-	-	-
Critical Hdwy Stg 2	-	-	-
Follow-up Hdwy	-	-	-
Pot Cap-1 Maneuver	0	-	-
Stage 1	0	-	-
Stage 2	0	-	-
Platoon blocked, %	-	-	-
Mov Cap-1 Maneuver	-	-	-
Mov Cap-2 Maneuver	-	-	-
Stage 1	-	-	-
Stage 2	-	-	-

Approach	EB	WB	SB
HCM Control Delay, s	0	0	0
HCM LOS			A

Minor Lane/Major Mvmt	EBT	WBT	WBR	SBLn1
Capacity (veh/h)	-	-	-	-
HCM Lane V/C Ratio	-	-	-	-
HCM Control Delay (s)	-	-	-	0
HCM Lane LOS	-	-	-	A
HCM 95th %tile Q(veh)	-	-	-	-

Intersection						
Int Delay, s/veh	1.1					
Movement	EBL	EBR	NBL	NBT	SBT	SBR
Lane Configurations	T			T		
Traffic Vol, veh/h	0	0	45	28	12	258
Future Vol, veh/h	0	0	45	28	12	258
Conflicting Peds, #/hr	0	0	0	0	0	0
Sign Control	Stop	Stop	Free	Free	Free	Free
RT Channelized	-	None	-	None	-	None
Storage Length	0	-	-	-	-	-
Veh in Median Storage, #	0	-	-	0	0	-
Grade, %	0	-	-	0	0	-
Peak Hour Factor	92	25	50	50	50	50
Heavy Vehicles, %	2	2	2	2	2	2
Mvmt Flow	0	0	90	56	24	516

Major/Minor	Minor2	Major1	Major2			
Conflicting Flow All	518	282	540	0	-	0
Stage 1	282	-	-	-	-	-
Stage 2	236	-	-	-	-	-
Critical Hdwy	6.42	6.22	4.12	-	-	-
Critical Hdwy Stg 1	5.42	-	-	-	-	-
Critical Hdwy Stg 2	5.42	-	-	-	-	-
Follow-up Hdwy	3.518	3.318	2.218	-	-	-
Pot Cap-1 Maneuver	518	757	1028	-	-	-
Stage 1	766	-	-	-	-	-
Stage 2	803	-	-	-	-	-
Platoon blocked, %				-	-	-
Mov Cap-1 Maneuver	471	757	1028	-	-	-
Mov Cap-2 Maneuver	471	-	-	-	-	-
Stage 1	697	-	-	-	-	-
Stage 2	803	-	-	-	-	-

Approach	EB	NB	SB
HCM Control Delay, s	0	5.4	0
HCM LOS	A		

Minor Lane/Major Mvmt	NBL	NBT	EBLn1	SBT	SBR
Capacity (veh/h)	1028	-	-	-	-
HCM Lane V/C Ratio	0.088	-	-	-	-
HCM Control Delay (s)	8.8	0	0	-	-
HCM Lane LOS	A	A	A	-	-
HCM 95th %tile Q(veh)	0.3	-	-	-	-

Lanes, Volumes, Timings
 9: Marksheffel Rd & Meadowbrook Pkwy

Short-Term Total
 PM Peak Hour

Lane Group	EBL	EBT	EBR	WBL	WBT	WBR	NBL	NBT	NBR	SBL	SBT	SBR
Lane Configurations												
Traffic Volume (vph)	158	15	112	69	10	59	70	1219	214	78	642	152
Future Volume (vph)	158	15	112	69	10	59	70	1219	214	78	642	152
Satd. Flow (prot)	3433	1863	1583	1770	1863	1583	1770	3539	1583	1770	3539	1583
Flt Permitted	0.748			0.745			0.359			0.091		
Satd. Flow (perm)	2703	1863	1583	1388	1863	1583	669	3539	1583	170	3539	1583
Satd. Flow (RTOR)			145			120			308			171
Peak Hour Factor	0.77	0.77	0.77	0.50	0.66	0.50	0.84	0.84	0.50	0.73	0.89	0.89
Shared Lane Traffic (%)												
Lane Group Flow (vph)	205	19	145	138	15	118	83	1451	428	107	721	171
Turn Type	pm+pt	NA	Perm	pm+pt	NA	Perm	pm+pt	NA	Perm	pm+pt	NA	Perm
Protected Phases	7	4		3	8		5	2		1	6	
Permitted Phases	4		4	8		8	2		2	6		6
Detector Phase	7	4	4	3	8	8	5	2	2	1	6	6
Switch Phase												
Minimum Initial (s)	4.0	4.0	4.0	4.0	4.0	4.0	4.0	4.0	4.0	4.0	4.0	4.0
Minimum Split (s)	9.0	10.0	10.0	9.0	10.0	10.0	9.0	11.0	11.0	9.0	11.0	11.0
Total Split (s)	13.0	36.0	36.0	13.0	36.0	36.0	16.0	62.0	62.0	16.0	62.0	62.0
Total Split (%)	10.2%	28.3%	28.3%	10.2%	28.3%	28.3%	12.6%	48.8%	48.8%	12.6%	48.8%	48.8%
Yellow Time (s)	3.0	4.0	4.0	3.0	4.0	4.0	3.0	5.0	5.0	3.0	5.0	5.0
All-Red Time (s)	2.0	2.0	2.0	2.0	2.0	2.0	2.0	2.0	2.0	2.0	2.0	2.0
Lost Time Adjust (s)	0.0	0.0	0.0	0.0	0.0	0.0	0.0	0.0	0.0	0.0	0.0	0.0
Total Lost Time (s)	5.0	6.0	6.0	5.0	6.0	6.0	5.0	7.0	7.0	5.0	7.0	7.0
Lead/Lag	Lead	Lag	Lag	Lead	Lag	Lag	Lead	Lag	Lag	Lead	Lag	Lag
Lead-Lag Optimize?	Yes	Yes	Yes	Yes	Yes	Yes	Yes	Yes	Yes	Yes	Yes	Yes
Recall Mode	None	None	None	None	None	None	None	Max	Max	None	Max	Max
Act Effct Green (s)	16.4	7.3	7.3	16.4	7.3	7.3	64.2	55.1	55.1	66.8	58.2	58.2
Actuated g/C Ratio	0.16	0.07	0.07	0.16	0.07	0.07	0.63	0.54	0.54	0.66	0.57	0.57
v/c Ratio	0.42	0.14	0.58	0.54	0.11	0.52	0.17	0.75	0.43	0.45	0.36	0.17
Control Delay	36.7	46.6	17.6	43.9	45.9	16.9	6.4	21.7	5.5	13.6	13.1	2.4
Queue Delay	0.0	0.0	0.0	0.0	0.0	0.0	0.0	0.0	0.0	0.0	0.0	0.0
Total Delay	36.7	46.6	17.6	43.9	45.9	16.9	6.4	21.7	5.5	13.6	13.1	2.4
LOS	D	D	B	D	D	B	A	C	A	B	B	A
Approach Delay		29.7			32.3			17.5			11.3	
Approach LOS		C			C			B			B	

Intersection Summary

Cycle Length: 127
 Actuated Cycle Length: 101.4
 Natural Cycle: 60
 Control Type: Actuated-Uncoordinated
 Maximum v/c Ratio: 0.75
 Intersection Signal Delay: 18.2
 Intersection Capacity Utilization 64.2%
 Analysis Period (min) 15
 Intersection LOS: B
 ICU Level of Service C

Splits and Phases: 9: Marksheffel Rd & Meadowbrook Pkwy



Short-Term Total 12/11/2017 PM Peak Hour

Synchron to Report

Lanes, Volumes, Timings
10: Marksheffel Rd & US 24

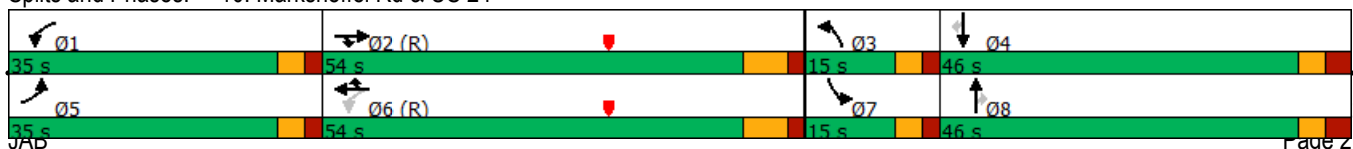
Short-Term Total
PM Peak Hour

Lane Group	EBL	EBT	EBR	WBL	WBT	WBR	NBL	NBT	NBR	SBL	SBT	SBR
Lane Configurations												
Traffic Volume (vph)	659	770	4	83	505	28	14	807	166	38	398	397
Future Volume (vph)	659	770	4	83	505	28	14	807	166	38	398	397
Satd. Flow (prot)	3433	3539	1583	1770	3539	1583	1770	3539	1583	1770	3539	1583
Flt Permitted	0.950			0.308			0.950			0.950		
Satd. Flow (perm)	3433	3539	1583	574	3539	1583	1770	3539	1583	1770	3539	1583
Satd. Flow (RTOR)			95			95			195			496
Peak Hour Factor	0.76	0.84	0.84	0.87	0.75	0.87	0.85	0.84	0.85	0.83	0.80	0.80
Shared Lane Traffic (%)												
Lane Group Flow (vph)	867	917	5	95	673	32	16	961	195	46	498	496
Turn Type	Prot	NA	Prot	pm+pt	NA	Prot	Prot	NA	Perm	Prot	NA	Perm
Protected Phases	5	2	2	1	6	6	3	8		7	4	
Permitted Phases				6					8			4
Detector Phase	5			1			3	8	8	7	4	4
Switch Phase												
Minimum Initial (s)	6.0	23.0	23.0	6.0	23.0	23.0	6.0	6.0	6.0	6.0	6.0	6.0
Minimum Split (s)	15.0	35.0	35.0	15.0	35.0	35.0	15.0	16.0	16.0	15.0	16.0	16.0
Total Split (s)	35.0	54.0	54.0	35.0	54.0	54.0	15.0	46.0	46.0	15.0	46.0	46.0
Total Split (%)	23.3%	36.0%	36.0%	23.3%	36.0%	36.0%	10.0%	30.7%	30.7%	10.0%	30.7%	30.7%
Yellow Time (s)	3.0	5.0	5.0	3.0	5.0	5.0	3.0	3.0	3.0	3.0	3.0	3.0
All-Red Time (s)	2.0	2.0	2.0	2.0	2.0	2.0	2.0	3.0	3.0	2.0	3.0	3.0
Lost Time Adjust (s)	0.0	-2.0	-2.0	0.0	-2.0	-2.0	0.0	-1.0	1.0	0.0	-1.0	1.0
Total Lost Time (s)	5.0	5.0	5.0	5.0	5.0	5.0	5.0	5.0	7.0	5.0	5.0	7.0
Lead/Lag	Lead	Lag	Lag	Lead	Lag	Lag	Lead	Lag	Lag	Lead	Lag	Lag
Lead-Lag Optimize?												
Recall Mode	None	C-Max	C-Max	None	C-Max	C-Max	None	None	None	None	None	None
Act Effct Green (s)	33.6	72.9	72.9	58.7	49.0	49.0	7.1	41.0	39.0	8.6	47.1	45.1
Actuated g/C Ratio	0.22	0.49	0.49	0.39	0.33	0.33	0.05	0.27	0.26	0.06	0.31	0.30
v/c Ratio	1.13	0.53	0.01	0.32	0.58	0.06	0.19	0.99	0.35	0.45	0.45	0.60
Control Delay	125.3	29.3	0.0	20.4	44.5	0.2	73.6	81.3	7.3	82.1	43.0	6.8
Queue Delay	0.0	0.0	0.0	0.0	0.0	0.0	0.0	0.0	0.0	0.0	0.0	0.0
Total Delay	125.3	29.3	0.0	20.4	44.5	0.2	73.6	81.3	7.3	82.1	43.0	6.8
LOS	F	C	A	C	D	A	E	F	A	F	D	A
Approach Delay		75.8			39.8			68.9			27.5	
Approach LOS		E			D			E			C	

Intersection Summary

Cycle Length: 150
 Actuated Cycle Length: 150
 Offset: 70 (47%), Referenced to phase 2:EBT and 6:WBTL, Start of FDW or yellow
 Natural Cycle: 115
 Control Type: Actuated-Coordinated
 Maximum v/c Ratio: 1.13
 Intersection Signal Delay: 57.6
 Intersection LOS: E
 Intersection Capacity Utilization 81.9%
 ICU Level of Service D
 Analysis Period (min) 15

Splits and Phases: 10: Marksheffel Rd & US 24



Lanes, Volumes, Timings
12: US 24 & Constitution Ave

Short-Term Total
PM Peak Hour

	↖	→	←	↖	↘	↙
Lane Group	EBL	EBT	WBT	WBR	SBL	SBR
Lane Configurations	↖	↕↕	↕↕	↖	↖↖	↖
Traffic Volume (vph)	71	868	418	197	324	60
Future Volume (vph)	71	868	418	197	324	60
Satd. Flow (prot)	1770	3539	3539	1583	3433	1583
Flt Permitted	0.458				0.950	
Satd. Flow (perm)	853	3539	3539	1583	3433	1583
Satd. Flow (RTOR)				229		68
Peak Hour Factor	0.84	0.84	0.91	0.86	0.83	0.88
Shared Lane Traffic (%)						
Lane Group Flow (vph)	85	1033	459	229	390	68
Turn Type	pm+pt	NA	NA	Perm	Prot	Perm
Protected Phases	5	2	6		4	
Permitted Phases	2			6		4
Detector Phase	5	2	6	6	4	4
Switch Phase						
Minimum Initial (s)	6.0	24.0	24.0	24.0	6.0	6.0
Minimum Split (s)	11.0	31.0	31.0	31.0	23.0	23.0
Total Split (s)	18.0	69.0	51.0	51.0	51.0	51.0
Total Split (%)	15.0%	57.5%	42.5%	42.5%	42.5%	42.5%
Yellow Time (s)	3.0	5.0	5.0	5.0	3.0	3.0
All-Red Time (s)	2.0	2.0	2.0	2.0	2.0	2.0
Lost Time Adjust (s)	0.0	0.0	0.0	0.0	0.0	0.0
Total Lost Time (s)	5.0	7.0	7.0	7.0	5.0	5.0
Lead/Lag	Lead		Lag	Lag		
Lead-Lag Optimize?	Yes		Yes	Yes		
Recall Mode	Min	C-Min	C-Min	C-Min	Min	Min
Act Effct Green (s)	90.8	88.8	76.7	76.7	19.2	19.2
Actuated g/C Ratio	0.76	0.74	0.64	0.64	0.16	0.16
v/c Ratio	0.12	0.39	0.20	0.21	0.71	0.22
Control Delay	4.7	6.6	9.8	1.8	54.9	11.3
Queue Delay	0.0	0.0	0.0	0.0	0.0	0.0
Total Delay	4.7	6.6	9.8	1.8	54.9	11.3
LOS	A	A	A	A	D	B
Approach Delay		6.4	7.1		48.4	
Approach LOS		A	A		D	

Intersection Summary

Cycle Length: 120
 Actuated Cycle Length: 120
 Offset: 112 (93%), Referenced to phase 2:EBTL and 6:WBT, Start of Green
 Natural Cycle: 65
 Control Type: Actuated-Coordinated
 Maximum v/c Ratio: 0.71
 Intersection Signal Delay: 15.1
 Intersection Capacity Utilization 48.4%
 Analysis Period (min) 15
 Intersection LOS: B
 ICU Level of Service A

Splits and Phases: 12: US 24 & Constitution Ave



HCM 6th TWSC
1: Meadowbrook Pkwy

Long-Term Total - Brookings Closed
AM Peak Hour




Intersection												
Int Delay, s/veh	31											
Movement	EBL	EBT	EBR	WBL	WBT	WBR	NBL	NBT	NBR	SBL	SBT	SBR
Lane Configurations		↕			↕			↕			↕	
Traffic Vol, veh/h	7	257	0	0	131	99	82	38	0	82	4	25
Future Vol, veh/h	7	257	0	0	131	99	82	38	0	82	4	25
Conflicting Peds, #/hr	0	0	0	0	0	0	0	0	0	0	0	0
Sign Control	Free	Free	Free	Free	Free	Free	Stop	Stop	Stop	Stop	Stop	Stop
RT Channelized	-	-	None	-	-	None	-	-	None	-	-	None
Storage Length	-	-	-	-	-	-	-	-	-	-	-	-
Veh in Median Storage, #	-	0	-	-	0	-	-	0	-	-	0	-
Grade, %	-	0	-	-	0	-	-	0	-	-	0	-
Peak Hour Factor	84	50	84	77	50	50	50	50	58	50	75	75
Heavy Vehicles, %	2	2	2	2	2	2	2	2	2	2	2	2
Mvmt Flow	8	514	0	0	262	198	164	76	0	164	5	33

Major/Minor	Major1			Major2			Minor1			Minor2		
Conflicting Flow All	460	0	0	514	0	0	910	990	514	929	891	361
Stage 1	-	-	-	-	-	-	530	530	-	361	361	-
Stage 2	-	-	-	-	-	-	380	460	-	568	530	-
Critical Hdwy	4.12	-	-	4.12	-	-	7.12	6.52	6.22	7.12	6.52	6.22
Critical Hdwy Stg 1	-	-	-	-	-	-	6.12	5.52	-	6.12	5.52	-
Critical Hdwy Stg 2	-	-	-	-	-	-	6.12	5.52	-	6.12	5.52	-
Follow-up Hdwy	2.218	-	-	2.218	-	-	3.518	4.018	3.318	3.518	4.018	3.318
Pot Cap-1 Maneuver	1101	-	-	1052	-	-	255	246	560	248	282	684
Stage 1	-	-	-	-	-	-	533	527	-	657	626	-
Stage 2	-	-	-	-	-	-	642	566	-	508	527	-
Platoon blocked, %		-	-	-	-	-						
Mov Cap-1 Maneuver	1101	-	-	1052	-	-	237	244	560	187	279	684
Mov Cap-2 Maneuver	-	-	-	-	-	-	237	244	-	187	279	-
Stage 1	-	-	-	-	-	-	528	522	-	650	626	-
Stage 2	-	-	-	-	-	-	606	566	-	430	522	-

Approach	EB	WB	NB	SB
HCM Control Delay, s	0.1	0	103.5	95.4
HCM LOS			F	F

Minor Lane/Major Mvmt	NBLn1	EBL	EBT	EBR	WBL	WBT	WBR	SBLn1
Capacity (veh/h)	239	1101	-	-	1052	-	-	214
HCM Lane V/C Ratio	1.004	0.008	-	-	-	-	-	0.947
HCM Control Delay (s)	103.5	8.3	0	-	0	-	-	95.4
HCM Lane LOS	F	A	A	-	A	-	-	F
HCM 95th %tile Q(veh)	9.6	0	-	-	0	-	-	8

Intersection	
Intersection Delay, s/veh	79.2
Intersection LOS	F

Movement	WBL	WBR	NBT	NBR	SBL	SBT
Lane Configurations						
Traffic Vol, veh/h	202	105	242	0	2	29
Future Vol, veh/h	202	105	242	0	2	29
Peak Hour Factor	0.40	0.40	0.50	0.50	0.86	0.86
Heavy Vehicles, %	2	2	2	2	2	2
Mvmt Flow	505	263	484	0	2	34
Number of Lanes	1	0	1	0	0	1

Approach	WB	NB	SB
Opposing Approach		SB	NB
Opposing Lanes	0	1	1
Conflicting Approach Left	NB		WB
Conflicting Lanes Left	1	0	1
Conflicting Approach Right	SB	WB	
Conflicting Lanes Right	1	1	0
HCM Control Delay	113.9	29.2	10.8
HCM LOS	F	D	B

Lane	NBLn1	WBLn1	SBLn1
Vol Left, %	0%	66%	6%
Vol Thru, %	100%	0%	94%
Vol Right, %	0%	34%	0%
Sign Control	Stop	Stop	Stop
Traffic Vol by Lane	242	307	31
LT Vol	0	202	2
Through Vol	242	0	29
RT Vol	0	105	0
Lane Flow Rate	484	768	36
Geometry Grp	1	1	1
Degree of Util (X)	0.792	1.173	0.067
Departure Headway (Hd)	6.338	5.501	7.318
Convergence, Y/N	Yes	Yes	Yes
Cap	576	668	492
Service Time	4.338	3.501	5.318
HCM Lane V/C Ratio	0.84	1.15	0.073
HCM Control Delay	29.2	113.9	10.8
HCM Lane LOS	D	F	B
HCM 95th-tile Q	7.6	25.5	0.2

Intersection						
Int Delay, s/veh	4.2					
Movement	EBL	EBT	WBT	WBR	SBL	SBR
Lane Configurations		↕	↕		↕	
Traffic Vol, veh/h	30	332	11	20	67	13
Future Vol, veh/h	30	332	11	20	67	13
Conflicting Peds, #/hr	0	0	0	0	0	0
Sign Control	Free	Free	Free	Free	Stop	Stop
RT Channelized	-	None	-	None	-	None
Storage Length	-	-	-	-	0	-
Veh in Median Storage, #	-	0	0	-	0	-
Grade, %	-	0	0	-	0	-
Peak Hour Factor	50	50	48	48	50	63
Heavy Vehicles, %	2	2	2	2	2	2
Mvmt Flow	60	664	23	42	134	21

Major/Minor	Major1	Major2	Minor2		
Conflicting Flow All	65	0	-	0	828 44
Stage 1	-	-	-	-	44 -
Stage 2	-	-	-	-	784 -
Critical Hdwy	4.12	-	-	-	6.42 6.22
Critical Hdwy Stg 1	-	-	-	-	5.42 -
Critical Hdwy Stg 2	-	-	-	-	5.42 -
Follow-up Hdwy	2.218	-	-	-	3.518 3.318
Pot Cap-1 Maneuver	1537	-	-	-	341 1026
Stage 1	-	-	-	-	978 -
Stage 2	-	-	-	-	450 -
Platoon blocked, %		-	-	-	
Mov Cap-1 Maneuver	1537	-	-	-	320 1026
Mov Cap-2 Maneuver	-	-	-	-	320 -
Stage 1	-	-	-	-	917 -
Stage 2	-	-	-	-	450 -

Approach	EB	WB	SB
HCM Control Delay, s	0.6	0	23
HCM LOS			C

Minor Lane/Major Mvmt	EBL	EBT	WBT	WBR	SBLn1
Capacity (veh/h)	1537	-	-	-	352
HCM Lane V/C Ratio	0.039	-	-	-	0.439
HCM Control Delay (s)	7.4	0	-	-	23
HCM Lane LOS	A	A	-	-	C
HCM 95th %tile Q(veh)	0.1	-	-	-	2.2

HCM 6th TWSC
4: Pinyon Jay Dr & Meadowbrook Pkwy

Long-Term Total - Brookings Closed
AM Peak Hour

Intersection												
Int Delay, s/veh	17											
Movement	EBL	EBT	EBR	WBL	WBT	WBR	NBL	NBT	NBR	SBL	SBT	SBR
Lane Configurations		↕	↗		↕			↕			↕	
Traffic Vol, veh/h	1	104	296	33	14	0	17	12	6	0	106	0
Future Vol, veh/h	1	104	296	33	14	0	17	12	6	0	106	0
Conflicting Peds, #/hr	0	0	0	0	0	0	0	0	0	0	0	0
Sign Control	Free	Free	Free	Free	Free	Free	Stop	Stop	Stop	Stop	Stop	Stop
RT Channelized	-	-	None	-	-	None	-	-	None	-	-	None
Storage Length	-	-	50	-	-	-	-	-	-	-	-	-
Veh in Median Storage, #	-	0	-	-	0	-	-	0	-	-	0	-
Grade, %	-	0	-	-	0	-	-	0	-	-	0	-
Peak Hour Factor	75	50	50	50	61	61	45	45	45	58	50	58
Heavy Vehicles, %	2	2	2	2	2	2	2	2	2	2	2	2
Mvmt Flow	1	208	592	66	23	0	38	27	13	0	212	0

Major/Minor	Major1			Major2			Minor1			Minor2		
Conflicting Flow All	23	0	0	800	0	0	471	365	208	681	957	23
Stage 1	-	-	-	-	-	-	210	210	-	155	155	-
Stage 2	-	-	-	-	-	-	261	155	-	526	802	-
Critical Hdwy	4.12	-	-	4.12	-	-	7.12	6.52	6.22	7.12	6.52	6.22
Critical Hdwy Stg 1	-	-	-	-	-	-	6.12	5.52	-	6.12	5.52	-
Critical Hdwy Stg 2	-	-	-	-	-	-	6.12	5.52	-	6.12	5.52	-
Follow-up Hdwy	2.218	-	-	2.218	-	-	3.518	4.018	3.318	3.518	4.018	3.318
Pot Cap-1 Maneuver	1592	-	-	823	-	-	503	563	832	364	258	1054
Stage 1	-	-	-	-	-	-	792	728	-	847	769	-
Stage 2	-	-	-	-	-	-	744	769	-	535	396	-
Platoon blocked, %	-	-	-	-	-	-	-	-	-	-	-	-
Mov Cap-1 Maneuver	1592	-	-	823	-	-	110	517	832	323	237	1054
Mov Cap-2 Maneuver	-	-	-	-	-	-	110	517	-	323	237	-
Stage 1	-	-	-	-	-	-	791	727	-	846	707	-
Stage 2	-	-	-	-	-	-	479	707	-	507	396	-

Approach	EB			WB			NB			SB		
HCM Control Delay, s	0			7.2			36.8			78.2		
HCM LOS							E			F		

Minor Lane/Major Mvmt	NBLn1	EBL	EBT	EBR	WBL	WBT	WBR	SBLn1
Capacity (veh/h)	189	1592	-	-	823	-	-	237
HCM Lane V/C Ratio	0.412	0.001	-	-	0.08	-	-	0.895
HCM Control Delay (s)	36.8	7.3	0	-	9.8	0	-	78.2
HCM Lane LOS	E	A	A	-	A	A	-	F
HCM 95th %tile Q(veh)	1.9	0	-	-	0.3	-	-	7.5

Intersection												
Int Delay, s/veh	20.6											
Movement	EBL	EBT	EBR	WBL	WBT	WBR	NBL	NBT	NBR	SBL	SBT	SBR
Lane Configurations		↗			↖		↖			↗	↗	
Traffic Vol, veh/h	0	69	1	4	3	0	1	0	0	27	106	299
Future Vol, veh/h	0	69	1	4	3	0	1	0	0	27	106	299
Conflicting Peds, #/hr	0	0	0	0	0	0	0	0	0	0	0	0
Sign Control	Free	Free	Free	Free	Free	Free	Stop	Stop	Stop	Stop	Stop	Stop
RT Channelized	-	-	None	-	-	None	-	-	None	-	-	None
Storage Length	-	-	-	-	-	-	0	-	-	0	-	-
Veh in Median Storage, #	-	0	-	-	0	-	-	0	-	-	0	-
Grade, %	-	0	-	-	0	-	-	0	-	-	0	-
Peak Hour Factor	50	50	50	88	88	88	25	25	25	50	50	50
Heavy Vehicles, %	2	2	2	2	2	2	2	2	2	2	2	2
Mvmt Flow	0	138	2	5	3	0	4	0	0	54	212	598

Major/Minor	Major1			Major2			Minor1			Minor2		
Conflicting Flow All	-	0	0	140	0	0	557	-	-	152	153	3
Stage 1	-	-	-	-	-	-	139	-	-	13	13	-
Stage 2	-	-	-	-	-	-	418	-	-	139	140	-
Critical Hdwy	-	-	-	4.12	-	-	7.12	-	-	7.12	6.52	6.22
Critical Hdwy Stg 1	-	-	-	-	-	-	6.12	-	-	6.12	5.52	-
Critical Hdwy Stg 2	-	-	-	-	-	-	6.12	-	-	6.12	5.52	-
Follow-up Hdwy	-	-	-	2.218	-	-	3.518	-	-	3.518	4.018	3.318
Pot Cap-1 Maneuver	0	-	-	1443	-	0	441	0	0	815	739	1081
Stage 1	0	-	-	-	-	0	864	0	0	1007	885	-
Stage 2	0	-	-	-	-	0	612	0	0	864	781	-
Platoon blocked, %	-	-	-	-	-	-	-	-	-	-	-	-
Mov Cap-1 Maneuver	-	-	-	1443	-	-	153	-	-	813	737	1081
Mov Cap-2 Maneuver	-	-	-	-	-	-	153	-	-	813	737	-
Stage 1	-	-	-	-	-	-	864	-	-	1007	882	-
Stage 2	-	-	-	-	-	-	207	-	-	864	781	-

Approach	EB			WB			NB			SB		
HCM Control Delay, s	0			4.3			29.2			24		
HCM LOS							D			C		

Minor Lane/Major Mvmt	NBLn1	EBT	EBR	WBL	WBT	SBLn1	SBLn2
Capacity (veh/h)	153	-	-	1443	-	813	963
HCM Lane V/C Ratio	0.026	-	-	0.003	-	0.066	0.841
HCM Control Delay (s)	29.2	-	-	7.5	0	9.7	24.9
HCM Lane LOS	D	-	-	A	A	A	C
HCM 95th %tile Q(veh)	0.1	-	-	0	-	0.2	10.3

Intersection						
Int Delay, s/veh	9					
Movement	EBL	EBR	NBL	NBT	SBT	SBR
Lane Configurations						
Traffic Vol, veh/h	97	3	1	1	12	4
Future Vol, veh/h	97	3	1	1	12	4
Conflicting Peds, #/hr	0	0	0	0	0	0
Sign Control	Stop	Stop	Free	Free	Free	Free
RT Channelized	-	None	-	None	-	None
Storage Length	0	-	-	-	-	-
Veh in Median Storage, #	0	-	-	0	0	-
Grade, %	0	-	-	0	0	-
Peak Hour Factor	38	38	50	50	57	57
Heavy Vehicles, %	2	2	2	2	2	2
Mvmt Flow	255	8	2	2	21	7

Major/Minor	Minor2	Major1		Major2	
Conflicting Flow All	31	25	28	0	0
Stage 1	25	-	-	-	-
Stage 2	6	-	-	-	-
Critical Hdwy	6.42	6.22	4.12	-	-
Critical Hdwy Stg 1	5.42	-	-	-	-
Critical Hdwy Stg 2	5.42	-	-	-	-
Follow-up Hdwy	3.518	3.318	2.218	-	-
Pot Cap-1 Maneuver	983	1051	1585	-	-
Stage 1	998	-	-	-	-
Stage 2	1017	-	-	-	-
Platoon blocked, %				-	-
Mov Cap-1 Maneuver	982	1051	1585	-	-
Mov Cap-2 Maneuver	982	-	-	-	-
Stage 1	997	-	-	-	-
Stage 2	1017	-	-	-	-

Approach	EB	NB	SB
HCM Control Delay, s	10	3.6	0
HCM LOS	B		

Minor Lane/Major Mvmt	NBL	NBT	EBLn1	SBT	SBR
Capacity (veh/h)	1585	-	984	-	-
HCM Lane V/C Ratio	0.001	-	0.267	-	-
HCM Control Delay (s)	7.3	0	10	-	-
HCM Lane LOS	A	A	B	-	-
HCM 95th %tile Q(veh)	0	-	1.1	-	-

Intersection						
Int Delay, s/veh	10.8					
Movement	EBT	EBR	WBL	WBT	NBL	NBR
Lane Configurations	↑↑	↑	↑	↑↑	↑	↑
Traffic Vol, veh/h	455	199	5	957	166	15
Future Vol, veh/h	455	199	5	957	166	15
Conflicting Peds, #/hr	0	0	0	0	0	0
Sign Control	Free	Free	Free	Free	Stop	Stop
RT Channelized	-	None	-	None	-	None
Storage Length	-	300	450	-	0	-
Veh in Median Storage, #	0	-	-	0	0	-
Grade, %	0	-	-	0	0	-
Peak Hour Factor	88	50	91	86	80	92
Heavy Vehicles, %	2	2	2	2	2	2
Mvmt Flow	517	398	5	1113	208	16

Major/Minor	Major1	Major2	Minor1	Minor2	Minor3
Conflicting Flow All	0	0	915	0	1084
Stage 1	-	-	-	-	517
Stage 2	-	-	-	-	567
Critical Hdwy	-	-	4.14	-	6.84
Critical Hdwy Stg 1	-	-	-	-	5.84
Critical Hdwy Stg 2	-	-	-	-	5.84
Follow-up Hdwy	-	-	2.22	-	3.52
Pot Cap-1 Maneuver	-	-	741	-	211
Stage 1	-	-	-	-	563
Stage 2	-	-	-	-	531
Platoon blocked, %	-	-	-	-	-
Mov Cap-1 Maneuver	-	-	741	-	210
Mov Cap-2 Maneuver	-	-	-	-	210
Stage 1	-	-	-	-	563
Stage 2	-	-	-	-	527

Approach	EB	WB	NB
HCM Control Delay, s	0	0	108.8
HCM LOS			F

Minor Lane/Major Mvmt	NBLn1	EBT	EBR	WBL	WBT
Capacity (veh/h)	222	-	-	741	-
HCM Lane V/C Ratio	1.008	-	-	0.007	-
HCM Control Delay (s)	108.8	-	-	9.9	-
HCM Lane LOS	F	-	-	A	-
HCM 95th %tile Q(veh)	9.3	-	-	0	-

Intersection						
Int Delay, s/veh	40.6					
Movement	EBL	EBR	NBL	NBT	SBT	SBR
Lane Configurations	↖	↗	↖	↕↕	↕↕	↗
Traffic Vol, veh/h	122	100	45	840	445	25
Future Vol, veh/h	122	100	45	840	445	25
Conflicting Peds, #/hr	0	0	0	0	0	0
Sign Control	Stop	Stop	Free	Free	Free	Free
RT Channelized	-	None	-	None	-	None
Storage Length	0	50	-	-	-	250
Veh in Median Storage, #	0	-	-	0	0	-
Grade, %	0	-	-	0	0	-
Peak Hour Factor	50	69	50	89	79	79
Heavy Vehicles, %	2	2	2	2	2	2
Mvmt Flow	244	145	90	944	563	32

Major/Minor	Minor2	Major1	Major2			
Conflicting Flow All	1215	282	595	0	-	0
Stage 1	563	-	-	-	-	-
Stage 2	652	-	-	-	-	-
Critical Hdwy	6.84	6.94	4.14	-	-	-
Critical Hdwy Stg 1	5.84	-	-	-	-	-
Critical Hdwy Stg 2	5.84	-	-	-	-	-
Follow-up Hdwy	3.52	3.32	2.22	-	-	-
Pot Cap-1 Maneuver	~ 174	715	977	-	-	-
Stage 1	534	-	-	-	-	-
Stage 2	480	-	-	-	-	-
Platoon blocked, %				-	-	-
Mov Cap-1 Maneuver	~ 158	715	977	-	-	-
Mov Cap-2 Maneuver	~ 158	-	-	-	-	-
Stage 1	485	-	-	-	-	-
Stage 2	480	-	-	-	-	-

Approach	EB	NB	SB
HCM Control Delay, s	208.6	0.8	0
HCM LOS	F		

Minor Lane/Major Mvmt	NBL	NBT	EBLn1	EBLn2	SBT	SBR
Capacity (veh/h)	977	-	158	715	-	-
HCM Lane V/C Ratio	0.092	-	1.544	0.203	-	-
HCM Control Delay (s)	9.1	-	\$ 325.8	11.3	-	-
HCM Lane LOS	A	-	F	B	-	-
HCM 95th %tile Q(veh)	0.3	-	16.3	0.8	-	-

Notes
 ~: Volume exceeds capacity \$: Delay exceeds 300s +: Computation Not Defined *: All major volume in platoon

Intersection						
Int Delay, s/veh	1.3					
Movement	EBL	EBR	NBL	NBT	SBT	SBR
Lane Configurations	Y			4	4	
Traffic Vol, veh/h	0	0	68	31	16	429
Future Vol, veh/h	0	0	68	31	16	429
Conflicting Peds, #/hr	0	0	0	0	0	0
Sign Control	Stop	Stop	Free	Free	Free	Free
RT Channelized	-	None	-	None	-	None
Storage Length	0	-	-	-	-	-
Veh in Median Storage, #	0	-	-	0	0	-
Grade, %	0	-	-	0	0	-
Peak Hour Factor	25	25	50	50	50	50
Heavy Vehicles, %	2	2	2	2	2	2
Mvmt Flow	0	0	136	62	32	858

Major/Minor	Minor2	Major1	Major2			
Conflicting Flow All	795	461	890	0	-	0
Stage 1	461	-	-	-	-	-
Stage 2	334	-	-	-	-	-
Critical Hdwy	6.42	6.22	4.12	-	-	-
Critical Hdwy Stg 1	5.42	-	-	-	-	-
Critical Hdwy Stg 2	5.42	-	-	-	-	-
Follow-up Hdwy	3.518	3.318	2.218	-	-	-
Pot Cap-1 Maneuver	357	600	761	-	-	-
Stage 1	635	-	-	-	-	-
Stage 2	725	-	-	-	-	-
Platoon blocked, %				-	-	-
Mov Cap-1 Maneuver	291	600	761	-	-	-
Mov Cap-2 Maneuver	402	-	-	-	-	-
Stage 1	518	-	-	-	-	-
Stage 2	725	-	-	-	-	-

Approach	EB	NB	SB
HCM Control Delay, s	0	7.4	0
HCM LOS	A		

Minor Lane/Major Mvmt	NBL	NBT	EBLn1	SBT	SBR
Capacity (veh/h)	761	-	-	-	-
HCM Lane V/C Ratio	0.179	-	-	-	-
HCM Control Delay (s)	10.8	0	0	-	-
HCM Lane LOS	B	A	A	-	-
HCM 95th %tile Q(veh)	0.6	-	-	-	-

Lanes, Volumes, Timings
 9: Marksheffel Rd & Meadowbrook Pkwy

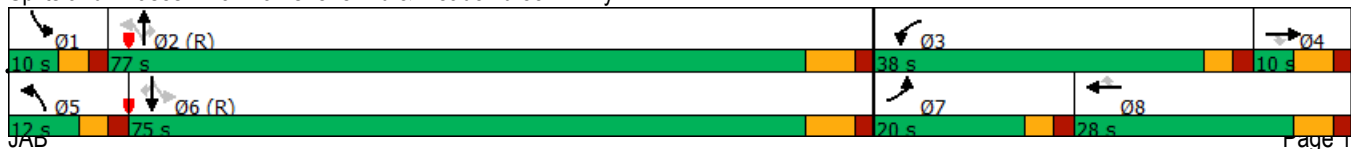
Long-Term Total - Brookings Closed
 AM Peak Hour

Lane Group	EBL	EBT	EBR	WBL	WBT	WBR	NBL	NBT	NBR	SBL	SBT	SBR
Lane Configurations												
Traffic Volume (vph)	143	5	64	368	14	102	128	900	257	78	2000	231
Future Volume (vph)	143	5	64	368	14	102	128	900	257	78	2000	231
Satd. Flow (prot)	3433	1863	1583	3433	1863	1583	1770	3539	1583	1770	5085	1583
Flt Permitted	0.950			0.950			0.057			0.221		
Satd. Flow (perm)	3433	1863	1583	3433	1863	1583	106	3539	1583	412	5085	1583
Satd. Flow (RTOR)			154			150			514			221
Peak Hour Factor	0.78	0.78	0.78	0.50	0.78	0.68	0.92	0.92	0.50	0.50	0.90	0.90
Shared Lane Traffic (%)												
Lane Group Flow (vph)	183	6	82	736	18	150	139	978	514	156	2222	257
Turn Type	Prot	NA	Perm	Prot	NA	Perm	pm+pt	NA	Perm	pm+pt	NA	Perm
Protected Phases	7	4		3	8		5	2		1	6	
Permitted Phases			4			8	2		2	6		6
Detector Phase	7	4	4	3	8	8	5	2	2	1	6	6
Switch Phase												
Minimum Initial (s)	4.0	4.0	4.0	4.0	4.0	4.0	4.0	4.0	4.0	4.0	4.0	4.0
Minimum Split (s)	9.0	10.0	10.0	9.0	10.0	10.0	9.0	11.0	11.0	9.0	11.0	11.0
Total Split (s)	20.0	10.0	10.0	38.0	28.0	28.0	12.0	77.0	77.0	10.0	75.0	75.0
Total Split (%)	14.8%	7.4%	7.4%	28.1%	20.7%	20.7%	8.9%	57.0%	57.0%	7.4%	55.6%	55.6%
Yellow Time (s)	3.0	4.0	4.0	3.0	4.0	4.0	3.0	5.0	5.0	3.0	5.0	5.0
All-Red Time (s)	2.0	2.0	2.0	2.0	2.0	2.0	2.0	2.0	2.0	2.0	2.0	2.0
Lost Time Adjust (s)	0.0	0.0	0.0	0.0	0.0	0.0	0.0	0.0	0.0	0.0	0.0	0.0
Total Lost Time (s)	5.0	6.0	6.0	5.0	6.0	6.0	5.0	7.0	7.0	5.0	7.0	7.0
Lead/Lag	Lead	Lag	Lag	Lead	Lag	Lag	Lead	Lag	Lag	Lead	Lag	Lag
Lead-Lag Optimize?	Yes	Yes	Yes	Yes	Yes	Yes	Yes	Yes	Yes	Yes	Yes	Yes
Recall Mode	None	None	None	None	None	None	None	C-Max	C-Max	None	C-Max	C-Max
Act Effct Green (s)	12.3	4.6	4.6	31.7	24.0	24.0	79.9	70.2	70.2	75.6	68.0	68.0
Actuated g/C Ratio	0.09	0.03	0.03	0.23	0.18	0.18	0.59	0.52	0.52	0.56	0.50	0.50
v/c Ratio	0.59	0.10	0.41	0.91	0.05	0.37	0.89	0.53	0.48	0.55	0.87	0.28
Control Delay	66.4	67.2	6.0	66.8	47.6	10.1	74.5	22.9	3.0	20.9	34.1	4.4
Queue Delay	0.0	0.0	0.0	0.0	0.0	0.0	0.0	0.0	0.0	0.0	0.0	0.0
Total Delay	66.4	67.2	6.0	66.8	47.6	10.1	74.5	22.9	3.0	20.9	34.1	4.4
LOS	E	E	A	E	D	B	E	C	A	C	C	A
Approach Delay		48.1			57.0			21.0			30.5	
Approach LOS		D			E			C			C	

Intersection Summary

Cycle Length: 135
 Actuated Cycle Length: 135
 Offset: 0 (0%), Referenced to phase 2:NBTL and 6:SBTL, Start of Green
 Natural Cycle: 90
 Control Type: Actuated-Coordinated
 Maximum v/c Ratio: 0.91
 Intersection Signal Delay: 32.9
 Intersection LOS: C
 Intersection Capacity Utilization 77.9%
 ICU Level of Service D
 Analysis Period (min) 15

Splits and Phases: 9: Marksheffel Rd & Meadowbrook Pkwy



Lanes, Volumes, Timings
10: Marksheffel Rd & US 24

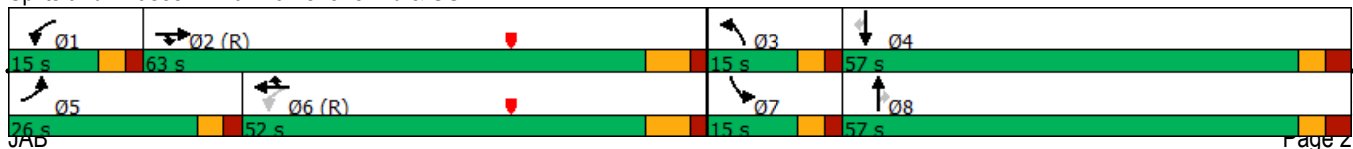
Long-Term Total - Brookings Closed
AM Peak Hour

Lane Group	EBL	EBT	EBR	WBL	WBT	WBR	NBL	NBT	NBR	SBL	SBT	SBR
Lane Configurations												
Traffic Volume (vph)	514	800	5	85	1915	485	5	580	220	10	1301	1121
Future Volume (vph)	514	800	5	85	1915	485	5	580	220	10	1301	1121
Satd. Flow (prot)	3433	5085	1583	3433	5085	1583	1770	3539	1583	1770	3539	1583
Flt Permitted	0.950			0.314			0.950			0.950		
Satd. Flow (perm)	3433	5085	1583	1135	5085	1583	1770	3539	1583	1770	3539	1583
Satd. Flow (RTOR)			95			200			239			386
Peak Hour Factor	0.72	0.92	0.92	0.89	0.89	0.89	0.92	0.88	0.92	0.86	0.85	0.79
Shared Lane Traffic (%)												
Lane Group Flow (vph)	714	870	5	96	2152	545	5	659	239	12	1531	1419
Turn Type	Prot	NA	Prot	pm+pt	NA	Prot	Prot	NA	Perm	Prot	NA	Perm
Protected Phases	5	2	2	1	6	6	3	8		7	4	
Permitted Phases				6					8			4
Detector Phase	5			1			3	8	8	7	4	4
Switch Phase												
Minimum Initial (s)	6.0	23.0	23.0	6.0	23.0	23.0	6.0	6.0	6.0	6.0	6.0	6.0
Minimum Split (s)	15.0	35.0	35.0	15.0	35.0	35.0	15.0	16.0	16.0	15.0	16.0	16.0
Total Split (s)	26.0	63.0	63.0	15.0	52.0	52.0	15.0	57.0	57.0	15.0	57.0	57.0
Total Split (%)	17.3%	42.0%	42.0%	10.0%	34.7%	34.7%	10.0%	38.0%	38.0%	10.0%	38.0%	38.0%
Yellow Time (s)	3.0	5.0	5.0	3.0	5.0	5.0	3.0	3.0	3.0	3.0	3.0	3.0
All-Red Time (s)	2.0	2.0	2.0	2.0	2.0	2.0	2.0	3.0	3.0	2.0	3.0	3.0
Lost Time Adjust (s)	0.0	-2.0	-2.0	0.0	-2.0	-2.0	0.0	-1.0	1.0	0.0	-1.0	1.0
Total Lost Time (s)	5.0	5.0	5.0	5.0	5.0	5.0	5.0	5.0	7.0	5.0	5.0	7.0
Lead/Lag	Lead	Lag	Lag	Lead	Lag	Lag	Lead	Lag	Lag	Lead	Lag	Lag
Lead-Lag Optimize?												
Recall Mode	None	C-Max	C-Max	None	C-Max	C-Max	None	None	None	None	None	None
Act Effct Green (s)	33.6	73.0	73.0	54.6	47.0	47.0	6.3	49.3	47.3	6.8	52.0	50.0
Actuated g/C Ratio	0.22	0.49	0.49	0.36	0.31	0.31	0.04	0.33	0.32	0.05	0.35	0.33
v/c Ratio	0.93	0.35	0.01	0.18	1.35	0.86	0.07	0.57	0.36	0.15	1.25	1.81
Control Delay	75.2	25.0	0.0	19.1	201.9	44.9	70.8	44.3	6.0	72.6	159.9	391.1
Queue Delay	0.0	0.0	0.0	0.0	0.0	0.0	0.0	0.0	0.0	0.0	0.0	0.0
Total Delay	75.2	25.0	0.0	19.1	201.9	44.9	70.8	44.3	6.0	72.6	159.9	391.1
LOS	E	C	A	B	F	D	E	D	A	E	F	F
Approach Delay		47.5			165.0			34.3			270.3	
Approach LOS		D			F			C			F	

Intersection Summary

Cycle Length: 150
 Actuated Cycle Length: 150
 Offset: 49 (33%), Referenced to phase 2:EBT and 6:WBTL, Start of FDW or yellow
 Natural Cycle: 145
 Control Type: Actuated-Coordinated
 Maximum v/c Ratio: 1.81
 Intersection Signal Delay: 165.8
 Intersection LOS: F
 Intersection Capacity Utilization 125.6%
 ICU Level of Service H
 Analysis Period (min) 15

Splits and Phases: 10: Marksheffel Rd & US 24



Lanes, Volumes, Timings
12: US 24 & Constitution Ave

Long-Term Total - Brookings Closed
AM Peak Hour

	↖	→	←	↗	↘	↙
Lane Group	EBL	EBT	WBT	WBR	SBL	SBR
Lane Configurations	↖↖	↖↖↖	↖↖↖	↖	↖↖	↖
Traffic Volume (vph)	175	855	2235	710	295	250
Future Volume (vph)	175	855	2235	710	295	250
Satd. Flow (prot)	3433	5085	5085	1583	3433	1583
Flt Permitted	0.050				0.950	
Satd. Flow (perm)	181	5085	5085	1583	3433	1583
Satd. Flow (RTOR)				789		126
Peak Hour Factor	0.85	0.85	0.94	0.90	0.82	0.88
Shared Lane Traffic (%)						
Lane Group Flow (vph)	206	1006	2378	789	360	284
Turn Type	pm+pt	NA	NA	Perm	Prot	Perm
Protected Phases	5	2	6		4	
Permitted Phases	2			6		4
Detector Phase	5	2	6	6	4	4
Switch Phase						
Minimum Initial (s)	6.0	24.0	24.0	24.0	6.0	6.0
Minimum Split (s)	11.0	31.0	31.0	31.0	23.0	23.0
Total Split (s)	13.0	82.0	69.0	69.0	38.0	38.0
Total Split (%)	10.8%	68.3%	57.5%	57.5%	31.7%	31.7%
Yellow Time (s)	3.0	5.0	5.0	5.0	3.0	3.0
All-Red Time (s)	2.0	2.0	2.0	2.0	2.0	2.0
Lost Time Adjust (s)	0.0	0.0	0.0	0.0	0.0	0.0
Total Lost Time (s)	5.0	7.0	7.0	7.0	5.0	5.0
Lead/Lag	Lead		Lag	Lag		
Lead-Lag Optimize?	Yes		Yes	Yes		
Recall Mode	Min	C-Min	C-Min	C-Min	Min	Min
Act Effct Green (s)	90.1	88.1	75.0	75.0	19.9	19.9
Actuated g/C Ratio	0.75	0.73	0.62	0.62	0.17	0.17
v/c Ratio	0.58	0.27	0.75	0.61	0.63	0.77
Control Delay	21.5	6.0	19.1	3.3	51.0	40.1
Queue Delay	0.0	0.0	0.0	0.0	0.0	0.0
Total Delay	21.5	6.0	19.1	3.3	51.0	40.1
LOS	C	A	B	A	D	D
Approach Delay		8.6	15.2		46.2	
Approach LOS		A	B		D	

Intersection Summary

Cycle Length: 120
 Actuated Cycle Length: 120
 Offset: 20 (17%), Referenced to phase 2:EBTL and 6:WBT, Start of Green
 Natural Cycle: 80
 Control Type: Actuated-Coordinated
 Maximum v/c Ratio: 0.77
 Intersection Signal Delay: 17.6
 Intersection Capacity Utilization 70.8%
 Analysis Period (min) 15
 Intersection LOS: B
 ICU Level of Service C

Splits and Phases: 12: US 24 & Constitution Ave



Lanes, Volumes, Timings
 9: Marksheffel Rd & Meadowbrook Pkwy

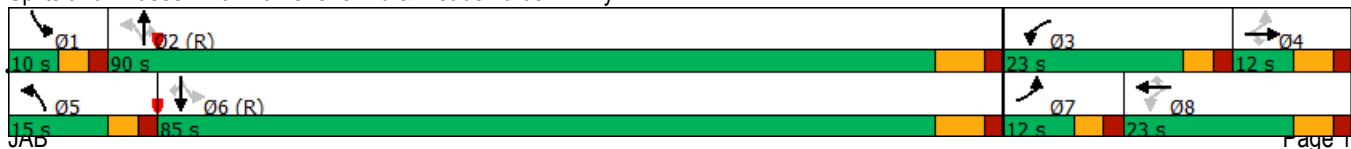
Long-Term Total - Brookings Open
 AM Peak Hour

Lane Group	EBL	EBT	EBR	WBL	WBT	WBR	NBL	NBT	NBR	SBL	SBT	SBR
Lane Configurations												
Traffic Volume (vph)	143	5	64	143	14	102	128	900	257	78	2000	231
Future Volume (vph)	143	5	64	143	14	102	128	900	257	78	2000	231
Satd. Flow (prot)	3433	1863	1583	1770	1863	1583	1770	3539	1583	1770	5085	1583
Flt Permitted	0.746			0.405			0.048			0.257		
Satd. Flow (perm)	2696	1863	1583	754	1863	1583	89	3539	1583	479	5085	1583
Satd. Flow (RTOR)			154			150			514			257
Peak Hour Factor	0.78	0.78	0.78	0.69	0.78	0.68	0.92	0.92	0.50	0.50	0.90	0.90
Shared Lane Traffic (%)												
Lane Group Flow (vph)	183	6	82	207	18	150	139	978	514	156	2222	257
Turn Type	pm+pt	NA	Perm	pm+pt	NA	Perm	pm+pt	NA	Perm	pm+pt	NA	Perm
Protected Phases	7	4		3	8		5	2		1	6	
Permitted Phases	4		4	8		8	2		2	6		6
Detector Phase	7	4	4	3	8	8	5	2	2	1	6	6
Switch Phase												
Minimum Initial (s)	4.0	4.0	4.0	4.0	4.0	4.0	4.0	4.0	4.0	4.0	4.0	4.0
Minimum Split (s)	9.0	10.0	10.0	9.0	10.0	10.0	9.0	11.0	11.0	9.0	11.0	11.0
Total Split (s)	12.0	12.0	12.0	23.0	23.0	23.0	15.0	90.0	90.0	10.0	85.0	85.0
Total Split (%)	8.9%	8.9%	8.9%	17.0%	17.0%	17.0%	11.1%	66.7%	66.7%	7.4%	63.0%	63.0%
Yellow Time (s)	3.0	4.0	4.0	3.0	4.0	4.0	3.0	5.0	5.0	3.0	5.0	5.0
All-Red Time (s)	2.0	2.0	2.0	2.0	2.0	2.0	2.0	2.0	2.0	2.0	2.0	2.0
Lost Time Adjust (s)	0.0	0.0	0.0	0.0	0.0	0.0	0.0	0.0	0.0	0.0	0.0	0.0
Total Lost Time (s)	5.0	6.0	6.0	5.0	6.0	6.0	5.0	7.0	7.0	5.0	7.0	7.0
Lead/Lag	Lead	Lag	Lag	Lead	Lag	Lag	Lead	Lag	Lag	Lead	Lag	Lag
Lead-Lag Optimize?	Yes	Yes	Yes	Yes	Yes	Yes	Yes	Yes	Yes	Yes	Yes	Yes
Recall Mode	None	None	None	None	None	None	None	C-Max	C-Max	None	C-Max	C-Max
Act Effct Green (s)	13.8	5.8	5.8	28.5	15.5	15.5	95.2	83.7	83.7	87.8	80.1	80.1
Actuated g/C Ratio	0.10	0.04	0.04	0.21	0.11	0.11	0.71	0.62	0.62	0.65	0.59	0.59
v/c Ratio	0.58	0.08	0.38	0.73	0.08	0.48	0.77	0.45	0.44	0.43	0.74	0.25
Control Delay	53.9	64.0	5.1	62.8	53.4	13.3	55.7	14.4	2.1	10.9	22.1	2.1
Queue Delay	0.0	0.0	0.0	0.0	0.0	0.0	0.0	0.0	0.0	0.0	0.0	0.0
Total Delay	53.9	64.0	5.1	62.8	53.4	13.3	55.7	14.4	2.1	10.9	22.1	2.1
LOS	D	E	A	E	D	B	E	B	A	B	C	A
Approach Delay		39.4			42.6			14.0			19.5	
Approach LOS		D			D			B			B	

Intersection Summary

Cycle Length: 135
 Actuated Cycle Length: 135
 Offset: 118 (87%), Referenced to phase 2:NBT and 6:SBTL, Start of Green
 Natural Cycle: 65
 Control Type: Actuated-Coordinated
 Maximum v/c Ratio: 0.77
 Intersection Signal Delay: 20.5
 Intersection Capacity Utilization 75.3%
 Analysis Period (min) 15
 Intersection LOS: C
 ICU Level of Service D

Splits and Phases: 9: Marksheffel Rd & Meadowbrook Pkwy



HCM 6th TWSC
1: Meadowbrook Pkwy

Long-Term Total - Brookings Closed
PM Peak Hour

Intersection												
Int Delay, s/veh	8.5											
Movement	EBL	EBT	EBR	WBL	WBT	WBR	NBL	NBT	NBR	SBL	SBT	SBR
Lane Configurations		↕			↕			↕			↕	
Traffic Vol, veh/h	6	180	1	0	114	81	68	27	1	58	4	23
Future Vol, veh/h	6	180	1	0	114	81	68	27	1	58	4	23
Conflicting Peds, #/hr	0	0	0	0	0	0	0	0	0	0	0	0
Sign Control	Free	Free	Free	Free	Free	Free	Stop	Stop	Stop	Stop	Stop	Stop
RT Channelized	-	-	None	-	-	None	-	-	None	-	-	None
Storage Length	-	-	-	-	-	-	-	-	-	-	-	-
Veh in Median Storage, #	-	0	-	-	0	-	-	0	-	-	0	-
Grade, %	-	0	-	-	0	-	-	0	-	-	0	-
Peak Hour Factor	70	50	70	75	50	50	50	50	50	50	80	80
Heavy Vehicles, %	2	2	2	2	2	2	2	2	2	2	2	2
Mvmt Flow	9	360	1	0	228	162	136	54	2	116	5	29

Major/Minor	Major1			Major2			Minor1			Minor2		
Conflicting Flow All	390	0	0	361	0	0	705	769	361	716	688	309
Stage 1	-	-	-	-	-	-	379	379	-	309	309	-
Stage 2	-	-	-	-	-	-	326	390	-	407	379	-
Critical Hdwy	4.12	-	-	4.12	-	-	7.12	6.52	6.22	7.12	6.52	6.22
Critical Hdwy Stg 1	-	-	-	-	-	-	6.12	5.52	-	6.12	5.52	-
Critical Hdwy Stg 2	-	-	-	-	-	-	6.12	5.52	-	6.12	5.52	-
Follow-up Hdwy	2.218	-	-	2.218	-	-	3.518	4.018	3.318	3.518	4.018	3.318
Pot Cap-1 Maneuver	1169	-	-	1198	-	-	351	332	684	345	369	731
Stage 1	-	-	-	-	-	-	643	615	-	701	660	-
Stage 2	-	-	-	-	-	-	687	608	-	621	615	-
Platoon blocked, %	-	-	-	-	-	-	-	-	-	-	-	-
Mov Cap-1 Maneuver	1169	-	-	1198	-	-	331	329	684	298	365	731
Mov Cap-2 Maneuver	-	-	-	-	-	-	331	329	-	298	365	-
Stage 1	-	-	-	-	-	-	637	609	-	694	660	-
Stage 2	-	-	-	-	-	-	655	608	-	559	609	-

Approach	EB	WB	NB	SB
HCM Control Delay, s	0.2	0	29.7	23.8
HCM LOS			D	C

Minor Lane/Major Mvmt	NBLn1	EBL	EBT	EBR	WBL	WBT	WBR	SBLn1
Capacity (veh/h)	332	1169	-	-	1198	-	-	339
HCM Lane V/C Ratio	0.578	0.007	-	-	-	-	-	0.442
HCM Control Delay (s)	29.7	8.1	0	-	0	-	-	23.8
HCM Lane LOS	D	A	A	-	A	-	-	C
HCM 95th %tile Q(veh)	3.4	0	-	-	0	-	-	2.2

Intersection	
Intersection Delay, s/veh	28.3
Intersection LOS	D

Movement	WBL	WBR	NBT	NBR	SBL	SBT
Lane Configurations						
Traffic Vol, veh/h	172	88	161	51	0	18
Future Vol, veh/h	172	88	161	51	0	18
Peak Hour Factor	0.42	0.42	0.50	0.50	0.56	0.56
Heavy Vehicles, %	2	2	2	2	2	2
Mvmt Flow	410	210	322	102	0	32
Number of Lanes	1	0	1	0	0	1

Approach	WB	NB	SB
Opposing Approach		SB	NB
Opposing Lanes	0	1	1
Conflicting Approach Left	NB		WB
Conflicting Lanes Left	1	0	1
Conflicting Approach Right	SB	WB	
Conflicting Lanes Right	1	1	0
HCM Control Delay	35.9	18.7	9.9
HCM LOS	E	C	A

Lane	NBLn1	WBLn1	SBLn1
Vol Left, %	0%	66%	0%
Vol Thru, %	76%	0%	100%
Vol Right, %	24%	34%	0%
Sign Control	Stop	Stop	Stop
Traffic Vol by Lane	212	260	18
LT Vol	0	172	0
Through Vol	161	0	18
RT Vol	51	88	0
Lane Flow Rate	424	619	32
Geometry Grp	1	1	1
Degree of Util (X)	0.656	0.893	0.057
Departure Headway (Hd)	5.572	5.192	6.421
Convergence, Y/N	Yes	Yes	Yes
Cap	649	700	555
Service Time	3.618	3.23	4.492
HCM Lane V/C Ratio	0.653	0.884	0.058
HCM Control Delay	18.7	35.9	9.9
HCM Lane LOS	C	E	A
HCM 95th-tile Q	4.9	11.3	0.2

Intersection						
Int Delay, s/veh	3					
Movement	EBL	EBT	WBT	WBR	SBL	SBR
Lane Configurations		↕	↕		↕	
Traffic Vol, veh/h	19	233	11	18	50	17
Future Vol, veh/h	19	233	11	18	50	17
Conflicting Peds, #/hr	0	0	0	0	0	0
Sign Control	Free	Free	Free	Free	Stop	Stop
RT Channelized	-	None	-	None	-	None
Storage Length	-	-	-	-	0	-
Veh in Median Storage, #	-	0	0	-	0	-
Grade, %	-	0	0	-	0	-
Peak Hour Factor	50	50	71	50	50	70
Heavy Vehicles, %	2	2	2	2	2	2
Mvmt Flow	38	466	15	36	100	24

Major/Minor	Major1	Major2	Minor2		
Conflicting Flow All	51	0	-	0	575 33
Stage 1	-	-	-	-	33 -
Stage 2	-	-	-	-	542 -
Critical Hdwy	4.12	-	-	-	6.42 6.22
Critical Hdwy Stg 1	-	-	-	-	5.42 -
Critical Hdwy Stg 2	-	-	-	-	5.42 -
Follow-up Hdwy	2.218	-	-	-	3.518 3.318
Pot Cap-1 Maneuver	1555	-	-	-	480 1041
Stage 1	-	-	-	-	989 -
Stage 2	-	-	-	-	583 -
Platoon blocked, %		-	-	-	
Mov Cap-1 Maneuver	1555	-	-	-	464 1041
Mov Cap-2 Maneuver	-	-	-	-	464 -
Stage 1	-	-	-	-	956 -
Stage 2	-	-	-	-	583 -

Approach	EB	WB	SB
HCM Control Delay, s	0.6	0	14.1
HCM LOS			B

Minor Lane/Major Mvmt	EBL	EBT	WBT	WBR	SBLn1
Capacity (veh/h)	1555	-	-	-	520
HCM Lane V/C Ratio	0.024	-	-	-	0.239
HCM Control Delay (s)	7.4	0	-	-	14.1
HCM Lane LOS	A	A	-	-	B
HCM 95th %tile Q(veh)	0.1	-	-	-	0.9

HCM 6th TWSC
4: Pinyon Jay Dr & Meadowbrook Pkwy

Long-Term Total - Brookings Closed
PM Peak Hour

Intersection												
Int Delay, s/veh	5											
Movement	EBL	EBT	EBR	WBL	WBT	WBR	NBL	NBT	NBR	SBL	SBT	SBR
Lane Configurations		↕	↗		↕			↕			↕	
Traffic Vol, veh/h	3	93	186	28	14	2	15	9	7	0	65	0
Future Vol, veh/h	3	93	186	28	14	2	15	9	7	0	65	0
Conflicting Peds, #/hr	0	0	0	0	0	0	0	0	0	0	0	0
Sign Control	Free	Free	Free	Free	Free	Free	Stop	Stop	Stop	Stop	Stop	Stop
RT Channelized	-	-	None	-	-	None	-	-	None	-	-	None
Storage Length	-	-	50	-	-	-	-	-	-	-	-	-
Veh in Median Storage, #	-	0	-	-	0	-	-	0	-	-	0	-
Grade, %	-	0	-	-	0	-	-	0	-	-	0	-
Peak Hour Factor	89	50	50	50	66	66	50	50	50	50	50	50
Heavy Vehicles, %	2	2	2	2	2	2	2	2	2	2	2	2
Mvmt Flow	3	186	372	56	21	3	30	18	14	0	130	0

Major/Minor	Major1			Major2			Minor1			Minor2		
Conflicting Flow All	24	0	0	558	0	0	392	328	186	529	699	23
Stage 1	-	-	-	-	-	-	192	192	-	135	135	-
Stage 2	-	-	-	-	-	-	200	136	-	394	564	-
Critical Hdwy	4.12	-	-	4.12	-	-	7.12	6.52	6.22	7.12	6.52	6.22
Critical Hdwy Stg 1	-	-	-	-	-	-	6.12	5.52	-	6.12	5.52	-
Critical Hdwy Stg 2	-	-	-	-	-	-	6.12	5.52	-	6.12	5.52	-
Follow-up Hdwy	2.218	-	-	2.218	-	-	3.518	4.018	3.318	3.518	4.018	3.318
Pot Cap-1 Maneuver	1591	-	-	1013	-	-	567	591	856	460	364	1054
Stage 1	-	-	-	-	-	-	810	742	-	868	785	-
Stage 2	-	-	-	-	-	-	802	784	-	631	508	-
Platoon blocked, %		-	-		-	-						
Mov Cap-1 Maneuver	1591	-	-	1013	-	-	383	556	856	421	343	1054
Mov Cap-2 Maneuver	-	-	-	-	-	-	383	556	-	421	343	-
Stage 1	-	-	-	-	-	-	808	740	-	865	741	-
Stage 2	-	-	-	-	-	-	624	740	-	604	506	-

Approach	EB			WB			NB			SB		
HCM Control Delay, s	0			6.1			13.4			21.8		
HCM LOS							B			C		

Minor Lane/Major Mvmt	NBLn1	EBL	EBT	EBR	WBL	WBT	WBR	SBLn1
Capacity (veh/h)	488	1591	-	-	1013	-	-	343
HCM Lane V/C Ratio	0.127	0.002	-	-	0.055	-	-	0.379
HCM Control Delay (s)	13.4	7.3	0	-	8.8	0	-	21.8
HCM Lane LOS	B	A	A	-	A	A	-	C
HCM 95th %tile Q(veh)	0.4	0	-	-	0.2	-	-	1.7

Intersection												
Int Delay, s/veh	14.3											
Movement	EBL	EBT	EBR	WBL	WBT	WBR	NBL	NBT	NBR	SBL	SBT	SBR
Lane Configurations		↔			↔			↔		↔	↔	
Traffic Vol, veh/h	0	45	1	0	3	0	0	0	3	23	90	255
Future Vol, veh/h	0	45	1	0	3	0	0	0	3	23	90	255
Conflicting Peds, #/hr	0	0	0	0	0	0	0	0	0	0	0	0
Sign Control	Free	Free	Free	Free	Free	Free	Stop	Stop	Stop	Stop	Stop	Stop
RT Channelized	-	-	None	-	-	None	-	-	None	-	-	None
Storage Length	-	-	-	-	-	-	-	-	-	0	-	-
Veh in Median Storage, #	-	0	-	-	0	-	-	0	-	-	0	-
Grade, %	-	0	-	-	0	-	-	0	-	-	0	-
Peak Hour Factor	63	50	63	38	38	38	75	75	75	50	50	50
Heavy Vehicles, %	2	2	2	2	2	2	2	2	2	2	2	2
Mvmt Flow	0	90	2	0	8	0	0	0	4	46	180	510

Major/Minor	Major1			Major2			Minor1			Minor2		
Conflicting Flow All	-	0	0	92	0	0	444	99	91	101	100	8
Stage 1	-	-	-	-	-	-	91	91	-	8	8	-
Stage 2	-	-	-	-	-	-	353	8	-	93	92	-
Critical Hdwy	-	-	-	4.12	-	-	7.12	6.52	6.22	7.12	6.52	6.22
Critical Hdwy Stg 1	-	-	-	-	-	-	6.12	5.52	-	6.12	5.52	-
Critical Hdwy Stg 2	-	-	-	-	-	-	6.12	5.52	-	6.12	5.52	-
Follow-up Hdwy	-	-	-	2.218	-	-	3.518	4.018	3.318	3.518	4.018	3.318
Pot Cap-1 Maneuver	0	-	-	1503	-	0	524	791	967	880	790	1074
Stage 1	0	-	-	-	-	0	916	820	-	1013	889	-
Stage 2	0	-	-	-	-	0	664	889	-	914	819	-
Platoon blocked, %	-	-	-	-	-	-	-	-	-	-	-	-
Mov Cap-1 Maneuver	-	-	-	1503	-	-	227	791	967	876	790	1074
Mov Cap-2 Maneuver	-	-	-	-	-	-	227	791	-	876	790	-
Stage 1	-	-	-	-	-	-	916	820	-	1013	889	-
Stage 2	-	-	-	-	-	-	278	889	-	910	819	-

Approach	EB	WB	NB	SB
HCM Control Delay, s	0	0	8.7	16.3
HCM LOS			A	C

Minor Lane/Major Mvmt	NBLn1	EBT	EBR	WBL	WBT	SBLn1	SBLn2
Capacity (veh/h)	967	-	-	1503	-	876	982
HCM Lane V/C Ratio	0.004	-	-	-	-	0.053	0.703
HCM Control Delay (s)	8.7	-	-	0	-	9.3	16.8
HCM Lane LOS	A	-	-	A	-	A	C
HCM 95th %tile Q(veh)	0	-	-	0	-	0.2	6.1

Intersection						
Int Delay, s/veh	7.7					
Movement	EBL	EBR	NBL	NBT	SBT	SBR
Lane Configurations	T			T		
Traffic Vol, veh/h	68	0	1	1	8	4
Future Vol, veh/h	68	0	1	1	8	4
Conflicting Peds, #/hr	0	0	0	0	0	0
Sign Control	Stop	Stop	Free	Free	Free	Free
RT Channelized	-	None	-	None	-	None
Storage Length	0	-	-	-	-	-
Veh in Median Storage, #	0	-	-	0	0	-
Grade, %	0	-	-	0	0	-
Peak Hour Factor	50	50	50	50	50	50
Heavy Vehicles, %	2	2	2	2	2	2
Mvmt Flow	136	0	2	2	16	8

Major/Minor	Minor2	Major1		Major2	
Conflicting Flow All	26	20	24	0	0
Stage 1	20	-	-	-	-
Stage 2	6	-	-	-	-
Critical Hdwy	6.42	6.22	4.12	-	-
Critical Hdwy Stg 1	5.42	-	-	-	-
Critical Hdwy Stg 2	5.42	-	-	-	-
Follow-up Hdwy	3.518	3.318	2.218	-	-
Pot Cap-1 Maneuver	989	1058	1591	-	-
Stage 1	1003	-	-	-	-
Stage 2	1017	-	-	-	-
Platoon blocked, %				-	-
Mov Cap-1 Maneuver	988	1058	1591	-	-
Mov Cap-2 Maneuver	988	-	-	-	-
Stage 1	1002	-	-	-	-
Stage 2	1017	-	-	-	-

Approach	EB	NB	SB
HCM Control Delay, s	9.2	3.6	0
HCM LOS	A		

Minor Lane/Major Mvmt	NBL	NBT	EBLn1	SBT	SBR
Capacity (veh/h)	1591	-	988	-	-
HCM Lane V/C Ratio	0.001	-	0.138	-	-
HCM Control Delay (s)	7.3	0	9.2	-	-
HCM Lane LOS	A	A	A	-	-
HCM 95th %tile Q(veh)	0	-	0.5	-	-

Intersection						
Int Delay, s/veh	6.4					
Movement	EBT	EBR	WBL	WBT	NBL	NBR
Lane Configurations	↑↑	↑	↑	↑↑	↑	↑
Traffic Vol, veh/h	790	210	10	607	86	5
Future Vol, veh/h	790	210	10	607	86	5
Conflicting Peds, #/hr	0	0	0	0	0	0
Sign Control	Free	Free	Free	Free	Stop	Stop
RT Channelized	-	None	-	None	-	None
Storage Length	-	300	450	-	0	-
Veh in Median Storage, #	0	-	-	0	0	-
Grade, %	0	-	-	0	0	-
Peak Hour Factor	84	50	91	84	68	80
Heavy Vehicles, %	2	2	2	2	2	2
Mvmt Flow	940	420	11	723	126	6

Major/Minor	Major1	Major2	Minor1	Minor2	Minor3
Conflicting Flow All	0	0	1360	0	1324
Stage 1	-	-	-	-	940
Stage 2	-	-	-	-	384
Critical Hdwy	-	-	4.14	-	6.84
Critical Hdwy Stg 1	-	-	-	-	5.84
Critical Hdwy Stg 2	-	-	-	-	5.84
Follow-up Hdwy	-	-	2.22	-	3.52
Pot Cap-1 Maneuver	-	-	501	-	147
Stage 1	-	-	-	-	340
Stage 2	-	-	-	-	658
Platoon blocked, %	-	-	-	-	-
Mov Cap-1 Maneuver	-	-	501	-	144
Mov Cap-2 Maneuver	-	-	-	-	144
Stage 1	-	-	-	-	340
Stage 2	-	-	-	-	644

Approach	EB	WB	NB
HCM Control Delay, s	0	0.2	106
HCM LOS			F

Minor Lane/Major Mvmt	NBLn1	EBT	EBR	WBL	WBT
Capacity (veh/h)	149	-	-	501	-
HCM Lane V/C Ratio	0.891	-	-	0.022	-
HCM Control Delay (s)	106	-	-	12.3	-
HCM Lane LOS	F	-	-	B	-
HCM 95th %tile Q(veh)	6.1	-	-	0.1	-

Intersection						
Int Delay, s/veh	62.5					
Movement	EBL	EBR	NBL	NBT	SBT	SBR
Lane Configurations	Y		Y	↑↑	↑↑	Y
Traffic Vol, veh/h	92	51	51	526	754	45
Future Vol, veh/h	92	51	51	526	754	45
Conflicting Peds, #/hr	0	0	0	0	0	0
Sign Control	Stop	Stop	Free	Free	Free	Free
RT Channelized	-	None	-	None	-	None
Storage Length	0	-	-	-	-	250
Veh in Median Storage, #	0	-	-	0	0	-
Grade, %	0	-	-	0	0	-
Peak Hour Factor	50	50	50	82	87	87
Heavy Vehicles, %	2	2	2	2	2	2
Mvmt Flow	184	102	102	641	867	52

Major/Minor	Minor2	Major1	Major2			
Conflicting Flow All	1392	434	919	0	-	0
Stage 1	867	-	-	-	-	-
Stage 2	525	-	-	-	-	-
Critical Hdwy	6.84	6.94	4.14	-	-	-
Critical Hdwy Stg 1	5.84	-	-	-	-	-
Critical Hdwy Stg 2	5.84	-	-	-	-	-
Follow-up Hdwy	3.52	3.32	2.22	-	-	-
Pot Cap-1 Maneuver	~ 133	570	738	-	-	-
Stage 1	372	-	-	-	-	-
Stage 2	558	-	-	-	-	-
Platoon blocked, %				-	-	-
Mov Cap-1 Maneuver	~ 115	570	738	-	-	-
Mov Cap-2 Maneuver	~ 115	-	-	-	-	-
Stage 1	321	-	-	-	-	-
Stage 2	558	-	-	-	-	-

Approach	EB	NB	SB
HCM Control Delay, s	\$ 422	1.5	0
HCM LOS	F		

Minor Lane/Major Mvmt	NBL	NBT	EBLn1	SBT	SBR
Capacity (veh/h)	738	-	161	-	-
HCM Lane V/C Ratio	0.138	-	1.776	-	-
HCM Control Delay (s)	10.7	-	\$ 422	-	-
HCM Lane LOS	B	-	F	-	-
HCM 95th %tile Q(veh)	0.5	-	20.8	-	-

Notes
 ~: Volume exceeds capacity \$: Delay exceeds 300s +: Computation Not Defined *: All major volume in platoon

Intersection						
Int Delay, s/veh	1					
Movement	EBL	EBR	NBL	NBT	SBT	SBR
Lane Configurations	T			T		
Traffic Vol, veh/h	0	0	41	28	12	262
Future Vol, veh/h	0	0	41	28	12	262
Conflicting Peds, #/hr	0	0	0	0	0	0
Sign Control	Stop	Stop	Free	Free	Free	Free
RT Channelized	-	None	-	None	-	None
Storage Length	0	-	-	-	-	-
Veh in Median Storage, #	0	-	-	0	0	-
Grade, %	0	-	-	0	0	-
Peak Hour Factor	92	25	50	50	50	50
Heavy Vehicles, %	2	2	2	2	2	2
Mvmt Flow	0	0	82	56	24	524

Major/Minor	Minor2	Major1	Major2			
Conflicting Flow All	506	286	548	0	-	0
Stage 1	286	-	-	-	-	-
Stage 2	220	-	-	-	-	-
Critical Hdwy	6.42	6.22	4.12	-	-	-
Critical Hdwy Stg 1	5.42	-	-	-	-	-
Critical Hdwy Stg 2	5.42	-	-	-	-	-
Follow-up Hdwy	3.518	3.318	2.218	-	-	-
Pot Cap-1 Maneuver	526	753	1021	-	-	-
Stage 1	763	-	-	-	-	-
Stage 2	817	-	-	-	-	-
Platoon blocked, %				-	-	-
Mov Cap-1 Maneuver	482	753	1021	-	-	-
Mov Cap-2 Maneuver	482	-	-	-	-	-
Stage 1	700	-	-	-	-	-
Stage 2	817	-	-	-	-	-

Approach	EB	NB	SB
HCM Control Delay, s	0	5.2	0
HCM LOS	A		

Minor Lane/Major Mvmt	NBL	NBT	EBLn1	SBT	SBR
Capacity (veh/h)	1021	-	-	-	-
HCM Lane V/C Ratio	0.08	-	-	-	-
HCM Control Delay (s)	8.8	0	0	-	-
HCM Lane LOS	A	A	A	-	-
HCM 95th %tile Q(veh)	0.3	-	-	-	-

Lanes, Volumes, Timings
 9: Marksheffel Rd & Meadowbrook Pkwy

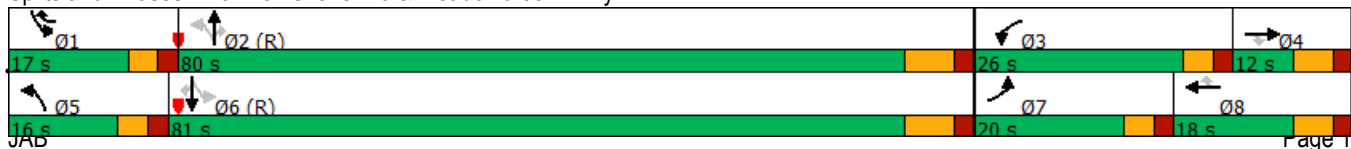
Long-Term Total - Brookings Closed
 PM Peak Hour

Lane Group	EBL	EBT	EBR	WBL	WBT	WBR	NBL	NBT	NBR	SBL	SBT	SBR
Lane Configurations												
Traffic Volume (vph)	275	30	150	317	25	138	100	1700	321	112	1050	336
Future Volume (vph)	275	30	150	317	25	138	100	1700	321	112	1050	336
Satd. Flow (prot)	3433	1863	1583	3433	1863	1583	1770	3539	1583	1770	5085	1583
Flt Permitted	0.950			0.950			0.198			0.053		
Satd. Flow (perm)	3433	1863	1583	3433	1863	1583	369	3539	1583	99	5085	1583
Satd. Flow (RTOR)			165			73			279			378
Peak Hour Factor	0.77	0.77	0.77	0.50	0.66	0.63	0.84	0.84	0.69	0.77	0.89	0.89
Shared Lane Traffic (%)												
Lane Group Flow (vph)	357	39	195	634	38	219	119	2024	465	145	1180	378
Turn Type	Prot	NA	Perm	Prot	NA	pm+ov	pm+pt	NA	Perm	pm+pt	NA	Perm
Protected Phases	7	4		3	8	1	5	2		1	6	
Permitted Phases			4			8	2		2	6		6
Detector Phase	7	4	4	3	8	1	5	2	2	1	6	6
Switch Phase												
Minimum Initial (s)	4.0	4.0	4.0	4.0	4.0	4.0	4.0	4.0	4.0	4.0	4.0	4.0
Minimum Split (s)	9.0	10.0	10.0	9.0	10.0	9.0	9.0	11.0	11.0	9.0	11.0	11.0
Total Split (s)	20.0	12.0	12.0	26.0	18.0	17.0	16.0	80.0	80.0	17.0	81.0	81.0
Total Split (%)	14.8%	8.9%	8.9%	19.3%	13.3%	12.6%	11.9%	59.3%	59.3%	12.6%	60.0%	60.0%
Yellow Time (s)	3.0	4.0	4.0	3.0	4.0	3.0	3.0	5.0	5.0	3.0	5.0	5.0
All-Red Time (s)	2.0	2.0	2.0	2.0	2.0	2.0	2.0	2.0	2.0	2.0	2.0	2.0
Lost Time Adjust (s)	0.0	0.0	0.0	0.0	0.0	0.0	0.0	0.0	0.0	0.0	0.0	0.0
Total Lost Time (s)	5.0	6.0	6.0	5.0	6.0	5.0	5.0	7.0	7.0	5.0	7.0	7.0
Lead/Lag	Lead	Lag	Lag	Lead	Lag	Lead	Lead	Lag	Lag	Lead	Lag	Lag
Lead-Lag Optimize?	Yes	Yes	Yes	Yes	Yes	Yes	Yes	Yes	Yes	Yes	Yes	Yes
Recall Mode	None	None	None	None	None	None	None	C-Max	C-Max	None	C-Max	C-Max
Act Effct Green (s)	18.6	6.0	6.0	21.0	10.7	25.5	84.5	73.9	73.9	89.5	76.4	76.4
Actuated g/C Ratio	0.14	0.04	0.04	0.16	0.08	0.19	0.63	0.55	0.55	0.66	0.57	0.57
v/c Ratio	0.75	0.48	0.86	1.19	0.26	0.61	0.37	1.04	0.47	0.72	0.41	0.36
Control Delay	67.9	82.1	45.7	150.2	62.0	39.5	11.1	63.7	8.5	47.9	17.2	2.4
Queue Delay	0.0	0.0	0.0	0.0	0.0	0.0	0.0	0.0	0.0	0.0	0.0	0.0
Total Delay	67.9	82.1	45.7	150.2	62.0	39.5	11.1	63.7	8.5	47.9	17.2	2.4
LOS	E	F	D	F	E	D	B	E	A	D	B	A
Approach Delay		61.5			119.2			51.5			16.5	
Approach LOS		E			F			D			B	

Intersection Summary

Cycle Length: 135
 Actuated Cycle Length: 135
 Offset: 0 (0%), Referenced to phase 2:NBTL and 6:SBTL, Start of Green
 Natural Cycle: 150
 Control Type: Actuated-Coordinated
 Maximum v/c Ratio: 1.19
 Intersection Signal Delay: 52.7
 Intersection LOS: D
 Intersection Capacity Utilization 83.9%
 ICU Level of Service E
 Analysis Period (min) 15

Splits and Phases: 9: Marksheffel Rd & Meadowbrook Pkwy



Lanes, Volumes, Timings
10: Marksheffel Rd & US 24

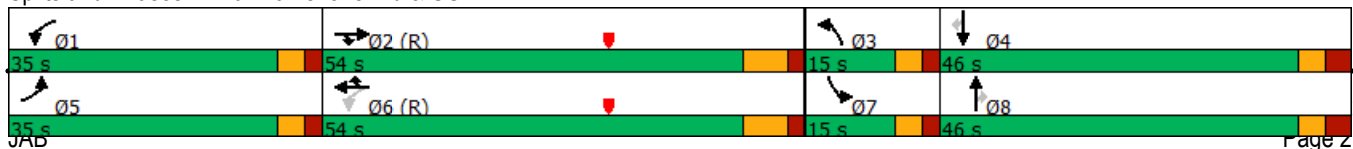
Long-Term Total - Brookings Closed
PM Peak Hour

Lane Group	EBL	EBT	EBR	WBL	WBT	WBR	NBL	NBT	NBR	SBL	SBT	SBR
Lane Configurations												
Traffic Volume (vph)	903	1500	10	185	800	85	20	1118	390	45	847	625
Future Volume (vph)	903	1500	10	185	800	85	20	1118	390	45	847	625
Satd. Flow (prot)	3433	5085	1583	3433	5085	1583	1770	3539	1583	1770	3539	1583
Flt Permitted	0.950			0.089			0.950			0.950		
Satd. Flow (perm)	3433	5085	1583	322	5085	1583	1770	3539	1583	1770	3539	1583
Satd. Flow (RTOR)			95			98			420			468
Peak Hour Factor	0.78	0.84	0.84	0.87	0.87	0.87	0.85	0.84	0.85	0.83	0.82	0.73
Shared Lane Traffic (%)												
Lane Group Flow (vph)	1158	1786	12	213	920	98	24	1331	459	54	1033	856
Turn Type	Prot	NA	Prot	pm+pt	NA	Prot	Prot	NA	Perm	Prot	NA	Perm
Protected Phases	5	2	2	1	6	6	3	8		7	4	
Permitted Phases				6					8			4
Detector Phase	5			1			3	8	8	7	4	4
Switch Phase												
Minimum Initial (s)	6.0	23.0	23.0	6.0	23.0	23.0	6.0	6.0	6.0	6.0	6.0	6.0
Minimum Split (s)	15.0	35.0	35.0	15.0	35.0	35.0	15.0	16.0	16.0	15.0	16.0	16.0
Total Split (s)	35.0	54.0	54.0	35.0	54.0	54.0	15.0	46.0	46.0	15.0	46.0	46.0
Total Split (%)	23.3%	36.0%	36.0%	23.3%	36.0%	36.0%	10.0%	30.7%	30.7%	10.0%	30.7%	30.7%
Yellow Time (s)	3.0	5.0	5.0	3.0	5.0	5.0	3.0	3.0	3.0	3.0	3.0	3.0
All-Red Time (s)	2.0	2.0	2.0	2.0	2.0	2.0	2.0	3.0	3.0	2.0	3.0	3.0
Lost Time Adjust (s)	0.0	-2.0	-2.0	0.0	-2.0	-2.0	0.0	-1.0	1.0	0.0	-1.0	1.0
Total Lost Time (s)	5.0	5.0	5.0	5.0	5.0	5.0	5.0	5.0	7.0	5.0	5.0	7.0
Lead/Lag	Lead	Lag	Lag	Lead	Lag	Lag	Lead	Lag	Lag	Lead	Lag	Lag
Lead-Lag Optimize?												
Recall Mode	None	C-Max	C-Max	None	C-Max	C-Max	None	None	None	None	None	None
Act Effct Green (s)	33.3	71.6	71.6	59.7	49.0	49.0	7.7	41.0	39.0	8.9	44.5	42.5
Actuated g/C Ratio	0.22	0.48	0.48	0.40	0.33	0.33	0.05	0.27	0.26	0.06	0.30	0.28
v/c Ratio	1.52	0.74	0.01	0.61	0.55	0.17	0.27	1.38	0.64	0.52	0.98	1.09
Control Delay	278.6	35.0	0.0	32.9	43.1	6.9	75.1	216.6	10.5	85.6	76.0	82.9
Queue Delay	0.0	0.0	0.0	0.0	0.0	0.0	0.0	0.0	0.0	0.0	0.0	0.0
Total Delay	278.6	35.0	0.0	32.9	43.1	6.9	75.1	216.6	10.5	85.6	76.0	82.9
LOS	F	C	A	C	D	A	E	F	B	F	E	F
Approach Delay		130.3			38.4			162.6			79.3	
Approach LOS		F			D			F			E	

Intersection Summary

Cycle Length: 150
 Actuated Cycle Length: 150
 Offset: 70 (47%), Referenced to phase 2:EBT and 6:WBTL, Start of FDW or yellow
 Natural Cycle: 145
 Control Type: Actuated-Coordinated
 Maximum v/c Ratio: 1.52
 Intersection Signal Delay: 111.0
 Intersection LOS: F
 Intersection Capacity Utilization 94.8%
 ICU Level of Service F
 Analysis Period (min) 15

Splits and Phases: 10: Marksheffel Rd & US 24



Lanes, Volumes, Timings
12: US 24 & Constitution Ave

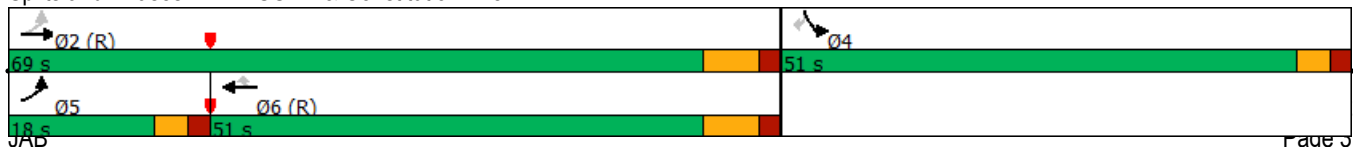
Long-Term Total - Brookings Closed
PM Peak Hour

	↖	→	←	↗	↘	↙
Lane Group	EBL	EBT	WBT	WBR	SBL	SBR
Lane Configurations	↖↖	↖↖↖	↖↖↖	↖	↖↖	↖
Traffic Volume (vph)	205	1730	945	371	676	125
Future Volume (vph)	205	1730	945	371	676	125
Satd. Flow (prot)	3433	5085	5085	1583	3433	1583
Flt Permitted	0.209				0.950	
Satd. Flow (perm)	755	5085	5085	1583	3433	1583
Satd. Flow (RTOR)				422		142
Peak Hour Factor	0.84	0.84	0.92	0.88	0.86	0.88
Shared Lane Traffic (%)						
Lane Group Flow (vph)	244	2060	1027	422	786	142
Turn Type	pm+pt	NA	NA	Perm	Prot	Perm
Protected Phases	5	2	6		4	
Permitted Phases	2			6		4
Detector Phase	5	2	6	6	4	4
Switch Phase						
Minimum Initial (s)	6.0	24.0	24.0	24.0	6.0	6.0
Minimum Split (s)	11.0	31.0	31.0	31.0	23.0	23.0
Total Split (s)	18.0	69.0	51.0	51.0	51.0	51.0
Total Split (%)	15.0%	57.5%	42.5%	42.5%	42.5%	42.5%
Yellow Time (s)	3.0	5.0	5.0	5.0	3.0	3.0
All-Red Time (s)	2.0	2.0	2.0	2.0	2.0	2.0
Lost Time Adjust (s)	0.0	0.0	0.0	0.0	0.0	0.0
Total Lost Time (s)	5.0	7.0	7.0	7.0	5.0	5.0
Lead/Lag	Lead		Lag	Lag		
Lead-Lag Optimize?	Yes		Yes	Yes		
Recall Mode	Min	C-Min	C-Min	C-Min	Min	Min
Act Effct Green (s)	75.8	73.8	59.9	59.9	34.2	34.2
Actuated g/C Ratio	0.63	0.62	0.50	0.50	0.28	0.28
v/c Ratio	0.36	0.66	0.40	0.42	0.80	0.26
Control Delay	11.1	17.0	20.5	3.4	46.4	5.8
Queue Delay	0.0	0.0	0.0	0.0	0.0	0.0
Total Delay	11.1	17.0	20.5	3.4	46.4	5.8
LOS	B	B	C	A	D	A
Approach Delay		16.4	15.5		40.1	
Approach LOS		B	B		D	

Intersection Summary

Cycle Length: 120
 Actuated Cycle Length: 120
 Offset: 112 (93%), Referenced to phase 2:EBTL and 6:WBT, Start of Green
 Natural Cycle: 65
 Control Type: Actuated-Coordinated
 Maximum v/c Ratio: 0.80
 Intersection Signal Delay: 20.8
 Intersection Capacity Utilization 62.7%
 Analysis Period (min) 15
 Intersection LOS: C
 ICU Level of Service B

Splits and Phases: 12: US 24 & Constitution Ave



Lanes, Volumes, Timings
 9: Marksheffel Rd & Meadowbrook Pkwy

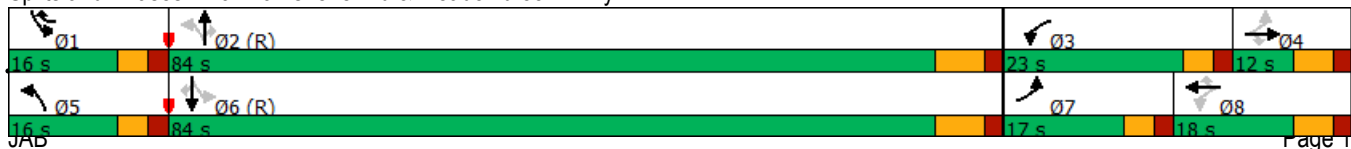
Long-Term Total - Brookings Open
 PM Peak Hour

Lane Group	EBL	EBT	EBR	WBL	WBT	WBR	NBL	NBT	NBR	SBL	SBT	SBR
Lane Configurations												
Traffic Volume (vph)	275	30	150	191	25	138	100	1700	321	112	1050	336
Future Volume (vph)	275	30	150	191	25	138	100	1700	321	112	1050	336
Satd. Flow (prot)	3433	1863	1583	1770	1863	1583	1770	3539	1583	1770	5085	1583
Flt Permitted	0.732			0.549			0.201			0.051		
Satd. Flow (perm)	2645	1863	1583	1023	1863	1583	374	3539	1583	95	5085	1583
Satd. Flow (RTOR)			187			73			298			378
Peak Hour Factor	0.77	0.77	0.77	0.62	0.66	0.63	0.84	0.84	0.69	0.77	0.89	0.89
Shared Lane Traffic (%)												
Lane Group Flow (vph)	357	39	195	308	38	219	119	2024	465	145	1180	378
Turn Type	pm+pt	NA	Perm	pm+pt	NA	pm+ov	pm+pt	NA	Perm	pm+pt	NA	Perm
Protected Phases	7	4		3	8	1	5	2		1	6	
Permitted Phases	4		4	8		8	2		2	6		6
Detector Phase	7	4	4	3	8	1	5	2	2	1	6	6
Switch Phase												
Minimum Initial (s)	4.0	4.0	4.0	4.0	4.0	4.0	4.0	4.0	4.0	4.0	4.0	4.0
Minimum Split (s)	9.0	10.0	10.0	9.0	10.0	9.0	9.0	11.0	11.0	9.0	11.0	11.0
Total Split (s)	17.0	12.0	12.0	23.0	18.0	16.0	16.0	84.0	84.0	16.0	84.0	84.0
Total Split (%)	12.6%	8.9%	8.9%	17.0%	13.3%	11.9%	11.9%	62.2%	62.2%	11.9%	62.2%	62.2%
Yellow Time (s)	3.0	4.0	4.0	3.0	4.0	3.0	3.0	5.0	5.0	3.0	5.0	5.0
All-Red Time (s)	2.0	2.0	2.0	2.0	2.0	2.0	2.0	2.0	2.0	2.0	2.0	2.0
Lost Time Adjust (s)	0.0	0.0	0.0	0.0	0.0	0.0	0.0	0.0	0.0	0.0	0.0	0.0
Total Lost Time (s)	5.0	6.0	6.0	5.0	6.0	5.0	5.0	7.0	7.0	5.0	7.0	7.0
Lead/Lag	Lead	Lag	Lag	Lead	Lag	Lead	Lead	Lag	Lag	Lead	Lag	Lag
Lead-Lag Optimize?	Yes	Yes	Yes	Yes	Yes	Yes	Yes	Yes	Yes	Yes	Yes	Yes
Recall Mode	None	None	None	None	None	None	None	C-Max	C-Max	None	C-Max	C-Max
Act Effct Green (s)	21.2	6.0	6.0	27.6	10.7	24.9	87.8	77.5	77.5	92.2	79.6	79.6
Actuated g/C Ratio	0.16	0.04	0.04	0.20	0.08	0.18	0.65	0.57	0.57	0.68	0.59	0.59
v/c Ratio	0.71	0.48	0.78	1.00	0.26	0.62	0.36	1.00	0.45	0.74	0.39	0.35
Control Delay	55.5	82.1	31.4	102.8	62.0	40.4	9.8	48.1	6.8	51.6	15.4	2.1
Queue Delay	0.0	0.0	0.0	0.0	0.0	0.0	0.0	0.0	0.0	0.0	0.0	0.0
Total Delay	55.5	82.1	31.4	102.8	62.0	40.4	9.8	48.1	6.8	51.6	15.4	2.1
LOS	E	F	C	F	E	D	A	D	A	D	B	A
Approach Delay		49.3			75.9			39.0			15.5	
Approach LOS		D			E			D			B	

Intersection Summary

Cycle Length: 135
 Actuated Cycle Length: 135
 Offset: 0 (0%), Referenced to phase 2:NBTL and 6:SBTL, Start of Green
 Natural Cycle: 110
 Control Type: Actuated-Coordinated
 Maximum v/c Ratio: 1.00
 Intersection Signal Delay: 36.6
 Intersection LOS: D
 Intersection Capacity Utilization 85.4%
 ICU Level of Service E
 Analysis Period (min) 15

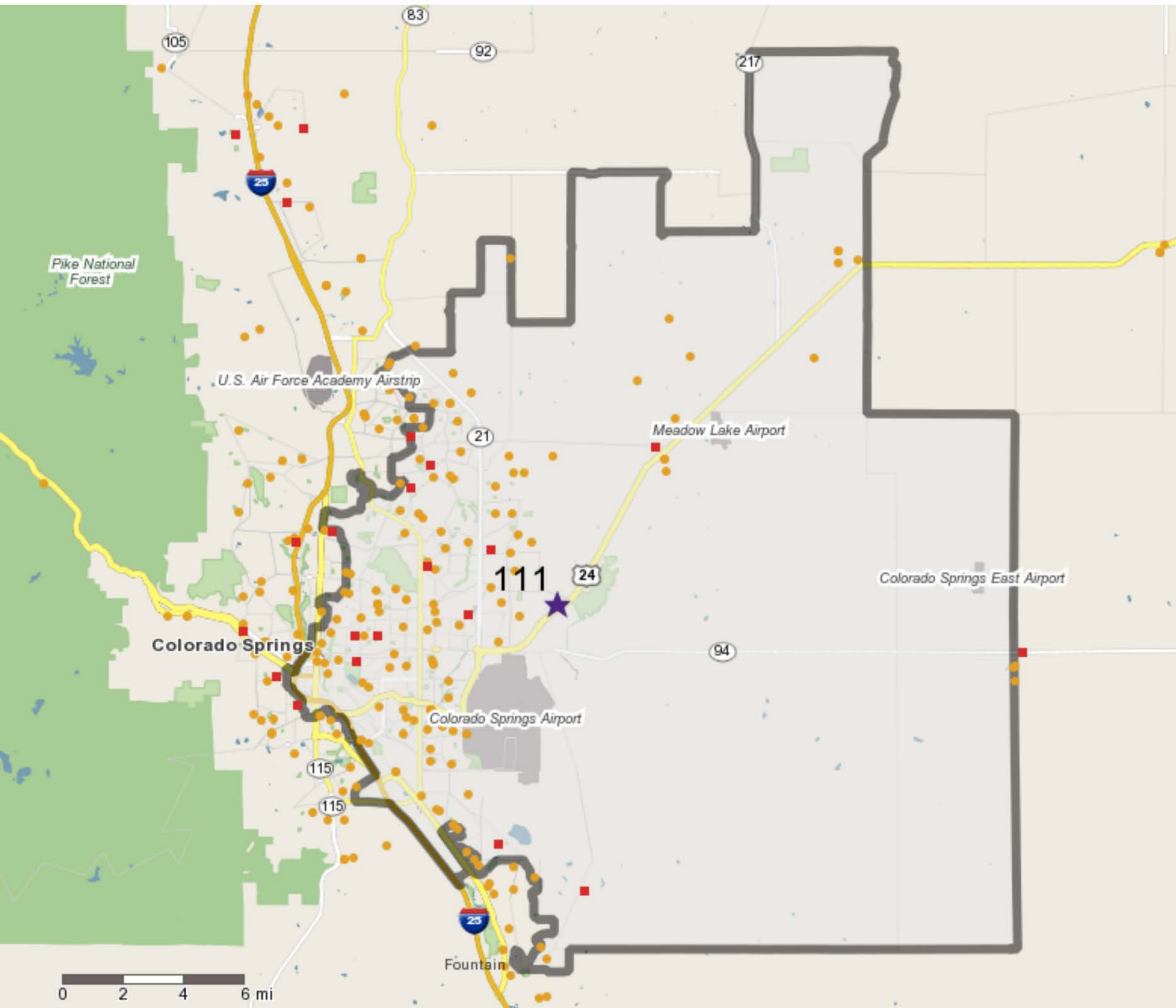
Splits and Phases: 9: Marksheffel Rd & Meadowbrook Pkwy



Drive Time Analysis and Census Data



TRADE AREA MAP



Ranking Areas - My Areas | Variable

Benchmark: Colorado

Area	Variable: Age		Base Count	Base %	% Pen	Index
	5-14 yrs	%				
1 - Internal to Claremont	853	1.40	4,889	1.17	17.45	120
2 - To/From the North on Hwy 24	4,254	6.96	27,730	6.62	15.34	105
3 - To/From the South on Marksheffel Rd	3,919	6.41	24,849	5.93	15.77	108
4 - To/From the South on Hwy 24	20,777	33.99	143,814	34.34	14.45	99
5 - To/From the West on Constitution Ave	16,915	27.67	129,150	30.84	13.10	90
6 - To/From the North on Marksheffel Rd	14,416	23.58	88,383	21.10	16.31	112

MSTA School Traffic Calculations



MSTA School Traffic Calculations

AM and PM Peak Traffic Estimates
(These numbers do not reflect peak hour traffic volumes)

School Name: MVA

Type: Urban Charter

Version: 102816

AM Cars / Student	PM Cars / Student	Avg. Car Length	PM At one Time
55.94%	39.15%	22.19	48.67%
52.91%	47.50%	22.19	46.12%
50.08%	47.58%	22.83	55.71%

MSTA School Queue Input					Calculations							
Grade Level	Student Population	Number of Buses	Staff Members	Student Drivers	PM Total Vehicles	PM Peak Vehicles	Average Queue Length	Total AM Trips	Total PM Trips	High Demand Length		
K - 10	772	11	65		303	148	3284	929	671	30%		
11th												
12th												
Sum >>					772	65	303	148	3284	929	671	4269

985

Grade K-10										
AM Trips Generated					PM Trips Generated					
Direction	Parents	Buses	Staff	Trips	Parents	Buses	Staff	Trips		
IN	432		65	497	303			303		
OUT	432			432	303		65	368		
AM K-10 Trips				929	PM K-10 Trips				671	

ADT
1600

NOTES

- Average Queue Length does not include an alternative traffic pattern required for high traffic demand days which is usually 30% additional length.
- Average Queue Length does not include the Student Loading Zone.
- Peak traffic volumes at schools normally occur within a 30-minute time period. (justifying a PHF of 0.5)

Grade 11-12									
AM Trips Generated					PM Trips Generated				
Direction	Parents	Buses	Staff	Trips	Parents	Buses	Staff	Trips	
IN									
OUT									
AM 11th Trips					PM 11th Trips				
Grade 12th									
AM Trips Generated					PM Trips Generated				
Direction	Parents	Buses	Staff	Trips	Parents	Buses	Staff	Trips	
IN									
OUT									
AM 12th Trips					PM 12th Trips				

All AM TRIPS	In	497
	Out	432
	Total	929

All PM TRIPS	In	303
	Out	368
	Total	671

1600

TIS_V2_redlines.pdf Markup Summary

Callout (7)

ncipal Arterial that extends west from US Hwy 24 to 1
adway adjacent to the site. The intersection with Me
lead. The speed limit is 30 mph adjacent to the study
a Major Collector that extends from SR 94 Road to t
tely parallel to US Hwy 24.

Revise to Urban
Residential Collector.
Identify the posted
speed.

Subject: Callout
Page Label: 3
Author: dsdlaforce
Date: 5/19/2020 1:16:49 PM
Status:
Color: ■
Layer:
Space:

Revise to Urban Residential Collector. Identify the posted speed.

simulation for the proposed school. As shown, all vehicles will enter off
or extend a vehicle up to 180 ft with a right turn will allow the
through the drive-off-lane loop in front of the school. A left turn will
proceed to allow entering the drive-off-lane loop.

Identify the posted
speed provided by
the proposed design.

Subject: Callout
Page Label: 2
Author: dsdlaforce
Date: 5/19/2020 12:46:21 PM
Status:
Color: ■
Layer:
Space:

quantify the queue length provided by the proposed design.

Revise from "Future"
to "proposed"

Subject: Callout
Page Label: 21
Author: dsdlaforce
Date: 5/19/2020 12:48:11 PM
Status:
Color: ■
Layer:
Space:

Revise from "Future" to "proposed"

Remove speed limit assembly along Meadowbrook
Pkwy. and relocate to Pinyon Jay Dr.

Subject: Callout
Page Label: 36
Author: dsdlaforce
Date: 5/19/2020 4:52:13 PM
Status:
Color: ■
Layer:
Space:

Remove speed limit assembly along Meadowbrook Pkwy. and relocate to Pinyon Jay Dr.

proposed school, based on 772 students. The si
100 feet of high demand queuing.

revise to signage not
flashers.

ended Improvements

Improvement	Timing
• Traffic signal operation	With the construction of the school
• Traffic signal operation	With the construction of the school
• Signal timing	With the construction of the school
• Signal timing	With the construction of the school
• Signal timing	With the construction of the school

Subject: Callout
Page Label: 14
Author: dsdlaforce
Date: 5/20/2020 10:45:14 AM
Status:
Color: ■
Layer:
Space:

revise to signage not flashers.

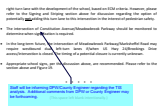
remove speed reduction on Meadowbrook
Parkway. There is no driveway access into the
school from Meadowbrook Parkway

Subject: Callout
Page Label: 14
Author: dsdlaforce
Date: 5/20/2020 10:47:00 AM
Status:
Color: ■
Layer:
Space:

remove speed reduction on Meadowbrook Parkway. There is no driveway access into the school from Meadowbrook Parkway

Table 3. Recommended Improvements

Improvement	Timing
• Traffic signal operation	With the construction of the school
• Traffic signal operation	With the construction of the school
• Signal timing	With the construction of the school
• Signal timing	With the construction of the school
• Signal timing	With the construction of the school



Subject: Callout
Page Label: 14
Author: dsdlaforce
Date: 5/20/2020 4:05:07 PM
Status:
Color: ■
Layer:
Space:

Staff will be informing DPW/County Engineer regarding the TIS analysis. Additional comments from DPW or County Engineer may be forthcoming.

Cloud (1)

for analysis results. Table 4 provides results showing levels of serv



Subject: Cloud
Page Label: 13
Author: dsdlaforce
Date: 5/20/2020 11:09:49 AM
Status:
Color: ■
Layer:
Space:

Cloud+ (2)



Subject: Cloud+
Page Label: 13
Author: dsdlaforce
Date: 5/20/2020 10:09:33 AM
Status:
Color: ■
Layer:
Space:

edit



Subject: Cloud+
Page Label: 12
Author: dsdlaforce
Date: 5/20/2020 11:05:19 AM
Status:
Color: ■
Layer:
Space:

For clarity, include an exhibit identifying the midblocks proposed to be removed. Staff only sees midblock ramps that are required at T-intersections.

The only mid-block crossing staff sees is on Pinyon Jar Dr between Hames Dr and Meadowbrook. Update narrative to include a recommendation for this midblock crossing.

Applicant must submit a deviation request to remove midblock crossings if said removal results in non-compliance with ECM Section 2.5.2.C.4 which notes access ramps on local roadways shall be spaced no greater than 600 feet apart, where spacing is greater than 600 feet, mid-block access ramps shall be provided.

File Attachment (1)



Subject: File Attachment
Page Label: 13
Author: dsdlaforce
Date: 5/20/2020 11:09:18 AM
Status:
Color: ■
Layer:
Space:

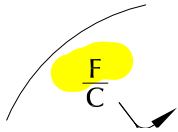
Highlight (7)

ction is
With a
urs.

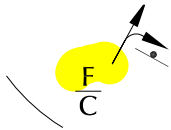
Subject: Highlight
Page Label: 10
Author: dsdlaforce
Date: 5/19/2020 5:34:31 PM
Status:
Color: ■
Layer:
Space:

Northbound left
scenario. With th
expected to fail. I
traffic signal, the
Meadowbrook P

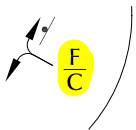
Subject: Highlight
Page Label: 10
Author: dsdlaforce
Date: 5/19/2020 5:34:36 PM
Status:
Color: ■
Layer:
Space:



Subject: Highlight
Page Label: 33
Author: dsdlaforce
Date: 5/20/2020 10:27:04 AM
Status:
Color: ■
Layer:
Space:



Subject: Highlight
Page Label: 33
Author: dsdlaforce
Date: 5/20/2020 10:27:06 AM
Status:
Color: ■
Layer:
Space:



Subject: Highlight
Page Label: 33
Author: dsdlaforce
Date: 5/20/2020 10:27:09 AM
Status:
Color: ■
Layer:
Space:

Intersection/Movement	Short
Meadowbrook Pkwy/Riverside Hwy	AM I
Northbound Approach	C
Southbound Approach	F
Meadowbrook Pkwy/Riverside Hwy	
Northbound Approach	F
Westbound Approach	F
Meadowbrook Pkwy/Riverside Hwy Dr	
Northbound Approach	F
Southbound Approach	F

Subject: Highlight
Page Label: 17
Author: dsdlaforce
Date: 5/20/2020 7:30:59 AM
Status:
Color: ■
Layer:
Space:

Northbound Approach	C	C
Southbound Approach	F	C
Meadowbrook Pkwy/Hames Dr	F	C
Northbound Approach	F	C
Westbound Approach	F	C
Meadowbrook Pkwy/Pinyon Jay Dr	F	C
Northbound Approach	F	B
Southbound Approach	F	C

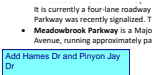
Subject: Highlight
Page Label: 17
Author: dsdlaforce
Date: 5/20/2020 7:31:29 AM
Status:
Color:
Layer:
Space:

Image (1)



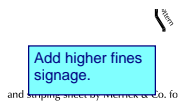
Subject: Image
Page Label: 15
Author: dsdlaforce
Date: 5/20/2020 1:49:14 PM
Status:
Color:
Layer:
Space:

Text Box (8)



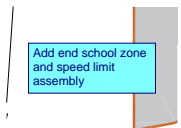
Subject: Text Box
Page Label: 3
Author: dsdlaforce
Date: 5/19/2020 1:16:35 PM
Status:
Color:
Layer:
Space:

Add Hames Dr and Pinyon Jay Dr



Subject: Text Box
Page Label: 36
Author: dsdlaforce
Date: 5/19/2020 5:06:25 PM
Status:
Color:
Layer:
Space:

Add higher fines signage.



Subject: Text Box
Page Label: 36
Author: dsdlaforce
Date: 5/20/2020 1:35:57 PM
Status:
Color:
Layer:
Space:

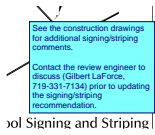
Add end school zone and speed limit assembly



Subject: Text Box
Page Label: 15
Author: dsdlaforce
Date: 5/20/2020 1:52:38 PM
Status:
Color:
Layer:
Space:

Add a school route plan map similar to the exhibit shown below.

The construction plans appears to require additional crosswalks in the vicinity of the school specifically the west side of Lantern/Hames intersection and north side of Hames/Pinyon Jay intersection.

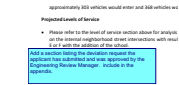


rol Signing and Striping

Subject: Text Box
Page Label: 36
Author: dsdlaforce
Date: 5/20/2020 10:52:45 AM
Status:
Color: ■
Layer:
Space:

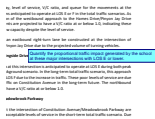
See the construction drawings for additional signing/striping comments.

Contact the review engineer to discuss (Gilbert LaForce, 719-331-7134) prior to updating the signing/striping recommendation.



Subject: Text Box
Page Label: 13
Author: dsdlaforce
Date: 5/20/2020 11:09:44 AM
Status:
Color: ■
Layer:
Space:

Add a section listing the deviation request the applicant has submitted and was approved by the Engineering Review Manager. include in the appendix.



Subject: Text Box
Page Label: 10
Author: dsdlaforce
Date: 5/20/2020 4:06:18 PM
Status:
Color: ■
Layer:
Space:

Quantify the proportional traffic impact generated by the school at these major intersections with LOS E or lower.



Subject: Text Box
Page Label: 33
Author: dsdlaforce
Date: 5/20/2020 4:07:42 PM
Status:
Color: ■
Layer:
Space:

Include a narrative under the Neighborhood Intersections on Pg 10 for Meadowbrook/Riverwalk and Meadowbrook/Hames intersection with recommendations to address the resulting LOS F due to the project.