



# Final Drainage Report

## **Ellicott School Addition - 2 Buildings**

**Project No. 61183**

**PCD File No. PPR-22-50**

**April 5, 2023**

# Final Drainage Report

for

**Ellicott School Addition - 2 Buildings**

**Project No. 61183**

**April 5, 2023**

prepared for

**Ellicott School District No 22**

322 S Ellicott Hwy  
Calhan, CO 80808  
719.683.2700

prepared by

**MVE, Inc.**

1903 Lelaray Street, Suite 200  
Colorado Springs, CO 80909  
719.635.5736

Copyright © MVE, Inc., 2022

61183-Final Drainage Report.odt

# Statements and Acknowledgments

## Engineer's Statement

The attached drainage plan and report were prepared under my direction and supervision and are correct to the best of my knowledge and belief. Said drainage report has been prepared according to the criteria established by El Paso County for drainage reports and said report is in conformity with the applicable master plan of the drainage basin. I accept responsibility for any liability caused by any negligent acts, errors or omissions on my part in preparing this report.

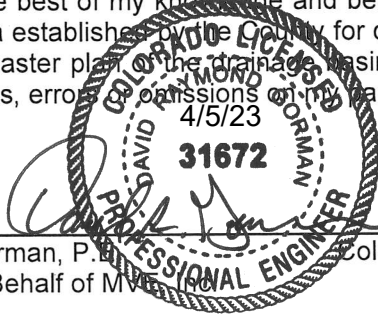

\_\_\_\_\_  
David R. Gorman, P.E. Colorado No. 31672  
For and on Behalf of MVA

4/5/2023

\_\_\_\_\_  
Date

## Developer's Statement

I, the owner/developer have read and will comply with all of the requirements specified in this drainage report and plan.

A handwritten signature in black ink, likely belonging to the School District Superintendent.

\_\_\_\_\_  
School District Superintendent  
Ellicott School District No 22

3/23/23

\_\_\_\_\_  
Date

## El Paso County

Filed in accordance with the requirements of the Drainage Criteria Manual, Volumes 1 and 2, El Paso County Engineering Criteria Manual and Land Development Code as amended.

\_\_\_\_\_  
Joshua Palmer, PE  
County Engineer / ECM Administrator

\_\_\_\_\_  
Date

# Contents

Statements and Acknowledgments.....	iii
Contents.....	v
Final Drainage Report.....	1
<b>1 General Location and Description.....</b>	<b>1</b>
1.1 Location.....	1
1.2 Description of Property.....	2
1.3 Description of Development.....	2
<b>2 Drainage Basins and Sub-Basins.....</b>	<b>3</b>
2.1 Major Basin Descriptions.....	3
2.2 Sub-Basin Description.....	3
<b>3 Drainage Design Criteria.....</b>	<b>3</b>
3.1 Development Criteria Reference.....	3
3.2 Hydrologic Criteria.....	4
3.3 Previous Drainage Studies.....	4
<b>4 Drainage Facility Design.....</b>	<b>4</b>
4.1 General Concept.....	4
4.2 Specific Details.....	4
4.3 Erosion Control.....	10
4.4 Proposed Swales and Water Quality Enhancement Control Measures.....	11
<b>5 Opinion of Probable Cost for Drainage Facilities.....</b>	<b>12</b>
<b>6 Drainage and Bridge Fees.....</b>	<b>13</b>

<b>7 Conclusion.....</b>	<b>13</b>
References.....	15
Appendices.....	17
<b>8 General Maps and Supporting Data.....</b>	<b>17</b>
<b>9 Hydrologic Calculations.....</b>	<b>18</b>
<b>10 Hydraulic Calculations.....</b>	<b>33</b>
<b>11 Report Maps.....</b>	<b>41</b>

# Final Drainage Report

The purpose of this Final Drainage Report is to identify drainage patterns and quantities within and affecting the proposed Ellicott School Addition - 2 Buildings site. The report will “identify specific solutions to problems on-site and off-site resulting from the proposed project. The report and included maps present results of hydrologic and drainage facilities analyses. The report will discuss the recommended drainage improvements to the site and identify drainage requirements relative to the proposed project. This report has been prepared and submitted in accordance with the requirements of the El Paso County development approval process. An Appendix is included with this report with pertinent calculations and graphs used in the drainage analyses and design. The scope of this report does not include the entirety of the site but is limited to the regions of the site where grading and construction will be occurring.

## 1 General Location and Description

### 1.1 Location

The proposed Ellicott School Addition - 2 Buildings site is located within the southwest quarter of Section 18, Township 14 South, Range 62 West of the 6th Principal Meridian, El Paso County, Colorado. The 28.51± acre site is situated north of Handle Road and east of South Ellicott Highway in El Paso County. The site contains an elementary school building that uses the address of 399 S Ellicott Highway, Calhan, CO 80808 and El Paso County Assessor's Schedule Number 2418000019. A **Vicinity Map** is included in the **Appendix**.

The south edge of the site is adjacent to Handle Road, and to the south of Handle road is an unplatted lot containing 109.82 acres, is owned by Bailey Teresa D and is zoned Agricultural (A-35) with El Paso County Assessor's Schedule Number 2400000220. An unplatted lot containing 40.45 acres, is owned by Jerry R Sales and Kathy A Sales, zoned Agricultural (A-35) is adjacent to the east of the site with El Paso County Assessor's Schedule Number 2418000013.

The western edge of the site is adjacent to South Ellicott highway, and adjacent to the highway on the west are two unplatted lots owned by Ellicott School District No. 22 and zoned Agricultural (A-35). The northern parcel to the east has El Paso County Assessor's Schedule Number 3413000024, containing 29.3 acres, and the southern parcel has El Paso County Assessor's Schedule Number 3413000025, containing 10.7 acres.

An unplatted lot containing 30 acres, is owned by Schubert Beverly J Living Trust and zoned Agricultural (A-35) is adjacent to the north of the site with El Paso County Assessor's Schedule Number 2418000006. Unplatted lot, containing 5.35 acres, is owned by El Paso County School District No 22 is zoned Agricultural (A-35), is also adjacent to the north of the site with El Paso County Assessor's Schedule Number 2418000018.

The site is located in El Paso County's Ellicott Consolidated Major Drainage Basin. The ultimate receiving water is Black Squirrel Creek which flows approximately 6,000 feet east of the east property line of the site.

## 1.2 Description of Property

The Ellicott School Addition - 2 Buildings site is zoned Agricultural - 35 Acres (A-35). The property is the location of an elementary school with existing elementary school building, a superintendent office building, and various ancillary buildings as well as gravel drives, parking lots and grass covered ball fields. There are existing 12" CMP culverts below the driveways connecting the site to the roadway at 5 locations along the edge of the site.

The site is covered with native prairie grasses and weeds in average condition having approximately 80% ground coverage with sparse trees and shrubs scattered. The existing site topography slopes easterly and southerly towards Handle Road with grades that range from 1% to 10% with areas in the northern and eastern portions with slopes that reach 22%. The main access to this project is from the existing public South Ellicott Highway. There is one (1) access point directly in front of Ellicott Sr High School at 375 S Ellicott Hwy as well as another access directly in front of Ellicott Elementary School at 399 S Ellicott Hwy.

The lowest point on the site is in the southeastern portion of the site. No major drainageways flow through the site and no significant drainage improvements or drainage facilities currently exist on the site except for the existing 12" CMP culverts below the driveways and the existing storm inlet east of the elementary school.

According to the National Resource Conservation Service, there are three (3) soil types in the immediate area of the Ellicott School Addition - 2 Buildings site. Columbine Gravelly Sandy Loam (map unit 19) makes up a portion of the soil in the eastern portion of the site and Truckton Loamy Sand (map unit 95) makes up a portion of the soil in the western portion. Truckton Sandy Loam (map unit 96) makes up a small portion of approximately 0.1 acres in the center portion of the site. A portion of the **Soil Map** and data tables from the **NRCS/USDA Web Soil Survey** and relevant Soil Descriptions from the **Soil Survey of El Paso County Area, Colorado** are included in the **Appendix**.<sup>1 2</sup>

Columbine Gravelly Sandy Loam is typically deep and well drained excessively drained. Permeability is very rapid, surface runoff is very low, and the hazard of erosion is slight to moderate. Columbine Gravelly Sandy Loam is classified as being part of Hydrologic Soil Group "A".

Truckton Loamy Sand is typically deep and well drained. Permeability is moderately rapid, surface runoff is low, and the hazard of erosion is moderate to high. Truckton Loamy Sand is classified as being part of Hydrologic Soil Group "A".

Truckton Sandy Loam is typically deep and well drained. Permeability is moderately rapid, surface runoff is very low, and the hazard of erosion is moderate. Truckton Sandy Loam is classified as being part of Hydrologic Soil Group "A".

The current Flood Insurance Study of the region includes Flood Insurance Rate Maps (FIRMs), effective December 7, 2018. The project site is included in Community Panel Number 08041C0809 G of the FIRMs for El Paso County, Colorado. No portion of the site lies within FEMA designated Special Flood Hazard Areas (SFHAs). An excerpt of the current **FEMA Flood Insurance Rate Maps** with the site delineated is included in the **Appendix**.<sup>3 4</sup>

## 1.3 Description of Development

The development on this site include site grading and construction of two (2) new buildings along with sidewalks, gravel drives, and connected utilities. Construction will be done in two phases, Phase I and Phase II. Phase I will consist of constructing one (1) Votech building having two (2) stories and 11,499 sf building footprint with a gravel access road, paved sidewalks, a rain garden, and landscaping. Phase I will serve Ellicott Sr High School at 375 S Ellicott Hwy. Phase II will consist of one (1) classroom building having one (1) story and 19,123 sf building footprint containing 13

---

1 WSS

2 SS-EPC

3 FIS

4 FIRM, Map No. 08041C0809G

classrooms, paved sidewalks, gravel access roads, a rain garden, and landscaping. Phase II will serve Ellicott Elementary School at 399 S Ellicott Hwy. The project also includes connecting internal potable water and sanitary sewer service lines.

## 2 Drainage Basins and Sub-Basins

### 2.1 Major Basin Descriptions

The Ellicott School Addition - 2 Buildings site is located in the Ellicott Consolidated Major Drainage Basin (CHBS1200). This basin drains to Black Squirrel Creek. The Ellicott School Addition - 2 Buildings site is located approximately 6,000 feet west of Black Squirrel Creek. The site is not included in a Drainage Basin Planning Study.

### 2.2 Sub-Basin Description

The existing drainage patterns of the site can be described by sixteen (16) on-site drainage basins. All existing basin delineations and data are depicted on the attached **Phase I Drainage Map (Existing)** and **Phase II Drainage Map (Existing)**. Flows exit the site in the Handle Road roadside ditch at the southeast corner of the site. A channel calculation, **Handle Road Ditch (Existing Conditions)**, is included in the **Appendix**.

The proposed drainage patterns of the site can be described by seventeen (17) on-site drainage basins. All proposed basin delineations and data are depicted on the attached **Phase I Drainage Map (Proposed)** and **Phase II Drainage Map (Proposed)**. Flows, in the proposed conditions, continue to exit the site in the Handle Road roadside ditch at the southeast corner of the site as in the existing conditions. A channel calculation, **Handle Road Ditch (Proposed Conditions)**, is included in the **Appendix**.

The northern edge of the site is located along a natural drainage basin boundary. The topography shows no offsite flows entering the on-site sub-basins mentioned in this report. All flows entering the project area are accounted for in the sub-basins mentioned in this report. All on-site sub-basins currently drain in a combination of sheet flow and concentrated flow across the site and exit the site at the southeastern corner going offsite into the north ditch of Handle Road and continuing east. The north ditch of Handle Road is a well vegetated, grassed ditch in good condition with existing CMP culverts underneath all driveways accessing the site that allow the flows in the north roadside ditch of Handle Road to remain uninterrupted. Flows continue east in the roadside ditch until reaching Black Squirrel Creek approximately 6,000 feet east of the east property line of the site.

## 3 Drainage Design Criteria

### 3.1 Development Criteria Reference

This Final Drainage Report for Ellicott School Addition - 2 Buildings has been prepared according to the report guidelines presented in the latest edition of *El Paso County Drainage Criteria Manual*<sup>5</sup>. The County has also adopted portions of the City of Colorado Springs Drainage Criteria Manual Volumes 1 and 2, especially concerning the calculation of rainfall runoff flow rates.<sup>6 7</sup> The hydrologic analysis is based on a collection of data from the DCM, the NRCS/USDA Web Soil Survey<sup>8</sup>, Existing topographic data by Clark Land Surveying Inc., and proposed site plan by Architivity, Ltd and MVE, Inc. The proposed rain gardens will be constructed per the recommendations of the Urban Storm Drainage Criteria Manual, Volume 3.<sup>9</sup> The control measures for this site meet the Water Quality Capture Volume (WQCV) Standard as outlined in the ECM Appendix I.7.1.C<sup>10</sup>. Two (2) rain gardens have been designed to provide treatment and infiltration of the WQCV. The bioretention calculation

5 DCMSection 1, Chapter 4.3 and 4.4

6 CS DCM Vol 1

7 CS DCM Vol 2

8 WSS

9 USDCM-V.3

10 ECM, Appendix I.7.1.C



was made with the aid of the “UD-BMP\_v3.07” spreadsheet developed by Mile High Flood District and is included in the **Appendix**.<sup>11</sup> Completed **SDI Forms** for both rain gardens are included in the **Appendix** demonstrating that each rain garden drain time is within the acceptable range. Flows exit the rain gardens through an emergency spillways and a weir calculations for the 100-yr storm, **100-yr Storm Rain Garden Spillway Inflow/Outflow Weir Calculations**, is included in the **Appendix**.

### 3.2 Hydrologic Criteria

For this Final Drainage Report, the Rational Method as described in the *City of Colorado Springs Drainage Criteria Manual (DCM)* has been used for all Storm Runoff calculations, as the development and all sub-basins are less than 130 acres in area. “Colorado Springs Rainfall Intensity Duration Frequency” curves, Figure 6-5 in the DCM, was used to obtain the design rainfall values; a copy is included in the **Appendix**. The “Overland (Initial) Flow Equation” (Eq. 6-8) in the DCM, and Manning's equation with estimated depths were used in time of concentration calculations. “Runoff Coefficients for Rational Method”, Table 6-6 in the DCM, was utilized as a guide in estimating runoff coefficient and Percent Impervious values; a copy is included in the **Appendix**. Peak runoff discharges were calculated for each drainage sub-basin for both the 5-year storm event and the 100-year storm event with the Rational Method formula, (Eq. 6-5) in the DCM.<sup>12</sup>

Porous Landscape Detention Areas (PLDs), more commonly known as **Rain Gardens** “utilizes bioretention is an engineered, depressed landscape area designed to capture and filter or infiltrate the water quality capture volume (WQCV)”<sup>13</sup>. Two rain gardens are proposed for this project site intended to provide water quality enhancement to their respective phase of development. The areas of the site designated as rain gardens are called out on the **Phase-I Drainage Map (Proposed)** and the **Phase-II Drainage Map (Proposed)** included in the **Appendix**. The soil where both rain gardens are proposed to be located is Columbine Gravelly Sandy Loam, classified as part of Hydrologic Soil Group “A”. It is typically deep, well drained to excessively drained and has very rapid permeability. The very rapid permeability of this soil will allow the full infiltration of the WQCV with a drain time compliant with the criteria.

No underdrain is planned for the two rain gardens on this project because it is believed that the existing soils are permeable enough to meet required drain times. However, onsite infiltration testing will be performed during construction. It is required that the native soil infiltration rates be equal to or greater than two (2) times the rate required to drain the WQCV in twelve hours. If it is found that infiltration rates do not meet criteria, an underdrain will be provided. After the test is completed during construction, an addendum to this Final Drainage Report will be submitted to El Paso County showing the testing results.

### 3.3 Previous Drainage Studies

There is no effective and official Drainage Basin Planning Study for the Ellicott Consolidated major drainage basin. No previous drainage report addresses flows relevant to the project site, and so none were used in the drainage design for this site. All properties adjacent to the site are unplatted and no drainage reports for these properties are expected to exist.

## 4 Drainage Facility Design

### 4.1 General Concept

The intent of the drainage concept presented in this Final Drainage Report is to maintain the existing drainage patterns on the site while addressing water quality requirements for the new Phase I and Phase II additions. Major and minor storm flows will continue to be safely conveyed through the site and downstream.

---

<sup>11</sup> UD-BMP

<sup>12</sup> CS DCM Vol 1

<sup>13</sup> USDCM-V.3, Chapter 4, Fact Sheet T-3, Page B1

The existing and proposed drainage hydrologic conditions are described in more detail below. Input data and results for all calculations are included in the **Appendix**. Drainage maps for the hydrology are also included in the **Appendix**.

## 4.2 Specific Details

### 4.2.1 Existing Hydrologic Conditions

The **Phase-I Drainage Map (Existing)** and **Phase-II Drainage Map (Existing)** depict the existing topographic mapping, drainage basin delineations, drainage patterns, existing drives, drainage facilities, and runoff quantities with a data table including drainage areas and flow rates and a channel calculation for the site outfall at the Handle Road roadside Ditch in the existing conditions is included in the **Appendix**.

The northern edge of the site is located along a natural drainage basin boundary. The topography shows no offsite flows entering the on-site sub-basins mentioned in this report. All flows entering the project area are accounted for in the sub-basins mentioned in this report. Flows exit the site at the southeastern corner of the site in the existing north roadside ditches on handle road. The existing stable flow path is adequate to carry the existing and developed flows. Flow velocities in the existing flow path are not erosive and require no special lining. The flow path delivers the flows east to Black Squirrel Creek located 6,000 feet east of the east property line of the site.

Existing sub-basin EX-A is 4.72 acres in area. This sub-basin is located on the northern edge of the site and contains a gravel parking, a portion of a paved private asphalt drive, portions of paved Ellicott Highway, concrete pavement and meadow/pasture area. Sub-basin EX-A produces peak discharges of  $Q_5 = 4.2$  cfs and  $Q_{100} = 13.5$  cfs (existing flows). Flows from the western portion of sub-basin EX-A drain easterly towards the existing depression located at Design Point 1 (DP1) in the form of sheet flow and an area of concentrated flow in the central portion. This area of concentrated flow initiates at the curb and gutter located on the north edge of the paved drive and extends to the existing swale which flows easterly into the depression. The depression overflows to drain south towards Design Point 3 (DP3).

Existing sub-basin EX-B, located in the north central portion of the site and bordering sub-basin EX-A to the south, is 0.44 acres in area. Sub-basin EX-B contains a portion of the paved private asphalt drive and concrete pavement, gravel parking area, meadow/pasture area, and a portion of a steel building. Peak storm runoff rates are  $Q_5 = 0.8$  cfs and  $Q_{100} = 1.8$  cfs (existing flows) which drain easterly towards Design Point 3 (DP3).

Existing sub-basin EX-C (6.62 acres) contains a paved batting cage and portions of a baseball field. The sub-basin generates flows of  $Q_5 = 0.5$  cfs and  $Q_{100} = 3.4$  cfs (existing flow), which drain westerly towards Design Point 2 (DP2). These flows combine with the flows from sub-basins EX-A and EX-B and drain into the existing swale located west of the existing ball field and flow south towards Design Point 3 (DP3).

Existing sub-basin EX-S1 (2.67 acres) is located south of sub-basins EX-B and EX-C and contains portions of a baseball field, gravel parking area, two steel buildings, one block building, two water tanks on a concrete pad, a portion of the paved private asphalt drive, and concrete pavement. Sub-basin EX-S1 produces peak discharges of  $Q_5 = 3.0$  cfs and  $Q_{100} = 8.4$  cfs (existing flows). Flows from the western portion of the sub-basin drain easterly and southerly towards DP5 and flows from the eastern portion of the sub-basin drain westerly and southerly towards DP5. An existing swale captures the combined flows from DP3 and the runoff from this sub-basin and conveys them south towards Design Point 5 (DP5) in the form of concentrated flow.

Existing sub-basin EX-S2 (1.21 acres) is located south of sub-basins EX-A and EX-B and contains portions of the existing High School building and associated portions of the paved private asphalt drive and concrete pavement. Sub-basin EX-S2 produces peak discharges of  $Q_5 = 4.4$  cfs and  $Q_{100} = 8.4$  cfs (existing flows). Flows from the existing building drain into downspouts and join flows from the paved portions of the sub-basin. All flows from this sub-basin are conveyed by existing curb and gutter to Design Point 4 (DP4).

Existing sub-basin EX-S3 (1.57 acres) is located south of sub-basin EX-S1 and contains portions of a softball field, a block building, and three steel buildings used as dugouts for the fields. Sub-basin EX-S3 produces peak discharges of  $Q_5 = 0.5$  cfs and  $Q_{100} = 3.5$  cfs (existing flows). Combined flows from DP5 enter the sub-basin from the north. Flows from sub-basin EX-S2 exit the curb and gutter at DP4 and drain onto a concrete pan and into a water quality pond located in the northwest corner of sub-basin EX-S3. The ponded water exits through a spillway and into an existing swale that conveys flows to the west central portion of sub-basin EX-S3. Flows from the western portion of the sub-basin drain easterly and southerly towards DP7 and flows from the eastern portion of the sub-basin drain westerly and southerly and combine with flows from DP6 to flow towards DP7.

Existing sub-basin EX-D (2.26 acres) is located in the central portion of the site, south of sub-basin EX-S2 and west of sub-basin EX-S3. This sub-basin contains a portion of a soccer field. Sub-basin EX-D produces peak discharges of  $Q_5 = 0.7$  cfs and  $Q_{100} = 4.9$  cfs (existing flows). Flows from the northern portions of this sub-basin drain easterly and southerly in the form of sheet flow towards the existing swale in the southern portion of the sub-basin, which convey the flows to Design Point 6 (DP6).

Existing sub-basin EX-S4 (3.65 acres) is located in the western portion of the site, south of sub-basin EX-A and contains the existing High School building, portion of the associated paved private asphalt drive and concrete pavement, portions of paved Ellicott Highway, paved parking areas, a single-story modular building, portions of the existing Elementary School building and associated concrete pavement, and a portion of a soccer field. Sub-basin EX-S4 produces peak discharges of  $Q_5 = 5.9$  cfs and  $Q_{100} = 13.6$  cfs (existing flows). Flows from this sub-basin drain southerly in a combination of sheet flow and concentrated flow (in curb and gutter and concrete swales) and enter sub-basin EX-S5.

Existing sub-basin EX-S5 (1.91 acres) is located in the southwestern corner of the site, south of sub-basin EX-S4 and contains a paved parking lot, gravel parking areas, and portions of paved Ellicott Highway and Handle Road. Sub-basin EX-S5 produces peak discharges of  $Q_5 = 4.9$  cfs and  $Q_{100} = 9.9$  cfs (existing flows). Flows from sub-basin EX-S4 enter at the northeastern corner of sub-basin EX-S5. Flows in this sub-basin drain southerly and easterly and are conveyed by curb and gutter to the existing 12" CMP culvert at Design Point 9 (DP9) on the existing Handle Road roadside ditch.

Existing sub-basin EX-S6 (1.07 acres) is located in the southern portion of the site, east of sub-basin EX-S5 and contains a portions of the existing Elementary School building, associated portions of concrete pavement, and portions of paved Handle Road. Sub-basin EX-S6 produces peak discharges of  $Q_5 = 2.1$  cfs and  $Q_{100} = 4.8$  cfs (existing flows). Flows from this sub-basin drain westerly and southerly towards the existing 12" CMP culverts on the Handle Road roadside ditch and combine with flows from DP9 at DP10.

Existing sub-basin EX-S7 (0.98 acres) is located in the central portion of the site, east of sub-basin EX-S6 and contains a portion of the existing Elementary School building, the associated portions concrete pavement, and a paved asphalt fire lane. Sub-basin EX-S7 produces peak discharges of  $Q_5 = 2.0$  cfs and  $Q_{100} = 4.3$  cfs (existing flows). Flows from this sub-basin drain easterly and southerly towards the existing storm drain inlet at Design Point 8 (DP8) which exits through an outlet approximately 190 feet southwest in sub-basin EX-S8 on the Handle Road roadside ditch.

Existing sub-basin EX-S8 (1.62 acres) is located in the central portion of the site, south of sub-basin EX-S7 and contains a portion of the existing Elementary School building, the associated portions concrete pavement, a concrete private drive, playgrounds, and a paved court. Sub-basin EX-S8 produces peak discharges of  $Q_5 = 2.4$  cfs and  $Q_{100} = 6.4$  cfs (existing flows). Flows from this sub-basin drain easterly and southerly towards the Handle Road roadside ditch. These flows, along with flows from the existing 12" CMP culvert at DP10 and flows from the storm drain outlet are combined at DP11.

Existing sub-basin EX-S9 (5.86 acres) is located in the central portion of the site, south of sub-basin EX-S3 and EX-D and contains a two ball fields, a portion of concrete pavement, a paved basketball court, and a gravel parking area. Sub-basin EX-S9 produces peak discharges of Q5 = 2.0 cfs and Q100 = 12.4 cfs (existing flows). Flows from DP7 enter at the central portion of the sub-basin. Flows from the western portion of the sub-basin drain easterly and southerly towards the Handle Road roadside ditch and flows from the eastern portion of the sub-basin drain westerly and southerly towards the Handle Road roadside ditch. Flows from DP11 combine with flows from this sub-basin in the Handle Road roadside ditch at Design Point 12 (DP12).

Existing sub-basin EX-S10 (2.65 acres) is located in the southeast corner of the site and contains an undeveloped pasture/meadow area. Sub-basin EX-S10 produces peak discharges of Q5 = 1.1 cfs and Q100 = 6.2 cfs (existing flows). Flows from this basin sheet flow southerly and combine with flows from DP12 in the Handle Road roadside ditch at Design Point 13 (DP13).

Design Point 13 is the site outfall. Flows exit the site in the Handle Road roadside ditch at the southeast corner of the site. A channel calculation, **Handle Road Ditch (Existing Conditions)**, is included in the **Appendix**. The flow path delivers the flows east to Black Squirrel Creek located 6,000 feet east of the east property line of the site.

Existing sub-basin EX-S11 (0.45 acres) is located on the east property line, northeast of EX-S10 and contains an undeveloped pasture/meadow area. Sub-basin EX-S11 produces peak discharges of Q5 = 0.2 cfs and Q100 = 1.4 cfs (existing flows). Flows from this basin drain southerly and easterly and sheet flow out of the site.

Existing sub-basin EX-S12 (1.68 acres) is located on the northeast corner of the site and contains an undeveloped pasture/meadow area and portions of a baseball field. Sub-basin EX-S12 produces peak discharges of Q5 = 0.5 cfs and Q100 = 3.8 cfs (existing flows). Flows from this basin drain southerly and easterly and sheet flow out of the site.

#### 4.2.2 Proposed Hydrologic Conditions

The **Phase-I Drainage Map (Proposed)** and **Phase-II Drainage Map (Proposed)** depict the proposed topographic mapping, drainage basin delineations, drainage patterns, proposed drives, drainage facilities, and runoff quantities with a data table including drainage areas and flow rates and a channel calculation for the site outfall at the Handle Road roadside Ditch in the proposed conditions is included in the **Appendix**.

Water quality treatment for disturbed areas and newly impervious areas on site will be provided by two (2) rain gardens, each one located downstream of each new building addition. The two rain gardens will provide water quality treatment to meet the Water Quality Capture Volume (WQCV) Standard as outlined in El Paso County's Engineering Criteria Manual and have been designed to provide treatment and infiltration of the WQCV.

The development of the site increases the flow rate of flows leaving the site by 2 cfs for a 100-year storm event (a 3% increase from the existing conditions). No detention for flood control is being provided because the downstream effects of the 3% increases in peak flow rates are negligible. The 2 cfs increase in flows for a 100-year storm event will have an inconsequential effect on peak flows in Black Squirrel Creek and do not present a hazard to the downstream properties, drainage basin, or drainageways. No storm detention is, therefore, being provided. Calculations are included in the **Appendix** for all proposed swales and the existing roadside ditch on handle road. All proposed swales are discussed in more detail in **4.4.1. Proposed Swales** and on the **Phase I - PBMP Tributary Map** and **Phase II - PBMP Tributary Map** included in the **Appendix**.

Disturbance as part of Post-Construction Stormwater Management exclusion criteria "*Aboveground and Underground Utilities activity - MS4 permit Part I.E.4.a.i (D)*" is delineated on the **Exclusions Map** and will require no permanent water quality treatment measure. Areas delineated as "**Untreated Applicable Development**", as discussed in more detail in **4.4.2. Water Quality Enhancement Control Measures**, are portions of the site where, diverting runoff towards the rain gardens would not be practicable given the physical conditions of the site and it is being requested

that those portions of the site be excluded from the applicable development area on this site to undergo permanent water quality treatment measures.

Proposed sub-basin A (4.23 acres) is located on the northern edge of site, and currently contains an existing gravel parking, a portion of existing paved private asphalt drive, portions of existing paved Ellicott Highway, existing concrete pavement, and meadow/pasture area. This basin contains an existing swale which initiates at the curb and gutter located on the north edge of the paved drive and extends easterly. This swale will be regraded to divert flows around the proposed Phase-I development. Sub-basin A produces peak developed discharges of  $Q_5 = 4.0$  cfs and  $Q_{100} = 12.2$  cfs (proposed flows). Flows from the western portion of sub-basin A drain easterly in a combination of sheet flow and an area of concentrated flow in the central portion of the basin towards the proposed swale. Flows exit the basin at Design Point 1 (DP1), as shown on the **Drainage Maps (Proposed)**, in the form of concentrated flow to enter sub-basin C where the swale continues. A channel calculation for that swale, **Swale C (DP1) (Proposed)**, is included in the **Appendix**.

Proposed sub-basin B1 (0.44 acres), located in the north central portion of the site and bordering sub-basin EX-A to the south, currently contains a portion of the existing paved private asphalt drive and concrete pavement, an existing gravel parking area, meadow/pasture area, and a portion of an existing steel building. This sub-basin will be further developed to include portions of the southwestern Phase-I concrete pavement and southern portion of the proposed gravel access road. The developed discharges from sub-basin B1 are  $Q_5 = 0.9$  cfs and  $Q_{100} = 1.9$  cfs (proposed flows). These flows travel overland easterly towards the southeastern corner of the basin and continue draining south towards Design Point 3 (DP3), as shown on the **Drainage Maps (Proposed)**.

Proposed sub-basin B2 (0.62 acres) will contain the proposed Phase-I building addition, a proposed gravel access road, proposed concrete sidewalks, and two proposed swales to convey flows to the proposed Phase-I rain garden. The developed discharges from sub-basin B2 are  $Q_5 = 1.5$  cfs and  $Q_{100} = 3.3$  cfs (proposed flows). The proposed Phase-I building addition will have downspouts on the north and south, as highlighted on the **Phase-I Drainage Map (Proposed)**. Two proposed swales will convey flows from this basin to the proposed Phase-I rain garden. Flows from the northern portion of the sub-basin drain to the proposed grassed swale located north and east of the new building and flow to the Phase-I rain garden at DP2, as shown on the **Drainage Maps (Proposed)**. A channel calculation for that swale, **Swale A (DP2) (Proposed)**, is included in the **Appendix**. Flows from the southern portion of the sub-basin will be conveyed by a proposed swale south of the new building to a 12" HDPE culvert connecting it to the proposed Phase-I rain garden to the east at Design Point 2 (DP2). A channel calculation for that swale, **Swale B (Culvert) (Proposed)**, is included in the **Appendix**. WQCV will be infiltrated through the soil and flows exceeding the WQCV will leave the Phase-I rain garden through the rip-rap lined spillway to continue south towards Design Point 3 (DP3). An existing swale located approximately 100 ft south of the proposed Phase-I rain garden spillway captures the combined flows from DP3 and conveys them south towards Design Point 5 (DP5). The flows in the existing swale are concentrated, as depicted by the "Existing Concentrated Flow" delineation on the **Phase-I PBMP Tributary Map**, and a channel calculation for that swale, **Existing Swale DP5 (Proposed Conditions)**, is included in the **Appendix**. The Phase I rain garden spillway acts to spread the flow and does not act to further concentrate the downstream flows any more than the existing conditions. The Phase I rain garden spillway is sufficiently wide to act as a level spreader as shown on the spillway detail for the Phase I rain garden spillway on the **Phase-I PBMP Tributary Map**.

Proposed sub-basin C (1.33 acres) currently contains an existing paved batting cage and portions of an existing baseball field, and will only be further developed by adding portions of a proposed swale and a proposed level spreader at the end of the swale. The developed discharges from sub-basin C are  $Q_5 = 0.4$  cfs and  $Q_{100} = 3.1$  cfs (proposed flows). Flows from this basin drain easterly towards the proposed swale and combine with flows from Design Point 1 (DP1), as shown on the **Drainage Maps (Proposed)**, to continue in the form of concentrated flow. This concentrated flow passes through the proposed level spreader then sheet flows to Design Point 3 (DP3).

Proposed sub-basin S1 (2.46 acres) is located south of sub-basin B1 and sub-basin C and contains portions of an existing baseball field, existing gravel parking area, two existing steel buildings, one

existing block building, two existing water tanks on a concrete pad, and a portion of the existing paved private asphalt drive and concrete pavement. Sub-basin S1 produces peak discharges of  $Q_5 = 3.0$  cfs and  $Q_{100} = 8.4$  cfs (Proposed Flows). Flows from the western portion of the sub-basin drain easterly and southerly towards DP5 and flows from the eastern portion of the sub-basin drain westerly and southerly towards DP5, as shown on the **Drainage Maps (Proposed)**. An existing swale captures the combined flows from DP3 and the runoff from this sub-basin and conveys them south towards Design Point 5 (DP5) in the form of concentrated flow. Flows in this basins will observe a minor increase due to the increased imperviousness upstream, however, the conveyance and concentration of the flows is identical to existing conditions. Time of concentration and imperviousness values for this basin are assumed to be unchanged from existing conditions. This basin will not be further developed, however, will observe land disturbance as part of the Phase-I utility activity and is considered part of the area delineated as "Post-Construction Stormwater Management exclusion criteria "Aboveground and Underground Utilities activity - MS4 permit Part I.E.4.a.i (D)", as shown on the **Exclusions Map**, and will require no permanent water quality treatment measure.

Proposed sub-basin D (2.19 acres) currently contains portions of existing concrete pavement and will be further developed by adding the Phase-II building addition and associated proposed concrete sidewalks and drain pan, a gravel access road and will be regraded to contain two proposed swales to convey flows to the proposed Phase-II rain garden. The sub-basin generates flows of  $Q_5 = 2.2$  cfs and  $Q_{100} = 6.6$  cfs (proposed flows). Runoff from this basin flows easterly and southerly towards the proposed swales which divert the flows away from the proposed building addition and south towards Design Point 6 (DP6), as shown on the **Drainage Maps (Proposed)**. The proposed swale located east of the proposed phase II building conveys flows from the eastern portion of the proposed Phase II building, eastern portion of associated sidewalk, and eastern portion of gravel access road to the proposed Phase-II rain garden. The proposed swale located west of the proposed phase II building collects runoff from the western proposed building downspouts and the western portion of the proposed gravel access road and conveys the flows to the proposed concrete pan, located north of the existing Elementary School building and existing concrete pan and south of the proposed Phase II building, which conveys the flows east to the proposed Phase II rain garden. A channel calculation for both swales is included in the **Appendix**. As shown on the channel calculation, given the side slopes of proposed swales, and the velocity and flow rate of the proposed flows, this flow path does not provide a hazard for erosion. The proposed swales will convey runoff from the proposed building, sidewalk, and gravel access road to the proposed rain garden at Design Point 6 (DP6), as shown on the **Drainage Maps (Proposed)**. WQCV will be infiltrated through the soil and flows exceeding the WQCV will leave the Phase-II rain garden through the rip-rap lined spillway to continue south towards Design Point 7 (DP7). There is an existing swale in the southern portion of the sub-basin where flow is concentrated, as depicted by the "Existing Concentrated Flow" delineation on the **Phase-II PBMP Tributary Map**. The existing swale will be regraded to construct the proposed Phase-II rain garden. The Phase II rain garden spillway acts to spread the flow and does not act to further concentrate the downstream flows any more than the existing conditions. The Phase II rain garden spillway is sufficiently wide to act as a level spreader as shown on the spillway detail for the Phase II rain garden spillway on the **Phase-II PBMP Tributary Map** and as demonstrated on the **100-yr Storm Rain Garden Spillway Inflow/Outflow Weir Calculations** included in the **Appendix**.

Proposed sub-basin S2 will not be further developed, however, will observe land disturbance as part of Post-Construction Stormwater Management exclusion criteria "Aboveground and Underground Utilities activity - MS4 permit Part I.E.4.a.i (D)", as shown on the **Exclusions Map**. Flows in this basins will observe a minor increase due to the increased imperviousness upstream, however, the conveyance and concentration of the flows is identical to existing conditions. Time of concentration and imperviousness values for this basin are assumed to be unchanged from existing conditions.

Proposed sub-basin S3 (1.69 acres) is located south of sub-basin S1. This sub-basin will only observe minor regrading as part of the construction of the Phase-II rain garden. Flows in this basins will observe a minor increase due to the increased imperviousness upstream, however, the conveyance and concentration of the flows is identical to existing conditions.

Proposed sub-basin S4 (3.60 acres) is located in the western portion of the site, south of sub-basin EX-A and contains the existing High School building and portion of the associated paved private asphalt drive and concrete pavement, portions of paved Ellicott Highway, paved parking areas, a single-story modular building, and portions of the existing Elementary School building and associated concrete pavement. As shown on the **Exclusions Map**, this basin will observe some disturbance as part of Post-Construction Stormwater Management exclusion criteria "Aboveground and Underground Utilities activity - MS4 permit Part I.E.4.a.i (D)".

Proposed sub-basin S9 (5.84 acres) is located in the central portion of the site, and will only observe minor regrading as part of the construction of the Phase-II rain garden. Flows in this basins will observe a minor increase due to the increased imperviousness upstream, however, the conveyance and concentration of the flows is identical to existing conditions.

Proposed sub-basins S5, S6, S7, S8, S10, S11, S12 will observe no land disturbance or construction activity. Flows in these basins will observe a minor increase due to the increased imperviousness upstream, however, the conveyance and concentration of the flows is identical to existing conditions. Time of concentration and imperviousness values for these basins are assumed to be unchanged from existing conditions.

The proposed conditions will allow the flows to exit the site at the same location. The southeastern corner of the site, Design Point 13, as shown on the **Drainage Maps (Proposed)**, is the proposed site outfall. Flows exit the site in the Handle Road roadside ditch. A channel calculation, **Handle Road Ditch (Proposed Conditions)**, is included in the **Appendix**. Flows exit the site with no considerable increase in flow rate from existing conditions: 2 cfs higher in flow rate for a 100-year storm event, and at a comparable velocity to existing conditions, making it a suitable outfall for the site and allowing the existing north roadside ditch on handle road to sufficiently carry the flows. Channel calculation for the Handle Road roadside ditch is included in the **Appendix** for both Existing and Proposed Conditions. The existing north roadside ditches on handle road has the capacity to handle the developed flows which contain an inconsequentially minor increase in flow rate at the point of reaching the site outfall and so the existing stable flow path is adequate to carry flows leaving the property. The flow path delivers the flows east to Black Squirrel Creek located 6,000 feet east of the east property line of the site.

### 4.3 Erosion Control

A channel calculation, **Handle Road Ditch (Proposed Conditions)**, is included in the **Appendix**. Flows exit the site in the proposed conditions at DP13, as shown on the **Drainage Maps (Proposed and Existing)** with no considerable increase in flow rate from existing conditions: 2 cfs higher in flow rate for a 100-year storm event (approximately 3% increase), and at a comparable velocity (less than 0.1 ft/s higher) to existing conditions, making it a suitable outfall for the site and allowing the existing north roadside ditch on handle road to sufficiently carry the flows without hazard for erosion. Channel calculation for the Handle Road roadside ditch is included in the **Appendix** for both Existing and Proposed Conditions.

During construction, Control Measures (CMs) for erosion control will be employed based on the previously referenced City of Colorado Springs Drainage Criteria Manual Volume 2 and the Erosion Control Plan for the site. During Construction, silt fencing, sediment control logs, vehicle tracking control and concrete washout area will be in place to minimize erosion from the site. Silt Fencing will be placed along the downstream sides of the disturbed areas. This will inhibit suspended sediment form leaving the site during construction. Silt fencing, Inlet Protection, and sediment control logs are to remain in place until the disturbed area is stabilized and until vegetation is reestablished in the other disturbed areas which are to be reseeded. Vehicle tracking control will be placed at the access points to the areas of construction/disturbance. Inlet protection will be placed at the outlet location, in the southern portion of the site. Temporary Sediment basins will be utilized on site for all areas of disturbance exceeding an acre in size. CMs will be utilized as deemed necessary by the contractor, engineer, owner, or County inspector and are not limited to the measures described above.

#### 4.4 Proposed Swales and Water Quality Enhancement Control Measures

##### 4.4.1 Proposed Swales

As shown on the **Phase I - PBMP Tributary Map** included in the **Appendix**, there are three swales associated with the proposed Phase-I development. Swales A and B convey flows from the proposed building, sidewalk, and gravel access road to the proposed Phase-I rain garden. The Phase I rain garden spillway acts to spread the flow and does not act to further concentrate the downstream flows any more than the existing conditions. Swale C divert flows away from the proposed rain garden and downstream towards a level spreader. As shown on the **Phase-I Drainage Map (Existing)**, flows from sub-basin EX-A reach an existing low point at DP1 and pond, then overflow to join flows from sub-basin EX-C downstream at DP2. As shown on the **Phase-I Drainage Map (Proposed)**, swale C diverts flows from sub-basin A, away from the rain garden, and towards DP1. Swale C continues south and conveys flows from sub-basin C downstream, diverting them away from the rain garden and towards Design Point 3. These flows continue south until they reach a level spreader. Flows from the north and east of the proposed Phase I addition are conveyed by swale A towards the rain garden. Flows from the south of the development are conveyed by swale B towards the rain garden through the proposed culvert. An earth berm will be graded south of the proposed phase I building in order to ensure all downspout flows enter swale B and flow to the Phase-I rain garden.

As shown on the **Phase II - PBMP Tributary Map** included in the **appendix**, there are two swales associated with the proposed Phase-II development. Swale D conveys flows from the eastern portion of the proposed Phase II building, eastern portion of associated sidewalk, and eastern portion of gravel access road to the proposed Phase-II rain garden. Swale E collects runoff from the western proposed building downspouts and the western portion of the proposed gravel access road and conveys the flows to the proposed concrete pan, located north of the existing Elementary School building and south of the proposed Phase II building, which conveys the flows east to the proposed Phase II rain garden. Channel calculations for both swales are included in the **Appendix**. As shown on the channel calculation, given the side slopes of the proposed swales, and the velocity and flow rate of the proposed flows, this flow path does not provide a hazard for erosion.

Channel calculations for all proposed swales showing proposed velocities and water depth for a 100-year storm event are included in the **Appendix**.

Flows in excess of the WQCV leave the rain garden over the flat Phase I and Phase II rain garden spillways, having crest lengths of 14.3' and 12' respectively – the maximum width allowed by site conditions. Flows exiting through the Phase I and Phase II rain garden spillways for the 100-yr storm create a water surface depth of 0.18' and 0.31' respectively as shown on the **100-yr Storm Rain Garden Spillway Inflow/Outflow Weir Calculations** included in the **Appendix**. The sufficiently wide spillways will evenly distribute the flows across the crest lengths of 14' and 12' and will allow the runoff to dispense downstream without concentrating the flow.

##### 4.4.2 Water Quality Enhancement Control Measures

Proposed flows from the developed areas of the site will be conveyed in proposed swales to two (2) proposed rain gardens, the conveyance of these flows are discussed in more detail in section **4.4.1. Proposed Swales** and in **4.2.2. Proposed Hydrologic Conditions** in Proposed sub-basin B2 and Proposed sub-basin E.

The areas of the site designated as rain gardens are called out on the **Phase-I Drainage Map (Proposed)** and the **Phase-II Drainage Map (Proposed)** included in the **Appendix**. The soil where both rain gardens are proposed to be located is Columbine Gravelly Sandy Loam, classified as part of Hydrologic Soil Group "A". It is typically deep, well drained to excessively drained and has very rapid permeability. The very rapid permeability of this soil will allow the full infiltration of the WQCV with a drain time compliant with the criteria. No underdrain is planned for the two rain gardens on this project because it is believed that the existing soils are permeable enough to meet required drain times. However, onsite infiltration testing will be performed during construction. It is required that the native soil infiltration rates be equal to or greater than two (2) times the rate required to drain the



WQCV in twelve hours. If it is found that infiltration rates do not meet criteria, an underdrain will be provided. After the test is completed during construction, an addendum to this Final Drainage Report will be submitted to El Paso County showing the testing results.

WQCV will be infiltrated through the soil and flows exceeding the WQCV will leave the rain garden through the rip-rap lined spillway. The rain garden spillways are sufficiently wide to act as a level spreader as shown on the spillways detail for the Phase-I rain garden spillway and the Phase-II rain garden spillway on the **Phase-I PBMP Tributary Map** and **Phase-II PBMP Tributary Map** respectively. Flows exiting through the Phase I and Phase II rain garden spillways for the 100-yr storm create a water surface depth of 0.18' and 0.31' respectively as shown on the **100-yr Storm Rain Garden Spillway Inflow/Outflow Weir Calculations** included in the **Appendix**.

Although the Water Quality Capture Volume (WQCV) Standard intends to provide treatment and/or infiltration of the WQCV and 100% of the *applicable development site* is captured, the ECM allows the County to exclude *“up to 20 percent, not to exceed 1 acre, of the applicable development site area when the County has determined that it is not practicable to capture runoff from portions of the site that will not drain towards control measures. In addition, the County must also determine that the implementation of a separate control measure for that portion of the site is not practicable.”* *“Applicable Development Site”*, in this context is assumed as all area included in *“Land disturbing activities”* as part of *“New Development”*<sup>14</sup>.

As shown on the **Exclusions Map**, areas delineated as **“Untreated Applicable Development”** comprises a total of 0.61 acres, less than 20% of the disturbed area and less than an acre in size. Diverting runoff from those areas towards the rain gardens would not be practicable given the physical conditions of the site and it is being requested that those portions of the site be excluded from the applicable development area on this site to undergo permanent water quality treatment measures. The total acreage excluded per Exclusion D (utilities) is 0.11 ac.

A Grading and Erosion Control Plan for the construction of the site has been prepared in accordance with the provisions of the DCM.

The El Paso County Engineering Criteria Manual<sup>15</sup> (Appendix I, Section I.7.2) requires the consideration of a “Four Step Process for receiving water protection that focuses on reducing runoff volumes, treating the water quality capture volume (WQCV), stabilizing drainageways, and implementing long term source controls”. The Four Step Process is incorporated in this project and the elements are discussed below.

- 1) Although the WQCV Base design standard is being used for this site, Runoff Reduction Practices as part of incorporating The Four Step Process are employed in this project. Impervious surfaces have been reduced as much as practically possible. There is only minimal concrete or other hard surfaces proposed. The proposed drive area will be stabilized with gravel, which remains a partially pervious surface. Minimized Directly Connected Impervious Areas (MDCIA) is employed on the project because runoff passes through open space meadow area before leaving the site.
- 2) All drainage paths on the site are stabilized with pavement or appropriate landscape treatment.
- 3) The project contains no potentially hazardous uses. All developed areas drain into a proposed WQCV BMP as allowed by applicable regrading.
- 4) The site contains no storage of potentially harmful substances or use of potentially harmful substances. No Site Specific or Other Source Control CMs are required.

## 5 Opinion of Probable Cost for Drainage Facilities

Costs for the drainage improvements for Ellicott School Addition - 2 Buildings are listed in the table below.

<sup>14</sup> ECM Appendix I.6.1.B.

<sup>15</sup> ECM, Appendix I

Item	Quantity	Unit	Unit Cost	Cost
12" HDPE Culvert Pipe	43	LF	\$52.00	\$2,236.00
12" HDPE Flared End Section	2	EA	\$330.00	\$660.00
Rain Garden – Earthwork	36	CY	\$8.00	\$288.00
Rain Garden – Type VL Rip Rap	53	Ton	\$89.00	\$4,717.00
Rain Garden – Growing Media	71	CY	\$60.00	\$4,260.00
Sub-Total				\$12,161.00
25% Contingency				\$3,040.25
<b>GRAND TOTAL</b>				<b>\$15,201.25</b>

## 6 Drainage and Bridge Fees

The site is not being platted. No Drainage or Bridge Fees are due for this project.

## 7 Conclusion

This Final Drainage Report presents existing and proposed drainage conditions for the proposed Ellicott School Addition - 2 Buildings project. The proposed development on this site include site grading and construction of two (2) new buildings along with sidewalks, gravel drives, and connected utilities. A Grading and Erosion Control Plan for the construction of the site has been prepared in accordance with the provisions of the DCM. The Four Step Process is incorporated in this project and Permanent Water quality treatment for the new disturbed and impervious areas on the site will be provided by two (2) rain gardens, each one located downstream of each new building addition. As shown on the **Exclusions Map**, areas delineated as “**Untreated Applicable Development**” produce runoff that would not practicably drain towards the WQCV given the physical conditions of the site and is being requested that those portions of the site be excluded from the applicable development area on this site to undergo permanent water quality treatment. This request is discussed in more detail in **4.4.2. Water Quality Enhancement Control Measures**.

The two rain gardens proposed for this site are intended to provide water quality enhancement to their respective phase of development. The soil where both rain gardens are proposed to be located is typically well drained to excessively drained and has very rapid permeability which will allow the full infiltration of the WQCV with a drain time compliant with the criteria. No underdrain is planned for the two rain gardens on this project because it is believed that the existing soils are permeable enough to meet required drain times. However, onsite infiltration testing will be performed during construction. It is required that the native soil infiltration rates be equal to or greater than two (2) times the rate required to drain the WQCV in twelve hours. If it is found that infiltration rates do not meet criteria, an underdrain will be provided. After the test is completed during construction, an addendum to this Final Drainage Report will be submitted to El Paso County showing the testing results.

WQCV will be infiltrated through the soil and flows exceeding the WQCV will leave the rain garden through the rip-rap lined spillway. The rain garden spillways are sufficiently wide to act as a level spreader. Flows exiting through the Phase I and Phase II rain garden spillways for the 100-yr storm create a water surface depth of 0.18' and 0.31' respectively as shown on the **100-yr Storm Rain Garden Spillway Inflow/Outflow Weir Calculations** included in the **Appendix**. The sufficiently wide spillways will evenly distribute the flows across the crest lengths of 14' and 12' and will allow the runoff to dispense downstream without concentrating the flow. The existing drainage patterns of the site are described above in **4.2.1. Existing Hydrologic Conditions** by sixteen (16) on-site drainage basins and the proposed drainage patterns of the site are described above in **4.2.2. Proposed Hydrologic Conditions** by seventeen (17) on-site drainage basins. Flows, in the proposed conditions, continue to exit the site in the Handle Road roadside ditch at the southeast corner of the site as in the existing conditions. The development of the site increases the rate of flows leaving the site by 2 cfs for a 100-year storm event (a 3% increase from the existing conditions). No detention for flood control is being provided because the downstream effects of the 3% increases in peak flow rates are negligible. The 2 cfs increase in flows for a 100-year storm event will have an inconsequential effect on peak flows in Black Squirrel Creek and do not present a hazard to the downstream properties, drainage basin, or drainageways. Calculations are included in the **Appendix** for all proposed swales and the existing roadside ditch on handle road. All proposed swales are discussed in more detail in **4.4.1. Proposed Swales** and on the **Phase I - PBMP Tributary Map** and **Phase II - PBMP Tributary Map** included in the **Appendix**. Flows exit the site with no considerable increase in flow rate from existing conditions: 2 cfs higher in flow rate for a 100-year storm event, and at a comparable velocity to existing conditions, making it a suitable outfall for the site and allowing the existing north roadside ditch on handle road to sufficiently carry the flows. Channel calculation for the Handle Road roadside ditch is included in the **Appendix** for both Existing and Proposed Conditions. The proposed project will not, with respect to stormwater runoff, negatively impact the adjacent properties and downstream properties.

# References

*NRCS/USDA Web Soil Survey*. United States Department of Agriculture, Natural Resources Conservation Service ("<https://websoilsurvey.nrcs.usda.gov/app/WebSoilSurvey.aspx>", accessed August, 2022).

*Soil Survey of El Paso County Area, Colorado*. Lynn Seymour Larsen (: National Cooperative Soil Survey, June, 1981).

*Flood Insurance Rate Map*. Federal Emergency Management Agency, National Flood Insurance Program (Washington D.C.: FEMA, December 7, 2018).

*Flood Insurance Study for El Paso County, Colorado and incorporated Areas*. Federal Emergency Management Agency (Washington D.C.: FEMA, December 7, 2018).

*Design Procedure Form: Rain Garden Spreadsheet*. Mile High Flood District ("[https://mhfd.org/wp-content/uploads/2020/03/UD-BMP\\_v3.07.xlsm](https://mhfd.org/wp-content/uploads/2020/03/UD-BMP_v3.07.xlsm)", accessed August, 2022).

*Urban Storm Drainage Criteria Manual Volume 3*. Mile High Flood District (Denver, Colorado: MHFD, October, 2019).

*City of Colorado Springs Drainage Criteria Manual, Volume 2: Stormwater Quality Policies, Procedures and Best Management Practices (BMPs)*. City of Colorado Springs Engineering Division (Colorado Springs: , May 2014).

*City of Colorado Springs Drainage Criteria Manual, Volume 1*. City of Colorado Springs Engineering Division (Colorado Springs: , May 2014).

*El Paso County Drainage Criteria Manual*. City of Colorado Springs, Department of Public Works; HDR Infrastructure, Inc.; El Paso County, Department of Public Works (: , Revised October 31, 2018).

*Engineering Criteria Manual County Of El Paso*. County Of El Paso (: , Revised: October 14, 2020).

# | Appendices

## **8 General Maps and Supporting Data**

Vicinity Map

Portions of Flood Insurance Rate Map

Portion of Drainage Area Identification Study Map

NRCS Soil Map and Tables

Soil Descriptions from Soil Survey of El Paso County Area, Colorado

Hydrologic Soil Group Map and Tables

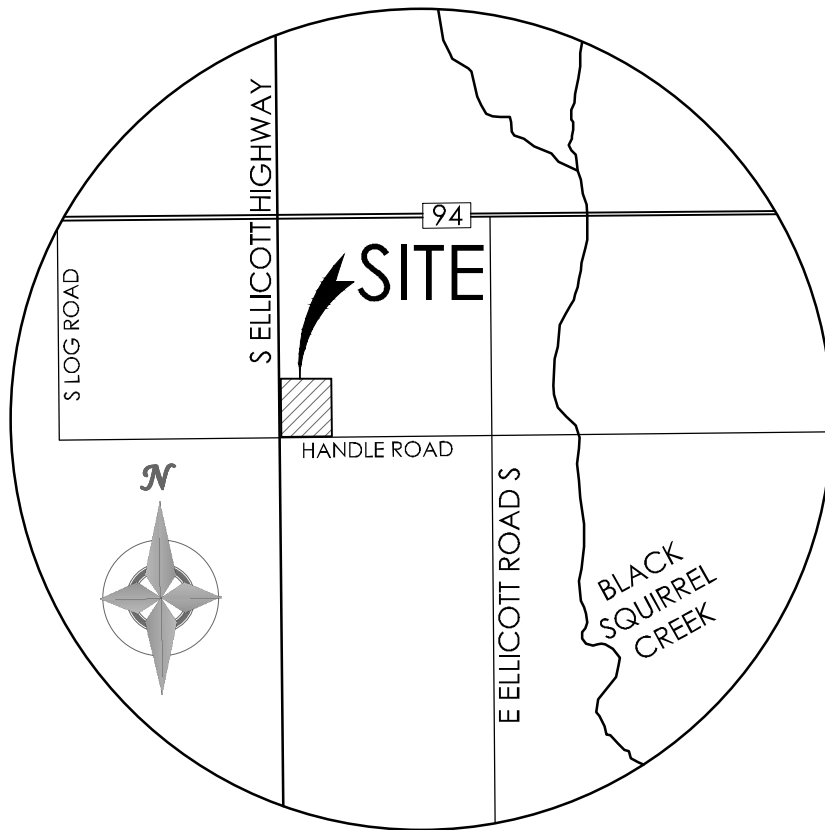

# VICINITY MAP

NOT TO SCALE

# National Flood Hazard Layer FIRMette



104°23'28"W 38°49'46"N

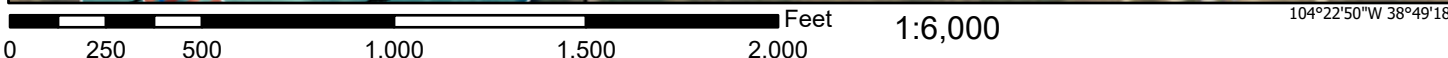

Basemap: USGS National Map: Orthoimagery: Data refreshed October, 2020

## Legend

SEE FIS REPORT FOR DETAILED LEGEND AND INDEX MAP FOR FIRM PANEL LAYOUT

- |                                    |  |   |
|------------------------------------|--|---|
| <b>SPECIAL FLOOD HAZARD AREAS</b>  |  | Without Base Flood Elevation (BFE)<br>Zone A, V, A99  |
|                                    |  | With BFE or Depth Zone AE, AO, AH, VE, AR   |
|                                    |  | Regulatory Floodway   |
| <b>OTHER AREAS OF FLOOD HAZARD</b> |  | 0.2% Annual Chance Flood Hazard, Areas of 1% annual chance flood with average depth less than one foot or with drainage areas of less than one square mile Zone X |
|                                    |  | Future Conditions 1% Annual Chance Flood Hazard Zone X  |
|                                    |  | Area with Reduced Flood Risk due to Levee. See Notes. Zone X  |
|                                    |  | Area with Flood Risk due to Levee Zone D  |
| <b>OTHER AREAS</b>                 |  | NO SCREEN Area of Minimal Flood Hazard Zone X   |
|                                    |  | Effective LOMRs   |
|                                    |  | Area of Undetermined Flood Hazard Zone D  |
| <b>GENERAL STRUCTURES</b>          |  | Channel, Culvert, or Storm Sewer  |
|                                    |  | Levee, Dike, or Floodwall   |
| <b>OTHER FEATURES</b>              |  | 20.2 Cross Sections with 1% Annual Chance Water Surface Elevation   |
|                                    |  | 17.5 Cross Sections with 1% Annual Chance Water Surface Elevation   |
|                                    |  | Coastal Transect  |
|                                    |  | Base Flood Elevation Line (BFE)   |
|                                    |  | Limit of Study  |
|                                    |  | Jurisdiction Boundary   |
|                                    |  | Coastal Transect Baseline   |
|                                    |  | Profile Baseline  |
|                                    |  | Hydrographic Feature  |
| <b>MAP PANELS</b>                  |  | Digital Data Available  |
|                                    |  | No Digital Data Available   |
|                                    |  | Unmapped  |



The pin displayed on the map is an approximate point selected by the user and does not represent an authoritative property location.

This map complies with FEMA's standards for the use of digital flood maps if it is not void as described below. The basemap shown complies with FEMA's basemap accuracy standards

The flood hazard information is derived directly from the authoritative NFHL web services provided by FEMA. This map was exported on 8/6/2022 at 1:10 PM and does not reflect changes or amendments subsequent to this date and time. The NFHL and effective information may change or become superseded by new data over time.

This map image is void if the one or more of the following map elements do not appear: basemap imagery, flood zone labels, legend, scale bar, map creation date, community identifiers, FIRM panel number, and FIRM effective date. Map images for unmapped and unmodernized areas cannot be used for regulatory purposes.

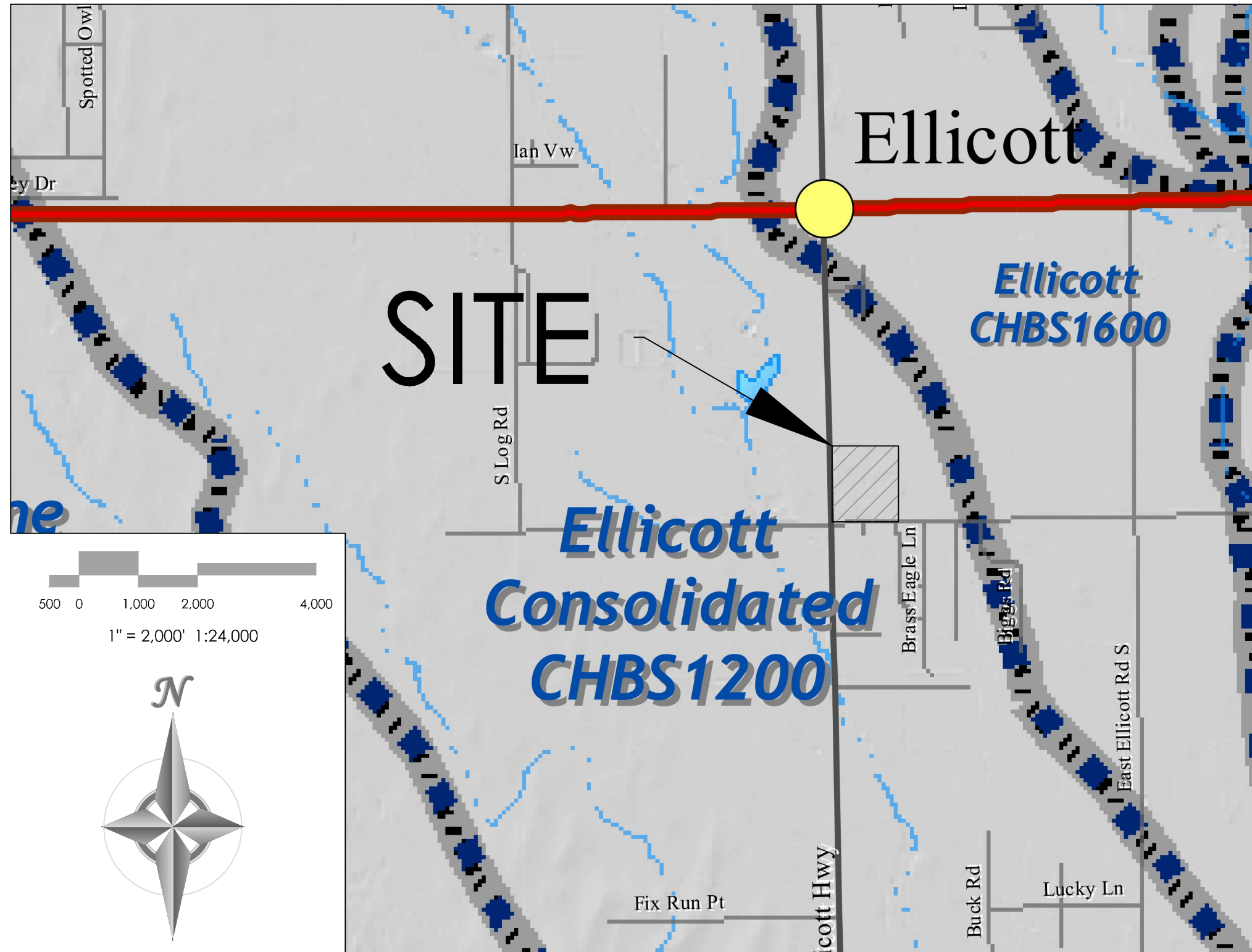



Custom Soil Resource Report  
Soil Map (61183 - Ellicott School 2 Building Addition)



Soil Map may not be valid at this scale.

Map Scale: 1:2,700 if printed on A portrait (8.5" x 11") sheet.



Map projection: Web Mercator Corner coordinates: WGS84 Edge tics: UTM Zone 13N WGS84



### MAP LEGEND

**Area of Interest (AOI)**

 Area of Interest (AOI)

**Soils**

 Soil Map Unit Polygons

 Soil Map Unit Lines

 Soil Map Unit Points

**Special Point Features**

-  Blowout
-  Borrow Pit
-  Clay Spot
-  Closed Depression
-  Gravel Pit
-  Gravelly Spot
-  Landfill
-  Lava Flow
-  Marsh or swamp
-  Mine or Quarry
-  Miscellaneous Water
-  Perennial Water
-  Rock Outcrop
-  Saline Spot
-  Sandy Spot
-  Severely Eroded Spot
-  Sinkhole
-  Slide or Slip
-  Sodic Spot

-  Spoil Area
-  Stony Spot
-  Very Stony Spot
-  Wet Spot
-  Other
-  Special Line Features

**Water Features**

 Streams and Canals

**Transportation**

-  Rails
-  Interstate Highways
-  US Routes
-  Major Roads
-  Local Roads

**Background**

 Aerial Photography

### MAP INFORMATION

The soil surveys that comprise your AOI were mapped at 1:24,000.

Warning: Soil Map may not be valid at this scale.

Enlargement of maps beyond the scale of mapping can cause misunderstanding of the detail of mapping and accuracy of soil line placement. The maps do not show the small areas of contrasting soils that could have been shown at a more detailed scale.

Please rely on the bar scale on each map sheet for map measurements.

Source of Map: Natural Resources Conservation Service  
 Web Soil Survey URL:  
 Coordinate System: Web Mercator (EPSG:3857)

Maps from the Web Soil Survey are based on the Web Mercator projection, which preserves direction and shape but distorts distance and area. A projection that preserves area, such as the Albers equal-area conic projection, should be used if more accurate calculations of distance or area are required.

This product is generated from the USDA-NRCS certified data as of the version date(s) listed below.

Soil Survey Area: El Paso County Area, Colorado  
 Survey Area Data: Version 20, Sep 2, 2022

Soil map units are labeled (as space allows) for map scales 1:50,000 or larger.

Date(s) aerial images were photographed: Sep 11, 2018—Oct 20, 2018

The orthophoto or other base map on which the soil lines were compiled and digitized probably differs from the background imagery displayed on these maps. As a result, some minor shifting of map unit boundaries may be evident.

## Map Unit Legend (61183 - Ellicott School 2 Building Addition)

Map Unit Symbol	Map Unit Name	Acres in AOI	Percent of AOI
19	Columbine gravelly sandy loam, 0 to 3 percent slopes	24.9	73.2%
95	Truckton loamy sand, 1 to 9 percent slopes	7.0	20.5%
96	Truckton sandy loam, 0 to 3 percent slopes	2.1	6.3%
<b>Totals for Area of Interest</b>		<b>34.1</b>	<b>100.0%</b>

## Map Unit Descriptions (61183 - Ellicott School 2 Building Addition)

The map units delineated on the detailed soil maps in a soil survey represent the soils or miscellaneous areas in the survey area. The map unit descriptions, along with the maps, can be used to determine the composition and properties of a unit.

A map unit delineation on a soil map represents an area dominated by one or more major kinds of soil or miscellaneous areas. A map unit is identified and named according to the taxonomic classification of the dominant soils. Within a taxonomic class there are precisely defined limits for the properties of the soils. On the landscape, however, the soils are natural phenomena, and they have the characteristic variability of all natural phenomena. Thus, the range of some observed properties may extend beyond the limits defined for a taxonomic class. Areas of soils of a single taxonomic class rarely, if ever, can be mapped without including areas of other taxonomic classes. Consequently, every map unit is made up of the soils or miscellaneous areas for which it is named and some minor components that belong to taxonomic classes other than those of the major soils.

Most minor soils have properties similar to those of the dominant soil or soils in the map unit, and thus they do not affect use and management. These are called noncontrasting, or similar, components. They may or may not be mentioned in a particular map unit description. Other minor components, however, have properties and behavioral characteristics divergent enough to affect use or to require different management. These are called contrasting, or dissimilar, components. They generally are in small areas and could not be mapped separately because of the scale used. Some small areas of strongly contrasting soils or miscellaneous areas are identified by a special symbol on the maps. If included in the database for a given area, the contrasting minor components are identified in the map unit descriptions along with some characteristics of each. A few areas of minor components may not have been observed, and consequently they are not mentioned in the descriptions, especially where the pattern was so complex that it was impractical to make enough observations to identify all the soils and miscellaneous areas on the landscape.

## Custom Soil Resource Report

The presence of minor components in a map unit in no way diminishes the usefulness or accuracy of the data. The objective of mapping is not to delineate pure taxonomic classes but rather to separate the landscape into landforms or landform segments that have similar use and management requirements. The delineation of such segments on the map provides sufficient information for the development of resource plans. If intensive use of small areas is planned, however, onsite investigation is needed to define and locate the soils and miscellaneous areas.

An identifying symbol precedes the map unit name in the map unit descriptions. Each description includes general facts about the unit and gives important soil properties and qualities.

Soils that have profiles that are almost alike make up a *soil series*. Except for differences in texture of the surface layer, all the soils of a series have major horizons that are similar in composition, thickness, and arrangement.

Soils of one series can differ in texture of the surface layer, slope, stoniness, salinity, degree of erosion, and other characteristics that affect their use. On the basis of such differences, a soil series is divided into *soil phases*. Most of the areas shown on the detailed soil maps are phases of soil series. The name of a soil phase commonly indicates a feature that affects use or management. For example, Alpha silt loam, 0 to 2 percent slopes, is a phase of the Alpha series.

Some map units are made up of two or more major soils or miscellaneous areas. These map units are complexes, associations, or undifferentiated groups.

A *complex* consists of two or more soils or miscellaneous areas in such an intricate pattern or in such small areas that they cannot be shown separately on the maps. The pattern and proportion of the soils or miscellaneous areas are somewhat similar in all areas. Alpha-Beta complex, 0 to 6 percent slopes, is an example.

An *association* is made up of two or more geographically associated soils or miscellaneous areas that are shown as one unit on the maps. Because of present or anticipated uses of the map units in the survey area, it was not considered practical or necessary to map the soils or miscellaneous areas separately. The pattern and relative proportion of the soils or miscellaneous areas are somewhat similar. Alpha-Beta association, 0 to 2 percent slopes, is an example.

An *undifferentiated group* is made up of two or more soils or miscellaneous areas that could be mapped individually but are mapped as one unit because similar interpretations can be made for use and management. The pattern and proportion of the soils or miscellaneous areas in a mapped area are not uniform. An area can be made up of only one of the major soils or miscellaneous areas, or it can be made up of all of them. Alpha and Beta soils, 0 to 2 percent slopes, is an example.

Some surveys include *miscellaneous areas*. Such areas have little or no soil material and support little or no vegetation. Rock outcrop is an example.

## El Paso County Area, Colorado

### 19—Columbine gravelly sandy loam, 0 to 3 percent slopes

#### Map Unit Setting

*National map unit symbol:* 367p  
*Elevation:* 6,500 to 7,300 feet  
*Mean annual precipitation:* 14 to 16 inches  
*Mean annual air temperature:* 46 to 50 degrees F  
*Frost-free period:* 125 to 145 days  
*Farmland classification:* Not prime farmland

#### Map Unit Composition

*Columbine and similar soils:* 97 percent  
*Minor components:* 3 percent  
*Estimates are based on observations, descriptions, and transects of the mapunit.*

#### Description of Columbine

##### Setting

*Landform:* Fans, fan terraces, flood plains  
*Down-slope shape:* Linear  
*Across-slope shape:* Linear  
*Parent material:* Alluvium

##### Typical profile

*A - 0 to 14 inches:* gravelly sandy loam  
*C - 14 to 60 inches:* very gravelly loamy sand

##### Properties and qualities

*Slope:* 0 to 3 percent  
*Depth to restrictive feature:* More than 80 inches  
*Drainage class:* Well drained  
*Runoff class:* Very low  
*Capacity of the most limiting layer to transmit water (Ksat):* High to very high (5.95 to 19.98 in/hr)  
*Depth to water table:* More than 80 inches  
*Frequency of flooding:* None  
*Frequency of ponding:* None  
*Available water supply, 0 to 60 inches:* Very low (about 2.5 inches)

##### Interpretive groups

*Land capability classification (irrigated):* 4e  
*Land capability classification (nonirrigated):* 6e  
*Hydrologic Soil Group:* A  
*Ecological site:* R049XY214CO - Gravelly Foothill  
*Hydric soil rating:* No

#### Minor Components

##### Fluvaquentic haplaquolls

*Percent of map unit:* 1 percent  
*Landform:* Swales  
*Hydric soil rating:* Yes

**Other soils**

*Percent of map unit:* 1 percent  
*Hydric soil rating:* No

**Pleasant**

*Percent of map unit:* 1 percent  
*Landform:* Depressions  
*Hydric soil rating:* Yes

**95—Truckton loamy sand, 1 to 9 percent slopes**

**Map Unit Setting**

*National map unit symbol:* 2yvrn  
*Elevation:* 5,800 to 7,100 feet  
*Mean annual precipitation:* 12 to 19 inches  
*Mean annual air temperature:* 46 to 50 degrees F  
*Frost-free period:* 90 to 155 days  
*Farmland classification:* Not prime farmland

**Map Unit Composition**

*Truckton and similar soils:* 87 percent  
*Minor components:* 13 percent  
*Estimates are based on observations, descriptions, and transects of the mapunit.*

**Description of Truckton**

**Setting**

*Landform:* Interfluves, fan remnants  
*Down-slope shape:* Linear  
*Across-slope shape:* Linear  
*Parent material:* Wind re-worked alluvium derived from arkose

**Typical profile**

*A - 0 to 4 inches:* loamy sand  
*Bt1 - 4 to 12 inches:* sandy loam  
*Bt2 - 12 to 19 inches:* sandy loam  
*C - 19 to 80 inches:* sandy loam

**Properties and qualities**

*Slope:* 1 to 9 percent  
*Depth to restrictive feature:* More than 80 inches  
*Drainage class:* Well drained  
*Runoff class:* Low  
*Capacity of the most limiting layer to transmit water (Ksat):* High (2.00 to 6.00 in/hr)  
*Depth to water table:* More than 80 inches  
*Frequency of flooding:* None  
*Frequency of ponding:* None  
*Calcium carbonate, maximum content:* 1 percent  
*Maximum salinity:* Nonsaline to very slightly saline (0.1 to 2.0 mmhos/cm)

## Custom Soil Resource Report

*Available water supply, 0 to 60 inches: Moderate (about 6.5 inches)*

### **Interpretive groups**

*Land capability classification (irrigated): 6e*

*Land capability classification (nonirrigated): 6e*

*Hydrologic Soil Group: A*

*Ecological site: R049XB210CO - Sandy Foothill*

*Hydric soil rating: No*

### **Minor Components**

#### **Blakeland**

*Percent of map unit: 5 percent*

*Landform: Interfluves, hills*

*Landform position (two-dimensional): Summit, shoulder, backslope*

*Landform position (three-dimensional): Crest, side slope*

*Down-slope shape: Linear, convex*

*Across-slope shape: Linear, convex*

*Ecological site: R049XB210CO - Sandy Foothill*

*Hydric soil rating: No*

#### **Bresser**

*Percent of map unit: 5 percent*

*Landform: Interfluves, terraces*

*Landform position (three-dimensional): Tread*

*Down-slope shape: Linear*

*Across-slope shape: Linear*

*Ecological site: R049XB210CO - Sandy Foothill*

*Hydric soil rating: No*

#### **Urban land**

*Percent of map unit: 2 percent*

*Hydric soil rating: No*

#### **Ellicott, occasionally flooded**

*Percent of map unit: 1 percent*

*Landform: Flood plains, drainageways*

*Down-slope shape: Linear*

*Across-slope shape: Linear, concave*

*Ecological site: R067BY031CO - Sandy Bottomland*

*Hydric soil rating: No*

## **96—Truckton sandy loam, 0 to 3 percent slopes**

### **Map Unit Setting**

*National map unit symbol: 2yvrd*

*Elevation: 5,400 to 7,000 feet*

*Mean annual precipitation: 14 to 23 inches*

*Mean annual air temperature: 45 to 52 degrees F*

*Frost-free period: 90 to 155 days*

## Custom Soil Resource Report

*Farmland classification:* Prime farmland if irrigated and the product of I (soil erodibility) x C (climate factor) does not exceed 60

### Map Unit Composition

*Truckton and similar soils:* 85 percent

*Minor components:* 15 percent

*Estimates are based on observations, descriptions, and transects of the mapunit.*

### Description of Truckton

#### Setting

*Landform:* Fan remnants, interfluves

*Down-slope shape:* Linear

*Across-slope shape:* Linear

*Parent material:* Wind re-worked alluvium derived from arkose

#### Typical profile

*A - 0 to 4 inches:* sandy loam

*Bt1 - 4 to 12 inches:* sandy loam

*Bt2 - 12 to 19 inches:* sandy loam

*C - 19 to 80 inches:* sandy loam

#### Properties and qualities

*Slope:* 0 to 3 percent

*Depth to restrictive feature:* More than 80 inches

*Drainage class:* Well drained

*Runoff class:* Very low

*Capacity of the most limiting layer to transmit water (Ksat):* High (2.00 to 6.00 in/hr)

*Depth to water table:* More than 80 inches

*Frequency of flooding:* None

*Frequency of ponding:* None

*Calcium carbonate, maximum content:* 1 percent

*Maximum salinity:* Nonsaline to very slightly saline (0.1 to 2.0 mmhos/cm)

*Available water supply, 0 to 60 inches:* Moderate (about 6.6 inches)

#### Interpretive groups

*Land capability classification (irrigated):* 3e

*Land capability classification (nonirrigated):* 4e

*Hydrologic Soil Group:* A

*Ecological site:* R049XB210CO - Sandy Foothill

*Hydric soil rating:* No

### Minor Components

#### Blakeland

*Percent of map unit:* 5 percent

*Landform:* Hills, interfluves

*Landform position (two-dimensional):* Shoulder, backslope, summit

*Landform position (three-dimensional):* Side slope, crest

*Down-slope shape:* Linear, convex

*Across-slope shape:* Linear, convex

*Ecological site:* R049XB210CO - Sandy Foothill

*Hydric soil rating:* No

#### Bresser

*Percent of map unit:* 5 percent



Custom Soil Resource Report

*Landform:* Terraces, interfluves  
*Landform position (three-dimensional):* Tread  
*Down-slope shape:* Linear  
*Across-slope shape:* Linear  
*Ecological site:* R049XB210CO - Sandy Foothill  
*Hydric soil rating:* No

**Pleasant, frequently ponded**

*Percent of map unit:* 2 percent  
*Landform:* Closed depressions  
*Down-slope shape:* Concave, linear  
*Across-slope shape:* Concave  
*Ecological site:* R067BY010CO - Closed Upland Depression  
*Hydric soil rating:* Yes

**Urban land**

*Percent of map unit:* 2 percent  
*Hydric soil rating:* No

**Ellicott, occasionally flooded**

*Percent of map unit:* 1 percent  
*Landform:* Drainageways, flood plains  
*Down-slope shape:* Linear  
*Across-slope shape:* Linear, concave  
*Ecological site:* R067BY031CO - Sandy Bottomland  
*Hydric soil rating:* No

gravelly subsoil is exposed during site preparation. Access roads must be designed to control surface runoff and help stabilize cut slopes. The Midway soil has poor potential for homesites and roads because of shallow depth to shale, high frost-action potential, and high shrink-swell potential. Special designs are necessary to overcome these limitations. Capability subclass VIIe.

**19—Columbine gravelly sandy loam, 0 to 3 percent slopes.** This deep, well drained to excessively drained soil formed in coarse textured material on alluvial terraces and fans and on flood plains. Elevation ranges from 6,500 to 7,300 feet. The average annual precipitation is about 15 inches, the average annual air temperature is about 47 degrees F, and the average frost-free period is about 135 days.

Typically, the surface layer is grayish brown gravelly sandy loam about 14 inches thick. The underlying material is light yellowish brown very gravelly loamy sand.

Included with this soil in mapping are small areas of Stapleton sandy loam, 3 to 8 percent slopes; Blendon sandy loam, 0 to 3 percent slopes; Louviers silty clay loam, 3 to 18 percent slopes; and Fluvaquent Haplaquolls, nearly level. In places the parent arkose beds of sandstone or shale are at a depth of 0 to 40 inches.

Permeability of this Columbine soil is very rapid. Effective rooting depth is 60 inches or more. Available water capacity is low to moderate. Surface runoff is slow, and the hazard of erosion is slight to moderate.

This soil is used mainly for grazing livestock and for wildlife habitat. It is also used for homesites.

Native vegetation is mainly western wheatgrass, side-oats grama, needleandthread, and little bluestem. The main shrub is true mountainmahogany.

Proper location of livestock watering facilities helps to control grazing.

Windbreaks and environmental plantings are fairly well suited to this soil. Blowing sand and low available water capacity are the principal limitations to the establishment of trees and shrubs. The soil is so loose that trees need to be planted in the rows. Supplemental irrigation may be needed to insure survival. Trees that are best suited and have good survival are Rocky Mountain juniper, eastern redcedar, ponderosa pine, and Siberian elm. Shrubs that are best suited are skunkbush sumac, lilac, and Siberian peashrub.

Rangeland wildlife, such as pronghorn antelope, cottontail, coyote, and scaled quail, is best adapted to life on this droughty soil. Forage production is typically loam, and proper livestock grazing management is necessary if wildlife and livestock share the range. Livestock watering developments are also important and are used by various wildlife species.

The main limitation of this soil for urban development is a hazard of flooding in some areas. Care must be taken when locating septic tank absorption fields because of possible pollution as a result of the very rapid permeability of this soil. Capability subclass VIe.

**20—Connerton-Rock outcrop complex, 8 to 90 percent slopes.** This moderately sloping to extremely steep complex is in the Garden of the Gods area, west of Colorado Springs. Elevation ranges from 6,200 to 6,500 feet. The average annual precipitation is about 16 inches, and the average annual air temperature is about 47 degrees F.

The Connerton soil makes up about 45 percent of the complex and has slopes of 8 to 30 percent, Rock outcrop makes up about 40 percent, and other soils about 15 percent.

Included with this complex in mapping are areas of Neville fine sandy loam, 3 to 9 percent slopes; Penrose-Manvel complex, 3 to 45 percent slopes; and Fortwingate-Rock outcrop complex, 15 to 60 percent slopes. Also included are small areas of soils that contain more sand than is typical for the series.

The Connerton soil is deep and well drained. It formed in alluvium derived from reddish sandstone on moderately sloping alluvial fans and valley side slopes. Typically, the surface layer is reddish brown loam about 13 inches thick. The substratum is reddish brown sandy clay loam.

Permeability of the Connerton soil is moderate. Effective rooting depth is 60 inches or more. Available water capacity is high. Surface runoff is medium to rapid, and the hazard of erosion is moderate. A few gullies are in areas of this soil, especially along paths and trails and in drainageways.

Rock outcrop is in long, narrow bands in the form of cliffs or as monoliths and monuments. It consists of red to gray sandstone and limestone.

This complex is used for recreation, wildlife habitat, homesites, and limited livestock grazing.

Native vegetation is mainly western wheatgrass, needlegrasses, big bluestem, side-oats grama, blue grama, and native bluegrasses.

If the range has deteriorated, blue grama, junegrass, and native bluegrasses increase. Sleepygrass and annuals replace these grasses if the range has seriously deteriorated. Seeding is a good practice if the range is in poor condition. Seeding of the native vegetation is desirable, but the range can also be seeded with tame species of grasses such as Nordan crested wheatgrass, Russian wild-rye, pubescent wheatgrass, or intermediate wheatgrass.

This complex is suited to the production of juniper and pinyon pine. It is capable of producing 4 cords per acre in a stand of trees that average 5 inches in diameter at a height of 1 foot. The limitations for the production of wood crops are the presence of stones on the surface and a high hazard of erosion. Stones on the surface can influence felling, yarding, and other operations involving the use of equipment. Special care must be taken to minimize erosion when harvesting timber.

This complex is relatively unproductive for vegetation, especially in times of drought, when annual production may be as low as 300 pounds per acre. Rangeland wildlife, such as antelope and scaled quail, can be encouraged by properly managing livestock grazing, installing livestock watering facilities, and reseeding range where needed.

Permeability of the Crowfoot soil is moderate. Effective rooting depth is 60 inches or more. Available water capacity is moderate. Surface runoff is medium, and the hazard of erosion is moderate. Some gullies are present in some drainageways and along stock trails.

The soils in this complex are used as rangeland, for recreation and wildlife habitat, and as homesites.

Native vegetation is mainly mountain muhly, bluestem, mountain brome, needleandthread, and blue grama. These soils are subject to invasion by Kentucky bluegrass and Gambel oak. Noticeable forbs are hairy goldenrod, geranium, milkvetch, low larkspur, fringed sage, and buckwheat.

Proper location of livestock watering facilities helps to control grazing. Timely deferment of grazing is needed to protect the plant cover.

Windbreaks and environmental plantings are fairly well suited to these soils. Blowing sand and moderate available water capacity are the main limitations for the establishment of trees and shrubs. The soils are so loose that trees need to be planted in shallow furrows and plant cover needs to be maintained between the rows. Supplemental irrigation may be needed to insure survival. Trees that are best suited and have good survival are Rocky Mountain juniper, eastern redcedar, ponderosa pine, and Siberian elm. Shrubs that are best suited are skunkbush sumac, lilac, and Siberian peashrub.

These soils are best suited to habitat for openland wildlife species, such as pronghorn antelope and sharp-tailed grouse. Although sharp-tailed grouse are not plentiful, they could be encouraged on these soils, especially where brush species are interspersed with grasses and forbs. If these soils are used as rangeland, wildlife production can be increased by managing livestock grazing to preclude overuse of the more desirable grass species and depletion of the various brush species.

The main limitations for urban uses are frost-action potential and slope on the Crowfoot soil and slope on the Tomah soil. Buildings and roads must be designed to overcome these limitations. Access roads must have adequate cut-slope grade and be provided with drains to control surface runoff. Maintaining the existing vegetation on building sites during construction helps to control erosion. Capability subclass VIe.

**94—Travessilla-Rock outcrop complex, 8 to 90 percent slopes.** This moderately sloping to extremely steep complex is mostly on rocky uplands (fig. 5). Elevation ranges from 6,200 to 6,700 feet. The average annual precipitation is about 15 inches, the average annual air temperature is about 47 degrees F, and the average frost-free period is about 140 days.

The Travessilla soil makes up about 45 percent of the complex, Rock outcrop about 30 percent, and included areas about 25 percent.

Included with this complex in mapping are areas of Bresser sandy loam, 5 to 9 percent slopes, Elbeth sandy loam, 8 to 15 percent slopes, Kettle gravelly loamy sand, 8 to 40 percent slopes, and Louviers silty clay loam, 3 to 18 percent slopes. The Elbeth and Kettle soils commonly are on the north-facing slopes.

The Travessilla soil is shallow and well drained. It formed in residuum derived from sandstone. Typically, the surface layer is light brownish gray sandy loam about 3 inches thick. The underlying material is pale brown sandy loam about 8 inches thick. Hard arkosic sandstone that has some fractures is at a depth of about 11 inches.

Permeability of the Travessilla soil is moderately rapid. Effective rooting depth is 6 to 20 inches. Available water capacity is low. Surface runoff is medium to rapid, and the hazard of erosion is high. Gullies are common along drainageways and trails.

Rock outcrop occurs mostly as ledges on cliffs.

This complex is used for urban development, as homesites, and for recreation and wildlife habitat.

This complex is suited to the production of ponderosa pine. The main limitations are the presence of stones and rock outcrop on the surface and a high hazard of erosion. Stones on the surface can hinder felling, yarding, and other operations involving the use of equipment. Practices must be used to minimize soil erosion when harvesting timber. The low available water capacity can influence seedling survival.

Wildlife on these soils is limited mostly to small animals such as cottontail, squirrel, and birds because of the extent of urban development. Ponderosa pine, mountainmahogany, Gambel oak, and various grasses provide food, cover, and nesting areas.

This complex is extensively used for urban development and as homesites (fig. 6). The main limitations for these uses are depth to bedrock, rock outcrop, and steep slopes. Septic tank absorption fields do not function properly because of the depth to bedrock. Special designs for buildings and roads and streets are needed to overcome the limitations. Plans for homesite development should provide for the preservation of as many trees as possible because of their esthetic value. Capability subclass VIIe.

**95—Truckton loamy sand, 1 to 9 percent slopes.** This deep, well drained soil formed in alluvium and residuum derived from arkosic sedimentary rock on uplands. Elevation ranges from 6,000 to 7,000 feet. The average annual precipitation is about 15 inches, the average annual air temperature is about 47 degrees F, and the average frost-free period is about 135 days.

Typically, the surface layer is grayish brown loamy sand about 8 inches thick. The subsoil is brown sandy loam about 18 inches thick. The substratum is light yellowish brown coarse sandy loam to a depth of 60 inches or more.

Included with this soil in mapping are small areas of Blakeland loamy sand, 1 to 9 percent slopes; Bresser sandy loam, 3 to 5 percent slopes; Bresser sandy loam, 5 to 9 percent slopes; Truckton sandy loam, 0 to 3 percent slopes; and Truckton sandy loam, 3 to 9 percent slopes.

Permeability of this Truckton soil is moderately rapid. Effective rooting depth is 60 inches or more. Available water capacity is moderate. Surface runoff is slow, and the hazard of erosion is moderate to high.

Almost all areas of this soil are used as rangeland. A few areas of crops such as alfalfa and corn are grown under sprinkler irrigation.

This soil is well suited to the production of native vegetation suitable for grazing. It is best suited to deep-rooted grasses. The native vegetation is mainly cool- and warm-season grasses such as western wheatgrass, side-oats grama, and needleandthread.

Proper range management is needed to prevent excessive removal of the plant cover. Interseeding is used to improve the existing vegetation. Deferment of grazing in spring increases plant vigor and soil stability. Properly locating livestock watering facilities helps to control grazing.

Windbreaks and environmental plantings are fairly well suited to this soil. Blowing sand is the main limitation for the establishment of trees and shrubs. The soil is so loose that trees need to be planted in shallow furrows and plant cover needs to be maintained between the rows. Supplemental irrigation may be needed to insure survival. Trees that are best suited and have good survival are Rocky Mountain juniper, eastern redcedar, ponderosa pine, and Siberian elm. Shrubs that are best suited are skunkbush sumac, lilac, and Siberian peashrub.

This soil is suited to wildlife habitat. It is best suited to openland and rangeland wildlife habitat. Rangeland wildlife, such as pronghorn antelope, can be encouraged by developing livestock watering facilities, properly managing livestock grazing, and reseeding range where needed.

This soil has good potential for use as homesites. The main limitation of this soil for roads and streets is frost action potential. Special designs for roads are needed to minimize this limitation. Practices are needed to control soil blowing and water erosion on construction sites where the plant cover has been removed. Capability subclass VIe, nonirrigated.

**96—Truckton sandy loam, 0 to 3 percent slopes.** This deep, well drained soil formed in alluvium and residuum derived from arkosic sedimentary rock on uplands. Elevation ranges from 6,000 to 7,000 feet. The average annual precipitation is about 15 inches, the average annual air temperature is about 47 degrees F, and the average frost-free period is about 135 days.

Typically, the surface layer is grayish brown sandy loam about 5 inches thick. The next layer is dark grayish brown sandy loam about 3 inches thick. The subsoil is brown sandy loam about 16 inches thick. The substratum is light yellowish brown coarse sandy loam to a depth of 60 inches or more.

Included with this soil in mapping are small areas of Blakeland loamy sand, 1 to 9 percent slopes; Bresser sandy loam, 0 to 3 percent slopes; Ellicott loamy coarse sand, 0 to 5 percent slopes; and Ustic Torrifluvents, loamy.

Permeability of this Truckton soil is moderately rapid. Effective rooting depth is 60 inches or more. Available water capacity is moderate. Surface runoff is slow, and the hazards of erosion and soil blowing are moderate.

This soil is used mainly for cultivated crops. It is also used for livestock grazing, for wildlife habitat, and as homesites.

Crops are commonly grown in combination with summer fallow because moisture is insufficient for annual cropping. Alfalfa can also be grown on this soil. When this soil is used as cropland, crop residue management and minimum tillage are necessary conservation practices.

This soil is well suited to the production of native vegetation suitable for grazing (fig. 7). It favors deep-rooted grasses. The native vegetation is mainly cool- and warm-season grasses such as western wheatgrass, side-oats grama, and needleandthread.

Proper range management is needed to prevent excessive removal of the plant cover. Interseeding is used to improve the existing vegetation. Deferment of grazing in spring increases plant vigor and soil stability. Properly locating livestock watering facilities helps to control grazing.

Windbreaks and environmental plantings generally are suited to this soil. Soil blowing is the main limitation to the establishment of trees and shrubs. This limitation can be overcome by cultivating only in the tree rows and leaving a strip of vegetation between the rows. Supplemental irrigation may be needed when planting and during dry periods. Trees that are best suited and have good survival are Rocky Mountain juniper, eastern redcedar, ponderosa pine, Siberian elm, Russian-olive, and hackberry. Shrubs that are best suited are skunkbush sumac, lilac, and Siberian peashrub.

This soil is suited to wildlife habitat. It is best suited to habitat for openland and rangeland wildlife. In cropland areas, habitat favorable for ring-necked pheasant, mourning dove, and many nongame species can be developed by establishing areas for nesting and escape cover. For pheasant, undisturbed nesting cover is vital and should be provided in plans for habitat development. This is especially true in areas of intensive farming. Rangeland wildlife, such as pronghorn antelope, can be encouraged by developing livestock watering facilities, properly managing livestock grazing, and reseeding range where needed.

This soil has good potential for use as homesites. The main limitation of this soil for roads and streets is frost-action potential. Special designs for roads are needed to overcome this limitation. Capability subclasses IIIe, nonirrigated, and IIe, irrigated.

**97—Truckton sandy loam, 3 to 9 percent slopes.** This deep, well drained soil formed in alluvium and residuum derived from arkosic sedimentary rock on uplands. Elevation ranges from 6,000 to 7,000 feet. The average annual precipitation is about 15 inches, the average annual air temperature is about 47 degrees F, and the average frost-free period is about 135 days.

Typically, the surface layer is grayish brown sandy loam about 5 inches thick. The next layer is dark grayish brown sandy loam about 3 inches thick. The subsoil is brown sandy loam about 16 inches thick. The substratum is light yellowish brown coarse sandy loam to a depth of 60 inches or more.

Custom Soil Resource Report  
Map—Hydrologic Soil Group (61183 - Ellicott School 2 Building Addition)

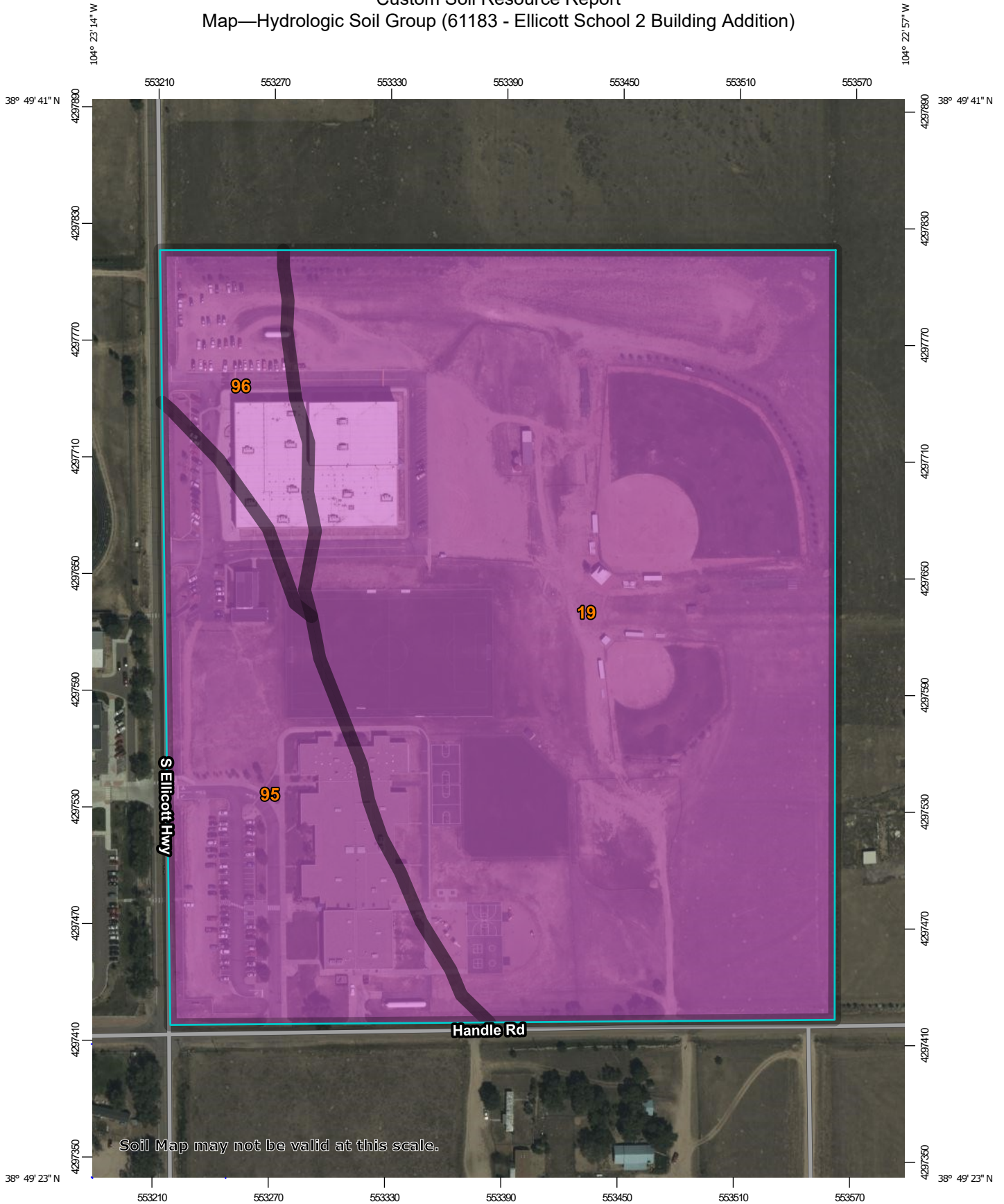

Soil Map may not be valid at this scale.

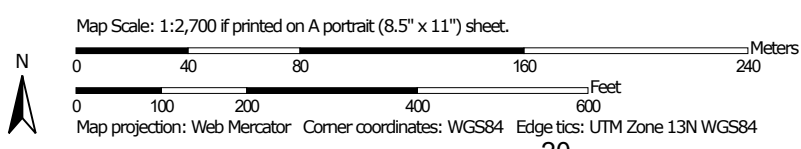









### MAP LEGEND









**Area of Interest (AOI)**  
 Area of Interest (AOI)

**Soils**





**Soil Rating Polygons**

-  A
-  A/D
-  B
-  B/D
-  C
-  C/D
-  D
-  Not rated or not available

**Soil Rating Lines**

-  A
-  A/D
-  B
-  B/D
-  C
-  C/D
-  D
-  Not rated or not available





**Soil Rating Points**

-  A
-  A/D
-  B
-  B/D

**Water Features**

-  Streams and Canals





**Transportation**

-  Rails
-  Interstate Highways
-  US Routes
-  Major Roads
-  Local Roads

**Background**

-  Aerial Photography

**Soils**

-  C
-  C/D
-  D
-  Not rated or not available

### MAP INFORMATION

The soil surveys that comprise your AOI were mapped at 1:24,000.

Warning: Soil Map may not be valid at this scale.

Enlargement of maps beyond the scale of mapping can cause misunderstanding of the detail of mapping and accuracy of soil line placement. The maps do not show the small areas of contrasting soils that could have been shown at a more detailed scale.

Please rely on the bar scale on each map sheet for map measurements.

Source of Map: Natural Resources Conservation Service  
 Web Soil Survey URL:  
 Coordinate System: Web Mercator (EPSG:3857)

Maps from the Web Soil Survey are based on the Web Mercator projection, which preserves direction and shape but distorts distance and area. A projection that preserves area, such as the Albers equal-area conic projection, should be used if more accurate calculations of distance or area are required.

This product is generated from the USDA-NRCS certified data as of the version date(s) listed below.

Soil Survey Area: El Paso County Area, Colorado  
 Survey Area Data: Version 20, Sep 2, 2022

Soil map units are labeled (as space allows) for map scales 1:50,000 or larger.

Date(s) aerial images were photographed: Sep 11, 2018—Oct 20, 2018

The orthophoto or other base map on which the soil lines were compiled and digitized probably differs from the background imagery displayed on these maps. As a result, some minor shifting of map unit boundaries may be evident.

**Table—Hydrologic Soil Group (61183 - Ellicott School 2 Building Addition)**

Map unit symbol	Map unit name	Rating	Acres in AOI	Percent of AOI
19	Columbine gravelly sandy loam, 0 to 3 percent slopes	A	24.9	73.2%
95	Truckton loamy sand, 1 to 9 percent slopes	A	7.0	20.5%
96	Truckton sandy loam, 0 to 3 percent slopes	A	2.1	6.3%
<b>Totals for Area of Interest</b>			<b>34.1</b>	<b>100.0%</b>

**Rating Options—Hydrologic Soil Group (61183 - Ellicott School 2 Building Addition)**

*Aggregation Method: Dominant Condition*

*Component Percent Cutoff: None Specified*

*Tie-break Rule: Higher*

## **9 Hydrologic Calculations**

Colorado Springs Rainfall Intensity Duration Frequency Figure 6-5

Runoff Coefficients and Percent Imperviousness Table 6-6

Hydrologic Calculations Summary Form SF-1 for Existing & Developed Conditions

Hydrologic Calculations Summary 5-yr Form SF-2 for Existing & Developed Conditions

Hydrologic Calculations Summary 100-yr Form SF-2 for Existing & Developed Conditions



**Figure 6-5. Colorado Springs Rainfall Intensity Duration Frequency**

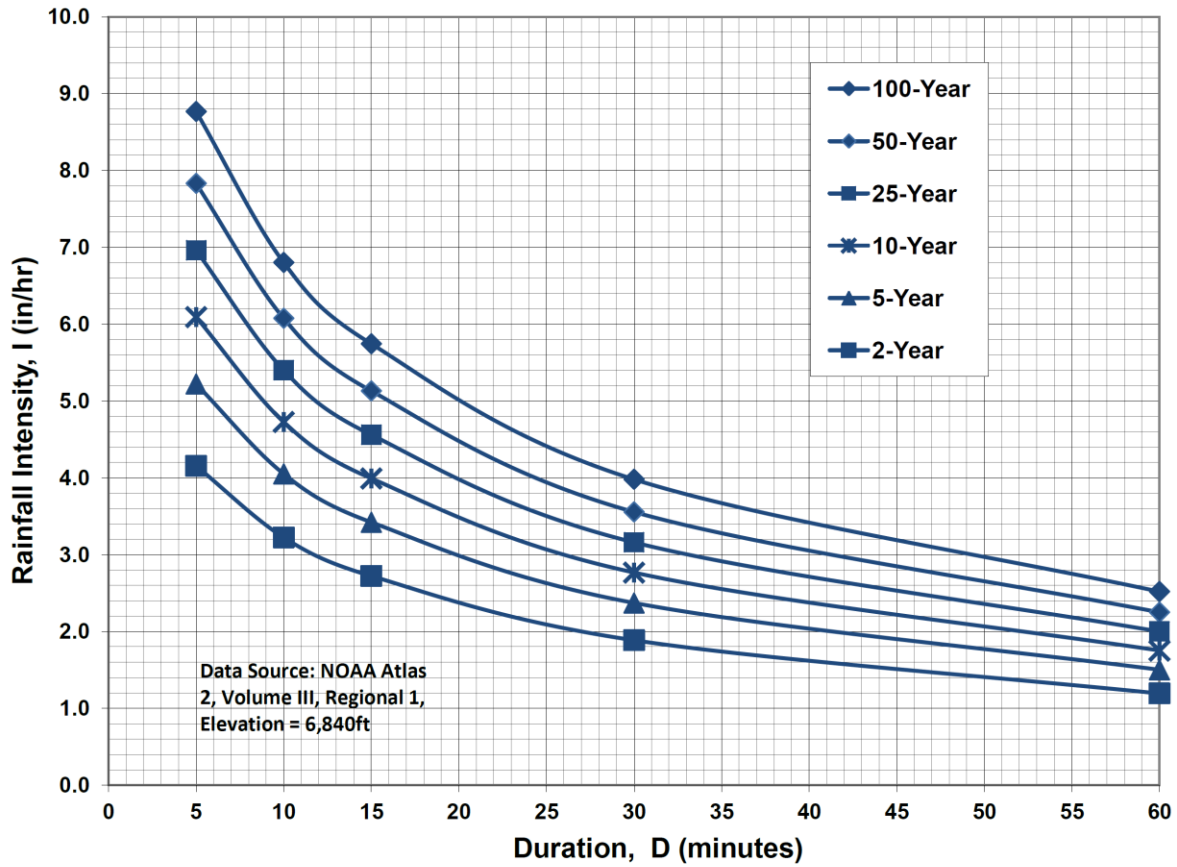

**IDF Equations**

$$I_{100} = -2.52 \ln(D) + 12.735$$

$$I_{50} = -2.25 \ln(D) + 11.375$$

$$I_{25} = -2.00 \ln(D) + 10.111$$

$$I_{10} = -1.75 \ln(D) + 8.847$$

$$I_5 = -1.50 \ln(D) + 7.583$$

$$I_2 = -1.19 \ln(D) + 6.035$$

Note: Values calculated by equations may not precisely duplicate values read from figure.

**Table 6-6. Runoff Coefficients for Rational Method**  
(Source: UDFCD 2001)

Land Use or Surface Characteristics	Percent Impervious	Runoff Coefficients											
		2-year		5-year		10-year		25-year		50-year		100-year	
		HSG A&B	HSG C&D	HSG A&B	HSG C&D	HSG A&B	HSG C&D	HSG A&B	HSG C&D	HSG A&B	HSG C&D	HSG A&B	HSG C&D
<b>Business</b>													
Commercial Areas	95	0.79	0.80	0.81	0.82	0.83	0.84	0.85	0.87	0.87	0.88	0.88	0.89
Neighborhood Areas	70	0.45	0.49	0.49	0.53	0.53	0.57	0.58	0.62	0.60	0.65	0.62	0.68
<b>Residential</b>													
1/8 Acre or less	65	0.41	0.45	0.45	0.49	0.49	0.54	0.54	0.59	0.57	0.62	0.59	0.65
1/4 Acre	40	0.23	0.28	0.30	0.35	0.36	0.42	0.42	0.50	0.46	0.54	0.50	0.58
1/3 Acre	30	0.18	0.22	0.25	0.30	0.32	0.38	0.39	0.47	0.43	0.52	0.47	0.57
1/2 Acre	25	0.15	0.20	0.22	0.28	0.30	0.36	0.37	0.46	0.41	0.51	0.46	0.56
1 Acre	20	0.12	0.17	0.20	0.26	0.27	0.34	0.35	0.44	0.40	0.50	0.44	0.55
<b>Industrial</b>													
Light Areas	80	0.57	0.60	0.59	0.63	0.63	0.66	0.66	0.70	0.68	0.72	0.70	0.74
Heavy Areas	90	0.71	0.73	0.73	0.75	0.75	0.77	0.78	0.80	0.80	0.82	0.81	0.83
<b>Parks and Cemeteries</b>													
Parks and Cemeteries	7	0.05	0.09	0.12	0.19	0.20	0.29	0.30	0.40	0.34	0.46	0.39	0.52
Playgrounds	13	0.07	0.13	0.16	0.23	0.24	0.31	0.32	0.42	0.37	0.48	0.41	0.54
Railroad Yard Areas	40	0.23	0.28	0.30	0.35	0.36	0.42	0.42	0.50	0.46	0.54	0.50	0.58
<b>Undeveloped Areas</b>													
Historic Flow Analysis-- Greenbelts, Agriculture	2	0.03	0.05	0.09	0.16	0.17	0.26	0.26	0.38	0.31	0.45	0.36	0.51
Pasture/Meadow	0	0.02	0.04	0.08	0.15	0.15	0.25	0.25	0.37	0.30	0.44	0.35	0.50
Forest	0	0.02	0.04	0.08	0.15	0.15	0.25	0.25	0.37	0.30	0.44	0.35	0.50
Exposed Rock	100	0.89	0.89	0.90	0.90	0.92	0.92	0.94	0.94	0.95	0.95	0.96	0.96
Offsite Flow Analysis (when landuse is undefined)	45	0.26	0.31	0.32	0.37	0.38	0.44	0.44	0.51	0.48	0.55	0.51	0.59
<b>Streets</b>													
Paved	100	0.89	0.89	0.90	0.90	0.92	0.92	0.94	0.94	0.95	0.95	0.96	0.96
Gravel	80	0.57	0.60	0.59	0.63	0.63	0.66	0.66	0.70	0.68	0.72	0.70	0.74
<b>Drive and Walks</b>													
Drive and Walks	100	0.89	0.89	0.90	0.90	0.92	0.92	0.94	0.94	0.95	0.95	0.96	0.96
<b>Roofs</b>													
Roofs	90	0.71	0.73	0.73	0.75	0.75	0.77	0.78	0.80	0.80	0.82	0.81	0.83
<b>Lawns</b>													
Lawns	0	0.02	0.04	0.08	0.15	0.15	0.25	0.25	0.37	0.30	0.44	0.35	0.50

Job No.: **61183**  
 Project: **Ellicott D22 – GS & HS Addition (EXISTING)**

Date: **4/5/2023 14:35**  
 Calcs By: **O. Ali**  
 Checked By: \_\_\_\_\_

**Time of Concentration** (Modified from Standard Form SF-1)

Sub-Basin	Sub-Basin Data				Overland			Shallow Channel				Channelized				t <sub>c</sub> Check		t <sub>c</sub> (min)
	Area (Acres)	C <sub>5</sub>	C <sub>100</sub> /CN	% Imp.	L <sub>0</sub> (ft)	S <sub>0</sub> (%)	t <sub>i</sub> (min)	L <sub>0t</sub> (ft)	S <sub>0t</sub> (ft/ft)	v <sub>0sc</sub> (ft/s)	t <sub>t</sub> (min)	L <sub>0c</sub> (ft)	S <sub>0c</sub> (ft/ft)	v <sub>0c</sub> (ft/s)	t <sub>c</sub> (min)	L (min)	t <sub>c,alt</sub> (min)	
EX-A	4.72	0.25	0.47	24%	100	3%	11.4	524	0.009	0.6	13.5	117	0.013	2.7	0.7	741	14.1	14.1
EX-B	0.44	0.45	0.61	53%	99	3%	8.6	174	0.009	0.6	4.5	0	0.000	0.0	0.0	273	11.5	11.5
EX-C	1.47	0.10	0.36	2%	100	0%	0.0	434	0.006	0.5	13.6	0	0.000	0.0	0.0	534	13.0	13.0
EX-D	2.26	0.08	0.35	0%	100	3%	13.6	258	0.012	0.8	5.7	220	0.005	1.1	3.2	578	13.2	13.2
EX-S1	2.67	0.29	0.50	32%	100	1%	18.3	168	0.015	0.9	3.3	224	0.004	1.6	2.4	492	12.7	12.7
EX-S2	1.21	0.71	0.80	85%	100	0%	0.0	55	0.027	3.3	0.3	232	0.006	2.6	1.5	387	12.2	5.0
EX-S3	1.57	0.09	0.36	1%	100	2%	16.0	393	0.011	0.7	8.7	0	0.000	0.0	0.0	493	12.7	12.7
EX-S4	3.65	0.46	0.63	48%	100	3%	8.1	764	0.007	1.7	7.5	0	0.000	0.0	0.0	864	14.8	14.8
EX-S5	1.91	0.61	0.73	70%	100	3%	6.2	50	0.020	2.8	0.3	375	0.004	2.1	3.0	525	12.9	9.5
EX-S6	1.07	0.47	0.63	52%	100	13%	4.9	90	0.022	1.0	1.4	378	0.005	2.0	3.2	568	13.2	9.5
EX-S7	0.98	0.53	0.68	61%	100	13%	4.4	288	0.002	0.8	5.8	207	0.005	1.9	1.8	595	13.3	12.0
EX-S8	1.62	0.36	0.55	35%	64	20%	4.0	295	0.017	0.9	5.4	0	0.000	0.0	0.0	359	12.0	9.4
EX-S9	5.86	0.10	0.36	2%	100	1%	22.7	726	0.006	0.6	22.0	167	0.003	0.8	3.4	993	15.5	15.5
EX-S10	2.65	0.11	0.37	4%	100	1%	22.5	440	0.010	0.7	10.4	0	0.000	0.0	0.0	540	13.0	13.0
EX-S11	0.45	0.08	0.35	0%	100	0%	0.0	95	0.026	1.1	1.4	0	0.000	0.0	0.0	195	11.1	5.0
EX-S12	1.68	0.08	0.35	0%	99	2%	16.0	284	0.011	0.7	6.6	0	0.000	0.0	0.0	383	12.1	12.1

Job No.: **61183**  
 Project: **Ellicott D22 – GS & HS Addition (PROPOSED)**

Date: **4/5/2023 14:35**  
 Calcs By: **O. Ali**  
 Checked By: \_\_\_\_\_

**Time of Concentration** (Modified from Standard Form SF-1)

Sub-Basin	Sub-Basin Data				Overland			Shallow Channel				Channelized				t <sub>c</sub> Check		t <sub>c</sub> (min)
	Area (Acres)	C <sub>5</sub>	C <sub>100</sub> /CN	% Imp.	L <sub>0</sub> (ft)	S <sub>0</sub> (%)	t <sub>i</sub> (min)	L <sub>0t</sub> (ft)	S <sub>0t</sub> (ft/ft)	v <sub>0sc</sub> (ft/s)	t <sub>t</sub> (min)	L <sub>0c</sub> (ft)	S <sub>0c</sub> (ft/ft)	v <sub>0c</sub> (ft/s)	t <sub>c</sub> (min)	L (min)	t <sub>c,alt</sub> (min)	
A	4.23	0.27	0.48	27%	100	3%	11.1	470	0.007	0.6	13.0	273	0.002	1.3	3.6	843	14.7	14.7
B1	0.44	0.53	0.67	64%	100	2%	9.0	177	0.011	0.7	4.0	0	0.000	0.0	0.0	277	11.5	11.5
B2	0.62	0.48	0.64	55%	51	16%	3.2	21	0.048	1.5	0.2	241	0.008	1.6	2.5	313	11.7	5.9
C	1.33	0.10	0.36	2%	100	8%	9.1	368	0.007	0.6	10.6	29	0.017	2.1	0.2	497	12.8	12.8
D	2.19	0.26	0.48	26%	100	3%	11.1	318	0.009	1.9	2.7	119	0.008	0.9	2.2	537	13.0	13.0
EX-S1	2.67	0.29	0.50	32%	100	1%	18.3	168	0.015	0.9	3.3	224	0.004	1.6	2.4	492	12.7	12.7
EX-S2	1.21	0.71	0.80	85%	100	0%	0.0	55	0.027	3.3	0.3	232	0.006	2.6	1.5	387	12.2	5.0
S3	1.69	0.09	0.36	1%	100	2%	15.9	393	0.011	0.7	8.7	0	0.000	0.0	0.0	493	12.7	12.7
S4	3.61	0.46	0.63	49%	100	3%	8.0	764	0.007	1.7	7.5	0	0.000	0.0	0.0	864	14.8	14.8
EX-S5	1.91	0.61	0.73	70%	100	3%	6.2	50	0.020	2.8	0.3	375	0.004	2.1	3.0	525	12.9	9.5
EX-S6	1.07	0.47	0.63	52%	100	13%	4.9	90	0.022	1.0	1.4	378	0.005	2.0	3.2	568	13.2	9.5
EX-S7	0.98	0.53	0.68	61%	100	13%	4.4	288	0.002	0.8	5.8	207	0.005	1.9	1.8	595	13.3	12.0
EX-S8	1.62	0.36	0.55	35%	64	20%	4.0	295	0.017	0.9	5.4	0	0.000	0.0	0.0	359	12.0	9.4
S9	5.84	0.10	0.36	2%	100	1%	22.7	726	0.006	0.6	22.0	167	0.003	0.8	3.4	993	15.5	15.5
EX-S10	2.65	0.11	0.37	4%	100	1%	22.5	440	0.010	0.7	10.4	0	0.000	0.0	0.0	540	13.0	13.0
EX-S11	0.45	0.08	0.35	0%	100	0%	0.0	95	0.026	1.1	1.4	0	0.000	0.0	0.0	195	11.1	5.0
EX-S12	1.68	0.08	0.35	0%	99	2%	16.0	284	0.011	0.7	6.6	0	0.000	0.0	0.0	383	12.1	12.1

Job No.: **61183**  
 Project: **Ellicott D22 – GS & HS Addition (EXISTING)**  
 Design Storm: **5-Year Storm (20% Probability)**  
 Jurisdiction: **DCM**

Date: **4/5/2023 14:35**  
 Calcs By: **O. Ali**  
 Checked By: \_\_\_\_\_

**Sub-Basin and Combined Flows** (Modified from Standard Form SF-2)

DP	Sub-Basin	Area (Acres)	C5	Direct Runoff				Combined Runoff				Streetflow			Pipe Flow					Travel Time		
				t <sub>c</sub>	CA	I5	Q5	t <sub>c</sub>	CA	I5	Q5	Slope	Length	Q	Q	Slope	Mnngs	Length	D <sub>Pipe</sub>	Length	V <sub>Osc</sub>	t <sub>t</sub>
				(min)	(Acres)	(in/hr)	(cfs)	(min)	(Acres)	(in/hr)	(cfs)	(%)	(ft)	(cfs)	(cfs)	(%)	n	(ft)	(in)	(ft)	(ft/s)	(min)
EX-DP1	EX-A	4.72	0.25	14.1	1.18	3.61	4.25															
	EX-B	0.44	0.45	11.5	0.20	3.92	0.77															
	EX-C	1.47	0.10	13.0	0.14	3.74	0.54															
EX-DP2		6.19	0.21					16.1	1.32	3.41	4.5											
EX-DP3		6.62	0.23					16.5	1.51	3.38	5.1											
	EX-S1	2.67	0.29	12.7	0.78	3.77	2.95															
EX-DP4	EX-S2	1.21	0.71	5.0	0.86	5.17	4.44															
EX-DP5		9.30	0.25					19.5	2.30	3.13	7.2											
EX-DP6	EX-D	2.26	0.08	13.2	0.18	3.71	0.67															
	EX-S3	1.57	0.09	12.7	0.14	3.77	0.53															
EX-DP7		14.34	0.24					23.2	3.48	2.87	10.0											
	EX-S4	3.65	0.46	14.8	1.67	3.54	5.90															
	EX-S5	1.91	0.61	9.5	1.16	4.21	4.90															
EX-DP9		5.56	0.51					17.4	2.83	3.30	9.3											
	EX-S6	1.07	0.47	9.5	0.51	4.21	2.13															
EX-DP10		6.63	0.50					20.2	3.34	3.07	10.3											
EX-DP8	EX-S7	0.98	0.53	12.0	0.52	3.86	2.01															
	EX-S8	1.62	0.36	9.4	0.58	4.23	2.44															
EX-DP11		9.22	0.48					22.5	4.44	2.91	12.9											
	EX-S9	5.86	0.10	15.5	0.57	3.47	1.98															
EX-DP12		29.42	0.29					29.0	8.49	2.53	21.5											
	EX-S10	2.65	0.11	13.0	0.29	3.74	1.08															
EX-DP13		32.07	0.27					31.4	8.78	2.41	21.2											
	EX-S11	0.45	0.08	5.0	0.04	5.17	0.19															
	EX-S12	1.68	0.08	12.1	0.13	3.84	0.51															

DCM:  $I = C1 * \ln(tc) + C2$   
 C1: 1.5  
 C1: 7.583

Job No.: **61183**  
 Project: **Ellicott D22 – GS & HS Addition (PROPOSED)**  
 Design Storm: **5-Year Storm (20% Probability)**  
 Jurisdiction: **DCM**

Date: **4/5/2023 14:35**  
 Calcs By: **O. Ali**  
 Checked By: \_\_\_\_\_

**Sub-Basin and Combined Flows** (Modified from Standard Form SF-2)

DP	Sub-Basin	Area (Acres)	C5	Direct Runoff				Combined Runoff				Streetflow			Pipe Flow					Travel Time		
				t <sub>c</sub>	CA	I5	Q5	t <sub>c</sub>	CA	I5	Q5	Slope	Length	Q	Q	Slope	Mnngs	Length	D <sub>Pipe</sub>	Length	V <sub>0sc</sub>	t <sub>t</sub>
				(min)	(Acres)	(in/hr)	(cfs)	(min)	(Acres)	(in/hr)	(cfs)	(%)	(ft)	(cfs)	(cfs)	(%)	n	(ft)	(in)	(ft)	(ft/s)	(min)
DP1	A	4.23	0.27	14.7	1.14	3.55	4.04															
	B1	0.44	0.53	11.5	0.23	3.91	0.92															
DP2	B2	0.62	0.48	5.9	0.30	4.91	1.47															
	C	1.33	0.10	12.8	0.13	3.76	0.50															
DP3		6.62	0.27					15.9	1.80	3.43	6.2											
	EX-S1	2.67	0.29	12.7	0.78	3.77	2.95															
DP4	EX-S2	1.21	0.71	5.0	0.86	5.17	4.44															
DP5		9.30	0.28					19.5	2.59	3.13	8.1											
DP6A	D	2.19	0.26	13.0	0.58	3.74	2.17															
	S3	1.69	0.09	12.7	0.15	3.77	0.57															
DP7		14.39	0.29					23.2	4.18	2.87	12.0											
	S4	3.61	0.46	14.8	1.66	3.54	5.89															
	EX-S5	1.91	0.61	9.5	1.16	4.21	4.90															
DP9		5.53	0.51					17.4	2.83	3.30	9.3											
	EX-S6	1.07	0.47	9.5	0.51	4.21	2.13															
DP10		6.60	0.51					20.2	3.33	3.07	10.2											
DP8	EX-S7	0.98	0.53	12.0	0.52	3.86	2.01															
	EX-S8	1.62	0.36	9.4	0.58	4.23	2.44															
DP11		9.19	0.48					22.5	4.43	2.91	12.9											
	S9	5.84	0.10	15.5	0.57	3.47	1.98															
DP12		29.42	0.31					29.0	9.18	2.53	23.3											
	EX-S10	2.65	0.11	13.0	0.29	3.74	1.08															
DP13		32.07	0.30					31.4	9.47	2.41	22.9											
	EX-S11	0.45	0.08	5.0	0.04	5.17	0.19															
	EX-S12	1.68	0.08	12.1	0.13	3.84	0.51															

DCM:  $I = C1 * \ln(tc) + C2$   
 C1: 1.5  
 C1: 7.583

Job No.: 61183

Project: Ellicott D22 – GS & HS Addition (EXISTING)

Design Storm: 100-Year Storm (1% Probability)

Jurisdiction: DCM

Date: 4/5/2023 14:35

Calcs By: O. Ali

Checked By: \_\_\_\_\_

**Sub-Basin and Combined Flows** (Modified from Standard Form SF-2)

DP	Sub-Basin	Area (Acres)	C100	Direct Runoff				Combined Runoff				Streetflow			Pipe Flow					Travel Time		
				t <sub>c</sub> (min)	CA (Acres)	I100 (in/hr)	Q100 (cfs)	t <sub>c</sub> (min)	CA (Acres)	I100 (in/hr)	Q100 (cfs)	Slope (%)	Length (ft)	Q (cfs)	Q (cfs)	Slope (%)	Mnngs n	Length (ft)	D <sub>Pipe</sub> (in)	Length (ft)	V <sub>0.5c</sub> (ft/s)	t <sub>t</sub> (min)
EX-DP1	EX-A	4.72	0.47	14.1	2.22	6.06	13.46															
	EX-B	0.44	0.61	11.5	0.27	6.58	1.75															
	EX-C	1.47	0.36	13.0	0.53	6.28	3.35															
EX-DP2		6.19	0.45					16.1	2.75	5.73	15.8											
EX-DP3		6.62	0.46					16.5	3.02	5.68	17.1											
	EX-S1	2.67	0.50	12.7	1.33	6.32	8.44															
EX-DP4	EX-S2	1.21	0.80	5.0	0.97	8.68	8.41															
EX-DP5		9.30	0.47					19.5	4.35	5.25	22.9											
EX-DP6	EX-D	2.26	0.35	13.2	0.79	6.23	4.93															
	EX-S3	1.57	0.36	12.7	0.56	6.32	3.54															
EX-DP7		14.34	0.47					23.2	6.68	4.81	32.1											
	EX-S4	3.65	0.63	14.8	2.28	5.94	13.56															
	EX-S5	1.91	0.73	9.5	1.41	7.07	9.93															
EX-DP9		5.56	0.66					17.4	3.69	5.54	20.4											
	EX-S6	1.07	0.63	9.5	0.68	7.07	4.77															
EX-DP10		6.63	0.66					20.2	4.36	5.16	22.5											
EX-DP8	EX-S7	0.98	0.68	12.0	0.66	6.48	4.27															
	EX-S8	1.62	0.55	9.4	0.90	7.10	6.36															
EX-DP11		9.22	0.64					22.5	5.92	4.89	28.9											
	EX-S9	5.86	0.36	15.5	2.12	5.83	12.37															
EX-DP12		29.42	0.50					29.0	14.72	4.25	62.6											
	EX-S10	2.65	0.37	13.0	0.99	6.27	6.18															
EX-DP13		32.07	0.49					31.4	15.70	4.05	63.6											
	EX-S11	0.45	0.35	5.0	0.16	8.68	1.38															
	EX-S12	1.68	0.35	12.1	0.59	6.45	3.78															

DCM:  $I = C1 * \ln(tc) + C2$

C1: 2.52

C1: 12.735

Job No.: 61183

Project: Ellicott D22 – GS & HS Addition (PROPOSED)

Design Storm: 100-Year Storm (1% Probability)

Jurisdiction: DCM

Date: 4/5/2023 14:35

Calcs By: O. Ali

Checked By: \_\_\_\_\_

**Sub-Basin and Combined Flows** (Modified from Standard Form SF-2)

DP	Sub-Basin	Area (Acres)	C100	Direct Runoff				Combined Runoff				Streetflow			Pipe Flow					Travel Time		
				t <sub>c</sub> (min)	CA (Acres)	I100 (in/hr)	Q100 (cfs)	t <sub>c</sub> (min)	CA (Acres)	I100 (in/hr)	Q100 (cfs)	Slope (%)	Length (ft)	Q (cfs)	Q (cfs)	Slope (%)	Mnngs n	Length (ft)	D <sub>Pipe</sub> (in)	Length (ft)	V <sub>0.5c</sub> (ft/s)	t <sub>t</sub> (min)
DP1	A	4.23	0.48	14.7	2.05	5.96	12.23															
	B1	0.44	0.67	11.5	0.30	6.57	1.94															
DP2	B2	0.62	0.64	5.9	0.39	8.25	3.25															
	C	1.33	0.36	12.8	0.49	6.32	3.07															
DP3	EX-S1	6.62	0.49					15.9	3.23	5.76	18.6											
	EX-S2	2.67	0.50	12.7	1.33	6.32	8.44															
DP4	EX-S2	1.21	0.80	5.0	0.97	8.68	8.41															
DP5		9.30	0.49					19.5	4.56	5.25	24.0											
DP6A	D	2.19	0.48	13.0	1.06	6.27	6.62															
	S3	1.69	0.36	12.7	0.60	6.32	3.81															
DP7		14.39	0.50					23.2	7.19	4.81	34.6											
	S4	3.61	0.63	14.8	2.27	5.94	13.49															
DP9	EX-S5	1.91	0.73	9.5	1.41	7.07	9.93															
	EX-S6	5.53	0.66					17.4	3.68	5.54	20.4											
DP10		1.07	0.63	9.5	0.68	7.07	4.77															
DP8	EX-S7	6.60	0.66					20.2	4.35	5.16	22.5											
	EX-S8	0.98	0.68	12.0	0.66	6.48	4.27															
DP11		1.62	0.55	9.4	0.90	7.10	6.36															
	S9	9.19	0.64					22.5	5.91	4.89	28.9											
DP12		5.84	0.36	15.5	2.12	5.83	12.35															
	EX-S10	29.42	0.52					29.0	15.21	4.25	64.7											
DP13		2.65	0.37	13.0	0.99	6.27	6.18															
	EX-S11	32.07	0.51					31.4	16.20	4.05	65.6											
	EX-S12	0.45	0.35	5.0	0.16	8.68	1.38															
	EX-S12	1.68	0.35	12.1	0.59	6.45	3.78															

DCM:  $I = C1 * \ln(tc) + C2$

C1: 2.52

C1: 12.735



## Sub-Basin Ex-A (DP1) Runoff Calculations

Job No.: 61183  
 Project: Ellicott D22 – GS & HS Addition  
 Jurisdiction: **DCM**  
 Runoff Coefficient: **Surface Type**

Date: 4/5/2023 14:35  
 Calcs by: O. Ali  
 Checked by: \_\_\_\_\_  
 Soil Type: **A**  
 Urbanization: **Urban**

### Basin Land Use Characteristics

Surface	Area		Runoff Coefficient						% Imperv.
	(SF)	(Acres)	C2	C5	C10	C25	C50	C100	
Pasture/Meadow	149,157	3.42	0.02	0.08	0.15	0.25	0.3	0.35	0%
Paved	19,402	0.45	0.89	0.9	0.92	0.94	0.95	0.96	100%
Gravel	36,530	0.84	0.57	0.59	0.63	0.66	0.68	0.7	80%
Roofs	354	0.01	0.71	0.73	0.75	0.78	0.8	0.81	90%
<b>Combined</b>	<b>205,443</b>	<b>4.72</b>	<b>0.20</b>	<b>0.25</b>	<b>0.31</b>	<b>0.39</b>	<b>0.43</b>	<b>0.47</b>	<b>23.8%</b>

205443

### Basin Travel Time

	Shallow Channel Ground Cover		Short Pasture/Lawns			
	$L_{max,Overland}$	100 ft			$C_v$	7
	L (ft)	$\Delta Z_0$ (ft)	$S_0$ (ft/ft)	v (ft/s)	t (min)	$t_{Alt}$ (min)
Total	741	9	-	-	-	-
Initial Time	100	3	0.025	-	11.4	14.1 DCM Eq. 6-8
Shallow Channel	524	5	0.009	0.6	13.5	- DCM Eq. 6-9
Channelized	117	2	0.013	2.7	0.7	- V-Ditch
				$t_c$	<b>14.1 min.</b>	

### Rainfall Intensity & Runoff

	2-Yr	5-Yr	10-Yr	25-Yr	50-Yr	100-Yr
<b>Intensity (in/hr)</b>	2.88	3.61	4.21	4.82	5.42	6.06
<b>Runoff (cfs)</b>	2.7	4.2	6.1	8.8	11.0	13.5
<b>Release Rates (cfs/ac)</b>	-	-	-	-	-	-
<b>Allowed Release (cfs)</b>	2.7	4.2	6.1	8.8	11.0	13.5

DCM:  $I = C1 * \ln(tc) + C2$

C1	1.19	1.5	1.75	2	2.25	2.52
C2	6.035	7.583	8.847	10.111	11.375	12.735

### Notes

## Sub-Basin Ex-B Runoff Calculations

Job No.: 61183  
 Project: Ellicott D22 – GS & HS Addition  
 Jurisdiction: **DCM**  
 Runoff Coefficient: **Surface Type**

Date: 4/5/2023 14:35  
 Calcs by: O. Ali  
 Checked by: \_\_\_\_\_  
 Soil Type: **A**  
 Urbanization: **Urban**

### Basin Land Use Characteristics

Surface	Area		Runoff Coefficient						% Imperv.
	(SF)	(Acres)	C2	C5	C10	C25	C50	C100	
Pasture/Meadow	7,278	0.17	0.02	0.08	0.15	0.25	0.3	0.35	0%
Paved	3,064	0.07	0.89	0.9	0.92	0.94	0.95	0.96	100%
Gravel	8,415	0.19	0.57	0.59	0.63	0.66	0.68	0.7	80%
Roofs	283	0.01	0.71	0.73	0.75	0.78	0.8	0.81	90%
<b>Combined</b>	<b>19,040</b>	<b>0.44</b>	<b>0.41</b>	<b>0.45</b>	<b>0.49</b>	<b>0.55</b>	<b>0.58</b>	<b>0.61</b>	<b>52.8%</b>

19040

### Basin Travel Time

	Shallow Channel	Ground Cover	Short Pasture/Lawns				
$L_{max,Overland}$	100	ft	$C_v$	7			
$L$ (ft)	$\Delta Z_0$ (ft)	$S_0$ (ft/ft)	$v$ (ft/s)	$t$ (min)	$t_{Alt}$ (min)		
Total	273	4	-	-	-		
Initial Time	99	3	0.025	-	8.6	11.5 DCM Eq. 6-8	
Shallow Channel	174	2	0.009	0.6	4.5	- DCM Eq. 6-9	
Channelized			0.000	0.0	0.0	- V-Ditch	
				$t_c$	<b>11.5 min.</b>		

### Rainfall Intensity & Runoff

	2-Yr	5-Yr	10-Yr	25-Yr	50-Yr	100-Yr
<b>Intensity (in/hr)</b>	3.13	3.92	4.57	5.22	5.88	6.58
<b>Runoff (cfs)</b>	0.6	<b>0.8</b>	1.0	1.3	1.5	<b>1.8</b>
<b>Release Rates (cfs/ac)</b>	-	-	-	-	-	-
<b>Allowed Release (cfs)</b>	0.6	<b>0.8</b>	1.0	1.3	1.5	<b>1.8</b>

DCM:  $I = C1 * \ln(tc) + C2$

C1	1.19	1.5	1.75	2	2.25	2.52
C2	6.035	7.583	8.847	10.111	11.375	12.735

### Notes

## Sub-Basin Ex-C Runoff Calculations

Job No.: 61183  
 Project: Ellicott D22 – GS & HS Addition  
 Jurisdiction: DCM  
 Runoff Coefficient: Surface Type

Date: 4/5/2023 14:35  
 Calcs by: O. Ali  
 Checked by: \_\_\_\_\_  
 Soil Type: A  
 Urbanization: Urban

### Basin Land Use Characteristics

Surface	Area		Runoff Coefficient						% Imperv.
	(SF)	(Acres)	C2	C5	C10	C25	C50	C100	
Pasture/Meadow	62,735	1.44	0.02	0.08	0.15	0.25	0.3	0.35	0%
Paved	1,357	0.03	0.89	0.9	0.92	0.94	0.95	0.96	100%
<b>Combined</b>	<b>64,092</b>	<b>1.47</b>	<b>0.04</b>	<b>0.10</b>	<b>0.17</b>	<b>0.26</b>	<b>0.31</b>	<b>0.36</b>	<b>2.1%</b>

64092

### Basin Travel Time

	Shallow Channel	Ground Cover	Short Pasture/Lawns				
	$L_{max,Overland}$	100 ft	$C_v$	7			
	L (ft)	$\Delta Z_0$ (ft)	$S_0$ (ft/ft)	v (ft/s)	t (min)	$t_{Alt}$ (min)	
Total	534	3	-	-	-	-	
Initial Time	100	0	0.000	-	0.0	13.0	DCM Eq. 6-8
Shallow Channel	434	3	0.006	0.5	13.6	-	DCM Eq. 6-9
Channelized			0.000	0.0	0.0	-	V-Ditch
				$t_c$	<b>13.0 min.</b>		

### Rainfall Intensity & Runoff

	2-Yr	5-Yr	10-Yr	25-Yr	50-Yr	100-Yr
<b>Intensity (in/hr)</b>	2.99	3.74	4.36	4.99	5.61	6.28
<b>Runoff (cfs)</b>	0.2	<b>0.5</b>	1.1	1.9	2.6	<b>3.4</b>
<b>Release Rates (cfs/ac)</b>	-	-	-	-	-	-
<b>Allowed Release (cfs)</b>	0.2	<b>0.5</b>	1.1	1.9	2.6	<b>3.4</b>

DCM:  $I = C1 * \ln(tc) + C2$

C1	1.19	1.5	1.75	2	2.25	2.52
C2	6.035	7.583	8.847	10.111	11.375	12.735

### Notes

## Sub-Basin Ex-D (DP6) Runoff Calculations

Job No.: 61183  
 Project: Ellicott D22 – GS & HS Addition  
 Jurisdiction: **DCM**  
 Runoff Coefficient: **Surface Type**

Date: 4/5/2023 14:35  
 Calcs by: O. Ali  
 Checked by: \_\_\_\_\_  
 Soil Type: **A**  
 Urbanization: **Urban**

### Basin Land Use Characteristics

Surface	Area		Runoff Coefficient						% Imperv.
	(SF)	(Acres)	C2	C5	C10	C25	C50	C100	
Pasture/Meadow	98,533	2.26	0.02	0.08	0.15	0.25	0.3	0.35	0%
<b>Combined</b>	<b>98,533</b>	<b>2.26</b>	<b>0.02</b>	<b>0.08</b>	<b>0.15</b>	<b>0.25</b>	<b>0.30</b>	<b>0.35</b>	<b>0.0%</b>

98533

### Basin Travel Time

	Shallow Channel Ground Cover		Short Pasture/Lawns			
	$L_{max,Overland}$	100 ft			$C_v$	7
	L (ft)	$\Delta Z_0$ (ft)	$S_0$ (ft/ft)	v (ft/s)	t (min)	$t_{Alt}$ (min)
Total	578	7	-	-	-	-
Initial Time	100	3	0.025	-	13.6	13.2 DCM Eq. 6-8
Shallow Channel	258	3	0.012	0.8	5.7	- DCM Eq. 6-9
Channelized	220	1	0.005	1.1	3.2	- V-Ditch
				$t_c$	<b>13.2 min.</b>	

### Rainfall Intensity & Runoff

	2-Yr	5-Yr	10-Yr	25-Yr	50-Yr	100-Yr
<b>Intensity (in/hr)</b>	2.96	3.71	4.33	4.95	5.57	6.23
<b>Runoff (cfs)</b>	0.1	<b>0.7</b>	1.5	2.8	3.8	<b>4.9</b>
<b>Release Rates (cfs/ac)</b>	-	-	-	-	-	-
<b>Allowed Release (cfs)</b>	0.1	<b>0.7</b>	1.5	2.8	3.8	<b>4.9</b>

DCM:  $I = C1 * \ln(tc) + C2$

C1	1.19	1.5	1.75	2	2.25	2.52
C2	6.035	7.583	8.847	10.111	11.375	12.735

### Notes

## Sub-Basin Ex-S1 Runoff Calculations

Job No.: 61183  
 Project: Ellicott D22 – GS & HS Addition  
 Jurisdiction: **DCM**  
 Runoff Coefficient: **Surface Type**

Date: 4/5/2023 14:35  
 Calcs by: O. Ali  
 Checked by: \_\_\_\_\_  
 Soil Type: **A**  
 Urbanization: **Urban**

### Basin Land Use Characteristics

Surface	Area		Runoff Coefficient						% Imperv.
	(SF)	(Acres)	C2	C5	C10	C25	C50	C100	
Pasture/Meadow	72,182	1.66	0.02	0.08	0.15	0.25	0.3	0.35	0%
Roofs	1,277	0.03	0.71	0.73	0.75	0.78	0.8	0.81	90%
Gravel	35,918	0.82	0.57	0.59	0.63	0.66	0.68	0.7	80%
Paved	6,964	0.16	0.89	0.9	0.92	0.94	0.95	0.96	100%
<b>Combined</b>	<b>116,341</b>	<b>2.67</b>	<b>0.25</b>	<b>0.29</b>	<b>0.35</b>	<b>0.42</b>	<b>0.46</b>	<b>0.50</b>	<b>31.7%</b>

116341

### Basin Travel Time

	Shallow Channel	Ground Cover	Short Pasture/Lawns				
$L_{max,Overland}$	100	ft	$C_v$	7			
$L$ (ft)	$\Delta Z_0$ (ft)	$S_0$ (ft/ft)	$v$ (ft/s)	$t$ (min)	$t_{Alt}$ (min)		
Total	492	4	-	-	-		
Initial Time	100	1	0.005	-	18.3	12.7	DCM Eq. 6-8
Shallow Channel	168	3	0.015	0.9	3.3	-	DCM Eq. 6-9
Channelized	224	1	0.004	1.6	2.4	-	V-Ditch
				$t_c$	<b>12.7 min.</b>		

### Rainfall Intensity & Runoff

	2-Yr	5-Yr	10-Yr	25-Yr	50-Yr	100-Yr
<b>Intensity (in/hr)</b>	3.01	3.77	4.39	5.02	5.65	6.32
<b>Runoff (cfs)</b>	2.0	<b>3.0</b>	4.1	5.7	7.0	<b>8.4</b>
<b>Release Rates (cfs/ac)</b>	-	-	-	-	-	-
<b>Allowed Release (cfs)</b>	2.0	<b>3.0</b>	4.1	5.7	7.0	<b>8.4</b>

DCM:  $I = C1 * \ln(tc) + C2$

C1	1.19	1.5	1.75	2	2.25	2.52
C2	6.035	7.583	8.847	10.111	11.375	12.735

### Notes

## Sub-Basin Ex-S2 (DP4) Runoff Calculations

Job No.: 61183  
 Project: Ellicott D22 – GS & HS Addition  
 Jurisdiction: **DCM**  
 Runoff Coefficient: **Surface Type**

Date: 4/5/2023 14:35  
 Calcs by: O. Ali  
 Checked by: \_\_\_\_\_  
 Soil Type: **A**  
 Urbanization: **Urban**

### Basin Land Use Characteristics

Surface	Area		Runoff Coefficient						% Imperv.
	(SF)	(Acres)	C2	C5	C10	C25	C50	C100	
Pasture/Meadow	3,851	0.09	0.02	0.08	0.15	0.25	0.3	0.35	0%
Roofs	40,450	0.93	0.71	0.73	0.75	0.78	0.8	0.81	90%
Paved	8,453	0.19	0.89	0.9	0.92	0.94	0.95	0.96	100%
<b>Combined</b>	<b>52,754</b>	<b>1.21</b>	<b>0.69</b>	<b>0.71</b>	<b>0.73</b>	<b>0.77</b>	<b>0.79</b>	<b>0.80</b>	<b>85.0%</b>

52754

### Basin Travel Time

	Shallow Channel Ground Cover		Paved areas/shallow paved swales			
	$L_{max,Overland}$	100 ft	$C_v$	20		
	L (ft)	$\Delta Z_0$ (ft)	$S_0$ (ft/ft)	v (ft/s)	t (min)	$t_{Alt}$ (min)
Total	387	3	-	-	-	-
Initial Time	100	0	0.000	-	0.0	12.2 DCM Eq. 6-8
Shallow Channel	55	2	0.027	3.3	0.3	- DCM Eq. 6-9
Channelized	232	2	0.006	2.6	1.5	- C&G
				$t_c$	<b>5.0 min.</b>	

### Rainfall Intensity & Runoff

	2-Yr	5-Yr	10-Yr	25-Yr	50-Yr	100-Yr
<b>Intensity (in/hr)</b>	4.12	5.17	6.03	6.89	7.75	8.68
<b>Runoff (cfs)</b>	3.4	<b>4.4</b>	5.4	6.4	7.4	<b>8.4</b>
<b>Release Rates (cfs/ac)</b>	-	-	-	-	-	-
<b>Allowed Release (cfs)</b>	3.4	<b>4.4</b>	5.4	6.4	7.4	<b>8.4</b>

DCM:  $I = C1 * \ln(tc) + C2$

C1	1.19	1.5	1.75	2	2.25	2.52
C2	6.035	7.583	8.847	10.111	11.375	12.735

### Notes

## Sub-Basin Ex-S3 Runoff Calculations

Job No.: 61183  
 Project: Ellicott D22 – GS & HS Addition  
 Jurisdiction: **DCM**  
 Runoff Coefficient: **Surface Type**

Date: 4/5/2023 14:35  
 Calcs by: O. Ali  
 Checked by: \_\_\_\_\_  
 Soil Type: **A**  
 Urbanization: **Urban**

### Basin Land Use Characteristics

Surface	Area		Runoff Coefficient						% Imperv.
	(SF)	(Acres)	C2	C5	C10	C25	C50	C100	
Pasture/Meadow	67,526	1.55	0.02	0.08	0.15	0.25	0.3	0.35	0%
Roofs	630	0.01	0.71	0.73	0.75	0.78	0.8	0.81	90%
Paved	289	0.01	0.89	0.9	0.92	0.94	0.95	0.96	100%
<b>Combined</b>	<b>68,445</b>	<b>1.57</b>	<b>0.03</b>	<b>0.09</b>	<b>0.16</b>	<b>0.26</b>	<b>0.31</b>	<b>0.36</b>	<b>1.3%</b>

68445

### Basin Travel Time

	Shallow Channel	Ground Cover	Short Pasture/Lawns				
	$L_{max,Overland}$	100 ft	$C_v$	7			
	L (ft)	$\Delta Z_0$ (ft)	$S_0$ (ft/ft)	v (ft/s)	t (min)	$t_{Alt}$ (min)	
Total	493	6	-	-	-	-	
Initial Time	100	2	0.015	-	16.0	12.7	DCM Eq. 6-8
Shallow Channel	393	5	0.011	0.7	8.7	-	DCM Eq. 6-9
Channelized			0.000	0.0	0.0	-	V-Ditch
				$t_c$	<b>12.7 min.</b>		

### Rainfall Intensity & Runoff

	2-Yr	5-Yr	10-Yr	25-Yr	50-Yr	100-Yr
<b>Intensity (in/hr)</b>	3.01	3.77	4.39	5.02	5.65	6.32
<b>Runoff (cfs)</b>	0.1	<b>0.5</b>	1.1	2.0	2.7	<b>3.5</b>
<b>Release Rates (cfs/ac)</b>	-	-	-	-	-	-
<b>Allowed Release (cfs)</b>	0.1	<b>0.5</b>	1.1	2.0	2.7	<b>3.5</b>

DCM:  $I = C1 * \ln(tc) + C2$

C1	1.19	1.5	1.75	2	2.25	2.52
C2	6.035	7.583	8.847	10.111	11.375	12.735

### Notes

## Sub-Basin Ex-S4 Runoff Calculations

Job No.: 61183  
 Project: Ellicott D22 – GS & HS Addition  
 Jurisdiction: **DCM**  
 Runoff Coefficient: **Surface Type**

Date: 4/5/2023 14:35  
 Calcs by: O. Ali  
 Checked by: \_\_\_\_\_  
 Soil Type: **A**  
 Urbanization: **Urban**

### Basin Land Use Characteristics

Surface	Area		Runoff Coefficient						% Imperv.
	(SF)	(Acres)	C2	C5	C10	C25	C50	C100	
Pasture/Meadow	78,206	1.80	0.02	0.08	0.15	0.25	0.3	0.35	0%
Roofs	29,366	0.67	0.71	0.73	0.75	0.78	0.8	0.81	90%
Paved	47,356	1.09	0.89	0.9	0.92	0.94	0.95	0.96	100%
Gravel	3,911	0.09	0.57	0.59	0.63	0.66	0.68	0.7	80%
<b>Combined</b>	<b>158,839</b>	<b>3.65</b>	<b>0.42</b>	<b>0.46</b>	<b>0.50</b>	<b>0.56</b>	<b>0.60</b>	<b>0.63</b>	<b>48.4%</b>

158839

### Basin Travel Time

	Shallow Channel Ground Cover		Paved areas/shallow paved swales			
	$L_{max,Overland}$	100 ft			$C_v$	20
	L (ft)	$\Delta Z_0$ (ft)	$S_0$ (ft/ft)	v (ft/s)	t (min)	$t_{Alt}$ (min)
Total	864	9	-	-	-	-
Initial Time	100	3	0.030	-	8.1	14.8 DCM Eq. 6-8
Shallow Channel	764	6	0.007	1.7	7.5	- DCM Eq. 6-9
Channelized			0.000	0.0	0.0	- V-Ditch
				$t_c$	<b>14.8 min.</b>	

### Rainfall Intensity & Runoff

	2-Yr	5-Yr	10-Yr	25-Yr	50-Yr	100-Yr
<b>Intensity (in/hr)</b>	2.83	3.54	4.13	4.72	5.31	5.94
<b>Runoff (cfs)</b>	4.3	<b>5.9</b>	7.6	9.7	11.5	<b>13.6</b>
<b>Release Rates (cfs/ac)</b>	-	-	-	-	-	-
<b>Allowed Release (cfs)</b>	4.3	<b>5.9</b>	7.6	9.7	11.5	<b>13.6</b>

DCM:  $I = C1 * \ln(tc) + C2$

C1	1.19	1.5	1.75	2	2.25	2.52
C2	6.035	7.583	8.847	10.111	11.375	12.735

### Notes



## Sub-Basin Ex-S5 Runoff Calculations

Job No.: 61183  
 Project: Ellicott D22 – GS & HS Addition  
 Jurisdiction: **DCM**  
 Runoff Coefficient: **Surface Type**

Date: 4/5/2023 14:35  
 Calcs by: O. Ali  
 Checked by: \_\_\_\_\_  
 Soil Type: **A**  
 Urbanization: **Urban**

### Basin Land Use Characteristics

Surface	Area		Runoff Coefficient						% Imperv.
	(SF)	(Acres)	C2	C5	C10	C25	C50	C100	
Pasture/Meadow	20,604	0.47	0.02	0.08	0.15	0.25	0.3	0.35	0%
Gravel	24,094	0.55	0.57	0.59	0.63	0.66	0.68	0.7	80%
Paved	38,705	0.89	0.89	0.9	0.92	0.94	0.95	0.96	100%
<b>Combined</b>	<b>83,403</b>	<b>1.91</b>	<b>0.58</b>	<b>0.61</b>	<b>0.65</b>	<b>0.69</b>	<b>0.71</b>	<b>0.73</b>	<b>69.5%</b>

83403

### Basin Travel Time

	Shallow Channel Ground Cover		Paved areas/shallow paved swales					
	$L_{max,Overland}$	ft	$C_v$					
	L (ft)	$\Delta Z_0$ (ft)	$S_0$ (ft/ft)	v (ft/s)	t (min)	$t_{Alt}$ (min)		
Total	525	6	-	-	-	-		
Initial Time	100	3	0.030	-	6.2	12.9	DCM Eq. 6-8	
Shallow Channel	50	1	0.020	2.8	0.3	-	DCM Eq. 6-9	
Channelized	375	2	0.004	2.1	3.0	-	C&G	
				$t_c$	<b>9.5 min.</b>			

### Rainfall Intensity & Runoff

	2-Yr	5-Yr	10-Yr	25-Yr	50-Yr	100-Yr
<b>Intensity (in/hr)</b>	3.36	4.21	4.91	5.61	6.31	7.07
<b>Runoff (cfs)</b>	3.7	<b>4.9</b>	6.1	7.4	8.6	<b>9.9</b>
<b>Release Rates (cfs/ac)</b>	-	-	-	-	-	-
<b>Allowed Release (cfs)</b>	3.7	<b>4.9</b>	6.1	7.4	8.6	<b>9.9</b>

DCM:  $I = C1 * \ln(tc) + C2$

C1	1.19	1.5	1.75	2	2.25	2.52
C2	6.035	7.583	8.847	10.111	11.375	12.735

### Notes

## Sub-Basin Ex-S6 Runoff Calculations

Job No.: 61183  
 Project: Ellicott D22 – GS & HS Addition  
 Jurisdiction: **DCM**  
 Runoff Coefficient: **Surface Type**

Date: 4/5/2023 14:35  
 Calcs by: O. Ali  
 Checked by: \_\_\_\_\_  
 Soil Type: **A**  
 Urbanization: **Urban**

### Basin Land Use Characteristics

Surface	Area		Runoff Coefficient						% Imperv.
	(SF)	(Acres)	C2	C5	C10	C25	C50	C100	
Pasture/Meadow	20,115	0.46	0.02	0.08	0.15	0.25	0.3	0.35	0%
Roofs	19,702	0.45	0.71	0.73	0.75	0.78	0.8	0.81	90%
Paved	6,676	0.15	0.89	0.9	0.92	0.94	0.95	0.96	100%
<b>Combined</b>	<b>46,493</b>	<b>1.07</b>	<b>0.44</b>	<b>0.47</b>	<b>0.51</b>	<b>0.57</b>	<b>0.61</b>	<b>0.63</b>	<b>52.5%</b>

46493

### Basin Travel Time

	Shallow Channel Ground Cover		Short Pasture/Lawns			
	$L_{max,Overland}$	100 ft			$C_v$	7
	L (ft)	$\Delta Z_0$ (ft)	$S_0$ (ft/ft)	v (ft/s)	t (min)	$t_{Alt}$ (min)
Total	568	17	-	-	-	-
Initial Time	100	13	0.130	-	4.9	13.2 DCM Eq. 6-8
Shallow Channel	90	2	0.022	1.0	1.4	- DCM Eq. 6-9
Channelized	378	2	0.005	2.0	3.2	- C&G
				$t_c$	<b>9.5 min.</b>	

### Rainfall Intensity & Runoff

	2-Yr	5-Yr	10-Yr	25-Yr	50-Yr	100-Yr
<b>Intensity (in/hr)</b>	3.36	4.21	4.91	5.61	6.32	7.07
<b>Runoff (cfs)</b>	1.6	2.1	2.7	3.4	4.1	4.8
<b>Release Rates (cfs/ac)</b>	-	-	-	-	-	-
<b>Allowed Release (cfs)</b>	1.6	2.1	2.7	3.4	4.1	4.8

DCM:  $I = C1 * \ln(tc) + C2$

C1	1.19	1.5	1.75	2	2.25	2.52
C2	6.035	7.583	8.847	10.111	11.375	12.735

### Notes

## Sub-Basin Ex-S7 (DP8) Runoff Calculations

Job No.: 61183  
 Project: Ellicott D22 – GS & HS Addition  
 Jurisdiction: **DCM**  
 Runoff Coefficient: **Surface Type**

Date: 4/5/2023 14:35  
 Calcs by: O. Ali  
 Checked by: \_\_\_\_\_  
 Soil Type: **A**  
 Urbanization: **Urban**

### Basin Land Use Characteristics

Surface	Area		Runoff Coefficient						% Imperv.
	(SF)	(Acres)	C2	C5	C10	C25	C50	C100	
Pasture/Meadow	14,462	0.33	0.02	0.08	0.15	0.25	0.3	0.35	0%
Roofs	21,954	0.50	0.71	0.73	0.75	0.78	0.8	0.81	90%
Paved	6,149	0.14	0.89	0.9	0.92	0.94	0.95	0.96	100%
<b>Combined</b>	<b>42,565</b>	<b>0.98</b>	<b>0.50</b>	<b>0.53</b>	<b>0.57</b>	<b>0.62</b>	<b>0.65</b>	<b>0.68</b>	<b>60.9%</b>

42565

### Basin Travel Time

	Shallow Channel Ground Cover		Paved areas/shallow paved swales				
	$L_{max,Overland}$	ft	$C_v$				20
	L (ft)	$\Delta Z_0$ (ft)	$S_0$ (ft/ft)	v (ft/s)	t (min)	$t_{Alt}$ (min)	
Total	595	15	-	-	-	-	
Initial Time	100	13	0.130	-	4.4	13.3	DCM Eq. 6-8
Shallow Channel	288	1	0.002	0.8	5.8	-	DCM Eq. 6-9
Channelized	207	1	0.005	1.9	1.8	-	C&G
				$t_c$	<b>12.0 min.</b>		

### Rainfall Intensity & Runoff

	2-Yr	5-Yr	10-Yr	25-Yr	50-Yr	100-Yr
<b>Intensity (in/hr)</b>	3.08	3.86	4.50	5.14	5.79	6.48
<b>Runoff (cfs)</b>	1.5	<b>2.0</b>	2.5	3.1	3.7	<b>4.3</b>
<b>Release Rates (cfs/ac)</b>	-	-	-	-	-	-
<b>Allowed Release (cfs)</b>	1.5	<b>2.0</b>	2.5	3.1	3.7	<b>4.3</b>

DCM:  $I = C1 * \ln(tc) + C2$

C1	1.19	1.5	1.75	2	2.25	2.52
C2	6.035	7.583	8.847	10.111	11.375	12.735

### Notes

## Sub-Basin Ex-S8 Runoff Calculations

Job No.: 61183  
 Project: Ellicott D22 – GS & HS Addition  
 Jurisdiction: **DCM**  
 Runoff Coefficient: **Surface Type**

Date: 4/5/2023 14:35  
 Calcs by: O. Ali  
 Checked by: \_\_\_\_\_  
 Soil Type: **A**  
 Urbanization: **Urban**

### Basin Land Use Characteristics

Surface	Area		Runoff Coefficient						% Imperv.
	(SF)	(Acres)	C2	C5	C10	C25	C50	C100	
Pasture/Meadow	45,290	1.04	0.02	0.08	0.15	0.25	0.3	0.35	0%
Roofs	6,348	0.15	0.71	0.73	0.75	0.78	0.8	0.81	90%
Paved	18,773	0.43	0.89	0.9	0.92	0.94	0.95	0.96	100%
<b>Combined</b>	<b>70,411</b>	<b>1.62</b>	<b>0.31</b>	<b>0.36</b>	<b>0.41</b>	<b>0.48</b>	<b>0.52</b>	<b>0.55</b>	<b>34.8%</b>

70411

### Basin Travel Time

	Shallow Channel Ground Cover		Short Pasture/Lawns			
	$L_{max,Overland}$	100 ft			$C_v$	7
	L (ft)	$\Delta Z_0$ (ft)	$S_0$ (ft/ft)	v (ft/s)	t (min)	$t_{Alt}$ (min)
Total	359	18	-	-	-	-
Initial Time	64	13	0.203	-	4.0	12.0 DCM Eq. 6-8
Shallow Channel	295	5	0.017	0.9	5.4	- DCM Eq. 6-9
Channelized			0.000	0.0	0.0	- V-Ditch
				$t_c$	<b>9.4 min.</b>	

### Rainfall Intensity & Runoff

	2-Yr	5-Yr	10-Yr	25-Yr	50-Yr	100-Yr
<b>Intensity (in/hr)</b>	3.37	4.23	4.93	5.64	6.34	7.10
<b>Runoff (cfs)</b>	1.7	<b>2.4</b>	3.3	4.4	5.3	<b>6.4</b>
<b>Release Rates (cfs/ac)</b>	-	-	-	-	-	-
<b>Allowed Release (cfs)</b>	1.7	<b>2.4</b>	3.3	4.4	5.3	<b>6.4</b>

DCM:  $I = C1 * \ln(tc) + C2$

C1	1.19	1.5	1.75	2	2.25	2.52
C2	6.035	7.583	8.847	10.111	11.375	12.735

### Notes

## Sub-Basin Ex-S9 Runoff Calculations

Job No.: 61183  
 Project: Ellicott D22 – GS & HS Addition  
 Jurisdiction: **DCM**  
 Runoff Coefficient: **Surface Type**

Date: 4/5/2023 14:35  
 Calcs by: O. Ali  
 Checked by: \_\_\_\_\_  
 Soil Type: **A**  
 Urbanization: **Urban**

### Basin Land Use Characteristics

Surface	Area		Runoff Coefficient						% Imperv.
	(SF)	(Acres)	C2	C5	C10	C25	C50	C100	
Pasture/Meadow	248,180	5.70	0.02	0.08	0.15	0.25	0.3	0.35	0%
Roofs	53	0.00	0.71	0.73	0.75	0.78	0.8	0.81	90%
Paved	3,228	0.07	0.89	0.9	0.92	0.94	0.95	0.96	100%
Gravel	3,588	0.08	0.57	0.59	0.63	0.66	0.68	0.7	80%
<b>Combined</b>	<b>255,049</b>	<b>5.86</b>	<b>0.04</b>	<b>0.10</b>	<b>0.17</b>	<b>0.26</b>	<b>0.31</b>	<b>0.36</b>	<b>2.4%</b>

255049

### Basin Travel Time

	Shallow Channel Ground Cover		Short Pasture/Lawns				
	$L_{max,Overland}$	100 ft			$C_v$	7	
	L (ft)	$\Delta Z_0$ (ft)	$S_0$ (ft/ft)	v (ft/s)	t (min)	$t_{Alt}$ (min)	
Total	993	6	-	-	-	-	
Initial Time	100	1	0.005	-	22.7	15.5	DCM Eq. 6-8
Shallow Channel	726	5	0.006	0.6	22.0	-	DCM Eq. 6-9
Channelized	167	1	0.003	0.8	3.4	-	Trap Ditch
				$t_c$	<b>15.5 min.</b>		

### Rainfall Intensity & Runoff

	2-Yr	5-Yr	10-Yr	25-Yr	50-Yr	100-Yr
<b>Intensity (in/hr)</b>	2.77	3.47	4.05	4.63	5.21	5.83
<b>Runoff (cfs)</b>	0.6	<b>2.0</b>	3.9	7.2	9.6	<b>12.4</b>
<b>Release Rates (cfs/ac)</b>	-	-	-	-	-	-
<b>Allowed Release (cfs)</b>	0.6	<b>2.0</b>	3.9	7.2	9.6	<b>12.4</b>

DCM:  $I = C1 * \ln(tc) + C2$

C1	1.19	1.5	1.75	2	2.25	2.52
C2	6.035	7.583	8.847	10.111	11.375	12.735

### Notes

## Sub-Basin Ex-S10 Runoff Calculations

Job No.: 61183  
 Project: Ellicott D22 – GS & HS Addition  
 Jurisdiction: **DCM**  
 Runoff Coefficient: **Surface Type**

Date: 4/5/2023 14:35  
 Calcs by: O. Ali  
 Checked by: \_\_\_\_\_  
 Soil Type: **A**  
 Urbanization: **Urban**

### Basin Land Use Characteristics

Surface	Area		Runoff Coefficient						% Imperv.
	(SF)	(Acres)	C2	C5	C10	C25	C50	C100	
Pasture/Meadow	111,143	2.55	0.02	0.08	0.15	0.25	0.3	0.35	0%
Gravel	883	0.02	0.57	0.59	0.63	0.66	0.68	0.7	80%
Paved	3,579	0.08	0.89	0.9	0.92	0.94	0.95	0.96	100%
<b>Combined</b>	<b>115,605</b>	<b>2.65</b>	<b>0.05</b>	<b>0.11</b>	<b>0.18</b>	<b>0.27</b>	<b>0.32</b>	<b>0.37</b>	<b>3.7%</b>

115605

### Basin Travel Time

	Shallow Channel	Ground Cover	Short Pasture/Lawns				
	$L_{max,Overland}$	100 ft	$C_v$	7			
	L (ft)	$\Delta Z_0$ (ft)	$S_0$ (ft/ft)	v (ft/s)	t (min)	$t_{Alt}$ (min)	
Total	540	5	-	-	-	-	
Initial Time	100	1	0.005	-	22.5	13.0	DCM Eq. 6-8
Shallow Channel	440	5	0.010	0.7	10.4	-	DCM Eq. 6-9
Channelized			0.000	0.0	0.0	-	V-Ditch
				$t_c$	<b>13.0 min.</b>		

### Rainfall Intensity & Runoff

	2-Yr	5-Yr	10-Yr	25-Yr	50-Yr	100-Yr
<b>Intensity (in/hr)</b>	2.98	3.74	4.36	4.98	5.60	6.27
<b>Runoff (cfs)</b>	0.4	1.1	2.1	3.6	4.8	6.2
<b>Release Rates (cfs/ac)</b>	-	-	-	-	-	-
<b>Allowed Release (cfs)</b>	0.4	1.1	2.1	3.6	4.8	6.2

DCM:  $I = C1 * \ln(tc) + C2$

C1	1.19	1.5	1.75	2	2.25	2.52
C2	6.035	7.583	8.847	10.111	11.375	12.735

### Notes

## Sub-Basin Ex-S11 Runoff Calculations

Job No.: 61183  
 Project: Ellicott D22 – GS & HS Addition  
 Jurisdiction: **DCM**  
 Runoff Coefficient: **Surface Type**

Date: 4/5/2023 14:35  
 Calcs by: O. Ali  
 Checked by: \_\_\_\_\_  
 Soil Type: **A**  
 Urbanization: **Urban**

### Basin Land Use Characteristics

Surface	Area		Runoff Coefficient						% Imperv.
	(SF)	(Acres)	C2	C5	C10	C25	C50	C100	
Pasture/Meadow	19,750	0.45	0.02	0.08	0.15	0.25	0.3	0.35	0%
<b>Combined</b>	<b>19,750</b>	<b>0.45</b>	<b>0.02</b>	<b>0.08</b>	<b>0.15</b>	<b>0.25</b>	<b>0.30</b>	<b>0.35</b>	<b>0.0%</b>

19750

### Basin Travel Time

	Shallow Channel Ground Cover		Short Pasture/Lawns			
	$L_{max,Overland}$	ft	$C_v$			
	L (ft)	$\Delta Z_0$ (ft)	$S_0$ (ft/ft)	v (ft/s)	t (min)	$t_{Alt}$ (min)
Total	195	3	-	-	-	-
Initial Time	100	0	0.000	-	0.0	11.1 DCM Eq. 6-8
Shallow Channel	95	3	0.026	1.1	1.4	- DCM Eq. 6-9
Channelized			0.000	0.0	0.0	- V-Ditch
				$t_c$	<b>5.0 min.</b>	

### Rainfall Intensity & Runoff

	2-Yr	5-Yr	10-Yr	25-Yr	50-Yr	100-Yr
<b>Intensity (in/hr)</b>	4.12	5.17	6.03	6.89	7.75	8.68
<b>Runoff (cfs)</b>	0.0	0.2	0.4	0.8	1.1	1.4
<b>Release Rates (cfs/ac)</b>	-	-	-	-	-	-
<b>Allowed Release (cfs)</b>	0.0	0.2	0.4	0.8	1.1	1.4

DCM:  $I = C1 * \ln(tc) + C2$

C1	1.19	1.5	1.75	2	2.25	2.52
C2	6.035	7.583	8.847	10.111	11.375	12.735

### Notes

## Sub-Basin Ex-S12 Runoff Calculations

Job No.: 61183  
 Project: Ellicott D22 – GS & HS Addition  
 Jurisdiction: **DCM**  
 Runoff Coefficient: **Surface Type**

Date: 4/5/2023 14:35  
 Calcs by: O. Ali  
 Checked by: \_\_\_\_\_  
 Soil Type: **A**  
 Urbanization: **Urban**

### Basin Land Use Characteristics

Surface	Area		Runoff Coefficient						% Imperv.
	(SF)	(Acres)	C2	C5	C10	C25	C50	C100	
Pasture/Meadow	72,998	1.68	0.02	0.08	0.15	0.25	0.3	0.35	0%
<b>Combined</b>	<b>72,998</b>	<b>1.68</b>	<b>0.02</b>	<b>0.08</b>	<b>0.15</b>	<b>0.25</b>	<b>0.30</b>	<b>0.35</b>	<b>0.0%</b>

72998

### Basin Travel Time

	Shallow Channel Ground Cover		Short Pasture/Lawns				
	$L_{max,Overland}$	ft	$C_v$				
	L (ft)	$\Delta Z_0$ (ft)	$S_0$ (ft/ft)	v (ft/s)	t (min)	$t_{Alt}$ (min)	
Total	383	5	-	-	-	-	
Initial Time	99	2	0.015	-	16.0	12.1	DCM Eq. 6-8
Shallow Channel	284	3	0.011	0.7	6.6	-	DCM Eq. 6-9
Channelized			0.000	0.0	0.0	-	V-Ditch
				$t_c$	<b>12.1 min.</b>		

### Rainfall Intensity & Runoff

	2-Yr	5-Yr	10-Yr	25-Yr	50-Yr	100-Yr
<b>Intensity (in/hr)</b>	3.07	3.84	4.48	5.12	5.76	6.45
<b>Runoff (cfs)</b>	0.1	<b>0.5</b>	1.1	2.1	2.9	<b>3.8</b>
<b>Release Rates (cfs/ac)</b>	-	-	-	-	-	-
<b>Allowed Release (cfs)</b>	0.1	<b>0.5</b>	1.1	2.1	2.9	<b>3.8</b>

DCM:  $I = C1 * \ln(tc) + C2$

C1	1.19	1.5	1.75	2	2.25	2.52
C2	6.035	7.583	8.847	10.111	11.375	12.735

### Notes



## Combined Sub-Basin Runoff Calculations - DP2 (Existing)

Includes Basins EX-A EX-C

Job No.:	<b>61183</b>	Date:	<b>4/5/2023 14:35</b>
Project:	<b>Ellicott D22 – GS &amp; HS Addition</b>	Calcs by:	<b>O. Ali</b>
Jurisdiction	<b>DCM</b>	Checked by:	
Runoff Coefficient	<b>Surface Type</b>	Soil Type	<b>A</b>
		Urbanization	<b>Urban</b>

### Basin Land Use Characteristics

Surface	Area		Runoff Coefficient						% Imperv.
	(SF)	(Acres)	C2	C5	C10	C25	C50	C100	
Pasture/Meadow	211,892	4.86	0.02	0.08	0.15	0.25	0.3	0.35	0%
Paved	20,759	0.48	0.89	0.9	0.92	0.94	0.95	0.96	100%
Gravel	36,530	0.84	0.57	0.59	0.63	0.66	0.68	0.7	80%
Roofs	354	0.01	0.71	0.73	0.75	0.78	0.8	0.81	90%
<b>Combined</b>	<b>269,535</b>	<b>6.19</b>	<b>0.16</b>	<b>0.21</b>	<b>0.28</b>	<b>0.36</b>	<b>0.40</b>	<b>0.45</b>	<b>18.7%</b>

### Basin Travel Time

	Sub-basin or Channel Type	Material Type	L (ft)	Elev. ΔZ <sub>0</sub> (ft)	Q <sub>i</sub> (cfs)	Base or Dia (ft)	Sides z:1 (ft/ft)	v (ft/s)	t (min)
Furthest Reach	EX-A	-	741	9	-	-	-	-	14.1
Channelized-1	Trap Ditch	2	96	0	13	20	8	0.8	2.0
Channelized-2									
Channelized-3									
Total			837	9					

2 = Natural, Winding, minimal vegetation/shallow grass

**t<sub>c</sub> (min) 16.1**

### Contributing Offsite Flows (Added to Runoff and Allowed Release, below.)

Contributing Basins/Areas

Q<sub>Minor</sub> (cfs) - 5-year Storm

Q<sub>Major</sub> (cfs) - 100-year Storm

### Rainfall Intensity & Runoff

	2-Yr	5-Yr	10-Yr	25-Yr	50-Yr	100-Yr
<b>Intensity (in/hr)</b>	2.73	3.41	3.98	4.55	5.12	5.73
<b>Site Runoff (cfs)</b>	2.74	<b>4.50</b>	6.78	10.12	12.75	<b>15.78</b>
<b>OffSite Runoff (cfs)</b>	-	<b>0.00</b>	-	-	-	<b>0.00</b>
<b>Release Rates (cfs/ac)</b>	-	-	-	-	-	-
<b>Allowed Release (cfs)</b>	-	<b>4.5</b>	-	-	-	<b>15.8</b>

DCM:  $I = C1 * \ln(tc) + C2$

C1	1.19	1.5	1.75	2	2.25	2.52
C2	6.035	7.583	8.847	10.111	11.375	12.735

### Notes

Runoff from Offsite basins have been assumed constant, despite additional times of concentration.

## Combined Sub-Basin Runoff Calculations - DP3 (Existing)

Includes Basins EX-A EX-B EX-C

Job No.:	<b>61183</b>	Date:	<b>4/5/2023 14:35</b>
Project:	<b>Ellicott D22 – GS &amp; HS Addition</b>	Calcs by:	<b>O. Ali</b>
Jurisdiction	<b>DCM</b>	Checked by:	
Runoff Coefficient	<b>Surface Type</b>	Soil Type	<b>A</b>
		Urbanization	<b>Urban</b>

### Basin Land Use Characteristics

Surface	Area		Runoff Coefficient						% Imperv.
	(SF)	(Acres)	C2	C5	C10	C25	C50	C100	
Pasture/Meadow	219,170	5.03	0.02	0.08	0.15	0.25	0.3	0.35	0%
Paved	23,823	0.55	0.89	0.9	0.92	0.94	0.95	0.96	100%
Gravel	44,945	1.03	0.57	0.59	0.63	0.66	0.68	0.7	80%
Roofs	637	0.01	0.71	0.73	0.75	0.78	0.8	0.81	90%
<b>Combined</b>	<b>288,575</b>	<b>6.62</b>	<b>0.18</b>	<b>0.23</b>	<b>0.29</b>	<b>0.37</b>	<b>0.41</b>	<b>0.46</b>	<b>20.9%</b>

### Basin Travel Time

	Sub-basin or Channel Type	Material Type	L (ft)	Elev. ΔZ <sub>0</sub> (ft)	Q <sub>i</sub> (cfs)	Base or Dia (ft)	Sides z:1 (ft/ft)	v (ft/s)	t (min)
Furthest Reach	EX-A	-	741	9	-	-	-	-	14.1
Channelized-1	Trap Ditch	2	109	0	13	20	8	0.8	2.4
Channelized-2									
Channelized-3									
Total			850	9					

2 = Natural, Winding, minimal vegetation/shallow grass

**t<sub>c</sub> (min) 16.5**

### Contributing Offsite Flows (Added to Runoff and Allowed Release, below.)

Contributing Basins/Areas

Q<sub>Minor</sub> (cfs) - 5-year Storm

Q<sub>Major</sub> (cfs) - 100-year Storm

### Rainfall Intensity & Runoff

	2-Yr	5-Yr	10-Yr	25-Yr	50-Yr	100-Yr
<b>Intensity (in/hr)</b>	2.70	3.38	3.94	4.51	5.07	5.68
<b>Site Runoff (cfs)</b>	3.20	<b>5.12</b>	7.57	11.11	13.91	<b>17.14</b>
<b>OffSite Runoff (cfs)</b>	-	<b>0.00</b>	-	-	-	<b>0.00</b>
<b>Release Rates (cfs/ac)</b>	-	-	-	-	-	-
<b>Allowed Release (cfs)</b>	-	<b>5.1</b>	-	-	-	<b>17.1</b>

DCM:  $I = C1 * \ln(tc) + C2$

C1	1.19	1.5	1.75	2	2.25	2.52
C2	6.035	7.583	8.847	10.111	11.375	12.735

### Notes

Runoff from Offsite basins have been assumed constant, despite additional times of concentration.

## Combined Sub-Basin Runoff Calculations - DP5 (Existing)

Includes Basins EX-A EX-B EX-C EX-S1

Job No.:	<b>61183</b>	Date:	<b>4/5/2023 14:35</b>
Project:	<b>Ellicott D22 – GS &amp; HS Addition</b>	Calcs by:	<b>O. Ali</b>
Jurisdiction	<b>DCM</b>	Checked by:	
Runoff Coefficient	<b>Surface Type</b>	Soil Type	<b>A</b>
		Urbanization	<b>Urban</b>

### Basin Land Use Characteristics

Surface	Area		Runoff Coefficient						% Imperv.
	(SF)	(Acres)	C2	C5	C10	C25	C50	C100	
Pasture/Meadow	291,352	6.69	0.02	0.08	0.15	0.25	0.3	0.35	0%
Paved	30,787	0.71	0.89	0.9	0.92	0.94	0.95	0.96	100%
Gravel	80,863	1.86	0.57	0.59	0.63	0.66	0.68	0.7	80%
Roofs	1,914	0.04	0.71	0.73	0.75	0.78	0.8	0.81	90%
<b>Combined</b>	<b>404,916</b>	<b>9.30</b>	<b>0.20</b>	<b>0.25</b>	<b>0.31</b>	<b>0.39</b>	<b>0.43</b>	<b>0.47</b>	<b>24.0%</b>

### Basin Travel Time

	Sub-basin or Channel Type	Material Type	L (ft)	Elev. ΔZ <sub>0</sub> (ft)	Q <sub>i</sub> (cfs)	Base or Dia (ft)	Sides z:1 (ft/ft)	v (ft/s)	t (min)
Furthest Reach	EX-A	-	741	9	-	-	-	-	14.1
Channelized-1	Trap Ditch	2	389	2	13	5	8	1.2	5.3
Channelized-2									
Channelized-3									
Total			1,130	10					

2 = Natural, Winding, minimal vegetation/shallow grass

**t<sub>c</sub> (min) 19.5**

### Contributing Offsite Flows (Added to Runoff and Allowed Release, below.)

Contributing Basins/Areas

Q<sub>Minor</sub> (cfs) - 5-year Storm

Q<sub>Major</sub> (cfs) - 100-year Storm

### Rainfall Intensity & Runoff

	2-Yr	5-Yr	10-Yr	25-Yr	50-Yr	100-Yr
<b>Intensity (in/hr)</b>	2.50	3.13	3.65	4.17	4.70	5.25
<b>Site Runoff (cfs)</b>	4.63	<b>7.19</b>	10.43	15.01	18.67	<b>22.88</b>
<b>OffSite Runoff (cfs)</b>	-	<b>0.00</b>	-	-	-	<b>0.00</b>
<b>Release Rates (cfs/ac)</b>	-	-	-	-	-	-
<b>Allowed Release (cfs)</b>	-	<b>7.2</b>	-	-	-	<b>22.9</b>

DCM:  $I = C1 * \ln(tc) + C2$

C1	1.19	1.5	1.75	2	2.25	2.52
C2	6.035	7.583	8.847	10.111	11.375	12.735

### Notes

Runoff from Offsite basins have been assumed constant, despite additional times of concentration.

## Combined Sub-Basin Runoff Calculations - DP7 (Existing)

Includes Basins EX-A EX-B EX-C EX-D EX-S1 EX-S2 EX-S3

Job No.:	<b>61183</b>	Date:	<b>4/5/2023 14:35</b>
Project:	<b>Ellicott D22 – GS &amp; HS Addition</b>	Calcs by:	<b>O. Ali</b>
Jurisdiction	<b>DCM</b>	Checked by:	
Runoff Coefficient	<b>Surface Type</b>	Soil Type	<b>A</b>
		Urbanization	<b>Urban</b>

### Basin Land Use Characteristics

Surface	Area		Runoff Coefficient						% Imperv.
	(SF)	(Acres)	C2	C5	C10	C25	C50	C100	
Pasture/Meadow	461,262	10.59	0.02	0.08	0.15	0.25	0.3	0.35	0%
Paved	39,529	0.91	0.89	0.9	0.92	0.94	0.95	0.96	100%
Gravel	80,863	1.86	0.57	0.59	0.63	0.66	0.68	0.7	80%
Roofs	42,994	0.99	0.71	0.73	0.75	0.78	0.8	0.81	90%
<b>Combined</b>	<b>624,648</b>	<b>14.34</b>	<b>0.19</b>	<b>0.24</b>	<b>0.30</b>	<b>0.38</b>	<b>0.42</b>	<b>0.47</b>	<b>22.9%</b>

### Basin Travel Time

	Sub-basin or Channel Type	Material Type	L (ft)	Elev. ΔZ <sub>0</sub> (ft)	Q <sub>i</sub> (cfs)	Base or Dia (ft)	Sides z:1 (ft/ft)	v (ft/s)	t (min)	
Furthest Reach	EX-A	-	741	9	-	-	-	-	14.1	
Channelized-1	Trap Ditch	2	389	2	13	5	8	1.2	5.3	
Channelized-2	Trap Ditch	2	283	3	13	20	8	1.3	3.7	
Channelized-3										
Total			1,413	13						
		2 = Natural, Winding, minimal vegetation/shallow grass							t <sub>c</sub>	23.2
		2 = Natural, Winding, minimal vegetation/shallow grass							(min)	

### Contributing Offsite Flows (Added to Runoff and Allowed Release, below.)

Contributing Basins/Areas \_\_\_\_\_

Q<sub>Minor</sub> \_\_\_\_\_ (cfs) - 5-year Storm

Q<sub>Major</sub> \_\_\_\_\_ (cfs) - 100-year Storm

### Rainfall Intensity & Runoff

	2-Yr	5-Yr	10-Yr	25-Yr	50-Yr	100-Yr
<b>Intensity (in/hr)</b>	2.29	2.87	3.34	3.82	4.30	4.81
<b>Site Runoff (cfs)</b>	6.37	<b>9.98</b>	14.49	21.01	26.20	<b>32.13</b>
<b>OffSite Runoff (cfs)</b>	-	<b>0.00</b>	-	-	-	<b>0.00</b>
<b>Release Rates (cfs/ac)</b>	-	-	-	-	-	-
<b>Allowed Release (cfs)</b>	-	<b>10.0</b>	-	-	-	<b>32.1</b>

DCM:  $I = C1 * \ln(tc) + C2$

C1	1.19	1.5	1.75	2	2.25	2.52
C2	6.035	7.583	8.847	10.111	11.375	12.735

### Notes

Runoff from Offsite basins have been assumed constant, despite additional times of concentration.

## Combined Sub-Basin Runoff Calculations - DP9 (Existing)

Includes Basins EX-S4 EX-S5

Job No.:	<b>61183</b>	Date:	<b>4/5/2023 14:35</b>
Project:	<b>Ellicott D22 – GS &amp; HS Addition</b>	Calcs by:	<b>O. Ali</b>
Jurisdiction	<b>DCM</b>	Checked by:	
Runoff Coefficient	<b>Surface Type</b>	Soil Type	<b>A</b>
		Urbanization	<b>Urban</b>

### Basin Land Use Characteristics

Surface	Area		Runoff Coefficient						% Imperv.
	(SF)	(Acres)	C2	C5	C10	C25	C50	C100	
Pasture/Meadow	98,810	2.27	0.02	0.08	0.15	0.25	0.3	0.35	0%
Paved	86,061	1.98	0.89	0.9	0.92	0.94	0.95	0.96	100%
Gravel	28,005	0.64	0.57	0.59	0.63	0.66	0.68	0.7	80%
Roofs	29,366	0.67	0.71	0.73	0.75	0.78	0.8	0.81	90%
<b>Combined</b>	<b>242,242</b>	<b>5.56</b>	<b>0.48</b>	<b>0.51</b>	<b>0.55</b>	<b>0.61</b>	<b>0.64</b>	<b>0.66</b>	<b>55.7%</b>

### Basin Travel Time

	Sub-basin or Channel Type	Material Type	L (ft)	Elev. ΔZ <sub>0</sub> (ft)	Q <sub>i</sub> (cfs)	Base or Dia (ft)	Sides z:1 (ft/ft)	v (ft/s)	t (min)
Furthest Reach	EX-S4	-	864	9	-	-	-	-	14.8
Channelized-1	C&G	Concrete	396	2	14	0	0	2.6	2.6
Channelized-2									
Channelized-3									
Total			1,260	11					
								<b>t<sub>c</sub> (min)</b>	<b>17.4</b>

### Contributing Offsite Flows (Added to Runoff and Allowed Release, below.)

Contributing Basins/Areas

Q<sub>Minor</sub> (cfs) - 5-year Storm

Q<sub>Major</sub> (cfs) - 100-year Storm

### Rainfall Intensity & Runoff

	2-Yr	5-Yr	10-Yr	25-Yr	50-Yr	100-Yr
<b>Intensity (in/hr)</b>	2.64	3.30	3.85	4.40	4.95	5.54
<b>Site Runoff (cfs)</b>	6.98	<b>9.34</b>	11.81	14.85	17.49	<b>20.42</b>
<b>OffSite Runoff (cfs)</b>	-	<b>0.00</b>	-	-	-	<b>0.00</b>
<b>Release Rates (cfs/ac)</b>	-	-	-	-	-	-
<b>Allowed Release (cfs)</b>	-	<b>9.3</b>	-	-	-	<b>20.4</b>

DCM:  $I = C1 * \ln(tc) + C2$

C1	1.19	1.5	1.75	2	2.25	2.52
C2	6.035	7.583	8.847	10.111	11.375	12.735

### Notes

Runoff from Offsite basins have been assumed constant, despite additional times of concentration.

## Combined Sub-Basin Runoff Calculations - DP10 (Existing)

Includes Basins EX-S4 EX-S5 EX-S6

Job No.:	<b>61183</b>	Date:	<b>4/5/2023 14:35</b>
Project:	<b>Ellicott D22 – GS &amp; HS Addition</b>	Calcs by:	<b>O. Ali</b>
Jurisdiction	<b>DCM</b>	Checked by:	
Runoff Coefficient	<b>Surface Type</b>	Soil Type	<b>A</b>
		Urbanization	<b>Urban</b>

### Basin Land Use Characteristics

Surface	Area		Runoff Coefficient						% Imperv.
	(SF)	(Acres)	C2	C5	C10	C25	C50	C100	
Pasture/Meadow	118,925	2.73	0.02	0.08	0.15	0.25	0.3	0.35	0%
Paved	92,737	2.13	0.89	0.9	0.92	0.94	0.95	0.96	100%
Gravel	28,005	0.64	0.57	0.59	0.63	0.66	0.68	0.7	80%
Roofs	49,068	1.13	0.71	0.73	0.75	0.78	0.8	0.81	90%
<b>Combined</b>	<b>288,735</b>	<b>6.63</b>	<b>0.47</b>	<b>0.50</b>	<b>0.55</b>	<b>0.60</b>	<b>0.63</b>	<b>0.66</b>	<b>55.2%</b>

### Basin Travel Time

	Sub-basin or Channel Type	Material Type	L (ft)	Elev. ΔZ <sub>0</sub> (ft)	Q <sub>i</sub> (cfs)	Base or Dia (ft)	Sides z:1 (ft/ft)	v (ft/s)	t (min)
Furthest Reach	EX-S4	-	864	9	-	-	-	-	14.8
Channelized-1	C&G	Concrete	546	2	14	0	0	2.3	4.0
Channelized-2	Trap Ditch	1	148	0	14	2	2	1.8	1.4
Channelized-3									
Total			1,558	11					
								<b>t<sub>c</sub> (min)</b>	<b>20.2</b>

1 = Man-made, Smooth, Straight

### Contributing Offsite Flows (Added to Runoff and Allowed Release, below.)

Contributing Basins/Areas

Q <sub>Minor</sub>	(cfs) - 5-year Storm
Q <sub>Major</sub>	(cfs) - 100-year Storm

### Rainfall Intensity & Runoff

	2-Yr	5-Yr	10-Yr	25-Yr	50-Yr	100-Yr
<b>Intensity (in/hr)</b>	2.46	3.07	3.59	4.10	4.61	5.16
<b>Site Runoff (cfs)</b>	7.66	<b>10.26</b>	12.98	16.35	19.28	<b>22.51</b>
<b>OffSite Runoff (cfs)</b>	-	<b>0.00</b>	-	-	-	<b>0.00</b>
<b>Release Rates (cfs/ac)</b>	-	-	-	-	-	-
<b>Allowed Release (cfs)</b>	-	<b>10.3</b>	-	-	-	<b>22.5</b>

DCM:  $I = C1 * \ln(tc) + C2$

C1	1.19	1.5	1.75	2	2.25	2.52
C2	6.035	7.583	8.847	10.111	11.375	12.735

### Notes

Runoff from Offsite basins have been assumed constant, despite additional times of concentration.

## Combined Sub-Basin Runoff Calculations - DP11 (Existing)

Includes Basins EX-S4 EX-S5 EX-S6 EX-S7 EX-S8

Job No.:	<b>61183</b>	Date:	<b>4/5/2023 14:35</b>
Project:	<b>Ellicott D22 – GS &amp; HS Addition</b>	Calcs by:	<b>O. Ali</b>
Jurisdiction	<b>DCM</b>	Checked by:	
Runoff Coefficient	<b>Surface Type</b>	Soil Type	<b>A</b>
		Urbanization	<b>Urban</b>

### Basin Land Use Characteristics

Surface	Area		Runoff Coefficient						% Imperv.
	(SF)	(Acres)	C2	C5	C10	C25	C50	C100	
Pasture/Meadow	178,677	4.10	0.02	0.08	0.15	0.25	0.3	0.35	0%
Paved	117,659	2.70	0.89	0.9	0.92	0.94	0.95	0.96	100%
Gravel	28,005	0.64	0.57	0.59	0.63	0.66	0.68	0.7	80%
Roofs	77,370	1.78	0.71	0.73	0.75	0.78	0.8	0.81	90%
<b>Combined</b>	<b>401,711</b>	<b>9.22</b>	<b>0.45</b>	<b>0.48</b>	<b>0.52</b>	<b>0.58</b>	<b>0.61</b>	<b>0.64</b>	<b>52.2%</b>

### Basin Travel Time

	Sub-basin or Channel Type	Material Type	L (ft)	Elev. ΔZ <sub>0</sub> (ft)	Q <sub>i</sub> (cfs)	Base or Dia (ft)	Sides z:1 (ft/ft)	v (ft/s)	t (min)
Furthest Reach	EX-S4	-	864	9	-	-	-	-	14.8
Channelized-1	C&G	Concrete	546	2	14	0	0	2.3	4.0
Channelized-2	Trap Ditch	1	192	1	14	2	2	2.1	1.5
Channelized-3	V-Ditch	1	343	2	14	0	3	2.7	2.2
Total			1,945	13					
								<b>t<sub>c</sub> (min)</b>	<b>22.5</b>

1 = Man-made, Smooth, Straight

### Contributing Offsite Flows (Added to Runoff and Allowed Release, below.)

Contributing Basins/Areas \_\_\_\_\_

Q<sub>Minor</sub> \_\_\_\_\_ (cfs) - 5-year Storm

Q<sub>Major</sub> \_\_\_\_\_ (cfs) - 100-year Storm

### Rainfall Intensity & Runoff

	2-Yr	5-Yr	10-Yr	25-Yr	50-Yr	100-Yr
<b>Intensity (in/hr)</b>	2.33	2.91	3.40	3.88	4.37	4.89
<b>Site Runoff (cfs)</b>	9.58	<b>12.92</b>	16.44	20.87	24.71	<b>28.93</b>
<b>OffSite Runoff (cfs)</b>	-	<b>0.00</b>	-	-	-	<b>0.00</b>
<b>Release Rates (cfs/ac)</b>	-	-	-	-	-	-
<b>Allowed Release (cfs)</b>	-	<b>12.9</b>	-	-	-	<b>28.9</b>

DCM:  $I = C1 * \ln(tc) + C2$

C1	1.19	1.5	1.75	2	2.25	2.52
C2	6.035	7.583	8.847	10.111	11.375	12.735

### Notes

Runoff from Offsite basins have been assumed constant, despite additional times of concentration.

## Combined Sub-Basin Runoff Calculations - DP12 (Existing)

Includes Basins EX-DP7 EX-DP11 EX-S9

Job No.:	<b>61183</b>	Date:	<b>4/5/2023 14:35</b>
Project:	<b>Ellicott D22 – GS &amp; HS Addition</b>	Calcs by:	<b>O. Ali</b>
Jurisdiction	<b>DCM</b>	Checked by:	
Runoff Coefficient	<b>Surface Type</b>	Soil Type	<b>A</b>
		Urbanization	<b>Urban</b>

### Basin Land Use Characteristics

Surface	Area		Runoff Coefficient						% Imperv.
	(SF)	(Acres)	C2	C5	C10	C25	C50	C100	
Pasture/Meadow	888,119	20.39	0.02	0.08	0.15	0.25	0.3	0.35	0%
Paved	160,416	3.68	0.89	0.9	0.92	0.94	0.95	0.96	100%
Gravel	112,456	2.58	0.57	0.59	0.63	0.66	0.68	0.7	80%
Roofs	120,417	2.76	0.71	0.73	0.75	0.78	0.8	0.81	90%
<b>Combined</b>	<b>1,281,408</b>	<b>29.42</b>	<b>0.24</b>	<b>0.29</b>	<b>0.34</b>	<b>0.42</b>	<b>0.46</b>	<b>0.50</b>	<b>28.0%</b>

### Basin Travel Time

	Sub-basin or Channel Type	Material Type	L (ft)	Elev. ΔZ <sub>0</sub> (ft)	Q <sub>i</sub> (cfs)	Base or Dia (ft)	Sides z:1 (ft/ft)	v (ft/s)	t (min)
Furthest Reach	EX-DP7	-	1,413	13	-	-	-	-	23.2
Channelized-1	Trap Ditch	2	476	3	32	20	8	1.4	5.8
Channelized-2									
Channelized-3									
Total			1,889	16					

2 = Natural, Winding, minimal vegetation/shallow grass

**t<sub>c</sub> (min) 29.0**

### Contributing Offsite Flows (Added to Runoff and Allowed Release, below.)

Contributing Basins/Areas

Q<sub>Minor</sub> (cfs) - 5-year Storm

Q<sub>Major</sub> (cfs) - 100-year Storm

### Rainfall Intensity & Runoff

	2-Yr	5-Yr	10-Yr	25-Yr	50-Yr	100-Yr
<b>Intensity (in/hr)</b>	2.03	2.53	2.96	3.38	3.80	4.25
<b>Site Runoff (cfs)</b>	14.45	<b>21.50</b>	30.00	41.96	51.63	<b>62.59</b>
<b>OffSite Runoff (cfs)</b>	-	<b>0.00</b>	-	-	-	<b>0.00</b>
<b>Release Rates (cfs/ac)</b>	-	-	-	-	-	-
<b>Allowed Release (cfs)</b>	-	<b>21.5</b>	-	-	-	<b>62.6</b>

DCM:  $I = C1 * \ln(tc) + C2$

C1	1.19	1.5	1.75	2	2.25	2.52
C2	6.035	7.583	8.847	10.111	11.375	12.735

### Notes

Runoff from Offsite basins have been assumed constant, despite additional times of concentration.



## Combined Sub-Basin Runoff Calculations - DP13 (Existing)

Includes Basins EX-DP12 EX-S10

Job No.:	<b>61183</b>	Date:	<b>4/5/2023 14:35</b>
Project:	<b>Ellicott D22 – GS &amp; HS Addition</b>	Calcs by:	<b>O. Ali</b>
Jurisdiction	<b>DCM</b>	Checked by:	
Runoff Coefficient	<b>Surface Type</b>	Soil Type	<b>A</b>
		Urbanization	<b>Urban</b>

### Basin Land Use Characteristics

Surface	Area		Runoff Coefficient						% Imperv.
	(SF)	(Acres)	C2	C5	C10	C25	C50	C100	
Pasture/Meadow	999,262	22.94	0.02	0.08	0.15	0.25	0.3	0.35	0%
Paved	163,995	3.76	0.89	0.9	0.92	0.94	0.95	0.96	100%
Gravel	113,339	2.60	0.57	0.59	0.63	0.66	0.68	0.7	80%
Roofs	120,417	2.76	0.71	0.73	0.75	0.78	0.8	0.81	90%
<b>Combined</b>	<b>1,397,013</b>	<b>32.07</b>	<b>0.23</b>	<b>0.27</b>	<b>0.33</b>	<b>0.41</b>	<b>0.45</b>	<b>0.49</b>	<b>26.0%</b>

### Basin Travel Time

	Sub-basin or Channel Type	Material Type	L (ft)	Elev. ΔZ <sub>0</sub> (ft)	Q <sub>i</sub> (cfs)	Base or Dia (ft)	Sides z:1 (ft/ft)	v (ft/s)	t (min)
Furthest Reach	EX-DP12	-	1,889	16	-	-	-	-	29.0
Channelized-1	V-Ditch	1	304	0	63	0	3	2.1	2.4
Channelized-2									
Channelized-3									
Total			2,193	16					

1 = Man-made, Smooth, Straight

**t<sub>c</sub> (min) 31.4**

### Contributing Offsite Flows (Added to Runoff and Allowed Release, below.)

Contributing Basins/Areas

Q<sub>Minor</sub> (cfs) - 5-year Storm

Q<sub>Major</sub> (cfs) - 100-year Storm

### Rainfall Intensity & Runoff

	2-Yr	5-Yr	10-Yr	25-Yr	50-Yr	100-Yr
<b>Intensity (in/hr)</b>	1.93	2.41	2.82	3.22	3.62	4.05
<b>Site Runoff (cfs)</b>	14.03	<b>21.18</b>	29.89	42.30	52.27	<b>63.58</b>
<b>OffSite Runoff (cfs)</b>	-	<b>0.00</b>	-	-	-	<b>0.00</b>
<b>Release Rates (cfs/ac)</b>	-	-	-	-	-	-
<b>Allowed Release (cfs)</b>	-	<b>21.2</b>	-	-	-	<b>63.6</b>

DCM:  $I = C1 * \ln(tc) + C2$

C1	1.19	1.5	1.75	2	2.25	2.52
C2	6.035	7.583	8.847	10.111	11.375	12.735

### Notes

Runoff from Offsite basins have been assumed constant, despite additional times of concentration.

## Sub-Basin A (DP1) Runoff Calculations

Job No.: 61183  
 Project: Ellicott D22 – GS & HS Addition  
 Jurisdiction: **DCM**  
 Runoff Coefficient: **Surface Type**

Date: 4/5/2023 14:35  
 Calcs by: O. Ali  
 Checked by: \_\_\_\_\_  
 Soil Type: **A**  
 Urbanization: **Urban**

### Basin Land Use Characteristics

Surface	Area		Runoff Coefficient						% Imperv.
	(SF)	(Acres)	C2	C5	C10	C25	C50	C100	
Pasture/Meadow	127,996	2.94	0.02	0.08	0.15	0.25	0.3	0.35	0%
Paved	19,402	0.45	0.89	0.9	0.92	0.94	0.95	0.96	100%
Gravel	36,530	0.84	0.57	0.59	0.63	0.66	0.68	0.7	80%
Roofs	354	0.01	0.71	0.73	0.75	0.78	0.8	0.81	90%
<b>Combined</b>	<b>184,282</b>	<b>4.23</b>	<b>0.22</b>	<b>0.27</b>	<b>0.33</b>	<b>0.40</b>	<b>0.44</b>	<b>0.48</b>	<b>26.6%</b>

184282

### Basin Travel Time

	Shallow Channel Ground Cover		Short Pasture/Lawns			
	$L_{max,Overland}$	100 ft			$C_v$	7
	L (ft)	$\Delta Z_0$ (ft)	$S_0$ (ft/ft)	v (ft/s)	t (min)	$t_{Alt}$ (min)
Total	843	7	-	-	-	-
Initial Time	100	3	0.025	-	11.1	14.7 DCM Eq. 6-8
Shallow Channel	470	4	0.007	0.6	13.0	- DCM Eq. 6-9
Channelized	273	1	0.002	1.3	3.6	- V-Ditch
				$t_c$	<b>14.7 min.</b>	

### Rainfall Intensity & Runoff

	2-Yr	5-Yr	10-Yr	25-Yr	50-Yr	100-Yr
<b>Intensity (in/hr)</b>	2.84	3.55	4.15	4.74	5.33	5.96
<b>Runoff (cfs)</b>	2.7	4.0	5.7	8.1	10.0	12.2
<b>Release Rates (cfs/ac)</b>	-	-	-	-	-	-
<b>Allowed Release (cfs)</b>	2.7	4.0	5.7	8.1	10.0	12.2

DCM:  $I = C1 * \ln(tc) + C2$

C1	1.19	1.5	1.75	2	2.25	2.52
C2	6.035	7.583	8.847	10.111	11.375	12.735

### Notes

## Sub-Basin B1 Runoff Calculations

Job No.: 61183  
 Project: Ellicott D22 – GS & HS Addition  
 Jurisdiction: **DCM**  
 Runoff Coefficient: **Surface Type**

Date: 4/5/2023 14:35  
 Calcs by: O. Ali  
 Checked by: \_\_\_\_\_  
 Soil Type: **A**  
 Urbanization: **Urban**

### Basin Land Use Characteristics

Surface	Area		Runoff Coefficient						% Imperv.
	(SF)	(Acres)	C2	C5	C10	C25	C50	C100	
Pasture/Meadow	4,861	0.11	0.02	0.08	0.15	0.25	0.3	0.35	0%
Paved	4,197	0.10	0.89	0.9	0.92	0.94	0.95	0.96	100%
Gravel	9,884	0.23	0.57	0.59	0.63	0.66	0.68	0.7	80%
Roofs	283	0.01	0.71	0.73	0.75	0.78	0.8	0.81	90%
<b>Combined</b>	<b>19,225</b>	<b>0.44</b>	<b>0.50</b>	<b>0.53</b>	<b>0.57</b>	<b>0.62</b>	<b>0.64</b>	<b>0.67</b>	<b>64.3%</b>

19225

### Basin Travel Time

	Shallow Channel	Ground Cover	Short Pasture/Lawns				
$L_{max,Overland}$	100	ft	$C_v$	7			
$L$ (ft)	$\Delta Z_0$ (ft)	$S_0$ (ft/ft)	$v$ (ft/s)	$t$ (min)	$t_{Alt}$ (min)		
Total	277	4	-	-	-		
Initial Time	100	2	0.015	-	9.0	11.5	DCM Eq. 6-8
Shallow Channel	177	2	0.011	0.7	4.0	-	DCM Eq. 6-9
Channelized			0.000	0.0	0.0	-	V-Ditch
				$t_c$	<b>11.5 min.</b>		

### Rainfall Intensity & Runoff

	2-Yr	5-Yr	10-Yr	25-Yr	50-Yr	100-Yr
<b>Intensity (in/hr)</b>	3.12	3.91	4.57	5.22	5.87	6.57
<b>Runoff (cfs)</b>	0.7	<b>0.9</b>	1.2	1.4	1.7	<b>1.9</b>
<b>Release Rates (cfs/ac)</b>	-	-	-	-	-	-
<b>Allowed Release (cfs)</b>	0.7	<b>0.9</b>	1.2	1.4	1.7	<b>1.9</b>

DCM:  $I = C1 * \ln(tc) + C2$

C1	1.19	1.5	1.75	2	2.25	2.52
C2	6.035	7.583	8.847	10.111	11.375	12.735

### Notes

## Sub-Basin B2 (DP2) Runoff Calculations

Job No.: 61183  
 Project: Ellicott D22 – GS & HS Addition  
 Jurisdiction: **DCM**  
 Runoff Coefficient: **Surface Type**

Date: 4/5/2023 14:35  
 Calcs by: O. Ali  
 Checked by: \_\_\_\_\_  
 Soil Type: **A**  
 Urbanization: **Urban**

### Basin Land Use Characteristics

Surface	Area		Runoff Coefficient						% Imperv.
	(SF)	(Acres)	C2	C5	C10	C25	C50	C100	
Pasture/Meadow	10,502	0.24	0.02	0.08	0.15	0.25	0.3	0.35	0%
Paved	2,647	0.06	0.89	0.9	0.92	0.94	0.95	0.96	100%
Gravel	2,346	0.05	0.57	0.59	0.63	0.66	0.68	0.7	80%
Roofs	11,504	0.26	0.71	0.73	0.75	0.78	0.8	0.81	90%
<b>Combined</b>	<b>26,999</b>	<b>0.62</b>	<b>0.45</b>	<b>0.48</b>	<b>0.52</b>	<b>0.58</b>	<b>0.61</b>	<b>0.64</b>	<b>55.1%</b>

26999

### Basin Travel Time

	Shallow Channel	Ground Cover	Short Pasture/Lawns				
	$L_{max,Overland}$	100 ft	$C_v$	7			
	L (ft)	$\Delta Z_0$ (ft)	$S_0$ (ft/ft)	v (ft/s)	t (min)	$t_{Alt}$ (min)	
Total	313	11	-	-	-	-	
Initial Time	51	8	0.157	-	3.2	11.7	DCM Eq. 6-8
Shallow Channel	21	1	0.048	1.5	0.2	-	DCM Eq. 6-9
Channelized	241	2	0.008	1.6	2.5	-	V-Ditch
				$t_c$	<b>5.9 min.</b>		

### Rainfall Intensity & Runoff

	2-Yr	5-Yr	10-Yr	25-Yr	50-Yr	100-Yr
<b>Intensity (in/hr)</b>	3.92	4.91	5.73	6.55	7.37	8.25
<b>Runoff (cfs)</b>	1.1	1.5	1.9	2.4	2.8	3.3
<b>Release Rates (cfs/ac)</b>	-	-	-	-	-	-
<b>Allowed Release (cfs)</b>	1.1	1.5	1.9	2.4	2.8	3.3

DCM:  $I = C1 * \ln(tc) + C2$

C1	1.19	1.5	1.75	2	2.25	2.52
C2	6.035	7.583	8.847	10.111	11.375	12.735

### Notes

## Sub-Basin C Runoff Calculations

Job No.: 61183  
 Project: Ellicott D22 – GS & HS Addition  
 Jurisdiction: **DCM**  
 Runoff Coefficient: **Surface Type**

Date: 4/5/2023 14:35  
 Calcs by: O. Ali  
 Checked by: \_\_\_\_\_  
 Soil Type: **A**  
 Urbanization: **Urban**

### Basin Land Use Characteristics

Surface	Area		Runoff Coefficient						% Imperv.
	(SF)	(Acres)	C2	C5	C10	C25	C50	C100	
Pasture/Meadow	56,715	1.30	0.02	0.08	0.15	0.25	0.3	0.35	0%
Paved	1,357	0.03	0.89	0.9	0.92	0.94	0.95	0.96	100%
<b>Combined</b>	<b>58,072</b>	<b>1.33</b>	<b>0.04</b>	<b>0.10</b>	<b>0.17</b>	<b>0.27</b>	<b>0.32</b>	<b>0.36</b>	<b>2.3%</b>

58072

### Basin Travel Time

	Shallow Channel	Ground Cover	Short Pasture/Lawns				
	$L_{max,Overland}$	100 ft	$C_v$	7			
	L (ft)	$\Delta Z_0$ (ft)	$S_0$ (ft/ft)	v (ft/s)	t (min)	$t_{Alt}$ (min)	
Total	497	11	-	-	-	-	
Initial Time	100	8	0.080	-	9.1	12.8	DCM Eq. 6-8
Shallow Channel	368	3	0.007	0.6	10.6	-	DCM Eq. 6-9
Channelized	29	1	0.017	2.1	0.2	-	V-Ditch
				$t_c$	<b>12.8 min.</b>		

### Rainfall Intensity & Runoff

	2-Yr	5-Yr	10-Yr	25-Yr	50-Yr	100-Yr
<b>Intensity (in/hr)</b>	3.00	3.76	4.39	5.02	5.65	6.32
<b>Runoff (cfs)</b>	0.2	<b>0.5</b>	1.0	1.8	2.4	<b>3.1</b>
<b>Release Rates (cfs/ac)</b>	-	-	-	-	-	-
<b>Allowed Release (cfs)</b>	0.2	<b>0.5</b>	1.0	1.8	2.4	<b>3.1</b>

DCM:  $I = C1 * \ln(tc) + C2$

C1	1.19	1.5	1.75	2	2.25	2.52
C2	6.035	7.583	8.847	10.111	11.375	12.735

### Notes

## Sub-Basin D (DP6) Runoff Calculations

Job No.: 61183  
 Project: Ellicott D22 – GS & HS Addition  
 Jurisdiction: DCM  
 Runoff Coefficient: Surface Type

Date: 4/5/2023 14:35  
 Calcs by: O. Ali  
 Checked by: \_\_\_\_\_  
 Soil Type: A  
 Urbanization: Urban

### Basin Land Use Characteristics

Surface	Area		Runoff Coefficient						% Imperv.
	(SF)	(Acres)	C2	C5	C10	C25	C50	C100	
Pasture/Meadow	68,305	1.57	0.02	0.08	0.15	0.25	0.3	0.35	0%
Gravel	4,328	0.10	0.57	0.59	0.63	0.66	0.68	0.7	80%
Paved	3,139	0.07	0.89	0.9	0.92	0.94	0.95	0.96	100%
Roofs	19,800	0.45	0.71	0.73	0.75	0.78	0.8	0.81	90%
<b>Combined</b>	<b>95,572</b>	<b>2.19</b>	<b>0.22</b>	<b>0.26</b>	<b>0.32</b>	<b>0.40</b>	<b>0.44</b>	<b>0.48</b>	<b>25.6%</b>

95572

### Basin Travel Time

	Shallow Channel Ground Cover		Paved areas/shallow paved swales			
	$L_{max,Overland}$	100 ft			$C_v$	20
	L (ft)	$\Delta Z_0$ (ft)	$S_0$ (ft/ft)	v (ft/s)	t (min)	$t_{Alt}$ (min)
Total	537	7	-	-	-	-
Initial Time	100	3	0.025	-	11.1	13.0 DCM Eq. 6-8
Shallow Channel	318	3	0.009	1.9	2.7	- DCM Eq. 6-9
Channelized	119	1	0.008	0.9	2.2	- V-Ditch
				$t_c$	<b>13.0 min.</b>	

### Rainfall Intensity & Runoff

	2-Yr	5-Yr	10-Yr	25-Yr	50-Yr	100-Yr
<b>Intensity (in/hr)</b>	2.98	3.74	4.36	4.98	5.61	6.27
<b>Runoff (cfs)</b>	1.4	<b>2.2</b>	3.1	4.4	5.4	<b>6.6</b>
<b>Release Rates (cfs/ac)</b>	-	-	-	-	-	-
<b>Allowed Release (cfs)</b>	1.4	<b>2.2</b>	3.1	4.4	5.4	<b>6.6</b>

DCM:  $I = C1 * \ln(tc) + C2$

C1	1.19	1.5	1.75	2	2.25	2.52
C2	6.035	7.583	8.847	10.111	11.375	12.735

### Notes

## Sub-Basin S3 Runoff Calculations

Job No.: 61183  
 Project: Ellicott D22 – GS & HS Addition  
 Jurisdiction: DCM  
 Runoff Coefficient: Surface Type

Date: 4/5/2023 14:35  
 Calcs by: O. Ali  
 Checked by: \_\_\_\_\_  
 Soil Type: A  
 Urbanization: Urban

### Basin Land Use Characteristics

Surface	Area		Runoff Coefficient						% Imperv.
	(SF)	(Acres)	C2	C5	C10	C25	C50	C100	
Pasture/Meadow	72,321	1.66	0.02	0.08	0.15	0.25	0.3	0.35	0%
Roofs	630	0.01	0.71	0.73	0.75	0.78	0.8	0.81	90%
Paved	289	0.01	0.89	0.9	0.92	0.94	0.95	0.96	100%
Gravel	218	0.01	0.57	0.59	0.63	0.66	0.68	0.7	80%
<b>Combined</b>	<b>73,458</b>	<b>1.69</b>	<b>0.03</b>	<b>0.09</b>	<b>0.16</b>	<b>0.26</b>	<b>0.31</b>	<b>0.36</b>	<b>1.4%</b>

73458

### Basin Travel Time

	Shallow Channel Ground Cover		Short Pasture/Lawns			
	$L_{max,Overland}$	100 ft			$C_v$	7
	L (ft)	$\Delta Z_0$ (ft)	$S_0$ (ft/ft)	v (ft/s)	t (min)	$t_{Alt}$ (min)
Total	493	6	-	-	-	-
Initial Time	100	2	0.015	-	15.9	12.7 DCM Eq. 6-8
Shallow Channel	393	5	0.011	0.7	8.7	- DCM Eq. 6-9
Channelized			0.000	0.0	0.0	- V-Ditch
				$t_c$	<b>12.7 min.</b>	

### Rainfall Intensity & Runoff

	2-Yr	5-Yr	10-Yr	25-Yr	50-Yr	100-Yr
<b>Intensity (in/hr)</b>	3.01	3.77	4.39	5.02	5.65	6.32
<b>Runoff (cfs)</b>	0.2	<b>0.6</b>	1.2	2.2	2.9	<b>3.8</b>
<b>Release Rates (cfs/ac)</b>	-	-	-	-	-	-
<b>Allowed Release (cfs)</b>	0.2	<b>0.6</b>	1.2	2.2	2.9	<b>3.8</b>

DCM:  $I = C1 * \ln(tc) + C2$

C1	1.19	1.5	1.75	2	2.25	2.52
C2	6.035	7.583	8.847	10.111	11.375	12.735

### Notes

## Sub-Basin S4 Runoff Calculations

Job No.: 61183  
 Project: Ellicott D22 – GS & HS Addition  
 Jurisdiction: **DCM**  
 Runoff Coefficient: **Surface Type**

Date: 4/5/2023 14:35  
 Calcs by: O. Ali  
 Checked by: \_\_\_\_\_  
 Soil Type: **A**  
 Urbanization: **Urban**

### Basin Land Use Characteristics

Surface	Area		Runoff Coefficient						% Imperv.
	(SF)	(Acres)	C2	C5	C10	C25	C50	C100	
Pasture/Meadow	76,776	1.76	0.02	0.08	0.15	0.25	0.3	0.35	0%
Roofs	29,366	0.67	0.71	0.73	0.75	0.78	0.8	0.81	90%
Paved	47,356	1.09	0.89	0.9	0.92	0.94	0.95	0.96	100%
Gravel	3,911	0.09	0.57	0.59	0.63	0.66	0.68	0.7	80%
<b>Combined</b>	<b>157,409</b>	<b>3.61</b>	<b>0.42</b>	<b>0.46</b>	<b>0.51</b>	<b>0.57</b>	<b>0.60</b>	<b>0.63</b>	<b>48.9%</b>

157409

### Basin Travel Time

	Shallow Channel	Ground Cover	Paved areas/shallow paved swales			
	$L_{max,Overland}$	100 ft			$C_v$	20
	L (ft)	$\Delta Z_0$ (ft)	$S_0$ (ft/ft)	v (ft/s)	t (min)	$t_{Alt}$ (min)
Total	864	9	-	-	-	-
Initial Time	100	3	0.030	-	8.0	14.8 DCM Eq. 6-8
Shallow Channel	764	6	0.007	1.7	7.5	- DCM Eq. 6-9
Channelized			0.000	0.0	0.0	- V-Ditch
				$t_c$	<b>14.8 min.</b>	

### Rainfall Intensity & Runoff

	2-Yr	5-Yr	10-Yr	25-Yr	50-Yr	100-Yr
<b>Intensity (in/hr)</b>	2.83	3.54	4.13	4.72	5.31	5.94
<b>Runoff (cfs)</b>	4.3	<b>5.9</b>	7.5	9.7	11.5	<b>13.5</b>
<b>Release Rates (cfs/ac)</b>	-	-	-	-	-	-
<b>Allowed Release (cfs)</b>	4.3	<b>5.9</b>	7.5	9.7	11.5	<b>13.5</b>

DCM:  $I = C1 * \ln(tc) + C2$

C1	1.19	1.5	1.75	2	2.25	2.52
C2	6.035	7.583	8.847	10.111	11.375	12.735

### Notes



## Sub-Basin S9 Runoff Calculations

Job No.: 61183  
 Project: Ellicott D22 – GS & HS Addition  
 Jurisdiction: **DCM**  
 Runoff Coefficient: **Surface Type**

Date: 4/5/2023 14:35  
 Calcs by: O. Ali  
 Checked by: \_\_\_\_\_  
 Soil Type: **A**  
 Urbanization: **Urban**

### Basin Land Use Characteristics

Surface	Area		Runoff Coefficient						% Imperv.
	(SF)	(Acres)	C2	C5	C10	C25	C50	C100	
Pasture/Meadow	247,615	5.68	0.02	0.08	0.15	0.25	0.3	0.35	0%
Roofs	53	0.00	0.71	0.73	0.75	0.78	0.8	0.81	90%
Paved	3,228	0.07	0.89	0.9	0.92	0.94	0.95	0.96	100%
Gravel	3,588	0.08	0.57	0.59	0.63	0.66	0.68	0.7	80%
<b>Combined</b>	<b>254,484</b>	<b>5.84</b>	<b>0.04</b>	<b>0.10</b>	<b>0.17</b>	<b>0.26</b>	<b>0.31</b>	<b>0.36</b>	<b>2.4%</b>

254484

### Basin Travel Time

	Shallow Channel	Ground Cover	Short Pasture/Lawns				
$L_{max,Overland}$	100	ft	$C_v$	7			
$L$ (ft)	$\Delta Z_0$ (ft)	$S_0$ (ft/ft)	$v$ (ft/s)	$t$ (min)	$t_{Alt}$ (min)		
Total	993	6	-	-	-		
Initial Time	100	1	0.005	-	22.7	15.5	DCM Eq. 6-8
Shallow Channel	726	5	0.006	0.6	22.0	-	DCM Eq. 6-9
Channelized	167	1	0.003	0.8	3.4	-	Trap Ditch
			$t_c$	<b>15.5 min.</b>			

### Rainfall Intensity & Runoff

	2-Yr	5-Yr	10-Yr	25-Yr	50-Yr	100-Yr
<b>Intensity (in/hr)</b>	2.77	3.47	4.05	4.63	5.21	5.83
<b>Runoff (cfs)</b>	0.6	<b>2.0</b>	3.9	7.2	9.5	<b>12.3</b>
<b>Release Rates (cfs/ac)</b>	-	-	-	-	-	-
<b>Allowed Release (cfs)</b>	0.6	<b>2.0</b>	3.9	7.2	9.5	<b>12.3</b>

DCM:  $I = C1 * \ln(tc) + C2$

C1	1.19	1.5	1.75	2	2.25	2.52
C2	6.035	7.583	8.847	10.111	11.375	12.735

### Notes

## Combined Sub-Basin Runoff Calculations - DP3 (Proposed)

Includes Basins A B1 B2 C

Job No.:	<b>61183</b>	Date:	<b>4/5/2023 14:35</b>
Project:	<b>Ellicott D22 – GS &amp; HS Addition</b>	Calcs by:	<b>O. Ali</b>
Jurisdiction	<b>DCM</b>	Checked by:	
Runoff Coefficient	<b>Surface Type</b>	Soil Type	<b>A</b>
		Urbanization	<b>Urban</b>

### Basin Land Use Characteristics

Surface	Area		Runoff Coefficient						% Imperv.
	(SF)	(Acres)	C2	C5	C10	C25	C50	C100	
Pasture/Meadow	200,074	4.59	0.02	0.08	0.15	0.25	0.3	0.35	0%
Paved	27,603	0.63	0.89	0.9	0.92	0.94	0.95	0.96	100%
Gravel	48,760	1.12	0.57	0.59	0.63	0.66	0.68	0.7	80%
Roofs	12,141	0.28	0.71	0.73	0.75	0.78	0.8	0.81	90%
<b>Combined</b>	<b>288,578</b>	<b>6.62</b>	<b>0.23</b>	<b>0.27</b>	<b>0.33</b>	<b>0.41</b>	<b>0.45</b>	<b>0.49</b>	<b>26.9%</b>

### Basin Travel Time

	Sub-basin or Channel Type	Material Type	L (ft)	Elev. ΔZ <sub>0</sub> (ft)	Q <sub>i</sub> (cfs)	Base or Dia (ft)	Sides z:1 (ft/ft)	v (ft/s)	t (min)
Furthest Reach	A	-	843	7	-	-	-	-	14.7
Channelized-1	V-Ditch	2	126	1	12	0	3	1.7	1.2
Channelized-2									
Channelized-3									
Total			969	7					

2 = Natural, Winding, minimal vegetation/shallow grass

**t<sub>c</sub> (min) 15.9**

### Contributing Offsite Flows (Added to Runoff and Allowed Release, below.)

Contributing Basins/Areas

Q<sub>Minor</sub> (cfs) - 5-year Storm

Q<sub>Major</sub> (cfs) - 100-year Storm

### Rainfall Intensity & Runoff

	2-Yr	5-Yr	10-Yr	25-Yr	50-Yr	100-Yr
<b>Intensity (in/hr)</b>	2.74	3.43	4.00	4.58	5.15	5.76
<b>Site Runoff (cfs)</b>	4.09	<b>6.18</b>	8.75	12.36	15.26	<b>18.58</b>
<b>OffSite Runoff (cfs)</b>	-	<b>0.00</b>	-	-	-	<b>0.00</b>
<b>Release Rates (cfs/ac)</b>	-	-	-	-	-	-
<b>Allowed Release (cfs)</b>	-	<b>6.2</b>	-	-	-	<b>18.6</b>

DCM:  $I = C1 * \ln(tc) + C2$

C1	1.19	1.5	1.75	2	2.25	2.52
C2	6.035	7.583	8.847	10.111	11.375	12.735

### Notes

Runoff from Offsite basins have been assumed constant, despite additional times of concentration.

## Combined Sub-Basin Runoff Calculations - DP5 (Proposed)

Includes Basins A B1 B2 C EX-S1

Job No.:	<b>61183</b>	Date:	<b>4/5/2023 14:35</b>
Project:	<b>Ellicott D22 – GS &amp; HS Addition</b>	Calcs by:	<b>O. Ali</b>
Jurisdiction	<b>DCM</b>	Checked by:	
Runoff Coefficient	<b>Surface Type</b>	Soil Type	<b>A</b>
		Urbanization	<b>Urban</b>

### Basin Land Use Characteristics

Surface	Area		Runoff Coefficient						% Imperv.
	(SF)	(Acres)	C2	C5	C10	C25	C50	C100	
Pasture/Meadow	272,256	6.25	0.02	0.08	0.15	0.25	0.3	0.35	0%
Paved	34,567	0.79	0.89	0.9	0.92	0.94	0.95	0.96	100%
Gravel	84,678	1.94	0.57	0.59	0.63	0.66	0.68	0.7	80%
Roofs	13,418	0.31	0.71	0.73	0.75	0.78	0.8	0.81	90%
<b>Combined</b>	<b>404,919</b>	<b>9.30</b>	<b>0.23</b>	<b>0.28</b>	<b>0.34</b>	<b>0.41</b>	<b>0.45</b>	<b>0.49</b>	<b>28.2%</b>

### Basin Travel Time

	Sub-basin or Channel Type	Material Type	L (ft)	Elev. ΔZ <sub>0</sub> (ft)	Q <sub>i</sub> (cfs)	Base or Dia (ft)	Sides z:1 (ft/ft)	v (ft/s)	t (min)
Furthest Reach	EX-A	-	741	9	-	-	-	-	14.1
Channelized-1	Trap Ditch	2	389	2	13	5	8	1.2	5.3
Channelized-2									
Channelized-3									
Total			1,130	10					

2 = Natural, Winding, minimal vegetation/shallow grass

**t<sub>c</sub> (min) 19.5**

### Contributing Offsite Flows (Added to Runoff and Allowed Release, below.)

Contributing Basins/Areas

Q<sub>Minor</sub> (cfs) - 5-year Storm

Q<sub>Major</sub> (cfs) - 100-year Storm

### Rainfall Intensity & Runoff

	2-Yr	5-Yr	10-Yr	25-Yr	50-Yr	100-Yr
<b>Intensity (in/hr)</b>	2.50	3.13	3.65	4.17	4.70	5.25
<b>Site Runoff (cfs)</b>	5.40	<b>8.09</b>	11.41	15.99	19.71	<b>23.96</b>
<b>OffSite Runoff (cfs)</b>	-	<b>0.00</b>	-	-	-	<b>0.00</b>
<b>Release Rates (cfs/ac)</b>	-	-	-	-	-	-
<b>Allowed Release (cfs)</b>	-	<b>8.1</b>	-	-	-	<b>24.0</b>

DCM:  $I = C1 * \ln(tc) + C2$

C1	1.19	1.5	1.75	2	2.25	2.52
C2	6.035	7.583	8.847	10.111	11.375	12.735

### Notes

Runoff from Offsite basins have been assumed constant, despite additional times of concentration.

## Combined Sub-Basin Runoff Calculations - DP7 (Proposed)

Includes Basins A B1 B2 C D EX-S1 EX-S2 S3

Job No.:	<b>61183</b>	Date:	<b>4/5/2023 14:35</b>
Project:	<b>Ellicott D22 – GS &amp; HS Addition</b>	Calcs by:	<b>O. Ali</b>
Jurisdiction	<b>DCM</b>	Checked by:	
Runoff Coefficient	<b>Surface Type</b>	Soil Type	<b>A</b>
		Urbanization	<b>Urban</b>

### Basin Land Use Characteristics

Surface	Area		Runoff Coefficient						% Imperv.
	(SF)	(Acres)	C2	C5	C10	C25	C50	C100	
Pasture/Meadow	416,733	9.57	0.02	0.08	0.15	0.25	0.3	0.35	0%
Paved	46,448	1.07	0.89	0.9	0.92	0.94	0.95	0.96	100%
Gravel	89,224	2.05	0.57	0.59	0.63	0.66	0.68	0.7	80%
Roofs	74,298	1.71	0.71	0.73	0.75	0.78	0.8	0.81	90%
<b>Combined</b>	<b>626,703</b>	<b>14.39</b>	<b>0.24</b>	<b>0.29</b>	<b>0.35</b>	<b>0.42</b>	<b>0.46</b>	<b>0.50</b>	<b>29.5%</b>

### Basin Travel Time

	Sub-basin or Channel Type	Material Type	L (ft)	Elev. ΔZ <sub>0</sub> (ft)	Q <sub>i</sub> (cfs)	Base or Dia (ft)	Sides z:1 (ft/ft)	v (ft/s)	t (min)	
Furthest Reach	EX-A	-	741	9	-	-	-	-	14.1	
Channelized-1	Trap Ditch	2	389	2	13	5	8	1.2	5.3	
Channelized-2	Trap Ditch	2	283	3	13	20	8	1.3	3.7	
Channelized-3										
Total			1,413	13						
		2 = Natural, Winding, minimal vegetation/shallow grass							t <sub>c</sub>	23.2
		2 = Natural, Winding, minimal vegetation/shallow grass							(min)	

### Contributing Offsite Flows (Added to Runoff and Allowed Release, below.)

Contributing Basins/Areas

Q<sub>Minor</sub> (cfs) - 5-year Storm

Q<sub>Major</sub> (cfs) - 100-year Storm

### Rainfall Intensity & Runoff

	2-Yr	5-Yr	10-Yr	25-Yr	50-Yr	100-Yr
<b>Intensity (in/hr)</b>	2.29	2.87	3.34	3.82	4.30	4.81
<b>Site Runoff (cfs)</b>	8.07	<b>11.98</b>	16.68	23.23	28.56	<b>34.59</b>
<b>OffSite Runoff (cfs)</b>	-	<b>0.00</b>	-	-	-	<b>0.00</b>
<b>Release Rates (cfs/ac)</b>	-	-	-	-	-	-
<b>Allowed Release (cfs)</b>	-	<b>12.0</b>	-	-	-	<b>34.6</b>

DCM:  $I = C1 * \ln(tc) + C2$

C1	1.19	1.5	1.75	2	2.25	2.52
C2	6.035	7.583	8.847	10.111	11.375	12.735

### Notes

Runoff from Offsite basins have been assumed constant, despite additional times of concentration.

## Combined Sub-Basin Runoff Calculations - DP9 (Proposed)

Includes Basins S4 EX-S5

Job No.:	<b>61183</b>	Date:	<b>4/5/2023 14:35</b>
Project:	<b>Ellicott D22 – GS &amp; HS Addition</b>	Calcs by:	<b>O. Ali</b>
Jurisdiction	<b>DCM</b>	Checked by:	
Runoff Coefficient	<b>Surface Type</b>	Soil Type	<b>A</b>
		Urbanization	<b>Urban</b>

### Basin Land Use Characteristics

Surface	Area		Runoff Coefficient						% Imperv.
	(SF)	(Acres)	C2	C5	C10	C25	C50	C100	
Pasture/Meadow	97,380	2.24	0.02	0.08	0.15	0.25	0.3	0.35	0%
Paved	86,061	1.98	0.89	0.9	0.92	0.94	0.95	0.96	100%
Gravel	28,005	0.64	0.57	0.59	0.63	0.66	0.68	0.7	80%
Roofs	29,366	0.67	0.71	0.73	0.75	0.78	0.8	0.81	90%
<b>Combined</b>	<b>240,812</b>	<b>5.53</b>	<b>0.48</b>	<b>0.51</b>	<b>0.55</b>	<b>0.61</b>	<b>0.64</b>	<b>0.66</b>	<b>56.0%</b>

### Basin Travel Time

	Sub-basin or Channel Type	Material Type	L (ft)	Elev. ΔZ <sub>0</sub> (ft)	Q <sub>i</sub> (cfs)	Base or Dia (ft)	Sides z:1 (ft/ft)	v (ft/s)	t (min)
Furthest Reach	EX-S4	-	864	9	-	-	-	-	14.8
Channelized-1	C&G	Concrete	396	2	14	0	0	2.6	2.6
Channelized-2									
Channelized-3									
Total			1,260	11					
								<b>t<sub>c</sub> (min)</b>	<b>17.4</b>

### Contributing Offsite Flows (Added to Runoff and Allowed Release, below.)

Contributing Basins/Areas

Q<sub>Minor</sub> (cfs) - 5-year Storm

Q<sub>Major</sub> (cfs) - 100-year Storm

### Rainfall Intensity & Runoff

	2-Yr	5-Yr	10-Yr	25-Yr	50-Yr	100-Yr
<b>Intensity (in/hr)</b>	2.64	3.30	3.85	4.40	4.95	5.54
<b>Site Runoff (cfs)</b>	6.98	<b>9.33</b>	11.79	14.81	17.44	<b>20.36</b>
<b>OffSite Runoff (cfs)</b>	-	<b>0.00</b>	-	-	-	<b>0.00</b>
<b>Release Rates (cfs/ac)</b>	-	-	-	-	-	-
<b>Allowed Release (cfs)</b>	-	<b>9.3</b>	-	-	-	<b>20.4</b>

DCM:  $I = C1 * \ln(tc) + C2$

C1	1.19	1.5	1.75	2	2.25	2.52
C2	6.035	7.583	8.847	10.111	11.375	12.735

### Notes

Runoff from Offsite basins have been assumed constant, despite additional times of concentration.

## Combined Sub-Basin Runoff Calculations - DP10 (Proposed)

Includes Basins S4 EX-S5 EX-S6

Job No.:	<b>61183</b>	Date:	<b>4/5/2023 14:35</b>
Project:	<b>Ellicott D22 – GS &amp; HS Addition</b>	Calcs by:	<b>O. Ali</b>
Jurisdiction	<b>DCM</b>	Checked by:	
Runoff Coefficient	<b>Surface Type</b>	Soil Type	<b>A</b>
		Urbanization	<b>Urban</b>

### Basin Land Use Characteristics

Surface	Area		Runoff Coefficient						% Imperv.
	(SF)	(Acres)	C2	C5	C10	C25	C50	C100	
Pasture/Meadow	117,495	2.70	0.02	0.08	0.15	0.25	0.3	0.35	0%
Paved	92,737	2.13	0.89	0.9	0.92	0.94	0.95	0.96	100%
Gravel	28,005	0.64	0.57	0.59	0.63	0.66	0.68	0.7	80%
Roofs	49,068	1.13	0.71	0.73	0.75	0.78	0.8	0.81	90%
<b>Combined</b>	<b>287,305</b>	<b>6.60</b>	<b>0.47</b>	<b>0.51</b>	<b>0.55</b>	<b>0.60</b>	<b>0.63</b>	<b>0.66</b>	<b>55.4%</b>

### Basin Travel Time

	Sub-basin or Channel Type	Material Type	L (ft)	Elev. ΔZ <sub>0</sub> (ft)	Q <sub>i</sub> (cfs)	Base or Dia (ft)	Sides z:1 (ft/ft)	v (ft/s)	t (min)
Furthest Reach	EX-S4	-	864	9	-	-	-	-	14.8
Channelized-1	C&G	Concrete	546	2	14	0	0	2.3	4.0
Channelized-2	Trap Ditch	1	148	0	14	2	2	1.8	1.4
Channelized-3									
Total			1,558	11					
								<b>t<sub>c</sub> (min)</b>	<b>20.2</b>

1 = Man-made, Smooth, Straight

### Contributing Offsite Flows (Added to Runoff and Allowed Release, below.)

Contributing Basins/Areas

Q <sub>Minor</sub>	(cfs) - 5-year Storm
Q <sub>Major</sub>	(cfs) - 100-year Storm

### Rainfall Intensity & Runoff

	2-Yr	5-Yr	10-Yr	25-Yr	50-Yr	100-Yr
<b>Intensity (in/hr)</b>	2.46	3.07	3.59	4.10	4.61	5.16
<b>Site Runoff (cfs)</b>	7.66	<b>10.25</b>	12.96	16.31	19.23	<b>22.45</b>
<b>OffSite Runoff (cfs)</b>	-	<b>0.00</b>	-	-	-	<b>0.00</b>
<b>Release Rates (cfs/ac)</b>	-	-	-	-	-	-
<b>Allowed Release (cfs)</b>	-	<b>10.2</b>	-	-	-	<b>22.5</b>

DCM:  $I = C1 * \ln(tc) + C2$

C1	1.19	1.5	1.75	2	2.25	2.52
C2	6.035	7.583	8.847	10.111	11.375	12.735

### Notes

Runoff from Offsite basins have been assumed constant, despite additional times of concentration.

## Combined Sub-Basin Runoff Calculations - DP11 (Proposed)

Includes Basins S4 EX-S5 EX-S6 EX-S7 EX-S8

Job No.:	<b>61183</b>	Date:	<b>4/5/2023 14:35</b>
Project:	<b>Ellicott D22 – GS &amp; HS Addition</b>	Calcs by:	<b>O. Ali</b>
Jurisdiction	<b>DCM</b>	Checked by:	
Runoff Coefficient	<b>Surface Type</b>	Soil Type	<b>A</b>
		Urbanization	<b>Urban</b>

### Basin Land Use Characteristics

Surface	Area		Runoff Coefficient						% Imperv.
	(SF)	(Acres)	C2	C5	C10	C25	C50	C100	
Pasture/Meadow	177,247	4.07	0.02	0.08	0.15	0.25	0.3	0.35	0%
Paved	117,659	2.70	0.89	0.9	0.92	0.94	0.95	0.96	100%
Gravel	28,005	0.64	0.57	0.59	0.63	0.66	0.68	0.7	80%
Roofs	77,370	1.78	0.71	0.73	0.75	0.78	0.8	0.81	90%
<b>Combined</b>	<b>400,281</b>	<b>9.19</b>	<b>0.45</b>	<b>0.48</b>	<b>0.53</b>	<b>0.58</b>	<b>0.61</b>	<b>0.64</b>	<b>52.4%</b>

### Basin Travel Time

	Sub-basin or Channel Type	Material Type	L (ft)	Elev. ΔZ <sub>0</sub> (ft)	Q <sub>i</sub> (cfs)	Base or Dia (ft)	Sides z:1 (ft/ft)	v (ft/s)	t (min)
Furthest Reach	EX-S4	-	864	9	-	-	-	-	14.8
Channelized-1	C&G	Concrete	546	2	14	0	0	2.3	4.0
Channelized-2	Trap Ditch	1	192	1	14	2	2	2.1	1.5
Channelized-3	V-Ditch	1	343	2	14	0	3	2.7	2.2
Total			1,945	13					
								<b>t<sub>c</sub> (min)</b>	<b>22.5</b>

1 = Man-made, Smooth, Straight

### Contributing Offsite Flows (Added to Runoff and Allowed Release, below.)

Contributing Basins/Areas: [Redacted]

Q<sub>Minor</sub>: [Redacted] (cfs) - 5-year Storm

Q<sub>Major</sub>: [Redacted] (cfs) - 100-year Storm

### Rainfall Intensity & Runoff

	2-Yr	5-Yr	10-Yr	25-Yr	50-Yr	100-Yr
<b>Intensity (in/hr)</b>	2.33	2.91	3.40	3.88	4.37	4.89
<b>Site Runoff (cfs)</b>	9.58	<b>12.91</b>	16.42	20.84	24.66	<b>28.87</b>
<b>OffSite Runoff (cfs)</b>	-	<b>0.00</b>	-	-	-	<b>0.00</b>
<b>Release Rates (cfs/ac)</b>	-	-	-	-	-	-
<b>Allowed Release (cfs)</b>	-	<b>12.9</b>	-	-	-	<b>28.9</b>

DCM:  $I = C1 * \ln(tc) + C2$

C1	1.19	1.5	1.75	2	2.25	2.52
C2	6.035	7.583	8.847	10.111	11.375	12.735

### Notes

Runoff from Offsite basins have been assumed constant, despite additional times of concentration.

## Combined Sub-Basin Runoff Calculations - DP12 (Proposed)

Includes Basins DP7 DP11 S9

Job No.:	<b>61183</b>	Date:	<b>4/5/2023 14:35</b>
Project:	<b>Ellicott D22 – GS &amp; HS Addition</b>	Calcs by:	<b>O. Ali</b>
Jurisdiction	<b>DCM</b>	Checked by:	
Runoff Coefficient	<b>Surface Type</b>	Soil Type	<b>A</b>
		Urbanization	<b>Urban</b>

### Basin Land Use Characteristics

Surface	Area		Runoff Coefficient						% Imperv.
	(SF)	(Acres)	C2	C5	C10	C25	C50	C100	
Pasture/Meadow	841,595	19.32	0.02	0.08	0.15	0.25	0.3	0.35	0%
Paved	167,335	3.84	0.89	0.9	0.92	0.94	0.95	0.96	100%
Gravel	120,817	2.77	0.57	0.59	0.63	0.66	0.68	0.7	80%
Roofs	151,721	3.48	0.71	0.73	0.75	0.78	0.8	0.81	90%
<b>Combined</b>	<b>1,281,468</b>	<b>29.42</b>	<b>0.27</b>	<b>0.31</b>	<b>0.37</b>	<b>0.44</b>	<b>0.48</b>	<b>0.52</b>	<b>31.3%</b>

### Basin Travel Time

	Sub-basin or Channel Type	Material Type	L (ft)	Elev. ΔZ <sub>0</sub> (ft)	Q <sub>i</sub> (cfs)	Base or Dia (ft)	Sides z:1 (ft/ft)	v (ft/s)	t (min)
Furthest Reach	EX-DP7	-	1,413	13	-	-	-	-	23.2
Channelized-1	Trap Ditch	2	476	3	32	20	8	1.4	5.8
Channelized-2									
Channelized-3									
Total			1,889	16					

2 = Natural, Winding, minimal vegetation/shallow grass

**t<sub>c</sub> (min) 29.0**

### Contributing Offsite Flows (Added to Runoff and Allowed Release, below.)

Contributing Basins/Areas

Q<sub>Minor</sub> (cfs) - 5-year Storm

Q<sub>Major</sub> (cfs) - 100-year Storm

### Rainfall Intensity & Runoff

	2-Yr	5-Yr	10-Yr	25-Yr	50-Yr	100-Yr
<b>Intensity (in/hr)</b>	2.03	2.53	2.96	3.38	3.80	4.25
<b>Site Runoff (cfs)</b>	15.95	<b>23.27</b>	31.91	43.89	53.67	<b>64.69</b>
<b>OffSite Runoff (cfs)</b>	-	<b>0.00</b>	-	-	-	<b>0.00</b>
<b>Release Rates (cfs/ac)</b>	-	-	-	-	-	-
<b>Allowed Release (cfs)</b>	-	<b>23.3</b>	-	-	-	<b>64.7</b>

DCM:  $I = C1 * \ln(tc) + C2$

C1	1.19	1.5	1.75	2	2.25	2.52
C2	6.035	7.583	8.847	10.111	11.375	12.735

### Notes

Runoff from Offsite basins have been assumed constant, despite additional times of concentration.



## Combined Sub-Basin Runoff Calculations - DP13 (Proposed)

Includes Basins DP12 EX-S10

Job No.:	<b>61183</b>	Date:	<b>4/5/2023 14:35</b>
Project:	<b>Ellicott D22 – GS &amp; HS Addition</b>	Calcs by:	<b>O. Ali</b>
Jurisdiction	<b>DCM</b>	Checked by:	
Runoff Coefficient	<b>Surface Type</b>	Soil Type	<b>A</b>
		Urbanization	<b>Urban</b>

### Basin Land Use Characteristics

Surface	Area		Runoff Coefficient						% Imperv.
	(SF)	(Acres)	C2	C5	C10	C25	C50	C100	
Pasture/Meadow	952,738	21.87	0.02	0.08	0.15	0.25	0.3	0.35	0%
Paved	170,914	3.92	0.89	0.9	0.92	0.94	0.95	0.96	100%
Gravel	121,700	2.79	0.57	0.59	0.63	0.66	0.68	0.7	80%
Roofs	151,721	3.48	0.71	0.73	0.75	0.78	0.8	0.81	90%
<b>Combined</b>	<b>1,397,073</b>	<b>32.07</b>	<b>0.25</b>	<b>0.30</b>	<b>0.35</b>	<b>0.43</b>	<b>0.47</b>	<b>0.51</b>	<b>29.0%</b>

### Basin Travel Time

	Sub-basin or Channel Type	Material Type	L (ft)	Elev. ΔZ <sub>0</sub> (ft)	Q <sub>i</sub> (cfs)	Base or Dia (ft)	Sides z:1 (ft/ft)	v (ft/s)	t (min)
Furthest Reach	EX-DP12	-	1,889	16	-	-	-	-	29.0
Channelized-1	V-Ditch	1	304	0	63	0	3	2.1	2.4
Channelized-2									
Channelized-3									
Total			2,193	16					

1 = Man-made, Smooth, Straight

**t<sub>c</sub> (min) 31.4**

### Contributing Offsite Flows (Added to Runoff and Allowed Release, below.)

Contributing Basins/Areas

Q<sub>Minor</sub> (cfs) - 5-year Storm

Q<sub>Major</sub> (cfs) - 100-year Storm

### Rainfall Intensity & Runoff

	2-Yr	5-Yr	10-Yr	25-Yr	50-Yr	100-Yr
<b>Intensity (in/hr)</b>	1.93	2.41	2.82	3.22	3.62	4.05
<b>Site Runoff (cfs)</b>	15.46	<b>22.85</b>	31.71	44.13	54.21	<b>65.59</b>
<b>OffSite Runoff (cfs)</b>	-	<b>0.00</b>	-	-	-	<b>0.00</b>
<b>Release Rates (cfs/ac)</b>	-	-	-	-	-	-
<b>Allowed Release (cfs)</b>	-	<b>22.9</b>	-	-	-	<b>65.6</b>

DCM:  $I = C1 * \ln(tc) + C2$

C1	1.19	1.5	1.75	2	2.25	2.52
C2	6.035	7.583	8.847	10.111	11.375	12.735

### Notes

Runoff from Offsite basins have been assumed constant, despite additional times of concentration.

## **10 Hydraulic Calculations**

MHFD Rain Garden Spreadsheet, "UD-BMP\_v3.07"

Rain Garden Spillway Inflow/Outflow Weir Calculations (100-yr storm)

Rain Garden Infiltration Design Calculations

Culvert Channel Calculation

Swales Channel Calculations

## Design Procedure Form: Rain Garden (RG)

UD-BMP (Version 3.07, March 2018)

Sheet 1 of 2

**Designer:** O. Ali  
**Company:** M.V.E. Inc.  
**Date:** March 20, 2023  
**Project:** Ellicott School Addition 2 bldgs  
**Location:** Phase I Addition SE Corner

<p>1. Basin Storage Volume</p> <p>A) Effective Imperviousness of Tributary Area, <math>I_a</math> (100% if all paved and roofed areas upstream of rain garden)</p> <p>B) Tributary Area's Imperviousness Ratio (<math>i = I_a/100</math>)</p> <p>C) Water Quality Capture Volume (WQCV) for a 12-hour Drain Time (<math>WQCV = 0.8 * (0.91 * i^3 - 1.19 * i^2 + 0.78 * i)</math>)</p> <p>D) Contributing Watershed Area (including rain garden area)</p> <p>E) Water Quality Capture Volume (WQCV) Design Volume <math>Vol = (WQCV / 12) * Area</math></p> <p>F) For Watersheds Outside of the Denver Region, Depth of Average Runoff Producing Storm</p> <p>G) For Watersheds Outside of the Denver Region, Water Quality Capture Volume (WQCV) Design Volume</p> <p>H) User Input of Water Quality Capture Volume (WQCV) Design Volume (Only if a different WQCV Design Volume is desired)</p>	<p><math>I_a = </math> <input type="text" value="55.1"/> %</p> <p><math>i = </math> <input type="text" value="0.551"/></p> <p>WQCV = <input type="text" value="0.18"/> watershed inches</p> <p>Area = <input type="text" value="26,999"/> sq ft</p> <p><math>V_{WQCV} = </math> <input type="text" value=""/> cu ft</p> <p><math>d_6 = </math> <input type="text" value="0.42"/> in</p> <p><math>V_{WQCV\ OTHER} = </math> <input type="text" value="388"/> cu ft</p> <p><math>V_{WQCV\ USER} = </math> <input type="text" value=""/> cu ft</p>
<p>2. Basin Geometry</p> <p>A) WQCV Depth (12-inch maximum)</p> <p>B) Rain Garden Side Slopes (<math>Z = 4</math> min., horiz. dist per unit vertical) (Use "0" if rain garden has vertical walls)</p> <p>C) Minimum Flat Surface Area</p> <p>D) Actual Flat Surface Area</p> <p>E) Area at Design Depth (Top Surface Area)</p> <p>F) Rain Garden Total Volume (<math>V_T = ((A_{Top} + A_{Actual}) / 2) * Depth</math>)</p>	<p><math>D_{WQCV} = </math> <input type="text" value="12"/> in</p> <p><math>Z = </math> <input type="text" value="3.00"/> ft / ft <span style="color: red;"><math>Z &lt; 4:1</math></span></p> <p><math>A_{Min} = </math> <input type="text" value="298"/> sq ft</p> <p><math>A_{Actual} = </math> <input type="text" value="315"/> sq ft</p> <p><math>A_{Top} = </math> <input type="text" value="1889"/> sq ft</p> <p><math>V_T = </math> <input type="text" value="1,102"/> cu ft</p>
<p>3. Growing Media</p>	<p>Choose One</p> <p><input checked="" type="radio"/> 18" Rain Garden Growing Media</p> <p><input type="radio"/> Other (Explain):</p> <p>_____</p> <p>_____</p>
<p>4. Underdrain System</p> <p>A) Are underdrains provided?</p> <p>B) Underdrain system orifice diameter for 12 hour drain time</p> <p style="margin-left: 20px;">i) Distance From Lowest Elevation of the Storage Volume to the Center of the Orifice</p> <p style="margin-left: 20px;">ii) Volume to Drain in 12 Hours</p> <p style="margin-left: 20px;">iii) Orifice Diameter, 3/8" Minimum</p>	<p>Choose One</p> <p><input type="radio"/> YES</p> <p><input checked="" type="radio"/> NO</p> <p><math>y = </math> <input type="text" value="N/A"/> ft</p> <p><math>Vol_{12} = </math> <input type="text" value="N/A"/> cu ft</p> <p><math>D_o = </math> <input type="text" value="N/A"/> in</p>

infiltration testing to be performed during construction. See Final Drainage Report

**Design Procedure Form: Rain Garden (RG)**

Sheet 2 of 2

**Designer:** O. Ali  
**Company:** M.V.E. Inc.  
**Date:** March 20, 2023  
**Project:** Ellicott School Addition 2 bldgs  
**Location:** Phase I Addition SE Corner

<p>5. Impermeable Geomembrane Liner and Geotextile Separator Fabric</p> <p>A) Is an impermeable liner provided due to proximity of structures or groundwater contamination?</p>	<p>Choose One</p> <p><input type="radio"/> YES</p> <p><input checked="" type="radio"/> NO</p>
<p>6. Inlet / Outlet Control</p> <p>A) Inlet Control</p>	<p>Choose One</p> <p><input type="radio"/> Sheet Flow- No Energy Dissipation Required</p> <p><input checked="" type="radio"/> Concentrated Flow- Energy Dissipation Provided</p>
<p>7. Vegetation</p>	<p>Choose One</p> <p><input checked="" type="radio"/> Seed (Plan for frequent weed control)</p> <p><input type="radio"/> Plantings</p> <p><input type="radio"/> Sand Grown or Other High Infiltration Sod</p>
<p>8. Irrigation</p> <p>A) Will the rain garden be irrigated?</p>	<p>Choose One</p> <p><input type="radio"/> YES</p> <p><input type="radio"/> NO</p>

Notes: Rain garden to be temporarily irrigated until vegetation cover is established as per Alternative Landscape Plan.

While 4:1 side slopes are recommended, the location of the rain garden only allows enough space for 3:1 side slopes. As the hazard of erosion for the soil in that portion of the site is slight to moderate, 3:1 side slopes is sufficient.

**Design Procedure Form: Rain Garden (RG)**

UD-BMP (Version 3.07, March 2018)

Sheet 1 of 2

**Designer:** O. Ali  
**Company:** M.V.E., Inc.  
**Date:** March 20, 2023  
**Project:** Ellicott School Addition 2 bldgs  
**Location:** Phase II Addition SE Corner

<p>1. Basin Storage Volume</p> <p>A) Effective Imperviousness of Tributary Area, <math>I_a</math> (100% if all paved and roofed areas upstream of rain garden)</p> <p>B) Tributary Area's Imperviousness Ratio (<math>i = I_a/100</math>)</p> <p>C) Water Quality Capture Volume (WQCV) for a 12-hour Drain Time (<math>WQCV = 0.8 * (0.91 * i^3 - 1.19 * i^2 + 0.78 * i)</math>)</p> <p>D) Contributing Watershed Area (including rain garden area)</p> <p>E) Water Quality Capture Volume (WQCV) Design Volume <math>Vol = (WQCV / 12) * Area</math></p> <p>F) For Watersheds Outside of the Denver Region, Depth of Average Runoff Producing Storm</p> <p>G) For Watersheds Outside of the Denver Region, Water Quality Capture Volume (WQCV) Design Volume</p> <p>H) User Input of Water Quality Capture Volume (WQCV) Design Volume (Only if a different WQCV Design Volume is desired)</p>	<p><math>I_a = </math> <input type="text" value="23.6"/> %</p> <p><math>i = </math> <input type="text" value="0.236"/></p> <p>WQCV = <input type="text" value="0.10"/> watershed inches</p> <p>Area = <input type="text" value="97,476"/> sq ft</p> <p><math>V_{WQCV} = </math> <input type="text" value=""/> cu ft</p> <p><math>d_6 = </math> <input type="text" value="0.42"/> in</p> <p><math>V_{WQCV\ OTHER} = </math> <input type="text" value="824"/> cu ft</p> <p><math>V_{WQCV\ USER} = </math> <input type="text" value=""/> cu ft</p>
<p>2. Basin Geometry</p> <p>A) WQCV Depth (12-inch maximum)</p> <p>B) Rain Garden Side Slopes (<math>Z = 4</math> min., horiz. dist per unit vertical) (Use "0" if rain garden has vertical walls)</p> <p>C) Minimum Flat Surface Area</p> <p>D) Actual Flat Surface Area</p> <p>E) Area at Design Depth (Top Surface Area)</p> <p>F) Rain Garden Total Volume (<math>V_T = ((A_{Top} + A_{Actual}) / 2) * Depth</math>)</p>	<p><math>D_{WQCV} = </math> <input type="text" value="12"/> in</p> <p><math>Z = </math> <input type="text" value="4.00"/> ft / ft</p> <p><math>A_{Min} = </math> <input type="text" value="460"/> sq ft</p> <p><math>A_{Actual} = </math> <input type="text" value="704"/> sq ft</p> <p><math>A_{Top} = </math> <input type="text" value="1705"/> sq ft</p> <p><math>V_T = </math> <input type="text" value="1,205"/> cu ft</p>
<p>3. Growing Media</p>	<p>Choose One</p> <p><input checked="" type="radio"/> 18" Rain Garden Growing Media</p> <p><input type="radio"/> Other (Explain):</p> <hr/> <hr/>
<p>4. Underdrain System</p> <p>A) Are underdrains provided?</p> <p>B) Underdrain system orifice diameter for 12 hour drain time</p> <p style="margin-left: 20px;">i) Distance From Lowest Elevation of the Storage Volume to the Center of the Orifice</p> <p style="margin-left: 20px;">ii) Volume to Drain in 12 Hours</p> <p style="margin-left: 20px;">iii) Orifice Diameter, 3/8" Minimum</p>	<p>Choose One</p> <p><input type="radio"/> YES</p> <p><input checked="" type="radio"/> NO</p> <p><math>y = </math> <input type="text" value="N/A"/> ft</p> <p><math>Vol_{12} = </math> <input type="text" value="N/A"/> cu ft</p> <p><math>D_o = </math> <input type="text" value="N/A"/> in</p> <div style="border: 2px solid red; background-color: red; color: black; padding: 5px; width: fit-content; margin-top: 10px;"> <p align="center">infiltration testing to be performed during construction. See Final Drainage Report</p> </div>

Design Procedure Form: Rain Garden (RG)

Sheet 2 of 2

Designer: O. Ali  
Company: M.V.E., Inc.  
Date: March 20, 2023  
Project: Ellicott School Addition 2 bldgs  
Location: Phase II Addition SE Corner

5. Impermeable Geomembrane Liner and Geotextile Separator Fabric  A) Is an impermeable liner provided due to proximity of structures or groundwater contamination?	Choose One <input type="radio"/> YES <input checked="" type="radio"/> NO
6. Inlet / Outlet Control  A) Inlet Control	Choose One <input type="radio"/> Sheet Flow- No Energy Dissipation Required <input checked="" type="radio"/> Concentrated Flow- Energy Dissipation Provided
7. Vegetation	Choose One <input checked="" type="radio"/> Seed (Plan for frequent weed control) <input type="radio"/> Plantings <input type="radio"/> Sand Grown or Other High Infiltration Sod
8. Irrigation  A) Will the rain garden be irrigated?	Choose One <input type="radio"/> YES <input type="radio"/> NO

Notes: Rain garden to be temporarily irrigated until vegetation cover is established as per alternative landscape plan.  
\_\_\_\_\_  
\_\_\_\_\_  
\_\_\_\_\_

Rain Garden Spillway Inflow/Outflow Weir Calculations (100-yr Storm )

# Weir Report

## INFLOW/OUTFLOW - PHASE I RAIN GARDEN - 100 YR STORM

### Trapezoidal Weir

Crest = Sharp  
Bottom Length (ft) = 14.33  
Total Depth (ft) = 0.50  
Side Slope (z:1) = 3.00

### Highlighted

Depth (ft) = 0.18  
Q (cfs) = 3.300  
Area (sqft) = 2.68  
Velocity (ft/s) = 1.23  
Top Width (ft) = 15.41

### Calculations

Weir Coeff. Cw = 3.10  
Compute by: Known Q  
Known Q (cfs) = 3.30

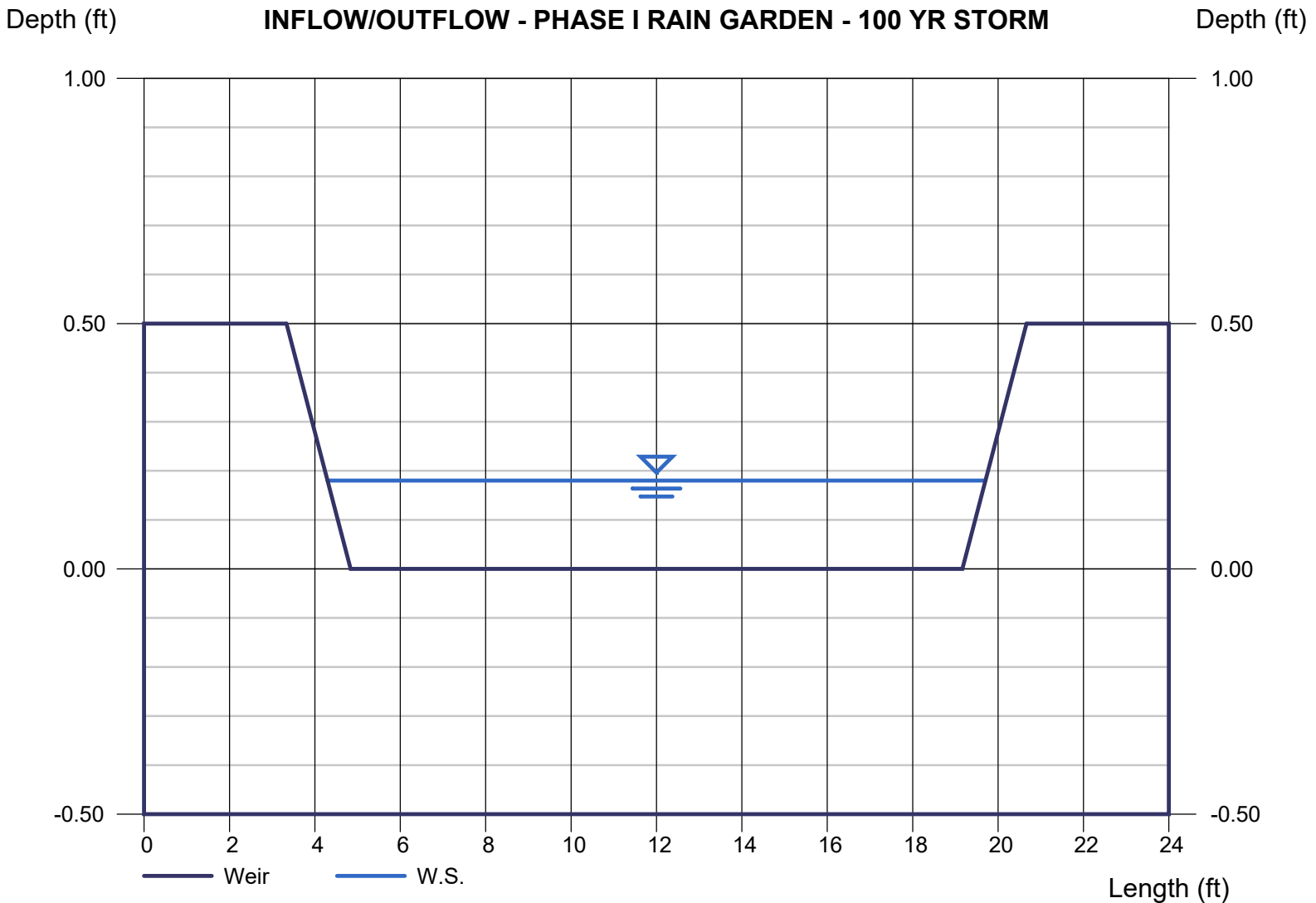



# Weir Report

## INFLOW/OUTFLOW - PHASE 2 RAIN GARDEN - 100 YR STORM

### Trapezoidal Weir

Crest = Sharp  
Bottom Length (ft) = 12.00  
Total Depth (ft) = 0.50  
Side Slope (z:1) = 3.00

### Highlighted

Depth (ft) = 0.31  
Q (cfs) = 6.600  
Area (sqft) = 4.01  
Velocity (ft/s) = 1.65  
Top Width (ft) = 13.86

### Calculations

Weir Coeff. Cw = 3.10  
Compute by: Known Q  
Known Q (cfs) = 6.60

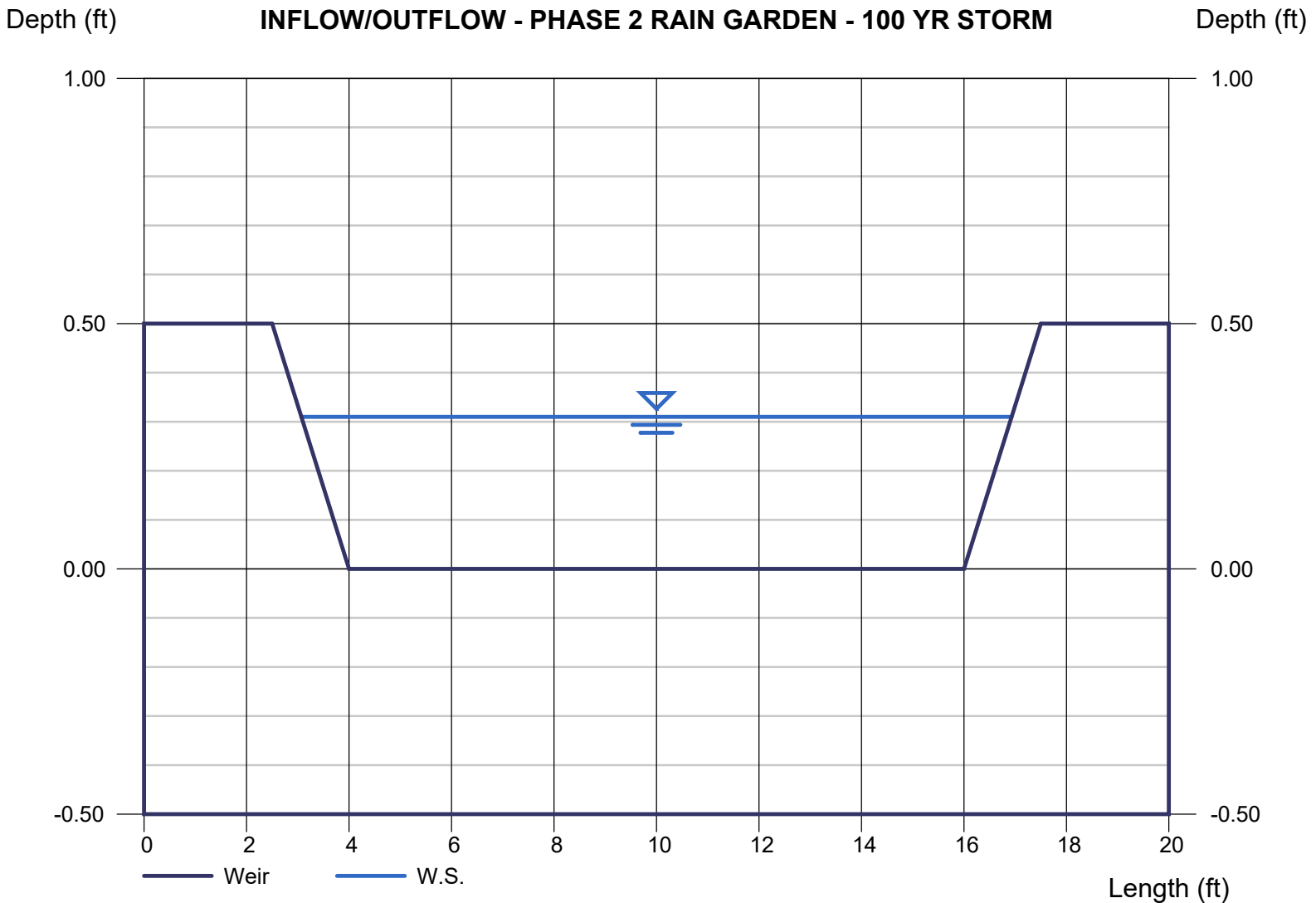

## Infiltration Design Calculations

*SDI-Design Data v2.00, Mile High Flood District*

*Point Precipitation Frequency Estimates, NOAA Atlas 14, Volume 8, Version 2*

*M.V.E., Inc. • Engineers • Surveyors*

*1903 Lelaray Street, Suite 200 • Colorado Springs, CO 80909 • Phone 719-635-5736*

*Fax 719-635-5450 • e-mail [mve@mvecivil.com](mailto:mve@mvecivil.com)*



# Stormwater Detention and Infiltration Design Data Sheet

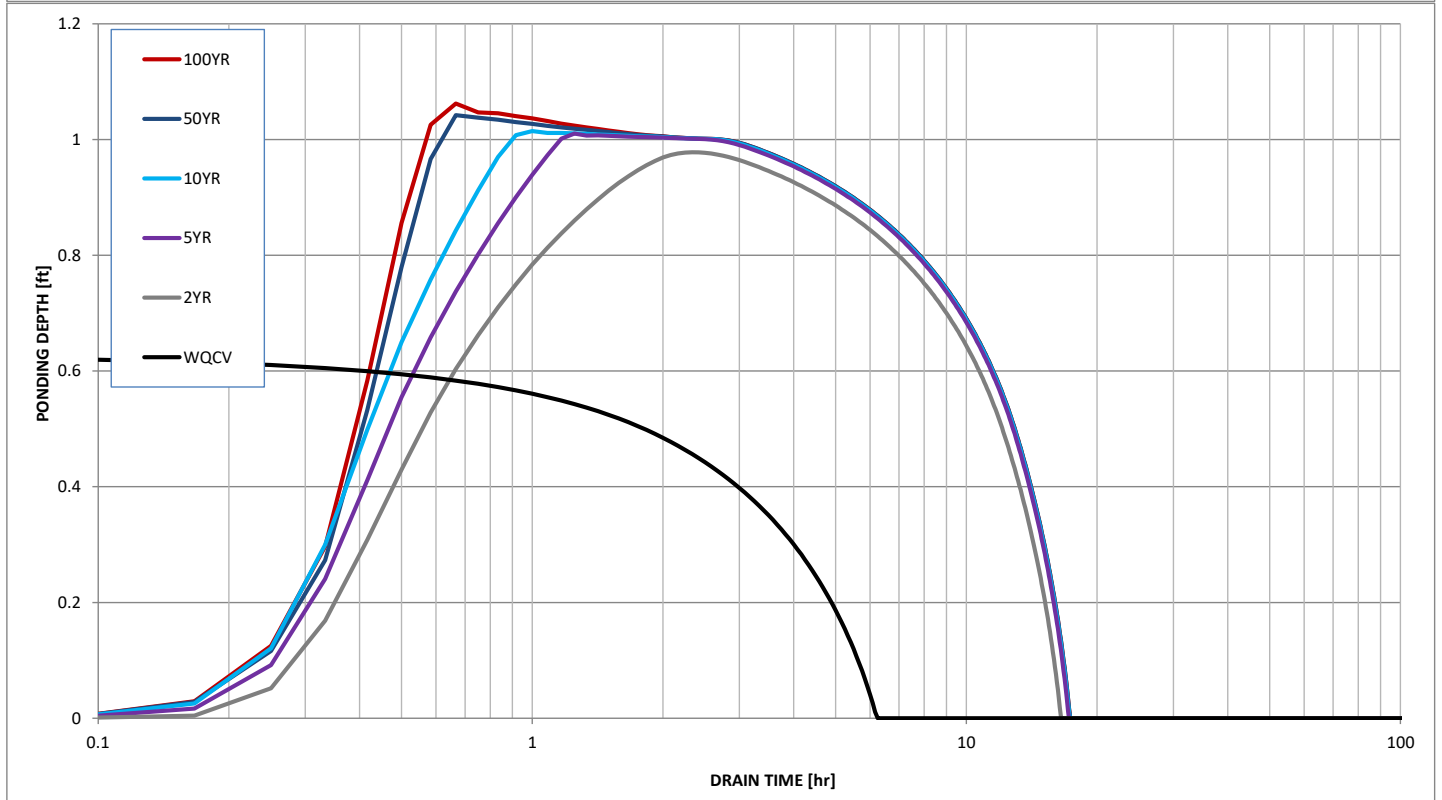
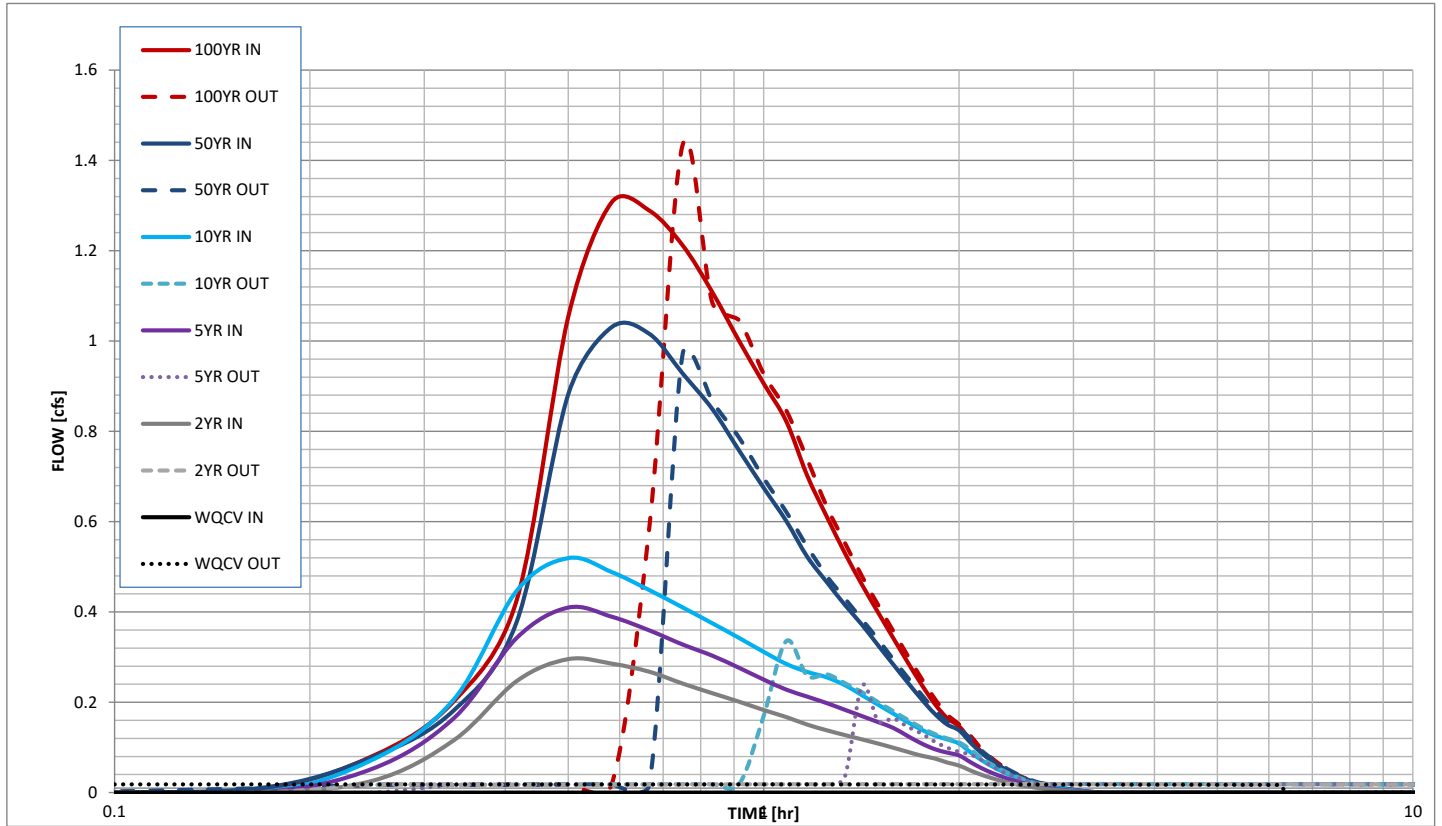



# Stormwater Detention and Infiltration Design Data Sheet

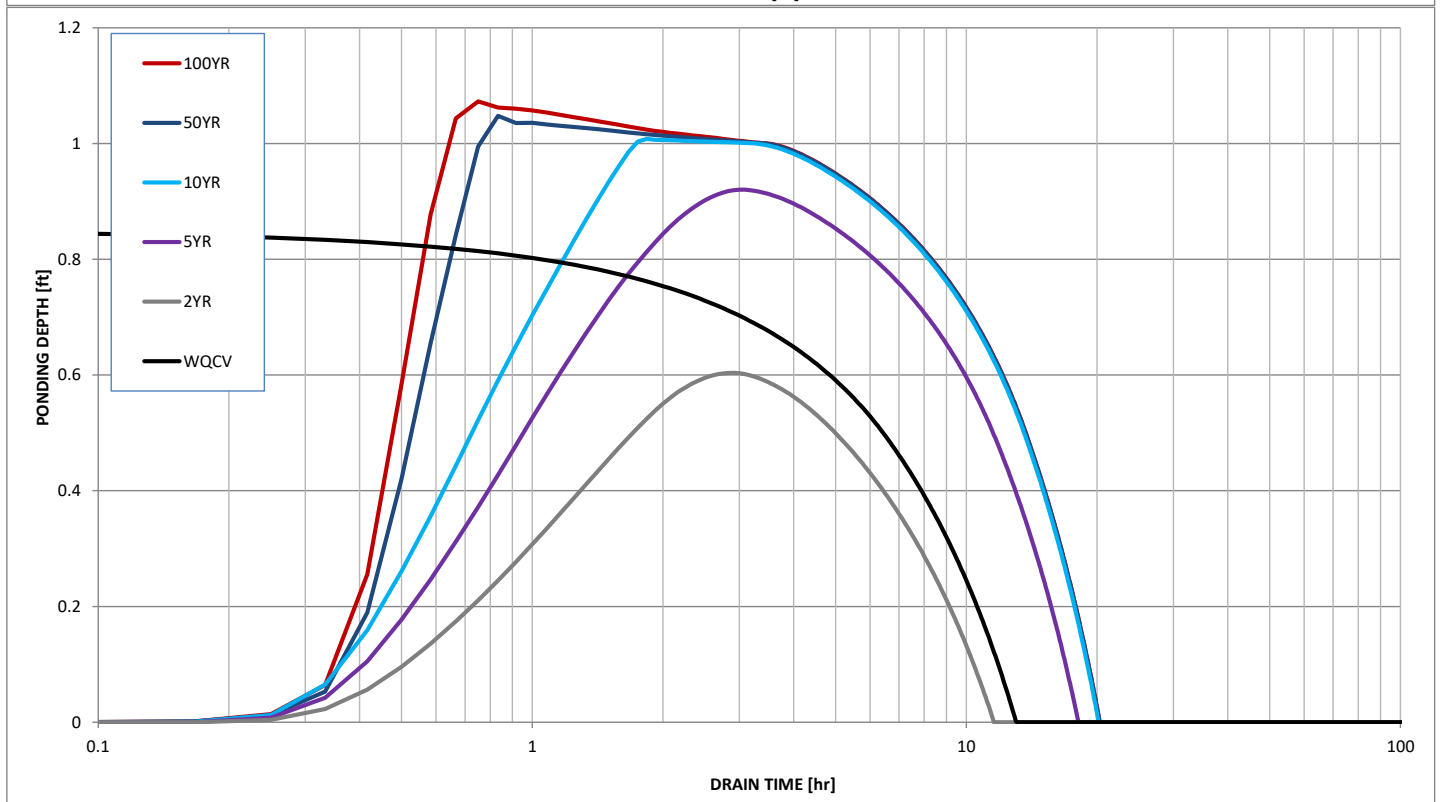
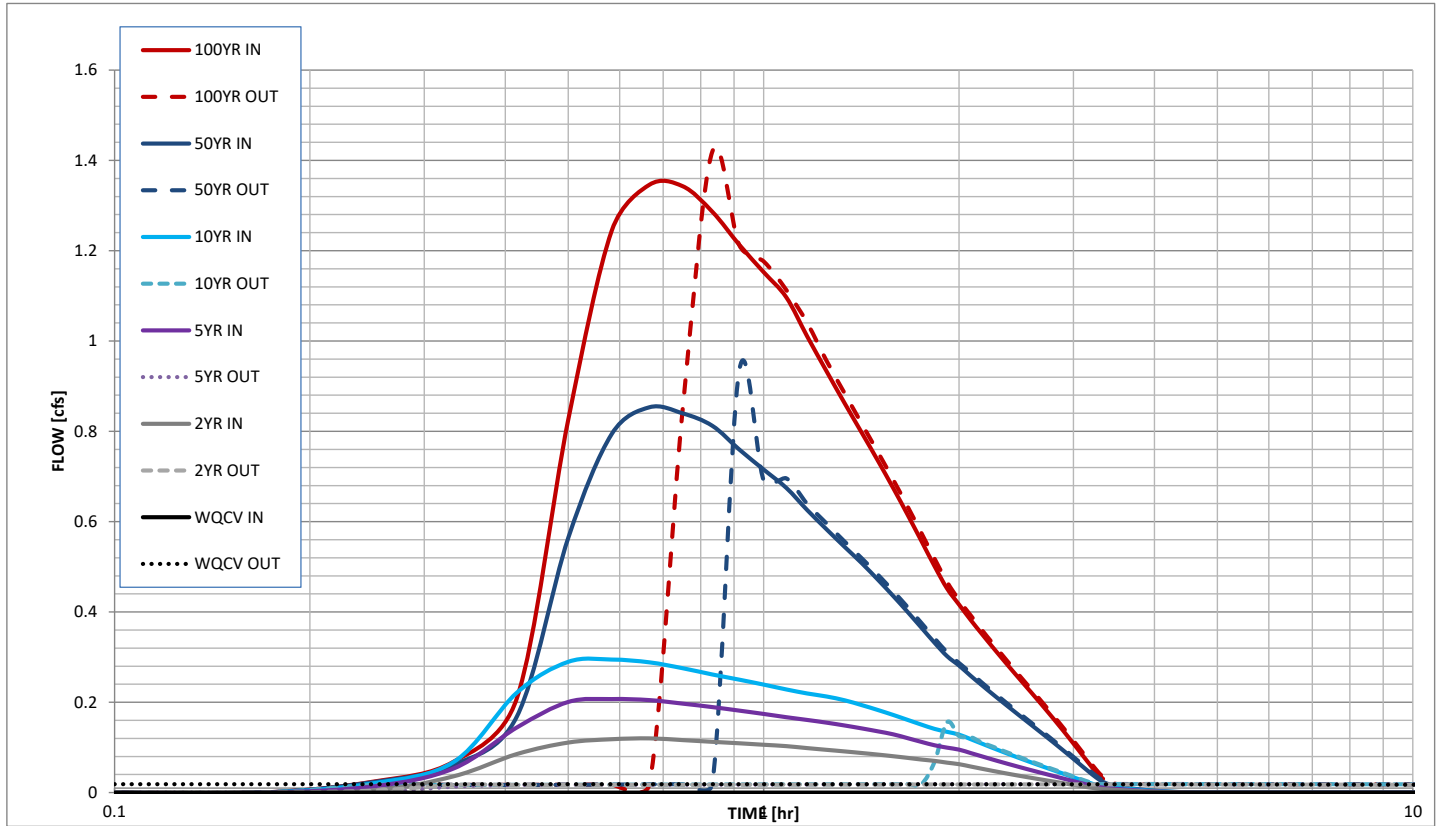



**NOAA Atlas 14, Volume 8, Version 2**  
**Location name: Calhan, Colorado, USA\***  
**Latitude: 38.8248°, Longitude: -104.3881°**  
**Elevation: 5983.36 ft\*\***



\* source: ESRI Maps  
 \*\* source: USGS

**POINT PRECIPITATION FREQUENCY ESTIMATES**

Sanja Perica, Deborah Martin, Sandra Pavlovic, Ishani Roy, Michael St. Laurent, Carl Trypaluk, Dale Unruh, Michael Yekta, Geoffrey Bonnin

NOAA, National Weather Service, Silver Spring, Maryland

[PF\\_tabular](#) | [PF\\_graphical](#) | [Maps & aeriels](#)

**PF tabular**

<b>PDS-based point precipitation frequency estimates with 90% confidence intervals (in inches)<sup>1</sup></b>										
Duration	Average recurrence interval (years)									
	1	2	5	10	25	50	100	200	500	1000
<b>5-min</b>	<b>0.242</b> (0.194-0.306)	<b>0.296</b> (0.237-0.374)	<b>0.390</b> (0.311-0.494)	<b>0.473</b> (0.376-0.603)	<b>0.596</b> (0.461-0.791)	<b>0.697</b> (0.526-0.933)	<b>0.804</b> (0.586-1.10)	<b>0.918</b> (0.642-1.28)	<b>1.08</b> (0.725-1.54)	<b>1.20</b> (0.787-1.74)
<b>10-min</b>	<b>0.354</b> (0.284-0.448)	<b>0.433</b> (0.347-0.548)	<b>0.571</b> (0.456-0.724)	<b>0.693</b> (0.550-0.882)	<b>0.873</b> (0.675-1.16)	<b>1.02</b> (0.770-1.37)	<b>1.18</b> (0.858-1.61)	<b>1.34</b> (0.940-1.88)	<b>1.58</b> (1.06-2.26)	<b>1.76</b> (1.15-2.55)
<b>15-min</b>	<b>0.432</b> (0.346-0.546)	<b>0.528</b> (0.423-0.668)	<b>0.696</b> (0.556-0.883)	<b>0.845</b> (0.671-1.08)	<b>1.07</b> (0.823-1.41)	<b>1.25</b> (0.939-1.67)	<b>1.44</b> (1.05-1.96)	<b>1.64</b> (1.15-2.29)	<b>1.92</b> (1.29-2.76)	<b>2.15</b> (1.41-3.11)
<b>30-min</b>	<b>0.652</b> (0.523-0.824)	<b>0.796</b> (0.637-1.01)	<b>1.05</b> (0.835-1.33)	<b>1.27</b> (1.01-1.61)	<b>1.60</b> (1.23-2.12)	<b>1.86</b> (1.41-2.50)	<b>2.15</b> (1.57-2.94)	<b>2.45</b> (1.72-3.43)	<b>2.88</b> (1.94-4.13)	<b>3.22</b> (2.10-4.65)
<b>60-min</b>	<b>0.834</b> (0.669-1.05)	<b>1.02</b> (0.820-1.29)	<b>1.35</b> (1.08-1.72)	<b>1.65</b> (1.31-2.10)	<b>2.08</b> (1.61-2.77)	<b>2.44</b> (1.84-3.27)	<b>2.82</b> (2.06-3.86)	<b>3.23</b> (2.26-4.52)	<b>3.79</b> (2.55-5.44)	<b>4.25</b> (2.78-6.14)
<b>2-hr</b>	<b>1.02</b> (0.819-1.28)	<b>1.25</b> (1.01-1.57)	<b>1.66</b> (1.34-2.09)	<b>2.03</b> (1.62-2.57)	<b>2.57</b> (2.00-3.39)	<b>3.02</b> (2.29-4.02)	<b>3.49</b> (2.56-4.75)	<b>4.00</b> (2.82-5.57)	<b>4.71</b> (3.19-6.71)	<b>5.28</b> (3.48-7.58)
<b>3-hr</b>	<b>1.09</b> (0.880-1.36)	<b>1.34</b> (1.09-1.68)	<b>1.79</b> (1.44-2.25)	<b>2.19</b> (1.76-2.76)	<b>2.79</b> (2.18-3.67)	<b>3.28</b> (2.50-4.35)	<b>3.80</b> (2.80-5.15)	<b>4.36</b> (3.08-6.04)	<b>5.14</b> (3.50-7.30)	<b>5.77</b> (3.82-8.26)
<b>6-hr</b>	<b>1.23</b> (0.997-1.52)	<b>1.48</b> (1.20-1.84)	<b>1.93</b> (1.56-2.40)	<b>2.34</b> (1.89-2.93)	<b>2.97</b> (2.34-3.89)	<b>3.50</b> (2.69-4.62)	<b>4.07</b> (3.02-5.49)	<b>4.68</b> (3.34-6.47)	<b>5.56</b> (3.82-7.86)	<b>6.28</b> (4.18-8.92)
<b>12-hr</b>	<b>1.35</b> (1.10-1.66)	<b>1.59</b> (1.30-1.97)	<b>2.04</b> (1.66-2.52)	<b>2.45</b> (1.98-3.04)	<b>3.08</b> (2.45-4.01)	<b>3.61</b> (2.80-4.75)	<b>4.19</b> (3.14-5.62)	<b>4.83</b> (3.47-6.62)	<b>5.73</b> (3.97-8.05)	<b>6.47</b> (4.35-9.13)
<b>24-hr</b>	<b>1.46</b> (1.20-1.79)	<b>1.71</b> (1.41-2.10)	<b>2.17</b> (1.78-2.66)	<b>2.59</b> (2.11-3.20)	<b>3.25</b> (2.60-4.21)	<b>3.81</b> (2.97-4.97)	<b>4.41</b> (3.33-5.88)	<b>5.08</b> (3.68-6.93)	<b>6.03</b> (4.21-8.42)	<b>6.81</b> (4.61-9.55)
<b>2-day</b>	<b>1.64</b> (1.35-1.99)	<b>1.88</b> (1.56-2.29)	<b>2.34</b> (1.93-2.86)	<b>2.77</b> (2.27-3.40)	<b>3.45</b> (2.78-4.44)	<b>4.03</b> (3.16-5.22)	<b>4.66</b> (3.54-6.18)	<b>5.36</b> (3.92-7.27)	<b>6.37</b> (4.48-8.84)	<b>7.19</b> (4.91-10.0)
<b>3-day</b>	<b>1.77</b> (1.47-2.15)	<b>2.06</b> (1.71-2.50)	<b>2.58</b> (2.14-3.14)	<b>3.06</b> (2.52-3.74)	<b>3.79</b> (3.06-4.84)	<b>4.40</b> (3.46-5.67)	<b>5.07</b> (3.86-6.67)	<b>5.79</b> (4.24-7.80)	<b>6.81</b> (4.81-9.40)	<b>7.64</b> (5.24-10.6)
<b>4-day</b>	<b>1.91</b> (1.59-2.31)	<b>2.23</b> (1.86-2.70)	<b>2.80</b> (2.32-3.40)	<b>3.32</b> (2.74-4.04)	<b>4.09</b> (3.30-5.19)	<b>4.73</b> (3.73-6.06)	<b>5.42</b> (4.13-7.10)	<b>6.16</b> (4.52-8.26)	<b>7.20</b> (5.09-9.89)	<b>8.04</b> (5.53-11.1)
<b>7-day</b>	<b>2.30</b> (1.92-2.76)	<b>2.66</b> (2.22-3.20)	<b>3.30</b> (2.75-3.97)	<b>3.86</b> (3.20-4.68)	<b>4.71</b> (3.81-5.93)	<b>5.41</b> (4.28-6.88)	<b>6.15</b> (4.71-7.99)	<b>6.94</b> (5.12-9.24)	<b>8.05</b> (5.73-11.0)	<b>8.94</b> (6.19-12.3)
<b>10-day</b>	<b>2.61</b> (2.19-3.13)	<b>3.01</b> (2.53-3.61)	<b>3.71</b> (3.10-4.46)	<b>4.33</b> (3.60-5.22)	<b>5.24</b> (4.26-6.57)	<b>5.99</b> (4.75-7.58)	<b>6.77</b> (5.21-8.77)	<b>7.61</b> (5.63-10.1)	<b>8.78</b> (6.27-11.9)	<b>9.71</b> (6.75-13.3)
<b>20-day</b>	<b>3.39</b> (2.86-4.03)	<b>3.96</b> (3.34-4.72)	<b>4.91</b> (4.13-5.86)	<b>5.72</b> (4.78-6.85)	<b>6.85</b> (5.57-8.46)	<b>7.74</b> (6.16-9.68)	<b>8.65</b> (6.67-11.1)	<b>9.58</b> (7.12-12.6)	<b>10.8</b> (7.78-14.6)	<b>11.8</b> (8.28-16.1)
<b>30-day</b>	<b>4.05</b> (3.43-4.80)	<b>4.75</b> (4.02-5.63)	<b>5.89</b> (4.97-6.99)	<b>6.82</b> (5.73-8.14)	<b>8.10</b> (6.59-9.92)	<b>9.08</b> (7.24-11.3)	<b>10.1</b> (7.78-12.8)	<b>11.0</b> (8.23-14.4)	<b>12.3</b> (8.88-16.5)	<b>13.3</b> (9.37-18.1)
<b>45-day</b>	<b>4.96</b> (4.22-5.85)	<b>5.78</b> (4.90-6.82)	<b>7.08</b> (5.99-8.37)	<b>8.13</b> (6.85-9.66)	<b>9.54</b> (7.77-11.6)	<b>10.6</b> (8.46-13.1)	<b>11.6</b> (9.01-14.6)	<b>12.6</b> (9.44-16.3)	<b>13.9</b> (10.1-18.5)	<b>14.9</b> (10.5-20.1)
<b>60-day</b>	<b>5.80</b> (4.94-6.81)	<b>6.67</b> (5.68-7.85)	<b>8.06</b> (6.84-9.51)	<b>9.17</b> (7.75-10.9)	<b>10.6</b> (8.68-12.9)	<b>11.7</b> (9.39-14.4)	<b>12.8</b> (9.93-16.0)	<b>13.8</b> (10.3-17.8)	<b>15.1</b> (10.9-19.9)	<b>16.0</b> (11.3-21.5)

<sup>1</sup> Precipitation frequency (PF) estimates in this table are based on frequency analysis of partial duration series (PDS). Numbers in parenthesis are PF estimates at lower and upper bounds of the 90% confidence interval. The probability that precipitation frequency estimates (for a given duration and average recurrence interval) will be greater than the upper bound (or less than the lower bound) is 5%. Estimates at upper bounds are not checked against probable maximum precipitation (PMP) estimates and may be higher than currently valid PMP values. Please refer to NOAA Atlas 14 document for more information.

[Back to Top](#)

**PF graphical**

PDS-based depth-duration-frequency (DDF) curves  
Latitude: 38.8248°, Longitude: -104.3881°

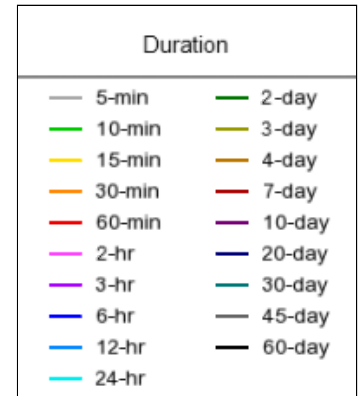
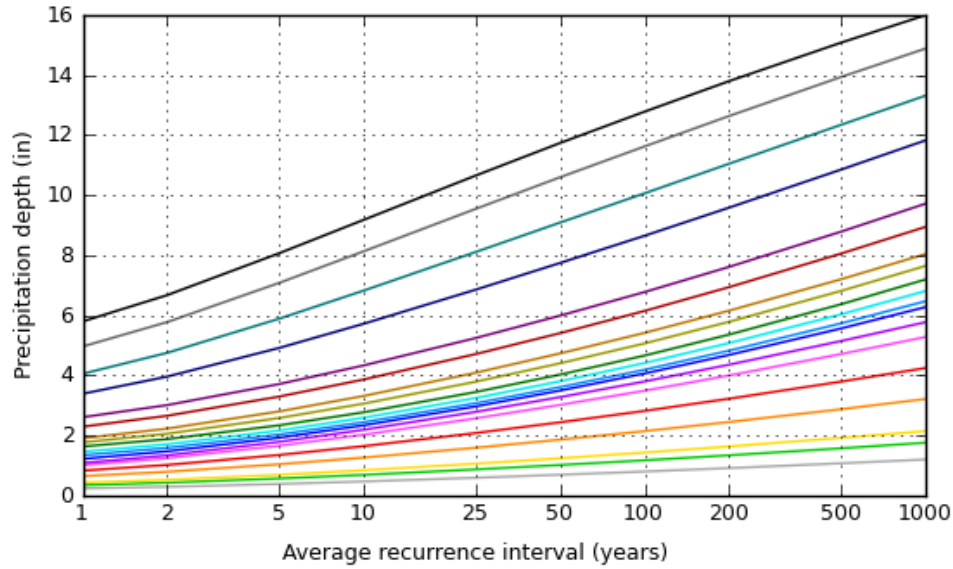
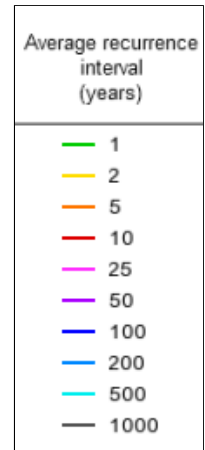
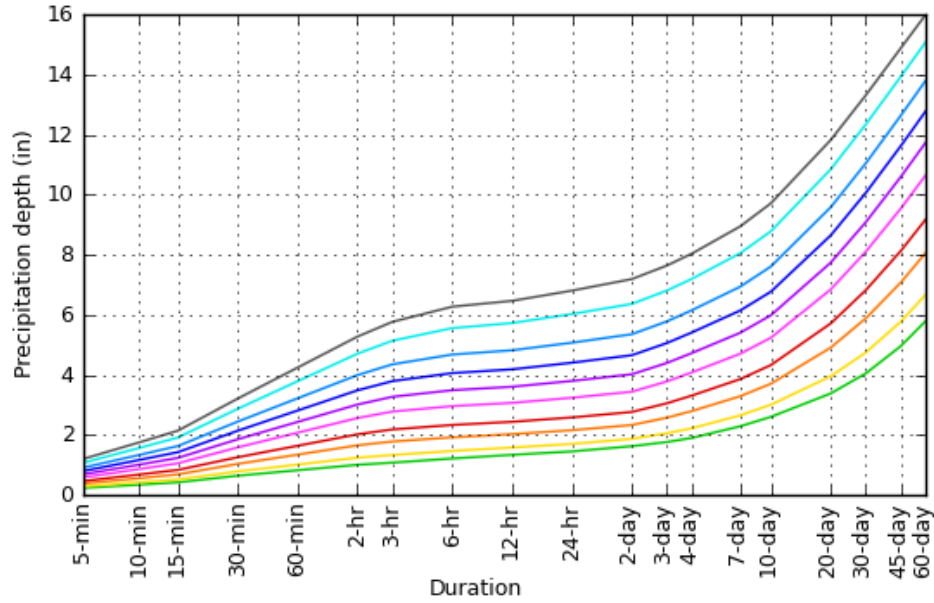

[Back to Top](#)

**Maps & aeriels**

**Small scale terrain**



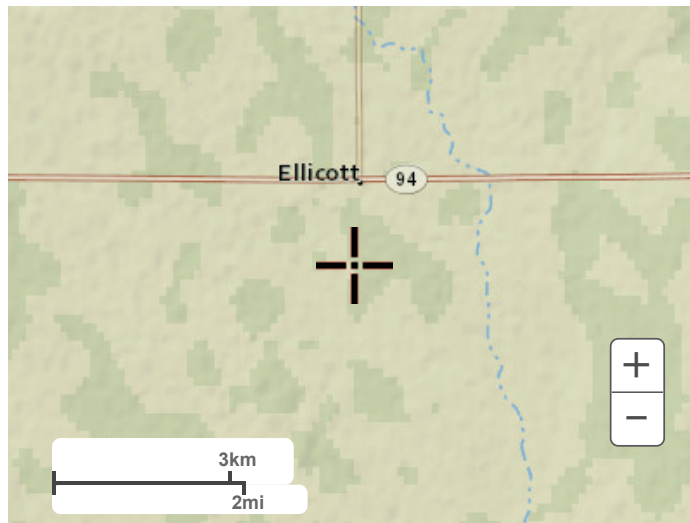

Large scale terrain



Large scale map

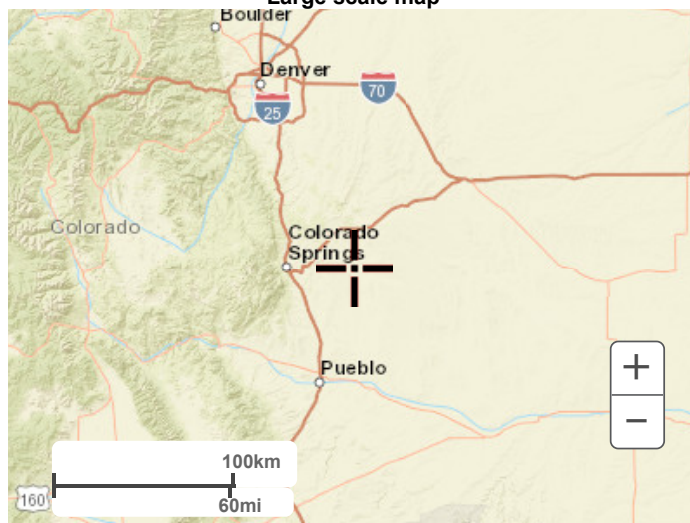

Large scale aerial

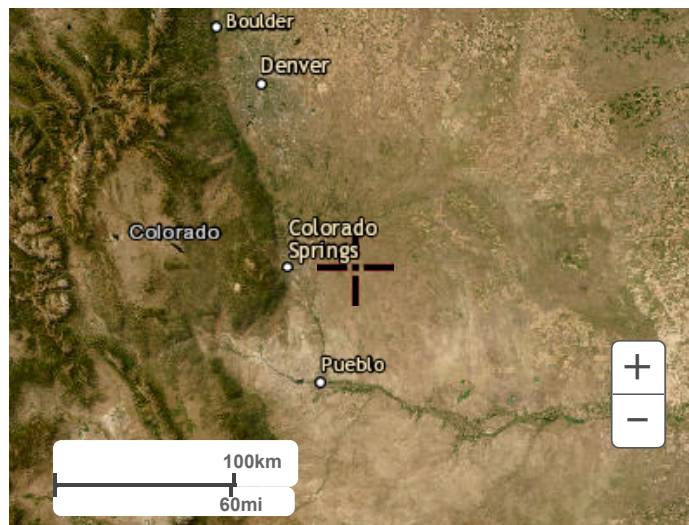

[Back to Top](#)

---

[US Department of Commerce](#)  
[National Oceanic and Atmospheric Administration](#)  
[National Weather Service](#)  
[National Water Center](#)  
1325 East West Highway  
Silver Spring, MD 20910  
Questions?: [HDSC.Questions@noaa.gov](mailto:HDSC.Questions@noaa.gov)

[Disclaimer](#)

Channel Calculations (100-yr Storm )

# Channel Report

## Phase I Culvert

### Circular

Diameter (ft) = 1.00

Invert Elev (ft) = 5974.50

Slope (%) = 1.16

N-Value = 0.011

### Calculations

Compute by: Known Q

Known Q (cfs) = 1.90

### Highlighted

Depth (ft) = 0.45

Q (cfs) = 1.900

Area (sqft) = 0.34

Velocity (ft/s) = 5.51

Wetted Perim (ft) = 1.47

Crit Depth,  $Y_c$  (ft) = 0.59

Top Width (ft) = 1.00

EGL (ft) = 0.92

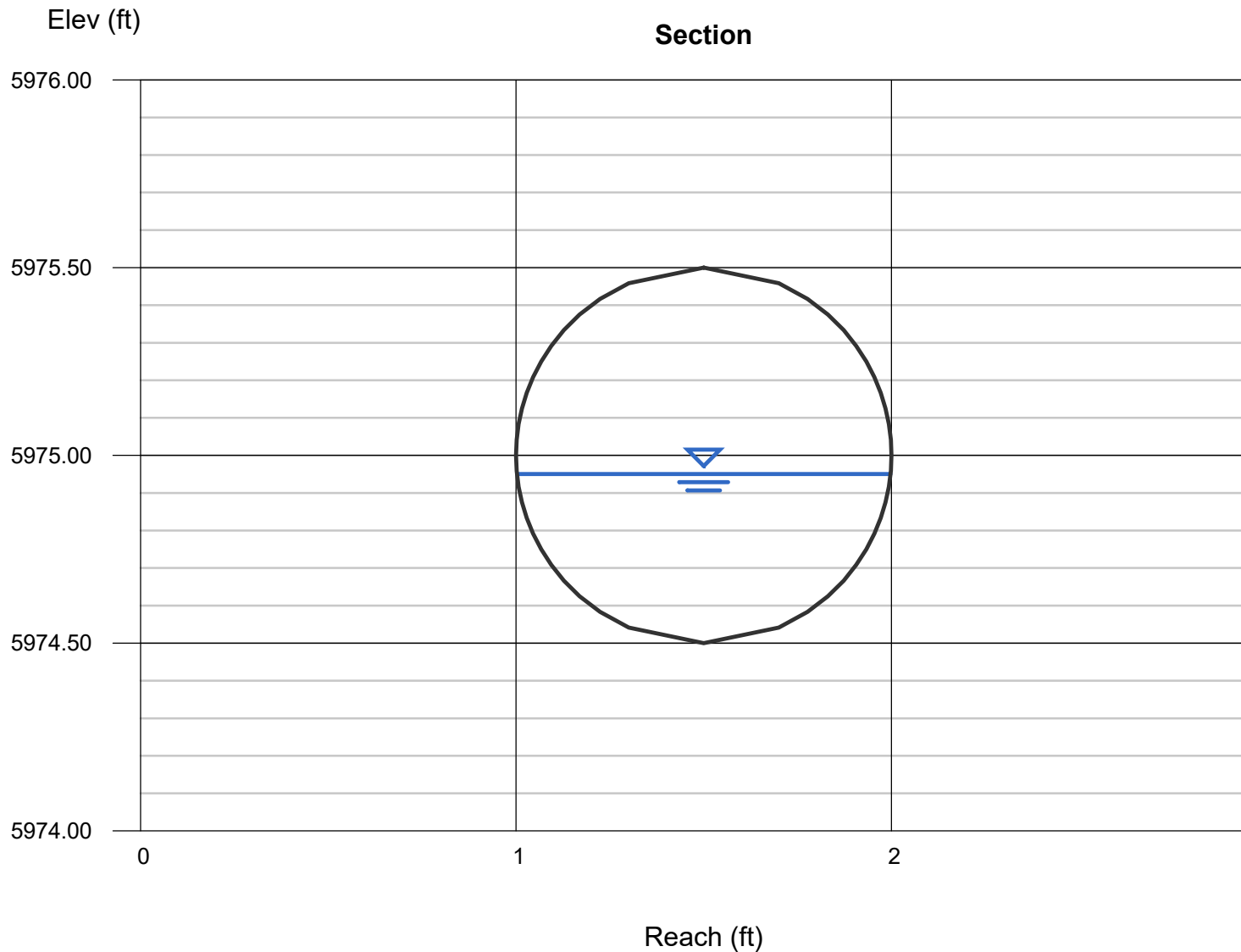

# Channel Report

## 61183-Swale A (DP2) (Proposed)

### Triangular

Side Slopes (z:1) = 3.00, 3.00  
Total Depth (ft) = 2.00

Invert Elev (ft) = 5974.00  
Slope (%) = 0.83  
N-Value = 0.040

### Calculations

Compute by: Known Q  
Known Q (cfs) = 3.30

### Highlighted

Depth (ft) = 0.80  
Q (cfs) = 3.300  
Area (sqft) = 1.92  
Velocity (ft/s) = 1.72  
Wetted Perim (ft) = 5.06  
Crit Depth, Yc (ft) = 0.60  
Top Width (ft) = 4.80  
EGL (ft) = 0.85

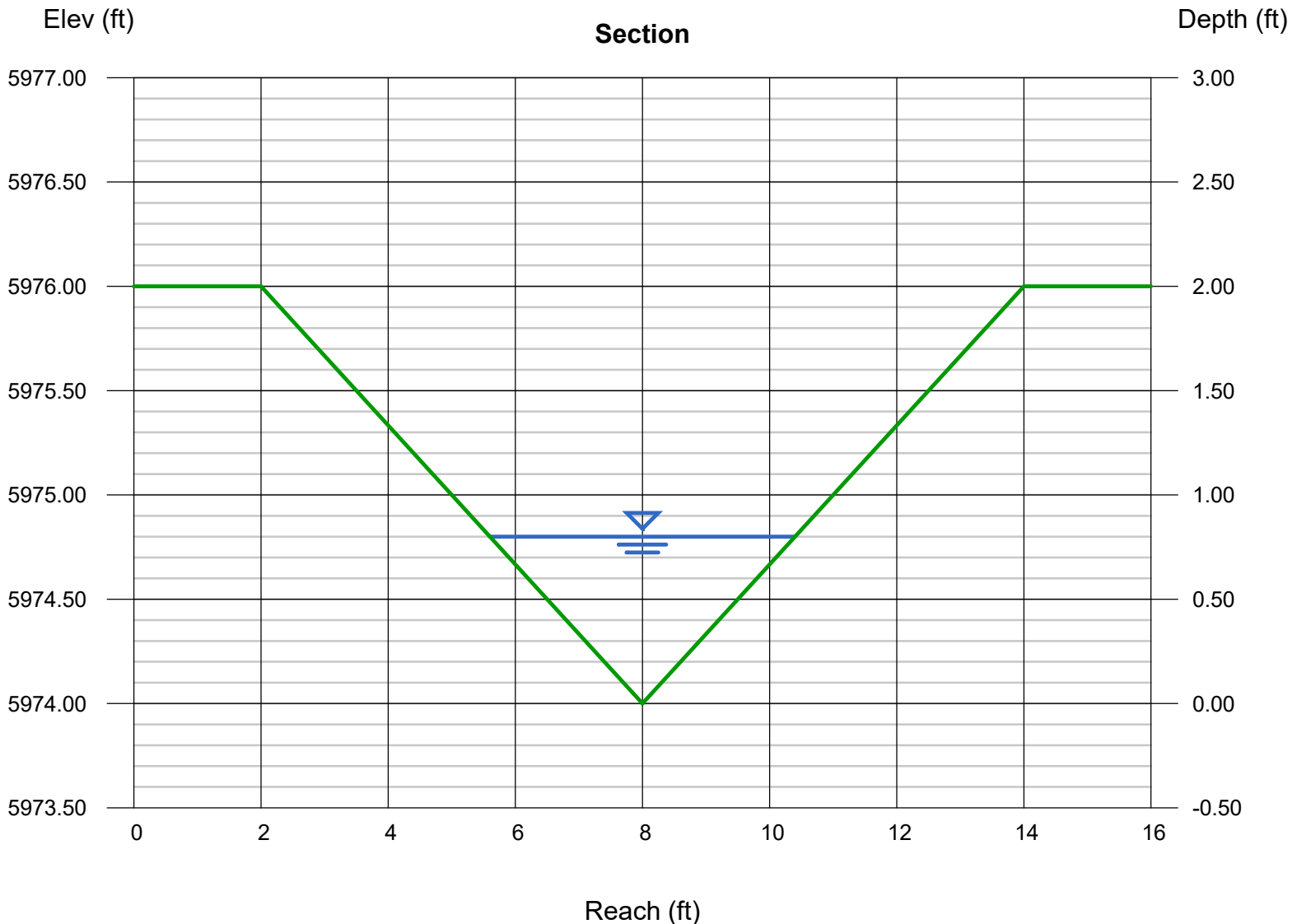

# Channel Report

## 61183-Swale B (Culvert) (Proposed)

### Triangular

Side Slopes (z:1) = 3.00, 3.00  
Total Depth (ft) = 1.50

Invert Elev (ft) = 5974.50  
Slope (%) = 0.70  
N-Value = 0.040

### Calculations

Compute by: Known Q  
Known Q (cfs) = 1.90

### Highlighted

Depth (ft) = 0.67  
Q (cfs) = 1.900  
Area (sqft) = 1.35  
Velocity (ft/s) = 1.41  
Wetted Perim (ft) = 4.24  
Crit Depth, Yc (ft) = 0.48  
Top Width (ft) = 4.02  
EGL (ft) = 0.70

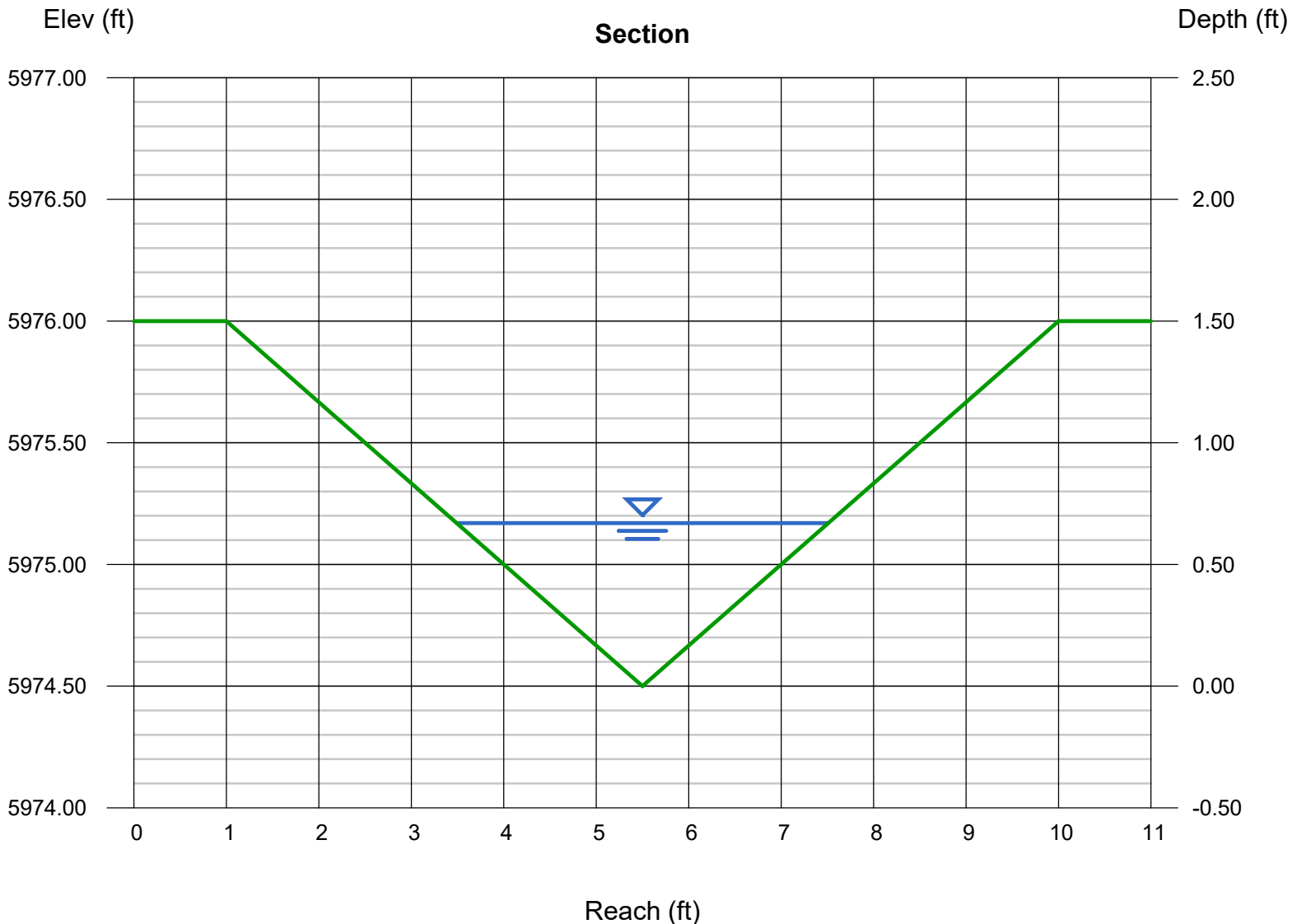

# Channel Report

## 61183-Swale C (DP1) (Proposed)

### Triangular

Side Slopes (z:1) = 3.00, 3.00  
Total Depth (ft) = 2.00

Invert Elev (ft) = 5974.00  
Slope (%) = 0.36  
N-Value = 0.040

### Calculations

Compute by: Known Q  
Known Q (cfs) = 12.20

### Highlighted

Depth (ft) = 1.51  
Q (cfs) = 12.20  
Area (sqft) = 6.84  
Velocity (ft/s) = 1.78  
Wetted Perim (ft) = 9.55  
Crit Depth, Yc (ft) = 1.01  
Top Width (ft) = 9.06  
EGL (ft) = 1.56

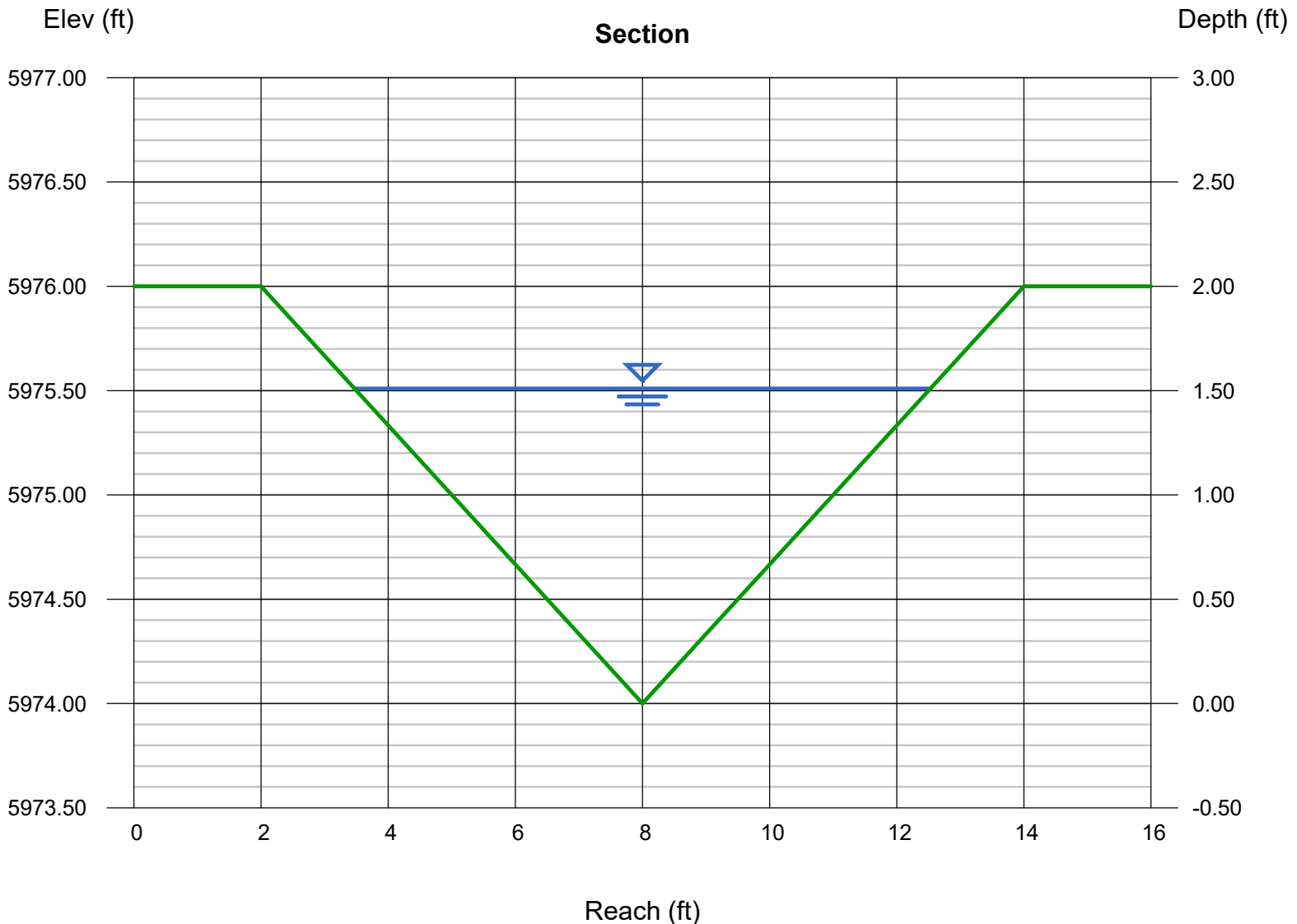

# Channel Report

## Existing Swale DP5 (Proposed Conditions)

### Triangular

Side Slopes (z:1) = 60.00, 12.00  
Total Depth (ft) = 1.00

Invert Elev (ft) = 5974.00  
Slope (%) = 0.23  
N-Value = 0.040

### Calculations

Compute by: Known Q  
Known Q (cfs) = 24.00

### Highlighted

Depth (ft) = 0.83  
Q (cfs) = 24.00  
Area (sqft) = 24.80  
Velocity (ft/s) = 0.97  
Wetted Perim (ft) = 59.80  
Crit Depth, Yc (ft) = 0.49  
Top Width (ft) = 59.76  
EGL (ft) = 0.84

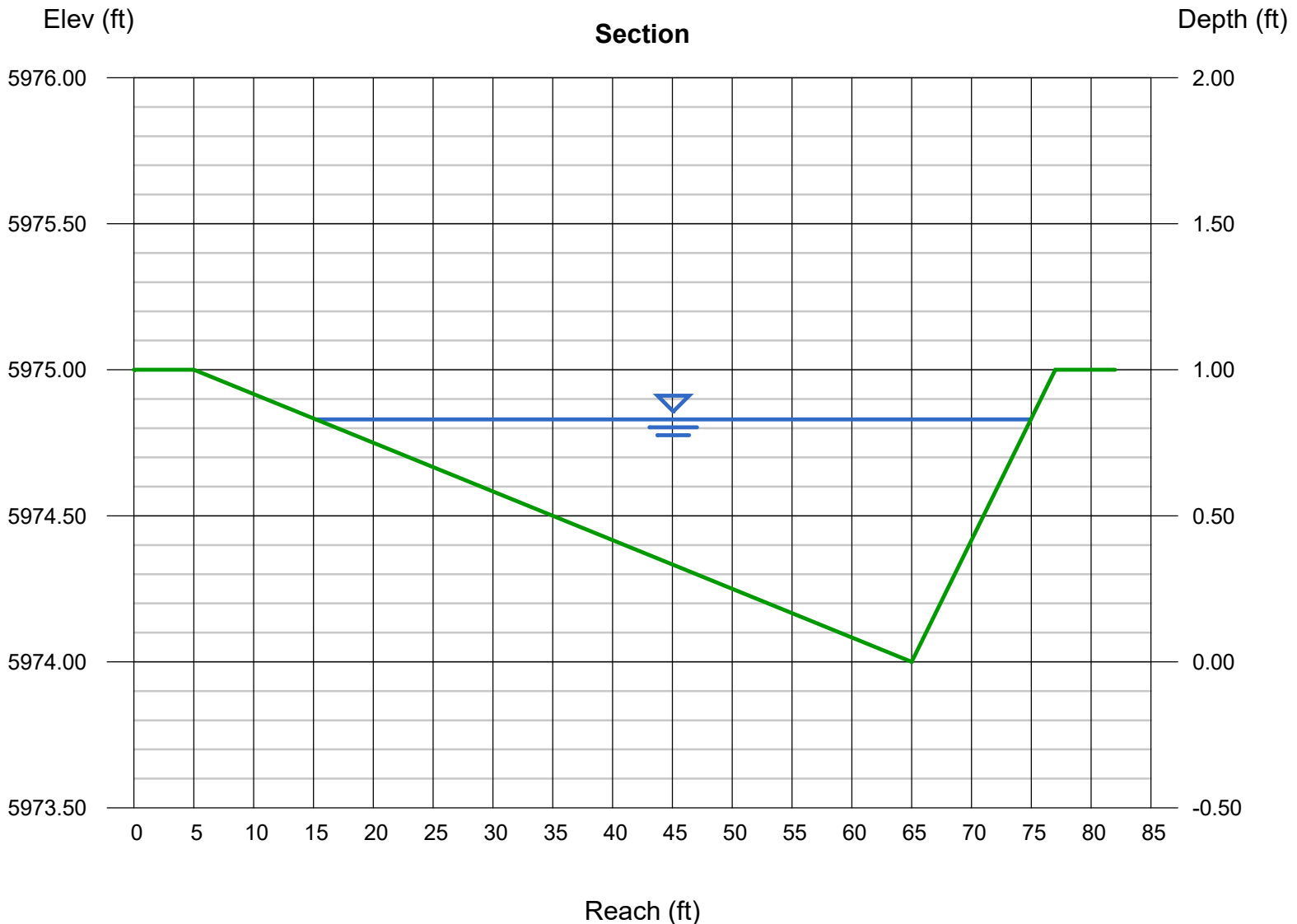



# Channel Report

## 61183-Swale D (DP6) (Proposed)

### Triangular

Side Slopes (z:1) = 6.50, 6.50  
Total Depth (ft) = 1.00

Invert Elev (ft) = 5974.50  
Slope (%) = 1.00  
N-Value = 0.040

### Calculations

Compute by: Known Q  
Known Q (cfs) = 6.60

### Highlighted

Depth (ft) = 0.74  
Q (cfs) = 6.600  
Area (sqft) = 3.56  
Velocity (ft/s) = 1.85  
Wetted Perim (ft) = 9.73  
Crit Depth, Yc (ft) = 0.58  
Top Width (ft) = 9.62  
EGL (ft) = 0.79

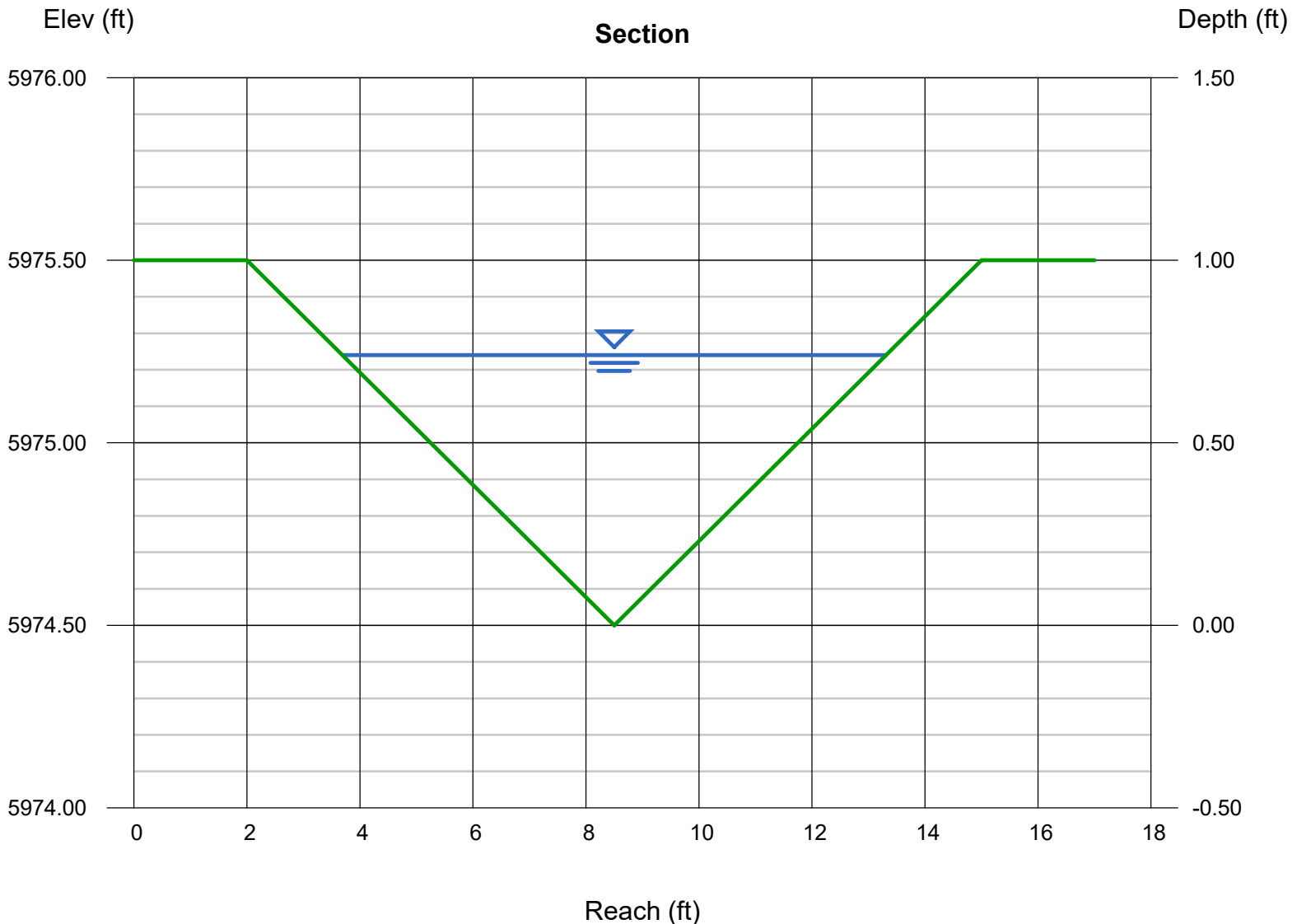

# Channel Report

## 61183-Swale E (Proposed)

### Triangular

Side Slopes (z:1) = 30.00, 10.00  
Total Depth (ft) = 1.00

Invert Elev (ft) = 5974.50  
Slope (%) = 1.30  
N-Value = 0.040

### Calculations

Compute by: Known Q  
Known Q (cfs) = 2.40

### Highlighted

Depth (ft) = 0.32  
Q (cfs) = 2.400  
Area (sqft) = 2.05  
Velocity (ft/s) = 1.17  
Wetted Perim (ft) = 12.82  
Crit Depth, Yc (ft) = 0.25  
Top Width (ft) = 12.80  
EGL (ft) = 0.34

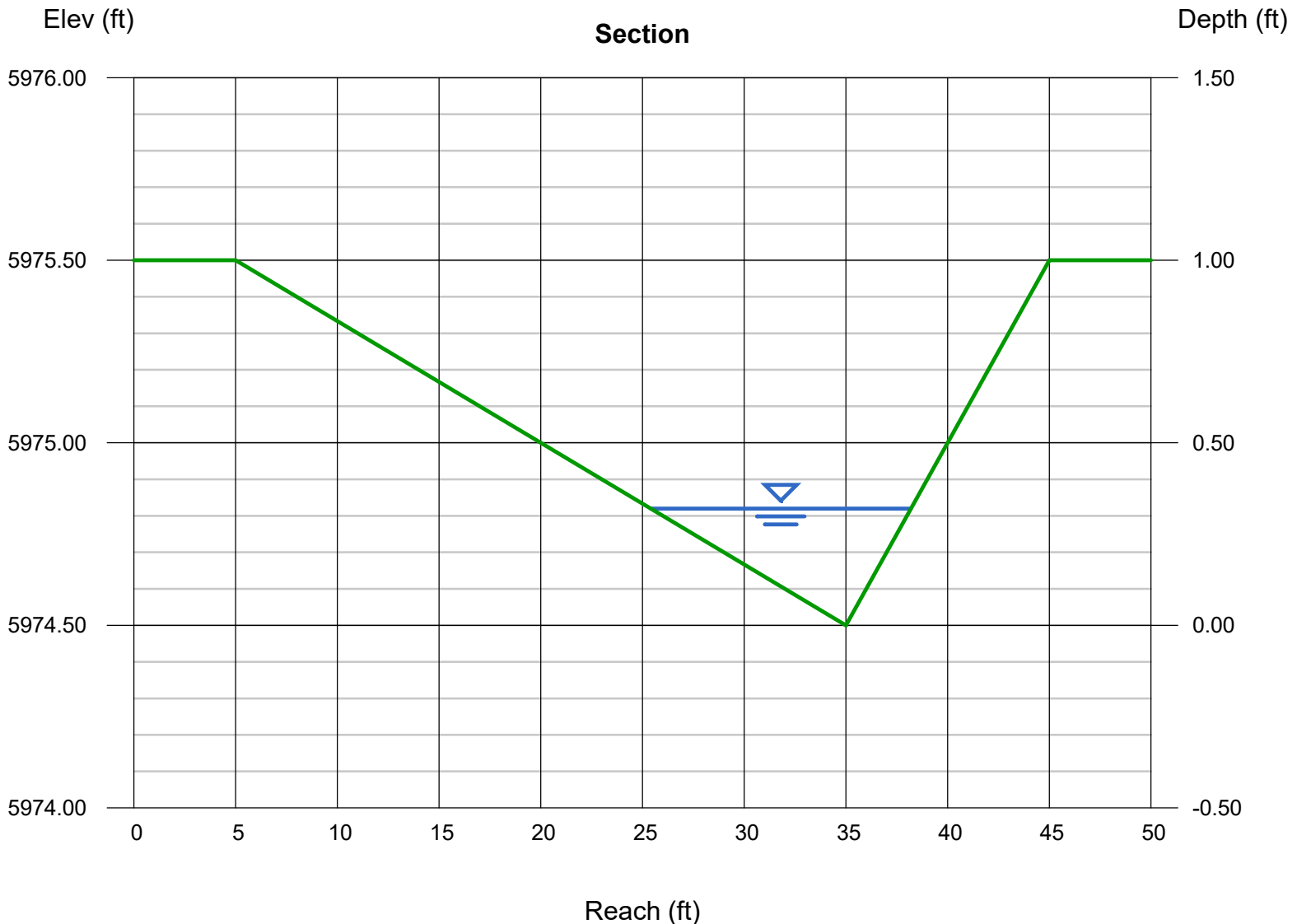

# Channel Report

## Handle Road Ditch (Existing Conditions)

### Triangular

Side Slopes (z:1) = 6.00, 4.00  
Total Depth (ft) = 2.50

Invert Elev (ft) = 5969.00  
Slope (%) = 0.50  
N-Value = 0.040

### Calculations

Compute by: Known Q  
Known Q (cfs) = 63.50

### Highlighted

Depth (ft) = 2.16  
Q (cfs) = 63.50  
Area (sqft) = 23.33  
Velocity (ft/s) = 2.72  
Wetted Perim (ft) = 22.04  
Crit Depth, Yc (ft) = 1.59  
Top Width (ft) = 21.60  
EGL (ft) = 2.28

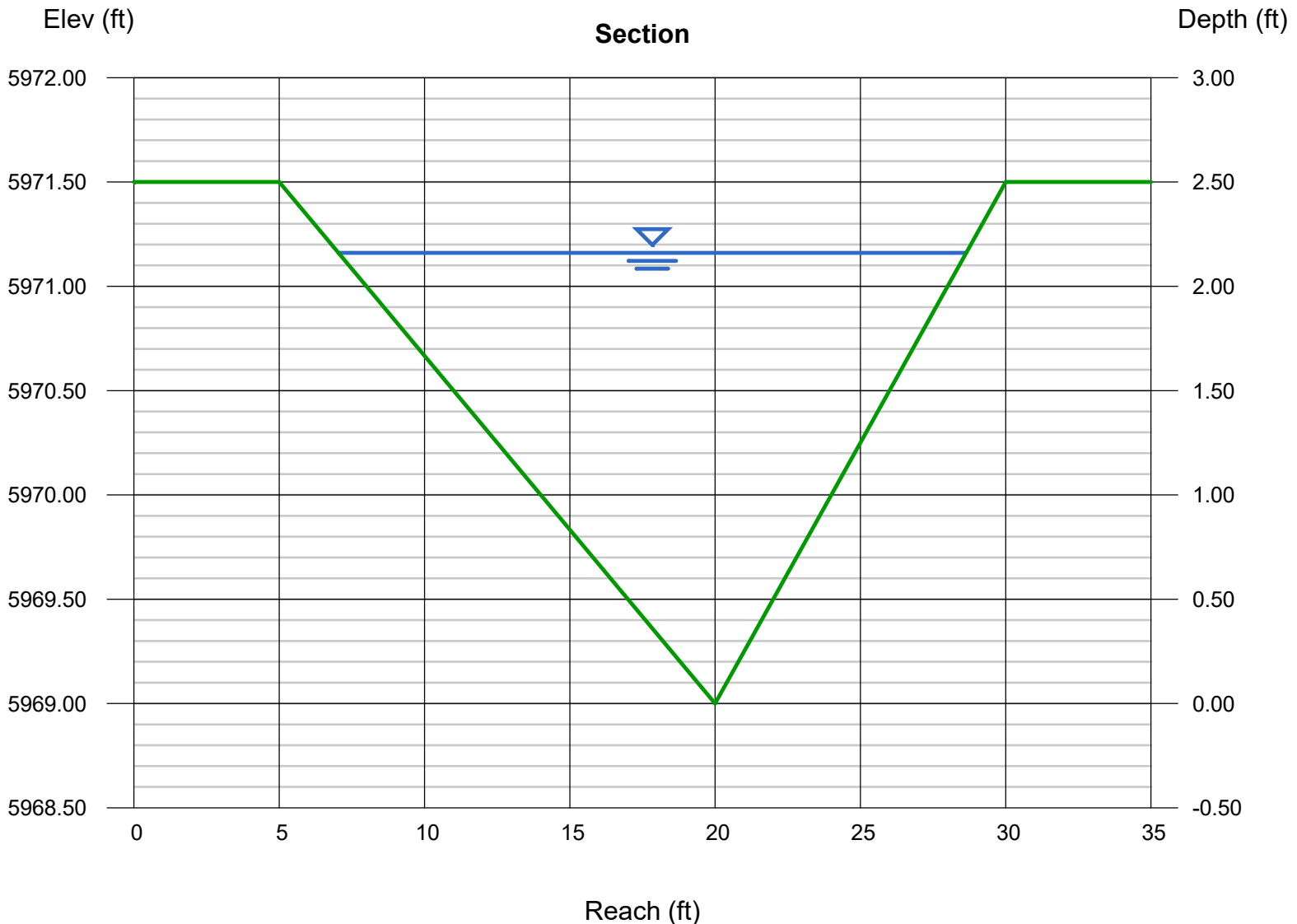

# Channel Report

## Handle Road Ditch (Proposed Conditions)

### Triangular

Side Slopes (z:1) = 6.00, 4.00  
Total Depth (ft) = 2.50

Invert Elev (ft) = 5969.00  
Slope (%) = 0.50  
N-Value = 0.040

### Calculations

Compute by: Known Q  
Known Q (cfs) = 65.50

### Highlighted



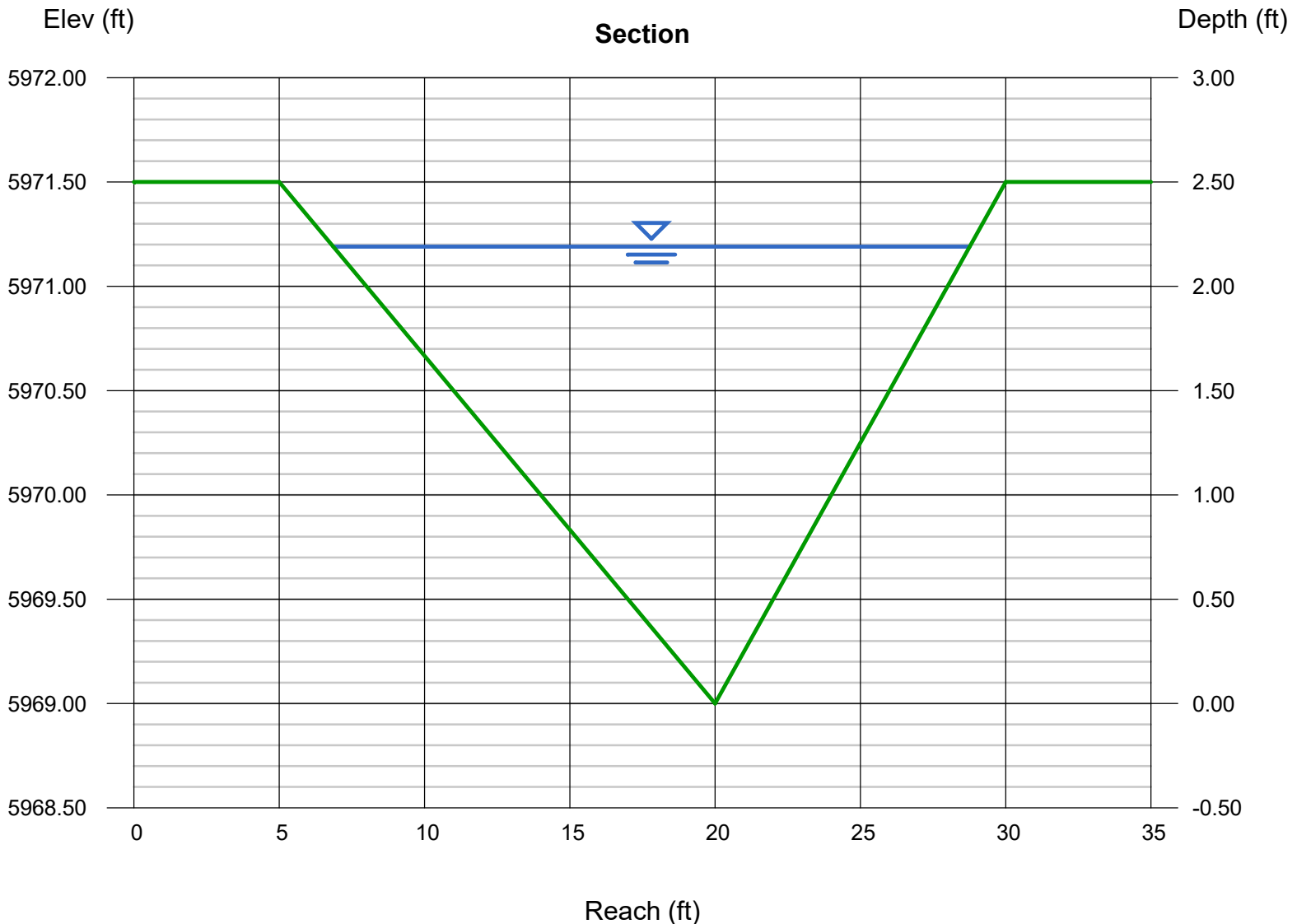



Depth (ft) = 2.19  
Q (cfs) = 65.50  
Area (sqft) = 23.98  
Velocity (ft/s) = 2.73  
Wetted Perim (ft) = 22.35  
Crit Depth, Yc (ft) = 1.61  
Top Width (ft) = 21.90  
EGL (ft) = 2.31



## 11 Report Maps

- Exclusions Map
- Drainage Maps (Existing)
  - Phase I Drainage Map (Existing)
  - Phase II Drainage Map (Existing)
- Drainage Maps (Proposed)
  - Phase I Drainage Map (Proposed)
  - Phase II Drainage Map (Proposed)
- PBMP Tributary Maps
  - Phase I - PBMP Tributary Map
  - Phase II - PBMP Tributary Map
- Downstream Conveyance Map

**LEGEND**

-  PROPERTY LINE
-  EASEMENT LINE
- EXISTING**
-  -5985- INDEX CONTOUR
-  -84- INTERMEDIATE CONTOUR
- PROPOSED**
-  -5985- INDEX CONTOUR
-  -84- INTERMEDIATE CONTOUR
-  DRAINAGE BASIN BOUNDARY (PROPOSED CONDITIONS)

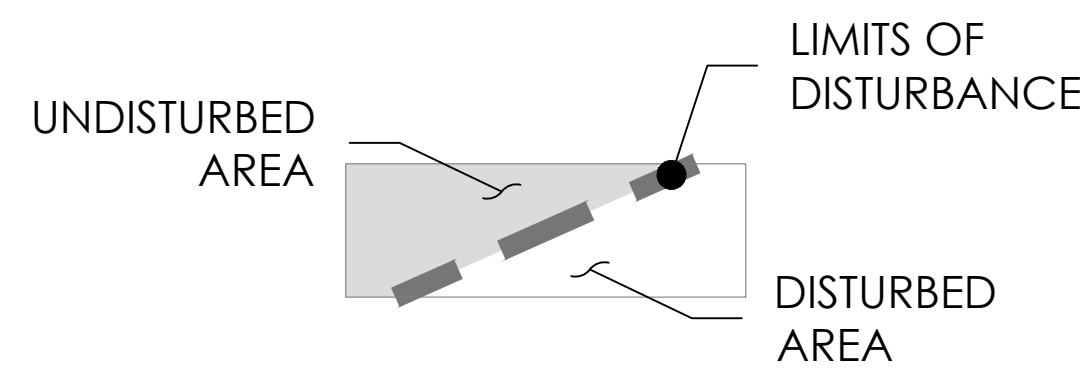

**SURFACE TYPES**

**AREA (ACRE)**

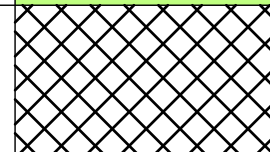
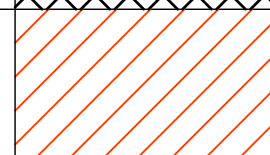
RAIN GARDENS TRIBUTARY AREA (WQCV STANDARD)		122,571 SF (2.81 ACRES)
EXCLUDED PER MS4 PERMIT I.E.4.A.I (D) (UTILITIES ACTIVITY)		4,574 SF (0.11 ACRES)
UNTREATED APPLICABLE DEVELOPMENT (REQUESTED 20% EXCLUSION UP TO 1 AC)		26,784 SF (0.61 ACRES)

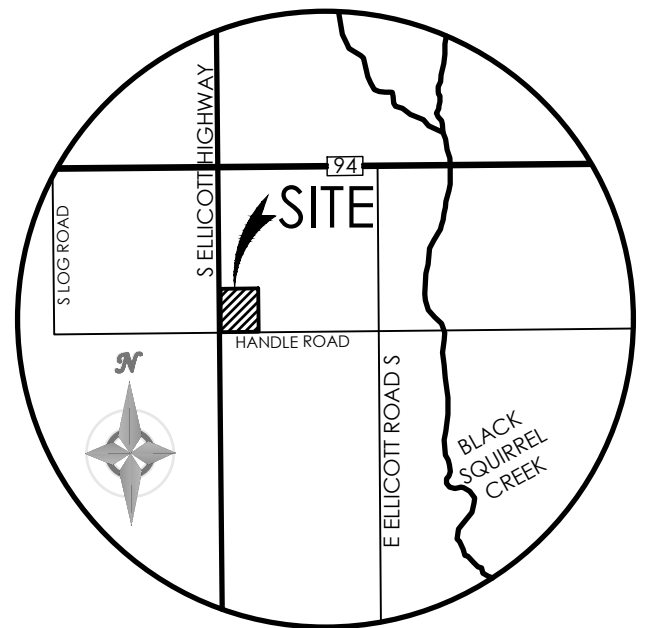
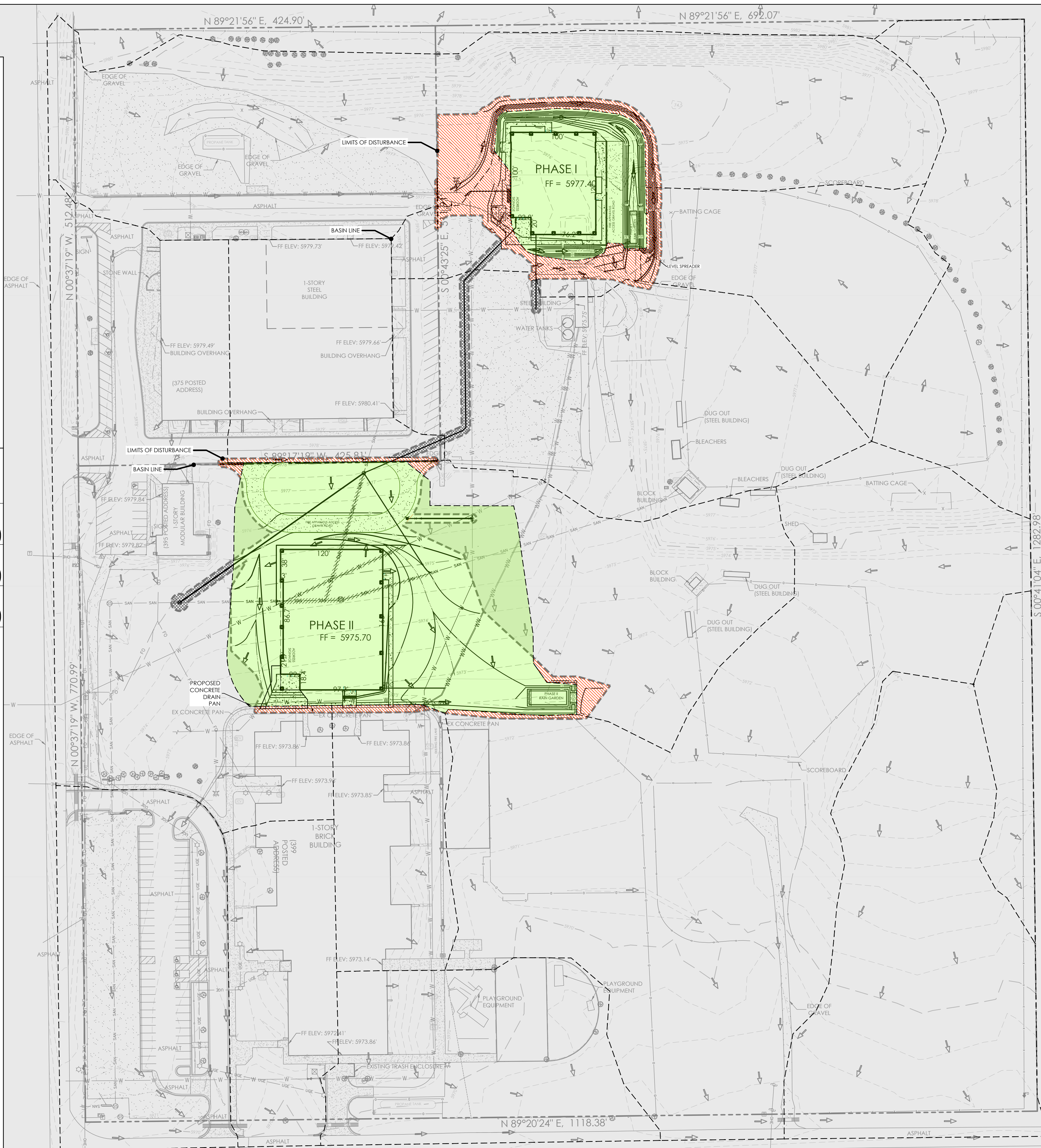

VICINITY MAP  
NOT TO SCALE

BENCHMARK

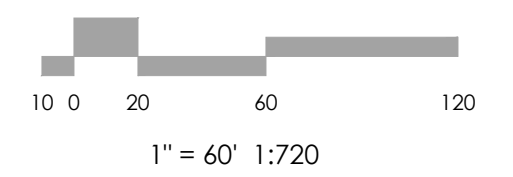
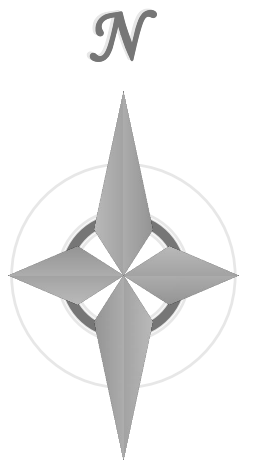

REVISIONS

DESIGNED BY \_\_\_\_\_  
DRAWN BY \_\_\_\_\_  
CHECKED BY \_\_\_\_\_  
AS-BUILTS BY \_\_\_\_\_  
CHECKED BY \_\_\_\_\_

ELLICOTT SCHOOL  
ADDITION 2 BLDGS

**EXCLUSIONS  
MAP**

MVE PROJECT 61183  
MVE DRAWING -BMP-Exclusions

APRIL 5, 2023  
SHEET 1 OF 1

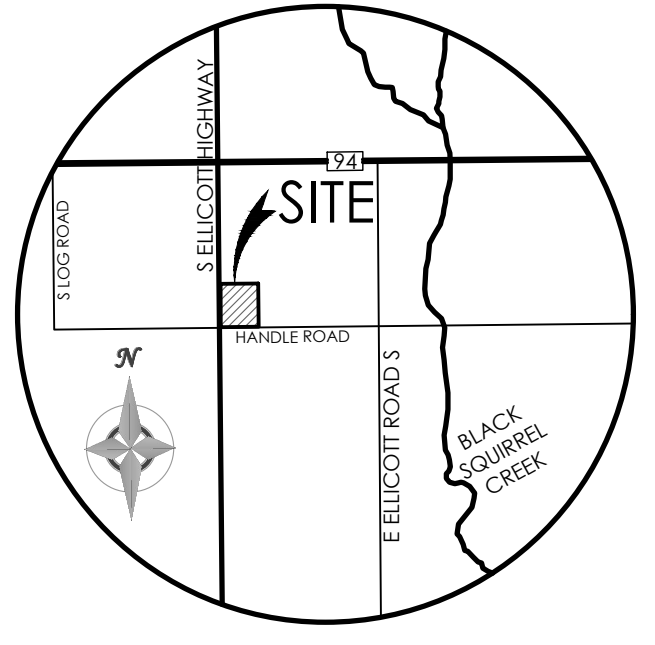
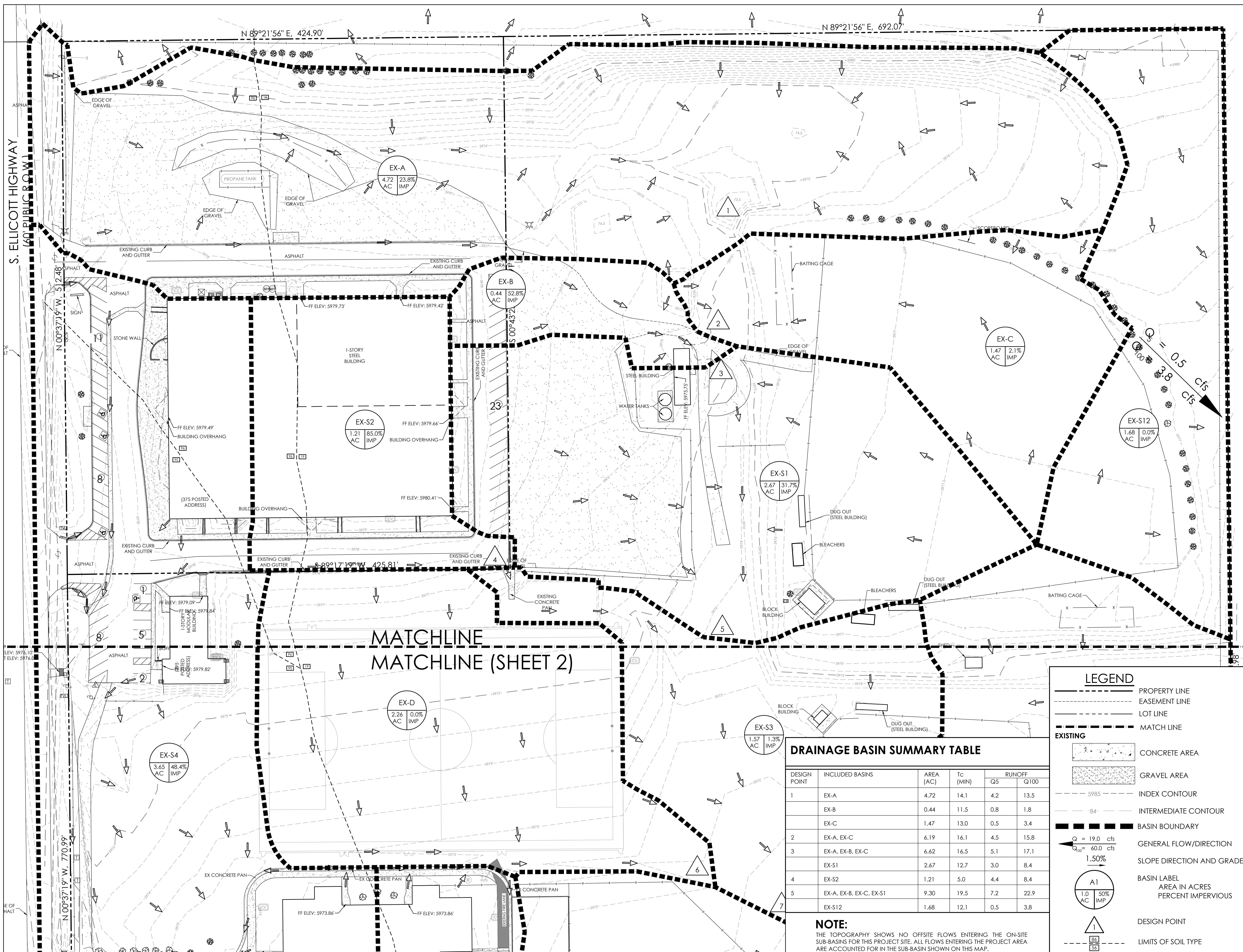

VICINITY MAP  
NOT TO SCALE

BENCHMARK  
THE EXISTING TOPOGRAPHY SHOWN ON THIS PLAN WAS PREPARED BY AND PROVIDED BY CLARK LAND SURVEYING INC. ELEVATIONS SHOWN ARE RELATIVE TO THE NAVD 88 VERTICAL DATUM.

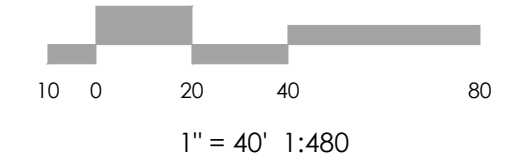
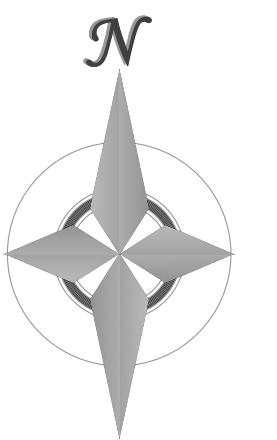

REVISIONS

DESIGNED BY  
DRAWN BY  
CHECKED BY  
AS-BUILTS BY  
CHECKED BY

ELLICOTT SCHOOL  
ADDITION 2 BLDGS

PHASE I  
DRAINAGE MAP  
(EXISTING)

MVE PROJECT 61183  
MVE DRAWING DRAIN-EX-1

APRIL 5, 2023  
SHEET 1 OF 2

MATCHLINE  
MATCHLINE (SHEET 2)

**LEGEND**

- PROPERTY LINE
- EASEMENT LINE
- LOT LINE
- - - MATCH LINE
- EXISTING
- [Pattern] CONCRETE AREA
- [Pattern] GRAVEL AREA
- - - 5985 INDEX CONTOUR
- - - -84- INTERMEDIATE CONTOUR
- BASIN BOUNDARY
- Q<sub>5</sub> = 19.0 cfs  
Q<sub>100</sub> = 60.0 cfs  
1.50% GENERAL FLOW/DIRECTION
- 1.50% SLOPE DIRECTION AND GRADE
- A1 BASIN LABEL  
1.0 AC 50% IMP AREA IN ACRES PERCENT IMPERVIOUS
- ▲ DESIGN POINT
- [Symbol] LIMITS OF SOIL TYPE

**DRAINAGE BASIN SUMMARY TABLE**

DESIGN POINT	INCLUDED BASINS	AREA (AC)	T <sub>c</sub> (MIN)	RUNOFF	
				Q <sub>5</sub>	Q <sub>100</sub>
1	EX-A	4.72	14.1	4.2	13.5
	EX-B	0.44	11.5	0.8	1.8
	EX-C	1.47	13.0	0.5	3.4
2	EX-A, EX-C	6.19	16.1	4.5	15.8
	EX-A, EX-B, EX-C	6.62	16.5	5.1	17.1
3	EX-S1	2.67	12.7	3.0	8.4
4	EX-S2	1.21	5.0	4.4	8.4
5	EX-A, EX-B, EX-C, EX-S1	9.30	19.5	7.2	22.9
	EX-S12	1.68	12.1	0.5	3.8

**NOTE:**  
THE TOPOGRAPHY SHOWS NO OFFSITE FLOWS ENTERING THE ON-SITE SUB-BASINS FOR THIS PROJECT SITE. ALL FLOWS ENTERING THE PROJECT AREA ARE ACCOUNTED FOR IN THE SUB-BASIN SHOWN ON THIS MAP.

DRAINAGE BASIN SUMMARY TABLE					
DESIGN POINT	INCLUDED BASINS	AREA (AC)	Tc (MIN)	RUNOFF (CFS)	
				Q5	Q100
6	EX-D	2.34	13.2	0.8	5.2
	EX-S3	1.57	12.7	0.5	3.5
7	DP3, EX-D, EX-S1, EX-S2, EX-S3	14.42	23.2	10.0	32.3
	EX-S4	3.60	14.8	5.8	13.4
	EX-S5	1.91	9.5	4.9	9.9
9	EX-S4, EX-S5	5.52	17.4	9.3	20.3
	EX-S6	1.07	9.5	2.1	4.8

DESIGN POINT	INCLUDED BASINS	AREA (AC)	Tc (MIN)	RUNOFF (CFS)	
				Q5	Q100
10	EX-S4, EX-S5, EX-S6	6.58	20.2	10.2	22.4
8	EX-S7	0.94	11.9	2.0	4.2
	EX-S8	1.62	9.4	2.4	6.4
11	DP10, EX-S7, EX-S8	9.14	22.5	12.8	28.7
	EX-S9	5.86	15.5	2.0	12.4
12	DP7, DP11, EX-S9	29.41	29.0	21.5	62.6
	EX-S10	2.65	13.0	1.1	6.2
13	DP12, EX-S10	32.07	31.4	21.2	63.6
	EX-S11	0.45	5.0	0.2	1.4

**NOTE:**

THE TOPOGRAPHY SHOWN NO OFFSITE FLOWS ENTERING THE ON-SITE SUB-BASINS FOR THIS PROJECT SITE. ALL FLOWS ENTERING THE PROJECT AREA ARE ACCOUNTED FOR IN THE SUB-BASIN SHOWN ON THIS MAP.

**LEGEND**

- PROPERTY LINE
- - - EASEMENT LINE
- LOT LINE
- MATCH LINE
- EXISTING**
- - - 5985 --- INDEX CONTOUR
- - - 84 --- INTERMEDIATE CONTOUR
- BASIN BOUNDARY
- LIMITS OF SOIL TYPE

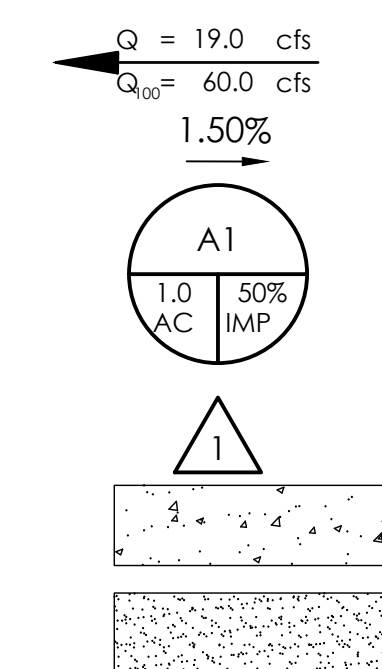

- GENERAL FLOW/DIRECTION
- SLOPE DIRECTION AND GRADE
- BASIN LABEL  
AREA IN ACRES  
PERCENT IMPERVIOUS
- DESIGN POINT
- CONCRETE AREA
- GRAVEL AREA

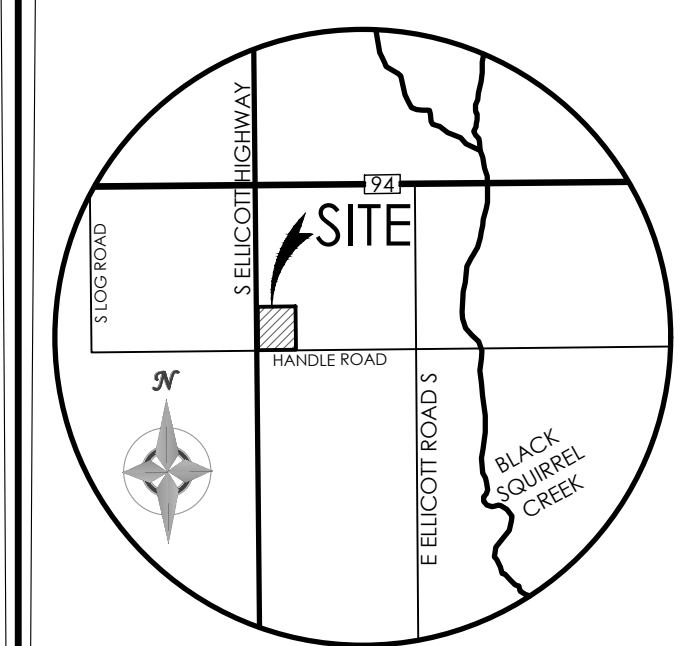

VICINITY MAP  
NOT TO SCALE

BENCHMARK  
THE EXISTING TOPOGRAPHY SHOWN ON THIS PLAN WAS PREPARED BY AND PROVIDED BY CLARK LAND SURVEYING INC. ELEVATIONS SHOWN ARE RELATIVE TO THE NAVD 88 VERTICAL DATUM.

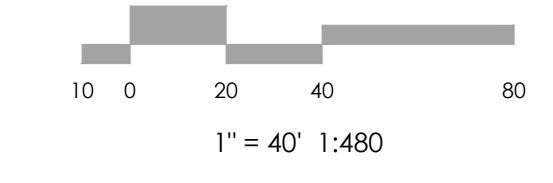
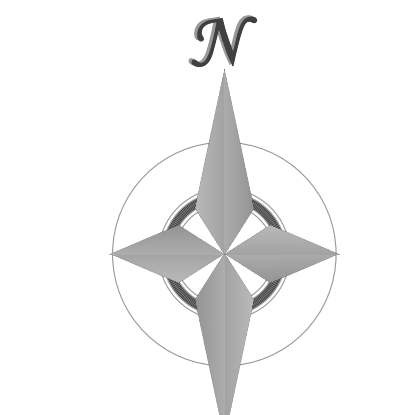

**MVE INC.**  
ENGINEERS / SURVEYORS

1903 Library Street, Suite 200 Colorado Springs, CO 80909 719.635.5736

REVISIONS

DESIGNED BY \_\_\_\_\_  
DRAWN BY \_\_\_\_\_  
CHECKED BY \_\_\_\_\_  
AS-BUILTS BY \_\_\_\_\_  
CHECKED BY \_\_\_\_\_

ELLICOTT SCHOOL  
ADDITION 2 BLDGS

PHASE II  
DRAINAGE MAP  
(EXISTING)

MVE PROJECT 61183  
MVE DRAWING DRAIN-EX-II

APRIL 5, 2023  
SHEET 2 OF 2

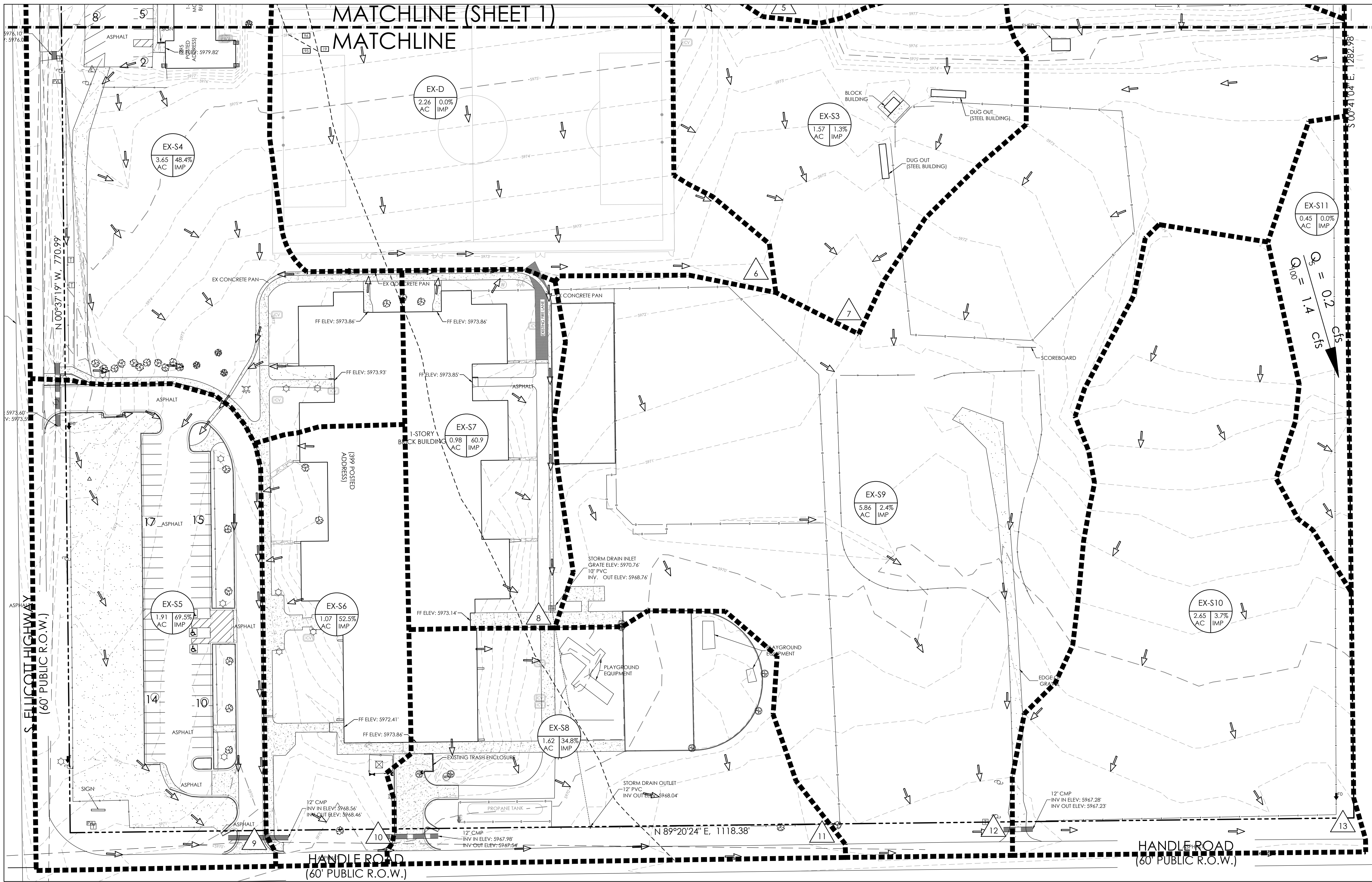



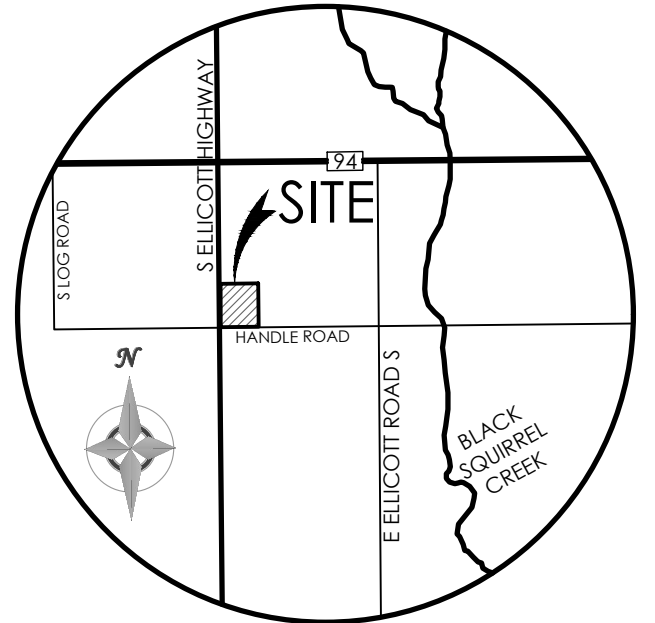
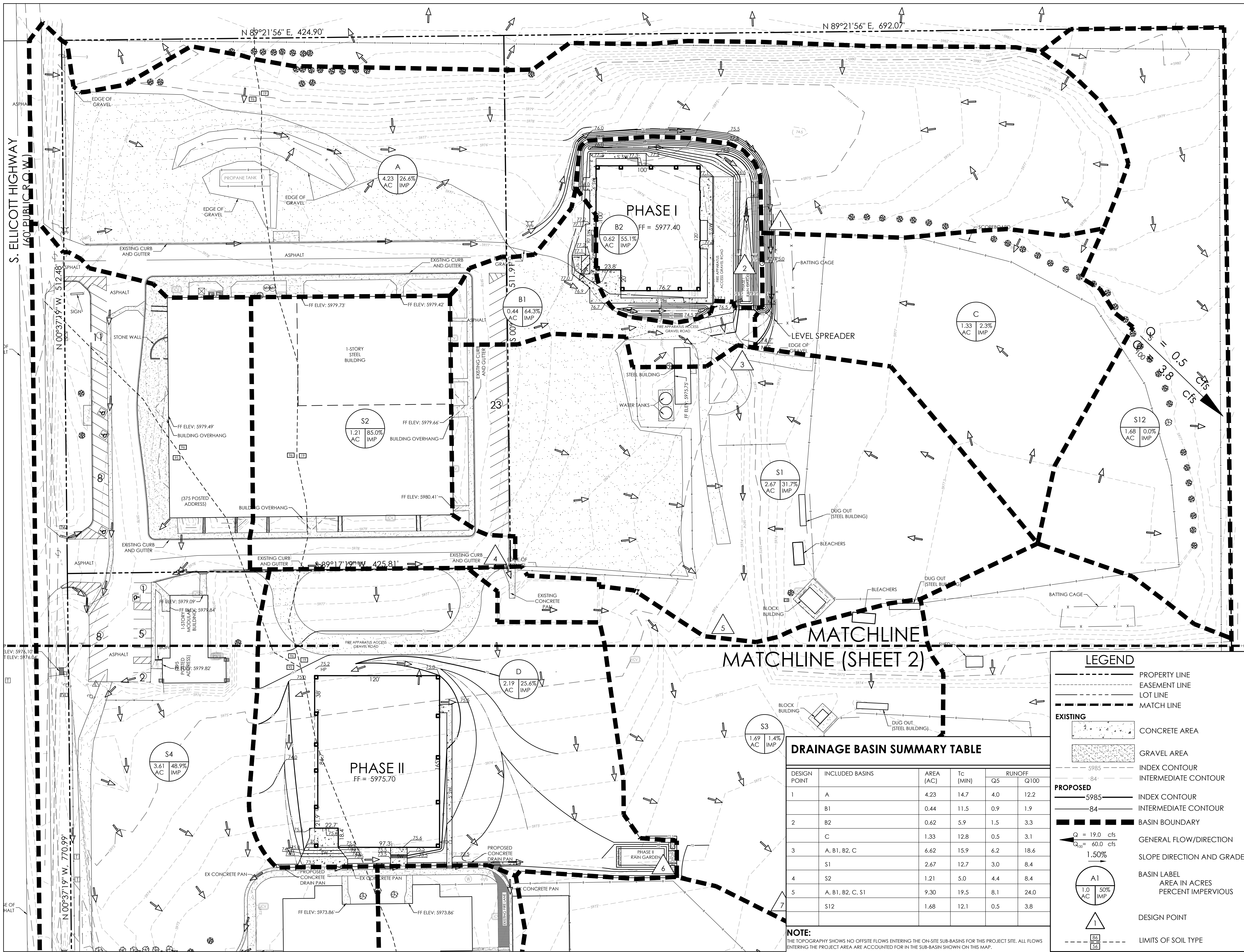

VICINITY MAP  
NOT TO SCALE

BENCHMARK  
THE EXISTING TOPOGRAPHY SHOWN ON THIS PLAN WAS PREPARED BY AND PROVIDED BY CLARK LAND SURVEYING INC. ELEVATIONS SHOWN ARE RELATIVE TO THE NAVD 88 VERTICAL DATUM.

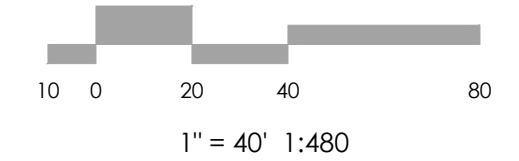
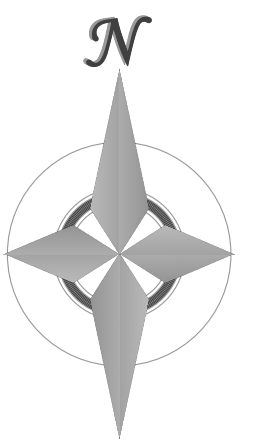

**MVE, INC.**  
ENGINEERS / SURVEYORS

1903 Library Street, Suite 200 Colorado Springs, CO 80909 719.635.5736

REVISIONS

MATCHLINE  
MATCHLINE (SHEET 2)

**LEGEND**

- PROPERTY LINE
- EASEMENT LINE
- LOT LINE
- MATCH LINE

**EXISTING**

- CONCRETE AREA
- GRAVEL AREA
- 5985 INDEX CONTOUR
- 84 INTERMEDIATE CONTOUR

**PROPOSED**

- 5985 INDEX CONTOUR
- 84 INTERMEDIATE CONTOUR
- BASIN BOUNDARY
- GENERAL FLOW/DIRECTION  
Q = 19.0 cfs  
Q<sub>100</sub> = 60.0 cfs
- SLOPE DIRECTION AND GRADE
- BASIN LABEL  
AREA IN ACRES  
PERCENT IMPERVIOUS
- DESIGN POINT
- LIMITS OF SOIL TYPE

**DRAINAGE BASIN SUMMARY TABLE**

DESIGN POINT	INCLUDED BASINS	AREA (AC)	Tc (MIN)	RUNOFF	
				Q5	Q100
1	A	4.23	14.7	4.0	12.2
	B1	0.44	11.5	0.9	1.9
2	B2	0.62	5.9	1.5	3.3
	C	1.33	12.8	0.5	3.1
3	A, B1, B2, C	6.62	15.9	6.2	18.6
	S1	2.67	12.7	3.0	8.4
4	S2	1.21	5.0	4.4	8.4
	A, B1, B2, C, S1	9.30	19.5	8.1	24.0
5	S12	1.68	12.1	0.5	3.8

**NOTE:**  
THE TOPOGRAPHY SHOWS NO OFFSITE FLOWS ENTERING THE ON-SITE SUB-BASINS FOR THIS PROJECT SITE. ALL FLOWS ENTERING THE PROJECT AREA ARE ACCOUNTED FOR IN THE SUB-BASIN SHOWN ON THIS MAP.

ELLICOTT SCHOOL  
ADDITION 2 BLDGS

PHASE I  
DRAINAGE MAP  
(PROPOSED)

MVE PROJECT 61183  
MVE DRAWING DRAIN-PP-I

APRIL 5, 2023  
SHEET 1 OF 2

DRAINAGE BASIN SUMMARY TABLE					
DESIGN POINT	INCLUDED BASINS	AREA (AC)	Tc (MIN)	RUNOFF (CFS)	
				Q5	Q100
6	D	2.19	13.0	2.2	6.6
	S3	1.69	12.7	0.6	3.8
7	DP3, D, S1, S2, S3	14.39	23.2	12.0	34.6
	S4	3.61	14.8	5.9	13.5
	S5	1.91	9.5	4.9	9.9
9	S4, S5	5.53	17.4	9.3	20.4
	S6	1.07	9.5	2.1	4.8

DESIGN POINT	INCLUDED BASINS	AREA (AC)	Tc (MIN)	RUNOFF (CFS)	
				Q5	Q100
10	S4, S5, S6	6.60	20.2	10.2	22.5
8	S7	0.98	12.0	2.0	4.3
	S8	1.62	9.4	2.4	6.4
11	DP10, S7, S8	9.19	22.5	12.9	28.9
	S9	5.84	15.5	2.0	12.3
12	DP7, DP11, S9	29.42	29.0	23.3	64.7
	S10	2.65	13.0	1.1	6.2
13	DP12, S10	32.07	31.4	21.2	63.6
	S11	0.45	5.0	0.2	1.4

**NOTE:**  
THE TOPOGRAPHY SHOWS NO OFFSITE FLOWS ENTERING THE ON-SITE SUB-BASINS FOR THIS PROJECT SITE. ALL FLOWS ENTERING THE PROJECT AREA ARE ACCOUNTED FOR IN THE SUB-BASIN SHOWN ON THIS MAP.

**LEGEND**

- PROPERTY LINE
- EASEMENT LINE
- LOT LINE
- MATCH LINE
- EXISTING
- INDEX CONTOUR
- INTERMEDIATE CONTOUR
- BASIN BOUNDARY
- LIMITS OF SOIL TYPE
- GENERAL FLOW/DIRECTION
- SLOPE DIRECTION AND GRADE
- BASIN LABEL  
AREA IN ACRES  
PERCENT IMPERVIOUS
- DESIGN POINT
- CONCRETE AREA
- GRAVEL AREA

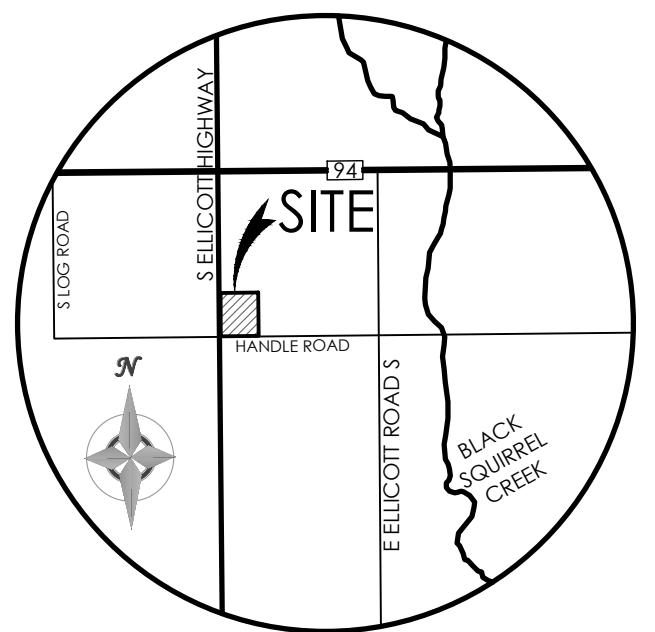

**VICINITY MAP**  
NOT TO SCALE

BENCHMARK  
THE EXISTING TOPOGRAPHY SHOWN ON THIS PLAN WAS PREPARED BY AND PROVIDED BY CLARK LAND SURVEYING INC. ELEVATIONS SHOWN ARE RELATIVE TO THE NAVD 88 VERTICAL DATUM.

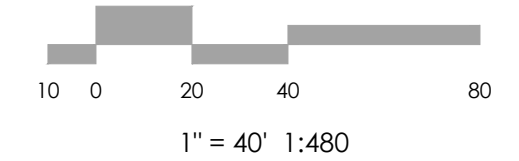
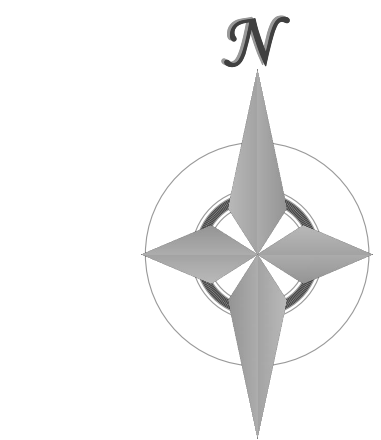
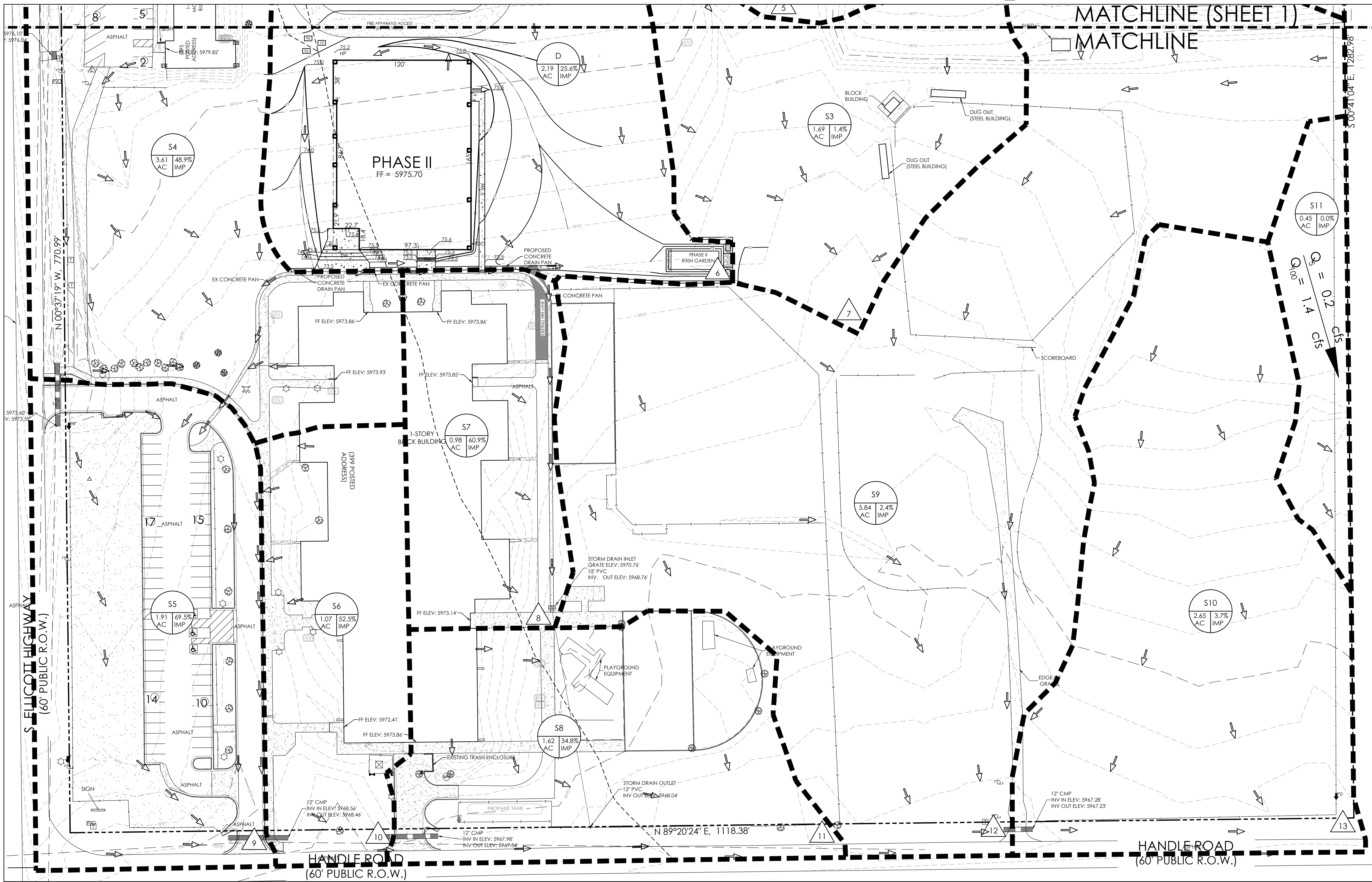

**MVE, INC.**  
ENGINEERS / SURVEYORS

1903 Library Street, Suite 200 Colorado Springs, CO 80909 719.635.5736

DESIGNED BY \_\_\_\_\_  
DRAWN BY \_\_\_\_\_  
CHECKED BY \_\_\_\_\_  
AS-BUILTS BY \_\_\_\_\_  
CHECKED BY \_\_\_\_\_

ELLICOTT SCHOOL  
ADDITION 2 BLDGS

PHASE II  
DRAINAGE MAP  
(PROPOSED)

MVE PROJECT 61183  
MVE DRAWING DRAIN-PP-II

APRIL 5, 2023  
SHEET 2 OF 2

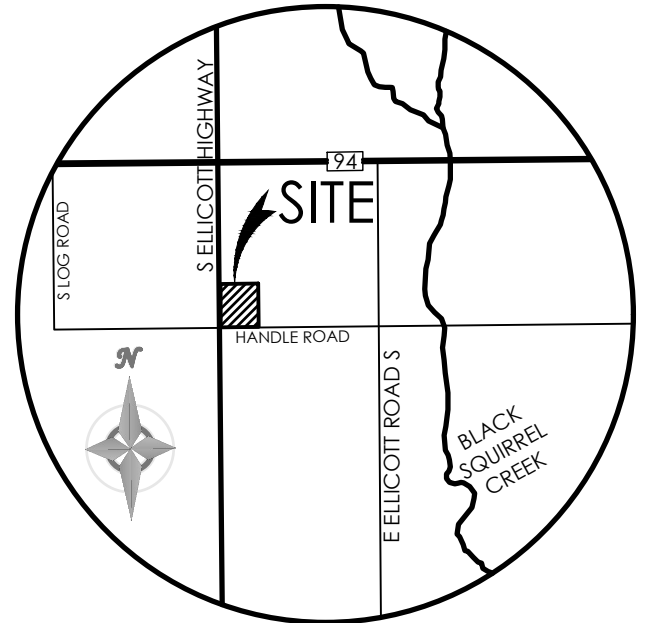
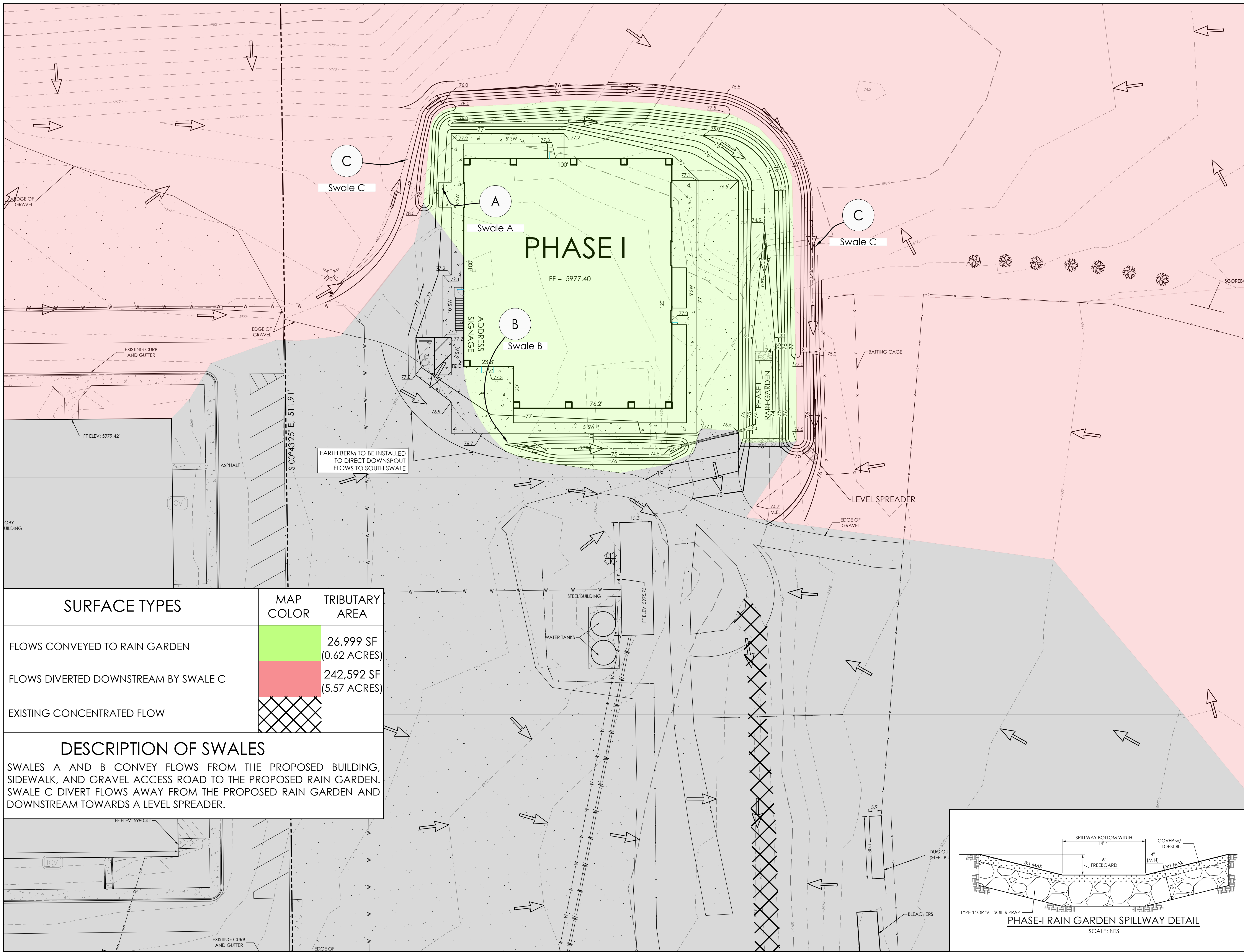

VICINITY MAP  
NOT TO SCALE

BENCHMARK  
THE EXISTING TOPOGRAPHY SHOWN ON THIS PLAN WAS PREPARED BY AND PROVIDED BY CLARK LAND SURVEYING INC. ELEVATIONS SHOWN ARE RELATIVE TO THE NAVD 88 VERTICAL DATUM.

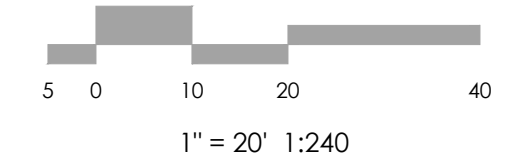
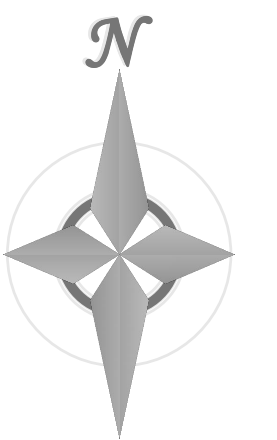

1" = 20' 1:240

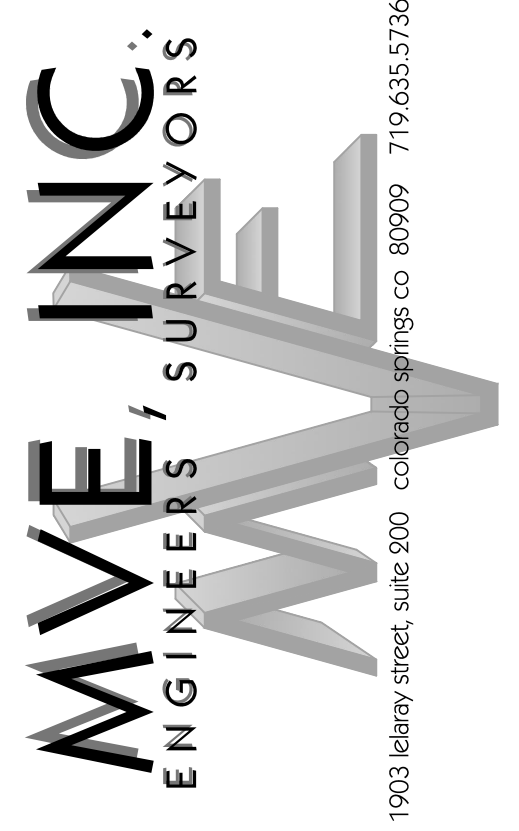

REVISIONS

DESIGNED BY \_\_\_\_\_  
DRAWN BY \_\_\_\_\_  
CHECKED BY \_\_\_\_\_  
AS-BUILTS BY \_\_\_\_\_  
CHECKED BY \_\_\_\_\_

ELLICOTT SCHOOL  
ADDITION 2 BLDGS

PHASE I - PBMP  
TRIBUTARY  
MAP

MVE PROJECT 61183  
MVE DRAWING PBMP-TRIB-I

APRIL 5, 2023  
SHEET 1 OF 2

SURFACE TYPES	MAP COLOR	TRIBUTARY AREA
FLows CONVEYED TO RAIN GARDEN		26,999 SF (0.62 ACRES)
FLows DIVERTED DOWNSTREAM BY SWALE C		242,592 SF (5.57 ACRES)
EXISTING CONCENTRATED FLOW		

**DESCRIPTION OF SWALES**  
SWALES A AND B CONVEY FLOWS FROM THE PROPOSED BUILDING, SIDEWALK, AND GRAVEL ACCESS ROAD TO THE PROPOSED RAIN GARDEN. SWALE C DIVERT FLOWS AWAY FROM THE PROPOSED RAIN GARDEN AND DOWNSTREAM TOWARDS A LEVEL SPREADER.

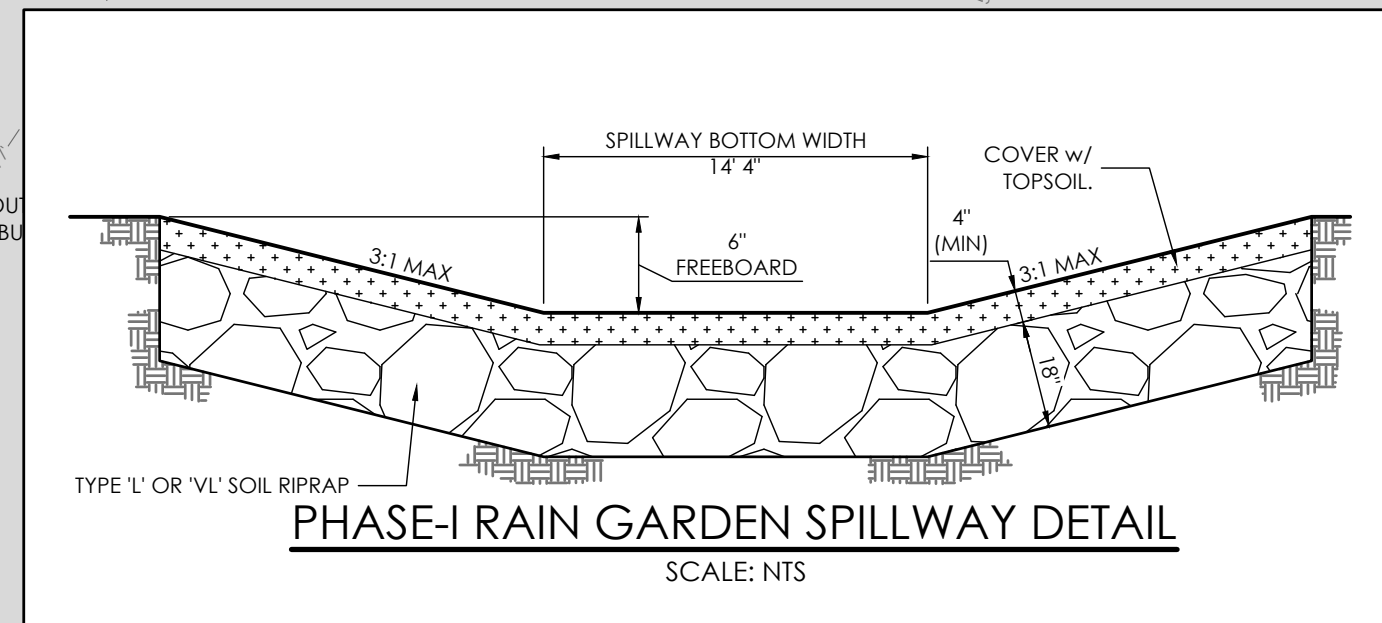

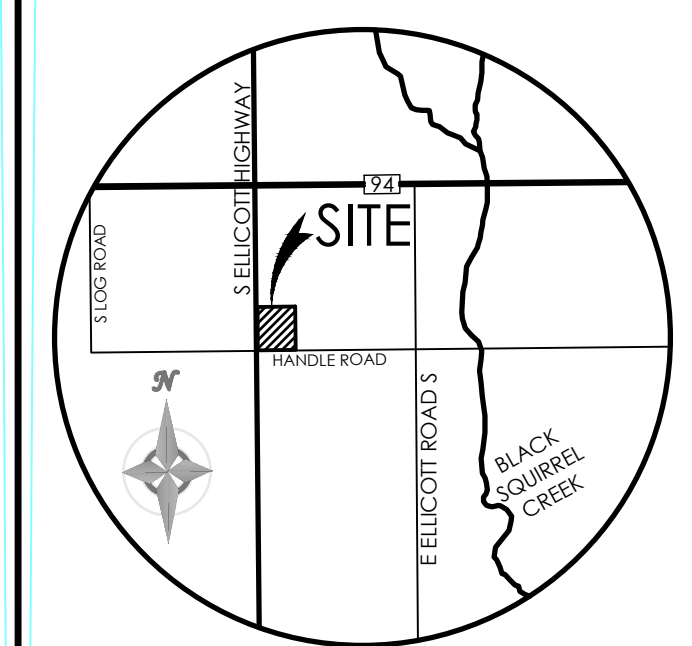
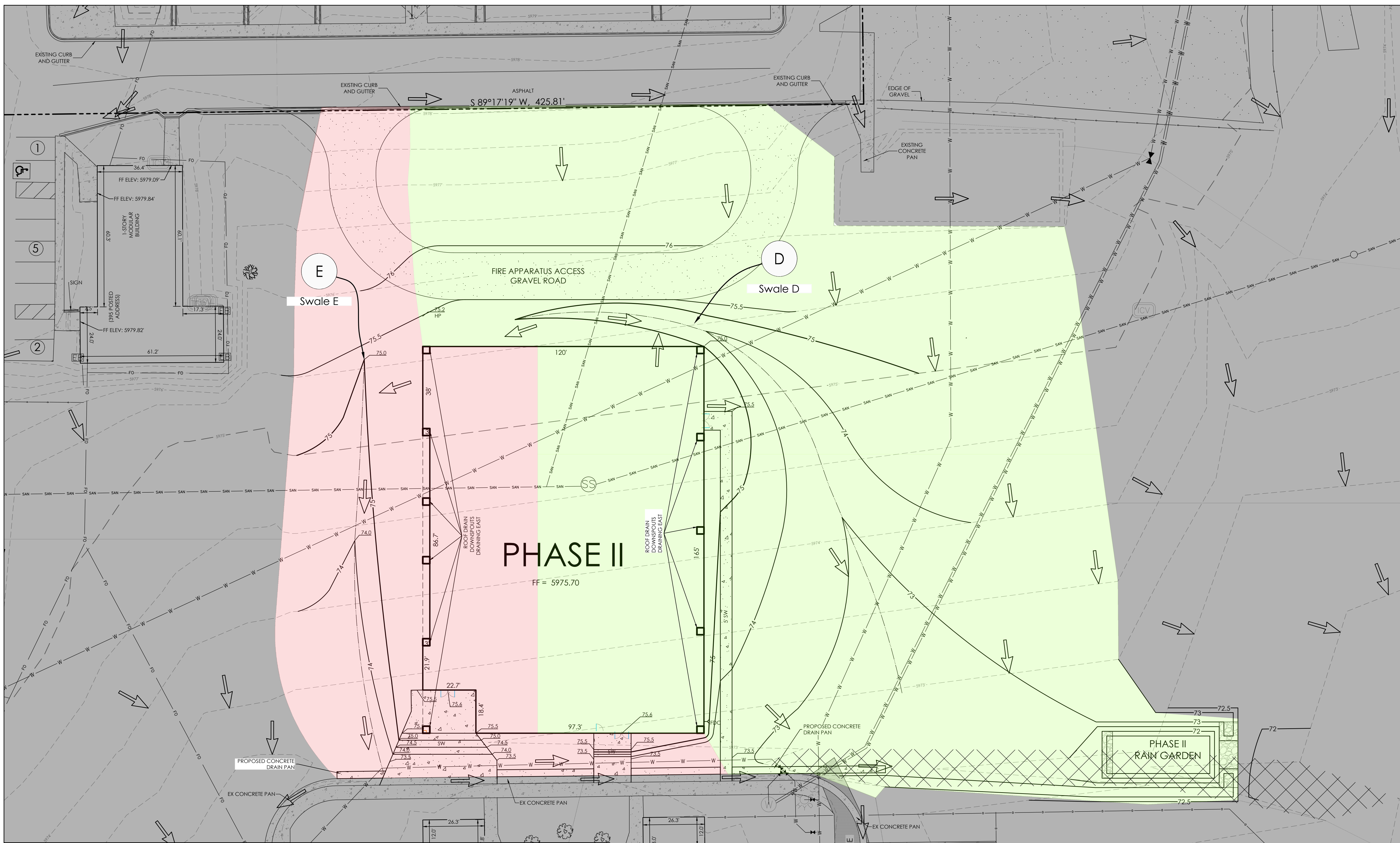

**VICINITY MAP**  
NOT TO SCALE

BENCHMARK  
THE EXISTING TOPOGRAPHY SHOWN ON THIS PLAN WAS PREPARED BY AND PROVIDED BY CLARK LAND SURVEYING INC. ELEVATIONS SHOWN ARE RELATIVE TO THE NAVD 88 VERTICAL DATUM.

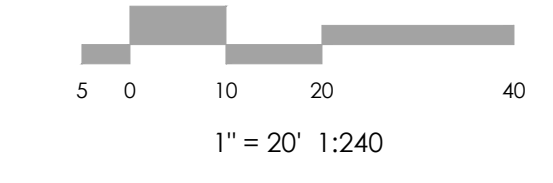
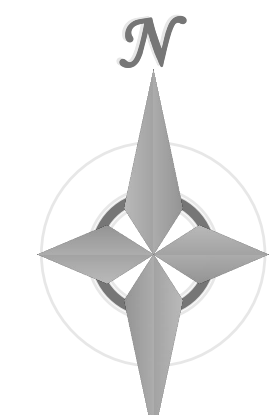

**MVE, INC.**  
ENGINEERS / SURVEYORS

1903 Library Street, Suite 200 Colorado Springs, CO 80909 719.635.5726

REVISIONS

DESIGNED BY \_\_\_\_\_  
DRAWN BY \_\_\_\_\_  
CHECKED BY \_\_\_\_\_  
AS-BUILTS BY \_\_\_\_\_  
CHECKED BY \_\_\_\_\_

**ELLICOTT SCHOOL  
ADDITION 2 BLDGS**

**PHASE II - PBMP  
TRIBUTARY  
MAP**

MVE PROJECT 61183  
MVE DRAWING PBMP-TRIB-II

**APRIL 5, 2023  
SHEET 2 OF 2**

**SURFACE TYPES**

	MAP COLOR	TRIBUTARY AREA
FLows TRIBUTARY TO RAIN GARDEN BY SWALE D		69,800 SF (1.60 ACRES)
FLows TRIBUTARY TO RAIN GARDEN CONVEYED TO CONCRETE PAN BY SWALE E		25,772 SF (0.59 ACRES)
EXISTING CONCENTRATED FLOW		

**DESCRIPTION OF SWALES**

SWALE D COLLECTS RUNOFF FROM THE EASTERN PROPOSED BUILDING DOWNSPOUTS, THE PROPOSED SIDEWALK ON THE EASTERN PORTION OF THE PROPOSED BUILDING, AND THE EASTERN PORTION OF THE PROPOSED GRAVEL ACCESS ROAD AND CONVEYS THE FLOWS EAST TO THE PROPOSED PHASE II RAIN GARDEN. SWALE E COLLECTS RUNOFF FROM THE WESTERN PROPOSED BUILDING DOWNSPOUTS AND THE WESTERN PORTION OF THE PROPOSED GRAVEL ACCESS ROAD AND CONVEYS THE FLOWS TO THE PROPOSED CONCRETE DRAIN PAN LOCATED SOUTH OF THE PROPOSED PHASE II BUILDING WHICH CONVEYS THE FLOWS EAST TO THE PROPOSED PHASE II RAIN GARDEN.

**3' CONCRETE DRAIN PAN DETAIL**  
SCALE 1" = 12"

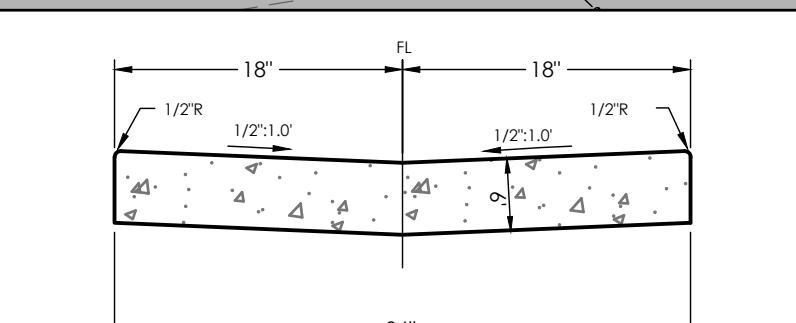

**PHASE-II RAIN GARDEN SPILLWAY DETAIL**  
SCALE: NTS

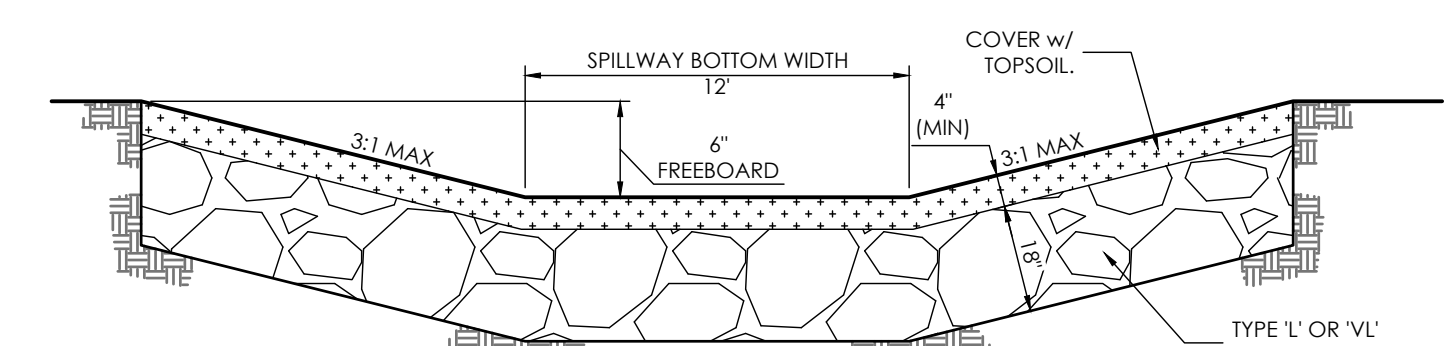

# Overall Reference Map showing downstream conveyance

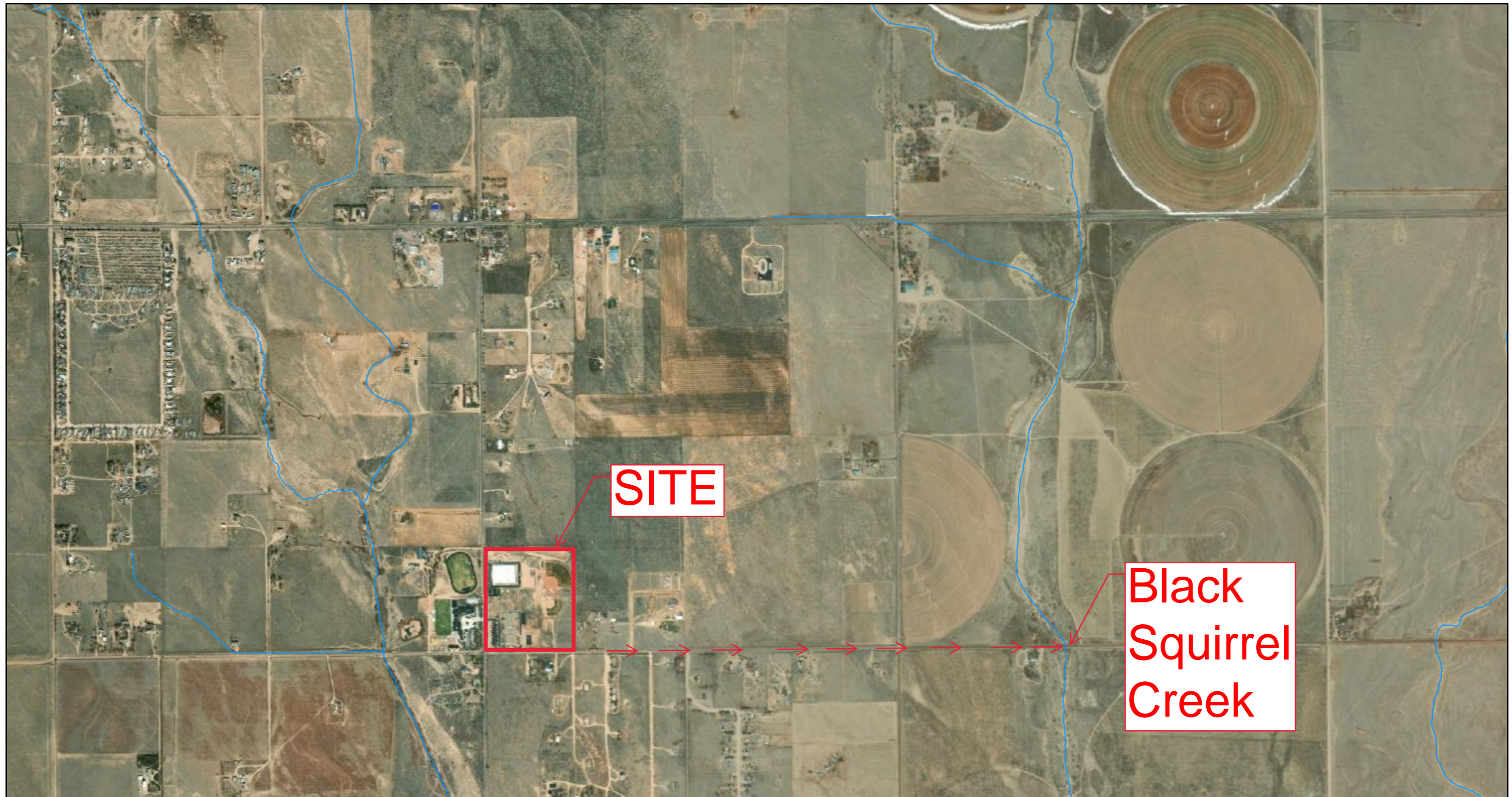

March 9, 2023

Creeks

— Intermittent

→ Flow Arrow

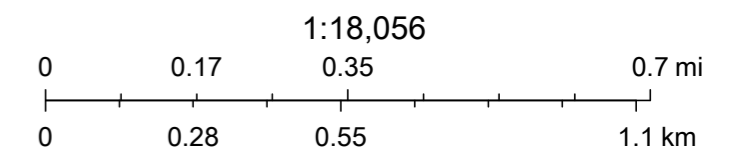

Maxar