

NAME: Z:\COLORADO SPRINGS OFFICE\3542_GLENEAGLE\CA\NSHETS\6324-S-ORAD.DWG
 PLOT DATE: May 22, 2018 11:00 AM, BY: CHRIS MEERS

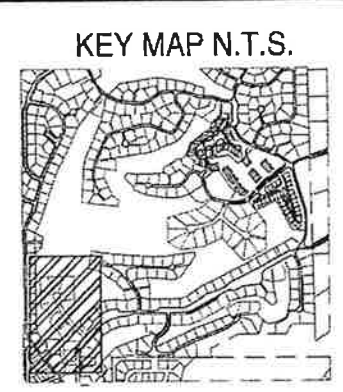

- LEGEND:**
- PROPOSED MAJOR CONTOUR
 - PROPOSED MINOR CONTOUR
 - - - EXISTING MAJOR CONTOUR
 - - - EXISTING MINOR CONTOUR
 - PROPOSED SANITARY
 - EXISTING SANITARY
 - PROPOSED SILT FENCE
 - LIMITS OF DISTURBANCE
 - CONSTRUCTION SITE BOUNDARIES
 - ⊗ EXISTING WATER VALVES
 - ⊗ EXISTING FIRE HYDRANT
 - ⊗ EXISTING FIRE HYDRANT TO BE REMOVED
 - ⊗ PROPOSED FIRE HYDRANT
 - ⊗ PROPOSED WATER VALVES & REDUCERS
 - ⊗ EXISTING SANITARY MANHOLE
 - ⊗ EXISTING SANITARY MANHOLE TO BE REMOVED
 - ⊗ PROPOSED SANITARY MANHOLE
 - CONCRETE WASHOUT
 - VEHICLE TRACKING CONTROL
 - STRAWBALE BARRIER
 - INLET PROTECTION
 - ROCK SOCKS



- SHEET INDEX**
- 1 - OVER ALL
 - 2 - STONE EAGLE PLACE & LOTS 1 & 12
 - 3 - GRADING & EROSION CONTROL DETAILS
 - 4 - GRADING & EROSION CONTROL DETAILS
 - 5 - GRADING & EROSION CONTROL DETAILS

OWNER'S STATEMENT:
 THE OWNER WILL COMPLY WITH THE REQUIREMENTS OF THE GRADING AND EROSION CONTROL PLAN.

Scott Gratrix 5/22/19
 G & S DEVELOPMENT, INC
 MR. SCOTT GRATRAX
 303-858-0599

ENGINEER'S STATEMENT:
 These detailed plans were prepared under my direction and supervision. Said plans and specifications have been prepared in accordance to the criteria established by the County for detailed roadway, drainage, grading and erosion control plans and specifications, and said plan and specifications are in conformity with applicable master drainage plans and master transportation plans. Said plans and specifications meet the purposes for which the particular roadway and drainage facilities are designed and are correct to the best of my knowledge and belief. I accept responsibility for any liability caused by any negligent acts, errors or omissions on my part in preparing these detailed plans and specifications.

Michael A. Bartusek
 Michael A. Bartusek, P.E. #23329
 RESPEC

DEVELOPER'S STATEMENT:
 I, the Developer, have read and will comply with all of the requirements specified on this plan.

By: Scott Gratrix
 Title: President
 Address: G & S Development, Inc
 9900 Pyramid Court, Suite 340
 Englewood, CO 80112

Scott Gratrix 5/22/19
 Scott Gratrix Date

ENGINEER'S STATEMENT:
 THIS GRADING AND EROSION CONTROL PLAN WAS PREPARED UNDER MY DIRECTION AND SUPERVISION AND IS CORRECT TO THE BEST OF MY KNOWLEDGE AND BELIEF. SAID PLAN HAS BEEN PREPARED ACCORDING TO THE CRITERIA ESTABLISHED BY THE COUNTY FOR GRADING AND EROSION CONTROL PLANS. I ACCEPT RESPONSIBILITY FOR ANY LIABILITY CAUSED BY ANY NEGLIGENT ACTS, ERRORS OR OMISSIONS ON MY PART IN PREPARING THIS PLAN.

Michael A. Bartusek
 MICHAEL BARTUSEK, COLORADO P.E. # 23329
 RESPEC

EL PASO COUNTY:
 COUNTY PLAN REVIEW IS PROVIDED ONLY FOR GENERAL CONFORMANCE WITH COUNTY DESIGN CRITERIA. THE COUNTY IS NOT RESPONSIBLE FOR THE ACCURACY AND ADEQUACY OF THE DESIGN, DIMENSIONS, AND/OR ELEVATIONS WHICH SHALL BE CONFIRMED AT THE JOB SITE. THE COUNTY THROUGH THE APPROVAL OF THIS DOCUMENT ASSUMES NO RESPONSIBILITY FOR COMPLETENESS AND/OR ACCURACY OF THIS DOCUMENT.

FILED IN ACCORDANCE WITH THE REQUIREMENTS OF THE EL PASO COUNTY LAND DEVELOPMENT CODE, DRAINAGE CRITERIA MANUAL, VOLUMES 1 AND 2, AND ENGINEERING CRITERIA MANUAL AS AMENDED.

Approved
 JENIFER IRVINE P.E.
 COUNTY ENGINEER/ECM ADMINISTRATOR
 06/04/2019 1:49:02 PM

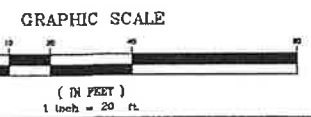

NOTE:
 IF CONSTRUCTION HAS NOT STARTED WITHIN 2 YEARS OF PLANS BEING SIGNED BY THE EL PASO COUNTY ENGINEER, THE PLANS WILL NEED TO BE RESUBMITTED FOR APPROVAL UNDER CURRENT CRITERIA.
 A MIN OF 18" DRIVEWAY CULVERTS SHALL BE DESIGNED AND PLACED BY THE CONTRACTOR FOR ALL LOTS ADJACENT TO DITCH SECTIONS AT TIME OF DEVELOPMENT

BENCHMARK:
 "TMS MONUMENT 100 IS N.G.S. TRIANGULATION STATION "MONUMENT" - A STANDARD TRIANGULATION STATION DISK. THE MARK IS APPROXIMATELY 0.7 MILES SOUTH ALONG INTERSTATE HIGHWAY 25 FROM THE BAPTIST ROAD OVERPASS. THE MARK IS 75.1 FEET SOUTHWEST OF A FENCE LINE AND 94.5 FEET WEST OF REFERENCE MONUMENT #1."
 ELEVATION - 8768.48 FEET NGVD '29

THE BASIS OF BEARINGS FOR THIS PROJECT IS THE WEST LINE OF THE NORTHWEST QUARTER OF THE NORTHWEST QUARTER OF SECTION 6, T12S, R66W N00°15'58"W - 1324.20 FEET, THE BEARING IS A GRID BEARING OF THE COLORADO STATE PLANE CENTRAL ZONE NAD 83. THE LINE IS MONUMENTED BY 1934 GLD BRASS CAP ON THE NORTH END AND A 2" DIAMETER ALUMINUM CAP PLS 4842 ON THE SOUTH END.

DESIGNED: MAB	REVISION:
DRAWN: HUB	
CHECKED: MAB	
DATE: 2/16/2019	
RESPEC: 620 S COLORADO BLVD DENVER, CO 80248 PHONE: (303) 757-3855	
STAMP:	
Know what's below. Call before you dig. PROJ NO: 03524 DWG NO: 03524-Dev-FR2	
GUMAN & ASSOCIATES, LLC 731 N. WEBER ST., SUITE 10 COLORADO SPRINGS, CO 80903	
GLENEAGLE SUBDIVISION FIL #2	
DRAINAGE, GRADING & EROSION CONTROL PLAN	
DRAWING NUMBER: C	
VR-18-018	SHEET 1

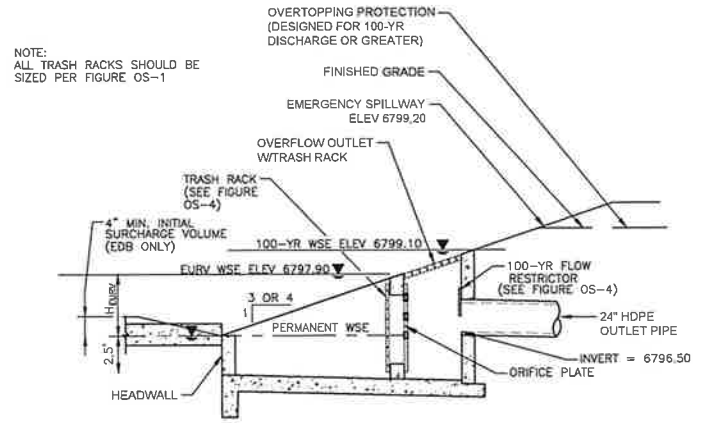
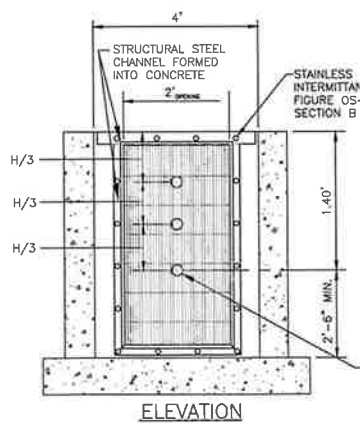
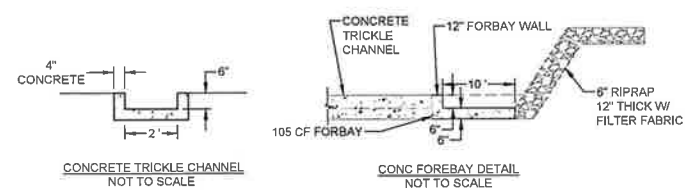

FIGURE OS-2 TYPICAL OUTLET STRUCTURE FOR FULL SPECTRUM DETENTION

OUTLET STRUCTURES DETAILS
NOT TO SCALE



ORIFICE PLATE NOTES:

1. PROVIDE CONTINUOUS NEOPRENE GASKET MATERIAL BETWEEN THE ORIFICE PLATE AND CONCRETE.
 2. BOLT PLATE TO CONCRETE 12" MAX. ON CENTER. SEE TABLE OS-2 FOR PLATE THICKNESS.
- EURV AND WQCV TRASH RACKS:
1. WELL-SCREEN TRASH RACKS SHALL BE STAINLESS STEEL AND SHALL BE ATTACHED BY INTERMITTENT WELDS ALONG THE EDGE OF THE MOUNTING FRAME.
 2. BAR GATE TRASH RACKS SHALL BE ALUMINUM AND SHALL BE BOLTED USING STAINLESS STEEL HARDWARE.
 3. TRASH RACK OPEN AREAS ARE FOR SPECIFIED TRASH RACK MATERIALS. TOTAL TRASH RACK SIZE MAY NEED TO BE ADJUSTED FOR MATERIALS HAVING DIFFERENT OPEN AREA/GROSS AREA RATIO R VALUE.
 4. STRUCTURAL DESIGN OF TRASH RACKS SHALL BE BASED ON FULL HYDROSTATIC HEAD WITH ZERO HEAD DOWNSTREAM OF THE RACK.
- OVERFLOW SAFETY GRATES:
1. ALL SAFETY GRATES SHALL BE MOUNTED USING STAINLESS STEEL HARDWARE AND PROVIDED WITH HINGED AND LOCKABLE OR BOLTABLE ACCESS PANELS.
 2. SAFETY GRATES SHALL BE STAINLESS STEEL, ALUMINUM, OR STEEL. STEEL GRATES SHALL BE HOT DIP GALVANIZED AND MAY BE HOT POWDER COATED AFTER GALVANIZING.
 3. SAFETY GRATES SHALL BE DESIGNED SUCH THAT THE DIAGONAL DIMENSION OF EACH OPENING IS SMALLER THAN THE DIAMETER OF THE OUTLET PIPE.
 4. STRUCTURAL DESIGN OF SAFETY GRATES SHALL BE BASED ON FULL HYDROSTATIC HEAD WITH ZERO HEAD DOWNSTREAM OF THE RACK.

FIGURE OS-4 ORIFICE PLATE AND TRASH RACK DETAILS AND NOTES

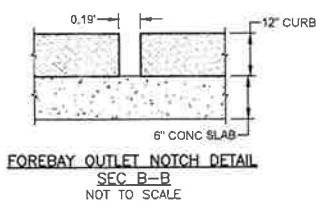
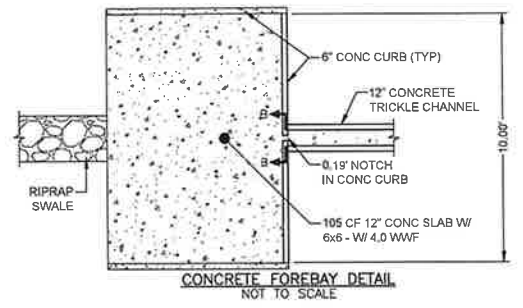
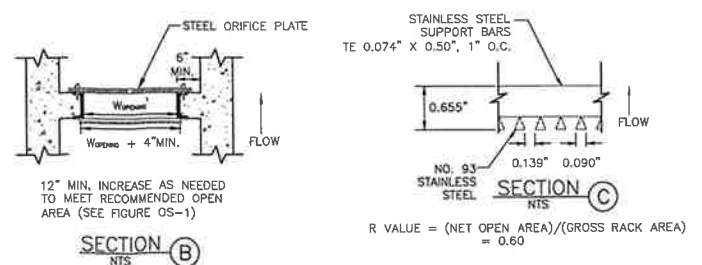
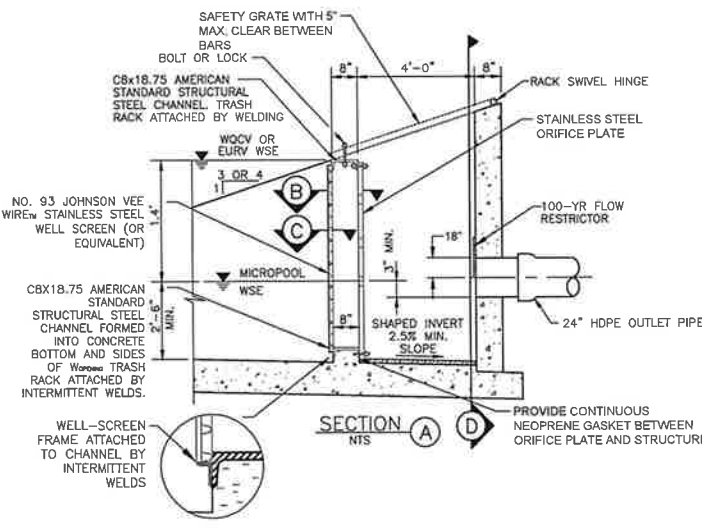
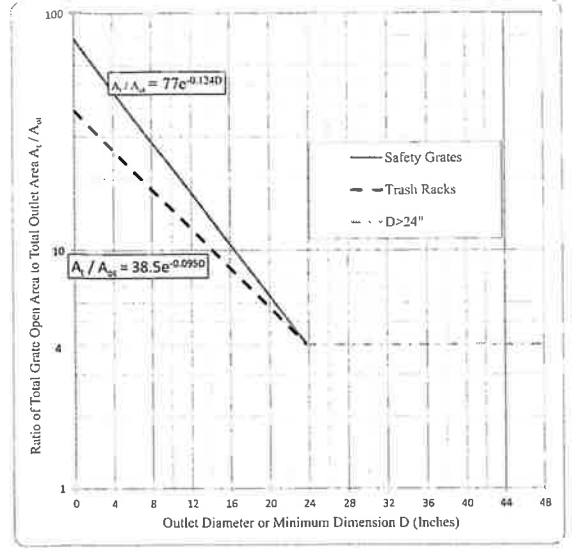
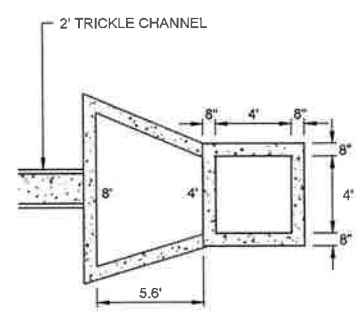
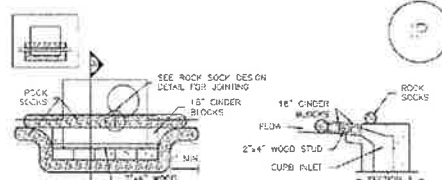

FIGURE OS-5 TYPICAL OUTLET STRUCTURE WITH WELL SCREEN TRASH RACK

1. ALL CONSTRUCTION AND MATERIALS SHALL BE IN ACCORDANCE WITH THE EL PASO COUNTY ENGINEERING SPECIFICATIONS.
 2. THE CONTRACTOR SHALL NOTIFY COLORADO STATE UTILITIES CENTRAL LOCATING (1-800-922-1987 AT LEAST 48 HOURS PRIOR TO ANY EXCAVATION SO THAT THEY MAY LOCATE THEIR FACILITIES. THE LOCATION OF FACILITIES SHOWN ON THE DRAWINGS IS FROM AVAILABLE RECORDS AND IS APPROXIMATE.
 3. ALL EXISTING UTILITY LOCATIONS SHOWN ON THE DRAWINGS REFLECT THE AVAILABLE INFORMATION AND DO NOT NECESSARILY INDICATE THE ACTUAL LOCATIONS. PRIOR TO ANY CONSTRUCTION THE CONTRACTOR SHALL VERIFY THE HORIZONTAL AND VERTICAL LOCATIONS OF ALL UTILITIES THAT MAY CONFLICT WITH OR OBSTRUCT THE NEW CONSTRUCTION, ANY REQUIRED RELOCATIONS THAT ARE NOT SPECIFICALLY SHOWN ON THE DRAWINGS SHALL BE COORDINATED WITH AND HAVE PRIOR APPROVAL OF EL PASO COUNTY UTILITIES.
 4. ALL DIMENSIONS ARE TO FACE OF CURB, EDGE OF ASPHALT & FLOWLINE OF PAN.
 5. ALL ELEVATIONS ARE TO TOP/ASPHALT & FLOWLINE/CURB UNLESS OTHERWISE NOTED.
- ALL STORM SEWER PIPE AND SANITARY SEWER PIPE LENGTHS AND SLOPES ARE SHOWN FROM CENTER OF STRUCTURE TO CENTER OF STRUCTURE

STANDARD NOTES FOR EL PASO COUNTY GRADING AND EROSION CONTROL PLANS

1. CONSTRUCTION MAY NOT COMMENCE UNTIL A CONSTRUCTION PERMIT IS OBTAINED FROM DEVELOPMENT SERVICES AND A PRE-CONSTRUCTION CONFERENCE IS HELD WITH PLANNING AND COMMUNITY DEVELOPMENT.
2. STORM-WATER DISCHARGES FROM CONSTRUCTION SITES SHALL NOT CAUSE OR THREATEN TO CAUSE POLLUTION, CONTAMINATION, OR DEGRADATION OF STATE WATERS. ALL WORK AND EARTH DISTURBANCE SHALL BE DONE IN A MANNER THAT MINIMIZES POLLUTION OF ANY ON-SITE OR OFF-SITE WATERS, INCLUDING WETLANDS.
3. NOTWITHSTANDING ANYTHING DEPICTED IN THESE PLANS IN WORDS OR GRAPHIC REPRESENTATION, ALL DESIGN AND CONSTRUCTION RELATED TO ROADS, STORM DRAINAGE AND EROSION CONTROL SHALL CONFORM TO THE STANDARDS AND REQUIREMENTS OF THE MOST RECENT VERSION OF THE RELEVANT ADOPTED EL PASO COUNTY STANDARDS, INCLUDING THE LAND DEVELOPMENT CODE, THE ENGINEERING CRITERIA MANUAL, THE DRAINAGE CRITERIA MANUAL, AND THE DRAINAGE CRITERIA MANUAL VOLUME 2. ANY DEVIATIONS TO REGULATIONS AND STANDARDS MUST BE REQUESTED, AND APPROVED, IN WRITING.
4. A SEPARATE STORM-WATER MANAGEMENT PLAN (SWMP) FOR THIS PROJECT SHALL BE COMPLETED AND AN EROSION AND STORM-WATER QUALITY CONTROL PERMIT (ESQCP) ISSUED PRIOR TO COMMENCING CONSTRUCTION. DURING CONSTRUCTION THE SWMP IS THE RESPONSIBILITY OF THE DESIGNATED STORM-WATER MANAGER, SHALL BE LOCATED ON SITE AT ALL TIMES AND SHALL BE KEPT UP TO DATE WITH WORK PROGRESS AND CHANGES IN THE FIELD. ONCE THE ESQCP HAS BEEN ISSUED, THE CONTRACTOR MAY INSTALL THE INITIAL STAGE EROSION AND SEDIMENT CONTROL BMPs AS INDICATED ON THE GEC. A PRE-CONSTRUCTION MEETING BETWEEN THE CONTRACTOR, ENGINEER, AND EL PASO COUNTY WILL BE HELD PRIOR TO ANY CONSTRUCTION. IT IS THE RESPONSIBILITY OF THE APPLICANT TO COORDINATE THE MEETING TIME AND PLACE WITH COUNTY PCD INSPECTIONS STAFF.
5. SOIL EROSION CONTROL MEASURES FOR ALL SLOPES, CHANNELS, DITCHES, OR ANY DISTURBED LAND AREA SHALL BE COMPLETED WITHIN 21 CALENDAR DAYS AFTER FINAL GRADING, OR FINAL EARTH DISTURBANCE HAS BEEN COMPLETED. DISTURBED AREAS AND STOCKPILES WHICH ARE NOT AT FINAL GRADE BUT WILL REMAIN DORMANT FOR LONGER THAN 30 DAYS SHALL ALSO BE MULCHED WITHIN 21 DAYS AFTER INTERIM GRADING. AN AREA THAT IS GOING TO REMAIN IN AN INTERIM STATE FOR MORE THAN 60 DAYS SHALL ALSO BE SEEDED. ALL TEMPORARY SOIL EROSION CONTROL MEASURES AND BMPs SHALL BE MAINTAINED UNTIL PERMANENT SOIL EROSION CONTROL MEASURES ARE IMPLEMENTED AND ESTABLISHED.
6. TEMPORARY SOIL EROSION CONTROL FACILITIES SHALL BE REMOVED AND EARTH DISTURBANCE AREAS GRADED AND STABILIZED WITH PERMANENT SOIL EROSION CONTROL MEASURES PURSUANT TO STANDARDS AND SPECIFICATION PRESCRIBED IN THE DCM VOLUME II AND THE ENGINEERING CRITERIA MANUAL (ECM) APPENDIX I.
7. ALL PERSONS ENGAGED IN EARTH DISTURBANCE SHALL IMPLEMENT AND MAINTAIN ACCEPTABLE SOIL EROSION AND SEDIMENT CONTROL MEASURES INCLUDING BMPs IN CONFORMANCE WITH THE EROSION CONTROL TECHNICAL STANDARDS OF THE DRAINAGE CRITERIA MANUAL (DCM) VOLUME II AND IN ACCORDANCE WITH THE STORM-WATER MANAGEMENT PLAN (SWMP).
8. ALL TEMPORARY EROSION CONTROL FACILITIES INCLUDING BMPs AND ALL PERMANENT FACILITIES INTENDED TO CONTROL EROSION OF ANY EARTH DISTURBANCE OPERATIONS, SHALL BE INSTALLED AS DEFINED IN THE APPROVED PLANS, THE SWMP AND THE DCM VOLUME II AND MAINTAINED THROUGHOUT THE DURATION OF THE EARTH DISTURBANCE OPERATION.
9. ANY EARTH DISTURBANCE SHALL BE CONDUCTED IN SUCH A MANNER SO AS TO EFFECTIVELY REDUCE ACCELERATED SOIL EROSION AND RESULTING SEDIMENTATION. ALL DISTURBANCES SHALL BE DESIGNED, CONSTRUCTED, AND COMPLETED SO THAT THE EXPOSED AREA OF ANY DISTURBED LAND SHALL BE LIMITED TO THE SHORTEST PRACTICAL PERIOD OF TIME.
10. ANY TEMPORARY OR PERMANENT FACILITY DESIGNED AND CONSTRUCTED FOR THE CONVEYANCE OF STORM-WATER AROUND, THROUGH, OR FROM THE EARTH DISTURBANCE AREA SHALL BE DESIGNED TO LIMIT THE DISCHARGE TO A NON-EROSIVE VELOCITY.
11. CONCRETE WASH WATER SHALL BE CONTAINED AND DISPOSED OF IN ACCORDANCE WITH THE SWMP. NO WASH WATER SHALL BE DISCHARGED TO OR ALLOWED TO RUNOFF TO STATE WATERS, INCLUDING ANY SURFACE OR SUBSURFACE STORM DRAINAGE SYSTEM OR FACILITIES.
12. EROSION CONTROL BLANKETING IS TO BE USED ON SLOPES STEEPER THAN 3:1.
13. BUILDING, CONSTRUCTION, EXCAVATION, OR OTHER WASTE MATERIALS SHALL NOT BE TEMPORARILY PLACED OR STORED IN THE STREET, ALLEY, OR OTHER PUBLIC WAY, UNLESS IN ACCORDANCE WITH AN APPROVED TRAFFIC CONTROL PLAN. BMPs MAY BE REQUIRED BY EL PASO COUNTY ENGINEERING IF DEEMED NECESSARY, BASED ON SPECIFIC CONDITIONS AND CIRCUMSTANCES.
14. VEHICLE TRACKING OF SOILS AND CONSTRUCTION DEBRIS OFF-SITE SHALL BE MINIMIZED. MATERIALS TRACKED OFF-SITE SHALL BE CLEANED UP AND PROPERLY DISPOSED OF IMMEDIATELY.
15. CONTRACTOR SHALL BE RESPONSIBLE FOR THE REMOVAL OF ALL WASTES FROM THE CONSTRUCTION SITE FOR DISPOSAL IN ACCORDANCE WITH LOCAL AND STATE REGULATORY REQUIREMENTS. NO CONSTRUCTION DEBRIS, TREE SLASH, BUILDING MATERIAL WASTES OR UNUSED BUILDING MATERIALS SHALL BE BURIED, DUMPED, OR DISCHARGED AT THE SITE.
16. THE OWNER, SITE DEVELOPER, CONTRACTOR, AND/OR THEIR AUTHORIZED AGENTS SHALL BE RESPONSIBLE FOR THE REMOVAL OF ALL CONSTRUCTION DEBRIS, DIRT, TRASH, ROCK, SEDIMENT, AND SAND THAT MAY ACCUMULATE IN THE STORM SEWER OR OTHER DRAINAGE CONVEYANCE SYSTEM AND STORM-WATER APPURTENANCES AS A RESULT OF SITE DEVELOPMENT.
17. THE QUANTITY OF MATERIALS STORED ON THE PROJECT SITE SHALL BE LIMITED, AS MUCH AS PRACTICAL, TO THAT QUANTITY REQUIRED TO PERFORM THE WORK IN AN ORDERLY SEQUENCE. ALL MATERIALS STORED ON-SITE SHALL BE STORED IN A NEAT, ORDERLY MANNER, IN THEIR ORIGINAL CONTAINERS, WITH ORIGINAL MANUFACTURER'S LABELS.
18. NO CHEMICALS ARE TO BE USED BY THE CONTRACTOR, WHICH HAVE THE POTENTIAL TO BE RELEASED IN STORM-WATER UNLESS PERMISSION FOR THE USE OF A SPECIFIC CHEMICAL IS GRANTED IN WRITING BY THE ECM ADMINISTRATOR. IN GRANTING THE USE OF SUCH CHEMICALS, SPECIAL CONDITIONS AND MONITORING MAY BE REQUIRED.
19. BULK STORAGE STRUCTURES FOR PETROLEUM PRODUCTS AND OTHER CHEMICALS SHALL HAVE ADEQUATE PROTECTION SO AS TO CONTAIN ALL SPILLS AND PREVENT ANY SPILLED MATERIAL FROM ENTERING STATE WATERS, INCLUDING ANY SURFACE OR SUBSURFACE STORM DRAINAGE SYSTEM OR FACILITIES.
20. NO PERSON SHALL CAUSE THE IMPEDIMENT OF STORM-WATER FLOW IN THE FLOW LINE OF THE CURB AND GUTTER OR IN THE DITCH-LINE.
21. INDIVIDUALS SHALL COMPLY WITH THE 'COLORADO WATER QUALITY CONTROL ACT' (TITLE 25, ARTICLE 8, CRS), AND THE 'CLEAN WATER ACT' (33 USC 1344), IN ADDITION TO THE REQUIREMENTS INCLUDED IN THE DCM VOLUME II AND THE ECM APPENDIX I. ALL APPROPRIATE PERMITS MUST BE OBTAINED BY THE CONTRACTOR PRIOR TO CONSTRUCTION (NPDES, FLOODPLAIN, 404, FUGITIVE DUST, ETC.). IN THE EVENT OF CONFLICTS BETWEEN THESE REQUIREMENTS AND LAWS, RULES, OR REGULATIONS OF OTHER FEDERAL, STATE, OR COUNTY AGENCIES, THE MORE RESTRICTIVE LAWS, RULES, OR REGULATIONS SHALL APPLY.
22. ALL CONSTRUCTION TRAFFIC MUST ENTER/EXIT THE SITE AT APPROVED CONSTRUCTION ACCESS POINTS.
23. PRIOR TO ACTUAL CONSTRUCTION THE PERMITEE SHALL VERIFY THE LOCATION OF EXISTING UTILITIES.
24. A WATER SOURCE SHALL BE AVAILABLE ON SITE DURING EARTHWORK OPERATIONS AND UTILIZED AS REQUIRED TO MINIMIZE DUST FROM EARTHWORK EQUIPMENT AND WIND.
25. THE SOILS REPORT FOR THIS SITE HAS BEEN PREPARED BY RMG INC AND SHALL BE CONSIDERED A PART OF THESE PLANS.
26. AT LEAST TEN DAYS PRIOR TO THE ANTICIPATED START OF CONSTRUCTION, FOR PROJECTS THAT WILL DISTURB 1 ACRE OR MORE, THE OWNER OR OPERATOR OF CONSTRUCTION ACTIVITY SHALL SUBMIT A PERMIT APPLICATION FOR STORM-WATER DISCHARGE TO THE COLORADO DEPARTMENT OF PUBLIC HEALTH AND ENVIRONMENT, WATER QUALITY DIVISION. THE APPLICATION CONTAINS CERTIFICATION OF COMPLETION OF A STORM-WATER MANAGEMENT PLAN (SWMP), OF WHICH THIS GRADING AND EROSION CONTROL PLAN MAY BE A PART. FOR INFORMATION OR APPLICATION MATERIALS CONTACT: COPHE, 4300 CHERRY CREEK DR. S., DENVER, CO 80246-1530, PH: 303-892-3500



IP-1. BLOCK AND ROCK SOCK SUMP OR ON GRADE INLET PROTECTION

- BLOCK AND ROCK SOCK SUMP INSTALLATION NOTES**
- SEE ROCK SOCK DESIGN DETAIL FOR INSTALLATION REQUIREMENTS.
 - CONCRETE "CONCRETE" BLOCKS SHALL BE Laid ON THEIR SIDES AROUND THE INLET IN A SINGLE ROW, ADJACENT ONE, WITH THE BACK END TACKED AWAY FROM THE CURB.
 - GRAVEL BAYS SHALL BE PLACED AROUND CONCRETE BLOCKS, CLOSELY ADJACENT ONE ANOTHER AND JOINED TOGETHER IN ACCORDANCE WITH ROCK SOCK DESIGN DETAIL.

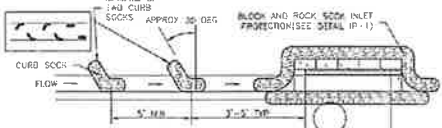

IP-2. CURB ROCK SOCKS UPSTREAM OF INLET PROTECTION

- CURB ROCK SOCK SUMP INSTALLATION NOTES**
- SEE ROCK SOCK DESIGN DETAIL, INSTALLATION REQUIREMENTS.
 - PLACEMENT OF THE SOCK SHALL BE APPROXIMATELY 30 DEGREES FROM PERPENDICULAR IN THE OPPOSITE DIRECTION OF FLOW.
 - SOCKS ARE TO BE FLUSH WITH THE CURB AND SPACED A MINIMUM OF 5 FEET APART.
 - AT LEAST TWO CURB SOCKS IN SERIES ARE REQUIRED UPSTREAM OF ON-GRADE GRATES.

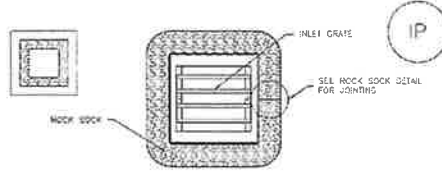

IP-3. ROCK SOCK SUMP/AREA INLET PROTECTION

- ROCK SOCK SUMP/AREA INLET PROTECTION NOTES**
- SEE ROCK SOCK DESIGN DETAIL FOR INSTALLATION REQUIREMENTS.
 - STRAW MATS/SEDIMENT CONTROL LOGS MAY BE USED IN PLACE OF ROCK SOCKS FOR INLETS IN PERVIOUS AREAS. INSTALL PER SEDIMENT CONTROL LOG DETAIL.

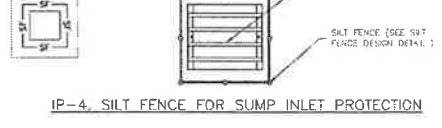

IP-4. SILT FENCE FOR SUMP INLET PROTECTION

- SILT FENCE SUMP INSTALLATION NOTES**
- SEE Silt FENCE DESIGN DETAIL FOR INSTALLATION REQUIREMENTS.
 - POINTS SHALL BE PLACED AT EACH CORNER OF THE INLET AND AROUND THE EDGES AT A MAXIMUM SPACING OF 3 FEET.
 - STRAW MATS/SEDIMENT CONTROL LOGS MAY BE USED IN PLACE OF SILT FENCE FOR INLETS IN PERVIOUS AREAS. INSTALL PER SEDIMENT CONTROL LOG DETAIL.

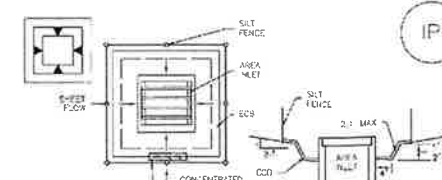

IP-5. OVEREXCAVATION INLET PROTECTION

- OVEREXCAVATION INLET PROTECTION NOTES**
- THIS FORM OF INLET PROTECTION IS PRIMARILY APPLICABLE FOR SITES THAT HAVE NOT YET REACHED FINAL GRADE AND SHOULD BE USED ONLY FOR INLETS WITH A RELATIVELY SMALL CONTRIBUTING DRAINAGE AREA.
 - WHEN USED FOR CONCENTRATED FLOWS, SHAPE BASIN IN 2:1 RATIO WITH LENGTH ORIENTED TOWARDS DIRECTION OF FLOW.
 - SEDIMENT MUST BE PERIODICALLY REMOVED FROM THE OVEREXCAVATED AREA.

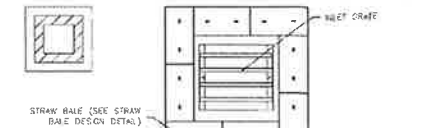

IP-6. STRAW BALE FOR SUMP INLET PROTECTION

- STRAW BALE SUMP INLET PROTECTION INSTALLATION NOTES**
- SEE STRAW BALE DESIGN DETAIL FOR INSTALLATION REQUIREMENTS.
 - BALES SHALL BE PLACED IN A SINGLE ROW AROUND THE INLET WITH ENDS OF BALES TIGHTLY ADJUTING ONE ANOTHER.

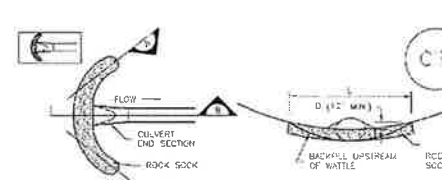

IP-7. CULVERT INLET PROTECTION

- CULVERT INLET PROTECTION INSTALLATION NOTES**
- SEE PLAN VIEW FOR: -LOCATION OF CULVERT INLET PROTECTION.
 - SEE ROCK SOCK DESIGN DETAIL FOR ROCK GRADATION REQUIREMENTS AND JOINTING DETAIL.

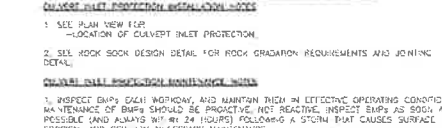

SBB-1. STRAW BALE

- STRAW BALE MAINTENANCE NOTES**
- INSPECT BMPs EACH WORKDAY, AND MAINTAIN THEM IN EFFECTIVE OPERATING CONDITION. MAINTENANCE OF BMPs SHOULD BE PROACTIVE, NOT REACTIVE. INSPECT BMPs AS SOON AS POSSIBLE (AND ALWAYS WITHIN 24 HOURS) FOLLOWING A STORM THAT CAUSES SURFACE EROSION, AND PERFORM NECESSARY MAINTENANCE.
 - FREQUENT OBSERVATIONS AND MAINTENANCE ARE NECESSARY TO MAINTAIN BMPs IN EFFECTIVE OPERATING CONDITION. INSPECTIONS AND CORRECTIVE MEASURES SHOULD BE DOCUMENTED THOROUGHLY.
 - WHERE BMPs HAVE FAILED, REPAIR OR REPLACEMENT SHOULD BE INITIATED UPON DISCOVERY OF THE FAILURE.
 - ROCK SOCKS SHALL BE REPLACED IF THEY BECOME HEAVILY SOILED, OR DAMAGED BEYOND REPAIR.
 - SEDIMENT ACCUMULATED UPSTREAM OF ROCK SOCKS SHALL BE REMOVED AS NEEDED TO MAINTAIN FUNCTIONALITY OF THE BMP. TYPICALLY WHEN DEPTH OF ACCUMULATED SEDIMENTS IS APPROXIMATELY 1/2 OF THE HEIGHT OF THE ROCK SOCK.
 - ROCK SOCKS ARE TO REMAIN IN PLACE UNTIL THE UPSTREAM DISTURBED AREA IS STABILIZED AND APPROVED BY THE LOCAL JURISDICTION.
 - WHEN ROCK SOCKS ARE REMOVED, ALL DISTURBED AREAS SHALL BE COVERED WITH TOPSOIL, SEED AND MULCHED OR OTHERWISE STABILIZED AS APPROVED BY LOCAL JURISDICTION.

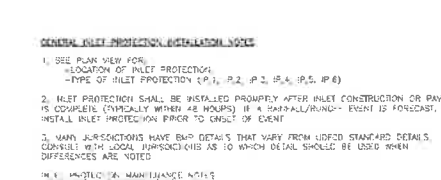

SBB-2. STRAW BALE

- STRAW BALE MAINTENANCE NOTES**
- INSPECT BMPs EACH WORKDAY, AND MAINTAIN THEM IN EFFECTIVE OPERATING CONDITION. MAINTENANCE OF BMPs SHOULD BE PROACTIVE, NOT REACTIVE. INSPECT BMPs AS SOON AS POSSIBLE (AND ALWAYS WITHIN 24 HOURS) FOLLOWING A STORM THAT CAUSES SURFACE EROSION, AND PERFORM NECESSARY MAINTENANCE.
 - FREQUENT OBSERVATIONS AND MAINTENANCE ARE NECESSARY TO MAINTAIN BMPs IN EFFECTIVE OPERATING CONDITION. INSPECTIONS AND CORRECTIVE MEASURES SHOULD BE DOCUMENTED THOROUGHLY.
 - WHERE BMPs HAVE FAILED, REPAIR OR REPLACEMENT SHOULD BE INITIATED UPON DISCOVERY OF THE FAILURE.
 - STRAW BALES SHALL BE REPLACED IF THEY BECOME HEAVILY SOILED, ROTTEN, OR DAMAGED BEYOND REPAIR.
 - SEDIMENT ACCUMULATED UPSTREAM OF STRAW BALE BARRIER SHALL BE REMOVED AS NEEDED TO MAINTAIN FUNCTIONALITY OF THE BMP. TYPICALLY WHEN DEPTH OF ACCUMULATED SEDIMENTS IS APPROXIMATELY 1/2 OF THE HEIGHT OF THE STRAW BALE BARRIER.
 - STRAW BALES ARE TO REMAIN IN PLACE UNTIL THE UPSTREAM DISTURBED AREA IS STABILIZED AND APPROVED BY THE LOCAL JURISDICTION.
 - WHEN STRAW BALES ARE REMOVED, ALL DISTURBED AREAS SHALL BE COVERED WITH TOPSOIL, SEED AND MULCHED OR OTHERWISE STABILIZED AS APPROVED BY LOCAL JURISDICTION.

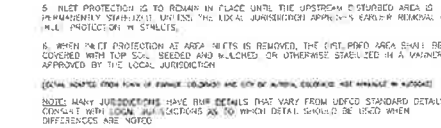

SBB-3. STRAW BALE

- STRAW BALE MAINTENANCE NOTES**
- INSPECT BMPs EACH WORKDAY, AND MAINTAIN THEM IN EFFECTIVE OPERATING CONDITION. MAINTENANCE OF BMPs SHOULD BE PROACTIVE, NOT REACTIVE. INSPECT BMPs AS SOON AS POSSIBLE (AND ALWAYS WITHIN 24 HOURS) FOLLOWING A STORM THAT CAUSES SURFACE EROSION, AND PERFORM NECESSARY MAINTENANCE.
 - FREQUENT OBSERVATIONS AND MAINTENANCE ARE NECESSARY TO MAINTAIN BMPs IN EFFECTIVE OPERATING CONDITION. INSPECTIONS AND CORRECTIVE MEASURES SHOULD BE DOCUMENTED THOROUGHLY.
 - WHERE BMPs HAVE FAILED, REPAIR OR REPLACEMENT SHOULD BE INITIATED UPON DISCOVERY OF THE FAILURE.
 - STRAW BALES SHALL BE REPLACED IF THEY BECOME HEAVILY SOILED, ROTTEN, OR DAMAGED BEYOND REPAIR.
 - SEDIMENT ACCUMULATED UPSTREAM OF STRAW BALE BARRIER SHALL BE REMOVED AS NEEDED TO MAINTAIN FUNCTIONALITY OF THE BMP. TYPICALLY WHEN DEPTH OF ACCUMULATED SEDIMENTS IS APPROXIMATELY 1/2 OF THE HEIGHT OF THE STRAW BALE BARRIER.
 - STRAW BALES ARE TO REMAIN IN PLACE UNTIL THE UPSTREAM DISTURBED AREA IS STABILIZED AND APPROVED BY THE LOCAL JURISDICTION.
 - WHEN STRAW BALES ARE REMOVED, ALL DISTURBED AREAS SHALL BE COVERED WITH TOPSOIL, SEED AND MULCHED OR OTHERWISE STABILIZED AS APPROVED BY LOCAL JURISDICTION.

GENERAL INLET PROTECTION INSTALLATION NOTES

- SEE PLAN VIEW FOR: -LOCATION OF INLET PROTECTION -TYPE OF INLET PROTECTION (P.1, P.2, P.3, P.4, P.5, P.6)
- INLET PROTECTION SHALL BE INSTALLED PROMPTLY AFTER CONSTRUCTION OR RAINING IS COMPLETE (TYPICALLY WITHIN 48 HOURS) IF A HAZARD/RUNOFF EVENT IS FORECAST. INSTALL INLET PROTECTION PRIOR TO ONSET OF EVENT.
- MANY JURISDICTIONS HAVE BMP DETAILS THAT VARY FROM UDFCD STANDARD DETAILS. CONSULT WITH LOCAL JURISDICTIONS AS TO WHICH DETAIL SHOULD BE USED WHEN DIFFERENCES ARE NOTED.
- INSTALLATION MAINTENANCE NOTES
- INSPECT BMPs EACH WORKDAY, AND MAINTAIN THEM IN EFFECTIVE OPERATING CONDITION. MAINTENANCE OF BMPs SHOULD BE PROACTIVE, NOT REACTIVE. INSPECT BMPs AS SOON AS POSSIBLE (AND ALWAYS WITHIN 24 HOURS) FOLLOWING A STORM THAT CAUSES SURFACE EROSION, AND PERFORM NECESSARY MAINTENANCE.
- FREQUENT OBSERVATIONS AND MAINTENANCE ARE NECESSARY TO MAINTAIN BMPs IN EFFECTIVE OPERATING CONDITION. INSPECTIONS AND CORRECTIVE MEASURES SHOULD BE DOCUMENTED THOROUGHLY.
- WHERE BMPs HAVE FAILED, REPAIR OR REPLACEMENT SHOULD BE INITIATED UPON DISCOVERY OF THE FAILURE.
- SEDIMENT ACCUMULATED UPSTREAM OF INLET PROTECTION SHALL BE REMOVED AS NECESSARY TO MAINTAIN BMP EFFECTIVENESS. TYPICALLY WHEN STORAGE VOLUME REACHES 50% OF CAPACITY, A DEPTH OF 6" WHEN SILT FENCE IS USED, OR 1/2 OF THE HEIGHT FOR STRAW BALES.
- INLET PROTECTION IS TO REMAIN IN PLACE UNTIL THE UPSTREAM DISTURBED AREA IS PERMANENTLY STABILIZED, UNLESS THE LOCAL JURISDICTION APPROVES EARLY REMOVAL OF INLET PROTECTION IN SITUATES.
- WHEN INLET PROTECTION AS AREA WEETS IS REMOVED, THE UPSTREAM AREA SHALL BE COVERED WITH TOP SOIL, SEEDS AND MULCHED OR OTHERWISE STABILIZED IN A MANNER APPROVED BY THE LOCAL JURISDICTION.

(DETAILS ADAPTED FROM TOWN OF PAVEN, COLORADO AND CITY OF ALPHEA, COLORADO. NOT AVAILABLE IN AUTOCAD)

NOTE: THE DETAILS INCLUDED WITH THIS FACT SHEET SHOW COMMONLY USED, CONVENTIONAL METHODS OF INLET PROTECTION IN THE DENVER METROPOLITAN AREA. THERE ARE MANY PROPRIETARY INLET PROTECTION METHODS ON THE MARKET. UDFCD NEITHER ENDORSES NOR DISAVOWS USE OF PROPRIETARY INLET PROTECTION. HOWEVER, IN THE EVENT PROPRIETARY METHODS ARE USED, THE APPROPRIATE DETAIL FROM THE MANUFACTURER MUST BE INCLUDED IN THE SWMP AND THE BMP MUST BE INSTALLED AND MAINTAINED AS SHOWN IN THE MANUFACTURER'S DETAILS.

NOTE: SOME MUNICIPALITIES SPECIFICALLY PROHIBIT THE USE OF STRAW BALES FOR INLET PROTECTION. CHECK WITH LOCAL JURISDICTION TO DETERMINE IF STRAW BALE INLET PROTECTION IS ACCEPTABLE.

NOTE: MANY JURISDICTIONS HAVE BMP DETAILS THAT VARY FROM UDFCD STANDARD DETAILS. CONSULT WITH LOCAL JURISDICTIONS AS TO WHICH DETAIL SHOULD BE USED WHEN DIFFERENCES ARE NOTED.

INLET PROTECTION - NOT TO SCALE

SC-5 Rock Sock (RS)

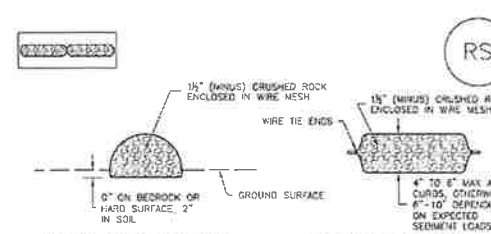

RS-1. ROCK SOCK PERIMETER CONTROL

- ROCK SOCK MAINTENANCE NOTES**
- INSPECT BMPs EACH WORKDAY, AND MAINTAIN THEM IN EFFECTIVE OPERATING CONDITION. MAINTENANCE OF BMPs SHOULD BE PROACTIVE, NOT REACTIVE. INSPECT BMPs AS SOON AS POSSIBLE (AND ALWAYS WITHIN 24 HOURS) FOLLOWING A STORM THAT CAUSES SURFACE EROSION, AND PERFORM NECESSARY MAINTENANCE.
 - FREQUENT OBSERVATIONS AND MAINTENANCE ARE NECESSARY TO MAINTAIN BMPs IN EFFECTIVE OPERATING CONDITION. INSPECTIONS AND CORRECTIVE MEASURES SHOULD BE DOCUMENTED THOROUGHLY.
 - WHERE BMPs HAVE FAILED, REPAIR OR REPLACEMENT SHOULD BE INITIATED UPON DISCOVERY OF THE FAILURE.
 - ROCK SOCKS SHALL BE REPLACED IF THEY BECOME HEAVILY SOILED, OR DAMAGED BEYOND REPAIR.
 - SEDIMENT ACCUMULATED UPSTREAM OF ROCK SOCKS SHALL BE REMOVED AS NEEDED TO MAINTAIN FUNCTIONALITY OF THE BMP. TYPICALLY WHEN DEPTH OF ACCUMULATED SEDIMENTS IS APPROXIMATELY 1/2 OF THE HEIGHT OF THE ROCK SOCK.
 - ROCK SOCKS ARE TO REMAIN IN PLACE UNTIL THE UPSTREAM DISTURBED AREA IS STABILIZED AND APPROVED BY THE LOCAL JURISDICTION.
 - WHEN ROCK SOCKS ARE REMOVED, ALL DISTURBED AREAS SHALL BE COVERED WITH TOPSOIL, SEED AND MULCHED OR OTHERWISE STABILIZED AS APPROVED BY LOCAL JURISDICTION.
- (DETAILS ADAPTED FROM TOWN OF PAVEN, COLORADO AND CITY OF ALPHEA, COLORADO. NOT AVAILABLE IN AUTOCAD)
- NOTE: MANY JURISDICTIONS HAVE BMP DETAILS THAT VARY FROM UDFCD STANDARD DETAILS. CONSULT WITH LOCAL JURISDICTIONS AS TO WHICH DETAIL SHOULD BE USED WHEN DIFFERENCES ARE NOTED.
- NOTE: THE DETAILS INCLUDED WITH THIS FACT SHEET SHOW COMMONLY USED, CONVENTIONAL METHODS OF ROCK SOCK INSTALLATION IN THE DENVER METROPOLITAN AREA. THERE ARE MANY OTHER SIMILAR PROPRIETARY PRODUCTS ON THE MARKET. UDFCD NEITHER ENDORSES NOR DISAVOWS USE OF PROPRIETARY PROTECTION PRODUCTS. HOWEVER, IN THE EVENT PROPRIETARY METHODS ARE USED, THE APPROPRIATE DETAIL FROM THE MANUFACTURER MUST BE INCLUDED IN THE SWMP AND THE BMP MUST BE INSTALLED AND MAINTAINED AS SHOWN IN THE MANUFACTURER'S DETAILS.
- | SOCK SIZE | MASS PERCENT PASSING SQUARE MESH SIZES | NO. 4 |
|-----------|--|----------|
| 2" | | 100 |
| 1 1/2" | | 90 - 100 |
| 1" | | 60 - 85 |
| 3/4" | | 0 - 15 |
| 3/8" | | 0 - 5 |
- MANHOLE SPECIFICATIONS FOR NO. 4 CORNER APPROPRIATE FOR CONCRETE PER MASHRO M43. ALL ROCK SHALL BE FRACTURED FACE, ALL SIDES.
- ROCK SOCK INSTALLATION NOTES**
- SEE PLAN VIEW FOR: -LOCATION(S) OF ROCK SOCKS
 - CRUSHED ROCK SHALL BE 1 1/2" (MINUS) IN SIZE WITH A FRACTURED FACE (ALL SIDES) AND SHALL COMPLY WITH GRADATION SHOWN ON THIS SHEET (1 1/2" MINUS)
 - WIRE MESH SHALL BE FABRICATED OF 10 GAUGE PDIULRY MESH, OR EQUIVALENT, WITH A MAXIMUM OPENING OF 1/2", RECOMMENDED MINIMUM ROLL WIDTH OF 18"
 - WIRE MESH SHALL BE SECURED USING "100 RINGS" OR WIRE TIES AT 6" CENTERS ALONG ALL JOINTS AND AT 2" CENTERS ON ENDS OF SOCKS.
 - SOME MUNICIPALITIES MAY ALLOW THE USE OF FILTER FABRIC AS AN ALTERNATIVE TO WIRE MESH FOR THE ROCK ENCLOSURE.

SC-3 Straw Bale Barrier (SBB)

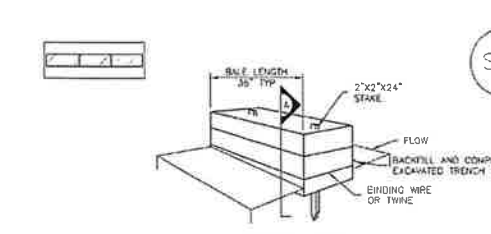

SBB-1. STRAW BALE

- STRAW BALE MAINTENANCE NOTES**
- INSPECT BMPs EACH WORKDAY, AND MAINTAIN THEM IN EFFECTIVE OPERATING CONDITION. MAINTENANCE OF BMPs SHOULD BE PROACTIVE, NOT REACTIVE. INSPECT BMPs AS SOON AS POSSIBLE (AND ALWAYS WITHIN 24 HOURS) FOLLOWING A STORM THAT CAUSES SURFACE EROSION, AND PERFORM NECESSARY MAINTENANCE.
 - FREQUENT OBSERVATIONS AND MAINTENANCE ARE NECESSARY TO MAINTAIN BMPs IN EFFECTIVE OPERATING CONDITION. INSPECTIONS AND CORRECTIVE MEASURES SHOULD BE DOCUMENTED THOROUGHLY.
 - WHERE BMPs HAVE FAILED, REPAIR OR REPLACEMENT SHOULD BE INITIATED UPON DISCOVERY OF THE FAILURE.
 - STRAW BALES SHALL BE REPLACED IF THEY BECOME HEAVILY SOILED, ROTTEN, OR DAMAGED BEYOND REPAIR.
 - SEDIMENT ACCUMULATED UPSTREAM OF STRAW BALE BARRIER SHALL BE REMOVED AS NEEDED TO MAINTAIN FUNCTIONALITY OF THE BMP. TYPICALLY WHEN DEPTH OF ACCUMULATED SEDIMENTS IS APPROXIMATELY 1/2 OF THE HEIGHT OF THE STRAW BALE BARRIER.
 - STRAW BALES ARE TO REMAIN IN PLACE UNTIL THE UPSTREAM DISTURBED AREA IS STABILIZED AND APPROVED BY THE LOCAL JURISDICTION.
 - WHEN STRAW BALES ARE REMOVED, ALL DISTURBED AREAS SHALL BE COVERED WITH TOPSOIL, SEED AND MULCHED OR OTHERWISE STABILIZED AS APPROVED BY LOCAL JURISDICTION.
- (DETAILS ADAPTED FROM TOWN OF PAVEN, COLORADO. NOT AVAILABLE IN AUTOCAD)
- NOTE: MANY JURISDICTIONS HAVE BMP DETAILS THAT VARY FROM UDFCD STANDARD DETAILS. CONSULT WITH LOCAL JURISDICTIONS AS TO WHICH DETAIL SHOULD BE USED WHEN DIFFERENCES ARE NOTED.

DESIGNED: MAB
DRAWN: HIG
CHECKED: MAB
DATE: 2/19/2019

REVISION

RESCOR COLORADO BLVD
730 S. SUITE 410
DENVER, CO 80246
PHONE (303) 757-9855

STAMP

811
Know what's below.
Call before you dig.

PROJ NO. 03524
DWG NM. 03524-Dev-FI2

GUMAN & ASSOCIATES, LLC
731 N. WEBER ST., SUITE 10
COLORADO SPRINGS, CO 80903

GLENEAGLE
SUBDIVISION #2

DRAINAGE, GRADING &
EROSION DETAILS

DRAWING NUMBER:
C
SHEET 4

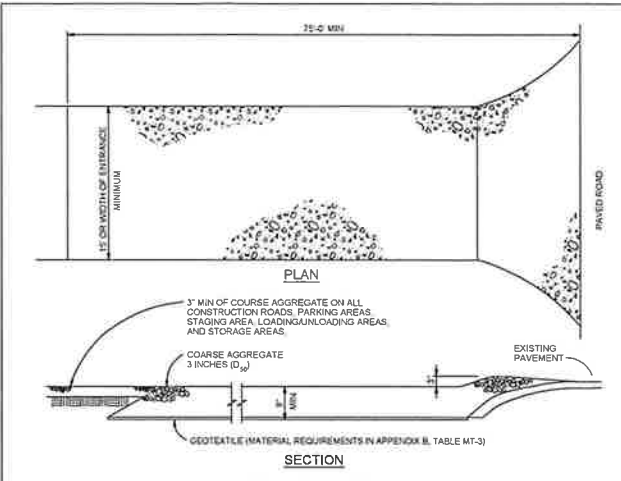

VEHICLE TRACKING NOTES

INSTALLATION REQUIREMENTS

1. ALL ENTRANCES TO THE CONSTRUCTION SITE ARE TO BE STABILIZED PRIOR TO CONSTRUCTION BEGINNING.
2. CONSTRUCTION ENTRANCES ARE TO BE BUILT WITH AN APRON TO ALLOW FOR TURNING TRAFFIC, BUT SHOULD NOT BE BUILT OVER EXISTING PAVEMENT EXCEPT FOR A SLIGHT OVERLAP.
3. AREAS TO BE STABILIZED ARE TO BE PROPERLY GRADED AND COMPACTED PRIOR TO LAYING DOWN GEOTEXTILE AND STONE.
4. CONSTRUCTION ROADS, PARKING AREAS, LOADING/UNLOADING ZONES, STORAGE AREAS, AND STAGING AREAS ARE TO BE STABILIZED.
5. CONSTRUCTION ROADS ARE TO BE BUILT TO CONFORM TO SITE GRADES, BUT SHOULD NOT HAVE SIDE SLOPES OR ROAD GRADES THAT ARE EXCESSIVELY STEEP.

MAINTENANCE REQUIREMENTS

1. REGULAR INSPECTIONS ARE TO BE MADE OF ALL STABILIZED AREAS, ESPECIALLY AFTER STORM EVENTS.
2. STONES ARE TO BE REAPPLIED PERIODICALLY AND WHEN REPAIR IS NECESSARY.
3. SEDIMENT TRACKED ONTO PAVED ROADS IS TO BE REMOVED DAILY BY SHOVELING OR SWEEPING. SEDIMENT IS NOT TO BE WASHED DOWN STORM SEWER DRAINS.
4. STORM SEWER INLET PROTECTION IS TO BE IN PLACE, INSPECTED, AND CLEANED IF NECESSARY.
5. OTHER ASSOCIATED SEDIMENT CONTROL MEASURES ARE TO BE INSPECTED TO ENSURE GOOD WORKING CONDITION.

City of Colorado Springs Stormwater Quality

Figure VT-2 Vehicle Tracking Application Examples

GENERAL NOTES

1. Do not prepare or seed frozen soils.
2. Do not seed when wind exceeds 5 mph.
3. Perform seeding only after preceding work affecting ground surface is completed.
4. Do not mulch over seeded areas when wind exceeds 15 mph.
5. Seed all disturbed areas.
6. Seed to be a blend of native prairie grasses.
7. Watering shall be provided in the form of watering trucks and spray bars.

MULCH MATERIALS

1. HAY OR STRAY MULCH
 - A) Chopped of oats, wheat or rye grass hay.
 - B) Free from noxious weed seeds.
 - C) Rotted, brittle or moldy hay is not acceptable.
 - D) 50% by weight greater than 10" inch length.
2. FIBER
 - A) Short wood fiber.
 - B) "Conwed", "Silver Fiber" or equivalent.

BED PREPARATION

1. Prepare to a minimum depth of 4" with disc hoes or chiseling tools.
2. Uproot all competitive vegetation.
3. Work soil uniformly to a smooth surface free of clods, stones over 2" in any dimension or any material which will interfere seeding equipment.
4. Till across slopes.
5. Do not till when soil moisture is unsuitable.
 - A) Soil texture after tillage shall be uniform, free of wet compressed or dry lumps.
6. Do not prepare seed bed more than twenty four hours in advance of seeding.
7. Fertilize at a rate of fifty (2) lbs. nitrogen per 1,000 sf.
 - A) Till fertilizer into soil a minimum of two (2) inches.

Species		lbs/acre drilled
Western Wheat Grass	<i>Paspalum smithii</i>	3.0
Stleals Grama	<i>Bouteloua curtipendula</i>	2.0
Slender Wheat Grass	<i>Schizachyrium scoparium</i>	2.0
Little Bluestem	<i>Bouteloua gracilis</i>	0.5
Switch Grass	<i>Panicum virgatum</i>	2.0
Sand Dropseed	<i>Sporobolus cryptandrus</i>	

EROSION CONTROL PLAN NOTES

1. All disturbed areas are to be reseeded.
2. Schedule of Grading - approximate time frame of one month to complete grading and installation of erosion control measures.
3. Temporary Sediment Barriers shall be kept in place and maintained until the vegetation has been reestablished. Removal of sediment is required once it reaches half the height of the sediment control log.

DESIGNED		DRAWN		CHECKED		DATE	
MAB	HIG	MAB	MAB				2/18/2019
RESPEC 720 S COLORADO BLVD SUITE 4105 DENVER, CO 80246 PHONE (303) 757-3655							

STAMP

PROJ. NO. 03524
DWG. NO. 03524-Dev-Fil2

GUMAN & ASSOCIATES, LLC
731 N. WEBER ST., SUITE 10
COLORADO SPRINGS, CO 80903

GLENEAGLE
SUBDIVISION FIL #2

DRAINAGE, GRADING &
EROSION DETAILS

DRAWING NUMBER:
C
SHEET 5

NAME: J. CO. SPRINGS OFFICE: 1425 S. W. 14th ST. COLORADO SPRINGS, CO 80905
 FILE: DATE: 03/21/2019 10:41:41 AM BY: C. R. B. ME. CS