

STORMWATER MANAGEMENT PLAN (SWMP)

For Colorado Construction Activities
at:

Fox Run Substation

Item 1. Add Qualified Stormwater Manager and Contractor Information to cover/title sheet. If unknown, add a placeholder to be updated prior to the pre-construction meeting:

QUALIFIED STORMWATER MANAGER

Name: _____

Company: _____

Address: _____

CONTRACTOR

Name: _____

Company: _____

Address: _____

Prepared for:



TRI-STATE G&T

A Touchstone Energy®
Cooperative 

**1100 W. 116TH AVENUE
WESTMINSTER, COLORADO 80234**

PCD Project Number: PPR-22-044

Prepared by:



DEL-MONT CONSULTANTS, INC.
ENGINEERING ▼ SURVEYING

125 Colorado Ave. ▼ Montrose, CO 81401 ▼ (970) 249-2251 ▼ (970) 249-2342 FAX
www.del-mont.com ▼ service@del-mont.com

DMC # 21036

Table of Contents:

1.0 INTRODUCTION..... 1

1.1 The National Pollutant Discharge Elimination System (NPDES) Process and Construction Stormwater Management Plan (SWMP) 1

1.2 Project Owner/Operator and Key Personnel..... 2

2.0 CONSTRUCTION ACTIVITY AND SITE DESCRIPTION 5

2.1 Project Location..... 5

2.2 Nature and Description of Construction Activities..... 5

2.3 Proposed Sequence of Activities..... 5

2.4 Estimation of the Total Area of Disturbance 5

2.5 Existing Soil Conditions 5

2.6 Existing Vegetation and Runoff Characteristics 6

2.7 Potential Pollutants 6

2.8 Allowable Sources of Non-Stormwater Discharges 8

2.9 Receiving Waters..... 8

2.10 Site Map..... 8

3.0 CONTROL MEASURES 9

3.1 Structural Measures for Erosion and Sediment Control..... 9

3.2 Non-Structural CMs for Erosion and Sediment Control 13

3.3 Phased CM Installation 17

3.4 Dedicated Concrete or Asphalt Batch Plants 17

3.5 Vehicle Tracking Control 17

3.6 Waste Management and Disposal (Including Concrete Washouts)..... 18

3.7 Product Specific Practices 18

3.8 Groundwater and Stormwater Dewatering..... 19

4.0 FINAL STABILIZATION AND LONG-TERM STORMWATER MANAGEMENT 20

4.1 Temporary Stabilization 20

4.2 Description of Final Stabilization Practices 20

4.3 Final Stabilization Methods 20

4.4 Final Stabilization Achievement..... 20

5.0 INSPECTION AND MAINTENANCE 22

5.1 Minimum Inspection Schedule 22

5.1.1 Post-storm inspections..... 22

5.1.2 Inspections at Completed Sites/Areas 22

5.1.3 Winter Conditions Inspections Exclusion..... 23

5.2 Inspection Requirements..... 23

5.2.1 Inspection Scope..... 23

5.2.2 Inspection Reports..... 23

5.3 Required Actions Following Site Inspections..... 24

5.4 CM Maintenance 24

5.5 Corrective Actions..... 25

- 5.6 SWMP Requirements..... 25
 - 5.6.1 SWMP Availability 25
 - 5.6.2 SWMP Retention..... 25
 - 5.6.3 SWMP Amendment 26
 - 5.6.4 Responsive SWMP Changes..... 26
- 5.7 RECORD KEEPING 27
- 6.0 SPILL PREVENTION AND RESPONSE 28
 - 6.1 Introduction 28
 - 6.2 Material Management Practices 28
 - 6.2.1 Good Housekeeping 28
 - 6.3 Product-Specific Practices 29
 - 6.3.1 Flammable and Combustible Liquids and Hazardous Materials 29
 - 6.3.2 Petroleum Products 29
 - 6.4 Spill Control and Cleanup..... 30
 - 6.5 Spill Reporting 30
 - 6.6 SWMP Modification Procedures Related to Reportable Releases..... 31

- APPENDIX A: Site Maps
- APPENDIX B: Soil Erosion and Sediment Control (CMs) Details
- APPENDIX C: Phased CM Implementation
- APPENDIX D: Inspection Forms
- APPENDIX E: Spill Report Form
- APPENDIX F: Permit Application and Permit
- APPENDIX G: NRCS Soils Report

1.0 INTRODUCTION

1.1 The National Pollutant Discharge Elimination System (NPDES) Process and Construction Stormwater Management Plan (SWMP)

This document establishes a plan to manage the quality of stormwater runoff from construction activities associated with the Fox Run Substation, El Paso County, CO. This project will disturb at least 1 acre or is part of a larger common plan of development, which will disturb more than 1 acre. For construction projects that require the disturbance of more than 1 acre, the U.S. Environmental Protection Agency (USEPA) requires that the project owner or contractor apply for a stormwater permit under the NPDES program. For the purposes of the NPDES program, construction activities are defined as clearing, grubbing, excavating, grading, import and placement of road material, improvements to existing or new drainage, installation of permanent drainage structures, installing landscaping improvements, paving (asphalt or concrete), construction of permanent structures, or any similar activity that causes native / undisturbed areas to be disturbed.

This NPDES permit program is administered in Colorado by the Colorado Department of Public Health and Environment (CDPHE), Water Quality Control Division (Division) under the Colorado Discharge Permit System (CDPS). CDPHE has a general permit for stormwater discharges from construction activities. The Construction Stormwater Permit (COR400000) was renewed and issued on October 31, 2018, and effective on April 2, 2019.

This document, including its attachments and appendices comprises the Stormwater Management Plan (SWMP) required by CDPHE's general permit for Stormwater Discharges from Construction Activities. This plan was written in accordance with the guidelines in the Division's Construction Guidance Document: "COR400000 Stormwater Management Plan Guidance". Reference material was used from the Urban Drainage and Flood Control District's Urban Storm Drainage Criteria Manual (V. 3) (updated 11/2010), the EPA "Developing Your Stormwater Pollution Prevention Plan, A Guide for Construction Sites" (May 2007), and the Colorado Department of Transportation (C.D.O.T.) Drainage Design Manual.

A permit application for Stormwater Discharges Associated with Construction Activity must be submitted to CDPHE at least 10 days prior to the start of construction, and the applicant must receive written notification that the Division granted permit coverage prior to conducting construction activities. The plan and permit will be available on-site while construction activities are taking place.

The USEPA and the State of Colorado have substantial penalties for non-compliance with the permit. Any permit non-compliance constitutes a violation of the Clean Water Act and is grounds for enforcement action including: permit termination; revocation, reissuance, or modifications; or denial of permit renewal application. Individuals responsible for such violations are subject to criminal, civil and administrative penalties.

The Construction Stormwater Permit only authorizes the discharges of the stormwater and those non-stormwater sources listed in Part 1.A.1. of the Construction Stormwater Permit. The permit does not cover discharges currently covered under an individual permit or a Division Low Risk Discharge Guidance developed in accordance with the Low Risk Discharge Policy (WQCD Policy 27).

1.2 Project Owner/Operator and Key Personnel

Owner/Operator:

Tri-State Generation and Transmission Association
1100 W. 116th Ave
Westminster, CO 80234

Contact for Owner/Operator:

Zach Sutton
Tri-State Generation and Transmission Association
1100 W. 116th Ave
Westminster, CO 80234
(303) 254-3833
zsutton@tristategt.org

The owner is the party that has overall control of the activities and that has funded the implementation of the construction plans and specifications. This is the party with ownership of, a long term lease of, or easements on the property on which the construction activity is occurring. The operator is the party that has operational control over day-to-day activities at the project site which are necessary to ensure compliance with the permit. This party is authorized to direct individuals at a site to carry out activities required by the permit. Tri-State owns/leases the Fox Run Substation property and has operational control over the activities at the project site.

SWMP Administrator/Qualified Stormwater Manager (QSM):

Zach Sutton
Tri-State Generation and Transmission Association
1100 W. 116th Ave
Westminster, CO 80234
(303) 254-3833
zsutton@tristategt.org

Qualified Stormwater Manager:

An individual knowledgeable in the principles and practices of erosion and sediment control and pollution prevention, and with the skills to assess conditions at construction sites that could impact stormwater quality and to assess the effectiveness of stormwater controls implemented to meet the requirements of this permit. Tri-State's Stormwater Administrator, Developer, and Inspector are all identified as Qualified Stormwater Managers (QSM).

The SWMP Administrator is responsible for developing, implementing, maintaining, and revising the SWMP. This individual serves as the comprehensive point of contact for all aspects of this SWMP.

SWMP Administrator/QSM Signature: _____

Name: _____

Title: _____

Date: _____

SWMP Developer/QSM:

David Schieldt, P.E.
Del-Mont Consultants, Inc.
125 Colorado Ave.
Montrose, CO 81401
dschieldt@del-mont.com
(970) 249-2251

The SWMP Developer is responsible for developing the SWMP in accordance with the requirements of the General Permit. Critically important in developing the SWMP is to identify all potential sources of pollution which may reasonably be expected to affect the quality of stormwater discharges associated with construction activity, to describe the practices to be used to reduce these pollutants, and to ensure that pollution prevention practices are based on good engineering practices (includes installation, implementation and maintenance requirements). The SWMP Developer is also available to adjust or update the plan as needed during construction, to make field visits and provide recommendations on appropriate Control Measures (CMs) for specific areas of concern or to determine if final stabilization has been achieved, and can help with administration of the plan or with Inactivation, Transfer, or Reassignment of the Permit.

SWMP Developer/QSM Signature: _____

SWMP Inspector/QSM Signature: _____

Name: _____

Title: _____

Date: _____

The SWMP Inspector is responsible for conducting and documenting required site inspections in accordance with the Permit. The SWMP Inspector must notify the Construction Contractor and the SWMP Administrator immediately if any additional or different CMs are required on the site, if

any CMs require maintenance, or if any CM has failed. During construction, the SWMP Inspector will assist the Construction Contractor with implementing and maintaining stormwater controls at the site and the SWMP Administrator with revising the SWMP as needed.

Construction Contractor:

Name: _____
Company: _____
Address: _____
Email: _____
Phone: _____

The Construction Contractor is responsible for installing and maintaining CMs as defined in the SWMP and is responsible for notifying the SWMP Administrator immediately if any CMs fail, require maintenance, or if additional CMs are required. The Construction Contractor will work closely with both the SWMP Inspector and the SWMP Administrator throughout the duration of the project.

2.0 CONSTRUCTION ACTIVITY AND SITE DESCRIPTION

2.1 Project Location

The proposed project includes a new Substation. The proposed substation yard is located on a 14.92-acre parcel owned by TSGT, situated in the NW ¼ of Section 21, Township 11 South, Range 66 West, 6th Principal Meridian in El Paso County, Colorado. The substation site is accessed from Sharhara Road.

2.2 Nature and Description of Construction Activities

The scope of this project is to build a new high voltage substation. The construction will include clearing/grubbing substation pad area, retaining wall installation, yard construction, grading drainage swales and detention pond, and installation of high voltage electrical equipment.

2.3 Proposed Sequence of Activities

Construction Task	Planned Start Month/Year
Install initial CMs	June 2023
Construct Substation	Summer 2023
Remove CMs no longer required	Fall 2023
Reclaim and stabilize all disturbed areas	Fall 2023
Remove all temporary CMs	Fall 2023
Site stabilization	Fall 2023
Close Construction Stormwater Permit	Fall 2023

2.4 Estimation of the Total Area of Disturbance

The total area of the site is 14.92 acres. The estimated area of the site to be disturbed by all construction-related activities is approximately 7 acres.

2.5 Existing Soil Conditions

Consistent with other similar sites in the El Paso County area, the Fox Run Substation site has the sandy soil with varying amounts of gravel, silt, and clay. A NRCS Soils Report (see Appendix G) confirms this typical soil and was used to develop and apply appropriate CMs. Engineering judgment and construction experience with local drainage patterns were relied on to develop appropriate CMs to prevent soil erosion and migration.

Item 8. Include soil erosion potential and impacts on discharge

2.6 Existing Vegetation and Runoff Characteristics

The site naturally drains to the northeast. The natural vegetation consists of native grasses and weeds. The site is estimated to have 30-60% ground cover prior to construction. The percent density was determined by examining a representative 10'x10' square and determining the plant density within the area. At final stabilization, ground cover should be greater than 70% of the pre-construction cover, 0.70 x 0.30-0.60, or approximately 20-40% vegetation coverage.

2.7 Potential Pollutants

The following chart identifies the potential pollutants that need to be addressed per the CDPS General Permit and their applicability to this project.

Potential Pollutant Source/Activity	Potential Pollutant	Potential with this Project?	Description of Activities	CMs Selected to Control Source
All disturbed and stored soils	Sediment	X	Construction of access road	Controlled Parking Controlled Site Entrance Designated Staging Area Detention Basins Drainage Swales/Check Dams Dust Control Good Housekeeping Practices Inlet Protection Natural Vegetative Barrier Seeding Silt Fence Straw Bales Straw Wattles (fiber rolls) Surface Roughening Vehicle Tracking Control
Vehicle Tracking of Sediments	Sediment	X	Delivery of construction materials; installation of sub-base materials; clearing and grubbing; daily construction traffic; construction of new access roads, excavation and removal of excess materials	Controlled Site Entrance Controlled Parking Designated Staging Area Dust Control Vehicle Tracking Control

Potential Pollutant Source/Activity	Potential Pollutant	Potential with this Project?	Description of Activities	CMs Selected to Control Source
Management of Contaminated soils	Fuel spill, runoff from contaminated area	X	On-Site vehicle maintenance & refueling	Spill Prevention Plan
Loading & Unloading Operations	Sediment, runoff from contaminated area	X	Equipment/material drop off and pick up; portable sanitary delivery & routine cleaning	Controlled Site Entrance Designated Staging Area
Outdoor storage activities	Sediment, Fuel spill, runoff from contaminated area	X	Construction material storage on-site for the duration of project	Controlled Site Entrance Designated Staging Area Spill Prevention Plan
Vehicle & equipment maintenance and refueling	Fuel spill, runoff from contaminated area	X	Vehicles & equipment which will remain at the site until work is completed will be maintained and refueled on site; fuels will not be stored on site	Controlled Parking Designated Vehicle Fueling and Maintenance Area Spill Prevention Plan
Significant dust or particulate generating processes	Dust	X	Construction of new pad area, grading pad, installation of structures	Dust Control
Routine Maintenance activities involving fertilizers, pesticides, detergents, etc.	Nitrogen, phosphorous		None	Project does not require use of these materials.
On site waste management practices	Debris, trash	X	Construction debris; portable sanitary facilities; personal trash	Designated Staging Area Solid Waste Management
Concrete truck & equipment washing	Concrete waste, concrete wash water		Equipment foundations	Concrete Washout(s)
Dedicated asphalt or concrete batch plants	Waste products, runoff from contaminated areas		None	Project will not require use of dedicated asphalt or concrete batch plants.
Non-industrial waste sources	Bacteria, parasites, viruses	X	Portable sanitary facilities; Personal trash and construction debris	Designated Staging Area Solid Waste Management

Potential Pollutant Source/Activity	Potential Pollutant	Potential with this Project?	Description of Activities	CMs Selected to Control Source
Other areas where spills could potentially occur	Runoff from contaminated areas		None	No other potential sources of pollutant were identified.
Irrigation Return Flows	Erosion/sediment from construction activities		None	No irrigation return flows expected on this project

2.8 Allowable Sources of Non-Stormwater Discharges

Irrigation return flows are not anticipated on this site. When construction activity involving concrete is required, a concrete washout will be installed in a designated area. No other allowable sources of discharge exist on the site.

2.9 Receiving Waters

Receiving waters include any classified or unclassified surface water segment (including tributaries) in the State of Colorado into which stormwater associated with construction activities discharges. This includes all water courses, even if they are usually dry, such as borrow ditches, arroyos, and other unnamed waterways. Runoff from the project site flows northeast, flowing overland through various drainages ultimately running to West Cherry Creek. Runoff from the substation will flow to the on-site detention pond to provide water quality treatment prior to discharge following historical drainage patterns. **There are no stream crossings** located within the construction site. There are no discharges to Outstanding Waters.

2.10 Site Map

The site map (see Appendix A) will show the following per the CDPS Permit:

- Construction site boundaries
- Flow arrows that depict stormwater flow directions on-site and runoff direction
- Entrances and exits (if applicable)
- All areas of ground disturbance including areas of cut and fill
- Areas used for vehicle parking, storage of building materials, equipment, soil or waste
- Locations of concrete washouts
- Locations of all structural CMs (including existing CMs)
- Locations of all non-structural CMs (including areas that will be subject to re-seeding)
- Locations of springs, streams, wetlands, and other surface waters (including areas that require pre-existing vegetation be maintained within 50 feet of a receiving water)
- Locations of all stream crossings located within the construction site boundary
 - Any other factors that are important to the site and/or the SWMP

3.0 CONTROL MEASURES

3.1 Structural Measures for Erosion and Sediment Control

Structural measures are those physical structures implemented at the site to minimize erosion and sediment transport. The CMs specified for use on the project are described below. Specific locations for CM implementation at the site are indicated on the site map in Appendix A. The installation details for these CMs are provided in Appendix B. This SWMP anticipates that not all of these CMs are going to be used and additional CMs may be added as site conditions change or climatic conditions warrant. If additional CMs are added, description and construction details will be added to Appendix B or to a revision of the Site Map prior to installation.

Concrete Washout

A concrete washout is used to capture waste water and waste products resulting from the cleaning of concrete equipment. The wash water is alkaline and can contaminate groundwater, increase the pH of receiving waters, clog storm drains, and harm wildlife. Examples of concrete washouts include, but is not limited to, a bermed excavation, a mobile disposal unit, small excavations located near the point of concrete placement, water tight vessels (such as a rigid pre-fabricated impermeable plastic wading pool, stock tanks, small dumpsters, buckets, etc.), and geotextile bags.

Control measures designed for concrete washout waste shall be implemented at the project site, and Tri-State will ensure that washing activities do not contribute pollutants to stormwater runoff or receiving waters. Discharges that may reach groundwater will flow through soil that has a buffering capacity prior to reaching groundwater. The concrete washout area shall not be located in an area where shallow groundwater may be present and would result in the soil buffering capacity not being adequate. Hardened concrete wastes on the ground will be picked up daily and disposed of properly

Concrete pours will be scheduled so that no pours occur when a storm event is anticipated. No concrete pours will be conducted during storm events. A concrete washout will not be necessary if all washout operations are performed off-site (at the vendor mixing plant for example).

Concrete washout will only be allowed in the designated area. For project phases with large amounts of concrete work, concrete washout will be conducted at a dedicated concrete washout pit installed and maintained on the site. For project phases with small amounts of concrete work, the driver will be directed to return to the mixing facility to washout the truck drum or a rigid pre-fabricated impermeable plastic wading pool can be used to contain the washout. If the concrete contractor is able to provide a prefabricated washout container, this will be used in place of constructing one onsite.

A concrete washout will be installed or provided prior to any construction activities that include the handling of materials containing cement (e.g. concrete, masonry, etc.). Concrete washouts will

be installed per the attached detail ("Concrete Washout Area" CWA-1 through CWA-4 from Urban Drainage and Flood Control District Drainage Criteria Manual Volume 3).

The concrete washout will be inspected daily during periods of concrete construction to make sure appropriate access control, tracking and containment is in place. Additionally, the project manager/superintendent will ensure that concrete washing is being conducted only at this designated area and that no damage is present at the washout. For lined washouts, the liner will be inspected for rips, tears, etc. Concrete operations will be suspended until any needed repairs are completed.

Maintenance will include the removal of excess material, cleaning, and general structural integrity of the installation as needed. The concrete washout will be cleaned of excess water and solids on a regular basis to maintain its proper function. The washout will be cleaned out when at 75% of capacity (50% if rigid containment is used). The concrete waste will be properly disposed by a qualified contractor.

If a water-tight vessel is used to contain concrete washout water, the following management practices will be followed:

- (1) The CM will be inspected for waterproof integrity prior to each use;
- (2) The CM will not be filled to more than 50% of capacity with either liquid or solid waste;
- (3) Immediately after concrete washing is complete, the CM will be covered with a waterproof barrier;
- (4) Upon termination of use of the washout site or when waste reaches 50% capacity, the accumulated waste will be removed from the site and properly disposed.

If unlined pits are used to contain concrete washout, the following management practices will be followed:

- (1) The use of the washout site must be temporary (less than 1 year);
- (2) The washout site will not be located in an area where groundwater may be present, such as near natural drainages, springs, or wetlands, or down slope of construction activity where runoff could flow into the washout;
- (3) Upon termination of use of the washout site, accumulated solid waste, including concrete waste and any contaminated soils, will be removed from the site to prevent on-site disposal of solid waste.

The washout will be removed when it is no longer needed.

Drainage Swales/Check Dams

Drainage swales and check dams may be constructed during the initial stages of new construction to ensure run-on and run-off are managed correctly. Check dams may also be constructed where existing drainage patterns cross onto the site and bring neighboring property run-on into the construction area. Check dams are generally constructed from rock, straw wattles, or straw bales. They are designed to slow water velocity allowing some sediment to settle. Check dams will be used in areas of concentrated flows along drainage swales. The check dam will be installed

across the entire width of the drainage swale in order to function properly. The center of the check dam should be lower than the sides. Drainage swales will be installed per the construction drawings and from Standard Plan No. M-208-1, Temporary Erosion Control, from the Colorado Department of Transportation (CDOT) 2006 M-Standard (Miscellaneous Standard) Plans, rev 8-2010. Check dams will be inspected for proper installation and sediment accumulation on the up-gradient side. Accumulated sediment and debris will be removed when the sediment level reaches one-half the height of the CM or at any time that sediment or debris adversely impacts the functioning of the CM. The removed sediment shall be placed with the topsoil stockpile and debris shall be hauled from site and disposed of. Check dam materials will be cleaned and replaced as needed to maintain function and integrity.

Inlet/culvert protection

Inlet protection consists of a barrier placed in front, around, or immediately up-gradient from the inlet or culvert. The most common forms of inlet protection are straw wattles or straw bales. Inlet protection is designed to slow stormwater flow into the inlet or culvert, allowing sediment time to settle and accumulate on the up-gradient side to the structure, without constricting the inlet throat. As permanent stormwater system inlets are constructed in areas with potential disturbed area run-off or when existing inlets are potentially impacted by construction activity, inlet protection will be installed. Any structure with a potential to receive run-off from non-stabilized surfaces will be treated with an inlet protection CM. Inlet protection will remain in place until all up-gradient areas are stabilized. See attached detail for further description and applications (excerpt from Standard Plan No. M-208-1, Temporary Erosion Control, from the Colorado Department of Transportation (CDOT) 2006 M-Standard (Miscellaneous Standard) Plans, rev 8-2010. Inlet protection will be inspected for damage, structural integrity, and proper installation in relationship to the culvert, and accumulated sediment/debris. Maintenance includes repairing or replacing as needed, repositioning the inlet protection and/or removing accumulated sediment.

Riprap

Rip rap is a layer of rock used to reduce the velocity of stormwater and to trap sediment. It is a permanent CM that is used to line channels, ditches, drainage swales, and at culvert inlets/outlets. The depth of the rip rap should be a minimum of twice the maximum rock diameter. A geotextile fabric can be used to extend the effectiveness of rip rap. See construction drawings regarding specifications of riprap.

Sediment Trap

Sediment traps are small impoundments which allow sediment to settle out which are generally installed in a drainage way or other point of discharge from a disturbed area. They are formed by excavating an area or by placing an earthen embankment across a low area or drainage swale. Typically, a spillway or outlet is constructed to allow the slow release of stormwater runoff. Sediment traps are commonly used at the outlets of diversion structures, slope drains or any other runoff that discharges waters containing sediment. If detailed engineering drawings specifically are not designed for this project, see attached installation detail and notes ("Sediment Trap" ST-1 through ST-3 from Urban Drainage and Flood Control District Drainage Criteria Manual Volume

3). Sediment Traps will be inspected for accumulated sediment, erosion and to ensure effective operation.

Silt Fence

Silt fence consists of geotextile fabric installed with at least six inches of the fabric entrenched into the soil attached to wooden stakes on the down-gradient side. Wire-backed fence may be used or additional stakes or lathe may be added on the down-gradient side for strengthening the fence around corners or in high wind conditions. Silt fence provides sediment control by reducing water velocity and ponding water to facilitate the deposition of sediment on the up-gradient side of the fence. Silt fence applications include, but are not limited to: project perimeter control, secondary containment, back of curb protection, containment for any disturbed or staging area, or around temporary material stockpiles (outer boundary). Silt fence is an optional CM to be used at the discretion of either the construction foreman and/or the SWMP Administrator. When silt fence is used, it will primarily be installed prior to clearing and grubbing operations in a new phase of construction where a sediment control measure is appropriate. Usually other CMs, such as natural vegetative barriers, straw wattles, and rock sediment traps, will be employed before use of silt fence. The primary application for silt fence will be in steeper sections of the project to protect the site from neighboring run-on or to direct project run-off toward a large sediment trap. Silt fence will be installed per the attached detail ("Silt Fence" SF-1 through Sf-4 from Urban Drainage and Flood Control District Drainage Criteria Manual Volume 3). Silt fence will be inspected regularly for sediment accumulation one-half the height of the fence, tears or holes in the fabric, broken stakes, and gaps in the fabric or areas where the fabric needs to be re-attached to the wooden stakes.

Straw Bales

A straw bale should be a minimum of 14" X 18" X 36" and have a minimum mass of 50 pounds. It should be composed of only vegetative matter, except for the binding. The straw bales should be bound by steel wire (minimum 14-gauge), nylon or polypropylene. Applications include, but are not limited to, check dams in swales, inlet protection, outlet protection, perimeter control, disturbed areas with significant potential for off-site drainage, protection from neighboring site run-on, or during the construction of drainage swales and ditches. Straw bales may also be used as "final discharge check dams" for drainage swales and ditches to slow run-off and collect sediment. Straw bales will be keyed into the soil perpendicular to the run-off flow. Straw bales will be installed per the attached detail (Excerpt from Standard Plan No. M-208-1, Temporary Erosion Control, from the Colorado Department of Transportation (CDOT) 2006 M-Standard (Miscellaneous Standard) Plans, rev 8-2010).

Straw Wattles (fiber rolls)

A straw wattle consists of a net or geotextile fabric filled with straw, excelsior, wood mulch or other fillers. Straw wattles reduce water velocity allowing sediment to accumulate on the up-gradient side of the straw wattle. Applications include, but are not limited to, disturbed areas with significant potential for off-site drainage, protection from neighboring site run-on, during the construction of drainage swales and ditches, slope stabilization, check dams in swales, back of curb protection, or temporary secondary containment for stock piles and materials storage. Straw

wattles will be keyed into the soil in a trench a minimum of two inches deep perpendicular to the run-off flow, secured in the trench using stakes, and backfilled on the up-gradient side. When necessary they will be stacked two courses high with joints off-set or overlapped. Straw wattles will be installed per the attached detail (Excerpt from Standard Plan No. M-208-1, Temporary Erosion Control, from the Colorado Department of Transportation (CDOT) 2006 M-Standard (Miscellaneous Standard) Plans, rev 8-2010). Straw wattles should be inspected for proper installation, structural integrity and sediment accumulation. A straw wattle that has been flattened out of round may not need to be replaced if they remain sufficiently sound to function appropriately on the up-gradient side of the straw wattle.

Topsoil Berm

A topsoil berm is a ridge of compacted soil which is used to prevent run-off and sheet flow of stormwater. The minimum height of the berm is 18 inches with side slopes less than 2:1. Topsoil berms shall be used to intercept and divert drainage to a designated outlet point. Topsoil berms will be installed per the attached detail (Excerpt from Standard Plan No. M-208-1, Temporary Erosion Control, from the Colorado Department of Transportation (CDOT) 2006 M-Standard (Miscellaneous Standard) Plans, rev 8-2010).

Vehicle Tracking Control

Vehicle tracking control will consist of an area with a geotextile liner and gravel, metal grate, medium-sized (6" to 12") rough-cut rocks, or asphalt/concrete "rumble strip". Tracking control is designed to cause soil to vibrate off equipment and vehicles as they transition from disturbed soils to paved areas. The vehicle tracking control will remain in place until access to the areas used by the control are stabilized or no longer needed. All appropriate points of ingress and egress, where traffic transitions from a stabilized road surface (e.g. gravel or pavement) to disturbed soil, will have vehicle tracking control installed. Tracking control will be moved or eliminated as on-site conditions and activities change. Tracking control will be inspected for depth of gravel/rock, presence of excess soil, proper usage and the overall general condition. Strict site access will be maintained throughout the project. Once the section is stabilized and surface drainage features are built, tracking pads will be removed in favor of controlled site access. See attached detail for further description and applications (Standard Plan No. M-208-1, Temporary Erosion Control, from the Colorado Department of Transportation (CDOT) 2006 M-Standard (Miscellaneous Standard) Plans, rev 8-2010).

3.2 Non-Structural CMs for Erosion and Sediment Control

Non-structural practices are those practices which when implemented will minimize erosion and sediment transport. Practices implemented at this site include interim stabilization practices, permanent stabilization practices (see Section 4), site-specific scheduling for implementation of the practices, and site management practices and personnel training. The CMs specified for the project are described below. Specific locations for CM implementation at the site are indicated on the site map in Appendix A. The installation details for these CMs are provided in Appendix B. Additional CMs may be added as site conditions change and will be identified in the "New CMs Added to the Site" form (Appendix C) prior to installation.

Controlled Parking

During construction activity, controlled parking areas will be established to allow workers to commute to/from the job site. Limited and designated parking areas will be established for all new phases of construction. This CM is an administrative measure to control access to/from the site.

Controlled Site Entrance

During construction activity or when construction activity is temporarily left in an intermediate state awaiting final treatment (concrete, finished gravel surface, etc.), controlled access will be established to direct traffic in/out and across/through the areas under construction. Limited access points will be established for all new phases of construction. This CM is an administrative measure to control access to/from the site and to ensure the general public is directed through the construction site via a safe and stabilized route.

Designated Staging Area

A designated staging area is a specific location on-site for stockpiling/staging materials or staging equipment for use on-site. A stabilized staging area allows for a central location for deliveries and storage of equipment when not in use, and to prevent disturbance of areas not scheduled for construction activities. Stabilized staging areas will be implemented as needed on site and will be located out of areas of active construction activity. If possible, the designated area will be located so it can be utilized during the entire construction period. Stabilized staging areas will be inspected for adequate vehicle tracking control and perimeter control. The staging area will be repaired or modified as needed. No hazardous material will be stored on site. This CM is an administrative measure to control access to/from the site.

Designated Vehicle Fueling and Maintenance Area

During all active construction phases, vehicle fueling and maintenance will only be conducted in a designated area. Any waste (oil, antifreeze, solvents, etc.) will be disposed according to manufacturer's instructions or Material Safety Data Sheets (MSDS). Vehicles and equipment will be inspected for leaks. Leaks will be repaired on site immediately or the vehicle/equipment will be removed from the site. Spill kits will be readily available. Any spills will be immediately cleaned up and properly dispose as described in Section 6.4, Spill Control and Cleanup. No fuel will be stored on-site.

Dust Control

Dust control reduces dust generated from disturbed surfaces and wind. To control dust that may be generated at the project site during construction, water will be applied from water trucks as needed. Care will be taken to apply water per industry standard in small volumes and at a low rate to prevent surface runoff. Correct application is just enough water to moisten the surface and calm dust, but not so much as to create standing water and mud.

Erosion Control Blankets (ECBs) and Turf Reinforcement Mats (TRMs)

ECBs and TRMs are sheets of straw, excelsior, coconut, manmade fiber, or combination thereof, usually contained between layers of netting to provide structural integrity. ECBs and TRMs provide a ground cover that reduces erosive action. TRMs are able to handle higher levels of

concentrated flows and are used mainly in channel applications. ECBs and TRMs may be used in conjunction with other velocity reducing CMs. ECB and TRM applications include, but are not limited to, slope and swale protection. See attached detail for further description and applications (Standard Plan No. M-208-1, Temporary Erosion Control, from the Colorado Department of Transportation (CDOT) 2006 M-Standard (Miscellaneous Standard) Plans, rev 8-2010). ECB and TRMs will be inspected for erosion underneath and at the sides, sediment accumulation, rips, tears and other structural problems. Maintenance will include removing sediment (to be placed with topsoil stockpile), re-securing material to ground, and re-trenching at up-gradient portions and sides as needed.

Good Housekeeping Practices

Good housekeeping will be used to keep potential areas where pollutants exist clean and orderly. Any containers, drums, and bags will be stored away from direct traffic routes to reduce the risk of accidental spills, stacked according to manufacturer's instructions, and stored on pallets or similar items. Materials which require spill containment practices (described in Section 6) shall be stored in close proximity to an appropriately stocked spill response kit. Hazardous materials will not be stored on this site. The site will be managed to keep materials, equipment, and portable sanitary facilities (these will additionally be staked to prevent/inhibit tipping) only in designated areas and promptly directing the thorough clean-up of any debris resulting from these operations. Stockpiles will be protected from run-on and run-off with berms, natural vegetative barriers, or structural CMs (straw wattles, straw bales, silt fence, etc.).

Mulching

Mulching uses materials such as grass, wood chips or fibers, hay, straw or native mowed vegetation to stabilize exposed or recently seeded soil and to reduce stormwater velocity and improve infiltration. It is most effective when used in conjunction with vegetation. Mulching can additionally aid vegetation growth by preventing birds from eating the seeds, retaining moisture, etc. Natural mulches will be used whenever possible. For steep slopes and critical areas, mulch matting with anchoring or matting will be utilized. The SWMP administrator will determine the appropriateness of utilizing mulching throughout the project. See attached detail for further description and applications (Figure C4-2, Mulching, from the Urban Drainage and Flood Control District Drainage Criteria Manual (V.3)). Since subject to erosion, mulched areas will be inspected frequently for effectiveness.

Natural Vegetative Barrier

A natural vegetative barrier is a preexisting vegetated area that is retained during construction to reduce water velocity and prevent erosion. Natural vegetative barrier provides a barrier zone where sediment is trapped, which reduces sediment discharge off-site, and are encouraged for any perimeter or environmentally sensitive areas. Whenever possible, a natural vegetative barrier will be maintained between the construction area and stormwater drainage areas. For best efficiency, buffer strips should be a minimum of 20' in length along the direction of flow; shorter distances should be supplemented with additional CMs.

Perimeter control

Perimeter control will control access during construction activity. Perimeter control will consist of various CMs, including, but not limited to controlled parking, controlled site entrances, vehicle tracking control, wire boundary fencing, etc. This CM is an administrative measure to control access to/from the site and to ensure the general public safety.

Seeding

Seeding involves the mechanical or hand application of specific seed mixes appropriate for the site location and soil type. Seeding provides plant growth to stabilize the soil reducing the likelihood of erosion or sediment transport and provides permanent stabilization. Drilling is the preferred method of seeding.

but no more than 14 days

As soon as practical, after the completion of final grading, disturbed surfaces as well as all areas which will not be hard surfaced or graveled, shall be properly prepared and seeded per the recommended seed mix below. To maximize seed germination and to utilize natural precipitation, seeding will normally occur from March to May or September to October. The SWMP Administrator will determine the appropriateness of seeding throughout the project. Seeding may be accompanied by an additional CM, such as mulching or straw mats, to protect the seed and soil from erosion during the germination and growth process. Straw mats will be stapled to the slopes and overlapped.

Stockpiled topsoil will be redistributed over areas to be seeded. At the discretion of the SWMP administrator, a soil conditioner (3CY per 1,000 SF) may be rototilled into the top 6" of the topsoil soil before fine grading. The topsoil shall be graded to a reasonably even and smooth surface. Seed shall be uniformly distributed over the area. Drilled seed shall be applied .25 to .5 inches deep in rows spaced no more than 7 inches apart. On slopes steeper than 3:1, seed shall be applied by a mechanical broadcaster or hand broadcast at double the rate required for drill seeding. All seed sown by mechanical broadcasters shall be raked or dragged into the soil to a depth of 1/2".

Seed mix to be provided by Contractor to be approved by the owner and EPC

All seed must comply with Colorado weed seed guidelines. There should be no prohibited/noxious weed species seeds in the mix. Use certified Pure Live Seed (PLS). Deliver in original unopened containers with seed tags dealers warranty analysis attached.

Seeded areas will be inspected every 14 days and after an erosion causing storm event to ensure that the soil stabilization method (e.g. surface roughening, erosion control blankets, etc.) was applied correctly and has not been compromised. The area will also be inspected for erosion and/or sediment deposition. If vegetation does not begin to grow in a seeded area after 4 to 6 weeks, the area will be reseeded, fertilized, and mulched. Maintenance items would include re-grading and seeding bare or areas of thin vegetative growth and/or adding additional CMs as appropriate. Seeded area will be inspected and monitored until the area obtains final stabilization.

Solid Waste Management

To reduce the risk of pollution at the project site, construction wastes require proper management and disposal. This includes location of refuse piles, materials that may be displaced by stormwater, trash disposal and spill prevention. Waste collection will be scheduled to prevent containers from overflowing. Debris stockpiles will be continuously monitored and disposed of properly throughout the construction period. Additionally, waste will be monitored around the site perimeter. The onsite portable sanitary facilities will be staked to prevent tipping and will be monitored and cleaned weekly. Trays can be used to contain spills. Any spills of sewage chemicals will be cleaned up according to Section 6.4.

Surface Roughening

Surface roughening consists of grooves or tracks installed in the soil surface, perpendicular to the slope. This is a temporary soil stabilization technique that works well in areas that will remain inactive for a short time. It reduces water velocity and promotes infiltration, thus decreasing the potential for erosion to occur. As areas are cleared, surfaces will be left rough to inhibit run-off sheeting from disturbed areas. Where practical, surfaces will be left in a roughened state and slopes will be graded (or “tracked”) parallel to the contour to further inhibit sheet flow drainage. Any disturbed areas with no construction activity planned for more than 14 days or longer will be surfaced roughened. See attached detail for further guidance and potential applications (“Surface Roughening” SR-1 through SR-4 from Urban Drainage and Flood Control District Drainage Criteria Manual Volume 3). In areas where it is impractical to apply surface roughening using tracked equipment the surface may be manually raked to create the desired texture.

3.3 Phased CM Installation

Phased CMs will be used in conjunction with the installation of permanent structural CMs (rip-rapped outfalls, culvert installations, etc.). Temporary additional sediment control and/or erosion control CMs will be added to the upstream side of the permanent CM. As an example, if new culverts are installed, rip-rapped scour protection will generally be installed at the outlet end. A temporary (phased) sediment control CM (usually straw bales or straw wattles) will be installed on the inlet side to prevent the culvert and the outlet rip-rap from silting in before the upstream ditch/drainage can be stabilized (usually with natural vegetation). Phased CMs can be a combination of both Structural and Non-Structural CMs. Refer to Appendix C for phased CM Installation.

3.4 Dedicated Concrete or Asphalt Batch Plants

No onsite concrete or asphalt production will be used for this project unless approved by the owner. All concrete and asphalt will be imported and placed the same day.

3.5 Vehicle Tracking Control

Vehicle tracking controls are used to prevent sediment transport from the construction site to paved or permanently graveled roads. These controls are:

- Controlled Parking
- Controlled Site Entrance
- Designated Staging Area
- Dust Control
- Vehicle Tracking Control, including management of general public traffic

3.6 Waste Management and Disposal (Including Concrete Washouts)

On-site waste disposal including personnel trash, construction debris, sanitary wastes, etc. is prohibited. The following practices shall be implemented as directed.

Concrete Washout

Designated concrete washout(s) will be installed on site during construction phases involving concrete. The location of these washout(s) will be added to the site map. No concrete waste will be discharged directly into the ground without a containment feature. The concrete waste and/or excess wash water will be properly disposed as needed. Additionally, signs will clearly indicate the concrete washout location. Concrete washout water will not be discharged to receiving waters, storm sewer systems or the ground.

Portable Sanitary Facilities

Portable sanitary facilities will be provided (if necessary) in a convenient, level location away from traffic areas at least three feet from curb flow lines and paved/driving surfaces, storm drains, or retention areas. A qualified contractor will maintain and clean the units, inspect for any deficiencies, and keep the units in good working order. Portable sanitary facilities will be adequately anchored to prevent tipping. The construction contractor will be responsible for ensuring that the units are properly used and maintained.

Solid Waste

Large amounts of solid waste are not anticipated to be generated during this project. The majority of solid waste will be collected, removed from site, and properly disposed on a daily basis. If dumpsters are needed, they will be installed in a convenient, level location away from traffic areas, storm drains, drainage areas, or retention areas. The dumpsters will be kept off of paved surfaces (to avoid damages to the asphalt) and a qualified contractor will empty the dumpsters, as needed. The site perimeter will be monitored to ensure that all site personnel utilize the proper waste disposal practices and facilities.

Hazardous Wastes

Fuel and hazardous materials will not be stored at the site.

3.7 Product Specific Practices

Due to the chemical makeup of specific products, certain handling and storage procedures are required to promote the safety of personnel and prevent the possibility of pollution. Site personnel

will be instructed to follow all directions and warnings for products used on the site. All pertinent information can be found on the Material Safety Data Sheets (MSDS) for each product. The appropriate MSDS will be located with each product container or in a readily accessible central location.

3.8 Groundwater and Stormwater Dewatering

Based on the shallow nature of construction, dewatering of groundwater or stormwater is not anticipated on this project. The Division's Low Risk Discharge Guidance for Discharges of Uncontaminated Groundwater to Land allows the discharge of construction dewatering to the ground, under specific conditions, when appropriate control measures are implemented. It does not allow discharge of construction dewatering of non-stormwater to be discharged to the surface waters or to storm sewer systems without separate permit coverage. Although the Construction Stormwater permit does not authorize the conditional discharge of construction dewatering to the ground, discharge of uncontaminated groundwater to land may be covered under the Low Risk Discharge Guidance when all the provisions in the guidance document are adhered to. In all cases when groundwater is encountered, a geotechnical and/or a professional engineer will be consulted before proceeding with the project.

4.0 FINAL STABILIZATION AND LONG-TERM STORMWATER MANAGEMENT

4.1 Temporary Stabilization

discuss pond

Temporary stabilization must be implemented for earth disturbing activities on any portion of the site where ground disturbing construction activity has permanently ceased, or temporarily ceased for more than 14 calendar days. Temporary stabilization methods may include, but are not limited to, tarps, soil tackifier, and hydroseed. The 14-day schedule may be exceeded when either the function of the specific area of the site requires it to remain disturbed, or, physical characteristics of the terrain and climate prevent stabilization. The constraints necessitating the alternative schedule must be documented, an alternate stabilization schedule provided, and all locations where the alternative schedule is applicable on the site map need to be identified.

4.2 Description of Final Stabilization Practices

Final stabilization for disturbed areas of the site will be to return to their original condition or to the improved design (native re-vegetated areas, access roads, gravel yards, drainage basins, etc.). For disturbed areas, temporary CMs will be maintained until the final surface cover is constructed or established.

4.3 Final Stabilization Methods

Final stabilization includes those measures taken to control pollutants in stormwater after soil disturbing activities are complete. Practices implemented to achieve final stabilization include:

- Preparation of the soil prior to seed application;
- Seed mix appropriate for the area will be broadcasted per recommended instructions;
- Maintaining appropriate erosion and sediment control CMs until final stabilization is achieved; and
- Removal of temporary CMs once work is completed and final stabilization achieved.

4.4 Final Stabilization Achievement

EPC Stormwater Inspector must complete a final inspection

Final stabilization of road surface areas and graveled areas will be achieved when the final surface (improved gravel surface, landscaping, etc.) is accepted by the Owner. Final stabilization will be reached when all ground surface disturbing activities at the site have been completed, and for all areas of ground surface disturbing activities where a uniform vegetative cover has been established with an individual plant density of at least 70 percent of pre-disturbance levels, or equivalent permanent, physical erosion reduction methods have been employed. Coverage under the Stormwater Construction Permit may be terminated by the permittee when the entire site has attained final stabilization, all temporary erosion and sediment control measures have been removed, and all components of the SWMP are complete. Vegetative ground cover shall be greater than 70% of the pre-construction cover, 0.70 x 0.3-0.60, or approximately 20-40%

vegetation coverage depending on the location, for areas of disturbance that are not hard surfaced, graveled, or landscaped. When the site has attained final stabilization and all temporary erosion and sediment control measures have been removed, the permittee will submit an Inactivation Notice form.

Item 26. Add a note stating that this project does not rely on control measures owned or operated by another entity.

5.0 INSPECTION AND MAINTENANCE

5.1 Minimum Inspection Schedule

A thorough inspection will be conducted within 7 calendar days of the commencement of construction activities, and in accordance with one of the following minimum frequencies:

- At least one inspection every 7 calendar days
- At least one inspection every 14 calendar days, PLUS post-storm even inspections conducted within 24 hours after the end of any precipitation or snowmelt event that causes surface erosion.
 - Post-storm inspections may be used to fulfill the 14-day routine inspection requirement.

Inspections will be conducted on either the 7 day or 14 day schedule, and may switch between these schedules as appropriate for the site. The inspection frequency will be noted on the inspection reports. There are no discharges to Outstanding Waters; therefore inspections will not be required at least once every 7 days.

5.1.1 Post-storm inspections

Post-storm inspections will be conducted within 24 hours after the end of any precipitation or snowmelt event that causes surface erosion. If no construction activities will occur following a storm event, post-storm event inspections will be conducted prior to re-commencing construction activities, but no later than 72 hours following the storm event. The delayed inspection will be documented in the inspection record.

5.1.2 Inspections at Completed Sites/Areas

For completed construction sites, an inspection of the site will be made at least once every month until final stabilization is reached. The following must be met in order for the site to be inspected on a monthly basis instead of every 14 days:

- All construction activities that will result in surface ground disturbance are completed;
- All activities required for final stabilization have been completed, with the exception of the application of seed that has not occurred due to seasonal conditions or the necessity for additional seed application to augment previous efforts; and
- The SWMP has been amended to indicate those areas that will be inspected in accordance with the reduced schedule.

The reduced frequency schedule also applies to the site or portions of the site where continuing construction activities can be conducted without disturbance of the ground surface.

5.1.3 Winter Conditions Inspections Exclusion

Inspections will not be conducted where construction activities are temporarily halted, snow cover exists over the entire site for an extended period, and melting conditions posing a risk of surface erosion do not exist. The following information will be documented in the inspection record for use of this exclusion:

- Dates when snow cover occurred,
- Date when construction activities ceased, and
- Date melting conditions began.

5.2 Inspection Requirements

Inspections should include a visual verification of whether all implemented control measures are in effective operational condition and are working as designed to minimize pollutant discharges. It should be determined if there are new potential sources of pollutants. The adequacy of control measures should be assessed to identify areas requiring new or modified control measures. All areas of non-compliance should be identified and corrective actions implemented.

5.2.1 Inspection Scope

The following items will be examined for evidence of, or the potential for, pollutants leaving the construction site boundaries, entering the stormwater drainage system, or discharging to state waters during the inspection and reported on the inspection reports:

- Construction site perimeter;
- All disturbed areas;
- Designated haul routes;
- Material and/or waste storage areas that are exposed to precipitation;
- Discharge locations;
- Locations where vehicles access the site; and
- All CMs implemented will be evaluated to ensure that they are maintained and operating correctly

5.2.2 Inspection Reports

The inspection report form is located in Appendix D. Inspection reports must identify any incidents of non-compliance with the terms and conditions of the general permit. The inspection records will be retained for three years from the expiration or inactivation of permit coverage.

The inspection record will note evidence of, or the potential for, pollutants leaving the construction site boundaries, entering the stormwater drainage system, or discharging to state waters.

The inspection report will include:

- The inspection date;
- Name(s) and title(s) of personnel making the inspection;
- Weather conditions at the time of inspection;
- Phase of construction at the time of inspection;
- Estimated acreage of disturbance at the time of inspection;
- Location(s) of discharges of sediment or other pollutants from the site;
- Location(s) of CMs that need to be maintained;
- Location(s) and identification of inadequate control measures
- Location(s) and identification of additional control measures needed that were not in place at the time of inspection
- Description of the minimum inspection frequency, and any deviations from the minimum inspection schedule;
- Identification of control measures observed that require routine maintenance (any control measure that is still operating in accordance with its design and the requirements of the permit, but requires maintenance to prevent a breach of the control measure).
- After adequate corrective action(s) have been taken, or where a report does not identify any incidents requiring corrective action, the report will contain a signed statement indicating “all corrective action and maintenance items identified during the inspection are complete, and the site is currently in compliance with the permit.”

5.3 Required Actions Following Site Inspections

CMs will be maintained or replaced in accordance with Sections 5.4 and 5.5 of this SWMP. The SWMP will be updated in accordance with Section 5.6.3. Where site inspections note the need for CM maintenance activities, CMs must be maintained such that the conditions in those sections are met.

5.4 CM Maintenance

All erosion and sediment control practices and other protective measures identified in the SWMP will be maintained in effective operating condition in accordance with Section 3.0 and Appendix B. CMs that are not adequately maintained in accordance with good engineering, hydrologic and pollution control practices are considered to be no longer operating effectively and will be modified or replaced. CMs implemented at the site must be adequately designed and maintained to provide control for all potential pollutant sources associated with the construction activity to prevent pollution or degradation of State waters. Where site inspections note the need for CM maintenance activities, CMs will be maintained such as these conditions are met. Maintenance

items include, but are not limited to: removal of accumulated sediment, repair or replacement of worn or damaged sections, repositioning to correct placement; and reinstallation of CMs displaced. Accumulated sediment and debris will be removed from a CM when the sediment level reaches one-half the height of the CM (unless otherwise noted in the design drawings or CM detail) or at any time that sediment or debris adversely impacts the functioning of the CM.

5.5 Corrective Actions

Adequate site assessment will be performed as part of the comprehensive inspection and maintenance procedures, to assess the adequacy of CMs at the site, and the necessity of changes to those CMs to ensure continued effective performance. When an inadequate control measure is identified, the following corrective action requirements apply:

All necessary steps must be taken to minimize or prevent the discharge of pollutants, until a control measure is implemented and made operational and/or an inadequate control measure is replaced or corrected and returned to effective operating condition.

- If it is infeasible to install or repair a control measure immediately after discovering the deficiency, the following information must be documented and kept on record:
 - Describe why it is infeasible to initiate the installation or repair immediately, and
 - Provide a schedule for installing or repairing the control measure and returning it to an effective operating condition as soon as possible.

If applicable, any unauthorized release or discharge must be removed and properly disposed of. Contaminated surfaces must be cleaned up to minimize discharges of the material in subsequent storm events.

5.6 SWMP Requirements

5.6.1 SWMP Availability

The SWMP will be implemented prior to commencement of construction activities. The SWMP will be kept accurate and up-to-date, and will reflect the actual on site ground conditions. Only changes in site conditions that require new or modified CMs need to be addressed in the SWMP.

5.6.2 SWMP Retention

A copy of the SWMP must be retained on site unless another location, specified by the permittee, is approved by the Division.

5.6.3 SWMP Amendment

The SWMP will be amended:

- When there is a change in design, construction, operation, or maintenance of the site, which would require the implementation of new or revised CMs; or
- If the SWMP proves to be ineffective in achieving the general objectives of controlling pollutants in stormwater discharges associated with construction activity; or
- When CMs are no longer necessary and are removed.

SWMP changes will be made prior to changes in the site conditions, except as noted below under “Responsive SWMP Changes.” SWMP revisions may include, but are not limited to: potential pollutant source identification; selection of appropriate CMs for site conditions; CM maintenance procedures; and interim and final stabilization practices.

The SWMP changes may include a schedule for further CM design and implementation, provided that, if any interim CMs are needed to comply with the permit, they are also included in the SWMP and implemented during the interim period.

For SWMP revisions made prior to or following a change(s) onsite, including revisions to sections addressing site conditions and control measures, a notation must be included in the plan that identifies; the date of the site change; the control measure removed or modified; the location(s) of those control measures; and any changes to the control measure(s).

5.6.4 Responsive SWMP Changes

The majority of SWMP revisions to address changing site conditions can be made immediately with simple field revisions to the SWMP. In the less common scenario where more complex development of materials to modify the SWMP are necessary, SWMP revisions will be made in accordance with the following requirements:

- The SWMP will be revised as soon as practicable, but in no case more than 72 hours after the change(s) in CM installation and/or implementation occur at the site, and
- A notation must be included in the site map prior to the site change(s) that includes the date of the change(s) in the field, an identification of the CM(s) removed or added, and the location(s) of those CM(s).

5.7 RECORD KEEPING

Copies of the SWMP, amendments to or changes to the SWMP, inspection records and all other data must be retained by the owner (permittee) for three (3) years after the expiration or inactivation of the permit.

6.0 SPILL PREVENTION AND RESPONSE

6.1 Introduction

This section describes measures to prevent, control, and minimize impacts from a spill of chemical products (hazardous, toxic, or petroleum substances) during construction of this project. This plan identifies the handling, transportation, storage, and disposal procedures for these chemical products and outlines procedures to be followed in the event of a spill.

6.2 Material Management Practices

Properly managing these materials on the site will greatly reduce the potential for stormwater pollution. Good housekeeping along with proper use and storage of these construction materials form the basis for proper management of chemical products.

6.2.1 Good Housekeeping

The proper use of materials and equipment along with the use of general common sense greatly reduce the potential for contaminating stormwater runoff. The following is a list of good housekeeping practices to be used during the construction project:

- Provide secondary containment (or equivalent protection) for any container containing 55 gallons or greater.
- Fueling of construction equipment will not be performed within 150 feet of definitive stormwater drainages.
- An effort will be made to store only enough product required to do the job.
- Materials will be stored in a neat, orderly manner, in appropriate closed containers, in secondary containment and, if possible, under a roof or other enclosure.
- Products will be kept in their original containers with the original manufacturer's label.
- Substances will not be mixed with one another unless recommended by the manufacturer.
- Whenever possible, all of the product will be used up before properly disposing of the container.
- Manufacturer's recommendations for proper use of a product will be followed.
- If surplus product must be disposed of, local and state recommended methods for proper disposal will be followed.

6.3 Product-Specific Practices

Due to the chemical makeup of specific products, certain handling and storage procedures are required to promote the safety of personnel and prevent the possibility of pollution. Care will be taken to follow all directions and warnings for products used on the site. All pertinent information can be found on the Material Safety Data Sheets (MSDS) for each product. The MSDSs will be located with each product container it represents or in a readily accessible central location. Several product-specific practices are listed in the following sections.

6.3.1 Flammable and Combustible Liquids and Hazardous Materials

All products will be stored in tightly sealed containers that are clearly labeled. The containers will be stored in secondary containment, which will be of sufficient size to contain the entire contents of the primary container plus a sufficient quantity for precipitation (a total of approximately 110 percent of the volume of the primary container). The secondary containment will be an impermeable containment basin to prevent any spills or leaks from reaching the ground. The containment may be one of the following or other means that meets the definition of impermeable: 1) a temporary earthen berm lined with 20-mil plastic, 2) a portable tank or basin, or 3) a galvanized steel trough.

After each storm event, all secondary containment areas will be inspected. If there is no visible sheen on the collected water, it can be pumped or drained to the ground in a manner that does not cause scouring. If a sheen is present, it must be cleaned up using absorbent materials prior to discharging or disposing of the water. The absorbent material will be disposed of properly.

6.3.2 Petroleum Products

In addition to the requirements above in Section 6.2.1, petroleum products are required to have some additional procedures for handling and storage to prevent the possibility of pollution. On-site vehicles will be monitored for leaks and receive regular maintenance to reduce the potential for leakage.

Bulk fuel or lubricating oil dispensers will have a valve that must be manually held open to allow the flow of fuel. When not in use, the fuel dispensing nozzles and/or associated hoses will be kept inside the containment basin. During fueling operations, personnel will be present at all times to detect and contain spills. If any spills or leaks occur, the activity will be stopped immediately, and the containment and cleanup will begin immediately. In addition, the contractor will follow the procedure listed in Section 6.4.

6.4 Spill Control and Cleanup

In addition to the material management practices discussed in Section 6.2, the following spill control and cleanup practices will be followed to prevent stormwater pollution in the event of a spill:

- Spills will be contained and cleaned up immediately after discovery.
- Manufacturer's methods for spill cleanup of a material will be followed as described on the material's MSDS.
- Materials and equipment needed for cleanup procedures ("spill kits") will be kept readily available on the site, either at an equipment storage area or on contractor's trucks. Equipment to be kept on the site may include but is not be limited to brooms, dust pans, shovels, granular absorbents, sand, sawdust, absorbent pads and socks, plastic and metal trash containers, gloves, and goggles.
- Drums containing used clean up materials will be labeled with the contents and date.
- Personnel on the site will be made aware of cleanup procedures and the location of spill cleanup equipment. In general, every vehicle with bulk fuel or petroleum lubrication supplies will be outfitted with a spill containment and clean-up kit.
- The contractor will be responsible for all cleanup activities in accordance with applicable local, state, and federal regulations.

6.5 Spill Reporting

If a spill occurs, the contractor is responsible for immediately (within 5 to 10 minutes) reporting the spill to the Owners Authorized Technical Representative/Project Manager the Tri-State Environmental Services at (303) 349-7711. Tri-State Environmental Services is responsible for calling all agencies in the event of a spill.

If there is a spill of antifreeze, gasoline or oils from personal vehicles, it does not need to be reported to Tri-State's Environmental Services or the SWMP Administrator, but should be documented and kept with the master SWMP. All spills should be documented using the "Spill Report" form provided in Appendix E and a record kept with the master SWMP. Copies of the forms can be found in Appendix E.

6.6 SWMP Modification Procedures Related to Reportable Releases

If a reportable release occurs, a modification to the SWMP must be made within 14 days. The modification will include: a description of the release, the date of the release, an explanation of why the spill happened, a description of procedures to prevent future spills and/or releases from happening, and a description of response procedures should a spill or release occur again and within 14 days of the release. A written description of the release must be submitted to the permitting authority that includes: a description of the release, including the type of material and an estimated amount of spill, the date of the release; an explanation of why the spill happened; and a description of the steps taken to prevent and control future releases. The SWMP Administrator will submit spill reports to the appropriate agencies. Modifications to the SWMP will be made by the SWMP Administrator, or his designee, and will be documented on the "New CMs Added to the Site" form in Appendix C.

APPENDIX A: Site Maps

STANDARD NOTES FOR EL PASO COUNTY GRADING AND EROSION CONTROL PLANS:

1. STORMWATER DISCHARGES FROM CONSTRUCTION SITES SHALL NOT CAUSE OR THREATEN TO CAUSE POLLUTION, CONTAMINATION, OR DEGRADATION OF STATE WATERS. ALL WORK AND EARTH DISTURBANCE SHALL BE DONE IN A MANNER THAT MINIMIZES POLLUTION OF ANY ON-SITE OR OFF-SITE WATERS, INCLUDING WETLANDS.
2. NOTWITHSTANDING ANYTHING DEPICTED IN THESE PLANS IN WORDS OR GRAPHIC REPRESENTATION, ALL DESIGN AND CONSTRUCTION RELATED TO ROADS, STORM DRAINAGE AND EROSION CONTROL SHALL CONFORM TO THE STANDARDS AND REQUIREMENTS OF THE MOST RECENT VERSION OF THE RELEVANT ADOPTED EL PASO COUNTY STANDARDS, INCLUDING THE LAND DEVELOPMENT CODE, THE ENGINEERING CRITERIA MANUAL, THE DRAINAGE CRITERIA MANUAL, AND THE DRAINAGE CRITERIA MANUAL VOLUME 2. ANY DEVIATIONS FROM REGULATIONS AND STANDARDS MUST BE REQUESTED, AND APPROVED, IN WRITING.
3. A SEPARATE STORMWATER MANAGEMENT PLAN (SMWP) FOR THIS PROJECT SHALL BE COMPLETED AND AN EROSION AND STORMWATER QUALITY CONTROL PERMIT (ESQCP) ISSUED PRIOR TO COMMENCING CONSTRUCTION. MANAGEMENT OF THE SMWP DURING CONSTRUCTION IS THE RESPONSIBILITY OF THE DESIGNATED QUALIFIED STORMWATER MANAGER OR CERTIFIED EROSION CONTROL INSPECTOR. THE SMWP SHALL BE LOCATED ON SITE AT ALL TIMES DURING CONSTRUCTION AND SHALL BE KEPT UP TO DATE WITH WORK PROGRESS AND CHANGES IN THE FIELD.
4. ONCE THE ESQCP IS APPROVED AND A "NOTICE TO PROCEED" HAS BEEN ISSUED, THE CONTRACTOR MAY INSTALL THE INITIAL STAGE EROSION AND SEDIMENT CONTROL MEASURES AS INDICATED ON THE APPROVED GEC. A PRECONSTRUCTION MEETING BETWEEN THE CONTRACTOR, ENGINEER, AND EL PASO COUNTY WILL BE HELD PRIOR TO ANY CONSTRUCTION. IT IS THE RESPONSIBILITY OF THE APPLICANT TO COORDINATE THE MEETING TIME AND PLACE WITH COUNTY STAFF.
5. CONTROL MEASURES MUST BE INSTALLED PRIOR TO COMMENCEMENT OF ACTIVITIES THAT COULD CONTRIBUTE POLLUTANTS TO STORMWATER CONTROL MEASURES FOR ALL SLOPES, CHANNELS, DITCHES, AND DISTURBED LAND AREAS SHALL BE INSTALLED IMMEDIATELY UPON COMPLETION OF THE DISTURBANCE.
6. ALL TEMPORARY SEDIMENT AND EROSION CONTROL MEASURES SHALL BE MAINTAINED AND REMAIN IN EFFECTIVE OPERATING CONDITION UNTIL PERMANENT SOIL EROSION CONTROL MEASURES ARE IMPLEMENTED AND FINAL STABILIZATION IS ESTABLISHED. ALL PERSONS ENGAGED IN LAND DISTURBANCE ACTIVITIES SHALL ASSESS THE ADEQUACY OF CONTROL MEASURES AT THE SITE AND IDENTIFY IF CHANGES TO THOSE CONTROL MEASURES ARE NEEDED TO ENSURE THE CONTINUED EFFECTIVE PERFORMANCE OF THE CONTROL MEASURES. ALL CHANGES TO TEMPORARY SEDIMENT AND EROSION CONTROL MEASURES MUST BE INCORPORATED INTO THE STORMWATER MANAGEMENT PLAN.
7. TEMPORARY STABILIZATION SHALL BE IMPLEMENTED ON DISTURBED AREAS AND STOCKPILES WHERE GROUND DISTURBING CONSTRUCTION ACTIVITY HAS PERMANENTLY CEASED OR TEMPORARILY CEASED FOR LONGER THAN 14 DAYS.
8. FINAL STABILIZATION MUST BE IMPLEMENTED AT ALL APPLICABLE CONSTRUCTION SITES. FINAL STABILIZATION IS ACHIEVED WHEN ALL GROUND DISTURBING ACTIVITIES ARE COMPLETE AND ALL DISTURBED AREAS EITHER HAVE A UNIFORM VEGETATIVE COVER WITH INDIVIDUAL PLANT DENSITY OF 70 PERCENT OF PRE-DISTURBANCE LEVELS ESTABLISHED OR EQUIVALENT PERMANENT ALTERNATIVE STABILIZATION METHOD IS IMPLEMENTED. ALL TEMPORARY SEDIMENT AND EROSION CONTROL MEASURES SHALL BE REMOVED UPON FINAL STABILIZATION AND BEFORE PERMIT CLOSURE.
9. ALL PERMANENT STORMWATER MANAGEMENT FACILITIES SHALL BE INSTALLED AS DESIGNED IN THE APPROVED PLANS. ANY PROPOSED CHANGES THAT EFFECT THE DESIGN OR FUNCTION OF PERMANENT STORMWATER MANAGEMENT STRUCTURES MUST BE APPROVED BY THE ECM ADMINISTRATOR PRIOR TO IMPLEMENTATION.
10. EARTH DISTURBANCES SHALL BE CONDUCTED IN SUCH A MANNER SO AS TO EFFECTIVELY MINIMIZE ACCELERATED SOIL EROSION AND RESULTING SEDIMENTATION. ALL DISTURBANCES SHALL BE DESIGNED, CONSTRUCTED, AND COMPLETED SO THAT THE EXPOSED AREA OF ANY DISTURBED LAND SHALL BE LIMITED TO THE SHORTEST PRACTICAL PERIOD OF TIME. PRE-EXISTING VEGETATION SHALL BE PROTECTED AND MAINTAINED WITHIN 50 HORIZONTAL FEET OF A WATERS OF THE STATE UNLESS SHOWN TO BE INFEASIBLE AND SPECIFICALLY REQUESTED AND APPROVED.
11. COMPACTION OF SOIL MUST BE PREVENTED IN AREAS DESIGNATED FOR INFILTRATION CONTROL MEASURES OR WHERE FINAL STABILIZATION WILL BE ACHIEVED BY VEGETATIVE COVER. AREAS DESIGNATED FOR INFILTRATION CONTROL MEASURES SHALL ALSO BE PROTECTED FROM SEDIMENTATION DURING CONSTRUCTION UNTIL FINAL STABILIZATION IS ACHIEVED. IF COMPACTION PREVENTION IS NOT FEASIBLE DUE TO SITE CONSTRAINTS, ALL AREAS DESIGNATED FOR INFILTRATION AND VEGETATION CONTROL MEASURES MUST BE LOOSENEED PRIOR TO INSTALLATION OF THE CONTROL MEASURE(S).
12. ANY TEMPORARY OR PERMANENT FACILITY DESIGNED AND CONSTRUCTED FOR THE CONVEYANCE OF STORMWATER AROUND, THROUGH, OR FROM THE EARTH DISTURBANCE AREA SHALL BE A STABILIZED CONVEYANCE DESIGNED TO MINIMIZE EROSION AND THE DISCHARGE OF SEDIMENT OFF SITE.
13. CONCRETE WASH WATER SHALL BE CONTAINED AND DISPOSED OF IN ACCORDANCE WITH THE SWMP. NO WASH WATER SHALL BE DISCHARGED TO OR ALLOWED TO ENTER STATE WATERS, INCLUDING ANY SURFACE OR SUBSURFACE STORM DRAINAGE SYSTEM OR FACILITIES. CONCRETE WASHOUTS SHALL NOT BE LOCATED IN AN AREA WHERE SHALLOW GROUNDWATER MAY BE PRESENT, OR WITHIN 50 FEET OF A SURFACE WATER BODY, CREEK OR STREAM.
14. DURING DEWATERING OPERATIONS OF UNCONTAMINATED GROUND WATER MAY BE DISCHARGED ON SITE, BUT SHALL NOT LEAVE THE SITE IN THE FORM OF SURFACE RUNOFF UNLESS AN APPROVED STATE DEWATERING PERMIT IS IN PLACE.
15. EROSION CONTROL BLANKETING OR OTHER PROTECTIVE COVERING SHALL BE USED ON SLOPES STEEPER THAN 3:1.
16. CONTRACTOR SHALL BE RESPONSIBLE FOR THE REMOVAL OF ALL WASTES FROM THE CONSTRUCTION SITE FOR DISPOSAL IN ACCORDANCE WITH LOCAL AND STATE REGULATORY REQUIREMENTS. NO CONSTRUCTION DEBRIS, TREE SLASH, BUILDING MATERIAL WASTES OR UNUSED BUILDING MATERIALS SHALL BE BURIED, DUMPED, OR DISCHARGED AT THE SITE.
17. WASTE MATERIALS SHALL NOT BE TEMPORARILY PLACED OR STORED IN THE STREET, ALLEY, OR OTHER PUBLIC WAY, UNLESS IN ACCORDANCE WITH AN APPROVED TRAFFIC CONTROL PLAN. CONTROL MEASURES MAY BE REQUIRED BY EL PASO COUNTY ENGINEERING IF DEEMED NECESSARY, BASED ON SPECIFIC CONDITIONS AND CIRCUMSTANCES.
18. TRACKING OF SOILS AND CONSTRUCTION DEBRIS OFF-SITE SHALL BE MINIMIZED. MATERIALS TRACKED OFF-SITE SHALL BE CLEANED UP AND PROPERLY DISPOSED OF IMMEDIATELY.
19. THE OWNER/DEVELOPER SHALL BE RESPONSIBLE FOR THE REMOVAL OF ALL CONSTRUCTION DEBRIS, DIRT, TRASH, ROCK, SEDIMENT, SOIL, AND SAND THAT MAY ACCUMULATE IN ROADS, STORM DRAINS AND OTHER DRAINAGE CONVEYANCE SYSTEMS AND STORMWATER APPURTENANCES AS A RESULT OF SITE DEVELOPMENT.
20. THE QUANTITY OF MATERIALS STORED ON THE PROJECT SITE SHALL BE LIMITED, AS MUCH AS PRACTICAL, TO THAT QUANTITY REQUIRED TO PERFORM THE WORK IN AN ORDERLY SEQUENCE. ALL MATERIALS STORED ON-SITE SHALL BE STORED IN A NEAT, ORDERLY MANNER, IN THEIR ORIGINAL CONTAINERS, WITH ORIGINAL MANUFACTURER'S LABELS.
21. NO CHEMICAL(S) HAVING THE POTENTIAL TO BE RELEASED IN STORMWATER ARE TO BE STORED OR USED ONSITE UNLESS PERMISSION FOR THE USE OF SUCH CHEMICAL(S) IS GRANTED IN WRITING BY THE ECM ADMINISTRATOR. IN GRANTING APPROVAL FOR THE USE OF SUCH CHEMICAL(S), SPECIAL CONDITIONS AND MONITORING MAY BE REQUIRED.
22. BULK STORAGE OF ALLOWED PETROLEUM PRODUCTS OR OTHER ALLOWED LIQUID CHEMICALS IN EXCESS OF 55 GALLONS SHALL REQUIRE ADEQUATE SECONDARY CONTAINMENT PROTECTION TO CONTAIN ALL SPILLS ONSITE AND TO PREVENT ANY SPILLED MATERIALS FROM ENTERING STATE WATERS. ANY SURFACE OR SUBSURFACE STORM DRAINAGE SYSTEM OR OTHER FACILITIES.
23. NO PERSON SHALL CAUSE THE IMPEDIMENT OF STORMWATER FLOW IN THE CURB AND GUTTER OR DITCH EXCEPT WITH APPROVED SEDIMENT CONTROL MEASURES.
24. OWNER/DEVELOPER AND THEIR AGENTS SHALL COMPLY WITH THE "COLORADO WATER QUALITY CONTROL ACT" (TITLE 25, ARTICLE 8, CRS), AND THE "CLEAN WATER ACT" (33 USC 1344), IN ADDITION TO THE REQUIREMENTS OF THE LAND DEVELOPMENT CODE, DCM VOLUME II AND THE ECM APPENDIX I. ALL APPROPRIATE PERMITS MUST BE OBTAINED BY THE CONTRACTOR PRIOR TO CONSTRUCTION (1041, NPDES, FLOODPLAIN, 404, FUGITIVE DUST, ETC.). IN THE EVENT OF CONFLICTS BETWEEN THESE REQUIREMENTS AND OTHER LAWS, RULES, OR REGULATIONS OF OTHER FEDERAL, STATE, LOCAL, OR COUNTY AGENCIES, THE MOST RESTRICTIVE LAWS, RULES, OR REGULATIONS SHALL APPLY.
25. ALL CONSTRUCTION TRAFFIC MUST ENTER/EXIT THE SITE ONLY AT APPROVED CONSTRUCTION ACCESS POINTS.
26. PRIOR TO CONSTRUCTION THE PERMITTEE SHALL VERIFY THE LOCATION OF EXISTING UTILITIES.
27. A WATER SOURCE SHALL BE AVAILABLE ON SITE DURING EARTHWORK OPERATIONS AND SHALL BE UTILIZED AS REQUIRED TO MINIMIZE DUST FROM EARTHWORK EQUIPMENT AND WIND.
28. THE SOILS REPORT FOR THIS SITE HAS BEEN PREPARED BY YEH AND ASSOCIATES AND SHALL BE CONSIDERED A PART OF THESE PLANS.
29. AT LEAST TEN (10) DAYS PRIOR TO THE ANTICIPATED START OF CONSTRUCTION, FOR PROJECTS THAT WILL DISTURB ONE (1) ACRE OR MORE, THE OWNER OR OPERATOR OF CONSTRUCTION ACTIVITY SHALL SUBMIT A PERMIT APPLICATION FOR STORMWATER DISCHARGE TO THE COLORADO DEPARTMENT OF PUBLIC HEALTH AND ENVIRONMENT, WATER QUALITY DIVISION. THE APPLICATION CONTAINS CERTIFICATION OF COMPLETION OF A STORMWATER MANAGEMENT PLAN (SMWP), OF WHICH THIS GRADING AND EROSION CONTROL PLAN MAY BE A PART. FOR INFORMATION OR APPLICATION MATERIALS CONTACT:
 COLORADO DEPARTMENT OF PUBLIC HEALTH AND ENVIRONMENT
 WATER QUALITY CONTROL DIVISION
 WQCD - PERMITS
 4300 CHERRY CREEK DRIVE SOUTH
 DENVER, CO 80246-1530
 ATTN: PERMITS UNIT

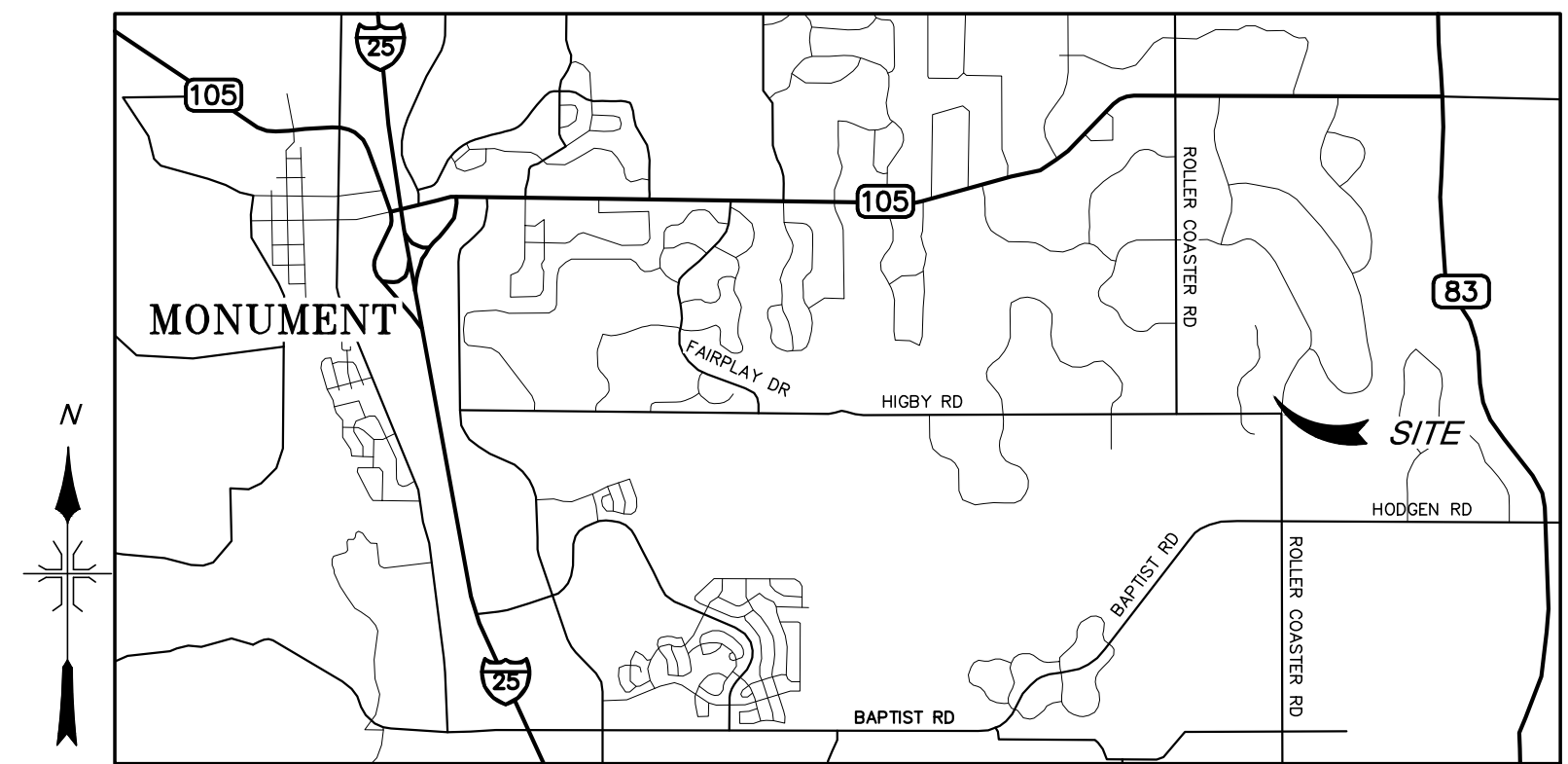

VICINITY MAP
N.T.S.

Site Coordinates (Lat/Long): 39.0808, -104.7858
 Address: 401 Higby Road, Monument, CO

ENGINEER'S STATEMENT:

These detailed plans and specifications were prepared under my direction and supervision. Said plans and specifications have been prepared according to the criteria established by the County for detailed roadway, drainage, grading and erosion control plans and specifications, and said plans and specifications are in conformity with applicable master drainage plans and master transportation plans. Said plans and specifications meet the purposes for which the particular roadway and drainage facilities are designed and are correct to the best of my knowledge and belief. I accept responsibility for any liability caused by any negligent acts, errors or omissions on my part in preparation of these detailed plans and specifications.

Engineer of Record Signature _____ Date _____

OWNER'S STATEMENT:

I, the owner/developer have read and will comply with the requirements of the grading and erosion control plan and all of the requirements specified in these detailed plans and specifications.

Owner Signature _____ Date _____

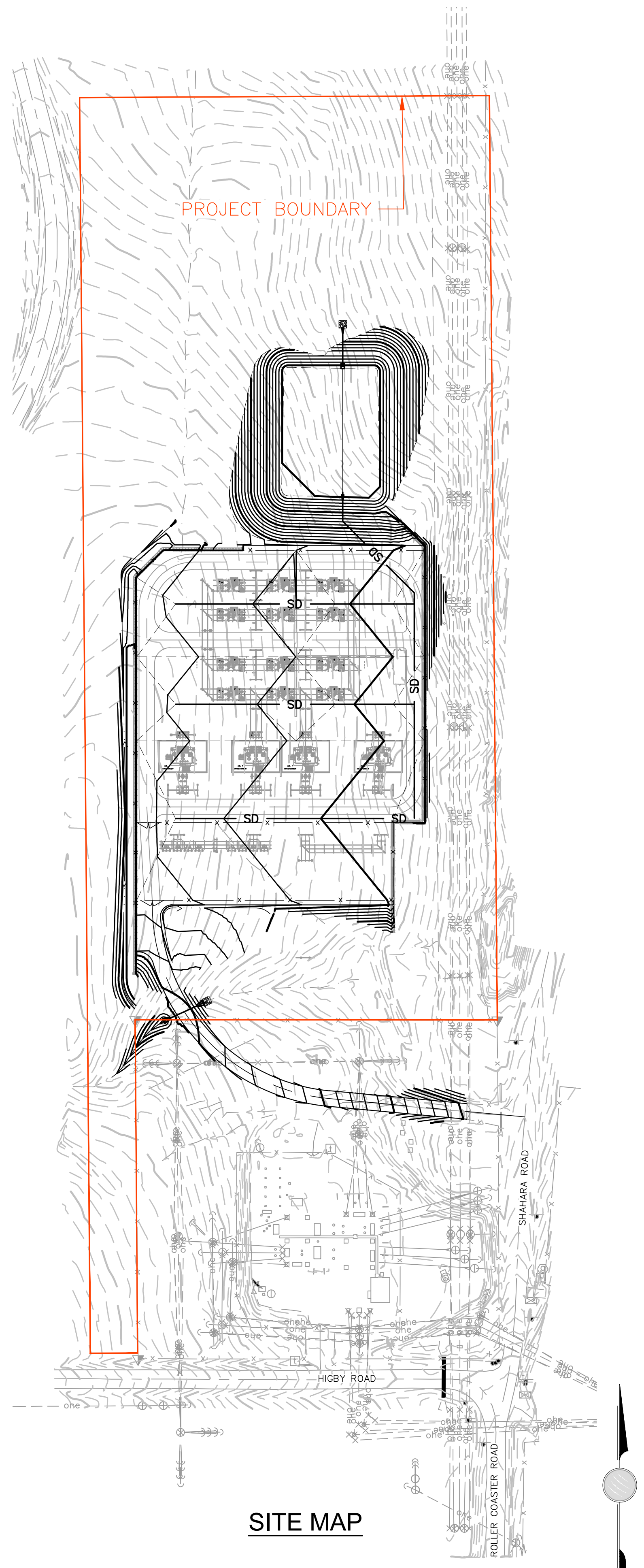

SITE MAP





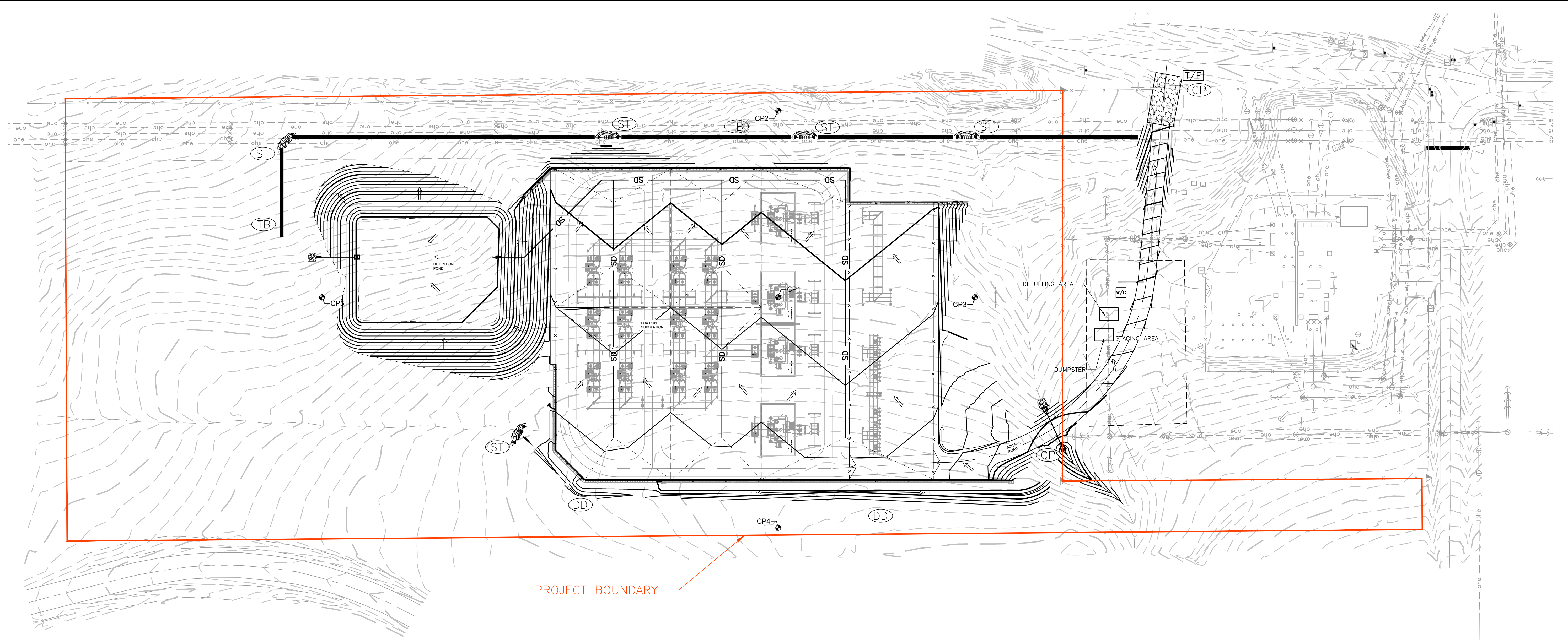

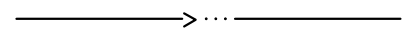

1" = 100'
 Scale in feet
 100' 0 100' 200'

<p>FOX RUN SUBSTATION</p> <p>EROSION CONTROL PLAN NOTES</p> <p>TRI-STATE GENERATION & TRANSMISSION ASSOCIATION, INCORPORATED</p> <p>1100 W. 116th Ave. P.O. Box 33890 Denver, Colorado 80233 303-452-6111</p> <p>UPDATED BY: TC/LEMIT 4/5/2022 12:02 PM Contract: 59088-4-01-SHEETS.dwg PATH: \\DMS14\Projects\Active Projects\2021\21038-1857-Monument Sub-Survey & Civil\Facility\Civil\Sheets\59088-4-01-SHEETS.dwg</p>		<p>Dwg. No. _____</p> <p>Mfr. _____</p> <p>Reference Drawings _____</p>		
<p>No. 7</p>	<p>Date _____</p>	<p>Appd. _____</p>	<p>Revision _____</p>	<p>M.F. _____</p>
<p>TRI-STATE Generation and Transmission Association, Inc. A Touchstone Energy Cooperative</p>		<p>Dwn: TMC</p>	<p>Date: 12/16/21</p>	<p>59088-A-01-016</p>

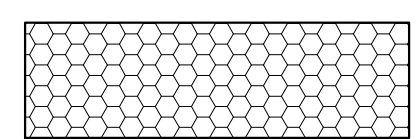

PROJECT BOUNDARY

SYMBOL LEGEND

-  DIVERSION DITCH (DD)
-  TOPSOIL BERM (TB)
-  SEDIMENT TRAP (ST)
-  STRAW WATTLE (SW)
-  CULVERT PROTECTION (CP)
-  INLET PROTECTION (IP)
-  TRACKING PAD (T/P)
-  CONCRETE WASHOUT (WITH LOCATION SIGN)
-  PORTABLE TOILET (W/C)

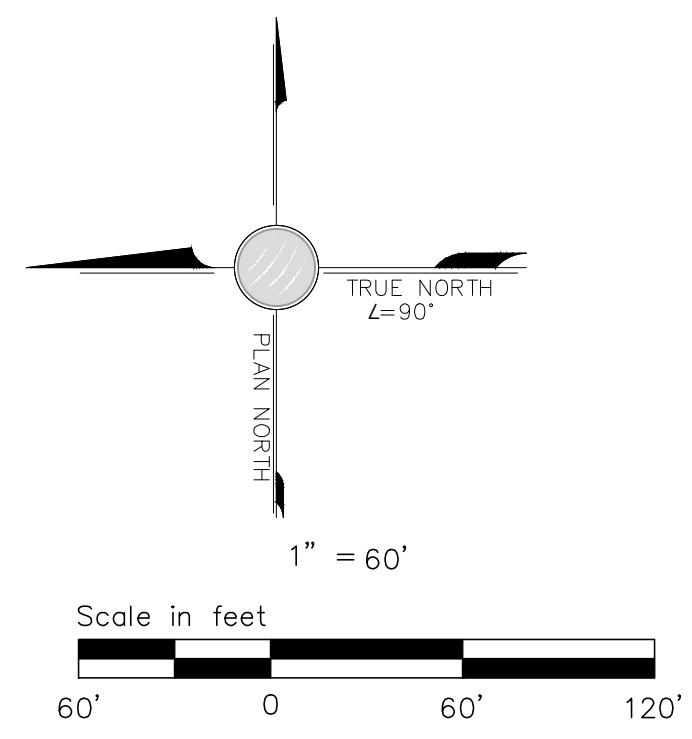

FOX RUN SUBSTATION
EROSION CONTROL PLAN
 TRI-STATE GENERATION & TRANSMISSION ASSOCIATION, INCORPORATED

TRI-STATE
 Generation and Transmission Association, Inc.
 A Touchstone Energy Cooperative
 1100 W. 116th Ave.
 P.O. Box 338905
 Denver, Colorado 80233
 303-452-6111

Dwn: TMC Date: 12/16/21
 Appd: Date:

S9088-A-01-017

No.	Date	Dwn.	Appd.	Revision	M.F.
7					
6					
5					
4					
3					
2					
1					

PRELIMINARY

APPENDIX B: Soil erosion and Sediment Control Measures (CMs) Details

Description

Check dams are temporary grade control structures placed in drainage channels to limit the erosivity of stormwater by reducing flow velocity. Check dams are typically constructed from rock, gravel bags, sand bags, or sometimes, proprietary devices. Reinforced check dams are typically constructed from rock and wire gabion. Although the primary function of check dams is to reduce the velocity of concentrated flows, a secondary benefit is sediment trapping upstream of the structure.



Photograph CD-1. Rock check dams in a roadside ditch. Photo courtesy of WWE.

Appropriate Uses

Use as a grade control for temporary drainage ditches or swales until final soil stabilization measures are established upstream and downstream. Check dams can be used on mild or moderately steep slopes. Check dams may be used under the following conditions:

- As temporary grade control facilities along waterways until final stabilization is established.
- Along permanent swales that need protection prior to installation of a non-erodible lining.
- Along temporary channels, ditches or swales that need protection where construction of a non-erodible lining is not practicable.
- Reinforced check dams should be used in areas subject to high flow velocities.

Design and Installation

Place check dams at regularly spaced intervals along the drainage swale or ditch. Check dams heights should allow for pools to develop upstream of each check dam, extending to the downstream toe of the check dam immediately upstream.

When rock is used for the check dam, place rock mechanically or by hand. Do not dump rocks into the drainage channel. Where multiple check dams are used, the top of the lower dam should be at the same elevation as the toe of the upper dam.

When reinforced check dams are used, install erosion control fabric under and around the check dam to prevent erosion on the upstream and downstream sides. Each section of the dam should be keyed in to reduce the potential for washout or undermining. A rock apron upstream and downstream of the dam may be necessary to further control erosion.

Check Dams	
Functions	
Erosion Control	Yes
Sediment Control	Moderate
Site/Material Management	No

Design details with notes are provided for the following types of check dams:

- Rock Check Dams (CD-1)
- Reinforced Check Dams (CD-2)

Sediment control logs may also be used as check dams; however, silt fence is not appropriate for use as a check dam. Many jurisdictions also prohibit or discourage use of straw bales for this purpose.

Maintenance and Removal

Replace missing rocks causing voids in the check dam. If gravel bags or sandbags are used, replace or repair torn or displaced bags.

Remove accumulated sediment, as needed to maintain BMP effectiveness, typically before the sediment depth upstream of the check dam is within ½ of the crest height. Remove accumulated sediment prior to mulching, seeding, or chemical soil stabilization. Removed sediment can be incorporated into the earthwork with approval from the Project Engineer, or disposed of at an alternate location in accordance with the standard specifications.

Check dams constructed in permanent swales should be removed when perennial grasses have become established, or immediately prior to installation of a non-erodible lining. All of the rock and accumulated sediment should be removed, and the area seeded and mulched, or otherwise stabilized.

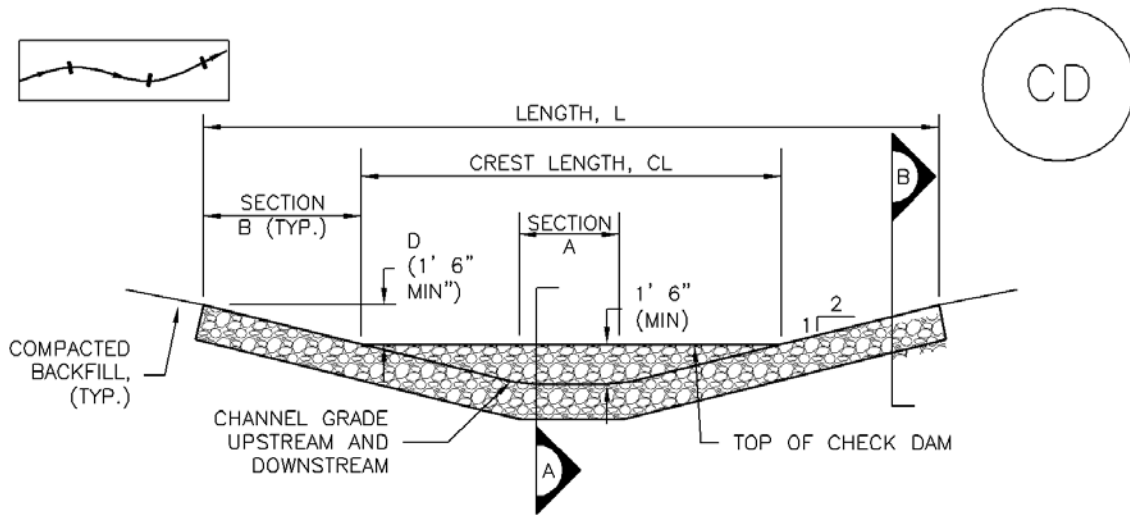

CHECK DAM ELEVATION VIEW

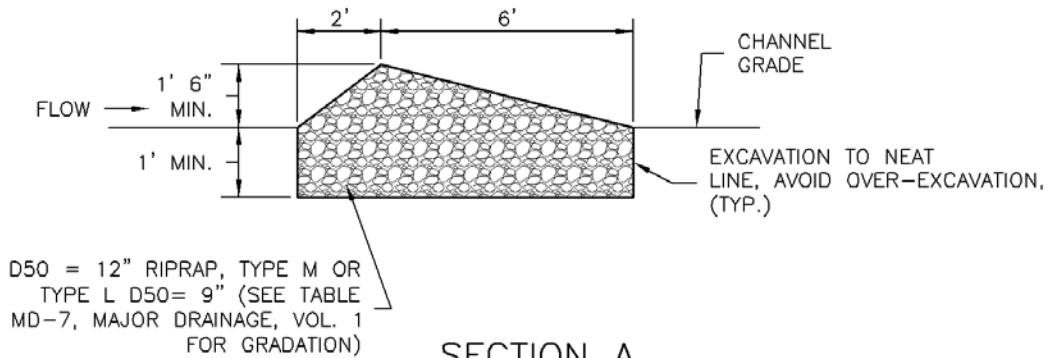

SECTION A

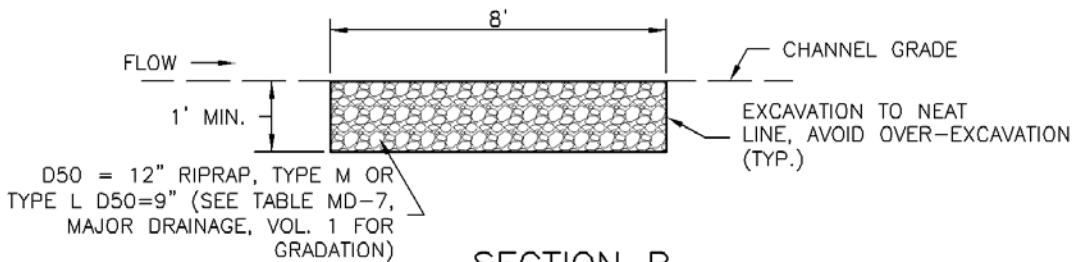

SECTION B

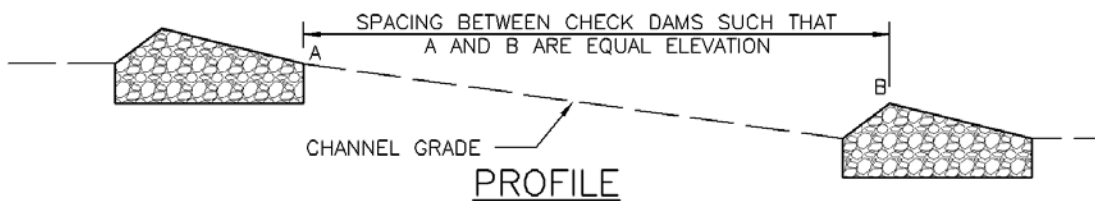

PROFILE

CD-1. CHECK DAM

CHECK DAM INSTALLATION NOTES

1. SEE PLAN VIEW FOR:
 - LOCATION OF CHECK DAMS.
 - CHECK DAM TYPE (CHECK DAM OR REINFORCED CHECK DAM).
 - LENGTH (L), CREST LENGTH (CL), AND DEPTH (D).
2. CHECK DAMS INDICATED ON INITIAL SWMP SHALL BE INSTALLED AFTER CONSTRUCTION FENCE, BUT PRIOR TO ANY UPSTREAM LAND DISTURBING ACTIVITIES.
3. RIPRAP UTILIZED FOR CHECK DAMS SHOULD BE OF APPROPRIATE SIZE FOR THE APPLICATION. TYPICAL TYPES OF RIPRAP USED FOR CHECK DAMS ARE TYPE M (D50 12") OR TYPE L (D50 9").
4. RIPRAP PAD SHALL BE TRENCHED INTO THE GROUND A MINIMUM OF 1'.
5. THE ENDS OF THE CHECK DAM SHALL BE A MINIMUM OF 1' 6" HIGHER THAN THE CENTER OF THE CHECK DAM.

CHECK DAM MAINTENANCE NOTES

1. INSPECT BMPs EACH WORKDAY, AND MAINTAIN THEM IN EFFECTIVE OPERATING CONDITION. MAINTENANCE OF BMPs SHOULD BE PROACTIVE, NOT REACTIVE. INSPECT BMPs AS SOON AS POSSIBLE (AND ALWAYS WITHIN 24 HOURS) FOLLOWING A STORM THAT CAUSES SURFACE EROSION, AND PERFORM NECESSARY MAINTENANCE.
2. FREQUENT OBSERVATIONS AND MAINTENANCE ARE NECESSARY TO MAINTAIN BMPs IN EFFECTIVE OPERATING CONDITION. INSPECTIONS AND CORRECTIVE MEASURES SHOULD BE DOCUMENTED THOROUGHLY.
3. WHERE BMPs HAVE FAILED, REPAIR OR REPLACEMENT SHOULD BE INITIATED UPON DISCOVERY OF THE FAILURE.
4. SEDIMENT ACCUMULATED UPSTREAM OF THE CHECK DAMS SHALL BE REMOVED WHEN THE SEDIMENT DEPTH IS WITHIN $\frac{1}{2}$ OF THE HEIGHT OF THE CREST.
5. CHECK DAMS ARE TO REMAIN IN PLACE UNTIL THE UPSTREAM DISTURBED AREA IS STABILIZED AND APPROVED BY THE LOCAL JURISDICTION.
6. WHEN CHECK DAMS ARE REMOVED, EXCAVATIONS SHALL BE FILLED WITH SUITABLE COMPACTED BACKFILL. DISTURBED AREA SHALL BE SEEDED AND MULCHED AND COVERED WITH GEOTEXTILE OR OTHERWISE STABILIZED IN A MANNER APPROVED BY THE LOCAL JURISDICTION.

(DETAILS ADAPTED FROM DOUGLAS COUNTY, COLORADO, NOT AVAILABLE IN AUTOCAD)

NOTE: MANY JURISDICTIONS HAVE BMP DETAILS THAT VARY FROM UDFCD STANDARD DETAILS. CONSULT WITH LOCAL JURISDICTIONS AS TO WHICH DETAIL SHOULD BE USED WHEN DIFFERENCES ARE NOTED.

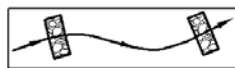

ALTERNATIVE TO STEPS ON BANKS ABOVE CREST:
DEFORM GABIONS AS NECESSARY TO ALIGN TOP OF GABIONS
WITH GROUND SURFACE: AVOID GAPS BETWEEN GABIONS

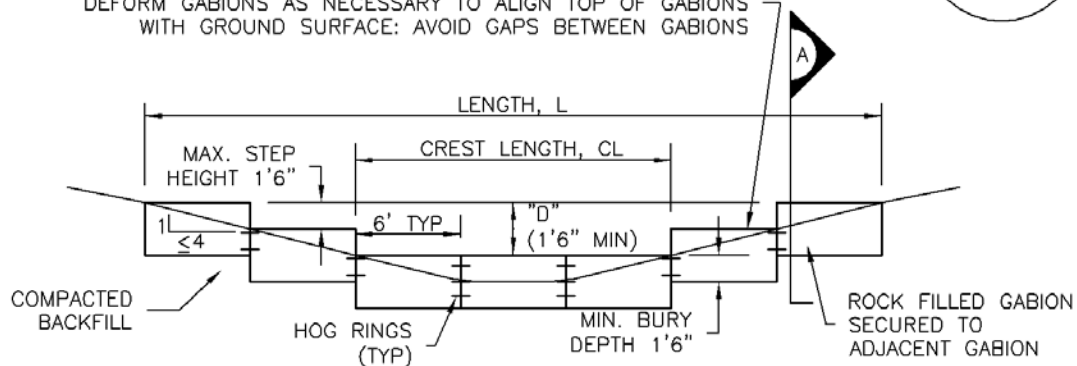

REINFORCED CHECK DAM ELEVATION VIEW

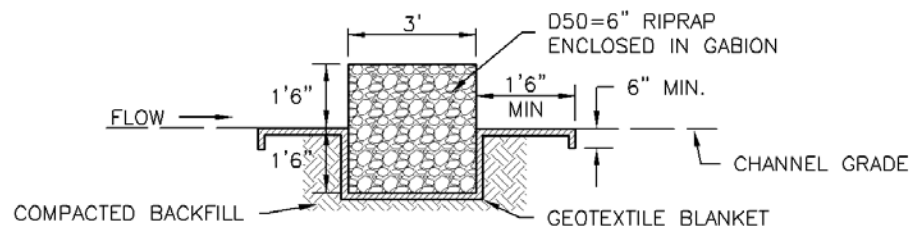

SECTION A

REINFORCED CHECK DAM INSTALLATION NOTES

1. SEE PLAN VIEW FOR:
 - LOCATIONS OF CHECK DAMS.
 - CHECK DAM TYPE (CHECK DAM OR REINFORCED CHECK DAM).
 - LENGTH (L), CREST LENGTH (CL), AND DEPTH (D).
2. CHECK DAMS INDICATED ON THE SWMP SHALL BE INSTALLED PRIOR TO AN UPSTREAM LAND-DISTURBING ACTIVITIES.
3. REINFORCED CHECK DAMS, GABIONS SHALL HAVE GALVANIZED TWISTED WIRE NETTING WITH A MAXIMUM OPENING DIMENSION OF $4\frac{1}{2}$ " AND A MINIMUM WIRE THICKNESS OF 0.10". WIRE "HOG RINGS" AT 4" SPACING OR OTHER APPROVED MEANS SHALL BE USED AT ALL GABION SEAMS AND TO SECURE THE GABION TO THE ADJACENT SECTION.
4. THE CHECK DAM SHALL BE TRENCHED INTO THE GROUND A MINIMUM OF 1' 6".
5. GEOTEXTILE BLANKET SHALL BE PLACED IN THE REINFORCED CHECK DAM TRENCH EXTENDING A MINIMUM OF 1' 6" ON BOTH THE UPSTREAM AND DOWNSTREAM SIDES OF THE REINFORCED CHECK DAM.

CD-2. REINFORCED CHECK DAM

REINFORCED CHECK DAM MAINTENANCE NOTES

1. INSPECT BMPs EACH WORKDAY, AND MAINTAIN THEM IN EFFECTIVE OPERATING CONDITION. MAINTENANCE OF BMPs SHOULD BE PROACTIVE, NOT REACTIVE. INSPECT BMPs AS SOON AS POSSIBLE (AND ALWAYS WITHIN 24 HOURS) FOLLOWING A STORM THAT CAUSES SURFACE EROSION, AND PERFORM NECESSARY MAINTENANCE.
2. FREQUENT OBSERVATIONS AND MAINTENANCE ARE NECESSARY TO MAINTAIN BMPs IN EFFECTIVE OPERATING CONDITION. INSPECTIONS AND CORRECTIVE MEASURES SHOULD BE DOCUMENTED THOROUGHLY.
3. WHERE BMPs HAVE FAILED, REPAIR OR REPLACEMENT SHOULD BE INITIATED UPON DISCOVERY OF THE FAILURE.
4. SEDIMENT ACCUMULATED UPSTREAM OF REINFORCED CHECK DAMS SHALL BE REMOVED AS NEEDED TO MAINTAIN THE EFFECTIVENESS OF BMP, TYPICALLY WHEN THE UPSTREAM SEDIMENT DEPTH IS WITHIN ½ THE HEIGHT OF THE CREST.
5. REPAIR OR REPLACE REINFORCED CHECK DAMS WHEN THERE ARE SIGNS OF DAMAGE SUCH AS HOLES IN THE GABION OR UNDERCUTTING.
6. REINFORCED CHECK DAMS ARE TO REMAIN IN PLACE UNTIL THE UPSTREAM DISTURBED AREA IS STABILIZED AND APPROVED BY THE LOCAL JURISDICTION.
7. WHEN REINFORCED CHECK DAMS ARE REMOVED, ALL DISTURBED AREAS SHALL BE COVERED WITH TOPSOIL, SEEDED AND MULCHED, AND COVERED WITH A GEOTEXTILE BLANKET, OR OTHERWISE STABILIZED AS APPROVED BY LOCAL JURISDICTION.

(DETAIL ADAPTED FROM DOUGLAS COUNTY, COLORADO AND CITY OF AURORA, COLORADO, NOT AVAILABLE IN AUTOCAD)

NOTE: MANY JURISDICTIONS HAVE BMP DETAILS THAT VARY FROM UDFCD STANDARD DETAILS. CONSULT WITH LOCAL JURISDICTIONS AS TO WHICH DETAIL SHOULD BE USED WHEN DIFFERENCES ARE NOTED.

Description

Concrete waste management involves designating and properly managing a specific area of the construction site as a concrete washout area. A concrete washout area can be created using one of several approaches designed to receive wash water from washing of tools and concrete mixer chutes, liquid concrete waste from dump trucks, mobile batch mixers, or pump trucks. Three basic approaches are available: excavation of a pit in the ground, use of an above ground storage area, or use of prefabricated haul-away concrete washout containers. Surface discharges of concrete washout water from construction sites are prohibited.



Photograph CWA-1. Example of concrete washout area. Note gravel tracking pad for access and sign.

Appropriate Uses

Concrete washout areas must be designated on all sites that will generate concrete wash water or liquid concrete waste from onsite concrete mixing or concrete delivery.

Because pH is a pollutant of concern for washout activities, when unlined pits are used for concrete washout, the soil must have adequate buffering capacity to result in protection of state groundwater standards; otherwise, a liner/containment must be used. The following management practices are recommended to prevent an impact from unlined pits to groundwater:

- The use of the washout site should be temporary (less than 1 year), and
- The washout site should be not be located in an area where shallow groundwater may be present, such as near natural drainages, springs, or wetlands.

Design and Installation

Concrete washout activities must be conducted in a manner that does not contribute pollutants to surface waters or stormwater runoff. Concrete washout areas may be lined or unlined excavated pits in the ground, commercially manufactured prefabricated washout containers, or aboveground holding areas constructed of berms, sandbags or straw bales with a plastic liner.

Although unlined washout areas may be used, lined pits may be required to protect groundwater under certain conditions.

Do not locate an unlined washout area within 400 feet of any natural drainage pathway or waterbody or within 1,000 feet of any wells or drinking water sources. Even for lined concrete washouts, it is advisable to locate the facility away from waterbodies and drainage paths. If site constraints make these

Concrete Washout Area	
Functions	
Erosion Control	No
Sediment Control	No
Site/Material Management	Yes

setbacks infeasible or if highly permeable soils exist in the area, then the pit must be installed with an impermeable liner (16 mil minimum thickness) or surface storage alternatives using prefabricated concrete washout devices or a lined aboveground storage area should be used.

Design details with notes are provided in Detail CWA-1 for pits and CWA-2 for aboveground storage areas. Pre-fabricated concrete washout container information can be obtained from vendors.

Maintenance and Removal

A key consideration for concrete washout areas is to ensure that adequate signage is in place identifying the location of the washout area. Part of inspecting and maintaining washout areas is ensuring that adequate signage is provided and in good repair and that the washout area is being used, as opposed to washout in non-designated areas of the site.

Remove concrete waste in the washout area, as needed to maintain BMP function (typically when filled to about two-thirds of its capacity). Collect concrete waste and deliver offsite to a designated disposal location.

Upon termination of use of the washout site, accumulated solid waste, including concrete waste and any contaminated soils, must be removed from the site to prevent on-site disposal of solid waste. If the wash water is allowed to evaporate and the concrete hardens, it may be recycled.



Photograph CWA-2. Prefabricated concrete washout. Photo courtesy of CDOT.



Photograph CWA-3. Earthen concrete washout. Photo courtesy of CDOT.

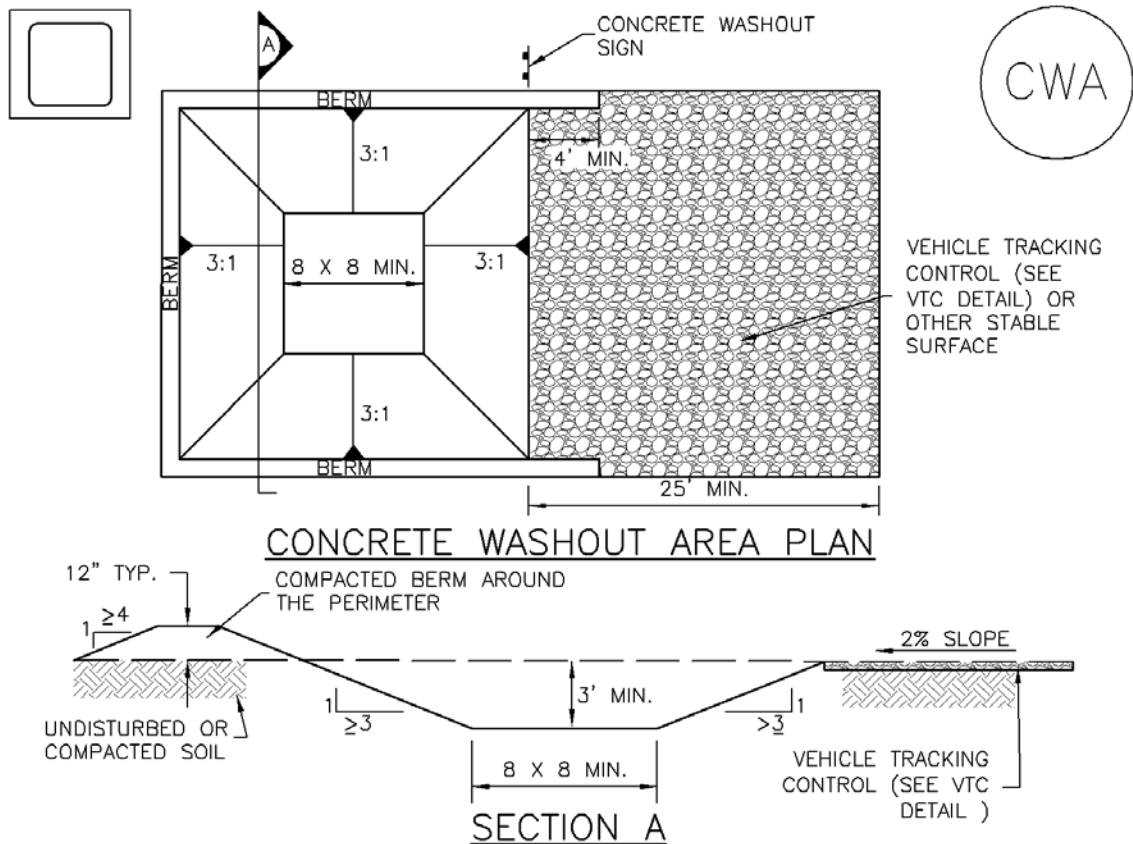

CWA-1. CONCRETE WASHOUT AREA

CWA INSTALLATION NOTES

1. SEE PLAN VIEW FOR:
-CWA INSTALLATION LOCATION.
2. DO NOT LOCATE AN UNLINED CWA WITHIN 400' OF ANY NATURAL DRAINAGE PATHWAY OR WATERBODY. DO NOT LOCATE WITHIN 1,000' OF ANY WELLS OR DRINKING WATER SOURCES. IF SITE CONSTRAINTS MAKE THIS INFEASIBLE, OR IF HIGHLY PERMEABLE SOILS EXIST ON SITE, THE CWA MUST BE INSTALLED WITH AN IMPERMEABLE LINER (16 MIL MIN. THICKNESS) OR SURFACE STORAGE ALTERNATIVES USING PREFABRICATED CONCRETE WASHOUT DEVICES OR A LINED ABOVE GROUND STORAGE ARE SHOULD BE USED.
3. THE CWA SHALL BE INSTALLED PRIOR TO CONCRETE PLACEMENT ON SITE.
4. CWA SHALL INCLUDE A FLAT SUBSURFACE PIT THAT IS AT LEAST 8' BY 8' SLOPES LEADING OUT OF THE SUBSURFACE PIT SHALL BE 3:1 OR FLATTER. THE PIT SHALL BE AT LEAST 3' DEEP.
5. BERM SURROUNDING SIDES AND BACK OF THE CWA SHALL HAVE MINIMUM HEIGHT OF 1'.
6. VEHICLE TRACKING PAD SHALL BE SLOPED 2% TOWARDS THE CWA.
7. SIGNS SHALL BE PLACED AT THE CONSTRUCTION ENTRANCE, AT THE CWA, AND ELSEWHERE AS NECESSARY TO CLEARLY INDICATE THE LOCATION OF THE CWA TO OPERATORS OF CONCRETE TRUCKS AND PUMP RIGS.
8. USE EXCAVATED MATERIAL FOR PERIMETER BERM CONSTRUCTION.

CWA MAINTENANCE NOTES

1. INSPECT BMPs EACH WORKDAY, AND MAINTAIN THEM IN EFFECTIVE OPERATING CONDITION. MAINTENANCE OF BMPs SHOULD BE PROACTIVE, NOT REACTIVE. INSPECT BMPs AS SOON AS POSSIBLE (AND ALWAYS WITHIN 24 HOURS) FOLLOWING A STORM THAT CAUSES SURFACE EROSION, AND PERFORM NECESSARY MAINTENANCE.

2. FREQUENT OBSERVATIONS AND MAINTENANCE ARE NECESSARY TO MAINTAIN BMPs IN EFFECTIVE OPERATING CONDITION. INSPECTIONS AND CORRECTIVE MEASURES SHOULD BE DOCUMENTED THOROUGHLY.

3. WHERE BMPs HAVE FAILED, REPAIR OR REPLACEMENT SHOULD BE INITIATED UPON DISCOVERY OF THE FAILURE.

4. THE CWA SHALL BE REPAIRED, CLEANED, OR ENLARGED AS NECESSARY TO MAINTAIN CAPACITY FOR CONCRETE WASTE. CONCRETE MATERIALS, ACCUMULATED IN PIT, SHALL BE REMOVED ONCE THE MATERIALS HAVE REACHED A DEPTH OF 2'.

5. CONCRETE WASHOUT WATER, WASTED PIECES OF CONCRETE AND ALL OTHER DEBRIS IN THE SUBSURFACE PIT SHALL BE TRANSPORTED FROM THE JOB SITE IN A WATER-TIGHT CONTAINER AND DISPOSED OF PROPERLY.

6. THE CWA SHALL REMAIN IN PLACE UNTIL ALL CONCRETE FOR THE PROJECT IS PLACED.

7. WHEN THE CWA IS REMOVED, COVER THE DISTURBED AREA WITH TOP SOIL, SEED AND MULCH OR OTHERWISE STABILIZED IN A MANNER APPROVED BY THE LOCAL JURISDICTION.

(DETAIL ADAPTED FROM DOUGLAS COUNTY, COLORADO AND THE CITY OF PARKER, COLORADO, NOT AVAILABLE IN AUTOCAD).

NOTE: MANY JURISDICTIONS HAVE BMP DETAILS THAT VARY FROM UDFCD STANDARD DETAILS. CONSULT WITH LOCAL JURISDICTIONS AS TO WHICH DETAIL SHOULD BE USED WHEN DIFFERENCES ARE NOTED.

CONCRETE WASHOUT "KIDDIE" POOL

N.T.S

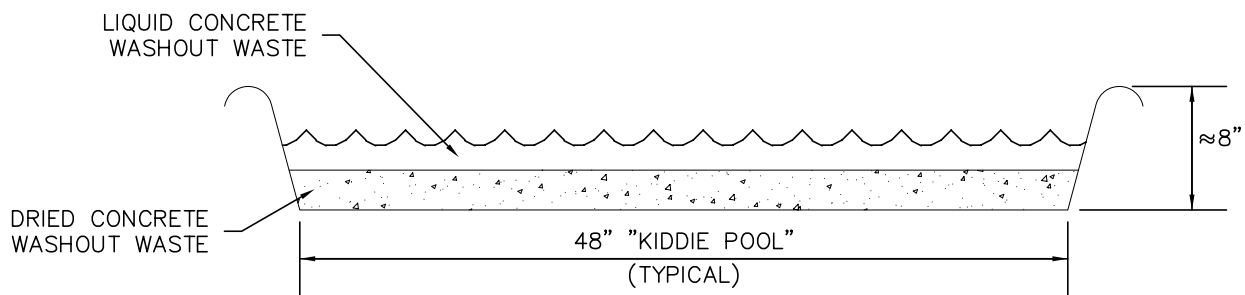

NOTES:

1. Use only rigid, prefabricated impermeable plastic wading pool.
2. Inspect Containment for waterproof integrity prior to each use.
3. Do not fill Containment more than 50% of capacity with either liquid or solid concrete waste.
4. Immediately after each use, cover the Containment with a waterproof barrier to prevent collection of rain water or snow.
5. Properly dispose of dried concrete waste at a landfill when the project is complete or when waste reaches a 50% capacity.



DEL-MONT CONSULTANTS, INC.
ENGINEERING ▾ SURVEYING ▾ PLANNING
128 Colorado Ave. ▾ Montrose, CO 81401 ▾ (877) 240-2251 ▾ (877) 240-2342 ext.
www.del-mont.com ▾ service@del-mont.com

DESIGNED BY:

N/A

SCALE:

N.T.S.

CHECKED BY:

SNS

FILE NAME:

CONCRETE WASHOUT - KIDDIE POOL

BMP DETAIL
CONCRETE WASHOUT - "KIDDIE" POOL

D.M. JOB NO.:

N/A

DATE ISSUED:

5-13-2011

SHEET:

1 of 1

Description

Inlet protection consists of permeable barriers installed around an inlet to filter runoff and remove sediment prior to entering a storm drain inlet. Inlet protection can be constructed from rock socks, sediment control logs, silt fence, block and rock socks, or other materials approved by the local jurisdiction. Area inlets can also be protected by over-excavating around the inlet to form a sediment trap.



Photograph IP-1. Inlet protection for a curb opening inlet.

Appropriate Uses

Install protection at storm sewer inlets that are operable during construction. Consider the potential for tracked-out sediment or temporary stockpile areas to contribute sediment to inlets when determining which inlets must be protected. This may include inlets in the general proximity of the construction area, not limited to downgradient inlets. Inlet protection is not a stand-alone BMP and should be used in conjunction with other upgradient BMPs.

Design and Installation

To function effectively, inlet protection measures must be installed to ensure that flows do not bypass the inlet protection and enter the storm drain without treatment. However, designs must also enable the inlet to function without completely blocking flows into the inlet in a manner that causes localized flooding. When selecting the type of inlet protection, consider factors such as type of inlet (e.g., curb or area, sump or on-grade conditions), traffic, anticipated flows, ability to secure the BMP properly, safety and other site-specific conditions. For example, block and rock socks will be better suited to a curb and gutter along a roadway, as opposed to silt fence or sediment control logs, which cannot be properly secured in a curb and gutter setting, but are effective area inlet protection measures.

Several inlet protection designs are provided in the Design Details. Additionally, a variety of proprietary products are available for inlet protection that may be approved for use by local governments. If proprietary products are used, design details and installation procedures from the manufacturer must be followed. Regardless of the type of inlet protection selected, inlet protection is most effective when combined with other BMPs such as curb socks and check dams. Inlet protection is often the last barrier before runoff enters the storm sewer or receiving water.

Design details with notes are provided for these forms of inlet protection:

- IP-1. Block and Rock Sock Inlet Protection for Sump or On-grade Inlets
- IP-2. Curb (Rock) Socks Upstream of Inlet Protection, On-grade Inlets

Inlet Protection (various forms)	
Functions	
Erosion Control	No
Sediment Control	Yes
Site/Material Management	No

IP-3. Rock Sock Inlet Protection for Sump/Area Inlet

IP-4. Silt Fence Inlet Protection for Sump/Area Inlet

IP-5. Over-excavation Inlet Protection

IP-6. Straw Bale Inlet Protection for Sump/Area Inlet

CIP-1. Culvert Inlet Protection

Proprietary inlet protection devices should be installed in accordance with manufacturer specifications.

More information is provided below on selecting inlet protection for sump and on-grade locations.

Inlets Located in a Sump

When applying inlet protection in sump conditions, it is important that the inlet continue to function during larger runoff events. For curb inlets, the maximum height of the protective barrier should be lower than the top of the curb opening to allow overflow into the inlet during larger storms without excessive localized flooding. If the inlet protection height is greater than the curb elevation, particularly if the filter becomes clogged with sediment, runoff will not enter the inlet and may bypass it, possibly causing localized flooding, public safety issues, and downstream erosion and damage from bypassed flows.

Area inlets located in a sump setting can be protected through the use of silt fence, concrete block and rock socks (on paved surfaces), sediment control logs/straw wattles embedded in the adjacent soil and stacked around the area inlet (on pervious surfaces), over-excavation around the inlet, and proprietary products providing equivalent functions.

Inlets Located on a Slope

For curb and gutter inlets on paved sloping streets, block and rock sock inlet protection is recommended in conjunction with curb socks in the gutter leading to the inlet. For inlets located along unpaved roads, also see the Check Dam Fact Sheet.

Maintenance and Removal

Inspect inlet protection frequently. Inspection and maintenance guidance includes:

- Inspect for tears that can result in sediment directly entering the inlet, as well as result in the contents of the BMP (e.g., gravel) washing into the inlet.
- Check for improper installation resulting in untreated flows bypassing the BMP and directly entering the inlet or bypassing to an unprotected downstream inlet. For example, silt fence that has not been properly trenched around the inlet can result in flows under the silt fence and directly into the inlet.
- Look for displaced BMPs that are no longer protecting the inlet. Displacement may occur following larger storm events that wash away or reposition the inlet protection. Traffic or equipment may also crush or displace the BMP.
- Monitor sediment accumulation upgradient of the inlet protection.

- Remove sediment accumulation from the area upstream of the inlet protection, as needed to maintain BMP effectiveness, typically when it reaches no more than half the storage capacity of the inlet protection. For silt fence, remove sediment when it accumulates to a depth of no more than 6 inches. Remove sediment accumulation from the area upstream of the inlet protection as needed to maintain the functionality of the BMP.
- Proprietary inlet protection devices should be inspected and maintained in accordance with manufacturer specifications. If proprietary inlet insert devices are used, sediment should be removed in a timely manner to prevent devices from breaking and spilling sediment into the storm drain.

Inlet protection must be removed and properly disposed of when the drainage area for the inlet has reached final stabilization.

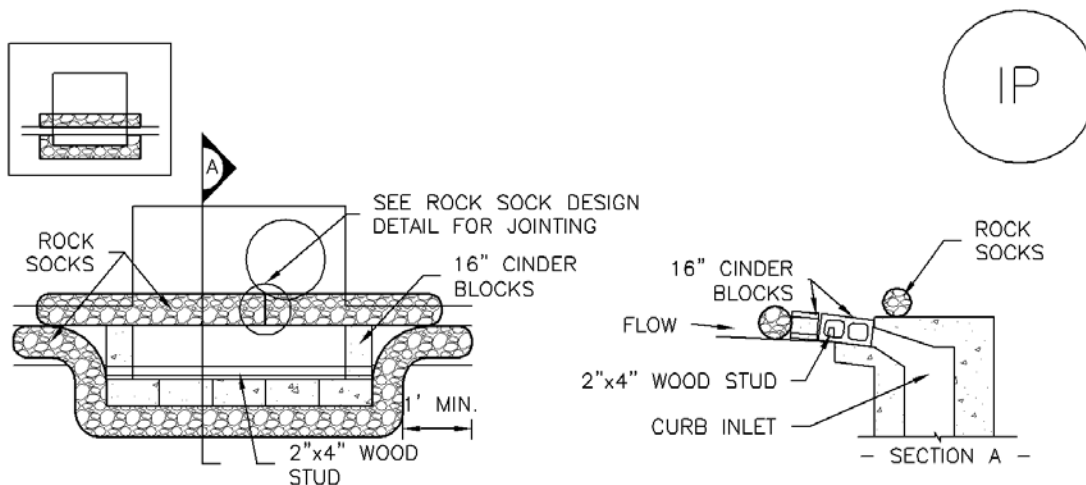

IP-1. BLOCK AND ROCK SOCK SUMP OR ON GRADE INLET PROTECTION

BLOCK AND CURB SOCK INLET PROTECTION INSTALLATION NOTES

1. SEE ROCK SOCK DESIGN DETAIL FOR INSTALLATION REQUIREMENTS.
2. CONCRETE "CINDER" BLOCKS SHALL BE LAID ON THEIR SIDES AROUND THE INLET IN A SINGLE ROW, ABUTTING ONE ANOTHER WITH THE OPEN END FACING AWAY FROM THE CURB.
3. GRAVEL BAGS SHALL BE PLACED AROUND CONCRETE BLOCKS, CLOSELY ABUTTING ONE ANOTHER AND JOINTED TOGETHER IN ACCORDANCE WITH ROCK SOCK DESIGN DETAIL.

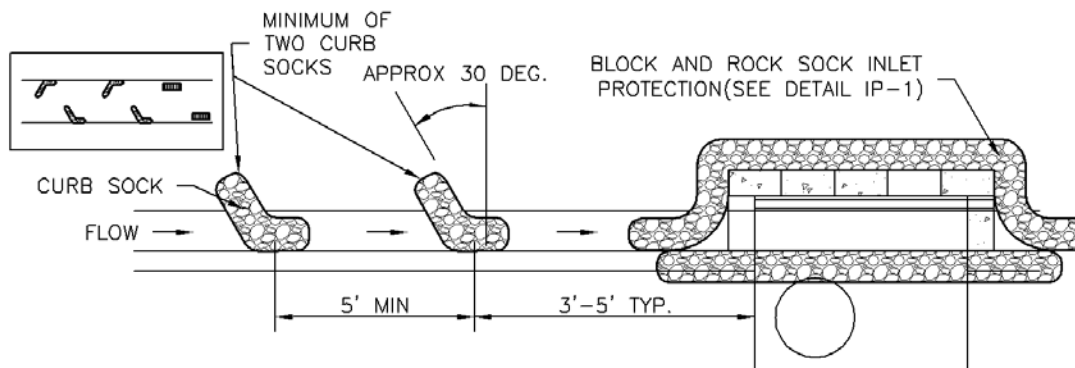

IP-2. CURB ROCK SOCKS UPSTREAM OF INLET PROTECTION

CURB ROCK SOCK INLET PROTECTION INSTALLATION NOTES

1. SEE ROCK SOCK DESIGN DETAIL INSTALLATION REQUIREMENTS.
2. PLACEMENT OF THE SOCK SHALL BE APPROXIMATELY 30 DEGREES FROM PERPENDICULAR IN THE OPPOSITE DIRECTION OF FLOW.
3. SOCKS ARE TO BE FLUSH WITH THE CURB AND SPACED A MINIMUM OF 5 FEET APART.
4. AT LEAST TWO CURB SOCKS IN SERIES ARE REQUIRED UPSTREAM OF ON-GRADE INLETS.

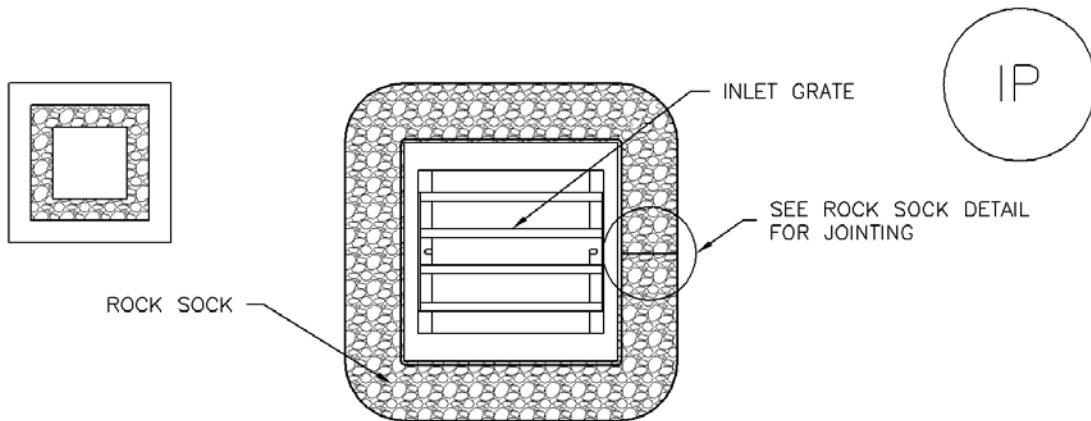

IP-3. ROCK SOCK SUMP/AREA INLET PROTECTION

ROCK SOCK SUMP/AREA INLET PROTECTION INSTALLATION NOTES

1. SEE ROCK SOCK DESIGN DETAIL FOR INSTALLATION REQUIREMENTS.
2. STRAW WATTLES/SEDIMENT CONTROL LOGS MAY BE USED IN PLACE OF ROCK SOCKS FOR INLETS IN PERVIOUS AREAS. INSTALL PER SEDIMENT CONTROL LOG DETAIL.

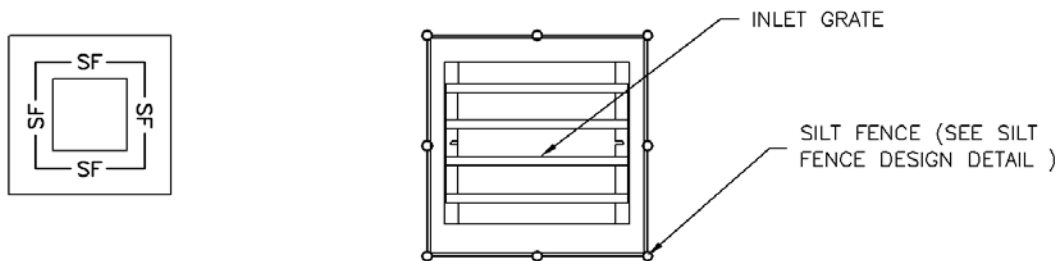

IP-4. SILT FENCE FOR SUMP INLET PROTECTION

SILT FENCE INLET PROTECTION INSTALLATION NOTES

1. SEE SILT FENCE DESIGN DETAIL FOR INSTALLATION REQUIREMENTS.
2. POSTS SHALL BE PLACED AT EACH CORNER OF THE INLET AND AROUND THE EDGES AT A MAXIMUM SPACING OF 3 FEET.
3. STRAW WATTLES/SEDIMENT CONTROL LOGS MAY BE USED IN PLACE OF SILT FENCE FOR INLETS IN PERVIOUS AREAS. INSTALL PER SEDIMENT CONTROL LOG DETAIL.

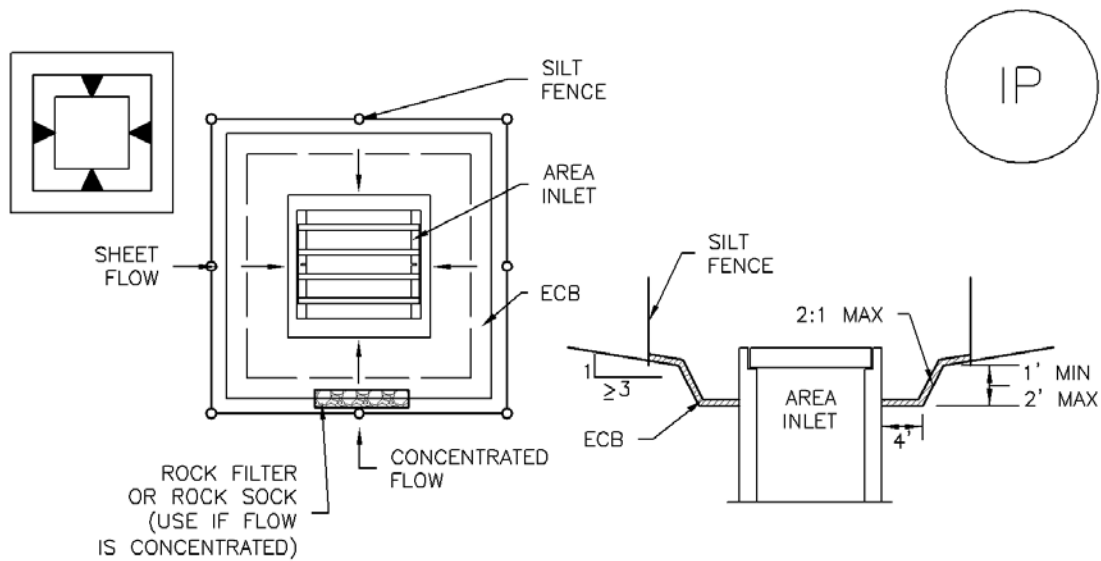

IP-5. OVEREXCAVATION INLET PROTECTION

OVEREXCAVATION INLET PROTECTION INSTALLATION NOTES

1. THIS FORM OF INLET PROTECTION IS PRIMARILY APPLICABLE FOR SITES THAT HAVE NOT YET REACHED FINAL GRADE AND SHOULD BE USED ONLY FOR INLETS WITH A RELATIVELY SMALL CONTRIBUTING DRAINAGE AREA.
2. WHEN USING FOR CONCENTRATED FLOWS, SHAPE BASIN IN 2:1 RATIO WITH LENGTH ORIENTED TOWARDS DIRECTION OF FLOW.
3. SEDIMENT MUST BE PERIODICALLY REMOVED FROM THE OVEREXCAVATED AREA.

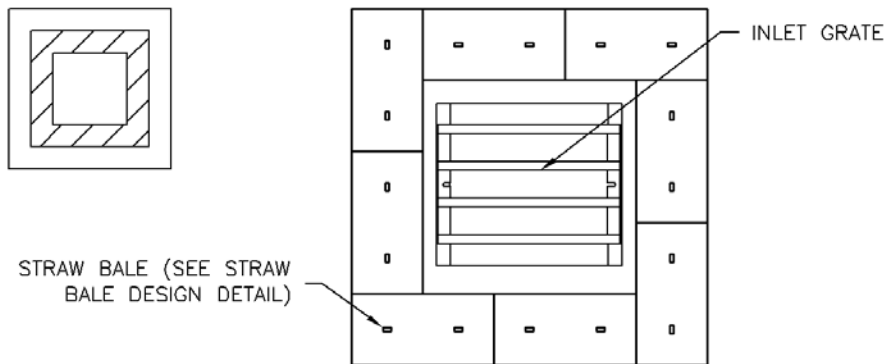

IP-6. STRAW BALE FOR SUMP INLET PROTECTION

STRAW BALE BARRIER INLET PROTECTION INSTALLATION NOTES

1. SEE STRAW BALE DESIGN DETAIL FOR INSTALLATION REQUIREMENTS.
2. BALES SHALL BE PLACED IN A SINGLE ROW AROUND THE INLET WITH ENDS OF BALES TIGHTLY ABUTTING ONE ANOTHER.

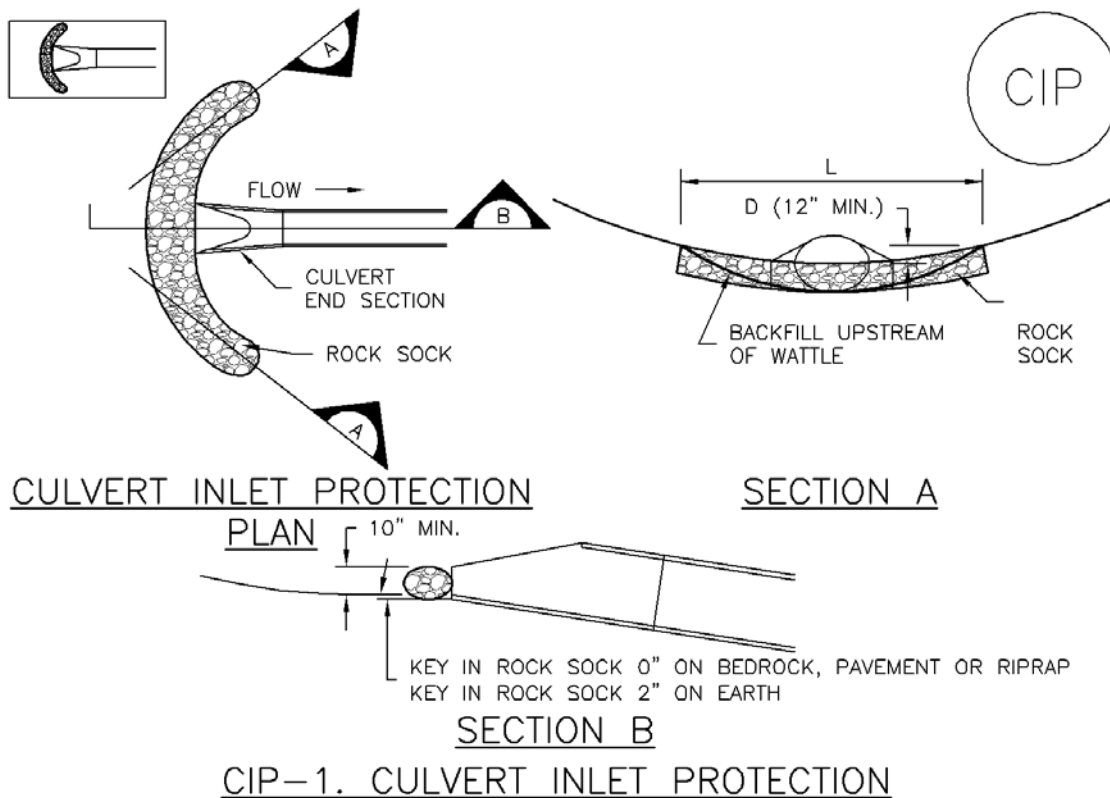

CULVERT INLET PROTECTION INSTALLATION NOTES

1. SEE PLAN VIEW FOR
-LOCATION OF CULVERT INLET PROTECTION.
2. SEE ROCK SOCK DESIGN DETAIL FOR ROCK GRADATION REQUIREMENTS AND JOINTING DETAIL.

CULVERT INLET PROTECTION MAINTENANCE NOTES

1. INSPECT BMPs EACH WORKDAY, AND MAINTAIN THEM IN EFFECTIVE OPERATING CONDITION. MAINTENANCE OF BMPs SHOULD BE PROACTIVE, NOT REACTIVE. INSPECT BMPs AS SOON AS POSSIBLE (AND ALWAYS WITHIN 24 HOURS) FOLLOWING A STORM THAT CAUSES SURFACE EROSION, AND PERFORM NECESSARY MAINTENANCE.
2. FREQUENT OBSERVATIONS AND MAINTENANCE ARE NECESSARY TO MAINTAIN BMPs IN EFFECTIVE OPERATING CONDITION. INSPECTIONS AND CORRECTIVE MEASURES SHOULD BE DOCUMENTED THOROUGHLY.
3. WHERE BMPs HAVE FAILED, REPAIR OR REPLACEMENT SHOULD BE INITIATED UPON DISCOVERY OF THE FAILURE.
4. SEDIMENT ACCUMULATED UPSTREAM OF THE CULVERT SHALL BE REMOVED WHEN THE SEDIMENT DEPTH IS 1/2 THE HEIGHT OF THE ROCK SOCK.
5. CULVERT INLET PROTECTION SHALL REMAIN IN PLACE UNTIL THE UPSTREAM DISTURBED AREA IS PERMANENTLY STABILIZED AND APPROVED BY THE LOCAL JURISDICTION.

(DETAILS ADAPTED FROM AURORA, COLORADO, NOT AVAILABLE IN AUTOCAD)

NOTE: MANY JURISDICTIONS HAVE BMP DETAILS THAT VARY FROM UDFCD STANDARD DETAILS. CONSULT WITH LOCAL JURISDICTIONS AS TO WHICH DETAIL SHOULD BE USED WHEN DIFFERENCES ARE NOTED.

GENERAL INLET PROTECTION INSTALLATION NOTES

1. SEE PLAN VIEW FOR:
 - LOCATION OF INLET PROTECTION.
 - TYPE OF INLET PROTECTION (IP.1, IP.2, IP.3, IP.4, IP.5, IP.6)
2. INLET PROTECTION SHALL BE INSTALLED PROMPTLY AFTER INLET CONSTRUCTION OR PAVING IS COMPLETE (TYPICALLY WITHIN 48 HOURS). IF A RAINFALL/RUNOFF EVENT IS FORECAST, INSTALL INLET PROTECTION PRIOR TO ONSET OF EVENT.
3. MANY JURISDICTIONS HAVE BMP DETAILS THAT VARY FROM UDFCD STANDARD DETAILS. CONSULT WITH LOCAL JURISDICTIONS AS TO WHICH DETAIL SHOULD BE USED WHEN DIFFERENCES ARE NOTED.

INLET PROTECTION MAINTENANCE NOTES

1. INSPECT BMPs EACH WORKDAY, AND MAINTAIN THEM IN EFFECTIVE OPERATING CONDITION. MAINTENANCE OF BMPs SHOULD BE PROACTIVE, NOT REACTIVE. INSPECT BMPs AS SOON AS POSSIBLE (AND ALWAYS WITHIN 24 HOURS) FOLLOWING A STORM THAT CAUSES SURFACE EROSION, AND PERFORM NECESSARY MAINTENANCE.
2. FREQUENT OBSERVATIONS AND MAINTENANCE ARE NECESSARY TO MAINTAIN BMPs IN EFFECTIVE OPERATING CONDITION. INSPECTIONS AND CORRECTIVE MEASURES SHOULD BE DOCUMENTED THOROUGHLY.
3. WHERE BMPs HAVE FAILED, REPAIR OR REPLACEMENT SHOULD BE INITIATED UPON DISCOVERY OF THE FAILURE.
4. SEDIMENT ACCUMULATED UPSTREAM OF INLET PROTECTION SHALL BE REMOVED AS NECESSARY TO MAINTAIN BMP EFFECTIVENESS, TYPICALLY WHEN STORAGE VOLUME REACHES 50% OF CAPACITY, A DEPTH OF 6" WHEN SILT FENCE IS USED, OR ¼ OF THE HEIGHT FOR STRAW BALES.
5. INLET PROTECTION IS TO REMAIN IN PLACE UNTIL THE UPSTREAM DISTURBED AREA IS PERMANENTLY STABILIZED, UNLESS THE LOCAL JURISDICTION APPROVES EARLIER REMOVAL OF INLET PROTECTION IN STREETS.
6. WHEN INLET PROTECTION AT AREA INLETS IS REMOVED, THE DISTURBED AREA SHALL BE COVERED WITH TOP SOIL, SEEDED AND MULCHED, OR OTHERWISE STABILIZED IN A MANNER APPROVED BY THE LOCAL JURISDICTION.

(DETAIL ADAPTED FROM TOWN OF PARKER, COLORADO AND CITY OF AURORA, COLORADO, NOT AVAILABLE IN AUTOCAD)

NOTE: MANY JURISDICTIONS HAVE BMP DETAILS THAT VARY FROM UDFCD STANDARD DETAILS. CONSULT WITH LOCAL JURISDICTIONS AS TO WHICH DETAIL SHOULD BE USED WHEN DIFFERENCES ARE NOTED.

NOTE: THE DETAILS INCLUDED WITH THIS FACT SHEET SHOW COMMONLY USED, CONVENTIONAL METHODS OF INLET PROTECTION IN THE DENVER METROPOLITAN AREA. THERE ARE MANY PROPRIETARY INLET PROTECTION METHODS ON THE MARKET. UDFCD NEITHER ENDORSES NOR DISCOURAGES USE OF PROPRIETARY INLET PROTECTION; HOWEVER, IN THE EVENT PROPRIETARY METHODS ARE USED, THE APPROPRIATE DETAIL FROM THE MANUFACTURER MUST BE INCLUDED IN THE SWMP AND THE BMP MUST BE INSTALLED AND MAINTAINED AS SHOWN IN THE MANUFACTURER'S DETAILS.

NOTE: SOME MUNICIPALITIES DISCOURAGE OR PROHIBIT THE USE OF STRAW BALES FOR INLET PROTECTION. CHECK WITH LOCAL JURISDICTION TO DETERMINE IF STRAW BALE INLET PROTECTION IS ACCEPTABLE.

Description

A straw bale barrier is a linear wall of straw bales designed to intercept sheet flow and trap sediment before runoff exits a disturbed area.

Appropriate Uses

Appropriate uses of properly installed straw bale barriers may include:

- As a perimeter control for a site or soil stockpile.
- As a sediment control at the toe of an erodible slope.
- Along the edge of a stream or drainage pathway to reduce sediment laden runoff from entering the waterway.
- As part of an inlet protection design in sump conditions (See Inlet Protection BMP).



Photograph SBB-1. Straw bale barrier used for perimeter control. Photo courtesy of Tom Gore.

Do not use straw bale barriers in areas of concentrated flow or in areas where ponding is not desirable. Straw bales tend to degrade quickly, so they should generally not be used in areas where longer term disturbance is expected.

Due to a history of inappropriate placement, poor installation, and short effective lifespan, the use of straw bales is discouraged or prohibited by some communities.

Design and Installation

The maximum recommended tributary drainage area per 100 lineal feet of straw bale barrier is 0.25 acres with a disturbed slope length of up to 150 feet and a tributary slope gradient no steeper than 3:1; longer and steeper slopes require additional measures. Design details with notes are provided in Detail SBB-1. To be effective, bales must be installed in accordance with the design details with proper trenching, staking, and binding. Jute and cotton string must not be used to bind the straw bale. The bales should be certified weed-free prior to use.

Maintenance and Removal

Check bales for rotting and replace as necessary. Straw bales degrade, and rotting bales require replacement on a regular basis (as often as every three months) depending on environmental conditions. Check for undercutting, bypassed flows, and displacement. Repair by properly re-installing the straw bale barrier and repairing washouts around the bales. Remove sediment accumulated behind the bale when it reaches one-quarter of the bale height. Remove and properly dispose of the straw bale once the upstream area has been stabilized. Areas of disturbance beneath the bale should be seeded and mulched when the bale is removed.

Straw Bale Barrier	
Functions	
Erosion Control	No
Sediment Control	Moderate
Site/Material Management	No

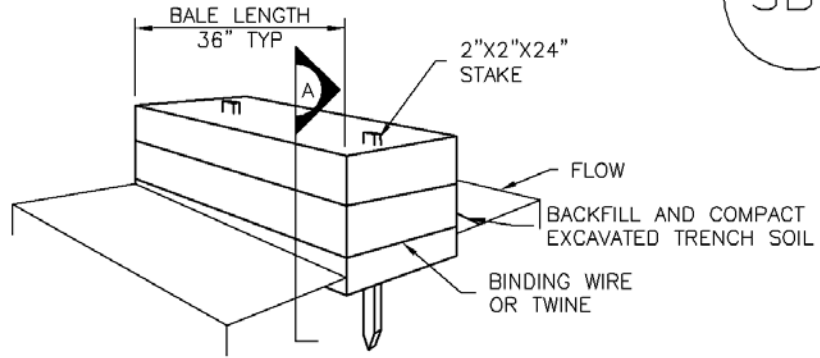
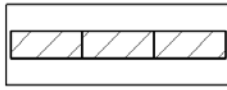

STRAW BALE

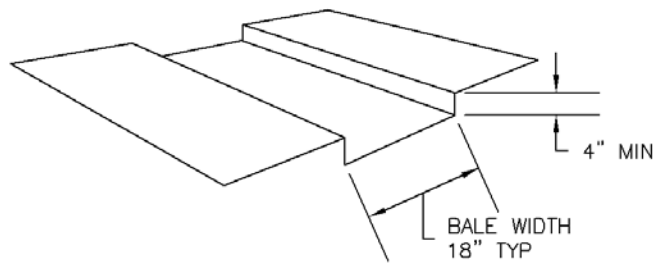

TRENCH FOR STRAW BALE

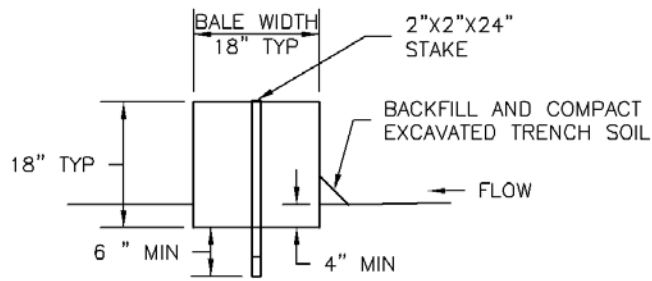

SECTION A

SBB-1. STRAW BALE

STRAW BALE INSTALLATION NOTES

1. SEE PLAN VIEW FOR:
-LOCATION(S) OF STRAW BALES.
2. STRAW BALES SHALL CONSIST OF CERTIFIED WEED FREE STRAW OR HAY. LOCAL JURISDICTIONS MAY REQUIRE PROOF THAT BALES ARE WEED FREE.
3. STRAW BALES SHALL CONSIST OF APPROXIMATELY 5 CUBIC FEET OF STRAW OR HAY AND WEIGH NOT LESS THAN 35 POUNDS.
4. WHEN STRAW BALES ARE USED IN SERIES AS A BARRIER, THE END OF EACH BALE SHALL BE TIGHTLY ABUTTING ONE ANOTHER.
5. STRAW BALE DIMENSIONS SHALL BE APPROXIMATELY 36"X18"X18".
6. A UNIFORM ANCHOR TRENCH SHALL BE EXCAVATED TO A DEPTH OF 4". STRAW BALES SHALL BE PLACED SO THAT BINDING TWINE IS ENCOMPASSING THE VERTICAL SIDES OF THE BALE(S). ALL EXCAVATED SOIL SHALL BE PLACED ON THE UPHILL SIDE OF THE STRAW BALE(S) AND COMPACTED.
7. TWO (2) WOODEN STAKES SHALL BE USED TO HOLD EACH BALE IN PLACE. WOODEN STAKES SHALL BE 2"X2"X24". WOODEN STAKES SHALL BE DRIVEN 6" INTO THE GROUND.

STRAW BALE MAINTENANCE NOTES

1. INSPECT BMPs EACH WORKDAY, AND MAINTAIN THEM IN EFFECTIVE OPERATING CONDITION. MAINTENANCE OF BMPs SHOULD BE PROACTIVE, NOT REACTIVE. INSPECT BMPs AS SOON AS POSSIBLE (AND ALWAYS WITHIN 24 HOURS) FOLLOWING A STORM THAT CAUSES SURFACE EROSION, AND PERFORM NECESSARY MAINTENANCE.
2. FREQUENT OBSERVATIONS AND MAINTENANCE ARE NECESSARY TO MAINTAIN BMPs IN EFFECTIVE OPERATING CONDITION. INSPECTIONS AND CORRECTIVE MEASURES SHOULD BE DOCUMENTED THOROUGHLY.
3. WHERE BMPs HAVE FAILED, REPAIR OR REPLACEMENT SHOULD BE INITIATED UPON DISCOVERY OF THE FAILURE.
4. STRAW BALES SHALL BE REPLACED IF THEY BECOME HEAVILY SOILED, ROTTEN, OR DAMAGED BEYOND REPAIR.
5. SEDIMENT ACCUMULATED UPSTREAM OF STRAW BALE BARRIER SHALL BE REMOVED AS NEEDED TO MAINTAIN FUNCTIONALITY OF THE BMP, TYPICALLY WHEN DEPTH OF ACCUMULATED SEDIMENTS IS APPROXIMATELY $\frac{1}{4}$ OF THE HEIGHT OF THE STRAW BALE BARRIER.
6. STRAW BALES ARE TO REMAIN IN PLACE UNTIL THE UPSTREAM DISTURBED AREA IS STABILIZED AND APPROVED BY THE LOCAL JURISDICTION.
7. WHEN STRAW BALES ARE REMOVED, ALL DISTURBED AREAS SHALL BE COVERED WITH TOPSOIL, SEEDED AND MULCHED OR OTHERWISE STABILIZED AS APPROVED BY LOCAL JURISDICTION.

(DETAILS ADAPTED FROM TOWN OF PARKER, COLORADO, NOT AVAILABLE IN AUTOCAD)

NOTE: MANY JURISDICTIONS HAVE BMP DETAILS THAT VARY FROM UDFCD STANDARD DETAILS. CONSULT WITH LOCAL JURISDICTIONS AS TO WHICH DETAIL SHOULD BE USED WHEN DIFFERENCES ARE NOTED.

Description

A sediment control log is a linear roll made of natural materials such as straw, coconut fiber, or other fibrous material trenched into the ground and held with a wooden stake. Sediment control logs are also often referred to as "straw wattles." They are used as a sediment barrier to intercept sheet flow runoff from disturbed areas.



Appropriate Uses

Sediment control logs can be used in the following applications to trap sediment:

- As perimeter control for stockpiles and the site.
- As part of inlet protection designs.
- As check dams in small drainage ditches. (Sediment control logs are not intended for use in channels with high flow velocities.)
- On disturbed slopes to shorten flow lengths (as an erosion control).
- As part of multi-layered perimeter control along a receiving water such as a stream, pond or wetland.



Photographs SCL-1 and SCL-2. Sediment control logs used as 1) a perimeter control around a soil stockpile; and, 2) as a "J-hook" perimeter control at the corner of a construction site.

Sediment control logs work well in combination with other layers of erosion and sediment controls.

Design and Installation

Sediment control logs should be installed along the contour to avoid concentrating flows. The maximum allowable tributary drainage area per 100 lineal feet of sediment control log, installed along the contour, is approximately 0.25 acres with a disturbed slope length of up to 150 feet and a tributary slope gradient no steeper than 3:1. Longer and steeper slopes require additional measures. This recommendation only applies to sediment control logs installed along the contour. When installed for other uses, such as perimeter control, it should be installed in a way that will not produce concentrated flows. For example, a "J-hook" installation may be appropriate to force runoff to pond and evaporate or infiltrate in multiple areas rather than concentrate and cause erosive conditions parallel to the BMP.

Sediment Control Log	
Functions	
Erosion Control	Moderate
Sediment Control	Yes
Site/Material Management	No

Although sediment control logs initially allow runoff to flow through the BMP, they can quickly become a barrier and should be installed is if they are impermeable.

Design details and notes for sediment control logs are provided in Detail SCL-1. Sediment logs must be properly trenched and staked into the ground to prevent undercutting, bypassing and displacement. When installed on slopes, sediment control logs should be installed along the contours (i.e., perpendicular to flow).

Improper installation can lead to poor performance. Be sure that sediment control logs are properly trenched, anchored and tightly jointed.

Maintenance and Removal

Be aware that sediment control logs will eventually degrade. Remove accumulated sediment before the depth is one-half the height of the sediment log and repair damage to the sediment log, typically by replacing the damaged section.

Once the upstream area is stabilized, remove and properly dispose of the logs. Areas disturbed beneath the logs may need to be seeded and mulched. Sediment control logs that are biodegradable may occasionally be left in place (e.g., when logs are used in conjunction with erosion control blankets as permanent slope breaks). However, removal of sediment control logs after final stabilization is typically recommended when used in perimeter control, inlet protection and check dam applications.

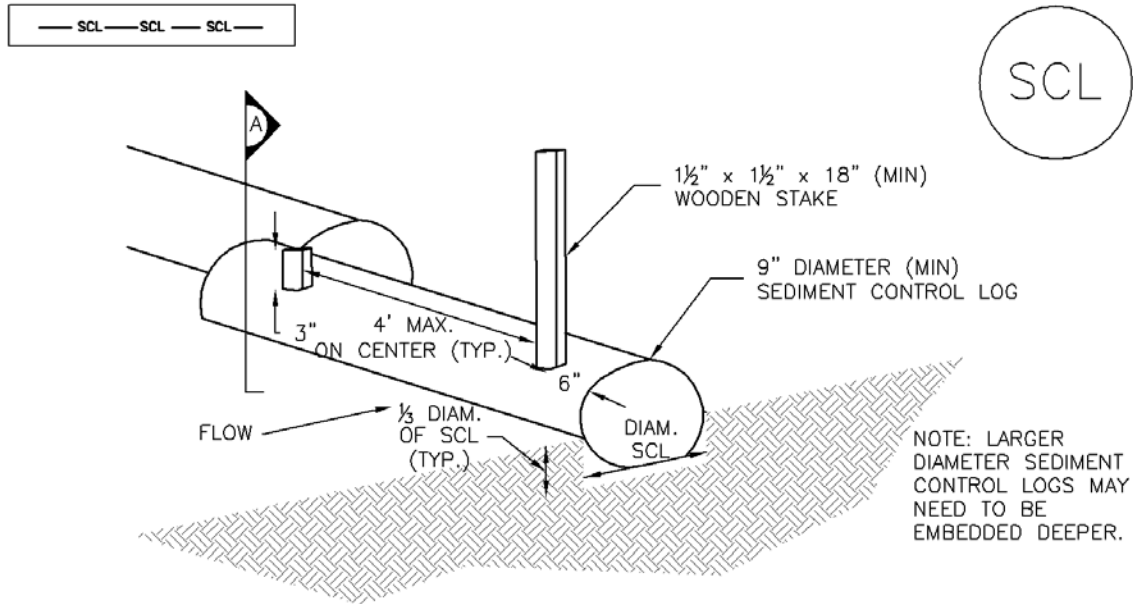

SEDIMENT CONTROL LOG

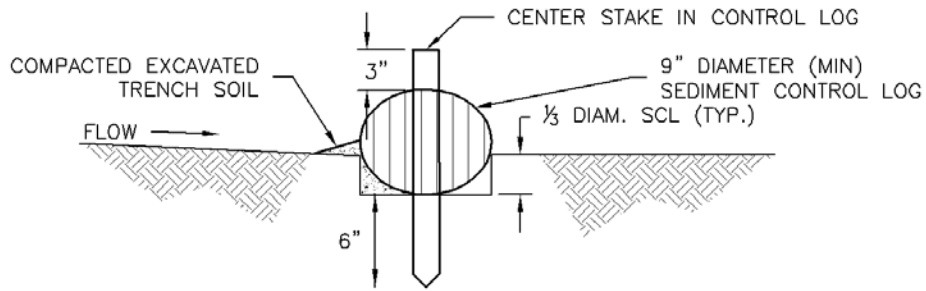

SECTION A

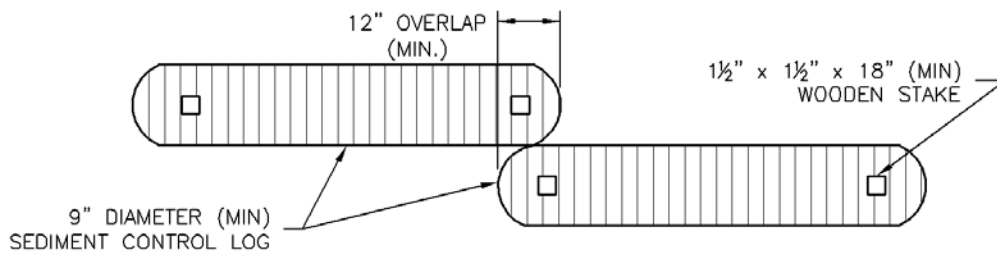

SEDIMENT CONTROL LOG JOINTS

SCL-1. SEDIMENT CONTROL LOG

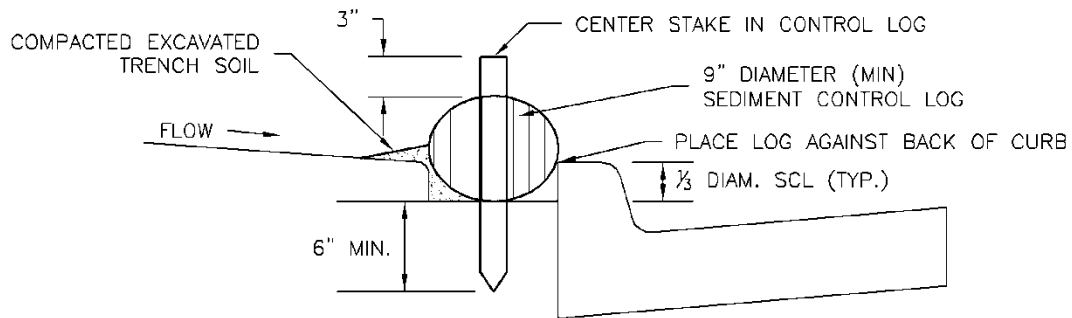

SCL-2. SEDIMENT CONTROL LOG AT BACK OF CURB

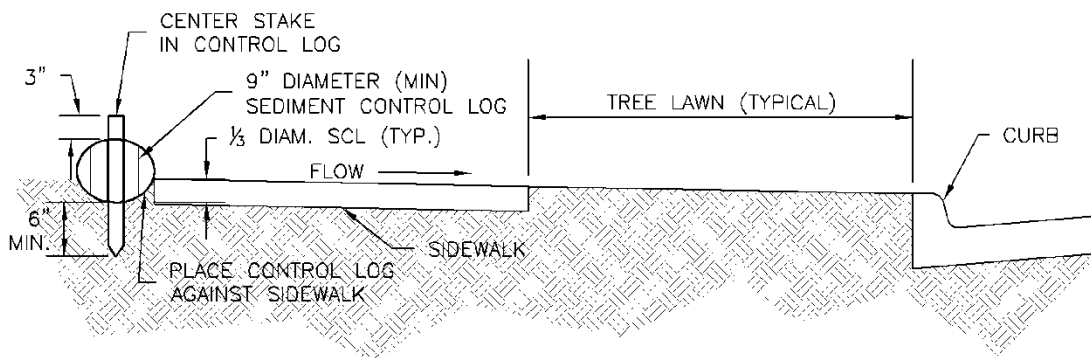

SCL-3. SEDIMENT CONTROL LOG AT SIDEWALK WITH TREE LAWN

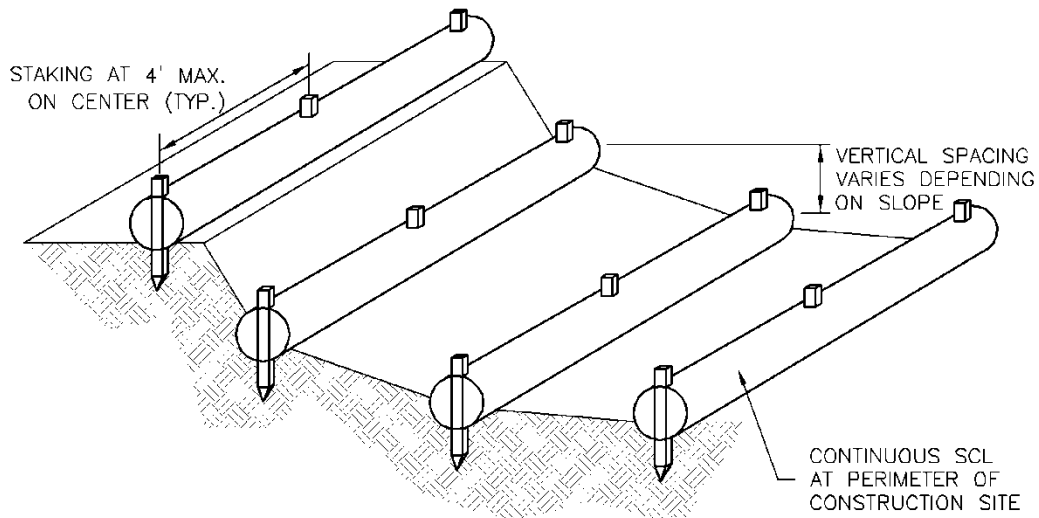

SCL-4. SEDIMENT CONTROL LOGS TO CONTROL SLOPE LENGTH

SEDIMENT CONTROL LOG INSTALLATION NOTES

1. SEE PLAN VIEW FOR LOCATION AND LENGTH OF SEDIMENT CONTROL LOGS.
2. SEDIMENT CONTROL LOGS THAT ACT AS A PERIMETER CONTROL SHALL BE INSTALLED PRIOR TO ANY UPGRADIENT LAND-DISTURBING ACTIVITIES.
3. SEDIMENT CONTROL LOGS SHALL CONSIST OF STRAW, COMPOST, EXCELSIOR OR COCONUT FIBER, AND SHALL BE FREE OF ANY NOXIOUS WEED SEEDS OR DEFECTS INCLUDING RIPS, HOLES AND OBVIOUS WEAR.
4. SEDIMENT CONTROL LOGS MAY BE USED AS SMALL CHECK DAMS IN DITCHES AND SWALES. HOWEVER, THEY SHOULD NOT BE USED IN PERENNIAL STREAMS OR HIGH VELOCITY DRAINAGE WAYS.
5. IT IS RECOMMENDED THAT SEDIMENT CONTROL LOGS BE TRENCHED INTO THE GROUND TO A DEPTH OF APPROXIMATELY $\frac{1}{3}$ OF THE DIAMETER OF THE LOG. IF TRENCHING TO THIS DEPTH IS NOT FEASIBLE AND/OR DESIRABLE (SHORT TERM INSTALLATION WITH DESIRE NOT TO DAMAGE LANDSCAPE) A LESSER TRENCHING DEPTH MAY BE ACCEPTABLE WITH MORE ROBUST STAKING
6. THE UPHILL SIDE OF THE SEDIMENT CONTROL LOG SHALL BE BACKFILLED WITH SOIL THAT IS FREE OF ROCKS AND DEBRIS. THE SOIL SHALL BE TIGHTLY COMPACTED INTO THE SHAPE OF A RIGHT TRIANGLE USING A SHOVEL OR WEIGHTED LAWN ROLLER.
7. FOLLOW MANUFACTURERS' GUIDANCE FOR STAKING. IF MANUFACTURERS' INSTRUCTIONS DO NOT SPECIFY SPACING, STAKES SHALL BE PLACED ON 4' CENTERS AND EMBEDDED A MINIMUM OF 6" INTO THE GROUND. 3" OF THE STAKE SHALL PROTRUDE FROM THE TOP OF THE LOG. STAKES THAT ARE BROKEN PRIOR TO INSTALLATION SHALL BE REPLACED.

SEDIMENT CONTROL LOG MAINTENANCE NOTES

1. INSPECT BMPs EACH WORKDAY, AND MAINTAIN THEM IN EFFECTIVE OPERATING CONDITION. MAINTENANCE OF BMPs SHOULD BE PROACTIVE, NOT REACTIVE. INSPECT BMPs AS SOON AS POSSIBLE (AND ALWAYS WITHIN 24 HOURS) FOLLOWING A STORM THAT CAUSES SURFACE EROSION, AND PERFORM NECESSARY MAINTENANCE.
2. FREQUENT OBSERVATIONS AND MAINTENANCE ARE NECESSARY TO MAINTAIN BMPs IN EFFECTIVE OPERATING CONDITION. INSPECTIONS AND CORRECTIVE MEASURES SHOULD BE DOCUMENTED THOROUGHLY.
3. WHERE BMPs HAVE FAILED, REPAIR OR REPLACEMENT SHOULD BE INITIATED UPON DISCOVERY OF THE FAILURE.
4. SEDIMENT ACCUMULATED UPSTREAM OF SEDIMENT CONTROL LOG SHALL BE REMOVED AS NEEDED TO MAINTAIN FUNCTIONALITY OF THE BMP, TYPICALLY WHEN DEPTH OF ACCUMULATED SEDIMENTS IS APPROXIMATELY $\frac{1}{2}$ OF THE HEIGHT OF THE SEDIMENT CONTROL LOG.
5. SEDIMENT CONTROL LOG SHALL BE REMOVED AT THE END OF CONSTRUCTION. IF DISTURBED AREAS EXIST AFTER REMOVAL, THEY SHALL BE COVERED WITH TOP SOIL, SEEDED AND MULCHED OR OTHERWISE STABILIZED IN A MANNER APPROVED BY THE LOCAL JURISDICTION.

(DETAILS ADAPTED FROM TOWN OF PARKER, COLORADO, JEFFERSON COUNTY, COLORADO, DOUGLAS COUNTY, COLORADO, AND CITY OF AURORA, COLORADO, NOT AVAILABLE IN AUTOCAD)

NOTE: MANY JURISDICTIONS HAVE BMP DETAILS THAT VARY FROM UDFCD STANDARD DETAILS. CONSULT WITH LOCAL JURISDICTIONS AS TO WHICH DETAIL SHOULD BE USED WHEN DIFFERENCES ARE NOTED.

Description

Sediment traps are formed by excavating an area or by placing an earthen embankment across a low area or drainage swale. Sediment traps are designed to capture drainage from disturbed areas less than one acre and allow settling of sediment.



Photograph ST-1. Sediment traps are used to collect sediment-laden runoff from disturbed area. Photo courtesy of EPA Menu of BMPs.

Appropriate Uses

Sediment traps can be used in combination with other layers of erosion and sediment controls to trap sediment from small drainage areas (less than one acre) or areas with localized high sediment loading. For example, sediment traps are often provided in conjunction with vehicle tracking controls and wheel wash facilities.

Design and Installation

A sediment trap consists of a small excavated basin with an earthen berm and a riprap outlet. The berm of the sediment trap may be constructed from the excavated material and must be compacted to 95 percent of the maximum density in accordance with ASTM D698. An overflow outlet must be provided at an elevation at least 6 inches below the top of the berm. See Detail ST-1 for additional design and installation information.

Maintenance and Removal

Inspect the sediment trap embankments for stability and seepage.

Remove accumulated sediment as needed to maintain the effectiveness of the sediment trap, typically when the sediment depth is approximately one-half the height of the outflow embankment.

Inspect the outlet for debris and damage. Repair damage to the outlet, and remove all obstructions.

A sediment trap should not be removed until the upstream area is sufficiently stabilized. Upon removal of the trap, the disturbed area should be covered with topsoil and stabilized.

Sediment Trap	
Functions	
Erosion Control	No
Sediment Control	Yes
Site/Material Management	No

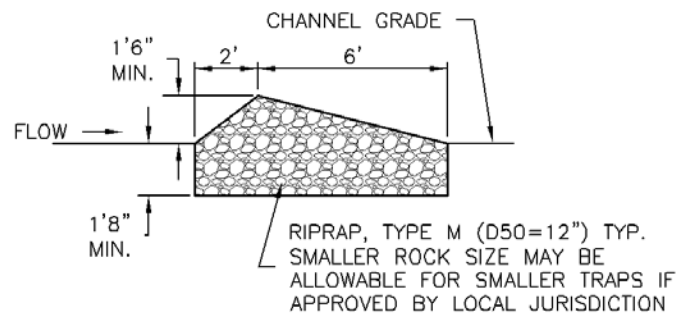
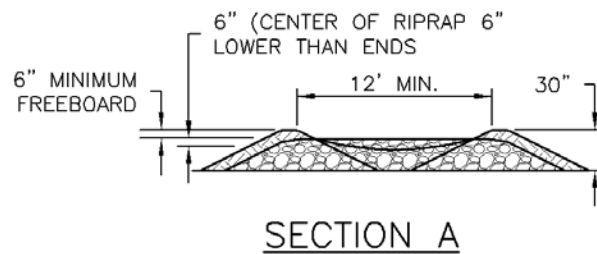
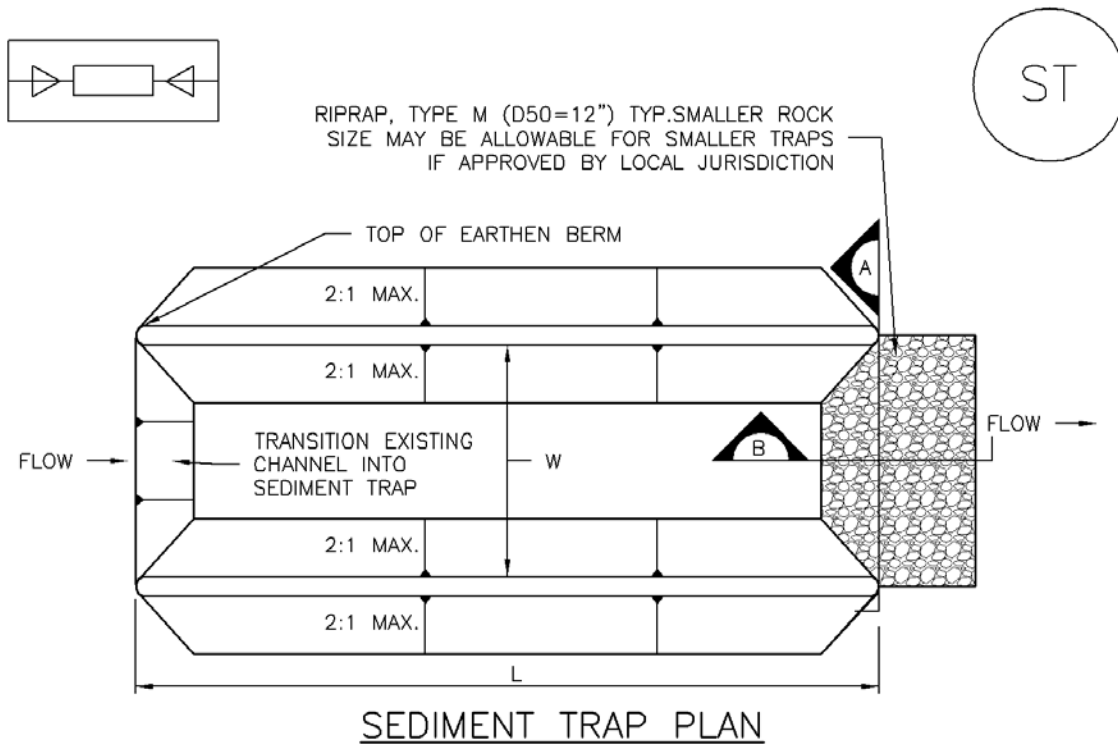

SECTION B
ST-1. SEDIMENT TRAP

SEDIMENT TRAP INSTALLATION NOTES

1. SEE PLAN VIEW FOR:
-LOCATION, LENGTH AND WIDTH OF SEDIMENT TRAP.
2. ONLY USE FOR DRAINAGE AREAS LESS THAN 1 ACRE.
3. SEDIMENT TRAPS SHALL BE INSTALLED PRIOR TO ANY UPGRADIENT LAND-DISTURBING ACTIVITIES.
4. SEDIMENT TRAP BERM SHALL BE CONSTRUCTED FROM MATERIAL FROM EXCAVATION. THE BERM SHALL BE COMPACTED TO 95% OF THE MAXIMUM DENSITY IN ACCORDANCE WITH ASTM D698.
5. SEDIMENT TRAP OUTLET TO BE CONSTRUCTED OF RIPRAP, TYPE M (D50=12") TYP. SMALLER ROCK SIZE MAY BE ALLOWABLE FOR SMALLER TRAPS IF APPROVED BY LOCAL JURISDICTION.
6. THE TOP OF THE EARTHEN BERM SHALL BE A MINIMUM OF 6" HIGHER THAN THE TOP OF THE RIPRAP OUTLET STRUCTURE.
7. THE ENDS OF THE RIPRAP OUTLET STRUCTURE SHALL BE A MINIMUM OF 6" HIGHER THAN THE CENTER OF THE OUTLET STRUCTURE.

SEDIMENT TRAP MAINTENANCE NOTES

1. INSPECT BMPs EACH WORKDAY, AND MAINTAIN THEM IN EFFECTIVE OPERATING CONDITION. MAINTENANCE OF BMPs SHOULD BE PROACTIVE, NOT REACTIVE. INSPECT BMPs AS SOON AS POSSIBLE (AND ALWAYS WITHIN 24 HOURS) FOLLOWING A STORM THAT CAUSES SURFACE EROSION, AND PERFORM NECESSARY MAINTENANCE.
2. FREQUENT OBSERVATIONS AND MAINTENANCE ARE NECESSARY TO MAINTAIN BMPs IN EFFECTIVE OPERATING CONDITION. INSPECTIONS AND CORRECTIVE MEASURES SHOULD BE DOCUMENTED THOROUGHLY.
3. WHERE BMPs HAVE FAILED, REPAIR OR REPLACEMENT SHOULD BE INITIATED UPON DISCOVERY OF THE FAILURE.
4. REMOVE SEDIMENT ACCUMULATED IN TRAP AS NEEDED TO MAINTAIN THE FUNCTIONALITY OF THE BMP, TYPICALLY WHEN THE SEDIMENT DEPTH REACHES $\frac{1}{2}$ THE HEIGHT OF THE RIPRAP OUTLET.
5. SEDIMENT TRAPS SHALL REMAIN IN PLACE UNTIL THE UPSTREAM DISTURBED AREA IS STABILIZED AND APPROVED BY THE LOCAL JURISDICTION.
6. WHEN SEDIMENT TRAPS ARE REMOVED, THE DISTURBED AREA SHALL BE COVERED WITH TOPSOIL, SEEDED AND MULCHED OR OTHERWISE STABILIZED IN A MANNER APPROVED BY THE LOCAL JURISDICTION.

(DETAILS ADAPTED FROM DOUGLAS COUNTY, COLORADO, NOT AVAILABLE IN AUTOCAD)

NOTE: MANY JURISDICTIONS HAVE BMP DETAILS THAT VARY FROM UDFCD STANDARD DETAILS. CONSULT WITH LOCAL JURISDICTIONS AS TO WHICH DETAIL SHOULD BE USED WHEN DIFFERENCES ARE NOTED.

Description

A silt fence is a woven geotextile fabric attached to wooden posts and trenched into the ground. It is designed as a sediment barrier to intercept sheet flow runoff from disturbed areas.

Appropriate Uses

A silt fence can be used where runoff is conveyed from a disturbed area as sheet flow. Silt fence is not designed to receive concentrated flow or to be used as a filter fabric. Typical uses include:

- Down slope of a disturbed area to accept sheet flow.
- Along the perimeter of a receiving water such as a stream, pond or wetland.
- At the perimeter of a construction site.



Photograph SF-1. Silt fence creates a sediment barrier, forcing sheet flow runoff to evaporate or infiltrate.

Design and Installation

Silt fence should be installed along the contour of slopes so that it intercepts sheet flow. The maximum recommended tributary drainage area per 100 lineal feet of silt fence, installed along the contour, is approximately 0.25 acres with a disturbed slope length of up to 150 feet and a tributary slope gradient no steeper than 3:1. Longer and steeper slopes require additional measures. This recommendation only applies to silt fence installed along the contour. Silt fence installed for other uses, such as perimeter control, should be installed in a way that will not produce concentrated flows. For example, a "J-hook" installation may be appropriate to force runoff to pond and evaporate or infiltrate in multiple areas rather than concentrate and cause erosive conditions parallel to the silt fence.

See Detail SF-1 for proper silt fence installation, which involves proper trenching, staking, securing the fabric to the stakes, and backfilling the silt fence. Properly installed silt fence should not be easily pulled out by hand and there should be no gaps between the ground and the fabric.

Silt fence must meet the minimum allowable strength requirements, depth of installation requirement, and other specifications in the design details. Improper installation of silt fence is a common reason for silt fence failure; however, when properly installed and used for the appropriate purposes, it can be highly effective.

Silt Fence	
Functions	
Erosion Control	No
Sediment Control	Yes
Site/Material Management	No

Maintenance and Removal

Inspection of silt fence includes observing the material for tears or holes and checking for slumping fence and undercut areas bypassing flows. Repair of silt fence typically involves replacing the damaged section with a new section. Sediment accumulated behind silt fence should be removed, as needed to maintain BMP effectiveness, typically before it reaches a depth of 6 inches.

Silt fence may be removed when the upstream area has reached final stabilization.



Photograph SF-2. When silt fence is not installed along the contour, a "J-hook" installation may be appropriate to ensure that the BMP does not create concentrated flow parallel to the silt fence. Photo courtesy of Tom Gore.

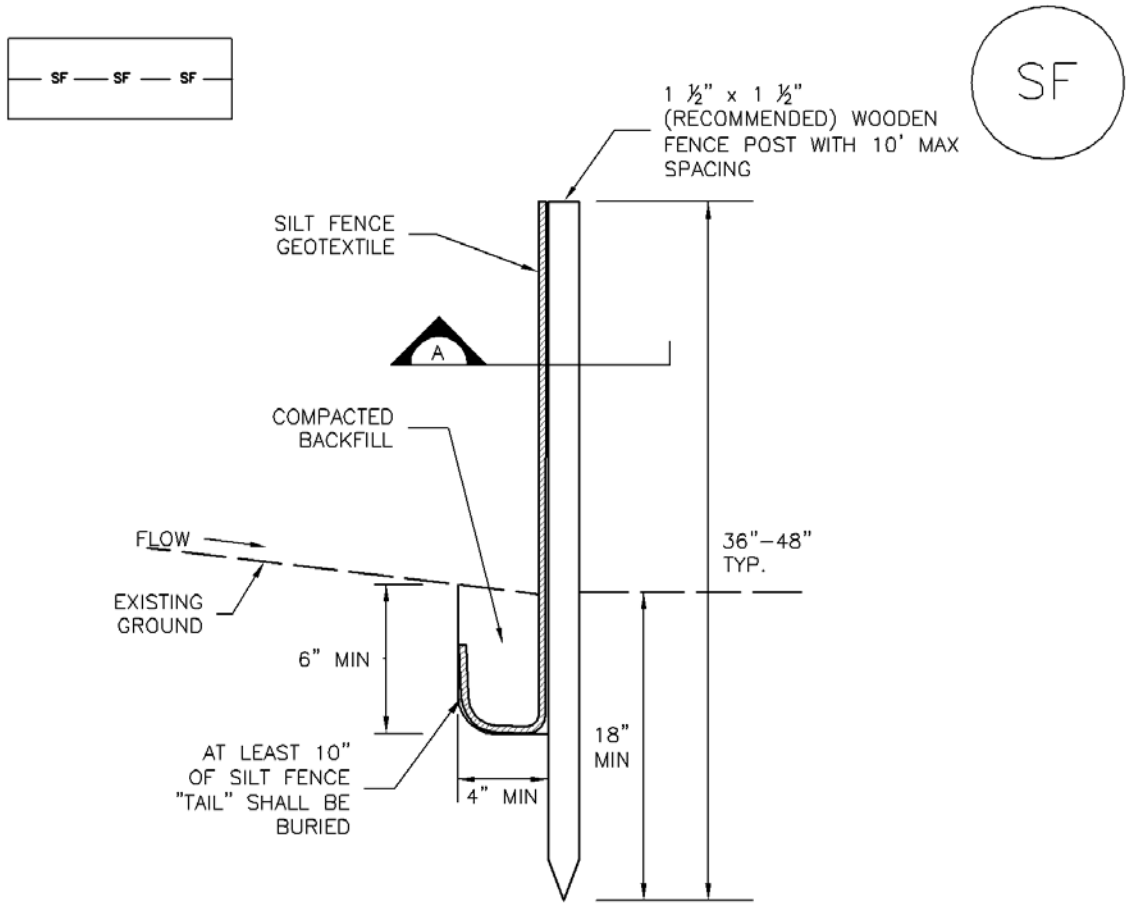

SILT FENCE

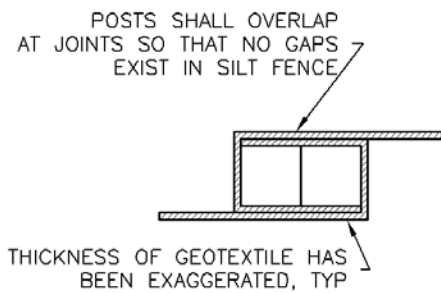
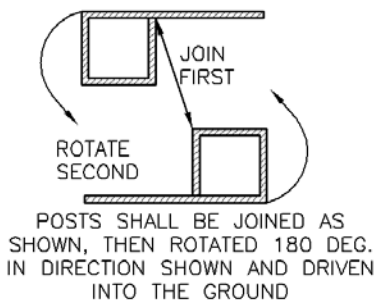

SECTION A

SF-1. SILT FENCE

SILT FENCE INSTALLATION NOTES

1. SILT FENCE MUST BE PLACED AWAY FROM THE TOE OF THE SLOPE TO ALLOW FOR WATER PONDING. SILT FENCE AT THE TOE OF A SLOPE SHOULD BE INSTALLED IN A FLAT LOCATION AT LEAST SEVERAL FEET (2-5 FT) FROM THE TOE OF THE SLOPE TO ALLOW ROOM FOR PONDING AND DEPOSITION.
2. A UNIFORM 6" X 4" ANCHOR TRENCH SHALL BE EXCAVATED USING TRENCHER OR SILT FENCE INSTALLATION DEVICE. NO ROAD GRADERS, BACKHOES, OR SIMILAR EQUIPMENT SHALL BE USED.
3. COMPACT ANCHOR TRENCH BY HAND WITH A "JUMPING JACK" OR BY WHEEL ROLLING. COMPACTION SHALL BE SUCH THAT SILT FENCE RESISTS BEING PULLED OUT OF ANCHOR TRENCH BY HAND.
4. SILT FENCE SHALL BE PULLED TIGHT AS IT IS ANCHORED TO THE STAKES. THERE SHOULD BE NO NOTICEABLE SAG BETWEEN STAKES AFTER IT HAS BEEN ANCHORED TO THE STAKES.
5. SILT FENCE FABRIC SHALL BE ANCHORED TO THE STAKES USING 1" HEAVY DUTY STAPLES OR NAILS WITH 1" HEADS. STAPLES AND NAILS SHOULD BE PLACED 3" ALONG THE FABRIC DOWN THE STAKE.
6. AT THE END OF A RUN OF SILT FENCE ALONG A CONTOUR, THE SILT FENCE SHOULD BE TURNED PERPENDICULAR TO THE CONTOUR TO CREATE A "J-HOOK." THE "J-HOOK" EXTENDING PERPENDICULAR TO THE CONTOUR SHOULD BE OF SUFFICIENT LENGTH TO KEEP RUNOFF FROM FLOWING AROUND THE END OF THE SILT FENCE (TYPICALLY 10' - 20').
7. SILT FENCE SHALL BE INSTALLED PRIOR TO ANY LAND DISTURBING ACTIVITIES.

SILT FENCE MAINTENANCE NOTES

1. INSPECT BMPs EACH WORKDAY, AND MAINTAIN THEM IN EFFECTIVE OPERATING CONDITION. MAINTENANCE OF BMPs SHOULD BE PROACTIVE, NOT REACTIVE. INSPECT BMPs AS SOON AS POSSIBLE (AND ALWAYS WITHIN 24 HOURS) FOLLOWING A STORM THAT CAUSES SURFACE EROSION, AND PERFORM NECESSARY MAINTENANCE.
2. FREQUENT OBSERVATIONS AND MAINTENANCE ARE NECESSARY TO MAINTAIN BMPs IN EFFECTIVE OPERATING CONDITION. INSPECTIONS AND CORRECTIVE MEASURES SHOULD BE DOCUMENTED THOROUGHLY.
3. WHERE BMPs HAVE FAILED, REPAIR OR REPLACEMENT SHOULD BE INITIATED UPON DISCOVERY OF THE FAILURE.
4. SEDIMENT ACCUMULATED UPSTREAM OF THE SILT FENCE SHALL BE REMOVED AS NEEDED TO MAINTAIN THE FUNCTIONALITY OF THE BMP, TYPICALLY WHEN DEPTH OF ACCUMULATED SEDIMENTS IS APPROXIMATELY 6".
5. REPAIR OR REPLACE SILT FENCE WHEN THERE ARE SIGNS OF WEAR, SUCH AS SAGGING, TEARING, OR COLLAPSE.
6. SILT FENCE IS TO REMAIN IN PLACE UNTIL THE UPSTREAM DISTURBED AREA IS STABILIZED AND APPROVED BY THE LOCAL JURISDICTION, OR IS REPLACED BY AN EQUIVALENT PERIMETER SEDIMENT CONTROL BMP.
7. WHEN SILT FENCE IS REMOVED, ALL DISTURBED AREAS SHALL BE COVERED WITH TOPSOIL, SEEDED AND MULCHED OR OTHERWISE STABILIZED AS APPROVED BY LOCAL JURISDICTION.

(DETAIL ADAPTED FROM TOWN OF PARKER, COLORADO AND CITY OF AURORA, NOT AVAILABLE IN AUTOCAD)

NOTE: MANY JURISDICTIONS HAVE BMP DETAILS THAT VARY FROM UDFCD STANDARD DETAILS. CONSULT WITH LOCAL JURISDICTIONS AS TO WHICH DETAIL SHOULD BE USED WHEN DIFFERENCES ARE NOTED.

Description

Surface roughening is an erosion control practice that involves tracking, scarifying, imprinting, or tilling a disturbed area to provide temporary stabilization of disturbed areas. Surface roughening creates variations in the soil surface that help to minimize wind and water erosion. Depending on the technique used, surface roughening may also help establish conditions favorable to establishment of vegetation.



Photograph SR-1. Surface roughening via imprinting for temporary stabilization.

Appropriate Uses

Surface roughening can be used to provide temporary stabilization of disturbed areas, such as when revegetation cannot be immediately established due to seasonal planting limitations. Surface roughening is not a stand-alone BMP, and should be used in conjunction with other erosion and sediment controls.

Surface roughening is often implemented in conjunction with grading and is typically performed using heavy construction equipment to track the surface. Be aware that tracking with heavy equipment will also compact soils, which is not desirable in areas that will be revegetated. Scarifying, tilling, or ripping are better surface roughening techniques in locations where revegetation is planned. Roughening is not effective in very sandy soils and cannot be effectively performed in rocky soil.

Design and Installation

Typical design details for surfacing roughening on steep and mild slopes are provided in Details SR-1 and SR-2, respectively.

Surface roughening should be performed either after final grading or to temporarily stabilize an area during active construction that may be inactive for a short time period. Surface roughening should create depressions 2 to 6 inches deep and approximately 6 inches apart. The surface of exposed soil can be roughened by a number of techniques and equipment. Horizontal grooves (running parallel to the contours of the land) can be made using tracks from equipment treads, stair-step grading, ripping, or tilling.

Fill slopes can be constructed with a roughened surface. Cut slopes that have been smooth graded can be roughened as a subsequent operation. Roughening should follow along the contours of the slope. The tracks left by truck mounted equipment working perpendicular to the contour can leave acceptable horizontal depressions; however, the equipment will also compact the soil.

Surface Roughening	
Functions	
Erosion Control	Yes
Sediment Control	No
Site/Material Management	No

Maintenance and Removal

Care should be taken not to drive vehicles or equipment over areas that have been surface roughened. Tire tracks will smooth the roughened surface and may cause runoff to collect into rills and gullies.

Because surface roughening is only a temporary control, additional treatments may be necessary to maintain the soil surface in a roughened condition.

Areas should be inspected for signs of erosion. Surface roughening is a temporary measure, and will not provide long-term erosion control.

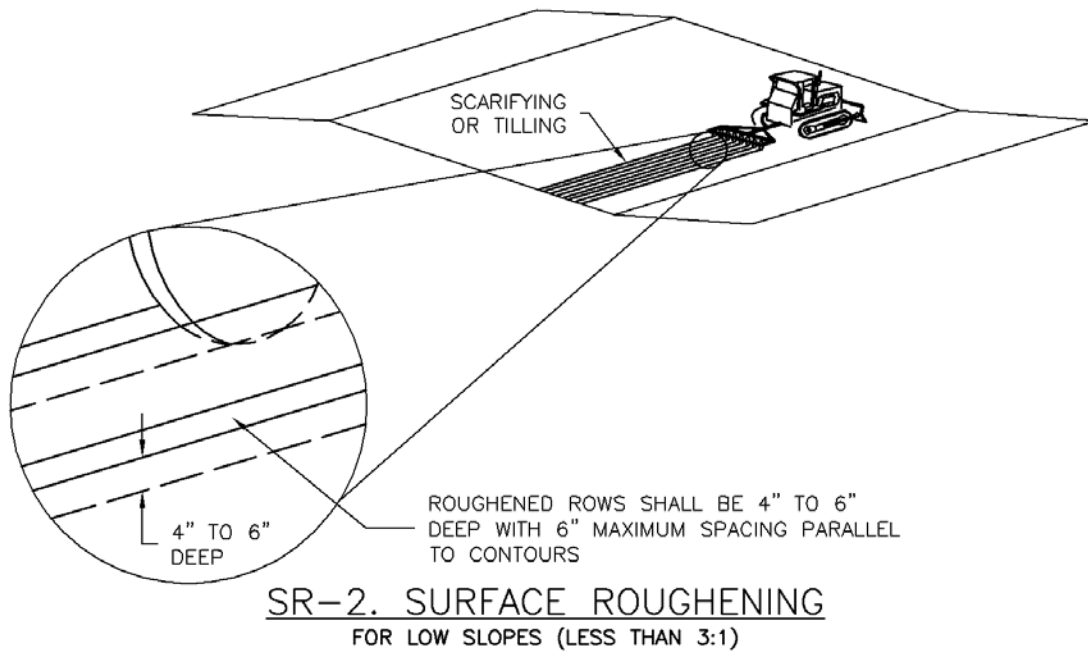
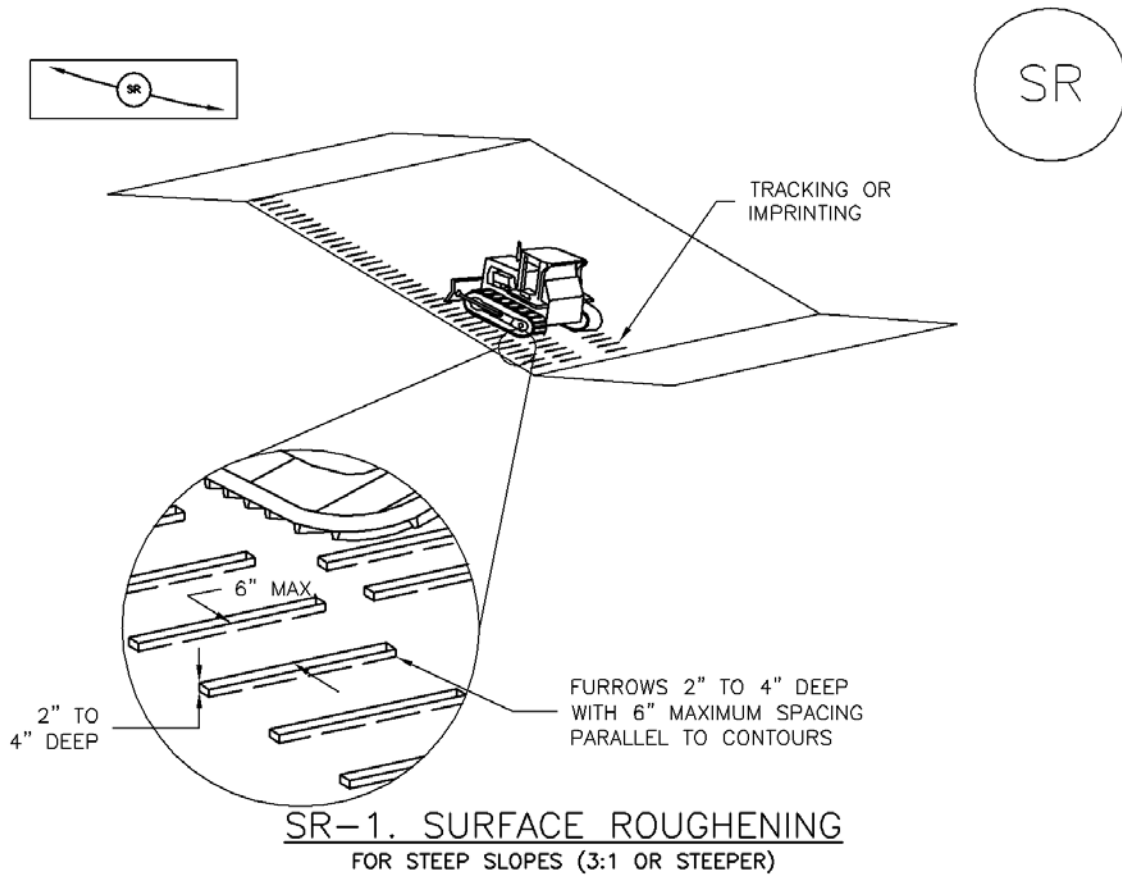

SURFACE ROUGHENING INSTALLATION NOTES

1. SEE PLAN VIEW FOR:
-LOCATION(S) OF SURFACE ROUGHENING.
2. SURFACE ROUGHENING SHALL BE PROVIDED PROMPTLY AFTER COMPLETION OF FINISHED GRADING (FOR AREAS NOT RECEIVING TOPSOIL) OR PRIOR TO TOPSOIL PLACEMENT OR ANY FORECASTED RAIN EVENT.
3. AREAS WHERE BUILDING FOUNDATIONS, PAVEMENT, OR SOD WILL BE PLACED WITHOUT DELAY IN THE CONSTRUCTION SEQUENCE, SURFACE ROUGHENING IS NOT REQUIRED.
4. DISTURBED SURFACES SHALL BE ROUGHENED USING RIPPING OR TILLING EQUIPMENT ON THE CONTOUR OR TRACKING UP AND DOWN A SLOPE USING EQUIPMENT TREADS.
5. A FARMING DISK SHALL NOT BE USED FOR SURFACE ROUGHENING.

SURFACE ROUGHENING MAINTENANCE NOTES

1. INSPECT BMPs EACH WORKDAY, AND MAINTAIN THEM IN EFFECTIVE OPERATING CONDITION. MAINTENANCE OF BMPs SHOULD BE PROACTIVE, NOT REACTIVE. INSPECT BMPs AS SOON AS POSSIBLE (AND ALWAYS WITHIN 24 HOURS) FOLLOWING A STORM THAT CAUSES SURFACE EROSION, AND PERFORM NECESSARY MAINTENANCE.
2. FREQUENT OBSERVATIONS AND MAINTENANCE ARE NECESSARY TO MAINTAIN BMPs IN EFFECTIVE OPERATING CONDITION. INSPECTIONS AND CORRECTIVE MEASURES SHOULD BE DOCUMENTED THOROUGHLY.
3. WHERE BMPs HAVE FAILED, REPAIR OR REPLACE UPON DISCOVERY OF THE FAILURE.
4. VEHICLES AND EQUIPMENT SHALL NOT BE DRIVEN OVER AREAS THAT HAVE BEEN SURFACE ROUGHENED.
5. IN NON-TURF GRASS FINISHED AREAS, SEEDING AND MULCHING SHALL TAKE PLACE DIRECTLY OVER SURFACE ROUGHENED AREAS WITHOUT FIRST SMOOTHING OUT THE SURFACE.
6. IN AREAS NOT SEEDED AND MULCHED AFTER SURFACE ROUGHENING, SURFACES SHALL BE RE-ROUGHENED AS NECESSARY TO MAINTAIN GROOVE DEPTH AND SMOOTH OVER RILL EROSION.

(DETAILS ADAPTED FROM TOWN OF PARKER, COLORADO, NOT AVAILABLE IN AUTOCAD)

NOTE: MANY JURISDICTIONS HAVE BMP DETAILS THAT VARY FROM UDFCD STANDARD DETAILS. CONSULT WITH LOCAL JURISDICTIONS AS TO WHICH DETAIL SHOULD BE USED WHEN DIFFERENCES ARE NOTED.

Description

Vehicle tracking controls provide stabilized construction site access where vehicles exit the site onto paved public roads. An effective vehicle tracking control helps remove sediment (mud or dirt) from vehicles, reducing tracking onto the paved surface.



Photograph VTC-1. A vehicle tracking control pad constructed with properly sized rock reduces off-site sediment tracking.

Appropriate Uses

Implement a stabilized construction entrance or vehicle tracking control where frequent heavy vehicle traffic exits the construction site onto a paved roadway. An effective vehicle tracking control is particularly important during the following conditions:

- Wet weather periods when mud is easily tracked off site.
- During dry weather periods where dust is a concern.
- When poorly drained, clayey soils are present on site.

Although wheel washes are not required in designs of vehicle tracking controls, they may be needed at particularly muddy sites.

Design and Installation

Construct the vehicle tracking control on a level surface. Where feasible, grade the tracking control towards the construction site to reduce off-site runoff. Place signage, as needed, to direct construction vehicles to the designated exit through the vehicle tracking control. There are several different types of stabilized construction entrances including:

VTC-1. Aggregate Vehicle Tracking Control. This is a coarse-aggregate surfaced pad underlain by a geotextile. This is the most common vehicle tracking control, and when properly maintained can be effective at removing sediment from vehicle tires.

VTC-2. Vehicle Tracking Control with Construction Mat or Turf Reinforcement Mat. This type of control may be appropriate for site access at very small construction sites with low traffic volume over vegetated areas. Although this application does not typically remove sediment from vehicles, it helps protect existing vegetation and provides a stabilized entrance.

Vehicle Tracking Control	
Functions	
Erosion Control	Moderate
Sediment Control	Yes
Site/Material Management	Yes

VTC-3. Stabilized Construction Entrance/Exit with Wheel Wash. This is an aggregate pad, similar to VTC-1, but includes equipment for tire washing. The wheel wash equipment may be as simple as hand-held power washing equipment to more advanced proprietary systems. When a wheel wash is provided, it is important to direct wash water to a sediment trap prior to discharge from the site.

Vehicle tracking controls are sometimes installed in combination with a sediment trap to treat runoff.

Maintenance and Removal

Inspect the area for degradation and replace aggregate or material used for a stabilized entrance/exit as needed. If the area becomes clogged and ponds water, remove and dispose of excess sediment or replace material with a fresh layer of aggregate as necessary.

With aggregate vehicle tracking controls, ensure rock and debris from this area do not enter the public right-of-way.

Remove sediment that is tracked onto the public right of way daily or more frequently as needed. Excess sediment in the roadway indicates that the stabilized construction entrance needs maintenance.

Ensure that drainage ditches at the entrance/exit area remain clear.

A stabilized entrance should be removed only when there is no longer the potential for vehicle tracking to occur. This is typically after the site has been stabilized.

When wheel wash equipment is used, be sure that the wash water is discharged to a sediment trap prior to discharge. Also inspect channels conveying the water from the wash area to the sediment trap and stabilize areas that may be eroding.

When a construction entrance/exit is removed, excess sediment from the aggregate should be removed and disposed of appropriately. The entrance should be promptly stabilized with a permanent surface following removal, typically by paving.



Photograph VTC-2. A vehicle tracking control pad with wheel wash facility. Photo courtesy of Tom Gore.

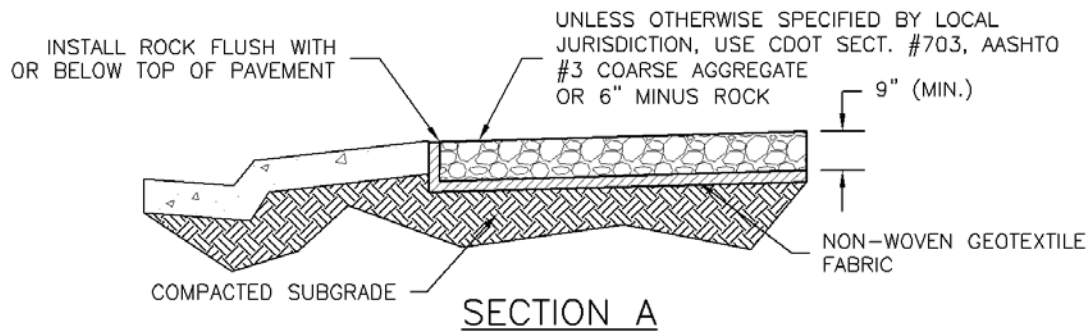
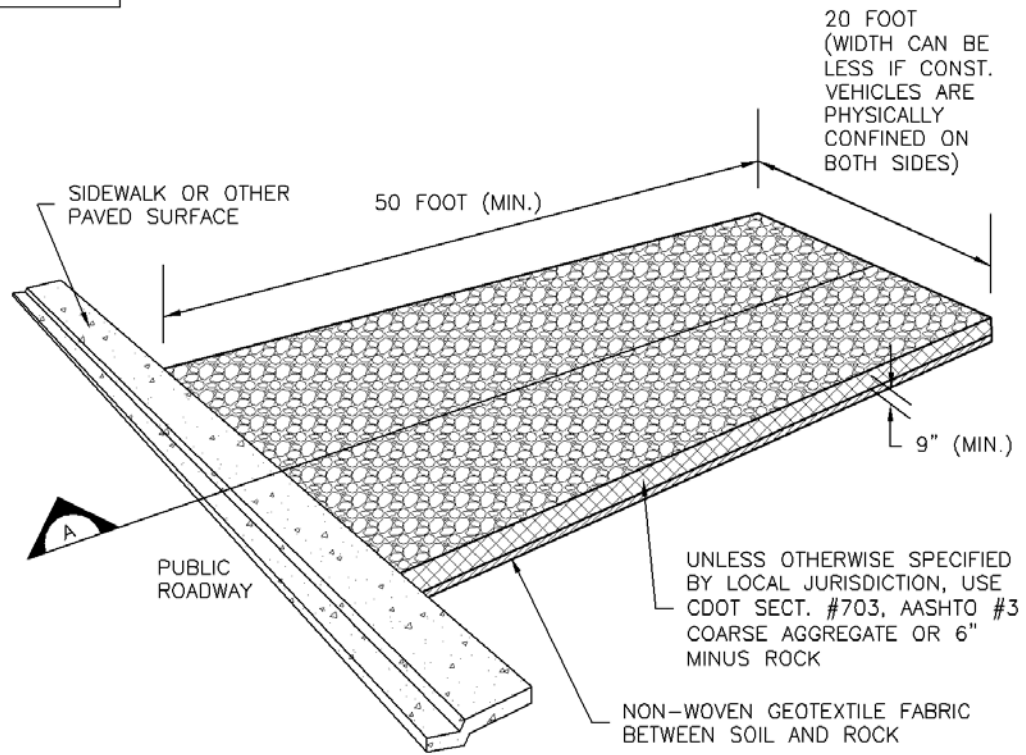
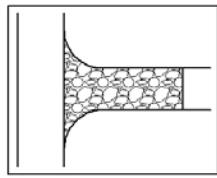

VTC-1. AGGREGATE VEHICLE TRACKING CONTROL

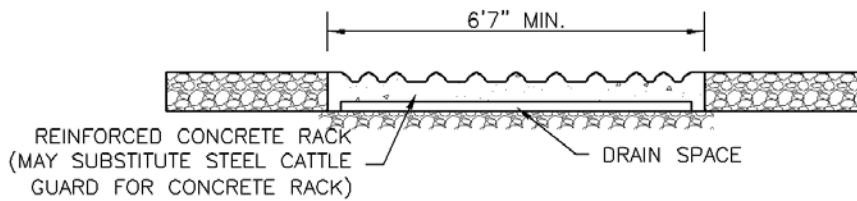
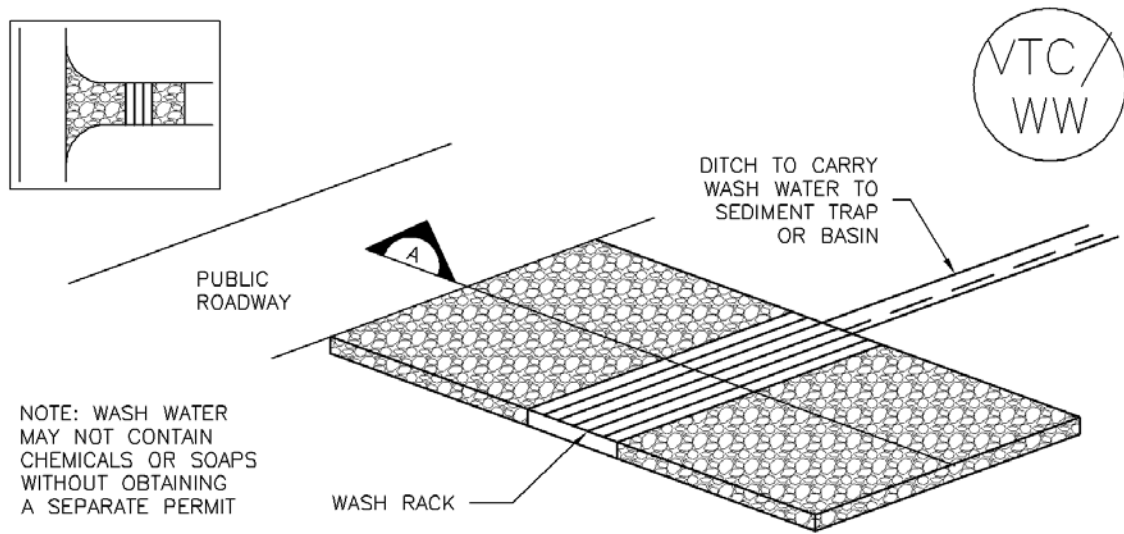

SECTION A

VTC-2. AGGREGATE VEHICLE TRACKING CONTROL WITH WASH RACK

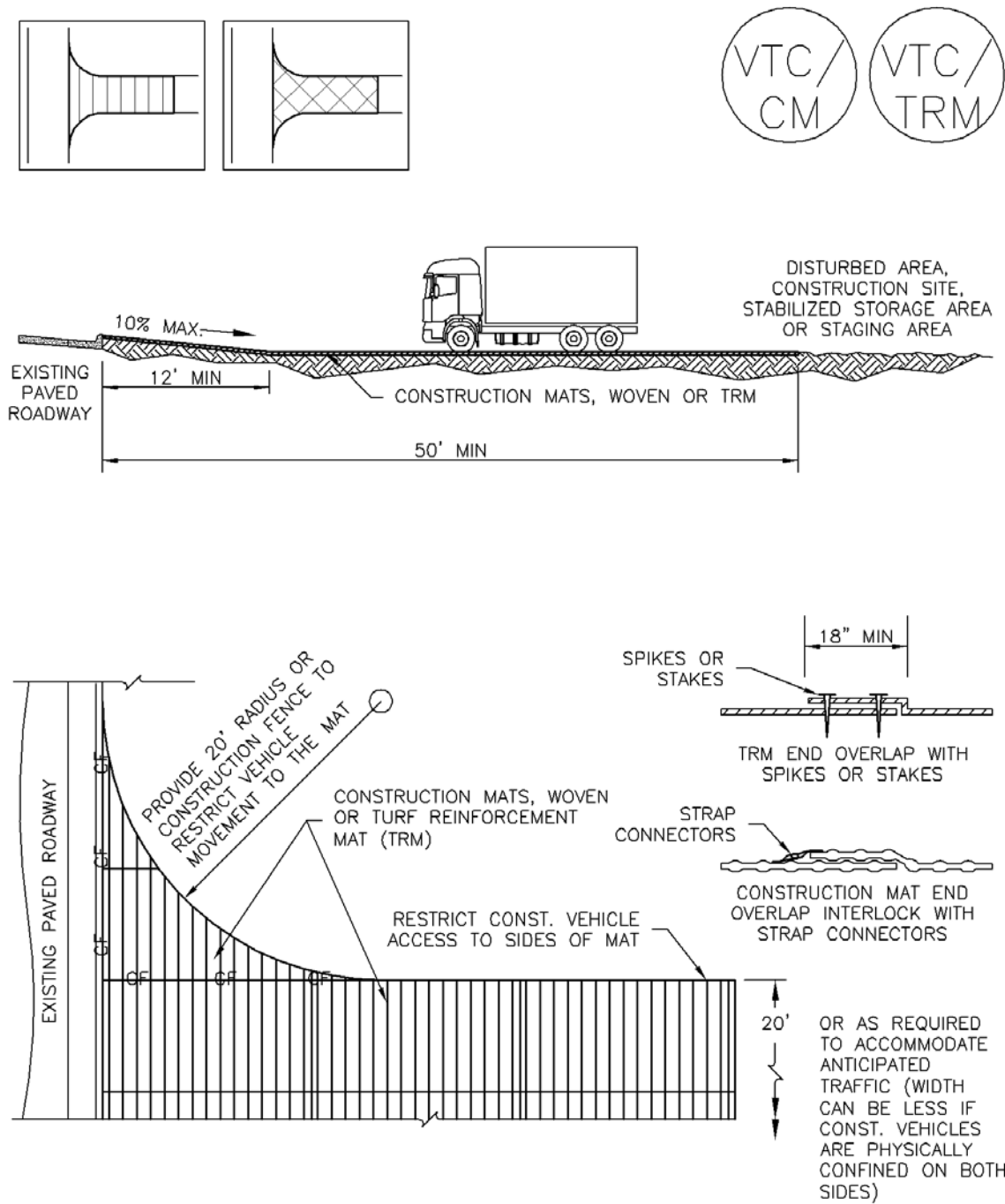

VTC-3. VEHICLE TRACKING CONTROL W/ CONSTRUCTION MAT OR TURF REINFORCEMENT MAT (TRM)

STABILIZED CONSTRUCTION ENTRANCE/EXIT INSTALLATION NOTES

1. SEE PLAN VIEW FOR
 - LOCATION OF CONSTRUCTION ENTRANCE(S)/EXIT(S).
 - TYPE OF CONSTRUCTION ENTRANCE(S)/EXITS(S) (WITH/WITHOUT WHEEL WASH, CONSTRUCTION MAT OR TRM).
2. CONSTRUCTION MAT OR TRM STABILIZED CONSTRUCTION ENTRANCES ARE ONLY TO BE USED ON SHORT DURATION PROJECTS (TYPICALLY RANGING FROM A WEEK TO A MONTH) WHERE THERE WILL BE LIMITED VEHICULAR ACCESS.
3. A STABILIZED CONSTRUCTION ENTRANCE/EXIT SHALL BE LOCATED AT ALL ACCESS POINTS WHERE VEHICLES ACCESS THE CONSTRUCTION SITE FROM PAVED RIGHT-OF-WAYS.
4. STABILIZED CONSTRUCTION ENTRANCE/EXIT SHALL BE INSTALLED PRIOR TO ANY LAND DISTURBING ACTIVITIES.
5. A NON-WOVEN GEOTEXTILE FABRIC SHALL BE PLACED UNDER THE STABILIZED CONSTRUCTION ENTRANCE/EXIT PRIOR TO THE PLACEMENT OF ROCK.
6. UNLESS OTHERWISE SPECIFIED BY LOCAL JURISDICTION, ROCK SHALL CONSIST OF DOT SECT. #703, AASHTO #3 COARSE AGGREGATE OR 6" (MINUS) ROCK.

STABILIZED CONSTRUCTION ENTRANCE/EXIT MAINTENANCE NOTES

1. INSPECT BMPs EACH WORKDAY, AND MAINTAIN THEM IN EFFECTIVE OPERATING CONDITION. MAINTENANCE OF BMPs SHOULD BE PROACTIVE, NOT REACTIVE. INSPECT BMPs AS SOON AS POSSIBLE (AND ALWAYS WITHIN 24 HOURS) FOLLOWING A STORM THAT CAUSES SURFACE EROSION, AND PERFORM NECESSARY MAINTENANCE.
2. FREQUENT OBSERVATIONS AND MAINTENANCE ARE NECESSARY TO MAINTAIN BMPs IN EFFECTIVE OPERATING CONDITION. INSPECTIONS AND CORRECTIVE MEASURES SHOULD BE DOCUMENTED THOROUGHLY.
3. WHERE BMPs HAVE FAILED, REPAIR OR REPLACEMENT SHOULD BE INITIATED UPON DISCOVERY OF THE FAILURE.
4. ROCK SHALL BE REAPPLIED OR REGRADED AS NECESSARY TO THE STABILIZED ENTRANCE/EXIT TO MAINTAIN A CONSISTENT DEPTH.
5. SEDIMENT TRACKED ONTO PAVED ROADS IS TO BE REMOVED THROUGHOUT THE DAY AND AT THE END OF THE DAY BY SHOVELING OR SWEEPING. SEDIMENT MAY NOT BE WASHED DOWN STORM SEWER DRAINS.

NOTE: MANY JURISDICTIONS HAVE BMP DETAILS THAT VARY FROM UDFCD STANDARD DETAILS. CONSULT WITH LOCAL JURISDICTIONS AS TO WHICH DETAIL SHOULD BE USED WHEN DIFFERENCES ARE NOTED.

(DETAILS ADAPTED FROM CITY OF BROOMFIELD, COLORADO, NOT AVAILABLE IN AUTOCAD)

Description

Rolled Erosion Control Products (RECPs) include a variety of temporary or permanently installed manufactured products designed to control erosion and enhance vegetation establishment and survivability, particularly on slopes and in channels. For applications where natural vegetation alone will provide sufficient permanent erosion protection, temporary products such as netting, open weave textiles and a variety of erosion control blankets (ECBs) made of biodegradable natural materials (e.g., straw, coconut fiber) can be used. For applications where natural vegetation alone will not be sustainable under expected flow conditions, permanent rolled erosion control products such as turf reinforcement mats (TRMs) can be used. In particular, turf reinforcement mats are designed for discharges that exert velocities and shear stresses that exceed the typical limits of mature natural vegetation.



Photograph RECP-1. Erosion control blanket protecting the slope from erosion and providing favorable conditions for revegetation.

Appropriate Uses

RECPs can be used to control erosion in conjunction with revegetation efforts, providing seedbed protection from wind and water erosion. These products are often used on disturbed areas on steep slopes, in areas with highly erosive soils, or as part of drainageway stabilization. In order to select the appropriate RECP for site conditions, it is important to have a general understanding of the general types of these products, their expected longevity, and general characteristics.

The Erosion Control Technology Council (ECTC 2005) characterizes rolled erosion control products according to these categories:

- **Mulch control netting:** A planar woven natural fiber or extruded geosynthetic mesh used as a temporary degradable rolled erosion control product to anchor loose fiber mulches.
- **Open weave textile:** A temporary degradable rolled erosion control product composed of processed natural or polymer yarns woven into a matrix, used to provide erosion control and facilitate vegetation establishment.
- **Erosion control blanket (ECB):** A temporary degradable rolled erosion control product composed of processed natural or polymer fibers which are mechanically, structurally or chemically bound together to form a continuous matrix to provide erosion control and facilitate vegetation establishment. ECBs can be further differentiated into rapidly degrading single-net and double-net types or slowly degrading types.

Rolled Erosion Control Products	
Functions	
Erosion Control	Yes
Sediment Control	No
Site/Material Management	No

EC-6 Rolled Erosion Control Products (RECP)

- **Turf Reinforcement Mat (TRM):** A rolled erosion control product composed of non-degradable synthetic fibers, filaments, nets, wire mesh, and/or other elements, processed into a permanent, three-dimensional matrix of sufficient thickness. TRMs, which may be supplemented with degradable components, are designed to impart immediate erosion protection, enhance vegetation establishment and provide long-term functionality by permanently reinforcing vegetation during and after maturation. Note: TRMs are typically used in hydraulic applications, such as high flow ditches and channels, steep slopes, stream banks, and shorelines, where erosive forces may exceed the limits of natural, unreinforced vegetation or in areas where limited vegetation establishment is anticipated.

Tables RECP-1 and RECP-2 provide guidelines for selecting rolled erosion control products appropriate to site conditions and desired longevity. Table RECP-1 is for conditions where natural vegetation alone will provide permanent erosion control, whereas Table RECP-2 is for conditions where vegetation alone will not be adequately stable to provide long-term erosion protection due to flow or other conditions.

Table RECP-1. ECTC Standard Specification for Temporary Rolled Erosion Control Products
(Adapted from Erosion Control Technology Council 2005)

Product Description	Slope Applications*		Channel Applications*	Minimum Tensile Strength ¹	Expected Longevity
	Maximum Gradient	C Factor ^{2,5}			
Mulch Control Nets	5:1 (H:V)	≤0.10 @ 5:1	0.25 lbs/ft ² (12 Pa)	5 lbs/ft (0.073 kN/m)	Up to 12 months
Netless Rolled Erosion Control Blankets	4:1 (H:V)	≤0.10 @ 4:1	0.5 lbs/ft ² (24 Pa)	5 lbs/ft (0.073 kN/m)	
Single-net Erosion Control Blankets & Open Weave Textiles	3:1 (H:V)	≤0.15 @ 3:1	1.5 lbs/ft ² (72 Pa)	50 lbs/ft (0.73 kN/m)	
Double-net Erosion Control Blankets	2:1 (H:V)	≤0.20 @ 2:1	1.75 lbs/ft ² (84 Pa)	75 lbs/ft (1.09 kN/m)	
Mulch Control Nets	5:1 (H:V)	≤0.10 @ 5:1	0.25 lbs/ft ² (12 Pa)	25 lbs/ft (0.36 kN/m)	24 months
Erosion Control Blankets & Open Weave Textiles (slowly degrading)	1.5:1 (H:V)	≤0.25 @ 1.5:1	2.00 lbs/ft ² (96 Pa)	100 lbs/ft (1.45 kN/m)	24 months
Erosion Control Blankets & Open Weave Textiles	1:1 (H:V)	≤0.25 @ 1:1	2.25 lbs/ft ² (108 Pa)	125 lbs/ft (1.82 kN/m)	36 months

* C Factor and shear stress for mulch control nettings must be obtained with netting used in conjunction with pre-applied mulch material. (See Section 5.3 of Chapter 7 Construction BMPs for more information on the C Factor.)

¹ Minimum Average Roll Values, Machine direction using ECTC Mod. ASTM D 5035.

² C Factor calculated as ratio of soil loss from RECP protected slope (tested at specified or greater gradient, H:V) to ratio of soil loss from unprotected (control) plot in large-scale testing.

³ Required minimum shear stress RECP (unvegetated) can sustain without physical damage or excess erosion (> 12.7 mm (0.5 in) soil loss) during a 30-minute flow event in large-scale testing.

⁴ The permissible shear stress levels established for each performance category are based on historical experience with products characterized by Manning's roughness coefficients in the range of 0.01 - 0.05.

⁵ Acceptable large-scale test methods may include ASTM D 6459, or other independent testing deemed acceptable by the engineer.

⁶ Per the engineer's discretion. Recommended acceptable large-scale testing protocol may include ASTM D 6460, or other independent testing deemed acceptable by the engineer.

EC-6 Rolled Erosion Control Products (RECP)

Table RECP-2. ECTC Standard Specification for Permanent¹ Rolled Erosion Control Products
(Adapted from: Erosion Control Technology Council 2005)

Product Type	Slope Applications	Channel Applications	
TRMs with a minimum thickness of 0.25 inches (6.35 mm) per ASTM D 6525 and UV stability of 80% per ASTM D 4355 (500 hours exposure).	Maximum Gradient	Maximum Shear Stress ^{4,5}	Minimum Tensile Strength ^{2,3}
	0.5:1 (H:V)	6.0 lbs/ft ² (288 Pa)	125 lbs/ft (1.82 kN/m)
	0.5:1 (H:V)	8.0 lbs/ft ² (384 Pa)	150 lbs/ft (2.19 kN/m)
	0.5:1 (H:V)	10.0 lbs/ft ² (480 Pa)	175 lbs/ft (2.55 kN/m)

¹ For TRMs containing degradable components, all property values must be obtained on the non-degradable portion of the matting alone.

² Minimum Average Roll Values, machine direction only for tensile strength determination using [ASTM D 6818](#) (Supersedes Mod. [ASTM D 5035](#) for RECPs)

³ Field conditions with high loading and/or high survivability requirements may warrant the use of a TRM with a tensile strength of 44 kN/m (3,000 lb/ft) or greater.

⁴ Required minimum shear stress TRM (fully vegetated) can sustain without physical damage or excess erosion (> 12.7 mm (0.5 in.) soil loss) during a 30-minute flow event in large scale testing.

⁵ Acceptable large-scale testing protocols may include [ASTM D 6460](#), or other independent testing deemed acceptable by the engineer.

Design and Installation

RECPs should be installed according to manufacturer's specifications and guidelines. Regardless of the type of product used, it is important to ensure no gaps or voids exist under the material and that all corners of the material are secured using stakes and trenching. Continuous contact between the product and the soil is necessary to avoid failure. Never use metal stakes to secure temporary erosion control products. Often wooden stakes are used to anchor RECPs; however, wood stakes may present installation and maintenance challenges and generally take a long time to biodegrade. Some local jurisdictions have had favorable experiences using biodegradable stakes.

This BMP Fact Sheet provides design details for several commonly used ECB applications, including:

ECB-1 Pipe Outlet to Drainageway

ECB-2 Small Ditch or Drainageway

ECB-3 Outside of Drainageway

Staking patterns are also provided in the design details according to these factors:

- ECB type
- Slope or channel type

For other types of RECPs including TRMs, these design details are intended to serve as general guidelines for design and installation; however, engineers should adhere to manufacturer's installation recommendations.

Maintenance and Removal

Inspection of erosion control blankets and other RECPs includes:

- Check for general signs of erosion, including voids beneath the mat. If voids are apparent, fill the void with suitable soil and replace the erosion control blanket, following the appropriate staking pattern.
- Check for damaged or loose stakes and secure loose portions of the blanket.

Erosion control blankets and other RECPs that are biodegradable typically do not need to be removed after construction. If they must be removed, then an alternate soil stabilization method should be installed promptly following removal.

Turf reinforcement mats, although generally resistant to biodegradation, are typically left in place as a dense vegetated cover grows in through the mat matrix. The turf reinforcement mat provides long-term stability and helps the established vegetation resist erosive forces.

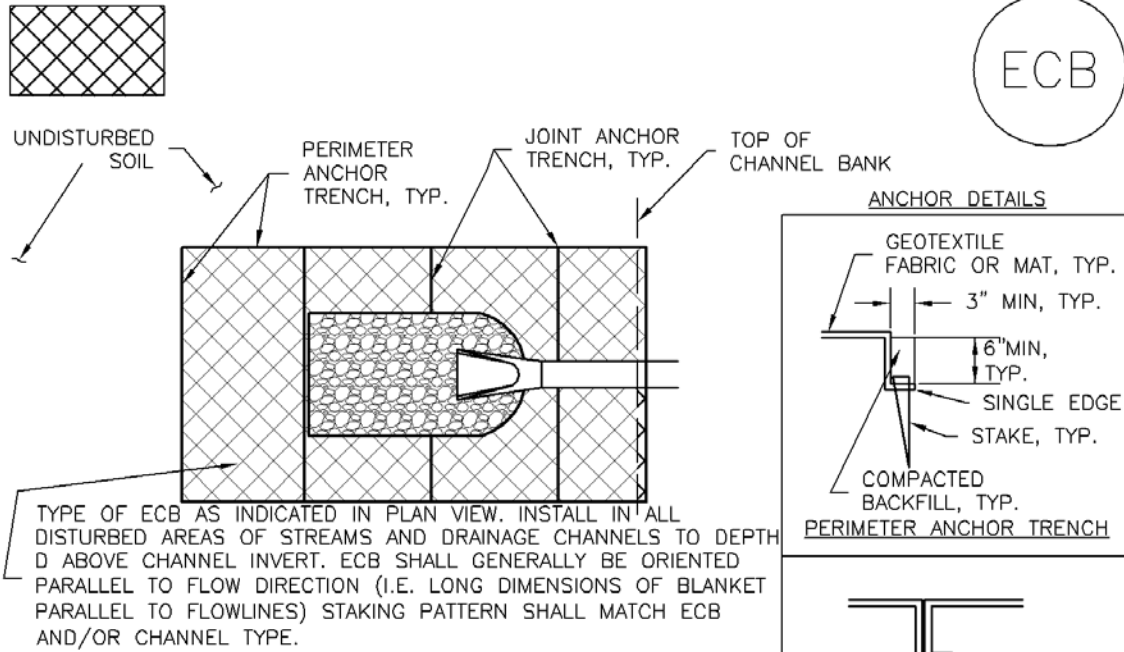

ECB-1. PIPE OUTLET TO DRAINAGEWAY

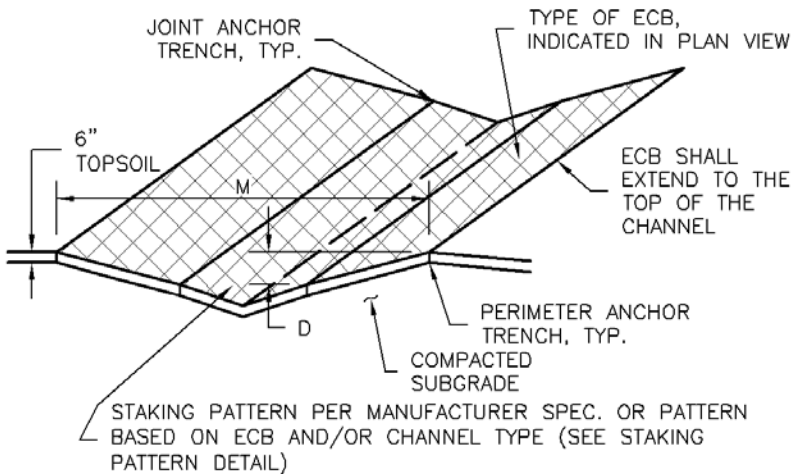

ECB-2. SMALL DITCH OR DRAINAGEWAY

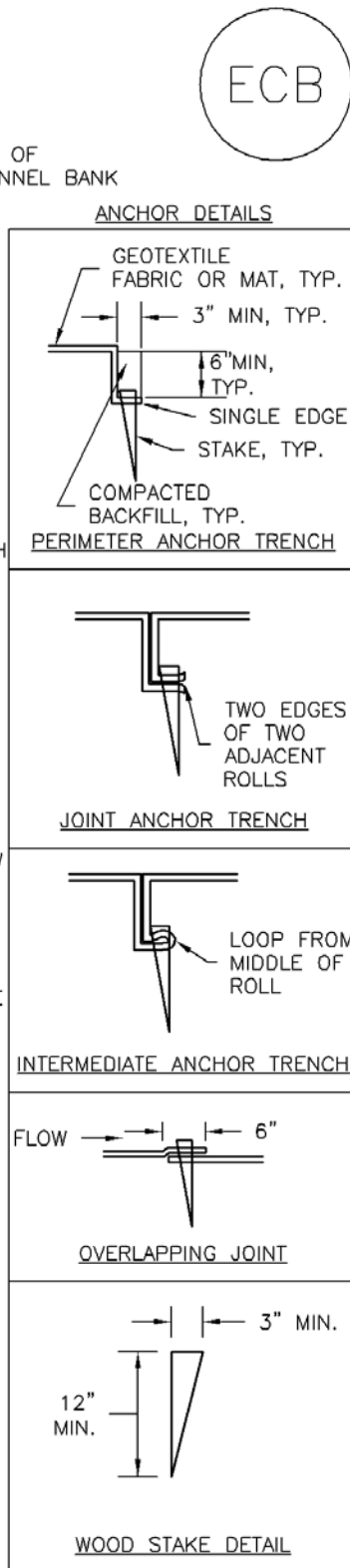

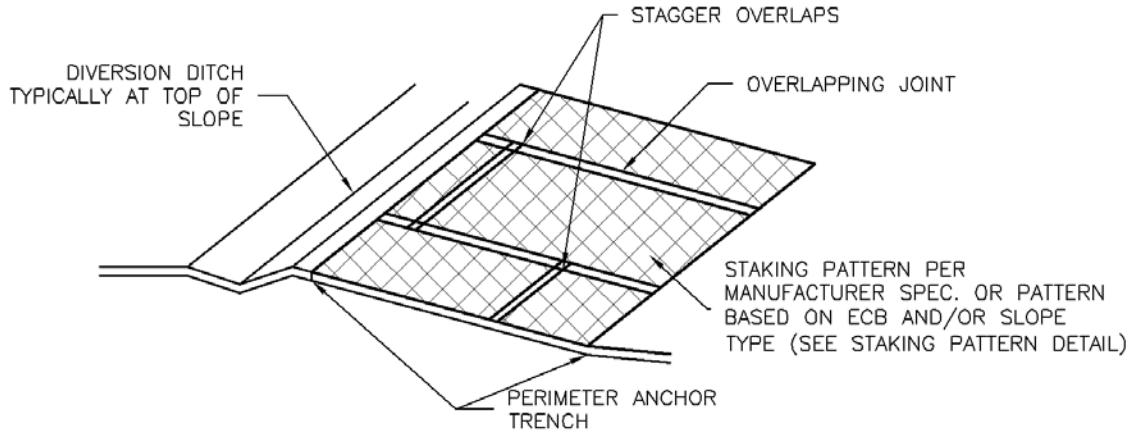

ECB-3. OUTSIDE OF DRAINAGEWAY

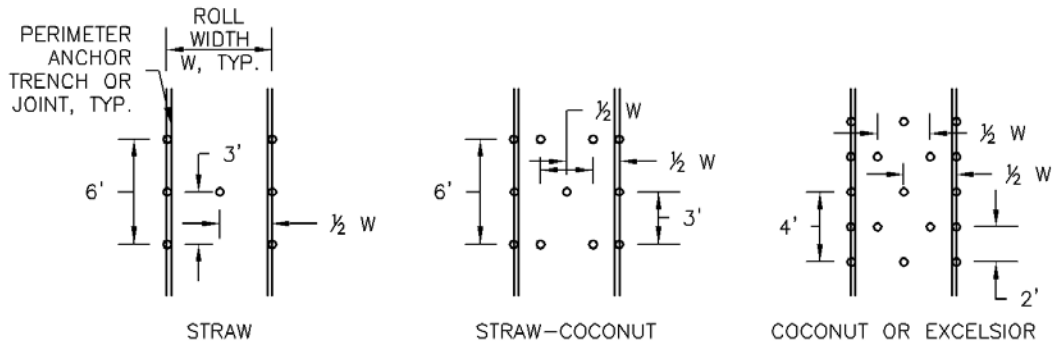

STAKING PATTERNS BY ECB TYPE

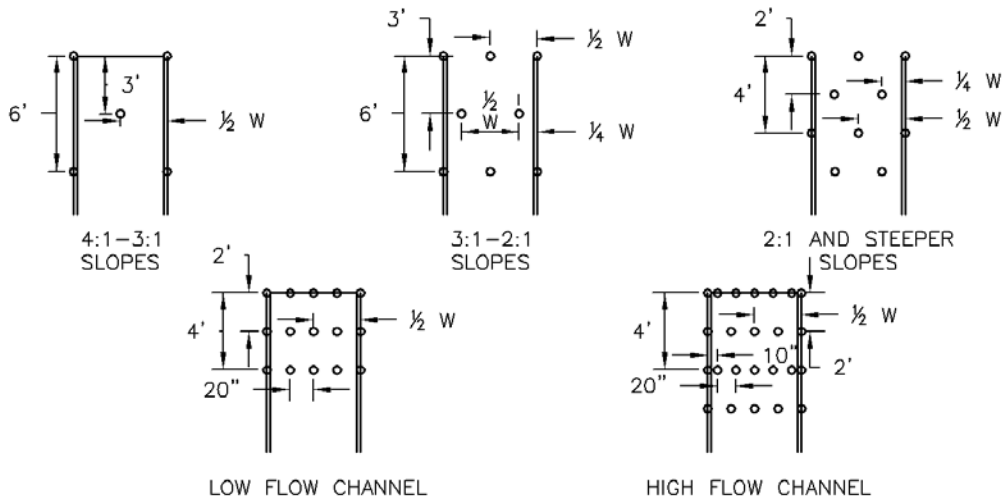

STAKING PATTERNS BY SLOPE OR CHANNEL TYPE

EROSION CONTROL BLANKET INSTALLATION NOTES

1. SEE PLAN VIEW FOR:
 - LOCATION OF ECB.
 - TYPE OF ECB (STRAW, STRAW-COCONUT, COCONUT, OR EXCELSIOR).
 - AREA, A, IN SQUARE YARDS OF EACH TYPE OF ECB.
2. 100% NATURAL AND BIODEGRADABLE MATERIALS ARE PREFERRED FOR RECPs, ALTHOUGH SOME JURISDICTIONS MAY ALLOW OTHER MATERIALS IN SOME APPLICATIONS.
3. IN AREAS WHERE ECBs ARE SHOWN ON THE PLANS, THE PERMITTEE SHALL PLACE TOPSOIL AND PERFORM FINAL GRADING, SURFACE PREPARATION, AND SEEDING AND MULCHING. SUBGRADE SHALL BE SMOOTH AND MOIST PRIOR TO ECB INSTALLATION AND THE ECB SHALL BE IN FULL CONTACT WITH SUBGRADE. NO GAPS OR VOIDS SHALL EXIST UNDER THE BLANKET.
4. PERIMETER ANCHOR TRENCH SHALL BE USED ALONG THE OUTSIDE PERIMETER OF ALL BLANKET AREAS.
5. JOINT ANCHOR TRENCH SHALL BE USED TO JOIN ROLLS OF ECBs TOGETHER (LONGITUDINALLY AND TRANSVERSELY) FOR ALL ECBs EXCEPT STRAW WHICH MAY USE AN OVERLAPPING JOINT.
6. INTERMEDIATE ANCHOR TRENCH SHALL BE USED AT SPACING OF ONE-HALF ROLL LENGTH FOR COCONUT AND EXCELSIOR ECBs.
7. OVERLAPPING JOINT DETAIL SHALL BE USED TO JOIN ROLLS OF ECBs TOGETHER FOR ECBs ON SLOPES.
8. MATERIAL SPECIFICATIONS OF ECBs SHALL CONFORM TO TABLE ECB-1.
9. ANY AREAS OF SEEDING AND MULCHING DISTURBED IN THE PROCESS OF INSTALLING ECBs SHALL BE RESEEDED AND MULCHED.
10. DETAILS ON DESIGN PLANS FOR MAJOR DRAINAGEWAY STABILIZATION WILL GOVERN IF DIFFERENT FROM THOSE SHOWN HERE.

TABLE ECB-1. ECB MATERIAL SPECIFICATIONS				
TYPE	COCONUT CONTENT	STRAW CONTENT	EXCELSIOR CONTENT	RECOMMENDED NETTING**
STRAW*	-	100%	-	DOUBLE/NATURAL
STRAW-COCONUT	30% MIN	70% MAX	-	DOUBLE/NATURAL
COCONUT	100%	-	-	DOUBLE/NATURAL
EXCELSIOR	-	-	100%	DOUBLE/NATURAL

*STRAW ECBs MAY ONLY BE USED OUTSIDE OF STREAMS AND DRAINAGE CHANNEL.
 **ALTERNATE NETTING MAY BE ACCEPTABLE IN SOME JURISDICTIONS

EROSION CONTROL BLANKET MAINTENANCE NOTES

1. INSPECT BMPs EACH WORKDAY, AND MAINTAIN THEM IN EFFECTIVE OPERATING CONDITION. MAINTENANCE OF BMPs SHOULD BE PROACTIVE, NOT REACTIVE. INSPECT BMPs AS SOON AS POSSIBLE (AND ALWAYS WITHIN 24 HOURS) FOLLOWING A STORM THAT CAUSES SURFACE EROSION, AND PERFORM NECESSARY MAINTENANCE.
2. FREQUENT OBSERVATIONS AND MAINTENANCE ARE NECESSARY TO MAINTAIN BMPs IN EFFECTIVE OPERATING CONDITION. INSPECTIONS AND CORRECTIVE MEASURES SHOULD BE DOCUMENTED THOROUGHLY.
3. WHERE BMPs HAVE FAILED, REPAIR OR REPLACEMENT SHOULD BE INITIATED UPON DISCOVERY OF THE FAILURE.
4. ECBs SHALL BE LEFT IN PLACE TO EVENTUALLY BIODEGRADE, UNLESS REQUESTED TO BE REMOVED BY THE LOCAL JURISDICTION.
5. ANY ECB PULLED OUT, TORN, OR OTHERWISE DAMAGED SHALL BE REPAIRED OR REINSTALLED. ANY SUBGRADE AREAS BELOW THE GEOTEXTILE THAT HAVE ERODED TO CREATED A VOID UNDER THE BLANKET, OR THAT REMAIN DEVOID OF GRASS SHALL BE REPAIRED, RESEDED AND MULCHED AND THE ECB REINSTALLED.

NOTE: MANY JURISDICTIONS HAVE BMP DETAILS THAT VARY FROM UDFCD STANDARD DETAILS. CONSULT WITH LOCAL JURISDICTIONS AS TO WHICH DETAIL SHOULD BE USED WHEN DIFFERENCES ARE NOTED.

(DETAILS ADAPTED FROM DOUGLAS COUNTY, COLORADO AND TOWN OF PARKER COLORADO, NOT AVAILABLE IN AUTOCAD)

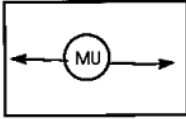

MULCHING

Definition

Application of plant residues or other suitable materials to the soil surface.

Purposes

1. To prevent erosion by protecting the soil surface from raindrop impact and reducing the velocity of overland flow.
2. To foster the growth of vegetation by increasing available moisture and providing insulation against extreme heat and cold.

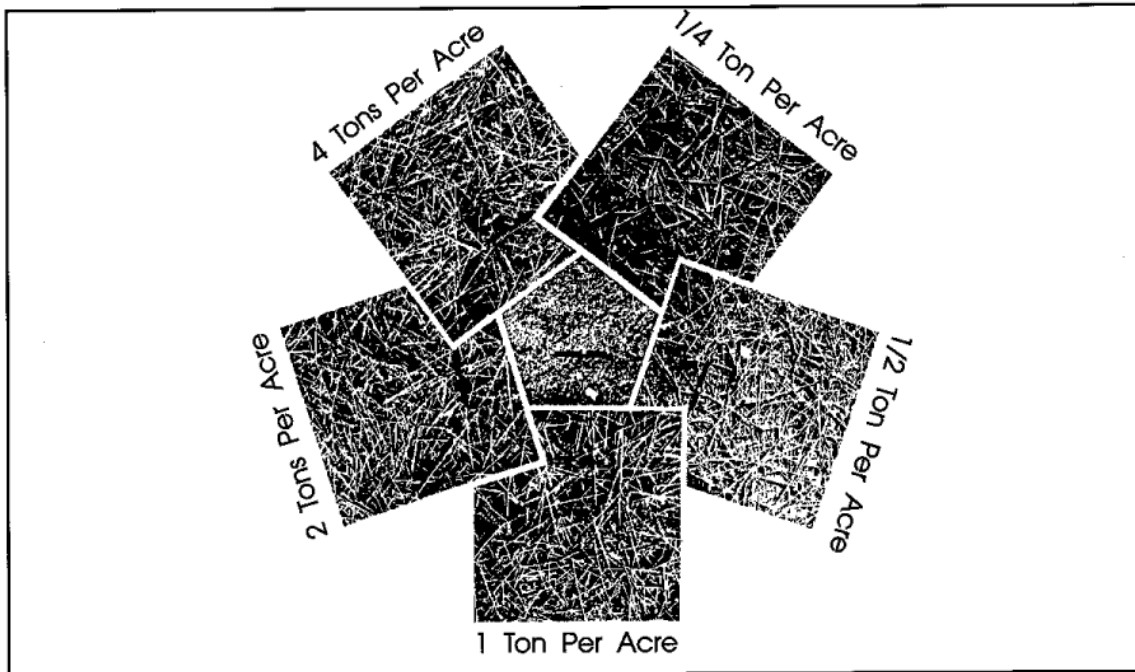

From: Environmental Protection Agency, 1976

Figure C4-2—Mulching

APPENDIX C: Phased CM Implementation

CMs – Phasing, Implementation and Maintenance

Phase	CM	Description/Function	Installation/Implementation	Inspection/Maintenance
Install initial CMs	Perimeter control	Perimeter control serves as erosion and sediment control and, when appropriate, access control during construction activity. At down gradient locations on the perimeter, controls will be installed where overland sheet flow has the potential to leave the site. In up-gradient areas perimeter control may be added to define project boundaries, limit on-site flows or protect off-site features.	<p>Perimeter control may consist of any number of CMs, including, but not limited to diversion ditch & dike, earthen berms, straw wattles, silt fence, construction fencing, controlled parking, controlled site entrance, vehicle tracking control, etc. See the plan for approximate locations and type proposed for installation.</p> <p>Perimeter control will remain in place until areas up-gradient of controls are stabilized.</p>	See CM specific discussions for inspection and maintenance issues.
Install initial CMs	Vehicle tracking control	Vehicle tracking control will consist of an area with a geotextile liner and gravel, metal grate, medium-sized (6" to 12") rough-cut rocks, or asphalt/concrete "rumble strip". Tracking control is designed to cause soil to vibrate off equipment and vehicles as they transition from disturbed soils to paved areas.	<p>All appropriate points of ingress and egress, from where traffic transitions from a stabilized road surface (e.g. gravel or pavement) to disturbed soil, will have a vehicle tracking control installed.</p> <p>Tracking control may be moved or eliminated as on-site conditions and activities change.</p>	<p>Tracking control should be inspected for depth of gravel/rock, presence of excess soil, proper usage and the overall general condition.</p> <p>The most common maintenance items include the removal of accumulated soil and addition of gravel/rock.</p>

CMs – Phasing, Implementation and Maintenance

Phase	CM	Description/Function	Installation/Implementation	Inspection/Maintenance
Install initial CMs	Designated Staging Area	<p>A stabilized staging area is a specific location on-site to stockpile/stage materials and equipment for use on-site.</p> <p>A stabilized staging area allows a central location for deliveries and storage of equipment when not in use, and to reduce disturbance of areas of the site not scheduled for disturbance through construction activities.</p>	<p>Stabilized staging areas generally consist of a cleared area of the site with vehicle tracking control and perimeter controls.</p> <p>Stabilized staging areas will be implemented as needed on site and will be located out of areas of active construction activity. If possible, the designated area will be located so it can be utilized during the entire construction period.</p>	<p>Stabilized staging areas should be inspected for adequate vehicle tracking control and perimeter control.</p> <p>Stabilized staging areas should function as designed or repaired or modified as needed.</p>
Initial stages of construction	Sediment Trap	<p>Sediment traps are small impoundments which allow sediment to settle out which are generally installed in a drainage way or other point of discharge from a disturbed area. They are formed by excavating an area or by placing an earthen embankment across a low area or drainage swale. Typically, a spillway or outlet is constructed to allow the slow release of stormwater runoff. Sediment traps are commonly used at the outlets of diversion structures, slope drains or any other runoff that discharges waters containing sediment.</p>	<p>Sediment traps will be installed prior to earth disturbing activities in areas where it's determined to be needed.</p>	<p>Sediment Trap will be inspected for accumulated sediment, erosion and to ensure effective operation</p>

CMs – Phasing, Implementation and Maintenance

Phase	CM	Description/Function	Installation/Implementation	Inspection/Maintenance
Initial stages of construction	Diversion Ditch	Diversion ditches are excavated channels, generally 6"-18" in depth which provide channelization of stormwater runoff for the purpose of directing sediment-laden flows to treatment facilities or interception of potential run-on flows to convey it around the disturbed area. All diversion ditches shall be of the 'unlined' type unless specifically noted on the plan.	Diversion ditches will be installed prior to earth disturbing activities in areas indicated on the site map.	Diversion ditches will be inspected for effectiveness and repaired or modified as necessary.
Clearing, Grubbing & Pad Grading	Natural Vegetative Barrier	A natural vegetative barrier is a preexisting vegetated, landscaped or sod/seed area that is retained to reduce water flow and prevent erosion over disturbed soil. Additionally, natural vegetative barriers provide a barrier zone where overland sheet flow velocity is dissipated and sediment trapped, reducing sediment discharge off-site.	Natural vegetative barriers are encouraged for any perimeter or environmentally sensitive areas. Whenever possible, a natural vegetative barrier will be maintained between the construction area and stormwater drainage areas.	Inspections include observation for sediment accumulation or erosion to the area. Should damage occur to a vegetative buffer strip a new or additional CM should be considered.
Construction of temporary material storage areas, improvement or construction of drainage features if needed	Straw Bales	A straw bale should be a minimum of 14" X 18" X 36" with a minimum mass of 50 pounds. It should be composed of only vegetative matter, except for the binding. The straw bales should be bound by steel wire (minimum 14-gauge), nylon or polypropylene. Applications include check dams in swales, inlet protection, outlet protection, perimeter control, disturbed areas with significant potential for off-site drainage, protection from neighboring site run-on, or during the construction of drainage swales and ditches.	The basic installation for a straw bale is to prepare a trench approximately four inches deep, secure the bale in the trench using stakes, and backfilled.	Straw bales will be inspected for proper installation, structural integrity and sediment accumulation. Straw bales degrade and need to be replaced on a regular basis.

CMs – Phasing, Implementation and Maintenance

Phase	CM	Description/Function	Installation/Implementation	Inspection/Maintenance
Installation of new culvert if needed	Inlet protection	<p>Inlet protection consists of a barrier material placed in front, around, or immediately up-gradient from the inlet. The most common forms of inlet protection are wire or fabric socks filled with rock or straw wattles.</p> <p>Inlet protection is designed to slow stormwater flow into the inlet, allowing sediment time to settle and accumulate on the up-gradient side of the structure, without constricting the inlet throat.</p>	<p>Inlet protection will be installed prior to earth disturbing activity. As permanent stormwater system inlets are constructed in areas with potential disturbed area run-off or when existing inlets are potentially impacted by construction activity, inlet protection will be installed. If conditions warrant, protection will be provided to prevent sediment from entering the inlet from above or behind the opening. Any structure with a potential to receive run-off from non-stabilized surfaces will be treated with an inlet protection CM.</p> <p>Inlet protection will remain in place until all up-gradient areas are stabilized.</p>	<p>Inlet protection will be inspected for damage, structural integrity and need for sediment removal.</p> <p>Maintenance includes repairing or replacing as needed, repositioning the inlet protection and/or removing accumulated sediment.</p>
Foundation construction	Concrete Wash-Out	<p>A concrete wash-out is designed to capture waste water and waste products resulting from the cleaning of concrete equipment.</p> <p>A concrete wash-out may not be necessary if all wash-out operations are performed off-site.</p>	<p>A concrete wash-out will be installed or provided prior to any construction activities that include the handling of materials containing cement (e.g. concrete, masonry, etc.).</p> <p>Examples of permanent installations include a bermed excavation, a mobile disposal unit, small excavations located near the point of concrete placement, water tight vessels such as rigid pre-fabricated impermeable plastic pools, stock tanks, small dumpsters, buckets, etc. and geotextile bags.</p>	<p>A concrete wash-out should be inspected to make sure appropriate access control, tracking and containment is in place.</p> <p>Maintenance would include the removal of excess material, and general structural integrity of the installation. Concrete wash-outs should be cleaned of excess water and solids when the capacity of the wash-out reaches no more than 50% (5" for rigid "kiddie" pools).</p>

CMs – Phasing, Implementation and Maintenance

Phase	CM	Description/Function	Installation/Implementation	Inspection/Maintenance
Throughout construction period	Dust Control	Dust control reduces dust generated from disturbed surfaces and wind.	Water will be applied from water trucks as needed. Correct application is just enough water to moisten the surface and calm dust, but not so much as to create standing water and mud.	Disturbed areas should be inspected for obvious signs of wind erosion and dust. This CM is implemented as needed.
As appropriate during all phases of construction which cause soil disturbances on sloped surfaces.	Surface Roughening	<p>Surface roughening consists of grooves or tracks installed in the soil surface, perpendicular to the slope. This is a temporary soil stabilization technique that works well in areas that will remain inactive for a short time.</p> <p>Surface roughening works by reducing water velocity and promoting infiltration, thus decreasing the potential for erosion to occur.</p>	<p>Any disturbed areas with no construction activity planned for longer than 14 days may be surfaced roughened. Surface roughening may be applied by creating a continuous furrow perpendicular to the slope. This can be done with the teeth on a loader bucket, ripping, disking or plowing equipment.</p> <p>Surface roughening can also be created by running tracked equipment up and down the slope.</p>	<p>Inspection of surface roughened areas would include proper implementation, structural integrity and areas of erosion or sediment accumulation.</p> <p>Maintenance for surface roughening would include re-applying the technique or installation of new or additional CMs.</p>
All Phases where appropriate to the water volume and velocity	Straw Wattles (fiber rolls)	Straw wattles consist of a net or geotextile fabric filled with straw, excelsior, wood mulch or other man made fillers. They reduce water velocity allowing sediment to accumulate on the up-gradient side of the wattle. Applications include, but are not limited to, slope stabilization, check dams in swales, back of curb protection and temporary secondary containment for stock piles and materials storage.	<p>The basic installation for a net wrapped wattle is to prepare a trench approximately three inches deep, secure the wattle in the trench using a stake or landscape pin, and backfill approximately 1/3 of the wattle on the up-gradient side.</p> <p>Wattles should be installed based on manufacturer's directions. Typical wattle installation details are provided.</p>	Straw wattles should be inspected for proper installation, structural integrity and sediment accumulation. Note: A wattle that has been flattened out of round may not need to be replaced if they remain sufficient to function appropriately on the up-gradient side of the wattle.

CMs – Phasing, Implementation and Maintenance

Phase	CM	Description/Function	Installation/Implementation	Inspection/Maintenance
All Phases where appropriate to the water volume and velocity	Check Dams	Rock check dams will be used in areas of concentrated flows along the swales to slow water velocity to allow sediment to settle and to prevent erosion. Additionally, this may be used in areas where existing drainage patterns cross onto the site and bring neighboring property run-on into the construction area.	The check dam will be installed across the entire width of the swale, with the center of the check dam lower than the sides.	Check dams should be inspected for proper installation, structural integrity and accumulated sediment. Maintenance would include repairing or replacing damaged rock berms and removing accumulated sediment.
After completion of construction activities	Erosion Control Mats & Seeding	Seeding involves the mechanical or hand application of a specific seed mixes appropriate for the site location and soil type. Seeding can be used as a permanent or temporary CM. Seeding provides plant growth to stabilize the soil reducing the likelihood of erosion or sediment transport.	As soon as practicable, after the completing of construction activities, soil should be properly prepared and seeded. The choice of seed mix will dictate application rates and methods. Seeding should always be accompanied by an additional CM, such as mulching or straw mat to protect the seed and soil from erosion during the germination and growth process.	Seed areas should be inspected to ensure that the straw mat was applied correctly and has not been compromised. The area should also be inspected for erosion and sediment deposition. Maintenance items would include re-grading and seeding bare or areas of thin vegetative growth and/or adding additional CMs as appropriate.

New CMs Added to the Site

Use the following space to provide information regarding new CMs added to site.

Phase	CM	Description/Function	Installation/Implementation	Inspection/Maintenance

APPENDIX D: Inspection Forms

StormWater Inspection Report

Facility Name		Permittee	
Date of Inspection		Weather Conditions	
Permit Certification #		Current Acres Disturbed	
Phase of Construction		Inspector Title	
Inspector Name		Location of SWMP	
Is the above inspector a qualified stormwater manager?			
<i>(permittee is responsible for ensuring that the inspector is a qualified stormwater manager)</i>			

GENERAL NOTES

INSPECTION FREQUENCY

Check the box that describes the minimum inspection frequency utilized when conducting each inspection	
At least one inspection every 7 calendar days	<input type="checkbox"/>
At least one inspection every 14 calendar days PLUS post-storm event inspections	<input type="checkbox"/>
<ul style="list-style-type: none"> This is a post-storm event inspection within 24 hours after storm. Event Date: 	<input type="checkbox"/>
Reduced inspection frequency - Include site conditions that warrant reduced inspection frequency	<input type="checkbox"/>
<ul style="list-style-type: none"> Post-storm inspections at temporarily idle sites (prior to construction/within 72 hours after storm) 	<input type="checkbox"/>
<ul style="list-style-type: none"> Inspections at completed sites/area (at least once every 30 days) 	<input type="checkbox"/>
<ul style="list-style-type: none"> Winter conditions exclusion 	<input type="checkbox"/>
Have there been any deviations from the minimum inspection schedule?	<input type="checkbox"/>
If yes, describe:	

INSPECTION REQUIREMENTS	RESULT	COMMENT
Are control measures in effective operational condition and working as designed in the specifications?		
Are there any new potential sources of pollutants? If answer is yes, list new pollutants in comments.		
Does the site require any new or modified control measures to minimize pollutant discharges?		
Are there any areas that require temporary or permanent stabilization? (e.g. slopes, inactive disturbed areas, stockpiles, etc.).		
Are there any Bulk storage (55 gal. or greater) of petroleum products and other liquid chemicals on site that require secondary containment?		
Are there any areas of non-compliance with the permit requirements? If answer is yes, implement corrective actions in section below.		

AREAS TO INSPECT

Is there evidence of, or the potential for, pollutants leaving the construction site boundaries, entering the stormwater drainage system or discharging to state waters at the following locations?

If "YES" describe discharge or potential for discharge below. Then document related maintenance, inadequate control measures and corrective actions on the appropriate subsequent forms.

Location	Result	Description
Construction site perimeter		
All disturbed areas		
Designated haul routes		
Material and waste storage areas exposed to precipitation		
Locations where stormwater has the potential to discharge offsite		
Locations where vehicles exit the site		
Other:		

StormWater Inspection Report

Has there been an incident of noncompliance requiring 24-hour notification? If YES, Document Below:	

INSPECTION CERTIFICATION

I certify this inspection is, to the best of my knowledge and belief, true, accurate and complete. I am aware that there are significant penalties for submitting false information.

Qualified Stormwater Manager/Inspector (Name, Title, Company & Signature)

Date:

COMPLIANCE CERTIFICATION

I verify that, to the best of my knowledge and belief, all corrective action and maintenance items identified during the inspection are complete, and the site is currently in compliance with the permit.

Qualified Stormwater Manager/Designee (Name, Title, Company & Signature)

Date:

APPENDIX E: Spill Reports



TRI-STATE GENERATION AND TRANSMISSION ASSOCIATION, INC.

**Construction Stormwater Pollution Prevention
Spill Report Form**

Spill Reported By: _____ Phone Number: _____

Details

Date Reported: _____ Time: _____

Date of Spill: _____ Time: _____

Name of the Facility: Fox Run Substation, El Paso County, CO

Describe Spill Location and Events Leading to Spill: _____

Material Spilled: _____

Source of Spill: _____

AMOUNT OF THE SPILL (GALLONS OR POUNDS): _____

Containment and Cleanup

Containment or Cleanup Action: _____

Date and Time Cleanup Completed or Terminated: _____

Description of Materials Contaminated: _____

Label on the Drum of Cleanup Materials: _____

Signed: _____

Contractor Superintendent or
Environmental Inspector

APPENDIX F: Permit Application and Permit



STATE OF COLORADO

COLORADO DEPARTMENT OF PUBLIC HEALTH AND ENVIRONMENT

Water Quality Control Division

CDPS GENERAL PERMIT
STORMWATER DISCHARGES ASSOCIATED WITH
CONSTRUCTION ACTIVITY
AUTHORIZATION TO DISCHARGE UNDER THE
COLORADO DISCHARGE PERMIT SYSTEM (CDPS)

In compliance with the provisions of the Colorado Water Quality Control Act, (25-8-101 et seq., CRS, 1973 as amended) and the Federal Water Pollution Control Act, as amended (33 U.S.C. 1251 et seq.; the "Act"), this permit authorizes the discharge of stormwater associated with construction activities (and specific allowable non-stormwater discharges in accordance with Part I.A.1. of the permit) certified under this permit, from those locations specified throughout the State of Colorado to specified waters of the State.

Such discharges shall be in accordance with the conditions of this permit. This permit specifically authorizes the facility listed on the certification to discharge in accordance with permit requirements and conditions set forth in Parts I and II hereof. All discharges authorized herein shall be consistent with the terms and conditions of this permit.

This permit becomes effective on April 1, 2019, and shall expire at midnight March 31, 2024.

Issued and signed this 1st day of November 2018.

COLORADO DEPARTMENT OF PUBLIC HEALTH AND ENVIRONMENT

Ellen Howard Kutzer, Permits Section Manager
Water Quality Control Division

Permit History

Originally signed and issued October 31, 2018; effective April 1, 2019.

Table of Contents

Part I	1
A. COVERAGE UNDER THIS PERMIT.....	1
1. Authorized Discharges	1
2. Limitations on Coverage.....	1
3. Permit Certification and Submittal Procedures	2
B. EFFLUENT LIMITATIONS	6
1. Requirements for Control Measures Used to Meet Effluent Limitations	6
2. Discharges to an Impaired Waterbody.....	9
3. General Requirements	10
C. STORMWATER MANAGEMENT PLAN (SWMP) REQUIREMENTS	11
1. SWMP General Requirements	11
2. SWMP Content	11
3. SWMP Review and Revisions	13
4. SWMP Availability.....	14
D. SITE INSPECTIONS.....	14
1. Person Responsible for Conducting Inspections	14
2. Inspection Frequency	14
3. Inspection Frequency for Discharges to Outstanding Waters.....	15
4. Reduced Inspection Frequency	15
5. Inspection Scope.....	16
E. DEFINITIONS	17
F. MONITORING.....	20
G. Oil and Gas Construction	21
Part II: Standard Permit Conditions.....	22
A. DUTY TO COMPLY.....	22
B. DUTY TO REAPPLY	22
C. NEED TO HALT OR REDUCE ACTIVITY NOT A DEFENSE	22
D. DUTY TO MITIGATE	22
E. PROPER OPERATION AND MAINTENANCE	22
F. PERMIT ACTIONS	22
G. PROPERTY RIGHTS	22
H. DUTY TO PROVIDE INFORMATION	23
I. INSPECTION AND ENTRY	23
J. MONITORING AND RECORDS	23
K. SIGNATORY REQUIREMENTS	24

- 1. Authorization to Sign:..... 24
- 2. Electronic Signatures 25
- 3. Change in Authorization to Sign 25
- L. REPORTING REQUIREMENTS 25
 - 1. Planned Changes..... 25
 - 2. Anticipated Non-Compliance 25
 - 3. Transfer of Ownership or Control 25
 - 4. Monitoring reports..... 26
 - 5. Compliance Schedules 26
 - 6. Twenty-four hour reporting..... 26
 - 7. Other non-compliance 27
 - 8. Other information 27
- M. BYPASS 27
 - 1. Bypass not exceeding limitations 27
 - 2. Notice of bypass 27
 - 3. Prohibition of Bypass..... 27
- N. UPSET..... 28
 - 1. Effect of an upset 28
 - 2. Conditions necessary for demonstration of an Upset 28
 - 3. Burden of Proof 28
- O. RETENTION OF RECORDS..... 28
 - 1. Post-Expiration or Termination Retention 28
 - 2. On-site Retention..... 29
- P. REOPENER CLAUSE..... 29
 - 1. Procedures for modification or revocation 29
 - 2. Water quality protection 29
- Q. SEVERABILITY..... 29
- R. NOTIFICATION REQUIREMENTS 29
 - 1. Notification to Parties 29
- S. RESPONSIBILITIES 30
 - 1. Reduction, Loss, or Failure of Treatment Facility 30
- T. Oil and Hazardous Substance Liability..... 30
- U. Emergency Powers..... 30
- V. Confidentiality 30
- W. Fees..... 30

X. Duration of Permit..... 30

Y. Section 307 Toxics..... 30

Part I

Note: At the first mention of terminology that has a specific connotation for the purposes of this permit, the terminology is electronically linked to the definitions section of the permit in Part I.E.

A. COVERAGE UNDER THIS PERMIT**1. Authorized Discharges**

This general permit authorizes [permittee\(s\)](#) to discharge the following to state waters: stormwater associated with [construction activity](#) and specified non-stormwater associated with construction activity. The following types of stormwater and non-stormwater discharges are authorized under this permit:

a. Allowable Stormwater Discharges

- i. Stormwater discharges associated with construction activity.
- ii. Stormwater discharges associated with producing earthen materials, such as soils, sand, and gravel dedicated to providing material to a single contiguous site, or within ¼ mile of a construction site (i.e. borrow or fill areas)
- iii. Stormwater discharges associated with [dedicated asphalt, concrete batch plants and masonry mixing stations](#) (Coverage under this permit is not required if alternative coverage has been obtained.)

b. Allowable Non-Stormwater Discharges

The following non-stormwater discharges are allowable under this permit if the discharges are identified in the stormwater management plan in accordance with Part I.C. and if they have appropriate [control measures](#) in accordance with Part I.B.1.

- i. Discharges from uncontaminated springs that do not originate from an area of land disturbance.
- ii. Discharges to the ground of concrete washout water associated with the washing of concrete tools and concrete mixer chutes. Discharges of concrete washout water must not leave the site as surface runoff or reach [receiving waters](#) as defined by this permit.
- iii. Discharges of landscape irrigation return flow.

c. Emergency Fire Fighting

Discharges resulting from emergency firefighting activities are authorized by this permit.

2. Limitations on Coverage

Discharges not authorized by this permit include, but are not limited to, the discharges and activities listed below. Permittees may seek individual or alternate general permit coverage for the discharges, as appropriate and available.

a. Discharges of Non-Stormwater

Discharges of non-stormwater, except the authorized non-stormwater discharges listed in Part I.A.1.b., are not eligible for coverage under this permit.

- b. Discharges Currently Covered by another Individual or General Permit
 - c. Discharges Currently Covered by a Water Quality Control Division (division) Low Risk Guidance Document
3. Permit Certification and Submittal Procedures
- a. Duty to apply
The following activities shall apply for coverage under this permit:
 - i. Construction sites that will disturb one acre or more; or
 - ii. Construction sites that are part of a [common plan of development or sale](#); or
 - iii. Stormwater discharges that are designated by the division as needing a stormwater permit because the discharge:
 - (a) Contributes to a violation of a water quality standard; or
 - (b) is a significant contributor of pollutants to state waters.
 - b. Application Requirements
To obtain authorization to discharge under this permit, applicants applying for coverage following the effective date of the renewal permit shall meet the following requirements:
 - i. Owners and operators submitting an application for permit coverage will be co-permittees subject to the same benefits, duties, and obligations under this permit.
 - ii. Signature requirements: Both the [owner](#) and [operator](#) (permittee) of the construction site, as defined in Part I.E., must agree to the terms and conditions of the permit and submit a completed application that includes the signature of both the owner and the operator. In cases where the duties of the owner and operator are managed by the owner, both application signatures may be completed by the owner. Both the owner and operator are responsible for ensuring compliance with all terms and conditions of the permit, including implementation of the stormwater management plan.
 - iii. Applicants must use the paper form provided by the division or the electronic form provided on the division's web-based application platform when applying for coverage under this permit.
 - iv. The applicant(s) must develop a stormwater management plan (SWMP) in accordance with the requirements of Part I.C. The applicant(s) must also certify that the SWMP is complete, or will be complete, prior to commencement of any construction activity.

- v. The applicant(s) must submit a complete, accurate, and signed permit application electronically, by mail or hand delivery to the division at least 10 days prior to the commencement of construction activity except that construction activities that are in response to a **public emergency related site** shall apply for coverage no later than 14 days after the commencement of construction activities. The provisions of this part in no way remove a violation of the Colorado Water Quality Control Act if a point source discharge occurs prior to the issuance of a CDPS permit.
 - vi. The application must be signed in accordance with the requirements of Part IA. Applications submitted by mail or hand delivered should be directed to:

Colorado Department of Public Health and Environment
Water Quality Control Division
Permits Section, WQCD-PS-B2
4300 Cherry Creek Drive South
Denver, CO 80246
 - vii. The applicant(s) must receive written notification that the division granted permit coverage prior to conducting construction activities except for construction activities that are in response to a public emergency related site
- c. Division Review of Permit Application
Within 10 days of receipt of the application, and following review of the application, the division may:
- i. Issue a certification of coverage;
 - ii. request additional information necessary to evaluate the discharge;
 - iii. delay the authorization to discharge pending further review;
 - iv. notify the applicant that additional terms and conditions are necessary; or
 - v. deny the authorization to discharge under this general permit.
- d. Alternative Permit Coverage
- i. Division Required Alternate Permit Coverage:
The Division may require an applicant or permittee to apply for an individual permit or an alternative general permit if it determines the discharge does not fall under the scope of this general permit. In this case, the Division will notify the applicant or permittee that an individual permit application is required.
 - ii. Permittee Request for alternate permit coverage:
A permittee authorized to discharge stormwater under this permit may request to be excluded from coverage under this general permit by applying for an individual permit. In this case, the permittee must submit an individual application, with reasons supporting the request, to the Division at least 180 days prior to any discharge. When an individual permit is issued, the permittee's authorization to discharge under this permit is terminated on the effective date of the individual permit.
- e. Submittal Signature Requirements

Documents required for submittal to the division in accordance with this permit, including applications for permit coverage and other documents as requested by the division, must include signatures by both the owner and the operator, except for instances where the duties of the owner and operator are managed by the owner.

Signatures on all documents submitted to the division as required by this permit must meet the Standard Signatory Requirements in Part II.K. of this permit in accordance with 40 C.F.R. 122.41(k).

i. Signature Certification

Any person(s) signing documents required for submittal to the Division must make the following certification:

"I certify under penalty of law that this document and all attachments were prepared under my direction or supervision in accordance with a system designed to assure that qualified personnel properly gather and evaluate the information submitted. Based on my inquiry of the person or persons who manage the system, or those persons directly responsible for gathering the information, the information submitted is, to the best of my knowledge and belief, true, accurate, and complete. I am aware that there are significant penalties for submitting false information, including the possibility of fine and imprisonment for knowing violations."

f. Compliance Document Signature Requirements

Documents which are required for compliance with the permit, but for which submittal to the division is not required unless specifically requested by the division, must be signed by the individual(s) designated as the Qualified Stormwater Manager, as defined in Part I.E.

i. Any person(s) signing inspection documents required for compliance with the permit must make the following statement:

"I verify that, to the best of my knowledge and belief, all corrective action and maintenance items identified during the inspection are complete, and the site is currently in compliance with the permit."

g. Field Wide Permit Coverage for Oil and Gas Construction

At the discretion of the division, a single permit certification may be issued to a single oil and gas permittee to cover construction activity related discharges from an oil and gas field at multiple locations that are not necessarily contiguous.

h. Permit Coverage without Application

Qualifying Local Program: When a small construction site is within the jurisdiction of a qualifying local program, the owner and operator of the construction activity are authorized to discharge stormwater associated with small construction activity under this general permit without the submittal of an application to the division. Sites covered by a qualifying local program are exempt from the following sections of this general permit:

Part I.A.3.a.; Part I.A.3.b.; Part I.A.3.c.; Part I.A.3.d.; Part I.A.3.g.; Part I.A.3.i.; Part I.A.3.j.; Part I.A.3.k.

Sites covered by a qualifying local program are subject to the following requirements:

- i. **Local Agency Authority:** This permit does not pre-empt or supersede the authority of local agencies to prohibit, restrict, or control discharges of stormwater to storm drain systems or other water courses within their jurisdiction.
 - ii. **Permit Coverage Termination:** When a site under a Qualifying Local Program is finally stabilized, coverage under this permit is automatically terminated.
 - iii. **Compliance with Qualifying Local Program:** Qualifying Local Program requirements that are equivalent to the requirements of this permit are incorporated by reference. Permittees authorized to discharge under this permit, must comply with the equivalent requirements of the Qualifying Local Program that has jurisdiction over the site as a condition of this permit.
 - iv. **Compliance with Remaining Permit Conditions.** Requirements of this permit that are in addition to or more stringent than the requirements of the Qualifying Local Program apply in addition to the requirements of the Qualifying Local Program.
 - v. **Written Authorization of Coverage:** The division or local municipality may require any permittee within the jurisdiction of a Qualifying Local Program covered under this permit to apply for, and obtain written authorization of coverage under this permit. The permittee must be notified in writing that an application for written authorization of coverage is required.
- i. **Permittee Initiated Permit Actions**
Permittee initiated permit actions, including but not limited to modifications, contact changes, transfers, reassignments, and terminations, shall be conducted following division guidance and using appropriate division-provided forms.
 - j. **Sale of Residence to Homeowner**
Residential construction sites only: The permittee may remove residential lots from permit coverage once the lot meets the following criteria:
 - i. the residential lot has been sold to the homeowner(s) for private residential use;
 - ii. a certificate of occupancy, or equivalent, is maintained on-site and is available during division inspections;
 - iii. the lot is less than one acre of disturbance;
 - iv. all construction activity conducted on the lot by the permittee is complete;
 - v. the permittee is not responsible for final stabilization of the lot; and
 - vi. the SWMP was modified to indicate the lot is no longer part of the construction activity.

If the residential lot meets the criteria listed above then activities occurring on the lot are no longer considered to be construction activities with a duty to apply and maintain permit coverage. Therefore, the permittee is not required to meet the final stabilization requirements and may terminate permit coverage for the lot.

k. Permit Expiration and Continuation of Permit Coverage

Authorization to discharge under this general permit shall expire at midnight on March 31, 2024. While Regulation 61.4 requires a permittee to submit an application for continuing permit coverage 180 days before the permit expires, the division is requiring that permittees desiring continued coverage under this general permit must reapply at least 90 days in advance of this permit expiration. The Division will determine if the permittee may continue to discharge stormwater under the terms of the general permit. An individual permit may be required for any facility not reauthorized to discharge under the reissued general permit.

If this permit is not reissued or replaced prior to the expiration date, it will be administratively continued and remain in force and effect. For permittees that have applied for continued permit coverage, discharges authorized under this permit prior to the expiration date will automatically remain covered by this permit until the earliest of:

- i. An authorization to discharge under a reissued permit, or a replacement of this permit, following the timely and appropriate submittal of a complete application requesting authorization to discharge under the new permit and compliance with the requirements of the new permit; or
- ii. The issuance and effect of a termination issued by the Division; or
- iii. The issuance or denial of an individual permit for the facility's discharges; or
- iv. A formal permit decision by the Division not to reissue this general permit, at which time the Division will identify a reasonable time period for covered dischargers to seek coverage under an alternative general permit or an individual permit. Coverage under this permit will cease when coverage under another permit is granted/authorized; or
- v. The Division has informed the permittee that discharges previously authorized under this permit are no longer covered under this permit.

B. EFFLUENT LIMITATIONS

1. Requirements for Control Measures Used to Meet Effluent Limitations

The permittee must implement control measures to **minimize** the discharge of pollutants from all potential pollutant sources at the site. Control measures must be installed prior to commencement of activities that may contribute pollutants to stormwater discharges. Control measures must be selected, designed, installed and maintained in accordance with good engineering, hydrologic and pollution control practices. Control measures implemented at the site must be designed to prevent pollution or degradation of state waters.

a. Stormwater Pollution Prevention

The permittee must implement structural and/or nonstructural control measures that effectively minimize erosion, sediment transport, and the release of other pollutants related to construction activity.

i. Control Measures for Erosion and Sediment Control

Control measures for erosion and sediment control may include, but are not limited to, wattles/sediment control logs, silt fences, earthen dikes, drainage swales, sediment traps, subsurface drains, pipe slope drains, inlet protection, outlet protection, gabions, sediment basins, temporary vegetation, permanent vegetation, mulching, geotextiles, sod stabilization, slope roughening, maintaining existing vegetation, protection of trees, and preservation of mature vegetation. Specific non-structural control measures must meet the requirements listed below.

Specific control measures must meet the requirements listed below.

- (a) Vehicle tracking controls shall either be implemented to minimize vehicle tracking of sediment from disturbed areas, or the areas where vehicle tracking occurs shall meet subsection Part I.B.1.a.i(b);
- (b) Stormwater runoff from all disturbed areas and soil storage areas for which permanent or temporary stabilization is not implemented, must flow to at least one control measure to minimize sediment in the discharge. This may be accomplished through filtering, settling, or straining. The control measure must be selected, designed, installed and adequately sized in accordance with good engineering, hydrologic and pollution control practices. The control measure(s) must contain or filter flows in order to prevent the bypass of flows without treatment and must be appropriate for stormwater runoff from disturbed areas and for the expected flow rate, duration, and flow conditions (i.e., sheet or concentrated flow);
- (c) Outlets that withdraw water from or near the surface shall be installed when discharging from basins and impoundments, unless **infeasible**.
- (d) Maintain pre-existing vegetation or equivalent control measures for areas within 50 horizontal feet of receiving waters as defined by this permit, unless **infeasible**.
- (e) Soil compaction must be minimized for areas where infiltration control measures will occur or where **final stabilization** will be achieved through vegetative cover.
- (f) Unless **infeasible**, topsoil shall be preserved for those areas of a site that will utilize vegetative final stabilization.
- (g) Minimize the amount of soil exposed during construction activity, including the disturbance of steep slopes.

ii. Practices for Other Common Pollutants

- (a) Bulk storage, 55 gallons or greater, for petroleum products and other liquid chemicals must have secondary containment, or equivalent protection, in order to contain **spills** and to prevent spilled material from entering state waters.
- (b) Control measures designed for concrete washout waste must be implemented. This includes washout waste discharged to the ground as authorized under this permit and washout waste from concrete trucks and masonry operations contained on site. The permittee must ensure the washing activities do not contribute pollutants to stormwater runoff, or receiving waters in accordance Part I.A.1.b.ii. Discharges that may reach groundwater must flow through soil

that has buffering capacity prior to reaching groundwater, as necessary to meet the effluent limits in this permit, including Part I.B.3.a. The concrete washout location shall not be located in an area where shallow groundwater may be present and would result in buffering capacity not being adequate, such as near natural drainages, springs, or wetlands. This permit authorizes discharges to the ground of concrete washout waste.

iii. Stabilization Requirements

The following requirements must be implemented for each site.

- (a) Temporary stabilization must be implemented for earth disturbing activities on any portion of the site where ground disturbing construction activity has permanently ceased, or temporarily ceased for more than 14 calendar days. Temporary stabilization methods may include, but are not limited to, tarps, soil tackifier, and hydroseed. The permittee may exceed the 14-day schedule when either the function of the specific area of the site requires it to remain disturbed, or, physical characteristics of the terrain and climate prevent stabilization. The SWMP must document the constraints necessitating the alternative schedule, provide the alternate stabilization schedule, and identify all locations where the alternative schedule is applicable on the site map.
- (b) Final stabilization must be implemented for all construction sites. Final stabilization is reached when all ground surface disturbing activities at the construction site are complete; and, for all areas of ground surface disturbing activities, either a uniform vegetative cover with an individual plant density of at least 70 percent of pre-disturbance levels is established, or equivalent permanent alternative stabilization methods are implemented. The division may approve alternative final stabilization criteria for specific operations.
- (c) Final stabilization must be designed and installed as a permanent feature. Final stabilization measures for obtaining a vegetative cover or alternative stabilization methods include, but are not limited to, the following as appropriate:
 - (1) Seed mix selection and application methods;
 - (2) Soil preparation and amendments;
 - (3) Soil stabilization methods (e.g., crimped straw, hydro mulch or rolled erosion control products);
 - (4) Appropriate sediment control measures as needed until final stabilization is achieved;
 - (5) Permanent pavement, hardscape, xeriscape, stabilized driving surfaces;
 - (6) Other alternative stabilization practices as applicable;

(d) The permittee(s) must ensure all temporary control measures are removed from the construction site once final stabilization is achieved, except when the control measure specifications allow the control measure to be left in place (i.e., bio-degradable control measures).

b. Maintenance

The permittee must ensure that all control measures remain in effective operating condition and are protected from activities that would reduce their effectiveness. Control measures must be maintained in accordance with good engineering, hydrologic and pollution control practices. Observations leading to the required maintenance of control measures can be made during a site inspection, or during general observations of site conditions. The necessary repairs or modifications to a [control measure requiring routine maintenance](#), as defined in Part I.E., must be conducted to maintain an effective operating condition. This section is not subject to the requirements in Part I.B.1.c. below.

c. Corrective Actions

The permittee must assess the adequacy of control measures at the site, and the need for changes to those control measures, to ensure continued effective performance. When an [inadequate control measure](#), as defined in Part I.E., is identified (i.e., new or replacement control measures become necessary), the following corrective action requirements apply. The permittee is in noncompliance with the permit until the inadequate control measure is replaced or corrected and returned to effective operating condition in compliance with Part I.B.1. and the general requirements in Part I.B.3. If the inadequate control measure results in noncompliance that meets the conditions of Part II.L., the permittee must also meet the requirements of that section.

i. The permittee must take all necessary steps to minimize or prevent the discharge of pollutants, until a control measure is implemented and made operational and/or an inadequate control measure is replaced or corrected and returned to effective operating condition. If it is infeasible to install or repair of control measure immediately after discovering the deficiency, the following must be documented and kept on record in accordance with the recordkeeping requirements in Part II.

(a) Describe why it is infeasible to initiate the installation or repair immediately; and

(b) Provide a schedule for installing or repairing the control measure and returning it to an effective operating condition as soon as possible.

ii. If applicable, the permittee must remove and properly dispose of any unauthorized release or discharge (e.g., discharge of non-stormwater, spill, or leak not authorized by this permit.) The permittee must also clean up any contaminated surfaces to minimize discharges of the material in subsequent storm events.

2. Discharges to an Impaired Waterbody

a. Total Maximum Daily Load (TMDL)

If the permittee's discharge flows to or could reasonably be expected to flow to any water body for which a TMDL has been approved, and stormwater discharges

associated with construction activity were assigned a pollutant-specific Wasteload Allocation (WLA) under the TMDL, the division may:

- i. ensure the WLA is implemented properly through alternative local requirements, such as by a municipal stormwater permit; or
- ii. notify the permittee of the WLA and amend the permittee's certification to add specific effluent limits and other requirements, as appropriate. The permittee may be required to do the following:
 - (a) under the permittee's SWMP, implement specific control measures based on requirements of the WLA, and evaluate whether the requirements are met through implementation of existing stormwater control measures or if additional control measures are necessary. Document the calculations or other evidence demonstrating that the requirements are expected to be met; and
 - (b) if the evaluation shows that additional or modified control measures are necessary, describe the type and schedule for the control measure additions or modifications.
- iii. Discharge monitoring may also be required. The permittee may maintain coverage under the general permit provided they comply with the applicable requirements outlined above. The division reserves the right to require individual or alternate general permit coverage.

3. General Requirements

- a. Discharges authorized by this permit shall not cause, have the reasonable potential to cause, or measurably contribute to an exceedance of any applicable water quality standard, including narrative standards for water quality.
- b. The division may require sampling and testing, on a case-by-case basis, in the event that there is reason to suspect that the SWMP is not adequately minimizing pollutants in stormwater or in order to measure the effectiveness of the control measures in removing pollutants in the effluent. Such monitoring may include Whole Effluent Toxicity testing.
- c. The permittee must comply with the lawful requirements of federal agencies, municipalities, counties, drainage districts and other local agencies including applicable requirements in Municipal Stormwater Management Programs developed to comply with CDPS permits. The permittee must comply with local stormwater management requirements, policies and guidelines including those for erosion and sediment control.
- d. All construction site wastes must be properly managed to prevent potential pollution of state waters. This permit does not authorize on-site waste disposal.
- e. This permit does not relieve the permittee of the reporting requirements in 40 CFR 110, 40 CFR 117 or 40 CFR 302. Any discharge of hazardous material must be handled in accordance with the division's Noncompliance Notification Requirements (see Part II.L. of the permit).

C. STORMWATER MANAGEMENT PLAN (SWMP) REQUIREMENTS**1. SWMP General Requirements**

- a. A SWMP shall be developed for each construction site covered by this permit. The SWMP must be prepared in accordance with good engineering, hydrologic and pollution control practices.
 - i. For public emergency related sites a SWMP shall be created no later than 14 days after the commencement of construction activities.
- b. The permittee must implement the provisions of the SWMP as written and updated, from commencement of construction activity until final stabilization is complete. The division may review the SWMP.
- c. A copy of the SWMP must be retained onsite or be onsite when construction activities are occurring at the site unless the permittee specifies another location and obtains approval from the division.

2. SWMP Content

- a. The SWMP, at a minimum, must include the following elements.
 - i. Qualified Stormwater Manager. The SWMP must list individual(s) by title and name who are designated as the site's qualified stormwater manager(s) responsible for implementing the SWMP in its entirety. This role may be filled by more than one individual.
 - ii. Spill Prevention and Response Plan. The SWMP must have a spill prevention and response plan. The plan may incorporate by reference any part of a Spill Prevention Control and Countermeasure (SPCC) plan under section 311 of the Clean Water Act (CWA) or a Spill Prevention Plan required by a separate CDPS permit. The relevant sections of any referenced plans must be available as part of the SWMP consistent with Part I.C.4.
 - iii. Materials Handling. The SWMP must describe and locate all control measures implemented at the site to minimize impacts from handling **significant materials** that could contribute pollutants to runoff. These handling procedures can include control measures for pollutants and activities such as, exposed storage of building materials, paints and solvents, landscape materials, fertilizers or chemicals, sanitary waste material, trash and equipment maintenance or fueling procedures.
 - iv. Potential Sources of Pollution. The SWMP must list all potential sources of pollution which may reasonably be expected to affect the quality of stormwater discharges associated with construction activity from the site. This shall include, but is not limited to, the following pollutant sources:
 - (a) disturbed and stored soils;
 - (b) vehicle tracking of sediments;
 - (c) management of contaminated soils;
 - (d) loading and unloading operations;

- (e) outdoor storage activities (erodible building materials, fertilizers, chemicals, etc.);
 - (f) vehicle and equipment maintenance and fueling;
 - (g) significant dust or particulate generating processes (e.g., saw cutting material, including dust);
 - (h) routine maintenance activities involving fertilizers, pesticides, herbicides, detergents, fuels, solvents, oils, etc.;
 - (i) on-site waste management practices (waste piles, liquid wastes, dumpsters);
 - (j) concrete truck/equipment washing, including washing of the concrete truck chute and associated fixtures and equipment;
 - (k) dedicated asphalt, concrete batch plants and masonry mixing stations;
 - (l) non-industrial waste sources such as worker trash and portable toilets.
- v. Implementation of Control Measures. The SWMP must include design specifications that contain information on the implementation of the control measure in accordance with good engineering hydrologic and pollution control practices; including as applicable drawings, dimensions, installation information, materials, implementation processes, control measure-specific inspection expectations, and maintenance requirements.

The SWMP must include a documented use agreement between the permittee and the owner or operator of any control measures located outside of the permitted area, that are utilized by the permittee's construction site for compliance with this permit, but not under the direct control of the permittee. The permittee is responsible for ensuring that all control measures located outside of their permitted area, that are being utilized by the permittee's construction site, are properly maintained and in compliance with all terms and conditions of the permit. The SWMP must include all information required of and relevant to any such control measures located outside the permitted area, including location, installation specifications, design specifications and maintenance requirements.

- vi. Site Description. The SWMP must include a site description which includes, at a minimum, the following:
- (a) the nature of the construction activity at the site;
 - (b) the proposed schedule for the sequence for major construction activities and the planned implementation of control measures for each phase. (e.g.: clearing, grading, utilities, vertical, etc.);
 - (c) estimates of the total acreage of the site, and the acreage expected to be disturbed by clearing, excavation, grading, or any other construction activities;
 - (d) a summary of any existing data used in the development of the construction site plans or SWMP that describe the soil or existing potential for soil erosion;

- (e) a description of the percent of existing vegetative ground cover relative to the entire site and the method for determining the percentage;
 - (f) a description of any allowable non-stormwater discharges at the site, including those being discharged under a division low risk discharge guidance policy;
 - (g) a description of areas receiving discharge from the site. Including a description of the immediate source receiving the discharge. If the stormwater discharge is to a municipal separate storm sewer system, the name of the entity owning that system, the location of the storm sewer discharge, and the ultimate receiving water(s); and
 - (h) a description of all stream crossings located within the construction site boundary.
- vii. Site Map. The SWMP must include a site map which includes, at a minimum, the following:
- (a) construction site boundaries;
 - (b) flow arrows that depict stormwater flow directions on-site and runoff direction;
 - (c) all areas of ground disturbance including areas of borrow and fill;
 - (d) areas used for storage of soil;
 - (e) locations of all waste accumulation areas, including areas for liquid, concrete, masonry, and asphalt;
 - (f) locations of dedicated asphalt, concrete batch plants and masonry mixing stations;
 - (g) locations of all structural control measures;
 - (h) locations of all non-structural control measures;
 - (i) locations of springs, streams, wetlands and other state waters, including areas that require pre-existing vegetation be maintained within 50 feet of a receiving water, where determined feasible in accordance with Part I.B.1.a.i.(d).; and
 - (j) locations of all stream crossings located within the construction site boundary.
- viii. Final Stabilization and Long Term Stormwater Management. The SWMP must describe the practices used to achieve final stabilization of all disturbed areas at the site and any planned practices to control pollutants in stormwater discharges that will occur after construction operations are completed. Including but not limited to, detention/retention ponds, rain gardens, stormwater vaults, etc.
- ix. Inspection Reports. The SWMP must include documented inspection reports in accordance with Part ID.

3. SWMP Review and Revisions

Permittees must keep a record of SWMP changes made that includes the date and identification of the changes. The SWMP must be amended when the following occurs:

- a. a change in design, construction, operation, or maintenance of the site requiring implementation of new or revised control measures;
- b. the SWMP proves ineffective in controlling pollutants in stormwater runoff in compliance with the permit conditions;
- c. control measures identified in the SWMP are no longer necessary and are removed;
and
- d. corrective actions are taken onsite that result in a change to the SWMP.

For SWMP revisions made prior to or following a change(s) onsite, including revisions to sections addressing site conditions and control measures, a notation must be included in the SWMP that identifies the date of the site change, the control measure removed, or modified, the location(s) of those control measures, and any changes to the control measure(s). The permittee must ensure the site changes are reflected in the SWMP. The permittee is noncompliant with the permit until the SWMP revisions have been made.

4. SWMP Availability

A copy of the SWMP must be provided upon request to the division, EPA, and any local agency with authority for approving sediment and erosion plans, grading plans or stormwater management plans within the time frame specified in the request. If the SWMP is required to be submitted to any of these entities, the submission must include a signed certification in accordance with Part I.A.3.e., certifying that the SWMP is complete and compliant with all terms and conditions of the permit.

All SWMPs required under this permit are considered reports that must be available to the public under Section 308(b) of the CWA and Section 61.5(4) of the CDPS regulations. The permittee must make plans available to members of the public upon request. However, the permittee may claim any portion of a SWMP as confidential in accordance with 40 CFR Part 2.

D. SITE INSPECTIONS

Site inspections must be conducted in accordance with the following requirements. The required inspection schedules are a minimum frequency and do not affect the permittee's responsibility to implement control measures in effective operating condition as prescribed in the SWMP. Proper maintenance of control measures may require more frequent inspections. Site inspections shall start within 7 calendar days of the commencement of construction activities on site.

1. Person Responsible for Conducting Inspections

The person(s) inspecting the site may be on the permittee's staff or a third party hired to conduct stormwater inspections under the direction of the permittee(s). The permittee is responsible for ensuring that the inspector is a qualified stormwater manager.

2. Inspection Frequency

Permittees must conduct site inspections in accordance with one of the following minimum frequencies, unless the site meets the requirements of Part ID.3

- a. At least one inspection every 7 calendar days. Or
- b. At least one inspection every 14 calendar days, if post-storm event inspections are conducted within 24 hours after the end of any precipitation or snowmelt event that causes surface erosion. Post-storm inspections may be used to fulfill the 14-day routine inspection requirement.
- c. When site conditions make the schedule required in this section impractical, the permittee may petition the Division to grant an alternate inspection schedule. The alternative inspection schedule may not be implemented prior to written approval by the division and incorporation into the SWMP.

3. Inspection Frequency for Discharges to Outstanding Waters

Permittees must conduct site inspections at least once every 7 calendar days for sites that discharge to a water body designated as an Outstanding Water by the Water Quality Control Commission.

4. Reduced Inspection Frequency

The permittee may perform site inspections at the following reduced frequencies when one of the following conditions exists:

a. Post-Storm Inspections at Temporarily Idle Sites

For permittees choosing to combine 14-day inspections and post-storm-event inspections, if no construction activities will occur following a storm event, post-storm event inspections must be conducted prior to re-commencing construction activities, but no later than 72 hours following the storm event. The delay of any post-storm event inspection must be documented in the inspection record. Routine inspections must still be conducted at least every 14 calendar days.

b. Inspections at Completed Sites/Areas

When the site, or portions of a site are awaiting establishment of a vegetative ground cover and final stabilization, the permittee must conduct a thorough inspection of the stormwater management system at least once every 30 days. Post-storm event inspections are not required under this schedule. This reduced inspection schedule is allowed if all of the following criteria are met:

- i. all construction activities resulting in ground disturbance are complete;
- ii. all activities required for final stabilization, in accordance with the SWMP, have been completed, with the exception of the application of seed that has not occurred due to seasonal conditions or the necessity for additional seed application to augment previous efforts; and
- iii. the SWMP has been amended to locate those areas to be inspected in accordance with the reduced schedule allowed for in this paragraph.

c. Winter Conditions Inspections Exclusion

Inspections are not required for sites that meet all of the following conditions: construction activities are temporarily halted, snow cover exists over the entire site for an extended period, and melting conditions posing a risk of surface erosion do not exist. This inspection exception is applicable only during the period where melting conditions do not exist, and applies to the routine 7-day, 14-day and monthly inspections, as well as the post-storm-event inspections. When this inspection exclusion is implemented, the following information must be documented in accordance with the requirements in Part II:

- i. dates when snow cover existed;
- ii. date when construction activities ceased; and
- iii. date melting conditions began.

5. Inspection Scope

a. Areas to be Inspected

When conducting a site inspection the following areas, if applicable, must be inspected for evidence of, or the potential for, pollutants leaving the construction site boundaries, entering the stormwater drainage system, or discharging to state waters:

- i. construction site perimeter;
- ii. all disturbed areas;
- iii. designated haul routes;
- iv. material and waste storage areas exposed to precipitation;
- v. locations where stormwater has the potential to discharge offsite; and
- vi. locations where vehicles exit the site.

b. Inspection Requirements

- i. Visually verify whether all implemented control measures are in effective operational condition and are working as designed in their specifications to minimize pollutant discharges.
- ii. Determine if there are new potential sources of pollutants.
- iii. Assess the adequacy of control measures at the site to identify areas requiring new or modified control measures to minimize pollutant discharges.
- iv. Identify all areas of non-compliance with the permit requirements and, if necessary, implement corrective action in accordance with Part IB.1.c.

c. Inspection Reports

The permittee must keep a record of all inspections conducted for each permitted site. Inspection reports must identify any incidents of noncompliance with the terms and conditions of this permit. Inspection records must be retained in accordance with Part II.O. and signed in accordance with Part I.A.3.f. At a minimum, the inspection report must include:

- i. the inspection date;

- ii. name(s) and title(s) of personnel conducting the inspection;
- iii. weather conditions at the time of inspection;
- iv. phase of construction at the time of inspection;
- v. estimated acreage of disturbance at the time of inspection
- vi. location(s) of discharges of sediment or other pollutants from the site;
- vii. location(s) of control measures needing maintenance;
- viii. location(s) and identification of inadequate control measures;
- ix. location(s) and identification of additional control measures are needed that were not in place at the time of inspection;
- x. description of the minimum inspection frequency (either in accordance with Part I.D.2., I.D.3. or I.D.4.) utilized when conducting each inspection.
- xi. deviations from the minimum inspection schedule as required in Part I.D.2.;
- xii. after adequate corrective action(s) and maintenance have been taken, or where a report does not identify any incidents requiring corrective action or maintenance, the report shall contain a statement as required in Part I.A.3.f.

E. DEFINITIONS

For the purposes of this permit:

- (1) Bypass - the intentional diversion of waste streams from any portion of a treatment facility in accordance with 40 CFR 122.41(m)(1)(i) and Regulation 61.2(12).
- (2) Common Plan of Development or Sale - A contiguous area where multiple separate and distinct construction activities may be taking place at different times on different schedules, but remain related. The Division has determined that "contiguous" means construction activities located in close proximity to each other (within ¼ mile). Construction activities are considered to be "related" if they share the same development plan, builder or contractor, equipment, storage areas, etc. "Common plan of development or sale" includes construction activities that are associated with the construction of field wide oil and gas permits for facilities that are related.
- (3) Construction Activity - Ground surface disturbing and associated activities (land disturbance), which include, but are not limited to, clearing, grading, excavation, demolition, installation of new or improved haul roads and access roads, staging areas, stockpiling of fill materials, and borrow areas. Construction does not include routine maintenance to maintain the original line and grade, hydraulic capacity, or original purpose of the facility. Activities to conduct repairs that are not part of routine maintenance or for replacement are construction activities and are not routine maintenance. Repaving activities where underlying and/or surrounding soil is exposed as part of the repaving operation are considered construction activities. Construction activity is from initial ground breaking to final stabilization regardless of ownership of the construction activities.
- (4) Control Measure - Any best management practice or other method used to prevent or reduce the discharge of pollutants to state waters. Control measures include, but are not limited to, best management practices. Control measures can include other methods such as the installation, operation, and maintenance of structural controls and treatment devices.

- (5) Control Measure Requiring Routine Maintenance - Any control measure that is still operating in accordance with its design and the requirements of this permit, but requires maintenance to prevent a breach of the control measure. See also inadequate control measure.
- (6) Dedicated Asphalt, Concrete Batch Plants and Masonry Mixing Stations - are batch plants or mixing stations located on, or within ¼ mile of, a construction site and that provide materials only to that specific construction site.
- (7) Final Stabilization - The condition reached when all ground surface disturbing activities at the site have been completed, and for all areas of ground surface disturbing activities where a uniform vegetative cover has been established with an individual plant density of at least 70 percent of pre-disturbance levels, or equivalent permanent, physical erosion reduction methods have been employed.
- (8) Good Engineering, Hydrologic and Pollution Control Practices: are methods, procedures, and practices that:
 - a. Are based on basic scientific fact(s).
 - b. Reflect best industry practices and standards.
 - c. Are appropriate for the conditions and pollutant sources.
 - d. Provide appropriate solutions to meet the associated permit requirements, including practice based effluent limits.
- (9) Inadequate Control Measure - Any control measure that is not designed or implemented in accordance with the requirements of the permit and/or any control measure that is not implemented to operate in accordance with its design. See also Control Measure Requiring Routine Maintenance.
- (10) Infeasible - Not technologically possible, or not economically practicable and achievable in light of best industry practices.
- (11) Minimize - reduce or eliminate to the extent achievable using control measures that are technologically available and economically practicable and achievable in light of best industry practice.
- (12) Municipality - A city, town, county, district, association, or other public body created by, or under, State law and having jurisdiction over disposal of sewage, industrial wastes, or other wastes, or a designated and approved management agency under section 208 of CWA (1987).
- (13) Municipal Separate Storm Sewer System (MS4) - A conveyance or system of conveyances (including roads with drainage systems, municipal streets, catch basins, curbs, gutters, ditches, man-made channels, or storm drains):
 - a) owned or operated by a State, city, town, county, district, association, or other public body (created by or pursuant to State law) having jurisdiction over disposal of sewage, industrial wastes, stormwater, or other wastes, including special districts under State law such as a sewer district, flood control district or drainage district, or similar entity, or a designated and approved management agency under section 208 of the CWA that discharges to state waters;
 - i. designed or used for collecting or conveying stormwater;
 - ii. are not a combined sewer; and
 - iii. are not part of a Publicly Owned Treatment Works (POTW). See 5 CCR 1002-61.2(62).
- (14) Municipal Stormwater Management Program - A stormwater program operated by a municipality, typically to meet the requirements of the municipalities MS4 discharge certification.

- (15) Operator - The party that has operational control over day-to-day activities at a project site which are necessary to ensure compliance with the permit. This party is authorized to direct individuals at a site to carry out activities required by the permit. (e.g. the general contractor)
- (16) Owner - The party that has overall control of the activities and that has funded the implementation of the construction plans and specifications. This is the party with ownership of, a long term lease of, or easements on the property on which the construction activity is occurring (e.g., the developer).
- (17) Permittee(s) - The owner and operator named in the discharge certification issued under this permit for the construction site specified in the certification.
- (18) Point Source - Any discernible, confined, and discrete conveyance, including, but not limited to, any pipe, ditch, channel, tunnel, conduit, well, discrete fissure, container, rolling stock, concentrated animal feeding operation, or vessel or other floating craft, from which pollutants are or may be discharged. Point source does not include irrigation return flow. See 5 CCR 102-61.2(75).
- (19) Pollutant - Dredged spoil, dirt, slurry, solid waste, incinerator residue, sewage, sewage sludge, garbage, trash, chemical waste, biological nutrient, biological material, radioactive material, heat, wrecked or discarded equipment, rock, sand, or any industrial, municipal or agricultural waste. See 5 CCR 1002-61.2(76).
- (20) Presentation of credentials - a government issued form of identification, if in person; or (ii) providing name, position and purpose of inspection if request to enter is made via telephone, email or other form of electronic communication. A Permittee's non-response to a request to enter upon presentation of credentials constitutes a denial to such request, and may result in violation of the Permit.
- (21) Process Water - Any water which, during manufacturing or processing, comes into contact with or results from the production of any raw material, intermediate product, finished product, by product or waste product.
- (22) Public Emergency Related Site - a project initiated in response to an unanticipated emergency (e.g., mud slides, earthquake, extreme flooding conditions, disruption in essential public services), for which the related work requires immediate authorization to avoid imminent endangerment to human health or the environment, or to reestablish essential public services.
- (23) Qualified Stormwater Manager - An individual knowledgeable in the principles and practices of erosion and sediment control and pollution prevention, and with the skills to assess conditions at construction sites that could impact stormwater quality and to assess the effectiveness of stormwater controls implemented to meet the requirements of this permit.
- (24) Qualifying Local Program - A municipal program for stormwater discharges associated with small construction activity that was formally approved by the division as a qualifying local program.
- (25) Receiving Water - Any classified or unclassified surface water segment (including tributaries) in the State of Colorado into which stormwater associated with construction activities discharges. This definition includes all water courses, even if they are usually dry, such as borrow ditches, arroyos, and other unnamed waterways.
- (26) Severe Property Damage - substantial physical damage to property, damage to the treatment facilities which causes them to become inoperable, or substantial and permanent loss of natural resources which can reasonably be expected to occur in the absence of a bypass. Severe property damage does not mean economic loss caused by delays in production. See 40 CFR 122.41(m)(1)(ii).

- (27) Significant Materials - Include, but not limited to, raw materials; fuels; materials such as solvents, detergents, and plastic pellets; finished materials such as metallic products; raw materials used in food processing or production; hazardous substances designated under section 101(14) of CERCLA; any chemical the permittee is required to report under section 313 of Title III of the Superfund Amendments and Reauthorization Act (SARA); fertilizers; pesticides; and waste products such as ashes, slag and sludge that have the potential to be released with stormwater discharges.
- (28) Small Construction Activity - The discharge of stormwater from construction activities that result in land disturbance of equal to, or greater than, one acre and less than five acres. Small construction activity also includes the disturbance of less than one acre of total land area that is part of a larger common plan of development or sale, if the larger common plan ultimately disturbs equal to, or greater than, one acre and less than five acres.
- (29) Spill - An unintentional release of solid or liquid material which may pollute state waters.
- (30) State Waters - means any and all surface and subsurface waters which are contained in or flow in or through this state, but does not include waters in sewage systems, waters in treatment works of disposal systems, waters in potable water distribution systems, and all water withdrawn for use until use and treatment have been completed.
- (31) Steep Slopes: where a local government, or industry technical manual (e.g., stormwater BMP manual) has defined what is to be considered a "steep slope", this permit's definition automatically adopts that definition. Where no such definition exists, steep slopes are automatically defined as those that are 3:1 or greater.
- (32) Stormwater - Precipitation runoff, snow melt runoff, and surface runoff and drainage. See 5 CCR 1002-61.2(103).
- (33) Total Maximum Daily Loads (TMDLs) -The sum of the individual wasteload allocations (WLA) for point sources and load allocations (LA) for nonpoint sources and natural background. For the purposes of this permit, a TMDL is a calculation of the maximum amount of a pollutant that a waterbody can receive and still meet water quality standards, and an allocation of that amount to the pollutant's sources. A TMDL includes WLAs, LAs, and must include a margin of safety (MOS), and account for seasonal variations. See section 303(d) of the CWA and 40 C.F.R. 130.2 and 130.7.
- (34) Upset - an exceptional incident in which there is unintentional and temporary noncompliance with permit effluent limitations because of factors beyond the reasonable control of the permittee. An upset does not include noncompliance to the extent caused by operational error, improperly designed treatment facilities, inadequate treatment facilities, lack of preventative maintenance, or careless or improper operation in accordance with 40 CFR 122.41(n) and Regulation 61.2(114).

F. MONITORING

The division may require sampling and testing, on a case-by-case basis. If the division requires sampling and testing, the division will send a notification to the permittee. Reporting procedures for any monitoring data collected will be included in the notification.

If monitoring is required, the following applies:

1. the thirty (30) day average must be determined by the arithmetic mean of all samples collected during a thirty (30) consecutive-day period; and
2. a grab sample, for monitoring requirements, is a single "dip and take" sample.

G. Oil and Gas Construction

Stormwater discharges associated with construction activities directly related to oil and gas exploration, production, processing, and treatment operations or transmission facilities are regulated under the Colorado Discharge Permit System Regulations (5 CCR 1002-61), and require coverage under this permit in accordance with that regulation. However, references in this permit to specific authority under the CWA do not apply to stormwater discharges associated with these oil and gas related construction activities, to the extent that the references are limited by the federal Energy Policy Act of 2005.

Part II: Standard Permit Conditions

A. DUTY TO COMPLY

The permittee must comply with all conditions of this permit. Any permit noncompliance constitutes a violation of the Water Quality Control Act and is grounds for:

- a. enforcement action;
- b. permit termination, revocation and reissuance, or modification; or
- c. denial of a permit renewal application.

B. DUTY TO REAPPLY

If the permittee wishes to continue an activity regulated by this permit after the expiration date of this permit, the permittee must apply for and obtain authorization as required by Part I.A.3.k. of the permit.

C. NEED TO HALT OR REDUCE ACTIVITY NOT A DEFENSE

It shall not be a defense for a permittee in an enforcement action that it would have been necessary to halt or reduce the permitted activity in order to maintain compliance with the conditions of this permit.

D. DUTY TO MITIGATE

A permittee must take all reasonable steps to minimize or prevent any discharge in violation of this permit which has a reasonable likelihood of adversely affecting human health or the environment.

E. PROPER OPERATION AND MAINTENANCE

A permittee must at all times properly operate and maintain all facilities and systems of treatment and control (and related appurtenances) that are installed or used by the permittee to achieve compliance with the conditions of this permit. Proper operation and maintenance also includes adequate laboratory controls and appropriate quality assurance procedures. This provision requires the operation of backup or auxiliary facilities or similar systems which are installed by the permittee only when the operation is necessary to achieve compliance with the conditions of this permit. This requirement can be met by meeting the requirements for Part I.B., I.C., and I.D. above. See also 40 C.F.R. § 122.41(e).

F. PERMIT ACTIONS

This permit may be modified, revoked and reissued, or terminated for cause. The permittee request for a permit modification, revocation and reissuance, or termination, or a notification of planned changes or anticipated noncompliance does not stay any permit condition. Any request for modification, revocation, reissuance, or termination under this permit must comply with all terms and conditions of Regulation 61.8(8).

G. PROPERTY RIGHTS

In accordance with 40 CFR 122.41(g) and 5 CCR 1002-61, 61.8(9):

1. The issuance of a permit does not convey any property or water rights in either real or personal property, or stream flows or any exclusive privilege.

2. The issuance of a permit does not authorize any injury to person or property or any invasion of personal rights, nor does it authorize the infringement of federal, state, or local laws or regulations.
3. Except for any toxic effluent standard or prohibition imposed under Section 307 of the Federal act or any standard for sewage sludge use or disposal under Section 405(d) of the Federal act, compliance with a permit during its term constitutes compliance, for purposes of enforcement, with Sections 301, 302, 306, 318, 403, and 405(a) and (b) of the Federal act. However, a permit may be modified, revoked and reissued, or terminated during its term for cause as set forth in Section 61.8(8) of the Colorado Discharge Permit System Regulations.

H. DUTY TO PROVIDE INFORMATION

The permittee shall furnish to the division, within a reasonable time, any information which the division may request to determine whether cause exists for modifying, revoking and reissuing, or terminating this permit, or to determine compliance with this permit. The permittee shall also furnish to the division, upon request, copies of records required to be kept by this permit in accordance with 40 CFR 122.41(h) and/or Regulation 61.8(3)(q).

I. INSPECTION AND ENTRY

The permittee shall allow the division and the authorized representative, upon the presentation of credentials as required by law, to allow for inspections to be conducted in accordance with 40 CFR 122.41(i), Regulation 61.8(3), and Regulation 61.8(4):

1. to enter upon the permittee's premises where a regulated facility or activity is located or in which any records are required to be kept under the terms and conditions of this permit;
2. at reasonable times to have access to and copy any records required to be kept under the terms and conditions of this permit;
3. at reasonable times, inspect any monitoring equipment or monitoring method required in the permit; and
4. to enter upon the permittee's premises in a reasonable manner and at a reasonable time to inspect or investigate, any actual, suspected, or potential source of water pollution, or any violation of the Colorado Water Quality Control Act. The investigation may include: sampling of any discharges, stormwater or process water, taking of photographs, interviewing site staff on alleged violations and other matters related to the permit, and assessing any and all facilities or areas within the site that may affect discharges, the permit, or an alleged violation.

The permittee shall provide access to the division or other authorized representatives upon presentation of proper credentials. A permittee's non-response to a request to enter upon presentation of credentials constitutes a denial of such request, and may result in a violation of the permit.

J. MONITORING AND RECORDS

1. Samples and measurements taken for the purpose of monitoring must be representative of the volume and nature of the monitored activity.

2. The permittee must retain records of all monitoring information, including all calibration and maintenance records and all original strip chart recordings for continuous monitoring instrumentation, copies of all reports required by this permit, and records of all data used to complete the application for this permit, for a period of at least three years from the date the permit expires or the date the permittee's authorization is terminated. This period may be extended by request of the division at any time.
3. Records of monitoring information must include:
 - a. The date, exact place, and time of sampling or measurements;
 - b. The individual(s) who performed the sampling or measurements;
 - c. The date(s) analyses were performed
 - d. The individual(s) who performed the analyses;
 - e. The analytical techniques or methods used; and
 - f. The results of such analyses.
4. Monitoring must be conducted according to test procedures approved under 40 CFR Part 136, unless other test procedures have been specified in the permit.

K. SIGNATORY REQUIREMENTS

1. Authorization to Sign:

All documents required to be submitted to the division by the permit must be signed in accordance with the following criteria:

- a. For a corporation: By a responsible corporate officer. For the purpose of this subsection, a responsible corporate officer means:
 - i. a president, secretary, treasurer, or vice president of the corporation in charge of a principal business function, or any other person who performs similar policy- or decision-making functions for the corporation, or
 - ii. the manager of one or more manufacturing, production, or operating facilities, provided, the manager is authorized to make management decisions which govern the operation of the regulated facility including having the explicit or implicit duty of making major capital investment recommendations, and initiating and directing other comprehensive measures to assure long term environmental compliance with environmental laws and regulations; the manager can ensure that the necessary systems are established or actions taken to gather complete and accurate information for permit application requirements; and where authority to sign documents has been assigned or delegated to the manager in accordance with corporate procedures.
- b. For a partnership or sole proprietorship: By a general partner or the proprietor, respectively; or
- c. For a municipality, state, federal, or other public agency: By either a principal executive officer or ranking elected official. For purposes of this subsection, a principal executive officer of a federal agency includes
 - i. (i) the chief executive officer of the agency, or

- ii. (ii) a senior executive officer having responsibility for the overall operations of a principal geographic unit of the agency. (e.g., Regional Administrator of EPA)

2. Electronic Signatures

For persons signing applications for coverage under this permit electronically, in addition to meeting other applicable requirements stated above, such signatures must meet the same signature, authentication, and identity-proofing standards set forth at 40 CFR § 3.2000(b) for electronic reports (including robust second-factor authentication). Compliance with this requirement can be achieved by submitting the application using the Colorado Environmental Online Service (CEOS) system.

3. Change in Authorization to Sign

If an authorization is no longer accurate because a different individual or position has responsibility for the overall operation of the facility, a new authorization must be submitted to the division, prior to the re-authorization, or together with any reports, information, or applications to be signed by an authorized representative.

L. REPORTING REQUIREMENTS

1. Planned Changes

The permittee shall give advance notice to the division, in writing, of any planned physical alterations or additions to the permitted facility in accordance with 40 CFR 122.41(l) and Regulation 61.8(5)(a). Notice is required only when:

- a. The alteration or addition to a permitted facility may meet one of the criteria for determining whether a facility is a new source in 40 CFR 122.29(b); or
- b. The alteration or addition could significantly change the nature or increase the quantity of pollutants discharged. This notification applies to pollutants which are subject neither to effluent limitations in the permit, nor to notification requirements under 40 CFR 122.41(a)(1).

2. Anticipated Non-Compliance

The permittee shall give advance notice to the division, in writing, of any planned changes in the permitted facility or activity that may result in noncompliance with permit requirements. The timing of notification requirements differs based on the type of non-compliance as described in subparagraphs 5, 6, 7, and 8 below.

3. Transfer of Ownership or Control

The permittee shall notify the division, in writing, ten (10) calendar days in advance of a proposed transfer of the permit. This permit is not transferable to any person except after notice is given to the division.

- a. Where a facility wants to change the name of the permittee, the original permittee (the first owner or operators) must submit a Notice of Termination.
- b. The new owner or operator must submit an application. See also signature requirements in Part II.K, above.
- c. A permit may be automatically transferred to a new permittee if:
 - i. The current permittee notifies the Division in writing 30 calendar days in advance of the proposed transfer date; and
 - ii. The notice includes a written agreement between the existing and new permittee(s) containing a specific date for transfer of permit responsibility, coverage and liability between them; and
 - iii. The division does not notify the existing permittee and the proposed new permittee of its intent to modify, or revoke and reissue the permit.
 - iv. Fee requirements of the Colorado Discharge Permit System Regulations, Section 61.15, have been met.

4. Monitoring reports

Monitoring results must be reported at the intervals specified in this permit per the requirements of 40 CFR 122.41(l)(4).

5. Compliance Schedules

Reports of compliance or noncompliance with, or any progress reports on, interim and final requirements contained in any compliance schedule in the permit, shall be submitted on the date listed in the compliance schedule section. The fourteen (14) calendar day provision in Regulation 61.8(4)(n)(i) has been incorporated into the due date.

6. Twenty-four hour reporting

In addition to the reports required elsewhere in this permit, the permittee shall report the following circumstances orally within twenty-four (24) hours from the time the permittee becomes aware of the circumstances, and shall mail to the division a written report containing the information requested within five (5) working days after becoming aware of the following circumstances:

- a. Circumstances leading to any noncompliance which may endanger health or the environment regardless of the cause of the incident;
- b. Circumstances leading to any unanticipated bypass which exceeds any effluent limitations in the permit;
- c. Circumstances leading to any upset which causes an exceedance of any effluent limitation in the permit;

- d. Daily maximum violations for any of the pollutants limited by Part I of this permit. This includes any toxic pollutant or hazardous substance or any pollutant specifically identified as the method to control any toxic pollutant or hazardous substance.
- e. The division may waive the written report required under subparagraph 6 of this section if the oral report has been received within 24 hours.

7. Other non-compliance

A permittee must report all instances of noncompliance at the time monitoring reports are due. If no monitoring reports are required, these reports are due at least annually in accordance with Regulation 61.8(4)(p). The annual report must contain all instances of non-compliance required under either subparagraph 5 or subparagraph 6 of this subsection.

8. Other information

Where a permittee becomes aware that it failed to submit any relevant facts in a permit application, or submitted incorrect information in a permit application, or in any report to the Permitting Authority, it has a duty to promptly submit such facts or information.

M. BYPASS

1. Bypass not exceeding limitations

The permittees may allow any bypass to occur which does not cause effluent limitations to be exceeded, but only if it also is for essential maintenance to assure efficient operation. These bypasses are not subject to the provisions of Part II.M.2 of this permit. See 40 CFR 122.41(m)(2).

2. Notice of bypass

- a. Anticipated bypass. If the permittee knows in advance of the need for a bypass, the permittee must submit prior notice, if possible at least ten days before the date of the bypass. See 40 CFR §122.41(m)(3)(i) and/or Regulation 61.9(5)(c).
- b. Unanticipated bypass. The permittee must submit notice of an unanticipated bypass in accordance with Part II.L.6. See 40 CFR §122.41(m)(3)(ii) .

3. Prohibition of Bypass

Bypasses are prohibited and the division may take enforcement action against the permittee for bypass, unless:

- i. the bypass is unavoidable to prevent loss of life, personal injury, or severe property damage;

- ii. There were no feasible alternatives to the bypass, such as the use of auxiliary treatment facilities, retention of untreated wastes, or maintenance during normal periods of equipment downtime. This condition is not satisfied if adequate backup equipment should have been installed in the exercise of reasonable engineering judgment to prevent a bypass which occurred during normal periods of equipment downtime or preventive maintenance; and
- iii. proper notices were submitted to the division.

N. UPSET

1. Effect of an upset

An upset constitutes an affirmative defense to an action brought for noncompliance with permit effluent limitations if the requirements of Part II.N.2. of this permit are met. No determination made during administrative review of claims that noncompliance was caused by upset, and before an action for noncompliance, is final administrative action subject to judicial review in accordance with Regulation 61.8(3)(j).

2. Conditions necessary for demonstration of an Upset

A permittee who wishes to establish the affirmative defense of upset shall demonstrate through properly signed contemporaneous operating logs, or other relevant evidence that

- a. an upset occurred and the permittee can identify the specific cause(s) of the upset;
- b. the permitted facility was at the time being properly operated and maintained; and
- c. the permittee submitted proper notice of the upset as required in Part II.L.6. (24-hour notice); and
- d. the permittee complied with any remedial measure necessary to minimize or prevent any discharge or sludge use or disposal in violation of this permit which has a reasonable likelihood of adversely affecting human health or the environment. In addition to the demonstration required above, a permittee who wishes to establish the affirmative defense of upset for a violation of effluent limitations based upon water quality standards shall also demonstrate through monitoring, modeling or other methods that the relevant standards were achieved in the receiving water.

3. Burden of Proof

In any enforcement proceeding, the permittee seeking to establish the occurrence of an upset has the burden of proof.

O. RETENTION OF RECORDS

1. Post-Expiration or Termination Retention

Copies of documentation required by this permit, including records of all data used to complete the application for permit coverage to be covered by this permit, must be

retained for at least three years from the date that permit coverage expires or is terminated. This period may be extended by request of EPA at any time.

2. On-site Retention

The permittee must retain an electronic version or hardcopy of the SWMP at the construction site from the date of the initiation of construction activities to the date of expiration or inactivation of permit coverage; unless another location, specified by the permittee, is approved by the division.

P. REOPENER CLAUSE

1. Procedures for modification or revocation

Permit modification or revocation of this permit or coverage under this permit will be conducted according to Regulation 61.8(8).

2. Water quality protection

If there is evidence indicating that the stormwater discharges authorized by this permit cause, have the reasonable potential to cause or contribute to an excursion above any applicable water quality standard, the permittee may be required to obtain an individual permit, or the permit may be modified to include different limitations and/or requirements.

Q. SEVERABILITY

The provisions of this permit are severable. If any provisions or the application of any provision of this permit to any circumstances, is held invalid, the application of such provision to other circumstances and the application of the remainder of this permit shall not be affected.

R. NOTIFICATION REQUIREMENTS

1. Notification to Parties

All notification requirements, excluding information submitted using the CEOS portal, shall be directed as follows:

- a. Oral Notifications, during normal business hours shall be to:
 - Clean Water Compliance Section
 - Water Quality Control Division
 - Telephone: (303) 692-3500
- b. Written notification shall be to:
 - Clean Water Compliance Section
 - Water Quality Control Division
 - Colorado Department of Public Health and Environment
 - WQCD-WQP-B2
 - 4300 Cherry Creek Drive South
 - Denver, CO 80246-1530

S. RESPONSIBILITIES**1. Reduction, Loss, or Failure of Treatment Facility**

The permittee has the duty to halt or reduce any activity if necessary to maintain compliance with the effluent limitations of the permit. It shall not be a defense for a permittee in an enforcement action that it would be necessary to halt or reduce the permitted activity in order to maintain compliance with the conditions of this permit.

T. Oil and Hazardous Substance Liability

Nothing in this permit shall be construed to preclude the institution of any legal action or relieve the permittee from any responsibilities, liabilities, or penalties to which the permittee is or may be subject to under Section 311 (Oil and Hazardous Substance Liability) of the CWA.

U. Emergency Powers

Nothing in this permit shall be construed to prevent or limit application of any emergency power of the division.

V. Confidentiality

Any information relating to any secret process, method of manufacture or production, or sales or marketing data which has been declared confidential by the permittee, and which may be acquired, ascertained, or discovered, whether in any sampling investigation, emergency investigation, or otherwise, shall not be publicly disclosed by any member, officer, or employee of the Water Quality Control Commission or the division, but shall be kept confidential. Any person seeking to invoke the protection of of this section shall bear the burden of proving its applicability. This section shall never be interpreted as preventing full disclosure of effluent data.

W. Fees

The permittee is required to submit payment of an annual fee as set forth in the 2016 amendments to the Water Quality Control Act. Section 25-8-502 (1.1) (b), and the Colorado Discharge Permit System Regulations 5 CCR 1002-61, Section 61.15 as amended. Failure to submit the required fee when due and payable is a violation of the permit and will result in enforcement action pursuant to Section 25-8-601 et. seq., C.R.S.1973 as amended.

X. Duration of Permit

The duration of a permit shall be for a fixed term and shall not exceed five (5) years. If the permittee desires to continue to discharge, a permit renewal application shall be submitted at least ninety (90) calendar days before this permit expires. Filing of a timely and complete application shall cause the expired permit to continue in force to the effective date of the new permit. The permit's duration may be extended only through administrative extensions and not through interim modifications. If the permittee anticipates there will be no discharge after the expiration date of this permit, the division should be promptly notified so that it can terminate the permit in accordance with Part I.A.3.i.

Y. Section 307 Toxics

If a toxic effluent standard or prohibition, including any applicable schedule of compliance specified, is established by regulation pursuant to Section 307 of the Federal Act for a toxic pollutant which is present in the permittee's discharge and such standard or prohibition is more stringent than any limitation upon such pollutant in the discharge permit, the division

shall institute proceedings to modify or revoke and reissue the permit to conform to the toxic effluent standard or prohibition

APPENDIX G: NRCS Soils Report

Custom Soil Resource Report for El Paso County Area, Colorado

Fox Run Substation



Preface

Soil surveys contain information that affects land use planning in survey areas. They highlight soil limitations that affect various land uses and provide information about the properties of the soils in the survey areas. Soil surveys are designed for many different users, including farmers, ranchers, foresters, agronomists, urban planners, community officials, engineers, developers, builders, and home buyers. Also, conservationists, teachers, students, and specialists in recreation, waste disposal, and pollution control can use the surveys to help them understand, protect, or enhance the environment.

Various land use regulations of Federal, State, and local governments may impose special restrictions on land use or land treatment. Soil surveys identify soil properties that are used in making various land use or land treatment decisions. The information is intended to help the land users identify and reduce the effects of soil limitations on various land uses. The landowner or user is responsible for identifying and complying with existing laws and regulations.

Although soil survey information can be used for general farm, local, and wider area planning, onsite investigation is needed to supplement this information in some cases. Examples include soil quality assessments (<http://www.nrcs.usda.gov/wps/portal/nrcs/main/soils/health/>) and certain conservation and engineering applications. For more detailed information, contact your local USDA Service Center (<https://offices.sc.egov.usda.gov/locator/app?agency=nrcs>) or your NRCS State Soil Scientist (http://www.nrcs.usda.gov/wps/portal/nrcs/detail/soils/contactus/?cid=nrcs142p2_053951).

Great differences in soil properties can occur within short distances. Some soils are seasonally wet or subject to flooding. Some are too unstable to be used as a foundation for buildings or roads. Clayey or wet soils are poorly suited to use as septic tank absorption fields. A high water table makes a soil poorly suited to basements or underground installations.

The National Cooperative Soil Survey is a joint effort of the United States Department of Agriculture and other Federal agencies, State agencies including the Agricultural Experiment Stations, and local agencies. The Natural Resources Conservation Service (NRCS) has leadership for the Federal part of the National Cooperative Soil Survey.

Information about soils is updated periodically. Updated information is available through the NRCS Web Soil Survey, the site for official soil survey information.

The U.S. Department of Agriculture (USDA) prohibits discrimination in all its programs and activities on the basis of race, color, national origin, age, disability, and where applicable, sex, marital status, familial status, parental status, religion, sexual orientation, genetic information, political beliefs, reprisal, or because all or a part of an individual's income is derived from any public assistance program. (Not all prohibited bases apply to all programs.) Persons with disabilities who require

alternative means for communication of program information (Braille, large print, audiotape, etc.) should contact USDA's TARGET Center at (202) 720-2600 (voice and TDD). To file a complaint of discrimination, write to USDA, Director, Office of Civil Rights, 1400 Independence Avenue, S.W., Washington, D.C. 20250-9410 or call (800) 795-3272 (voice) or (202) 720-6382 (TDD). USDA is an equal opportunity provider and employer.

Contents

Preface	2
How Soil Surveys Are Made	5
Soil Map	8
Soil Map.....	9
Legend.....	10
Map Unit Legend.....	11
Map Unit Descriptions.....	11
El Paso County Area, Colorado.....	13
40—Kettle gravelly loamy sand, 3 to 8 percent slopes.....	13
68—Peyton-Pring complex, 3 to 8 percent slopes.....	14
92—Tomah-Crowfoot loamy sands, 3 to 8 percent slopes.....	15
References	18

How Soil Surveys Are Made

Soil surveys are made to provide information about the soils and miscellaneous areas in a specific area. They include a description of the soils and miscellaneous areas and their location on the landscape and tables that show soil properties and limitations affecting various uses. Soil scientists observed the steepness, length, and shape of the slopes; the general pattern of drainage; the kinds of crops and native plants; and the kinds of bedrock. They observed and described many soil profiles. A soil profile is the sequence of natural layers, or horizons, in a soil. The profile extends from the surface down into the unconsolidated material in which the soil formed or from the surface down to bedrock. The unconsolidated material is devoid of roots and other living organisms and has not been changed by other biological activity.

Currently, soils are mapped according to the boundaries of major land resource areas (MLRAs). MLRAs are geographically associated land resource units that share common characteristics related to physiography, geology, climate, water resources, soils, biological resources, and land uses (USDA, 2006). Soil survey areas typically consist of parts of one or more MLRA.

The soils and miscellaneous areas in a survey area occur in an orderly pattern that is related to the geology, landforms, relief, climate, and natural vegetation of the area. Each kind of soil and miscellaneous area is associated with a particular kind of landform or with a segment of the landform. By observing the soils and miscellaneous areas in the survey area and relating their position to specific segments of the landform, a soil scientist develops a concept, or model, of how they were formed. Thus, during mapping, this model enables the soil scientist to predict with a considerable degree of accuracy the kind of soil or miscellaneous area at a specific location on the landscape.

Commonly, individual soils on the landscape merge into one another as their characteristics gradually change. To construct an accurate soil map, however, soil scientists must determine the boundaries between the soils. They can observe only a limited number of soil profiles. Nevertheless, these observations, supplemented by an understanding of the soil-vegetation-landscape relationship, are sufficient to verify predictions of the kinds of soil in an area and to determine the boundaries.

Soil scientists recorded the characteristics of the soil profiles that they studied. They noted soil color, texture, size and shape of soil aggregates, kind and amount of rock fragments, distribution of plant roots, reaction, and other features that enable them to identify soils. After describing the soils in the survey area and determining their properties, the soil scientists assigned the soils to taxonomic classes (units). Taxonomic classes are concepts. Each taxonomic class has a set of soil characteristics with precisely defined limits. The classes are used as a basis for comparison to classify soils systematically. Soil taxonomy, the system of taxonomic classification used in the United States, is based mainly on the kind and character of soil properties and the arrangement of horizons within the profile. After the soil

Custom Soil Resource Report

scientists classified and named the soils in the survey area, they compared the individual soils with similar soils in the same taxonomic class in other areas so that they could confirm data and assemble additional data based on experience and research.

The objective of soil mapping is not to delineate pure map unit components; the objective is to separate the landscape into landforms or landform segments that have similar use and management requirements. Each map unit is defined by a unique combination of soil components and/or miscellaneous areas in predictable proportions. Some components may be highly contrasting to the other components of the map unit. The presence of minor components in a map unit in no way diminishes the usefulness or accuracy of the data. The delineation of such landforms and landform segments on the map provides sufficient information for the development of resource plans. If intensive use of small areas is planned, onsite investigation is needed to define and locate the soils and miscellaneous areas.

Soil scientists make many field observations in the process of producing a soil map. The frequency of observation is dependent upon several factors, including scale of mapping, intensity of mapping, design of map units, complexity of the landscape, and experience of the soil scientist. Observations are made to test and refine the soil-landscape model and predictions and to verify the classification of the soils at specific locations. Once the soil-landscape model is refined, a significantly smaller number of measurements of individual soil properties are made and recorded. These measurements may include field measurements, such as those for color, depth to bedrock, and texture, and laboratory measurements, such as those for content of sand, silt, clay, salt, and other components. Properties of each soil typically vary from one point to another across the landscape.

Observations for map unit components are aggregated to develop ranges of characteristics for the components. The aggregated values are presented. Direct measurements do not exist for every property presented for every map unit component. Values for some properties are estimated from combinations of other properties.

While a soil survey is in progress, samples of some of the soils in the area generally are collected for laboratory analyses and for engineering tests. Soil scientists interpret the data from these analyses and tests as well as the field-observed characteristics and the soil properties to determine the expected behavior of the soils under different uses. Interpretations for all of the soils are field tested through observation of the soils in different uses and under different levels of management. Some interpretations are modified to fit local conditions, and some new interpretations are developed to meet local needs. Data are assembled from other sources, such as research information, production records, and field experience of specialists. For example, data on crop yields under defined levels of management are assembled from farm records and from field or plot experiments on the same kinds of soil.

Predictions about soil behavior are based not only on soil properties but also on such variables as climate and biological activity. Soil conditions are predictable over long periods of time, but they are not predictable from year to year. For example, soil scientists can predict with a fairly high degree of accuracy that a given soil will have a high water table within certain depths in most years, but they cannot predict that a high water table will always be at a specific level in the soil on a specific date.

After soil scientists located and identified the significant natural bodies of soil in the survey area, they drew the boundaries of these bodies on aerial photographs and

Custom Soil Resource Report

identified each as a specific map unit. Aerial photographs show trees, buildings, fields, roads, and rivers, all of which help in locating boundaries accurately.

Soil Map

The soil map section includes the soil map for the defined area of interest, a list of soil map units on the map and extent of each map unit, and cartographic symbols displayed on the map. Also presented are various metadata about data used to produce the map, and a description of each soil map unit.

Custom Soil Resource Report Soil Map

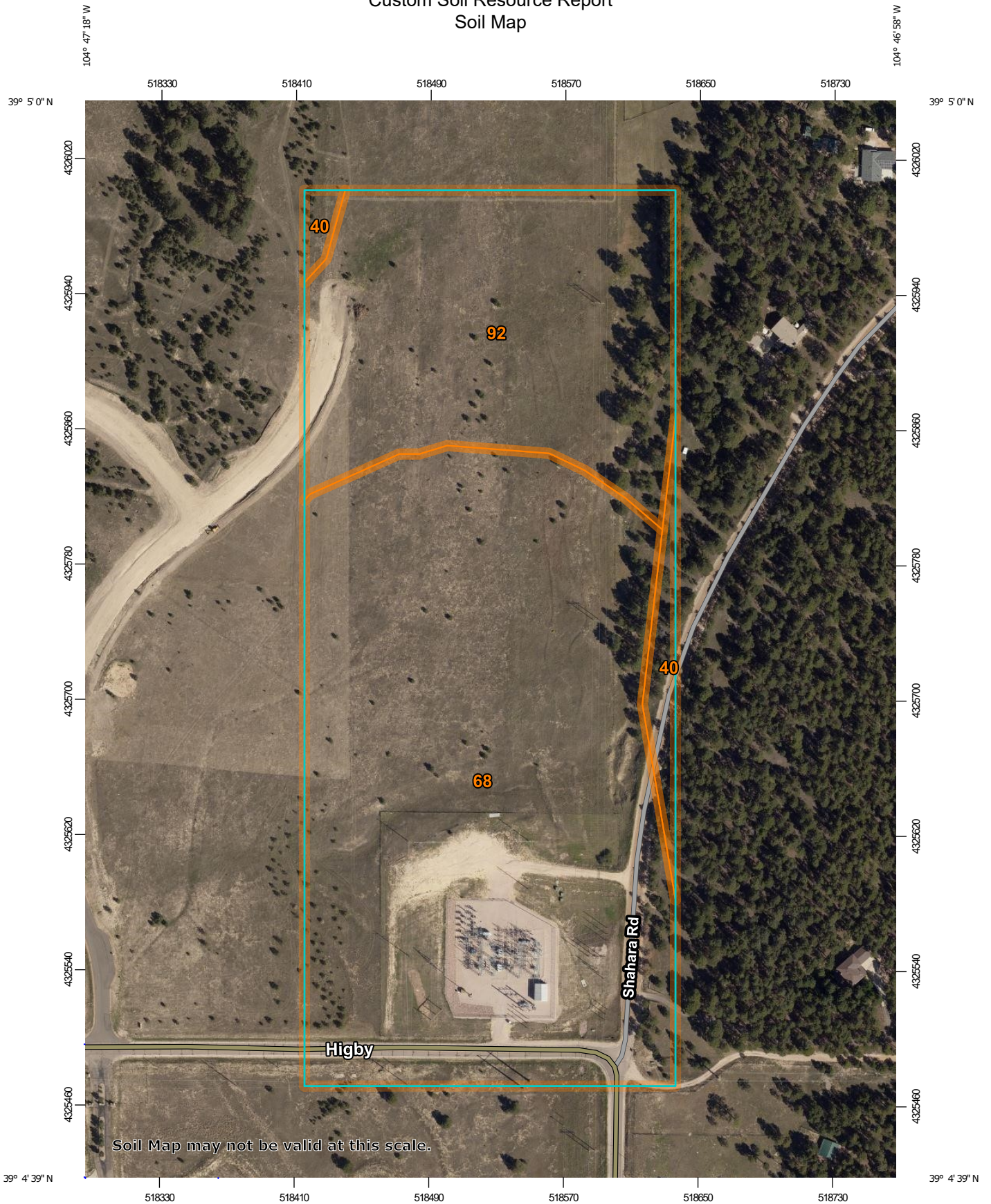

Soil Map may not be valid at this scale.



Map Scale: 1:3,110 if printed on A portrait (8.5" x 11") sheet.



Map projection: Web Mercator Corner coordinates: WGS84 Edge tics: UTM Zone 13N WGS84

MAP LEGEND

Area of Interest (AOI)

 Area of Interest (AOI)

Soils

 Soil Map Unit Polygons

 Soil Map Unit Lines

 Soil Map Unit Points

Special Point Features





-  Blowout
-  Borrow Pit
-  Clay Spot
-  Closed Depression
-  Gravel Pit
-  Gravelly Spot
-  Landfill
-  Lava Flow
-  Marsh or swamp
-  Mine or Quarry
-  Miscellaneous Water
-  Perennial Water
-  Rock Outcrop
-  Saline Spot
-  Sandy Spot
-  Severely Eroded Spot
-  Sinkhole
-  Slide or Slip
-  Sodic Spot

-  Spoil Area
-  Stony Spot
-  Very Stony Spot
-  Wet Spot
-  Other
-  Special Line Features

Water Features

 Streams and Canals

Transportation

-  Rails
-  Interstate Highways
-  US Routes
-  Major Roads
-  Local Roads

Background

 Aerial Photography

MAP INFORMATION

The soil surveys that comprise your AOI were mapped at 1:24,000.

Warning: Soil Map may not be valid at this scale.

Enlargement of maps beyond the scale of mapping can cause misunderstanding of the detail of mapping and accuracy of soil line placement. The maps do not show the small areas of contrasting soils that could have been shown at a more detailed scale.

Please rely on the bar scale on each map sheet for map measurements.

Source of Map: Natural Resources Conservation Service
 Web Soil Survey URL:
 Coordinate System: Web Mercator (EPSG:3857)

Maps from the Web Soil Survey are based on the Web Mercator projection, which preserves direction and shape but distorts distance and area. A projection that preserves area, such as the Albers equal-area conic projection, should be used if more accurate calculations of distance or area are required.

This product is generated from the USDA-NRCS certified data as of the version date(s) listed below.

Soil Survey Area: El Paso County Area, Colorado
 Survey Area Data: Version 19, Aug 31, 2021

Soil map units are labeled (as space allows) for map scales 1:50,000 or larger.

Date(s) aerial images were photographed: Aug 19, 2018—Sep 23, 2018

The orthophoto or other base map on which the soil lines were compiled and digitized probably differs from the background imagery displayed on these maps. As a result, some minor shifting of map unit boundaries may be evident.

Map Unit Legend

Map Unit Symbol	Map Unit Name	Acres in AOI	Percent of AOI
40	Kettle gravelly loamy sand, 3 to 8 percent slopes	0.9	3.1%
68	Peyton-Pring complex, 3 to 8 percent slopes	19.3	66.5%
92	Tomah-Crowfoot loamy sands, 3 to 8 percent slopes	8.8	30.4%
Totals for Area of Interest		29.0	100.0%

Map Unit Descriptions

The map units delineated on the detailed soil maps in a soil survey represent the soils or miscellaneous areas in the survey area. The map unit descriptions, along with the maps, can be used to determine the composition and properties of a unit.

A map unit delineation on a soil map represents an area dominated by one or more major kinds of soil or miscellaneous areas. A map unit is identified and named according to the taxonomic classification of the dominant soils. Within a taxonomic class there are precisely defined limits for the properties of the soils. On the landscape, however, the soils are natural phenomena, and they have the characteristic variability of all natural phenomena. Thus, the range of some observed properties may extend beyond the limits defined for a taxonomic class. Areas of soils of a single taxonomic class rarely, if ever, can be mapped without including areas of other taxonomic classes. Consequently, every map unit is made up of the soils or miscellaneous areas for which it is named and some minor components that belong to taxonomic classes other than those of the major soils.

Most minor soils have properties similar to those of the dominant soil or soils in the map unit, and thus they do not affect use and management. These are called noncontrasting, or similar, components. They may or may not be mentioned in a particular map unit description. Other minor components, however, have properties and behavioral characteristics divergent enough to affect use or to require different management. These are called contrasting, or dissimilar, components. They generally are in small areas and could not be mapped separately because of the scale used. Some small areas of strongly contrasting soils or miscellaneous areas are identified by a special symbol on the maps. If included in the database for a given area, the contrasting minor components are identified in the map unit descriptions along with some characteristics of each. A few areas of minor components may not have been observed, and consequently they are not mentioned in the descriptions, especially where the pattern was so complex that it was impractical to make enough observations to identify all the soils and miscellaneous areas on the landscape.

The presence of minor components in a map unit in no way diminishes the usefulness or accuracy of the data. The objective of mapping is not to delineate pure taxonomic classes but rather to separate the landscape into landforms or

Custom Soil Resource Report

landform segments that have similar use and management requirements. The delineation of such segments on the map provides sufficient information for the development of resource plans. If intensive use of small areas is planned, however, onsite investigation is needed to define and locate the soils and miscellaneous areas.

An identifying symbol precedes the map unit name in the map unit descriptions. Each description includes general facts about the unit and gives important soil properties and qualities.

Soils that have profiles that are almost alike make up a *soil series*. Except for differences in texture of the surface layer, all the soils of a series have major horizons that are similar in composition, thickness, and arrangement.

Soils of one series can differ in texture of the surface layer, slope, stoniness, salinity, degree of erosion, and other characteristics that affect their use. On the basis of such differences, a soil series is divided into *soil phases*. Most of the areas shown on the detailed soil maps are phases of soil series. The name of a soil phase commonly indicates a feature that affects use or management. For example, Alpha silt loam, 0 to 2 percent slopes, is a phase of the Alpha series.

Some map units are made up of two or more major soils or miscellaneous areas. These map units are complexes, associations, or undifferentiated groups.

A *complex* consists of two or more soils or miscellaneous areas in such an intricate pattern or in such small areas that they cannot be shown separately on the maps. The pattern and proportion of the soils or miscellaneous areas are somewhat similar in all areas. Alpha-Beta complex, 0 to 6 percent slopes, is an example.

An *association* is made up of two or more geographically associated soils or miscellaneous areas that are shown as one unit on the maps. Because of present or anticipated uses of the map units in the survey area, it was not considered practical or necessary to map the soils or miscellaneous areas separately. The pattern and relative proportion of the soils or miscellaneous areas are somewhat similar. Alpha-Beta association, 0 to 2 percent slopes, is an example.

An *undifferentiated group* is made up of two or more soils or miscellaneous areas that could be mapped individually but are mapped as one unit because similar interpretations can be made for use and management. The pattern and proportion of the soils or miscellaneous areas in a mapped area are not uniform. An area can be made up of only one of the major soils or miscellaneous areas, or it can be made up of all of them. Alpha and Beta soils, 0 to 2 percent slopes, is an example.

Some surveys include *miscellaneous areas*. Such areas have little or no soil material and support little or no vegetation. Rock outcrop is an example.

El Paso County Area, Colorado

40—Kettle gravelly loamy sand, 3 to 8 percent slopes

Map Unit Setting

National map unit symbol: 368g
Elevation: 7,000 to 7,700 feet
Farmland classification: Not prime farmland

Map Unit Composition

Kettle and similar soils: 85 percent
Estimates are based on observations, descriptions, and transects of the mapunit.

Description of Kettle

Setting

Landform: Hills
Landform position (three-dimensional): Side slope
Down-slope shape: Linear
Across-slope shape: Linear
Parent material: Sandy alluvium derived from arkose

Typical profile

E - 0 to 16 inches: gravelly loamy sand
Bt - 16 to 40 inches: gravelly sandy loam
C - 40 to 60 inches: extremely gravelly loamy sand

Properties and qualities

Slope: 3 to 8 percent
Depth to restrictive feature: More than 80 inches
Drainage class: Somewhat excessively drained
Runoff class: Low
Capacity of the most limiting layer to transmit water (Ksat): High (2.00 to 6.00 in/hr)
Depth to water table: More than 80 inches
Frequency of flooding: None
Frequency of ponding: None
Available water supply, 0 to 60 inches: Low (about 3.4 inches)

Interpretive groups

Land capability classification (irrigated): None specified
Land capability classification (nonirrigated): 4e
Hydrologic Soil Group: B
Ecological site: F048AY908CO - Mixed Conifer
Hydric soil rating: No

Minor Components

Other soils

Percent of map unit:
Hydric soil rating: No

Pleasant

Percent of map unit:
Landform: Depressions
Hydric soil rating: Yes

68—Peyton-Pring complex, 3 to 8 percent slopes

Map Unit Setting

National map unit symbol: 369f

Elevation: 6,800 to 7,600 feet

Farmland classification: Not prime farmland

Map Unit Composition

Peyton and similar soils: 40 percent

Pring and similar soils: 30 percent

Estimates are based on observations, descriptions, and transects of the mapunit.

Description of Peyton

Setting

Landform: Hills

Landform position (three-dimensional): Side slope

Down-slope shape: Linear

Across-slope shape: Linear

Parent material: Arkosic alluvium derived from sedimentary rock and/or arkosic residuum weathered from sedimentary rock

Typical profile

A - 0 to 12 inches: sandy loam

Bt - 12 to 25 inches: sandy clay loam

BC - 25 to 35 inches: sandy loam

C - 35 to 60 inches: sandy loam

Properties and qualities

Slope: 3 to 5 percent

Depth to restrictive feature: More than 80 inches

Drainage class: Well drained

Runoff class: Low

Capacity of the most limiting layer to transmit water (Ksat): Moderately high (0.20 to 0.60 in/hr)

Depth to water table: More than 80 inches

Frequency of flooding: None

Frequency of ponding: None

Available water supply, 0 to 60 inches: Moderate (about 7.3 inches)

Interpretive groups

Land capability classification (irrigated): None specified

Land capability classification (nonirrigated): 4c

Hydrologic Soil Group: B

Ecological site: R049XY216CO - Sandy Divide

Hydric soil rating: No

Description of Pring

Setting

Landform: Hills
Landform position (three-dimensional): Side slope
Down-slope shape: Linear
Across-slope shape: Linear
Parent material: Arkosic alluvium derived from sedimentary rock

Typical profile

A - 0 to 14 inches: coarse sandy loam
C - 14 to 60 inches: gravelly sandy loam

Properties and qualities

Slope: 3 to 8 percent
Depth to restrictive feature: More than 80 inches
Drainage class: Well drained
Runoff class: Low
Capacity of the most limiting layer to transmit water (Ksat): High (2.00 to 6.00 in/hr)
Depth to water table: More than 80 inches
Frequency of flooding: None
Frequency of ponding: None
Available water supply, 0 to 60 inches: Low (about 6.0 inches)

Interpretive groups

Land capability classification (irrigated): None specified
Land capability classification (nonirrigated): 3e
Hydrologic Soil Group: B
Ecological site: R048AY222CO - Loamy Park
Hydric soil rating: No

Minor Components

Other soils

Percent of map unit:
Hydric soil rating: No

Pleasant

Percent of map unit:
Landform: Depressions
Hydric soil rating: Yes

92—Tomah-Crowfoot loamy sands, 3 to 8 percent slopes

Map Unit Setting

National map unit symbol: 36b9
Elevation: 7,300 to 7,600 feet
Farmland classification: Not prime farmland

Map Unit Composition

Tomah and similar soils: 50 percent

Crowfoot and similar soils: 30 percent

Estimates are based on observations, descriptions, and transects of the mapunit.

Description of Tomah

Setting

Landform: Hills, alluvial fans

Landform position (three-dimensional): Side slope, crest

Down-slope shape: Linear

Across-slope shape: Linear

Parent material: Alluvium derived from arkose and/or residuum weathered from arkose

Typical profile

A - 0 to 10 inches: loamy sand

E - 10 to 22 inches: coarse sand

Bt - 22 to 48 inches: stratified coarse sand to sandy clay loam

C - 48 to 60 inches: coarse sand

Properties and qualities

Slope: 3 to 8 percent

Depth to restrictive feature: More than 80 inches

Drainage class: Well drained

Runoff class: Medium

Capacity of the most limiting layer to transmit water (Ksat): Moderately high to high (0.60 to 2.00 in/hr)

Depth to water table: More than 80 inches

Frequency of flooding: None

Frequency of ponding: None

Available water supply, 0 to 60 inches: Low (about 4.6 inches)

Interpretive groups

Land capability classification (irrigated): None specified

Land capability classification (nonirrigated): 4e

Hydrologic Soil Group: B

Ecological site: R049XY216CO - Sandy Divide

Hydric soil rating: No

Description of Crowfoot

Setting

Landform: Alluvial fans, hills

Landform position (three-dimensional): Side slope, crest

Down-slope shape: Linear

Across-slope shape: Linear

Parent material: Alluvium

Typical profile

A - 0 to 12 inches: loamy sand

E - 12 to 23 inches: sand

Bt - 23 to 36 inches: sandy clay loam

C - 36 to 60 inches: coarse sand

Properties and qualities

Slope: 3 to 8 percent

Custom Soil Resource Report

Depth to restrictive feature: More than 80 inches

Drainage class: Well drained

Runoff class: Medium

Capacity of the most limiting layer to transmit water (Ksat): Moderately high to high
(0.60 to 2.00 in/hr)

Depth to water table: More than 80 inches

Frequency of flooding: None

Frequency of ponding: None

Available water supply, 0 to 60 inches: Low (about 4.7 inches)

Interpretive groups

Land capability classification (irrigated): None specified

Land capability classification (nonirrigated): 4e

Hydrologic Soil Group: B

Ecological site: R049XY216CO - Sandy Divide

Hydric soil rating: No

Minor Components

Other soils

Percent of map unit:

Hydric soil rating: No

Pleasant

Percent of map unit:

Landform: Depressions

Hydric soil rating: Yes

References

- American Association of State Highway and Transportation Officials (AASHTO). 2004. Standard specifications for transportation materials and methods of sampling and testing. 24th edition.
- American Society for Testing and Materials (ASTM). 2005. Standard classification of soils for engineering purposes. ASTM Standard D2487-00.
- Cowardin, L.M., V. Carter, F.C. Golet, and E.T. LaRoe. 1979. Classification of wetlands and deep-water habitats of the United States. U.S. Fish and Wildlife Service FWS/OBS-79/31.
- Federal Register. July 13, 1994. Changes in hydric soils of the United States.
- Federal Register. September 18, 2002. Hydric soils of the United States.
- Hurt, G.W., and L.M. Vasilas, editors. Version 6.0, 2006. Field indicators of hydric soils in the United States.
- National Research Council. 1995. Wetlands: Characteristics and boundaries.
- Soil Survey Division Staff. 1993. Soil survey manual. Soil Conservation Service. U.S. Department of Agriculture Handbook 18. http://www.nrcs.usda.gov/wps/portal/nrcs/detail/national/soils/?cid=nrcs142p2_054262
- Soil Survey Staff. 1999. Soil taxonomy: A basic system of soil classification for making and interpreting soil surveys. 2nd edition. Natural Resources Conservation Service, U.S. Department of Agriculture Handbook 436. http://www.nrcs.usda.gov/wps/portal/nrcs/detail/national/soils/?cid=nrcs142p2_053577
- Soil Survey Staff. 2010. Keys to soil taxonomy. 11th edition. U.S. Department of Agriculture, Natural Resources Conservation Service. http://www.nrcs.usda.gov/wps/portal/nrcs/detail/national/soils/?cid=nrcs142p2_053580
- Tiner, R.W., Jr. 1985. Wetlands of Delaware. U.S. Fish and Wildlife Service and Delaware Department of Natural Resources and Environmental Control, Wetlands Section.
- United States Army Corps of Engineers, Environmental Laboratory. 1987. Corps of Engineers wetlands delineation manual. Waterways Experiment Station Technical Report Y-87-1.
- United States Department of Agriculture, Natural Resources Conservation Service. National forestry manual. http://www.nrcs.usda.gov/wps/portal/nrcs/detail/soils/home/?cid=nrcs142p2_053374
- United States Department of Agriculture, Natural Resources Conservation Service. National range and pasture handbook. <http://www.nrcs.usda.gov/wps/portal/nrcs/detail/national/landuse/rangepasture/?cid=stelprdb1043084>

Custom Soil Resource Report

United States Department of Agriculture, Natural Resources Conservation Service. National soil survey handbook, title 430-VI. http://www.nrcs.usda.gov/wps/portal/nrcs/detail/soils/scientists/?cid=nrcs142p2_054242

United States Department of Agriculture, Natural Resources Conservation Service. 2006. Land resource regions and major land resource areas of the United States, the Caribbean, and the Pacific Basin. U.S. Department of Agriculture Handbook 296. http://www.nrcs.usda.gov/wps/portal/nrcs/detail/national/soils/?cid=nrcs142p2_053624

United States Department of Agriculture, Soil Conservation Service. 1961. Land capability classification. U.S. Department of Agriculture Handbook 210. http://www.nrcs.usda.gov/Internet/FSE_DOCUMENTS/nrcs142p2_052290.pdf