

Final Drainage Report
for
Rolling Hills Ranch North Standalone Grading
at
Meridian Ranch



EL PASO COUNTY, COLORADO

May 2022

Prepared For:

GTL DEVELOPMENT, INC.
P.O. Box 80036
San Diego, CA 92138

Prepared By:
Tech Contractors
11886 Stapleton Drive
Falcon, CO 80831
719.495.7444

PCD Project No. EGP222

CERTIFICATIONS

Design Engineer's Statement:

The attached drainage plan and report were prepared under my direction and supervision and are correct to the best of my knowledge and belief. Said drainage report has been prepared according to the criteria established by the County for drainage reports and said report is in conformity with the applicable master plan of the drainage basin. I accept responsibility for any liability caused by any negligent acts, errors or omissions on my part in preparing this report.

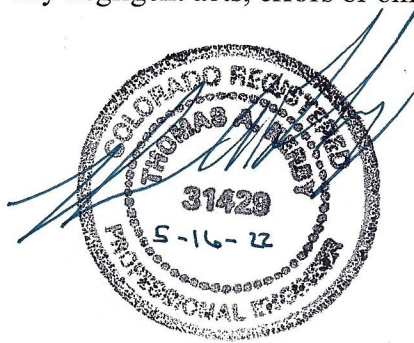

Thomas A. Kerby, P.E. #31429

Owner/Developer's Statement:

I, the owner/developer have read and will comply with all of the requirements specified in this drainage report and plan.

Raul Guzman, Vice President
GTL Development, Inc.
P.O. Box 80036
San Diego, CA 92138

5/16/2022

Date

El Paso County:

Filed in accordance with the requirements of the Drainage Criteria Manual, Volumes 1 & 2, El Paso County Engineering Criteria Manual and Land Development Code as amended.

APPROVED
Engineering Department

County Engineer / ECM Administrator

06/15/2022 2:05:24 PM

Date

EPC Planning & Community
Development Department

**Rolling Hills Ranch at Meridian Ranch PUD
Final Drainage Report**

Table of Contents

EXECUTIVE SUMMARY	<i>i</i>
INTRODUCTION	<i>1</i>
Purpose	1
Scope	1
Background	1
EXISTING CONDITIONS	<i>3</i>
General Location	3
Land Use	3
Climate	3
Topography and Floodplains	3
Geology	3
Natural Hazards Analysis	6
DRAINAGE BASINS AND SUB-BASINS	<i>6</i>
DRAINAGE DESIGN CRITERIA	<i>7</i>
SCS Hydrograph Procedure	7
Full Spectrum Design	7
DRAINAGE CALCULATIONS	<i>8</i>
SCS General Overview	8
SCS Calculations	9
Historic Drainage - SCS Calculation Method	9
Graded Drainage - SCS Calculation Method	10
Future Drainage - SCS Calculation Method	12
Rational Calculations	13
DETENTION POND	<i>14</i>
Existing Pond G Detention Storage Criteria	14
Downstream Analysis	15
PROPOSED PERMANENT CONSTRUCTION	<i>16</i>
General Concept	16
Various Improved Drainage Courses/Swales	16
Water Quality Structure at DP9b	17
Permanent Storm Drainage Pipes	17
EROSION CONTROL DESIGN	<i>18</i>
General Concept	18
Four Step Process	18
Temporary Sedimentation Pond	19
Detention Pond	19
Silt Fence	19
Erosion Bales	19
Miscellaneous	19
REFERENCES	<i>20</i>

Figures

Figure 1: Vicinity Map 2
Figure 2: FEMA Floodplain Map..... 4
Figure 3: Soils Map 5
Figure 4 - Meridian Ranch SCS Method – Historic Basin Map.....APPENDIX H
Figure 5 - Meridian Ranch SCS Method – Graded Basin MapAPPENDIX H
Figure 6 - Meridian Ranch SCS Method – Graded 200-Scale Basin MapAPPENDIX H
Figure 7- Meridian Ranch SCS Method – Future Basin MapAPPENDIX H

Tables

Table 1: SCS Runoff Curve Numbers 7
Table 2: Detention Pond Summary: 7
Table 3: Historic Drainage Basins – SCS..... 9
Table 4: Graded Drainage Basins-SCS 10
Table 5: Future Drainage Basins-SCS..... 12
Table 6: Existing Pond G Summary Data 14
Table 7: Key Design Point Comparison - SCS 15

Appendices:

- Appendix A - HEC-HMS Data
- Appendix B - Detention Pond Information
- Appendix C – Outlet Protection Design
- Appendix D – Water Quality & Temporary Sedimentation Ponds
- Appendix E – Channel Hydraulics
- Appendix F – Rip-Rap Rundown Protection
- Appendix G – Soil Resource Report
- Appendix H – Drainage Maps

EXECUTIVE SUMMARY

The purpose of the following Final Drainage Report (FDR) is to present the changes to the drainage patterns as a result the Rolling Hills Ranch North Standalone Grading (RHRN Grading) development. Runoff quantities and proposed facilities have been calculated using the current City of Colorado Springs/El Paso County Drainage Criteria Manual (DCM) (1994 version) and portions of the City of Colorado Springs Drainage Criteria Manual, Volume 1 (DCM-1) ((2014 version).

This report is based on the current version of the Meridian Ranch Sketch Plan amendment as adopted by the El Paso County Board of Commissioners on August 24, 2021. Hydrologic calculations follow method outlined in Chapter 6 of the 2014 version of the City of Colorado Springs Drainage Criteria Manual (COSDCM) as adopted by the El Paso County Board of County Commissioners by Resolution 15-042. Chapter 6 addresses the hydrologic calculation methods and includes an updated hydrograph to be used with storm drainage runoff. The Board adopted by the same resolution, Section 3.2.1 of Chapter 13 of the COSDCM referencing Full Spectrum Detention; the concept “provides better control of the full range of runoff rates that pass-through detention facilities than the convention multi-stage concept. This section of the COSDCM identifies the necessity to provide full spectrum detention but does not prescribe a methodology to reach such the detention requirements. This report includes hydrologic models from HEC-HMS for the historic, graded, and future conditions for the 2-yr, 5-yr, 10-yr, 50-yr, and 100-yr design storm frequencies. The graded and the future conditions include the existing detention facilities and modeled such that *“frequent and infrequent inflows are released at rates approximating undeveloped conditions”*

RHRN Grading encompasses 198± acres and is located in Section 20, Township 12 South, Range 64 West of the 6th Principal Meridian. It is approximately 12 miles northeast of the city of Colorado Springs, 2.5 miles north of the unincorporated town of Falcon, and immediately north of the Woodmen Hills development.

The Rolling Hills Ranch North Grading project is located within Gieck Ranch Drainage Basin. The Gieck Ranch Basin has been studied but has not received final approval from El Paso County. The developer has agreed to meet the requirements of the studied Gieck Ranch Basin but as yet to be approved Drainage Basin Study.

Based on the design parameters the development of the project will not adversely affect downstream properties.

INTRODUCTION

Purpose

The purpose of the following Final Drainage Report (FDR) is to present proposed changes to the drainage patterns as a result of the development of RHRN Grading. The report outlines the proposed drainage mitigation based on calculated developed flows for the graded and the ultimate fully developed conditions in excess of allowable existing runoff discharge.

Scope

The scope of this report includes:

- Location and description of the proposed development stating the proposed land use, density, acreage, and adjacent features to the site.
- Calculations for design peak flows from all off-site tributary drainage areas.
- Calculations for design peak flows within the proposed project area for all drainage areas.
- Discussion of major drainage facilities required as a result of the development.
- Discussion and analysis of existing and proposed facilities.

Runoff quantities and proposed facilities have been calculated using the current City of Colorado Springs/El Paso County Drainage Criteria Manual (DCM) (1994 version) and those portions of the City of Colorado Springs Drainage Criteria Manual, Volume 1 (DCM-1) ((2014 version) adopted by Resolution 15-042 of the El Paso County Board of County Commissioners.

Background

On November 16, 2000, the El Paso County Board of County Commissioners approved the rezoning of the Meridian Ranch project (PUD-00-010) from A-35 to PUD with several conditions. Condition number seven stated in part that “drainage plans shall release and/or retain at approximately eight percent (80%) of historic rates.” At the time of the initial approvals there were no drainage improvements downstream of the Meridian Ranch project and the existing natural channels were shallow and undefined.

The Sketch Plan Amendment (SKP-17-001) was processed and approved in 2018 by the El Paso County Board of County Commissioners by resolution 18-104 for Meridian Ranch. The resolution eliminated the required restriction of 80% of historic peak flow rates mentioned above. The detention pond proposed with this project will release at historic or less peak flow rates as per the current El Paso County stormwater requirements.

No development has occurred downstream of this project except for portions of the Falcon Regional Park providing ballparks and associated parking. The Meridian Ranch MDDP and this report indicate the Eastonville Road culvert crossing located downstream of this project does not provide enough capacity for the historic flow rates. It is anticipated that this culvert will be upgraded at the time of the Eastonville Road construction.

Current calculations show the future design discharge of the existing Pond G to the Falcon Regional Park to be below historic flow rates at full buildout for the full spectrum of design storms.

Rolling Hills Ranch Grading

Figure 1: Vicinity Map

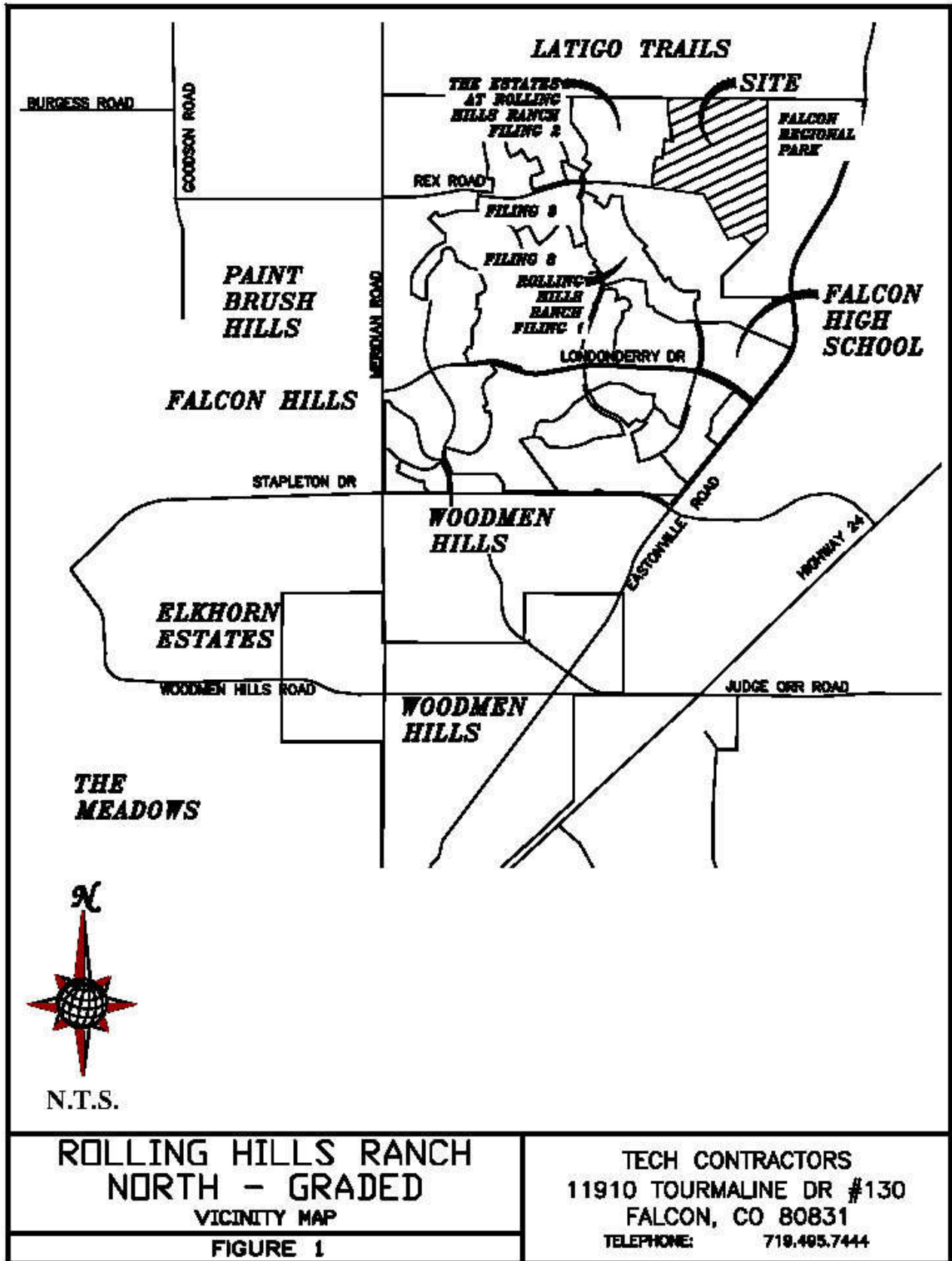

EXISTING CONDITIONS

General Location

Rolling Hills Ranch Grading project encompasses 198± acres and is located in Section 20 Township 12 South, Range 64 West of the 6th Principal Meridian. It is approximately 12 miles northeast of the city of Colorado Springs, 2.5 miles north of the unincorporated town of Falcon, and immediately north of the Woodmen Hills development.

Land Use

Historically, ranching dominated the area surrounding Meridian Ranch; however, currently urbanization has occurred in the general vicinity. Most notably, urbanization is occurring to the north with Latigo Trails, to the south in the Woodmen Hills Subdivision, to the east in Four Way Ranch, to the west in the Falcon Hills subdivision, and to the northwest in the Paint Brush Hills subdivision.

Climate

Mild summers and winter, light precipitation; high evaporation and moderately high wind velocities characterize the climate of the study area. The average annual monthly temperature is 48.4 F with an average monthly low of 30.3 F in the winter and an average monthly high of 68.1 F in the summer. Two years in ten will have maximum temperature higher than 98 F and a minimum temperature lower than -16 F. Precipitation averages 15.73" annually, with 80% of this occurring during the months of April through September. The average annual Class A pan evaporation is 45 inches. (Soil Survey of El Paso County Area, Colorado).

Topography and Floodplains

The topography of the site is typical of a high desert, short prairie grass with relatively flat slopes generally ranging from 2% to 4%. The project site drains generally from the northwest to southeast and is tributary to the Black Squirrel Creek.

The Flood Insurance Rate Maps (FIRM No. 08041C0552G, dated 12/07/2018) indicates that this project is not located within a designated floodplain. Please see Figure 2: Rolling Hills Ranch Grading Federal Emergency Management Agency (FEMA) Floodplain Map.

Geology

The National Resources Conservation Service (NRCS) soil survey records indicate that the service area is predominately covered by soils classified in the Columbine (62 ac.) and Stapleton series (136 ac.). These series are categorized in the Hydrological Soil Groups A & B.

The Columbine (19) gravelly sandy loam is a deep, well-drained to excessively drained soil formed in coarse textured material on alluvial terraces, fans and flood plains. Permeability of this soil is very rapid. Available water capacity is low to moderate, surface runoff is slow, and the hazard of erosion is slight to moderate. The Columbine series is categorized as a Hydrological Soil Group A.

This soil is used mainly for grazing livestock, for wildlife habitat and for home sites. The main limitation of this soil for urban development is a hazard of flooding in some areas.

Rolling Hills Ranch Grading

Figure 2: FEMA Floodplain Map

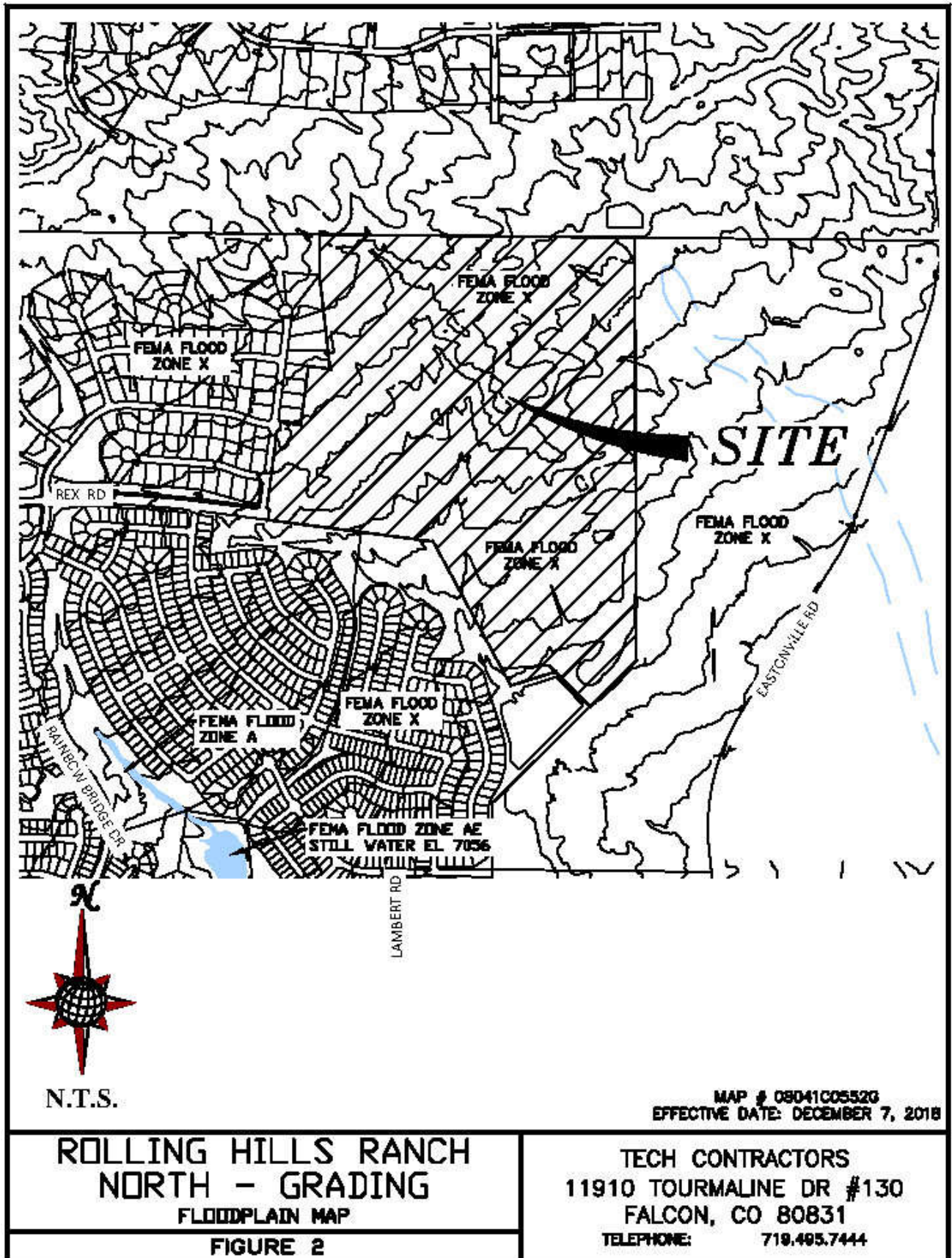

Rolling Hills Ranch Grading

Figure 3: Soils Map

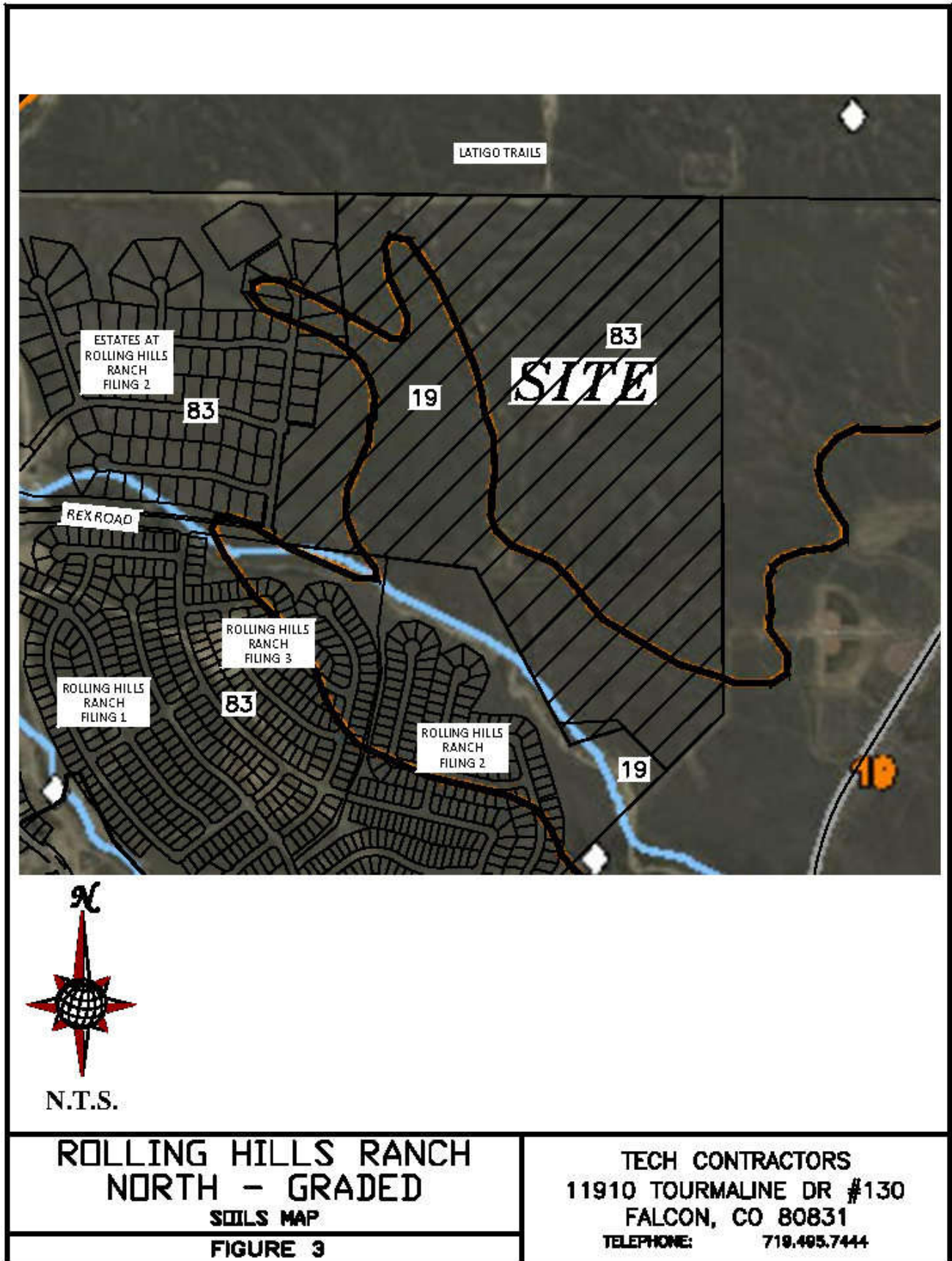

The Stapleton (83) sandy loam is a deep, non-calcareous, well-drained soil formed in alluvium derived from arkosic bedrock on uplands. Permeability of this soil is rapid. Available water capacity is moderate, surface runoff is slow, and the hazard of erosion and soil blowing is moderate. The Stapleton series is categorized as a Hydrological Soil Group B.

This soil is suited to habitat for open land and rangeland wildlife. The main limitation of this soil for urban development is frost-action potential.

Typically, these soils are well-drained, gravelly sandy loams that form on alluvial terraces and fans and exhibit high permeability and low available water capacity with depth to bedrock greater than 6 feet.

Note: (#) indicates Soil Conservation Survey soil classification number. See Figure 3 Rolling Hills Ranch Grading – Soils Map.

Natural Hazards Analysis

Natural hazards analysis indicates that no unusual surface or subsurface hazards are located near the vicinity. However, because the soils are cohesionless, sloughing of steep banks during drilling and/or excavation could occur. By citing improvements in a manner that provides an opportunity to lay the banks of excavations back at a 1:1 slope during construction, the problems associated with sloughing soils can be minimized.

DRAINAGE BASINS AND SUB-BASINS

The site is near the top of the Gieck Ranch Drainage Basin and accepts flow from areas north of the project site within portions of the Latigo Trails development.

Three different scenarios were analyzed for the drainage conditions for the project. The first scenario analyzes the historic conditions for Meridian Ranch. This condition has the project site and all the tributary areas in the pre-development state; where the entirety of project and the surrounding area are modeled in the undeveloped, undisturbed condition, alternatively called the historic condition.

The second scenario is the graded condition scenario, and it consists of the current existing conditions for all tributary areas whether developed or undeveloped/historic with the addition of project site in the proposed graded condition. The current existing conditions assume all approved projects tributary to the site are at full buildout. This condition was analyzed to ensure the full spectrum of historic flow rates exiting the Meridian Ranch development are maintained after the development of RHRN Grading is completed.

The graded scenario was analyzed to ensure that the historic flow rates at the outlets of the existing Pond G (Design Point G12) located upstream of and adjacent to the Falcon Regional Park are maintained.

The final scenario analyzes the future build out conditions for the entirety of Meridian Ranch to ensure any proposed storm drain facilities installed to protect surrounding property and existing facilities because of the grading operations on the project are able to properly convey the peak flow rates that exit the project.

DRAINAGE DESIGN CRITERIA

SCS Hydrograph Procedure

The US Army Corp of Engineers HEC-HMS computer program was used to model the Soil Conservation Service (SCS) Hydrograph procedure to determine final design parameters for the major drainage facilities within the project. Onsite basin areas were calculated using aerial topography of the site and approved final design data. Times of concentration were estimated using the SCS procedures described in the DCM. Based upon the hydrologic soil type, the natural conditions found in the basins and the runoff curve numbers (CN) chart from Table 6-10 of the City of Colorado Springs DCM for Antecedent Runoff Condition II (ARC II), the following CN values were used for the given conditions.

Table 1: SCS Runoff Curve Numbers

Condition	CN*	School	80
Residential Lots (5 acre)	63	Parks/Open Space	62
Residential Lots (2.5 acre)	66	Commercial	85
Residential Lots (1 acre)	68	Roadways	98
Residential Lots (1/2 acre)	70	Graded	67
Residential Lots (1/3 acre)	72	Golf Course	62
Residential Lots (1/4 acre)	75	Latigo Undeveloped	65
Residential Lots (1/5 acre)	78	Undeveloped	61
Residential Lots (1/6 acre)	80		

*Curve Numbers were interpolated and based on amount of impervious area per lot. The 24 hour storm precipitation values were selected from the NOAA Atlas 14, Volume 8, Version 2 for the Meridian Ranch location (Latitude 38.9783°, Longitude -104.5842°, Elevation 7054 ft). These numbers along with SCS information were used as input to the U.S. Army Corp of Engineers HEC-HMS computer model to determine design runoffs. See the table for all the design storm events in Appendix A. These numbers along with SCS information were used as input to the U.S. Army Corp of Engineers HEC-HMS computer model to determine design runoffs.

Full Spectrum Design

The City of Colorado Springs adopted a new Drainage Criteria Manual (DCM) in 2014 which incorporated the use of *Full Spectrum Design* for storm drainage analysis for projects located within the city limits. El Paso County adopted portions of the City's 2014 DCM by resolution in January 2015; the County resolution adopted Chapter 6 (Hydrology) and Section 3.2.1 of Chapter 13 (Full Spectrum Detention) for projects located outside of the City of Colorado Springs establishing the Full Spectrum Design on the storm drainage analysis of detention facilities. This report has incorporated the use of full spectrum in the analysis using the SCS Method to determine the size requirements for the detention pond during the graded and future conditions.

The idea behind full spectrum detention is to release the developed runoff flow rates that will approximate those of the pre-developed condition. The design of the existing Pond G and the outlet control structure meets or exceeds the intent and spirit of the concept.

Table 2: Detention Pond Summary:

POND G				
	PEAK INFLOW	PEAK OUTFLOW	PEAK STORAGE	PEAK ELEVATION
	CFS	CFS	AC-FT	FT
GRADED CONDITIONS				
2-YEAR STORM	17	4.4	3.9	7026.4
5-YEAR STORM	62	15	8.0	7027.3
10-YEAR STORM	127	40	10.5	7027.8
50-YEAR STORM	412	275	19.5	7029.3
100-YEAR STORM	625	442	24.3	7030.1
FUTURE CONDITIONS				
2-YEAR STORM	47	5.3	5.7	7026.9
5-YEAR STORM	108	21	8.9	7027.5
10-YEAR STORM	187	52	11.5	7028.0
50-YEAR STORM	477	293	20.1	7029.4
100-YEAR STORM	663	450	24.9	7030.2

DRAINAGE CALCULATIONS

SCS General Overview

The project is located within the Gieck Ranch Drainage Basin; storm water runoff will be conveyed across the site overland and within existing and proposed storm drain networks to existing and proposed detention ponds. Portions of the site tributary the existing Detention Pond G will be directed to a proposed temporary sedimentation pond to be located upstream of the pond then conveyed to the pond. The portions of the site that are tributary the existing Detention Pond G, but not directly connected will have runoff directed to proposed temporary sedimentation ponds to be located upstream as needed prior to discharging into an existing channel to be conveyed to the detention pond. Additionally, the existing detention Pond G will be utilized as a combination sedimentation/detention pond until such time as the tributary areas establish sufficient ground cover or development in the area is complete.

Those portions of the site tributary the existing Detention Pond G will be directed to a proposed temporary sedimentation pond (TSP) to be located upstream of Pond G then conveyed to the Pond G. Five TSPs are strategically located throughout the project grading (see map in Appendix D) where the storm drainage will surface flow off the lot pads to the street rough cut and be directed overland to the TSP. TSP 1, 2, & 3 discharge into a drainage course where the flow is directed to the permanent WQ structure. Flow from TSP 4 is directed downstream to TSP 5 and discharged into Pond G.

The detention facilities have been adequately sized such that the developed flows detained and released will approximate the historic flow rates for the various design storm events as outlined in the El Paso County DCM and those sections of the City of Colorado Springs DCM-1 adopted by the El Paso County Board of County Commissioners.

Figure 4: Rolling Hills Ranch North – Historic Conditions Map, Figure 5: Rolling Hills Ranch North – Graded Conditions Map and Figure 6: Rolling Hills Ranch North – Future Conditions Map depict the historic, graded and future general drainage patterns for Rolling Hills Ranch North Grading.

The purpose of this report is to show that the proposed grading operations of the Rolling Hills Ranch North area of Meridian Ranch will not adversely impact the existing drainage facilities adjacent to and downstream of the graded area and that the existing Pond G is properly sized for the anticipated future development of Rolling Hills Ranch North.

SCS Calculations

Historic Drainage - SCS Calculation Method

Following is a tabulation of the surface drainage characteristics under Existing Conditions using the SCS calculation method. Please refer to Figure 4 – Rolling Hills Ranch North SCS Calculations - Historic Basin Map.

Table 3: Historic Drainage Basins – SCS

HISTORIC SCS (Full Spectrum)						
	Drainage Area (SQ. MI.)	Peak Discharge Q100 (CFS)	Peak Discharge Q50 (CFS)	Peak Discharge Q10 (CFS)	Peak Discharge Q5 (CFS)	Peak Discharge Q2 (CFS)
OS06	0.1313	80	52	12	3.8	0.5
OS06-G02	0.1313	77	52	11	3.7	0.5
OS05	0.0578	39	26	5.6	1.8	0.2
OS05-G01	0.0578	38	25	5.5	1.7	0.2
HG01	0.0547	32	21	4.7	1.5	0.2
G01	0.1125	70	46	10	3.2	0.5
G01-G02	0.1125	68	46	9.9	3.2	0.5
HG02	0.0906	45	30	6.7	2.3	0.4
G02	0.3344	191	127	27	9.0	1.3
G02-G03	0.3344	190	125	27	9.0	1.3
HG03	0.1828	77	51	12	4.3	0.7
OS07	0.0328	25	17	4.5	1.7	0.3
OS07-G03	0.0328	24	17	4.3	1.7	0.3
G03	0.5500	291	192	42	15	2.3
G03-G04	0.5500	281	189	42	14	2.3
OS09	0.1547	91	63	19	8.3	1.9
OS09-G04	0.1547	90	62	18	8.3	1.9
HG04	0.0891	40	26	5.9	2.1	0.3
HG05	0.1125	49	32	7.4	2.6	0.4
OS08	0.0406	35	25	7.7	3.4	0.7
OS08-G04	0.0406	34	24	7.4	3.4	0.7
G04	0.9469	493	332	76	28	4.7
G04-G05	0.9469	488	318	76	27	4.7
HG06A	0.1375	49	32	7.6	2.9	0.5
G05	1.0844	536	350	84	30	5.2
G05-G06	1.0844	520	348	83	30	5.2
HG06B	0.1031	33	22	5.3	2.0	0.4
G06	1.1875	551	369	88	32	5.5
HG14	0.2297	79	52	12	4.7	0.8
HG13	0.1053	38	25	5.8	2.2	0.4
G14	0.1053	38	25	5.8	2.2	0.4
G07-G08	0.1053	37	25	5.8	2.2	0.4
G16	0.3350	116	77	18	6.8	1.2

Graded Drainage - SCS Calculation Method

Following is a tabulation of the surface drainage characteristics for the graded conditions using the SCS calculation method. Please refer to Figure 5 – Rolling Hills Ranch North SCS Calculations – Graded Basin Map

Table 4: Graded Drainage Basins-SCS

GRADED SCS (Full Spectrum)						
	Drainage Area (SQ. MI.)	Peak Discharge Q100 (CFS)	Peak Discharge Q50 (CFS)	Peak Discharge Q10 (CFS)	Peak Discharge Q5 (CFS)	Peak Discharge Q2 (CFS)
OS06	0.1313	80	52	12	3.8	0.5
G1a	0.1313	80	52	12	3.8	0.5
G1a-G2	0.1313	79	52	11	3.7	0.5
OS05	0.0578	39	26	5.6	1.8	0.2
OS05-G1	0.0578	39	25	5.5	1.7	0.2
FG01	0.0538	31	22	7.0	3.4	0.9
FG01-G1	0.0538	31	22	7.0	3.4	0.9
G1	0.1116	61	41	11	4.9	1.1
G1-G2	0.1116	61	41	11	4.8	1.1
FG02	0.0391	32	22	6.4	2.7	0.5
G2	0.2820	167	112	27	10	1.9
G2-G3	0.2820	163	108	27	10	1.9
FG03	0.0203	24	17	6	3.0	0.8
FG04	0.0172	22	16	6	3.1	0.9
G3	0.3195	185	123	31	12	2.4
FG06	0.0675	56	40	12	5.8	1.3
FG05	0.0580	45	33	12	6.7	2.4
OS07ab	0.0170	12	8	2	0.5	0.1
OS07ab-POND F	0.0170	12	7.6	1.7	0.5	0.1
POND F IN	0.4620	293	200	54	23	5.1
POND F	0.4620	178	121	16	8.0	2.1
POND F-G7	0.4620	177	120	16	8.0	2.1
OS07c	0.0158	13	8.6	1.8	0.6	0.1
OS07c-G4	0.0158	13	8.2	1.8	0.5	0.1
FG21a	0.0095	5.9	4.0	1.0	0.4	0.1
G4	0.0253	19	12	2.8	0.9	0.1
G4-G7	0.0253	17	12	2.7	0.9	0.1
FG21b	0.0150	21	16	6.5	3.9	1.7
G7	0.5023	189	127	18	8.7	2.3
G7-G8	0.5023	188	127	18	8.7	2.3
FG22	0.1400	124	90	32	17	5.3
OS08a	0.0469	29	19	4.4	1.5	0.2
OS08-G8	0.0469	29	19	4.3	1.5	0.2
FG23a	0.0216	21	15	5.2	2.7	0.8
OS07d	0.0036	2.6	1.7	0.4	0.1	0.0
OS07d-G8	0.0036	2.6	1.7	0.4	0.1	0.0
G8	0.7144	283	179	48	25	7.6
G8-G10	0.7144	282	179	47	24	7.6
OS08b	0.1167	72	49	14	6.1	1.3
OS08b-G9a	0.1167	71	49	14	6.0	1.2
FG24b	0.0589	41	30	10	4.9	1.4
FG24a	0.0359	23	15	4.0	1.6	0.3
OS09a	0.0279	17	11	2.8	1.0	0.2
OS09a-G9a	0.0279	17	11	2.7	1.0	0.2
G9a	0.2394	148	100	28	12	2.6
G9a-G9b	0.2394	145	100	28	12	2.6
FG24d	0.0307	23	16	4.7	2.1	0.4
FG24c	0.0291	26	18	5.8	2.9	0.8

GRADED SCS (Full Spectrum)						
	Drainage Area (SQ. MI.)	Peak Discharge Q100 (CFS)	Peak Discharge Q50 (CFS)	Peak Discharge Q10 (CFS)	Peak Discharge Q5 (CFS)	Peak Discharge Q2 (CFS)
G9b	0.2992	181	122	34	15	3.3
REX RD WQCV	0.2992	170	122	33	15	3.3
G9b-G10	0.2992	169	121	33	14	3.3
FG23b	0.0235	18	12	3.0	1.1	0.2
G10	1.0371	456	284	77	36	8.2
G10-G11	1.0371	455	283	76	36	8.1
FG23c	0.0109	11	7.7	2	1.0	0.2
G11	1.0480	458	285	77	36	8.3
FG25	0.1084	111	84	36	22	9.9
FG28	0.0184	15	11	3.1	1.3	0.2
POND G IN-WEST	1.1748	541	352	108	53	14
FG27	0.0679	42	29	9.5	4.6	1.3
FG26	0.0570	45	32	11	5.1	1.3
G13	0.0570	45	32	11	5.1	1.3
G13-POND G	0.0570	45	32	10	5.1	1.3
POND G IN-EAST	0.1249	84	60	19	9.5	2.5
POND G	1.2997	442	275	40	15	4.4
G12	1.2997	442	275	40	15	4.4
G12-G06	1.2997	442	273	40	15	4.4
FG29	0.0983	60	39	8.9	2.9	0.4
FG32	0.0402	21	14	3.1	1.0	0.2
FG32-G06	0.0402	21	14	3.1	1.0	0.2
G06	1.4382	466	288	43	16	4.7
OS09b	0.0711	27	18	4.2	1.5	0.3
OS09b-G14	0.0711	27	18	4.2	1.5	0.3
FG34	0.0275	20	13	3.3	1.2	0.2
G14	0.0986	35	23	5.6	2.2	0.4
G14-G15	0.0986	35	23	5.6	2.2	0.4
FG35	0.0282	20	14	3.3	1.1	0.2
G15	0.1268	44	28	6.8	2.7	0.5
G15-G16	0.1268	44	28	6.8	2.7	0.5
FG37	0.0797	53	37	9.9	4.0	0.7
FG36	0.0286	20	14	4.3	2.0	0.5
FG36-G16	0.0286	20	14	4.3	2.0	0.5
G16	0.2351	114	74	17	6.6	1.3

Future Drainage - SCS Calculation Method

Following is a tabulation of the surface drainage characteristics for the future conditions using the SCS calculation method. Please refer to Figure 6 - Rolling Hills Ranch North SCS Calculations – Future Basins Map

Table 5: Future Drainage Basins-SCS

FUTURE SCS (Full Spectrum)						
	Drainage Area (SQ. MI.)	Peak Discharge Q100 (CFS)	Peak Discharge Q50 (CFS)	Peak Discharge Q10 (CFS)	Peak Discharge Q5 (CFS)	Peak Discharge Q2 (CFS)
OS06	0.1313	80	52	12	3.8	0.5
G1a	0.1313	80	52	12	3.8	0.5
G1a-G2	0.1313	79	52	11	3.7	0.5
OS05	0.0578	39	26	5.6	1.8	0.2
OS05-G1	0.0578	39	25	5.5	1.7	0.2
FG01	0.0538	31	22	7.0	3.4	0.9
FG01-G1	0.0538	31	22	7.0	3.4	0.9
G1	0.1116	61	41	11	4.9	1.1
G1-G2	0.1116	61	41	11	4.8	1.1
FG02	0.0391	32	22	6.4	2.7	0.5
G2	0.2820	167	112	27	10	1.9
G2-G3	0.2820	163	108	27	10	1.9
FG03	0.0203	24	17	5.9	3.0	0.8
FG04	0.0172	22	16	5.8	3.1	0.9
G3	0.3195	185	123	31	12	2.4
FG06	0.0675	56	40	12	5.8	1.3
FG05	0.0580	45	33	12	6.7	2.4
OS07ab	0.0170	12	7.9	1.8	0.5	0.1
OS07ab-POND F	0.0170	12	7.6	1.7	0.5	0.1
POND F IN	0.4620	293	200	54	23	5.1
POND F	0.4620	178	121	16	8.0	2.1
POND F-G7	0.4620	177	120	16	8.0	2.1
OS07c	0.0296	19	12	2.7	0.9	0.1
OS07c-G4	0.0296	19	12	2.6	0.9	0.1
FG21a	0.0095	5.9	4.0	1.0	0.4	0.1
G4	0.0391	25	16	3.6	1.2	0.2
G4-G7	0.0391	24	16	3.5	1.2	0.2
FG21b	0.0150	21	16	6.5	3.9	1.7
G7	0.5161	194	131	18	8.9	2.3
G7-G8	0.5161	194	131	18	8.9	2.3
FG22	0.1354	121	88	32	17	5.4
OS08a	0.0251	16	11	2.3	0.7	0.1
OS08-G8	0.0251	16	10	2.3	0.7	0.1
FG23a	0.0216	21	15	5.2	2.7	0.8
OS07d	0.0034	2.5	1.6	0.4	0.1	0.0
OS07d-G8	0.0034	2.4	1.6	0.3	0.1	0.0
G8	0.7016	279	178	46	24	7.7
G8-G10	0.7016	278	177	45	24	7.6
FG24b	0.0589	76	57	24	15	6.5
FG24a	0.0348	24	16	4.5	2.0	0.4
OS08b	0.0165	9.5	6.3	1.4	0.5	0.1
OS08b-G9a	0.0165	9.4	6.0	1.4	0.5	0.1
OS09a	0.0093	5.3	3.5	0.8	0.3	0.04
OS09a-G9a	0.0093	5.2	3.4	0.7	0.3	0.04
G9a	0.1195	97	71	28	16	6.7
G9a-G9b	0.1195	96	70	27	16	6.6
FG24c	0.0291	40	30	13	8.4	4.0
FG24d	0.0262	39	30	14	8.7	4.4

FUTURE SCS (Full Spectrum)						
	Drainage Area (SQ. MI.)	Peak Discharge Q100 (CFS)	Peak Discharge Q50 (CFS)	Peak Discharge Q10 (CFS)	Peak Discharge Q5 (CFS)	Peak Discharge Q2 (CFS)
G9b	0.1748	170	127	53	32	14
REX RD W/QCV	0.1748	158	125	51	31	14
G9b-G10	0.1748	158	123	50	31	13
FG23b	0.0236	17	11	2.7	0.9	0.1
G10	0.9000	390	263	90	46	15
G10-G11	0.9000	389	254	85	44	15
FG23c	0.0109	11	7.6	2.2	1.0	0.2
G11	0.9109	393	258	86	44	15
FG25	0.1084	111	84	36	22	9.9
FG28	0.0184	15	10	3.0	1.2	0.2
POND G IN-WEST	1.0377	503	350	122	63	22
FG27	0.0679	98	79	42	30	18
FG26	0.0570	65	50	24	16	8.2
G13	0.0570	65	50	24	16	8.2
G13-POND G	0.0570	64	50	24	16	8.1
POND G IN-EAST	0.1249	160	127	64	44	25
POND G	1.1626	450	293	52	21	5.3
G12	1.1626	450	293	52	21	5.3
G12-G06	1.1626	449	293	52	21	5.3
FG29	0.0983	60	39	8.9	2.9	0.4
FG32	0.0402	51	40	20	14	7.5
FG32-G06	0.0402	50	40	19	13	7.4
G06	1.3011	491	317	57	22	7.5
OS09b	0.0435	23	15	3.3	1.1	0.2
OS09b-G14	0.0435	22	15	3.3	1.1	0.2
FG34	0.0275	20	13	3.3	1.3	0.2
G14	0.0710	38	25	5.7	2.0	0.3
G14-G15	0.0710	38	25	5.6	2.0	0.3
FG35	0.0282	25	18	5.6	2.5	0.5
G15	0.0992	54	35	8.0	3.0	0.6
G15-G16	0.0992	53	35	7.9	3.0	0.6
FG37	0.0797	53	37	9.9	4.0	0.7
FG36	0.0286	20	14	4.3	2.0	0.5
FG36-G16	0.0286	20	14	4.3	2.0	0.5
G16	0.2075	124	81	19	7.8	1.6

Rational Calculations

The Rational Hydrologic Calculation Method is typically used to estimate the total runoff from the 5-year and the 100-year design storm to establish the storm drainage design for systems with tributary areas of less than 100 acres. There are no permanent storm drainage systems proposed with this phase of construction that have tributary areas of less than 100 acres. Therefore there is no rational calculation analysis with this report.

DETENTION POND

Existing Pond G Detention Storage Criteria

The existing Detention Pond G is located west of the Falcon Regional Park, east of Rolling Hills Ranch Filing 2, and south of this project, it was constructed as a part of the Rolling Hills Ranch Grading operations. The pond is owned and maintained by the Meridian Service Metropolitan District (MSMD) and has been in operation and is functioning as intended since 2021 with no reported issues. A maintenance agreement between the Meridian Service Metropolitan District and El Paso County has been recorded as a part of the Meridian Ranch Filing 2 Final Plat process.

The SCS calculation method was used to determine inflow and outflow from the detention pond to ensure the developed runoff does not overcharge the pond and the discharges do not adversely impact drainage patterns downstream. The ultimate future build-out design of the tributary areas was analyzed to ensure the sizing of the pond would be adequate after development of Meridian Ranch is complete. This SCS calculation can be found in the appendix.

An analysis of the SCS calculations show the development of Rolling Hills Ranch North and the discharge flow rates from the existing Pond G do not adversely impact the downstream drainage patterns. No additional improvements or modifications are necessary to this pond as a result of the grading operations nor the full buildout of Rolling Hills Ranch North. Table 6 provides summary data for the various design storms for the completed development for all areas tributary to Pond G including Rolling Hills Ranch North.

Table 6: Existing Pond G Summary Data

POND G				
	PEAK INFLOW	PEAK OUTFLOW	PEAK STORAGE	PEAK ELEVATION
	CFS	CFS	AC-FT	FT
GRADED CONDITIONS				
2-YEAR STORM	17	4.4	3.9	7026.4
5-YEAR STORM	62	15	8.0	7027.3
10-YEAR STORM	127	40	10.5	7027.8
50-YEAR STORM	412	275	19.5	7029.3
100-YEAR STORM	625	442	24.3	7030.1
FUTURE CONDITIONS				
2-YEAR STORM	47	5.3	5.7	7026.9
5-YEAR STORM	108	21	8.9	7027.5
10-YEAR STORM	187	52	11.5	7028.0
50-YEAR STORM	477	293	20.1	7029.4
100-YEAR STORM	663	450	24.9	7030.2

Water quality (WQCV) was added to the required storage volume when the pond was designed and constructed in 2021. The pond was constructed to meet the final build-out condition. The WQCV of 0.9 ac-ft. was added to the detention of the minor storm and half (0.45 ac-ft.) was added to the detention volume of the major storm. This was accomplished with respect to the HEC-HMS computer run by providing a starting detention volume of 2.2 ft. for the 5-year storm and 1.8 ft. for the 100-year

storm. The resulting storage elevations for the various design storms remain well below the emergency spillway elevation. See Appendix B for more information.

The WQCV was calculated by using the equations found in Volume 2, of the Drainage Criteria Manual (DCM). The release rate from the WQCV is generally very small, which helps minimize downstream impacts. Detaining the WQCV also serves to cleanse the “first flush” of runoff from the higher initial concentration of sediment and pollutants by allowing for settlement to occur. This greatly improves the quality of runoff, leaving the facility and reduces the potential for erosion. The positive impact on water quality is expected to be significant, particularly during the construction phase of the development.

Downstream Analysis

The outlet (DP G12) for Pond G is located west of the Falcon Regional Park, upstream of Eastonville Rd (DP G06). Pond G will discharge 442 CFS during the 100-yr storm event into an existing natural drainage course that traverses the regional park. The 100-year historical peak flow rate at the western boundary of the regional park is 536 CFS. The calculated 100-year developed flow rate will be 82% of the historic flow rate. The developed peak flow rate for the full spectrum of design storms are calculated to be below that of the corresponding historic peak flow rates. See Table 7 for a complete comparative list of the peak flow rates for the key design points impacted by the development of Rolling Hills Ranch.

Table 7: Key Design Point Comparison - SCS

MERIDIAN RANCH DISCHARGE KEY DESIGN POINTS					
Graded Conditions		Peak Discharge Q100 (CFS)	Peak Discharge Q50 (CFS)	Peak Discharge Q10 (CFS)	Peak Discharge Q5 (CFS)
G12 - DISCHARGE POINT AT REGIONAL PARK (G05 - HISTORIC)	Historic	536	350	84	30
	Graded	442	275	40	15
	% of Historic	82%	79%	48%	50%
G06 - EASTONVILLE ROAD ¹	Historic	551	369	88	32
	Graded	466	288	43	16
	% of Historic	85%	78%	48%	51%
G14 - DISCHARGE POINT AT REGIONAL PARK (G07 - HISTORIC)	Historic	38	25	5.8	2.2
	Graded	35	23	5.6	2.2
	% of Historic	94%	94%	97%	100%
G16 - EASTONVILLE ROAD ¹	Historic	116	77	18	6.8
	Graded	114	74	17	6.6
	% of Historic	98%	96%	93%	97%

¹ Flow rate at Eastonville Rd. listed for reference only

MERIDIAN RANCH DISCHARGE KEY DESIGN POINTS					
Future Conditions		Peak Discharge Q100 (CFS)	Peak Discharge Q50 (CFS)	Peak Discharge Q10 (CFS)	Peak Discharge Q5 (CFS)
G12 - DISCHARGE POINT AT REGIONAL PARK (G05 - HISTORIC)	Historic	536	350	84	30
	Future	450	293	52	21
	% of Historic	84%	84%	62%	68%
G06 - EASTONVILLE ROAD ¹	Historic	551	369	88	32
	Future	491	317	57	22
	% of Historic	89%	86%	65%	71%
G14 - DISCHARGE POINT AT REGIONAL PARK (G07 - HISTORIC)	Historic	38	25	5.8	2.2
	Future	38	25	5.7	2.0
	% of Historic	102%	102%	98%	91%
G16 - EASTONVILLE ROAD ¹	Historic	116	77	18	6.8
	Future	124	81	19	7.8
	% of Historic	106%	106%	103%	114%

¹ Flow rate at Eastonville Rd. listed for reference only

PROPOSED PERMANENT CONSTRUCTION

General Concept

There are several items that are intended to be installed as permanent structures or drainage features with the grading operations. It is understood that these items are subject to review and approval during the final plat processing for project that the structures or features ultimately fall within. The proposed items include improved drainage courses to convey anticipated drainage around and through the future proposed single family final plat projects and storm drainage pipelines to safely convey interim and anticipated future developed storm water drainage flows to the existing Detention Pond G.

A brief description of each structure or feature is provided below with more detailed information and calculations to be provided with the Final Drainage Report with the respective final plat processing.

Various Improved Drainage Courses/Swales

Two existing natural drainage courses exist that convey runoff from Latigo Trails located adjacent to and north of Meridian Ranch. One is labeled as the center channel divided into north and south sections as created by a future residential street to be constructed north of Rex Road. The second drainage course is located near the northeastern corner of the project that will be constructed to redirect the stormwater runoff around the future proposed subdivision and discharge the flow into the same natural drainage course at near the same historic flow rates. A swale is proposed along the eastern boundary with the regional park south of Rex Road that will minor stormwater runoff from rear lots to the existing Pond G.

The northeastern drainage course will convey stormwater runoff from the Latigo Trails off-site basin OS09b around the future Rolling Hills Ranch North Filing 2 to DP G14 at a point in the same natural drainage course near the common boundary with the Falcon Regional Park. The anticipated future 100-year flow rate to DP G14 will approximate the historic flow rate of nearly 40 CFS. The discharge point onto the regional park will be shaped to blend into the natural channel. No rip-rap is proposed as the future flow is anticipated to be less than historic.

The center channel is located between Latigo Trails off-site basin OS09a and design points G9a and G9b. The anticipated future developed 100-year flow rates for the center channel will be roughly 100 CFS between Latigo Trails and DP G9a and roughly 170 CFS between DP G9a and DP G9b. The channel is designed to convey the development safely to the future Rex Road where it will be collected and conveyed downstream.

The proposed swale along the eastern portion of the future Sanctuary Filing 1 at Meridian Ranch to be located south of Rex Road will convey minor flows from rear yards to the existing Pond G. The anticipated 100-year flow rate will range in value from 5.8 CFS on the north-south segment and 9.6 CFS along the southwesterly draining portion of the swale.

See Appendices E & H, drainage maps and plans for hydraulic analysis and more information.

Water Quality Structure at DP9b

A permanent Water Quality Structure will be installed at Design Point G9b on the north side of future Rex Road where 54" RCP will convey the developed flow southerly to a natural sandy bottom dry drainage course. The water quality structure will be a Type D inlet modified with a face plate and micro pool to provide first flush cleansing for minor storm events of less than 2-year frequency. The modified Type D inlet and 54" RCP will safely convey the anticipated 100-year flow from the developed areas of Rolling Hills Ranch North to the natural sandy bottomed channel. There will be sufficient volume upstream to allow for the head buildup for the inlet to safely accept a storm event larger than 100-year. Should the inlet and storm drainage pipe become blocked, the runoff will cross Rex Road and will be safely conveyed overland in a broad trapezoidal channel from Rex Road to the natural sandy bottom channel.

A pond maintenance agreement, easement and operations manual will be processed with the grading project. See Appendices D, F, & H, drainage maps and plans for calculations and more information.

Permanent Storm Drainage Pipes

Two segments of storm drainage pipes are proposed with the grading project. A 54" CMP is proposed from the above-mentioned Water Quality Structure located at DP G9b to DP G10 and another 54" is proposed from Temporary Sedimentation Basin 5 to existing Pond G.

The storm drain pipe from DP G9b is a 54" RCP and is roughly 620 feet long, having a capacity of 190 CFS and will convey 160 CFS at roughly 13 FPS. The final hydraulics will be provided with the Sanctuary Filing 1 at Meridian Ranch Final Drainage Report.

The 54" RCP storm drain pipe located at the outlet of the temporary sedimentation basin near Pond G. The outlet temporary sedimentation basin will have a 60" CMP riser that will serve as the water quality structure and the open end to the riser will provide emergency overflow capacity. The 54" RCP will be connected to the 60" CMP riser while the temporary sedimentation basin is in use. When the temporary sedimentation basin is no longer needed, the storm drain system for the Sanctuary at Meridian Ranch with a pair of sump inlets will be connected to the 54" RCP. The future flow through the 54" RCP for the 100-year storm event will approximate 170 CFS. The final hydraulics will be provided with the Sanctuary Filing 1 at Meridian Ranch Final Drainage Report.

See Appendices C & F, drainage maps and plans for calculations and more information.

EROSION CONTROL DESIGN

General Concept

Historically, erosion on this property has been held to a minimum by a variety of natural features and agricultural practices including:

- Substantial prairie grass growth
- Construction of drainage arresting berms
- Construction of multiple stock ponds along drainage courses

Existing temporary sediment ponds will also help to minimize erosion by reducing both the volume and velocity of the peak runoff.

During construction, best management practices (BMP) for erosion control will be employed based on El Paso County Criteria. BMP's will be utilized as deemed necessary by the contractor and/or engineer and are not limited to the measures shown on the construction drawing set. The contractor shall minimize the amount of area disturbed during all construction activities.

In general the following shall be applied in developing the sequence of major activities:

- Install down-slope and side-slope perimeter BMP's before the land disturbing activity occurs.
- Do not disturb an area until it is necessary for the construction activity to proceed
- Cover or stabilize as soon as possible.
- Time the construction activities to reduce the impacts from seasonal climatic changes or weather events.
- The construction of filtration BMP's should wait until the end of the construction project when upstream drainage areas have been stabilized.
- Do not remove the temporary perimeter controls until after all upstream areas are stabilized.

Four Step Process

The following four step process is recommended for selecting structural BMP's in developing urban areas:

Step 1: Employ Runoff Reduction Practices

This development incorporates wider rights-of-way than other developments, thus decreasing the amount area devoted to pavement. The rights-of-way within Meridian Ranch are 20% wider, 60 ft. instead of 50 ft., creating more landscaped area within the development.

More than 20% of the project has open space, creating a lower density development.

Homeowners and builders are encouraged to direct roof drains to the sideyards where the runoff will travel overland to the streets and creating an opportunity to allow the runoff to infiltrate into the ground.

Step 2: Stabilize Drainageways

The drainage swales located within the project are designed to have a wide flat bottom and slope reducing the velocity of the concentrated flow traveling along the drainageway. The construction of the swale also included erosion control mat along most of the length of the various swales. Straw logs or rip-rip have been incorporated at steeper sections of the swales to reduce velocities and erosion.

A natural arroyo drainage course exists adjacent to the project near the southwest side. This natural sandy bottom arroyo will readily infiltrate runoff during lower intensity, more frequent rain events; decreasing the total stormwater volume leaving the sight.

Step 3: Provide Water Quality Capture Volume (WQCV)

An existing extended detention pond with water quality capture volume is located to the south of the project that was designed to accommodate the runoff from this development.

The project includes a proposed Water Quality Control Structure north of Rex Road. The structure is of sufficient size to accommodate the runoff from portions of the project north of Rex Road.

Step 4: Consider Need for Industrial and Commercial BMP's

This project is neither industrial nor commercial and therefore this section does not apply.

The measures from Steps 1, 2, & 3 incorporated into the design of the project work together to promote greater infiltration rates and reduce the total volume of storm runoff from the project. A key component of the design is the overland sheet flow directed toward the drainage swales, this allows the runoff to move across the land at a lower rate and increase the likelihood of infiltration. By directing the runoff toward the sandy bottom arroyo, the water has increased chances to infiltrate. By providing a regional water quality facility the design provides greater flexibility to direct the runoff to natural swales to convey to the facility as opposed to conveyance through storm drain pipe.

Temporary Sedimentation Pond

Temporary sedimentation ponds installed during the overlot grading process will act as the primary water quality control for the areas upstream during construction. Runoff will travel overland toward the existing sedimentation ponds, collected and diverted into the proposed storm drain system and discharged into existing downstream systems. The pond will provide initial sediment control over exposed upstream areas.

Detention Pond

The existing detention pond will act as the primary water quality control for the areas within the project boundaries. Runoff will travel overland toward the natural drainage swales or be collected by the proposed storm drainage system and diverted into the detention pond where practical. The pond will serve a dual purpose: first, by facilitating the settling of sediment in runoff during and after construction (by means of the WQCV) and, second, by maintaining runoff at or below existing levels.

Silt Fence

Silt fence will be placed along downstream limits of disturbed areas. This will prevent suspended sediment from leaving the site during infrastructure construction. Silt fencing is to remain in place until vegetation is reestablished.

Erosion Bales

Erosion bales will be placed ten (10) feet from the inlet of all culverts during construction to prevent culverts from filling with sediment. Erosion bales will remain in place until vegetation is reestablished. Erosion bale checks will be used on slopes greater than 1 percent to reduce flow velocities until vegetation is reestablished.

Miscellaneous

Best erosion control practices will be utilized as deemed necessary by the Contractor or Engineer and are not limited to the measures described above.

REFERENCES

1. “City of Colorado Springs/El Paso County Drainage Criteria Manual” September 1987, Revised November 1991, Revised October 1994.
2. Chapter 6, Hydrology and Chapter 11, Storage, Section 3.2.1 of the “City of Colorado Springs Drainage Criteria Manual” May 2014.
3. “Volume 2, El Paso County/City of Colorado Springs Drainage Criteria Manual- Stormwater Quality Policies, Procedures and Best Management Practices” November 1, 2002.
4. Flood Insurance Rate Study for El Paso County, Colorado and Incorporated Areas. Federal Emergency Management Agency, Revised March 17, 1997.
5. Soils Survey of El Paso County area, Natural Resources Conservation Services of Colorado.
6. Master Development Drainage Plan Meridian Ranch. August 2000. Prepared by URS Corp.
7. Revision to Master Development Drainage Plan Meridian Ranch. July 2021. Prepared by Tech Contractors.
8. Master Development Drainage Plan Latigo Trails. October 2001. Prepared by URS Corp.
9. Final Drainage Report for Estates at Rolling Hills Ranch Filing 2. September 2020. Prepared by Tech Contractors.
10. Final Drainage Report for Rolling Hills Ranch Filing 2. November 2020. Prepared by Tech Contractors.
11. Final Drainage Report for Rolling Hills Ranch Filing 3. May 2021. Prepared by Tech Contractors.

Appendices

Appendix A - HEC-HMS Data

Input Data

Rolling Hills Ranch North Grading

BASIN	AREA		CURVE NO.	LAG TIME (min)
	(acre)	(mi ²)		
HISTORIC				
OS05	37	0.0578	61.0	15.2
OS06	84	0.1313	61.0	18.7
OS07	21	0.0328	63.1	15.4
OS08	26	0.0406	65.7	15.9
OS09	98	0.1527	65.0	29.5
HG01	35	0.0547	61.0	19.6
HG02	58	0.0906	61.0	25.4
HG03	117	0.1828	61.1	33.8
HG04	57	0.0891	61.0	30.7
HG05	72	0.1125	61.0	31.8
HG06A	88	0.1375	61.0	43.2
HG06B	66	0.1031	61.0	49.5
HG07	63	0.0984	61.0	28.3
HG08	85	0.1328	61.0	22.9
HG09	114	0.1781	61.0	35.6
HG10	88	0.1375	61.0	61.4
HG11	131	0.2047	61.0	40.4
HG12	83	0.1297	61.0	32.0
HG13	54	0.0844	63.1	21.2
HG14	147	0.2297	61.0	45.1
HG15	164	0.2563	61.0	65.1
HG18	21	0.0328	61.0	14.1
HG19	3	0.0047	61.0	6.1
HG20	1	0.0016	61.0	6.9
HG21	14	0.0219	61.0	13.8

BASIN	AREA		CURVE NO.	LAG TIME (min)
	(acre)	(mi ²)		
GRADED				
OS05	37	0.0578	61.0	15.2
OS06	84	0.1313	61.0	18.7
OS07ab	11	0.0170	61.0	13.9
OS07c	10	0.0158	61.0	10.9
OS07d	2	0.0036	61.0	13.1
OS08a	30	0.0469	61.4	19.0
OS08b	75	0.1167	64.4	25.6
OS09a	18	0.0279	62.2	21.0
OS09b	46	0.0711	61.2	37.7
FG01	34	0.0538	66.4	33.8
FG02	25	0.0391	64.6	16.1
FG03	13	0.0203	68.0	11.6
FG04	11	0.0172	68.0	7.6
FG05	37	0.0580	70.1	28.4
FG06	43	0.0675	66.1	18.4
FG21a	6	0.0095	62.6	21.4
FG21b	10	0.0150	73.1	12.7
FG22	90	0.1400	68.8	20.3
FG23a	14	0.0216	68.6	18.0
FG23b	15	0.0235	62.5	15.0
FG23c	7	0.0109	65.4	12.1
FG24a	23	0.0359	63.1	21.9
FG24b	38	0.0589	67.3	26.6
FG24c	19	0.0291	67.0	18.1
FG24d	20	0.0307	64.9	19.2
FG25	69	0.1084	74.1	23.8
FG26	36	0.0570	66.9	20.9
FG27	43	0.0679	66.6	31.0
FG28	12	0.0184	64.3	14.8
FG29	63	0.0982	61.2	19.1
FG32	26	0.0402	61.0	23.9
FG34	18	0.0275	62.6	17.0
FG35	18	0.0282	61.7	14.2
FG36	18	0.0286	65.9	24.2
FG37	51	0.0797	63.5	20.2

BASIN	AREA		CURVE NO.	LAG TIME (min)
	(acre)	(mi ²)		
FUTURE				
OS05	37	0.0578	61.0	15.2
OS06	84	0.1313	61.0	18.7
OS07ab	11	0.0170	61.0	13.9
OS07c	19	0.0296	61.0	17.4
OS07d	2.2	0.0034	61.0	13.1
OS08a	16	0.0251	61.0	16.7
OS08b	11	0.0165	61.0	20.3
OS09a	5.9	0.0093	61.0	20.9
OS09b	28	0.0435	61.0	24.3
FG01	34	0.0538	66.4	33.8
FG02	25	0.0391	64.6	16.1
FG03	13	0.0203	68.0	11.6
FG04	11	0.0172	68.0	7.6
FG05	37	0.0580	70.1	28.4
FG06	43	0.0675	66.1	18.4
FG21a	6.1	0.0095	62.6	21.4
FG21b	10	0.0150	73.1	12.7
FG22	87	0.1354	69.0	20.3
FG23a	14	0.0216	68.6	18.0
FG23b	15	0.0236	61.8	15.0
FG23c	7.0	0.0109	65.2	12.1
FG24a	22	0.0348	64.3	21.9
FG24b	38	0.0589	73.4	14.5
FG24c	19	0.0291	75.0	14.7
FG24d	17	0.0262	76.4	13.9
FG25	69	0.1084	74.1	23.8
FG26	36	0.0570	78.0	25.5
FG27	43	0.0679	83.3	22.1
FG28	12	0.0184	64.1	14.8
FG29	63	0.0983	61.2	19.1
FG32	26	0.0402	80.0	23.9
FG34	18	0.0275	63.7	22.1
FG35	18	0.0282	65.5	14.2
FG36	18	0.0286	65.9	24.2
FG37	51	0.0797	63.5	20.2



POINT PRECIPITATION FREQUENCY ESTIMATES

Sanja Perica, Deborah Martin, Sandra Pavlovic, Ishani Roy, Michael St. Laurent, Carl Trypaluk,
 Dale Unruh, Michael Yekta, Geoffery Bonnin

NOAA, National Weather Service, Silver Spring, Maryland

[PF_tabular](#) | [PF_graphical](#) | [Maps & aeriels](#)

PF tabular

PDS-based point precipitation frequency estimates with 90% confidence intervals (in inches)¹										
Duration	Average recurrence interval (years)									
	1	2	5	10	25	50	100	200	500	1000
5-min	0.239 (0.190-0.301)	0.291 (0.232-0.367)	0.381 (0.302-0.482)	0.460 (0.363-0.585)	0.576 (0.442-0.764)	0.670 (0.501-0.899)	0.770 (0.556-1.06)	0.875 (0.606-1.23)	1.02 (0.680-1.48)	1.14 (0.737-1.66)
10-min	0.349 (0.278-0.441)	0.426 (0.339-0.538)	0.558 (0.443-0.706)	0.674 (0.532-0.857)	0.843 (0.647-1.12)	0.982 (0.734-1.32)	1.13 (0.814-1.55)	1.28 (0.888-1.80)	1.50 (0.996-2.16)	1.67 (1.08-2.44)
15-min	0.426 (0.340-0.538)	0.519 (0.413-0.656)	0.680 (0.540-0.861)	0.822 (0.648-1.04)	1.03 (0.789-1.36)	1.20 (0.895-1.61)	1.37 (0.993-1.89)	1.56 (1.08-2.20)	1.82 (1.22-2.64)	2.03 (1.31-2.97)
30-min	0.608 (0.485-0.768)	0.741 (0.590-0.936)	0.969 (0.769-1.23)	1.17 (0.923-1.49)	1.46 (1.12-1.94)	1.70 (1.27-2.28)	1.95 (1.41-2.68)	2.21 (1.53-3.12)	2.58 (1.72-3.73)	2.87 (1.86-4.20)
60-min	0.778 (0.620-0.982)	0.934 (0.744-1.18)	1.21 (0.962-1.54)	1.47 (1.16-1.86)	1.84 (1.42-2.46)	2.16 (1.62-2.91)	2.50 (1.81-3.44)	2.87 (1.99-4.05)	3.38 (2.26-4.91)	3.80 (2.46-5.56)
2-hr	0.948 (0.762-1.19)	1.13 (0.905-1.41)	1.46 (1.16-1.83)	1.76 (1.40-2.22)	2.23 (1.73-2.96)	2.62 (1.99-3.51)	3.05 (2.23-4.18)	3.52 (2.47-4.95)	4.19 (2.82-6.04)	4.73 (3.09-6.87)
3-hr	1.04 (0.839-1.29)	1.22 (0.986-1.52)	1.57 (1.26-1.96)	1.90 (1.51-2.38)	2.41 (1.90-3.21)	2.86 (2.18-3.83)	3.35 (2.47-4.59)	3.90 (2.75-5.47)	4.68 (3.18-6.75)	5.33 (3.50-7.71)
6-hr	1.21 (0.980-1.49)	1.40 (1.14-1.73)	1.78 (1.44-2.21)	2.16 (1.74-2.68)	2.76 (2.19-3.65)	3.29 (2.53-4.38)	3.88 (2.88-5.28)	4.53 (3.23-6.34)	5.49 (3.76-7.88)	6.29 (4.17-9.04)
12-hr	1.39 (1.14-1.70)	1.62 (1.33-1.98)	2.06 (1.68-2.53)	2.48 (2.02-3.06)	3.16 (2.53-4.14)	3.76 (2.92-4.96)	4.42 (3.31-5.97)	5.15 (3.70-7.14)	6.22 (4.30-8.85)	7.10 (4.75-10.1)
24-hr	1.61 (1.33-1.95)	1.88 (1.55-2.29)	2.39 (1.97-2.92)	2.88 (2.35-3.52)	3.63 (2.91-4.69)	4.27 (3.34-5.58)	4.98 (3.75-6.66)	5.75 (4.17-7.90)	6.87 (4.78-9.70)	7.79 (5.25-11.1)
2-day	1.86 (1.55-2.24)	2.19 (1.83-2.64)	2.79 (2.31-3.36)	3.33 (2.75-4.04)	4.15 (3.35-5.30)	4.85 (3.81-6.25)	5.59 (4.25-7.39)	6.40 (4.67-8.70)	7.55 (5.30-10.6)	8.49 (5.77-12.0)
3-day	2.04 (1.71-2.45)	2.41 (2.01-2.88)	3.05 (2.54-3.66)	3.63 (3.01-4.38)	4.51 (3.65-5.71)	5.24 (4.14-6.72)	6.03 (4.59-7.92)	6.87 (5.03-9.29)	8.07 (5.69-11.2)	9.04 (6.18-12.7)
4-day	2.20 (1.85-2.62)	2.58 (2.16-3.08)	3.25 (2.72-3.89)	3.86 (3.21-4.63)	4.77 (3.87-6.01)	5.53 (4.38-7.06)	6.34 (4.85-8.31)	7.22 (5.31-9.73)	8.46 (5.98-11.7)	9.46 (6.50-13.2)
7-day	2.60 (2.20-3.08)	3.00 (2.54-3.56)	3.71 (3.13-4.41)	4.36 (3.65-5.20)	5.33 (4.36-6.67)	6.14 (4.89-7.78)	7.00 (5.40-9.11)	7.93 (5.87-10.6)	9.26 (6.59-12.8)	10.3 (7.14-14.4)
10-day	2.96 (2.51-3.48)	3.39 (2.88-4.00)	4.16 (3.52-4.92)	4.85 (4.08-5.76)	5.88 (4.82-7.31)	6.73 (5.38-8.48)	7.63 (5.91-9.88)	8.61 (6.39-11.5)	9.97 (7.13-13.7)	11.1 (7.70-15.4)
20-day	3.95 (3.38-4.61)	4.55 (3.89-5.32)	5.57 (4.75-6.52)	6.44 (5.46-7.58)	7.68 (6.32-9.39)	8.67 (6.97-10.8)	9.69 (7.54-12.4)	10.8 (8.04-14.1)	12.2 (8.79-16.6)	13.3 (9.36-18.4)
30-day	4.75 (4.09-5.51)	5.49 (4.72-6.38)	6.70 (5.74-7.81)	7.72 (6.58-9.04)	9.12 (7.52-11.1)	10.2 (8.24-12.6)	11.3 (8.83-14.3)	12.4 (9.32-16.2)	13.9 (10.1-18.7)	15.0 (10.6-20.6)
45-day	5.73 (4.96-6.62)	6.62 (5.72-7.65)	8.05 (6.93-9.33)	9.21 (7.89-10.7)	10.8 (8.91-12.9)	12.0 (9.68-14.6)	13.1 (10.3-16.5)	14.3 (10.7-18.5)	15.8 (11.4-21.1)	16.9 (12.0-23.0)
60-day	6.56 (5.70-7.55)	7.55 (6.55-8.69)	9.12 (7.88-10.5)	10.4 (8.92-12.0)	12.1 (9.98-14.4)	13.3 (10.8-16.1)	14.5 (11.4-18.1)	15.6 (11.8-20.2)	17.1 (12.5-22.8)	18.2 (12.9-24.8)

¹ Precipitation frequency (PF) estimates in this table are based on frequency analysis of partial duration series (PDS).

Numbers in parenthesis are PF estimates at lower and upper bounds of the 90% confidence interval. The probability that precipitation frequency estimates (for a given duration and average recurrence interval) will be greater than the upper bound (or less than the lower bound) is 5%. Estimates at upper bounds are not checked against probable maximum precipitation (PMP) estimates and may be higher than currently valid PMP values.

Please refer to NOAA Atlas 14 document for more information.

HISTORIC SCS (100-YEAR)				
HYDROLOGIC ELEMENT	DRAINAGE AREA (SQ. MI.)	DISCHARGE PEAK Q100 (CFS)	TIME OF PEAK	TOTAL VOLUME Q100 (AC. FT.)
OS06	0.1313	80	01Jul2015, 12:12	9.3
OS06-G02	0.1313	77	01Jul2015, 12:24	9.2
OS05	0.0578	39	01Jul2015, 12:12	4.1
OS05-G01	0.0578	38	01Jul2015, 12:12	4.1
HG01	0.0547	32	01Jul2015, 12:12	3.9
G01	0.1125	70	01Jul2015, 12:12	7.9
G01-G02	0.1125	68	01Jul2015, 12:24	7.8
HG02	0.0906	45	01Jul2015, 12:24	6.4
G02	0.3344	191	01Jul2015, 12:24	23
G02-G03	0.3344	190	01Jul2015, 12:30	23
HG03	0.1828	77	01Jul2015, 12:30	13
OS07	0.0328	25	01Jul2015, 12:12	2.6
OS07-G03	0.0328	24	01Jul2015, 12:30	2.5
G03	0.5500	291	01Jul2015, 12:30	38
G03-G04	0.5500	281	01Jul2015, 12:30	38
OS09	0.1547	91	01Jul2015, 12:24	13
OS09-G04	0.1547	90	01Jul2015, 12:30	13
HG04	0.0891	40	01Jul2015, 12:30	6.3
HG05	0.1125	49	01Jul2015, 12:30	7.9
OS08	0.0406	35	01Jul2015, 12:12	3.6
OS08-G04	0.0406	34	01Jul2015, 12:30	3.5
G04	0.9469	493	01Jul2015, 12:30	69
G04-G05	0.9469	488	01Jul2015, 12:36	68
HG06A	0.1375	49	01Jul2015, 12:42	9.6
G05	1.0844	536	01Jul2015, 12:36	78
G05-G06	1.0844	520	01Jul2015, 12:36	78
HG06B	0.1031	33	01Jul2015, 12:48	7.2
G06	1.1875	551	01Jul2015, 12:42	85
HG14	0.2297	79	01Jul2015, 12:42	16
HG13	0.0844	54	01Jul2015, 12:18	6.6
G07	0.0844	54	01Jul2015, 12:18	6.6
G07-G08	0.0844	53	01Jul2015, 12:18	6.6
G16	0.3141	117	01Jul2015, 12:30	23

Highlighted green rows reference key design points (Typical all charts this section)

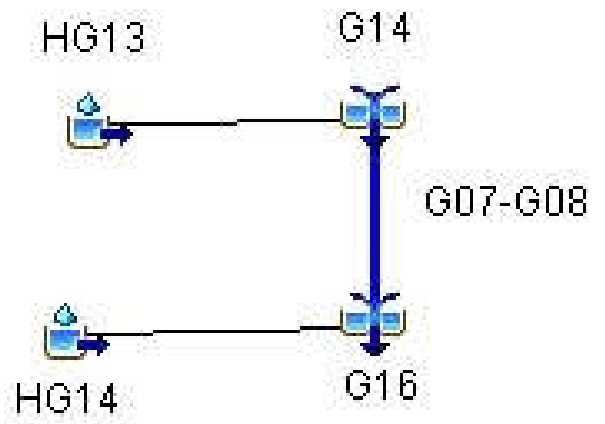
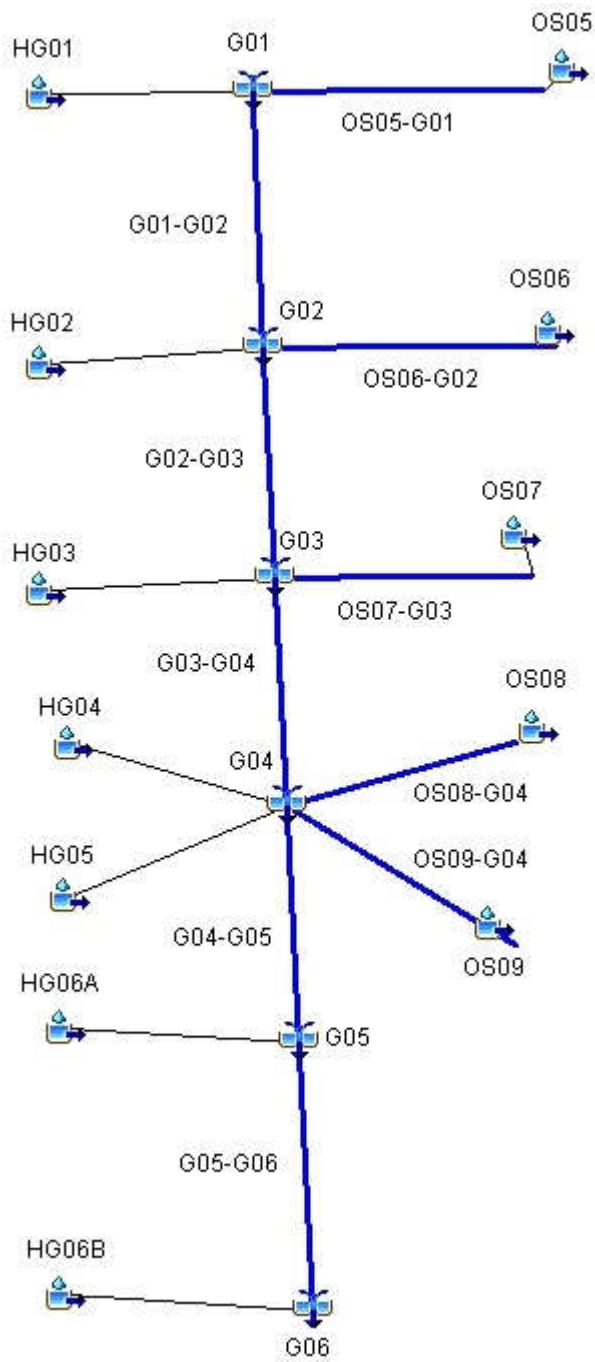

HISTORIC SCS (50-YEAR)				
HYDROLOGIC ELEMENT	DRAINAGE AREA (SQ. MI.)	DISCHARGE PEAK Q50 (CFS)	TIME OF PEAK	TOTAL VOLUME Q50 (AC. FT.)
OS06	0.1313	52	01Jul2015, 12:12	6.5
OS06-G02	0.1313	52	01Jul2015, 12:24	6.4
OS05	0.0578	26	01Jul2015, 12:12	2.9
OS05-G01	0.0578	25	01Jul2015, 12:18	2.9
HG01	0.0547	21	01Jul2015, 12:18	2.7
G01	0.1125	46	01Jul2015, 12:18	5.6
G01-G02	0.1125	46	01Jul2015, 12:24	5.5
HG02	0.0906	30	01Jul2015, 12:24	4.5
G02	0.3344	127	01Jul2015, 12:24	16
G02-G03	0.3344	125	01Jul2015, 12:30	16
HG03	0.1828	51	01Jul2015, 12:30	9.1
OS07	0.0328	17	01Jul2015, 12:12	1.9
OS07-G03	0.0328	17	01Jul2015, 12:30	1.8
G03	0.5500	192	01Jul2015, 12:30	27
G03-G04	0.5500	189	01Jul2015, 12:36	27
OS09	0.1547	63	01Jul2015, 12:24	9.6
OS09-G04	0.1547	62	01Jul2015, 12:36	9.4
HG04	0.0891	26	01Jul2015, 12:30	4.4
HG05	0.1125	32	01Jul2015, 12:30	5.6
OS08	0.0406	25	01Jul2015, 12:12	2.6
OS08-G04	0.0406	24	01Jul2015, 12:36	2.5
G04	0.9469	332	01Jul2015, 12:36	49
G04-G05	0.9469	318	01Jul2015, 12:42	48
HG06A	0.1375	32	01Jul2015, 12:42	6.7
G05	1.0844	350	01Jul2015, 12:42	55
G05-G06	1.0844	348	01Jul2015, 12:42	55
HG06B	0.1031	22	01Jul2015, 12:54	5.0
G06	1.1875	369	01Jul2015, 12:42	60
HG14	0.2297	52	01Jul2015, 12:48	11
HG13	0.0844	37	01Jul2015, 12:18	4.7
G07	0.0844	37	01Jul2015, 12:18	4.7
G07-G08	0.0844	36	01Jul2015, 12:24	4.7
G16	0.3141	77	01Jul2015, 12:30	16

Highlighted green rows reference key design points (Typical all charts this section)

HISTORIC SCS (10-YEAR)				
HYDROLOGIC ELEMENT	DRAINAGE AREA (SQ. MI.)	DISCHARGE PEAK Q10 (CFS)	TIME OF PEAK	TOTAL VOLUME Q10 (AC. FT.)
OS06	0.1313	12	01Jul2015, 12:18	2.2
OS06-G02	0.1313	11	01Jul2015, 12:30	2.1
OS05	0.0578	5.6	01Jul2015, 12:12	1.0
OS05-G01	0.0578	5.5	01Jul2015, 12:24	0.9
HG01	0.0547	4.7	01Jul2015, 12:18	0.9
G01	0.1125	10	01Jul2015, 12:24	1.9
G01-G02	0.1125	9.9	01Jul2015, 12:36	1.8
HG02	0.0906	6.7	01Jul2015, 12:30	1.5
G02	0.3344	27	01Jul2015, 12:36	5.4
G02-G03	0.3344	27	01Jul2015, 12:48	5.3
HG03	0.1828	12	01Jul2015, 12:42	3.0
OS07	0.0328	4.5	01Jul2015, 12:12	0.7
OS07-G03	0.0328	4.3	01Jul2015, 12:48	0.7
G03	0.5500	42	01Jul2015, 12:48	8.9
G03-G04	0.5500	42	01Jul2015, 12:54	8.8
OS09	0.1547	19	01Jul2015, 12:30	3.6
OS09-G04	0.1547	18	01Jul2015, 12:42	3.5
HG04	0.0891	5.9	01Jul2015, 12:36	1.5
HG05	0.1125	7.4	01Jul2015, 12:36	1.8
OS08	0.0406	7.7	01Jul2015, 12:12	1.0
OS08-G04	0.0406	7.4	01Jul2015, 12:48	1.0
G04	0.9469	76	01Jul2015, 12:54	17
G04-G05	0.9469	76	01Jul2015, 12:54	16
HG06A	0.1375	7.6	01Jul2015, 12:54	2.2
G05	1.0844	84	01Jul2015, 12:54	19
G05-G06	1.0844	83	01Jul2015, 13:00	19
HG06B	0.1031	5.3	01Jul2015, 13:00	1.7
G06	1.1875	88	01Jul2015, 13:00	20
HG14	0.2297	12	01Jul2015, 12:54	3.7
HG13	0.0844	9.5	01Jul2015, 12:18	1.7
G07	0.0844	9.5	01Jul2015, 12:18	1.7
G07-G08	0.0844	9.4	01Jul2015, 12:30	1.7
G16	0.3141	19	01Jul2015, 12:36	5.4

Highlighted green rows reference key design points (Typical all charts this section)

HISTORIC SCS (5-YEAR)				
HYDROLOGIC ELEMENT	DRAINAGE AREA (SQ. MI.)	DISCHARGE PEAK Q5 (CFS)	TIME OF PEAK	TOTAL VOLUME Q5 (AC. FT.)
OS06	0.1313	3.8	01Jul2015, 12:24	1.1
OS06-G02	0.1313	3.7	01Jul2015, 12:42	1.1
OS05	0.0578	1.8	01Jul2015, 12:18	0.5
OS05-G01	0.0578	1.7	01Jul2015, 12:30	0.5
HG01	0.0547	1.5	01Jul2015, 12:24	0.5
G01	0.1125	3.2	01Jul2015, 12:30	1.0
G01-G02	0.1125	3.2	01Jul2015, 12:48	0.9
HG02	0.0906	2.3	01Jul2015, 12:36	0.8
G02	0.3344	9.0	01Jul2015, 12:42	2.8
G02-G03	0.3344	9.0	01Jul2015, 13:00	2.7
HG03	0.1828	4.3	01Jul2015, 12:48	1.6
OS07	0.0328	1.7	01Jul2015, 12:18	0.4
OS07-G03	0.0328	1.7	01Jul2015, 13:00	0.4
G03	0.5500	15	01Jul2015, 13:00	4.6
G03-G04	0.5500	14	01Jul2015, 13:12	4.5
OS09	0.1547	8.3	01Jul2015, 12:36	2.1
OS09-G04	0.1547	8.3	01Jul2015, 12:48	2.0
HG04	0.0891	2.1	01Jul2015, 12:42	0.8
HG05	0.1125	2.6	01Jul2015, 12:42	0.9
OS08	0.0406	3.4	01Jul2015, 12:12	0.6
OS08-G04	0.0406	3.4	01Jul2015, 13:00	0.6
G04	0.9469	28	01Jul2015, 13:12	8.7
G04-G05	0.9469	27	01Jul2015, 13:18	8.6
HG06A	0.1375	2.9	01Jul2015, 13:00	1.1
G05	1.0844	30	01Jul2015, 13:18	9.8
G05-G06	1.0844	30	01Jul2015, 13:24	9.6
HG06B	0.1031	2.0	01Jul2015, 13:12	0.9
G06	1.1875	32	01Jul2015, 13:24	10
HG14	0.2297	4.7	01Jul2015, 13:06	1.9
HG13	0.0844	3.8	01Jul2015, 12:24	0.9
G07	0.0844	3.8	01Jul2015, 12:24	0.9
G07-G08	0.0844	3.7	01Jul2015, 12:36	0.9
G16	0.3141	7.4	01Jul2015, 12:54	2.8

Highlighted green rows reference key design points (Typical all charts this section)

HISTORIC SCS (2-YEAR)				
HYDROLOGIC ELEMENT	DRAINAGE AREA (SQ. MI.)	DISCHARGE PEAK Q2 (CFS)	TIME OF PEAK	TOTAL VOLUME Q2 (AC. FT.)
OS06	0.1313	0.5	01Jul2015, 13:30	0.3
OS06-G02	0.1313	0.5	01Jul2015, 14:00	0.3
OS05	0.0578	0.2	01Jul2015, 13:24	0.2
OS05-G01	0.0578	0.2	01Jul2015, 13:42	0.2
HG01	0.0547	0.2	01Jul2015, 13:36	0.1
G01	0.1125	0.5	01Jul2015, 13:36	0.3
G01-G02	0.1125	0.5	01Jul2015, 14:06	0.3
HG02	0.0906	0.4	01Jul2015, 13:42	0.2
G02	0.3344	1.3	01Jul2015, 14:00	0.8
G02-G03	0.3344	1.3	01Jul2015, 14:30	0.8
HG03	0.1828	0.7	01Jul2015, 13:54	0.5
OS07	0.0328	0.3	01Jul2015, 12:54	0.1
OS07-G03	0.0328	0.3	01Jul2015, 14:12	0.1
G03	0.5500	2.3	01Jul2015, 14:24	1.4
G03-G04	0.5500	2.3	01Jul2015, 14:42	1.3
OS09	0.1547	1.9	01Jul2015, 12:54	0.8
OS09-G04	0.1547	1.9	01Jul2015, 13:18	0.8
HG04	0.0891	0.3	01Jul2015, 13:48	0.2
HG05	0.1125	0.4	01Jul2015, 13:54	0.3
OS08	0.0406	0.7	01Jul2015, 12:24	0.2
OS08-G04	0.0406	0.7	01Jul2015, 13:36	0.2
G04	0.9469	4.7	01Jul2015, 14:36	2.8
G04-G05	0.9469	4.7	01Jul2015, 14:48	2.8
HG06A	0.1375	0.5	01Jul2015, 14:12	0.3
G05	1.0844	5.2	01Jul2015, 14:48	3.1
G05-G06	1.0844	5.2	01Jul2015, 15:00	3.0
HG06B	0.1031	0.4	01Jul2015, 14:24	0.3
G06	1.1875	5.5	01Jul2015, 15:00	3.3
HG14	0.2297	0.8	01Jul2015, 14:18	0.6
HG13	0.0844	0.7	01Jul2015, 13:00	0.3
G07	0.0844	0.7	01Jul2015, 13:00	0.3
G07-G08	0.0844	0.6	01Jul2015, 13:18	0.3
G16	0.3141	1.4	01Jul2015, 13:54	0.9

Highlighted green rows reference key design points (Typical all charts this section)

GRADED SCS (100-YEAR)				
HYDROLOGIC ELEMENT	DRAINAGE AREA (SQ. MI.)	PEAK DISCHARGE Q100 (CFS)	TIME OF PEAK	TOTAL VOLUME Q100 (AC. FT.)
OS06	0.1313	80	01Jul2015, 12:12	9.3
G1a	0.1313	80	01Jul2015, 12:12	9.3
G1a-G2	0.1313	79	01Jul2015, 12:18	9.2
OS05	0.0578	39	01Jul2015, 12:12	4.1
OS05-G1	0.0578	39	01Jul2015, 12:12	4.1
FG01	0.0538	31	01Jul2015, 12:30	4.9
FG01-G1	0.0538	31	01Jul2015, 12:30	4.9
G1	0.1116	61	01Jul2015, 12:18	9.0
G1-G2	0.1116	61	01Jul2015, 12:18	9.0
FG02	0.0391	32	01Jul2015, 12:12	3.3
G2	0.2820	167	01Jul2015, 12:18	21
G2-G3	0.2820	163	01Jul2015, 12:18	21
FG03	0.0203	24	01Jul2015, 12:06	2.0
FG04	0.0172	22	01Jul2015, 12:00	1.7
G3	0.3195	185	01Jul2015, 12:18	25
FG06	0.0675	56	01Jul2015, 12:12	6.1
FG05	0.0580	45	01Jul2015, 12:24	6.1
OS07ab	0.0170	12	01Jul2015, 12:06	1.2
OS07ab-POND F	0.0170	12	01Jul2015, 12:18	1.2
POND F IN	0.4620	293	01Jul2015, 12:18	38
POND F	0.4620	178	01Jul2015, 12:42	36
POND F-G7	0.4620	177	01Jul2015, 12:42	36
OS07c	0.0158	13	01Jul2015, 12:06	1.1
OS07c-G4	0.0158	13	01Jul2015, 12:12	1.1
FG21a	0.0095	5.9	01Jul2015, 12:18	0.7
G4	0.0253	19	01Jul2015, 12:12	1.8
G4-G7	0.0253	17	01Jul2015, 12:18	1.8
FG21b	0.0150	21	01Jul2015, 12:06	1.8
G7	0.5023	189	01Jul2015, 12:42	39
G7-G8	0.5023	188	01Jul2015, 12:42	39
FG22	0.1400	124	01Jul2015, 12:12	14
OS08a	0.0469	29	01Jul2015, 12:12	3.4
OS08-G8	0.0469	29	01Jul2015, 12:18	3.4
FG23a	0.0216	21	01Jul2015, 12:12	2.2
OS07d	0.0036	2.6	01Jul2015, 12:06	0.3
OS07d-G8	0.0036	2.6	01Jul2015, 12:12	0.3
G8	0.7144	283	01Jul2015, 12:30	59
G8-G10	0.7144	282	01Jul2015, 12:36	59
OS08b	0.1167	72	01Jul2015, 12:18	9.7
OS08b-G9a	0.1167	71	01Jul2015, 12:30	9.6
FG24b	0.0589	41	01Jul2015, 12:24	5.6
FG24a	0.0359	23	01Jul2015, 12:18	2.8
OS09a	0.0279	17	01Jul2015, 12:18	2.1
OS09a-G9a	0.0279	17	01Jul2015, 12:24	2.1
G9a	0.2394	148	01Jul2015, 12:24	20
G9a-G9b	0.2394	145	01Jul2015, 12:30	20
FG24d	0.0307	23	01Jul2015, 12:12	2.6
FG24c	0.0291	26	01Jul2015, 12:12	2.7
G9b	0.2992	181	01Jul2015, 12:24	25
REX RD WQCV	0.2992	170	01Jul2015, 12:30	25

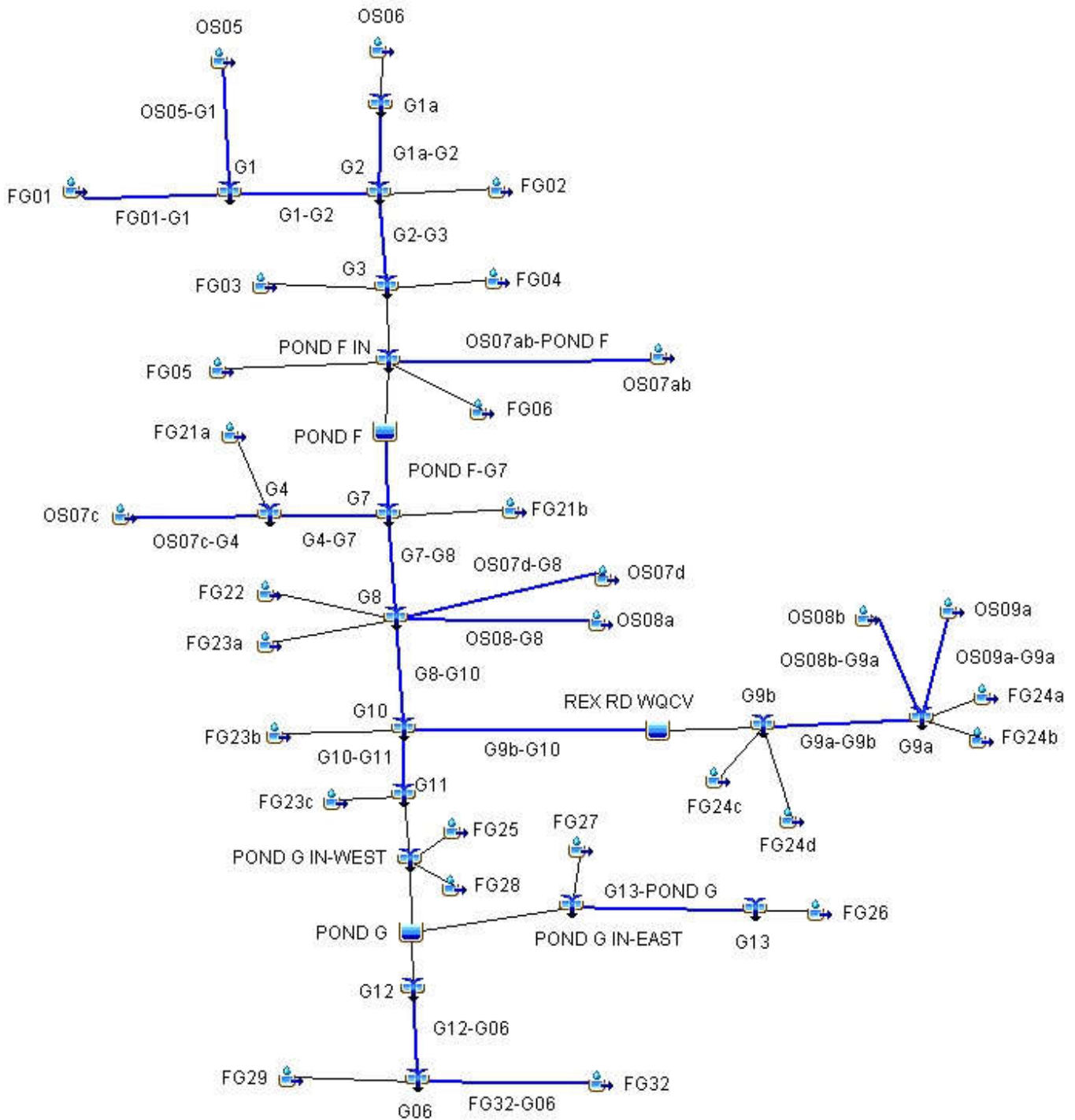

GRADED SCS (100-YEAR)				
HYDROLOGIC ELEMENT	DRAINAGE AREA (SQ. MI.)	PEAK DISCHARGE Q100 (CFS)	TIME OF PEAK	TOTAL VOLUME Q100 (AC. FT.)
G9b-G10	0.2992	169	01Jul2015, 12:30	25
FG23b	0.0235	18	01Jul2015, 12:12	1.8
G10	1.0371	456	01Jul2015, 12:36	85
G10-G11	1.0371	455	01Jul2015, 12:36	85
FG23c	0.0109	11	01Jul2015, 12:06	1.0
G11	1.0480	458	01Jul2015, 12:36	86
FG25	0.1084	111	01Jul2015, 12:18	13
FG28	0.0184	15	01Jul2015, 12:12	1.5
POND G IN-WEST	1.1748	541	01Jul2015, 12:30	101
FG27	0.0679	42	01Jul2015, 12:24	6.2
FG26	0.0570	45	01Jul2015, 12:18	5.3
G13	0.0570	45	01Jul2015, 12:18	5.3
G13-POND G	0.0570	45	01Jul2015, 12:18	5.3
POND G IN-EAST	0.1249	84	01Jul2015, 12:24	11
POND G	1.2997	442	01Jul2015, 12:54	102
G12	1.2997	442	01Jul2015, 12:54	102
G12-G06	1.2997	442	01Jul2015, 13:00	102
FG29	0.0983	60	01Jul2015, 12:12	7.0
FG32	0.0402	21	01Jul2015, 12:18	2.8
FG32-G06	0.0402	21	01Jul2015, 12:24	2.8
G06	1.4382	466	01Jul2015, 13:00	111
OS09b	0.0711	28	01Jul2015, 12:36	5.0
OS09b-G14	0.0711	28	01Jul2015, 12:42	5.0
FG34	0.0275	17	01Jul2015, 12:18	2.1
G14	0.0986	39	01Jul2015, 12:30	7.1
G14-G15	0.0986	39	01Jul2015, 12:36	7.0
FG35	0.0282	20	01Jul2015, 12:12	2.1
G15	0.1268	46	01Jul2015, 12:30	9.1
G15-G16	0.1268	46	01Jul2015, 12:36	9.1
FG37	0.0797	53	01Jul2015, 12:12	6.4
FG36	0.0286	20	01Jul2015, 12:18	2.5
FG36-G16	0.0286	20	01Jul2015, 12:24	2.5
G16	0.2351	109	01Jul2015, 12:24	18

Highlighted green rows reference key design points (Typical all charts this section)

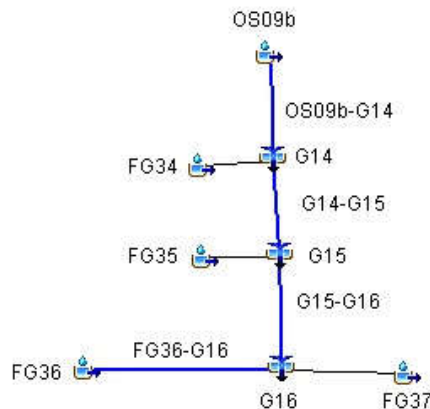

GRADED SCS (50-YEAR)				
HYDROLOGIC ELEMENT	DRAINAGE AREA (SQ. MI.)	PEAK DISCHARGE Q50 (CFS)	TIME OF PEAK	TOTAL VOLUME Q50 (AC. FT.)
OS06	0.1313	52	01Jul2015, 12:12	6.5
G1a	0.1313	52	01Jul2015, 12:12	6.5
G1a-G2	0.1313	52	01Jul2015, 12:18	6.5
OS05	0.0578	26	01Jul2015, 12:12	2.9
OS05-G1	0.0578	25	01Jul2015, 12:12	2.9
FG01	0.0538	22	01Jul2015, 12:30	3.6
FG01-G1	0.0538	22	01Jul2015, 12:30	3.6
G1	0.1116	41	01Jul2015, 12:18	6.4
G1-G2	0.1116	41	01Jul2015, 12:18	6.4
FG02	0.0391	22	01Jul2015, 12:12	2.4
G2	0.2820	112	01Jul2015, 12:18	15
G2-G3	0.2820	108	01Jul2015, 12:24	15
FG03	0.0203	17	01Jul2015, 12:06	1.5
FG04	0.0172	16	01Jul2015, 12:00	1.3
G3	0.3195	123	01Jul2015, 12:18	18
FG06	0.0675	40	01Jul2015, 12:12	4.4
FG05	0.0580	33	01Jul2015, 12:24	4.6
OS07ab	0.0170	7.9	01Jul2015, 12:12	0.9
OS07ab-POND F	0.0170	7.6	01Jul2015, 12:18	0.8
POND F IN	0.4620	200	01Jul2015, 12:18	28
POND F	0.4620	121	01Jul2015, 12:42	26
POND F-G7	0.4620	120	01Jul2015, 12:48	26
OS07c	0.0158	8.6	01Jul2015, 12:06	0.8
OS07c-G4	0.0158	8.2	01Jul2015, 12:12	0.8
FG21a	0.0095	4.0	01Jul2015, 12:18	0.5
G4	0.0253	12	01Jul2015, 12:12	1.3
G4-G7	0.0253	12	01Jul2015, 12:18	1.3
FG21b	0.0150	16	01Jul2015, 12:06	1.4
G7	0.5023	127	01Jul2015, 12:48	28
G7-G8	0.5023	127	01Jul2015, 12:48	28
FG22	0.1400	90	01Jul2015, 12:12	11
OS08a	0.0469	19	01Jul2015, 12:12	2.4
OS08-G8	0.0469	19	01Jul2015, 12:18	2.4
FG23a	0.0216	15	01Jul2015, 12:12	1.6
OS07d	0.0036	1.7	01Jul2015, 12:06	0.2
OS07d-G8	0.0036	1.7	01Jul2015, 12:18	0.2
G8	0.7144	179	01Jul2015, 12:42	43
G8-G10	0.7144	179	01Jul2015, 12:48	42
OS08b	0.1167	49	01Jul2015, 12:24	7.0
OS08b-G9a	0.1167	49	01Jul2015, 12:30	6.9
FG24b	0.0589	30	01Jul2015, 12:24	4.1
FG24a	0.0359	15	01Jul2015, 12:18	2.0
OS09a	0.0279	11	01Jul2015, 12:18	1.5
OS09a-G9a	0.0279	11	01Jul2015, 12:30	1.5
G9a	0.2394	100	01Jul2015, 12:24	14
G9a-G9b	0.2394	100	01Jul2015, 12:30	14
FG24d	0.0307	16	01Jul2015, 12:12	1.9
FG24c	0.0291	18	01Jul2015, 12:12	2.0
G9b	0.2992	122	01Jul2015, 12:24	18
REX RD WQCV	0.2992	122	01Jul2015, 12:30	18

GRADED SCS (50-YEAR)				
HYDROLOGIC ELEMENT	DRAINAGE AREA (SQ. MI.)	PEAK DISCHARGE Q50 (CFS)	TIME OF PEAK	TOTAL VOLUME Q50 (AC. FT.)
G9b-G10	0.2992	121	01Jul2015, 12:30	18
FG23b	0.0235	12	01Jul2015, 12:12	1.3
G10	1.0371	284	01Jul2015, 12:42	62
G10-G11	1.0371	283	01Jul2015, 12:42	61
FG23c	0.0109	7.7	01Jul2015, 12:06	0.7
G11	1.0480	285	01Jul2015, 12:42	62
FG25	0.1084	84	01Jul2015, 12:18	10
FG28	0.0184	11	01Jul2015, 12:12	1.1
POND G IN-WEST	1.1748	352	01Jul2015, 12:24	74
FG27	0.0679	29	01Jul2015, 12:24	4.6
FG26	0.0570	32	01Jul2015, 12:18	3.9
G13	0.0570	32	01Jul2015, 12:18	3.9
G13-POND G	0.0570	32	01Jul2015, 12:18	3.9
POND G IN-EAST	0.1249	60	01Jul2015, 12:24	8.4
POND G	1.2997	275	01Jul2015, 13:06	72
G12	1.2997	275	01Jul2015, 13:06	72
G12-G06	1.2997	273	01Jul2015, 13:12	72
FG29	0.0983	39	01Jul2015, 12:18	5.0
FG32	0.0402	14	01Jul2015, 12:18	2.0
FG32-G06	0.0402	14	01Jul2015, 12:24	2.0
G06	1.4382	288	01Jul2015, 13:06	79
OS09b	0.0711	19	01Jul2015, 12:36	3.5
OS09b-G14	0.0711	18	01Jul2015, 12:42	3.5
FG34	0.0275	11	01Jul2015, 12:18	1.5
G14	0.0986	26	01Jul2015, 12:30	5.0
G14-G15	0.0986	25	01Jul2015, 12:42	5.0
FG35	0.0282	14	01Jul2015, 12:12	1.5
G15	0.1268	30	01Jul2015, 12:36	6.4
G15-G16	0.1268	30	01Jul2015, 12:36	6.4
FG37	0.0797	37	01Jul2015, 12:18	4.6
FG36	0.0286	14	01Jul2015, 12:18	1.9
FG36-G16	0.0286	14	01Jul2015, 12:24	1.8
G16	0.2351	71	01Jul2015, 12:24	13

Highlighted green rows reference key design points (Typical all charts this section)

GRADED SCS (10-YEAR)				
HYDROLOGIC ELEMENT	DRAINAGE AREA (SQ. MI.)	PEAK DISCHARGE Q10 (CFS)	TIME OF PEAK	TOTAL VOLUME Q10 (AC. FT.)
OS06	0.1313	12	01Jul2015, 12:18	2.2
G1a	0.1313	12	01Jul2015, 12:18	2.2
G1a-G2	0.1313	11	01Jul2015, 12:24	2.1
OS05	0.0578	5.6	01Jul2015, 12:12	1.0
OS05-G1	0.0578	5.5	01Jul2015, 12:18	1.0
FG01	0.0538	7.0	01Jul2015, 12:36	1.4
FG01-G1	0.0538	7.0	01Jul2015, 12:36	1.4
G1	0.1116	11	01Jul2015, 12:24	2.3
G1-G2	0.1116	11	01Jul2015, 12:30	2.3
FG02	0.0391	6.4	01Jul2015, 12:12	0.9
G2	0.2820	27	01Jul2015, 12:24	5.4
G2-G3	0.2820	27	01Jul2015, 12:30	5.3
FG03	0.0203	5.9	01Jul2015, 12:06	0.6
FG04	0.0172	5.8	01Jul2015, 12:06	0.5
G3	0.3195	31	01Jul2015, 12:30	6.4
FG06	0.0675	12	01Jul2015, 12:18	1.7
FG05	0.0580	12	01Jul2015, 12:24	2.0
OS07ab	0.0170	1.8	01Jul2015, 12:12	0.3
OS07ab-POND F	0.0170	1.7	01Jul2015, 12:30	0.3
POND F IN	0.4620	54	01Jul2015, 12:24	10
POND F	0.4620	16	01Jul2015, 13:48	9.1
POND F-G7	0.4620	16	01Jul2015, 13:54	9.0
OS07c	0.0158	1.8	01Jul2015, 12:06	0.3
OS07c-G4	0.0158	1.8	01Jul2015, 12:18	0.3
FG21a	0.0095	1.0	01Jul2015, 12:24	0.2
G4	0.0253	2.8	01Jul2015, 12:18	0.4
G4-G7	0.0253	2.7	01Jul2015, 12:24	0.4
FG21b	0.0150	6.5	01Jul2015, 12:06	0.6
G7	0.5023	18	01Jul2015, 13:42	10
G7-G8	0.5023	18	01Jul2015, 13:42	9.9
FG22	0.1400	32	01Jul2015, 12:18	4.3
OS08a	0.0469	4.4	01Jul2015, 12:18	0.8
OS08-G8	0.0469	4.3	01Jul2015, 12:24	0.8
FG23a	0.0216	5.2	01Jul2015, 12:12	0.7
OS07d	0.0036	0.4	01Jul2015, 12:12	0.1
OS07d-G8	0.0036	0.4	01Jul2015, 12:24	0.1
G8	0.7144	48	01Jul2015, 12:18	16
G8-G10	0.7144	47	01Jul2015, 12:30	15
OS08b	0.1167	14	01Jul2015, 12:24	2.6
OS08b-G9a	0.1167	14	01Jul2015, 12:36	2.5
FG24b	0.0589	9.8	01Jul2015, 12:24	1.6
FG24a	0.0359	4.0	01Jul2015, 12:24	0.7
OS09a	0.0279	2.8	01Jul2015, 12:24	0.5
OS09a-G9a	0.0279	2.7	01Jul2015, 12:36	0.5
G9a	0.2394	28	01Jul2015, 12:36	5.4
G9a-G9b	0.2394	28	01Jul2015, 12:36	5.3
FG24d	0.0307	4.7	01Jul2015, 12:18	0.7
FG24c	0.0291	5.8	01Jul2015, 12:12	0.8
G9b	0.2992	34	01Jul2015, 12:36	6.9
REX RD WQCV	0.2992	33	01Jul2015, 12:42	6.7

GRADED SCS (10-YEAR)				
HYDROLOGIC ELEMENT	DRAINAGE AREA (SQ. MI.)	PEAK DISCHARGE Q10 (CFS)	TIME OF PEAK	TOTAL VOLUME Q10 (AC. FT.)
G9b-G10	0.2992	33	01Jul2015, 12:42	6.7
FG23b	0.0235	3.0	01Jul2015, 12:12	0.5
G10	1.0371	77	01Jul2015, 12:30	23
G10-G11	1.0371	76	01Jul2015, 12:36	22
FG23c	0.0109	2.3	01Jul2015, 12:06	0.3
G11	1.0480	77	01Jul2015, 12:36	23
FG25	0.1084	36	01Jul2015, 12:18	4.7
FG28	0.0184	3.1	01Jul2015, 12:12	0.4
POND G IN-WEST	1.1748	108	01Jul2015, 12:30	28
FG27	0.0679	9.5	01Jul2015, 12:30	1.8
FG26	0.0570	11	01Jul2015, 12:18	1.5
G13	0.0570	11	01Jul2015, 12:18	1.5
G13-POND G	0.0570	10	01Jul2015, 12:24	1.5
POND G IN-EAST	0.1249	19	01Jul2015, 12:24	3.3
POND G	1.2997	40	01Jul2015, 14:36	23
G12	1.2997	40	01Jul2015, 14:36	23
G12-G06	1.2997	40	01Jul2015, 14:48	23
FG29	0.0983	8.9	01Jul2015, 12:18	1.7
FG32	0.0402	3.1	01Jul2015, 12:24	0.7
FG32-G06	0.0402	3.1	01Jul2015, 12:30	0.7
G06	1.4382	43	01Jul2015, 14:42	25
OS09b	0.0711	4.4	01Jul2015, 12:42	1.2
OS09b-G14	0.0711	4.3	01Jul2015, 12:54	1.2
FG34	0.0275	2.8	01Jul2015, 12:24	0.5
G14	0.0986	6.1	01Jul2015, 12:42	1.7
G14-G15	0.0986	6.1	01Jul2015, 12:54	1.7
FG35	0.0282	3.3	01Jul2015, 12:12	0.5
G15	0.1268	7.3	01Jul2015, 12:54	2.2
G15-G16	0.1268	7.3	01Jul2015, 12:54	2.1
FG37	0.0797	10	01Jul2015, 12:18	1.7
FG36	0.0286	4.3	01Jul2015, 12:24	0.7
FG36-G16	0.0286	4.3	01Jul2015, 12:30	0.7
G16	0.2351	16	01Jul2015, 12:24	4.5

Highlighted green rows reference key design points (Typical all charts this section)

GRADED SCS (5-YEAR)				
HYDROLOGIC ELEMENT	DRAINAGE AREA (SQ. MI.)	PEAK DISCHARGE Q5 (CFS)	TIME OF PEAK	TOTAL VOLUME Q5 (AC. FT.)
OS06	0.1313	3.8	01Jul2015, 12:24	0.2
G1a	0.1313	3.8	01Jul2015, 12:24	0.2
G1a-G2	0.1313	3.7	01Jul2015, 12:30	0.2
OS05	0.0578	1.8	01Jul2015, 12:18	0.2
OS05-G1	0.0578	1.7	01Jul2015, 12:24	0.2
FG01	0.0538	3.4	01Jul2015, 12:36	0.3
FG01-G1	0.0538	3.4	01Jul2015, 12:36	0.3
G1	0.1116	4.9	01Jul2015, 12:36	0.2
G1-G2	0.1116	4.8	01Jul2015, 12:36	0.2
FG02	0.0391	2.7	01Jul2015, 12:18	0.2
G2	0.2820	10	01Jul2015, 12:30	0.2
G2-G3	0.2820	10	01Jul2015, 12:42	0.2
FG03	0.0203	3.0	01Jul2015, 12:06	0.3
FG04	0.0172	3.1	01Jul2015, 12:06	0.3
G3	0.3195	12	01Jul2015, 12:36	0.2
FG06	0.0675	5.8	01Jul2015, 12:18	0.3
FG05	0.0580	6.7	01Jul2015, 12:30	0.4
OS07ab	0.0170	0.5	01Jul2015, 12:18	0.2
OS07ab-POND F	0.0170	0.5	01Jul2015, 12:42	0.2
POND F IN	0.4620	23	01Jul2015, 12:36	0.2
POND F	0.4620	8.0	01Jul2015, 14:12	0.2
POND F-G7	0.4620	8.0	01Jul2015, 14:24	0.2
OS07c	0.0158	0.6	01Jul2015, 12:12	0.2
OS07c-G4	0.0158	0.5	01Jul2015, 12:30	0.2
FG21a	0.0095	0.4	01Jul2015, 12:24	0.2
G4	0.0253	0.9	01Jul2015, 12:24	0.2
G4-G7	0.0253	0.9	01Jul2015, 12:30	0.2
FG21b	0.0150	3.9	01Jul2015, 12:06	0.5
G7	0.5023	8.7	01Jul2015, 14:18	0.2
G7-G8	0.5023	8.7	01Jul2015, 14:24	0.2
FG22	0.1400	17	01Jul2015, 12:18	0.4
OS08a	0.0469	1.5	01Jul2015, 12:24	0.2
OS08-G8	0.0469	1.5	01Jul2015, 12:30	0.2
FG23a	0.0216	2.7	01Jul2015, 12:18	0.4
OS07d	0.0036	0.1	01Jul2015, 12:18	0.2
OS07d-G8	0.0036	0.1	01Jul2015, 12:30	0.2
G8	0.7144	25	01Jul2015, 12:18	0.2
G8-G10	0.7144	24	01Jul2015, 12:30	0.2
OS08b	0.1167	6.1	01Jul2015, 12:30	0.2
OS08b-G9a	0.1167	6.0	01Jul2015, 12:48	0.2
FG24b	0.0589	4.9	01Jul2015, 12:30	0.3
FG24a	0.0359	1.6	01Jul2015, 12:24	0.2
OS09a	0.0279	1.0	01Jul2015, 12:24	0.2
OS09a-G9a	0.0279	1.0	01Jul2015, 12:48	0.2
G9a	0.2394	12	01Jul2015, 12:42	0.2
G9a-G9b	0.2394	12	01Jul2015, 12:48	0.2
FG24d	0.0307	2.1	01Jul2015, 12:18	0.3
FG24c	0.0291	2.9	01Jul2015, 12:18	0.3
G9b	0.2992	15	01Jul2015, 12:48	0.2
REX RD WQCV	0.2992	15	01Jul2015, 12:48	0.2

GRADED SCS (5-YEAR)				
HYDROLOGIC ELEMENT	DRAINAGE AREA (SQ. MI.)	PEAK DISCHARGE Q5 (CFS)	TIME OF PEAK	TOTAL VOLUME Q5 (AC. FT.)
G9b-G10	0.2992	14	01Jul2015, 12:48	0.2
FG23b	0.0235	1.1	01Jul2015, 12:18	0.2
G10	1.0371	36	01Jul2015, 12:30	0
G10-G11	1.0371	36	01Jul2015, 12:36	0
FG23c	0.0109	1.0	01Jul2015, 12:12	0.3
G11	1.0480	36	01Jul2015, 12:36	0
FG25	0.1084	22	01Jul2015, 12:18	0.5
FG28	0.0184	1.3	01Jul2015, 12:12	0.2
POND G IN-WEST	1.1748	53	01Jul2015, 12:36	0
FG27	0.0679	4.6	01Jul2015, 12:36	0.3
FG26	0.0570	5.1	01Jul2015, 12:18	0.3
G13	0.0570	5.1	01Jul2015, 12:18	0.3
G13-POND G	0.0570	5.1	01Jul2015, 12:24	0.3
POND G IN-EAST	0.1249	9.5	01Jul2015, 12:30	0.3
POND G	1.2997	15	01Jul2015, 17:36	0
G12	1.2997	15	01Jul2015, 17:36	0
G12-G06	1.2997	15	01Jul2015, 17:48	0
FG29	0.0983	2.9	01Jul2015, 12:24	0.2
FG32	0.0402	1.0	01Jul2015, 12:30	0.2
FG32-G06	0.0402	1.0	01Jul2015, 12:36	0.2
G06	1.4382	16	01Jul2015, 17:48	0
OS09b	0.0711	1.6	01Jul2015, 12:54	0.2
OS09b-G14	0.0711	1.6	01Jul2015, 13:00	0.2
FG34	0.0275	1.1	01Jul2015, 12:24	0.2
G14	0.0986	2.3	01Jul2015, 13:00	0.2
G14-G15	0.0986	2.3	01Jul2015, 13:12	0.2
FG35	0.0282	1.1	01Jul2015, 12:18	0.2
G15	0.1268	2.9	01Jul2015, 13:06	0.2
G15-G16	0.1268	2.9	01Jul2015, 13:18	0.2
FG37	0.0797	4.0	01Jul2015, 12:24	0.2
FG36	0.0286	2.0	01Jul2015, 12:24	0.3
FG36-G16	0.0286	2.0	01Jul2015, 12:36	0.3
G16	0.2351	6.6	01Jul2015, 12:30	0.2

Highlighted green rows reference key design points (Typical all charts this section)

GRADED SCS (2-YEAR)				
HYDROLOGIC ELEMENT	DRAINAGE AREA (SQ. MI.)	PEAK DISCHARGE Q2 (CFS)	TIME OF PEAK	TOTAL VOLUME Q2 (AC. FT.)
OS06	0.1313	0.5	01Jul2015, 13:30	0.3
G1a	0.1313	0.5	01Jul2015, 13:30	0.3
G1a-G2	0.1313	0.5	01Jul2015, 13:48	0.3
OS05	0.0578	0.2	01Jul2015, 13:24	0.2
OS05-G1	0.0578	0.2	01Jul2015, 13:30	0.2
FG01	0.0538	0.9	01Jul2015, 12:48	0.4
FG01-G1	0.0538	0.9	01Jul2015, 12:48	0.4
G1	0.1116	1.1	01Jul2015, 12:54	0.5
G1-G2	0.1116	1.1	01Jul2015, 13:00	0.5
FG02	0.0391	0.5	01Jul2015, 12:30	0.2
G2	0.2820	1.9	01Jul2015, 13:18	1.0
G2-G3	0.2820	1.9	01Jul2015, 13:30	1.0
FG03	0.0203	0.8	01Jul2015, 12:12	0.2
FG04	0.0172	0.9	01Jul2015, 12:06	0.1
G3	0.3195	2.4	01Jul2015, 13:24	1.3
FG06	0.0675	1.3	01Jul2015, 12:24	0.4
FG05	0.0580	2.4	01Jul2015, 12:30	0.6
OS07ab	0.0170	0.1	01Jul2015, 13:18	0.0
OS07ab-POND F	0.0170	0.1	01Jul2015, 14:00	0.0
POND F IN	0.4620	5.1	01Jul2015, 12:42	2.4
POND F	0.4620	2.1	01Jul2015, 17:54	1.6
POND F-G7	0.4620	2.1	01Jul2015, 18:06	1.5
OS07c	0.0158	0.1	01Jul2015, 13:06	0.0
OS07c-G4	0.0158	0.1	01Jul2015, 13:36	0.0
FG21a	0.0095	0.1	01Jul2015, 13:06	0.0
G4	0.0253	0.1	01Jul2015, 13:30	0.1
G4-G7	0.0253	0.1	01Jul2015, 13:36	0.1
FG21b	0.0150	1.7	01Jul2015, 12:12	0.2
G7	0.5023	2.3	01Jul2015, 17:48	1.8
G7-G8	0.5023	2.3	01Jul2015, 17:54	1.8
FG22	0.1400	5.3	01Jul2015, 12:24	1.2
OS08a	0.0469	0.2	01Jul2015, 13:24	0.1
OS08-G8	0.0469	0.2	01Jul2015, 13:30	0.1
FG23a	0.0216	0.8	01Jul2015, 12:18	0.2
OS07d	0.0036	0.0	01Jul2015, 13:18	0.0
OS07d-G8	0.0036	0.0	01Jul2015, 13:36	0.0
G8	0.7144	7.6	01Jul2015, 12:18	3.3
G8-G10	0.7144	7.6	01Jul2015, 12:42	3.2
OS08b	0.1167	1.3	01Jul2015, 12:54	0.6
OS08b-G9a	0.1167	1.2	01Jul2015, 13:18	0.5
FG24b	0.0589	1.4	01Jul2015, 12:36	0.4
FG24a	0.0359	0.3	01Jul2015, 13:00	0.1
OS09a	0.0279	0.2	01Jul2015, 13:12	0.1
OS09a-G9a	0.0279	0.2	01Jul2015, 13:42	0.1
G9a	0.2394	2.6	01Jul2015, 13:12	1.2
G9a-G9b	0.2394	2.6	01Jul2015, 13:18	1.2
FG24d	0.0307	0.4	01Jul2015, 12:36	0.2
FG24c	0.0291	0.8	01Jul2015, 12:24	0.2
G9b	0.2992	3.3	01Jul2015, 13:12	1.6
REX RD WQCV	0.2992	3.3	01Jul2015, 13:18	1.4

GRADED SCS (2-YEAR)				
HYDROLOGIC ELEMENT	DRAINAGE AREA (SQ. MI.)	PEAK DISCHARGE Q2 (CFS)	TIME OF PEAK	TOTAL VOLUME Q2 (AC. FT.)
G9b-G10	0.2992	3.3	01Jul2015, 13:24	1.4
FG23b	0.0235	0.2	01Jul2015, 13:00	0.1
G10	1.0371	8.2	01Jul2015, 13:12	4.7
G10-G11	1.0371	8.1	01Jul2015, 13:18	4.7
FG23c	0.0109	0.2	01Jul2015, 12:18	0.1
G11	1.0480	8.3	01Jul2015, 13:18	4.7
FG25	0.1084	9.9	01Jul2015, 12:24	1.7
FG28	0.0184	0.2	01Jul2015, 12:30	0.1
POND G IN-WEST	1.1748	14	01Jul2015, 12:48	6.5
FG27	0.0679	1.3	01Jul2015, 12:42	0.5
FG26	0.0570	1.3	01Jul2015, 12:30	0.4
G13	0.0570	1.3	01Jul2015, 12:30	0.4
G13-POND G	0.0570	1.3	01Jul2015, 12:36	0.4
POND G IN-EAST	0.1249	2.5	01Jul2015, 12:36	0.8
POND G	1.2997	4.4	02Jul2015, 00:00	3.4
G12	1.2997	4.4	02Jul2015, 00:00	3.4
G12-G06	1.2997	4.4	02Jul2015, 00:00	3.3
FG29	0.0983	0.4	01Jul2015, 13:30	0.3
FG32	0.0402	0.2	01Jul2015, 13:42	0.1
FG32-G06	0.0402	0.2	01Jul2015, 13:48	0.1
G06	1.4382	4.7	01Jul2015, 23:48	3.7
OS09b	0.0711	0.3	01Jul2015, 14:00	0.2
OS09b-G14	0.0711	0.3	01Jul2015, 14:12	0.2
FG34	0.0275	0.2	01Jul2015, 13:12	0.1
G14	0.0986	0.4	01Jul2015, 14:00	0.3
G14-G15	0.0986	0.4	01Jul2015, 14:24	0.3
FG35	0.0282	0.2	01Jul2015, 13:06	0.1
G15	0.1268	0.6	01Jul2015, 14:18	0.4
G15-G16	0.1268	0.6	01Jul2015, 14:30	0.3
FG37	0.0797	0.7	01Jul2015, 12:54	0.3
FG36	0.0286	0.5	01Jul2015, 12:36	0.2
FG36-G16	0.0286	0.5	01Jul2015, 12:48	0.2
G16	0.2351	1.3	01Jul2015, 14:06	0.8

Highlighted green rows reference key design points (Typical all charts this section)

FUTURE SCS (100-YEAR)				
HYDROLOGIC ELEMENT	DRAINAGE AREA (SQ. MI.)	PEAK DISCHARGE Q100 (CFS)	TIME OF PEAK	TOTAL VOLUME Q100 (AC. FT.)
OS06	0.1313	80	01Jul2015, 12:12	9.3
G1a	0.1313	80	01Jul2015, 12:12	9.3
G1a-G2	0.1313	79	01Jul2015, 12:18	9.2
OS05	0.0578	39	01Jul2015, 12:12	4.1
OS05-G1	0.0578	39	01Jul2015, 12:12	4.1
FG01	0.0538	31	01Jul2015, 12:30	4.9
FG01-G1	0.0538	31	01Jul2015, 12:30	4.9
G1	0.1116	61	01Jul2015, 12:18	9.0
G1-G2	0.1116	61	01Jul2015, 12:18	9.0
FG02	0.0391	32	01Jul2015, 12:12	3.3
G2	0.2820	167	01Jul2015, 12:18	21
G2-G3	0.2820	163	01Jul2015, 12:18	21
FG03	0.0203	24	01Jul2015, 12:06	2.0
FG04	0.0172	22	01Jul2015, 12:00	1.7
G3	0.3195	185	01Jul2015, 12:18	25
FG06	0.0675	56	01Jul2015, 12:12	6.1
FG05	0.0580	45	01Jul2015, 12:24	6.1
OS07ab	0.0170	12	01Jul2015, 12:06	1.2
OS07ab-POND F	0.0170	12	01Jul2015, 12:18	1.2
POND F IN	0.4620	293	01Jul2015, 12:18	38
POND F	0.4620	178	01Jul2015, 12:42	36
POND F-G7	0.4620	177	01Jul2015, 12:42	36
OS07c	0.0296	19	01Jul2015, 12:12	2.1
OS07c-G4	0.0296	19	01Jul2015, 12:18	2.1
FG21a	0.0095	5.9	01Jul2015, 12:18	0.7
G4	0.0391	25	01Jul2015, 12:18	2.8
G4-G7	0.0391	24	01Jul2015, 12:18	2.8
FG21b	0.0150	21	01Jul2015, 12:06	1.8
G7	0.5161	194	01Jul2015, 12:42	40
G7-G8	0.5161	194	01Jul2015, 12:42	40
FG22	0.1354	121	01Jul2015, 12:12	14
OS08a	0.0251	16	01Jul2015, 12:12	1.8
OS08-G8	0.0251	16	01Jul2015, 12:18	1.8
FG23a	0.0216	21	01Jul2015, 12:12	2.2
OS07d	0.0034	2.5	01Jul2015, 12:06	0.2
OS07d-G8	0.0034	2.4	01Jul2015, 12:12	0.2
G8	0.7016	279	01Jul2015, 12:30	58
G8-G10	0.7016	278	01Jul2015, 12:36	58
FG24b	0.0589	76	01Jul2015, 12:06	7.1
FG24a	0.0348	24	01Jul2015, 12:18	2.9
OS08b	0.0165	9.5	01Jul2015, 12:18	1.2
OS08b-G9a	0.0165	9.4	01Jul2015, 12:30	1.1
OS09a	0.0093	5.3	01Jul2015, 12:18	0.7
OS09a-G9a	0.0093	5.2	01Jul2015, 12:30	0.6
G9a	0.1195	97	01Jul2015, 12:12	12
G9a-G9b	0.1195	96	01Jul2015, 12:12	12
FG24c	0.0291	40	01Jul2015, 12:06	3.7
FG24d	0.0262	39	01Jul2015, 12:06	3.5

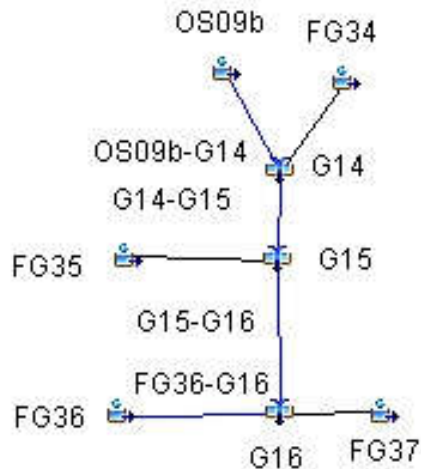
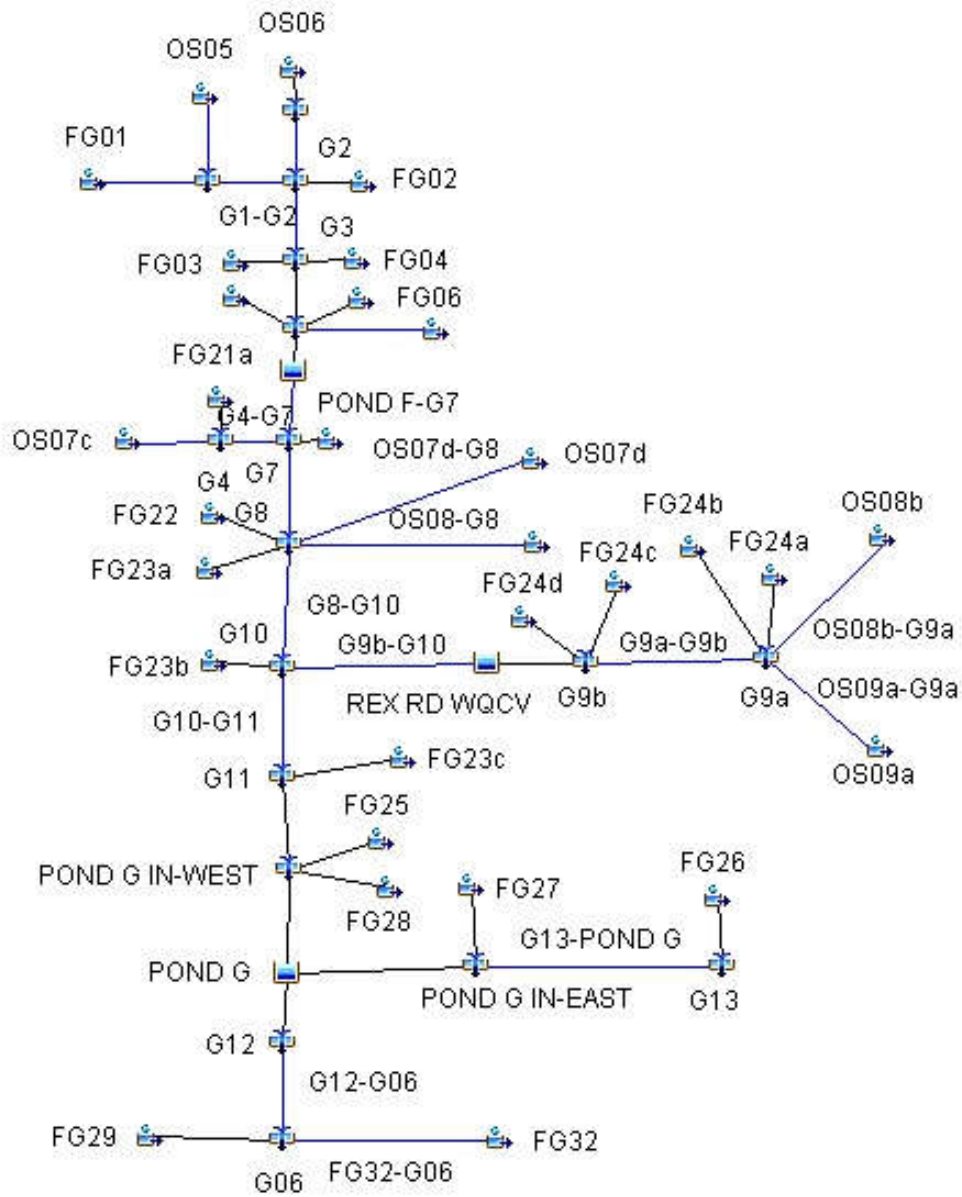

FUTURE SCS (100-YEAR)				
HYDROLOGIC ELEMENT	DRAINAGE AREA (SQ. MI.)	PEAK DISCHARGE Q100 (CFS)	TIME OF PEAK	TOTAL VOLUME Q100 (AC. FT.)
G9b	0.1748	170	01Jul2015, 12:12	19
REX RD WQCV	0.1748	158	01Jul2015, 12:18	19
G9b-G10	0.1748	158	01Jul2015, 12:18	19
FG23b	0.0236	17	01Jul2015, 12:12	1.7
G10	0.9000	390	01Jul2015, 12:24	78
G10-G11	0.9000	389	01Jul2015, 12:30	78
FG23c	0.0109	11	01Jul2015, 12:06	1.0
G11	0.9109	393	01Jul2015, 12:30	79
FG25	0.1084	111	01Jul2015, 12:18	13
FG28	0.0184	15	01Jul2015, 12:12	1.5
POND G IN-WEST	1.0377	503	01Jul2015, 12:24	94
FG27	0.0679	98	01Jul2015, 12:12	11
FG26	0.0570	65	01Jul2015, 12:18	8.0
G13	0.0570	65	01Jul2015, 12:18	8.0
G13-POND G	0.0570	64	01Jul2015, 12:24	8.0
POND G IN-EAST	0.1249	160	01Jul2015, 12:18	19
POND G	1.1626	450	01Jul2015, 12:48	103
G12	1.1626	450	01Jul2015, 12:48	103
G12-G06	1.1626	449	01Jul2015, 12:54	102
FG29	0.0983	60	01Jul2015, 12:12	7.0
FG32	0.0402	51	01Jul2015, 12:18	6.1
FG32-G06	0.0402	50	01Jul2015, 12:18	6.1
G06	1.3011	491	01Jul2015, 12:48	115
OS09b	0.0435	23	01Jul2015, 12:18	3.1
OS09b-G14	0.0435	22	01Jul2015, 12:24	3.1
FG34	0.0275	18	01Jul2015, 12:18	2.2
G14	0.0710	39	01Jul2015, 12:24	5.3
G14-G15	0.0710	39	01Jul2015, 12:30	5.2
FG35	0.0282	25	01Jul2015, 12:06	2.5
G15	0.0992	52	01Jul2015, 12:24	7.7
G15-G16	0.0992	52	01Jul2015, 12:24	7.6
FG37	0.0797	53	01Jul2015, 12:12	6.4
FG36	0.0286	20	01Jul2015, 12:18	2.5
FG36-G16	0.0286	20	01Jul2015, 12:24	2.5
G16	0.2075	119	01Jul2015, 12:18	17

Highlighted green rows reference key design points (Typical all charts this section)

FUTURE SCS (50-YEAR)				
HYDROLOGIC ELEMENT	DRAINAGE AREA (SQ. MI.)	PEAK DISCHARGE Q50 (CFS)	TIME OF PEAK	TOTAL VOLUME Q50 (AC. FT.)
OS06	0.1313	52	01Jul2015, 12:12	6.5
G1a	0.1313	52	01Jul2015, 12:12	6.5
G1a-G2	0.1313	52	01Jul2015, 12:18	6.5
OS05	0.0578	26	01Jul2015, 12:12	2.9
OS05-G1	0.0578	25	01Jul2015, 12:12	2.9
FG01	0.0538	22	01Jul2015, 12:30	3.6
FG01-G1	0.0538	22	01Jul2015, 12:30	3.6
G1	0.1116	41	01Jul2015, 12:18	6.4
G1-G2	0.1116	41	01Jul2015, 12:18	6.4
FG02	0.0391	22	01Jul2015, 12:12	2.4
G2	0.2820	112	01Jul2015, 12:18	15
G2-G3	0.2820	108	01Jul2015, 12:24	15
FG03	0.0203	17	01Jul2015, 12:06	1.5
FG04	0.0172	16	01Jul2015, 12:00	1.3
G3	0.3195	123	01Jul2015, 12:18	18
FG06	0.0675	40	01Jul2015, 12:12	4.4
FG05	0.0580	33	01Jul2015, 12:24	4.6
OS07ab	0.0170	7.9	01Jul2015, 12:12	0.9
OS07ab-POND F	0.0170	7.6	01Jul2015, 12:18	0.8
POND F IN	0.4620	200	01Jul2015, 12:18	28
POND F	0.4620	121	01Jul2015, 12:42	26
POND F-G7	0.4620	120	01Jul2015, 12:48	26
OS07c	0.0296	12	01Jul2015, 12:12	1.5
OS07c-G4	0.0296	12	01Jul2015, 12:18	1.5
FG21a	0.0095	4	01Jul2015, 12:18	0.5
G4	0.0391	16	01Jul2015, 12:18	2.0
G4-G7	0.0391	16	01Jul2015, 12:24	2.0
FG21b	0.0150	16	01Jul2015, 12:06	1.4
G7	0.5161	131	01Jul2015, 12:48	29
G7-G8	0.5161	131	01Jul2015, 12:48	29
FG22	0.1354	88	01Jul2015, 12:12	10
OS08a	0.0251	11	01Jul2015, 12:12	1.3
OS08-G8	0.0251	10	01Jul2015, 12:18	1.2
FG23a	0.0216	15	01Jul2015, 12:12	1.6
OS07d	0.0034	1.6	01Jul2015, 12:06	0.2
OS07d-G8	0.0034	1.6	01Jul2015, 12:18	0.2
G8	0.7016	178	01Jul2015, 12:42	42
G8-G10	0.7016	177	01Jul2015, 12:48	42
FG24b	0.0589	57	01Jul2015, 12:06	5.4
FG24a	0.0348	16	01Jul2015, 12:18	2.1
OS08b	0.0165	6.3	01Jul2015, 12:18	0.8
OS08b-G9a	0.0165	6.0	01Jul2015, 12:36	0.8
OS09a	0.0093	3.5	01Jul2015, 12:18	0.5
OS09a-G9a	0.0093	3.4	01Jul2015, 12:30	0.5
G9a	0.1195	71	01Jul2015, 12:12	8.8
G9a-G9b	0.1195	70	01Jul2015, 12:12	8.7
FG24c	0.0291	30	01Jul2015, 12:06	2.9
FG24d	0.0262	30	01Jul2015, 12:06	2.7

FUTURE SCS (50-YEAR)				
HYDROLOGIC ELEMENT	DRAINAGE AREA (SQ. MI.)	PEAK DISCHARGE Q50 (CFS)	TIME OF PEAK	TOTAL VOLUME Q50 (AC. FT.)
G9b	0.1748	127	01Jul2015, 12:12	14
REX RD WQCV	0.1748	125	01Jul2015, 12:12	14
G9b-G10	0.1748	123	01Jul2015, 12:12	14
FG23b	0.0236	11	01Jul2015, 12:12	1.2
G10	0.9000	263	01Jul2015, 12:18	57
G10-G11	0.9000	254	01Jul2015, 12:24	57
FG23c	0.0109	7.6	01Jul2015, 12:06	0.7
G11	0.9109	258	01Jul2015, 12:24	57
FG25	0.1084	84	01Jul2015, 12:18	10
FG28	0.0184	10	01Jul2015, 12:12	1.1
POND G IN-WEST	1.0377	350	01Jul2015, 12:18	69
FG27	0.0679	79	01Jul2015, 12:12	9.1
FG26	0.0570	50	01Jul2015, 12:18	6.3
G13	0.0570	50	01Jul2015, 12:18	6.3
G13-POND G	0.0570	50	01Jul2015, 12:24	6.3
POND G IN-EAST	0.1249	127	01Jul2015, 12:18	15
POND G	1.1626	293	01Jul2015, 12:54	75
G12	1.1626	293	01Jul2015, 12:54	75
G12-G06	1.1626	293	01Jul2015, 13:00	74
FG29	0.0983	39	01Jul2015, 12:18	5.0
FG32	0.0402	40	01Jul2015, 12:18	4.8
FG32-G06	0.0402	40	01Jul2015, 12:18	4.8
G06	1.3011	317	01Jul2015, 13:00	84
OS09b	0.0435	15	01Jul2015, 12:24	2.2
OS09b-G14	0.0435	15	01Jul2015, 12:24	2.1
FG34	0.0275	12	01Jul2015, 12:18	1.6
G14	0.0710	26	01Jul2015, 12:24	3.7
G14-G15	0.0710	26	01Jul2015, 12:30	3.7
FG35	0.0282	18	01Jul2015, 12:06	1.8
G15	0.0992	35	01Jul2015, 12:24	5.5
G15-G16	0.0992	34	01Jul2015, 12:30	5.5
FG37	0.0797	37	01Jul2015, 12:18	4.6
FG36	0.0286	14	01Jul2015, 12:18	1.9
FG36-G16	0.0286	14	01Jul2015, 12:24	1.8
G16	0.2075	79	01Jul2015, 12:24	12

Highlighted green rows reference key design points (Typical all charts this section)

FUTURE SCS (10-YEAR)				
HYDROLOGIC ELEMENT	DRAINAGE AREA (SQ. MI.)	PEAK DISCHARGE Q10 (CFS)	TIME OF PEAK	TOTAL VOLUME Q10 (AC. FT.)
OS06	0.1313	12	01Jul2015, 12:18	2.2
G1a	0.1313	12	01Jul2015, 12:18	2.2
G1a-G2	0.1313	11	01Jul2015, 12:24	2.1
OS05	0.0578	5.6	01Jul2015, 12:12	1.0
OS05-G1	0.0578	5.5	01Jul2015, 12:18	1.0
FG01	0.0538	7.0	01Jul2015, 12:36	1.4
FG01-G1	0.0538	7.0	01Jul2015, 12:36	1.4
G1	0.1116	11	01Jul2015, 12:24	2.3
G1-G2	0.1116	11	01Jul2015, 12:30	2.3
FG02	0.0391	6.4	01Jul2015, 12:12	0.9
G2	0.2820	27	01Jul2015, 12:24	5.4
G2-G3	0.2820	27	01Jul2015, 12:30	5.3
FG03	0.0203	5.9	01Jul2015, 12:06	0.6
FG04	0.0172	5.8	01Jul2015, 12:06	0.5
G3	0.3195	31	01Jul2015, 12:30	6.4
FG06	0.0675	12	01Jul2015, 12:18	1.7
FG05	0.0580	12	01Jul2015, 12:24	2.0
OS07ab	0.0170	1.8	01Jul2015, 12:12	0.3
OS07ab-POND F	0.0170	1.7	01Jul2015, 12:30	0.3
POND F IN	0.4620	54	01Jul2015, 12:24	10
POND F	0.4620	16	01Jul2015, 13:48	9.1
POND F-G7	0.4620	16	01Jul2015, 13:54	9.0
OS07c	0.0296	2.7	01Jul2015, 12:18	0.5
OS07c-G4	0.0296	2.6	01Jul2015, 12:30	0.5
FG21a	0.0095	1.0	01Jul2015, 12:24	0.2
G4	0.0391	3.6	01Jul2015, 12:24	0.7
G4-G7	0.0391	3.5	01Jul2015, 12:30	0.7
FG21b	0.0150	6.5	01Jul2015, 12:06	0.6
G7	0.5161	18	01Jul2015, 13:36	10
G7-G8	0.5161	18	01Jul2015, 13:42	10
FG22	0.1354	32	01Jul2015, 12:18	4.3
OS08a	0.0251	2.3	01Jul2015, 12:18	0.4
OS08-G8	0.0251	2.3	01Jul2015, 12:24	0.4
FG23a	0.0216	5.2	01Jul2015, 12:12	0.7
OS07d	0.0034	0.4	01Jul2015, 12:12	0.1
OS07d-G8	0.0034	0.3	01Jul2015, 12:24	0.1
G8	0.7016	46	01Jul2015, 12:18	16
G8-G10	0.7016	45	01Jul2015, 12:24	15
FG24b	0.0589	24	01Jul2015, 12:12	2.5
FG24a	0.0348	4.5	01Jul2015, 12:18	0.8
OS08b	0.0165	1.4	01Jul2015, 12:18	0.3
OS08b-G9a	0.0165	1.4	01Jul2015, 12:42	0.3
OS09a	0.0093	0.8	01Jul2015, 12:24	0.2
OS09a-G9a	0.0093	0.7	01Jul2015, 12:42	0.2
G9a	0.1195	28	01Jul2015, 12:12	3.7
G9a-G9b	0.1195	27	01Jul2015, 12:12	3.6
FG24c	0.0291	13	01Jul2015, 12:12	1.3
FG24d	0.0262	14	01Jul2015, 12:06	1.3

FUTURE SCS (10-YEAR)				
HYDROLOGIC ELEMENT	DRAINAGE AREA (SQ. MI.)	PEAK DISCHARGE Q10 (CFS)	TIME OF PEAK	TOTAL VOLUME Q10 (AC. FT.)
G9b	0.1748	53	01Jul2015, 12:12	6.3
REX RD WQCV	0.1748	51	01Jul2015, 12:12	6.1
G9b-G10	0.1748	50	01Jul2015, 12:18	6.1
FG23b	0.0236	2.7	01Jul2015, 12:12	0.4
G10	0.9000	90	01Jul2015, 12:24	22
G10-G11	0.9000	85	01Jul2015, 12:30	22
FG23c	0.0109	2.2	01Jul2015, 12:06	0.3
G11	0.9109	86	01Jul2015, 12:30	22
FG25	0.1084	36	01Jul2015, 12:18	4.7
FG28	0.0184	3.0	01Jul2015, 12:12	0.4
POND G IN-WEST	1.0377	122	01Jul2015, 12:24	27
FG27	0.0679	42	01Jul2015, 12:18	4.9
FG26	0.0570	24	01Jul2015, 12:18	3.1
G13	0.0570	24	01Jul2015, 12:18	3.1
G13-POND G	0.0570	24	01Jul2015, 12:24	3.1
POND G IN-EAST	0.1249	64	01Jul2015, 12:18	8.0
POND G	1.1626	52	01Jul2015, 13:48	27
G12	1.1626	52	01Jul2015, 13:48	27
G12-G06	1.1626	52	01Jul2015, 13:54	27
FG29	0.0983	8.9	01Jul2015, 12:18	1.7
FG32	0.0402	20	01Jul2015, 12:18	2.4
FG32-G06	0.0402	19	01Jul2015, 12:18	2.4
G06	1.3011	57	01Jul2015, 13:48	31
OS09b	0.0435	3.3	01Jul2015, 12:24	0.7
OS09b-G14	0.0435	3.3	01Jul2015, 12:36	0.7
FG34	0.0275	3.3	01Jul2015, 12:24	0.6
G14	0.0710	6.2	01Jul2015, 12:30	1.3
G14-G15	0.0710	6.1	01Jul2015, 12:42	1.3
FG35	0.0282	5.6	01Jul2015, 12:12	0.7
G15	0.0992	8.4	01Jul2015, 12:36	1.9
G15-G16	0.0992	8.3	01Jul2015, 12:42	1.9
FG37	0.0797	9.9	01Jul2015, 12:18	1.7
FG36	0.0286	4.3	01Jul2015, 12:24	0.7
FG36-G16	0.0286	4.3	01Jul2015, 12:30	0.7
G16	0.2075	19	01Jul2015, 12:36	4.3

Highlighted green rows reference key design points (Typical all charts this section)

FUTURE SCS (5-YEAR)				
HYDROLOGIC ELEMENT	DRAINAGE AREA (SQ. MI.)	PEAK DISCHARGE Q5 (CFS)	TIME OF PEAK	TOTAL VOLUME Q5 (AC. FT.)
OS06	0.1313	3.8	01Jul2015, 12:24	1.1
G1a	0.1313	3.8	01Jul2015, 12:24	1.1
G1a-G2	0.1313	3.7	01Jul2015, 12:30	1.1
OS05	0.0578	1.8	01Jul2015, 12:18	0.5
OS05-G1	0.0578	1.7	01Jul2015, 12:24	0.5
FG01	0.0538	3.4	01Jul2015, 12:36	0.8
FG01-G1	0.0538	3.4	01Jul2015, 12:36	0.8
G1	0.1116	4.9	01Jul2015, 12:36	1.3
G1-G2	0.1116	4.8	01Jul2015, 12:36	1.3
FG02	0.0391	2.7	01Jul2015, 12:18	0.5
G2	0.2820	10	01Jul2015, 12:30	2.9
G2-G3	0.2820	10	01Jul2015, 12:42	2.9
FG03	0.0203	3.0	01Jul2015, 12:06	0.4
FG04	0.0172	3.1	01Jul2015, 12:06	0.3
G3	0.3195	12	01Jul2015, 12:36	3.5
FG06	0.0675	5.8	01Jul2015, 12:18	1.0
FG05	0.0580	6.7	01Jul2015, 12:30	1.2
OS07ab	0.0170	0.5	01Jul2015, 12:18	0.2
OS07ab-POND F	0.0170	0.5	01Jul2015, 12:42	0.1
POND F IN	0.4620	23	01Jul2015, 12:36	5.9
POND F	0.4620	8.0	01Jul2015, 14:12	4.8
POND F-G7	0.4620	8.0	01Jul2015, 14:24	4.8
OS07c	0.0296	0.9	01Jul2015, 12:24	0.3
OS07c-G4	0.0296	0.9	01Jul2015, 12:36	0.3
FG21a	0.0095	0.4	01Jul2015, 12:24	0.1
G4	0.0391	1.2	01Jul2015, 12:36	0.3
G4-G7	0.0391	1.2	01Jul2015, 12:36	0.3
FG21b	0.0150	3.9	01Jul2015, 12:06	0.4
G7	0.5161	8.9	01Jul2015, 14:12	5.5
G7-G8	0.5161	8.9	01Jul2015, 14:18	5.5
FG22	0.1354	17	01Jul2015, 12:18	2.6
OS08a	0.0251	0.7	01Jul2015, 12:24	0.2
OS08-G8	0.0251	0.7	01Jul2015, 12:30	0.2
FG23a	0.0216	2.7	01Jul2015, 12:18	0.4
OS07d	0.0034	0.1	01Jul2015, 12:18	0.0
OS07d-G8	0.0034	0.1	01Jul2015, 12:30	0.0
G8	0.7016	24	01Jul2015, 12:18	8.7
G8-G10	0.7016	24	01Jul2015, 12:30	8.5
FG24b	0.0589	15	01Jul2015, 12:12	1.6
FG24a	0.0348	2.0	01Jul2015, 12:24	0.4
OS08b	0.0165	0.5	01Jul2015, 12:24	0.1
OS08b-G9a	0.0165	0.5	01Jul2015, 13:00	0.1
OS09a	0.0093	0.3	01Jul2015, 12:30	0.1
OS09a-G9a	0.0093	0.3	01Jul2015, 13:00	0.1
G9a	0.1195	16	01Jul2015, 12:12	2.3
G9a-G9b	0.1195	16	01Jul2015, 12:18	2.2
FG24c	0.0291	8.4	01Jul2015, 12:12	0.9
FG24d	0.0262	8.7	01Jul2015, 12:06	0.9

FUTURE SCS (5-YEAR)				
HYDROLOGIC ELEMENT	DRAINAGE AREA (SQ. MI.)	PEAK DISCHARGE Q5 (CFS)	TIME OF PEAK	TOTAL VOLUME Q5 (AC. FT.)
G9b	0.1748	32	01Jul2015, 12:12	4.0
REX RD WQCV	0.1748	31	01Jul2015, 12:18	3.9
G9b-G10	0.1748	31	01Jul2015, 12:18	3.9
FG23b	0.0236	0.9	01Jul2015, 12:18	0.2
G10	0.9000	46	01Jul2015, 12:30	13
G10-G11	0.9000	44	01Jul2015, 12:36	12
FG23c	0.0109	1.0	01Jul2015, 12:12	0.2
G11	0.9109	44	01Jul2015, 12:36	13
FG25	0.1084	22	01Jul2015, 12:18	3.1
FG28	0.0184	1.2	01Jul2015, 12:12	0.2
POND G IN-WEST	1.0377	63	01Jul2015, 12:30	16
FG27	0.0679	30	01Jul2015, 12:18	3.5
FG26	0.0570	16	01Jul2015, 12:18	2.1
G13	0.0570	16	01Jul2015, 12:18	2.1
G13-POND G	0.0570	16	01Jul2015, 12:24	2.1
POND G IN-EAST	0.1249	44	01Jul2015, 12:18	5.7
POND G	1.1626	21	01Jul2015, 15:24	14
G12	1.1626	21	01Jul2015, 15:24	14
G12-G06	1.1626	21	01Jul2015, 15:36	14
FG29	0.0983	2.9	01Jul2015, 12:24	0.9
FG32	0.0402	14	01Jul2015, 12:18	1.7
FG32-G06	0.0402	13	01Jul2015, 12:24	1.7
G06	1.3011	22	01Jul2015, 15:30	17
OS09b	0.0435	1.1	01Jul2015, 12:30	0.4
OS09b-G14	0.0435	1.1	01Jul2015, 12:42	0.4
FG34	0.0275	1.4	01Jul2015, 12:24	0.3
G14	0.0710	2.2	01Jul2015, 12:36	0.7
G14-G15	0.0710	2.2	01Jul2015, 12:48	0.7
FG35	0.0282	2.5	01Jul2015, 12:12	0.4
G15	0.0992	3.3	01Jul2015, 12:48	1.1
G15-G16	0.0992	3.2	01Jul2015, 12:54	1.0
FG37	0.0797	4.0	01Jul2015, 12:24	0.9
FG36	0.0286	2.0	01Jul2015, 12:24	0.4
FG36-G16	0.0286	2.0	01Jul2015, 12:36	0.4
G16	0.2075	7.8	01Jul2015, 12:24	2.4

Highlighted green rows reference key design points (Typical all charts this section)

FUTURE SCS (2-YEAR)				
HYDROLOGIC ELEMENT	DRAINAGE AREA (SQ. MI.)	PEAK DISCHARGE Q2 (CFS)	TIME OF PEAK	TOTAL VOLUME Q2 (AC. FT.)
OS06	0.1313	0.5	01Jul2015, 13:30	0.3
G1a	0.1313	0.5	01Jul2015, 13:30	0.3
G1a-G2	0.1313	0.5	01Jul2015, 13:48	0.3
OS05	0.0578	0.2	01Jul2015, 13:24	0.2
OS05-G1	0.0578	0.2	01Jul2015, 13:30	0.2
FG01	0.0538	0.9	01Jul2015, 12:48	0.4
FG01-G1	0.0538	0.9	01Jul2015, 12:48	0.4
G1	0.1116	1.1	01Jul2015, 12:54	0.5
G1-G2	0.1116	1.1	01Jul2015, 13:00	0.5
FG02	0.0391	0.5	01Jul2015, 12:30	0.2
G2	0.2820	1.9	01Jul2015, 13:18	1.0
G2-G3	0.2820	1.9	01Jul2015, 13:30	1.0
FG03	0.0203	0.8	01Jul2015, 12:12	0.2
FG04	0.0172	0.9	01Jul2015, 12:06	0.1
G3	0.3195	2.4	01Jul2015, 13:24	1.3
FG06	0.0675	1.3	01Jul2015, 12:24	0.4
FG05	0.0580	2.4	01Jul2015, 12:30	0.6
OS07ab	0.0170	0.1	01Jul2015, 13:18	0.0
OS07ab-POND F	0.0170	0.1	01Jul2015, 14:00	0.0
POND F IN	0.4620	5.1	01Jul2015, 12:42	2.4
POND F	0.4620	2.1	01Jul2015, 17:54	1.6
POND F-G7	0.4620	2.1	01Jul2015, 18:06	1.5
OS07c	0.0296	0.1	01Jul2015, 13:30	0.1
OS07c-G4	0.0296	0.1	01Jul2015, 13:54	0.1
FG21a	0.0095	0.1	01Jul2015, 13:06	0.0
G4	0.0391	0.2	01Jul2015, 13:42	0.1
G4-G7	0.0391	0.2	01Jul2015, 13:42	0.1
FG21b	0.0150	1.7	01Jul2015, 12:12	0.2
G7	0.5161	2.3	01Jul2015, 17:48	1.8
G7-G8	0.5161	2.3	01Jul2015, 17:54	1.8
FG22	0.1354	5.4	01Jul2015, 12:24	1.2
OS08a	0.0251	0.1	01Jul2015, 13:30	0.1
OS08-G8	0.0251	0.1	01Jul2015, 13:36	0.1
FG23a	0.0216	0.8	01Jul2015, 12:18	0.2
OS07d	0.0034	0.0	01Jul2015, 13:18	0.0
OS07d-G8	0.0034	0.0	01Jul2015, 13:36	0.0
G8	0.7016	7.7	01Jul2015, 12:18	3.3
G8-G10	0.7016	7.6	01Jul2015, 12:42	3.1
FG24b	0.0589	6.5	01Jul2015, 12:12	0.9
FG24a	0.0348	0.4	01Jul2015, 12:48	0.2
OS08b	0.0165	0.1	01Jul2015, 13:36	0.0
OS08b-G9a	0.0165	0.1	01Jul2015, 14:30	0.0
OS09a	0.0093	0.0	01Jul2015, 13:36	0.0
OS09a-G9a	0.0093	0.0	01Jul2015, 14:24	0.0
G9a	0.1195	6.7	01Jul2015, 12:12	1.1
G9a-G9b	0.1195	6.6	01Jul2015, 12:18	1.1
FG24c	0.0291	4.0	01Jul2015, 12:12	0.5
FG24d	0.0262	4.4	01Jul2015, 12:12	0.5

FUTURE SCS (2-YEAR)				
HYDROLOGIC ELEMENT	DRAINAGE AREA (SQ. MI.)	PEAK DISCHARGE Q2 (CFS)	TIME OF PEAK	TOTAL VOLUME Q2 (AC. FT.)
G9b	0.1748	14	01Jul2015, 12:12	2.1
REX RD WQCV	0.1748	14	01Jul2015, 12:18	1.9
G9b-G10	0.1748	13	01Jul2015, 12:24	1.9
FG23b	0.0236	0.1	01Jul2015, 13:06	0.1
G10	0.9000	15	01Jul2015, 12:42	5.2
G10-G11	0.9000	15	01Jul2015, 12:48	5.1
FG23c	0.0109	0.2	01Jul2015, 12:18	0.1
G11	0.9109	15	01Jul2015, 12:48	5.2
FG25	0.1084	9.9	01Jul2015, 12:24	1.7
FG28	0.0184	0.2	01Jul2015, 12:36	0.1
POND G IN-WEST	1.0377	22	01Jul2015, 12:24	6.9
FG27	0.0679	18	01Jul2015, 12:18	2.2
FG26	0.0570	8.2	01Jul2015, 12:24	1.2
G13	0.0570	8.2	01Jul2015, 12:24	1.2
G13-POND G	0.0570	8.1	01Jul2015, 12:24	1.2
POND G IN-EAST	0.1249	25	01Jul2015, 12:18	3.5
POND G	1.1626	5.3	02Jul2015, 00:00	4.7
G12	1.1626	5.3	02Jul2015, 00:00	4.7
G12-G06	1.1626	5.3	02Jul2015, 00:00	4.5
FG29	0.0983	0.4	01Jul2015, 13:30	0.3
FG32	0.0402	7.5	01Jul2015, 12:18	1.0
FG32-G06	0.0402	7.4	01Jul2015, 12:24	1.0
G06	1.3011	7.5	01Jul2015, 12:24	5.8
OS09b	0.0435	0.2	01Jul2015, 13:42	0.1
OS09b-G14	0.0435	0.2	01Jul2015, 13:54	0.1
FG34	0.0275	0.3	01Jul2015, 12:54	0.1
G14	0.0710	0.4	01Jul2015, 13:30	0.2
G14-G15	0.0710	0.4	01Jul2015, 14:00	0.2
FG35	0.0282	0.5	01Jul2015, 12:18	0.2
G15	0.0992	0.6	01Jul2015, 13:48	0.4
G15-G16	0.0992	0.6	01Jul2015, 14:00	0.4
FG37	0.0797	0.7	01Jul2015, 12:54	0.3
FG36	0.0286	0.5	01Jul2015, 12:36	0.2
FG36-G16	0.0286	0.5	01Jul2015, 12:48	0.2
G16	0.2075	1.6	01Jul2015, 12:48	0.9

Highlighted green rows reference key design points (Typical all charts this section)

Appendix B - Detention Pond Information

STAGE/STORAGE/DISCHARGE CURVES FOR DETENTIOA1:U54N POND ANALYSIS

Meridian Ranch Proposed Detention Pond G - GRADED CONDITIONS (G12)
Geck Basin - El Paso County, Colorado

Data for outlet pipe and grate:

Type	H or V	Dimensions Width (ft.) X Height (ft.)	Dia.(in)	(sqft)
Circular	Orifice 1a: V		1.75	Area = 0.017 Elev to cl = 7023.50
Circular	Orifice 1b: V		1.75	Area = 0.017 Elev to cl = 7024.10
Circular	Orifice 1c: V		1.75	Area = 0.017 Elev to cl = 7024.80
Rectangular	Orifice 2: V	8.6	1.04	Area = 8.944 Elev to cl = 7027.62
Rectangular	Orifice 3: V	2	0.43	Area = 0.860 Elev to cl = 7025.44
Rectangular	Orifice 4: V	4.1	0.64	Area = 2.624 Elev to cl = 7027.82
Rectangular	Orifice 5: V	8.6	1.04	Area = 8.944 Elev to cl = 7027.62

Data for spillway and embankment:

embankment length =	500
embankment elev =	7033.5
spillway length =	130
spillway elevation =	7031.5
100 year storage elev.=	7030.1
100 year storage vol.=	24.3
100 year discharge=	442
5 year storage elev.=	7027.3
5 year storage vol.=	8.0
5 year discharge=	15
WQCV storage elev.=	7025.2
WQCV storage vol.=	0.9
1/2 WQCV storage elev.=	7024.8
1/2 WQCV storage vol.=	0.45

Stand Pipe Dimensions

Rec Grate	20	x	8	Elev =	7028.14
Circ. Grate		dia.		Elev =	7028.14

50 year storage vol.=	19.5
50 year storage elev.=	7029.3
50 year discharge=	275
10 year storage vol.=	10.5
10 year storage elev.=	7027.8
10 year discharge=	40
2 year storage vol.=	3.9
2 year storage elev.=	7026.4
2 year discharge=	4.4

Outlet Culvert Dimensions

	Width (ft.)		Height (ft.)		Dia. (ft.)	Type
Outlet Culvert	10	x	4			Rectangular
Area	40.0		TOP			
Outlet I. E.	7022.5		7027.50			
Wall Thick.	12	in.				

STAGE		STORAGE				DISCHARGE											GRATE (max outflow)		PIPE		REALIZED CULVERT OUTFLOW	TOTAL FLOW
ELEV	HEIGHT	AREA		VOLUME		TOP OF BANK	SPILLWAY	ORIFICE (max outflow)					Rectangular	PIPE		REALIZED CULVERT OUTFLOW	TOTAL FLOW					
		sqft	acre	acft	cum acft			1a	1b	1c	2	3		4	5			1	2			
7023	0	0	0.00	0.0	0.000	-	-	-	-	-	-	-	-	-	-	-	10	-	-			
7024	1	2285	0.05	0.0	0.026	-	-	0.06	-	-	-	-	-	-	-	-	51	0.1	0.06			
7025	2	42192	0.97	0.5	0.537	-	-	0.10	0.08	0.04	-	-	-	-	-	-	111	0.2	0.21			
7026	3	127336	2.92	1.9	2.483	-	-	0.13	0.11	0.09	-	3.1	-	-	-	-	184	3.4	3.44			
7026.5	3.5	169390	3.89	3.6	4.180	-	-	0.14	0.12	0.10	-	4.3	-	-	-	-	224	4.6	4.64			
7027	4	211444	4.85	2.2	6.365	-	-	0.15	0.14	0.12	-	5.2	-	-	-	-	268	5.6	5.59			
7027.5	4.5	234356	5.38	4.6	8.814	-	-	0.16	0.15	0.13	6.5	6.0	-	6.5	-	-	304	19	19.45			
7028	5	257267	5.91	5.4	11.745	-	-	0.17	0.16	0.14	22.0	6.6	4.3	22.0	-	-	337	56	55.51			
7028.5	5.5	264583	6.07	5.7	14.541	-	-	0.18	0.17	0.15	40.4	7.2	10.4	40.4	23	-	373	122	122.30			
7029	6	271899	6.24	6.1	17.819	-	-	0.19	0.18	0.16	50.6	7.8	13.7	50.6	86	-	406	209	209.39			
7029.5	6.5	277060	6.36	11.7	20.555	-	-	0.21	0.19	0.17	59.0	8.3	16.4	59.0	171	-	436	315	314.68			
7030	7	282220	6.48	9.4	23.956	-	-	0.21	0.20	0.18	66.4	8.8	18.7	66.4	274	-	464	435	434.93			
7030.5	7.5	287904	6.61	6.5	27.039	-	-	0.21	0.20	0.19	73.1	9.3	20.7	73.1	392	-	491	491	490.92			
7031	8	293587	6.74	6.6	30.565	-	-	0.22	0.21	0.20	79.2	9.8	22.5	79.2	522	-	516	516	516.22			
7031.5	8.5	297735	6.84	6.7	33.762	-	-	0.23	0.22	0.21	84.8	10.2	24.2	84.8	665	-	540	540	540.33			
7032	9	301883	6.93	3.4	37.203	137.9	137.9	0.23	0.23	0.22	90.1	10.6	25.8	90.1	819	-	563	563	701.30			
7032.5	9.5	309236	7.10	7.0	40.729	390.0	390.0	0.24	0.23	0.22	95.1	11.0	27.3	95.1	983	-	586	586	975.59			
7033	10	316589	7.27	3.6	44.320	716.5	716.5	0.25	0.24	0.23	99.9	11.4	28.8	99.9	1,157	-	607	607	1,323.43			

- Notes:
- 1) Top-of-bank and spillway flows are weir equations from section 11.3.1 in the DCM. $Q=CLH^{1.5}$ (C=3.0)
 - 2) Orifice flows are also from section 11.3.1. $Q=CA(2gH)^{0.5}$ (C=6)
 - 3) Grate flows are determined from equations 7-2 and 7-3. Weir Flow $Q=(3PH^{1.5})/F$, Orifice Flow $Q=4.815*AH^{0.5}$
 - 4) Pipe flows use the lesser of: 1) Inlet control equations 27 & 28, page 146 of HDS No. 5 - or - 2) Allowable Pipe Flow equation on page 11-9 of the DCM. Use Table 9, page 147-148, HDS No. 5 for formulas 26 & 27.

STAGE/STORAGE/DISCHARGE CURVES FOR DETENTION POND ANALYSIS

**Meridian Ranch Proposed Detention Pond G-FUTURE CONDITIONS (G12)
Gieck Basin - El Paso County, Colorado**

Data for outlet pipe and grate:

Type	H or V	Dimensions Width (ft.) X Height (ft.)	Dia.(in)	(sqft)
Circular	Orifice 1a: V		1.75	Area = 0.017 Elev to cl = 7023.50
Circular	Orifice 1b: V		1.75	Area = 0.017 Elev to cl = 7024.10
Circular	Orifice 1c: V		1.75	Area = 0.017 Elev to cl = 7024.80
Rectangular	Orifice 2: V	8.6	1.04	Area = 8.944 Elev to cl = 7027.62
Rectangular	Orifice 3: V	2	0.43	Area = 0.860 Elev to cl = 7025.44
Rectangular	Orifice 4: V	4.1	0.64	Area = 2.624 Elev to cl = 7027.82
Rectangular	Orifice 5: V	8.6	1.04	Area = 8.944 Elev to cl = 7027.62

Data for spillway and embankment:

embankment length =	500
embankment elev =	7033.5
spillway length =	130
spillway elevation =	7031.5
100 year storage elev.=	7030.1
100 year storage vol.=	24.8
100 year discharge=	450
5 year storage elev.=	7027.5
5 year storage vol.=	9.0
5 year discharge=	21
WQCV storage elev.=	7025.2
WQCV storage vol.=	0.9
1/2 WQCV storage elev.=	7024.8
1/2 WQCV storage vol.=	0.45

Stand Pipe Dimensions

Rec Grate	20	x	8	Elev = 7028.14
Circ. Grate		dia.		Elev = 7028.14

50 year storage vol.=	20.0
50 year storage elev.=	7029.4
50 year discharge=	293
10 year storage vol.=	11.5
10 year storage elev.=	7028.0
10 year discharge=	52
2 year storage vol.=	5.7
2 year storage elev.=	7026.8
2 year discharge=	5.3

Outlet Culvert Dimensions

Outlet Culvert	Width (ft.)	H or V	Height (ft.)	Dia. (ft.)	Type
Outlet Culvert	10	x	4		Rectangular
Area	40.0		TOP		
Outlet I. E.	7022.5		7027.50		
Wall Thick.	12	in.			

ELEV	HEIGHT	STORAGE				DISCHARGE										GRATE (max outflow) Rectangular	PIPE		REALIZED CULVERT OUTFLOW	TOTAL FLOW
		AREA		VOLUME		TOP OF BANK	SPILLWAY	ORIFICE					(max outflow)	1	2					
		sqft	acre	acft	cum acft			1a	1b	1c	2	3					4	5		
7023	0	0	0.00	0.0	0.000	-	-	-	-	-	-	-	-	-	-	-	10	-	-	
7024	1	2285	0.05	0.0	0.026	-	-	0.06	-	-	-	-	-	-	-	-	51	0.1	0.06	
7025	2	42192	0.97	0.5	0.537	-	-	0.10	0.08	0.04	-	-	-	-	-	-	111	0.2	0.21	
7026	3	127336	2.92	1.9	2.483	-	-	0.13	0.11	0.09	-	3.1	-	-	-	-	184	3.4	3.44	
7026.5	3.5	169390	3.89	3.6	4.180	-	-	0.14	0.12	0.10	-	4.3	-	-	-	-	224	4.6	4.64	
7027	4	211444	4.85	2.2	6.365	-	-	0.15	0.14	0.12	-	5.2	-	-	-	-	268	5.6	5.59	
7027.5	4.5	234356	5.38	4.6	8.814	-	-	0.16	0.15	0.13	6.5	6.0	-	6.5	-	-	304	19	19.45	
7028	5	257267	5.91	5.4	11.745	-	-	0.17	0.16	0.14	22.0	6.6	4.3	22.0	-	-	337	56	55.51	
7028.5	5.5	264583	6.07	5.7	14.541	-	-	0.18	0.17	0.15	40.4	7.2	10.4	40.4	23	-	373	122	122.30	
7029	6	271899	6.24	6.1	17.819	-	-	0.19	0.18	0.16	50.6	7.8	13.7	50.6	86	-	406	209	209.39	
7029.5	6.5	277060	6.36	11.7	20.555	-	-	0.21	0.19	0.17	59.0	8.3	16.4	59.0	171	-	436	315	314.68	
7030	7	282220	6.48	9.4	23.956	-	-	0.21	0.20	0.18	66.4	8.8	18.7	66.4	274	-	464	435	434.93	
7030.5	7.5	287904	6.61	6.5	27.039	-	-	0.21	0.20	0.19	73.1	9.3	20.7	73.1	392	-	491	491	490.92	
7031	8	293587	6.74	6.6	30.565	-	-	0.22	0.21	0.20	79.2	9.8	22.5	79.2	522	-	516	516	516.22	
7031.5	8.5	297735	6.84	6.7	33.762	-	-	0.23	0.22	0.21	84.8	10.2	24.2	84.8	665	-	540	540	540.33	
7032	9	301883	6.93	3.4	37.203	137.9	137.9	0.23	0.23	0.22	90.1	10.6	25.8	90.1	819	-	563	563	701.30	
7032.5	9.5	309236	7.10	7.0	40.729	390.0	390.0	0.24	0.23	0.22	95.1	11.0	27.3	95.1	983	-	586	586	975.59	
7033	10	316589	7.27	3.6	44.320	716.5	716.5	0.25	0.24	0.23	99.9	11.4	28.8	99.9	1,157	-	607	607	1,323.43	

- Notes:
- 1) Top-of-bank and spillway flows are weir equations from section 11.3.1 in the DCM. $Q=CLH^{1.5}$ (C=3.0)
 - 2) Orifice flows are also from section 11.3.1. $Q=CA(2gH)^{.5}$ (C=6)
 - 3) Grate flows are determined from equations 7-2 and 7-3. Weir Flow $Q=(3PH^{1.5})/F$, Orifice Flow $Q=4.815*AH^{0.5}$
 - 4) Pipe flows use the lesser of: 1) Inlet control equations 27 & 28, page 146 of HDS No. 5 - or - 2) Allowable Pipe Flow equation on page 11-9 of the DCM. Use Table 9, page 147-148, HDS No. 5 for formulas 26 & 27.

ROLLING HILLS RANCH NORTH GRADING INTERIM CONDITION

Simulation Run: RHRN GRADED -100 YR Reservoir: POND G

Start of Run:	01Jul2015, 00:00	Basin Model:	WW Grading
End of Run:	02Jul2015, 00:00	Meteorologic Model:	SCS TYPE IIA 100YR
Compute Time:	16Mar2022 14:10:16	Control Specifications:	24 HR-2 MIN.

Volume Units: AC-FT

Computed Results:

Peak Inflow:	619 (CFS)	Date/Time of Peak Inflow:	01Jul2015, 12:24
Peak Outflow:	442 (CFS)	Date/Time of Peak Outflow:	01Jul2015, 12:48
Total Inflow :	112.6 (AC-FT)	Peak Storage:	24.4 (AC-FT)
Total Outflow:	102.4 (AC-FT)	Peak Elevation:	7030.1 (FT)

Simulation Run: RHRN GRADED -005 YR Reservoir: POND G

Start of Run:	01Jul2015, 00:00	Basin Model:	WW Grading
End of Run:	02Jul2015, 00:00	Meteorologic Model:	SCS TYPE IIA 005YR
Compute Time:	16Mar2022 14:10:16	Control Specifications:	24 HR-2 MIN.

Volume Units: AC-FT

Computed Results:

Peak Inflow:	62 (CFS)	Date/Time of Peak Inflow:	01Jul2015, 12:24
Peak Outflow:	15 (CFS)	Date/Time of Peak Outflow:	01Jul2015, 15:18
Total Inflow :	18.0 (AC-FT)	Peak Storage:	8.0 (AC-FT)
Total Outflow:	10.8 (AC-FT)	Peak Elevation:	7027.3 (FT)

ROLLING HILLS RANCH NORTH GRADING FUTURE CONDITION

Simulation Run: F-100 YR Reservoir: POND G

Start of Run:	01Jul2015, 00:00	Basin Model:	Future SCS
End of Run:	02Jul2015, 00:00	Meteorologic Model:	SCS TYPE IIA 100YR
Compute Time:	30Mar2022 14:13:12	Control Specifications:	24 HR-2 MIN.

Volume Units: AC-FT

Computed Results:

Peak Inflow:	653 (CFS)	Date/Time of Peak Inflow:	01Jul2015, 12:30
Peak Outflow:	450 (CFS)	Date/Time of Peak Outflow:	01Jul2015, 12:54
Total Inflow :	113.1 (AC-FT)	Peak Storage:	24.8 (AC-FT)
Total Outflow:	103.1 (AC-FT)	Peak Elevation:	7030.1 (FT)

Simulation Run: F-005 YR Reservoir: POND G

Start of Run:	01Jul2015, 00:00	Basin Model:	Future SCS
End of Run:	02Jul2015, 00:00	Meteorologic Model:	SCS TYPE IIA 005YR
Compute Time:	30Mar2022 14:13:12	Control Specifications:	24 HR-2 MIN.

Volume Units: AC-FT

Computed Results:

Peak Inflow:	101 (CFS)	Date/Time of Peak Inflow:	01Jul2015, 12:30
Peak Outflow:	21 (CFS)	Date/Time of Peak Outflow:	01Jul2015, 15:24
Total Inflow :	21.6 (AC-FT)	Peak Storage:	8.9 (AC-FT)
Total Outflow:	14.4 (AC-FT)	Peak Elevation:	7027.5 (FT)

Appendix C – Outlet Protection Design

Again, enter Figure HS-19a using the smaller d/D (or d/H) ratio to find the A/A_{full} ratio. Then,

$$A = (A/A_{full})A_{full} \quad (\text{HS-16c})$$

Finally,

$$V = Q/A \quad (\text{HS-16d})$$

In which for Equations 16a through 16d above:

A_{full} = cross-sectional area of the pipe (ft²)

A = area of the design flow in the end of the pipe (ft²)

n = Manning's n for the pipe full depth

Q_{full} = pipe full discharge at its slope (cfs)

R = hydraulic radius of the pipe flowing full, ft [$R_{full} = D/4$ for circular pipes, $R_{full} = A_{full}/(2H + 2w)$ for rectangular pipes, where D = diameter of a circular conduit, H = height of a rectangular conduit, and w = width of a rectangular conduit (ft)]

S_o = longitudinal slope of the pipe (ft/ft)

V = design flow velocity at the pipe outlet (ft/sec)

V_{full} = flow velocity of the pipe flowing full (ft/sec)

3.4.3.2 Riprap Size

For the design velocity, use [Figure HS-20c](#) to find the size and type of the riprap to use in the scour protection basin downstream of the pipe outlet (i.e., B18, H, M or L). First, calculate the riprap sizing design parameter, P_d , namely,

$$P_d = (V^2 + gd)^{1/2} \quad (\text{HS-16e})$$

in which:

V = design flow velocity at pipe outlet (ft/sec)

g = acceleration due to gravity = 32.2 ft/sec²

d = design depth of flow at pipe outlet (ft)

necessary when the receiving or downstream channel may have little or no flow or tailwater at time when the pipe or culvert is in operation. Design criteria are provided in Figures HS-19a through HS-20c.

3.4.2 Objective

By providing a low tailwater basin at the end of a storm sewer conduit or culvert, the kinetic energy of the discharge is dissipated under controlled conditions without causing scour at the channel bottom.

[Photograph HS-12](#) shows a fairly large low tailwater basin.

3.4.3 Low Tailwater Basin Design

Low tailwater is defined as being equal to or less than $\frac{1}{3}$ of the height of the storm sewer, that is:

$$y_t \leq \frac{D}{3} \quad \text{or} \quad y_t \leq \frac{H}{3}$$

in which:

y_t = tailwater depth at design

D = diameter of circular pipe (ft)

H = height of rectangular pipe (ft)

3.4.3.1 Finding Flow Depth and Velocity of Storm Sewer Outlet Pipe

The first step in the design of a scour protection basin at the outlet of a storm sewer is to find the depth and velocity of flow at the outlet. Pipe-full flow can be found using Manning's equation.

$$Q_{full} = \frac{1.49}{n} A_{full} (R_{full})^{2/3} S_o^{1/2} \quad (\text{HS-16a})$$

Then and the pipe-full velocity can be found using the continuity equation.

$$V_{full} = Q_{full} / A_{full} \quad (\text{HS-16a})$$

The normal depth of flow, d , and the velocity in a conduit can be found with the aid of [Figure HS-20a](#) and [Figure HS-20b](#). Using the known design discharge, Q , and the calculated pipe-full discharge, Q_{full} , enter Figure HS-20a with the value of Q/Q_{full} and find d/D for a circular pipe or d/H for a rectangular pipe.

Compare the value of d/D (or d/H) with the one obtained from Figure HS-20b using the Froude parameter.

$$Q/D^{2.5} \quad \text{or} \quad Q/(wH^{1/5}) \quad (\text{HS-16a})$$

Choose the smaller of the two (d/D or d/H) ratios to calculate the flow depth at the end of the pipe.

$$d = D(d/D) \quad \text{or} \quad d = H(d/H) \quad (\text{HS-16b})$$

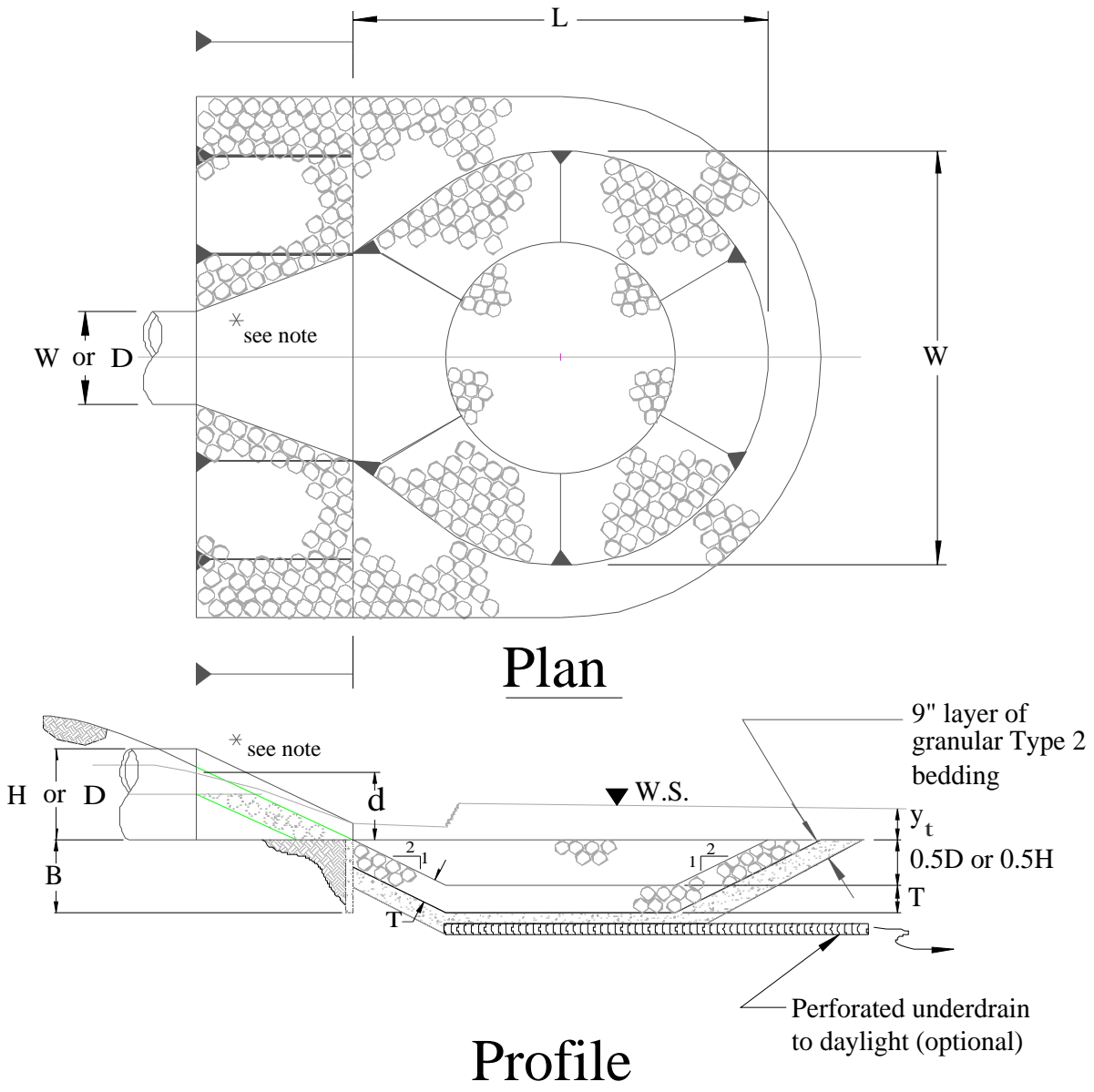

* Note: For rectangular conduits use a standard design for a headwall with wingwalls, paved bottom between the wingwalls, with an end cutoff wall extending to a minimum depth equal to B

**Figure HS-19—Low Tailwater Riprap Basins for Storm Sewer Pipe Outlets—
Low Tailwater Basin at Pipe Outlets
(Stevens and Urbonas 1996)**

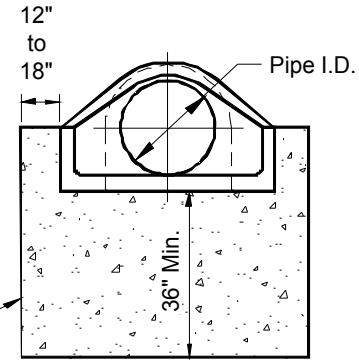
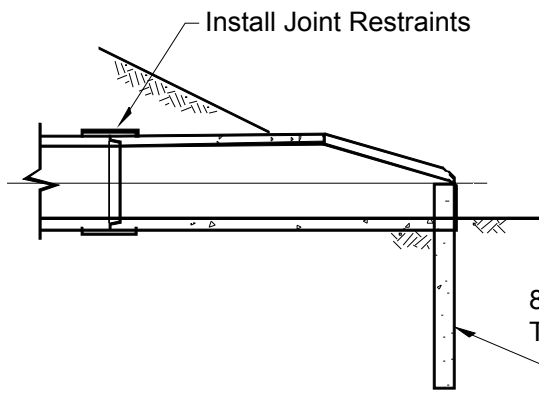
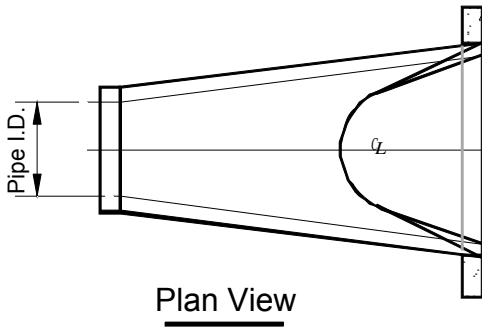

Figure HS-19a—Concrete Flared End Section with Cutoff Wall for all Pipe Outlets



Photograph HS-12—Upstream and downstream views of a low tailwater basin in Douglas County protecting downstream wetland area. Burying and revegetation of the rock would blend the structure better with the adjacent terrain.

When the riprap sizing design parameter indicates conditions that place the design above the Type H riprap line in [Figure HS-20](#), use B18, or larger, grouted boulders. An alternative to a grouted boulder or loose riprap basin is to use the standard USBR Impact Basin VI or one of its modified versions, described earlier in this Chapter of the *Manual*.

After the riprap size has been selected, the minimum thickness of the riprap layer, T , in feet, in the basin is set at:

$$T = 1.75D_{50} \tag{HS-17}$$

in which:

D_{50} = the median size of the riprap (see Table HS-9.)

Table HS-9—Median (i.e., D_{50}) Size of District's Riprap/Boulder

Riprap Type	D_{50} —Median Rock Size (inches)
L	9
M	12
H	18
B18	18 (minimum dimension of grouted boulders)

3.4.3.3 Basin Length

The minimum length of the basin, L , in [Figure HS-19](#), is defined as being the greater of the following:

for circular pipe: $L = 4D$ or $L = (D)^{1/2} \left(\frac{V}{2} \right)$ (HS-18)

for rectangular pipe: $L = 4H$ or $L = (H)^{1/2} \left(\frac{V}{2} \right)$ (HS-19)

in which:

L = basin length

H = height of rectangular conduit

V = design flow velocity at outlet

D = diameter of circular conduit

3.4.3.4 Basin Width

The minimum width, W , of the basin downstream of the pipe's flared end section is set as follows:

for circular pipes: $W = 4D$ (HS-20)

for rectangular pipe: $W = w + 4H$ (HS-21)

in which,

W = basin width ([Figure HS-19](#))

D = diameter of circular conduit

w = width of rectangular conduit

3.4.3.5 Other Design Requirements

All slopes in the pre-shaped riprapped basin are 2H to 1V.

Provide pipe joint fasteners and a structural concrete cutoff wall at the end of the flared end section for a circular pipe or a headwall with wingwalls and a paved bottom between the walls, both with a cutoff wall that extends down to a depth of:

$$B = \frac{D}{2} + T \text{ or } B = \frac{H}{2} + T \quad (\text{HS-22})$$

in which,

B = cutoff wall depth

D = diameter of circular conduit

T = Equation HS-17

The riprap must be extended up the outlet embankment's slope to the mid-pipe level.

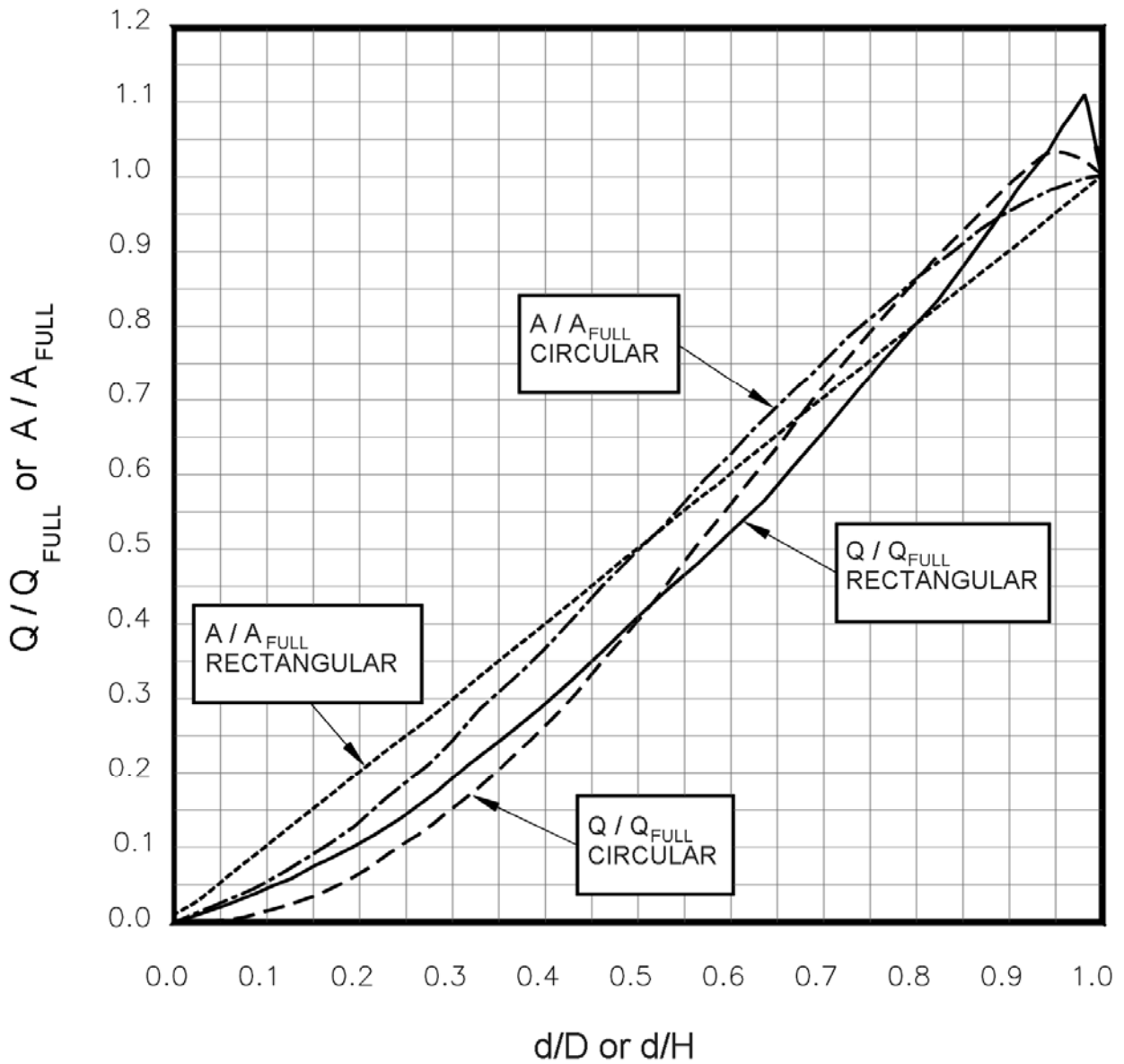

**Figure HS-20a—Low Tailwater Riprap Basins for Storm Sewer Pipe Outlets—
Discharge and Flow Area Relationships for Circular and Rectangular Pipes**
(Ratios for Flow Based on Manning's n Varying With Depth)
(Stevens and Urbonas 1996)

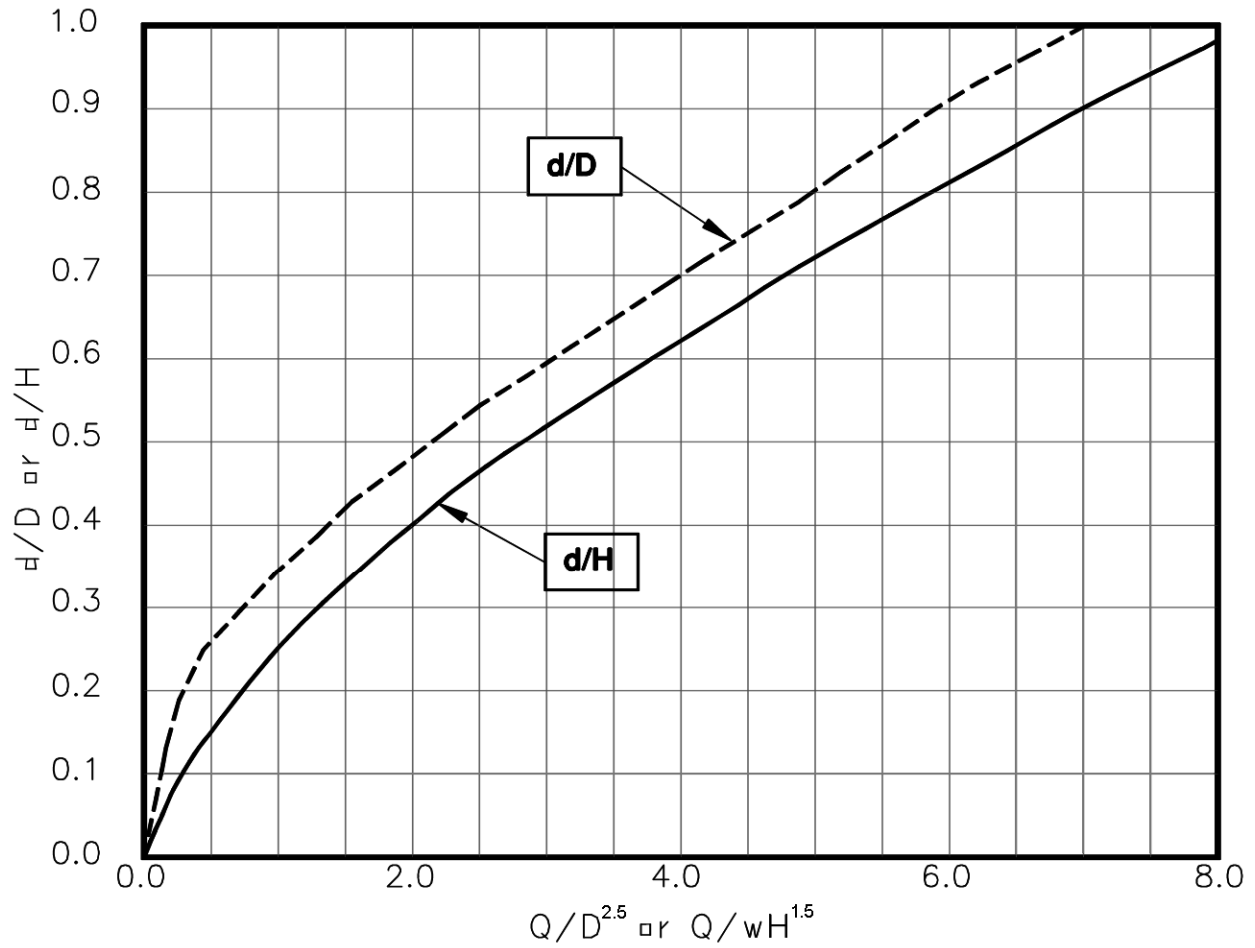

**Figure HS-20b—Low Tailwater Riprap Basins for Storm Sewer Pipe Outlets—
Brink Depth for Horizontal Pipe Outlets**
(Stevens and Urbonas 1996)

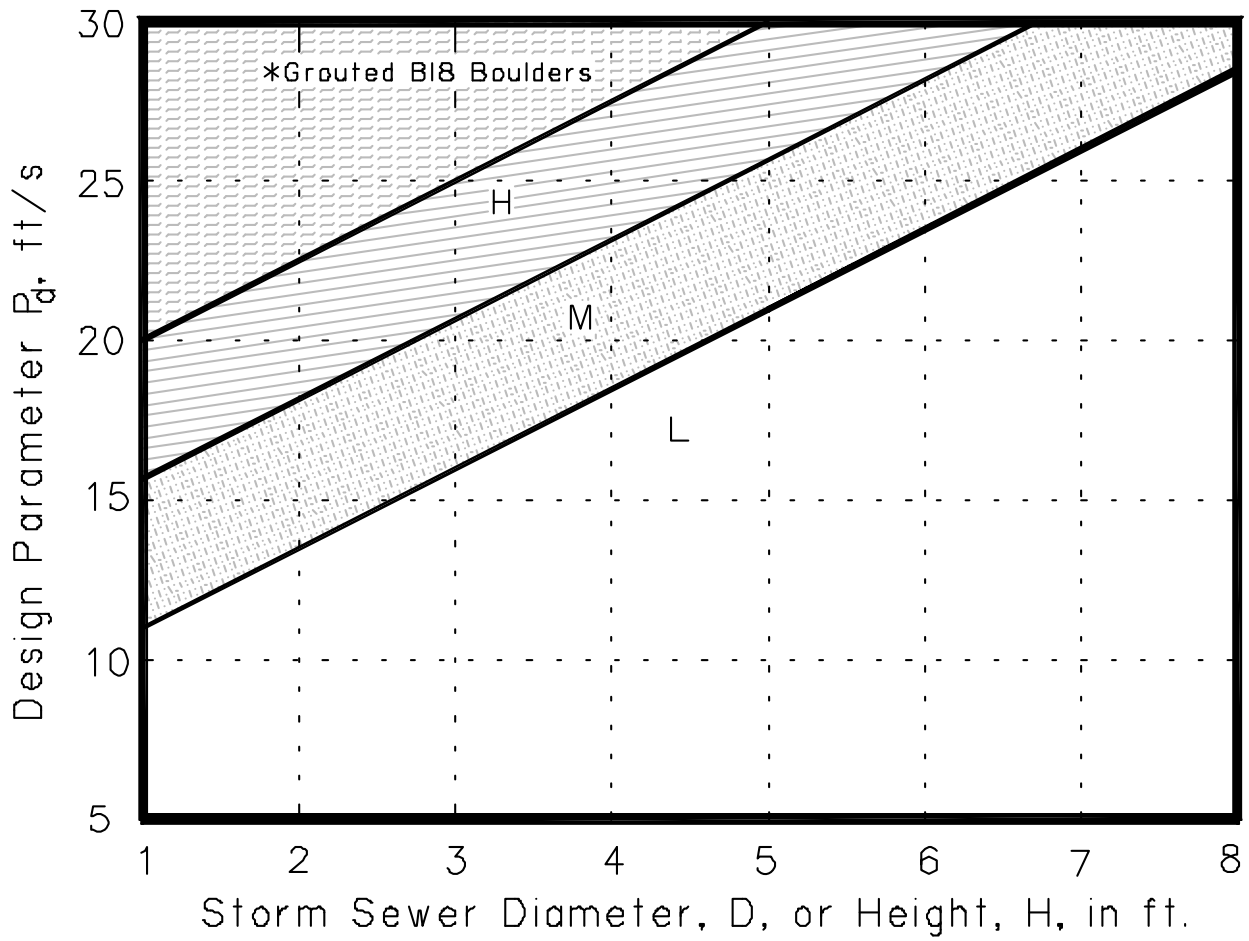

**Figure HS-20c—Low Tailwater Riprap Basins for Storm Sewer Pipe Outlets—
Riprap Selection Chart for Low Tailwater Basin at Pipe Outlet**
(Stevens and Urbonas 1996)

RIP RAP PLUNGE POOL

Urban Drainage & Flood Control District Pipe Outlet Design
Low Tailwater Design ($y_t \leq D/3$)

OUTLET # **OS-1 Future**

Outlet Size (D) :	54 in.	Discharge (q):	160 CFS
Capacity (Q): (full flow)	145 CFS	Flow depth (d): (calculated)	36.7 in.

Q _{full} =	145 CFS	q/Q _{full} =	1.10
A _{full} =	15.9 SF		
V _{full} =	9.1 FPS	Q/D ^{2.5} =	3.7

d/D	0.95	from HS-20a using q/Q _{full}
d/D	0.68	from HS-20b using Q/D ^{2.5}

A' (A/A _{full})	0.68	from HS-20a using smaller d/D from above	Flow Area (a=A' x A _{full})	10.8 SF
------------------------------	------	---	--	---------

Outlet Velocity (V = q/a) 14.8 FPS

$$P_d = (V^2 + gd)^{1/2} = 18$$

RIP-RAP SIZE: **M** from HS-20c * Chart shows Type L but Will use Type M
d₅₀ = 12 in T = 1.75 x d₅₀ 1.75 ft

Basin Length (L)	18.0 FT.	Cutoff Wall Depth	4 FT
Basin Width (W)	18.0 FT.	(B=D/2+T)	

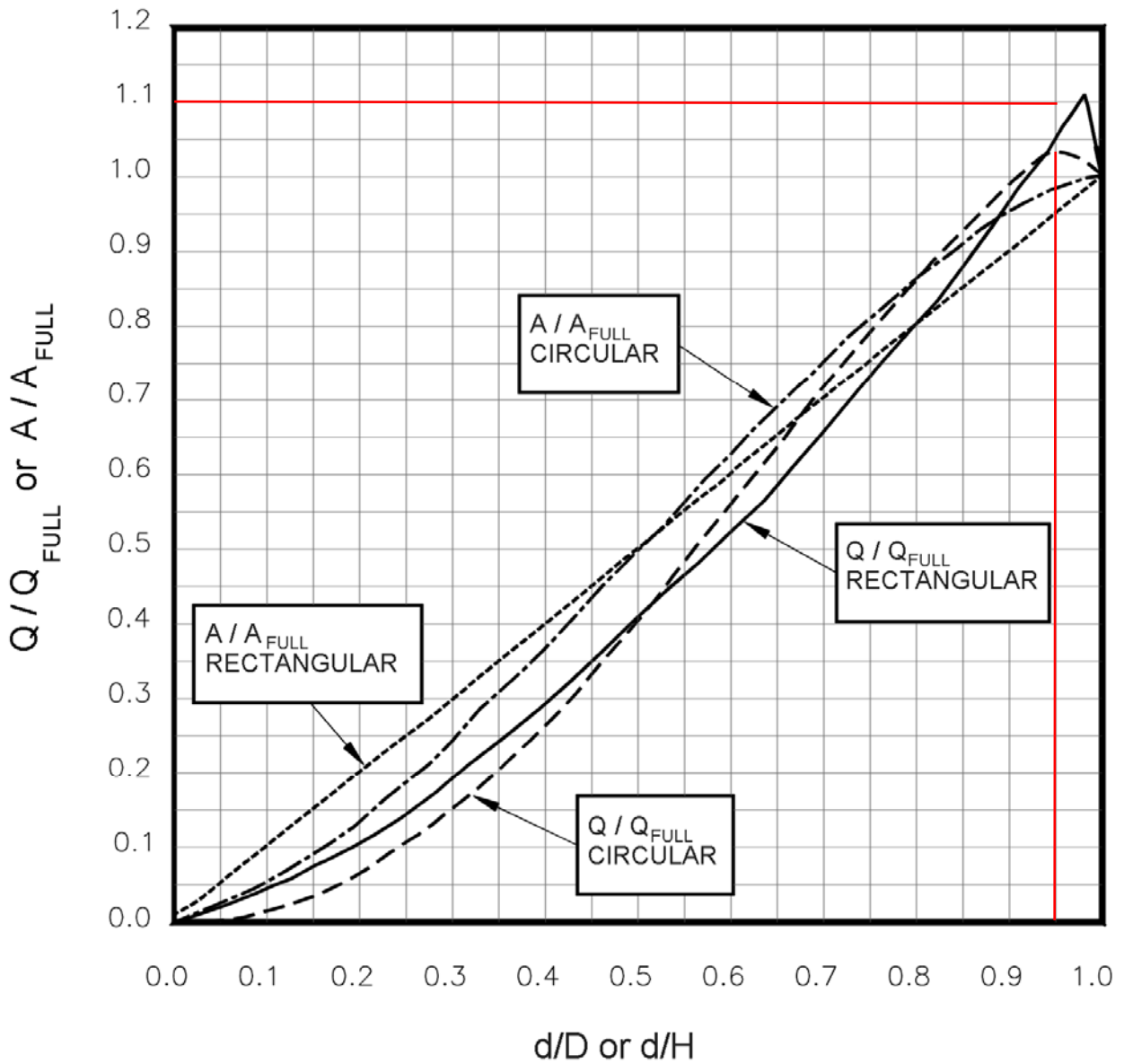

**Figure HS-20a—Low Tailwater Riprap Basins for Storm Sewer Pipe Outlets—
Discharge and Flow Area Relationships for Circular and Rectangular Pipes**
(Ratios for Flow Based on Manning's n Varying With Depth)
(Stevens and Urbonas 1996)

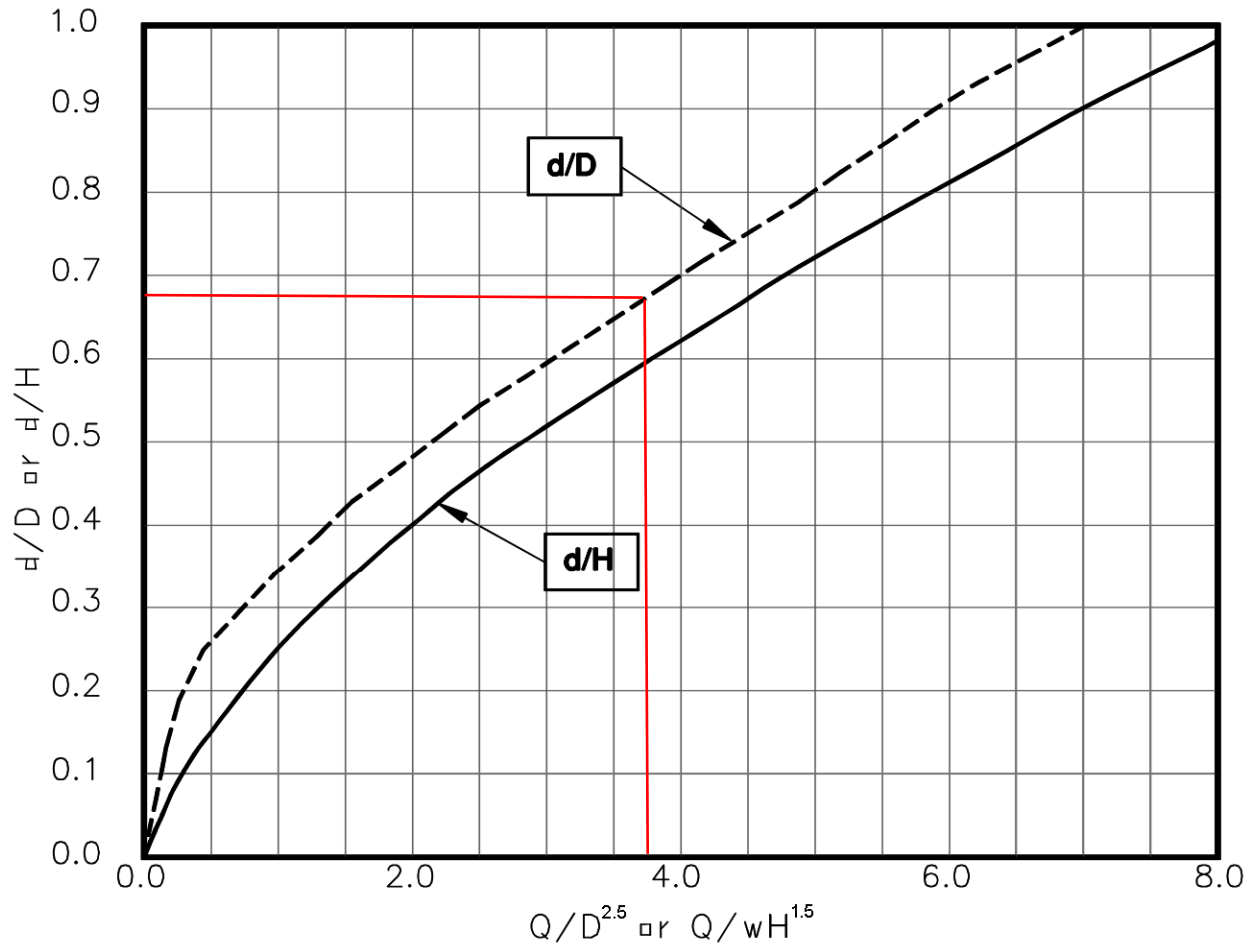

**Figure HS-20b—Low Tailwater Riprap Basins for Storm Sewer Pipe Outlets—
Brink Depth for Horizontal Pipe Outlets**
(Stevens and Urbonas 1996)

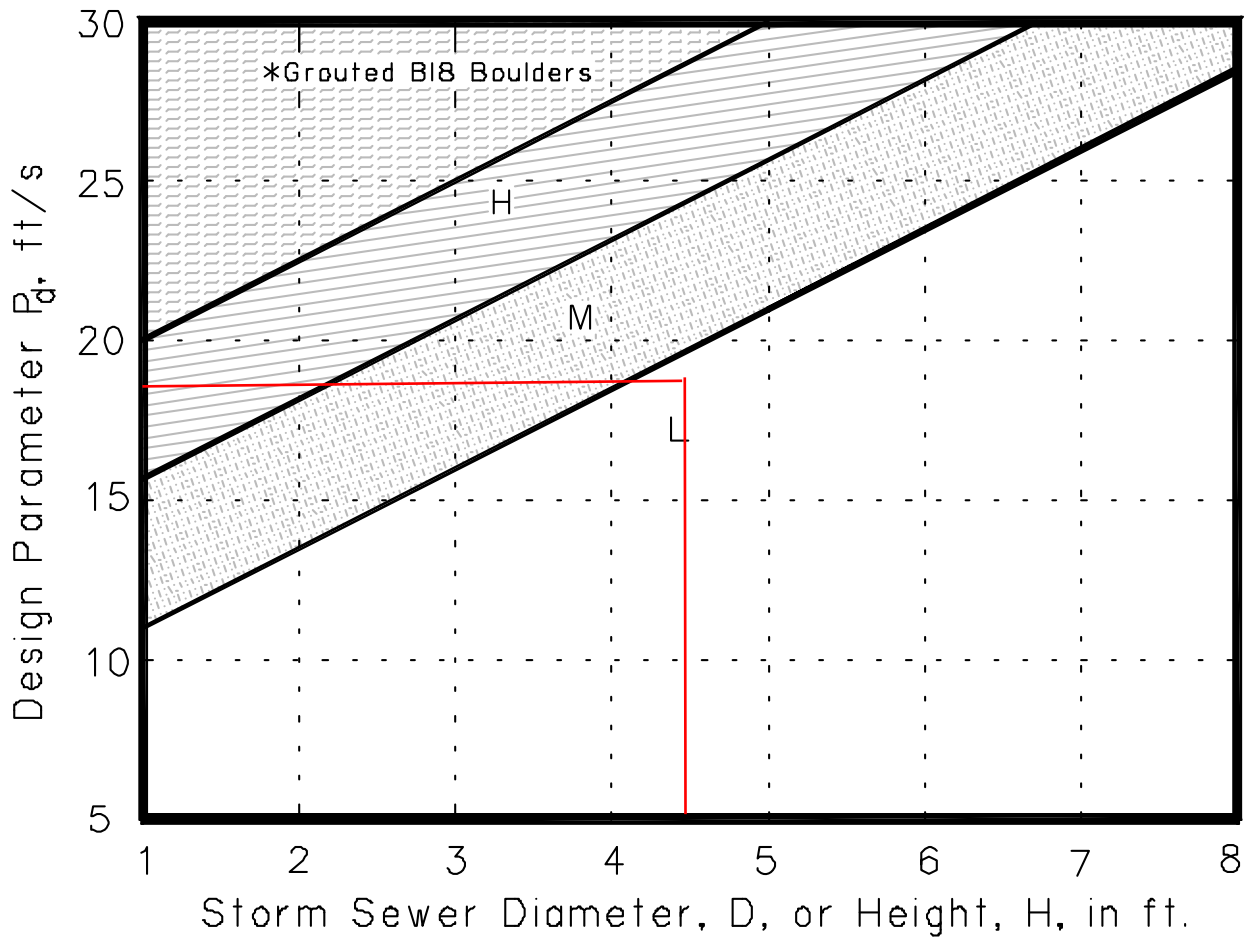

**Figure HS-20c—Low Tailwater Riprap Basins for Storm Sewer Pipe Outlets—
Riprap Selection Chart for Low Tailwater Basin at Pipe Outlet
(Stevens and Urbonas 1996)**

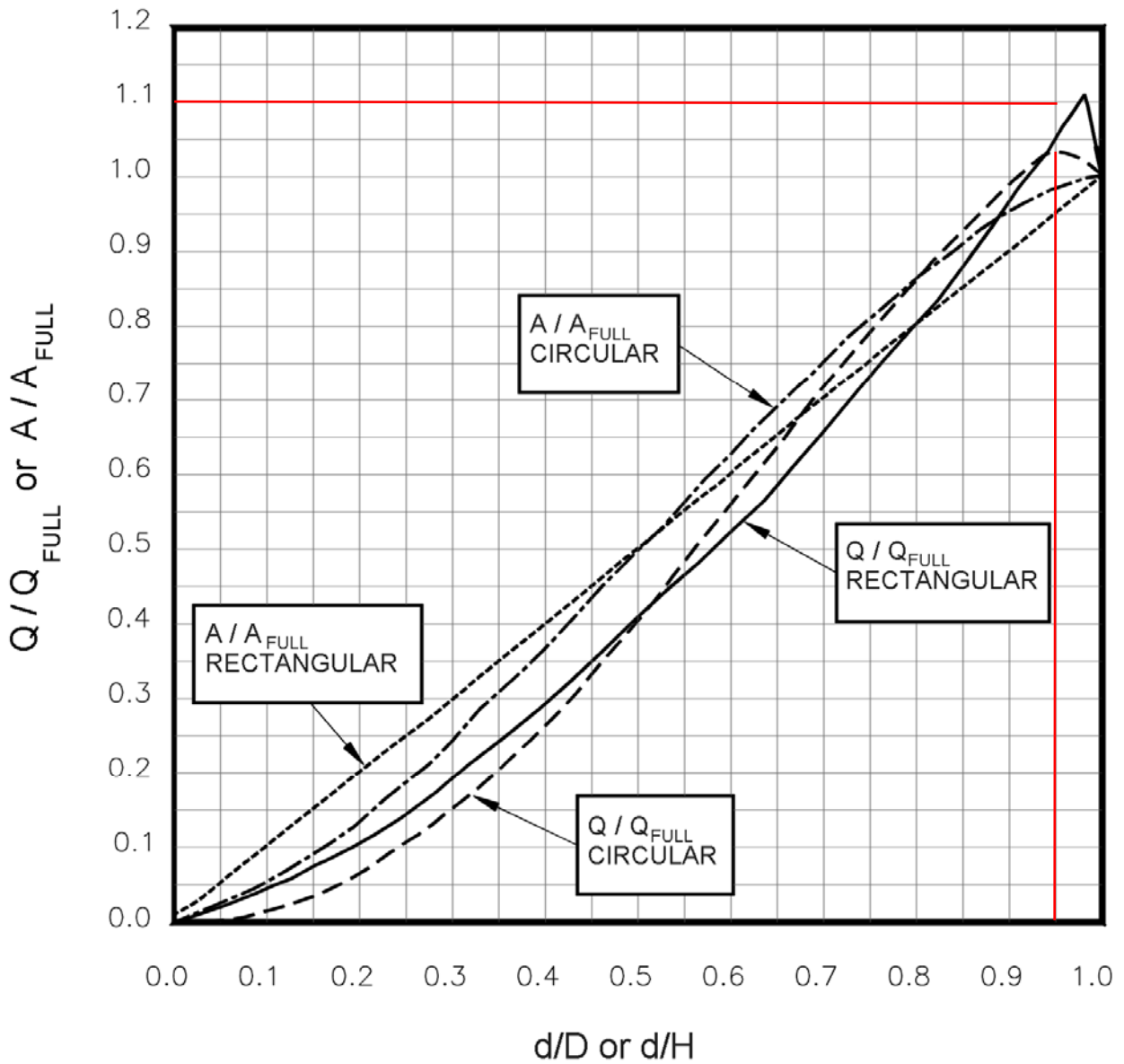

**Figure HS-20a—Low Tailwater Riprap Basins for Storm Sewer Pipe Outlets—
Discharge and Flow Area Relationships for Circular and Rectangular Pipes**
(Ratios for Flow Based on Manning's n Varying With Depth)
(Stevens and Urbonas 1996)

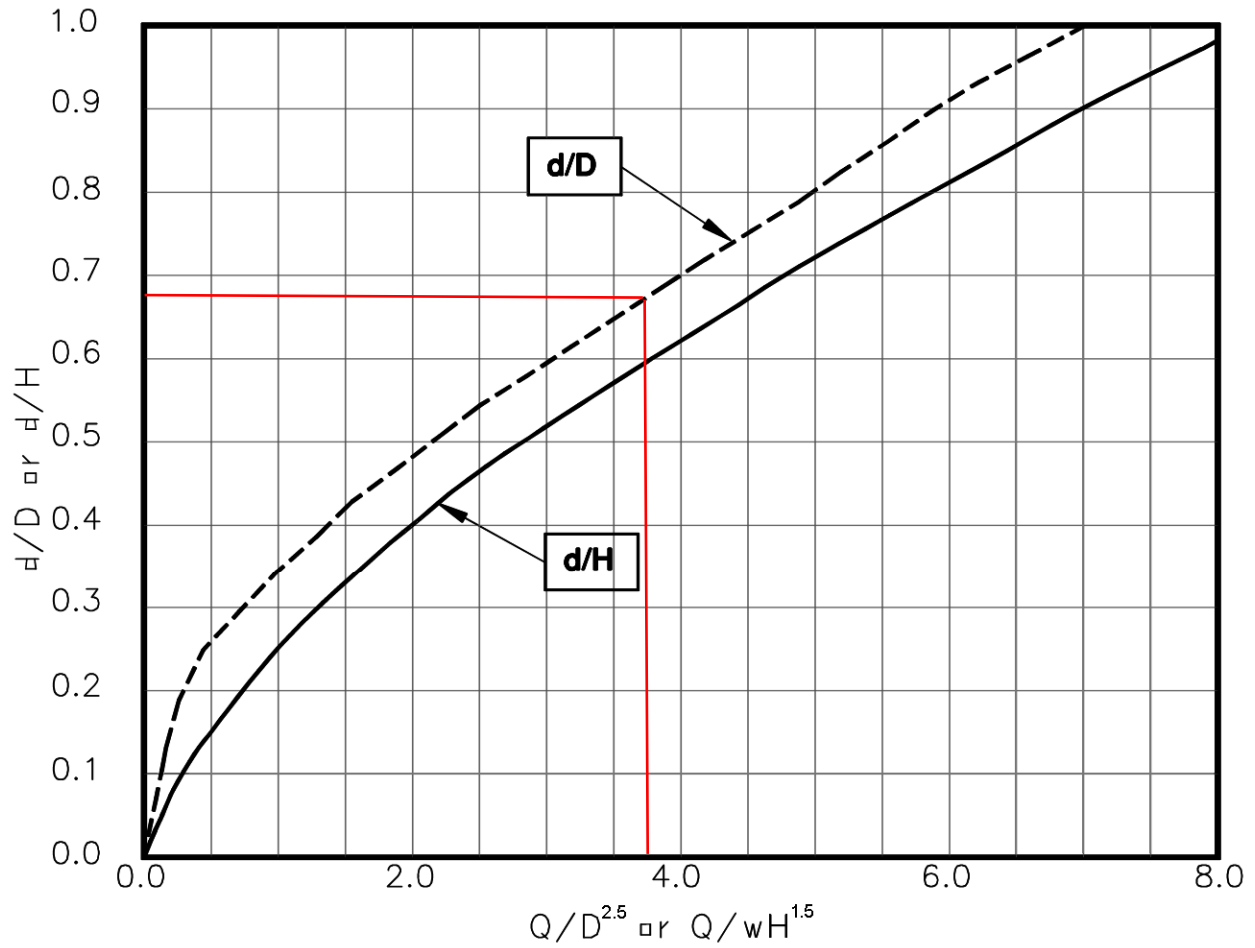

**Figure HS-20b—Low Tailwater Riprap Basins for Storm Sewer Pipe Outlets—
Brink Depth for Horizontal Pipe Outlets**
(Stevens and Urbonas 1996)

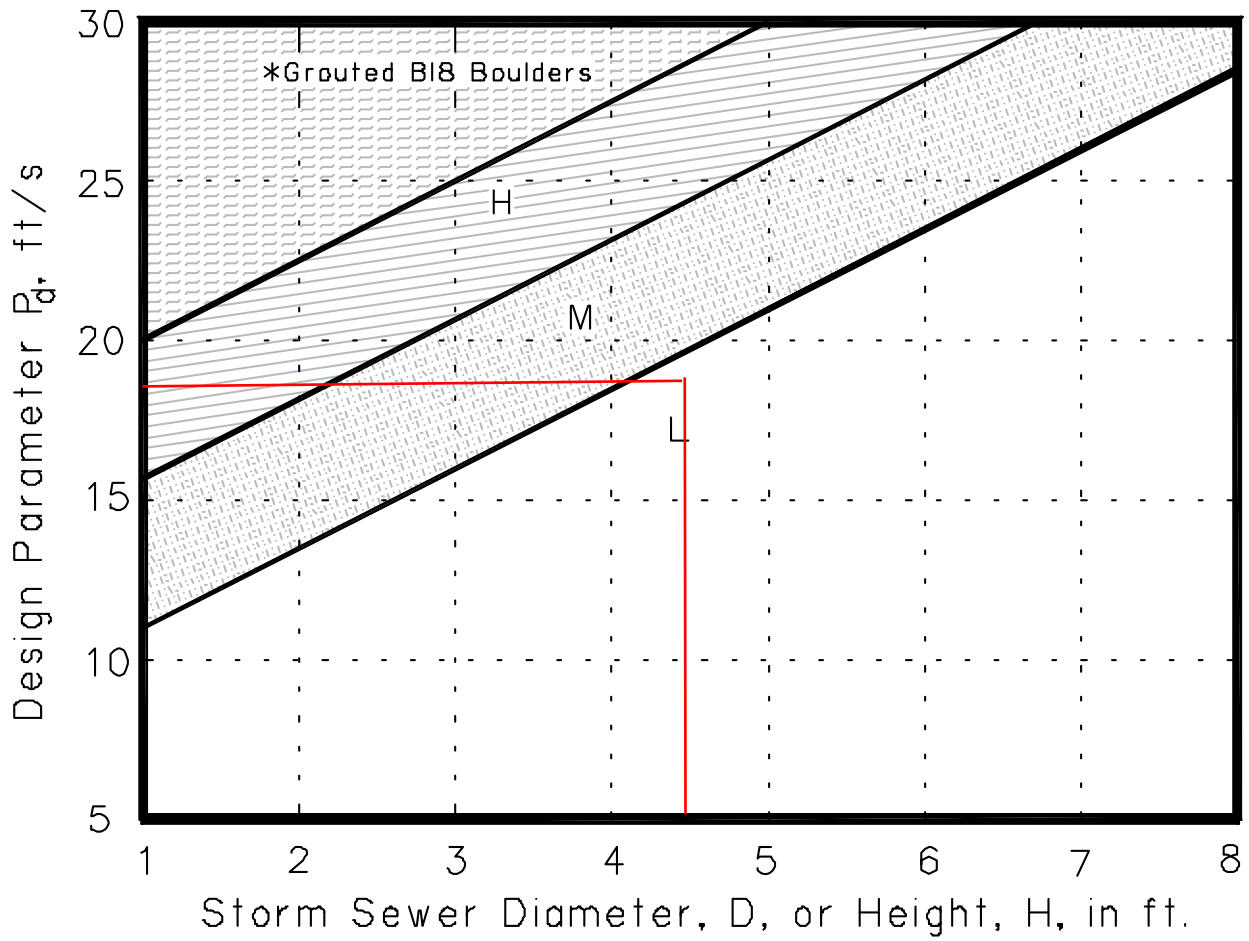

**Figure HS-20c—Low Tailwater Riprap Basins for Storm Sewer Pipe Outlets—
Riprap Selection Chart for Low Tailwater Basin at Pipe Outlet**
(Stevens and Urbonas 1996)

RIP RAP PLUNGE POOL

Urban Drainage & Flood Control District Pipe Outlet Design
Low Tailwater Design ($y_t \leq D/3$)

OUTLET # **OS-2**

Outlet Size (D) :	54	in.	Discharge (q):	172	CFS
Capacity (Q): (full flow)	198	CFS	Flow depth (d): (calculated)	37.8	in.

Q _{full} =	198 CFS	q/Q _{full} =	0.87
A _{full} =	15.9 SF		
V _{full} =	12.4 FPS	Q/D ^{2.5} =	4.0

d/D	0.81	from HS-20a using q/Q _{full}
d/D	0.70	from HS-20b using Q/D ^{2.5}

A' (A/A _{full})	0.70	from HS-20a using smaller d/D from above	Flow Area (a=A' x A _{full})	11.1	SF
------------------------------	------	---	--	------	----

Outlet Velocity (V = q/a) 15.4 FPS

$P_d = (V^2 + gd)^{1/2} =$ 18

RIP-RAP SIZE: **M** from HS-20c

d₅₀ = 12 in T=1.75xd₅₀ 1.75 ft

Basin Length (L)	18.0 FT.	Cutoff Wall Depth	4	FT
Basin Width (W)	18.0 FT.	(B=D/2+T)		

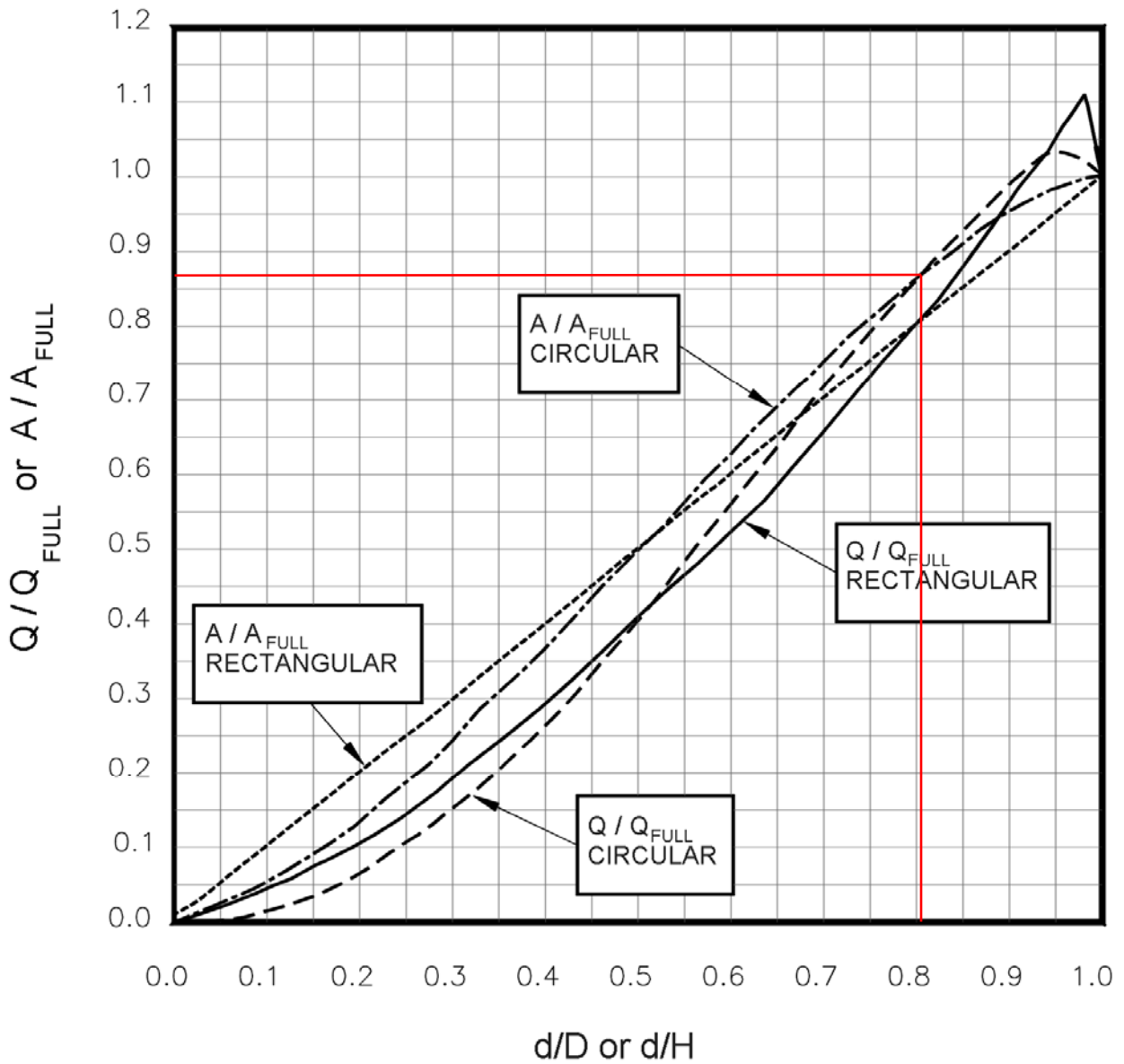

**Figure HS-20a—Low Tailwater Riprap Basins for Storm Sewer Pipe Outlets—
Discharge and Flow Area Relationships for Circular and Rectangular Pipes**
(Ratios for Flow Based on Manning's n Varying With Depth)
(Stevens and Urbonas 1996)

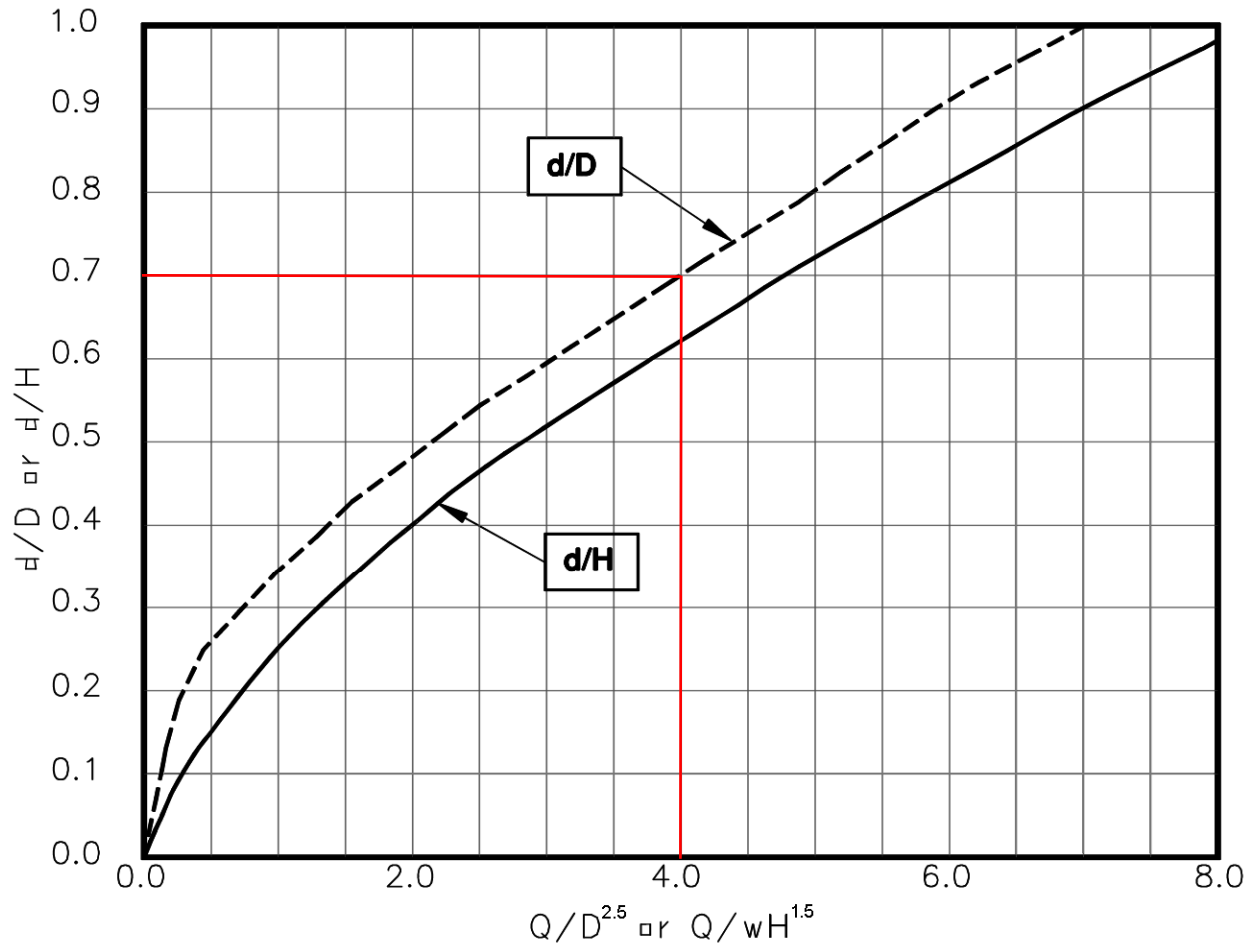

**Figure HS-20b—Low Tailwater Riprap Basins for Storm Sewer Pipe Outlets—
Brink Depth for Horizontal Pipe Outlets**
(Stevens and Urbonas 1996)

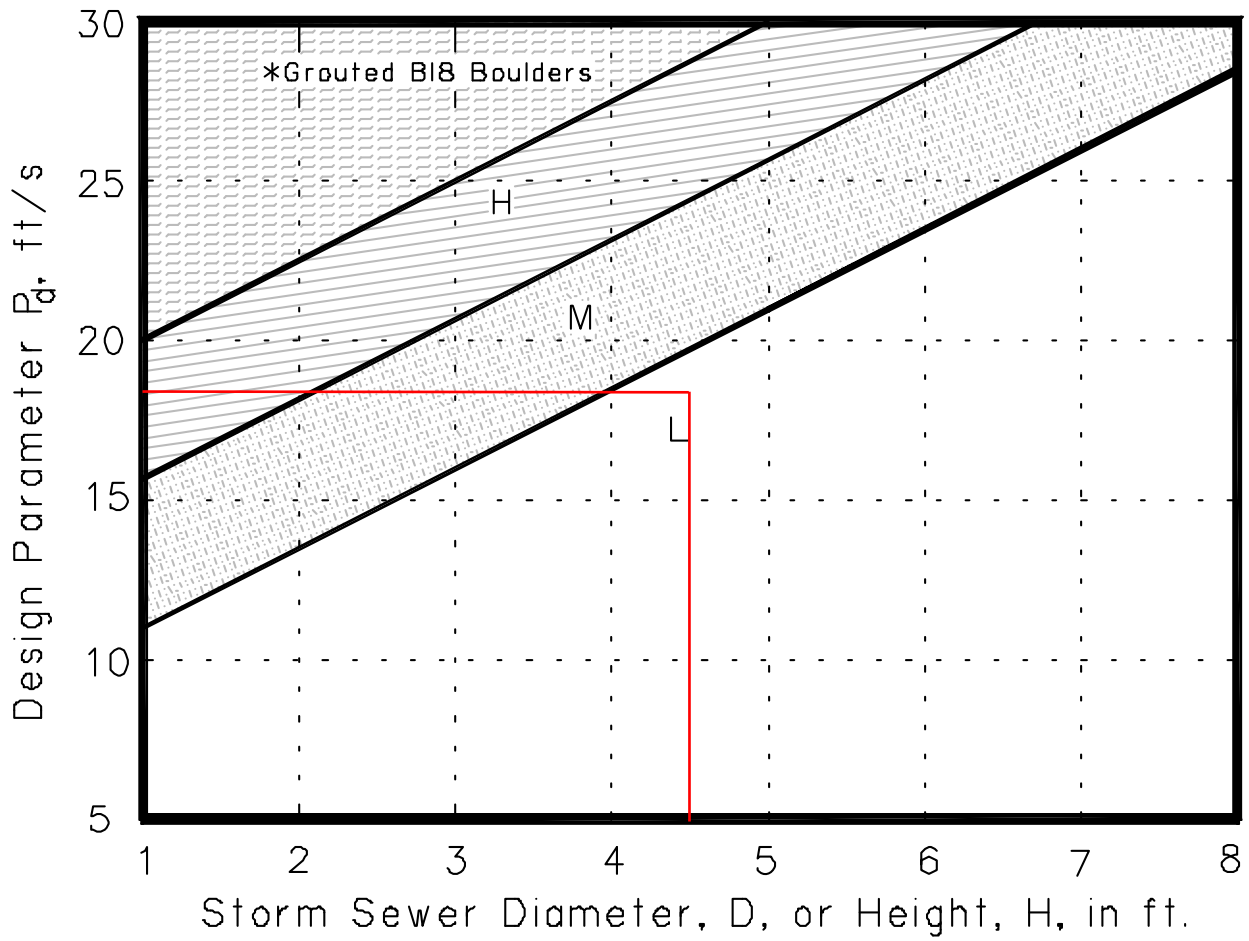

**Figure HS-20c—Low Tailwater Riprap Basins for Storm Sewer Pipe Outlets—
Riprap Selection Chart for Low Tailwater Basin at Pipe Outlet
(Stevens and Urbonas 1996)**

Appendix D – Water Quality & Temporary Sedimentation Ponds



Scale
AS SHOWN

Drawn by
TAK

Checked by
RG

Date
MAR 2022

Sheet Number
A

WATER QUALITY MAP

TEMPORARY SED PONDS
ROLLING HILLS RANCH NORTH GRADING

TECH CONTRACTORS
11886 STAPLETON DRIVE
FALCON, CO 80831
TELEPHONE: 719.495.7444
FAX: 719.495.3349

REX ROAD DP G9b
WQCV Control Riser Calculations

TRIBUTARY AREA	112	acres
DRAIN TIME	40	hr
<i>a</i>	1	
IMPERVIOUSNESS RATIO	0.26	
<i>i</i>		
DEPTH OF OUTLET	2.3	ft.
WQCV	0.14	inches
WQCV DESIGN VOL	0.34	ac-ft
<i>K</i> ₄₀	0.46	
AREA PER RISER ¹	2.58	in ²
<i>a</i>		
No. of Columns	1	
No. of Holes	1	per column
Area per Hole	2.58	in ²
Hole size	1 3/4	in
Steel Plate Thickness	1/4	in
¹ AREA PER ROW PER RISER		
Actual area per row per hole:	2.41	in ²
Actual area per riser:	2.4	in ²
Actual area per riser:	0.017	ft ²

TABLE SB-2							
Hole Dia (in)		Area per Row (in ²)					
Holes per Row		1	2	3	4	5	6
Min steel thickness		1/4	5/16	3/8	3/8	3/8	1/2
1/4	0.2500	0.05	0.10	0.15	0.20	0.25	0.29
5/16	0.3125	0.08	0.15	0.23	0.31	0.38	0.46
3/8	0.3750	0.11	0.22	0.33	0.44	0.55	0.66
7/16	0.4375	0.15	0.30	0.45	0.60	0.75	0.90
1/2	0.5000	0.20	0.39	0.59	0.79	0.98	1.18
9/16	0.5625	0.25	0.50	0.75	0.99	1.24	1.49
5/8	0.6250	0.31	0.61	0.92	1.23	1.53	1.84
11/16	0.6875	0.37	0.74	1.11	1.48	1.86	2.23
3/4	0.7500	0.44	0.88	1.33	1.77	2.21	2.65
7/8	0.8750	0.60	1.20	1.80	2.41	3.01	3.61
1	1.0000	0.79	1.57	2.36	3.14	3.93	4.71
1 1/8	1.1250	0.99	1.99	2.98	3.98	4.97	5.96
1 1/4	1.2500	1.23	2.45	3.68	4.91	6.14	7.36
1 3/8	1.3750	1.48	2.97	4.45	5.94	7.42	8.91
1 1/2	1.5000	1.77	3.53	5.30	7.07	8.84	10.60
1 5/8	1.6250	2.07	4.15	6.22	8.30	10.37	12.44
1 3/4	1.7500	2.41	4.81	7.22	9.62	12.03	14.43
1 7/8	1.8750	2.76	5.52	8.28	11.04	13.81	16.57
2	2.0000	3.14	6.28	9.42	12.57	15.71	18.85
n = Number of columns of perforations							

STAGE/STORAGE/DISCHARGE CURVES FOR DETENTION POND ANALYSIS

Rex Road Water Quality Pond - Graded Condition (G9b)

Gieck Basin - El Paso County, Colorado

Data for spillway and embankment:

embankment length =	500
embankment elev =	7065
spillway length =	130
spillway elevation =	7064.5
100 year storage elev.=	7063.3
100 year storage vol.=	1.0
100 year discharge=	170
5 year storage elev.=	7058.8
5 year storage vol.=	0.2
5 year discharge=	15
WQCV storage elev.=	7058.1
WQCV storage vol.=	0.1
1/2 WQCV storage elev.=	7057.2
1/2 WQCV storage vol.=	0.06

Data for outlet pipe and grate:

		Type		Dimensions						
		H or V	Width (ft.)	X Height (ft.)	Dia.(in)	(sqft)				
Circular	Orifice 1:	V			1.875	Area =	0.019	Elev to cl =	7056.33	
Rectangular	Orifice 2:	V	6	3.7		Area =	22.200	Elev to cl =	7059.85	
None Selected	Orifice 3:	V				Area =	0.000	Elev to cl =	0.00	
None Selected	Orifice 4:	V				Area =	0.000	Elev to cl =	0.00	
Stand Pipe Dimensions										
Rec Grate		7.3	x	2.9	Elev =	7061.70	50 year storage elev.=			7061.6
Circ. Grate			dia.		Elev =	7061.70	50 year discharge=			122
							10 year storage elev.=			7059.5
							10 year discharge=			33
							2 year storage elev.=			7058.3
							2 year discharge=			3.3

Outlet Culvert Dimensions

	Width (ft.)	H or V	Height (ft.)	Dia. (ft.)	Type
Outlet Culvert		x		4.5	Circular
Area	15.9		TOP		
Outlet I. E.	7055.8		7060.77		
Wall Thick.	6.25	in.			

STAGE		STORAGE				DISCHARGE											
ELEV	HEIGHT	AREA		VOLUME		TOP OF BANK	SPILLWAY	ORIFICE (max outflow)				GRATE (max outflow)	PIPE		REALIZED CULVERT OUTFLOW	TOTAL FLOW	
		sqft	acre	acft	cum acft			1	2	3	4		1	2			
7055.75	0	0	0.00	0.000	0.000			-	-	-	-	-	-	-	-	-	
7057	1.25	2797	0.06	0.040	0.040	-	-	0.08	-	-	-	-	-	9	-	0.08	0.08
7058	2.25	3757	0.09	0.075	0.115	-	-	0.12	-	-	-	-	-	26	-	0.12	0.12
7058.25	2.50	4023	0.09	0.022	0.138	-	-	0.13	2.3	-	-	-	-	32	-	2.38	2.38
7058.5	2.75	4288	0.10	0.024	0.162	-	-	0.14	6.4	-	-	-	-	38	-	6.50	6.50
7059	3.25	4819	0.11	0.052	0.214	-	-	0.15	18.0	-	-	-	-	51	-	18.2	18.15
7060	4.25	5944	0.14	0.124	0.337	-	-	0.18	50.9	-	-	-	-	80	-	51.1	51.09
7061	5.25	7176	0.16	0.151	0.488	-	-	0.20	93.5	-	-	-	-	113	-	93.7	93.73
7062	6.25	8632	0.20	0.181	0.669	-	-	0.22	144.0	-	-	6	-	144	-	143.9	143.85
7063	7.25	10139	0.23	0.215	0.885	-	-	0.24	189.7	-	-	59	-	164	-	164.5	164.46
7064	8.25	12030	0.28	0.254	1.139	-	-	0.26	217.8	-	-	138	-	183	-	182.8	182.77
7064.5	8.75	13160	0.30	0.278	1.418	-	-	0.26	230.5	-	-	187	-	191	-	191.3	191.26
7065	9.25	14290	0.33	0.302	1.720	137.9	137.9	0.27	242.6	-	-	187	-	199	-	199.4	337.29

- Notes:
- 1) Top-of-bank and spillway flows are weir equations from section 11.3.1 in the DCM. $Q=CLH^{1.5}$ (C=3.0)
 - 2) Orifice flows are also from section 11.3.1. $Q=CA(2gH)^{.5}$ (C=6)
 - 3) Grate flows are determined from equations 7-2 and 7-3. Weir Flow $Q=(3PH^{1.5})/F$, Orifice Flow $Q=4.815*AH^{0.5}$
 - 4) Pipe flows use the lesser of: 1) Inlet control equations 27 & 28, page 146 of HDS No. 5 - or - 2) Allowable Pipe Flow equation on page 11-9 of the DCM. Use Table 9, page 147-148, HDS No. 5 for formulas 26 & 27.

STAGE/STORAGE/DISCHARGE CURVES FOR DETENTION POND ANALYSIS

**Rex Road Water Quality Pond - Future Condition (G9b)
Gieck Basin - El Paso County, Colorado**

Data for spillway and embankment:

embankment length =	500
embankment elev =	7065
spillway length =	130
spillway elevation =	7064.5
100 year storage elev.=	7062.7
100 year storage vol.=	0.6
100 year discharge=	158
5 year storage elev.=	7059.4
5 year storage vol.=	0.2
5 year discharge=	31
WQCV storage elev.=	7058.1
WQCV storage vol.=	0.08
1/2 WQCV storage elev.=	7057.3
1/2 WQCV storage vol.=	0.04

Data for outlet pipe and grate:

Type	H or V	Dimensions		Dia.(in)	(sqft)
		Width (ft.)	X Height (ft.)		
Circular	Orifice 1:	V		1.875	Area = 0.019
Rectangular	Orifice 2:	V	6	3.7	Area = 22.200
None Selected	Orifice 3:	V			Area = 0.000
None Selected	Orifice 4:	V			Area = 0.000

Stand Pipe Dimensions

Rec Grate	7.3	x	2.9	Elev = 7061.70
Circ. Grate		dia.		Elev = 7061.70

50 year storage elev.=	7061.6
50 year discharge=	125
10 year storage elev.=	7060.0
10 year discharge=	51
2 year storage elev.=	7058.8
2 year discharge=	14
WQCV storage elev.=	7058.1
WQCV discharge=	0.6

Outlet Culvert Dimensions

Outlet Culvert	Width (ft.)	H or V	Height (ft.)	Dia. (ft.)	Type
	15.9	x	4.5	4.5	Circular
Area	15.9		TOP		
Outlet I. E.	7056.3		7061.13		
Wall Thick.	4.5	in.			

STAGE		STORAGE				DISCHARGE										REALIZED CULVERT OUTFLOW	TOTAL FLOW
ELEV	HEIGHT	AREA		VOLUME		TOP OF BANK	SPILLWAY	ORIFICE (max outflow)				GRATE (max outflow) Rectangular	PIPE				
		sqft	acre	acft	cum acft			1	2	3	4		1	2			
7055.75	0	0	0.00	0.000	0.000			-	-	-	-	-	-	-	-	-	-
7057	1.25	1794	0.04	0.026	0.026	-	-	0.08	-	-	-	-	-	9		0.08	0.08
7058	2.25	2674	0.06	0.051	0.077	-	-	0.12	-	-	-	-	-	26		0.12	0.12
7058.25	2.50	2967	0.07	0.016	0.093	-	-	0.13	2.3	-	-	-	-	32		2.38	2.38
7058.5	2.75	3261	0.07	0.018	0.111	-	-	0.14	6.4	-	-	-	-	38		6.50	6.50
7059	3.25	3847	0.09	0.041	0.152	-	-	0.15	18.0	-	-	-	-	51		18.2	18.15
7060	4.25	4770	0.11	0.099	0.251	-	-	0.18	50.9	-	-	-	-	80		51.1	51.09
7061	5.25	5819	0.13	0.122	0.372	-	-	0.20	93.5	-	-	-	-	113		93.7	93.73
7062	6.25	7105	0.16	0.148	0.521	-	-	0.22	144.0	-	-	-	6	144		143.9	143.85
7063	7.25	8460	0.19	0.179	0.699	-	-	0.24	189.7	-	-	-	59	164		164.5	164.46
7064	8.25	10687	0.25	0.220	0.919	-	-	0.26	217.8	-	-	-	138	183		182.8	182.77
7064.5	8.75	11709	0.27	0.244	1.163	-	-	0.26	230.5	-	-	-	187	191		191.3	191.26
7065	9.25	12730	0.29	0.269	1.432	137.9	137.9	0.27	242.6	-	-	-	187	199		199.4	337.29

- Notes:
- 1) Top-of-bank and spillway flows are weir equations from section 11.3.1 in the DCM. $Q=CLH^{1.5}$ (C=3.0)
 - 2) Orifice flows are also from section 11.3.1. $Q=CA(2gH)^{0.5}$ (C=.6)
 - 3) Grate flows are determined from equations 7-2 and 7-3. Weir Flow $Q=(3PH^{1.5})/F$, Orifice Flow $Q=4.815*AH^{0.5}$
 - 4) Pipe flows use the lesser of: 1) Inlet control equations 27 & 28, page 146 of HDS No. 5 - or - 2) Allowable Pipe Flow equation on page 11-9 of the DCM. Use Table 9, page 147-148, HDS No. 5 for formulas 26 & 27.

**ROLLING HILLS RANCH NORTH GRADING
TEMPORARY SEDIMENTATION SIZING**

TEMP POND 1

Tributary Area: Required Volume Depth at Outlet
32.3 ac. 1.3 ac-ft 5.7 ft.

Area required
per Row
1.1 in²

WS Elev: 7086.7

No. of
columns
2

Hole size
13/16 in

STAGE			STORAGE			
STAGE	ELEV	HEIGHT	AREA		VOLUME	
			sqft	acre	acft	cum acft
1	7081	0	20	0.000	0.000	0.00
2	7082	1	2259	0.05	0.03	0.03
3	7083	2	7622	0.17	0.11	0.14
4	7084	3	11817	0.27	0.22	0.36
5	7085	4	15588	0.36	0.31	0.68
6	7086	5	18467	0.42	0.39	1.07
7	7087	6	21418	0.49	0.46	1.53

TABLE SB-2

Minimum steel thickness	1	2	3	4	5	6	
	1/4	5/16	3/8	3/8	3/8	1/2	
1/2	0.5000	0.20	0.39	0.59	0.79	0.98	1.18
9/16	0.5625	0.25	0.50	0.75	0.99	1.24	1.49
5/8	0.6250	0.31	0.61	0.92	1.23	1.53	1.84
11/16	0.6875	0.37	0.74	1.11	1.48	1.86	2.23
3/4	0.7500	0.44	0.88	1.33	1.77	2.21	2.65
13/16	0.8125	0.52	1.04	1.56	2.07	2.59	3.11
7/8	0.8750	0.60	1.20	1.80	2.41	3.01	3.61
15/16	0.9375	0.69	1.38	2.07	2.76	3.45	4.14
1	1.0000	0.79	1.57	2.36	3.14	3.93	4.71
1 1/16	1.0625	0.89	1.77	2.66	3.55	4.43	5.32

**ROLLING HILLS RANCH NORTH GRADING
TEMPORARY SEDIMENTATION SIZING**

TEMP POND 2

Tributary Area: 5.4 ac. Required Volume: 0.2 ac-ft Depth at Outlet: 3.3 ft.

Area required
per Row
0.3 in²

WS Elev: 7085.8

No. of columns: 1
Hole size: 9/16 in

STAGE			STORAGE			
STAGE	ELEV	HEIGHT	AREA		VOLUME	
			sqft	acre	acft	cum acft
1	7082.5	0	1174	0.027	0.000	0.00
2	7083	0.5	1903	0.04	0.02	0.02
3	7084	1.5	2564	0.06	0.05	0.07
4	7085	2.5	3299	0.08	0.07	0.14
5	7086	3.5	4105	0.09	0.08	0.22
6	7087	4.5	4985	0.11	0.10	0.33

TABLE SB-2

Minimum steel thickness		1	2	3	4	5	6
		1/4	5/16	3/8	3/8	3/8	1/2
1/2	0.5000	0.20	0.39	0.59	0.79	0.98	1.18
9/16	0.5625	0.25	0.50	0.75	0.99	1.24	1.49
5/8	0.6250	0.31	0.61	0.92	1.23	1.53	1.84
11/16	0.6875	0.37	0.74	1.11	1.48	1.86	2.23
3/4	0.7500	0.44	0.88	1.33	1.77	2.21	2.65
13/16	0.8125	0.52	1.04	1.56	2.07	2.59	3.11
7/8	0.8750	0.60	1.20	1.80	2.41	3.01	3.61
15/16	0.9375	0.69	1.38	2.07	2.76	3.45	4.14
1	1.0000	0.79	1.57	2.36	3.14	3.93	4.71
1 1/16	1.0625	0.89	1.77	2.66	3.55	4.43	5.32

**ROLLING HILLS RANCH NORTH GRADING
TEMPORARY SEDIMENTATION SIZING**

TEMP POND 3

Tributary Area: 18.1 ac. Required Volume: 0.7 ac-ft Depth at Outlet: 5.2 ft.

Area required
per Row
0.6 in²

WS Elev: 7078.7

No. of columns: 3 Hole size: 1/2 in

STAGE			STORAGE			
STAGE	ELEV	HEIGHT	AREA		VOLUME	
			sqft	acre	acft	cum acft
1	7073.5	0	30	0.001	0.000	0.00
2	7074	0.5	1305	0.03	0.01	0.01
3	7075	1.5	4455	0.10	0.07	0.07
4	7076	2.5	6208	0.14	0.12	0.20
5	7077	3.5	7544	0.17	0.16	0.35
6	7078	4.5	8949	0.21	0.19	0.54
7	7079	5.5	10425	0.24	0.22	0.77

TABLE SB-2

Minimum steel thickness	1	2	3	4	5	6	
	1/4	5/16	3/8	3/8	3/8	1/2	
1/2	0.5000	0.20	0.39	0.59	0.79	0.98	1.18
9/16	0.5625	0.25	0.50	0.75	0.99	1.24	1.49
5/8	0.6250	0.31	0.61	0.92	1.23	1.53	1.84
11/16	0.6875	0.37	0.74	1.11	1.48	1.86	2.23
3/4	0.7500	0.44	0.88	1.33	1.77	2.21	2.65
13/16	0.8125	0.52	1.04	1.56	2.07	2.59	3.11
7/8	0.8750	0.60	1.20	1.80	2.41	3.01	3.61
15/16	0.9375	0.69	1.38	2.07	2.76	3.45	4.14
1	1.0000	0.79	1.57	2.36	3.14	3.93	4.71
1 1/16	1.0625	0.89	1.77	2.66	3.55	4.43	5.32

**ROLLING HILLS RANCH NORTH GRADING
TEMPORARY SEDIMENTATION SIZING**

TEMP POND 4

Tributary Area: Required Volume Depth at Outlet
36.5 ac. 1.5 ac-ft 4.9 ft.

Area required
 per Row
 1.3 in²

WS Elev: 7062.9

No. of
 columns
2

Hole size
 7/8 in

STAGE			STORAGE			
STAGE	ELEV	HEIGHT	AREA		VOLUME	
			sqft	acre	acft	cum acft
1	7058	0	30	0.001	0.000	0.00
2	7059	1	3739	0.09	0.04	0.04
3	7060	2	4848	0.11	0.10	0.14
4	7061	3	12385	0.28	0.20	0.34
5	7062	4	27845	0.64	0.46	0.80
6	7063	5	38900	0.89	0.77	1.57
7	7064	6	48859	1.12	1.01	2.57

TABLE SB-2

Minimum steel thickness	1	2	3	4	5	6	
	1/4	5/16	3/8	3/8	3/8	1/2	
1/2	0.5000	0.20	0.39	0.59	0.79	0.98	1.18
9/16	0.5625	0.25	0.50	0.75	0.99	1.24	1.49
5/8	0.6250	0.31	0.61	0.92	1.23	1.53	1.84
11/16	0.6875	0.37	0.74	1.11	1.48	1.86	2.23
3/4	0.7500	0.44	0.88	1.33	1.77	2.21	2.65
13/16	0.8125	0.52	1.04	1.56	2.07	2.59	3.11
7/8	0.8750	0.60	1.20	1.80	2.41	3.01	3.61
15/16	0.9375	0.69	1.38	2.07	2.76	3.45	4.14
1	1.0000	0.79	1.57	2.36	3.14	3.93	4.71
1 1/16	1.0625	0.89	1.77	2.66	3.55	4.43	5.32

**ROLLING HILLS RANCH NORTH GRADING
TEMPORARY SEDIMENTATION SIZING**

TEMP POND 5

Tributary Area: 38.9 ac. Required Volume: 1.6 ac-ft Depth at Outlet: 7.0 ft.

Area required
per Row
1.4 in²

WS Elev: 7040.5

No. of columns: 2 Hole size: 15/16 in

STAGE			STORAGE			
STAGE	ELEV	HEIGHT	AREA		VOLUME	
			sqft	acre	acft	cum acft
1	7033.5	0	30	0.001	0.000	0.00
2	7034	0.5	1994	0.05	0.01	0.01
3	7035	1.5	4040	0.09	0.07	0.08
4	7036	2.5	6835	0.16	0.12	0.21
5	7037	3.5	9578	0.22	0.19	0.39
6	7038	4.5	12395	0.28	0.25	0.65
7	7039	5.5	15286	0.35	0.32	0.96
8	7040	6.5	18252	0.42	0.38	1.35
9	7041	7.5	21292	0.49	1.42	1.81

TABLE SB-2

Minimum steel thickness		1	2	3	4	5	6
		1/4	5/16	3/8	3/8	3/8	1/2
1/2	0.5000	0.20	0.39	0.59	0.79	0.98	1.18
9/16	0.5625	0.25	0.50	0.75	0.99	1.24	1.49
5/8	0.6250	0.31	0.61	0.92	1.23	1.53	1.84
11/16	0.6875	0.37	0.74	1.11	1.48	1.86	2.23
3/4	0.7500	0.44	0.88	1.33	1.77	2.21	2.65
13/16	0.8125	0.52	1.04	1.56	2.07	2.59	3.11
7/8	0.8750	0.60	1.20	1.80	2.41	3.01	3.61
15/16	0.9375	0.69	1.38	2.07	2.76	3.45	4.14
1	1.0000	0.79	1.57	2.36	3.14	3.93	4.71
1 1/16	1.0625	0.89	1.77	2.66	3.55	4.43	5.32

Appendix E – Channel Hydraulics

Trapezoidal Channel (RHRN Grading.fm8)

Label	Roughness Coefficient	Channel Slope (ft/ft)	Normal Depth (in)	Bottom Width (ft)	Discharge (cfs)	Flow Area (ft ²)	Wetted Perimeter (ft)	Hydraulic Radius (in)	Top Width (ft)	Critical Depth (in)	Critical Slope (ft/ft)	Velocity (ft/s)	Velocity Head (ft)	Specific Energy (ft)	Froude Number	Flow Type
Channel North 1%	0.030	0.010	12.8	20.00	120.00	26.0	28.8	10.8	28.56	11.6	0.014	4.62	0.33	1.40	0.854	Subcritical
Channel North 1.5%	0.030	0.015	11.4	20.00	120.00	22.7	27.9	9.8	27.62	11.6	0.014	5.29	0.43	1.39	1.029	Supercritical
Channel North 2%	0.030	0.020	10.5	20.00	120.00	20.6	27.2	9.1	27.02	11.6	0.014	5.82	0.53	1.40	1.174	Supercritical
Channel North 4%	0.030	0.040	8.6	20.00	120.00	16.4	25.9	7.6	25.75	11.6	0.014	7.31	0.83	1.55	1.612	Supercritical
Channel North 25%	0.078	0.250	8.8	20.00	120.00	16.9	26.1	7.8	25.88	11.6	0.095	7.12	0.79	1.52	1.555	Supercritical
Channel South 1%	0.030	0.010	14.6	20.00	150.00	30.2	30.0	12.1	29.71	13.4	0.014	4.97	0.38	1.60	0.870	Subcritical
Channel South 2%	0.030	0.020	12.0	20.00	150.00	23.9	28.2	10.2	27.97	13.4	0.014	6.27	0.61	1.61	1.196	Supercritical
Channel South 3%	0.030	0.030	10.6	20.00	150.00	20.9	27.3	9.2	27.10	13.4	0.014	7.18	0.80	1.69	1.441	Supercritical
Channel South 4%	0.030	0.040	9.8	20.00	150.00	19.0	26.7	8.5	26.54	13.4	0.014	7.89	0.97	1.78	1.643	Supercritical
Channel South 25%	0.078	0.250	10.0	20.00	150.00	19.5	26.9	8.7	26.68	13.4	0.092	7.69	0.92	1.75	1.586	Supercritical
Rex Overflow Channel	0.030	0.010	10.8	40.00	170.00	39.0	47.4	9.9	47.17	9.6	0.015	4.35	0.29	1.19	0.844	Subcritical
Rex Overflow Channel Rundown	0.078	0.250	7.3	40.00	170.00	25.8	45.0	6.9	44.87	9.6	0.098	6.58	0.67	1.28	1.529	Supercritical
Channel East 0.8%	0.030	0.008	10.5	10.00	40.00	11.8	17.2	8.2	16.98	8.6	0.016	3.4	0.18	1.05	0.719	Subcritical
Channel East 1%	0.030	0.010	9.8	10.00	40.00	10.8	16.7	7.8	16.52	8.6	0.016	3.70	0.21	1.03	0.807	Subcritical
Channel East 2%	0.030	0.020	8.1	10.00	40.00	8.5	15.5	6.6	15.38	8.6	0.016	4.69	0.34	1.01	1.111	Supercritical
Channel East 2.5%	0.030	0.025	7.6	10.00	40.00	7.9	15.2	6.2	15.05	8.6	0.016	5.06	0.40	1.03	1.231	Supercritical
Channel East 10%	0.030	0.100	5.1	10.00	40.00	5.0	13.5	4.4	13.40	8.6	0.016	8.05	1.01	1.43	2.329	Supercritical

Note: Solved for Normal Depth, Friction Method = Manning Formula, Left & Right Side Slopes = 4:1

RHRN Grading.fm8
3/21/2022

Bentley Systems, Inc. Haestad Methods Solution Center
27 Siemon Company Drive Suite 200 W
Watertown, CT 06795 USA +1-203-755-1666

FlowMaster
[10.03.00.03]
Page 1 of 1



Specification Sheet

VMax® SC250® Turf Reinforcement Mat

DESCRIPTION

The composite turf reinforcement mat (C-TRM) shall be a machine-produced mat of 70% straw and 30% coconut fiber matrix incorporated into permanent three-dimensional turf reinforcement matting. The matrix shall be evenly distributed across the entire width of the matting and stitch bonded between a heavy duty UV stabilized nettings with 0.50 x 0.50 inch (1.27 x 1.27 cm) openings, an ultra heavy UV stabilized, dramatically corrugated (crimped) intermediate netting with 0.5 x 0.5 inch (1.27 x 1.27 cm) openings, and covered by an heavy duty UV stabilized nettings with 0.50 x 0.50 inch (1.27 x 1.27 cm) openings. The middle corrugated netting shall form prominent closely spaced ridges across the entire width of the mat. The three nettings shall be stitched together on 1.50 inch (3.81cm) centers with UV stabilized polypropylene thread to form permanent three-dimensional turf reinforcement matting. All mats shall be manufactured with a colored thread stitched along both outer edges as an overlap guide for adjacent mats.

The SC250 shall meet Type 5A, 5B, and 5C specification requirements established by the Erosion Control Technology Council (ECTC) and Federal Highway Administration's (FHWA) FP-03 Section 713.18

Material Content

Matrix	70% Straw Fiber	0.35 lb/sq yd (0.19 kg/sm)
	30% Coconut Fiber	0.15 lbs/sq yd (0.08 kg/sm)
Netting	Top and Bottom, UV-Stabilized Polypropylene	5 lb/1000 sq ft (2.44 kg/100 sm)
	Middle, Corrugated UV-Stabilized Polypropylene	24 lb/1000 sf (11.7 kg/100 sm)
Thread	Polypropylene, UV Stable	

Standard Roll Sizes

Width	6.5 ft (2.0 m)	8 ft (2.44m)
Length	55.5 ft (16.9 m)	90 ft (27.4 m)
Weight ± 10%	34 lbs (15.42 kg)	70 lbs (31.8 kg)
Area	40 sq yd (33.4 sm)	80 sq. yd. (66.8 sm)

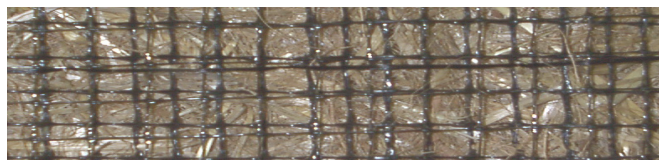

Index Property	Test Method	Typical
Thickness	ASTM D6525	0.62 in. (15.75 mm)
Resiliency	ASTM 6524	95.2%
Density	ASTM D792	0.891 g/cm ³
Mass/Unit Area	ASTM 6566	16.13 oz/sy (548 g/sm)
UV Stability	ASTM D4355/ 1000 HR	80%
Porosity	ECTC Guidelines	99%
Stiffness	ASTM D1388	222.65 oz-in.
Light Penetration	ASTM D6567	4.1%
Tensile Strength - MD	ASTM D6818	709 lbs/ft (10.51 kN/m)
Elongation - MD	ASTM D6818	23.9%
Tensile Strength - TD	ASTM D6818	712 lbs/ft (10.56 kN/m)
Elongation - TD	ASTM D6818	36.9%
Biomass Improvement	ASTM D7322	441%

Design Permissible Shear Stress

	Short Duration	Long Duration
Phase 1: Unvegetated	3.0 psf (144 Pa)	2.5 psf (120 Pa)
Phase 2: Partially Veg.	8.0 psf (383 Pa)	8.0 psf (383 Pa)
Phase 3: Fully Veg.	10.0 psf (480 Pa)	8.0 psf (383 Pa)
Unvegetated Velocity	9.5 fps (2.9 m/s)	
Vegetated Velocity	15 fps (4.6 m/s)	

Slope Design Data: C Factors

Slope Length (L)	Slope Gradients (S)		
	≤ 3:1	3:1 – 2:1	≥ 2:1
≤ 20 ft (6 m)	0.0010	0.0209	0.0507
20-50 ft	0.0081	0.0266	0.0574
≥ 50 ft (15.2 m)	0.0455	0.0555	0.081

Roughness Coefficients – Unveg.

Flow Depth	Manning's n
≤ 0.50 ft (0.15 m)	0.040
0.50 – 2.0 ft	0.040-0.012
≥ 2.0 ft (0.60 m)	0.011



Western Green
4609 E. Boonville-New Harmony Rd.
Evansville, IN 47725

nagreen.com
800-772-2040

©2019, North American Green is a registered trademark from Western Green. Certain products and/or applications described or illustrated herein are protected under one or more U.S. patents. Other U.S. patents are pending, and certain foreign patents and patent applications may also exist. Trademark rights also apply as indicated herein. Final determination of the suitability of any information or material for the use contemplated, and its manner of use, is the sole responsibility of the user. Printed in the U.S.A.

Channel Superelevation Calculations

The below calculations are representative of the most critical locations. The results show there is sufficient freeboard at each channel bend.

The Channel North 25-foot radius bend near 24+50 requires 0.4 extra feet on the outside of the bend where more than 1.5 feet of freeboard is provided.

The Channel East 175-foot radius bend near 16+00 requires 0.1 extra feet on the outside of the bend where 1 foot of freeboard is provided.

The Channel East 30-foot radius bend near 11+75 requires 0.9 extra feet on the outside of the bend where approximately 3 feet of freeboard is provided.

See the calculations below and the grading plans for more information.

CHANNEL SUPERELEVATION

CHANNEL NORTH

STA = 24+50

$H=Cv^2w/Rg$

Flow Type Subcritical

C = coefficient	0.5	subcritical flow
	1.0	supercritical flow
v = average velocity	fps	
W = Channel width at level water surface	ft	
g = acceleration of gravity constant, 32.2 ft/sec ²	32.2 ft/sec ²	
R = Channel radius of curvature	ft	
H = additional height of freeboard on outside edge of channel	ft	

c = 0.5

v = 4.62

W = 28.56

R = 25

H = 0.4

CHANNEL EAST

STA = 16+00

$H=Cv^2w/Rg$

Flow Type Supercritical

C = coefficient	0.5	subcritical flow
	1.0	supercritical flow
v = average velocity	fps	
W = Channel width at level water surface	ft	
g = acceleration of gravity constant, 32.2 ft/sec ²	32.2 ft/sec ²	
R = Channel radius of curvature	ft	
H = additional height of freeboard on outside edge of channel	ft	

c = 1

v = 4.69

W = 15.38

R = 175

H = 0.1

CHANNEL EAST

STA = 11+75

$H=Cv^2w/Rg$

Flow Type Supercritical

C = coefficient	0.5	subcritical flow
	1.0	supercritical flow
v = average velocity	fps	
W = Channel width at level water surface	ft	
g = acceleration of gravity constant, 32.2 ft/sec ²	32.2 ft/sec ²	
R = Channel radius of curvature	ft	
H = additional height of freeboard on outside edge of channel	ft	

c = 1

v = 8.05

W = 13.4

R = 30

H = 0.9

East Swale - Northern Portion

Project Description	
Friction Method	Manning Formula
Solve For	Normal Depth
Input Data	
Roughness Coefficient	0.030
Channel Slope	0.008 ft/ft
Left Side Slope	4.000 H:V
Right Side Slope	4.000 H:V
Discharge	5.80 cfs
Results	
Normal Depth	9.5 in
Flow Area	2.5 ft ²
Wetted Perimeter	6.5 ft
Hydraulic Radius	4.6 in
Top Width	6.31 ft
Critical Depth	8.0 in
Critical Slope	0.020 ft/ft
Velocity	2.33 ft/s
Velocity Head	0.08 ft
Specific Energy	0.87 ft
Froude Number	0.655
Flow Type	Subcritical
GVF Input Data	
Downstream Depth	0.0 in
Length	0.0 ft
Number Of Steps	0
GVF Output Data	
Upstream Depth	0.0 in
Profile Description	N/A
Profile Headloss	0.00 ft
Downstream Velocity	0.00 ft/s
Upstream Velocity	0.00 ft/s
Normal Depth	9.5 in
Critical Depth	8.0 in
Channel Slope	0.008 ft/ft
Critical Slope	0.020 ft/ft

East Swale - Southern Portion

Project Description	
Friction Method	Manning Formula
Solve For	Normal Depth

Input Data	
Roughness Coefficient	0.030
Channel Slope	0.008 ft/ft
Left Side Slope	4.000 H:V
Right Side Slope	4.000 H:V
Discharge	9.60 cfs

Results	
Normal Depth	11.4 in
Flow Area	3.6 ft ²
Wetted Perimeter	7.9 ft
Hydraulic Radius	5.5 in
Top Width	7.62 ft
Critical Depth	9.8 in
Critical Slope	0.018 ft/ft
Velocity	2.65 ft/s
Velocity Head	0.11 ft
Specific Energy	1.06 ft
Froude Number	0.677
Flow Type	Subcritical

GVF Input Data	
Downstream Depth	0.0 in
Length	0.0 ft
Number Of Steps	0

GVF Output Data	
Upstream Depth	0.0 in
Profile Description	N/A
Profile Headloss	0.00 ft
Downstream Velocity	0.00 ft/s
Upstream Velocity	0.00 ft/s
Normal Depth	11.4 in
Critical Depth	9.8 in
Channel Slope	0.008 ft/ft
Critical Slope	0.018 ft/ft

Appendix F – Rip-Rap Rundown Protection

ROCK CHUTE DESIGN

Location: Open Space North Channel

Q	120	CFS	D ₅₀	10	in.
S _{ch}	0.25	ft/ft	D ₅₀ * F _s	12	in.
W	20	ft/ft			
q _t	6	CFS/ft			
F _s	1.2				

for S_{ch} ≥ 0.10 (10:1) i.e. 5:1 or 0.20 ft/ft

$$D_{50} = \left[\frac{q_t (S_{ch})^{0.58}}{3.95(10)^{-2}} \right]^{1.89} \quad (\text{Equation 2})$$

* Design of Rock Chutes by Robinson, Rice, Kadavy, ASAE, 1998

ROCK CHUTE DESIGN

Location: Open Space South Channel

Q	150	CFS	D ₅₀	11 in.
S _{ch}	0.25	ft/ft	D ₅₀ * F _s	14 in.
W	20	ft/ft		
q _t	7.5	CFS/ft		
F _s	1.2			

for S_{ch} ≥ 0.10 (10:1) i.e. 5:1 or 0.20 ft/ft

$$D_{50} = \left[\frac{q_t (S_{ch})^{0.58}}{3.95(10)^{-2}} \right]^{1.89} \quad (\text{Equation 2})$$

* Design of Rock Chutes by Robinson, Rice, Kadavy, ASAE, 1998

ROCK CHUTE DESIGN

Location: Rex Road Overflow Rundown

Q	150	CFS	D ₅₀	8 in.
S _{ch}	0.25	ft/ft	D ₅₀ * F _s	10 in.
W	40	ft/ft		
q _t	3.75	CFS/ft		
F _s	1.2			

for S_{ch} ≥ 0.10 (10:1) i.e. 5:1 or 0.20 ft/ft

$$D_{50} = \left[\frac{q_t (S_{ch})^{0.58}}{3.95(10)^{-2}} \right]^{1.89} \quad (\text{Equation 2})$$

* Design of Rock Chutes by Robinson, Rice, Kadavy, ASAE, 1998

Appendix G – Soil Resource Report

Custom Soil Resource Report for El Paso County Area, Colorado

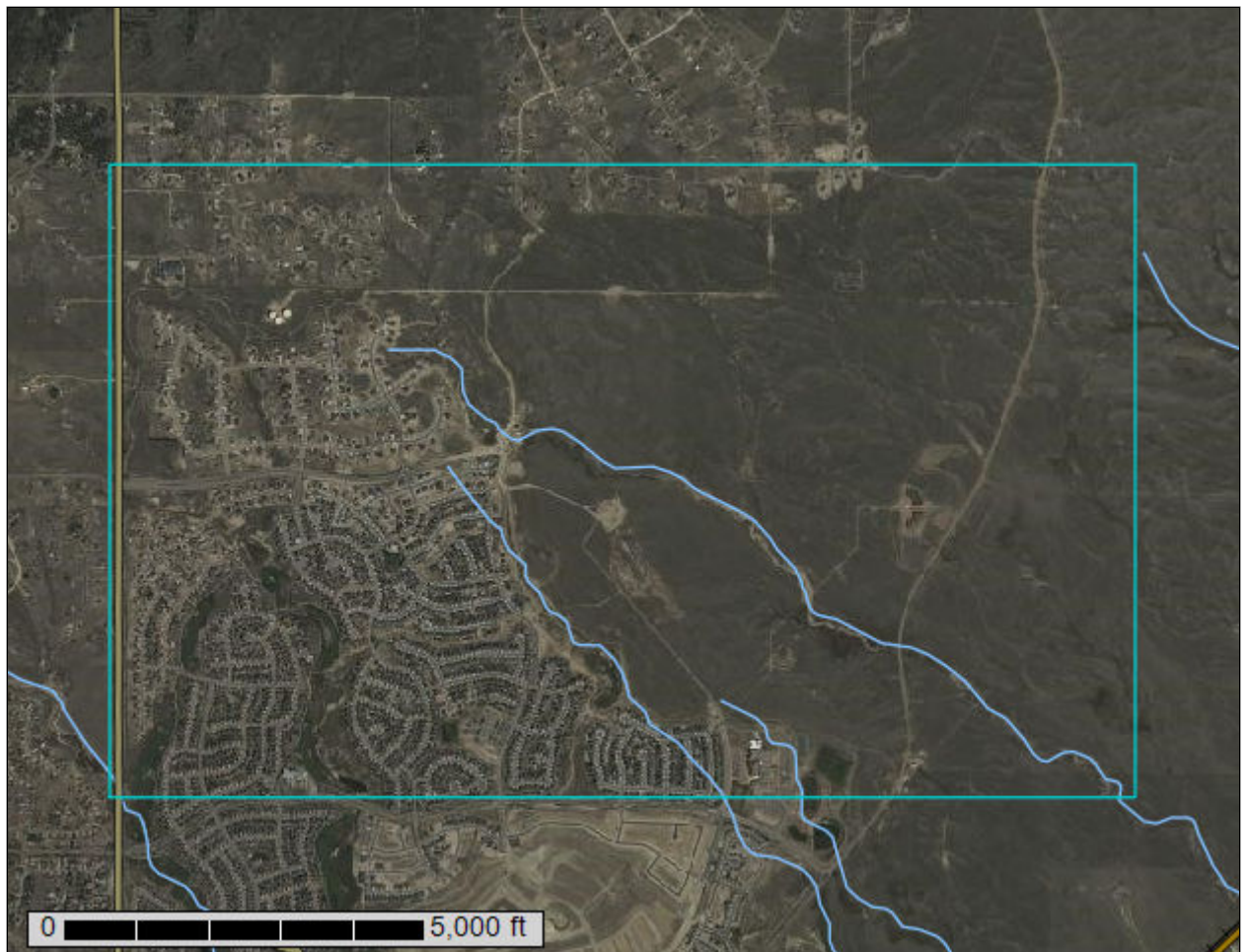

Preface

Soil surveys contain information that affects land use planning in survey areas. They highlight soil limitations that affect various land uses and provide information about the properties of the soils in the survey areas. Soil surveys are designed for many different users, including farmers, ranchers, foresters, agronomists, urban planners, community officials, engineers, developers, builders, and home buyers. Also, conservationists, teachers, students, and specialists in recreation, waste disposal, and pollution control can use the surveys to help them understand, protect, or enhance the environment.

Various land use regulations of Federal, State, and local governments may impose special restrictions on land use or land treatment. Soil surveys identify soil properties that are used in making various land use or land treatment decisions. The information is intended to help the land users identify and reduce the effects of soil limitations on various land uses. The landowner or user is responsible for identifying and complying with existing laws and regulations.

Although soil survey information can be used for general farm, local, and wider area planning, onsite investigation is needed to supplement this information in some cases. Examples include soil quality assessments (<http://www.nrcs.usda.gov/wps/portal/nrcs/main/soils/health/>) and certain conservation and engineering applications. For more detailed information, contact your local USDA Service Center (<https://offices.sc.egov.usda.gov/locator/app?agency=nrcs>) or your NRCS State Soil Scientist (http://www.nrcs.usda.gov/wps/portal/nrcs/detail/soils/contactus/?cid=nrcs142p2_053951).

Great differences in soil properties can occur within short distances. Some soils are seasonally wet or subject to flooding. Some are too unstable to be used as a foundation for buildings or roads. Clayey or wet soils are poorly suited to use as septic tank absorption fields. A high water table makes a soil poorly suited to basements or underground installations.

The National Cooperative Soil Survey is a joint effort of the United States Department of Agriculture and other Federal agencies, State agencies including the Agricultural Experiment Stations, and local agencies. The Natural Resources Conservation Service (NRCS) has leadership for the Federal part of the National Cooperative Soil Survey.

Information about soils is updated periodically. Updated information is available through the NRCS Web Soil Survey, the site for official soil survey information.

The U.S. Department of Agriculture (USDA) prohibits discrimination in all its programs and activities on the basis of race, color, national origin, age, disability, and where applicable, sex, marital status, familial status, parental status, religion, sexual orientation, genetic information, political beliefs, reprisal, or because all or a part of an individual's income is derived from any public assistance program. (Not all prohibited bases apply to all programs.) Persons with disabilities who require

alternative means for communication of program information (Braille, large print, audiotape, etc.) should contact USDA's TARGET Center at (202) 720-2600 (voice and TDD). To file a complaint of discrimination, write to USDA, Director, Office of Civil Rights, 1400 Independence Avenue, S.W., Washington, D.C. 20250-9410 or call (800) 795-3272 (voice) or (202) 720-6382 (TDD). USDA is an equal opportunity provider and employer.

Contents

Preface	2
How Soil Surveys Are Made	5
Soil Map	8
Soil Map.....	9
Legend.....	10
Map Unit Legend.....	11
Map Unit Descriptions.....	11
El Paso County Area, Colorado.....	13
19—Columbine gravelly sandy loam, 0 to 3 percent slopes.....	13
71—Pring coarse sandy loam, 3 to 8 percent slopes.....	14
83—Stapleton sandy loam, 3 to 8 percent slopes.....	15
References	17

How Soil Surveys Are Made

Soil surveys are made to provide information about the soils and miscellaneous areas in a specific area. They include a description of the soils and miscellaneous areas and their location on the landscape and tables that show soil properties and limitations affecting various uses. Soil scientists observed the steepness, length, and shape of the slopes; the general pattern of drainage; the kinds of crops and native plants; and the kinds of bedrock. They observed and described many soil profiles. A soil profile is the sequence of natural layers, or horizons, in a soil. The profile extends from the surface down into the unconsolidated material in which the soil formed or from the surface down to bedrock. The unconsolidated material is devoid of roots and other living organisms and has not been changed by other biological activity.

Currently, soils are mapped according to the boundaries of major land resource areas (MLRAs). MLRAs are geographically associated land resource units that share common characteristics related to physiography, geology, climate, water resources, soils, biological resources, and land uses (USDA, 2006). Soil survey areas typically consist of parts of one or more MLRA.

The soils and miscellaneous areas in a survey area occur in an orderly pattern that is related to the geology, landforms, relief, climate, and natural vegetation of the area. Each kind of soil and miscellaneous area is associated with a particular kind of landform or with a segment of the landform. By observing the soils and miscellaneous areas in the survey area and relating their position to specific segments of the landform, a soil scientist develops a concept, or model, of how they were formed. Thus, during mapping, this model enables the soil scientist to predict with a considerable degree of accuracy the kind of soil or miscellaneous area at a specific location on the landscape.

Commonly, individual soils on the landscape merge into one another as their characteristics gradually change. To construct an accurate soil map, however, soil scientists must determine the boundaries between the soils. They can observe only a limited number of soil profiles. Nevertheless, these observations, supplemented by an understanding of the soil-vegetation-landscape relationship, are sufficient to verify predictions of the kinds of soil in an area and to determine the boundaries.

Soil scientists recorded the characteristics of the soil profiles that they studied. They noted soil color, texture, size and shape of soil aggregates, kind and amount of rock fragments, distribution of plant roots, reaction, and other features that enable them to identify soils. After describing the soils in the survey area and determining their properties, the soil scientists assigned the soils to taxonomic classes (units). Taxonomic classes are concepts. Each taxonomic class has a set of soil characteristics with precisely defined limits. The classes are used as a basis for comparison to classify soils systematically. Soil taxonomy, the system of taxonomic classification used in the United States, is based mainly on the kind and character of soil properties and the arrangement of horizons within the profile. After the soil

Custom Soil Resource Report

scientists classified and named the soils in the survey area, they compared the individual soils with similar soils in the same taxonomic class in other areas so that they could confirm data and assemble additional data based on experience and research.

The objective of soil mapping is not to delineate pure map unit components; the objective is to separate the landscape into landforms or landform segments that have similar use and management requirements. Each map unit is defined by a unique combination of soil components and/or miscellaneous areas in predictable proportions. Some components may be highly contrasting to the other components of the map unit. The presence of minor components in a map unit in no way diminishes the usefulness or accuracy of the data. The delineation of such landforms and landform segments on the map provides sufficient information for the development of resource plans. If intensive use of small areas is planned, onsite investigation is needed to define and locate the soils and miscellaneous areas.

Soil scientists make many field observations in the process of producing a soil map. The frequency of observation is dependent upon several factors, including scale of mapping, intensity of mapping, design of map units, complexity of the landscape, and experience of the soil scientist. Observations are made to test and refine the soil-landscape model and predictions and to verify the classification of the soils at specific locations. Once the soil-landscape model is refined, a significantly smaller number of measurements of individual soil properties are made and recorded. These measurements may include field measurements, such as those for color, depth to bedrock, and texture, and laboratory measurements, such as those for content of sand, silt, clay, salt, and other components. Properties of each soil typically vary from one point to another across the landscape.

Observations for map unit components are aggregated to develop ranges of characteristics for the components. The aggregated values are presented. Direct measurements do not exist for every property presented for every map unit component. Values for some properties are estimated from combinations of other properties.

While a soil survey is in progress, samples of some of the soils in the area generally are collected for laboratory analyses and for engineering tests. Soil scientists interpret the data from these analyses and tests as well as the field-observed characteristics and the soil properties to determine the expected behavior of the soils under different uses. Interpretations for all of the soils are field tested through observation of the soils in different uses and under different levels of management. Some interpretations are modified to fit local conditions, and some new interpretations are developed to meet local needs. Data are assembled from other sources, such as research information, production records, and field experience of specialists. For example, data on crop yields under defined levels of management are assembled from farm records and from field or plot experiments on the same kinds of soil.

Predictions about soil behavior are based not only on soil properties but also on such variables as climate and biological activity. Soil conditions are predictable over long periods of time, but they are not predictable from year to year. For example, soil scientists can predict with a fairly high degree of accuracy that a given soil will have a high water table within certain depths in most years, but they cannot predict that a high water table will always be at a specific level in the soil on a specific date.

After soil scientists located and identified the significant natural bodies of soil in the survey area, they drew the boundaries of these bodies on aerial photographs and

Custom Soil Resource Report

identified each as a specific map unit. Aerial photographs show trees, buildings, fields, roads, and rivers, all of which help in locating boundaries accurately.

Soil Map

The soil map section includes the soil map for the defined area of interest, a list of soil map units on the map and extent of each map unit, and cartographic symbols displayed on the map. Also presented are various metadata about data used to produce the map, and a description of each soil map unit.

Custom Soil Resource Report Soil Map

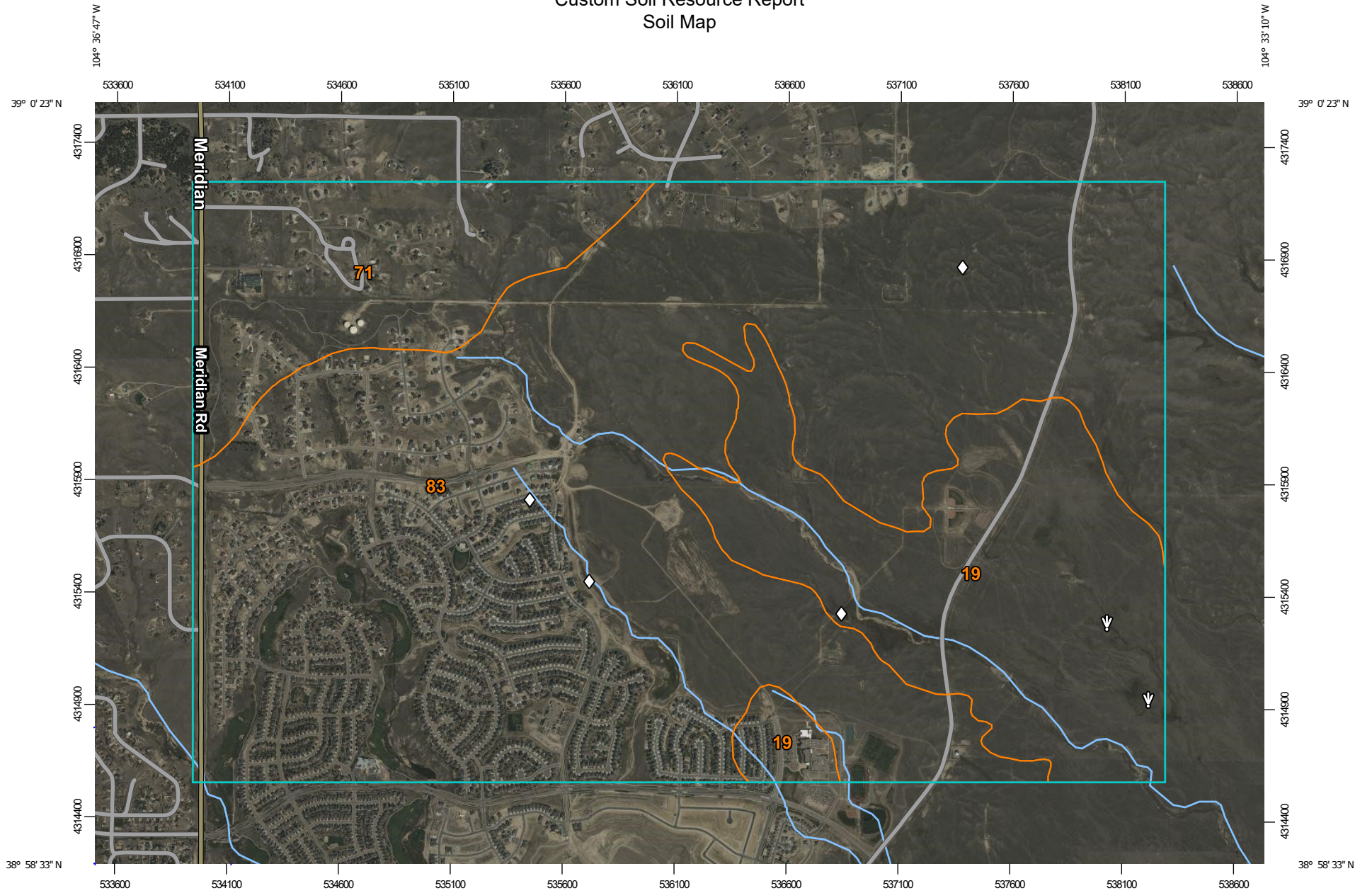

Map Scale: 1:23,900 if printed on A landscape (11" x 8.5") sheet.

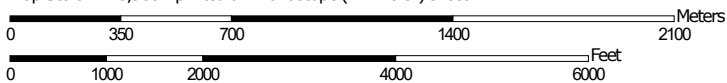

Map projection: Web Mercator Corner coordinates: WGS84 Edge tics: UTM Zone 13N WGS84





MAP LEGEND

Area of Interest (AOI)

 Area of Interest (AOI)

Soils







 Soil Map Unit Polygons

 Soil Map Unit Lines

 Soil Map Unit Points

Special Point Features





-  Blowout
-  Borrow Pit
-  Clay Spot
-  Closed Depression
-  Gravel Pit
-  Gravelly Spot
-  Landfill
-  Lava Flow
-  Marsh or swamp
-  Mine or Quarry
-  Miscellaneous Water
-  Perennial Water
-  Rock Outcrop
-  Saline Spot
-  Sandy Spot
-  Severely Eroded Spot
-  Sinkhole
-  Slide or Slip
-  Sodic Spot

-  Spoil Area
-  Stony Spot
-  Very Stony Spot
-  Wet Spot
-  Other
-  Special Line Features

Water Features

 Streams and Canals

Transportation

-  Rails
-  Interstate Highways
-  US Routes
-  Major Roads
-  Local Roads

Background

 Aerial Photography

MAP INFORMATION

The soil surveys that comprise your AOI were mapped at 1:24,000.

Please rely on the bar scale on each map sheet for map measurements.

Source of Map: Natural Resources Conservation Service
 Web Soil Survey URL:
 Coordinate System: Web Mercator (EPSG:3857)

Maps from the Web Soil Survey are based on the Web Mercator projection, which preserves direction and shape but distorts distance and area. A projection that preserves area, such as the Albers equal-area conic projection, should be used if more accurate calculations of distance or area are required.

This product is generated from the USDA-NRCS certified data as of the version date(s) listed below.

Soil Survey Area: El Paso County Area, Colorado
 Survey Area Data: Version 19, Aug 31, 2021

Soil map units are labeled (as space allows) for map scales 1:50,000 or larger.

Date(s) aerial images were photographed: Sep 11, 2018—Oct 20, 2018

The orthophoto or other base map on which the soil lines were compiled and digitized probably differs from the background imagery displayed on these maps. As a result, some minor shifting of map unit boundaries may be evident.

Map Unit Legend

Map Unit Symbol	Map Unit Name	Acres in AOI	Percent of AOI
19	Columbine gravelly sandy loam, 0 to 3 percent slopes	575.5	20.0%
71	Pring coarse sandy loam, 3 to 8 percent slopes	339.8	11.8%
83	Stapleton sandy loam, 3 to 8 percent slopes	1,964.3	68.2%
Totals for Area of Interest		2,879.9	100.0%

Map Unit Descriptions

The map units delineated on the detailed soil maps in a soil survey represent the soils or miscellaneous areas in the survey area. The map unit descriptions, along with the maps, can be used to determine the composition and properties of a unit.

A map unit delineation on a soil map represents an area dominated by one or more major kinds of soil or miscellaneous areas. A map unit is identified and named according to the taxonomic classification of the dominant soils. Within a taxonomic class there are precisely defined limits for the properties of the soils. On the landscape, however, the soils are natural phenomena, and they have the characteristic variability of all natural phenomena. Thus, the range of some observed properties may extend beyond the limits defined for a taxonomic class. Areas of soils of a single taxonomic class rarely, if ever, can be mapped without including areas of other taxonomic classes. Consequently, every map unit is made up of the soils or miscellaneous areas for which it is named and some minor components that belong to taxonomic classes other than those of the major soils.

Most minor soils have properties similar to those of the dominant soil or soils in the map unit, and thus they do not affect use and management. These are called noncontrasting, or similar, components. They may or may not be mentioned in a particular map unit description. Other minor components, however, have properties and behavioral characteristics divergent enough to affect use or to require different management. These are called contrasting, or dissimilar, components. They generally are in small areas and could not be mapped separately because of the scale used. Some small areas of strongly contrasting soils or miscellaneous areas are identified by a special symbol on the maps. If included in the database for a given area, the contrasting minor components are identified in the map unit descriptions along with some characteristics of each. A few areas of minor components may not have been observed, and consequently they are not mentioned in the descriptions, especially where the pattern was so complex that it was impractical to make enough observations to identify all the soils and miscellaneous areas on the landscape.

The presence of minor components in a map unit in no way diminishes the usefulness or accuracy of the data. The objective of mapping is not to delineate pure taxonomic classes but rather to separate the landscape into landforms or

Custom Soil Resource Report

landform segments that have similar use and management requirements. The delineation of such segments on the map provides sufficient information for the development of resource plans. If intensive use of small areas is planned, however, onsite investigation is needed to define and locate the soils and miscellaneous areas.

An identifying symbol precedes the map unit name in the map unit descriptions. Each description includes general facts about the unit and gives important soil properties and qualities.

Soils that have profiles that are almost alike make up a *soil series*. Except for differences in texture of the surface layer, all the soils of a series have major horizons that are similar in composition, thickness, and arrangement.

Soils of one series can differ in texture of the surface layer, slope, stoniness, salinity, degree of erosion, and other characteristics that affect their use. On the basis of such differences, a soil series is divided into *soil phases*. Most of the areas shown on the detailed soil maps are phases of soil series. The name of a soil phase commonly indicates a feature that affects use or management. For example, Alpha silt loam, 0 to 2 percent slopes, is a phase of the Alpha series.

Some map units are made up of two or more major soils or miscellaneous areas. These map units are complexes, associations, or undifferentiated groups.

A *complex* consists of two or more soils or miscellaneous areas in such an intricate pattern or in such small areas that they cannot be shown separately on the maps. The pattern and proportion of the soils or miscellaneous areas are somewhat similar in all areas. Alpha-Beta complex, 0 to 6 percent slopes, is an example.

An *association* is made up of two or more geographically associated soils or miscellaneous areas that are shown as one unit on the maps. Because of present or anticipated uses of the map units in the survey area, it was not considered practical or necessary to map the soils or miscellaneous areas separately. The pattern and relative proportion of the soils or miscellaneous areas are somewhat similar. Alpha-Beta association, 0 to 2 percent slopes, is an example.

An *undifferentiated group* is made up of two or more soils or miscellaneous areas that could be mapped individually but are mapped as one unit because similar interpretations can be made for use and management. The pattern and proportion of the soils or miscellaneous areas in a mapped area are not uniform. An area can be made up of only one of the major soils or miscellaneous areas, or it can be made up of all of them. Alpha and Beta soils, 0 to 2 percent slopes, is an example.

Some surveys include *miscellaneous areas*. Such areas have little or no soil material and support little or no vegetation. Rock outcrop is an example.

El Paso County Area, Colorado

19—Columbine gravelly sandy loam, 0 to 3 percent slopes

Map Unit Setting

National map unit symbol: 367p
Elevation: 6,500 to 7,300 feet
Mean annual precipitation: 14 to 16 inches
Mean annual air temperature: 46 to 50 degrees F
Frost-free period: 125 to 145 days
Farmland classification: Not prime farmland

Map Unit Composition

Columbine and similar soils: 97 percent
Minor components: 3 percent
Estimates are based on observations, descriptions, and transects of the mapunit.

Description of Columbine

Setting

Landform: Flood plains, fan terraces, fans
Down-slope shape: Linear
Across-slope shape: Linear
Parent material: Alluvium

Typical profile

A - 0 to 14 inches: gravelly sandy loam
C - 14 to 60 inches: very gravelly loamy sand

Properties and qualities

Slope: 0 to 3 percent
Depth to restrictive feature: More than 80 inches
Drainage class: Well drained
Runoff class: Very low
Capacity of the most limiting layer to transmit water (Ksat): High to very high (5.95 to 19.98 in/hr)
Depth to water table: More than 80 inches
Frequency of flooding: None
Frequency of ponding: None
Available water supply, 0 to 60 inches: Very low (about 2.5 inches)

Interpretive groups

Land capability classification (irrigated): 4e
Land capability classification (nonirrigated): 6e
Hydrologic Soil Group: A
Ecological site: R049XY214CO - Gravelly Foothill
Hydric soil rating: No

Minor Components

Fluvaquentic haplaquolls

Percent of map unit: 1 percent
Landform: Swales
Hydric soil rating: Yes

Other soils

Percent of map unit: 1 percent
Hydric soil rating: No

Pleasant

Percent of map unit: 1 percent
Landform: Depressions
Hydric soil rating: Yes

71—Pring coarse sandy loam, 3 to 8 percent slopes

Map Unit Setting

National map unit symbol: 369k
Elevation: 6,800 to 7,600 feet
Farmland classification: Not prime farmland

Map Unit Composition

Pring and similar soils: 85 percent
Estimates are based on observations, descriptions, and transects of the mapunit.

Description of Pring

Setting

Landform: Hills
Landform position (three-dimensional): Side slope
Down-slope shape: Linear
Across-slope shape: Linear
Parent material: Arkosic alluvium derived from sedimentary rock

Typical profile

A - 0 to 14 inches: coarse sandy loam
C - 14 to 60 inches: gravelly sandy loam

Properties and qualities

Slope: 3 to 8 percent
Depth to restrictive feature: More than 80 inches
Drainage class: Well drained
Runoff class: Low
Capacity of the most limiting layer to transmit water (Ksat): High (2.00 to 6.00 in/hr)
Depth to water table: More than 80 inches
Frequency of flooding: None
Frequency of ponding: None
Available water supply, 0 to 60 inches: Low (about 6.0 inches)

Interpretive groups

Land capability classification (irrigated): None specified
Land capability classification (nonirrigated): 3e
Hydrologic Soil Group: B
Ecological site: R048AY222CO - Loamy Park
Hydric soil rating: No

Minor Components

Pleasant

Percent of map unit:
Landform: Depressions
Hydric soil rating: Yes

Other soils

Percent of map unit:
Hydric soil rating: No

83—Stapleton sandy loam, 3 to 8 percent slopes

Map Unit Setting

National map unit symbol: 369z
Elevation: 6,500 to 7,300 feet
Mean annual precipitation: 14 to 16 inches
Mean annual air temperature: 46 to 48 degrees F
Frost-free period: 125 to 145 days
Farmland classification: Not prime farmland

Map Unit Composition

Stapleton and similar soils: 97 percent
Minor components: 3 percent
Estimates are based on observations, descriptions, and transects of the mapunit.

Description of Stapleton

Setting

Landform: Hills
Landform position (three-dimensional): Side slope
Down-slope shape: Linear
Across-slope shape: Linear
Parent material: Sandy alluvium derived from arkose

Typical profile

A - 0 to 11 inches: sandy loam
Bw - 11 to 17 inches: gravelly sandy loam
C - 17 to 60 inches: gravelly loamy sand

Properties and qualities

Slope: 3 to 8 percent
Depth to restrictive feature: More than 80 inches
Drainage class: Well drained
Runoff class: Low
Capacity of the most limiting layer to transmit water (Ksat): High (2.00 to 6.00 in/hr)
Depth to water table: More than 80 inches
Frequency of flooding: None
Frequency of ponding: None

Custom Soil Resource Report

Available water supply, 0 to 60 inches: Low (about 4.7 inches)

Interpretive groups

Land capability classification (irrigated): None specified

Land capability classification (nonirrigated): 3e

Hydrologic Soil Group: B

Ecological site: R049XY214CO - Gravelly Foothill

Hydric soil rating: No

Minor Components

Fluvaquentic haplaquolls

Percent of map unit: 1 percent

Landform: Swales

Hydric soil rating: Yes

Other soils

Percent of map unit: 1 percent

Hydric soil rating: No

Pleasant

Percent of map unit: 1 percent

Landform: Depressions

Hydric soil rating: Yes

References

- American Association of State Highway and Transportation Officials (AASHTO). 2004. Standard specifications for transportation materials and methods of sampling and testing. 24th edition.
- American Society for Testing and Materials (ASTM). 2005. Standard classification of soils for engineering purposes. ASTM Standard D2487-00.
- Cowardin, L.M., V. Carter, F.C. Golet, and E.T. LaRoe. 1979. Classification of wetlands and deep-water habitats of the United States. U.S. Fish and Wildlife Service FWS/OBS-79/31.
- Federal Register. July 13, 1994. Changes in hydric soils of the United States.
- Federal Register. September 18, 2002. Hydric soils of the United States.
- Hurt, G.W., and L.M. Vasilas, editors. Version 6.0, 2006. Field indicators of hydric soils in the United States.
- National Research Council. 1995. Wetlands: Characteristics and boundaries.
- Soil Survey Division Staff. 1993. Soil survey manual. Soil Conservation Service. U.S. Department of Agriculture Handbook 18. http://www.nrcs.usda.gov/wps/portal/nrcs/detail/national/soils/?cid=nrcs142p2_054262
- Soil Survey Staff. 1999. Soil taxonomy: A basic system of soil classification for making and interpreting soil surveys. 2nd edition. Natural Resources Conservation Service, U.S. Department of Agriculture Handbook 436. http://www.nrcs.usda.gov/wps/portal/nrcs/detail/national/soils/?cid=nrcs142p2_053577
- Soil Survey Staff. 2010. Keys to soil taxonomy. 11th edition. U.S. Department of Agriculture, Natural Resources Conservation Service. http://www.nrcs.usda.gov/wps/portal/nrcs/detail/national/soils/?cid=nrcs142p2_053580
- Tiner, R.W., Jr. 1985. Wetlands of Delaware. U.S. Fish and Wildlife Service and Delaware Department of Natural Resources and Environmental Control, Wetlands Section.
- United States Army Corps of Engineers, Environmental Laboratory. 1987. Corps of Engineers wetlands delineation manual. Waterways Experiment Station Technical Report Y-87-1.
- United States Department of Agriculture, Natural Resources Conservation Service. National forestry manual. http://www.nrcs.usda.gov/wps/portal/nrcs/detail/soils/home/?cid=nrcs142p2_053374
- United States Department of Agriculture, Natural Resources Conservation Service. National range and pasture handbook. <http://www.nrcs.usda.gov/wps/portal/nrcs/detail/national/landuse/rangepasture/?cid=stelprdb1043084>

Custom Soil Resource Report

United States Department of Agriculture, Natural Resources Conservation Service. National soil survey handbook, title 430-VI. http://www.nrcs.usda.gov/wps/portal/nrcs/detail/soils/scientists/?cid=nrcs142p2_054242

United States Department of Agriculture, Natural Resources Conservation Service. 2006. Land resource regions and major land resource areas of the United States, the Caribbean, and the Pacific Basin. U.S. Department of Agriculture Handbook 296. http://www.nrcs.usda.gov/wps/portal/nrcs/detail/national/soils/?cid=nrcs142p2_053624

United States Department of Agriculture, Soil Conservation Service. 1961. Land capability classification. U.S. Department of Agriculture Handbook 210. http://www.nrcs.usda.gov/Internet/FSE_DOCUMENTS/nrcs142p2_052290.pdf

Appendix H – Drainage Maps

ROLLING HILLS RANCH NORTH

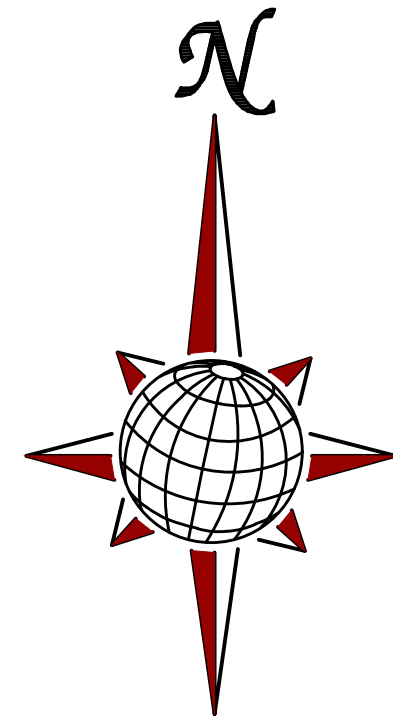
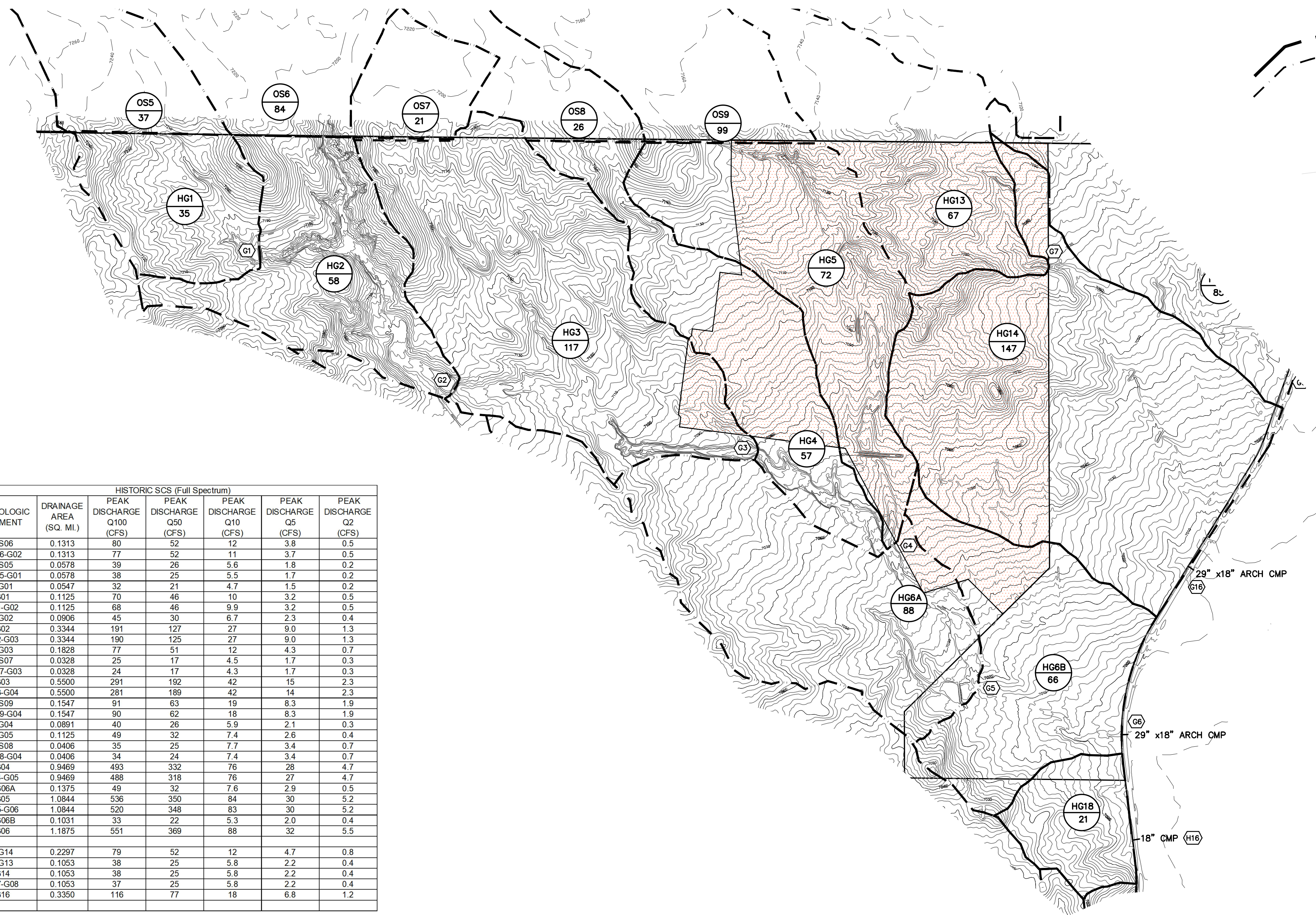
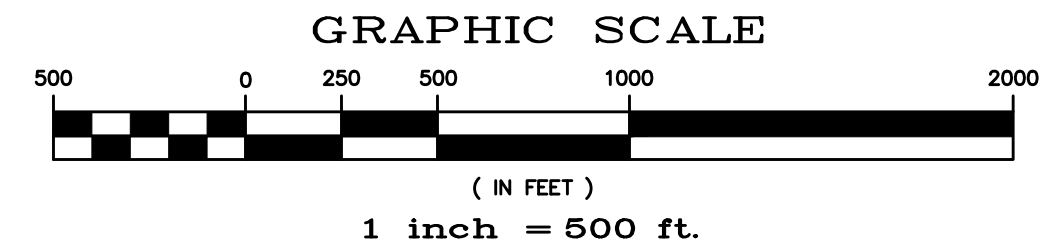

HYDROLOGIC ELEMENT	DRAINAGE AREA (SQ. MI.)	HISTORIC SCS (Full Spectrum)				
		PEAK DISCHARGE Q100 (CFS)	PEAK DISCHARGE Q50 (CFS)	PEAK DISCHARGE Q10 (CFS)	PEAK DISCHARGE Q5 (CFS)	PEAK DISCHARGE Q2 (CFS)
OS06	0.1313	80	52	12	3.8	0.5
OS06-G02	0.1313	77	52	11	3.7	0.5
OS05	0.0578	39	26	5.6	1.8	0.2
OS05-G01	0.0578	38	25	5.5	1.7	0.2
HG01	0.0547	32	21	4.7	1.5	0.2
G01	0.1125	70	46	10	3.2	0.5
G01-G02	0.1125	68	46	9.9	3.2	0.5
HG02	0.0906	45	30	6.7	2.3	0.4
G02	0.3344	191	127	27	9.0	1.3
G02-G03	0.3344	190	125	27	9.0	1.3
HG03	0.1828	77	51	12	4.3	0.7
OS07	0.0328	25	17	4.5	1.7	0.3
OS07-G03	0.0328	24	17	4.3	1.7	0.3
G03	0.5500	291	192	42	15	2.3
G03-G04	0.5500	281	189	42	14	2.3
OS09	0.1547	91	63	19	8.3	1.9
OS09-G04	0.1547	90	62	18	8.3	1.9
HG04	0.0891	40	26	5.9	2.1	0.3
HG05	0.1125	49	32	7.4	2.6	0.4
OS08	0.0406	35	25	7.7	3.4	0.7
OS08-G04	0.0406	34	24	7.4	3.4	0.7
G04	0.9469	493	332	76	28	4.7
G04-G05	0.9469	488	318	76	27	4.7
HG06A	0.1375	49	32	7.6	2.9	0.5
G05	1.0844	536	350	84	30	5.2
G05-G06	1.0844	520	348	83	30	5.2
HG06B	0.1031	33	22	5.3	2.0	0.4
G06	1.1875	551	369	88	32	5.5
HG14	0.2297	79	52	12	4.7	0.8
HG13	0.1053	38	25	5.8	2.2	0.4
G14	0.1053	38	25	5.8	2.2	0.4
G07-G08	0.1053	37	25	5.8	2.2	0.4
G16	0.3350	116	77	18	6.8	1.2

Scale	AS SHOWN	of	Drawn by	Checked by	Date	Revisions	No.	Date	Appr.	Date
			TAK	RA	MAY 2022					
			TECH CONTRACTORS							
			11886 STAPLETON DRIVE							
			FALCON, CO 80831							
			TELEPHONE: 719.495.7444							
			FAX: 719.495.3349							
										
			MERIDIAN RANCH							
			HISTORIC CONDITIONS - SCS MAP							
			ROLLING HILLS RANCH NORTH							
			GRADED CONDITIONS							

HISTORIC CONDITIONS - SCS MAP

FIGURE 4

S:\OneDrive\City\Rolling Hills Ranch North\Rolling Hills Ranch North Sheets\Drainage Maps\Graded\RRR North Graded - SCS - HIST.dwg, 5/10/2022 2:26:13 PM

ROLLING HILLS RANCH NORTH

GRADED SCS (Full Spectrum)						
DRAINAGE AREA (SQ. MI.)	PEAK DISCHARGE Q100 (CFS)	PEAK DISCHARGE Q50 (CFS)	PEAK DISCHARGE Q10 (CFS)	PEAK DISCHARGE Q5 (CFS)	PEAK DISCHARGE Q2 (CFS)	
OS06	0.1313	80	52	12	3.8	0.5
G1a	0.1313	80	52	12	3.8	0.5
G1a-G2	0.1313	79	52	11	3.7	0.5
OS05	0.0578	39	26	5.6	1.8	0.2
OS05-G1	0.0578	39	25	5.5	1.7	0.2
FG01	0.0538	31	22	7.0	3.4	0.9
FG01-G1	0.0538	31	22	7.0	3.4	0.9
G1	0.1116	61	41	11	4.9	1.1
G1-G2	0.1116	61	41	11	4.8	1.1
FG02	0.0391	32	22	6.4	2.7	0.5
G2	0.2820	167	112	27	10	1.9
G2-G3	0.2820	163	108	27	10	1.9
FG03	0.0203	24	17	5.9	3.0	0.8
FG04	0.0172	22	16	5.8	3.1	0.9
G3	0.3195	185	123	31	12	2.4
FG06	0.0675	56	40	12	5.8	1.3
FG05	0.0580	45	33	12	6.7	2.4
OS07ab	0.0170	12	7.9	1.8	0.5	0.1
OS07ab-POND F	0.0170	12	7.6	1.7	0.5	0.1
POND F IN	0.4620	293	200	54	23	5.1
POND F	0.4620	178	121	16	8.0	2.1
POND F-G7	0.4620	177	120	16	8.0	2.1
OS07c	0.0158	13	8.6	1.8	0.6	0.1
OS07c-G4	0.0158	13	8.2	1.8	0.5	0.1
FG21a	0.0095	5.9	4.0	1.0	0.4	0.1
G4	0.0253	19	12	2.8	0.9	0.1
G4-G7	0.0253	17	12	2.7	0.9	0.1
FG21b	0.0150	21	16	6.5	3.9	1.7
G7	0.5023	189	127	18	8.7	2.3
G7-G8	0.5023	188	127	18	8.7	2.3
FG22	0.1400	124	90	32	17	5.3
OS08a	0.0469	29	19	4.4	1.5	0.2
OS08-G8	0.0469	29	19	4.3	1.5	0.2
FG23a	0.0216	21	15	5.2	2.7	0.8
OS07d	0.0036	2.6	1.7	0.4	0.1	0.0
OS07d-G8	0.0036	2.6	1.7	0.4	0.1	0.0
G8	0.7144	283	179	48	25	7.6
G8-G10	0.7144	282	179	47	24	7.6
OS08b	0.1167	72	49	14	6.1	1.3
OS08b-G9a	0.1167	71	49	14	6.0	1.2
FG24b	0.0589	41	30	9.8	4.9	1.4
FG24a	0.0359	23	15	4.0	1.6	0.3
OS09a	0.0279	17	11	2.8	1.0	0.2
OS09a-G9a	0.0279	17	11	2.7	1.0	0.2
G9a	0.2394	148	100	28	12	2.6
G9a-G9b	0.2394	145	100	28	12	2.6
FG24d	0.0307	23	16	4.7	2.1	0.4
FG24c	0.0291	26	18	5.8	2.9	0.8
G9b	0.2992	181	122	34	15	3.3
REX RD WQCV	0.2992	170	122	33	15	3.3
G9b-G10	0.2992	169	121	33	14	3.3
FG23b	0.0235	18	12	3.0	1.1	0.2
G10	1.0371	456	284	77	36	8.2
G10-G11	1.0371	455	283	76	36	8.1
FG23c	0.0109	11	7.7	2.3	1.0	0.2
G11	1.0480	458	285	77	36	8.3
FG25	0.1084	111	84	36	22	9.9
FG28	0.0184	15	11	3.1	1.3	0.2
POND G IN-WEST	1.1748	541	352	108	53	14
FG27	0.0679	42	29	9.5	4.6	1.3
FG26	0.0570	45	32	11	5.1	1.3
G13	0.0570	45	32	11	5.1	1.3
G13-POND G	0.0570	45	32	10	5.1	1.3
POND G IN-EAST	0.1249	84	60	19	9.5	2.5
POND G	1.2997	442	275	40	15	4.4
G12	1.2997	442	275	40	15	4.4
G12-G06	1.2997	442	273	40	15	4.4
FG29	0.0983	60	39	8.9	2.9	0.4
FG32	0.0402	21	14	3.1	1.0	0.2
FG32-G06	0.0402	21	14	3.1	1.0	0.2
G06	1.4382	466	288	43	16	4.7
OS09b	0.0711	27	18	4.2	1.5	0.3
OS09b-G14	0.0711	27	18	4.2	1.5	0.3
FG34	0.0275	20	13	3.3	1.2	0.2
G14	0.0986	35	23	5.6	2.2	0.4
G14-G15	0.0986	35	23	5.6	2.2	0.4
FG35	0.0282	20	14	3.3	1.1	0.2
G15	0.1268	44	28	6.8	2.7	0.5
G15-G16	0.1268	44	28	6.8	2.7	0.5
FG37	0.0797	53	37	9.9	4.0	0.7
FG36	0.0286	20	14	4.3	2.0	0.5
FG36-G16	0.0286	20	14	4.3	2.0	0.5
G16	0.2351	114	74	17	6.6	1.3

*NOTE: PRELIMINARY STORAGE VOLUMES AND OUTFLOW QUANTITIES HAVE BEEN PROVIDED FOR EACH OF THE FUTURE DETENTION FACILITIES LOCATED WITHIN THE DEVELOPMENT. THE ACTUAL STORAGE VOLUMES AND DISCHARGE RATES WILL BE DETERMINED UPON A COMPLETE ANALYSIS FOR EACH DETENTION FACILITY PRIOR TO CONSTRUCTION. THE VALUES GIVEN FOR DISCHARGE AND VOLUME ARE ESTIMATES FOR PLANNING PURPOSES ONLY.

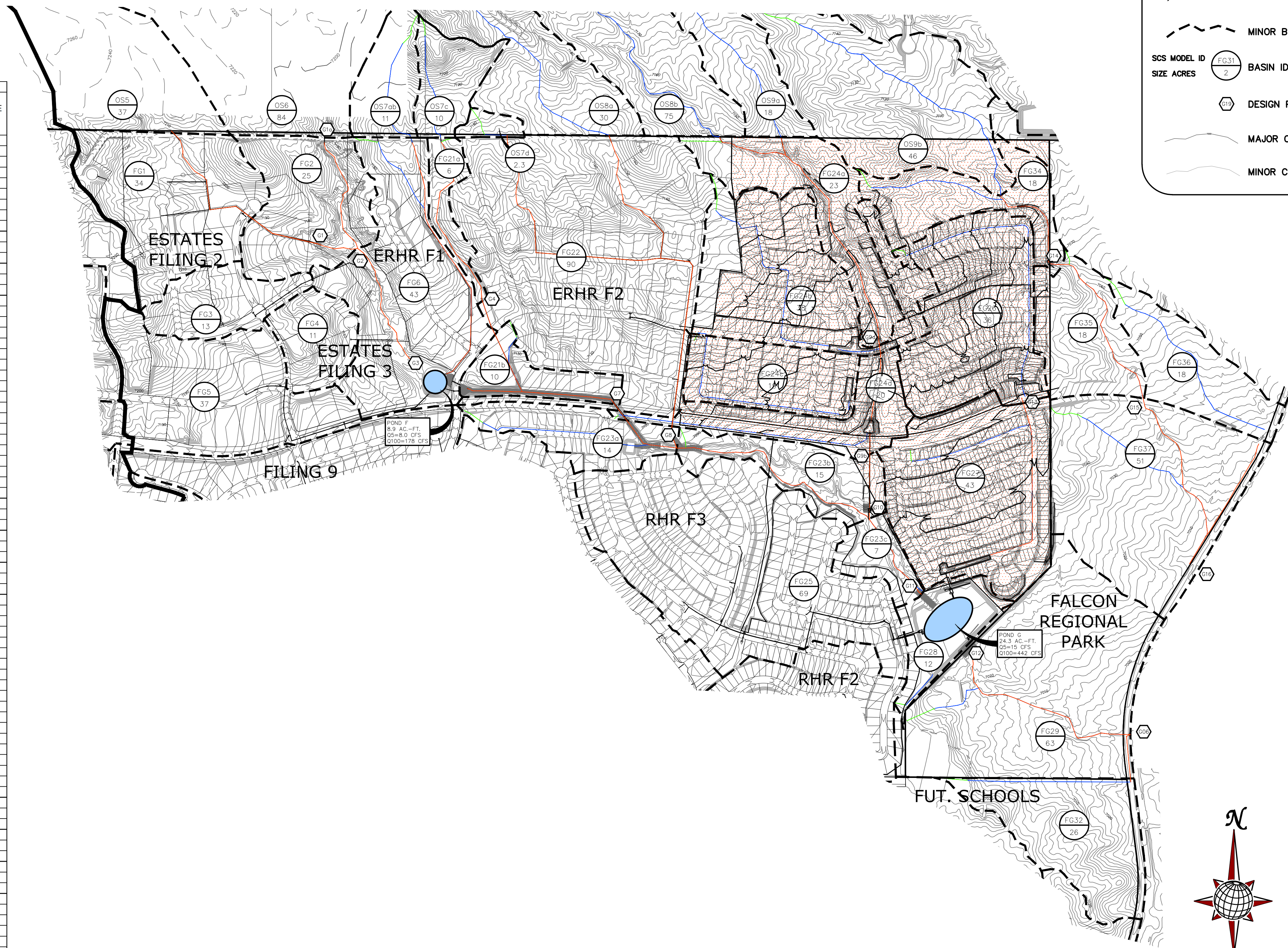

GRADED CONDITIONS - SCS MAP

FIGURE 5

Revisions		No.	
Date	Inst.	No.	

TECH CONTRACTORS 11886 STAPLETON DRIVE FALCON, CO 80831 TELEPHONE: 719.495.7444 FAX: 719.495.3349			
 MERIDIAN RANCH			
GRADED CONDITIONS - SCS MAP ROLLING HILLS RANCH NORTH			
Drawn by	TAK	Checked by	RA
AS SHOWN		Date	MAY 2022
Scale		of	

ROLLING HILLS RANCH NORTH



LEGEND

- MAJOR BASIN BOUNDARY
- MINOR BASIN BOUNDARY
- SCS MODEL ID / SIZE ACRES: FG31 / 2 BASIN IDENTIFICATION
- DESIGN POINT
- MAJOR CONTOUR INTERVAL
- MINOR CONTOUR INTERVAL

*NOTE: PRELIMINARY STORAGE VOLUMES AND OUTFLOW QUANTITIES HAVE BEEN PROVIDED FOR EACH OF THE FUTURE DETENTION FACILITIES LOCATED WITHIN THE DEVELOPMENT. THE ACTUAL STORAGE VOLUMES AND DISCHARGE RATES WILL BE DETERMINED UPON A COMPLETE ANALYSIS FOR EACH DETENTION FACILITY PRIOR TO CONSTRUCTION. THE VALUES GIVEN FOR DISCHARGE AND VOLUME ARE ESTIMATES FOR PLANNING PURPOSES ONLY.

GRADED CONDITIONS - 200 SCALE

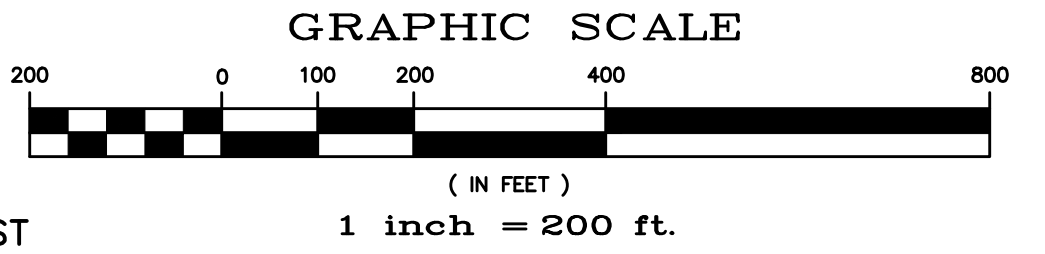

FIGURE 6

Scale	AS SHOWN	-	-	-	-	-	-	-	-
	of	-	-	-	-	-	-	-	-
Drawn by	TAK	Checked by	RA	Date	MAY 2022				
Revisions	No.								
	No.	Date	Inst.	Appr.	Date	Inst.	Appr.	Date	Inst.
TECH CONTRACTORS 11886 STAPLETON DRIVE FALCON, CO 80831 TELEPHONE: 719.495.7444 FAX: 719.495.3349									
GRADED CONDITIONS - SCS MAP ROLLING HILLS RANCH NORTH									

ROLLING HILLS RANCH NORTH

LEGEND

- MAJOR BASIN BOUNDARY
- MINOR BASIN BOUNDARY
- SCS MODEL ID: **FG31** 2
SIZE ACRES: BASIN IDENTIFICATION
- DESIGN POINT
- MAJOR CONTOUR INTERVAL
- MINOR CONTOUR INTERVAL

FUTURE SCS (Full Spectrum)						
	DRAINAGE AREA (SQ. MI.)	PEAK DISCHARGE Q100 (CFS)	PEAK DISCHARGE Q50 (CFS)	PEAK DISCHARGE Q10 (CFS)	PEAK DISCHARGE Q5 (CFS)	PEAK DISCHARGE Q2 (CFS)
OS06	0.1313	80	52	12	3.8	0.5
G1a	0.1313	80	52	12	3.8	0.5
G1a-G2	0.1313	79	52	11	3.7	0.5
OS05	0.0578	39	26	5.6	1.8	0.2
OS05-G1	0.0578	39	25	5.5	1.7	0.2
FG01	0.0538	31	22	7.0	3.4	0.9
FG01-G1	0.0538	31	22	7.0	3.4	0.9
G1	0.1116	61	41	11	4.9	1.1
G1-G2	0.1116	61	41	11	4.8	1.1
FG02	0.0391	32	22	6.4	2.7	0.5
G2	0.2820	167	112	27	10	1.9
G2-G3	0.2820	163	108	27	10	1.9
FG03	0.0203	24	17	5.9	3.0	0.8
FG04	0.0172	22	16	5.8	3.1	0.9
G3	0.3195	185	123	31	12	2.4
FG06	0.0675	56	40	12	5.8	1.3
FG05	0.0580	45	33	12	6.7	2.4
OS07ab	0.0170	12	7.9	1.8	0.5	0.1
OS07ab-POND F	0.0170	12	7.8	1.7	0.5	0.1
POND F IN	0.4620	293	200	54	23	5.1
POND F	0.4620	178	121	16	8.0	2.1
POND F-G7	0.4620	177	120	16	8.0	2.1
OS07c	0.0296	19	12	2.7	0.9	0.1
OS07c-G4	0.0296	19	12	2.6	0.9	0.1
FG21a	0.0095	5.9	4.0	1.0	0.4	0.1
G4	0.0391	25	16	3.6	1.2	0.2
G4-G7	0.0391	24	16	3.5	1.2	0.2
FG21b	0.0150	21	16	6.5	3.9	1.7
G7	0.5161	194	131	18	8.9	2.3
G7-G8	0.5161	194	131	18	8.9	2.3
FG22	0.1354	121	88	32	17	5.4
OS08a	0.0251	16	11	2.3	0.7	0.1
OS08-G8	0.0251	16	10	2.3	0.7	0.1
FG23a	0.0216	21	15	5.2	2.7	0.8
OS07d	0.0034	2.5	1.6	0.4	0.1	0.0
OS07d-G8	0.0034	2.4	1.6	0.3	0.1	0.0
G8	0.7016	279	178	46	24	7.7
G8-G10	0.7016	278	177	45	24	7.6
FG24b	0.0589	76	57	24	15	6.5
FG24a	0.0348	24	16	4.5	2.0	0.4
OS08b	0.0165	9.5	6.3	1.4	0.5	0.1
OS08b-G9a	0.0165	9.4	6.0	1.4	0.5	0.1
OS09a	0.0093	5.3	3.5	0.8	0.3	0.0
OS09a-G9a	0.0093	5.2	3.4	0.7	0.3	0.0
G9a	0.1195	97	71	28	16	6.7
G9a-G9b	0.1195	96	70	27	16	6.6
FG24c	0.0291	40	30	13	8.4	4.0
FG24d	0.0262	39	30	14	8.7	4.4
G9b	0.1748	170	127	53	32	14
REXRD WQCV	0.1748	158	125	51	31	14
G9b-G10	0.1748	158	123	50	31	13
FG23b	0.0236	17	11	2.7	0.9	0.1
G10	0.9000	390	263	90	46	15
G10-G11	0.9000	389	254	85	44	15
FG23c	0.0109	11	7.6	2.2	1.0	0.2
G11	0.9109	393	258	86	44	15
FG25	0.1084	111	84	36	22	9.9
FG28	0.0184	15	10	3.0	1.2	0.2
POND G IN-WEST	1.0377	503	350	122	63	22
FG27	0.0679	98	79	42	30	18
FG26	0.0570	65	50	24	16	8.2
G13	0.0570	65	50	24	16	8.2
G13-POND G	0.0570	64	50	24	16	8.1
POND G IN-EAST	0.1249	160	127	64	44	25
POND G	1.1626	450	293	52	21	5.3
G12	1.1626	450	293	52	21	5.3
G12-G06	1.1626	449	293	52	21	5.3
FG29	0.0983	60	39	8.9	2.9	0.4
FG32	0.0402	51	40	20	14	7.5
FG32-G06	0.0402	50	40	19	13	7.4
G06	1.3011	491	317	57	22	7.5
OS09b	0.0435	23	15	3.3	1.1	0.2
OS09b-G14	0.0435	22	15	3.3	1.1	0.2
FG34	0.0275	20	13	3.3	1.3	0.2
G14	0.0710	38	25	5.7	2.0	0.3
G14-G15	0.0710	38	25	5.6	2.0	0.3
FG35	0.0282	25	18	5.6	2.5	0.5
G15	0.0992	54	35	8.0	3.0	0.6
G15-G16	0.0992	53	35	7.9	3.0	0.6
FG37	0.0797	53	37	9.9	4.0	0.7
FG36	0.0286	20	14	4.3	2.0	0.5
FG36-G16	0.0286	20	14	4.3	2.0	0.5
G16	0.2075	124	81	19	7.8	1.6

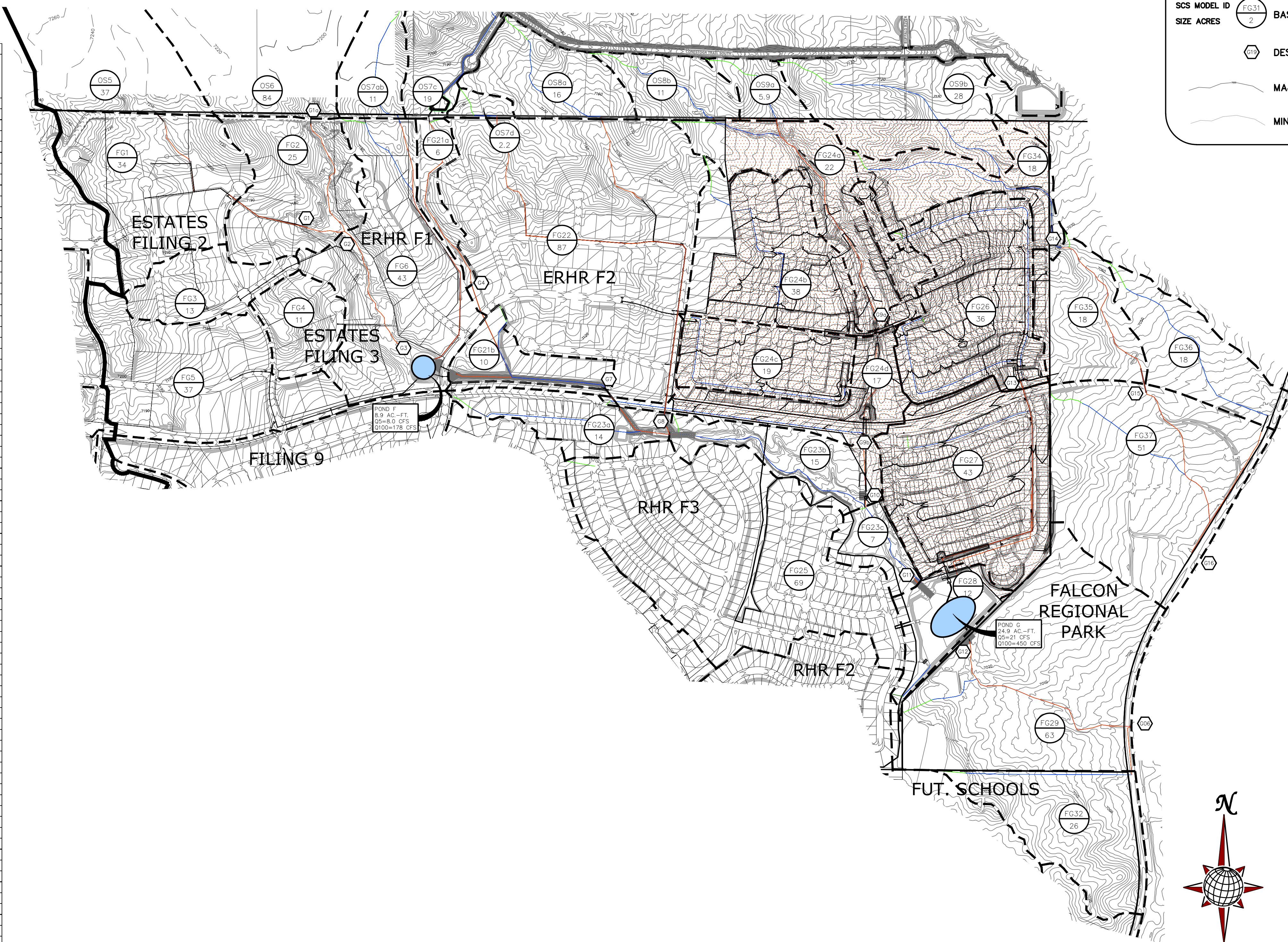

*NOTE: PRELIMINARY STORAGE VOLUMES AND OUTFLOW QUANTITIES HAVE BEEN PROVIDED FOR EACH OF THE FUTURE DETENTION FACILITIES LOCATED WITHIN THE DEVELOPMENT. THE ACTUAL STORAGE VOLUMES AND DISCHARGE RATES WILL BE DETERMINED UPON A COMPLETE ANALYSIS FOR EACH DETENTION FACILITY PRIOR TO CONSTRUCTION. THE VALUES GIVEN FOR DISCHARGE AND VOLUME ARE ESTIMATES FOR PLANNING PURPOSES ONLY.

FUTURE CONDITIONS - SCS MAP

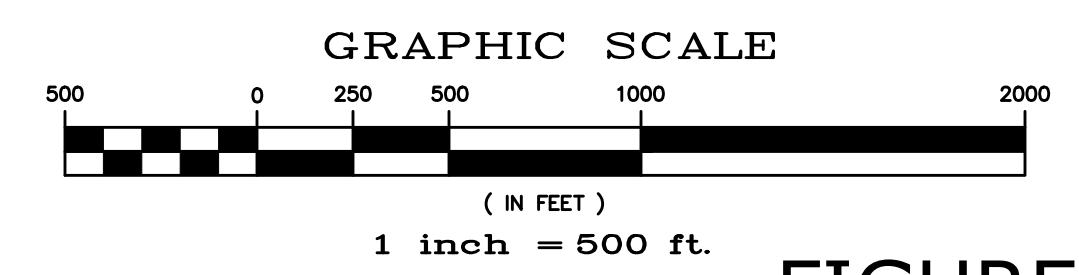

FIGURE 7

Drawn by	Checked by	Date	Scale	AS SHOWN	of	No.	Revisions	Date	Inst.	Appr.	Date
		MAY 2022									
			TECH CONTRACTORS 11886 STAPLETON DRIVE FALCON, CO 80831 TELEPHONE: 719.495.7444 FAX: 719.495.3349			MERIDIAN RANCH			FUTURE CONDITIONS - SCS MAP ROLLING HILLS RANCH NORTH FUD - FDR		

S:\0\mde\C\m\p\Rolling Hills Ranch North Filing 1\DWG\PLAN SHEETS\DRAINAGE MAPS\GRADED\ERHR NORTH GRADED - SCS - FUD.dwg, 5/10/2022, 2:28:34 PM