

Temporary Field Office must meet the following setbacks for the RM-30 zoning district:

Front: 25ft
Side & Rear: 15ft

Temporary Field Office and Storage shall cease and the subject property shall be restored within 30 days after the project is completed in accordance with Section 5.2.21.A of the Land Development Code.

LEGEND

- PROPERTY LINE
- 100 YEAR FLOODPLAIN
- LIMITS OF CONSTRUCTION/DISTURBANCE
- SILT FENCE
- CONSTRUCTION FENCE
- TEMPORARY OUTLET PROTECTION
- CULVERT INLET/OUTLET PROTECTION
- CONCRETE WASHOUT AREA
- STABILIZED STAGING AREA
- EROSION CONTROL BLANKET
- VEHICLE TRACKING CONTROL
- SOIL STOCKPILE
- TEMPORARY SEDIMENT BASIN
- SEEDING AND MULCHING
- CHECK DAM
- DIVERSION SWALE
- ROCK SOCKS
- EXISTING FLOW ARROW
- EXISTING MINOR CONTOUR
- EXISTING MAJOR CONTOUR
- PROPOSED MAJOR CONTOUR
- PROPOSED MINOR CONTOUR
- PROPOSED DRAINAGE SWALE

LIMITS OF CONSTRUCTION

TOTAL DISTURBANCE	= ±12.26 ACRES
OFFSITE DISTURBANCE	= ±0.66 ACRES
TOTAL	= ±12.92 ACRES

Base Surface	Comparison Surface	Cut	Fill	Net
EG	FG	18276 Cu. Yd.	17846 Cu. Yd.	492 Cu. Yd. <Fill>

Approved
By: *Justin Kilgore*
Planning Manager
Date: 06/13/2023
El Paso County Planning & Community Development

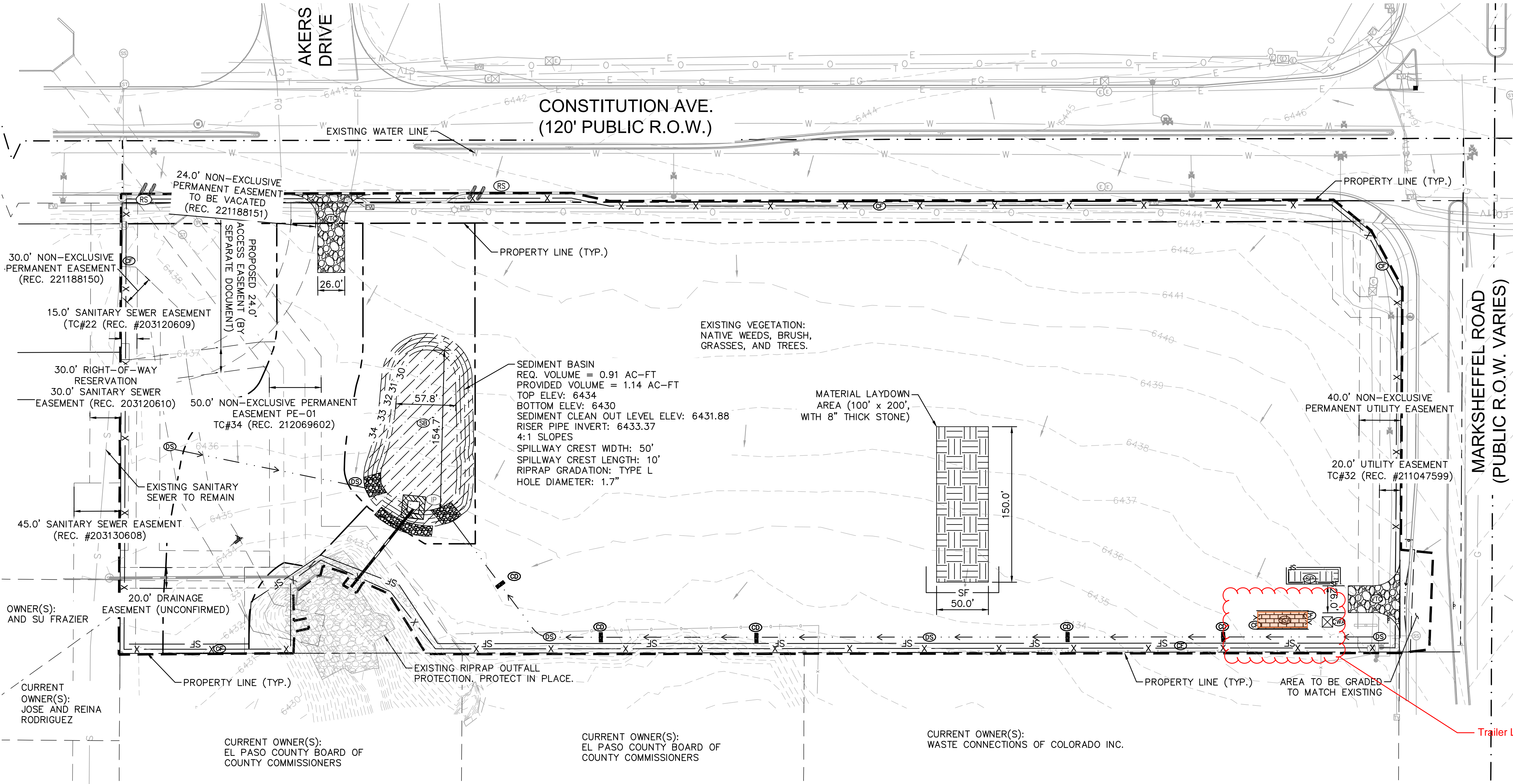

- ### NOTES
- THE INTENT OF THIS PLAN IS TO IDENTIFY THE EROSION CONTROL PRACTICES RECOMMENDED. THE CONTRACTOR SHALL REFERENCE ADDITIONAL CONSTRUCTION PLANS FOR DEMOLITION OF EXISTING AND CONSTRUCTION OF PROPOSED IMPROVEMENTS.
 - ADJACENT STREETS SHALL BE KEPT CLEAN AND FREE OF SEDIMENT AND/OR DEBRIS AT ALL TIMES.
 - TEMPORARY STABILIZATION (TS) SHALL BE IMPLEMENTED WITHIN THE DISTURBED PORTIONS OF THE PROJECT SITE NO LATER THAN 14 DAYS FOLLOWING THE CEASE OF CONSTRUCTION ACTIVITIES WITHIN THE DISTURBED AREAS.
 - PERMANENT STABILIZATION (PS) MAY BE USED WITHIN AREAS OF TEMPORARY STABILIZATION (TS) AT THE CONTRACTOR'S DISCRETION. STABILIZATION SHALL BE APPLIED IN ACCORDANCE WITH APPLICABLE TEMPORARY STABILIZATION SEQUENCING REQUIREMENTS.
 - CONTRACTOR SHALL UTILIZE ROLLED EROSION CONTROL PRODUCTS ON ALL SLOPES 3H:1V OR GREATER TO ACHIEVE REQUIRED STABILIZATION.
 - CONTRACTOR SHALL MAINTAIN ACCEPTABLE EROSION CONTROL PRACTICES WITHIN THE ANTICIPATED LIMITS OF CONSTRUCTION IDENTIFIED HEREIN. BEST MANAGEMENT PRACTICES AND STABILIZATION SHALL BE COMPLETED AS IDENTIFIED HEREIN IN ACCORDANCE WITH OWNER REQUIREMENTS.
 - ALL WORK IN THE AKERS ROAD AND CONSTITUTION AVENUE ROW REQUIRES A ROW PERMIT FROM EL PASO COUNTY. CONTRACTOR IS RESPONSIBLE FOR APPLYING FOR AND OBTAINING ALL NECESSARY ROW PERMITS.
 - SILT FENCE TO BE INSTALLED PRIOR TO COMMENCEMENT OF ONSITE GRADING AND CONSTRUCTION ACTIVITIES.
 - DEMOLITION, REMOVAL, OVEREXCAVATION AND SOIL TREATMENT SHALL BE IN ACCORDANCE WITH THE GEOTECHNICAL ENGINEER RECOMMENDATIONS AS NOTED IN THE APPROVED PROJECT GEOTECHNICAL REPORT.
 - SEE THIS SHEET FOR RISER PIPE AND SEDIMENT BASIN DETAILS.

Temporary Sediment Basin Design Summary

BASIN NAME	TRIBUTARY AREA (AC)	REQUIRED VOLUME (AC-FT)	PROVIDED VOLUME (AC-FT)	WATER SURFACE ELEVATION (FT)	BASIN TOP ELEVATION (FT)	BASIN BOTTOM ELEVATION (FT)	SPILLWAY CREST LENGTH (FT)
A	10.96	0.91	0.91	6433.37	6434.00	6430.00	50.00

Temporary Pipe Outfall Design Summary

BASIN NAME	100% STORAGE ELEVATION (RISER TOP) (FT)	50% STORAGE ELEVATION (CENTER OF BOTTOM HOLE) (FT)	HOLE DIAMETER (IN)	NUMBER OF COLUMNS	NUMBER OF ROWS	UPSTREAM INVERT OF PIPE OUTFALL (FT)	DOWNSTREAM INVERT OF PIPE OUTFALL (FT)
A	6433.37	6431.88	1.7	1	3	6430.90	6421.00

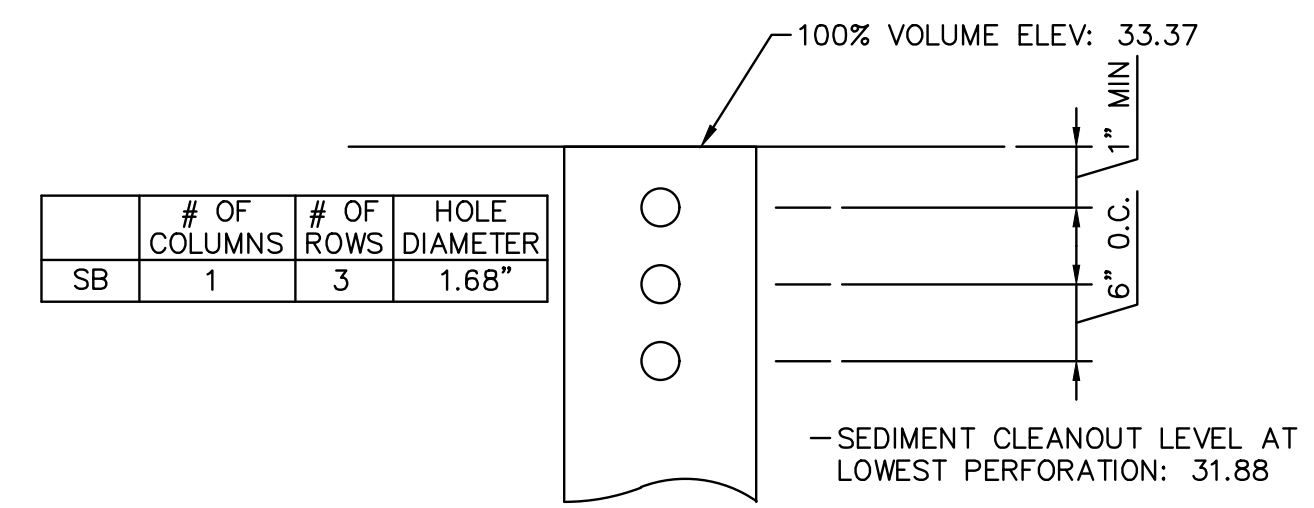

811 Know what's below. Call before you dig.

CALL UTILITY NOTIFICATION CENTER OF COLORADO
1-800-922-1987
CALL 2-BUSINESS DAYS IN ADVANCE BEFORE YOU DIG, GRADE, OR EXCAVATE FOR THE MARKING OF UNDERGROUND MEMBER UTILITIES

