



FINAL DRAINAGE LETTER TANNER RANCH  
FILING NO.1

**Tanner Ranch Filing No. 1**  
El Paso County, Colorado

Prepared for:

**Pusan Holdings, LLC**  
**5801 N. Union Blvd, Suite 100**  
**Colorado Springs, CO 80918**  
**Contact: Ben Wilbor**

Prepared by:

**Kimley-Horn and Associates, Inc.**  
**2 North Nevada Avenue, Suite 900**  
**Colorado Springs, CO 80903**  
**(719) 453-0181**  
**Contact: Kevin Kofford, P.E.**

Project #: 296172000

Prepared: March 30, 2026

**Kimley»Horn**



**CERTIFICATION**

**ENGINEERS STATEMENT**

This report and plan for the drainage design of the Pond A Tanner Ranch Filing No. 1 was prepared by me (or under my direct supervision) and is correct to the best of my knowledge and belief. Said report and plan has been prepared according to the criteria established by the County for drainage reports. I accept responsibility for any liability caused by any negligent acts, errors, or omissions on my part in preparing this report.

SIGNATURE (Affix Seal): \_\_\_\_\_  
Kevin R. Kofford \_\_\_\_\_ Date  
Colorado P.E. No. 57234

**DEVELOPER'S STATEMENT**

I, the developer, have read and will comply with all of the requirements specified in this Drainage Report and Plan.

\_\_\_\_\_  
Name of Developer

\_\_\_\_\_  
Authorized Signature \_\_\_\_\_ Date

\_\_\_\_\_  
Printed Name

\_\_\_\_\_  
Title

\_\_\_\_\_  
Address

**EL PASO COUNTY**

Filed in accordance with the requirements of the Drainage Criteria Manual, Volumes 1 and 2, El Paso County Engineering Criteria Manual and Land Development Code as amended.

\_\_\_\_\_  
County Engineer/ ECM Administrator \_\_\_\_\_ Date

Conditions:

**TABLE OF CONTENTS**

**Contents**

**CERTIFICATION ..... 1**  
ENGINEERS STATEMENT ..... 1  
DEVELOPER’S STATEMENT..... 1  
EL PASO COUNTY ..... 1

**TABLE OF CONTENTS ..... 2**

**INTRODUCTION ..... 3**  
PURPOSE AND SCOPE OF STUDY ..... 3  
LOCATION ..... 3  
DESCRIPTION OF PROPERTY ..... 3  
SOILS DATA ..... 3

**DRAINAGE DESIGN CRITERIA..... 4**  
PREVIOUS DRAINAGE STUDIES ..... 4  
DEVELOPMENT DESIGN CRITERIA REFERENCE ..... 4  
HYDROLOGIC CRITERIA..... 4  
HYDRAULIC CRITERIA ..... 4  
VARIANCES FROM CRITERIA ..... 4

**EXISTING DRAINAGE CONDITIONS ..... 4**  
*Existing Sub-Basin Summary* ..... 4  
*Sub-Basin EX-A*..... 4

**PROPOSED DRAINAGE CONDITIONS..... 5**  
*Proposed Sub-Basin Summary*..... 5  
*Sub-Basin A-2* ..... 5

**FOUR-STEP PROCESS ..... 5**

**DRAINAGE FACILITY DESIGN ..... 6**

**FLOODPLAIN STATEMENT ..... 6**

**GRADING AND EROSION CONTROL..... 6**

**REFERENCES ..... 7**

**APPENDIX ..... 8**

**APPENDIX A – VICINITY MAP ..... 9**

**APPENDIX B – FEMA FIRM PANEL ..... 10**

**APPENDIX C – NRCS SOIL SURVEY ..... 11**

**APPENDIX D – HYDROLOGIC CALCULATIONS ..... 12**

**APPENDIX E – HYDRAULIC CALCULATIONS..... 13**

**APPENDIX F – PREVIOUS DRAINAGE STUDIES ..... 14**

## **INTRODUCTION**

### ***PURPOSE AND SCOPE OF STUDY***

The purpose of this Final Drainage Letter (“FDL”) is to outline the required drainage improvements and grading design necessary to support the proposed upgrades to Pond A on the Tanner Ranch Project located at 350 N Dinner Bell Drive (the “Property” or “Site”), Town of Calhan, County of El Paso, State of Colorado. The Final Drainage Report for Tanner Ranch Filing No. 1 was completed by WestWorks Engineering and approved by El Paso County dated July 18<sup>th</sup>, 2005. This Final Drainage Letter identifies the existing Pond A condition and proposed improvements to the Pond A associated with the proposed repairs and improvements to existing infrastructure to bring into Preliminary Acceptance with the County.

### ***LOCATION***

The Property was previously platted and developed with an existing land use as single-family residential. The Project is located in Section 18, Township 14 south, Range 61 west of the 6<sup>th</sup> Principal Meridian, County of El Paso, State of Colorado. The Site is bounded by Highway 94 to the north, S Calhan Highway to the east, Handle Road to the south, and vacant properties to the west (see Vicinity map in Appendix).

The overall project consists of repairing and maintaining the existing infrastructure consisting of paving the existing roadways, removing sediment from roadside ditches and pond bottoms, and other required improvements to bring the overall Project to Preliminary Acceptance with the County. As part of the overall Project, upgrading Pond A is required with these improvements.

### ***DESCRIPTION OF PROPERTY***

The overall Project is located on approximately 209 Acres (EPC Parcel No. 1418002020). In existing conditions, the Site has been partially developed with a gravel road and single family homes. Existing vegetation on the Site consists of natural vegetation with scattered patches of native shrubs and trees. Currently, the site provides stormwater quality in detention ponds scattered throughout the site. The existing Pond A was constructed per the approved Construction Documents completed by WestWorks Engineering and approved by El Paso County and dated July 18, 2005. Since the time of construction, drainage standards have been modified by El Paso County. Pond A will be upgraded to meet the current County Standards and follow the Mile High Flood District guidance on extended detention basins. The area currently draining to Pond A is ±15.40 acres in size and is in the northeast portion of the Site. This Final Drainage Letter describes the upgrades with associated calculations found in the **Appendix**. The overall project site generally drains from northwest to southeast with slopes ranging from 1% to 10%. Runoff from the site outfalls into local tributaries that eventually outfalls into Pond Creek.

### ***SOILS DATA***

NRCS soil data for the Site is provided in the Appendix and the onsite soils are almost entirely USCS Hydrologic Soil Group B. Group B soils have moderate infiltration rates.

## **DRAINAGE DESIGN CRITERIA**

### ***PREVIOUS DRAINAGE STUDIES***

Previous drainage studies include Final Drainage Report for Tanner Ranch Filing No. 1 prepared by Westworks Engineering. This drainage study is used as the basis for the drainage delineation and design for the Pond A improvements.

### ***DEVELOPMENT DESIGN CRITERIA REFERENCE***

The proposed storm facilities follow the El Paso County Drainage Criteria Manual (the “CRITERIA”), El Paso Engineering Criteria Manual (the “ECM”), and the Mile High Flood District Urban Storm Drainage Criteria Manual (the “MANUAL”). Site drainage is not significantly impacted by such constraints as utilities or existing development. Further detail regarding onsite drainage patterns is provided in the Proposed Drainage Conditions Section.

### ***HYDROLOGIC CRITERIA***

The 5-year and 100-year design storm events were used in determining rainfall and runoff for the proposed drainage calculations per section 6 of the CRITERIA. Table 6-2 of the CRITERIA is the source for rainfall data for the 5-year and 100-year design storm events. Design runoff was calculated using the Rational Method for developed conditions as established in the CRITERIA and MANUAL. Runoff coefficients for the proposed development were determined using Table 6-6 of the CRITERIA by calculating weighted impervious values for each specific site basin. Based upon this approach, the drainage design provided for the Site is conservative and in keeping with the zoning and historic drainage concept for the area.

### ***HYDRAULIC CRITERIA***

The proposed site will be designed in accordance with the CRITERIA and MANUAL. Floodplain identification was determined using FIRM panels by FEMA and information provided in the CRITERIA.

### ***VARIANCES FROM CRITERIA***

There are no proposed variances from the El Paso County Drainage Criteria.

## **EXISTING DRAINAGE CONDITIONS**

The Site was divided into 4 sub-basins in the approved overall Final Drainage Report. For the purposes of examining Pond A, Sub-basin A is the only basin that will be examined. The approved report was written in 2005 and runoff coefficient values have been updated since then. Because of this, updated runoff calculations have been provided in summary below and in the **Appendix**. Overall delineation of the basins did not change from the approved Drainage Report.

### **Existing Sub-Basin Summary**

#### **Sub-Basin EX-A**

Sub-Basin EX-A is 43.50 acres and consists of the northeastern portion of the Site. This sub-basin is undeveloped and consists of native grasses and trees. The runoff developed within this basin sheet flows

overland from the northwest to southeast at slopes that range approximately 2-5%. Flows are currently captured by an existing 18" culvert that outflows into the property to the east. The direct runoff from sub-basin EX-A is 7.11 CFS for the 5-year event and 52.20 cfs for the 100-year event.

## PROPOSED DRAINAGE CONDITIONS

The proposed Site has been divided into one (1) on-site sub-basin: A-2. Calculations of the proposed sub-basin were previously completed in the previously approved drainage report. These calculations have been updated to meet current standards in the Criteria. The divided sub-basin includes everything flowing to Pond A. The proposed updated hydrologic calculations are provided in the **Appendix**. The proposed drainage map from the previous drainage report is also included in the **Appendix**. In the proposed conditions, stormwater generally travels from the proposed road to the northeast and travels in a natural swale to Pond A. The water is then collected into the existing Pond A and is released at less than existing conditions to the neighboring property. Runoff calculations for sub-basin A-2 have been summarized below.

### Proposed Sub-Basin Summary

#### Sub-Basin A-2

Sub-Basin A-2 is 15.40 acres and consists of the areas tributary to Pond A. This sub-basin consists of a portion of a proposed upgraded road, residential lots that are greater than 2.5 acres, and undeveloped landscape area. The runoff developed from this basin sheets flows through the site into a natural swale at 2-5% slopes. Flows are captured in Pond A and then released at less than historic rates to the adjacent property. The weighed imperviousness for the sub-basin is 8.50%. The developed direct runoff from sub-basin A-2 is 7.08 cfs for the 5-year event and 29.71 cfs for the 100-year event.

## FOUR-STEP PROCESS

### Step 1: Employ Runoff Reduction Practices

Within the basin draining to the pond, there are three (3) 2.5-acre single-family lots. Per Section I.7.1B of Appendix I of the ECM, the single-family residences fall under the large lot exemption as the total impervious area is less than 10% of the area. A BESQCP permit will be required by the County to prevent erosion and mitigate any runoff due to those activities.

Pond A water-quality detention basin is proposed to be upgraded as a part of this project and will have a water quality capture volume designed to accommodate the total imperviousness from the proposed upgraded paved road. The final Pond A design takes into account the total tributary area and total overall weighted imperviousness for the total studied tributary drainage area.

### Step 2: Stabilize Drainageways

Generally, stormwater runoff from the site ultimately drains through existing tributaries into Pond Creek. There are no proposed drainageway improvements anticipated as a part of this project. The Site maintains 2-5% imperviousness under existing and proposed conditions. The existing gravel road will be upgraded as a part of this project and a proposed paved road will be added to serve future development of the residential lots.

### **Step 3: Provide Water Quality Capture Volume (WQCV)**

Pond A was designed with a water quality capture volume to include the proposed paved road and associated imperviousness. However, the updated design of Pond A accounts for the final tributary areas adjacent to Pond A and updated associated overall imperviousness. Large lots are exempt from the Water Quality Capture Volume as indicated in I.7.1.B.5.

#### **Large Lot - Single Family Sites**

A single-family residential lot, or agricultural zoned lands, greater than or equal to 2.5 acres in size per dwelling and having a total lot impervious area of less than 10 percent. A total lot imperviousness greater than 10 percent is allowed when a study specific to the watershed and/or MS4 shows that expected soil and vegetation conditions are suitable for infiltration/filtration of the WQCV for a typical site, and the permittee accepts such study as applicable within its MS4 boundaries. The maximum total lot impervious covered under this exclusion shall be 20 percent.

### **Step 4: Consider need for Industrial and Commercial BMPs**

The proposed Project consists of residential lots with a Final Plat. There are no industrial and commercial uses or developments proposed with the project.

## **DRAINAGE FACILITY DESIGN**

A private full spectrum extended detention basin ("Pond A") is proposed to provide water quality for the proposed paved road upgrades, and to provide adequate capture volume for all tributary flows entering from offsite or being generated onsite. The required capture volume for water quality is 0.017 ac-ft. There is approximately 15.40 acres of area tributary to Pond A. This tributary area is delineated in the previously approved final drainage report proposed drainage map in the **Appendix**. The required 100-year detention volume for tributary area to Pond A is 0.604 ac-ft. The total volume provided for Pond A is 3.287 ac-ft. The proposed detention facility includes a tickle channel, a concrete cast-in-place outlet structure, and a 6" type VL (12" depth) riprap emergency spillway. The detention facility is designed to adequately manage stormwater flows as required the County and State. Flows leaving the Pond do so at ~50% of the pre-existing condition. Design documents for the proposed detention facility are included in the **Appendix**.

## **FLOODPLAIN STATEMENT**

According to the National Flood Insurance Program, Flood Insurance Rate Map Panel 08041C0850G with an effective date of December 7<sup>th</sup>, 2018, the subject property is entirely within Zone X and is located outside of the 100-year and 500-year flood plains. This panel is included in the **Appendix**.

## **GRADING AND EROSION CONTROL**

Grading and erosion control plans have been submitted concurrently with this Final Drainage Letter.

## REFERENCES

1. El Paso County Drainage Criteria Manual, Vol. 1 and 2, October 1994.
2. El Paso County Engineering Criteria Manual, December 2004, Revised 2016
3. Mile High Flood District Drainage Criteria Manual (MHFDCM), Vol. 1, prepared by Wright-McLaughlin Engineers, June 2001, with latest revisions.
4. Flood Insurance Rate Map, El Paso County, Colorado and Incorporated Areas, Map Number 08041C0850G Effective Date December 7, 2018, prepared by the Federal Emergency Management Agency (FEMA).
5. “Custom Soil Resource Report for El Paso County Area, Colorado” prepared by USGS National Cooperative Soil Survey, September 9<sup>th</sup>, 2025.
6. “Final Drainage Report for Tanner Ranch Filing No. 1” prepared by WestWorks Engineering, July 18<sup>th</sup>, 2005.

**APPENDIX**

**APPENDIX A – VICINITY MAP**

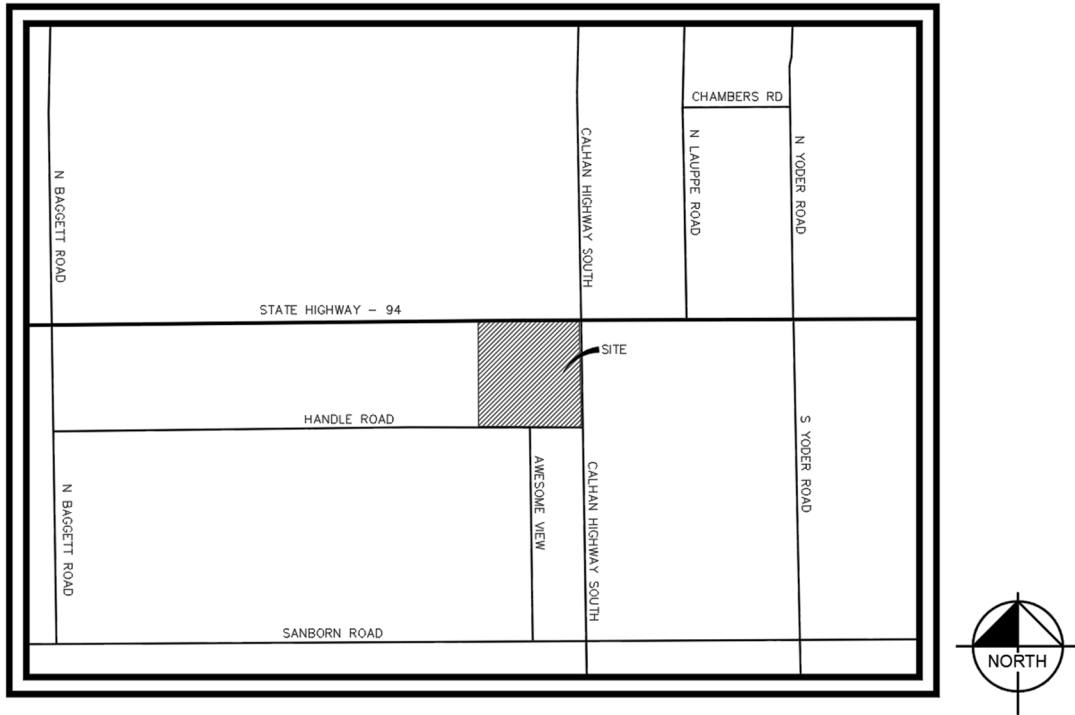

VICINITY MAP  
N.T.S.

**APPENDIX B – FEMA FIRM PANEL**

**NOTES TO USERS**

This map is for use in administering the National Flood Insurance Program. It does not necessarily identify all areas subject to flooding, particularly from local drainage sources of small size. The community map repository should be consulted for possible updated or additional flood hazard information.

To obtain more detailed information in areas where **Base Flood Elevations (BFEs)** and/or **Floodways** have been determined, users are encouraged to consult the Flood Profiles and Floodway Data and/or Summary of Stillwater Elevations tables contained within the Flood Insurance Study (FIS) report that accompanies this FIRMs. Users should be aware that BFEs shown on the FIRMs represent rounded whole-foot elevations. These BFEs are intended for flood insurance rating purposes only and should not be used as the sole source of flood elevation information. Accordingly, flood elevation data presented in the FIS report should be utilized in conjunction with the FIRMs for purposes of construction and/or floodplain management.

**Coastal Base Flood Elevations** shown on this map apply only to landward of 0' North American Vertical Datum of 1988 (NAVD88). Users of this FIRMs should be aware that coastal flood elevations are also provided in the Summary of Stillwater Elevations table in the Flood Insurance Study report for this jurisdiction. Elevations shown in the Summary of Stillwater Elevations table should be used for construction and/or floodplain management purposes when they are higher than the elevations shown on the FIRMs.

Boundaries of the **floodways** were computed at cross sections and interpolated between cross sections. The floodways were based on hydraulic considerations with regard to requirements of the National Flood Insurance Program. Floodway widths and other pertinent floodway data are provided in the Flood Insurance Study report for this jurisdiction.

Certain areas not in Special Flood Hazard Areas may be protected by **flood control structures**. Refer to section 2.4 "Flood Protection Measures" of the Flood Insurance Study report for information on flood control structures for this jurisdiction.

The projection used in the preparation of this map was Universal Transverse Mercator (UTM) zone 13. The horizontal datum was NAD83. GRS80 adjusted differences in datum, spheroid, projection or UTM zones used in the production of FIRMs for adjacent jurisdictions may result in slight positional differences in map features across jurisdiction boundaries. These differences do not affect the accuracy of this FIRMs.

Flood elevations on this map are referenced to the **North American Vertical Datum of 1988 (NAVD88)**. These flood elevations must be compared to structure and ground elevations referenced to the same datum. For information regarding conversion between the National Geodetic Vertical Datum of 1929 and the North American Vertical Datum of 1988, visit the National Geodetic Survey website at <http://www.ngs.noaa.gov/> or contact the National Geodetic Survey at the following address:

NGS Information Services  
NOMA, NINGS12  
National Geodetic Survey  
SSM/C, BIOC2  
1315 East-West Highway  
Silver Spring, MD 20910-3282

To obtain current elevation, description and/or location information for **bench marks** shown on this map, please contact the Information Services Branch of the National Geodetic Survey at (301) 713-3242 or visit its website at <http://www.ngs.noaa.gov/>.

**Base Map** information shown on this FIRMs was provided in digital format by El Paso County, Colorado Springs Utilities, and Anderson Consulting Engineers, Inc. These data are current as of 2008.

This map reflects more detailed and up-to-date **stream channel configurations and floodplain delineations** than those shown on the previous FIRMs for this jurisdiction. The floodplains and floodways that were transferred from the previous FIRMs may have been adjusted to conform to these new stream channel configurations. As a result, the Flood Profiles and Floodway Data tables in the Flood Insurance Study Report (which contains authoritative hydraulic data) may reflect stream channel distances that differ from what is shown on this map. The profile baselines depicted on this map represent the hydraulic modeling baselines that match the flood profiles and Floodway Data Tables if applicable, in the FIS report. As a result, the profile baselines may deviate significantly from the new base map channel representation and may appear outside of the floodplain.

**Corporate limits** shown on this map are based on the best data available at the time of publication. Because changes due to annexations or de-annexations may have occurred after this map was published, map users should contact appropriate community officials to verify current corporate limit locations.

Please refer to the separately printed **Map Index** for an overview map of the county showing the layout of map panels, community map repository addresses, and a Listing of Communities table containing National Flood Insurance Program dates for each community as well as a listing of the panels on which each community is located.

Contact **FEMA Map Service Center (MSC)** via the FEMA Map Information eXchange (FMIX) 1-877-336-2627 for information on available products associated with the FIRMs. Available products may include previously issued Letters of Map Change, a Flood Insurance Study Report, and/or digital versions of this map. The MSC may also be reached by Fax at 1-800-368-9620 and its website at <http://www.msc.fema.gov/>.

If you have **questions about this map** or questions concerning the National Flood Insurance Program in general, please call 1-877-FEMA-MAAP (1-877-336-2627) or visit the FEMA website at <http://www.fema.gov/business/fip/>.

**El Paso County Vertical Datum Offset Table**

Flooding Source	Vertical Datum Offset (ft)

REFER TO SECTION 2.3 OF THE EL PASO COUNTY FLOOD INSURANCE STUDY FOR STREAM OR STREAM VERTICAL DATUM CONVERSION INFORMATION

**Panel Location Map**

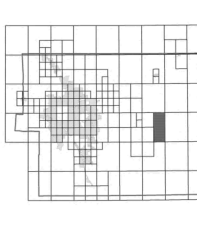

THIS PANEL SHOWN AT A SCALE OF 1"=500' ON MAP NUMBER 08041C0830

THIS PANEL SHOWN AT A SCALE OF 1"=500' ON MAP NUMBER 08041C0840

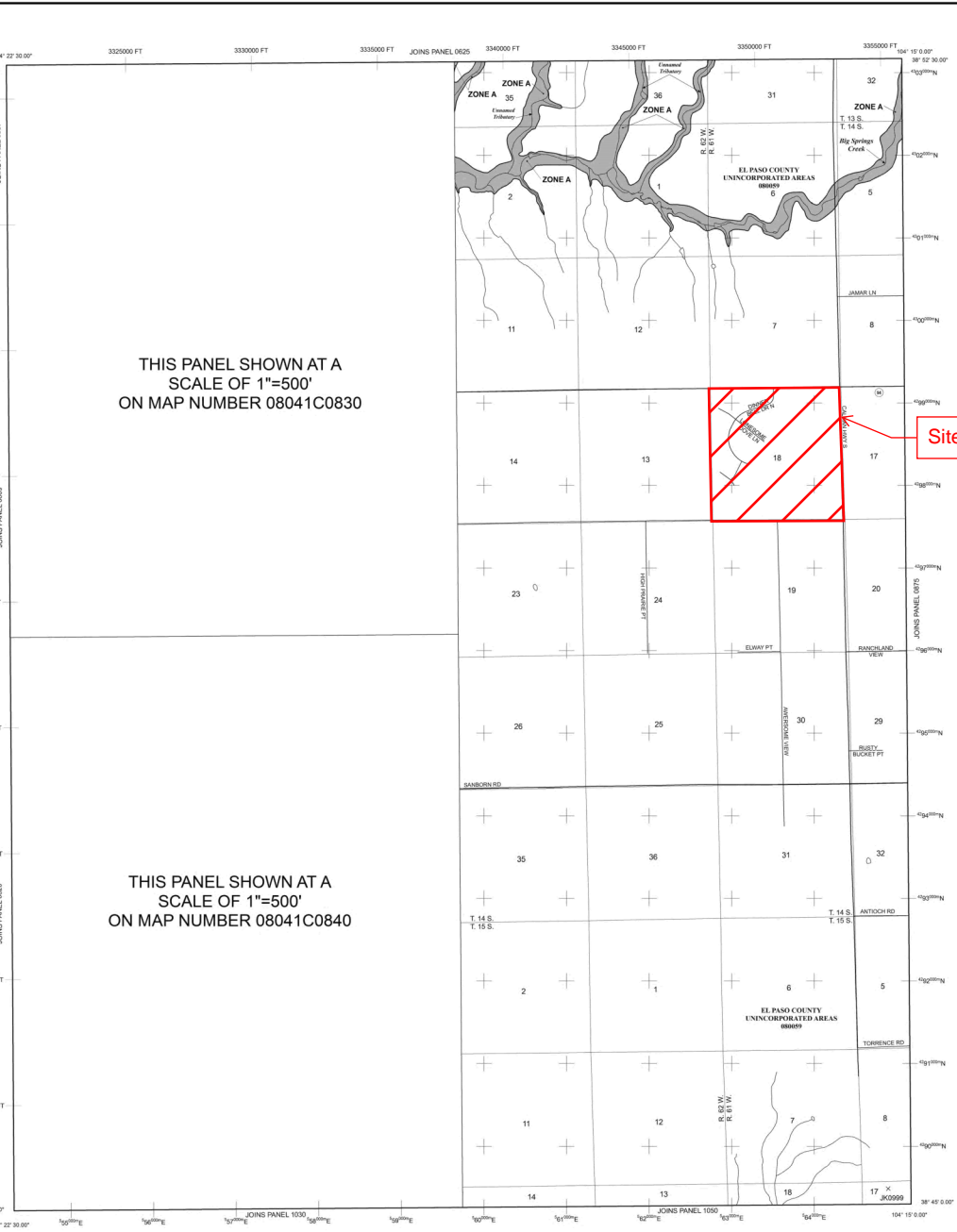

**LEGEND**

- SPECIAL FLOOD HAZARD AREAS (SFHAs) SUBJECT TO INUNDATION BY THE 1% ANNUAL CHANCE FLOOD
- The 1% annual chance flood (100-year flood), also known as the base flood, is the flood that has a 1% chance of being equaled or exceeded in any given year. The Special Flood Hazard Area is the area subject to flooding by the 1% annual chance flood. Areas of Special Flood Hazard Zones A, AE, AH, AO, AR, AV, V, VE, and VE-1. The Base Flood Elevation is the water-surface elevation of the 1% annual chance flood.
- ZONE A** No base flood elevation determined. Base Flood Elevation determined.
- ZONE AE** Flood depths of 1 to 3 feet (locally areas of ponding); Base Flood Elevation determined.
- ZONE AH** Flood depths of 1 to 3 feet (locally areas of ponding); average depth determined; for areas of shallow sea flooding, wavelets also determined.
- ZONE AR** Special Flood Hazard Area Formerly protected from the 1% annual chance flood by a flood control system that was subsequently destroyed. Zone AR areas include the former flood control system, if any, retained to provide floodway protection.
- ZONE AV** Area to be protected from 1% annual chance flood by a Federal flood protection system under construction; no base flood elevations determined.
- ZONE V** Coastal flood zone with velocity hazard (wave action); no base flood elevations determined.
- ZONE VE** Coastal flood zone with velocity hazard (wave action); Base Flood Elevation determined.
- FLOODWAY AREAS IN ZONE AE
- OTHER FLOOD AREAS
- ZONE X** Areas of 0.2% annual chance flood, areas of 1% annual chance flood with average depths of 1 to 3 feet with average areas less than 1 square mile; and areas protected by levees from 1% annual chance flood.
- OTHER AREAS
- ZONE X** Areas determined to be outside the 0.2% annual chance floodplain.
- ZONE D** Areas in which flood hazards are undetermined, but possible.
- COASTAL BARRIER RESOURCES SYSTEM (CBRS) AREAS
- OTHERWISE PROTECTED AREAS (OPAs)
- Floodplain boundary
- Floodway boundary
- Zone D boundary
- CBRS and OPA boundary
- Boundary of Special Flood Hazard Areas of different Base Flood Elevation
- 512 (EL 987) Base Flood Elevation line and value; elevation in feet; elevation in feet
- Cross section line
- Geographic coordinates referenced to the North American Datum of 1983 (NAD 83)
- 1000-meter Universal Transverse Mercator grid cells, zone 13
- 400000 FT 5000-foot grid ticks; Colorado State Plane coordinate system, central area (FIPS/USGS 5003); Lambert Conformal Conic Projection
- DX5510 Bench mark (see explanation in Notes to Users section of this FIS report)
- M1.5 River Mile
- MAP REPOSITORIES Refer to Map Repositories list on Map Index
- EFFECTIVE DATE OF COUNTYWIDE FLOOD INSURANCE RATE MAP MARCH 17, 1997
- EFFECTIVE DATES OF REVISIONS TO THIS PANEL DECEMBER 7, 2018 To update corporate limits, to change Base Flood Elevations and Special Flood Hazard Areas, to update map format, to add roads and road names, and to incorporate previously issued Letters of Map Revision.
- For community map revision history prior to countywide mapping, refer to the Community Map History "Name Lookup" in the Flood Insurance Study report for this jurisdiction.
- To determine if flood insurance is available in this community, contact your insurance agent or call the National Flood Insurance Program at 1-800-638-6623.

**NATIONAL FLOOD INSURANCE PROGRAM**

**PANEL 0850G**

**FIRM FLOOD INSURANCE RATE MAP**

**EL PASO COUNTY, COLORADO AND INCORPORATED AREAS**

**PANEL 850 OF 1300**  
(SEE MAP INDEX FOR FIRM PANEL LAYOUT)

CONTAINS:

COMMUNITY	NUMBER	PANEL	SUFFIX
EL PASO COUNTY	0850	0850	G

MAP NUMBER 08041C0850G

MAP REVISED DECEMBER 7, 2018

Federal Emergency Management Agency



Additional Flood Hazard information and resources are available from local communities and the Colorado Water Conservation Board.

**APPENDIX C – NRCS SOIL SURVEY**

# Custom Soil Resource Report for El Paso County Area, Colorado



# Soil Map

---

The soil map section includes the soil map for the defined area of interest, a list of soil map units on the map and extent of each map unit, and cartographic symbols displayed on the map. Also presented are various metadata about data used to produce the map, and a description of each soil map unit.

# Custom Soil Resource Report Soil Map



Soil Map may not be valid at this scale.

Map Scale: 1:13,500 if printed on A landscape (11" x 8.5") sheet.



Map projection: Web Mercator Corner coordinates: WGS84 Edge tics: UTM Zone 13N WGS84



### MAP LEGEND

**Area of Interest (AOI)**

 Area of Interest (AOI)



















**Soils**







 Soil Map Unit Polygons

 Soil Map Unit Lines

 Soil Map Unit Points

**Special Point Features**





-  Blowout
-  Borrow Pit
-  Clay Spot
-  Closed Depression
-  Gravel Pit
-  Gravelly Spot
-  Landfill
-  Lava Flow
-  Marsh or swamp
-  Mine or Quarry
-  Miscellaneous Water
-  Perennial Water
-  Rock Outcrop
-  Saline Spot
-  Sandy Spot
-  Severely Eroded Spot
-  Sinkhole
-  Slide or Slip
-  Sodic Spot

-  Spoil Area
-  Stony Spot
-  Very Stony Spot
-  Wet Spot
-  Other
-  Special Line Features

**Water Features**

 Streams and Canals

**Transportation**

-  Rails
-  Interstate Highways
-  US Routes
-  Major Roads
-  Local Roads

**Background**

 Aerial Photography

### MAP INFORMATION

The soil surveys that comprise your AOI were mapped at 1:24,000.

Warning: Soil Map may not be valid at this scale.

Enlargement of maps beyond the scale of mapping can cause misunderstanding of the detail of mapping and accuracy of soil line placement. The maps do not show the small areas of contrasting soils that could have been shown at a more detailed scale.

Please rely on the bar scale on each map sheet for map measurements.

Source of Map: Natural Resources Conservation Service  
 Web Soil Survey URL:  
 Coordinate System: Web Mercator (EPSG:3857)

Maps from the Web Soil Survey are based on the Web Mercator projection, which preserves direction and shape but distorts distance and area. A projection that preserves area, such as the Albers equal-area conic projection, should be used if more accurate calculations of distance or area are required.

This product is generated from the USDA-NRCS certified data as of the version date(s) listed below.

Soil Survey Area: El Paso County Area, Colorado  
 Survey Area Data: Version 22, Sep 3, 2024

Soil map units are labeled (as space allows) for map scales 1:50,000 or larger.

Date(s) aerial images were photographed: Sep 11, 2018—Oct 20, 2018

The orthophoto or other base map on which the soil lines were compiled and digitized probably differs from the background imagery displayed on these maps. As a result, some minor shifting of map unit boundaries may be evident.

## Map Unit Legend

Map Unit Symbol	Map Unit Name	Acres in AOI	Percent of AOI
2	Ascalon sandy loam, 1 to 3 percent slopes	374.9	60.2%
3	Ascalon sandy loam, 3 to 9 percent slopes	223.6	35.9%
6	Bijou sandy loam, 0 to 3 percent slopes	4.9	0.8%
11	Bresser sandy loam, cool, 0 to 3 percent slopes	19.4	3.1%
<b>Totals for Area of Interest</b>		<b>622.8</b>	<b>100.0%</b>

## Map Unit Descriptions

The map units delineated on the detailed soil maps in a soil survey represent the soils or miscellaneous areas in the survey area. The map unit descriptions, along with the maps, can be used to determine the composition and properties of a unit.

A map unit delineation on a soil map represents an area dominated by one or more major kinds of soil or miscellaneous areas. A map unit is identified and named according to the taxonomic classification of the dominant soils. Within a taxonomic class there are precisely defined limits for the properties of the soils. On the landscape, however, the soils are natural phenomena, and they have the characteristic variability of all natural phenomena. Thus, the range of some observed properties may extend beyond the limits defined for a taxonomic class. Areas of soils of a single taxonomic class rarely, if ever, can be mapped without including areas of other taxonomic classes. Consequently, every map unit is made up of the soils or miscellaneous areas for which it is named and some minor components that belong to taxonomic classes other than those of the major soils.

Most minor soils have properties similar to those of the dominant soil or soils in the map unit, and thus they do not affect use and management. These are called noncontrasting, or similar, components. They may or may not be mentioned in a particular map unit description. Other minor components, however, have properties and behavioral characteristics divergent enough to affect use or to require different management. These are called contrasting, or dissimilar, components. They generally are in small areas and could not be mapped separately because of the scale used. Some small areas of strongly contrasting soils or miscellaneous areas are identified by a special symbol on the maps. If included in the database for a given area, the contrasting minor components are identified in the map unit descriptions along with some characteristics of each. A few areas of minor components may not have been observed, and consequently they are not mentioned in the descriptions, especially where the pattern was so complex that it was impractical to make enough observations to identify all the soils and miscellaneous areas on the landscape.

## Custom Soil Resource Report

The presence of minor components in a map unit in no way diminishes the usefulness or accuracy of the data. The objective of mapping is not to delineate pure taxonomic classes but rather to separate the landscape into landforms or landform segments that have similar use and management requirements. The delineation of such segments on the map provides sufficient information for the development of resource plans. If intensive use of small areas is planned, however, onsite investigation is needed to define and locate the soils and miscellaneous areas.

An identifying symbol precedes the map unit name in the map unit descriptions. Each description includes general facts about the unit and gives important soil properties and qualities.

Soils that have profiles that are almost alike make up a *soil series*. Except for differences in texture of the surface layer, all the soils of a series have major horizons that are similar in composition, thickness, and arrangement.

Soils of one series can differ in texture of the surface layer, slope, stoniness, salinity, degree of erosion, and other characteristics that affect their use. On the basis of such differences, a soil series is divided into *soil phases*. Most of the areas shown on the detailed soil maps are phases of soil series. The name of a soil phase commonly indicates a feature that affects use or management. For example, Alpha silt loam, 0 to 2 percent slopes, is a phase of the Alpha series.

Some map units are made up of two or more major soils or miscellaneous areas. These map units are complexes, associations, or undifferentiated groups.

A *complex* consists of two or more soils or miscellaneous areas in such an intricate pattern or in such small areas that they cannot be shown separately on the maps. The pattern and proportion of the soils or miscellaneous areas are somewhat similar in all areas. Alpha-Beta complex, 0 to 6 percent slopes, is an example.

An *association* is made up of two or more geographically associated soils or miscellaneous areas that are shown as one unit on the maps. Because of present or anticipated uses of the map units in the survey area, it was not considered practical or necessary to map the soils or miscellaneous areas separately. The pattern and relative proportion of the soils or miscellaneous areas are somewhat similar. Alpha-Beta association, 0 to 2 percent slopes, is an example.

An *undifferentiated group* is made up of two or more soils or miscellaneous areas that could be mapped individually but are mapped as one unit because similar interpretations can be made for use and management. The pattern and proportion of the soils or miscellaneous areas in a mapped area are not uniform. An area can be made up of only one of the major soils or miscellaneous areas, or it can be made up of all of them. Alpha and Beta soils, 0 to 2 percent slopes, is an example.

Some surveys include *miscellaneous areas*. Such areas have little or no soil material and support little or no vegetation. Rock outcrop is an example.

## El Paso County Area, Colorado

### 2—Ascalon sandy loam, 1 to 3 percent slopes

#### Map Unit Setting

*National map unit symbol:* 367q  
*Elevation:* 5,500 to 6,500 feet  
*Mean annual precipitation:* 14 to 16 inches  
*Mean annual air temperature:* 47 to 50 degrees F  
*Frost-free period:* 130 to 150 days  
*Farmland classification:* Prime farmland if irrigated

#### Map Unit Composition

*Ascalon and similar soils:* 98 percent  
*Minor components:* 2 percent  
*Estimates are based on observations, descriptions, and transects of the mapunit.*

#### Description of Ascalon

##### Setting

*Landform:* Flats  
*Landform position (three-dimensional):* Talf  
*Down-slope shape:* Linear  
*Across-slope shape:* Linear  
*Parent material:* Mixed alluvium and/or eolian deposits

##### Typical profile

*A - 0 to 8 inches:* sandy loam  
*Bt - 8 to 21 inches:* sandy clay loam  
*BC - 21 to 27 inches:* sandy loam  
*Ck1 - 27 to 48 inches:* sandy loam  
*Ck2 - 48 to 60 inches:* loamy sand

##### Properties and qualities

*Slope:* 1 to 3 percent  
*Depth to restrictive feature:* More than 80 inches  
*Drainage class:* Well drained  
*Runoff class:* Low  
*Capacity of the most limiting layer to transmit water (Ksat):* Moderately high to high  
(0.60 to 2.00 in/hr)  
*Depth to water table:* More than 80 inches  
*Frequency of flooding:* None  
*Frequency of ponding:* None  
*Calcium carbonate, maximum content:* 10 percent  
*Maximum salinity:* Nonsaline to very slightly saline (0.0 to 2.0 mmhos/cm)  
*Available water supply, 0 to 60 inches:* Moderate (about 7.1 inches)

##### Interpretive groups

*Land capability classification (irrigated):* 3e  
*Land capability classification (nonirrigated):* 4e  
*Hydrologic Soil Group:* B  
*Ecological site:* R069XY026CO - Sandy Plains  
*Other vegetative classification:* SANDY PLAINS (069BY026CO)  
*Hydric soil rating:* No

**Minor Components**

**Other soils**

*Percent of map unit:* 1 percent  
*Hydric soil rating:* No

**Pleasant**

*Percent of map unit:* 1 percent  
*Landform:* Depressions  
*Hydric soil rating:* Yes

**3—Ascalon sandy loam, 3 to 9 percent slopes**

**Map Unit Setting**

*National map unit symbol:* 2tlny  
*Elevation:* 3,870 to 5,960 feet  
*Mean annual precipitation:* 13 to 18 inches  
*Mean annual air temperature:* 46 to 54 degrees F  
*Frost-free period:* 95 to 155 days  
*Farmland classification:* Not prime farmland

**Map Unit Composition**

*Ascalon and similar soils:* 85 percent  
*Minor components:* 15 percent  
*Estimates are based on observations, descriptions, and transects of the mapunit.*

**Description of Ascalon**

**Setting**

*Landform:* Interfluves  
*Landform position (two-dimensional):* Backslope  
*Landform position (three-dimensional):* Side slope  
*Down-slope shape:* Linear  
*Across-slope shape:* Linear  
*Parent material:* Wind-reworked alluvium and/or calcareous sandy eolian deposits

**Typical profile**

*Ap - 0 to 6 inches:* sandy loam  
*Bt1 - 6 to 12 inches:* sandy clay loam  
*Bt2 - 12 to 19 inches:* sandy clay loam  
*Bk1 - 19 to 35 inches:* fine sandy loam  
*Bk2 - 35 to 80 inches:* fine sandy loam

**Properties and qualities**

*Slope:* 3 to 9 percent  
*Depth to restrictive feature:* More than 80 inches  
*Drainage class:* Well drained  
*Runoff class:* Medium  
*Capacity of the most limiting layer to transmit water (Ksat):* Moderately high to high  
(0.60 to 5.98 in/hr)

## Custom Soil Resource Report

*Depth to water table:* More than 80 inches  
*Frequency of flooding:* None  
*Frequency of ponding:* None  
*Calcium carbonate, maximum content:* 10 percent  
*Maximum salinity:* Nonsaline (0.1 to 1.9 mmhos/cm)  
*Sodium adsorption ratio, maximum:* 1.0  
*Available water supply, 0 to 60 inches:* Moderate (about 7.1 inches)

### Interpretive groups

*Land capability classification (irrigated):* 6e  
*Land capability classification (nonirrigated):* 6e  
*Hydrologic Soil Group:* B  
*Ecological site:* R067BY024CO - Sandy Plains  
*Hydric soil rating:* No

### Minor Components

#### Olnest

*Percent of map unit:* 10 percent  
*Landform:* Interfluves  
*Landform position (two-dimensional):* Backslope  
*Landform position (three-dimensional):* Side slope  
*Down-slope shape:* Linear  
*Across-slope shape:* Linear  
*Ecological site:* R067BY024CO - Sandy Plains  
*Hydric soil rating:* No

#### Vona

*Percent of map unit:* 5 percent  
*Landform:* Interfluves  
*Landform position (two-dimensional):* Backslope  
*Landform position (three-dimensional):* Side slope  
*Down-slope shape:* Linear  
*Across-slope shape:* Linear  
*Ecological site:* R067BY024CO - Sandy Plains  
*Hydric soil rating:* No

## 6—Bijou sandy loam, 0 to 3 percent slopes

### Map Unit Setting

*National map unit symbol:* 2tqxr  
*Elevation:* 5,700 to 6,200 feet  
*Mean annual precipitation:* 14 to 16 inches  
*Mean annual air temperature:* 50 to 54 degrees F  
*Frost-free period:* 130 to 170 days  
*Farmland classification:* Prime farmland if irrigated and the product of I (soil erodibility) x C (climate factor) does not exceed 60

### Map Unit Composition

*Bijou and similar soils:* 85 percent

## Custom Soil Resource Report

*Minor components: 15 percent*  
*Estimates are based on observations, descriptions, and transects of the mapunit.*

### Description of Bijou

#### Setting

*Landform: Sand sheets*  
*Landform position (two-dimensional): Summit*  
*Landform position (three-dimensional): Interfluve*  
*Down-slope shape: Linear*  
*Across-slope shape: Linear*  
*Parent material: Eolian sands*

#### Typical profile

*A - 0 to 4 inches: sandy loam*  
*Bt1 - 4 to 8 inches: sandy loam*  
*Bt2 - 8 to 21 inches: sandy loam*  
*Bw - 21 to 28 inches: sandy loam*  
*C - 28 to 79 inches: loamy coarse sand*

#### Properties and qualities

*Slope: 0 to 3 percent*  
*Depth to restrictive feature: More than 80 inches*  
*Drainage class: Somewhat excessively drained*  
*Capacity of the most limiting layer to transmit water (Ksat): High (2.00 to 6.00 in/hr)*  
*Depth to water table: More than 80 inches*  
*Frequency of flooding: None*  
*Frequency of ponding: None*  
*Maximum salinity: Nonsaline (0.1 to 0.2 mmhos/cm)*  
*Available water supply, 0 to 60 inches: Low (about 5.0 inches)*

#### Interpretive groups

*Land capability classification (irrigated): 3e*  
*Land capability classification (nonirrigated): 4c*  
*Hydrologic Soil Group: A*  
*Ecological site: R067BY024CO - Sandy Plains*  
*Hydric soil rating: No*

### Minor Components

#### Valent

*Percent of map unit: 10 percent*  
*Landform: Sand sheets*  
*Landform position (two-dimensional): Backslope*  
*Landform position (three-dimensional): Side slope*  
*Down-slope shape: Linear*  
*Across-slope shape: Linear*  
*Ecological site: R067BY015CO - Deep Sand*  
*Hydric soil rating: No*

#### Oldest

*Percent of map unit: 5 percent*  
*Landform: Swales*  
*Down-slope shape: Linear*  
*Across-slope shape: Concave*  
*Ecological site: R067BY024CO - Sandy Plains*

*Hydric soil rating:* No

## **11—Bresser sandy loam, cool, 0 to 3 percent slopes**

### **Map Unit Setting**

*National map unit symbol:* 2tlph

*Elevation:* 5,850 to 6,880 feet

*Mean annual precipitation:* 15 to 19 inches

*Mean annual air temperature:* 48 to 52 degrees F

*Frost-free period:* 100 to 130 days

*Farmland classification:* Prime farmland if irrigated and the product of I (soil erodibility) x C (climate factor) does not exceed 60

### **Map Unit Composition**

*Bresser, cool, and similar soils:* 85 percent

*Minor components:* 15 percent

*Estimates are based on observations, descriptions, and transects of the mapunit.*

### **Description of Bresser, Cool**

#### **Setting**

*Landform:* Interfluves

*Landform position (two-dimensional):* Summit

*Landform position (three-dimensional):* Interfluve

*Down-slope shape:* Linear

*Across-slope shape:* Convex

*Parent material:* Tertiary aged alluvium derived from arkose

#### **Typical profile**

*Ap - 0 to 5 inches:* sandy loam

*Bt1 - 5 to 8 inches:* sandy loam

*Bt2 - 8 to 27 inches:* sandy clay loam

*Bt3 - 27 to 36 inches:* sandy loam

*C - 36 to 80 inches:* loamy coarse sand

#### **Properties and qualities**

*Slope:* 0 to 3 percent

*Depth to restrictive feature:* More than 80 inches

*Drainage class:* Well drained

*Runoff class:* Low

*Capacity of the most limiting layer to transmit water (Ksat):* Moderately high to high  
(0.60 to 6.00 in/hr)

*Depth to water table:* More than 80 inches

*Frequency of flooding:* None

*Frequency of ponding:* None

*Calcium carbonate, maximum content:* 5 percent

*Maximum salinity:* Nonsaline to very slightly saline (0.1 to 2.0 mmhos/cm)

*Available water supply, 0 to 60 inches:* Low (about 5.4 inches)

#### **Interpretive groups**

*Land capability classification (irrigated):* 3e

Custom Soil Resource Report

*Land capability classification (nonirrigated): 4c*  
*Hydrologic Soil Group: B*  
*Ecological site: R049XB210CO - Sandy Foothill*  
*Hydric soil rating: No*

**Minor Components**

**Truckton**

*Percent of map unit: 10 percent*  
*Landform: Interfluves*  
*Landform position (two-dimensional): Summit*  
*Landform position (three-dimensional): Interfluve*  
*Down-slope shape: Linear*  
*Across-slope shape: Linear*  
*Ecological site: R049XB210CO - Sandy Foothill*  
*Hydric soil rating: No*

**Yoder**

*Percent of map unit: 5 percent*  
*Landform: Alluvial fans*  
*Down-slope shape: Linear*  
*Across-slope shape: Linear*  
*Ecological site: R049XY214CO - Gravelly Foothill*  
*Hydric soil rating: No*

# Soil Information for All Uses

---

## Soil Properties and Qualities

The Soil Properties and Qualities section includes various soil properties and qualities displayed as thematic maps with a summary table for the soil map units in the selected area of interest. A single value or rating for each map unit is generated by aggregating the interpretive ratings of individual map unit components. This aggregation process is defined for each property or quality.

## Soil Qualities and Features

Soil qualities are behavior and performance attributes that are not directly measured, but are inferred from observations of dynamic conditions and from soil properties. Example soil qualities include natural drainage, and frost action. Soil features are attributes that are not directly part of the soil. Example soil features include slope and depth to restrictive layer. These features can greatly impact the use and management of the soil.

## Hydrologic Soil Group

Hydrologic soil groups are based on estimates of runoff potential. Soils are assigned to one of four groups according to the rate of water infiltration when the soils are not protected by vegetation, are thoroughly wet, and receive precipitation from long-duration storms.

The soils in the United States are assigned to four groups (A, B, C, and D) and three dual classes (A/D, B/D, and C/D). The groups are defined as follows:

Group A. Soils having a high infiltration rate (low runoff potential) when thoroughly wet. These consist mainly of deep, well drained to excessively drained sands or gravelly sands. These soils have a high rate of water transmission.

Group B. Soils having a moderate infiltration rate when thoroughly wet. These consist chiefly of moderately deep or deep, moderately well drained or well drained soils that have moderately fine texture to moderately coarse texture. These soils have a moderate rate of water transmission.

## Custom Soil Resource Report

Group C. Soils having a slow infiltration rate when thoroughly wet. These consist chiefly of soils having a layer that impedes the downward movement of water or soils of moderately fine texture or fine texture. These soils have a slow rate of water transmission.

Group D. Soils having a very slow infiltration rate (high runoff potential) when thoroughly wet. These consist chiefly of clays that have a high shrink-swell potential, soils that have a high water table, soils that have a claypan or clay layer at or near the surface, and soils that are shallow over nearly impervious material. These soils have a very slow rate of water transmission.

If a soil is assigned to a dual hydrologic group (A/D, B/D, or C/D), the first letter is for drained areas and the second is for undrained areas. Only the soils that in their natural condition are in group D are assigned to dual classes.

# Custom Soil Resource Report Map—Hydrologic Soil Group

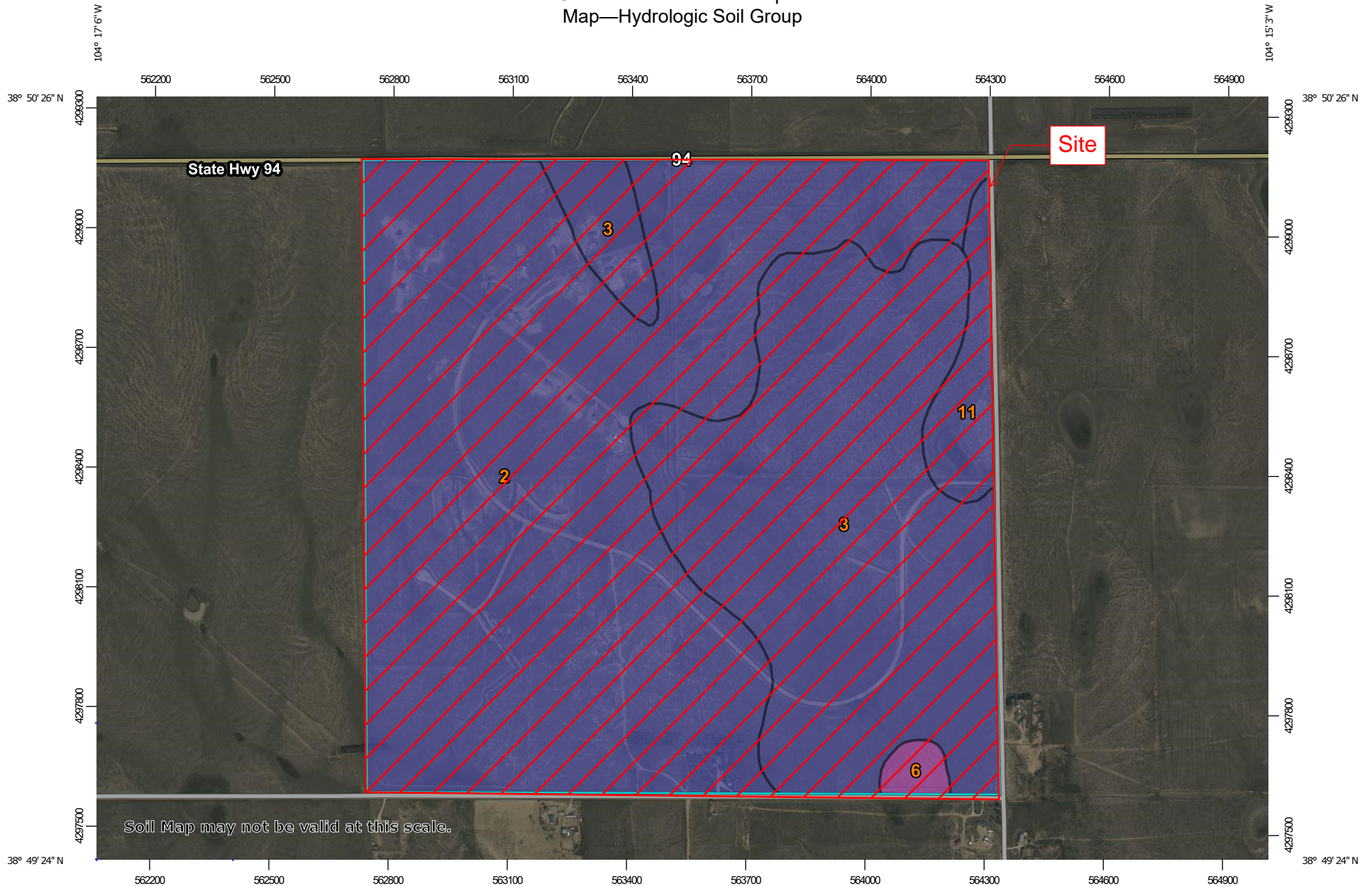

Soil Map may not be valid at this scale.

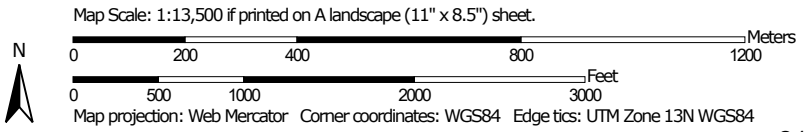

### MAP LEGEND

**Area of Interest (AOI)**









 Area of Interest (AOI)

**Soils**

**Soil Rating Polygons**





-  A
-  A/D
-  B
-  B/D
-  C
-  C/D
-  D
-  Not rated or not available

**Soil Rating Lines**

-  A
-  A/D
-  B
-  B/D
-  C
-  C/D
-  D
-  Not rated or not available

**Soil Rating Points**





-  A
-  A/D
-  B
-  B/D

-  C
-  C/D
-  D
-  Not rated or not available

**Water Features**

 Streams and Canals

**Transportation**

-  Rails
-  Interstate Highways
-  US Routes
-  Major Roads
-  Local Roads

**Background**

 Aerial Photography

### MAP INFORMATION

The soil surveys that comprise your AOI were mapped at 1:24,000.

Warning: Soil Map may not be valid at this scale.

Enlargement of maps beyond the scale of mapping can cause misunderstanding of the detail of mapping and accuracy of soil line placement. The maps do not show the small areas of contrasting soils that could have been shown at a more detailed scale.

Please rely on the bar scale on each map sheet for map measurements.

Source of Map: Natural Resources Conservation Service  
 Web Soil Survey URL:  
 Coordinate System: Web Mercator (EPSG:3857)

Maps from the Web Soil Survey are based on the Web Mercator projection, which preserves direction and shape but distorts distance and area. A projection that preserves area, such as the Albers equal-area conic projection, should be used if more accurate calculations of distance or area are required.

This product is generated from the USDA-NRCS certified data as of the version date(s) listed below.

Soil Survey Area: El Paso County Area, Colorado  
 Survey Area Data: Version 22, Sep 3, 2024

Soil map units are labeled (as space allows) for map scales 1:50,000 or larger.

Date(s) aerial images were photographed: Sep 11, 2018—Oct 20, 2018

The orthophoto or other base map on which the soil lines were compiled and digitized probably differs from the background imagery displayed on these maps. As a result, some minor shifting of map unit boundaries may be evident.

**Table—Hydrologic Soil Group**

Map unit symbol	Map unit name	Rating	Acres in AOI	Percent of AOI
2	Ascalon sandy loam, 1 to 3 percent slopes	B	374.9	60.2%
3	Ascalon sandy loam, 3 to 9 percent slopes	B	223.6	35.9%
6	Bijou sandy loam, 0 to 3 percent slopes	A	4.9	0.8%
11	Bresser sandy loam, cool, 0 to 3 percent slopes	B	19.4	3.1%
<b>Totals for Area of Interest</b>			<b>622.8</b>	<b>100.0%</b>

**Rating Options—Hydrologic Soil Group**

*Aggregation Method: Dominant Condition*

*Component Percent Cutoff: None Specified*

*Tie-break Rule: Higher*

---

**APPENDIX D – HYDROLOGIC CALCULATIONS**



**NOAA Atlas 14, Volume 8, Version 2**  
**Location name: Yoder, Colorado, USA\***  
**Latitude: 38.8322°, Longitude: -104.2663°**  
**Elevation: m/ft\*\***  
 \* source: ESRI Maps  
 \*\* source: USGS



**POINT PRECIPITATION FREQUENCY ESTIMATES**

Sanja Perica, Deborah Martin, Sandra Pavlovic, Ishani Roy, Michael St. Laurent, Carl Trypaluk, Dale Unruh, Michael Yekta, Geoffery Bonnin

NOAA, National Weather Service, Silver Spring, Maryland

[PF tabular](#) | [PF graphical](#) | [Maps & aerials](#)

**PF tabular**

<b>PDS-based point precipitation frequency estimates with 90% confidence intervals (in inches)<sup>1</sup></b>										
Duration	Average recurrence interval (years)									
	1	2	5	10	25	50	100	200	500	1000
<b>5-min</b>	<b>0.247</b> (0.196-0.315)	<b>0.301</b> (0.239-0.385)	<b>0.397</b> (0.313-0.508)	<b>0.483</b> (0.379-0.620)	<b>0.610</b> (0.468-0.817)	<b>0.715</b> (0.535-0.967)	<b>0.827</b> (0.598-1.14)	<b>0.947</b> (0.658-1.34)	<b>1.12</b> (0.747-1.62)	<b>1.25</b> (0.814-1.82)
<b>10-min</b>	<b>0.362</b> (0.287-0.461)	<b>0.441</b> (0.350-0.563)	<b>0.581</b> (0.459-0.744)	<b>0.707</b> (0.555-0.907)	<b>0.893</b> (0.685-1.20)	<b>1.05</b> (0.783-1.42)	<b>1.21</b> (0.876-1.67)	<b>1.39</b> (0.964-1.96)	<b>1.64</b> (1.09-2.36)	<b>1.83</b> (1.19-2.67)
<b>15-min</b>	<b>0.441</b> (0.350-0.563)	<b>0.538</b> (0.426-0.687)	<b>0.709</b> (0.560-0.907)	<b>0.862</b> (0.677-1.11)	<b>1.09</b> (0.835-1.46)	<b>1.28</b> (0.955-1.73)	<b>1.48</b> (1.07-2.04)	<b>1.69</b> (1.18-2.39)	<b>1.99</b> (1.33-2.88)	<b>2.24</b> (1.45-3.26)
<b>30-min</b>	<b>0.665</b> (0.527-0.848)	<b>0.808</b> (0.640-1.03)	<b>1.06</b> (0.837-1.36)	<b>1.29</b> (1.01-1.65)	<b>1.63</b> (1.25-2.18)	<b>1.91</b> (1.42-2.58)	<b>2.20</b> (1.59-3.04)	<b>2.52</b> (1.76-3.57)	<b>2.98</b> (1.99-4.30)	<b>3.34</b> (2.17-4.86)
<b>60-min</b>	<b>0.845</b> (0.670-1.08)	<b>1.04</b> (0.825-1.33)	<b>1.38</b> (1.09-1.77)	<b>1.69</b> (1.32-2.17)	<b>2.14</b> (1.64-2.86)	<b>2.50</b> (1.87-3.38)	<b>2.89</b> (2.09-3.99)	<b>3.30</b> (2.30-4.66)	<b>3.88</b> (2.60-5.61)	<b>4.35</b> (2.83-6.33)
<b>2-hr</b>	<b>1.03</b> (0.819-1.30)	<b>1.28</b> (1.02-1.62)	<b>1.71</b> (1.36-2.17)	<b>2.09</b> (1.65-2.66)	<b>2.64</b> (2.04-3.51)	<b>3.10</b> (2.33-4.15)	<b>3.58</b> (2.60-4.89)	<b>4.08</b> (2.86-5.72)	<b>4.79</b> (3.23-6.87)	<b>5.36</b> (3.51-7.74)
<b>3-hr</b>	<b>1.09</b> (0.876-1.38)	<b>1.37</b> (1.10-1.73)	<b>1.85</b> (1.48-2.34)	<b>2.27</b> (1.80-2.88)	<b>2.88</b> (2.22-3.79)	<b>3.37</b> (2.54-4.48)	<b>3.89</b> (2.84-5.28)	<b>4.43</b> (3.11-6.17)	<b>5.19</b> (3.51-7.40)	<b>5.79</b> (3.81-8.33)
<b>6-hr</b>	<b>1.26</b> (1.01-1.57)	<b>1.51</b> (1.21-1.88)	<b>1.95</b> (1.57-2.45)	<b>2.36</b> (1.89-2.97)	<b>2.98</b> (2.33-3.92)	<b>3.50</b> (2.67-4.64)	<b>4.05</b> (2.99-5.49)	<b>4.66</b> (3.30-6.45)	<b>5.51</b> (3.77-7.82)	<b>6.20</b> (4.12-8.85)
<b>12-hr</b>	<b>1.37</b> (1.11-1.70)	<b>1.62</b> (1.31-2.00)	<b>2.06</b> (1.66-2.56)	<b>2.46</b> (1.98-3.08)	<b>3.08</b> (2.44-4.03)	<b>3.61</b> (2.78-4.76)	<b>4.18</b> (3.11-5.62)	<b>4.80</b> (3.43-6.60)	<b>5.68</b> (3.91-7.99)	<b>6.39</b> (4.28-9.05)
<b>24-hr</b>	<b>1.48</b> (1.21-1.82)	<b>1.73</b> (1.41-2.13)	<b>2.19</b> (1.78-2.70)	<b>2.61</b> (2.11-3.23)	<b>3.26</b> (2.59-4.22)	<b>3.80</b> (2.95-4.97)	<b>4.40</b> (3.30-5.87)	<b>5.05</b> (3.64-6.89)	<b>5.98</b> (4.15-8.34)	<b>6.73</b> (4.54-9.45)
<b>2-day</b>	<b>1.66</b> (1.37-2.03)	<b>1.91</b> (1.57-2.33)	<b>2.36</b> (1.94-2.89)	<b>2.79</b> (2.28-3.43)	<b>3.46</b> (2.77-4.45)	<b>4.02</b> (3.15-5.22)	<b>4.65</b> (3.52-6.16)	<b>5.33</b> (3.88-7.22)	<b>6.31</b> (4.43-8.75)	<b>7.12</b> (4.84-9.91)
<b>3-day</b>	<b>1.80</b> (1.49-2.19)	<b>2.09</b> (1.73-2.54)	<b>2.62</b> (2.16-3.19)	<b>3.10</b> (2.54-3.78)	<b>3.82</b> (3.06-4.87)	<b>4.42</b> (3.46-5.69)	<b>5.08</b> (3.85-6.67)	<b>5.78</b> (4.22-7.78)	<b>6.78</b> (4.77-9.34)	<b>7.60</b> (5.19-10.5)
<b>4-day</b>	<b>1.93</b> (1.60-2.34)	<b>2.26</b> (1.88-2.74)	<b>2.84</b> (2.35-3.45)	<b>3.36</b> (2.76-4.09)	<b>4.13</b> (3.32-5.24)	<b>4.77</b> (3.74-6.10)	<b>5.45</b> (4.14-7.12)	<b>6.17</b> (4.51-8.26)	<b>7.20</b> (5.07-9.86)	<b>8.02</b> (5.50-11.1)
<b>7-day</b>	<b>2.31</b> (1.93-2.78)	<b>2.68</b> (2.24-3.23)	<b>3.34</b> (2.77-4.02)	<b>3.91</b> (3.24-4.73)	<b>4.76</b> (3.84-5.98)	<b>5.46</b> (4.31-6.93)	<b>6.20</b> (4.74-8.04)	<b>6.99</b> (5.14-9.28)	<b>8.09</b> (5.74-11.0)	<b>8.98</b> (6.20-12.3)
<b>10-day</b>	<b>2.63</b> (2.20-3.14)	<b>3.04</b> (2.54-3.64)	<b>3.75</b> (3.13-4.50)	<b>4.38</b> (3.64-5.28)	<b>5.30</b> (4.30-6.63)	<b>6.06</b> (4.79-7.65)	<b>6.85</b> (5.25-8.84)	<b>7.69</b> (5.68-10.2)	<b>8.87</b> (6.31-12.0)	<b>9.80</b> (6.80-13.4)
<b>20-day</b>	<b>3.42</b> (2.89-4.06)	<b>4.00</b> (3.37-4.75)	<b>4.97</b> (4.18-5.91)	<b>5.79</b> (4.84-6.92)	<b>6.94</b> (5.64-8.55)	<b>7.86</b> (6.24-9.79)	<b>8.79</b> (6.77-11.2)	<b>9.75</b> (7.24-12.7)	<b>11.1</b> (7.92-14.8)	<b>12.1</b> (8.44-16.3)
<b>30-day</b>	<b>4.11</b> (3.48-4.85)	<b>4.81</b> (4.08-5.69)	<b>5.96</b> (5.04-7.06)	<b>6.92</b> (5.81-8.22)	<b>8.23</b> (6.70-10.0)	<b>9.24</b> (7.36-11.4)	<b>10.2</b> (7.92-12.9)	<b>11.3</b> (8.39-14.6)	<b>12.6</b> (9.06-16.7)	<b>13.6</b> (9.58-18.4)
<b>45-day</b>	<b>5.04</b> (4.29-5.92)	<b>5.87</b> (4.99-6.90)	<b>7.20</b> (6.10-8.48)	<b>8.27</b> (6.98-9.78)	<b>9.71</b> (7.92-11.7)	<b>10.8</b> (8.63-13.2)	<b>11.9</b> (9.19-14.9)	<b>12.9</b> (9.63-16.6)	<b>14.2</b> (10.3-18.7)	<b>15.2</b> (10.8-20.4)
<b>60-day</b>	<b>5.90</b> (5.04-6.91)	<b>6.80</b> (5.80-7.96)	<b>8.22</b> (6.99-9.65)	<b>9.36</b> (7.92-11.0)	<b>10.9</b> (8.87-13.1)	<b>12.0</b> (9.59-14.6)	<b>13.0</b> (10.1-16.2)	<b>14.1</b> (10.5-18.0)	<b>15.4</b> (11.1-20.1)	<b>16.3</b> (11.6-21.8)

<sup>1</sup> Precipitation frequency (PF) estimates in this table are based on frequency analysis of partial duration series (PDS). Numbers in parenthesis are PF estimates at lower and upper bounds of the 90% confidence interval. The probability that precipitation frequency estimates (for a given duration and average recurrence interval) will be greater than the upper bound (or less than the lower bound) is 5%. Estimates at upper bounds are not checked against probable maximum precipitation (PMP) estimates and may be higher than currently valid PMP values. Please refer to NOAA Atlas 14 document for more information.

[Back to Top](#)

**PF graphical**

PDS-based depth-duration-frequency (DDF) curves

Latitude: 38.8322°, Longitude: -104.2663°

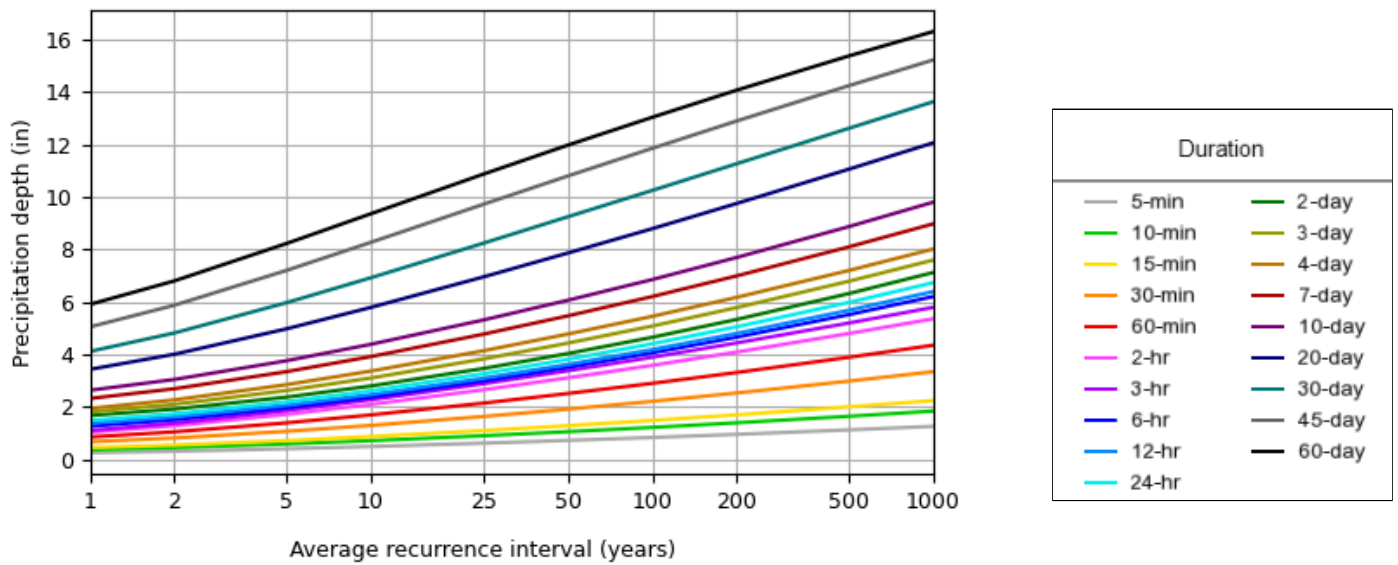
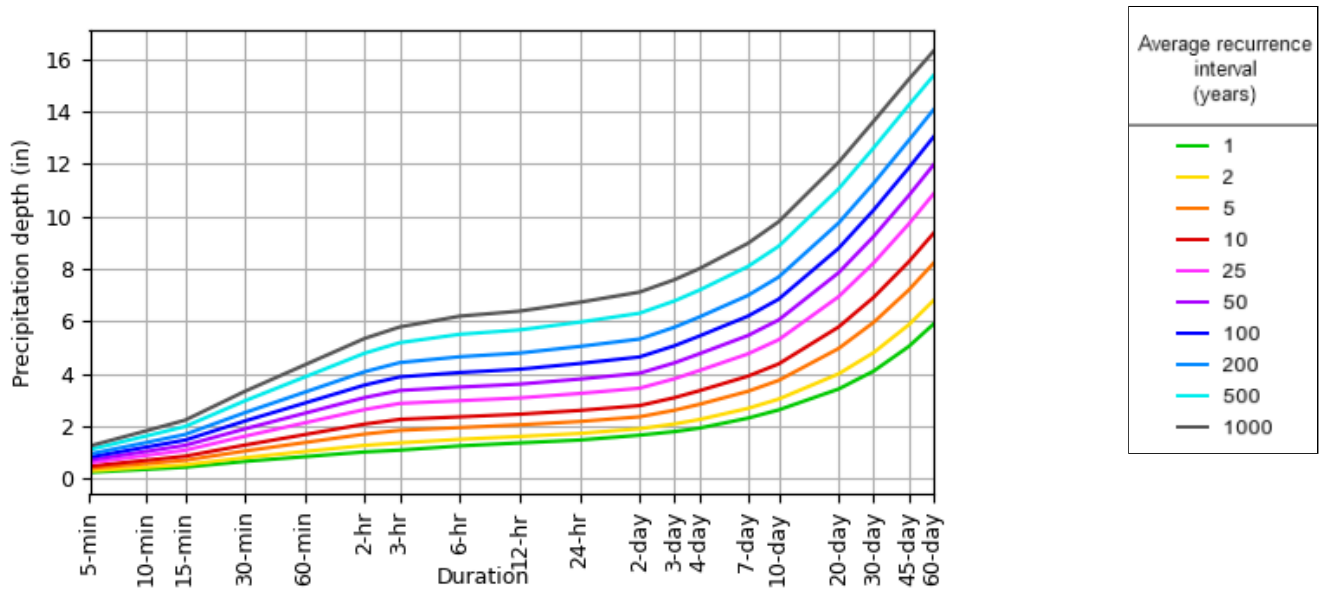

[Back to Top](#)

**Maps & aerials**

**Small scale terrain**

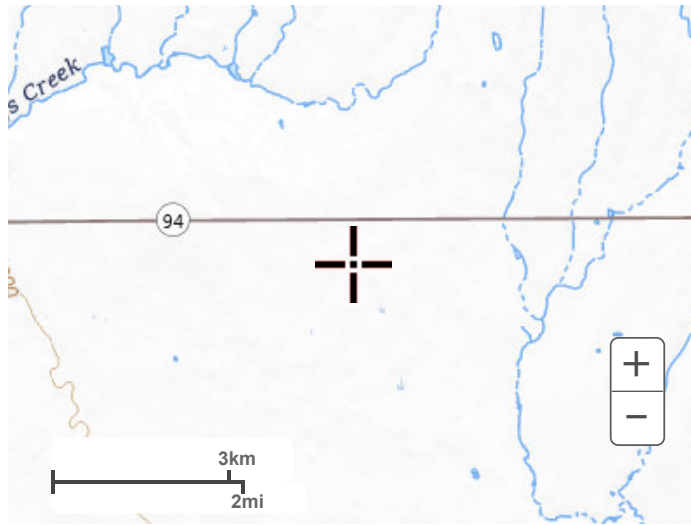

Large scale terrain



Large scale map

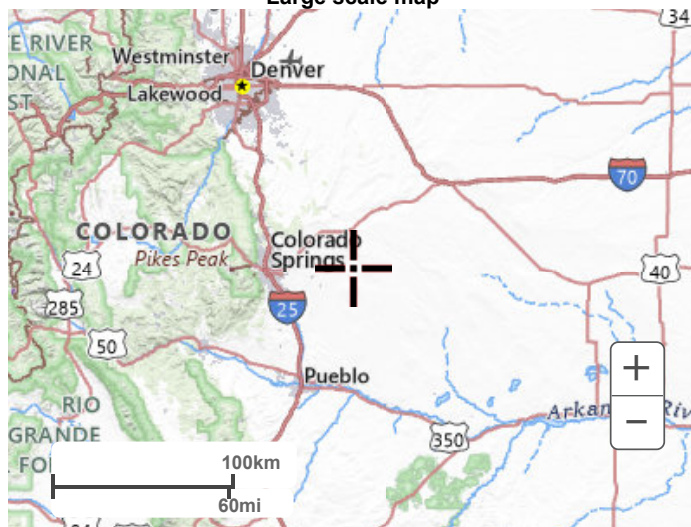

Large scale aerial



[Back to Top](#)

---

[US Department of Commerce](#)  
[National Oceanic and Atmospheric Administration](#)  
[National Weather Service](#)  
[National Water Center](#)  
1325 East West Highway  
Silver Spring, MD 20910  
Questions?: [HDSC.Questions@noaa.gov](mailto:HDSC.Questions@noaa.gov)

[Disclaimer](#)



**STANDARD FORM SF-1 (EXISTING CONDITIONS)  
RUNOFF COEFFICIENTS - IMPERVIOUS CALCULATION**

PROJECT NAME: **Tanner Ranch Pond A**  
 PROJECT NUMBER: 296172000  
 CALCULATED BY: MEO  
 CHECKED BY: KRK

HYDROLOGIC SOIL GROUP: A

Impervious values and runoff coefficients are taken from the El Paso County Drainage Criteria Manual (Vol. 1 Update)	<u>LAND USE (HSG A/B):</u>			PAVEMENT	GRAVEL	LANDSCAPE						
	2-YEAR COEFF.	0.89	0.57	0.02								
	5-YEAR COEFF.	0.90	0.59	0.08								
	10-YEAR COEFF.	0.92	0.63	0.15								
	100-YEAR COEFF.	0.96	0.70	0.35								
	IMPERVIOUS %	100%	80%	0%								
DESIGN BASIN	DESIGN POINT	PAVEMENT AREA (SF)	GRAVEL AREA (SF)	LANDSCAPE AREA (SF)	TOTAL AREA (SF)	TOTAL AREA (AC)	C(2)	C(5)	C(10)	C(100)	Imp %	HSG
<b>Basins</b>												
EX-A	DP-EXA			1,894,860	1,894,860	43.50	0.02	0.08	0.15	0.35	0%	A
<b>BASIN SUBTOTAL</b>		-	-	1,894,860	1,894,860	43.50	0.02	0.08	0.15	0.35	0.00%	A
		0%	0%	100%	100%	100%						

**STANDARD FORM SF-2 (EXISTING CONDITIONS)  
Time of Concentration**

PROJECT NAME: **Tanner Ranch Pond A**  
 PROJECT NUMBER: **296008000**  
 CALCULATED BY: **MEO**  
 CHECKED BY: **KRK**

SUB-BASIN DATA			INITIAL TIME (T <sub>i</sub> )			TRAVEL TIME (T <sub>t</sub> )					T <sub>c</sub> CHECK (URBANIZED BASINS)				FINAL T <sub>c</sub>	
DESIGN BASIN (1)	AREA Ac (2)	C5 (3)	LENGTH Ft (4)	SLOPE % (5)	T <sub>i</sub> Min. (6)	LENGTH Ft (7)	SLOPE % (8)	C <sub>v</sub> (9)	VEL fps (11)	T <sub>t</sub> Min. (12)	COMP. t <sub>c</sub> (13)	TOTAL LENGTH (14)	TOTAL SLOPE (15)	TOTAL IMP. (16)	T <sub>c</sub> Min. (17)	Min.
<b>All Basins</b>																
EX-A	1,894,860	0.08	500	4.0%	26.3	1161	4.0%	7.0	1.4	13.8	40.2	1661	4.0%	0%	41.4	40.2

$$t_i = \frac{0.395(1.1 - C_s)\sqrt{L_i}}{S_o^{0.33}} \quad t_t = \frac{L_t}{60K\sqrt{S_o}} = \frac{L_t}{60V_t} \quad t_c = (26 - 17i) + \frac{L_t}{60(14i + 9)\sqrt{S_o}}$$

**STANDARD FORM SF-3 (EXISTING CONDITIONS)  
STORM DRAINAGE DESIGN - RATIONAL METHOD 5 YEAR EVENT**

PROJECT NAME: **Tanner Ranch Pond A**  
 PROJECT NUMBER: 296008000  
 CALCULATED BY: MEO  
 CHECKED BY: KRK

$P_1$  (1-Hour Rainfall) = **1.38**

STORM LINE (1)	DESIGN POINT (2)	DIRECT RUNOFF							TOTAL RUNOFF				REMARKS (22)
		DESIGN BASIN (3)	AREA (AC) (4)	RUNOFF COEFF (5)	$t_c$ (min) (6)	$C*A$ (ac) (7)	$I$ (in/hr) (8)	$Q$ (cfs) (9)	$t_c$ (max) (10)	$S(C*A)$ (ac) (11)	$I$ (in/hr) (12)	$Q$ (cfs) (13)	
<b>All Basins</b>													
	DP-EXA	EX-A	43.50	0.08	40.2	3.48	2.04	7.11					

Figure 6-5. Colorado Springs Rainfall Intensity Duration Frequency

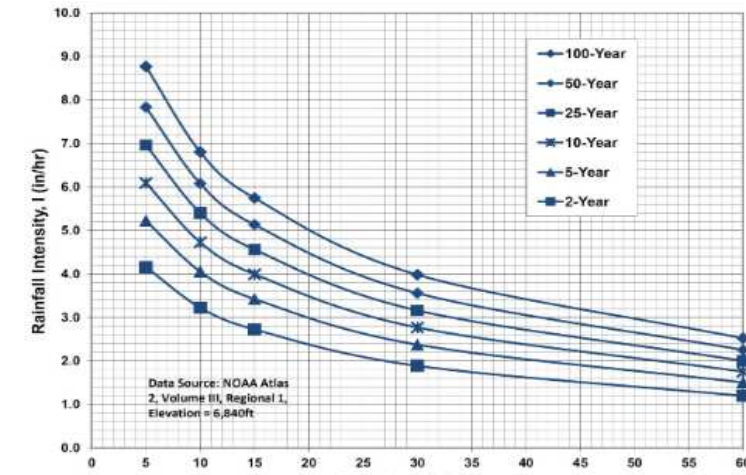

**IDF Equations**

$$I_{100} = -2.52 \ln(D) + 12.735$$

$$I_{50} = -2.25 \ln(D) + 11.375$$

$$I_{25} = -2.00 \ln(D) + 10.111$$

$$I_{10} = -1.75 \ln(D) + 8.847$$

$$I_5 = -1.50 \ln(D) + 7.583$$

$$I_2 = -1.19 \ln(D) + 6.035$$

Note: Values calculated by equations may not precisely

**STANDARD FORM SF-3 (EXISTING CONDITIONS)  
STORM DRAINAGE DESIGN - RATIONAL METHOD 100 YEAR EVENT**

PROJECT NAME: **Tanner Ranch Pond A**  
 PROJECT NUMBER: 296008000  
 CALCULATED BY: MEO  
 CHECKED BY: KRK

P<sub>1</sub> (1-Hour Rainfall) = **2.89**

STORM LINE (1)	DESIGN POINT (2)	DIRECT RUNOFF							TOTAL RUNOFF				REMARKS (22)
		DESIGN BASIN (3)	AREA (AC) (4)	RUNOFF COEFF (5)	t <sub>c</sub> (min) (6)	C*A(ac) (7)	I (in/hr) (8)	Q (cfs) (9)	t <sub>c</sub> (max) (10)	S(C*A) (ac) (11)	I (in/hr) (12)	Q (cfs) (13)	
<b>All Basins</b>													
	DP-EXA	EX-A	43.50	0.35	40.2	15.23	3.43	52.20					

Figure 6-5. Colorado Springs Rainfall Intensity Duration Frequency

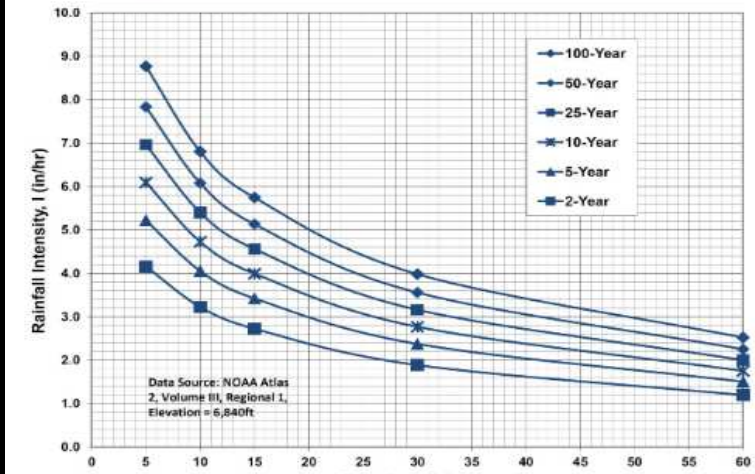

**IDF Equations**

$$I_{100} = -2.52 \ln(D) + 12.735$$

$$I_{50} = -2.25 \ln(D) + 11.375$$

$$I_{25} = -2.00 \ln(D) + 10.111$$

$$I_{10} = -1.75 \ln(D) + 8.847$$

$$I_5 = -1.50 \ln(D) + 7.583$$

$$I_2 = -1.19 \ln(D) + 6.035$$

Note: Values calculated by equations may not precisely



## EXISTING CONDITIONS

Tanner Ranch Pond A

DATE: 3/10/2026

PROJECT NUMBER: 296008000

CALCULATED BY: MEO

CHECKED BY: KRK

### EXISTING RATIONAL CALCULATIONS SUMMARY

DESIGN POINT	TRIBUTARY BASINS	TRIBUTARY AREA (AC)	PEAK FLOWS (CFS)	
			Q5	Q100
<b>On-site Basins</b>				
DP-EXA	EX-A	43.50	7.11	52.20
<b>Total</b>		43.50	7.11	52.20



**STANDARD FORM SF-1 (PROPOSED CONDITIONS)  
RUNOFF COEFFICIENTS - IMPERVIOUS CALCULATION**

PROJECT NAME: **Tanner Ranch Pond A**  
 PROJECT NUMBER: 296172000  
 CALCULATED BY: MEO  
 CHECKED BY: KRK

HYDROLOGIC SOIL GROUP: A

Impervious values and runoff coefficients are taken from the El Paso County Drainage Criteria Manual (Vol. 1 Update)	RESIDENTIAL													
	LAND USE (HSG A/B):	PAVEMENT	(>2.5AC)	GRAVEL	LANDSCAPE									
	2-YEAR COEFF.	0.89	0.12	0.57	0.02									
	5-YEAR COEFF.	0.90	0.20	0.59	0.08									
	10-YEAR COEFF.	0.92	0.27	0.63	0.15									
100-YEAR COEFF.	0.96	0.44	0.70	0.35										
IMPERVIOUS %	100%	11%	80%	0%										
DESIGN BASIN	DESIGN POINT	PAVEMENT AREA (SF)	RESIDENTIAL (>2.5AC) AREA (SF)	GRAVEL AREA (SF)	LANDSCAPE AREA (SF)	TOTAL AREA (SF)	TOTAL AREA (AC)	C(2)	C(5)	C(10)	C(100)	Imp %	HSG	
<b>Basins</b>														
A-2	POND A	17,612	358,136	-	295,076	670,824	15.40	0.41	0.17	0.23	0.41	8%	A	
<b>BASIN SUBTOTAL</b>		17,612	358,136	-	295,076	670,824	15.40	0.10	0.17	0.23	0.41	8.50%	A	
		3%	53%	0%	44%	100%	100%							

**STANDARD FORM SF-2 (PROPOSED CONDITIONS)  
Time of Concentration**

PROJECT NAME: **Tanner Ranch Pond A**  
 PROJECT NUMBER: **296008000**  
 CALCULATED BY: **MEO**  
 CHECKED BY: **KRK**

SUB-BASIN DATA			INITIAL TIME (T <sub>i</sub> )			TRAVEL TIME (T <sub>t</sub> )					T <sub>c</sub> CHECK (URBANIZED BASINS)				FINAL T <sub>c</sub>	
DESIGN BASIN (1)	AREA Ac (2)	C5 (3)	LENGTH Ft (4)	SLOPE % (5)	T <sub>i</sub> Min. (6)	LENGTH Ft (7)	SLOPE % (8)	C <sub>v</sub> (9)	VEL fps (11)	T <sub>t</sub> Min. (12)	COMP. t <sub>c</sub> (13)	TOTAL LENGTH (14)	TOTAL SLOPE (15)	TOTAL IMP. (16)	T <sub>c</sub> Min. (17)	Min.
<b>All Basins</b>																
A-2	670,824	0.17	300	4.0%	18.7	500	4.0%	7.0	1.4	6.0	24.6	800	4.0%	8%	31.1	24.6

$$t_i = \frac{0.395(1.1 - C_s)\sqrt{L_i}}{S_o^{0.33}} \quad t_t = \frac{L_t}{60K\sqrt{S_o}} = \frac{L_t}{60V_t} \quad t_c = (26 - 17i) + \frac{L_t}{60(14i + 9)\sqrt{S_o}}$$

**STANDARD FORM SF-3 (PROPOSED CONDITIONS)  
STORM DRAINAGE DESIGN - RATIONAL METHOD 5 YEAR EVENT**

PROJECT NAME: **Tanner Ranch Pond A**  
 PROJECT NUMBER: 296008000  
 CALCULATED BY: MEO  
 CHECKED BY: KRK

P<sub>1</sub> (1-Hour Rainfall) = **1.38**

STORM LINE (1)	DESIGN POINT (2)	DIRECT RUNOFF							TOTAL RUNOFF				REMARKS (22)
		DESIGN BASIN (3)	AREA (AC) (4)	RUNOFF COEFF (5)	t <sub>c</sub> (min) (6)	C*A(ac) (7)	I (in/hr) (8)	Q (cfs) (9)	t <sub>c</sub> (max) (10)	S(C*A) (ac) (11)	I (in/hr) (12)	Q (cfs) (13)	
<b>All Basins</b>													
	POND A	A-2	15.40	0.17	24.6	2.55	2.78	7.08					

Figure 6-5. Colorado Springs Rainfall Intensity Duration Frequency

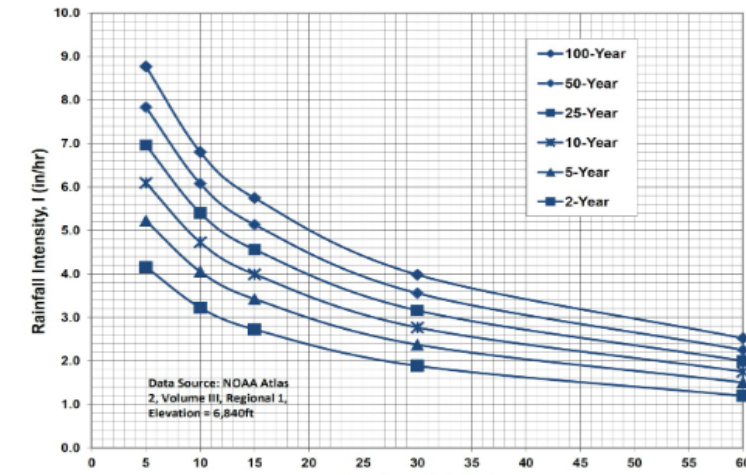

**IDF Equations**

$$I_{100} = -2.52 \ln(D) + 12.735$$

$$I_{50} = -2.25 \ln(D) + 11.375$$

$$I_{25} = -2.00 \ln(D) + 10.111$$

$$I_{10} = -1.75 \ln(D) + 8.847$$

$$I_5 = -1.50 \ln(D) + 7.583$$

$$I_2 = -1.19 \ln(D) + 6.035$$

Note: Values calculated by equations may not precisely

**STANDARD FORM SF-3 (PROPOSED CONDITIONS)  
STORM DRAINAGE DESIGN - RATIONAL METHOD 100 YEAR EVENT**

PROJECT NAME: **Tanner Ranch Pond A**  
 PROJECT NUMBER: 296008000  
 CALCULATED BY: MEO  
 CHECKED BY: KRK

P<sub>1</sub> (1-Hour Rainfall) = **2.89**

STORM LINE (1)	DESIGN POINT (2)	DIRECT RUNOFF							TOTAL RUNOFF				REMARKS (22)
		DESIGN BASIN (3)	AREA (AC) (4)	RUNOFF COEFF (5)	t <sub>c</sub> (min) (6)	C*A(ac) (7)	I (in/hr) (8)	Q (cfs) (9)	t <sub>c</sub> (max) (10)	S(C*A) (ac) (11)	I (in/hr) (12)	Q (cfs) (13)	
<b>All Basins</b>													
	POND A	A-2	15.40	0.41	24.6	6.38	4.66	29.71					

Figure 6-5. Colorado Springs Rainfall Intensity Duration Frequency

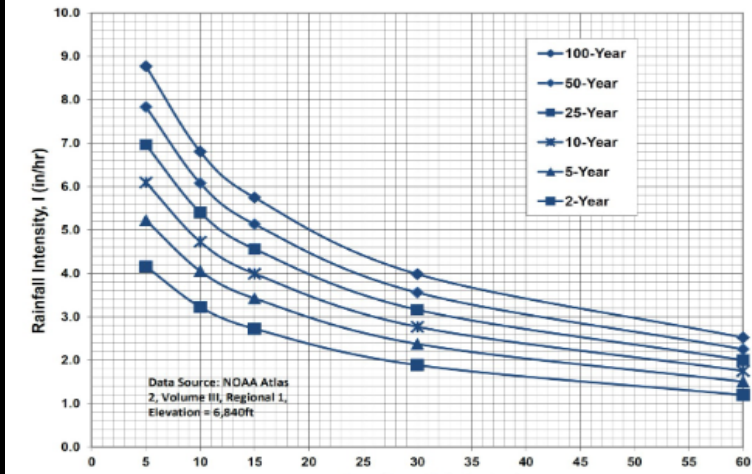

**IDF Equations**

$$I_{100} = -2.52 \ln(D) + 12.735$$

$$I_{50} = -2.25 \ln(D) + 11.375$$

$$I_{25} = -2.00 \ln(D) + 10.111$$

$$I_{10} = -1.75 \ln(D) + 8.847$$

$$I_5 = -1.50 \ln(D) + 7.583$$

$$I_2 = -1.19 \ln(D) + 6.035$$

Note: Values calculated by equations may not precisely



## PROPOSED CONDITIONS

Tanner Ranch Pond A

DATE: 3/10/2026

PROJECT NUMBER: 296008000

CALCULATED BY: MEO

CHECKED BY: KRK

### EXISTING RATIONAL CALCULATIONS SUMMARY

DESIGN POINT	TRIBUTARY BASINS	TRIBUTARY AREA (AC)	PEAK FLOWS (CFS)	
			Q5	Q100
<b>On-site Basins</b>				
POND A	A-2	15.40	7.08	29.71
<b>Total</b>		15.40	7.08	29.71

**APPENDIX E – HYDRAULIC CALCULATIONS**



# DETENTION BASIN STAGE-STORAGE TABLE BUILDER

MHFD-Detention, Version 4.06 (July 2022)

Project: \_\_\_\_\_  
 Basin ID: \_\_\_\_\_

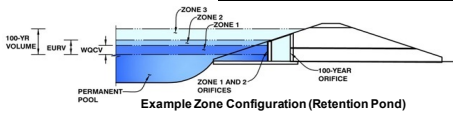

**Watershed Information**

Selected BMP Type =	<b>EDB</b>
Watershed Area =	15.40 acres
Watershed Length =	1,200 ft
Watershed Length to Centroid =	600 ft
Watershed Slope =	0.040 ft/ft
Watershed Imperviousness =	8.50% percent
Percentage Hydrologic Soil Group A =	0.0% percent
Percentage Hydrologic Soil Group B =	100.0% percent
Percentage Hydrologic Soil Groups C/D =	0.0% percent
Target WQCV Drain Time =	40.0 hours
Location for 1-hr Rainfall Depths =	User Input

After providing required inputs above including 1-hour rainfall depths, click "Run CUHP" to generate runoff hydrographs using the embedded Colorado Urban Hydrograph Procedure.

Water Quality Capture Volume (WQCV) =	0.017 acre-feet
Excess Urban Runoff Volume (EURV) =	0.121 acre-feet
2-yr Runoff Volume (P1 = 1.04 in.) =	0.079 acre-feet
5-yr Runoff Volume (P1 = 1.38 in.) =	0.320 acre-feet
10-yr Runoff Volume (P1 = 1.69 in.) =	0.601 acre-feet
25-yr Runoff Volume (P1 = 2.14 in.) =	1.282 acre-feet
50-yr Runoff Volume (P1 = 2.5 in.) =	1.718 acre-feet
100-yr Runoff Volume (P1 = 2.89 in.) =	2.312 acre-feet
500-yr Runoff Volume (P1 = 3.88 in.) =	3.597 acre-feet
Approximate 2-yr Detention Volume =	0.067 acre-feet
Approximate 5-yr Detention Volume =	0.112 acre-feet
Approximate 10-yr Detention Volume =	0.262 acre-feet
Approximate 25-yr Detention Volume =	0.415 acre-feet
Approximate 50-yr Detention Volume =	0.449 acre-feet
Approximate 100-yr Detention Volume =	0.604 acre-feet

**Define Zones and Basin Geometry**

Zone 1 Volume (WQCV) =	0.017 acre-feet
Zone 2 Volume (EURV - Zone 1) =	0.104 acre-feet
Zone 3 Volume (100-year - Zones 1 & 2) =	0.483 acre-feet
Total Detention Basin Volume =	0.604 acre-feet
Initial Surcharge Volume (ISV) =	user ft <sup>3</sup>
Initial Surcharge Depth (ISD) =	user ft
Total Available Detention Depth (H <sub>total</sub> ) =	user ft
Depth of Trickle Channel (H <sub>TC</sub> ) =	user ft
Slope of Trickle Channel (S <sub>TC</sub> ) =	user ft/ft
Slopes of Main Basin Sides (S <sub>main</sub> ) =	user H:V
Basin Length-to-Width Ratio (R <sub>L/W</sub> ) =	user
Initial Surcharge Area (A <sub>ISV</sub> ) =	user ft <sup>2</sup>
Surcharge Volume Length (L <sub>LSV</sub> ) =	user ft
Surcharge Volume Width (W <sub>LSV</sub> ) =	user ft
Depth of Basin Floor (H <sub>FLOOR</sub> ) =	user ft
Length of Basin Floor (L <sub>FLOOR</sub> ) =	user ft
Width of Basin Floor (W <sub>FLOOR</sub> ) =	user ft
Area of Basin Floor (A <sub>FLOOR</sub> ) =	user ft <sup>2</sup>
Volume of Basin Floor (V <sub>FLOOR</sub> ) =	user ft <sup>3</sup>
Depth of Main Basin (H <sub>MAN</sub> ) =	user ft
Length of Main Basin (L <sub>MAN</sub> ) =	user ft
Width of Main Basin (W <sub>MAN</sub> ) =	user ft
Area of Main Basin (A <sub>MAN</sub> ) =	user ft <sup>2</sup>
Volume of Main Basin (V <sub>MAN</sub> ) =	user ft <sup>3</sup>
Calculated Total Basin Volume (V <sub>total</sub> ) =	user acre-feet

Optional User Overrides

0.017	acre-feet
0.121	acre-feet
1.04	inches
1.38	inches
1.69	inches
2.14	inches
2.50	inches
2.89	inches
3.88	inches

WQCV override, see previous sheet.

Depth Increment =	ft	Stage - Storage Description	Stage (ft)	Optional Override Stage (ft)	Length (ft)	Width (ft)	Area (ft <sup>2</sup> )	Optional Override Area (ft <sup>2</sup> )	Area (acre)	Volume (ft <sup>3</sup> )	Volume (ac-ft)
6217.5		Top of Micropool	--	0.00	--	--	--	1,218	0.028		
		6218.5	--	0.50	--	--	--	7,162	0.164	2,095	0.048
		6218.5	--	1.00	--	--	--	18,472	0.424	8,503	0.195
		6219	--	1.50	--	--	--	30,280	0.695	20,691	0.475
		6219.5	--	2.00	--	--	--	44,247	1.016	39,323	0.903
		6220	--	2.50	--	--	--	60,256	1.383	65,449	1.502
		6220.5	--	3.00	--	--	--	77,152	1.771	99,801	2.291
		6221	--	3.50	--	--	--	96,293	2.211	143,162	3.287

# DETENTION BASIN STAGE-STORAGE TABLE BUILDER

*MHFD-Detention, Version 4.06 (July 2022)*

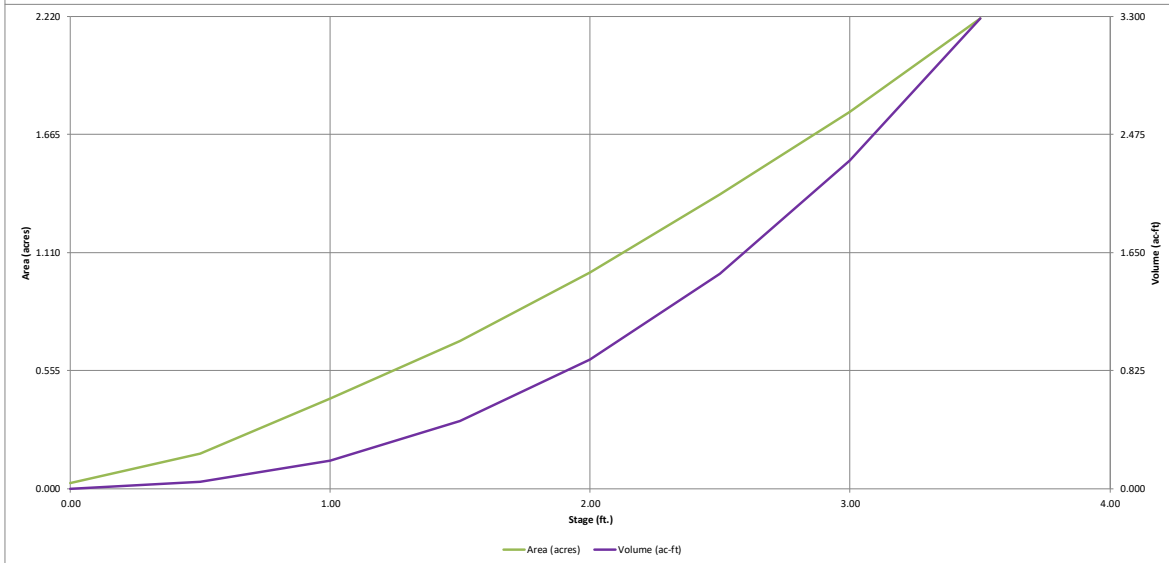
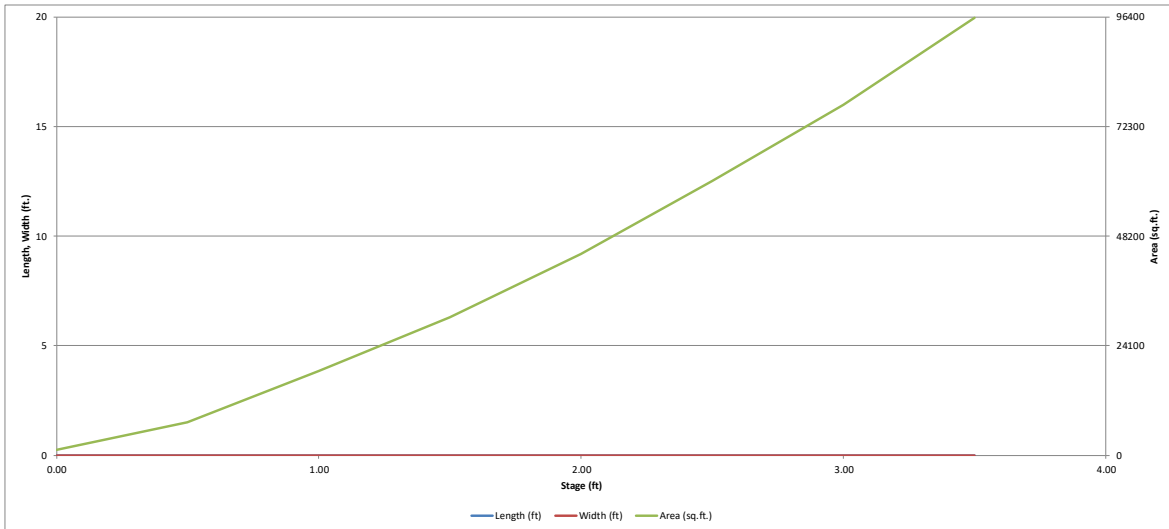

# DETENTION BASIN OUTLET STRUCTURE DESIGN

MHFD-*Detention, Version 4.06 (July 2022)*

**Project:** \_\_\_\_\_

**Basin ID:** \_\_\_\_\_

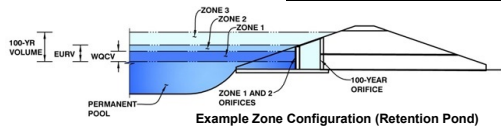

	Estimated Stage (ft)	Estimated Volume (ac-ft)	Outlet Type
Zone 1 (WQCV)	0.27	0.017	Orifice Plate
Zone 2 (EURV)	0.81	0.104	Orifice Plate
Zone 3 (100-year)	1.68	0.483	Weir&Pipe (Restrict)
<b>Total (all zones)</b>		<b>0.604</b>	

**User Input: Orifice at Underdrain Outlet (typically used to drain WQCV in a Filtration BMP)**

Underdrain Orifice Invert Depth =	N/A	ft (distance below the filtration media surface)	Underdrain Orifice Area =	N/A	ft <sup>2</sup>
Underdrain Orifice Diameter =	N/A	inches	Underdrain Orifice Centroid =	N/A	feet

**User Input: Orifice Plate with one or more orifices or Elliptical Slot Weir (typically used to drain WQCV and/or EURV in a sedimentation BMP)**

Centroid of Lowest Orifice =	0.00	ft (relative to basin bottom at Stage = 0 ft)	WQ Orifice Area per Row =	N/A	ft <sup>2</sup>
Depth at top of Zone using Orifice Plate =	0.81	ft (relative to basin bottom at Stage = 0 ft)	Elliptical Half-Width =	N/A	feet
Orifice Plate: Orifice Vertical Spacing =	N/A	inches	Elliptical Slot Centroid =	N/A	feet
Orifice Plate: Orifice Area per Row =	N/A	sq. inches	Elliptical Slot Area =	N/A	ft <sup>2</sup>

**User Input: Stage and Total Area of Each Orifice Row (numbered from lowest to highest)**

	Row 1 (required)	Row 2 (optional)	Row 3 (optional)	Row 4 (optional)	Row 5 (optional)	Row 6 (optional)	Row 7 (optional)	Row 8 (optional)
Stage of Orifice Centroid (ft)	0.00	0.25	0.50					
Orifice Area (sq. inches)	0.44	0.89	1.48					
	Row 9 (optional)	Row 10 (optional)	Row 11 (optional)	Row 12 (optional)	Row 13 (optional)	Row 14 (optional)	Row 15 (optional)	Row 16 (optional)
Stage of Orifice Centroid (ft)								
Orifice Area (sq. inches)								

**User Input: Vertical Orifice (Circular or Rectangular)**

Invert of Vertical Orifice =	Not Selected	Not Selected	ft (relative to basin bottom at Stage = 0 ft)	Vertical Orifice Area =	Not Selected	Not Selected	ft <sup>2</sup>
Depth at top of Zone using Vertical Orifice =	N/A	N/A	ft (relative to basin bottom at Stage = 0 ft)	Vertical Orifice Centroid =	N/A	N/A	feet
Vertical Orifice Diameter =	N/A	N/A	inches				

**User Input: Overflow Weir (Dropbox with Flat or Sloped Grate and Outlet Pipe OR Rectangular/Trapezoidal Weir and No Outlet Pipe)**

Overflow Weir Front Edge Height, Ho =	Zone 3 Weir: 0.81	Not Selected: N/A	ft (relative to basin bottom at Stage = 0 ft)	Height of Grate Upper Edge, H <sub>1</sub> =	Zone 3 Weir: 1.54	Not Selected: N/A	feet
Overflow Weir Front Edge Length =	3.92	N/A	feet	Overflow Weir Slope Length =	3.01	N/A	feet
Overflow Weir Grate Slope =	4.00	N/A	H:V	Grate Open Area / 100-yr Orifice Area =	42.42	N/A	ft <sup>2</sup>
Horiz. Length of Weir Sides =	2.92	N/A	feet	Overflow Grate Open Area w/o Debris =	8.21	N/A	ft <sup>2</sup>
Overflow Grate Type =	Type C Grate	N/A		Overflow Grate Open Area w/ Debris =	4.11	N/A	ft <sup>2</sup>
Debris Clogging % =	50%	N/A	%				

**User Input: Outlet Pipe w/ Flow Restriction Plate (Circular Orifice, Restrictor Plate, or Rectangular Orifice)**

Depth to Invert of Outlet Pipe =	Zone 3 Restrictor: 0.23	Not Selected: N/A	ft (distance below basin bottom at Stage = 0 ft)	Outlet Orifice Area =	Zone 3 Restrictor: 0.19	Not Selected: N/A	ft <sup>2</sup>
Outlet Pipe Diameter =	18.00	N/A	inches	Outlet Orifice Centroid =	0.15	N/A	feet
Restrictor Plate Height Above Pipe Invert =	3.00		inches	Half-Central Angle of Restrictor Plate on Pipe =	0.84	N/A	radians

**User Input: Emergency Spillway (Rectangular or Trapezoidal)**

Spillway Invert Stage =	2.00	ft (relative to basin bottom at Stage = 0 ft)	Spillway Design Flow Depth =	0.47	feet
Spillway Crest Length =	20.00	feet	Stage at Top of Freeboard =	3.47	feet
Spillway End Slopes =	4.00	H:V	Basin Area at Top of Freeboard =	2.18	acres
Freeboard above Max Water Surface =	1.00	feet	Basin Volume at Top of Freeboard =	3.20	acre-ft

**Routed Hydrograph Results**

*The user can override the default CUHP hydrographs and runoff volumes by entering new values in the Inflow Hydrographs table (Columns W through AF).*

	WQCV	EURV	2 Year	5 Year	10 Year	25 Year	50 Year	100 Year	500 Year
Design Storm Return Period =	N/A	N/A	1.04	1.38	1.69	2.14	2.50	2.89	3.88
One-Hour Rainfall Depth (in) =	N/A	N/A	1.04	1.38	1.69	2.14	2.50	2.89	3.88
CUHP Runoff Volume (acre-ft) =	0.017	0.121	0.079	0.320	0.601	1.282	1.718	2.312	3.597
Inflow Hydrograph Volume (acre-ft) =	N/A	N/A	0.079	0.320	0.601	1.282	1.718	2.312	3.597
CUHP Predevelopment Peak Q (cfs) =	N/A	N/A	0.3	3.8	7.1	16.1	21.1	27.2	41.6
OPTIONAL Override Predevelopment Peak Q (cfs) =	N/A	N/A							
Predevelopment Unit Peak Flow, q (cfs/acre) =	N/A	N/A	0.02	0.25	0.46	1.04	1.37	1.76	2.70
Peak Inflow Q (cfs) =	N/A	N/A	1.1	4.7	8.1	17.1	22.1	28.2	42.7
Peak Outflow Q (cfs) =	0.0	0.1	0.0	0.8	1.2	3.3	8.0	14.9	28.8
Ratio Peak Outflow to Predevelopment Q =	N/A	N/A	N/A	0.2	0.2	0.2	0.4	0.5	0.7
Structure Controlling Flow =	Plate	Overflow Weir 1	Plate	Overflow Weir 1	Outlet Plate 1	Spillway	Spillway	Spillway	Spillway
Max Velocity through Grate 1 (fps) =	N/A	N/A	N/A	0.1	0.1	0.2	0.2	0.2	0.2
Max Velocity through Grate 2 (fps) =	N/A	N/A	N/A	N/A	N/A	N/A	N/A	N/A	N/A
Time to Drain 97% of Inflow Volume (hours) =	37	64	59	60	49	40	34	29	20
Time to Drain 99% of Inflow Volume (hours) =	40	72	66	74	70	61	55	50	42
Maximum Ponding Depth (ft) =	0.27	0.81	0.62	1.12	1.47	2.10	2.22	2.36	2.56
Area at Maximum Ponding Depth (acres) =	0.10	0.33	0.23	0.48	0.68	1.08	1.18	1.27	1.42
Maximum Volume Stored (acre-ft) =	0.017	0.124	0.072	0.245	0.454	0.997	1.144	1.303	1.573

# DETENTION BASIN OUTLET STRUCTURE DESIGN

*MHFD-Detention, Version 4.06 (July 2022)*

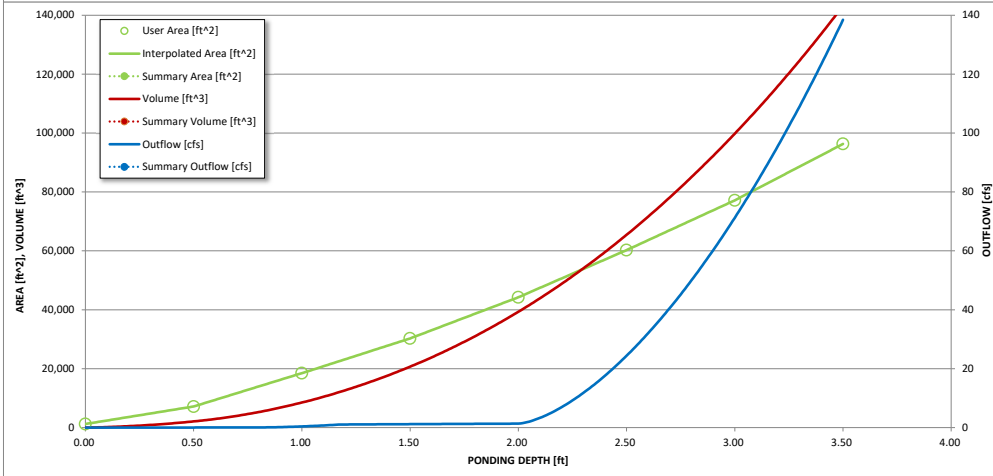
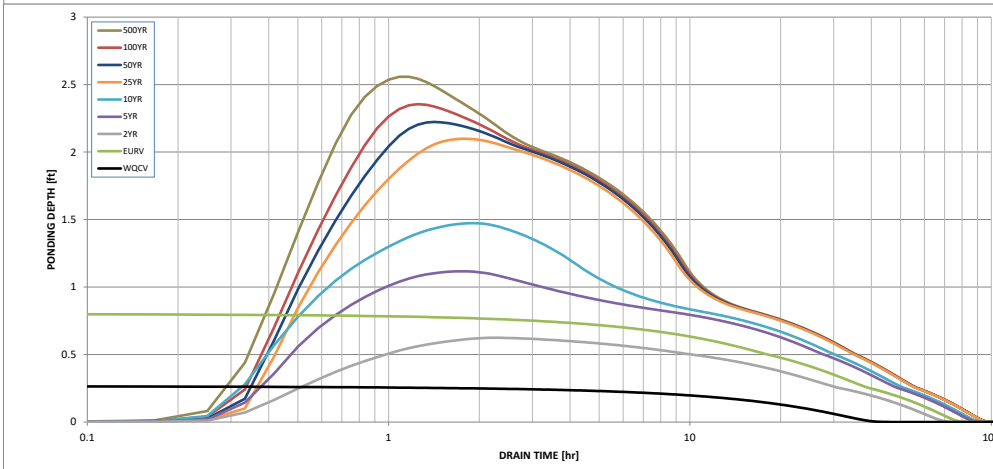
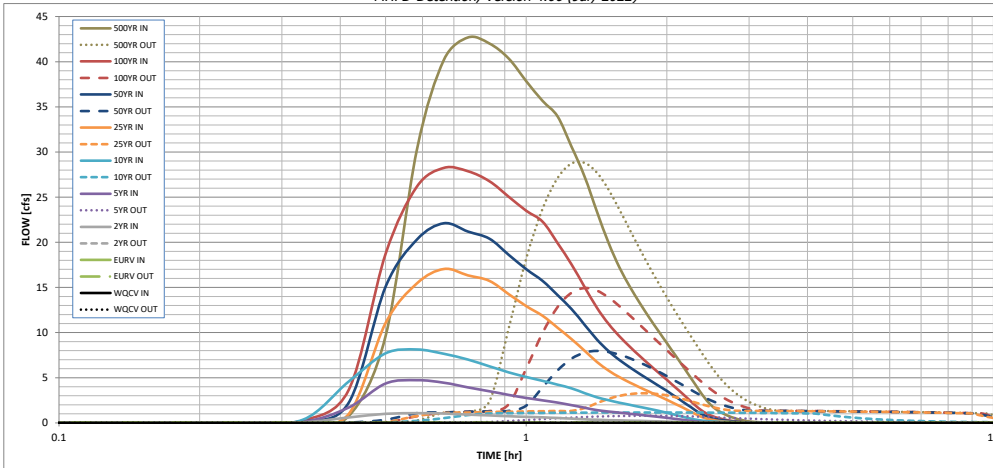

S-A-V-D Chart Axis Override

	X-axis	Left Y-Axis	Right Y-Axis
minimum bound			
maximum bound			

# DETERMINATION OF CULVERT HEADWATER AND OUTLET PROTECTION

MHFD-Culvert, Version 4.01 (April 2025)

**Project:** Miller Downs  
**ID:** FSD Pond Outfall

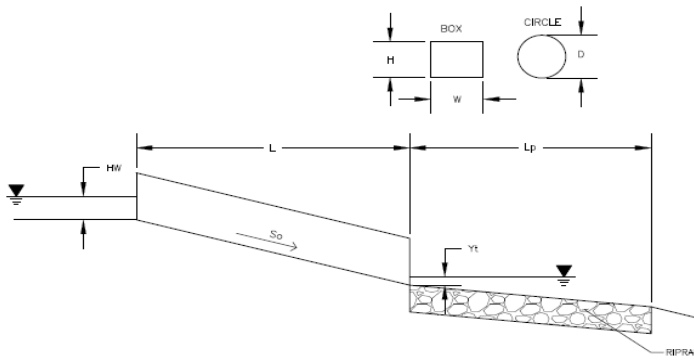

**Soil Type:**

Choose One:  Sandy  
 Non-Sandy

**Supercritical Flow! Using Adjusted Diameter to calculate protection type.**

Design Information:	
Design Discharge	Q = <input type="text" value="1.1"/> cfs
<b>Circular Culvert:</b>	
Barrel Diameter in Inches	D = <input type="text" value="18"/> inches
Inlet Edge Type (Choose from pull-down list)	Grooved Edge Projecting
<b>OR:</b>	
<b>Box Culvert:</b>	
Barrel Height (Rise) in Feet	H (Rise) = <input type="text"/> ft
Barrel Width (Span) in Feet	W (Span) = <input type="text"/> ft
Inlet Edge Type (Choose from pull-down list)	
Number of Barrels	# Barrels = <input type="text" value="1"/>
Inlet Elevation	Elev IN = <input type="text" value="6217.27"/> ft
Outlet Elevation <b>OR</b> Slope	Elev OUT = <input type="text" value="6217.15"/> ft
Culvert Length	L = <input type="text" value="19"/> ft
Manning's Roughness	n = <input type="text" value="0.012"/>
Bend Loss Coefficient	k <sub>b</sub> = <input type="text" value="0"/>
Exit Loss Coefficient	k <sub>x</sub> = <input type="text" value="1"/>
Tailwater Surface Elevation	Y <sub>t</sub> , Elevation = <input type="text"/> ft
Max Allowable Channel Velocity	V = <input type="text" value="7"/> ft/s
Calculated Results:	
Culvert Cross Sectional Area Available	A = <input type="text" value="1.77"/> ft <sup>2</sup>
Culvert Normal Depth	Y <sub>n</sub> = <input type="text" value="0.35"/> ft
Culvert Critical Depth	Y <sub>c</sub> = <input type="text" value="0.39"/> ft
Froude Number	Fr = <input type="text" value="1.23"/> <b>Supercritical!</b>
Entrance Loss Coefficient	k <sub>e</sub> = <input type="text" value="0.20"/>
Friction Loss Coefficient	k <sub>f</sub> = <input type="text" value="0.29"/>
Sum of All Loss Coefficients	k <sub>s</sub> = <input type="text" value="1.49"/> ft
<b>Headwater:</b>	
Inlet Control Headwater	HW <sub>I</sub> = <input type="text" value="0.53"/> ft
Outlet Control Headwater	HW <sub>O</sub> = <input type="text" value="N/A"/> ft
<b>Design Headwater Elevation</b>	<b>HW = <input type="text" value="N/A"/> ft</b>
<b>Headwater/Diameter OR Headwater/Rise Ratio</b>	<b>HW/D = <input type="text" value="N/A"/></b>
<b>Outlet Control Headwater Approximation Method Inaccurate for Low Flow - Backwater Calculations Required</b>	
<b>Outlet Protection:</b>	
Flow/(Diameter <sup>2.5</sup> )	Q/D <sup>2.5</sup> = <input type="text" value="0.40"/> ft <sup>0.5</sup> /s
Tailwater Surface Height	Y <sub>t</sub> = <input type="text" value="0.60"/> ft
Tailwater/Diameter	Y <sub>t</sub> /D = <input type="text" value="0.40"/>
Expansion Factor	1/(2*tan(Θ)) = <input type="text" value="6.70"/>
Flow Area at Max Channel Velocity	A <sub>t</sub> = <input type="text" value="0.16"/> ft <sup>2</sup>
Width of Equivalent Conduit for Multiple Barrels	W <sub>eq</sub> = <input type="text" value="-"/> ft
<b>Length of Riprap Protection</b>	<b>L<sub>p</sub> = <input type="text" value="5"/> ft</b>
<b>Width of Riprap Protection at Downstream End</b>	<b>T = <input type="text" value="3"/> ft</b>
Adjusted Diameter for Supercritical Flow	Da = <input type="text" value="0.93"/> ft
Minimum Theoretical Riprap Size	d <sub>50 min</sub> = <input type="text" value="1"/> in
Nominal Riprap Size	d <sub>50 nominal</sub> = <input type="text" value="6"/> in
<b>MHFD Riprap Type</b>	<b>Type = <input type="text" value="VL"/></b>

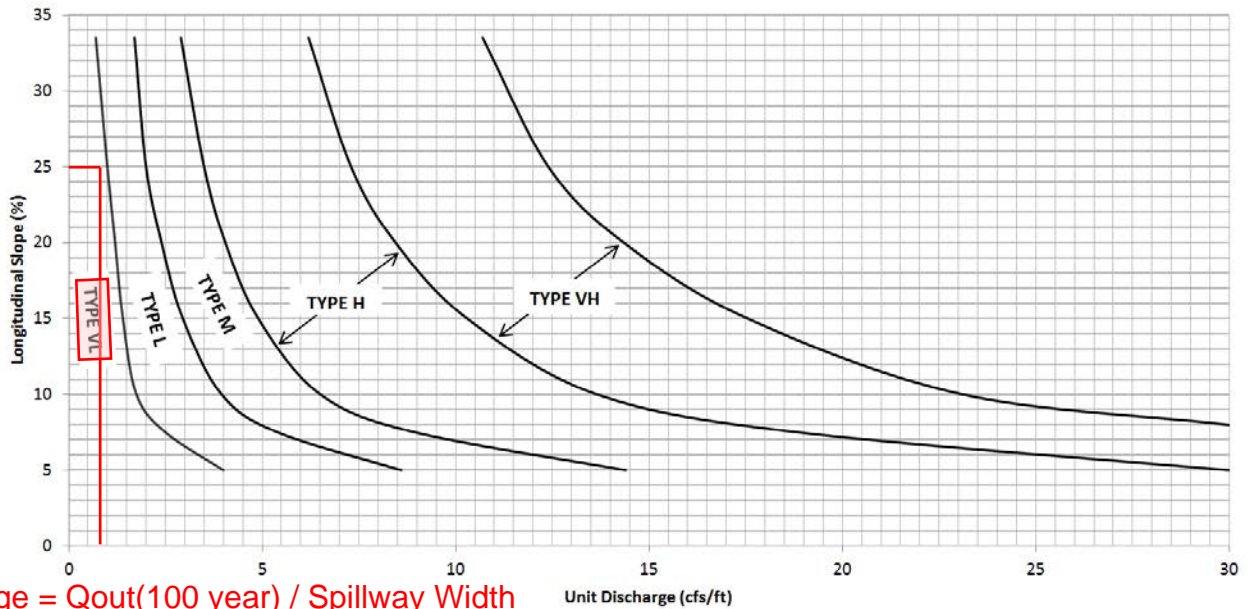
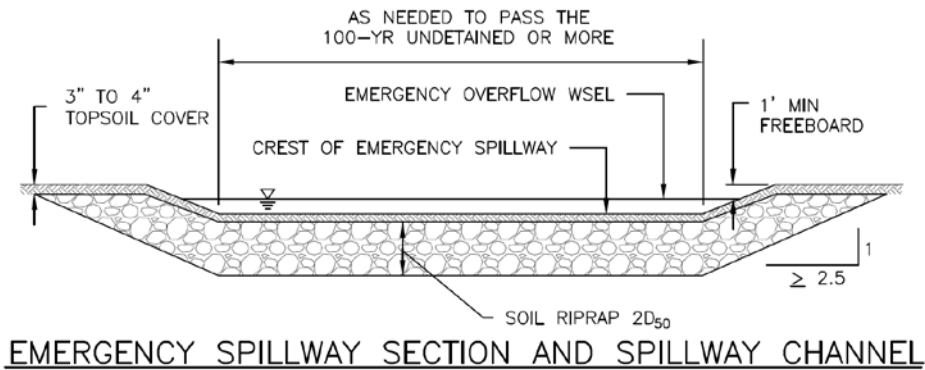
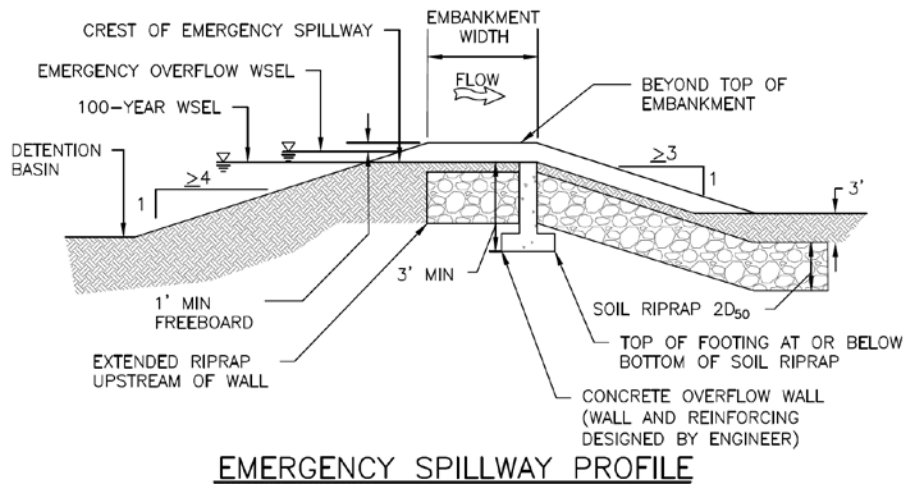

Figure 12-21. Embankment protection details and rock sizing chart (adapted from Arapahoe County)

**APPENDIX F – PREVIOUS DRAINAGE STUDIES**



**FINAL DRAINAGE REPORT  
FOR  
TANNER RANCH FILING NO. 1**

**January 17, 2005**  
*Revised June 16, 2005*  
*Revised July 18, 2005*

Prepared for:

High Plains Land & Cattle, LLC  
9 Ridge Road  
Colorado Springs, CO 80904  
(719) 475-0517

WestWorks Job #90330

# FINAL DRAINAGE REPORT for TANNER RANCH FILING NO. 1

## Engineer's Statement:

The attached drainage plan and report were prepared under my direction and supervision and are correct to the best of my knowledge and belief. Said drainage report has been prepared according to the criteria established by the City/County for drainage reports and said report is in conformity with the master plan of the drainage basin. I accept responsibility for any liability caused by any negligent acts, errors, or omissions on my part in preparing this report.

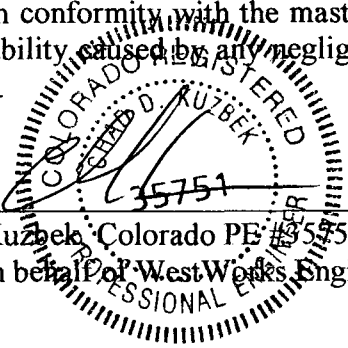

\_\_\_\_\_  
Chad D. Kuzbek, Colorado PE #35751  
For and on behalf of West Works Engineering

7/18/05  
Date

## Developer's Statement:

I, the developer have read and will comply with all of the requirements specified in this drainage report and plan.

Tanner Ranch, LLC  
Business Name

By: [Signature]  
Title: MANAGER / OWNER

Address: 9 Ridge Road  
Colorado Springs, CO 80904

## El Paso County, Colorado:

Filed in accordance with Section 51.1 of the El Paso County Land Development Code, as amended.

[Signature]  
For the County Engineer

7-20-05  
Date

Conditions:

# FINAL DRAINAGE REPORT for TANNER RANCH FILING NO. 1

## TABLE OF CONTENTS

<u>Description</u>	<u>Page</u>
Table of Contents	1
Engineer's Statement	2
Developer's Statement	2
El Paso County Approval	2
Purpose	3
General Location & Description	3
Drainage Basins & Sub-basins	4
Existing Drainage Conditions	4
Developed Drainage Conditions	4
Drainage Design Criteria	6
Drainage Facility Design	7
Floodplain Statement	7
Erosion Control Plan Statement	8
Drainage Fees	8
Opinion of Probable Cost	8
<b>APPENDIX:</b>	
Vicinity Map	
F.E.M.A. Floodplain Map	
S.C.S. Soils Map	
Time of Concentration Calculations	
Riprap Sizing Calculations	
WQCV Sizing Calculations	
Pond Outfall Structure Details	
Typical Road Section	
Typical Swale Sections	
Hydraulic Calculations	
Existing Conditions Hydrologic Analysis, Minor Storm	
Existing Conditions Hydrologic Analysis, Major Storm	
Developed Conditions Hydrologic Analysis, Minor Storm	
Developed Conditions Hydrologic Analysis, Major Storm	
Drainage Maps (Existing & Proposed Conditions)	

# FINAL DRAINAGE REPORT for TANNER RANCH FILING NO. 1

**Engineer's Statement:**

The attached drainage plan and report were prepared under my direction and supervision and are correct to the best of my knowledge and belief. Said drainage report has been prepared according the criteria established by the City/County for drainage reports and said report is in conformity with the master plan of the drainage basin. I accept responsibility for any liability caused by any negligent acts, errors, or omissions on my part in preparing this report.

\_\_\_\_\_  
Chad D. Kuzbek, Colorado PE #35751  
For and on behalf of WestWorks Engineering

\_\_\_\_\_  
Date

**Developer's Statement:**

I, the developer have read and will comply with all of the requirements specified in this drainage report and plan.

High Plains Land & Cattle, LLC

Business Name

By: \_\_\_\_\_

Title: \_\_\_\_\_

Address: 9 Ridge Road

Colorado Springs, CO 80904

**El Paso County, Colorado:**

Filed in accordance with Section 51.1 of the El Paso County Land Development Code, as amended.

\_\_\_\_\_  
For the County Engineer

\_\_\_\_\_  
Date

Conditions:

# FINAL DRAINAGE REPORT for TANNER RANCH FILING NO. 1

## PURPOSE

The purpose of this drainage report is to identify specific solutions to problems on site and off-site resulting from the development of this subdivision to be platted.

## GENERAL LOCATION AND DESCRIPTION

Tanner Ranch Filing No. 1 is a 209-acre subdivision within a portion of Section 18, Township 14 south, Range 62 west of the 6<sup>th</sup> P.M. in El Paso County, Colorado. Filing No. 1 represents the first phase of the overall 480-acre subdivision approved for development. More specifically, the site is located on the south side State Hwy 94 between Ellicott to the east and Yoder to the west (see Vicinity Map in Appendix). The study area is in the Upper Pond Creek Drainage Basin. There are no Drainage or Bridge Fees currently in the Upper Pond Creek Drainage Basin.

The site is currently undeveloped and covered mostly with native grasses. The site is generally flat, sloping generally from northwest to southeast over grades of 1% to 3%. Proposed development of Filing No. 1 includes 46 low density single-family residential lots with public asphalt streets.

According to the Soil Survey of El Paso County, prepared by the Soil Conservation Service, existing soils consist of the following soil types (see map in Appendix):

- Map Symbol 96 – “Truckton sandy loam”: slow surface runoff, moderate erosion hazard (Hydrologic Soil Group ‘B’)
- Map Symbol 95 – “Truckton loamy sand”: slow surface runoff, moderate to high erosion hazard (Hydrologic Soil Group ‘B’)
- Map Symbol 101 – “Ustic Torrfluvents, loamy”: slow surface runoff, moderate to high erosion hazard (Hydrologic Soil Group ‘B’)
- Map Symbol 11 – “Bresser sandy loam”: slow surface runoff, slight to moderate erosion hazard (Hydrologic Soil Group ‘B’)
- Map Symbol 19 – “Columbine gravelly sandy loam”: slow surface runoff, slight to moderate erosion hazard (Hydrologic Soil Group ‘A’)
- Map Symbol 4 – “Badland series”: rapid runoff, high erosion hazard (Hydrologic Soil Group ‘D’)

The majority of the site consists of the Truckton series; therefore Hydrologic Soil Group ‘B’ is used for calculation purposes.

## DRAINAGE BASINS AND SUB-BASINS

The overall 480-acre site is divided into 4 Major Basins – A, B, C, & D. Existing condition analysis adds the prefix “EX” to each of the Major Basins (e.g. EX-A). Developed condition analysis further divides the Major Basins into Sub-Basins, such as, A1, A2, B1, B2, etc. Each major basin will have a proposed on-site detention pond to detain developed flows and release them at or below historic peak flow levels. All on-site detention ponds shall be privately owned and maintained by the HOA. Developed flows are calculated for the entire 480-acre site for pond sizing. Future filings within this subdivision will need to design any proposed culvert crossings and swales and confirm the each detention pond will function as designed.

### Existing Drainage Conditions:

The site is currently undeveloped and covered with mostly native grasses. Runoff travels overland over gentle slopes, sometimes forming general drainageways, to adjacent properties. The site is divided into the following Major Basins for analysis (See Existing Conditions Drainage Map in Appendix):

Basin EX-A consists of 43.5 acres and generates runoff of  $Q_5 = 25$  cfs and  $Q_{100} = 63$  cfs at Design Point exA (DP-exA). DP-exA represents overland flow travel onto the adjacent property to the east.

Basin EX-B consists of 224.3 acres and generates runoff of  $Q_{10} = 26$  cfs and  $Q_{100} = 96$  cfs at DP-exB. Also draining to DP-exB is off-site Basin OS1. Basin OS1 consists of 22.3 acres and generates runoff of  $Q_5 = 15$  cfs and  $Q_{100} = 38$  cfs. The total combined flow at DP-exB is  $Q_{10} = 28$  cfs and  $Q_{100} = 106$  cfs. DP-exB is an existing 18” CMP culvert under Handle Road.

Basin EX-C consists of 177.1 acres and generates runoff of  $Q_{10} = 18$  cfs and  $Q_{100} = 66$  cfs at DP-exC. DP-exC is an existing 24” CMP culvert under Handle Road.

Basin EX-D consists of 26.0 acres and generates runoff of  $Q_5 = 15$  cfs and  $Q_{100} = 36$  cfs at DP-exD. DP-exD is the existing roadside ditch along the west side of South Calhan Hwy.

### Developed Drainage Conditions:

Proposed development of Filing No. 1 includes 46 low density single-family residential lots on 209 acres. The overall development of the entire 480-acre site will include 93 low density single-family residential lots. Analysis of the Major Basins is as follows (See Developed Conditions Drainage Map in Appendix):

#### MAJOR BASIN A:

Basin A1 includes 26.0 acres and generates runoff of  $Q_5 = 22$  cfs and  $Q_{100} = 51$  cfs at DP-A1. DP-A1 is a proposed 18” CMP culvert running under Dinner Bell Drive. The culvert at DP-A1 will drain directly onto the adjacent property. Therefore, this culvert includes Water Quality Capture Volume (WQCV) and the special outfall structure (see pond outfall details in Appendix). The outflow from the Pond created at DP-A1 is  $Q_5 = 1$  cfs and  $Q_{100} =$

4 cfs. The outfall from DP-A1 shall be protected by a 4' wide x 6' long  $D_{50} = 6''$  diameter riprap (1' thick). Basin A2 includes 15.4 acres and generates runoff of  $Q_5 = 13$  cfs and  $Q_{100} = 31$  cfs to Pond A. Outflow from Pond A is  $Q_5 = 1$  cfs and  $Q_{100} = 2$  cfs. The outfall structure is a proposed 18" CMP culvert with a WCQV orifice plate (see pond outfall details in Appendix). The outfall from Pond A shall be protected by a 4' wide x 6' long  $D_{50} = 6''$  diameter riprap (1' thick). Basin A3 includes 2.1 acres and generates runoff of  $Q_5 = 2$  cfs and  $Q_{100} = 4$  cfs. Basins A1 and A3 do not drain into Pond A. The total combined peak flow from Basins A1, A2, and A3 is  $Q_5 = 2$  cfs and  $Q_{100} = 7$  cfs (DP A). This is less than the existing peak flows from Basin EX-A of  $Q_5 = 25$  cfs and  $Q_{100} = 63$  cfs; therefore development of this basin will not adversely impact downstream properties.

#### MAJOR BASIN B:

Basin B1 includes 24.0 acres and generates runoff of  $Q_5 = 16$  cfs and  $Q_{100} = 39$  cfs at DP-B1. DP-B1 is a proposed 24" CMP culvert with riprap outfall protection running under Dinner Bell Drive. Basin B2 includes 6.4 acres and generates runoff of  $Q_5 = 5$  cfs and  $Q_{100} = 12$  cfs at DP-B2. DP-B2 is a proposed 18" CMP culvert running under Dinner Bell Drive. Basin B3 includes 44.0 acres and generates runoff of  $Q_5 = 34$  cfs and  $Q_{100} = 81$  cfs. The combined flows of Basins B1, B2, and B3 will be routed south via proposed Swale #1. Swale #1 is intended to prevent developed flows from traveling onto the adjacent property prior to heading south. Swale #1 is a proposed grass-lined trapezoidal swale with a 10' bottom width and 3:1 side slopes to a minimum depth of 2'. The slope of Swale #1 is 0.5% and the 100-year velocity is approximately 3.6 fps. This is within El Paso County permissible channel velocities. Swale #1 ends at the Filing No. 1 boundary. The swale flow will continue southeast over the existing ground into Basin B4. Future development of Basin B4 may require the continuation of Swale #1 to accommodate future lot layouts, road crossings, etc. Basin B4 includes 66.3 acres of future development that will generate runoff of  $Q_5 = 49$  cfs and  $Q_{100} = 115$  cfs at DP-B4. The total combined flow at DP-B4 is  $Q_{10} = 24$  cfs and  $Q_{100} = 153$  cfs. DP-B4 is a pair of proposed 24" CMP culverts with riprap outfall protection running under Dinner Bell Drive. Runoff at DP-B4 will overtop the roadway, however it is within El Paso County allowable roadway overtopping criteria. Basin B5 includes 86.0 acres of future development that will generate runoff of  $Q_5 = 62$  cfs and  $Q_{100} = 148$  cfs to Pond B. The total combined developed flow to Pond B from Basins B1, B2, B3, B4, B5, and OS1 is  $Q_5 = 59$  cfs and  $Q_{100} = 247$  cfs. Outflow from Pond B is  $Q_{10} = 6$  cfs and  $Q_{100} = 20$  cfs at DP-B. The outfall structure is a proposed 30" CMP culvert with a WCQV orifice plate (see pond outfall details in Appendix). The outfall from Pond B shall be protected by a 10' wide x 20' long  $D_{50} = 12''$  diameter riprap (2' thick). The outflow from Pond B is less than the existing peak flows from Basin EX-B of  $Q_{10} = 26$  cfs and  $Q_{100} = 96$  cfs; therefore development of this basin will not adversely impact downstream properties. DP-B is an existing 18" CMP culvert running under Handle Road. Runoff at DP-B will overtop the roadway; however it is within El Paso County allowable roadway overtopping criteria.

#### MAJOR BASIN C:

Basin C1 includes 43.1 acres and generates runoff of  $Q_5 = 24$  cfs and  $Q_{100} = 57$  cfs at DP-C1. DP-C1 is a pair of proposed 30" CMP culverts with riprap outfall protection running under Blue Duck Way. The total combined flow at DP-C1 ( $Q_5 = 32$  cfs and  $Q_{100} = 57$  cfs) includes runoff from Basins C2 and C3. Basin C2 includes 13.7 acres and generates runoff

of  $Q_5 = 10$  cfs and  $Q_{100} = 24$  cfs at DP-C2. DP-C2 is a proposed 24" CMP culvert with riprap outfall protection running under Dinner Bell Drive. Basin C3 includes 8.9 acres and generates runoff of  $Q_5 = 8$  cfs and  $Q_{100} = 9$  cfs. DP-C3 is a proposed 18" CMP culvert running under Dinner Bell Drive. Basin C4 includes 7.1 acres and generates runoff of  $Q_5 = 6$  cfs and  $Q_{100} = 14$  cfs. The combined flows of Basins C1, C2, and C4 will be routed south via proposed Swale #2. Swale #2 is intended to route developed flows through an existing buffalo wallow (or low area) and into Pond C. Swale #2 is a proposed grass-lined trapezoidal swale with a 10' bottom width and 4:1 side slopes to a minimum depth of 2'. The slope of Swale #2 is 0.5% and 1.1% resulting in 100-year velocities of approximately 3.8 fps and 5.0 fps respectively. These are within El Paso County permissible channel velocities. Swale #2 ends by tapering out into Pond C. Future development of Cross Bow Court will require the design of a culvert crossing with Swale #2. Basin C5 includes 21.1 acres and generates runoff of  $Q_5 = 16$  cfs and  $Q_{100} = 37$  cfs. Basin C6 includes 80.5 acres of future development that will generate runoff of  $Q_5 = 56$  cfs and  $Q_{100} = 134$  cfs to Pond C. The total combined developed flow to Pond C from Basins C1, C2, C3, C4, C5, and C6 is  $Q_{10} = 52$  cfs and  $Q_{100} = 155$  cfs. Outflow from Pond C is  $Q_{10} = 3$  cfs and  $Q_{100} = 13$  cfs at DP-C. The outfall structure is a proposed 30" CMP culvert with a WCQV orifice plate (see pond outfall details in Appendix). The outfall from Pond D shall be protected by a 10' wide x 20' long  $D_{50} = 12$ " diameter riprap (2' thick). The outflow from Pond C is less than the existing peak flows from Basin EX-C of  $Q_{10} = 18$  cfs and  $Q_{100} = 66$  cfs; therefore development of this basin will not adversely impact downstream properties. DP-C is an existing 24" CMP culvert running under Handle Road. Runoff at DP-C will overtop the roadway; however it is within El Paso County allowable roadway overtopping criteria.

#### MAJOR BASIN D:

Basin D1 includes 5.8 acres of future development that will generate runoff of  $Q_5 = 5$  cfs and  $Q_{100} = 12$  cfs at DP-D. Basin D2 includes 20.2 acres of future development that will generate runoff of  $Q_5 = 18$  cfs and  $Q_{100} = 43$  cfs to Pond D. Outflow from Pond D is  $Q_5 = 1$  cfs and  $Q_{100} = 3$  cfs. The outfall structure is a proposed 18" CMP culvert with a WCQV orifice plate (see pond outfall details in Appendix). The outfall from Pond D shall be protected by a 4' wide x 6' long  $D_{50} = 6$ " diameter riprap (1' thick). Basin D1 does not drain into Pond D. The total combined peak flow from Basins D1 and D2 is  $Q_5 = 5$  cfs and  $Q_{100} = 13$  cfs (DP-D). This is less than the existing peak flows from Basin EX-D of  $Q_5 = 15$  cfs and  $Q_{100} = 36$  cfs; therefore development of this basin will not adversely impact downstream properties.

#### DRAINAGE DESIGN CRITERIA

This drainage report was prepared in accordance to the criteria established in the City of Colorado Springs and El Paso County Drainage Criteria Manual, updated in October 1994. This report has taken into the account the results and recommendations of the following previous drainage studies:

"Master Development Drainage Plan and Preliminary Drainage Report for Tanner Ranch," prepared by JPS Engineering, dated October 29, 2001

Per the City/County Drainage Criteria Manual and the request of El Paso County, WestWorks Engineering used the Rational Method for analysis of any individual basins or total tributary area less than 100 acres. The SCS Unit Hydrograph Procedure (TR-20) for individual drainage basins or total tributary areas greater than 100 acres. This methodology is implemented in accordance with the City/County Drainage Criteria Manual Guidelines.

For the Rational Method, flows are calculated for the 5-year and 100-year recurrence intervals. The average runoff coefficients, 'C' values, are taken from Table 5-1 and the Intensity-Duration-Frequency curves are taken from Figure 5-1 of the City/County Drainage Criteria Manual. Time of concentration for overland flow and channel are calculated per Section 5.2.3 of the City/County Drainage Criteria Manual. Calculations for the Rational Method, if used, are shown in the Appendix of this report. Any detention volume, in drainage total tributary basin areas less than 100 acres is calculated using the Modified Rational Method. The Modified Rational Method calculations are performed with the aid of HydroCAD version 7.00. Per the City/County Drainage Criteria Manual, the Modified Rational Method is only recommended for detention pond analysis on total tributary areas up to 20 acres. Per the specific request of El Paso County Development Services Engineering, this methodology was used on pond analyses with tributary areas up to 100 acres.

For the SCS Unit Hydrograph Procedure (TR-20), WestWorks Engineering uses the aid of HydroCAD version 7.00 for runoff calculations, routing quantities, and detention. Runoff quantities are analyzed for storms with recurrence intervals of 10 years and 100 years. The 24-hour storm distributions are based on a Type IIA distribution as shown in Figure 5-5b of the City/County Drainage Criteria Manual. Rainfall depths are based on the Isopluvial maps in City/County Drainage Criteria Manual Figures 5-4d and 5-4e. The 10-year 24-hour rainfall depth for this site is 3.0 inches. The 100-year 24-hour rainfall depth for this site is 4.4 inches. Runoff Curve Numbers are taken from Tables 5-6 and 5-7 (using AMC II) of the City/County Drainage Criteria Manual. Calculations for the SCS Unit Hydrograph Procedure (TR-20) are shown in the Appendix of this report.

### **DRAINAGE FACILITY DESIGN**

All culverts and open channels are sized using the procedures outlined in the City/County Drainage Criteria Manual Chapters 7, 8, 9, and 10 respectively. All of the drainage systems, including the streets, are designed to safely route the 5-year and 100-year storm flows.

### **FLOODPLAIN STATEMENT**

To the best of my knowledge and belief, no portion of Tanner Ranch Filing No. 1 is within a F.E.M.A. designated floodplain per Flood Insurance Rate Map Community Panel No. 08041C0850 F, effective March 17<sup>th</sup>, 1997.

## EROSION CONTROL PLAN

The City of Colorado Springs/El Paso County Drainage Criteria Manual specifies that an Erosion Control Plan and associated cost estimate be submitted in conjunction with the Final Drainage Report. We respectfully request the Erosion Control Plan be submitted in conjunction with the site construction drawings and construction assurances posted prior to obtaining a grading permit.

## DRAINAGE FEES

The study area is in the Upper Pond Creek Drainage Basin. There are no Drainage or Bridge Fees currently in the Upper Pond Creek Drainage Basin.

## OPINION OF PROBABLE COST

(Non-Reimbursable Private Facilities)

<u>Description</u>	<u>Quantity</u>	<u>Unit Cost</u>	<u>Total Cost</u>
1. 18" CMP	190 LF	\$ 20/LF	\$ 3,800
2. 24" CMP	200 LF	\$ 25/LF	\$ 5,000
3. 30" CMP	150 LF	\$ 30/LF	\$ 4,500
3. Riprap	125 CY	\$ 35/CY	\$ 4,375
	Subtotal		\$17,675
	10% Contingency		\$ 1,768
	<b>TOTAL</b>		<b><u>\$19,443</u></b>

This opinion of probable cost is made on the basis of experience and qualifications and represents WestWorks Engineering's best judgment as an experienced and qualified professional firm, familiar with the construction industry. WestWorks Engineering cannot and will not guarantee that actual construction costs will not vary from this opinion of probable cost.

**APPENDIX**

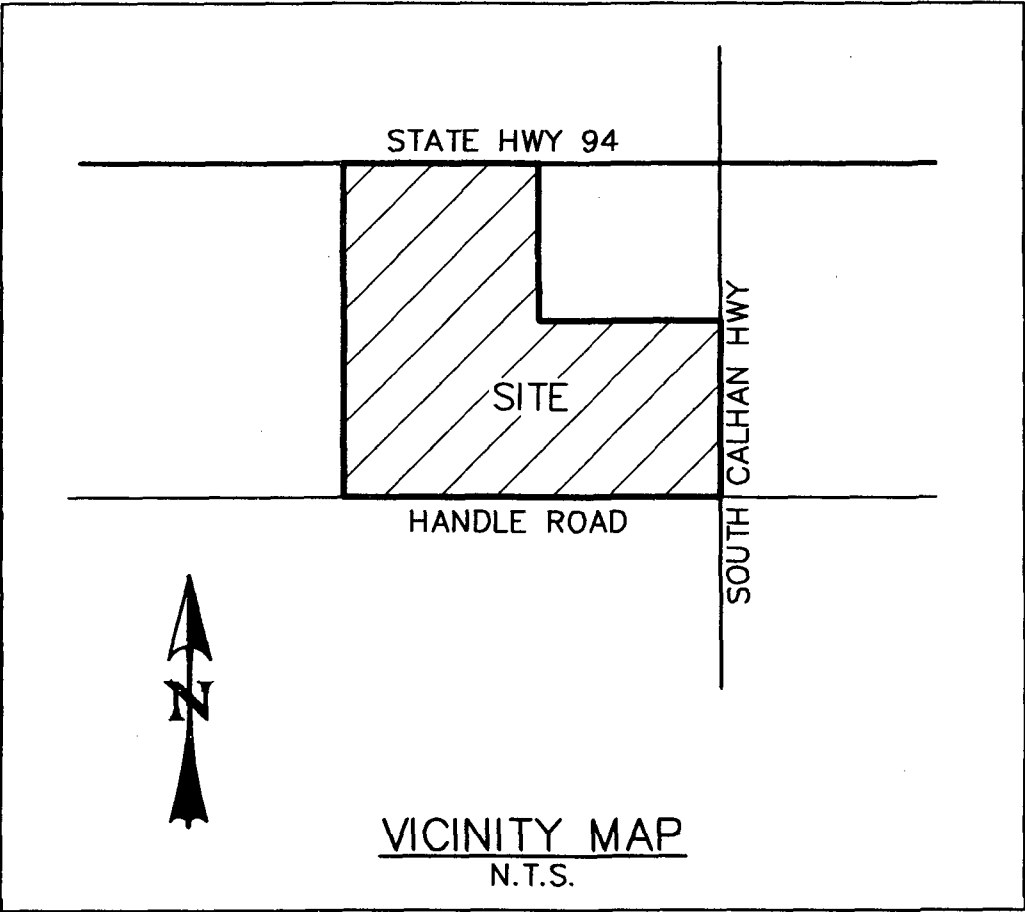

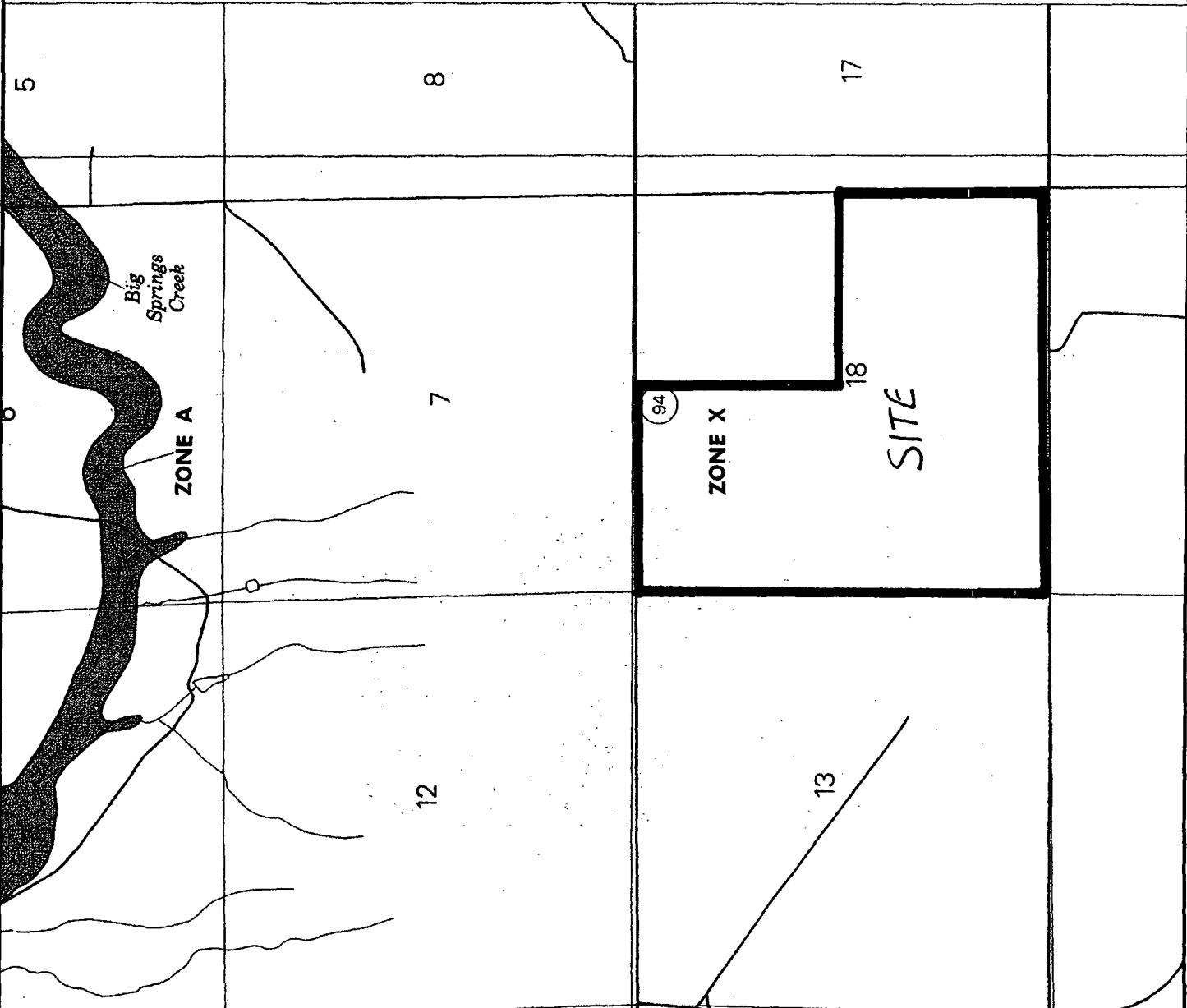

NATIONAL FLOOD INSURANCE PROGRAM

**FIRM**  
**FLOOD INSURANCE RATE MAP**  
 EL PASO COUNTY,  
 COLORADO AND  
 INCORPORATED AREAS

PANEL 850 OF 1300  
 (SEE MAP INDEX FOR PANELS NOT PRINTED)

CONTAINS:  
 COMMUNITY  
 EL PASO COUNTY  
 UNINCORPORATED AREAS

NUMBER PANEL SUFFIX  
 08008 0850 F

MAP NUMBER  
 08041G0850 F  
 EFFECTIVE DATE:  
 MARCH 17, 1997



Federal Emergency Management Agency

This is an official copy of a portion of the above referenced flood map. It was extracted using F-MIT On-Line. This map does not reflect changes or amendments which may have been made subsequent to the date on the title block. For the latest product information about National Flood Insurance Program flood maps check the FEMA Flood Map Store at [www.msc.fema.gov](http://www.msc.fema.gov)

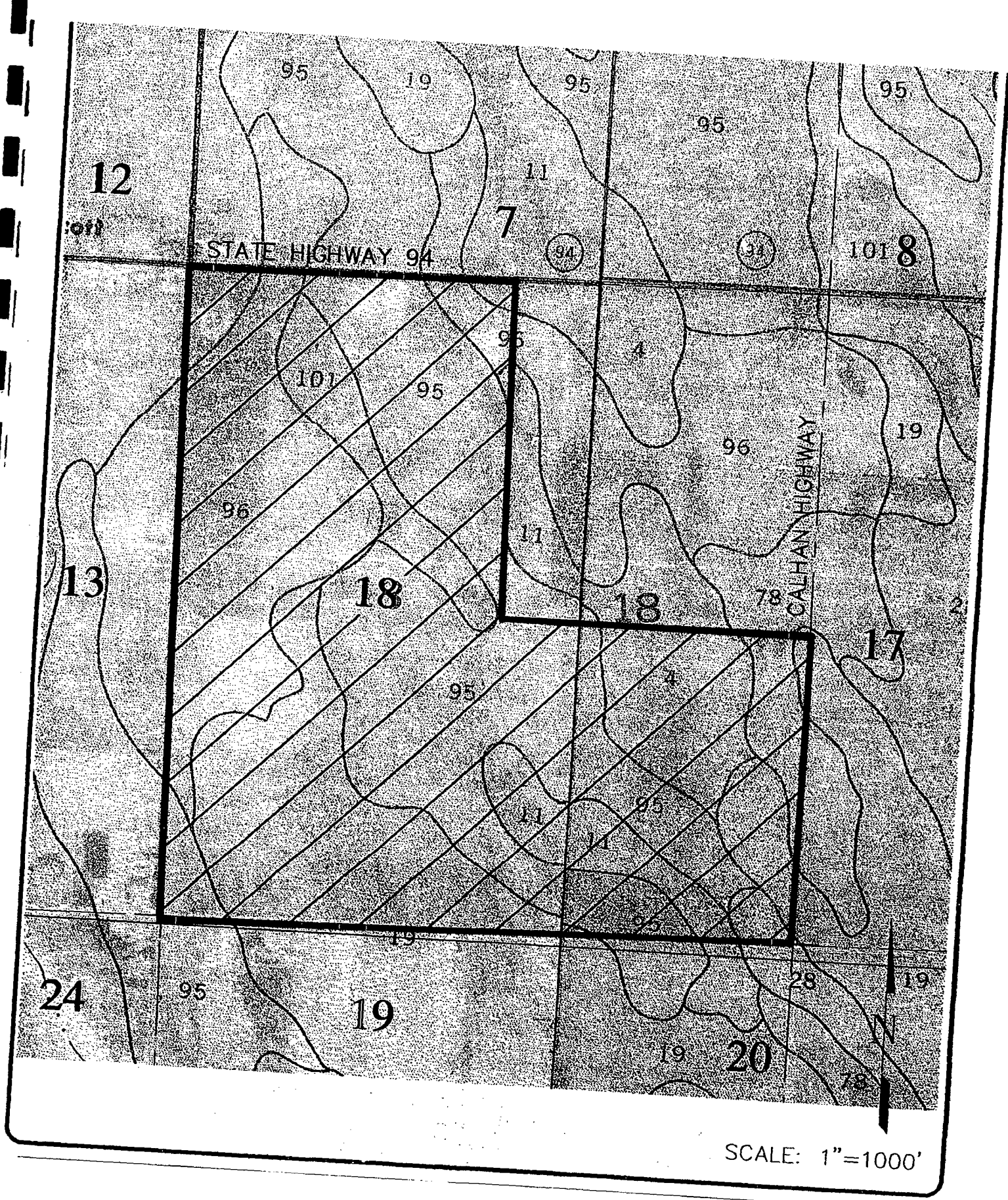

SCALE: 1"=1000'

S.C.S. SOILS  
MAP

### Time of Concentration Calculations

Sub-Basin Area [ac]	Time of Concentration, Tc [min.]					Sub-Basin Area [ac]	Time of Concentration, Tc [min.]					Sub-Basin Area [ac]	Time of Concentration, Tc [min.]				
	Flowline	L [ft.]	S [%]	v [ft/s]	Tc [min.]		Flowline	L [ft.]	S [%]	v [ft/s]	Tc [min.]		Flowline	L [ft.]	S [%]	v [ft/s]	Tc [min.]
<u>EX1</u> 43.5	overland	850	3.5		30.5	<u>OS1</u> 22.3	overland	300	2.0		21.9						
	channel	520	1.5	4.29	2.0		channel	680	1.5	4.29	2.6						
	Total Tc = <b>32.5</b>						Total Tc = <b>24.5</b>										
<u>EX2</u> 224.3	overland	800	1.3		41.2												
	channel	6250	1.1	3.67	28.4												
	Total Tc = <b>69.6</b>																
<u>EX3</u> 177.1	overland	1000	0.8		54.1												
	channel	6252	1.0	3.50	29.8												
	Total Tc = <b>83.9</b>																
<u>EX4</u> 26	overland	830	2.4		34.2												
	channel	0	0.0	0.35	0.0												
	Total Tc = <b>34.2</b>																



Project: Tanner Ranch Filing No. 1

Job No.: 90330

Engineer: Chad Kuzbek, PE

Date: December 17, 2004

### Time of Concentration Calculations

Sub-Basin Area [ac]	Time of Concentration, Tc [min.]					Sub-Basin Area [ac]	Time of Concentration, Tc [min.]					Sub-Basin Area [ac]	Time of Concentration, Tc [min.]				
	Flowline	L [ft.]	S [%]	v [ft/s]	Tc [min.]		Flowline	L [ft.]	S [%]	v [ft/s]	Tc [min.]		Flowline	L [ft.]	S [%]	v [ft/s]	Tc [min.]
<u>A-1</u> 26	overland	300	2.3		20.9	<u>B-4</u> 66.3	overland	300	3.0		19.1	<u>C-4</u> 7.1	overland	300	2.7		19.8
	channel	1050	2.9	5.96	<u>2.9</u>		channel	2240	1.0	3.50	<u>10.7</u>		channel	560	0.7	2.93	<u>3.2</u>
Total Tc =					<b>23.8</b>	Total Tc =					<b>29.8</b>	Total Tc =					<b>23.0</b>
<u>A-2</u> 17.5	overland	300	3.0		19.1	<u>B-5</u> 86	overland	300	2.7		19.8	<u>C-5</u> 21.1	overland	300	2.0		21.9
	channel	1070	1.8	4.70	<u>3.8</u>		channel	2530	1.3	3.99	<u>10.6</u>		channel	1760	1.3	3.99	<u>7.4</u>
Total Tc =					<b>22.9</b>	Total Tc =					<b>30.3</b>	Total Tc =					<b>29.2</b>
<u>B-1</u> 24	overland	300	1.0		27.5	<u>C-1</u> 43.1	overland	300	0.7		31.0	<u>C-6</u> 80.5	overland	300	2.7		19.8
	channel	1330	1.0	3.50	<u>6.3</u>		channel	3590	1.2	3.83	<u>15.6</u>		channel	2290	0.8	3.13	<u>12.2</u>
Total Tc =					<b>33.9</b>	Total Tc =					<b>46.6</b>	Total Tc =					<b>32.0</b>
<u>B-2</u> 6.4	overland	300	1.3		25.2	<u>C-2</u> 13.7	overland	300	1.3		25.2	<u>D-1</u> 5.8	overland	300	3.3		18.5
	channel	490	1.4	4.14	<u>2.0</u>		channel	1050	1.7	4.56	<u>3.8</u>		channel	950	2.1	5.07	<u>3.1</u>
Total Tc =					<b>27.2</b>	Total Tc =					<b>29.1</b>	Total Tc =					<b>21.6</b>
<u>B-3</u> 44	overland	300	2.7		19.8	<u>C-3</u> 8.9	overland	300	3.0		19.1	<u>D-2</u> 20.2	overland	300	3.3		18.5
	channel	1780	1.5	4.29	<u>6.9</u>		channel	540	1.9	4.82	<u>1.9</u>		channel	510	2.0	4.95	<u>1.7</u>
Total Tc =					<b>26.7</b>	Total Tc =					<b>21.0</b>	Total Tc =					<b>20.2</b>
<u>A-3</u> 2.1	overland	300	1.7		23.1							overland	300	1.7		23.1	
	channel	50	2.0	4.95	<u>0.2</u>							channel	50	2.0	4.95	<u>0.2</u>	
Total Tc =					<b>23.2</b>						Total Tc =					<b>23.2</b>	



Project: Tanner Ranch Filing No. 1

Job No.: 90330

Engineer: Chad Kuzbek, PE

Date: December 17, 2004

# RIPRAP SIZING

Channel Section Description	Velocity V [ft/s]	Slope, S [ft/ft]	Specific Gravity	*Channel/Riprap Relationship	Rock Type	Mean Particle Size [in]
Design Point A1	3.3	1.00%	2.5	1.15	N/A	<i>none req'd</i>
Pond A Discharge	2.1	1.00%	2.5	0.73	N/A	<i>none req'd</i>
Design Point B1	4.7	1.00%	2.5	1.64	VL	<b>6</b>
Design Point B2	3.8	1.00%	2.5	1.33	N/A	<i>none req'd</i>
Design Point B4	5.8	1.00%	2.5	2.03	VL	<b>6</b>
Pond B Discharge	4.6	1.00%	2.5	1.61	VL	<b>6</b>
Design Point C1	5.5	1.00%	2.5	1.92	VL	<b>6</b>
Design Point C2	5	1.00%	2.5	1.75	VL	<b>6</b>
Design Point C3	3.6	1.00%	2.5	1.26	N/A	<i>none req'd</i>
Pond C Discharge	4.3	1.00%	2.5	1.50	VL	<b>6</b>

\*Channel/Riprap Relationship =  $\frac{V \cdot S^{0.17}}{(S_s - 1)^{0.66}}$

\*taken from El Paso County Drainage Criteria Manual Section 10.10

where: V = mean channel flow velocity [ft/sec]  
 S = longitudinal channel slope [ft/ft]  
 S<sub>s</sub> = specific gravity of stone (min = 2.5)

# Design Procedure Form: Extended Detention Basin (EDB) - Sedimentation Facility

Designer: Chad Kuzbek, PE  
 Company: WestWorks Engineering  
 Date: June 14, 2005  
 Project: Tanner Ranch Filing No. 1

## Pond A1

<p>1. Basin Storage Volume</p> <p>A) Tributary Area's Imperviousness Ratio (<math>i = I_a / 100</math>)</p> <p>B) Contributing Watershed Area (Area)</p> <p>C) Water Quality Capture Volume (WQCV)  <math>(WQCV = 1.0 * (0.91 * I^3 - 1.19 * I^2 + 0.78 * I))</math></p> <p>D) Design Volume: <math>Vol = (WQCV / 12) * Area * 1.2</math></p>	<p><math>I_a = \frac{4.00}{100} \%</math></p> <p><math>i = \frac{0.04}{100}</math></p> <p>Area = <u>26.0</u> acres</p> <p>WQCV = <u>0.03</u> watershed inches</p> <p>Vol = <u>0.076</u> acre-feet                  (0.10 ac-ft provided)</p>
---	--

## Pond A

<p>1. Basin Storage Volume</p> <p>A) Tributary Area's Imperviousness Ratio (<math>i = I_a / 100</math>)</p> <p>B) Contributing Watershed Area (Area)</p> <p>C) Water Quality Capture Volume (WQCV)  <math>(WQCV = 1.0 * (0.91 * I^3 - 1.19 * I^2 + 0.78 * I))</math></p> <p>D) Design Volume: <math>Vol = (WQCV / 12) * Area * 1.2</math></p>	<p><math>I_a = \frac{4.00}{100} \%</math></p> <p><math>i = \frac{0.04}{100}</math></p> <p>Area = <u>15.4</u> acres</p> <p>WQCV = <u>0.03</u> watershed inches</p> <p>Vol = <u>0.045</u> acre-feet                  (0.42 ac-ft provided)</p>
---	--

## Pond B

<p>1. Basin Storage Volume</p> <p>A) Tributary Area's Imperviousness Ratio (<math>i = I_a / 100</math>)</p> <p>B) Contributing Watershed Area (Area)</p> <p>C) Water Quality Capture Volume (WQCV)  <math>(WQCV = 1.0 * (0.91 * I^3 - 1.19 * I^2 + 0.78 * I))</math></p> <p>D) Design Volume: <math>Vol = (WQCV / 12) * Area * 1.2</math></p>	<p><math>I_a = \frac{4.00}{100} \%</math></p> <p><math>i = \frac{0.04}{100}</math></p> <p>Area = <u>249.0</u> acres</p> <p>WQCV = <u>0.03</u> watershed inches</p> <p>Vol = <u>0.731</u> acre-feet                  (1.52 ac-ft provided)</p>
---	---

# Design Procedure Form: Extended Detention Basin (EDB) - Sedimentation Facility

Designer: Chad Kuzbek, PE  
 Company: WestWorks Engineering  
 Date: June 14, 2005  
 Project: Tanner Ranch Filing No. 1

## Pond C

<p>1. Basin Storage Volume</p> <p>A) Tributary Area's Imperviousness Ratio (<math>i = I_a / 100</math>)</p> <p>B) Contributing Watershed Area (Area)</p> <p>C) Water Quality Capture Volume (WQCV) (<math>WQCV = 1.0 * (0.91 * I^3 - 1.19 * I^2 + 0.78 * I)</math>)</p> <p>D) Design Volume: <math>Vol = (WQCV / 12) * Area * 1.2</math></p>	<p><math>I_a = \frac{4.00}{100} \%</math></p> <p><math>i = \frac{0.04}{100}</math></p> <p>Area = <u>174.4</u> acres</p> <p>WQCV = <u>0.03</u> watershed inches</p> <p>Vol = <u>0.512</u> acre-feet (1.52 ac-ft provided)</p>
--	--

## Pond D

<p>1. Basin Storage Volume</p> <p>A) Tributary Area's Imperviousness Ratio (<math>i = I_a / 100</math>)</p> <p>B) Contributing Watershed Area (Area)</p> <p>C) Water Quality Capture Volume (WQCV) (<math>WQCV = 1.0 * (0.91 * I^3 - 1.19 * I^2 + 0.78 * I)</math>)</p> <p>D) Design Volume: <math>Vol = (WQCV / 12) * Area * 1.2</math></p>	<p><math>I_a = \frac{4.00}{100} \%</math></p> <p><math>i = \frac{0.04}{100}</math></p> <p>Area = <u>20.2</u> acres</p> <p>WQCV = <u>0.03</u> watershed inches</p> <p>Vol = <u>0.059</u> acre-feet (0.24 ac-ft provided)</p>
--	---

## WATER QUALITY POND Maintenance Recommendations

Extended detention basins have low to moderate maintenance requirements. Routine and nonroutine maintenance is necessary to assure performance, enhance aesthetics, and protect structural integrity. The dry basins can result in nuisance complaints if not properly designed or maintained. Bio-degradable pesticides may be required to limit insect problems. Frequent debris removal and grass-mowing can reduce aesthetic complaints. If a shallow wetland or marshy area is included, mosquito breeding and nuisance odors could occur if the water becomes stagnant. Access to critical elements of the pond (inlet, outlet, spillway, and sediment collection areas) must be provided. The basic elements of the maintenance requirements are presented in Table EDB-1.

TABLE EDB-1  
Extended Detention Basin Maintenance Considerations

Required Action	Maintenance Objective	Frequency of Action
Lawn mowing and lawn care	Occasional mowing to limit unwanted vegetation. Maintain irrigated turf grass as 2 to 4 inches tall and nonirrigated native turf grasses at 4 to 6 inches.	Routine – Depending on aesthetic requirements.
Debris and litter removal	Remove debris and litter from the entire pond to minimize outlet clogging and improve aesthetics.	Routine – Including just before annual storm seasons (that is, April and May) and following significant rainfall events.
Erosion and sediment control	Repair and revegetate eroded areas in the basin and channels.	Nonroutine – Periodic and repair as necessary based on inspection.
Structural	Repair pond inlets, outlets, forebays, low flow channel liners, and energy dissipators whenever damage is discovered.	Nonroutine – Repair as needed based on regular inspections.
Inspections	Inspect basins to insure that the basin continues to function as initially intended. Examine the outlet for clogging, erosion, slumping, excessive sedimentation levels, overgrowth, embankment and spillway integrity, and damage to any structural element.	Routine – Annual inspection of hydraulic and structural facilities. Also check for obvious problems during routine maintenance visits, especially for plugging of outlets.
Nuisance control	Address odor, insects, and overgrowth issues associated with stagnant or standing water in the bottom zone.	Nonroutine – Handle as necessary per inspection or local complaints.
Sediment removal	Remove accumulated sediment from the forebay, micro-pool, and the bottom of the basin.	Nonroutine – Performed when sediment accumulation occupies 20 percent of the WQCV. This may vary considerably, but expect to do this every 10 to 20 years, as necessary per inspection if no construction activities take place in the tributary watershed. More often if they do. The forebay and the micro-pool will require more frequent cleanout than other areas of the basin, say every 1 or 2 years.

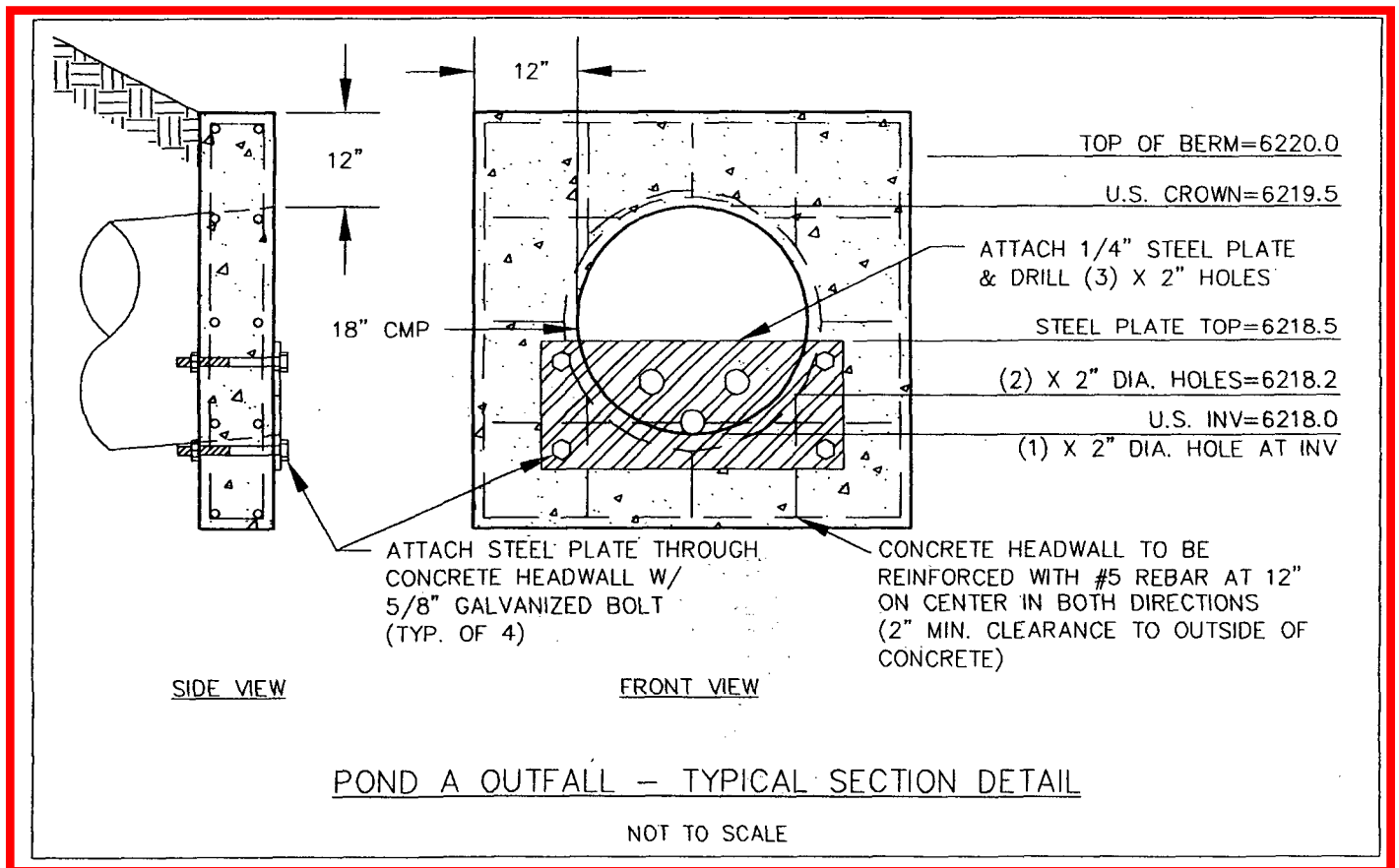
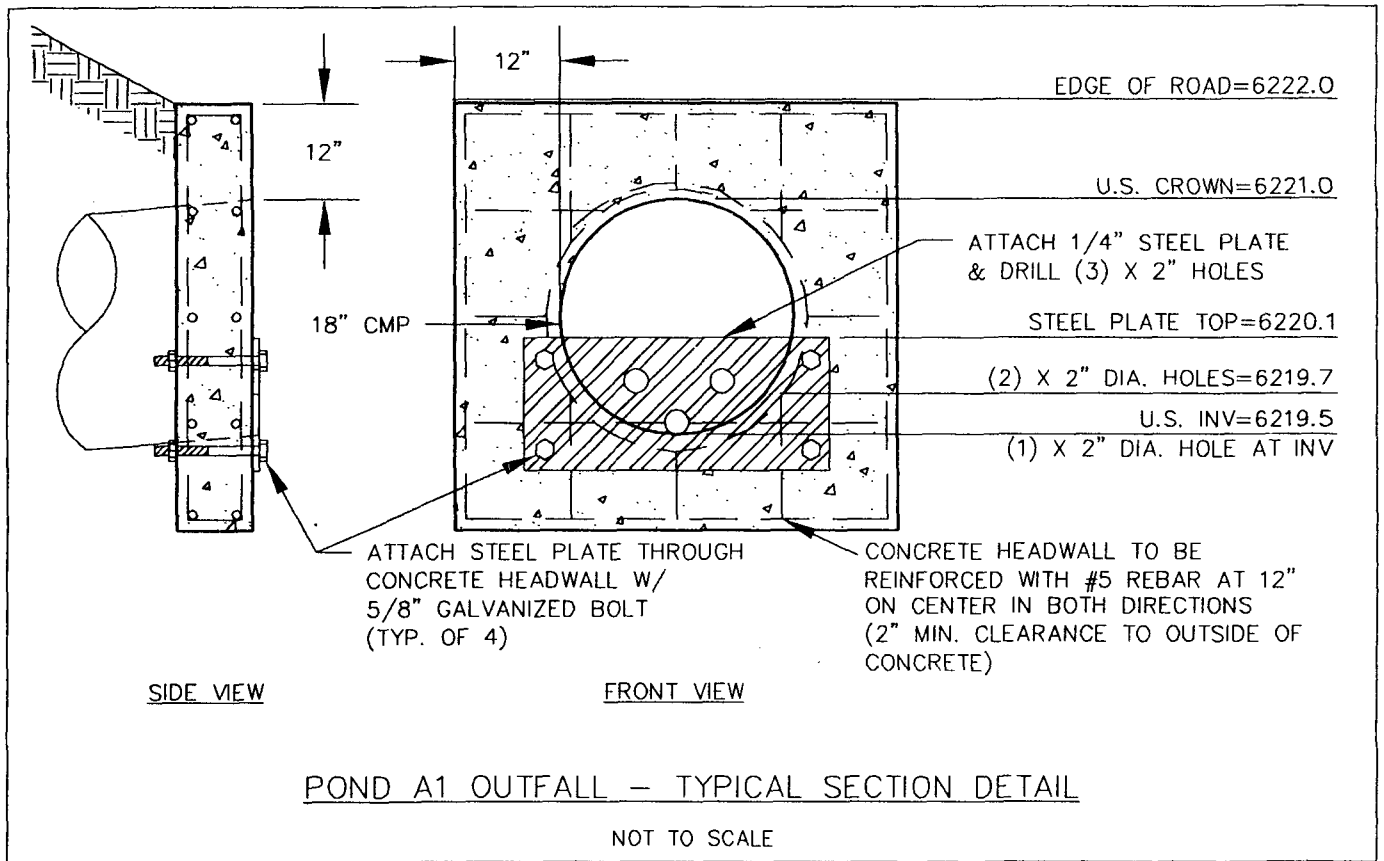

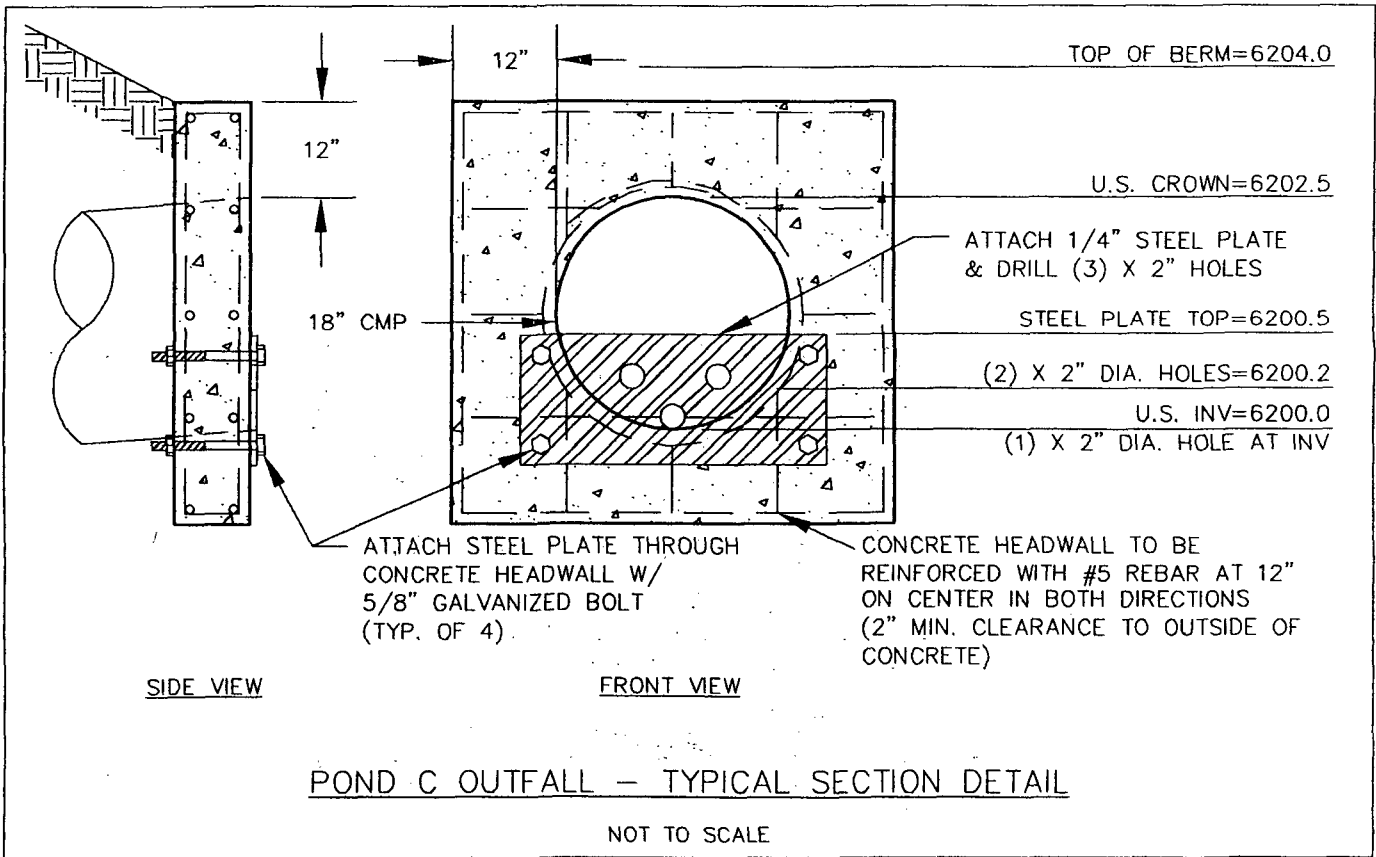
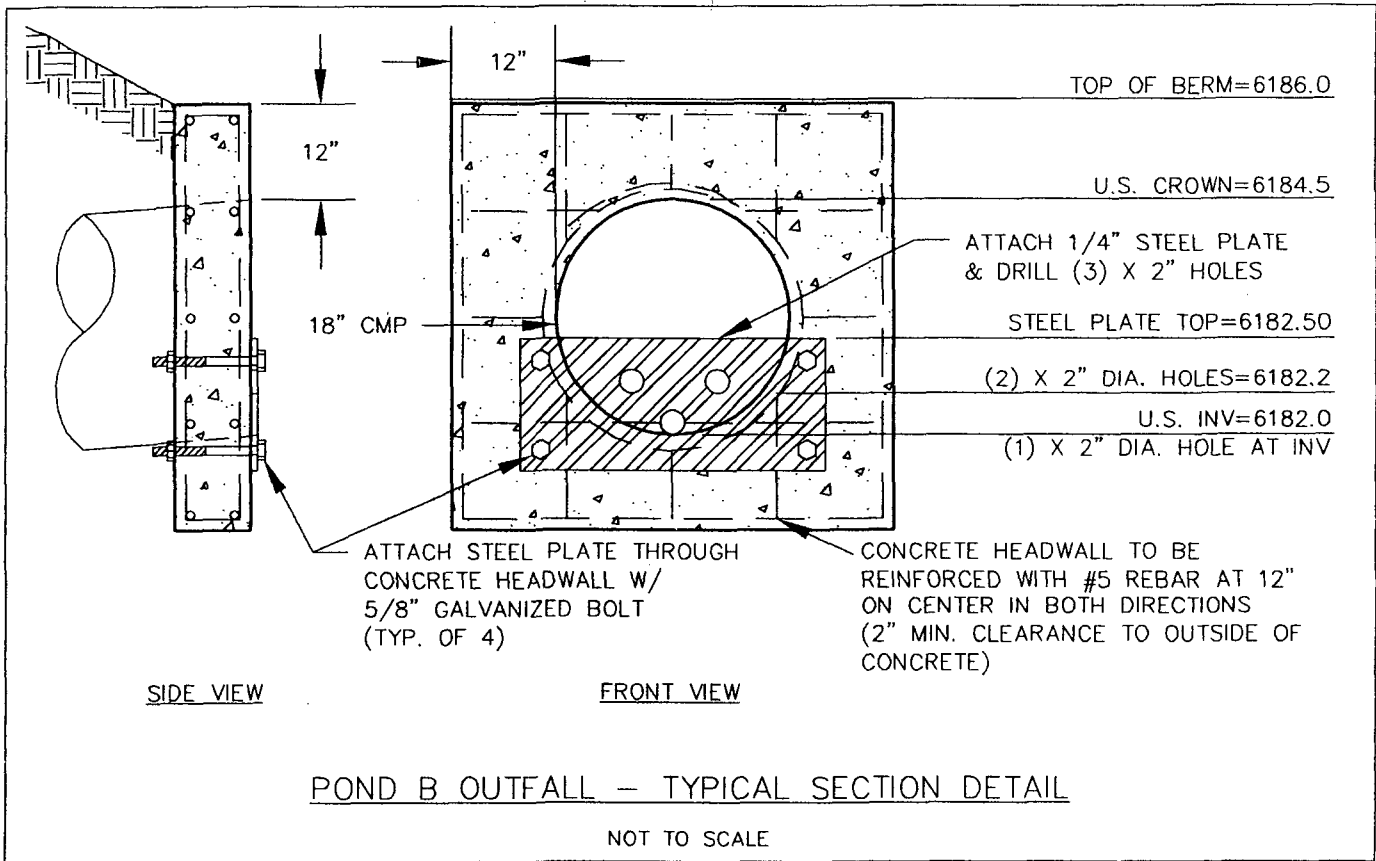

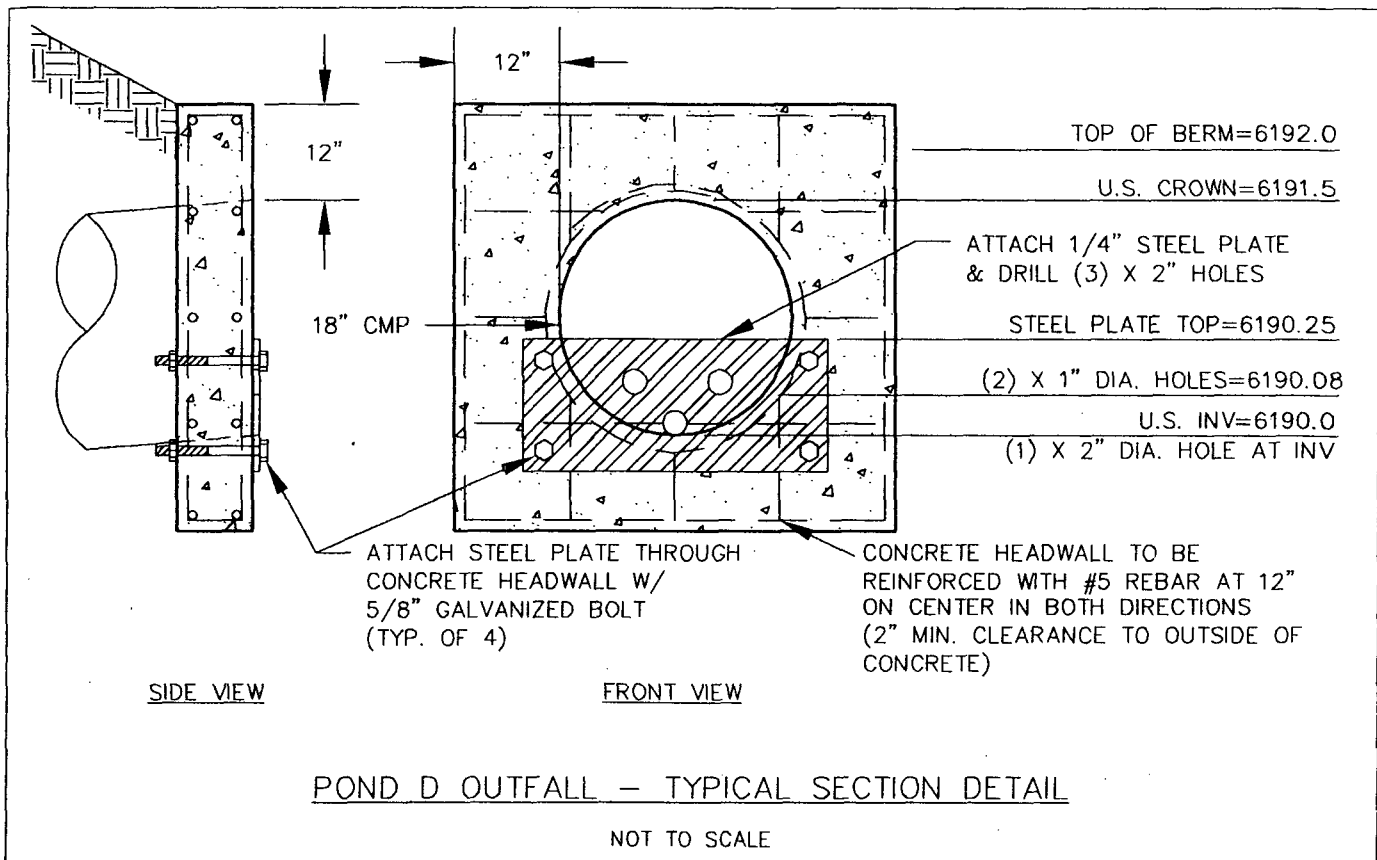

**POND OUTFALL NOTES:**

1. EMBANKMENT SLOPES AROUND HEADWALL TO BE GRADED FLUSH WITH TOP AND SIDE EDGES OF THE HEADWALL. SEE GRADING PLAN FOR SOIL COMPACTION REQUIREMENTS.
2. THE POND OUTFALL STRUCTURE SHALL BE LOCATED SUCH THAT THE INVERT OF THE OUTFALL IS AT THE LOWEST POINT OF THE POND. OR THE BOTTOM OF THE POND SHALL BE GRADED SO THAT THE INVERT OF THE OUTFALL IS AT THE LOWEST POINT OF THE POND.

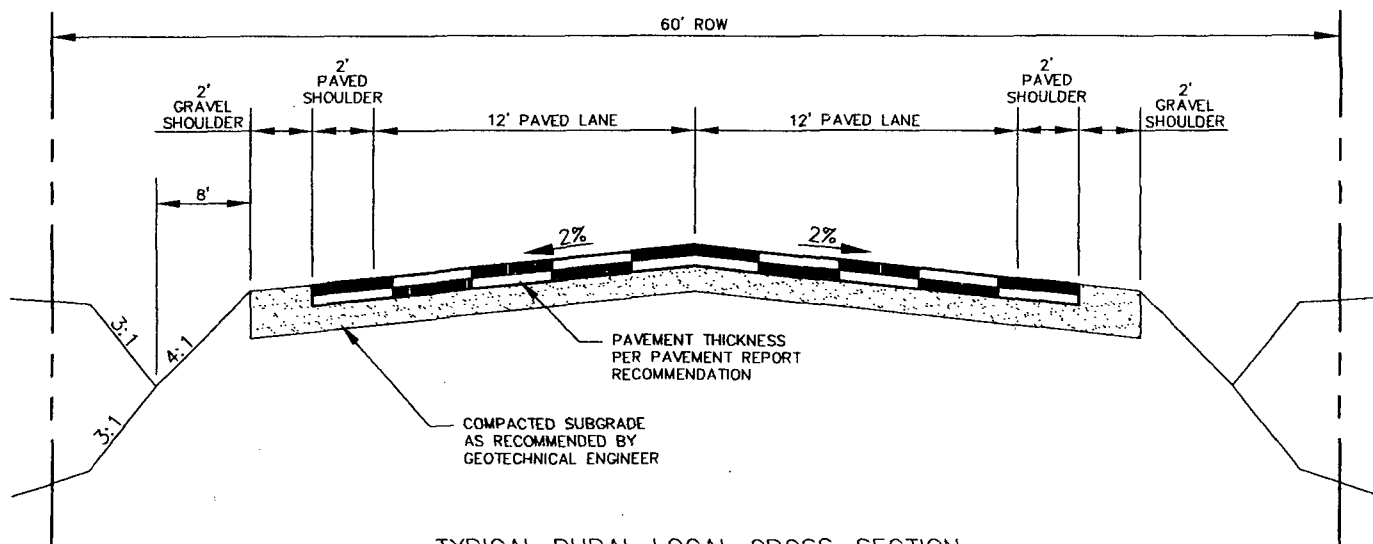

TYPICAL RURAL LOCAL CROSS-SECTION  
N.T.S.

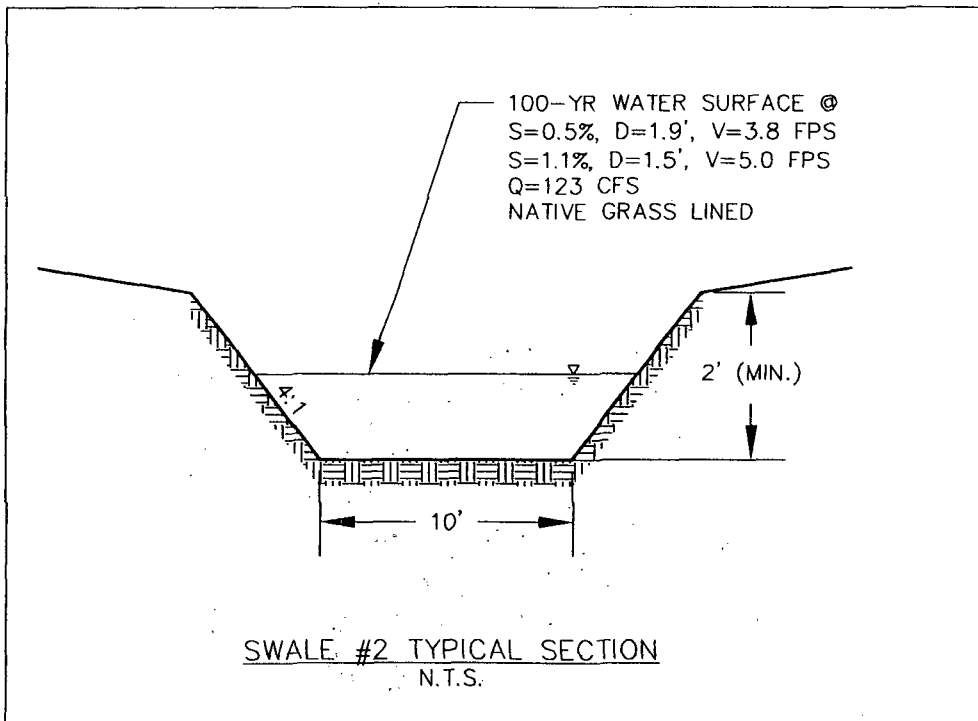
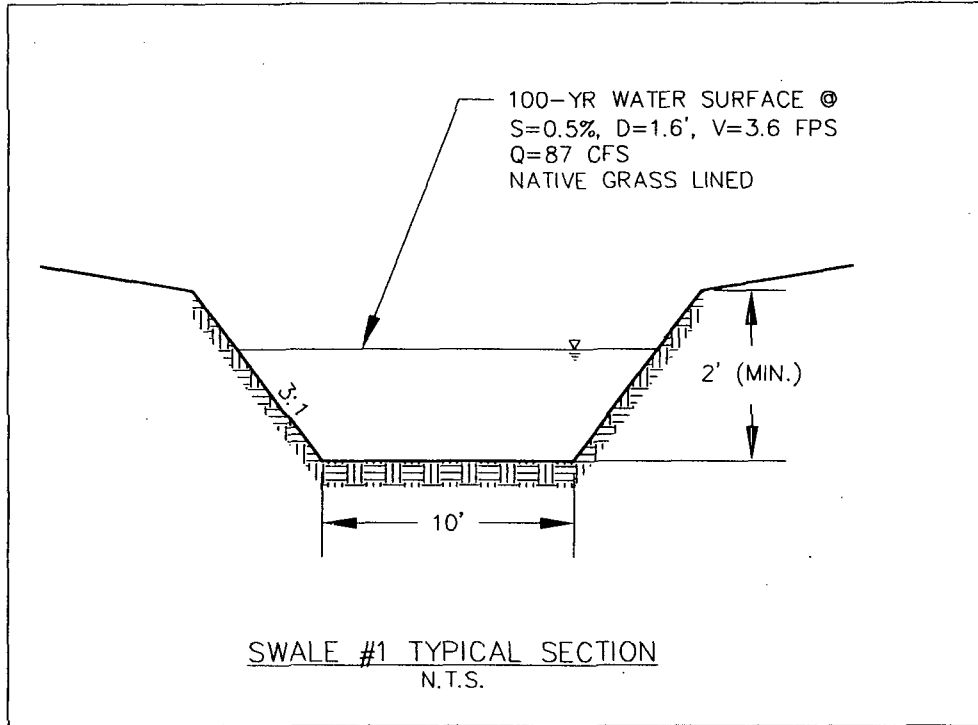

SWALE #1

TRAPEZOIDAL CHANNEL ANALYSIS  
NORMAL DEPTH COMPUTATION

June 16, 2005

=====

PROGRAM INPUT DATA

=====

DESCRIPTION	VALUE
Flow Rate (cfs).....	87.0 ← $Q_{100}$
Channel Bottom Slope (ft/ft).....	0.005 ← $S = 0.5\%$
Manning's Roughness Coefficient (n-value).....	0.033
Channel Left Side Slope (horizontal/vertical).....	3.0
Channel Right Side Slope (horizontal/vertical).....	3.0
Channel Bottom Width (ft).....	10.0

=====

COMPUTATION RESULTS

=====

DESCRIPTION	VALUE
Normal Depth (ft).....	1.63 ← $D_{100}$
Flow Velocity (fps).....	3.58
Froude Number.....	0.57 ← $V_{100}$
Velocity Head (ft).....	0.2
Energy Head (ft).....	1.83
Cross-Sectional Area of Flow (sq ft).....	24.27
Top Width of Flow (ft).....	19.78

=====

HYDROCALC Hydraulics for Windows, Version 1.2a Copyright (c) 1996  
Dodson & Associates, Inc., 5629 FM 1960 West, Suite 314, Houston, TX 77069  
Phone: (281) 440-3787, Fax: (281) 440-4742, Email: software@dodson-hydro.com  
All Rights Reserved.

SWALE #2

TRAPEZOIDAL CHANNEL ANALYSIS  
NORMAL DEPTH COMPUTATION

December 23, 2004

=====

DESCRIPTION	VALUE
Flow Rate (cfs).....	123.0 ← $Q_{100}$
Channel Bottom Slope (ft/ft).....	0.005 ← $S=0.5\%$
Manning's Roughness Coefficient (n-value).....	0.033
Channel Left Side Slope (horizontal/vertical).....	4.0
Channel Right Side Slope (horizontal/vertical).....	4.0
Channel Bottom Width (ft).....	10.0

=====

DESCRIPTION	VALUE
Normal Depth (ft).....	1.87 ← $D_{100}$
Flow Velocity (fps).....	3.76 ← $V_{100}$
Froude Number.....	0.58
Velocity Head (ft).....	0.22
Energy Head (ft).....	2.09
Cross-Sectional Area of Flow (sq ft).....	32.69
Top Width of Flow (ft).....	24.96

=====

HYDROCALC Hydraulics for Windows, Version 1.2a Copyright (c) 1996  
Dodson & Associates, Inc., 5629 FM 1960 West, Suite 314, Houston, TX 77069  
Phone: (281) 440-3787, Fax: (281) 440-4742, Email: software@dodson-hydro.com  
All Rights Reserved.

SWALE #2

TRAPEZOIDAL CHANNEL ANALYSIS  
NORMAL DEPTH COMPUTATION

December 23, 2004

=====

DESCRIPTION	VALUE
Flow Rate (cfs).....	123.0 ← $Q_{100}$
Channel Bottom Slope (ft/ft).....	0.011 ← $S = 1.1\%$
Manning's Roughness Coefficient (n-value).....	0.033
Channel Left Side Slope (horizontal/vertical).....	4.0
Channel Right Side Slope (horizontal/vertical).....	4.0
Channel Bottom Width (ft).....	10.0

=====

DESCRIPTION	VALUE
Normal Depth (ft).....	1.53 ← $D_{100}$
Flow Velocity (fps).....	5.0 ← $V_{100}$
Froude Number.....	0.837
Velocity Head (ft).....	0.39
Energy Head (ft).....	1.92
Cross-Sectional Area of Flow (sq ft).....	24.61
Top Width of Flow (ft).....	22.22

=====

HYDROCALC Hydraulics for Windows, Version 1.2a Copyright (c) 1996  
Dodson & Associates, Inc., 5629 FM 1960 West, Suite 314, Houston, TX 77069  
Phone: (281) 440-3787, Fax: (281) 440-4742, Email: software@dodson-hydro.com  
All Rights Reserved.

PIPE CULVERT ANALYSIS  
COMPUTATION OF CULVERT PERFORMANCE CURVE

DP EX-B  
-EX 18" CMA CAPACITY

December 27, 2004

PROGRAM INPUT DATA

DESCRIPTION	VALUE
Culvert Diameter (ft).....	1.5 ← 18"
FHWA Chart Number.....	2
FHWA Scale Number (Type of Culvert Entrance).....	3
Manning's Roughness Coefficient (n-value).....	0.024 ← CMA
Entrance Loss Coefficient of Culvert Opening.....	0.8
Culvert Length (ft).....	40.0
Invert Elevation at Downstream end of Culvert (ft).....	100.0
Invert Elevation at Upstream end of Culvert (ft).....	100.4
Culvert Slope (ft/ft).....	0.01
Starting Flow Rate (cfs).....	1.0
Incremental Flow Rate (cfs).....	1.0
Ending Flow Rate (cfs).....	16.0
Starting Tailwater Depth (ft).....	0.1
Incremental Tailwater Depth (ft).....	0.1
Ending Tailwater Depth (ft).....	1.6

COMPUTATION RESULTS

Flow Rate (cfs)	Tailwater Depth (ft)	Headwater (ft) Inlet Control	Headwater (ft) Outlet Control	Normal Depth (ft)	Critical Depth (ft)	Depth at Outlet (ft)	Outlet Velocity (fps)
1.0	0.1	0.51	0.59	0.43	0.37	0.37	2.92
2.0	0.2	0.77	0.86	0.61	0.53	0.53	3.55
3.0	0.3	0.99	1.07	0.77	0.66	0.66	4.02
4.0	0.4	1.19	1.27	0.93	0.77	0.77	4.41
5.0	0.5	1.39	1.45	1.09	0.86	0.86	4.77
6.0	0.6	1.58	1.65	1.32	0.95	0.95	5.11
7.0	0.7	1.77	1.87	1.5	1.02	1.02	5.44
8.0	0.8	2.02	1.9	1.5	1.1	1.5	4.53
9.0	0.9	2.24	2.24	1.5	1.16	1.16	6.13
10.0	1.0	2.57	2.59	1.5	1.22	1.22	6.5
11.0	1.1	2.95	2.98	1.5	1.27	1.27	6.89
12.0	1.2	3.35	3.37	1.5	1.31	1.31	7.31
13.0	1.3	3.8	3.81	1.5	1.35	1.35	7.76
14.0	1.4	4.27	4.26	1.5	1.38	1.5	7.92
15.0	1.5	4.79	5.9	1.5	1.41	1.5	8.49
16.0	1.6	5.34	6.66	1.5	1.42	1.5	9.05

Q CAPACITY

HYDROCALC Hydraulics for Windows, Version 1.2a Copyright (c) 1996  
 Dodson & Associates, Inc., 5629 FM 1960 West, Suite 314, Houston, TX 77069  
 Phone: (281) 440-3787, Fax: (281) 440-4742, Email: software@dodson-hydro.com  
 All Rights Reserved.

- DESIGN POINT B AND EX-B

- EX 18" CMA ON HANDLE ROAD
- $Q_{100}$  (HISTORIC) = 101 CFS
- $Q_{100}$  (DEVELOPED) = 50 CFS
- MAXIMUM OVERTOPPING DEPTH = 6 INCHES

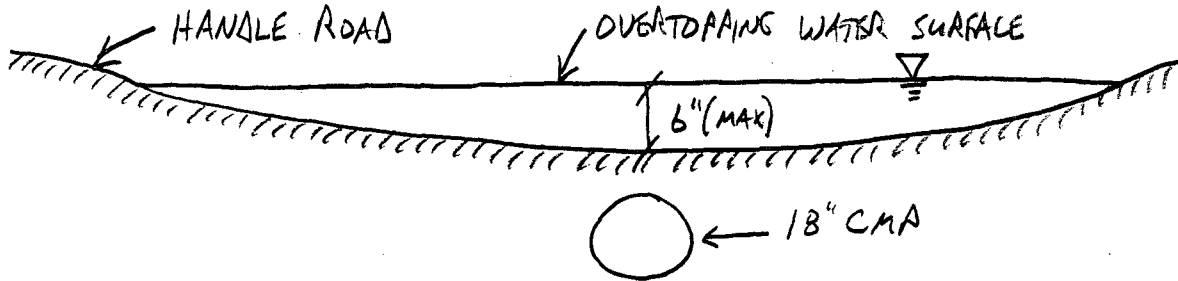

USE MANNING'S EQUATION TO FIND  $Q$  (MAX):

$$Q_{(MAX)} = \frac{1.49}{n} A R^{2/3} \sqrt{S} + \text{CULVERT CAPACITY}$$

OVERTOPPING FLOW

$$= \frac{1.49}{0.023} (62 \text{ FT}^2) \left( \frac{62 \text{ FT}^2}{248 \text{ FT}} \right)^{2/3} \sqrt{0.01} + 6 \text{ CFS}$$

$$= 159 \text{ CFS} + 6 \text{ CFS}$$

$$Q_{(MAX)} = 165 \text{ CFS} > 50 \text{ CFS } (Q_{100}) \therefore \text{EX CULVERT ADEQUATE}$$

22-141 50 SHEETS  
 22-142 100 SHEETS  
 22-144 200 SHEETS



PIPE CULVERT ANALYSIS  
COMPUTATION OF CULVERT PERFORMANCE CURVE

DP EX-C  
-EX 24" CMA CAPACITY

December 27, 2004

PROGRAM INPUT DATA

DESCRIPTION	VALUE
Culvert Diameter (ft).....	2.0 ← 24"
FHWA Chart Number.....	2
FHWA Scale Number (Type of Culvert Entrance).....	3
Manning's Roughness Coefficient (n-value).....	0.024 ← CMA
Entrance Loss Coefficient of Culvert Opening.....	0.8
Culvert Length (ft).....	40.0
Invert Elevation at Downstream end of Culvert (ft).....	100.0
Invert Elevation at Upstream end of Culvert (ft).....	100.4
Culvert Slope (ft/ft).....	0.01
Starting Flow Rate (cfs).....	1.0
Incremental Flow Rate (cfs).....	1.0
Ending Flow Rate (cfs).....	16.0
Starting Tailwater Depth (ft).....	0.1
Incremental Tailwater Depth (ft).....	0.1
Ending Tailwater Depth (ft).....	1.6

COMPUTATION RESULTS

Flow Rate (cfs)	Tailwater Depth (ft)	Headwater Inlet Control (ft)	Headwater Outlet Control (ft)	Normal Depth (ft)	Critical Depth (ft)	Depth at Outlet (ft)	Outlet Velocity (fps)
1.0	0.1	0.46	0.54	0.39	0.34	0.34	2.77
2.0	0.2	0.67	0.78	0.55	0.49	0.49	3.34
3.0	0.3	0.85	0.96	0.67	0.6	0.6	3.75
4.0	0.4	1.01	1.13	0.79	0.7	0.7	4.07
5.0	0.5	1.15	1.27	0.89	0.79	0.79	4.35
6.0	0.6	1.29	1.41	0.99	0.87	0.87	4.6
7.0	0.7	1.43	1.54	1.08	0.94	0.94	4.83
8.0	0.8	1.56	1.66	1.18	1.01	1.01	5.05
9.0	0.9	1.69	1.78	1.27	1.07	1.07	5.26
10.0	1.0	1.81	1.9	1.37	1.13	1.13	5.45
11.0	1.1	1.94	2.02	1.48	1.19	1.19	5.65
12.0	1.2	2.07	2.14	1.6	1.24	1.24	5.84
13.0	1.3	2.19	2.26	1.78	1.3	1.3	6.01
14.0	1.4	2.32	2.39	2.0	1.35	1.4	5.96
15.0	1.5	2.45	2.52	2.0	1.4	1.5	5.93
16.0	1.6	2.61	2.69	2.0	1.44	1.6	5.94

Q CAPACITY

HYDROCALC Hydraulics for Windows, Version 1.2a Copyright (c) 1996  
 Dodson & Associates, Inc., 5629 FM 1960 West, Suite 314, Houston, TX 77069  
 Phone: (281) 440-3787, Fax: (281) 440-4742, Email: software@dodson-hydro.com  
 All Rights Reserved.

- DESIGN POINT C AND EX-C

- EX 24" CMP ON HANDLE ROAD
- $Q_{100}$  (HISTORIC) = 66 CFS
- $Q_{100}$  (DEVELOPED) = 40 CFS
- MAXIMUM OVERTOPPING DEPTH = 6 INCHES

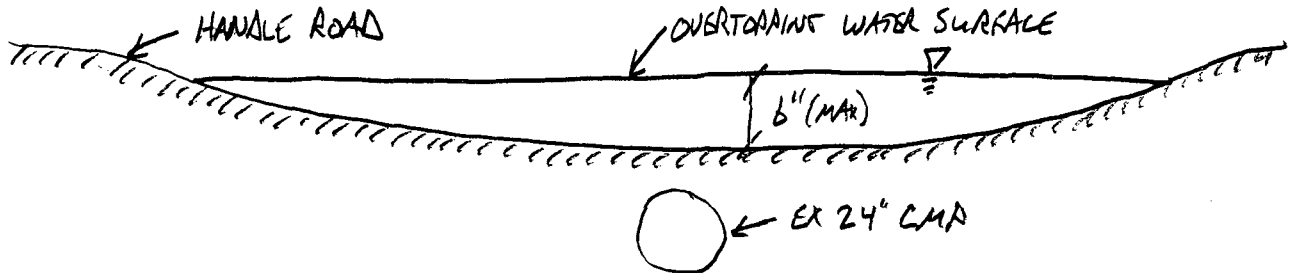

USE MANNING'S EQN TO FIND  $Q_{(max)}$ :

$$Q_{(max)} = \underbrace{\frac{1.49}{n} A R^{2/3} \sqrt{S}}_{\text{OVERTOPPING FLOW}} + \text{CULVERT CAPACITY}$$

$$= \frac{1.49}{0.023} (120 \text{ FT}^2) \left( \frac{120 \text{ FT}^2}{480 \text{ FT}} \right)^{2/3} \sqrt{0.01} + 15 \text{ CFS}$$

$$= 308 \text{ CFS} + 15 \text{ CFS}$$

$$= 323 \text{ CFS} > 40 \text{ CFS } (Q_{100}) \therefore \text{EX CULVERT IS ADEQUATE}$$

TABLE 10-4

MAXIMUM PERMISSIBLE VELOCITIES FOR EARTH CHANNELS WITH  
VARIED GRASS LININGS AND SLOPES

<u>Channel Slope</u>	<u>Lining</u>	<u>Permissible Mean Channel Velocity *</u> (ft/sec)
0 - 5%	Sodded grass	7
	Bermudagrass	6
	Reed canarygrass	5
	Tall fescue	5
	Kentucky bluegrass	5
	Grass-legume mixture	4
	Red fescue	2.5
	Redtop	2.5
	Sericea lespedeza	2.5
	Annual lespedeza	2.5
	Small grains (temporary)	2.5
5 - 10%	Sodded grass	6
	Bermudagrass	5
	Reed canarygrass	4
	Tall fescue	4
	Kentucky bluegrass	4
	Grass-legume mixture	3
Greater than 10%	Sodded grass	5
	Bermudagrass	4
	Reed canarygrass	3
	Tall fescue	3
	Kentucky bluegrass	3

---

\* For highly erodible soils, decrease permissible velocities by 25%.

\* Grass lined channels are dependent upon assurances of continuous growth and maintenance of grass.

TABLE 10-2 (Continued)

TYPICAL ROUGHNESS COEFFICIENTS FOR OPEN CHANNELS

<u>Type of Channel and Description</u>	<u>Minimum</u>	<u>Normal</u>	<u>Maximum</u>
c. Concrete bottom float finished with sides of			
1. Dressed stone in mortar	0.015	0.017	0.020
2. Random stone in mortar	0.017	0.020	0.024
3. Cement rubble masonry, plastered	0.016	0.020	0.024
4. Cement rubble masonry	0.020	0.025	0.030
5. Dry rubble or riprap	0.020	0.030	0.035
d. Gravel bottom with sides of			
1. Formed concrete	0.017	0.020	0.025
2. Random stone in mortar	0.020	0.023	0.026
3. Dry rubble or riprap	0.023	0.033	0.036
e. Asphalt			
1. Smooth		0.013	
2. Rough		0.016	
f. Grassed	0.030	0.040	0.050

TABLE 10-3

MAXIMUM PERMISSIBLE DESIGN  
OPEN CHANNEL FLOW VELOCITIES IN EARTH\*

<u>Soil Types</u>	<u>Permissible Mean Channel Velocity</u> (ft/sec)
Fine Sand (noncolloidal)	2.0
Coarse Sand (noncolloidal)	4.0
Sandy Loam (noncolloidal)	2.5
Silt Loam (noncolloidal)	3.0
Ordinary Firm Loam	3.5
Silty Clay	3.5
Fine Gravel	5.0
Stiff Clay (very colloidal)	5.0
Graded, Loam to Cobbles (noncolloidal)	5.0
Graded, Silt to Cobbles (colloidal)	5.5
Alluvial Silts (noncolloidal)	3.5
Alluvial Silts (colloidal)	5.0
Coarse Gravel (noncolloidal)	6.0
Cobbles and Shingles	5.5
Hard Shales and Hard Pans	6.0
Soft Shales	3.5
Soft Sandstone	8.0
Sound rock (usu. igneous or hard metamorphic)	20.0

\* These velocities shall be used in conjunction with scour calculations and as approved by City/County.

TABLE 6-4

**ALLOWABLE CULVERT OVERTOPPINGS\***

<u>Drainage Classification</u>	<u>Initial Drainage System Maximum Depth</u>	<u>Major Drainage System Maximum Depth</u>
Types A & B (Local/Residential and Collector)	Headwater Depth Ratio is Less Than Pipe Height	12 inches of depth at the gutter flow line
Types A & B (Local/Residential and collector without C+G)	Headwater Depth Ratio is Less Than Pipe Height	6 inches of depth at the street
Types C & D (Arterial, Highway or Freeway with or without Roadside Ditch)**	Headwater Depth Ratio is Less Than Pipe Height	No shoulder encroachment

\* A culvert is defined as any buried structure with both a clear opening less than 200 square feet, and span less than 20 feet and capacity less than 1500 cfs.

\*\*On state highways, CDOH criteria shall be utilized.

TABLE 6-5

**ALLOWABLE CULVERT HEADWATER DEPTHS FOR DESIGN FLOWS**

<u>Clear Opening (Ft<sup>2</sup>)</u>	<u>Hw/D</u>
200 or Greater	See allowable bridge clearance
200 to 50	<u>500 - Area</u>
	300
50 or Less	Greater than 1.5 If approved by City/County.

The Engineer shall consider various factors in determining permissible headwater depths such as backwater effects, possible flooding, embankment erosion, overtopping and public safety.

**6.4.2 Allowable Clearance for Bridges and Other Major Drainageway Crossings**

All structures classified as bridge shall not be overtopped. For clear span bridges, the minimum clearance between the bridge low chord and the water surface profile shall be a minimum of 2 feet for the 100-year design flow. For box culverts classified as bridges or culverts at major drainageways (100-year flows greater than 1500 cfs) adequate freeboard shall be provided for the passage of debris and should be no less than 2 feet.

**EXISTING CONDITIONS  
HYDROLOGIC CALCULATIONS  
INITIAL STORM  
(RATIONAL METHOD – 5 YEAR)  
(TR-20 – 10 YEAR)**



Basin EX-A



Design Point EX-A



Basin EX-D



Design Point EX-D

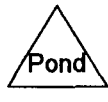
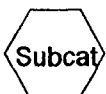

**Drainage Diagram for Rational-5YR Existing**  
Prepared by WestWorks Engineering 6/16/2005  
HydroCAD® 7.00 s/n 002053 © 1986-2003 Applied Microcomputer Systems

**Rational-5YR Existing**

El Paso County 5-Year Duration=33 min, Inten=2.29 in/hr

Prepared by WestWorks Engineering

Page 1

HydroCAD® 7.00 s/n 002053 © 1986-2003 Applied Microcomputer Systems

6/16/2005

**Subcatchment EX-A: Basin EX-A**

Runoff = 25.15 cfs @ 0.55 hrs, Volume= 1.141 af, Depth= 0.31"

Runoff by Rational method, Rise/Fall=1.0/1.0 xTc, Time Span= 0.00-3.00 hrs, dt= 0.01 hrs  
El Paso County 5-Year Duration=33 min, Inten=2.29 in/hr

Area (ac)	C	Description
43.500	0.25	Pasture/grassland/range, Good, HSG B

Tc (min)	Length (feet)	Slope (ft/ft)	Velocity (ft/sec)	Capacity (cfs)	Description
32.5					Direct Entry, Basin EX-A

**Subcatchment EX-A: Basin EX-A**

Hydrograph

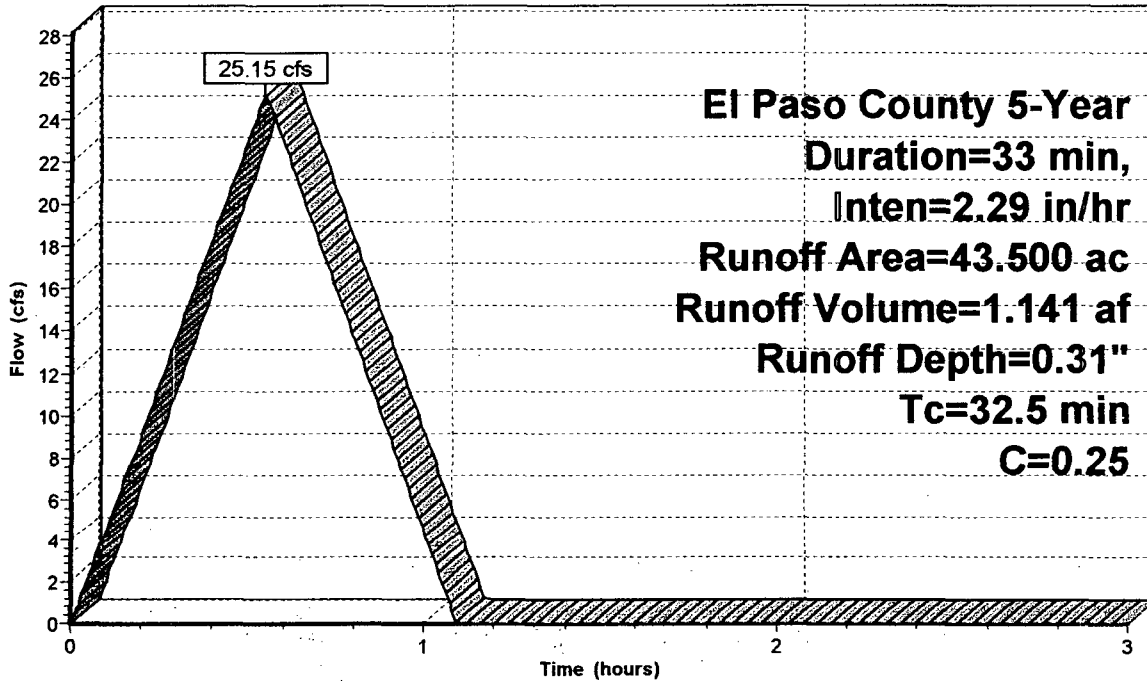

Runoff

Link DPexA: Design Point EX-A

Inflow Area = 43.500 ac, Inflow Depth = 0.31" for 5-Year event  
Inflow = 25.15 cfs @ 0.55 hrs, Volume= 1.141 af  
Primary = 25.15 cfs @ 0.55 hrs, Volume= 1.141 af, Atten= 0%, Lag= 0.0 min

Primary outflow = Inflow, Time Span= 0.00-3.00 hrs, dt= 0.01 hrs

Link DPexA: Design Point EX-A

Hydrograph

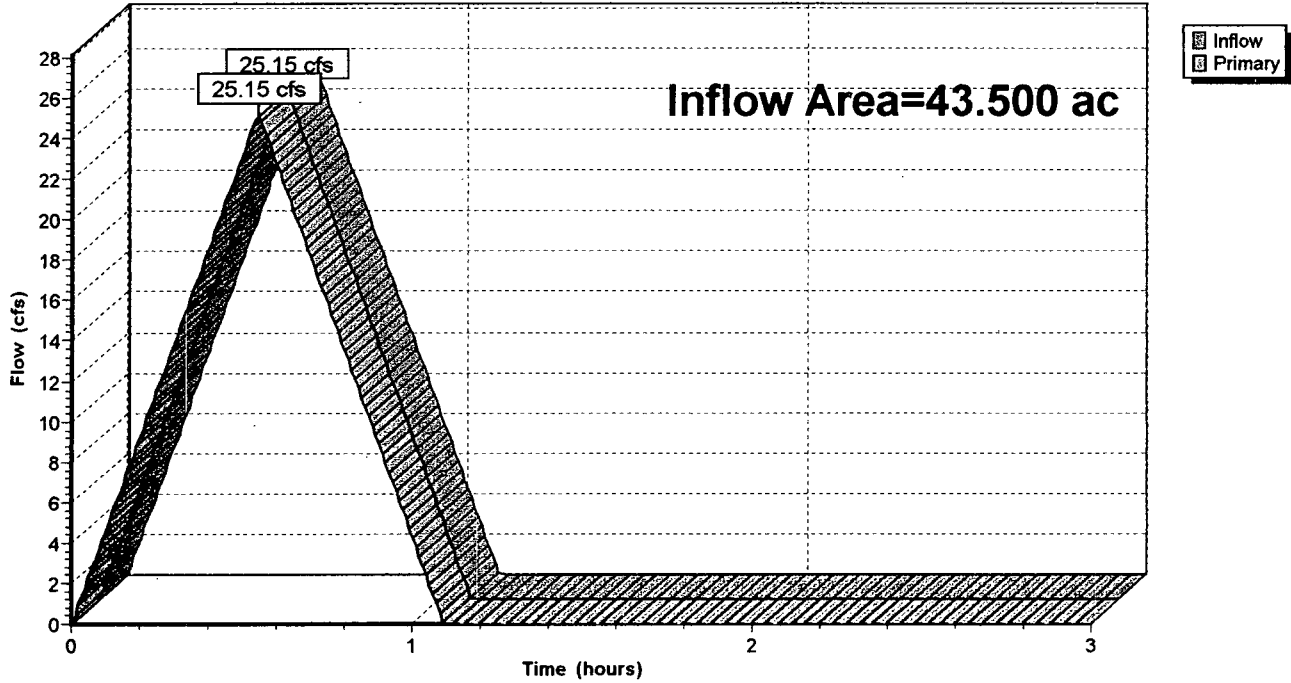

**Rational-5YR Existing**

El Paso County 5-Year Duration=34 min, Inten=2.25 in/hr

Prepared by WestWorks Engineering

Page 1

HydroCAD® 7.00 s/n 002053 © 1986-2003 Applied Microcomputer Systems

6/16/2005

**Subcatchment EX-D: Basin EX-D**

Runoff = 14.59 cfs @ 0.57 hrs, Volume= 0.687 af, Depth= 0.32"

Runoff by Rational method, Rise/Fall=1.0/1.0 xTc, Time Span= 0.00-3.00 hrs, dt= 0.01 hrs  
El Paso County 5-Year Duration=34 min, Inten=2.25 in/hr

Area (ac)	C	Description
26.000	0.25	Pasture/grassland/range, Good, HSG B

Tc (min)	Length (feet)	Slope (ft/ft)	Velocity (ft/sec)	Capacity (cfs)	Description
34.2					Direct Entry, Basin EX-D

**Subcatchment EX-D: Basin EX-D**

Hydrograph

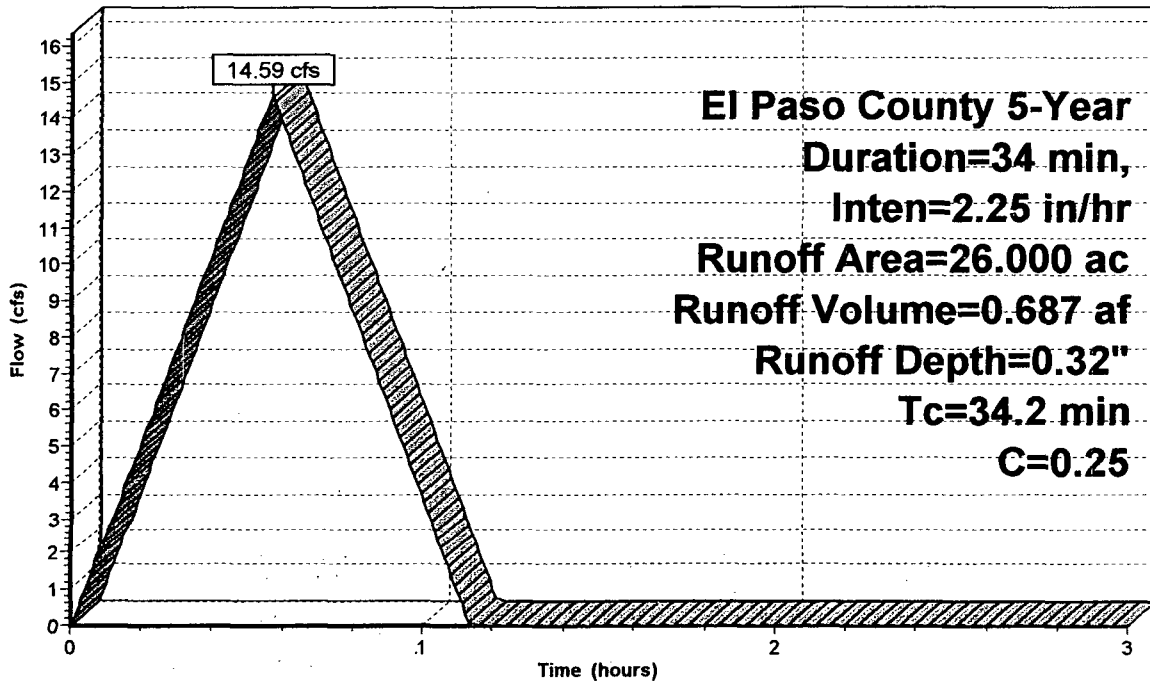

Link DPexD: Design Point EX-D

Inflow Area = 26.000 ac, Inflow Depth = 0.32" for 5-Year event  
Inflow = 14.59 cfs @ 0.57 hrs, Volume= 0.687 af  
Primary = 14.59 cfs @ 0.57 hrs, Volume= 0.687 af, Atten= 0%, Lag= 0.0 min

Primary outflow = Inflow, Time Span= 0.00-3.00 hrs, dt= 0.01 hrs

Link DPexD: Design Point EX-D

Hydrograph

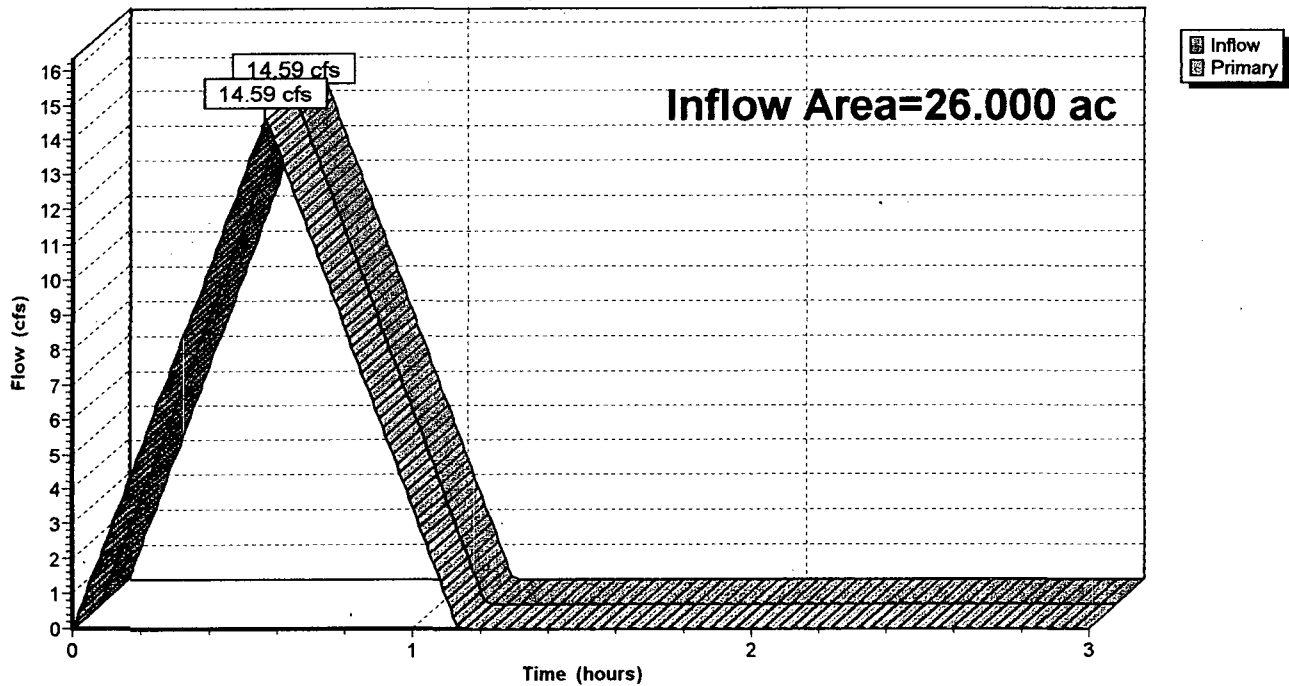

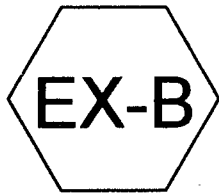

Basin EX-B & OS1



Design Point EX-B

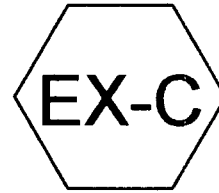

Basin EX-C



Design Point EX-C

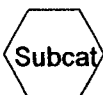

**TR20-10YR-24HR Existing**

Type IIA 24-hr Rainfall=3.00"

Prepared by WestWorks Engineering

Page 2

HydroCAD® 7.00 s/n 002053 © 1986-2003 Applied Microcomputer Systems

6/16/2005

Time span=0.00-20.00 hrs, dt=0.05 hrs, 401 points

Runoff by SCS TR-20 method, UH=SCS

Reach routing by Stor-Ind+Trans method - Pond routing by Stor-Ind method

**Subcatchment EX-B: Basin EX-B & OS1**

Runoff Area=246.600 ac Runoff Depth=0.33"  
Tc=69.6 min CN=61 Runoff=28.26 cfs 6.809 af

**Subcatchment EX-C: Basin EX-C**

Runoff Area=177.100 ac Runoff Depth=0.33"  
Tc=83.9 min CN=61 Runoff=17.61 cfs 4.855 af

**Link DPexB: Design Point EX-B**

Inflow=28.26 cfs 6.809 af  
Primary=28.26 cfs 6.809 af

**Link DPexC: Design Point EX-C**

Inflow=17.61 cfs 4.855 af  
Primary=17.61 cfs 4.855 af

**Total Runoff Area = 423.700 ac Runoff Volume = 11.664 af Average Runoff Depth = 0.33"**

**TR20-10YR-24HR Existing**

Type IIA 24-hr Rainfall=3.00"

Prepared by WestWorks Engineering

Page 3

HydroCAD® 7.00 s/n 002053 © 1986-2003 Applied Microcomputer Systems

6/16/2005

**Subcatchment EX-B: Basin EX-B & OS1**

Runoff = 28.26 cfs @ 6.90 hrs, Volume= 6.809 af, Depth= 0.33"

Runoff by SCS TR-20 method, UH=SCS, Time Span= 0.00-20.00 hrs, dt= 0.05 hrs  
Type IIA 24-hr Rainfall=3.00"

Area (ac)	CN	Description
224.300	61	Pasture/grassland/range, Good, HSG B
22.300	61	Basin OS1
246.600	61	Weighted Average

Tc (min)	Length (feet)	Slope (ft/ft)	Velocity (ft/sec)	Capacity (cfs)	Description
69.6					Direct Entry, Basin EX-B

**Subcatchment EX-C: Basin EX-C**

Runoff = 17.61 cfs @ 7.13 hrs, Volume= 4.855 af, Depth= 0.33"

Runoff by SCS TR-20 method, UH=SCS, Time Span= 0.00-20.00 hrs, dt= 0.05 hrs  
Type IIA 24-hr Rainfall=3.00"

Area (ac)	CN	Description
177.100	61	Pasture/grassland/range, Good, HSG B

Tc (min)	Length (feet)	Slope (ft/ft)	Velocity (ft/sec)	Capacity (cfs)	Description
83.9					Direct Entry, Basin EX-C

**Link DPexB: Design Point EX-B**

Inflow Area = 246.600 ac, Inflow Depth = 0.33"  
 Inflow = 28.26 cfs @ 6.90 hrs, Volume= 6.809 af  
 Primary = 28.26 cfs @ 6.90 hrs, Volume= 6.809 af, Atten= 0%, Lag= 0.0 min

Primary outflow = Inflow, Time Span= 0.00-20.00 hrs, dt= 0.05 hrs

**Link DPexC: Design Point EX-C**

Inflow Area = 177.100 ac, Inflow Depth = 0.33"  
 Inflow = 17.61 cfs @ 7.13 hrs, Volume= 4.855 af  
 Primary = 17.61 cfs @ 7.13 hrs, Volume= 4.855 af, Atten= 0%, Lag= 0.0 min

Primary outflow = Inflow, Time Span= 0.00-20.00 hrs, dt= 0.05 hrs

**EXISTING CONDITIONS  
HYDROLOGIC CALCULATIONS  
MAJOR STORM  
(RATIONAL METHOD – 100 YEAR)  
(TR-20 – 100 YEAR)**



Basin EX-A



Design Point EX-A



Basin EX-D



Design Point EX-D

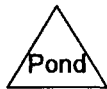

**Drainage Diagram for Rational-100YR Existing**  
Prepared by WestWorks Engineering 6/16/2005  
HydroCAD® 7.00 s/n 002053 © 1986-2003 Applied Microcomputer Systems

**Rational-100YR Existing**

*El Paso County 100-Year Duration=33 min, Inten=4.08 in/hr*

Prepared by WestWorks Engineering

HydroCAD® 7.00 s/n 002053 © 1986-2003 Applied Microcomputer Systems

**Subcatchment EX-A: Basin EX-A**

Runoff = 62.72 cfs @ 0.55 hrs, Volume= 2.847 af, Depth= 0.79"

Runoff by Rational method, Rise/Fall=1.0/1.0 xTc, Time Span= 0.00-3.00 hrs, dt= 0.01 hrs  
 El Paso County 100-Year Duration=33 min, Inten=4.08 in/hr

Area (ac)	C	Description
43.500	0.35	Pasture/grassland/range, Good, HSG B

Tc (min)	Length (feet)	Slope (ft/ft)	Velocity (ft/sec)	Capacity (cfs)	Description
32.5					Direct Entry, Basin EX-A

**Subcatchment EX-A: Basin EX-A**

Hydrograph

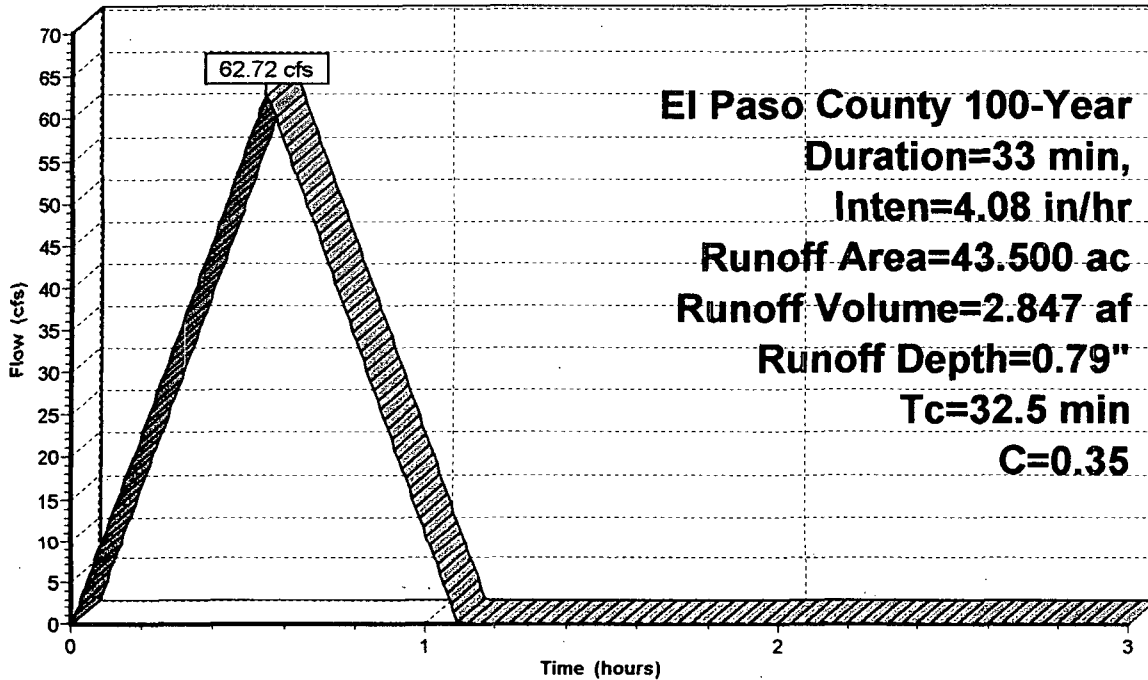

Runoff

Link DPexA: Design Point EX-A

Inflow Area = 43.500 ac, Inflow Depth = 0.79" for 100-Year event  
Inflow = 62.72 cfs @ 0.55 hrs, Volume= 2.847 af  
Primary = 62.72 cfs @ 0.55 hrs, Volume= 2.847 af, Atten= 0%, Lag= 0.0 min

Primary outflow = Inflow, Time Span= 0.00-3.00 hrs, dt= 0.01 hrs

Link DPexA: Design Point EX-A

Hydrograph

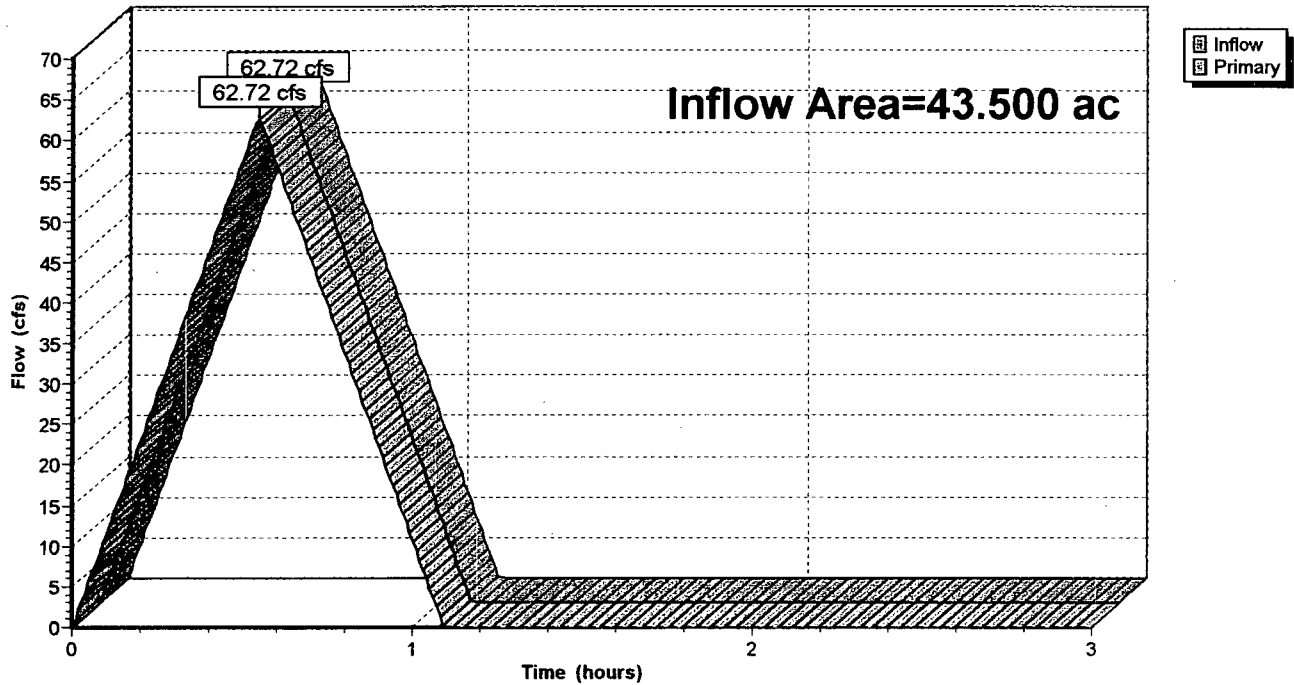

**Rational-100YR Existing**

El Paso County 100-Year Duration=34 min, Inten=4.01 in/hr

Prepared by WestWorks Engineering

Page 1

HydroCAD® 7.00 s/n 002053 © 1986-2003 Applied Microcomputer Systems

6/16/2005

**Subcatchment EX-D: Basin EX-D**

Runoff = 36.39 cfs @ 0.57 hrs, Volume= 1.713 af, Depth= 0.79"

Runoff by Rational method, Rise/Fall=1.0/1.0 xTc, Time Span= 0.00-3.00 hrs, dt= 0.01 hrs  
El Paso County 100-Year Duration=34 min, Inten=4.01 in/hr

Area (ac)	C	Description
26.000	0.35	Pasture/grassland/range, Good, HSG B

Tc (min)	Length (feet)	Slope (ft/ft)	Velocity (ft/sec)	Capacity (cfs)	Description
34.2					Direct Entry, Basin EX-D

**Subcatchment EX-D: Basin EX-D**

Hydrograph

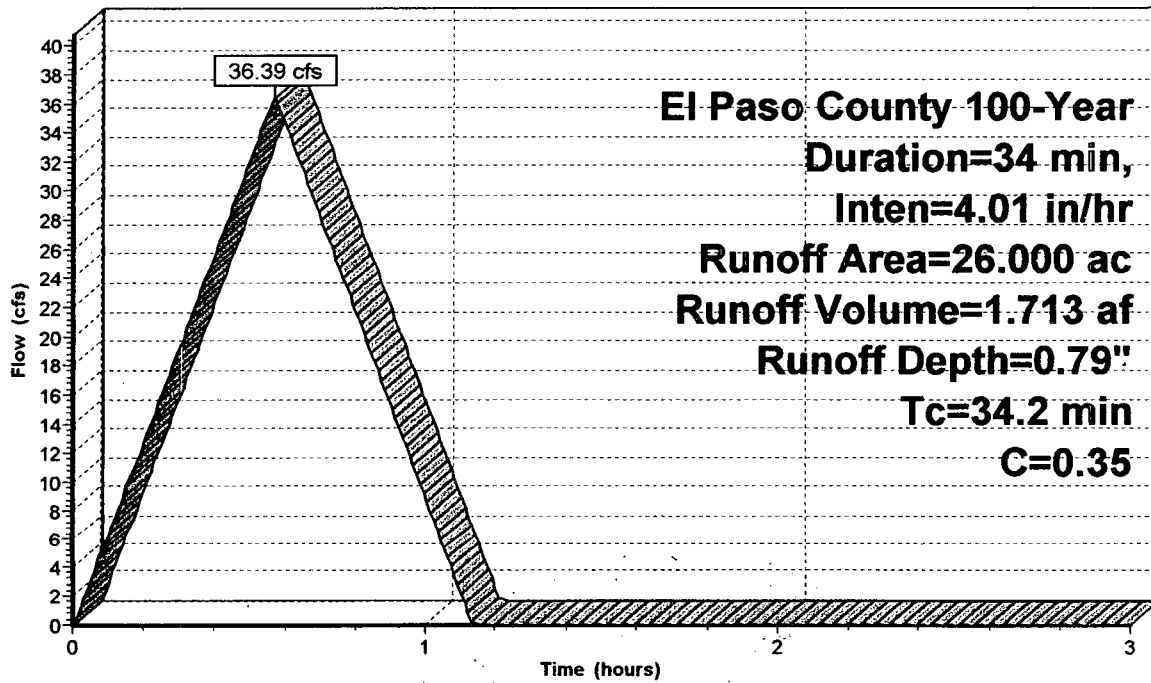

Link DPexD: Design Point EX-D

Inflow Area = 26.000 ac, Inflow Depth = 0.79" for 100-Year event  
Inflow = 36.39 cfs @ 0.57 hrs, Volume= 1.713 af  
Primary = 36.39 cfs @ 0.57 hrs, Volume= 1.713 af, Atten= 0%, Lag= 0.0 min

Primary outflow = Inflow, Time Span= 0.00-3.00 hrs, dt= 0.01 hrs

Link DPexD: Design Point EX-D

Hydrograph

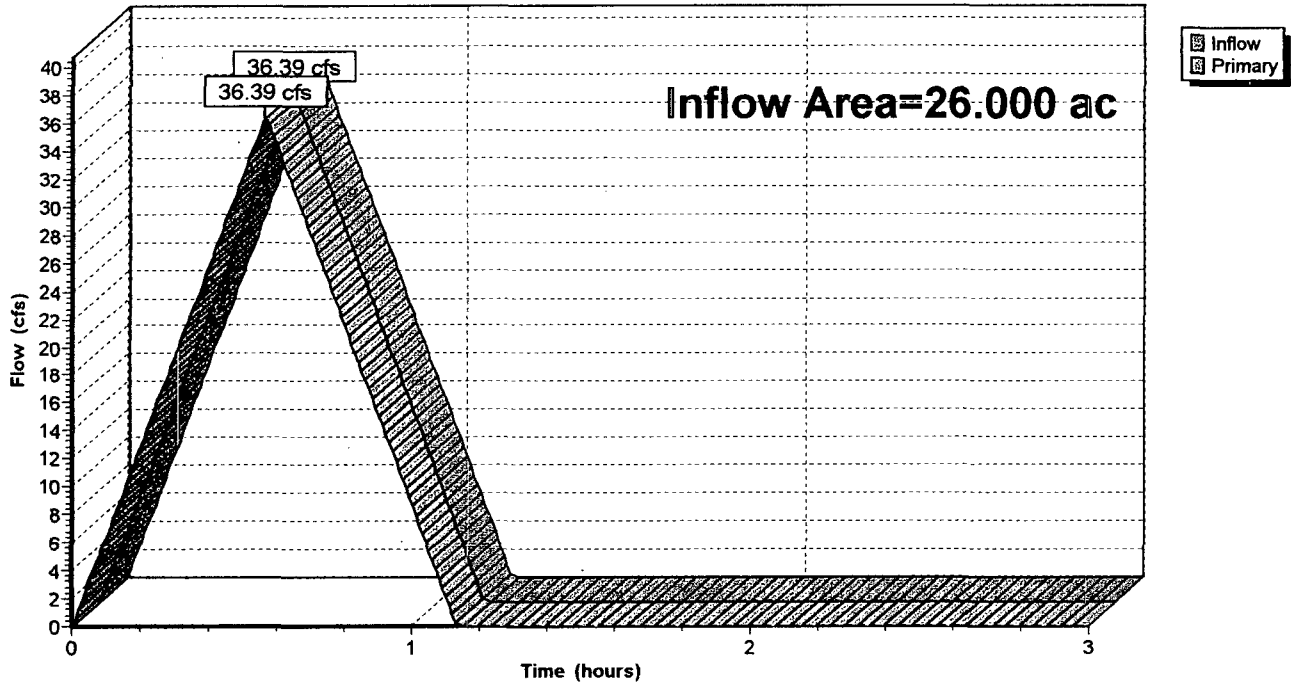

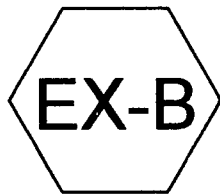

Basin EX-B & OS1



Design Point EX-B

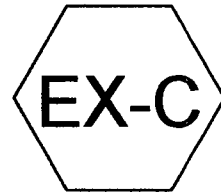

Basin EX-C



Design Point EX-C

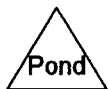
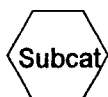

**TR20-100YR-24HR Existing**

Type IIA 24-hr Rainfall=4.40"

Prepared by WestWorks Engineering

Page 2

HydroCAD® 7.00 s/n 002053 © 1986-2003 Applied Microcomputer Systems

6/16/2005

Time span=0.00-20.00 hrs, dt=0.05 hrs, 401 points

Runoff by SCS TR-20 method, UH=SCS

Reach routing by Stor-Ind+Trans method - Pond routing by Stor-Ind method

**Subcatchment EX-B: Basin EX-B & OS1**

Runoff Area=246.600 ac Runoff Depth=0.95"  
Tc=69.6 min CN=61 Runoff=106.04 cfs 19.559 af

**Subcatchment EX-C: Basin EX-C**

Runoff Area=177.100 ac Runoff Depth=0.95"  
Tc=83.9 min CN=61 Runoff=65.58 cfs 13.970 af

**Link DPexB: Design Point EX-B**

Inflow=106.04 cfs 19.559 af  
Primary=106.04 cfs 19.559 af

**Link DPexC: Design Point EX-C**

Inflow=65.58 cfs 13.970 af  
Primary=65.58 cfs 13.970 af

**Total Runoff Area = 423.700 ac Runoff Volume = 33.530 af Average Runoff Depth = 0.95"**

**TR20-100YR-24HR Existing**

Type IIA 24-hr Rainfall=4.40"

Prepared by WestWorks Engineering

Page 3

HydroCAD® 7.00 s/n 002053 © 1986-2003 Applied Microcomputer Systems

6/16/2005

**Subcatchment EX-B: Basin EX-B & OS1**

Runoff = 106.04 cfs @ 6.81 hrs, Volume= 19.559 af, Depth= 0.95"

Runoff by SCS TR-20 method, UH=SCS, Time Span= 0.00-20.00 hrs, dt= 0.05 hrs  
Type IIA 24-hr Rainfall=4.40"

Area (ac)	CN	Description
224.300	61	Pasture/grassland/range, Good, HSG B
22.300	61	Basin OS1
246.600	61	Weighted Average

Tc (min)	Length (feet)	Slope (ft/ft)	Velocity (ft/sec)	Capacity (cfs)	Description
69.6					Direct Entry, Basin EX-B

**Subcatchment EX-C: Basin EX-C**

Runoff = 65.58 cfs @ 7.01 hrs, Volume= 13.970 af, Depth= 0.95"

Runoff by SCS TR-20 method, UH=SCS, Time Span= 0.00-20.00 hrs, dt= 0.05 hrs  
Type IIA 24-hr Rainfall=4.40"

Area (ac)	CN	Description
177.100	61	Pasture/grassland/range, Good, HSG B

Tc (min)	Length (feet)	Slope (ft/ft)	Velocity (ft/sec)	Capacity (cfs)	Description
83.9					Direct Entry, Basin EX-C

**Link DPexB: Design Point EX-B**

Inflow Area = 246.600 ac, Inflow Depth = 0.95"  
 Inflow = 106.04 cfs @ 6.81 hrs, Volume= 19.559 af  
 Primary = 106.04 cfs @ 6.81 hrs, Volume= 19.559 af, Atten= 0%, Lag= 0.0 min

Primary outflow = Inflow, Time Span= 0.00-20.00 hrs, dt= 0.05 hrs

**Link DPexC: Design Point EX-C**

Inflow Area = 177.100 ac, Inflow Depth = 0.95"  
 Inflow = 65.58 cfs @ 7.01 hrs, Volume= 13.970 af  
 Primary = 65.58 cfs @ 7.01 hrs, Volume= 13.970 af, Atten= 0%, Lag= 0.0 min

Primary outflow = Inflow, Time Span= 0.00-20.00 hrs, dt= 0.05 hrs

**DEVELOPED CONDITIONS  
HYDROLOGIC CALCULATIONS  
MINOR STORM  
(RATIONAL METHOD – 5 YEAR)  
(TR-20 – 10 YEAR)**

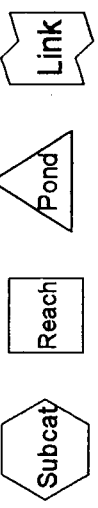
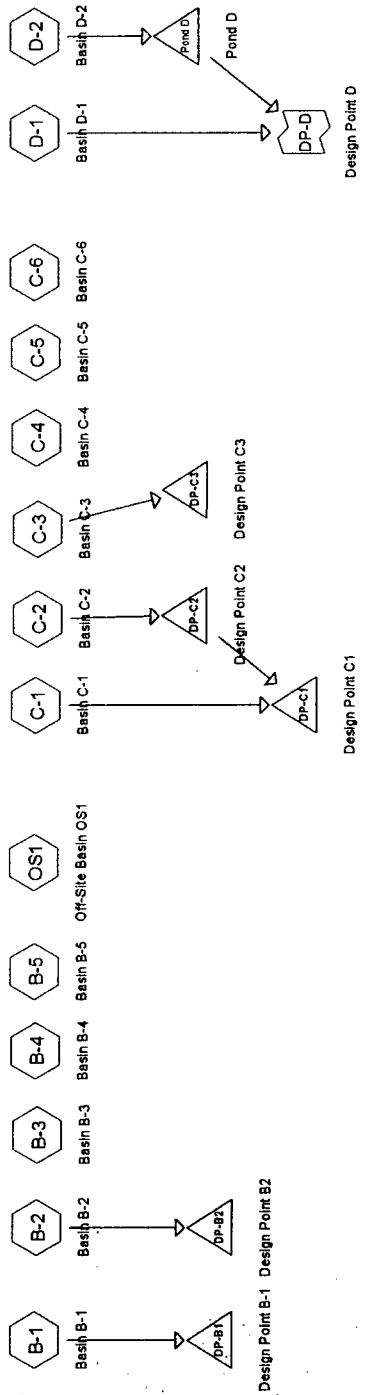
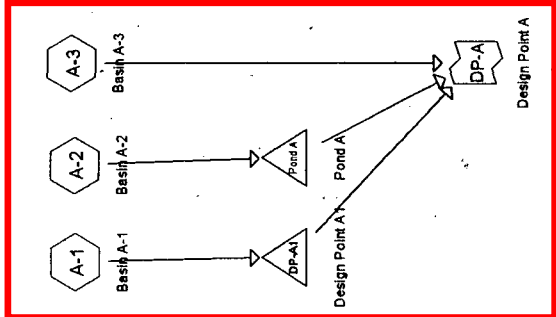

**Drainage Diagram for Rational-5YR Developed**  
 Prepared by WestWorks Engineering 6/16/2005  
 HydroCAD® 7.00 s/n 002053 © 1986-2003 Applied Microcomputer Systems

**Rational-5YR Developed**

El Paso County 5-Year Duration=24 min, Inten=2.74 in/hr

Prepared by WestWorks Engineering

Page 1

HydroCAD® 7.00 s/n 002053 © 1986-2003 Applied Microcomputer Systems

6/16/2005

**Subcatchment A-1: Basin A-1**

Runoff = 21.55 cfs @ 0.40 hrs, Volume= 0.712 af, Depth= 0.33"

Runoff by Rational method, Rise/Fall=1.0/1.0 xTc, Time Span= 0.00-3.00 hrs, dt= 0.01 hrs  
El Paso County 5-Year Duration=24 min, Inten=2.74 in/hr

Area (ac)	C	Description
26.000	0.30	5 acre lots, 12% imp, HSG B

Tc (min)	Length (feet)	Slope (ft/ft)	Velocity (ft/sec)	Capacity (cfs)	Description
23.8					Direct Entry, Basin A-1

**Subcatchment A-1: Basin A-1**

Hydrograph

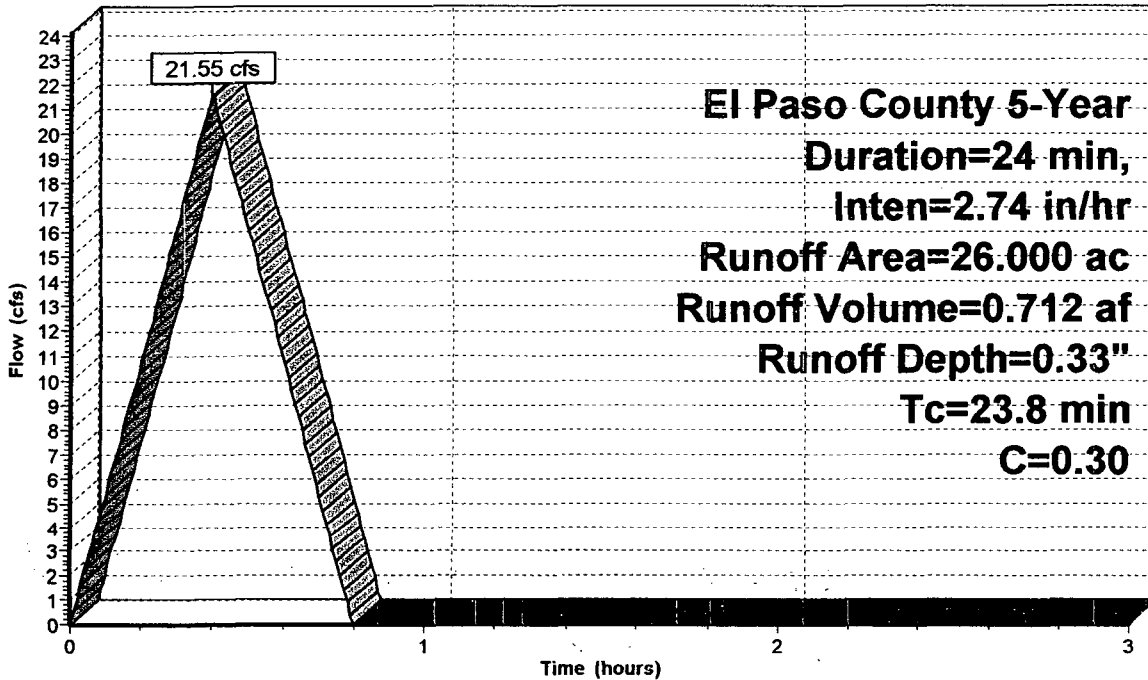

**Rational-5YR Developed**

El Paso County 5-Year Duration=24 min, Inten=2.74 in/hr

Prepared by WestWorks Engineering

Page 1

HydroCAD® 7.00 s/n 002053 © 1986-2003 Applied Microcomputer Systems

6/16/2005

**Pond DP-A1: Design Point A1**

Inflow Area = 26.000 ac, Inflow Depth = 0.33" for 5-Year event  
 Inflow = 21.55 cfs @ 0.40 hrs, Volume= 0.712 af  
 Outflow = 1.25 cfs @ 0.77 hrs, Volume= 0.209 af, Atten= 94%, Lag= 22.5 min  
 Primary = 1.25 cfs @ 0.77 hrs, Volume= 0.209 af

Routing by Stor-Ind method, Time Span= 0.00-3.00 hrs, dt= 0.01 hrs  
 Peak Elev= 6,220.67' @ 0.77 hrs Surf.Area= 0.700 ac Storage= 0.678 af  
 Plug-Flow detention time= 83.4 min calculated for 0.209 af (29% of inflow)  
 Center-of-Mass det. time= 71.7 min ( 95.6 - 23.9 )

#	Invert	Avail.Storage	Storage Description
1	6,220.00'	2.033 af	<b>Custom Stage Data (Prismatic)</b> Listed below

Elevation (feet)	Surf.Area (acres)	Inc.Store (acre-feet)	Cum.Store (acre-feet)
6,220.00	0.067	0.000	0.000
6,222.00	1.966	2.033	2.033

#	Routing	Invert	Outlet Devices
1	Primary	6,219.70'	<b>2.0" Vert. Orifice/Grate X 2.00</b> C= 0.600
2	Primary	6,220.10'	<b>14.2" x 50.0' long Culvert</b> CMP, projecting, no headwall, Ke= 0.900 Outlet Invert= 6,219.00' S= 0.0220 ' /' n= 0.024 Cc= 0.900

**Primary OutFlow** Max=1.25 cfs @ 0.77 hrs HW=6,220.67' (Free Discharge)

1=Orifice/Grate (Orifice Controls 0.20 cfs @ 4.5 fps)  
 2=Culvert (Inlet Controls 1.05 cfs @ 2.0 fps)

**Pond DP-A1: Design Point A1**

Hydrograph

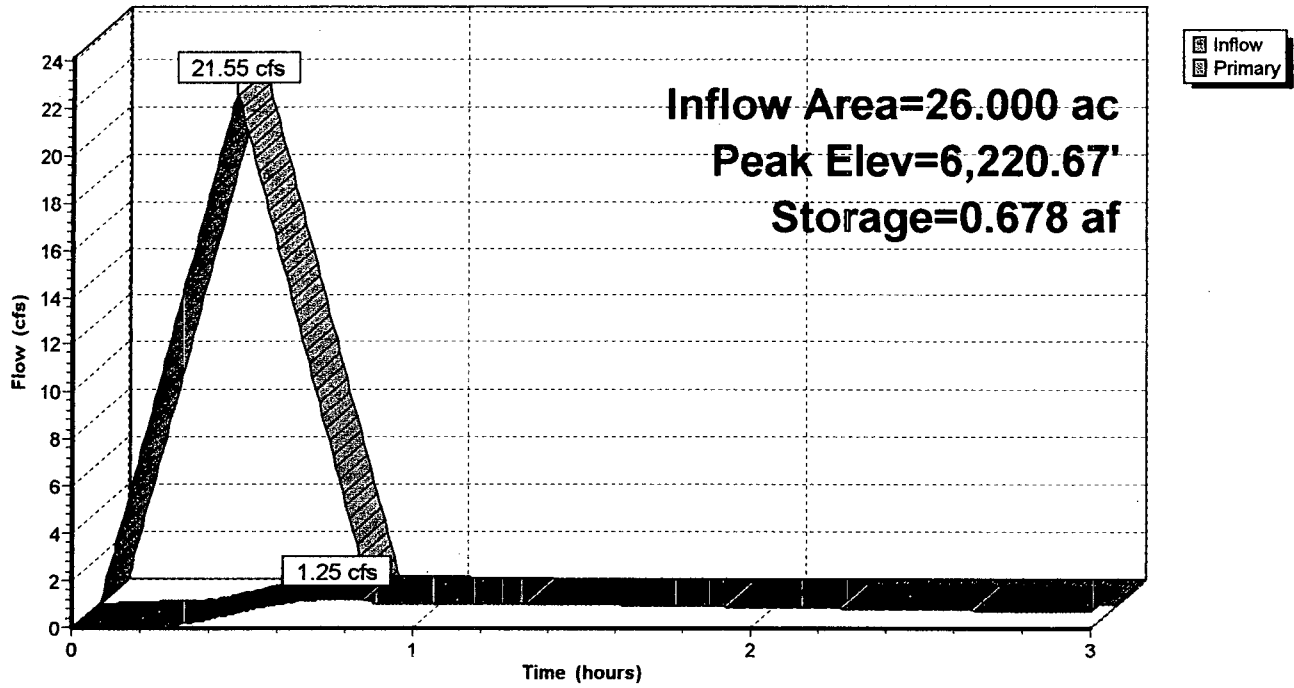

**Rational-5YR Developed**

El Paso County 5-Year Duration=23 min, Inten=2.80 in/hr

Prepared by WestWorks Engineering

HydroCAD® 7.00 s/n 002053 © 1986-2003 Applied Microcomputer Systems

**Subcatchment A-2: Basin A-2**

Runoff = 12.99 cfs @ 0.38 hrs, Volume= 0.413 af, Depth= 0.32"

Runoff by Rational method, Rise/Fall=1.0/1.0 xTc, Time Span= 0.00-3.00 hrs, dt= 0.01 hrs  
El Paso County 5-Year Duration=23 min, Inten=2.80 in/hr

Area (ac)	C	Description
15.400	0.30	2 acre lots, 12% imp, HSG B

Tc (min)	Length (feet)	Slope (ft/ft)	Velocity (ft/sec)	Capacity (cfs)	Description
22.9					Direct Entry, Basin A-2

**Subcatchment A-2: Basin A-2**

Hydrograph

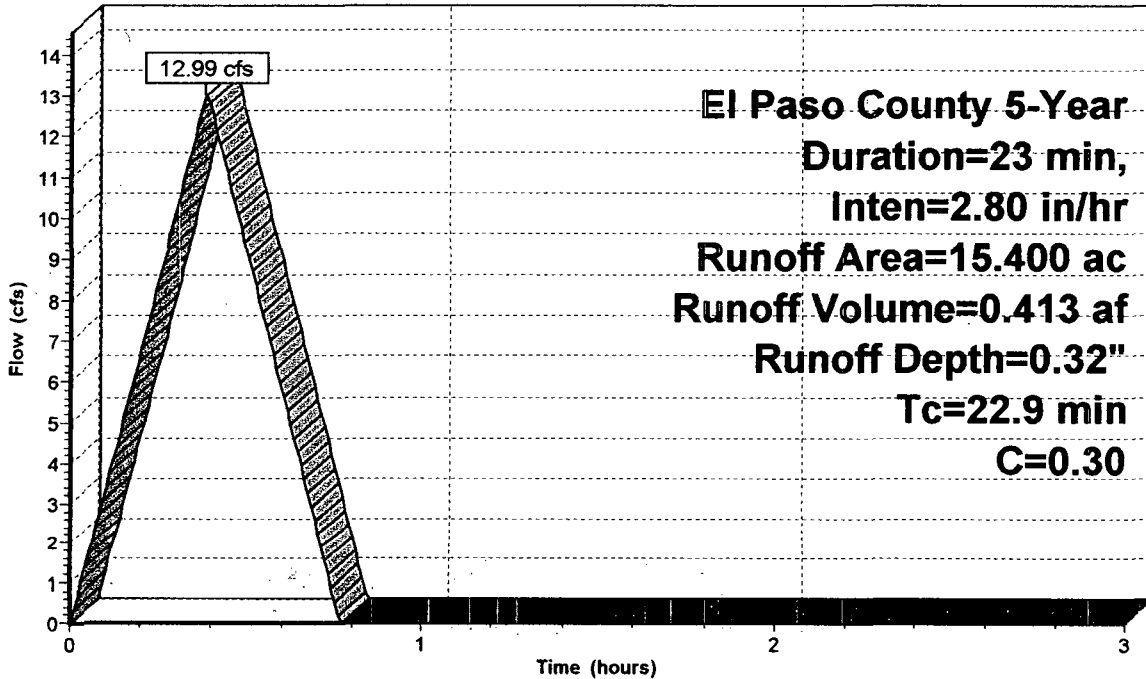

**Rational-5YR Developed**

*El Paso County 5-Year Duration=23 min, Inten=2.80 in/hr*

Prepared by WestWorks Engineering

Page 1

HydroCAD® 7.00 s/n 002053 © 1986-2003 Applied Microcomputer Systems

6/16/2005

**Pond Pond A: Pond A**

Inflow Area = 15.400 ac, Inflow Depth = 0.32" for 5-Year event  
 Inflow = 12.99 cfs @ 0.38 hrs, Volume= 0.413 af  
 Outflow = 0.10 cfs @ 0.76 hrs, Volume= 0.019 af, Atten= 99%, Lag= 23.0 min  
 Primary = 0.10 cfs @ 0.76 hrs, Volume= 0.019 af

Routing by Stor-Ind method, Time Span= 0.00-3.00 hrs, dt= 0.01 hrs  
 Peak Elev= 6,218.49' @ 0.76 hrs Surf.Area= 0.444 ac Storage= 0.411 af  
 Plug-Flow detention time= 99.0 min calculated for 0.019 af (5% of inflow)  
 Center-of-Mass det. time= 80.8 min ( 103.8 - 23.0 )

#	Invert	Avail.Storage	Storage Description
1	6,218.00'	1.678 af	<b>Custom Stage Data (Prismatic)</b> Listed below

Elevation (feet)	Surf.Area (acres)	Inc.Store (acre-feet)	Cum.Store (acre-feet)
6,218.00	0.064	0.000	0.000
6,220.00	1.614	1.678	1.678

#	Routing	Invert	Outlet Devices
1	Primary	6,218.20'	<b>2.0" Vert. Orifice/Grate X 2.00</b> C= 0.600
2	Primary	6,218.50'	<b>15.1" x 20.0' long Culvert</b> CMP, projecting, no headwall, Ke= 0.900 Outlet Invert= 6,217.80' S= 0.0350 '/' n= 0.022 Cc= 0.900

**Primary OutFlow** Max=0.10 cfs @ 0.76 hrs HW=6,218.49' (Free Discharge)

1=Orifice/Grate (Orifice Controls 0.10 cfs @ 2.2 fps)

2=Culvert ( Controls 0.00 cfs)

**Pond Pond A: Pond A**

Hydrograph

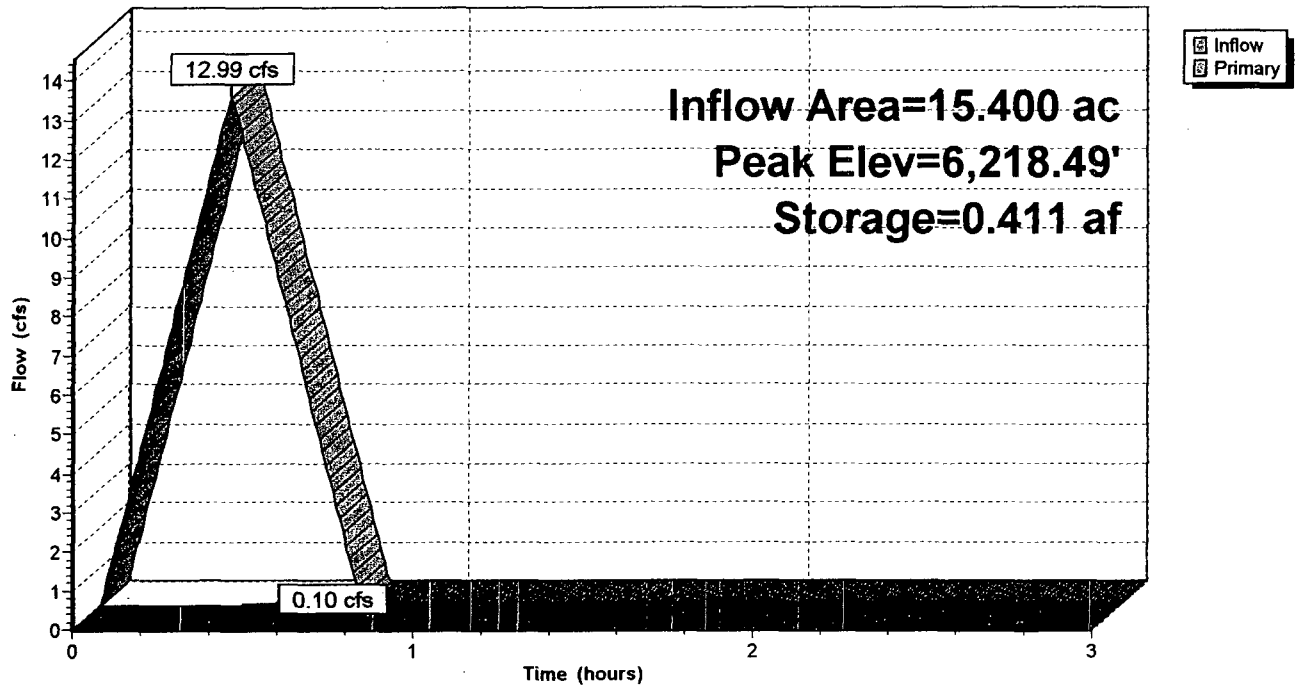

Subcatchment A-3: Basin A-3

Runoff = 1.75 cfs @ 0.38 hrs, Volume= 0.056 af, Depth= 0.32"

Runoff by Rational method, Rise/Fall=1.0/1.0 xTc, Time Span= 0.00-3.00 hrs, dt= 0.01 hrs  
El Paso County 5-Year Duration=23 min, Inten=2.80 in/hr

Area (ac)	C	Description
2.100	0.30	5 acre lots, 12% imp, HSG B

Tc (min)	Length (feet)	Slope (ft/ft)	Velocity (ft/sec)	Capacity (cfs)	Description
23.2					Direct Entry, Basin A-3

Subcatchment A-3: Basin A-3

Hydrograph

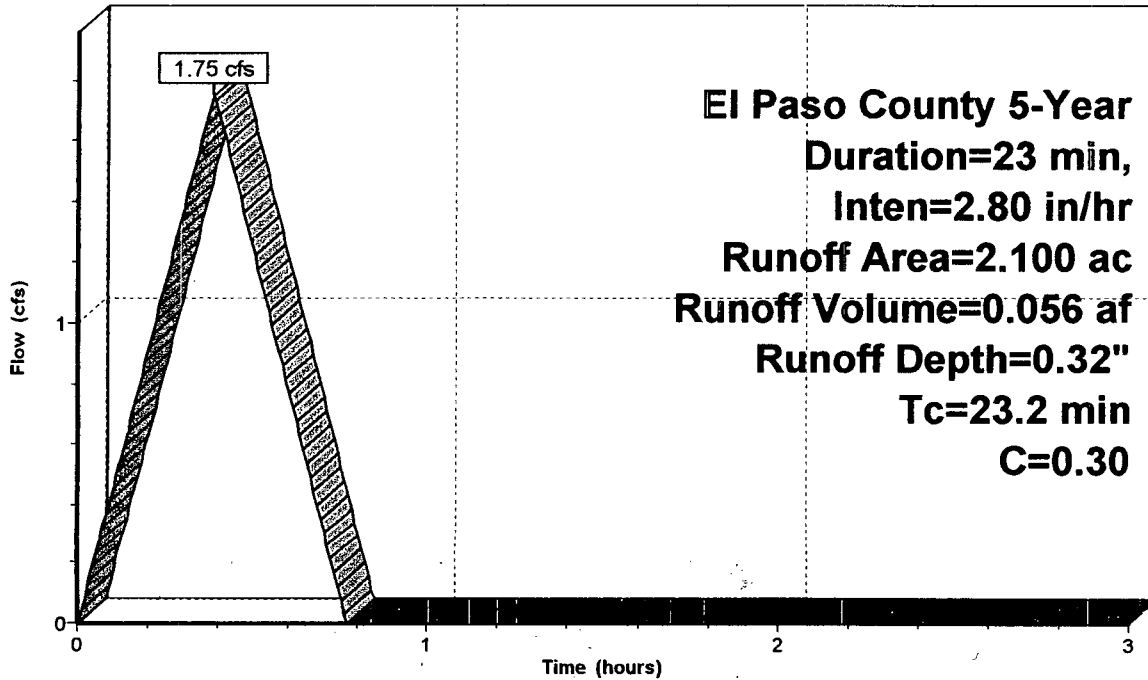

Link DP-A: Design Point A

Inflow Area = 43.500 ac, Inflow Depth = 0.08" for 5-Year event  
Inflow = 2.14 cfs @ 0.40 hrs, Volume= 0.286 af  
Primary = 2.14 cfs @ 0.40 hrs, Volume= 0.286 af, Atten= 0%, Lag= 0.0 min

Primary outflow = Inflow, Time Span= 0.00-3.00 hrs, dt= 0.01 hrs

Link DP-A: Design Point A

Hydrograph

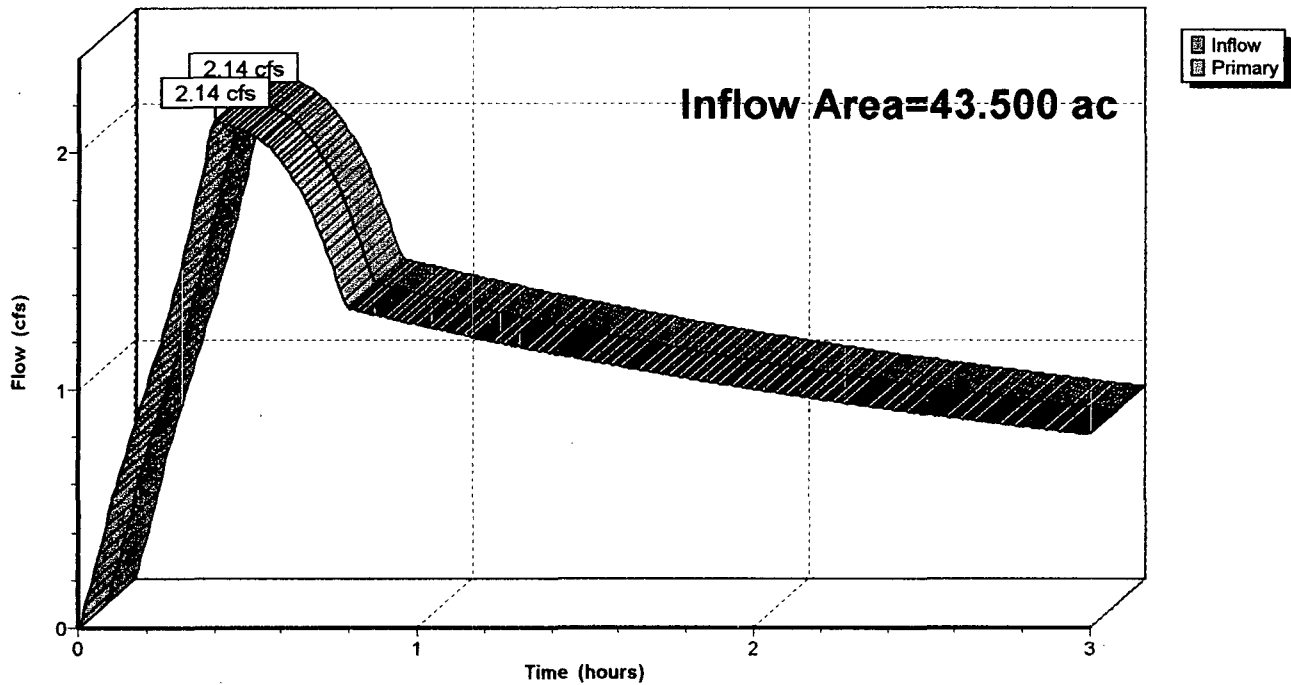

**Rational-5YR Developed**

*El Paso County 5-Year Duration=34 min, Inten=2.25 in/hr*

Prepared by WestWorks Engineering

Page 1

HydroCAD® 7.00 s/n 002053 © 1986-2003 Applied Microcomputer Systems

6/16/2005

**Subcatchment B-1: Basin B-1**

Runoff = 16.26 cfs @ 0.57 hrs, Volume= 0.765 af, Depth= 0.38"

Runoff by Rational method, Rise/Fall=1.0/1.0 xTc, Time Span= 0.00-3.00 hrs, dt= 0.01 hrs  
El Paso County 5-Year Duration=34 min, Inten=2.25 in/hr

Area (ac)	C	Description
24.000	0.30	2 acre lots, 12% imp, HSG B

Tc (min)	Length (feet)	Slope (ft/ft)	Velocity (ft/sec)	Capacity (cfs)	Description
33.9					Direct Entry, Basin B-1

**Subcatchment B-1: Basin B-1**

Hydrograph

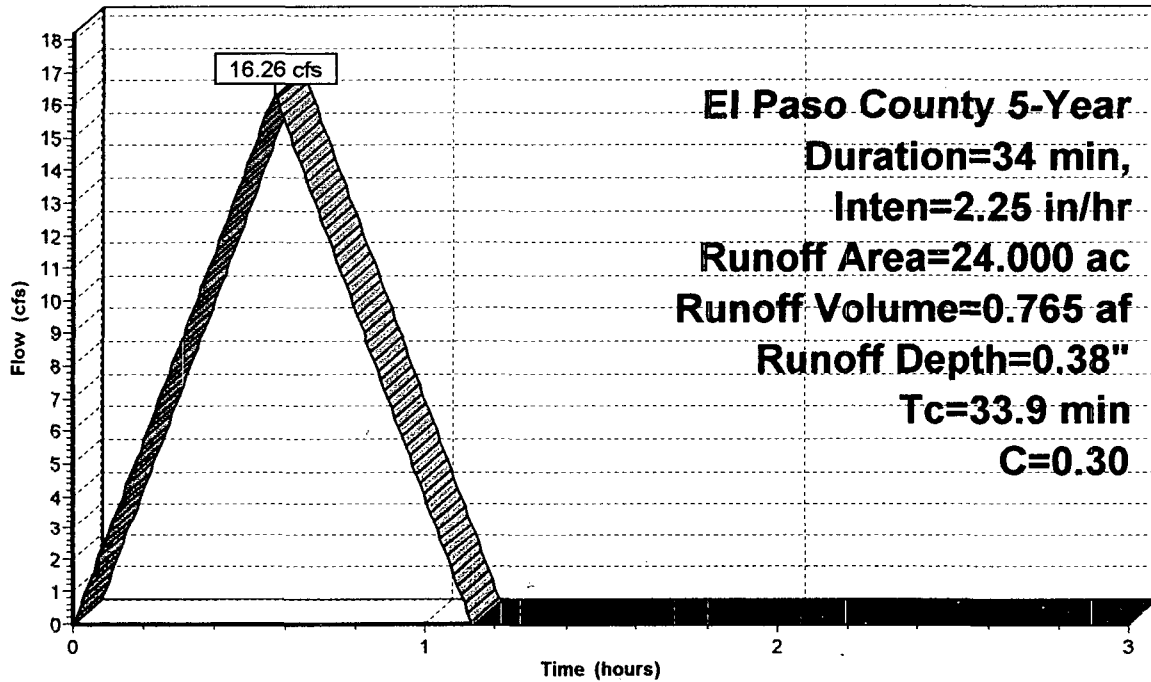

**Pond DP-B1: Design Point B-1**

Inflow Area = 24.000 ac, Inflow Depth = 0.38" for 5-Year event  
 Inflow = 16.26 cfs @ 0.57 hrs, Volume= 0.765 af  
 Outflow = 7.42 cfs @ 0.87 hrs, Volume= 0.734 af, Atten= 54%, Lag= 18.5 min  
 Primary = 7.42 cfs @ 0.87 hrs, Volume= 0.734 af

Routing by Stor-Ind method, Time Span= 0.00-3.00 hrs, dt= 0.01 hrs  
 Peak Elev= 6,245.01' @ 0.87 hrs Surf.Area= 0.401 ac Storage= 0.442 af  
 Plug-Flow detention time= 40.2 min calculated for 0.731 af (96% of inflow)  
 Center-of-Mass det. time= 39.3 min ( 73.3 - 34.0 )

#	Invert	Avail.Storage	Storage Description
1	6,243.00'	2.049 af	<b>Custom Stage Data (Prismatic)</b> Listed below

Elevation (feet)	Surf.Area (acres)	Inc.Store (acre-feet)	Cum.Store (acre-feet)
6,243.00	0.005	0.000	0.000
6,244.00	0.077	0.041	0.041
6,246.00	0.721	0.798	0.839
6,247.00	1.700	1.210	2.049

#	Routing	Invert	Outlet Devices
1	Primary	6,243.50'	<b>24.0" x 50.0' long Culvert</b> CMP, end-section conforming to fill, Ke= 0.500 Outlet Invert= 6,243.00' S= 0.0100 '/ n= 0.024 Cc= 0.900

**Primary OutFlow** Max=7.42 cfs @ 0.87 hrs HW=6,245.01' (Free Discharge)  
 ↑1=Culvert (Barrel Controls 7.42 cfs @ 4.1 fps)

**Pond DP-B1: Design Point B-1**

Hydrograph

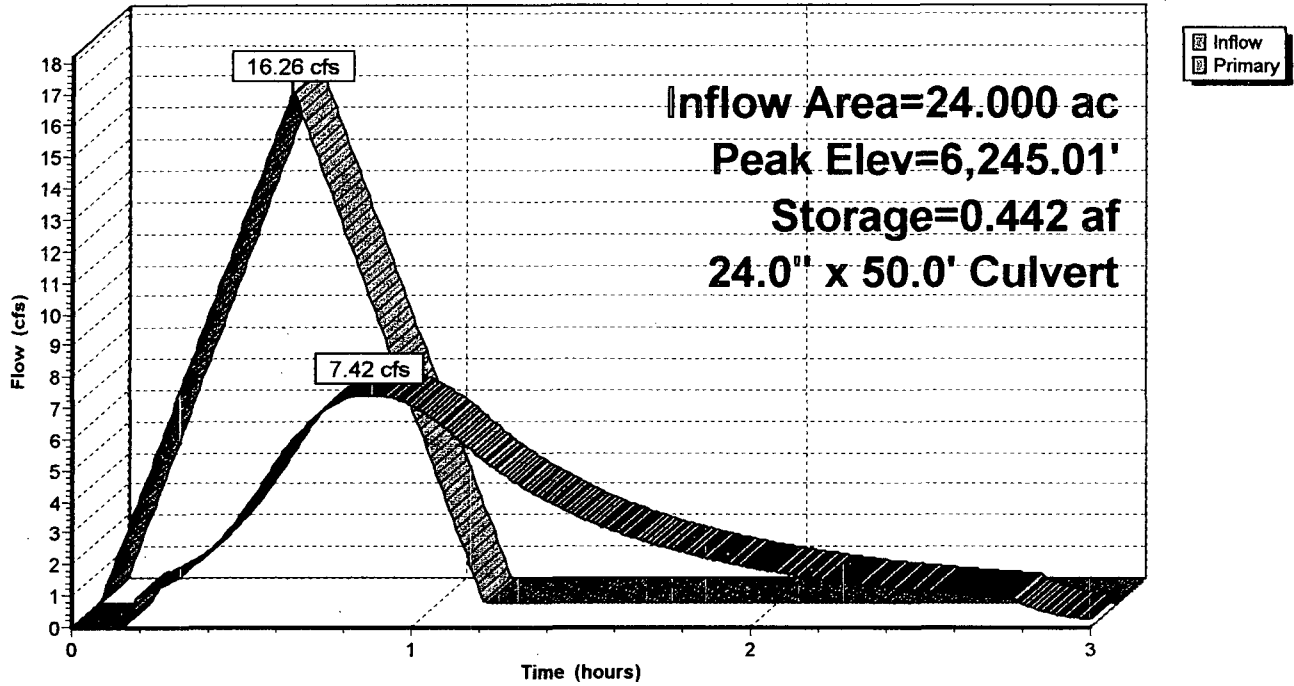

**Rational-5YR Developed**

El Paso County 5-Year Duration=27 min, Inten=2.57 in/hr

Prepared by WestWorks Engineering

Page 1

HydroCAD® 7.00 s/n 002053 © 1986-2003 Applied Microcomputer Systems

6/16/2005

**Subcatchment B-2: Basin B-2**

Runoff = 4.94 cfs @ 0.45 hrs, Volume= 0.184 af, Depth= 0.34"

Runoff by Rational method, Rise/Fall=1.0/1.0 xTc, Time Span= 0.00-3.00 hrs, dt= 0.01 hrs  
El Paso County 5-Year Duration=27 min, Inten=2.57 in/hr

Area (ac)	C	Description
6.400	0.30	2 acre lots, 12% imp, HSG B

Tc (min)	Length (feet)	Slope (ft/ft)	Velocity (ft/sec)	Capacity (cfs)	Description
27.2					Direct Entry, Basin B-2

**Subcatchment B-2: Basin B-2**

Hydrograph

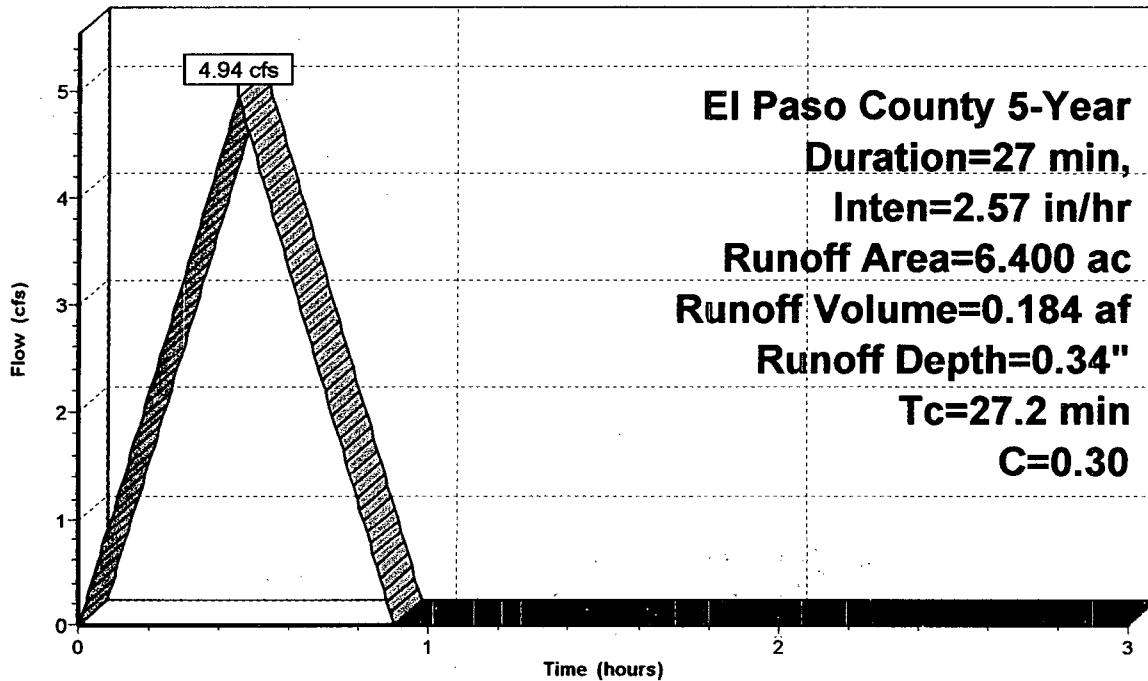

**Pond DP-B2: Design Point B2**

Inflow Area = 6.400 ac, Inflow Depth = 0.34" for 5-Year event  
 Inflow = 4.94 cfs @ 0.45 hrs, Volume= 0.184 af  
 Outflow = 1.37 cfs @ 0.78 hrs, Volume= 0.131 af, Atten= 72%, Lag= 19.5 min  
 Primary = 1.37 cfs @ 0.78 hrs, Volume= 0.131 af

Routing by Stor-Ind method, Time Span= 0.00-3.00 hrs, dt= 0.01 hrs  
 Peak Elev= 6,244.64' @ 0.78 hrs Surf.Area= 0.151 ac Storage= 0.144 af  
 Plug-Flow detention time= 55.3 min calculated for 0.131 af (71% of inflow)  
 Center-of-Mass det. time= 50.2 min ( 77.2 - 27.0 )

#	Invert	Avail.Storage	Storage Description
1	6,244.00'	0.446 af	Custom Stage Data (Prismatic) Listed below

Elevation (feet)	Surf.Area (acres)	Inc.Store (acre-feet)	Cum.Store (acre-feet)
6,244.00	0.019	0.000	0.000
6,246.00	0.427	0.446	0.446

#	Routing	Invert	Outlet Devices
1	Primary	6,244.00'	18.0" x 50.0' long Culvert CMP, end-section conforming to fill, Ke= 0.500 Outlet Invert= 6,243.50' S= 0.0100' /' n= 0.022 Cc= 0.900

Primary OutFlow Max=1.37 cfs @ 0.78 hrs HW=6,244.64' (Free Discharge)  
 1=Culvert (Barrel Controls 1.37 cfs @ 2.8 fps)

**Pond DP-B2: Design Point B2**

Hydrograph

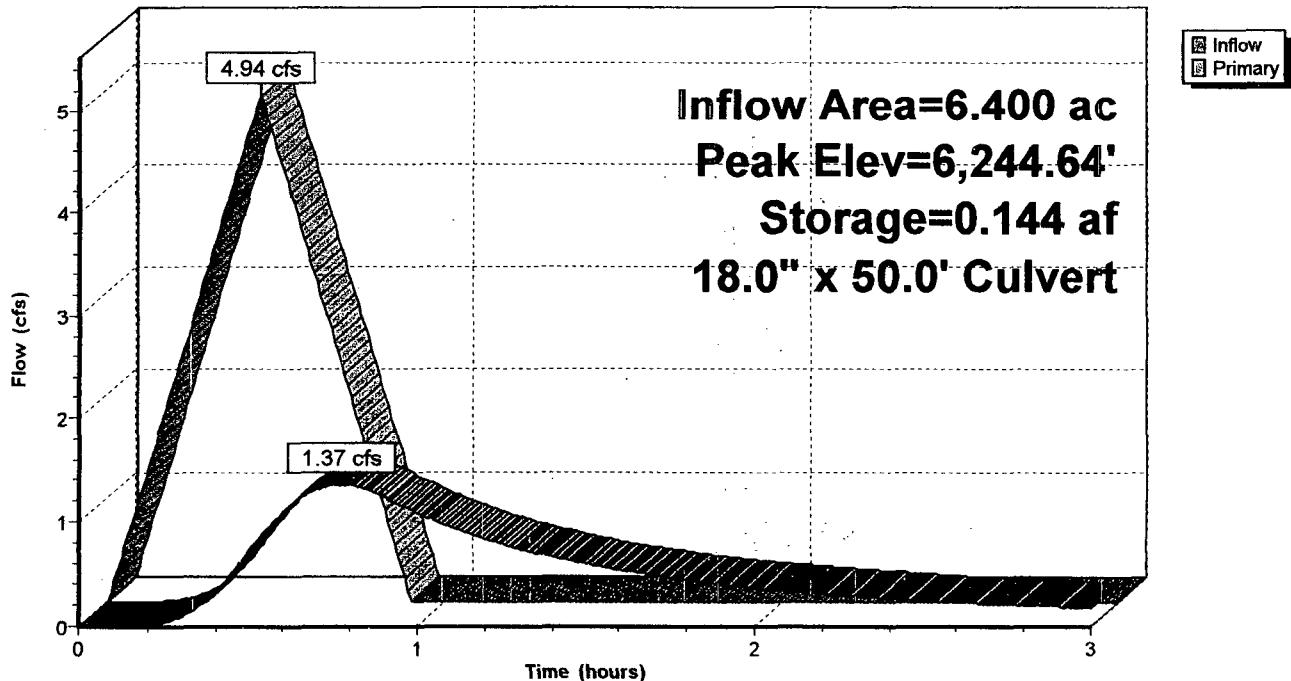

**Rational-5YR Developed**

El Paso County 5-Year Duration=27 min, Inten=2.57 in/hr

Prepared by WestWorks Engineering

Page 1

HydroCAD® 7.00 s/n 002053 © 1986-2003 Applied Microcomputer Systems

6/16/2005

**Subcatchment B-3: Basin B-3**

Runoff = 34.22 cfs @ 0.45 hrs, Volume= 1.272 af, Depth= 0.35"

Runoff by Rational method, Rise/Fall=1.0/1.0 xTc, Time Span= 0.00-3.00 hrs, dt= 0.01 hrs  
El Paso County 5-Year Duration=27 min, Inten=2.57 in/hr

Area (ac)	C	Description
44.000	0.30	5 acre lots, 12% imp, HSG B

Tc (min)	Length (feet)	Slope (ft/ft)	Velocity (ft/sec)	Capacity (cfs)	Description
26.7					Direct Entry, Basin B-3

**Subcatchment B-3: Basin B-3**

Hydrograph

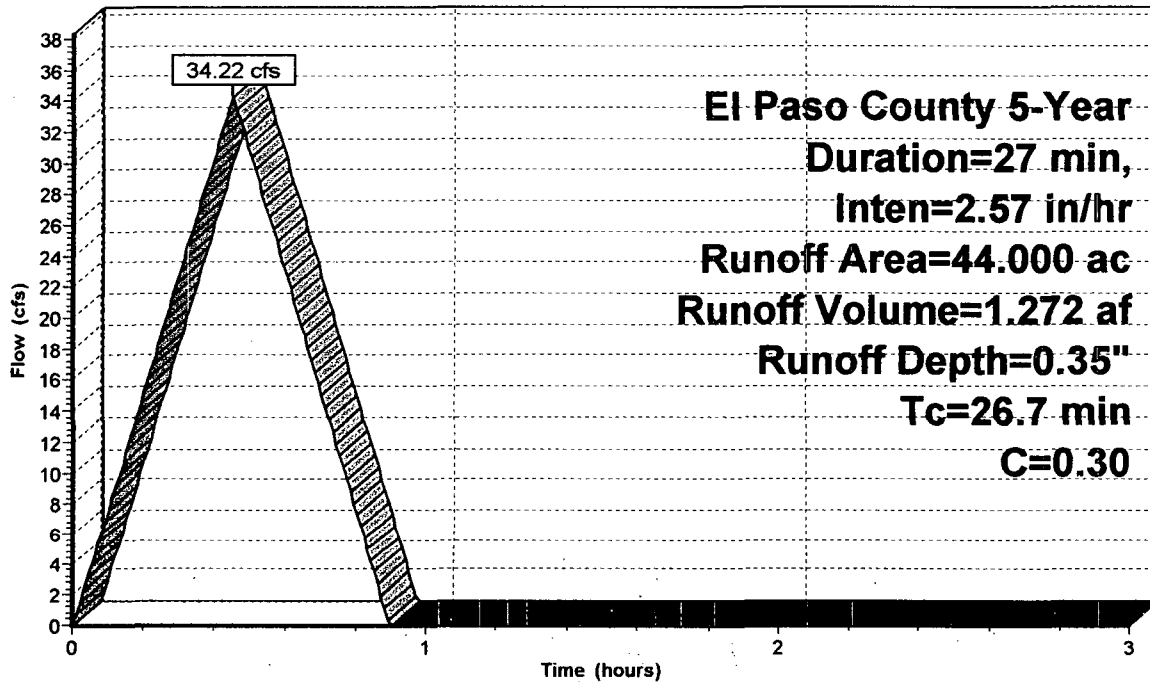

**Rational-5YR Developed**

El Paso County 5-Year Duration=30 min, Inten=2.42 in/hr

Prepared by WestWorks Engineering

Page 1

HydroCAD® 7.00 s/n 002053 © 1986-2003 Applied Microcomputer Systems

6/16/2005

**Subcatchment B-4: Basin B-4**

Runoff = 48.54 cfs @ 0.50 hrs, Volume= 2.006 af, Depth= 0.36"

Runoff by Rational method, Rise/Fall=1.0/1.0 xTc, Time Span= 0.00-3.00 hrs, dt= 0.01 hrs  
 El Paso County 5-Year Duration=30 min, Inten=2.42 in/hr

Area (ac)	C	Description
66.300	0.30	5 acre lots, 12% imp, HSG B

Tc (min)	Length (feet)	Slope (ft/ft)	Velocity (ft/sec)	Capacity (cfs)	Description
29.8					Direct Entry, Basin B-4

**Subcatchment B-4: Basin B-4**

Hydrograph

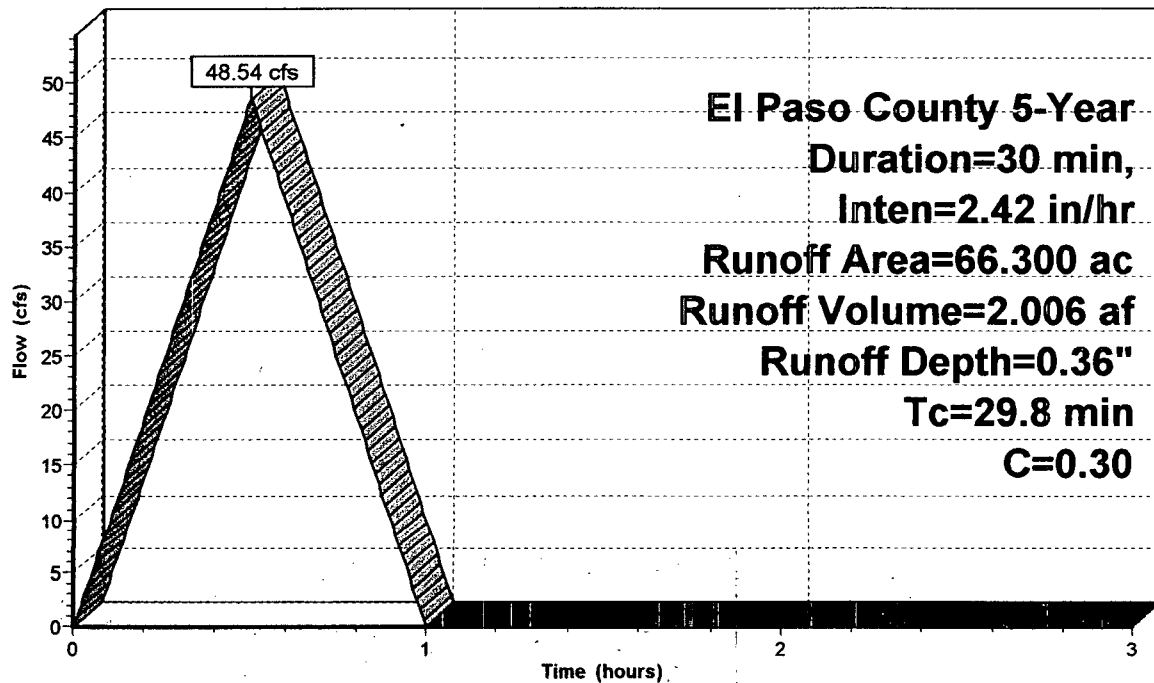

**El Paso County 5-Year  
 Duration=30 min,  
 Inten=2.42 in/hr  
 Runoff Area=66.300 ac  
 Runoff Volume=2.006 af  
 Runoff Depth=0.36"  
 Tc=29.8 min  
 C=0.30**

**Rational-5YR Developed**

*El Paso County 5-Year Duration=30 min, Inten=2.42 in/hr*

Prepared by WestWorks Engineering

Page 1

HydroCAD® 7.00 s/n 002053 © 1986-2003 Applied Microcomputer Systems

6/16/2005

**Subcatchment B-5: Basin B-5**

Runoff = 62.33 cfs @ 0.50 hrs, Volume= 2.576 af, Depth= 0.36"

Runoff by Rational method, Rise/Fall=1.0/1.0 xTc, Time Span= 0.00-3.00 hrs, dt= 0.01 hrs  
El Paso County 5-Year Duration=30 min, Inten=2.42 in/hr

Area (ac)	C	Description
86.000	0.30	5 acre lots, 12% imp, HSG B

Tc (min)	Length (feet)	Slope (ft/ft)	Velocity (ft/sec)	Capacity (cfs)	Description
30.3					Direct Entry, Basin B-5

**Subcatchment B-5: Basin B-5**

Hydrograph

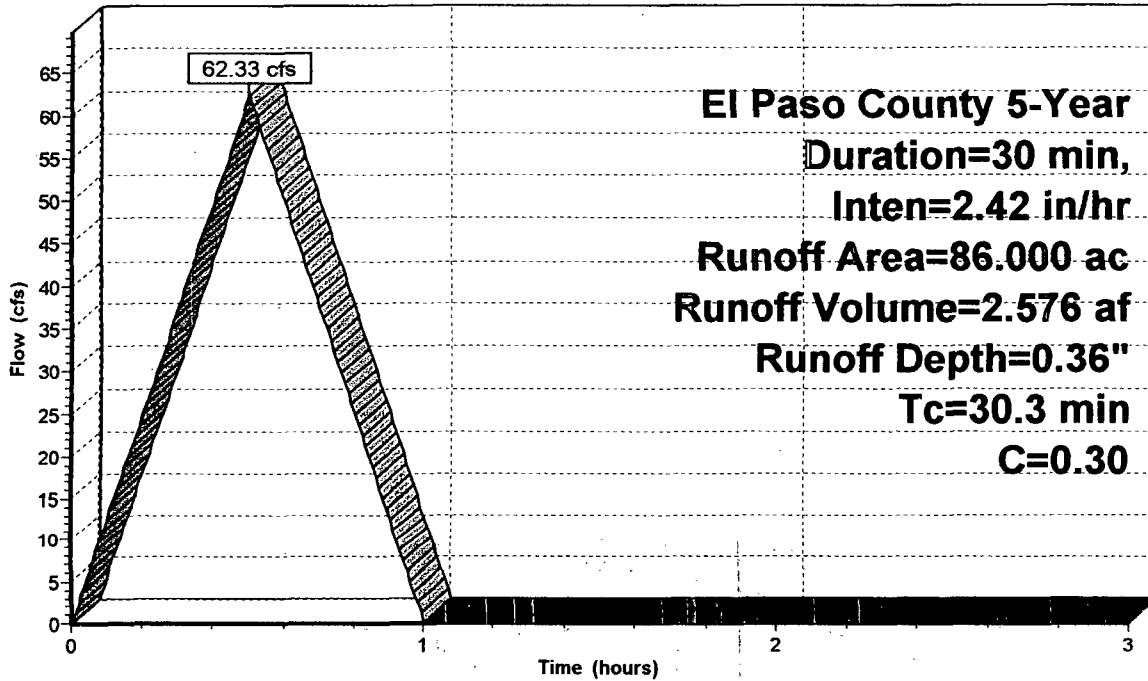

Runoff

**Rational-5YR Developed**

El Paso County 5-Year Duration=25 min, Inten=2.68 in/hr

Prepared by WestWorks Engineering

Page 1

HydroCAD® 7.00 s/n 002053 © 1986-2003 Applied Microcomputer Systems

6/16/2005

**Subcatchment OS1: Off-Site Basin OS1**

Runoff = 15.08 cfs @ 0.41 hrs, Volume= 0.519 af, Depth= 0.28"

Runoff by Rational method, Rise/Fall=1.0/1.0 xTc, Time Span= 0.00-3.00 hrs, dt= 0.01 hrs  
El Paso County 5-Year Duration=25 min, Inten=2.68 in/hr

Area (ac)	C	Description
22.300	0.25	Pasture/grassland/range, Good, HSG B

Tc (min)	Length (feet)	Slope (ft/ft)	Velocity (ft/sec)	Capacity (cfs)	Description
24.5					Direct Entry, Basin OS1

**Subcatchment OS1: Off-Site Basin OS1**

Hydrograph

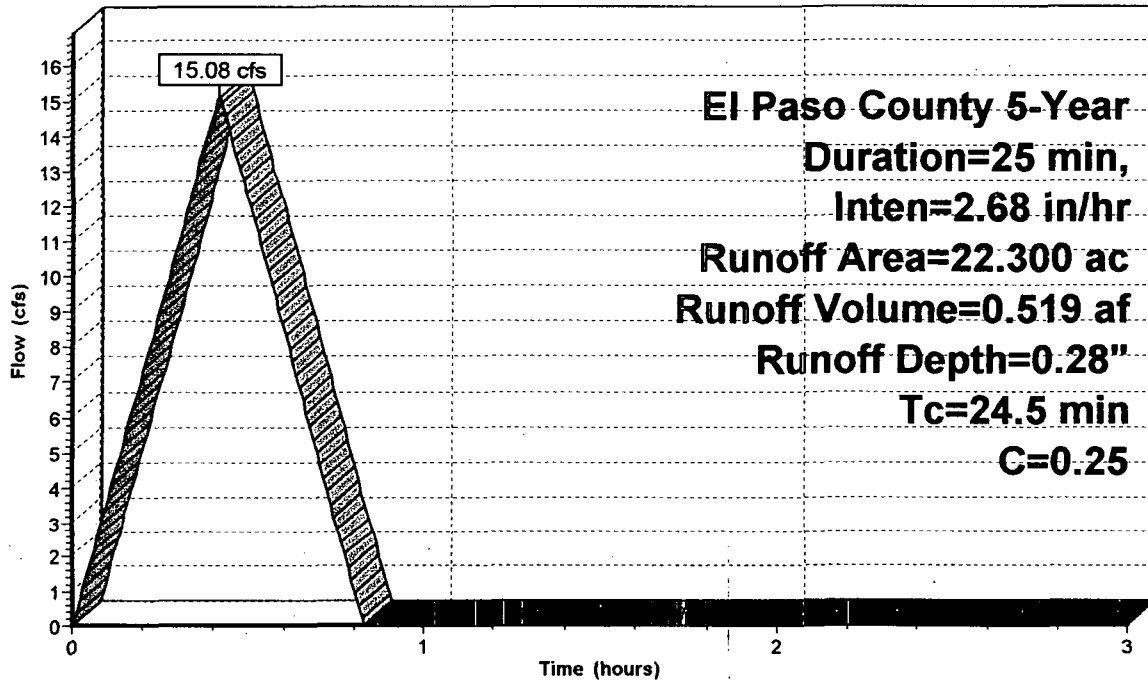

**Rational-5YR Developed**

El Paso County 5-Year Duration=47 min, Inten=1.85 in/hr

Prepared by WestWorks Engineering

Page 1

HydroCAD® 7.00 s/n 002053 © 1986-2003 Applied Microcomputer Systems

6/16/2005

**Subcatchment C-1: Basin C-1**

Runoff = 24.12 cfs @ 0.78 hrs, Volume= 1.561 af, Depth= 0.43"

Runoff by Rational method, Rise/Fall=1.0/1.0 xTc, Time Span= 0.00-3.00 hrs, dt= 0.01 hrs  
El Paso County 5-Year Duration=47 min, Inten=1.85 in/hr

Area (ac)	C	Description
43.100	0.30	2 acre lots, 12% imp, HSG B

Tc (min)	Length (feet)	Slope (ft/ft)	Velocity (ft/sec)	Capacity (cfs)	Description
46.6					Direct Entry, Basin C-1

**Subcatchment C-1: Basin C-1**

Hydrograph

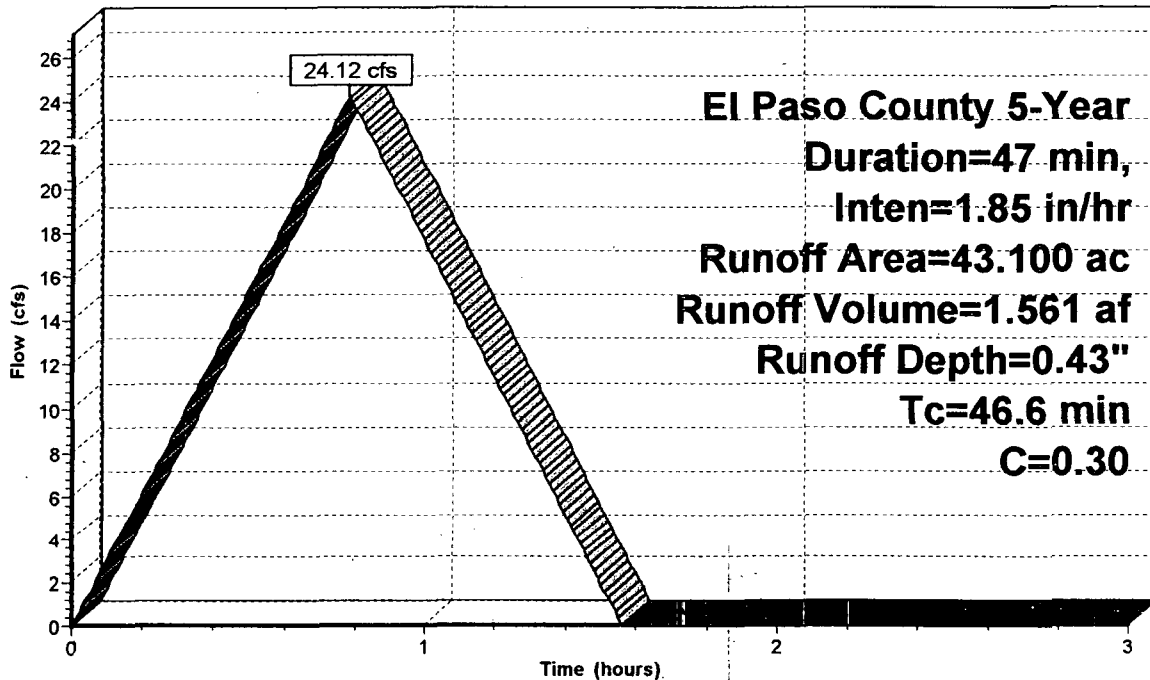

**Rational-5YR Developed**

*El Paso County 5-Year Duration=47 min, Inten=1.85 in/hr*

Prepared by WestWorks Engineering

Page 1

HydroCAD® 7.00 s/n 002053 © 1986-2003 Applied Microcomputer Systems

6/16/2005

**Pond DP-C1: Design Point C1**

Inflow Area = 56.800 ac, Inflow Depth = 0.43" for 5-Year event  
 Inflow = 31.79 cfs @ 0.78 hrs, Volume= 2.058 af  
 Outflow = 31.71 cfs @ 0.79 hrs, Volume= 2.058 af, Atten= 0%, Lag= 0.3 min  
 Primary = 31.71 cfs @ 0.79 hrs, Volume= 2.058 af

Routing by Stor-Ind method, Time Span= 0.00-3.00 hrs, dt= 0.01 hrs  
 Peak Elev= 6,213.81' @ 0.79 hrs Surf.Area= 0.015 ac Storage= 0.019 af  
 Plug-Flow detention time= 0.5 min calculated for 2.051 af (100% of inflow)  
 Center-of-Mass det. time= 0.5 min ( 45.9 - 45.4 )

#	Invert	Avail.Storage	Storage Description
1	6,212.00'	0.894 af	Custom Stage Data (Prismatic) Listed below

Elevation (feet)	Surf.Area (acres)	Inc.Store (acre-feet)	Cum.Store (acre-feet)
6,212.00	0.005	0.000	0.000
6,214.00	0.016	0.021	0.021
6,215.50	1.148	0.873	0.894

#	Routing	Invert	Outlet Devices
1	Primary	6,211.70'	30.0" x 50.0' long Culvert X 2.00 CMP, end-section conforming to fill, Ke= 0.500 Outlet Invert= 6,211.20' S= 0.0100 '/ n= 0.024 Cc= 0.900

**Primary OutFlow** Max=31.67 cfs @ 0.79 hrs HW=6,213.81' (Free Discharge)

↑1=Culvert (Barrel Controls 31.67 cfs @ 4.8 fps)

### Pond DP-C1: Design Point C1

Hydrograph

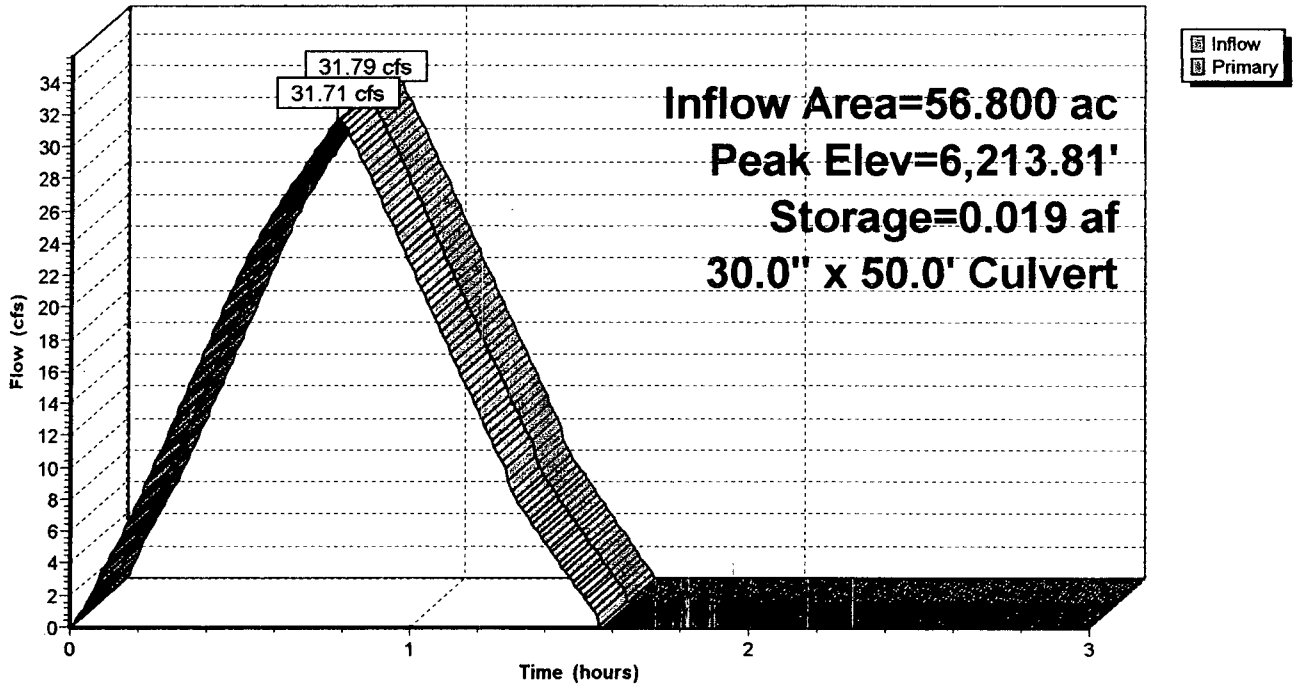

**Rational-5YR Developed**

*El Paso County 5-Year Duration=29 min, Inten=2.47 in/hr*

Prepared by WestWorks Engineering

Page 1

HydroCAD® 7.00 s/n 002053 © 1986-2003 Applied Microcomputer Systems

6/16/2005

**Subcatchment C-2: Basin C-2**

Runoff = 10.14 cfs @ 0.48 hrs, Volume= 0.407 af, Depth= 0.36"

Runoff by Rational method, Rise/Fall=1.0/1.0 xTc, Time Span= 0.00-3.00 hrs, dt= 0.01 hrs  
El Paso County 5-Year Duration=29 min, Inten=2.47 in/hr

Area (ac)	C	Description
13.700	0.30	2 acre lots, 12% imp, HSG B

Tc (min)	Length (feet)	Slope (ft/ft)	Velocity (ft/sec)	Capacity (cfs)	Description
29.1					Direct Entry, Basin C-2

**Subcatchment C-2: Basin C-2**

Hydrograph

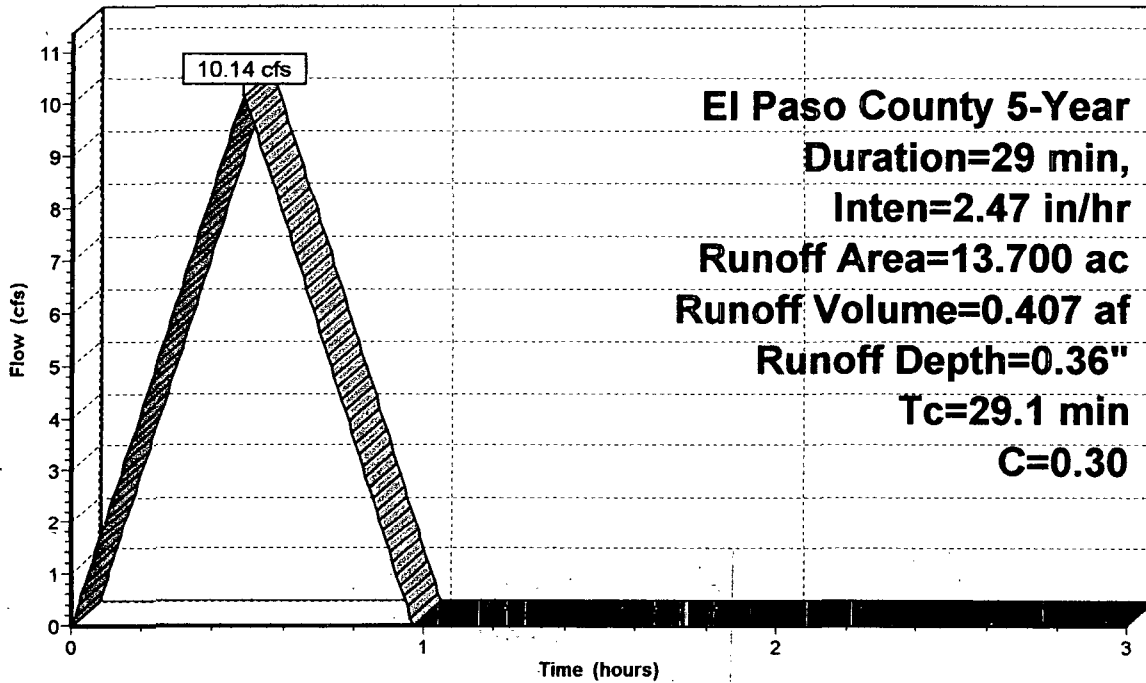

**Pond DP-C2: Design Point C2**

Inflow Area = 13.700 ac, Inflow Depth = 0.36" for 5-Year event  
 Inflow = 10.14 cfs @ 0.48 hrs, Volume= 0.407 af  
 Outflow = 9.52 cfs @ 0.52 hrs, Volume= 0.407 af, Atten= 6%, Lag= 2.0 min  
 Primary = 9.52 cfs @ 0.52 hrs, Volume= 0.407 af

Routing by Stor-Ind method, Time Span= 0.00-3.00 hrs, dt= 0.01 hrs  
 Peak Elev= 6,221.76' @ 0.52 hrs Surf.Area= 0.052 ac Storage= 0.039 af  
 Plug-Flow detention time= 3.0 min calculated for 0.406 af (100% of inflow)  
 Center-of-Mass det. time= 3.0 min ( 32.0 - 29.0 )

#	Invert	Avail.Storage	Storage Description
1	6,220.50'	0.301 af	<b>Custom Stage Data (Prismatic) Listed below</b>
	<b>Elevation (feet)</b>	<b>Surf.Area (acres)</b>	<b>Inc.Store (acre-feet)</b>
	6,220.50	0.000	0.000
	6,222.00	0.062	0.046
	6,223.33	0.321	0.255

#	Routing	Invert	Outlet Devices
1	Primary	6,220.00'	<b>24.0" x 50.0' long Culvert</b> CMP, end-section conforming to fill, Ke= 0.500 Outlet Invert= 6,219.50' S= 0.0100 '/ n= 0.024 Cc= 0.900

**Primary OutFlow** Max=9.52 cfs @ 0.52 hrs HW=6,221.76' (Free Discharge)  
 ↳ **1=Culvert** (Barrel Controls 9.52 cfs @ 4.3 fps)

Pond DP-C2: Design Point C2

Hydrograph

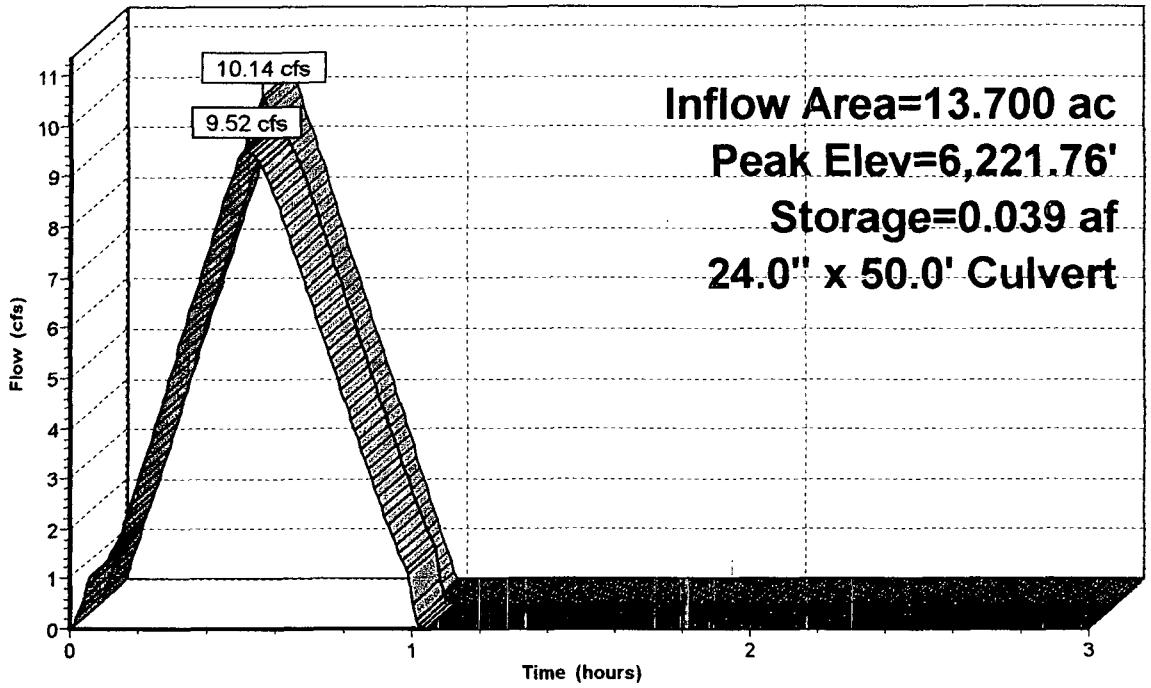

Inflow  
Primary

Inflow Area=13.700 ac

Peak Elev=6,221.76'

Storage=0.039 af

24.0" x 50.0' Culvert

**Rational-5YR Developed**

*El Paso County 5-Year Duration=21 min, Inten=2.94 in/hr*

Prepared by WestWorks Engineering

Page 1

HydroCAD® 7.00 s/n 002053 © 1986-2003 Applied Microcomputer Systems

6/16/2005

**Subcatchment C-3: Basin C-3**

Runoff = 7.92 cfs @ 0.35 hrs, Volume= 0.229 af, Depth= 0.31"

Runoff by Rational method, Rise/Fall=1.0/1.0 xTc, Time Span= 0.00-3.00 hrs, dt= 0.01 hrs  
 El Paso County 5-Year Duration=21 min, Inten=2.94 in/hr

Area (ac)	C	Description
8.900	0.30	2 acre lots, 12% imp, HSG B

Tc (min)	Length (feet)	Slope (ft/ft)	Velocity (ft/sec)	Capacity (cfs)	Description
21.0					Direct Entry, Basin C-3

**Subcatchment C-3: Basin C-3**

Hydrograph

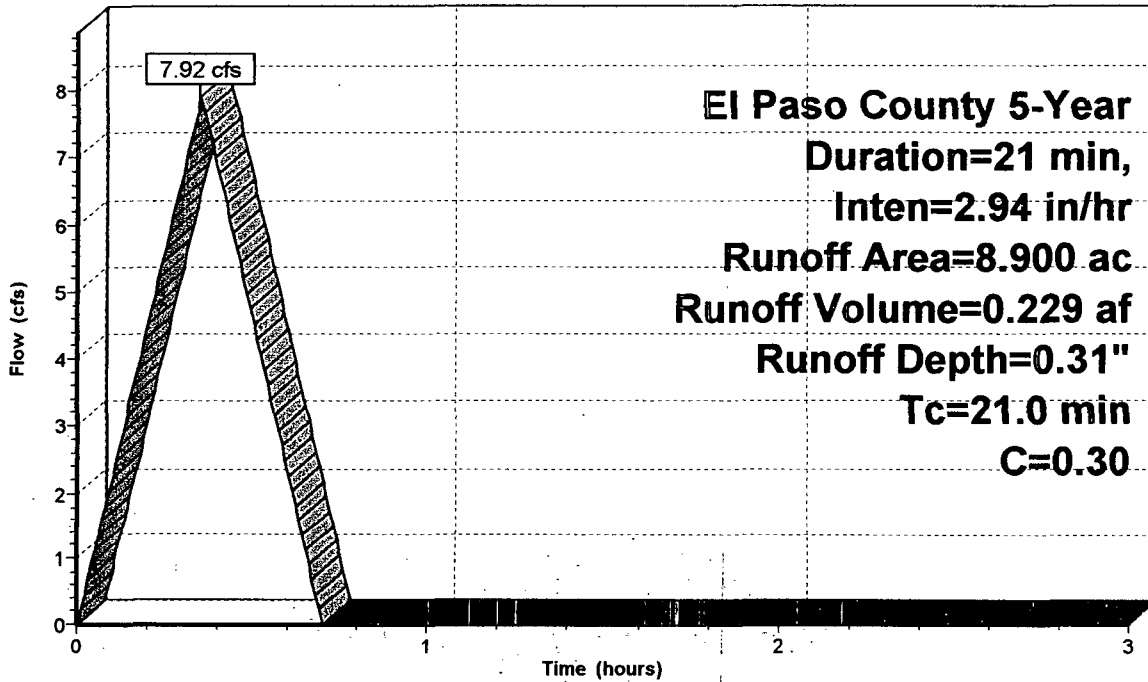

Runoff

**El Paso County 5-Year  
 Duration=21 min,  
 Inten=2.94 in/hr  
 Runoff Area=8.900 ac  
 Runoff Volume=0.229 af  
 Runoff Depth=0.31"  
 Tc=21.0 min  
 C=0.30**

**Pond DP-C3: Design Point C3**

Inflow Area = 8.900 ac, Inflow Depth = 0.31" for 5-Year event  
 Inflow = 7.92 cfs @ 0.35 hrs, Volume= 0.229 af  
 Outflow = 1.91 cfs @ 0.62 hrs, Volume= 0.229 af, Atten= 76%, Lag= 15.9 min  
 Primary = 1.91 cfs @ 0.62 hrs, Volume= 0.229 af

Routing by Stor-Ind method, Time Span= 0.00-3.00 hrs, dt= 0.01 hrs  
 Peak Elev= 6,220.30' @ 0.62 hrs Surf.Area= 0.239 ac Storage= 0.161 af  
 Plug-Flow detention time= 43.0 min calculated for 0.229 af (100% of inflow)  
 Center-of-Mass det. time= 42.9 min (63.9 - 21.0)

#	Invert	Avail.Storage	Storage Description
1	6,220.00'	1.083 af	<b>Custom Stage Data (Prismatic)</b> Listed below

Elevation (feet)	Surf.Area (acres)	Inc.Store (acre-feet)	Cum.Store (acre-feet)
6,220.00	0.110	0.000	0.000
6,222.00	0.973	1.083	1.083

#	Routing	Invert	Outlet Devices
1	Primary	6,219.50'	<b>18.0" x 50.0' long Culvert</b> CMP, end-section conforming to fill, Ke= 0.500 Outlet Invert= 6,219.00' S= 0.0100 '/' n= 0.024 Cc= 0.900

**Primary OutFlow** Max=1.91 cfs @ 0.62 hrs HW=6,220.30' (Free Discharge)  
 ↳1=Culvert (Barrel Controls 1.91 cfs @ 2.9 fps)

**Pond DP-C3: Design Point C3**

Hydrograph

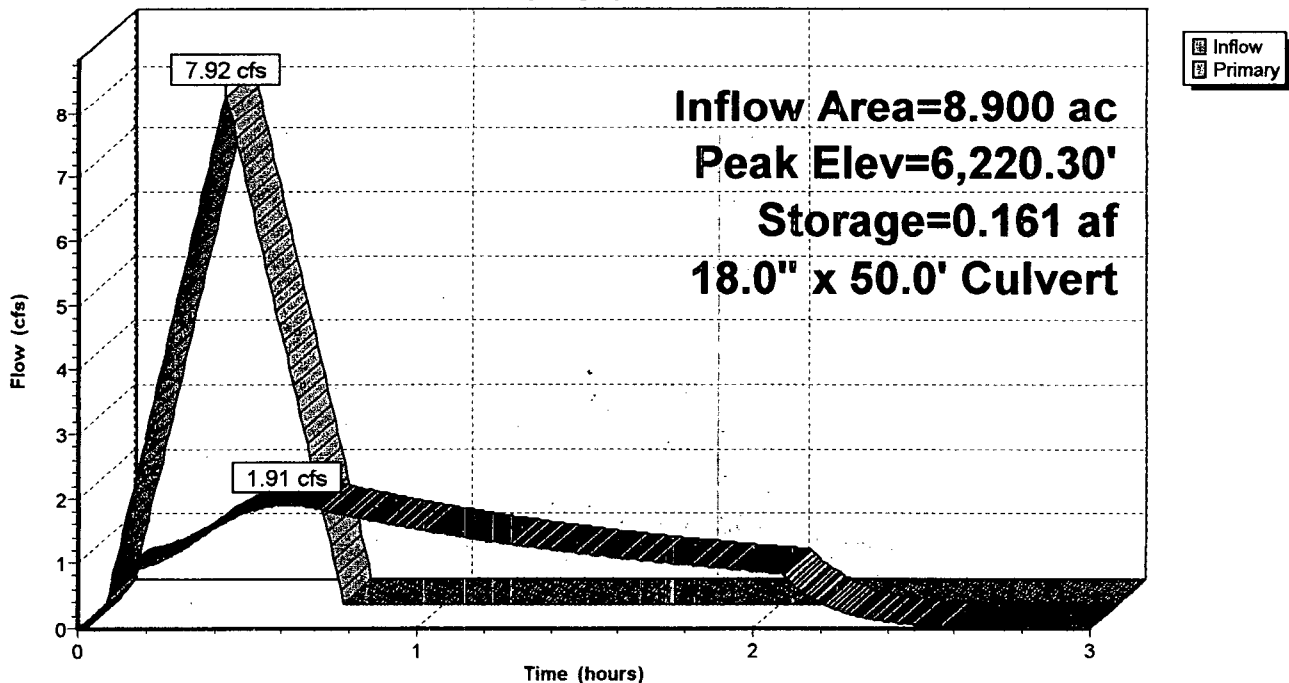

**Rational-5YR Developed**

*El Paso County 5-Year Duration=23 min, Inten=2.80 in/hr*

Prepared by WestWorks Engineering

Page 1

HydroCAD® 7.00 s/n 002053 © 1986-2003 Applied Microcomputer Systems

6/16/2005

**Subcatchment C-4: Basin C-4**

Runoff = 5.97 cfs @ 0.38 hrs, Volume= 0.191 af, Depth= 0.32"

Runoff by Rational method, Rise/Fall=1.0/1.0 xTc, Time Span= 0.00-3.00 hrs, dt= 0.01 hrs  
 El Paso County 5-Year Duration=23 min, Inten=2.80 in/hr

Area (ac)	C	Description
7.100	0.30	2 acre lots, 12% imp, HSG B

Tc (min)	Length (feet)	Slope (ft/ft)	Velocity (ft/sec)	Capacity (cfs)	Description
23.0					Direct Entry, Basin C-4

**Subcatchment C-4: Basin C-4**

Hydrograph

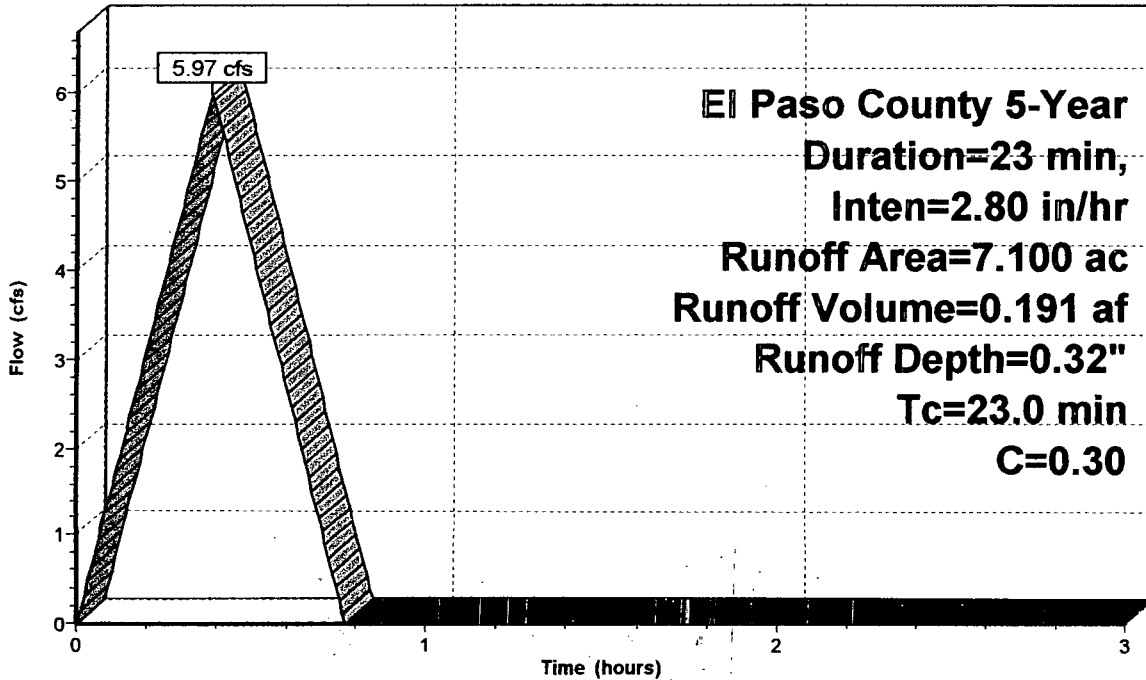

Runoff

**El Paso County 5-Year  
 Duration=23 min,  
 Inten=2.80 in/hr  
 Runoff Area=7.100 ac  
 Runoff Volume=0.191 af  
 Runoff Depth=0.32"  
 Tc=23.0 min  
 C=0.30**

**Rational-5YR Developed**

El Paso County 5-Year Duration=29 min, Inten=2.47 in/hr

Prepared by WestWorks Engineering

Page 1

HydroCAD® 7.00 s/n 002053 © 1986-2003 Applied Microcomputer Systems

6/16/2005

**Subcatchment C-5: Basin C-5**

Runoff = 15.56 cfs @ 0.48 hrs, Volume= 0.625 af, Depth= 0.36"

Runoff by Rational method, Rise/Fall=1.0/1.0 xTc, Time Span= 0.00-3.00 hrs, dt= 0.01 hrs  
El Paso County 5-Year Duration=29 min, Inten=2.47 in/hr

Area (ac)	C	Description
21.100	0.30	2 acre lots, 12% imp, HSG B

Tc (min)	Length (feet)	Slope (ft/ft)	Velocity (ft/sec)	Capacity (cfs)	Description
29.2					Direct Entry, Basin C-5

**Subcatchment C-5: Basin C-5**

Hydrograph

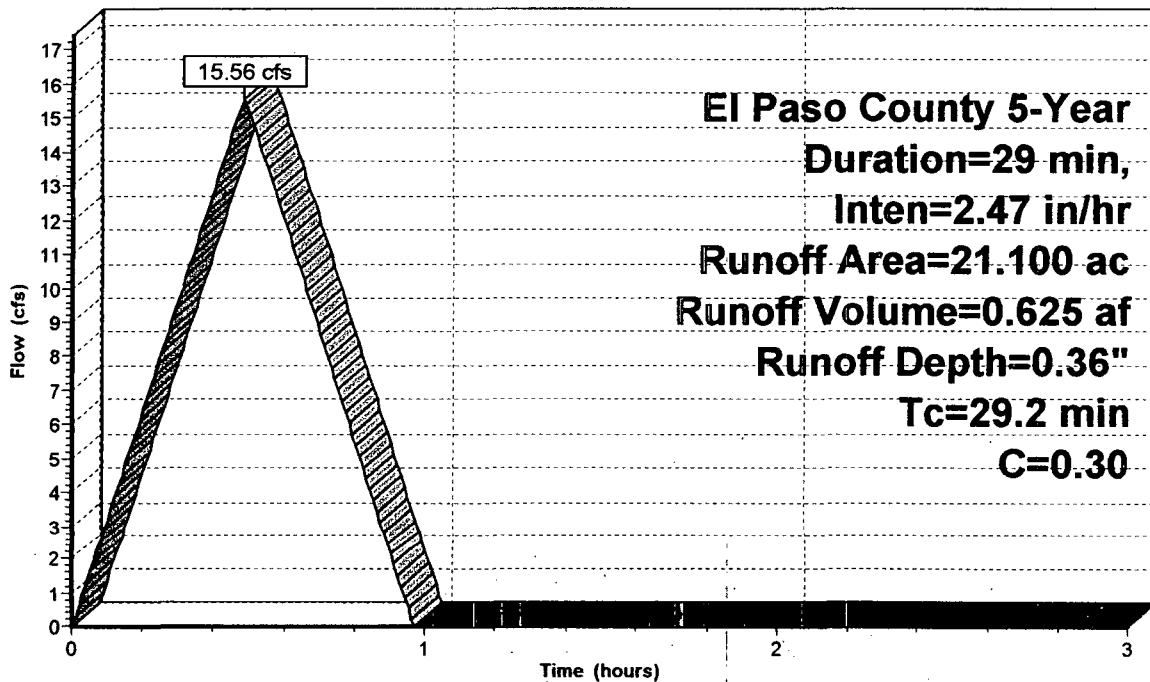

Runoff

**Rational-5YR Developed**

El Paso County 5-Year Duration=32 min, Inten=2.33 in/hr

Prepared by WestWorks Engineering

Page 1

HydroCAD® 7.00 s/n 002053 © 1986-2003 Applied Microcomputer Systems

6/16/2005

**Subcatchment C-6: Basin C-6**

Runoff = 56.43 cfs @ 0.53 hrs, Volume= 2.501 af, Depth= 0.37"

Runoff by Rational method, Rise/Fall=1.0/1.0 xTc, Time Span= 0.00-3.00 hrs, dt= 0.01 hrs  
El Paso County 5-Year Duration=32 min, Inten=2.33 in/hr

Area (ac)	C	Description
80.500	0.30	2 acre lots, 12% imp, HSG B

Tc (min)	Length (feet)	Slope (ft/ft)	Velocity (ft/sec)	Capacity (cfs)	Description
32.0					Direct Entry, Basin C-6

**Subcatchment C-6: Basin C-6**

Hydrograph

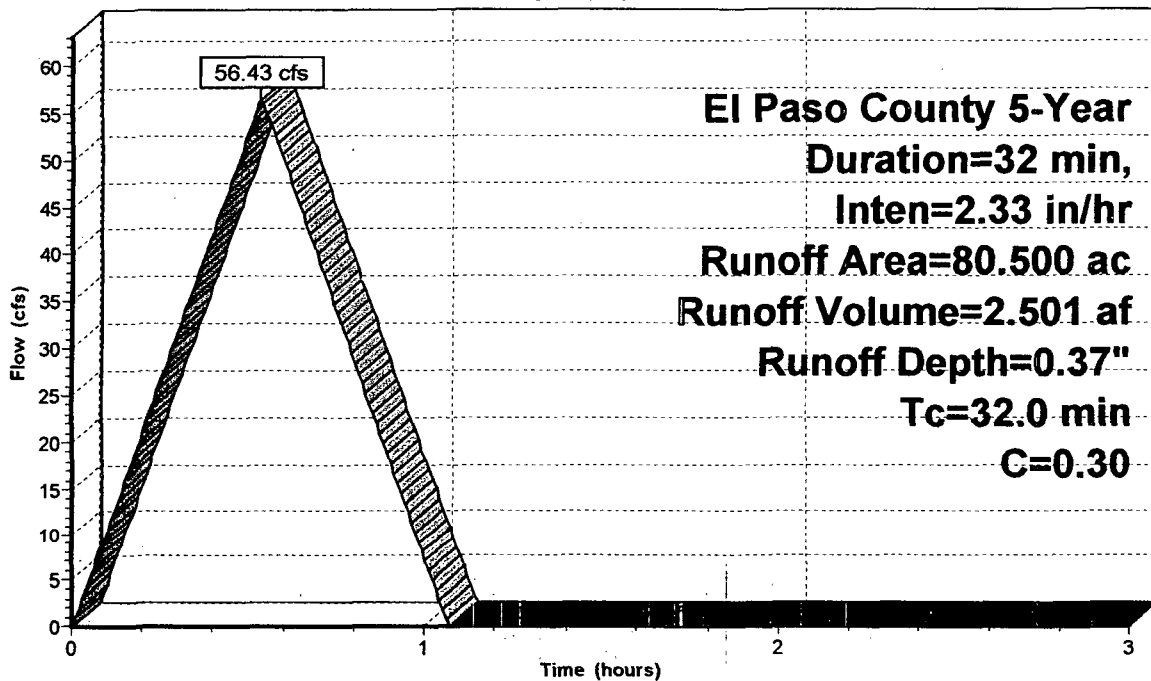

**Rational-5YR Developed**

El Paso County 5-Year Duration=22 min, Inten=2.87 in/hr

Prepared by WestWorks Engineering

Page 1

HydroCAD® 7.00 s/n 002053 © 1986-2003 Applied Microcomputer Systems

6/16/2005

**Subcatchment D-1: Basin D-1**

Runoff = 5.04 cfs @ 0.36 hrs, Volume= 0.153 af, Depth= 0.32"

Runoff by Rational method, Rise/Fall=1.0/1.0 xTc, Time Span= 0.00-3.00 hrs, dt= 0.01 hrs  
El Paso County 5-Year Duration=22 min, Inten=2.87 in/hr

Area (ac)	C	Description
5.800	0.30	2 acre lots, 12% imp, HSG B

Tc (min)	Length (feet)	Slope (ft/ft)	Velocity (ft/sec)	Capacity (cfs)	Description
21.6					Direct Entry, Basin D-1

**Subcatchment D-1: Basin D-1**

Hydrograph

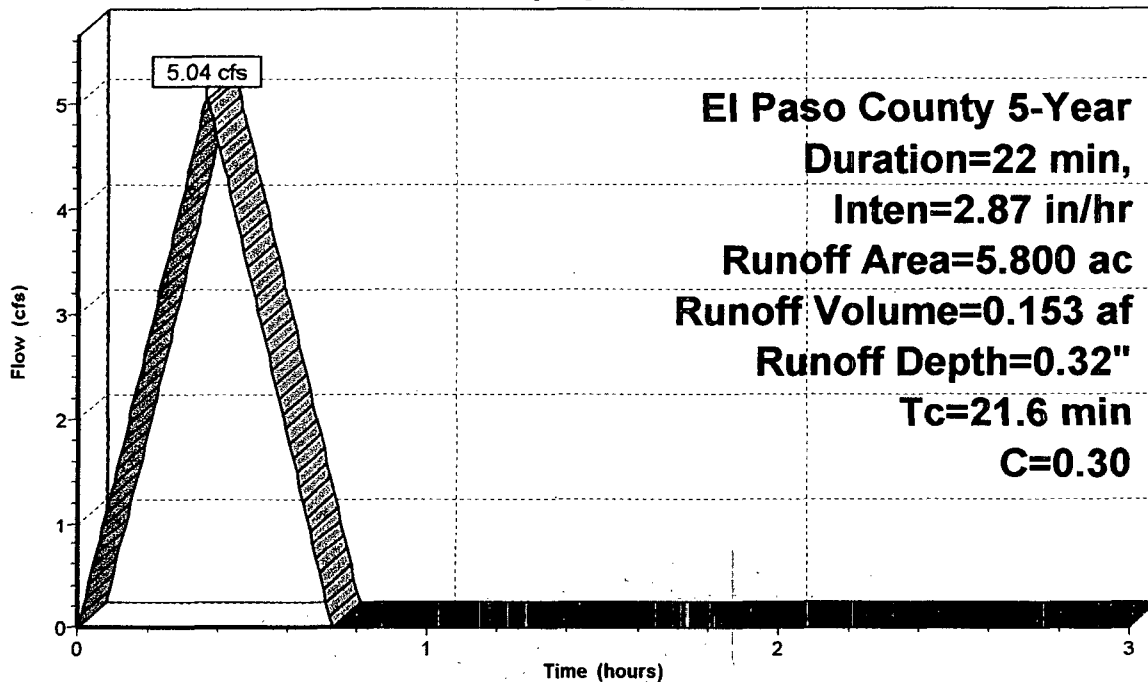

**Rational-5YR Developed**

*El Paso County 5-Year Duration=20 min, Inten=3.01 in/hr*

Prepared by WestWorks Engineering

Page 1

HydroCAD® 7.00 s/n 002053 © 1986-2003 Applied Microcomputer Systems

6/16/2005

**Subcatchment D-2: Basin D-2**

Runoff = 18.05 cfs @ 0.33 hrs, Volume= 0.502 af, Depth= 0.30"

Runoff by Rational method, Rise/Fall=1.0/1.0 xTc, Time Span= 0.00-3.00 hrs, dt= 0.01 hrs

El Paso County 5-Year Duration=20 min, Inten=3.01 in/hr

Area (ac)	C	Description
20.200	0.30	2 acre lots, 12% imp, HSG B

Tc (min)	Length (feet)	Slope (ft/ft)	Velocity (ft/sec)	Capacity (cfs)	Description
20.2					Direct Entry, Basin D-2

**Subcatchment D-2: Basin D-2**

Hydrograph

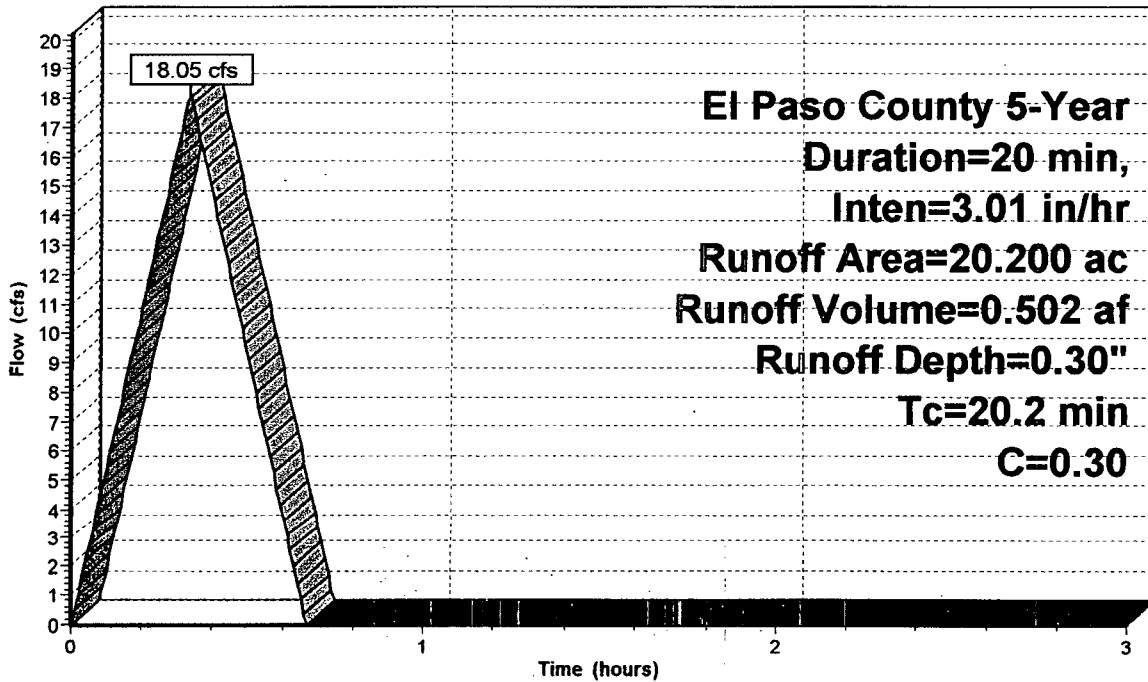

**Rational-5YR Developed**

*El Paso County 5-Year Duration=20 min, Inten=3.01 in/hr*

Prepared by WestWorks Engineering

Page 1

HydroCAD® 7.00 s/n 002053 © 1986-2003 Applied Microcomputer Systems

6/16/2005

**Pond Pond D: Pond D**

Inflow Area = 20.200 ac, Inflow Depth = 0.30" for 5-Year event  
 Inflow = 18.05 cfs @ 0.33 hrs, Volume= 0.502 af  
 Outflow = 0.32 cfs @ 0.66 hrs, Volume= 0.056 af, Atten= 98%, Lag= 19.8 min  
 Primary = 0.32 cfs @ 0.66 hrs, Volume= 0.056 af

Routing by Stor-Ind method, Time Span= 0.00-3.00 hrs, dt= 0.01 hrs  
 Peak Elev= 6,190.52' @ 0.66 hrs Surf.Area= 0.659 ac Storage= 0.496 af  
 Plug-Flow detention time= 92.4 min calculated for 0.056 af (11% of inflow)  
 Center-of-Mass det. time= 78.7 min ( 98.7 - 20.0 )

#	Invert	Avail.Storage	Storage Description
1	6,190.00'	1.921 af	<b>Custom Stage Data (Prismatic)</b> Listed below

Elevation (feet)	Surf.Area (acres)	Inc.Store (acre-feet)	Cum.Store (acre-feet)
6,190.00	0.337	0.000	0.000
6,192.00	1.584	1.921	1.921

#	Routing	Invert	Outlet Devices
1	Primary	6,190.08'	<b>1.0" Vert. Orifice/Grate X 2.00</b> C= 0.600
2	Primary	6,190.25'	<b>17.0" x 15.0' long Culvert</b> CMP, projecting, no headwall, Ke= 0.900 Outlet Invert= 6,189.80' S= 0.0300 '/' n= 0.022 Cc= 0.900

**Primary OutFlow** Max=0.32 cfs @ 0.66 hrs HW=6,190.52' (Free Discharge)

1=Orifice/Grate (Orifice Controls 0.03 cfs @ 3.0 fps)

2=Culvert (Inlet Controls 0.29 cfs @ 1.4 fps)

Pond Pond D: Pond D

Hydrograph

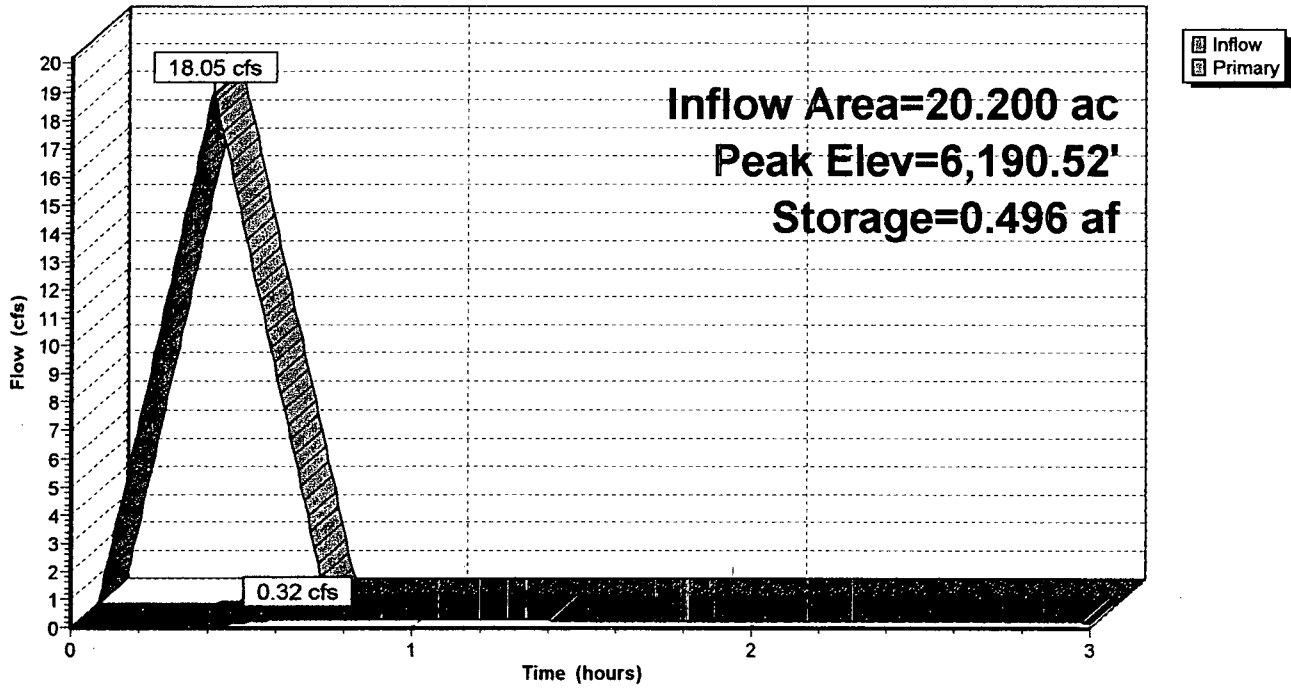

Link DP-D: Design Point D

Inflow Area = 26.000 ac, Inflow Depth = 0.10" for 5-Year event  
Inflow = 5.07 cfs @ 0.36 hrs, Volume= 0.219 af  
Primary = 5.07 cfs @ 0.36 hrs, Volume= 0.219 af, Atten= 0%, Lag= 0.0 min

Primary outflow = Inflow, Time Span= 0.00-3.00 hrs, dt= 0.01 hrs

Link DP-D: Design Point D

Hydrograph

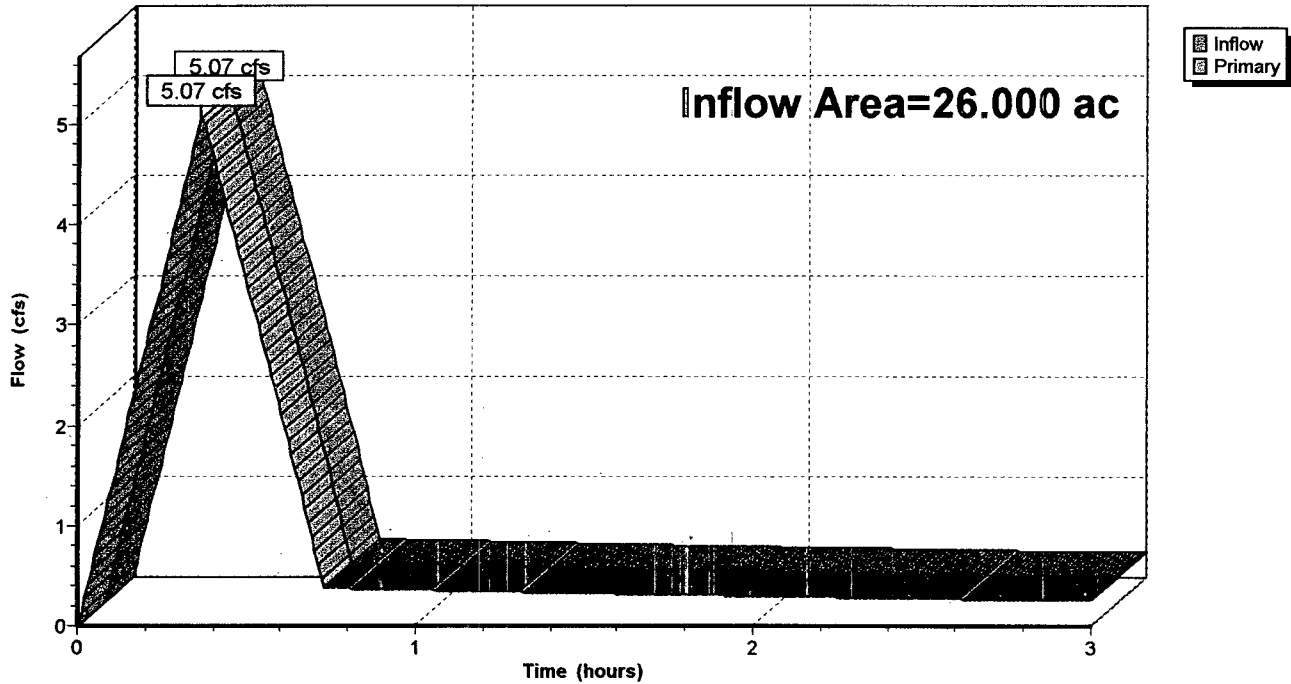

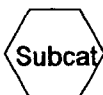
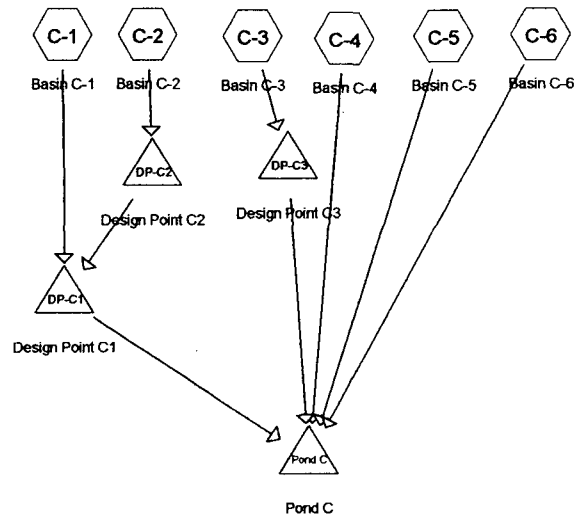
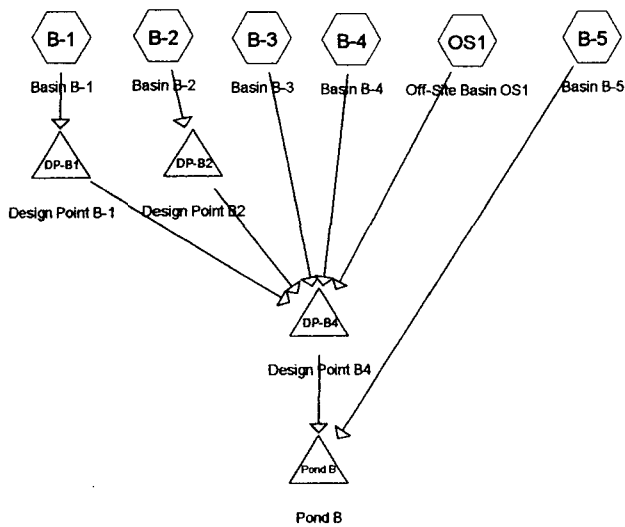

**Drainage Diagram for TR20-10YR-24HR Developed**  
 Prepared by WestWorks Engineering 6/16/2005  
 HydroCAD® 7.00 s/n 002053 © 1986-2003 Applied Microcomputer Systems

**TR20-10YR-24HR Developed**

Type IIA 24-hr Rainfall=3.00"

Prepared by WestWorks Engineering

Page 2

HydroCAD® 7.00 s/n 002053 © 1986-2003 Applied Microcomputer Systems

6/16/2005

Time span=0.00-20.00 hrs, dt=0.01 hrs, 2001 points

Runoff by SCS TR-20 method, UH=SCS

Reach routing by Stor-Ind+Trans method - Pond routing by Stor-Ind method

<b>Subcatchment B-1: Basin B-1</b>	Runoff Area=24.000 ac Runoff Depth=0.47" Tc=33.9 min CN=65 Runoff=7.89 cfs 0.945 af
<b>Subcatchment B-2: Basin B-2</b>	Runoff Area=6.400 ac Runoff Depth=0.47" Tc=27.2 min CN=65 Runoff=2.49 cfs 0.253 af
<b>Subcatchment B-3: Basin B-3</b>	Runoff Area=44.000 ac Runoff Depth=0.47" Tc=26.7 min CN=65 Runoff=17.46 cfs 1.737 af
<b>Subcatchment B-4: Basin B-4</b>	Runoff Area=66.300 ac Runoff Depth=0.47" Tc=29.8 min CN=65 Runoff=24.04 cfs 2.614 af
<b>Subcatchment B-5: Basin B-5</b>	Runoff Area=86.000 ac Runoff Depth=0.47" Tc=30.3 min CN=65 Runoff=30.98 cfs 3.390 af
<b>Subcatchment C-1: Basin C-1</b>	Runoff Area=43.100 ac Runoff Depth=0.47" Tc=46.6 min CN=65 Runoff=11.01 cfs 1.687 af
<b>Subcatchment C-2: Basin C-2</b>	Runoff Area=13.700 ac Runoff Depth=0.47" Tc=29.1 min CN=65 Runoff=5.07 cfs 0.540 af
<b>Subcatchment C-3: Basin C-3</b>	Runoff Area=8.900 ac Runoff Depth=0.48" Tc=21.0 min CN=65 Runoff=4.18 cfs 0.352 af
<b>Subcatchment C-4: Basin C-4</b>	Runoff Area=7.100 ac Runoff Depth=0.47" Tc=23.0 min CN=65 Runoff=3.13 cfs 0.281 af
<b>Subcatchment C-5: Basin C-5</b>	Runoff Area=21.100 ac Runoff Depth=0.47" Tc=29.2 min CN=65 Runoff=7.76 cfs 0.832 af
<b>Subcatchment C-6: Basin C-6</b>	Runoff Area=80.500 ac Runoff Depth=0.47" Tc=32.0 min CN=65 Runoff=27.57 cfs 3.171 af
<b>Subcatchment OS1: Off-Site Basin OS1</b>	Runoff Area=22.300 ac Runoff Depth=0.34" Tc=24.5 min CN=61 Runoff=5.68 cfs 0.630 af
<b>Pond DP-B1: Design Point B-1</b>	Peak Elev=6,244.45' Storage=0.219 af Inflow=7.89 cfs 0.945 af 24.0" x 50.0' Culvert Outflow=3.44 cfs 0.912 af
<b>Pond DP-B2: Design Point B2</b>	Peak Elev=6,244.39' Storage=0.088 af Inflow=2.49 cfs 0.253 af 18.0" x 50.0' Culvert Outflow=0.52 cfs 0.215 af
<b>Pond DP-B4: Design Point B4</b>	Peak Elev=6,194.50' Storage=0.652 af Inflow=48.32 cfs 6.109 af Outflow=30.25 cfs 6.041 af

Pond DP-C1: Design Point C1	Peak Elev=6,213.06' Storage=0.011 af Inflow=15.04 cfs 2.220 af 30.0" x 50.0' Culvert Outflow=15.04 cfs 2.220 af
Pond DP-C2: Design Point C2	Peak Elev=6,221.68' Storage=0.036 af Inflow=5.07 cfs 0.540 af 24.0" x 50.0' Culvert Outflow=4.85 cfs 0.533 af
Pond DP-C3: Design Point C3	Peak Elev=6,220.15' Storage=0.080 af Inflow=4.18 cfs 0.352 af 18.0" x 50.0' Culvert Outflow=1.29 cfs 0.351 af
Pond Pond B: Pond B	Peak Elev=6,183.60' Storage=4.918 af Inflow=58.99 cfs 9.431 af Outflow=5.82 cfs 5.243 af
Pond Pond C: Pond C	Peak Elev=6,201.36' Storage=4.119 af Inflow=52.19 cfs 6.855 af Outflow=3.01 cfs 2.934 af

Total Runoff Area = 423.400 ac Runoff Volume = 16.432 af Average Runoff Depth = 0.47"

**TR20-10YR-24HR Developed**

Type IIA 24-hr Rainfall=3.00"

Prepared by WestWorks Engineering

Page 4

HydroCAD® 7.00 s/n 002053 © 1986-2003 Applied Microcomputer Systems

6/16/2005

**Subcatchment B-1: Basin B-1**

Runoff = 7.89 cfs @ 6.36 hrs, Volume= 0.945 af, Depth= 0.47"

Runoff by SCS TR-20 method, UH=SCS, Time Span= 0.00-20.00 hrs, dt= 0.01 hrs  
Type IIA 24-hr Rainfall=3.00"

Area (ac)	CN	Description
24.000	65	2 acre lots, 12% imp, HSG B

Tc (min)	Length (feet)	Slope (ft/ft)	Velocity (ft/sec)	Capacity (cfs)	Description
33.9					Direct Entry, Basin B-1

**Subcatchment B-2: Basin B-2**

Runoff = 2.49 cfs @ 6.26 hrs, Volume= 0.253 af, Depth= 0.47"

Runoff by SCS TR-20 method, UH=SCS, Time Span= 0.00-20.00 hrs, dt= 0.01 hrs  
Type IIA 24-hr Rainfall=3.00"

Area (ac)	CN	Description
6.400	65	2 acre lots, 12% imp, HSG B

Tc (min)	Length (feet)	Slope (ft/ft)	Velocity (ft/sec)	Capacity (cfs)	Description
27.2					Direct Entry, Basin B-2

**Subcatchment B-3: Basin B-3**

Runoff = 17.46 cfs @ 6.26 hrs, Volume= 1.737 af, Depth= 0.47"

Runoff by SCS TR-20 method, UH=SCS, Time Span= 0.00-20.00 hrs, dt= 0.01 hrs  
Type IIA 24-hr Rainfall=3.00"

Area (ac)	CN	Description
44.000	65	2 acre lots, 12% imp, HSG B

Tc (min)	Length (feet)	Slope (ft/ft)	Velocity (ft/sec)	Capacity (cfs)	Description
26.7					Direct Entry, Basin B-3

**Subcatchment B-4: Basin B-4**

Runoff = 24.04 cfs @ 6.29 hrs, Volume= 2.614 af, Depth= 0.47"

Runoff by SCS TR-20 method, UH=SCS, Time Span= 0.00-20.00 hrs, dt= 0.01 hrs  
Type IIA 24-hr Rainfall=3.00"

**TR20-10YR-24HR Developed**

Type IIA 24-hr Rainfall=3.00"

Prepared by WestWorks Engineering

Page 5

HydroCAD® 7.00 s/n 002053 © 1986-2003 Applied Microcomputer Systems

6/16/2005

Area (ac)	CN	Description
66.300	65	2 acre lots, 12% imp, HSG B

Tc (min)	Length (feet)	Slope (ft/ft)	Velocity (ft/sec)	Capacity (cfs)	Description
29.8					Direct Entry, Basin B-4

**Subcatchment B-5: Basin B-5**

Runoff = 30.98 cfs @ 6.30 hrs, Volume= 3.390 af, Depth= 0.47"

Runoff by SCS TR-20 method, UH=SCS, Time Span= 0.00-20.00 hrs, dt= 0.01 hrs  
Type IIA 24-hr Rainfall=3.00"

Area (ac)	CN	Description
86.000	65	2 acre lots, 12% imp, HSG B

Tc (min)	Length (feet)	Slope (ft/ft)	Velocity (ft/sec)	Capacity (cfs)	Description
30.3					Direct Entry, Basin B-5

**Subcatchment C-1: Basin C-1**

Runoff = 11.01 cfs @ 6.52 hrs, Volume= 1.687 af, Depth= 0.47"

Runoff by SCS TR-20 method, UH=SCS, Time Span= 0.00-20.00 hrs, dt= 0.01 hrs  
Type IIA 24-hr Rainfall=3.00"

Area (ac)	CN	Description
43.100	65	2 acre lots, 12% imp, HSG B

Tc (min)	Length (feet)	Slope (ft/ft)	Velocity (ft/sec)	Capacity (cfs)	Description
46.6					Direct Entry, Basin C-1

**Subcatchment C-2: Basin C-2**

Runoff = 5.07 cfs @ 6.30 hrs, Volume= 0.540 af, Depth= 0.47"

Runoff by SCS TR-20 method, UH=SCS, Time Span= 0.00-20.00 hrs, dt= 0.01 hrs  
Type IIA 24-hr Rainfall=3.00"

Area (ac)	CN	Description
13.700	65	2 acre lots, 12% imp, HSG B

Tc (min)	Length (feet)	Slope (ft/ft)	Velocity (ft/sec)	Capacity (cfs)	Description
29.1					Direct Entry, Basin C-2

**TR20-10YR-24HR Developed**

Type IIA 24-hr Rainfall=3.00"

Prepared by WestWorks Engineering

Page 6

HydroCAD® 7.00 s/n 002053 © 1986-2003 Applied Microcomputer Systems

6/16/2005

**Subcatchment C-3: Basin C-3**

Runoff = 4.18 cfs @ 6.18 hrs, Volume= 0.352 af, Depth= 0.48"

Runoff by SCS TR-20 method, UH=SCS, Time Span= 0.00-20.00 hrs, dt= 0.01 hrs  
Type IIA 24-hr Rainfall=3.00"

Area (ac)	CN	Description
8.900	65	2 acre lots, 12% imp, HSG B

Tc (min)	Length (feet)	Slope (ft/ft)	Velocity (ft/sec)	Capacity (cfs)	Description
21.0					Direct Entry, Basin C-3

**Subcatchment C-4: Basin C-4**

Runoff = 3.13 cfs @ 6.21 hrs, Volume= 0.281 af, Depth= 0.47"

Runoff by SCS TR-20 method, UH=SCS, Time Span= 0.00-20.00 hrs, dt= 0.01 hrs  
Type IIA 24-hr Rainfall=3.00"

Area (ac)	CN	Description
7.100	65	2 acre lots, 12% imp, HSG B

Tc (min)	Length (feet)	Slope (ft/ft)	Velocity (ft/sec)	Capacity (cfs)	Description
23.0					Direct Entry, Basin C-4

**Subcatchment C-5: Basin C-5**

Runoff = 7.76 cfs @ 6.29 hrs, Volume= 0.832 af, Depth= 0.47"

Runoff by SCS TR-20 method, UH=SCS, Time Span= 0.00-20.00 hrs, dt= 0.01 hrs  
Type IIA 24-hr Rainfall=3.00"

Area (ac)	CN	Description
21.100	65	2 acre lots, 12% imp, HSG B

Tc (min)	Length (feet)	Slope (ft/ft)	Velocity (ft/sec)	Capacity (cfs)	Description
29.2					Direct Entry, Basin C-5

**Subcatchment C-6: Basin C-6**

Runoff = 27.57 cfs @ 6.33 hrs, Volume= 3.171 af, Depth= 0.47"

Runoff by SCS TR-20 method, UH=SCS, Time Span= 0.00-20.00 hrs, dt= 0.01 hrs  
Type IIA 24-hr Rainfall=3.00"

**TR20-10YR-24HR Developed**

Type IIA 24-hr Rainfall=3.00"

Prepared by WestWorks Engineering

Page 7

HydroCAD® 7.00 s/n 002053 © 1986-2003 Applied Microcomputer Systems

6/16/2005

Area (ac)	CN	Description
80.500	65	2 acre lots, 12% imp, HSG B

Tc (min)	Length (feet)	Slope (ft/ft)	Velocity (ft/sec)	Capacity (cfs)	Description
32.0					Direct Entry, Basin C-6

**Subcatchment OS1: Off-Site Basin OS1**

Runoff = 5.68 cfs @ 6.24 hrs, Volume= 0.630 af, Depth= 0.34"

Runoff by SCS TR-20 method, UH=SCS, Time Span= 0.00-20.00 hrs, dt= 0.01 hrs  
Type IIA 24-hr Rainfall=3.00"

Area (ac)	CN	Description
22.300	61	Pasture/grassland/range, Good, HSG B

Tc (min)	Length (feet)	Slope (ft/ft)	Velocity (ft/sec)	Capacity (cfs)	Description
24.5					Direct Entry, Basin OS1

**Pond DP-B1: Design Point B-1**

Inflow Area = 24.000 ac, Inflow Depth = 0.47"  
 Inflow = 7.89 cfs @ 6.36 hrs, Volume= 0.945 af  
 Outflow = 3.44 cfs @ 6.78 hrs, Volume= 0.912 af, Atten= 56%, Lag= 25.3 min  
 Primary = 3.44 cfs @ 6.78 hrs, Volume= 0.912 af

Routing by Stor-Ind method, Time Span= 0.00-20.00 hrs, dt= 0.01 hrs  
 Peak Elev= 6,244.45' @ 6.78 hrs Surf.Area= 0.220 ac Storage= 0.219 af  
 Plug-Flow detention time= 49.3 min calculated for 0.912 af (97% of inflow)  
 Center-of-Mass det. time= 28.4 min ( 601.4 - 572.9 )

#	Invert	Avail.Storage	Storage Description
1	6,243.00'	2.049 af	Custom Stage Data (Prismatic) Listed below

Elevation (feet)	Surf.Area (acres)	Inc.Store (acre-feet)	Cum.Store (acre-feet)
6,243.00	0.005	0.000	0.000
6,244.00	0.077	0.041	0.041
6,246.00	0.721	0.798	0.839
6,247.00	1.700	1.210	2.049

#	Routing	Invert	Outlet Devices
1	Primary	6,243.50'	24.0" x 50.0' long Culvert CMP, end-section conforming to fill, Ke= 0.500 Outlet Invert= 6,243.00' S=0.0100 '/ n= 0.022 Cc= 0.900

Primary OutFlow Max=3.44 cfs @ 6.78 hrs HW=6,244.45' (Free Discharge)

1=Culvert (Barrel Controls 3.44 cfs @ 3.5 fps)

**TR20-10YR-24HR Developed**

Type IIA 24-hr Rainfall=3.00"

Prepared by WestWorks Engineering

Page 8

HydroCAD® 7.00 s/n 002053 © 1986-2003 Applied Microcomputer Systems

6/16/2005

**Pond DP-B2: Design Point B2**

Inflow Area = 6.400 ac, Inflow Depth = 0.47"  
 Inflow = 2.49 cfs @ 6.26 hrs, Volume= 0.253 af  
 Outflow = 0.52 cfs @ 6.97 hrs, Volume= 0.215 af, Atten= 79%, Lag= 42.7 min  
 Primary = 0.52 cfs @ 6.97 hrs, Volume= 0.215 af

Routing by Stor-Ind method, Time Span= 0.00-20.00 hrs, dt= 0.01 hrs  
 Peak Elev= 6,244.39' @ 6.97 hrs Surf.Area= 0.099 ac Storage= 0.088 af  
 Plug-Flow detention time= 170.0 min calculated for 0.215 af (85% of inflow)  
 Center-of-Mass det. time= 88.3 min ( 656.9 - 568.6 )

#	Invert	Avail.Storage	Storage Description
1	6,244.00'	0.446 af	Custom Stage Data (Prismatic) Listed below
Elevation (feet)	Surf.Area (acres)	Inc.Store (acre-feet)	Cum.Store (acre-feet)
6,244.00	0.019	0.000	0.000
6,246.00	0.427	0.446	0.446

#	Routing	Invert	Outlet Devices
1	Primary	6,244.00'	18.0" x 50.0' long Culvert CMP, end-section conforming to fill, Ke= 0.500 Outlet Invert= 6,243.50' S= 0.0100 ' n= 0.022 Cc= 0.900

Primary OutFlow Max=0.52 cfs @ 6.97 hrs HW=6,244.39' (Free Discharge)  
 ↑1=Culvert (Barrel Controls 0.52 cfs @ 2.1 fps)

**Pond DP-B4: Design Point B4**

Inflow Area = 163.000 ac, Inflow Depth = 0.45"  
 Inflow = 48.32 cfs @ 6.27 hrs, Volume= 6.109 af  
 Outflow = 30.25 cfs @ 6.52 hrs, Volume= 6.041 af, Atten= 37%, Lag= 14.7 min  
 Primary = 30.25 cfs @ 6.52 hrs, Volume= 6.041 af

Routing by Stor-Ind method, Time Span= 0.00-20.00 hrs, dt= 0.01 hrs  
 Peak Elev= 6,194.50' @ 6.52 hrs Surf.Area= 0.516 ac Storage= 0.652 af  
 Plug-Flow detention time= 15.4 min calculated for 6.038 af (99% of inflow)  
 Center-of-Mass det. time= 8.6 min ( 588.3 - 579.7 )

#	Invert	Avail.Storage	Storage Description
1	6,192.00'	1.821 af	Custom Stage Data (Prismatic) Listed below
Elevation (feet)	Surf.Area (acres)	Inc.Store (acre-feet)	Cum.Store (acre-feet)
6,192.00	0.009	0.000	0.000
6,194.00	0.253	0.262	0.262
6,196.00	1.306	1.559	1.821

#	Routing	Invert	Outlet Devices
1	Primary	6,192.00'	24.0" x 50.0' long Culvert X 2.00 CMP, end-section conforming to fill, Ke= 0.500

2 Primary 6,195.00' Outlet Invert= 6,191.50' S= 0.0100 '/ n= 0.022 Cc= 0.900  
**Roadway Overtop**  
 Head (feet) 0.00 0.50  
 Disch. (cfs) 0.00 280.00

Primary OutFlow Max=30.26 cfs @ 6.52 hrs HW=6,194.50' (Free Discharge)

1=Culvert (Barrel Controls 30.26 cfs @ 4.9 fps)

2=Roadway Overtop ( Controls 0.00 cfs)

**Pond DP-C1: Design Point C1**

[88] Warning: Qout>Qin may require Finer Routing>1

Inflow Area = 56.800 ac, Inflow Depth = 0.47"  
 Inflow = 15.04 cfs @ 6.46 hrs, Volume= 2.220 af  
 Outflow = 15.04 cfs @ 6.47 hrs, Volume= 2.220 af, Atten= 0%, Lag= 0.3 min  
 Primary = 15.04 cfs @ 6.47 hrs, Volume= 2.220 af

Routing by Stor-Ind method, Time Span= 0.00-20.00 hrs, dt= 0.01 hrs  
 Peak Elev= 6,213.06' @ 6.47 hrs Surf.Area= 0.011 ac Storage= 0.011 af  
 Plug-Flow detention time= 0.6 min calculated for 2.219 af (100% of inflow)  
 Center-of-Mass det. time= 0.4 min ( 580.5 - 580.1 )

#	Invert	Avail.Storage	Storage Description
1	6,212.00'	5.735 af	Custom Stage Data (Prismatic) Listed below
	Elevation (feet)	Surf.Area (acres)	Inc.Store (acre-feet) Cum.Store (acre-feet)
	6,212.00	0.005	0.000 0.000
	6,214.00	0.016	0.021 0.021
	6,216.00	1.295	1.311 1.332
	6,218.00	3.108	4.403 5.735

#	Routing	Invert	Outlet Devices
1	Primary	6,211.70'	30.0" x 50.0' long Culvert X 2.00 CMP, end-section conforming to fill, Ke= 0.500 Outlet Invert= 6,211.20' S= 0.0100 '/ n= 0.024 Cc= 0.900

Primary OutFlow Max=15.04 cfs @ 6.47 hrs HW=6,213.06' (Free Discharge)

1=Culvert (Barrel Controls 15.04 cfs @ 4.0 fps)

**Pond DP-C2: Design Point C2**

Inflow Area = 13.700 ac, Inflow Depth = 0.47"  
 Inflow = 5.07 cfs @ 6.30 hrs, Volume= 0.540 af  
 Outflow = 4.85 cfs @ 6.34 hrs, Volume= 0.533 af, Atten= 4%, Lag= 2.7 min  
 Primary = 4.85 cfs @ 6.34 hrs, Volume= 0.533 af

Routing by Stor-Ind method, Time Span= 0.00-20.00 hrs, dt= 0.01 hrs

**TR20-10YR-24HR Developed**

Type IIA 24-hr Rainfall=3.00"

Prepared by WestWorks Engineering  
HydroCAD® 7.00 s/n 002053 © 1986-2003 Applied Microcomputer SystemsPage 10  
6/16/2005Peak Elev= 6,221.68' @ 6.34 hrs Surf.Area= 0.049 ac Storage= 0.036 af  
Plug-Flow detention time= 15.1 min calculated for 0.533 af (99% of inflow)  
Center-of-Mass det. time= 6.9 min ( 576.8 - 569.8 )

#	Invert	Avail.Storage	Storage Description
1	6,220.50'	0.301 af	Custom Stage Data (Prismatic) Listed below

Elevation (feet)	Surf.Area (acres)	Inc.Store (acre-feet)	Cum.Store (acre-feet)
6,220.50	0.000	0.000	0.000
6,222.00	0.062	0.046	0.046
6,223.33	0.321	0.255	0.301

#	Routing	Invert	Outlet Devices
1	Primary	6,220.50'	24.0" x 50.0' long Culvert CMP, end-section conforming to fill, Ke= 0.500 Outlet Invert= 6,220.00' S= 0.0100 /' n= 0.024 Cc= 0.900

Primary OutFlow Max=4.85 cfs @ 6.34 hrs HW=6,221.68' (Free Discharge)  
↑1=Culvert (Barrel Controls 4.85 cfs @ 3.6 fps)**Pond DP-C3: Design Point C3**

Inflow Area =	8.900 ac,	Inflow Depth =	0.48"
Inflow =	4.18 cfs @	6.18 hrs, Volume=	0.352 af
Outflow =	1.29 cfs @	6.54 hrs, Volume=	0.351 af, Atten= 69%, Lag= 21.3 min
Primary =	1.29 cfs @	6.54 hrs, Volume=	0.351 af

Routing by Stor-Ind method, Time Span= 0.00-20.00 hrs, dt= 0.01 hrs  
Peak Elev= 6,220.15' @ 6.54 hrs Surf.Area= 0.174 ac Storage= 0.080 af  
Plug-Flow detention time= 22.0 min calculated for 0.351 af (100% of inflow)  
Center-of-Mass det. time= 19.1 min ( 583.8 - 564.7 )

#	Invert	Avail.Storage	Storage Description
1	6,220.00'	1.083 af	Custom Stage Data (Prismatic) Listed below

Elevation (feet)	Surf.Area (acres)	Inc.Store (acre-feet)	Cum.Store (acre-feet)
6,220.00	0.110	0.000	0.000
6,222.00	0.973	1.083	1.083

#	Routing	Invert	Outlet Devices
1	Primary	6,219.50'	18.0" x 50.0' long Culvert CMP, end-section conforming to fill, Ke= 0.500 Outlet Invert= 6,219.00' S= 0.0100 /' n= 0.024 Cc= 0.900

Primary OutFlow Max=1.29 cfs @ 6.54 hrs HW=6,220.15' (Free Discharge)  
↑1=Culvert (Barrel Controls 1.29 cfs @ 2.6 fps)

**TR20-10YR-24HR Developed**

Type IIA 24-hr Rainfall=3.00"

Prepared by WestWorks Engineering

Page 11

HydroCAD® 7.00 s/n 002053 © 1986-2003 Applied Microcomputer Systems

6/16/2005

**Pond Pond B: Pond B**

Inflow Area = 249.000 ac, Inflow Depth = 0.45"  
 Inflow = 58.99 cfs @ 6.33 hrs, Volume= 9.431 af  
 Outflow = 5.82 cfs @ 9.81 hrs, Volume= 5.243 af, Atten= 90%, Lag= 208.5 min  
 Primary = 5.82 cfs @ 9.81 hrs, Volume= 5.243 af

Routing by Stor-Ind method, Time Span= 0.00-20.00 hrs, dt= 0.01 hrs  
 Peak Elev= 6,183.60' @ 9.81 hrs Surf.Area= 3.964 ac Storage= 4.918 af  
 Plug-Flow detention time= 377.7 min calculated for 5.243 af (56% of inflow)  
 Center-of-Mass det. time= 206.1 min ( 788.1 - 581.9 )

#	Invert	Avail.Storage	Storage Description
1	6,182.00'	18.024 af	Custom Stage Data (Prismatic) Listed below

Elevation (feet)	Surf.Area (acres)	Inc.Store (acre-feet)	Cum.Store (acre-feet)
6,182.00	1.586	0.000	0.000
6,184.00	4.555	6.141	6.141
6,186.00	7.328	11.883	18.024

#	Routing	Invert	Outlet Devices
1	Primary	6,182.20'	2.0" Vert. Orifice/Grate X 2.00 C= 0.600
2	Primary	6,182.50'	27.8" x 25.0' long Culvert CMP, projecting, no headwall, Ke= 0.900 Outlet Invert= 6,181.75' S= 0.0300 '/ n= 0.024 Cc= 0.900

Primary OutFlow Max=5.82 cfs @ 9.81 hrs HW=6,183.60' (Free Discharge)  
 1=Orifice/Grate (Orifice Controls 0.24 cfs @ 5.5 fps)  
 2=Culvert (Inlet Controls 5.58 cfs @ 2.8 fps)

**Pond Pond C: Pond C**

Inflow Area = 174.400 ac, Inflow Depth = 0.47"  
 Inflow = 52.19 cfs @ 6.34 hrs, Volume= 6.855 af  
 Outflow = 3.01 cfs @ 13.92 hrs, Volume= 2.934 af, Atten= 94%, Lag= 454.8 min  
 Primary = 3.01 cfs @ 13.92 hrs, Volume= 2.934 af

Routing by Stor-Ind method, Time Span= 0.00-20.00 hrs, dt= 0.01 hrs  
 Peak Elev= 6,201.36' @ 13.92 hrs Surf.Area= 3.692 ac Storage= 4.119 af  
 Plug-Flow detention time= 432.6 min calculated for 2.934 af (43% of inflow)  
 Center-of-Mass det. time= 247.7 min ( 822.4 - 574.7 )

#	Invert	Avail.Storage	Storage Description
1	6,200.00'	20.381 af	Custom Stage Data (Prismatic) Listed below

Elevation (feet)	Surf.Area (acres)	Inc.Store (acre-feet)	Cum.Store (acre-feet)
6,200.00	1.196	0.000	0.000
6,202.00	4.876	6.072	6.072
6,204.00	9.433	14.309	20.381

**TR20-10YR-24HR Developed**

Type IIA 24-hr Rainfall=3.00"

Prepared by WestWorks Engineering

Page 12

HydroCAD® 7.00 s/n 002053 © 1986-2003 Applied Microcomputer Systems

6/16/2005

---

#	Routing	Invert	Outlet Devices
1	Primary	6,200.20'	<b>2.0" Vert. Orifice/Grate X 2.00</b> C= 0.600
2	Primary	6,200.50'	<b>27.8" x 25.0' long Culvert</b> CMP, projecting, no headwall, Ke= 0.900 Outlet Invert= 6,200.25' S= 0.0100 /' n= 0.024 Cc= 0.900

---

**Primary OutFlow** Max=3.01 cfs @ 13.92 hrs HW=6,201.36' (Free Discharge)

└1=Orifice/Grate (Orifice Controls 0.22 cfs @ 5.0 fps)

└2=Culvert (Barrel Controls 2.79 cfs @ 2.9 fps)

**DEVELOPED CONDITIONS  
HYDROLOGIC CALCULATIONS  
MAJOR STORM  
(RATIONAL METHOD – 100 YEAR)  
(TR-20 – 100 YEAR)**

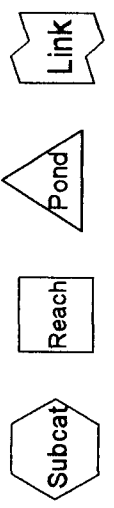
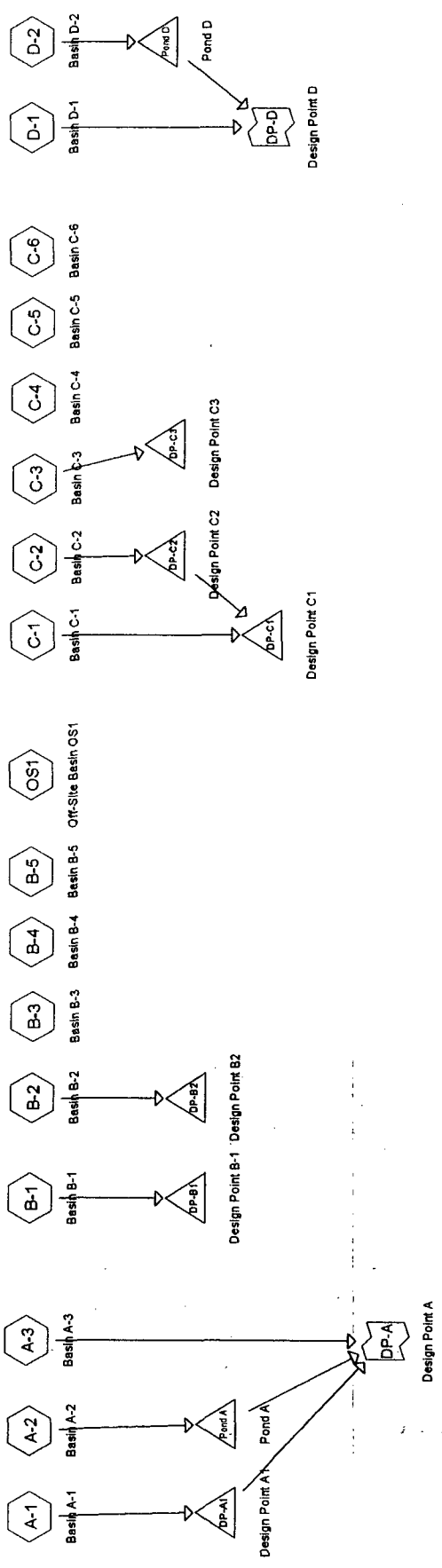

**Drainage Diagram for Rational-100YR Developed**  
 Prepared by WestWorks Engineering 6/16/2005  
 HydroCAD® 7.00 s/n 002053 © 1986-2003 Applied Microcomputer Systems

**Rational-100YR Developed**

El Paso County 100-Year Duration=24 min, Inten=4.88 in/hr

Prepared by WestWorks Engineering

Page 1

HydroCAD® 7.00 s/n 002053 © 1986-2003 Applied Microcomputer Systems

6/16/2005

**Subcatchment A-1: Basin A-1**

Runoff = 51.19 cfs @ 0.40 hrs, Volume= 1.692 af, Depth= 0.78"

Runoff by Rational method, Rise/Fall=1.0/1.0 xTc, Time Span= 0.00-3.00 hrs, dt= 0.01 hrs  
El Paso County 100-Year Duration=24 min, Inten=4.88 in/hr

Area (ac)	C	Description
26.000	0.40	5 acre lots, 12% imp, HSG B

Tc (min)	Length (feet)	Slope (ft/ft)	Velocity (ft/sec)	Capacity (cfs)	Description
23.8					Direct Entry, Basin A-1

**Subcatchment A-1: Basin A-1**

Hydrograph

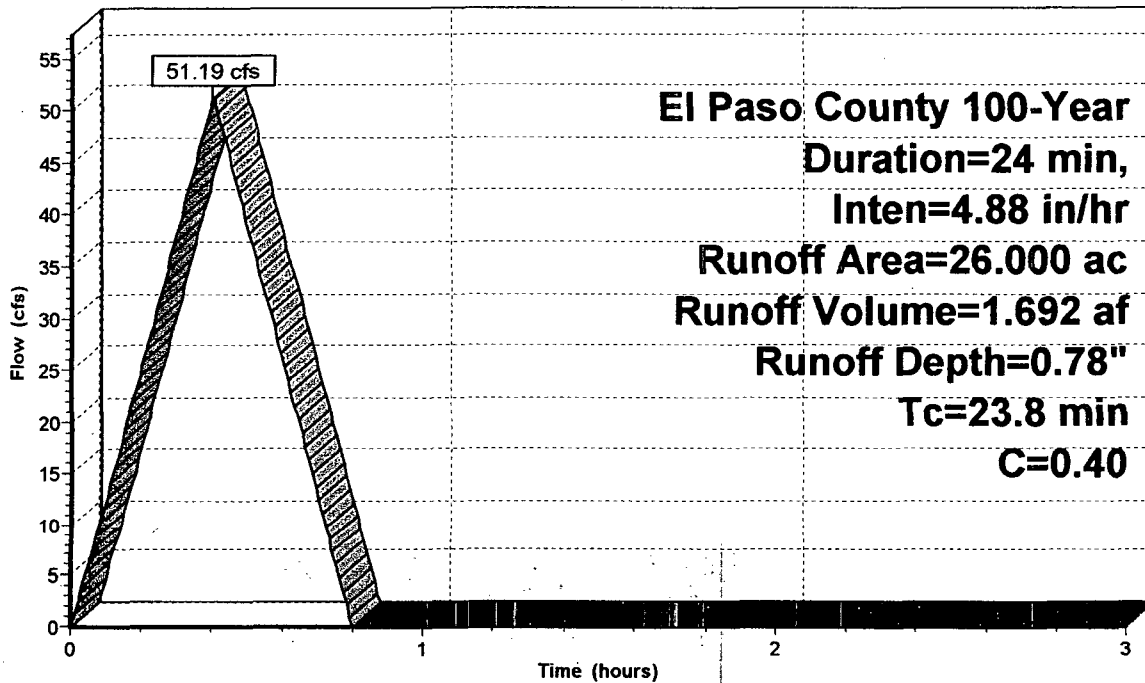

**Pond DP-A1: Design Point A1**

Inflow Area = 26.000 ac, Inflow Depth = 0.78" for 100-Year event  
 Inflow = 51.19 cfs @ 0.40 hrs, Volume= 1.692 af  
 Outflow = 4.13 cfs @ 0.76 hrs, Volume= 0.722 af, Atten= 92%, Lag= 21.9 min  
 Primary = 4.13 cfs @ 0.76 hrs, Volume= 0.722 af

Routing by Stor-Ind method, Time Span= 0.00-3.00 hrs, dt= 0.01 hrs  
 Peak Elev= 6,221.54' @ 0.76 hrs Surf.Area= 1.531 ac Storage= 1.567 af  
 Plug-Flow detention time= 80.1 min calculated for 0.722 af (43% of inflow)  
 Center-of-Mass det. time= 70.9 min ( 94.8 - 23.9 )

#	Invert	Avail.Storage	Storage Description
1	6,220.00'	2.033 af	<b>Custom Stage Data (Prismatic)</b> Listed below

Elevation (feet)	Surf.Area (acres)	Inc.Store (acre-feet)	Cum.Store (acre-feet)
6,220.00	0.067	0.000	0.000
6,222.00	1.966	2.033	2.033

#	Routing	Invert	Outlet Devices
1	Primary	6,219.70'	<b>2.0" Vert. Orifice/Grate X 2.00</b> C= 0.600
2	Primary	6,220.10'	<b>14.2" x 50.0' long Culvert</b> CMP, projecting, no headwall, Ke= 0.900 Outlet Invert= 6,219.00' S= 0.0220 /' n= 0.024 Cc= 0.900

**Primary OutFlow** Max=4.13 cfs @ 0.76 hrs HW=6,221.54' (Free Discharge)

└1=Orifice/Grate (Orifice Controls 0.28 cfs @ 6.4 fps)

└2=Culvert (Inlet Controls 3.85 cfs @ 3.5 fps)

### Pond DP-A1: Design Point A1

Hydrograph

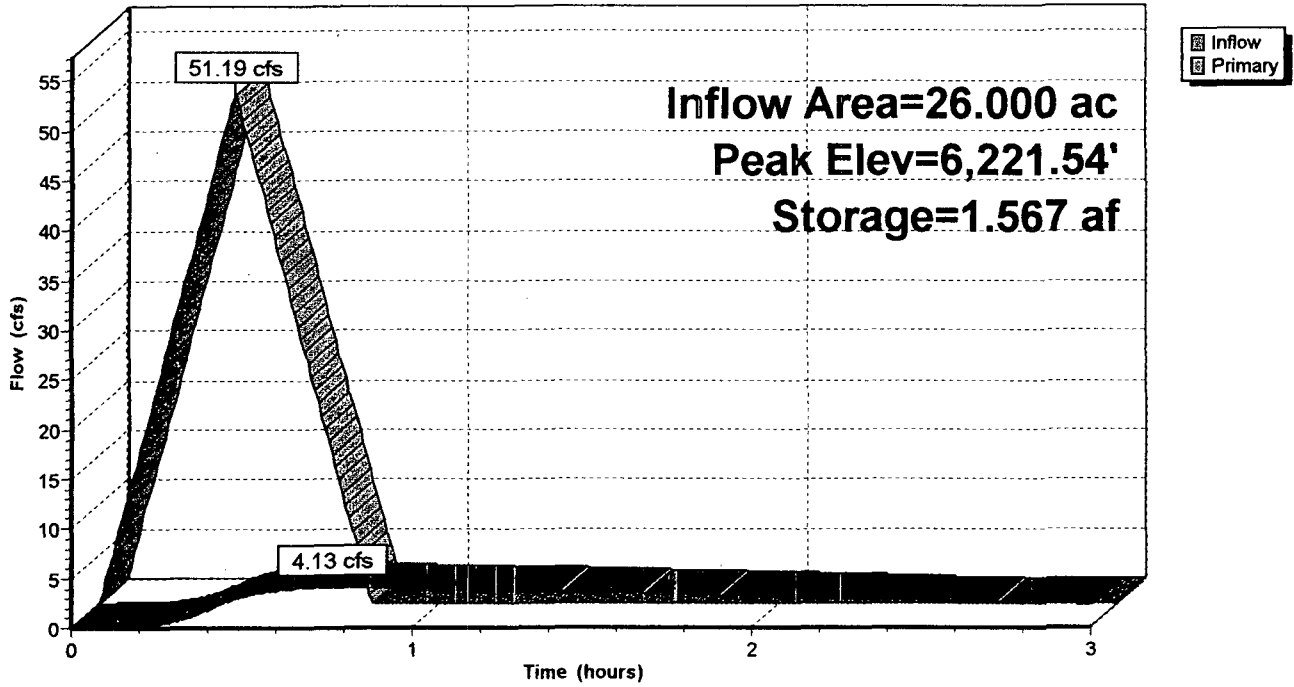

**Subcatchment A-2: Basin A-2**

Runoff = 30.88 cfs @ 0.38 hrs, Volume= 0.982 af, Depth= 0.77"

Runoff by Rational method, Rise/Fall=1.0/1.0 xTc, Time Span= 0.00-3.00 hrs, dt= 0.01 hrs  
 El Paso County 100-Year Duration=23 min, Inten=4.99 in/hr

Area (ac)	C	Description
15.400	0.40	5 acre lots, 12% imp, HSG B

Tc (min)	Length (feet)	Slope (ft/ft)	Velocity (ft/sec)	Capacity (cfs)	Description
22.9					Direct Entry, Basin A-2

**Subcatchment A-2: Basin A-2**

Hydrograph

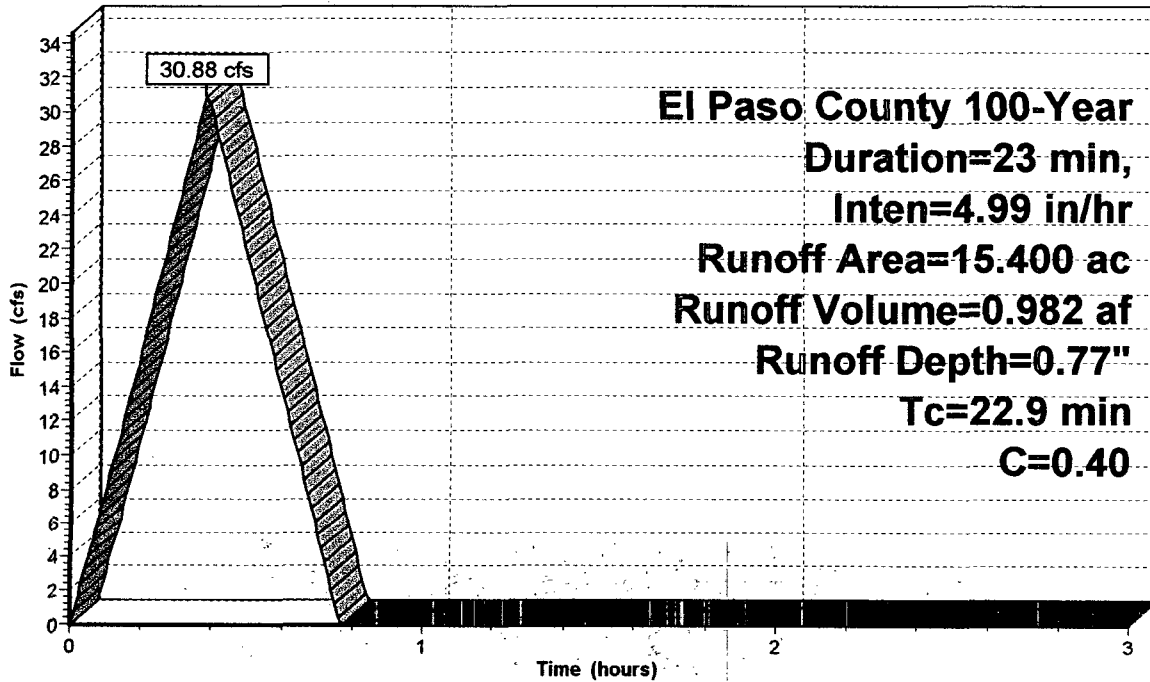

**Rational-100YR Developed**

El Paso County 100-Year Duration=23 min, Inten=4.99 in/hr

Prepared by WestWorks Engineering

Page 1

HydroCAD® 7.00 s/n 002053 © 1986-2003 Applied Microcomputer Systems

6/16/2005

**Subcatchment A-3: Basin A-3**

Runoff = 4.16 cfs @ 0.38 hrs, Volume= 0.133 af, Depth= 0.76"

Runoff by Rational method, Rise/Fall=1.0/1.0 xTc, Time Span= 0.00-3.00 hrs, dt= 0.01 hrs  
 El Paso County 100-Year Duration=23 min, Inten=4.99 in/hr

Area (ac)	C	Description
2.100	0.40	5 acre lots, 12% imp, HSG B

Tc (min)	Length (feet)	Slope (ft/ft)	Velocity (ft/sec)	Capacity (cfs)	Description
23.2					Direct Entry, Basin A-3

**Subcatchment A-3: Basin A-3**

Hydrograph

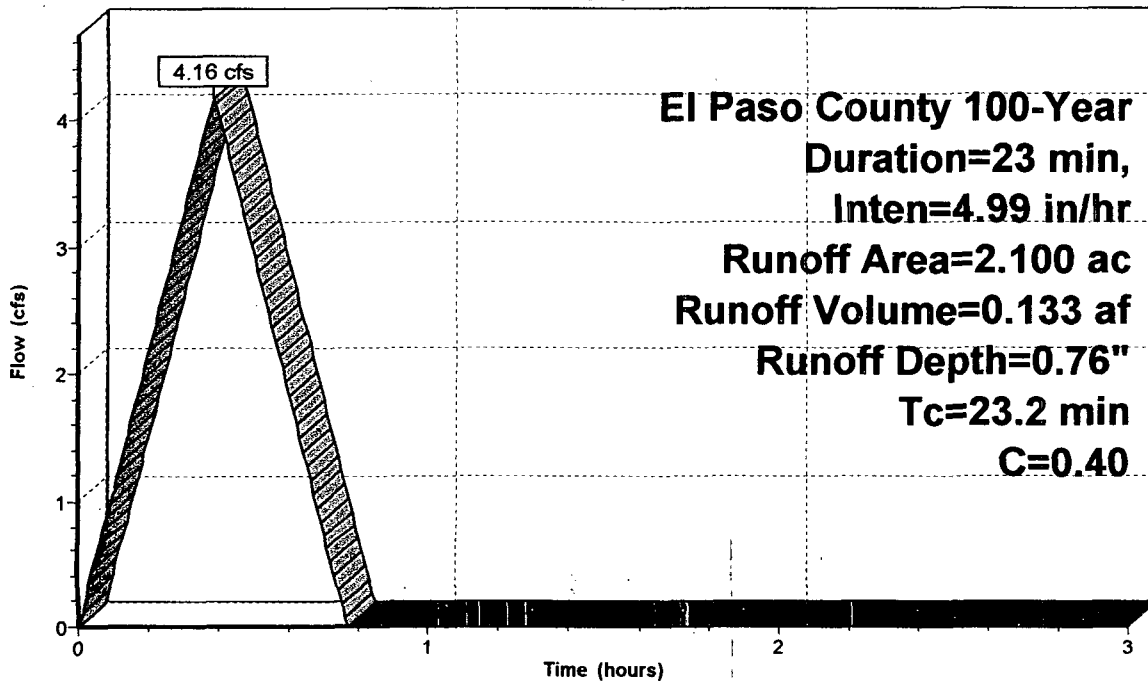

**Pond Pond A: Pond A**

Inflow Area = 15.400 ac, Inflow Depth = 0.77" for 100-Year event  
 Inflow = 30.88 cfs @ 0.38 hrs, Volume= 0.982 af  
 Outflow = 1.53 cfs @ 0.75 hrs, Volume= 0.229 af, Atten= 95%, Lag= 21.9 min  
 Primary = 1.53 cfs @ 0.75 hrs, Volume= 0.229 af

Routing by Stor-Ind method, Time Span= 0.00-3.00 hrs, dt= 0.01 hrs  
 Peak Elev= 6,219.13' @ 0.75 hrs Surf.Area= 0.942 ac Storage= 0.951 af  
 Plug-Flow detention time= 84.6 min calculated for 0.228 af (23% of inflow)  
 Center-of-Mass det. time= 72.4 min ( 95.4 - 23.0 )

#	Invert	Avail.Storage	Storage Description
1	6,218.00'	1.678 af	<b>Custom Stage Data (Prismatic)</b> Listed below

Elevation (feet)	Surf.Area (acres)	Inc.Store (acre-feet)	Cum.Store (acre-feet)
6,218.00	0.064	0.000	0.000
6,220.00	1.614	1.678	1.678

#	Routing	Invert	Outlet Devices
1	Primary	6,218.20'	<b>2.0" Vert. Orifice/Grate X 2.00</b> C= 0.600
2	Primary	6,218.50'	<b>15.1" x 20.0' long Culvert</b> CMP, projecting, no headwall, Ke= 0.900 Outlet Invert= 6,217.80' S= 0.0350 '/ n= 0.022 Cc= 0.900

**Primary OutFlow** Max=1.53 cfs @ 0.75 hrs HW=6,219.13' (Free Discharge)

1=Orifice/Grate (Orifice Controls 0.19 cfs @ 4.4 fps)

2=Culvert (Inlet Controls 1.34 cfs @ 2.1 fps)

Pond Pond A: Pond A

Hydrograph

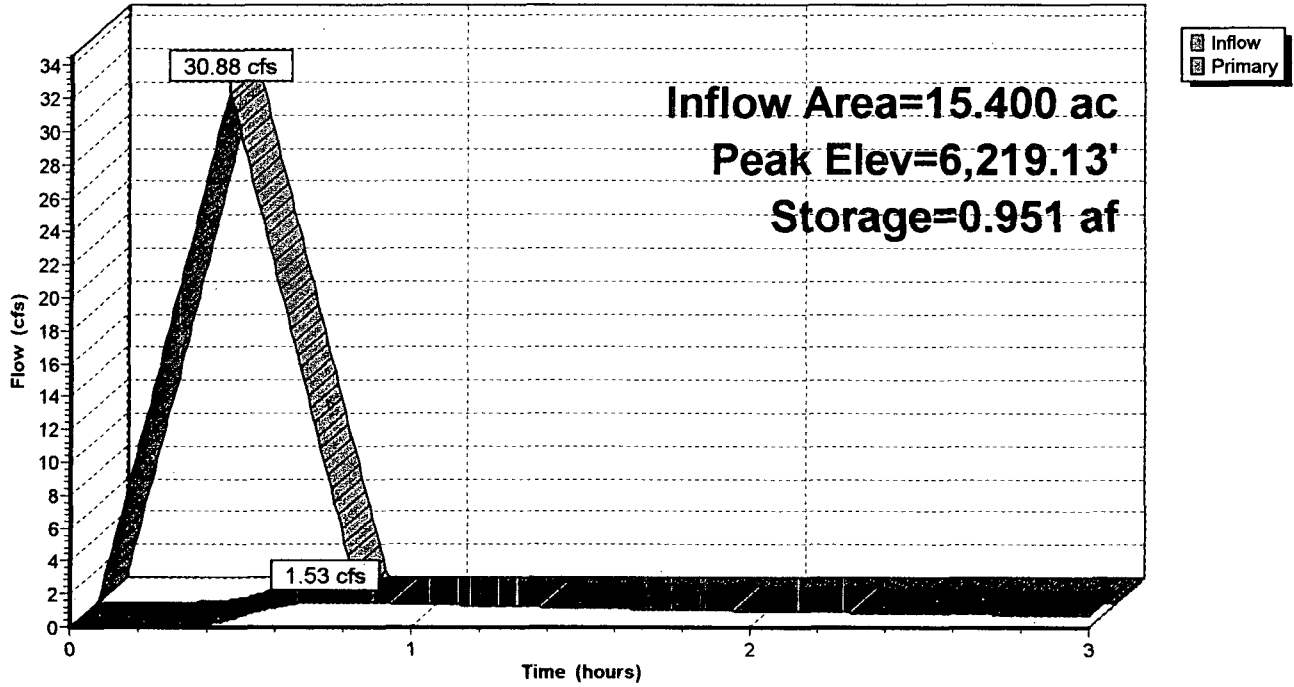

Link DP-A: Design Point A

Inflow Area = 43.500 ac, Inflow Depth = 0.30" for 100-Year event  
Inflow = 7.03 cfs @ 0.57 hrs, Volume= 1.098 af  
Primary = 7.03 cfs @ 0.57 hrs, Volume= 1.098 af, Atten= 0%, Lag= 0.0 min

Primary outflow = Inflow, Time Span= 0.00-3.00 hrs, dt= 0.01 hrs

Link DP-A: Design Point A

Hydrograph

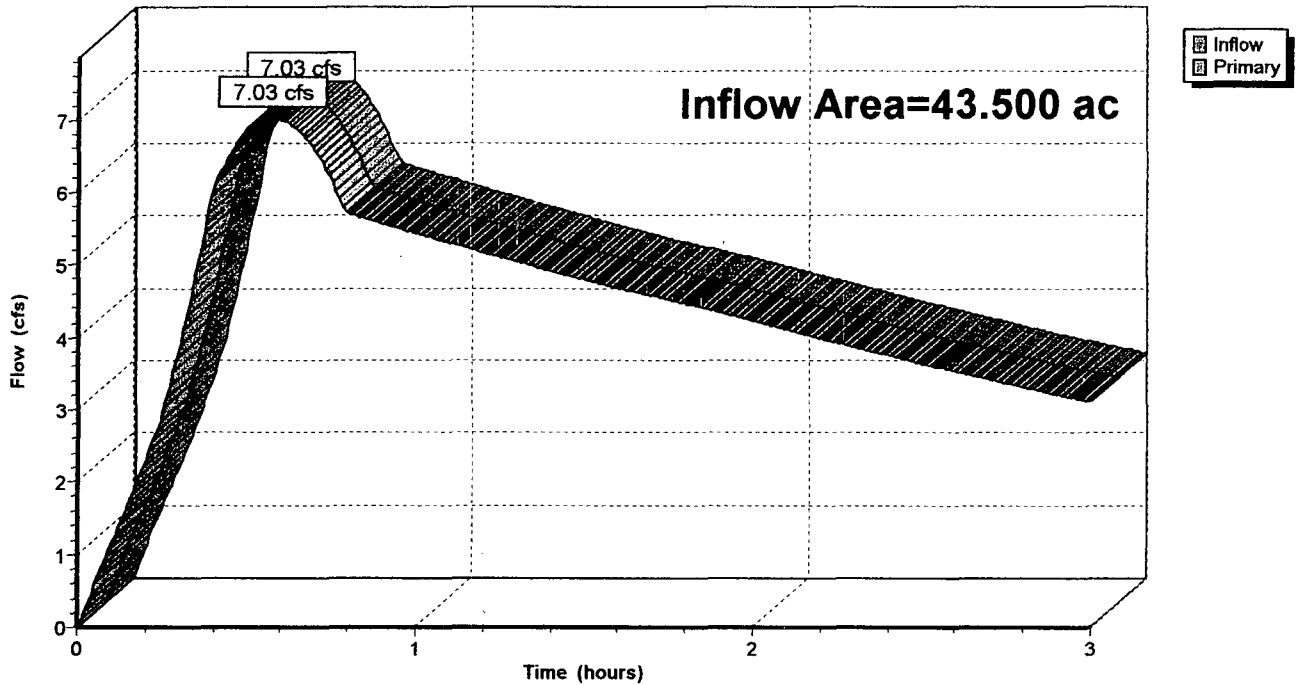

**Subcatchment B-1: Basin B-1**

Runoff = 38.64 cfs @ 0.57 hrs, Volume= 1.818 af, Depth= 0.91"

Runoff by Rational method, Rise/Fall=1.0/1.0 xTc, Time Span= 0.00-3.00 hrs, dt= 0.01 hrs  
 El Paso County 100-Year Duration=34 min, Inten=4.01 in/hr

Area (ac)	C	Description
24.000	0.40	2 acre lots, 12% imp, HSG B

Tc (min)	Length (feet)	Slope (ft/ft)	Velocity (ft/sec)	Capacity (cfs)	Description
33.9					Direct Entry, Basin B-1

**Subcatchment B-1: Basin B-1**

Hydrograph

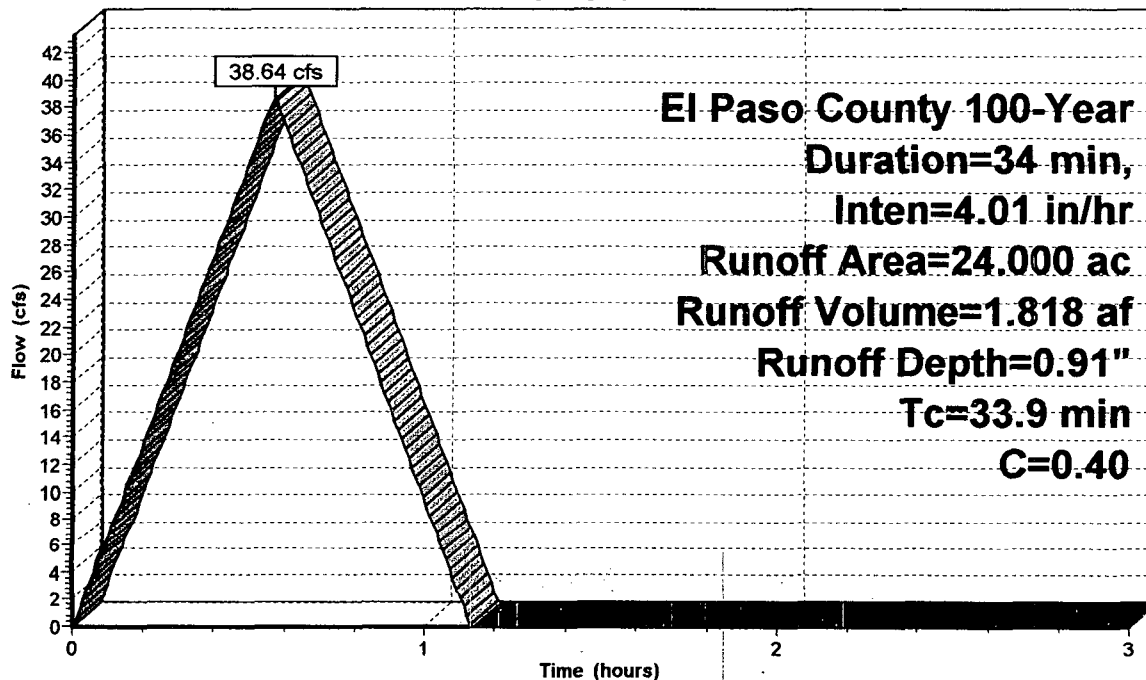

**Rational-100YR Developed**

*El Paso County 100-Year Duration=34 min, Inten=4.01 in/hr*

Prepared by WestWorks Engineering

Page 1

HydroCAD® 7.00 s/n 002053 © 1986-2003 Applied Microcomputer Systems

6/16/2005

**Pond DP-B1: Design Point B-1**

Inflow Area = 24.000 ac, Inflow Depth = 0.91" for 100-Year event  
 Inflow = 38.64 cfs @ 0.57 hrs, Volume= 1.818 af  
 Outflow = 14.64 cfs @ 0.71 hrs, Volume= 1.738 af, Atten= 62%, Lag= 8.8 min  
 Primary = 14.64 cfs @ 0.71 hrs, Volume= 1.738 af

Routing by Stor-Ind method, Time Span= 0.00-3.00 hrs, dt= 0.01 hrs  
 Peak Elev= 6,246.19' @ 0.92 hrs Surf.Area= 0.909 ac Storage= 1.072 af  
 Plug-Flow detention time= 40.3 min calculated for 1.732 af (95% of inflow)  
 Center-of-Mass det. time= 39.3 min ( 73.3 - 34.0 )

#	Invert	Avail.Storage	Storage Description
1	6,243.00'	2.049 af	<b>Custom Stage Data (Prismatic)</b> Listed below

Elevation (feet)	Surf.Area (acres)	Inc.Store (acre-feet)	Cum.Store (acre-feet)
6,243.00	0.005	0.000	0.000
6,244.00	0.077	0.041	0.041
6,246.00	0.721	0.798	0.839
6,247.00	1.700	1.210	2.049

#	Routing	Invert	Outlet Devices
1	Primary	6,243.50'	<b>24.0" x 50.0' long Culvert</b> CMP, end-section conforming to fill, Ke= 0.500 Outlet Invert= 6,243.00' S= 0.0100 '/ n= 0.024 Cc= 0.900

**Primary OutFlow** Max=14.65 cfs @ 0.71 hrs HW=6,246.09' (Free Discharge)

←1=Culvert (Barrel Controls 14.65 cfs @ 4.7 fps)

**Pond DP-B1: Design Point B-1**

Hydrograph

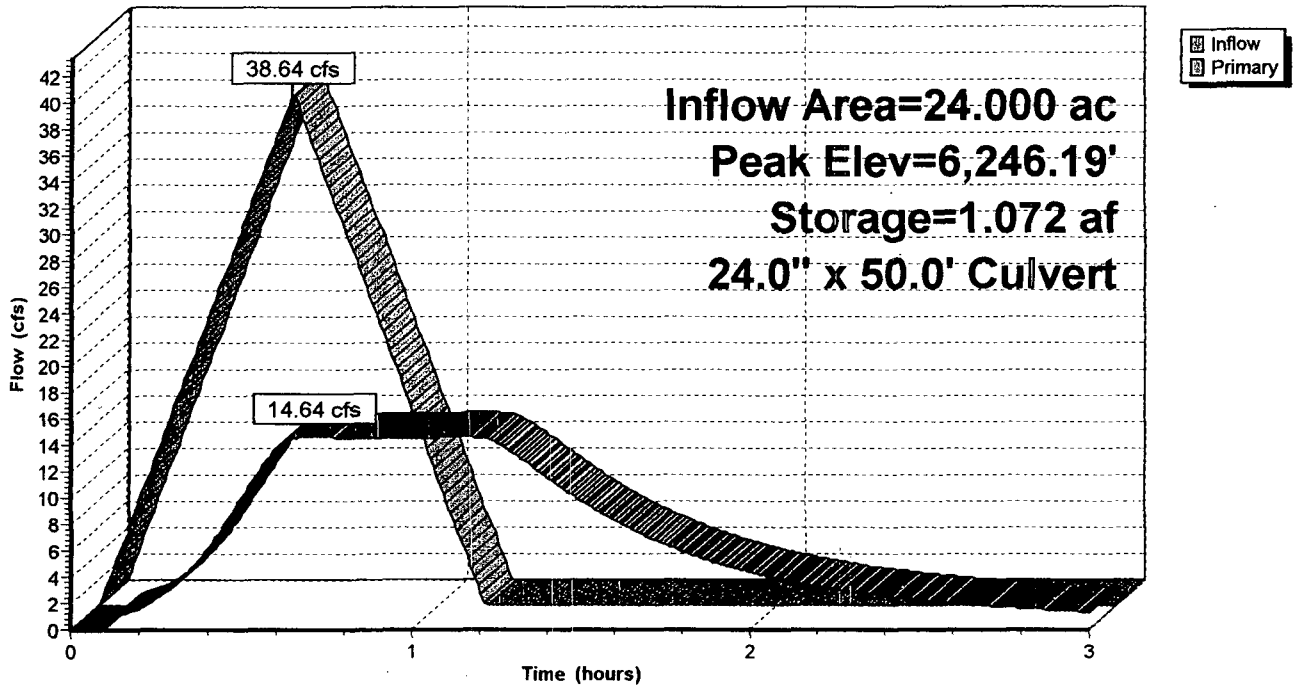

**Subcatchment B-2: Basin B-2**

Runoff = 11.71 cfs @ 0.45 hrs, Volume= 0.435 af, Depth= 0.82"

Runoff by Rational method, Rise/Fall=1.0/1.0 xTc, Time Span= 0.00-3.00 hrs, dt= 0.01 hrs  
 El Paso County 100-Year Duration=27 min, Inten=4.57 in/hr

Area (ac)	C	Description
6.400	0.40	2 acre lots, 12% imp, HSG B

Tc (min)	Length (feet)	Slope (ft/ft)	Velocity (ft/sec)	Capacity (cfs)	Description
27.2					Direct Entry, Basin B-2

**Subcatchment B-2: Basin B-2**

Hydrograph

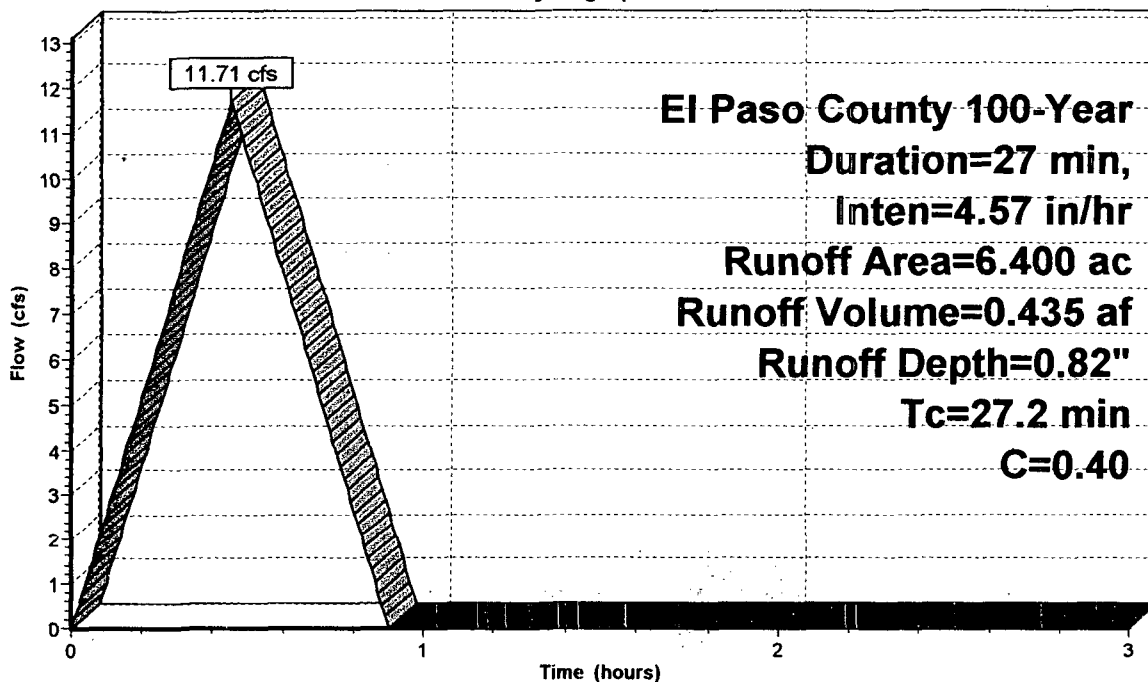

Runoff

**El Paso County 100-Year  
 Duration=27 min,  
 Inten=4.57 in/hr  
 Runoff Area=6.400 ac  
 Runoff Volume=0.435 af  
 Runoff Depth=0.82"  
 Tc=27.2 min  
 C=0.40**

**Pond DP-B2: Design Point B2**

Inflow Area = 6.400 ac, Inflow Depth = 0.82" for 100-Year event  
 Inflow = 11.71 cfs @ 0.45 hrs, Volume= 0.435 af  
 Outflow = 4.68 cfs @ 0.72 hrs, Volume= 0.370 af, Atten= 60%, Lag= 16.2 min  
 Primary = 4.68 cfs @ 0.72 hrs, Volume= 0.370 af

Routing by Stor-Ind method, Time Span= 0.00-3.00 hrs, dt= 0.01 hrs  
 Peak Elev= 6,245.31' @ 0.72 hrs Surf.Area= 0.286 ac Storage= 0.292 af  
 Plug-Flow detention time= 42.1 min calculated for 0.369 af (85% of inflow)  
 Center-of-Mass det. time= 39.4 min ( 66.4 - 27.0 )

#	Invert	Avail.Storage	Storage Description
1	6,244.00'	0.446 af	Custom Stage Data (Prismatic) Listed below

Elevation (feet)	Surf.Area (acres)	Inc.Store (acre-feet)	Cum.Store (acre-feet)
6,244.00	0.019	0.000	0.000
6,246.00	0.427	0.446	0.446

#	Routing	Invert	Outlet Devices
1	Primary	6,244.00'	18.0" x 50.0' long Culvert CMP, end-section conforming to fill, Ke= 0.500 Outlet Invert= 6,243.50' S= 0.0100' /' n= 0.022 Cc= 0.900

Primary OutFlow Max=4.68 cfs @ 0.72 hrs HW=6,245.31' (Free Discharge)  
 ↳1=Culvert (Barrel Controls 4.68 cfs @ 3.8 fps)

**Pond DP-B2: Design Point B2**

Hydrograph

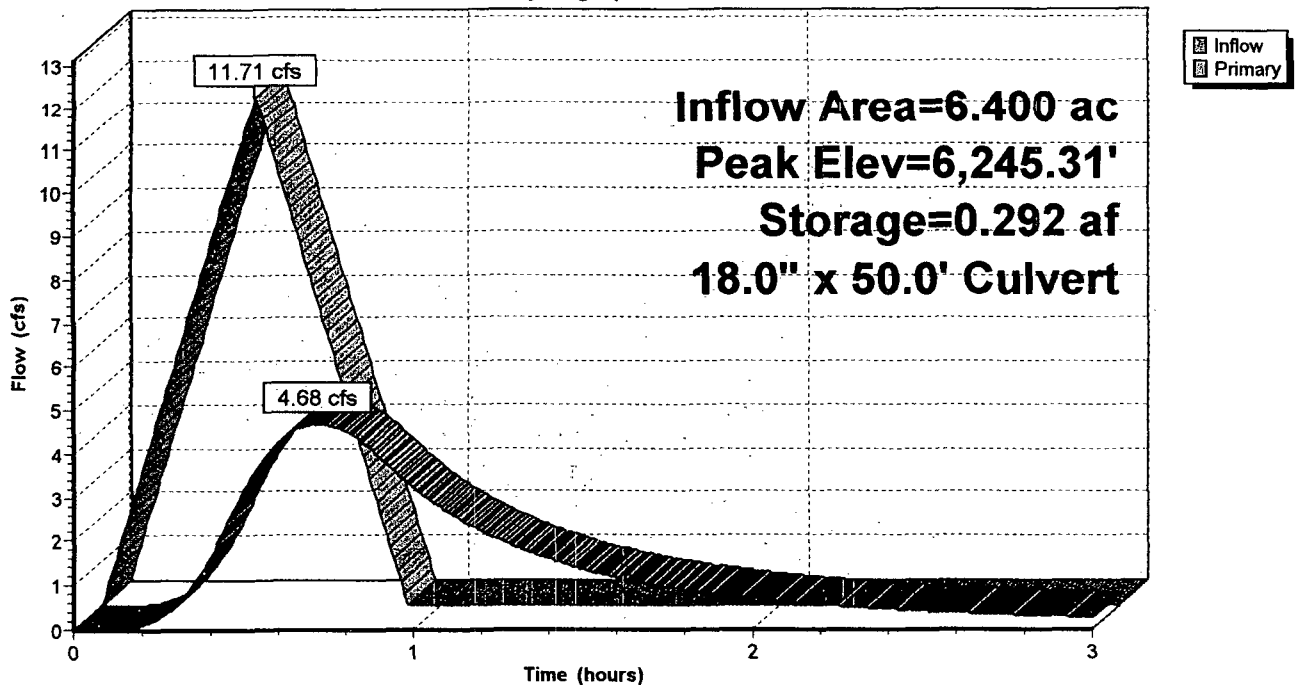

**Rational-100YR Developed**

*El Paso County 100-Year Duration=27 min, Inten=4.57 in/hr*

Prepared by WestWorks Engineering

Page 1

HydroCAD® 7.00 s/n 002053 © 1986-2003 Applied Microcomputer Systems

6/16/2005

**Subcatchment B-3: Basin B-3**

Runoff = 81.14 cfs @ 0.45 hrs, Volume= 3.016 af, Depth= 0.82"

Runoff by Rational method, Rise/Fall=1.0/1.0 xTc, Time Span= 0.00-3.00 hrs, dt= 0.01 hrs  
El Paso County 100-Year Duration=27 min, Inten=4.57 in/hr

Area (ac)	C	Description
44.000	0.40	5 acre lots, 12% imp, HSG B

Tc (min)	Length (feet)	Slope (ft/ft)	Velocity (ft/sec)	Capacity (cfs)	Description
26.7					Direct Entry, Basin B-3

**Subcatchment B-3: Basin B-3**

Hydrograph

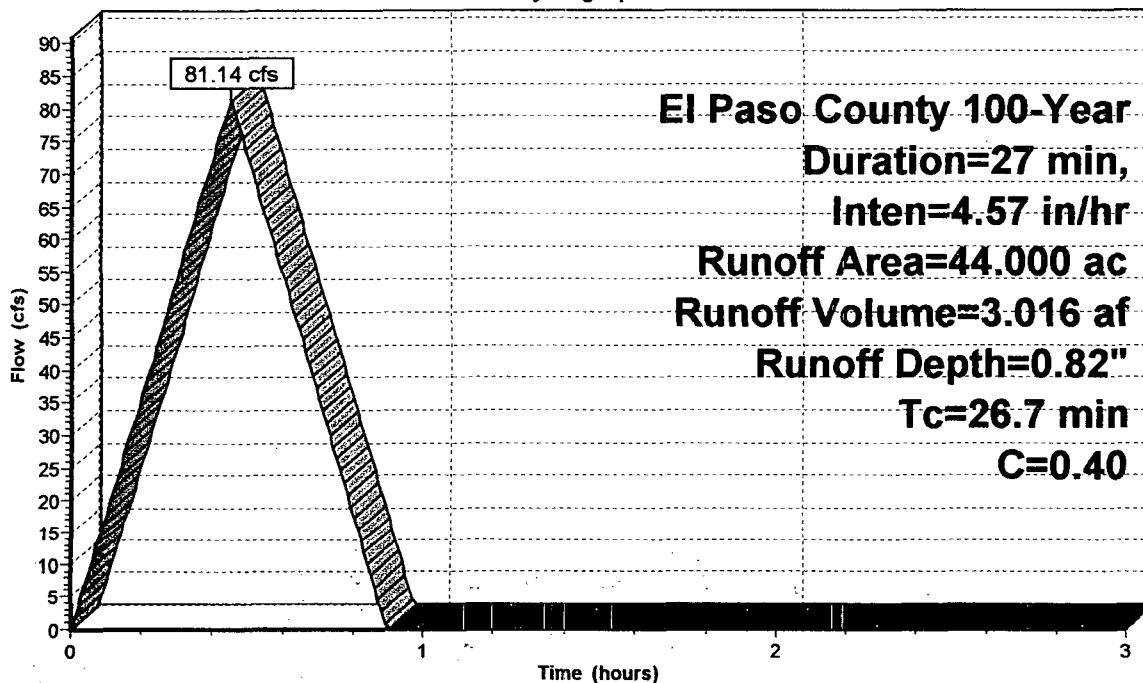

Runoff

**Rational-100YR Developed**

*El Paso County 100-Year Duration=30 min, Inten=4.31 in/hr*

Prepared by WestWorks Engineering

Page 1

HydroCAD® 7.00 s/n 002053 © 1986-2003 Applied Microcomputer Systems

6/16/2005

**Subcatchment B-4: Basin B-4**

Runoff = 115.27 cfs @ 0.50 hrs, Volume= 4.763 af, Depth= 0.86"

Runoff by Rational method, Rise/Fall=1.0/1.0 xTc, Time Span= 0.00-3.00 hrs, dt= 0.01 hrs  
 El Paso County 100-Year Duration=30 min, Inten=4.31 in/hr

Area (ac)	C	Description
66.300	0.40	5 acre lots, 12% imp, HSG B

Tc (min)	Length (feet)	Slope (ft/ft)	Velocity (ft/sec)	Capacity (cfs)	Description
29.8					Direct Entry, Basin B-4

**Subcatchment B-4: Basin B-4**

Hydrograph

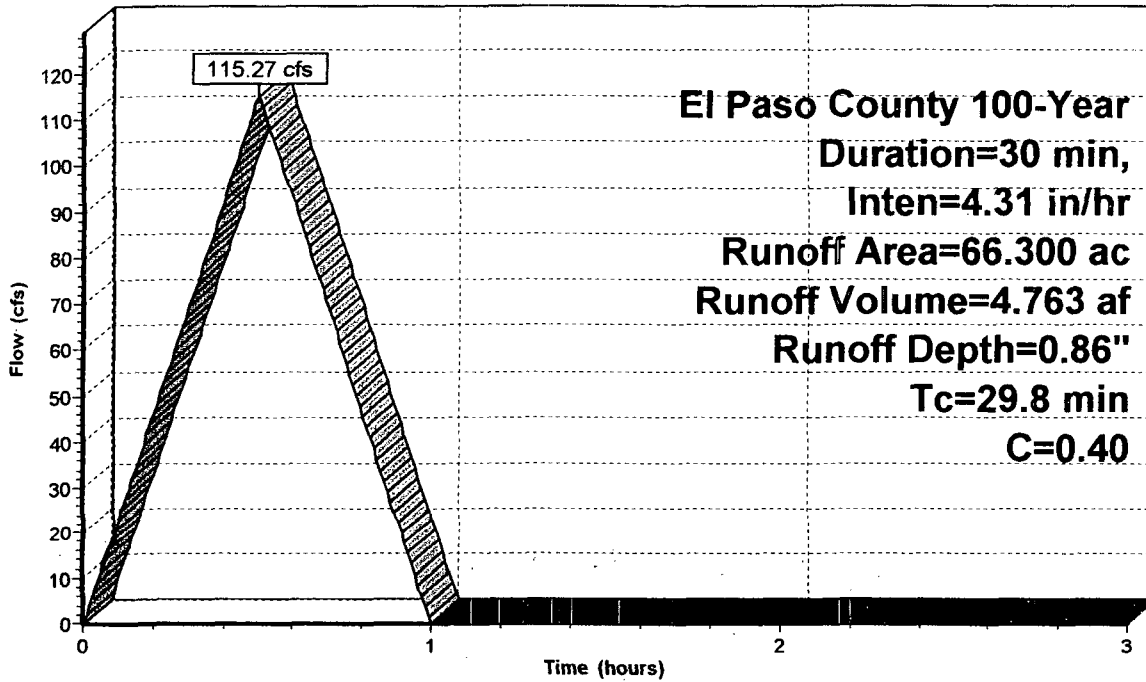

**El Paso County 100-Year  
 Duration=30 min,  
 Inten=4.31 in/hr  
 Runoff Area=66.300 ac  
 Runoff Volume=4.763 af  
 Runoff Depth=0.86"  
 Tc=29.8 min  
 C=0.40**

**Rational-100YR Developed**

*El Paso County 100-Year Duration=30 min, Inten=4.31 in/hr*

Prepared by WestWorks Engineering

Page 1

HydroCAD® 7.00 s/n 002053 © 1986-2003 Applied Microcomputer Systems

6/16/2005

**Subcatchment B-5: Basin B-5**

Runoff = 148.02 cfs @ 0.50 hrs, Volume= 6.117 af, Depth= 0.85"

Runoff by Rational method, Rise/Fall=1.0/1.0 xTc, Time Span= 0.00-3.00 hrs, dt= 0.01 hrs  
 El Paso County 100-Year Duration=30 min, Inten=4.31 in/hr

Area (ac)	C	Description
86.000	0.40	5 acre lots, 12% imp, HSG B

Tc (min)	Length (feet)	Slope (ft/ft)	Velocity (ft/sec)	Capacity (cfs)	Description
30.3					Direct Entry, Basin B-5

**Subcatchment B-5: Basin B-5**

Hydrograph

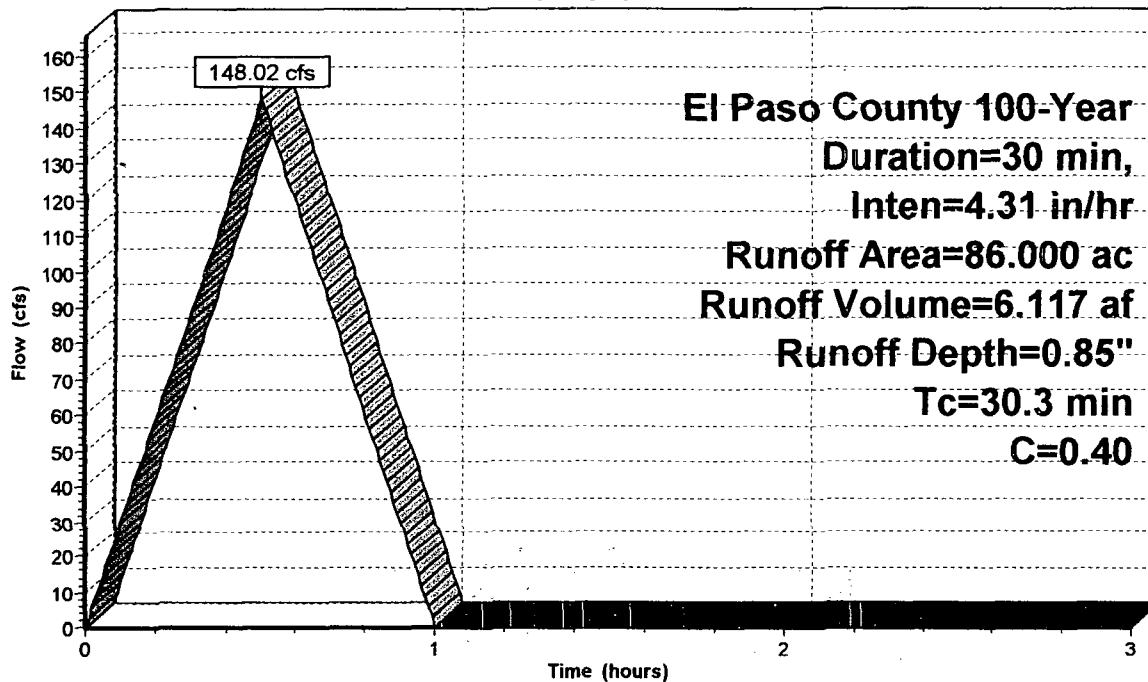

Runoff

**Subcatchment OS1: Off-Site Basin OS1**

Runoff = 37.56 cfs @ 0.41 hrs, Volume= 1.293 af, Depth= 0.70"

Runoff by Rational method, Rise/Fall=1.0/1.0 xTc, Time Span= 0.00-3.00 hrs, dt= 0.01 hrs  
 El Paso County 100-Year Duration=25 min, Inten=4.77 in/hr

Area (ac)	C	Description
22.300	0.35	Pasture/grassland/range, Good, HSG B

Tc (min)	Length (feet)	Slope (ft/ft)	Velocity (ft/sec)	Capacity (cfs)	Description
24.5					Direct Entry, Basin OS1

**Subcatchment OS1: Off-Site Basin OS1**

Hydrograph

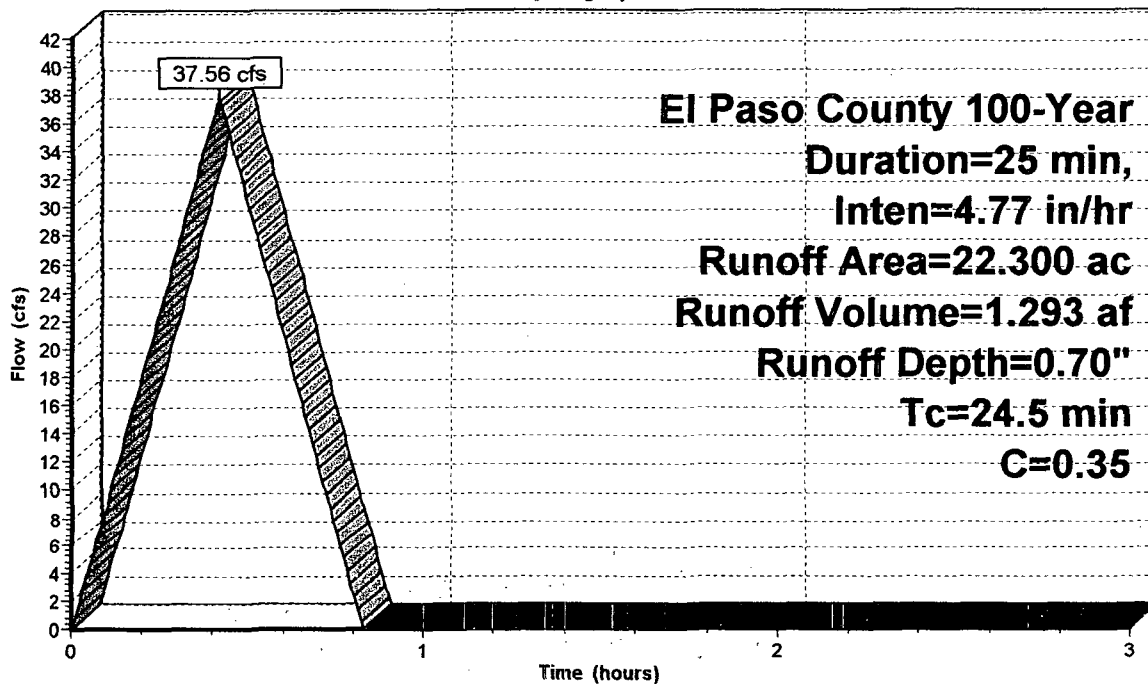

**Rational-100YR Developed**

*El Paso County 100-Year Duration=47 min, Inten=3.29 in/hr*

Prepared by WestWorks Engineering

Page 1

HydroCAD® 7.00 s/n 002053 © 1986-2003 Applied Microcomputer Systems

6/16/2005

**Subcatchment C-1: Basin C-1**

Runoff = 57.19 cfs @ 0.78 hrs, Volume= 3.702 af, Depth= 1.03"

Runoff by Rational method, Rise/Fall=1.0/1.0 xTc, Time Span= 0.00-3.00 hrs, dt= 0.01 hrs  
El Paso County 100-Year Duration=47 min, Inten=3.29 in/hr

Area (ac)	C	Description
43.100	0.40	2 acre lots, 12% imp, HSG B

Tc (min)	Length (feet)	Slope (ft/ft)	Velocity (ft/sec)	Capacity (cfs)	Description
46.6					Direct Entry, Basin C-1

**Subcatchment C-1: Basin C-1**

Hydrograph

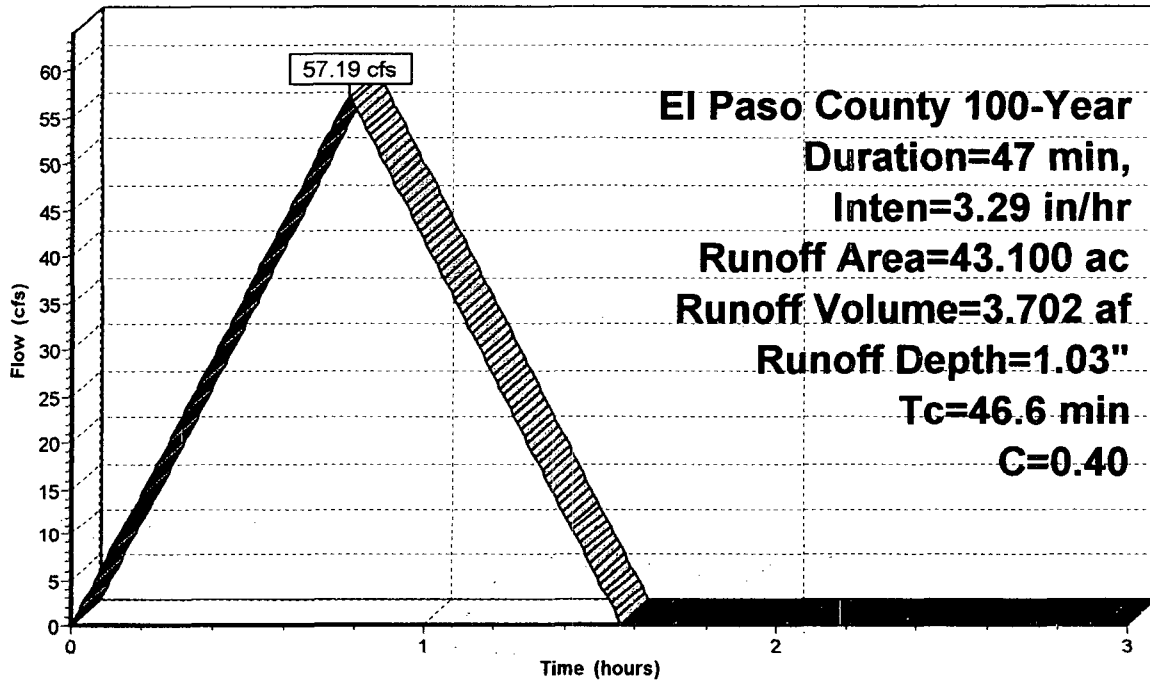

**Pond DP-C1: Design Point C1**

Inflow Area = 56.800 ac, Inflow Depth = 1.03" for 100-Year event  
 Inflow = 71.81 cfs @ 0.78 hrs, Volume= 4.879 af  
 Outflow = 53.81 cfs @ 1.03 hrs, Volume= 4.879 af, Atten= 25%, Lag= 14.8 min  
 Primary = 53.81 cfs @ 1.03 hrs, Volume= 4.879 af

Routing by Stor-Ind method, Time Span= 0.00-3.00 hrs, dt= 0.01 hrs  
 Peak Elev= 6,215.14' @ 1.03 hrs Surf.Area= 0.873 ac Storage= 0.682 af  
 Plug-Flow detention time= 5.3 min calculated for 4.863 af (100% of inflow)  
 Center-of-Mass det. time= 5.3 min ( 51.5 - 46.2 )

#	Invert	Avail.Storage	Storage Description
1	6,212.00'	0.894 af	<b>Custom Stage Data (Prismatic)</b> Listed below

Elevation (feet)	Surf.Area (acres)	Inc.Store (acre-feet)	Cum.Store (acre-feet)
6,212.00	0.005	0.000	0.000
6,214.00	0.016	0.021	0.021
6,215.50	1.148	0.873	0.894

#	Routing	Invert	Outlet Devices
1	Primary	6,211.70'	<b>30.0" x 50.0' long Culvert X 2.00</b> CMP, end-section conforming to fill, Ke= 0.500 Outlet Invert= 6,211.20' S= 0.0100 '/ n= 0.024 Cc= 0.900

**Primary OutFlow** Max=53.81 cfs @ 1.03 hrs HW=6,215.14' (Free Discharge)

↑1=Culvert (Barrel Controls 53.81 cfs @ 5.5 fps)

Pond DP-C1: Design Point C1

Hydrograph

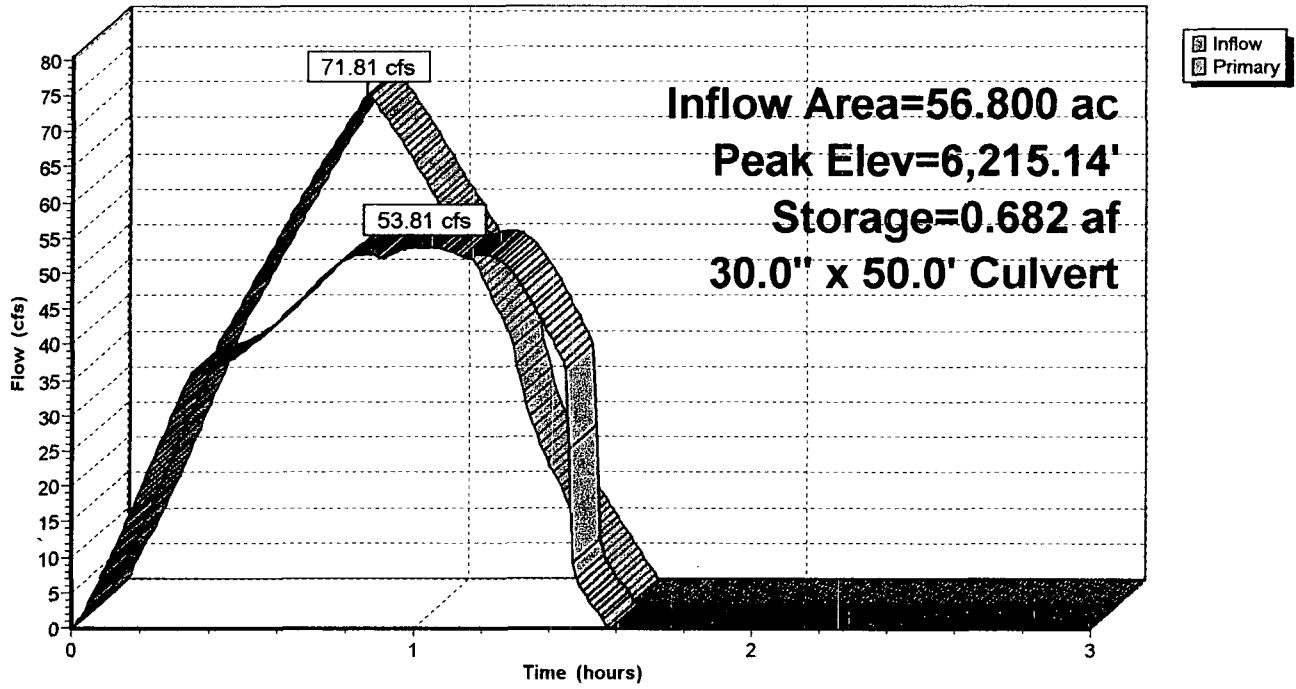

**Rational-100YR Developed**

*El Paso County 100-Year Duration=29 min, Inten=4.40 in/hr*

Prepared by WestWorks Engineering

HydroCAD® 7.00 s/n 002053 © 1986-2003 Applied Microcomputer Systems

**Subcatchment C-2: Basin C-2**

Runoff = 24.08 cfs @ 0.48 hrs, Volume= 0.968 af, Depth= 0.85"

Runoff by Rational method, Rise/Fall=1.0/1.0 xTc, Time Span= 0.00-3.00 hrs, dt= 0.01 hrs  
El Paso County 100-Year Duration=29 min, Inten=4.40 in/hr

Area (ac)	C	Description
13.700	0.40	2 acre lots, 12% imp, HSG B

Tc (min)	Length (feet)	Slope (ft/ft)	Velocity (ft/sec)	Capacity (cfs)	Description
29.1					Direct Entry, Basin C-2

**Subcatchment C-2: Basin C-2**

Hydrograph

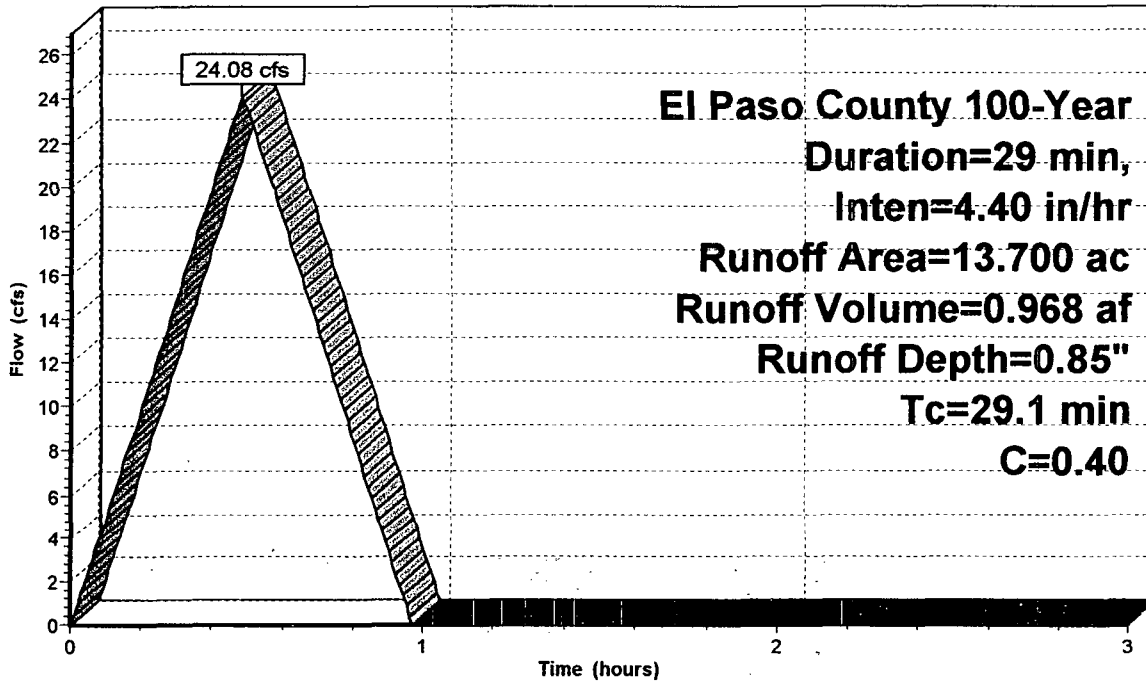

**Pond DP-C2: Design Point C2**

Inflow Area = 13.700 ac, Inflow Depth = 0.85" for 100-Year event  
 Inflow = 24.08 cfs @ 0.48 hrs, Volume= 0.968 af  
 Outflow = 15.68 cfs @ 0.65 hrs, Volume= 0.968 af, Atten= 35%, Lag= 10.3 min  
 Primary = 15.68 cfs @ 0.65 hrs, Volume= 0.968 af

Routing by Stor-Ind method, Time Span= 0.00-3.00 hrs, dt= 0.01 hrs  
 Peak Elev= 6,222.90' @ 0.65 hrs Surf.Area= 0.238 ac Storage= 0.219 af  
 Plug-Flow detention time= 6.8 min calculated for 0.965 af (100% of inflow)  
 Center-of-Mass det. time= 6.8 min ( 35.8 - 29.0 )

#	Invert	Avail.Storage	Storage Description
1	6,220.50'	0.301 af	<b>Custom Stage Data (Prismatic)</b> Listed below

Elevation (feet)	Surf.Area (acres)	Inc.Store (acre-feet)	Cum.Store (acre-feet)
6,220.50	0.000	0.000	0.000
6,222.00	0.062	0.046	0.046
6,223.33	0.321	0.255	0.301

#	Routing	Invert	Outlet Devices
1	Primary	6,220.00'	<b>24.0" x 50.0' long Culvert</b> CMP, end-section conforming to fill, Ke= 0.500 Outlet Invert= 6,219.50' S= 0.0100 '/ n= 0.024 Cc= 0.900

**Primary OutFlow** Max=15.68 cfs @ 0.65 hrs HW=6,222.90' (Free Discharge)  
 ↳ **1=Culvert** (Barrel Controls 15.68 cfs @ 5.0 fps)

Pond DP-C2: Design Point C2

Hydrograph

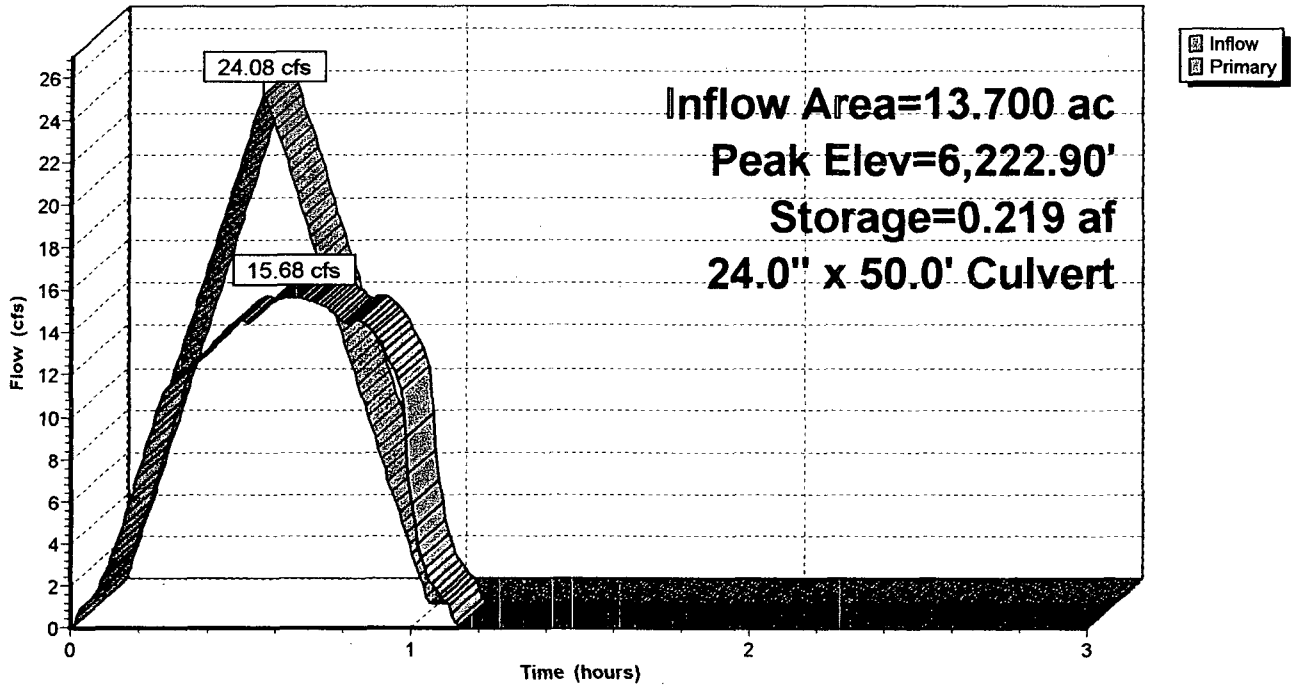

Subcatchment C-3: Basin C-3

Runoff = 18.77 cfs @ 0.35 hrs, Volume= 0.543 af, Depth= 0.73"

Runoff by Rational method, Rise/Fall=1.0/1.0 xTc, Time Span= 0.00-3.00 hrs, dt= 0.01 hrs  
El Paso County 100-Year Duration=21 min, Inten=5.23 in/hr

Area (ac)	C	Description
8.900	0.40	2 acre lots, 12% imp, HSG B

Tc (min)	Length (feet)	Slope (ft/ft)	Velocity (ft/sec)	Capacity (cfs)	Description
21.0					Direct Entry, Basin C-3

Subcatchment C-3: Basin C-3

Hydrograph

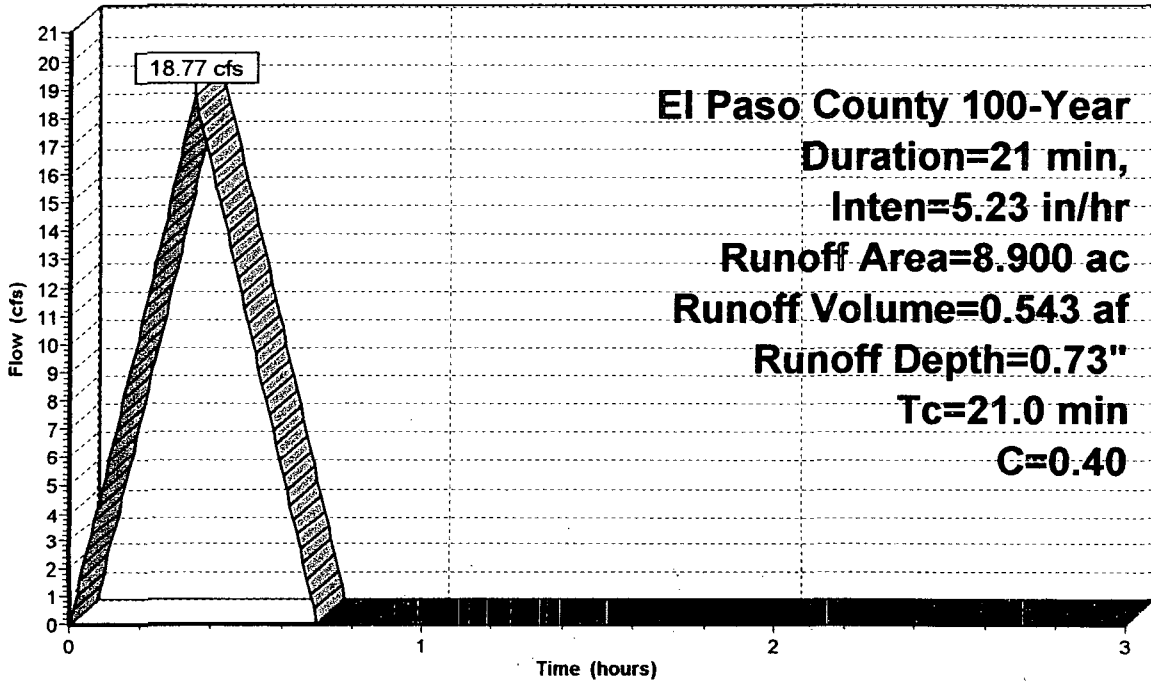

Runoff

**Pond DP-C3: Design Point C3**

Inflow Area = 8.900 ac, Inflow Depth = 0.73" for 100-Year event  
 Inflow = 18.77 cfs @ 0.35 hrs, Volume= 0.543 af  
 Outflow = 4.19 cfs @ 0.62 hrs, Volume= 0.522 af, Atten= 78%, Lag= 16.3 min  
 Primary = 4.19 cfs @ 0.62 hrs, Volume= 0.522 af

Routing by Stor-Ind method, Time Span= 0.00-3.00 hrs, dt= 0.01 hrs  
 Peak Elev= 6,220.76' @ 0.62 hrs Surf.Area= 0.439 ac Storage= 0.413 af  
 Plug-Flow detention time= 55.2 min calculated for 0.520 af (96% of inflow)  
 Center-of-Mass det. time= 54.8 min ( 75.8 - 21.0 )

#	Invert	Avail.Storage	Storage Description
1	6,220.00'	1.083 af	<b>Custom Stage Data (Prismatic)</b> Listed below

Elevation (feet)	Surf.Area (acres)	Inc.Store (acre-feet)	Cum.Store (acre-feet)
6,220.00	0.110	0.000	0.000
6,222.00	0.973	1.083	1.083

#	Routing	Invert	Outlet Devices
1	Primary	6,219.50'	<b>18.0" x 50.0' long Culvert</b> CMP, end-section conforming to fill, Ke= 0.500 Outlet Invert= 6,219.00' S= 0.0100 ' n= 0.024 Cc= 0.900

**Primary OutFlow** Max=4.19 cfs @ 0.62 hrs HW=6,220.76' (Free Discharge)  
 ←1=Culvert (Barrel Controls 4.19 cfs @ 3.6 fps)

**Pond DP-C3: Design Point C3**

Hydrograph

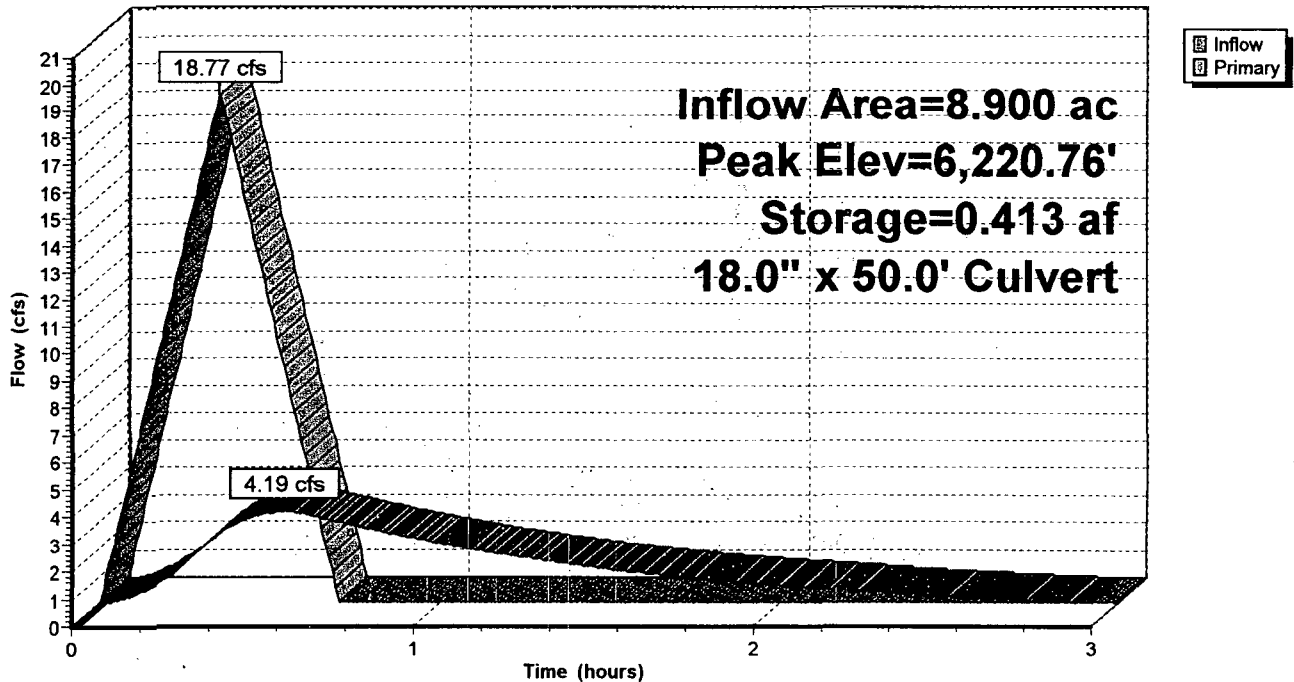

**Subcatchment C-4: Basin C-4**

Runoff = 14.18 cfs @ 0.38 hrs, Volume= 0.453 af, Depth= 0.77"

Runoff by Rational method, Rise/Fall=1.0/1.0 xTc, Time Span= 0.00-3.00 hrs, dt= 0.01 hrs  
 El Paso County 100-Year Duration=23 min, Inten=4.99 in/hr

Area (ac)	C	Description
7.100	0.40	2 acre lots, 12% imp, HSG B

Tc (min)	Length (feet)	Slope (ft/ft)	Velocity (ft/sec)	Capacity (cfs)	Description
23.0					Direct Entry, Basin C-4

**Subcatchment C-4: Basin C-4**

Hydrograph

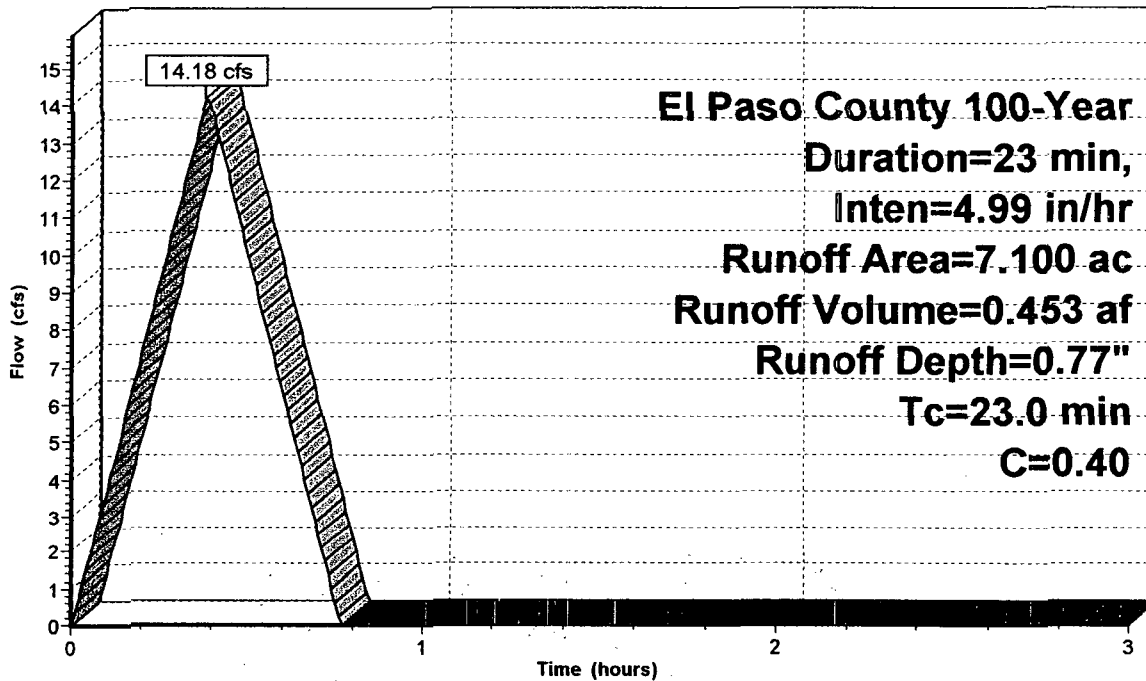

Runoff

**El Paso County 100-Year  
 Duration=23 min,  
 Inten=4.99 in/hr  
 Runoff Area=7.100 ac  
 Runoff Volume=0.453 af  
 Runoff Depth=0.77"  
 Tc=23.0 min  
 C=0.40**

**Rational-100YR Developed**

*El Paso County 100-Year Duration=29 min, Inten=4.40 in/hr*

Prepared by WestWorks Engineering

Page 1

HydroCAD® 7.00 s/n 002053 © 1986-2003 Applied Microcomputer Systems

6/16/2005

**Subcatchment C-5: Basin C-5**

Runoff = 36.96 cfs @ 0.48 hrs, Volume= 1.485 af, Depth= 0.84"

Runoff by Rational method, Rise/Fall=1.0/1.0 xTc, Time Span= 0.00-3.00 hrs, dt= 0.01 hrs  
 El Paso County 100-Year Duration=29 min, Inten=4.40 in/hr

Area (ac)	C	Description
21.100	0.40	2 acre lots, 12% imp, HSG B

Tc (min)	Length (feet)	Slope (ft/ft)	Velocity (ft/sec)	Capacity (cfs)	Description
29.2					Direct Entry, Basin C-5

**Subcatchment C-5: Basin C-5**

Hydrograph

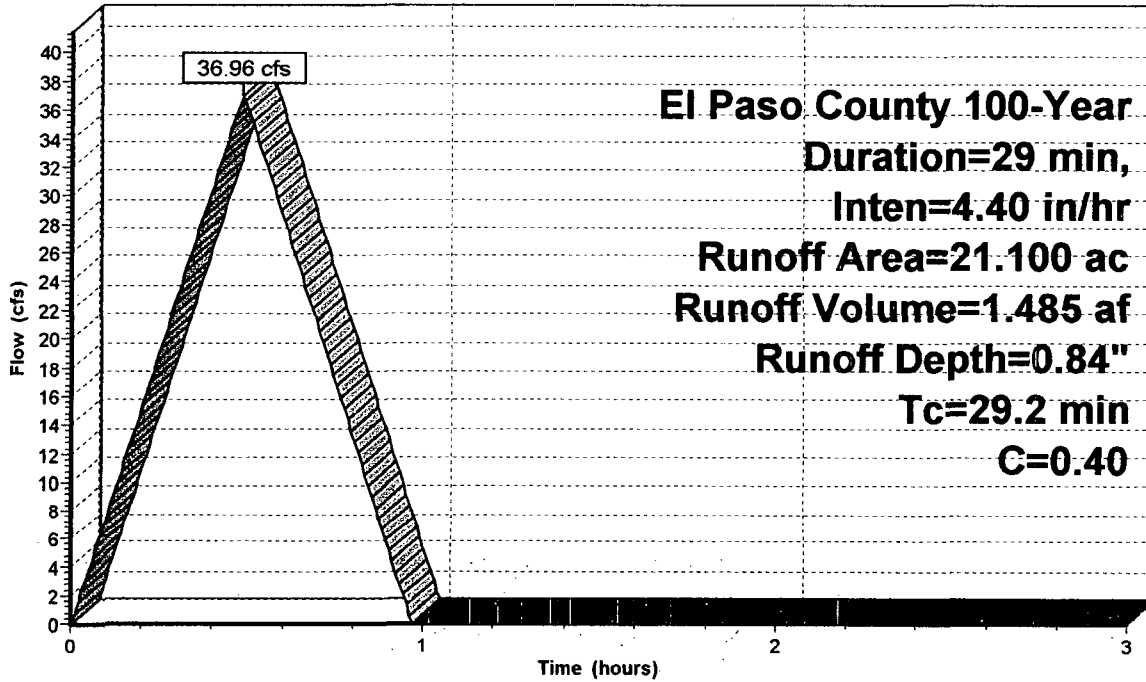

**Rational-100YR Developed**

*El Paso County 100-Year Duration=32 min, Inten=4.15 in/hr*

Prepared by WestWorks Engineering

Page 1

HydroCAD® 7.00 s/n 002053 © 1986-2003 Applied Microcomputer Systems

6/16/2005

**Subcatchment C-6: Basin C-6**

Runoff = 134.01 cfs @ 0.53 hrs, Volume= 5.939 af, Depth= 0.89"

Runoff by Rational method, Rise/Fall=1.0/1.0 xTc, Time Span= 0.00-3.00 hrs, dt= 0.01 hrs

El Paso County 100-Year Duration=32 min, Inten=4.15 in/hr

Area (ac)	C	Description
80.500	0.40	2 acre lots, 12% imp, HSG B

Tc (min)	Length (feet)	Slope (ft/ft)	Velocity (ft/sec)	Capacity (cfs)	Description
32.0					Direct Entry, Basin C-6

**Subcatchment C-6: Basin C-6**

Hydrograph

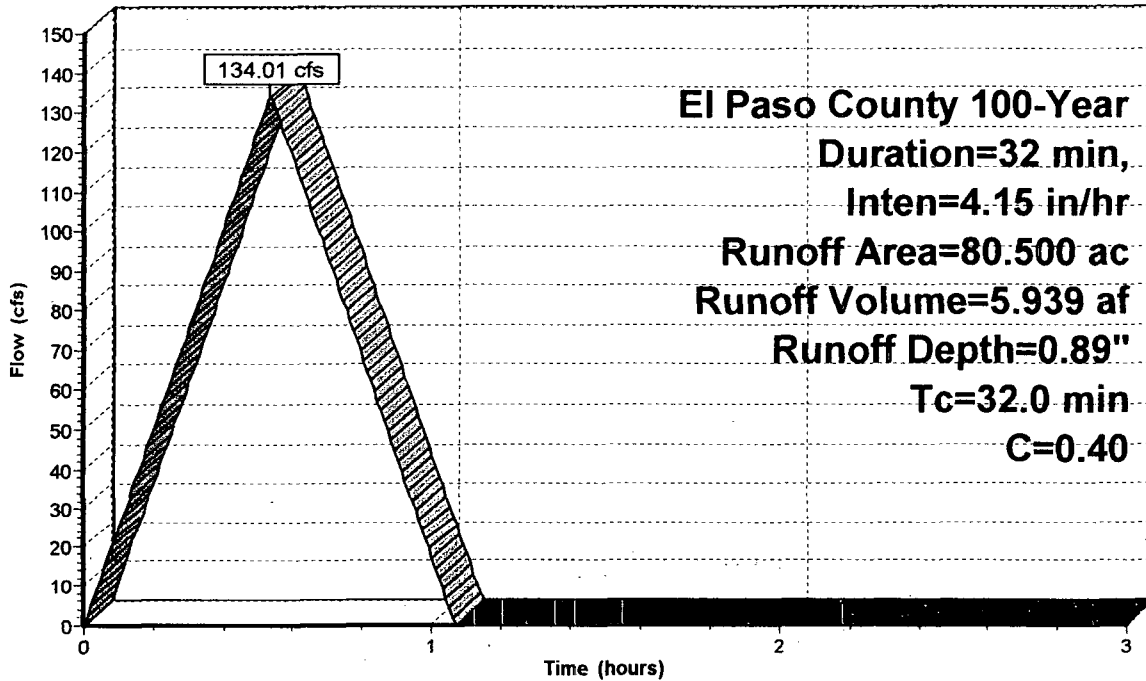

Runoff

**Rational-100YR Developed**

*El Paso County 100-Year Duration=22 min, Inten=5.11 in/hr*

Prepared by WestWorks Engineering

Page 1

HydroCAD® 7.00 s/n 002053 © 1986-2003 Applied Microcomputer Systems

6/16/2005

**Subcatchment D-1: Basin D-1**

Runoff = 11.97 cfs @ 0.36 hrs, Volume= 0.362 af, Depth= 0.75"

Runoff by Rational method, Rise/Fall=1.0/1.0 xTc, Time Span= 0.00-3.00 hrs, dt= 0.01 hrs  
 El Paso County 100-Year Duration=22 min, Inten=5.11 in/hr

Area (ac)	C	Description
5.800	0.40	2 acre lots, 12% imp, HSG B

Tc (min)	Length (feet)	Slope (ft/ft)	Velocity (ft/sec)	Capacity (cfs)	Description
21.6					Direct Entry, Basin D-1

**Subcatchment D-1: Basin D-1**

Hydrograph

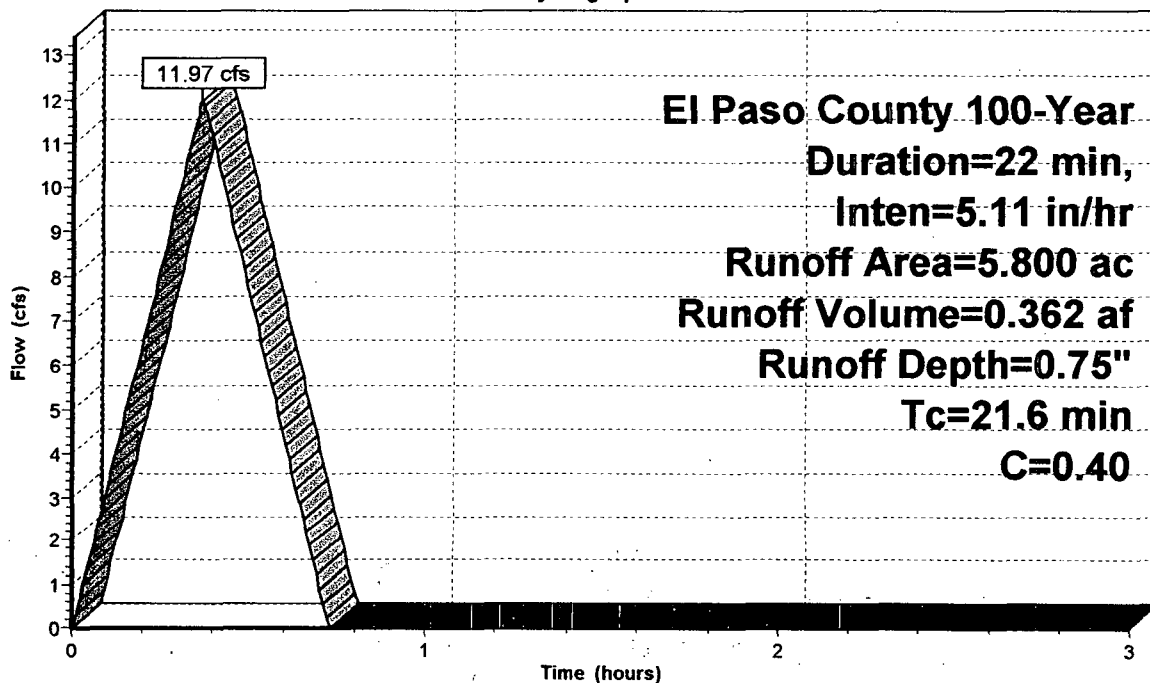

**Rational-100YR Developed**

*El Paso County 100-Year Duration=20 min, Inten=5.37 in/hr*

Prepared by WestWorks Engineering

Page 1

HydroCAD® 7.00 s/n 002053 © 1986-2003 Applied Microcomputer Systems

6/16/2005

**Subcatchment D-2: Basin D-2**

Runoff = 42.94 cfs @ 0.33 hrs, Volume= 1.193 af, Depth= 0.71"

Runoff by Rational method, Rise/Fall=1.0/1.0 xTc, Time Span= 0.00-3.00 hrs, dt= 0.01 hrs  
El Paso County 100-Year Duration=20 min, Inten=5.37 in/hr

Area (ac)	C	Description
20.200	0.40	2 acre lots, 12% imp, HSG B

Tc (min)	Length (feet)	Slope (ft/ft)	Velocity (ft/sec)	Capacity (cfs)	Description
20.2					Direct Entry, Basin D-2

**Subcatchment D-2: Basin D-2**

Hydrograph

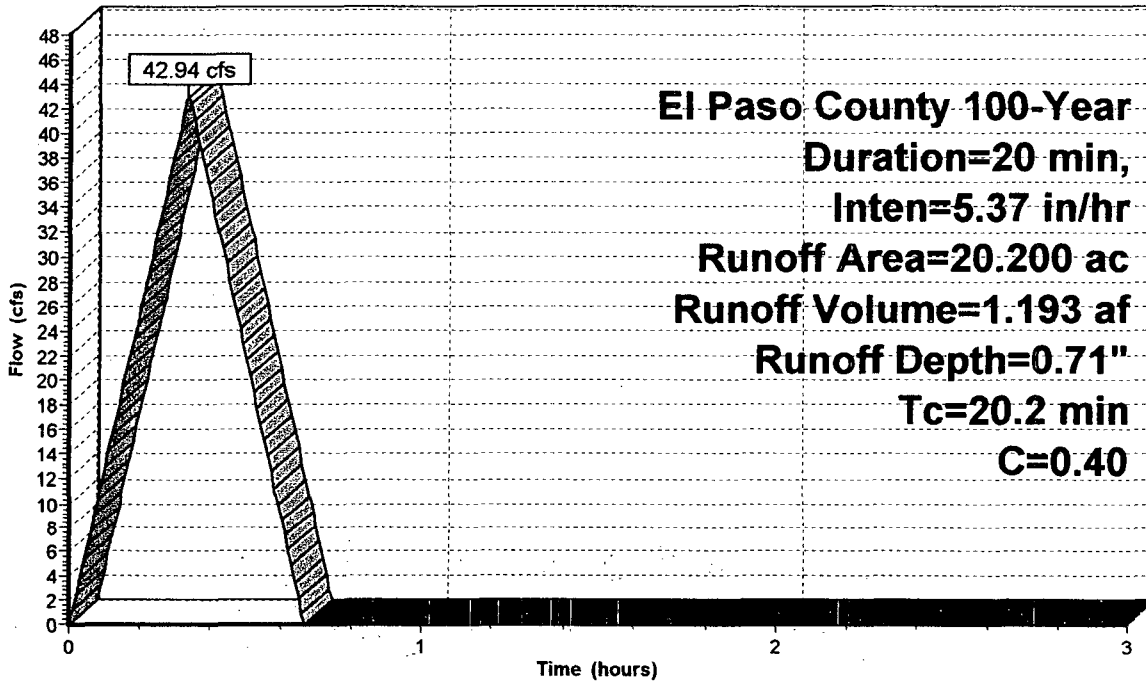

Runoff

**Rational-100YR Developed**

*El Paso County 100-Year Duration=20 min, Inten=5.37 in/hr*

Prepared by WestWorks Engineering

Page 1

HydroCAD® 7.00 s/n 002053 © 1986-2003 Applied Microcomputer Systems

6/16/2005

**Pond Pond D: Pond D**

Inflow Area = 20.200 ac, Inflow Depth = 0.71" for 100-Year event  
 Inflow = 42.94 cfs @ 0.33 hrs, Volume= 1.193 af  
 Outflow = 2.91 cfs @ 0.64 hrs, Volume= 0.422 af, Atten= 93%, Lag= 18.7 min  
 Primary = 2.91 cfs @ 0.64 hrs, Volume= 0.422 af

Routing by Stor-Ind method, Time Span= 0.00-3.00 hrs, dt= 0.01 hrs  
 Peak Elev= 6,191.18' @ 0.64 hrs Surf.Area= 1.074 ac Storage= 1.136 af  
 Plug-Flow detention time= 78.8 min calculated for 0.422 af (35% of inflow)  
 Center-of-Mass det. time= 70.0 min ( 90.0 - 20.0 )

#	Invert	Avail.Storage	Storage Description
1	6,190.00'	1.921 af	Custom Stage Data (Prismatic) Listed below

Elevation (feet)	Surf.Area (acres)	Inc.Store (acre-feet)	Cum.Store (acre-feet)
6,190.00	0.337	0.000	0.000
6,192.00	1.584	1.921	1.921

#	Routing	Invert	Outlet Devices
1	Primary	6,190.08'	1.0" Vert. Orifice/Grate X 2.00 C= 0.600
2	Primary	6,190.25'	17.0" x 15.0' long Culvert CMP, projecting, no headwall, Ke= 0.900 Outlet Invert= 6,189.80' S= 0.0300 '/ n= 0.022 Cc= 0.900

**Primary OutFlow** Max=2.91 cfs @ 0.64 hrs HW=6,191.18' (Free Discharge)

1=Orifice/Grate (Orifice Controls 0.05 cfs @ 5.0 fps)

2=Culvert (Inlet Controls 2.85 cfs @ 2.6 fps)

**Pond Pond D: Pond D**

Hydrograph

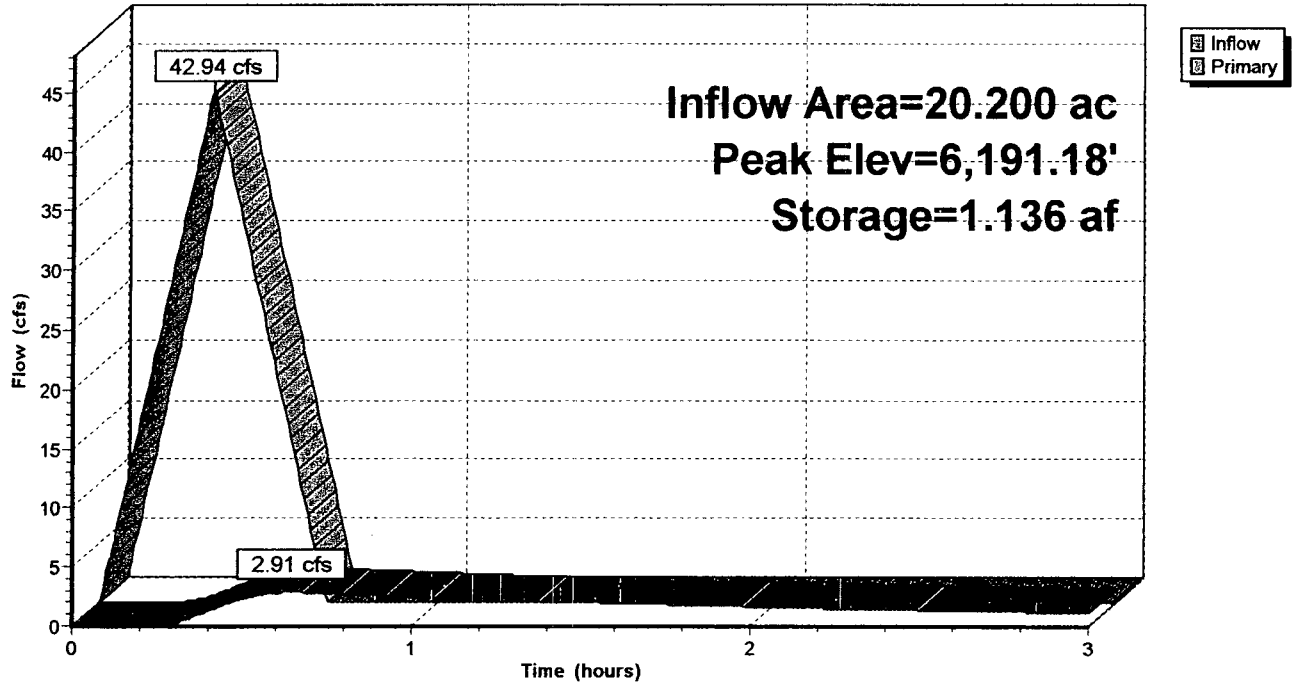

**Link DP-D: Design Point D**

Inflow Area = 26.000 ac, Inflow Depth = 0.38" for 100-Year event  
Inflow = 12.74 cfs @ 0.37 hrs, Volume= 0.826 af  
Primary = 12.74 cfs @ 0.37 hrs, Volume= 0.826 af, Atten= 0%, Lag= 0.0 min

Primary outflow = Inflow, Time Span= 0.00-3.00 hrs, dt= 0.01 hrs

**Link DP-D: Design Point D**

Hydrograph

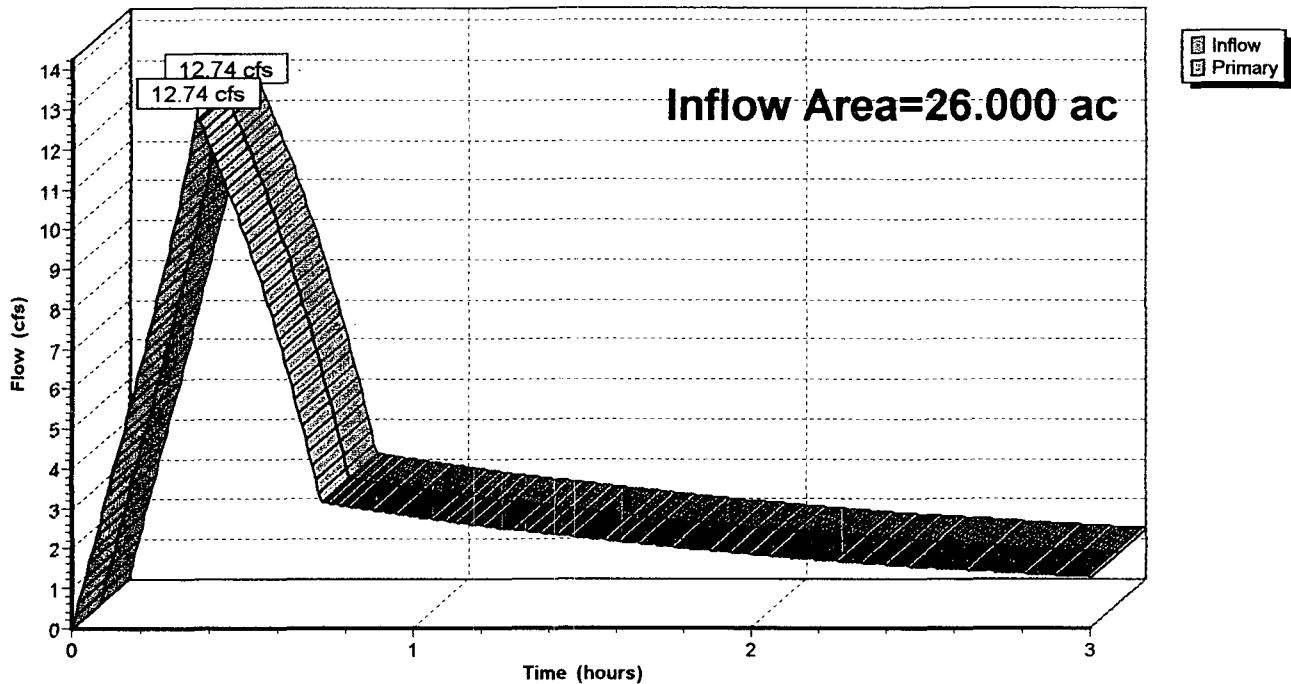

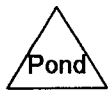
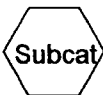
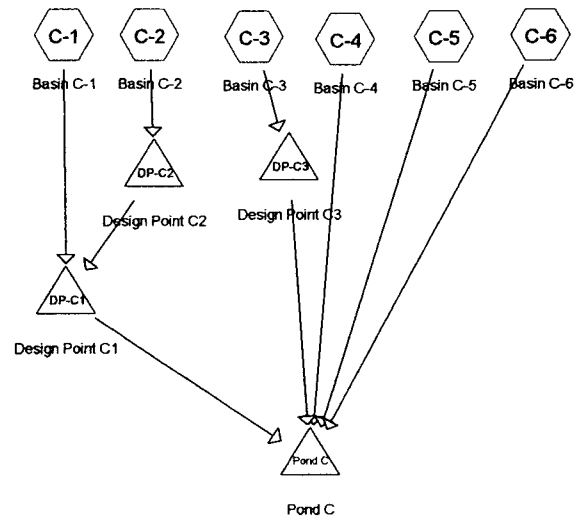
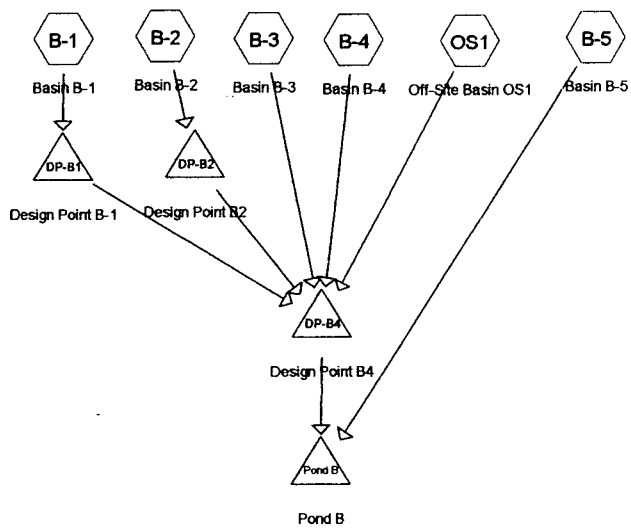

**Drainage Diagram for TR20-100YR-24HR Developed**  
 Prepared by WestWorks Engineering 6/16/2005  
 HydroCAD® 7.00 s/n 002053 © 1986-2003 Applied Microcomputer Systems

Time span=0.00-20.00 hrs, dt=0.01 hrs, 2001 points

Runoff by SCS TR-20 method, UH=SCS

Reach routing by Stor-Ind+Trans method - Pond routing by Stor-Ind method

<b>Subcatchment B-1: Basin B-1</b>	Runoff Area=24.000 ac Runoff Depth=1.20" Tc=33.9 min CN=65 Runoff=24.29 cfs 2.402 af
<b>Subcatchment B-2: Basin B-2</b>	Runoff Area=6.400 ac Runoff Depth=1.20" Tc=27.2 min CN=65 Runoff=7.58 cfs 0.642 af
<b>Subcatchment B-3: Basin B-3</b>	Runoff Area=44.000 ac Runoff Depth=1.20" Tc=26.7 min CN=65 Runoff=52.98 cfs 4.415 af
<b>Subcatchment B-4: Basin B-4</b>	Runoff Area=66.300 ac Runoff Depth=1.20" Tc=29.8 min CN=65 Runoff=73.91 cfs 6.645 af
<b>Subcatchment B-5: Basin B-5</b>	Runoff Area=86.000 ac Runoff Depth=1.20" Tc=30.3 min CN=65 Runoff=94.91 cfs 8.618 af
<b>Subcatchment C-1: Basin C-1</b>	Runoff Area=43.100 ac Runoff Depth=1.20" Tc=46.6 min CN=65 Runoff=34.46 cfs 4.295 af
<b>Subcatchment C-2: Basin C-2</b>	Runoff Area=13.700 ac Runoff Depth=1.20" Tc=29.1 min CN=65 Runoff=15.56 cfs 1.373 af
<b>Subcatchment C-3: Basin C-3</b>	Runoff Area=8.900 ac Runoff Depth=1.21" Tc=21.0 min CN=65 Runoff=12.40 cfs 0.895 af
<b>Subcatchment C-4: Basin C-4</b>	Runoff Area=7.100 ac Runoff Depth=1.21" Tc=23.0 min CN=65 Runoff=9.36 cfs 0.713 af
<b>Subcatchment C-5: Basin C-5</b>	Runoff Area=21.100 ac Runoff Depth=1.20" Tc=29.2 min CN=65 Runoff=23.83 cfs 2.115 af
<b>Subcatchment C-6: Basin C-6</b>	Runoff Area=80.500 ac Runoff Depth=1.20" Tc=32.0 min CN=65 Runoff=85.19 cfs 8.062 af
<b>Subcatchment OS1: Off-Site Basin OS1</b>	Runoff Area=22.300 ac Runoff Depth=0.97" Tc=24.5 min CN=61 Runoff=21.50 cfs 1.799 af
<b>Pond DP-B1: Design Point B-1</b>	Peak Elev=6,245.50' Storage=0.638 af Inflow=24.29 cfs 2.402 af 24.0" x 50.0' Culvert Outflow=11.91 cfs 2.365 af
<b>Pond DP-B2: Design Point B2</b>	Peak Elev=6,244.96' Storage=0.213 af Inflow=7.58 cfs 0.642 af 18.0" x 50.0' Culvert Outflow=2.81 cfs 0.591 af
<b>Pond DP-B4: Design Point B4</b>	Peak Elev=6,195.21' Storage=1.203 af Inflow=153.20 cfs 15.814 af Outflow=152.47 cfs 15.716 af

**TR20-100YR-24HR Developed**

Type IIA 24-hr Rainfall=4.40"

Prepared by WestWorks Engineering

Page 3

HydroCAD® 7.00 s/n 002053 © 1986-2003 Applied Microcomputer Systems

6/16/2005

**Pond DP-C1: Design Point C1** Peak Elev=6,214.21' Storage=0.157 af Inflow=46.07 cfs 5.658 af  
30.0" x 50.0' Culvert Outflow=40.87 cfs 5.657 af

**Pond DP-C2: Design Point C2** Peak Elev=6,222.55' Storage=0.151 af Inflow=15.56 cfs 1.373 af  
24.0" x 50.0' Culvert Outflow=11.77 cfs 1.363 af

**Pond DP-C3: Design Point C3** Peak Elev=6,220.56' Storage=0.304 af Inflow=12.40 cfs 0.895 af  
18.0" x 50.0' Culvert Outflow=3.16 cfs 0.892 af

**Pond Pond B: Pond B** Peak Elev=6,185.13' Storage=12.828 af Inflow=247.33 cfs 24.334 af  
Outflow=19.76 cfs 17.732 af

**Pond Pond C: Pond C** Peak Elev=6,202.49' Storage=9.596 af Inflow=155.26 cfs 17.438 af  
Outflow=12.63 cfs 11.577 af

**Total Runoff Area = 423.400 ac Runoff Volume = 41.972 af Average Runoff Depth = 1.19"**

**TR20-100YR-24HR Developed**

Type IIA 24-hr Rainfall=4.40"

Prepared by WestWorks Engineering

Page 4

HydroCAD® 7.00 s/n 002053 © 1986-2003 Applied Microcomputer Systems

6/16/2005

**Subcatchment B-1: Basin B-1**

Runoff = 24.29 cfs @ 6.30 hrs, Volume= 2.402 af, Depth= 1.20"

Runoff by SCS TR-20 method, UH=SCS, Time Span= 0.00-20.00 hrs, dt= 0.01 hrs  
Type IIA 24-hr Rainfall=4.40"

Area (ac)	CN	Description
24.000	65	2 acre lots, 12% imp, HSG B

Tc (min)	Length (feet)	Slope (ft/ft)	Velocity (ft/sec)	Capacity (cfs)	Description
33.9					Direct Entry, Basin B-1

**Subcatchment B-2: Basin B-2**

Runoff = 7.58 cfs @ 6.23 hrs, Volume= 0.642 af, Depth= 1.20"

Runoff by SCS TR-20 method, UH=SCS, Time Span= 0.00-20.00 hrs, dt= 0.01 hrs  
Type IIA 24-hr Rainfall=4.40"

Area (ac)	CN	Description
6.400	65	2 acre lots, 12% imp, HSG B

Tc (min)	Length (feet)	Slope (ft/ft)	Velocity (ft/sec)	Capacity (cfs)	Description
27.2					Direct Entry, Basin B-2

**Subcatchment B-3: Basin B-3**

Runoff = 52.98 cfs @ 6.23 hrs, Volume= 4.415 af, Depth= 1.20"

Runoff by SCS TR-20 method, UH=SCS, Time Span= 0.00-20.00 hrs, dt= 0.01 hrs  
Type IIA 24-hr Rainfall=4.40"

Area (ac)	CN	Description
44.000	65	2 acre lots, 12% imp, HSG B

Tc (min)	Length (feet)	Slope (ft/ft)	Velocity (ft/sec)	Capacity (cfs)	Description
26.7					Direct Entry, Basin B-3

**Subcatchment B-4: Basin B-4**

Runoff = 73.91 cfs @ 6.26 hrs, Volume= 6.645 af, Depth= 1.20"

Runoff by SCS TR-20 method, UH=SCS, Time Span= 0.00-20.00 hrs, dt= 0.01 hrs  
Type IIA 24-hr Rainfall=4.40"

**TR20-100YR-24HR Developed**

Type IIA 24-hr Rainfall=4.40"

Prepared by WestWorks Engineering

Page 5

HydroCAD® 7.00 s/n 002053 © 1986-2003 Applied Microcomputer Systems

6/16/2005

Area (ac)	CN	Description
66.300	65	2 acre lots, 12% imp, HSG B

Tc (min)	Length (feet)	Slope (ft/ft)	Velocity (ft/sec)	Capacity (cfs)	Description
29.8					Direct Entry, Basin B-4

**Subcatchment B-5: Basin B-5**

Runoff = 94.91 cfs @ 6.26 hrs, Volume= 8.618 af, Depth= 1.20"

Runoff by SCS TR-20 method, UH=SCS, Time Span= 0.00-20.00 hrs, dt= 0.01 hrs  
Type IIA 24-hr Rainfall=4.40"

Area (ac)	CN	Description
86.000	65	2 acre lots, 12% imp, HSG B

Tc (min)	Length (feet)	Slope (ft/ft)	Velocity (ft/sec)	Capacity (cfs)	Description
30.3					Direct Entry, Basin B-5

**Subcatchment C-1: Basin C-1**

Runoff = 34.46 cfs @ 6.47 hrs, Volume= 4.295 af, Depth= 1.20"

Runoff by SCS TR-20 method, UH=SCS, Time Span= 0.00-20.00 hrs, dt= 0.01 hrs  
Type IIA 24-hr Rainfall=4.40"

Area (ac)	CN	Description
43.100	65	2 acre lots, 12% imp, HSG B

Tc (min)	Length (feet)	Slope (ft/ft)	Velocity (ft/sec)	Capacity (cfs)	Description
46.6					Direct Entry, Basin C-1

**Subcatchment C-2: Basin C-2**

Runoff = 15.56 cfs @ 6.24 hrs, Volume= 1.373 af, Depth= 1.20"

Runoff by SCS TR-20 method, UH=SCS, Time Span= 0.00-20.00 hrs, dt= 0.01 hrs  
Type IIA 24-hr Rainfall=4.40"

Area (ac)	CN	Description
13.700	65	2 acre lots, 12% imp, HSG B

Tc (min)	Length (feet)	Slope (ft/ft)	Velocity (ft/sec)	Capacity (cfs)	Description
29.1					Direct Entry, Basin C-2

**TR20-100YR-24HR Developed**

Type IIA 24-hr Rainfall=4.40"

Prepared by WestWorks Engineering

Page 6

HydroCAD® 7.00 s/n 002053 © 1986-2003 Applied Microcomputer Systems

6/16/2005

**Subcatchment C-3: Basin C-3**

Runoff = 12.40 cfs @ 6.16 hrs, Volume= 0.895 af, Depth= 1.21"

Runoff by SCS TR-20 method, UH=SCS, Time Span= 0.00-20.00 hrs, dt= 0.01 hrs  
Type IIA 24-hr Rainfall=4.40"

Area (ac)	CN	Description
8.900	65	2 acre lots, 12% imp, HSG B

Tc (min)	Length (feet)	Slope (ft/ft)	Velocity (ft/sec)	Capacity (cfs)	Description
21.0					Direct Entry, Basin C-3

**Subcatchment C-4: Basin C-4**

Runoff = 9.36 cfs @ 6.18 hrs, Volume= 0.713 af, Depth= 1.21"

Runoff by SCS TR-20 method, UH=SCS, Time Span= 0.00-20.00 hrs, dt= 0.01 hrs  
Type IIA 24-hr Rainfall=4.40"

Area (ac)	CN	Description
7.100	65	2 acre lots, 12% imp, HSG B

Tc (min)	Length (feet)	Slope (ft/ft)	Velocity (ft/sec)	Capacity (cfs)	Description
23.0					Direct Entry, Basin C-4

**Subcatchment C-5: Basin C-5**

Runoff = 23.83 cfs @ 6.26 hrs, Volume= 2.115 af, Depth= 1.20"

Runoff by SCS TR-20 method, UH=SCS, Time Span= 0.00-20.00 hrs, dt= 0.01 hrs  
Type IIA 24-hr Rainfall=4.40"

Area (ac)	CN	Description
21.100	65	2 acre lots, 12% imp, HSG B

Tc (min)	Length (feet)	Slope (ft/ft)	Velocity (ft/sec)	Capacity (cfs)	Description
29.2					Direct Entry, Basin C-5

**Subcatchment C-6: Basin C-6**

Runoff = 85.19 cfs @ 6.29 hrs, Volume= 8.062 af, Depth= 1.20"

Runoff by SCS TR-20 method, UH=SCS, Time Span= 0.00-20.00 hrs, dt= 0.01 hrs  
Type IIA 24-hr Rainfall=4.40"

**TR20-100YR-24HR Developed**

Type IIA 24-hr Rainfall=4.40"

Prepared by WestWorks Engineering  
 HydroCAD® 7.00 s/n 002053 © 1986-2003 Applied Microcomputer Systems

Page 7  
 6/16/2005

Area (ac)	CN	Description
80.500	65	2 acre lots, 12% imp, HSG B

Tc (min)	Length (feet)	Slope (ft/ft)	Velocity (ft/sec)	Capacity (cfs)	Description
32.0					Direct Entry, Basin C-6

**Subcatchment OS1: Off-Site Basin OS1**

Runoff = 21.50 cfs @ 6.21 hrs, Volume= 1.799 af, Depth= 0.97"

Runoff by SCS TR-20 method, UH=SCS, Time Span= 0.00-20.00 hrs, dt= 0.01 hrs  
 Type IIA 24-hr Rainfall=4.40"

Area (ac)	CN	Description
22.300	61	Pasture/grassland/range, Good, HSG B

Tc (min)	Length (feet)	Slope (ft/ft)	Velocity (ft/sec)	Capacity (cfs)	Description
24.5					Direct Entry, Basin OS1

**Pond DP-B1: Design Point B-1**

Inflow Area = 24.000 ac, Inflow Depth = 1.20"  
 Inflow = 24.29 cfs @ 6.30 hrs, Volume= 2.402 af  
 Outflow = 11.91 cfs @ 6.66 hrs, Volume= 2.365 af, Atten= 51%, Lag= 21.4 min  
 Primary = 11.91 cfs @ 6.66 hrs, Volume= 2.365 af

Routing by Stor-Ind method, Time Span= 0.00-20.00 hrs, dt= 0.01 hrs  
 Peak Elev= 6,245.50' @ 6.66 hrs Surf.Area= 0.559 ac Storage= 0.638 af  
 Plug-Flow detention time= 40.3 min calculated for 2.365 af (98% of inflow)  
 Center-of-Mass det. time= 30.3 min ( 566.4 - 536.1 )

#	Invert	Avail.Storage	Storage Description
1	6,243.00'	2.049 af	Custom Stage Data (Prismatic) Listed below

Elevation (feet)	Surf.Area (acres)	Inc.Store (acre-feet)	Cum.Store (acre-feet)
6,243.00	0.005	0.000	0.000
6,244.00	0.077	0.041	0.041
6,246.00	0.721	0.798	0.839
6,247.00	1.700	1.210	2.049

#	Routing	Invert	Outlet Devices
1	Primary	6,243.50'	24.0" x 50.0' long Culvert CMP, end-section conforming to fill, Ke= 0.500 Outlet Invert= 6,243.00' S= 0.0100 '/' n= 0.022 Cc= 0.900

Primary OutFlow Max=11.91 cfs @ 6.66 hrs HW=6,245.50' (Free Discharge)  
 ←1=Culvert (Barrel Controls 11.91 cfs @ 4.7 fps)

**TR20-100YR-24HR Developed**

Type IIA 24-hr Rainfall=4.40"

Prepared by WestWorks Engineering

Page 8

HydroCAD® 7.00 s/n 002053 © 1986-2003 Applied Microcomputer Systems

6/16/2005

**Pond DP-B2: Design Point B2**

Inflow Area = 6.400 ac, Inflow Depth = 1.20"  
 Inflow = 7.58 cfs @ 6.23 hrs, Volume= 0.642 af  
 Outflow = 2.81 cfs @ 6.59 hrs, Volume= 0.591 af, Atten= 63%, Lag= 21.8 min  
 Primary = 2.81 cfs @ 6.59 hrs, Volume= 0.591 af

Routing by Stor-Ind method, Time Span= 0.00-20.00 hrs, dt= 0.01 hrs  
 Peak Elev= 6,244.96' @ 6.59 hrs Surf.Area= 0.214 ac Storage= 0.213 af  
 Plug-Flow detention time= 102.8 min calculated for 0.591 af (92% of inflow)  
 Center-of-Mass det. time= 54.1 min ( 585.6 - 531.5 )

#	Invert	Avail.Storage	Storage Description
1	6,244.00'	0.446 af	Custom Stage Data (Prismatic) Listed below

Elevation (feet)	Surf.Area (acres)	Inc.Store (acre-feet)	Cum.Store (acre-feet)
6,244.00	0.019	0.000	0.000
6,246.00	0.427	0.446	0.446

#	Routing	Invert	Outlet Devices
1	Primary	6,244.00'	18.0" x 50.0' long Culvert CMP, end-section conforming to fill, Ke= 0.500 Outlet Invert= 6,243.50' S= 0.0100 ' n= 0.022 Cc= 0.900

Primary OutFlow Max=2.80 cfs @ 6.59 hrs HW=6,244.96' (Free Discharge)  
 ↑ 1=Culvert (Barrel Controls 2.80 cfs @ 3.4 fps)

**Pond DP-B4: Design Point B4**

Inflow Area = 163.000 ac, Inflow Depth = 1.16"  
 Inflow = 153.20 cfs @ 6.26 hrs, Volume= 15.814 af  
 Outflow = 152.47 cfs @ 6.27 hrs, Volume= 15.716 af, Atten= 0%, Lag= 0.7 min  
 Primary = 152.47 cfs @ 6.27 hrs, Volume= 15.716 af

Routing by Stor-Ind method, Time Span= 0.00-20.00 hrs, dt= 0.01 hrs  
 Peak Elev= 6,195.21' @ 6.27 hrs Surf.Area= 0.889 ac Storage= 1.203 af  
 Plug-Flow detention time= 12.5 min calculated for 15.708 af (99% of inflow)  
 Center-of-Mass det. time= 8.5 min ( 549.3 - 540.8 )

#	Invert	Avail.Storage	Storage Description
1	6,192.00'	1.821 af	Custom Stage Data (Prismatic) Listed below

Elevation (feet)	Surf.Area (acres)	Inc.Store (acre-feet)	Cum.Store (acre-feet)
6,192.00	0.009	0.000	0.000
6,194.00	0.253	0.262	0.262
6,196.00	1.306	1.559	1.821

#	Routing	Invert	Outlet Devices
1	Primary	6,192.00'	24.0" x 50.0' long Culvert X 2.00 CMP, end-section conforming to fill, Ke= 0.500

**TR20-100YR-24HR Developed**

Type IIA 24-hr Rainfall=4.40"

Prepared by WestWorks Engineering

Page 9

HydroCAD® 7.00 s/n 002053 © 1986-2003 Applied Microcomputer Systems

6/16/2005

2 Primary 6,195.00' Outlet Invert= 6,191.50' S= 0.0100 ' n= 0.022 Cc= 0.900  
**Roadway Overtop**  
 Head (feet) 0.00 0.50  
 Disch. (cfs) 0.00 280.00

**Primary OutFlow** Max=152.42 cfs @ 6.27 hrs HW=6,195.21' (Free Discharge)

1=Culvert (Barrel Controls 36.35 cfs @ 5.8 fps)  
 2=Roadway Overtop (Custom Controls 116.06 cfs)

**Pond DP-C1: Design Point C1**

Inflow Area = 56.800 ac, Inflow Depth = 1.20"  
 Inflow = 46.07 cfs @ 6.47 hrs, Volume= 5.658 af  
 Outflow = 40.87 cfs @ 6.62 hrs, Volume= 5.657 af, Atten= 11%, Lag= 9.2 min  
 Primary = 40.87 cfs @ 6.62 hrs, Volume= 5.657 af

Routing by Stor-Ind method, Time Span= 0.00-20.00 hrs, dt= 0.01 hrs  
 Peak Elev= 6,214.21' @ 6.62 hrs Surf.Area= 0.149 ac Storage= 0.157 af  
 Plug-Flow detention time= 1.1 min calculated for 5.657 af (100% of inflow)  
 Center-of-Mass det. time= 0.9 min ( 544.3 - 543.4 )

#	Invert	Avail.Storage	Storage Description
1	6,212.00'	5.735 af	<b>Custom Stage Data (Prismatic) Listed below</b>

Elevation (feet)	Surf.Area (acres)	Inc.Store (acre-feet)	Cum.Store (acre-feet)
6,212.00	0.005	0.000	0.000
6,214.00	0.016	0.021	0.021
6,216.00	1.295	1.311	1.332
6,218.00	3.108	4.403	5.735

#	Routing	Invert	Outlet Devices
1	Primary	6,211.70'	<b>30.0" x 50.0' long Culvert X 2.00</b> CMP, end-section conforming to fill, Ke= 0.500 Outlet Invert= 6,211.20' S= 0.0100 ' n= 0.024 Cc= 0.900

**Primary OutFlow** Max=40.87 cfs @ 6.62 hrs HW=6,214.21' (Free Discharge)

1=Culvert (Barrel Controls 40.87 cfs @ 5.2 fps)

**Pond DP-C2: Design Point C2**

Inflow Area = 13.700 ac, Inflow Depth = 1.20"  
 Inflow = 15.56 cfs @ 6.24 hrs, Volume= 1.373 af  
 Outflow = 11.77 cfs @ 6.41 hrs, Volume= 1.363 af, Atten= 24%, Lag= 10.2 min  
 Primary = 11.77 cfs @ 6.41 hrs, Volume= 1.363 af

Routing by Stor-Ind method, Time Span= 0.00-20.00 hrs, dt= 0.01 hrs  
 Peak Elev= 6,222.55' @ 6.41 hrs Surf.Area= 0.168 ac Storage= 0.151 af  
 Plug-Flow detention time= 10.8 min calculated for 1.363 af (99% of inflow)  
 Center-of-Mass det. time= 6.0 min ( 538.8 - 532.8 )

**TR20-100YR-24HR Developed**

Type IIA 24-hr Rainfall=4.40"

Prepared by WestWorks Engineering

Page 10

HydroCAD® 7.00 s/n 002053 © 1986-2003 Applied Microcomputer Systems

6/16/2005

#	Invert	Avail.Storage	Storage Description
1	6,220.50'	0.301 af	<b>Custom Stage Data (Prismatic)</b> Listed below

Elevation (feet)	Surf.Area (acres)	Inc.Store (acre-feet)	Cum.Store (acre-feet)
6,220.50	0.000	0.000	0.000
6,222.00	0.062	0.046	0.046
6,223.33	0.321	0.255	0.301

#	Routing	Invert	Outlet Devices
1	Primary	6,220.50'	<b>24.0" x 50.0' long Culvert</b> CMP, end-section conforming to fill, Ke= 0.500 Outlet Invert= 6,220.00' S= 0.0100 '/ n= 0.024 Cc= 0.900

**Primary OutFlow** Max=11.77 cfs @ 6.41 hrs HW=6,222.55' (Free Discharge)  
 ↑=Culvert (Barrel Controls 11.77 cfs @ 4.6 fps)

**Pond DP-C3: Design Point C3**

Inflow Area = 8.900 ac, Inflow Depth = 1.21"  
 Inflow = 12.40 cfs @ 6.16 hrs, Volume= 0.895 af  
 Outflow = 3.16 cfs @ 6.55 hrs, Volume= 0.892 af, Atten= 74%, Lag= 23.0 min  
 Primary = 3.16 cfs @ 6.55 hrs, Volume= 0.892 af

Routing by Stor-Ind method, Time Span= 0.00-20.00 hrs, dt= 0.01 hrs  
 Peak Elev= 6,220.56' @ 6.55 hrs Surf.Area= 0.352 ac Storage= 0.304 af  
 Plug-Flow detention time= 44.3 min calculated for 0.891 af (100% of inflow)  
 Center-of-Mass det. time= 41.9 min ( 569.2 - 527.2 )

#	Invert	Avail.Storage	Storage Description
1	6,220.00'	1.083 af	<b>Custom Stage Data (Prismatic)</b> Listed below

Elevation (feet)	Surf.Area (acres)	Inc.Store (acre-feet)	Cum.Store (acre-feet)
6,220.00	0.110	0.000	0.000
6,222.00	0.973	1.083	1.083

#	Routing	Invert	Outlet Devices
1	Primary	6,219.50'	<b>18.0" x 50.0' long Culvert</b> CMP, end-section conforming to fill, Ke= 0.500 Outlet Invert= 6,219.00' S= 0.0100 '/ n= 0.024 Cc= 0.900

**Primary OutFlow** Max=3.16 cfs @ 6.55 hrs HW=6,220.56' (Free Discharge)  
 ↑=Culvert (Barrel Controls 3.16 cfs @ 3.3 fps)

**Pond Pond B: Pond B**

Inflow Area = 249.000 ac, Inflow Depth = 1.17"  
 Inflow = 247.33 cfs @ 6.27 hrs, Volume= 24.334 af  
 Outflow = 19.76 cfs @ 8.48 hrs, Volume= 17.732 af, Atten= 92%, Lag= 132.8 min  
 Primary = 19.76 cfs @ 8.48 hrs, Volume= 17.732 af

Routing by Stor-Ind method, Time Span= 0.00-20.00 hrs, dt= 0.01 hrs

**TR20-100YR-24HR Developed**

Type IIA 24-hr Rainfall=4.40"

Prepared by WestWorks Engineering

Page 11

HydroCAD® 7.00 s/n 002053 © 1986-2003 Applied Microcomputer Systems

6/16/2005

Peak Elev= 6,185.13' @ 8.48 hrs Surf.Area= 6.115 ac Storage= 12.828 af  
 Plug-Flow detention time= 331.7 min calculated for 17.723 af (73% of inflow)  
 Center-of-Mass det. time= 209.9 min ( 753.7 - 543.7 )

#	Invert	Avail.Storage	Storage Description
1	6,182.00'	18.024 af	<b>Custom Stage Data (Prismatic)</b> Listed below

Elevation (feet)	Surf.Area (acres)	Inc.Store (acre-feet)	Cum.Store (acre-feet)
6,182.00	1.586	0.000	0.000
6,184.00	4.555	6.141	6.141
6,186.00	7.328	11.883	18.024

#	Routing	Invert	Outlet Devices
1	Primary	6,182.20'	<b>2.0" Vert. Orifice/Grate X 2.00</b> C= 0.600
2	Primary	6,182.50'	<b>27.8" x 25.0' long Culvert</b> CMP, projecting, no headwall, Ke= 0.900 Outlet Invert= 6,181.75' S= 0.0300 '/ n= 0.024 Cc= 0.900

**Primary OutFlow** Max=19.76 cfs @ 8.48 hrs HW=6,185.13' (Free Discharge)

- 1=Orifice/Grate (Orifice Controls 0.35 cfs @ 8.1 fps)
- 2=Culvert (Inlet Controls 19.41 cfs @ 4.6 fps)

**Pond Pond C: Pond C**

Inflow Area = 174.400 ac, Inflow Depth = 1.20"  
 Inflow = 155.26 cfs @ 6.29 hrs, Volume= 17.438 af  
 Outflow = 12.63 cfs @ 8.55 hrs, Volume= 11.577 af, Atten= 92%, Lag= 136.0 min  
 Primary = 12.63 cfs @ 8.55 hrs, Volume= 11.577 af

Routing by Stor-Ind method, Time Span= 0.00-20.00 hrs, dt= 0.01 hrs  
 Peak Elev= 6,202.49' @ 8.55 hrs Surf.Area= 5.998 ac Storage= 9.596 af  
 Plug-Flow detention time= 358.3 min calculated for 11.571 af (66% of inflow)  
 Center-of-Mass det. time= 223.3 min ( 762.4 - 539.2 )

#	Invert	Avail.Storage	Storage Description
1	6,200.00'	20.381 af	<b>Custom Stage Data (Prismatic)</b> Listed below

Elevation (feet)	Surf.Area (acres)	Inc.Store (acre-feet)	Cum.Store (acre-feet)
6,200.00	1.196	0.000	0.000
6,202.00	4.876	6.072	6.072
6,204.00	9.433	14.309	20.381

#	Routing	Invert	Outlet Devices
1	Primary	6,200.20'	<b>2.0" Vert. Orifice/Grate X 2.00</b> C= 0.600
2	Primary	6,200.50'	<b>27.8" x 25.0' long Culvert</b> CMP, projecting, no headwall, Ke= 0.900 Outlet Invert= 6,200.25' S= 0.0100 '/ n= 0.024 Cc= 0.900

**Primary OutFlow** Max=12.63 cfs @ 8.55 hrs HW=6,202.49' (Free Discharge)

- 1=Orifice/Grate (Orifice Controls 0.31 cfs @ 7.2 fps)
- 2=Culvert (Barrel Controls 12.32 cfs @ 4.3 fps)

**DRAINAGE MAPS  
(EXISTING & DEVELOPED CONDITIONS)**

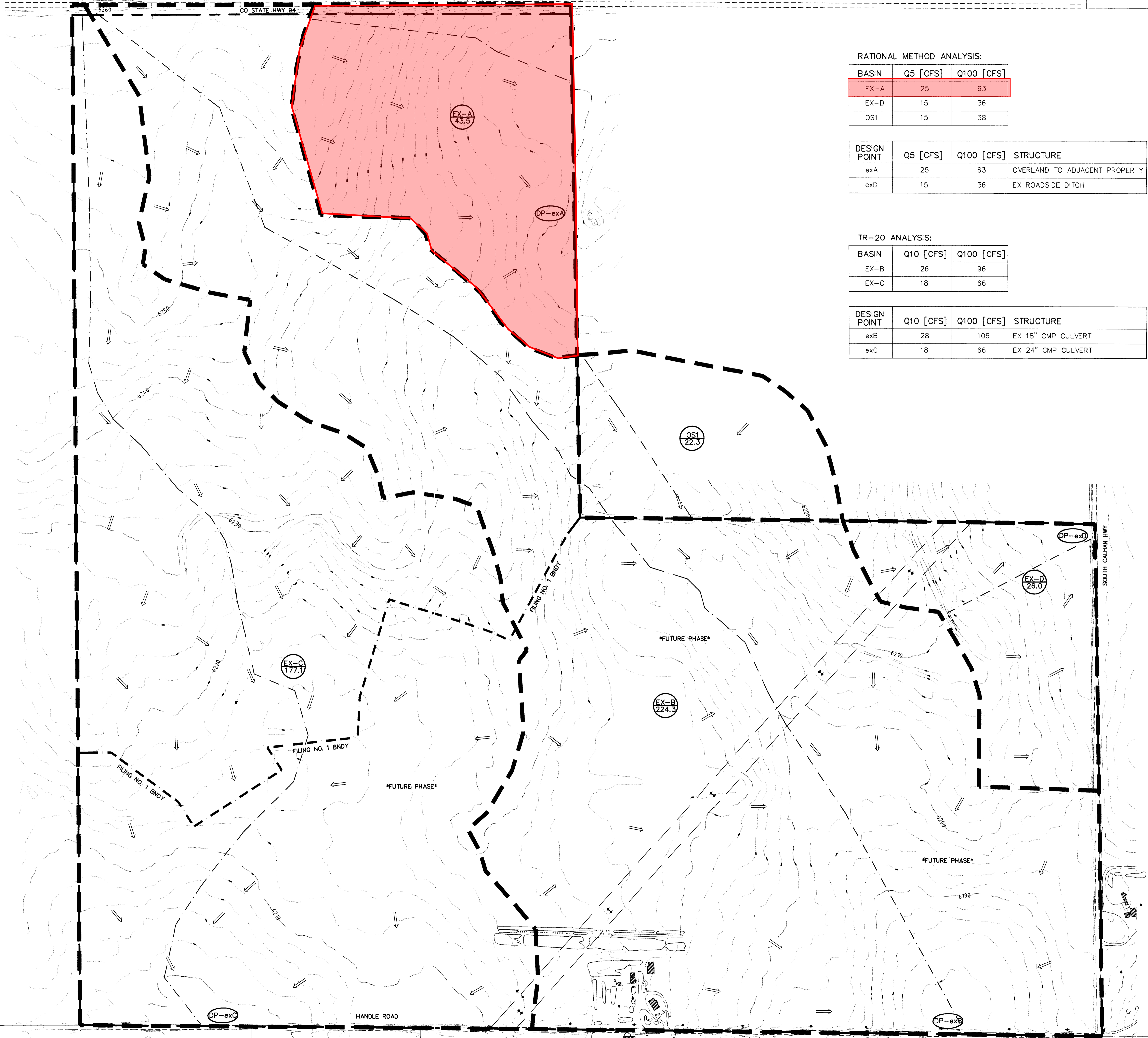

RATIONAL METHOD ANALYSIS:

BASIN	Q5 [CFS]	Q100 [CFS]
EX-A	25	63
EX-D	15	36
OS1	15	38

DESIGN POINT	Q5 [CFS]	Q100 [CFS]	STRUCTURE
exA	25	63	OVERLAND TO ADJACENT PROPERTY
exD	15	36	EX ROADSIDE DITCH

TR-20 ANALYSIS:

BASIN	Q10 [CFS]	Q100 [CFS]
EX-B	26	96
EX-C	18	66

DESIGN POINT	Q10 [CFS]	Q100 [CFS]	STRUCTURE
exB	28	106	EX 18" CMP CULVERT
exC	18	66	EX 24" CMP CULVERT

LEGEND

- BASIN IDENTIFIER A
- BASIN AREA [AC] 1.0
- DESIGN POINT IDENTIFIER DP-D
- DRAINAGE BASIN BOUNDARY
- SURFACE FLOW DIRECTION  →
- EXISTING MAJOR CONTOUR (10')
- EXISTING MINOR CONTOUR (2')
- PROPOSED MAJOR CONTOUR (10')
- PROPOSED MINOR CONTOUR (2')
- TIME OF CONCENTRATION PATH

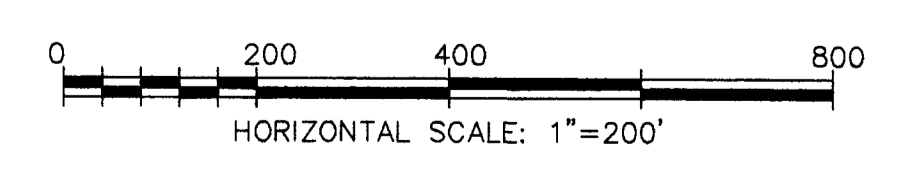

REV.	DESCRIPTION	BY	DATE
1.	PER EL PASO COUNTY DEVELOPMENT SERVICES ENGINEERING COMMENTS	CDK	6/14/05

FOR BURIED UTILITY INFORMATION  
**48 HRS BEFORE YOU DIG**  
 CALL 1-800-922-1987  
 UTILITY NOTIFICATION CENTER OF COLORADO  
 IT'S THE LAW

PREPARED FOR:  
**HIGH PLAINS LAND & CATTLE, LLC**  
 9 RIDGE ROAD  
 COLORADO SPRINGS, CO 80904  
 (719) 475-0517

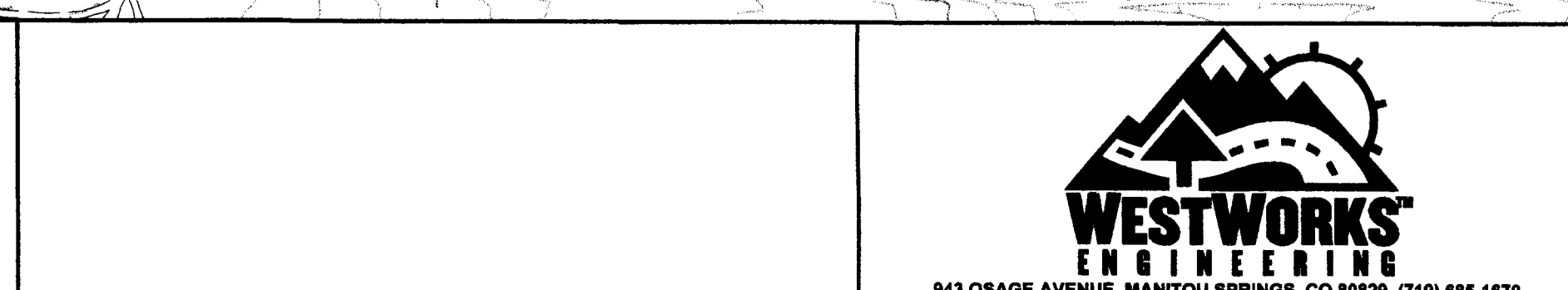

**TANNER RANCH SUBDIVISION**  
**FILING NO. 1**  
**FINAL DRAINAGE REPORT**  
**EXISTING CONDITIONS**

DRAWN BY: CDK	DATE: 6/16/05
SCALE: 1"=200'	JOB NUMBER: 90330
SHEET	1 OF 2

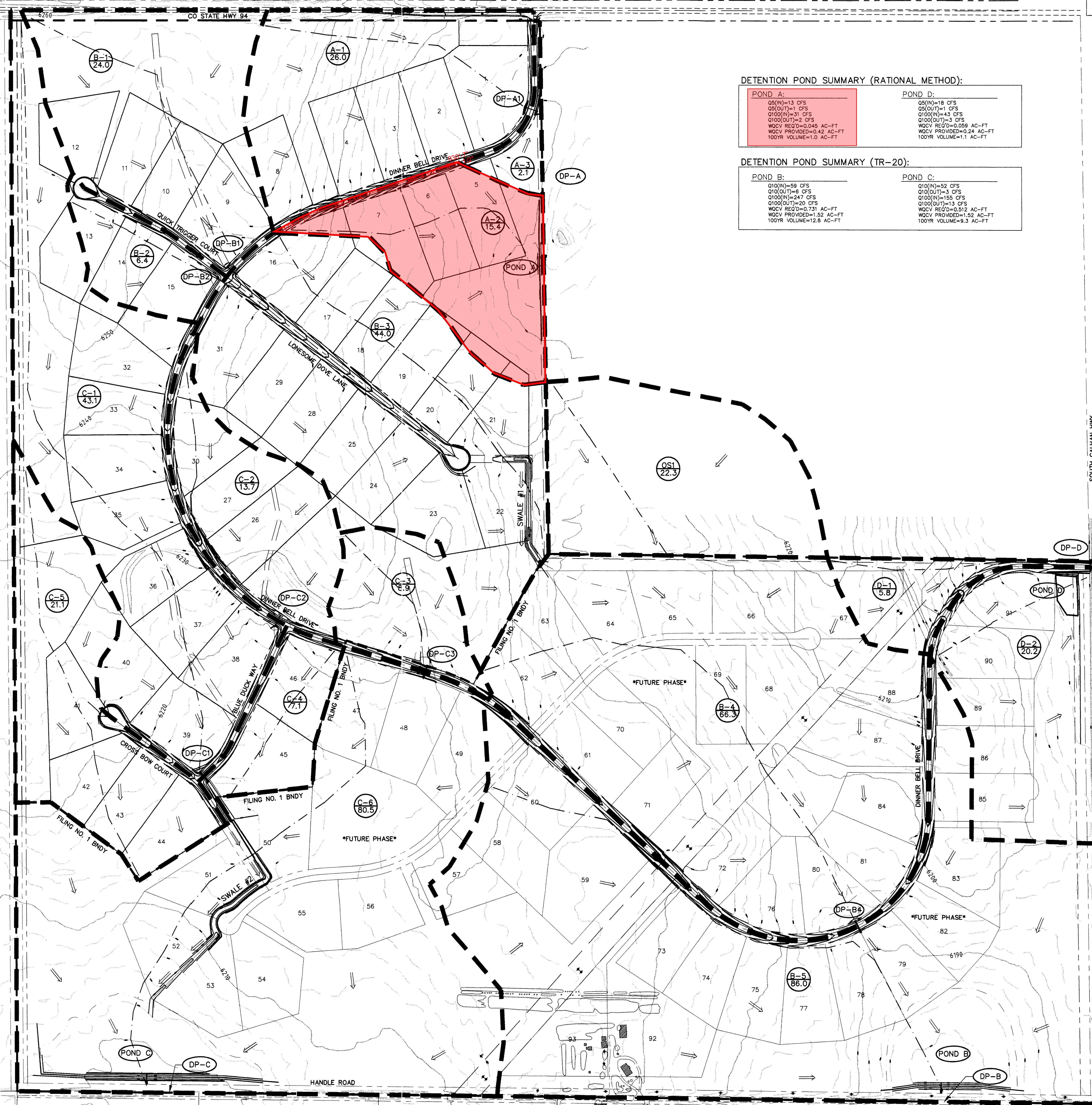

**DETENTION POND SUMMARY (RATIONAL METHOD):**

<b>POND A:</b> Q5(N)=13 CFS Q5(OUT)=1 CFS Q100(N)=31 CFS Q100(OUT)=2 CFS WQCV REQ'D=0.045 AC-FT WQCV PROVIDED=0.42 AC-FT 100YR VOLUME=1.0 AC-FT	<b>POND D:</b> Q5(N)=18 CFS Q5(OUT)=1 CFS Q100(N)=43 CFS Q100(OUT)=3 CFS WQCV REQ'D=0.059 AC-FT WQCV PROVIDED=0.24 AC-FT 100YR VOLUME=11 AC-FT
--	---

**DETENTION POND SUMMARY (TR-20):**

<b>POND B:</b> Q10(N)=59 CFS Q10(OUT)=6 CFS Q100(N)=247 CFS Q100(OUT)=20 CFS WQCV REQ'D=0.731 AC-FT WQCV PROVIDED=1.52 AC-FT 100YR VOLUME=12.8 AC-FT	<b>POND C:</b> Q10(N)=52 CFS Q10(OUT)=3 CFS Q100(N)=155 CFS Q100(OUT)=13 CFS WQCV REQ'D=0.512 AC-FT WQCV PROVIDED=1.52 AC-FT 100YR VOLUME=9.3 AC-FT
---	--

**RATIONAL METHOD ANALYSIS:**

BASIN	Q5 [CFS]	Q100 [CFS]
A-1	22	51
A-2	13	31
A-3	2	4
B-1	16	39
B-2	5	12
B-3	34	81
B-4	49	115
B-5	62	148
C-1	24	57
C-2	10	24
C-3	8	19
C-4	6	14
C-5	16	37
C-6	56	134
D-1	5	12
D-2	18	43
OS1	15	38

**RATIONAL METHOD ANALYSIS:**

DESIGN POINT	Q5 [CFS]	Q100 [CFS]	STRUCTURE
A1	22	51	18" CMP CULVERT
A	2	7	OVERLAND TO ADJACENT PROPERTY
B1	16	39	24" CMP CULVERT
B2	5	12	18" CMP CULVERT
C1	32	57	DUAL 30" CMP CULVERTS
C2	10	24	24" CMP CULVERT
C3	8	19	18" CMP CULVERT
D	5	13	EX ROADSIDE DITCH

**TR-20 ANALYSIS:**

DESIGN POINT	Q10 [CFS]	Q100 [CFS]	STRUCTURE
B4	24	153	DUAL 24" CMP CULVERTS
B	6	20	EX 18" CMP CULVERT
C	3	13	EX 24" CMP CULVERT

- LEGEND**
- BASIN IDENTIFIER A
  - BASIN AREA [AC] 1.0
  - DESIGN POINT IDENTIFIER DP-0
  - DRAINAGE BASIN BOUNDARY
  - SURFACE FLOW DIRECTION
  - EXISTING MAJOR CONTOUR (10')
  - EXISTING MINOR CONTOUR (2')
  - PROPOSED MAJOR CONTOUR (10')
  - PROPOSED MINOR CONTOUR (2')
  - TIME OF CONCENTRATION PATH

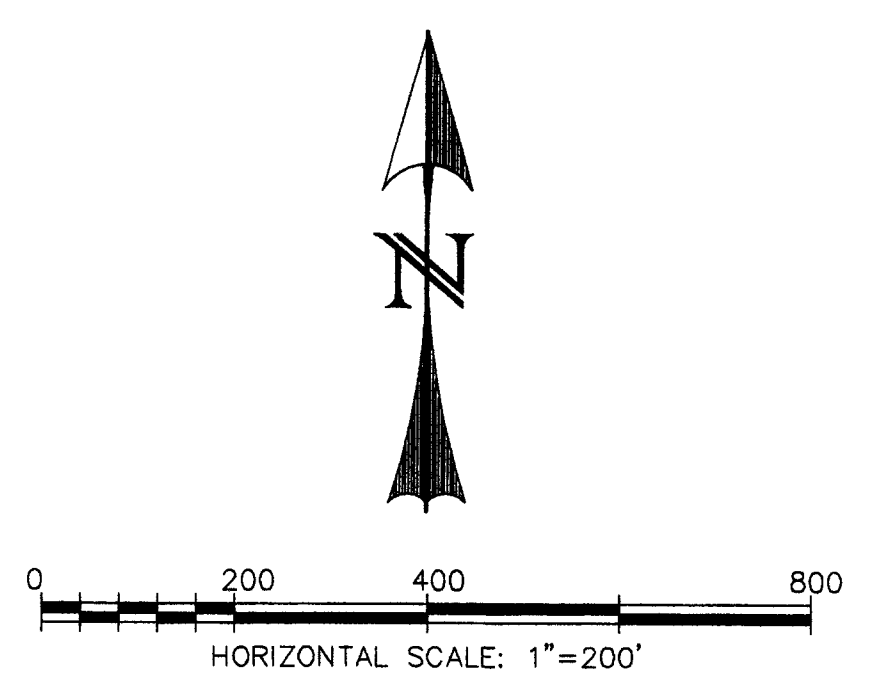

REV.	DESCRIPTION	BY	DATE
1.	PER EL PASO COUNTY DEVELOPMENT SERVICES ENGINEERING COMMENTS	CDK	6/14/05

FOR BURIED UTILITY INFORMATION  
**48 HRS BEFORE YOU DIG**  
 CALL 1-800-922-1987  
 UTILITY NOTIFICATION CENTER OF COLORADO  
 IT'S THE LAW

PREPARED FOR:  
**HIGH PLAINS LAND & CATTLE, LLC**  
 9 RIDGE ROAD  
 COLORADO SPRINGS, CO 80904  
 (719) 475-0517

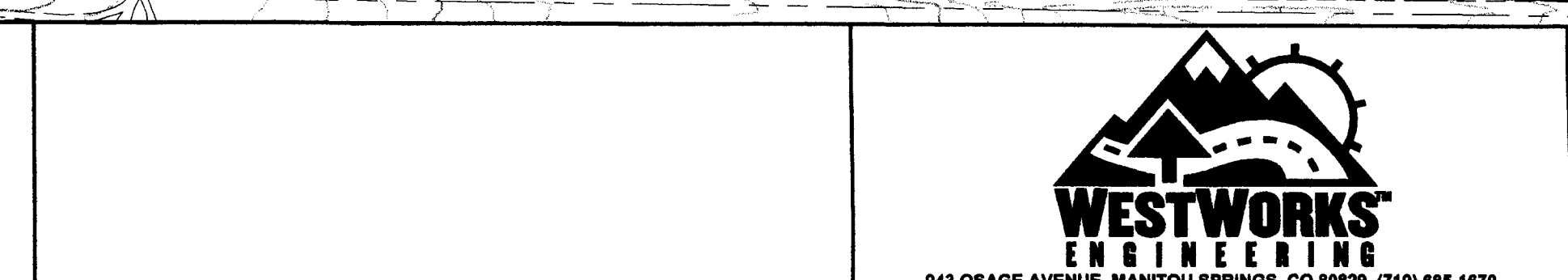

**TANNER RANCH SUBDIVISION**  
 FILING NO. 1  
**FINAL DRAINAGE REPORT**  
 DEVELOPED CONDITIONS

DRAWN BY: CDK	DATE: 6/16/05
SCALE: 1"=200'	SHEET
JOB NUMBER: 90330	2 OF 2



2 North Nevada, Suite 900  
Colorado Springs, Colorado 80903

Project: Tanner Ranch Filing No. 1- Pond A  
Project Number:  
Date: April 1, 2026

Prepared By: MEO
Checked By: KRK

Pond A	Item	Unit	Quantity	Unit Cost	Cost
	Concrete Trickle Channel	LF	205	\$ 64.00	\$13,120.00
	Concrete Micropool	EA	1	\$ 5,000.00	\$5,000.00
	Concrete Outlet Structure	EA	1	\$ 8,500.00	\$8,500.00
	18" RCP Outfall Pipe	LF	19	\$ 111.00	\$2,109.00
	18" RCP FES	EA	1	\$ 666.00	\$666.00
	Outfall Riprap Protection	CY	1	\$ 210.00	\$210.00
	Rip Rap Emergency Spillway	CY	34	\$ 210.00	\$7,140.00
	Maintenance Road (6" Thick)	CY	195	\$ 56.00	\$10,920.00
	Total				\$47,665.00

**Conceptual Opinion of Probable Construction Cost**

The Engineer has no control over the cost of labor, materials, equipment, or over the Contractor's methods of determining prices or over competitive bidding or market conditions. Opinions of probable costs provided herein are based on the information known to Engineer at this time and represent only the Engineer's judgment as a design professional familiar with the construction industry. The Engineer cannot and does not guarantee that proposals, bids, or actual construction costs will not vary from its opinions of probable costs.