



STORMWATER MANAGEMENT PLAN

**LOT 2 ELM GROVE VILLA
SMITH PLUMBING
PCD FILING NO.:** PPR2143

STORMWATER PERMIT # COR _____
CERTIFICATION # _____

Owner/Developer:

Great Dane Ventures, LLC
5903 High Noon Ave
Colorado Springs, CO 80923

SWMP Preparer:

Galloway & Company, Inc.
1155 Kelly Johnson Blvd., Suite 305
Colorado Springs, CO 80918

Contractor:

Hammers Construction
1411 Woolsey Heights
Colorado Springs, CO 80915

***SWMP Administrator / Qualified
Stormwater Manager:***

To be Determined

Date:

Prepared: June 8, 2021

SWMP Location:

On-Site (Copy) and Hammers
Construction (Original)



TABLE OF CONTENTS

SWMP REPORT REVISION LOG

I. PROJECT DESCRIPTION.....	4
II. PHASING AND PROPOSE CONSTRUCTION SEQUENCE	4
III. FINAL STABILIZATION	5
IV. PRE-DEVELOPMENT CONDITIONS & SOILS	6
V. DESCRIPTION OF POTENTIAL POLLUTANTS	7
VI. AREAS AND VOLUMES.....	11
VII. APPROPRIATE CONTROLS AND MEASURES	11
VIII. MATERIALS HANDLING AND SPILL PREVENTION	14
X. RECEIVING WATERS.....	17
IX. INSPECTION AND RECORD KEEPING	17

Appendices:

- A. Vicinity Map
- B. Soils Map
- C. FEMA Floodplain Map
- D. GESCP Plan
- E. BMP Details
- F. ESQCP Permit

SWMP REPORT REVISION LOG

REVISION #	DATE	BY	COMMENTS
1.			
2.			
3.			
4.			
5.			
6.			
7.			
8.			
9.			
10.			
11.			
12.			
13.			

other project docs state 1.62. Revise docs as needed.

I. PROJECT DESCRIPTION

LOCATION

Elm Grove Villa subdivision is located in the southwest quarter of Section 1 and the southeast quarter of Section 2, Township 15 South, Range 66 West of the 6th P.M. in the Town of Security, Colorado. Lot 2 Elm Grove Villa, also referred to as Smith Plumbing, is a 1.51 acre lot which is currently undeveloped. It is located east of Main Street (a.k.a. Hancock Expressway) and south of Bradley Road (a.k.a. Cable Lane) in Security, Colorado, located within El Paso County.

LEGAL DESCRIPTION

The legal description is:

LOT 2 ELM GROVE VILLA

BASIS OF BEARING:

BEARINGS ARE BASED ON WEST LINE OF SECTION 1, TOWNSHIP 15 SOUTH, RANGE 66 WEST, MONUMENTED ON THE NORTH END BY A 6' WITNESS CORNER, FOUND, 3.5" ALUMINUM CAP, "T24S R66W W.C. 6.00' S 35 S36 S2 S1 T1 1/4 S R55W 2012 PLS 24313" AND ON THE SOUTH END BY A 3.5" ALUMINUM CAP, FOUND, "RMPS 19625", AND IS CONSIDERED TO BEAR N00°42'04"W.

DESCRIPTION OF PROPERTY

The project site contains approximately 1.51 acres and is comprised of undeveloped land covered sparsely by native grasses and weeds. This site was platted as part of the Elm Grove Villa project, a planned townhouse development. The site is located south of Bradley Road and east of Main Street.

CONSTRUCTION ACTIVITY

Construction activities include but are not limited to the infrastructure to support the proposed commercial building, which includes grading, asphalt pavement for access & parking, stormwater conveyance (pipes, inlets, swales, etc.), water service line, sanitary sewer service line and stormwater quality pond. Construction will commence with preliminary over lot grading followed by utility installation. Construction will be completed with final stabilization including asphalt pavement, curb and gutter, sidewalks and landscaping.

Temporary stabilization measures (silt fence) will be installed prior to beginning construction. During construction temporary stabilization measures including inlet protection will be utilized to control stormwater runoff. Once final stabilization is achieved, temporary erosion control measures will be removed.

II. PHASING AND PROPOSE CONSTRUCTION SEQUENCE

PHASING

Construction activities will be completed in three phases including Initial, interim and final. Initial phase includes the installation of silt fence around the entire project Limit of Disturbance and inlet

protection around exiting inlets. Interim phase includes the installation of temporary sediment controls as construction progresses. Refer to the provided phasing table on the Grading and Erosion Control Plans. The final phase will be completed once the site is stabilized and all temporary measures are removed. All 3 phases are included in the Construction Drawing plan set.

CONSTRUCTION DOCUMENTATION

Construction drawings are provided with this document showing each of these phases and are intended to be a “living” document used by the SWMP Manager to document construction activities. See section IX “Inspection and Record Keeping” for additional information.

PROPOSED SEQUENCE FOR MAJOR CONSTRUCTION ACTIVITIES

Construction for the development of this project is currently projected to begin in May of 2021. It is estimated that construction activities will be completed by December 2021. Final stabilization is expected in the spring of 2022. The anticipated sequence of construction is as follows:
Falcon Meadows at Bent Grass Filing No. 1:

Initial:

1. Installation of perimeter silt fence as shown on the grading and erosion control plans.
2. Placement of inlet protection erosion control measures along existing roadways.

Interim:

3. Site Clearing/Grubbing and topsoil stockpiling.
4. Construct Stabilized Staging Area as shown on the grading and erosion control plans.
5. Install Vehicle Tracking Control at entrances as shown on the grading and erosion control plans.
6. Construct temporary sediment basin as necessary.
7. Rough grading of the site.
8. Construct underground water/sewer/storm.

Final:

9. Construct curb/gutter and pavement.
10. Final stabilize areas outside of ROW.
11. Construct gas/electric/cable/phone areas.
12. Final stabilize.
13. Final erosion control measures as areas are completed. (Final BMP's)
14. Remove construction BMP's

See Section VI “Areas and Volumes” for information on anticipated disturbed area and grading volumes.

III. FINAL STABILIZATION

Final site stabilization will be achieved when all final landscaping and paving is complete and when vegetation density is greater than 70 percent of pre-disturbance density over its entire area. The remainder of the site will consist of hardscape (drives and walks) or be a part of the

building footprint. All final stabilization on the site will be of a permanent nature. All temporary BMPs will be removed upon completion of construction. It is the responsibility of the contractor to remove all dirt and garbage from the site.

Permanent BMP's such as the water quality pond will be owned and maintained by owner. A water quality detention pond will be provided with forebays, trickle channels, and an outlet structure. This Permanent BMP structure is designed and provided on the Construction Drawing Plan set.

IV. PRE-DEVELOPMENT CONDITIONS & SOILS

FLOODWAY

According to the current FEMA Flood Insurance Rate Map (FIRM) Panel No. 08041C0763 G, dated December 7, 2018 (See Appendix for the FEMA FIRM Exhibit) this site is designated as Zone X (outside 0.2% chance of flood), area of minimal flood hazard.

EXISTING VEGETATION

Existing vegetation and soils were determined from in-person field site visits and existing aerial inspection from Google Earth and the United States Department of Agriculture Natural Resources Conservation Service (NRCS) Web Soil Survey. The site is currently undeveloped. Vegetation consists of native grasses/weeds. There is no brush or trees within the area to be graded. Ground cover is estimated at 50% density.

EXISTING DRAINAGE PATTERNS

The site is fully contained within the Security Drainage basin. Drainage through the site is generally north to south. Drainage is collected in 2 existing on-site inlets. Flows are then released on the existing townhome development south of the site and conveyed to an existing detention pond, eventually releasing into Fountain Creek.

EXISTING SLOPES

Existing slopes are around 1-6% that direct runoff to an existing channel that conveys flow to an existing detention pond which outfalls to Fountain Creek.

EXISTING SOIL TYPES

Soil data was obtained from the United States Department of Agriculture Natural Resources Conservation Service (NRCS) Web Soil Survey.

The following table summarizes the characteristics of the soil type:

Soil	Hydro Group	Shrink/Swell Potential	Permeability	Surface Runoff Potential	Erosion Hazard
8-Blakeland loamy sand, 1 to 9 percent slopes	A	Low	High	Very Low	Slight

The existing soil types have a slight potential for erosion which can be mitigated by employing appropriate downstream construction BMP's before/during/after construction to limit potential impacts to stormwater discharges. The potential impacts are sediment discharge into the existing conveyance system. Sediment should be minimized to the extents possible to the existing facilities. Potential impacts from runoff flowing to the existing conveyance will be mitigated by constructing a temporary sediment basin in the new pond location and by grading the site to reduce drainage area. The contractor shall employ the most appropriate method of erosion control measures based on the El Paso County/City of Colorado Springs Drainage Criteria Manual, Vol. 2 or as directed by the SWMP administrator or his representative.

More detailed soils information can be found in the SCS soils survey for El Paso County.

V. DESCRIPTION OF POTENTIAL POLLUTANTS

Potential sources of sediment to stormwater runoff include earth moving and concrete activities associated with grading and landscaping.

Potential pollutants and sources, other than sediment, to stormwater runoff include Trash, debris, line transfer, Dewatering, fueling and equipment failure.

A dewatering permit is not required

Construction activities produce many different kinds of pollutants which may cause storm water contamination problems. Grading activities remove rocks, vegetation and other erosion controlling surfaces, resulting in the exposure of underlying soil to the elements. Because the soil surface is unprotected, soil and sand particles are easily picked up by wind and/or washed away by rain or other water sources.

The following sections highlight the potential sources of pollution at the Project Site and list the "Best Management" strategies that will be used to prevent migration of pollution offsite. This Project Site does not rely on control measures owned or operated by another entity. Chemical materials stored indoors or that have no reasonable chance of impacting storm water quality will not be discussed in this plan.

Materials of significance stored on the project site include:

- Sediment
- Concrete Washout
- Cement
- Trash & Debris
- Sanitary Wastes
- Fuels & Oils

WIND EROSION & DUST CONTROL

Pollutant: Sediment Best Management Strategies:

- Daily inspections will occur for areas experiencing excessive winds, vehicle traffic, or precipitation events.
- Water trucks will spray down dust on the project Site as needed to not impact adjacent properties.
- Attention will be given to prevent the overuse of water in dust control operations to minimize any muddying of the surface and possible sediment transportation.

VEHICULAR TRANSPORT

Pollutant: Sediment Tracking Best Management Strategies:

- Construct a stabilized construction entrance to provide ingress and egress of the site.
- Restrict access to the stabilized construction entrance.
- Fencing will be erected if problems with access control are evident.
- Maintain track out pads by fluffing up the rock material or by adding additional rock as needed.
- Inspect, sweep and clean adjacent streets where track out is evident.

STOCKPILES

Pollutant: Sediment Best Management Strategies:

- Locate stockpiles clear of any water flow paths.
- Locate stockpiles within the property boundary.
- Stockpiles will have erosion control devices as needed installed around the base to prevent the migration of soil.
- Topsoil stockpiles and disturbed portions of the site where construction activity temporarily ceases for at least 14 days will be stabilized with temporary seed and mulch no later than 14 days from the last construction activity in the area.

GRADING, TRENCHING, EXPORT/IMPORT

Pollutant: Sediment Best management Strategies:

- Earth moving will be minimized by the engineering balancing of the site.
- Disturbed portions of the site where construction activity temporarily ceases for at least 14 days will be stabilized with temporary seed and mulch no later than 14 days from the last construction activity in the area.
- Seed bed preparation is not required if soil is in loose condition.
- Prior to seeding, fertilizer shall be applied to each acre to be stabilized in accordance with the manufacturer's specifications.
- If required seeding areas shall be mulched with straw to a uniformed cover. The straw mulch is to be tacked into place by a disk with blades set nearly straight.
- A site specific erosion control drawing has been developed showing the location of Best Management practices to be used during site construction.

- Where indicated on the erosion control plan, Best Management Practices will be installed.
- Material shall be in accordance with the plans and specifications and all construction shall be provided in accordance with the manufacturer's specifications.
- All BMP's will be inspected bi-weekly and cleaned/maintained as required.

WASTE, RESIDUAL CONCRETE

Pollutant: Concrete, paint, and Phosphoric Acid Best Management Strategies:

- A cleanup and washout area will be designated and posted.
- Subcontractors will be instructed on the locations and importance of the washout and cleanup areas. No on-site disposal is allowed.
- Instruct subcontractors to remove waste for which proper onsite disposal facilities are not provided back to their own facilities for ultimate transport, storage & disposal.
- Subcontractors and subcontractor employees are held responsible for improper washout.

SANITARY FACILITIES, TRASH CONTAINERS & LITTERING

Pollutant: Bacteria, Ammonia, Trash Best Management Strategies:

- Portable facilities will be regularly serviced to prevent excessive waste containment and overflow.
- Portable facilities will be located a minimum of 50 feet from state waters. They shall be adequately staked and cleaned on a weekly basis. They will be inspected daily for spills.
- All waste materials will be collected and stored in a container which will meet all local and any state solid waste management regulations.
- Trash dumpsters will be emptied prior to becoming 90% full or when debris control becomes an issue.
- Employees will be instructed on the importance of recycling and waste management, and will be held responsible for improper waste management.

FUELING, HAZARDOUS MATERIALS, EQUIPMENT LEAKAGE, FERTILIZER

Pollutant: Petroleum Hydrocarbons, Ethylene Glycol, Sediment Best Management Strategies:

- MSDS sheets will be maintained in the project trailer for all onsite materials
- All dry materials such as cement will be covered and protected from rain.
- Secondary containment will be provided for stored fuel, oil, paint and any material classified as hazardous.
- Subcontractors are responsible for hazardous waste removal back to their own facilities for ultimate transportation, storage and disposal.
- Supplies will be kept onsite as necessary to control any potential spill.
- Employees will be held responsible for any illegal dumping.
- Seals will be checked by a qualified professional on all equipment and containers containing significant materials that could contribute potential pollutants and will be replaced as necessary.
- Equipment will be inspected by a qualified professional.

- Drip pans will be available for minor leaks and during fueling operations.
- Fueling nozzles, gauges, hoses, seals, and emergency shutoff valves will be inspected for leaks prior to use.
- Under no circumstances during fueling will the fueling hose/nozzle be left unattended.
- Fertilizers used will be applied only in the minimum amounts recommended by soil tests.
- Once applied, fertilizers will be worked into the soil to limit exposure to storm water.
- Stored fertilizer will be protected from exposure to precipitation and storm water runoff.

DEWATERING – not needed.

This shown for information only Pollutant: Sediment, Oil and/or Grease and Phosphoric Acid Best Management Strategies:

All dewatering will be filtered through rock and/or woven geo mesh fabric.

All dewatering will be tested for Pollutants per state guidelines weekly.

CONCRETE AND ASPHALT BATCH PLANT – not needed.

This shown for information only There are no existing batch plants located on this project site and there are no proposed batch plants in the future.

DRILLING SLURRY FOR DRILLING PIERS. – not needed.

This is shown for information only. No drilling slurry is allowed to be deposited onto the job site. All drilling slurry shall be collected and pumped into an on-site frac tank and shall be disposed of off-site.

There are no major potential pollutants anticipated to be used on the site.

ADDITIONAL (NONSTRUCTURAL) BEST MANAGEMENT PRACTICES FOR SEDIMENT:

1. Earth moving will be minimized by the engineering balancing of the site.
2. Disturbed portions of the site where construction activity temporarily ceases for at least 14 days will be stabilized with temporary seed and mulch no later than 14 days from the last construction activity in the area.
3. Seed bed preparation is not required if soil is in loose condition.
4. Prior to seeding, fertilizer shall be applied to each acre to be stabilized in accordance with the manufacturer's specifications.
5. If required seeding areas shall be mulched with straw to a uniformed cover. The straw mulch is to be tacked into place by a disk with blades set nearly straight.
6. A site-specific erosion control drawing has been developed showing the location of Best Management practices to be used during site construction.
7. Where indicated on the erosion control plan, Best Management Practices will be installed.
8. Material shall be in accordance with the plans and specifications and all construction shall be provided in accordance with the manufacturer's specifications.
9. All BMP's will be inspected bi-weekly and cleaned/maintained as required.

ESQCP says 1.62 and 1.62. Revise to remove discrepancy.

VI. AREAS AND VOLUMES

The site consists of 1.5 acres. 1.4 acres is expected to be disturbed.

The unadjusted cut and fill quantities as of the writing of this report are listed below:

Cut Volume = 16 Cubic Yards

Fill Volume = 6,608 Cubic Yards

Net Volume = 6,592 Cubic Yards (Fill)

Note: The Total disturbed area shall be updated on the SWMP as changes occur.

VII. APPROPRIATE CONTROLS AND MEASURES

Also refer to attached Erosion and Sediment Control notes and plans included in the site plans

MINIMIZE DISTURBED AREA AND PROTECT NATURAL FEATURES AND SOIL

All work will occur inside the limits of construction per the erosion Control Site Plan.

PHASE CONSTRUCTION ACTIVITY The sequence for the installation and removal of erosion and sediment control measures is as follows: Perimeter control measures (silt barriers and fencing) installed at designated areas as noted on the site plans (Exhibit 1), cleaning of street surfaces during construction if applicable, site grading, installation of utilities, paving final and grading, installation of sod or other vegetation, removal of temporary practices and perimeter controls, and site cleanup.

CONTROL STORMWATER FLOWING ONTO AND THROUGH THE PROJECT

Offsite stormwater flows adjacent to this project site from the East Tributary of Jimmy Camp Creek. On-site stormwater will be directed to proposed ponds that will function as sedimentation basins so that no sediment enters the downstream receiving waters into the East Tributary.

STABILIZE SOILS

No disturbed area which is not actively being worked shall remain denuded for more than 14 calendar days unless otherwise authorized by the director. Temporary cover by seeding or mulching should be provided on areas which will be exposed for a period greater than 14 days before permanent stabilization can be achieved. Permanent cover should be provided on all areas as soon as possible, by means of seeding and mulching, straw or hay mulch is required. All soil stock piles and borrow areas must be protected with silt fence within 14 days after grading. All slopes within the project limits that are found to be eroding excessively within two years of permanent stabilization shall be provided additional slope stabilization methods such as seeding and mulching. Water is to be used for dust control. The Contractor will prevent the escape of this water and any sediment it may carry from the construction site.

PROTECT SLOPES

Temporary stabilization will include the installation of silt fences on level contours spaces at 10-20 foot intervals. Slopes will be seeded and covered with hay, straw or erosion control blankets

on slopes greater than 3:1 as needed to provide for temporary stabilization until vegetation is permanently established. All slopes within the project limits that are found to be eroding excessively within two years of permanent stabilization shall be provided additional slope stabilization methods such as seeding and mulching. Where slopes are steeper than 3:1 erosion control blankets (per specification requirements) will be utilized for final stabilization.

PROTECT STORM DRAIN INLETS

Inlet protection will be installed as soon as storm drain inlets are installed and before land disturbance activities begin in areas with existing storm drain systems. At the Contractor's discretion, additional temporary erosion control practices to include rock bags and sand bag barriers may be installed to prevent sediment movement. Inlet protection will include rock bags erosion logs curb inlet sediment filters where an overflow capacity is necessary to prevent excessive ponding in front of the curb inlet. Concrete block and wire screen inlet protection if used detail will be included Appendix prior to installation, will be used where heavy flows are expected and where an overflow capacity is necessary to prevent excessive ponding around the inlet. Inlet protection devices will be inspected and accumulated sediment will be removed as needed.

ESTABLISH PERIMETER CONTROLS AND SEDIMENT BARRIERS

Temporary stabilization will include the installation of silt fences on the downslope perimeter of project area. The silt fence will be trenched in on the uphill side 6 inches deep and 6 inches wide as detailed in the silt fence exhibit. Sediment will be removed when it reaches 1/3 the height of the fence. Silt fence will be inspected and replaced or repaired as needed.

RETAIN SEDIMENT ON-SITE

Temporary sediment traps shall be installed to detain sediment laden runoff from small watersheds for a period long enough to allow sediment to settle before discharge into receiving waters. For small drainage locations smaller sediment traps should be used. At a minimum, silt fences, vegetative buffer strips or equivalent sediment controls are required for all down-slope boundaries (and for those side slope boundaries deemed appropriate as dictated by individual site conditions) of the construction. The use of a combination of sediment and erosion control measures in order to achieve maximum pollutant removal will be utilized. Sediment traps will be checked regularly for sediment cleanout. Sediments shall be removed and the trap restored to its original dimensions when the sediment has accumulated to one half the design volume of the wet storage. Sediment shall be disposed in suitable areas and in such a manner that will not erode or cause sedimentation problems. The gravel outlets will be checked regularly for sediment buildup which will prevent damage. If the gravel is clogged by sediment, it shall be removed and cleaned or replaced.

An alternate to sediment traps are temporary sediment basins.

ESTABLISH STABILIZED CONSTRUCTION EXITS

The construction entrance will be established in the entry points of roads. The construction entrance will be at least 50 feet in length and approximately 12 feet wide and graded so runoff

does not leave the site. The aggregate will be established at 8 inches thick on top of 4 inch minimum thick free draining material on top of geotextile and will consist of Type G dense graded material. A stabilized stone pad with a filter fabric under liner will be placed at points of vehicular ingress and egress.

ADDITIONAL BMP'S BMP SCHEDULE:

All Sediment and Erosion control BMP's (detailed below and only on BMP site map and details if utilized onsite) will be installed prior to any excavation or demolition and will be coordinated with the construction schedule. As construction changes and new temporary BMP's are needed to control sediment and erosion temporary BMP's will be installed within 24 hours of inspection report.

RECOMMENDED BMP'S: ALL RECOMMENDED BMP'S WILL BE INSTALLED PRIOR TO EXCAVATION NEAR ANY SENSITIVE AREAS.

Silt Fence is to be installed in sensitive areas to protect stream channels, pond, and overland runoff. On this site it will be used to protect runoff from the slip pits. See Silt Fence Detail. Removal of this BMP will occur only after vegetation is established to a minimum of 70% pre construction coverage and after removal of BMP all sediment builds up will be removed and the area exposed shall be seeded.

Vehicle Tracking Control is needed at the main construction entrance location. Vehicle tracking control shall be installed at the edge of the construction staging area where construction vehicles regularly exit onto existing asphalt road. If sediment tracking occurs it will be cleaned within 24 hours.

See Vehicle Tracking Control Detail in Construction Drawings. Removal of this BMP will occur only after project is substantially complete and is ready for seeding operations; the area will then be seeded per specification with the rest of the project.

Portable Toilets: Portable toilets are brought in from a service contractor and will be maintained in accordance with standard waste disposal practices using vacuum trucks and place on stable ground to minimize risk of spillage. All portable toilets will be kept a minimum of 500' from any waterway.

Waste Disposal: If needed Roll offs will be utilized for standard construction waste. A qualified contractor will remove waste weekly and take to an appropriate dump site off this project.

Portable toilets will be located a minimum of 10ft from stormwater inlets and 50ft from state waters. They will be secured at all four corners to prevent overturning and cleaned on a weekly basis. They will be inspected daily for spills.

PERMANENT BMP'S:

Re-vegetation: During construction any disturbed area not being currently worked left dormant longer than 14 days will be re-vegetated per specification with native seed and mulched and crimped with weed free straw.

All BMPs shall be installed and maintained in accordance with the most recent Urban Drainage and Flood Control District Urban Storm Drainage Criteria Manual.

VIII. MATERIALS HANDLING AND SPILL PREVENTION

MATERIAL HANDLING AND WASTE MANAGEMENT

The site will use a private refuse collector that will remove litter twice weekly. No less than one litter receptacle will be present at the construction site. In the event that unusual items such as tanks, cylinders, unidentified containers, etc. which could contain potentially hazardous materials are discovered or disturbed, the Fire and Rescue services will be notified. Litter and debris will be picked up and disposed of properly daily. Temporary toilet facilities will be located 500 feet away from any storm drain inlets and all waters of the state.

ESTABLISH PROPER BUILDING MATERIAL STAGING AREAS

A designated staging area will be used, location to be determined based on available space in the field and plans will be redline. The staging area will be contained per SWMP guidelines. All Equipment and Materials will be brought into the site as needed.

DESIGNATE WASHOUT AREAS

A concrete washout will be installed to detail as shown on the Construction Drawings and will be placed more than 500 feet away from any waters of the state.

ESTABLISH PROPER EQUIPMENT/VEHICLE FUELING AND MAINTENANCE PRACTICES

During construction the site will be exposed to operation and maintenance of construction equipment. The contractor shall be responsible for all activities such as fueling, oil changing, lubrication and repair which require use of petroleum products. Such products shall be transported to and from the site in special trucks equipped for that purpose. No waste petroleum products, rags, residue, or equipment parts shall be left on site. In the event of a spill or leak, causing soil to be contaminated, that soil shall be excavated placed in sealed barrels and removed from the site for transport to an approved location for disposal.

CONTROL EQUIPMENT/VEHICLE WASHING

This activity will not be allowed onsite.

ANY ADDITIONAL BMPs

Additional BMP's will be added to this SWMP as needed.

ALLOWABLE NON-STORMWATER DISCHARGE MANAGEMENT

There are no visible natural springs or irrigation, or other non-stormwater discharges anticipated to be encountered.

SELECTING POST-CONSTRUCTION BMPs

Post Construction BMPs. Re-vegetation including seeding, mulching and erosion control blanket will be final BMP's. Permanent stabilization will be achieved with 70% preconstruction vegetative establishment.

SPILL PREVENTION AND CONTROL PLAN

The SITE SUPERINTENDENT will act as the point of contact for any spill that occurs at this jobsite. The project manager will be responsible for implementation of prevention practices, spill containment / cleanup, worker training, reporting and complete documentation in the event of a spill. The ECO shall immediately notify the Owner, /Construction Manager, STATE and the Local Fire Department in addition to the legally required Federal, State, and Local reporting channels (including the National Response Center, 800.424.8802) if a reportable quantity is released to the environment.

SPILL PREVENTION BEST MANAGEMENT PRACTICES This section describes spill prevention methods Best Management Practices (BMP) that will be practiced to eliminate spills before they happen.

- **Equipment Staging and Maintenance:** Store and maintain equipment in a designated area Reduce the amount of hazardous materials and waste by substituting non-hazardous or less hazardous materials. Use secondary containment (drain pan) to catch spills when removing or changing fluids. Use proper equipment (pumps, funnels) to transfer fluids Keep spill kits readily accessible Check incoming vehicles for leaking oil and fluids. Transfer used fluids and oil filters to waste or recycling drums immediately following generation. Inspect equipment routinely for leaks and spills Repair equipment immediately, if necessary, implement a preventative maintenance schedule for equipment and vehicles.
- **Fueling Area:** Perform fueling in designated fueling area minimum 50' away from federal waters Use secondary containment (drain pan) to catch spills Use proper equipment (pumps, funnels) to transfer fluids Keep spill kits readily accessible Inspect fueling areas routinely for leaks and spills Hazardous Material Storage Areas Reduce the amount of hazardous materials by substituting non-hazardous or Less hazardous materials.
- **Hazardous Material Storage Areas:** Minimize the quantity of hazardous materials brought onsite Store hazardous materials in a designated area away from drainage points.
- **Unexpected Contaminated Soil and Water:** Perform all excavation activities carefully and only after the Owner/Construction Manager directed any activities.

SPILL CONTAINMENT METHODS

The following discussion identifies the types of secondary containment that will be used in the event of a spill. The Table below summarizes the containment methods for each potential source.

- **Equipment Staging and Maintenance Area:** An equipment leak from a fuel tank, equipment seal, or hydraulic line will be contained within a spill containment cell placed beneath all stationary potential leak sources. An undetected leak from

parked equipment will be cleaned up using hand shovels and containerized in a 55-gallon steel drum for offsite disposal.

- **Fueling Area:** A small spill during fueling operations will be contained using fuel absorbent pads at the nozzle. The transfer of fuel into portable equipment will be performed using a funnel and/or hand pump and a spill pad used to absorb any incidental spills/drips. Any leaking tanks or drums will have fluids removed and transferred to another tank, drum, or container for the fluids. A spill response kit will be located near the fueling area or on the fuel truck for easy access. The spill response kit will include plastic sheeting, tarps, over pack drums, absorbent litter, and shovels.
- **Hazardous Material Storage Area:** A spill from containers or cans in a hazardous material storage area will be contained within the storage cabinet these materials are kept in.
- **Unexpected Contaminated Soil:** If contaminated soil is encountered during the project, the Owner/Construction Manager will be notified immediately. Small quantities of suspected contaminated soil will be placed on a 6-mil plastic liner and covered with 6-mil plastic. A soil berm or silt fence will be used to contain the stockpile and prevent migration of contaminated liquids in the soil.

Spill Prevention and Containment Methods Table

Potential Spill Source	Response Method
Equipment Staging and Maintenance Area	Spill containment pad, spill kit, pumps, funnels
Fueling Area (site equipment only)	Spill containment pad, spill kit, pumps, funnels
Hazardous Material Staging Area	Spill containment pad, spill kit, pumps, funnels
Unexpected Contaminated Soil	Plastic liner, plastic cover, soil berm, hay bales, lined super sacks

SPILL COUNTERMEASURES

Every preventative measure shall be taken to keep contaminated or hazardous materials contained. If a release occurs, the following actions shall be taken:

1. **Stop the Spill:** The severity of a spill at the site is anticipated to be minimal as large containers/quantities of Hazardous Materials (HM) are not anticipated. The type of spill would occur while dispensing material at the HM storage facility and would likely be contained in secondary containment. Thus, the use spill kits or other available absorbent materials should stop the spill.
2. **Warn Others:** Notify co-workers and supervisory personnel of the release. Notify emergency responders if appropriate. For site personnel, an alarm system will consist of three one second blasts on an air horn sounded by the person discovering a spill or fire. In the event of any spill, the Superintendent and Project Manager shall be notified if the spill is 5 gallons or more the STATE will be contacted along with the Fire Department.
3. **Isolate the Area:** Prevent public access to the area and continue to minimize the spread of the material. Minimize personal exposure throughout emergency response actions.

4. Containment: A spill shall only be contained by trained personnel and if it is safe to do so. **DO NOT PLACE YOURSELF IN DANGER.** Attempt to extinguish a fire only if it is in the incipient stage; trash can size or smaller. For larger spills, wait for the arrival of emergency response personnel and provide directions to the location of the emergency.
5. Complete a Spill and Incident Report: For each spill of a Hazardous Material a spill and incident report shall be completed and submitted to the Owner/Construction Manager and if applicable to the Engineer and the State of Colorado Department of Public Health and Environment

X. RECEIVING WATERS

The project site is located within the Security Drainage Basin. Stormwater from this site drains to an existing detention pond that outfalls to Fountain Creek.

Stream Crossing – No stream crossing is required for this development.

IX. INSPECTION AND RECORD KEEPING

The project is subject to inspections by the Colorado Division of Public Health and Environment (CDPHE), the Environmental Protection Agency (EPA), and El Paso County at any time.

Inspection of the stormwater management system shall be performed, by the SWMP Administrator, at least every 14 calendar days and after the occurrence of precipitation or snow melt event that may cause noticeable erosion or run-off. Time span greater than 14 calendar days is a violation of the CDPS permit.

SWMP ADMINISTRATOR

The individual(s), position, or title responsible for developing, implementing, maintaining, and revising the SWMP is to be determined upon award of the project. The individual(s) will be sufficiently qualified for the required duties per the *El Paso County ECM Appendix I.5*. The individual listed as the Erosion Control Supervisor shall fill out the information below and place in the on-site copy before beginning installation of the BMPs for this site and notify the County of the appropriate contact information.

SWMP Administrator Name:

Cell Phone:

Office Phone:

Email:

INSPECTION SCHEDULES

Inspections of the stormwater management system are required at least every 14 calendar days and within 24 hours after any precipitation or snowmelt event that causes surface runoff. A more frequent inspection schedule may be necessary to ensure that BMPs continue to operate as designed.

Differences or modifications in the field from the approved SWMP are required to be made within 72 hours site changes are observed. The SWMP shall be onsite at all times when onsite construction activity is occurring.

INSPECTION SCOPE

The construction site perimeter, all disturbed areas, material and/or waste storage areas that are exposed to precipitation, discharge locations, and locations where vehicles access the site shall be inspected for evidence of, or the potential for pollutants leaving the construction site boundaries or discharging to State Waters. All erosion and sediment control practices identified in the SWMP shall be evaluated to ensure that they are maintained and operating correctly.

INSPECTION REPORT

A thorough record of inspection shall be maintained and identify any incidents of non-compliance with the SWMP. Inspection records shall be retained for three years from expiration or inactivation of permit coverage. Federal, State, local authority reserves the right to request that a copy of the inspection reports be submitted. At a minimum, the inspection report shall include the following:

1. Inspection date
2. Name(s) and title(s) and signature(s) of personnel making the inspection
3. Location(s) of discharges of sediment or other pollutants from the site
4. Location(s) of BMPs that need to be maintained
5. Location(s) of BMPs that failed to operate as designed or proved inadequate for a particular location
6. Location(s) where additional BMPs are needed or were not in place at the time of inspection
7. Deviations from the minimum inspection schedule
8. Description of corrective action for items c, d, e and f above, dates corrective action(s) taken, and measures taken to prevent future violations, including requisite changes to the SWMP, as necessary
9. After adequate corrective action(s) have been taken, or where a report does not identify any incidents requiring corrective action, the report shall contain a signed statement indicating the site is in compliance with the permit to the best of the signer's knowledge and belief
10. The date and amount of storm or snowmelt events that cause erosion.

BMP MAINTENANCE/REPLACEMENT AND FAILED BMPs

Adequate site assessment shall be performed as part of comprehensive Inspection and Maintenance procedures to assess the adequacy of BMPs at the site and to evaluate the necessity of changes to those BMPs to ensure continued effective performance. Where site assessment results in the determination that new or replacement BMPs are necessary, the BMPs shall be installed to ensure ongoing implementation. Failed BMPs must be addressed as soon as possible, in most cases immediately, to ensure continued performance and minimize

the likelihood of pollutant discharge. The SWMP shall be updated once new BMPs are installed or failed BMPs replaced. A specific timeline for implementing maintenance procedures is not included in the State Permit because BMP maintenance is expected to be proactive, not responsive. Observations resulting in BMP maintenance activities can be made during a site inspection, or during general observations of site conditions. BMPs shall be maintained per DCM2 criteria and ECM criteria. Please refer to the Appendix for specific maintenance required for each BMP.

PLAN REVIEW AND REVISIONS

1. The plan must be signed in accordance with the general permit.
2. The plan must be made available, upon request, to CDPHE, United States Environmental Protection Agency, or operator of the local municipal storm sewer system, if applicable.
3. The plan must be amended whenever there is a change in design, construction, operation or maintenance that could have a significant effect on the potential for the discharge of pollutants to State Waters. It also must be amended if it is found to be ineffective in controlling pollutants present in stormwater.

RECORD KEEPING AND DOCUMENTING OF INSPECTION

The permittee shall retain a copy of the SWMP required by this permit (including a copy of the permit language) at the construction site (or other local location accessible to the Director; a State or local agency approving sediment and erosion plans, grading plans, or stormwater management plans; local government officials; or the operator of a municipal separate storm sewer receiving discharges from the site) from the date of project initiation to the date of final stabilization. Permittees with day-to-day operational control over SWMP implementation shall have a copy of the SWMP available at a central location on-site for the use of all operators and those identified as having responsibilities under the SWMP whenever they are on the construction site. If minor modifications to the SWMP are required, they shall be recorded on the owner's copy of the SWMP and be available during inspections. Whenever a significant change is made to the SWMP (including changes to design, construction, operation or maintenance), an amended SWMP shall be submitted for review and approval. The following documents must be kept in a field office, trailer, shed or vehicle that is onsite during normal working hours:

1. A completed and signed copy of the Notice of Intent
2. The permit coverage letter from the Colorado Department of Public Health and Environment (CDPHE)
3. The Stormwater Management Plan
4. Site Inspection Records
5. A copy of the Colorado General Permit for Stormwater Discharges from Construction Activities

If a reasonable onsite location is not available, then the documents may be retained at a readily available alternative location, preferably with the SWMP plan contact. If the site is inactive, then the documents may be stored at a local office.

All records and information must be kept for at least three years or longer if requested by the Colorado Department of Public Health and Environment or United States Environmental Protection Agency.

RECORD KEEPING

The SWMP is a "living document" that is continuously reviewed and modified. The ECS shall make changes to the SWMP, including but not limited to: additions, deletions, changing locations of BMP's shall be marked in the plans, dated and initialed at time of occurrence.

All inspection and maintenance activities or other repairs will be documented by the ECS and the records kept on the project site.

Records of spill, leaks or overflows that result in the discharge of pollutants will be documented and maintained. The following Information will be recorded for all occurrences:

1. Time and date
2. Weather conditions
3. Reasons for spill
4. A release of any chemical, oil, petroleum product, sewage, etc., which may enter state waters must be reported.

At 14-day inspections incidents of noncompliance, such as uncontrolled releases of pollutants including mud, muddy water or measurable quantities of sediment found off-site shall be noted, along with a brief explanation as to measures taken to prevent future violations and measures taken to clean up sediment that has left the site.

After measures have been taken to correct any problems and recorded, or where a report does not identify incidents of noncompliance, the report shall contain a signed certification indicating the site is in compliance.

Signature Page:

Engineer's Statement:

The Erosion and Stormwater Quality Control/Grading Plan was prepared under my direction and supervision and is correct to the best of my knowledge and belief. If such work is performed in accordance with the grading and erosion control plan, the work will not become a hazard to life and limb, endanger property, or adversely affect the safety, use, or stability of public way, drainage channel, or other property.

Grant Dennis

Date

Registered Professional Engineer
State of Colorado No. 51622

Developer's Statement:

The owner will comply with the requirements of the Erosion and Stormwater Quality Control Plan including temporary BMP inspection requirements and final stabilization requirements. I acknowledge the responsibility to determine whether the construction activities on these plans require Colorado Discharge Permit System (CDPS) permitting for Stormwater discharges associated with Construction Activity.

Developer/ Owner Signature: _____

Name of Developer/ Owner: _____

DBA: _____ Phone: _____

Title: _____ Email: _____

Address: _____ Fax: _____

APPENDIX A

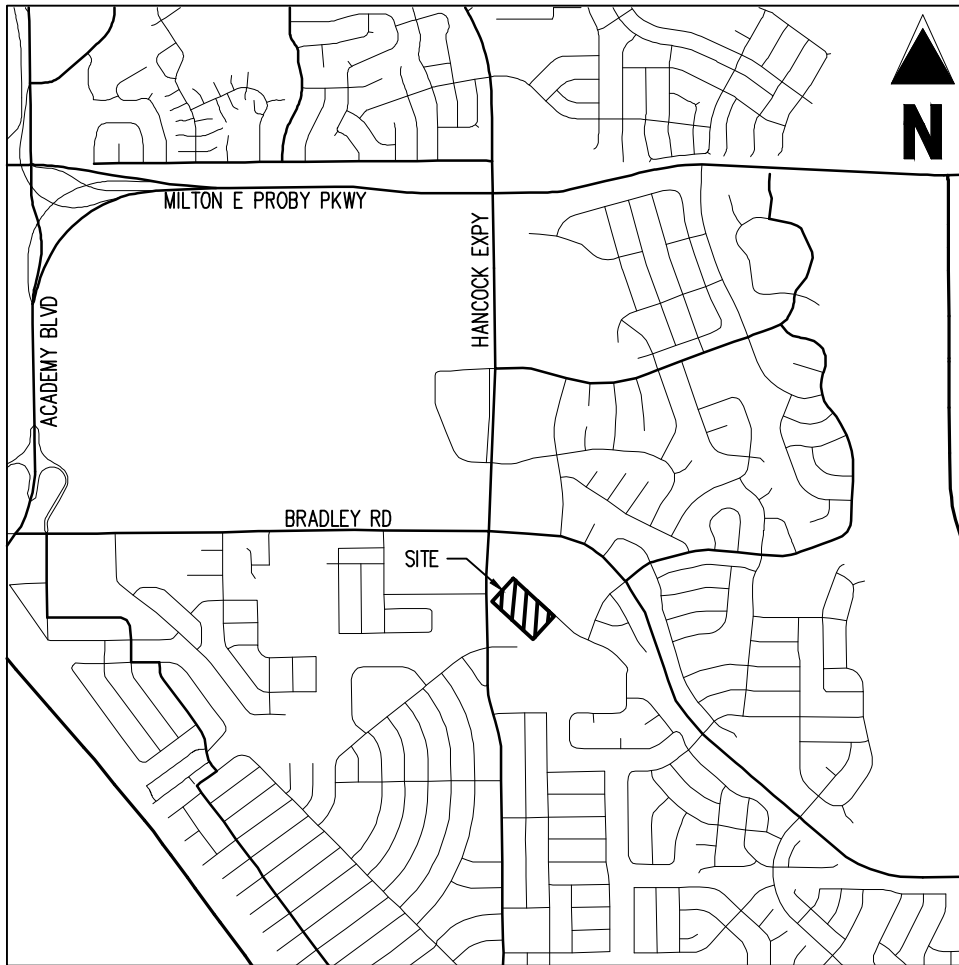

VICINITY MAP

SCALE: 1"=500'

LOT 2 ELM GROVE VILLA

1875 MAIN STREET
 SCALE: 1"=1,000'
 VICINITY MAP

Project No: HCI000008.20

Drawn By: TJE

Checked By: CMD

Date: 06/19/2020

Galloway

1155 Kelly Johnson Blvd., Suite 305
 Colorado Springs, CO 80920
 719.900.7220 • GallowayUS.com

APPENDIX B

Soil Map—El Paso County Area, Colorado
(1875 Main Street USGS Soil Survey Map)



Soil Map may not be valid at this scale.

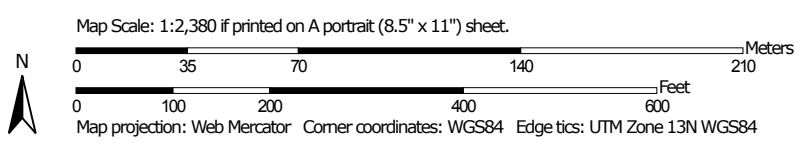



MAP LEGEND

Area of Interest (AOI)

 Area of Interest (AOI)

Soils

 Soil Map Unit Polygons

 Soil Map Unit Lines

 Soil Map Unit Points

Special Point Features



Blowout



Borrow Pit



Clay Spot



Closed Depression



Gravel Pit



Gravelly Spot



Landfill



Lava Flow



Marsh or swamp



Mine or Quarry



Miscellaneous Water



Perennial Water



Rock Outcrop



Saline Spot



Sandy Spot



Severely Eroded Spot



Sinkhole



Slide or Slip



Sodic Spot



Spoil Area



Stony Spot



Very Stony Spot



Wet Spot



Other



Special Line Features

Water Features



Streams and Canals

Transportation



Rails



Interstate Highways



US Routes



Major Roads



Local Roads

Background



Aerial Photography

MAP INFORMATION

The soil surveys that comprise your AOI were mapped at 1:24,000.

Warning: Soil Map may not be valid at this scale.

Enlargement of maps beyond the scale of mapping can cause misunderstanding of the detail of mapping and accuracy of soil line placement. The maps do not show the small areas of contrasting soils that could have been shown at a more detailed scale.

Please rely on the bar scale on each map sheet for map measurements.

Source of Map: Natural Resources Conservation Service

Web Soil Survey URL:

Coordinate System: Web Mercator (EPSG:3857)

Maps from the Web Soil Survey are based on the Web Mercator projection, which preserves direction and shape but distorts distance and area. A projection that preserves area, such as the Albers equal-area conic projection, should be used if more accurate calculations of distance or area are required.

This product is generated from the USDA-NRCS certified data as of the version date(s) listed below.

Soil Survey Area: El Paso County Area, Colorado

Survey Area Data: Version 16, Sep 10, 2018

Soil map units are labeled (as space allows) for map scales 1:50,000 or larger.

Date(s) aerial images were photographed: Jun 3, 2014—Jun 17, 2014

The orthophoto or other base map on which the soil lines were compiled and digitized probably differs from the background imagery displayed on these maps. As a result, some minor shifting of map unit boundaries may be evident.

Map Unit Legend

Map Unit Symbol	Map Unit Name	Acres in AOI	Percent of AOI
8	Blakeland loamy sand, 1 to 9 percent slopes	24.4	100.0%
Totals for Area of Interest		24.4	100.0%

APPENDIX C

NOTES TO USERS

This map is for use in administering the National Flood Insurance Program. It does not necessarily identify all areas subject to flooding, particularly from local drainage sources of small size. The community map repository should be consulted for possible updated or additional flood hazard information.

To obtain more detailed information in areas where **Base Flood Elevations (BFEs)** and/or **floodways** have been determined, users are encouraged to consult the Flood Profiles and Floodway Data and/or Summary of Stillwater Elevations tables contained within the Flood Insurance Study (FIS) report that accompanies this FIRM. Users should be aware that BFEs shown on the FIRM represent rounded whole-foot elevations. These BFEs are intended for flood insurance rating purposes only and should not be used as the sole source of flood elevation information. Accordingly, flood elevation data presented in the FIS report should be utilized in conjunction with the FIRM for purposes of construction and/or floodplain management.

Coastal Base Flood Elevations shown on this map apply only landward of 0.0' North American Vertical Datum of 1988 (NAVD88). Users of this FIRM should be aware that coastal flood elevations are also provided in the Summary of Stillwater Elevations table in the Flood Insurance Study report for this jurisdiction. Elevations shown in the Summary of Stillwater Elevations table should be used for construction and/or floodplain management purposes when they are higher than the elevations shown on this FIRM.

Boundaries of the **floodways** were computed at cross sections and interpolated between cross sections. The floodways were based on hydraulic considerations with regard to requirements of the National Flood Insurance Program. Floodway widths and other pertinent floodway data are provided in the Flood Insurance Study report for this jurisdiction.

Certain areas not in Special Flood Hazard Areas may be protected by **flood control structures**. Refer to section 2.4 "Flood Protection Measures" of the Flood Insurance Study report for information on flood control structures for this jurisdiction.

The **projection** used in the preparation of this map was Universal Transverse Mercator (UTM) zone 13. The **horizontal datum** was NAD83, GRS80 spheroid. Differences in datum, spheroid, projection or UTM zones zones used in the production of FIRMs for adjacent jurisdictions may result in slight positional differences in map features across jurisdiction boundaries. These differences do not affect the accuracy of this FIRM.

Flood elevations on this map are referenced to the **North American Vertical Datum of 1988 (NAVD88)**. These flood elevations must be compared to structure and ground elevations referenced to the same **vertical datum**. For information regarding conversion between the National Geodetic Vertical Datum of 1929 and the North American Vertical Datum of 1988, visit the National Geodetic Survey website at <http://www.ngs.noaa.gov/> or contact the National Geodetic Survey at the following address:

NGS Information Services
 NOAA, NINGS12
 National Geodetic Survey
 SSMC-3, #9202
 1315 East-West Highway
 Silver Spring, MD 20910-3282

To obtain current elevation, description, and/or location information for **bench marks** shown on this map, please contact the Information Services Branch of the National Geodetic Survey at (301) 713-3242 or visit its website at <http://www.ngs.noaa.gov/>.

Base Map information shown on this FIRM was provided in digital format by El Paso County, Colorado Springs Utilities, City of Fountain, Bureau of Land Management, National Oceanic and Atmospheric Administration, United States Geological Survey, and Anderson Consulting Engineers, Inc. These data are current as of 2006.

This map reflects more detailed and up-to-date **stream channel configurations** and **floodplain delineations** than those shown on the previous FIRM for this jurisdiction. The floodplains and floodways that were transferred from the previous FIRM may have been adjusted to conform to these new stream channel configurations. As a result, the Flood Profiles and Floodway Data tables in the Flood Insurance Study Report (which contains authoritative hydraulic data) may reflect stream channel distances that differ from what is shown on this map. The profile baselines depicted on this map represent the hydraulic modeling baselines that match the flood profiles and Floodway Data Tables if applicable, in the FIS report. As a result, the profile baselines may deviate significantly from the new base map channel representation and may appear outside of the floodplain.

Corporate limits shown on this map are based on the best data available at the time of publication. Because changes due to annexations or de-annexations may have occurred after this map was published, map users should contact appropriate community officials to verify current corporate limit locations.

Please refer to the separately printed **Map Index** for an overview map of the county showing the layout of map panels; community map repository addresses; and a Listing of Communities table containing National Flood Insurance Program dates for each community as well as a listing of the panels on which each community is located.

Contact **FEMA Map Service Center (MSC)** via the FEMA Map Information eXchange (FMIX) 1-877-336-2627 for information on available products associated with this FIRM. Available products may include previously issued Letters of Map Change, a Flood Insurance Study Report, and/or digital versions of this map. The MSC may also be reached by Fax at 1-800-358-9620 and its website at <http://www.msc.fema.gov/>.

If you have **questions about this map** or questions concerning the National Flood Insurance Program in general, please call 1-877-FEMA MAP (1-877-336-2627) or visit the FEMA website at <http://www.fema.gov/business/nfp>.

El Paso County Vertical Datum Offset Table

Flooding Source	Vertical Datum Offset (ft)
REFER TO SECTION 3.3 OF THE EL PASO COUNTY FLOOD INSURANCE STUDY FOR STREAM BY STREAM VERTICAL DATUM CONVERSION INFORMATION	

Panel Location Map

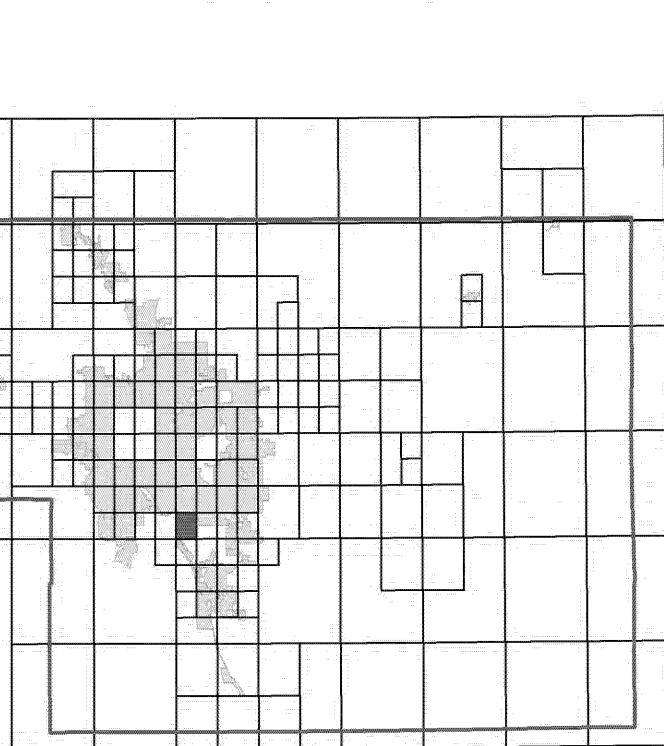

This Digital Flood Insurance Rate Map (DFIRM) was produced through a Cooperating Technical Partner (CTP) agreement between the State of Colorado Water Conservation Board (CWCB) and the Federal Emergency Management Agency (FEMA).

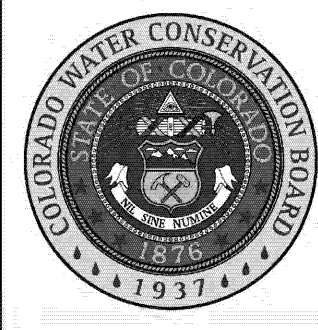

Additional Flood Hazard information and resources are available from local communities and the Colorado Water Conservation Board.

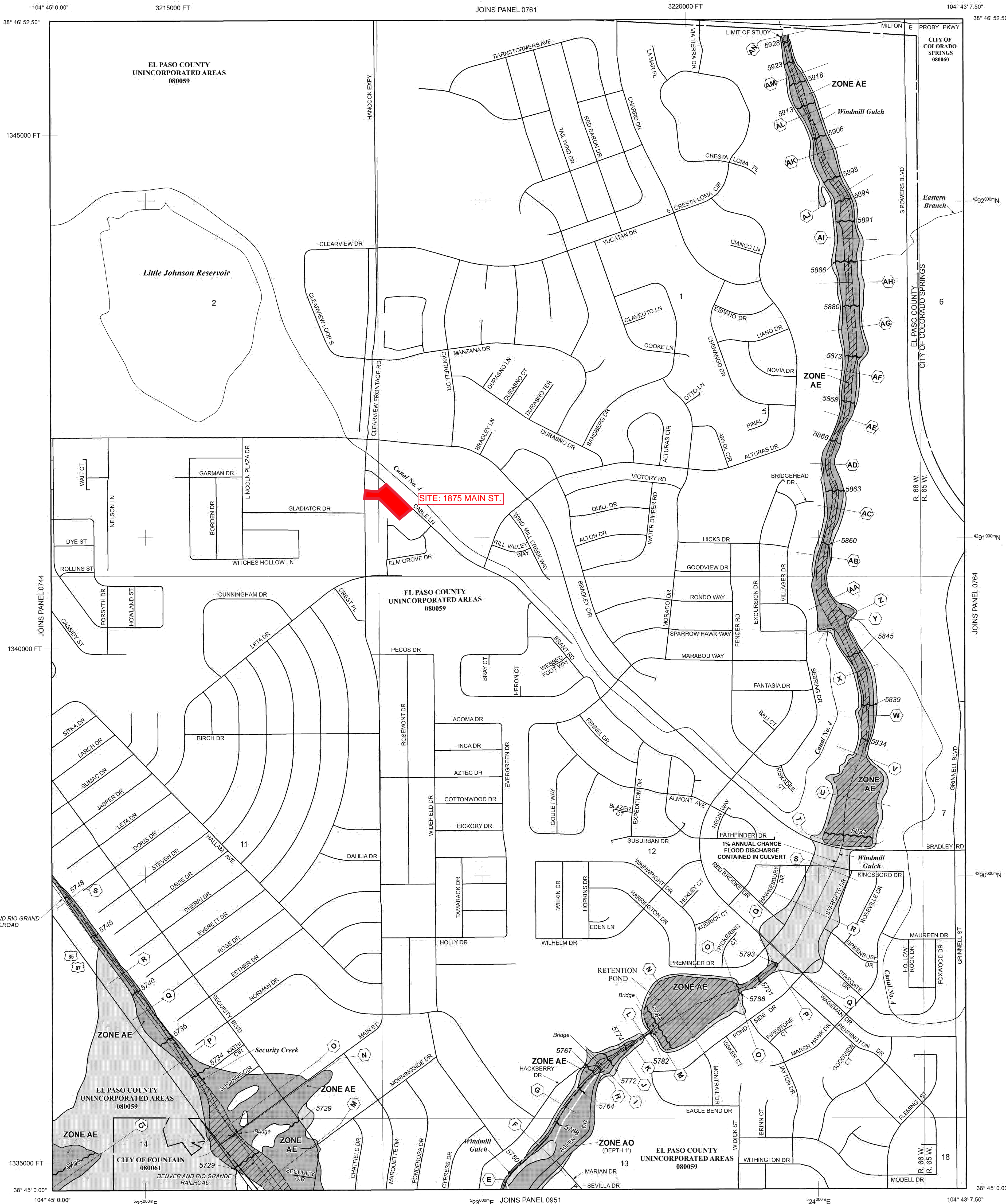

NOTE: MAP AREA SHOWN ON THIS PANEL IS LOCATED WITHIN TOWNSHIP 15 SOUTH, RANGE 65 WEST, AND TOWNSHIP 15 SOUTH, RANGE 66 WEST.

LEGEND

SPECIAL FLOOD HAZARD AREAS (SFHAS) SUBJECT TO INUNDATION BY THE 1% ANNUAL CHANCE FLOOD

The 1% annual chance flood (100-year flood), also known as the base flood, is the flood that has a 1% chance of being equalled or exceeded in any given year. The Special Flood Hazard Area is the area subject to flooding by the 1% annual chance flood. Areas of Special Flood Hazard include Zones A, AE, AH, AO, AR, AV, and VE. The Base Flood Elevation is the water-surface elevation of the 1% annual chance flood.

ZONE A No Base Flood Elevations determined.
ZONE AE Base Flood Elevations determined.
ZONE AH Flood depths of 1 to 3 feet (usually areas of ponding); Base Flood Elevations determined.

ZONE AO Flood depths of 1 to 3 feet (usually sheet flow on sloping terrain); average depths determined. For areas of alluvial fan flooding, velocities also determined.

ZONE AR Special Flood Hazard Area Formerly protected from the 1% annual chance flood by a flood control system that was subsequently decommissioned. Zone AR indicates that the former flood control system is being restored to provide protection from the 1% annual chance or greater flood.

ZONE AV Area to be protected from 1% annual chance flood by a Federal flood protection system under construction; no Base Flood Elevations determined.

ZONE VE Coastal flood zone with velocity hazard (wave action); no Base Flood Elevations determined.

FLOODWAY AREAS IN ZONE AE
 The floodway is the channel of a stream plus any adjacent floodplain areas that must be kept free of encroachment so that the 1% annual chance flood can be carried without substantial increases in flood heights.

OTHER FLOOD AREAS
ZONE X Areas of 0.2% annual chance flood; areas of 1% annual chance flood with average depths of less than 1 foot, or with drainage areas less than 1 square mile, and areas protected by levees from 1% annual chance flood.

OTHER AREAS
ZONE X Areas determined to be outside the 0.2% annual chance floodplain.
ZONE D Areas in which flood hazards are undetermined, but possible.

COASTAL BARRIER RESOURCES SYSTEM (CBRS) AREAS

OTHERWISE PROTECTED AREAS (OPAs)
 CBRS areas and OPAs are normally located within or adjacent to Special Flood Hazard Areas.

Floodplain boundary
 Floodway boundary
 Zone D Boundary
 CBRS and OPA boundary

Boundary dividing Special Flood Hazard Areas of different Base Flood Elevations, flood depths or flood velocities.
 (EL 987)

513 Base Flood Elevation line and value; elevation in feet*
 (EL 987) Base Flood Elevation value where uniform within zone; elevation in feet*

* Referenced to the North American Vertical Datum of 1988 (NAVD 88)

A-A Cross section line
 23-23 Transsect line

97° 07' 30.00" 32° 22' 30.00" Geographic coordinates referenced to the North American Datum of 1983 (NAD 83)

4726500N 1000-meter Universal Transverse Mercator grid ticks, zone 13

6000000 FT 5000-foot grid ticks: Colorado State Plane coordinate system, central zone (FIPSZONE 0902), Lambert Conformal Conic Projection

DX5510 Bench mark (see explanation in Notes to Users section of this FIRM panel)
 M1.5 River Mile

MAP REPOSITORIES
 Refer to Map Repository list on Map Index

EFFECTIVE DATE OF COUNTYWIDE FLOOD INSURANCE RATE MAP
 MARCH 17, 1997

EFFECTIVE DATE(S) OF REVISION(S) TO THIS PANEL
 DECEMBER 7, 2018 - to update corporate limits, to change Base Flood Elevations and Special Flood Hazard Areas, to update map format, to add roads and road names, and to incorporate previously issued Letters of Map Revision.

For community map revision history prior to countywide mapping, refer to the Community Map History Table located in the Flood Insurance Study report for this jurisdiction.

To determine if flood insurance is available in this community, contact your insurance agent or call the National Flood Insurance Program at 1-800-638-6620.

MAP SCALE 1" = 500'
 250 0 500 1000 FEET
 150 0 150 300 METERS

NFP
PANEL 0763G
FIRM
FLOOD INSURANCE RATE MAP
EL PASO COUNTY, COLORADO AND INCORPORATED AREAS
PANEL 763 OF 1300
 (SEE MAP INDEX FOR FIRM PANEL LAYOUT)
 CONTAINS:

COMMUNITY	NUMBER	PANEL	SUFFIX
COLORADO SPRINGS, CITY OF	08060	0763	G
EL PASO COUNTY	08059	0763	G
FOUNTAIN, CITY OF	08081	0763	G

 Notice to User: The Map Number shown below should be used when placing map orders. The Community Number shown above should be used on insurance applications for the subject community.
MAP NUMBER 08041C0763G
MAP REVISED DECEMBER 7, 2018
 Federal Emergency Management Agency

APPENDIX D

STANDARD NOTES FOR GEC PLANS

- STORMWATER DISCHARGES FROM CONSTRUCTION SITES SHALL NOT CAUSE OR THREATEN TO CAUSE POLLUTION, CONTAMINATION, OR DEGRADATION OF STATE WATERS. ALL WORK AND EARTH DISTURBANCE SHALL BE DONE IN A MANNER THAT MINIMIZES POLLUTION OF ANY ON-SITE OR OFFSITE WATERS, INCLUDING WETLANDS.
- NOTWITHSTANDING ANYTHING DEPICTED IN THESE PLANS IN WORDS OR GRAPHIC REPRESENTATION, ALL DESIGN AND CONSTRUCTION RELATED TO ROADS, STORM DRAINAGE AND EROSION CONTROL SHALL CONFORM TO THE STANDARDS AND REQUIREMENTS OF THE MOST RECENT VERSION OF THE RELEVANT ADOPTED EL PASO COUNTY STANDARDS, INCLUDING THE LAND DEVELOPMENT CODE, THE ENGINEERING CRITERIA MANUAL, THE DRAINAGE CRITERIA MANUAL, AND THE DRAINAGE CRITERIA MANUAL VOLUME 2. ANY DEVIATIONS TO REGULATIONS AND STANDARDS MUST BE REQUESTED, AND APPROVED, IN WRITING.
- A SEPARATE STORMWATER MANAGEMENT PLAN (SWMP) FOR THIS PROJECT SHALL BE COMPLETED AND AN EROSION AND STORMWATER QUALITY CONTROL PERMIT (ESQCP) ISSUED PRIOR TO COMMENCING CONSTRUCTION. MANAGEMENT OF THE SWMP DURING CONSTRUCTION IS THE RESPONSIBILITY OF THE DESIGNATED QUALIFIED STORMWATER MANAGER OR CERTIFIED EROSION CONTROL INSPECTOR. THE SWMP SHALL BE LOCATED ON SITE AT ALL TIMES DURING CONSTRUCTION AND SHALL BE KEPT UP TO DATE WITH WORK PROGRESS AND CHANGES IN THE FIELD.
- ONCE THE ESQCP IS APPROVED AND A "NOTICE TO PROCEED" HAS BEEN ISSUED, THE CONTRACTOR MAY INSTALL THE INITIAL STAGE EROSION AND SEDIMENT CONTROL MEASURES AS INDICATED ON THE APPROVED GEC. A PRE-CONSTRUCTION MEETING BETWEEN THE CONTRACTOR, ENGINEER AND EL PASO COUNTY WILL BE HELD PRIOR TO ANY CONSTRUCTION. IT IS THE RESPONSIBILITY OF THE APPLICANT TO COORDINATE THE MEETING TIME AND PLACE WITH COUNTY STAFF.
- CONTROL MEASURES MUST BE INSTALLED PRIOR TO COMMENCEMENT OF ACTIVITIES THAT MAY CONTRIBUTE POLLUTANTS TO STORMWATER. TEMPORARY SEDIMENT AND EROSION CONTROL MEASURES FOR ALL SLOPES, CHANNELS, DITCHES, OR ANY DISTURBED LAND AREA SHALL BE COMPLETED IMMEDIATELY UPON COMPLETION OF THE DISTURBANCE.
- ALL TEMPORARY SEDIMENT AND EROSION CONTROL MEASURES SHALL BE MAINTAINED AND REMAIN IN EFFECTIVE OPERATING CONDITION UNTIL PERMANENT SOIL EROSION CONTROL MEASURES ARE IMPLEMENTED AND FINAL STABILIZATION IS ESTABLISHED. ALL PERSONS ENGAGED IN LAND DISTURBANCE ACTIVITIES SHALL ASSESS THE ADEQUACY OF CONTROL MEASURES AT THE SITE AND IDENTIFY IF CHANGES TO THESE CONTROL MEASURES IS NEEDED TO ENSURE THE CONTINUED EFFECTIVE PERFORMANCE OF THE CONTROL MEASURES. ALL CHANGES TO TEMPORARY SEDIMENT AND EROSION CONTROL MEASURES MUST BE INCORPORATED INTO THE STORMWATER MANAGEMENT PLAN PRIOR TO IMPLEMENTATION.
- TEMPORARY STABILIZATION SHALL BE IMPLEMENTED ON DISTURBED AREAS AND STOCKPILES WHERE GROUND DISTURBING CONSTRUCTION ACTIVITY HAS PERMANENTLY CEASED OR TEMPORARILY CEASED FOR LONGER THAN 14 DAYS. AN AREA THAT IS GOING TO REMAIN IN AN INTERM STATE FOR MORE THAN 60 DAYS SHALL ALSO BE STABILIZED.
- FINAL STABILIZATION MUST BE IMPLEMENTED AT ALL APPLICABLE CONSTRUCTION SITES. FINAL STABILIZATION IS ACHIEVED WHEN ALL GROUND DISTURBING ACTIVITIES ARE COMPLETE AND ALL DISTURBED AREAS EITHER HAVE A UNIFORM VEGETATIVE COVER WITH INDIVIDUAL PLANT DENSITY OF 70 PERCENT OF PRE-DISTURBANCE LEVELS ESTABLISHED OR EQUIVALENT PERMANENT ALTERNATIVE STABILIZATION METHOD IS IMPLEMENTED. ALL TEMPORARY SEDIMENT AND EROSION CONTROL MEASURES SHALL BE REMOVED UPON FINAL STABILIZATION AND BEFORE PERMIT CLOSURE.
- ALL PERMANENT STORMWATER MANAGEMENT FACILITIES SHALL BE INSTALLED AS DEFINED IN THE APPROVED PLANS. ANY PROPOSED CHANGES THAT EFFECT THE HYDROLOGY OR HYDRAULICS OF A PERMANENT STORMWATER MANAGEMENT STRUCTURES MUST BE APPROVED BY THE EGM ADMINISTRATOR PRIOR TO IMPLEMENTATION.
- EARTH DISTURBANCES SHALL BE CONDUCTED IN SUCH A MANNER SO AS TO EFFECTIVELY MINIMIZE ACCELERATED SOIL EROSION AND RESULTING SEDIMENTATION. ALL DISTURBANCES SHALL BE DESIGNED, CONSTRUCTED, AND COMPLETED SO THAT THE EXPOSED AREA OF ANY DISTURBED LAND SHALL BE LIMITED TO THE SHORTEST PRACTICAL PERIOD OF TIME. PRE-EXISTING VEGETATION SHALL BE PROTECTED AND MAINTAINED WITHIN 50 HORIZONTAL FEET OF A WATER OF THE STATE UNLESS SHOWN TO BE INFEASIBLE AND SPECIFICALLY REQUESTED AND APPROVED.
- COMPACTION OF SOIL MUST BE PREVENTED IN AREAS DESIGNATED FOR INFILTRATION CONTROL MEASURES OR WHERE FINAL STABILIZATION WILL BE ACHIEVED BY VEGETATIVE COVER. AREAS DESIGNATED FOR INFILTRATION CONTROL SHALL ALSO BE PROTECTED FROM SEDIMENTATION DURING CONSTRUCTION UNTIL FINAL STABILIZATION IS ACHIEVED.
- ANY TEMPORARY OR PERMANENT FACILITY DESIGNED AND CONSTRUCTED FOR THE CONVEYANCE OF STORMWATER AROUND, THROUGH, OR FROM THE EARTH DISTURBANCE AREA SHALL BE A STABILIZED CONVEYANCE DESIGNED TO MINIMIZE EROSION AND THE DISCHARGE OF SEDIMENT OFF SITE.
- CONCRETE WASH WATER SHALL BE CONTAINED AND DISPOSED OF IN ACCORDANCE WITH THE SWMP. NO WASH WATER SHALL BE DISCHARGED TO OR ALLOWED TO RUNOFF TO STATE WATERS, INCLUDING ANY SURFACE OR SUBSURFACE STORM DRAINAGE SYSTEM OR FACILITIES. CONCRETE WASHOUT SHALL NOT BE LOCATED IN AN AREA WHERE SHALLOW GROUNDWATER MAY BE PRESENT, OR WITHIN 50 FEET OF A SURFACE WATER BODY.
- DURING DEWATERING OPERATIONS OF UNCONTAMINATED GROUND WATER MAY BE DISCHARGED ON SITE, BUT SHALL NOT LEAVE THE SITE IN THE FORM OF SURFACE RUNOFF UNLESS AN APPROVED STATE DEWATERING PERMIT IS IN PLACE.
- EROSION CONTROL, BLANKETING OR OTHER PROTECTIVE COVERING SHALL BE USED ON SLOPES STEEPER THAN 3:1.
- CONTRACTOR SHALL BE RESPONSIBLE FOR THE REMOVAL OF ALL WASTES FROM THE CONSTRUCTION SITE FOR DISPOSAL IN ACCORDANCE WITH LOCAL AND STATE REGULATORY REQUIREMENTS. NO CONSTRUCTION DEBRIS, TREE SLASH, BUILDING MATERIAL WASTES OR UNUSED BUILDING MATERIALS SHALL BE BURIED, DUMPED OR DISCHARGED AT THE SITE.
- WASTE MATERIALS SHALL NOT BE TEMPORARILY PLACED OR STORED IN THE STREET, ALLEY, OR OTHER PUBLIC WAY, UNLESS IN ACCORDANCE WITH AN APPROVED TRAFFIC CONTROL PLAN. CONTROL MEASURES MAY BE REQUIRED BY EL PASO COUNTY ENGINEERING IF DEEMED NECESSARY, BASED ON SPECIFIC CONDITIONS AND CIRCUMSTANCES.
- TRACKING OF SOILS AND CONSTRUCTION DEBRIS OFF-SITE SHALL BE MINIMIZED. MATERIALS TRACKED OFFSITE SHALL BE CLEANED UP AND PROPERLY DISPOSED OF IMMEDIATELY.
- THE OWNER/DEVELOPER SHALL BE RESPONSIBLE FOR THE REMOVAL OF ALL CONSTRUCTION DEBRIS, DIRT, TRASH, ROCK, SEDIMENT, AND SAND THAT MAY ACCUMULATE IN ROADS, STORM DRAINS AND OTHER DRAINAGE CONVEYANCE SYSTEM AND STORMWATER APPURTENANCES AS A RESULT OF SITE DEVELOPMENT.
- THE QUANTITY OF MATERIALS STORED ON THE PROJECT SITE SHALL BE LIMITED, AS MUCH AS PRACTICAL, TO THAT QUANTITY REQUIRED TO PERFORM THE WORK IN AN ORDERLY SEQUENCE. ALL MATERIALS STORED ON-SITE SHALL BE STORED IN A NEAT, ORDERLY MANNER, IN THEIR ORIGINAL CONTAINERS, WITH ORIGINAL MANUFACTURER'S LABELS.
- NO CHEMICALS ARE TO BE USED BY THE CONTRACTOR, WHICH HAVE THE POTENTIAL TO BE RELEASED IN STORMWATER UNLESS PERMISSION FOR THE USE OF A SPECIFIC CHEMICAL IS GRANTED IN WRITING BY THE EGM ADMINISTRATOR. IN GRANTING THE USE OF SUCH CHEMICALS, SPECIAL CONDITIONS AND MONITORING MAY BE REQUIRED.
- BULK STORAGE OF PETROLEUM PRODUCTS OR OTHER LIQUID CHEMICALS IN EXCESS OF 55 GALLONS SHALL HAVE ADEQUATE SECONDARY CONTAINMENT PROTECTION TO CONTAIN ALL SPILLS AND PREVENT ANY SPILLED MATERIAL FROM ENTERING STATE WATERS, INCLUDING ANY SURFACE OR SUBSURFACE STORM DRAINAGE SYSTEM OR FACILITIES.
- NO PERSON SHALL CAUSE THE IMPEDIMENT OF STORMWATER FLOW IN THE CURB AND GUTTER OR DITCH EXCEPT WITH APPROVED SEDIMENT CONTROL MEASURES.
- OWNER/DEVELOPER AND THEIR AGENTS SHALL COMPLY WITH THE "COLORADO WATER QUALITY CONTROL ACT" (TITLE 25, ARTICLE 8, CRS) AND THE "CLEAN WATER ACT" (33 USC 1344), IN ADDITION TO THE REQUIREMENTS OF THE LAND DEVELOPMENT CODE, DCM VOLUME II AND THE EGM APPENDIX I. ALL APPROPRIATE PERMITS MUST BE OBTAINED BY THE CONTRACTOR PRIOR TO CONSTRUCTION (DAM, WIPES, FLOODPLAIN, 404, FUGITIVE DUST, ETC.). IN THE EVENT OF CONFLICTS BETWEEN THESE REQUIREMENTS AND OTHER LAWS, RULES, OR REGULATIONS OF OTHER FEDERAL, STATE, LOCAL OR COUNTY AGENCIES, THE MOST RESTRICTIVE LAWS, RULES OR REGULATIONS SHALL APPLY.
- ALL CONSTRUCTION TRAFFIC MUST ENTER/EXIT THE SITE AT APPROVED CONSTRUCTION ACCESS POINTS.
- PRIOR TO ACTUAL CONSTRUCTION THE PERMITEE SHALL VERIFY THE LOCATION OF EXISTING UTILITIES.
- A WATER SOURCE SHALL BE AVAILABLE ON SITE DURING EARTHWORK OPERATIONS AND UTILIZED AS REQUIRED TO MINIMIZE DUST FROM EARTHWORK EQUIPMENT AND WIND.
- THE SOILS REPORT, TITLED "SUBSURFACE SOIL INVESTIGATION - UPDATE - 1875 MAIN STREET" FOR THIS SITE HAS BEEN PREPARED BY ENTTECH ENGINEERING, DATED APRIL 15, 2021 AND SHALL BE CONSIDERED A PART OF THESE PLANS.
- AT LEAST TEN (10) DAYS PRIOR TO THE ANTICIPATED START OF CONSTRUCTION, FOR PROJECTS THAT WILL DISTURB ONE (1) ACRE OR MORE, THE OWNER OR OPERATOR OF CONSTRUCTION ACTIVITY SHALL SUBMIT A PERMIT APPLICATION FOR STORMWATER DISCHARGE TO THE COLORADO DEPARTMENT OF PUBLIC HEALTH AND ENVIRONMENT, WATER QUALITY DIVISION. THE APPLICATION CONTAINS CERTIFICATION OF COMPLETION OF A STORMWATER MANAGEMENT PLAN (SWMP), OF WHICH THIS GRADING AND EROSION CONTROL PLAN MAY BE A PART. FOR INFORMATION OR APPLICATION MATERIALS CONTACT:
COLORADO DEPARTMENT OF PUBLIC HEALTH AND ENVIRONMENT
WATER QUALITY CONTROL DIVISION
WQCD - PERMITS
4300 CHERRY CREEK DRIVE SOUTH
DENVER, CO 80246-1530
ATN:PERMITS UNIT

STANDARD NOTES FOR CONSTRUCTION PLANS

- ALL DRAINAGE AND ROADWAY CONSTRUCTION SHALL MEET THE STANDARDS AND SPECIFICATIONS OF THE CITY OF COLORADO SPRINGS/EL PASO COUNTY DRAINAGE CRITERIA MANUAL, VOLUMES 1 AND 2, AND THE EL PASO COUNTY ENGINEERING CRITERIA MANUAL.
- CONTRACTOR SHALL BE RESPONSIBLE FOR THE NOTIFICATION AND FIELD NOTIFICATION OF ALL EXISTING UTILITIES, WHETHER SHOWN ON THE PLANS OR NOT, BEFORE BEGINNING CONSTRUCTION. LOCATION OF EXISTING UTILITIES SHALL BE VERIFIED BY THE CONTRACTOR PRIOR TO CONSTRUCTION. CALL 811 TO CONTACT THE UTILITY NOTIFICATION CENTER OF COLORADO (UNCC).
- CONTRACTOR SHALL KEEP A COPY OF THESE APPROVED PLANS, THE GRADING AND EROSION CONTROL PLAN, THE STORMWATER MANAGEMENT PLAN (SWMP), THE SOILS AND GEOTECHNICAL REPORT, AND THE APPROPRIATE DESIGN AND CONSTRUCTION STANDARDS AND SPECIFICATIONS AT THE JOB SITE AT ALL TIMES, INCLUDING THE FOLLOWING:
A. EL PASO COUNTY ENGINEERING CRITERIA MANUAL (ECM)
B. CITY OF COLORADO SPRINGS/EL PASO COUNTY DRAINAGE CRITERIA MANUAL, VOLUMES 1 AND 2
C. COLORADO DEPARTMENT OF TRANSPORTATION (CDOT) STANDARD SPECIFICATIONS FOR ROAD AND BRIDGE CONSTRUCTION
D. CDOT M & S STANDARDS
- NOTWITHSTANDING ANYTHING DEPICTED IN THESE PLANS IN WORDS OR GRAPHIC REPRESENTATION, ALL DESIGN AND CONSTRUCTION RELATED TO ROADS, STORM DRAINAGE AND EROSION CONTROL SHALL CONFORM TO THE STANDARDS AND REQUIREMENTS OF THE MOST RECENT VERSION OF THE RELEVANT ADOPTED EL PASO COUNTY STANDARDS, INCLUDING THE LAND DEVELOPMENT CODE, THE ENGINEERING CRITERIA MANUAL, THE DRAINAGE CRITERIA MANUAL, AND THE DRAINAGE CRITERIA MANUAL VOLUME 2. ANY DEVIATIONS FROM REGULATIONS AND STANDARDS MUST BE REQUESTED, AND APPROVED, IN WRITING. ANY MODIFICATIONS NECESSARY TO MEET CRITERIA AFTER THE-FACT WILL BE ENTIRELY THE DEVELOPER'S RESPONSIBILITY TO RECTIFY.
- IT IS THE DESIGN ENGINEER'S RESPONSIBILITY TO ACCURATELY SHOW EXISTING CONDITIONS, BOTH ON-SITE AND OFF-SITE, ON THE CONSTRUCTION PLANS. ANY MODIFICATIONS NECESSARY DUE TO CONFLICTS, OMISSIONS, OR CHANGED CONDITIONS WILL BE ENTIRELY THE DEVELOPER'S RESPONSIBILITY TO RECTIFY.
- CONTRACTOR SHALL SCHEDULE A PRE-CONSTRUCTION MEETING WITH EL PASO COUNTY PLANNING AND COMMUNITY DEVELOPMENT (PCD) - INSPECTORS, PRIOR TO STARTING CONSTRUCTION.
- IT IS THE CONTRACTOR'S RESPONSIBILITY TO UNDERSTAND THE REQUIREMENTS OF ALL JURISDICTIONAL AGENCIES AND TO OBTAIN ALL REQUIRED PERMITS, INCLUDING BUT NOT LIMITED TO EL PASO COUNTY EROSION AND STORMWATER QUALITY CONTROL PERMIT (ESQCP), REGIONAL BUILDING FLOODPLAIN DEVELOPMENT PERMIT, U.S. ARMY CORPS OF ENGINEERS-ISSUED 401 AND/OR 404 PERMITS, AND COUNTY AND STATE FUGITIVE DUST PERMITS.
- CONTRACTOR SHALL NOT DEVIATE FROM THE PLANS WITHOUT FIRST OBTAINING WRITTEN APPROVAL FROM THE DESIGN ENGINEER AND PCD. CONTRACTOR SHALL NOTIFY THE DESIGN ENGINEER IMMEDIATELY UPON DISCOVERY OF ANY ERRORS OR INCONSISTENCIES.
- ALL STORM DRAIN PIPE SHALL BE CLASS III RCP UNLESS OTHERWISE NOTED AND APPROVED BY PCD.
- CONTRACTOR SHALL COORDINATE GEOTECHNICAL TESTING PER EGM STANDARDS. PAVEMENT DESIGN SHALL BE APPROVED BY EL PASO COUNTY PCD PRIOR TO PLACEMENT OF CURB AND GUTTER AND PAVEMENT.
- ALL CONSTRUCTION TRAFFIC MUST ENTER/EXIT THE SITE AT APPROVED CONSTRUCTION ACCESS POINTS.
- SIGHT VISIBILITY TRIANGLES AS IDENTIFIED IN THE PLANS SHALL BE PROVIDED AT ALL INTERSECTIONS. OBSTRUCTIONS GREATER THAN 18 INCHES ABOVE FLOWLINE ARE NOT ALLOWED WITHIN SIGHT TRIANGLES.
- SIGNING AND STRIPING SHALL COMPLY WITH EL PASO COUNTY DOT AND MUTCD CRITERIA. (IF APPLICABLE, ADDITIONAL SIGNING AND STRIPING NOTES WILL BE PROVIDED.)
- CONTRACTOR SHALL OBTAIN ANY PERMITS REQUIRED BY EL PASO COUNTY DOT, INCLUDING WORK WITHIN THE RIGHT-OF-WAY AND SPECIAL TRANSPORT PERMITS.
- THE LIMITS OF CONSTRUCTION SHALL REMAIN WITHIN THE PROPERTY LINE UNLESS OTHERWISE NOTED. THE OWNER/DEVELOPER SHALL OBTAIN WRITTEN PERMISSION AND EASEMENTS, WHERE REQUIRED, FROM ADJOINING PROPERTY OWNER(S) PRIOR TO ANY OFF-SITE DISTURBANCE, GRADING, OR CONSTRUCTION.

EROSION CONTROL NOTES

- AT LEAST TEN DAYS PRIOR TO THE ANTICIPATED START OF CONSTRUCTION, FOR PROJECTS THAT WILL DISTURB 1 ACRE OR MORE, THE OWNER OR OPERATOR OF THE CONSTRUCTION ACTIVITY SHALL SUBMIT A PERMIT APPLICATION FOR STORMWATER DISCHARGE TO THE COLORADO DEPARTMENT OF PUBLIC HEALTH AND ENVIRONMENT, WATER QUALITY CONTROL DIVISION. THE APPLICATION CONTAINS CERTIFICATION OF COMPLETION OF A STORMWATER MANAGEMENT PLAN (SWMP), OF WHICH THIS GRADING AND EROSION CONTROL PLAN MAY BE A PART. FOR INFORMATION OR APPLICATION MATERIALS CONTACT:
COLORADO DEPARTMENT OF PUBLIC HEALTH AND ENVIRONMENT
WATER QUALITY CONTROL DIVISION
WQCD - PERMITS
4300 CHERRY CREEK DRIVE SOUTH
DENVER, CO 80246-1530
ATN: PERMITS UNIT
- ALL DISTURBED AREAS TO BE RESEEDED UPON COMPLETION OF OVERLOT GRADING AND EROSION CONTROL MEASURES HAVE BEEN INSTALLED OR WITHIN 60 DAYS, WHOEVER IS LESS TIME.
- CONSTRUCTION FENCE AND SILT FENCE OFFSET FOR CLARITY. CONTRACTOR TO ENSURE BMPs ARE PLACED DOWNSTREAM OF DISTURBED AREAS TO PREVENT SEDIMENT FROM LEAVING THE SITE.

GENERAL CONSTRUCTION NOTES

- IT SHALL BE THE RESPONSIBILITY OF THE CONTRACTOR TO VERIFY THE EXISTENCE AND LOCATION OF ALL UNDERGROUND UTILITIES ALONG THE ROUTE OF THE WORK. THE OMISSION FROM OR THE INCLUSION OF UTILITY LOCATIONS ON THE PLANS IS NOT TO BE CONSIDERED AS THE NONEXISTENCE OF OR A DEFINITE LOCATION OF EXISTING UNDERGROUND UTILITIES.
- THE CONTRACTOR SHALL TAKE THE NECESSARY PRECAUTIONS TO PROTECT EXISTING UTILITIES FROM DAMAGE DUE TO THIS OPERATION. ANY DAMAGE TO THE UTILITIES WILL BE REPLACED AT THE CONTRACTORS EXPENSE AND ANY SERVICE DISRUPTION WILL BE SETTLED BY THE CONTRACTOR.
- ADDITIONAL EROSION CONTROL STRUCTURES MAY BE REQUIRED AT THE TIME OF CONSTRUCTION.
- ALL BACKFILL, SUB-BASE AND / OR BASE COURSE (CLASS 6) MATERIAL SHALL BE COMPACTED TO THE SOILS ENGINEERS RECOMMENDATIONS, AND APPROVED BY EL PASO COUNTY DEVELOPMENT SERVICES ENGINEERING DIVISION.
- ALL STATIONING IS CENTERLINE UNLESS OTHERWISE INDICATED. ALL ELEVATIONS ARE FLOW LINE UNLESS OTHERWISE INDICATED.
- ALL DISTURBED PAVEMENT EDGES SHALL BE CUT TO NEAT LINES. REPAIR SHALL CONFORM TO THE EPC ECM APPENDIX K - 1.2C.
- ALL CULVERT AND STORM PIPES SHALL BE SMOOTH INTERIOR CORRUGATED POLYETHYLENE PIPE (HDPE), OR REINFORCED CONCRETE PIPE (RCP). ALL CULVERTS SHALL BE PLACED COMPLETE WITH FLARED END SECTIONS. ADEQUACY OF MATERIAL THICKNESS FOR ANY CSP INSTALLED SHALL BE VERIFIED BY OWNERS GEOTECHNICAL ENGINEER TO SUPPORT MINIMUM 50 YEAR DESIGN LIFE. CULVERTS MUST CONFORM TO EPC ECM SECTION 3.32 - CULVERTS.
- TYPE M RIP-RAP WITH 4" OF TYPE II GRANULAR BEDDING AND M19A1 180N OR EQUAL MAY BE SUBSTITUTED WHERE TYPE L RIP-RAP WITH M19A1 F1W 700 OR EQUAL IS SPECIFIED.
- ALL MATERIALS AND INSTALLATION PROCEDURES SHALL BE IN COMPLIANCE WITH ANY AND ALL APPLICABLE EL PASO COUNTY STANDARDS AND WITH WOODMAN HILLS METRO DISTRICT CONSULTING ENGINEER APPROVAL.
- ALL POTABLE WATER MAINS SHALL BE ANWA C900-SDR18 PVC WITH PUSH-ON SINGLE GASKET TYPE JOINTS AND SHALL MEET THE REQUIREMENTS OF ANSI / NSF 61.
- SANITARY SEWER PIPE AND FITTINGS: PVC 4" ASTM D3034, TYPE PSM, SDR 35; PUSH-ON JOINTS AND MOLDED RUBBER GASKETS MAXIMUM HORIZONTAL DEFLECTIONS, AFTER INSTALLATION AND BACK FILLING SHALL NOT EXCEED 3% OF THE PIPE DIAMETER. (MINIMUM CURVE RADIUS IS 100' FOR 6" PVC SANITARY SEWER MAIN)

HAMMERS CONSTRUCTION, LLC | EL PASO COUNTY | 67000088 | 6015 PAPER/PROJECT/CD/CONTRACT/CDL/CONTRACTING | CHAMBERLAIN | 01/2021



1155 Kelly Johnson Blvd., Suite 305
Colorado Springs, CO 80920
719.900.7220
GallowayUS.com

COPYRIGHT
THESE PLANS ARE AN INSTRUMENT OF SERVICE AND ARE THE PROPERTY OF GALLOWAY, AND MAY NOT BE DUPLICATED, DISCLOSED, OR REPRODUCED WITHOUT THE WRITTEN CONSENT OF GALLOWAY. COPYRIGHTS AND INFRINGEMENTS WILL BE ENFORCED AND PROSECUTED.



CONSTRUCTION DOCUMENTS
SMITH PLUMBING & HEATING
FOR
HAMMERS CONSTRUCTION, LLC

1875 MAIN STREET
COLORADO SPRINGS, CO 80911 - EL PASO COUNTY

#	Date	Issue / Description	Init.

Project No:	HCI000008
Drawn By:	TPT
Checked By:	CMD
Date:	6/7/2021

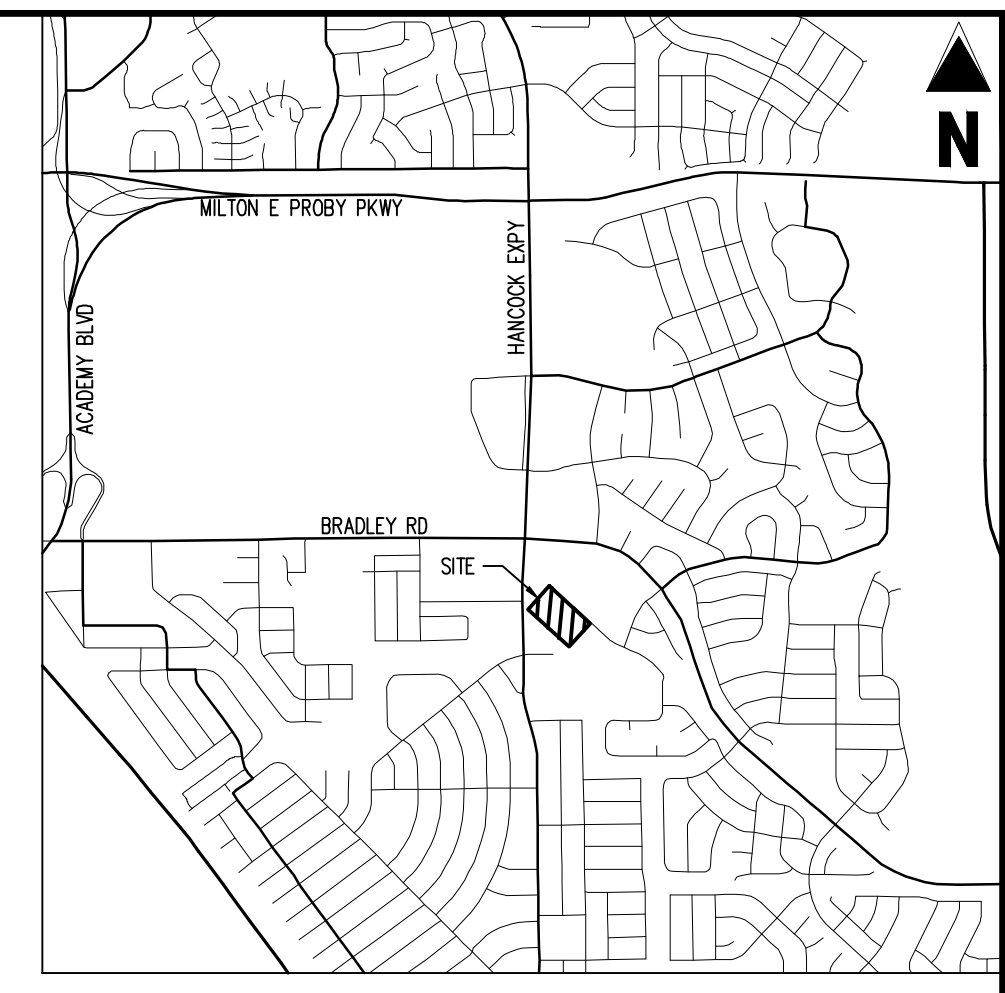

VICINITY MAP
SCALE: 1"=500'

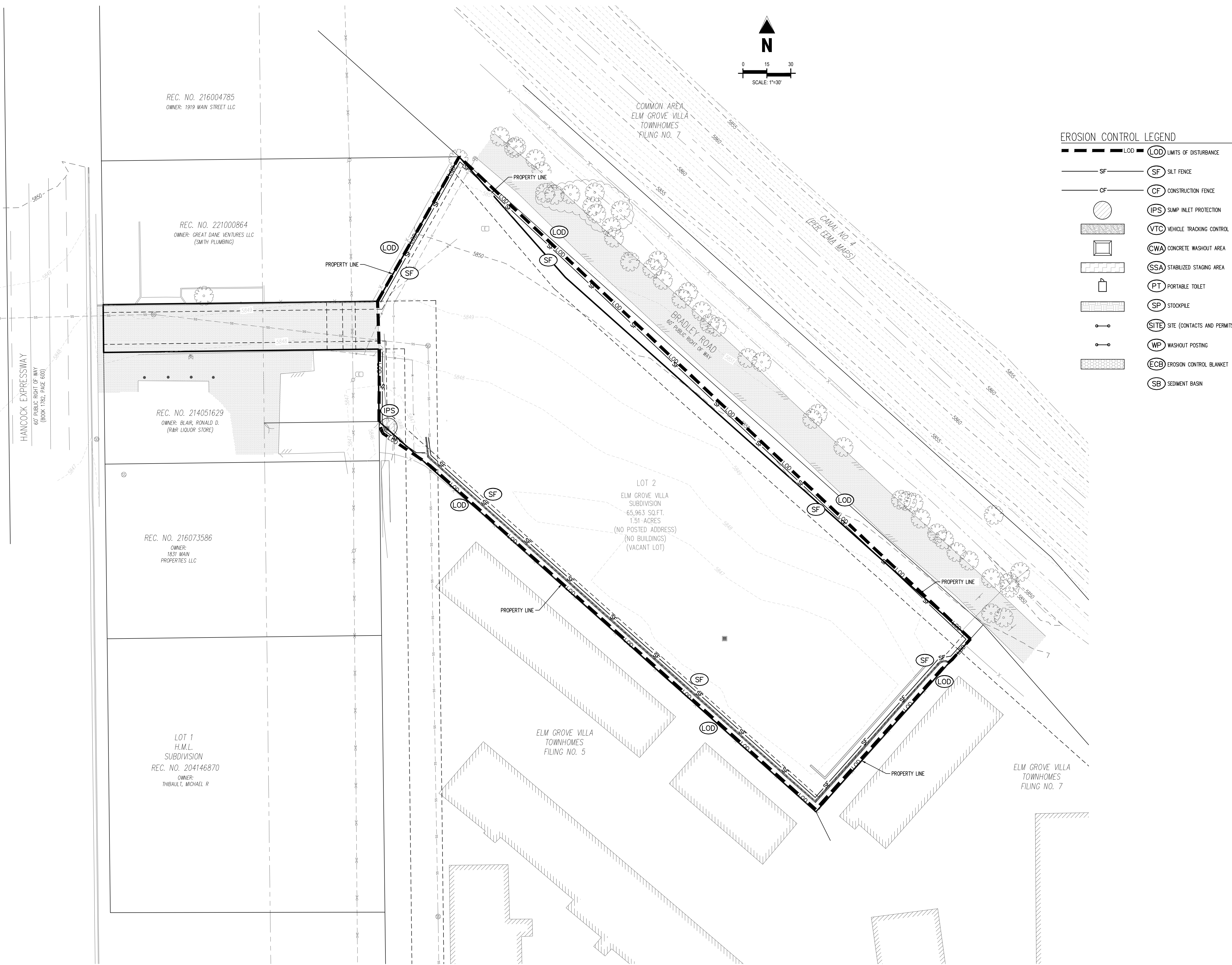
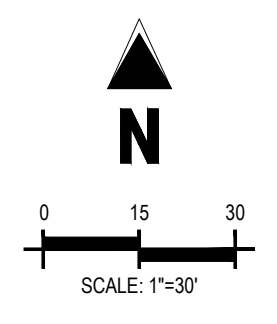

EROSION CONTROL LEGEND

- LOD LIMITS OF DISTURBANCE
- SF SILT FENCE
- CF CONSTRUCTION FENCE
- IPS SUMP INLET PROTECTION
- VTC VEHICLE TRACKING CONTROL
- CWA CONCRETE WASHOUT AREA
- SSA STABILIZED STAGING AREA
- PT PORTABLE TOILET
- SP STOCKPILE
- SITE (CONTACTS AND PERMITS)
- WP WASHOUT POSTING
- ECB EROSION CONTROL BLANKET
- SB SEDIMENT BASIN

GRADING LEGEND

- PROPERTY BOUNDARY LINE
- ADJACENT PROPERTY BOUNDARY LINE
- PROPOSED SETBACK
- EXISTING EASEMENT LINE
- PROPOSED BUILDING OUTLINE
- EXISTING ASPHALT EDGE
- EXISTING MAJOR CONTOUR
- EXISTING MINOR CONTOUR
- PROPOSED MAJOR CONTOUR
- PROPOSED MINOR CONTOUR
- PROPOSED WATER LINE
- EXISTING WATER LINE
- PROPOSED SANITARY SEWER LINE
- EXISTING SANITARY SEWER LINE
- PROPOSED STORM DRAIN LINE
- EXISTING STORM DRAIN LINE
- PROPOSED DRAINAGE FEATURE OUTLINE
- PROPOSED SWALE WITH FLOW DIRECTION
- EXISTING TOE SLOPE
- CUT / FILL
- PROPOSED RETAINING WALL
- EXISTING RETAINING WALL
- PROPOSED RIP RAP
- EXISTING ASPHALT PAVING
- SPOT ELEVATION - HIGH POINT
- SPOT ELEVATION - LOW POINT
- SPOT ELEVATION - FINISH GRADE
- PROPOSED SLOPE (PERCENT)
- PROPOSED SLOPE (RISE-RUN)
- FLOW ARROW

NOTES

1. ADD 5800 TO ALL SPOT ELEVATIONS
2. THE PLAN SHALL NOT SUBSTANTIALLY CHANGE THE DEPTH OF COVER, OR ACCESS TO UTILITY FACILITIES. ADDITIONALLY, THE PLAN SHALL NOT INCREASE OR DIVERT WATER TOWARDS UTILITY FACILITIES. ANY CHANGES TO UTILITY FACILITIES TO ACCOMMODATE THE PLAN MUST BE DISCUSSED AND AGREED TO BY THE AFFECTED UTILITY PRIOR TO IMPLEMENTING THE PLAN. THE RESULTING COST TO RELOCATE PROTECT UTILITIES, OR PROVIDE INTERIM ACCESS IS AT THE EXPENSE OF THE PLAN APPLICANT.
3. NO WETLANDS ARE PRESENT ON THIS SITE.
4. THE EROSION CONTROL DELINEATED ON THIS PLAN SHALL BE REGULARLY UPDATED BY THE CONTRACTORS.
5. CONTRACTOR SHALL PROTECT ALL AREAS OUTSIDE OF THE CONSTRUCTION LIMITS WITH SILT FENCE OR OTHER METHOD TO PROTECT UNDISTURBED AREAS FROM EROSION.
6. ALL TEMPORARY OR PERMANENT GRADING DISTURBANCES SHALL BE RE-SEEDDED AND MULCHED PER EL PASO COUNTY CRITERIA AND SPECIFICATIONS.
7. EXISTING VEGETATION CONSISTS OF NATURAL GRASSES AND SHRUBS.

EROSION CONTROL PHASING SCHEDULE

PHASE	DESCRIPTION
INITIAL	INSTALL SILT FENCE, ALL INLET PROTECTION MEASURES ON EXISTING INLETS, AND CURB SOCKS.
INTERIM	INSTALL PROPOSED WATER QUALITY CAPTURE VOLUME DETENTION BASIN W/ ALL PERMANENT CONTROL MEASURES. THEN, INSTALL STABILIZED STAGING AREA, VEHICLE TRACKING CONTROL AT ENTRANCE, AND CONCRETE WASHOUT AREA. FINALLY, INSTALL PROPOSED STORM SEWER.
FINAL	CONSTRUCT CURB/GUTTER AND PAVEMENT. REMOVE CONSTRUCTION BMP'S ONCE VERTICAL CONSTRUCTION AND APPLICABLE LANDSCAPING IS COMPLETE.

BASIS OF BEARINGS

BEARINGS ARE BASED ON WEST LINE OF SECTION 1, TOWNSHIP 15 SOUTH, RANGE 66 WEST, MONUMENTED ON THE NORTH END BY A 6" WITNESS CORNER, FOUND, 3.5" ALUMINUM CAP, "T245 R66W W.C. 6.00' S 35 536 S2 S1 T1 S 155W 2012 PLS 24313" AND ON THE SOUTH END BY A 3.5" ALUMINUM CAP, FOUND, "RMP5 19625", AND IS CONSIDERED TO BEAR N00°42'04"W.

BENCHMARK

PUBLISHED BENCHMARK
FIMS MONUMENT FX35
ELEVATION = 5980.39 (NAVD88)

CAUTION - NOTICE TO CONTRACTOR

1. ALL UTILITY LOCATIONS SHOWN ARE BASED ON MAPS PROVIDED BY THE APPROPRIATE UTILITY COMPANY AND FIELD SURFACE EVIDENCE AT THE TIME OF SURVEY AND IS TO BE CONSIDERED AN APPROXIMATE LOCATION ONLY. IT IS THE CONTRACTOR'S RESPONSIBILITY TO FIELD VERIFY THE LOCATION OF ALL UTILITIES, PUBLIC OR PRIVATE, WHETHER SHOWN ON THE PLANS OR NOT, PRIOR TO CONSTRUCTION. REPORT ANY DISCREPANCIES TO THE ENGINEER PRIOR TO CONSTRUCTION.
2. WHERE A PROPOSED UTILITY CROSSES AN EXISTING UTILITY, IT IS THE CONTRACTOR'S RESPONSIBILITY TO FIELD VERIFY THE HORIZONTAL AND VERTICAL LOCATION OF SUCH EXISTING UTILITY, EITHER THROUGH POT-HOLING OR ALTERNATIVE METHOD. REPORT INFORMATION TO THE ENGINEER PRIOR TO CONSTRUCTION.

Know what's below.
Call before you dig.



#	Date	Issue / Description	Init.

Project No: HCl000008
Drawn By: TPPT
Checked By: CMD
Date: 6/17/2021

EROSION CONTROL INITIAL PLAN

APPENDIX E

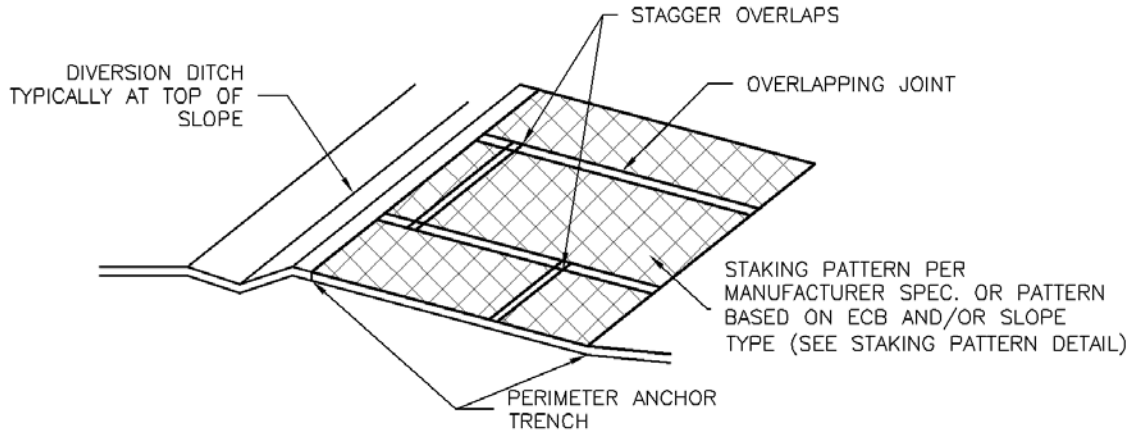

ECB-3. OUTSIDE OF DRAINAGEWAY

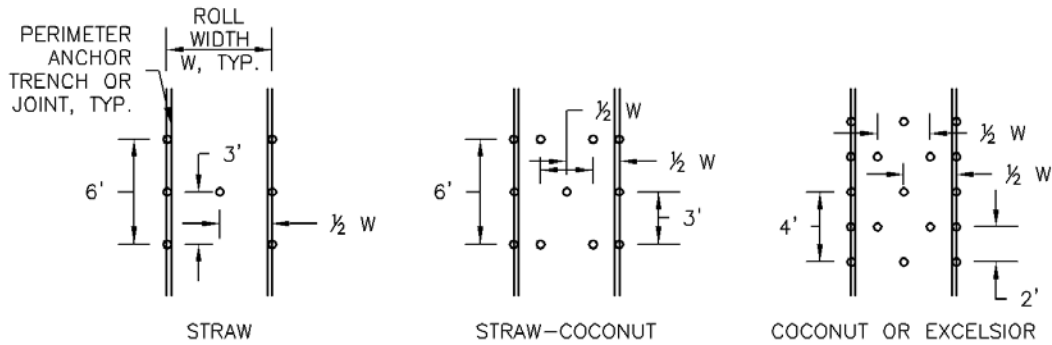

STAKING PATTERNS BY ECB TYPE

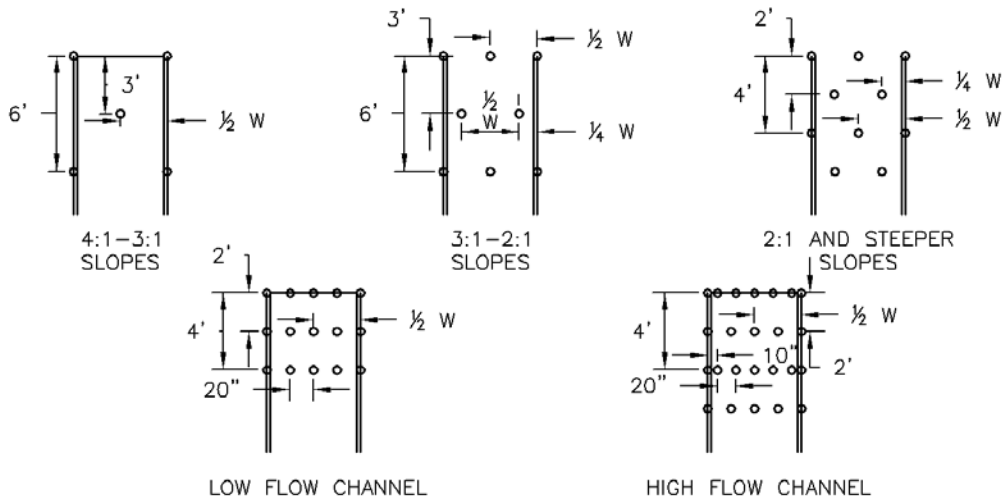

STAKING PATTERNS BY SLOPE OR CHANNEL TYPE

EROSION CONTROL BLANKET INSTALLATION NOTES

1. SEE PLAN VIEW FOR:
 - LOCATION OF ECB.
 - TYPE OF ECB (STRAW, STRAW-COCONUT, COCONUT, OR EXCELSIOR).
 - AREA, A, IN SQUARE YARDS OF EACH TYPE OF ECB.
2. 100% NATURAL AND BIODEGRADABLE MATERIALS ARE PREFERRED FOR RECPs, ALTHOUGH SOME JURISDICTIONS MAY ALLOW OTHER MATERIALS IN SOME APPLICATIONS.
3. IN AREAS WHERE ECBs ARE SHOWN ON THE PLANS, THE PERMITTEE SHALL PLACE TOPSOIL AND PERFORM FINAL GRADING, SURFACE PREPARATION, AND SEEDING AND MULCHING. SUBGRADE SHALL BE SMOOTH AND MOIST PRIOR TO ECB INSTALLATION AND THE ECB SHALL BE IN FULL CONTACT WITH SUBGRADE. NO GAPS OR VOIDS SHALL EXIST UNDER THE BLANKET.
4. PERIMETER ANCHOR TRENCH SHALL BE USED ALONG THE OUTSIDE PERIMETER OF ALL BLANKET AREAS.
5. JOINT ANCHOR TRENCH SHALL BE USED TO JOIN ROLLS OF ECBs TOGETHER (LONGITUDINALLY AND TRANSVERSELY) FOR ALL ECBs EXCEPT STRAW WHICH MAY USE AN OVERLAPPING JOINT.
6. INTERMEDIATE ANCHOR TRENCH SHALL BE USED AT SPACING OF ONE-HALF ROLL LENGTH FOR COCONUT AND EXCELSIOR ECBs.
7. OVERLAPPING JOINT DETAIL SHALL BE USED TO JOIN ROLLS OF ECBs TOGETHER FOR ECBs ON SLOPES.
8. MATERIAL SPECIFICATIONS OF ECBs SHALL CONFORM TO TABLE ECB-1.
9. ANY AREAS OF SEEDING AND MULCHING DISTURBED IN THE PROCESS OF INSTALLING ECBs SHALL BE RESEEDED AND MULCHED.
10. DETAILS ON DESIGN PLANS FOR MAJOR DRAINAGEWAY STABILIZATION WILL GOVERN IF DIFFERENT FROM THOSE SHOWN HERE.

TABLE ECB-1. ECB MATERIAL SPECIFICATIONS				
TYPE	COCONUT CONTENT	STRAW CONTENT	EXCELSIOR CONTENT	RECOMMENDED NETTING**
STRAW*	-	100%	-	DOUBLE/NATURAL
STRAW-COCONUT	30% MIN	70% MAX	-	DOUBLE/NATURAL
COCONUT	100%	-	-	DOUBLE/NATURAL
EXCELSIOR	-	-	100%	DOUBLE/NATURAL

*STRAW ECBs MAY ONLY BE USED OUTSIDE OF STREAMS AND DRAINAGE CHANNEL.
 **ALTERNATE NETTING MAY BE ACCEPTABLE IN SOME JURISDICTIONS

EROSION CONTROL BLANKET MAINTENANCE NOTES

1. INSPECT BMPs EACH WORKDAY, AND MAINTAIN THEM IN EFFECTIVE OPERATING CONDITION. MAINTENANCE OF BMPs SHOULD BE PROACTIVE, NOT REACTIVE. INSPECT BMPs AS SOON AS POSSIBLE (AND ALWAYS WITHIN 24 HOURS) FOLLOWING A STORM THAT CAUSES SURFACE EROSION, AND PERFORM NECESSARY MAINTENANCE.
2. FREQUENT OBSERVATIONS AND MAINTENANCE ARE NECESSARY TO MAINTAIN BMPs IN EFFECTIVE OPERATING CONDITION. INSPECTIONS AND CORRECTIVE MEASURES SHOULD BE DOCUMENTED THOROUGHLY.
3. WHERE BMPs HAVE FAILED, REPAIR OR REPLACEMENT SHOULD BE INITIATED UPON DISCOVERY OF THE FAILURE.
4. ECBs SHALL BE LEFT IN PLACE TO EVENTUALLY BIODEGRADE, UNLESS REQUESTED TO BE REMOVED BY THE LOCAL JURISDICTION.
5. ANY ECB PULLED OUT, TORN, OR OTHERWISE DAMAGED SHALL BE REPAIRED OR REINSTALLED. ANY SUBGRADE AREAS BELOW THE GEOTEXTILE THAT HAVE ERODED TO CREATED A VOID UNDER THE BLANKET, OR THAT REMAIN DEVOID OF GRASS SHALL BE REPAIRED, RESEDED AND MULCHED AND THE ECB REINSTALLED.

NOTE: MANY JURISDICTIONS HAVE BMP DETAILS THAT VARY FROM UDFCD STANDARD DETAILS. CONSULT WITH LOCAL JURISDICTIONS AS TO WHICH DETAIL SHOULD BE USED WHEN DIFFERENCES ARE NOTED.

(DETAILS ADAPTED FROM DOUGLAS COUNTY, COLORADO AND TOWN OF PARKER COLORADO, NOT AVAILABLE IN AUTOCAD)

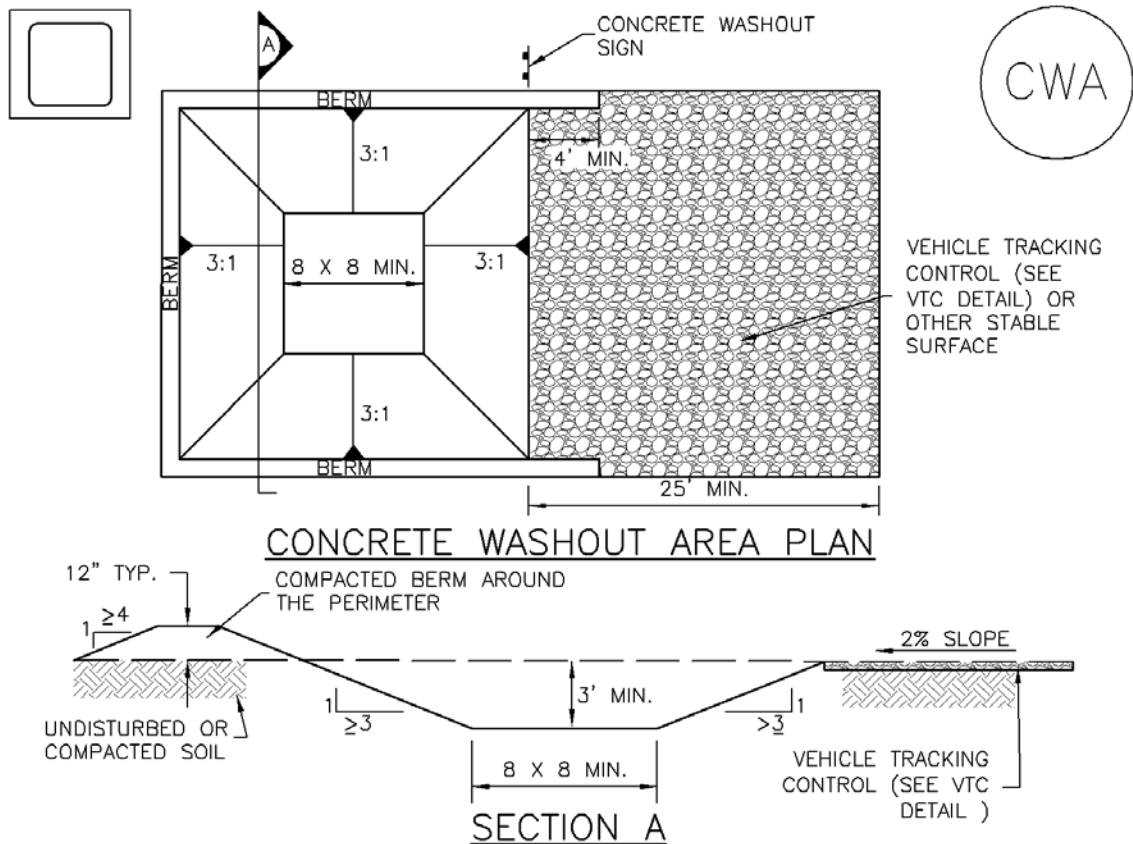

CWA-1. CONCRETE WASHOUT AREA

CWA INSTALLATION NOTES

1. SEE PLAN VIEW FOR:
-CWA INSTALLATION LOCATION.
2. DO NOT LOCATE AN UNLINED CWA WITHIN 400' OF ANY NATURAL DRAINAGE PATHWAY OR WATERBODY. DO NOT LOCATE WITHIN 1,000' OF ANY WELLS OR DRINKING WATER SOURCES. IF SITE CONSTRAINTS MAKE THIS INFEASIBLE, OR IF HIGHLY PERMEABLE SOILS EXIST ON SITE, THE CWA MUST BE INSTALLED WITH AN IMPERMEABLE LINER (16 MIL MIN. THICKNESS) OR SURFACE STORAGE ALTERNATIVES USING PREFABRICATED CONCRETE WASHOUT DEVICES OR A LINED ABOVE GROUND STORAGE ARE SHOULD BE USED.
3. THE CWA SHALL BE INSTALLED PRIOR TO CONCRETE PLACEMENT ON SITE.
4. CWA SHALL INCLUDE A FLAT SUBSURFACE PIT THAT IS AT LEAST 8' BY 8' SLOPES LEADING OUT OF THE SUBSURFACE PIT SHALL BE 3:1 OR FLATTER. THE PIT SHALL BE AT LEAST 3' DEEP.
5. BERM SURROUNDING SIDES AND BACK OF THE CWA SHALL HAVE MINIMUM HEIGHT OF 1'.
6. VEHICLE TRACKING PAD SHALL BE SLOPED 2% TOWARDS THE CWA.
7. SIGNS SHALL BE PLACED AT THE CONSTRUCTION ENTRANCE, AT THE CWA, AND ELSEWHERE AS NECESSARY TO CLEARLY INDICATE THE LOCATION OF THE CWA TO OPERATORS OF CONCRETE TRUCKS AND PUMP RIGS.
8. USE EXCAVATED MATERIAL FOR PERIMETER BERM CONSTRUCTION.

CWA MAINTENANCE NOTES

1. INSPECT BMPs EACH WORKDAY, AND MAINTAIN THEM IN EFFECTIVE OPERATING CONDITION. MAINTENANCE OF BMPs SHOULD BE PROACTIVE, NOT REACTIVE. INSPECT BMPs AS SOON AS POSSIBLE (AND ALWAYS WITHIN 24 HOURS) FOLLOWING A STORM THAT CAUSES SURFACE EROSION, AND PERFORM NECESSARY MAINTENANCE.

2. FREQUENT OBSERVATIONS AND MAINTENANCE ARE NECESSARY TO MAINTAIN BMPs IN EFFECTIVE OPERATING CONDITION. INSPECTIONS AND CORRECTIVE MEASURES SHOULD BE DOCUMENTED THOROUGHLY.

3. WHERE BMPs HAVE FAILED, REPAIR OR REPLACEMENT SHOULD BE INITIATED UPON DISCOVERY OF THE FAILURE.

4. THE CWA SHALL BE REPAIRED, CLEANED, OR ENLARGED AS NECESSARY TO MAINTAIN CAPACITY FOR CONCRETE WASTE. CONCRETE MATERIALS, ACCUMULATED IN PIT, SHALL BE REMOVED ONCE THE MATERIALS HAVE REACHED A DEPTH OF 2'.

5. CONCRETE WASHOUT WATER, WASTED PIECES OF CONCRETE AND ALL OTHER DEBRIS IN THE SUBSURFACE PIT SHALL BE TRANSPORTED FROM THE JOB SITE IN A WATER-TIGHT CONTAINER AND DISPOSED OF PROPERLY.

6. THE CWA SHALL REMAIN IN PLACE UNTIL ALL CONCRETE FOR THE PROJECT IS PLACED.

7. WHEN THE CWA IS REMOVED, COVER THE DISTURBED AREA WITH TOP SOIL, SEED AND MULCH OR OTHERWISE STABILIZED IN A MANNER APPROVED BY THE LOCAL JURISDICTION.

(DETAIL ADAPTED FROM DOUGLAS COUNTY, COLORADO AND THE CITY OF PARKER, COLORADO, NOT AVAILABLE IN AUTOCAD).

NOTE: MANY JURISDICTIONS HAVE BMP DETAILS THAT VARY FROM UDFCD STANDARD DETAILS. CONSULT WITH LOCAL JURISDICTIONS AS TO WHICH DETAIL SHOULD BE USED WHEN DIFFERENCES ARE NOTED.

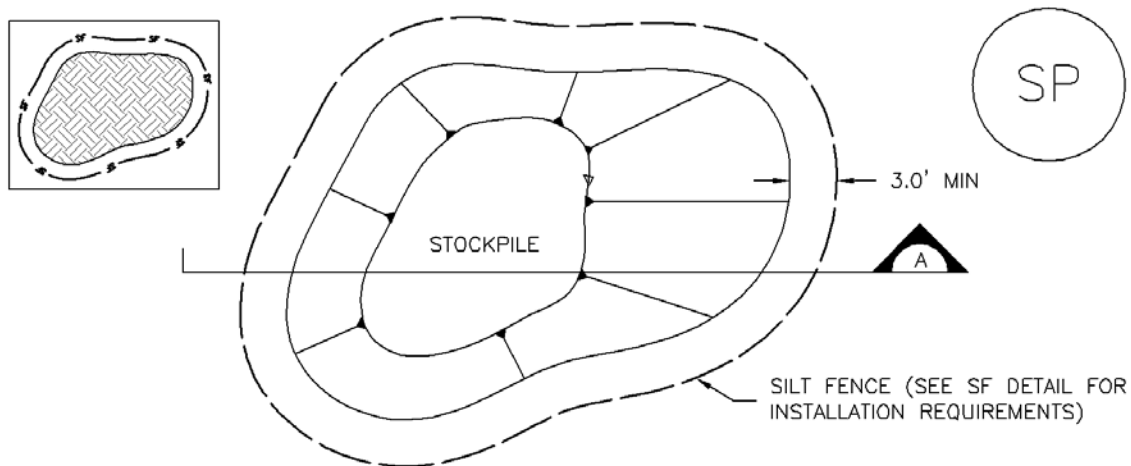

STOCKPILE PROTECTION PLAN

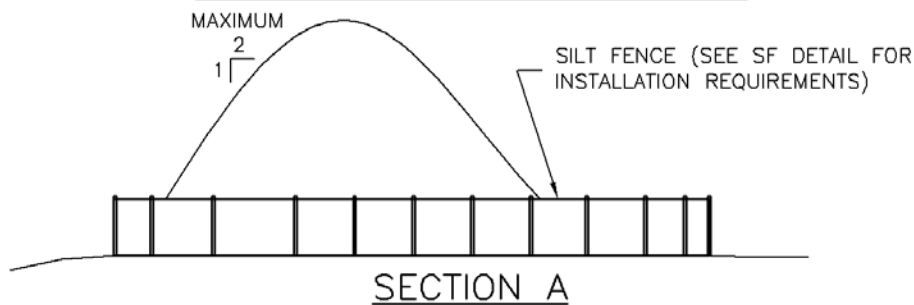

SP-1. STOCKPILE PROTECTION

STOCKPILE PROTECTION INSTALLATION NOTES

1. SEE PLAN VIEW FOR:
 - LOCATION OF STOCKPILES.
 - TYPE OF STOCKPILE PROTECTION.
2. INSTALL PERIMETER CONTROLS IN ACCORDANCE WITH THEIR RESPECTIVE DESIGN DETAILS. SILT FENCE IS SHOWN IN THE STOCKPILE PROTECTION DETAILS; HOWEVER, OTHER TYPES OF PERIMETER CONTROLS INCLUDING SEDIMENT CONTROL LOGS OR ROCK SOCKS MAY BE SUITABLE IN SOME CIRCUMSTANCES. CONSIDERATIONS FOR DETERMINING THE APPROPRIATE TYPE OF PERIMETER CONTROL FOR A STOCKPILE INCLUDE WHETHER THE STOCKPILE IS LOCATED ON A PERVIOUS OR IMPERVIOUS SURFACE, THE RELATIVE HEIGHTS OF THE PERIMETER CONTROL AND STOCKPILE, THE ABILITY OF THE PERIMETER CONTROL TO CONTAIN THE STOCKPILE WITHOUT FAILING IN THE EVENT THAT MATERIAL FROM THE STOCKPILE SHIFTS OR SLUMPS AGAINST THE PERIMETER, AND OTHER FACTORS.
3. STABILIZE THE STOCKPILE SURFACE WITH SURFACE ROUGHENING, TEMPORARY SEEDING AND MULCHING, EROSION CONTROL BLANKETS, OR SOIL BINDERS. SOILS STOCKPILED FOR AN EXTENDED PERIOD (TYPICALLY FOR MORE THAN 60 DAYS) SHOULD BE SEEDING AND MULCHED WITH A TEMPORARY GRASS COVER ONCE THE STOCKPILE IS PLACED (TYPICALLY WITHIN 14 DAYS). USE OF MULCH ONLY OR A SOIL BINDER IS ACCEPTABLE IF THE STOCKPILE WILL BE IN PLACE FOR A MORE LIMITED TIME PERIOD (TYPICALLY 30-60 DAYS).
4. FOR TEMPORARY STOCKPILES ON THE INTERIOR PORTION OF A CONSTRUCTION SITE, WHERE OTHER DOWNGRADIENT CONTROLS, INCLUDING PERIMETER CONTROL, ARE IN PLACE, STOCKPILE PERIMETER CONTROLS MAY NOT BE REQUIRED.

STOCKPILE PROTECTION MAINTENANCE NOTES

1. INSPECT BMPs EACH WORKDAY, AND MAINTAIN THEM IN EFFECTIVE OPERATING CONDITION. MAINTENANCE OF BMPs SHOULD BE PROACTIVE, NOT REACTIVE. INSPECT BMPs AS SOON AS POSSIBLE (AND ALWAYS WITHIN 24 HOURS) FOLLOWING A STORM THAT CAUSES SURFACE EROSION, AND PERFORM NECESSARY MAINTENANCE.

2. FREQUENT OBSERVATIONS AND MAINTENANCE ARE NECESSARY TO MAINTAIN BMPs IN EFFECTIVE OPERATING CONDITION. INSPECTIONS AND CORRECTIVE MEASURES SHOULD BE DOCUMENTED THOROUGHLY.

3. WHERE BMPs HAVE FAILED, REPAIR OR REPLACEMENT SHOULD BE INITIATED UPON DISCOVERY OF THE FAILURE.

STOCKPILE PROTECTION MAINTENANCE NOTES

4. IF PERIMETER PROTECTION MUST BE MOVED TO ACCESS SOIL STOCKPILE, REPLACE PERIMETER CONTROLS BY THE END OF THE WORKDAY.

5. STOCKPILE PERIMETER CONTROLS CAN BE REMOVED ONCE ALL THE MATERIAL FROM THE STOCKPILE HAS BEEN USED.

(DETAILS ADAPTED FROM PARKER, COLORADO, NOT AVAILABLE IN AUTOCAD)

NOTE: MANY JURISDICTIONS HAVE BMP DETAILS THAT VARY FROM UDFCD STANDARD DETAILS. CONSULT WITH LOCAL JURISDICTIONS AS TO WHICH DETAIL SHOULD BE USED WHEN DIFFERENCES ARE NOTED.

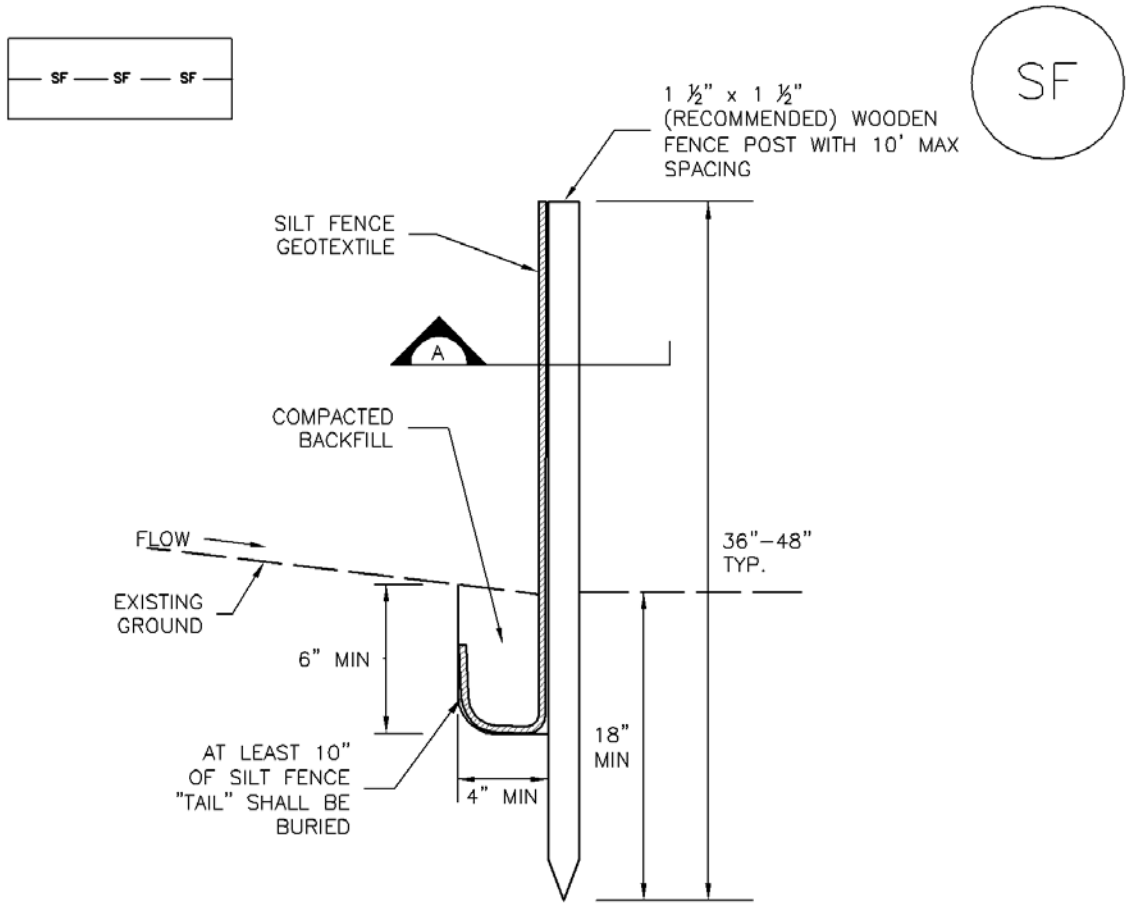

SILT FENCE

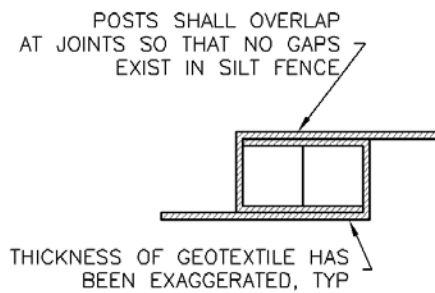
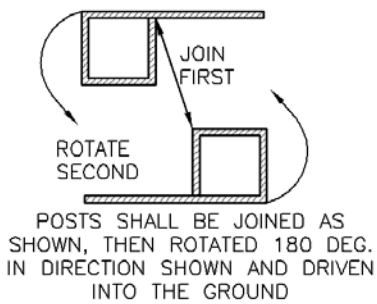

SECTION A

SF-1. SILT FENCE

SILT FENCE INSTALLATION NOTES

1. SILT FENCE MUST BE PLACED AWAY FROM THE TOE OF THE SLOPE TO ALLOW FOR WATER PONDING. SILT FENCE AT THE TOE OF A SLOPE SHOULD BE INSTALLED IN A FLAT LOCATION AT LEAST SEVERAL FEET (2-5 FT) FROM THE TOE OF THE SLOPE TO ALLOW ROOM FOR PONDING AND DEPOSITION.
2. A UNIFORM 6" X 4" ANCHOR TRENCH SHALL BE EXCAVATED USING TRENCHER OR SILT FENCE INSTALLATION DEVICE. NO ROAD GRADERS, BACKHOES, OR SIMILAR EQUIPMENT SHALL BE USED.
3. COMPACT ANCHOR TRENCH BY HAND WITH A "JUMPING JACK" OR BY WHEEL ROLLING. COMPACTION SHALL BE SUCH THAT SILT FENCE RESISTS BEING PULLED OUT OF ANCHOR TRENCH BY HAND.
4. SILT FENCE SHALL BE PULLED TIGHT AS IT IS ANCHORED TO THE STAKES. THERE SHOULD BE NO NOTICEABLE SAG BETWEEN STAKES AFTER IT HAS BEEN ANCHORED TO THE STAKES.
5. SILT FENCE FABRIC SHALL BE ANCHORED TO THE STAKES USING 1" HEAVY DUTY STAPLES OR NAILS WITH 1" HEADS. STAPLES AND NAILS SHOULD BE PLACED 3" ALONG THE FABRIC DOWN THE STAKE.
6. AT THE END OF A RUN OF SILT FENCE ALONG A CONTOUR, THE SILT FENCE SHOULD BE TURNED PERPENDICULAR TO THE CONTOUR TO CREATE A "J-HOOK." THE "J-HOOK" EXTENDING PERPENDICULAR TO THE CONTOUR SHOULD BE OF SUFFICIENT LENGTH TO KEEP RUNOFF FROM FLOWING AROUND THE END OF THE SILT FENCE (TYPICALLY 10' - 20').
7. SILT FENCE SHALL BE INSTALLED PRIOR TO ANY LAND DISTURBING ACTIVITIES.

SILT FENCE MAINTENANCE NOTES

1. INSPECT BMPs EACH WORKDAY, AND MAINTAIN THEM IN EFFECTIVE OPERATING CONDITION. MAINTENANCE OF BMPs SHOULD BE PROACTIVE, NOT REACTIVE. INSPECT BMPs AS SOON AS POSSIBLE (AND ALWAYS WITHIN 24 HOURS) FOLLOWING A STORM THAT CAUSES SURFACE EROSION, AND PERFORM NECESSARY MAINTENANCE.
2. FREQUENT OBSERVATIONS AND MAINTENANCE ARE NECESSARY TO MAINTAIN BMPs IN EFFECTIVE OPERATING CONDITION. INSPECTIONS AND CORRECTIVE MEASURES SHOULD BE DOCUMENTED THOROUGHLY.
3. WHERE BMPs HAVE FAILED, REPAIR OR REPLACEMENT SHOULD BE INITIATED UPON DISCOVERY OF THE FAILURE.
4. SEDIMENT ACCUMULATED UPSTREAM OF THE SILT FENCE SHALL BE REMOVED AS NEEDED TO MAINTAIN THE FUNCTIONALITY OF THE BMP, TYPICALLY WHEN DEPTH OF ACCUMULATED SEDIMENTS IS APPROXIMATELY 6".
5. REPAIR OR REPLACE SILT FENCE WHEN THERE ARE SIGNS OF WEAR, SUCH AS SAGGING, TEARING, OR COLLAPSE.
6. SILT FENCE IS TO REMAIN IN PLACE UNTIL THE UPSTREAM DISTURBED AREA IS STABILIZED AND APPROVED BY THE LOCAL JURISDICTION, OR IS REPLACED BY AN EQUIVALENT PERIMETER SEDIMENT CONTROL BMP.
7. WHEN SILT FENCE IS REMOVED, ALL DISTURBED AREAS SHALL BE COVERED WITH TOPSOIL, SEEDED AND MULCHED OR OTHERWISE STABILIZED AS APPROVED BY LOCAL JURISDICTION.

(DETAIL ADAPTED FROM TOWN OF PARKER, COLORADO AND CITY OF AURORA, NOT AVAILABLE IN AUTOCAD)

NOTE: MANY JURISDICTIONS HAVE BMP DETAILS THAT VARY FROM UDFCD STANDARD DETAILS. CONSULT WITH LOCAL JURISDICTIONS AS TO WHICH DETAIL SHOULD BE USED WHEN DIFFERENCES ARE NOTED.

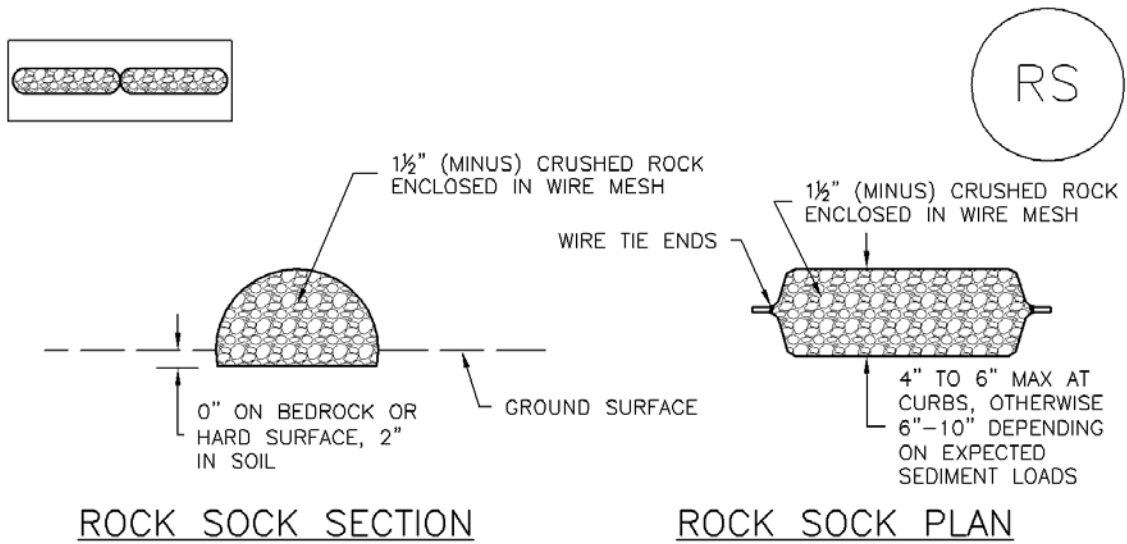

ROCK SOCK SECTION

ROCK SOCK PLAN

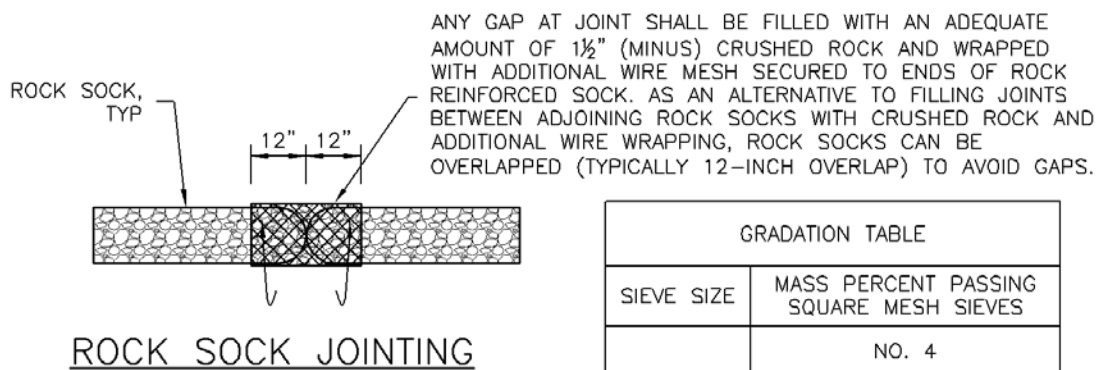

ROCK SOCK JOINTING

ANY GAP AT JOINT SHALL BE FILLED WITH AN ADEQUATE AMOUNT OF 1½" (MINUS) CRUSHED ROCK AND WRAPPED WITH ADDITIONAL WIRE MESH SECURED TO ENDS OF ROCK REINFORCED SOCK. AS AN ALTERNATIVE TO FILLING JOINTS BETWEEN ADJOINING ROCK SOCKS WITH CRUSHED ROCK AND ADDITIONAL WIRE WRAPPING, ROCK SOCKS CAN BE OVERLAPPED (TYPICALLY 12-INCH OVERLAP) TO AVOID GAPS.

GRADATION TABLE	
SIEVE SIZE	MASS PERCENT PASSING SQUARE MESH SIEVES
	NO. 4
2"	100
1½"	90 - 100
1"	20 - 55
¾"	0 - 15
⅜"	0 - 5

MATCHES SPECIFICATIONS FOR NO. 4 COARSE AGGREGATE FOR CONCRETE PER AASHTO M43. ALL ROCK SHALL BE FRACTURED FACE, ALL SIDES.

ROCK SOCK INSTALLATION NOTES

1. SEE PLAN VIEW FOR:
-LOCATION(S) OF ROCK SOCKS.
2. CRUSHED ROCK SHALL BE 1½" (MINUS) IN SIZE WITH A FRACTURED FACE (ALL SIDES) AND SHALL COMPLY WITH GRADATION SHOWN ON THIS SHEET (1½" MINUS).
3. WIRE MESH SHALL BE FABRICATED OF 10 GAGE POULTRY MESH, OR EQUIVALENT, WITH A MAXIMUM OPENING OF ½", RECOMMENDED MINIMUM ROLL WIDTH OF 48"
4. WIRE MESH SHALL BE SECURED USING "HOG RINGS" OR WIRE TIES AT 6" CENTERS ALONG ALL JOINTS AND AT 2" CENTERS ON ENDS OF SOCKS.
5. SOME MUNICIPALITIES MAY ALLOW THE USE OF FILTER FABRIC AS AN ALTERNATIVE TO WIRE MESH FOR THE ROCK ENCLOSURE.

RS-1. ROCK SOCK PERIMETER CONTROL

ROCK SOCK MAINTENANCE NOTES

1. INSPECT BMPs EACH WORKDAY, AND MAINTAIN THEM IN EFFECTIVE OPERATING CONDITION. MAINTENANCE OF BMPs SHOULD BE PROACTIVE, NOT REACTIVE. INSPECT BMPs AS SOON AS POSSIBLE (AND ALWAYS WITHIN 24 HOURS) FOLLOWING A STORM THAT CAUSES SURFACE EROSION, AND PERFORM NECESSARY MAINTENANCE.
2. FREQUENT OBSERVATIONS AND MAINTENANCE ARE NECESSARY TO MAINTAIN BMPs IN EFFECTIVE OPERATING CONDITION. INSPECTIONS AND CORRECTIVE MEASURES SHOULD BE DOCUMENTED THOROUGHLY.
3. WHERE BMPs HAVE FAILED, REPAIR OR REPLACEMENT SHOULD BE INITIATED UPON DISCOVERY OF THE FAILURE.
4. ROCK SOCKS SHALL BE REPLACED IF THEY BECOME HEAVILY SOILED, OR DAMAGED BEYOND REPAIR.
5. SEDIMENT ACCUMULATED UPSTREAM OF ROCK SOCKS SHALL BE REMOVED AS NEEDED TO MAINTAIN FUNCTIONALITY OF THE BMP, TYPICALLY WHEN DEPTH OF ACCUMULATED SEDIMENTS IS APPROXIMATELY $\frac{1}{2}$ OF THE HEIGHT OF THE ROCK SOCK.
6. ROCK SOCKS ARE TO REMAIN IN PLACE UNTIL THE UPSTREAM DISTURBED AREA IS STABILIZED AND APPROVED BY THE LOCAL JURISDICTION.
7. WHEN ROCK SOCKS ARE REMOVED, ALL DISTURBED AREAS SHALL BE COVERED WITH TOPSOIL, SEEDED AND MULCHED OR OTHERWISE STABILIZED AS APPROVED BY LOCAL JURISDICTION.

(DETAIL ADAPTED FROM TOWN OF PARKER, COLORADO AND CITY OF AURORA, COLORADO, NOT AVAILABLE IN AUTOCAD)

NOTE: MANY JURISDICTIONS HAVE BMP DETAILS THAT VARY FROM UDFCD STANDARD DETAILS. CONSULT WITH LOCAL JURISDICTIONS AS TO WHICH DETAIL SHOULD BE USED WHEN DIFFERENCES ARE NOTED.

NOTE: THE DETAILS INCLUDED WITH THIS FACT SHEET SHOW COMMONLY USED, CONVENTIONAL METHODS OF ROCK SOCK INSTALLATION IN THE DENVER METROPOLITAN AREA. THERE ARE MANY OTHER SIMILAR PROPRIETARY PRODUCTS ON THE MARKET. UDFCD NEITHER NDORSES NOR DISCOURAGES USE OF PROPRIETARY PROTECTION PRODUCTS; HOWEVER, IN THE EVENT PROPRIETARY METHODS ARE USED, THE APPROPRIATE DETAIL FROM THE MANUFACTURER MUST BE INCLUDED IN THE SWMP AND THE BMP MUST BE INSTALLED AND MAINTAINED AS SHOWN IN THE MANUFACTURER'S DETAILS.

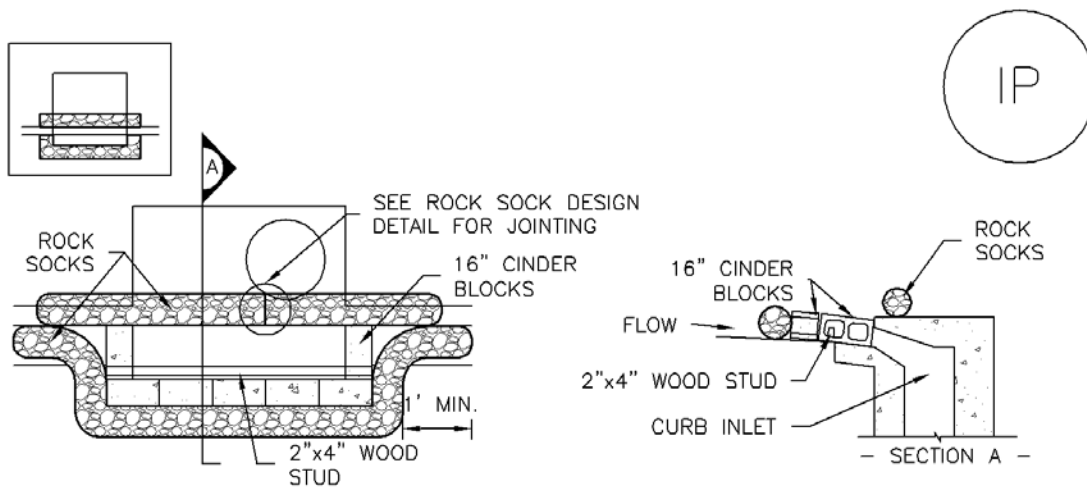

IP-1. BLOCK AND ROCK SOCK SUMP OR ON GRADE INLET PROTECTION

BLOCK AND CURB SOCK INLET PROTECTION INSTALLATION NOTES

1. SEE ROCK SOCK DESIGN DETAIL FOR INSTALLATION REQUIREMENTS.
2. CONCRETE "CINDER" BLOCKS SHALL BE LAID ON THEIR SIDES AROUND THE INLET IN A SINGLE ROW, ABUTTING ONE ANOTHER WITH THE OPEN END FACING AWAY FROM THE CURB.
3. GRAVEL BAGS SHALL BE PLACED AROUND CONCRETE BLOCKS, CLOSELY ABUTTING ONE ANOTHER AND JOINTED TOGETHER IN ACCORDANCE WITH ROCK SOCK DESIGN DETAIL.

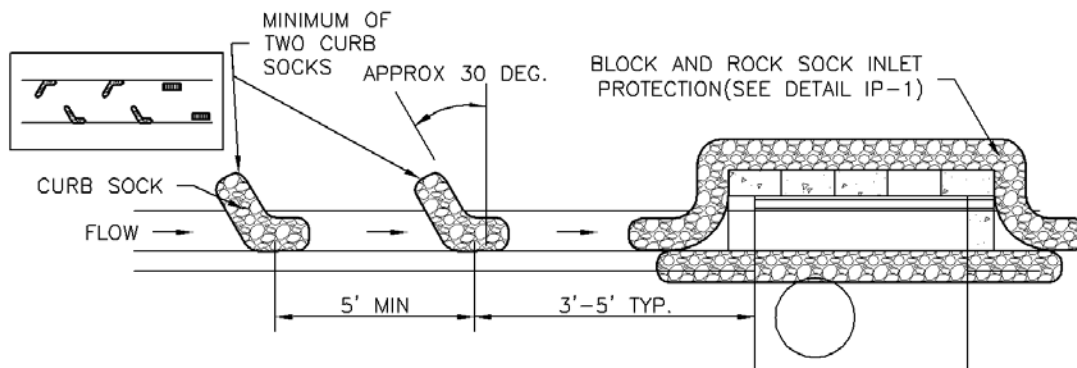

IP-2. CURB ROCK SOCKS UPSTREAM OF INLET PROTECTION

CURB ROCK SOCK INLET PROTECTION INSTALLATION NOTES

1. SEE ROCK SOCK DESIGN DETAIL INSTALLATION REQUIREMENTS.
2. PLACEMENT OF THE SOCK SHALL BE APPROXIMATELY 30 DEGREES FROM PERPENDICULAR IN THE OPPOSITE DIRECTION OF FLOW.
3. SOCKS ARE TO BE FLUSH WITH THE CURB AND SPACED A MINIMUM OF 5 FEET APART.
4. AT LEAST TWO CURB SOCKS IN SERIES ARE REQUIRED UPSTREAM OF ON-GRADE INLETS.

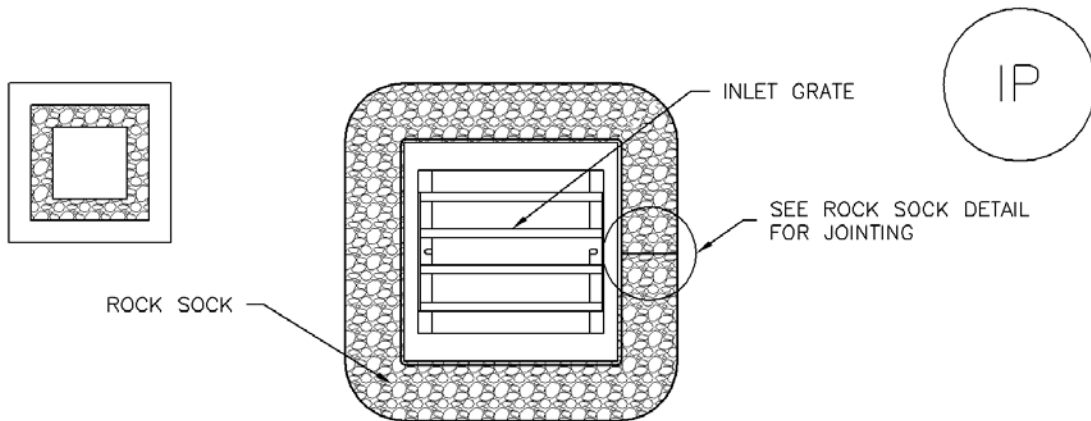

IP-3. ROCK SOCK SUMP/AREA INLET PROTECTION

ROCK SOCK SUMP/AREA INLET PROTECTION INSTALLATION NOTES

1. SEE ROCK SOCK DESIGN DETAIL FOR INSTALLATION REQUIREMENTS.
2. STRAW WATTLES/SEDIMENT CONTROL LOGS MAY BE USED IN PLACE OF ROCK SOCKS FOR INLETS IN PERVIOUS AREAS. INSTALL PER SEDIMENT CONTROL LOG DETAIL.

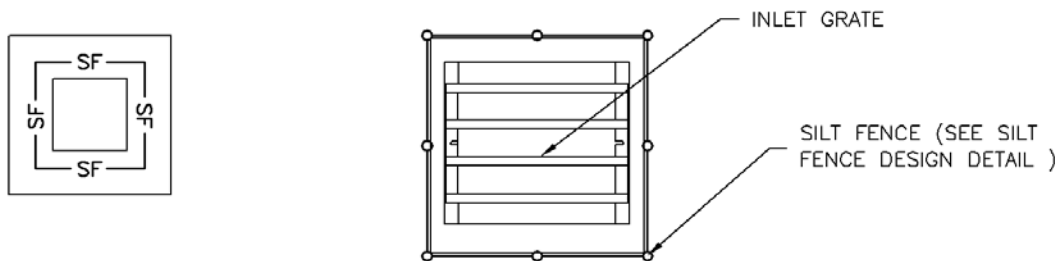

IP-4. SILT FENCE FOR SUMP INLET PROTECTION

SILT FENCE INLET PROTECTION INSTALLATION NOTES

1. SEE SILT FENCE DESIGN DETAIL FOR INSTALLATION REQUIREMENTS.
2. POSTS SHALL BE PLACED AT EACH CORNER OF THE INLET AND AROUND THE EDGES AT A MAXIMUM SPACING OF 3 FEET.
3. STRAW WATTLES/SEDIMENT CONTROL LOGS MAY BE USED IN PLACE OF SILT FENCE FOR INLETS IN PERVIOUS AREAS. INSTALL PER SEDIMENT CONTROL LOG DETAIL.

GENERAL INLET PROTECTION INSTALLATION NOTES

1. SEE PLAN VIEW FOR:
 - LOCATION OF INLET PROTECTION.
 - TYPE OF INLET PROTECTION (IP.1, IP.2, IP.3, IP.4, IP.5, IP.6)
2. INLET PROTECTION SHALL BE INSTALLED PROMPTLY AFTER INLET CONSTRUCTION OR PAVING IS COMPLETE (TYPICALLY WITHIN 48 HOURS). IF A RAINFALL/RUNOFF EVENT IS FORECAST, INSTALL INLET PROTECTION PRIOR TO ONSET OF EVENT.
3. MANY JURISDICTIONS HAVE BMP DETAILS THAT VARY FROM UDFCD STANDARD DETAILS. CONSULT WITH LOCAL JURISDICTIONS AS TO WHICH DETAIL SHOULD BE USED WHEN DIFFERENCES ARE NOTED.

INLET PROTECTION MAINTENANCE NOTES

1. INSPECT BMPs EACH WORKDAY, AND MAINTAIN THEM IN EFFECTIVE OPERATING CONDITION. MAINTENANCE OF BMPs SHOULD BE PROACTIVE, NOT REACTIVE. INSPECT BMPs AS SOON AS POSSIBLE (AND ALWAYS WITHIN 24 HOURS) FOLLOWING A STORM THAT CAUSES SURFACE EROSION, AND PERFORM NECESSARY MAINTENANCE.
2. FREQUENT OBSERVATIONS AND MAINTENANCE ARE NECESSARY TO MAINTAIN BMPs IN EFFECTIVE OPERATING CONDITION. INSPECTIONS AND CORRECTIVE MEASURES SHOULD BE DOCUMENTED THOROUGHLY.
3. WHERE BMPs HAVE FAILED, REPAIR OR REPLACEMENT SHOULD BE INITIATED UPON DISCOVERY OF THE FAILURE.
4. SEDIMENT ACCUMULATED UPSTREAM OF INLET PROTECTION SHALL BE REMOVED AS NECESSARY TO MAINTAIN BMP EFFECTIVENESS, TYPICALLY WHEN STORAGE VOLUME REACHES 50% OF CAPACITY, A DEPTH OF 6" WHEN SILT FENCE IS USED, OR ¼ OF THE HEIGHT FOR STRAW BALES.
5. INLET PROTECTION IS TO REMAIN IN PLACE UNTIL THE UPSTREAM DISTURBED AREA IS PERMANENTLY STABILIZED, UNLESS THE LOCAL JURISDICTION APPROVES EARLIER REMOVAL OF INLET PROTECTION IN STREETS.
6. WHEN INLET PROTECTION AT AREA INLETS IS REMOVED, THE DISTURBED AREA SHALL BE COVERED WITH TOP SOIL, SEEDED AND MULCHED, OR OTHERWISE STABILIZED IN A MANNER APPROVED BY THE LOCAL JURISDICTION.

(DETAIL ADAPTED FROM TOWN OF PARKER, COLORADO AND CITY OF AURORA, COLORADO, NOT AVAILABLE IN AUTOCAD)

NOTE: MANY JURISDICTIONS HAVE BMP DETAILS THAT VARY FROM UDFCD STANDARD DETAILS. CONSULT WITH LOCAL JURISDICTIONS AS TO WHICH DETAIL SHOULD BE USED WHEN DIFFERENCES ARE NOTED.

NOTE: THE DETAILS INCLUDED WITH THIS FACT SHEET SHOW COMMONLY USED, CONVENTIONAL METHODS OF INLET PROTECTION IN THE DENVER METROPOLITAN AREA. THERE ARE MANY PROPRIETARY INLET PROTECTION METHODS ON THE MARKET. UDFCD NEITHER ENDORSES NOR DISCOURAGES USE OF PROPRIETARY INLET PROTECTION; HOWEVER, IN THE EVENT PROPRIETARY METHODS ARE USED, THE APPROPRIATE DETAIL FROM THE MANUFACTURER MUST BE INCLUDED IN THE SWMP AND THE BMP MUST BE INSTALLED AND MAINTAINED AS SHOWN IN THE MANUFACTURER'S DETAILS.

NOTE: SOME MUNICIPALITIES DISCOURAGE OR PROHIBIT THE USE OF STRAW BALES FOR INLET PROTECTION. CHECK WITH LOCAL JURISDICTION TO DETERMINE IF STRAW BALE INLET PROTECTION IS ACCEPTABLE.

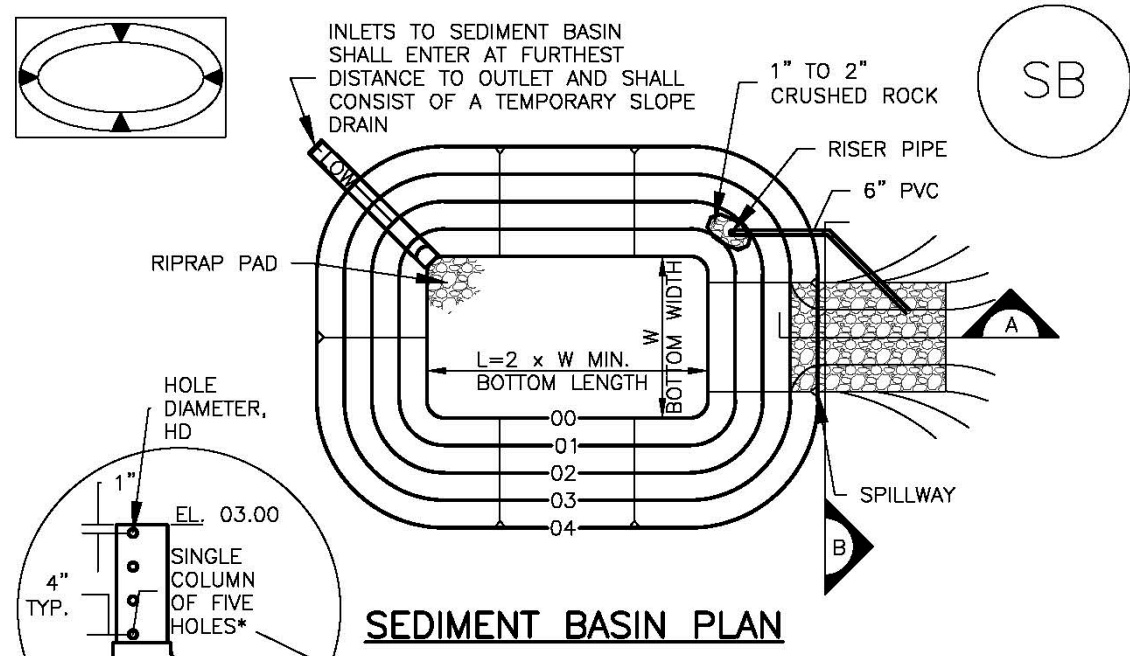

*EXCEPT WHERE THE HOLES EXCEED 1" DIAMETER, THEN UP TO TWO COLUMNS OF SAME SIZED HOLES MAY BE USED

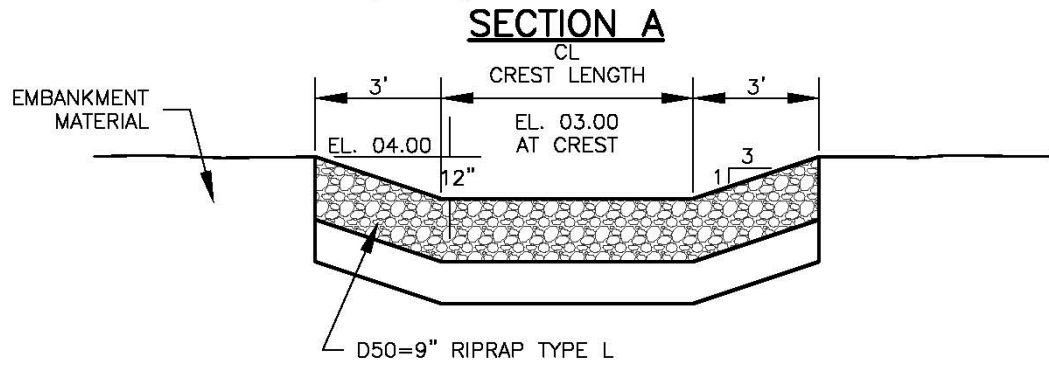
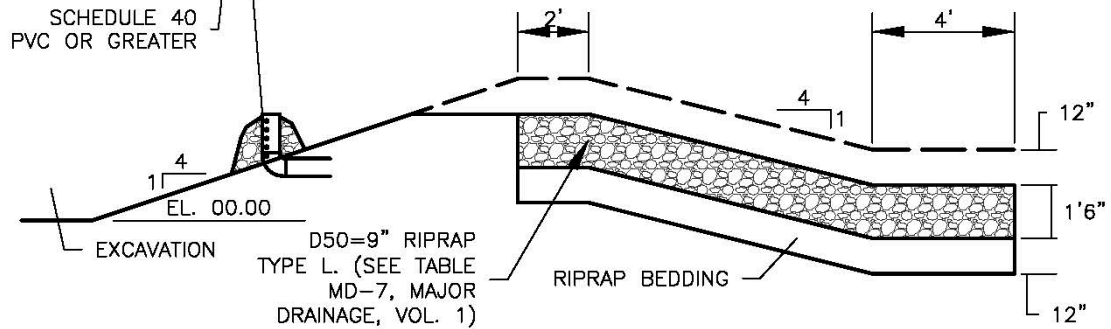

TABLE SB-1. SIZING INFORMATION FOR STANDARD SEDIMENT BASIN			
Upstream Drainage Area (rounded to nearest acre), (ac)	Basin Bottom Width (W), (ft)	Spillway Crest Length (CL), (ft)	Hole Diameter (HD), (in)
1	12 1/2	2	9/32
2	21	3	13/16
3	28	5	1/2
4	33 1/2	6	9/16
5	38 1/2	8	2 1/32
6	43	9	2 1/32
7	47 1/4	11	2 5/32
8	51	12	2 7/32
9	55	13	7/8
10	58 1/4	15	1 5/16
11	61	16	3 1/32
12	64	18	1
13	67 1/2	19	1 1/16
14	70 1/2	21	1 1/8
15	73 1/4	22	1 3/16

SEDIMENT BASIN INSTALLATION NOTES

1. SEE PLAN VIEW FOR:
 - LOCATION OF SEDIMENT BASIN.
 - TYPE OF BASIN (STANDARD BASIN OR NONSTANDARD BASIN).
 - FOR STANDARD BASIN, BOTTOM WIDTH W, CREST LENGTH CL, AND HOLE DIAMETER, HD.
 - FOR NONSTANDARD BASIN, SEE CONSTRUCTION DRAWINGS FOR DESIGN OF BASIN INCLUDING RISER HEIGHT H, NUMBER OF COLUMNS N, HOLE DIAMETER HD AND PIPE DIAMETER D.
2. FOR STANDARD BASIN, BOTTOM DIMENSION MAY BE MODIFIED AS LONG AS BOTTOM AREA IS NOT REDUCED.
3. SEDIMENT BASINS SHALL BE INSTALLED PRIOR TO ANY OTHER LAND-DISTURBING ACTIVITY THAT RELIES ON ON BASINS AS AS A STORMWATER CONTROL.
4. EMBANKMENT MATERIAL SHALL CONSIST OF SOIL FREE OF DEBRIS, ORGANIC MATERIAL, AND ROCKS OR CONCRETE GREATER THAN 3 INCHES AND SHALL HAVE A MINIMUM OF 15 PERCENT BY WEIGHT PASSING THE NO. 200 SIEVE.
5. EMBANKMENT MATERIAL SHALL BE COMPACTED TO AT LEAST 95 PERCENT OF MAXIMUM DENSITY IN ACCORDANCE WITH ASTM D698.
6. PIPE SCH 40 OR GREATER SHALL BE USED.
7. THE DETAILS SHOWN ON THESE SHEETS PERTAIN TO STANDARD SEDIMENT BASIN(S) FOR DRAINAGE AREAS LESS THAN 15 ACRES. SEE CONSTRUCTION DRAWINGS FOR EMBANKMENT, STORAGE VOLUME, SPILLWAY, OUTLET, AND OUTLET PROTECTION DETAILS FOR ANY SEDIMENT BASIN(S) THAT HAVE BEEN INDIVIDUALLY DESIGNED FOR DRAINAGE AREAS LARGER THAN 15 ACRES.

SEDIMENT BASIN MAINTENANCE NOTES

1. INSPECT BMPs EACH WORKDAY, AND MAINTAIN THEM IN EFFECTIVE OPERATING CONDITION. MAINTENANCE OF BMPs SHOULD BE PROACTIVE, NOT REACTIVE. INSPECT BMPs AS SOON AS POSSIBLE (AND ALWAYS WITHIN 24 HOURS) FOLLOWING A STORM THAT CAUSES SURFACE EROSION, AND PERFORM NECESSARY MAINTENANCE.
2. FREQUENT OBSERVATIONS AND MAINTENANCE ARE NECESSARY TO MAINTAIN BMPs IN EFFECTIVE OPERATING CONDITION. INSPECTIONS AND CORRECTIVE MEASURES SHOULD BE DOCUMENTED THOROUGHLY.
3. WHERE BMPs HAVE FAILED, REPAIR OR REPLACEMENT SHOULD BE INITIATED UPON DISCOVERY OF THE FAILURE.
4. SEDIMENT ACCUMULATED IN BASIN SHALL BE REMOVED AS NEEDED TO MAINTAIN BMP EFFECTIVENESS, TYPICALLY WHEN SEDIMENT DEPTH REACHES ONE FOOT (I.E., TWO FEET BELOW THE SPILLWAY CREST).
5. SEDIMENT BASINS ARE TO REMAIN IN PLACE UNTIL THE UPSTREAM DISTURBED AREA IS STABILIZED AND GRASS COVER IS ACCEPTED BY THE LOCAL JURISDICTION.
6. WHEN SEDIMENT BASINS ARE REMOVED, ALL DISTURBED AREAS SHALL BE COVERED WITH TOPSOIL, SEEDED AND MULCHED OR OTHERWISE STABILIZED AS APPROVED BY LOCAL JURISDICTION.

(DETAILS ADAPTED FROM DOUGLAS COUNTY, COLORADO)

NOTE: MANY JURISDICTIONS HAVE BMP DETAILS THAT VARY FROM UDFCD STANDARD DETAILS. CONSULT WITH LOCAL JURISDICTIONS AS TO WHICH DETAIL SHOULD BE USED WHEN DIFFERENCES ARE NOTED.

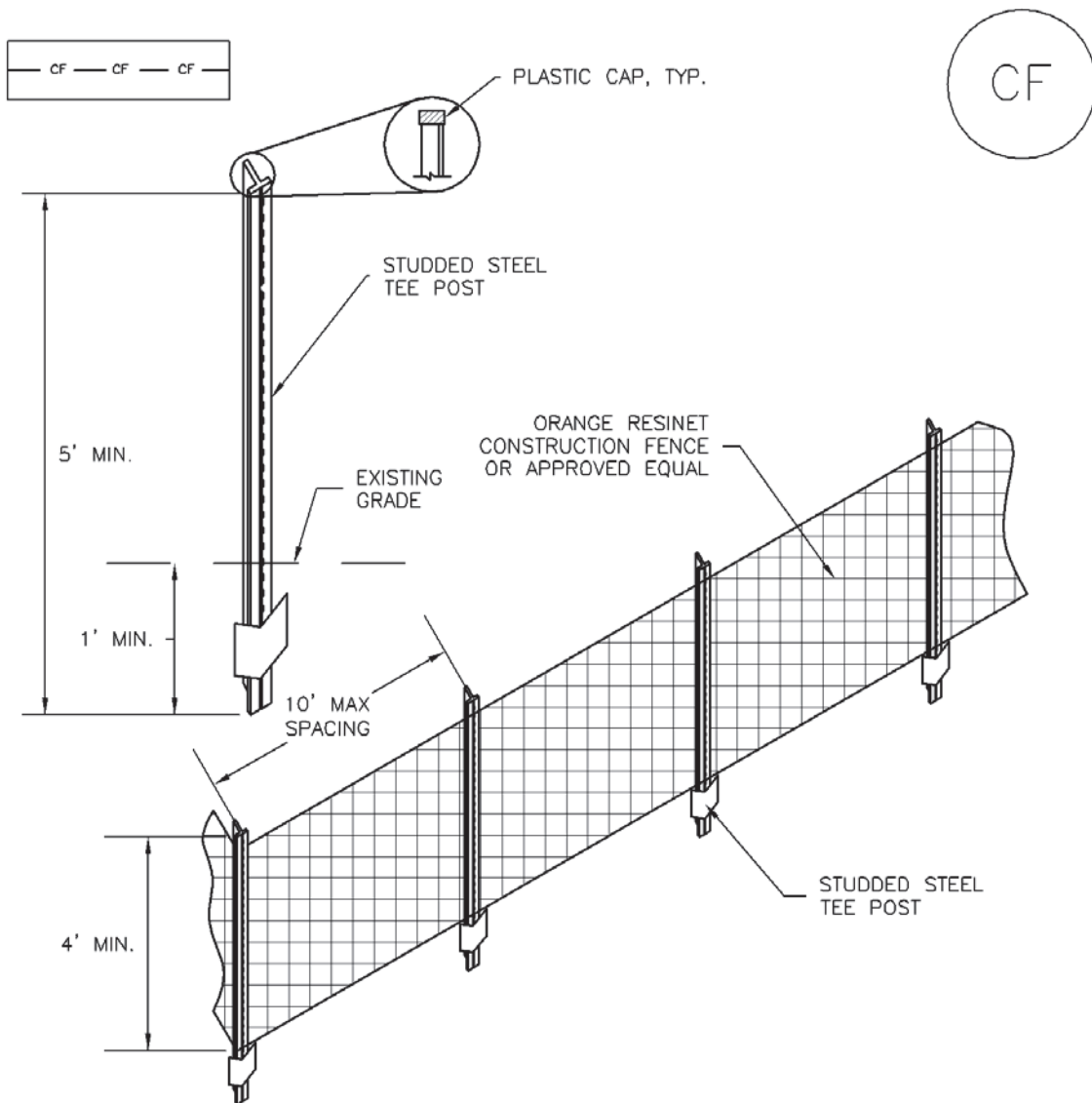

CF-1. PLASTIC MESH CONSTRUCTION FENCE

CONSTRUCTION FENCE INSTALLATION NOTES

1. SEE PLAN VIEW FOR:
-LOCATION OF CONSTRUCTION FENCE.
2. CONSTRUCTION FENCE SHOWN SHALL BE INSTALLED PRIOR TO ANY LAND DISTURBING ACTIVITIES.
3. CONSTRUCTION FENCE SHALL BE COMPOSED OF ORANGE, CONTRACTOR-GRADE MATERIAL THAT IS AT LEAST 4' HIGH. METAL POSTS SHOULD HAVE A PLASTIC CAP FOR SAFETY.
4. STUDED STEEL TEE POSTS SHALL BE UTILIZED TO SUPPORT THE CONSTRUCTION FENCE. MAXIMUM SPACING FOR STEEL TEE POSTS SHALL BE 10'.
5. CONSTRUCTION FENCE SHALL BE SECURELY FASTENED TO THE TOP, MIDDLE, AND BOTTOM OF EACH POST.

CONSTRUCTION FENCE MAINTENANCE NOTES

1. INSPECT BMPs EACH WORKDAY, AND MAINTAIN THEM IN EFFECTIVE OPERATING CONDITION. MAINTENANCE OF BMPs SHOULD BE PROACTIVE, NOT REACTIVE. INSPECT BMPs AS SOON AS POSSIBLE (AND ALWAYS WITHIN 24 HOURS) FOLLOWING A STORM THAT CAUSES SURFACE EROSION, AND PERFORM NECESSARY MAINTENANCE.
2. FREQUENT OBSERVATIONS AND MAINTENANCE ARE NECESSARY TO MAINTAIN BMPs IN EFFECTIVE OPERATING CONDITION. INSPECTIONS AND CORRECTIVE MEASURES SHOULD BE DOCUMENTED THOROUGHLY.
3. WHERE BMPs HAVE FAILED, REPAIR OR REPLACEMENT SHOULD BE INITIATED UPON DISCOVERY OF THE FAILURE.
4. CONSTRUCTION FENCE SHALL BE REPAIRED OR REPLACED WHEN THERE ARE SIGNS OF DAMAGE SUCH AS RIPS OR SAGS. CONSTRUCTION FENCE IS TO REMAIN IN PLACE UNTIL THE UPSTREAM DISTURBED AREA IS STABILIZED AND APPROVED BY THE LOCAL JURISDICTION.
5. WHEN CONSTRUCTION FENCES ARE REMOVED, ALL DISTURBED AREAS ASSOCIATED WITH THE INSTALLATION, MAINTENANCE, AND/OR REMOVAL OF THE FENCE SHALL BE COVERED WITH TOPSOIL, SEEDED AND MULCHED, OR OTHERWISE STABILIZED AS APPROVED BY LOCAL JURISDICTION.

NOTE: MANY JURISDICTIONS HAVE BMP DETAILS THAT VARY FROM UDFCD STANDARD DETAILS. CONSULT WITH LOCAL JURISDICTIONS AS TO WHICH DETAIL SHOULD BE USED WHEN DIFFERENCES ARE NOTED.

(DETAIL ADAPTED FROM TOWN OF PARKER, COLORADO, NOT AVAILABLE IN AUTOCAD)

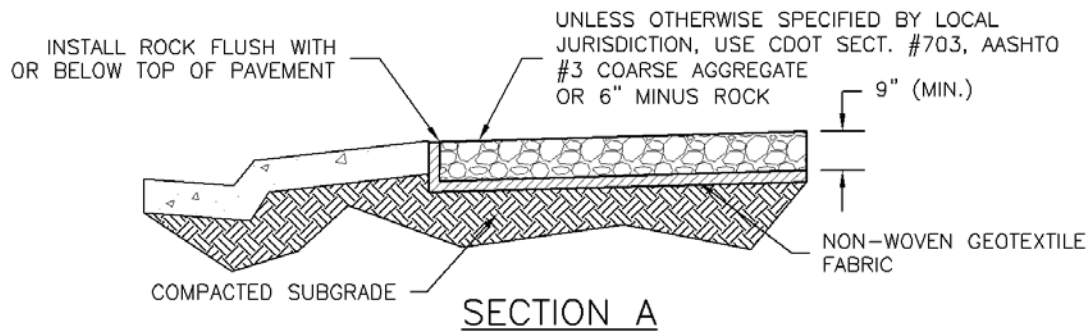
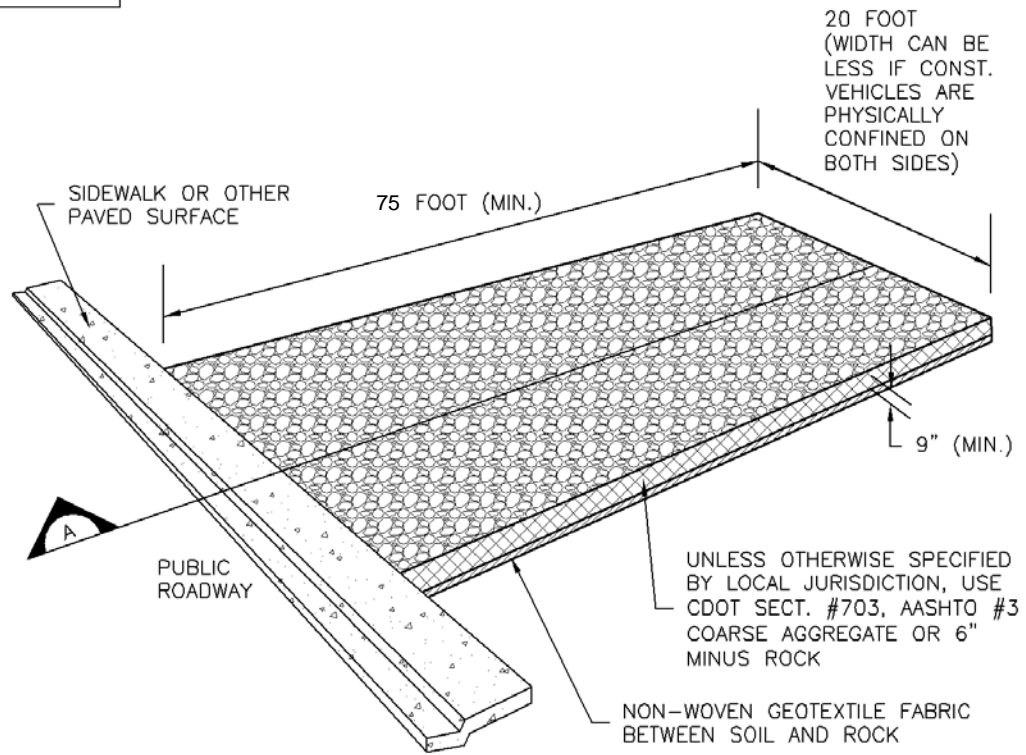
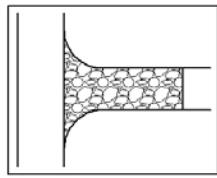

VTC-1. AGGREGATE VEHICLE TRACKING CONTROL

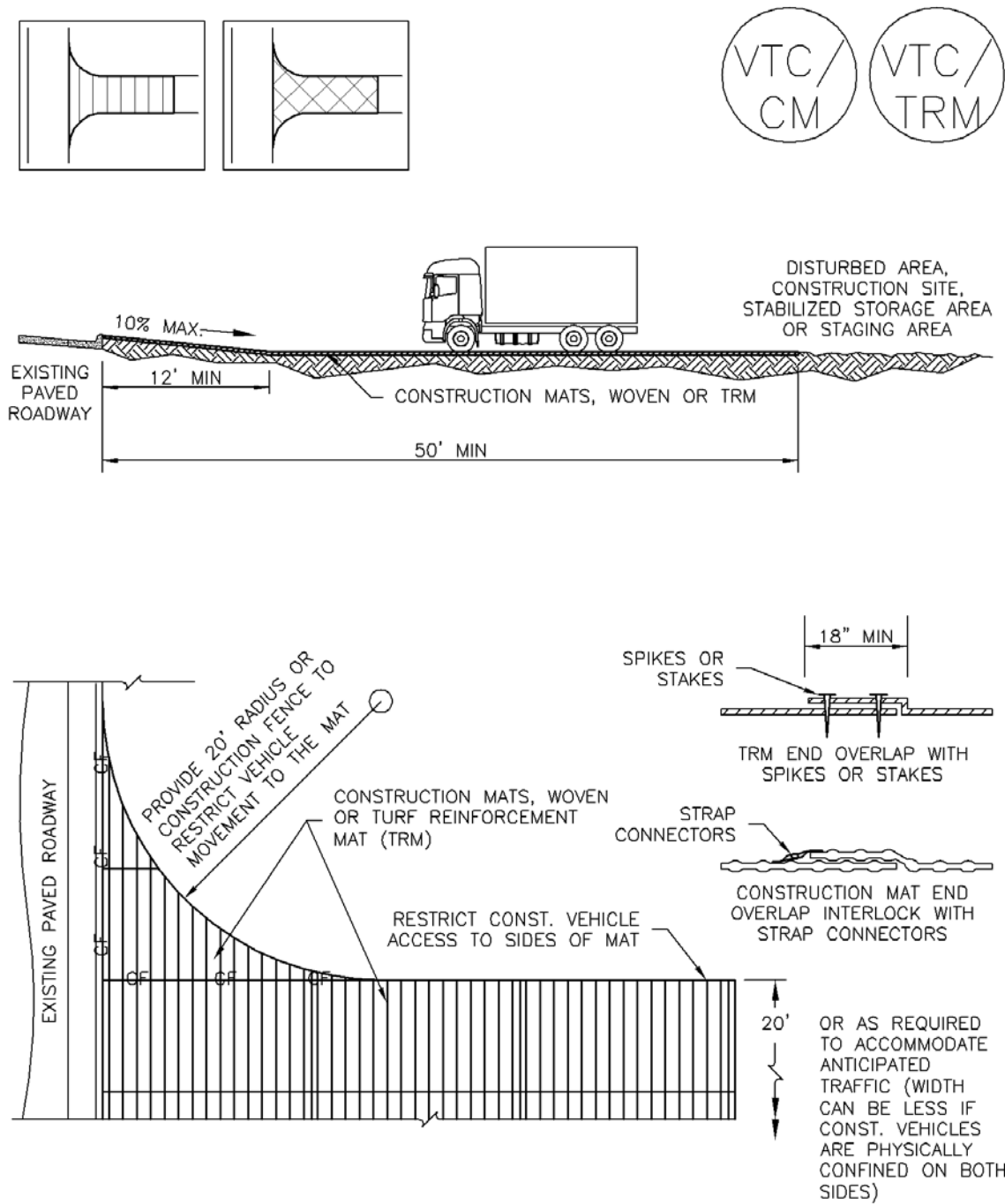

VTC-3. VEHICLE TRACKING CONTROL W/ CONSTRUCTION MAT OR TURF REINFORCEMENT MAT (TRM)

STABILIZED CONSTRUCTION ENTRANCE/EXIT INSTALLATION NOTES

1. SEE PLAN VIEW FOR
 - LOCATION OF CONSTRUCTION ENTRANCE(S)/EXIT(S).
 - TYPE OF CONSTRUCTION ENTRANCE(S)/EXITS(S) (WITH/WITHOUT WHEEL WASH, CONSTRUCTION MAT OR TRM).
2. CONSTRUCTION MAT OR TRM STABILIZED CONSTRUCTION ENTRANCES ARE ONLY TO BE USED ON SHORT DURATION PROJECTS (TYPICALLY RANGING FROM A WEEK TO A MONTH) WHERE THERE WILL BE LIMITED VEHICULAR ACCESS.
3. A STABILIZED CONSTRUCTION ENTRANCE/EXIT SHALL BE LOCATED AT ALL ACCESS POINTS WHERE VEHICLES ACCESS THE CONSTRUCTION SITE FROM PAVED RIGHT-OF-WAYS.
4. STABILIZED CONSTRUCTION ENTRANCE/EXIT SHALL BE INSTALLED PRIOR TO ANY LAND DISTURBING ACTIVITIES.
5. A NON-WOVEN GEOTEXTILE FABRIC SHALL BE PLACED UNDER THE STABILIZED CONSTRUCTION ENTRANCE/EXIT PRIOR TO THE PLACEMENT OF ROCK.
6. UNLESS OTHERWISE SPECIFIED BY LOCAL JURISDICTION, ROCK SHALL CONSIST OF DOT SECT. #703, AASHTO #3 COARSE AGGREGATE OR 6" (MINUS) ROCK.

STABILIZED CONSTRUCTION ENTRANCE/EXIT MAINTENANCE NOTES

1. INSPECT BMPs EACH WORKDAY, AND MAINTAIN THEM IN EFFECTIVE OPERATING CONDITION. MAINTENANCE OF BMPs SHOULD BE PROACTIVE, NOT REACTIVE. INSPECT BMPs AS SOON AS POSSIBLE (AND ALWAYS WITHIN 24 HOURS) FOLLOWING A STORM THAT CAUSES SURFACE EROSION, AND PERFORM NECESSARY MAINTENANCE.
2. FREQUENT OBSERVATIONS AND MAINTENANCE ARE NECESSARY TO MAINTAIN BMPs IN EFFECTIVE OPERATING CONDITION. INSPECTIONS AND CORRECTIVE MEASURES SHOULD BE DOCUMENTED THOROUGHLY.
3. WHERE BMPs HAVE FAILED, REPAIR OR REPLACEMENT SHOULD BE INITIATED UPON DISCOVERY OF THE FAILURE.
4. ROCK SHALL BE REAPPLIED OR REGRADED AS NECESSARY TO THE STABILIZED ENTRANCE/EXIT TO MAINTAIN A CONSISTENT DEPTH.
5. SEDIMENT TRACKED ONTO PAVED ROADS IS TO BE REMOVED THROUGHOUT THE DAY AND AT THE END OF THE DAY BY SHOVELING OR SWEEPING. SEDIMENT MAY NOT BE WASHED DOWN STORM SEWER DRAINS.

NOTE: MANY JURISDICTIONS HAVE BMP DETAILS THAT VARY FROM UDFCD STANDARD DETAILS. CONSULT WITH LOCAL JURISDICTIONS AS TO WHICH DETAIL SHOULD BE USED WHEN DIFFERENCES ARE NOTED.

(DETAILS ADAPTED FROM CITY OF BROOMFIELD, COLORADO, NOT AVAILABLE IN AUTOCAD)

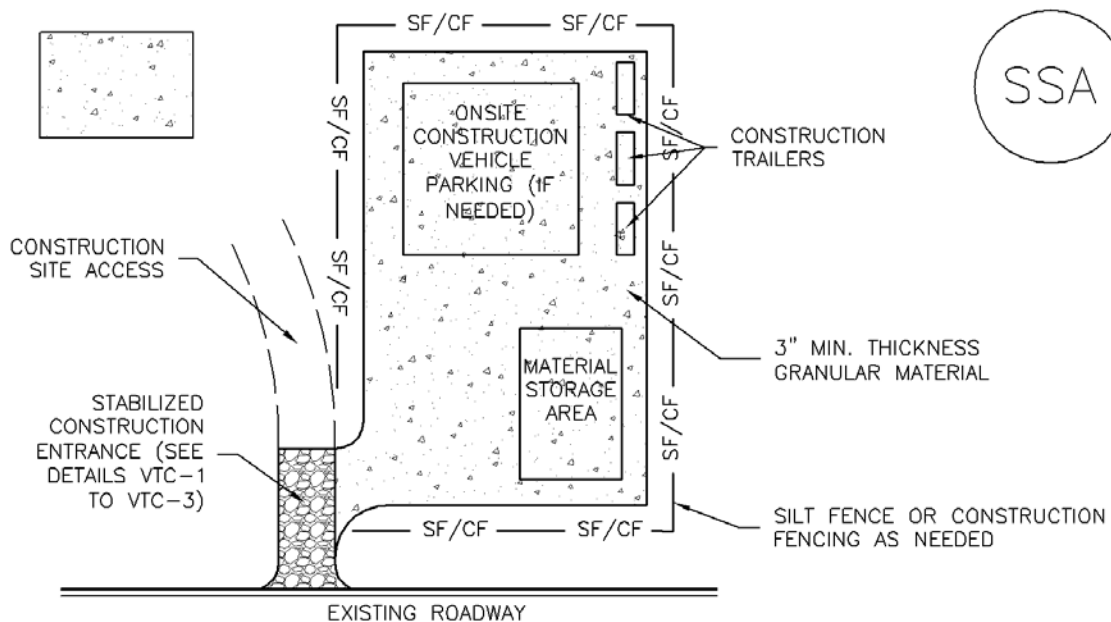

SSA-1. STABILIZED STAGING AREA

STABILIZED STAGING AREA INSTALLATION NOTES

1. SEE PLAN VIEW FOR
 - LOCATION OF STAGING AREA(S).
 - CONTRACTOR MAY ADJUST LOCATION AND SIZE OF STAGING AREA WITH APPROVAL FROM THE LOCAL JURISDICTION.
2. STABILIZED STAGING AREA SHOULD BE APPROPRIATE FOR THE NEEDS OF THE SITE. OVERSIZING RESULTS IN A LARGER AREA TO STABILIZE FOLLOWING CONSTRUCTION.
3. STAGING AREA SHALL BE STABILIZED PRIOR TO OTHER OPERATIONS ON THE SITE.
4. THE STABILIZED STAGING AREA SHALL CONSIST OF A MINIMUM 3" THICK GRANULAR MATERIAL.
5. UNLESS OTHERWISE SPECIFIED BY LOCAL JURISDICTION, ROCK SHALL CONSIST OF DOT SECT. #703, AASHTO #3 COARSE AGGREGATE OR 6" (MINUS) ROCK.
6. ADDITIONAL PERIMETER BMPs MAY BE REQUIRED INCLUDING BUT NOT LIMITED TO SILT FENCE AND CONSTRUCTION FENCING.

STABILIZED STAGING AREA MAINTENANCE NOTES

1. INSPECT BMPs EACH WORKDAY, AND MAINTAIN THEM IN EFFECTIVE OPERATING CONDITION. MAINTENANCE OF BMPs SHOULD BE PROACTIVE, NOT REACTIVE. INSPECT BMPs AS SOON AS POSSIBLE (AND ALWAYS WITHIN 24 HOURS) FOLLOWING A STORM THAT CAUSES SURFACE EROSION, AND PERFORM NECESSARY MAINTENANCE.
2. FREQUENT OBSERVATIONS AND MAINTENANCE ARE NECESSARY TO MAINTAIN BMPs IN EFFECTIVE OPERATING CONDITION. INSPECTIONS AND CORRECTIVE MEASURES SHOULD BE DOCUMENTED THOROUGHLY.
3. WHERE BMPs HAVE FAILED, REPAIR OR REPLACEMENT SHOULD BE INITIATED UPON DISCOVERY OF THE FAILURE.
4. ROCK SHALL BE REAPPLIED OR REGRADED AS NECESSARY IF RUTTING OCCURS OR UNDERLYING SUBGRADE BECOMES EXPOSED.

STABILIZED STAGING AREA MAINTENANCE NOTES

5. STABILIZED STAGING AREA SHALL BE ENLARGED IF NECESSARY TO CONTAIN PARKING, STORAGE, AND UNLOADING/LOADING OPERATIONS.

6. THE STABILIZED STAGING AREA SHALL BE REMOVED AT THE END OF CONSTRUCTION. THE GRANULAR MATERIAL SHALL BE REMOVED OR, IF APPROVED BY THE LOCAL JURISDICTION, USED ON SITE, AND THE AREA COVERED WITH TOPSOIL, SEEDED AND MULCHED OR OTHERWISE STABILIZED IN A MANNER APPROVED BY LOCAL JURISDICTION.

NOTE: MANY MUNICIPALITIES PROHIBIT THE USE OF RECYCLED CONCRETE AS GRANULAR MATERIAL FOR STABILIZED STAGING AREAS DUE TO DIFFICULTIES WITH RE-ESTABLISHMENT OF VEGETATION IN AREAS WHERE RECYCLED CONCRETE WAS PLACED.

NOTE: MANY JURISDICTIONS HAVE BMP DETAILS THAT VARY FROM UDFCD STANDARD DETAILS. CONSULT WITH LOCAL JURISDICTIONS AS TO WHICH DETAIL SHOULD BE USED WHEN DIFFERENCES ARE NOTED.

(DETAILS ADAPTED FROM DOUGLAS COUNTY, COLORADO, NOT AVAILABLE IN AUTOCAD)

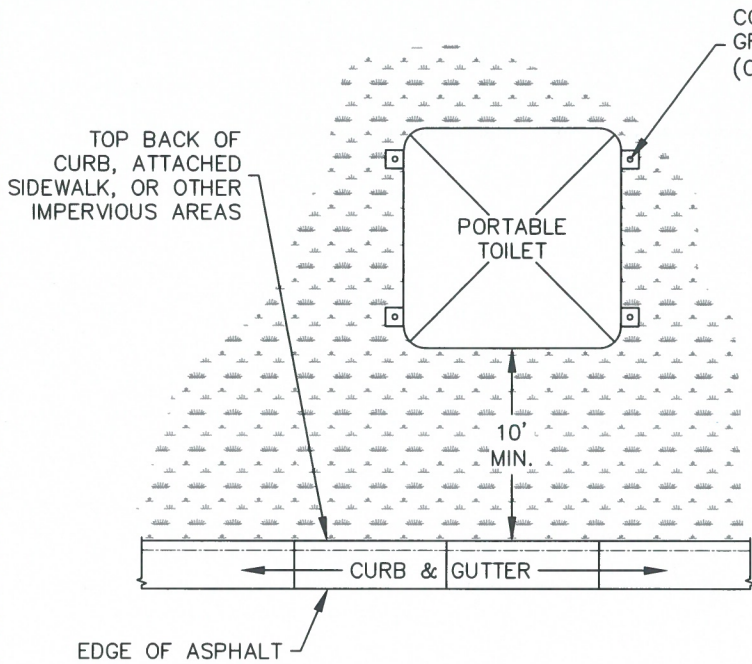

PORTABLE TOILET PLAN

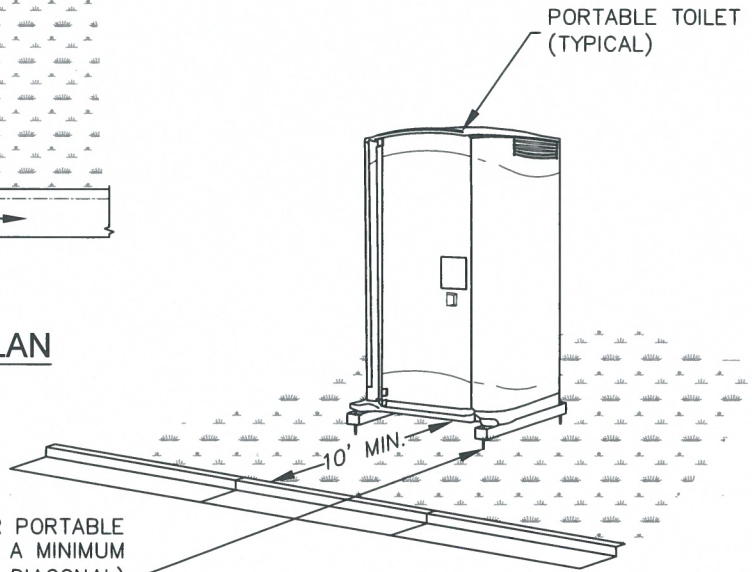

ISOMETRIC

CONTRACTOR SHALL ANCHOR PORTABLE TOILET TO THE GROUND, AT A MINIMUM OF TWO OPPOSING CORNERS (ON A DIAGONAL) USING U-SHAPED REBAR STAKES OR OTHER EFFECTIVE ANCHORING

INSTALLATION NOTES

1. PORTABLE TOILETS SHALL BE PLACED A MINIMUM OF 10 FEET BEHIND ALL CURBS, SIDEWALKS, AND OTHER IMPERVIOUS AREAS; 50 FEET FROM STORM INLETS, AND 100 FEET FROM WATERWAYS.
2. PORTABLE TOILETS IN THE RIGHT-OF-WAY ARE REQUIRED TO BE PLACED ON MOBILE TRAILERS AND MUST BE ANCHORED OR WEIGHTED DOWN. PORTABLE TOILETS MAY BE INSTALLED IN ACCORDANCE WITH NOTE #1 IN STAGING AREAS/YARDS.
3. PORTABLE TOILETS SHALL BE SECURELY ANCHORED TO THE GROUND USING U-SHAPED REBAR STAKES, OR OTHER EFFECTIVE ANCHORING.
4. ANCHORING SHALL BE POSITIONED ON AT LEAST TWO OPPOSING (DIAGONAL) CORNERS.
5. TOILET CONTAINMENT PANS MAY BE USED IN PLACE OF A TRAILER AT THE GEC INSPECTOR'S DISCRETION. TOILET CONTAINMENT PANS MUST BE ANCHORED IN PLACE AND MUST NOT BE USED WITHIN THE CITY R.O.W.

MAINTENANCE NOTES

1. FREQUENT OBSERVATIONS AND MAINTENANCE ARE NECESSARY TO MAINTAIN CONTROL MEASURES IN EFFECTIVE OPERATING CONDITION. INSPECTIONS AND CORRECTIVE MEASURES SHOULD BE DOCUMENTED THOROUGHLY.
2. PORTABLE TOILETS SHALL BE SERVICED AT THE NECESSARY INTERVALS TO ELIMINATE THE POSSIBILITY OF OVERFLOW.
3. WHEN THE PORTABLE TOILETS ARE REMOVED, ANY DISTURBED AREAS ASSOCIATED WITH THE INSTALLATION, MAINTENANCE, AND/OR REMOVAL OF THE TOILETS MUST BE PERMANENTLY STABILIZED.

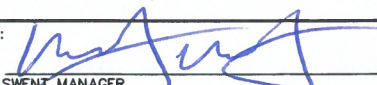

PORTABLE TOILET		
APPROVED: 		
SWENT MANAGER		
ISSUED: 2/19/19	REVISED: 8/19/2020	DRAWING NO. 900-PTM

APPENDIX F

EROSION AND STORMWATER QUALITY CONTROL PERMIT (ESQCP) EL PASO COUNTY APPLICATION AND PERMIT

APPLICANT INFORMATION

PERMIT NUMBER

Owner Information	
Owner	Great Dane Ventures, LLC
Name (person of responsibility)	Eva Robinson
Company/Agency	Great Dane Ventures
Position of Applicant	Managing Member
Address (physical address, not PO Box)	5903 High Noon Ave
City	Colorado Springs
State	CO
Zip Code	80923
Mailing address, if different from above	Same as above
Telephone	
FAX number	
Email Address	
Cellular Phone number	
Contractor/Operator Information	
Name (person of responsibility)	
Company	Hammers Construction
Address (physical address, not PO Box)	1411 Woolsey Heights
City	Colorado Springs
State	CO
Zip Code	80915
Mailing address, if different from above	Same as above
Telephone	719-570-1599
FAX number	719-570-7008
Email Address	
Cellular Phone number	
Erosion Control Supervisor (ECS)*	
ECS Phone number*	
ECS Cellular Phone number*	

*Required for all applicants. May be provided at later date pending securing a contract when applicable.

PROJECT INFORMATION

Project Information	
Project Name	Lot 2 Elm Grove Villa
Legal Description	Lot 2 Elm Grove Villa
Address (or nearest major cross streets)	1875 Main Street Colorado Springs, CO 80911
Acreage (total and disturbed)	Total: 1.51 acres Disturbed: 1.43 acres
Schedule	Start of Construction: August 2021 Completion of Construction: December 2021 Final Stabilization: Spring 2022
Project Purpose	Installation of supporting infrastructure including grading for a commercial building and parking area.
Description of Project	Lot 2 Elm Grove Villa will construct 12,000 sf office building with storage garages, along with an asphalt parking lot and associated infrastructure. The site is located east of Main Street and south of Bradley Road (a.k.a. Cable Lane) in Security, Co.
Tax Schedule Number	6501312002

FOR OFFICE USE ONLY

The following signature from the ECM Administrator signifies the approval of this ESQCP. All work shall be performed in accordance with the permit, the El Paso County Engineering Criteria Manual (ECM) Standards, City of Colorado Springs Drainage Criteria Manual, Volume 2 (DCM2) as adopted by El Paso County Addendum, approved plans, and any attached conditions. The approved plans are an enforceable part of the ESQCP. Construction activity, except for the installation of initial construction BMPs is not permitted until issuance of a Construction permit and Notice to Proceed.

Signature of ECM Administrator: _____

Date _____

1.1 REQUIRED SUBMISSIONS

In addition to this completed and signed application, the following items must be submitted to obtain an ESQCP:

- Permit fees
- Stormwater Management Plan (SWMP) meeting the requirements of DCM2 and ECM either as part of the plan set or as a separate document;
- Cost estimates of construction and maintenance of construction and permanent stormwater control measures (Cost estimates shall be provided on a unit cost basis for all stormwater BMPs);
- Financial surety in an amount agreeable to the ECM Administrator based on the cost estimates of the stormwater quality protection measures provided. The financial surety shall be provided in the form of a Letter of Credit, Surety with a Bonding Company, or other forms acceptable to El Paso County;
- Operation and Maintenance Plan for any proposed permanent stormwater control measures; and
- Signed Private Detention Basin/Stormwater Quality Best Management Practice Maintenance Agreement and Easement, if any permanent stormwater control measures are to be located on site.

1.2 RESPONSIBILITY FOR DAMAGE

The County and its officers and employees, including but not limited to the ECM Administrator, shall not be answerable or accountable in any manner, for injury to or death of any person, including but not limited to a permit holder, persons employed by the permit holder, persons acting in behalf of the permit holder, or for damage to property resulting from any activities undertaken by a permit holder or under the direction of a permit holder. The permit holder shall be responsible for any liability imposed by law and for injuries to or death of any person, including but not limited to the permit holder, persons employed by the permit holder, persons acting in behalf of the permit holder, or damage to property arising out of work or other activity permitted and done by the permit holder under a permit, or arising out of the failure on the permit holder's part to perform the obligations under any permit in respect to maintenance or any other obligations, or resulting from defects or obstructions, or from any cause whatsoever during the progress of the work, or other activity, or at any subsequent time work or other activity is being performed under the obligations provided by and contemplated by the permit.

To the extent allowed by law, the permit holder shall indemnify, save, and hold harmless the County and its officers and employees, including but not limited to the BOCC and ECM Administrator, from all claims, suits or actions of every name, kind and description brought for or on account of injuries to or death of any person, including but not limited to the permit holder, persons employed by the permit holder, persons acting in behalf of the permit holder and the public, or damage to property resulting from the performance of work or other activity under the permit, or arising out of the failure on the permit holder's part to perform his obligations under any permit in respect to maintenance or any other obligations, or resulting from defects or obstructions, or from any cause whatsoever during the progress of the work, or other activity or at any subsequent time work or other activity is being performed under the obligations provided by and contemplated by the permit, except as otherwise provided by state law. The permit holder waives any and all rights to any type of expressed or implied indemnity against the County, its officers or employees.

1.3 APPLICATION CERTIFICATION

We, as the Applicants or the representative of the Applicants, hereby certify that this application is correct and complete as per the requirements presented in this application and the El Paso County Engineering Criteria Manual and Drainage Criteria Manual, Volume 2 and El Paso County Addendum.

We, as the Applicants or the representatives of the Applicants, have read and will comply with all of the requirements of the specified Stormwater Management Plan and any other documents specifying stormwater best management practices to be used on the site including permit conditions that may be required by the ECM Administrator. We understand that the stormwater control measures are to be maintained on the site and revised as necessary to protect stormwater quality as the project progresses. We further understand that a Construction Permit must be obtained and all necessary stormwater quality control measures are to be installed in accordance with the SWMP, the El Paso County Engineering Criteria Manual, Drainage Criteria Manual, Volume 2 and El Paso County Addendum before land disturbance begins and that failure to comply will result in a Stop Work Order and may result in other penalties as allowed by law. We further understand and agree to indemnify, save, and hold harmless the County and its officers and employees, including but not limited to the BOCC and ECM Administrator, from all claims, suits or actions of every name, kind and description as outlined in Section 1.2 Responsibility for Damage.

Signature of Owner or Representative

Date: _____

Print Name of Owner or Representative

Signature of Owner or Representative

Date: _____

Print Name of Owner or Representative

Signature of Operator or Representative

Date: _____

Print Name of Operator or Representative

Permit Fee \$ _____

Surcharge \$ _____

Financial Surety \$ _____

Type of Surety _____

Total \$ _____