

# Stormwater Management Plan

## The Shire at Old Ranch (TSOR)

File Number: VA202

Parcels: 6223000058, 6223000059, 6223000060, 6223000061

Prepared for: KESS Properties

Mark Phelan  
4955 Austin Bluffs Parkway  
Colorado Springs, CO, 80918

Monica Phelan  
10755 Howells Rd.  
Colorado Springs, CO, 80908

Prepared by:

Kyle Katsos  
8050 Freemantle Dr.  
Colorado Springs, CO 80920

### **Qualified Stormwater Manager:**

Name: \_\_\_\_\_

Address: \_\_\_\_\_

Phone: \_\_\_\_\_

### **Contractor:**

Name: \_\_\_\_\_

Address: \_\_\_\_\_

Phone: \_\_\_\_\_

# Contents

- Introduction.....2**
- Project Overview.....3**
  - Site Description..... 3
  - Construction Activities..... 3
  - Sequence of Construction Activity..... 4
  - Area and Volume Estimates..... 4
  - Existing Soil..... 5
  - Existing Vegetation..... 5
  - Potential Stormwater Pollution Sources..... 5
  - Potential Non-Stormwater Runoff..... 6
  - Receiving Waters..... 6
- Best Management Practices (BMPs) for Managing Stormwater Quality..... 6**
  - Structural Erosion and Sediment Controls..... 6
  - Nonstructural Erosion and Sediment Controls..... 7
  - Material Handling and Spill Prevention..... 8
  - Final Stabilization and Long-Term Stormwater Management..... 8
  - Inspection and Maintenance..... 9
  - SWMP Revision Procedure..... 9
  - Batch Plants, Wetlands, and Control Measures by Others..... 10
- Appendix..... 12**

## Introduction

This Stormwater Management Plan (SWMP), mandated for Colorado Discharge Permit System certification, aligns with the State of Colorado's guidelines for construction-related stormwater discharges. Its objective is to identify and mitigate potential stormwater pollutants through Best Management Practices (BMPs), ensuring water quality protection. A current SWMP must be accessible on-site throughout construction and stabilization.

A designated SWMP Administrator (same as Qualified Stormwater Manager), appointed by the Permit Holder or their agent, will oversee SWMP implementation, maintenance, and revisions. This individual, potentially the Construction Project Manager, Owner, Site Superintendent, or otherwise appointed, serves as the primary contact for SWMP matters, equipped with the necessary knowledge and authority for effective stormwater quality management.

# Project Overview

## Site Description

The project is located east of the intersection of Powers Blvd and Old Ranch Road. It is bounded by Old Ranch Rd to the south, Howells Rd to the west, Ridgeway Ln. to the north and adjacent RR-5 properties to the east.

Township 12S Range 66 W SW4SW4 Sec 23 El Paso County, Colorado

These parcels are at the very southwest corner of the Black Forest and located within the Kettle Creek Drainage Basin. The land to the north and east of The Shire at Old Ranch (TSOR) has not been developed beyond large-lot residential uses.

There are no drainageways on our property and there are no indications of anything other than sheet flow entering or leaving the property.



The site comprises four contiguous 5 acre parcels. Each of the four properties has a single family residence with domestic wells and septic systems.

- 3820 Old Ranch Rd #6226000061
- 3890 Old Ranch Rd. #6226000060
- 10655 Howells Rd. #6226000059
- 10755 Howells Rd. #6226000058

## Construction Activities

Site preparation to include clearing and grubbing needed to establish perimeter controls. Installation of Initial BMPs to include silt fence, sediment control logs, stawbales, and vehicle

tracking control. Notify El Paso County for initial inspection. Rough grading of the interior of the site. Construction of proposed structures. Final grading of the site. Removal of temporary BMPs. Installation of proposed landscaping to include revegetation of disturbed areas. Achieve Final Stabilization.

## Sequence of Construction Activity

The planned sequence of construction is as follows:

1. Install all off-site erosion control measures; Silt Fences, Sediment Control Logs, Strawbales and Vehicle Tracking Control along downslope perimeter and protecting interior residential spaces.
2. Install all utilities that go under roads and to OWTS in the NW.
3. Grade the interior, generally including the entrance drives, the main loop road (less Habitat Way, far north loop) and commercial core area. Left ungraded for this phase is everything outside the main drive loop (Resilient Way) except entrance drives.
4. Build all drainage features as both short and long term stormwater management strategies with intermediate and final erosion control elements. This includes areas along the north, west and south sides. Silt fences would border downhill sides of grass lined swales and ponds. this is our primary erosion control strategy.
5. Buildings would be built sequentially beginning with the commercial core, specifically Co-op and attached Greenhouse.
6. Revegetate disturbed areas. This includes gardens and landscaping.
7. The three workshops (SW), northernmost greenhouse, the six energy independent habitations, animal barn, bath house and yurts will follow after the commercial core is functioning.

Construction scheduled to begin May 2024 with construction completed and final stabilization slated for completion by November 2030.

Building construction will proceed sequentially to minimize the amount of concurrent soil disturbance.

## Area and Volume Estimates

The Shire at Old Ranch encompasses 20.05 total acres. Within that total area, approximately 2.3 acres (21 separate bioretentions) will be built, sequentially, into bioretentions and re-stabilized immediately following initial silt fence installation.

The first phase of construction will encompass 5.05 acres including the main drive loop and commercial core. This area will also be constructed sequentially to minimize soil disturbance.

The second phase of construction will encompass 4.11 acres and include the remaining structures outside the commercial core. Construction will also proceed sequentially to minimize cumulative soil disturbance.

## Existing Soil

Discuss soil erosion potential and impacts to discharge along with describing the soil type.

Geotechnical exploration reveals a few inches of topsoil beneath which are fairly consistent fine sands, SW, SM. Sandstone was discovered at 13' in just one test hole in the upper reach (east side). All other test bores showed sand/silt down to 20' maximum test depth. Percolation tests have found the soil capable of infiltrating water at 1.18 to 1.67 inches/hour.

USDA identifies this soils as sandy loam with some sand-clay loam (Peyton-Pring). The soil has a hydrologic Group B classification and a capacity of the most limiting layer to be 2.0-6.0 inches/hour.

Areas to the east and north have similar soil (Group B) and slopes. There are no drainageways or structures on the property and there is no sign that anything other than sheet flow may have ever entered the property along the east side or flowed off this property.

The property is not within a designated floodplain and FEMA classifies our property as "Area of Minimal Flood Hazard"

## Existing Vegetation

The existing groundcover consists primarily of grasses in fair to good condition covering approximately 75% of the site as determined by visual observation. This will serve as a basis for determining final stabilization at the conclusion of the project. Photographs of existing vegetative ground cover may also be used to verify existing conditions.

Additionally, there are clusters of trees throughout the 20-acres consisting primarily of New Mexican Locust, Ponderosa Pine, Pinyon Pine, Gambel Oak, and Juniper. A wood mulch groundcover exists where trees are dense.

Shrubs varieties such as Goji berry, Elderberry, American Plum, Siberian Peashrub, Currant, Oregon Grape Holly, Lilac, and Juniper exist in abundance and will be kept.

Existing trees and shrubs are located outside of the disturbed construction area and will not require protections.

## Potential Stormwater Pollution Sources

Sediment resulting from erosion is the greatest risk for stormwater pollution. There is potential for sediment carrying stormwater to originate from several points across the site, and such runoff might deposit sediment onto any of the downhill roadways. Erosion control and sediment reduction measures will be implemented to mitigate potential pollution from sediment. Such measures are described in the Best Management Practices section.

No significant storage of chemicals will occur on site except small amounts of vehicle and equipment fuel and maintenance chemicals (oil, antifreeze, hydraulic fluid, etc.) may be stored on site, but all such materials will be stored in appropriately contained and managed facilities.

Chemicals released from vehicles and equipment may also be a source of stormwater pollution. No significant maintenance of vehicles and equipment and no vehicle and equipment washing may be performed on site “Rinsing of construction vehicles carrying concrete may only be performed in designated concrete rinse facilities.”

## Potential Non-Stormwater Runoff

Water from the rinsing of construction vehicles carrying concrete may be a potential source of non-stormwater runoff. The utilization of a mobile concrete rinse basin will mitigate the potential of such rinse water becoming a non-stormwater runoff source.

Temporary irrigation for the establishment of ground cover may also be a source of non-stormwater runoff from the site. This non-stormwater runoff is permitted under the Stormwater Construction Permit; however, appropriate irrigation practices will be used to limit the potential of runoff, and any runoff that does occur will be treated with the same control measures applied to stormwater runoff. Proper management of the irrigation schedules and duration will minimize excess irrigation runoff. The construction BMP's described below which are to remain in place until ground cover is established, as well as the permanent BMP's described below will mitigate the potential of such irrigation water becoming a non-stormwater runoff source.

## Receiving Waters

Discharge from the site flows westward into stormwater facilities of Northfork and Cordera. The ultimate receiving waters are Kettle Creek and subsequently Fountain Creek.

## Best Management Practices (BMPs) for Managing Stormwater Quality

This SWMP will cover both structural and non-structural BMPs for preventing pollution of stormwater. Erosion control BMPs will be utilized to prevent erosion and are considered primary and preferred for pollution prevention. Sediment controls will be considered secondary and utilized where erosion control practices are not possible or fully effective.

## Structural Erosion and Sediment Controls

Drainage swales will serve direct sheet flows to a system of distributed bioretentions. These swales will be constructed via cut berm method, unless contractor deems otherwise, and will be re-vegetated immediately following construction. The locations of swales are detailed on the SWMP Map, and details for the installation and maintenance of the drainage swales is included in the Appendix.

Prior to any other construction activities, vehicle tracking controls (VTC) will be installed at the construction site access point. Vehicle tracking control are identified on the SWMP Map and details for the installation and maintenance of the controls are included in the appendix.

Before any grading or significant disturbance occurs, silt fence will be installed along the downhill perimeters of the site and downhill from bioretentions. Silt fence locations are identified on the SWMP Map and details for the installation and maintenance of silt fences are included in the Appendix. In addition to silt fencing indicated on the SWMP Map, silt fences may be installed wherever the contractor deems them necessary or helpful.

bioretentions will be utilized extensively around the site to sequester sheet flows. The distributed bioretention concept will serve to capture and sink water close to where it falls before it has a chance to build volume or speed to create erosion. The location of bioretentions is identified on the SWMP Map and details for the installation and maintenance of bioretentions are included in the Appendix.

Sediment control logs will be utilized around the VTC and at the contractor's discretion to manage erosion and sedimentation. Sediment control logs may not be indicated on the SWMP Map, but their installation and maintenance is detailed in the Appendix nonetheless.

## Nonstructural Erosion and Sediment Controls

To minimize the total amount of soil exposed at any one time, construction activities will be phased as described in the Sequence of Construction Activity. Additionally, an undisturbed "buffer" will be preserved around as much of the site as possible to help control erosion and sediment laden runoff. The undisturbed buffer is continuous around the site with the exception of private residential driveways.

Before construction activities commence in any area of the site, the full layer of topsoil will be stripped only from the portions of that area that are to be disturbed and will be stockpiled in location identified on the SWMP Map. Rather than stripping topsoil from the entire site at once, as has been the traditional practice in some cases, topsoil will be stripped from particular areas of the site only as construction work progresses to that area as described in the above section Sequence of Construction Activity.

Soils stockpiled for more than 60 days will be seeded and mulched within 14 days of completion of stockpiling activities.

As seasonally appropriate, seeding will be conducted on disturbed areas immediately or within 14 days of completion of final grading. Seeding will also be completed on areas that have not reached final grade, but will remain dormant (undisturbed) for longer than 1 year.

## Material Handling and Spill Prevention

A rigorous “good housekeeping” program will be implemented across the site to further prevent stormwater pollution by materials used and stored on-site.

No significant storage of chemicals and other potentially pollutive materials will be allowed on site. Only those chemicals and materials necessary for the described construction activities may be stored on site, and then only in the smallest amounts reasonable and for the shortest time possible.

Portable toilets will be staked on all four corners to prevent blow over, and will be cleaned on a weekly or bi-weekly basis. Portable toilets must be installed on an appropriately leveled pad, which should be prepared prior to their arrival onsite.

No significant maintenance of vehicles and equipment and no vehicle and equipment washing will be performed on site.

Any spills of potential pollutants on the site related to the construction activities will be addressed according to the requirements of Colorado Department of Public Health and Environment, Hazardous Materials and Waste Management Division.

Appropriate spill prevention and response measures will be implemented on the site. The details and specifications referenced above in this section provide general and specific guidelines for spill prevention and response measures relating to the various potential non-sediment pollution sources.

No groundwater and/or stormwater dewatering activities are proposed or expected for the proposed construction activities.

No significant waste generation is expected as a result of the proposed construction activities.

Any minor waste that is produced will be disposed of properly.

SWMP Checklist Item 13. Discuss inspection procedure for checking waste disposal bins for leaks and overflowing capacity. And discuss frequency that they will be emptied (or at what level of capacity would trigger the need to be emptied).

## Final Stabilization and Long-Term Stormwater Management

According to the Stormwater Construction Permit “Final stabilization is reached when all soil disturbing activities at the site have been completed, and uniform vegetative cover has been established with a density of at least 70 percent of pre-disturbance levels or equivalent permanent, physical erosion reduction methods have been employed.” This level of coverage will be established concurrent with the forecasted construction completion date of November 2030. Revegetation will be achieved through the full implementation of the Landscape Plan to include tree and shrub planting, mulching, and seeding of disturbed areas.

Structural BMP’s detailed above and on the SWMP Map will remain in force until final stabilization is achieved. After BMPs are removed the resulting disturbed areas shall be seeded and mulched.

Discus Long-Term SW Management: There are proposed infiltration ponds designed to permanently treat the sites WQCV.



## Inspection and Maintenance

The primary purpose of a regular inspection is to “determine if there is evidence of, or the potential for, pollutants entering the drainage system.” The Stormwater Construction Permit mandates a thorough inspection of the stormwater management system at least every 14 days, and after any precipitation or snowmelt event that causes stormwater runoff across the ground. This frequency is the minimum requirement, with more frequent inspections and maintenance of the stormwater management system typically necessary for effectively reducing pollutants in stormwater discharges from construction sites. Accordingly, the site will undergo weekly inspections and additional inspections post-precipitation or snowmelt events causing runoff.

The inspections will cover the construction site perimeter, stormwater discharge points including storm drain system inlets and culverts, and the implementation of BMPs like inlet protection, site entrance vehicle tracking controls, silt fences, straw bale barriers, and straw bale check structures. The inspections also extend to observing disturbed areas, stabilized and revegetated areas with a focus on potential erosion issues, material storage areas to check for leaks and spills, and the efficiency of runoff management around topsoil stockpiles. Concrete rinse facilities and all structural BMPs on site will be closely examined during each inspection to ensure they continue to meet design and operational standards and effectively control pollutants.

signatures, (SWMP Checklist Item 25)

After each inspection, necessary repairs and preventative maintenance will be conducted on BMPs to maintain their functionality. If a BMP is found ineffective in preventing pollutant discharge despite being in good repair, it will be promptly modified or supplemented with additional measures.

An Inspection Log, maintained on site, will document all inspections of the stormwater management system, maintenance, and repair activities of BMPs. This log will include records of any non-compliance incidents, such as uncontrolled pollutant discharges, along with measures taken for cleanup and prevention of future discharges. It will also contain records of any spills, leaks, or overflows of potential pollutants, regardless of whether these incidents result in stormwater pollution. Following inspections that reveal no non-compliance, or after addressing any issues of non-compliance, a Certification confirming the site's compliance will be signed and dated. Regular maintenance of the Inspection Log and Certification forms part of this SWMP's ongoing commitments. A template for the Inspection Log can be found at the beginning of the Appendix.

## SWMP Revision Procedure

The SWMP needs updating to accurately mirror the current conditions on-site whenever there are changes in BMPs or other site factors. Such changes can include the removal or addition of BMPs, identification of new sources of potential pollutants, alterations in the installation, implementation, or maintenance of BMPs, and updates to the site map or descriptions. Updates

to the SWMP should ideally be done before any changes occur on-site, except in the case of urgent modifications, which are outlined as follows:

The person in charge of the SWMP will be a Qualified Stormwater Manager (QSM), who is also referred to as the SWMP Administrator. This individual is tasked with the SWMP's implementation, maintenance, and updates. The SWMP Administrator will manually update the Site Map on a full-size hard copy to reflect any additions, deletions, or alterations to BMPs. The QSM's qualifications will adhere to the standards set forth in the Engineering Criteria Manual Appendix I.5.2.A.

Revisions to the SWMP must be carried out immediately after on-field adjustments to BMP installation or implementation to rectify issues. If changes require the development of new materials for the SWMP (like designing a retention pond's capacity), these revisions should be done as quickly as possible, but no later than 72 hours after the changes.

The SWMP is considered a dynamic document that undergoes continual review and updates. This process is a key part of effectively managing stormwater quality issues at the site and is managed by the SWMP Administrator.

## Batch Plants, Wetlands, and Control Measures by Others

This project will not feature any dedicated batch plants on site. Additionally, it does not include springs, streams, wetlands, or other surface waters, nor areas necessitating the maintenance of pre-existing vegetation within 50 feet of receiving waters. Control measures for this project will not depend on operation by external entities.



# Appendix

COLORADO DEPARTMENT OF TRANSPORTATION STORMWATER FIELD INSPECTION REPORT - ACTIVE CONSTRUCTION			
(1) Project Name:	(2) Project Contractor:	(3) SWMP Administrator (Qualified Stormwater Manager) Erosion Control Inspector:	
(4) CDOT Project Engineer/CDOT Designee:	(5) Other Attendee(s) (Name and Title):		
(6) CDOT Project Number:	(7) Project Code (Sub Account #):	(8) CDPS-SCP Certification#:	(9) CDOT Region:
(10) Date of Project Inspection:	(11) Weather at Time of Inspection:		

## (12) REASON FOR INSPECTION / EXCLUSION

Routine Inspection: (A routine erosion control inspection shall be conducted at a minimum, once every 7 Calendar Days)

Runoff Event: (Post-storm event inspections must be conducted within 24 hours after the end of any precipitation or snowmelt event that causes surface erosion. If no construction activities will occur following a storm event, post-storm event inspections shall be conducted prior to re-commencing construction activities, but no later than 72 hours following the storm event. The occurrence of any such delayed inspection must be documented in the inspection record.) Routine inspections still must be conducted every 7 calendar days.  
Storm Start Date: \_\_\_\_\_ Approximate End Time of Storm (hrs): \_\_\_\_\_

Third Party Request: Winter Conditions Inspections Exclusion: Inspections are not required at sites where construction activities are temporarily halted, snow cover exists over the **entire site** for an extended period, **and melting conditions posing a risk of surface erosion do not exist**. This exception is applicable only during the period where **melting conditions do not exist**, and applies to the routine 7-day inspections, as well as the post-storm-event inspections. If **visual inspection** of the site verifies that all of these conditions are satisfied, document the conditions in section 17 (General Notes) and proceed to section 18 (Inspection Certification). Documentation must include: dates when snow cover existed, date when construction activities ceased, and date when melting conditions began.

Other:

## (13) SWMP MANAGEMENT

	Yes	No	N/A	(g) Reason for N/A
(a) Is the SWMP located on site?	<input type="checkbox"/>	<input type="checkbox"/>	<input type="checkbox"/>	
(b) Are changes to the SWMP documents noted and approved?	<input type="checkbox"/>	<input type="checkbox"/>	<input type="checkbox"/>	
(c) Are the inspection reports retained in the SWMP?	<input type="checkbox"/>	<input type="checkbox"/>	<input type="checkbox"/>	
(d) Are corrective actions from the last inspection completed?	<input type="checkbox"/>	<input type="checkbox"/>	<input type="checkbox"/>	
(e) Is the Spill Response Plan updated in the SWMP?	<input type="checkbox"/>	<input type="checkbox"/>	<input type="checkbox"/>	
(f) Is a list of potential pollutants updated in the SWMP?	<input type="checkbox"/>	<input type="checkbox"/>	<input type="checkbox"/>	

## (14) CURRENT CONSTRUCTION ACTIVITIES

(a) Describe current phase of construction activities

(b) Estimate of disturbed area at the time of the inspection, use guidance found in 208.04 (e):

	Acres	Notes
Temporary Stabilization (includes areas of vertically tracked and/or surface roughened temporary stabilizing surface treatments) +		
Interim Stabilization (spray on soil tackifier such as organic mulch tackifier, bonded fiber matrix, wood cellulose fiber with tackifier, etc.) +		
Permanent Stabilization (includes areas of permanent seeding that have not achieved 70% of pre-disturbance vegetation levels) +		
Other (Includes ground disturbing, clearing and grubbing, materials storage, equipment staging, haul roads) +		
Total acres of disturbance (includes cumulative total number of acres including: temporary, interim, permanent stabilized and other) =		

(c) Has the SWMP Phased Control Measure Implementation Matrix been updated?  Yes  No

(15) CONSTRUCTION SITE ASSESSMENT & CORRECTIVE ACTIONS **\*\*Off-site Pollutant Discharges are a Violation of the Permit and Reason for Immediate Project Suspension\*\***

The Construction Site Boundary/Limits of Construction (LOC), all disturbed areas, designated haul roads, material and/or waste storage areas that are exposed to precipitation, discharge locations, and locations where vehicles exit the site shall be inspected for evidence of, or the potential for, pollutants leaving the LOC, entering the stormwater drainage system, or discharging to State waters. If there is evidence of sediment or other pollutants discharging from the site, see section 16 (Construction Site Assessment).

All erosion and sediment control practices identified in the SWMP shall be evaluated to ensure that they are maintained and operating correctly. Identify the condition of the control measure, using more than one letter if necessary: (I) Inadequate control measure; (M) Maintenance is needed; (A) Additional control measure is needed; (R) Remove control measure. Keep copies of this blank page for additional room if needed.

Continuous maintenance is required on all control measures. As per CDP5-SCP: "Control measures that are not operating effectively, have proven to be inadequate, or have failed must be addressed as soon as possible, immediately in most cases."

Location	Control Measure	Condition	Comments: Description of Corrective Action and Preventative Measure Taken	Date Completed & Initials

**(16) CONSTRUCTION SITE ASSESSMENT    \*\*Off-site Pollutant Discharges are a Violation of the Permit and Reason for Immediate Project Suspension\*\***

- (a) Is there evidence of discharge of sediment or other pollutants from the site?     Yes     No  
 \*If yes, explain the discharge, the location and the associated corrective actions in section 15 (Construction Site Assessment & Corrective Actions) or section 18 (General Notes).
- (b) Has sediment or other pollutants discharging from the site reached State waters?     Yes     No  
 \*If yes, see subsection 208.03(c) and Part I.L.6 of the permit for reporting requirements.

**(17) GENERAL NOTES**

**(18) INSPECTION CERTIFICATION**

By signing this form, I certify that I attended the inspection in accordance with specification 208.03.

Contractor's SWMP Administrator (Qualified Stormwater Manager)

Print Name:

Signature Required:

Date:

Contractor's Erosion Control Inspector (If Needed):

Print Name:

Signature (if needed)

Date:

**(19) COMPLIANCE CERTIFICATION**

I verify that, to the best of my knowledge and belief, that if any corrective action items were identified during the inspection, those corrective actions are complete, and the site is currently in compliance with the permit (Part I.A.3.f.i).

Contractor's SWMP Administrator/ECI

Print Name:

Signature Required:

Date:

Contractor's Superintendent/Approved Designee

Print Name:

Signature Required:

Date:

CDOT Project Engineer/CDOT Designee

Print Name:

Signature Required:

Date:

## Stormwater Management Field Inspection Report Instructions

**State waters** are defined to be any and all surface and subsurface waters which are contained in or flow through the state, including, streams, rivers, lakes, drainage ditches, storm drains, ground water, and wetlands, but not including waters in sewage systems, waters in treatment works of disposal systems, waters in potable water distribution systems, and all water withdrawn for use until use and treatment have been completed. (Per subsection 107.25 and 25-8-103 (19) CRS)

- (3) **SWMP Administrator (Qualified Stormwater Manager) and Erosion Control Inspector:** Indicate the name(s) of the individual responsible for implementing, maintaining and revising the SWMP. An Erosion Control Inspector(s) may be the SWMP Administrator in projects with not more than 40 acres of disturbance (see 208.03(c)).
- (4) **CDOT Project Engineer/CDOT Designee:** Indicate the name of the CDOT representative performing the inspection with the SWMP Administrator/Erosion Control Inspector(s). This person should be the Project Engineer or an authorized representative.
- (9) **CDPS-SCP Certification #:** Indicate the Colorado Discharge Permit System (CDPS) Stormwater Construction Permit (SCP) (for Stormwater Discharges Associated with Construction Activities) certification number, issued by CDPHE, for the project which the report is being completed. Certification number can be found on the first page of the SCP.
- (12) **Reason(s) for Inspection / Exclusion:** Indicate the purpose for the inspection or exclusion. These inspections are required to comply with the CDOT Specifications and the CDPS-SCP.
- Routine Inspections. These inspections are required at least every 7 calendar days during active construction. Suspended projects require the 7 calendar day inspection unless snow cover exists over the entire site for an extended period of time, and melting conditions do not exist (see, Winter Conditions Inspections Exclusions).  Runoff Event Inspection for Active Sites. See page 1 for definition.
  - Third Party Request. Indicate the name of the third party requesting the inspection and, if known, the reason the request was made.
  - Winter Conditions Inspections Exclusions. See page 1 for definition. An inspection does not need to be completed, but use this form to document the conditions that meet the Exclusion.  Other. Specify any other reason(s) that resulted in the inspection.
- (13) **SWMP Management:** Review the SWMP records and documents and use a ✓ to answer the question. To comply with CDOT Standard Specifications and the CDPS-SCP, all of the items identified must be adhered to. If No is checked, indicate the necessary corrective action in section 15 (Construction Site Assessment & Corrective Actions). Specification 208.03(d).
- a) A copy of the SWMP must be retained on site, unless another location (specified by the permit) is approved by the Division.
  - b) Indicate all changes that have been made to any portion of the SWMP documents during construction. Changes shall be dated and signed at the time of occurrence. Amendments may include items listed in subsection 208.03(d).
  - c) The SWMP Administrator shall keep a record of inspections. Inspection reports must identify any incidents of noncompliance with the terms and conditions of the CDOT specifications or the CDPS-SCP. Inspection records must be retained for three years from expiration or inactivation of permit coverage.
  - d) Are corrective actions from the last inspection completed? Is a description of the corrective action(s), the date(s) of the corrective action(s), and the measure(s) taken to prevent future violations (including changes to the SWMP, as necessary) documented?
  - e) Subsection 208.06(c) requires that a Spill Response Plan be developed and implemented to establish operating procedures and that the necessary employee training be provided to minimize accidental releases of pollutants that can contaminate stormwater runoff. Records of spills, leaks or overflows that result in the discharge of pollutants must be documented and maintained. Information that should be recorded for all occurrences include the time and date, weather conditions, reasons for spill, etc. Some spills may need to be reported to the Water Quality Control Division immediately.
  - f) Subsection 107.25(b)6 requires the Erosion Control Supervisor to identify and describe all potential pollutant sources, including materials and activities, and evaluate them for the potential to contribute pollutants to stormwater discharge.
  - g) If N/A is checked for any of the items (a) through (f), indicate why in the space provided, if additional space is needed indicate in section 17 (General Notes).

## Stormwater Management Field Inspection Report Instructions (continued)

### (14) Current Construction Activities:

- a) Provide a short description of the current construction activities/phase at the project site; include summary of grading activities, installation of utilities, paving, excavation, landscaping, etc.
  - (1) Estimate of disturbed area at the time of the inspection, use guidance found in 208.04 (e). Estimate the acres of disturbed area at the time of the inspection. Include clearing, grading, excavation activities, areas receiving overburden (e.g. stockpiles), demolition areas and areas with heavy equipment/vehicle traffic, installation of new or improved haul roads and access roads, staging areas, borrow areas and storage that will disturb existing vegetative cover. (Areas that have been: hard armored or paved should not be counted for total disturbance).
- b) Has the Phased control measure Implementation Matrix on the SWMP been updated? As part of the inspection the Phased control measure Implementation matrix for both the structural and non-structural control measures found at the beginning of the SWMP sheets must be reviewed to ensure that "In use on site" box is checked for control measures currently in use at the time of the inspection.

### (15) Construction Site Assessment & Corrective Actions: Inspect the construction site and indicate where control measure feature(s) identified in section 13 (SWMP Management), require corrective action. Erosion and sediment control practices identified in the SWMP shall be evaluated to ensure that they are operating correctly.

- Condition. Identify the condition of the control measure, using more than one letter (identified in section 15) if necessary.
- Location. Site location (e.g., project station number, mile marker, intersection quadrant, etc.).
- Control measure. Indicate the type of control measure at this location that requires corrective action (e.g., silt fence, erosion logs, soil retention blankets, etc.).
- Date Completed & Initials. Date and initial when the corrective action was completed and the preventative measure statement finished.
- Description of Corrective Action and Preventative Measure Taken. Provide the proposed corrective action needed to bring the area or control measure into compliance. Once corrective actions are completed, state the measures taken to prevent future violations and ensure that the control measures are operating correctly, including the required changes made to the SWMP.

**Inadequate control measure:** Is any control measure that is not designed or implemented in accordance with the requirements of the permit and/or any control measure that is not implemented to operate in accordance with its design, this includes control measures that have not been implemented for pollution sources. If it is infeasible to install or repair the control measure immediately after discovering the deficiency the reason must be documented and a schedule included to return the control measure to effective operating condition as soon as possible.

**Control measures requiring routine maintenance:** Any control measure that is still operating in accordance with its design and the requirements of the permit, but requires maintenance to prevent a breach of the control measure. These items are not subject to the corrective action requirements as specified in Part I.b.1.c of the permit.

**Additional:** Any control measure inadequate for its application or an area with insufficient control measure(s). If it is infeasible to install revised or additional control measure(s) immediately after discovering the deficiency the reason must be documented and a schedule included to return the control measure to effective operating condition as soon as possible.

**Remove:** Control measure no longer necessary

### (16) Construction Site Assessment: Was there any off site discharge of sediment at this site since the last inspection?

- a) Is there evidence of discharge of sediment or other pollutants from the site? **Off-site pollutant discharges are a violation of the permit.** (The construction site perimeter, all disturbed areas, material and/or waste storage areas that are exposed to precipitation, discharge locations, and locations where vehicles access the site shall be inspected for evidence of, or the potential for, pollutants leaving the construction site boundaries, entering the stormwater drainage system).
- b) Are pollutants discharging to State water?
- c) Has sediment or other pollutants discharging from the site reached State waters? **Off-site pollutant discharges are a violation of the permit.** If off site discharge has occurred, explain the discharge and the corrective actions in section 15 (Construction Site Assessment & Corrective Actions) or section 17 (General Notes).



- (17) General Notes: Indicate any additional notes that add detail to the inspection; this may include positive practices noted on the project.
- (18) Inspection Certification: In accordance with 208.03, required personnel shall sign to verify that they were in attendance.
- (19) Compliance Certification: After all corrections have been made, this signature must be completed in accordance with Part I.A.3.f of the CDPS-SCP.

## Description

Earth dikes and drainage swales are temporary storm conveyance channels constructed either to divert runoff around slopes or to convey runoff to additional sediment control BMPs prior to discharge of runoff from a site. Drainage swales may be lined or unlined, but if an unlined swale is used, it must be well compacted and capable of resisting erosive velocities.

## Appropriate Uses

Earth dikes and drainage swales are typically used to control the flow path of runoff at a construction site by diverting runoff around areas prone to erosion, such as steep slopes. Earth dikes and drainage swales may also be constructed as temporary conveyance features. This will direct runoff to additional sediment control treatment BMPs, such as sediment traps or basins.



**Photograph ED/DS-1.** Example of an earth dike used to divert flows at a construction site. Photo courtesy of CDOT.

## Design and Installation

When earth dikes are used to divert water for slope protection, the earth dike typically consists of a horizontal ridge of soil placed perpendicular to the slope and angled slightly to provide drainage along the contour. The dike is used in conjunction with a swale or a small channel upslope of the berm to convey the diverted water. Temporary diversion dikes can be constructed by excavation of a V-shaped trench or ditch and placement of the fill on the downslope side of the cut. There are two types of placement for temporary slope diversion dikes:

- A dike located at the top of a slope to divert upland runoff away from the disturbed area and convey it in a temporary or permanent channel.
- A diversion dike located at the base or mid-slope of a disturbed area to intercept runoff and reduce the effective slope length.

Depending on the project, either an earth dike or drainage swale may be more appropriate. If there is a need for cut on the project, then an excavated drainage swale may be better suited. When the project is primarily fill, then a conveyance constructed using a berm may be the better option.

**All dikes or swales receiving runoff from a disturbed area should direct stormwater to a sediment control BMP such as a sediment trap or basin.**

<b>Earth Dikes and Drainage Swales</b>	
<b>Functions</b>	
Erosion Control	Yes
Sediment Control	Moderate
Site/Material Management	No

# **EC-10      Earth Dikes and Drainage Swales (ED/DS)**

---

**Unlined dikes or swales should only be used for intercepting sheet flow runoff and are not intended for diversion of concentrated flows.**

Details with notes are provided for several design variations, including:

ED-1. Unlined Earth Dike formed by Berm

DS-1. Unlined Excavated Swale

DS-2. Unlined Swale Formed by Cut and Fill

DS-3. ECB-lined Swale

DS-4. Synthetic-lined Swale

DS-5. Riprap-lined Swale

The details also include guidance on permissible velocities for cohesive channels if unlined approaches will be used.

## **Maintenance and Removal**

Inspect earth dikes for stability, compaction, and signs of erosion and repair. Inspect side slopes for erosion and damage to erosion control fabric. Stabilize slopes and repair fabric as necessary. If there is reoccurring extensive damage, consider installing rock check dams or lining the channel with riprap.

If drainage swales are not permanent, remove dikes and fill channels when the upstream area is stabilized. Stabilize the fill or disturbed area immediately following removal by revegetation or other permanent stabilization method approved by the local jurisdiction.

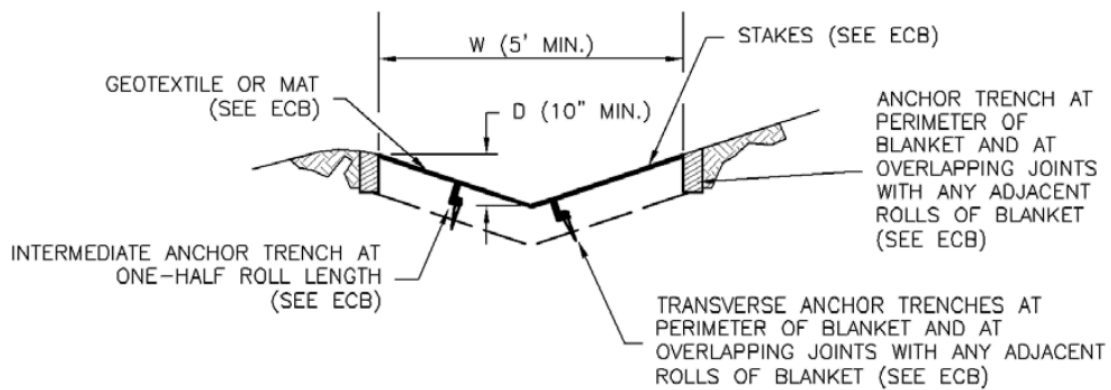
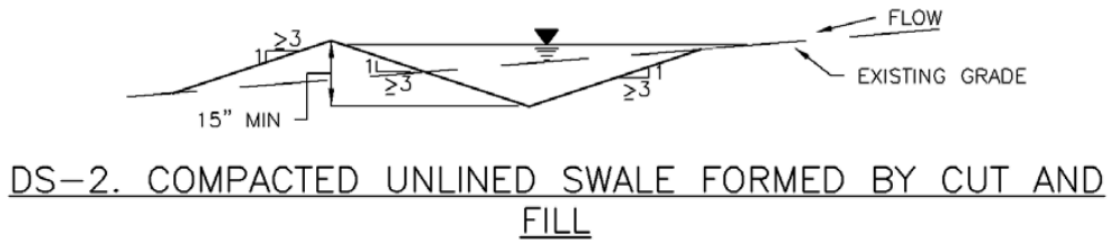
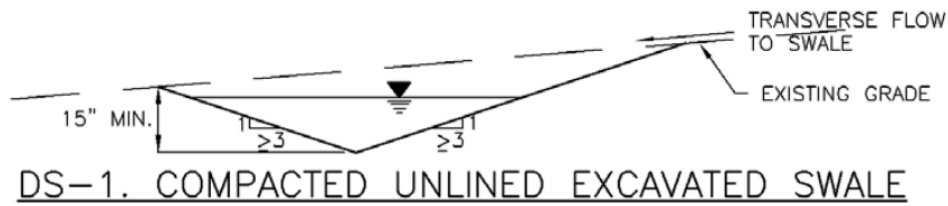
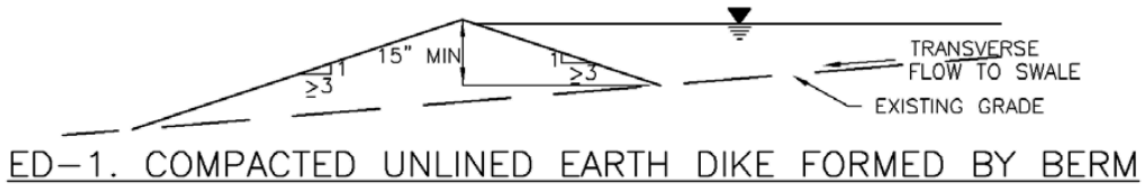
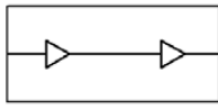

# EC-10 Earth Dikes and Drainage Swales (ED/DS)

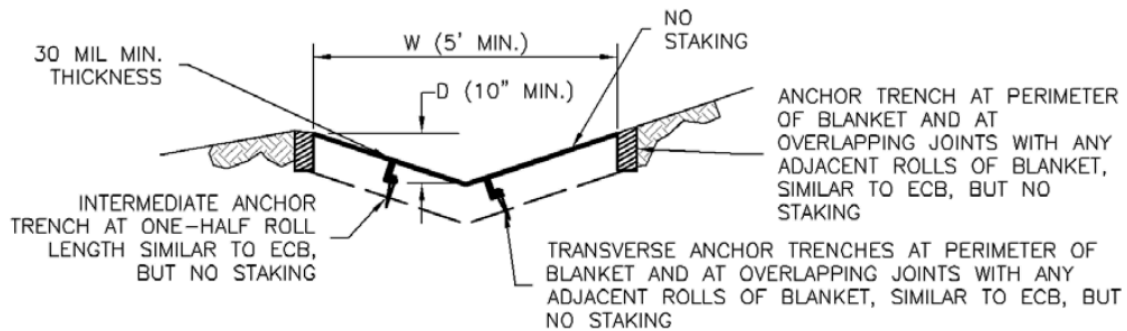

DS-4. SYNTHETIC LINED SWALE

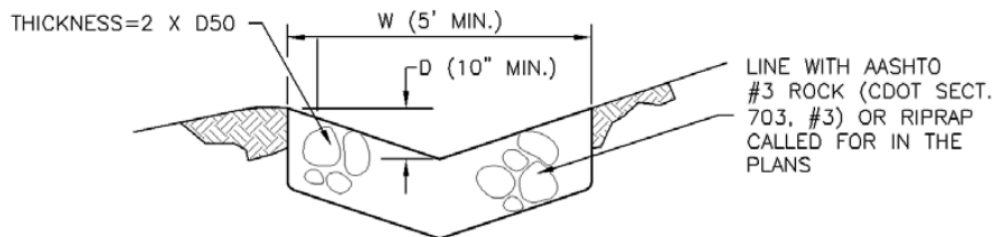

DS-5. RIPRAP LINED SWALE

## EARTH DIKE AND DRAINAGE SWALE INSTALLATION NOTES

1. SEE SITE PLAN FOR:
  - LOCATION OF DIVERSION SWALE
  - TYPE OF SWALE (UNLINED, COMPACTED AND/OR LINED).
  - LENGTH OF EACH SWALE.
  - DEPTH, D, AND WIDTH, W DIMENSIONS.
  - FOR ECB/TRM LINED DITCH, SEE ECB DETAIL.
  - FOR RIPRAP LINED DITCH, SIZE OF RIPRAP, D50.
2. SEE DRAINAGE PLANS FOR DETAILS OF PERMANENT CONVEYANCE FACILITIES AND/OR DIVERSION SWALES EXCEEDING 2-YEAR FLOW RATE OR 10 CFS.
3. EARTH DIKES AND SWALES INDICATED ON SWMP PLAN SHALL BE INSTALLED PRIOR TO LAND-DISTURBING ACTIVITIES IN PROXIMITY.
4. EMBANKMENT IS TO BE COMPACTED TO 90% OF MAXIMUM DENSITY AND WITHIN 2% OF OPTIMUM MOISTURE CONTENT ACCORDING TO ASTM D698.
5. SWALES ARE TO DRAIN TO A SEDIMENT CONTROL BMP.
6. FOR LINED DITCHES, INSTALLATION OF ECB/TRM SHALL CONFORM TO THE REQUIREMENTS OF THE ECB DETAIL.
7. WHEN CONSTRUCTION TRAFFIC MUST CROSS A DIVERSION SWALE, INSTALL A TEMPORARY CULVERT WITH A MINIMUM DIAMETER OF 12 INCHES.

## EARTH DIKE AND DRAINAGE SWALE MAINTENANCE NOTES

1. INSPECT BMPs EACH WORKDAY, AND MAINTAIN THEM IN EFFECTIVE OPERATING CONDITION. MAINTENANCE OF BMPs SHOULD BE PROACTIVE, NOT REACTIVE. INSPECT BMPs AS SOON AS POSSIBLE (AND ALWAYS WITHIN 24 HOURS) FOLLOWING A STORM THAT CAUSES SURFACE EROSION, AND PERFORM NECESSARY MAINTENANCE.
2. FREQUENT OBSERVATIONS AND MAINTENANCE ARE NECESSARY TO MAINTAIN BMPs IN EFFECTIVE OPERATING CONDITION. INSPECTIONS AND CORRECTIVE MEASURES SHOULD BE DOCUMENTED THOROUGHLY.
3. WHERE BMPs HAVE FAILED, REPAIR OR REPLACEMENT SHOULD BE INITIATED UPON DISCOVERY OF THE FAILURE.
4. SWALES SHALL REMAIN IN PLACE UNTIL THE END OF CONSTRUCTION; IF APPROVED BY LOCAL JURISDICTION, SWALES MAY BE LEFT IN PLACE.
5. WHEN A SWALE IS REMOVED, THE DISTURBED AREA SHALL BE COVERED WITH TOPSOIL, SEEDED AND MULCHED OR OTHERWISE STABILIZED IN A MANNER APPROVED BY LOCAL JURISDICTION.

(DETAIL ADAPTED FROM DOUGLAS COUNTY, COLORADO AND THE CITY OF COLORADO SPRINGS, COLORADO, NOT AVAILABLE IN AUTOCAD)

NOTE: MANY JURISDICTIONS HAVE BMP DETAILS THAT VARY FROM UDFCD STANDARD DETAILS. CONSULT WITH LOCAL JURISDICTIONS AS TO WHICH DETAIL SHOULD BE USED WHEN DIFFERENCES ARE NOTED.

## Description

Vehicle tracking controls provide stabilized construction site access where vehicles exit the site onto paved public roads. An effective vehicle tracking control helps remove sediment (mud or dirt) from vehicles, reducing tracking onto the paved surface.



**Photograph VTC-1.** A vehicle tracking control pad constructed with properly sized rock reduces off-site sediment tracking.

## Appropriate Uses

Implement a stabilized construction entrance or vehicle tracking control where frequent heavy vehicle traffic exits the construction site onto a paved roadway. An effective vehicle tracking control is particularly important during the following conditions:

- Wet weather periods when mud is easily tracked off site.
- During dry weather periods where dust is a concern.
- When poorly drained, clayey soils are present on site.

Although wheel washes are not required in designs of vehicle tracking controls, they may be needed at particularly muddy sites.

## Design and Installation

Construct the vehicle tracking control on a level surface. Where feasible, grade the tracking control towards the construction site to reduce off-site runoff. Place signage, as needed, to direct construction vehicles to the designated exit through the vehicle tracking control. There are several different types of stabilized construction entrances including:

**VTC-1. Aggregate Vehicle Tracking Control.** This is a coarse-aggregate surfaced pad underlain by a geotextile. This is the most common vehicle tracking control, and when properly maintained can be effective at removing sediment from vehicle tires.

**VTC-2. Vehicle Tracking Control with Construction Mat or Turf Reinforcement Mat.** This type of control may be appropriate for site access at very small construction sites with low traffic volume over vegetated areas. Although this application does not typically remove sediment from vehicles, it helps protect existing vegetation and provides a stabilized entrance.

<b>Vehicle Tracking Control</b>	
<b>Functions</b>	
Erosion Control	Moderate
Sediment Control	Yes
Site/Material Management	Yes

**VTC-3. Stabilized Construction Entrance/Exit with Wheel Wash.** This is an aggregate pad, similar to VTC-1, but includes equipment for tire washing. The wheel wash equipment may be as simple as hand-held power washing equipment to more advanced proprietary systems. When a wheel wash is provided, it is important to direct wash water to a sediment trap prior to discharge from the site.

Vehicle tracking controls are sometimes installed in combination with a sediment trap to treat runoff.

## Maintenance and Removal

Inspect the area for degradation and replace aggregate or material used for a stabilized entrance/exit as needed. If the area becomes clogged and ponds water, remove and dispose of excess sediment or replace material with a fresh layer of aggregate as necessary.

With aggregate vehicle tracking controls, ensure rock and debris from this area do not enter the public right-of-way.

Remove sediment that is tracked onto the public right of way daily or more frequently as needed. Excess sediment in the roadway indicates that the stabilized construction entrance needs maintenance.

Ensure that drainage ditches at the entrance/exit area remain clear.

A stabilized entrance should be removed only when there is no longer the potential for vehicle tracking to occur. This is typically after the site has been stabilized.

When wheel wash equipment is used, be sure that the wash water is discharged to a sediment trap prior to discharge. Also inspect channels conveying the water from the wash area to the sediment trap and stabilize areas that may be eroding.

When a construction entrance/exit is removed, excess sediment from the aggregate should be removed and disposed of appropriately. The entrance should be promptly stabilized with a permanent surface following removal, typically by paving.



**Photograph VTC-2.** A vehicle tracking control pad with wheel wash facility. Photo courtesy of Tom Gore.



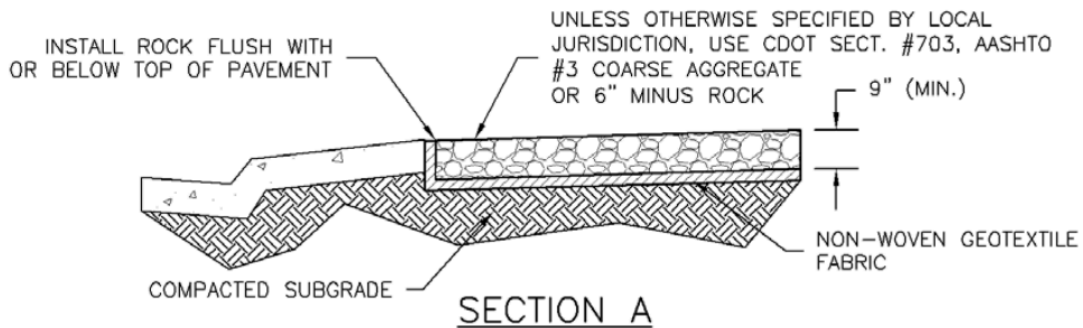
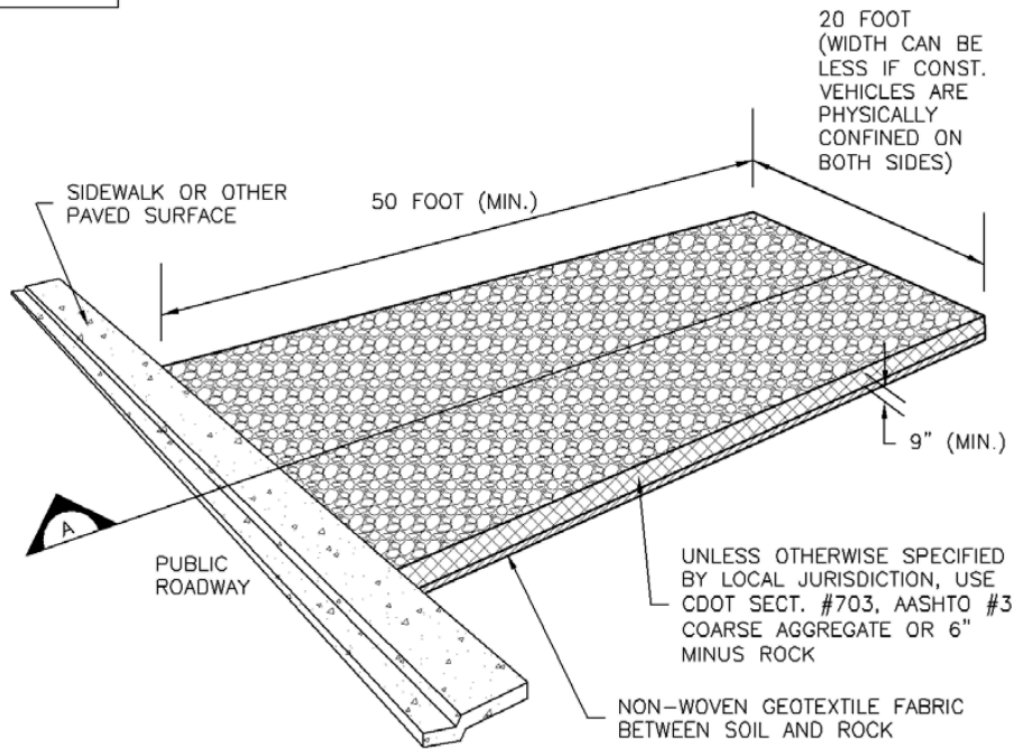
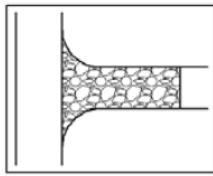

## VTC-1. AGGREGATE VEHICLE TRACKING CONTROL

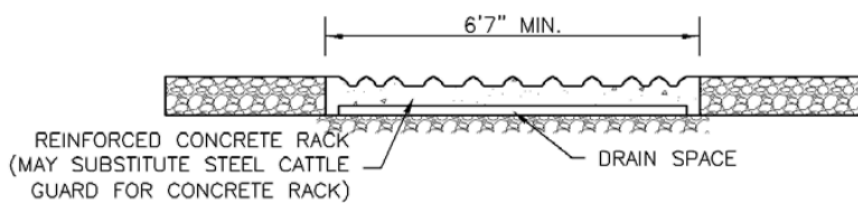
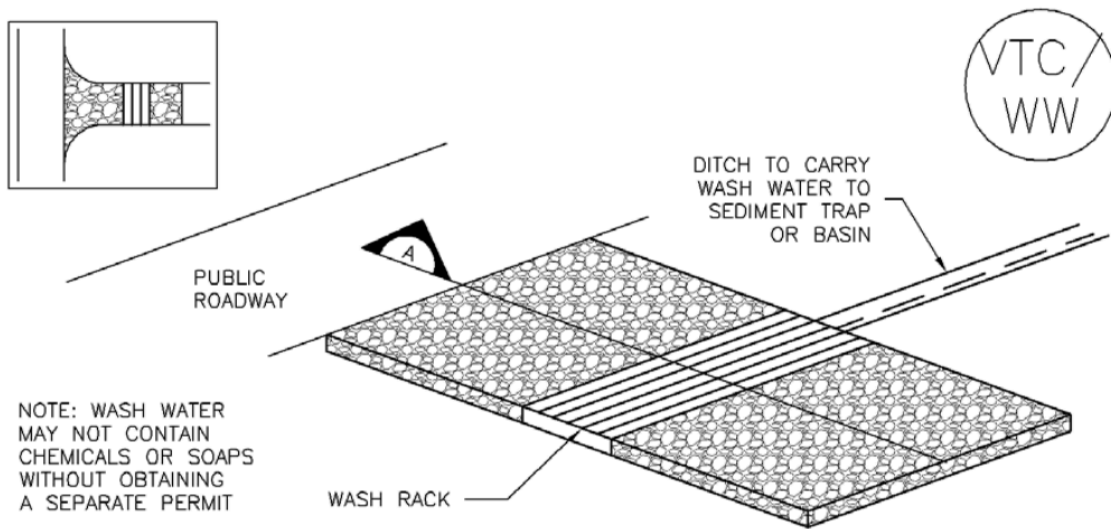

SECTION A

VTC-2. AGGREGATE VEHICLE TRACKING CONTROL WITH WASH RACK

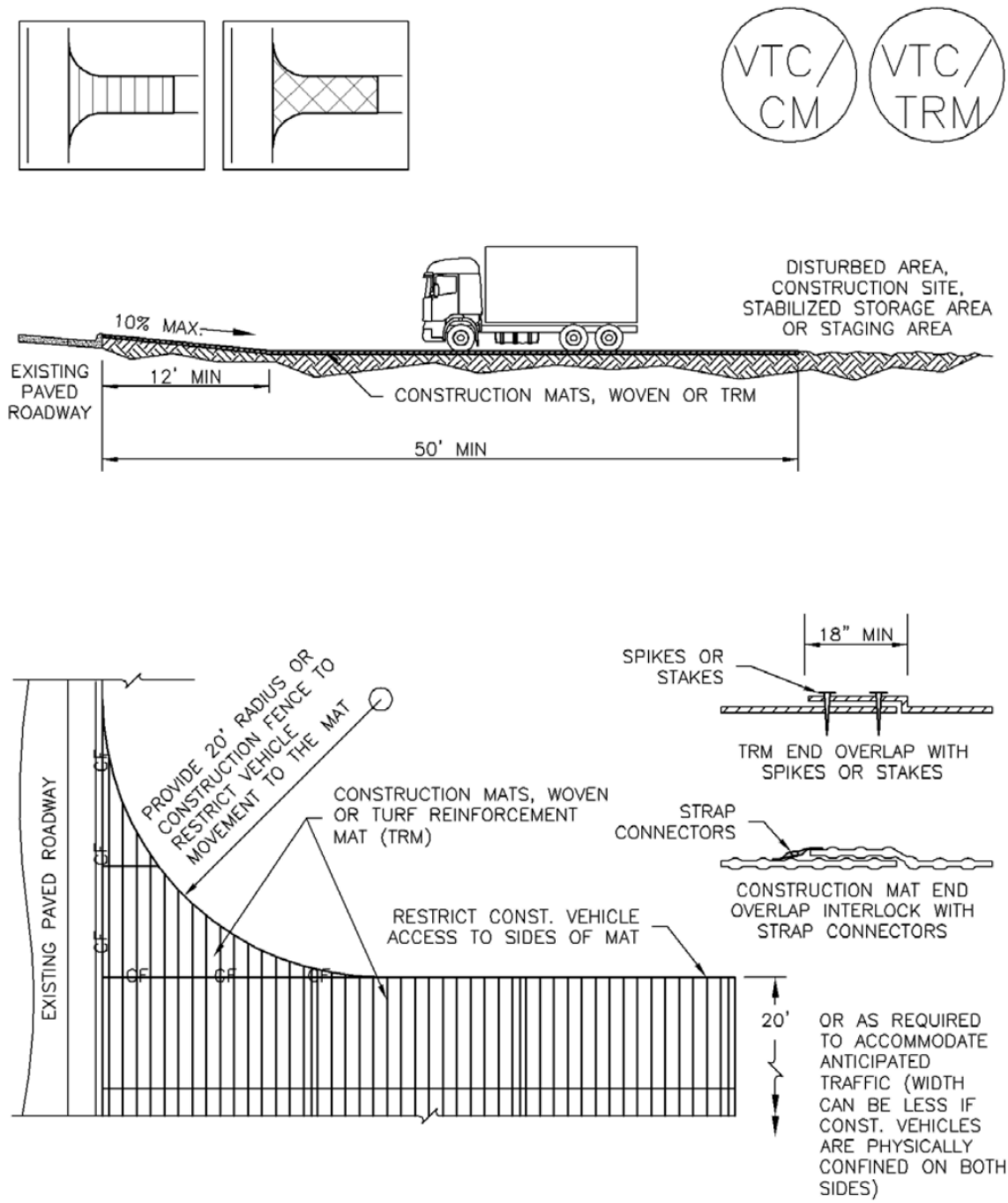

## VTC-3. VEHICLE TRACKING CONTROL W/ CONSTRUCTION MAT OR TURF REINFORCEMENT MAT (TRM)

STABILIZED CONSTRUCTION ENTRANCE/EXIT INSTALLATION NOTES

1. SEE PLAN VIEW FOR
  - LOCATION OF CONSTRUCTION ENTRANCE(S)/EXIT(S).
  - TYPE OF CONSTRUCTION ENTRANCE(S)/EXITS(S) (WITH/WITHOUT WHEEL WASH, CONSTRUCTION MAT OR TRM).
2. CONSTRUCTION MAT OR TRM STABILIZED CONSTRUCTION ENTRANCES ARE ONLY TO BE USED ON SHORT DURATION PROJECTS (TYPICALLY RANGING FROM A WEEK TO A MONTH) WHERE THERE WILL BE LIMITED VEHICULAR ACCESS.
3. A STABILIZED CONSTRUCTION ENTRANCE/EXIT SHALL BE LOCATED AT ALL ACCESS POINTS WHERE VEHICLES ACCESS THE CONSTRUCTION SITE FROM PAVED RIGHT-OF-WAYS.
4. STABILIZED CONSTRUCTION ENTRANCE/EXIT SHALL BE INSTALLED PRIOR TO ANY LAND DISTURBING ACTIVITIES.
5. A NON-WOVEN GEOTEXTILE FABRIC SHALL BE PLACED UNDER THE STABILIZED CONSTRUCTION ENTRANCE/EXIT PRIOR TO THE PLACEMENT OF ROCK.
6. UNLESS OTHERWISE SPECIFIED BY LOCAL JURISDICTION, ROCK SHALL CONSIST OF DOT SECT. #703, AASHTO #3 COARSE AGGREGATE OR 6" (MINUS) ROCK.

STABILIZED CONSTRUCTION ENTRANCE/EXIT MAINTENANCE NOTES

1. INSPECT BMPs EACH WORKDAY, AND MAINTAIN THEM IN EFFECTIVE OPERATING CONDITION. MAINTENANCE OF BMPs SHOULD BE PROACTIVE, NOT REACTIVE. INSPECT BMPs AS SOON AS POSSIBLE (AND ALWAYS WITHIN 24 HOURS) FOLLOWING A STORM THAT CAUSES SURFACE EROSION, AND PERFORM NECESSARY MAINTENANCE.
2. FREQUENT OBSERVATIONS AND MAINTENANCE ARE NECESSARY TO MAINTAIN BMPs IN EFFECTIVE OPERATING CONDITION. INSPECTIONS AND CORRECTIVE MEASURES SHOULD BE DOCUMENTED THOROUGHLY.
3. WHERE BMPs HAVE FAILED, REPAIR OR REPLACEMENT SHOULD BE INITIATED UPON DISCOVERY OF THE FAILURE.
4. ROCK SHALL BE REAPPLIED OR REGRADED AS NECESSARY TO THE STABILIZED ENTRANCE/EXIT TO MAINTAIN A CONSISTENT DEPTH.
5. SEDIMENT TRACKED ONTO PAVED ROADS IS TO BE REMOVED THROUGHOUT THE DAY AND AT THE END OF THE DAY BY SHOVELING OR SWEEPING. SEDIMENT MAY NOT BE WASHED DOWN STORM SEWER DRAINS.

NOTE: MANY JURISDICTIONS HAVE BMP DETAILS THAT VARY FROM UDFCD STANDARD DETAILS. CONSULT WITH LOCAL JURISDICTIONS AS TO WHICH DETAIL SHOULD BE USED WHEN DIFFERENCES ARE NOTED.

(DETAILS ADAPTED FROM CITY OF BROOMFIELD, COLORADO, NOT AVAILABLE IN AUTOCAD)

## Description

A silt fence is a woven geotextile fabric attached to wooden posts and trenched into the ground. It is designed as a sediment barrier to intercept sheet flow runoff from disturbed areas.

## Appropriate Uses

A silt fence can be used where runoff is conveyed from a disturbed area as sheet flow. Silt fence is not designed to receive concentrated flow or to be used as a filter fabric. Typical uses include:

- Down slope of a disturbed area to accept sheet flow.
- Along the perimeter of a receiving water such as a stream, pond or wetland.
- At the perimeter of a construction site.



**Photograph SF-1.** Silt fence creates a sediment barrier, forcing sheet flow runoff to evaporate or infiltrate.

## Design and Installation

Silt fence should be installed along the contour of slopes so that it intercepts sheet flow. The maximum recommended tributary drainage area per 100 lineal feet of silt fence, installed along the contour, is approximately 0.25 acres with a disturbed slope length of up to 150 feet and a tributary slope gradient no steeper than 3:1. Longer and steeper slopes require additional measures. This recommendation only applies to silt fence installed along the contour. Silt fence installed for other uses, such as perimeter control, should be installed in a way that will not produce concentrated flows. For example, a "J-hook" installation may be appropriate to force runoff to pond and evaporate or infiltrate in multiple areas rather than concentrate and cause erosive conditions parallel to the silt fence.

See Detail SF-1 for proper silt fence installation, which involves proper trenching, staking, securing the fabric to the stakes, and backfilling the silt fence. Properly installed silt fence should not be easily pulled out by hand and there should be no gaps between the ground and the fabric.

Silt fence must meet the minimum allowable strength requirements, depth of installation requirement, and other specifications in the design details. Improper installation of silt fence is a common reason for silt fence failure; however, when properly installed and used for the appropriate purposes, it can be highly effective.

<b>Silt Fence</b>	
<b>Functions</b>	
Erosion Control	No
Sediment Control	Yes
Site/Material Management	No

## Maintenance and Removal

Inspection of silt fence includes observing the material for tears or holes and checking for slumping fence and undercut areas bypassing flows. Repair of silt fence typically involves replacing the damaged section with a new section. Sediment accumulated behind silt fence should be removed, as needed to maintain BMP effectiveness, typically before it reaches a depth of 6 inches.

Silt fence may be removed when the upstream area has reached final stabilization.



**Photograph SF-2.** When silt fence is not installed along the contour, a "J-hook" installation may be appropriate to ensure that the BMP does not create concentrated flow parallel to the silt fence. Photo courtesy of Tom Gore.

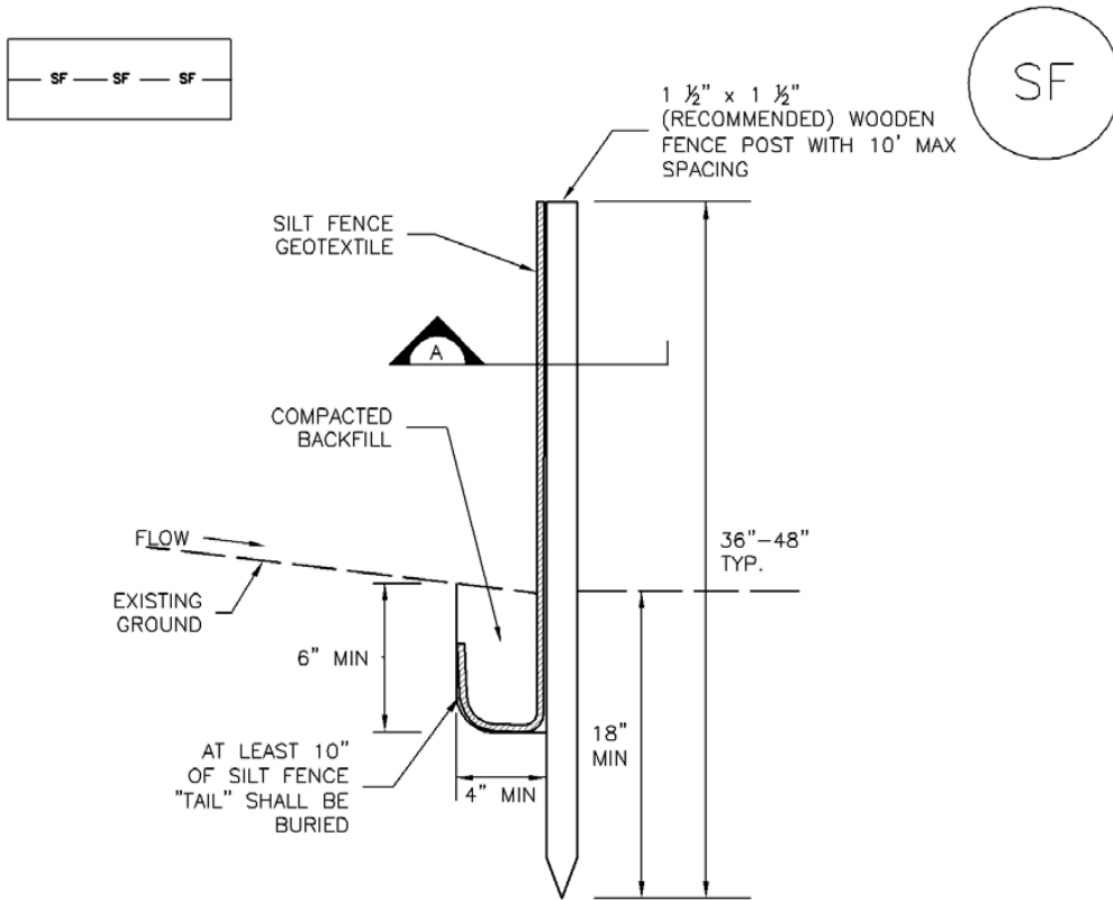

## SILT FENCE

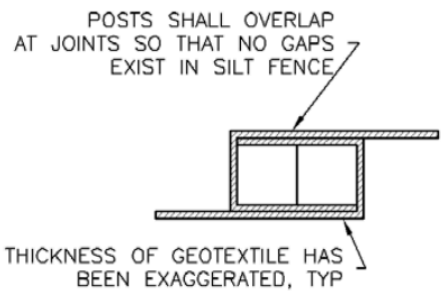
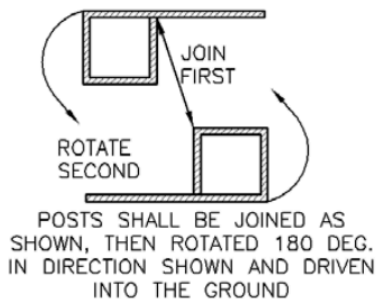

## SECTION A

## SF-1. SILT FENCE

SILT FENCE INSTALLATION NOTES

1. SILT FENCE MUST BE PLACED AWAY FROM THE TOE OF THE SLOPE TO ALLOW FOR WATER PONDING. SILT FENCE AT THE TOE OF A SLOPE SHOULD BE INSTALLED IN A FLAT LOCATION AT LEAST SEVERAL FEET (2-5 FT) FROM THE TOE OF THE SLOPE TO ALLOW ROOM FOR PONDING AND DEPOSITION.
2. A UNIFORM 6" X 4" ANCHOR TRENCH SHALL BE EXCAVATED USING TRENCHER OR SILT FENCE INSTALLATION DEVICE. NO ROAD GRADERS, BACKHOES, OR SIMILAR EQUIPMENT SHALL BE USED.
3. COMPACT ANCHOR TRENCH BY HAND WITH A "JUMPING JACK" OR BY WHEEL ROLLING. COMPACTION SHALL BE SUCH THAT SILT FENCE RESISTS BEING PULLED OUT OF ANCHOR TRENCH BY HAND.
4. SILT FENCE SHALL BE PULLED TIGHT AS IT IS ANCHORED TO THE STAKES. THERE SHOULD BE NO NOTICEABLE SAG BETWEEN STAKES AFTER IT HAS BEEN ANCHORED TO THE STAKES.
5. SILT FENCE FABRIC SHALL BE ANCHORED TO THE STAKES USING 1" HEAVY DUTY STAPLES OR NAILS WITH 1" HEADS. STAPLES AND NAILS SHOULD BE PLACED 3" ALONG THE FABRIC DOWN THE STAKE.
6. AT THE END OF A RUN OF SILT FENCE ALONG A CONTOUR, THE SILT FENCE SHOULD BE TURNED PERPENDICULAR TO THE CONTOUR TO CREATE A "J-HOOK." THE "J-HOOK" EXTENDING PERPENDICULAR TO THE CONTOUR SHOULD BE OF SUFFICIENT LENGTH TO KEEP RUNOFF FROM FLOWING AROUND THE END OF THE SILT FENCE (TYPICALLY 10' - 20').
7. SILT FENCE SHALL BE INSTALLED PRIOR TO ANY LAND DISTURBING ACTIVITIES.

SILT FENCE MAINTENANCE NOTES

1. INSPECT BMPs EACH WORKDAY, AND MAINTAIN THEM IN EFFECTIVE OPERATING CONDITION. MAINTENANCE OF BMPs SHOULD BE PROACTIVE, NOT REACTIVE. INSPECT BMPs AS SOON AS POSSIBLE (AND ALWAYS WITHIN 24 HOURS) FOLLOWING A STORM THAT CAUSES SURFACE EROSION, AND PERFORM NECESSARY MAINTENANCE.
2. FREQUENT OBSERVATIONS AND MAINTENANCE ARE NECESSARY TO MAINTAIN BMPs IN EFFECTIVE OPERATING CONDITION. INSPECTIONS AND CORRECTIVE MEASURES SHOULD BE DOCUMENTED THOROUGHLY.
3. WHERE BMPs HAVE FAILED, REPAIR OR REPLACEMENT SHOULD BE INITIATED UPON DISCOVERY OF THE FAILURE.
4. SEDIMENT ACCUMULATED UPSTREAM OF THE SILT FENCE SHALL BE REMOVED AS NEEDED TO MAINTAIN THE FUNCTIONALITY OF THE BMP, TYPICALLY WHEN DEPTH OF ACCUMULATED SEDIMENTS IS APPROXIMATELY 6".
5. REPAIR OR REPLACE SILT FENCE WHEN THERE ARE SIGNS OF WEAR, SUCH AS SAGGING, TEARING, OR COLLAPSE.
6. SILT FENCE IS TO REMAIN IN PLACE UNTIL THE UPSTREAM DISTURBED AREA IS STABILIZED AND APPROVED BY THE LOCAL JURISDICTION, OR IS REPLACED BY AN EQUIVALENT PERIMETER SEDIMENT CONTROL BMP.
7. WHEN SILT FENCE IS REMOVED, ALL DISTURBED AREAS SHALL BE COVERED WITH TOPSOIL, SEEDED AND MULCHED OR OTHERWISE STABILIZED AS APPROVED BY LOCAL JURISDICTION.

(DETAIL ADAPTED FROM TOWN OF PARKER, COLORADO AND CITY OF AURORA, NOT AVAILABLE IN AUTOCAD)

**NOTE:** MANY JURISDICTIONS HAVE BMP DETAILS THAT VARY FROM UDFCD STANDARD DETAILS. CONSULT WITH LOCAL JURISDICTIONS AS TO WHICH DETAIL SHOULD BE USED WHEN DIFFERENCES ARE NOTED.



## Description

A BMP that utilizes bioretention is an engineered, depressed landscape area designed to capture and filter or infiltrate the water quality capture volume (WQCV). BMPs that utilize bioretention are frequently referred to as rain gardens or porous landscape detention areas (PLDs). The term PLD is common in the UDFCD region as this manual first published the BMP by this name in 1999. In an effort to be consistent with terms most prevalent in the stormwater industry, this document generally refers to the treatment process as *bioretention* and to the BMP as a *rain garden*.



**Photograph B-1.** This recently constructed rain garden provides bioretention of pollutants, as well as an attractive amenity for a residential building. Treatment should improve as vegetation matures.

The design of a rain garden may provide detention for events exceeding that of the WQCV. There are generally two ways to achieve this. The design can provide the flood control volume above the WQCV or the design can provide and slowly release the flood control volume in an area downstream of one or more rain gardens. See the *Storage* chapter in Volume 2 of the USDCM for more information.

This infiltrating BMP requires consultation with a geotechnical engineer when proposed adjacent to a structure. A geotechnical engineer can assist with evaluating the suitability of soils, identifying potential impacts, and establishing minimum distances between the BMP and structures.

### Terminology

The term *bioretention* refers to the treatment process although it is also frequently used to describe a BMP that provides biological uptake and retention of the pollutants found in stormwater runoff. This BMP is sometimes referred to as a *porous landscape detention (PLD) area* or *rain garden*.

<b>Bioretention (Rain Garden)</b>	
<b>Functions</b>	
LID/Volume Red.	Yes
WQCV Capture	Yes
WQCV+Flood Control	Yes
Fact Sheet Includes EURV Guidance	No
<b>Typical Effectiveness for Targeted Pollutants<sup>3</sup></b>	
Sediment/Solids	Very Good <sup>1</sup>
Nutrients	Moderate
Total Metals	Good
Bacteria	Moderate
<b>Other Considerations</b>	
Life-cycle Costs <sup>4</sup>	Moderate
<sup>1</sup> Not recommended for watersheds with high sediment yields (unless pretreatment is provided). <sup>3</sup> Based primarily on data from the International Stormwater BMP Database ( <a href="http://www.bmpdatabase.org">www.bmpdatabase.org</a> ). <sup>4</sup> Based primarily on BMP-REALCOST available at <a href="http://www.udfcd.org">www.udfcd.org</a> . Analysis based on a single installation (not based on the maximum recommended watershed tributary to each BMP).	

## Site Selection

This BMP allows WQCV treatment within one or more areas designated for landscape (see design step 7 for suggested vegetation). In this way, it is an excellent alternative to extended detention basins for small sites. A typical rain garden serves a tributary area of one impervious acre or less, although they can be designed for larger tributary areas. Multiple installations can be used within larger sites. Rain gardens should not be used when a baseflow is anticipated. They are typically small and installed in locations such as:

- Parking lot islands
- Street medians
- Landscape areas between the road and a detached walk
- Planter boxes that collect roof drains

Bioretention requires a stable watershed. Retrofit applications are typically successful for this reason. When the watershed includes phased construction, sparsely vegetated areas, or steep slopes in sandy soils, consider another BMP or provide pretreatment before runoff from these areas reaches the rain garden.

The surface of the rain garden should be flat. For this reason, rain gardens can be more difficult to incorporate into steeply sloping terrain; however, terraced applications of these facilities have been successful in other parts of the country.

When bioretention (and other BMPs used for infiltration) are located adjacent to buildings or pavement areas, protective measures should be implemented to avoid adverse impacts to these structures. Oversaturated subgrade soil underlying a structure can cause the structure to settle or result in moisture-related problems. Wetting of expansive soils or bedrock can cause swelling, resulting in structural movements. A geotechnical engineer should evaluate the potential impact of the BMP on adjacent structures based on an evaluation of the subgrade soil, groundwater, and bedrock conditions at the site. Additional minimum requirements include:

- In locations where subgrade soils do not allow infiltration and/or where infiltration could adversely impact adjacent structures, include a drainage layer (with underdrain) under the growing medium.
- In locations where potentially expansive soils or bedrock exist, placement of a rain garden adjacent to structures and pavement should only be considered if the BMP includes a drainage layer (with underdrain) and an impermeable geomembrane liner designed to restrict seepage.

## Benefits

- Bioretention uses multiple treatment processes to remove pollutants, including sedimentation, filtering, adsorption, evapotranspiration, and biological uptake of constituents.
- Stormwater treatment occurs within attractive landscaped areas.
- There is a potential reduction of irrigation requirements by taking advantage of site runoff.

## Limitations

- Additional design and construction steps are required for placement of any ponding or infiltration area near or upgradient from a building foundation and/or when expansive (low to high swell) soils exist. This is discussed in the design procedure section.
- In developing or otherwise erosive watersheds, high sediment loads can clog the facility.

## Designing for Maintenance

Recommended maintenance practices for all BMPs are in Chapter 6 of this manual. During design, consider the following to ensure ease of maintenance over the long-term:

- Do not put a filter sock on the underdrain. This is not necessary and can cause the underdrain to clog.
- The best surface cover for a rain garden is full vegetation. Use rock mulch sparingly within the rain garden because rock mulch limits infiltration and is more difficult to maintain. Wood mulch handles sediment build-up better than rock mulch; however, wood mulch floats and may clog the overflow depending on the configuration of the outlet or settle unevenly. Some municipalities may not allow wood mulch for this reason.
- Consider all potential maintenance requirements such as mowing (if applicable) and replacement of the growing medium. Consider the method and equipment for each task required. For example, in a large rain garden where the use of hand tools is not feasible, does the shape and configuration of the rain garden allow for removal of the growing medium using a backhoe?
- Provide pre-treatment when it will reduce the extent and frequency of maintenance necessary to maintain function over the life of the BMP. For example, if the tributary is larger than one acre, prone to debris or the use of sand for ice control, consider a small forebay.
- Make the rain garden as shallow as possible. Increasing the depth unnecessarily can create erosive side slopes and complicate maintenance. Shallow rain gardens are also more attractive.
- Design and adjust the irrigation system (temporary or permanent) to provide appropriate water for the establishment and maintenance of selected vegetation.

### Is Pretreatment Needed?

Designing the inflow gutter to the rain garden at a minimal slope of 0.5% can facilitate sediment and debris deposition prior to flows entering the BMP. Be aware, this will reduce maintenance of the BMP, but may require more frequent sweeping of the gutter to ensure that the sediment does not impede flow into the rain garden.

## Design Procedure and Criteria

1. **Subsurface Exploration and Determination of a No-Infiltration, Partial Infiltration, or Full Infiltration Section:** Infiltration BMPs can have three basic types of sections. The appropriate section will depend on land use and activities, proximity to adjacent structures and soil characteristics. Sections of each installation type are shown in Figure B-1.
  - **No-Infiltration Section:** This section includes an underdrain and an impermeable liner that prevents infiltration of stormwater into the subgrade soils. Consider using this section when any of the following conditions exist:
    - The site is a stormwater hotspot and infiltration could result in contamination of groundwater.
    - The site is located over contaminated soils and infiltration could mobilize these contaminants.
    - The facility is located over potentially expansive soils or bedrock that could swell due to infiltration and potentially damage adjacent structures (e.g., building foundation or pavement).
  - **Partial Infiltration Section:** This section does not include an impermeable liner, and allows some infiltration. Stormwater that does not infiltrate is collected and removed by an underdrain

system.

- **Full Infiltration Section:** This section is designed to infiltrate the water stored in the basin into the subgrade below. UDFCD recommends a minimum infiltration rate of 2 times the rate needed to drain the WQCV over 12 hours. A conservative design could utilize the partial infiltration section with the addition of a valve at the underdrain outlet. In the event that infiltration does not remain adequate following construction, the valve could be opened and allow this section to operate as a partial infiltration section.

A geotechnical engineer should scope and perform a subsurface study. Typical geotechnical investigation needed to select and design the section includes:

- Prior to exploration review geologic and geotechnical information to assess near-surface soil, bedrock and groundwater conditions that may be encountered and anticipated ranges of infiltration rate for those materials. For example, if the facility is located adjacent to a structure and the site is located in a general area of known shallow, potentially expansive bedrock, a no-infiltration section will likely be required. It is also possible that this BMP may be infeasible, even with a liner, if there is a significant potential for damage to the adjacent structures (e.g., areas of dipping bedrock).
- Drill exploratory borings or exploratory pits to characterize subsurface conditions beneath the subgrade and develop requirements for subgrade preparation. Drill at least one boring or pit for every 40,000 ft<sup>2</sup>, and at least two borings or pits for sites between 10,000 ft<sup>2</sup> and 40,000 ft<sup>2</sup>. The boring or pit should extend at least 5 feet below the bottom of the base, and at least 20 feet in areas where there is a potential of encountering potentially expansive soils or bedrock. More borings or pits at various depths may be required by the geotechnical engineer in areas where soil types may change, in low-lying areas where subsurface drainage may collect, or where the water table is likely within 8 feet below the planned bottom of the base or top of subgrade. Installation of temporary monitoring wells in selected borings or pits for monitoring groundwater levels over time should be considered where shallow groundwater is encountered.
- Perform laboratory tests on samples obtained from the borings or pits to initially characterize the subgrade, evaluate the possible section type, and to assess subgrade conditions for supporting traffic loads. Consider the following tests: moisture content (ASTM D 2216); dry density (ASTM D 2936); Atterberg limits (ASTM D 4318); gradation (ASTM D 6913); swell-consolidation (ASTM D 4546); subgrade support testing (R-value, CBR or unconfined compressive strength); and hydraulic conductivity. A geotechnical engineer should determine the appropriate test method based on the soil type.
- For sites where a full infiltration section may be feasible, perform on-site infiltration tests using a double-ring infiltrometer (ASTM D 3385). Perform at least one test for every 160,000 ft<sup>2</sup> and at least two tests for sites between 40,000 ft<sup>2</sup> and 160,000 ft<sup>2</sup>. The tests should be located near completed borings or pits so the test results and subsurface conditions encountered in the borings can be compared, and at least one test should be located near the boring or pit showing the most unfavorable infiltration condition. The test should be performed at the planned top of subgrade underlying the growing media.
- Be aware that actual infiltration rates are highly variable dependent on soil type, density and moisture content and degree of compaction as well as other environmental and construction influences. Actual rates can differ an order of magnitude or more from those indicated by infiltration or permeability testing. Select the type of section based on careful assessment of the subsurface exploration and testing data.

The following steps outline the design procedure and criteria, with Figure B-1 providing a corresponding cross-section.

2. **Basin Storage Volume:** Provide a storage volume based on a 12-hour drain time.

Find the required WQCV (watershed inches of runoff). Using the imperviousness of the tributary area (or effective imperviousness where LID elements are used upstream), use Figure 3-2 located in Chapter 3 of this manual to determine the WQCV based on a 12-hour drain time.

Calculate the design volume as follows:

$$V = \left[ \frac{\text{WQCV}}{12} \right] A \quad \text{Equation B-1}$$

Where:

$V$  = design volume (ft<sup>3</sup>)

$A$  = area of watershed tributary to the rain garden (ft<sup>2</sup>)

3. **Basin Geometry:** UDFCD recommends a maximum WQCV ponding depth of 12 inches to maintain vegetation properly. Provide an inlet or other means of overflow at this elevation. Depending on the type of vegetation planted, a greater depth may be utilized to detain larger (more infrequent) events. The bottom surface of the rain garden, also referred to here as the filter area, should be flat. Sediment will reside on the filter area of the rain garden; therefore, if the filter area is too small, it may clog prematurely. If the filter area is not flat, the lowest area of the filter is more likely to clog as it will have a higher sediment loading. Increasing the filter area will reduce clogging and decrease the frequency of maintenance. Equation B-2 provides a minimum filter area allowing for some of the volume to be stored beyond the area of the filter (i.e., above the sideslopes of the rain garden).

Note that the total surcharge volume provided by the design must also equal or exceed the design volume. Where needed to meet the the required volume, also consider the porosity of the media at 14 percent. Use vertical walls or slope the sides of the basin to achieve the required volume. Sideslopes should be no steeper than 4:1 (horizontal:vertical).

$$A_F = 0.02 AI \quad \text{Equation B-2}$$

Where:

$A_F$  = minimum (flat) filter area (ft<sup>2</sup>)

$A$  = area tributary to the rain garden (ft<sup>2</sup>)

$I$  = imperviousness of area tributary to the rain garden (percent expressed as a decimal)

4. **Growing Medium:** Provide a minimum of 18 inches of growing medium to enable establishment of the roots of the vegetation (see Figure B-1). A previous version of this manual specified a mixture consisting of 85% coarse sand and a 15% compost/shredded paper mixture (by volume). Based on field monitoring of this medium, compost was removed to reduce export of nutrients and fines and silts were added to both benefit the vegetation and increase capture of metals in stormwater.

Table B-1 specifies the growing media as well as other materials discussed in this Fact Sheet. Growing media is engineered media that requires a high level of quality control and must almost always be imported. Obtaining a particle size distribution and nutrient analysis is the only way to ensure that the media is acceptable. UDFCD has identified placement of media not meeting the specification as the most frequent cause of failure. Sample the media after delivery and prior to placement or obtain a sample from the supplier in advance of delivery and placement and have this analyzed prior to delivery.

#### **Other Rain Garden Growing Medium Amendments**

The specified growing medium was designed for filtration ability, clogging characteristics, and vegetative health. It is important to preserve the function provided by the rain garden growing medium when considering additional materials for incorporation into the growing medium or into the standard section shown in Figure B-1. When desired, amendments may be included to improve water quality or to benefit vegetative health as long as they do not add nutrients, pollutants, or modify the infiltration rate. For example, a number of products, including steel wool, capture and retain dissolved phosphorus (Erickson 2009). When phosphorus is a target pollutant, proprietary materials with similar characteristics may be considered. Do not include amendments such as top soil, sandy loam, and compost.

Table B-1. Material specification for bioretention/rain garden facilities

Material	Specification	Submittals	Testing	Notes
Bioretention Growing Media (soil + organics)	Bioretention soil	Particle size distribution and nutrient analysis required.		Percentages are in weight.
	Bioretention organics			
Landscape mulch	3 to 5% shredded mulch (by weight of growing media)			bioretention soil required. Aged 6 months (minimum). Aged 6 months (minimum). No weed fabric allowed.
	Shredded hardwood			
Underdrain aggregate	CDDT filter material (Class B or C as specified)	Particle size distribution required.		
Underdrain Pipe	Pipe diameter and type	Maximum slot width (inches)	Minimum open area (per foot)	Pipe must conform to requirements of ASTM designation F949. There shall be no evidence of splitting, cracking, or breaking when the pipe is tested per ASTM test method D2412 in accordance with F949 section 7.5 and ASTM F794 section 8.5.
Impermeable liner	4-inch slotted PVC	0.032	1.90 in. <sup>2</sup>	Thermal welding required for fully lined facilities (not a curtain). Leak testing in the field required.
	6-inch slotted PVC	0.032	1.98 in. <sup>2</sup>	
	Thickness, % Tolerance		Test method	
	Tensile strength, kN/m (lbf/in)	+/-5	ASTM D 1593	
	Modulus at 100% elongation, kN/m	12.25 (70)	ASTM D882, method B	
	Ultimate elongation, %	5.25 (30)	ASTM D882, method B	
	Tear resistance, N(lbs)	360	ASTM D882, method A	
	Low temperature impact, °C (°F)	38 (8.5)	ASTM D 1004	
	Volatiles loss, % maximum	-29 (-20)	ASTM D 1790	
	Pinholes, no. per 8 m <sup>2</sup> (no. per 10 yd. <sup>2</sup> )	0.7	ASTM D882, method A	
Bonded seam strength, % of tensile	1 (max)	NA		
	80	NA		

5. **Underdrain System:** When using an underdrain system, provide a control orifice sized to drain the design volume in 12 hours or more (see Equation B-3). Use a minimum orifice size of 3/8 inch to avoid clogging. This will provide detention and slow release of the WQCV, providing water quality benefits and reducing impacts to downstream channels. Space underdrain pipes a maximum of 20 feet on center. Provide cleanouts to enable maintenance of the underdrain. Cleanouts can also be used to conduct an inspection (by camera) of the underdrain system to ensure that the pipe was not crushed or disconnected during construction.

Calculate the diameter of the orifice for a 12-hour drain time using Equation B-3 (Use a minimum orifice size of 3/8 inch to avoid clogging.):

$$D_{12 \text{ hour drain time}} = \sqrt{\frac{V}{1414 y^{0.41}}} \quad \text{Equation B-3}$$

Where:

- $D$  = orifice diameter (in)
- $y$  = distance from the lowest elevation of the storage volume (i.e., surface of the filter) to the center of the orifice (ft)
- $V$  = volume (WQCV or the portion of the WQCV in the rain garden) to drain in 12 hours (ft<sup>3</sup>)

In previous versions of this manual, UDFCD recommended that the underdrain be placed in an aggregate layer and that a geotextile (separator fabric) be placed between this aggregate and the growing medium. This version of the manual replaces that section with materials that, when used together, eliminate the need for a separator fabric.

The underdrain system should be placed within an 6-inch-thick section of CDOT Class B or Class C filter material meeting the gradation in Table B-1. Use slotted pipe that meets the slot dimensions provided in Table B-3.



## 6. Impermeable Geomembrane Liner and Geotextile Separator Fabric

**Separator Fabric:** For no-infiltration sections, install a 30 mil (minimum) PVC geomembrane liner, per Table B-1, on the bottom and sides of the basin, extending up at least to the top of the underdrain layer. Provide at least 9 inches (12 inches if possible) of cover over the membrane where it is attached to the wall to protect the membrane from UV deterioration. The geomembrane should be field-seamed using a dual track welder, which allows for non-destructive testing of almost all field seams. A small amount of single track is allowed in limited areas to seam around pipe perforations, to patch seams removed for destructive seam testing, and for limited repairs. The liner should be installed with slack to prevent tearing due to backfill, compaction, and settling. Place CDOT Class B geotextile separator fabric above the geomembrane to protect it from being punctured during the placement of the filter material above the liner. If the subgrade contains angular rocks or other material that could puncture the geomembrane, smooth-roll the surface to create a suitable surface. If smooth-rolling the surface does not provide a suitable surface, also place the separator fabric between the geomembrane and the underlying subgrade. This should only be done when necessary because fabric placed under the geomembrane can increase seepage losses through pinholes or other geomembrane defects. Connect the geomembrane to perimeter concrete walls around the basin perimeter, creating a watertight seal between the geomembrane and the walls using a continuous batten bar and anchor connection (see Figure B-3). Where the need for the impermeable membrane is not as critical, the membrane can be attached with a nitrile-based vinyl adhesive. Use watertight PVC boots for underdrain pipe penetrations through the liner (see Figure B-2) or the technique shown in photo B-2.



**Photograph B-2.** The impermeable membrane in this photo has ripped from the bolts due to placement of the media without enough slack in the membrane.



**Photograph B-3.** Ensure a water-tight connection where the underdrain penetrated the liner. The heat-welded “boot” shown here is an alternative to the clamped detail shown in Figure B-2.

**Table B-2. Physical requirements for separator fabric<sup>1</sup>**

Property	Class B		Test Method
	Elongation < 50% <sup>2</sup>	Elongation > 50% <sup>2</sup>	
Grab Strength, N (lbs.)	800 (180)	510 (115)	ASTM D 4632
Puncture Resistance, N (lbs.)	310 (70)	180 (40)	ASTM D 4833
Trapezoidal Tear Strength, N (lbs.)	310 (70)	180 (40)	ASTM D 4533
Apparent Opening Size, mm (US Sieve Size)	AOS < 0.3mm (US Sieve Size No. 50)		ASTM D 4751
Permittivity, sec <sup>-1</sup>	0.02 default value, must also be greater than that of soil		ASTM D 4491
Permeability, cm/sec	k fabric > k soil for all classes		ASTM D 4491
Ultraviolet Degradation at 500 hours	50% strength retained for all classes		ASTM D 4355

<sup>1</sup> Strength values are in the weaker principle direction

<sup>2</sup> As measured in accordance with ASTM D 4632

7. **Inlet and Outlet Control:** In order to provide the proper drain time, the bioretention area can be restricted at the underdrain outlet with an orifice plate or can be designed without an underdrain (provided the subgrade meets the requirements above). Equation B-3 is a simplified equation for sizing an orifice plate for a 12-hour drain time. UD-BMP or UD-Detention, available at [www.udfcd.org](http://www.udfcd.org), also perform this calculation.

How flow enters and exits the BMP is a function of the overall drainage concept for the site. Curb cuts can be designed to both allow stormwater into the rain garden as well as to provide release of stormwater in excess of the WQCV. Roadside rain gardens located on a steep site might pool and overflow into downstream cells with a single curb cut, level spreader, or outlet structure located at the most downstream cell. When selecting the



**Photograph B-4.** The curb cut shown allows flows to enter this rain garden while excess flows bypass the facility.

type and location of the outlet structure, ensure runoff will not short-circuit the rain garden. This is a frequent problem when using a curb inlet located outside the rain garden for overflow.

For rain gardens with concentrated points of inflow, provide a forebay and energy dissipation. A depressed concrete slab works best for a forebay. It helps maintain a vertical drop at the inlet and allows for easily removal of sediment using a square shovel. Where rock is used for energy dissipation, provide separator fabric between the rock and growing medium to minimize subsidence.

8. **Vegetation:** UDFCD recommends that the filter area be vegetated with drought tolerant species that thrive in sandy soils. Table B-3 provides a suggested seed mix for sites that will not need to be irrigated after the grass has been established.

Mix seed well and broadcast, followed by hand raking to cover seed and then mulched. Hydromulching can be effective for large areas. Do not place seed when standing water or snow is present or if the ground is frozen. Weed control is critical in the first two to three years, especially when starting with seed.

When using sod, specify sand-grown sod. Do not use conventional sod. Conventional sod is grown in clay soil that will seal the filter area, greatly reducing overall function of the BMP.

When using an impermeable liner, select plants with diffuse (or fibrous) root systems, not taproots. Taproots can damage the liner and/or underdrain pipe. Avoid trees and large shrubs that may interfere with restorative maintenance. Plant these outside of the area of growing medium. Use a cutoff wall to ensure that roots do not grow into the underdrain or place trees and shrubs a conservative distance from the underdrain.

9. **Irrigation:** Provide spray irrigation at or above the WQCV elevation or place temporary irrigation on top of the rain garden surface. Do not place sprinkler heads on the flat surface. Remove temporary irrigation when vegetation is established. If left in place this will become buried over time and will be damaged during maintenance operations.

Adjust irrigation schedules during the growing season to provide the minimum water necessary to maintain plant health and to maintain the available pore space for infiltration.

### Designing for Flood Protection

Provide the WQCV in rain gardens that direct excess flow into to a landscaped basin designed for flood control or design a single basin to provide water quality and flood control. See the *Storage* chapter in Volume 2 of the USDCM for more information. UD-Detention, available at [www.udfcd.org](http://www.udfcd.org), will facilitate design either alternative.

Table B-3. Native seed mix for rain gardens

Common Name	Scientific Name	Variety	PLS <sup>2</sup> lbs per Acre	Ounces per Acre
Sand bluestem	Andropogon hallii	Garden	3.5	
Sideoats grama	Bouteloua curtipendula	Butte	3	
Prairie sandreed	Calamovilfa longifolia	Goshen	3	
Indian ricegrass	Oryzopsis hymenoides	Paloma	3	
Switchgrass	Panicum virgatum	Blackwell	4	
Western wheatgrass	Pascopyrum smithii	Ariba	3	
Little bluestem	Schizachyrium scoparium	Patura	3	
Alkali sacaton	Sporobolus airoides		3	
Sand dropseed	Sporobolus cryptandrus		3	
Pasture sage <sup>1</sup>	Artemisia frigida			2
Blue aster <sup>1</sup>	Aster laevis			4
Blanket flower <sup>1</sup>	Gaillardia aristata			8
Prairie coneflower <sup>1</sup>	Ratibida columnifera			4
Purple prairieclover <sup>1</sup>	Dalea (Petalostemum) purpurea			4
Sub-Totals:			27.5	22
<b>Total lbs per acre:</b>			<b>28.9</b>	

<sup>1</sup> Wildflower seed (optional) for a more diverse and natural look.<sup>2</sup> PLS = Pure Live Seed.

## Aesthetic Design

In addition to effective stormwater quality treatment, rain gardens can be attractively incorporated into a site within one or several landscape areas. Aesthetically designed rain gardens will typically either reflect the character of their surroundings or become distinct features within their surroundings. Guidelines for each approach are provided below.

### Reflecting the Surrounding

- Determine design characteristics of the surrounding. This becomes the context for the drainage improvement. Use these characteristics in the structure.
- Create a shape or shapes that "fix" the forms surrounding the improvement. Make the improvement part of the existing surrounding.
- The use of material is essential in making any new improvement an integral part of the whole. Select materials that are as similar as possible to the surrounding architectural/engineering materials. Select materials from the same source if possible. Apply materials in the same quantity, manner, and method as original material.
- Size is an important feature in seamlessly blending the addition into its context. If possible, the overall size of the improvement should look very similar to the overall sizes of other similar objects in the improvement area.
- The use of the word texture in terms of the structure applies predominantly to the selection of plant material. The materials used should as closely as possible, blend with the size and texture of other plant material used in the surrounding. The plants may or may not be the same, but should create a similar feel, either individually or as a mass.

#### Reflective Design

A reflective design borrows the characteristics, shapes, colors, materials, sizes and textures of the built surroundings. The result is a design that fits seamlessly and unobtrusively in its environment.

### Creating a Distinct Feature

Designing the rain garden as a distinct feature is limited only by budget, functionality, and client preference. There is far more latitude in designing a rain garden that serves as a distinct feature. If this is the intent, the main consideration beyond functionality is that the improvement create an attractive addition to its surroundings. The use of form, materials, color, and so forth focuses on the improvement itself and does not necessarily reflect the surroundings, depending on the choice of the client or designer.

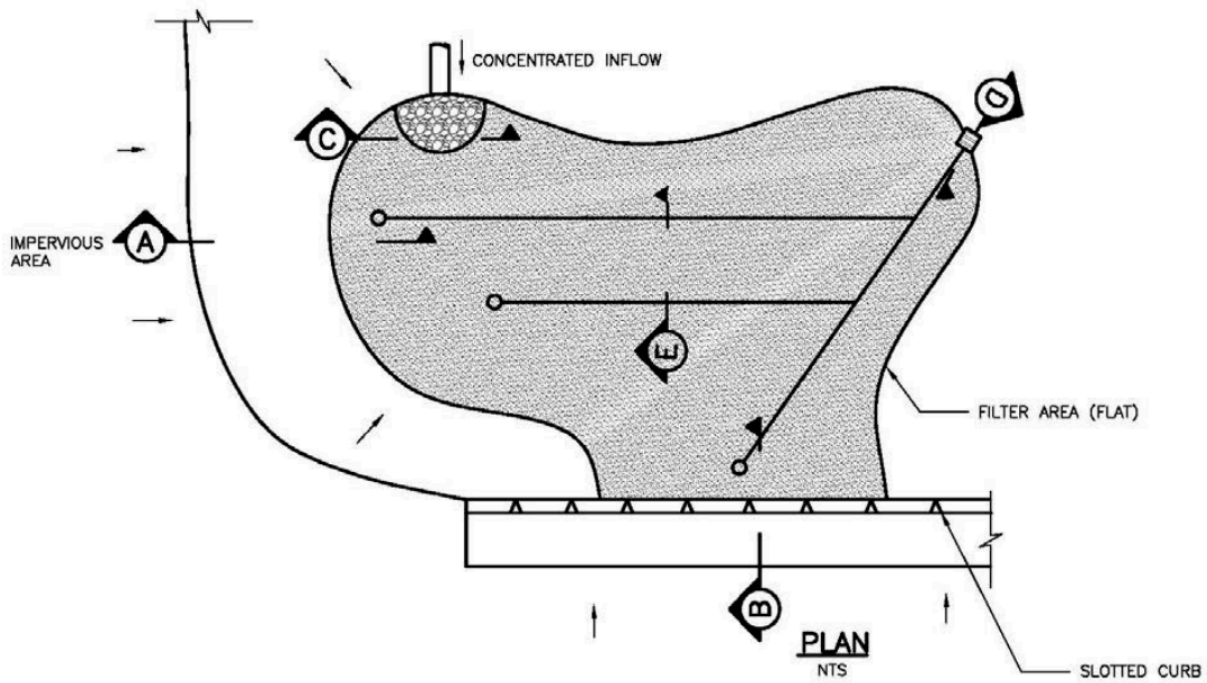
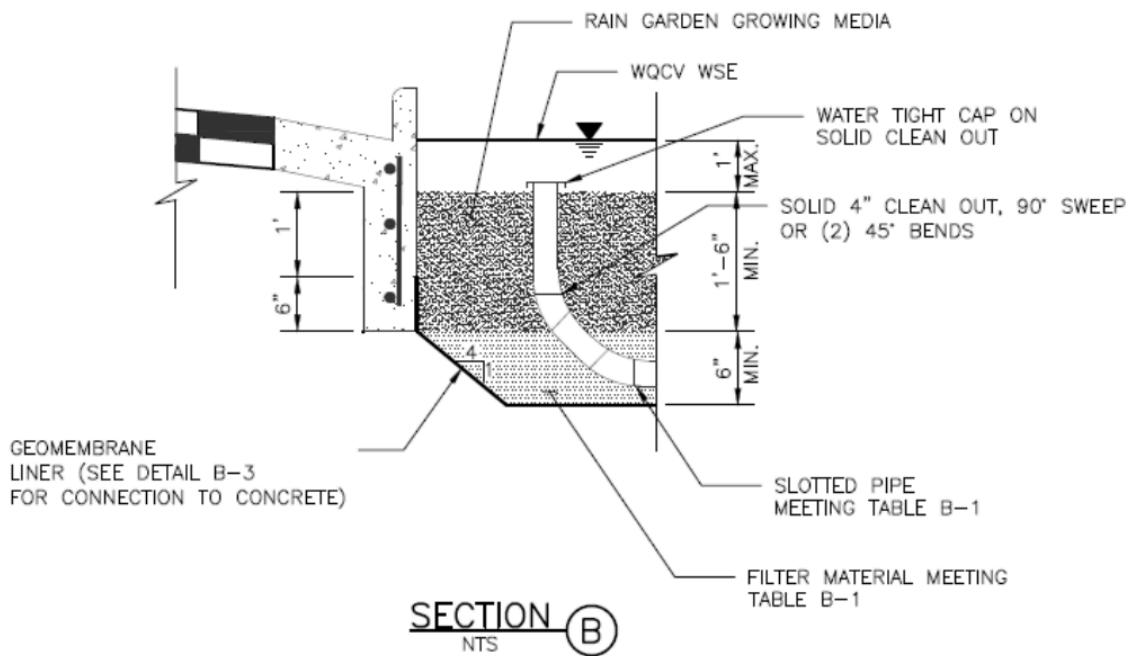
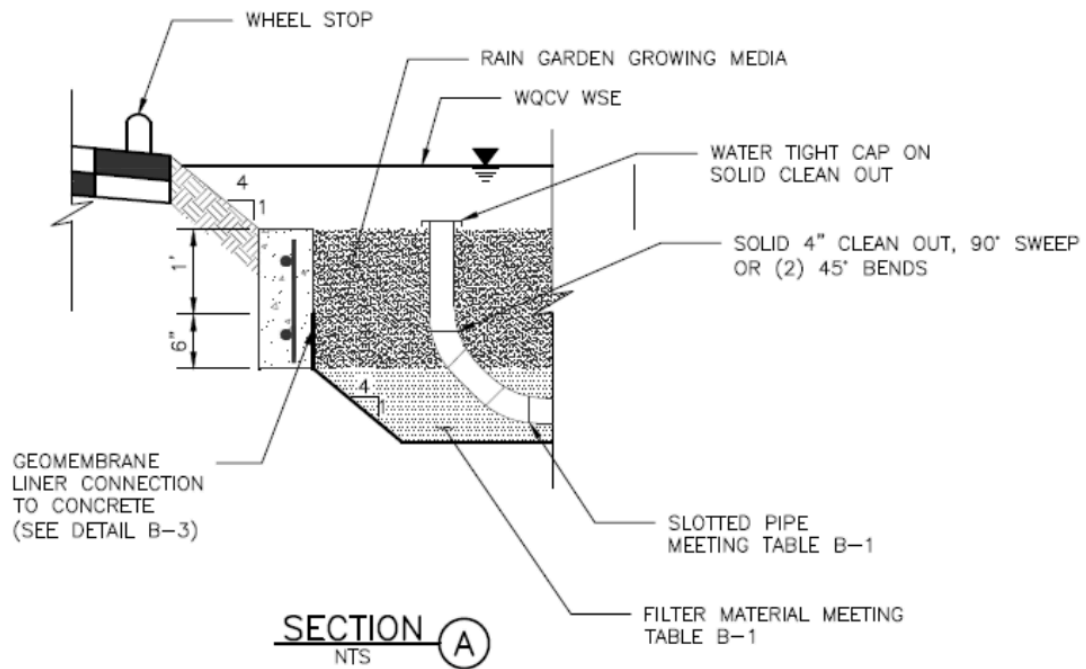
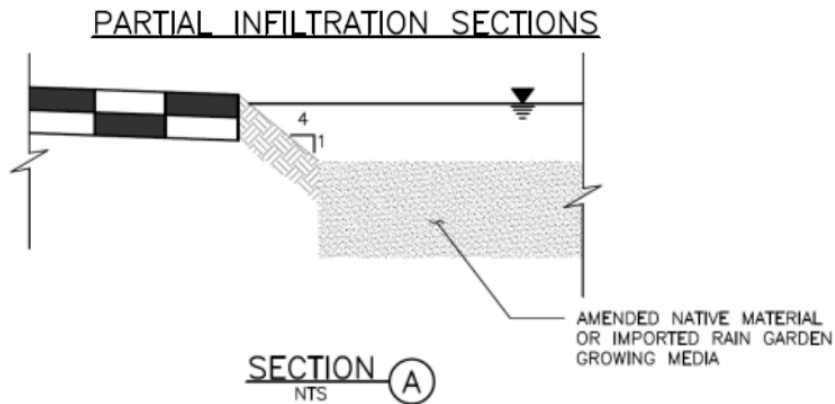
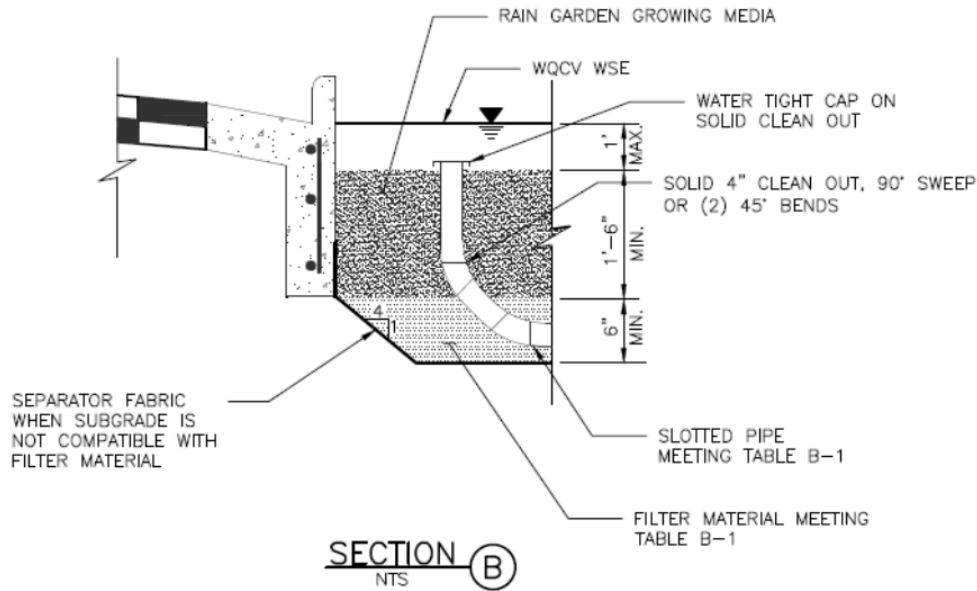
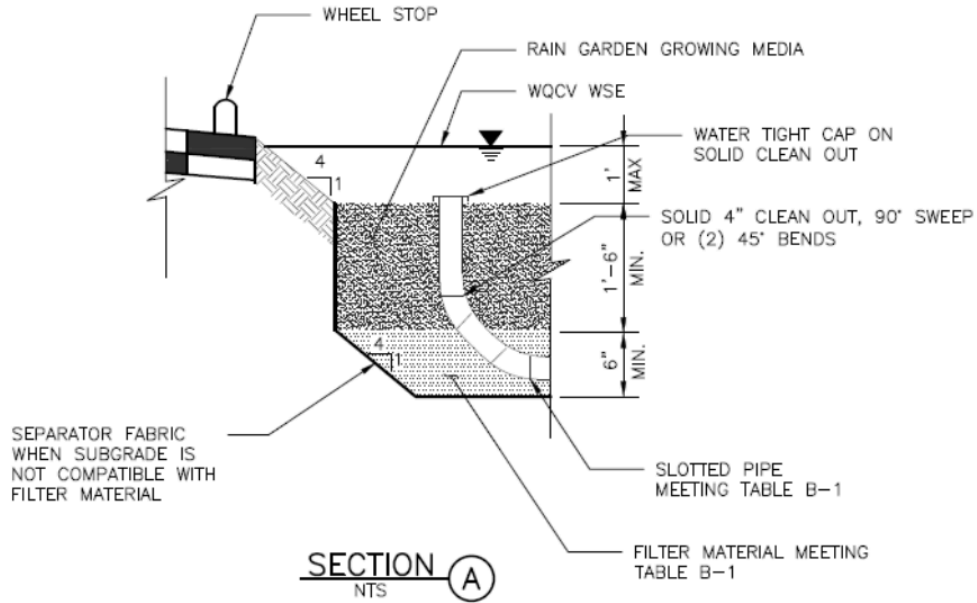

Figure B-1 – Typical rain garden plan and sections



## NO-INFILTRATION SECTIONS



**FULL INFILTRATION SECTION**



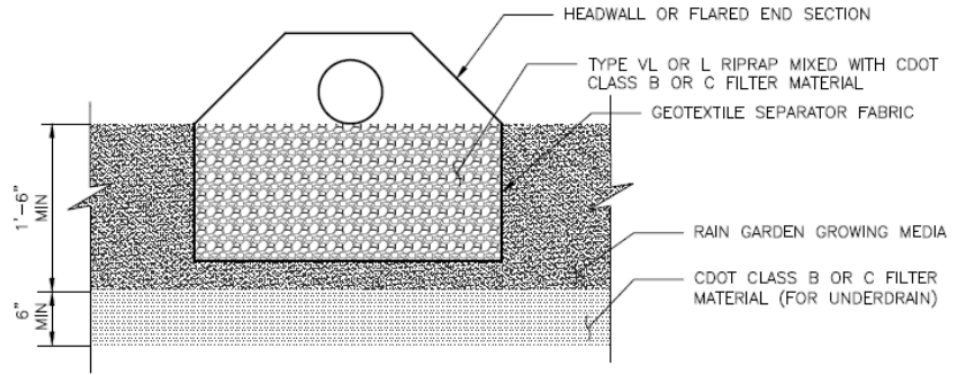

**SECTION C**  
NTS

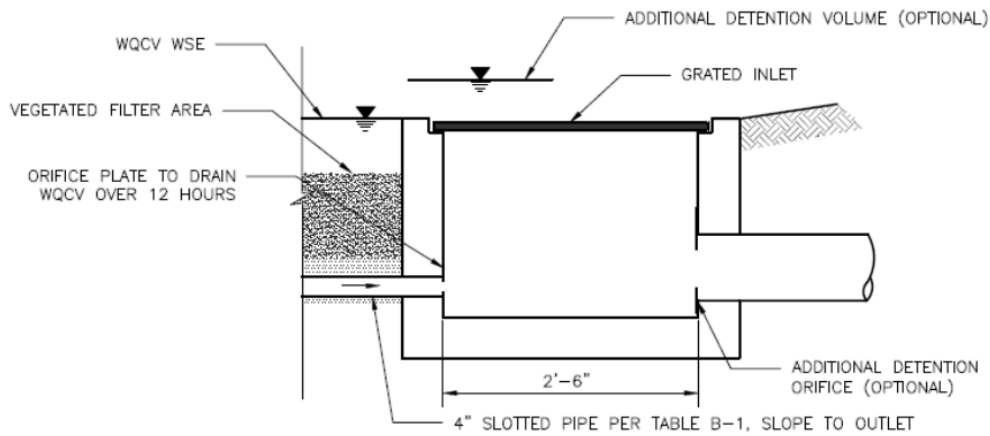

**SECTION D**  
NTS

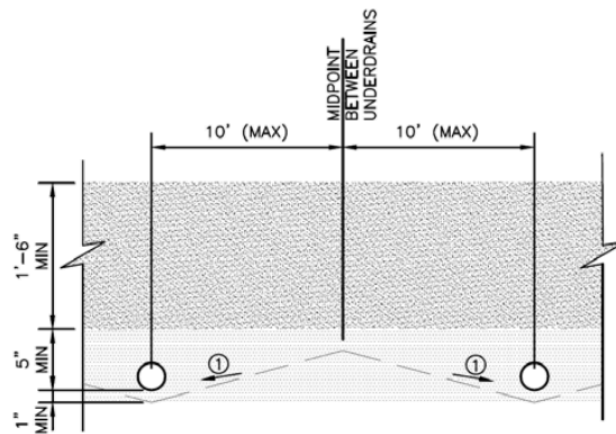

① SLOPE (STRAIGHT GRADE) SUBGRADE (2-10%) TO UNDERDRAIN TO REDUCE SATURATED SOIL CONDITIONS BETWEEN STORM EVENTS (OPTIONAL)

**SECTION E**  
NTS

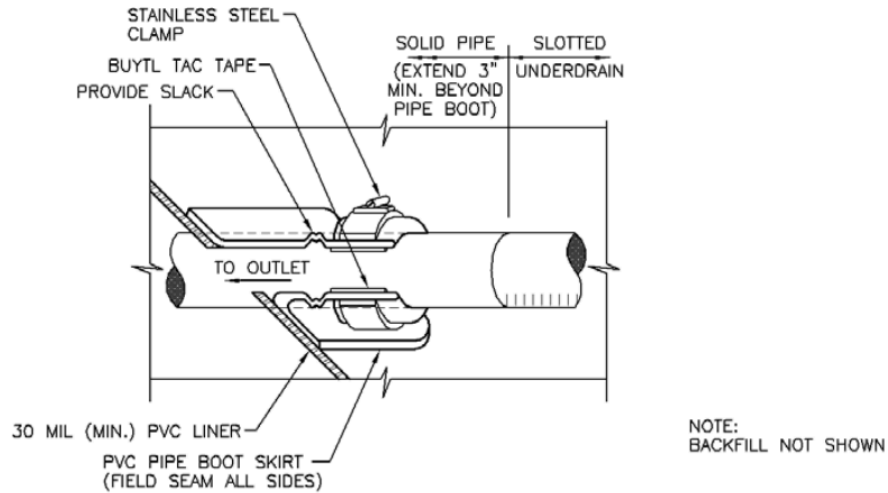

Figure B-2. Geomembrane Liner/Underdrain Penetration Detail

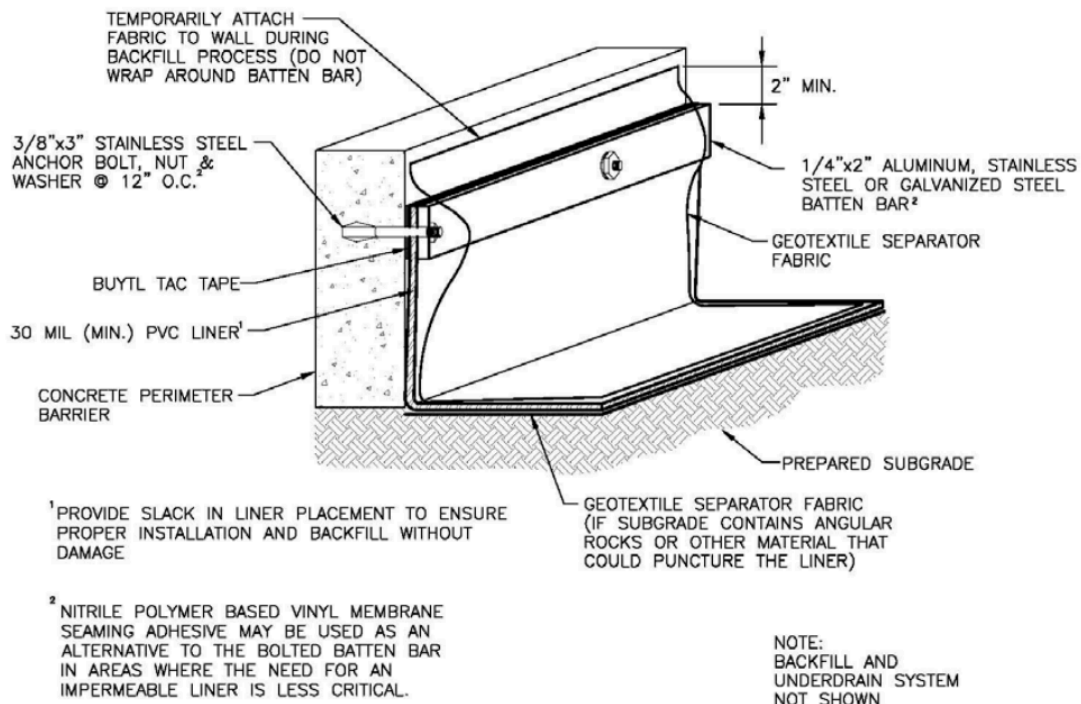

Figure B-3. Geomembrane Liner/Concrete Connection Detail

## Construction Considerations

Proper construction of rain gardens involves careful attention to material specifications, final grades, and construction details. For a successful project, implement the following practices:

- Protect area from excessive sediment loading during construction. This is the most common cause of clogging of rain gardens. The portion of the site draining to the rain garden must be stabilized before allowing flow into the rain garden. This includes completion of paving operations.
- Avoid over compaction of the area to preserve infiltration rates (for partial and full infiltration sections).
- Provide construction observation to ensure compliance with design specifications. Improper installation, particularly related to facility dimensions and elevations and underdrain elevations, is a common problem with rain gardens.
- When using an impermeable liner, ensure enough slack in the liner to allow for backfill, compaction, and settling without tearing the liner.
- Provide necessary quality assurance and quality control (QA/QC) when constructing an impermeable geomembrane liner system, including but not limited to fabrication testing, destructive and non-destructive testing of field seams, observation of geomembrane material for tears or other defects, and air lace testing for leaks in all field seams and penetrations. QA/QC should be overseen by a professional engineer. Consider requiring field reports or other documentation from the engineer.
- Provide adequate construction staking to ensure that the site properly drains into the facility, particularly with respect to surface drainage away from adjacent buildings. Photo B-3 and Photo B-4 illustrate a construction error for an otherwise correctly designed series of rain gardens.



**Photograph B-3.** Inadequate construction staking may have contributed to flows bypassing this rain garden.



**Photograph B-4.** Runoff passed the upgradient rain garden, shown Photo B-3, and flooded this downstream rain garden.

**References**

- Erickson, Andy. 2009. Field Applications of Enhanced Sand Filtration. University of Minnesota *Stormwater Management Practice Assessment Project Update*. <http://wrc.umn.edu>.
- Hunt, William F., Davis, Allen P., Traver, Robert. G. 2012. "Meeting Hydrologic and Water Quality Goals through Targeted Bioretention Design" *Journal of Environmental Engineering*. (2012) 138:698-707. Print.

