



LSC TRANSPORTATION CONSULTANTS, INC.
2504 East Pikes Peak Avenue, Suite 304
Colorado Springs, CO 80909
(719) 633-2868
FAX (719) 633-5430
E-mail: lsc@lsctrans.com
Website: <http://www.lsctrans.com>

Meadowlake Industrial Park
Filing No. 1 Preliminary Plan
Traffic Impact Study
EPC PCD File No. SP236
(LSC #S234040)
January 10, 2025

Traffic Engineer's Statement

This traffic report and supporting information were prepared under my responsible charge and they comport with the standard of care. So far as is consistent with the standard of care, said report was prepared in general conformance with the criteria established by the County for traffic reports.

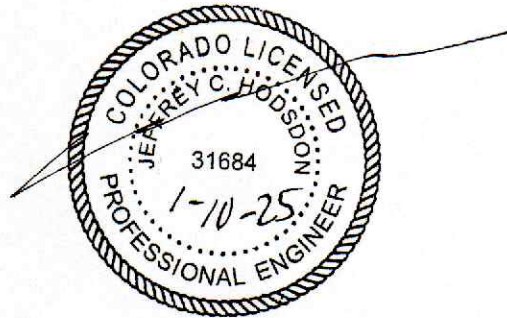

Developer's Statement

I, the Developer, have read and will comply with all commitments made on my behalf within this report.

Date

Meadowlake Industrial Park Filing No. 1 Preliminary Plan Traffic Impact Study

Prepared for:
Meadowlake Developments, LLC
P.O. Box 1385
Colorado Springs, CO 80901

Contact: Kevin O'Neil

JANUARY 10, 2025

LSC Transportation Consultants
Prepared by: Jeffrey C. Hodsdon, P.E.

EPC PCD File No.: SP236
LSC #S234040



CONTENTS

- REPORT CONTENTS 1
- LIST OF OTHER TRAFFIC REPORTS USED IN THE PREPARATION OF THIS REPORT..... 2
- STUDY AREA DETERMINATION..... 2
 - Study Area Basis for Individual Full TIS..... 2
- LAND USE AND ACCESS 3
 - Site Land Use..... 3
 - Site Access..... 3
- INTERSECTION SIGHT DISTANCE 4
 - Entering Sight Distance 4
 - Stopping Sight Distance to Downstream Intersection..... 4
- ROAD AND TRAFFIC CONDITIONS AND *MTCP* CLASSIFICATION 4
 - Existing Roadways..... 4
 - Existing Traffic Volumes 6
- PEDESTRIAN AND BICYCLE FACILITIES 7
- TRIP GENERATION..... 7
- TRIP DISTRIBUTION AND ASSIGNMENT..... 8
 - Trip Directional Distribution..... 8
 - Site-Generated Traffic..... 8
 - Short-Term 8
 - Long-Term (For Reference Only) 8
 - Short Term (2025) Baseline/Background Traffic Volumes..... 9
 - Short-Term (2025) Baseline Plus Site-Generated Traffic Volumes 9
 - Long-Term Background and Total Traffic Volumes 9
- LEVEL OF SERVICE ANALYSIS 10
 - Curtis Road/Pagoda Bush Street (Full-Movement Site Access) 10
 - US Highway 24/Stapleton Road 10
 - Judge Orr Road/Curtis Road 11
 - Falcon Highway/Curtis Road 11
 - Two-Way Stop-Sign Control 11
 - All-Way Stop-Sign Control 11

VEHICLE QUEUEING ANALYSIS	11
Queuing Analysis Terminology	11
Upstream Block Time	11
Storage Block Time.....	11
Maximum Queue	12
95 th -Percentile Queue	12
Queuing Analysis Results.....	12
Falcon Highway/Curtis Road	12
Judge Orr Road/Curtis Road	13
ALL-WAY STOP-CONTROL (AWSC) Warrants Evaluation – Falcon Highway/Curtis Road.....	14
AUXILIARY TURN-LANE ANALYSIS, INTERSECTION CONFIGURATION, AND TRAFFIC CONTROL... 14	
Auxiliary Turn-Lane Requirements	14
Turn-Lane Criteria	14
Curtis Road/Pagoda Bush Street (Site Access).....	14
Short Term	14
Long Term	15
Stapleton Drive/Judge Orr Road/Curtis Road.....	15
Short Term	15
Long Term	16
Falcon Highway/Curtis Road	16
Short Term	16
Long Term	17
Long Term	18
ROADWAY CLASSIFICATIONS	18
ROADWAY SEGMENT IMPROVEMENTS	19
Curtis Road.....	19
Falcon Highway	19
DEVIATIONS AND WAIVERS.....	19
Curtis Road/ Falcon Highway Intersection - Eastbound Left-Turn Lane Lengthening.....	19
Curtis Road Interim Cross Section Adjacent to the Site Frontage.....	20

COUNTY ROAD IMPROVEMENT FEE PROGRAM	20
Transportation Impact Fees	20
MTCP Improvements	20
MULTI-MODAL TRANSPORTATION AND TDM OPPORTUNITIES	21
CDOT PROCESS AND REQUIREMENTS	21
IMPROVEMENTS TABLE	22
ESCROW ANALYSIS	22
FINDINGS AND CONCLUSIONS	22
Enclosures:	23
Table 2 - Table 4	
Figures 1-7	
Traffic Count Reports	
Synchro LOS Reports	
SimTraffic Queuing Reports	
Appendix A	
Appendix B	
Appendix C	
Meadowlake Industrial Filing No. 1 Preliminary Plans	
Key Pages from the Master TIS	



LSC TRANSPORTATION CONSULTANTS, INC.
2504 East Pikes Peak Avenue, Suite 304
Colorado Springs, CO 80909
(719) 633-2868
FAX (719) 633-5430
E-mail: lsc@lsctrans.com
Website: <http://www.lsctrans.com>

January 10, 2025

Mr. Kevin O'Neil
Meadowlake Developments, LLC
P.O. Box 1385
Colorado Springs, CO 80901

RE: Meadowlake Industrial Park
Filing No. 1 Preliminary Plan
El Paso County, CO
EPC PCD File No.: [SP236](#)
LSC #S234040

Dear Mr. O'Neil,

LSC Transportation Consultants, Inc. has prepared this traffic impact study for the proposed Meadowlake Industrial Park Filing No. 1 Preliminary Plan. Meadowlake Industrial Park is located northwest of the intersection of Falcon Highway/Curtis Road in El Paso County, Colorado. The 51.3-acre Filing No. 1 would be the first area to develop within the overall industrial park. The site is located within the eastern area of the overall industrial park along Curtis Road about one-quarter mile north of Falcon Highway. As part of this initial development, one site-access point is proposed to Curtis Road. This report has been prepared to accompany the Preliminary Plan submittal to El Paso County.

REPORT CONTENTS

The preparation of this report included the following:

- An inventory of existing roadway and traffic conditions on major thoroughfares adjacent to the site, including surface conditions, functional classification, widths, pavement markings, traffic control signs, posted speed limits, intersection and access spacing, roadway and intersection alignments, roadway grades, and auxiliary turn lanes;
- Weekday peak-hour turning-movement traffic counts at the study-area intersections;
- Estimated average weekday traffic (ADT) volumes on Falcon Highway, Curtis Road, Meridian Road, Judge Orr Road, and US Highway 24 (US Hwy 24);
- Projections of 2025 short-term background traffic volumes;
- The proposed preliminary plan site land use and access plan;

- Estimates of average weekday and weekday peak-hour trip generation for the proposed preliminary plan land uses and the estimated directional distribution of site-generated vehicle trips on roadways and intersections adjacent to and in the vicinity of the site;
- Projected site-generated and resulting total peak-hour intersection traffic volumes at the following “study-area” intersections:
 - Curtis Road/north site access (full-movement)
 - Falcon Highway/Curtis Road
 - Curtis Road/Judge Orr Road
 - US Highway 24/Stapleton Road
- Projected total short-term daily and peak-hour traffic volumes at the study-area intersections;
- Projected short-term Intersection level of service analysis at the study-area intersections;
- Evaluation of the short-term projected intersection volumes to determine potential short-term requirements for any auxiliary right-/left-turn lanes at the proposed site-access points, based on the criteria in El Paso County’s *Engineering Criteria Manual (ECM)*; and
- Short-term roadway improvement recommendations and potential requirement for escrow contributions toward future improvements.

LIST OF OTHER TRAFFIC REPORTS USED IN THE PREPARATION OF THIS REPORT

- The July 29, 2022 Meadowlake Industrial Park Master TIS
- TIS Reports for Saddlehorn Ranch
- Esteban Rodriguez Sketch Plan Master Traffic Impact Study
- Jane Davis Ranch Sketch Plan Master Traffic Impact Study

STUDY AREA DETERMINATION

Study Area Basis for Individual Full TIS

Per Section B.2.3.B of El Paso County’s *Engineering Criteria Manual (ECM)*:

The limits of the transportation network to be studied shall be based on the size and extent of the proposed development, the existing and future land uses, and traffic conditions on and near the site.

Additionally, off-site intersections which should be included for a full traffic impact study include those which meet the following criteria:

Additional offsite major intersections where: the project contributes a 10 percent impact (during either the A.M. or P.M. peak hour) to any approach leg of the

intersection where the intersection is operating at a LOS of C or better in the Short-Range Horizon

LSC has calculated the percent increase in traffic for projected site-generated traffic volumes vs. existing traffic volumes. Site-generated trips only include those for Filing 1 only during the short term. Please refer to Appendix A for this analysis.

LAND USE AND ACCESS

Figure 1 shows the site location relative to the adjacent and nearby roadways. The site is located northwest of the intersection of Falcon Highway/Curtis Road about one-quarter mile north of that intersection. Meadow Lake Airport is located north and west of Meadowlake Industrial Park. The parcel east of Curtis Road is currently vacant. The Saddlehorn Ranch development site is located to the northeast along the east side of Falcon Highway.

Site Land Use

The preliminary plan is shown in Figure 2. The preliminary plan sheets are attached for reference. The site is zoned I-2. The Master TIS had assumed ITE Land Use "130 – Industrial Park" for this preliminary plan area. The anticipated development, for the purpose of this report, is best represented by ITE Land Use "150 – Warehousing."

Note: The specific uses of this Preliminary Plan site shall be limited to those included in this Filing No. 1 Preliminary Plan traffic impact study (TIS) submitted with EPC PCD File No. SP236. The applicant shall be required to provide a revised traffic impact study to be submitted and approved prior to initiation of any uses beyond those included in this traffic impact study.

The total Filing No. 1 Preliminary Plan acreage is 36.56. Based on the 0.29 floor area ratio (FAR) assumed in the rezone report, the estimated building square footage of the Filing No. 1 Preliminary Plan is 461,841 square feet (462 KSF).

Site Access

One access is proposed to initially serve the preliminary plan area. This access, Pagoda Bush Street, will be a public street, and will intersect Curtis Road one-half mile north of Falcon Highway, consistent with the July 29, 2022 master TIS for the Meadowlake Industrial Park. This half-mile spacing between Curtis/Pagoda Bush would meet the *ECM* access spacing requirement.

In the future, additional access points will be available with the future completion of the overall internal street system within the greater industrial park. These are shown in the July 29, 2022 TIS report.

INTERSECTION SIGHT DISTANCE

Entering Sight Distance

Intersection entering sight distance at the proposed Pagoda Bush/Curtis Road intersection (proposed site-access) would meet sight-distance requirements in *ECM* Table 2-21. The following are the existing sight-distance measurements. These measurements were conducted in the field by LSC. The measurements were taken from a driver's eye height of 3.5 feet to an approaching vehicle height of 3.5 feet.

- Greater than 1,000 feet looking north along Curtis Road from Pagoda Bush
- Greater than 1,000 feet looking south along Curtis Road from Pagoda Bush

The lines of sight for the proposed Pagoda Bush/Curtis Road intersection will need to be kept clear of any sight-distance obstructions. This includes landscaping, signage, etc. proposed as part of the site development.

Stopping Sight Distance to Downstream Intersection

Stopping sight distance along Curtis Road approaching the proposed Pagoda Bush/Curtis intersection location meets stopping sight-distance requirements in *ECM* Table 2-17. The following are the existing sight-distance measurements. These measurements were conducted in the field by LSC. The measurements were taken from the driver's eye height of an approaching vehicle to a height of 3.5 feet at the center of each intersection.

- Greater than 1,000 feet south to Pagoda Bush from a southbound motorist on Curtis Road approaching the intersection from the north
- Greater than 1,000 feet north to Pagoda Bush from a northbound motorist on Curtis Road approaching the intersection from the south

ROAD AND TRAFFIC CONDITIONS AND *MTCP* CLASSIFICATION

Existing Roadways

Figure 1 and Figure 2 show the roads adjacent to and in the vicinity of the site. Adjacent roads serving the site are identified below followed by a brief description of each:

US Highway 24 (US Hwy 24) is located about one mile north of the site (via Curtis Road) and about 1.5 miles west of the site (via Judge Orr Road). This State Highway extends locally from the City of Colorado Springs to Peyton in a northeasterly direction and then continuing east. US Hwy 24 is planned to be widened to four lanes through the Falcon area and is classified as an E-X – Expressway by the Colorado Department of Transportation (CDOT). The posted speed limit on US Hwy 24 at Stapleton Road is 65 miles per hour (mph). Auxiliary left-turn lanes currently exist on the northbound and southbound approaches at the intersections of Stapleton/US Hwy 24 and US Hwy 24/Judge Orr. The intersection of US Hwy 24/Stapleton is

currently TWSC-controlled. CDOT has indicated that this intersection is on the list of intersections programmed for signalization. Per the *US 24 Planning and Environmental Linkages (PEL) Study*, US Hwy 24 will be expanded to four lanes in the vicinity of the site within the next 20 years. However, since the preparation of the PEL study, more detailed planning for US Hwy 24 has been completed, and a design project is currently underway for expansion to four lanes between Garrett Road and Woodmen Road. This current project may have altered the timing of highway widening east of Woodmen Road. The following is posted on the US Highway 24 improvements website *"Funding was recently allocated for next steps in project development. This includes furthering design of US 24, widening to four lanes from Garrett Road to Stapleton Road [the current CDOT project is Garrett Road to Woodmen Road] and creating a new Access Control Plan from Elbert Road to the El Paso/Elbert County line. CDOT will continue to look for funding sources to design and construct study recommendations."*

Judge Orr Road is a two-lane roadway that extends east from Eastonville Road across most of El Paso County. It is shown on the *El Paso County 2045 Major Transportation Corridors Plan* and the *2065 Preserved Corridor Network Plan* as a Rural Minor Arterial (**two-lane**) adjacent to the site (and west of Curtis Road). Posted speed limits within the study area range from 45 to 55 mph. West of Curtis Road, the speed limit is 45 mph, while it generally increases to 55 mph east of Curtis Road. The intersection of US Hwy 24/Judge Orr is currently signalized. Due to the oblique angle of this intersection, the eastbound and westbound approaches are split-phased. The *US 24 Access Control Plan/PEL Study* shows future plans for realignment of Judge Orr at US Hwy 24 to improve the intersection and provide an intersection angle closer to 90 degrees.

Curtis Road is a two-lane roadway that extends south from the intersection of Judge Orr Road/Stapleton Road intersection to Drennan Road. It is shown as a two-lane, Rural Minor Arterial on El Paso County's *2045 Major Transportation Corridors Plan (MTCP)* and a four-lane Principal Arterial on the *2065 Corridor Preservation Plan*. In the vicinity of Judge Orr Road, the posted speed limit is 45 mph. The intersection of Curtis Road/Stapleton Road/Judge Orr Road is two-way, stop-sign controlled. Generally, Curtis Road is an "unimproved," two-lane paved road between Judge Orr and Falcon Highway. However, upgrades are planned as part of the Saddlehorn Development.

Falcon Highway extends from US Hwy 24 to Ellicott Highway and is classified as a two-lane Major Collector on the 2045 El Paso County *MTCP*. In the vicinity, the posted speed limit is 55 mph. Currently, the intersection of Falcon Highway/Curtis Road has auxiliary right- and lanes on the eastbound approach and auxiliary left-turn lanes on the westbound, northbound, and southbound approaches. The intersection is two-way, stop sign-controlled (TWSC), with the stop signs on the northbound and southbound approaches.

Existing Traffic Volumes

Vehicular turning-movement counts were conducted at the study-area intersections. Figure 3 shows these turning-movement volumes (raw count data are attached) and the average weekday traffic volumes (estimated based on factored peak-hour count data) on the study-area roadways.

- Curtis Road/Falcon Highway
 - Wednesday, May 17, 2023 from 6:30 – 8:30 a.m.
 - Wednesday, May 17, 2023 from 4:00 – 6:00 p.m.
- Curtis Road/Judge Orr Road
 - Thursday, November 2, 2023 from 4:00 – 6:00 p.m.
 - Tuesday, November 7, 2023 from 6:30 – 8:30 a.m.
- US 24/Judge Orr Road
 - Tuesday, April 2, 2024 from 6:30 – 8:30 a.m.
 - Tuesday, April 2, 2024 from 4:00 – 6:00 p.m.
- US 24/New Meridian Road
 - Thursday, May 4, 2023 from 6:30 – 8:30 a.m.
 - Thursday, May 4, 2023 from 4:00 – 6:00 p.m.
- US 24/Stapleton Drive
 - Tuesday, January 10, 2023 from 6:30 – 8:30 a.m.
 - Tuesday, January 10, 2023 from 4:00 – 6:00 p.m.
- New Meridian Road/Falcon Highway
 - Thursday, April 28, 2022 from 6:30 – 8:30 a.m.
 - Thursday, April 28, 2022 from 4:00 – 6:00 p.m.

Existing Levels of Service

Level of service (LOS) is a quantitative measure of the level of congestion or delay at an intersection and is indicated on a scale from “A” to “F.” LOS A is indicative of little congestion or delay. LOS F indicates a high level of congestion or delay. Table 1 shows the level of service delay ranges for signalized and unsignalized intersections.

Table 1: Intersection Levels of Service Delay Ranges

Level of Service	Signalized Intersections	Unsignalized Intersections
	Average Control Delay (seconds per vehicle)	Average Control Delay (seconds per vehicle) ⁽¹⁾
A	10.0 sec or less	10.0 sec or less
B	10.1-20.0 sec	10.1-15.0 sec
C	20.1-35.0 sec	15.1-25.0 sec
D	35.1-55.0 sec	25.1-35.0 sec
E	55.1-80.0 sec	35.1-50.0 sec
F	80.1 sec or more	50.1 sec or more

(1) For unsignalized intersections, if V/C ratio is greater than 1.0 the level of service is LOS F, regardless of the projected average control delay per vehicle.

Figure 3 also shows a summary of the existing levels of service, lane geometry and traffic control.

PEDESTRIAN AND BICYCLE FACILITIES

The new 2045 *MTCP* presents multi-modal improvements in a different manner, but the following roadway improvement projects were included in the **2016 *MTCP*** as being needed by the year 2040 per Map 15 and Table 5:

- M4 – Falcon Highway from Meridian Road to South Peyton Highway
 - Bicycle and secondary regional trail improvements (6.95 miles)
- M7 – Elbert Road from US 24 to Judge Orr Road
 - Bicycle improvements (2.32 miles)
- M8 – Judge Orr Road from Eastonville Road to South Peyton Highway
 - Bicycle improvements (2.98 miles)
- M9 – Stapleton Road from Meridian Road to US 24
 - Bicycle improvements (2.56 miles)

TRIP GENERATION

Estimates of the vehicle trips projected to be generated by Filing No. 1 of Meadowlake Industrial Park have been made using the nationally published trip-generation rates from *Trip Generation, 11th Edition, 2021* by the Institute of Transportation Engineers (ITE). Trip-generation rates from ITE Land Use Category 150 – “Warehousing” have been used to develop the trip-generation estimates for the preliminary plan site.

Table 2, attached, presents the estimated site trip generation.

The proposed Meadowlake Industrial Park Filing No. 1 is projected to generate about 790 new, external vehicle trips on the average weekday during a 24-hour period, with approximately half entering and half exiting the site. During the morning peak hour, approximately 60 entering vehicles and 18 exiting vehicles would be generated. Approximately 23 entering and 60 exiting vehicles (less internal capture trips) would be generated by the site during the evening peak hour.

TRIP DISTRIBUTION AND ASSIGNMENT

Trip Directional Distribution

Estimating the directional distribution of site-generated vehicle trips to the study-area roads and intersections is a necessary component in determining the site's traffic impacts. Figure 4 shows the percentages of the site-generated vehicle trips projected to be oriented to and from the site's major approaches. Estimates have been based on Figure 4a of the master TIS report.

Site-Generated Traffic

Short-Term

Short-term site-generated traffic volumes have been estimated at the study-area intersections. The volumes have been calculated by applying the short-term directional-distribution percentages (from Figure 4) to the trip-generation estimates (from Table 2). Figure 5 shows the projected short-term site-generated traffic volumes for the weekday morning and evening peak hours.

Long-Term (For Reference Only)

The July 29, 2022 TIS included estimates of the overall buildout long-term site-generated traffic volumes for the overall Meadowlake Industrial Park. **Figures 7a, 7b, and 7c of that TIS** showed those buildout volumes. **Appendix B** of this report includes a copy of the long-term distribution estimate from **Figure 5 of that TIS** report (Appendix Figure B-1). Appendix B also includes the long-term site-generated traffic for the Filing No. 1 preliminary plan (Appendix Figures B-2 and B-3), based on that Figure 5 (included as Appendix Figure B-1) from the July 29, 2022 TIS report applied to the current trip-generation estimate (Table 2 of this report).

Short Term (2025) Baseline/Background Traffic Volumes

The 2025 baseline/background traffic-volume estimates are shown in Figure 6. These estimates assume the following:

- A three (3) percent per year growth rate applied to existing volumes (includes minor volume-balancing adjustments to the 2022 Judge Orr Road/Curtis Road counts).
- Additionally, traffic projected for buildout of Saddlehorn Ranch Filing Nos. 1 and 2 has been included in the 2025 baseline volumes.
- A portion of the trips from the Esteban and Davis: Included Jane Davis TAZ 1, and one third of Esteban Rodriguez residential.

Note: the short-term (2025) baseline/background volumes are exclusive of any trips to be generated by this preliminary plan area or the overall Meadowlake Industrial Park.

Short-Term (2025) Baseline Plus Site-Generated Traffic Volumes

Figure 7 shows the sum of the 2025 short-term total traffic (background traffic volumes from Figure 6 plus site-generated traffic volumes from Figure 5). These volumes represent the projected short-term **total** traffic (assuming buildout of the Filing No. 1 preliminary plan development).

Long-Term Background and Total Traffic Volumes

The July 29, 2022 "Master" TIS report included long-term/20-year-horizon projections for the overall Meadowlake Industrial Park, which included this initial preliminary plan development area. Please refer to that TIS report for long-term projected volumes, which assume buildout of the project.

Per the July 29, 2022 "Master" TIS report:

The 20402 background traffic volumes are generally based on the projections presented in the MTCP, but adjustments have been made to account for the removal of the PUD, urban-density land use and corresponding trip generation from the former Santa Fe Springs development area. For more information and details, please refer to PCD File Nos. [P178](#) through [P1714](#). The County rezoned the former Santa Fe Springs development parcels to A-5, A-35, F-5, RR.5, RR2.5, and RR 2, which replaced the Santa Fe Springs PUD 1 zoning.

US Hwy 24 volumes are estimates by LSC based, in part, on the Colorado Department of Transportation US 24 Planning and Environmental Linkages Study Final Corridor Conditions Report (dated December 2016). These volumes assume the 2042 roadway system including the extension of Stapleton Road west to Briargate Parkway. Traffic from the proposed Meadowlake Industrial Park is not included in the 2042 background traffic volumes.

LEVEL OF SERVICE ANALYSIS

LOS values have been included on each figure for each turning movement/approach during the weekday morning and evening peak hours for the proposed site-access intersection and off-site intersections in the study area:

- Figure 3: Existing Traffic, Lane Geometry, Traffic Control, and LOS
- Figure 6: 2025 Background Traffic, Lane Geometry, Traffic Control, and LOS
- Figure 7: 2025 Total Traffic (Background + Site), Lane Geometry, Traffic Control, and LOS

Please refer to the Master TIS report showing long-term projected levels of service assuming buildout of the project. An excerpt from the Master TIS containing applicable pages has been attached to this report, for reference.

Curtis Road/Pagoda Bush Street (Full-Movement Site Access)

All approaches and individual turning movements are projected to operate at LOS B or better during both the AM and PM peak hours of the short-term total scenario.

US Highway 24/Stapleton Road

Currently, the intersection of US 24/Stapleton is two-way stop-sign controlled (TWSC). The following turning movements currently operate at LOS E or worse, with or without the addition of site-generated traffic: northwest-bound left, northwest-bound through, southeast-bound left, and southeast-bound through.

Once signalized, all individual turning movements and the intersection overall would operate at LOS B or better during both short-term peak hours, with or without the addition of site-generated traffic.

It is our understanding that this is on CDOT's list of intersections to be signalized. The timing of signal installation by CDOT is presumably based on their priority system for signal installations. Signal escrows have been required, by CDOT, of several area projects, including this one. This was identified in the October 31, 2023 CDOT comment memo.

The October 31, 2023 CDOT comment memo did not identify any specific requirement(s) with respect to additional auxiliary turn lanes or modifications to existing auxiliary lanes at this intersection. This is likely because there is already a full set of acceleration/deceleration lanes in-place on US Highway 24 at this intersection. This project will still need to go through the access permit process with CDOT and access permits will need to provide all the detailed requirements as part of the permit terms and conditions.

Judge Orr Road/Curtis Road

All individual approaches/turning movements at the intersection of Judge Orr/Curtis are projected to operate at LOS C or better during both short-term peak hours, with or without the addition of Filing 1 site-generated traffic.

Falcon Highway/Curtis Road

Two-Way Stop-Sign Control

If Falcon Highway/Curtis Road were to remain two-way stop sign-controlled, the following individual approaches/turning movements are projected to remain at LOS E or worse during both short-term peak hours: northbound left-turn and southbound through/right, with or without the addition of site-generated traffic.

All-Way Stop-Sign Control

If the intersection of Falcon Highway/Curtis Road were to be converted from TWSC to AWSC, all individual turning movements would operate at LOS C or better during both peak hours of the 2025 Baseline Total traffic scenario.

VEHICLE QUEUEING ANALYSIS

A SimTraffic queueing analysis was performed to estimate the maximum queues for key turning movements at the intersections of Falcon Highway/Curtis Road and Judge Orr Road/Curtis Road.

Queueing Analysis Terminology

Upstream Block Time

“Upstream block time” represents the percentage of time during the peak hour in which the entry point for a turn lane upstream of the subject intersection is blocked by a queue in the adjacent through lane.

Storage Block Time

“Storage block time” is the proportion of time in which the turn lane’s queue exceeds the available storage length and left-turning vehicles effectively overspill the turn lane in the model into the adjacent through lane.

Maximum Queue

“Maximum queue” represents the maximum queue length observed for each individual lane during the 15-minute analysis period. SimTraffic records the maximum back of queue observed for every two-minute period. In SimTraffic, a vehicle is considered queued whenever it is behind another vehicle traveling at less than 10 feet/second (approximately 7 mph) or at a stop bar. The maximum observed queue may not occur during the same interval in which the highest upstream block time (percent) or storage block time (percent) occurs. SimTraffic reports have reported the highest value for each metric for each turn lane/approach, regardless if they occur in the same 15-minute interval.

95th-Percentile Queue

Reported queue length for auxiliary turn lanes in SimTraffic is generally limited by the turn-lane length. SimTraffic simply reports the maximum observed queue length during simulations. The reported 95th-percentile queue is also part of the results.

Queuing Analysis Results

The following analysis assumes that the following modifications at the intersection of Curtis Road/Falcon Highway:

- Intersection would be converted to all-way stop control.
- A new right-turn lane would be added to the southbound approach.

The worst-case queue from the AM and PM peak hours for key tuning movements at both intersections is reported below. Please refer to the attached SimTraffic queue reports and Synchro analysis reports for additional details.

Falcon Highway/Curtis Road

Eastbound Left

SimTraffic simulation results indicate the following worst-case modeled queue lengths in the eastbound left-turn lane (as it exists today) approaching the Curtis Road/Falcon Highway intersection:

- Maximum queue – 35 feet
- 95th-percentile queue – 37 feet
- Upstream block time – 0 percent
- Storage block time – 0 percent

Southbound Left

SimTraffic simulation results indicate the following queue lengths in the southbound left-turn lane on Curtis Road approaching Falcon Highway:

- Maximum queue – 79 feet
- 95th-percentile queue – 61 feet
- Upstream block time – 0 percent
- Storage block time – 0 percent

Southbound Through

SimTraffic simulation results indicate the following queue lengths in the southbound through lane on Curtis Road approaching Falcon Highway:

- Maximum queue – 190 feet
- 95th-percentile queue – 190 feet
- Upstream block time – 0 percent
- Storage block time – 0 percent

Southbound Right

SimTraffic simulation results indicate the following queue lengths in the southbound right-turn lane on Curtis Road approaching Falcon Highway:

- Maximum queue – 59 feet
- 95th-percentile queue – 51 feet
- Upstream block time – 0 percent
- Storage block time – 0 percent

Judge Orr Road/Curtis Road

Northbound-Left

HCM 6th-edition results indicate the following queue lengths in the northbound left-turn lane on Curtis Road approaching Judge Orr Road:

- 95th-percentile queue – 80 feet (3.2 vehicles)

Northbound-Through/Right

HCM 6th-edition results indicate the following queue lengths in the shared northbound through/right-turn lane on Curtis Road approaching Judge Orr Road:

- 95th-percentile queue – 65 feet (2.6 vehicles)

ALL-WAY STOP-CONTROL (AWSC) WARRANTS EVALUATION – FALCON HIGHWAY/CURTIS ROAD

Please refer to the attached Appendix A which includes this evaluation. An update with additional details/volume counts could be provided at the Site Development/Platting stage of development.

AUXILIARY TURN-LANE ANALYSIS, INTERSECTION CONFIGURATION, AND TRAFFIC CONTROL

Auxiliary Turn-Lane Requirements

The need for auxiliary left- and right-turn lanes at the study-area intersections has been evaluated to determine if lane improvements would be required, based on short-term total traffic, to meet the County's *Engineering Criteria Manual's (ECM)* auxiliary turn-lane criteria. Also, this report identifies needed laneage for the long- term future, based on the Master TIS. For cases where improvements are not triggered in the short term with Filing No 1 Preliminary Plan but may become needed long term/at project buildout, this report identifies the potential for escrow contribution, as applicable.

Deceleration lanes shall meet design criteria specified in El Paso County's *Engineering Criteria Manual (ECM Tables 2-24 and 2-27)* or the Colorado State Highway Access Code (CDOT) for US Hwy 24.

Table 3 (attached) presents details regarding auxiliary turn lanes at the study-area intersections.

Turn-Lane Criteria

Table 3 includes peak-hour auxiliary left- and right-turn lane thresholds according to *ECM* criteria. Roadway classifications for key area County thoroughfares include:

- Principal Arterial – Stapleton Road, Meridian Road
- Minor Arterial – Judge Orr Road, Curtis Road.
- Rural Major Collector - Falcon Highway
- Urban Non-Residential Collector (but privately owned street): Pagoda Bush Street

Curtis Road/Pagoda Bush Street (Site Access)

Short Term

The intersection of Curtis Road/Pagoda Bush Street will require a northbound left-turn deceleration lane and a separate eastbound-left-turn lane for exiting traffic.

Long Term

The Master TIS shows a future southbound right-turn lane, northbound left-turn lane, and eastbound left-turn lane (and the eastbound travel lane on Pagoda Bush Street marked as a right-turn lane). Based on buildout site traffic, the northbound left-turn lane was shown to include 150 feet of storage length (in addition to the deceleration and taper lengths).

The Master TIS also showed a southbound right-turn acceleration lane on Curtis Road. However, note that the classification of Curtis Road has since changed to Minor Arterial with the 2024 *MTCP* and acceleration lanes are generally not required on Minor Arterial roadways.

Stapleton Drive/Judge Orr Road/Curtis Road

Short Term

Based on November 2023 traffic counts, the eastbound **AM peak-hour** right-turn volume exceeds the *ECM*-threshold right turning volume of 50 vph for which a right-turn lane is prescribed. The eastbound **PM peak-hour** volume does not currently exceed this threshold and the 2025 short-term baseline-plus-Filing No. 1 Preliminary Plan site-generated eastbound PM peak-hour volume is projected to be just below this threshold.

Regarding short- or intermediate-term need for this right-turn lane, *Colorado State Highway Access Code* Section 3.5 (5) has a provision for a 20-year travel-lane maximum volume which could be applied as rationale for potential deferment of the installation of the turn lane in the short term. This provision reads:

“The auxiliary lanes required in the category design standards may be waived when the 20th year predicted roadway volumes conflicting with the turning vehicle are below the following minimum volume thresholds. The right turn deceleration lane may be dropped if the volume in the travel lane is predicted to be below 150 DHV.”

Neither the AM nor PM peak-hour eastbound through-plus-right-turn volume is **currently** at the 150 vph level. For the short-term total (2025 background plus site) traffic condition shown in Figure 7 the AM peak-hour eastbound through-plus-right turn lane volume is shown to remain below the 150 vph threshold (by seven vehicles per hour) and the PM peak-hour eastbound **right-turn** movement is not projected to exceed 50 (projected 45).

However, both values are close to the potential provision thresholds and the background intersection traffic movements are expected to increase over time, with either the PM peak-hour right-turn volume increasing to over 50 and/or the AM peak-hour through movement increasing to over 150. With the addition of Saddlehorn Filing No. 3 and likely growth in through traffic, and possibly additional trips by other area development projects

(some currently still at the sketch plan stage), it is likely that this CDOT access-code provision will no longer apply by the time this preliminary plan is built out. Therefore, the lane should be programmed for completion with this preliminary plan. At the time of Filing 1 plat, this could be re-analyzed to confirm this. At a minimum, Filing No. 1, or an initial sub-filing, if applicable, should escrow for pro rata share of this improvement.

Please refer to Table 4 for more details regarding the evaluation of potential turn lane needs and timing of potential roadway improvements at this intersection.

Long Term

LSC has assumed that the intersection of Judge Orr/Curtis would be converted from TWSC to a roundabout during the long-term buildout scenario. This intersection improvement was previously recommended in the *Saddlehorn Ranch*, *Jane Davis Ranch*, and *Esteban Rodriguez* traffic studies. Additionally, Judge Orr Road and Curtis Road are assumed to have one through lane in each direction (per the 2045 *MTCP*).

Falcon Highway/Curtis Road

The intersection of Falcon Highway/Curtis Road could potentially be signed AWSC during the short term once AWSC warrants are met, as all approaches would operate at LOS C or better in the short term with AWSC.

A preliminary AWSC warrant analysis is attached to this report. This analysis could be expanded upon at the site-development plan or platting stage.

Short Term

Note: based on short-term projections, the following auxiliary turn-lane upgrades would not be necessary under these conditions:

- Southbound Right-Turn Lane:
 - With the current TWSC and north/south stop-sign orientation, as the southbound right-turn lane as a “speed-change lane” would not be necessary. **However, as the addition of a southbound right-turn lane would improve the level of service for the southbound through movements, LSC is recommending the turn lane be installed (unless the intersection control is changed to AWSC in the short term).**
 - If the intersection were changed to AWSC.
 - If a roundabout were to be constructed at the intersection of Falcon Highway/Curtis Road.

Short-Term Southbound Right-Turn Lane Details:

The addition of a southbound right-turn lane is recommended in the short term to improve the level of service, as mentioned above. Potentially, a southbound right-turn “stacking” lane could potentially be an interim improvement, provided the approach remains stop-sign controlled. If the TWSC orientation were switched or if the intersection is signalized, the full-length *ECM* deceleration lane would be needed. Under these conditions and based on a design speed of 50 mph on Curtis Road, this southbound right-turn lane would be required to be 510 feet, consisting of:

- 235 feet of deceleration length
- 75 feet of additional storage length for stop-controlled intersections (*ECM* Table 2-30)
- 200 feet of approach taper

Eastbound Approach – Left-Turn Lane Lengthening

Lengthening of the existing left-turn deceleration lane on Falcon Highway would be required based on *ECM* turning-volume threshold criteria. However, a deviation has been prepared to defer the implementation of this improvement, as the previously recommended/proposed triggers are not met for this improvement.

Based on the short-term total traffic projections from SimTraffic simulations, the 95th-percentile queue length for the eastbound left-turn lane during either 2025 Total peak hour would be 37 feet. Thus, the recommended “trigger” of an eastbound left-turn projected queue (95th percentile) which exceeds 50 feet, is not likely to be met.

Please refer to the **improvements table** and the deviation request form for details.

Westbound Approach

Based on the short-term total traffic projections, the **westbound right-turn** volume is projected to remain below the threshold of 50 vph. LSC recommends re-checking at the final plat and with future phases of the project. Meanwhile, fair share escrow amounts will be likely be required with the final plat.

Long Term

Southbound Approach

[from the Master TIS] *A new southbound right-turn deceleration lane would be needed if a traffic signal were to be constructed or if needed to maintain an acceptable level of service as an intersection (with TWSC or AWSC).* As mentioned above in the short-term section, LSC is recommending the southbound right-turn lane with the addition of site-generated traffic

from this preliminary plan's development, as it would result in a better LOS for some movements.

The existing southbound left-turn lane is 395 feet, consisting of 290 feet of full-width lane length plus a 105-foot taper. This does not meet the *ECM*'s requirement of 510 feet for this turn lane. As such, the southbound left-turn lane should be lengthened to 510 feet, consisting of:

- 235 feet of deceleration length
- 75 feet of additional storage length for stop-controlled intersections (*ECM* Table 2-30)
- 200 feet of approach taper

Until a determination is made on the future traffic control — signal or roundabout — an abbreviated turn lane would be an option with escrow of funds for a fair share to extend the lane in the future, if necessary. This may include an option to defer payment of escrow until the next plat, as a signal is unlikely to be installed in the short term.

This should also include provisions for:

1. Return of escrow if one or more of these improvements ends up not being necessary (as in the case of a future roundabout).
2. Cost recovery for construction of an abbreviated or full-length turn lane from other area developments impacting this intersection.

Long Term

Westbound Approach

The Master TIS showed the following, with caveats.

Westbound right-turn deceleration lane

- 290-foot deceleration lane
- 240-foot approach taper
- 55:1 redirect taper length

ROADWAY CLASSIFICATIONS

Primary internal streets within the Preliminary Plan will be classified as Urban, Non-Residential Collector streets. These include the main entry street, Pagoda Bush Street, and Aspen Daisy Drive, the main north-south street. The other streets shown on the Preliminary Plan will be Private Local streets. These include Zinnia Point, Mariposa Lily Grove, and Sundrop View. Individual lot access will be to these private, local streets. The preliminary plan contains the proposed cross section for the Urban, Local (Private) streets.

ROADWAY SEGMENT IMPROVEMENTS

Curtis Road

Please refer to Table 4 for details regarding roadway improvements. Curtis Road should ultimately be improved to a two-lane, Rural Minor Arterial. Dedication of right-of-way for one half of a two-lane Minor Arterial. This would amount to 72 feet from centerline, which includes the "base" 50-feet of half ROW plus 16 additional feet to allow for one-half of the width for a left-turn lane and a separate right-turn deceleration lane and four-foot outside paved shoulder adjacent to the right-turn lane (this also includes four additional feet to allow for an interim left-turn lane to be shifted to the west due to the property constraints on the east side). ROW **reservation** of 18-feet of additional width to achieve 90 feet from centerline for the future four-lane Principal Arterial corridor preservation would be required. Table 4 calls out specific recommended short-term improvements to Curtis Road, between the south property line and the south terminus of the Saddlehorn Filing No. 1 improvements.

Falcon Highway

This report does not recommend any Falcon Highway roadway-**segment** improvements associated with this Filing 1 Preliminary Plan application. However, Table 4 includes Falcon Highway **intersection-related** items under Nos. 5.1, 6.1, and 8.1 through 8.5.

DEVIATIONS AND WAIVERS

The following deviation is included with this submittal.

Curtis Road/ Falcon Highway Intersection - Eastbound Left-Turn Lane Lengthening

A deviation to allow continued use of the existing lane and tapers and defer this improvement (based on short-term turning volumes/associated queue length). There is a drainage channel just to the west. The development would contribute a fair-share escrow amount toward a future improvement. This deviation request form, which was included with the prior submittal, has been updated. Depending on/pending approval of this deviation, the development would contribute a fair-share escrow amount toward a future improvement. Detailed conditions of approval, similar to those imposed on the Saddlehorn development with respect to this improvement, have been added to the deviation.

The future improvement would encompass bringing the existing turn lane up to *ECM* standards. The *ECM* criteria for turn lanes require elements of deceleration distance plus stacking distance plus taper length. On a roadway with a 60-mph design speed (55 posted), the required full-width, left-turn lane length is 290 feet plus left-turn stacking/queuing distance. The required transition taper is 240 feet. For this turn lane, the stacking requirement would be 50 feet (100 feet based on long-term projections) and the resulting total prescribed turn-lane length would be 580 feet. Redirect tapers as a ratio of 55:1 would also need to be part of the design.

Please refer to the deviation form included with this submittal for additional detail and justification.

Curtis Road Interim Cross Section Adjacent to the Site Frontage

This deviation request is to allow a modified, interim cross section for Curtis Road adjacent to the site and north to tie into the Curtis Road improvements adjacent to the Saddlehorn development. The need for the deviation is the necessary ROW for the full Rural Minor Arterial cross section is not available. The applicant does not control the private property along the east side of Curtis Road. Please refer to the deviation request included with this resubmittal.

COUNTY ROAD IMPROVEMENT FEE PROGRAM

Transportation Impact Fees

Per *ECM Appendix B: State what the current applicable Transportation Impact Fees are and what option the developer will be selecting for payment.*

The applicant will be required to participate in this program. The PID option will be identified with the Plat submittal.

It is the responsibility of the applicant to present any credit requests to the road impact fee advisory committee for consideration.

MTCP Improvements

Per the County TIS Checklist: *State whether the MTCP or other approved corridor study calls for the construction of improvements in the immediate area.*

The following roadway improvement projects have been identified as being needed by the year 2045 per Figure 27 of El Paso County's 2045 *MTCP*.

Note: this list below is not intended to suggest that this project must complete all these improvements, rather simply echoing a general list from the *MTCP* of nearby improvements called out on the *MTCP*, based on the collective impacts of new development in El Paso County in general. Please refer to Table 4 for specific recommendations with respect to this development.

512 – Curtis Road from Judge Orr Road to State Highway 94 (\$10,900,000) (Note: See Improvements Table 4 Item No. 1.1)

- Existing conditions – 2-lane Rural Unimproved County Road
- Future conditions – 2-lane Rural Minor Arterial

159 – Judge Orr Road from Eastonville Road to Peyton Highway (\$43,000,000) (Note: See Improvements Table 4 Item No. 5.2 regarding the intersection of US Highway 24/Judge Orr Road and item Nos. 7.1 – 7.4 for the Judge Orr/Stapleton intersection)

- Existing conditions – 2-lane Minor Arterial
- Future conditions – 2-lane Rural Minor Arterial/Urban Major Collector

Per the County TIS Checklist: *State whether or not any improvements affected by the project are reimbursable under the current Major Transportation Corridors Plan (MTCP) and Road Fee program.*

Specific “eligible improvements” associated with this project – i.e., which improvements the project will need to construct and determine if those improvements will qualify as eligible for credit (and reimbursement) – are called out in the improvements table for any specific recommendations with respect to obligations for this development.

MULTI-MODAL TRANSPORTATION AND TDM OPPORTUNITIES

The new 2045 *MTCP* presents multi-modal improvements in a different manner, but the following roadway improvement projects were included in the **2016 *MTCP*** as being needed by the year 2040 per Map 15 and Table 5

- M4 – Falcon Highway from Meridian Road to South Peyton Highway
 - Bicycle and secondary regional trail improvements (6.95 miles)
- M7 – Elbert Road from US Hwy 24 to Judge Orr Road
 - Bicycle improvements (2.32 miles)
- M8 – Judge Orr Road from Eastonville Road to South Peyton Highway
 - Bicycle improvements (2.98 miles)
- M9 – Stapleton Road from Meridian Road to US 24
 - Bicycle improvements (2.56 miles)

Also, the Falcon Park-and-Ride facility recently opened at the intersection of Meridian Road/Swingline Road.

CDOT PROCESS AND REQUIREMENTS

- US Hwy 24/Stapleton is planned to be signalized. The CDOT comment letter dated October 31, 2023, indicated that the applicant will be required to escrow a fair share amount toward this future traffic signal. An access permit will be required to process the escrow.
- The letter identifies a required escrow amount of \$92,000.

LSC Note: There are a number of developments – in progress and future/planned - in the area which will also add traffic to the intersection of US Hwy 24/Stapleton and impact the 4-hour warrant. As CDOT collects escrow for other developments, LSC recommends that as the collective impact trips (directly impacting the 4-hour warrant volumes) by area developments begins to exceed the 60-vehicle-per-hour denominator, fair-share recalculation of pro-rata share escrow amounts and credit be provided to developments according to the updated fair-share calculations. Also, once the signal is installed, credit should be provided from the Countywide Fee Program based on a ratio of fee program unit signal cost divided by the \$650,000 total signal cost.

- Please refer to the CDOT comment letter or Table 4 for detailed calculations and additional information.
- The CDOT comment letter and Table 4 list some other CDOT access permitting requirements for other offsite intersections.

IMPROVEMENTS TABLE

Please refer to Table 4, which presents the recommendations for roadway improvements.

ESCROW ANALYSIS

The escrow analysis will be provided with the plat submittal.

Note: There are a number of developments – in progress and future/planned – in the area which will also add traffic to these intersections needing turn lane improvements. As El Paso County collects escrow for other developments also impacting these turning movements, LSC recommends that as the collective impact trips directly impacting these turn movements, fair-share recalculation of pro-rata share escrow amounts and credit be provided to developments according to the updated fair-share calculations. Also, once the improvements are completed, applicable/allowable Countywide Fee Program credits for construction of intersection approach improvements (turn lanes) be applied based on a ratio of fee program unit cost divided by the improvement cost.

FINDINGS AND CONCLUSIONS

- The proposed Meadowlake Industrial Park Filing No. 1 is projected to generate about 790 new, external vehicle trips on the average weekday during a 24-hour period, with approximately half entering and half exiting the site.
- During the morning peak hour, approximately 60 entering vehicles and 18 exiting vehicles would be generated.
- Approximately 23 entering and 60 exiting vehicles (less internal capture trips) would be generated by the site during the evening peak hour.
- Some stop-sign- controlled turning movements are projected to operate at LOS E or F in the 2025 short term horizon year. The short-term level of service would be C or better if

AWSC traffic control is utilized. The intersection of US Highway 24/Stapleton is projected to continue to have side street levels of service E or F until signalized.

- Please refer to the Improvements Table 4 for a detailed list of roadway system improvements and/or escrow requirements toward future improvements.
- Please refer to the "Auxiliary Turn-Lane Analysis" section above for recommendations.
- The major internal streets within the site will be designed to meet Urban Non-Residential Collector criteria prescribed in the *ECM*. Classifications for the **minor** internal roads will be private, local streets.
- CDOT State Highway Access Permit applications will be submitted at the site development plan stage of development, or in conjunction with the plat.

* * * * *

Please contact me if you have any questions regarding this report.

Respectfully Submitted,

LSC TRANSPORTATION CONSULTANTS, INC.

By: Jeffrey C. Hodsdon, P.E.
Principal

JCH/JAB:jas

Enclosures: Table 2 - Table 4
Figures 1-7
Traffic Count Reports
Synchro LOS Reports
SimTraffic Queuing Reports
Appendix A
Appendix B
Appendix C
Meadowlake Industrial Filing No. 1 Preliminary Plans
Key Pages from the Master TIS

Tables 2-4



Table 2: Trip-Generation Estimate

TAZ	ITE Land Use		Land Use Details				Trip Generation Rates ²				Trips Generated						
			Value	Units	% Floor Area	Value	Units ¹	Average Weekday		A.M. Peak		P.M. Peak		Average Weekday		A.M. Peak	
	Code	Description						In	Out	In	Out	In	Out	In	Out	In	Out
1	150	Warehousing	36.560	Acres	29%	462	KSF	1.71	0.13	0.04	0.05	0.13	790	60	18	23	60
¹ KSF = 1,000 square feet of building floor area ² Source: <i>Trip Generation, 11th Edition (2021)</i> by the Institute of Transportation Engineers (ITE)																	
9/22/2023																	

Table 3: Auxiliary Turn Lane Criteria Comparison (page 1 of 3)

Judge Orr Road + Curtis Road/Stapleton Road							
Criteria	SBL	WBL	NBL	NBR	EBL	EBR	WBR
Existing Traffic Control	Stop-sign	none	Stop-sign	Stop-sign	none	none	none
Assumed Short-Term Traffic Control	Stop-sign	none	Stop-sign	Stop-sign	none	none	none
Existing Volume (vph, AM/PM)	5 / 18	24 / 2	40 / 54	5/6	3 / 2	73 / 24	14 / 13
2025 Total Volume (vph, AM/PM)	5 / 34	28 / 3	61 / 77	5/9	7 / 7	87 / 45	25 / 13
Turn Lane Threshold Warrant (vph)	Existing	Existing	Existing	25	Existing	50	50
Volume Exceeds Threshold?	Lane	Lane*	Lane*	No	Lane	YES**	No
Design Speed (mph)	50	50*	50	50	50	50	60
		*Saddlehorn approved CDs	*Saddlehorn approved CDs				
Existing Turn Lane Lengths (*LANES SHOWN ON SADDLEHORN CDs)							
Total Existing Length (ft)	535	495*	825*	-	522	-	-
Deceleration Length (ft)							
Storage Length (ft)	265	240*	285*	-	250	-	-
Taper Length (ft)	270	255*	540*	-	272	-	-
ECM-Prescribed Turn Lane Lengths (based on 2025 Total Volume; *45 mph posted speed limit on Judge Orr shown on Saddlehorn CDs)							
Total ECM-Prescribed Length (ft)	485	485*	535		435	435	
Deceleration Length (ft)	235	235*	235		235	235	
Storage Length (ft)	50	50*	100		0	0	
Taper Length (ft)	200	200*	200		200	200	
Projected Site-Generated Traffic - Short Term							
Site-Generated Volume (vph, AM/PM)	none	1/0	3/10	0/1	none	6/3	none
Recommended Turn Lane modifications or new turn lane installation w/Filing No. 1 Preliminary Plan							
Total Length (ft)	-	-	-	-	-	435	-
Deceleration Length (ft)	-	-	-	-	-	235	-
Storage Length (ft)	-	-	-	-	-	0	-
Taper Length (ft)	-	-	-	-	-	200	-
Recommendations Related to Future Improvement							
Recommendation shown in the Master TIS Escrow for Future Lane Improvement?			YES			NO - INSTALL IMPROVEMENT*	No
Notes about ECM Criteria							
Improvements Table Reference #	-	-	7.4		-	7.1	-
Meets ECM Criteria (based on ST Total)?	No*	Yes	No*		Yes		-
Associated Notes	<p>*Only because the lane was striped with a slightly shorter lane and slightly longer taper. The total length exceeds ECM requirements and matching "the letter" of the ECM-prescribed lengths would only involve restriping. However, that is not necessary at this point, as the southbound approach is currently stop-sign controlled (no speed change differential from SB through traffic).</p> <p>Saddlehorn Filing 3 approved CD plans show upgrade.</p> <p>*Currently a stop-controlled approach (no speed change differential from NB through traffic). Also, based on 2025 Short Term Total 95th percentile queue plus 235', the existing lane will be adequate in the short-term.</p> <p>Storage length not required, as EBL lane not required (below the threshold)</p> <p>** SEE REPORT NARRATIVE regarding updated assessment of lane timing and need.</p>						
Date: 10/18/2024							

Table 3: Auxiliary Turn Lane Criteria Comparison (page 2 of 3)

Curtis Road + Pagoda Bush Street				
Criteria	EBL	EBR	NBL	SBR
Existing Traffic Control				
Proposed Short-Term Traffic Control	Stop-sign	Stop-sign	none	none
Existing Volumes (vph, AM/PM)				
2025 Total Volumes (vph, AM/PM)	8 / 26	10 / 34	38 / 13	22 / 9
Turn Lane Threshold Warrant (vph)	25	50	10	25
Projected Volume Exceeds ECM Threshold?	Yes	No	Yes	No
Design Speed (mph) (see notes)	40	40	50	50
Existing Turn Lane Lengths				
Total Length (ft)				
Deceleration Length (ft)				
Storage Length (ft)				
Taper Length (ft)				
ECM-Prescribed Turn Lane Lengths (Short-Term)				
Total Length (ft)	365		485	
Deceleration Length (ft)	155		235	
Storage Length (ft)	50		50	
Taper Length (ft)	160		200	
Projected Site-Generated Traffic - Short Term				
Site-Generated Volume (vph, AM/PM)	8/26	10/34	38/13	22/9
Recommended Turn Lane Lengths				
Total Length (ft)	350		485	
Deceleration Length (ft)	---	see note	---	235
Storage Length (ft)	250		50	see note
Taper Length (ft) (see note)	100		200	
Recommendations Related to Future Improvement				
Recommendation shown in the Master TIS Escrow for Future Lane Improvement?	N/A - On Site Improvement			
Notes about ECM Criteria				
Improvements Table Reference #	-	-	10b.2	10b.1
If lane required, do dimensions meet ECM Crit	No	see note	Yes	-
Additional Notes	<p>Although the ECM turn lane threshold is met for the EB LT movement, the lane would not be needed for "speed change purpose (as all eastbound vehicles will be slowing for the stop sign, then turning), nor based on the need to mitigate a LOS deficiency. However, the applicant is designing this street with a separate left-turn bay to accommodate future development.</p>		<p>NBL turn lane is required as part of this preliminary plan; However, applicant may want to design for longer stacking length to accommodate future development.</p>	<p>SBR turn lane not required, as projected volume is < 25 vph. However, applicant may elect to build or complete grading/prep-work with other improvements to accommodate future development.</p>
Date: 11/14/2024				

Table 3: Auxiliary Turn Lane Criteria Comparison (page 3 of 3)

Falcon Highway + Curtis Road							
Criteria	SBL	SBR	WBL	WBR	NBL	EBL	EBR
Existing Traffic Control	Stop-sign	Stop-sign	none	none	Stop-sign	none	none
Assumed Short-Term Traffic Control*	Stop-sign	Stop-sign	none*	none*	Stop-sign	none*	none*
Existing Volume (vph, AM/PM)	7 / 21	24 / 14	13 / 8	43 / 11	62 / 228	13 / 11	252 / 63
2025 Total Volume (vph, AM/PM)	8 / 25	53 / 57	14 / 8	49 / 13	66 / 242	51 / 48	267 / 67
Turn Lane Threshold Warrant (vph)	10	25	25	50	10	25	50
Volume Exceeds Threshold?	Existing Lane	Yes*	Existing Lane	No	Existing Lane	Existing Lane	Existing Lane
Design Speed (mph)	50	50	60	60	50	60	60
Existing Turn Lane Lengths							
Total Length (ft)	405		360		510	395	395
Deceleration Length (ft)						275'	
Storage Length (ft)	295		275		365	(effective length 290-310')	275
Taper Length (ft)	110		85		145	120 (100' - 110')	120
ECM-Prescribed Turn Lane Lengths							
Total Length (ft)	485	485		530	685	580	530
Deceleration Length (ft)	235	235		290	235	290	290
Storage Length (ft)	50	50		0	250	50	0
Taper Length (ft)	200	200		240	200	240	240
Projected Site-Generated Traffic - Short Term							
Site-Generated Volume (vph, AM/PM)	1/3	7/26	None	3/1	None	30/10	None
Recommended Turn Lane modifications or new turn lane installation WITH the Filing No. 1 Preliminary Plan							
Total Length (ft)	-	435	-	-	-	-	-
Deceleration Length (ft)	-	235*	-	-	-	-	-
Storage Length (ft)	-	--	-	-	-	-	-
Taper Length (ft)	-	200'	-	-	-	-	-
Recommendations Related to Future Improvement							
Recommendation shown in the Master TIS Escrow for Future Lane Improvement?	YES	See narrative*		YES		YES	
Notes about ECM Criteria							
Improvements Table Reference #	-	8.2	-	8.4	8.5	8.3	-
Meets ECM Criteria?	-	-	-	-	-	No	-
Additional Notes	*Currently a stop-controlled approach. Please refer to the report narrative and improvement table for additional details.	*Currently a stop-controlled approach. Please refer to the report narrative and improvements table for additional details.	Volume does not exceed threshold.	WBR turn lane not required based on projected 2025 total traffic estimates (Filing 1), as projected volume is < 50 vph.	Filing 1 site traffic would not add to the NBL turn lane; Also, Currently a stop-controlled approach.	See Deviation Request; Escrow towards the cost of future lengthening.	Neither Filing 1 nor Future Phases of site traffic would add to volumes for the EBR turn lane.

Date: 08/28/2024

Table 4
(page 1 of 3)
Meadowlake Industrial Park
Filing No. 1 Preliminary Plan
Roadway Improvements

Roadway Segment Improvements			
Item #	Improvement	Timing	Responsibility
1.1	Curtis Road (Short-Term) -- South property line of Filing No. 1 to south end of planned Saddlehorn improvements Upgrade to 2-lane Minor Arterial. Please refer to the deviation request.	Filing No. 1 Preliminary Plan: Upgrade Curtis Road from the south property boundary north to the south end of the Saddlehorn Ranch improvements. Incorporate paved and gravel shoulders comparable to the Saddlehorn Ranch Filing No. 1 approved CDs. Please refer to the deviation request. The left-turn lane may need to be positioned off-center to the west given ROW constraints on the east side. Standard redirect taper ratios should be used to shift through lanes. If the southbound right-turn lane is not constructed with this first preliminary plan, install the paved and gravel shoulders. For the first 100+/- feet north and south of the access, install the radii in the anticipated ultimate location (to accommodate the width for a future SB RT decel and accel lanes plus shoulders) and pave a short temporary tapered pavement area to tie in with the the interim improvements. Also see turn lane improvements section of this table.	Applicant
Adjacent County Arterial Roadway ROW Requirements			
Item #	Improvement	Timing	Responsibility
2.1	<u>Curtis Road</u> 2-Lane Rural Minor Arterial 100' ROW, but 132' total to accommodate left and right turn auxiliary lanes on both sides.	With the Filing No. 1 Plat: Show dedication of 72' of 1/2 ROW on the west side along the site frontage (including the existing 30').	Applicant (west side - half ROW)
2.2	<u>Curtis Road</u> 4-Lane Rural Principal Arterial 180' right-of-way preservation	Filing No. 1 Preliminary Plan: Show 90' of 1/2 ROW preservation on the west side along the site frontage.	Applicant (west side - half ROW)
Internal Subdivision Roadways			
Item #	Improvement	Timing	Responsibility
3.1	Construct major internal streets to County Urban Non-Residential Collector Standards.	With Filing No. 1	Applicant
3.2	Construct minor internal streets as private Urban Local Streets as shown on the Preliminary Plan.	With Filing No. 1, as development occurs	Applicant
CDOT Off-Site Intersections			
US Highway 24/Stapleton Intersection (CDOT)			
Item #	Improvement	Timing	Responsibility
4.1	Submit Access Permit Application to CDOT	Submit access permit application with the /plat stage of the development process.	Applicant
4.2	Escrow towards cost of signalization. CDOT Escrow for Participation in the cost of future signalization - \$92,000** (Note: Opportunity for County fee Program credit/reimbursement for a portion; also opportunity for cost recovery as other area project are required to escrow funds and if/when this development's overall fair share percentage is reduced accordingly in the future.	Escrow required w/the access permit process at the site development plan/Plat.	Applicant to escrow funds (as part of the CDOT access permit process) toward the future signal per the CDOT comment letter.
US Highway 24/Falcon Highway and US Highway 24/Judge Orr Intersections (CDOT)			
Item #	Improvement	Timing	Responsibility
5.1	Falcon Highway with connection to SH 24G: Submittal Access Permit Applications to CDOT will be required for the: - Falcon Highway with connection to SH24G A State Highway Access Permit(s) are required by El Paso County or the Development for escrows for the equal fair share amount of the intersection signal at these intersections. (Per CDOT review letter dated October 31, 2023).	Submit access permit application(s) at the platting/site development plan stage. A requirement for escrow as part of the required CDOT access permit process has been identified; however, no amount was specified in the comment letter and these intersections are already signalized.	Applicant (El Paso County will likely be the Permittee)
5.2	Judge Orr Road connection to SH 24G 'Submittal Access Permit Applications to CDOT will be required for the: - - Judge Orr Road with connection to SH24G A State Highway Access Permit(s) are required by El Paso County or the Development for escrows for the equal fair share amount of the intersection signal at these intersections. (Per CDOT review letter dated October 31, 2023).	Submit access permit application(s) at the Preliminary Plan or platting/site development plan stage. A requirement for escrow as part of the required CDOT access permit process has been identified, however no amount was specified in the comment letter and these intersections are already signalized.	Applicant (El Paso County will likely be the Permittee)

Table 4
(page 2 of 3)
Meadowlake Industrial Park
Filing No. 1 Preliminary Plan
Roadway Improvements

El Paso County Off-Site Intersections			
Falcon Highway/Meridian Road Intersection			
6.1	<u>Short Term</u> Westbound right-turn deceleration lane	Currently warranted by ECM	Escrow portion toward improvement with Filing No. 1 final plat (fee program credit per fee program provisions)
Judge Orr/Curtis Road Intersection			
Item #	Improvement	Timing	Responsibility
7.1	<u>Short Term</u> Eastbound right-turn deceleration lane	Currently warranted by the ECM; construct this improvement with this preliminary Plan.	Applicant
7.2	<u>Short Term - Traffic Control</u> This TIS indicates the intersection would continue to operate at an acceptable LOS with the current TWSC in the 2025/Short Term based on the Background + Filing No. 1 Site Traffic Scenario.	This TIS indicates the intersection would continue to operate at an acceptable LOS with the current TWSC in the 2025/Short Term based on the Background + Filing No. 1 Site Traffic Scenario.	N/A
7.3	<u>Long Term (or Prior to 2040) - Traffic Control</u> This intersection is likely an eligible intersection for future signalization within the fee program. This TIS indicates the intersection would continue to operate at an acceptable LOS with the current TWSC in the 2025/Short Term. <i>Master Study: Participate on a pro-rata basis with a fair share contribution or upgrade the intersection, potentially including new traffic control, to mitigate anticipated substandard level of service, as necessary.</i>	Once LOS of AWSC drops below acceptable levels; and/or once signal warrants are met. Depends on the pace and intensity of development of this site and the rate of other area development and associated background traffic growth. This TIS indicates the intersection would continue to operate at an acceptable LOS with the current TWSC in the 2025/Short Term based on the Background + Filing No. 1 Site Traffic Scenario.	The applicant will pay fee program traffic impact fees. This intersection is likely an eligible intersection for future signalization within the fee program. Additionally, any required improvements due to future development of the overall Meadowlake Industrial Park plan.
7.4	<u>Long Term (if signalized in the future, or w/TWSC if Stop-sign orientation switched to eastbound/westbound)</u> Potential future need to lengthen northbound left-turn deceleration lane - provide pro-rata share escrow toward potential future lengthening of lane. <i>Master Study: Lengthen northbound left-turn deceleration lane.</i>	Lane lengthening not currently needed with this Preliminary plan <i>Master Study: As needed based on future speed limit and turning volume/stacking length criteria.</i>	Applicant - Escrow Pro-rata share for potential future lane lengthening. <i>Master Study: Escrow for improvement or construction if warranted at the time of development (fee program credit per fee program provisions).</i>
Adjacent & Access Intersections			
Curtis Road/Falcon Highway			
Item #	Improvement	Timing	Responsibility
8.1	<u>From Master Study (for Reference)</u> <u>Short Term/Long Term</u> <i>Change to AWSC traffic control as necessary. Participate on a pro-rata basis with a fair share contribution toward upgrade the intersection, potentially including new traffic control, to mitigate substandard level of service, as necessary. Significant improvements may be needed in the short term if rapid site buildout and area growth occurs. Otherwise, intermediate term.</i>	<u>From Master Study (for Reference)</u> <i>Once LOS of AWSC drops below acceptable levels; and/or once signal warrants are met. Depends on the pace and intensity of development of this site and the rate of other area development and associated background traffic growth.</i>	<u>From Master Study (for Reference)</u> <i>The applicant will pay fee program traffic impact fees and any required intersection improvements (or participation) may be fee-program eligible for credit based on the program guidelines.</i> This intersection is likely an eligible intersection for future signalization within the fee program.
8.1a	<u>Short Term:</u> This TIS indicates the intersection would operate at LOS F/E (AM/PM) on the northbound approach with the current TWSC based on the in the 2025/Short Term based on the Background + Filing No. 1 Site Traffic Scenario. Consideration for interim conversion to AWSC.	Consider traffic-control change to interim AWSC once warrants for AWSC control are met.	Applicant
8.1b	<u>Long Term (or Prior to 2040)</u> This intersection is likely an eligible intersection for future signalization within the fee program. See above item 8.1a relative to the Short Term. A roundabout may also be considered. <i>Master Study (for reference:) Participate on a pro-rata basis with a fair share contribution or upgrade the intersection, potentially including new traffic control, to mitigate anticipated substandard level of service, as necessary.</i>	Once LOS of AWSC control (interim change to AWSC in the short term) drops below acceptable levels and/or once signal warrants are met. Depends on the pace and intensity of development of this site and the rate of other area development and associated background traffic growth.	Applicant and/or other developments
8.2	<u>Short Term</u> Unless the intersection control is changed to AWSC in the short term, construct a southbound-right-turn lane on Curtis Road approaching Falcon Highway with the addition of site-generated traffic from this preliminary plan's development, as it would result in a better LOS for some movements. Potentially, a southbound right-turn "stacking" lane, rather than the full-length deceleration-plus-stacking lane, could potentially be an interim improvement, provided the approach remains stop-sign controlled. Long Term: ONLY needed in the case of a future signalized intersection or reverse of the TWSC stop-sign traffic control orientation, or as needed in the future for acceptable operations. See footnote below. MASTER STUDY: <i>Short Term (if planned to be signalized in the future)</i> <i>Construct SB right-turn lane on Curtis Road approaching Falcon Highway.</i>	Unless the intersection control is changed to AWSC in the short term, install with this preliminary plan. Full-length deceleration lane only required upon signalization or reversal of the stop-sign traffic control orientation, or as needed in the future for acceptable operations. See footnote below. If the intersection control is changed to AWSC in the short term, escrow funds with site development plans/plats under this Preliminary plan toward this potential future improvement.	Applicant - Responsibility will likely be shared between this project and Saddlehorn Ranch, with the cost shared; if lane is constructed, recovery from any escrowed funds may apply.
8.3	<u>Short Term</u> Escrow toward the cost of future lengthening of the existing EB left-turn deceleration lane on Falcon Highway approaching Curtis Road. Deviation is included with this submittal.	Previously recommended "trigger" from Saddlehorn Ranch: once projected queue (95th percentile) exceeds 50 feet. LSC suggests the same trigger for this project. When warrants require improvements, a deviation would be submitted. A deviation request, if approved, would allow interim use of the existing lane and taper (based on short term total turning volumes /associated queue length). Deviation is included with this submittal. Note: EPC comments on Saddlehorn Filing No. 4 indicate "construct with Filing 4 if warranted based on 50' queuing length, per conditions of approval." A similar condition would likely apply to this development, provided the deviation is approved.	Escrow for pro-rata share of future improvement. Responsibility will likely be shared between this project and Saddlehorn Ranch, with the cost shared.
8.4	<u>Short Term</u> WB right-turn deceleration lane on Falcon Highway approaching Curtis Road. <u>From Master Study (for Reference)</u> <i>Construct WB right-turn deceleration lane on Falcon Highway approaching Curtis Road.</i> This turn lane is not projected to be warranted based on Filing No. 1 Preliminary Plan projected volume. Escrow toward the cost of future WB right-turn deceleration lane on Falcon Highway approaching Curtis Road.	This turn lane is not projected to be warranted based on Filing No. 1 Preliminary Plan projected volume.	Escrow for pro-rata share of improvement
8.5	<u>From Master TIS:</u> <u>Long Term (if planned to be signalized in the future)</u> <i>Lengthen northbound left-turn deceleration lane</i> This Preliminary Plan is not projected to add to this northbound left turn lane in the short term as no access is planned for Falcon Highway with the Filing No. 1 Preliminary Plan.	N/A with this Preliminary Plan As needed based on future speed limit and turning volume/stacking length criteria	N/A with this Preliminary Plan Escrow for improvement or construction if warranted at the time of development (fee program credit per fee program provisions)

Table 4
(page 3 of 3)
Meadowlake Industrial Park
Filing No. 1 Preliminary Plan
Roadway Improvements

Curtis Road/Pagoda Bush Street (Full-Movement Access)			
Item #	Improvement	Timing	Responsibility
10a.1	<u>Short Term & Long Term</u> Master Study: w/ Roundabout Option - Construct one-lane modern roundabout, expandable to a two-lane roundabout. Roundabout not proposed with the Preliminary Plan.	Roundabout not proposed with the Preliminary Plan. Once warranted - with future MLIP development, as necessary to maintain acceptable intersection operations.	Applicant
OR			
10b.1	<u>Short Term</u> Southbound right-turn deceleration lane on Curtis Rd approaching the site access.	This turn lane is not projected to be warranted based on Filing No. 1 Preliminary Plan projected right turn volume. The applicant may elect (volunteer) to install this turn lane as part of the access construction and required left turn lane improvement. See design notes under item 1.	Applicant
10b.2	<u>Short Term</u> Northbound left-turn deceleration lane on Curtis Rd approaching the site access. See Design notes under item 1.1	With site development plan/plat. This turn lane is projected to be warranted based on Filing No. 1 Preliminary Plan projected volumes.	Applicant
10b.3	<u>Short Term</u> Southbound right-turn acceleration lane on Curtis Rd for right-turning traffic exiting the site access.	This auxiliary lane is not projected to be warranted based on Filing No. 1 Preliminary Plan projected volume.	Applicant
10b.4a	<u>Short Term</u> Construct intersection w/Stop-sign control for the eastbound approach. See design notes under item 1.1.	With site development plan/plat.	Applicant
10b.4b	<u>Long Term</u> <i>From Master TIS: Install traffic signal</i> A signal warrant would not be met based on Filing No. 1 Preliminary Plan projected volume.	Once warranted - with future MLIP development, as necessary to maintain acceptable intersection operations.	Applicant
Item 4.2 Note: CDOT Formula taken from CDOT review letter:US24 & Stapleton: Based on the average AM & PM site-generated passenger cars directly impacting the 4-hour signal warrant, the Meadowlake Industrial Park Filing No. 1 development is required to escrow \$92,000 (8.5 new vehicles / 60 vehicles-to-warrant x \$650K/signal cost) to CDOT for the construction of the traffic signal.			
Item 8.2 Note: The default ECM trigger for this potential right turn lane is 25 vph, and the threshold would be met with 2025 background or site-generated (and total) traffic. However, since the southbound approach is currently Stop-sign controlled, the turn lane is not currently needed due to mitigate speed differential between through traffic and right turning traffic. LSC recommends the following triggers: <ul style="list-style-type: none"> o Once the intersection is signalized (if as signal is the selected future traffic control instead of a modern roundabout) or o If El Paso County switches the orientation of the stop signs such that Curtis is changed to the "major street" and Falcon Highway is changed to the "minor street" (the intersection remains two-way, stop-sign control). o If or needed for operations – i.e., to maintain an acceptable level of service as an intersection with TWSC or AWSC; The southbound-right-turn lane with the addition of site-generated traffic from this preliminary plan's development is recommended, as it would result in a better LOS for some movements. 			
LSC Transportation Consultants, Inc. (REV. 1-10-25) (11/15/2024)			

Figures 1-7



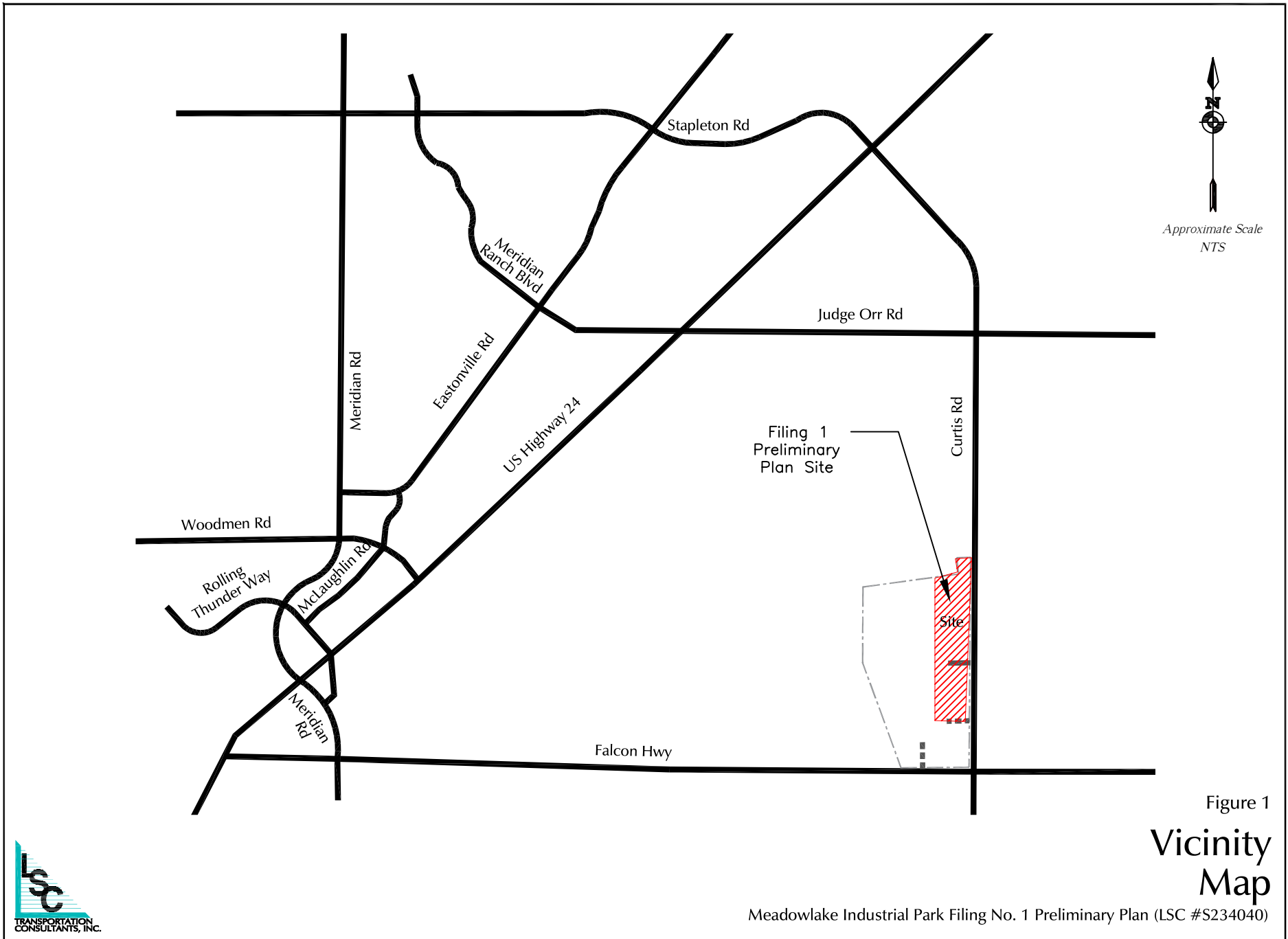
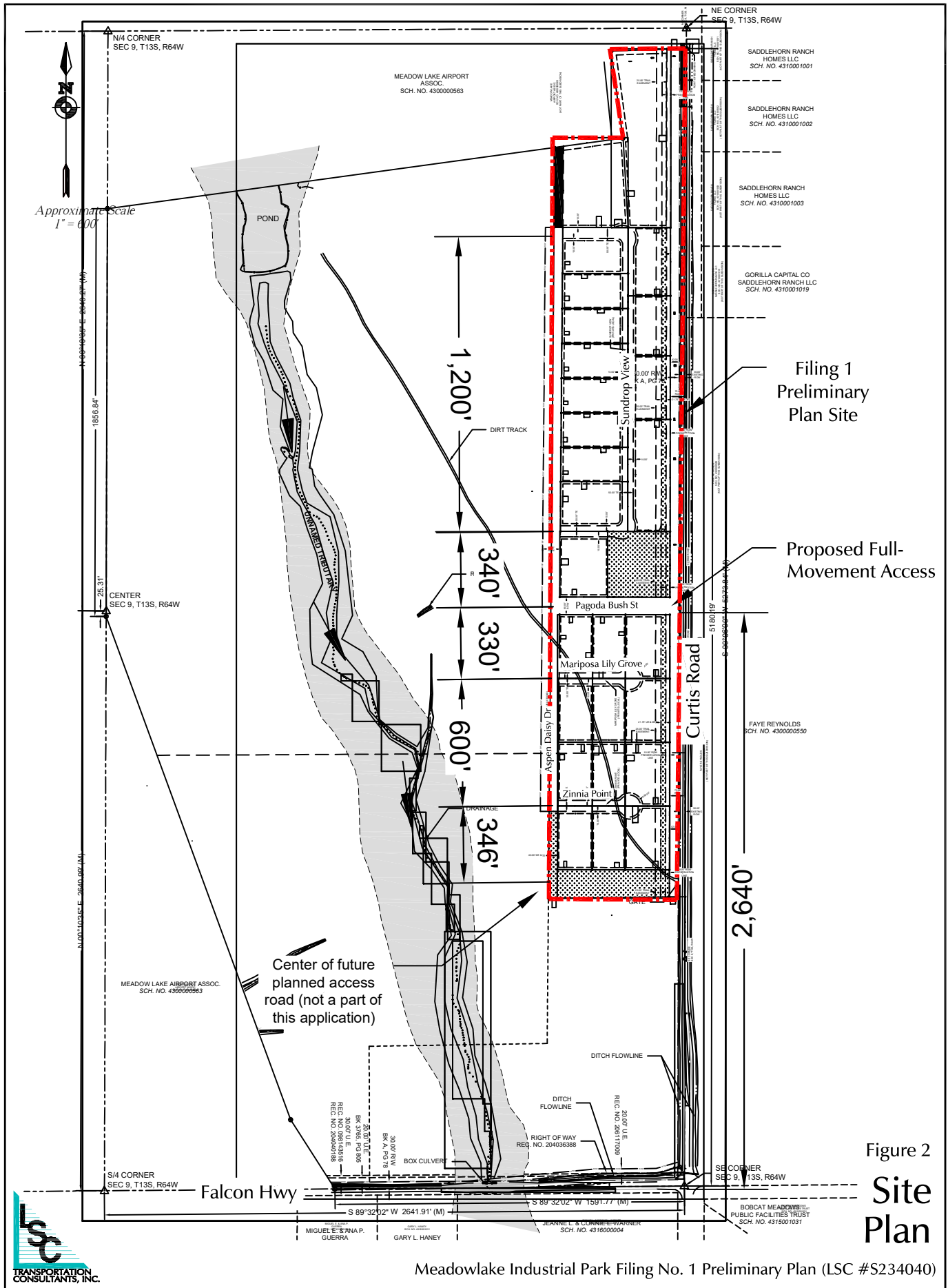

Figure 1
Vicinity
Map

Meadowlake Industrial Park Filing No. 1 Preliminary Plan (LSC #S234040)





Filing 1
Preliminary
Plan Site

Proposed Full-
Movement Access

Figure 2
**Site
Plan**



MIGUEL E. SAINA P. GUERRA GARY L. HANEY JEANNE L. & CORNELL WARNER

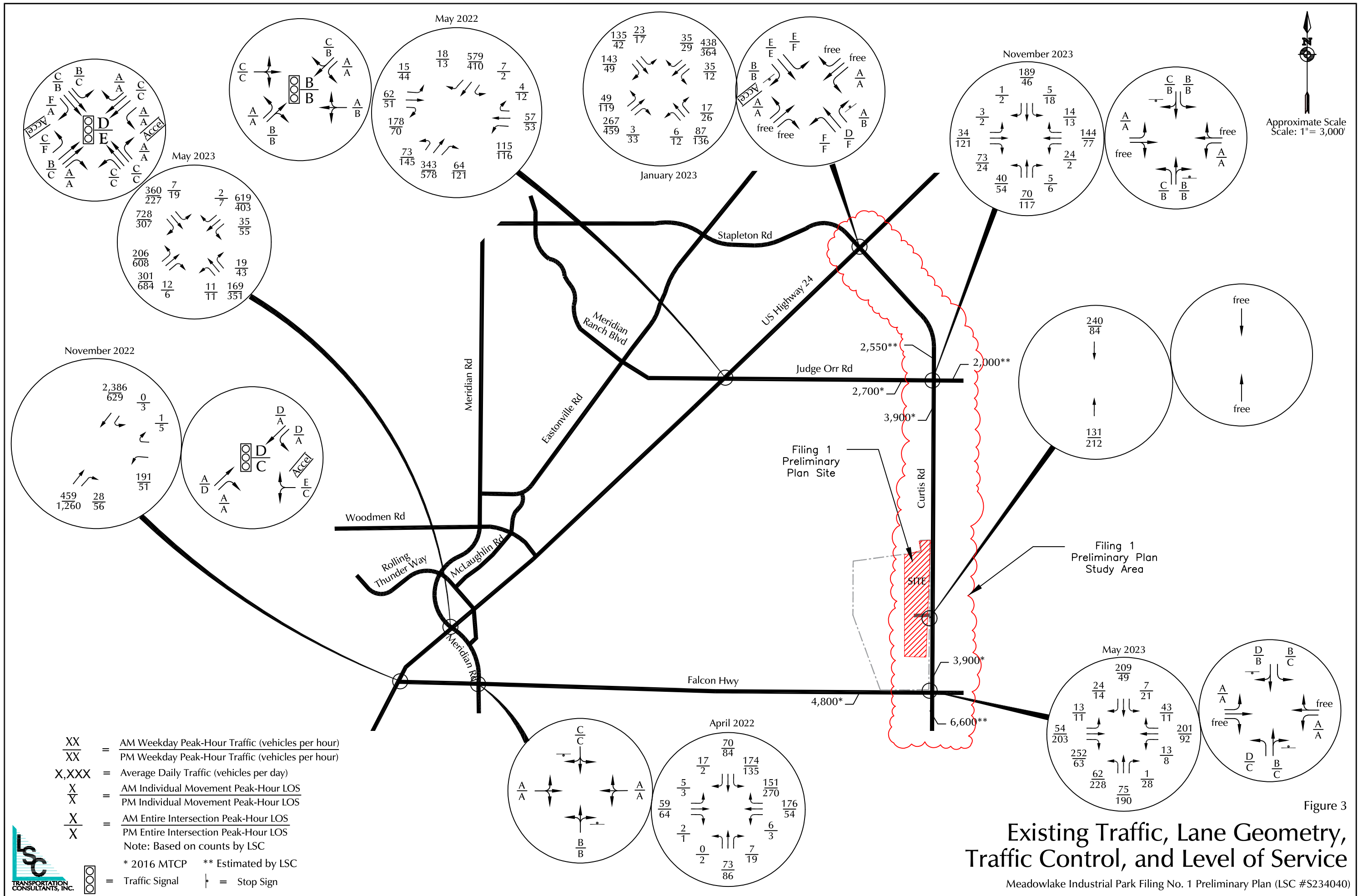



Approximate Scale
Scale: 1" = 3,000'

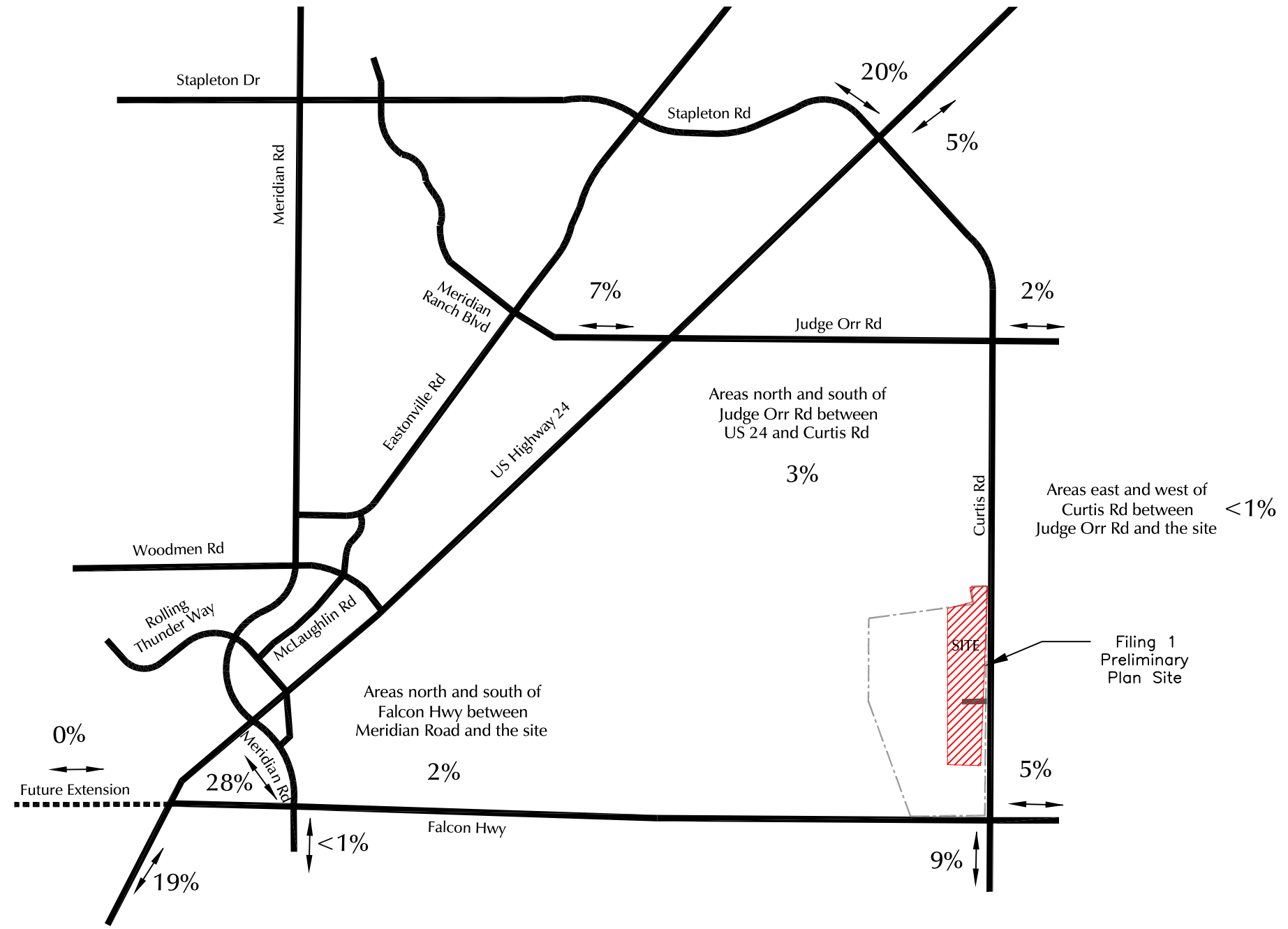

XX% = Directional Distribution of Site-Generated Trips

Figure 4
Short-Term Directional Distribution
 Meadowlake Industrial Park Filing No. 1 Preliminary Plan (LSC #S234040)



Approximate Scale
Scale: 1" = 3,000'

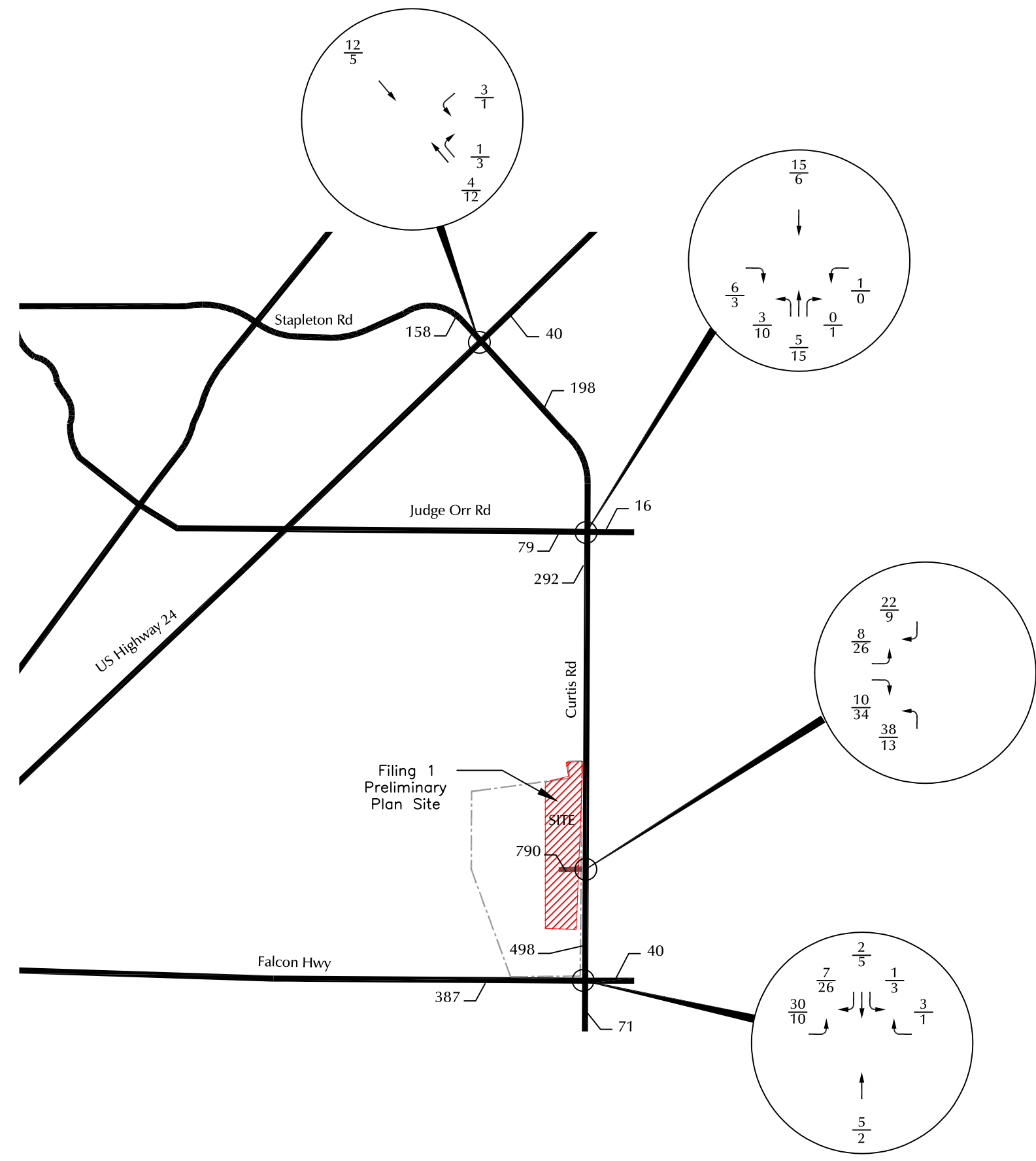

$\frac{XX}{XX}$ = AM Weekday Peak-Hour Traffic (vehicles per hour)
 $\frac{XX}{XX}$ = PM Weekday Peak-Hour Traffic (vehicles per hour)
 X,XXX = Average Daily Traffic (vehicles per day)

Figure 5
Short-Term Site-Generated Traffic
 Meadowlake Industrial Park Filing No. 1 Preliminary Plan (LSC #S234040)

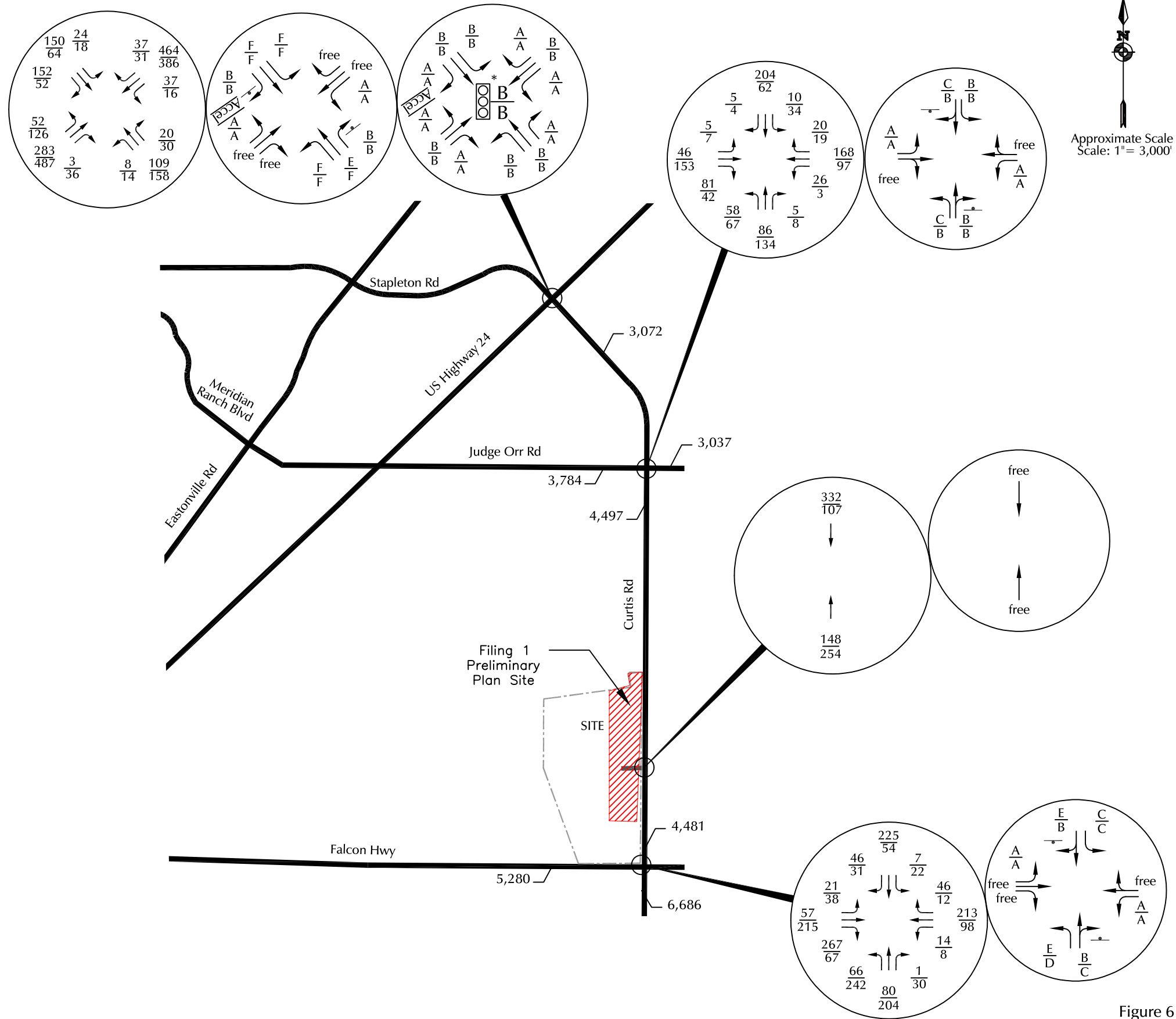

- $\frac{XX}{XX}$ = AM Weekday Peak-Hour Traffic (vehicles per hour)
PM Weekday Peak-Hour Traffic (vehicles per hour)
- X,XXX = Average Daily Traffic (vehicles per day)
- $\frac{X}{X}$ = AM Individual Movement Peak-Hour LOS
PM Individual Movement Peak-Hour LOS
- $\frac{X}{X}$ = AM Entire Intersection Peak-Hour LOS
PM Entire Intersection Peak-Hour LOS

= Traffic Signal = Stop Sign

*Assumed signalized by CDOT by 2025

2025 Background Traffic, Lane Geometry, Traffic Control, and Level of Service

Figure 6



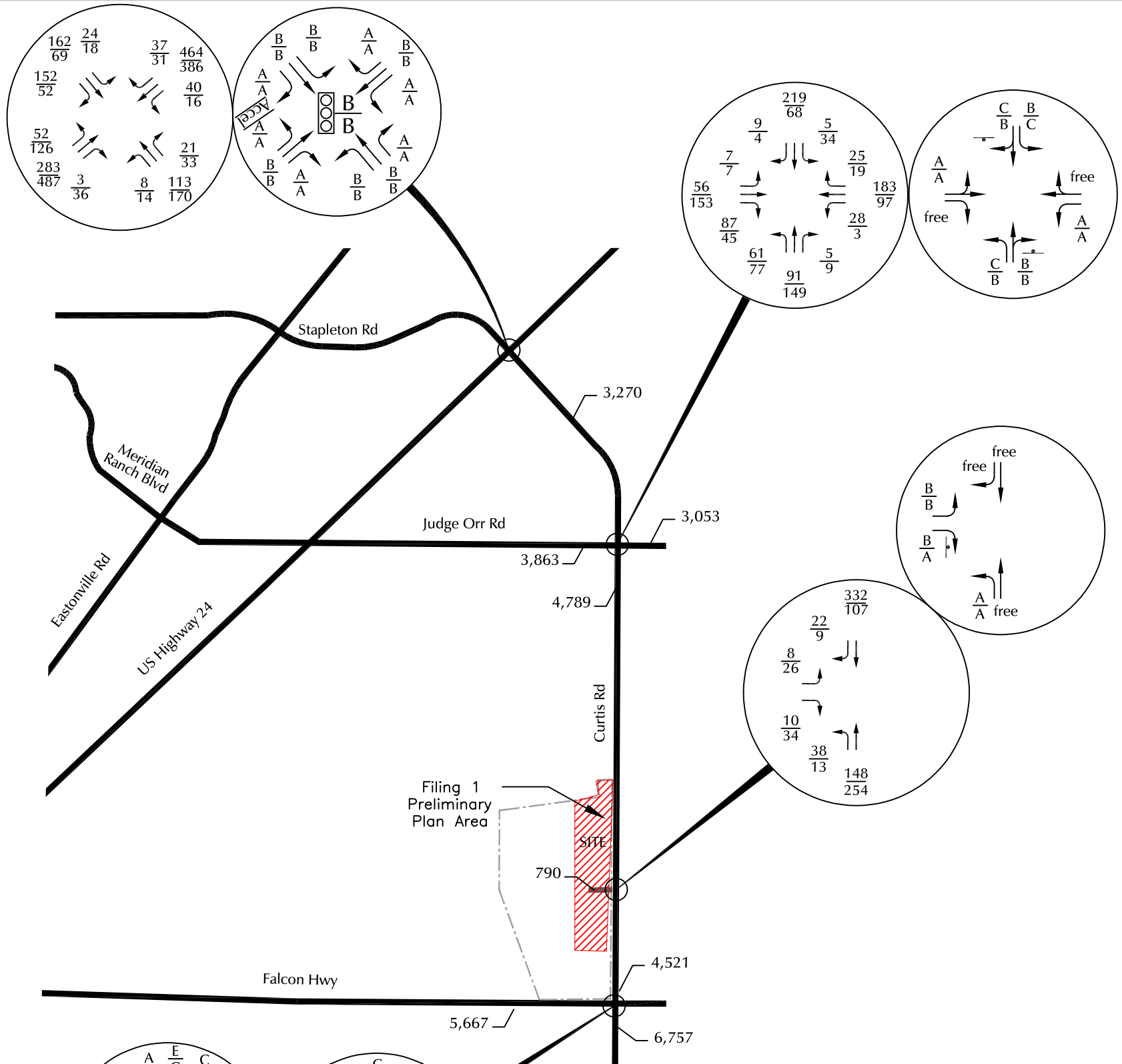

- $\frac{XX}{XX}$ = AM Weekday Peak-Hour Traffic (vehicles per hour)
PM Weekday Peak-Hour Traffic (vehicles per hour)
- X,XXX = Average Daily Traffic (vehicles per day)
- $\frac{X}{X}$ = AM Individual Movement Peak-Hour LOS
PM Individual Movement Peak-Hour LOS
- $\frac{X}{X}$ = AM Entire Intersection Peak-Hour LOS
PM Entire Intersection Peak-Hour LOS
- = Traffic Signal = Stop Sign
- TWSC = Two-way, Stop-sign control.
- AWSC = All-way, Stop-sign control

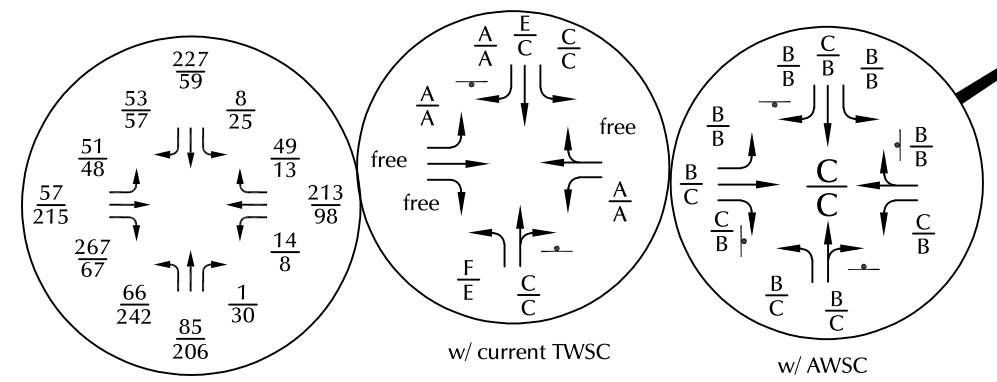
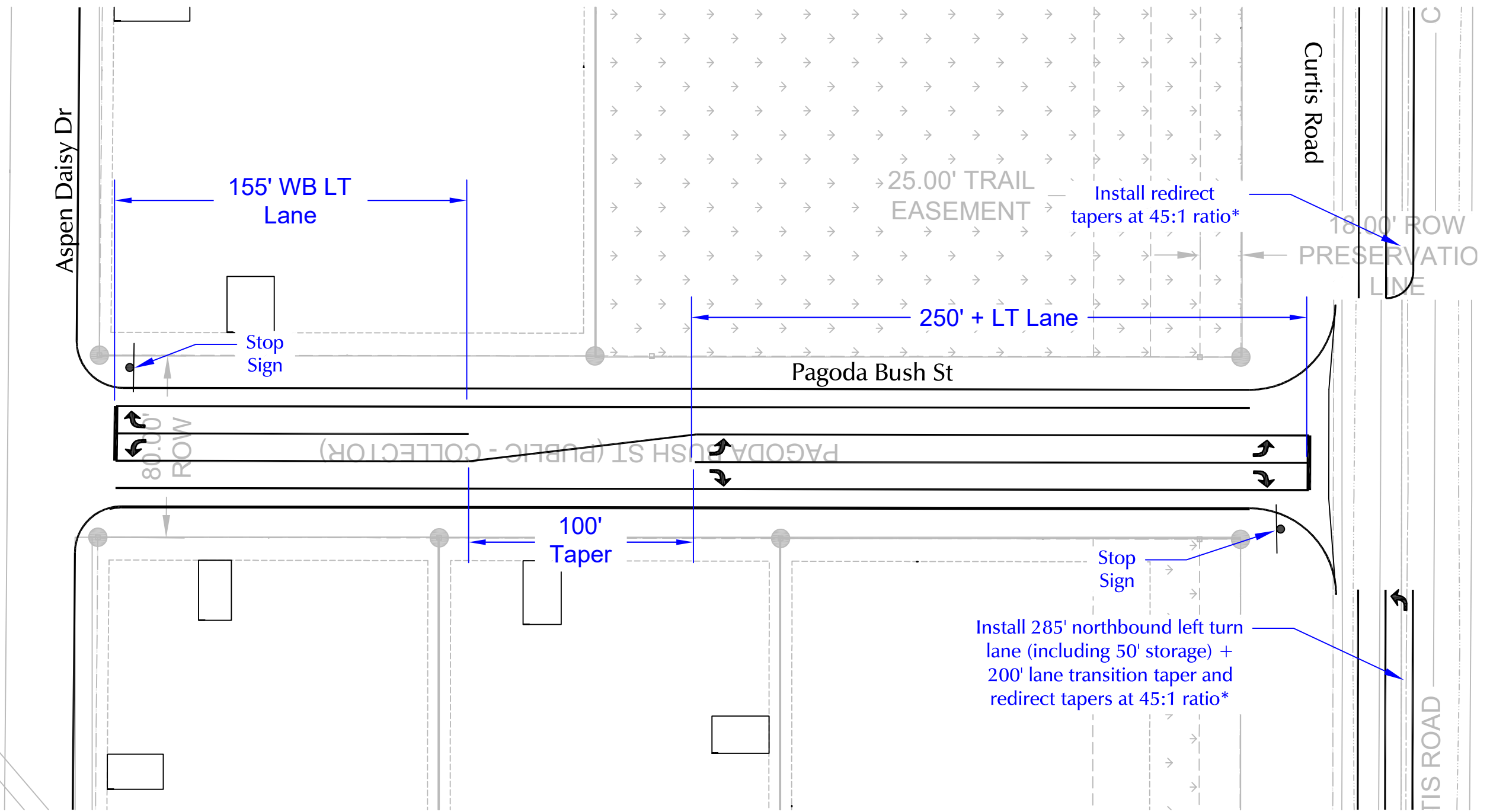

Figure 7
**2025 Total Traffic,
 Lane Geometry, Traffic
 Control, and Level of Service**
 Meadowlake Industrial Park Filing No. 1 Preliminary Plan (LSC #S234040)



Approximate Scale
1" = 50'



*Note: 270' with symmetrical widening
540' with single-side widening

Figure 8
Proposed Phase 1/Short-Term Laneage - Curtis Road and Pagoda Bush St

Meadowlake Industrial Park Filing No. 1 Preliminary Plan (LSC #S234040)





Approximate Scale
Scale: 1" = 3,000'

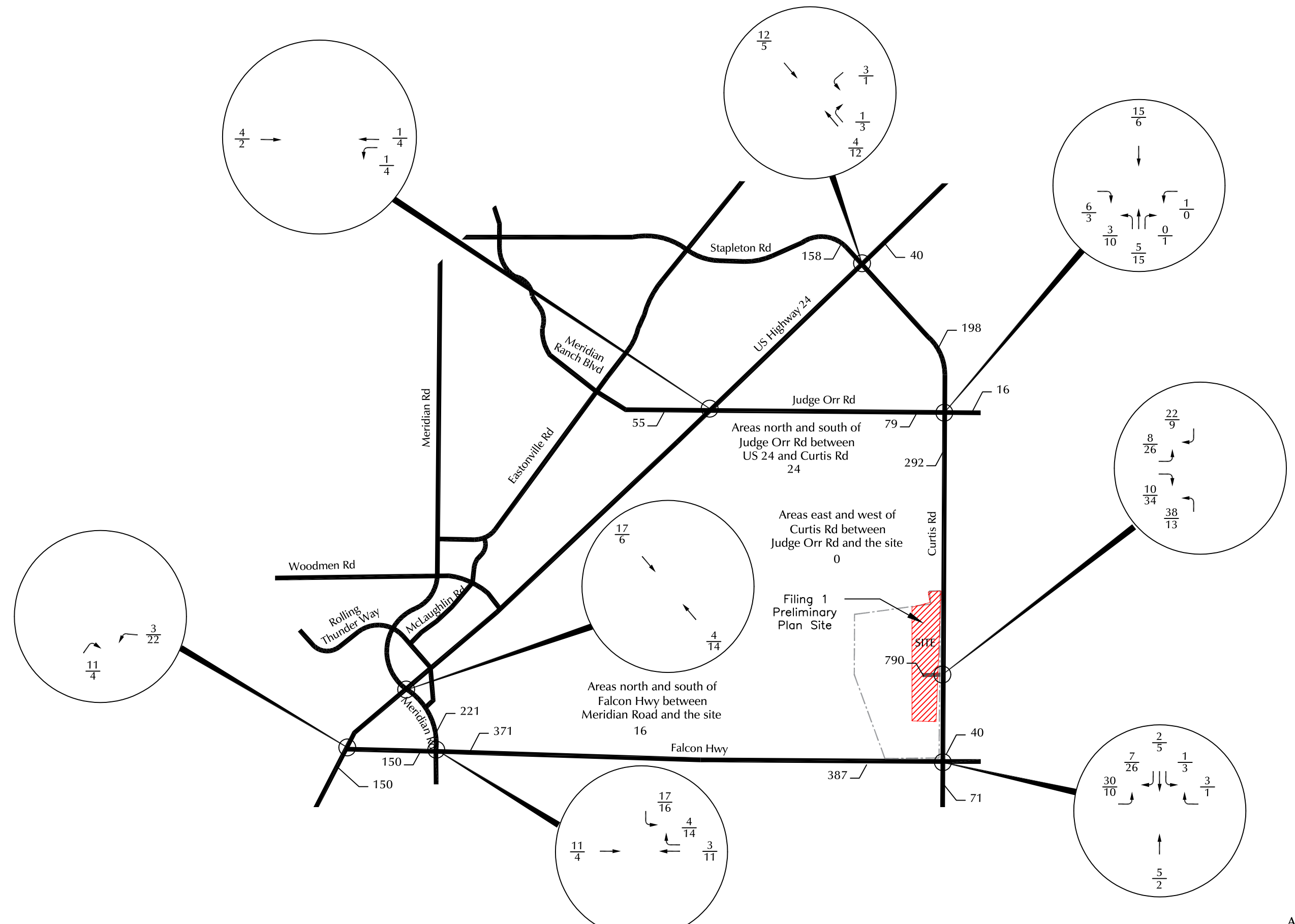

$\frac{XX}{XX}$ = AM Weekday Peak-Hour Traffic (vehicles per hour)
 $\frac{XX}{XX}$ = PM Weekday Peak-Hour Traffic (vehicles per hour)
 X,XXX = Average Daily Traffic (vehicles per day)

*Expanded to show site-generated traffic at the Master TIS study area intersections, for reference, and used in the Appendix B study area determination

Appendix Figure A-1
Short-Term Site-Generated Traffic*
 Meadowlake Industrial Park Filing No. 1 Preliminary Plan (LSC #S234040)

Traffic Counts



LSC Transportation Consultants, Inc.

2504 E. Pikes Peak Ave, Suite 304
 Colorado Springs, CO 80909
 719-633-2868

File Name : Curtis Rd - Judge Orr Rd AM 11-23

Site Code : S234040

Start Date : 11/7/2023

Page No : 1

Groups Printed- Unshifted

Start Time	Stapleton Rd Southbound					Judge Orr Rd Westbound					Curtis Rd Northbound					Judge Orr Rd Eastbound					Int. Total
	Right	Thru	Left	Peds	App. Total	Right	Thru	Left	Peds	App. Total	Right	Thru	Left	Peds	App. Total	Right	Thru	Left	Peds	App. Total	
06:30	0	11	0	0	11	1	6	1	0	8	0	3	2	0	5	5	1	1	0	7	31
06:35	0	16	1	0	17	1	7	0	0	8	0	1	2	0	3	4	1	0	0	5	33
06:40	0	8	0	0	8	2	8	0	0	10	0	6	2	0	8	9	1	1	0	11	37
06:45	0	12	0	0	12	1	13	2	0	16	1	3	2	0	6	10	2	1	0	13	47
06:50	0	14	0	0	14	0	6	1	0	7	0	9	2	0	11	7	2	1	0	10	42
06:55	0	20	0	0	20	1	11	2	0	14	0	5	1	0	6	7	6	0	0	13	53
Total	0	81	1	0	82	6	51	6	0	63	1	27	11	0	39	42	13	4	0	59	243
07:00	0	10	0	0	10	1	7	1	0	9	0	7	3	0	10	5	1	1	0	7	36
07:05	0	25	0	0	25	1	18	2	0	21	0	9	4	0	13	7	4	0	0	11	70
07:10	0	19	1	0	20	2	11	4	0	17	0	7	4	0	11	7	3	0	0	10	58
07:15	0	15	2	0	17	2	10	5	0	17	1	8	3	0	12	5	4	0	0	9	55
07:20	0	14	0	0	14	0	18	2	0	20	1	3	8	0	12	3	4	0	0	7	53
07:25	1	15	0	0	16	4	11	1	0	16	0	3	2	0	5	2	3	0	0	5	42
07:30	0	15	1	0	16	0	20	2	0	22	1	3	2	0	6	10	1	0	0	11	55
07:35	0	17	1	0	18	1	5	2	0	8	0	7	5	0	12	5	1	0	0	6	44
07:40	0	13	0	0	13	1	14	0	0	15	0	6	4	0	10	5	3	0	0	8	46
07:45	2	11	0	0	13	1	6	0	0	7	0	4	1	0	5	3	4	0	0	7	32
07:50	0	10	1	0	11	2	10	0	0	12	1	2	2	0	5	4	5	0	0	9	37
07:55	2	5	0	0	7	0	11	0	0	11	1	3	3	0	7	2	1	1	0	4	29
Total	5	169	6	0	180	15	141	19	0	175	5	62	41	0	108	58	34	2	0	94	557
08:00	1	12	0	0	13	0	6	0	0	6	0	1	2	0	3	0	3	1	0	4	26
08:05	0	11	1	0	12	0	7	1	0	8	0	2	2	0	4	2	4	0	0	6	30
08:10	0	8	0	0	8	1	7	0	0	8	0	3	3	0	6	4	4	0	0	8	30
08:15	1	7	0	0	8	1	7	0	0	8	0	3	1	0	4	4	7	0	0	11	31
08:20	0	7	2	0	9	0	7	0	0	7	0	2	1	0	3	1	4	0	0	5	24
08:25	0	11	1	0	12	1	7	1	0	9	0	3	0	0	3	3	9	0	0	12	36
Grand Total	7	306	11	0	324	24	233	27	0	284	6	103	61	0	170	114	78	7	0	199	977
Apprch %	2.2	94.4	3.4	0		8.5	82	9.5	0		3.5	60.6	35.9	0		57.3	39.2	3.5	0		
Total %	0.7	31.3	1.1	0	33.2	2.5	23.8	2.8	0	29.1	0.6	10.5	6.2	0	17.4	11.7	8	0.7	0	20.4	

LSC Transportation Consultants, Inc.

2504 E. Pikes Peak Ave, Suite 304
 Colorado Springs, CO 80909
 719-633-2868

File Name : Curtis Rd - Judge Orr Rd AM 11-23

Site Code : S234040

Start Date : 11/7/2023

Page No : 2

Start Time	Stapleton Rd Southbound					Judge Orr Rd Westbound					Curtis Rd Northbound					Judge Orr Rd Eastbound					Int. Total
	Right	Thru	Left	Peds	App. Total	Right	Thru	Left	Peds	App. Total	Right	Thru	Left	Peds	App. Total	Right	Thru	Left	Peds	App. Total	
Peak Hour Analysis From 06:30 to 08:25 - Peak 1 of 1																					
Peak Hour for Entire Intersection Begins at 06:45																					
06:45	0	12	0	0	12	1	13	2	0	16	1	3	2	0	6	10	2	1	0	13	47
06:50	0	14	0	0	14	0	6	1	0	7	0	9	2	0	11	7	2	1	0	10	42
06:55	0	20	0	0	20	1	11	2	0	14	0	5	1	0	6	7	6	0	0	13	53
07:00	0	10	0	0	10	1	7	1	0	9	0	7	3	0	10	5	1	1	0	7	36
07:05	0	25	0	0	25	1	18	2	0	21	0	9	4	0	13	7	4	0	0	11	70
07:10	0	19	1	0	20	2	11	4	0	17	0	7	4	0	11	7	3	0	0	10	58
07:15	0	15	2	0	17	2	10	5	0	17	1	8	3	0	12	5	4	0	0	9	55
07:20	0	14	0	0	14	0	18	2	0	20	1	3	8	0	12	3	4	0	0	7	53
07:25	1	15	0	0	16	4	11	1	0	16	0	3	2	0	5	2	3	0	0	5	42
07:30	0	15	1	0	16	0	20	2	0	22	1	3	2	0	6	10	1	0	0	11	55
07:35	0	17	1	0	18	1	5	2	0	8	0	7	5	0	12	5	1	0	0	6	44
07:40	0	13	0	0	13	1	14	0	0	15	0	6	4	0	10	5	3	0	0	8	46
Total Volume	1	189	5	0	195	14	144	24	0	182	4	70	40	0	114	73	34	3	0	110	601
% App. Total	0.5	96.9	2.6	0		7.7	79.1	13.2	0		3.5	61.4	35.1	0		66.4	30.9	2.7	0		
PHF	.083	.630	.208	.000	.650	.292	.600	.400	.000	.689	.333	.648	.417	.000	.731	.608	.472	.250	.000	.705	.715

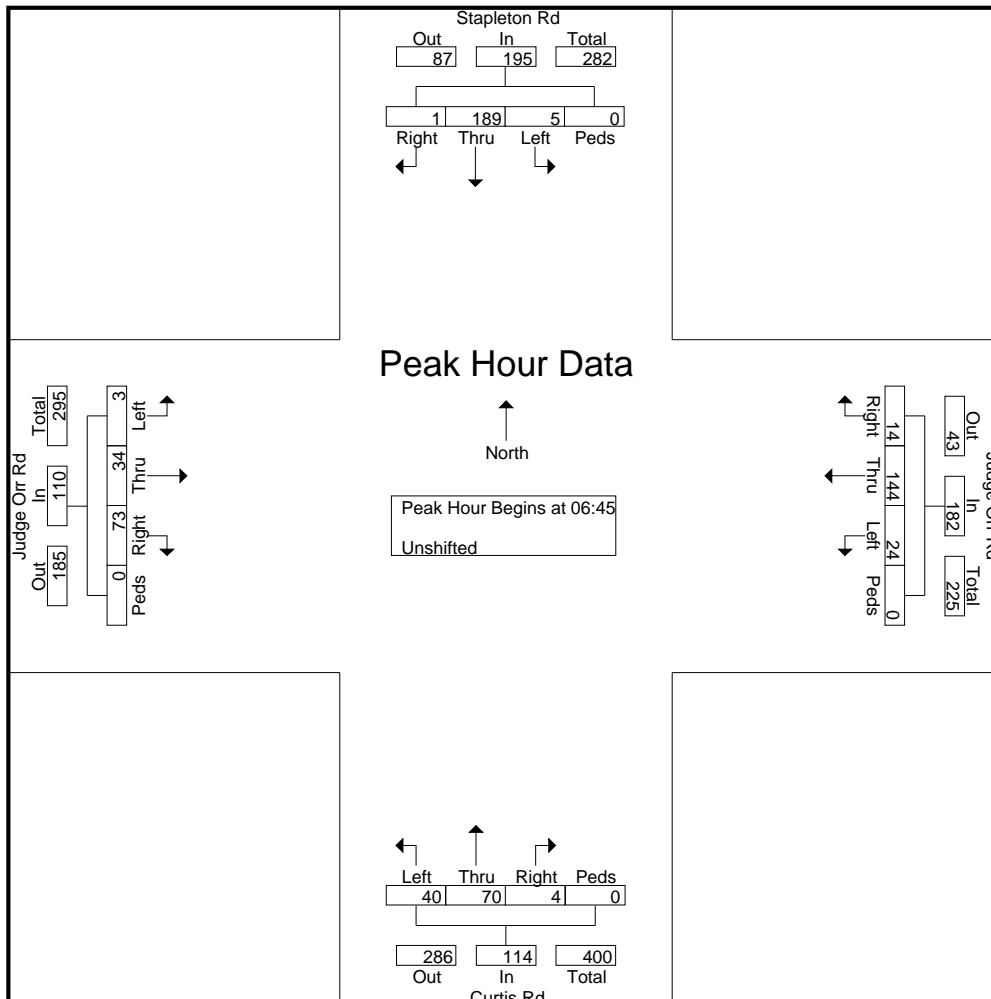

LSC Transportation Consultants, Inc.

2504 E. Pikes Peak Ave, Suite 304
 Colorado Springs, CO 80909
 719-633-2868

File Name : Curtis Rd - Judge Orr Rd AM 11-23

Site Code : S234040

Start Date : 11/7/2023

Page No : 3

Start Time	Stapleton Rd Southbound					Judge Orr Rd Westbound					Curtis Rd Northbound					Judge Orr Rd Eastbound					Int. Total
	Right	Thru	Left	Peds	App. Total	Right	Thru	Left	Peds	App. Total	Right	Thru	Left	Peds	App. Total	Right	Thru	Left	Peds	App. Total	

Peak Hour Analysis From 06:30 to 08:25 - Peak 1 of 1

Peak Hour for Each Approach Begins at:

	06:50					06:45					06:45					06:40				
+0 mins.	0	14	0	0	14	1	13	2	0	16	1	3	2	0	6	9	1	1	0	11
+5 mins.	0	20	0	0	20	0	6	1	0	7	0	9	2	0	11	10	2	1	0	13
+10 mins.	0	10	0	0	10	1	11	2	0	14	0	5	1	0	6	7	2	1	0	10
+15 mins.	0	25	0	0	25	1	7	1	0	9	0	7	3	0	10	7	6	0	0	13
+20 mins.	0	19	1	0	20	1	18	2	0	21	0	9	4	0	13	5	1	1	0	7
+25 mins.	0	15	2	0	17	2	11	4	0	17	0	7	4	0	11	7	4	0	0	11
+30 mins.	0	14	0	0	14	2	10	5	0	17	1	8	3	0	12	7	3	0	0	10
+35 mins.	1	15	0	0	16	0	18	2	0	20	1	3	8	0	12	5	4	0	0	9
+40 mins.	0	15	1	0	16	4	11	1	0	16	0	3	2	0	5	3	4	0	0	7
+45 mins.	0	17	1	0	18	0	20	2	0	22	1	3	2	0	6	2	3	0	0	5
+50 mins.	0	13	0	0	13	1	5	2	0	8	0	7	5	0	12	10	1	0	0	11
+55 mins.	2	11	0	0	13	1	14	0	0	15	0	6	4	0	10	5	1	0	0	6
Total Volume	3	188	5	0	196	14	144	24	0	182	4	70	40	0	114	77	32	4	0	113
% App. Total	1.5	95.9	2.6	0		7.7	79.1	13.2	0		3.5	61.4	35.1	0		68.1	28.3	3.5	0	
PHF	.125	.627	.208	.000	.653	.292	.600	.400	.000	.689	.333	.648	.417	.000	.731	.642	.444	.333	.000	.724

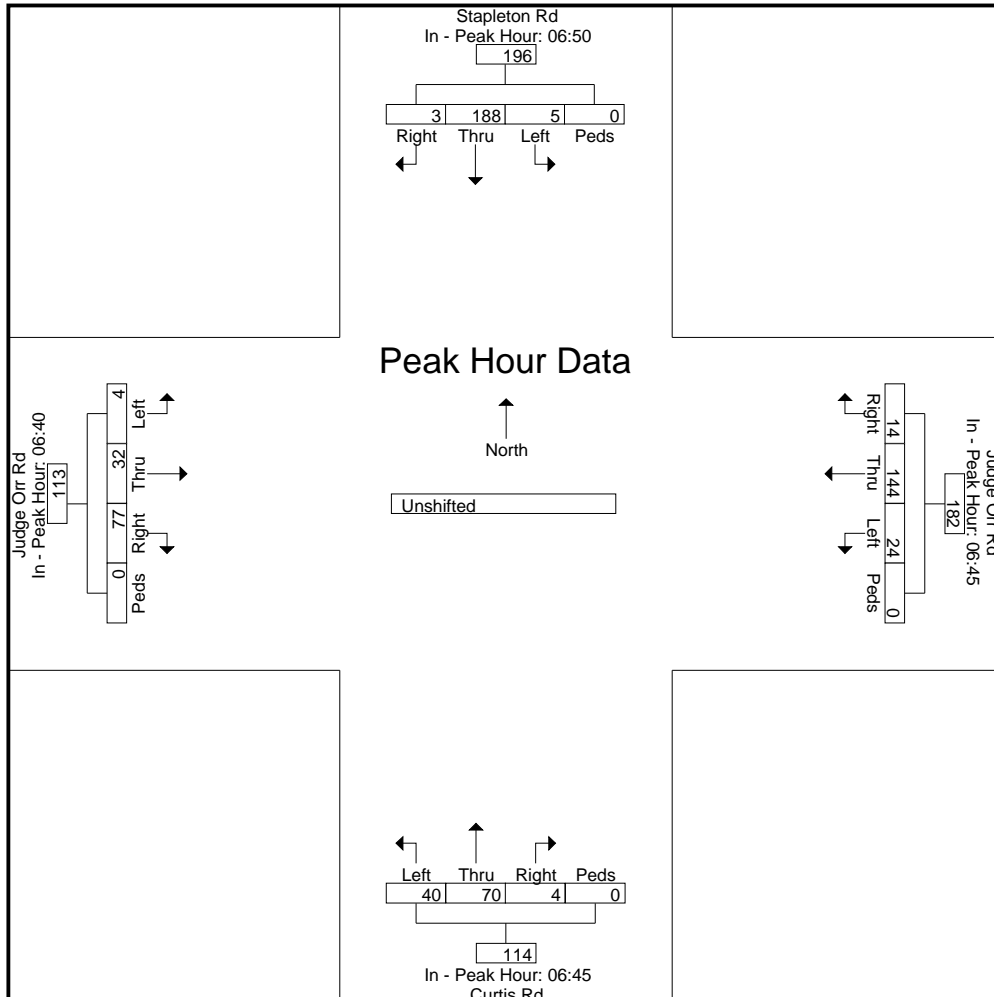

LSC Transportation Consultants, Inc.

2504 E. Pikes Peak Ave, Suite 304
 Colorado Springs, CO 80909
 719-633-2868

File Name : Curtis Rd - Judge Orr Rd PM 11-23

Site Code : S234040

Start Date : 11/2/2023

Page No : 1

Groups Printed- Unshifted

Start Time	Stapleton Rd Southbound					Judge Orr Rd Westbound					Curtis Rd Northbound					Judge Orr Rd Eastbound					Int. Total
	Right	Thru	Left	Peds	App. Total	Right	Thru	Left	Peds	App. Total	Right	Thru	Left	Peds	App. Total	Right	Thru	Left	Peds	App. Total	
16:00	0	4	2	0	6	1	2	1	0	4	0	8	4	0	12	2	8	0	0	10	32
16:05	0	5	3	0	8	0	2	0	0	2	0	9	5	0	14	2	9	0	0	11	35
16:10	0	6	3	0	9	3	5	1	0	9	0	12	6	0	18	1	15	0	0	16	52
16:15	1	3	1	0	5	0	11	0	0	11	0	6	5	0	11	3	9	0	0	12	39
16:20	0	3	0	0	3	0	7	0	0	7	1	9	4	0	14	1	10	0	0	11	35
16:25	1	6	2	0	9	2	11	0	0	13	1	22	11	0	34	0	12	1	0	13	69
16:30	0	8	2	0	10	2	6	0	0	8	0	10	4	0	14	2	6	0	0	8	40
16:35	0	3	0	0	3	3	1	1	0	5	1	11	5	0	17	3	10	0	0	13	38
16:40	0	2	1	0	3	0	10	0	0	10	0	4	3	0	7	1	10	0	0	11	31
16:45	0	3	1	0	4	2	6	0	0	8	1	8	4	0	13	2	9	0	0	11	36
16:50	0	2	2	0	4	0	5	0	0	5	0	7	5	0	12	4	8	0	0	12	33
16:55	0	2	2	0	4	1	5	0	0	6	2	6	2	0	10	2	14	0	0	16	36
Total	2	47	19	0	68	14	71	3	0	88	6	112	58	0	176	23	120	1	0	144	476
17:00	0	2	1	0	3	0	5	0	0	5	0	10	4	0	14	3	5	1	0	9	31
17:05	0	6	3	0	9	0	5	0	0	5	0	12	1	0	13	2	13	0	0	15	42
17:10	1	2	3	0	6	0	2	0	0	2	0	11	3	0	14	1	9	0	0	10	32
17:15	0	5	4	0	9	0	7	0	0	7	2	6	6	0	14	6	15	0	0	21	51
17:20	0	5	4	0	9	1	5	0	0	6	0	10	2	0	12	1	9	0	0	10	37
17:25	0	1	1	0	2	0	5	0	0	5	0	14	8	0	22	2	13	1	0	16	45
17:30	0	2	2	0	4	1	5	1	0	7	0	7	5	0	12	2	12	0	0	14	37
17:35	0	2	1	0	3	0	3	0	0	3	1	11	3	0	15	1	9	0	0	10	31
17:40	0	4	2	0	6	0	3	0	0	3	0	3	1	0	4	1	10	0	0	11	24
17:45	1	6	4	0	11	0	12	0	0	12	0	9	0	0	9	2	11	0	0	13	45
17:50	0	3	0	0	3	2	5	0	0	7	1	12	2	0	15	1	10	0	0	11	36
17:55	1	4	2	0	7	2	6	0	0	8	0	6	5	0	11	1	7	0	0	8	34
Total	3	42	27	0	72	6	63	1	0	70	4	111	40	0	155	23	123	2	0	148	445
Grand Total	5	89	46	0	140	20	134	4	0	158	10	223	98	0	331	46	243	3	0	292	921
Apprch %	3.6	63.6	32.9	0		12.7	84.8	2.5	0		3	67.4	29.6	0		15.8	83.2	1	0		
Total %	0.5	9.7	5	0	15.2	2.2	14.5	0.4	0	17.2	1.1	24.2	10.6	0	35.9	5	26.4	0.3	0	31.7	

LSC Transportation Consultants, Inc.

2504 E. Pikes Peak Ave, Suite 304
 Colorado Springs, CO 80909
 719-633-2868

File Name : Curtis Rd - Judge Orr Rd PM 11-23

Site Code : S234040

Start Date : 11/2/2023

Page No : 2

Start Time	Stapleton Rd Southbound					Judge Orr Rd Westbound					Curtis Rd Northbound					Judge Orr Rd Eastbound					Int. Total
	Right	Thru	Left	Peds	App. Total	Right	Thru	Left	Peds	App. Total	Right	Thru	Left	Peds	App. Total	Right	Thru	Left	Peds	App. Total	
Peak Hour Analysis From 16:00 to 17:55 - Peak 1 of 1																					
Peak Hour for Entire Intersection Begins at 16:10																					
16:10	0	6	3	0	9	3	5	1	0	9	0	12	6	0	18	1	15	0	0	16	52
16:15	1	3	1	0	5	0	11	0	0	11	0	6	5	0	11	3	9	0	0	12	39
16:20	0	3	0	0	3	0	7	0	0	7	1	9	4	0	14	1	10	0	0	11	35
16:25	1	6	2	0	9	2	11	0	0	13	1	22	11	0	34	0	12	1	0	13	69
16:30	0	8	2	0	10	2	6	0	0	8	0	10	4	0	14	2	6	0	0	8	40
16:35	0	3	0	0	3	3	1	1	0	5	1	11	5	0	17	3	10	0	0	13	38
16:40	0	2	1	0	3	0	10	0	0	10	0	4	3	0	7	1	10	0	0	11	31
16:45	0	3	1	0	4	2	6	0	0	8	1	8	4	0	13	2	9	0	0	11	36
16:50	0	2	2	0	4	0	5	0	0	5	0	7	5	0	12	4	8	0	0	12	33
16:55	0	2	2	0	4	1	5	0	0	6	2	6	2	0	10	2	14	0	0	16	36
17:00	0	2	1	0	3	0	5	0	0	5	0	10	4	0	14	3	5	1	0	9	31
17:05	0	6	3	0	9	0	5	0	0	5	0	12	1	0	13	2	13	0	0	15	42
Total Volume	2	46	18	0	66	13	77	2	0	92	6	117	54	0	177	24	121	2	0	147	482
% App. Total	3	69.7	27.3	0		14.1	83.7	2.2	0		3.4	66.1	30.5	0		16.3	82.3	1.4	0		
PHF	.167	.479	.500	.000	.550	.361	.583	.167	.000	.590	.250	.443	.409	.000	.434	.500	.672	.167	.000	.766	.582

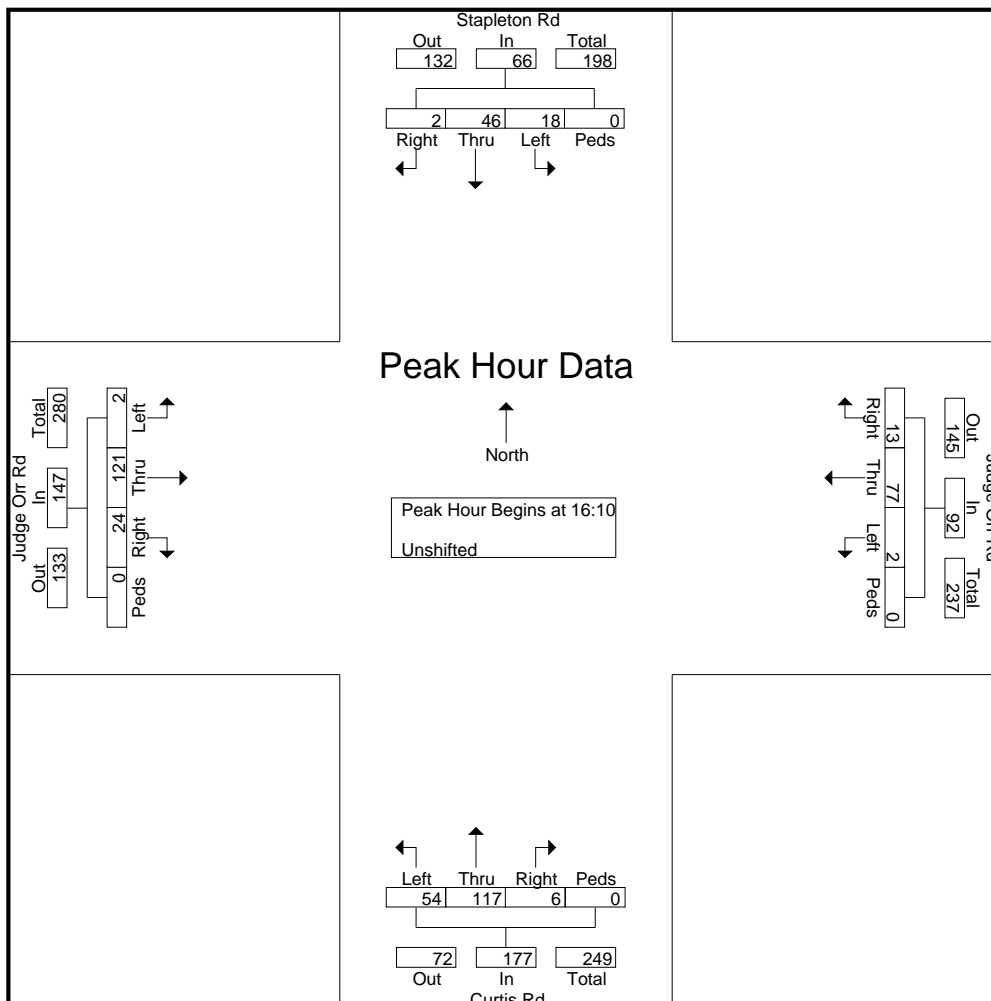

LSC Transportation Consultants, Inc.

2504 E. Pikes Peak Ave, Suite 304
 Colorado Springs, CO 80909
 719-633-2868

File Name : Curtis Rd - Judge Orr Rd PM 11-23

Site Code : S234040

Start Date : 11/2/2023

Page No : 3

Start Time	Stapleton Rd Southbound					Judge Orr Rd Westbound					Curtis Rd Northbound					Judge Orr Rd Eastbound					Int. Total
	Right	Thru	Left	Peds	App. Total	Right	Thru	Left	Peds	App. Total	Right	Thru	Left	Peds	App. Total	Right	Thru	Left	Peds	App. Total	

Peak Hour Analysis From 16:00 to 17:55 - Peak 1 of 1

Peak Hour for Each Approach Begins at:

	16:25					16:10					16:05					16:35				
+0 mins.	1	6	2	0	9	3	5	1	0	9	0	9	5	0	14	3	10	0	0	13
+5 mins.	0	8	2	0	10	0	11	0	0	11	0	12	6	0	18	1	10	0	0	11
+10 mins.	0	3	0	0	3	0	7	0	0	7	0	6	5	0	11	2	9	0	0	11
+15 mins.	0	2	1	0	3	2	11	0	0	13	1	9	4	0	14	4	8	0	0	12
+20 mins.	0	3	1	0	4	2	6	0	0	8	1	22	11	0	34	2	14	0	0	16
+25 mins.	0	2	2	0	4	3	1	1	0	5	0	10	4	0	14	3	5	1	0	9
+30 mins.	0	2	2	0	4	0	10	0	0	10	1	11	5	0	17	2	13	0	0	15
+35 mins.	0	2	1	0	3	2	6	0	0	8	0	4	3	0	7	1	9	0	0	10
+40 mins.	0	6	3	0	9	0	5	0	0	5	1	8	4	0	13	6	15	0	0	21
+45 mins.	1	2	3	0	6	1	5	0	0	6	0	7	5	0	12	1	9	0	0	10
+50 mins.	0	5	4	0	9	0	5	0	0	5	2	6	2	0	10	2	13	1	0	16
+55 mins.	0	5	4	0	9	0	5	0	0	5	0	10	4	0	14	2	12	0	0	14
Total Volume	2	46	25	0	73	13	77	2	0	92	6	114	58	0	178	29	127	2	0	158
% App. Total	2.7	63	34.2	0		14.1	83.7	2.2	0		3.4	64	32.6	0		18.4	80.4	1.3	0	
PHF	.167	.479	.521	.000	.608	.361	.583	.167	.000	.590	.250	.432	.439	.000	.436	.403	.706	.167	.000	.627

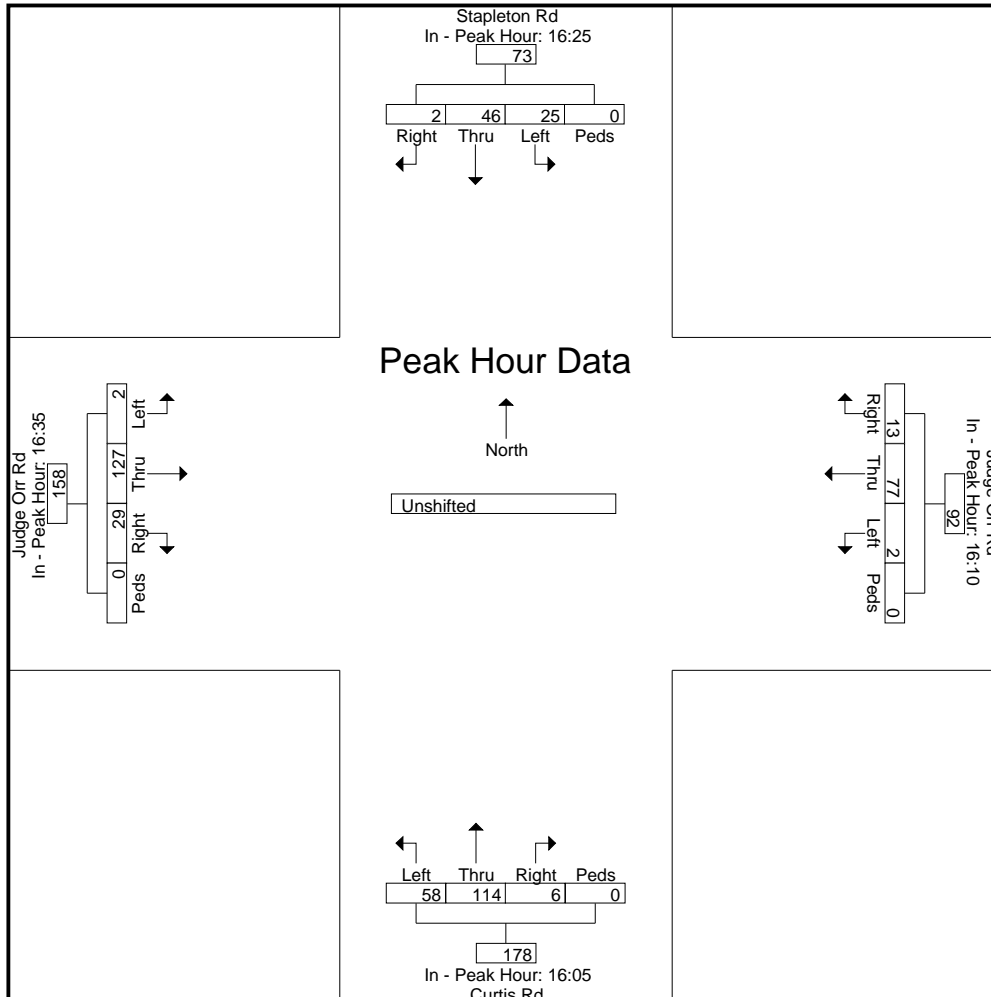

LSC Transportation Consultants, Inc.

2504 E. Pikes Peak Ave, Suite 304
 Colorado Springs, CO 80909
 719-633-2868

File Name : Curtis Rd - Falcon Hwy AM 5-23

Site Code : S224220

Start Date : 5/17/2023

Page No : 1

Groups Printed- Unshifted

Start Time	Curtis Rd Southbound					Falcon Hwy Westbound					Curtis Rd Northbound					Falcon Hwy Eastbound					Int. Total
	Right	Thru	Left	Peds	App. Total	Right	Thru	Left	Peds	App. Total	Right	Thru	Left	Peds	App. Total	Right	Thru	Left	Peds	App. Total	
06:30	0	12	1	0	13	2	12	3	0	17	0	1	6	0	7	8	0	1	0	9	46
06:35	1	19	2	0	22	0	20	1	0	21	0	2	7	0	9	11	1	0	0	12	64
06:40	0	16	1	0	17	1	14	3	0	18	1	2	3	0	6	19	2	0	0	21	62
06:45	1	15	1	0	17	2	12	0	0	14	0	4	11	0	15	16	1	1	0	18	64
06:50	1	11	0	0	12	2	15	1	0	18	0	3	5	0	8	14	4	2	0	20	58
06:55	1	17	0	0	18	2	23	0	0	25	0	9	1	0	10	15	2	0	0	17	70
Total	4	90	5	0	99	9	96	8	0	113	1	21	33	0	55	83	10	4	0	97	364
07:00	0	16	0	0	16	1	10	3	0	14	0	9	6	0	15	18	3	0	0	21	66
07:05	3	13	0	0	16	7	15	0	0	22	0	6	3	0	9	38	6	2	0	46	93
07:10	1	16	1	0	18	1	25	0	0	26	1	6	4	0	11	9	7	1	0	17	72
07:15	2	21	2	0	25	4	23	2	0	29	0	6	6	0	12	23	3	1	0	27	93
07:20	1	21	1	0	23	6	15	1	0	22	0	7	5	0	12	27	4	1	0	32	89
07:25	1	15	0	0	16	4	23	2	0	29	0	5	3	0	8	28	8	0	0	36	89
07:30	3	15	0	0	18	7	18	2	0	27	0	7	5	0	12	26	5	0	0	31	88
07:35	2	30	1	0	33	3	9	1	0	13	0	7	9	0	16	19	4	4	0	27	89
07:40	8	19	1	0	28	4	13	1	0	18	0	6	4	0	10	19	7	1	0	27	83
07:45	0	14	3	0	17	0	11	0	0	11	0	2	2	0	4	14	5	0	0	19	51
07:50	3	12	4	0	19	1	16	1	0	18	0	4	2	0	6	14	2	2	0	18	61
07:55	0	7	1	0	8	1	19	1	0	21	1	5	9	0	15	8	6	0	0	14	58
Total	24	199	14	0	237	39	197	14	0	250	2	70	58	0	130	243	60	12	0	315	932
08:00	2	15	3	0	20	2	10	1	0	13	0	1	5	0	6	12	8	1	0	21	60
08:05	0	5	0	0	5	5	9	2	0	16	0	1	7	0	8	17	4	2	0	23	52
08:10	0	5	0	0	5	0	16	2	0	18	0	4	6	0	10	12	10	0	0	22	55
08:15	1	12	0	0	13	3	11	2	0	16	0	1	2	0	3	10	4	1	0	15	47
08:20	1	9	2	0	12	2	14	1	0	17	1	1	1	0	3	9	6	1	0	16	48
08:25	2	7	0	0	9	1	14	0	0	15	0	3	7	0	10	9	8	3	0	20	54
Grand Total	34	342	24	0	400	61	367	30	0	458	4	102	119	0	225	395	110	24	0	529	1612
Apprch %	8.5	85.5	6	0		13.3	80.1	6.6	0		1.8	45.3	52.9	0		74.7	20.8	4.5	0		
Total %	2.1	21.2	1.5	0	24.8	3.8	22.8	1.9	0	28.4	0.2	6.3	7.4	0	14	24.5	6.8	1.5	0	32.8	

LSC Transportation Consultants, Inc.

2504 E. Pikes Peak Ave, Suite 304
 Colorado Springs, CO 80909
 719-633-2868

File Name : Curtis Rd - Falcon Hwy AM 5-23
 Site Code : S224220
 Start Date : 5/17/2023
 Page No : 2

Start Time	Curtis Rd Southbound					Falcon Hwy Westbound					Curtis Rd Northbound					Falcon Hwy Eastbound					Int. Total
	Right	Thru	Left	Peds	App. Total	Right	Thru	Left	Peds	App. Total	Right	Thru	Left	Peds	App. Total	Right	Thru	Left	Peds	App. Total	
Peak Hour Analysis From 06:30 to 08:25 - Peak 1 of 1																					
Peak Hour for Entire Intersection Begins at 06:45																					
06:45	1	15	1	0	17	2	12	0	0	14	0	4	11	0	15	16	1	1	0	18	64
06:50	1	11	0	0	12	2	15	1	0	18	0	3	5	0	8	14	4	2	0	20	58
06:55	1	17	0	0	18	2	23	0	0	25	0	9	1	0	10	15	2	0	0	17	70
07:00	0	16	0	0	16	1	10	3	0	14	0	9	6	0	15	18	3	0	0	21	66
07:05	3	13	0	0	16	7	15	0	0	22	0	6	3	0	9	38	6	2	0	46	93
07:10	1	16	1	0	18	1	25	0	0	26	1	6	4	0	11	9	7	1	0	17	72
07:15	2	21	2	0	25	4	23	2	0	29	0	6	6	0	12	23	3	1	0	27	93
07:20	1	21	1	0	23	6	15	1	0	22	0	7	5	0	12	27	4	1	0	32	89
07:25	1	15	0	0	16	4	23	2	0	29	0	5	3	0	8	28	8	0	0	36	89
07:30	3	15	0	0	18	7	18	2	0	27	0	7	5	0	12	26	5	0	0	31	88
07:35	2	30	1	0	33	3	9	1	0	13	0	7	9	0	16	19	4	4	0	27	89
07:40	8	19	1	0	28	4	13	1	0	18	0	6	4	0	10	19	7	1	0	27	83
Total Volume	24	209	7	0	240	43	201	13	0	257	1	75	62	0	138	252	54	13	0	319	954
% App. Total	10	87.1	2.9	0		16.7	78.2	5.1	0		0.7	54.3	44.9	0		79	16.9	4.1	0		
PHF	.250	.581	.292	.000	.606	.512	.670	.361	.000	.739	.083	.694	.470	.000	.719	.553	.563	.271	.000	.578	.855

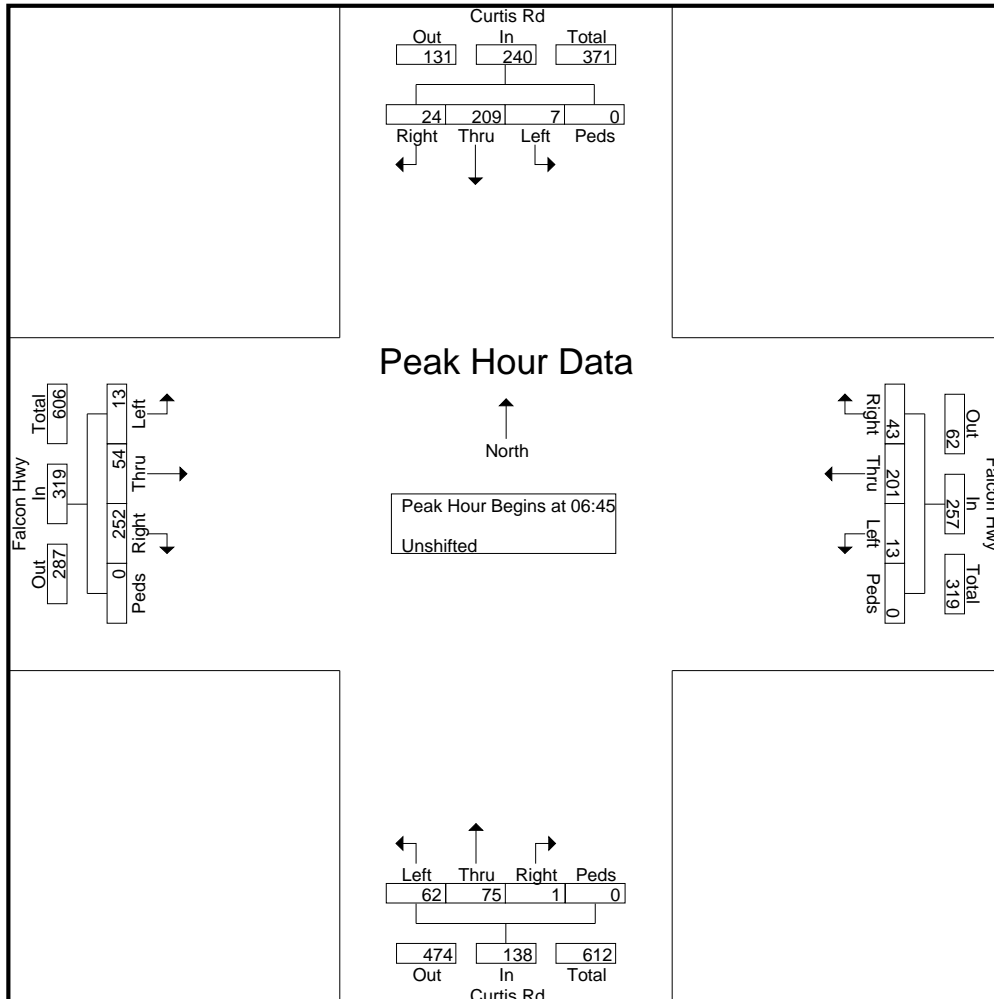

LSC Transportation Consultants, Inc.

2504 E. Pikes Peak Ave, Suite 304
 Colorado Springs, CO 80909
 719-633-2868

File Name : Curtis Rd - Falcon Hwy AM 5-23
 Site Code : S224220
 Start Date : 5/17/2023
 Page No : 3

Start Time	Curtis Rd Southbound					Falcon Hwy Westbound					Curtis Rd Northbound					Falcon Hwy Eastbound					Int. Total
	Right	Thru	Left	Peds	App. Total	Right	Thru	Left	Peds	App. Total	Right	Thru	Left	Peds	App. Total	Right	Thru	Left	Peds	App. Total	
Peak Hour Analysis From 06:30 to 08:25 - Peak 1 of 1																					
Peak Hour for Each Approach Begins at:																					
	06:55					06:35					06:45					06:50					
+0 mins.	1	17	0	0	18	0	20	1	0	21	0	4	11	0	15	14	4	2	0	20	
+5 mins.	0	16	0	0	16	1	14	3	0	18	0	3	5	0	8	15	2	0	0	17	
+10 mins.	3	13	0	0	16	2	12	0	0	14	0	9	1	0	10	18	3	0	0	21	
+15 mins.	1	16	1	0	18	2	15	1	0	18	0	9	6	0	15	38	6	2	0	46	
+20 mins.	2	21	2	0	25	2	23	0	0	25	0	6	3	0	9	9	7	1	0	17	
+25 mins.	1	21	1	0	23	1	10	3	0	14	1	6	4	0	11	23	3	1	0	27	
+30 mins.	1	15	0	0	16	7	15	0	0	22	0	6	6	0	12	27	4	1	0	32	
+35 mins.	3	15	0	0	18	1	25	0	0	26	0	7	5	0	12	28	8	0	0	36	
+40 mins.	2	30	1	0	33	4	23	2	0	29	0	5	3	0	8	26	5	0	0	31	
+45 mins.	8	19	1	0	28	6	15	1	0	22	0	7	5	0	12	19	4	4	0	27	
+50 mins.	0	14	3	0	17	4	23	2	0	29	0	7	9	0	16	19	7	1	0	27	
+55 mins.	3	12	4	0	19	7	18	2	0	27	0	6	4	0	10	14	5	0	0	19	
Total Volume	25	209	13	0	247	37	213	15	0	265	1	75	62	0	138	250	58	12	0	320	
% App. Total	10.1	84.6	5.3	0		14	80.4	5.7	0		0.7	54.3	44.9	0		78.1	18.1	3.8	0		
PHF	.260	.581	.271	.000	.624	.440	.710	.417	.000	.761	.083	.694	.470	.000	.719	.548	.604	.250	.000	.580	

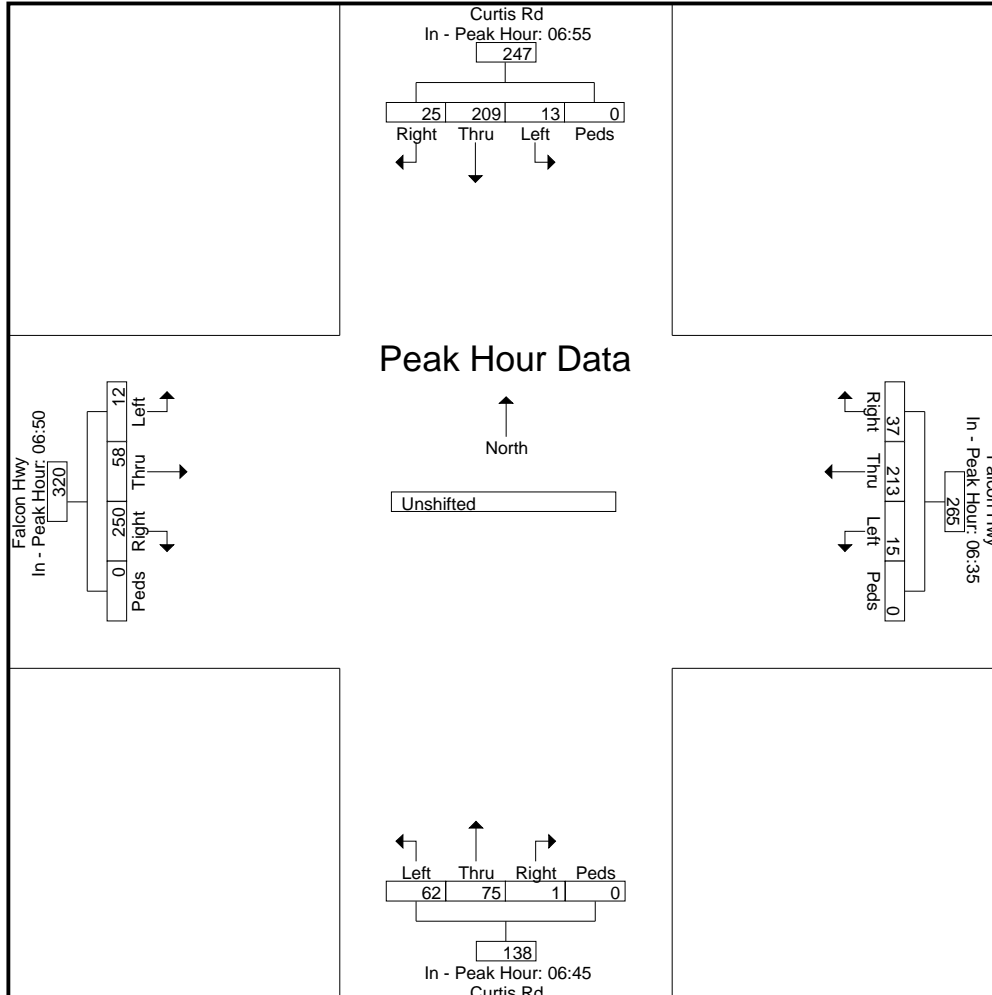

LSC Transportation Consultants, Inc.

2504 E. Pikes Peak Ave, Suite 304
 Colorado Springs, CO 80909
 719-633-2868

File Name : Curtis Rd - Falcon Hwy PM 5-23

Site Code : S224220

Start Date : 5/17/2023

Page No : 1

Groups Printed- Unshifted

Start Time	Curtis Rd Southbound					Falcon Hwy Westbound					Curtis Rd Northbound					Falcon Hwy Eastbound					Int. Total
	Right	Thru	Left	Peds	App. Total	Right	Thru	Left	Peds	App. Total	Right	Thru	Left	Peds	App. Total	Right	Thru	Left	Peds	App. Total	
16:00	1	5	1	0	7	0	5	1	0	6	2	6	21	0	29	5	18	3	0	26	68
16:05	0	4	2	0	6	1	9	1	0	11	1	13	11	0	25	5	20	1	0	26	68
16:10	2	7	1	0	10	0	4	1	0	5	0	11	20	0	31	3	10	1	0	14	60
16:15	0	5	0	0	5	1	11	1	0	13	2	17	21	0	40	3	18	2	0	23	81
16:20	0	4	0	0	4	0	4	0	0	4	3	8	21	0	32	7	21	2	0	30	70
16:25	0	2	1	0	3	0	8	2	0	10	0	26	24	0	50	9	28	0	0	37	100
16:30	0	3	0	0	3	1	8	0	0	9	2	19	20	0	41	7	12	0	0	19	72
16:35	0	4	1	0	5	0	11	2	0	13	5	17	16	0	38	7	13	1	0	21	77
16:40	2	2	3	0	7	1	5	0	0	6	2	15	19	0	36	3	19	3	0	25	74
16:45	6	5	2	0	13	1	5	0	0	6	3	25	18	0	46	3	13	0	0	16	81
16:50	2	5	1	0	8	2	11	0	0	13	4	16	23	0	43	9	16	0	0	25	89
16:55	0	4	6	0	10	1	8	0	0	9	5	10	17	0	32	4	15	1	0	20	71
Total	13	50	18	0	81	8	89	8	0	105	29	183	231	0	443	65	203	14	0	282	911
17:00	5	4	4	0	13	3	8	1	0	12	1	13	18	0	32	3	18	0	0	21	78
17:05	1	3	2	0	6	4	6	1	0	11	2	10	15	0	27	5	12	1	0	18	62
17:10	1	2	3	0	6	0	8	0	0	8	4	11	11	0	26	2	17	2	0	21	61
17:15	0	4	2	0	6	1	10	0	0	11	2	9	9	0	20	6	19	1	0	26	63
17:20	0	2	0	0	2	0	11	0	0	11	4	13	6	0	23	5	18	1	0	24	60
17:25	0	2	0	0	2	1	12	1	0	14	7	19	14	0	40	8	11	1	0	20	76
17:30	0	5	3	0	8	1	10	0	0	11	7	6	10	0	23	10	11	1	0	22	64
17:35	1	3	0	0	4	1	5	0	0	6	6	11	12	0	29	8	18	1	0	27	66
17:40	0	2	1	0	3	2	9	1	0	12	0	8	7	0	15	3	17	0	0	20	50
17:45	0	9	3	0	12	4	5	1	0	10	3	5	4	0	12	2	12	1	0	15	49
17:50	0	3	1	0	4	3	8	0	0	11	3	8	8	0	19	4	13	0	0	17	51
17:55	0	0	4	0	4	1	8	0	0	9	4	6	4	0	14	3	20	1	0	24	51
Total	8	39	23	0	70	21	100	5	0	126	43	119	118	0	280	59	186	10	0	255	731
Grand Total	21	89	41	0	151	29	189	13	0	231	72	302	349	0	723	124	389	24	0	537	1642
Apprch %	13.9	58.9	27.2	0		12.6	81.8	5.6	0		10	41.8	48.3	0		23.1	72.4	4.5	0		
Total %	1.3	5.4	2.5	0	9.2	1.8	11.5	0.8	0	14.1	4.4	18.4	21.3	0	44	7.6	23.7	1.5	0	32.7	

LSC Transportation Consultants, Inc.

2504 E. Pikes Peak Ave, Suite 304
 Colorado Springs, CO 80909
 719-633-2868

File Name : Curtis Rd - Falcon Hwy PM 5-23
 Site Code : S224220
 Start Date : 5/17/2023
 Page No : 2

Start Time	Curtis Rd Southbound					Falcon Hwy Westbound					Curtis Rd Northbound					Falcon Hwy Eastbound					Int. Total
	Right	Thru	Left	Peds	App. Total	Right	Thru	Left	Peds	App. Total	Right	Thru	Left	Peds	App. Total	Right	Thru	Left	Peds	App. Total	
Peak Hour Analysis From 16:00 to 17:55 - Peak 1 of 1																					
Peak Hour for Entire Intersection Begins at 16:05																					
16:05	0	4	2	0	6	1	9	1	0	11	1	13	11	0	25	5	20	1	0	26	68
16:10	2	7	1	0	10	0	4	1	0	5	0	11	20	0	31	3	10	1	0	14	60
16:15	0	5	0	0	5	1	11	1	0	13	2	17	21	0	40	3	18	2	0	23	81
16:20	0	4	0	0	4	0	4	0	0	4	3	8	21	0	32	7	21	2	0	30	70
16:25	0	2	1	0	3	0	8	2	0	10	0	26	24	0	50	9	28	0	0	37	100
16:30	0	3	0	0	3	1	8	0	0	9	2	19	20	0	41	7	12	0	0	19	72
16:35	0	4	1	0	5	0	11	2	0	13	5	17	16	0	38	7	13	1	0	21	77
16:40	2	2	3	0	7	1	5	0	0	6	2	15	19	0	36	3	19	3	0	25	74
16:45	6	5	2	0	13	1	5	0	0	6	3	25	18	0	46	3	13	0	0	16	81
16:50	2	5	1	0	8	2	11	0	0	13	4	16	23	0	43	9	16	0	0	25	89
16:55	0	4	6	0	10	1	8	0	0	9	5	10	17	0	32	4	15	1	0	20	71
17:00	5	4	4	0	13	3	8	1	0	12	1	13	18	0	32	3	18	0	0	21	78
Total Volume	17	49	21	0	87	11	92	8	0	111	28	190	228	0	446	63	203	11	0	277	921
% App. Total	19.5	56.3	24.1	0		9.9	82.9	7.2	0		6.3	42.6	51.1	0		22.7	73.3	4	0		
PHF	.236	.583	.292	.000	.558	.306	.697	.333	.000	.712	.467	.609	.792	.000	.743	.583	.604	.306	.000	.624	.768

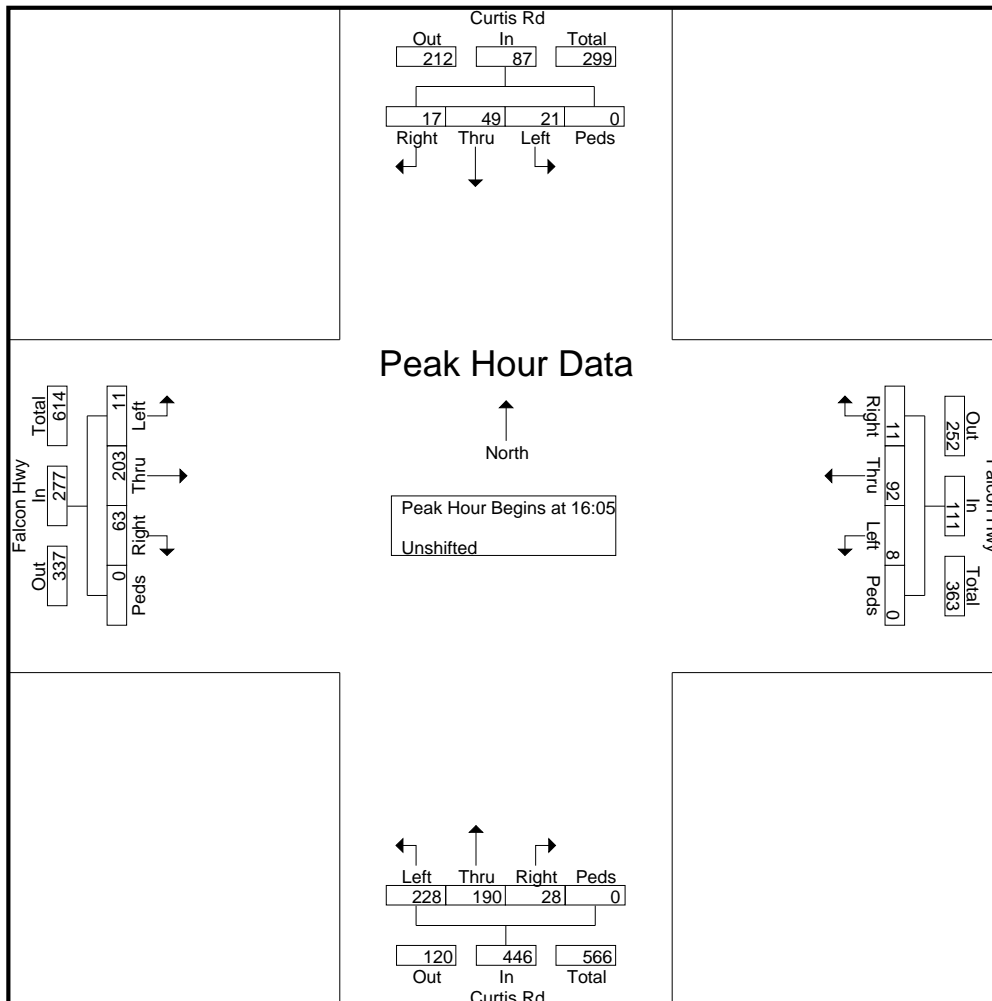

LSC Transportation Consultants, Inc.

2504 E. Pikes Peak Ave, Suite 304
 Colorado Springs, CO 80909
 719-633-2868

File Name : Curtis Rd - Falcon Hwy PM 5-23
 Site Code : S224220
 Start Date : 5/17/2023
 Page No : 3

Start Time	Curtis Rd Southbound					Falcon Hwy Westbound					Curtis Rd Northbound					Falcon Hwy Eastbound					Int. Total
	Right	Thru	Left	Peds	App. Total	Right	Thru	Left	Peds	App. Total	Right	Thru	Left	Peds	App. Total	Right	Thru	Left	Peds	App. Total	
Peak Hour Analysis From 16:00 to 17:55 - Peak 1 of 1																					
Peak Hour for Each Approach Begins at:																					
	16:05					16:50					16:10					16:00					
+0 mins.	0	4	2	0	6	2	11	0	0	13	0	11	20	0	31	5	18	3	0	26	
+5 mins.	2	7	1	0	10	1	8	0	0	9	2	17	21	0	40	5	20	1	0	26	
+10 mins.	0	5	0	0	5	3	8	1	0	12	3	8	21	0	32	3	10	1	0	14	
+15 mins.	0	4	0	0	4	4	6	1	0	11	0	26	24	0	50	3	18	2	0	23	
+20 mins.	0	2	1	0	3	0	8	0	0	8	2	19	20	0	41	7	21	2	0	30	
+25 mins.	0	3	0	0	3	1	10	0	0	11	5	17	16	0	38	9	28	0	0	37	
+30 mins.	0	4	1	0	5	0	11	0	0	11	2	15	19	0	36	7	12	0	0	19	
+35 mins.	2	2	3	0	7	1	12	1	0	14	3	25	18	0	46	7	13	1	0	21	
+40 mins.	6	5	2	0	13	1	10	0	0	11	4	16	23	0	43	3	19	3	0	25	
+45 mins.	2	5	1	0	8	1	5	0	0	6	5	10	17	0	32	3	13	0	0	16	
+50 mins.	0	4	6	0	10	2	9	1	0	12	1	13	18	0	32	9	16	0	0	25	
+55 mins.	5	4	4	0	13	4	5	1	0	10	2	10	15	0	27	4	15	1	0	20	
Total Volume	17	49	21	0	87	20	103	5	0	128	29	187	232	0	448	65	203	14	0	282	
% App. Total	19.5	56.3	24.1	0		15.6	80.5	3.9	0		6.5	41.7	51.8	0		23	72	5	0		
PHF	.236	.583	.292	.000	.558	.417	.715	.417	.000	.762	.483	.599	.806	.000	.747	.602	.604	.389	.000	.635	

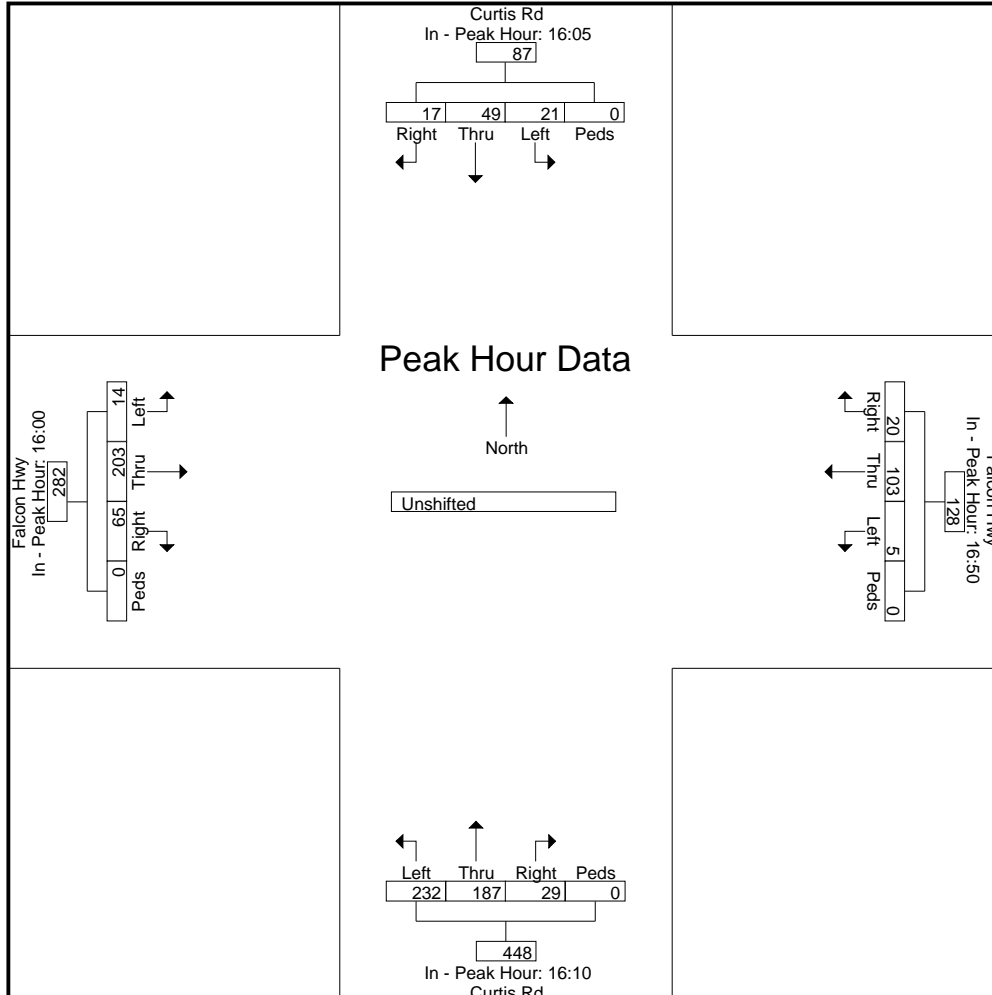

LSC Transportation Consultants, Inc.

2504 E. Pikes Peak Ave, Suite 304
 Colorado Springs, CO 80909
 719-633-2868

File Name : Curtis Rd - Judge Orr Rd AM
 Site Code : S214950
 Start Date : 4/21/2022
 Page No : 1

Groups Printed- Unshifted

Start Time	Curtis Rd Southbound					Judge Orr Rd Westbound					Curtis Rd Northbound					Judge Orr Rd Eastbound					Int. Total
	Right	Thru	Left	Peds	App. Total	Right	Thru	Left	Peds	App. Total	Right	Thru	Left	Peds	App. Total	Right	Thru	Left	Peds	App. Total	
06:30	0	42	1	0	43	2	29	2	0	33	0	9	4	0	13	14	5	0	0	19	108
06:45	0	40	3	0	43	6	27	5	0	38	0	12	6	0	18	13	9	0	0	22	121
Total	0	82	4	0	86	8	56	7	0	71	0	21	10	0	31	27	14	0	0	41	229
07:00	0	44	0	0	44	8	34	5	0	47	0	26	9	0	35	19	10	0	0	29	155
07:15	0	40	1	0	41	12	31	6	0	49	0	25	10	0	35	22	8	0	0	30	155
07:30	0	42	4	0	46	7	24	3	0	34	0	14	10	0	24	25	7	1	0	33	137
07:45	1	42	2	0	45	3	32	2	0	37	1	11	8	0	20	12	5	1	0	18	120
Total	1	168	7	0	176	30	121	16	0	167	1	76	37	0	114	78	30	2	0	110	567
08:00	1	17	7	0	25	4	18	2	0	24	0	8	3	0	11	5	7	1	0	13	73
08:15	1	17	3	0	21	3	21	1	0	25	2	14	2	0	18	7	13	0	0	20	84
Grand Total	3	284	21	0	308	45	216	26	0	287	3	119	52	0	174	117	64	3	0	184	953
Apprch %	1	92.2	6.8	0		15.7	75.3	9.1	0		1.7	68.4	29.9	0		63.6	34.8	1.6	0		
Total %	0.3	29.8	2.2	0	32.3	4.7	22.7	2.7	0	30.1	0.3	12.5	5.5	0	18.3	12.3	6.7	0.3	0	19.3	

LSC Transportation Consultants, Inc.

2504 E. Pikes Peak Ave, Suite 304
 Colorado Springs, CO 80909
 719-633-2868

File Name : Curtis Rd - Judge Orr Rd AM

Site Code : S214950

Start Date : 4/21/2022

Page No : 2

Start Time	Curtis Rd Southbound					Judge Orr Rd Westbound					Curtis Rd Northbound					Judge Orr Rd Eastbound					Int. Total
	Right	Thru	Left	Peds	App. Total	Right	Thru	Left	Peds	App. Total	Right	Thru	Left	Peds	App. Total	Right	Thru	Left	Peds	App. Total	
Peak Hour Analysis From 6:30:00 AM to 8:15:00 AM - Peak 1 of 1																					
Peak Hour for Entire Intersection Begins at 6:45:00 AM																					
6:45:00 AM	0	40	3	0	43	6	27	5	0	38	0	12	6	0	18	13	9	0	0	22	121
7:00:00 AM	0	44	0	0	44	8	34	5	0	47	0	26	9	0	35	19	10	0	0	29	155
7:15:00 AM	0	40	1	0	41	12	31	6	0	49	0	25	10	0	35	22	8	0	0	30	155
7:30:00 AM	0	42	4	0	46	7	24	3	0	34	0	14	10	0	24	25	7	1	0	33	137
Total Volume	0	166	8	0	174	33	116	19	0	168	0	77	35	0	112	79	34	1	0	114	568
% App. Total	0	95.4	4.6	0		19.6	69	11.3	0		0	68.8	31.2	0		69.3	29.8	0.9	0		
PHF	.000	.943	.500	.000	.946	.688	.853	.792	.000	.857	.000	.740	.875	.000	.800	.790	.850	.250	.000	.864	.916

LSC Transportation Consultants, Inc.

2504 E. Pikes Peak Ave, Suite 304
 Colorado Springs, CO 80909
 719-633-2868

File Name : Curtis Rd - Judge Orr Rd AM
 Site Code : S214950
 Start Date : 4/21/2022
 Page No : 3

Start Time	Curtis Rd Southbound					Judge Orr Rd Westbound					Curtis Rd Northbound					Judge Orr Rd Eastbound					Int. Total
	Right	Thru	Left	Peds	App. Total	Right	Thru	Left	Peds	App. Total	Right	Thru	Left	Peds	App. Total	Right	Thru	Left	Peds	App. Total	
Peak Hour Analysis From 6:30:00 AM to 8:15:00 AM - Peak 1 of 1																					
Peak Hour for Each Approach Begins at:																					
	7:00:00 AM					6:45:00 AM					7:00:00 AM					6:45:00 AM					
+0 mins.	0	44	0	0	44	6	27	5	0	38	0	26	9	0	35	13	9	0	0	22	
+5 mins.	0	40	1	0	41	8	34	5	0	47	0	25	10	0	35	19	10	0	0	29	
+10 mins.	0	42	4	0	46	12	31	6	0	49	0	14	10	0	24	22	8	0	0	30	
+15 mins.	1	42	2	0	45	7	24	3	0	34	1	11	8	0	20	25	7	1	0	33	
Total Volume	1	168	7	0	176	33	116	19	0	168	1	76	37	0	114	79	34	1	0	114	
% App. Total	0.6	95.5	4	0		19.6	69	11.3	0		0.9	66.7	32.5	0		69.3	29.8	0.9	0		
PHF	.250	.955	.438	.000	.957	.688	.853	.792	.000	.857	.250	.731	.925	.000	.814	.790	.850	.250	.000	.864	

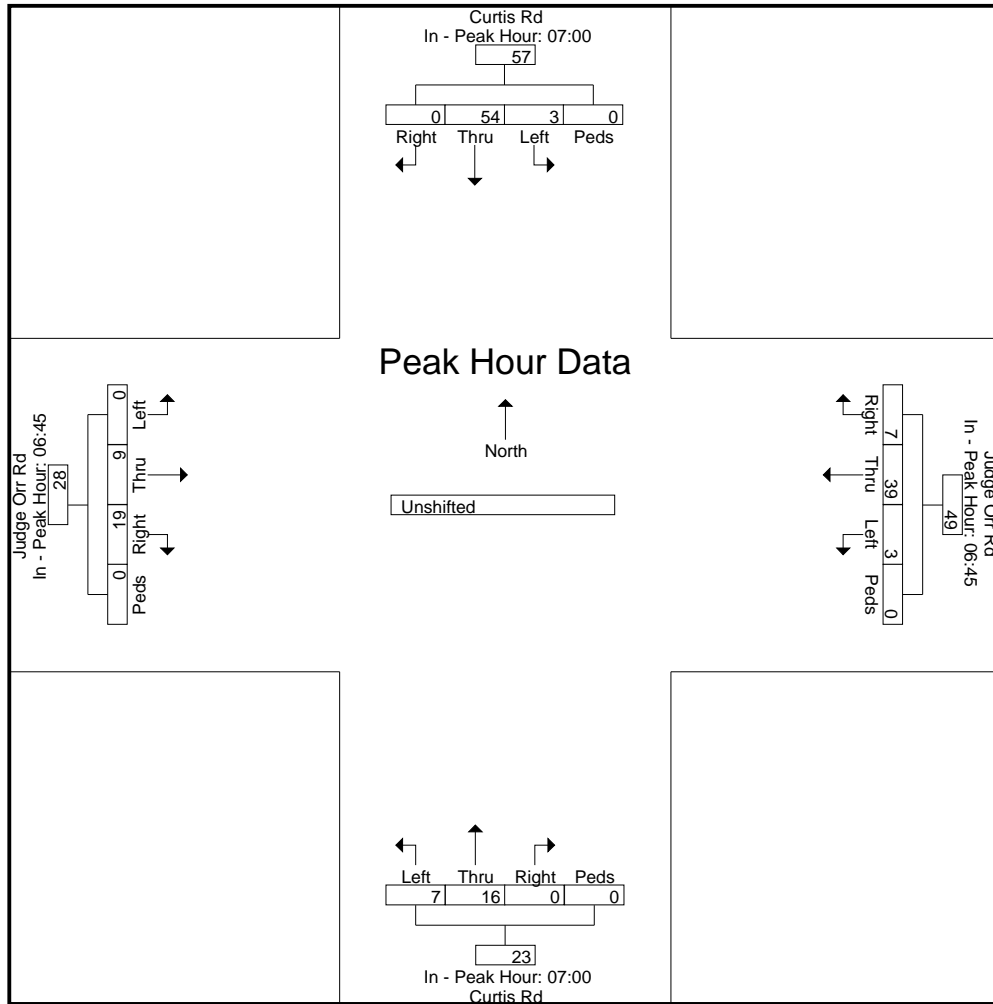

LSC Transportation Consultants, Inc.

2504 E. Pikes Peak Ave, Suite 304
 Colorado Springs, CO 80909
 719-633-2868

File Name : Curtis Rd - Judge Orr Rd PM

Site Code : S214950

Start Date : 4/21/2022

Page No : 1

Groups Printed- Unshifted

Start Time	Curtis Rd Southbound					Judge Orr Rd Westbound					Curtis Rd Northbound					Judge Orr Rd Eastbound					Int. Total
	Right	Thru	Left	Peds	App. Total	Right	Thru	Left	Peds	App. Total	Right	Thru	Left	Peds	App. Total	Right	Thru	Left	Peds	App. Total	
16:00	2	12	4	1	19	1	25	1	0	27	2	33	15	0	50	9	31	0	0	40	136
16:15	1	10	2	0	13	4	13	1	0	18	4	38	18	0	60	9	21	0	0	30	121
16:30	0	11	5	0	16	5	11	0	0	16	5	30	13	0	48	7	30	2	0	39	119
16:45	2	14	5	0	21	3	15	0	0	18	7	36	20	0	63	4	28	1	0	33	135
Total	5	47	16	1	69	13	64	2	0	79	18	137	66	0	221	29	110	3	0	142	511
17:00	0	9	4	0	13	4	10	0	0	14	6	41	11	0	58	5	32	1	0	38	123
17:15	1	15	2	0	18	3	15	0	0	18	2	23	11	0	36	8	22	1	0	31	103
17:30	1	10	9	0	20	5	11	0	0	16	2	17	6	0	25	6	36	0	0	42	103
17:45	1	13	9	0	23	0	19	1	0	20	1	18	4	0	23	3	23	1	0	27	93
Total	3	47	24	0	74	12	55	1	0	68	11	99	32	0	142	22	113	3	0	138	422
Grand Total	8	94	40	1	143	25	119	3	0	147	29	236	98	0	363	51	223	6	0	280	933
Apprch %	5.6	65.7	28	0.7		17	81	2	0		8	65	27	0		18.2	79.6	2.1	0		
Total %	0.9	10.1	4.3	0.1	15.3	2.7	12.8	0.3	0	15.8	3.1	25.3	10.5	0	38.9	5.5	23.9	0.6	0	30	

LSC Transportation Consultants, Inc.

2504 E. Pikes Peak Ave, Suite 304
 Colorado Springs, CO 80909
 719-633-2868

File Name : Curtis Rd - Judge Orr Rd PM

Site Code : S214950

Start Date : 4/21/2022

Page No : 2

Start Time	Curtis Rd Southbound					Judge Orr Rd Westbound					Curtis Rd Northbound					Judge Orr Rd Eastbound					Int. Total
	Right	Thru	Left	Peds	App. Total	Right	Thru	Left	Peds	App. Total	Right	Thru	Left	Peds	App. Total	Right	Thru	Left	Peds	App. Total	
Peak Hour Analysis From 4:00:00 PM to 5:45:00 PM - Peak 1 of 1																					
Peak Hour for Entire Intersection Begins at 4:00:00 PM																					
4:00:00 PM	2	12	4	1	19	1	25	1	0	27	2	33	15	0	50	9	31	0	0	40	136
4:15:00 PM	1	10	2	0	13	4	13	1	0	18	4	38	18	0	60	9	21	0	0	30	121
4:30:00 PM	0	11	5	0	16	5	11	0	0	16	5	30	13	0	48	7	30	2	0	39	119
4:45:00 PM	2	14	5	0	21	3	15	0	0	18	7	36	20	0	63	4	28	1	0	33	135
Total Volume	5	47	16	1	69	13	64	2	0	79	18	137	66	0	221	29	110	3	0	142	511
% App. Total	7.2	68.1	23.2	1.4		16.5	81	2.5	0		8.1	62	29.9	0		20.4	77.5	2.1	0		
PHF	.625	.839	.800	.250	.821	.650	.640	.500	.000	.731	.643	.901	.825	.000	.877	.806	.887	.375	.000	.888	.939

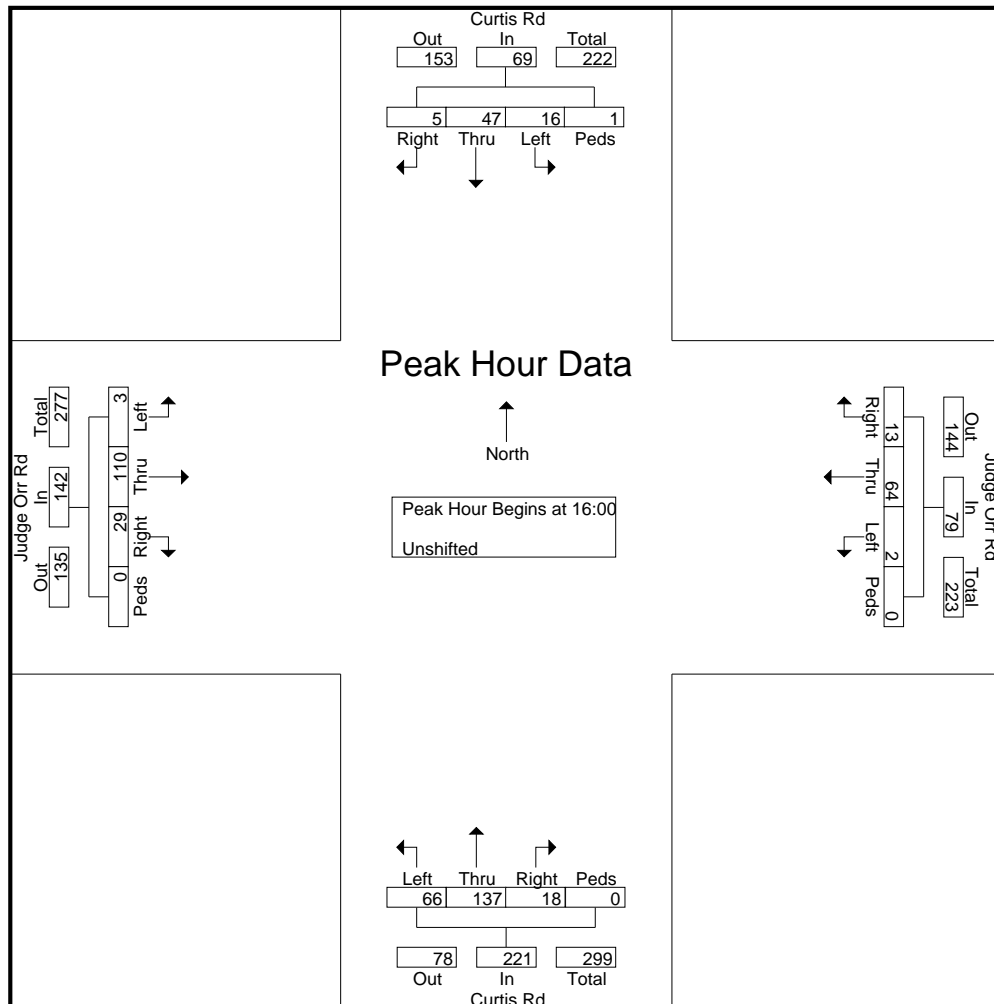

LSC Transportation Consultants, Inc.

2504 E. Pikes Peak Ave, Suite 304
 Colorado Springs, CO 80909
 719-633-2868

File Name : Curtis Rd - Judge Orr Rd PM

Site Code : S214950

Start Date : 4/21/2022

Page No : 3

Start Time	Curtis Rd Southbound					Judge Orr Rd Westbound					Curtis Rd Northbound					Judge Orr Rd Eastbound					Int. Total
	Right	Thru	Left	Peds	App. Total	Right	Thru	Left	Peds	App. Total	Right	Thru	Left	Peds	App. Total	Right	Thru	Left	Peds	App. Total	

Peak Hour Analysis From 4:00:00 PM to 5:45:00 PM - Peak 1 of 1
 Peak Hour for Each Approach Begins at:

	5:00:00 PM					4:00:00 PM					4:15:00 PM					4:45:00 PM				
+0 mins.	0	9	4	0	13	1	25	1	0	27	4	38	18	0	60	4	28	1	0	33
+5 mins.	1	15	2	0	18	4	13	1	0	18	5	30	13	0	48	5	32	1	0	38
+10 mins.	1	10	9	0	20	5	11	0	0	16	7	36	20	0	63	8	22	1	0	31
+15 mins.	1	13	9	0	23	3	15	0	0	18	6	41	11	0	58	6	36	0	0	42
Total Volume	3	47	24	0	74	13	64	2	0	79	22	145	62	0	229	23	118	3	0	144
% App. Total	4.1	63.5	32.4	0		16.5	81	2.5	0		9.6	63.3	27.1	0		16	81.9	2.1	0	
PHF	.750	.783	.667	.000	.804	.650	.640	.500	.000	.731	.786	.884	.775	.000	.909	.719	.819	.750	.000	.857

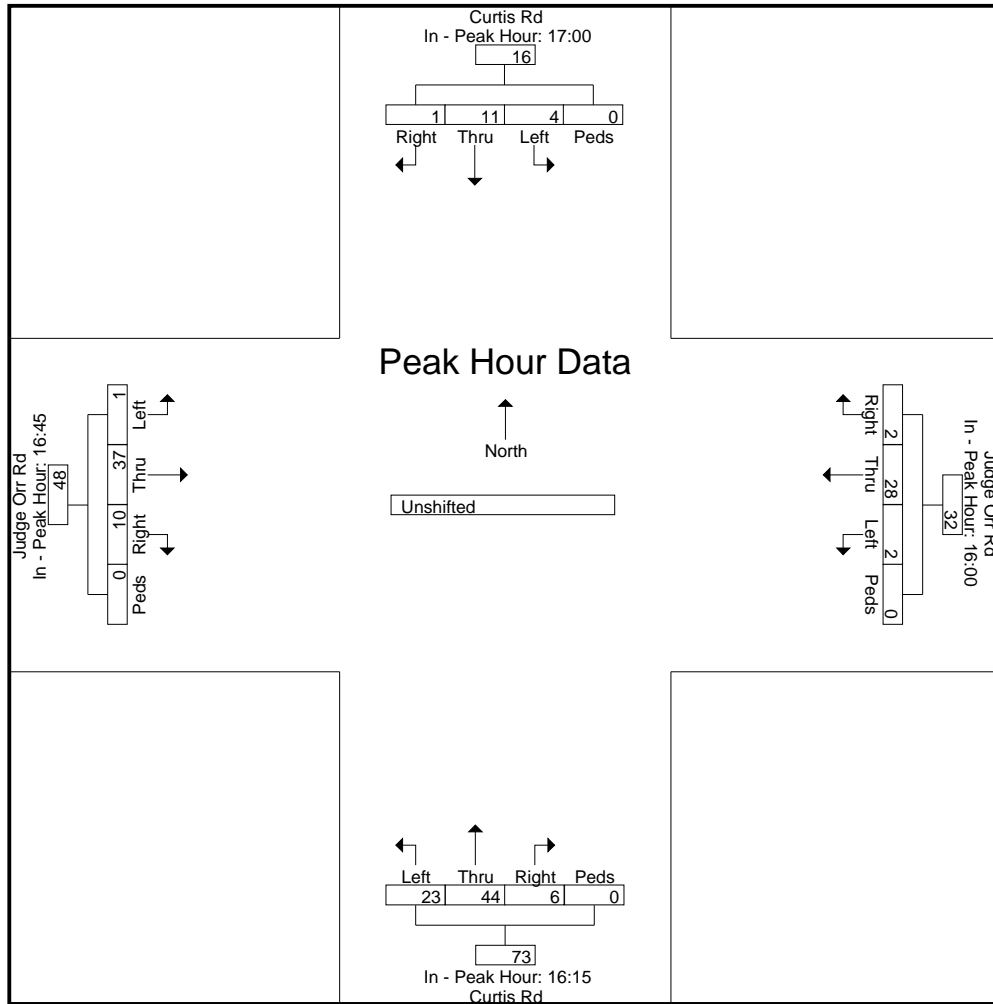

LSC Transportation Consultants, Inc.

2504 E. Pikes Peak Ave, Suite 304
 Colorado Springs, CO 80909
 719-633-2868

File Name : Hwy 24 - Stapleton Rd AM 1-23
 Site Code : S224640
 Start Date : 1/10/2023
 Page No : 1

Groups Printed- Unshifted

Start Time	Hwy 24 Southbound					Stapleton Dr Westbound					Hwy 24 Northbound					Stapleton Dr Eastbound					Int. Total
	Right	Thru	Left	Peds	App. Total	Right	Thru	Left	Peds	App. Total	Right	Thru	Left	Peds	App. Total	Right	Thru	Left	Peds	App. Total	
06:30	1	29	1	0	31	0	1	1	0	2	1	7	1	0	9	20	11	1	0	32	74
06:35	0	33	0	0	33	1	4	0	0	5	0	12	0	0	12	11	11	2	0	24	74
06:40	0	35	2	0	37	1	0	0	0	1	0	13	2	0	15	16	8	2	0	26	79
06:45	3	41	3	0	47	1	6	3	0	10	1	22	4	0	27	13	9	2	0	24	108
06:50	3	32	1	0	36	1	3	0	0	4	1	15	7	0	23	14	7	1	0	22	85
06:55	2	22	1	0	25	2	8	0	0	10	0	24	6	0	30	16	13	0	0	29	94
Total	9	192	8	0	209	6	22	4	0	32	3	93	20	0	116	90	59	8	0	157	514
07:00	4	35	3	0	42	2	6	0	0	8	0	29	2	0	31	7	13	1	0	21	102
07:05	4	33	4	0	41	1	10	0	0	11	0	22	4	0	26	7	11	6	0	24	102
07:10	0	33	3	0	36	4	11	1	0	16	0	30	5	0	35	15	12	2	0	29	116
07:15	2	36	2	0	40	4	14	1	0	19	0	29	7	0	36	13	15	3	0	31	126
07:20	4	46	1	0	51	1	6	0	0	7	0	30	4	0	34	11	13	1	0	25	117
07:25	5	51	8	0	64	0	7	0	0	7	0	28	0	0	28	10	7	1	0	18	117
07:30	2	34	2	0	38	0	7	0	0	7	1	16	6	0	23	9	20	2	0	31	99
07:35	6	40	5	0	51	0	9	1	0	10	0	9	2	0	11	12	7	2	0	21	93
07:40	4	31	1	0	36	0	7	2	0	9	0	9	3	0	12	5	9	0	0	14	71
07:45	1	31	1	0	33	2	5	1	0	8	0	13	6	0	19	6	17	2	0	25	85
07:50	3	21	4	0	28	0	5	0	0	5	1	18	1	0	20	10	15	2	0	27	80
07:55	2	15	3	0	20	1	1	0	0	2	0	16	4	0	20	8	5	1	0	14	56
Total	37	406	37	0	480	15	88	6	0	109	2	249	44	0	295	113	144	23	0	280	1164
08:00	3	39	2	0	44	0	6	0	0	6	0	10	5	0	15	4	10	2	0	16	81
08:05	1	30	0	0	31	1	2	1	0	4	2	19	5	0	26	4	6	4	0	14	75
08:10	2	27	2	0	31	2	2	1	0	5	0	13	4	0	17	5	6	0	0	11	64
08:15	4	31	0	0	35	5	1	2	0	8	0	7	5	0	12	8	5	2	0	15	70
08:20	5	22	3	0	30	1	7	0	0	8	0	3	3	0	6	7	4	1	0	12	56
08:25	4	34	1	0	39	0	2	0	0	2	1	14	0	0	15	4	7	5	0	16	72
Grand Total	65	781	53	0	899	30	130	14	0	174	8	408	86	0	502	235	241	45	0	521	2096
Apprch %	7.2	86.9	5.9	0		17.2	74.7	8	0		1.6	81.3	17.1	0		45.1	46.3	8.6	0		
Total %	3.1	37.3	2.5	0	42.9	1.4	6.2	0.7	0	8.3	0.4	19.5	4.1	0	24	11.2	11.5	2.1	0	24.9	

LSC Transportation Consultants, Inc.

2504 E. Pikes Peak Ave, Suite 304
 Colorado Springs, CO 80909
 719-633-2868

File Name : Hwy 24 - Stapleton Rd AM 1-23

Site Code : S224640

Start Date : 1/10/2023

Page No : 2

Start Time	Hwy 24 Southbound					Stapleton Dr Westbound					Hwy 24 Northbound					Stapleton Dr Eastbound					Int. Total
	Right	Thru	Left	Peds	App. Total	Right	Thru	Left	Peds	App. Total	Right	Thru	Left	Peds	App. Total	Right	Thru	Left	Peds	App. Total	
Peak Hour Analysis From 06:30 to 08:25 - Peak 1 of 1																					
Peak Hour for Entire Intersection Begins at 06:40																					
06:40	0	35	2	0	37	1	0	0	0	1	0	13	2	0	15	16	8	2	0	26	79
06:45	3	41	3	0	47	1	6	3	0	10	1	22	4	0	27	13	9	2	0	24	108
06:50	3	32	1	0	36	1	3	0	0	4	1	15	7	0	23	14	7	1	0	22	85
06:55	2	22	1	0	25	2	8	0	0	10	0	24	6	0	30	16	13	0	0	29	94
07:00	4	35	3	0	42	2	6	0	0	8	0	29	2	0	31	7	13	1	0	21	102
07:05	4	33	4	0	41	1	10	0	0	11	0	22	4	0	26	7	11	6	0	24	102
07:10	0	33	3	0	36	4	11	1	0	16	0	30	5	0	35	15	12	2	0	29	116
07:15	2	36	2	0	40	4	14	1	0	19	0	29	7	0	36	13	15	3	0	31	126
07:20	4	46	1	0	51	1	6	0	0	7	0	30	4	0	34	11	13	1	0	25	117
07:25	5	51	8	0	64	0	7	0	0	7	0	28	0	0	28	10	7	1	0	18	117
07:30	2	34	2	0	38	0	7	0	0	7	1	16	6	0	23	9	20	2	0	31	99
07:35	6	40	5	0	51	0	9	1	0	10	0	9	2	0	11	12	7	2	0	21	93
Total Volume	35	438	35	0	508	17	87	6	0	110	3	267	49	0	319	143	135	23	0	301	1238
% App. Total	6.9	86.2	6.9	0		15.5	79.1	5.5	0		0.9	83.7	15.4	0		47.5	44.9	7.6	0		
PHF	.486	.716	.365	.000	.661	.354	.518	.167	.000	.482	.250	.742	.583	.000	.738	.745	.563	.319	.000	.809	.819

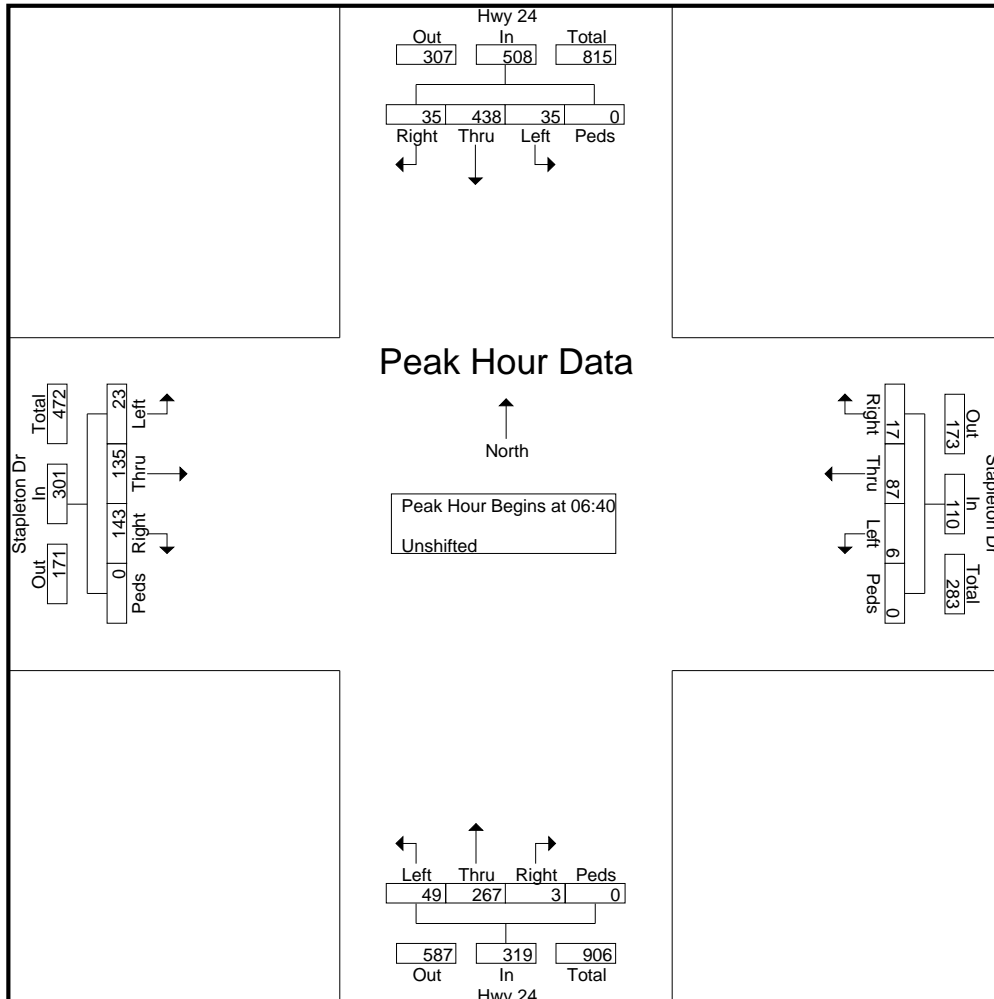

LSC Transportation Consultants, Inc.

2504 E. Pikes Peak Ave, Suite 304
 Colorado Springs, CO 80909
 719-633-2868

File Name : Hwy 24 - Stapleton Rd AM 1-23
 Site Code : S224640
 Start Date : 1/10/2023
 Page No : 3

Start Time	Hwy 24 Southbound					Stapleton Dr Westbound					Hwy 24 Northbound					Stapleton Dr Eastbound					Int. Total
	Right	Thru	Left	Peds	App. Total	Right	Thru	Left	Peds	App. Total	Right	Thru	Left	Peds	App. Total	Right	Thru	Left	Peds	App. Total	
Peak Hour Analysis From 06:30 to 08:25 - Peak 1 of 1																					
Peak Hour for Each Approach Begins at:																					
	06:40					06:45					06:35					06:30					
+0 mins.	0	35	2	0	37	1	6	3	0	10	0	12	0	0	12	20	11	1	0	32	
+5 mins.	3	41	3	0	47	1	3	0	0	4	0	13	2	0	15	11	11	2	0	24	
+10 mins.	3	32	1	0	36	2	8	0	0	10	1	22	4	0	27	16	8	2	0	26	
+15 mins.	2	22	1	0	25	2	6	0	0	8	1	15	7	0	23	13	9	2	0	24	
+20 mins.	4	35	3	0	42	1	10	0	0	11	0	24	6	0	30	14	7	1	0	22	
+25 mins.	4	33	4	0	41	4	11	1	0	16	0	29	2	0	31	16	13	0	0	29	
+30 mins.	0	33	3	0	36	4	14	1	0	19	0	22	4	0	26	7	13	1	0	21	
+35 mins.	2	36	2	0	40	1	6	0	0	7	0	30	5	0	35	7	11	6	0	24	
+40 mins.	4	46	1	0	51	0	7	0	0	7	0	29	7	0	36	15	12	2	0	29	
+45 mins.	5	51	8	0	64	0	7	0	0	7	0	30	4	0	34	13	15	3	0	31	
+50 mins.	2	34	2	0	38	0	9	1	0	10	0	28	0	0	28	11	13	1	0	25	
+55 mins.	6	40	5	0	51	0	7	2	0	9	1	16	6	0	23	10	7	1	0	18	
Total Volume	35	438	35	0	508	16	94	8	0	118	3	270	47	0	320	153	130	22	0	305	
% App. Total	6.9	86.2	6.9	0		13.6	79.7	6.8	0		0.9	84.4	14.7	0		50.2	42.6	7.2	0		
PHF	.486	.716	.365	.000	.661	.333	.560	.222	.000	.518	.250	.750	.560	.000	.741	.638	.722	.306	.000	.794	

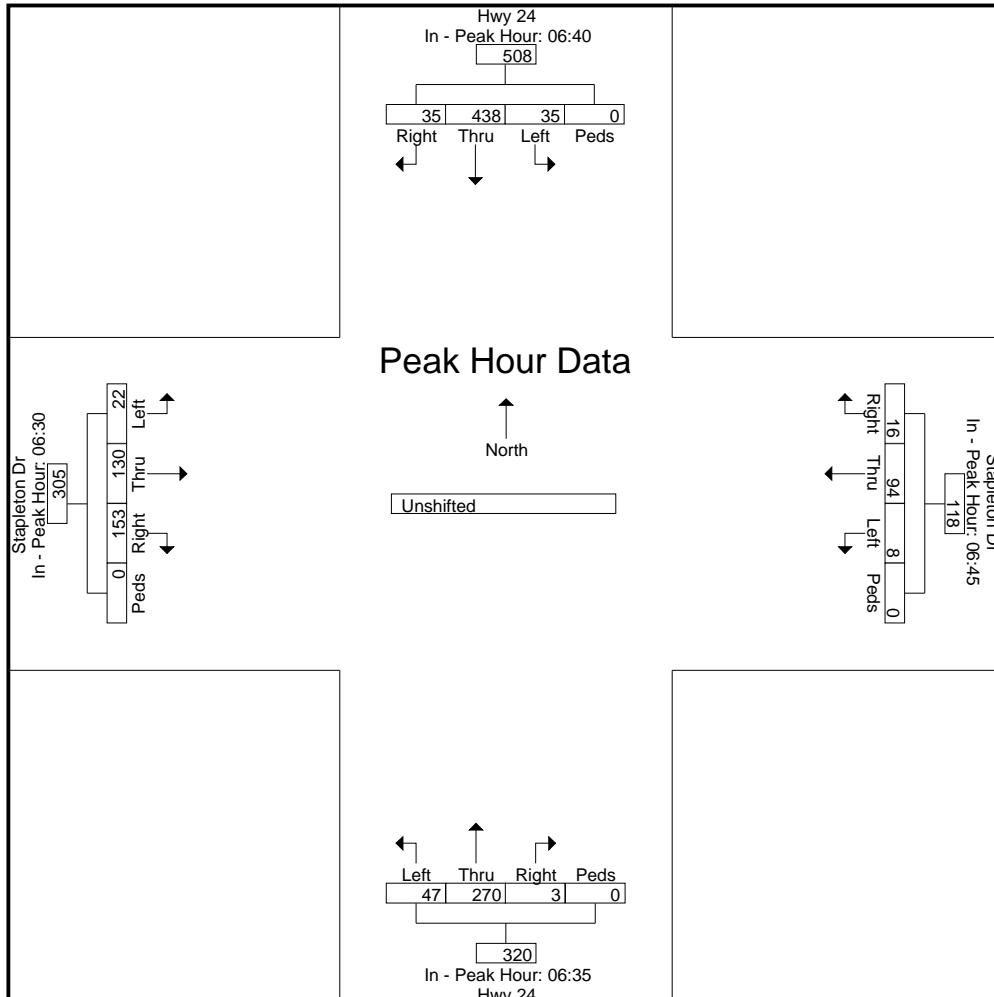

LSC Transportation Consultants, Inc.

2504 E. Pikes Peak Ave, Suite 304
 Colorado Springs, CO 80909
 719-633-2868

File Name : Hwy 24 - Stapleton Rd AM PM

Site Code : S224640

Start Date : 1/10/2023

Page No : 1

Groups Printed- Unshifted

Start Time	Hwy 24 Southbound					Stapleton Dr Westbound					Hwy 24 Northbound					Stapleton Dr Eastbound					Int. Total
	Right	Thru	Left	Peds	App. Total	Right	Thru	Left	Peds	App. Total	Right	Thru	Left	Peds	App. Total	Right	Thru	Left	Peds	App. Total	
06:30	1	29	1	0	31	0	1	1	0	2	1	7	1	0	9	20	11	1	0	32	74
06:35	0	33	0	0	33	1	4	0	0	5	0	12	0	0	12	11	11	2	0	24	74
06:40	0	35	2	0	37	1	0	0	0	1	0	13	2	0	15	16	8	2	0	26	79
06:45	3	41	3	0	47	1	6	3	0	10	1	22	4	0	27	13	9	2	0	24	108
06:50	3	32	1	0	36	1	3	0	0	4	1	15	7	0	23	14	7	1	0	22	85
06:55	2	22	1	0	25	2	8	0	0	10	0	24	6	0	30	16	13	0	0	29	94
Total	9	192	8	0	209	6	22	4	0	32	3	93	20	0	116	90	59	8	0	157	514
07:00	4	35	3	0	42	2	6	0	0	8	0	29	2	0	31	7	13	1	0	21	102
07:05	4	33	4	0	41	1	10	0	0	11	0	22	4	0	26	7	11	6	0	24	102
07:10	0	33	3	0	36	4	11	1	0	16	0	30	5	0	35	15	12	2	0	29	116
07:15	2	36	2	0	40	4	14	1	0	19	0	29	7	0	36	13	15	3	0	31	126
07:20	4	46	1	0	51	1	6	0	0	7	0	30	4	0	34	11	13	1	0	25	117
07:25	5	51	8	0	64	0	7	0	0	7	0	28	0	0	28	10	7	1	0	18	117
07:30	2	34	2	0	38	0	7	0	0	7	1	16	6	0	23	9	20	2	0	31	99
07:35	6	40	5	0	51	0	9	1	0	10	0	9	2	0	11	12	7	2	0	21	93
07:40	4	31	1	0	36	0	7	2	0	9	0	9	3	0	12	5	9	0	0	14	71
07:45	1	31	1	0	33	2	5	1	0	8	0	13	6	0	19	6	17	2	0	25	85
07:50	3	21	4	0	28	0	5	0	0	5	1	18	1	0	20	10	15	2	0	27	80
07:55	2	15	3	0	20	1	1	0	0	2	0	16	4	0	20	8	5	1	0	14	56
Total	37	406	37	0	480	15	88	6	0	109	2	249	44	0	295	113	144	23	0	280	1164
08:00	3	39	2	0	44	0	6	0	0	6	0	10	5	0	15	4	10	2	0	16	81
08:05	1	30	0	0	31	1	2	1	0	4	2	19	5	0	26	4	6	4	0	14	75
08:10	2	27	2	0	31	2	2	1	0	5	0	13	4	0	17	5	6	0	0	11	64
08:15	4	31	0	0	35	5	1	2	0	8	0	7	5	0	12	8	5	2	0	15	70
08:20	5	22	3	0	30	1	7	0	0	8	0	3	3	0	6	7	4	1	0	12	56
08:25	4	34	1	0	39	0	2	0	0	2	1	14	0	0	15	4	7	5	0	16	72
*** BREAK ***																					
Total	19	183	8	0	210	9	20	4	0	33	3	66	22	0	91	32	38	14	0	84	418
16:00	2	26	0	0	28	3	7	1	0	11	0	41	13	0	54	3	3	4	0	10	103
16:05	3	25	0	0	28	4	6	0	0	10	0	46	15	0	61	1	2	5	0	8	107
16:10	3	32	0	0	35	2	8	0	0	10	3	35	15	0	53	6	4	2	0	12	110
16:15	3	36	1	0	40	3	9	1	0	13	4	45	7	0	56	4	1	2	0	7	116
16:20	0	31	3	0	34	1	7	1	0	9	2	46	15	0	63	4	2	1	0	7	113
16:25	1	24	1	0	26	2	11	0	0	13	3	47	8	0	58	5	10	3	0	18	115
16:30	1	23	0	0	24	0	10	2	0	12	1	42	7	0	50	5	3	2	0	10	96
16:35	2	32	1	0	35	1	5	1	0	7	4	34	4	0	42	2	1	1	0	4	88
16:40	5	29	1	0	35	2	13	0	0	15	1	29	7	0	37	4	9	1	0	14	101
16:45	3	31	2	0	36	5	10	3	0	18	2	31	13	0	46	3	2	2	0	7	107
16:50	1	32	1	0	34	2	11	0	0	13	4	39	7	0	50	6	4	2	0	12	109

LSC Transportation Consultants, Inc.

2504 E. Pikes Peak Ave, Suite 304
 Colorado Springs, CO 80909
 719-633-2868

File Name : Hwy 24 - Stapleton Rd AM PM

Site Code : S224640

Start Date : 1/10/2023

Page No : 2

Groups Printed- Unshifted

Start Time	Hwy 24 Southbound					Stapleton Dr Westbound					Hwy 24 Northbound					Stapleton Dr Eastbound					Int. Total
	Right	Thru	Left	Peds	App. Total	Right	Thru	Left	Peds	App. Total	Right	Thru	Left	Peds	App. Total	Right	Thru	Left	Peds	App. Total	
16:55	5	29	1	0	35	3	15	2	0	20	3	31	15	0	49	2	4	2	0	8	112
Total	29	350	11	0	390	28	112	11	0	151	27	466	126	0	619	45	45	27	0	117	1277
17:00	3	22	0	0	25	0	20	0	0	20	1	37	13	0	51	8	1	0	0	9	105
17:05	2	30	0	0	32	4	6	1	0	11	7	47	14	0	68	2	4	0	0	6	117
17:10	3	45	1	0	49	3	19	1	0	23	1	31	9	0	41	4	1	1	0	6	119
17:15	3	29	1	0	33	1	4	1	0	6	0	46	7	0	53	3	1	1	0	5	97
17:20	3	27	1	0	31	4	11	1	0	16	3	34	8	0	45	3	5	2	0	10	102
17:25	3	21	0	0	24	3	2	0	0	5	0	30	11	0	41	2	4	2	0	8	78
17:30	3	18	0	0	21	5	8	0	0	13	2	43	8	0	53	1	3	0	0	4	91
17:35	3	17	0	0	20	2	6	0	0	8	0	33	14	0	47	2	1	3	0	6	81
17:40	1	18	0	0	19	2	6	2	0	10	1	32	6	0	39	0	1	3	0	4	72
17:45	4	24	1	0	29	2	4	1	0	7	1	51	7	0	59	3	2	1	0	6	101
17:50	1	13	0	0	14	1	6	1	0	8	0	48	13	0	61	2	5	3	0	10	93
17:55	3	18	0	0	21	3	7	0	0	10	1	23	9	0	33	4	7	2	0	13	77
Total	32	282	4	0	318	30	99	8	0	137	17	455	119	0	591	34	35	18	0	87	1133
Grand Total	126	1413	68	0	1607	88	341	33	0	462	52	1329	331	0	1712	314	321	90	0	725	4506
Apprch %	7.8	87.9	4.2	0		19	73.8	7.1	0		3	77.6	19.3	0		43.3	44.3	12.4	0		
Total %	2.8	31.4	1.5	0	35.7	2	7.6	0.7	0	10.3	1.2	29.5	7.3	0	38	7	7.1	2	0	16.1	

LSC Transportation Consultants, Inc.

2504 E. Pikes Peak Ave, Suite 304
 Colorado Springs, CO 80909
 719-633-2868

File Name : Hwy 24 - Stapleton Rd AM PM

Site Code : S224640

Start Date : 1/10/2023

Page No : 3

Start Time	Hwy 24 Southbound					Stapleton Dr Westbound					Hwy 24 Northbound					Stapleton Dr Eastbound					Int. Total
	Right	Thru	Left	Peds	App. Total	Right	Thru	Left	Peds	App. Total	Right	Thru	Left	Peds	App. Total	Right	Thru	Left	Peds	App. Total	
Peak Hour Analysis From 06:30 to 17:55 - Peak 1 of 1																					
Peak Hour for Entire Intersection Begins at 16:15																					
16:15	3	36	1	0	40	3	9	1	0	13	4	45	7	0	56	4	1	2	0	7	116
16:20	0	31	3	0	34	1	7	1	0	9	2	46	15	0	63	4	2	1	0	7	113
16:25	1	24	1	0	26	2	11	0	0	13	3	47	8	0	58	5	10	3	0	18	115
16:30	1	23	0	0	24	0	10	2	0	12	1	42	7	0	50	5	3	2	0	10	96
16:35	2	32	1	0	35	1	5	1	0	7	4	34	4	0	42	2	1	1	0	4	88
16:40	5	29	1	0	35	2	13	0	0	15	1	29	7	0	37	4	9	1	0	14	101
16:45	3	31	2	0	36	5	10	3	0	18	2	31	13	0	46	3	2	2	0	7	107
16:50	1	32	1	0	34	2	11	0	0	13	4	39	7	0	50	6	4	2	0	12	109
16:55	5	29	1	0	35	3	15	2	0	20	3	31	15	0	49	2	4	2	0	8	112
17:00	3	22	0	0	25	0	20	0	0	20	1	37	13	0	51	8	1	0	0	9	105
17:05	2	30	0	0	32	4	6	1	0	11	7	47	14	0	68	2	4	0	0	6	117
17:10	3	45	1	0	49	3	19	1	0	23	1	31	9	0	41	4	1	1	0	6	119
Total Volume	29	364	12	0	405	26	136	12	0	174	33	459	119	0	611	49	42	17	0	108	1298
% App. Total	7.2	89.9	3	0		14.9	78.2	6.9	0		5.4	75.1	19.5	0		45.4	38.9	15.7	0		
PHF	.483	.674	.333	.000	.689	.433	.567	.333	.000	.630	.393	.814	.661	.000	.749	.510	.350	.472	.000	.500	.909

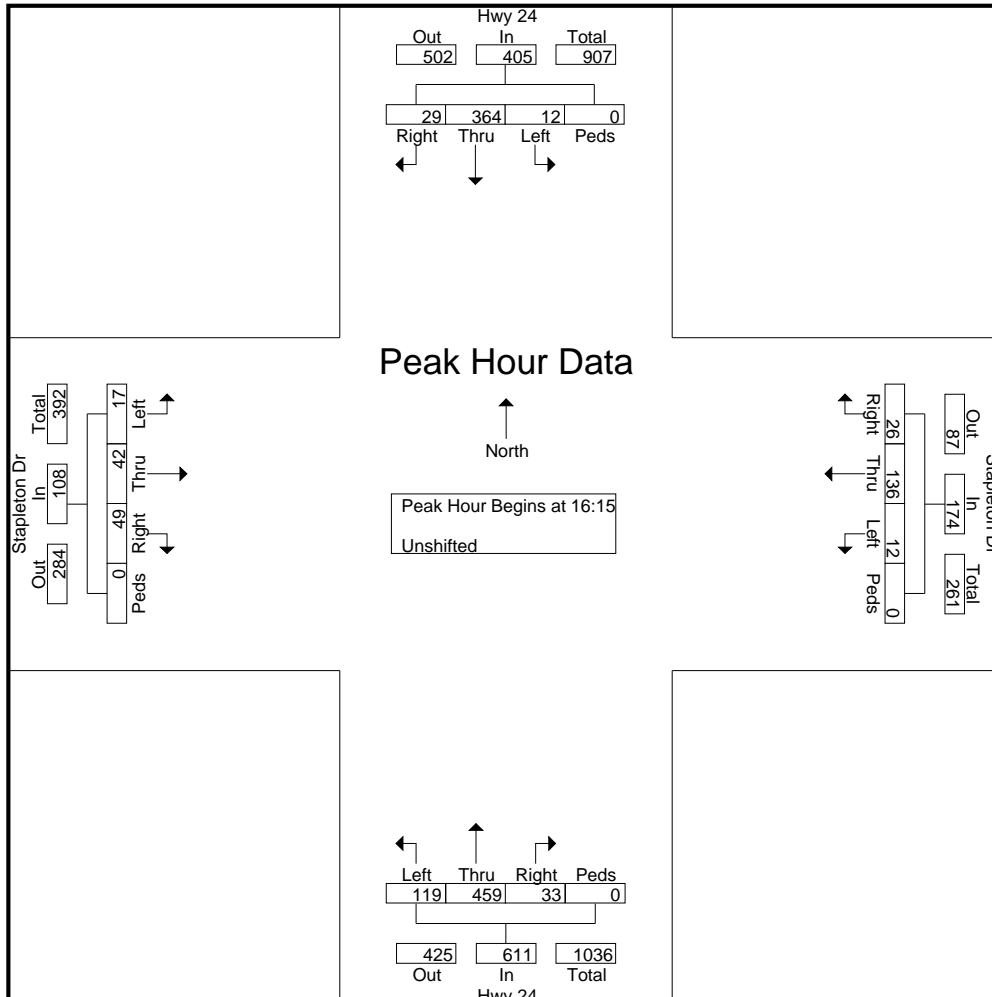

LSC Transportation Consultants, Inc.

2504 E. Pikes Peak Ave, Suite 304
 Colorado Springs, CO 80909
 719-633-2868

File Name : Hwy 24 - Stapleton Rd AM PM
 Site Code : S224640
 Start Date : 1/10/2023
 Page No : 4

Start Time	Hwy 24 Southbound					Stapleton Dr Westbound					Hwy 24 Northbound					Stapleton Dr Eastbound					Int. Total
	Right	Thru	Left	Peds	App. Total	Right	Thru	Left	Peds	App. Total	Right	Thru	Left	Peds	App. Total	Right	Thru	Left	Peds	App. Total	

Peak Hour Analysis From 06:30 to 17:55 - Peak 1 of 1
 Peak Hour for Each Approach Begins at:

	06:40					16:15					16:10					06:30				
+0 mins.	0	35	2	0	37	3	9	1	0	13	3	35	15	0	53	20	11	1	0	32
+5 mins.	3	41	3	0	47	1	7	1	0	9	4	45	7	0	56	11	11	2	0	24
+10 mins.	3	32	1	0	36	2	11	0	0	13	2	46	15	0	63	16	8	2	0	26
+15 mins.	2	22	1	0	25	0	10	2	0	12	3	47	8	0	58	13	9	2	0	24
+20 mins.	4	35	3	0	42	1	5	1	0	7	1	42	7	0	50	14	7	1	0	22
+25 mins.	4	33	4	0	41	2	13	0	0	15	4	34	4	0	42	16	13	0	0	29
+30 mins.	0	33	3	0	36	5	10	3	0	18	1	29	7	0	37	7	13	1	0	21
+35 mins.	2	36	2	0	40	2	11	0	0	13	2	31	13	0	46	7	11	6	0	24
+40 mins.	4	46	1	0	51	3	15	2	0	20	4	39	7	0	50	15	12	2	0	29
+45 mins.	5	51	8	0	64	0	20	0	0	20	3	31	15	0	49	13	15	3	0	31
+50 mins.	2	34	2	0	38	4	6	1	0	11	1	37	13	0	51	11	13	1	0	25
+55 mins.	6	40	5	0	51	3	19	1	0	23	7	47	14	0	68	10	7	1	0	18
Total Volume	35	438	35	0	508	26	136	12	0	174	35	463	125	0	623	153	130	22	0	305
% App. Total	6.9	86.2	6.9	0		14.9	78.2	6.9	0		5.6	74.3	20.1	0		50.2	42.6	7.2	0	
PHF	.486	.716	.365	.000	.661	.433	.567	.333	.000	.630	.417	.821	.694	.000	.763	.638	.722	.306	.000	.794

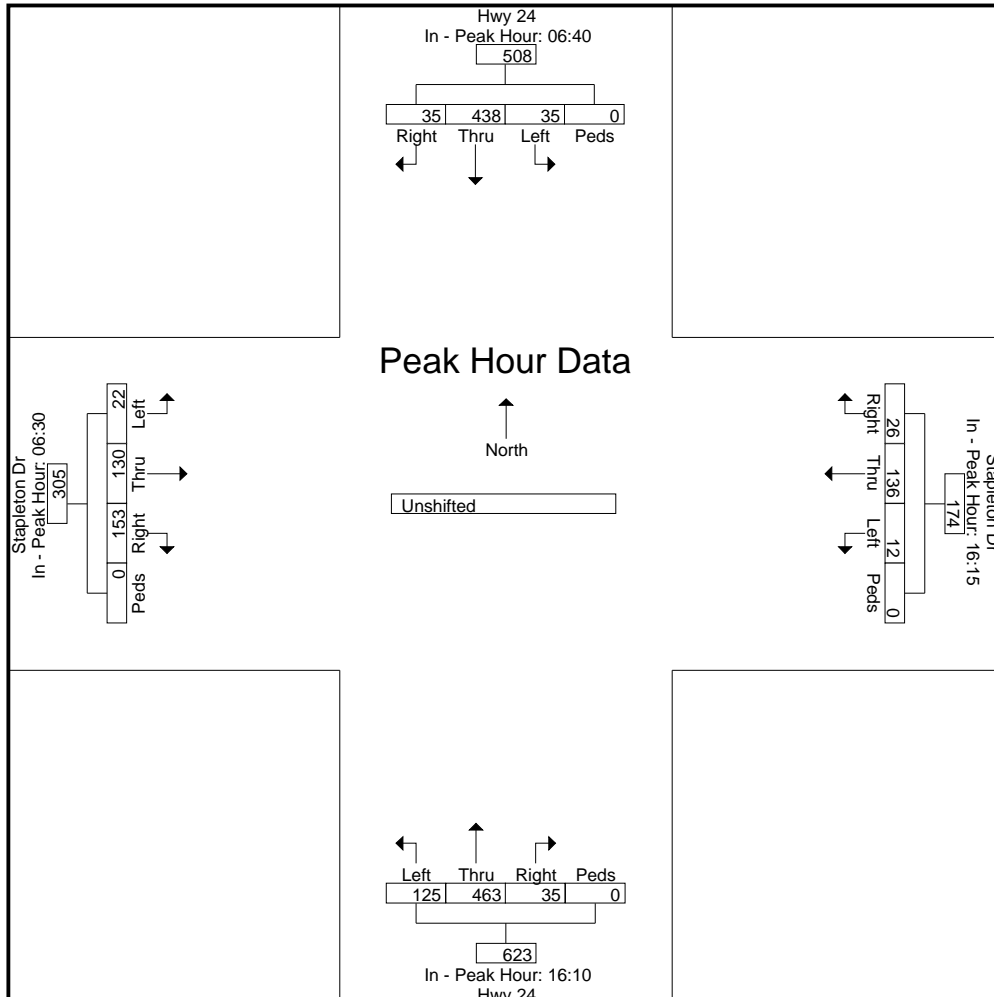

Level of Service Reports



Lanes, Volumes, Timings
1: US 24 & Falcon Hwy

2023 Existing
AM



Lane Group	WBL	WBR	NET	NER	SWL	SWT
Lane Configurations						
Traffic Volume (vph)	191	1	459	28	0	1386
Future Volume (vph)	191	1	459	28	0	1386
Ideal Flow (vphpl)	1900	1900	1900	1900	1900	1900
Storage Length (ft)	0	0		490	555	
Storage Lanes	1	0		1	1	
Taper Length (ft)	25				300	
Lane Util. Factor	1.00	1.00	1.00	1.00	1.00	1.00
Frt	0.999			0.850		
Flt Protected	0.953					
Satd. Flow (prot)	1773	0	1863	1583	1863	1863
Flt Permitted	0.953					
Satd. Flow (perm)	1773	0	1863	1583	1863	1863
Right Turn on Red		Yes		Yes		
Satd. Flow (RTOR)				30		
Link Speed (mph)	55		65			65
Link Distance (ft)	1594		843			880
Travel Time (s)	19.8		8.8			9.2
Peak Hour Factor	0.87	0.87	0.92	0.92	0.95	0.95
Adj. Flow (vph)	220	1	499	30	0	1459
Shared Lane Traffic (%)						
Lane Group Flow (vph)	221	0	499	30	0	1459
Enter Blocked Intersection	No	No	No	No	No	No
Lane Alignment	Left	Right	Left	Right	Left	Left
Median Width(ft)	12		12			12
Link Offset(ft)	0		0			0
Crosswalk Width(ft)	16		16			16
Two way Left Turn Lane						
Headway Factor	1.00	1.00	1.00	1.00	1.00	1.00
Turning Speed (mph)	15	9		9	15	
Number of Detectors	1		2	1	1	2
Detector Template	Left		Thru	Right	Left	Thru
Leading Detector (ft)	20		100	20	20	100
Trailing Detector (ft)	0		0	0	0	0
Detector 1 Position(ft)	0		0	0	0	0
Detector 1 Size(ft)	20		6	20	20	6
Detector 1 Type	Cl+Ex		Cl+Ex	Cl+Ex	Cl+Ex	Cl+Ex
Detector 1 Channel						
Detector 1 Extend (s)	0.0		0.0	0.0	0.0	0.0
Detector 1 Queue (s)	0.0		0.0	0.0	0.0	0.0
Detector 1 Delay (s)	0.0		0.0	0.0	0.0	0.0
Detector 2 Position(ft)			94			94
Detector 2 Size(ft)			6			6
Detector 2 Type			Cl+Ex			Cl+Ex
Detector 2 Channel						
Detector 2 Extend (s)			0.0			0.0
Turn Type	Prot		NA	Perm	Perm	NA
Protected Phases	4		2			6
Permitted Phases				2	6	

Lanes, Volumes, Timings
1: US 24 & Falcon Hwy

2023 Existing
AM



Lane Group	WBL	WBR	NET	NER	SWL	SWT
Detector Phase	4		2	2	6	6
Switch Phase						
Minimum Initial (s)	5.0		5.0	5.0	5.0	5.0
Minimum Split (s)	22.5		22.5	22.5	22.5	22.5
Total Split (s)	20.0		70.0	70.0	70.0	70.0
Total Split (%)	22.2%		77.8%	77.8%	77.8%	77.8%
Maximum Green (s)	15.5		65.5	65.5	65.5	65.5
Yellow Time (s)	3.5		3.5	3.5	3.5	3.5
All-Red Time (s)	1.0		1.0	1.0	1.0	1.0
Lost Time Adjust (s)	0.0		0.0	0.0	0.0	0.0
Total Lost Time (s)	4.5		4.5	4.5	4.5	4.5
Lead/Lag						
Lead-Lag Optimize?						
Vehicle Extension (s)	3.0		3.0	3.0	3.0	3.0
Recall Mode	None		None	None	Max	Max
Walk Time (s)	7.0		7.0	7.0	7.0	7.0
Flash Dont Walk (s)	11.0		11.0	11.0	11.0	11.0
Pedestrian Calls (#/hr)	0		0	0	0	0
Act Effect Green (s)	14.5		68.6	68.6		68.6
Actuated g/C Ratio	0.16		0.74	0.74		0.74
v/c Ratio	0.79		0.36	0.03		1.05
Control Delay	57.6		5.1	1.3		54.3
Queue Delay	0.0		0.0	0.0		0.0
Total Delay	57.6		5.1	1.3		54.3
LOS	E		A	A		D
Approach Delay	57.6		4.9			54.3
Approach LOS	E		A			D
Queue Length 50th (ft)	120		88	0		~933
Queue Length 95th (ft)	#208		131	6		#1186
Internal Link Dist (ft)	1514		763			800
Turn Bay Length (ft)				490		
Base Capacity (vph)	298		1386	1186		1386
Starvation Cap Reductn	0		0	0		0
Spillback Cap Reductn	0		0	0		0
Storage Cap Reductn	0		0	0		0
Reduced v/c Ratio	0.74		0.36	0.03		1.05

Intersection Summary

Area Type:	Other
Cycle Length:	90
Actuated Cycle Length:	92.1
Natural Cycle:	120
Control Type:	Actuated-Uncoordinated
Maximum v/c Ratio:	1.05
Intersection Signal Delay:	42.8
Intersection LOS:	D
Intersection Capacity Utilization:	91.1%
ICU Level of Service:	F
Analysis Period (min):	15
~ Volume exceeds capacity, queue is theoretically infinite. Queue shown is maximum after two cycles.	

























95th percentile volume exceeds capacity, queue may be longer.
 Queue shown is maximum after two cycles.

Splits and Phases: 1: US 24 & Falcon Hwy

↗ Ø2	↖ Ø4
70 s	20 s
↙ Ø6	
70 s	

Lanes, Volumes, Timings
2: US 24 & Meridian Rd

2023 Existing
AM

												
Lane Group	SEL	SET	SER	NWL	NWT	NWR	NEL	NET	NER	SWL	SWT	SWR
Lane Configurations												
Traffic Volume (vph)	7	360	728	11	169	19	206	301	12	35	619	2
Future Volume (vph)	7	360	728	11	169	19	206	301	12	35	619	2
Ideal Flow (vphpl)	1900	1900	1900	1900	1900	1900	1900	1900	1900	1900	1900	1900
Storage Length (ft)	195		195	195		195	555		490	555		490
Storage Lanes	1		1	1		1	1		1	1		1
Taper Length (ft)	180			180			300			300		
Lane Util. Factor	1.00	0.95	1.00	1.00	0.95	1.00	1.00	1.00	1.00	1.00	1.00	1.00
Frt			0.850			0.850			0.850			0.850
Flt Protected	0.950			0.950			0.950			0.950		
Satd. Flow (prot)	1770	3539	1583	1770	3539	1583	1770	1863	1583	1770	1863	1583
Flt Permitted	0.624			0.464			0.130			0.564		
Satd. Flow (perm)	1162	3539	1583	864	3539	1583	242	1863	1583	1051	1863	1583
Right Turn on Red			Yes			Yes			Yes			Yes
Satd. Flow (RTOR)			377			109			109			109
Link Speed (mph)		40		40			65			65		
Link Distance (ft)		873		1300			985			695		
Travel Time (s)		14.9		22.2			10.3			7.3		
Peak Hour Factor	0.92	0.92	0.92	0.83	0.83	0.83	0.93	0.93	0.93	0.93	0.93	0.93
Adj. Flow (vph)	8	391	791	13	204	23	222	324	13	38	666	2
Shared Lane Traffic (%)												
Lane Group Flow (vph)	8	391	791	13	204	23	222	324	13	38	666	2
Enter Blocked Intersection	No	No	No	No	No	No	No	No	No	No	No	No
Lane Alignment	Left	Left	Right	Left	Left	Right	Left	Left	Right	Left	Left	Right
Median Width(ft)		12		12			12			12		
Link Offset(ft)		0		0			0			0		
Crosswalk Width(ft)		16		16			16			16		
Two way Left Turn Lane												
Headway Factor	1.00	1.00	1.00	1.00	1.00	1.00	1.00	1.00	1.00	1.00	1.00	1.00
Turning Speed (mph)	15		9	15		9	15		9	15		9
Number of Detectors	1	2	1	1	2	1	1	2	1	1	2	1
Detector Template	Left	Thru	Right	Left	Thru	Right	Left	Thru	Right	Left	Thru	Right
Leading Detector (ft)	20	100	20	20	100	20	20	100	20	20	100	20
Trailing Detector (ft)	0	0	0	0	0	0	0	0	0	0	0	0
Detector 1 Position(ft)	0	0	0	0	0	0	0	0	0	0	0	0
Detector 1 Size(ft)	20	6	20	20	6	20	20	6	20	20	6	20
Detector 1 Type	Cl+Ex	Cl+Ex	Cl+Ex	Cl+Ex	Cl+Ex	Cl+Ex	Cl+Ex	Cl+Ex	Cl+Ex	Cl+Ex	Cl+Ex	Cl+Ex
Detector 1 Channel												
Detector 1 Extend (s)	0.0	0.0	0.0	0.0	0.0	0.0	0.0	0.0	0.0	0.0	0.0	0.0
Detector 1 Queue (s)	0.0	0.0	0.0	0.0	0.0	0.0	0.0	0.0	0.0	0.0	0.0	0.0
Detector 1 Delay (s)	0.0	0.0	0.0	0.0	0.0	0.0	0.0	0.0	0.0	0.0	0.0	0.0
Detector 2 Position(ft)		94		94			94			94		
Detector 2 Size(ft)		6		6			6			6		
Detector 2 Type		Cl+Ex		Cl+Ex			Cl+Ex			Cl+Ex		
Detector 2 Channel												
Detector 2 Extend (s)		0.0		0.0			0.0			0.0		
Turn Type	Perm	NA	Perm	Perm	NA	Perm	pm+pt	NA	Perm	pm+pt	NA	Perm
Protected Phases		6		2		2	7	4		3		8
Permitted Phases	6		6	2		2	4		4	8		8

Lanes, Volumes, Timings
2: US 24 & Meridian Rd

2023 Existing
AM



Lane Group	SEL	SET	SER	NWL	NWT	NWR	NEL	NET	NER	SWL	SWT	SWR
Detector Phase	6	6	6	2	2	2	7	4	4	3	8	8
Switch Phase												
Minimum Initial (s)	5.0	5.0	5.0	5.0	5.0	5.0	5.0	5.0	5.0	5.0	5.0	5.0
Minimum Split (s)	22.5	22.5	22.5	22.5	22.5	22.5	9.5	22.5	22.5	9.5	22.5	22.5
Total Split (s)	12.0	12.0	12.0	12.0	12.0	12.0	12.0	36.0	36.0	12.0	36.0	36.0
Total Split (%)	20.0%	20.0%	20.0%	20.0%	20.0%	20.0%	20.0%	60.0%	60.0%	20.0%	60.0%	60.0%
Maximum Green (s)	7.5	7.5	7.5	7.5	7.5	7.5	7.5	31.5	31.5	7.5	31.5	31.5
Yellow Time (s)	3.5	3.5	3.5	3.5	3.5	3.5	3.5	3.5	3.5	3.5	3.5	3.5
All-Red Time (s)	1.0	1.0	1.0	1.0	1.0	1.0	1.0	1.0	1.0	1.0	1.0	1.0
Lost Time Adjust (s)	0.0	0.0	0.0	0.0	0.0	0.0	0.0	0.0	0.0	0.0	0.0	0.0
Total Lost Time (s)	4.5	4.5	4.5	4.5	4.5	4.5	4.5	4.5	4.5	4.5	4.5	4.5
Lead/Lag							Lead	Lag	Lag	Lead	Lag	Lag
Lead-Lag Optimize?							Yes	Yes	Yes	Yes	Yes	Yes
Vehicle Extension (s)	3.0	3.0	3.0	3.0	3.0	3.0	3.0	3.0	3.0	3.0	3.0	3.0
Recall Mode	Max	Max	Max	Max	Max	Max	None	None	None	None	None	None
Walk Time (s)	7.0	7.0	7.0	7.0	7.0	7.0		7.0	7.0		7.0	7.0
Flash Dont Walk (s)	11.0	11.0	11.0	11.0	11.0	11.0		11.0	11.0		11.0	11.0
Pedestrian Calls (#/hr)	0	0	0	0	0	0		0	0		0	0
Act Effct Green (s)	18.1	18.1	18.1	18.1	18.1	18.1	36.9	34.1	34.1	32.3	26.2	26.2
Actuated g/C Ratio	0.28	0.28	0.28	0.28	0.28	0.28	0.56	0.52	0.52	0.49	0.40	0.40
v/c Ratio	0.02	0.40	1.11	0.05	0.21	0.04	0.71	0.33	0.01	0.06	0.89	0.00
Control Delay	20.0	21.9	86.0	20.6	20.3	0.2	25.9	11.4	0.0	5.9	34.4	0.0
Queue Delay	0.0	0.0	0.0	0.0	0.0	0.0	0.0	0.0	0.0	0.0	0.0	0.0
Total Delay	20.0	21.9	86.0	20.6	20.3	0.2	25.9	11.4	0.0	5.9	34.4	0.0
LOS	B	C	F	C	C	A	C	B	A	A	C	A
Approach Delay		64.5			18.4			16.9			32.7	
Approach LOS		E			B			B			C	
Queue Length 50th (ft)	3	71	~269	4	35	0	37	57	0	6	237	0
Queue Length 95th (ft)	12	113	#489	16	57	0	#140	147	0	15	#421	0
Internal Link Dist (ft)		793			1220			905			615	
Turn Bay Length (ft)	195		195	195		195	555		490	555		490
Base Capacity (vph)	321	980	710	239	980	517	312	988	891	624	902	823
Starvation Cap Reductn	0	0	0	0	0	0	0	0	0	0	0	0
Spillback Cap Reductn	0	0	0	0	0	0	0	0	0	0	0	0
Storage Cap Reductn	0	0	0	0	0	0	0	0	0	0	0	0
Reduced v/c Ratio	0.02	0.40	1.11	0.05	0.21	0.04	0.71	0.33	0.01	0.06	0.74	0.00

Intersection Summary

Area Type:	Other
Cycle Length:	60
Actuated Cycle Length:	65.5
Natural Cycle:	80
Control Type:	Actuated-Uncoordinated
Maximum v/c Ratio:	1.11
Intersection Signal Delay:	42.2
Intersection LOS:	D
Intersection Capacity Utilization:	93.1%
ICU Level of Service:	F
Analysis Period (min):	15
~ Volume exceeds capacity, queue is theoretically infinite. Queue shown is maximum after two cycles.	

95th percentile volume exceeds capacity, queue may be longer.
 Queue shown is maximum after two cycles.

Splits and Phases: 2: US 24 & Meridian Rd

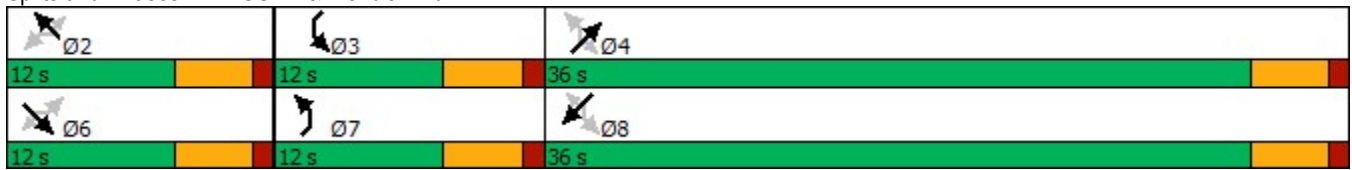

Lanes, Volumes, Timings
3: US 24 & Judge Orr

2023 Existing
AM



Lane Group	EBL	EBT	EBR	WBL	WBT	WBR	NEL	NET	NER	SWL	SWT	SWR
Lane Configurations		↕			↕		↕	↕		↕	↕	
Traffic Volume (vph)	15	62	178	115	57	4	73	343	64	7	579	18
Future Volume (vph)	15	62	178	115	57	4	73	343	64	7	579	18
Ideal Flow (vphpl)	1900	1900	1900	1900	1900	1900	1900	1900	1900	1900	1900	1900
Storage Length (ft)	0		0	0		0	850		0	700		0
Storage Lanes	0		0	0		0	1		0	1		0
Taper Length (ft)	25			25			280			300		
Lane Util. Factor	1.00	1.00	1.00	1.00	1.00	1.00	1.00	1.00	1.00	1.00	1.00	1.00
Frt		0.906			0.997			0.976			0.996	
Flt Protected		0.997			0.969		0.950			0.950		
Satd. Flow (prot)	0	1683	0	0	1800	0	1770	1818	0	1770	1855	0
Flt Permitted		0.975			0.582		0.185			0.440		
Satd. Flow (perm)	0	1645	0	0	1081	0	345	1818	0	820	1855	0
Right Turn on Red			Yes			Yes			Yes			Yes
Satd. Flow (RTOR)		193			2			16				3
Link Speed (mph)		45			45			55				55
Link Distance (ft)		801			719			1315				2758
Travel Time (s)		12.1			10.9			16.3				34.2
Peak Hour Factor	0.92	0.92	0.92	0.87	0.87	0.87	0.92	0.92	0.92	0.93	0.93	0.93
Adj. Flow (vph)	16	67	193	132	66	5	79	373	70	8	623	19
Shared Lane Traffic (%)												
Lane Group Flow (vph)	0	276	0	0	203	0	79	443	0	8	642	0
Enter Blocked Intersection	No	No	No	No	No	No	No	No	No	No	No	No
Lane Alignment	Left	Left	Right	Left	Left	Right	Left	Left	Right	Left	Left	Right
Median Width(ft)		0			0			12				12
Link Offset(ft)		0			0			0				0
Crosswalk Width(ft)		16			16			16				16
Two way Left Turn Lane												
Headway Factor	1.00	1.00	1.00	1.00	1.00	1.00	1.00	1.00	1.00	1.00	1.00	1.00
Turning Speed (mph)	15		9	15		9	15		9	15		9
Number of Detectors	1	2		1	2		1	2		1	2	
Detector Template	Left	Thru		Left	Thru		Left	Thru		Left	Thru	
Leading Detector (ft)	20	100		20	100		20	100		20	100	
Trailing Detector (ft)	0	0		0	0		0	0		0	0	
Detector 1 Position(ft)	0	0		0	0		0	0		0	0	
Detector 1 Size(ft)	20	6		20	6		20	6		20	6	
Detector 1 Type	Cl+Ex	Cl+Ex		Cl+Ex	Cl+Ex		Cl+Ex	Cl+Ex		Cl+Ex	Cl+Ex	
Detector 1 Channel												
Detector 1 Extend (s)	0.0	0.0		0.0	0.0		0.0	0.0		0.0	0.0	
Detector 1 Queue (s)	0.0	0.0		0.0	0.0		0.0	0.0		0.0	0.0	
Detector 1 Delay (s)	0.0	0.0		0.0	0.0		0.0	0.0		0.0	0.0	
Detector 2 Position(ft)		94			94			94				94
Detector 2 Size(ft)		6			6			6				6
Detector 2 Type		Cl+Ex			Cl+Ex			Cl+Ex				Cl+Ex
Detector 2 Channel												
Detector 2 Extend (s)		0.0			0.0			0.0				0.0
Turn Type	pm+pt	NA		pm+pt	NA		pm+pt	NA		pm+pt	NA	
Protected Phases	7	4		3	8		5	2		1	6	
Permitted Phases	4			8			2			6		

Lanes, Volumes, Timings
3: US 24 & Judge Orr

2023 Existing
AM











Lane Group	EBL	EBT	EBR	WBL	WBT	WBR	NEL	NET	NER	SWL	SWT	SWR
Detector Phase	7	4		3	8		5	2		1	6	
Switch Phase												
Minimum Initial (s)	5.0	5.0		5.0	5.0		5.0	5.0		5.0	5.0	
Minimum Split (s)	9.5	22.5		9.5	22.5		9.5	22.5		9.5	22.5	
Total Split (s)	8.5	21.5		8.5	21.5		8.5	21.5		8.5	21.5	
Total Split (%)	14.2%	35.8%		14.2%	35.8%		14.2%	35.8%		14.2%	35.8%	
Maximum Green (s)	4.0	17.0		4.0	17.0		4.0	17.0		4.0	17.0	
Yellow Time (s)	3.5	3.5		3.5	3.5		3.5	3.5		3.5	3.5	
All-Red Time (s)	1.0	1.0		1.0	1.0		1.0	1.0		1.0	1.0	
Lost Time Adjust (s)		0.0			0.0		0.0	0.0		0.0	0.0	
Total Lost Time (s)		4.5			4.5		4.5	4.5		4.5	4.5	
Lead/Lag	Lead	Lag		Lead	Lag		Lead	Lag		Lead	Lag	
Lead-Lag Optimize?	Yes	Yes		Yes	Yes		Yes	Yes		Yes	Yes	
Vehicle Extension (s)	3.0	3.0		3.0	3.0		3.0	3.0		3.0	3.0	
Recall Mode	None	None		None	None		None	Max		None	Max	
Walk Time (s)		7.0			7.0			7.0			7.0	
Flash Dont Walk (s)		11.0			11.0			11.0			11.0	
Pedestrian Calls (#/hr)		0			0			0			0	
Act Effct Green (s)		12.1			12.1		22.6	21.9		21.0	18.9	
Actuated g/C Ratio		0.27			0.27		0.51	0.49		0.47	0.42	
v/c Ratio		0.47			0.69		0.26	0.49		0.02	0.82	
Control Delay		8.0			28.6		8.5	12.1		6.4	27.7	
Queue Delay		0.0			0.0		0.0	0.0		0.0	0.0	
Total Delay		8.0			28.6		8.5	12.1		6.4	27.7	
LOS		A			C		A	B		A	C	
Approach Delay		8.0			28.6			11.6			27.5	
Approach LOS		A			C			B			C	
Queue Length 50th (ft)		18			51		9	62		1	165	
Queue Length 95th (ft)		63			103		28	#212		6	#390	
Internal Link Dist (ft)		721			639			1235			2678	
Turn Bay Length (ft)							850			700		
Base Capacity (vph)		761			424		305	899		472	784	
Starvation Cap Reductn		0			0		0	0		0	0	
Spillback Cap Reductn		0			0		0	0		0	0	
Storage Cap Reductn		0			0		0	0		0	0	
Reduced v/c Ratio		0.36			0.48		0.26	0.49		0.02	0.82	

Intersection Summary

























Area Type: Other
 Cycle Length: 60
 Actuated Cycle Length: 44.7
 Natural Cycle: 75
 Control Type: Actuated-Uncoordinated
 Maximum v/c Ratio: 0.82
 Intersection Signal Delay: 19.3
 Intersection LOS: B
 Intersection Capacity Utilization 75.4%
 ICU Level of Service D
 Analysis Period (min) 15
 # 95th percentile volume exceeds capacity, queue may be longer.
 Queue shown is maximum after two cycles.

Splits and Phases: 3: US 24 & Judge Orr

 Ø1 8.5 s	 Ø2 21.5 s	 Ø3 8.5 s	 Ø4 21.5 s
 Ø5 8.5 s	 Ø6 21.5 s	 Ø7 8.5 s	 Ø8 21.5 s

Lanes, Volumes, Timings
4: US 24 & Curtis/Stapleton

2023 Existing
AM

												
Lane Group	SEL	SET	SER	NWL	NWT	NWR	NEL	NET	NER	SWL	SWT	SWR
Lane Configurations												
Traffic Volume (vph)	23	135	143	6	87	17	49	267	3	35	438	35
Future Volume (vph)	23	135	143	6	87	17	49	267	3	35	438	35
Ideal Flow (vphpl)	1900	1900	1900	1900	1900	1900	1900	1900	1900	1900	1900	1900
Storage Length (ft)	190		325	215		215	890		1000	790		790
Storage Lanes	1		1	1		0	1		1	1		1
Taper Length (ft)	240			200			190			190		
Lane Util. Factor	1.00	1.00	1.00	1.00	1.00	1.00	1.00	1.00	1.00	1.00	1.00	1.00
Frt			0.850			0.850			0.850			0.850
Flt Protected	0.950			0.950			0.950			0.950		
Satd. Flow (prot)	1770	1863	1583	1770	1863	1583	1770	1863	1583	1770	1863	1583
Flt Permitted	0.689			0.663			0.311			0.546		
Satd. Flow (perm)	1283	1863	1583	1235	1863	1583	579	1863	1583	1017	1863	1583
Right Turn on Red			Yes			Yes			Yes			Yes
Satd. Flow (RTOR)			191			191			191			191
Link Speed (mph)		45			45			55			55	
Link Distance (ft)		1349			1298			2758			1426	
Travel Time (s)		20.4			19.7			34.2			17.7	
Peak Hour Factor	0.92	0.92	0.92	0.83	0.83	0.83	0.92	0.92	0.92	0.92	0.92	0.92
Adj. Flow (vph)	25	147	155	7	105	20	53	290	3	38	476	38
Shared Lane Traffic (%)												
Lane Group Flow (vph)	25	147	155	7	105	20	53	290	3	38	476	38
Enter Blocked Intersection	No	No	No	No	No	No	No	No	No	No	No	No
Lane Alignment	Left	Left	Right	Left	Left	Right	Left	Left	Right	Left	Left	Right
Median Width(ft)		12			12			12			12	
Link Offset(ft)		0			0			0			0	
Crosswalk Width(ft)		16			16			16			16	
Two way Left Turn Lane												
Headway Factor	1.00	1.00	1.00	1.00	1.00	1.00	1.00	1.00	1.00	1.00	1.00	1.00
Turning Speed (mph)	15		9	15		9	15		9	15		9
Number of Detectors	1	2	1	1	2	1	1	2	1	1	2	1
Detector Template	Left	Thru	Right	Left	Thru	Right	Left	Thru	Right	Left	Thru	Right
Leading Detector (ft)	20	100	20	20	100	20	20	100	20	20	100	20
Trailing Detector (ft)	0	0	0	0	0	0	0	0	0	0	0	0
Detector 1 Position(ft)	0	0	0	0	0	0	0	0	0	0	0	0
Detector 1 Size(ft)	20	6	20	20	6	20	20	6	20	20	6	20
Detector 1 Type	Cl+Ex	Cl+Ex	Cl+Ex	Cl+Ex	Cl+Ex	Cl+Ex	Cl+Ex	Cl+Ex	Cl+Ex	Cl+Ex	Cl+Ex	Cl+Ex
Detector 1 Channel												
Detector 1 Extend (s)	0.0	0.0	0.0	0.0	0.0	0.0	0.0	0.0	0.0	0.0	0.0	0.0
Detector 1 Queue (s)	0.0	0.0	0.0	0.0	0.0	0.0	0.0	0.0	0.0	0.0	0.0	0.0
Detector 1 Delay (s)	0.0	0.0	0.0	0.0	0.0	0.0	0.0	0.0	0.0	0.0	0.0	0.0
Detector 2 Position(ft)		94			94			94			94	
Detector 2 Size(ft)		6			6			6			6	
Detector 2 Type		Cl+Ex			Cl+Ex			Cl+Ex			Cl+Ex	
Detector 2 Channel												
Detector 2 Extend (s)		0.0			0.0			0.0			0.0	
Turn Type	pm+pt	NA	Perm	pm+pt	NA	Perm	pm+pt	NA	Perm	pm+pt	NA	Perm
Protected Phases	1	6		5	2		7	4		3	8	
Permitted Phases	6		6	2		2	4		4	8		8

Lanes, Volumes, Timings
4: US 24 & Curtis/Stapleton

2023 Existing
AM











Lane Group	SEL	SET	SER	NWL	NWT	NWR	NEL	NET	NER	SWL	SWT	SWR
Detector Phase	1	6	6	5	2	2	7	4	4	3	8	8
Switch Phase												
Minimum Initial (s)	5.0	5.0	5.0	5.0	5.0	5.0	5.0	5.0	5.0	5.0	5.0	5.0
Minimum Split (s)	9.5	22.5	22.5	9.5	22.5	22.5	9.5	22.5	22.5	9.5	22.5	22.5
Total Split (s)	8.5	21.5	21.5	8.5	21.5	21.5	8.5	21.5	21.5	8.5	21.5	21.5
Total Split (%)	14.2%	35.8%	35.8%	14.2%	35.8%	35.8%	14.2%	35.8%	35.8%	14.2%	35.8%	35.8%
Maximum Green (s)	4.0	17.0	17.0	4.0	17.0	17.0	4.0	17.0	17.0	4.0	17.0	17.0
Yellow Time (s)	3.5	3.5	3.5	3.5	3.5	3.5	3.5	3.5	3.5	3.5	3.5	3.5
All-Red Time (s)	1.0	1.0	1.0	1.0	1.0	1.0	1.0	1.0	1.0	1.0	1.0	1.0
Lost Time Adjust (s)	0.0	0.0	0.0	0.0	0.0	0.0	0.0	0.0	0.0	0.0	0.0	0.0
Total Lost Time (s)	4.5	4.5	4.5	4.5	4.5	4.5	4.5	4.5	4.5	4.5	4.5	4.5
Lead/Lag	Lead	Lag	Lag	Lead	Lag	Lag	Lead	Lag	Lag	Lead	Lag	Lag
Lead-Lag Optimize?	Yes	Yes	Yes	Yes	Yes	Yes	Yes	Yes	Yes	Yes	Yes	Yes
Vehicle Extension (s)	3.0	3.0	3.0	3.0	3.0	3.0	3.0	3.0	3.0	3.0	3.0	3.0
Recall Mode	None	Min	Min	None	Min	Min	None	None	None	None	None	None
Walk Time (s)		7.0	7.0		7.0	7.0		7.0	7.0		7.0	7.0
Flash Dont Walk (s)		11.0	11.0		11.0	11.0		11.0	11.0		11.0	11.0
Pedestrian Calls (#/hr)		0	0		0	0		0	0		0	0
Act Effct Green (s)	9.4	8.9	8.9	9.4	8.9	8.9	17.0	15.8	15.8	17.0	15.8	15.8
Actuated g/C Ratio	0.25	0.23	0.23	0.25	0.23	0.23	0.45	0.41	0.41	0.45	0.41	0.41
v/c Ratio	0.07	0.34	0.30	0.02	0.24	0.04	0.14	0.38	0.00	0.07	0.62	0.05
Control Delay	12.2	17.1	4.1	11.8	16.1	0.1	7.3	12.2	0.0	6.9	17.4	0.1
Queue Delay	0.0	0.0	0.0	0.0	0.0	0.0	0.0	0.0	0.0	0.0	0.0	0.0
Total Delay	12.2	17.1	4.1	11.8	16.1	0.1	7.3	12.2	0.0	6.9	17.4	0.1
LOS	B	B	A	B	B	A	A	B	A	A	B	A
Approach Delay		10.6			13.4			11.3			15.5	
Approach LOS		B			B			B			B	
Queue Length 50th (ft)	4	22	0	1	16	0	4	28	0	3	52	0
Queue Length 95th (ft)	17	83	26	7	57	0	25	142	0	19	#294	0
Internal Link Dist (ft)		1269			1218			2678			1346	
Turn Bay Length (ft)	190		325	215		215	890		1000	790		790
Base Capacity (vph)	372	894	859	365	894	859	392	894	859	538	894	859
Starvation Cap Reductn	0	0	0	0	0	0	0	0	0	0	0	0
Spillback Cap Reductn	0	0	0	0	0	0	0	0	0	0	0	0
Storage Cap Reductn	0	0	0	0	0	0	0	0	0	0	0	0
Reduced v/c Ratio	0.07	0.16	0.18	0.02	0.12	0.02	0.14	0.32	0.00	0.07	0.53	0.04

Intersection Summary

Area Type:	Other
Cycle Length:	60
Actuated Cycle Length:	38.2
Natural Cycle:	65
Control Type:	Actuated-Uncoordinated
Maximum v/c Ratio:	0.62
Intersection Signal Delay:	13.1
Intersection LOS:	B
Intersection Capacity Utilization:	47.3%
ICU Level of Service:	A
Analysis Period (min):	15
# 95th percentile volume exceeds capacity, queue may be longer. Queue shown is maximum after two cycles.	

Splits and Phases: 4: US 24 & Curtis/Stapleton

 Ø1	 Ø2	 Ø3	 Ø4
8.5 s	21.5 s	8.5 s	21.5 s
 Ø5	 Ø6	 Ø7	 Ø8
8.5 s	21.5 s	8.5 s	21.5 s

Intersection												
Int Delay, s/veh	10.3											
Movement	SEL	SET	SER	NWL	NWT	NWR	NEL	NET	NER	SWL	SWT	SWR
Lane Configurations	↖	↗	↖	↖	↗	↖	↖	↗	↖	↖	↗	↖
Traffic Vol, veh/h	23	135	143	6	87	17	49	267	3	35	438	35
Future Vol, veh/h	23	135	143	6	87	17	49	267	3	35	438	35
Conflicting Peds, #/hr	0	0	0	0	0	0	0	0	0	0	0	0
Sign Control	Stop	Stop	Stop	Stop	Stop	Stop	Free	Free	Free	Free	Free	Free
RT Channelized	-	-	None	-	-	None	-	-	None	-	-	None
Storage Length	190	-	325	215	-	-	890	-	1000	790	-	790
Veh in Median Storage, #	-	0	-	-	0	-	-	0	-	-	0	-
Grade, %	-	0	-	-	0	-	-	0	-	-	0	-
Peak Hour Factor	92	92	92	83	83	83	92	92	92	92	92	92
Heavy Vehicles, %	2	2	2	2	2	2	2	2	2	2	2	2
Mvmt Flow	25	147	155	7	105	20	53	290	3	38	476	38

Major/Minor	Minor2		Minor1		Major1			Major2				
Conflicting Flow All	1012	951	476	1118	986	290	514	0	0	293	0	0
Stage 1	552	552	-	396	396	-	-	-	-	-	-	-
Stage 2	460	399	-	722	590	-	-	-	-	-	-	-
Critical Hdwy	7.12	6.52	6.22	7.12	6.52	6.22	4.12	-	-	4.12	-	-
Critical Hdwy Stg 1	6.12	5.52	-	6.12	5.52	-	-	-	-	-	-	-
Critical Hdwy Stg 2	6.12	5.52	-	6.12	5.52	-	-	-	-	-	-	-
Follow-up Hdwy	3.518	4.018	3.318	3.518	4.018	3.318	2.218	-	-	2.218	-	-
Pot Cap-1 Maneuver	218	260	589	184	248	749	1052	-	-	1269	-	-
Stage 1	518	515	-	629	604	-	-	-	-	-	-	-
Stage 2	581	602	-	418	495	-	-	-	-	-	-	-
Platoon blocked, %	-	-	-	-	-	-	-	-	-	-	-	-
Mov Cap-1 Maneuver	128	240	589	66	229	749	1052	-	-	1269	-	-
Mov Cap-2 Maneuver	128	240	-	66	229	-	-	-	-	-	-	-
Stage 1	492	500	-	598	574	-	-	-	-	-	-	-
Stage 2	439	572	-	211	480	-	-	-	-	-	-	-

Approach	SE		NW		NE		SW	
HCM Control Delay, s	27.8		31.5		1.3		0.5	
HCM LOS	D		D					

Minor Lane/Major Mvmt	NEL	NET	NERN	NWLn1	NWLn2	NWLn3	SELn1	SELn2	SELn3	SWL	SWT	SWR
Capacity (veh/h)	1052	-	-	66	229	749	128	240	589	1269	-	-
HCM Lane V/C Ratio	0.051	-	-	0.11	0.458	0.027	0.195	0.611	0.264	0.03	-	-
HCM Control Delay (s)	8.6	-	-	66.1	33.3	9.9	39.8	41.1	13.3	7.9	-	-
HCM Lane LOS	A	-	-	F	D	A	E	E	B	A	-	-
HCM 95th %tile Q(veh)	0.2	-	-	0.4	2.2	0.1	0.7	3.6	1.1	0.1	-	-

Intersection												
Int Delay, s/veh	8											
Movement	EBL	EBT	EBR	WBL	WBT	WBR	NBL	NBT	NBR	SBL	SBT	SBR
Lane Configurations	↔	↔		↔	↔		↔	↔		↔	↔	
Traffic Vol, veh/h	3	34	73	24	144	14	40	70	4	5	189	1
Future Vol, veh/h	3	34	73	24	144	14	40	70	4	5	189	1
Conflicting Peds, #/hr	0	0	0	0	0	0	0	0	0	0	0	0
Sign Control	Free	Free	Free	Free	Free	Free	Stop	Stop	Stop	Stop	Stop	Stop
RT Channelized	-	-	None	-	-	None	-	-	None	-	-	None
Storage Length	0	-	-	0	-	-	0	-	-	0	-	-
Veh in Median Storage, #	-	0	-	-	0	-	-	0	-	-	0	-
Grade, %	-	0	-	-	0	-	-	0	-	-	0	-
Peak Hour Factor	83	83	83	87	87	87	83	83	83	87	87	87
Heavy Vehicles, %	2	2	2	2	2	2	2	2	2	2	2	2
Mvmt Flow	4	41	88	28	166	16	48	84	5	6	217	1

Major/Minor	Major1			Major2			Minor1			Minor2		
Conflicting Flow All	182	0	0	129	0	0	432	331	85	368	367	174
Stage 1	-	-	-	-	-	-	93	93	-	230	230	-
Stage 2	-	-	-	-	-	-	339	238	-	138	137	-
Critical Hdwy	4.12	-	-	4.12	-	-	7.12	6.52	6.22	7.12	6.52	6.22
Critical Hdwy Stg 1	-	-	-	-	-	-	6.12	5.52	-	6.12	5.52	-
Critical Hdwy Stg 2	-	-	-	-	-	-	6.12	5.52	-	6.12	5.52	-
Follow-up Hdwy	2.218	-	-	2.218	-	-	3.518	4.018	3.318	3.518	4.018	3.318
Pot Cap-1 Maneuver	1393	-	-	1457	-	-	534	588	974	588	562	869
Stage 1	-	-	-	-	-	-	914	818	-	773	714	-
Stage 2	-	-	-	-	-	-	676	708	-	865	783	-
Platoon blocked, %		-	-		-	-						
Mov Cap-1 Maneuver	1393	-	-	1457	-	-	363	575	974	511	550	869
Mov Cap-2 Maneuver	-	-	-	-	-	-	363	575	-	511	550	-
Stage 1	-	-	-	-	-	-	911	816	-	771	700	-
Stage 2	-	-	-	-	-	-	457	695	-	770	781	-

Approach	EB	WB	NB	SB
HCM Control Delay, s	0.2	1	13.7	15.7
HCM LOS			B	C

Minor Lane/Major Mvmt	NBLn1	NBLn2	EBL	EBT	EBR	WBL	WBT	WBR	SBLn1	SBLn2
Capacity (veh/h)	363	588	1393	-	-	1457	-	-	511	551
HCM Lane V/C Ratio	0.133	0.152	0.003	-	-	0.019	-	-	0.011	0.396
HCM Control Delay (s)	16.4	12.2	7.6	-	-	7.5	-	-	12.1	15.8
HCM Lane LOS	C	B	A	-	-	A	-	-	B	C
HCM 95th %tile Q(veh)	0.5	0.5	0	-	-	0.1	-	-	0	1.9

Intersection												
Int Delay, s/veh	10.5											
Movement	EBL	EBT	EBR	WBL	WBT	WBR	NBL	NBT	NBR	SBL	SBT	SBR
Lane Configurations	↙	↑	↗	↙	↑	↗	↙	↑	↗	↙	↑	↗
Traffic Vol, veh/h	13	54	252	13	201	43	62	75	1	7	209	24
Future Vol, veh/h	13	54	252	13	201	43	62	75	1	7	209	24
Conflicting Peds, #/hr	0	0	0	0	0	0	0	0	0	0	0	0
Sign Control	Free	Free	Free	Free	Free	Free	Stop	Stop	Stop	Stop	Stop	Stop
RT Channelized	-	-	None	-	-	None	-	-	None	-	-	None
Storage Length	0	-	0	0	-	-	0	-	-	0	-	-
Veh in Median Storage, #	-	0	-	-	0	-	-	0	-	-	0	-
Grade, %	-	0	-	-	0	-	-	0	-	-	0	-
Peak Hour Factor	92	92	92	92	92	92	83	83	83	87	87	87
Heavy Vehicles, %	2	2	2	2	2	2	2	2	2	2	2	2
Mvmt Flow	14	59	274	14	218	47	75	90	1	8	240	28

Major/Minor	Major1			Major2			Minor1			Minor2		
Conflicting Flow All	265	0	0	333	0	0	491	380	59	540	631	242
Stage 1	-	-	-	-	-	-	87	87	-	270	270	-
Stage 2	-	-	-	-	-	-	404	293	-	270	361	-
Critical Hdwy	4.12	-	-	4.12	-	-	7.12	6.52	6.22	7.12	6.52	6.22
Critical Hdwy Stg 1	-	-	-	-	-	-	6.12	5.52	-	6.12	5.52	-
Critical Hdwy Stg 2	-	-	-	-	-	-	6.12	5.52	-	6.12	5.52	-
Follow-up Hdwy	2.218	-	-	2.218	-	-	3.518	4.018	3.318	3.518	4.018	3.318
Pot Cap-1 Maneuver	1299	-	-	1226	-	-	488	552	1007	453	398	797
Stage 1	-	-	-	-	-	-	921	823	-	736	686	-
Stage 2	-	-	-	-	-	-	623	670	-	736	626	-
Platoon blocked, %	-	-	-	-	-	-	-	-	-	-	-	-
Mov Cap-1 Maneuver	1299	-	-	1226	-	-	235	540	1007	388	389	797
Mov Cap-2 Maneuver	-	-	-	-	-	-	235	540	-	388	389	-
Stage 1	-	-	-	-	-	-	911	814	-	728	678	-
Stage 2	-	-	-	-	-	-	384	663	-	646	619	-

Approach	EB			WB			NB			SB		
HCM Control Delay, s	0.3			0.4			19.4			28.3		
HCM LOS							C			D		

Minor Lane/Major Mvmt	NBLn1	NBLn2	EBL	EBT	EBR	WBL	WBT	WBR	SBLn1	SBLn2
Capacity (veh/h)	235	543	1299	-	-	1226	-	-	388	411
HCM Lane V/C Ratio	0.318	0.169	0.011	-	-	0.012	-	-	0.021	0.652
HCM Control Delay (s)	27.3	13	7.8	-	-	8	-	-	14.5	28.7
HCM Lane LOS	D	B	A	-	-	A	-	-	B	D
HCM 95th %tile Q(veh)	1.3	0.6	0	-	-	0	-	-	0.1	4.5

Intersection												
Int Delay, s/veh	9.1											
Movement	EBL	EBT	EBR	WBL	WBT	WBR	NBL	NBT	NBR	SBL	SBT	SBR
Lane Configurations		↕			↕			↕			↕	
Traffic Vol, veh/h	5	59	2	6	176	151	0	73	7	174	70	17
Future Vol, veh/h	5	59	2	6	176	151	0	73	7	174	70	17
Conflicting Peds, #/hr	0	0	0	0	0	0	0	0	0	0	0	0
Sign Control	Free	Free	Free	Free	Free	Free	Stop	Stop	Stop	Stop	Stop	Stop
RT Channelized	-	-	None	-	-	None	-	-	None	-	-	None
Storage Length	-	-	-	-	-	-	-	-	-	-	-	-
Veh in Median Storage, #	-	0	-	-	0	-	-	0	-	-	0	-
Grade, %	-	0	-	-	0	-	-	0	-	-	0	-
Peak Hour Factor	83	83	83	92	92	92	83	83	83	92	92	92
Heavy Vehicles, %	2	2	2	2	2	2	2	2	2	2	2	2
Mvmt Flow	6	71	2	7	191	164	0	88	8	189	76	18

Major/Minor	Major1			Major2			Minor1			Minor2		
Conflicting Flow All	355	0	0	73	0	0	418	453	72	419	372	273
Stage 1	-	-	-	-	-	-	84	84	-	287	287	-
Stage 2	-	-	-	-	-	-	334	369	-	132	85	-
Critical Hdwy	4.12	-	-	4.12	-	-	7.12	6.52	6.22	7.12	6.52	6.22
Critical Hdwy Stg 1	-	-	-	-	-	-	6.12	5.52	-	6.12	5.52	-
Critical Hdwy Stg 2	-	-	-	-	-	-	6.12	5.52	-	6.12	5.52	-
Follow-up Hdwy	2.218	-	-	2.218	-	-	3.518	4.018	3.318	3.518	4.018	3.318
Pot Cap-1 Maneuver	1204	-	-	1527	-	-	545	503	990	544	558	766
Stage 1	-	-	-	-	-	-	924	825	-	720	674	-
Stage 2	-	-	-	-	-	-	680	621	-	871	824	-
Platoon blocked, %		-	-		-	-						
Mov Cap-1 Maneuver	1204	-	-	1527	-	-	472	497	990	462	552	766
Mov Cap-2 Maneuver	-	-	-	-	-	-	472	497	-	462	552	-
Stage 1	-	-	-	-	-	-	919	821	-	716	670	-
Stage 2	-	-	-	-	-	-	585	617	-	767	820	-

Approach	EB			WB			NB			SB		
HCM Control Delay, s	0.6			0.1			13.5			21.4		
HCM LOS							B			C		

Minor Lane/Major Mvmt	NBLn1	EBL	EBT	EBR	WBL	WBT	WBR	SBLn1
Capacity (veh/h)	520	1204	-	-	1527	-	-	497
HCM Lane V/C Ratio	0.185	0.005	-	-	0.004	-	-	0.571
HCM Control Delay (s)	13.5	8	0	-	7.4	0	-	21.4
HCM Lane LOS	B	A	A	-	A	A	-	C
HCM 95th %tile Q(veh)	0.7	0	-	-	0	-	-	3.5

Lanes, Volumes, Timings
1: US 24 & Falcon Hwy

2023 Existing
PM



Lane Group	WBL	WBR	NET	NER	SWL	SWT
Lane Configurations						
Traffic Volume (vph)	51	5	1260	56	3	629
Future Volume (vph)	51	5	1260	56	3	629
Ideal Flow (vphpl)	1900	1900	1900	1900	1900	1900
Storage Length (ft)	0	0		490	555	
Storage Lanes	1	0		1	1	
Taper Length (ft)	25				300	
Lane Util. Factor	1.00	1.00	1.00	1.00	1.00	1.00
Frt	0.988			0.850		
Flt Protected	0.956				0.950	
Satd. Flow (prot)	1759	0	1863	1583	1770	1863
Flt Permitted	0.956				0.061	
Satd. Flow (perm)	1759	0	1863	1583	114	1863
Right Turn on Red		Yes		Yes		
Satd. Flow (RTOR)	5			59		
Link Speed (mph)	55		65			65
Link Distance (ft)	1594		843			880
Travel Time (s)	19.8		8.8			9.2
Peak Hour Factor	0.83	0.83	0.95	0.95	0.93	0.93
Adj. Flow (vph)	61	6	1326	59	3	676
Shared Lane Traffic (%)						
Lane Group Flow (vph)	67	0	1326	59	3	676
Enter Blocked Intersection	No	No	No	No	No	No
Lane Alignment	Left	Right	Left	Right	Left	Left
Median Width(ft)	12		12			12
Link Offset(ft)	0		0			0
Crosswalk Width(ft)	16		16			16
Two way Left Turn Lane						
Headway Factor	1.00	1.00	1.00	1.00	1.00	1.00
Turning Speed (mph)	15	9		9	15	
Number of Detectors	1		2	1	1	2
Detector Template	Left		Thru	Right	Left	Thru
Leading Detector (ft)	20		100	20	20	100
Trailing Detector (ft)	0		0	0	0	0
Detector 1 Position(ft)	0		0	0	0	0
Detector 1 Size(ft)	20		6	20	20	6
Detector 1 Type	Cl+Ex		Cl+Ex	Cl+Ex	Cl+Ex	Cl+Ex
Detector 1 Channel						
Detector 1 Extend (s)	0.0		0.0	0.0	0.0	0.0
Detector 1 Queue (s)	0.0		0.0	0.0	0.0	0.0
Detector 1 Delay (s)	0.0		0.0	0.0	0.0	0.0
Detector 2 Position(ft)			94			94
Detector 2 Size(ft)			6			6
Detector 2 Type			Cl+Ex			Cl+Ex
Detector 2 Channel						
Detector 2 Extend (s)			0.0			0.0
Turn Type	Prot		NA	Perm	Perm	NA
Protected Phases	6		8			4
Permitted Phases				8	4	

Lanes, Volumes, Timings
1: US 24 & Falcon Hwy

2023 Existing
PM



Lane Group	WBL	WBR	NET	NER	SWL	SWT
Detector Phase	6		8	8	4	4
Switch Phase						
Minimum Initial (s)	5.0		5.0	5.0	5.0	5.0
Minimum Split (s)	22.5		22.5	22.5	22.5	22.5
Total Split (s)	20.0		70.0	70.0	70.0	70.0
Total Split (%)	22.2%		77.8%	77.8%	77.8%	77.8%
Maximum Green (s)	15.5		65.5	65.5	65.5	65.5
Yellow Time (s)	3.5		3.5	3.5	3.5	3.5
All-Red Time (s)	1.0		1.0	1.0	1.0	1.0
Lost Time Adjust (s)	0.0		0.0	0.0	0.0	0.0
Total Lost Time (s)	4.5		4.5	4.5	4.5	4.5
Lead/Lag						
Lead-Lag Optimize?						
Vehicle Extension (s)	3.0		3.0	3.0	3.0	3.0
Recall Mode	Max		None	None	Max	Max
Walk Time (s)	7.0		7.0	7.0	7.0	7.0
Flash Dont Walk (s)	11.0		11.0	11.0	11.0	11.0
Pedestrian Calls (#/hr)	0		0	0	0	0
Act Effect Green (s)	18.0		65.5	65.5	65.5	65.5
Actuated g/C Ratio	0.19		0.71	0.71	0.71	0.71
v/c Ratio	0.19		1.01	0.05	0.04	0.51
Control Delay	30.8		41.4	1.3	5.3	7.9
Queue Delay	0.0		0.0	0.0	0.0	0.0
Total Delay	30.8		41.4	1.3	5.3	7.9
LOS	C		D	A	A	A
Approach Delay	30.8		39.6			7.8
Approach LOS	C		D			A
Queue Length 50th (ft)	31		~685	0	1	155
Queue Length 95th (ft)	61		#1071	10	3	228
Internal Link Dist (ft)	1514		763			800
Turn Bay Length (ft)				490	555	
Base Capacity (vph)	346		1319	1138	80	1319
Starvation Cap Reductn	0		0	0	0	0
Spillback Cap Reductn	0		0	0	0	0
Storage Cap Reductn	0		0	0	0	0
Reduced v/c Ratio	0.19		1.01	0.05	0.04	0.51

Intersection Summary

Area Type:	Other
Cycle Length:	90
Actuated Cycle Length:	92.5
Natural Cycle:	90
Control Type:	Actuated-Uncoordinated
Maximum v/c Ratio:	1.01
Intersection Signal Delay:	29.2
Intersection LOS:	C
Intersection Capacity Utilization:	78.0%
ICU Level of Service:	D
Analysis Period (min):	15
~ Volume exceeds capacity, queue is theoretically infinite. Queue shown is maximum after two cycles.	





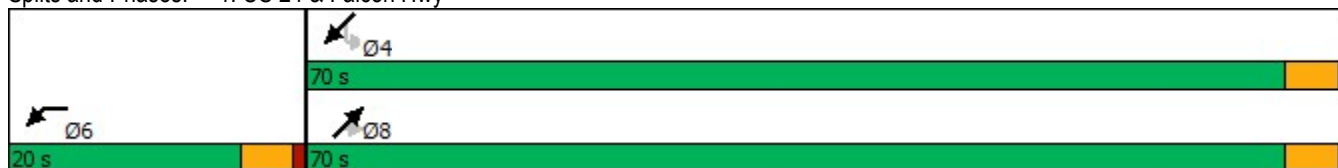



















95th percentile volume exceeds capacity, queue may be longer.
Queue shown is maximum after two cycles.

Splits and Phases: 1: US 24 & Falcon Hwy



Lanes, Volumes, Timings
2: US 24 & Meridian Rd

2023 Existing
PM

												
Lane Group	SEL	SET	SER	NWL	NWT	NWR	NEL	NET	NER	SWL	SWT	SWR
Lane Configurations												
Traffic Volume (vph)	19	227	307	11	351	43	608	684	6	55	403	7
Future Volume (vph)	19	227	307	11	351	43	608	684	6	55	403	7
Ideal Flow (vphpl)	1900	1900	1900	1900	1900	1900	1900	1900	1900	1900	1900	1900
Storage Length (ft)	195		195	195		195	555		490	555		490
Storage Lanes	1		1	1		1	1		1	1		1
Taper Length (ft)	180			180			300			300		
Lane Util. Factor	1.00	0.95	1.00	1.00	0.95	1.00	1.00	1.00	1.00	1.00	1.00	1.00
Frt			0.850			0.850			0.850			0.850
Flt Protected	0.950			0.950			0.950			0.950		
Satd. Flow (prot)	1770	3539	1583	1770	3539	1583	1770	1863	1583	1770	1863	1583
Flt Permitted	0.488			0.600			0.295			0.159		
Satd. Flow (perm)	909	3539	1583	1118	3539	1583	550	1863	1583	296	1863	1583
Right Turn on Red			Yes			Yes			Yes			Yes
Satd. Flow (RTOR)			330			109			109			109
Link Speed (mph)		40			40			65			65	
Link Distance (ft)		873			1300			985			695	
Travel Time (s)		14.9			22.2			10.3			7.3	
Peak Hour Factor	0.93	0.93	0.93	0.92	0.92	0.92	0.95	0.95	0.95	0.92	0.92	0.92
Adj. Flow (vph)	20	244	330	12	382	47	640	720	6	60	438	8
Shared Lane Traffic (%)												
Lane Group Flow (vph)	20	244	330	12	382	47	640	720	6	60	438	8
Enter Blocked Intersection	No	No	No	No	No	No	No	No	No	No	No	No
Lane Alignment	Left	Left	Right	Left	Left	Right	Left	Left	Right	Left	Left	Right
Median Width(ft)		12			12			12			12	
Link Offset(ft)		0			0			0			0	
Crosswalk Width(ft)		16			16			16			16	
Two way Left Turn Lane												
Headway Factor	1.00	1.00	1.00	1.00	1.00	1.00	1.00	1.00	1.00	1.00	1.00	1.00
Turning Speed (mph)	15		9	15		9	15		9	15		9
Number of Detectors	1	2	1	1	2	1	1	2	1	1	2	1
Detector Template	Left	Thru	Right	Left	Thru	Right	Left	Thru	Right	Left	Thru	Right
Leading Detector (ft)	20	100	20	20	100	20	20	100	20	20	100	20
Trailing Detector (ft)	0	0	0	0	0	0	0	0	0	0	0	0
Detector 1 Position(ft)	0	0	0	0	0	0	0	0	0	0	0	0
Detector 1 Size(ft)	20	6	20	20	6	20	20	6	20	20	6	20
Detector 1 Type	Cl+Ex	Cl+Ex	Cl+Ex	Cl+Ex	Cl+Ex	Cl+Ex	Cl+Ex	Cl+Ex	Cl+Ex	Cl+Ex	Cl+Ex	Cl+Ex
Detector 1 Channel												
Detector 1 Extend (s)	0.0	0.0	0.0	0.0	0.0	0.0	0.0	0.0	0.0	0.0	0.0	0.0
Detector 1 Queue (s)	0.0	0.0	0.0	0.0	0.0	0.0	0.0	0.0	0.0	0.0	0.0	0.0
Detector 1 Delay (s)	0.0	0.0	0.0	0.0	0.0	0.0	0.0	0.0	0.0	0.0	0.0	0.0
Detector 2 Position(ft)		94			94			94			94	
Detector 2 Size(ft)		6			6			6			6	
Detector 2 Type		Cl+Ex			Cl+Ex			Cl+Ex			Cl+Ex	
Detector 2 Channel												
Detector 2 Extend (s)		0.0			0.0			0.0			0.0	
Turn Type	Perm	NA	Perm	Perm	NA	Perm	pm+pt	NA	Perm	pm+pt	NA	Perm
Protected Phases		6			2		7	4		3		8
Permitted Phases	6		6	2		2	4		4	8		8

Lanes, Volumes, Timings
2: US 24 & Meridian Rd

2023 Existing
PM



Lane Group	SEL	SET	SER	NWL	NWT	NWR	NEL	NET	NER	SWL	SWT	SWR
Detector Phase	6	6	6	2	2	2	7	4	4	3	8	8
Switch Phase												
Minimum Initial (s)	5.0	5.0	5.0	5.0	5.0	5.0	5.0	5.0	5.0	5.0	5.0	5.0
Minimum Split (s)	22.5	22.5	22.5	22.5	22.5	22.5	9.5	22.5	22.5	9.5	22.5	22.5
Total Split (s)	12.0	12.0	12.0	12.0	12.0	12.0	12.0	36.0	36.0	12.0	36.0	36.0
Total Split (%)	20.0%	20.0%	20.0%	20.0%	20.0%	20.0%	20.0%	60.0%	60.0%	20.0%	60.0%	60.0%
Maximum Green (s)	7.5	7.5	7.5	7.5	7.5	7.5	7.5	31.5	31.5	7.5	31.5	31.5
Yellow Time (s)	3.5	3.5	3.5	3.5	3.5	3.5	3.5	3.5	3.5	3.5	3.5	3.5
All-Red Time (s)	1.0	1.0	1.0	1.0	1.0	1.0	1.0	1.0	1.0	1.0	1.0	1.0
Lost Time Adjust (s)	0.0	0.0	0.0	0.0	0.0	0.0	0.0	0.0	0.0	0.0	0.0	0.0
Total Lost Time (s)	4.5	4.5	4.5	4.5	4.5	4.5	4.5	4.5	4.5	4.5	4.5	4.5
Lead/Lag							Lead	Lag	Lag	Lead	Lag	Lag
Lead-Lag Optimize?							Yes	Yes	Yes	Yes	Yes	Yes
Vehicle Extension (s)	3.0	3.0	3.0	3.0	3.0	3.0	3.0	3.0	3.0	3.0	3.0	3.0
Recall Mode	Max	Max	Max	Max	Max	Max	None	None	None	None	None	None
Walk Time (s)	7.0	7.0	7.0	7.0	7.0	7.0		7.0	7.0		7.0	7.0
Flash Dont Walk (s)	11.0	11.0	11.0	11.0	11.0	11.0		11.0	11.0		11.0	11.0
Pedestrian Calls (#/hr)	0	0	0	0	0	0		0	0		0	0
Act Effct Green (s)	18.4	18.4	18.4	18.4	18.4	18.4	33.2	29.1	29.1	29.5	23.0	23.0
Actuated g/C Ratio	0.29	0.29	0.29	0.29	0.29	0.29	0.53	0.46	0.46	0.47	0.37	0.37
v/c Ratio	0.08	0.24	0.47	0.04	0.37	0.09	1.46	0.84	0.01	0.21	0.64	0.01
Control Delay	20.9	19.8	5.5	20.2	20.8	0.4	237.1	26.8	0.0	7.5	20.4	0.0
Queue Delay	0.0	0.0	0.0	0.0	0.0	0.0	0.0	0.0	0.0	0.0	0.0	0.0
Total Delay	20.9	19.8	5.5	20.2	20.8	0.4	237.1	26.8	0.0	7.5	20.4	0.0
LOS	C	B	A	C	C	A	F	C	A	A	C	A
Approach Delay		11.9			18.6			125.3			18.6	
Approach LOS		B			B			F			B	
Queue Length 50th (ft)	6	43	0	4	71	0	~264	260	0	9	131	0
Queue Length 95th (ft)	23	73	58	16	111	2	#579	#477	0	22	211	0
Internal Link Dist (ft)		793			1220			905			615	
Turn Bay Length (ft)	195		195	195		195	555		490	555		490
Base Capacity (vph)	265	1034	696	326	1034	540	438	953	863	323	953	863
Starvation Cap Reductn	0	0	0	0	0	0	0	0	0	0	0	0
Spillback Cap Reductn	0	0	0	0	0	0	0	0	0	0	0	0
Storage Cap Reductn	0	0	0	0	0	0	0	0	0	0	0	0
Reduced v/c Ratio	0.08	0.24	0.47	0.04	0.37	0.09	1.46	0.76	0.01	0.19	0.46	0.01

Intersection Summary

Area Type:	Other
Cycle Length:	60
Actuated Cycle Length:	62.9
Natural Cycle:	80
Control Type:	Actuated-Uncoordinated
Maximum v/c Ratio:	1.46
Intersection Signal Delay:	67.4
Intersection LOS:	E
Intersection Capacity Utilization:	81.9%
ICU Level of Service:	D
Analysis Period (min):	15
~ Volume exceeds capacity, queue is theoretically infinite. Queue shown is maximum after two cycles.	

95th percentile volume exceeds capacity, queue may be longer.
 Queue shown is maximum after two cycles.

Splits and Phases: 2: US 24 & Meridian Rd

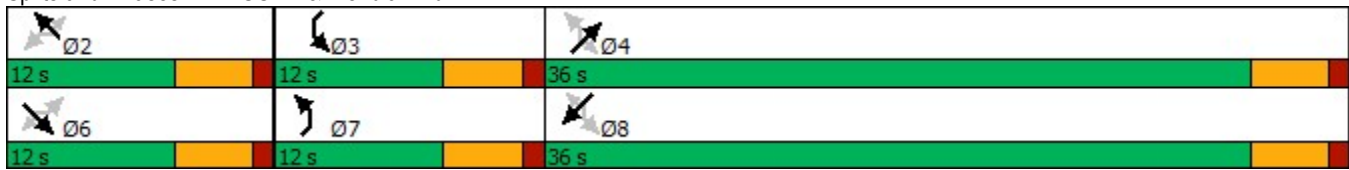

Lanes, Volumes, Timings
3: US 24 & Judge Orr

2023 Existing
PM



Lane Group	EBL	EBT	EBR	WBL	WBT	WBR	NEL	NET	NER	SWL	SWT	SWR
Lane Configurations		↕			↕		↕	↕		↕	↕	
Traffic Volume (vph)	44	51	70	116	53	12	145	578	121	2	410	13
Future Volume (vph)	44	51	70	116	53	12	145	578	121	2	410	13
Ideal Flow (vphpl)	1900	1900	1900	1900	1900	1900	1900	1900	1900	1900	1900	1900
Storage Length (ft)	0		0	0		0	850		0	700		0
Storage Lanes	0		0	0		0	1		0	1		0
Taper Length (ft)	25			25			280			300		
Lane Util. Factor	1.00	1.00	1.00	1.00	1.00	1.00	1.00	1.00	1.00	1.00	1.00	1.00
Frt		0.943			0.991			0.974			0.995	
Flt Protected		0.987			0.969		0.950			0.950		
Satd. Flow (prot)	0	1734	0	0	1789	0	1770	1814	0	1770	1853	0
Flt Permitted		0.876			0.690		0.366			0.210		
Satd. Flow (perm)	0	1539	0	0	1274	0	682	1814	0	391	1853	0
Right Turn on Red			Yes			Yes			Yes			Yes
Satd. Flow (RTOR)		68			7			17			3	
Link Speed (mph)		45			45			55			55	
Link Distance (ft)		801			719			1315			2758	
Travel Time (s)		12.1			10.9			16.3			34.2	
Peak Hour Factor	0.83	0.83	0.83	0.87	0.87	0.87	0.93	0.93	0.93	0.92	0.92	0.92
Adj. Flow (vph)	53	61	84	133	61	14	156	622	130	2	446	14
Shared Lane Traffic (%)												
Lane Group Flow (vph)	0	198	0	0	208	0	156	752	0	2	460	0
Enter Blocked Intersection	No	No	No	No	No	No	No	No	No	No	No	No
Lane Alignment	Left	Left	Right	Left	Left	Right	Left	Left	Right	Left	Left	Right
Median Width(ft)		0			0			12			12	
Link Offset(ft)		0			0			0			0	
Crosswalk Width(ft)		16			16			16			16	
Two way Left Turn Lane												
Headway Factor	1.00	1.00	1.00	1.00	1.00	1.00	1.00	1.00	1.00	1.00	1.00	1.00
Turning Speed (mph)	15		9	15		9	15		9	15		9
Number of Detectors	1	2		1	2		1	2		1	2	
Detector Template	Left	Thru		Left	Thru		Left	Thru		Left	Thru	
Leading Detector (ft)	20	100		20	100		20	100		20	100	
Trailing Detector (ft)	0	0		0	0		0	0		0	0	
Detector 1 Position(ft)	0	0		0	0		0	0		0	0	
Detector 1 Size(ft)	20	6		20	6		20	6		20	6	
Detector 1 Type	Cl+Ex	Cl+Ex		Cl+Ex	Cl+Ex		Cl+Ex	Cl+Ex		Cl+Ex	Cl+Ex	
Detector 1 Channel												
Detector 1 Extend (s)	0.0	0.0		0.0	0.0		0.0	0.0		0.0	0.0	
Detector 1 Queue (s)	0.0	0.0		0.0	0.0		0.0	0.0		0.0	0.0	
Detector 1 Delay (s)	0.0	0.0		0.0	0.0		0.0	0.0		0.0	0.0	
Detector 2 Position(ft)		94			94			94			94	
Detector 2 Size(ft)		6			6			6			6	
Detector 2 Type		Cl+Ex			Cl+Ex			Cl+Ex			Cl+Ex	
Detector 2 Channel												
Detector 2 Extend (s)		0.0			0.0			0.0			0.0	
Turn Type	pm+pt	NA		pm+pt	NA		pm+pt	NA		pm+pt	NA	
Protected Phases	7	4		3	8		5	2		1	6	
Permitted Phases	4			8			2			6		

Lanes, Volumes, Timings
3: US 24 & Judge Orr

2023 Existing
PM











Lane Group	EBL	EBT	EBR	WBL	WBT	WBR	NEL	NET	NER	SWL	SWT	SWR
Detector Phase	7	4		3	8		5	2		1	6	
Switch Phase												
Minimum Initial (s)	5.0	5.0		5.0	5.0		5.0	5.0		5.0	5.0	
Minimum Split (s)	9.5	22.5		9.5	22.5		9.5	22.5		9.5	22.5	
Total Split (s)	8.5	21.5		8.5	21.5		8.5	21.5		8.5	21.5	
Total Split (%)	14.2%	35.8%		14.2%	35.8%		14.2%	35.8%		14.2%	35.8%	
Maximum Green (s)	4.0	17.0		4.0	17.0		4.0	17.0		4.0	17.0	
Yellow Time (s)	3.5	3.5		3.5	3.5		3.5	3.5		3.5	3.5	
All-Red Time (s)	1.0	1.0		1.0	1.0		1.0	1.0		1.0	1.0	
Lost Time Adjust (s)		0.0			0.0		0.0	0.0		0.0	0.0	
Total Lost Time (s)		4.5			4.5		4.5	4.5		4.5	4.5	
Lead/Lag	Lead	Lag		Lead	Lag		Lead	Lag		Lead	Lag	
Lead-Lag Optimize?	Yes	Yes		Yes	Yes		Yes	Yes		Yes	Yes	
Vehicle Extension (s)	3.0	3.0		3.0	3.0		3.0	3.0		3.0	3.0	
Recall Mode	None	None		None	None		None	Max		None	Max	
Walk Time (s)		7.0			7.0			7.0			7.0	
Flash Dont Walk (s)		11.0			11.0			11.0			11.0	
Pedestrian Calls (#/hr)		0			0			0			0	
Act Effct Green (s)		11.7			12.1		26.6	27.2		24.0	22.4	
Actuated g/C Ratio		0.26			0.27		0.59	0.60		0.53	0.49	
v/c Ratio		0.44			0.60		0.31	0.69		0.01	0.50	
Control Delay		13.2			22.9		8.5	18.1		6.5	15.9	
Queue Delay		0.0			0.0		0.0	0.0		0.0	0.0	
Total Delay		13.2			22.9		8.5	18.1		6.5	15.9	
LOS		B			C		A	B		A	B	
Approach Delay		13.2			22.9			16.5			15.9	
Approach LOS		B			C			B			B	
Queue Length 50th (ft)		29			49		18	134		0	101	
Queue Length 95th (ft)		63			97		49	#476		3	#242	
Internal Link Dist (ft)		721			639			1235			2678	
Turn Bay Length (ft)							850			700		
Base Capacity (vph)		641			501		499	1095		333	916	
Starvation Cap Reductn		0			0		0	0		0	0	
Spillback Cap Reductn		0			0		0	0		0	0	
Storage Cap Reductn		0			0		0	0		0	0	
Reduced v/c Ratio		0.31			0.42		0.31	0.69		0.01	0.50	

Intersection Summary

Area Type:	Other
Cycle Length:	60
Actuated Cycle Length:	45.4
Natural Cycle:	80
Control Type:	Actuated-Uncoordinated
Maximum v/c Ratio:	0.69
Intersection Signal Delay:	16.7
Intersection LOS:	B
Intersection Capacity Utilization:	74.4%
ICU Level of Service:	D
Analysis Period (min):	15
# 95th percentile volume exceeds capacity, queue may be longer. Queue shown is maximum after two cycles.	

Splits and Phases: 3: US 24 & Judge Orr

 Ø1 8.5 s	 Ø2 21.5 s	 Ø3 8.5 s	 Ø4 21.5 s
 Ø5 8.5 s	 Ø6 21.5 s	 Ø7 8.5 s	 Ø8 21.5 s

Lanes, Volumes, Timings
4: US 24 & Curtis/Stapleton

2023 Existing
PM

Lane Group	SEL	SET	SER	NWL	NWT	NWR	NEL	NET	NER	SWL	SWT	SWR
Lane Configurations												
Traffic Volume (vph)	17	42	49	12	136	26	119	459	33	12	364	29
Future Volume (vph)	17	42	49	12	136	26	119	459	33	12	364	29
Ideal Flow (vphpl)	1900	1900	1900	1900	1900	1900	1900	1900	1900	1900	1900	1900
Storage Length (ft)	190		325	215		215	890		1000	790		790
Storage Lanes	1		1	1		0	1		1	1		1
Taper Length (ft)	240			200			190			190		
Lane Util. Factor	1.00	1.00	1.00	1.00	1.00	1.00	1.00	1.00	1.00	1.00	1.00	1.00
Frt			0.850			0.850			0.850			0.850
Flt Protected	0.950			0.950			0.950			0.950		
Satd. Flow (prot)	1770	1863	1583	1770	1863	1583	1770	1863	1583	1770	1863	1583
Flt Permitted	0.658			0.724			0.356			0.379		
Satd. Flow (perm)	1226	1863	1583	1349	1863	1583	663	1863	1583	706	1863	1583
Right Turn on Red			Yes			Yes			Yes			Yes
Satd. Flow (RTOR)			191			191			191			191
Link Speed (mph)		45		45			55			55		
Link Distance (ft)		1349		1298			2758			1426		
Travel Time (s)		20.4		19.7			34.2			17.7		
Peak Hour Factor	0.83	0.83	0.83	0.87	0.87	0.87	0.93	0.93	0.93	0.92	0.92	0.92
Adj. Flow (vph)	20	51	59	14	156	30	128	494	35	13	396	32
Shared Lane Traffic (%)												
Lane Group Flow (vph)	20	51	59	14	156	30	128	494	35	13	396	32
Enter Blocked Intersection	No	No	No	No	No	No	No	No	No	No	No	No
Lane Alignment	Left	Left	Right	Left	Left	Right	Left	Left	Right	Left	Left	Right
Median Width(ft)		12		12			12			12		
Link Offset(ft)		0		0			0			0		
Crosswalk Width(ft)		16		16			16			16		
Two way Left Turn Lane												
Headway Factor	1.00	1.00	1.00	1.00	1.00	1.00	1.00	1.00	1.00	1.00	1.00	1.00
Turning Speed (mph)	15		9	15		9	15		9	15		9
Number of Detectors	1	2	1	1	2	1	1	2	1	1	2	1
Detector Template	Left	Thru	Right	Left	Thru	Right	Left	Thru	Right	Left	Thru	Right
Leading Detector (ft)	20	100	20	20	100	20	20	100	20	20	100	20
Trailing Detector (ft)	0	0	0	0	0	0	0	0	0	0	0	0
Detector 1 Position(ft)	0	0	0	0	0	0	0	0	0	0	0	0
Detector 1 Size(ft)	20	6	20	20	6	20	20	6	20	20	6	20
Detector 1 Type	Cl+Ex	Cl+Ex	Cl+Ex	Cl+Ex	Cl+Ex	Cl+Ex	Cl+Ex	Cl+Ex	Cl+Ex	Cl+Ex	Cl+Ex	Cl+Ex
Detector 1 Channel												
Detector 1 Extend (s)	0.0	0.0	0.0	0.0	0.0	0.0	0.0	0.0	0.0	0.0	0.0	0.0
Detector 1 Queue (s)	0.0	0.0	0.0	0.0	0.0	0.0	0.0	0.0	0.0	0.0	0.0	0.0
Detector 1 Delay (s)	0.0	0.0	0.0	0.0	0.0	0.0	0.0	0.0	0.0	0.0	0.0	0.0
Detector 2 Position(ft)		94		94			94			94		
Detector 2 Size(ft)		6		6			6			6		
Detector 2 Type		Cl+Ex		Cl+Ex			Cl+Ex			Cl+Ex		
Detector 2 Channel												
Detector 2 Extend (s)		0.0		0.0			0.0			0.0		
Turn Type	pm+pt	NA	Perm	pm+pt	NA	Perm	pm+pt	NA	Perm	pm+pt	NA	Perm
Protected Phases	1	6		5	2		7	4		3	8	
Permitted Phases	6		6	2		2	4		4	8		8

Lanes, Volumes, Timings
4: US 24 & Curtis/Stapleton

2023 Existing
PM











Lane Group	SEL	SET	SER	NWL	NWT	NWR	NEL	NET	NER	SWL	SWT	SWR
Detector Phase	1	6	6	5	2	2	7	4	4	3	8	8
Switch Phase												
Minimum Initial (s)	5.0	5.0	5.0	5.0	5.0	5.0	5.0	5.0	5.0	5.0	5.0	5.0
Minimum Split (s)	9.5	22.5	22.5	9.5	22.5	22.5	9.5	22.5	22.5	9.5	22.5	22.5
Total Split (s)	8.5	21.5	21.5	8.5	21.5	21.5	8.5	21.5	21.5	8.5	21.5	21.5
Total Split (%)	14.2%	35.8%	35.8%	14.2%	35.8%	35.8%	14.2%	35.8%	35.8%	14.2%	35.8%	35.8%
Maximum Green (s)	4.0	17.0	17.0	4.0	17.0	17.0	4.0	17.0	17.0	4.0	17.0	17.0
Yellow Time (s)	3.5	3.5	3.5	3.5	3.5	3.5	3.5	3.5	3.5	3.5	3.5	3.5
All-Red Time (s)	1.0	1.0	1.0	1.0	1.0	1.0	1.0	1.0	1.0	1.0	1.0	1.0
Lost Time Adjust (s)	0.0	0.0	0.0	0.0	0.0	0.0	0.0	0.0	0.0	0.0	0.0	0.0
Total Lost Time (s)	4.5	4.5	4.5	4.5	4.5	4.5	4.5	4.5	4.5	4.5	4.5	4.5
Lead/Lag	Lead	Lag	Lag	Lead	Lag	Lag	Lead	Lag	Lag	Lead	Lag	Lag
Lead-Lag Optimize?	Yes	Yes	Yes	Yes	Yes	Yes	Yes	Yes	Yes	Yes	Yes	Yes
Vehicle Extension (s)	3.0	3.0	3.0	3.0	3.0	3.0	3.0	3.0	3.0	3.0	3.0	3.0
Recall Mode	None	Min	Min	None	Min	Min	None	None	None	None	None	None
Walk Time (s)		7.0	7.0		7.0	7.0		7.0	7.0		7.0	7.0
Flash Dont Walk (s)		11.0	11.0		11.0	11.0		11.0	11.0		11.0	11.0
Pedestrian Calls (#/hr)		0	0		0	0		0	0		0	0
Act Effct Green (s)	9.7	9.1	9.1	9.7	9.1	9.1	20.6	20.0	20.0	17.9	14.8	14.8
Actuated g/C Ratio	0.24	0.22	0.22	0.24	0.22	0.22	0.50	0.49	0.49	0.44	0.36	0.36
v/c Ratio	0.06	0.12	0.12	0.04	0.38	0.06	0.29	0.54	0.04	0.03	0.59	0.05
Control Delay	12.5	15.8	0.5	12.2	18.6	0.2	8.6	14.6	0.1	6.9	17.8	0.1
Queue Delay	0.0	0.0	0.0	0.0	0.0	0.0	0.0	0.0	0.0	0.0	0.0	0.0
Total Delay	12.5	15.8	0.5	12.2	18.6	0.2	8.6	14.6	0.1	6.9	17.8	0.1
LOS	B	B	A	B	B	A	A	B	A	A	B	A
Approach Delay		8.3			15.4			12.7			16.2	
Approach LOS		A			B			B			B	
Queue Length 50th (ft)	4	9	0	3	30	0	11	55	0	1	71	0
Queue Length 95th (ft)	14	33	0	11	84	0	50	#311	0	10	#227	0
Internal Link Dist (ft)		1269			1218			2678			1346	
Turn Bay Length (ft)	190		325	215		215	890		1000	790		790
Base Capacity (vph)	344	813	799	360	813	799	446	969	915	416	813	799
Starvation Cap Reductn	0	0	0	0	0	0	0	0	0	0	0	0
Spillback Cap Reductn	0	0	0	0	0	0	0	0	0	0	0	0
Storage Cap Reductn	0	0	0	0	0	0	0	0	0	0	0	0
Reduced v/c Ratio	0.06	0.06	0.07	0.04	0.19	0.04	0.29	0.51	0.04	0.03	0.49	0.04

Intersection Summary

Area Type:	Other
Cycle Length:	60
Actuated Cycle Length:	41.1
Natural Cycle:	65
Control Type:	Actuated-Uncoordinated
Maximum v/c Ratio:	0.59
Intersection Signal Delay:	13.7
Intersection LOS:	B
Intersection Capacity Utilization:	53.7%
ICU Level of Service:	A
Analysis Period (min):	15
# 95th percentile volume exceeds capacity, queue may be longer. Queue shown is maximum after two cycles.	

Splits and Phases: 4: US 24 & Curtis/Stapleton

 Ø1	 Ø2	 Ø3	 Ø4
8.5 s	21.5 s	8.5 s	21.5 s
 Ø5	 Ø6	 Ø7	 Ø8
8.5 s	21.5 s	8.5 s	21.5 s

Intersection												
Int Delay, s/veh	27.9											
Movement	SEL	SET	SER	NWL	NWT	NWR	NEL	NET	NER	SWL	SWT	SWR
Lane Configurations	↖	↗	↖	↖	↗	↖	↖	↗	↖	↖	↗	↖
Traffic Vol, veh/h	17	42	49	12	136	26	119	459	33	12	364	29
Future Vol, veh/h	17	42	49	12	136	26	119	459	33	12	364	29
Conflicting Peds, #/hr	0	0	0	0	0	0	0	0	0	0	0	0
Sign Control	Stop	Stop	Stop	Stop	Stop	Stop	Free	Free	Free	Free	Free	Free
RT Channelized	-	-	None	-	-	None	-	-	None	-	-	None
Storage Length	190	-	325	215	-	-	890	-	1000	790	-	790
Veh in Median Storage, #	-	0	-	-	0	-	-	0	-	-	0	-
Grade, %	-	0	-	-	0	-	-	0	-	-	0	-
Peak Hour Factor	83	83	83	87	87	87	93	93	93	92	92	92
Heavy Vehicles, %	2	2	2	2	2	2	2	2	2	2	2	2
Mvmt Flow	20	51	59	14	156	30	128	494	35	13	396	32

Major/Minor	Minor2		Minor1		Major1			Major2				
Conflicting Flow All	1283	1207	396	1243	1204	494	428	0	0	529	0	0
Stage 1	422	422	-	750	750	-	-	-	-	-	-	-
Stage 2	861	785	-	493	454	-	-	-	-	-	-	-
Critical Hdwy	7.12	6.52	6.22	7.12	6.52	6.22	4.12	-	-	4.12	-	-
Critical Hdwy Stg 1	6.12	5.52	-	6.12	5.52	-	-	-	-	-	-	-
Critical Hdwy Stg 2	6.12	5.52	-	6.12	5.52	-	-	-	-	-	-	-
Follow-up Hdwy	3.518	4.018	3.318	3.518	4.018	3.318	2.218	-	-	2.218	-	-
Pot Cap-1 Maneuver	142	183	653	151	184	575	1131	-	-	1038	-	-
Stage 1	609	588	-	403	419	-	-	-	-	-	-	-
Stage 2	350	404	-	558	569	-	-	-	-	-	-	-
Platoon blocked, %								-	-	-	-	-
Mov Cap-1 Maneuver	~ 14	160	653	94	161	575	1131	-	-	1038	-	-
Mov Cap-2 Maneuver	~ 14	160	-	94	161	-	-	-	-	-	-	-
Stage 1	540	580	-	357	372	-	-	-	-	-	-	-
Stage 2	171	358	-	457	562	-	-	-	-	-	-	-

Approach	SE		NW		NE		SW	
HCM Control Delay, s	144.1		98.9		1.7		0.3	
HCM LOS	F		F					

Minor Lane/Major Mvmt	NEL	NET	NERN	NWLn1	NWLn2	NWLn3	SELn1	SELn2	SELn3	SWL	SWT	SWR
Capacity (veh/h)	1131	-	-	94	161	575	14	160	653	1038	-	-
HCM Lane V/C Ratio	0.113	-	-	0.147	0.971	0.052	1.463	0.316	0.09	0.013	-	-
HCM Control Delay (s)	8.6	-	-	49.8	119.9	11.6	790.7	37.6	11.1	8.5	-	-
HCM Lane LOS	A	-	-	E	F	B	F	E	B	A	-	-
HCM 95th %tile Q(veh)	0.4	-	-	0.5	7.4	0.2	3.2	1.3	0.3	0	-	-

Notes
 ~: Volume exceeds capacity \$: Delay exceeds 300s +: Computation Not Defined *: All major volume in platoon

Intersection												
Int Delay, s/veh	6											
Movement	EBL	EBT	EBR	WBL	WBT	WBR	NBL	NBT	NBR	SBL	SBT	SBR
Lane Configurations	↶	↷		↶	↷		↶	↷		↶	↷	
Traffic Vol, veh/h	2	121	24	2	77	13	54	117	6	18	46	2
Future Vol, veh/h	2	121	24	2	77	13	54	117	6	18	46	2
Conflicting Peds, #/hr	0	0	0	0	0	0	0	0	0	0	0	0
Sign Control	Free	Free	Free	Free	Free	Free	Stop	Stop	Stop	Stop	Stop	Stop
RT Channelized	-	-	None	-	-	None	-	-	None	-	-	None
Storage Length	0	-	-	0	-	-	0	-	-	0	-	-
Veh in Median Storage, #	-	0	-	-	0	-	-	0	-	-	0	-
Grade, %	-	0	-	-	0	-	-	0	-	-	0	-
Peak Hour Factor	83	83	83	83	83	83	87	87	87	83	83	83
Heavy Vehicles, %	2	2	2	2	2	2	2	2	2	2	2	2
Mvmt Flow	2	146	29	2	93	16	62	134	7	22	55	2

Major/Minor	Major1			Major2			Minor1			Minor2		
Conflicting Flow All	109	0	0	175	0	0	299	278	161	340	284	101
Stage 1	-	-	-	-	-	-	165	165	-	105	105	-
Stage 2	-	-	-	-	-	-	134	113	-	235	179	-
Critical Hdwy	4.12	-	-	4.12	-	-	7.12	6.52	6.22	7.12	6.52	6.22
Critical Hdwy Stg 1	-	-	-	-	-	-	6.12	5.52	-	6.12	5.52	-
Critical Hdwy Stg 2	-	-	-	-	-	-	6.12	5.52	-	6.12	5.52	-
Follow-up Hdwy	2.218	-	-	2.218	-	-	3.518	4.018	3.318	3.518	4.018	3.318
Pot Cap-1 Maneuver	1481	-	-	1401	-	-	653	630	884	614	625	954
Stage 1	-	-	-	-	-	-	837	762	-	901	808	-
Stage 2	-	-	-	-	-	-	869	802	-	768	751	-
Platoon blocked, %	-	-	-	-	-	-	-	-	-	-	-	-
Mov Cap-1 Maneuver	1481	-	-	1401	-	-	606	629	884	508	624	954
Mov Cap-2 Maneuver	-	-	-	-	-	-	606	629	-	508	624	-
Stage 1	-	-	-	-	-	-	836	761	-	900	807	-
Stage 2	-	-	-	-	-	-	806	801	-	627	750	-

Approach	EB			WB			NB			SB		
HCM Control Delay, s	0.1			0.2			12			11.6		
HCM LOS							B			B		

Minor Lane/Major Mvmt	NBLn1	NBLn2	EBL	EBT	EBR	WBL	WBT	WBR	SBLn1	SBLn2
Capacity (veh/h)	606	638	1481	-	-	1401	-	-	508	633
HCM Lane V/C Ratio	0.102	0.222	0.002	-	-	0.002	-	-	0.043	0.091
HCM Control Delay (s)	11.6	12.2	7.4	-	-	7.6	-	-	12.4	11.3
HCM Lane LOS	B	B	A	-	-	A	-	-	B	B
HCM 95th %tile Q(veh)	0.3	0.8	0	-	-	0	-	-	0.1	0.3

Intersection												
Int Delay, s/veh	10.2											
Movement	EBL	EBT	EBR	WBL	WBT	WBR	NBL	NBT	NBR	SBL	SBT	SBR
Lane Configurations	↖	↑	↗	↖	↑	↗	↖	↑	↗	↖	↑	↗
Traffic Vol, veh/h	11	203	63	8	92	11	228	190	28	21	49	14
Future Vol, veh/h	11	203	63	8	92	11	228	190	28	21	49	14
Conflicting Peds, #/hr	0	0	0	0	0	0	0	0	0	0	0	0
Sign Control	Free	Free	Free	Free	Free	Free	Stop	Stop	Stop	Stop	Stop	Stop
RT Channelized	-	-	None	-	-	None	-	-	None	-	-	None
Storage Length	0	-	0	0	-	-	0	-	-	0	-	-
Veh in Median Storage, #	-	0	-	-	0	-	-	0	-	-	0	-
Grade, %	-	0	-	-	0	-	-	0	-	-	0	-
Peak Hour Factor	92	92	92	83	83	83	92	92	92	83	83	83
Heavy Vehicles, %	2	2	2	2	2	2	2	2	2	2	2	2
Mvmt Flow	12	221	68	10	111	13	248	207	30	25	59	17

Major/Minor	Major1			Major2			Minor1			Minor2		
Conflicting Flow All	124	0	0	289	0	0	421	389	221	536	451	118
Stage 1	-	-	-	-	-	-	245	245	-	138	138	-
Stage 2	-	-	-	-	-	-	176	144	-	398	313	-
Critical Hdwy	4.12	-	-	4.12	-	-	7.12	6.52	6.22	7.12	6.52	6.22
Critical Hdwy Stg 1	-	-	-	-	-	-	6.12	5.52	-	6.12	5.52	-
Critical Hdwy Stg 2	-	-	-	-	-	-	6.12	5.52	-	6.12	5.52	-
Follow-up Hdwy	2.218	-	-	2.218	-	-	3.518	4.018	3.318	3.518	4.018	3.318
Pot Cap-1 Maneuver	1463	-	-	1273	-	-	543	546	819	455	504	934
Stage 1	-	-	-	-	-	-	759	703	-	865	782	-
Stage 2	-	-	-	-	-	-	826	778	-	628	657	-
Platoon blocked, %	-	-	-	-	-	-	-	-	-	-	-	-
Mov Cap-1 Maneuver	1463	-	-	1273	-	-	479	537	819	303	496	934
Mov Cap-2 Maneuver	-	-	-	-	-	-	479	537	-	303	496	-
Stage 1	-	-	-	-	-	-	753	697	-	858	776	-
Stage 2	-	-	-	-	-	-	743	772	-	422	652	-

Approach	EB			WB			NB			SB		
HCM Control Delay, s	0.3			0.6			18.2			13.9		
HCM LOS							C			B		

Minor Lane/Major Mvmt	NBLn1	NBLn2	EBL	EBT	EBR	WBL	WBT	WBR	SBLn1	SBLn2
Capacity (veh/h)	479	562	1463	-	-	1273	-	-	303	554
HCM Lane V/C Ratio	0.517	0.422	0.008	-	-	0.008	-	-	0.084	0.137
HCM Control Delay (s)	20.3	16	7.5	-	-	7.8	-	-	18	12.5
HCM Lane LOS	C	C	A	-	-	A	-	-	C	B
HCM 95th %tile Q(veh)	2.9	2.1	0	-	-	0	-	-	0.3	0.5

Intersection												
Int Delay, s/veh	7.7											
Movement	EBL	EBT	EBR	WBL	WBT	WBR	NBL	NBT	NBR	SBL	SBT	SBR
Lane Configurations		↕			↕			↕			↕	
Traffic Vol, veh/h	3	64	1	3	54	270	2	86	19	135	84	2
Future Vol, veh/h	3	64	1	3	54	270	2	86	19	135	84	2
Conflicting Peds, #/hr	0	0	0	0	0	0	0	0	0	0	0	0
Sign Control	Free	Free	Free	Free	Free	Free	Stop	Stop	Stop	Stop	Stop	Stop
RT Channelized	-	-	None	-	-	None	-	-	None	-	-	None
Storage Length	-	-	-	-	-	-	-	-	-	-	-	-
Veh in Median Storage, #	-	0	-	-	0	-	-	0	-	-	0	-
Grade, %	-	0	-	-	0	-	-	0	-	-	0	-
Peak Hour Factor	83	83	83	92	92	92	83	83	83	87	87	87
Heavy Vehicles, %	2	2	2	2	2	2	2	2	2	2	2	2
Mvmt Flow	4	77	1	3	59	293	2	104	23	155	97	2

























Major/Minor	Major1			Major2			Minor1			Minor2		
Conflicting Flow All	352	0	0	78	0	0	347	444	78	361	298	206
Stage 1	-	-	-	-	-	-	86	86	-	212	212	-
Stage 2	-	-	-	-	-	-	261	358	-	149	86	-
Critical Hdwy	4.12	-	-	4.12	-	-	7.12	6.52	6.22	7.12	6.52	6.22
Critical Hdwy Stg 1	-	-	-	-	-	-	6.12	5.52	-	6.12	5.52	-
Critical Hdwy Stg 2	-	-	-	-	-	-	6.12	5.52	-	6.12	5.52	-
Follow-up Hdwy	2.218	-	-	2.218	-	-	3.518	4.018	3.318	3.518	4.018	3.318
Pot Cap-1 Maneuver	1207	-	-	1520	-	-	607	508	983	595	614	835
Stage 1	-	-	-	-	-	-	922	824	-	790	727	-
Stage 2	-	-	-	-	-	-	744	628	-	854	824	-
Platoon blocked, %		-	-		-	-						
Mov Cap-1 Maneuver	1207	-	-	1520	-	-	529	505	983	487	610	835
Mov Cap-2 Maneuver	-	-	-	-	-	-	529	505	-	487	610	-
Stage 1	-	-	-	-	-	-	919	822	-	788	725	-
Stage 2	-	-	-	-	-	-	641	626	-	727	822	-

Approach	EB			WB			NB			SB		
HCM Control Delay, s	0.4			0.1			13.5			17.9		
HCM LOS							B			C		

Minor Lane/Major Mvmt	NBLn1	EBL	EBT	EBR	WBL	WBT	WBR	SBLn1
Capacity (veh/h)	553	1207	-	-	1520	-	-	530
HCM Lane V/C Ratio	0.233	0.003	-	-	0.002	-	-	0.479
HCM Control Delay (s)	13.5	8	0	-	7.4	0	-	17.9
HCM Lane LOS	B	A	A	-	A	A	-	C
HCM 95th %tile Q(veh)	0.9	0	-	-	0	-	-	2.6

Lanes, Volumes, Timings
4: US 24 & Curtis/Stapleton

2025 Baseline
AM

												
Lane Group	SEL	SET	SER	NWL	NWT	NWR	NEL	NET	NER	SWL	SWT	SWR
Lane Configurations												
Traffic Volume (vph)	24	150	152	8	109	20	52	283	3	37	464	37
Future Volume (vph)	24	150	152	8	109	20	52	283	3	37	464	37
Ideal Flow (vphpl)	1900	1900	1900	1900	1900	1900	1900	1900	1900	1900	1900	1900
Storage Length (ft)	190		325	215		215	890		1000	790		790
Storage Lanes	1		1	1		0	1		1	1		1
Taper Length (ft)	240			200			190			190		
Lane Util. Factor	1.00	1.00	1.00	1.00	1.00	1.00	1.00	1.00	1.00	1.00	1.00	1.00
Frt			0.850			0.850			0.850			0.850
Flt Protected	0.950			0.950			0.950			0.950		
Satd. Flow (prot)	1770	1863	1583	1770	1863	1583	1770	1863	1583	1770	1863	1583
Flt Permitted	0.673			0.654			0.284			0.521		
Satd. Flow (perm)	1254	1863	1583	1218	1863	1583	529	1863	1583	970	1863	1583
Right Turn on Red			Yes			Yes			Yes			Yes
Satd. Flow (RTOR)			191			191			191			191
Link Speed (mph)		45			45			55			55	
Link Distance (ft)		1349			1298			2758			1426	
Travel Time (s)		20.4			19.7			34.2			17.7	
Peak Hour Factor	0.92	0.92	0.92	0.83	0.83	0.83	0.92	0.92	0.92	0.92	0.92	0.92
Adj. Flow (vph)	26	163	165	10	131	24	57	308	3	40	504	40
Shared Lane Traffic (%)												
Lane Group Flow (vph)	26	163	165	10	131	24	57	308	3	40	504	40
Enter Blocked Intersection	No	No	No	No	No	No	No	No	No	No	No	No
Lane Alignment	Left	Left	Right	Left	Left	Right	Left	Left	Right	Left	Left	Right
Median Width(ft)		12			12			12			12	
Link Offset(ft)		0			0			0			0	
Crosswalk Width(ft)		16			16			16			16	
Two way Left Turn Lane												
Headway Factor	1.00	1.00	1.00	1.00	1.00	1.00	1.00	1.00	1.00	1.00	1.00	1.00
Turning Speed (mph)	15		9	15		9	15		9	15		9
Number of Detectors	1	2	1	1	2	1	1	2	1	1	2	1
Detector Template	Left	Thru	Right	Left	Thru	Right	Left	Thru	Right	Left	Thru	Right
Leading Detector (ft)	20	100	20	20	100	20	20	100	20	20	100	20
Trailing Detector (ft)	0	0	0	0	0	0	0	0	0	0	0	0
Detector 1 Position(ft)	0	0	0	0	0	0	0	0	0	0	0	0
Detector 1 Size(ft)	20	6	20	20	6	20	20	6	20	20	6	20
Detector 1 Type	Cl+Ex	Cl+Ex	Cl+Ex	Cl+Ex	Cl+Ex	Cl+Ex	Cl+Ex	Cl+Ex	Cl+Ex	Cl+Ex	Cl+Ex	Cl+Ex
Detector 1 Channel												
Detector 1 Extend (s)	0.0	0.0	0.0	0.0	0.0	0.0	0.0	0.0	0.0	0.0	0.0	0.0
Detector 1 Queue (s)	0.0	0.0	0.0	0.0	0.0	0.0	0.0	0.0	0.0	0.0	0.0	0.0
Detector 1 Delay (s)	0.0	0.0	0.0	0.0	0.0	0.0	0.0	0.0	0.0	0.0	0.0	0.0
Detector 2 Position(ft)		94			94			94			94	
Detector 2 Size(ft)		6			6			6			6	
Detector 2 Type		Cl+Ex			Cl+Ex			Cl+Ex			Cl+Ex	
Detector 2 Channel												
Detector 2 Extend (s)		0.0			0.0			0.0			0.0	
Turn Type	pm+pt	NA	Perm	pm+pt	NA	Perm	pm+pt	NA	Perm	pm+pt	NA	Perm
Protected Phases	1	6		5	2		7	4		3	8	
Permitted Phases	6		6	2		2	4		4	8		8

Lanes, Volumes, Timings
4: US 24 & Curtis/Stapleton

2025 Baseline
AM











Lane Group	SEL	SET	SER	NWL	NWT	NWR	NEL	NET	NER	SWL	SWT	SWR
Detector Phase	1	6	6	5	2	2	7	4	4	3	8	8
Switch Phase												
Minimum Initial (s)	5.0	5.0	5.0	5.0	5.0	5.0	5.0	5.0	5.0	5.0	5.0	5.0
Minimum Split (s)	9.5	22.5	22.5	9.5	22.5	22.5	9.5	22.5	22.5	9.5	22.5	22.5
Total Split (s)	8.5	21.5	21.5	8.5	21.5	21.5	8.5	21.5	21.5	8.5	21.5	21.5
Total Split (%)	14.2%	35.8%	35.8%	14.2%	35.8%	35.8%	14.2%	35.8%	35.8%	14.2%	35.8%	35.8%
Maximum Green (s)	4.0	17.0	17.0	4.0	17.0	17.0	4.0	17.0	17.0	4.0	17.0	17.0
Yellow Time (s)	3.5	3.5	3.5	3.5	3.5	3.5	3.5	3.5	3.5	3.5	3.5	3.5
All-Red Time (s)	1.0	1.0	1.0	1.0	1.0	1.0	1.0	1.0	1.0	1.0	1.0	1.0
Lost Time Adjust (s)	0.0	0.0	0.0	0.0	0.0	0.0	0.0	0.0	0.0	0.0	0.0	0.0
Total Lost Time (s)	4.5	4.5	4.5	4.5	4.5	4.5	4.5	4.5	4.5	4.5	4.5	4.5
Lead/Lag	Lead	Lag	Lag	Lead	Lag	Lag	Lead	Lag	Lag	Lead	Lag	Lag
Lead-Lag Optimize?	Yes	Yes	Yes	Yes	Yes	Yes	Yes	Yes	Yes	Yes	Yes	Yes
Vehicle Extension (s)	3.0	3.0	3.0	3.0	3.0	3.0	3.0	3.0	3.0	3.0	3.0	3.0
Recall Mode	None	Min	Min	None	Min	Min	None	None	None	None	None	None
Walk Time (s)		7.0	7.0		7.0	7.0		7.0	7.0		7.0	7.0
Flash Dont Walk (s)		11.0	11.0		11.0	11.0		11.0	11.0		11.0	11.0
Pedestrian Calls (#/hr)		0	0		0	0		0	0		0	0
Act Effct Green (s)	9.9	9.3	9.3	9.9	9.3	9.3	18.2	16.9	16.9	18.2	16.9	16.9
Actuated g/C Ratio	0.25	0.23	0.23	0.25	0.23	0.23	0.46	0.43	0.43	0.46	0.43	0.43
v/c Ratio	0.07	0.37	0.32	0.03	0.30	0.05	0.15	0.39	0.00	0.08	0.63	0.05
Control Delay	12.0	17.3	4.5	11.6	16.5	0.1	7.8	12.7	0.0	7.3	18.5	0.1
Queue Delay	0.0	0.0	0.0	0.0	0.0	0.0	0.0	0.0	0.0	0.0	0.0	0.0
Total Delay	12.0	17.3	4.5	11.6	16.5	0.1	7.8	12.7	0.0	7.3	18.5	0.1
LOS	B	B	A	B	B	A	A	B	A	A	B	A
Approach Delay		10.9			13.8			11.8			16.5	
Approach LOS		B			B			B			B	
Queue Length 50th (ft)	4	25	0	1	20	0	5	31	0	3	58	0
Queue Length 95th (ft)	17	91	30	9	68	0	28	157	0	21	#331	0
Internal Link Dist (ft)		1269			1218			2678			1346	
Turn Bay Length (ft)	190		325	215		215	890		1000	790		790
Base Capacity (vph)	368	848	825	362	848	825	375	848	825	530	848	825
Starvation Cap Reductn	0	0	0	0	0	0	0	0	0	0	0	0
Spillback Cap Reductn	0	0	0	0	0	0	0	0	0	0	0	0
Storage Cap Reductn	0	0	0	0	0	0	0	0	0	0	0	0
Reduced v/c Ratio	0.07	0.19	0.20	0.03	0.15	0.03	0.15	0.36	0.00	0.08	0.59	0.05

Intersection Summary

Area Type:	Other
Cycle Length:	60
Actuated Cycle Length:	39.7
Natural Cycle:	65
Control Type:	Actuated-Uncoordinated
Maximum v/c Ratio:	0.63
Intersection Signal Delay:	13.7
Intersection LOS:	B
Intersection Capacity Utilization:	49.2%
ICU Level of Service:	A
Analysis Period (min):	15
# 95th percentile volume exceeds capacity, queue may be longer. Queue shown is maximum after two cycles.	

Splits and Phases: 4: US 24 & Curtis/Stapleton

 Ø1	 Ø2	 Ø3	 Ø4
8.5 s	21.5 s	8.5 s	21.5 s
 Ø5	 Ø6	 Ø7	 Ø8
8.5 s	21.5 s	8.5 s	21.5 s

Intersection												
Int Delay, s/veh	9.2											
Movement	EBL	EBT	EBR	WBL	WBT	WBR	NBL	NBT	NBR	SBL	SBT	SBR
Lane Configurations	↖	↗		↖	↗		↖	↗		↖	↗	
Traffic Vol, veh/h	5	46	81	26	168	20	58	86	5	10	204	5
Future Vol, veh/h	5	46	81	26	168	20	58	86	5	10	204	5
Conflicting Peds, #/hr	0	0	0	0	0	0	0	0	0	0	0	0
Sign Control	Free	Free	Free	Free	Free	Free	Stop	Stop	Stop	Stop	Stop	Stop
RT Channelized	-	-	None	-	-	None	-	-	None	-	-	None
Storage Length	0	-	-	0	-	-	0	-	-	0	-	-
Veh in Median Storage, #	-	0	-	-	0	-	-	0	-	-	0	-
Grade, %	-	0	-	-	0	-	-	0	-	-	0	-
Peak Hour Factor	83	83	83	87	87	87	83	83	83	87	87	87
Heavy Vehicles, %	2	2	2	2	2	2	2	2	2	2	2	2
Mvmt Flow	6	55	98	30	193	23	70	104	6	11	234	6

Major/Minor	Major1			Major2			Minor1			Minor2		
Conflicting Flow All	216	0	0	153	0	0	501	392	104	436	430	205
Stage 1	-	-	-	-	-	-	116	116	-	265	265	-
Stage 2	-	-	-	-	-	-	385	276	-	171	165	-
Critical Hdwy	4.12	-	-	4.12	-	-	7.12	6.52	6.22	7.12	6.52	6.22
Critical Hdwy Stg 1	-	-	-	-	-	-	6.12	5.52	-	6.12	5.52	-
Critical Hdwy Stg 2	-	-	-	-	-	-	6.12	5.52	-	6.12	5.52	-
Follow-up Hdwy	2.218	-	-	2.218	-	-	3.518	4.018	3.318	3.518	4.018	3.318
Pot Cap-1 Maneuver	1354	-	-	1428	-	-	480	544	951	531	518	836
Stage 1	-	-	-	-	-	-	889	800	-	740	689	-
Stage 2	-	-	-	-	-	-	638	682	-	831	762	-
Platoon blocked, %	-	-	-	-	-	-	-	-	-	-	-	-
Mov Cap-1 Maneuver	1354	-	-	1428	-	-	298	530	951	440	505	836
Mov Cap-2 Maneuver	-	-	-	-	-	-	298	530	-	440	505	-
Stage 1	-	-	-	-	-	-	885	797	-	737	675	-
Stage 2	-	-	-	-	-	-	405	668	-	715	759	-

Approach	EB			WB			NB			SB		
HCM Control Delay, s	0.3			0.9			16.2			18		
HCM LOS							C			C		

Minor Lane/Major Mvmt	NBLn1	NBLn2	EBL	EBT	EBR	WBL	WBT	WBR	SBLn1	SBLn2
Capacity (veh/h)	298	543	1354	-	-	1428	-	-	440	510
HCM Lane V/C Ratio	0.234	0.202	0.004	-	-	0.021	-	-	0.026	0.471
HCM Control Delay (s)	20.7	13.3	7.7	-	-	7.6	-	-	13.4	18.2
HCM Lane LOS	C	B	A	-	-	A	-	-	B	C
HCM 95th %tile Q(veh)	0.9	0.7	0	-	-	0.1	-	-	0.1	2.5

Intersection												
Int Delay, s/veh	13.4											
Movement	EBL	EBT	EBR	WBL	WBT	WBR	NBL	NBT	NBR	SBL	SBT	SBR
Lane Configurations	↙	↑	↗	↙	↑		↙	↗		↙	↗	
Traffic Vol, veh/h	21	57	267	14	213	46	66	80	1	7	225	46
Future Vol, veh/h	21	57	267	14	213	46	66	80	1	7	225	46
Conflicting Peds, #/hr	0	0	0	0	0	0	0	0	0	0	0	0
Sign Control	Free	Free	Free	Free	Free	Free	Stop	Stop	Stop	Stop	Stop	Stop
RT Channelized	-	-	None	-	-	None	-	-	None	-	-	None
Storage Length	0	-	0	0	-	-	0	-	-	0	-	-
Veh in Median Storage, #	-	0	-	-	0	-	-	0	-	-	0	-
Grade, %	-	0	-	-	0	-	-	0	-	-	0	-
Peak Hour Factor	92	92	92	92	92	92	83	83	83	92	92	92
Heavy Vehicles, %	2	2	2	2	2	2	2	2	2	2	2	2
Mvmt Flow	23	62	290	15	232	50	80	96	1	8	245	50

Major/Minor	Major1			Major2			Minor1			Minor2		
Conflicting Flow All	282	0	0	352	0	0	543	420	62	589	685	257
Stage 1	-	-	-	-	-	-	108	108	-	287	287	-
Stage 2	-	-	-	-	-	-	435	312	-	302	398	-
Critical Hdwy	4.12	-	-	4.12	-	-	7.12	6.52	6.22	7.12	6.52	6.22
Critical Hdwy Stg 1	-	-	-	-	-	-	6.12	5.52	-	6.12	5.52	-
Critical Hdwy Stg 2	-	-	-	-	-	-	6.12	5.52	-	6.12	5.52	-
Follow-up Hdwy	2.218	-	-	2.218	-	-	3.518	4.018	3.318	3.518	4.018	3.318
Pot Cap-1 Maneuver	1280	-	-	1207	-	-	451	525	1003	420	371	782
Stage 1	-	-	-	-	-	-	897	806	-	720	674	-
Stage 2	-	-	-	-	-	-	600	658	-	707	603	-
Platoon blocked, %	-	-	-	-	-	-	-	-	-	-	-	-
Mov Cap-1 Maneuver	1280	-	-	1207	-	-	187	509	1003	350	360	782
Mov Cap-2 Maneuver	-	-	-	-	-	-	187	509	-	350	360	-
Stage 1	-	-	-	-	-	-	881	791	-	707	666	-
Stage 2	-	-	-	-	-	-	351	650	-	609	592	-

Approach	EB			WB			NB			SB		
HCM Control Delay, s	0.5			0.4			24.5			35.7		
HCM LOS							C			E		

Minor Lane/Major Mvmt	NBLn1	NBLn2	EBL	EBT	EBR	WBL	WBT	WBR	SBLn1	SBLn2
Capacity (veh/h)	187	512	1280	-	-	1207	-	-	350	396
HCM Lane V/C Ratio	0.425	0.191	0.018	-	-	0.013	-	-	0.022	0.744
HCM Control Delay (s)	37.8	13.7	7.9	-	-	8	-	-	15.5	36.2
HCM Lane LOS	E	B	A	-	-	A	-	-	C	E
HCM 95th %tile Q(veh)	1.9	0.7	0.1	-	-	0	-	-	0.1	5.9

Intersection												
Int Delay, s/veh	14.8											
Movement	SEL	SET	SER	NWL	NWT	NWR	NEL	NET	NER	SWL	SWT	SWR
Lane Configurations	↘	↗	↗	↘	↗	↗	↘	↗	↗	↘	↗	↗
Traffic Vol, veh/h	24	150	152	8	109	20	52	283	3	37	464	37
Future Vol, veh/h	24	150	152	8	109	20	52	283	3	37	464	37
Conflicting Peds, #/hr	0	0	0	0	0	0	0	0	0	0	0	0
Sign Control	Stop	Stop	Stop	Stop	Stop	Stop	Free	Free	Free	Free	Free	Free
RT Channelized	-	-	None	-	-	None	-	-	None	-	-	None
Storage Length	-	-	325	215	-	215	890	-	1000	790	-	790
Veh in Median Storage, #	-	0	-	-	0	-	-	0	-	-	0	-
Grade, %	-	0	-	-	0	-	-	0	-	-	0	-
Peak Hour Factor	92	92	92	83	83	83	92	92	92	92	92	92
Heavy Vehicles, %	2	2	2	2	2	2	2	2	2	2	2	2
Mvmt Flow	26	163	165	10	131	24	57	308	3	40	504	40

Major/Minor	Minor2		Minor1			Major1			Major2			
Conflicting Flow All	1085	1009	504	1190	1046	308	544	0	0	311	0	0
Stage 1	584	584	-	422	422	-	-	-	-	-	-	-
Stage 2	501	425	-	768	624	-	-	-	-	-	-	-
Critical Hdwy	7.12	6.52	6.22	7.12	6.52	6.22	4.12	-	-	4.12	-	-
Critical Hdwy Stg 1	6.12	5.52	-	6.12	5.52	-	-	-	-	-	-	-
Critical Hdwy Stg 2	6.12	5.52	-	6.12	5.52	-	-	-	-	-	-	-
Follow-up Hdwy	3.518	4.018	3.318	3.518	4.018	3.318	2.218	-	-	2.218	-	-
Pot Cap-1 Maneuver	194	240	568	165	228	732	1025	-	-	1249	-	-
Stage 1	498	498	-	609	588	-	-	-	-	-	-	-
Stage 2	552	586	-	394	478	-	-	-	-	-	-	-
Platoon blocked, %	-	-	-	-	-	-	-	-	-	-	-	-
Mov Cap-1 Maneuver	87	219	568	43	208	732	1025	-	-	1249	-	-
Mov Cap-2 Maneuver	87	219	-	43	208	-	-	-	-	-	-	-
Stage 1	470	482	-	575	555	-	-	-	-	-	-	-
Stage 2	385	553	-	179	463	-	-	-	-	-	-	-

Approach	SE		NW			NE			SW		
HCM Control Delay, s	37.7		46.2			1.3			0.5		
HCM LOS	E		E								

Minor Lane/Major Mvmt	NEL	NET	NERN	NWLn1	NWLn2	NWLn3	SELn1	SELn2	SELn3	SWL	SWT	SWR
Capacity (veh/h)	1025	-	-	43	208	732	87	219	568	1249	-	-
HCM Lane V/C Ratio	0.055	-	-	0.224	0.631	0.033	0.3	0.744	0.291	0.032	-	-
HCM Control Delay (s)	8.7	-	-	111.4	48	10.1	63.2	57.8	13.9	8	-	-
HCM Lane LOS	A	-	-	F	E	B	F	F	B	A	-	-
HCM 95th %tile Q(veh)	0.2	-	-	0.7	3.7	0.1	1.1	5.1	1.2	0.1	-	-

Lanes, Volumes, Timings
3: US 24 & Judge Orr

2025 Baseline
PM



Lane Group	EBL	EBT	EBR	WBL	WBT	WBR	NEL	NET	NER	SWL	SWT	SWR
Lane Configurations		↕			↕		↕	↕		↕	↕	
Traffic Volume (vph)	44	51	70	116	53	12	145	578	121	2	410	13
Future Volume (vph)	44	51	70	116	53	12	145	578	121	2	410	13
Ideal Flow (vphpl)	1900	1900	1900	1900	1900	1900	1900	1900	1900	1900	1900	1900
Storage Length (ft)	0		0	0		0	850		0	700		0
Storage Lanes	0		0	0		0	1		0	1		0
Taper Length (ft)	25			25			280			300		
Lane Util. Factor	1.00	1.00	1.00	1.00	1.00	1.00	1.00	1.00	1.00	1.00	1.00	1.00
Frt		0.943			0.991			0.974			0.995	
Flt Protected		0.987			0.969		0.950			0.950		
Satd. Flow (prot)	0	1734	0	0	1789	0	1770	1814	0	1770	1853	0
Flt Permitted		0.876			0.690		0.366			0.210		
Satd. Flow (perm)	0	1539	0	0	1274	0	682	1814	0	391	1853	0
Right Turn on Red			Yes			Yes			Yes			Yes
Satd. Flow (RTOR)		68			7			17			3	
Link Speed (mph)		45			45			55			55	
Link Distance (ft)		801			719			1315			2758	
Travel Time (s)		12.1			10.9			16.3			34.2	
Peak Hour Factor	0.83	0.83	0.83	0.87	0.87	0.87	0.93	0.93	0.93	0.92	0.92	0.92
Adj. Flow (vph)	53	61	84	133	61	14	156	622	130	2	446	14
Shared Lane Traffic (%)												
Lane Group Flow (vph)	0	198	0	0	208	0	156	752	0	2	460	0
Enter Blocked Intersection	No	No	No	No	No	No	No	No	No	No	No	No
Lane Alignment	Left	Left	Right	Left	Left	Right	Left	Left	Right	Left	Left	Right
Median Width(ft)		0			0			12			12	
Link Offset(ft)		0			0			0			0	
Crosswalk Width(ft)		16			16			16			16	
Two way Left Turn Lane												
Headway Factor	1.00	1.00	1.00	1.00	1.00	1.00	1.00	1.00	1.00	1.00	1.00	1.00
Turning Speed (mph)	15		9	15		9	15		9	15		9
Number of Detectors	1	2		1	2		1	2		1	2	
Detector Template	Left	Thru		Left	Thru		Left	Thru		Left	Thru	
Leading Detector (ft)	20	100		20	100		20	100		20	100	
Trailing Detector (ft)	0	0		0	0		0	0		0	0	
Detector 1 Position(ft)	0	0		0	0		0	0		0	0	
Detector 1 Size(ft)	20	6		20	6		20	6		20	6	
Detector 1 Type	Cl+Ex	Cl+Ex		Cl+Ex	Cl+Ex		Cl+Ex	Cl+Ex		Cl+Ex	Cl+Ex	
Detector 1 Channel												
Detector 1 Extend (s)	0.0	0.0		0.0	0.0		0.0	0.0		0.0	0.0	
Detector 1 Queue (s)	0.0	0.0		0.0	0.0		0.0	0.0		0.0	0.0	
Detector 1 Delay (s)	0.0	0.0		0.0	0.0		0.0	0.0		0.0	0.0	
Detector 2 Position(ft)		94			94			94			94	
Detector 2 Size(ft)		6			6			6			6	
Detector 2 Type		Cl+Ex			Cl+Ex			Cl+Ex			Cl+Ex	
Detector 2 Channel												
Detector 2 Extend (s)		0.0			0.0			0.0			0.0	
Turn Type	pm+pt	NA		pm+pt	NA		pm+pt	NA		pm+pt	NA	
Protected Phases	7	4		3	8		5	2		1	6	
Permitted Phases	4			8			2			6		

Lanes, Volumes, Timings
3: US 24 & Judge Orr

2025 Baseline
PM











Lane Group	EBL	EBT	EBR	WBL	WBT	WBR	NEL	NET	NER	SWL	SWT	SWR
Detector Phase	7	4		3	8		5	2		1	6	
Switch Phase												
Minimum Initial (s)	5.0	5.0		5.0	5.0		5.0	5.0		5.0	5.0	
Minimum Split (s)	9.5	22.5		9.5	22.5		9.5	22.5		9.5	22.5	
Total Split (s)	8.5	21.5		8.5	21.5		8.5	21.5		8.5	21.5	
Total Split (%)	14.2%	35.8%		14.2%	35.8%		14.2%	35.8%		14.2%	35.8%	
Maximum Green (s)	4.0	17.0		4.0	17.0		4.0	17.0		4.0	17.0	
Yellow Time (s)	3.5	3.5		3.5	3.5		3.5	3.5		3.5	3.5	
All-Red Time (s)	1.0	1.0		1.0	1.0		1.0	1.0		1.0	1.0	
Lost Time Adjust (s)		0.0			0.0		0.0	0.0		0.0	0.0	
Total Lost Time (s)		4.5			4.5		4.5	4.5		4.5	4.5	
Lead/Lag	Lead	Lag		Lead	Lag		Lead	Lag		Lead	Lag	
Lead-Lag Optimize?	Yes	Yes		Yes	Yes		Yes	Yes		Yes	Yes	
Vehicle Extension (s)	3.0	3.0		3.0	3.0		3.0	3.0		3.0	3.0	
Recall Mode	None	None		None	None		None	Max		None	Max	
Walk Time (s)		7.0			7.0			7.0			7.0	
Flash Dont Walk (s)		11.0			11.0			11.0			11.0	
Pedestrian Calls (#/hr)		0			0			0			0	
Act Effct Green (s)		11.7			12.1		26.6	27.2		24.0	22.4	
Actuated g/C Ratio		0.26			0.27		0.59	0.60		0.53	0.49	
v/c Ratio		0.44			0.60		0.31	0.69		0.01	0.50	
Control Delay		13.2			22.9		8.5	18.1		6.5	15.9	
Queue Delay		0.0			0.0		0.0	0.0		0.0	0.0	
Total Delay		13.2			22.9		8.5	18.1		6.5	15.9	
LOS		B			C		A	B		A	B	
Approach Delay		13.2			22.9			16.5			15.9	
Approach LOS		B			C			B			B	
Queue Length 50th (ft)		29			49		18	134		0	101	
Queue Length 95th (ft)		63			97		49	#476		3	#242	
Internal Link Dist (ft)		721			639			1235			2678	
Turn Bay Length (ft)							850			700		
Base Capacity (vph)		641			501		499	1095		333	916	
Starvation Cap Reductn		0			0		0	0		0	0	
Spillback Cap Reductn		0			0		0	0		0	0	
Storage Cap Reductn		0			0		0	0		0	0	
Reduced v/c Ratio		0.31			0.42		0.31	0.69		0.01	0.50	

Intersection Summary

























Area Type:	Other
Cycle Length:	60
Actuated Cycle Length:	45.4
Natural Cycle:	80
Control Type:	Actuated-Uncoordinated
Maximum v/c Ratio:	0.69
Intersection Signal Delay:	16.7
Intersection LOS:	B
Intersection Capacity Utilization:	74.4%
ICU Level of Service:	D
Analysis Period (min):	15
# 95th percentile volume exceeds capacity, queue may be longer. Queue shown is maximum after two cycles.	

Splits and Phases: 3: US 24 & Judge Orr

 Ø1 8.5 s	 Ø2 21.5 s	 Ø3 8.5 s	 Ø4 21.5 s
 Ø5 8.5 s	 Ø6 21.5 s	 Ø7 8.5 s	 Ø8 21.5 s

Lanes, Volumes, Timings
4: US 24 & Curtis/Stapleton

2025 Baseline
PM

												
Lane Group	SEL	SET	SER	NWL	NWT	NWR	NEL	NET	NER	SWL	SWT	SWR
Lane Configurations												
Traffic Volume (vph)	17	42	49	12	136	26	119	459	33	12	364	29
Future Volume (vph)	17	42	49	12	136	26	119	459	33	12	364	29
Ideal Flow (vphpl)	1900	1900	1900	1900	1900	1900	1900	1900	1900	1900	1900	1900
Storage Length (ft)	190		325	215		215	890		1000	790		790
Storage Lanes	1		1	1		0	1		1	1		1
Taper Length (ft)	240			200			190			190		
Lane Util. Factor	1.00	1.00	1.00	1.00	1.00	1.00	1.00	1.00	1.00	1.00	1.00	1.00
Frt			0.850			0.850			0.850			0.850
Flt Protected	0.950			0.950			0.950			0.950		
Satd. Flow (prot)	1770	1863	1583	1770	1863	1583	1770	1863	1583	1770	1863	1583
Flt Permitted	0.658			0.724			0.356			0.379		
Satd. Flow (perm)	1226	1863	1583	1349	1863	1583	663	1863	1583	706	1863	1583
Right Turn on Red			Yes			Yes			Yes			Yes
Satd. Flow (RTOR)			191			191			191			191
Link Speed (mph)		45			45			55			55	
Link Distance (ft)		1349			1298			2758			1426	
Travel Time (s)		20.4			19.7			34.2			17.7	
Peak Hour Factor	0.83	0.83	0.83	0.87	0.87	0.87	0.93	0.93	0.93	0.92	0.92	0.92
Adj. Flow (vph)	20	51	59	14	156	30	128	494	35	13	396	32
Shared Lane Traffic (%)												
Lane Group Flow (vph)	20	51	59	14	156	30	128	494	35	13	396	32
Enter Blocked Intersection	No	No	No	No	No	No	No	No	No	No	No	No
Lane Alignment	Left	Left	Right	Left	Left	Right	Left	Left	Right	Left	Left	Right
Median Width(ft)		12			12			12			12	
Link Offset(ft)		0			0			0			0	
Crosswalk Width(ft)		16			16			16			16	
Two way Left Turn Lane												
Headway Factor	1.00	1.00	1.00	1.00	1.00	1.00	1.00	1.00	1.00	1.00	1.00	1.00
Turning Speed (mph)	15		9	15		9	15		9	15		9
Number of Detectors	1	2	1	1	2	1	1	2	1	1	2	1
Detector Template	Left	Thru	Right	Left	Thru	Right	Left	Thru	Right	Left	Thru	Right
Leading Detector (ft)	20	100	20	20	100	20	20	100	20	20	100	20
Trailing Detector (ft)	0	0	0	0	0	0	0	0	0	0	0	0
Detector 1 Position(ft)	0	0	0	0	0	0	0	0	0	0	0	0
Detector 1 Size(ft)	20	6	20	20	6	20	20	6	20	20	6	20
Detector 1 Type	Cl+Ex	Cl+Ex	Cl+Ex	Cl+Ex	Cl+Ex	Cl+Ex	Cl+Ex	Cl+Ex	Cl+Ex	Cl+Ex	Cl+Ex	Cl+Ex
Detector 1 Channel												
Detector 1 Extend (s)	0.0	0.0	0.0	0.0	0.0	0.0	0.0	0.0	0.0	0.0	0.0	0.0
Detector 1 Queue (s)	0.0	0.0	0.0	0.0	0.0	0.0	0.0	0.0	0.0	0.0	0.0	0.0
Detector 1 Delay (s)	0.0	0.0	0.0	0.0	0.0	0.0	0.0	0.0	0.0	0.0	0.0	0.0
Detector 2 Position(ft)		94			94			94			94	
Detector 2 Size(ft)		6			6			6			6	
Detector 2 Type		Cl+Ex			Cl+Ex			Cl+Ex			Cl+Ex	
Detector 2 Channel												
Detector 2 Extend (s)		0.0			0.0			0.0			0.0	
Turn Type	pm+pt	NA	Perm	pm+pt	NA	Perm	pm+pt	NA	Perm	pm+pt	NA	Perm
Protected Phases	1	6		5	2		7	4		3	8	
Permitted Phases	6		6	2		2	4		4	8		8

Lanes, Volumes, Timings
4: US 24 & Curtis/Stapleton

2025 Baseline
PM











Lane Group	SEL	SET	SER	NWL	NWT	NWR	NEL	NET	NER	SWL	SWT	SWR
Detector Phase	1	6	6	5	2	2	7	4	4	3	8	8
Switch Phase												
Minimum Initial (s)	5.0	5.0	5.0	5.0	5.0	5.0	5.0	5.0	5.0	5.0	5.0	5.0
Minimum Split (s)	9.5	22.5	22.5	9.5	22.5	22.5	9.5	22.5	22.5	9.5	22.5	22.5
Total Split (s)	8.5	21.5	21.5	8.5	21.5	21.5	8.5	21.5	21.5	8.5	21.5	21.5
Total Split (%)	14.2%	35.8%	35.8%	14.2%	35.8%	35.8%	14.2%	35.8%	35.8%	14.2%	35.8%	35.8%
Maximum Green (s)	4.0	17.0	17.0	4.0	17.0	17.0	4.0	17.0	17.0	4.0	17.0	17.0
Yellow Time (s)	3.5	3.5	3.5	3.5	3.5	3.5	3.5	3.5	3.5	3.5	3.5	3.5
All-Red Time (s)	1.0	1.0	1.0	1.0	1.0	1.0	1.0	1.0	1.0	1.0	1.0	1.0
Lost Time Adjust (s)	0.0	0.0	0.0	0.0	0.0	0.0	0.0	0.0	0.0	0.0	0.0	0.0
Total Lost Time (s)	4.5	4.5	4.5	4.5	4.5	4.5	4.5	4.5	4.5	4.5	4.5	4.5
Lead/Lag	Lead	Lag	Lag	Lead	Lag	Lag	Lead	Lag	Lag	Lead	Lag	Lag
Lead-Lag Optimize?	Yes	Yes	Yes	Yes	Yes	Yes	Yes	Yes	Yes	Yes	Yes	Yes
Vehicle Extension (s)	3.0	3.0	3.0	3.0	3.0	3.0	3.0	3.0	3.0	3.0	3.0	3.0
Recall Mode	None	Min	Min	None	Min	Min	None	None	None	None	None	None
Walk Time (s)		7.0	7.0		7.0	7.0		7.0	7.0		7.0	7.0
Flash Dont Walk (s)		11.0	11.0		11.0	11.0		11.0	11.0		11.0	11.0
Pedestrian Calls (#/hr)		0	0		0	0		0	0		0	0
Act Effct Green (s)	9.7	9.1	9.1	9.7	9.1	9.1	20.6	20.0	20.0	17.9	14.8	14.8
Actuated g/C Ratio	0.24	0.22	0.22	0.24	0.22	0.22	0.50	0.49	0.49	0.44	0.36	0.36
v/c Ratio	0.06	0.12	0.12	0.04	0.38	0.06	0.29	0.54	0.04	0.03	0.59	0.05
Control Delay	12.5	15.8	0.5	12.2	18.6	0.2	8.6	14.6	0.1	6.9	17.8	0.1
Queue Delay	0.0	0.0	0.0	0.0	0.0	0.0	0.0	0.0	0.0	0.0	0.0	0.0
Total Delay	12.5	15.8	0.5	12.2	18.6	0.2	8.6	14.6	0.1	6.9	17.8	0.1
LOS	B	B	A	B	B	A	A	B	A	A	B	A
Approach Delay		8.3			15.4			12.7			16.2	
Approach LOS		A			B			B			B	
Queue Length 50th (ft)	4	9	0	3	30	0	11	55	0	1	71	0
Queue Length 95th (ft)	14	33	0	11	84	0	50	#311	0	10	#227	0
Internal Link Dist (ft)		1269			1218			2678			1346	
Turn Bay Length (ft)	190		325	215		215	890		1000	790		790
Base Capacity (vph)	344	813	799	360	813	799	446	969	915	416	813	799
Starvation Cap Reductn	0	0	0	0	0	0	0	0	0	0	0	0
Spillback Cap Reductn	0	0	0	0	0	0	0	0	0	0	0	0
Storage Cap Reductn	0	0	0	0	0	0	0	0	0	0	0	0
Reduced v/c Ratio	0.06	0.06	0.07	0.04	0.19	0.04	0.29	0.51	0.04	0.03	0.49	0.04

Intersection Summary

Area Type:	Other
Cycle Length:	60
Actuated Cycle Length:	41.1
Natural Cycle:	65
Control Type:	Actuated-Uncoordinated
Maximum v/c Ratio:	0.59
Intersection Signal Delay:	13.7
Intersection LOS:	B
Intersection Capacity Utilization:	53.7%
ICU Level of Service:	A
Analysis Period (min):	15
# 95th percentile volume exceeds capacity, queue may be longer. Queue shown is maximum after two cycles.	

Splits and Phases: 4: US 24 & Curtis/Stapleton

 Ø1	 Ø2	 Ø3	 Ø4
8.5 s	21.5 s	8.5 s	21.5 s
 Ø5	 Ø6	 Ø7	 Ø8
8.5 s	21.5 s	8.5 s	21.5 s

Intersection												
Int Delay, s/veh	6.8											
Movement	EBL	EBT	EBR	WBL	WBT	WBR	NBL	NBT	NBR	SBL	SBT	SBR
Lane Configurations	↖	↗		↖	↗		↖	↗		↖	↗	
Traffic Vol, veh/h	7	153	42	3	97	19	67	134	8	34	62	4
Future Vol, veh/h	7	153	42	3	97	19	67	134	8	34	62	4
Conflicting Peds, #/hr	0	0	0	0	0	0	0	0	0	0	0	0
Sign Control	Free	Free	Free	Free	Free	Free	Stop	Stop	Stop	Stop	Stop	Stop
RT Channelized	-	-	None	-	-	None	-	-	None	-	-	None
Storage Length	0	-	-	0	-	-	0	-	-	0	-	-
Veh in Median Storage, #	-	0	-	-	0	-	-	0	-	-	0	-
Grade, %	-	0	-	-	0	-	-	0	-	-	0	-
Peak Hour Factor	87	87	87	83	83	83	87	87	87	83	83	83
Heavy Vehicles, %	2	2	2	2	2	2	2	2	2	2	2	2
Mvmt Flow	8	176	48	4	117	23	77	154	9	41	75	5

Major/Minor	Major1			Major2			Minor1			Minor2		
Conflicting Flow All	140	0	0	224	0	0	393	364	200	435	377	129
Stage 1	-	-	-	-	-	-	216	216	-	137	137	-
Stage 2	-	-	-	-	-	-	177	148	-	298	240	-
Critical Hdwy	4.12	-	-	4.12	-	-	7.12	6.52	6.22	7.12	6.52	6.22
Critical Hdwy Stg 1	-	-	-	-	-	-	6.12	5.52	-	6.12	5.52	-
Critical Hdwy Stg 2	-	-	-	-	-	-	6.12	5.52	-	6.12	5.52	-
Follow-up Hdwy	2.218	-	-	2.218	-	-	3.518	4.018	3.318	3.518	4.018	3.318
Pot Cap-1 Maneuver	1443	-	-	1345	-	-	566	564	841	531	555	921
Stage 1	-	-	-	-	-	-	786	724	-	866	783	-
Stage 2	-	-	-	-	-	-	825	775	-	711	707	-
Platoon blocked, %	-	-	-	-	-	-	-	-	-	-	-	-
Mov Cap-1 Maneuver	1443	-	-	1345	-	-	501	559	841	411	550	921
Mov Cap-2 Maneuver	-	-	-	-	-	-	501	559	-	411	550	-
Stage 1	-	-	-	-	-	-	781	720	-	861	781	-
Stage 2	-	-	-	-	-	-	740	773	-	550	703	-

Approach	EB			WB			NB			SB		
HCM Control Delay, s	0.3			0.2			13.7			13.2		
HCM LOS							B			B		

Minor Lane/Major Mvmt	NBLn1	NBLn2	EBL	EBT	EBR	WBL	WBT	WBR	SBLn1	SBLn2
Capacity (veh/h)	501	570	1443	-	-	1345	-	-	411	564
HCM Lane V/C Ratio	0.154	0.286	0.006	-	-	0.003	-	-	0.1	0.141
HCM Control Delay (s)	13.5	13.8	7.5	-	-	7.7	-	-	14.7	12.4
HCM Lane LOS	B	B	A	-	-	A	-	-	B	B
HCM 95th %tile Q(veh)	0.5	1.2	0	-	-	0	-	-	0.3	0.5

Intersection												
Int Delay, s/veh	13.7											
Movement	EBL	EBT	EBR	WBL	WBT	WBR	NBL	NBT	NBR	SBL	SBT	SBR
Lane Configurations	↖	↑	↗	↖	↑	↗	↖	↑	↗	↖	↑	↗
Traffic Vol, veh/h	38	215	67	8	98	12	242	204	30	22	54	31
Future Vol, veh/h	38	215	67	8	98	12	242	204	30	22	54	31
Conflicting Peds, #/hr	0	0	0	0	0	0	0	0	0	0	0	0
Sign Control	Free	Free	Free	Free	Free	Free	Stop	Stop	Stop	Stop	Stop	Stop
RT Channelized	-	-	None	-	-	None	-	-	None	-	-	None
Storage Length	0	-	0	0	-	-	0	-	-	0	-	-
Veh in Median Storage, #	-	0	-	-	0	-	-	0	-	-	0	-
Grade, %	-	0	-	-	0	-	-	0	-	-	0	-
Peak Hour Factor	92	92	92	83	83	83	92	92	92	83	83	83
Heavy Vehicles, %	2	2	2	2	2	2	2	2	2	2	2	2
Mvmt Flow	41	234	73	10	118	14	263	222	33	27	65	37

Major/Minor	Major1			Major2			Minor1			Minor2		
Conflicting Flow All	132	0	0	307	0	0	512	468	234	625	534	125
Stage 1	-	-	-	-	-	-	316	316	-	145	145	-
Stage 2	-	-	-	-	-	-	196	152	-	480	389	-
Critical Hdwy	4.12	-	-	4.12	-	-	7.12	6.52	6.22	7.12	6.52	6.22
Critical Hdwy Stg 1	-	-	-	-	-	-	6.12	5.52	-	6.12	5.52	-
Critical Hdwy Stg 2	-	-	-	-	-	-	6.12	5.52	-	6.12	5.52	-
Follow-up Hdwy	2.218	-	-	2.218	-	-	3.518	4.018	3.318	3.518	4.018	3.318
Pot Cap-1 Maneuver	1453	-	-	1254	-	-	472	493	805	397	452	926
Stage 1	-	-	-	-	-	-	695	655	-	858	777	-
Stage 2	-	-	-	-	-	-	806	772	-	567	608	-
Platoon blocked, %	-	-	-	-	-	-	-	-	-	-	-	-
Mov Cap-1 Maneuver	1453	-	-	1254	-	-	390	475	805	235	436	926
Mov Cap-2 Maneuver	-	-	-	-	-	-	390	475	-	235	436	-
Stage 1	-	-	-	-	-	-	676	637	-	834	771	-
Stage 2	-	-	-	-	-	-	703	766	-	345	591	-

Approach	EB			WB			NB			SB		
HCM Control Delay, s	0.9			0.5			25.5			15.1		
HCM LOS							D			C		

Minor Lane/Major Mvmt	NBLn1	NBLn2	EBL	EBT	EBR	WBL	WBT	WBR	SBLn1	SBLn2
Capacity (veh/h)	390	501	1453	-	-	1254	-	-	235	540
HCM Lane V/C Ratio	0.674	0.508	0.028	-	-	0.008	-	-	0.113	0.19
HCM Control Delay (s)	31.4	19.4	7.5	-	-	7.9	-	-	22.3	13.2
HCM Lane LOS	D	C	A	-	-	A	-	-	C	B
HCM 95th %tile Q(veh)	4.8	2.8	0.1	-	-	0	-	-	0.4	0.7

Intersection												
Int Delay, s/veh	28.6											
Movement	SEL	SET	SER	NWL	NWT	NWR	NEL	NET	NER	SWL	SWT	SWR
Lane Configurations	↘	↑	↗	↘	↑	↗	↘	↑	↗	↘	↑	↗
Traffic Vol, veh/h	18	64	52	14	158	30	126	487	36	16	386	31
Future Vol, veh/h	18	64	52	14	158	30	126	487	36	16	386	31
Conflicting Peds, #/hr	0	0	0	0	0	0	0	0	0	0	0	0
Sign Control	Stop	Stop	Stop	Stop	Stop	Stop	Free	Free	Free	Free	Free	Free
RT Channelized	-	-	None	-	-	None	-	-	None	-	-	None
Storage Length	0	-	0	0	-	0	0	-	0	0	-	0
Veh in Median Storage, #	-	0	-	-	0	-	-	0	-	-	0	-
Grade, %	-	0	-	-	0	-	-	0	-	-	0	-
Peak Hour Factor	83	83	83	87	87	87	93	93	93	92	92	92
Heavy Vehicles, %	2	2	2	2	2	2	2	2	2	2	2	2
Mvmt Flow	22	77	63	16	182	34	135	524	39	17	420	34

Major/Minor	Minor2		Minor1		Major1		Major2					
Conflicting Flow All	1376	1287	420	1335	1282	524	454	0	0	563	0	0
Stage 1	454	454	-	794	794	-	-	-	-	-	-	-
Stage 2	922	833	-	541	488	-	-	-	-	-	-	-
Critical Hdwy	7.12	6.52	6.22	7.12	6.52	6.22	4.12	-	-	4.12	-	-
Critical Hdwy Stg 1	6.12	5.52	-	6.12	5.52	-	-	-	-	-	-	-
Critical Hdwy Stg 2	6.12	5.52	-	6.12	5.52	-	-	-	-	-	-	-
Follow-up Hdwy	3.518	4.018	3.318	3.518	4.018	3.318	2.218	-	-	2.218	-	-
Pot Cap-1 Maneuver	122	164	633	131	~ 165	553	1107	-	-	1008	-	-
Stage 1	586	569	-	381	400	-	-	-	-	-	-	-
Stage 2	324	384	-	525	550	-	-	-	-	-	-	-
Platoon blocked, %	-	-	-	-	-	-	-	-	-	-	-	-
Mov Cap-1 Maneuver	-	142	633	61	~ 142	553	1107	-	-	1008	-	-
Mov Cap-2 Maneuver	-	142	-	61	~ 142	-	-	-	-	-	-	-
Stage 1	515	559	-	335	351	-	-	-	-	-	-	-
Stage 2	129	337	-	401	541	-	-	-	-	-	-	-

Approach	SE	NW	NE	SW
HCM Control Delay, s		186.9	1.7	0.3
HCM LOS	-	F		

Minor Lane/Major Mvmt	NEL	NET	NERNWLn1	NWLn2	NWLn3	SELn1	SELn2	SELn3	SWL	SWT	SWR	
Capacity (veh/h)	1107	-	-	61	142	553	-	142	633	1008	-	-
HCM Lane V/C Ratio	0.122	-	-	0.264	1.279	0.062	-	0.543	0.099	0.017	-	-
HCM Control Delay (s)	8.7	-	-	84	229.2	11.9	-	57	11.3	8.6	-	-
HCM Lane LOS	A	-	-	F	F	B	-	F	B	A	-	-
HCM 95th %tile Q(veh)	0.4	-	-	0.9	11.1	0.2	-	2.7	0.3	0.1	-	-

Notes
 ~: Volume exceeds capacity \$: Delay exceeds 300s +: Computation Not Defined *: All major volume in platoon

Intersection	
Intersection Delay, s/veh	16.5
Intersection LOS	C

























Movement	EBL	EBT	EBR	WBL	WBT	WBR	NBL	NBT	NBR	SBL	SBT	SBR
Lane Configurations	↘	↑	↘	↘	↘		↘	↘		↘	↑	↘
Traffic Vol, veh/h	51	57	267	14	213	49	66	85	1	8	227	53
Future Vol, veh/h	51	57	267	14	213	49	66	85	1	8	227	53
Peak Hour Factor	0.92	0.92	0.92	0.92	0.92	0.92	0.87	0.87	0.87	0.92	0.92	0.92
Heavy Vehicles, %	2	2	2	2	2	2	2	2	2	2	2	2
Mvmt Flow	55	62	290	15	232	53	76	98	1	9	247	58
Number of Lanes	1	1	1	1	1	0	1	1	0	1	1	1

Approach	EB	WB	NB	SB
Opposing Approach	WB	EB	SB	NB
Opposing Lanes	2	3	3	2
Conflicting Approach Left	SB	NB	EB	WB
Conflicting Lanes Left	3	2	3	2
Conflicting Approach Right	NB	SB	WB	EB
Conflicting Lanes Right	2	3	2	3
HCM Control Delay	15.5	19.7	13	16.8
HCM LOS	C	C	B	C

Lane	NBLn1	NBLn2	EBLn1	EBLn2	EBLn3	WBLn1	WBLn2	SBLn1	SBLn2	SBLn3
Vol Left, %	100%	0%	100%	0%	0%	100%	0%	100%	0%	0%
Vol Thru, %	0%	99%	0%	100%	0%	0%	81%	0%	100%	0%
Vol Right, %	0%	1%	0%	0%	100%	0%	19%	0%	0%	100%
Sign Control	Stop	Stop	Stop	Stop	Stop	Stop	Stop	Stop	Stop	Stop
Traffic Vol by Lane	66	86	51	57	267	14	262	8	227	53
LT Vol	66	0	51	0	0	14	0	8	0	0
Through Vol	0	85	0	57	0	0	213	0	227	0
RT Vol	0	1	0	0	267	0	49	0	0	53
Lane Flow Rate	76	99	55	62	290	15	285	9	247	58
Geometry Grp	6	6	6	6	6	6	6	6	6	6
Degree of Util (X)	0.179	0.219	0.122	0.128	0.54	0.034	0.585	0.02	0.523	0.111
Departure Headway (Hd)	8.499	7.981	7.92	7.411	6.699	8.039	7.398	8.144	7.635	6.922
Convergence, Y/N	Yes	Yes	Yes	Yes	Yes	Yes	Yes	Yes	Yes	Yes
Cap	421	448	452	483	537	444	487	439	471	516
Service Time	6.276	5.758	5.684	5.175	4.463	5.805	5.164	5.912	5.403	4.69
HCM Lane V/C Ratio	0.181	0.221	0.122	0.128	0.54	0.034	0.585	0.021	0.524	0.112
HCM Control Delay	13.1	13	11.8	11.3	17.1	11.1	20.2	11.1	18.5	10.6
HCM Lane LOS	B	B	B	B	C	B	C	B	C	B
HCM 95th-tile Q	0.6	0.8	0.4	0.4	3.2	0.1	3.7	0.1	3	0.4

Lanes, Volumes, Timings
4: US 24 & Curtis/Stapleton

2025 Baseline + Site
AM

												
Lane Group	SEL	SET	SER	NWL	NWT	NWR	NEL	NET	NER	SWL	SWT	SWR
Lane Configurations												
Traffic Volume (vph)	24	162	152	8	113	21	52	283	3	40	464	37
Future Volume (vph)	24	162	152	8	113	21	52	283	3	40	464	37
Ideal Flow (vphpl)	1900	1900	1900	1900	1900	1900	1900	1900	1900	1900	1900	1900
Storage Length (ft)	190		325	215		215	890		1000	790		790
Storage Lanes	1		1	1		0	1		1	1		1
Taper Length (ft)	240			200			190			190		
Lane Util. Factor	1.00	1.00	1.00	1.00	1.00	1.00	1.00	1.00	1.00	1.00	1.00	1.00
Frt			0.850			0.850			0.850			0.850
Flt Protected	0.950			0.950			0.950			0.950		
Satd. Flow (prot)	1770	1863	1583	1770	1863	1583	1770	1863	1583	1770	1863	1583
Flt Permitted	0.670			0.646			0.282			0.519		
Satd. Flow (perm)	1248	1863	1583	1203	1863	1583	525	1863	1583	967	1863	1583
Right Turn on Red			Yes			Yes			Yes			Yes
Satd. Flow (RTOR)			191			191			191			191
Link Speed (mph)		45			45			55			55	
Link Distance (ft)		1349			1298			2758			1426	
Travel Time (s)		20.4			19.7			34.2			17.7	
Peak Hour Factor	0.92	0.92	0.92	0.83	0.83	0.83	0.92	0.92	0.92	0.92	0.92	0.92
Adj. Flow (vph)	26	176	165	10	136	25	57	308	3	43	504	40
Shared Lane Traffic (%)												
Lane Group Flow (vph)	26	176	165	10	136	25	57	308	3	43	504	40
Enter Blocked Intersection	No	No	No	No	No	No	No	No	No	No	No	No
Lane Alignment	Left	Left	Right	Left	Left	Right	Left	Left	Right	Left	Left	Right
Median Width(ft)		12			12			12			12	
Link Offset(ft)		0			0			0			0	
Crosswalk Width(ft)		16			16			16			16	
Two way Left Turn Lane												
Headway Factor	1.00	1.00	1.00	1.00	1.00	1.00	1.00	1.00	1.00	1.00	1.00	1.00
Turning Speed (mph)	15		9	15		9	15		9	15		9
Number of Detectors	1	2	1	1	2	1	1	2	1	1	2	1
Detector Template	Left	Thru	Right	Left	Thru	Right	Left	Thru	Right	Left	Thru	Right
Leading Detector (ft)	20	100	20	20	100	20	20	100	20	20	100	20
Trailing Detector (ft)	0	0	0	0	0	0	0	0	0	0	0	0
Detector 1 Position(ft)	0	0	0	0	0	0	0	0	0	0	0	0
Detector 1 Size(ft)	20	6	20	20	6	20	20	6	20	20	6	20
Detector 1 Type	Cl+Ex	Cl+Ex	Cl+Ex	Cl+Ex	Cl+Ex	Cl+Ex	Cl+Ex	Cl+Ex	Cl+Ex	Cl+Ex	Cl+Ex	Cl+Ex
Detector 1 Channel												
Detector 1 Extend (s)	0.0	0.0	0.0	0.0	0.0	0.0	0.0	0.0	0.0	0.0	0.0	0.0
Detector 1 Queue (s)	0.0	0.0	0.0	0.0	0.0	0.0	0.0	0.0	0.0	0.0	0.0	0.0
Detector 1 Delay (s)	0.0	0.0	0.0	0.0	0.0	0.0	0.0	0.0	0.0	0.0	0.0	0.0
Detector 2 Position(ft)		94			94			94			94	
Detector 2 Size(ft)		6			6			6			6	
Detector 2 Type		Cl+Ex			Cl+Ex			Cl+Ex			Cl+Ex	
Detector 2 Channel												
Detector 2 Extend (s)		0.0			0.0			0.0			0.0	
Turn Type	pm+pt	NA	Perm	pm+pt	NA	Perm	pm+pt	NA	Perm	pm+pt	NA	Perm
Protected Phases	1	6		5	2		7	4		3	8	
Permitted Phases	6		6	2		2	4		4	8		8

Lanes, Volumes, Timings
4: US 24 & Curtis/Stapleton

2025 Baseline + Site
AM











Lane Group	SEL	SET	SER	NWL	NWT	NWR	NEL	NET	NER	SWL	SWT	SWR
Detector Phase	1	6	6	5	2	2	7	4	4	3	8	8
Switch Phase												
Minimum Initial (s)	5.0	5.0	5.0	5.0	5.0	5.0	5.0	5.0	5.0	5.0	5.0	5.0
Minimum Split (s)	9.5	22.5	22.5	9.5	22.5	22.5	9.5	22.5	22.5	9.5	22.5	22.5
Total Split (s)	8.5	21.5	21.5	8.5	21.5	21.5	8.5	21.5	21.5	8.5	21.5	21.5
Total Split (%)	14.2%	35.8%	35.8%	14.2%	35.8%	35.8%	14.2%	35.8%	35.8%	14.2%	35.8%	35.8%
Maximum Green (s)	4.0	17.0	17.0	4.0	17.0	17.0	4.0	17.0	17.0	4.0	17.0	17.0
Yellow Time (s)	3.5	3.5	3.5	3.5	3.5	3.5	3.5	3.5	3.5	3.5	3.5	3.5
All-Red Time (s)	1.0	1.0	1.0	1.0	1.0	1.0	1.0	1.0	1.0	1.0	1.0	1.0
Lost Time Adjust (s)	0.0	0.0	0.0	0.0	0.0	0.0	0.0	0.0	0.0	0.0	0.0	0.0
Total Lost Time (s)	4.5	4.5	4.5	4.5	4.5	4.5	4.5	4.5	4.5	4.5	4.5	4.5
Lead/Lag	Lead	Lag	Lag	Lead	Lag	Lag	Lead	Lag	Lag	Lead	Lag	Lag
Lead-Lag Optimize?	Yes	Yes	Yes	Yes	Yes	Yes	Yes	Yes	Yes	Yes	Yes	Yes
Vehicle Extension (s)	3.0	3.0	3.0	3.0	3.0	3.0	3.0	3.0	3.0	3.0	3.0	3.0
Recall Mode	None	Min	Min	None	Min	Min	None	None	None	None	None	None
Walk Time (s)		7.0	7.0		7.0	7.0		7.0	7.0		7.0	7.0
Flash Dont Walk (s)		11.0	11.0		11.0	11.0		11.0	11.0		11.0	11.0
Pedestrian Calls (#/hr)		0	0		0	0		0	0		0	0
Act Effct Green (s)	10.2	9.7	9.7	10.2	9.7	9.7	18.3	17.0	17.0	18.3	17.0	17.0
Actuated g/C Ratio	0.25	0.24	0.24	0.25	0.24	0.24	0.46	0.42	0.42	0.46	0.42	0.42
v/c Ratio	0.07	0.39	0.31	0.03	0.30	0.05	0.15	0.39	0.00	0.08	0.64	0.05
Control Delay	11.9	17.4	4.3	11.5	16.4	0.2	8.1	12.9	0.0	7.5	18.9	0.1
Queue Delay	0.0	0.0	0.0	0.0	0.0	0.0	0.0	0.0	0.0	0.0	0.0	0.0
Total Delay	11.9	17.4	4.3	11.5	16.4	0.2	8.1	12.9	0.0	7.5	18.9	0.1
LOS	B	B	A	B	B	A	A	B	A	A	B	A
Approach Delay		11.1			13.7			12.0			16.8	
Approach LOS		B			B			B			B	
Queue Length 50th (ft)	4	27	0	1	20	0	5	32	0	4	59	0
Queue Length 95th (ft)	17	96	29	9	70	0	28	160	0	23	#337	0
Internal Link Dist (ft)		1269			1218			2678			1346	
Turn Bay Length (ft)	190		325	215		215	890		1000	790		790
Base Capacity (vph)	373	842	820	366	842	820	371	842	820	525	842	820
Starvation Cap Reductn	0	0	0	0	0	0	0	0	0	0	0	0
Spillback Cap Reductn	0	0	0	0	0	0	0	0	0	0	0	0
Storage Cap Reductn	0	0	0	0	0	0	0	0	0	0	0	0
Reduced v/c Ratio	0.07	0.21	0.20	0.03	0.16	0.03	0.15	0.37	0.00	0.08	0.60	0.05

Intersection Summary

Area Type:	Other
Cycle Length:	60
Actuated Cycle Length:	40.1
Natural Cycle:	65
Control Type:	Actuated-Uncoordinated
Maximum v/c Ratio:	0.64
Intersection Signal Delay:	13.9
Intersection LOS:	B
Intersection Capacity Utilization:	49.2%
ICU Level of Service:	A
Analysis Period (min):	15
# 95th percentile volume exceeds capacity, queue may be longer. Queue shown is maximum after two cycles.	

Splits and Phases: 4: US 24 & Curtis/Stapleton

 Ø1	 Ø2	 Ø3	 Ø4
8.5 s	21.5 s	8.5 s	21.5 s
 Ø5	 Ø6	 Ø7	 Ø8
8.5 s	21.5 s	8.5 s	21.5 s

Intersection												
Int Delay, s/veh	10.2											
Movement	EBL	EBT	EBR	WBL	WBT	WBR	NBL	NBT	NBR	SBL	SBT	SBR
Lane Configurations	↶	↷		↶	↷		↶	↷		↶	↷	
Traffic Vol, veh/h	7	56	87	28	183	25	61	91	5	5	219	9
Future Vol, veh/h	7	56	87	28	183	25	61	91	5	5	219	9
Conflicting Peds, #/hr	0	0	0	0	0	0	0	0	0	0	0	0
Sign Control	Free	Free	Free	Free	Free	Free	Stop	Stop	Stop	Stop	Stop	Stop
RT Channelized	-	-	None	-	-	None	-	-	None	-	-	None
Storage Length	0	-	-	0	-	-	0	-	-	0	-	-
Veh in Median Storage, #	-	0	-	-	0	-	-	0	-	-	0	-
Grade, %	-	0	-	-	0	-	-	0	-	-	0	-
Peak Hour Factor	87	87	87	87	87	87	87	87	87	87	87	87
Heavy Vehicles, %	2	2	2	2	2	2	2	2	2	2	2	2
Mvmt Flow	8	64	100	32	210	29	70	105	6	6	252	10

Major/Minor	Major1			Major2			Minor1			Minor2		
Conflicting Flow All	239	0	0	164	0	0	550	433	114	475	469	225
Stage 1	-	-	-	-	-	-	130	130	-	289	289	-
Stage 2	-	-	-	-	-	-	420	303	-	186	180	-
Critical Hdwy	4.12	-	-	4.12	-	-	7.12	6.52	6.22	7.12	6.52	6.22
Critical Hdwy Stg 1	-	-	-	-	-	-	6.12	5.52	-	6.12	5.52	-
Critical Hdwy Stg 2	-	-	-	-	-	-	6.12	5.52	-	6.12	5.52	-
Follow-up Hdwy	2.218	-	-	2.218	-	-	3.518	4.018	3.318	3.518	4.018	3.318
Pot Cap-1 Maneuver	1328	-	-	1414	-	-	446	516	939	500	492	814
Stage 1	-	-	-	-	-	-	874	789	-	719	673	-
Stage 2	-	-	-	-	-	-	611	664	-	816	750	-
Platoon blocked, %	-	-	-	-	-	-	-	-	-	-	-	-
Mov Cap-1 Maneuver	1328	-	-	1414	-	-	252	501	939	409	478	814
Mov Cap-2 Maneuver	-	-	-	-	-	-	252	501	-	409	478	-
Stage 1	-	-	-	-	-	-	869	784	-	715	658	-
Stage 2	-	-	-	-	-	-	364	649	-	699	746	-

Approach	EB			WB			NB			SB		
HCM Control Delay, s	0.4			0.9			18.1			20.6		
HCM LOS							C			C		

Minor Lane/Major Mvmt	NBLn1	NBLn2	EBL	EBT	EBR	WBL	WBT	WBR	SBLn1	SBLn2
Capacity (veh/h)	252	513	1328	-	-	1414	-	-	409	486
HCM Lane V/C Ratio	0.278	0.215	0.006	-	-	0.023	-	-	0.014	0.539
HCM Control Delay (s)	24.7	13.9	7.7	-	-	7.6	-	-	13.9	20.7
HCM Lane LOS	C	B	A	-	-	A	-	-	B	C
HCM 95th %tile Q(veh)	1.1	0.8	0	-	-	0.1	-	-	0	3.2

Intersection						
Int Delay, s/veh	1					
Movement	EBL	EBR	NBL	NBT	SBT	SBR
Lane Configurations	↖	↗	↖	↗	↗	↖
Traffic Vol, veh/h	8	10	38	148	332	22
Future Vol, veh/h	8	10	38	148	332	22
Conflicting Peds, #/hr	0	0	0	0	0	0
Sign Control	Stop	Stop	Free	Free	Free	Free
RT Channelized	-	None	-	None	-	None
Storage Length	0	0	385	-	-	235
Veh in Median Storage, #	0	-	-	0	0	-
Grade, %	0	-	-	0	0	-
Peak Hour Factor	78	78	87	87	92	92
Heavy Vehicles, %	2	2	2	2	2	2
Mvmt Flow	10	13	44	170	361	24

Major/Minor	Minor2	Major1	Major2			
Conflicting Flow All	619	361	385	0	-	0
Stage 1	361	-	-	-	-	-
Stage 2	258	-	-	-	-	-
Critical Hdwy	6.42	6.22	4.12	-	-	-
Critical Hdwy Stg 1	5.42	-	-	-	-	-
Critical Hdwy Stg 2	5.42	-	-	-	-	-
Follow-up Hdwy	3.518	3.318	2.218	-	-	-
Pot Cap-1 Maneuver	452	684	1173	-	-	-
Stage 1	705	-	-	-	-	-
Stage 2	785	-	-	-	-	-
Platoon blocked, %				-	-	-
Mov Cap-1 Maneuver	435	684	1173	-	-	-
Mov Cap-2 Maneuver	435	-	-	-	-	-
Stage 1	678	-	-	-	-	-
Stage 2	785	-	-	-	-	-

Approach	EB	NB	SB
HCM Control Delay, s	11.8	1.7	0
HCM LOS	B		

Minor Lane/Major Mvmt	NBL	NBT	EBLn1	EBLn2	SBT	SBR
Capacity (veh/h)	1173	-	435	684	-	-
HCM Lane V/C Ratio	0.037	-	0.024	0.019	-	-
HCM Control Delay (s)	8.2	-	13.5	10.4	-	-
HCM Lane LOS	A	-	B	B	-	-
HCM 95th %tile Q(veh)	0.1	-	0.1	0.1	-	-

Intersection												
Int Delay, s/veh	15.6											
Movement	EBL	EBT	EBR	WBL	WBT	WBR	NBL	NBT	NBR	SBL	SBT	SBR
Lane Configurations	↖	↑	↗	↖	↑	↗	↖	↑	↗	↖	↑	↗
Traffic Vol, veh/h	51	57	267	14	213	49	66	85	1	8	227	53
Future Vol, veh/h	51	57	267	14	213	49	66	85	1	8	227	53
Conflicting Peds, #/hr	0	0	0	0	0	0	0	0	0	0	0	0
Sign Control	Free	Free	Free	Free	Free	Free	Stop	Stop	Stop	Stop	Stop	Stop
RT Channelized	-	-	None	-	-	None	-	-	None	-	-	None
Storage Length	0	-	0	0	-	-	0	-	-	0	-	0
Veh in Median Storage, #	-	0	-	-	0	-	-	0	-	-	0	-
Grade, %	-	0	-	-	0	-	-	0	-	-	0	-
Peak Hour Factor	92	92	92	92	92	92	87	87	87	92	92	92
Heavy Vehicles, %	2	2	2	2	2	2	2	2	2	2	2	2
Mvmt Flow	55	62	290	15	232	53	76	98	1	9	247	58

Major/Minor	Major1			Major2			Minor1			Minor2		
Conflicting Flow All	285	0	0	352	0	0	613	487	62	656	751	259
Stage 1	-	-	-	-	-	-	172	172	-	289	289	-
Stage 2	-	-	-	-	-	-	441	315	-	367	462	-
Critical Hdwy	4.12	-	-	4.12	-	-	7.12	6.52	6.22	7.12	6.52	6.22
Critical Hdwy Stg 1	-	-	-	-	-	-	6.12	5.52	-	6.12	5.52	-
Critical Hdwy Stg 2	-	-	-	-	-	-	6.12	5.52	-	6.12	5.52	-
Follow-up Hdwy	2.218	-	-	2.218	-	-	3.518	4.018	3.318	3.518	4.018	3.318
Pot Cap-1 Maneuver	1277	-	-	1207	-	-	405	481	1003	379	340	780
Stage 1	-	-	-	-	-	-	830	756	-	719	673	-
Stage 2	-	-	-	-	-	-	595	656	-	653	565	-
Platoon blocked, %	-	-	-	-	-	-	-	-	-	-	-	-
Mov Cap-1 Maneuver	1277	-	-	1207	-	-	134	455	1003	303	322	780
Mov Cap-2 Maneuver	-	-	-	-	-	-	134	455	-	303	322	-
Stage 1	-	-	-	-	-	-	794	723	-	688	665	-
Stage 2	-	-	-	-	-	-	342	648	-	540	541	-

Approach	EB			WB			NB			SB		
HCM Control Delay, s	1.1			0.4			35.5			37.8		
HCM LOS							E			E		

Minor Lane/Major Mvmt	NBLn1	NBLn2	EBL	EBT	EBR	WBL	WBT	WBR	SBLn1	SBLn2	SBLn3
Capacity (veh/h)	134	458	1277	-	-	1207	-	-	303	322	780
HCM Lane V/C Ratio	0.566	0.216	0.043	-	-	0.013	-	-	0.029	0.766	0.074
HCM Control Delay (s)	62.2	15	7.9	-	-	8	-	-	17.2	45	10
HCM Lane LOS	F	C	A	-	-	A	-	-	C	E	B
HCM 95th %tile Q(veh)	2.8	0.8	0.1	-	-	0	-	-	0.1	6	0.2

Intersection	
Intersection Delay, s/veh	15.2
Intersection LOS	C

Movement	EBL	EBT	EBR	WBL	WBT	WBR	NBL	NBT	NBR	SBL	SBT	SBR
Lane Configurations	↶	↶	↶	↶	↶		↶	↶		↶	↶	↶
Traffic Vol, veh/h	48	215	67	8	98	13	242	206	30	25	59	57
Future Vol, veh/h	48	215	67	8	98	13	242	206	30	25	59	57
Peak Hour Factor	0.92	0.92	0.92	0.83	0.83	0.83	0.92	0.92	0.92	0.83	0.83	0.83
Heavy Vehicles, %	2	2	2	2	2	2	2	2	2	2	2	2
Mvmt Flow	52	234	73	10	118	16	263	224	33	30	71	69
Number of Lanes	1	1	1	1	1	0	1	1	0	1	1	1

























Approach	EB	WB	NB	SB
Opposing Approach	WB	EB	SB	NB
Opposing Lanes	2	3	3	2
Conflicting Approach Left	SB	NB	EB	WB
Conflicting Lanes Left	3	2	3	2
Conflicting Approach Right	NB	SB	WB	EB
Conflicting Lanes Right	2	3	2	3
HCM Control Delay	14.7	13.5	17.3	11.5
HCM LOS	B	B	C	B

Lane	NBLn1	NBLn2	EBLn1	EBLn2	EBLn3	WBLn1	WBLn2	SBLn1	SBLn2	SBLn3
Vol Left, %	100%	0%	100%	0%	0%	100%	0%	100%	0%	0%
Vol Thru, %	0%	87%	0%	100%	0%	0%	88%	0%	100%	0%
Vol Right, %	0%	13%	0%	0%	100%	0%	12%	0%	0%	100%
Sign Control	Stop	Stop	Stop	Stop	Stop	Stop	Stop	Stop	Stop	Stop
Traffic Vol by Lane	242	236	48	215	67	8	111	25	59	57
LT Vol	242	0	48	0	0	8	0	25	0	0
Through Vol	0	206	0	215	0	0	98	0	59	0
RT Vol	0	30	0	0	67	0	13	0	0	57
Lane Flow Rate	263	257	52	234	73	10	134	30	71	69
Geometry Grp	6	6	6	6	6	6	6	6	6	6
Degree of Util (X)	0.542	0.486	0.114	0.477	0.134	0.022	0.29	0.07	0.154	0.136
Departure Headway (Hd)	7.415	6.819	7.859	7.353	6.643	8.395	7.803	8.334	7.824	7.111
Convergence, Y/N	Yes	Yes	Yes	Yes	Yes	Yes	Yes	Yes	Yes	Yes
Cap	487	528	457	491	540	427	460	430	458	504
Service Time	5.151	4.555	5.599	5.092	4.382	6.143	5.55	6.083	5.573	4.859
HCM Lane V/C Ratio	0.54	0.487	0.114	0.477	0.135	0.023	0.291	0.07	0.155	0.137
HCM Control Delay	18.6	15.9	11.6	16.7	10.4	11.3	13.7	11.7	12	11
HCM Lane LOS	C	C	B	C	B	B	B	B	B	B
HCM 95th-tile Q	3.2	2.6	0.4	2.5	0.5	0.1	1.2	0.2	0.5	0.5

Intersection				
Intersection Delay, s/veh	7.1			
Intersection LOS	A			
Approach	EB	WB	NB	SB
Entry Lanes	1	1	1	1
Conflicting Circle Lanes	1	1	1	1
Adj Approach Flow, veh/h	312	135	487	142
Demand Flow Rate, veh/h	317	137	497	145
Vehicles Circulating, veh/h	106	489	278	376
Vehicles Exiting, veh/h	415	286	145	250
Ped Vol Crossing Leg, #/h	0	0	0	0
Ped Cap Adj	1.000	1.000	1.000	1.000
Approach Delay, s/veh	5.3	6.0	9.1	5.4
Approach LOS	A	A	A	A
Lane	Left	Left	Left	Left
Designated Moves	LTR	LTR	LTR	LTR
Assumed Moves	LTR	LTR	LTR	LTR
RT Channelized				
Lane Util	1.000	1.000	1.000	1.000
Follow-Up Headway, s	2.609	2.609	2.609	2.609
Critical Headway, s	4.976	4.976	4.976	4.976
Entry Flow, veh/h	317	137	497	145
Cap Entry Lane, veh/h	1238	838	1039	940
Entry HV Adj Factor	0.983	0.984	0.980	0.977
Flow Entry, veh/h	312	135	487	142
Cap Entry, veh/h	1217	824	1018	919
V/C Ratio	0.256	0.163	0.478	0.154
Control Delay, s/veh	5.3	6.0	9.1	5.4
LOS	A	A	A	A
95th %tile Queue, veh	1	1	3	1

Lanes, Volumes, Timings
4: US 24 & Curtis/Stapleton

2023 Existing + Site
PM

												
Lane Group	SEL	SET	SER	NWL	NWT	NWR	NEL	NET	NER	SWL	SWT	SWR
Lane Configurations												
Traffic Volume (vph)	17	47	49	12	148	29	119	459	33	13	364	29
Future Volume (vph)	17	47	49	12	148	29	119	459	33	13	364	29
Ideal Flow (vphpl)	1900	1900	1900	1900	1900	1900	1900	1900	1900	1900	1900	1900
Storage Length (ft)	190		325	215		215	890		1000	790		790
Storage Lanes	1		1	1		0	1		1	1		1
Taper Length (ft)	240			200			190			190		
Lane Util. Factor	1.00	1.00	1.00	1.00	1.00	1.00	1.00	1.00	1.00	1.00	1.00	1.00
Frt			0.850			0.850			0.850			0.850
Flt Protected	0.950			0.950			0.950			0.950		
Satd. Flow (prot)	1770	1863	1583	1770	1863	1583	1770	1863	1583	1770	1863	1583
Flt Permitted	0.650			0.720			0.354			0.376		
Satd. Flow (perm)	1211	1863	1583	1341	1863	1583	659	1863	1583	700	1863	1583
Right Turn on Red			Yes			Yes			Yes			Yes
Satd. Flow (RTOR)			191			191			191			191
Link Speed (mph)		45			45			55			55	
Link Distance (ft)		1349			1298			2758			1426	
Travel Time (s)		20.4			19.7			34.2			17.7	
Peak Hour Factor	0.83	0.83	0.83	0.87	0.87	0.87	0.93	0.93	0.93	0.92	0.92	0.92
Adj. Flow (vph)	20	57	59	14	170	33	128	494	35	14	396	32
Shared Lane Traffic (%)												
Lane Group Flow (vph)	20	57	59	14	170	33	128	494	35	14	396	32
Enter Blocked Intersection	No	No	No	No	No	No	No	No	No	No	No	No
Lane Alignment	Left	Left	Right	Left	Left	Right	Left	Left	Right	Left	Left	Right
Median Width(ft)		12			12			12			12	
Link Offset(ft)		0			0			0			0	
Crosswalk Width(ft)		16			16			16			16	
Two way Left Turn Lane												
Headway Factor	1.00	1.00	1.00	1.00	1.00	1.00	1.00	1.00	1.00	1.00	1.00	1.00
Turning Speed (mph)	15		9	15		9	15		9	15		9
Number of Detectors	1	2	1	1	2	1	1	2	1	1	2	1
Detector Template	Left	Thru	Right	Left	Thru	Right	Left	Thru	Right	Left	Thru	Right
Leading Detector (ft)	20	100	20	20	100	20	20	100	20	20	100	20
Trailing Detector (ft)	0	0	0	0	0	0	0	0	0	0	0	0
Detector 1 Position(ft)	0	0	0	0	0	0	0	0	0	0	0	0
Detector 1 Size(ft)	20	6	20	20	6	20	20	6	20	20	6	20
Detector 1 Type	Cl+Ex	Cl+Ex	Cl+Ex	Cl+Ex	Cl+Ex	Cl+Ex	Cl+Ex	Cl+Ex	Cl+Ex	Cl+Ex	Cl+Ex	Cl+Ex
Detector 1 Channel												
Detector 1 Extend (s)	0.0	0.0	0.0	0.0	0.0	0.0	0.0	0.0	0.0	0.0	0.0	0.0
Detector 1 Queue (s)	0.0	0.0	0.0	0.0	0.0	0.0	0.0	0.0	0.0	0.0	0.0	0.0
Detector 1 Delay (s)	0.0	0.0	0.0	0.0	0.0	0.0	0.0	0.0	0.0	0.0	0.0	0.0
Detector 2 Position(ft)		94			94			94			94	
Detector 2 Size(ft)		6			6			6			6	
Detector 2 Type		Cl+Ex			Cl+Ex			Cl+Ex			Cl+Ex	
Detector 2 Channel												
Detector 2 Extend (s)		0.0			0.0			0.0			0.0	
Turn Type	pm+pt	NA	Perm	pm+pt	NA	Perm	pm+pt	NA	Perm	pm+pt	NA	Perm
Protected Phases	1	6		5	2		7	4		3	8	
Permitted Phases	6		6	2		2	4		4	8		8

Lanes, Volumes, Timings
4: US 24 & Curtis/Stapleton

2023 Existing + Site
PM











Lane Group	SEL	SET	SER	NWL	NWT	NWR	NEL	NET	NER	SWL	SWT	SWR
Detector Phase	1	6	6	5	2	2	7	4	4	3	8	8
Switch Phase												
Minimum Initial (s)	5.0	5.0	5.0	5.0	5.0	5.0	5.0	5.0	5.0	5.0	5.0	5.0
Minimum Split (s)	9.5	22.5	22.5	9.5	22.5	22.5	9.5	22.5	22.5	9.5	22.5	22.5
Total Split (s)	8.5	21.5	21.5	8.5	21.5	21.5	8.5	21.5	21.5	8.5	21.5	21.5
Total Split (%)	14.2%	35.8%	35.8%	14.2%	35.8%	35.8%	14.2%	35.8%	35.8%	14.2%	35.8%	35.8%
Maximum Green (s)	4.0	17.0	17.0	4.0	17.0	17.0	4.0	17.0	17.0	4.0	17.0	17.0
Yellow Time (s)	3.5	3.5	3.5	3.5	3.5	3.5	3.5	3.5	3.5	3.5	3.5	3.5
All-Red Time (s)	1.0	1.0	1.0	1.0	1.0	1.0	1.0	1.0	1.0	1.0	1.0	1.0
Lost Time Adjust (s)	0.0	0.0	0.0	0.0	0.0	0.0	0.0	0.0	0.0	0.0	0.0	0.0
Total Lost Time (s)	4.5	4.5	4.5	4.5	4.5	4.5	4.5	4.5	4.5	4.5	4.5	4.5
Lead/Lag	Lead	Lag	Lag	Lead	Lag	Lag	Lead	Lag	Lag	Lead	Lag	Lag
Lead-Lag Optimize?	Yes	Yes	Yes	Yes	Yes	Yes	Yes	Yes	Yes	Yes	Yes	Yes
Vehicle Extension (s)	3.0	3.0	3.0	3.0	3.0	3.0	3.0	3.0	3.0	3.0	3.0	3.0
Recall Mode	None	Min	Min	None	Min	Min	None	None	None	None	None	None
Walk Time (s)		7.0	7.0		7.0	7.0		7.0	7.0		7.0	7.0
Flash Dont Walk (s)		11.0	11.0		11.0	11.0		11.0	11.0		11.0	11.0
Pedestrian Calls (#/hr)		0	0		0	0		0	0		0	0
Act Effct Green (s)	10.0	9.5	9.5	10.0	9.5	9.5	20.7	20.1	20.1	18.0	14.9	14.9
Actuated g/C Ratio	0.24	0.23	0.23	0.24	0.23	0.23	0.50	0.48	0.48	0.43	0.36	0.36
v/c Ratio	0.06	0.13	0.12	0.04	0.40	0.07	0.29	0.55	0.04	0.03	0.59	0.05
Control Delay	12.4	15.7	0.5	12.2	18.7	0.2	8.8	14.9	0.1	7.1	18.1	0.1
Queue Delay	0.0	0.0	0.0	0.0	0.0	0.0	0.0	0.0	0.0	0.0	0.0	0.0
Total Delay	12.4	15.7	0.5	12.2	18.7	0.2	8.8	14.9	0.1	7.1	18.1	0.1
LOS	B	B	A	B	B	A	A	B	A	A	B	A
Approach Delay		8.6			15.5			13.0			16.5	
Approach LOS		A			B			B			B	
Queue Length 50th (ft)	4	11	0	3	33	0	12	57	0	1	73	0
Queue Length 95th (ft)	13	36	0	11	91	0	51	#316	0	10	#231	0
Internal Link Dist (ft)		1269			1218			2678			1346	
Turn Bay Length (ft)	190		325	215		215	890		1000	790		790
Base Capacity (vph)	349	806	793	367	806	793	441	962	910	411	806	793
Starvation Cap Reductn	0	0	0	0	0	0	0	0	0	0	0	0
Spillback Cap Reductn	0	0	0	0	0	0	0	0	0	0	0	0
Storage Cap Reductn	0	0	0	0	0	0	0	0	0	0	0	0
Reduced v/c Ratio	0.06	0.07	0.07	0.04	0.21	0.04	0.29	0.51	0.04	0.03	0.49	0.04

Intersection Summary

Area Type:	Other
Cycle Length:	60
Actuated Cycle Length:	41.6
Natural Cycle:	65
Control Type:	Actuated-Uncoordinated
Maximum v/c Ratio:	0.59
Intersection Signal Delay:	14.0
Intersection LOS:	B
Intersection Capacity Utilization:	53.7%
ICU Level of Service:	A
Analysis Period (min):	15
# 95th percentile volume exceeds capacity, queue may be longer. Queue shown is maximum after two cycles.	

Splits and Phases: 4: US 24 & Curtis/Stapleton

 Ø1	 Ø2	 Ø3	 Ø4
8.5 s	21.5 s	8.5 s	21.5 s
 Ø5	 Ø6	 Ø7	 Ø8
8.5 s	21.5 s	8.5 s	21.5 s

Intersection												
Int Delay, s/veh	7.3											
Movement	EBL	EBT	EBR	WBL	WBT	WBR	NBL	NBT	NBR	SBL	SBT	SBR
Lane Configurations	↶	↷		↶	↷		↶	↷		↶	↷	
Traffic Vol, veh/h	7	153	45	3	97	19	77	149	9	34	68	4
Future Vol, veh/h	7	153	45	3	97	19	77	149	9	34	68	4
Conflicting Peds, #/hr	0	0	0	0	0	0	0	0	0	0	0	0
Sign Control	Free	Free	Free	Free	Free	Free	Stop	Stop	Stop	Stop	Stop	Stop
RT Channelized	-	-	None	-	-	None	-	-	None	-	-	None
Storage Length	0	-	-	0	-	-	0	-	-	0	-	-
Veh in Median Storage, #	-	0	-	-	0	-	-	0	-	-	0	-
Grade, %	-	0	-	-	0	-	-	0	-	-	0	-
Peak Hour Factor	87	87	87	83	83	83	87	87	87	83	83	83
Heavy Vehicles, %	2	2	2	2	2	2	2	2	2	2	2	2
Mvmt Flow	8	176	52	4	117	23	89	171	10	41	82	5

Major/Minor	Major1			Major2			Minor1			Minor2		
Conflicting Flow All	140	0	0	228	0	0	398	366	202	446	381	129
Stage 1	-	-	-	-	-	-	218	218	-	137	137	-
Stage 2	-	-	-	-	-	-	180	148	-	309	244	-
Critical Hdwy	4.12	-	-	4.12	-	-	7.12	6.52	6.22	7.12	6.52	6.22
Critical Hdwy Stg 1	-	-	-	-	-	-	6.12	5.52	-	6.12	5.52	-
Critical Hdwy Stg 2	-	-	-	-	-	-	6.12	5.52	-	6.12	5.52	-
Follow-up Hdwy	2.218	-	-	2.218	-	-	3.518	4.018	3.318	3.518	4.018	3.318
Pot Cap-1 Maneuver	1443	-	-	1340	-	-	562	562	839	523	552	921
Stage 1	-	-	-	-	-	-	784	723	-	866	783	-
Stage 2	-	-	-	-	-	-	822	775	-	701	704	-
Platoon blocked, %	-	-	-	-	-	-	-	-	-	-	-	-
Mov Cap-1 Maneuver	1443	-	-	1340	-	-	492	557	839	391	547	921
Mov Cap-2 Maneuver	-	-	-	-	-	-	492	557	-	391	547	-
Stage 1	-	-	-	-	-	-	779	719	-	861	781	-
Stage 2	-	-	-	-	-	-	730	773	-	525	700	-

Approach	EB			WB			NB			SB		
HCM Control Delay, s	0.3			0.2			14.2			13.5		
HCM LOS							B			B		

Minor Lane/Major Mvmt	NBLn1	NBLn2	EBL	EBT	EBR	WBL	WBT	WBR	SBLn1	SBLn2
Capacity (veh/h)	492	568	1443	-	-	1340	-	-	391	560
HCM Lane V/C Ratio	0.18	0.32	0.006	-	-	0.003	-	-	0.105	0.155
HCM Control Delay (s)	13.9	14.3	7.5	-	-	7.7	-	-	15.3	12.6
HCM Lane LOS	B	B	A	-	-	A	-	-	C	B
HCM 95th %tile Q(veh)	0.7	1.4	0	-	-	0	-	-	0.3	0.5

Intersection						
Int Delay, s/veh	1.7					
Movement	EBL	EBR	NBL	NBT	SBT	SBR
Lane Configurations	↖	↗	↖	↗	↗	↖
Traffic Vol, veh/h	26	34	13	254	107	9
Future Vol, veh/h	26	34	13	254	107	9
Conflicting Peds, #/hr	0	0	0	0	0	0
Sign Control	Stop	Stop	Free	Free	Free	Free
RT Channelized	-	None	-	None	-	None
Storage Length	0	0	385	-	-	235
Veh in Median Storage, #	0	-	-	0	0	-
Grade, %	0	-	-	0	0	-
Peak Hour Factor	83	83	92	92	83	83
Heavy Vehicles, %	2	2	2	2	2	2
Mvmt Flow	31	41	14	276	129	11

Major/Minor	Minor2	Major1	Major2			
Conflicting Flow All	433	129	140	0	-	0
Stage 1	129	-	-	-	-	-
Stage 2	304	-	-	-	-	-
Critical Hdwy	6.42	6.22	4.12	-	-	-
Critical Hdwy Stg 1	5.42	-	-	-	-	-
Critical Hdwy Stg 2	5.42	-	-	-	-	-
Follow-up Hdwy	3.518	3.318	2.218	-	-	-
Pot Cap-1 Maneuver	580	921	1443	-	-	-
Stage 1	897	-	-	-	-	-
Stage 2	748	-	-	-	-	-
Platoon blocked, %				-	-	-
Mov Cap-1 Maneuver	574	921	1443	-	-	-
Mov Cap-2 Maneuver	574	-	-	-	-	-
Stage 1	888	-	-	-	-	-
Stage 2	748	-	-	-	-	-

Approach	EB	NB	SB
HCM Control Delay, s	10.2	0.4	0
HCM LOS	B		

Minor Lane/Major Mvmt	NBL	NBT	EBLn1	EBLn2	SBT	SBR
Capacity (veh/h)	1443	-	574	921	-	-
HCM Lane V/C Ratio	0.01	-	0.055	0.044	-	-
HCM Control Delay (s)	7.5	-	11.6	9.1	-	-
HCM Lane LOS	A	-	B	A	-	-
HCM 95th %tile Q(veh)	0	-	0.2	0.1	-	-

Intersection												
Int Delay, s/veh	16.2											
Movement	EBL	EBT	EBR	WBL	WBT	WBR	NBL	NBT	NBR	SBL	SBT	SBR
Lane Configurations	↖	↑	↗	↖	↑	↗	↖	↑	↗	↖	↑	↗
Traffic Vol, veh/h	48	215	67	8	98	13	242	206	30	25	59	57
Future Vol, veh/h	48	215	67	8	98	13	242	206	30	25	59	57
Conflicting Peds, #/hr	0	0	0	0	0	0	0	0	0	0	0	0
Sign Control	Free	Free	Free	Free	Free	Free	Stop	Stop	Stop	Stop	Stop	Stop
RT Channelized	-	-	None	-	-	None	-	-	None	-	-	None
Storage Length	0	-	0	0	-	-	0	-	-	0	-	0
Veh in Median Storage, #	-	0	-	-	0	-	-	0	-	-	0	-
Grade, %	-	0	-	-	0	-	-	0	-	-	0	-
Peak Hour Factor	92	92	92	83	83	83	92	92	92	83	83	83
Heavy Vehicles, %	2	2	2	2	2	2	2	2	2	2	2	2
Mvmt Flow	52	234	73	10	118	16	263	224	33	30	71	69

Major/Minor	Major1			Major2			Minor1			Minor2		
Conflicting Flow All	134	0	0	307	0	0	554	492	234	649	557	126
Stage 1	-	-	-	-	-	-	338	338	-	146	146	-
Stage 2	-	-	-	-	-	-	216	154	-	503	411	-
Critical Hdwy	4.12	-	-	4.12	-	-	7.12	6.52	6.22	7.12	6.52	6.22
Critical Hdwy Stg 1	-	-	-	-	-	-	6.12	5.52	-	6.12	5.52	-
Critical Hdwy Stg 2	-	-	-	-	-	-	6.12	5.52	-	6.12	5.52	-
Follow-up Hdwy	2.218	-	-	2.218	-	-	3.518	4.018	3.318	3.518	4.018	3.318
Pot Cap-1 Maneuver	1451	-	-	1254	-	-	443	478	805	383	439	924
Stage 1	-	-	-	-	-	-	676	641	-	857	776	-
Stage 2	-	-	-	-	-	-	786	770	-	551	595	-
Platoon blocked, %	-	-	-	-	-	-	-	-	-	-	-	-
Mov Cap-1 Maneuver	1451	-	-	1254	-	-	345	457	805	219	420	924
Mov Cap-2 Maneuver	-	-	-	-	-	-	345	457	-	219	420	-
Stage 1	-	-	-	-	-	-	652	618	-	826	770	-
Stage 2	-	-	-	-	-	-	655	764	-	325	574	-

Approach	EB			WB			NB			SB		
HCM Control Delay, s	1.1			0.5			31.5			14.4		
HCM LOS							D			B		

Minor Lane/Major Mvmt	NBLn1	NBLn2	EBL	EBT	EBR	WBL	WBT	WBR	SBLn1	SBLn2	SBLn3
Capacity (veh/h)	345	484	1451	-	-	1254	-	-	219	420	924
HCM Lane V/C Ratio	0.762	0.53	0.036	-	-	0.008	-	-	0.138	0.169	0.074
HCM Control Delay (s)	42.2	20.5	7.6	-	-	7.9	-	-	24	15.3	9.2
HCM Lane LOS	E	C	A	-	-	A	-	-	C	C	A
HCM 95th %tile Q(veh)	6.1	3.1	0.1	-	-	0	-	-	0.5	0.6	0.2

Queuing Reports



Intersection: 3: Curtis Rd & Falcon Hwy, Interval #1

Movement	EB	EB	WB	NB	NB	SB	SB	SB
Directions Served	L	R	L	L	TR	L	T	R
Maximum Queue (ft)	22	14	21	45	63	22	124	45
Average Queue (ft)	5	7	6	23	27	5	79	29
95th Queue (ft)	21	18	23	47	59	24	124	51
Link Distance (ft)					641		762	
Upstream Blk Time (%)								
Queuing Penalty (veh)								
Storage Bay Dist (ft)	275	275	255	365		290		265
Storage Blk Time (%)								
Queuing Penalty (veh)								

Intersection: 3: Curtis Rd & Falcon Hwy, Interval #2

Movement	EB	EB	WB	WB	NB	NB	SB	SB	SB
Directions Served	L	R	L	TR	L	TR	L	T	R
Maximum Queue (ft)	34	32	24	8	56	62	29	169	40
Average Queue (ft)	14	14	6	2	32	28	8	105	26
95th Queue (ft)	37	34	27	17	67	61	30	190	44
Link Distance (ft)				845		641		762	
Upstream Blk Time (%)									
Queuing Penalty (veh)									
Storage Bay Dist (ft)	275	275	255		365		290		265
Storage Blk Time (%)									
Queuing Penalty (veh)									

Intersection: 3: Curtis Rd & Falcon Hwy, Interval #3

Movement	EB	EB	WB	WB	NB	NB	SB	SB	SB
Directions Served	L	R	L	TR	L	TR	L	T	R
Maximum Queue (ft)	25	16	11	13	41	37	30	141	41
Average Queue (ft)	9	8	2	2	20	20	7	81	25
95th Queue (ft)	27	19	14	14	40	37	27	140	43
Link Distance (ft)				845		641		762	
Upstream Blk Time (%)									
Queuing Penalty (veh)									
Storage Bay Dist (ft)	275	275	255		365		290		265
Storage Blk Time (%)									
Queuing Penalty (veh)									

Intersection: 3: Curtis Rd & Falcon Hwy, Interval #4

Movement	EB	EB	WB	WB	NB	NB	SB	SB	SB
Directions Served	L	R	L	TR	L	TR	L	T	R
Maximum Queue (ft)	24	13	11	12	46	46	17	148	45
Average Queue (ft)	12	7	3	2	19	25	3	86	28
95th Queue (ft)	30	18	17	11	37	47	19	167	51
Link Distance (ft)				845		641		762	
Upstream Blk Time (%)									
Queuing Penalty (veh)									
Storage Bay Dist (ft)	275	275	255		365		290		265
Storage Blk Time (%)								0	
Queuing Penalty (veh)								0	

Intersection: 3: Curtis Rd & Falcon Hwy, All Intervals

Movement	EB	EB	WB	WB	NB	NB	SB	SB	SB
Directions Served	L	R	L	TR	L	TR	L	T	R
Maximum Queue (ft)	35	34	32	29	60	79	35	199	59
Average Queue (ft)	10	9	4	1	23	25	6	88	27
95th Queue (ft)	30	23	21	12	50	53	25	159	47
Link Distance (ft)				845		641		762	
Upstream Blk Time (%)									
Queuing Penalty (veh)									
Storage Bay Dist (ft)	275	275	255		365		290		265
Storage Blk Time (%)								0	
Queuing Penalty (veh)								0	

Network Summary

Network wide Queuing Penalty, Interval #1: 0
Network wide Queuing Penalty, Interval #2: 0
Network wide Queuing Penalty, Interval #3: 0
Network wide Queuing Penalty, Interval #4: 0
Network wide Queuing Penalty, All Intervals: 0

Intersection: 3: Curtis Rd & Falcon Hwy, Interval #1

Movement	EB	WB	WB	NB	NB	SB	SB	SB
Directions Served	L	L	TR	L	TR	L	T	R
Maximum Queue (ft)	22	16	4	112	89	37	56	44
Average Queue (ft)	5	2	1	70	50	17	32	27
95th Queue (ft)	21	14	7	115	90	43	61	51
Link Distance (ft)			845		1025		763	
Upstream Blk Time (%)								
Queuing Penalty (veh)								
Storage Bay Dist (ft)	275	255		365		290		265
Storage Blk Time (%)								
Queuing Penalty (veh)								

Intersection: 3: Curtis Rd & Falcon Hwy, Interval #2

Movement	EB	EB	WB	NB	NB	SB	SB	SB
Directions Served	L	R	L	L	TR	L	T	R
Maximum Queue (ft)	20	2	9	151	83	32	58	46
Average Queue (ft)	2	0	1	71	53	16	34	28
95th Queue (ft)	13	4	10	128	90	39	60	56
Link Distance (ft)					1025		763	
Upstream Blk Time (%)								
Queuing Penalty (veh)								
Storage Bay Dist (ft)	275	275	255	365		290		265
Storage Blk Time (%)								
Queuing Penalty (veh)								

Intersection: 3: Curtis Rd & Falcon Hwy, Interval #3

Movement	EB	EB	WB	NB	NB	SB	SB	SB
Directions Served	L	R	L	L	TR	L	T	R
Maximum Queue (ft)	14	3	10	131	78	28	44	48
Average Queue (ft)	2	0	2	63	43	15	28	26
95th Queue (ft)	14	4	14	145	78	36	48	41
Link Distance (ft)					1025		763	
Upstream Blk Time (%)								
Queuing Penalty (veh)								
Storage Bay Dist (ft)	275	275	255	365		290		265
Storage Blk Time (%)								
Queuing Penalty (veh)								

Intersection: 3: Curtis Rd & Falcon Hwy, Interval #4

Movement	EB	EB	EB	WB	NB	NB	SB	SB	SB
Directions Served	L	T	R	L	L	TR	L	T	R
Maximum Queue (ft)	22	3	2	5	174	78	38	47	56
Average Queue (ft)	5	0	0	1	88	42	14	32	31
95th Queue (ft)	22	4	3	7	197	75	41	52	57
Link Distance (ft)	749			1025			763		
Upstream Blk Time (%)									
Queuing Penalty (veh)									
Storage Bay Dist (ft)	275	275		255	365	290		265	
Storage Blk Time (%)	0								
Queuing Penalty (veh)	0								

Intersection: 3: Curtis Rd & Falcon Hwy, All Intervals

Movement	EB	EB	EB	WB	WB	NB	NB	SB	SB	SB
Directions Served	L	T	R	L	TR	L	TR	L	T	R
Maximum Queue (ft)	27	3	5	21	4	220	106	47	69	68
Average Queue (ft)	4	0	0	2	0	73	47	15	32	28
95th Queue (ft)	18	2	3	12	3	152	84	40	56	52
Link Distance (ft)	749			845			1025		763	
Upstream Blk Time (%)										
Queuing Penalty (veh)										
Storage Bay Dist (ft)	275	275		255	365	290		265		
Storage Blk Time (%)	0									
Queuing Penalty (veh)	0									

Network Summary

Network wide Queuing Penalty, Interval #1: 0
Network wide Queuing Penalty, Interval #2: 0
Network wide Queuing Penalty, Interval #3: 0
Network wide Queuing Penalty, Interval #4: 0
Network wide Queuing Penalty, All Intervals: 0

Appendix A



Appendix A: STUDY AREA DETERMINATION

Study Area Basis for Individual Full TIS

Per Section B.2.3.B of El Paso County's *Engineering Criteria Manual* (ECM):

The limits of the transportation network to be studied shall be based on the size and extent of the proposed development, the existing and future land uses, and traffic conditions on and near the site.

Additionally, off-site intersections which should be included for a full traffic impact study include those which meet the following criteria:

Additional offsite major intersections where: the project contributes a 10 percent impact (during either the A.M. or P.M. peak hour) to any approach leg of the intersection where the intersection is operating at a LOS of C or better in the Short-Range Horizon

LSC has calculated the percent increase in traffic for projected site-generated traffic volumes vs. existing traffic volumes. Site-generated trips only include those for Filing 1 (during the short term). Figure 3 presents the existing traffic volumes used in the calculation and Appendix Figure A-1 presents the short-term site-generated traffic at the offsite intersections evaluated in this analysis. Based on these calculations, the following intersections meet the ECM's "10 percent impact" threshold:

Intersection	Max % Increase vs. Existing Volumes ¹	Meets ECM's Off-Site 10% Impact
US 24 + Falcon Hwy	5.6%	No
US 24 + New Meridian	3.0%	No
US 24 + Judge Orr	2.8%	No
US 24 + Stapleton	7.0%	No
Judge Orr + Curtis/Stapleton	11.7%	Yes
Curtis + Sagebrush	14.9%	No
Curtis + Sharpstown	24.8%	Yes
Falcon Hwy + Curtis	13.6%	Yes
Falcon Hwy + West Access	6.7%	No
Falcon Hwy + New Meridian	11.2%	Yes

¹ Based on weighted average of AM + PM traffic volumes

Although the intersection of US 24/Stapleton Road would not meet the ECM’s 10-percent off-site impact requirement, LSC has included this intersection in the short-term total analysis as CDOT is requesting escrow for a future signal. This intersection is currently unsignalized.

Existing traffic volumes on the eastbound approach at Falcon Highway/New Meridian Road are projected to increase by 11.2 percent following the completion of Filing 1. However, this is a low-volume approach, with currently only 68 and 66 total eastbound vehicles during the AM and PM peak hours, respectively. Only 11 and 4 vehicles are projected to pass through the intersection of Falcon Highway/New Meridian Road during the AM and PM peak hours, respectively, following the completion of Filing 1. Due to the low peak-hour volumes both with and without site-generated traffic, LSC has not included Falcon Highway/New Meridian Road in the short-term total analysis. Please refer to Appendix Tables A-1 A-7 (on the next page) for more details.

Appendix Table A-1: US 24 + Falcon Hwy

Roadway		Existing		Site (ST, Filing 1 Only)		% Increase		
Approach	Name	AM	PM	AM	PM	AM	PM	Weighted Avg
SW	US 24	2386	632	0	0	0.0%	0.0%	0.0%
WB	Falcon Hwy	192	56	3	11	1.6%	19.6%	5.6%
NE	US 24	487	1316	11	4	2.3%	0.3%	0.8%
EB	Falcon Hwy	0	0	0	0	-	-	-

Appendix Table A-2: US 24 + New Meridian Rd

Roadway		Existing		Site (ST, Filing 1 Only)		% Increase		
Approach	Name	AM	PM	AM	PM	AM	PM	Weighted Avg
SE	US 24	1095	553	17	6	1.6%	1.1%	1.4%
SW	New Meridian Rd	656	465	0	0	0.0%	0.0%	0.0%
NW	US 24	199	405	4	14	2.0%	3.5%	3.0%
NE	New Meridian Rd	519	1298	0	0	0.0%	0.0%	0.0%

Appendix Table A-3: US 24 + Judge Orr Rd

Roadway		Existing		Site (ST, Filing 1 Only)		% Increase		
Approach	Name	AM	PM	AM	PM	AM	PM	Weighted Avg
SW	US 24	604	425	0	0	0.0%	0.0%	0.0%
WB	Judge Orr Rd	176	181	2	8	1.1%	4.4%	2.8%
NE	US 24	480	844	0	0	0.0%	0.0%	0.0%
EB	Judge Orr Rd	255	165	4	2	1.6%	1.2%	1.4%

Appendix Table A-4: US 24 + Stapleton Rd

Roadway		Existing		Site (ST, Filing 1 Only)		% Increase		
Approach	Name	AM	PM	AM	PM	AM	PM	Weighted Avg
SW	US 24	508	405	3	1	0.6%	0.2%	0.4%
NW	Stapleton Rd	110	174	5	15	4.5%	8.6%	7.0%
NE	US 24	319	611	0	0	0.0%	0.0%	0.0%
SE	Stapleton Rd	301	108	12	5	4.0%	4.6%	4.2%

Appendix Table A-5: Judge Orr Rd + Curtis Rd/Stapleton Rd

Roadway		Existing		Site (ST, Filing 1 Only)		% Increase		
Approach	Name	AM	PM	AM	PM	AM	PM	Weighted Avg
SB	Curtis Rd	195	66	15	6	7.7%	9.1%	8.0%
WB	Judge Orr Rd	182	92	1	0	0.5%	0.0%	0.4%
NB	Stapleton Rd	114	177	8	26	7.0%	14.7%	11.7%
EB	Judge Orr Rd	110	147	6	3	5.5%	2.0%	3.5%

Appendix Table A-6: Falcon Hwy + Curtis Rd

Roadway		Existing		Site (ST, Filing 1 Only)		% Increase		
Approach	Name	AM	PM	AM	PM	AM	PM	Weighted Avg
SB	Curtis Rd	240	84	10	34	4.2%	40.5%	13.6%
WB	Curtis Rd	257	111	3	1	1.2%	0.9%	1.1%
NB	Falcon Hwy	138	446	5	2	3.6%	0.4%	1.2%
EB	Falcon Hwy	319	277	30	10	9.4%	3.6%	6.7%

Appendix Table A-7: Falcon Hwy + New Meridian Rd

Roadway		Existing		Site (ST, Filing 1 Only)		% Increase		
Approach	Name	AM	PM	AM	PM	AM	PM	Weighted Avg
SB	New Meridian Rd	261	221	17	6	6.5%	2.7%	4.8%
WB	New Meridian Rd	333	327	7	25	2.1%	7.6%	4.8%
NB	Falcon Hwy	80	107	0	0	0.0%	0.0%	0.0%
EB	Falcon Hwy	66	68	11	4	16.7%	5.9%	11.2%

Appendix B





Approximate Scale
Scale: 1" = 3,000'

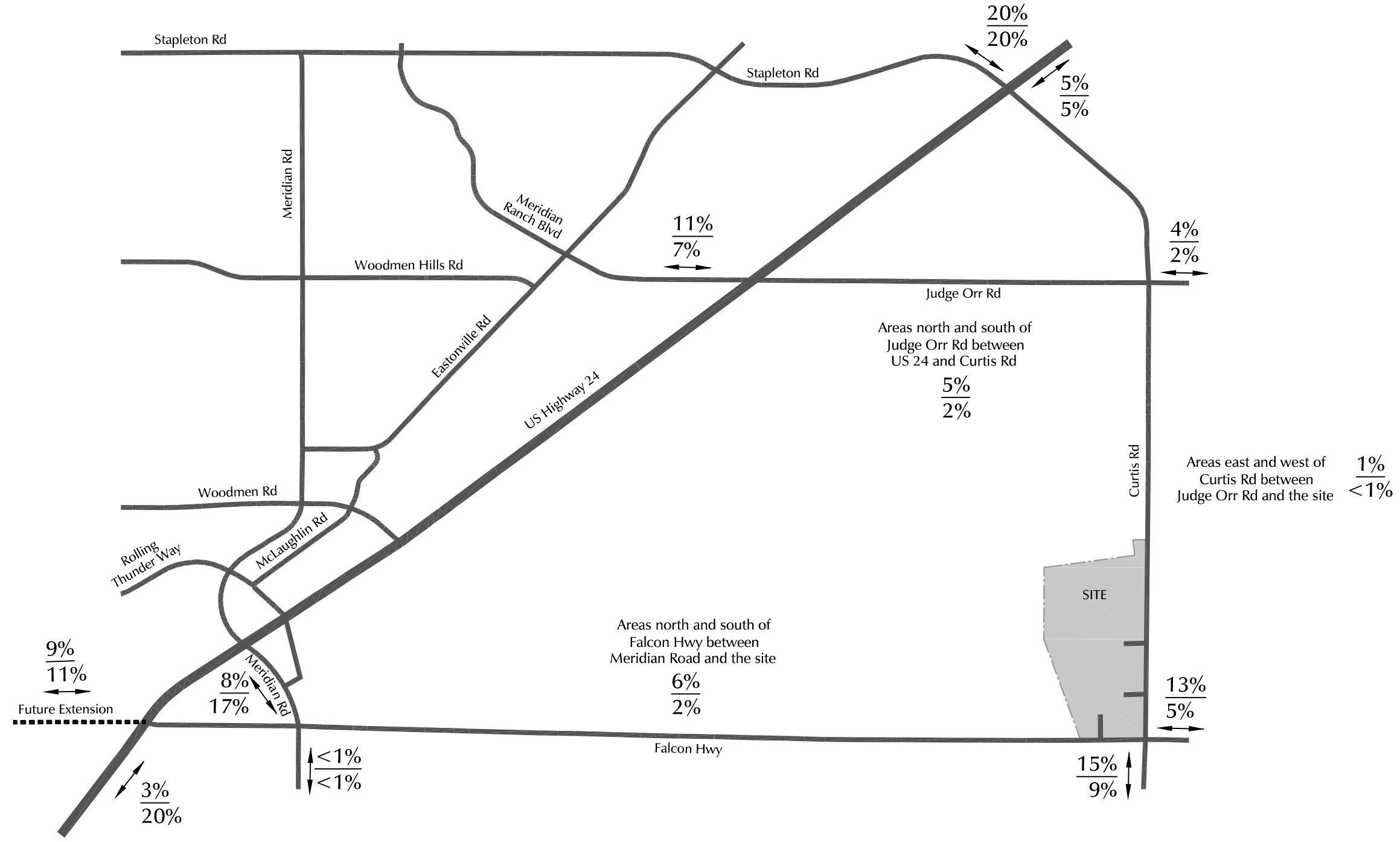

Appendix Figure B-1
(A copy of Figure 5 from the Master TIS report dated July 29, 2022)



$\frac{XX\%}{XX\%} = \frac{\text{Directional Distribution for Primary Trips to/from Commercial Land Uses}}{\text{Directional Distribution for Primary Trips to/from Industrial Land Uses}}$

Long-Term Directional Distribution - Primary Trips

Meadowlake Industrial Park (LSC #S214950)

Traffic Volume - Net New Site Trips

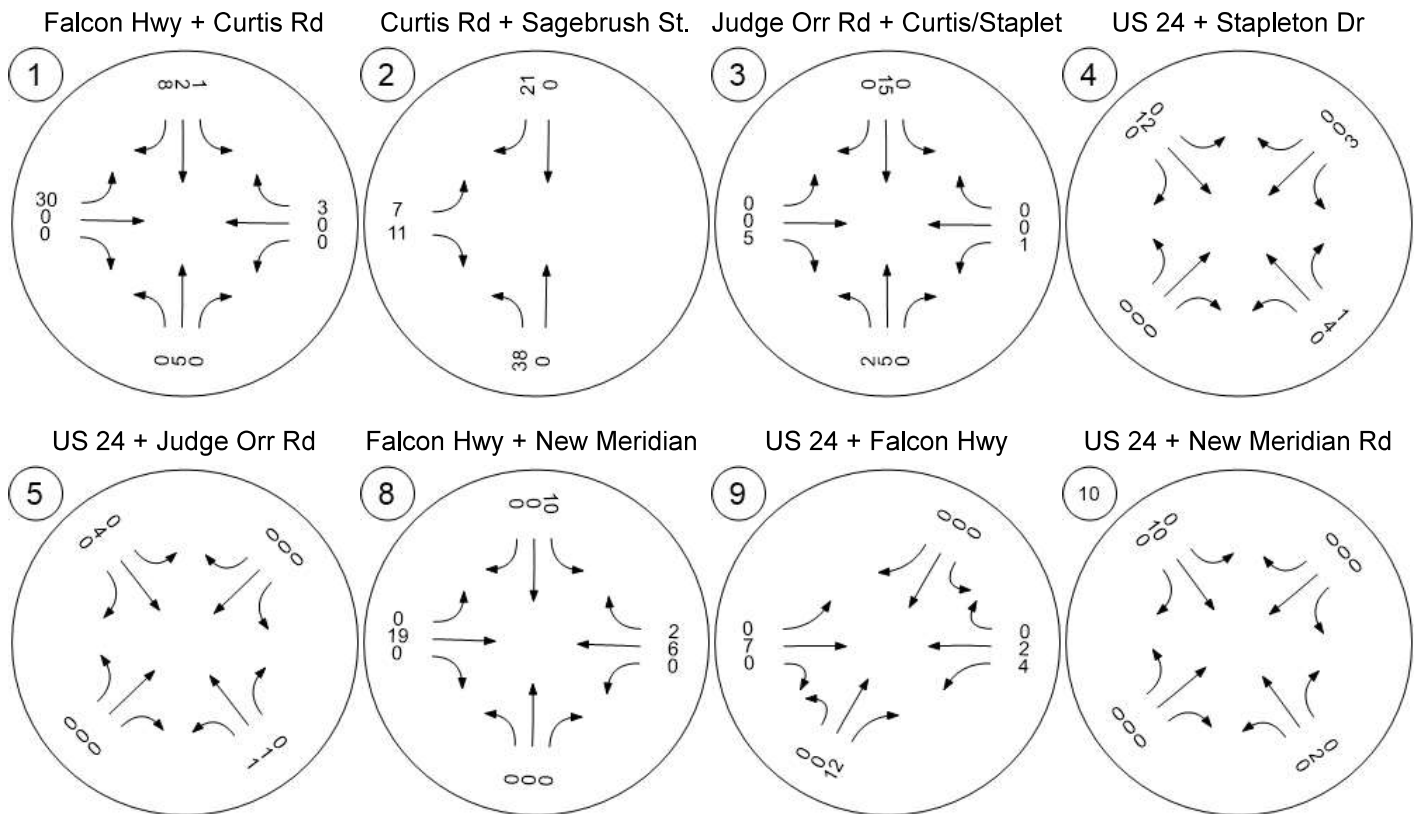

Traffic Volume - Net New Site Trips

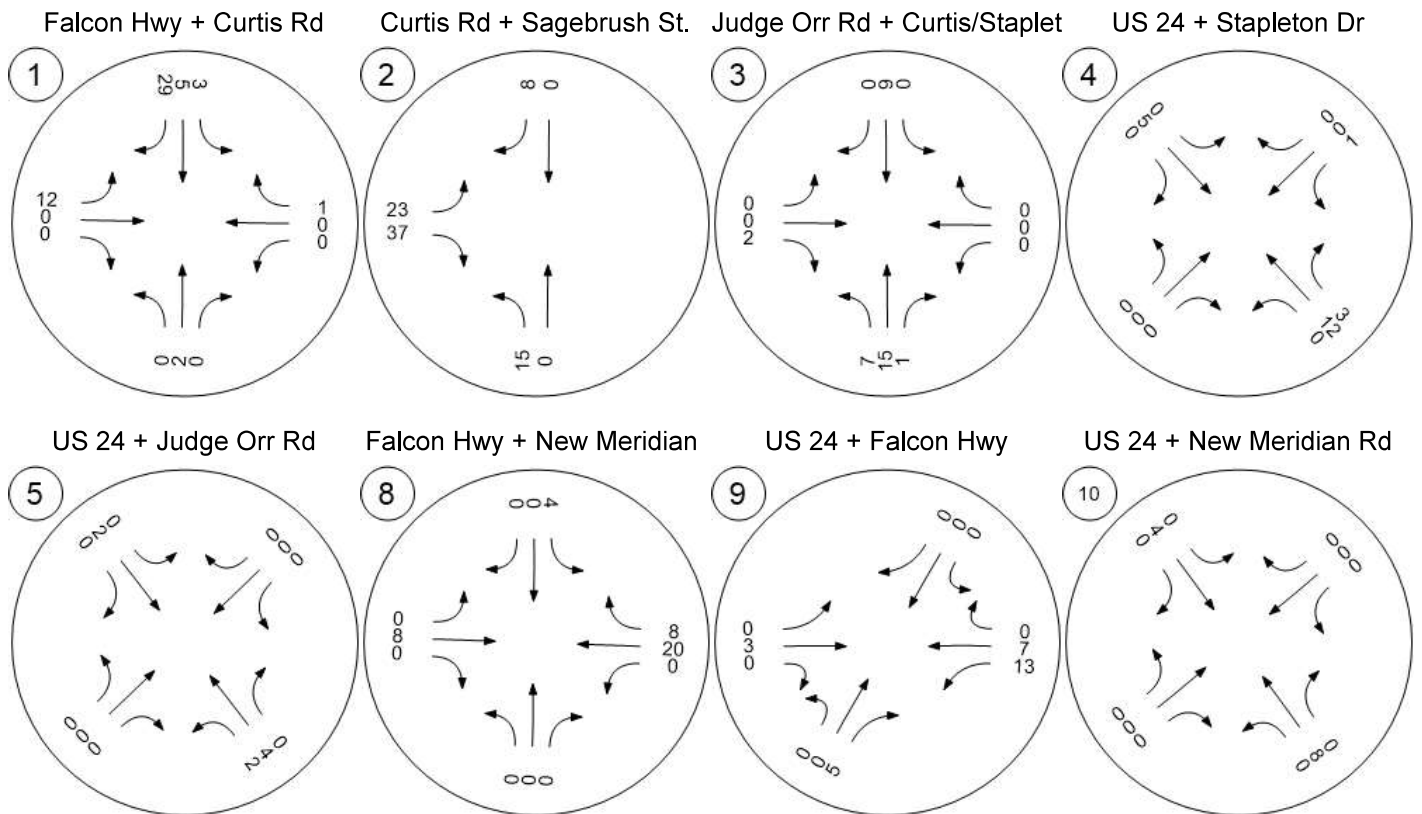

Appendix C



APPENDIX C – Preliminary AWSC Warrants Evaluation – Falcon Highway/Curtis Road

The following is an excerpt from the *MUTCD* regarding “warrants” for all-way stop control (AWSC):

Section 2B.12 All-Way Stop Control

Support:

01 The provisions in the following sections describe warrants for the recommended engineering study to determine all-way stop control. Warrants are not a substitute for engineering judgment. The fact that a warrant for a particular traffic control device is met is not conclusive justification to install or not install all-way stop control. Because each intersection will have unique characteristics that affect its operational performance or safety, it is the engineering study for a given intersection that is ultimately the basis for a decision to install or not install all-way stop control.

02 All-way stop controls at intersections with substantially differing approach volumes can reduce the effectiveness of these devices for all roadway users.

Guidance:

03 *The decision to establish all-way stop control at an unsignalized intersection should be based on an engineering study. The engineering study for all-way stop control should include an analysis of factors related to the existing operation and safety at the intersection, the potential to improve these conditions, and the applicable factors contained in the following all-way stop control warrants:*

- A. *All-Way Stop Control Warrant A: Crash Experience (see Section 2B.13)*
- B. *All-Way Stop Control Warrant B: Sight Distance (see Section 2B.14)*
- C. *All-Way Stop Control Warrant C: Transition to Signal Control or Transition to Yield Control at a Circular Intersection (see Section 2B.15)*
- D. *All-Way Stop Control Warrant D: 8-Hour Volume (Vehicles, Pedestrians, Bicycles) (see Section 2B.16)*
- E. *All-Way Stop Control Warrant E: Other Factors (see Section 2B.17)*

The following presents evaluation of this intersection with respect to each AWSC warrant listed in the *MUTCD* section 2B.12.

A. Crash Experience

For a four-leg intersection, there are five or more reported crashes in a 12-month period or six or more reported crashes in a 36-month period that were of a type susceptible to correction by the installation of all-way stop control

LSC is in the process of obtaining the latest three-year crash history at the intersection of Curtis Road and Falcon Highway.

B. Sight Distance

This is an existing intersection. There are minor horizontal-alignment shifts in the vicinity of the intersection. There is also some vertical curvature along Falcon Highway in the vicinity that potentially affect available lines of sight and sight distance. Advance intersection warning signs with supplemental 45-mph speed plates exist on the eastbound and westbound approaches. These may have been installed based on a sight-distance evaluation or other reasons. County Public Works may be able to provide this information.

C. Transition to Signal Control or Transition to Yield Control at a Circular Intersection

The implementation of AWSC in the future, once needed to reduce delay and improve LOS for the southbound approach, could be considered a “transitional” traffic-control measure. The potential need to signalize the intersection of Falcon Highway/Curtis Road in the future exists, but the timing would depend on both overall growth in traffic demand on these roadways. Also, a future roundabout may be selected by EPC Public Works as the future traffic control, rather than traffic signal. In either case, AWSC traffic control would be “transitional.”

D. Eight-Hour Volumes

Section 2B.16 All-Way Stop Control Warrant D: 8-Hour Volume (Vehicles, Pedestrians, Bicycles)	
Option:	
01	All-way stop control may be installed at an intersection where an engineering study indicates: <ul style="list-style-type: none"> A. The combined motor vehicle, bicycle, and pedestrian volume entering the intersection from the major-street approaches is at least 300 units per hour for each of any 8 hours of a typical day; and B. The combined motor vehicle, bicycle, and pedestrian volume entering the intersection from the minor-street approaches is at least 200 units per hour for each of any of the same 8 hours.
02	If the 85th-percentile approach speed of the major-street traffic exceeds 40 mph, the minimum vehicular volume warrants may be reduced to 70 percent of the values given in Items A and B in Paragraph 1 of this Section.

Four hours of projected volumes were analyzed for this intersection. Volumes reflect motor-vehicle demand, as pedestrian/bicycle demand is low. Please refer to Appendix Table C-1 below for details.

All four hours analyzed would meet the *MUTCD*'s minimum-volume combination on major and minor streets to meet an AWSC warrant at the Falcon Highway/Curtis Road intersection. Potentially, other hours of the day are projected to meet both of these thresholds, but four additional hours would need to meet both minor and major street thresholds.

Item D of the *MUTCD* AWSC warrant analysis at the Falcon Highway/Curtis Road intersection could be expanded to include additional volume data at the future platting/access permitting stage of the development process for this development, which could include full evaluation of the off-peak hours as well (8-10 hours of the day).

**Appendix Table C-1: AWSC Warrant Analysis
Curtis Road/Falcon Highway Intersection**

Analysis Period			Minor Street			Major Street			Overall
Peak Period	Start	End	2025 Total Volume	MUTCD Minimum	Meets Threshold	2025 Total Volume	MUTCD Minimum	Meets Threshold	Meets Threshold
AM Hour 1	6:30	7:30	261	200	✓	591	300	✓	Yes
AM Hour 2	7:30	8:30	254	200	✓	528	300	✓	Yes
PM Hour 1	16:00	17:00	475	200	✓	457	300	✓	Yes
PM Hour 2	17:00	18:00	300	200	✓	440	300	✓	Yes
11/14/2024	# of hours of the 4 analyzed which meet the Major and minor street thresholds:								4 hours

E. Other Factors

- 01 All-way stop control may be installed at an intersection where an engineering study indicates that all-way stop control is needed due to other factors not addressed in the other all-way stop control warrants. Such other factors may include, but are not limited to, the following:
- A. The need to control left-turn conflicts,
 - B. An intersection of two residential neighborhood collector (through) streets of similar design and operating characteristics where all-way stop control would improve traffic operational characteristics of the intersection, or
 - C. Where pedestrian and/or bicyclist movements support the installation of all-way stop control.

Part “A” may apply. There is a relatively heavy northbound-left volume at the intersection during the PM peak hour. Left-turn major-street sight distance may have some effect on left-turn operations.

Part “B” does not apply since neither Falcon Highway nor Curtis Road are residential/local roadways.

Part “C” may become more applicable in the future with growth in the area and any increase in non-motorized travel demand that may accompany such growth. However, the character of the area will likely remain rural, so pedestrian bicycle activity is anticipated to remain minimal.

Additionally, implementation of AWSC at the Falcon Highway/Curtis Road intersection would mitigate the projected short-term levels of service below D and would result in all individual turning movements operating at LOS C or better during both 2025 Total peak hours. Additionally, the intersection approach volumes are relatively well-balanced, although notably directional by peak hour.

Meadowlake Industrial Filing No. 1 Preliminary Plans



PRELIMINARY PLAN MEADOW LAKE INDUSTRIAL PHASE 1

A PART OF THE EAST HALF OF SECTION 9, TOWNSHIP 13 SOUTH, RANGE 64 WEST OF
THE SIXTH PRINCIPAL MERIDIAN, COUNTY OF EL PASO, STATE OF COLORADO

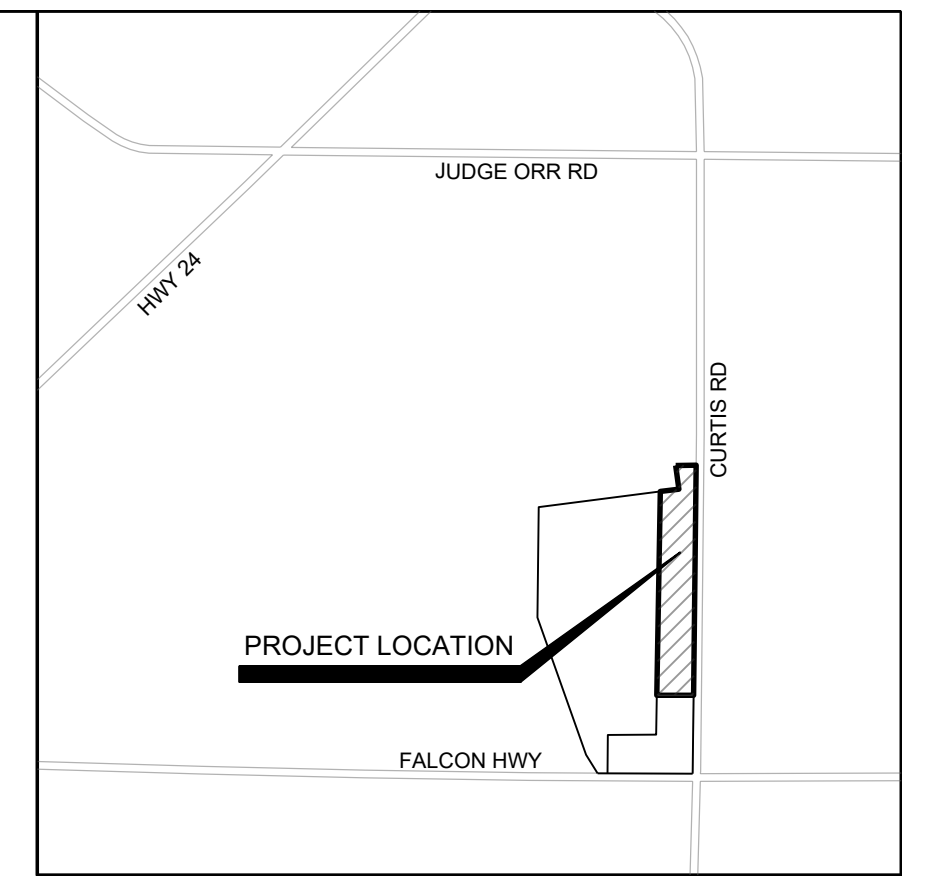

VICINITY MAP
(NOT TO SCALE)

PROJECT DESCRIPTION:

Property is to be subdivided into 27 parcels to be used for an industrial park.

KNOW ALL MEN BY THESE PRESENTS:

That the undersigned, Meadowlake Developments LLC, being the owner of the following described tract of land:

SURVEYED DESCRIPTION:

A tract of land in the East Half of Section 9, Township 13 South, Range 64 West of the Sixth Principal Meridian, El Paso County, Colorado described as follows:

Beginning at a point that is S 00°06'00" W 93.65 feet from the Northeast Corner of the Northeast Quarter of said Section 9; thence S 00°06'00" W 3864.51 feet along the East Line of said Section 9; thence S 89°17'36" W 622.94 feet; thence N 00°29'28" E 3422.09 feet; thence N 82°12'06" E 313.87 feet; thence N 07°45'48" W 400.00 feet; thence N 88°06'51" E 343.54 feet to the point of beginning, containing 51.3 acres.

Subject to easements and restrictions of record.

GEOLOGIC HAZARD NOTE:

A "SOIL AND GEOLOGY STUDY, MEADOWLAKE INDUSTRIAL, EL PASO COUNTY, COLORADO" PREPARED BY RMG - ROCKY MOUNTAIN GROUP, JOB NO. 192628, LAST DATED SEPTEMBER 30, 2023, IS INCLUDED IN FILE SP236 AND AVAILABLE AT THE EL PASO COUNTY PLANNING AND COMMUNITY DEVELOPMENT DEPARTMENT. THE REPORT INDICATED GEOLOGIC HAZARDS WERE NOT FOUND TO BE PRESENT AT THIS SITE. THE GEOLOGIC CONSTRAINTS FOUND ON-SITE INCLUDE:

- POTENTIALLY EXPANSIVE SOILS/BEDROCK,
- POTENTIALLY COMPRESSIVE SOILS,
- SEASONALLY SHALLOW GROUNDWATER,
- SEISMICITY AND RADON.

ADDITIONALLY, NO BELOW-GRADE BASEMENT AREAS WILL BE ALLOWED UNLESS A YEAR-LONG GROUND WATER MONITORING PROGRAM HAS BEEN COMPLETED.

EASEMENTS:

UNLESS OTHERWISE INDICATED, ALL SIDE, FRONT, AND REAR LOT LINES ARE HEREBY PLATTED ON EITHER SIDE WITH A 5 FEET PUBLIC UTILITY AND DRAINAGE EASEMENT UNLESS OTHERWISE INDICATED. ALL EXTERIOR SUBDIVISION BOUNDARIES ARE HEREBY PLATTED WITH A 7 FEET PUBLIC UTILITY AND DRAINAGE EASEMENT. THE SOLE RESPONSIBILITY FOR THE MAINTENANCE OF THESE EASEMENTS IS HEREBY VESTED WITH THE INDIVIDUAL PROPERTY OWNERS.

ENVIRONMENTAL:

DEVELOPER SHALL COMPLY WITH FEDERAL AND STATE LAWS, REGULATIONS, ORDINANCES, REVIEW AND PERMIT REQUIREMENTS, AND OTHER AGENCY REQUIREMENTS, IF ANY, OF APPLICABLE AGENCIES, INCLUDING, BUT NOT LIMITED TO, THE COLORADO DIVISION OF WILDLIFE, COLORADO DEPARTMENT OF TRANSPORTATION, U.S. ARMY CORPS OF ENGINEERS, AND THE U.S. FISH & WILDLIFE SERVICE REGARDING THE ENDANGERED SPECIES ACT, PARTICULARLY AS IT RELATES TO THE LISTED SPECIES (E.G., PREBLE'S MEADOW JUMPING MOUSE).

EASEMENT AND TRACT MAINTENANCE:

TRACT A

- TRACT A SHALL BE UTILIZED AS A DRAINAGE TRACT. OWNERSHIP AND MAINTENANCE OF TRACT A SHALL BE VESTED TO MEADOWLAKE METROPOLITAN DISTRICT NOS. 1-3.
- TRACT A OF THIS PROPERTY IS SUBJECT TO A PRIVATE DETENTION BASIN/STORMWATER QUALITY BMP MAINTENANCE AGREEMENT AND EASEMENT TO BE RECORDED WITH SUBSEQUENT FINAL PLAT APPLICATIONS.
- TRACT A IS ENCOMPASSED BY A BLANKET UTILITY EASEMENT.

TRACT B

- TRACT B SHALL BE UTILIZED AS A DRAINAGE TRACT. OWNERSHIP AND MAINTENANCE OF TRACT B SHALL BE VESTED TO MEADOWLAKE METROPOLITAN DISTRICT NOS. 1-3.
- TRACT B OF THIS PROPERTY IS SUBJECT TO A PRIVATE DETENTION BASIN/STORMWATER QUALITY BMP MAINTENANCE AGREEMENT AND EASEMENT TO BE RECORDED WITH SUBSEQUENT FINAL PLAT APPLICATIONS.
- TRACT B IS ENCOMPASSED BY A BLANKET UTILITY EASEMENT.

GENERAL NOTES:

1. NO EASEMENTS, RESTRICTIONS, SETBACKS, OR OTHER MATTER OF RECORD, IF ANY, AFFECTING THE TITLE OF THIS PROPERTY ARE SHOWN, EXCEPT AS PLATTED, AS PER AGREEMENT WITH THE LANDOWNER.
2. NO GAPS OR OVERLAPS EXIST.
3. THERE ARE NO LINES OF POSSESSION THAT AFFECT THIS SURVEY.
4. PARENT TRACT IS RECORDED AS INSTRUMENT #221072372, CLERK & RECORDER'S OFFICE, EL PASO COUNTY, COLORADO.
5. ALL BUILDING SETBACK REQUIREMENTS SHALL BE DETERMINED BY THE ZONING DISTRICT, UNLESS OTHERWISE NOTED.
6. THIS SURVEY DOES NOT CONSTITUTE A TITLE SEARCH BY SMH CONSULTANTS, TO DETERMINE OWNERSHIP OR EASEMENTS OF RECORD, FOR INFORMATION REGARDING EASEMENTS, AND RIGHT OF WAY, SMH CONSULTANTS RELIED UPON THE TITLE POLICY PREPARED BY LAND TITLE GUARANTEE COMPANY, DATED MARCH 23, 2021.
7. BASIS OF BEARINGS IS THE SEAST LINE OF SECTION 9, TOWNSHIP 13 SOUTH, RANGE 64 WEST, MONUMENTED AS SHOWN AND ASSUMED TO BEAR SOUTH 00 DEGREES, 06 MINUTES 00 SECONDS WEST, 93.65 FEET.
8. SHARED ONSITE WASTEWATER TREATMENT SYSTEMS WILL BE UTILIZED. THE ULTIMATE LOCATION WILL BE DETERMINED AT THE TIME OF THE FINAL PLAT. AN EASEMENT WILL BE DEPICTED ON THE FINAL PLAT AND A MAINTENANCE AGREEMENT RECORDED. REFERENCE THE SOILS AND GEOLOGY REPORT FOR POTENTIAL LOCATIONS.
9. ALL PROPERTY OWNERS ARE RESPONSIBLE FOR MAINTAINING PROPER STORMWATER DRAINAGE IN AND THROUGH THEIR PROPERTY. PUBLIC DRAINAGE EASEMENTS AS SPECIFICALLY NOTED ON THE PLAT SHALL BE MAINTAINED BY THE INDIVIDUAL LOT OWNERS UNLESS OTHERWISE INDICATED. STRUCTURES, FENCES, MATERIALS OR LANDSCAPING THAT COULD IMPEDE THE FLOW OF RUNOFF SHALL NOT BE PLACED IN DRAINAGE EASEMENTS.
10. NO STRUCTURES OR MAJOR MATERIAL STORAGE ACTIVITIES ARE PERMITTED WITHIN THE DESIGNATED DRAINAGE EASEMENTS, EXCEPT FENCES. FENCES SHALL NOT IMPEDE RUNOFF FROM REACHING DRAINAGE SWALES.
11. WATER SERVICE FOR THIS SUBDIVISION IS PROVIDED BY MEADOWLAKE METROPOLITAN DISTRICT NOS. 1-3 SUBJECT TO PROVIDERS' RULES, REGULATIONS AND SPECIFICATIONS.
12. ACCESS TO ALL LOTS SHALL BE THROUGH THE SHOWN TRAVEL EASEMENTS. THE RESPONSIBILITY AND MAINTENANCE OF SAID EASEMENTS ARE SUBJECT TO THE MAINTENANCE AGREEMENT AND ALL COVENANTS AND RESTRICTIONS CONTAINED THEREIN, THAT WILL BE RECORDED WITH THE FINAL PLAT.
13. NO DRIVEWAY SHALL BE ESTABLISHED UNLESS AN ACCESS PERMIT HAS BEEN GRANTED BY EL PASO COUNTY. INDIVIDUAL LOT PURCHASERS ARE RESPONSIBLE FOR CONSTRUCTING DRIVEWAYS.
14. ALL STRUCTURAL FOUNDATIONS ON THE LOTS IN THIS SUBDIVISION SHALL BE LOCATED AND DESIGNED BY A PROFESSIONAL ENGINEER, CURRENTLY REGISTERED IN THE STATE OF COLORADO. NATURAL DRAINAGE LOCATIONS SHALL BE AVOIDED BY CONSTRUCTION AND SITE-SPECIFIC FOUNDATION/SEPTIC INVESTIGATIONS SHALL BE REQUIRED.
15. MAILBOXES SHALL BE INSTALLED IN ACCORDANCE WITH ALL EL PASO COUNTY AND THE UNITED STATES POSTAL SERVICE REGULATIONS.
16. THE FOLLOWING REPORTS HAVE BEEN SUBMITTED IN ASSOCIATION WITH THE PRELIMINARY PLAN FOR THIS SUBDIVISION AND ARE ON FILE AT THE EL PASO COUNTY PLANNING AND COMMUNITY DEVELOPMENT DEPARTMENT: DRAINAGE REPORT, ON-SITE WASTEWATER TREATMENT REPORT, SOILS AND GEOLOGY REPORT, FIRE PROTECTION REPORT, AND TRAFFIC IMPACT STUDY.
17. CONTOURS ARE DERIVED FROM TOPOGRAPHIC SURVEY PERFORMED BY SMH CONSULTANTS.
18. THERE SHALL BE NO DIRECT LOT ACCESS TO CURTIS RD, GREENFIELD AVE OR SAGEBRUSH ST.
19. ANY PERSON WHO KNOWINGLY REMOVES, ALTERS OR DEFACES ANY PUBLIC LAND SURVEY MONUMENT OR LAND BOUNDARY MONUMENT OR ACCESSORY COMMITS A CLASS TWO (2) MISDEMEANOR PURSUANT TO C.R.S. § 18-4-508¹.
20. ALL FUTURE LOT OWNERS SHALL SUBMIT AN ENGINEERED SITE PLAN AT TIME OF BUILDING PERMIT.
21. THE PRIVATE ROADS AS SHOWN ON THIS PLAT WILL NOT BE MAINTAINED BY EL PASO COUNTY UNTIL AND UNLESS THE STREETS ARE CONSTRUCTED IN CONFORMANCE WITH EL PASO COUNTY STANDARDS IN EFFECT AT THE DATE OF THE REQUEST FOR DEDICATION AND MAINTENANCE.
22. THE SUBDIVIDER(S) AGREES ON BEHALF OF HIM/HERSELF AND ANY DEVELOPER OR BUILDER SUCCESSORS AND ASSIGNEES THAT SUBDIVIDER AND/OR SAID SUCCESSORS AND ASSIGNEES SHALL BE REQUIRED TO PAY TRAFFIC IMPACT FEES IN ACCORDANCE WITH EL PASO COUNTY ROAD IMPACT FEE PROGRAM RESOLUTION (RESOLUTION NO. 19-471), OR ANY AMENDMENTS THERETO, AT OR PRIOR TO THE TIME OF BUILDING PERMIT SUBMITTALS. THE FEE OBLIGATION, IF NOT PAID AT FINAL PLAT RECORDING, SHALL BE DOCUMENTED ON ALL SALES DOCUMENTS AND PLAT NOTES TO ENSURE THAT A TITLE SEARCH WOULD FIND THE FEE OBLIGATION BEFORE SALE OF THE PROPERTY.
23. THE PARTIES RESPONSIBLE FOR THIS PLAN HAVE FAMILIARIZED THEMSELVES WITH ALL CURRENT ACCESSIBILITY CRITERIA AND SPECIFICATIONS AND THE PROPOSED PLAN REFLECTS ALL SITE ELEMENTS REQUIRED BY THE APPLICABLE ADA DESIGN STANDARDS AND GUIDELINES AS PUBLISHED BY THE UNITED STATES DEPARTMENT OF JUSTICE. APPROVAL OF THIS PLAN BY EL PASO COUNTY DOES NOT ASSURE COMPLIANCE WITH THE ADA OR ANY REGULATIONS OR GUIDELINES ENACTED OR PROMULGATED UNDER OR WITH RESPECT TO SUCH LAWS.
24. THIS PROPERTY IS PRESENTLY LOCATED IN THE VICINITY OF AN AIRPORT, WITHIN WHAT IS KNOWN AS AN AIRPORT INFLUENCE AREA. FOR THIS REASON, THE PROPERTY MAY BE SUBJECT TO SOME ANNOYANCES OR INCONVENIENCES ASSOCIATED WITH PROXIMITY TO AIRPORT OPERATIONS (E.G. NOISE, VIBRATION, OR ODORS), INDIVIDUAL SENSITIVITIES TO THOSE ANNOYANCES CAN VARY FROM PERSON TO PERSON. YOU MAY WISH TO CONSIDER WHAT AIRPORT ANNOYANCES, IF ANY, ARE ASSOCIATED WITH THE PROPERTY BEFORE YOU COMPLETE YOUR PURCHASE AND DETERMINE WHETHER THEY ARE ACCEPTABLE TO YOU.
25. THE SPECIFIC USES SHALL BE LIMITED TO THOSE INCLUDED IN THIS PHASE 1 PRELIMINARY PLAN TRAFFIC IMPACT STUDY (TIS) SUBMITTED WITH EPC PCD FILE NO. SP236 UNLESS A REVISED TRAFFIC IMPACT STUDY IS SUBMITTED AND APPROVED FOR ANY USES BEYOND THOSE INCLUDED IN THIS TRAFFIC IMPACT STUDY.
26. ONSITE WATER QUALITY AND DETENTION FOR LOT 1 AND LOT 15 SHALL BE THE RESPONSIBILITY OF THE FUTURE PROPERTY OWNER. THE DESIGN AND A DETENTION MAINTENANCE AGREEMENT SHALL BE PROVIDED AT THE TIME OF THE SITE DEVELOPMENT PLAN APPLICATION.
27. THE 25' TRAIL EASEMENT DEPICTED WITHIN THE LOTS MAY BE VACATED IF AN ATTACHED OR DETACHED TRAIL IS CONSTRUCTED WITHIN THE RIGHT-OF-WAY OR RIGHT-OF-WAY PRESERVATION.

SHEET INDEX

1	PRELIMINARY PLAN COVER SHEET
2	PRELIMINARY OVERALL SITE PLAN
3	PRELIMINARY ENLARGED SITE PLAN
4	PRELIMINARY ENLARGED SITE PLAN
SP01	PRELIMINARY PLAN SITE PLAN
SP02	PRELIMINARY PLAN SITE PLAN

OWNER:
MEADOWLAKE DEVELOPMENTS LLC
PO BOX 1385
COLORADO SPRINGS, CO 80901
719-445-6050

TOTAL ACREAGE:
TOTAL TRACT ACREAGE = 3.8 ACRES
TOTAL PARCEL ACREAGE = 37.78 ACRES
TOTAL ROW ACREAGE = 9.72 ACRES
TOTAL: 51.3 ACRES

SURVEYOR:
TIM SLOAN, VICE-PRESIDENT
SMH CONSULTANTS, P.A.
411 S. TEJON ST., STE. 1
COLORADO SPRINGS, CO 80903
719-465-2145

SERVICE PROVIDERS:
FALCON FIRE PROTECTION DISTRICT
MOUNTAIN VIEW ELECTRIC ASSOC.
BLACK HILLS ENERGY
DOMESTIC WELLS
INDIVIDUAL SEWAGE DISPOSAL SYSTEMS

CIVIL ENGINEER:
HR GREEN - COLORADO SPRINGS
1975 RESEARCH PKWY., STE. 230
COLORADO SPRINGS, CO 80920
719-394-2440

SITE DATA:

ZONING:	I-2
TAX SCHEDULE NUMBER:	4300000637, 4300000638, 4300000640, 4300000641, 4300000642
LAND USE:	INDUSTRIAL PARK
SITE AREA:	51.3 ACRES
PROPERTY ADDRESSES:	PROPERTIES DO NOT CURRENTLY HAVE ASSIGNED ADDRESSES

DENSITY AND DIMENSIONAL STANDARDS FOR INDUSTRIAL DISTRICT I-2							
ZONING DISTRICT	ZONING DISTRICT AREA MINIMUM	MINIMUM LOT SIZE	FRONT	REAR	SIDE	MAXIMUM LOT COVERAGE	MAXIMUM HEIGHT
I-2	20 ACRES	1 ACRE ¹¹	50 FT ^{5.11}	50 FT ^{5.11}	30 FT ^{5.11}	35%	45 FT

⁵ MINIMUM BUILDING SETBACK DISTANCE FROM ANY ADJOINING RESIDENTIAL ZONING DISTRICT BOUNDARY IS 125 FEET. THE PCD DIRECTOR MAY ALLOW A REDUCTION IN THE SETBACK WHERE APPROPRIATE ACTIONS ARE TAKEN INCLUDING LANDSCAPING, FENCINGS, BERMS OR BUILDING DESIGN, OR WHERE THE USE CAN BE LIMITED TO MITIGATE POTENTIAL IMPACTS.

¹¹ IF THE BUILDING IS ESTABLISHED AS OR CONVERTED TO CONDOMINIUM UNITS IN ACCORDANCE WITH CHAPTER 7 OF THIS CODE, THE BUILDING AND LOT SHALL MEET THE MINIMUM LOT AREA AND SETBACKS, BUT THE INDIVIDUAL UNITS ARE NOT REQUIRED TO MEET THE MINIMUM LOT AREA, MAXIMUM LOT COVERAGE, OR SETBACK REQUIREMENTS.

DATE SUBMITTED: 09/13/2023
REVISIONS:



Civil Engineering • Land Surveying • Landscape Architecture
www.smhconsultants.com
Manhattan, KS - HQ P: (785) 776-0541 • Dodge City, KS P: (620) 255-1952
Overland Park, KS P: (913) 444-9615 • Colorado Springs, CO P: (719) 465-2145
Survey Prepared April 4, 2022

Drawn By: JAM Project #2212-0483 TDS #88 PCD File #SP236

DECEMBER 2024

PRELIMINARY OVERALL SITE PLAN MEADOW LAKE INDUSTRIAL PHASE 1

A PART OF THE EAST HALF OF SECTION 9, TOWNSHIP 13 SOUTH, RANGE 64 WEST OF
THE SIXTH PRINCIPAL MERIDIAN, COUNTY OF EL PASO, STATE OF COLORADO

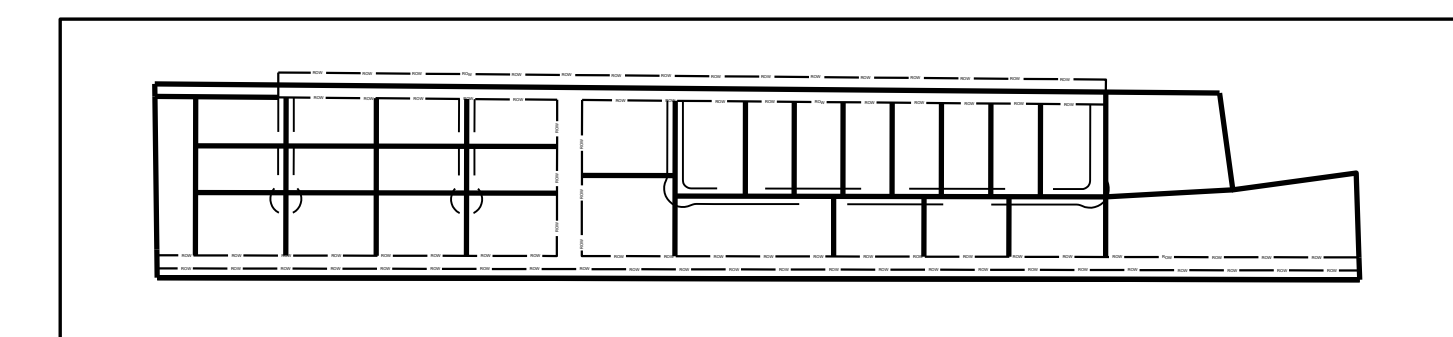
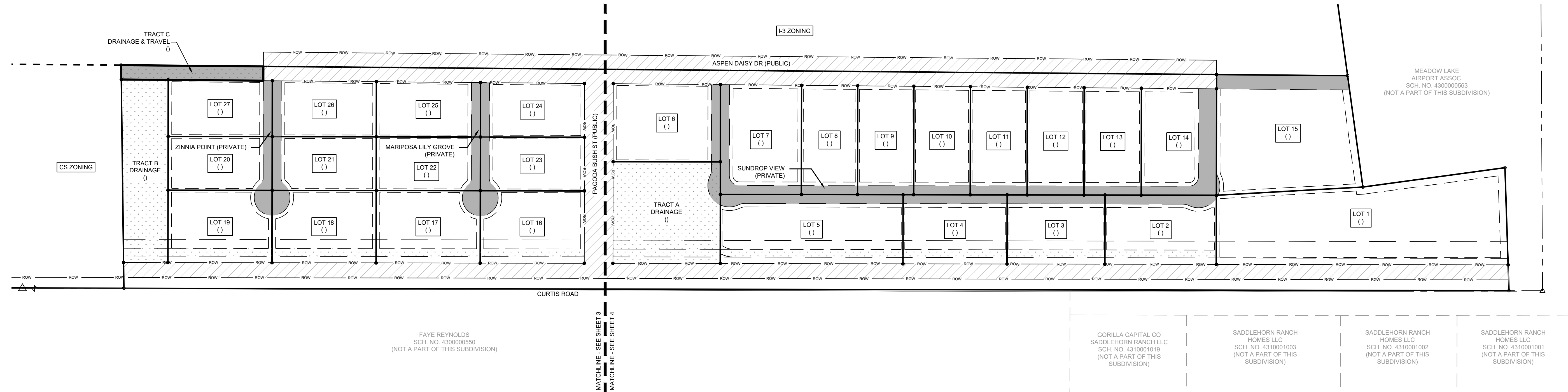

KEY MAP
(NOT TO SCALE)

LEGEND

- MONUMENT FOUND (1/2" REBAR) W/PLS38374 CAP
- 1/2"x24" REBAR W/PLS38374 Cap Set
- △ SECTION CORNER, NOTE: ALL SECTION CORNER MONUMENT ORIGINS ARE UNKNOWN UNLESS OTHERWISE NOTED.
- * ASSUMED BEARING
- (D) DEED DIMENSION
- (S) SURVEYED DIMENSION
- DE DRAINAGE EASEMENT
- UE UTILITY EASEMENT
- TE TRAVEL EASEMENT
- [Dotted Hatch] DRAINAGE EASEMENT HATCH
- [Solid Hatch] TRAVEL EASEMENT HATCH
- [Diagonal Hatch] RIGHT OF WAY HATCH

LINETYPE LEGEND

- ADJACENT PROPERTY LINE
- PROPERTY LINE
- - - SECTION LINE
- - - TRAVEL EASEMENT
- - - UTILITY EASEMENT
- ROW RIGHT OF WAY
- - - MATCHLINE

DATE SUBMITTED: 09/13/2023
REVISIONS:



SMH
CONSULTANTS

Civil Engineering • Land Surveying • Landscape Architecture
www.smhconsultants.com
Manhattan, KS - HQ P: (785) 776-0541 • Dodge City, KS P: (620) 255-1952
Kansas City P: (913) 444-9615 • Colorado Springs, CO P: (719) 465-2145
Survey Prepared April 4, 2022

Drawn By: JAM Project #2212-0483 TDS #88 PCD File #SP236
DECEMBER 2024

PRELIMINARY ENLARGED SITE PLAN MEADOW LAKE INDUSTRIAL PHASE 1

A PART OF THE EAST HALF OF SECTION 9, TOWNSHIP 13 SOUTH, RANGE 64 WEST OF
THE SIXTH PRINCIPAL MERIDIAN, COUNTY OF EL PASO, STATE OF COLORADO

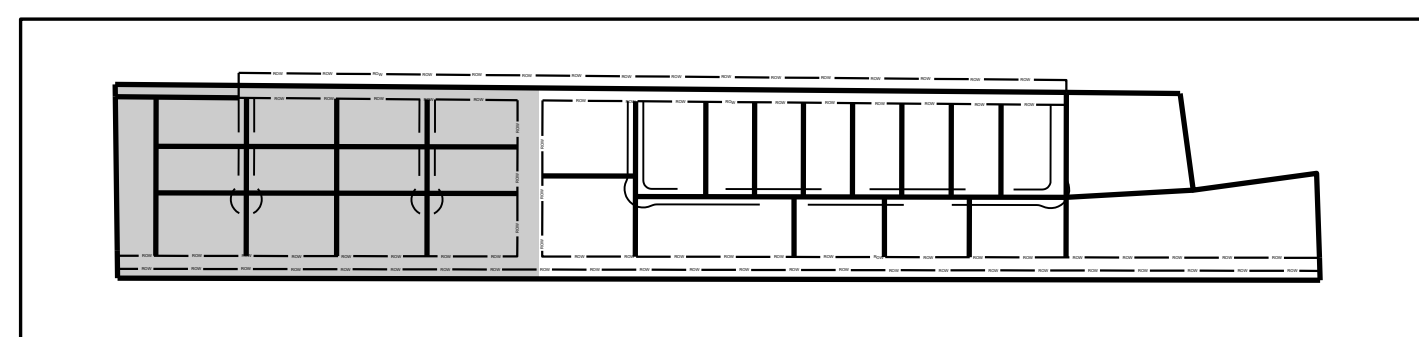
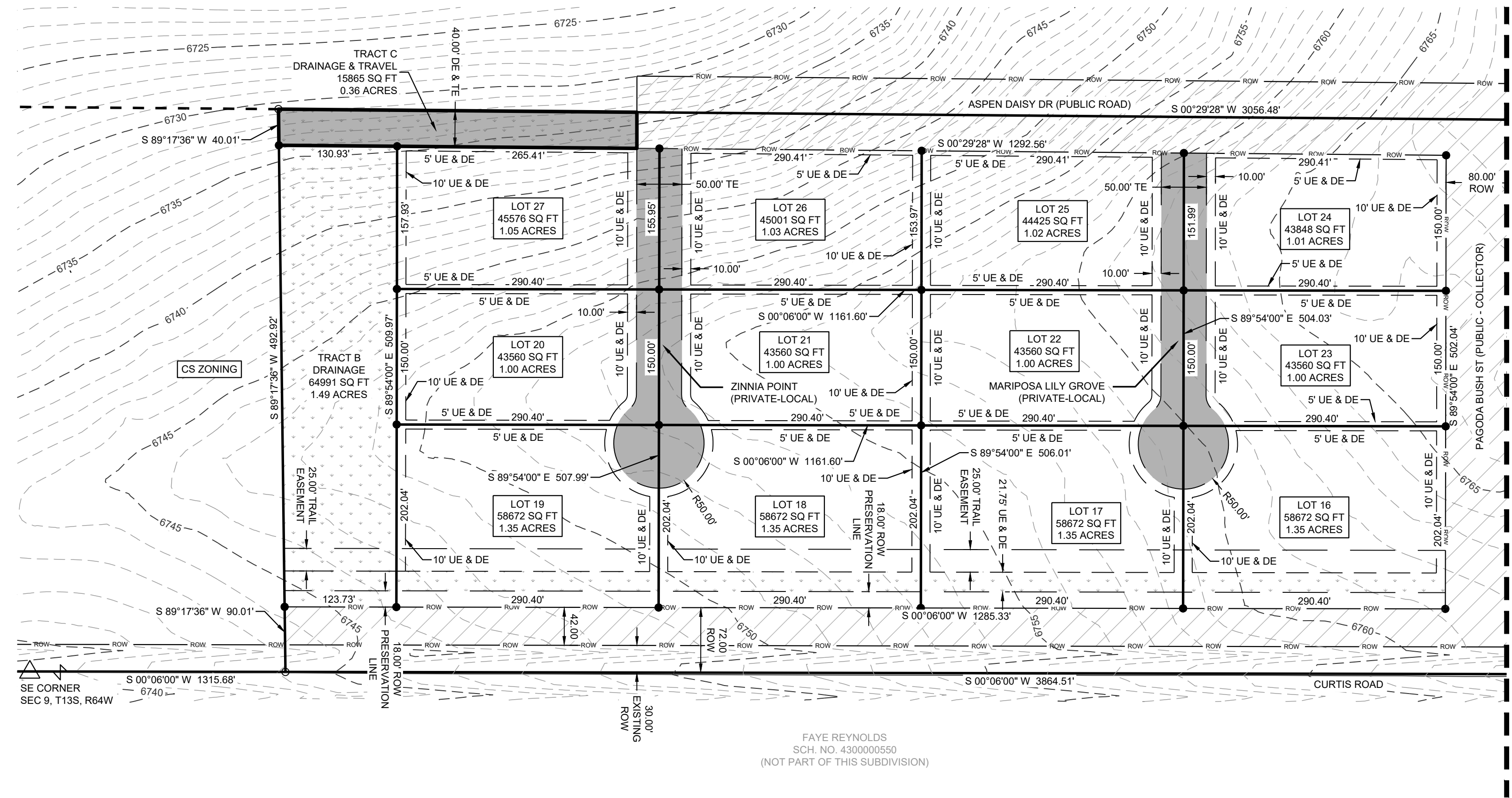

KEY MAP
(NOT TO SCALE)

- LEGEND**
- MONUMENT FOUND (1/2" REBAR) W/PLS38374 CAP
 - 1/2"x24" REBAR W/PLS38374 Cap Set
 - △ SECTION CORNER, NOTE: ALL SECTION CORNER MONUMENT ORIGINS ARE UNKNOWN UNLESS OTHERWISE NOTED.
 - * ASSUMED BEARING
 - (D) DEED DIMENSION
 - (S) SURVEYED DIMENSION
 - DE DRAINAGE EASEMENT
 - UE PUBLIC UTILITY EASEMENT
 - TE TRAVEL EASEMENT
 - DRAINAGE EASEMENT HATCH
 - TRAVEL EASEMENT HATCH
 - RIGHT OF WAY HATCH

- LINETYPE LEGEND**
- ADJACENT PROPERTY LINE
 - PROPERTY LINE
 - - - SECTION LINE
 - - - TRAVEL EASEMENT
 - - - UTILITY EASEMENT
 - ROW
 - RIGHT OF WAY
 - MATCHLINE

DATE SUBMITTED: 09/13/2023
REVISIONS:

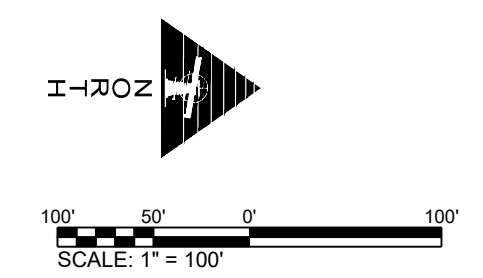

SMH
CONSULTANTS

Civil Engineering • Land Surveying • Landscape Architecture
www.smhconsultants.com
Manhattan, KS - HQ P: (785) 776-0541 • Dodge City, KS P: (620) 255-1952
Kansas City P: (913) 444-9615 • Colorado Springs, CO P: (719) 465-2145
Survey Prepared April 4, 2022
Drawn By: JAM Project #2212-0483 TDS #88 PCD File #SP236

DECEMBER 2024

PRELIMINARY ENLARGED SITE PLAN MEADOW LAKE INDUSTRIAL PHASE 1

A PART OF THE EAST HALF OF SECTION 9, TOWNSHIP 13 SOUTH, RANGE 64 WEST OF
THE SIXTH PRINCIPAL MERIDIAN, COUNTY OF EL PASO, STATE OF COLORADO

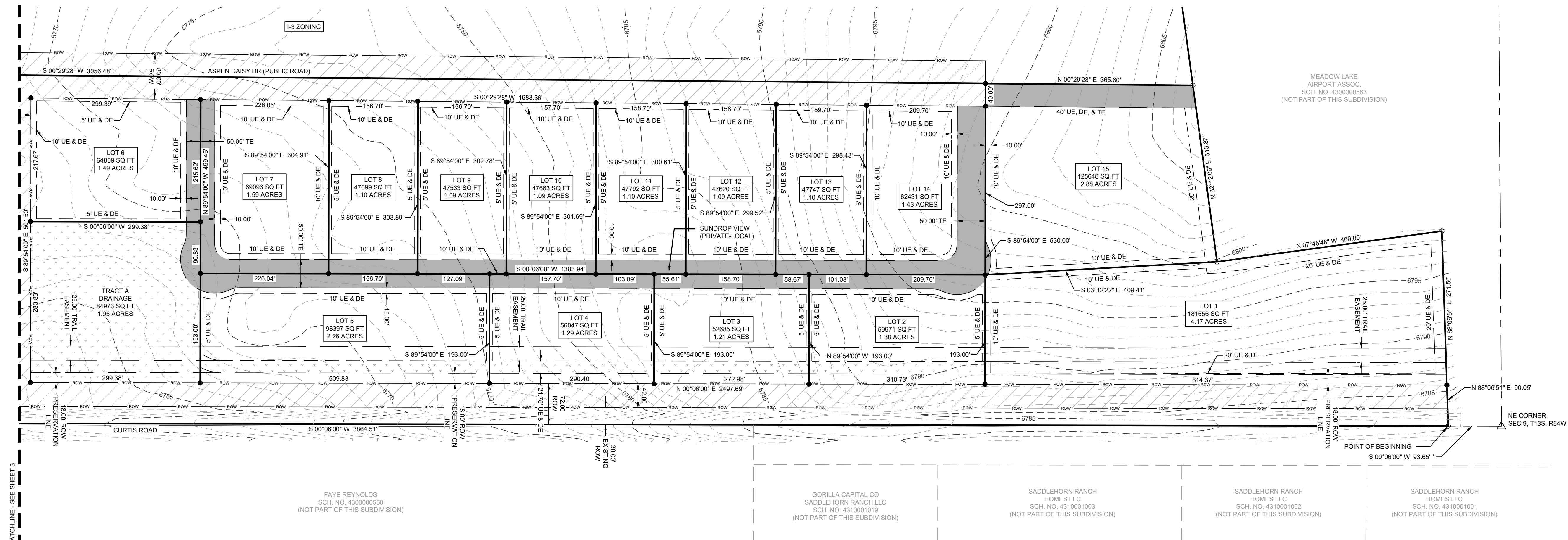

MEADOW LAKE AIRPORT ASSOC.
SCH. NO. 430000563
(NOT PART OF THIS SUBDIVISION)

FAYE REYNOLDS
SCH. NO. 430000550
(NOT PART OF THIS SUBDIVISION)

GORILLA CAPITAL CO
SADDLEHORN RANCH LLC
SCH. NO. 4310001019
(NOT PART OF THIS SUBDIVISION)

SADDLEHORN RANCH
HOMES LLC
SCH. NO. 4310001003
(NOT PART OF THIS SUBDIVISION)

SADDLEHORN RANCH
HOMES LLC
SCH. NO. 4310001002
(NOT PART OF THIS SUBDIVISION)

SADDLEHORN RANCH
HOMES LLC
SCH. NO. 4310001001
(NOT PART OF THIS SUBDIVISION)

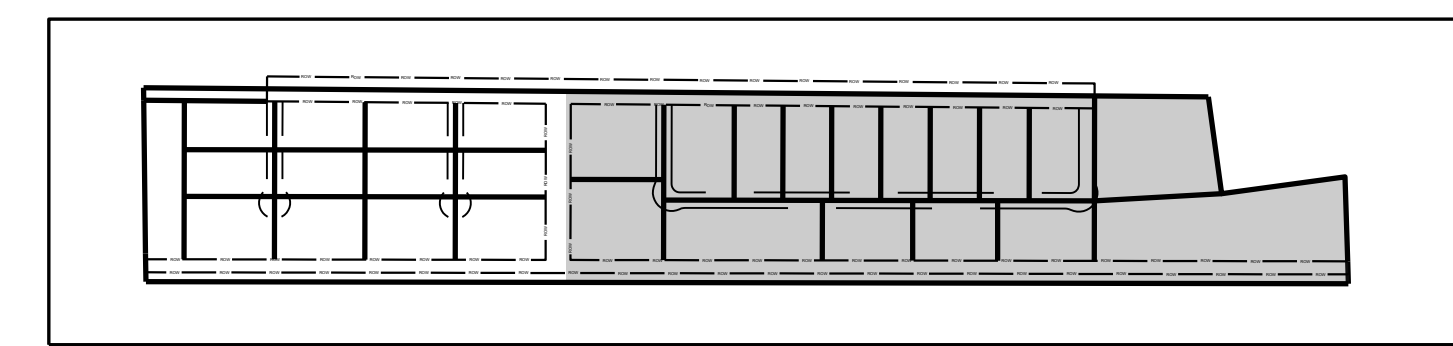

KEY MAP
(NOT TO SCALE)

LEGEND

- MONUMENT FOUND (1/2" REBAR) W/PLS38374 CAP
- 1/2"x24" REBAR W/PLS38374 Cap Set
- △ SECTION CORNER, NOTE: ALL SECTION CORNER MONUMENT ORIGINS ARE UNKNOWN UNLESS OTHERWISE NOTED.
- * ASSUMED BEARING
- (D) DEED DIMENSION
- (S) SURVEYED DIMENSION
- DE DRAINAGE EASEMENT
- UE PUBLIC UTILITY EASEMENT
- TE TRAVEL EASEMENT
- DRAINAGE EASEMENT HATCH
- TRAVEL EASEMENT HATCH
- RIGHT OF WAY HATCH

LINETYPE LEGEND

- ADJACENT PROPERTY LINE
- PROPERTY LINE
- - - SECTION LINE
- - - TRAVEL EASEMENT
- - - UTILITY EASEMENT
- ROW
- RIGHT OF WAY
- MATCHLINE

DATE SUBMITTED: 09/13/2023
REVISIONS:

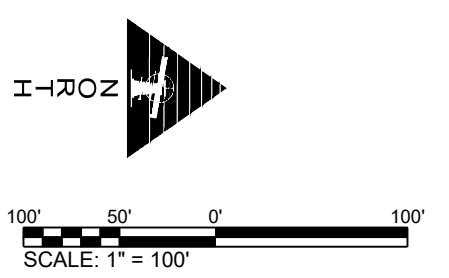

SMH
CONSULTANTS

Civil Engineering • Land Surveying • Landscape Architecture
www.smhconsultants.com
Manhattan, KS - HQ P: (785) 776-0541 • Dodge City, KS P: (620) 255-1952
Kansas City P: (913) 444-9615 • Colorado Springs, CO P: (719) 465-2145
Survey Prepared April 4, 2022
Drawn By: JAM Project #2212-0483 TDS #88 PCD File #SP236

DECEMBER 2024

CALLAHAN, SEAN, 1/2/2025 10:18 AM

HR GREEN - Xref: xj-1-dh01-2774; Key_Map; Site_Plan_Keynotes; xc-dgn-2774; xc-row-2774; xv-dgn-2774; xv-row-2774; xv-uti-2774; rdy-tycols; Legend_Prelim_Plan; xc-dgn-future-2774

PRELIMINARY PLAN MEADOW LAKE INDUSTRIAL PHASE 1

A PART OF THE EAST HALF OF SECTION 9, TOWNSHIP 13 SOUTH, RANGE 64 WEST OF THE SIXTH PRINCIPAL MERIDIAN, COUNTY OF EL PASO, STATE OF COLORADO

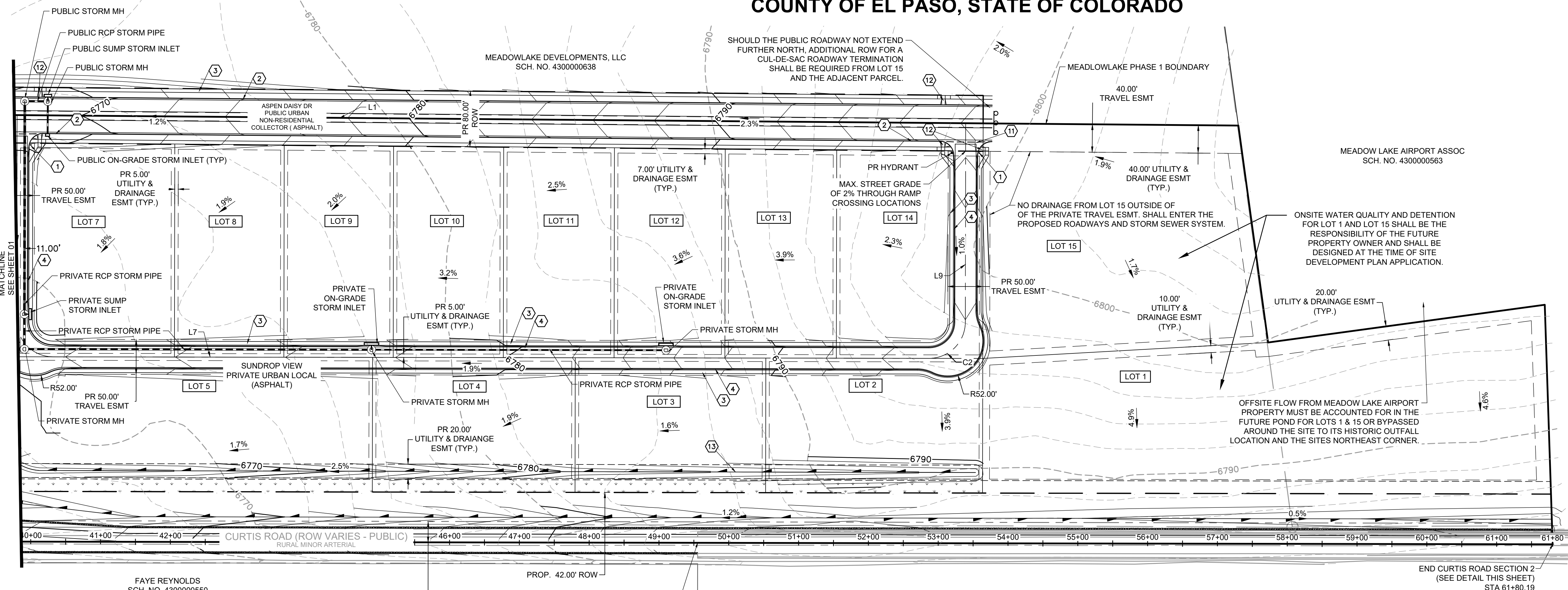

SITE PLAN KEYNOTES

- 1 PROPOSED 30" R1-1 STOP SIGN W/ STREET NAME SIGNS
- 2 PROPOSED EPC TYPE "A" NON-MOUNTABLE VERTICAL CURB AND GUTTER
- 3 PROPOSED 5' CONCRETE SIDEWALK
- 4 PROPOSED EPC TYPE "C" MOUNTABLE CURB AND GUTTER
- 5 PROPOSED 15' MAINTENANCE ACCESS ROAD, 6" MINIMUM OF GRAVEL SHALL MEET MATERIAL SPECIFICATIONS PRESENTED ON TABLE D-7 IN THE EL PASO COUNTY ENGINEERING CRITERIA MANUAL
- 6 PROPOSED FOREBAY (PRIVATE)
- 7 PROPOSED TRICKLE CHANNEL 4' WIDTH, 1" DEPTH (PRIVATE)
- 8 PROPOSED EMERGENCY SPILLWAY WITH EMBANKMENT PROTECTION (RIP-RAP)
- 9 PROPOSED OUTLET STRUCTURE (PRIVATE)
- 10 PROPOSED MICRO POOL (PRIVATE)
- 11 PROPOSED 6" CONCRETE CROSS PAN PER DETAIL SD_2-26 IN THE EL PASO COUNTY ENGINEERING MANUAL
- 12 PROPOSED PEDESTRIAN RAMP PER DETAIL SD_2-40 IN THE EL PASO COUNTY ENGINEERING MANUAL
- 13 PROPOSED ROLLED MAT LINED SWALE (PERMANENT TURF REINFORCEMENT MAT OR EQUIV.)

ROADWAY CENTERLINE DATA TABLE

Line Table						
Line #	Length	Direction	ROADWAY NAME	CLASSIFICATION	PUBLIC/PRIVATE	ROW/ESMT WIDTH
L1	3056.48	S 0°29'28" W	ASPEN DAISY DR	URBAN NON RESIDENTIAL COLLECTOR	PUBLIC	80'
L5	294.45	N 89°54'00" W	SUNDROP VIEW	URBAN LOCAL	PRIVATE	50'
L7	1181.42	S 0°06'00" W	SUNDROP VIEW	URBAN LOCAL	PRIVATE	50'
L9	285.17	S 89°54'00" E	SUNDROP VIEW	URBAN LOCAL	PRIVATE	50'

Curve Table						
Curve #	Length	Radius	Delta	ROADWAY NAME	CLASSIFICATION	PUBLIC/PRIVATE
C1	81.68	52.00	90°00'00"	SUNDROP VIEW	URBAN LOCAL	PRIVATE
C2	81.68	52.00	90°00'00"	SUNDROP VIEW	URBAN LOCAL	PRIVATE



CURTIS ROAD - MODIFIED RURAL MINOR ARTERIAL - INTERIM FUTURE (PUBLIC)

LEGEND

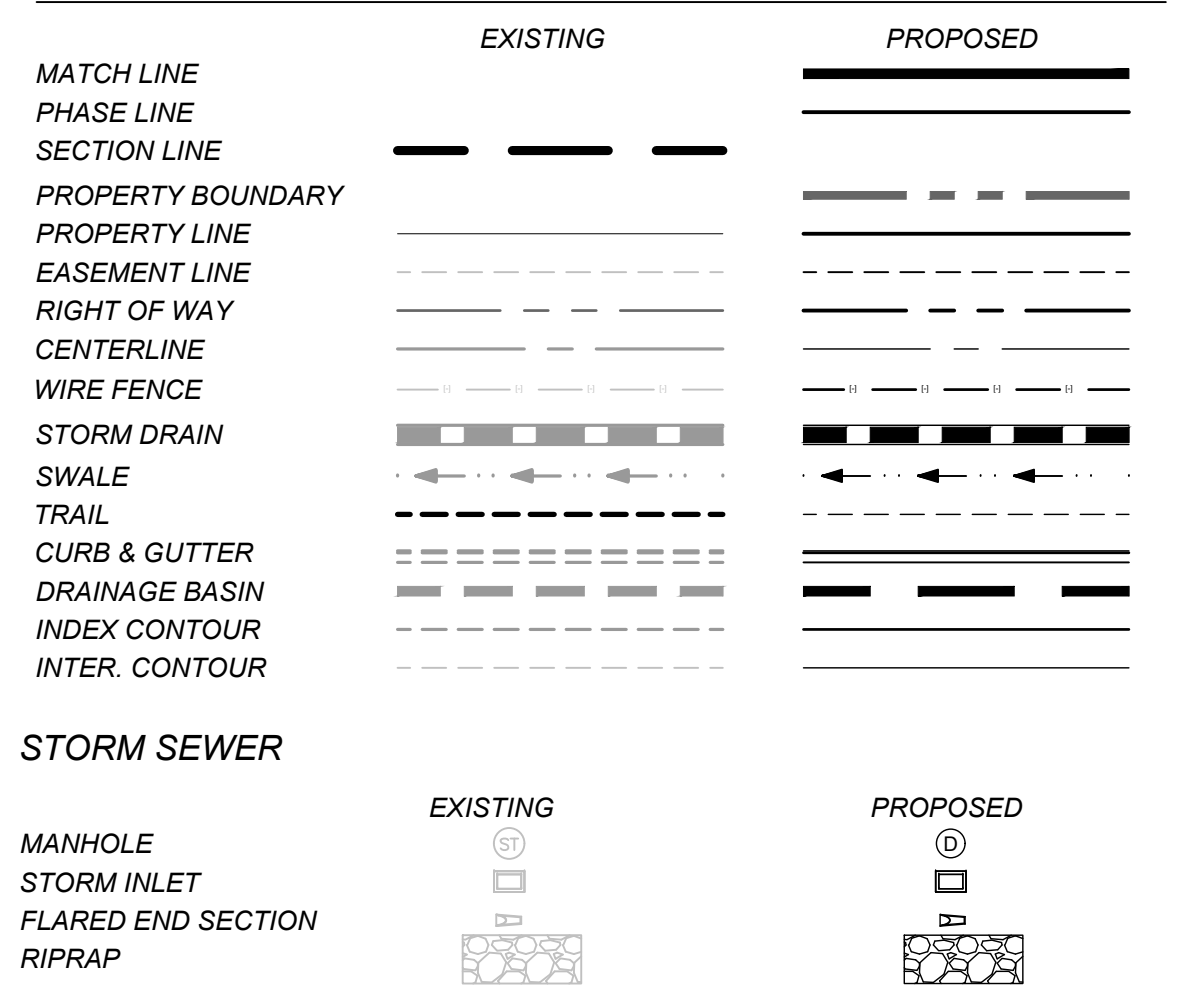

DRAWN BY: AXB JOB DATE: 12/31/2024
 APPROVED: CM JOB NUMBER: 2202774
 CAD DATE: 1/2/2025
 CAD FILE: J:\2022\2202774\CAD\DWG\Site\Site_Plan

NO.	DATE	BY	REVISION DESCRIPTION

HR GREEN - COLORADO SPRINGS
 1975 RESEARCH PARKWAY SUITE 230
 COLORADO SPRINGS, CO 80920
 PHONE: 719.384.2440
 FAX: 713.965.0044

MEADOW LAKE INDUSTRIAL PHASE 1
 MEADOWLAKE DEVELOPMENTS, LLC
 EL PASO COUNTY, CO

PRELIMINARY PLAN
 SITE PLAN

SHEET
 SP 02

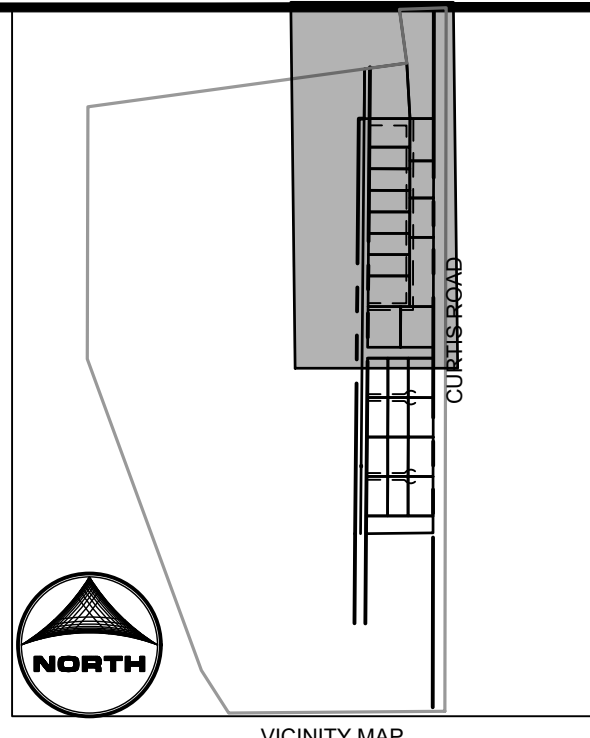

VICINITY MAP SCALE: NTS



EPC EDARP FILE NO. SP236

Key Pages from the Master TIS





LSC TRANSPORTATION CONSULTANTS, INC.
2504 East Pikes Peak Avenue, Suite 304
Colorado Springs, CO 80909
(719) 633-2868
FAX (719) 633-5430
E-mail: lsc@lsctrans.com
Website: <http://www.lsctrans.com>

**Pages from the Master TIS
Long Term Volume Projections**

Meadowlake Industrial Park
Master Traffic Impact Study
PCD File No. CS221, I221, I222
(LSC #S214950)
July 29, 2022

Traffic Engineer's Statement

This traffic report and supporting information were prepared under my responsible charge and they comport with the standard of care. So far as is consistent with the standard of care, said report was prepared in general conformance with the criteria established by the County for traffic reports.



Developer's Statement

I, the Developer, have read and will comply with all commitments made on my behalf within this report.

8/18/2022

Date

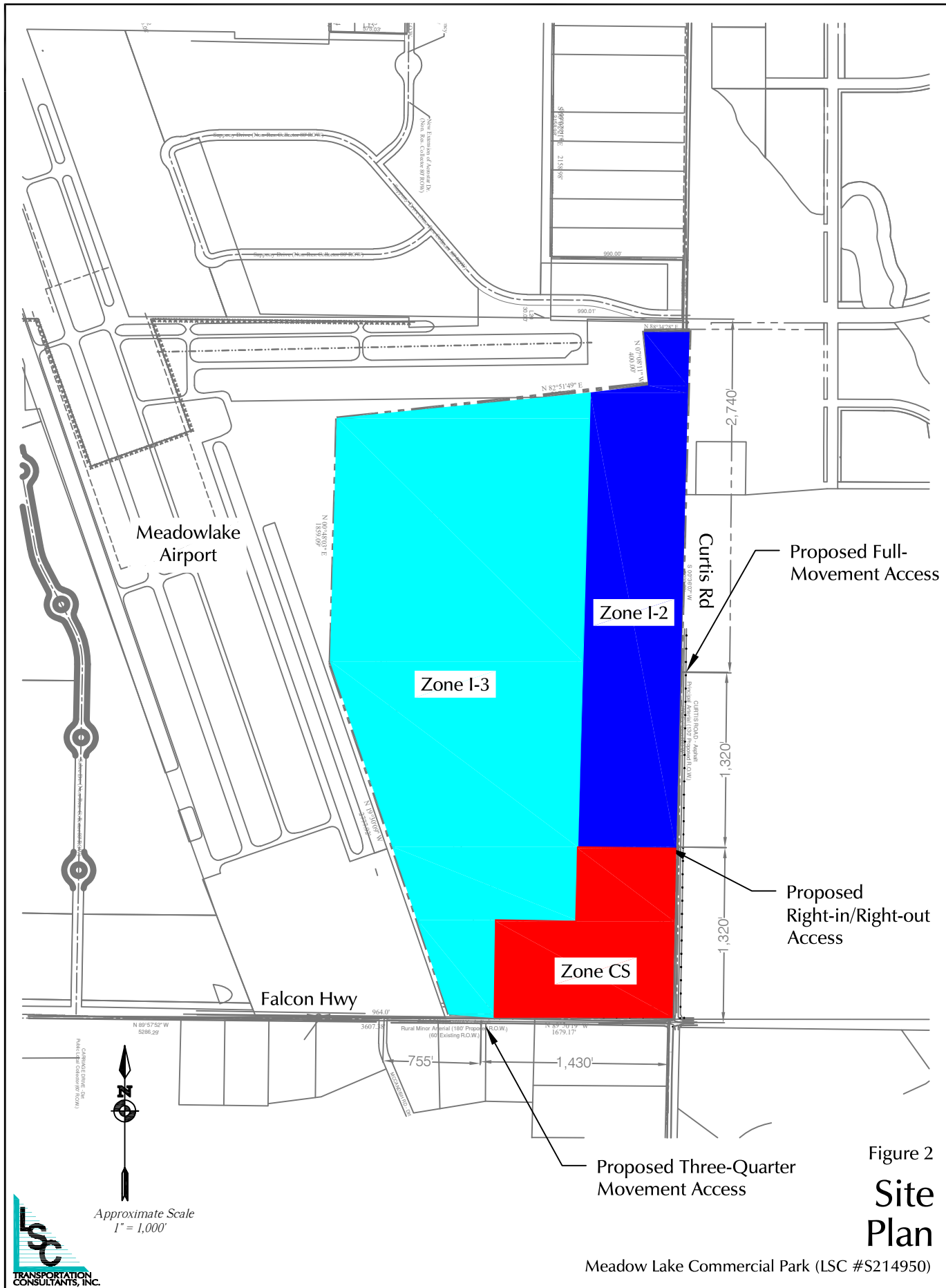

Figure 2
Site Plan

Meadow Lake Commercial Park (LSC #S214950)



Table 6: Detailed Trip Generation Estimate

TAZ	ITE		Parcel Sizes on Site Plan		Usable Area		Trip Generation Rates ²				Driveway Trips Generated				Internal Capture		%	%	%	Total External Trips Generated									
			Value	Units ¹	% Floor Area	Value	Units ¹	Average Weekday	A.M.		P.M.		Average Weekday	A.M.		P.M.		Average Weekday	Peak Hours	Primary Trips	Diverted Trips	Pass-By Trips	Average Weekday	A.M.		P.M.			
									In	Out	In	Out		In	Out	In	Out							In	Out	In	Out	In	Out
Currently-Proposed Site Plan																													
1, 3, 4, 5	130	Industrial Park	174.280	Acres	29%	2201.575	KSF	3.37	0.28	0.06	0.07	0.27	7419	606	142	165	584	0%	0%	100%	0%	0%	7419	606	142	165	584		
2	770	Business Park	9.555	Acres	25%	104.054	KSF	12.44	1.15	0.20	0.32	0.90	1294	119	21	33	94	0%	0%	95%	5%	0%	1230	113	20	31	89		
2	821	Strip Retail Plaza w/o Supermarket (40-150 KSF)	9.555	Acres	18%	74.919	KSF	94.49	2.19	1.34	4.33	4.70	6725	148	90	292	317	5%	10%	41%	25%	34%	2757	61	37	120	130		
													Total	15439	873	254	490	994						Total	11406	780	199	316	803
Comparison to Previous Site Plan																													
-	-	Previously-Approved Land Uses	-	-	-	-	-	-	-	-	-	-	13343	390	124	426	607	-	-	-	-	-	13343	390	124	426	607		
-	-	Currently-Proposed Land Uses	-	-	-	-	-	-	-	-	-	-	15439	873	254	490	994	-	-	-	-	-	11406	780	199	316	803		
													Change in Trip Generation					Change in Trip Generation					-1937	390	75	-110	196		

¹ KSF = 1,000 square feet

² Source: *Trip Generation, 11th Edition (2021)* by the Institute of Transportation Engineers (ITE)

Updated by LSC 06/28/2022

Site-Generated Traffic

Short-Term

Short-term site-generated traffic volumes have been estimated at the study area intersections. The volumes have been calculated by applying the short-term directional distribution percentages estimated by LSC (from Figure 4) to the trip-generation estimates (from Table 6). Figure 6 shows the projected short-term site-generated traffic volumes for the weekday morning and evening peak hours. The figure also shows the estimated average daily traffic volumes (ADTs).

Long-Term

Long-term site-generated traffic volumes have been estimated at the study area intersections. The volumes have been calculated by applying the long-term directional distribution percentages estimated by LSC (from Figure 5) to the trip-generation estimates (from Table 6). Figure 7 shows the projected site-generated traffic volumes for the weekday morning and evening peak hours. The figure also shows the estimated average daily traffic volumes (ADTs).

Existing-Plus-Site-Generated Traffic Volumes

Figure 8 shows the sum of the existing traffic volumes (from Figure 3) and short-term site-generated peak-hour traffic volumes (shown in Figure 6). These volumes represent the projected short-term total traffic following site buildout. Laneage and traffic control at the study-area intersections following site buildout are shown in Figure 8.

2042 Background Traffic Volumes

The 2042 background traffic volumes are generally based on the projections presented in the *MTCP*, but adjustments have been made to account for the removal of the PUD, urban-density land use and corresponding trip generation from the former Santa Fe Springs development area. For more information and details, please refer to PCD File Nos. P178 through P1714. The County rezoned the former Santa Fe Springs development parcels to A-5, A-35, F-5, RR.5, RR2.5, and RR-2, which replaced the Santa Fe Springs PUD 1 zoning.

US Hwy 24 volumes are estimates by LSC based, in part, on the Colorado Department of Transportation *US 24 Planning and Environmental Linkages Study Final Corridor Conditions Report* (dated December 2016). These volumes assume the 2042 roadway system including the extension of Stapleton Road west to Briargate Parkway. Traffic from the proposed Meadowlake Industrial Park is **not** included in the 2042 **background** traffic volumes.



Approximate Scale
Scale: 1" = 3,000'

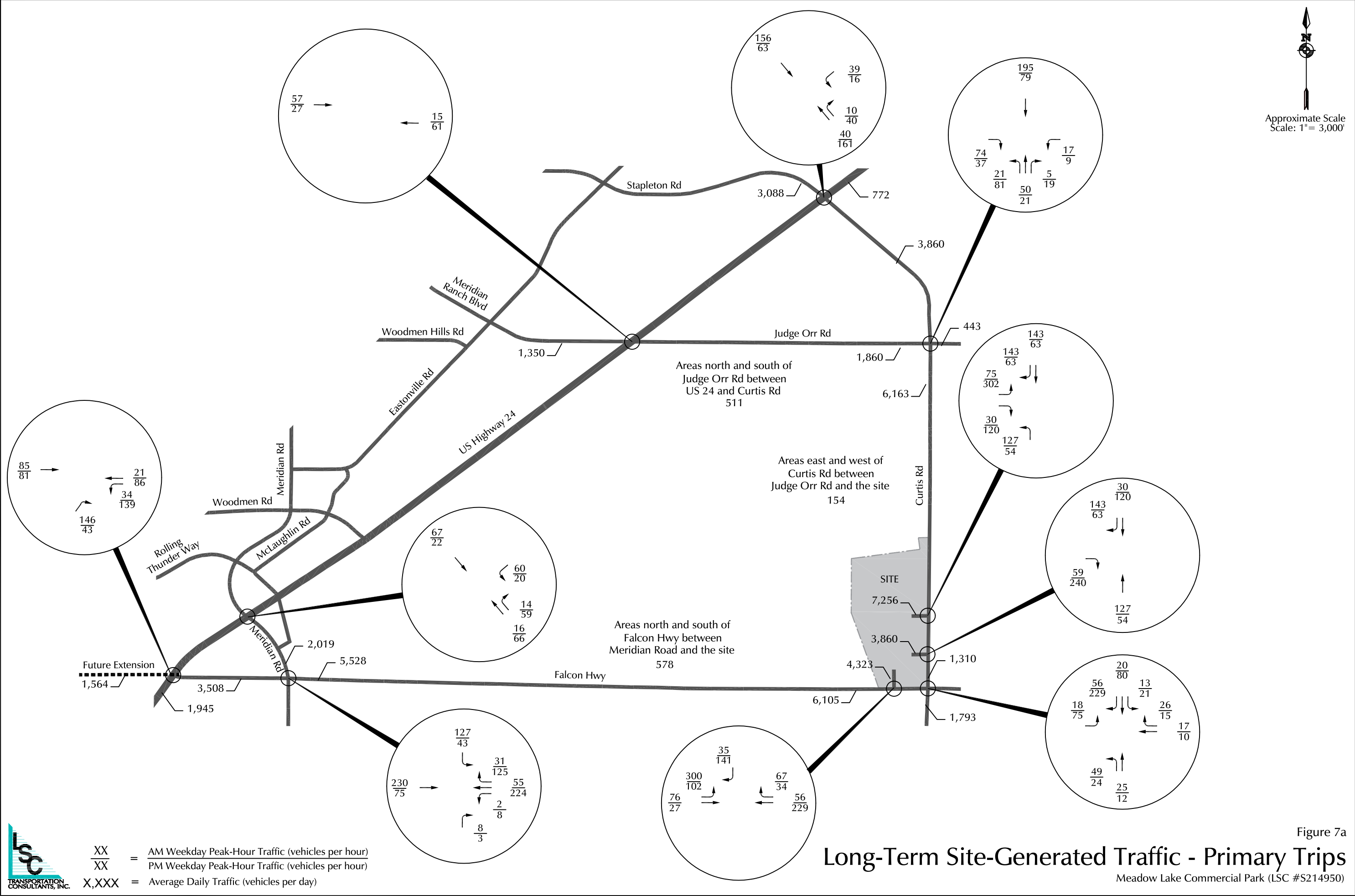

Long-Term Site-Generated Traffic - Primary Trips

Figure 7a

Meadow Lake Commercial Park (LSC #S214950)



Approximate Scale
Scale: 1" = 3,000'

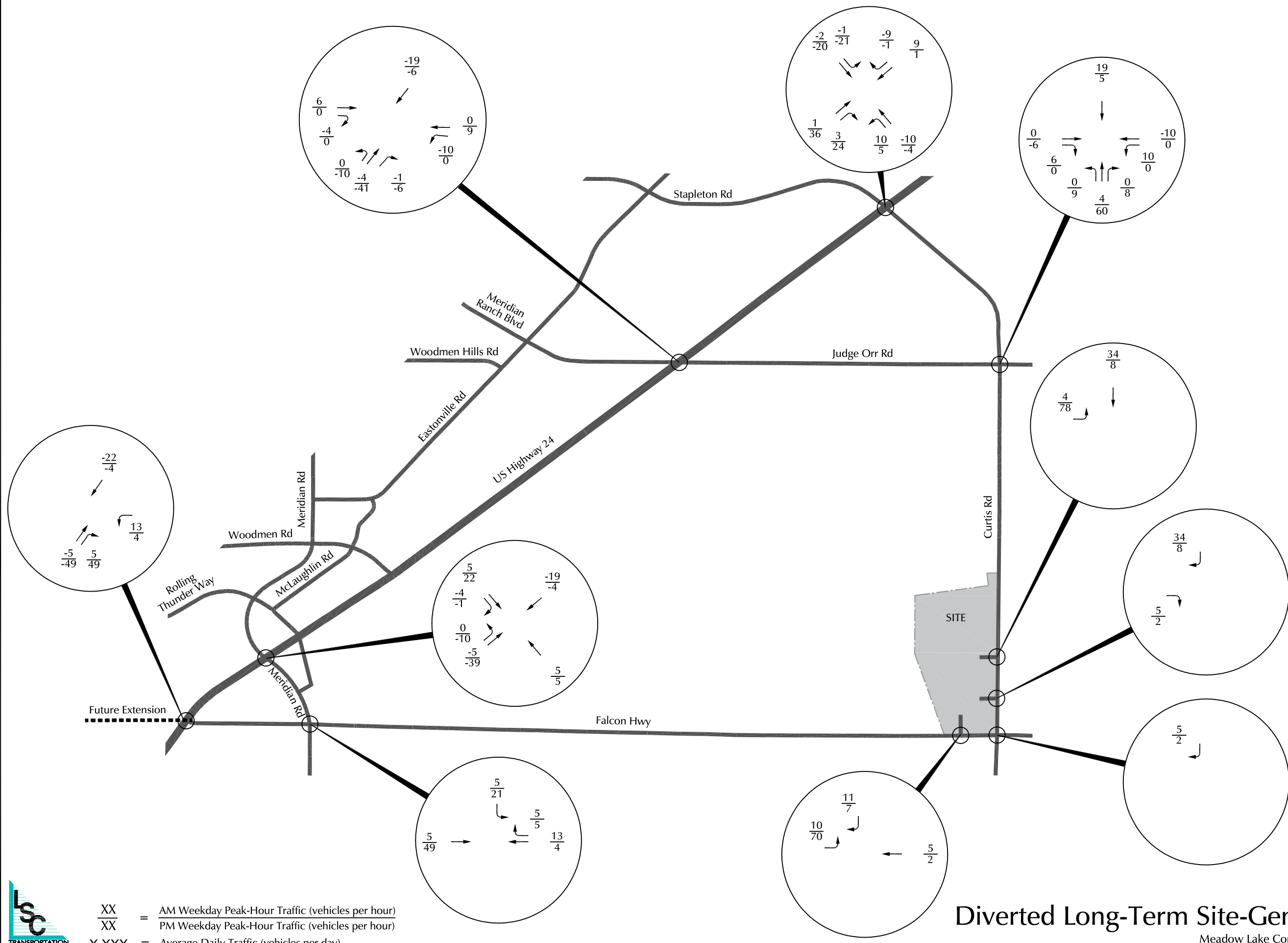

$\frac{XX}{XX}$ = AM Weekday Peak-Hour Traffic (vehicles per hour)
 $\frac{XX}{XX}$ = PM Weekday Peak-Hour Traffic (vehicles per hour)
 X,XXX = Average Daily Traffic (vehicles per day)

Diverted Long-Term Site-Generated Traffic

Meadow Lake Commercial Park (LSC #S214950)

Figure 7b



Approximate Scale
Scale: 1" = 3,000'

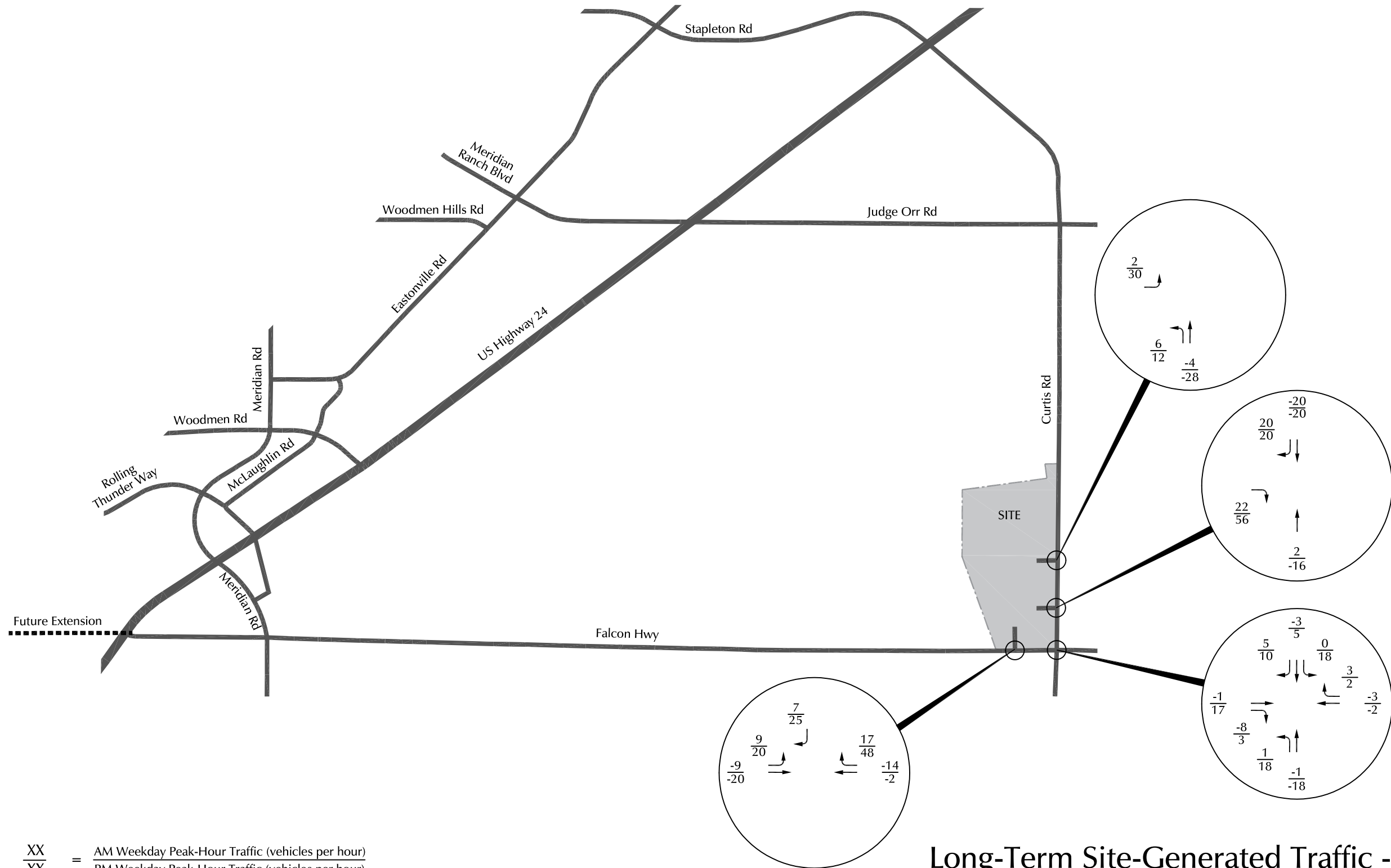

$\frac{XX}{XX}$ = AM Weekday Peak-Hour Traffic (vehicles per hour)
 $\frac{XX}{XX}$ = PM Weekday Peak-Hour Traffic (vehicles per hour)
 X,XXX = Average Daily Traffic (vehicles per day)

Long-Term Site-Generated Traffic - Pass-by Trips

Meadow Lake Commercial Park (LSC #S214950)

Figure 7c

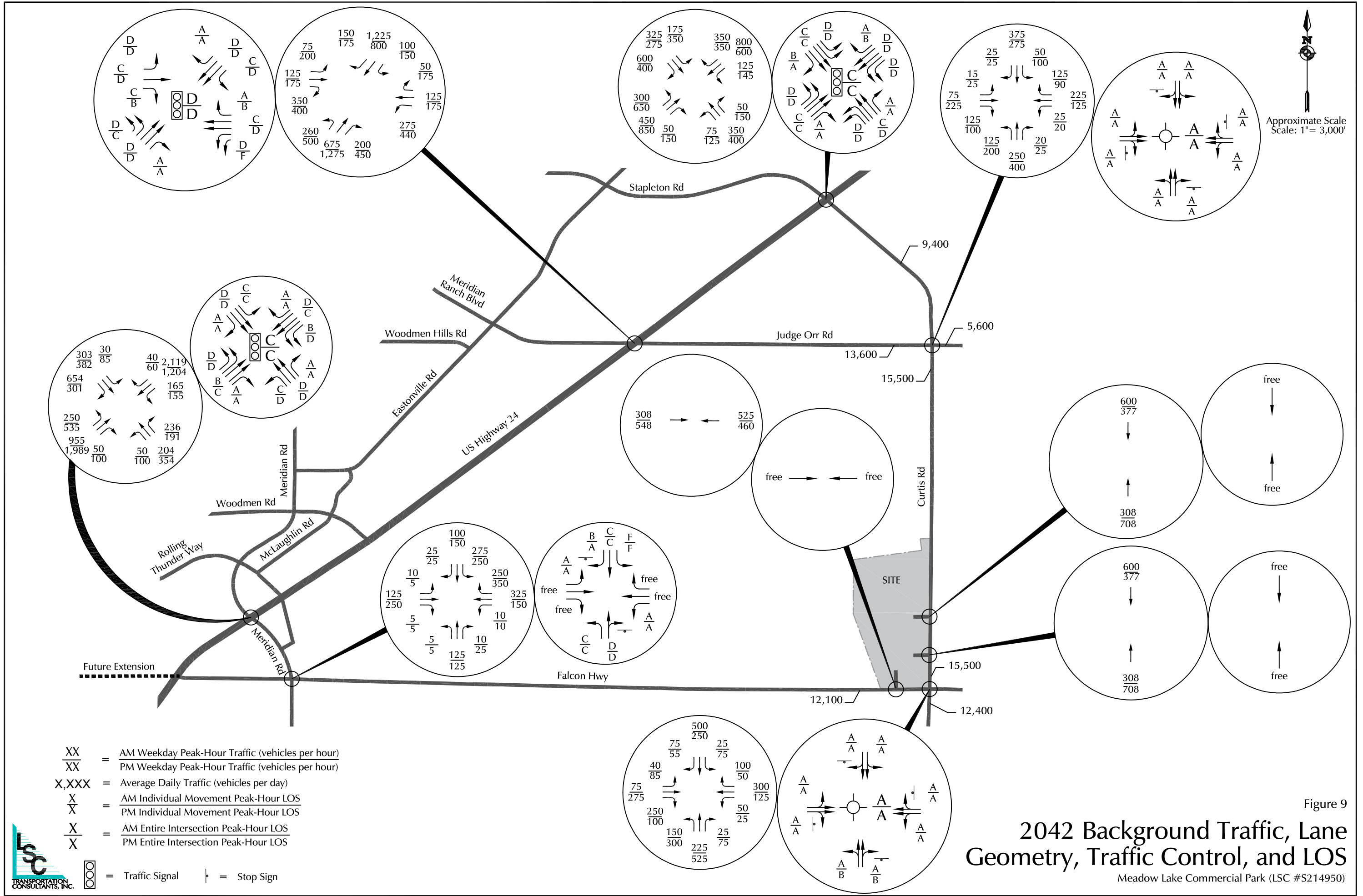
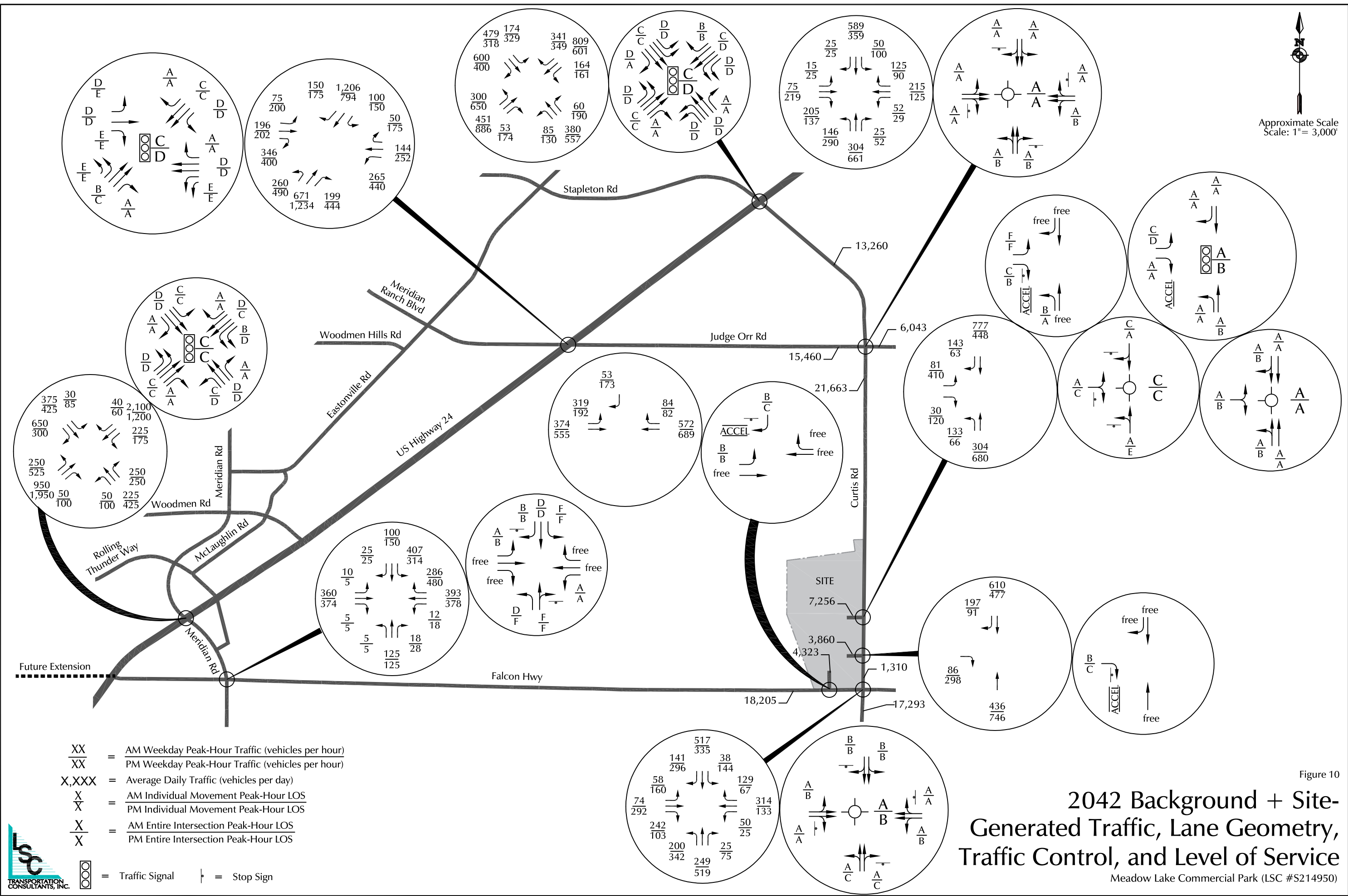
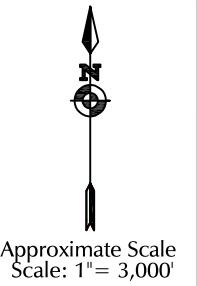

Figure 9
2042 Background Traffic, Lane Geometry, Traffic Control, and LOS
 Meadow Lake Commercial Park (LSC #S214950)



$\frac{XX}{XX}$ = AM Weekday Peak-Hour Traffic (vehicles per hour)
 $\frac{XX}{XX}$ = PM Weekday Peak-Hour Traffic (vehicles per hour)
 X,XXX = Average Daily Traffic (vehicles per day)
 $\frac{X}{X}$ = AM Individual Movement Peak-Hour LOS
 $\frac{X}{X}$ = PM Individual Movement Peak-Hour LOS
 $\frac{X}{X}$ = AM Entire Intersection Peak-Hour LOS
 $\frac{X}{X}$ = PM Entire Intersection Peak-Hour LOS

= Traffic Signal = Stop Sign



Figure 10

2042 Background + Site-Generated Traffic, Lane Geometry, Traffic Control, and Level of Service

Meadow Lake Commercial Park (LSC #S214950)